

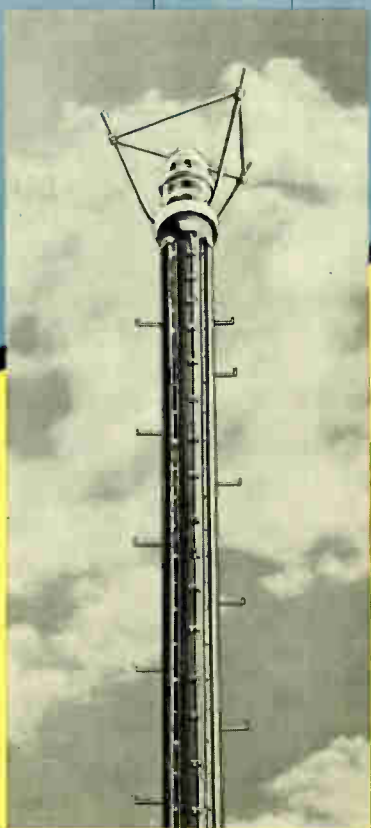

TRANSMITTERS • ANTENNAS • TOWERS • ACCESSORIES

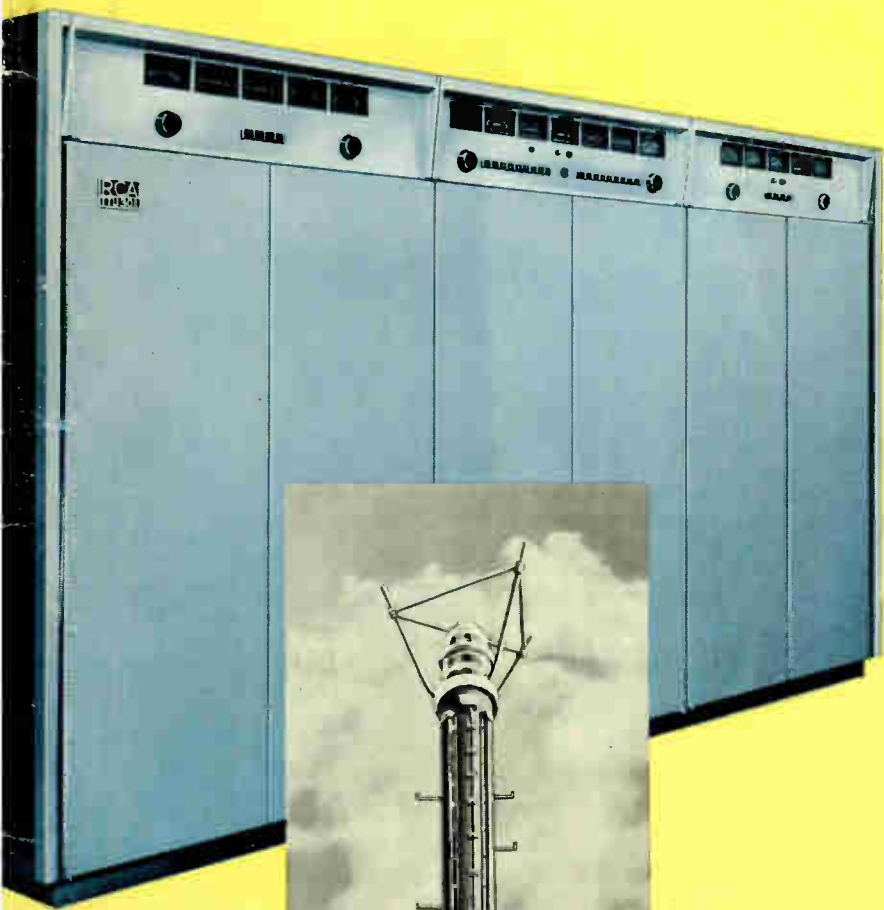

TRANSMITTING
uhf-tv
EQUIPMENT



PRICE
LIST
FOR

TRANSMITTING
uhf-tv
EQUIPMENT

Prices Effective Sept. 1, 1966



The Most Trusted Name in Television

Ordering Information

RCA broadcast equipment is sold directly to broadcast stations through the Broadcast Sales Representatives operating out of the convenient sales offices listed below. These Broadcast specialists are available to assist you in discussing the application of broadcast equipment.

In ordering equipment, please indicate the Master Item (MI) number for each equipment. This will help us to speed the shipment to you. You will find the Master Item (MI) numbers are used to identify the equipment on the invoices and packing slips. The "Literature" column provides ready page reference to latest bound equipment catalog as well as the latest broadcast catalog for individual equipment items.

The Purchaser shall be responsible for all transportation charges, and shipments will normally be forwarded with shipping charges "collect." However, shipping charges can be prepaid and added to the billing invoice if your purchase order authorizes this method. We suggest that you consider the latter procedure since it eliminates the necessity of having petty cash on hand at the time of delivery. Your purchase order should specify the method of transportation desired, otherwise RCA will use its best judgment. The cheapest method of transportation is not always used as this may not always result in the most rapid delivery. Certain items, such as vacuum tubes, are usually shipped by Express because of the design of carrying container, insurance, etc.

RCA Broadcast Sales Offices

Atlanta, Ga. 1121 Rhodes-Haverty Bldg. Tel. 524-7703	30303	Dallas, Texas 210-C Court Terrace Exchange Park, North Tel. 351-5361	75235	St. Louis, Mo. 7710 Carondelet Ave. Tel. 862-3660	63105
Austin, Texas Northwest Professional Bldg. 5425-B Burnet Rd. Tel. 453-8233	78756	Denver, Colo. Suite 223, 2785 N. Speer Blvd. Tel. 477-6832	80211	San Francisco, Calif. 343 Sansome St. Tel. 956-4818	94104
Birmingham, Ala. Office Park Circle Bldg. #10 Tel. 871-1155	35223	Indianapolis, Ind. 501 N. LaSalle St. Tel. 635-9000	46201	Seattle, Wash. 2246 First Ave., S. Tel. 622-8350	98134
Burbank, Calif. 2700 W. Olive Ave. Tel. 849-6741	91505	Kansas City, Mo. 7711 State Line Rd. Tel. 363-6770	64114	Southfield, (Detroit) Mich. 20830 Rutland Ave. Tel. 357-0080	48076
Camden, N. J. Front & Cooper Sts. Tel. 963-8000 Ext. PC-3592	08102	Meadow Lands, (Pittsburgh) Penna. Washington County Tel. 341-5294	15347	Washington, D.C. 1725 "K" St., N.W. Tel. 337-8500	20006
Charlotte, N. C. 330 Charlottetown Center Tel. 333-3996	28204	Memphis, Tenn. 2110 Airways Blvd. Tel. 743-9442	38114	West Newton, (Boston) Mass. 950 Watertown Street Tel. 969-6010	02165
Chicago, Ill. 2000 Merchandise Mart Plaza Tel. 467-5900	60654	Minneapolis, Minn. 4522 Excelsior Blvd. Tel. 929-3303	55416	West Palm Beach, Fla. 3900 Monet Rd. Palm Beach Gardens Tel. 844-7351	33403
Cincinnati, Ohio 8234 Winton Road Tel. 822-8810	45224	New York, N. Y. Rm. 1219, 30 Rockefeller Plaza Tel. 689-7200	10020	RCA International Div. Central & Terminal Avenues Clark, N. J. Tel. 382-1000	07066
Cleveland, Ohio 1600 Keith Bldg. Tel. 241-3450	44115	Orlando, Florida 5330 Diplomat Circle, Suite 30 Tel. 644-9135	32810		

UHF TV Transmitting Equipment Price List

	Catalog Page	References Sheet	MI No.	Price
Adaptor, Type N to Type HN.....	109	B.5520	19089-19	\$ 30.00
Amplifier, Distribution, Type TA-33.....	50	B.4717	ES-556933	335.00
Amplitude Equalizer	50	B.4717	34035	40.00
Analyzers:				
TV Sideband Response, Type BW-5C.....	57	B.4722	ES-34010-C	2,750.00
TV Sideband Response, Type BWU-5C.....	57	B.4722	ES-34009-C	3,350.00
Antennas:				
UHF TV Pylon.....	69	B.5102	Custom	See under "Pylon"
"Zee" Panel	89	B.5110	Custom	On Application
"Vee-Zee" Panel	89	B.5110	Custom	On Application
Cable, Coaxial RG-8/U	60	B.4722	MI-74A	0.14 per ft.
Carrier-Off Monitor	52	B.4724	ES-27235	790.00
Chopper Relay	56	B.4932	#211711	93.54
Chopper, Vertical Interval Electronic (use with BWU-4B)	—	—	43993-B	350.00
Connector, Anchor Insulator	109	B.5520	19089-10A	21.40
Couplers:				
Directional, for use with MI-19089 Transmission Line	60	B.4722	ES-34231-1, 2	220.00
Directional, for use with MI-27791 Transmission Line	60	B.4722	ES-34231-1, 8	220.00
Directional, for use with MI-19387 Transmission Line	60	B.4722	ES-34232-1, 2	275.00
Directional, for use with MI-27792 Transmission Line	60	B.4722	ES-34232-1, 5	307.00
Console, Transmitter Control, Type TTC-5B	45	B.4304	ES-561900	6,950.00
Crystal Unit, Type TMV-129P	—	B.4600	27497	115.00
Demodulators:				
Visual Sideband, Type BW-4B (FCC)	55	B.4932	ES-34048	2,680.00
Visual Sideband, Type BW-4B (CCIR)	55	B.4932	MI-826557	On Application
Visual Sideband, Type BWU-4B (FCC)	55	B.4932	ES-34049-B	3,250.00
Visual Sideband, Type BWU-4B (CCIR)	55	B.4932	826559	On Application
Directional Coupler, For use with:				
MI-19089 Transmission Line	60	B.4722	ES-34231-1, 2	220.00
MI-27791 Transmission Line	60	B.4722	ES-34231-1, 8	220.00
MI-19387 Transmission Line	60	B.4722	ES-34232-1, 2	275.00
MI-27792 Transmission Line	60	B.4722	ES-34232-1, 5	307.00
Distribution Amplifier, Type TA-33	50	B.4717	ES-556933	335.00
Envelope Delay Measuring Equipment:				
BW-8A (FCC)	61	B.4721	34063	2,980.00
BW-8A1 (CCIR)	61	B.4721	34068	On Application
Equalizer, Amplitude	50	B.4717	34035	40.00
Exciter, Spare Group (for TTU-50C Transmitter)	36	B.5040	ES-560281	9,500.00
Filters:				
Low Pass Video	51	B.4713	27132-A	655.00
UHF Harmonic (Channels 14-43)	63	B.5510	561549-L-CH	525.00
UHF Harmonic (Channels 44-83)	63	B.5510	561549-H-CH	525.00
Filterplexers:				
2 kW UHF	65	B.5515	19086-HM	9,400.00
12½ kW UHF	65	B.5515	19086-J	9,800.00
30 kW UHF	65	B.5515	19086-F	12,900.00
60 kW UHF Waveguide (Channels 14-43)	67	B.5530	561550-CH	25,000.00
60 kW UHF Waveguide (Channels 44-83)	67	B.5530	561551-CH	25,000.00

UHF TV TRANSMITTING EQUIPMENT PRICE LIST

	Catalog Page	References Sheet	MI No.	Price
Frequency and Modulation Monitors:				
115 Volt, 50 Hertz	53	B.4715	Model H02-335-ER	\$ 3,265.00
115 Volt, 60 Hertz	53	B.4715	Model 335-ER	2,700.00
230 Volt, 50 Hertz	53	B.4715	Model H03-335-ER	3,265.00
Generator, Marker	56	B.4932	WR-99A	242.50
Generators, Emergency	—	—	—	On Application
Hangers, Transmission Line	107	—	—	—
Harmonic Filters:				
For UHF Channels 14-43	63	B.5510	561549-L-CH	525.00
For UHF Channels 44-83	63	B.5510	561549-H-CH	525.00
Low Pass Video Filter	51	B.4713	27132-A	655.00
Marker Generator	56	B.4932	WR-99A	242.50
Meter, Plate Current	56	B.4932	21200-C1	99.50
Monitors:				
Carrier-Off	52	B.4724	27235	790.00
Frequency and Modulation, 115V 50 Hz	53	B.4713	Model H02-335-ER	3,265.00
Frequency and Modulation, 115V 60 Hz	53	B.4713	Model 335-ER	2,700.00
Frequency and Modulation, 230V 50 Hz	53	B.4713	Model H03-335-ER	3,265.00
Monitoring Diodes:				
UHF	64	B.5946	19364	395.00
VHF	56	B.4932	19051-B	130.00
Mounting Frame	50	B.4717	577300	75.00
Oscillator, TV Sweep	56	B.4932	WR-69A	295.00
Oscilloscopes:				
General Purpose	60	B.4722	WO-91B	249.00
Wide Band	56	B.4932	TO-524AD	1,495.00
Phase Equalizer Equipment Complete	49	B.4717	ES-34034-B	2,890.00
Plate Current Meter	56	B.4932	21200-C1	99.50
Power Distribution Modules:				
For 115V, 60 Hz	50	B.4717	556648-1	95.00
For 230V, 50 Hz	50	B.4717	556648-2	On Application
Pressurizing Equipment	108	—	—	—
Pylon Antennas:				
TFU-6C	72	B.5102	Custom	4,450.00
TFU-6J	72	B.5102	Custom	5,800.00
TFU-24DL	73	B.5102	Custom	19,800.00
TFU-24DM	73	B.5102	Custom	18,300.00
TFU-27DJ	73	B.5102	Custom	18,300.00
TFU-30J	74	B.5102	Custom	34,500.00
TFU-25G	74	B.5102	Custom	49,500.00
TFU-46K	74	B.5102	Custom	99,500.00
TFU-24DAS	74	B.5102	Custom	79,500.00
TFU-30JDA	74	B.5102	Custom	On Application
Reducer, 50 Ohm 3 1/8" to Type N	109	B.5520	19089-17	112.00
Reducer Transformer	111	B.5524	19387-4-CH	262.00
Relay, Chopper	56	B.4932	#211711	93.54
RF Loads:				
1200 Watt (Including Wattmeter)	109	B.5520	19197	735.00
15/25 kW UHF (470-890 MHz)	111	B.5524	19198-A2	1,260.00
50 kW (Including Wattmeter)	111	B.5524	ES-561408-CH	4,200.00

UHF TV TRANSMITTING EQUIPMENT PRICE LIST

	Catalog Page	References Sheet	MI No.	Price
Sideband Response Analyzers:				
VHF Type BW-5C	57	B.4722	ES-34010-C	\$ 2,750.00
UHF Type BWU-5C	57	B.4722	ES-34009-C	3,350.00
Switches, Transmission Line	108	—	—	—
Towers, Television Antenna	97	B.5800	Custom	On Application
Transformer, Reducer	111	B.5524	19387-4-CH	262.00
Transmission Line:				
3 1/8" Bolt Flanged 50 Ohm	105	—	19089	—
6 1/8" Bolt Flanged 75 Ohm	105	—	19387	—
3 1/8" Universal 50 Ohm	105	—	27791-D	—
6 1/8" Universal 75 Ohm	105	—	27792-D	—
9 3/8" Universal 75 Ohm	105	—	27793-D	—
Transmission Line Hangers	107	—	—	—
Transmission Line Section (for mounting BW-5C Directional Coupler):				
3 1/8" 51.5 Ohm Flanged Transmission Line	60	B.4722	19313-48	—
3 1/8" 51.5 Ohm Flanged Transmission Line	60	B.4722	19313-49	—
3 1/8" 50 Ohm Transmission Line	60	B.4722	27912-12	—
Transmission Line Switches	108	—	—	—
Transmitter Control Console, Type TTC-5B	45	B.4304	ES-561900	6,950.00
Transmitters:				
TTU-2A 2 kW UHF	5	B.5002	ES-560237	78,500.00
TTU-10A 10 kW	13	B.5010	ES-560243	149,500.00
TTU-30A 30 kW UHF	21	B.5030	ES-560250	199,500.00
TTU-50C 55 kW UHF	29	B.5040	ES-560275	285,000.00
TTU-50C1 55 kW UHF	37	B.5042	ES-560276	299,500.00
TTU-150A 150 kW UHF	—	—	Custom	On Application
Tubes:				
Complete set of spares for TTU-2A	12	B.5002	ES-560238	6,035.00
Complete set of spares for TTU-10A	20	B.5010	ES-560244	8,035.00
Complete set of spares for TTU-30A	28	B.5030	ES-560251	14,735.00
Complete set of spares for TTU-50C/50C1	36	B.5040	ES-560279	21,895.00
Minimum set of spares for TTU-2A/10A	12	B.5002	ES-560239	3,135.00
Minimum set of spares for TTU-30A/50C/50C1	28	B.5030	ES-560252	7,450.00
Spares for Carrier-Off Monitor	52	B.4724	27825	25.30
FCC spares for Carrier-Off Monitor	52	B.4724	27831	12.65
Set of spares for BW-4B	56	B.4932	34014	41.25
Set of spares for BWU-4B	56	B.4932	34015	41.25
Set of spares for 335-ER Frequency and Modulation Monitor	—	—	—	15.00
"Vee-Zee" Panel Antennas	89	B.5110	Custom	On Application
Vertical Interval Electronic Chopper (for BWU-4B)	—	—	43993-B	350.00
Visual Sideband Demodulators:				
BW-4B (FCC)	55	B.4932	ES-34048	2,680.00
BW-4B (CCIR)	55	B.4932	826557	On Application
BWU-4B (FCC)	55	B.4932	ES-34049-B	3,250.00
BWU-4B (CCIR)	55	B.4932	826559	On Application
VoltOhmyst (Senior Model)	56	B.4932	WV-98C	79.50
Wattmeters:				
RF Thruline (0-15 kW for MI-19198-A2)	110	B.5522	27350	500.00
RF Thruline (0-25 kW for MI-19198-A2)	110	B.5522	27363	500.00
Waveguide Filterplexers:				
60 kW for UHF Channels 14-42	67	B.5530	561550	25,000.00
60 kW for UHF Channels 43-83	67	B.5530	561551	25,000.00
"Zee" Panel Antennas	89	B.5110	Custom	On Application

Broadcast Equipment, Sales Policy

FOREWORD

The present statement sets forth basic conditions under which RCA sells broadcast equipment as described in our catalog, and notes certain supplemental information. This statement does not apply to the sale of tubes or sound film recording equipment, for which separate standard sales and lease policies are in effect.

RCA broadcast equipment is sold directly through RCA Sales representatives, who are familiar with broadcast equipment.

CONTRACT PROCEDURE

All Sales based on orders for transmitters, antennas and custom built or special apparatus and on orders over \$5,000 are made in accordance with the conditions of the RCA Standard Proposal Form for the sale of broadcast equipment and with any agreement stipulated thereon for individual customers.

PRICES

RCA broadcast equipment domestic prices are net f.o.b. factory or warehouse, which is Camden, New Jersey, for most items. These prices do not include any federal, state or local taxes based upon use or measured by sale or use and unless otherwise noted do not include federal excise tax. Any such taxes in effect at the time of shipment will be billed separately or will be included in the prices when required and will be due and payable upon delivery.

RCA's prices do not include installation or installation supervision unless specifically mentioned in a written condition or proposal. Purchaser assumes responsibility for installation and operation of the equipment as well as for obtaining all necessary licenses, permits, etc.

NOTE: The service of factory trained personnel who are specialists in the supervision of the installation of broadcast equipment and its maintenance and repair may be obtained through an order placed with the RCA Service Company, Inc. It is recommended that the advantages of this service be considered at the time of purchase of any major broadcast equipment.

In the case of orders under the Standard Proposal Form the billing prices are based on those prices effective at the date of the order to the extent indicated in the final contract. In the case of orders not under the Standard Proposal Form the billing prices are those prices in effect on the date of shipment.

RCA endeavors to keep its published prices current; however, all published prices are subject to change without notice.

Prices for items marked with a symbol (e) are estimates only and are subject to adjustment to those in effect on the date of shipment.

In the event the estimated prices quoted herein are exceeded by more than 10% and the billing price cannot be established by mutual agreement prior to shipment, such items may be cancelled without liability to RCA or Purchaser by either party giving written notice to the other.

PAYMENT

Terms of payment are subject to approval of RCA's Credit Department at Camden, New Jersey.

DELIVERY

RCA's delivery of broadcast equipment will be f.o.b. factory or warehouse, which is Camden, New Jersey for most items. The Purchaser shall be responsible for all transportation charges, and shipments will normally be forwarded with shipping charges "collect." As an accommodation, when specifically requested to do so by the Purchaser's order, RCA will prepay transportation charges and invoice them to the Purchaser as a separate item.

Delivery will be made to a carrier specified by the Purchaser, unless none is specified, in which event it will be to a common carrier selected by RCA. In the absence of specific

routing instructions from the purchaser, RCA's judgment with respect to the selection of a route will be final.

As a special service with respect to shipments overland, by inland waterways or by air we carry All Risk Transportation Insurance for the benefit of our Broadcast Equipment customers, and your interests will be amply protected in all shipments of equipment while in transit by the methods indicated above, at no additional expense to you, provided that you inspect all shipments within 15 days after receipt and report within that time in writing any shortages or damages to the carrier and to RCA.

RCA will endeavor to meet delivery schedules but it assumes no liability for damages of whatever kind for delays in delivery. No delays in delivery shall relieve the purchaser of his obligation of performance.

PATENT LICENSES

RCA broadcast equipment is licensed for radio telephone or television broadcast transmission under United States patents owned by RCA or under United States patents under which RCA is licensed.

PATENT PROTECTION

RCA, at its own expense, will defend any suit which may be brought against purchaser for infringement of United States patents by the equipment furnished when sold or used for radio telephone or television broadcast transmission, and in any such suit will satisfy any final award for such infringement. This is upon the condition that purchaser gives RCA prompt notice of such suit and full right and opportunity to conduct the defense thereof, together with full information and all reasonable cooperation, and upon the further condition that the claimed infringement does not result from the combination of the equipment furnished with other equipment, apparatus, or devices not furnished by RCA. No costs or expenses shall be incurred for the account of RCA without its written consent. If purchaser's sale or use of such equipment for radio telephone or television broadcast transmission shall be prevented by permanent injunction, RCA shall substitute for the infringing equipment or parts other equally suitable equipment or parts, or at RCA's option obtain for purchaser the right to sell or continue the use of such equipment, or at RCA's option take back such equipment and refund any sums purchaser has paid RCA therefor, less a reasonable amount for use, damage and obsolescence.

WARRANTY

Except for electronic tubes, which bear their own warranty which accompanies them at the time of their sale, RCA warrants its broadcast equipment to be free from defects in material and workmanship under normal use and service for a period of one year from the date of delivery. RCA's obligations under this warranty are limited to the repair or replacement of defective parts and the shipment of such repaired or replacement parts to the purchaser f.o.b. factory. Equipment furnished by RCA but listed as manufactured by another bears only the warranty given by such other manufacturer. No warranties other than those set forth herein are given or are to be implied with respect to broadcast equipment. In no event is RCA liable for consequential damages.

REPAIRED AND RETURNED APPARATUS

Before an apparatus is returned to RCA for repairs or adjustments, shipping instructions and an identifying number should be obtained from the nearest RCA Sales Office. RCA assumes no responsibility for unauthorized returns.

EQUIPMENT MODIFICATIONS AND WITHDRAWALS

RCA reserves the right to make, without notice, modifications of the equipment described in this catalog without affecting its right to sell such equipment under orders based on the catalog description, provided, however, that the modifications shall not materially affect performance. These modifications of equipment may be made by RCA or its suppliers from time to time for reasons such as improvement in performance, simplification in design, or availability of material. RCA also reserves the right to withdraw from sale, without notice, any equipment described in our catalog.

ACCEPTANCE OF ORDER

No order shall be binding upon RCA until accepted by it in writing at Camden, New Jersey, and the banking, negotiation or other use of the down payment shall not constitute an acceptance by RCA. Orders received by Sales Offices will be forwarded promptly to RCA's Camden Office.



RADIO CORPORATION OF AMERICA

BROADCAST & COMMUNICATIONS PRODUCTS DIVISION • CAMDEN, N. J. 08102

J. Frank

**UHF TV
TRANSMITTING
EQUIPMENT
CATALOG**



THE MOST TRUSTED NAME IN TELEVISION

ABOUT THIS CATALOG

This catalog provides information on RCA UHF Television Transmitting Equipment. Other RCA Broadcast Equipment Catalogs supply information on TV Camera, TV Film, TV Tape, Terminal and Switching, and Audio equipment; also on AM, FM and VHF TV transmitters, antennas, and transmission line.

The information contained in this catalog is intended to serve as a buying guide for the user. Complete specifications and ordering information are supplied. Readers who desire more information or individual bulletins on particular equipment items are invited to write to their RCA Broadcast Representative.

OTHER RCA TECHNICAL PRODUCTS

RCA also manufactures many other electronic products, including: two-way radio and microwave relay communications equipment; optical and magnetic film recording equipment; sound systems of all types; 16mm projectors and magnetic recorders; industrial inspection and automation equipment; scientific instruments, such as the electron microscope; closed-circuit television systems; and many types of custom-built equipment for industry, the military, educational and medical services. Information describing these products may be obtained from RCA Sales Offices in the United States and Canada or internationally from local RCA Distributors or RCA International Division.

PRICES

Domestic prices of the equipment shown in this catalog are provided in a separate price list. Equipments are identified by type and MI (Master Item) numbers which are used to identify apparatus on invoices and packing slips. International prices for the various equipment items shown in this catalog are available from RCA Distributors or RCA International Division.

HOW TO ORDER

The RCA Television Transmitting Equipment shown in this catalog is sold through RCA Broadcast Representatives, who are familiar with broadcast equipment and related problems. These RCA Representatives are located in convenient offices throughout the United States. Domestic orders for equipment, or requests for additional information, should be directed to the nearest RCA Sales Office. International Readers are invited to contact their local RCA Distributor or the RCA International Division Office.

Contents

	Page
TTU-2A UHF Transmitter	5
TTU-10A UHF Transmitter	13
TTU-30A UHF Transmitter	21
TTU-50C UHF Transmitter	29
TTU-50C1 UHF Transmitter	37
Control Console	45
Transmitter Accessories	49
Transmitter Test Equipment	55
UHF Filters & Filterplexers	63
UHF Antennas	69
Towers	97
Transmission Line and RF Loads	105
Index	112

2-KW UHF TV Transmitter, Type TTU-2A

- Minimum investment
- Maximum performance
- Economical operation

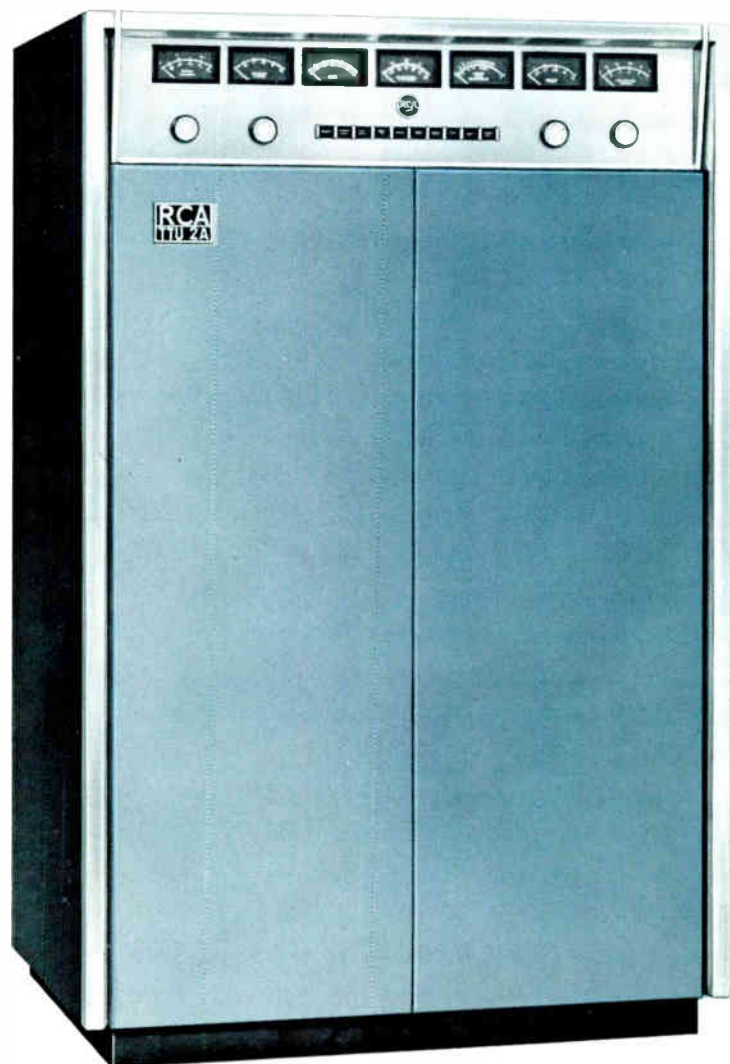

Air Cooled 2-KW UHF Television Transmitter

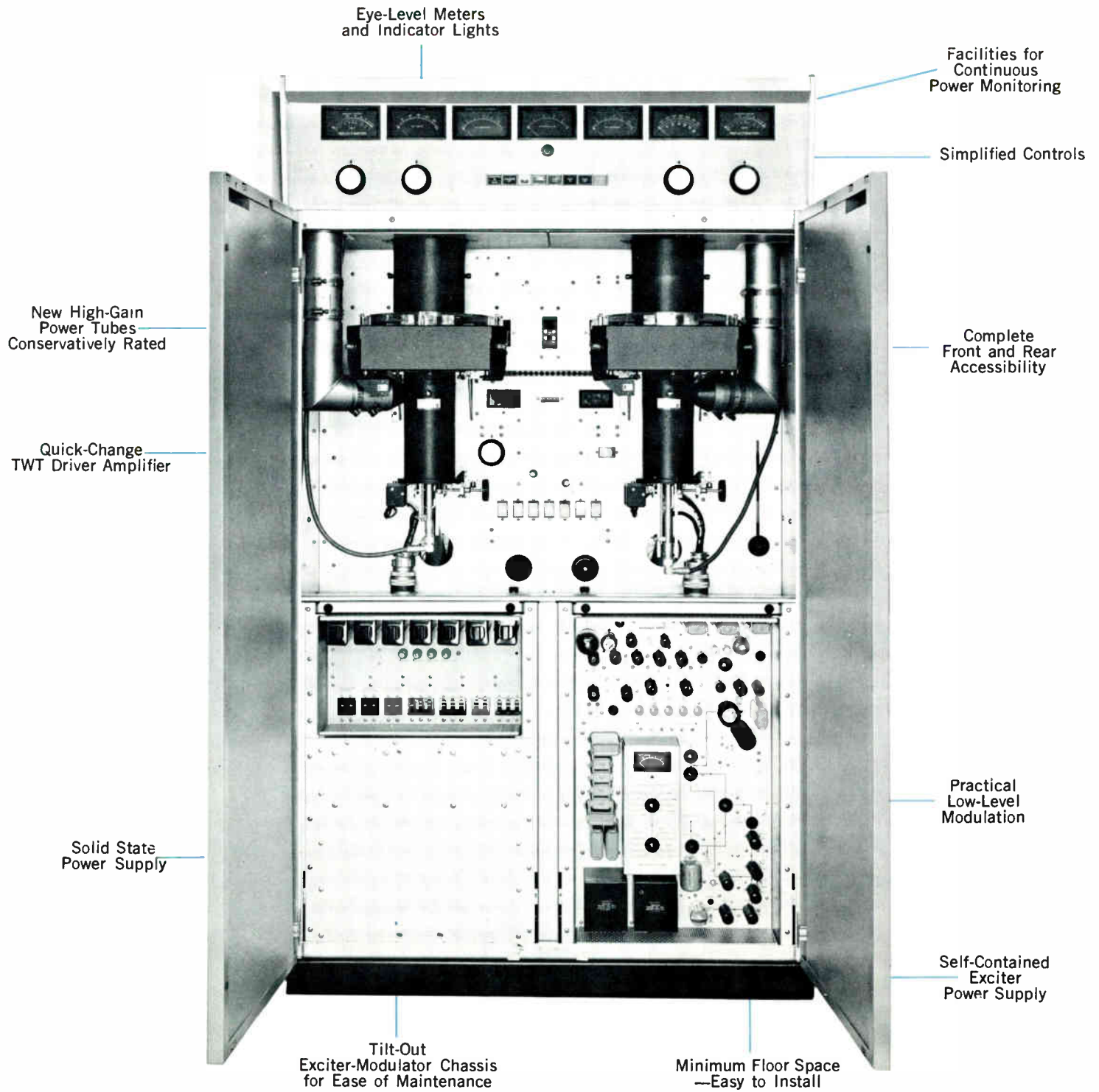

2-KW UHF Television Transmitter, Type TTU-2A

The RCA TTU-2A UHF Television Transmitter is specifically designed to answer the needs of broadcasters for top performance, compact design and long-life. This all air-cooled equipment provides reliable and economical low-power operation for stations operating on any specified channel between 14 and 83. It has a rated output of 2 kilowatts peak visual power when measured at the output of the filterplexer, and 0.225 to 2.8 kW aural power. Used with standard UHF antennas, the TTU-2A is capable of delivering up to 50-kW ERP

The Model TTU-2A provides a means to start broadcasting with a minimum investment in equipment and technical manpower. The transmitter serves as the basic driver section for the more powerful 10-kW UHF transmitter. Broadcasters can increase UHF power at a later date by adding a second cabinet containing additional PA stages and related power handling equipment. The transmitter can be ordered to meet any domestic or most international station's operating specifications. It is designed for remote control.

Description

The TTU-2A is a completely new design utilizing the latest engineering design techniques to provide the best possible monochrome or color reliability for locally or remotely controlled station operation. Frequency stability of both aural and visual sections is exceptional and permits reliable offset carrier operation.

Simplified Operation

The 2-kW UHF Transmitter is housed in the new low-profile 77-inch cabinet where the operator has complete fingertip control over operation

of the transmitter. Built-in remote control circuitry, including metering points for remotely monitoring operating parameters, permits operation at an auxiliary control console or other remote center. All normal operating controls are motor driven and may also be operated from a remote location.

Low Operating Costs

The new TTU-2A design soon pays for itself in lower operating and maintenance costs. In addition to its small physical size, minimum use of

floor space, and ease of installation, the transmitter employs the latest proven innovations such as solid state rectifiers in the external power supply, fewer tubes, simplified controls, precision frequency control, and so on. It is the first commercial broadcast television transmitter to employ long life traveling wave tubes similar to those used in microwave transmission. This tube is in itself a complete high gain RF amplifier. It permits an amplification from 1 Watt to 250 Watts in a single stage. It requires no tuning controls.

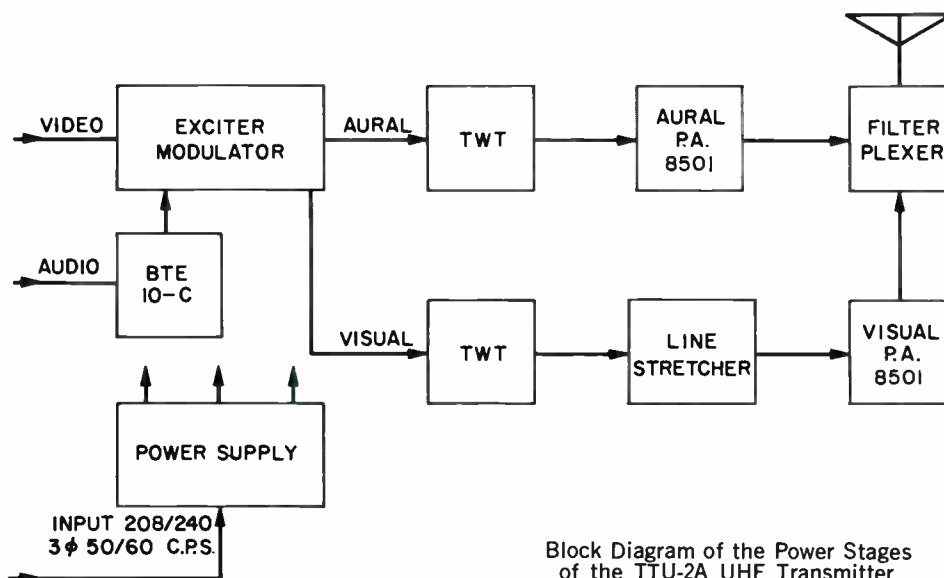

Block Diagram of the Power Stages of the TTU-2A UHF Transmitter

New Look Design

Complete Accessibility

The Transmitter is housed in a single cabinet which features double doors front and rear permitting maximum accessibility. An attractive powder blue and midnight blue finish provides a new look to RCA UHF studio and transmitter equipment. A separate unitized power supply houses the plate transformer and rectifier.

Remote Unattended Operation

One-man operation of the transmitter or even remote unattended operation is possible with the TTU-2A. Simplified controls, indicator lights and necessary meters are located above the front door at convenient eye-level. Facilities are provided to permit continuous picture monitoring at various points in the system. Attractive illuminated controls include: transmitter on/air on, transmitter off, filament on, interlocks, plate ready, plate on, plate off, and overload/overload reset buttons. A matching operating console is available as optional equipment.

Circuit Description

The TTU-2A transmitter is driven by a low power exciter containing both visual and aural chains. The separation of visual and aural carrier frequencies are accurately maintained. The RF chain is driven by a crystal controlled oscillator as a primary source of frequency control. Three doubler stages, a tripler stage and a doubler/tripler stage provide low power drive for the two 4055 mixers. The FM aural signal is derived from the new RCA BTE-10C exciter which operates with only half the number of tubes of the former exciter. There are no series or cascaded modulators to adjust for low frequency response. The 4055 mixer is a new ceramic pencil triode which has great mechanical rigidity and provides a modulated aural carrier output of one-half watt.

A signal derived from the RF chain after the second 6686 doubler is fed to an amplifier and its output together with the video input is fed to a mixer and modulated stage to

derive a 1-watt modulated visual carrier output. Aural and visual carrier outputs operate separately so if the aural carrier fails the transmitter still retains a picture signal. Tuning of the drive chain for the two mixers is simple and can be observed on a built-in multimeter. Long life tubes are used in the TTU-2A.

New Traveling Wave Tube

A unique feature of the transmitter is the grid modulation of the mixer which needs only low level video. Use of a traveling wave tube as the first RF amplifier makes possible the low power modulation. The TW tube provides an amplification from 1 Watt to 250 Watts in a single stage. It serves as a complete high gain RF amplifier, having a nominal power gain of 26 decibels.

The use of traveling wave tubes in microwave transmission show that they have a long life history. They can operate at UHF frequencies without tuning devices. This greatly simplifies transmitter maintenance and reduces the cost of operation.

Aural/Visual Exciter/Modulator Block Diagram.

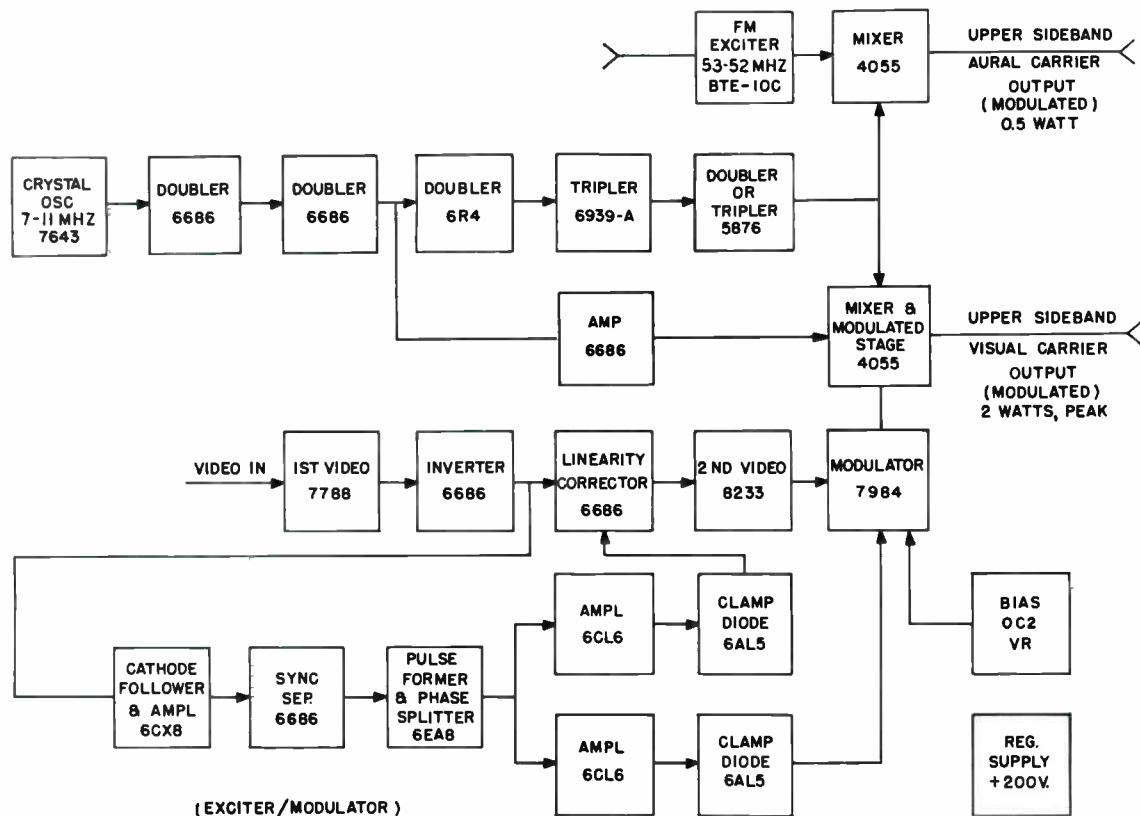

Select Features

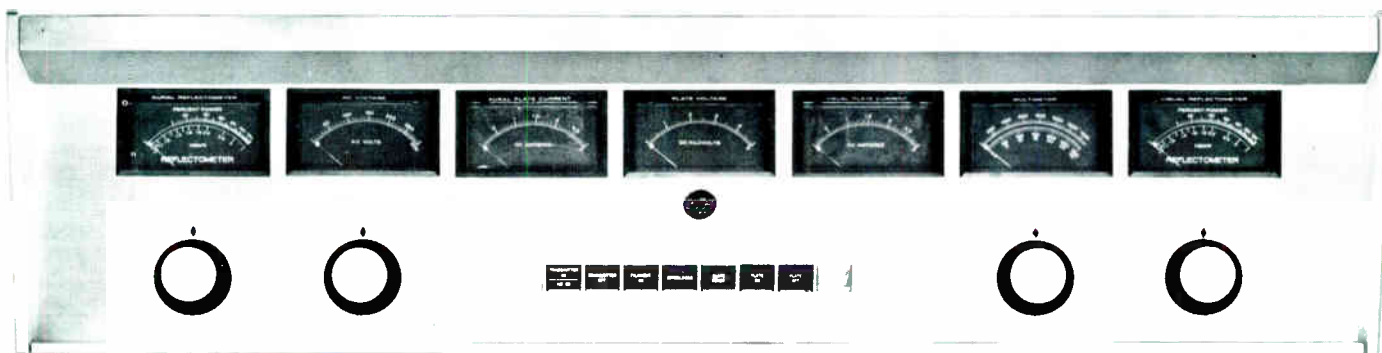

EYE-LEVEL METERS AND CENTRALIZED CONTROLS—White-on-black meter scales reduce eyestrain and improve log-keeping accuracy while illuminated control buttons quickly indicate operational status.

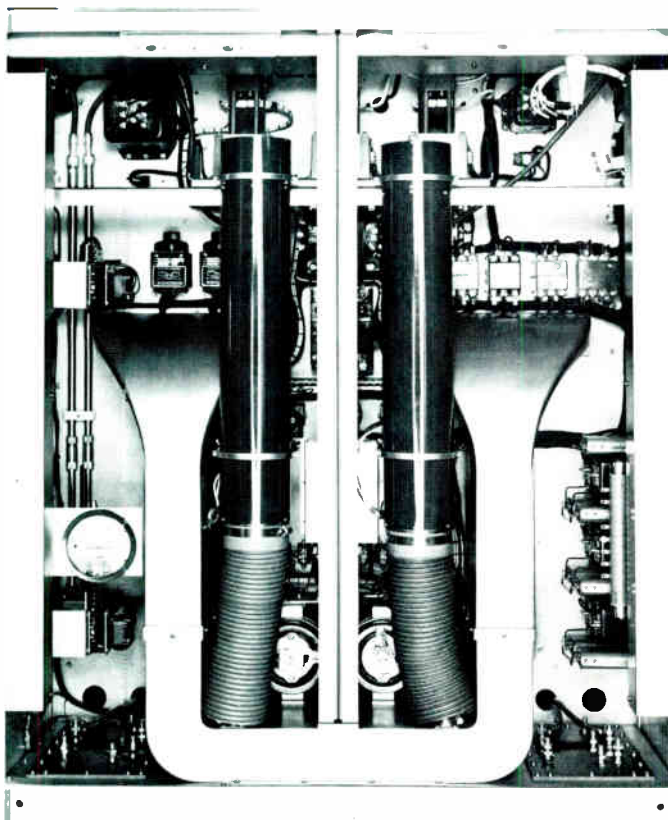

ACCESSIBILITY UNLIMITED—Strategic component locations add convenience and speed to maintenance.

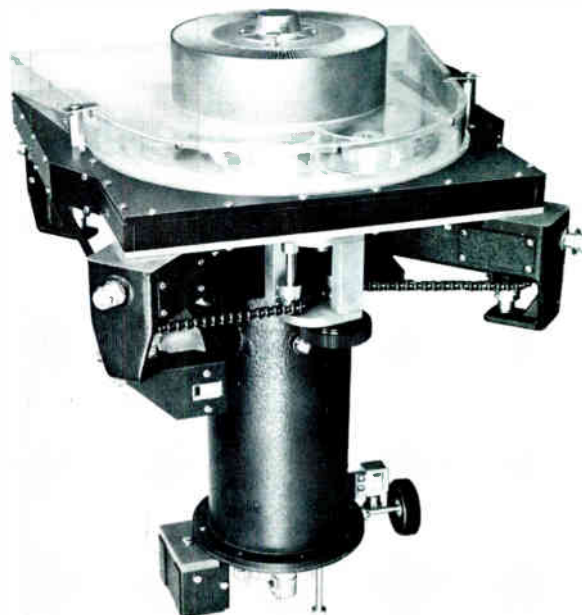

AIR-COOLED POWER AMPLIFIER STAGES use Type 8501 ceramic tetrodes operating well within ratings for long life.

Direct FM Aural Exciter For Full Fidelity Sound

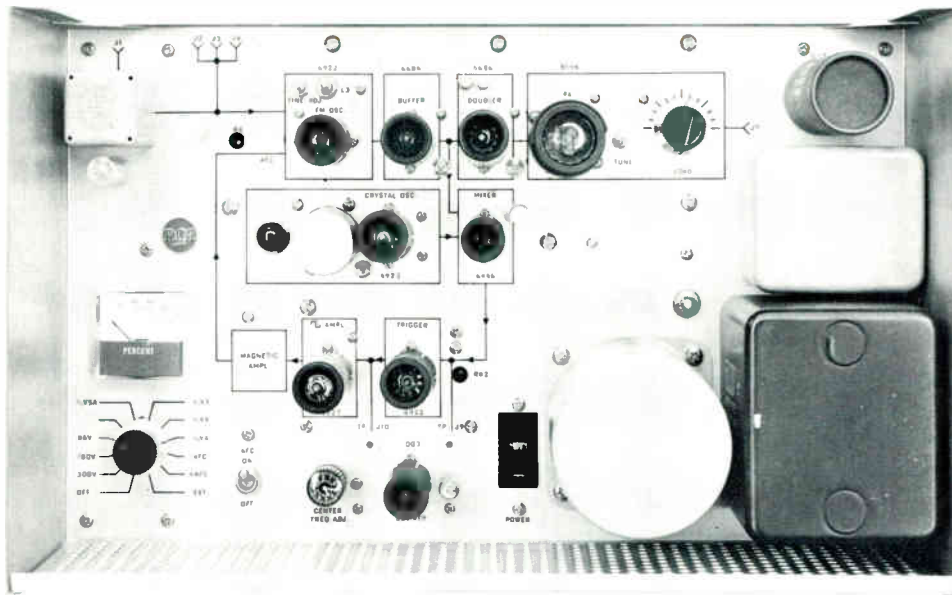

DIRECT FM AURAL EXCITER delivers full fidelity sound. A magnetic amplifier AFC system maintains close control of the aural carrier frequency.



HIGH-GAIN TRAVELING WAVE TUBE used in the driver amplifiers is a broadband device that requires no tuning at any channel frequency.

Traveling Wave Tube Requires No Tuning

Air-Cooled Power Amplifiers

A forced air-cooled 8501 Tube is employed as the final stage in both the aural and visual chain. This UHF power tetrode features a tungsten filament and co-axial construction. It is capable of delivering 5-kW synchronizing level power output in class "B" TV service and 5-kW in CW service up to 900 MHz. A blower is required for coolant. Prior to the visual PA a phase shifter or line stretcher serves in the video circuit as a phasing unit. Sliding contacts in a variable section of line provide a double tuned circuit effect on the input of the 8501 tube.

Unitized Power Supply

A compact, unitized power supply furnishes power for the TTU-2A transmitter. The supply uses solid state rectifier modules. A safety disconnect switch located in the transmitter cabinet provides positive disconnect of all incoming power for personnel protection during maintenance. High current wiring is required in the power supply cabinet only. This power supply may be located either near the transmitter or in a separate and unheated area if space limitations so dictate.

Remote Control

The TTU-2A is designed for remote control. Metering points for remotely monitoring operating parameters including aural and visual power output, aural and visual plate voltage, and aural and visual plate current are provided. Normal operating functions such as video gain, pedestal level, aural and visual excitation, and overload reset are motor driven and may be operated from a remote location. Reflectometers are provided for use in the output transmission lines of both the aural and visual amplifiers.

Specifications

Performance

	FCC Specs	CCIR SPECS ¹
Type of Emission:		
Visual	A5	A5
Aural	F3	F3
Frequency Range	470 to 890 MHz	470 to 890 MHz
Rated Power Output:		
Visual	2.0 kW ²	2.0 kW ²
Aural	0.225 kW to 2.8 kW ³	0.2 kW to 2.8 kW ³
R.F. Output		
Impedance	50 ohms	50 ohms
Input Impedance:		
Visual	75 ohms	75 ohms
Aural	150/600 ohms	150/600 ohms
Input Level:		
Visual	0.7 volt	0.7 volt
Aural	10 ±2 dBm for ±25 KHz deviation	16 ±2 dBm for ±50 KHz deviation
Amplitude vs. Frequency Response	Uniform ±1 dB from 30 to 15,000 Hz	Uniform ±1 dB from 30 to 15,000 Hz
Upper Sideband Response at Carrier ⁴ :		
+0.5 MHz	+1, -1.5 dB	+0.5, -1.5 dB
+1.25 MHz	+1, -1.5 dB	—
+1.5 MHz	—	Reference
+2.0 MHz	+1, -1.5 dB	±1.0 dB
+3.0 MHz	+1, -1.5 dB	±1.0 dB
+3.58 MHz	+1, -1.5 dB	—
+4.18 MHz	+1, -3.0 dB	—
+4.43 MHz	—	+0.5, -1.5 dB
+4.75 MHz	-20 dB max.	—
+5.0 MHz	—	+1.0, -4.0 dB
+5.75 MHz	—	-20 dB max.
Lower Sideband Response at Carrier ⁴ :		
-0.5 MHz	+1, -1.5 dB	+0.5, -1.5 dB
-0.75 MHz	—	+0.5, -4.0 dB
-1.25 MHz	-20 dB max.	-20 dB max.
-3.58 MHz	-42 dB max.	—
Variation in Frequency Response with Brightness ⁵	±1.5 dB	±1.5 dB
Carrier Frequency Stability ⁶ :		
Visual	±500 Hz	±500 Hz
Aural	±500 Hz	±500 Hz
Modulation Capability:		
Visual	12.5 ±2.5% (reference white)	12.5 ±2.5% (reference white)
Aural	±100 KHz	±100 KHz
Audio Frequency Distortion	1.0% max. 30 to 15,000 Hz	1.0% max. 30 to 15,000 Hz
FM Noise	58 dB below ±25 KHz deviation	64 dB below ±50 KHz deviation
AM Noise:		
Visual	48 dB r.m.s. below 100% modulation ⁹	48 dB r.m.s. below 100% modulation ⁹
Aural	50 dB below carrier	50 dB below carrier
Amplitude Variation Over One Video Frame	Less than 3% of the peak of sync level	Less than 3% of the peak of sync level
Regulation of Output	7%	7%
Burst vs. Sub-carrier Phase ¹⁰	±6°	±6°

	FCC Specs	CCIR SPECS ¹
Subcarrier Phase vs. Brightness ¹¹	±7° total less than 10°	±7° total less than 10°
Linearity (Differential Gain) ¹²	1.5 dB max.	0.85 m/M
Subcarrier Amplitude ¹³	±10% max.	±10% max.
Envelope Delay vs. Frequency ¹⁴	±80 nsec. from 0.2 to 2.0 MHz ±40 nsec. from 0.2 to 3.58 MHz ±80 nsec. at 4.18 MHz	±80 nsec. from 0.2 to 2.0 MHz ±40 nsec. from 2.0 to 4.43 MHz ±80 nsec. from 4.43 MHz to upper sideband limit

Electrical

	FCC Specs	CCIR Specs
Transmitter Power Line Requirements	208/240 V, 3-phase 60 Hz	380/400/415 V, 3-phase 50 Hz
Slow Line Variations	±5% max.	±5% max.
Rapid Line Variations	±3% max.	±3% max.
Power Consumption:		
Black Picture (approx.)	30 kW	30 kW
Average Picture (approx.)	25 kW	25 kW
Power Factor (approx.)	90%	90%
Crystal Heaters:		
Line	115 V, 1-phase 50/60 Hz	115 V, 1-phase 50/60 Hz
Power Consumption	7½ Watts	7½ Watts

¹ Polarity of visual modulation—negative, asymmetric sideband.

² Measured at the output of the sideband filter or filterplexer.

³ Aural power continuously adjustable from 0.225 kW to 2.8 kW measured at the input of filterplexer. Useable power depends on filterplexer.

⁴ FCC Specifications—Measure with respect to the response at 200 KHz, as measured by the BWU-5B Sideband Response Analyzer at transmitter mid-characteristic. 4.75 Hz attenuation requires use of MI-27132-A LP filter in the video input circuit. CCIR Specifications—measure with respect to the response at 1.5 MHz.

⁵ FCC Specifications—Measure with respect to the response at 200 KHz. CCIR Specifications—Measure with respect to response at 1.5 MHz.

⁶ Maximum variation with respect to the response at mid-characteristic measured with the BWU-5B Sideband Response Analyzer at brightness levels of 22.5% and 67.5% of sync peak, using approximately 20% (peak to peak) modulation.

⁷ Maximum variation for a period of 10 days without circuit adjustment over an ambient temperature range of +10°C to +45°C (meets FCC specifications over ambient range of -20°C to +45°C).

⁸ With any modulating frequency 30 to 15,000 Hz with ±50 KHz deviation.

⁹ RMS hum and noise level 50 Hz to 15 KHz. Extraneous modulation (unrelated to video modulation) above 15 KHz within the visual passband 40 dB below 100% modulation.

¹⁰ Maximum departure from the theoretical when reproducing saturated primary colors and their complements at 75% amplitude.

¹¹ Maximum phase difference with respect to burst, measured after the VSBF, for any brightness level between 75% and 15% of the sync peak using 10% (peak to peak) modulation. This is equivalent to 5% (peak to peak) modulation as indicated by a conventional diode demodulator. In addition, the total differential phase between any two levels shall not exceed 10°.

¹² Maximum variation of amplitude of the sine wave modulation frequency when superimposed on staircase or ramp modulation which is adjusted for excursion modulation depth of the sine wave to be 20% peak to peak of low frequency. CCIR Linearity is 0.85 at 0.2 MHz and 1.5 MHz with Brightness excursion 65 to 17%, and 0.85 at 4.43 MHz with Brightness excursion 75 to 17%.

¹³ Maximum departure from the theoretical when reproducing saturated primary colors and their complements at 75% amplitude.

¹⁴ FCC Specifications—Maximum departure from standard curve. The tolerances vary linearly between 2.1 and 3.58 MHz and between 3.58 MHz and 4.18 Hz. To meet the specification a properly terminated phase correction network, ES-34034-B is required in the video input circuit of the transmitter. CCIR Specifications—Maximum departure from standard curve. The tolerances vary linearly between 2.1 and 4.43 MHz and between 4.43 MHz and 5.0 MHz. To meet the specifications a properly terminated phase correction network is required in the video input circuit of the transmitter.

Mechanical

	FCC Specs.	CCIR Specs. ¹
Dimensions Overall:		
Transmitter	48 1/4" wide, 33" deep, 77" high	1.22 m wide, .833 m deep, 1.96 m high
Power Supply	52" wide, 23" deep, 52" high (or 74" with Lid open)	1.32 m wide, .584 m deep, 1.32 m high (or 1.88 m with lid open)
Finish:		
Transmitter	Powder blue and midnight blue, aluminum trim	Shadow blue and midnight blue, aluminum trim
Maximum Altitude.....	7500 feet	2286 meters

	FCC Specs.	CCIR Specs. ¹
Ambient Temperature	-20° to +45°C	-20° to +45°C

Accessories

Complete Set of Spare Tubes.....	ES-560238
Minimum Set of Spare Tubes.....	ES-560239
BWU-4B Demodulator	ES-34049-B
BWU-5C Sideband Response Analyzer.....	ES-34009-C
BW-8A Envelope Delay Measuring Set (FCC Standards)	MI-34063
BW-8A Envelope Delay Measuring Set (CCIR Standards)	MI-34068

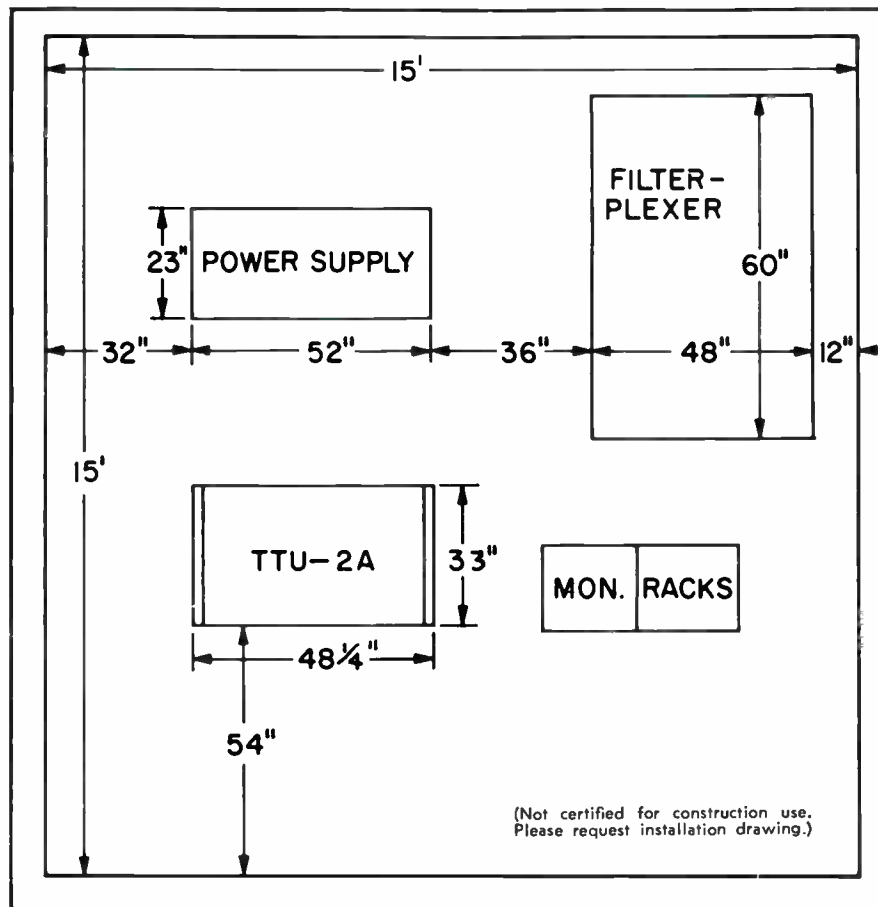

SPACE SAVING FLOOR PLAN makes efficient use of valuable floor area. The separate unitized power supplies may be located in the basement or other normally unused area.

Ordering Information

TTU-2A 2 kW UHF Television Transmitter . . . Two basic models are available as follows:

For 208/240 volt, 60 Hz input order ES-560237 which includes UHF TV Transmitter (2 kW visual, 0.225 to 2.8 kW aural) with tubes, filterplexer, low pass video filter, harmonic filters and set of crystals.

For 380/415 volt, 50 Hz input order ES-560240 which includes UHF TV Transmitter (2 kW visual, 0.2 to 2.8 kW aural) with tubes. Output power and required filters to be determined in accordance with required operating standards.

10-KW UHF TV Transmitter, Type TTU-10A

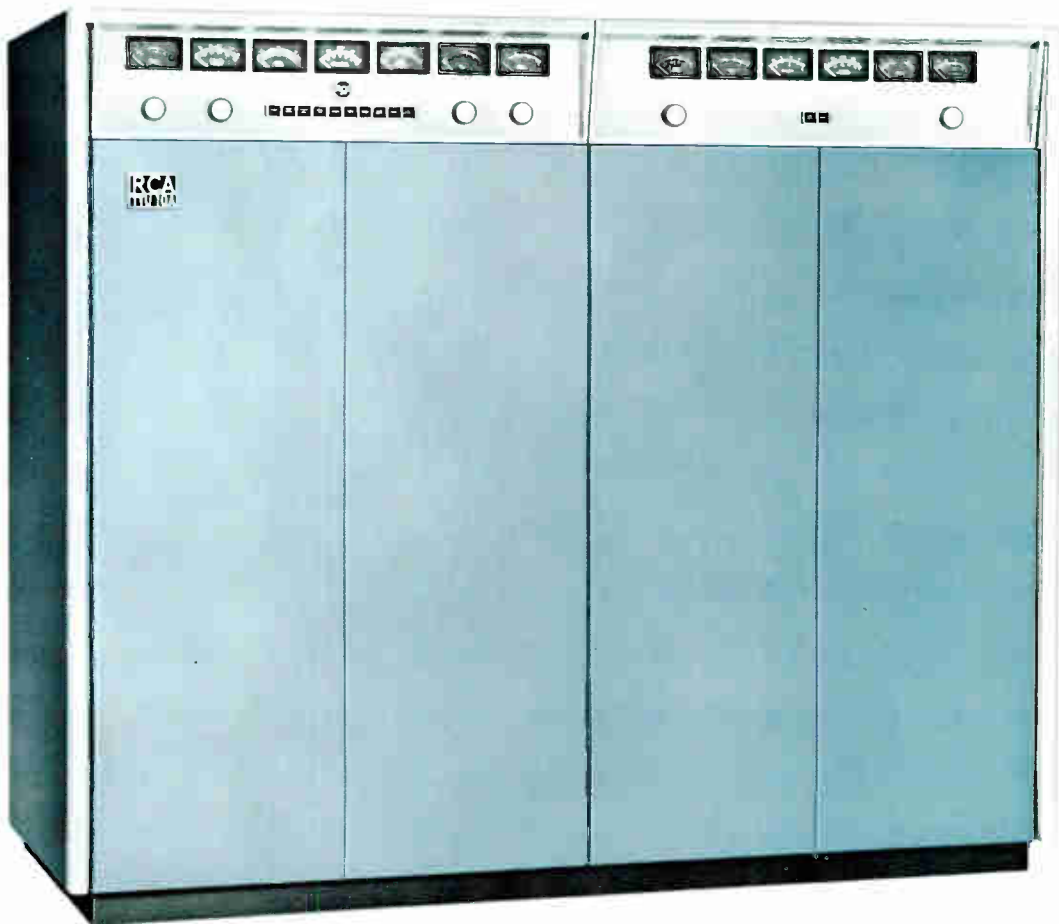

- Minimum floor space
- Excellent performance
- Fully air-cooled

Air Cooled 10-KW UHF Television Transmitter

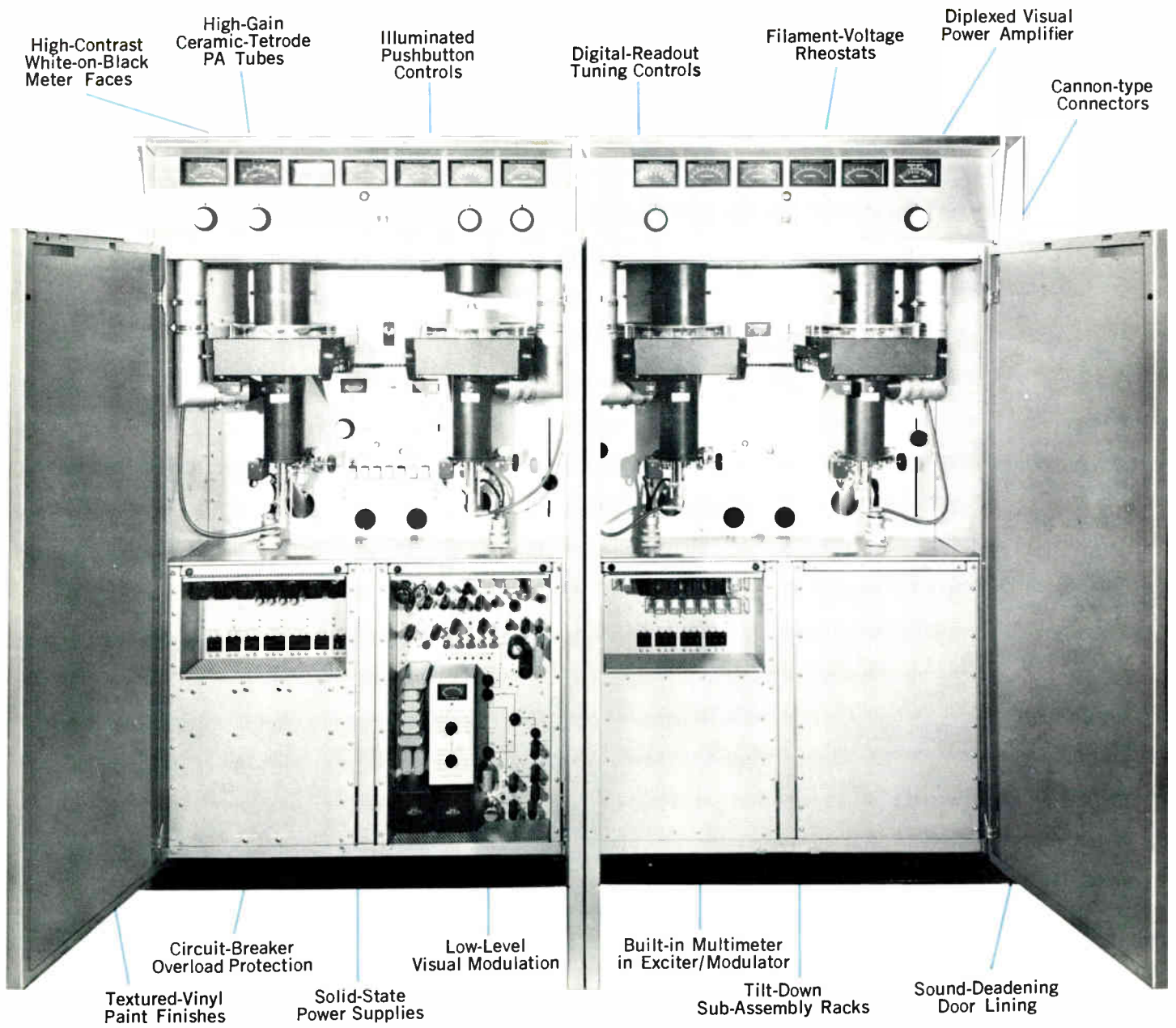

10-KW UHF Television Transmitter, Type TTU-10A

The RCA TTU-10A UHF Television Transmitter is designed specifically to fill the requirement for a medium power UHF transmitter facility. It offers the broadcaster top performance, compact design and features built-in circuitry for remote control. This completely air-cooled equipment provides reliable and economical medium power operation on any specified channel, 14 through 83 (470-890 MHz). It has a rated output of 10 kW peak visual power when measured at the output of the filterplexer and 0.225 to 2.8 kW of aural power. Combined with standard UHF antennas, the TTU-10A is capable of furnishing up to 250 kW ERP.

The TTU-10A transmitter utilizes as a driver the low power 2 kW (TTU-2A) transmitter. The visual output of the 2 kW unit is fed into a linear amplifier stage with a resultant 10 kW peak visual output. The aural output of 0.225 to 2.8 kW is consistent with the new FCC ruling permitting as little as a 10:1 visual to aural power ratio for UHF stations. Operation of the TTU-10A with a 4:1 power ratio results in considerable reduction of operating cost. The new TTU-10A can be ordered to meet any domestic or most international TV published operating standards.

Description

The TTU-10A Transmitter is a completely new design. It utilizes the latest engineering design techniques to provide the best possible reliability for locally or remotely controlled station operation. It is designed for color or monochrome operation. Frequency stability of

both the aural and visual sections is better than FCC requirements and permits reliable off-set carrier operation.

Designed for Remote Control

The 10-kW UHF transmitter is housed in low-profile 77-inch cabi-

nets where the operator has complete fingertip control over operation of the transmitter. Built-in remote control circuitry, including metering points for remotely monitoring operating parameters, permits operation at the auxiliary control console or other remote center. All

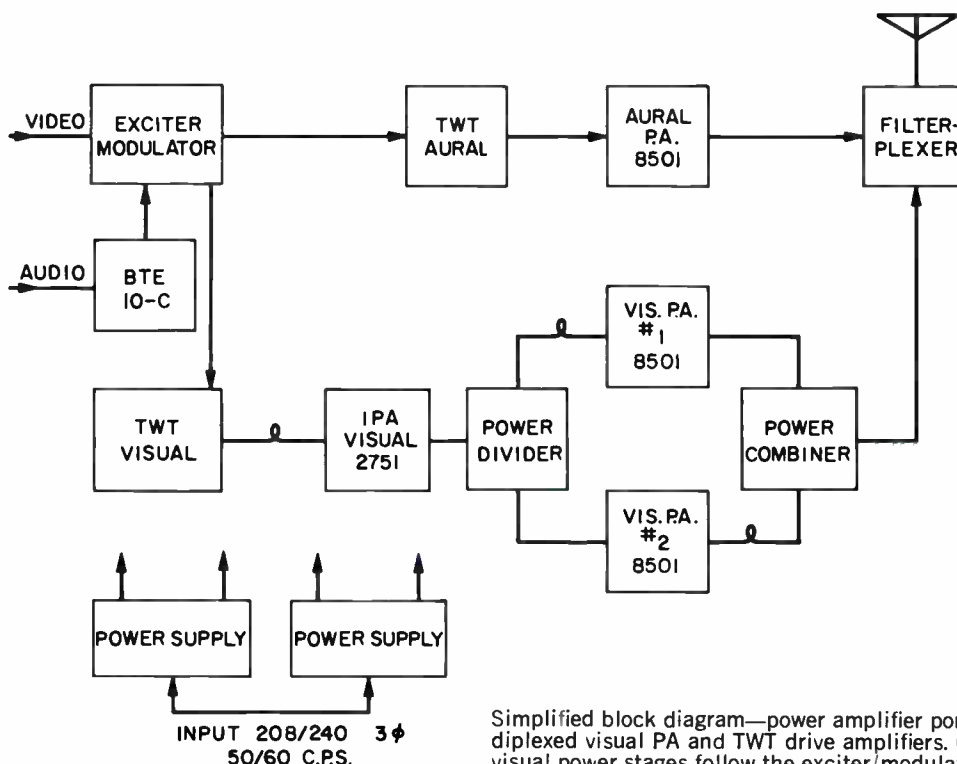

normal operating controls are motor-driven and may also be operated from a remote location.

Low Operating Costs

The new TTU-10A design soon pays for itself in lower operating and maintenance costs. In addition to its compact physical size, minimum use of floor space, and ease of installation, the transmitter employs the latest proven innovations such as solid state rectifiers in the external power supply, fewer tubes, simplified controls, precision frequency control, and so on. It is the first commercial transmitter design to employ long life traveling wave tubes similar to those used in microwave transmission. This tube is in itself a complete high gain RF amplifier. It permits an amplification from 1 Watt to 250 Watts in a single stage. The tube requires no tuning controls.

The transmitter can be ordered to meet any domestic and most international station's operating specifications.

Easy to Install and Service

The RCA Type TTU-10A UHF TV Transmitter is housed in the

newly styled 77-inch high cabinets which feature front and rear doors permitting maximum accessibility. An attractive powder blue and midnight blue finish provides a modern look to this UHF transmitter. Separate, unitized power supplies house the plate transformers and rectifiers.

Simplified Operation

One-man operation of the transmitter or even remote unattended operation is possible with the TTU-10A. Simplified controls, indicator lights and necessary meters are located above the front doors at convenient eye-level. Facilities are provided to permit continuous picture monitoring at various points in the system. Attractive illuminated controls include: transmitter on/air on, transmitter off, filament on, interlocks, plate ready, plate on, plate off, and overload/overload reset buttons.

Circuit Description

The TTU-10A transmitter is driven by an exciter containing both visual and aural chains. There is accurate control of the separation

of visual and aural carrier frequencies. The RF chain is driven by a crystal controlled oscillator as a primary source of frequency control. Three doubler stages, a tripler stage and a doubler/tripler stage provide low power drive for the two 4055 mixers. The FM aural signal is derived from the new RCA BTE-10C exciter which operates with only half the number of tubes of the former exciter. There are no series or cascaded modulators to adjust for low frequency response. The 4055 mixer is a new developmental ceramic pencil triode which has great mechanical rigidity and provides a modulated aural carrier output of one-half Watt.

A signal derived from the r-f chain after the second 6686 doubler is fed to an amplifier and its output together with the video input is fed to a mixer and modulator stage to derive a 1-Watt modulated visual carrier output. Aural and visual carrier outputs operate separately so if the aural carrier fails the transmitter still retains a picture signal. Tuning of the drive chain for the two mixers is relatively simple. Long life tubes are used in the TTU-10A.

Aural/Visual Exciter/Modulator Block Diagram.

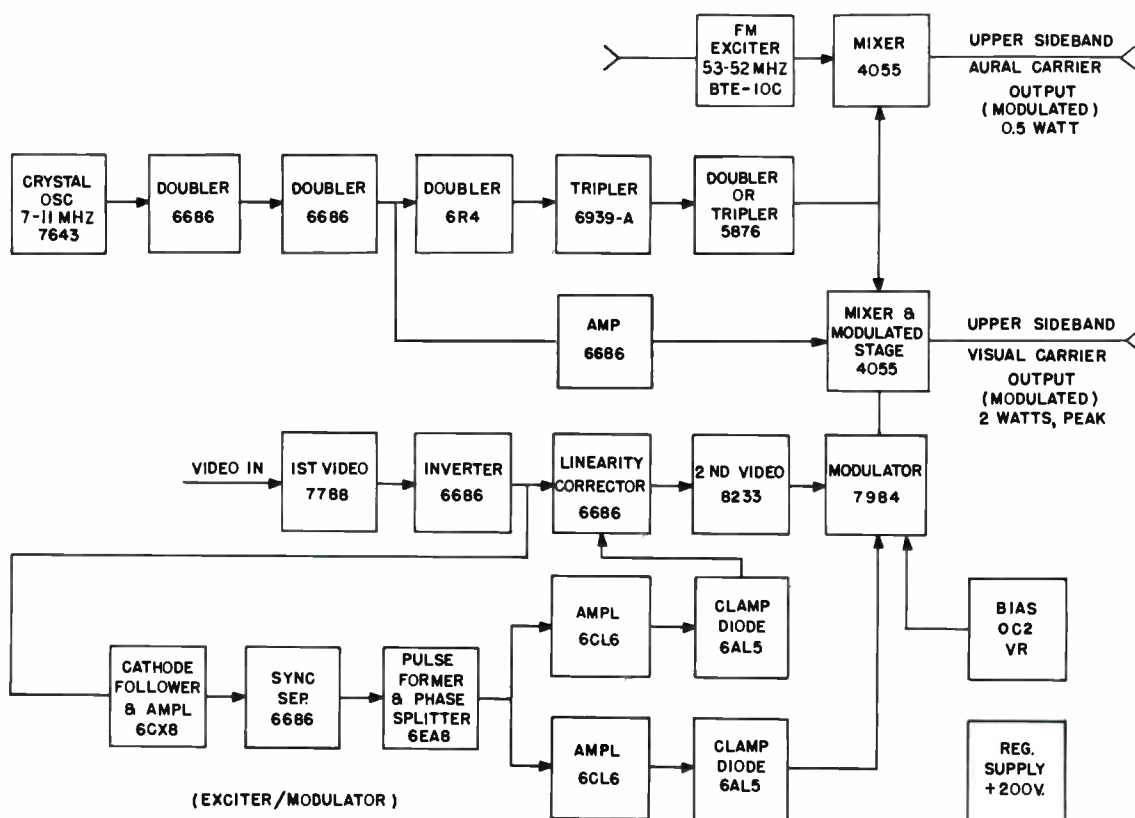

Select Features



EYE-LEVEL METERS AND CENTRALIZED CONTROLS—White-on-black meter scales reduce eyestrain and improve log-keeping accuracy while illuminated control buttons quickly indicate operational status.

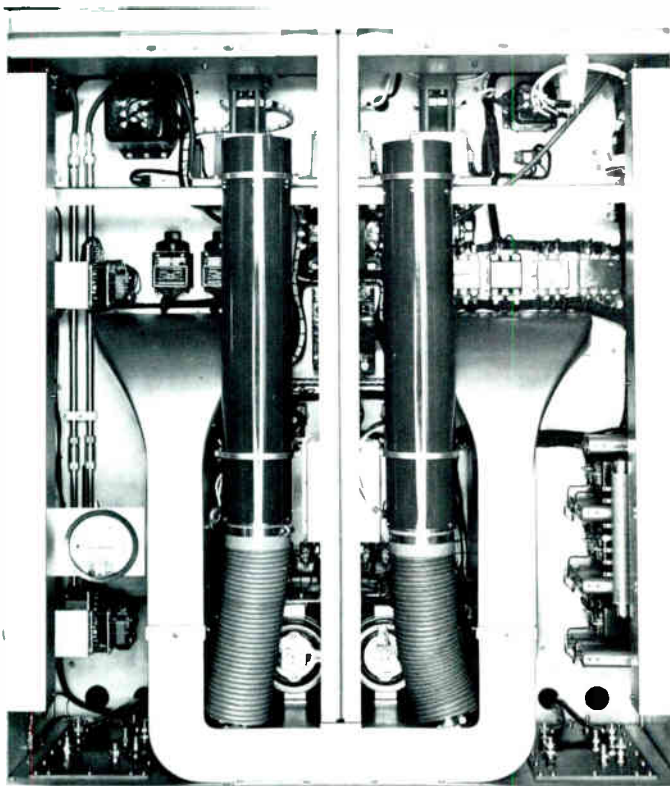

ACCESSIBILITY UNLIMITED—Strategic component locations add convenience and speed to maintenance.

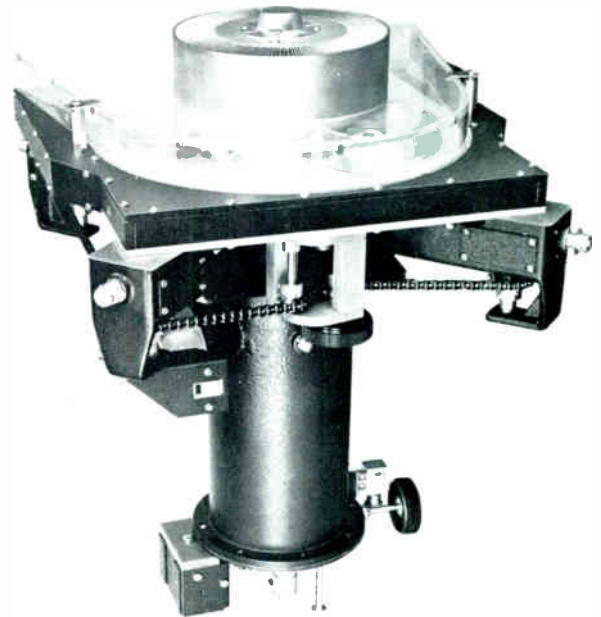

AIR-COOLED POWER AMPLIFIER STAGES use Type 8501 ceramic tetrodes operating well within ratings for long life.

Direct FM Aural Exciter For Full Fidelity Sound

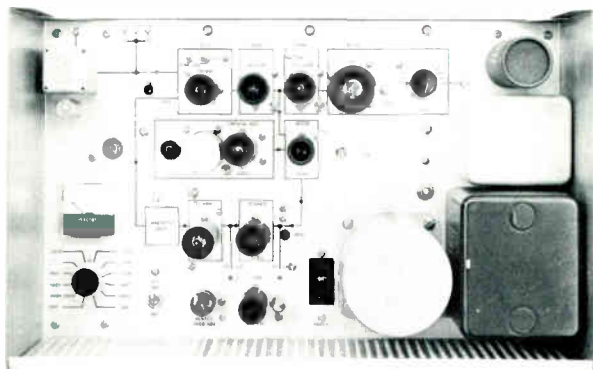

DIRECT FM AURAL EXCITER delivers full fidelity sound. A magnetic amplifier AFC system maintains close control of the aural carrier frequency.

HIGH-GAIN TRAVELING WAVE TUBE used in the driver amplifiers is a broadband device that requires no tuning at any channel frequency.



Traveling Wave Tube Requires No Tuning

New Traveling Wave Tube

A unique feature of the transmitter is the grid modulation of the mixer which needs only low level video. Use of a traveling wave tube as the first RF amplifier makes possible the low power modulation. The TW tube provides an amplification from 1 Watt to 250 Watts in a single stage. It serves as a complete high gain RF amplifier, having a nominal power gain of 26 decibels.

The use of traveling wave tubes in microwave transmission show that they have a long life history. They operate at UHF frequencies without tuning devices. This greatly simplifies transmitter maintenance and reduces the cost of operation.

Power Amplifiers

A forced air cooled 8501 tube with a nominal output of 2 kW peak visual is used to drive a pair of diplexed tubes of the same type, the output of which is then combined to effect a 10 kW peak visual output. A single air-cooled 8501 tube is used for the aural output. The cavities for all of the high power tubes are

identical, which results in easier and more effective routine maintenance and a minimum requirement for replacement parts. The type 8501 tube is a UHF power tetrode which features a tungsten filament and coaxial construction. It is capable of delivering a 5 kW synchronizing level power output in Class "B" TV service and 5 kW in CW service up to 900 MHz. Cavity design for the 8501 tube makes use of latest engineering techniques and components to reduce maintenance costs. Teflon r-f bypass capacitors are used throughout. The diplexing of two type 8501 tubes in the final visual amplifier makes use of practical and proven diplexing circuitry which has been so successful and reliable in the latest RCA VHF designs. Failure of one final amplifier tube during operation could allow continued operation at reduced power without loss of air time.

Unitized Power Supplies

Two compact, unitized power supplies furnish power for the TTU-10A transmitter. Each supply uses solid state rectifier plug-in modules.

The power supplies may be located either near the transmitter or in a separate and unheated area if space limitations require. A safety disconnect switch located in the transmitter cabinet provides positive disconnect of all incoming power for personnel protection during maintenance. High current wiring is required only in the power supply cabinets. Installation of the TTU-10A can be made in a minimum of time.

Remote Control

The TTU-10A is designed for remote control. Metering points for remotely monitoring operating parameters including aural and visual power output, aural and visual plate voltage, and aural and visual plate current are provided. Normal operating functions such as video gain, pedestal level, aural and visual excitation, and overload reset are motor driven and may be operated from a remote location. Reflectometers are provided for use in the output transmission lines of both the aural and visual amplifiers.

Specifications

Performance

	FCC Specs.	CCIR Specs. ¹
Type of Emission:		
Visual	A5	A5
Aural	F3	F3
Frequency Range.....	470-890 MHz	470-890 MHz
Rated Power Output:		
Visual ²	10 kW	10 kW
Aural ³	0.225 to 2.8 kW	0.2 to 2.8 kW
R-F Output Impedance	50 ohms	50 ohms
Input Impedance:		
Visual	75 ohms	75 ohms
Aural	150/600 ohms	150/600 ohms
Input Level:		
Visual	0.7 volt peak-to-peak min.	0.7 volt peak-to-peak min. (composite video)
Aural	+10 ±2 dBm for ±25 kHz deviation	+16 ±2 dBm for ±50 kHz deviation
Amplitude vs. Frequency Response....	Uniform ±1 dB from 30 to 15,000 Hz	Uniform ±1 dB from 30 to 15,000 Hz
Upper Sideband Response at Carrier ⁴ :		
+0.5 MHz	+1, -1.5 dB	+0.5, -1.5 dB
+1.25 MHz	+1, -1.5 dB	Reference
+1.5 MHz	—	±1.0 dB
+2.0 MHz	+1, -1.5 dB	±1.0 dB
+3.0 MHz	+1, -1.5 dB	—
+3.58 MHz	+1, -1.5 dB	—
+4.18 MHz	+1, -3.0 dB	—
+4.43 MHz	—	+0.5, -1.5 dB
+4.75 MHz	-20 dB max.	—
+5.0 MHz	—	+1.0, -4.0 dB
+5.75 MHz	—	-20 dB max.
Lower Sideband Response at Carrier ⁵ :		
-0.5 MHz	+1, -1.5 dB	+0.5, -1.5 dB
-0.75 MHz	—	+0.5, -4.0 dB
-1.25 MHz	-20 dB max.	-20 dB max.
-3.58 MHz	-42 dB max.	—
Variation in Frequency Response with Brightness ⁶	±1.5 dB	±1.5 dB
Carrier Frequency Stability ⁷ :		
Visual	±500 Hz	±500 Hz
Aural	±500 Hz	±500 Hz
Aural	±200 Hz ⁸	±200 Hz ⁸
Modulation Capability:		
Visual	12.5 ±2.5% (reference white)	12.5 ±2.5% (reference white)
Aural	±100 kHz	±100 kHz
Audio Frequency Distortion	1% max. 30-15,000 Hz	1% max. 30-15,000 Hz
FM Noise:		
±25 kHz Swing.....	58 dB below ±25 kHz deviation	64 dB below ±50 kHz deviation
AM Noise, r.m.s.:		
Visual	45 dB r.m.s. below 100% modulation ⁹	45 dB r.m.s. below 100% modulation ⁹
Aural	50 dB below Carrier	50 dB below Carrier
Amplitude Variation Over One Picture Frame	Less than 3% of the peak of sync level	Less than 3% of the peak of sync level
Regulation of Output Burst vs. Sub-carrier Phase ¹⁰	7% max. ±6°	7% max. ±6°

	FCC Specs.	CCIR Specs. ¹
Subcarrier Phase vs. Brightness ¹¹	±7° total less than 10°	±7° total less than 10°
Linearity (Differential Gain) ¹²	1.5 dB max.	0.85 m/M
Subcarrier Amplitude ¹³	±10% max.	±10% max.
Envelope Delay vs. Frequency ¹⁴	±80 nsec. from 0.2 to 2.0 MHz ±40 nsec. at 3.58 MHz ±80 ns at 4.18 MHz	±80 nsec. from 0.2 to 2.0 MHz ±40 nsec. from 2.0 to 4.43 MHz ±80 nsec. from 4.43 MHz to upper sideband limit
Harmonic Attenuation, ratio of any single harmonic to peak visual fundamental	At least 60 dB	At least 60 dB
Electrical		
Power Line Requirements:		
Transmitter:		
Line	208/240 volts, 3 phase, 60 Hz	380/400/415 volts, 3 phase, 50 Hz
Slow Line Variations	±5% max.	±5% max.
Rapid Line Variations	±3% max.	±3% max.
Power Consumption,		
Black Picture (approx.)	75 kW	75 kW
Average Picture (approx.)	63 kW	63 kW
Power Factor (approx.)	90%	90%
Crystal Heaters:		
Line	115 volts, single phase, 50/60 Hz	115 volts, single phase, 50/60 Hz
Power Consumption	7½ Watts	7½ Watts

¹ Polarity of visual modulation—negative, asymmetric sideband.
² Measured at the output of the sideband filter or filterplexer.
³ Aural power continuously adjustable from 0.225 kW to 2.8 kW measured at the input of filterplexer.
⁴ FCC Specifications—Measure with respect to the response at 200 kHz, as measured by the BWU-5C Sideband Response Analyzer at transmitter mid-characteristic. 4.75 Hz attenuation requires use of M1-27132-A LP filter in the video input circuit. CCIR Specifications—measure with respect to the response at 1.5 MHz.
⁵ FCC Specifications—Measure with respect to the response at 200 kHz. CCIR Specifications—Measure with respect to response at 1.5 MHz.
⁶ Maximum variation with respect to the response at mid-characteristic measured with the BWU-5C Sideband Response Analyzer at brightness levels of 22.5% and 67.5% of sync peak, using approximately 20% (peak to peak) modulation.
⁷ Maximum variation for a period of 10 days without circuit adjustment over an ambient temperature range of +10°C to +45°C (meets FCC specifications over ambient range of -20°C to +45°C).
⁸ With any modulating frequency 30 to 15,000 Hz with ±50 kHz deviation.
⁹ RMS hum and noise level 50 Hz to 15 kHz. Extraneous modulation (unrelated to video modulation) above 15 kHz within the visual passband 40 dB below 100% modulation.
¹⁰ Maximum departure from the theoretical when reproducing saturated primary colors and their complements at 75% amplitude.
¹¹ Maximum phase difference with respect to burst, measured after the VSBF, for any brightness level between 75% and 15% of the sync peak using 10% (peak to peak) modulation. This is equivalent to 5% (peak to peak) modulation as indicated by a conventional diode demodulator. In addition, the total differential phase between any two levels shall not exceed 10°.
¹² Maximum variation of amplitude of the sine wave modulation frequency when superimposed on staircase or ramp modulation which is adjusted for excursion modulation depth of the sine wave to be 20% peak to peak of low frequency. CCIR Linearity is 0.85 at 0.2 MHz and 1.5 MHz with Brightness excursion 65 to 17%, and 0.85 at 4.43 MHz with Brightness excursion 75 to 17%.
¹³ Maximum departure from the theoretical when reproducing saturated primary colors and their complements at 75% amplitude.
¹⁴ FCC Specifications—Maximum departure from standard curve. The tolerances vary linearly between 2.1 and 3.58 MHz and between 3.58 MHz and 4.18 Hz. To meet the specification a properly terminated phase correction network, ES-34034-B is required in the video input circuit of the transmitter. CCIR Specifications—Maximum departure from standard curve. The tolerances vary linearly between 2.1 and 4.43 MHz and between 4.43 MHz and 5.0 MHz. To meet the specifications a properly terminated phase correction network is required in the video input circuit of the transmitter.

Mechanical

	FCC Specs.	CCIR Specs. ¹
Dimensions Overall:		
Transmitter	92¼" x 33" x 77"	2.34 m x .838 m x 1.96 m
Power Supplies ¹⁵	52" x 23" x 52" (plus 22" with lid up)	1.32 m x .584 m x 1.32 m (plus .559 m with lid up)
Finish:		
Transmitter	Powder blue and Midnight blue, aluminum trim	Powder blue and Midnight blue, aluminum trim
Maximum Altitude ¹⁶	7500 feet	2286 meters
Ambient Temperature	-20° to +45°C.	-20° to +45°C.

¹⁴ Dimensions given are for one power supply. Two power supplies, of identical dimensions, are required for the TTU-10A transmitter.

¹⁶ Blowers can be provided for operation at higher altitudes.

Accessories

Complete Set of Spare Tubes.....	ES-560244
Minimum Set of Spare Tubes.....	ES-560245
BWU-4B Demodulator	ES-34049-B
BWU-5C Sideband Response Analyzer	ES-34009-C
BW-8A Envelope Delay Measuring Set.....	MI-34063
Transmitter Control Console.....	ES-561900

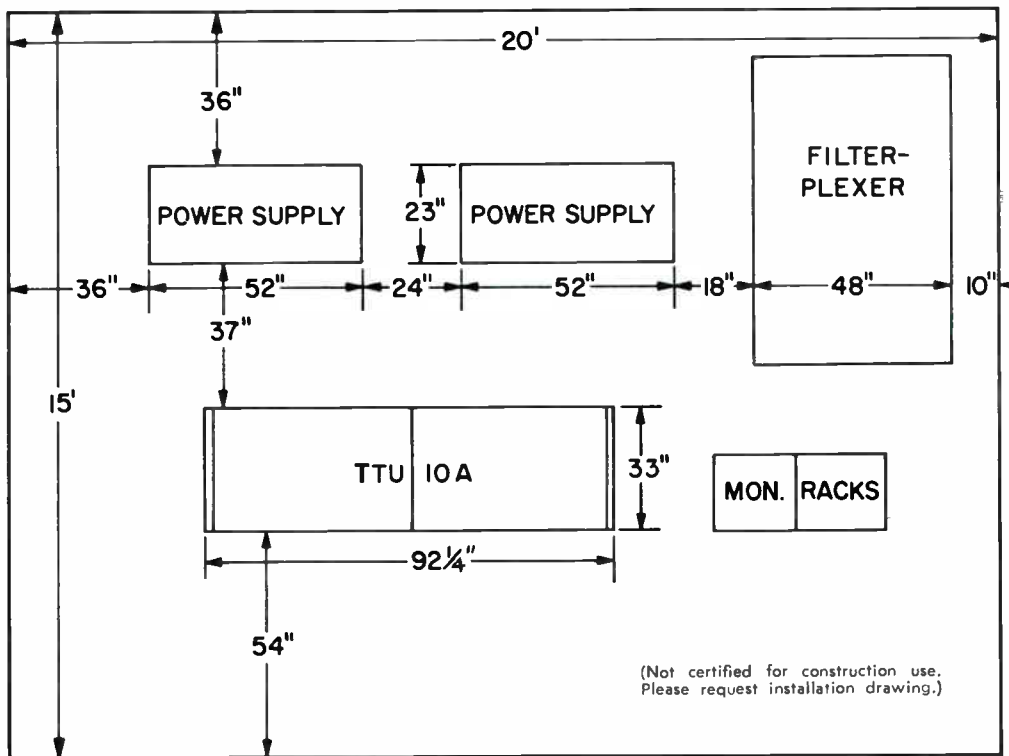

SPACE SAVING FLOOR PLAN makes efficient use of valuable floor area. The separate unitized power supplies may be located in the basement or other normally unused area.

Ordering Information

TTU-10A 10 kW UHF Television Transmitter . . .
Two basic models are available as follows:

For 208/240 volt, 60 Hz input order ES-560243 which includes UHF TV Transmitter (10 kW visual, 0.225 to 2.8 kW aural) with tubes, filterplexer, low pass filter, harmonic filters and set of crystals.

For 380/415 volt, 50 Hz input order ES-560246 which includes UHF TV Transmitter (10 kW visual, 0.2 to 2.8 kW aural) with tubes. Output power and required filters to be determined in accordance with required operating standards.

30 KW UHF TV Transmitter, Type TTU-30A

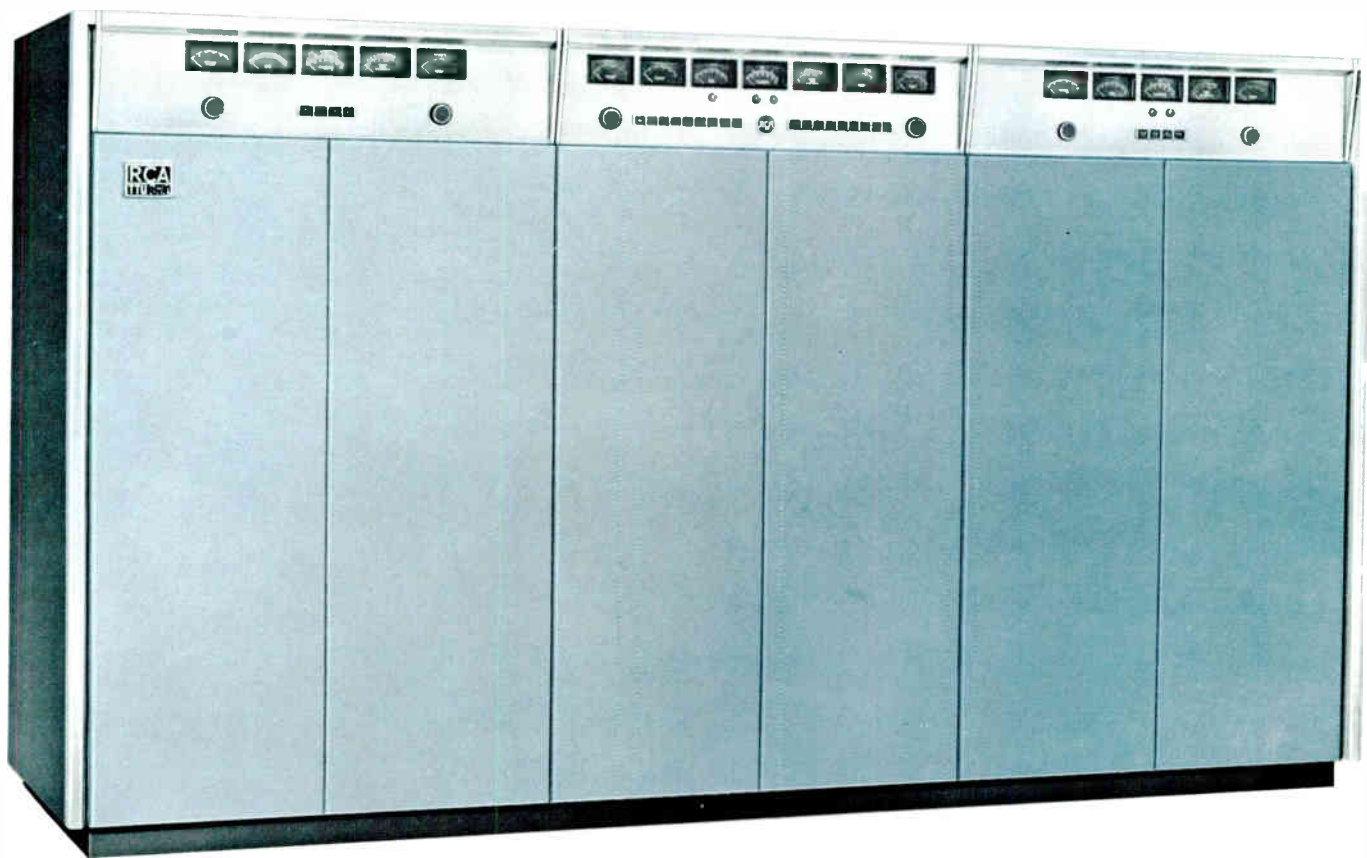

Simplified control • Vapor-cooled klystrons • Quick tube-change

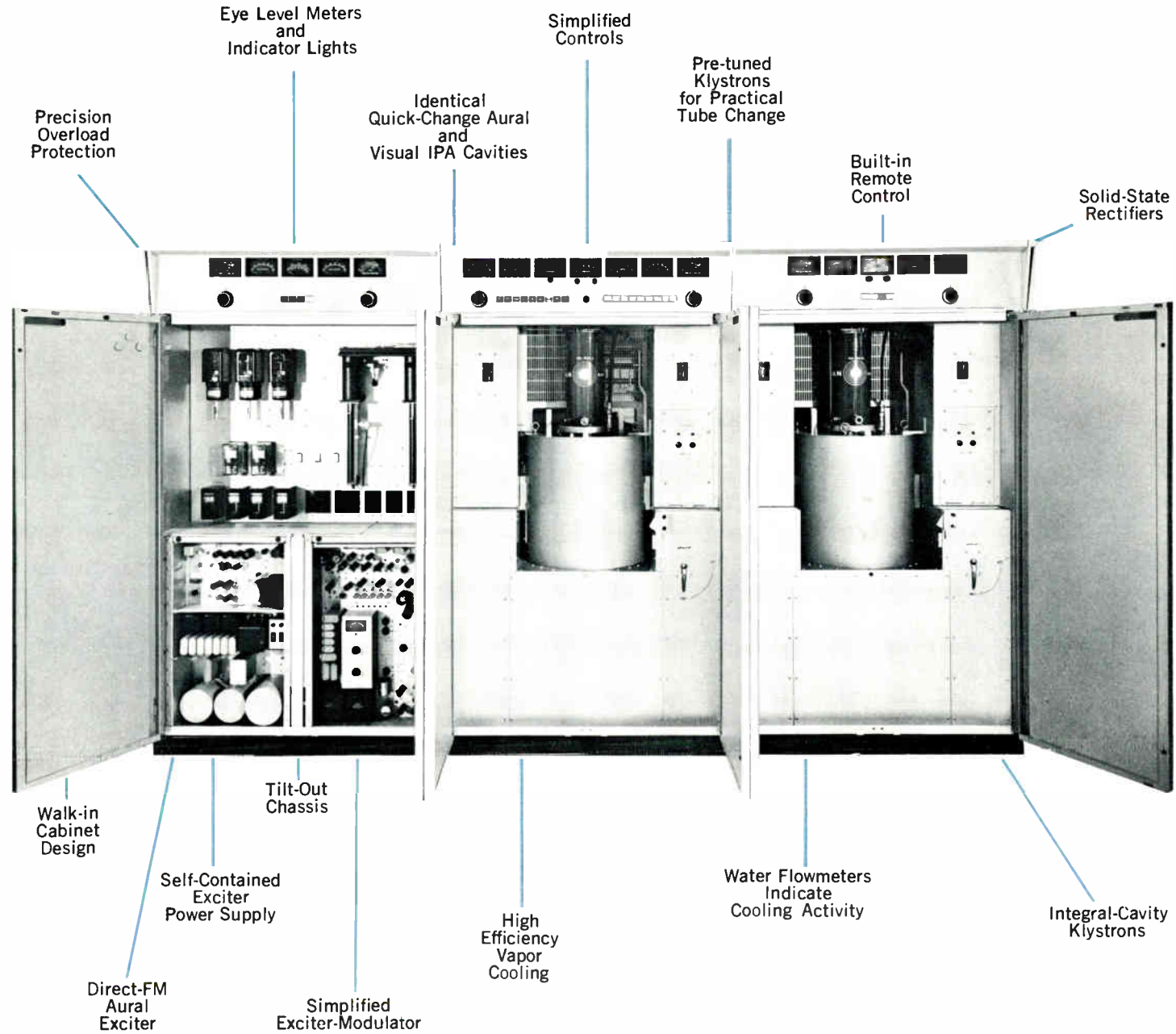

30 KW UHF Television Transmitter, Type TTU-30A

The RCA Type TTU-30A is a 30-kilowatt transmitter designed for 1,000,000-watt effective radiated power. This completely new high-power transmitter has a rated power output of 30-kW peak visual and 3.3 to 16-kW aural when used on 4.5 MHz separation standards (25 kW peak visual and 3.3 to 16-kW aural power for 5.0 and 5.5 MHz separation standards). The transmitter employs the same type of vapor-cooled klystrons used in the TTU-50C and can be modified to a TTU-50C in the field.

The TTU-30A is designed for remote control. Metering points are provided for

functions are motor driven and therefore can be operated remotely.

The transmitter is designed to meet FCC or CCIR recommendations. For 460-volt, 60 Hz input, the ES-560250 model should be specified. For 380/415-volt 50 Hz input, order ES-560253.

The TTU-30A UHF Television Transmitter represents RCA's newest offering for broadcasters. Included are features such as the integral-cavity vapor-cooled klystron, low-profile styling, solid-state circuitry and built-in provisions for remote control. The increased efficiency of the new klystron offers considerable savings in oper-

Description

The TTU-30A is one of RCA's "New Look" transmitters that represent a major advance in UHF technology. Incorporating all the benefits of reliable solid state devices, of new broad-band amplifier tubes with much higher gain and greater power capability, the video modulation at fractional watt levels, the transmitter achieves simplicity and small size, yet packs more power per cubic foot than any predecessor.

Economical Power

The transmitter is economical and easy to operate. Though the physical space required is small, effective

planning of component placement for maximum accessibility makes the transmitter easy to maintain. Both small physical size and ease of maintenance result in direct savings in installation and operating costs. Every effort has been made in the TTU-30A to incorporate mechanical and electrical features to allow one-man operation of this high power transmitter, either locally or from a remote point.

The TTU-30A is housed in three new low profile 77-inch cabinets with eye-level meters and convenient finger-tip controls. Built-in remote

control circuitry, including metering points for remotely monitoring operating parameters, permits operation at an auxiliary control console or remote point. All normal operating controls are motor-driven and may also be operated from a remote location.

Circuit Description

Ease of installation, operation and maintenance is enhanced by use of modern, reliable circuitry. Video and audio modulation takes place at a low level, thus eliminating the need for a high power modulator. Use of high gain klystron tubes makes it

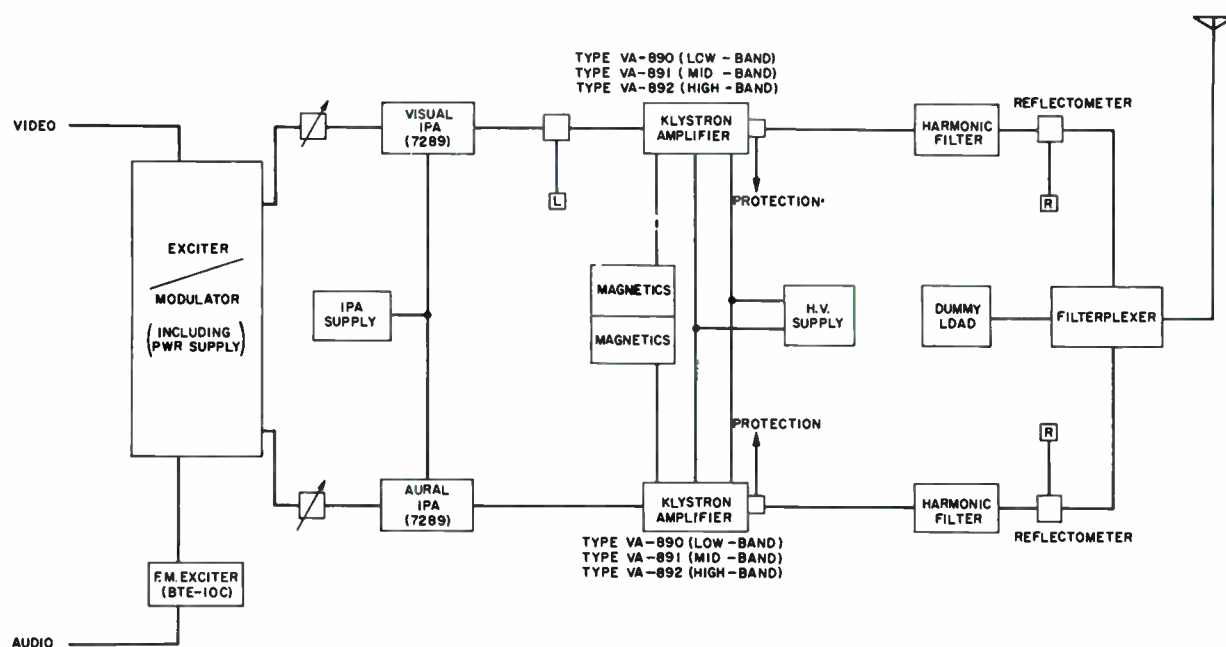

Block Diagram of TTU-30A UHF Television Transmitter.

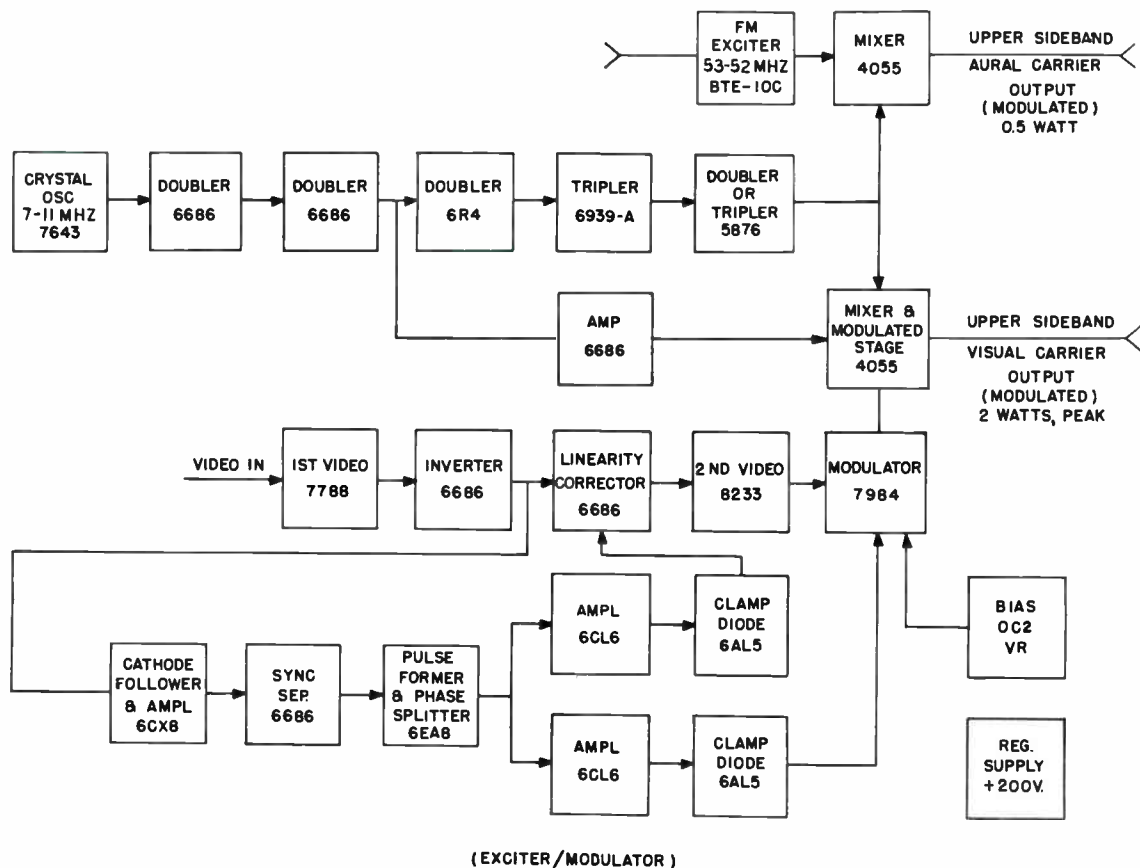

Aural/Visual Exciter/Modulator Block Diagram.

possible to effect a high amplification in a single, pre-tuned r-f stage.

Direct-FM Exciter

The modern circuitry used in the TTU-30A transmitter utilizes the standard BTE-10C FM exciter to develop a stable, high quality, direct frequency modulated aural signal. The newly designed FM exciter uses a total of nine tubes—half as many as used in the previous model. Only four tubes are required to maintain an FM output signal, one indication of the reliability built into the entire TTU-30A transmitter.

The design retains RCA's "Direct-FM" modulation with particular emphasis being placed on ease of adjustment and reliable operation. All r-f stages use single-tuned circuits. A built-in meter, and easily accessible test points allow metering and checking during operation. An AFC on-off toggle switch and simplified controls including the power on-off switch are all easily accessible on the chassis of the exciter.

A self-contained silicon power supply is used. Premium tubes, carrying a 10,000 hour guarantee, have been used for reliability and long life. The BTE-10C lends itself particularly well to unattended and remote operation.

Simplified Exciter Modulator

The exciter/modulator develops a highly stable, crystal-controlled frequency which is heterodyned with both the modulated video and aural signals, resulting in aural and visual output carriers separated by 4.5 MHz (5.0 and 5.5 MHz for CCIR recommendations). The aural signal is then fed through a variable motor-driven attenuator to an RF amplifier using a single type 7289 tube. The output of this stage drives the aural klystron.

Visual modulation takes place at the grid of a pencil triode, type 4055. All RF stages preceding this

are operated Class "C" and are simply tuned by meter indications for maximum output. The output of the mixer stage is a double-tuned cavity, the correct tuning of which can be observed by monitoring the output of a built-in diode demodulator. The video modulated output of this stage, a nominal 2 Watts peak, is fed through a variable attenuator, then amplified in the following cavity tuned amplifier using a single type 7289 tube. The variable attenuator is motor-driven and, in addition to providing a good load impedance on the modulated stage, serves as the visual excitation control.

Exciter Plus Only Two RF Stages

Following the exciter there are two identical RF stages in each channel consisting of a cavity tuned 7289 tetrode IPA and the klystron power amplifier. These tubes and cavities are identical and therefore interchangeable between the aural and visual channels.

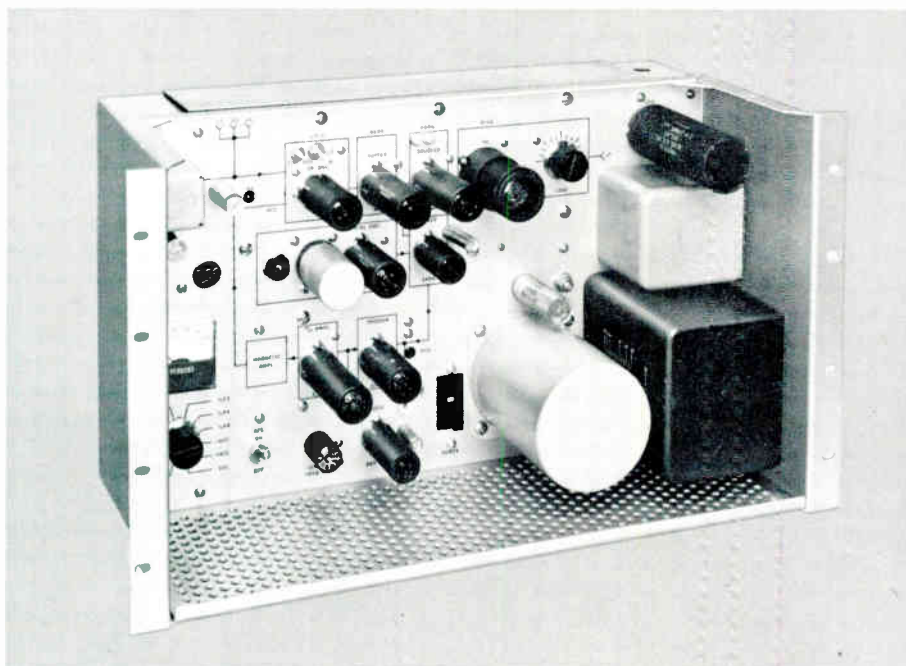

FULL-FIDELITY AURAL EXCITER—Using the direct-FM principle, this exciter is ready for TV stereo sound when adopted.

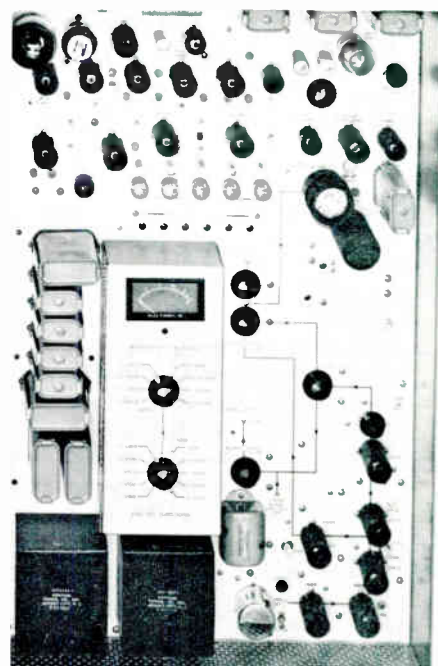

LOW-LEVEL VISUAL MODULATION takes place in this modern exciter/modulator—resulting in improved transmitted picture quality and increased modulator reliability.

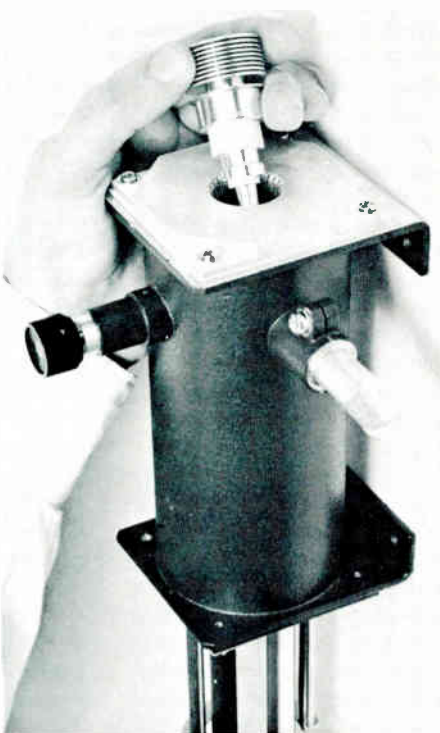

CERAMIC-TETRODE DRIVER AMPLIFIERS couple exciter/modulator output to the klystrons. The drivers are identical for aural and visual portions thus allowing interchangeability.

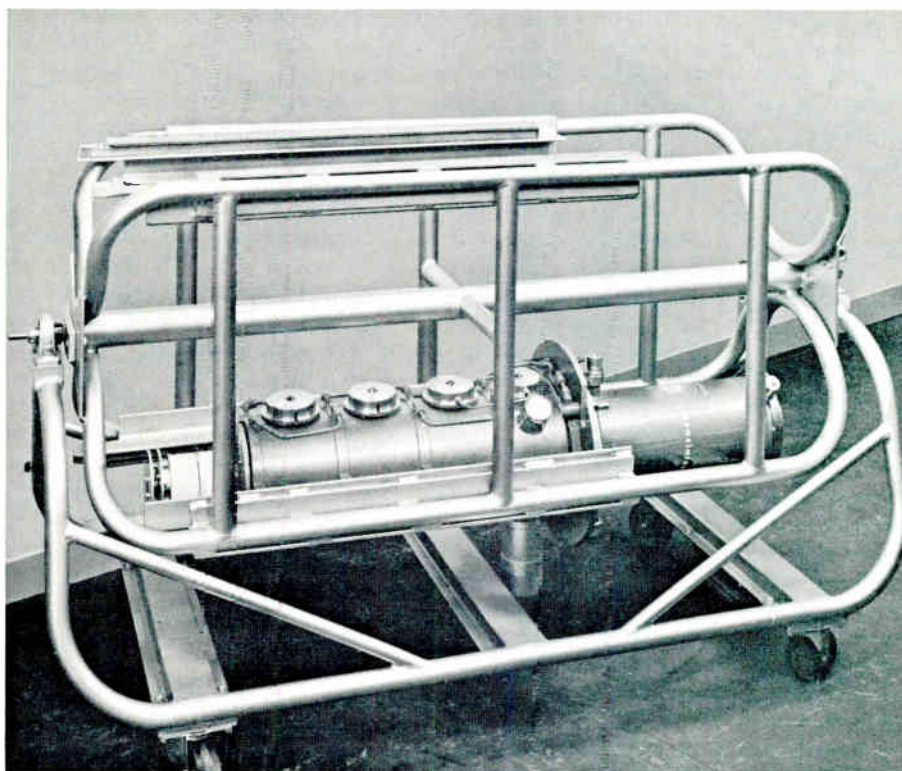

INTEGRAL-CAVITY KLYSTRONS are pretuned for operating frequency at factory and quick-change is provided by this "klystron carriage".

Pretuned Klystron Amplifiers

Easy Tube Change

The high power klystrons may be easily installed by one operator. The factory-tuned klystron is transferred in a horizontal position directly from the shipping carriage. By an ingenious built-in loading device, the klystron can then be easily installed in the transmitter from the klystron carriage. No unusual ceiling height is required as the klystron remains in a horizontal position until it has been completely installed in the transmitter. It is then tilted into a vertical position by a device which is an integral part of the transmitter. Further, factory pre-tuning eliminates the station-site preparation required by external-cavity designs.

The TTU-30A Transmitter may be installed in virtually any room of appropriate width and length. The typical floor plan shows a practical set-up.

Klystron Power Amplifier

The aural and visual amplifiers each use a vapor-cooled integral cavity klystron of the Varian type VA-890 series. The TTU-30A is the first UHF TV-broadcast transmitter to use vapor cooling. The increased efficiency of a vapor system for cooling over one of either air or water results in a considerable saving in operating costs. The vapor-cooled TTU-30A requires a power input of 10 kw less than would be required for the same transmitter if it were water-cooled. Use of integral cavities means that the klystron, when received, is tuned for operation on the intended channel. Tedious assembly or pre-tuning is not needed at transmitter site.

Long-Life Power Supplies

Solid state rectifiers are used throughout. These and other power supply components are located on vertical panels which form the transmitter enclosure, as indicated in the floor plan. Experience has shown that components mounted in this manner are easily accessible for maintenance and are effectively cooled, resulting in long life.

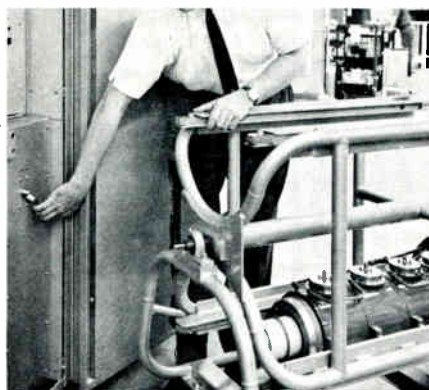

Open Water Drain

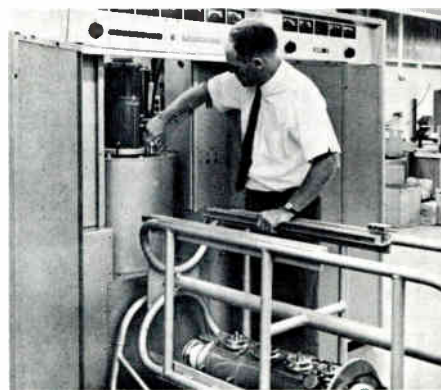

Disconnect Inlet

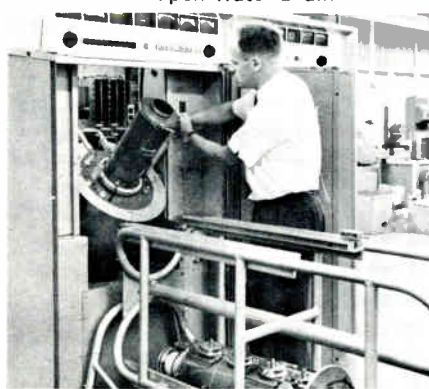

Tilt Klystron

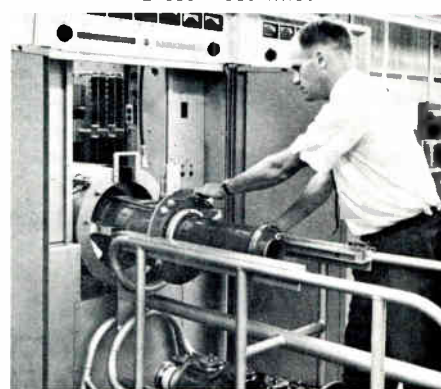

Roll Klystron Out

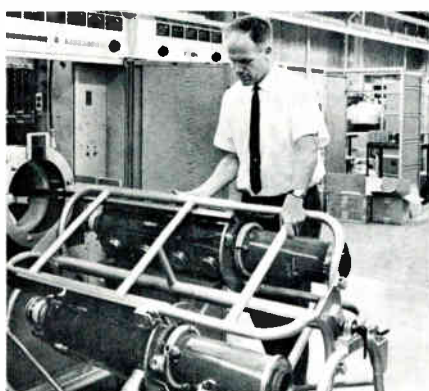

Tumble Carriage

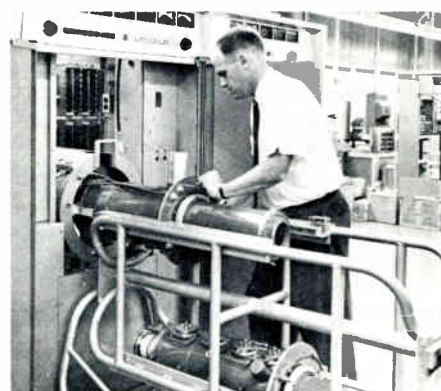

Roll Klystron In



Reconnect Water

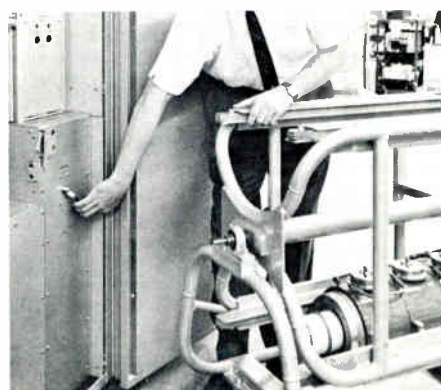

Close Water Drain

Specifications

Performance

	FCC Specs.	CCIR Specs. ¹
Type of Emission:		
Visual	A5	A5
Aural	F3	F3
Frequency Range.....	470-890 MHz (Ch. 14-83)	470-960 MHz
Rated Power Output:		
Visual ²	30 kW	25 kW
Aural ³	3.3 to 17 kW	3.3-16 kW
R-F Output Impedance ⁴	50 ohms	50 ohms
Input Impedance:		
Visual	75 ohms	75 ohms
Aural	500/150 ohms	600/150 ohms
Input Level:		
Visual	0.7 volt peak-to-peak min.	0.7 volt peak-to-peak min.
Aural	+10 ±2 dBm for ±25 kHz deviation	+16 ±2 dbm for 50 kHz deviation
Amplitude vs. Frequency Response....	Uniform ±1 dB from 50 to 15 kHz	—
Upper Sideband Response at Carrier: ⁵		
	FCC	CCIR
		5.0 MHz 5.5 MHz
+0.5 MHz	+1, -1.5 dB	+0.5, -1.5 dB +0.5, -1.5 dB
+1.25 MHz	+1, -1.5 dB	—
+1.5 MHz	+1, -1.5 dB	— Reference
+2.0 MHz	+1, -1.5 dB	—
+3.0 MHz	+1, -1.5 dB	+1, -1.0 dB +1.0, -1.0 dB
+3.58 MHz	+1, -1.5 dB	—
+4.18 MHz	+1, -3.0 dB	—
+4.43 MHz	—	+0.5, -1.5 dB +0.5, -1.5 dB
+4.75 MHz	-20 dB max.	—
+5.0 MHz	—	+1.0, -4.0 dB +0.5, -1.5 dB
+5.5 MHz	—	— +1.0, -4.0 dB
+5.75 MHz	—	-20 dB max. —
+6.25 MHz	—	— -20 dB max.
Lower Sideband Response at Carrier: ⁶		
-0.5 MHz	+1, -1.5 dB	+0.5, -1.5 dB +1.0, -1.0 dB
-0.75 MHz	—	+0.5, -4.0 dB +1.0, -1.0 dB
-1.0 MHz	—	— +0.5, -1.5 dB
-1.25 MHz	-20 dB max.	-20 dB max. -20 dB max.
-2.25 MHz	—	—
-3.58 MHz	-42 dB max.	—
Variation in Frequency Response with Brightness ⁷	±1.5 dB	±1.0 dB
Carrier Frequency Stability: ⁸		
Visual	±1 kHz	±500 Hz
Aural	±500 Hz ⁹	±200 Hz ⁹
Modulation Capability:		
Visual	12.5 ±2.5% (reference white)	12.5 ±2.5% (reference white)
Aural	±50 kHz	±100 kHz
Audio Frequency Distortion	1% max. 30 Hz-15 kHz	1% max. 30 Hz-15 kHz
FM Noise	58 dB below ±25 kHz deviation	64 dB below ±50 kHz deviation
AM Noise, Visual:.....	48 dB r.m.s. below 100% mod.	48 dB r.m.s. below 100% mod.
Aural	50 dB below carrier	50 dB below carrier

	FCC Specs.	CCIR Specs. ¹
Amplitude Variation over One Picture Frame	Less than 3% of the peak of sync level	Less than 3% of the peak of sync level
Regulation of Output Burst vs. Subcarrier Phase ¹⁰	7% max., 2% actual	7% max., 2% actual
Subcarrier Phase vs. Brightness ¹¹	±6° max.	±6°
Subcarrier Amplitude ⁹	±10% max.	±10% max.
Linearity (Differential Gain) ¹²	±7° max.	±7°, total less than 10°
Envelope Delay vs. Frequency ¹³	1.5 dB max.	0.85 m/M
Harmonic Attenuation, ratio of any single harmonic to peak visual fundamental ¹⁴	±80 ns from 0.2 to 2.0 MHz ±40 ns at 3:58 MHz ±80 ns at 4:18 MHz	±80 ns 0.2 to 2.0 MHz ±40 ns 2.0 to 4.43 MHz ±80 ns 4.43 MHz to upper sideband limit
	At least 60 dB	At least 60 dB

Electrical

AC Line Input.....	440/460/480 v, 3-phase 60 Hz	380/400/415 v, 3-phase 50 Hz 440/460/450 v, 3-phase 60 Hz ±3% max.
Slow Line Variations	±3% max.	±3% max.
Rapid Line Variations	±3% max.	±3% max.
Regulation	3% max.	3% max.
Power Consumption:	128 kW for 30 kW	125 kW for 25 kW 105 kW for 20 kW

¹Polarity of visual modulation—negative, asymmetric sideband.

²Measured at the output of the filterplexer.

³Measured at the input to the filterplexer. Usable output depends upon filterplexer rating.

⁴Output impedance of amplifier. Filterplexer output impedance 75 ohm EIA flanged 6/8-inch line. Transformations to other standard lines available.

⁵With respect to the response at 200 kHz, as measured by the BWU-5C Sideband Response Analyzer at transmitter mid-characteristic. Aural carrier plus .25 MHz response requires a LP filter in the video input circuit.

⁶With respect to the response at 200 kHz (4.5 MHz separation standards or 1.5 MHz other standards) at transmitter mid-characteristic.

⁷Maximum variation with respect to the response at mid-characteristic measured with the BWU-5C Sideband Response Analyzer at brightness levels of 22.5% and 67.5% of sync peak, using approximately 20% (peak to peak) modulation.

⁸Maximum variation for a period of 30 days without circuit adjustment over an ambient temperature range of +10°C to +45°C. (meets FCC specifications over ambient range of +1°C. to +45°C.)

⁹Maximum variation with respect to the standard separation between aural and visual carriers. (4.5 MHz—FCC) (5.5 MHz—CCIR)

¹⁰Maximum departure from the theoretical when reproducing saturated primary colors and their complements at 75% amplitude.

¹¹Maximum phase difference with respect to burst, measured after the VSBF, for any brightness level between 75% and 15% of the sync peak using 10% (peak to peak) modulation. This is equivalent to 5% (peak to peak) modulation as indicated by a conventional diode demodulator. In addition, the total differential phase between any two levels shall not exceed 10°.

¹²Maximum variation in the amplitude of a 3.58 MHz sine wave modulating signal as the brightness level is varied between 75% and 15% of sync peak. The gain shall be adjusted for 10% (peak to peak) modulation of the 3.58 MHz signal when the brightness is at pedestal level. This is equivalent to 5% (peak to peak) modulation as indicated by a conventional diode demodulator connected after the VSBF.

¹³Maximum departure from standard curve. The tolerances vary linearly between 2.1 and color subcarrier frequency and between color subcarrier frequency and upper sideband limit and between 3.58 MHz and 4.18 MHz. To meet the specification a properly terminated phase correction network, ES-34034-B is required in the video input circuit of the transmitter.

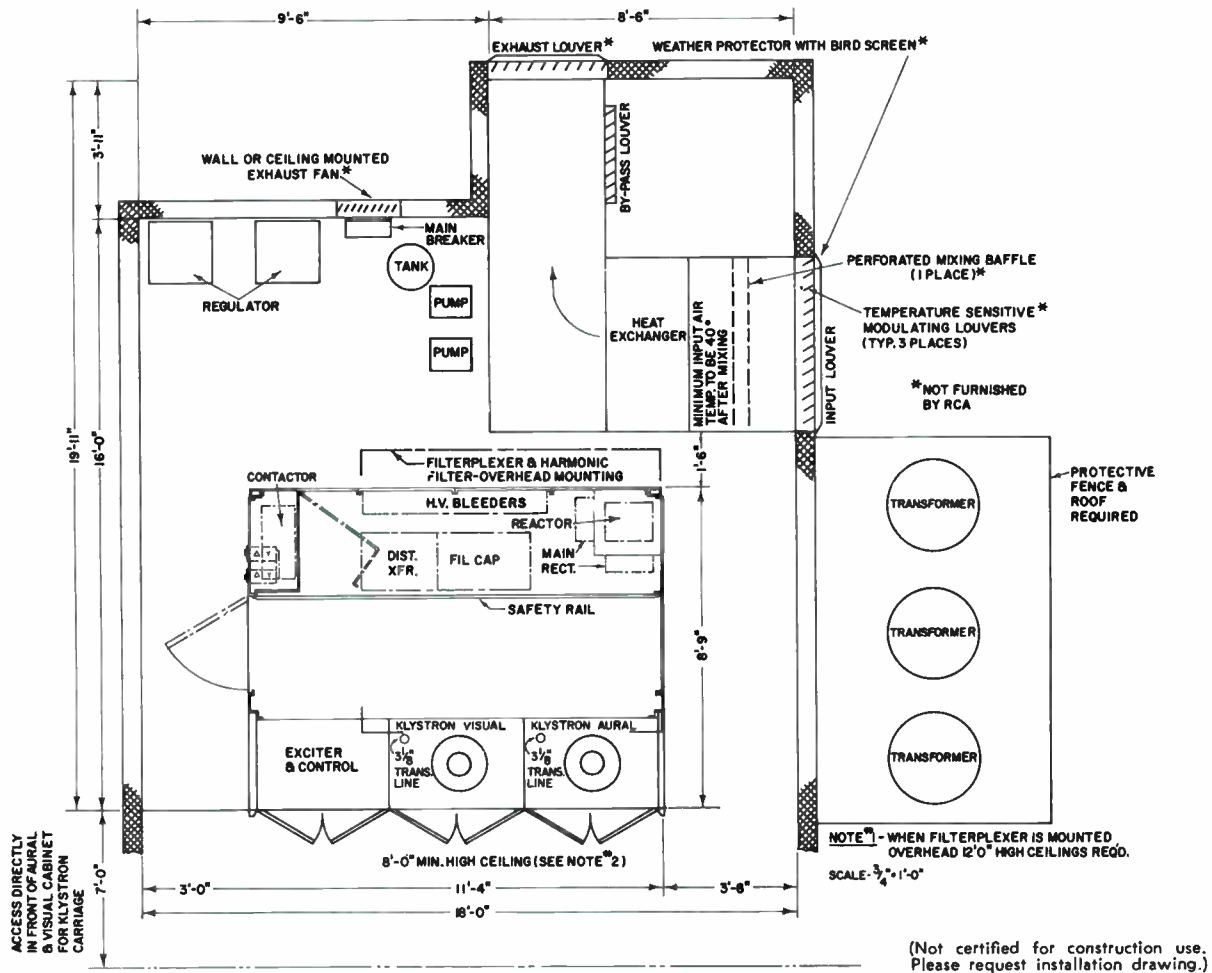

Space Saving Floor Plan of TTU-30A UHF Television Transmitter.

	FCC Specs.	CCIR Specs. ¹
Power Factor (approx.)	90%	90%
Crystal Heaters:		
Line	115 v, 1-phase 50/60 Hz	115 v, 1-phase 50/60 Hz
Power Consumption	7½ watts	7½ watts
Mechanical		
Dimensions Overall:		
Width	136"	345.5 cm
Height	77"	195.6 cm
Depth	105"	266.7 cm
Finish:		
Transmitter	Powder and Midnight blue, aluminum trim	Powder and Midnight blue, aluminum trim

	FCC Specs.	CCIR Specs. ¹
Maximum Altitude ¹	7500 feet	2286 meters
Ambient Temperature ¹	+1°C. to +45°C. max.	+1°C. to +45°C. max.

Accessories

Complete Set of Spare Tubes	ES-560251
Minimum Set of Spare Tubes	ES-560252
BWU-4B Demodulator	ES-34049-B
BWU-5C Sideband Response Analyzer	ES-34009-C
BW-8A Envelope Delay Measuring Set	MI-34063
Transmitter Control Console	ES-561900

¹Air Input Temperature to Heat Exchanger +10°C. to +45°C. to 7500 ft. (2286 meters). Air Temperature in transmitter area: 45°C. at Sea Level; 40°C. to 3300 ft. (1005.84 meters); 35°C. to 5000 ft. (1524 meters); 30°C. to 7500 ft. (2286 meters).

Ordering Information

TTU-30A 30 kW UHF Television Transmitter . . .
Two basic models are available as follows:

For 440/460/480 volt, 60 Hz input order ES-560250 which includes UHF TV Transmitter (30 kW visual, 3.3 to 17 kW aural) with tubes, filterplexer, two sets crystals, two harmonic filters and low pass filter.

For 380/400/415 volt, 50 Hz input order ES-560253 which includes UHF TV Transmitter (25 kW visual, 3.3 to 16 kW aural) with tubes. Output power and required filters to be determined in accordance with required operation standards.

55 KW UHF TV Transmitter, Type TTU-50C

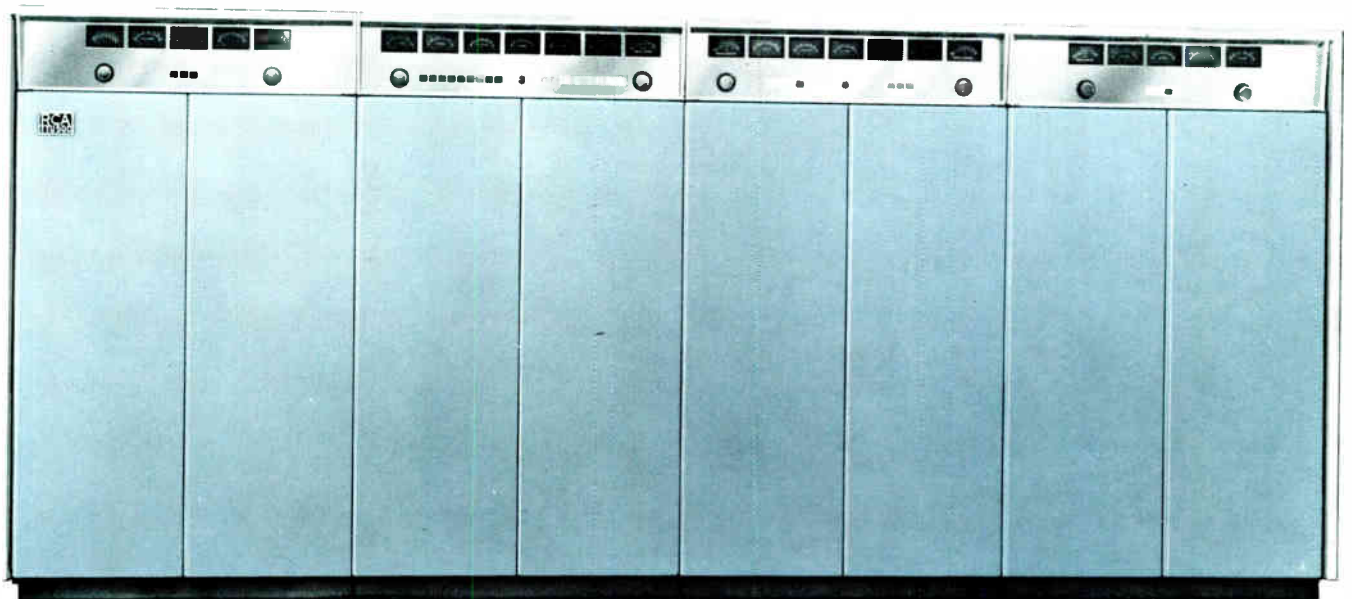

Diplexed Output • Vapor-Cooled Klystrons • Quick Tube-Change

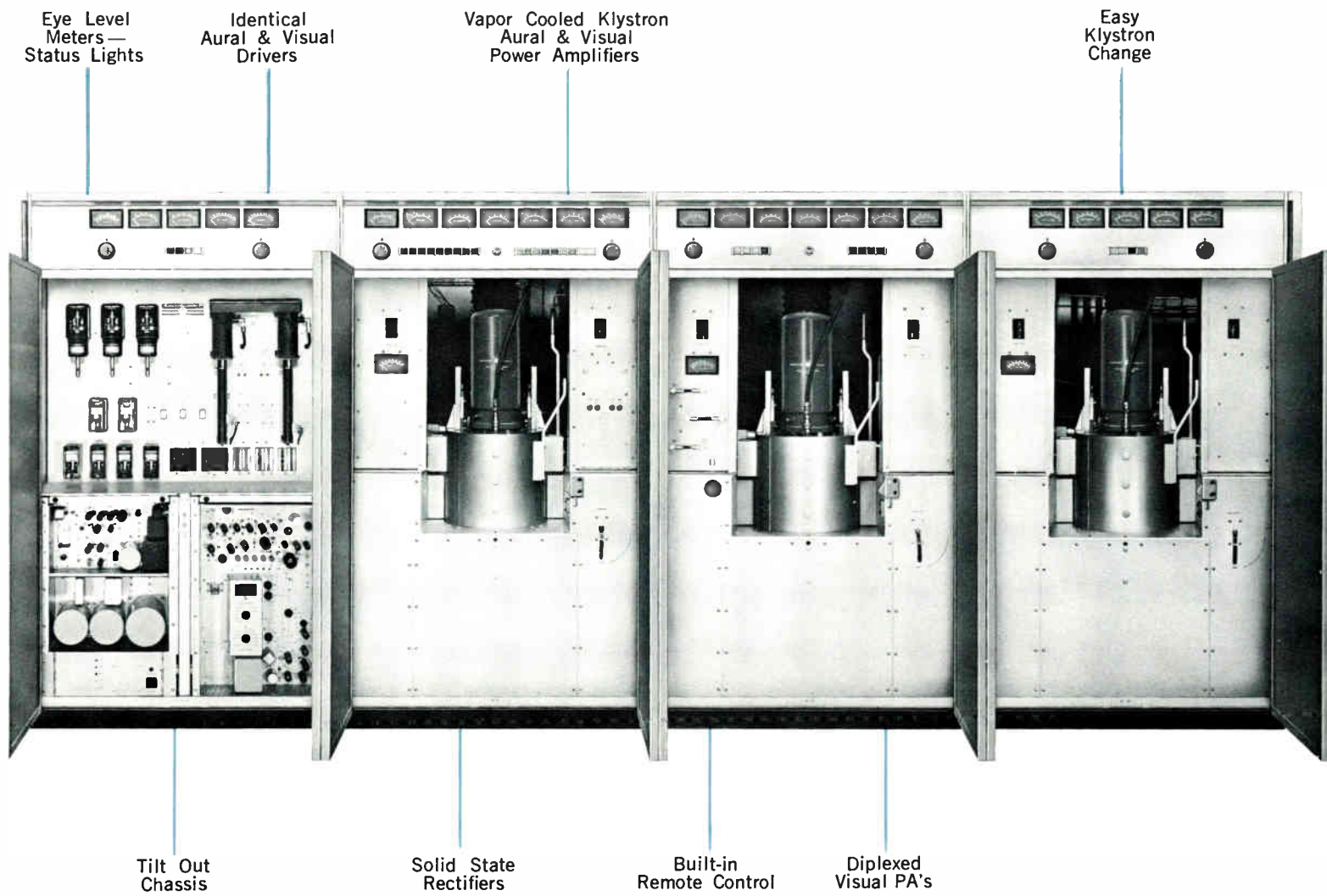

Modern "New Look" UHF Transmitter

The TTU-50C UHF Television Transmitter is a 55-kilowatt klystron-powered equipment offering broadcasters the latest techniques in UHF design. Included are features such as the integral cavity, vapor cooled klystron, low profile styling, solid state circuitry, built in provisions for remote control, and diplexed output for added reliability. The increased efficiency and high power sensitivity of the new klystron offers considerable savings in operating costs.

The transmitter provides effective radiated powers of more than two megawatts for metropolitan markets. It meets FCC or CCIR specifications. Model ES-560275 should be specified for FCC standards and 440/460/480 volt, 60 Hz input. For CCIR

standards and 380/400/415 volt, 50 Hz input, order ES-560277.

The TTU-50C is economical and easy to operate. Though the space required is small, components are located for maximum accessibility. Small physical size and ease of maintenance result in direct savings in installation and operation. New mechanical and electrical features permit one-man operation of this high power transmitter either locally or from a remote point.

Overall reliability is enhanced by use of a diplexed output stage. Redundancy can be further increased by addition of a standby exciter/modulator and RF switching units available as optional accessories.

Description

The transmitter is housed in four new low profile 77-inch cabinets with eye-level meters and convenient finger-tip controls. Built-in remote control circuitry, including metering points for remotely monitoring operating parameters, permits operation at an auxiliary control console or remote point. All normal operating controls are motor-driven and may

also be operated from a remote location.

Circuit Description

Ease of installation, operation and maintenance is enhanced by use of modern, reliable circuitry. Video and audio modulation takes place at a low level, thus eliminating the need for a high power modulator. Use of

high gain klystron tubes makes it possible to effect a high amplification in a single, pre-tuned r.f. stage.

Direct-FM Exciter

The modern circuitry used in the TTU-50C transmitter utilizes the standard BTE-10C FM exciter to develop a stable, high quality, direct frequency modulated aural signal.

Block diagram of TTU-50C UHF Television Transmitter.

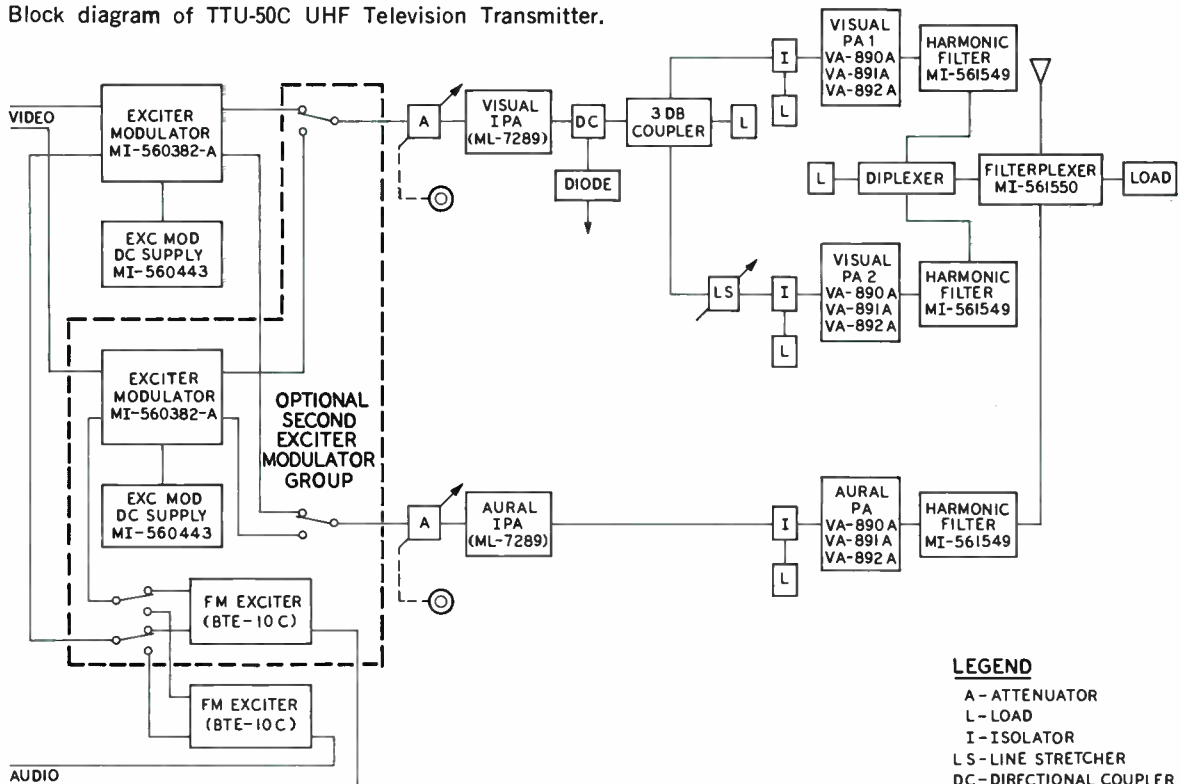

LEGEND

- A - ATTENUATOR
- L - LOAD
- I - ISOLATOR
- LS - LINE STRETCHER
- DC - DIRECTIONAL COUPLER

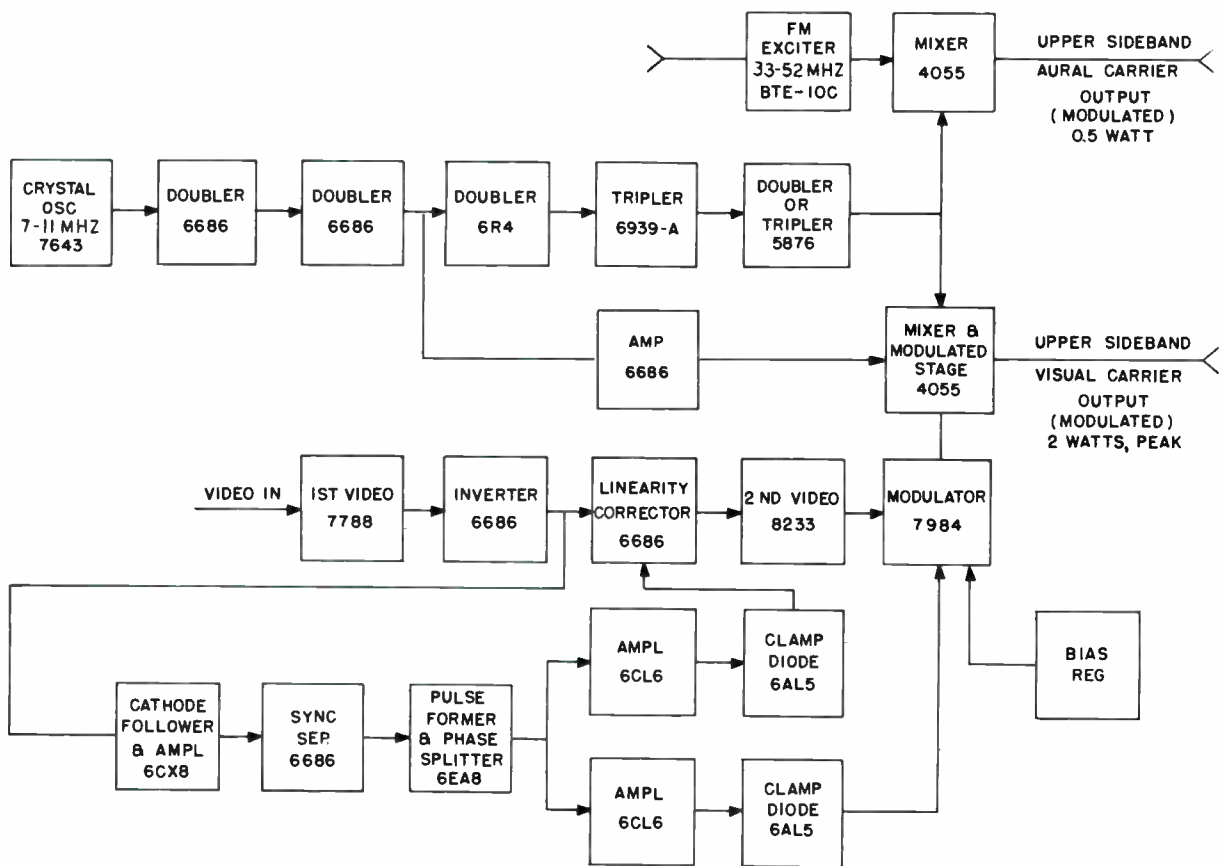

Aural/Visual Exciter/Modulator Block Diagram.

The newly designed FM exciter uses a total of nine tubes—half as many as used in the previous model. Only four tubes are required to maintain an aural output signal, an indication of the reliability built into the entire transmitter.

The design retains RCA's "Direct-FM" modulation which features ease of adjustment and reliable operation. All RF stages use single-tuned circuits. A built-in meter, and easily accessible test points allow metering and checking during operation. An AFC on-off toggle switch and simplified controls including the power on-off switch are all easily accessible on the chassis of the exciter.

A self-contained silicon power supply is used in the exciter. Premium tubes, carrying a 10,000 hour guarantee are used in the r-f circuits for reliability and long life. The BTE 10C lends itself particularly well to unattended and remote operation.

Simplified Exciter Modulator

The exciter/modulator develops a highly stable, crystal-controlled frequency which is heterodyned with both the modulated video and aural signals, resulting in aural and visual output carriers separated by 4.5 MHz (5.5 MHz for CCIR Standards). The aural signal is then fed through a variable motor-driven attenuator to an RF amplifier using a single type 7289 tube. The output of this stage drives the aural klystron to an output of 16 kW.

Visual modulation takes place at the grid of a pencil triode, type 4055. All RF stages preceding this are operated Class "C" and are simply tuned by meter indications for maximum output. The output of the mixer stage is a double-tuned cavity. The video modulated output of this stage, a nominal 2 watts peak, is fed through a variable attenuator, then

amplified in the following cavity tuned amplifier using a single type 7289 tube. The variable attenuator is motor-driven and, in addition to providing a good load impedance on the modulated stage, serves as the visual excitation control.

IPA Stages

Following the exciter, the aural and visual signals are amplified separately by identical cavity tuned IPA stages, each employing a Type 7289 triode. The signals are then fed to their respective klystron output stages. Both IPA stages are broadband tuned and capable of operating as a visual amplifier. Therefore, should the need arise, a simple change of small coaxial connectors at the front of the transmitter will permit the visual signal to be fed through either IPA stage while the aural signal may be fed directly to the aural klystron.

Design Features

SIMPLE, PROVED DIRECT FM

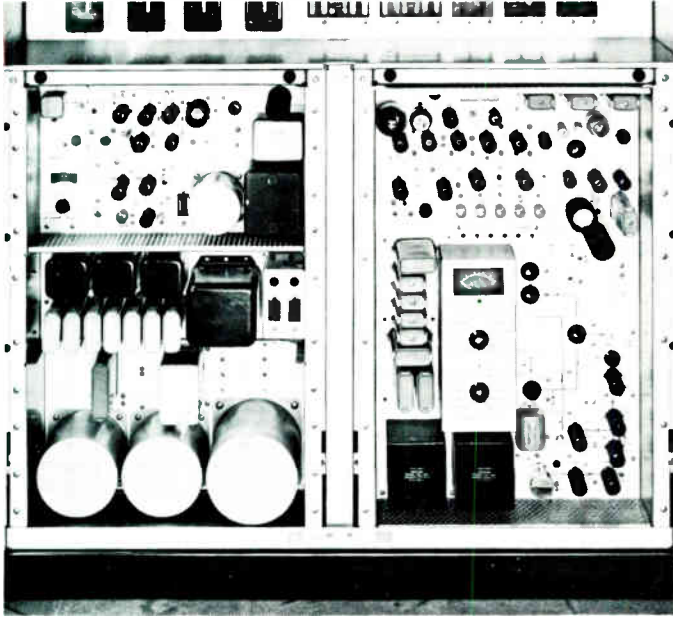

Reliable exciter/modulator employs 10,000 hour premium tubes.

LONG LIFE SOLID STATE RECTIFIERS

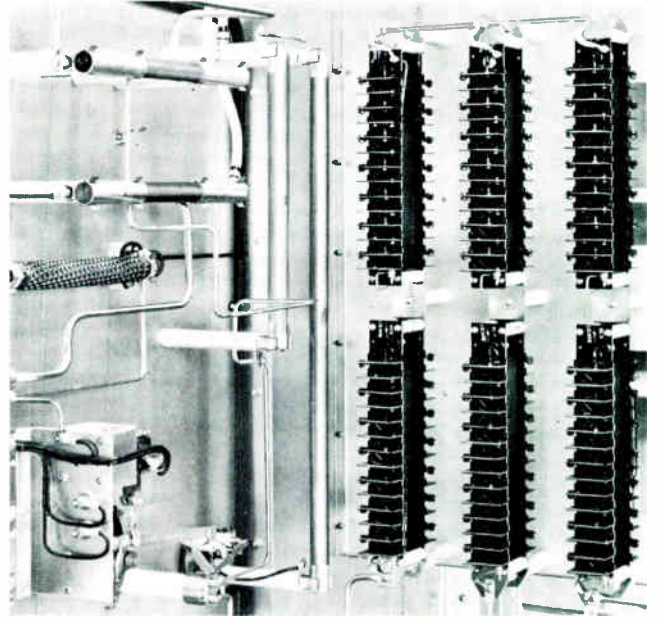

Silicon rectifiers are modularized for easy maintenance.

DIPLEXED VISUAL POWER AMPLIFIER

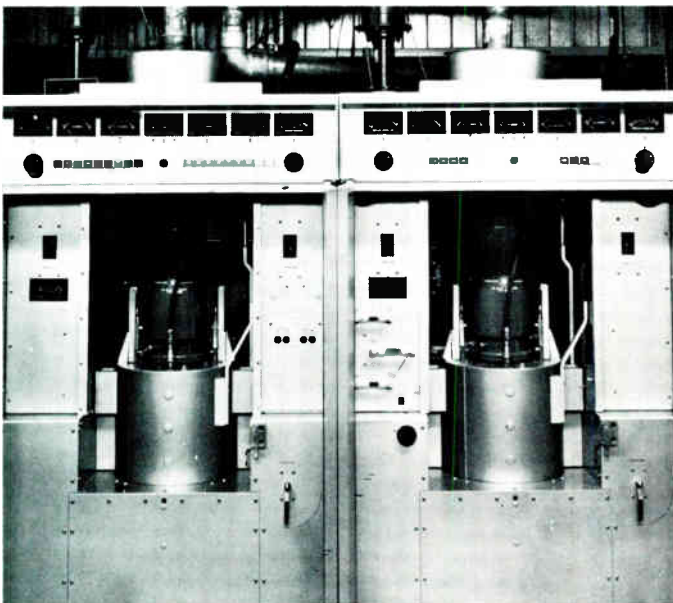

Vapor-cooled klystrons contribute independently to output.

BUILT-IN MOTOR DRIVEN CONTROLS

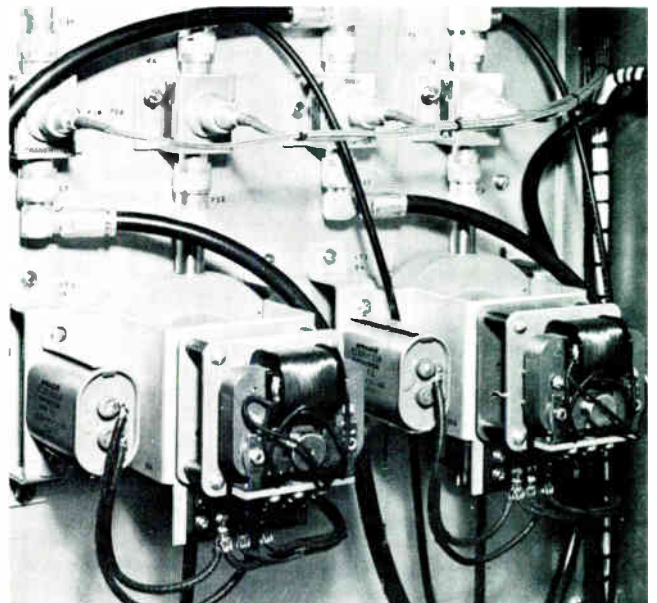

Standard equipment in readiness for remote control.

Diplexed, Pre-Tuned Klystrons

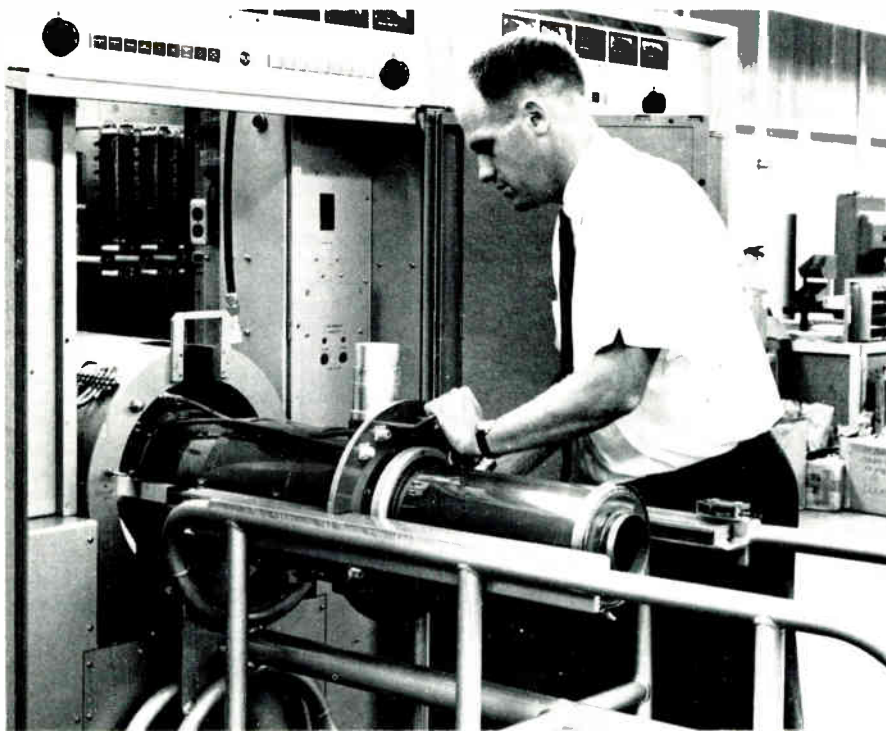

Klystron is easily changed by tilting and sliding into four wheel carriage, then revolving carriage and easing replacement into transmitter.

Klystron Power Amplifiers

Aural and visual power amplifiers in the TTU-50C each use vapor cooled, integral cavity klystrons of the Varian Type VA-890 Series. Use of integral cavities means that the klystrons are tuned at the factory, eliminating the station site preparation which is required by external cavity designs. Three identical klystrons are used in the transmitter.

The TTU-50 Series are the first 55 kW television broadcast transmitters to use the new vapor cooled klystrons. The increased efficiency of a vapor cooling system over either air or water cooled systems results in a considerable saving in operating costs. The vapor cooled TTU-50C, for example, requires a power input of approximately 10 kW less than would be required for the same transmitter if it were water cooled.

The integral cavity klystron is easily installed by one operator. It is transferred in a horizontal position directly from the shipping container into a four-wheel carriage, then by an ingenious loading device, is rolled into the transmitter. The tube remains in a horizontal position until completely installed, after which it is tilted to a vertical position and locked. No unusually high ceilings are required as with some klystrons.

Diplexing Increases Reliability

One of the three klystrons is employed in the aural PA. The visual PA uses two klystrons in a diplexed arrangement. Diplexing is more than just paralleling two tubes. Each tube contributes independently to the output. If either tube fails, the other tube continues to operate unaffected. Diplexing achieves an increased reliability, which according to studies, improves 150 percent in any redundant system employing identical elements. The design also offers the possibility, in an emergency, of patching in one of the diplexed visual amplifiers to take over for a disabled aural PA, and thus keep the transmitter on the air.

These features, plus the interchangeable drivers and optional spare exciter represent a great forward step in design to achieve the dependability required in today's television transmitter operations.

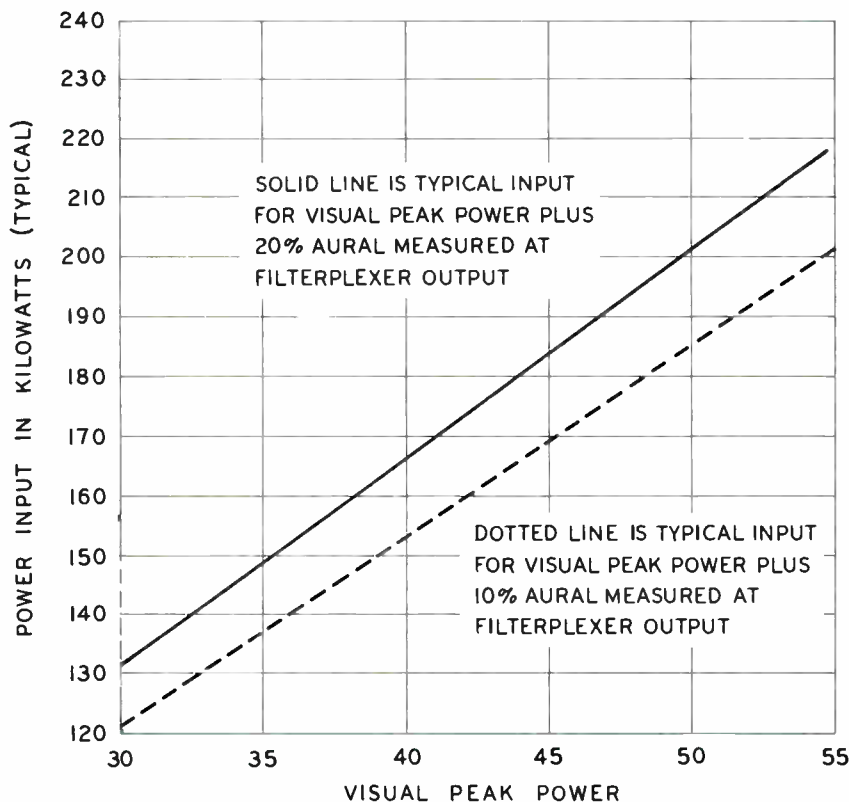

Curve showing power consumption for given power output values.

Specifications

Performance*

	FCC Specs.	CCIR Specs.
Type of Emission:		
Visual	A5	A5
Aural	F3	F3
Frequency Range.....	470-890 MHz (Ch. 14-83)	470-890 MHz
Rated Power Output:		
Visual ¹	55 kW	40 kW
Aural ²	6.0 to 16 kW	6.0 to 16 kW
R-F Output		
Impedance ³	50 ohms, 3/8" flanged	50 ohms, 3/8" flanged
Input Impedance:		
Visual	75 ohms	75 ohms
Aural	600/150 ohms	600/150 ohms
Input Level:		
Visual	0.7 volt peak-to-peak min.	0.7 volt peak-to-peak min.
Aural	+10 ±2 dBm for ± 25 kHz deviation	+16 ±2 dBm for 50 kHz deviation
Amplitude vs. Frequency Response....	Uniform ±1 dB from 50 to 15,000 kHz	—
Upper Sideband Response at Carrier:	FCC ⁴	CCIR ⁵
		5.0 MHz Carrier Separation 5.5 MHz
+0.5 MHz	+1, -1.5 dB	+0.5, -1.5 dB
+1.25 MHz	+1, -1.5 dB	—
+1.5 MHz	+1, -1.5 dB	Reference
+2.0 MHz	+1, -1.5 dB	—
+3.0 MHz	+1, -1.5 dB	+1.0 -1.0 dB
+3.58 MHz	+1, -1.5 dB	—
+4.18 MHz	+1, -3.0 dB	—
+4.43 MHz	—	+0.5, -1.5 dB
+4.75 MHz	-20 dB max.	—
+5.0 MHz	—	+1.0, -4.0 dB
+5.5 MHz	—	+0.5, -1.5 dB
+5.75 MHz	—	+1.0, -4.0 dB
+6.25 MHz	—	-20 dB max.
Lower Sideband Response at Carrier:		
-0.5 MHz	+1, -1.5 dB	+0.5, -1.5 dB
-0.75 MHz	—	+0.5, -4.0 dB
-1.0 MHz	—	+1.0, -1.0 dB
-1.25 MHz	—	+0.5, -1.5 dB
-2.25 MHz	-20 dB max.	-20 dB max.
-3.58 MHz	—	+0.5, -4.0 dB
-4.43 MHz	-42 dB max.	-20 dB max.
Variation in Frequency Response with Brightness ⁶	±1.5 dB	±1.0 dB
Carrier Frequency Stability: ⁷		
Visual	±500 Hz	±500 Hz
Aural	±500 Hz ⁸	±200 Hz ⁸
Modulation Capability:		
Visual	12.5 ±2.5% (reference white)	12.5 ±2.5% (reference white)
Aural	±50 kHz	±100 kHz
Audio Frequency Distortion	1% max. 30 Hz to 15 kHz	1% max., 30 Hz to 15 kHz
FM Noise	-58 dB below ±25 kHz swing	-64 dB below ±50 kHz deviation
AM Noise, r.m.s.:		
Visual ⁹	48 dB r.m.s. below 100% mod.	48 dB r.m.s. below 100% mod.
Aural	50 dB below carrier	50 dB below carrier

* Specifications shown are measured and stated in terms of meeting United States FCC requirements. This transmitter can meet various foreign standards.

	FCC Specs.	CCIR Specs.
Amplitude Variation Over One Picture Frame	Less than 3% of the peak of sync level	Less than 3% of the peak of sync level
Regulation of Output Burst vs. Subcarrier Phase ¹⁰	3% max.	3% max.
Subcarrier Phase vs. Brightness ¹¹	±6° max.	±6° max.
Subcarrier Amplitude ¹⁰	±7° max. total less than 10°	±7°, total less than 10°
Linearity (Differential Gain) ¹²	±10% max.	±10% max.
Envelope Delay vs. Frequency ¹³	1.5 dB max.	See Note ¹²
+80 ns from 0.2 to 2.0 MHz		±80 ns, 0.2 to 2.0 MHz
+40 ns at 3.58 MHz		±40 ns, at 4.43 MHz
+80 ns at 4.18 MHz		±80 ns, 4.43 MHz to upper sideband limit
Harmonic Attenuation, ratio of any single harmonic to peak visual fundamental ¹³	At least -60 dB	At least -60 dB

	FCC Specs.	CCIR Specs.
Electrical		
AC Line Input.....	440/460/480 V, 3-phase, 60 Hz 4 wire	380/400/415 V, 3-phase, 50 Hz 4 wire
Slow Line Variations	±3% max.	±3% max.
Rapid Line Variations	±3% max.	±3% max.
Regulation	3% max.	3% max.
Power Consumption....	See Power Curve	240 kW
Power Factor (approx.)	90%	90%
Crystal Heaters:		
Line	115 V, 1-phase 50/60 Hz	220 V, 1-phase 50/60 Hz
Power Consumption....	7½ watts	7½ watts

¹Measured at the output of the filterplexer.

²Measured at the input to the filterplexer.

³Output of RF Amplifier. Output of visual diplexer and filterplexer are 6-1/8" 75 ohm EIA flange.

⁴With respect to the response at 200 kHz, as measured by the RCA BWU-5C Sideband Response Analyzer and with the transmitter adjusted for mid-characteristics. An MI-27132-A Low Pass Video Filter is required in the input circuit.

⁵With respect to the response at 1.5 MHz as measured by the RCA BWU-5C Sideband Response Analyzer and with the transmitter adjusted for mid-characteristics. Use of a 5.75 MHz Video Low Pass Filter is required.

⁶Maximum variation with respect to the response at mid-characteristic measured with the BWU-5C Sideband Response Analyzer using approximately 20 percent (peak to peak) modulation at brightness levels of 22.5 percent and 67.5 percent of peak for FCC specifications and for brightness levels of 25 percent and 60 percent, for CCIR specifications.

⁷Maximum variation for a period of 10 days without circuit adjustment over an ambient temperature range of +10°C to +45°C. (Meets FCC specifications over an ambient range of +1°C to +45°C.)

⁸Maximum variation with respect to separation between aural and visual carriers.

⁹RMS hum and noise level 50 Hz to 15 kHz. Extraneous modulation (unrelated to video modulation) above 15 kHz within the visual passband 40 db below 100% modulation.

¹⁰Maximum departure from the theoretical when reproducing saturated primary colors and their complements at 75% amplitude.

¹¹Maximum phase difference with respect to burst, measured after the sideband filter, for any brightness level between 75% and 15% of the sync peak using 10% (peak to peak) modulation. This is equivalent to 5% peak to peak as indicated by a conventional diode demodulator. In addition, the total differential phase between any two levels shall not exceed 10°.

¹²Maximum variation of amplitude of the sine wave modulation frequency when superimposed on staircase or ramp modulation which is adjusted for brightness excursion stated. Modulation depth of the sine wave to be 20% peak to peak. CCIR Linearity is 0.85 at 0.2 MHz, 1.5 MHz and 4.43 MHz with Brightness excursion 65 to 17% for 0.2 and 1.5 MHz and 75 to 17% at 4.43 MHz.

¹³Maximum departure from standard curve. The tolerances vary linearly between 2.1 and color subcarrier frequency and between color subcarrier frequency and upper sideband limit. To meet the specification a properly terminated phase correction network is required in the video input circuit of the transmitter.

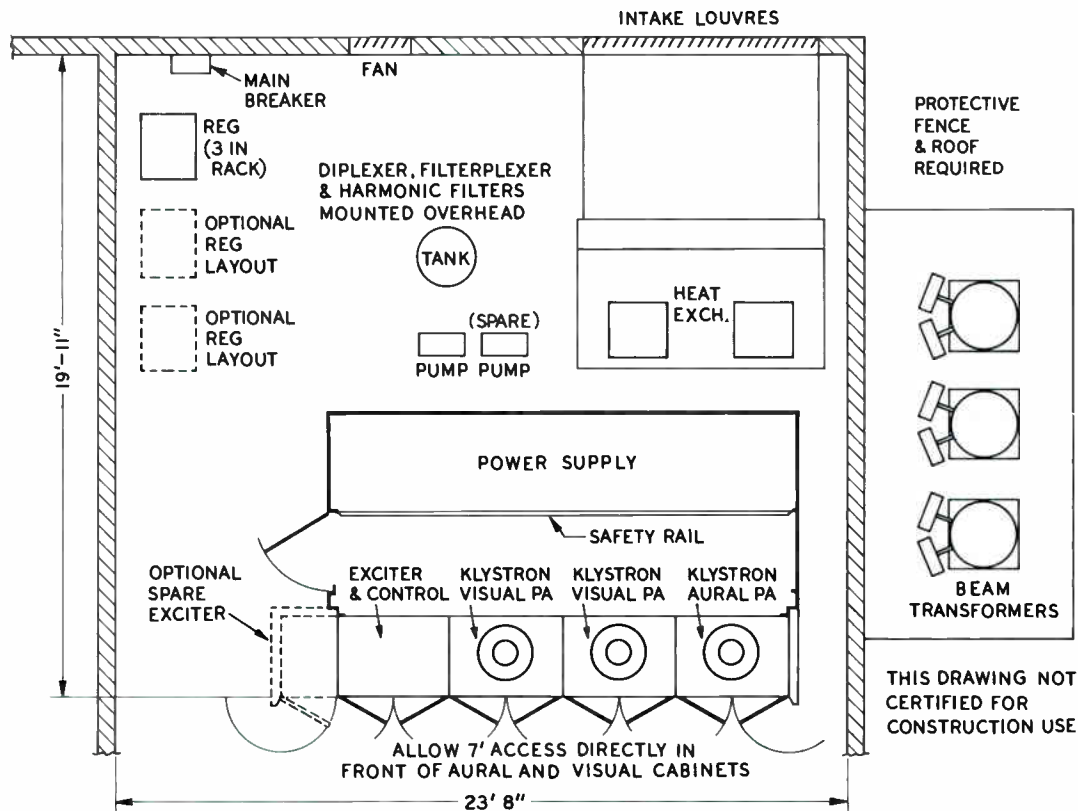

Space Saving Floor Plan of TTU-50C UHF Television Transmitter.

Mechanical

	FCC Specs.	CCIR Specs.
Dimensions Overall: Transmitter Cabinet	180" long, 105" deep, 77" high	457 cm long, 266.7 cm deep, 195.6 cm high
Finish: Transmitter	Powder and Midnight blue, aluminum trim	Powder and Midnight blue, aluminum trim
Maximum Altitude	7500 feet	2286 meters
Ambient Temperature ¹¹	+1°C. to +45°C. max.	+1°C. to +45°C. max.

¹¹Air Input Temperature to Heat Exchanger +10°C. to +45°C. to 7500 ft. (2286 meters.)

Air Temperature in transmitter area:
45°C. at Sea level; 40°C. to 3300 ft. (1005.84 meters); 35°C. to 5000 ft. (1524 meters) 30°C. to 7500 ft. (2286 meters).

Accessories

Complete Set of Spare Tubes.....	ES-560279
Minimum Set of Spare Tubes.....	ES-560252
Spare Exciter Group	ES-560281
BWU-4C Demodulator	ES-34049
BWU-5C Sideband Response Analyzer.....	ES-34009-B
BW-8A Envelope Delay Measuring Set.....	MI-34063
BW-8A1 Envelope Delay Measuring Set.....	MI-34068
Transmitter Control Console.....	ES-561900

For 440/460/480 Volt, 60 Hz input and FCC standards order ES-560275

For 380/400/415 Volt, 50 Hz input and CCIR standards order ES-560277

Ordering Information

TTU-50C UHF TV Transmitter 55 kW visual 6.0 to 16 kW aural with tubes, filterplexer, two sets crystals, two harmonic filters and low pass filter

Output power and required filters to be determined in accordance with required operating standards

55 KW UHF TV Transmitter, Type TTU-50C1

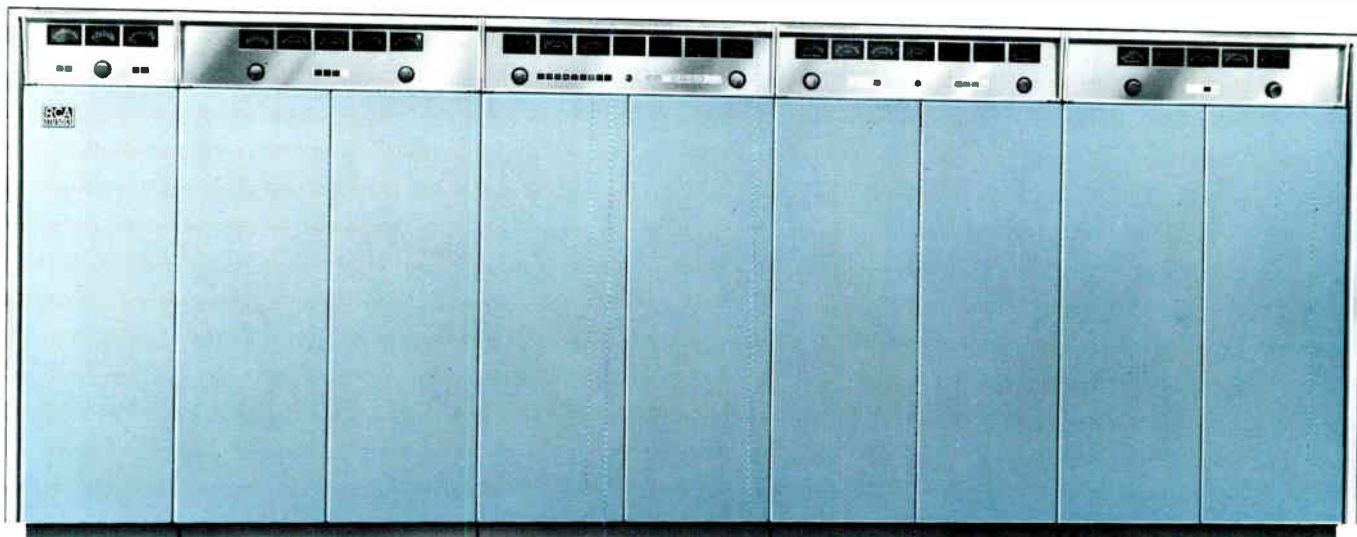

Diplexed Output • Vapor-Cooled Klystrons • Standby Facilities

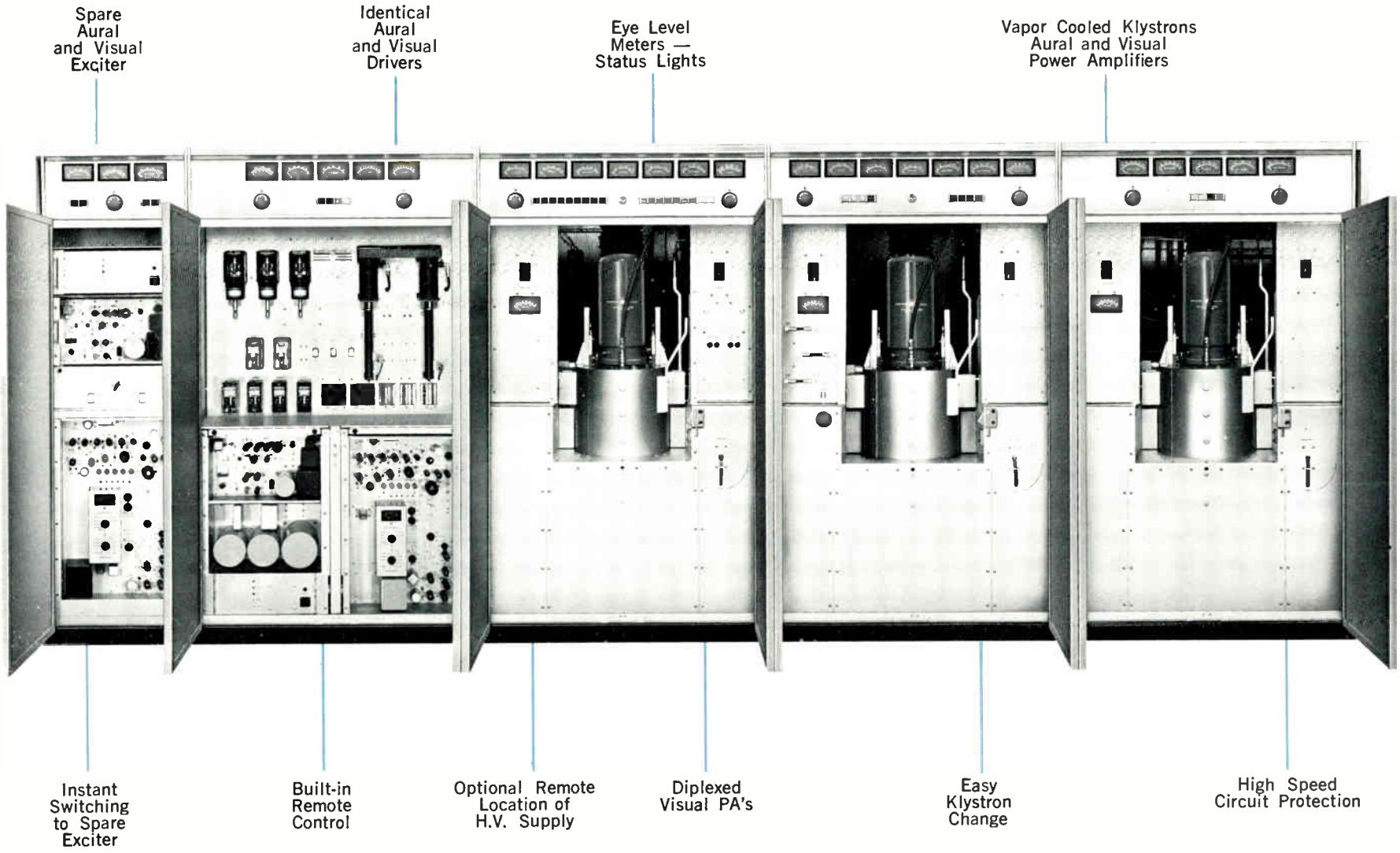

Industry's Most Versatile High Power Transmitter

The new 55 kW UHF transmitter, Type TTU-50C1, is the finest of RCA's high power UHF offerings to broadcasters. Features such as the vapor cooled, integral cavity klystrons with their high power sensitivity, the interchangeability of aural and visual amplifier stages, and the solid state rectifier and power supply circuits, greatly enhance the transmitter's operating efficiency and performance. Reliability is increased by duplexed visual power amplifiers and a spare "hot" exciter/modulator that can be switched in for emergency standby.

The TTU-50C1 offers a measure of backup that almost equals a second transmitter. Identical IPA and PA stages for aural and visual, plus unique patch facilities, provide a redundancy that permits up to 50 percent normal transmitter power to be maintained should any of the three klystrons fail. If necessary, the aural

IPA can be substituted for a disabled visual IPA, or one of the visual PA's can replace a disabled aural PA. Each klystron cabinet includes switching facilities to remove the cabinet from the circuit for repairs without interrupting normal operation of the remainder of the transmitter.

The transmitter is economical and easy to operate. Though the space required is small, components are placed for maximum accessibility. Both small size and ease of maintenance result in direct savings in installation and operation.

The TTU-50C1 is designed to provide effective radiated power of over two megawatts for metropolitan markets. There are models to meet FCC or CCIR specifications. Model ES-560276 should be specified for FCC standards and 440/460/480 volts, 60 Hz input. For CCIR standards and 380/400/415 volts, 50 Hz input, order ES-560278.

Description

The transmitter is housed in new low profile 77-inch cabinets with eye level meters and fingertip controls. Built in remote control circuitry, including metering points for remote

monitoring, permit operation at an auxiliary control console or remote point. All normal operating controls are motor driven and thus can be actuated from a remote location.

The floor plan shown for the transmitter is typical. However, several other layouts are possible since the main rectifier cubicle and heat exchanger can be detached

Block diagram of TTU-50C1 UHF Television Transmitter.

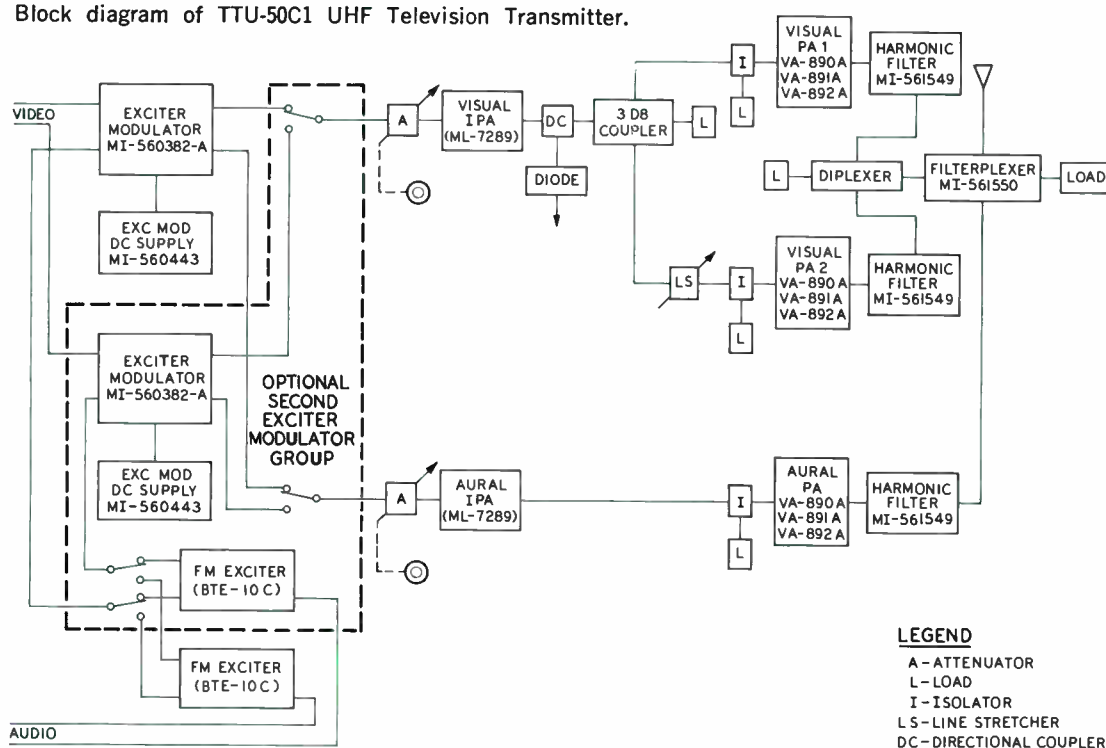

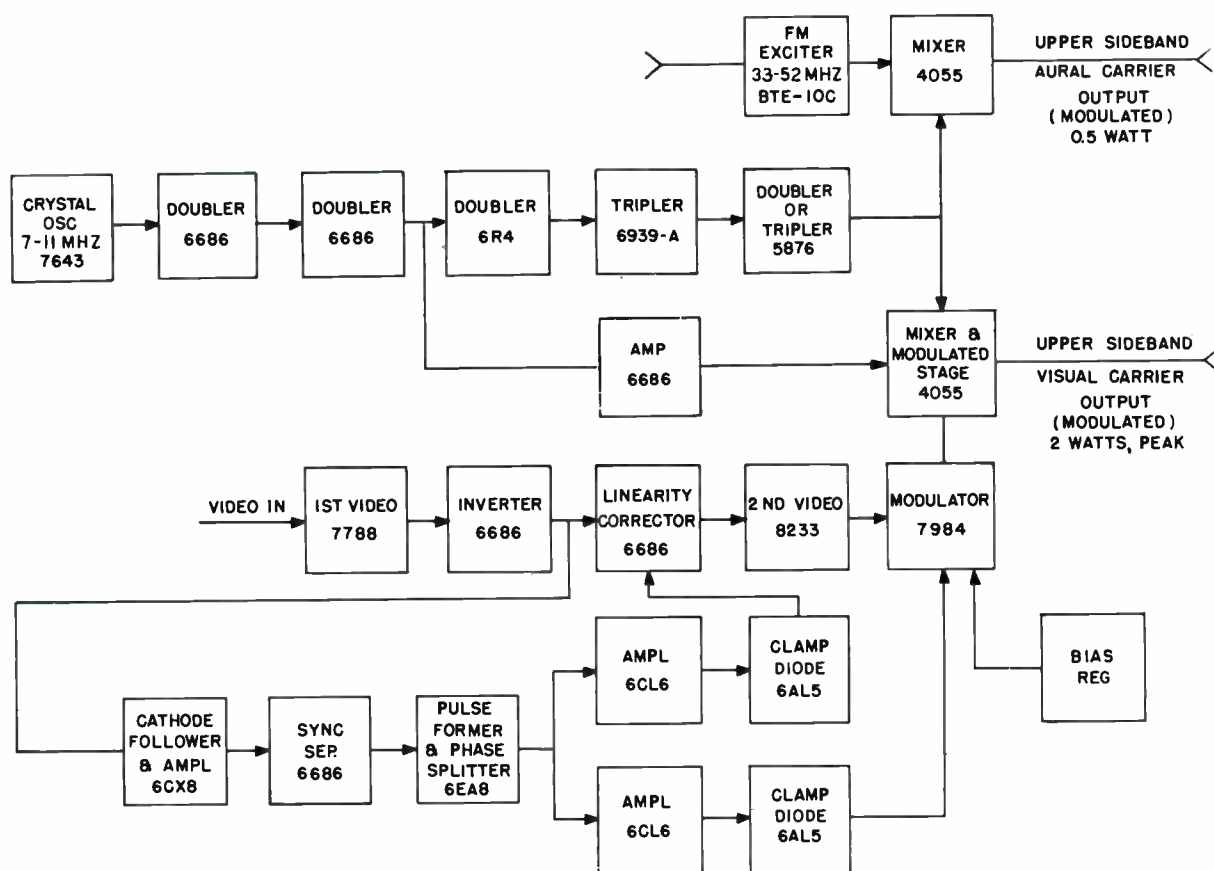

Aural/Visual Exciter/Modulator Block Diagram.

from the RF cabinets and located in an adjacent room or even on another level.

Direct FM Exciter

Modern circuitry used in the TTU-50C1 utilizes the reliable BTE-10C FM exciter to develop a stable, high quality, direct FM aural signal. This new exciter uses only nine tubes—half the number in the previous model. Of these, only four are required to maintain an aural output signal, an indication of the reliability potential built into the transmitter.

Pretuned Klystron Power Amplifiers

Aural and visual power amplifiers each use vapor cooled, integral cavity klystrons of the Varian Type VA-890 series. Use of integral cavities means that the klystron is tuned at the factory, eliminating the station site preparation required by external cavity designs. Three

identical klystrons are used in the transmitter.

The TTU-50 Series are the first 55 kW TV broadcast transmitters to use vapor cooling. The increased efficiency of a vapor cooling system over one of either air or water results in a considerable saving in operating costs. The vapor-cooled TTU-50C1 requires a power input of approximately 10 kW less than would be required for the same transmitter if it were water cooled.

The integral cavity klystron is easily installed by one operator. It is transferred in a horizontal position directly from the shipping container into a four-wheel carriage, then by an ingenious loading device, into the transmitter. The tube remains in a horizontal position until completely installed in the transmitter. It is then tilted to a vertical position and locked. No unusual

ceiling height is required as with some klystrons.

Diplexing Increases Reliability

One of the three klystrons is employed in the aural PA. Two klystrons in a diplexed arrangement are used in the visual PA. Diplexing is more than just paralleling two tubes. If either tube fails, the other continues to operate, unaffected. Diplexing achieves an increased reliability, which according to studies, improves 150 percent in any redundant system employing identical elements. The design also offers the possibility in an emergency of patching in one of the diplexed amplifiers to take over for a disabled aural PA and thus stay on the air.

These features plus the spare exciter and interchangeable drivers represent a great forward step in design to achieve the dependability required in television transmitter operation.

Design Features

LONG LIFE SILICON RECTIFIERS

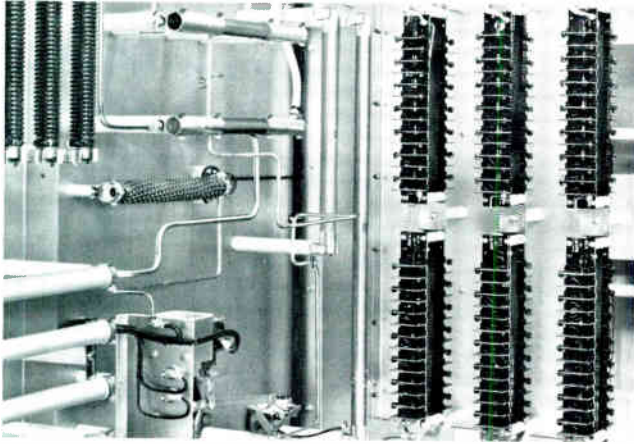

Modularized for easy maintenance.

SIMPLE, PROVED CIRCUITRY

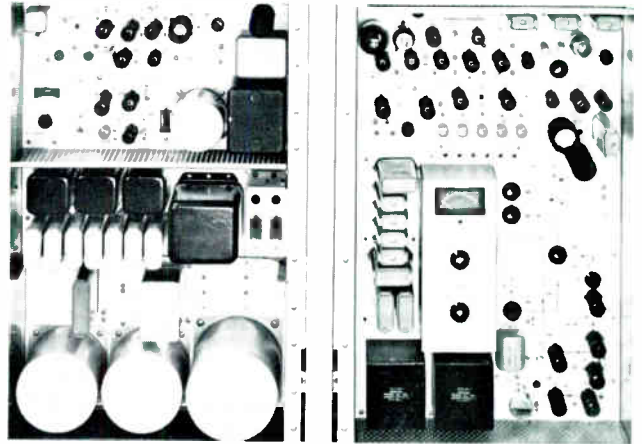

Exciter/modulator employing premium 10,000 hour tubes.

INSTANT SELECTION OF SPARE EXCITER

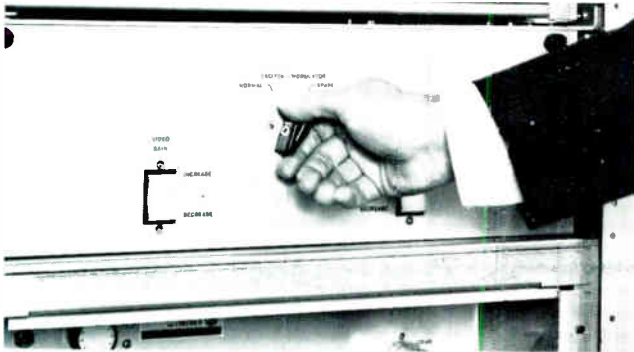

Complete standby exciter/modulator with power supply.

QUICK ISOLATION FOR "ON-AIR" SERVICING

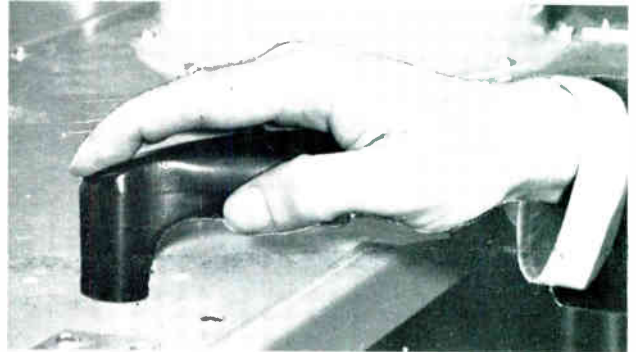

Switch for each klystron cabinet disconnects cubicle from operating transmitter.

EASY BY-PASSING OF INOPERATIVE DRIVER

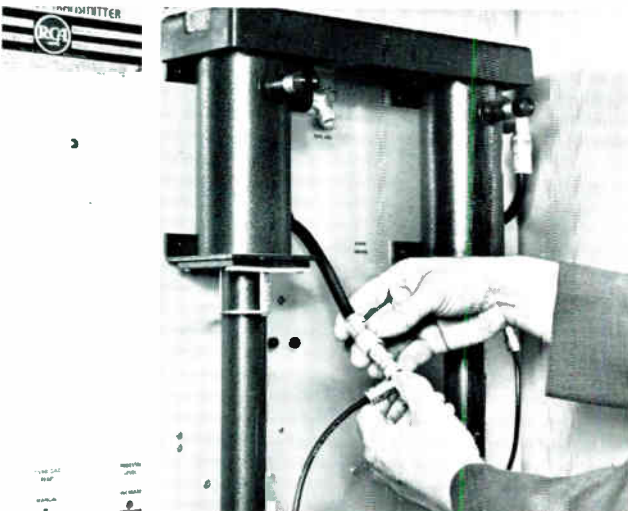

Simple cable change substitutes aural IPA for visual IPA.

SIMPLE PATCHING OF DISABLED PA

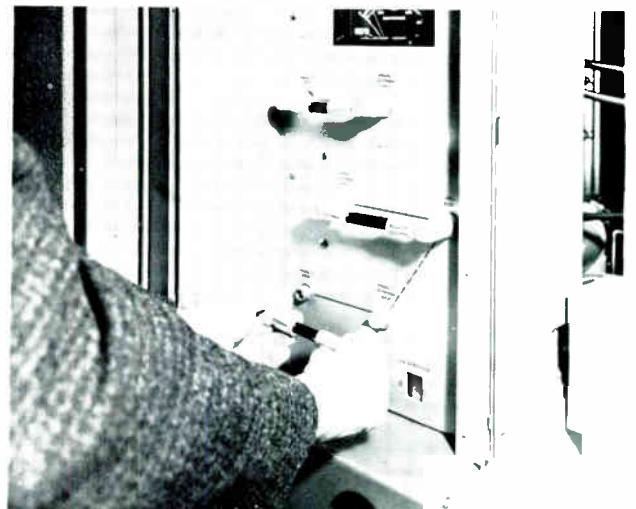

Unique patch panel permits instant use of visual PA for aural PA.

Pretuned Klystron Amplifiers

The design retains RCA's "Direct-FM" modulation with particular emphasis being placed on ease of adjustment and reliable operation. All RF stages use single-tuned circuits. A built-in meter, and easily accessible test points allow metering and checking during operation. An AFC on-off toggle switch and simplified controls including the power on-off switch are all easily accessible on the chassis of the exciter.

A self-contained silicon power supply is used in the exciter. Premium tubes, carrying a 10,000 hour guarantee are used in the RF circuits for reliability and long life. The BTE-10C lends itself particularly well to unattended and remote operation.

Simplified Exciter Modulator

The exciter/modulator develops a highly stable, crystal-controlled frequency which is heterodyned with both the modulated video and aural signals, resulting in aural and visual output carriers separated by 4.5 MHz (5.5 MHz for CCIR Standards). The aural signal is then fed through a variable motor-driven attenuator to an RF amplifier using a single type 7289 tube. The output of this stage drives the aural klystron to an output of 16 kW.

Visual modulation takes place at the grid of a pencil triode, type 4055. All RF stages preceding this are operated Class "C" and are simply tuned by meter indications for maximum output. The output of the mixer stage is a double-tuned cavity. The video modulated output of this stage, a nominal 2 watts peak, is fed through a variable attenuator, then amplified in the following cavity tuned amplifier using a single type 7289 tube. The variable attenuator is motor-driven and, in addition to providing a good load impedance on the modulated stage, serves as the visual excitation control.

IPA Stages

Following the exciter, the aural and visual signals are amplified separately by identical cavity tuned IPA stages, each employing a Type 7289 triode. The signals are then fed to their respective klystron output stages. Both IPA stages are broadband tuned and capable of operating as a visual amplifier. Therefore, should the need arise, a simple change of small coaxial connectors at the front of the transmitter will permit the visual signal to be fed through either IPA stage while the aural signal may be fed directly to the aural klystron.

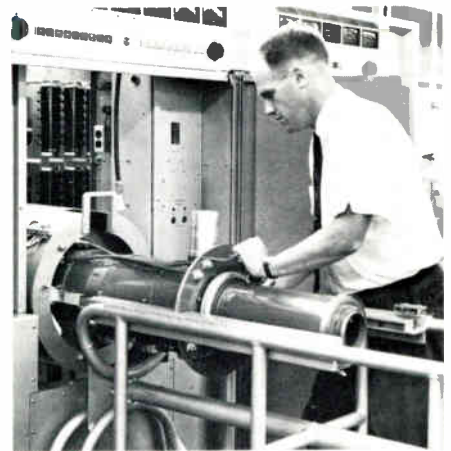

Klystrons are easily rolled into place with special carriage loading device.



Chassis units slide forward on rails for easy inspection.

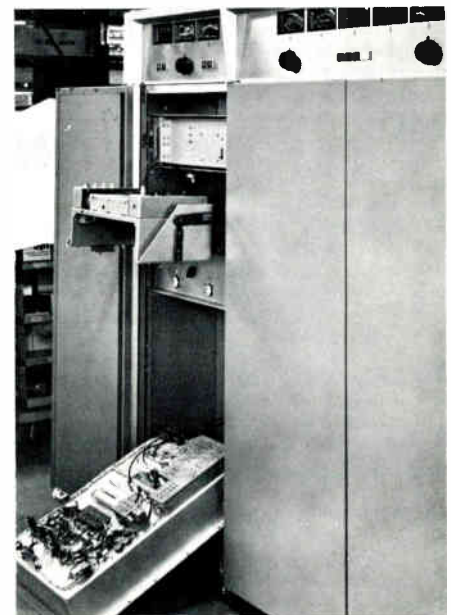

Units are hinged to tilt forward for complete accessibility.

Curve showing power input vs power output values.

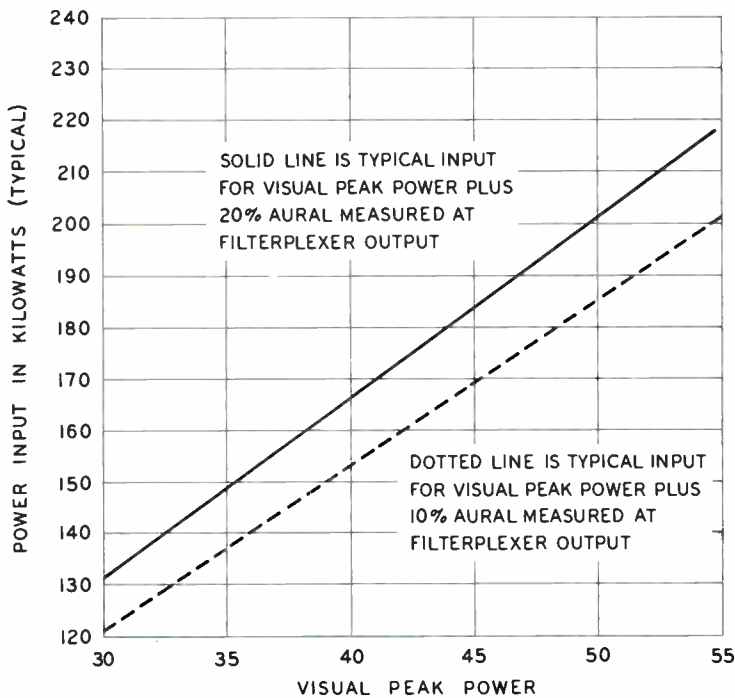

Specifications

Performance*

	FCC Specs.	CCIR Specs.
Type of Emission:		
Visual	A5	A5
Aural	F3	F3
Frequency Range	470-890 MHz (Ch. 14-83)	470-890 MHz
Rated Power Output:		
Visual ¹	55 kW	40 kW
Aural ²	6.0 to 16 kW	6.0 to 16 kW
R-F Output		
Impedance ³	50 ohms, 3/8" flanged	50 ohms, 3/8" flanged
Input Impedance:		
Visual	75 ohms	75 ohms
Aural	600/150 ohms	600/150 ohms
Input Level:		
Visual	0.7 volt peak-to-peak min.	0.7 volt peak-to-peak min.
Aural	+10 ±2 dBm for ±25 kHz deviation	+16 ±2 dBm for 50 kHz deviation
Amplitude vs. Frequency Response....	Uniform ±1 dB from 50 to 15,000 kHz	—
Upper Sideband Response at Carrier:	FCC ⁴	CCIR ⁵
		5.0 MHz Carrier Separation 5.5 MHz
+0.5 MHz	+1, -1.5 dB	+0.5, -1.5 dB +0.5, -1.5 dB
+1.25 MHz	+1, -1.5 dB	—
+1.5 MHz	+1, -1.5 dB	—
+2.0 MHz	+1, -1.5 dB	—
+3.0 MHz	+1, -1.5 dB	+1.0, -1.0 dB +1, -1.0 dB
+3.58 MHz	+1, -1.5 dB	—
+4.18 MHz	+1, -3.0 dB	—
+4.43 MHz	—	+0.5, -1.5 dB +0.5, -1.5 dB
+4.75 MHz	-20 dB max.	—
+5.0 MHz	—	+1.0, -4.0 dB +0.5, -1.5 dB
+5.5 MHz	—	—
+5.75 MHz	—	-20 dB max. +0.5, -4.0 dB
+6.25 MHz	—	—
Lower Sideband Response at Carrier:		
-0.5 MHz	+1, -1.5 dB	+0.5, -1.5 dB +1.0, -1.0 dB
-0.75 MHz	—	+0.5, -4.0 dB +1.0, -1.0 dB
-1.0 MHz	—	—
-1.25 MHz	-20 dB max.	—
-2.25 MHz	—	+0.5, -1.5 dB -20 dB max.
-3.58 MHz	-42 dB max.	—
-4.43 MHz	—	-42 dB max. -42 dB max.
Variation in Frequency Response with Brightness ⁶	±1.5 dB	±1.0 dB
Carrier Frequency Stability: ⁷		
Visual	±500 Hz	±500 Hz
Aural	±500 Hz ⁸	±200 Hz ⁸
Modulation Capability:		
Visual	12.5 ±2.5% (reference white)	12.5 ±2.5% (reference white)
Aural	±50 kHz	±100 kHz
Audio Frequency Distortion	1% max. 30 Hz to 15 kHz	1% max., 30 Hz to 15 kHz
FM Noise	-58 dB below ±25 kHz swing	-64 dB below ±50 kHz deviation
AM Noise, r.m.s.:		
Visual ⁹	48 dB r.m.s. below 100% mod.	48 dB r.m.s. below 100% mod.
Aural	50 dB below carrier	50 dB below carrier

* Specifications shown are measured and stated in terms of meeting United States FCC requirements. This transmitter can meet various foreign standards.

	FCC Specs.	CCIR Specs.
Amplitude Variation Over One Picture Frame	Less than 3% of the peak of sync level	Less than 3% of the peak of sync level
Regulation of Output Burst vs. Subcarrier Phase ¹⁰	3% max.	3% max.
Subcarrier Phase vs. Brightness ¹¹	±6° max.	±6° max.
Subcarrier Amplitude ¹⁰	±7% max. total less than 10°	±7°, total less than 10°
Linearity (Differential Gain) ¹²	±10% max.	±10° max.
Envelope Delay vs. Frequency ¹³	1.5 dB max.	See Note ¹²
Harmonic Attenuation, ratio of any single harmonic to peak visual fundamental ¹³	+80 ns from 0.2 to 2.0 MHz +40 ns at 3.58 MHz +80 ns at 4.18 MHz	±80 ns, 0.2 to 2.0 MHz ±40 ns, at 4.43 MHz ±80 ns, 4.43 MHz to upper sideband limit

Electrical

AC Line Input	440/460/480 V, 3-phase, 60 Hz 4 wire	380/400/415 V, 3-phase, 50 Hz 4 wire
Slow Line Variations	±3% max.	±3% max.
Rapid Line Variations	±3% max.	±3% max.
Regulation	3% max.	3% max.
Power Consumption....	See Power Curve	240 kW
Power Factor (approx.)	90%	90%
Crystal Heaters:		
Line	115 V, 1-phase 50/60 Hz	220 V, 1-phase 50/60 Hz
Power Consumption....	7½ watts	7½ watts

¹Measured at the output of the filterplexer.

²Measured at the input to the filterplexer.

³Output of RF Amplifier. Output of visual diplexer and filterplexer are 6-1/8" 75 ohm EIA flange.

⁴With respect to the response at 200 kHz, as measured by the RCA BWU-5C Sideband Response Analyzer and with the transmitter adjusted for mid-characteristics. An MI-27132-A Low Pass Video Filter is required in the input circuit.

⁵With respect to the response at 1.5 MHz as measured by the RCA BWU-5C Sideband Response Analyzer and with the transmitter adjusted for mid-characteristics. Use of a 5.75 MHz Video Low Pass Filter is required.

⁶Maximum variation with respect to the response at mid-characteristic measured with the BWU-5C Sideband Response Analyzer using approximately 20 percent (peak to peak) modulation at brightness levels of 22.5 percent and 67.5 percent of peak for FCC specifications and for brightness levels of 25 percent and 60 percent for CCIR specifications.

⁷Maximum variation for a period of 10 days without circuit adjustment over an ambient temperature range of +10°C to +45°C. (Meets FCC specifications over an ambient range of +1°C to +45°C.)

⁸Maximum variation with respect to separation between aural and visual carriers.

⁹RMS hum and noise level 50 Hz to 15 kHz. Extraneous modulation (unrelated to video modulation) above 15 kHz within the visual passband 40 dB below 100% modulation.

¹⁰Maximum departure from the theoretical when reproducing saturated primary colors and their complements at 75% amplitude.

¹¹Maximum phase difference with respect to burst, measured after the sideband filter, for any brightness level between 75% and 15% of the sync peak using 10% (peak to peak) modulation. This is equivalent to 5% peak to peak as indicated by a conventional diode demodulator. In addition, the total differential phase between any two levels shall not exceed 10°.

¹²Maximum variation of amplitude of the sine wave modulation frequency when superimposed on staircase or ramp modulation which is adjusted for brightness excursion stated. Modulation depth of the sine wave to be 20% peak to peak. CCIR Linearity is 0.85 at 0.2 MHz, 1.5 MHz and 4.43 MHz with Brightness excursion 65 to 17% for 0.2 and 1.5 MHz and 75 to 17% at 4.43 MHz.

¹³Maximum departure from standard curve. The tolerances vary linearly between 2.1 and color subcarrier frequency and between color subcarrier frequency and upper sideband limit. To meet the specification a properly terminated phase correction network is required in the video input circuit of the transmitter.

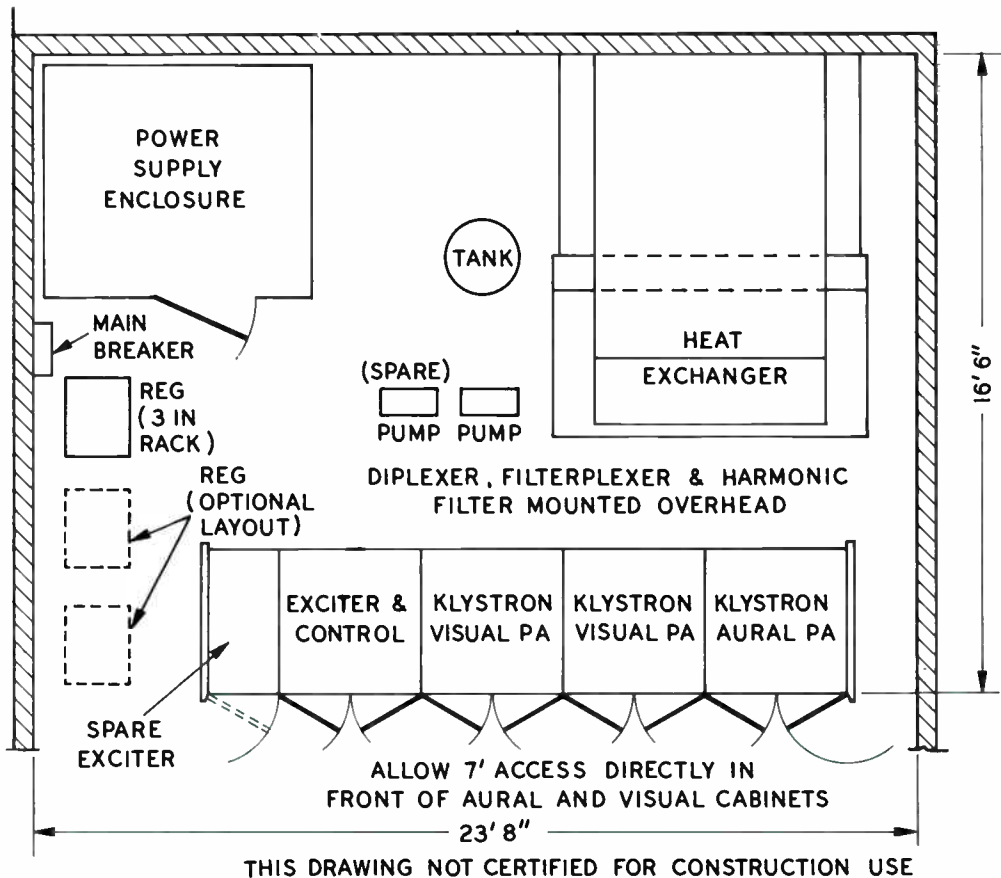

Space Saving Floor Plan of TTU-50C1 UHF Television Transmitter.

Mechanical

	FCC Specs.	CCIR Specs.
Dimensions Overall: Transmitter Cabinet	180" long, 105" deep, 77" high	457 cm long, 266.7 cm deep, 195.6 cm high
Finish: Transmitter	Powder and Midnight blue, aluminum trim	Powder and Midnight blue, aluminum trim
Maximum Altitude	7500 feet	2286 meters
Ambient Temperature ¹⁴	+1°C. to +45°C. max.	+1°C. to +45°C. max.

¹⁴Air Input Temperature to Heat Exchanger +10°C. to +45°C. to 7500 ft. (2286 meters.)
Air Temperature in transmitter area:
45°C. at Sea level; 40°C. to 3300 ft. (1005.84 meters); 35°C. to 5000 ft. (1524 meters); 30°C. to 7500 ft. (2286 meters).

Accessories

Complete Set of Spare Tubes	ES-560279
Minimum Set of Spare Tubes	ES-560252
Spare Exciter Group	ES-560281
BWU-4C Demodulator	ES-34049
BWU-5C Sideband Response Analyzer	ES-34009-B
BW-8A Envelope Delay Measuring Set	MI-34063
BW-8A1 Envelope Delay Measuring Set	MI-34068
Transmitter Control Console	ES-561900

Ordering Information

For 440/460/480 Volt, 60 Hz input, FCC standards, order ES-560276

For 380/400/415 Volt, 50 Hz input, and CCIR standards, order ES-560278

TTU-50C1 UHF TV Transmitter 55 kW visual 6.0 to 16 kW aural with tubes, filterplexer, two sets crystals, two harmonic filters and low pass filter

Output power and required filters to be determined in accordance with required operating standards

Transmitter Control Console, Type TTC-5B

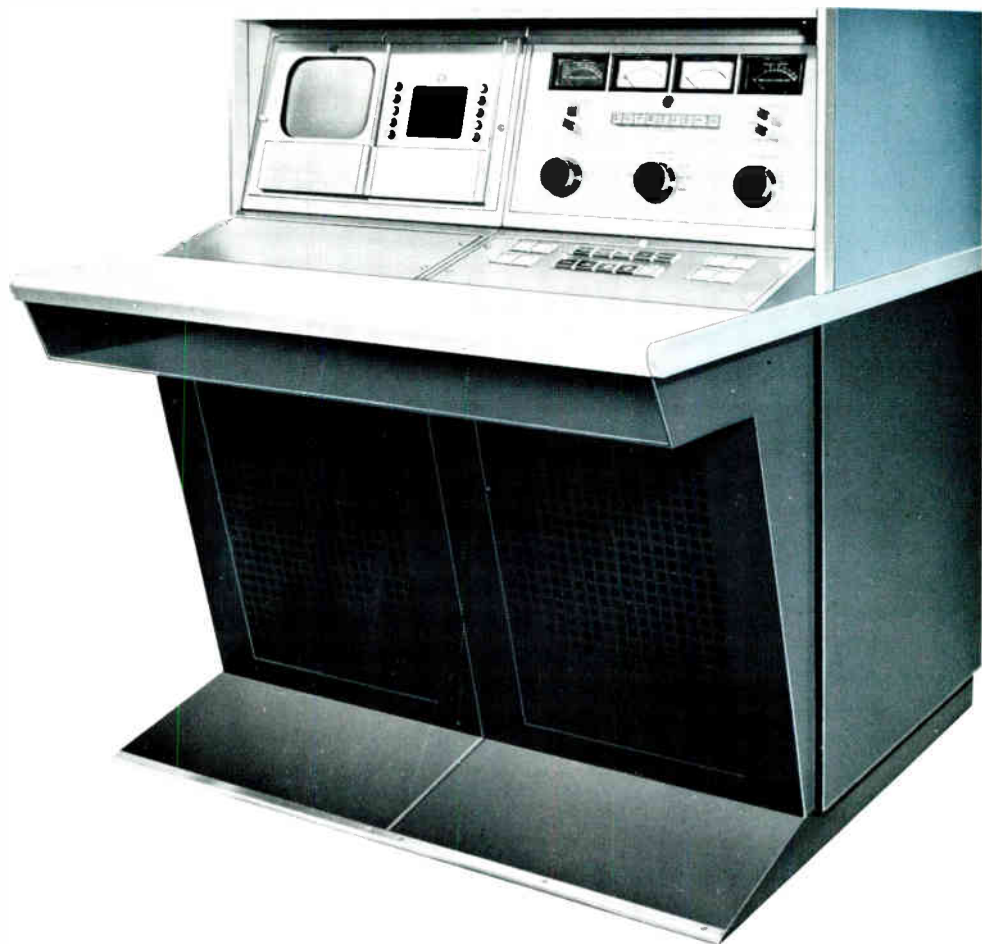

- “New Look” control center
- Wide band picture monitor
- Transistorized waveform monitor
- Remote metering

Transmitter Control Console, Type TTC-5B

RCA Transmitter Control Consoles afford a complete monitoring and operating center for broadcast transmitters. Assembled at the time of installation from standard console housings, panels and metering and monitoring units, the console provides custom planned control exactly suited to each transmitter.

A basic console, the Type TTC-5B, contains audio and video gain and monitoring circuits, and necessary indicating

lights, switches and meters for normal transmitter operation. It includes the "New Look" transistorized picture and waveform monitors, for viewing the picture and the video signal at various points throughout the transmitter. There are provisions for switching between two program channels, aural as well as visual. It permits previewing of the unused program line, or both lines when neither is in use. The audio lines can be monitored at any time.

Description

The TTC-5B Transmitter Control Console is a custom equipment made up of four major units: a set of panels and accessories that must be ordered according to type of transmitter and including a transmitter control and indicator panel; an 8-inch picture monitor; a waveform monitor and monitor control panel. The console proper which is made up of two 22-inch base and turret sections and related assembly plates, angles, etc. Other features include a program line selector, an aural modulation monitor meter for use with the TV station monitor, and assembly hardware.

Centralized Transmitter Control

The transmitter control and indicator panels contain finger-tip switches and pushbuttons for transmitter supervisory control and operation. All necessary control functions can be extended to the console such as Transmitter On/Off, PA Plate, Aural Driver Plate, Visual Driver Plate and Overload Reset functions. Tally lights that operate on 115 Volts AC obtained from the transmitter, indicate functional status. A 115-Volt step-down transformer supplies 6.3 Volts for the meter lights and chopper.

Transistorized Monitors

The TTC-5B is equipped with an eight-inch picture monitor, model TM-19, and a five-inch waveform monitor, Type TO-1. Both of these units mount in the left console hous-

ing. Both have self-contained power supplies, thus eliminating any need for external sources of DC power. The video signal is fed from the TTC-5B control panel to the TO-4 Waveform Monitor and is looped through to the TM-19 Picture Monitor where it is terminated with a 75 ohm termination. Either the picture monitor or waveform monitor may be pulled forward in the mounting for rapid inspection or adjustment. The waveform monitor is supplied with a graticule calibrated for indicating video depth of modulation as required for transmitter monitoring. The TTC-5B may be used for monitoring either FCC or CCIR standards.

Remote Metering Facilities

The Monitor Control Panel is designed to work in conjunction with standard input and monitoring equipment racks. It requires one set of these racks or equivalent components, for full use of its facilities. The Monitor Control Panel includes four major circuit functions and other related ones, namely, meter circuits, audio monitor circuits, video monitor circuits, and aural input signal level indication and control.

The four meters provide continuous indication of visual power output, aural power output, aural transmitter input level and aural percentage modulation. The power output functions are provided by meters which duplicate the reflec-

tometer meters on the transmitter. The aural transmitter input level is indicated by a VU meter with a suitable multiplier pad connected to the input line of the aural transmitter; and the aural modulation percentage is indicated by a meter which matches the VU meter but repeats the indication of the aural monitor in the racks.

7-Point Pushbutton Monitoring

In addition to the audio metering the aural monitoring circuits provide means for connecting the input of an audio monitoring amplifier through adjustable bridging networks to any of seven points in the aural system from input line to off the air monitor. Two of these positions are spares which may be used for any desired auxiliary function. The video monitoring circuits permit connection of any one of eight monitoring points in the visual transmitter system to the inputs of both the picture and waveform monitors. One of these is a spare, and like the audio monitoring spares, may be used as desired. Potentiometers in every monitor termination insure proper termination and level adjustment.

Aural Master Gain Control

In order to make the monitoring facilities more useful, an audio gain control with twenty 1 dB steps is provided for connection ahead of the program amplifier (usually a

limiting amplifier) so that the aural input to the transmitter can be controlled. In addition, a lamp in parallel with the overmodulation flasher of the aural monitor and a switch to control the chopper of the visual monitor are provided with a rheostat to dim the lights in the meters to suit the ambient light around the console.

“New Look” Styling

Two basic modular console units make up the standard housing of the

TTC-5B. Each console unit includes a 20-inch base section, a single-height turret top, and appropriate end bells and trim. A remote control section is included in one of the console sections. The modular design permits numerous configurations that meet practically any station requirement. The TTC-5B is finished in the new RCA shadow blue and midnight blue finish and is styled to be compatible with the “New Look” transmitters.

Though the above-mentioned con-

trol, metering and monitoring units are supplied with the standard TTC-5B console, many variations are possible. The console housings can provide additional panel and internal space so that special requirements for custom switching, monitoring, amplifying or indicating devices can be added. It is also possible to integrate the basic components of the TTC-5B console with other video console equipment where a combination transmitter and studio console is desired.

TTC-5B Combines Versatility and Simplicity of Operation

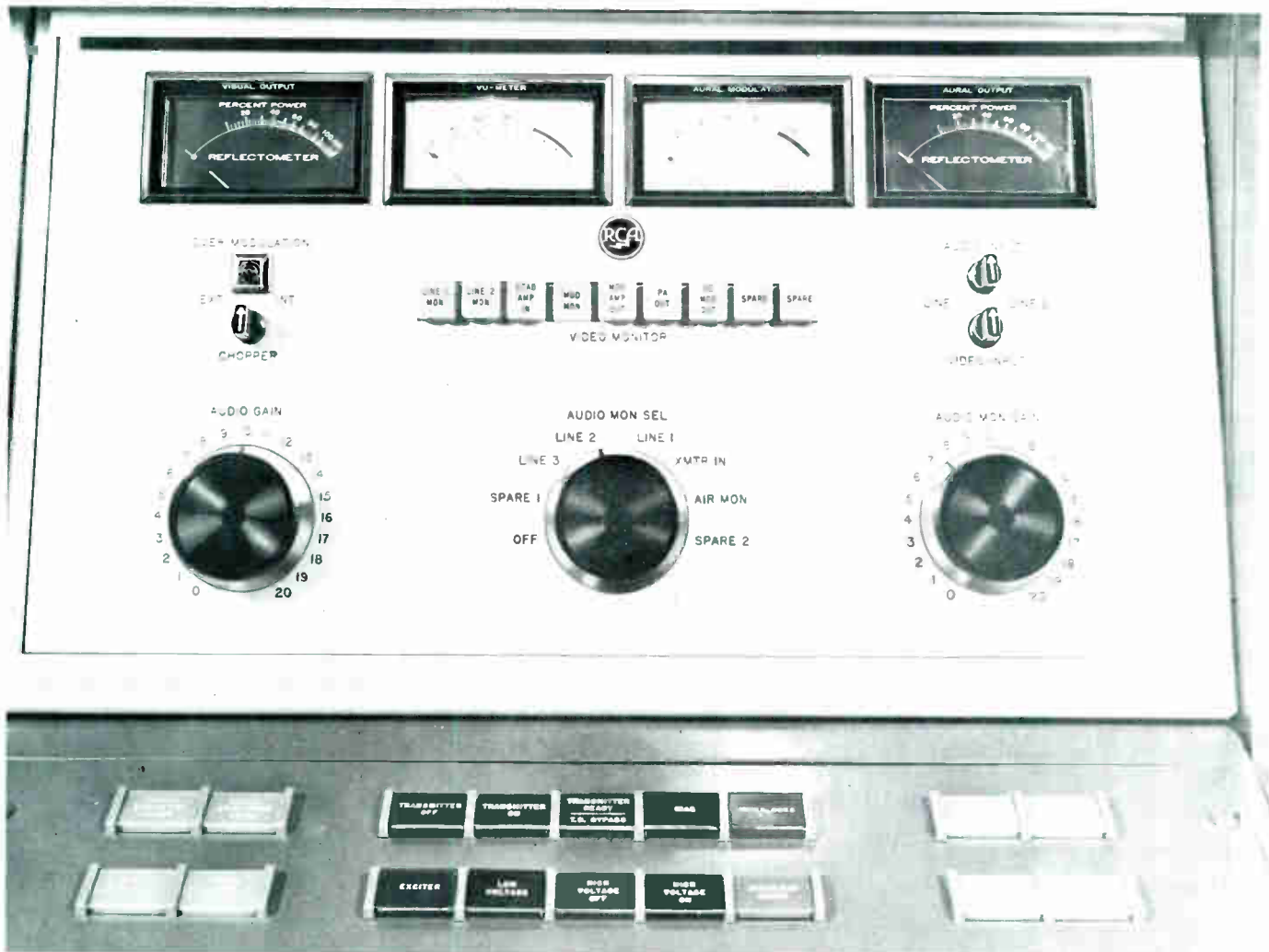

Major transmitter controls and status indicators can be extended to TTC-5B including transmitter ON/OFF, Ready/By-pass, bias, interlocks, exciter, low voltage, high voltage on/off, and overload reset. Raise/lower controls for visual and aural excitation, video gain and black level are grouped separately.

On the monitor control panel above, four remote meters provide continuous indication of visual power output, aural power output, aural transmitter input level and aural percentage modulation when properly interconnected to the transmitter. There are also controls for meter circuits, video and aural monitor circuits, and aural input signal level indication and control.

FUNCTIONAL DIAGRAM

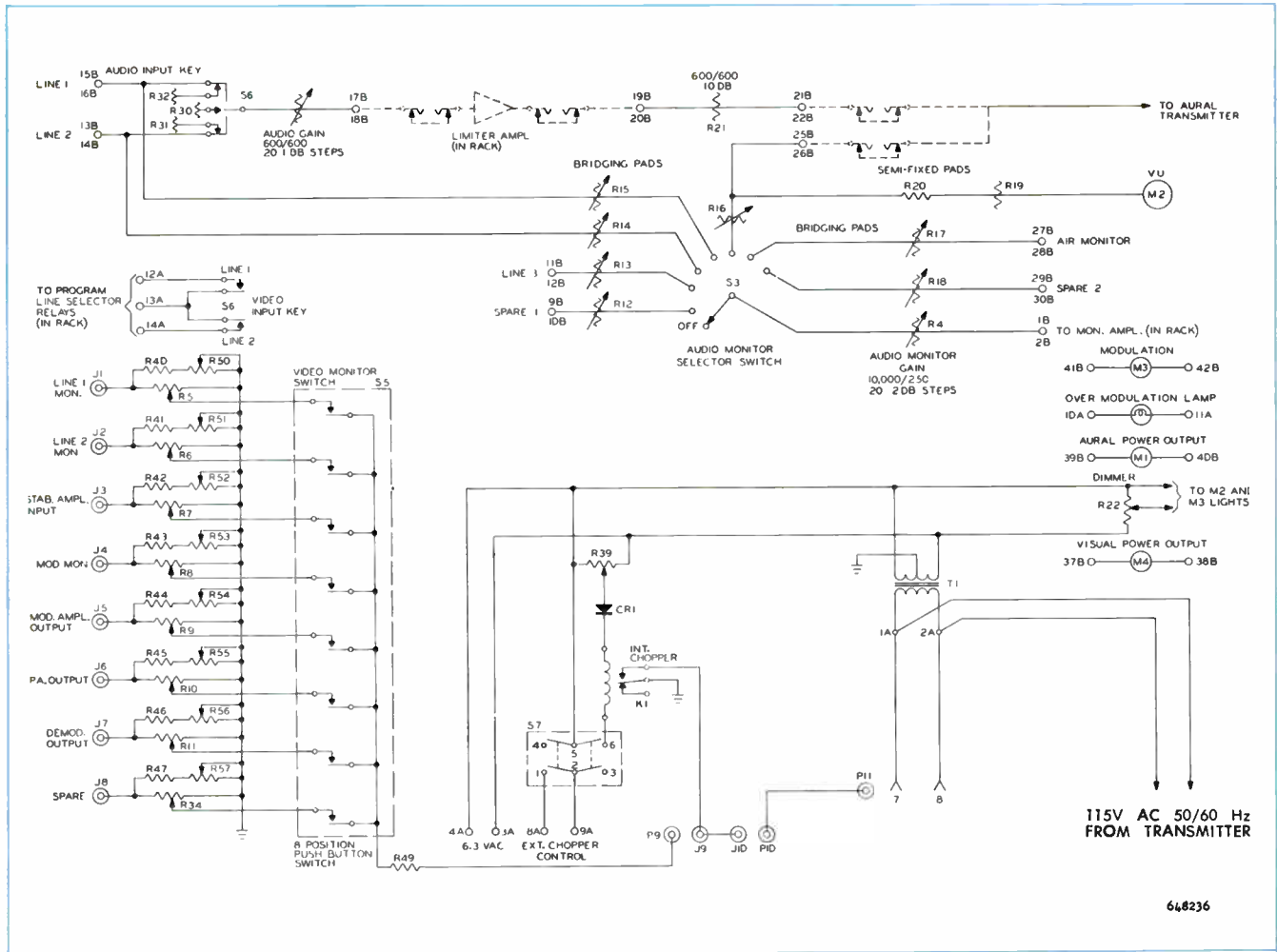

648236

Specifications

Impedances:

Audio Line Input (2).....	600 ohms, balanced
Audio Line Output.....	600 ohms, balanced
Audio Monitor Input.....	10,000 ohms, balanced
Audio Monitor Output.....	250 ohms, balanced
Master Monitor Inputs (6).....	75 ohms, unbalanced
VU Meter Circuit (across transmitter input).....	7,500 ohms

Volume Controls:

Audio Gain	600/600 ohms, 20 steps, 1 dB per step; initial insertion loss zero
------------------	---

Audio Monitor Gain.....10,000 to 250 ohms, 20 steps,
2 dB per step; tapered; last step infinite; insertion loss
38 dB

Power Requirements:

Indicator Lights 115 Volts AC, from transmitter
Meter Lights 115 Volts AC, 50/60 Hz

Dimensions (overall):

Width..... 41" (104.1 cm)
Depth..... 44½" (113 cm)
Height..... 45¼" (115 cm)

Weight (approximately)..... 500 lbs. (226.8 kg.)

Ordering Information

TTC-5B Transmitter Control Console Equipment
for Types TTU-2A, TTU-10A, TTU-30A, TTU-50C,
TTU-50C1 Transmitters ES-561900

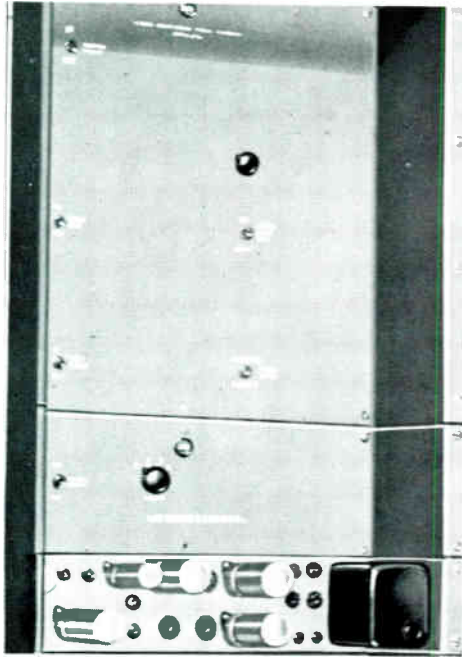

- Permits variable envelope delay correction at both high and low video frequencies
- Simple switching system permits selection of optimum delay correction
- Employs passive elements only—no tubes or power supplies
- No internal adjustments necessary—factory sealed to prevent accidental changes

Phase Equalizer Equipment

Description

The RCA Phase Equalizer Equipment, Type ES-34034-B, is designed to compensate for various distortions introduced in video transmission systems by such components as the color receiver, transmitter, vestigial sideband filter, notch diplexer and terminal equipment. The equipment greatly improves color edges and color transitions, and provides better time correspondence between luminance and chrominance information. It is required by all RCA TV transmitters to meet FCC color specifications.

The equipment consists essentially of three elements—a High Frequency Phase Equalizer, MI-34026, a Low Frequency Phase Equalizer, MI-34025, and an Amplitude Equalizer, MI-34035. The High Frequency Equalizer is designed for insertion in the video input to a color television transmitter to compensate for envelope delay distortion due to such fac-

tors as high frequency cut-off of a color receiver, a sound notch filter, and for any additional envelope delay distortions in the high video part of the spectrum which is introduced by the transmitter or terminal equipment. The Low Frequency Phase Equalizer corrects envelope delay distortion at low frequencies caused by the vestigial sideband filter, and improves overall transient response of the entire transmitter-to-receiver system.

Both the High and Low Frequency Phase Equalizers consist of passive, all-pass, constant resistance bridged-T networks composed entirely of reactive elements. Both are mounted on bathtub-type chassis designed for standard 19-inch rack-mounting.

The MI-34025 Low Frequency Phase Equalizer requires 5¼ inches of rack space. The front panel contains only two switches: (1) a rotary switch which enables selection of any one of four envelope delay characteristics, and (2) a toggle switch

which connects the equalizer in or out of the video circuit as desired. Four degrees of delay compensation are provided for the region below 2.0 MHz. A section of Type RG-11/U 75-ohm coaxial cable is supplied to connect the equalizer into the transmitter video system in series with the Receiver Equalizer section of the High Frequency Phase Equalizer. The unit has been properly adjusted at the factory and all internal adjustments have been sealed in to prevent accidental changes.

The RCA High Frequency Phase Equalizer, MI-34026, consists of three circuit networks requiring 17½ inches of rack space. The first is the receiver equalizer section which provides the envelope delay curve to meet the FCC color specification, and compensates for the high frequency cut-off of an average color receiver. Correction is required above 3 megahertz. A toggle switch is provided for switching the receiver equalizer in or out of the circuit. The second network is the notch equalizer section which must be used

if a sound notch filter (such as a Filterplexer) is used in the transmitter. There are provisions for selection of one or two basic envelope delay curves by means of a toggle switch, and another switch allows cutting the notch equalizer in or out of the circuit. Finally, there is the variable equalizer section which compensates for small system variations. A five-position rotary switch selects one of five degrees of variation in combination with the selection of an optional fixed section. Thus there are ten possible delay curves provided. A separate toggle switch allows this network to be switched in or out of the circuit. All controls, consisting of six switches, are mounted on the front panel. The unit has been carefully adjusted at the factory for correct operation, and the adjustments have been sealed to prevent accidental change.

The notch and variable equalizer networks are designed for insertion in series between distribution amplifiers, whereas, the receiver equalizer should be patched in series with the Low Frequency Phase Equalizer, between distribution amplifiers. The High and Low Frequency Phase Equalizers are supplied with precision 75 ohm ± 1 percent coaxial terminations which are color coded with a red band.

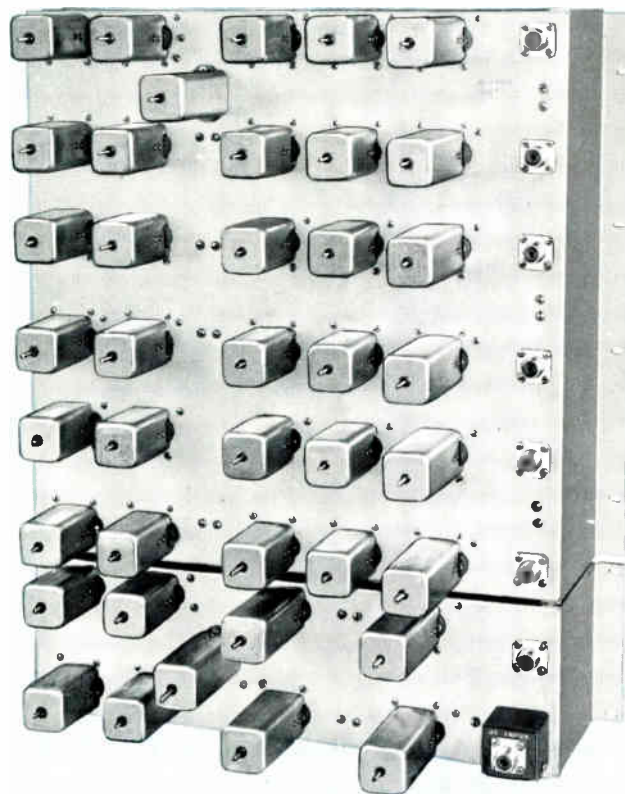

Rear view of Phase Equalizer Equipment showing one Amplitude Equalizer unit mounted in lower right corner on the Low Frequency Chassis.

Specifications

Type of Circuit.....	Bridged "T" passive network (No tubes or power supply required)
Impedance.....	Input and output: 75 ohms
Type of Signal.....	Composite video; color or monochrome
Circuit Attenuation (total for all phase equalizers).....	2.5 dB
Sweep Frequency Response to 4.2 MHz with use of one Amplitude Equalizer	± 0.5 dB
Delay Correction:	
Low Frequency Phase Equalizer.....	Constant envelope delay from 2.0 MHz to 4.2 MHz; four envelope delay curves in frequency range from 0 to 2.0 MHz)
High Frequency Phase Equalizer:	
Receiver Equalizer.....	Follows FCC specified curve
Notch Equalizer.....	Constant envelope delay from 0 to 3 MHz; choice of 2 curves above 3 MHz
Variable Equalizer.....	Constant envelope delay from 0 to 2 MHz; choice of 10 curves above 2 MHz
Low Frequency Phase Equalizer.....	19" wide, 5 1/4" high, 10" deep; wt. 9 lbs. 48.26 cm, 13.34 cm, 25.4 cm; 4.08 kg.

High Frequency Phase Equalizers.....	19" wide, 17 1/2" high, 10" deep; wt. 23 lbs. 48.26 cm, 44.45 cm, 25.4 cm; 10.43 kg.
Amplitude Equalizer.....	1 1/2" wide, 1 1/2" high, 2 1/2" deep; 3.81 cm, 3.81 cm, 6.35 cm; wt. approx. 5 oz. 0.15 kg.

Accessories

TA-33 Distribution Amplifier (2 required).....	ES-556933
Mounting Frame	MI-557300
Power Distribution Module, 115 Volts, 60 Hz	MI-556648-1
Power Distribution Module, 230 Volts, 50 Hz	MI-556648-2
	3.81 cm, 3.81 cm, 6.35 cm; 0.15 kg.

Ordering Information

Phase Equalizer Equipment, complete.....	ES-34034-B
Consisting of:	
1—Low Frequency Phase Equalizer on Rack-mounting Chassis, including 1 75-ohm coaxial termination, 2 connectors for RG-11/U coaxial cable, and Instruction Book (IB-36195-1)	MI-34025
1—High Frequency Phase Equalizer on Rack-mounting Chassis, including 1 75-ohm coaxial termination, 2 connectors for RG-11/U coaxial cable, and Instruction Book (IB-36196-1)	MI-34026
1—Amplitude Equalizer	MI-34035

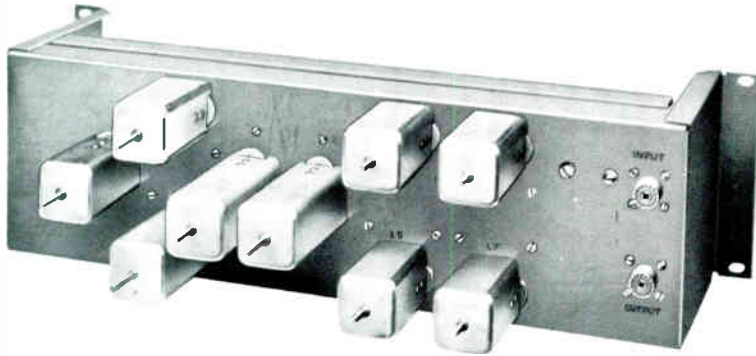

- Attenuates all video frequencies above 4.75 MHz by 23 dB or more
- Insertion loss less than 0.5 dB
- No degradation of either monochrome or color picture
- No adjustments necessary

Low Pass Video Filter

Description

The Low Pass Video Filter, MI-27132-A, is used to reduce adjacent channel interference between television stations. The filter will attenuate video frequencies above 4.2 MHz so that the video response is down at least 23 dB at 4.75 MHz. This unit when inserted in the video section of a television transmitter will permit operation of the equipment in conformance with FCC regulations. The filter will pass all frequencies from 0 to 4.2 MHz with no more than 0.5 dB attenuation. An all-pass phase equalizer corrects any phase distortion which is introduced as a result of the sharp cutoff.

The MI-27132-A Filter is a passive network consisting of a series of 12 coils wound on standard coil-forms and mounted on a chassis suitable for standard rack mounting. The circuit is an M-derived low-pass filter followed by a 5-section bridge T, phase equalizer. The insertion loss of the filter is never greater than 0.5 dB; and the envelope delay vs. frequency characteristics remains flat to within ± 0.03 microseconds from 0 to 3.5 MHz and ± 0.04 microseconds from 3.5 to 4 MHz. The amplitude vs. frequency response is flat within ± 0.5 dB in the video frequency

range from 0 to 4.2 MHz, and is -23 dB or more in the frequency range from 4.75 to 10 MHz. The low pass video filter requires that the impedance of the signal source be 75 ohms, non-reactive. No adjustments to the circuit or equipment are necessary at any time, and no power supply is required.

The filter is mounted on a standard 19-inch wide chassis. One operating control, an in and out switch,

is located on the front panel. The equipment is provided with input and output plugs and a load resistor assembly necessary for connecting the filter into the 75-ohm line between camera output and the input of the transmitter. The filter is usually inserted in the line following the stabilizing amplifier and can be mounted in the same rack with the stabilizing amplifier, phase equalizer and other equipment.

Specifications

Electrical

Input:	
Source Impedance.....	75 ohms, non-reactive
Input Impedance.....	75 ohms, non-reactive
Output:	
Load Impedance	75 ohms, $\pm 1\%$
Output Impedance.....	75 ohms, $\pm 1\%$
Insertion Loss	
(from 75 ohm source to 75 ohm load)	0.5 dB max.
Frequency Response	Flat within 0.5 dB from 0 to 4.2 MHz, -23 dB or more from 4.75 to 10 MHz, -26 dB at 6 MHz

Mechanical

Overall Dimensions.....	19" wide, 5 $\frac{1}{4}$ " high, 10" deep (48.3 cm wide, 13.3 cm high, 25.4 cm deep)
Weight.....	5 lbs. (2.3 kg.)

Ordering Information

4.75 MHz Low Pass Filter, completeMI-27132-A



- Protects in event of power failure or arc over
- Adjustable to any desired power and overload level
- Separate circuits for aural and visual sections

Carrier Off Monitor

Description

The ES-27235 Carrier Off Monitor and Remote Power Indicator is a convenient accessory for use with RCA television transmitters. It acts in conjunction with the reflectometer units to trip the transmitter overload circuit in the event of arc over in the amplifier circuit.

This unit includes a remote power indicator circuit which also uses the DC voltage from the reflectometers. This circuit consists of cathode followers and provides a low voltage, low impedance source necessary for remote power output monitoring over telephone lines.

The monitor may be connected so that it will compare the voltage from the transmitter output reflectometer to a DC reference voltage. Two complete circuits are provided—one for the aural and one for the visual transmitter. Disabling switches are included with the equipment to disconnect the transmitter overload circuits during tune-up.

The remote power indicator also operates from the output reflectometer circuits. Two cathode follower circuits are used. One provides a voltage reference level, and the other provides a low voltage which varies with the input signal (reflectometer

output). The voltage appearing at the output terminals is therefore proportional to the reflectometer voltage and has good linearity due to the cancellation of Edison effect in the tubes.

The monitor and remote indicator are mounted on a bathtub type chassis designed for standard rack mounting. All operating knobs are located on the front panel, as well as the red "Carrier-Off" lights and the amber "Disabled" lights. Screw-driver adjustments are provided for making other adjustments such as input level, sensitivity and power indicator balance.

Specifications

Signal Input Voltage (output from reflectometer)	50 to 150 Volts (less than 50 Volts at reduced sensitivity)
Differential Voltage to Trip	15% min. (depending on transmitter power)
Input Impedance:	
Driver	3.7 megohms, min.
Amplifier	2.16 megohms, min.
Output Relay Contacts	2 normally open
Output Impedance (Remote Power Indicator)	5000 ohms
Output Voltage (Remote Power Indicator)	1.2 Volt, max.
Tube Complement	4—5814A, 2—OD3

Power Requirements:

Filament	208-230 Volts, 50/60 Hz, 10 Watts
Control	115 Volts, 50/60 Hz
DC Input	350 Volt (minimum), 94 mA
Dimensions (overall)	19" wide, 5-7/32" high, 9½" deep (48.26 cm, 15.92 cm, 24.13 cm)
Weight	10 lbs. approx. (4.5 kg)
Finish	Silver gray

Accessories

Set of Spare Tubes	MI-27825
Set of FCC Spare Tubes	MI-27831

Ordering Information

Carrier Off Monitor (Complete).....ES-27235*

*Sales order must specify type of transmitter with which Monitor is to be used.

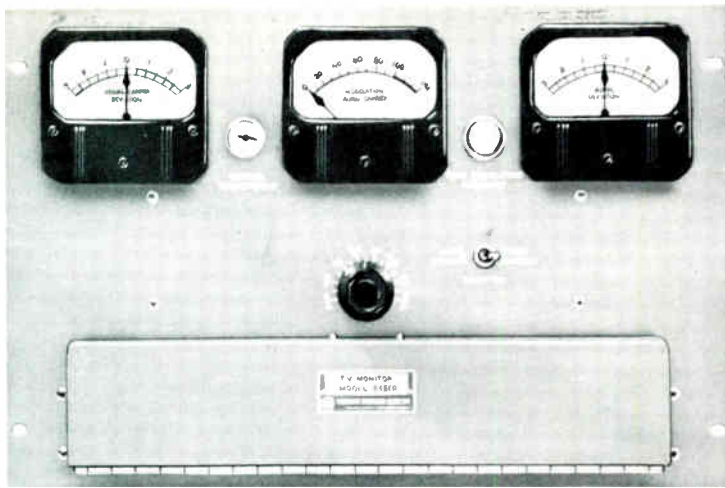

- Provides accurate check that TV transmitter is operating within FCC specifications
- Covers all TV channels, 41.25 to 940 MHz
- External meters may be remotely located
- All adjustments made from front panel

Frequency and Modulation Monitor

Description

The Model 335-ER Hewlett Packard Frequency Monitor and Modulation Meter monitors the carrier frequencies of both the aural and visual TV transmitters, and measures the degree of aural modulation. Through the use of the pulse counter-type frequency meter circuit, it provides reliable, accurate operation over long periods of time and requires no adjustment during use. Because of the unit's compact size, a minimum amount of relay rack space is required for its installation.

Three panel meters on the equipment monitor the frequencies of the visual and aural carriers and the percent modulation on the aural carrier with 100 percent modulation equal to 25 kHz deviation. All indications are presented simultaneously. The monitor can be used with any one of the TV channels for either color or monochrome applications. The circuit arrangement also accommodates stations that may have offset carriers. Full provision is made for the use of a remote peak modulation lamp as well as remote indicating meters. All operating adjustments can be made on the front panel of the monitor.

Indicates Aural Distortion

In addition to its primary function of indicating the percentage modulation of the aural carrier and

monitoring the frequencies of both carriers, the 335-ER is also arranged so that it provides the necessary output voltages for measuring the FM and AM noise levels and for determining the frequency response and distortion characteristics of the aural transmitter.

Crystal Controlled Oscillator

The Model 335-ER Frequency Monitor and Modulation Meter features a master oscillator, controlled by a crystal operating in the 20-30 megahertz region. The crystal is mounted in a carefully-designed oven that controls temperature to within approximately 0.10 degree C. Oven temperature is indicated by a thermometer readable at the front panel. The master oscillator is provided with a vernier knob adjustment for correcting long time drift.

Forced Air Cooling

Highest quality components are used throughout. All filter capacitors are oil-filled. A forced air cooling system assures low operating temperature for long-life and stable performance.

A cathode-coupled type oscillator circuit has been selected because of the exceptionally small effect varying stray capacities have on the frequency of the crystal used in this arrangement. As a further precaution, a constant-voltage type transformer is provided to regulate the master-oscillator filaments.

Circuit Description

The master oscillator drives a tuned multiplier which feeds into the separate multipliers for the visual and aural channels of the monitor. In the visual channel the output of the first multiplier is multiplied until it is 4.35 MHz above the assigned visual carrier frequency of the station. The output of the visual mixer is then a frequency of 4.35 MHz when the visual carrier is exactly at its assigned frequency. The 4.35 MHz output of the first visual mixer is then mixed with the output of a 4.3535-megahertz crystal controlled oscillator to obtain a difference frequency of 3.5 Hz.

The output of the second visual channel mixer is passed through a filter that removes the 15,750 Hz line frequency component in order to avoid the possibility of interaction of this frequency with the visual deviation meter circuit. The output waveform from the filter is squared and applied to the pulse counter circuit which operates the visual carrier deviation meter. This meter is calibrated in deviation from -3 to $+3$ kilohertz.

Aural Channel

The aural channel of the monitor is similar to but necessarily more elaborate than the visual channel. The master crystal oscillator frequency is so selected that when multiplied by the first multiplier and by the aural multiplier a frequency 150 kHz below the assigned

aural carrier frequency is supplied to the aural mixer. The output of the aural mixer is then a frequency of 150 kHz when the aural carrier is exactly at its assigned frequency.

The difference frequency voltage is squared and applied to the pulse-counter type discriminator. This counter is similar to the counter in the visual channel except that it contains circuitry that acts as a discriminator for the FM modulation on the aural carrier. The discriminator is highly linear as indicated by the fact that the distortion in the entire monitor from all sources is less than 0.25 percent at 100 percent modulation at frequencies below the knee of the standard 75 microsecond de-emphasis curve.

The discriminator operates the aural carrier deviation meter which is calibrated from -3 to +3 kHz. The wider deviation range of this meter when compared with the video carrier deviation meter allows for the greater FCC tolerance on aural channel frequency than on visual channel frequency. The audio

voltage obtained from the discriminator is amplified and applied to the percent modulation meter circuit and to the peak-modulation lamp circuit. The point at which the peak-modulation lamp flashes is adjustable from 50 to 120 percent modulation.

Two Audio Outputs

The percent modulation meter is operated from a peak-reading type voltmeter circuit whose time constant is adjusted so that the ballistic characteristics of the meter are in conformance with those of a standard VU meter. A panel switch is provided so that either positive or negative modulation swings can be measured. Two separate audio outputs are provided by the output audio amplifier. One is a high-level output which provides approximately 10 volts at low audio frequencies at 100 percent modulation. This output is primarily intended for use in making measurements of distortion and frequency response characteristics of the aural modulation. The output is

provided from a high-quality system which has a response flat within 0.5 dB from 50 to 15,000 Hz. Distortion in the system is less than 0.25 percent at full output and noise is at least 65 dB below full output. The second audio output is provided from a balanced underground source. At low frequencies a maximum of 1 milliwatt is delivered to a 600-ohm load. This output is useful for aural monitoring of the program. A 150 kHz local oscillator is provided in the aural carrier channel to make possible an occasional check of the accuracy of the pulse-counting discriminator.

Compact, Rack-Mounting Unit

The 335-ER is housed in a small unit, designed for standard rack mounting. It may be provided in a number of finishes to match the station's transmitter color scheme. It operates from a regular power line. External meters are available as accessories. When ordering, power line requirements, visual and aural frequencies and offset carrier operation, if any, must be specified.

Specifications

Frequency Range	41.25 MHz to 940 MHz, including off-set channels*
R-F Power Required	Less than 1 Watt
Ambient Operating Temperature (max.).....	45°C
Aural and Visual Frequency Monitor:	
Deviation Range	+3 kHz to -3 kHz mean frequency deviation
Accuracy	Channels 2-6 is ±500 Hz for 90 days Channels 7-13 is ±500 Hz for 45 days Channels 14-83 is ±500 Hz for 14 days
Aural Modulation Meter:	
Modulation Range.....	Meter reads full scale on modulation swing of 33.3 kHz. Scale calibrated to 100% at 25 kHz swing and 133% at 33.3 kHz swing. Also includes dB scale (0 dB = 100%)
Accuracy.....	Within ±5% of indicated modulation percentage over entire scale
Meter Characteristics.....	Meter damped in accordance with FCC requirements
Frequency Response	Flat within ±0.5 dB from 50 to 15,000 Hz

*Specify visual and aural frequencies when ordering and offset carrier operation, if any.

Modulation Peak Indicator:	
Peak Flash Range.....	From 50% to 120% modulation (25 kHz = 100%)
Audio Output:	
Frequency Range	50 to 15,000 Hz. Response flat within ±0.5 dB. Equipped with standard 75 microsecond de-emphasis circuit.
High Impedance Output	10 Volts into 100,000 ohms at 100% modulation at low frequencies. Distortion less than 0.25% at 100% modulation. Residual noise at least 65 dB below output level, corresponding to 100% modulation at low frequencies.
Monitoring Output.....	1 milliwatt into 600 ohms, balanced, at 100% modulation, at low frequencies
Inter-carrier Spacing Accuracy	±5 Hertz for 6 months on all channels
Power Line Requirements	
115 Volts, 60 Hertz, single phase, 100 Watts; 230 Volts, 50 Hertz, single phase, 100 Watts	
Tube Complement:	
10—12AT7, 1—6U8, 3—6AH6, 1—OB2, 4—5687, 1—2D21, 1—6SJ7, 1—6AS7	
Dimensions.....	19" wide, 12½" high, 13" deep (48.26 cm, 31.75 cm, 33 cm)
Weight.....	67 lbs., (30.4 kg.)
Finish	Silver Grey

Ordering Information

Hewlett Packard Frequency and Modulation Monitor, complete with tubes in place, power cord, 2 coaxial connectors for RF inputs, and instruction book.

Monitor for 115 Volts, 60 Hertz	Model 335-ER
Monitor for 115 Volts, 50 Hertz	Model HO2-335-ER
Monitor for 230 Volts, 50 Hertz	Model HO3-335-ER

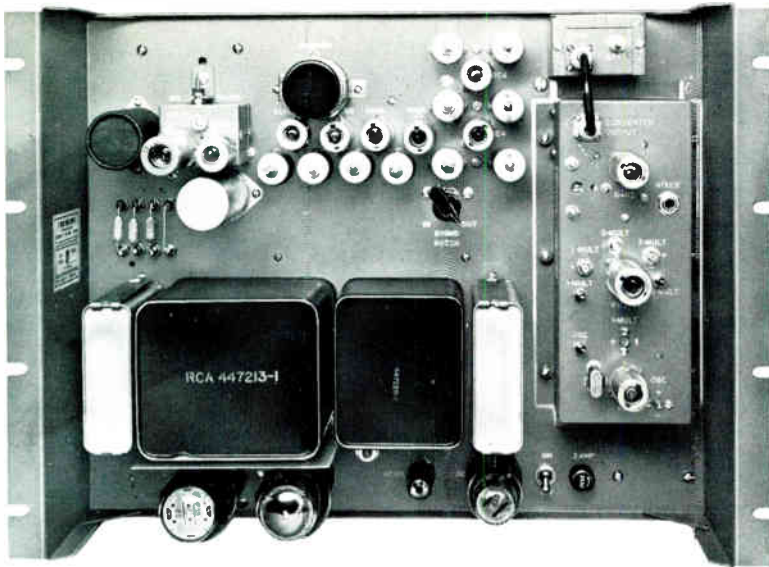

- Monitor transmitter output any channel 2 to 60 (54-752 MHz)
- Directional coupler may be mounted anywhere in transmission line
- Remote ON-OFF control of zero reference line
- Transient response typical of ideal receiver

Visual Sideband Demodulator, Type BW-4B/BWU-4B

Description

The BW-4B/BWU-4B Visual Sideband Demodulator is designed for use with a station Waveform Monitor unit to permit a visual quality observation of either monochrome or color signals delivered to the antenna of a VHF or UHF television transmitter. The BW-4B equipment is used for Channels 2 to 13 (54-216 MHz), the BWU-4B for UHF channels 14 to 60 (470-752 MHz).

The Demodulator is designed for two major uses. First, it provides the broadcaster with a kinescope and CRO presentation, limited in channel width, to be typical of the best home receiver, and as such subject to the basic limitations of bandwidth and vestigial reception inherent in the NTSC TV system. Secondly, it provides a demodulator without the restrictions of bandwidth or phase, which will be useful to the broadcaster for measuring certain performance characteristics of the TV transmitter. This type of measurement is made during non-programming periods with aural carrier off.

50 dB Sound Rejection

In the first use, a 50 dB trap rejects the sound carrier and as a result reduces the video response to a 4.0 MHz bandwidth. Under these conditions, the BW-4B provides a typical

composite kinescope and CRO picture, showing resolution, vertical waveform, horizontal waveform, percent sync and depth of modulation. In the second usage, with the sound notch switched out so that the Demodulator is not limiting in phase or amplitude response at the high end, transmitter characteristics, such as amplitude response, transient response, and envelope delay may be observed. The transmitter may thus be adjusted to meet EIA and FCC standards.

The BW-4B/BWU-4B Demodulator is basically a super-heterodyne TV receiver designed for vestigial reception and includes a crystal-controlled heterodyne oscillator, mixer, IF system, sound rejection circuits, a wing trap, a video detector

and a video amplifier. For VHF Channels, a "VHF" Converter is mounted in place on the chassis. For UHF Channels 14 to 60 a "UHF" Converter is substituted.

Supplied With Directional Coupler

A directional coupler, MI-19396-1B or ES-34231, designed to mount in the transmission line, is included as a part of the Demodulator equipment. This coupler samples the transmitter output and supplies a proper level of RF voltage to the converter input. This coupler may be inserted into the transmission line at any of several points between the vestigial sideband filter and the antenna. Normally, it is installed at a point following the VSBF or Filterplexer where the transmitter ves-

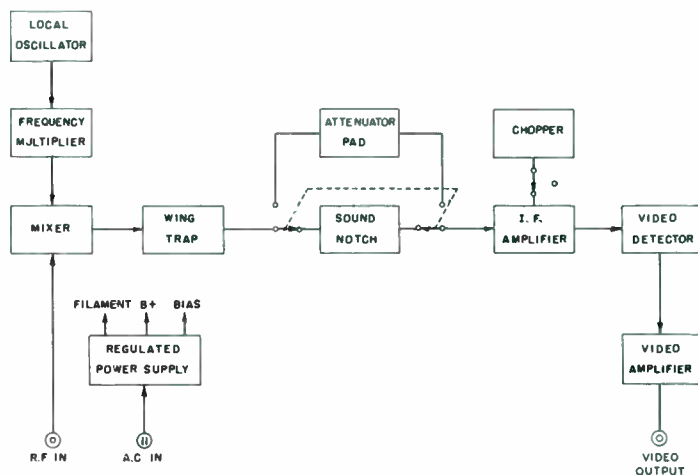

tigial characteristics have been established. The video output of the Demodulator is dependent upon a proper setting of the pick-up level of the coupler, and should be adjusted to provide a peak of sync level of video of 1.0 Volt across the normal BW-4B/BWU-4B output.

For measuring depth of picture modulation, a zero power reference line must be established on the CRO. This function is performed by

a mechanical chopper working in the grid of the IF stages. The action of the chopper is to reduce the second detector input to zero at a 60 hertz repetition rate on approximately a 50/50 time basis. The circuit is arranged so that a remote switch, for instance in the transmitter console, may be utilized to control the operation of the chopper.

Phase Compensated

The demodulator is phase com-

pensated for "notch in" conditions, and for "notch out" conditions. For both these conditions the low frequency envelope delay is flat. For "notch in" conditions, the high frequency envelope delay has a rising characteristic and is tailored to be that of the accepted "average" NTSC TV receiver, i.e., complementary to the FCC standard transmitter curve. For "notch out" conditions the high frequency delay curve is substantially flat.

Specifications

Electrical

Frequency Range:	
BW-4B	Channels 2 to 13 (54-216 MHz)
BWU-4B	Channels 14 to 60 (470-752 MHz)
Input Required	1.0 Volt RF
Video Output	Max. of 1.0 Volt peak-to-peak across 75 ohms from chopper zero reference to sync peak (sync negative)
Amplitude vs. Frequency Response	
With sound notch out	± 0.5 dB from 0.20 MHz to 4.5 MHz
With sound notch in	± 0.5 dB from 0.20 MHz to 4.0 MHz
Differential Gain	10% between reference white, 12.5% and peak of sync, 100%
Phase vs. Amplitude	Six (6) degrees or less for modulating signals having luminance levels from 12.5% to 75% of sync peak
Low Frequency Response	Less than 2% tilt on 60 Hz square wave
Envelope Delay	
With sound notch out	Flat within ± 0.03 microsecond up to 4.18 MHz compared to the average delay between 0.05 MHz and 0.20 MHz
With sound notch in	Flat within ± 0.03 microsecond of standard receiver curve up to 3.58 MHz compared to the average delay between 0.05 MHz and 0.20 MHz. The tolerance increases linearly with respect to frequency to ± 0.1 microsecond at 4.0 MHz
Output Hum and Noise	40 dB below 2 Volts peak-to-peak output
Sound Rejection	More than 50 dB aural signal rejection at ± 25 kHz deviation from carrier frequency
Power Source Required	105 to 125 Volts AC, 50/60 Hz, 250 Watts (3 amp slo-blo fuse)
D-C Output Voltages	250 Volts (regulated) -10 Volts (unregulated), -3 Volts (unregulated)
Sound Rejection	More than 50 dB aural signal rejection at ± 25 kHz deviation from carrier frequency
Power Source Required	115/220 Volts AC, 50/60 Hz, 250 Watts (3 amp slo-blo fuse)
D-C Power Supply Voltages	250 Volts (regulated) -10 Volts (unregulated), -3 Volts (unregulated)

Tube Complement:

IF, Video and Power Supply Unit:	
2-6C4	1-1N64
4-6CB6	1-6AS7
1-5R4-GY	1-OC3
1-6AK6	1-6197
1-6AH6	
VHF Converter Unit (BW-4B Only):	
1-6J6	1-6AS6
1-6CB6 (Chan. 7-13)	
UHF Converter Unit (BWU-4B Only):	
1-6J6	1-6485
1-6BQ7A	1-1N82A

Mechanical

IF, Video and Power Supply Chassis:	
Dimensions (overall)	19" wide, 14" high, 14" deep (48.26 cm x 35.56 cm x 35.56 cm)
Weight	41 lbs. (18.6 kg)
VHF or UHF RF Converter (mounts on IF, Video, and Power Supply Chassis):	
Dimensions (overall)	4½" wide, 9½" high, 4½" deep (11.43 cm x 24.13 cm x 11.43 cm)
Weight	2 lbs. (0.9 kg)
Ambient Temperature	-15°C to 45°C
Relative Humidity	0 to 95%

Accessories

Senior VoltOhmyst	WV-98C
Plate Current Meter	MI-21200-C1
Wideband Oscilloscope, Type TO-524AD	MI-26500-A
Marker Generator	WR-99A
Television Sweep Oscillator	WR-69A
Chopper Relay	#211711
Complete Spare Tube Kit for BW-4B	MI-34014-A
Complete Spare Tube Kit for BWU-4B	MI-34015
VHF Monitoring Diode	MI-19051-B
UHF Monitoring Diode	MI-19364
BW-5C Sideband Response Analyzer (VHF)	ES-34010-B
BWU-5C Sideband Response Analyzer (UHF)	ES-34009-B

Ordering Information

VHF Type BW-4B Visual Sideband Demodulator.....	ES-34048
UHF Type BWU-4B Visual Sideband Demodulator.....	ES-34049-B



- Accurately measures transmitter frequency response without internal connections and with transmitter at normal power output
- Visually presents upper and lower sideband response
- Provides immediate evaluation of transmitter tuning adjustments
- Includes base line reference

TV Sideband Response Analyzers, BW-5C/BWU-5C

Description

The sideband response analyzer is a device for measuring the overall "amplitude versus frequency" characteristic of a VHF television transmitter. In conjunction with an oscilloscope it separates and visually presents the upper and lower sideband response. Its primary use is for tuning the over-coupled broadband r-f circuits of television transmitters and measuring their amplitude response characteristic. Since it includes a video sweep oscillator, it can also be used in adjusting video amplifiers, modulators, etc.

The Type BW-5C analyzer is required for a VHF TV station and Type BWU-5C analyzer for a UHF TV station.

The BW-5C and BWU-5C Sideband Response Analyzers provide for the display, on a suitable oscilloscope, of the entire sideband fre-

quency response capabilities of any TV transmitter including its sideband filter. Such visual presentation permits immediate evaluation of transmitter adjustment without laborious point-to-point curve plotting, and facilitates the adjustments by indicating the effectiveness of the adjustments as they are made.

Quality Video Sweep Oscillator

The BW-5C analyzer consists of video sweep generating circuits to provide transmitter modulation; calibrated marker circuits to develop a continuously variable frequency marker; synchronized receiver circuits to develop vertical deflection for the oscilloscope and to insure a narrow passband for a high definition sideband response presentation; sweep generating circuits, which include retrace, blanking, and phasing facilities, to develop horizontal de-

flection for the oscilloscope; and power supply circuits all assembled on a recessed box chassis suitable for assembly in a relay rack. Operating controls for the unit are all mounted on the front panel which is held in position by two captive knurled screws at the top edge.

Complete Accessibility

The panel can be swung down to give access to the interior for ease of maintenance. A three-contact connector on the panel provides connection to an oscilloscope. Other connections to the unit are made at the rear of the chassis. The necessary output cables, power cord, and connectors are all supplied with the equipment.

BWU-5C Analyzer

The BWU-5C includes all the equipment furnished by the BW-5C and in addition has an RF input sec-

tion, MI-34005-C, built on a 5¼-inch panel and chassis designed to mount in a standard 19-inch rack. The rf unit with tubes in place, power cord, and output cable, are required to modify the BW-5C for operation on UHF television channel. Except for the frequency ranges covered, the BW-5C and the BWU-5C equipments function similarly.

Circuit Description

Basically the analyzer, both BW-5C and BWU-5C, provides modulation for the transmitter by mixing the output of a 130-MHz fixed oscillator with the output of a sweep oscillator, which varies in frequency above and below 130 MHz to the amount required (see block diagram). The mixer provides a video signal swept at twice power line frequency which is amplified and ap-

plied as modulation to the transmitter. The output voltage of this circuit is indicated on a push-to-read meter.

The transmitter modulated output is sampled and mixed with the sweep oscillator output. Among the many sum and difference frequencies that occur in the output of the RF Mixer, a constant frequency component will exist due to the combination of the instantaneous sweep frequency with one of the transmitter sideband frequencies. This component is selected by the fixed-tuned receiver and the output of the receiver is fed to an oscilloscope, the sweep of which is properly phased to agree with the sweep frequency variations. The resultant pattern displays the transmitter sideband response over the range of modulation frequencies employed.

Circuits are included that develop a marker pulse which can be adjusted to indicate the frequency at any point on the pattern by means of a calibrated dial and knob. Blanking is provided to eliminate pattern retrace but can be cut off by means of a panel mounted switch. Power supply circuits in the chassis provide heater and regulated plate voltages for the equipment.

Accessory Equipment

To provide maximum utility, a portable type oscilloscope is recommended for use with the analyzer. A 35-foot cable is supplied which allows the indicator to be readily moved to any vantage point within the limit of cable length. Other additional equipment necessary to make a complete installation, but not supplied except by separate order include, RG-11U coaxial cable, MI-83,

Block Diagram of Type BW-5C TV Sideband Response Analyzer.

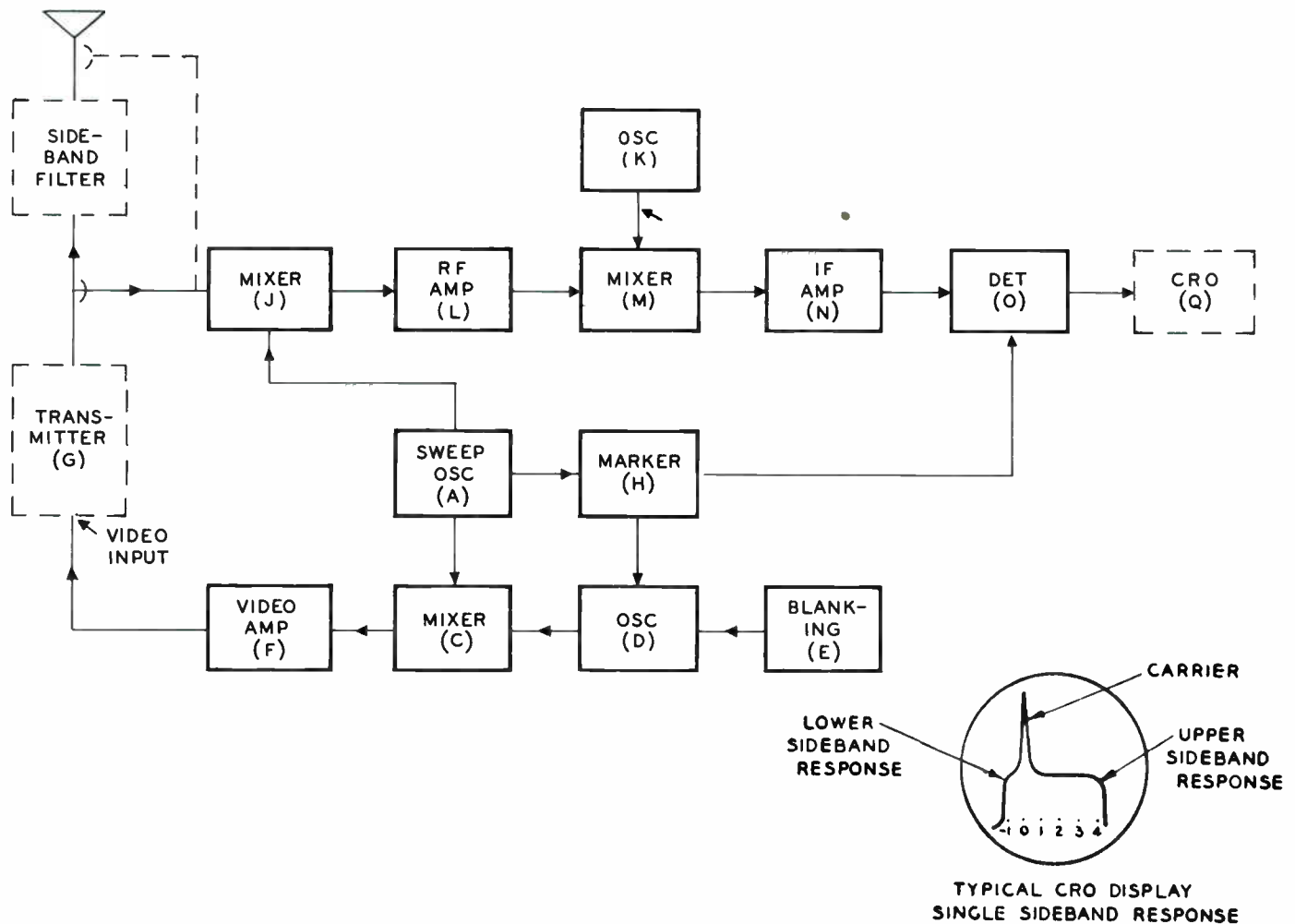

and RG-8/U coaxial cable, MI-74 as required. In some installations a directional coupler and section of 3/8-inch, 51.5-ohm or 3/8-inch, 50-ohm coaxial transmission line housing for the directional coupler should be provided.

Wide-Band Frequency Converter

Operation on the UHF channels is made possible through the use of a wide-band frequency converter which changes the sampled output frequency of a UHF television transmitter to a channel 2 frequency, within the normal range of the BW-5C analyzer. The RF input section which functions as a conventional superheterodyne converter has a power switch, indicator lamp, and fuses mounted on the power supply chassis. All the tuning controls are located on the top of the converter chassis.

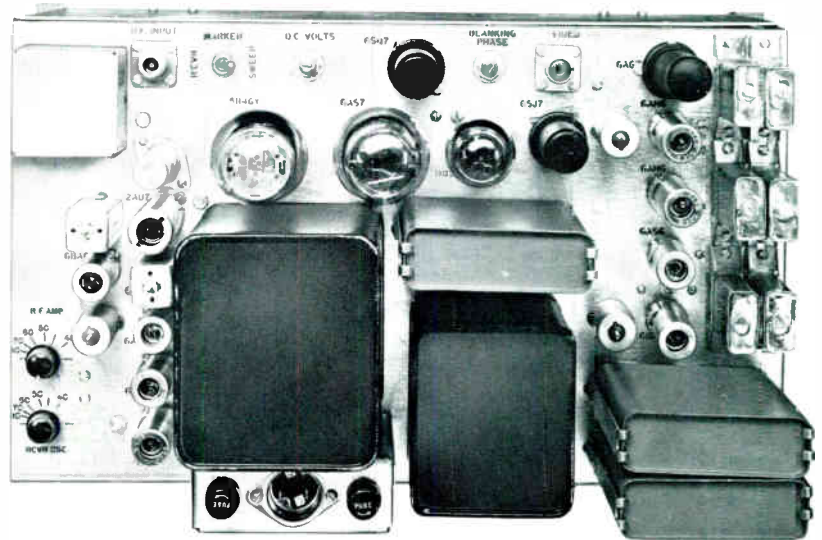

Rear View of Sideband Response Analyzer BW-5C.

Connection Diagram for BW-5C/BWU-5C.

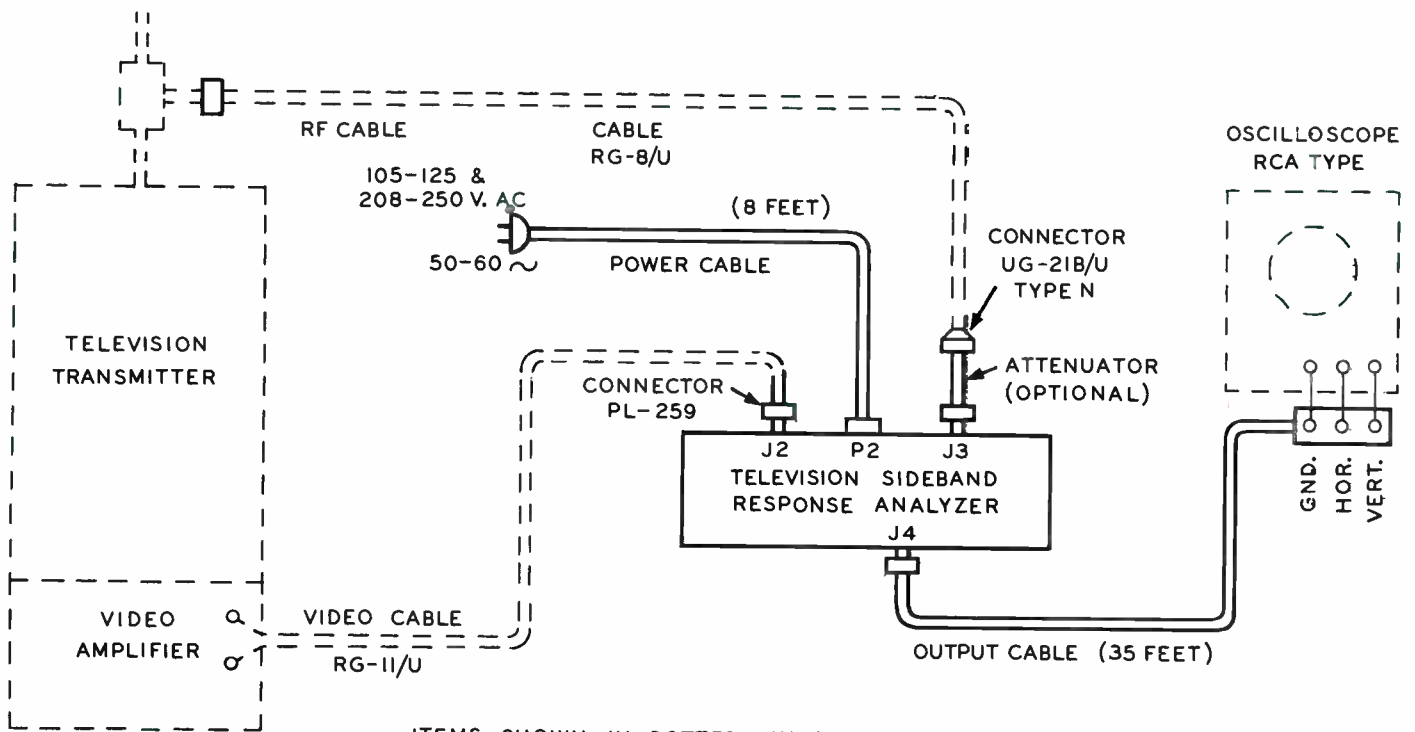

ITEMS SHOWN IN DOTTED LINES NOT FURNISHED WITH MI-34000

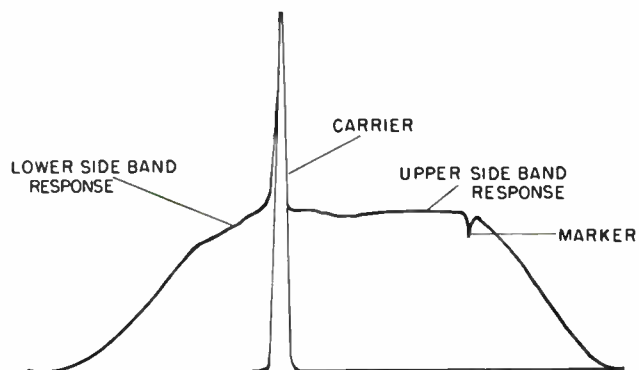

Typical response pattern of a TV transmitter using BW-5C Sideband Analyzer, illustrating the wave shape of lower and upper sidebands.

Electrical (BW-5C)

RF Input

Frequency.....55.25-83.25 MHz channels 2 to 6)
175.25-211.25 MHz (channels 7 to 13)

Voltage5 to 1.0 Volt

Impedance50/51.5 ohms

Outputs

Receiver Signal

Output Termination.....High impedance oscilloscope input

LinearityError referred to 14-Volt carrier pip

Indicated Actual Response

-25 dB -24 dB

-30 dB -28 dB

-35 dB -33 dB

Noise LevelGreater than 50 dB below 14 Volts

Receiver Gain Control Range10 dB

Video Sweep

Voltage0 to 2 Volts peak-to-peak

Frequency.....10-0-10 MHz sweep width
continuously adjustable

Center Frequency.....Adjustable ± 2 MHz

Sweep RatePower line frequency

Repetition Rate.....2 times power line frequency

Frequency Response ± 5 dB 10 kHz to 5 MHz
 ± 1.0 dB 50 kHz to 7 MHz

DistortionLess than 3% at 2 Volts pp

Oscilloscope Sweep

Open Circuit Voltage4.5 Volts pp

Frequency.....Same as power line

Wave Form.....Same as power line

Internal Impedance12,000 ohms

Phase Adjustment $\pm 70^\circ$

Operating Conditions.....5°C to 45°C ambient temperature
0-95% relative humidity
Supply Voltage105-125/208-250 Volts AC
Supply Frequency.....50-60 Hz
Power Consumption200 Watts
Power Receptacle...1" male motor-plug (power cord supplied)
Power SupplyInternal (260 Volts DC regulated)

Tube Complement (BW-5C)

2—6J6, 2—12AU7, 1—6SQ7, 1—6BA6, 3—6AS6, 2—6AH6AW,
1—6AG7, 1—5R4-GY, 2—6AU6, 1—6C4, 1—6AS7-G, 1—6AG5,
1—OC3, 1—12AT7

Electrical (BWU-5C)

RF INPUT UNIT, MI-34005-C

Input and Output Impedances.....50 ohms

Frequency Range.....450 to 900 MHz (channels 14 to 83)

Overall Bandwidth.....20 MHz

Response ± 1 dB within 10 MHz of center frequency

$\pm 1/2$ dB within 5 MHz of center frequency

LinearityWithin ± 1 dB for input signals
to the attenuator ranging from 0.1 to 3.0 Volts. (Normal
converter input is 1 Volt with input of 2.0 Volts to the
attenuator).

Output0.3 Volt across 50 ohm load with 2.0 Volt
rms input to attenuator (channel 2)

Power Supply110/220 Volts, 50/60 hertz,
single phase, 35 Watts

Tube Complement (BWU-5C)

1—6J6, 1—6BQ7, 1—6AH6AW, 1—1N82A, 1—5Z4, 1—OA2,
1—OB2

Mechanical

Mounting—Relay Rack.....10 $\frac{1}{2}$ " high, 19" wide, 14 $\frac{1}{2}$ " deep
(26.67 cm, 48.26 cm, 36.83 cm)

ColorSilver gray

Weight58 lbs.
(26.7 kg)

UHF Converter

Dimensions.....19" wide, 5 $\frac{1}{4}$ " high, 7 $\frac{3}{4}$ " deep
(48.26 cm, 13.34 cm, 19.68 cm)

Weight.....14 lbs. (6.35 kg)

Accessories

Transmission Line Section for Mounting BW-5C

Directional Coupler (Specify one):

3 $\frac{1}{8}$ " 51.5-ohm Flanged Transmission Line.....MI-19313-48

3 $\frac{1}{8}$ " 51.5-ohm Unflanged Transmission Line.....MI-19313-49

3 $\frac{1}{8}$ " 50-ohm Transmission Line.....MI-27912-12

RG-8/U Coaxial Cable.....MI-74

BWU-5C Directional Coupler for use with:

MI-19089 Transmission Line.....ES-34231-1, 2

MI-27791 Transmission Line.....ES-34231-1, 8

MI-19387 Transmission Line.....ES-34232-1, 2

MI-27792 Transmission Line.....ES-34232-1, 5

VoltOhmystWV-98C

Isolating Resistor for VoltOhmyst Probe 270K ohm, $\frac{1}{2}$ Watt,
non-inductive with lead on test end not longer than $\frac{3}{8}$ "

RF Sweep Signal Generator for 1775 MHz (BWU-5C)—WR-69B

UHF Signal Generator (for BWU-5C).....WR-86A

Oscilloscope.....TO-524-AD or WO-91A

Ordering Information

BW-5C VHF TV Sideband

Response Analyzer Equipment (Ch. 2-13).....ES-34010-C

Including:

1 MI-34000-C Analyzer (tubes in place)

1 MI-19396-1B Directional Coupler

1 MI-19396-3 Transmission Line Section for MI-19396-1B

1 Instruction Book

BWU-5C UHF TV Sideband

Response Analyzer Equipment (Ch. 14-83).....ES-34009-C

1 MI-34000-C Type BW-5C Sideband Response Analyzer

1 MI-34005-C RF Input Section of the BWU-5C

1 ES-34231-1, 2 Directional Coupler

1 MI-34065-* Channel Frequency Crystal

(*Sales order to specify frequency required)

2 Instruction Books

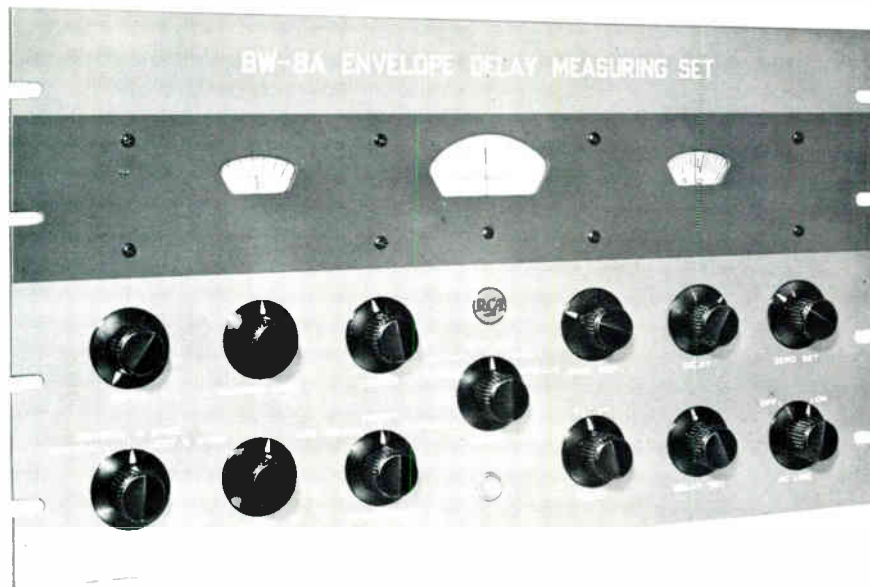

- Convenient and simple to operate
- Single frequency method of measurement
- Direct reading dial
- Excellent performance—Envelope delay 0 to 0.67 microseconds; accuracy +3 percent, ±0.01 microseconds
- Choice of rack or portable mountings

Envelope Delay Measuring Equipment, Type BW-8A/8A1

Description

The BW-8A/8A1 Envelope Delay Measuring Equipment is designed for field measurement of the incremental slope of the phase-versus-frequency characteristic (usually referred to as envelope delay) of television transmitter systems. It can also be used to measure the absolute delay of video equipment. By maintaining proper phase relationship between the various frequencies in the TV system, such effects as leading white, trailing smear, ringing and misregistration can be corrected.

The BW-8 equipment is a small chassis mounted unit, easy to use. It provides a low frequency phase reference in order to measure the relative envelope delay in the region from 1.3 MHz to 4.3 MHz or 1.3 to 6.0 MHz as referred to the average delay between 0 and 189 kHz or 187.5 kHz (F_A). The instrument is direct reading. All operating controls are located on the front panel for ease of operation. The unit may be housed

in a standard rack mounting where it occupies only 10½ inches.

When measuring a video amplifier or any other equipment having input and output at video frequencies, no auxiliary equipment is required. When a complete transmitter is being measured the only auxiliary unit required is an RF demodulator to feed the video signal to the receiver portion of the BW-8. The RCA BW-4 Series of Visual Sideband Demodulators or MI-19051-B/19364 Diode Demodulator can be used for this purpose. When sync and blanking are desired, they may be obtained from a studio sync generator, fed to the BW-8 generator section and combined with the BW-8 generator signal components to supply a composite test signal.

Built-in Power Supply

The BW-8 Envelope Delay Measuring consists of a generator that feeds the system to be measured, and

a receiver section which evaluates the envelope delay of the signals after they have passed through the system under test. The generator section provides two signal sources. One is a reference frequency (F_A) derived from an internal crystal oscillator or from the twelfth harmonic of the horizontal sync frequency supplied from an external source. The second is a carrier signal (F_C) which may be varied. The receiver section contains two amplifier-limiter chains to detect and amplify video from the unit under test. A phase shifter consisting of an RLC network may be switched into either amplifier chain to permit compensation of either positive or negative time delay. It is calibrated to read delay in microseconds. The generator section occupies the left section of the chassis, the receiver chains are on the right. An electronically regulated power supply is built in on the rear of the chassis.

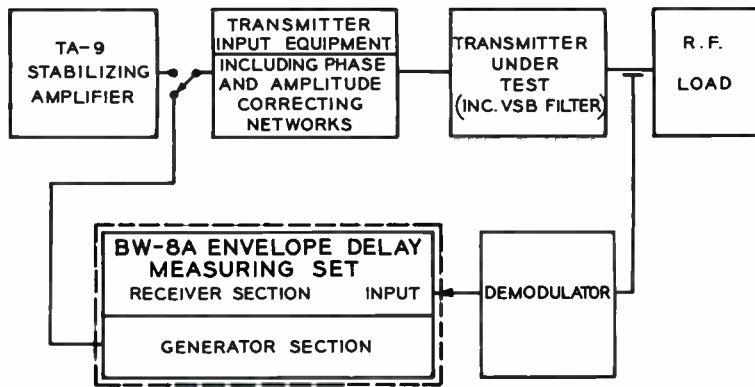

Position 1 measures peak amplitude of the output test signal fed to the transmitter. Position 2 measures the amplitude of the signal at the input of the receiver. Position 3 is for balancing the VTVM and positions 4 and 5 are for use as a null indicator for the phase detector. Position 4 is for lower sensitivity for initial balancing of the phase detector. By means of another switch, the phase shifter network can be introduced into either one of the two receiver chains, allowing compensation of positive or negative phase delay.

Front Panel Control

All controls of the BW-8 Envelope Delay Measuring Set are located on the front panel, those of the generator being on the left side and those of the receiver on the right. The output and input connectors, as well as the external sync input, the power connector and the fuse holder, are located on the rear of the chassis. The dial on the left con-

trols the carrier frequency F_c and is directly calibrated. The right-hand dial drives a precision 3-turn potentiometer that controls the phase shifter. The dial is calibrated in delay, from 0.01 to 0.68 microseconds and may be measured with an accuracy of ± 3 percent ± 0.01 microseconds.

The VTVM (null indicator) is connected to a 5-position switch.

Other controls located on the front panel include an a-c line switch; "Sync Amplitude" which regulates the amount of sync incorporated in the test signal; a "Zero Set" used to balance the VTVM when its switch is in position 3; and a "Delay Set", used to balance the delay of the measuring set when the operation switch is in the "direct" position.

Specifications

Performance

Envelope Delay.....	0 to ± 0.67 microseconds
Frequency Range:	
BW-8A	1.3 to 4.3 MHz
BW-8A1	1.3 to 6.0 MHz
Reference Frequency:	
BW-8A...Average Envelope Delay between 0 and 0.189 kHz	
BW-8A1...Average Envelope Delay between 0 and 187.5 kHz	
Delay Accuracy.....	$\pm 3\%$ ± 0.01 microseconds
Carrier Frequency Accuracy	$\pm 2\%$ ± 0.05 MHz
Output Test Signal	0 to 2 Volt, peak-to-peak
Output Impedance.....	75 ohms
Input Test Signal	0.1 Volt, peak-to-peak min.
Input Impedance.....	75 ohms $\pm 2\%$
Horizontal Sync and Blanking	1 Volt peak-to-peak, min.
Input Impedance (Sync).....	75 ohms $\pm 1\%$
Power Requirements:	
BW-8A	105-125 Volts AC, 50/60 Hz, 180 Watts
BW-8A1	115/230 Volts, 50/60 Hz, 180 Watts
Tube and Semi-Conductor Complement:	
4—6U8, 1—6BA7, 1—5687, 2—6AN8, 2—6AW8, 1—5R4-GY,	
1—6AS7-G, 1—6AG5, 1—OC3, 1—2N585, 2—1N100, 3—1N90	

Mechanical

Mounting.....	Standard 19" rack
Operating Conditions.....	5°C to 45° C (41°F to 113°F), 0-95% relative humidity
Dimensions (Overall).....	19" wide, 10½" high, 14½" deep (48.26 cm, 26.67 cm, 36.83 cm)
Weight.....	35 lbs. (16.33 kg.)

Accessories

Type BW-4B VHF Visual Sideband Demodulator.....	ES-34048
Type BW-4B1 VHF Visual Sideband Demodulator (CCIR).....	MI-826557
Type BWU-4B UHF Visual Sideband Demodulator.....	ES-34049-B
Type BWU-4B1 UHF Visual Sideband Demodulator (CCIR).....	MI-826559
VHF Monitoring Diode.....	MI-19051-B
UHF Monitoring Diode.....	MI-19364

Ordering Information

Type BW-8A Envelope Delay Measuring Set (1.3 to 4.3 MHz)	MI-34063
Type BW-8A1 Envelope Delay Measuring Set (1.3 to 6.0 MHz)	MI-34068



- Effective suppression of harmonic radiation when used with RCA UHF transmitters
- Pretuned at factory for optimum VSWR
- Small, light weight, easy to install
- Requires no maintenance

UHF Harmonic Filter

Description

The UHF Harmonic Filter is essentially a band pass filter wherein cavities are used instead of lumped circuit components to provide the requisite pass and rejection characteristics at UHF frequencies. Attenuation is accomplished in a series of radial cavities in a reflective type circuit. The radial cavity sections are made from cast high tensile strength aluminum with a precision machined interior finish. The individual sections are assembled into a series of fixed-tuned cavities terminated with standard bronze flanges.

The filter may be installed and used for transmission in either direction. It is, however, recommended that the two filters be connected as close to the visual and aural transmitter outputs as possible. The filter terminations are both 50 Ohm, 3-1/8-inch coaxial flanges, one male and one female.

Specifications

Frequency	470-960 MHz
Power Rating	18 kW average, 30 kW (peak)
Input Impedance and Connection	50 ohm, 3 1/8" UHF flanged coaxial line (MI-19089)
Output Impedance and Connection	50 ohm, 3 1/8" UHF flanged coaxial line (MI-19089)
VSWR.....	1.10 or better
Attenuation	60 dB or greater when used with RCA UHF transmitters and filterplexers
Mounting.....	Horizontal or vertical
Ambient Temperature.....	Minimum 0°C, 45°C maximum
Dimensions:	
MI-561549-L.....	24 3/4" long, 8" largest diameter (62.87 cm long, 20.32 cm largest diameter)
MI-561549-H.....	19 1/8" long, 8" largest diameter (48.58 cm long, 20.32 cm largest diameter)
Weight.....	30 lbs. (13.6 kg)

Ordering Information

UHF Harmonic Filter for Channels 14-43.....MI-561549-L-Ch*
 UHF Harmonic Filter for Channels 44-83.....MI-561549-H-Ch*

* (Specify station channel number and quantity of two filters for use with RCA TTU-2A, TTU-10A and TTU-30A UHF Transmitters)

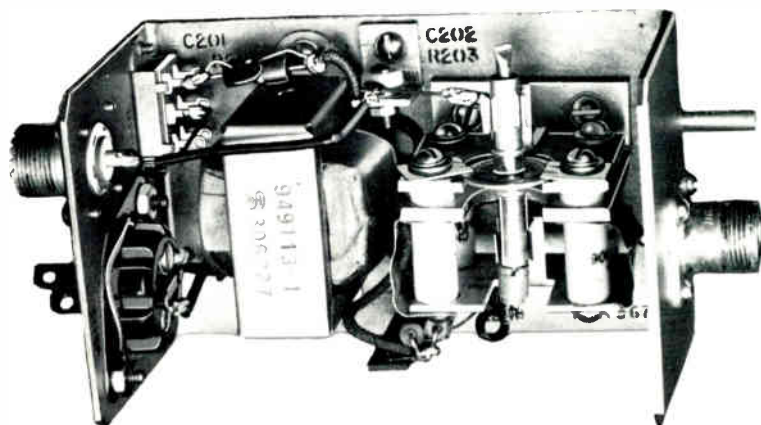

- Permits CRO display of modulation envelope in conjunction with video sweep input to the transmitter in L position
- Input circuit compensated for uniform RF pickup over all UHF channels
- Automatically energized whenever monitoring equipment is in operation

UHF Monitoring Diode,

Description

The UHF Monitoring Diode, MI-19364, is designed for mounting at any point on the visual transmission line between the transmitter and the filterplexer. The video output of the unit when fed to the master monitor or equivalent unit will permit observation of the picture delivered by the TV transmitter. It is designed for use on all UHF channels.

The diode consists of a triode serving as a diode whose cathodes are capacity coupled by a probe to the transmission line inner conductor. The plates are connected through a load resistor to the 75-ohm output circuit. Filament voltage for the triode is supplied from a 115 Volt AC supply. A directional coupler is required for use with the diode. The unit, together with its coupler, mounts on 3¼-inch or 6½-inch coaxial transmission line.

Specifications

Frequency Range	470-960 MHz
Output Impedance.....	75 ohms
Output Voltage	1 Volt peak-to-peak
Tube Complement, 1—5675.....	Pencil triode
Dimensions (overall).....	6¼" long, 3" wide, 2½" high (15.88 cm, 7.62 cm, 6.35 cm)
Weight.....	3 lbs. (1.4 kg.)

Accessories

Directional Coupler for 3¼" Transmission Line 51.5 ohm	ES-34231-1, 2
Directional Coupler for 6½" Transmission Line 75 ohm	ES-34232-1, 2
Directional Coupler for 3¼" Universal Line 50 ohm	ES-34231-1, 8
Directional Coupler for 6½" Universal Line 75 ohm	ES-34232-1, 5

Ordering Information

UHF Diode Demodulator.....	MI-19364
----------------------------	----------

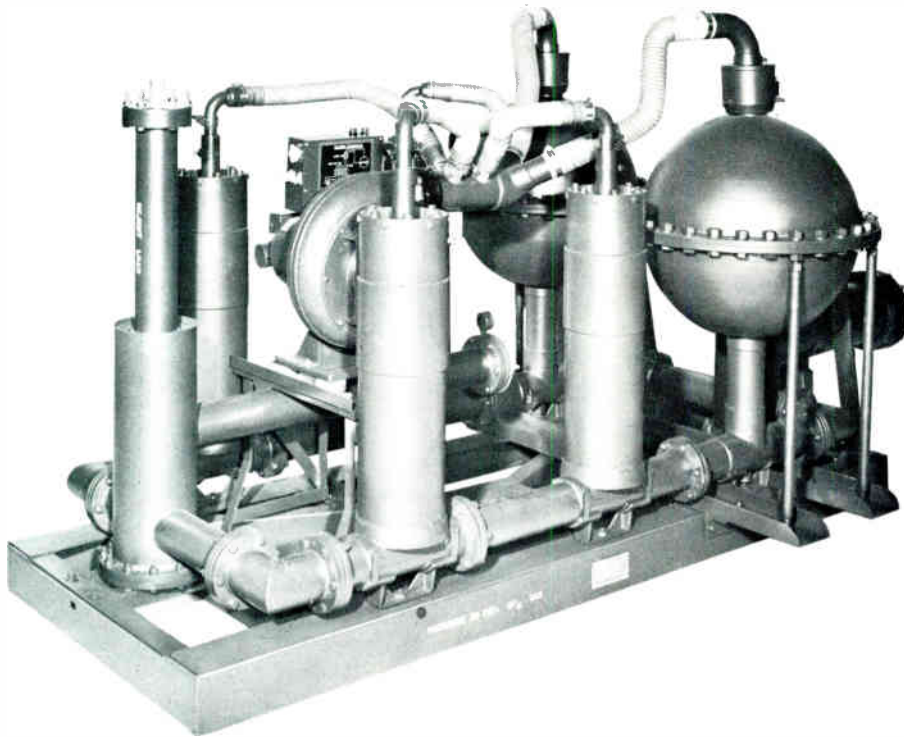

- Economical—combines functions of sideband filter and diplexer
- Suitable for color transmission
- Insertion loss less than ½ dB at both the visual and aural carrier frequency
- Pretuned—no adjustments necessary
- TV power rating from 1 to 30 kW
- Invar temperature compensation
- Constant input impedance

UHF Filterplexers

Description

The RCA UHF Filterplexers connect the aural and visual transmitters to a common antenna feedline with negligible interaction or cross-talk, and shape the transmitter frequency response to conform to vestigial sideband television transmission standards. Power ratings from 1 to 30 kilowatts can be achieved by the three units offered.

All the filterplexers are assembled on an open frame. This provides maximum ventilation and is suitable for convenient table, floor or ceiling mounting. The filterplexers should be mounted upright on their base and a clearance of at least one foot should be allowed from surround-

ing walls. The units are ruggedly constructed and employ Invar for temperature compensation.

RCA Filterplexers consist essentially of two bridge-baluns connected to two equal lengths of interconnecting coaxial transmission line and filter circuits (cavities) on each of the two interconnecting coaxial lines. The units are pressurized as shown under specifications with nitrogen or sulphur hexafluoride gas to prevent deterioration and reduce changes in tuning.

The filterplexers combine the high quality performance characteristics of both a sideband filter and a diplexer. The vestigial sideband characteristics are obtained by having the lower sideband frequencies at-

tenuated to more than 20 dB from the low edge of the channel (1.25 megahertz) to 4.25 megahertz below the picture carrier. The inputs are designed to have a constant input impedance over the band of frequencies produced.

Channel frequency must be specified when ordering the unit. The size of the filterplexer is determined by the frequency. The minimum dimensions (equipments supplied for 890 megahertz) and maximum dimensions (units supplied for 470 megahertz) are shown in the specifications under dimensions. Units used on other frequencies vary in size between these two extremes. A blower kit is included with each filterplexer to cool the coaxial and spherical cavities.

Specifications

Description	MI-19086-HM	MI-19086-J	MI-19086-F
Frequency	470-890 MHz	470-890 MHz	470-890 MHz
Power Rating (Peak Visual).....	2 kW	12.5 kW	30 kW
Visual to Aural ratio	25% or less	25% or less	25% or less
Minimum Efficiency (visual but not aural losses are included in transmitter peak power rating):			
Aural	90% (0.46 dB loss)	90% (0.46 dB loss)	90% (0.46 dB loss)
Visual	90% (0.46 dB loss)	90% (0.46 dB loss)	90% (0.46 dB loss)
Output Impedance	50 ohms	50 ohms	75 ohms
Input Impedance (aural and visual).....	50 ohms	50 ohms	50 ohms
Maximum Visual Input VSWR (Referred to visual carrier frequency):			
-4.5 MHz to -1.25 MHz.....	1.3/1	1.3/1	1.3/1
-1.25 MHz to +4.2 MHz.....	1.15/1	1.15/1	1.15/1
+4.2 MHz to +4.5 MHz.....	1.3/1	1.3/1	1.3/1
Maximum Aural Input VSWR (Referred to visual carrier frequency):			
4.5 MHz to ±100 kHz.....	1.3/1	1.3/1	1.3/1
Maximum Ambient Temperature.....	45°C	45°C	45°C
Minimum Ambient Temperature.....	15°C	15°C	15°C
Gas	Nitrogen	Sulphur hexafluoride	Sulphur hexafluoride
Gas Pressure	12 psi	24 psi	28 psi
Blower Line Requirements.....	230 V, 1 ph, 50/60 Hz	230 V, 1 ph, 50/60 Hz	230 V, 1 ph, 50/60 Hz
Dimensions Overall (approx.)			
Length	68 to 74 inches 1.73 to 1.88 m	68 to 74 inches 1.73 to 1.88 m	76 to 87 inches 1.93 to 2.21 m
Width	38 to 48 inches 0.97 to 1.22 m	38 to 48 inches 0.97 to 1.22 m	38 to 48 inches 0.97 to 1.22 m
Height	36 to 43 inches 0.91 to 1.09 m	36 to 43 inches 0.91 to 1.09 m	49 to 58 inches 1.24 to 1.47 m
Mounting	Upright; table or ceiling	Upright; table or ceiling	Upright; table or ceiling
Connections:			
Input (aural and visual).....	3½", 50 ohm flanged (MI-19089)	3½", 50 ohm flanged (MI-19089)	3½", 50 ohm flanged (MI-19089)
Output	3½", 50 ohm flanged (MI-19089)	3½", 50 ohm flanged (MI-19089)	6½", 75 ohm flanged (MI-19387)
Weight (approx.)	950 lbs. 435 kg	950 lbs. 435 kg	1000 lbs. 455 kg

Ordering Information

2 kW Filterplexer, nitrogen gassed 12 psi,
with blower, 80 Watt reject loadMI-19086-HM*

12.5 kW Filterplexer, SF6 gassed 24 psi,
with blower, 1200 Watt reject loadMI-19086-J

30 kW Filterplexer, SF6 gassed 28 psi,
with blower, 1200 Watt reject loadMI-19086-F

* Specify channel frequency when ordering.

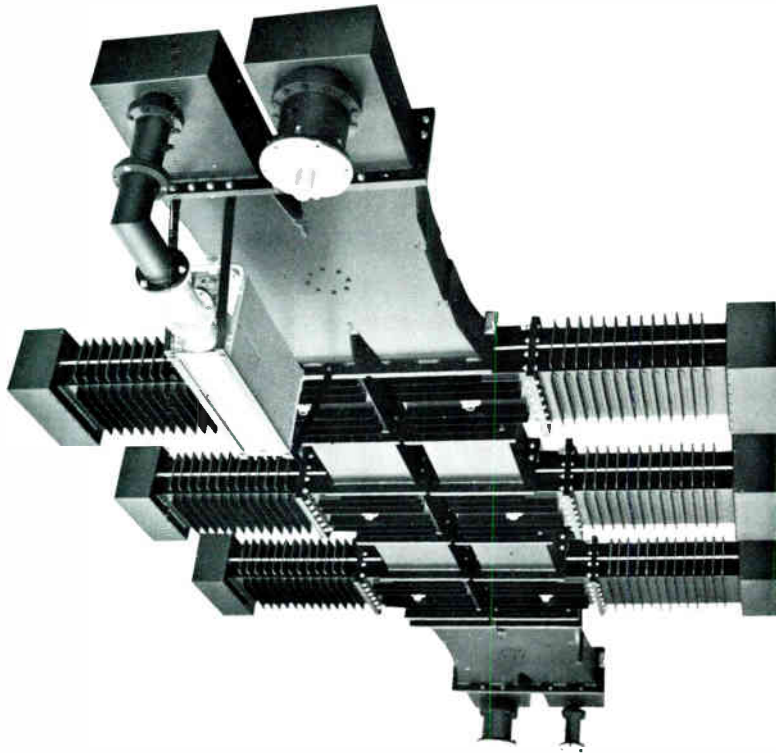

- Power rating of 60 kW peak visual
- High efficiency
- Free convection cooling—silent operation
- No pressurization required
- Functions as sideband filter and diplexer
- Ideal for color transmission

60-KW UHF Waveguide Filterplexers

Description

60-kW UHF Waveguide Filterplexers, MI-561550 to cover channels 14 to 42 and MI-561551 for channels 43 to 83, are offered by RCA to connect the aural and visual transmitters to a common antenna feedline with high efficiency and negligible interaction. They also shape the transmitter frequency response to conform to FCC vestigial sideband television transmission standards.

Both filterplexers have a peak visual power rating of 60 kW and aural power rating of 12 kW and are capable of higher ratings when provided with suitable output transitions.

The RCA Waveguide Filterplexer consists essentially of two identical waveguide transmission lines with three waveguide cavities. Hybrid

junctions are used to interconnect the two sections and provide input and output ports. Due to its inherent high power capability, the waveguide type design requires no gassing or pressurization. Free convection cooling is enhanced by a special cavity-fin design. Thus silent operation is obtained since no blowers are required.

Waveguide Filterplexers combine the high quality performance characteristics of both a well-designed sideband filter and diplexer. The vestigial sideband characteristics are obtained by having the lower sideband frequencies attenuated to more than 20 dB from the low edge of the channel to 4.25 MHz below the picture carrier frequency. The inputs

are designed to have a constant input impedance over the band of frequencies produced.

The filterplexers are constructed of high conductivity aluminum and assembled to provide a minimum height design. This configuration is ideal for ceiling mounting, thus saving valuable floor space. Adequate tie points are provided for ceiling mounting. Channel frequency must be specified when ordering the equipment, since the size of the filterplexer is determined by the channel. Approximate dimensions may be found on the specification page.

All filterplexers are pretuned and adjusted at the factory and are provided with a suitable reject load.

Typical installation of Channel 48 Filterplexer.

Note: Coaxial connections may be made either from above or below the Filterplexer.

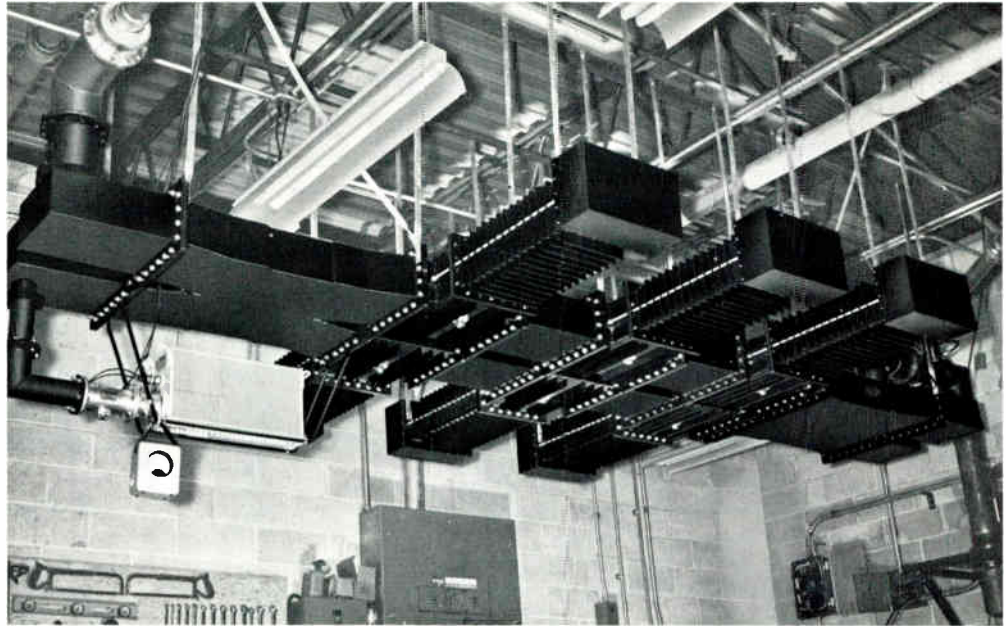

Specifications

Electrical

Power*:	
Peak visual.....	60 kW
Aural	12 kW
Efficiency (typ. meas.):	
Visual	97%
Aural	94%
Max. Visual Input VSWR:	
-4.5 MHz to -1.20 MHz	1.20:1
-1.20 MHz to +4.20 MHz	1.15:1
+4.20 MHz to +4.50 MHz	1.20:1
Max. Aural Input VSWR	1.20:1
Connections:	
Aural Input	3 $\frac{1}{8}$ " , 50 ohm flanged coaxial MI-19089
Visual Input	6 $\frac{1}{8}$ " , 75 ohm flanged coaxial MI-19387
Antenna Output	6 $\frac{1}{8}$ " , 75 ohm flanged coaxial MI-19387

Mounting	Ceiling
Ambient Temperature	0° C. min. to 45° C. max.

Mechanical

	MI-561550	MI-561551
Dimensions: (approx.)		
Length	228" to 195" 5.79 to 4.95 M	198" to 168" 5.04 to 4.27 M
Width	140" to 100" 3.56 to 2.54 M	105" to 81" 2.67 to 2.06 M
Height	36" (91.44 cm)	36" (91.44 cm)
Weight (approx.)	1200 lbs. (545 kg.)	900 lbs. (408 kg.)

* An MI-561550 rating of 100 kW and an MI-561551 rating of 80 kW peak visual can be achieved with suitable output transitions.

Ordering Information

60-kW UHF Waveguide Filterplexer for Channels 14 to 42	MI-561550
60-kW UHF Waveguide Filterplexer for Channels 43 to 83	MI-561551
(Specify channel frequency when ordering)	



- Input power ratings to achieve 5 Mw ERP
- Shaped high fill vertical patterns
- Electrical and mechanical beam tilting
- Directional horizontal patterns
- Single feed point
- Rugged simple construction—no protruding elements
- Measured vertical pattern supplied

UHF TV Pylon Antennas

Description

The RCA Pylon is the antenna being used by the majority of today's UHF stations. These antennas are available with power input ratings to 150 kW and power gains to 46. Television stations can choose from a variety of vertical and horizontal patterns (omni-directional or directional) to fit almost any terrain situation. All the Pylons have built-in

beam tilt. This assures best possible coverage with minimum power lost to radiation above the horizon. RCA can also furnish a complete matched system—from transmitter to antenna to assure maximum performance for any station.

The detailed electrical and mechanical characteristics of the various types are listed under the

Specifications. These specifications will provide the broadcaster with data needed for:

1. The choice of the proper antenna for a given terrain situation.
2. FCC filing purposes.
3. Tower requirements.
4. Shipping and erection.

ELECTRICAL CHARACTERISTICS

The RCA UHF Pylon Antenna combines the functions of radiator and supporting structure in a heavy duty slotted cylinder. The unique copper feed system forms a coaxial transmission line with the outer slotted cylinder. The copper tube is an outer conductor for a transmission line to the approximate center of the antenna where the only feed point is located. Energy is coupled from the field inside the antenna to the radiating slot by means of an aluminum bar coupler bolted to the inside edge of the slot. In the TFU-24DL and DM Pylon Antennas the excitation is accomplished with a loop coupler. The input connection for all UHF antennas is at the base end.

Gain

The gain of an omnidirectional antenna increases as layers are stacked above each other. This stacking takes energy, which for a single layer is radiated at high vertical angles where it serves no useful purpose, and compresses it into a beam which is directed towards the service area. The gain is hence proportional to the height of the antenna aperture in wavelengths which can be computed from the value of H_2 listed under Mechanical Data. The theoretical gain for a long antenna is 1.22 times the height of the aperture in wavelengths. To approach this value, every point of the antenna must radiate an in-phase signal of equal amplitude. Such an antenna will produce areas of relatively low signal strength at regular intervals in the service area. For low gain antennas of the order of six, these will occur within one mile or less from the antenna for a height of 1000 feet above terrain. At this close distance, the actual value of field strength is still adequate. For a gain of 25 however, these low signal areas are within five miles from the antenna, and for a gain of 50, within ten miles from the antenna.¹ This is usually in the primary service area of the antenna and positive means must be used to fill these areas. This is done by varying the energy radiated from the slots in amplitude or in phase or in both. Practical values of gain for such an-

¹ For 0 degree beam tilt, the approximate location of the minima farthest from the antenna in miles is .00019 times the aperture of the antenna in wavelengths times the height in feet above terrain.

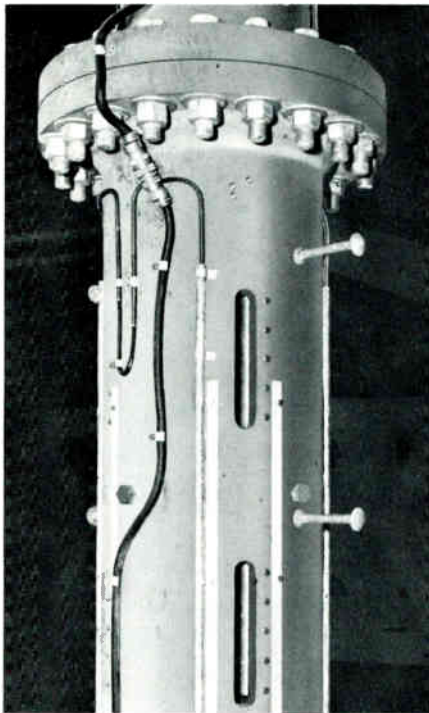

View showing several layers at the center of a TFU-46K with the aluminum bar coupler installed.

tennas vary from 0.8 to 1.0 times the aperture in wavelengths depending upon the amount of "fill" in the vertical pattern. For a properly designed antenna, the lower this figure is, the heavier the "fill". This "fill" insures null free operation and a good local signal. Values of gain over a dipole for the various antenna types are given in Table 1. The number in the type number is the nominal vertical gain.

Vertical Patterns

The vertical pattern is a plot of the relative field strength vs. vertical angle transmitted in a given vertical plane. For antennas of the slotted cylinder type, the vertical plane pat-

tern is substantially the same in all directions. Calculated vertical patterns for the various Pylon Antennas are shown on the following pages.

As can be seen from Table 1, there are several types of vertical patterns available. Such as broad beam, null filled, and shaped patterns. A null filled pattern is one in which the locations of the nulls are still discernible, but positive means—such as varying the amplitude of the radiated signal—have been used to fill these nulls. For the antenna types shown using null filled patterns, it will be found that most of these have a gain of approximately 1.0 times the aperture in wavelengths.

Other types shown have a "shaped" pattern. In such a pattern, both the amplitude and phase of the radiated energy in each layer is varied to produce a smooth pattern below the horizon. Above the horizon, the energy is partially cancelled. With the heavy fill employed, the gain is about 0.8 times the antenna aperture in wavelengths. The vertical pattern shows how the radiated energy is distributed and its proper choice is an important factor in good coverage.

Estimating Field Strength

By using the vertical patterns and the height distance chart and knowing the height of the antenna above terrain, the radiated power, the terrain conditions, and the location of the areas to be served in miles from the antenna, it is possible to estimate field strengths using a propagation formula.²

Beam Tilt

Beam tilt is the angle of the maximum in the vertical pattern below

² A method of calculating field strengths for shadowed areas is given in the NAB Engineering Handbook, pages 2-16 to 2-22.

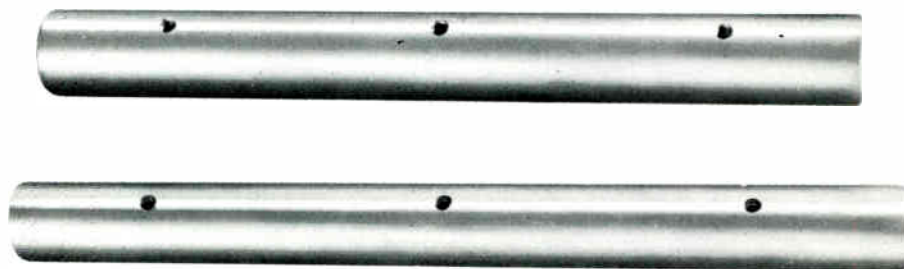

Two typical aluminum bar couplers as used in the RCA Pylon Antenna.

the horizontal and is substantially the same in all directions. Electrical beam tilt is built into each antenna and cannot be changed after fabrication. A certain amount of beam tilt is necessary merely to obtain maximum radiation towards the horizon as shown in the height distance chart. Some additional beam tilt is usually desirable which may improve local coverage markedly, while only slightly reducing the signal at the horizon.

The antenna gain is constant for any beam tilt except for the RCA "D", "DA" and "J" series of antennas as shown on the vertical patterns. Pylon antenna patterns for other than the "D", "DA" and "J" series are shown for a 0.5 degree tilt but can also be obtained for other angles.

Mechanical beam tilting may be incorporated in all RCA Pylon Antennas by using stainless steel shims which are supplied with the antenna. Since a component of the dead weight of the antenna is added into the overturn value M, when mechanical tilt is used, the antenna and tower stresses should be recalculated.

A combination of mechanical and electrical tilt may often be employed advantageously to improve signal level in a particular direction when the antenna is located on a plateau or mountain range overlooking a valley. With the proper combination, the main beam of the antenna can be directed downward toward the service area, while a horizontal beam is directed backwards across the plateau.

Peak TV Power Rating

The power ratings in the Specifications are based on the visual power at the peak of the synchronizing pulse which is known as the TV power rating. The total power should not exceed the ratings shown on the chart entitled "Peak TV Power Rating Curves." The rating is based on an ambient temperature of 104 degrees F or 40 degrees C in still air.

With the TFU-46K Antenna it is possible to radiate the maximum allowable power of 5 megawatts using a 109 kilowatt input to the antenna. Five megawatts is also possible with an antenna having a vertical gain of 25 if a directional

antenna is used which has a horizontal gain approaching 2.

Pylon Antenna Characteristics

There are numerous types of antenna designs. For each antenna certain end results are desired such as gain, vertical pattern, beam tilt, horizontal pattern, impedance and power rating. In some types of antennas these characteristics are interlocking so that compromises between these characteristics may be necessary. In the RCA pylon antenna each of the above characteristics has an independent parameter which can be controlled to give optimum performance for each item. For instance, each layer of one wavelength in height can be varied in phase and amplitude to produce a given vertical pattern. The horizontal pattern is independently controlled by the number of slots and their disposition around the circumference of the pylon. The power rating is controlled by the size of the inner conductor, etc. This results in flexibility of design without compromise.

MECHANICAL DESIGN

The steel outer conductor consists of one or two slotted pipe sections. The sections are bolted together with appropriate flanges. The slotted pipe sections are of sufficient strength so that they serve the dual function of a supporting structure and radiator thus eliminating the field distortion often caused by a supporting structure. All welding is done by certified welders. Furthermore, all welds on the pole are subjected to rigorous gamma ray examination. All antennas are supplied with a tower mounting flange.

Feed System

The feed system which is coaxial with the outer pipe continues down through the tower top. This feed system or inner conductor is a copper tube which forms a transmission line with the outer slotted cylinder. It is supported laterally by dielectric centering pins and vertically by the clamping spoke short. Pole steps projecting from the outer shell provide a means of reaching the beacon or any part of the antenna. Lifting lugs are provided for erecting the antenna. Mechanical dimensions necessary for designing the tower top plate, wind load reactions, and other mechanical data are shown under Specifications.

Lighting Provisions

A plate is provided for mounting the 300 millimeter beacon. The beacon which is an accessory item is not supplied with the antenna, but is normally a part of the tower lighting equipment. A beacon cable is factory installed on the antenna for connection to the tower top junction box.

WEATHER PROTECTION

Thorough consideration has been given to all aspects of weather protection. Much practical information has been gained in the hundreds of antennas supplied for TV broadcast services over the last twenty years.

Corrosion Resistance

The slotted cylinder is constructed of hot dip galvanized open-hearth structural steel to obtain extremely long life. All hardware and metal parts are manufactured of corrosion resistant metals which will give long life both in highly industrialized areas and in a salt atmosphere. Pole steps are hot dipped galvanized forged steel; mounting flange bolts are hot dip galvanized steel; leveling shims are stainless steel;

Cross section of typical UHF Pylon Antenna.

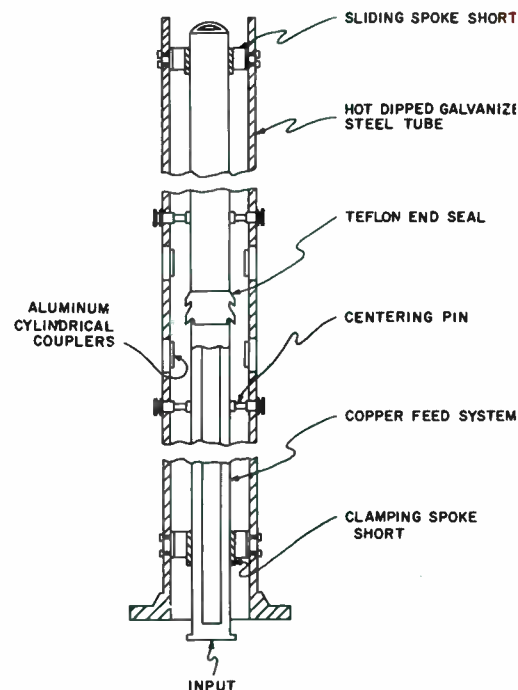

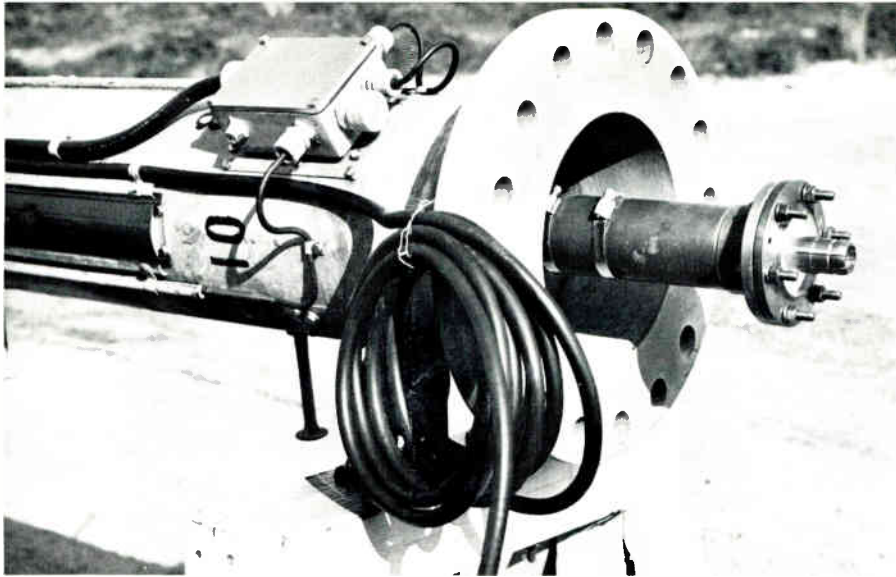

Base of UHF antenna showing deicer, deicer junction box and beacon cable. The antenna input is also shown.

beacon mounting and ventilation grills are constructed of hot dip galvanized steel. The inner conductor is a copper transmission line using teflon supporting insulators; coupling probes are aluminum bar stock; "spoke shorts" are brass and bronze. Slot covers are polyethylene containing anti-oxidant and ultraviolet inhibiting dye.

Wind

The antennas are designed according to EIA specifications of 50 pounds per square foot (psf) on flats and 33 psf on cylindrical surfaces, except where noted under mechanical data. This is equivalent to a true extreme velocity of 110 miles per hour with no ice. Reactions and moments for various antenna sizes based on the stated loadings are shown. Antennas with higher ratings can be provided on request.

Ice or Snow

Deicer systems are available which consists of Calrod type heaters clamped to the antenna pole longitudinally between rows of slots. Deicers are an optional item except for certain antennas where they are included. Deicers are recommended in

areas and heights where ice is likely to form.

Since the deicers are factory installed they must be ordered concurrently with the antenna. The voltage, phase, and average power requirements are shown in Table 1.

A temperature operated automatic deicer control, MI-27369, is supplied for activating the building contactor of the deicing system at preset temperature range limits. This building contactor is not supplied as part of the antenna deicing equipment.

This automatic deicer control will prevent ice formation from getting a head start with a consequent deicing period. This is especially true for tall towers where climatic conditions may be different than at ground level.

Lightning

Since the antenna consists basically of a slotted cylinder which is firmly grounded to the tower, and since the inner conductor is also grounded to the outer at the top and bottom, it is highly improbable that lightning will damage the antenna. How-

ever, to protect the 300mm beacon at the top of the antenna, a branching type of lightning protector is furnished. The tower must be well grounded to make the lightning protection effective.

EQUIPMENT SUPPLIED

RCA can supply a UHF TV Pylon antenna to provide various amounts of gain and fill for various channels as listed in Table 1. Following are the special features and applications of each type. Calculated vertical patterns are also provided on the following pages.

TFU-6C

The TFU-6C is a low gain, light weight, omnidirectional antenna which may be used as a standby antenna, or for stations serving a small area where ERP requirements are low. The antenna has a gain of six. The vertical pattern is quite broad. It will accommodate up to 10 kW input. Essentially, it is a continuation of a 3 1/8-inch transmission line except that it is constructed of heavy aluminum tubing. Cylindrical couplers excite the slots as in the larger antennas. A mounting flange is provided for mounting at the tower top or for mounting on an outrigger plate at the side of the tower or inside the tower. The circularity figures in "Specifications" hold only for top mounting. For side mounting the pattern will vary considerably. No provision is made for mounting obstruction lighting since the beacon lamp may be mounted at the tower top for an antenna of this height. A protective radome is supplied with this antenna.

TFU-6J

The TFU-6J Antenna has a gain of six and covers the entire UHF channel range from 14 to 83. It is an ideal emergency antenna since it has a relatively high input power rating (38 to 22 kW from channels 14-83) and a very broad beam providing very high local signals. With the RCA TTU-2A transmitter, it is admirably suited for the 10 kW ERP requirement of the proposed community channels in the Channel 70-83 region. The small antenna size presents a minimum wind load. A standard base mounting flange is provided.

This photo shows an RCA Ultragain Antenna being pattern tested on the 15 ton turntable at the Gibbsboro, N. J. antenna test site.



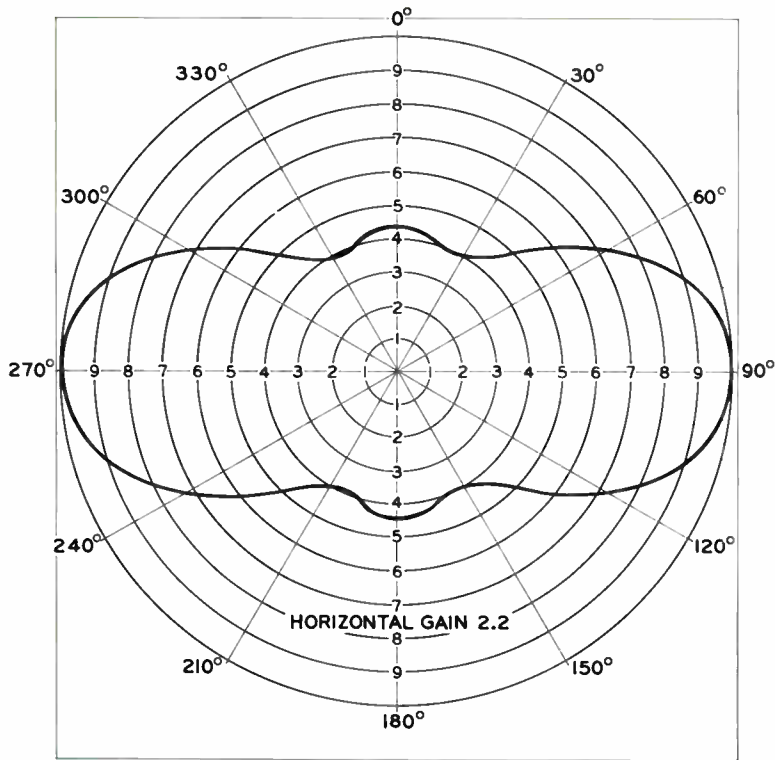

Typical horizontal "peanut" pattern obtained with RCA UHF Pylon Antenna.

TFU-24DL and TFU-24DM

These are medium gain, low power, loop coupled type antennas for Channels 14 through 30 (TFU-24DL) and Channels 31 through 50 (TFU-24DM). The power input capability for the TFU-24DL is 15 kW and 13½ kW for the TFU-24DM. The gain for a beam tilt of zero degree is 24. This gain decreases with beam tilt as shown on the vertical patterns. The vertical patterns are null filled. This fill increases markedly as the beam tilt is increased. A zero degree beam tilt pattern is generally not desirable because of the very low null fill.

TFU-27DJ

The TFU-27DJ replaces the TFU-27DH antenna. The TFU-27DJ is offered for channels 31 through 70. It uses cylindrical couplers and has a power input rating as shown by curve "D" of the Peak TV Power Rating Curves. The TFU-27DJ does overlap the TFU-24DM antenna for channels 31 through 50. Thus, a TFU-27DJ with its higher gain and higher input power capability can be provided if the TFU-24DM does not quite meet your requirements.

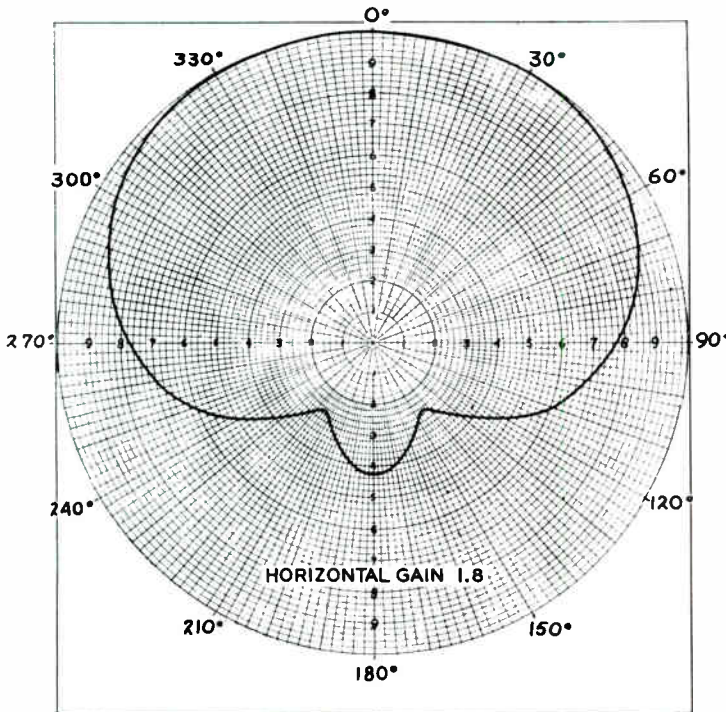

Typical horizontal "skull" pattern obtained with RCA UHF Pylon Antenna.

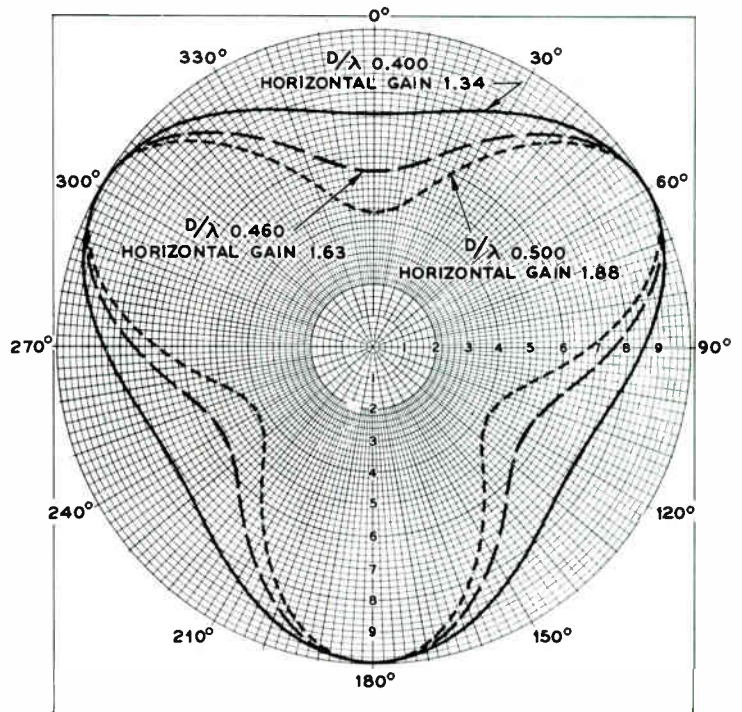

Three typical horizontal "tri-lobe" patterns obtained with RCA UHF Pylon Antenna.

TFU-30J

The TFU-30J is a medium gain, medium input power capability antenna. The input power rating ranges from 80 kW at channel 14 to 56 kW at channel 70 as shown by curve "C". The gain for a beam tilt of zero degree is 30. This gain decreases with beam tilt as shown on the vertical patterns. The vertical patterns are null filled. This fill increases markedly as the beam tilt is increased. A zero degree beam tilt pattern is generally not desirable because of the very low null fill.

TFU-25G

This medium gain high input power capability antenna provides a shaped vertical pattern with heavy fill. The gain does not change with beam tilt. The input power rating ranges from 136 kW at Channel 14 to 105 kW at Channel 55 as shown in curve "B". See curve "C" for ratings from Channel 56 to 70. This antenna is primarily designed to provide a strong local signal.

TFU-46K

This is a high gain antenna designed to achieve a megawatt of radiated power with a 30 kW transmitter for nominal lengths of 6 $\frac{1}{8}$ -inch transmission line. The vertical pattern is designed to provide a substantially uniform field over flat terrain. The TFU-46K has a power input rating which will permit 5 megawatts of radiated power from Channel 14 to 40. Even though this input rating may not be contemplated for some years, this antenna will permit the power change to be made later.

DIRECTIONAL ANTENNAS

TFU-24DAS

This high input power capability directional antenna is offered in any of three basic directional patterns; the skull, peanut and tri-lobe. The effective radiated power in the maximum direction can be increased by approximately 1.8 using a semi-circular shaped pattern and by approxi-

mately 2.2 using a peanut shaped pattern. The exact gain depends upon the channel. Directional antennas can be side mounted on existing towers. When the minima in the horizontal pattern is placed towards the tower, the pattern in the forward direction is distorted by a minimal amount. The input power rating of the TFU-24DAS (6 $\frac{1}{8}$ inch input) ranges from 80 kW at channel 14 to 56 kW at channel 70 as shown by curve "C". A higher input power rating of 155 kW at Channel 14 to 132 kW at channel 40 can be achieved with a 9 $\frac{3}{16}$ inch antenna input.

TFU-30JDA

This antenna has the same general directional pattern characteristics as the TFU-24DAS. The frequency range is from Channels 14 to 50. The vertical pattern is approximately the same as the TFU-30J antenna for the same beam tilt. The TFU-30JDA is also offered in any of the three basic directional patterns; the skull, peanut and tri-lobe. Power input ratings approximate curve "D" for the lower channels and curve "E" for the higher channels. Further information will be supplied on request.

Choice of Antennas

Following are some general observations.

1. Most UHF antennas are either high gain (of the order of 46) or medium gain (of the order of 25). The higher gain results from narrowing the main beam. For a given transmitter input, the high gain antenna may sacrifice local coverage for more distant coverage. Hence if a higher gain antenna is contemplated, local field strengths should be calculated. It is generally advisable to maintain a 100 dBu level over the important local area to be covered. In hilly terrain it may be desirable to increase this figure by 10 dB or more.¹

If fields of this order cannot be achieved with a high gain an-

tenna, the transmitter power should be increased to achieve it or a lower gain antenna used.

2. An increase in height over terrain has the same general effect as increasing the gain of an antenna. For distant areas within line of sight covered by the main beam of the antenna the field strength in millivolts per meter for a given ERP increases approximately as the height over smooth terrain. However, the nearby areas generally receive less field strength since the vertical angle looking up towards the antenna is steeper to a point where the vertical pattern usually radiates less energy. Hence an increase in height should be studied in the same manner as an increase in gain.
3. The maximum area is covered with a given ERP from the center of the area to be served. If the antenna is located on the perimeter instead of in the center of the same area using a directional antenna, the area covered drops to approximately one-half or less. This results from the fact that the service radius varies approximately as the fourth root of the ERP. If a natural low cost height is available at the perimeter which is approximately three times as high as that which would be used in the valley, the full area can be recovered. The economics of each situation should be studied. Because of the fourth root relationship between the service radius and the ERP, a voltage plot of a directional antenna can be misleading. The area to be covered should be calculated using propagation formulas to obtain a true evaluation. Often the benefits may be found to be marginal and possibly detrimental.

The previous points are offered to show that a thorough study is advisable in planning any UHF antenna installation.

¹ Fields behind obstructions can be calculated using a method outlined in Section 2-16 to 22 of the NAB Handbook.

Electrical Specifications

Power GainAs listed in Table 1

Vertical Pattern.....See following pages for various types.

The patterns shown are calculated. These are typical patterns of what will actually be achieved. One measured pattern of a plane which most closely represents the average of the measured planes is furnished with each antenna (except TFU-6C and TFU-6J). The comparison patterns on page 77 indicate the correlation to be expected between calculated and measured patterns.

Beam Tilt.....Specify at time of ordering.

Beam tilts for the TFU-25G, TFU-24DAS, and the TFU-46K are shown on the vertical pattern with a 0.5 degree tilt. Since for these antennas, the gain does not change with beam tilt, the vertical pattern for other beam tilts can be determined by placing the center (half power points) of the main beam at the desired beam tilt.

CircularityWithin ± 1 dB
TFU-6C Circularity is within ± 2 dB for channels 14-24, ± 3 dB for channels 25-57.

ImpedanceVSWR within ± 1.1 to 1. At the time of manufacture all antennas are adjusted for a minimum reflection in the picture pass band (-0.75 to $+4.2$ from picture carrier). Since a flat 1.0 to 1.0 VSWR over the channel does not provide an adequately low reflection value, adjusting the VSWR to lower values in the picture carrier region may at times raise values outside the picture pass band to higher values than 1.1 such as 1.2 for antennas as the TFU-46K and the TFU-24DAS.

Peak TV Power Rating.....As listed in Table 1 and associated Peak TV power rating curves on page 77. Peak TV power ratings are based on black level visual power and 20% aural power for a 40°C ambient. Multiply values by 0.8 for 50°C. ambient.

Input TerminalAs listed in Table 1

TABLE 1

Type Number	Channel Range	Gain		TV Power Rating kW ³	Input Terminal MI Number	Deicer Requirements			Vertical Pattern Type
						kW per ft. of ht. H2	AC Supply		
		Power	DB				Standard	Special ¹⁰	
TFU-6C	14-57	6	7.78	10	19089 ⁵	—	Radome	—	Broad beam
TFU-6J	14-83	6	7.78	D	19089 ⁵	.30	230—1 ϕ	230—3 ϕ	Broad beam
TFU-24DL	14-30	24 ²	13.80	15	19089 ⁵	.45	460—3 ϕ	230—3 ϕ	Filled
TFU-24DM	31-50	24 ²	13.80	13.5	19089 ⁵	.30	460—3 ϕ	230—3 ϕ	Filled
TFU-27DJ	31-70 ¹	27 ²	14.31	D	19089 ⁵	.60	460—3 ϕ	230—3 ϕ	Filled
TFU-30J	14-70 ¹	30 ²	14.77	C	27792 ⁶	.60	460—3 ϕ	230—3 ϕ	Filled
TFU-25G	14-55	25	13.98	B	27792 ^{6, 7}	.60	460—3 ϕ	230—3 ϕ	Shaped
TFU-25G	56-70 ¹	25	13.98	C	27792 ⁶	.60	460—3 ϕ	230—3 ϕ	Shaped
TFU-46K	14-40	46	16.63	A	27793 ⁸	.60	460—3 ϕ	— ⁹	Shaped
TFU-46K	41-55	46	16.63	B	27792 ⁶	.60	460—3 ϕ	— ⁹	Shaped
TFU-46K	56-70 ¹	46	16.63	C	27792 ⁶	.60	460—3 ϕ	— ⁹	Shaped
TFU-30JDA	14-50	On Application					460—3 ϕ	230—3 ϕ	Filled
TFU-24DAS	14-70 ¹	24	13.80	C ⁴	27792	.60	460—3 ϕ	230—3 ϕ	Shaped

¹ The upper channel shown is 70 since Channels 70-83 have been tentatively indicated as community channels with a maximum ERP of 10 kW. Any of the antennas marked 1 can be supplied for Channels 71-83 upon application.

² Gain stated is for 0° beam tilt. To determine gains for other tilts, see vertical patterns.

³ See appropriate "Peak TV Power Rating Curve" listed by channel.

⁴ The rating is limited by the input transmission line. Antennas for Channels 14-40 may be specified for higher input power ratings as shown by curve "A". Page 77.

⁵ MI-19089 is 3/8" EIA flange, 50 ohms.

⁶ MI-27792 is RCA Universal 6/8", 75 ohm line—MI-19387 6/8" EIA flange 75 ohm input may be specified.

⁷ For Channels 14-40, MI-27793 9-3/16" Universal flange, 75 ohms may be specified.

⁸ 9-3/16" Universal flange, 75 ohms.

⁹ Not Available.

¹⁰ Supplied at extra cost.

DEPRESSION ANGLE VERSUS DISTANCE FOR VARIOUS TOWER HEIGHTS

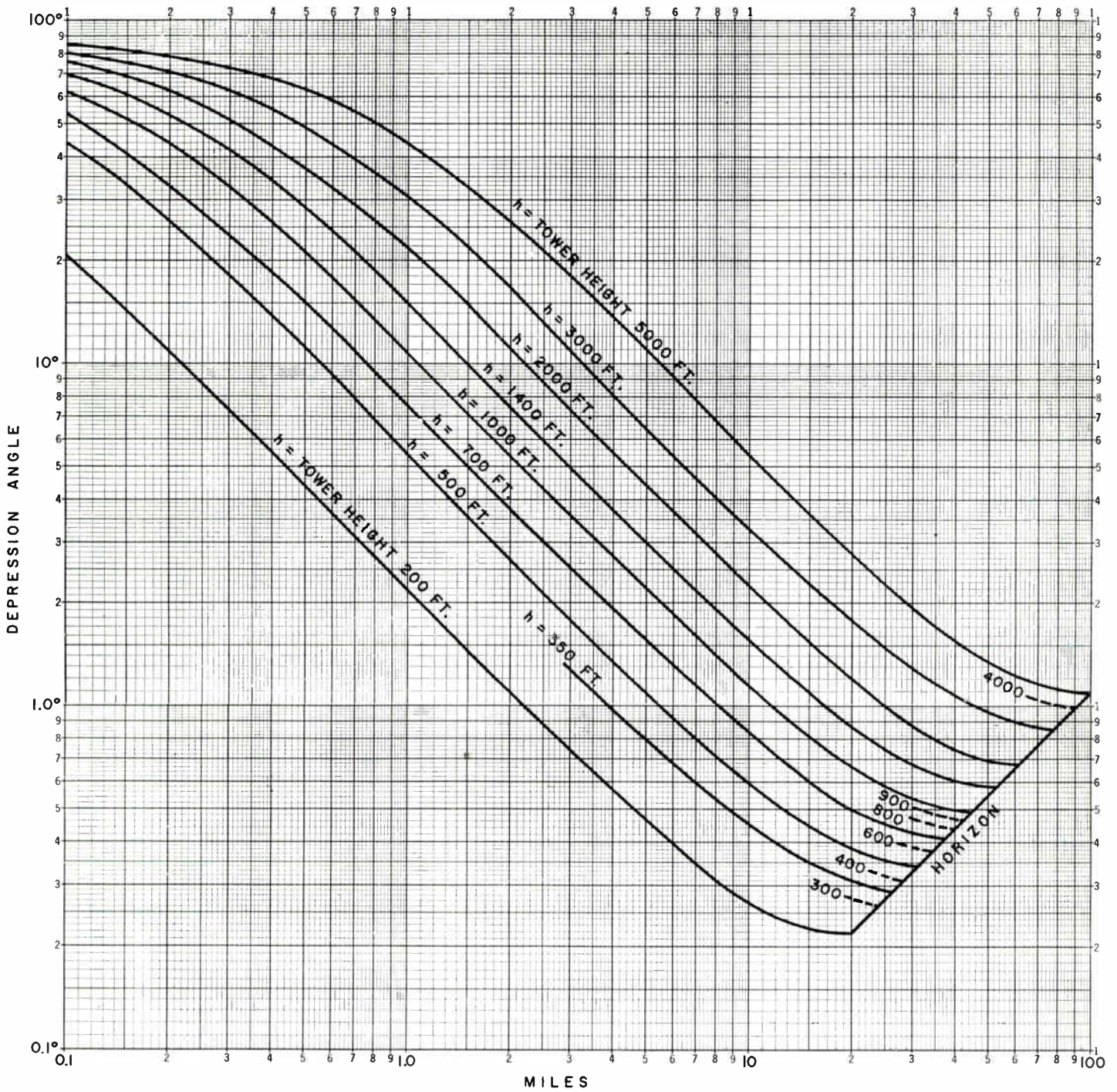

PEAK TV POWER RATING CURVES

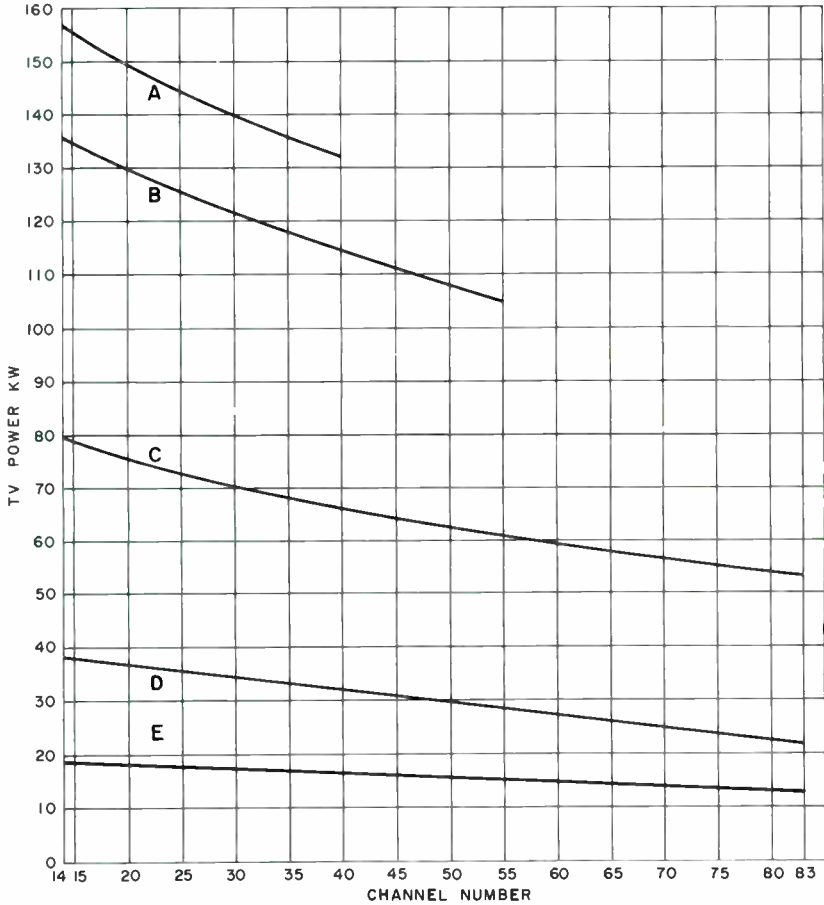

Based on 0.6 black level visual power and 0.2 aural power.

Comparison between the calculated vertical pattern and the measured vertical pattern. (Solid line is measured and broken line is calculated.)

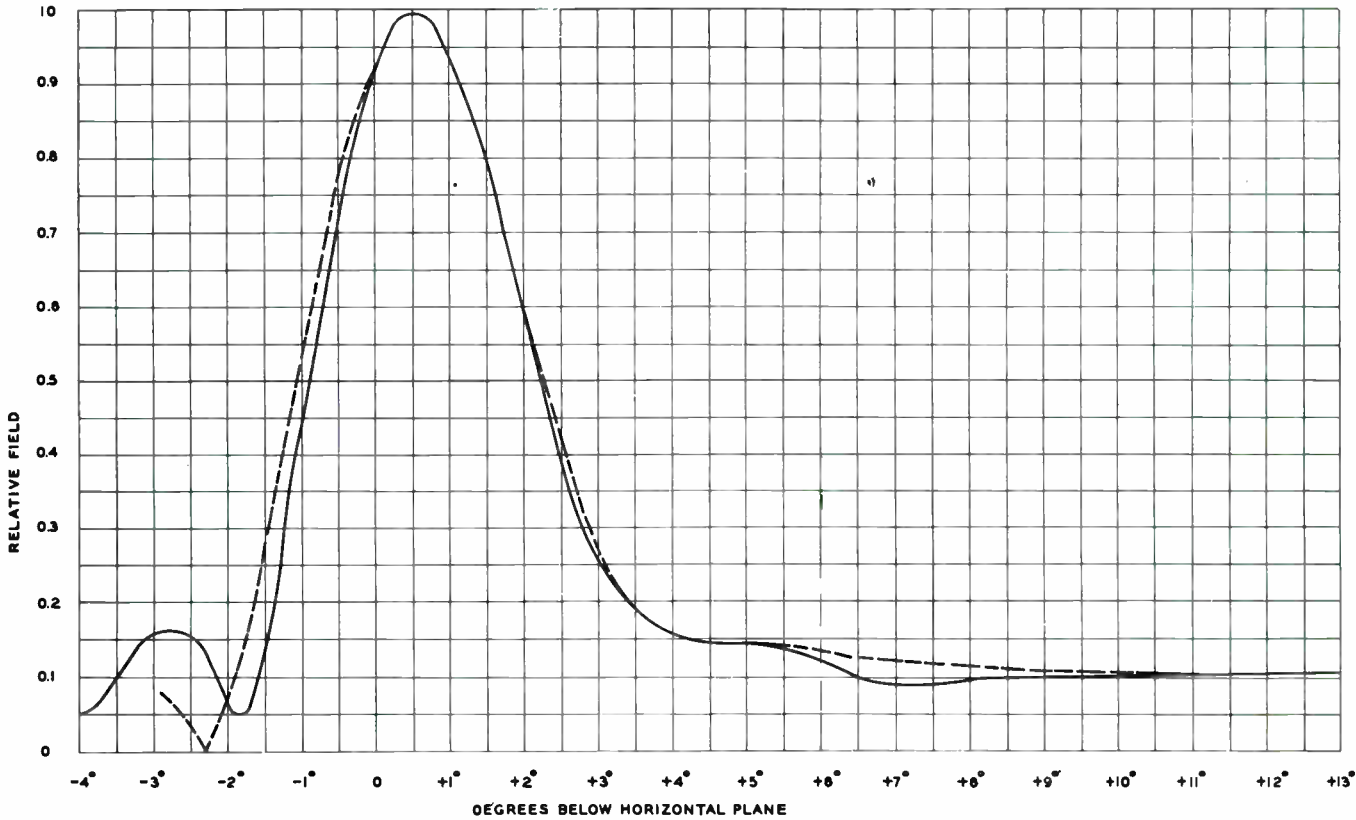

CALCULATED VERTICAL PATTERNS FOR TFU-24DL and TFU-24DM ANTENNAS

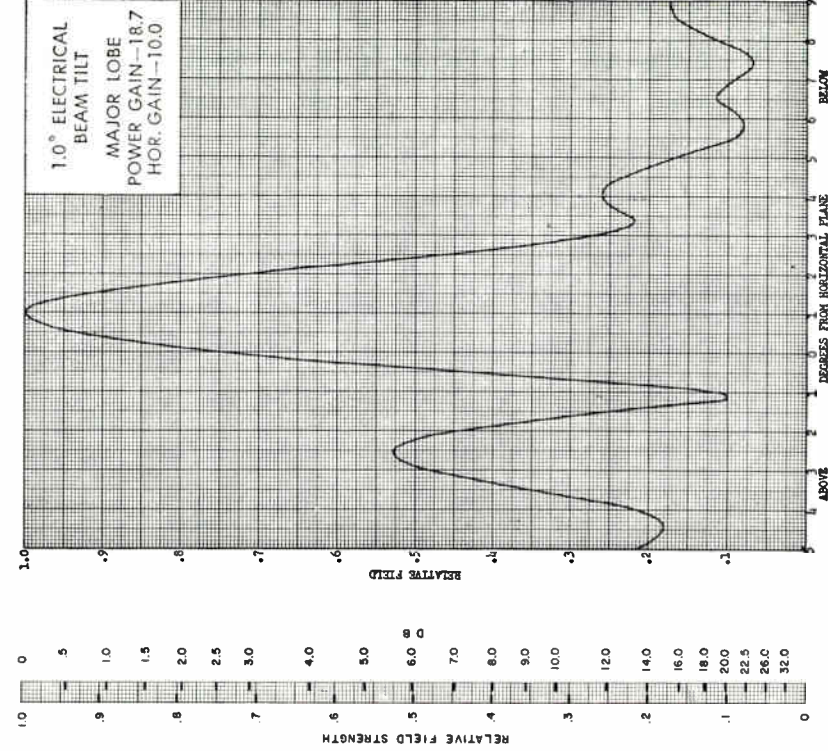
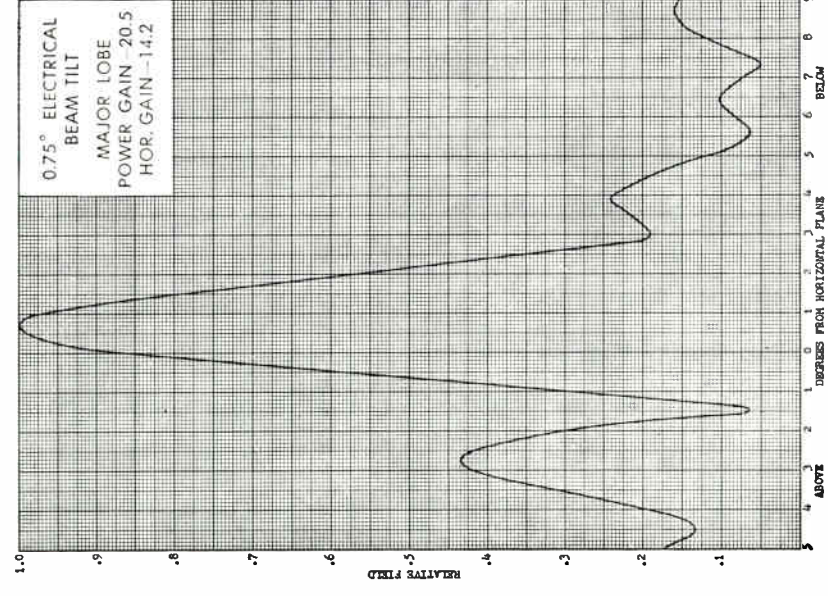
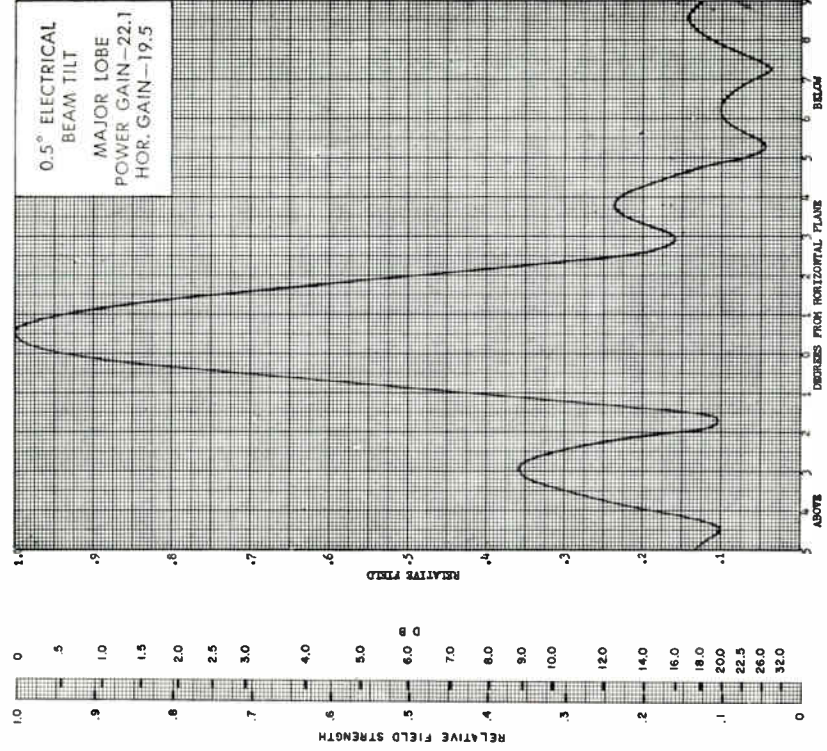
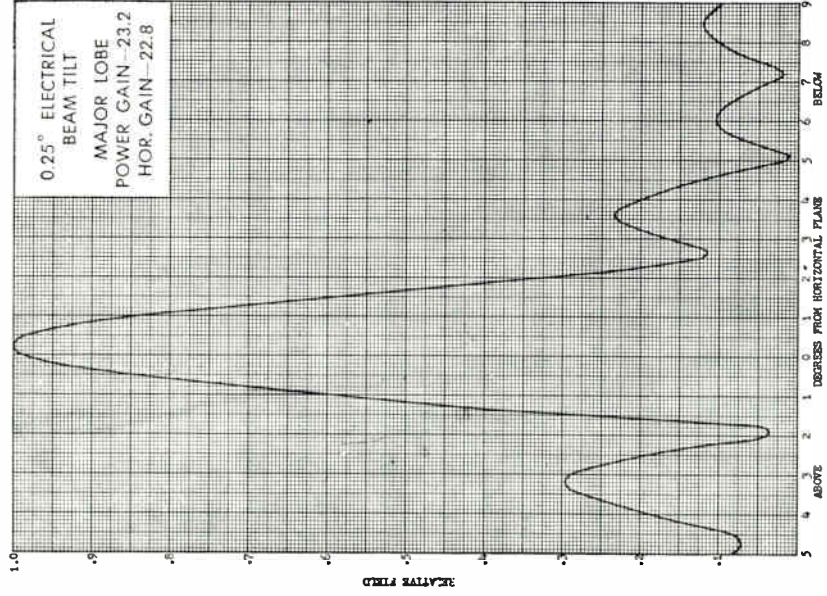

CALCULATED VERTICAL PATTERNS FOR TFU-27DJ ANTENNA

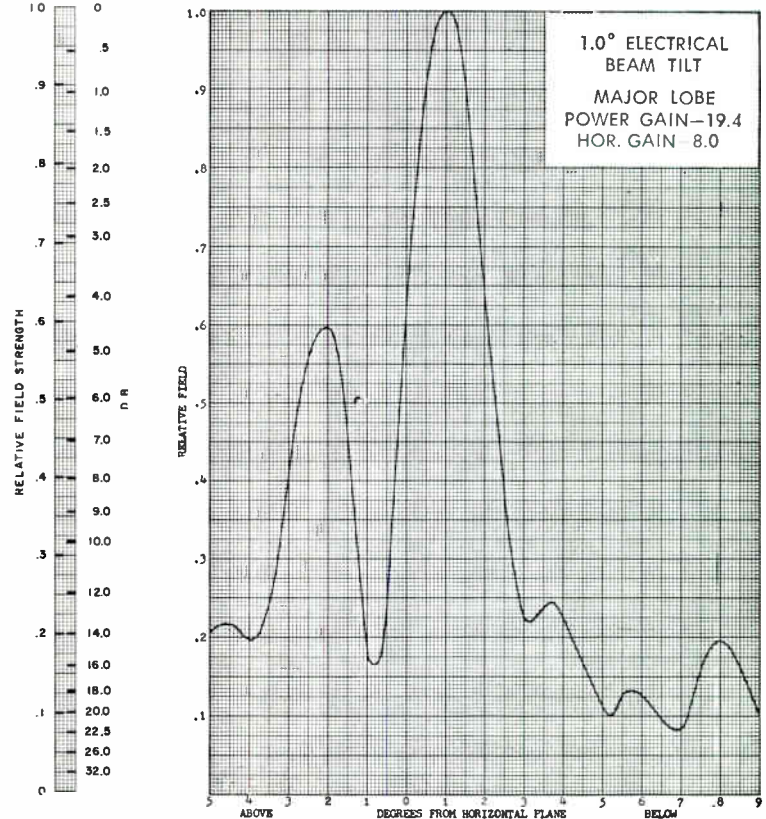
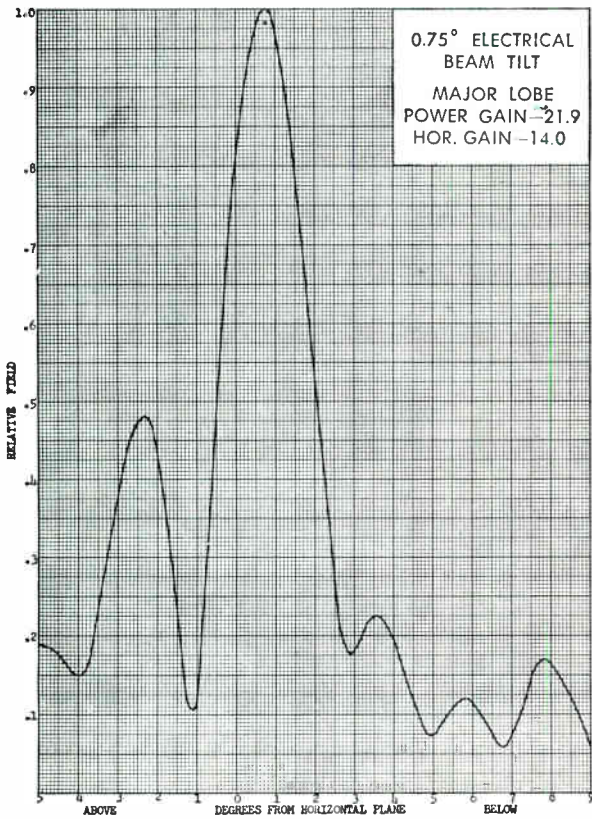
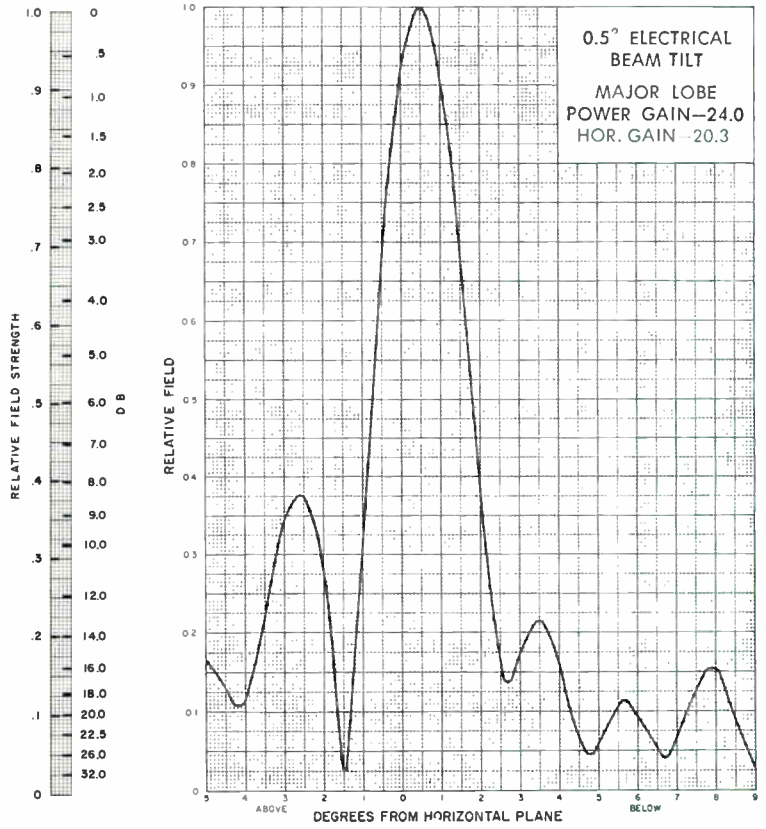
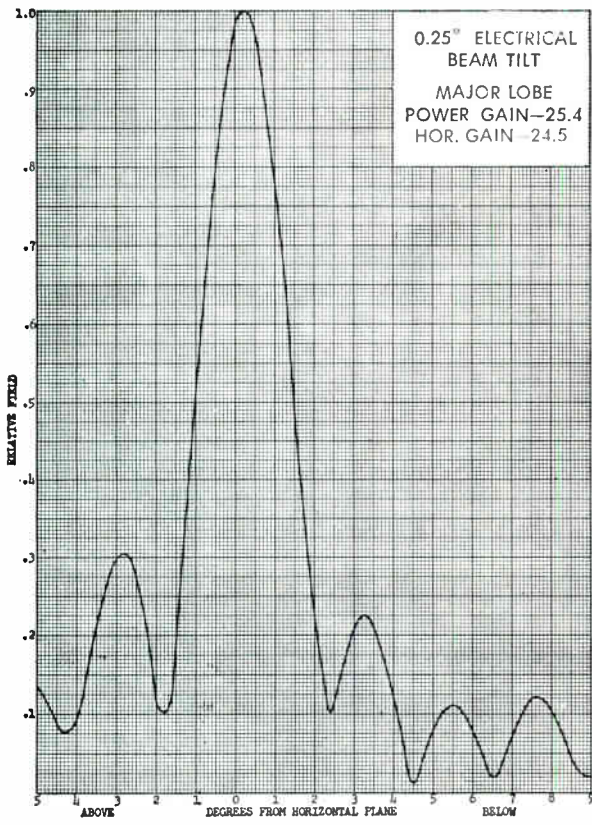

CALCULATED VERTICAL PATTERNS FOR TFU-30J ANTENNA

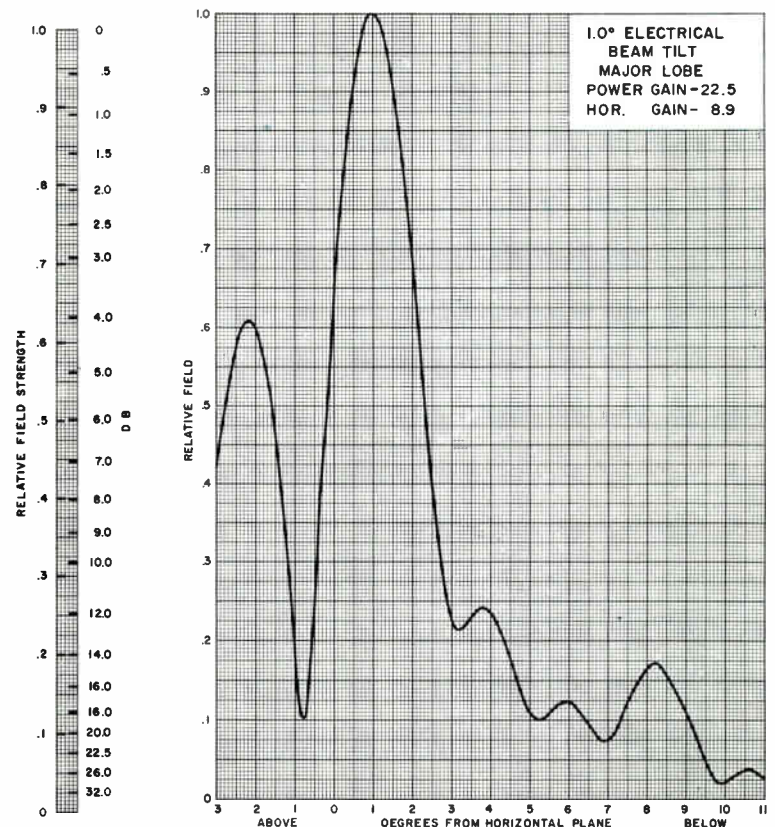
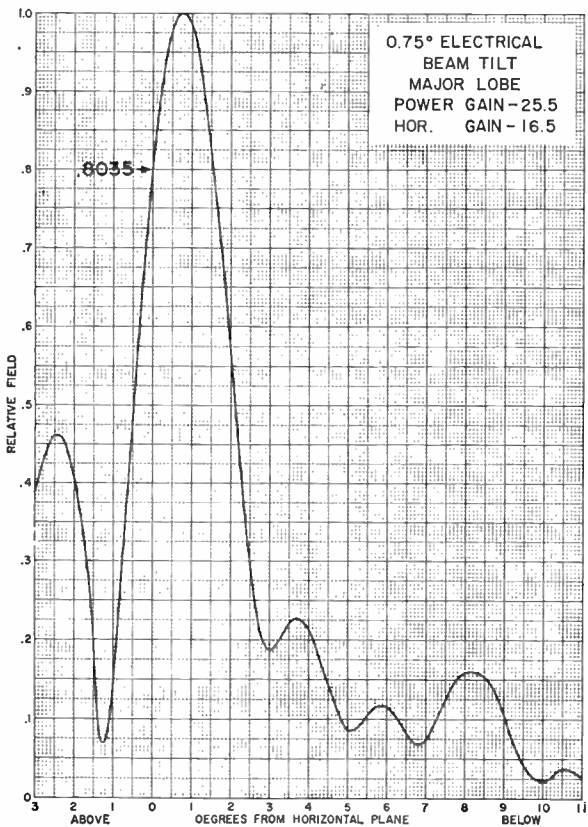
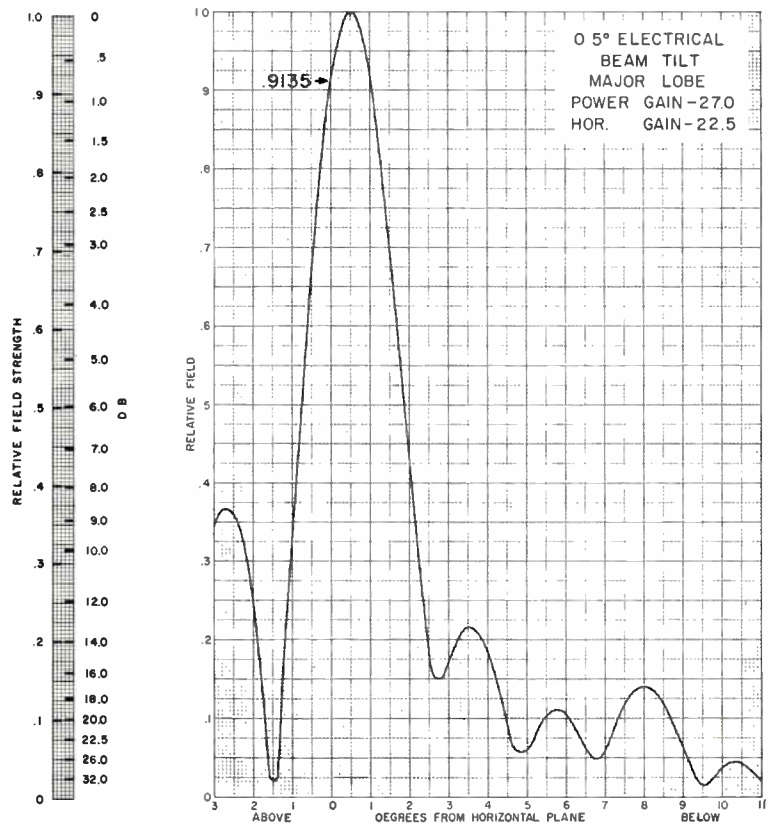
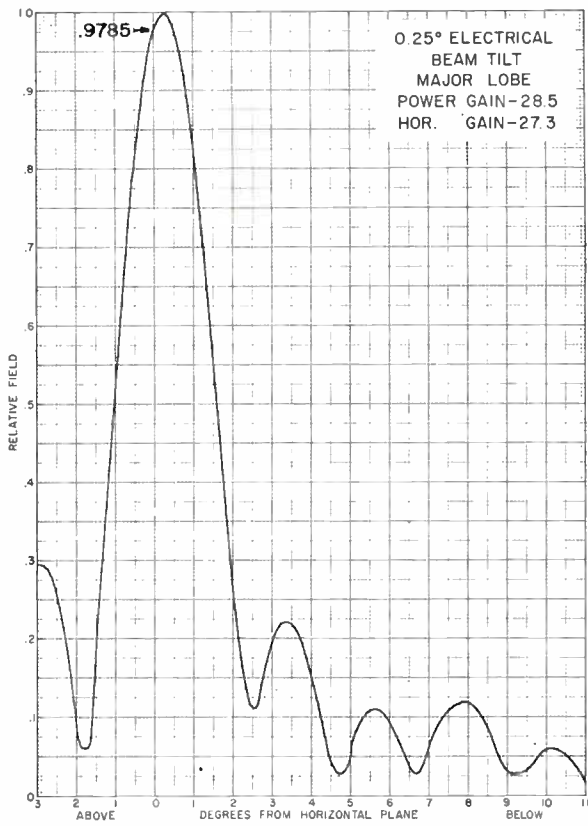

CALCULATED VERTICAL PATTERNS FOR OTHER TFU ANTENNAS

TFU-6J/6C

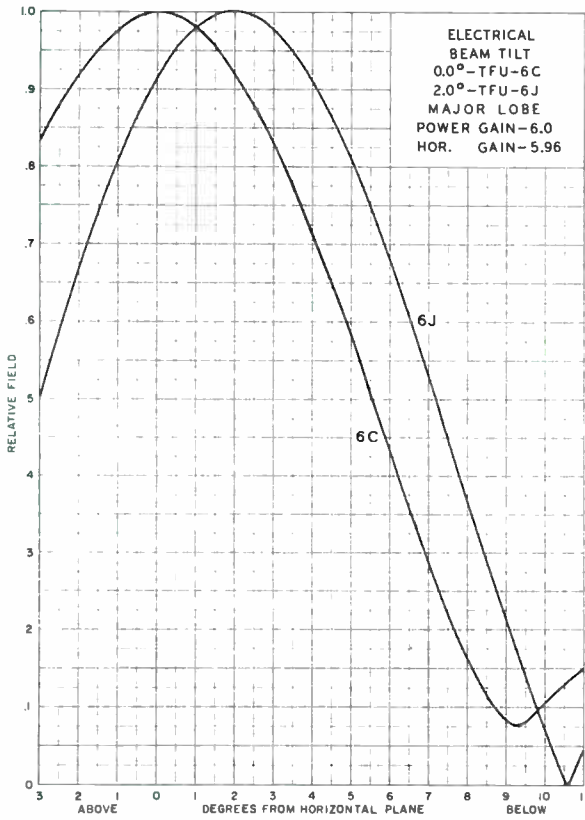

TFU-24DAS

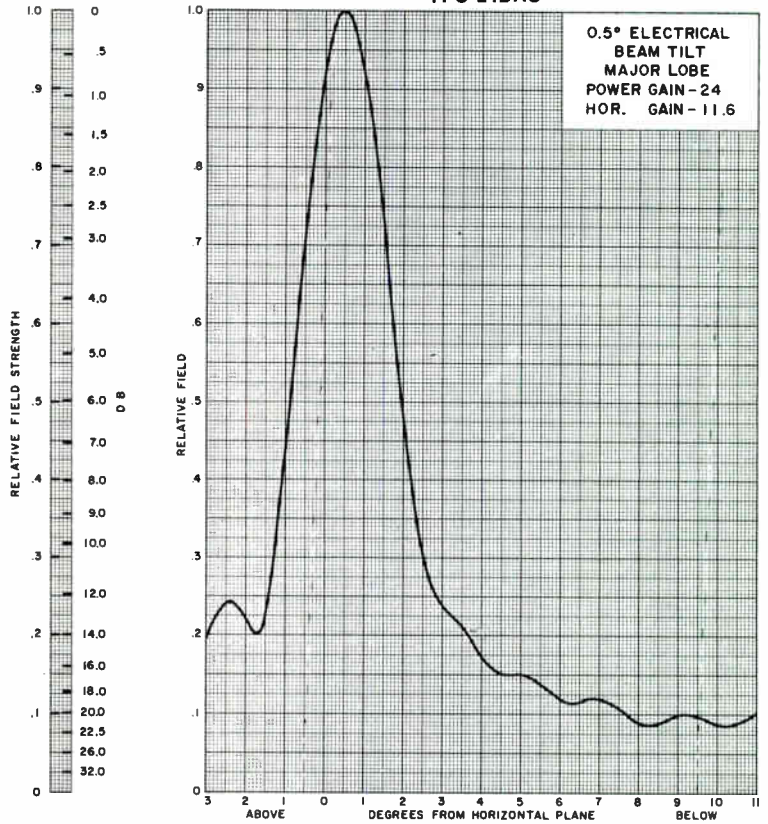

TFU-25G

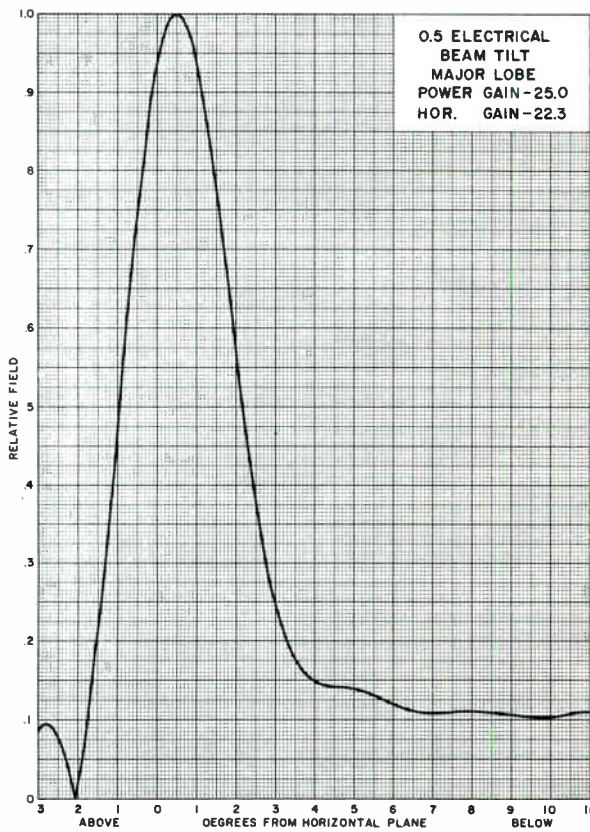

TFU-46K

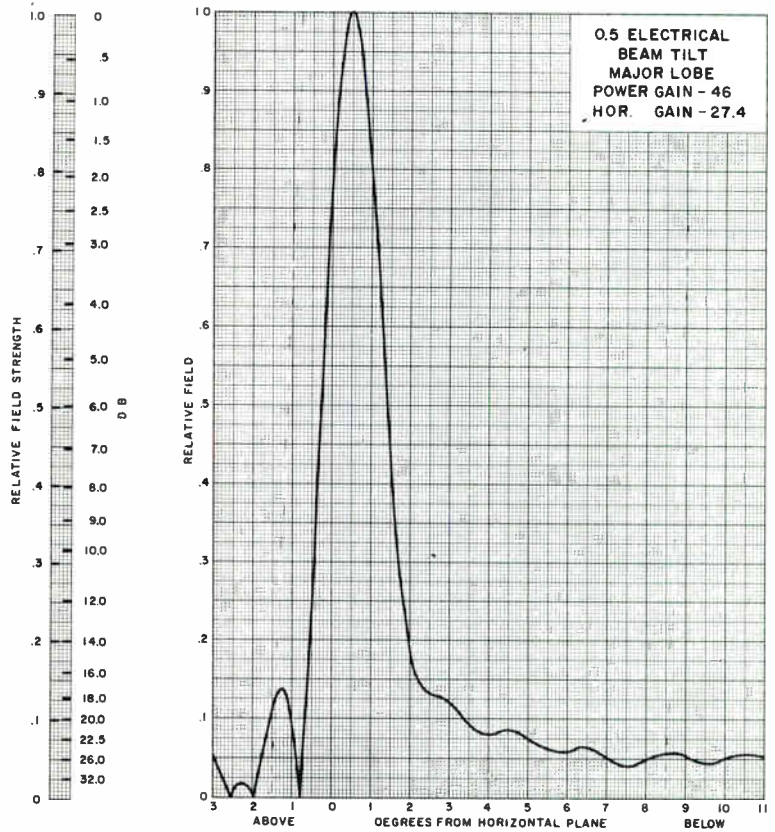

Mechanical Specifications

UHF Pylon mechanical data is provided on the following pages. This data includes constants, outline drawings, and complete antenna dimensions and reactions. A convenient table defining the mechanical symbols used is also included on the facing page.

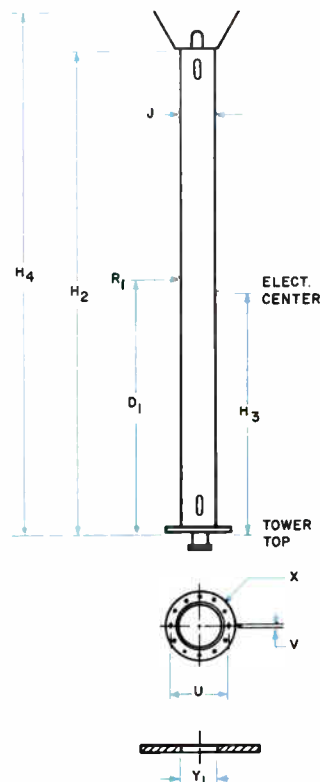

Use this sketch with antennas on this page.

CONSTANTS

TFU-6C	TFU-6J	TFU-24DL	TFU-30J(H)
Channel 14 — 57	Channel 14 — 83	Channel 14 — 30	Channel 51 — 70
$H_3 = 0.5 \times H_2$	$H_3 = 0.5 \times H_2$	$H_3 = 0.5 \times H_2$	$H_3 = 0.5 \times H_2$
$H_4 = H_2 + 2.0$	$H_4 = H_2 + 4.0$	$H_4 = H_2 + 5.2$	$H_4 = H_2 + 4.0$
$l = 50/33$	$l = 50/33$	$l = 50/33$	$l = 50/33$
$J = 6$	$J = 8\frac{5}{8}$	$J = 10\frac{3}{4}$	$J = 10\frac{3}{4}$
$L = H_4$	$L = H_2$	$L = H_2$	$L = H_2$
$N = 1$	$N = 1$	$N = 1$	$N = 1$
$P = \text{Wt.}$	$P = W$	$P = W$	$P = W$
$U = 10$	$U = 13$	$U = 15\frac{1}{4}$	$U = 15\frac{1}{4}$
$V = \frac{1}{2}$	$V = 1.0$	$V = 1\frac{1}{8}$	$V = 1\frac{1}{8}$
$X = 8$	$X = 12$	$X = 16$	$X = 16$
$Y_1 = 5\frac{3}{4}$	$Y_1 = 8$	$Y_1 = 10$	$Y_1 = 10$
TFU-24DM	TFU-27DJ	TFU-30J(L)	TFU-25G
Channel 31 — 50	Channel 31 — 70	Channel 14 — 50	Channel 14 — 70
$H_3 = 0.5 \times H_2$	$H_3 = 0.5 \times H_2$	$H_3 = 0.5 \times H_2$	$H_3 = 0.5 \times H_2$
$H_4 = H_2 + 5.2$	$H_4 = H_2 + 4.0$	$H_4 = H_2 + 4.0$	$H_4 = H_2 + 4.0$
$l = 50/33$	$l = 50/33$	$l = 50/33$	$l = 50/33$
$J = 8\frac{5}{8}$	$J = 6\frac{5}{8}$	$J = 12\frac{3}{4}$	$J = 14$
$L = H_2$	$L = H_2$	$L = H_2$	$L = H_2$
$N = 1$	$N = 1$	$N = 1$	$N = 1$
$P = W$	$P = W$	$P = W$	$P = W$
$U = 13$	$U = 10\frac{5}{8}$	$U = 17\frac{3}{4}$	$U = 20\frac{1}{4}$
$V = 1$	$V = \frac{7}{8}$	$V = 1\frac{1}{4}$	$V = 1\frac{1}{4}$
$X = 12$	$X = 12$	$X = 16$	$X = 20$
$Y_1 = 8$	$Y_1 = 6$	$Y_1 = 12$	$Y_1 = 15\frac{1}{4}$

TFU-46K(L)		TFU-46K(M)		TFU-46K(H)	
Channel 14	40	Channel 41	55	Channel 51	70
$H_3 = 0.5 \times H_2$		$H_3 = 0.5 \times H_2$		$H_3 = 0.5 \times H_2$	
$H_4 = H_2 + 4.0$		$H_4 = H_2 + 4.0$		$H_4 = H_2 + 4.0$	
$l = 50/33$		$l = 50/33$		$l = 50/33$	
$J = 18$		$J = 16$		$J = 14$	
$L = 0.5 \times H_2$		$L = 0.5 \times H_2$		$L = 0.5 \times H_2$	
$N = 2$		$N = 2$		$N = 2$	
$P = 0.5 \times W$		$P = 0.5 \times W$		$P = 0.5 \times W$	
$U = 25\frac{3}{4}$		$U = 23\frac{3}{4}$		$U = 20\frac{3}{4}$	
$V = 1\frac{3}{4}$		$V = 1\frac{3}{4}$		$V = 1\frac{3}{8}$	
$X = 20$		$X = 20$		$X = 20$	
$Y_1 = 18$		$Y_1 = 16\frac{3}{4}$		$Y_1 = 15\frac{1}{4}$	

TFU-24DAS(L)		TFU-24DAS(M)		TFU-24DAS(H)	
Channel 14	30	Channel 31	50	Channel 56	70
$H_3 = 0.5 \times H_2$		$H_3 = 0.5 \times H_2$		$H_3 = 0.5 \times H_2$	
$H_4 = H_2 + 4.0$		$H_4 = H_2 + 4.0$		$H_4 = H_2 + 4.0$	
$l = 50/33$		$l = 50/33$		$l = 50/33$	
$J = 10\frac{3}{4}$		$J = 8\frac{5}{8}$		$J = 6\frac{5}{8}$	
$L = 0.5 \times H_2$		$L = 0.5 \times H_2$		$L = 0.5 \times H_2$	
$N = 2$		$N = 1$		$N = 1$	
$P = 0.5 \times W$		$P = 0.5 \times W$		$P = 0.5 \times W$	
$U = 15\frac{1}{4}$		$U = 13\frac{3}{4}$		$U = 10\frac{5}{8}$	
$V = 1\frac{1}{8}$		$V = 1\frac{1}{8}$		$V = \frac{7}{8}$	
$X = 16$		$X = 12$		$X = 12$	
$Y_1 = 12$		$Y_1 = 9\frac{1}{4}$		$Y_1 = 8\frac{1}{2}$	

Use this sketch with antennas on this page.

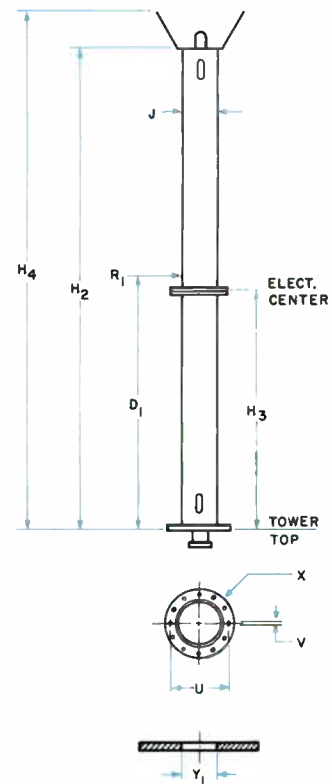

	SYMBOL	UNITS	DEFINITION
DEFINITION OF MECHANICAL SYMBOLS 	D_1	feet	Distance from tower top to center of wind loaded area of antenna
	H_2	feet	Height of pole (only) above tower top
	H_3	feet	Height of Electrical Center above tower top
	H_4	feet	Height of antenna above tower top including lightning protector
	l	psf	Wind pressure for which the antenna is designed
	J	inches	Pole diameter excluding slot covers
	L	feet	Shipping length of longest pole section
	M	Kip-feet	Overturn moment— $R_1 D_1$ (thousands of foot pounds)
	N		Number of sections in which pole is shipped
	P	pounds	Weight of heaviest pole section
	R_1	pounds	Wind reaction at center of wind loaded area
	U	inches	Diameter of bolt circle of base flange
	V	inches	Bolt diameter used in base flange
	W	tons	Weight of complete antenna including inner conductor.
X		Number of equally spaced bolts used in base flange	
Y_1	inches	Clearance hole diameter required in tower top for antenna or feed system	

UHF PYLON ANTENNA DIMENSIONS AND REACTIONS

TYPE TFU-6C UHF TELEVISION ANTENNA

Channel	H ₂	D ₁	R ₁	M (ft. lbs.)	Wt. (lbs.)
14	15.0	7.5	248	1870	110
15	14.9	7.45	245	1825	109
16	14.7	7.35	243	1783	108
17	14.5	7.25	239	1742	106
18	14.4	7.20	238	1700	105
19	14.2	7.10	234	1663	104
20	14.0	7.01	231	1623	103
21	13.9	6.95	229	1590	102
22	13.7	6.85	226	1553	101
23	13.6	6.80	224	1518	100
24	13.4	6.70	222	1486	99
25	13.3	6.64	219	1454	98
26	13.1	6.55	217	1430	97
27	13.0	6.50	215	1394	96
28	12.9	6.44	212	1365	95
29	12.7	6.37	210	1337	94
30	12.6	6.30	208	1310	93
31	12.5	6.24	206	1283	92
32	12.4	6.17	204	1257	92
33	12.2	6.11	202	1232	91
34	12.1	6.05	200	1208	90
35	12.0	6.00	198	1188	90
36	11.9	5.94	196	1163	89
37	11.8	5.88	194	1142	88
38	11.7	5.82	192	1120	87
39	11.6	5.77	190	1100	87
40	11.4	5.72	189	1081	86
41	11.3	5.68	187	1060	85
42	11.2	5.62	185	1042	85
43	11.1	5.57	184	1022	84
44	11.0	5.52	182	1002	84
45	10.9	5.47	181	989	83
46	10.9	5.43	179	972	82
47	10.8	5.38	178	953	82
48	10.7	5.33	176	940	81
49	10.6	5.28	174	922	81
50	10.5	5.25	173	912	80
51	10.4	5.20	172	894	79
52	10.3	5.16	170	880	79
53	10.2	5.12	169	864	78
54	10.2	5.08	168	850	78
55	10.1	5.04	166	837	78
56	10.0	5.00	165	825	77
57	9.9	4.96	164	812	76

TYPE TFU-6J UHF TELEVISION ANTENNA

Channel	H ₂	D ₁	R ₁	M (ft. lbs.)	Wt. (lbs.)
14	16.9	10.3	590	6060	1140
15	16.7	10.2	580	5950	1130
16	16.5	10.1	580	5840	1120
17	16.3	10.1	570	5730	1110
18	16.2	10.0	560	5620	1100
19	16.0	10.0	560	5530	1090
20	15.8	9.9	550	5430	1080
21	15.6	9.8	550	5350	1070
22	15.5	9.8	540	5260	1060
23	15.3	9.6	540	5180	1050

TYPE TFU-6J ANTENNA (Continued)

Channel	H ₂	D ₁	R ₁	M (ft. lbs.)	Wt. (lbs.)
24	15.2	9.5	540	5100	1040
25	15.0	9.5	530	5010	1030
26	14.9	9.3	530	4930	1020
27	14.7	9.3	520	4850	1010
28	14.6	9.2	520	4770	1000
29	14.4	9.1	520	4700	990
30	14.3	9.0	510	4630	980
31	14.2	9.0	510	4560	970
32	14.0	8.9	510	4500	970
33	13.9	8.9	500	4480	960
34	13.8	8.8	500	4370	950
35	13.7	8.7	500	4320	950
36	13.6	8.7	490	4260	940
37	13.5	8.6	490	4200	930
38	13.4	8.5	490	4150	930
39	13.2	8.5	480	4100	920
40	13.1	8.4	480	4050	910
41	13.0	8.4	480	3990	910
42	12.9	8.4	470	3940	900
43	12.8	8.3	470	3890	890
44	12.7	8.2	470	3840	890
45	12.6	8.2	460	3800	880
46	12.5	8.2	460	3750	880
47	12.4	8.1	460	3710	870
48	12.3	8.0	460	3670	860
49	12.2	8.0	450	3620	860
50	12.1	7.9	450	3570	850
51	12.0	7.9	450	3540	850
52	11.9	7.8	450	3500	840
53	11.8	7.8	440	3460	840
54	11.7	7.7	440	3420	830
55	11.6	7.7	440	3380	820
56	11.5	7.6	440	3340	820
57	11.4	7.6	430	3300	810
58	11.3	7.6	430	3260	810
59	11.3	7.5	430	3220	800
60	11.2	7.5	430	3180	790
61	11.1	7.5	420	3150	790
62	11.0	7.4	420	3120	780
63	10.9	7.4	420	3080	780
64	10.8	7.3	420	3050	770
65	10.8	7.3	410	3020	770
66	10.7	7.3	410	2980	760
67	10.6	7.2	410	2950	760
68	10.5	7.2	410	2920	760
69	10.5	7.1	400	2890	750
70	10.4	7.1	400	2850	750
71	10.3	7.1	400	2830	750
72	10.3	7.0	400	2800	740
73	10.2	7.0	400	2780	740
74	10.2	7.0	400	2750	740
75	10.1	7.0	390	2730	730
76	10.0	7.0	390	2700	720
77	10.0	6.9	390	2680	720
78	9.9	6.9	390	2660	720
79	9.9	6.9	390	2640	710
80	9.8	6.8	390	2620	710
81	9.8	6.8	380	2600	710
82	9.7	6.8	380	2580	700
83	9.7	6.8	380	2570	700

UHF PYLON ANTENNA DIMENSIONS AND REACTIONS

TYPE TFU-24DL UHF TELEVISION ANTENNA

Channel	H ₂	D ₁	R ₁	M	W
14	53.1	28.3	1900	53.7	1.6
15	52.4	28.0	1880	52.5	1.6
16	51.8	27.6	1860	51.4	1.6
17	51.4	27.4	1840	50.3	1.6
18	50.8	27.0	1830	49.3	1.6
19	49.9	26.7	1810	48.3	1.6
20	49.6	26.4	1790	47.3	1.5
21	49.1	26.2	1770	46.3	1.5
22	48.4	25.9	1750	45.4	1.5
23	47.8	25.6	1740	44.5	1.5
24	47.3	25.5	1720	43.8	1.5
25	46.9	25.1	1700	42.6	1.5
26	46.3	24.9	1680	41.8	1.4
27	45.8	24.5	1670	40.9	1.4
28	45.3	24.2	1650	40.0	1.4
29	45.0	24.0	1630	39.2	1.4
30	44.4	23.8	1610	38.4	1.4

TYPE TFU-24DM UHF TELEVISION ANTENNA

Channel	H ₂	D ₁	R ₁	M	W
31	43.3	23.7	1320	31.3	1.3
32	43.0	23.5	1310	30.8	1.3
33	42.8	23.2	1300	30.2	1.3
34	42.1	22.9	1290	29.5	1.3
35	41.8	22.6	1280	29.0	1.3
36	41.6	22.4	1270	28.5	1.3
37	40.9	22.2	1260	28.0	1.2
38	40.6	21.9	1250	27.4	1.2
39	40.3	21.7	1240	26.9	1.2
40	39.9	21.5	1230	26.4	1.2
41	39.6	21.2	1220	25.9	1.2
42	39.3	21.0	1210	25.5	1.2
43	38.8	20.9	1200	25.1	1.2
44	38.7	20.8	1190	24.8	1.2
45	38.3	20.7	1180	24.4	1.2
46	38.0	20.5	1170	24.0	1.2
47	37.7	20.5	1160	23.8	1.1
48	37.3	20.3	1160	23.5	1.1
49	37.1	20.3	1150	23.3	1.1
50	36.8	20.3	1140	23.1	1.1

TYPE TFU-27DJ UHF TELEVISION ANTENNA

Channel	H ₂	D ₁	R ₁	M	W
31	46.5	25.2	1410	35.6	1.4
32	46.0	25.0	1400	35.0	1.4
33	45.5	24.7	1390	34.4	1.4
34	45.0	24.4	1380	33.7	1.4
35	44.6	24.3	1360	33.1	1.4
36	44.2	24.1	1350	32.5	1.4
37	43.8	23.9	1340	32.0	1.4
38	43.3	23.7	1330	31.5	1.4
39	42.9	23.6	1310	30.9	1.4
40	42.5	23.2	1300	30.2	1.3
41	42.1	23.1	1290	29.8	1.3
42	41.7	23.0	1280	29.4	1.3
43	41.3	22.8	1270	28.9	1.3
44	41.0	22.6	1260	28.5	1.3
45	40.7	22.4	1250	28.0	1.3
46	40.3	22.2	1240	27.5	1.3
47	40.0	21.9	1230	27.0	1.3
48	39.7	21.8	1220	26.6	1.3
49	39.3	21.7	1210	26.2	1.2
50	39.0	21.5	1200	25.8	1.2

Channel	H ₂	D ₁	R ₁	M	W
51	38.5	21.3	1190	25.3	1.2
52	38.3	21.2	1180	25.0	1.2
53	38.0	20.9	1170	24.5	1.2
54	37.7	20.7	1160	24.0	1.2
55	37.4	20.5	1150	23.6	1.2
56	37.0	20.2	1150	23.2	1.2
57	36.8	20.0	1140	22.8	1.2
58	36.5	19.9	1130	22.5	1.2
59	36.2	19.8	1120	22.1	1.1
60	35.9	19.7	1110	21.7	1.1
61	35.7	19.4	1100	21.4	1.1
62	35.4	19.1	1100	21.0	1.1
63	35.1	19.1	1090	20.8	1.1
64	34.8	19.0	1080	20.5	1.1
65	34.6	18.7	1080	20.2	1.1
66	34.3	18.7	1070	20.0	1.1
67	34.0	18.6	1060	19.8	1.1
68	33.8	18.6	1060	19.6	1.1
69	33.5	18.5	1050	19.5	1.1
70	33.3	18.5	1040	19.4	1.1

UHF PYLON ANTENNA DIMENSIONS AND REACTIONS

TYPE TFU-30J UHF TELEVISION ANTENNA

0° — 0.75° Beam Tilt

Channel	H ₂	D ₁	R ₁	M	W
14	56.2	29.6	2390	70.6	3.4
15	55.5	29.2	2360	69.0	3.4
16	54.8	28.9	2330	67.4	3.4
17	54.2	28.5	2310	65.9	3.3
18	53.5	28.2	2280	64.4	3.3
19	52.8	27.9	2260	63.0	3.2
20	52.3	27.6	2230	61.6	3.2
21	51.7	27.3	2210	60.3	3.2
22	51.1	26.9	2190	59.0	3.1
23	50.5	26.7	2160	57.7	3.1
24	50.0	26.5	2140	56.6	3.1
25	49.5	26.1	2120	55.4	3.0
26	49.0	25.8	2100	54.2	3.0
27	48.5	25.6	2080	53.1	3.0
28	48.0	25.4	2060	52.4	2.9
29	47.5	25.1	2040	51.2	2.9
30	47.0	24.9	2020	50.3	2.9
31	46.5	24.6	2000	49.3	2.9
32	46.0	24.4	1980	48.4	2.8
33	45.5	24.2	1960	47.5	2.8
34	45.0	24.0	1940	46.5	2.8
35	44.6	23.8	1920	45.7	2.8
36	44.2	23.5	1910	44.8	2.7
37	43.8	23.2	1890	43.9	2.7
38	43.3	23.0	1870	43.0	2.7
39	42.9	22.8	1860	42.4	2.7
40	42.5	22.6	1840	41.6	2.6
41	42.1	22.3	1830	40.8	2.6
42	41.7	22.1	1810	40.0	2.6
43	41.3	21.9	1800	39.4	2.6
44	41.0	21.7	1780	38.7	2.6
45	40.7	21.5	1770	38.0	2.5
46	40.3	21.4	1750	37.5	2.5
47	40.0	21.4	1740	37.2	2.5
48	39.7	21.1	1720	36.3	2.5
49	39.3	20.9	1710	35.7	2.4
50	39.2	20.8	1710	35.5	2.4
51	39.0	20.7	1700	35.2	2.4
52	38.5	20.8	1490	31.0	1.3
53	38.3	20.7	1470	30.5	1.3
54	38.0	20.5	1460	29.9	1.3
55	37.7	20.4	1440	29.4	1.3
56	37.4	20.3	1430	29.0	1.3
57	37.0	20.1	1420	28.5	1.3
58	36.8	20.0	1400	28.0	1.3
59	36.5	19.9	1390	27.7	1.3
60	36.2	19.7	1380	27.2	1.3
61	35.9	19.6	1370	26.8	1.2
62	35.7	19.4	1360	26.4	1.2
63	35.4	19.3	1350	26.0	1.2
64	35.1	19.2	1340	25.7	1.2
65	34.8	19.0	1330	25.3	1.2
66	34.6	18.9	1320	25.0	1.2
67	34.3	18.8	1310	24.7	1.2
68	34.0	18.6	1310	24.3	1.2
69	33.8	18.5	1300	24.0	1.2
70	33.5	18.4	1290	23.7	1.2

TYPE TFU-30J UHF TELEVISION ANTENNA

1° Beam Tilt

Channel	H ₂	D ₁	R ₁	M	W
14	57.3	30.2	2430	73.4	3.5
15	56.6	29.8	2410	71.8	3.4
16	55.9	29.5	2380	70.2	3.4
17	55.3	29.1	2350	68.5	3.4
18	54.6	28.9	2320	67.0	3.3
19	53.9	28.4	2300	65.4	3.3
20	53.3	28.1	2270	63.9	3.2
21	52.8	27.7	2250	62.4	3.2
22	52.2	27.5	2220	61.0	3.2
23	51.6	27.1	2200	59.6	3.1
24	51.0	26.9	2170	58.3	3.1
25	50.5	26.6	2150	57.1	3.1
26	49.9	26.3	2130	56.0	3.0
27	49.3	26.1	2110	55.0	3.0
28	48.8	25.8	2090	53.9	3.0
29	48.3	25.5	2070	52.8	2.9
30	47.8	25.4	2050	52.0	2.9
31	47.3	25.1	2030	51.0	2.9
32	46.8	24.9	2010	50.0	2.9
33	46.4	24.7	1990	49.1	2.8
34	46.0	24.5	1970	48.3	2.8
35	45.5	24.2	1960	47.5	2.8
36	45.0	24.0	1940	46.6	2.7
37	44.6	23.8	1920	45.7	2.7
38	44.2	23.7	1900	45.0	2.7
39	43.8	23.4	1890	44.1	2.7
40	43.3	23.1	1870	43.2	2.6
41	42.9	23.0	1850	42.6	2.6
42	42.5	22.7	1840	41.8	2.6
43	42.1	22.6	1820	41.1	2.6
44	41.7	22.3	1810	40.4	2.6
45	41.3	22.2	1800	39.7	2.5
46	41.0	21.9	1780	39.0	2.5
47	40.6	21.8	1760	38.4	2.5
48	40.3	21.6	1750	37.8	2.5
49	40.0	21.5	1730	37.2	2.5
50	39.7	21.3	1720	36.7	2.4
51	39.2	21.2	1480	31.4	1.4
52	38.9	21.1	1470	31.0	1.3
53	38.6	20.9	1460	30.5	1.3
54	38.3	20.7	1450	30.1	1.3
55	37.9	20.5	1440	29.6	1.3
56	37.6	20.4	1430	29.1	1.3
57	37.3	20.2	1420	28.7	1.3
58	37.0	20.1	1410	28.4	1.3
59	36.7	19.9	1400	27.9	1.3
60	36.4	19.8	1390	27.5	1.3
61	36.2	19.7	1380	27.1	1.3
62	35.9	19.6	1370	26.8	1.2
63	35.6	19.4	1360	26.3	1.2
64	35.3	19.3	1350	26.0	1.2
65	35.1	19.1	1340	25.6	1.2
66	34.8	19.1	1330	25.4	1.2
67	34.6	18.9	1320	25.0	1.2
68	34.3	18.9	1310	24.7	1.2
69	34.1	18.7	1300	24.3	1.2
70	33.8	18.7	1290	24.1	1.2

UHF PYLON ANTENNA DIMENSIONS AND REACTIONS

TYPE TFU-25G UHF TELEVISION ANTENNA

TYPE TFU-46K UHF TELEVISION ANTENNA

Channel	H ₂	D ₁	R ₁	M	W
14	69.1	35.9	3040	109.1	3.8
15	68.2	35.5	3010	106.9	3.7
16	67.5	35.2	2970	104.5	3.7
17	66.7	34.9	2940	102.3	3.6
18	65.9	34.4	2910	100.0	3.6
19	65.2	34.0	2880	97.9	3.5
20	64.3	33.7	2840	95.7	3.5
21	63.5	33.2	2810	93.4	3.5
22	62.8	33.0	2780	91.6	3.4
23	62.0	32.5	2760	89.7	3.4
24	61.3	32.1	2730	87.8	3.4
25	60.6	31.8	2700	85.9	3.3
26	59.9	31.5	2670	84.0	3.3
27	59.3	31.0	2640	82.0	3.2
28	58.7	30.7	2610	80.1	3.2
29	58.0	30.4	2580	78.5	3.2
30	57.4	30.1	2560	77.0	3.1
31	56.8	29.7	2530	75.2	3.1
32	56.3	29.5	2500	73.9	3.1
33	55.7	29.1	2480	72.2	3.0
34	55.1	28.8	2460	70.9	3.0
35	54.6	28.6	2430	69.5	3.0
36	54.0	28.3	2410	68.3	3.0
37	53.5	28.2	2380	67.2	2.9
38	53.0	28.0	2360	66.0	2.9
39	52.5	27.7	2340	64.8	2.9
40	52.0	27.4	2320	63.7	2.9
41	51.5	27.2	2300	62.5	2.8
42	51.0	26.9	2280	61.4	2.8
43	50.5	26.6	2260	60.2	2.8
44	50.0	26.4	2240	59.2	2.8
45	49.6	26.2	2220	58.1	2.7
46	49.2	25.9	2200	57.0	2.7
47	48.8	25.7	2180	56.0	2.7
48	48.3	25.5	2160	55.1	2.7
49	47.8	25.3	2140	54.2	2.6
50	47.4	25.0	2130	53.3	2.6
51	47.0	24.9	2110	52.5	2.6
52	46.6	24.6	2090	51.5	2.6
53	46.3	24.4	2080	50.7	2.5
54	45.8	24.2	2060	50.0	2.5
55	45.5	24.0	2050	49.2	2.5
56	45.1	23.8	2030	48.4	2.5
57	44.8	23.6	2020	47.7	2.2
58	44.4	23.5	2000	47.0	2.2
59	44.0	23.2	1990	46.2	2.2
60	43.7	23.0	1980	45.5	2.2
61	43.3	22.9	1960	45.0	2.2
62	43.0	22.7	1950	44.3	2.2
63	42.7	22.6	1930	43.6	2.1
64	42.3	22.4	1920	43.0	2.1
65	42.0	22.2	1910	42.4	2.1
66	41.8	22.1	1890	41.8	2.1
67	41.5	22.0	1880	41.3	2.1
68	41.2	21.9	1860	40.7	2.1
69	40.9	21.7	1850	40.2	2.1
70	40.6	21.6	1840	39.7	2.0

Channel	H ₂	D ₁	R ₁	M	W
14	123.4	62.7	6760	424	14.6
15	121.8	62.0	6670	414	14.4
16	120.3	61.4	6580	403	14.2
17	118.9	60.4	6510	393	14.0
18	117.5	59.9	6430	385	13.8
19	116.2	59.0	6360	375	13.6
20	114.8	58.5	6280	367	13.5
21	113.6	57.6	6220	358	13.3
22	112.8	57.0	6150	350	13.1
23	111.2	56.4	6080	343	13.0
24	110.0	55.7	6020	335	12.8
25	108.8	55.1	5950	328	12.7
26	107.6	54.5	5890	321	12.5
27	106.4	53.9	5830	314	12.3
28	105.2	53.4	5770	308	12.2
29	104.1	52.9	5710	302	12.0
30	102.8	52.5	5640	296	11.9
31	101.8	52.0	5580	290	11.8
32	100.8	51.6	5530	285	11.6
33	99.7	51.1	5480	280	11.5
34	98.6	50.6	5420	274	11.4
35	97.6	50.1	5370	269	11.3
36	96.6	49.6	5320	264	11.2
37	95.7	49.0	5270	258	11.1
38	94.8	48.5	5220	253	11.0
39	93.8	48.0	5170	248	10.9
40	93.0	47.5	5110	243	10.8
41	92.9	47.6	4580	218	10.3
42	92.1	47.2	4540	214	10.3
43	91.3	46.7	4500	210	10.2
44	90.5	46.3	4470	207	10.1
45	89.6	46.0	4430	204	10.0
46	88.9	45.6	4390	200	9.9
47	88.1	45.2	4360	197	9.8
48	87.2	44.9	4320	194	9.7
49	86.5	44.4	4280	190	9.7
50	85.7	44.0	4240	187	9.6
51	85.0	43.7	4210	184	9.5
52	84.2	43.4	4170	181	9.4
53	83.5	43.1	4140	178	9.3
54	82.8	42.9	4100	176	9.3
55	82.2	42.5	4070	173	9.2
56	81.3	42.0	3570	150	7.7
57	80.7	41.8	3540	148	7.6
58	80.1	41.6	3510	146	7.6
59	79.4	41.0	3490	143	7.5
60	78.8	40.8	3460	141	7.5
61	78.2	40.6	3430	139	7.4
62	77.5	40.3	3400	137	7.4
63	76.9	40.0	3380	135	7.3
64	76.3	39.7	3350	133	7.3
65	75.7	39.4	3330	131	7.2
66	75.1	39.0	3310	129	7.2
67	74.6	38.7	3280	127	7.1
68	74.0	38.4	3250	125	7.1
69	73.5	38.1	3230	123	7.0
70	72.9	38.0	3210	122	7.0

UHF PYLON ANTENNA DIMENSIONS AND REACTIONS
TYPE TFU-24DAS UHF TELEVISION ANTENNA

Channel	H ₂	D ₁	R ₁	M	W
14	63.6	33.6	2170	72.8	4.1
15	62.8	33.2	2150	71.3	4.0
16	62.1	32.9	2120	69.8	4.0
17	61.4	32.5	2090	68.0	3.9
18	60.6	32.1	2070	66.5	3.9
19	59.8	31.8	2040	65.0	3.9
20	59.1	31.4	2020	63.4	3.8
21	58.4	31.0	2000	62.0	3.8
22	57.7	30.7	1980	60.7	3.7
23	57.1	30.5	1950	59.4	3.7
24	56.5	30.2	1930	58.2	3.6
25	55.8	30.0	1910	57.3	3.6
26	55.2	29.5	1890	55.6	3.6
27	54.6	29.1	1870	54.5	3.5
28	54.0	28.8	1860	53.5	3.5
29	53.4	28.5	1840	52.4	3.5
30	52.9	28.2	1820	51.4	3.4
31	52.3	28.3	1490	42.2	2.3
32	51.7	28.0	1480	41.5	2.3
33	51.2	27.7	1470	40.7	2.2
34	50.6	27.6	1450	40.0	2.2
35	50.1	27.3	1440	39.3	2.2
36	49.6	26.9	1430	38.5	2.2
37	49.2	26.6	1420	37.8	2.2
38	48.7	26.5	1400	37.1	2.1
39	48.3	26.3	1390	36.5	2.1
40	47.8	25.9	1380	35.8	2.1
41	47.3	25.7	1370	35.2	2.1
42	46.9	25.4	1360	34.5	2.1
43	46.5	25.2	1350	34.0	2.0
44	46.0	24.9	1340	33.4	2.0
45	45.6	24.8	1320	32.8	2.0
46	45.2	24.7	1310	32.3	2.0
47	44.8	24.5	1300	31.8	2.0
48	44.4	24.3	1290	31.3	2.0
49	44.0	24.1	1280	30.8	1.9
50	43.7	23.8	1270	30.3	1.9
51	43.3	24.2	1020	24.7	1.1
52	42.9	24.0	1010	24.3	1.1
53	42.5	23.7	1010	23.9	1.1
54	42.1	23.5	1000	23.5	1.1
55	41.8	23.4	990	23.2	1.1
56	41.5	23.0	990	22.8	1.1
57	41.2	23.0	980	22.5	1.1
58	40.9	22.9	970	22.2	1.1
59	40.6	22.6	970	21.9	1.1
60	40.3	22.6	960	21.7	1.0
61	40.0	22.2	960	21.3	1.0
62	39.6	22.1	950	21.0	1.0
63	39.3	22.1	940	20.8	1.0
64	39.0	21.8	940	20.5	1.0
65	38.7	21.7	930	20.2	1.0
66	38.4	21.4	930	19.9	1.0
67	38.1	21.3	920	19.6	1.0
68	37.8	21.3	910	19.4	1.0
69	37.5	21.1	910	19.2	1.0
70	37.3	21.1	900	19.0	1.0



- Meets UHF omnidirectional or directional requirements—Vertical and horizontal patterns may be “sculptured”
- End loading for VSWR stability
- Simple construction—Rugged design
- Stackable for various gains around or on top of towers
- Radome supplied with each antenna—No electrical deicing required
- Grounded radiator provides additional lightning protection

Vee-Zee and Zee Panel Type UHF Antennas

Description

The RCA “Vee-Zee” and “Zee” Panel Type UHF Antennas are designed especially to meet requirements in the UHF range for either an omnidirectional or directional antenna which can be stacked around a tower, the top of which is used to support antennas for other services. They are also useful as a top-mounted directional antenna where it is desirable to closely control or “sculpture” vertical and horizontal patterns. Either type antenna is therefore, a useful supplement to the standard RCA Pylons that have proved ideal for both omnidirectional and certain types of direc-

tional patterns in top-mounted applications.

With each element complete and electrically independent in itself, a great flexibility in application is achieved through a building block approach. Almost any desired antenna pattern can be achieved by the proper placement of one antenna panel relative to other panels, and by varying the relative power input and phase of signal. The large aperture of each element, fed from a single end seal, strikes a balance between the mechanical complexity of many feedpoints and a lack of

flexibility in pattern shaping resulting from too few feedpoints.

Radiating Elements

The new UHF antennas employ two types of radiating elements—the “Zee” Panel and the “Vee-Zee”. The “Zee” antenna comprises zig-zag radiating elements branching two ways from a central feed-point along a flat reflecting plane. The “Vee-Zee” has the same configuration except that both the elements and the reflecting panel are bent along a central longitudinal line to form a forward opening “Vee”. (See Fig. 1).

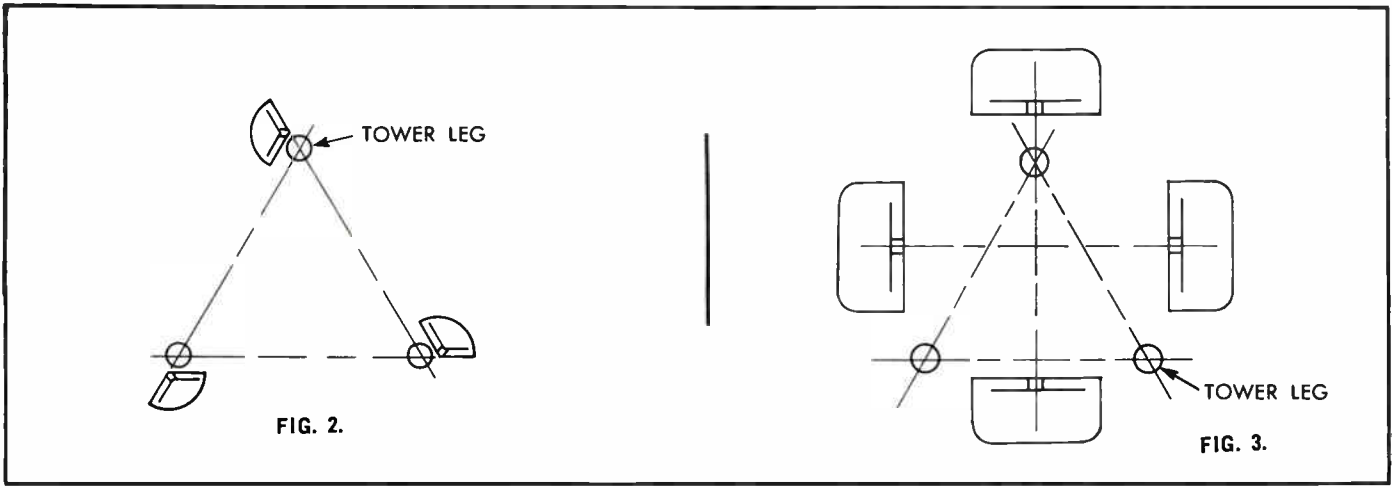

FIG. 2.

FIG. 3.

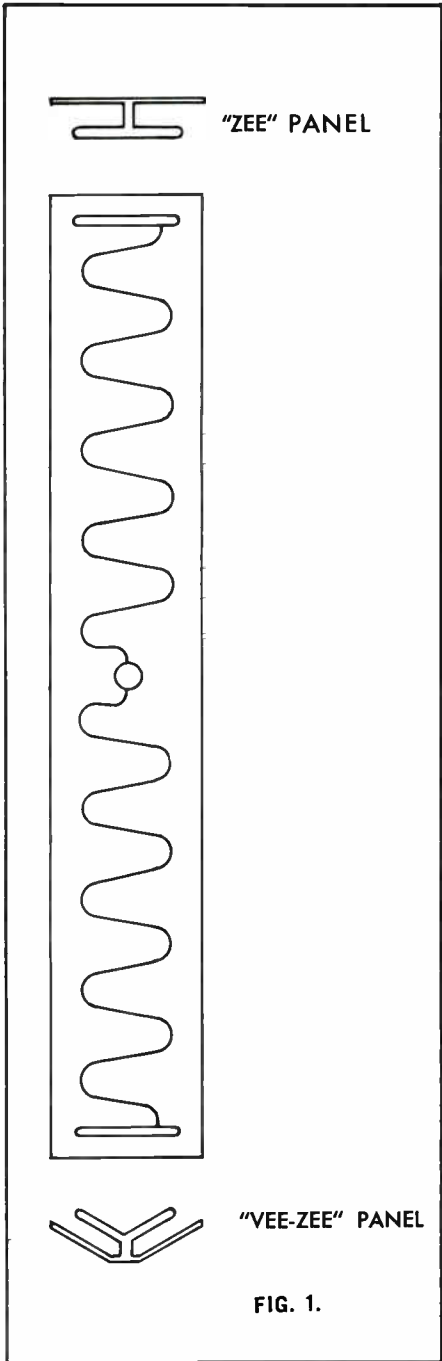

FIG. 1.

The basic radiator operates on the proven traveling wave principle. To assure that the RCA panel antenna rigorously conforms to this principle, a unique "end loading" design is incorporated, one at each end of the radiating elements.

This strict adherence to the traveling wave principle provides inherent VSWR stability.

While both types of radiating elements are identical in electrical concept, their physical shapes offers advantages for particular requirements. Thus, where several services are stacked requiring relatively large size tower structures, excellent circularity for omnidirectional use and flexibility for directional use, may be obtained at UHF frequencies by mounting three "Vee-Zee" radiators, one on each of the three tower legs, so as to fire tangentially around the tower. (Fig. 2)

Where the antenna is to be mounted on top of the tower, either "Vee-Zee" radiators (usually three in number) firing tangentially, (Fig. 2) or "Zee" Panels (normally four in number) firing radially, (Fig. 3) can be used, depending on the shape of the pattern desired.

Horizontal Patterns

Excellent circularities varying between ± 1 and ± 3 dB (depending on application) are achieved by feeding equal power to all elements in a horizontal plane. Directional patterns are obtained by varying the amplitude and phase of the signals radiated, by changing relative spacings, and directions of fire of the various elements. Examples of pattern shapes that can be achieved are shown in the pattern diagrams. (Fig. 7 thru 19)

These typical calculated horizontal patterns are plotted in terms of dB. The dotted circle on each pat-

tern represents the relative field (in dB) that would be received for an omnidirectional antenna when fed the same power as the directional having the same vertical gain. A great variety of other patterns are available to meet UHF omnidirectional or directional requirements.

Vertical Patterns

The number of elements stacked vertically and the amplitudes and phases of the signals radiated by the elements will determine vertical patterns. "Sculpturing" can be done to either have zero nulls where distant coverage and maximum gain are desired, or filled nulls where thorough close-in coverage is necessary.

Beam tilt can be achieved in all directions, or only in selective directions by either tilting individual panels, or by electrical phasing of successive radiators, or both.

Gain

Gain is a measure of the degree to which the vertical pattern has been compressed to force the signal out parallel to the earth and to which the horizontal pattern has been designed to force the signal in given azimuth directions. It therefore is a function of the number and orientation of radiating elements and of phases and amplitudes of currents in these elements. The "Vee-Zee" and "Zee" Panel antennas provide more flexibility of choice for each of these variables than can be obtained with any other type of antenna.

Certain relationships should be borne in mind in considering the gain to be used:

1. Effective Radiated Power (ERP) in a given direction = transmitter power \times efficiency of transmission line \times antenna gain (in that direction).

2. Gain G_d (in a given direction) = gain G_v of the vertical pattern \times gain G_H of the horizontal pattern, (if the vertical pattern is the same in all directions). Gain is thus affected by all radiators in an antenna.
3. Gain must be sacrificed (normally by from 0 to 15 percent) to obtain null fill. Thus more stacked vertical panels may be required to obtain a desired gain in a filled pattern.
4. Approximate gains for a single layer of "Vee-Zee" Panels at UHF frequencies radiating omni-

directionally are shown in figure 4. Slightly higher gains are achieved by use of the "Zee" Panels.

Power Handling

"Vee-Zee" and "Zee" Panel Antenna Systems are normally designed for either 30 kW or 60 kW input to accept the power reaching the antenna from the most commonly employed transmitters. (Power into antenna = transmitter power \times efficiency of transmission line.) If desired, antennas with higher or lower power ratings can be supplied on application.

Mechanical Characteristics

Size and weight of single radiators of these antennas for UHF frequencies vary by channel. Approximate lengths and weights for single radiators are shown in the accompanying chart. (Fig. 5) Widths are roughly $0.7 \times$ wavelength of operation. The radiators are easily handled for shipment and erection.

Windloading

All antenna elements are designed to withstand 115 mile per hour wind velocities (55 lbs/sq. ft. on flat surfaces—37 lbs/sq. ft. on round surfaces). The actual windloads for a given wind involve the supporting

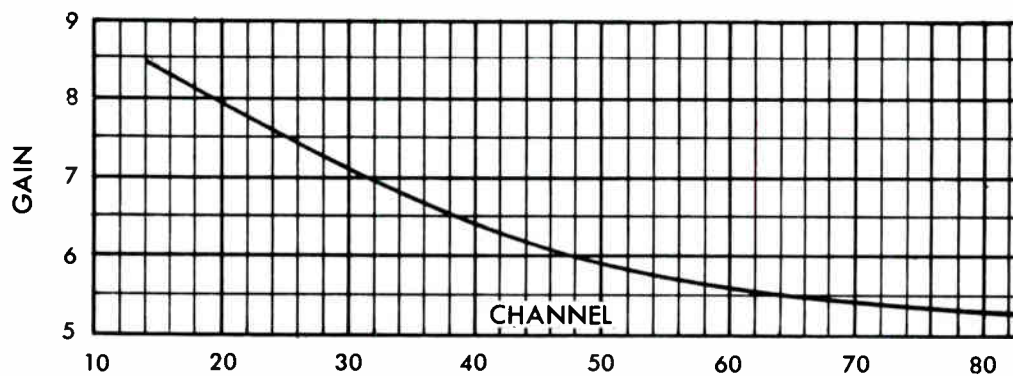

FIG. 4.

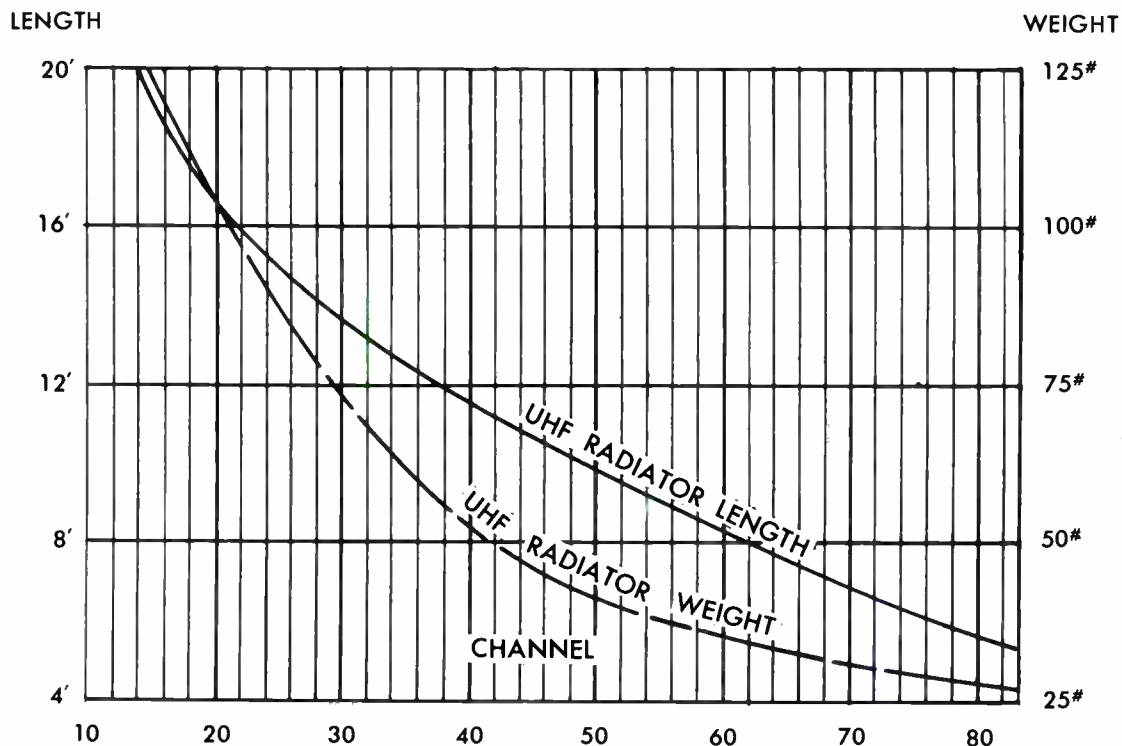

FIG. 5.

structure as well as the radiators and so vary with each application. Estimated loadings for a single layer of three "Vee-Zee" or four "Zee" Panel antennas, with typical feed system but exclusive of the supporting structure are given in Fig. 6. Loadings on multiple layers may be obtained by multiplying these values by the number of layers. Approximate overturns (in foot-pounds) for top mounted antennas are obtained by multiplying the loadings by half the height of the antenna (in feet).

Lightning Protection

The RCA "Vee-Zee" and "Zee" Panel top mounted antennas are supplied with top-hat lightning protector. Whether top or side mounted both ends of each radiating element are grounded. This reduces to a minimum the possibility of lightning damages.

Radome

An easily removable radome is supplied for protection from atmospheric conditions and possible climbing damage.

Quotations

For antenna and/or tower quotation purposes, contact Broadcast Antenna Merchandising, Camden, New Jersey prior to any firm commitment.

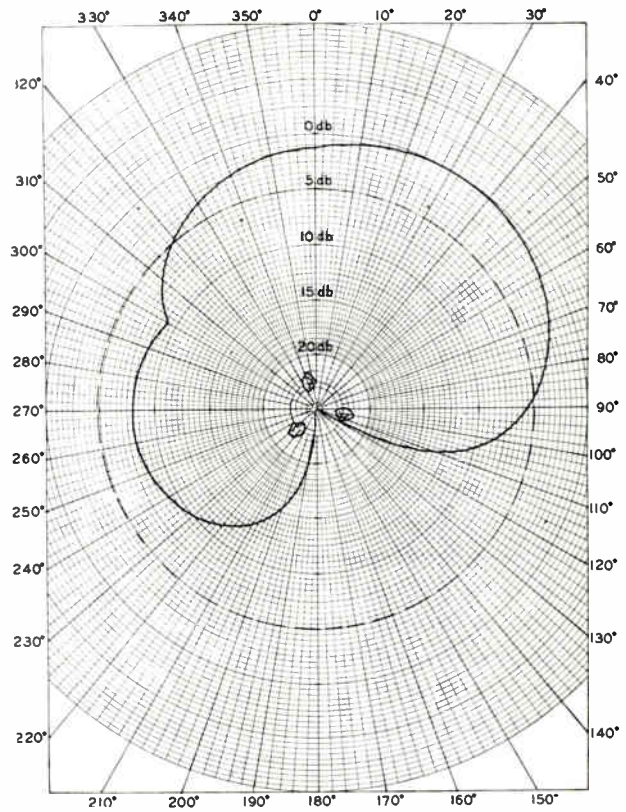

FIG. 7. Top Mounted
Horizontal Directive Gain 3.17, 5.0 dB.

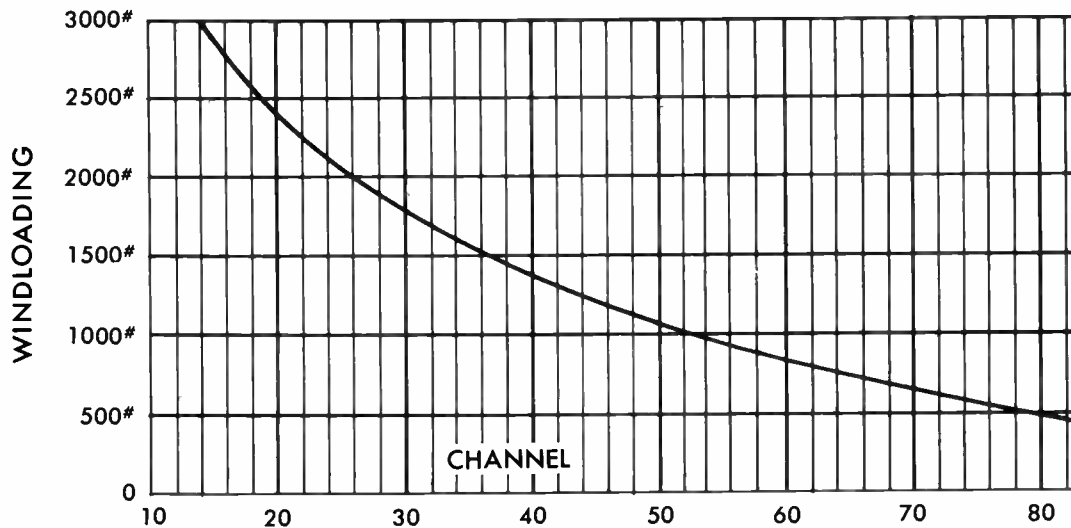

FIG. 6.

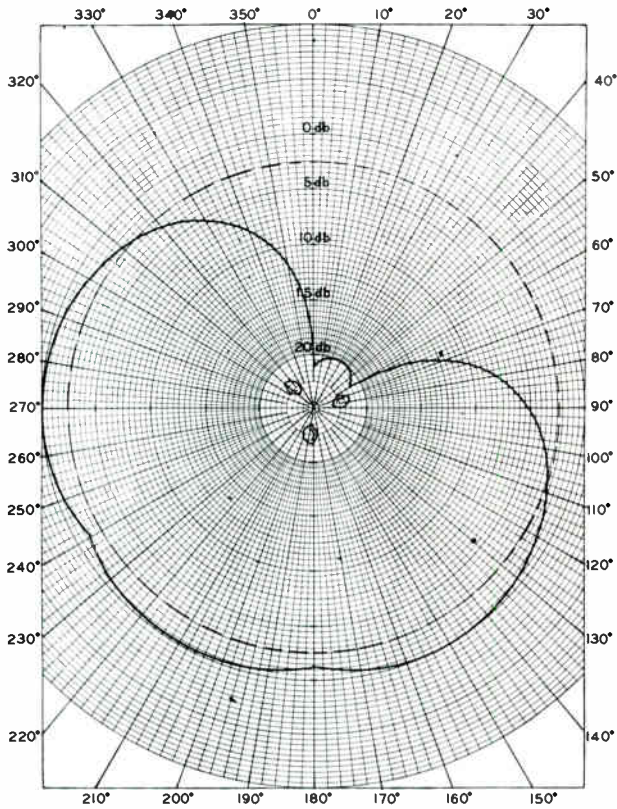

FIG. 8. Top Mounted
Horizontal Directive Gain 1.76, 2.5 dB.

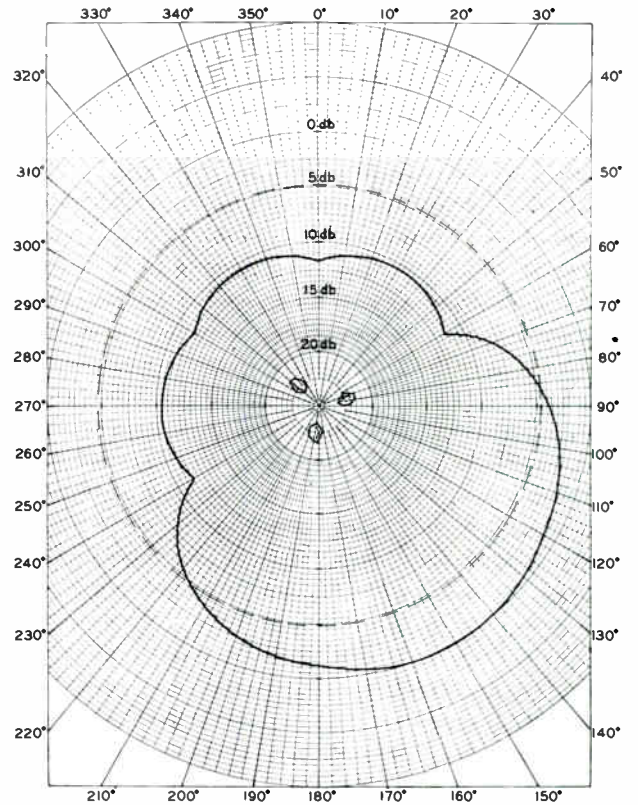

FIG. 9. Top Mounted
Horizontal Directive Gain 3.02, 4.8 dB.

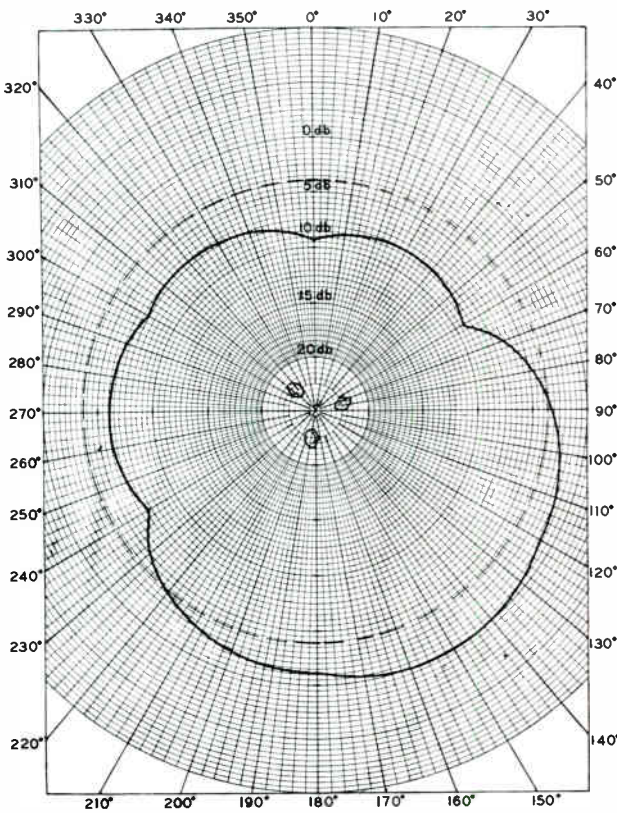

FIG. 10. Top Mounted
Horizontal Directive Gain 2.43, 3.9 dB.

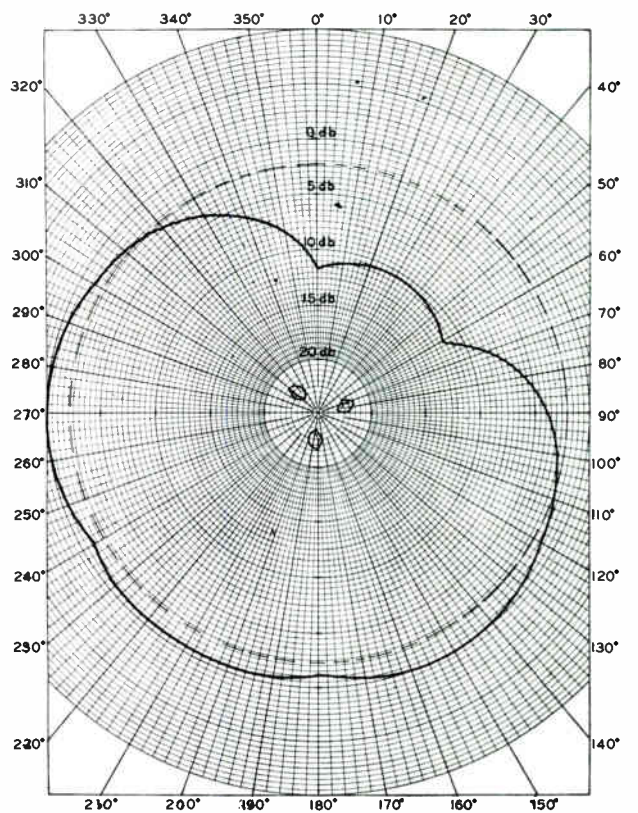

FIG. 11. Top Mounted
Horizontal Directive Gain 1.68, 2.3 dB.

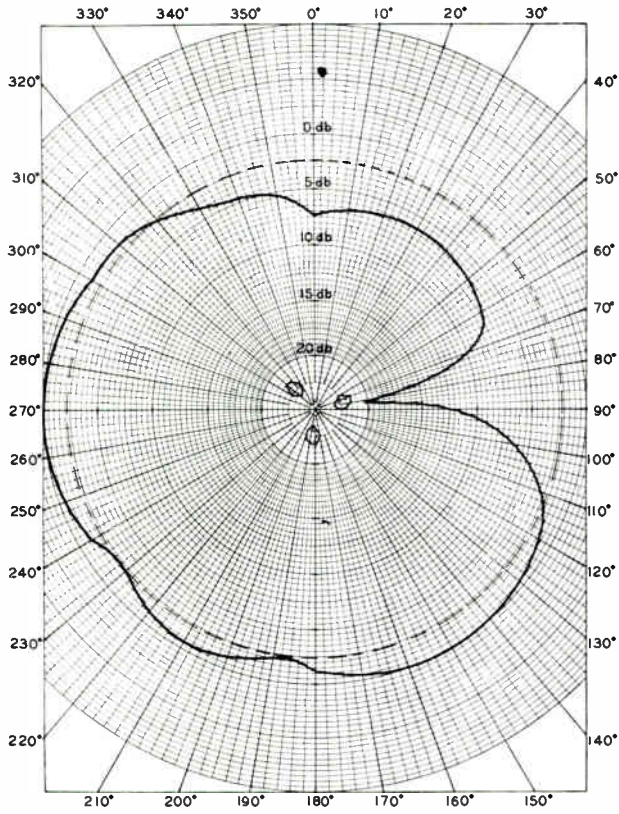

FIG. 12. Top Mounted
Horizontal Directive Gain 1.72, 2.4 dB.

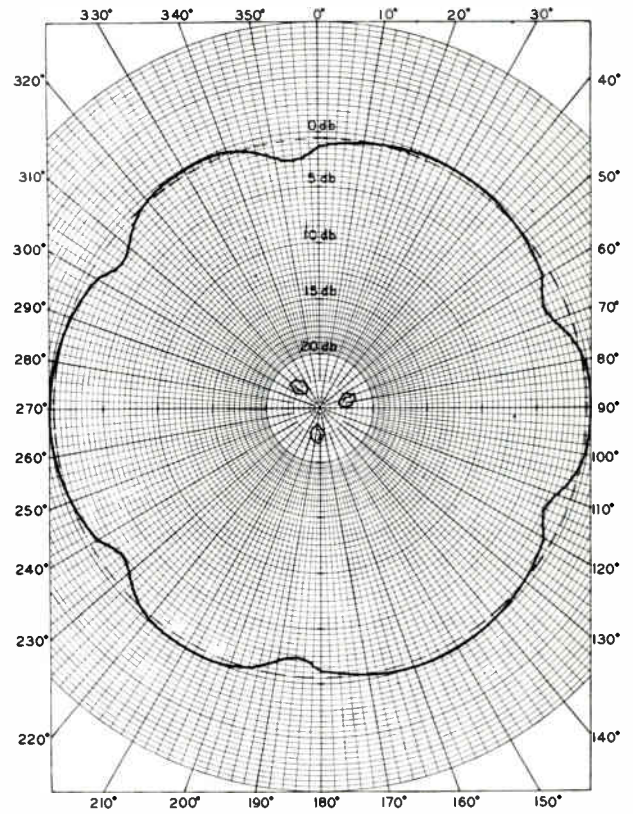

FIG. 13. Mounted Around Tower
Channel 14, 7 ft. 6" face

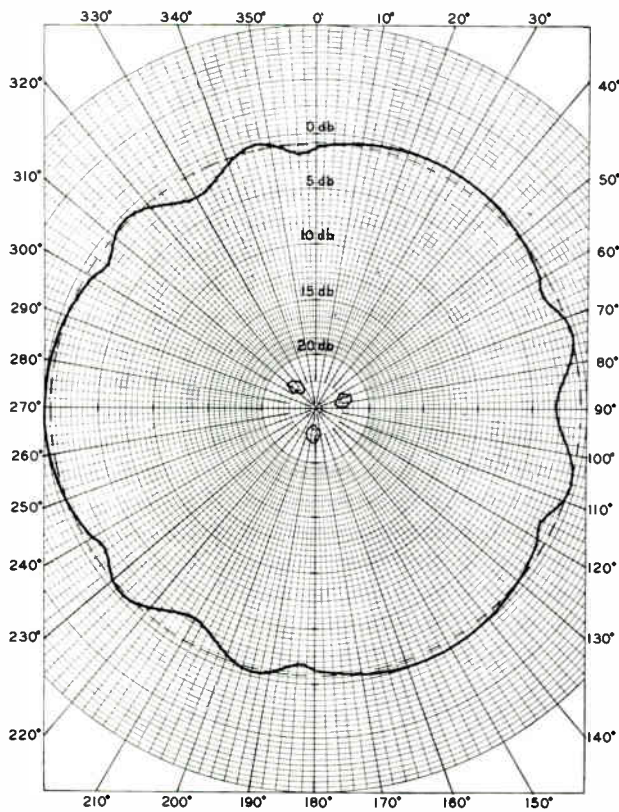

FIG. 14. Mounted Around Tower
Channel 14, 10 ft. 0" face

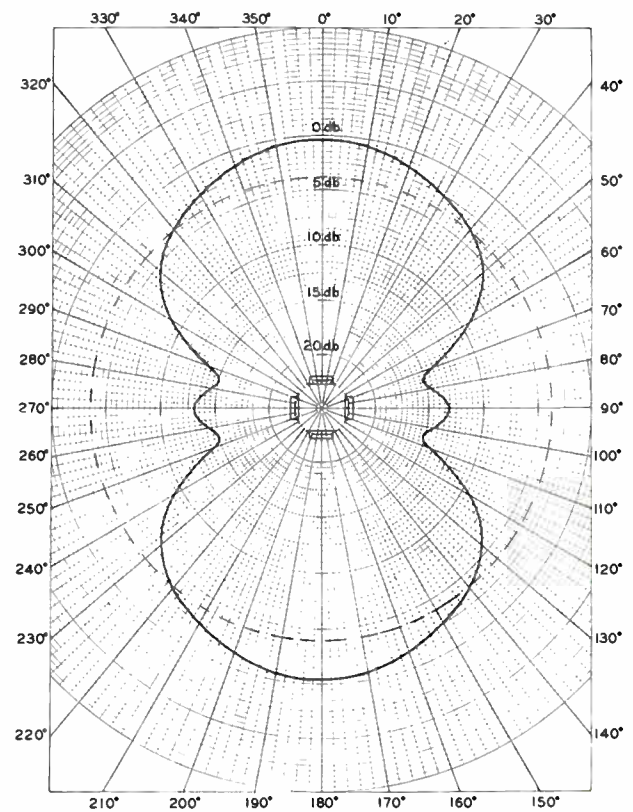

FIG. 15. Top Mounted (square support)
Horizontal Directive Gain 2.39, 3.8 dB.

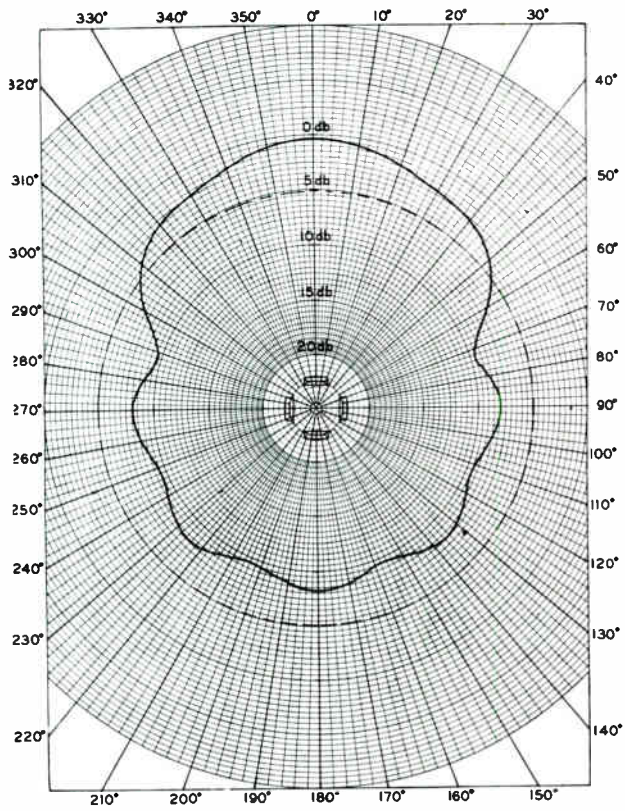

FIG. 16. Top Mounted (square support)
Horizontal Directive Gain 3.24, 5.1 dB.

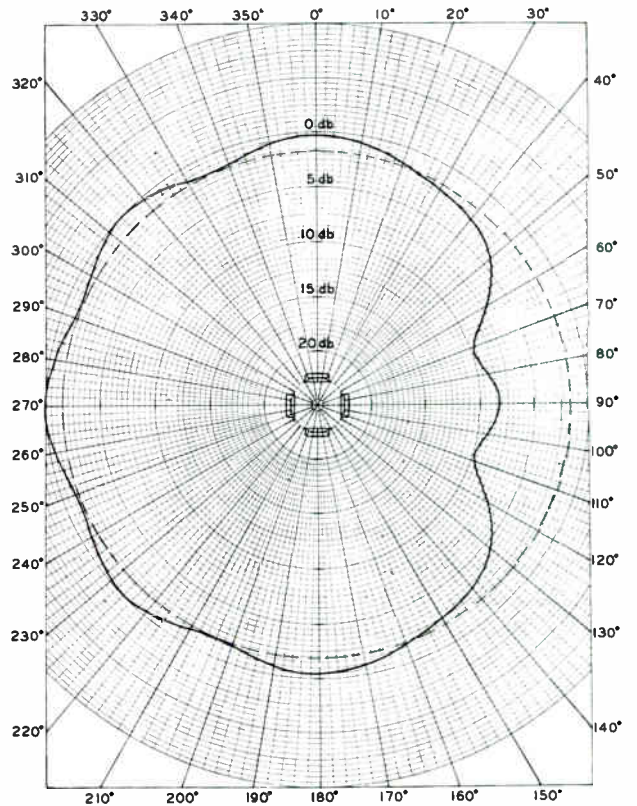

FIG. 17. Top Mounted (square support)
Horizontal Directive Gain 1.49, 1.7 dB.

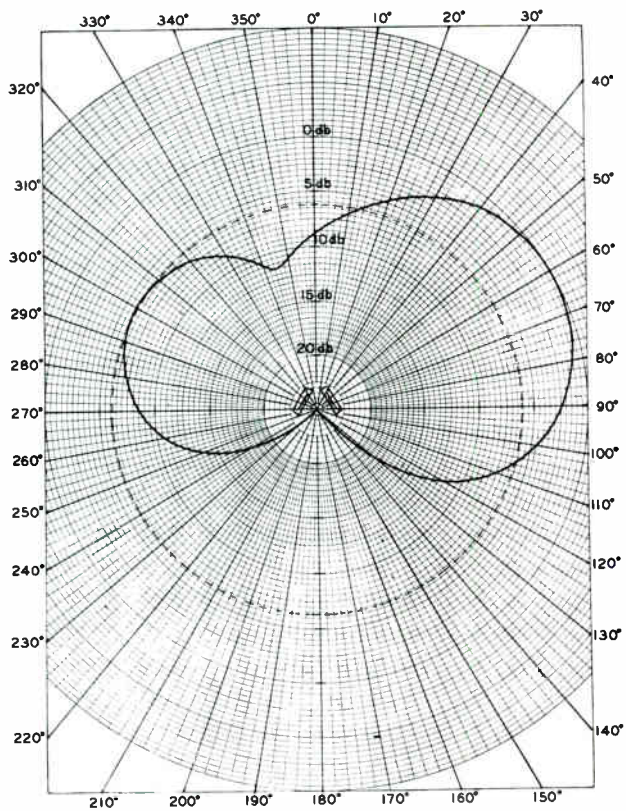

FIG. 18. Top Mounted (triangular tower)
Horizontal Directive Gain 4.21, 6.2 dB.

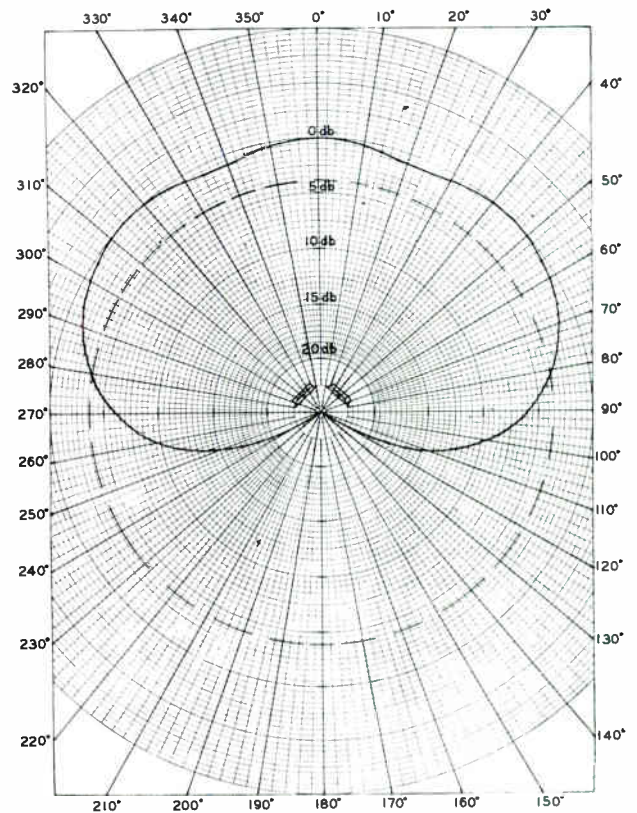
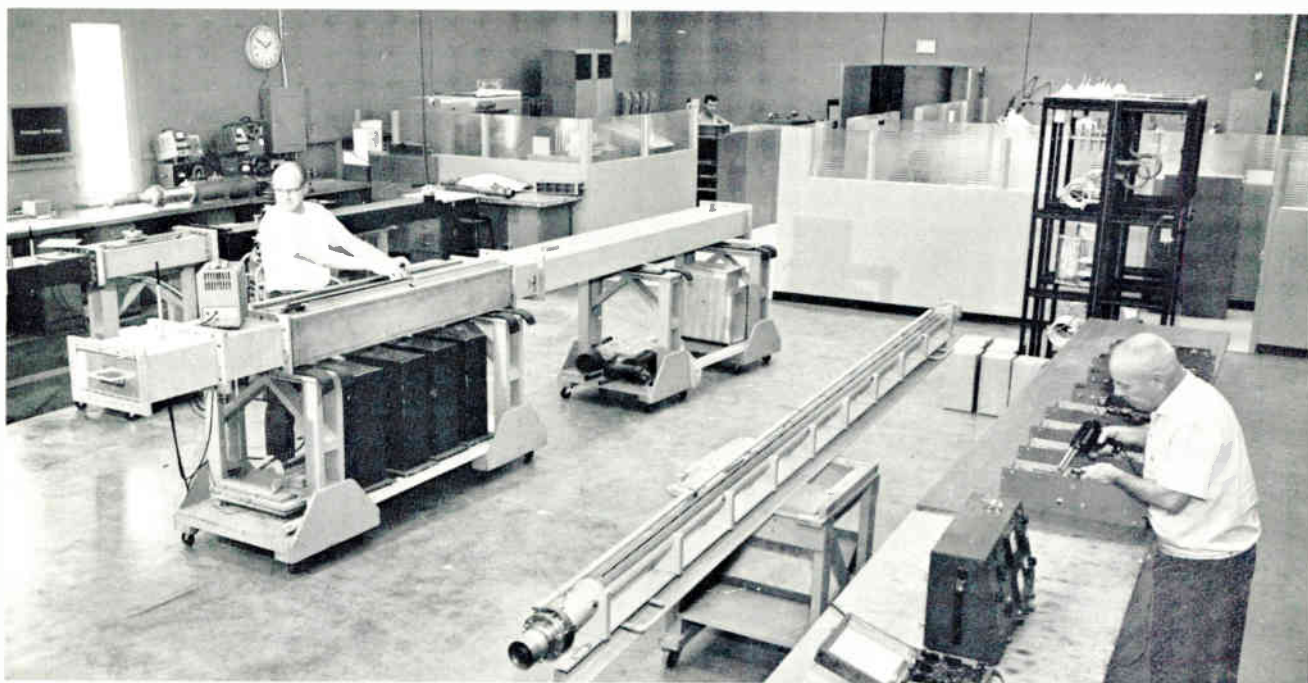

FIG. 19. Top Mounted (square tower)
Horizontal Directive Gain 2.42, 3.8 dB.

RCA Expands Antenna Facilities



New equipment and additional land paves way to new developments and speedier delivery of broadcast antennas. Above is shown the new antenna engineering center on 75-acre Gibbsboro, New Jersey site. Below is overall view of the antenna lab, where an engineer conducts a waveguide experiment.



Ordering Information

"Vee-Zee" and "Zee" Panel Antennas are supplied by RCA on a custom basis since the size and number of panels employed to form an array will vary with each station's requirements.

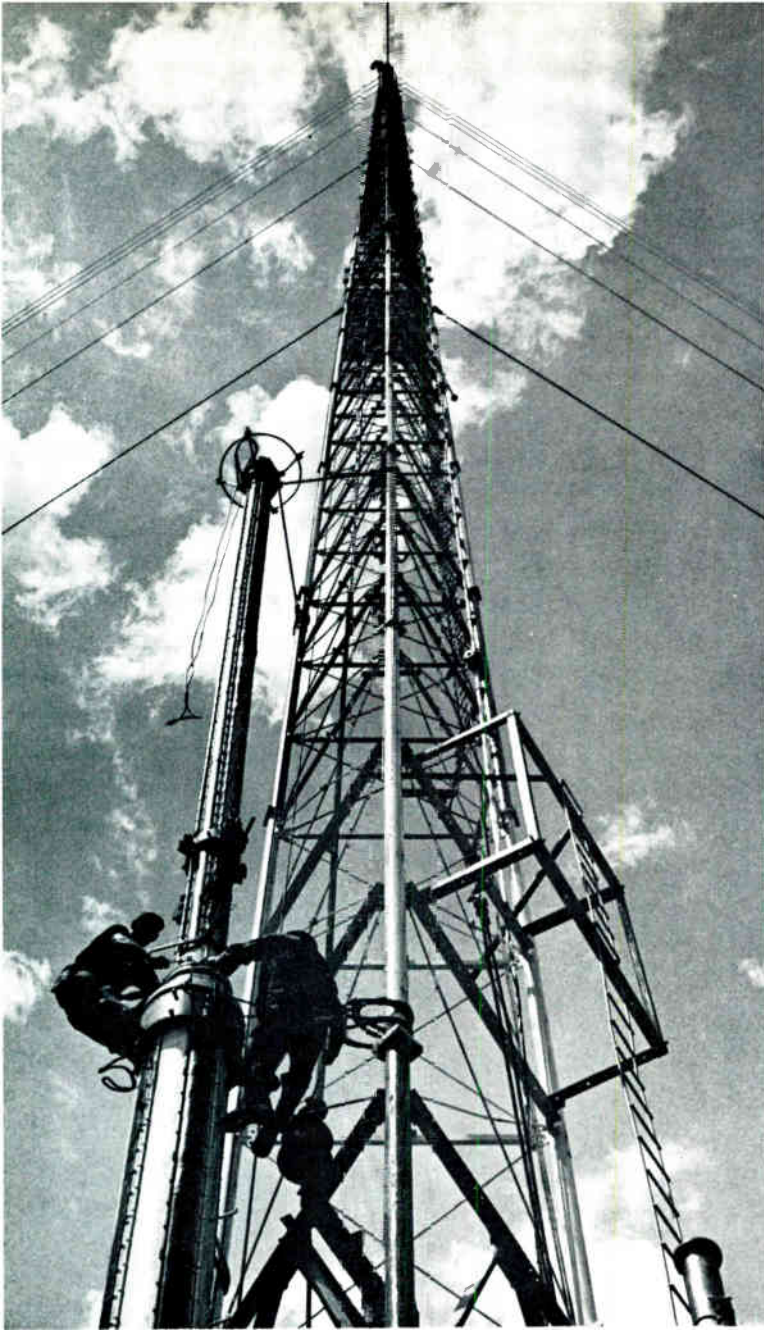

- Designs by experienced tower engineers
- Single contract service—complete tower planning, design, fabrication, installation and inspection, one responsibility
- Variety of types and heights to fit site, antenna, accessory and load requirements
- Custom designed structures to meet special or unusual requirements
- Complete tower accessories

Television Antenna Towers

Description

A wide selection of towers to support the various type RCA UHF and VHF Television Antennas is available for all applications. Included are self-supporting and guyed designs. Custom towers for multiple antenna applications are also available.

RCA, as a representative of tower manufacturers, is qualified to assist the Broadcaster in the planning and selection of the proper tower and a qualified erector. A popular, one contract, one responsibility, service is available.

Design Considerations

Relatively flat country with low surrounding hills lends itself well to the installation of tall supporting structures. Towers over 500 feet in height are usually guyed and the usual cross sectional shape is triangular so that three point guying can be used. Guyed tower costs are lower than for self-supporting structures because less steel is used and erection is less costly. The availability of land and the area involved for guy anchorage however increase costs of this type of tower. A useful method for estimating the land required for a guyed structure is to

consider the distance to the farthest guy anchorage as being approximately 70 percent the tower height. For self supporting tower the distance between tower legs is usually 10 percent of the height.

Guyed Towers

Guyed towers normally are constant in cross-section along their entire height. They are supported by steel guy cables which span out to steel reinforced concrete anchors buried in the earth. Such towers are available with either fixed or pivoted bases. Each has certain advantages. A pivoted base tower tapers to a

point at the bottom. The tower and the foundation are connected at this single point. The tower will remain upright and plumb even if the foundation shifts unevenly. Because of this feature, pivoted base towers are normally used when the soil at the site may have unknown load-bearing qualities. Each leg of a fixed base tower is bolted to the foundation making the tower-to-foundation connection a rigid one. Fixed base towers permit direct installation of transmission lines at the ground level. They also permit installation of the elevator bottom landing closer to the ground.

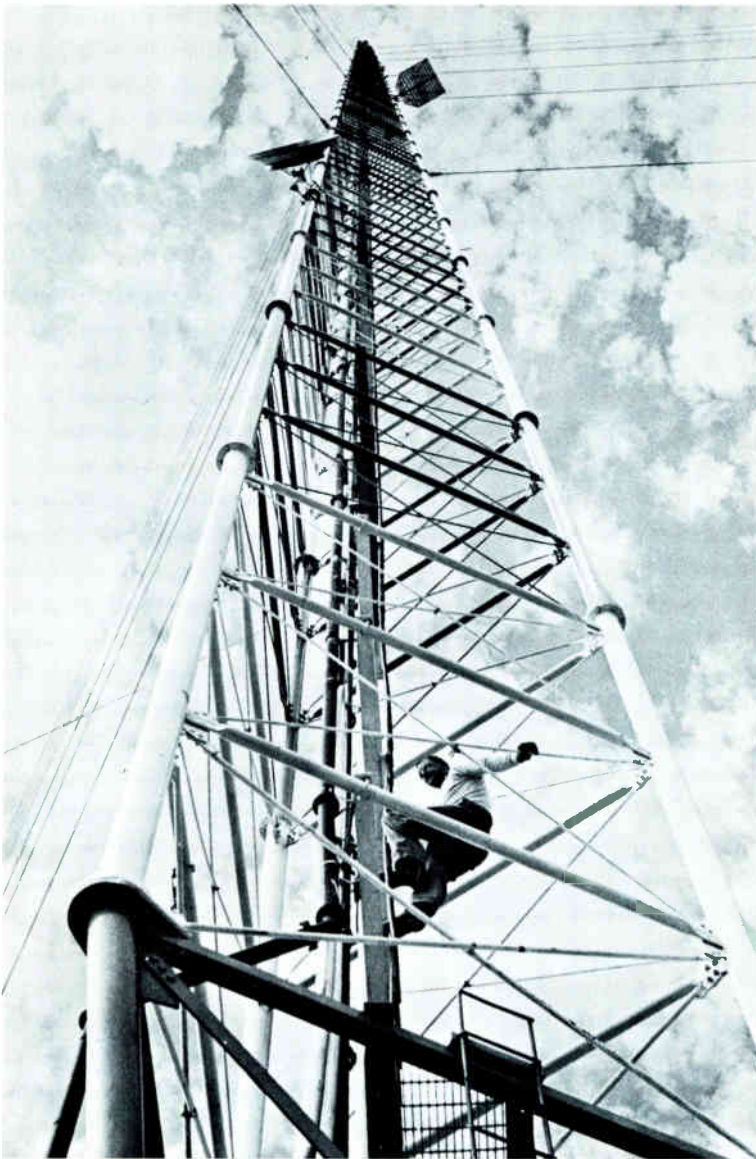

Guyed television towers can achieve great height at less cost than self-supporting structures where land value is not a determining factor. Towers are triangular and are available with either fixed or pivoted base.

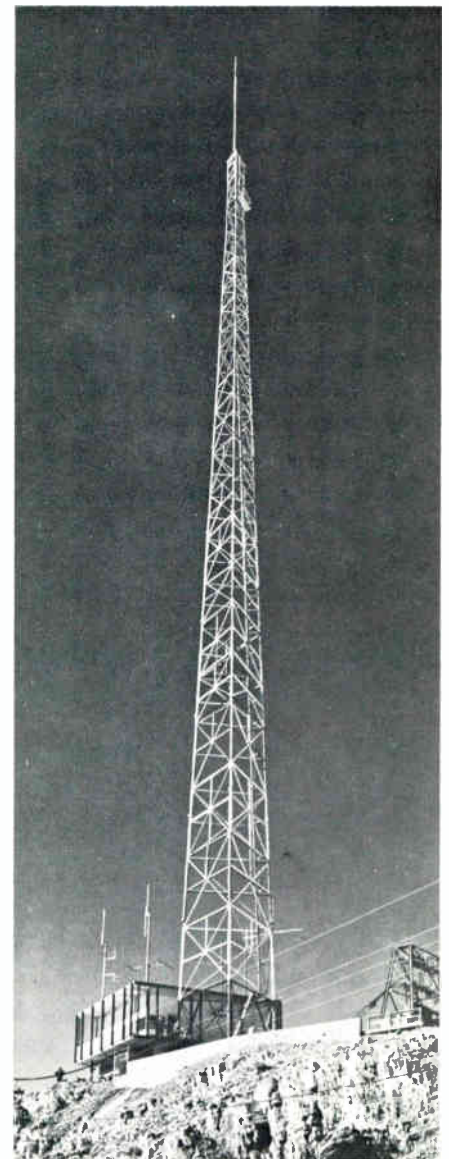

Ranger Peak, 1900 feet above average terrain, near El Paso, Texas is an ideal site for KTSM-TV's self-supporting type antenna tower.

Self-Supporting Towers

Self-supporting towers are wide at the base and taper gradually to the top. They are not supported by guy cables but depend upon their tapered configuration for stability. Such towers are especially advantageous in city and congested districts where availability of land is limited.

The use of towers upon tall buildings is often quite practical. This normally results in smaller towers and shorter transmission lines, especially if the building is high enough to conform to the desired antenna height. Building frameworks must be reinforced and erection problems sometimes become quite complex.

Mountain-top sites in general do not lend themselves to guyed towers due to limited land area available for guy points. As a result, most of the mountain top installations are of the self-supporting type. Since coverage is proportional to height a strategically located mountain top site is desirable. On a mountain top, a short tower is acceptable to mount the antenna away from close-in reflecting objects.

Multiple Antenna Towers

Towers carrying a number of antennas, either in a stacked arrangement or with all antennas at the same height on a top platform, or with a combination of platform and side mounted antennas can be supplied. Multiple antenna towers save each station on land cost, enable each station to utilize the area's best site, simplify air-space clearance problems, and greatly reduce receiving antenna orientation problems.

Tower Foundations

Tower foundation design is based upon a laboratory analysis of the load bearing capacity of the soil in which the foundation will be placed, together with a determination of the uplift the foundation will be required to withstand. It is sometimes necessary to reinforce foundations with steel, wood or concrete piling. Swampy land provides a poor foundation base. Sand, gravel and clay soils are normally satisfactory. Shale or rock are good. A steel reinforced concrete foundation supports and fixes the base of most towers. Anchor bolts for the tower are cast right into the foundation with just the threaded ends protruding.

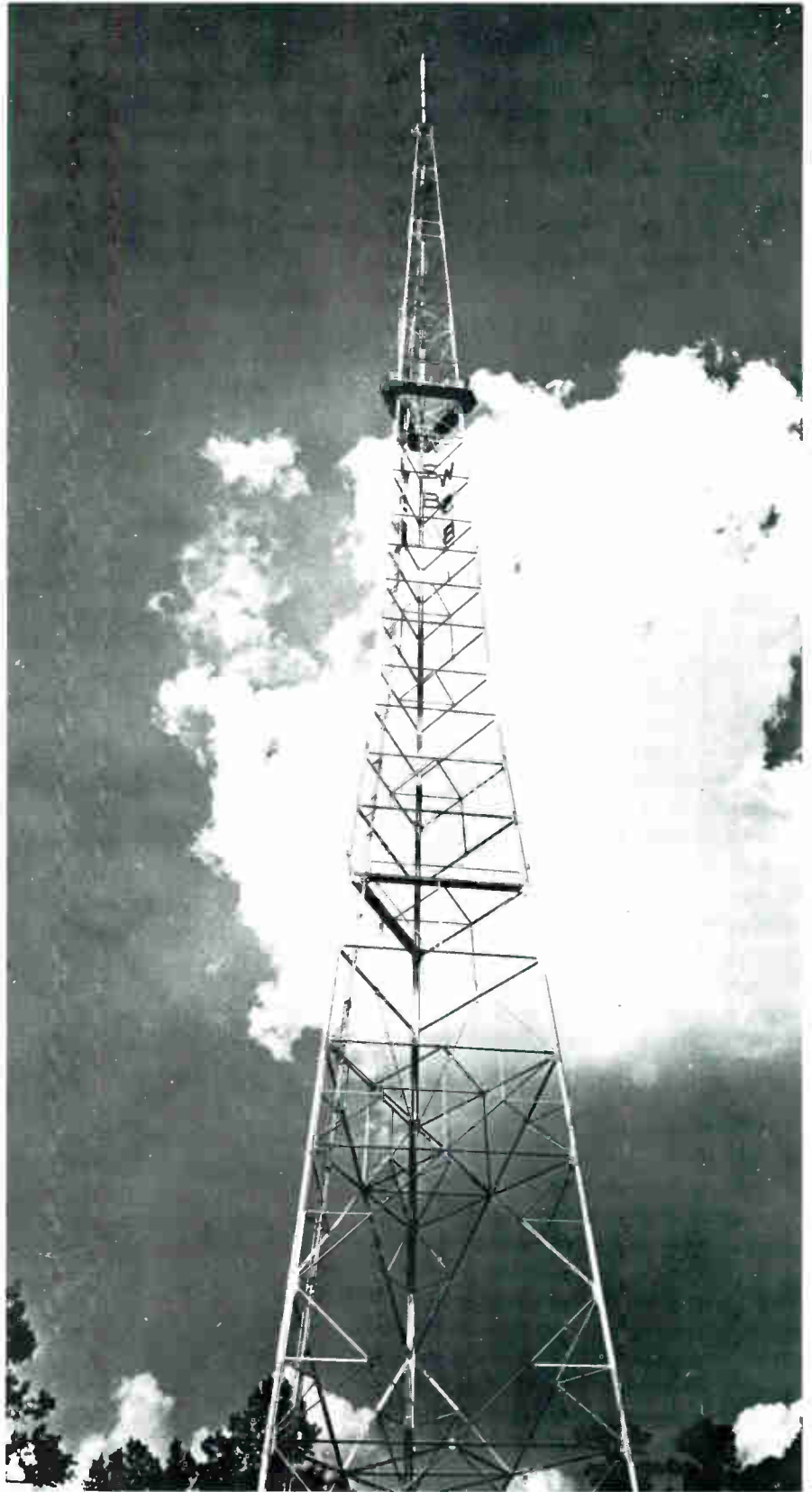

Station WSB's triangular self-supporting tower rises skyward to support a pylon antenna. Such towers are recommended where sites are in congested areas or where a tower is designed for erection on a roof-top.

Weather Protection

The steel superstructure may be hot dip galvanized steel where corrosive action due to fumes, salt air, etc. are known to exist. Galvanizing can be omitted if the tower sections are heavy and painting is done frequently. Climbing ladders should be located inside the tower if at all possible and preferably near the tower legs. By placing the ladder within the tower, the lattice braces form a safety cage for the serviceman. Rungs are spaced for easy climbing or descent.

Tower Elevators

Tower elevators are recommended on towers of 1000 feet or more in height. They eliminate the danger of long periods of interrupted service through making it possible for a technician to get up the tower fast in any kind of weather. They also enable the engineer or station manager to give on-the-spot supervision to work performed on the tower, without climbing. Finally, elevators greatly simplify routine maintenance. Conventional passenger elevator safety devices should be a part of every tower elevator system.

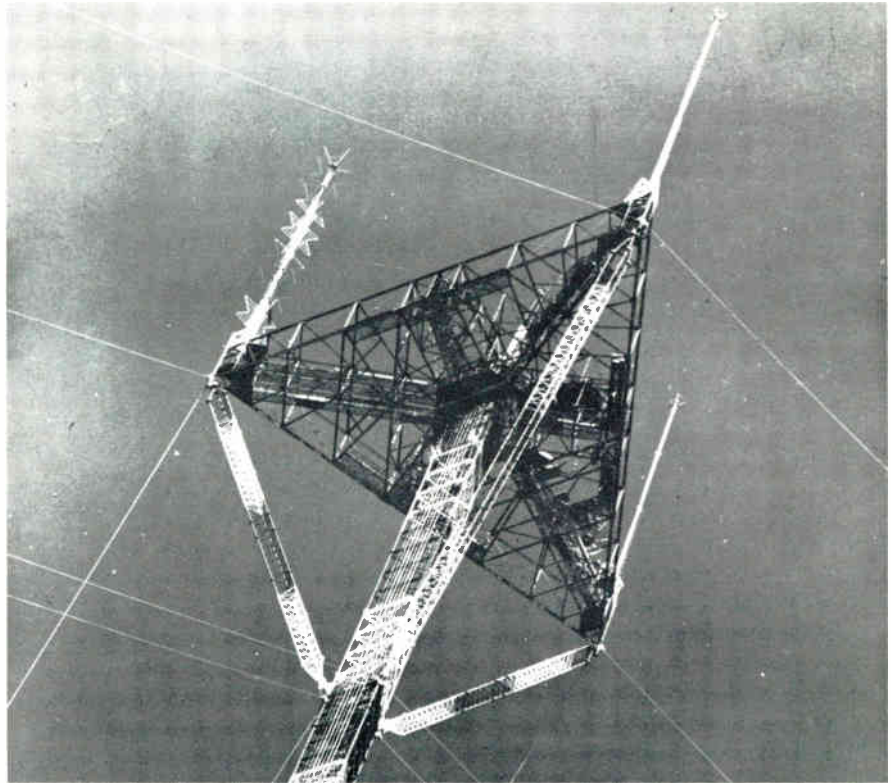

1500-foot top platform multiple antenna support tower affords substantially increased coverage for Stations KCRA, KOVR and KXTV in Stockton-Sacramento area. The economies afforded through a single tower, as opposed to three separate structures, are obvious.

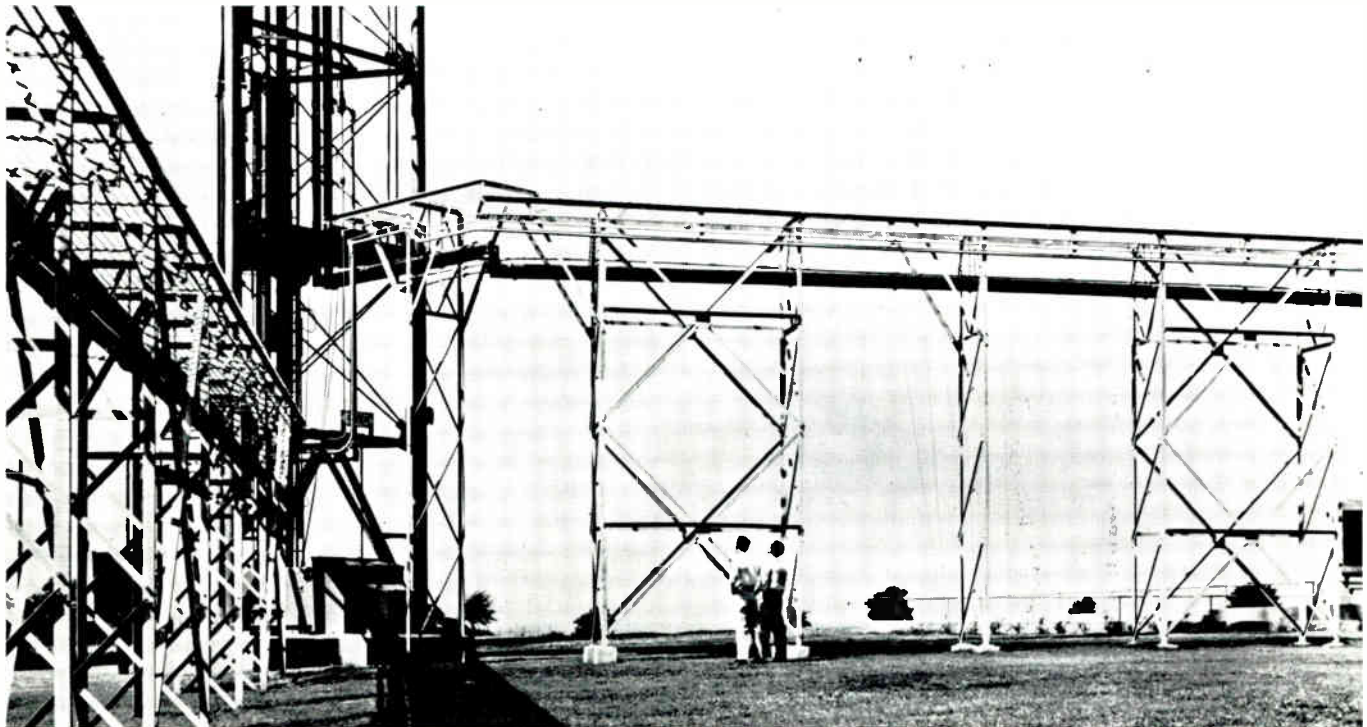

TV tower showing horizontal transmission line runs protected by ice shields.

Service Platforms

Tower platforms are featured in most tower designs. Inside platforms are located at each light level to provide a safe rest and work area for the tower maintenance workers. Outside platforms with railings can be installed at any level required to provide convenient access to side mounted equipment. Top platforms to carry multiple antenna installations are fitted with catwalks, railings and ladders to provide easy access to antennas and transmission lines.

Telephone lines and jack boxes can be installed on the tower to provide quick communication between maintenance workers on the tower and the ground.

Lightning Protection

All RCA antennas mounted on the top of a tower are provided with branching type lightning protectors. These consist of four rods disposed symmetrically about the 300mm beacon and extend above it. The parts are ruggedly built and are hot dip galvanized. The branching type initiated by RCA has been used on hundreds of antennas and have been highly effective on tall towers in areas having the highest incidence of lightning in the country.

Tower Lighting

Complete tower lighting systems, designed in accordance with FCC and FAA requirements, are supplied with each tower. Lighting systems contain a series of flashing beacons and obstruction lights at intermediate levels. The number of beacons and lights required varies with the tower height. A photo-electric lighting control, to automatically turn the tower lights on at sunset, off at sunrise, is supplied as a part of each lighting system. A lamp failure indicator panel can be installed in the transmitter building as auxiliary equipment.

A pole socket and guide flange is used to support and steady superturnstile antennas of the usual "bury" type. The guide flange is mounted at the tower top to keep the antenna perpendicular to the ground. The pole socket receives the weight of the antenna. It is mounted fifteen percent of the pole length below the tower top. RCA furnishes the pole socket and guide flange



By placing a service ladder within the tower, the lattice braces form a safety cage for the servicemen.

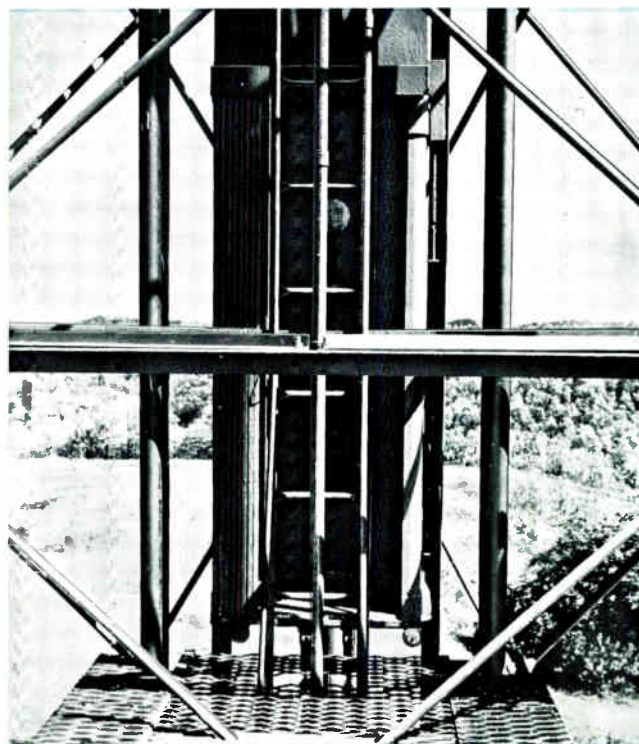

Tower elevators greatly simplify maintenance and should be considered for all towers of great height.

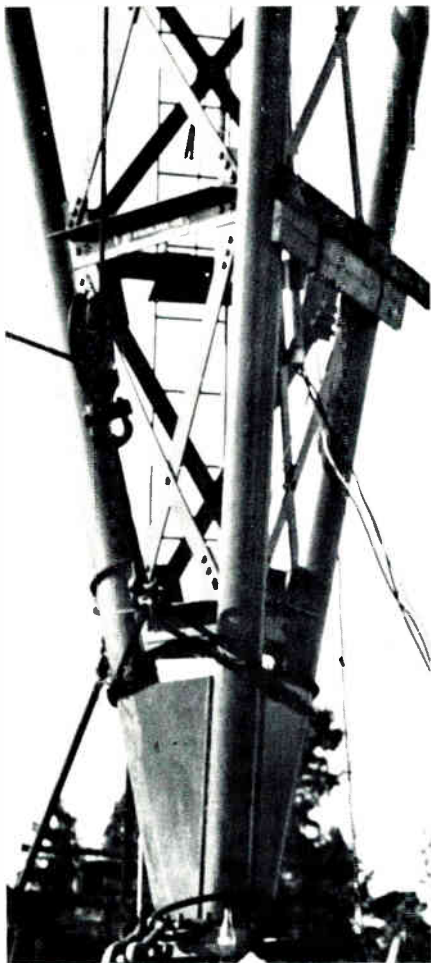

Typical anchorage for pivoted base type of guyed tower. Connected at a single point, the tower will remain upright and plumb even if the foundation shifts unevenly.

with each superturnstile antenna except the Models TF-12AM and TF-12AL. For these two types, the tower manufacturers fabricate the pole socket and guide flange.

Where necessary, arrangements may be made to provide a pedestal type mount that effectively mounts the antenna on the tower top and eliminates the "bury" section.

The twelve-section superturnstiles have an r-f combining network which is accommodated below the tower top. Provisions are made so that tower cross bracing does not interfere. Mounting provisions are supplied for hangers to support this network.

Traveling wave antennas are furnished with a flange at the base for mounting on the tower top.

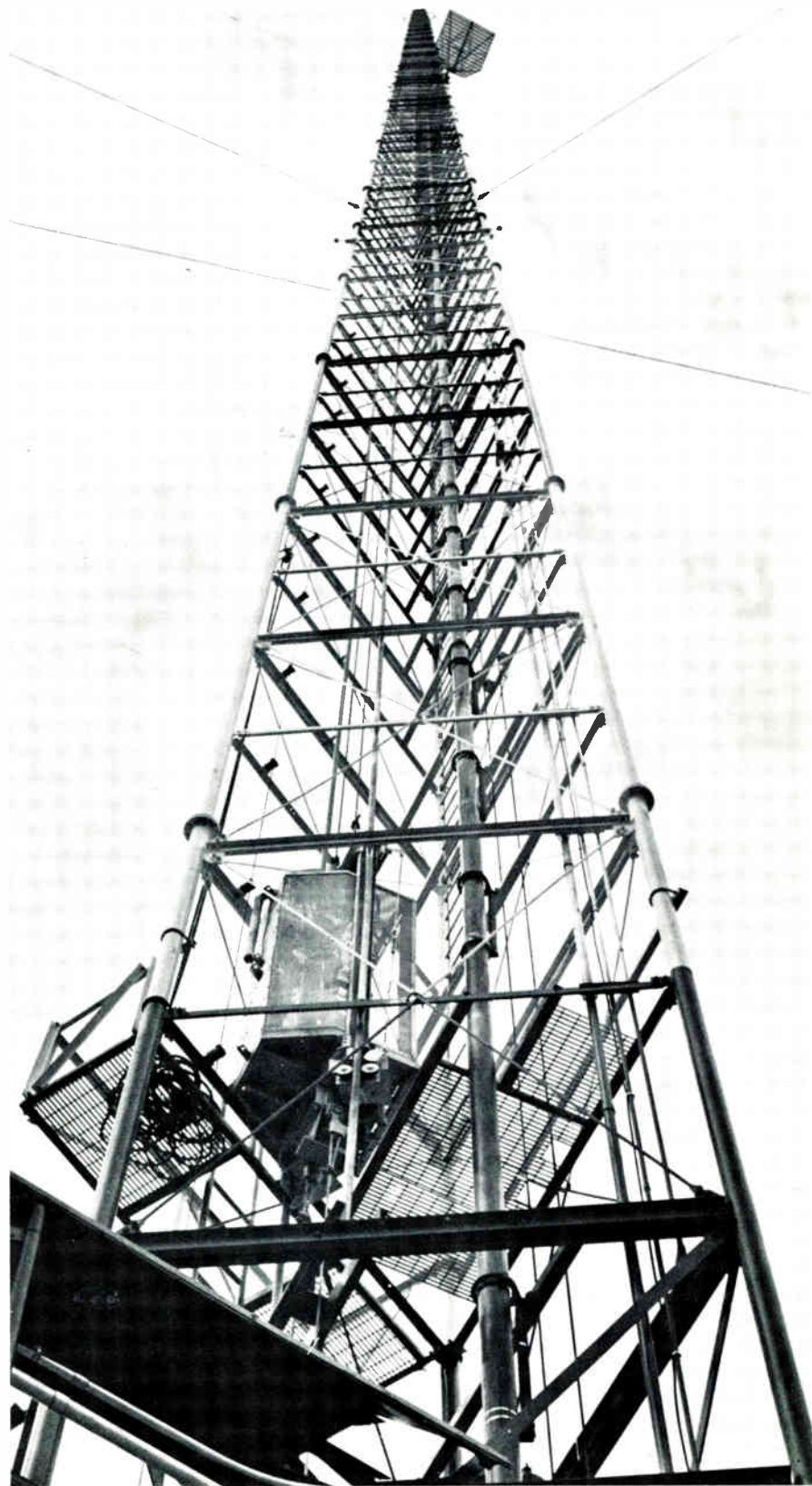

Vertical run of transmission line inside a triangular cross-section tower. Spring-tensioned hangers allow movement of the line due to thermal expansion and contraction.

UHF Antenna Mountings

The standard UHF transmitting antenna is the UHF Pylon. It is flange mounted directly to the tower top plate. Tapered wedges are supplied to obtain mechanical beam tilting of the antenna where specified.

Transmission Lines

Careful consideration is given to the layout and support of transmission line on the tower to allow for expansion and contraction of line and ease of maintenance. The tower manufacturer will consult with RCA engineers to be sure there is adequate support for the line and that a minimum number of elbows are used between the antenna input and the vertical run down the tower. The tower company will supply supports for spring hangers from the top to the base of the tower. Outline drawings with dimensions are available for all types of transmission lines and will be used in making a layout. These are shown in the RCA Transmission Line Catalog.

adequate support for the line and that a minimum number of elbows are used between the antenna input and the vertical run down the tower. The tower company will supply supports for spring hangers from the top to the base of the tower. Outline drawings with dimensions are available for all types of transmission lines and will be used in making a layout. These are shown in the RCA Transmission Line Catalog.

Wind Load

Most towers are currently built to 50/33 pound loading. This means

that tower members are designed to resist a horizontal wind pressure of 50 pounds per square foot of projected area on all flat surfaces and 33 pounds on round surfaces.

Provision is made for all additional loadings caused by antenna, ladders, transmission and power lines, etc. and is applied to the projected area of the structure. The total load specified is applied in the direction which will cause the maximum stress in the various members. Where high winds or heavy icing is prevalent higher loading is often specified.

WIND VELOCITY AND CORRESPONDING WIND PRESSURE ON TOWERS

EIA STANDARD SPECIFICATION

Actual Wind Velocity MPH	Wind Pressure on Flat Surfaces $P = .004 V^2$	Wind Pressure on Round Surfaces	Estimated Survival Velocities F. S. 1.65
10	.4	.266	12.9
20	1.6	1.067	25.8
30	3.6	2.4	38.6
40	6.4	4.27	51.5
50	10.0	6.67	64.4
60	14.4	9.6	77.3
70.7	20.0	13.33	91.1
80	25.6	17.1	103.0
86.6	30.0	20.0	111.5
90	32.4	21.6	115.9
100	40.0	26.7	128.8
110	48.4	32.3	141.7
111.8	50.0	33.3	144.0
120	57.6	38.5	154.6
122.5	60.0	40.0	157.8
130	67.6	45.0	167.4
132.3	70.0	46.67	170.4
140	78.4	52.33	180.3
141.4	80.0	53.33	182.1
150	90.0	60.0	193.2
160	102.2	68.2	206.1
170	115.6	77.0	219.0
180	129.6	86.6	231.8
190	144.4	96.3	244.7
200	160.0	106.66	257.6

Factor of Safety

2.5	Guy cables proof tested hardware
1.65	Tension and bending
1.70-1.94	Compression

NOTE: Cables made up with safety clip connections are derated to 85% of breaking strength.

Specifications

Every tower is custom built to meet station requirements. RCA is equipped to supply a tower completely designed to meet station requirements. By specifying RCA you are assured a satisfactory installation.

Towers are designed in accordance with EIA Specifications.* Consultation with RCA Broadcast Representatives will help to determine every requirement. Call or write your nearest representative. In order to facilitate selection of the tower most suitable, and as an aid to the station in determining specific requirements, a sample questionnaire is included here.

Tower Considerations

The following procedure may be helpful as a check list in considering tower requirements.

1. Determine station location with respect to service area. This study which will involve among other things joint operation with other stations, FAA approval, cost of land, zoning restrictions, local regulations, etc., will result in a decision to use:
 - a. A self-supporting tower when land is unavailable as in city limits or on top of a building.
 - b. Or a guyed tower where land is available and a greater height is desired.
 - c. Or a multiple antenna tower.
2. Determine design parameters:
 - a. Wind load for area in which tower is located.
 - b. Deflection at tower top for type of service required.
 - c. Type of antenna which is to be supported.
3. Determine tower accessories such as:
 - a. Ladders.
 - b. Platforms.
 - c. Railings.
 - d. Lighting.
 - e. Microwave dishes.
4. Determine method of routing transmission line taking into account:
 - a. Accessibility.
 - b. Location of structural members.
 - c. Location of special networks below tower top.

Accessories

RCA can furnish in addition to the antenna supporting tower, tower lighting equipment and installation and erection assistance.

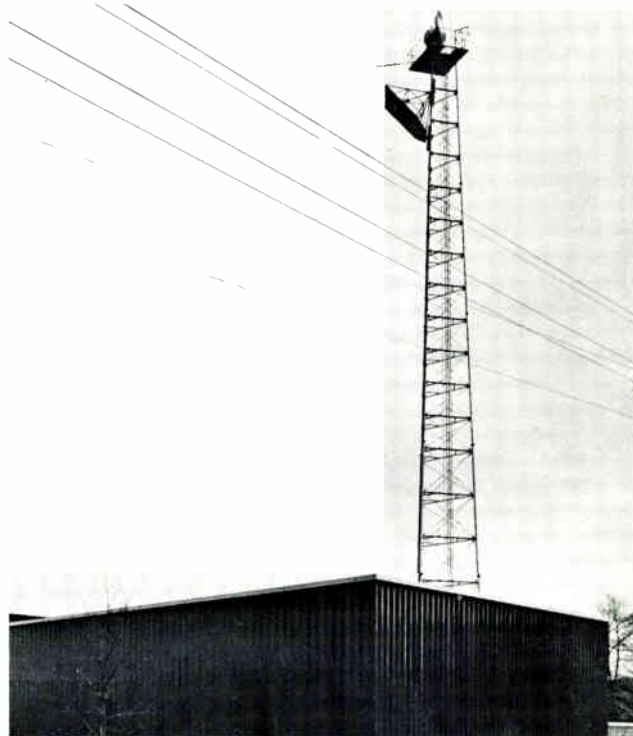

Self-supporting 135-foot microwave tower at Station WAVE-TV showing two receiving dishes on platform—one fixed and one rotatable. The reflector handles a 7000 MHz STL microwave and also a 2000 MHz STL, both with roof-mounted antennas.

Antenna Tower Questionnaire

LOCATION

City State.....

QUOTATIONS TO BE FURNISHED

(Check those required)

Tower Guyed ()
 Self-supporting ()
 Multiple ()

Tower Lighting Equipment..... ()

Tower Erection:

Antenna and Assembly Installation..... ()
 Transmission Line Installation..... ()

SPECIFICATIONS

Tower Height: Ground to top of tower.....
 Ground to top of base insulator.....

Tower Use: Antenna support.....

Channel or Frequency.....

TV Antenna: Type.....

Description.....

Transmission Lines: Size No.

Design Load:

Remarks:

(Special requirements, site accessibility, etc.)

* EIA Standard "Structure Standards for Steel Transmitting Antennas, Supporting Steel Towers" RS-222.

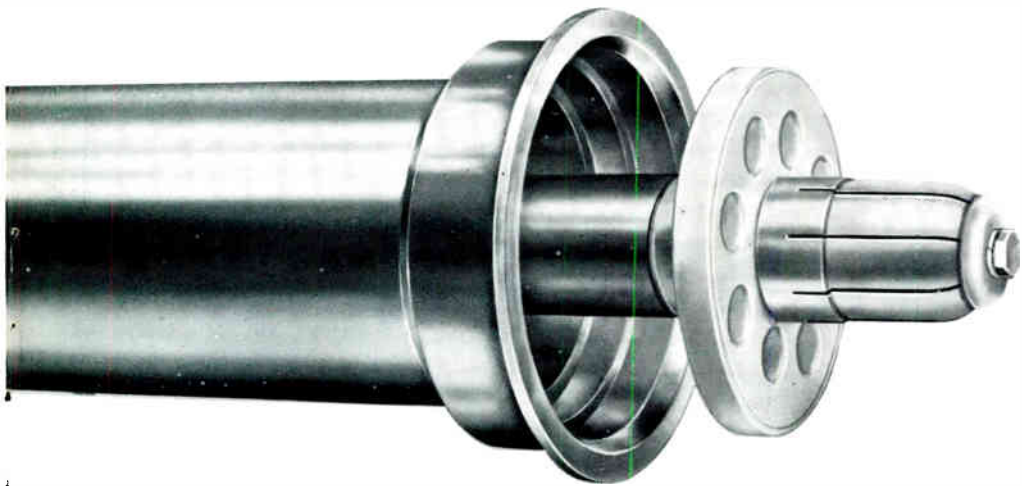

- Designed for UHF
- Maximum stability provided by low-loss Teflon dielectric
- Excellent power handling capability
- Minimum attenuation—maximum efficiency—low standing wave ratio
- Complete line of fittings and accessories for installation versatility

Transmission Line Equipment

Description

RCA offers a wide choice of UHF transmission lines, specifically designed to provide highest efficiency and minimum power loss in transferring energy to the antenna.

Types and sizes should be chosen to assure greatest economy for given frequency and power ranges. The selected power rating should equal or exceed the power output of the transmitter. If power in-

creases are contemplated, it may be economical to install larger line, thus saving the expense of a new installation at a later time.

RCA transmission line for UHF is available either with a Universal Teflon insulated coaxial transmission line, or as a bolt flanged Teflon insulated line. The Universal line is available in $3\frac{1}{8}$ inch, $6\frac{1}{8}$ inch, and $9\frac{3}{16}$ inch diameter sizes,

while the bolt flanged UHF type is supplied in $3\frac{1}{8}$ inch and $6\frac{1}{8}$ inch diameters. In addition, waveguide transmission line can be supplied for special UHF applications.

The general characteristics of RCA transmission line for UHF applications are included in the data table below. Planners should consult RCA's standard transmission line catalogs for details.

UHF TRANSMISSION LINE TYPES AND CLASSES OF SERVICE

SIZE	STOCK NO.	DESCRIPTION	IMPEDANCE	WEIGHT PER 100 FT.	CLASS OF SERVICE
UNIVERSAL					
$3\frac{1}{8}$ "	MI-27791-D	Quick disconnect flanged fittings—pressurized	50 ohm	280	UHF/VHF TV, FM (all channels)
$6\frac{1}{8}$ "	MI-27792-D	Quick disconnect flanged fittings—pressurized	50 ohm	650	UHF/VHF TV, FM (all channels)
$9\frac{3}{16}$ "	MI-27793-D	Quick disconnect flanged fittings—pressurized	75 ohm	1100	UHF/VHF TV (UHF channels 14 thru 40 and all VHF TV)
BOLT FLANGED UHF					
$3\frac{1}{8}$ "	MI-19089	Flanged fittings—pressurized	75 ohm	270	UHF/VHF TV (all channels)
$6\frac{1}{8}$ "	MI-19387	Flanged fittings—pressurized	75 ohm	720	UHF (all channels)

The Right Transmission Line For Every Application



Universal Coaxial Transmission Line.

RCA Universal Line

RCA's Universal Coaxial Transmission Line is a high efficiency Teflon insulated coaxial cable that can be used for both UHF and VHF applications. Employing conductors made of high conductivity, hard drawn copper tubing, Universal line is available in standard 20 and 19½ foot lengths. However, these lengths may be cut shorter if necessary. A flat characteristic impedance of 50 ohms for the 3 1/8 inch or 75 ohms for the 6 1/8 and 9 3/16 inch lines across a wide range of frequencies is made possible by undercutting the inner conductor at each Teflon disk support insulator thus avoiding an impedance discontinuity of "bump" at the support points. Only a few pounds pressure of dry nitrogen or dehydrated air is necessary to keep the line clean and dry. A complete line of accessories including elbows, transformers, adaptors, and hangers are available for use with Universal line. Mating line coupling are male and female with a fully captive gasket and a single-bolt clamp. The design is such that the clamp fits only when the flanges are fully mated. Connections are inherently swivel. Each coupling is Heliarc welded to the outer tubing. The anchor insulator bullet assembly is clamped between the flanges and thus supports the inner conductor on vertical runs.

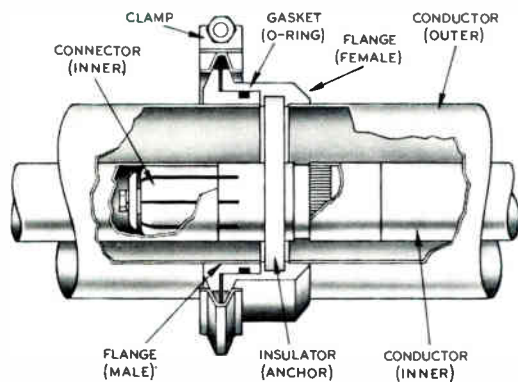

Universal Line Connector Assembly Cutaway.



Detail View of Typical Inner Conductor Expansion Joint.

Built in Expansion Joint

RCA Universal line and the special bolt flanged UHF line described later both utilize a unique expansion joint. In use, there is differential expansion between the inner and outer conductor of the transmission line. In ordinary lines, this movement takes place within the inner conductor along an internal wristband spring. No lubrication is required and no copper chips can fall on the Teflon insulators.

UHF Teflon Bolt Flange Line

RCA UHF Bolt Flange Teflon line is designed especially for UHF applications to provide high efficiency transfer of power with minimum attenuation and extremely low VSWR. Developed by RCA, the line employs high conductivity hard drawn copper tubing. It has the inherent advantages of flat characteristic impedance of 50 ohms for the $3\frac{1}{8}$ inch line and 75 ohms for the $6\frac{1}{8}$ inch line over a wide range of frequencies. The line is supplied in standard lengths of $19\frac{1}{2}$ and 20 feet with flanges heliarc welded to ends, and may be cut at any reasonable point along its length without changing operating impedance. The inner conductor is undercut at each Teflon disk support so that the effect will be a characteristic impedance equal to the air dielectric portion of the line over the useful operating range.

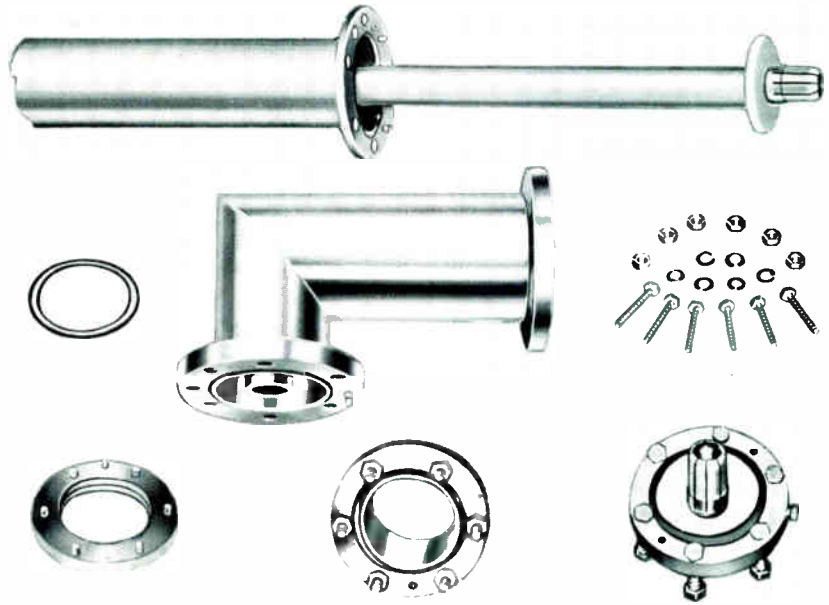

Flanged UHF Bolt Flanged Teflon Coaxial Transmission Line.

Complete Transmission Line Accessories

Transmission Line Hangers

RCA offers a complete line of fixed and expansion type hangers to provide the utmost flexibility, efficiency and economy in supporting transmission line runs from the transmitter and up the tower to the antenna. Hangers are designed for

maximum ease of installation. Their materials resist deterioration, and rugged construction assures permanent, reliable installations. The many types include insulated as well as non-insulated designs. They are described in detail in RCA Transmission Line Catalog literature.



Expansion Hanger.



Fixed Hanger.



Three-Point Expansion Hanger.

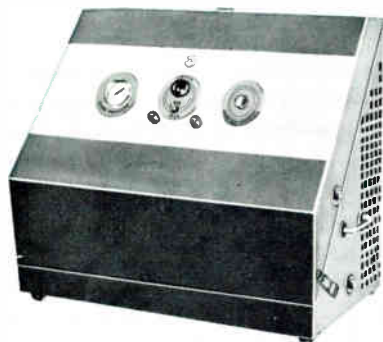

Single Desiccant Dehydrator.

Pressurizing Equipment

It is extremely important that UHF lines be pressurized with either nitrogen or dehydrated air to keep the lines moisture free and thus less susceptible to arc over due to moisture, or fracture from freezing in cold weather. RCA offers a choice of dehydrators which operate economically from a 115 volt 50/60 hertz source.

Line gassing and dehydrator accessories are provided for use with all types of RCA Television Transmission line systems. A wide choice of fittings is available for lines incorporating double or single desiccant type dehydrators or bottled nitrogen for line pressurizing. They provide maximum performance and protection of gassed transmission line runs.



Manual Transfer Panel.

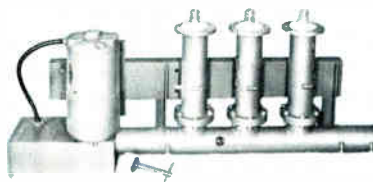

Motor Driven Coaxial Switch.

Transmission Line Switches

Available in a variety of styles, RCA manual and motor-driven transfer panels provide a convenient and rapid means of switching coaxial transmission line circuits that extend between the transmitter and antenna for power cutback, dummy load switching, emergency antenna switching and other functions. The manual panels are offered in two types; a 3-pole panel with one U-type connector, and a 7-pole panel with three U-type connectors. Custom built arrangements can be provided.

Motor driven coaxial switches are single pole, two position switches permitting rapid remote control of the circuits. Micro switches are built in to operate indicators and power interlock circuits since RF power removal is necessary during operation of the switch. For these switches maximum VSWR is 1.04 to 1.0 or better for the ordered channel.



Directional Coupler and Coupler Housing Section.

Directional Couplers

RCA UHF Directional Couplers afford a means for coupling monitoring equipment to the transmitter output lines for tests in tuning, operation and maintenance. Directional properties of the couplers permit sampling without the variations in frequency response observed with non-directional couplers. Each coupler includes an etched scale to permit accurate calibration.

Units such as the Sideband Response Analyzer BWU-5C, Demodulator BWU-4B and Monitoring Diodes utilize directional couplers to provide signal sampling for these instruments. Reflectometers for VSWR and power output measurements require one coupler for incident and one for reflected wave readings.

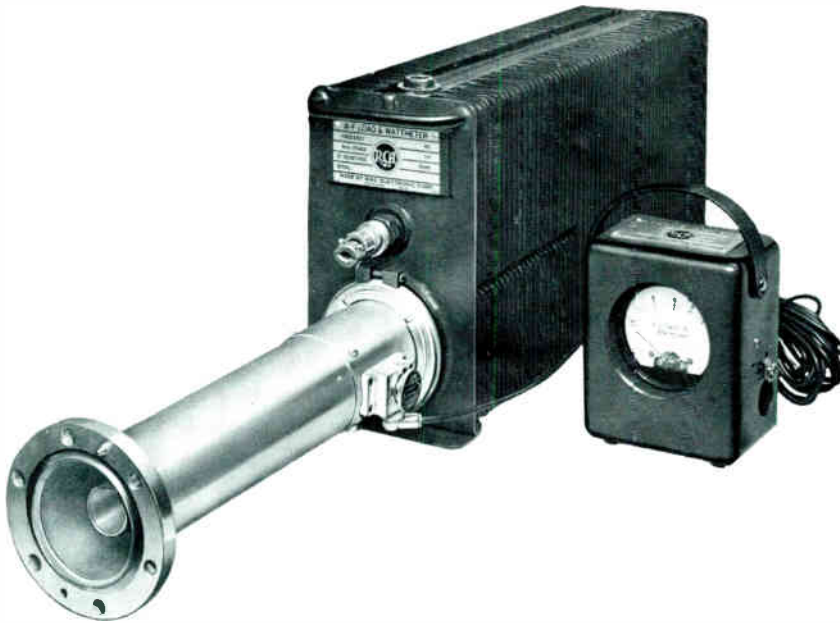

- Performs dummy TV antenna and RF power measurement functions
- Easily installed—occupies little space
- Reads directly in watts
- Reads incident or reflected power

1200 Watt RF Load and Wattmeter

Description

The MI-19197 RF Load and Wattmeter is an air-cooled type 1200 Watt (2 kW peak picture power) unit designed for use in measuring the power output of the aural and visual sections of UHF television transmitters. The load properly terminates the output of either the visual or aural transmitter and reads the average RF power. It may also be used as a dummy antenna for transmitter tuning.

The RF Load is equipped with flanged fitting to mate with MI-19089 3 $\frac{1}{8}$ -inch, 50 ohm line, and is specified for use with RCA's Type TTU-2A UHF Transmitters. The equipment's power dissipating section consists of the load resistor and a liquid coolant which are contained in a finned radiator structure. The power measuring section consists of a short length of transmission line (Thru-line), a meter, and two wattmeter elements which provide 0-150 Watt and 0-1500 Watt full-scale meter deflection. A thermoswitch is also supplied.

The wattmeter element is a reflectometer which consists of a coupling loop, a crystal detector, and a filter network. The wattmeter element may be rotated 180 degrees in

the transmission line housing. This permits it to indicate the incident power to the load, or the reflected power from the load.

The MI-19197 also serves as the reject load resistor on the RCA MI-

19086 Filterplexer series. In this application, the inner conductor of the transmission line section is specifically optimized to give a VSWR of 1.02 or better for the operating channel.

Specifications

Frequency Range	470 to 960 MHz
Power Rating (Avg. at 7500 ft. max. ele.)	1200 Watts
RF Input Impedance	50 ohms
Ambient Temperature:	
Maximum	45°C
Minimum	10°C
Mounting	Horizontal, vent plug up
Coolant Capacity	1.7 gallons
Water Required	None (air cooled)
Dimensions: (Overall):	36 $\frac{5}{8}$ " long, 6 $\frac{3}{8}$ " wide, 10 $\frac{3}{4}$ " high (93.03 cm, 16.19 cm, 27.31 cm)
Weight	48 lbs. (21.8 kg)

Accessories

Reducer, 50 ohm, 3 $\frac{1}{8}$ " to Type N	MI-19089-17
Adapter, Type N to Type HN	MI-19089-19
Connector (anchor insulator)	MI-19089-10A

Ordering Information

RF Load, 1 Wattmeter, 1 Wattmeter Element (0-1500 Watts) and 1 Wattmeter Element (0-150 Watts)	MI-19197
---	----------

15/25 kW UHF RF Load MI-19198-A2 shown with accessory MI-27350 Thru-line RF Wattmeter and MI-19089-10A connector.

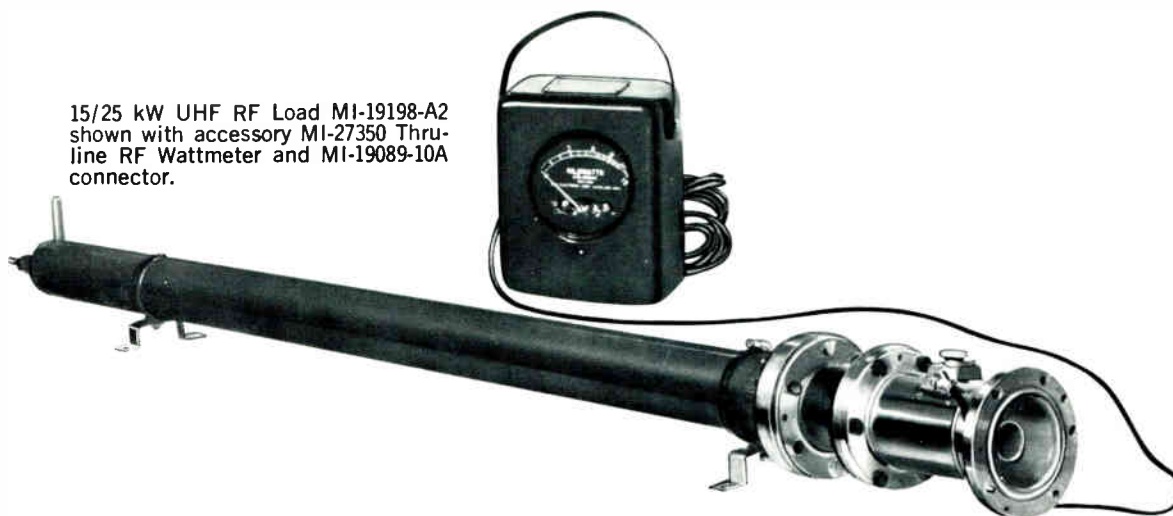

- Performs dummy TV antenna and RF power measurement functions
- Easily installed—occupies little space
- Thru-line RF wattmeter reads directly in watts
- Reads incident or reflected power

15/25 KW UHF RF Load

Description

The MI-19198-A2 15/25 kW RF Load (40 kW peak visual power) is a termination type unit for operation in the UHF frequency range. It is recommended for use with the RCA Type TTU-10A and TTU-30A transmitters. This unit may be connected to either of the transmitter outputs, or the output of the filterplexer. It is equipped with a 3 1/8-inch, 50 ohm flanged input fitting to mate with MI-19089 line. An MI-19387-4CH reducer transformer is required for connection to a 6 1/8-inch, 75 ohm filterplexer output. A thermostitch is also supplied.

The MI-19198-A2 load utilizes a column of tap water for power dissipation. The input of the load consists of a polyethylene transformer section to provide a correct impedance match to the connecting line. The opposite end of the line is short circuited and contains the input and output water connections. The water flows through the inner conductor and enters the space between the inner and outer conductor through small perforations in the inner conductor adjacent to the transformer section. The water flow continues to the output drain connection.

Broadband wattmeters, with scale ranges of 0 to 15 kW or 0 to 25 kW, can be provided as accessory equipment. The Thru-line unit and associated wattmeter element allow

direct incident power readings, or with a 180 degree turn, a reading of the reflected power. A connector MI-19089-10A is required between the load and Thru-line unit.

Specifications

Frequency Range	470 to 960 MHz
Power Rating (Avg. at 8000 ft. max. ele.)	25 kW
RF Input Impedance	50 ohms
Ambient Temperature:	
Maximum	45°C
Minimum	5°C
Mounting	Horizontal, water output up
Water Required (Potable tap)	4.5 to 8.3 gpm (40°C max.)
Dimensions: (including	
Thru-line)89 1/4" long, 5 3/4" wide, 5 3/4" high
	(226.85 cm, 14.61 cm, 14.61 cm)
Weight: (including Thru-line)	50 bs. (22.68 kg)

Accessories

Connector (anchor insulator)	MI-19089-10A
Thru-line RF Wattmeter (0-15 kW for MI-19198-A2)	MI-27350*
Thru-line RF Wattmeter (0-25 kW for MI-19198-A2)	MI-27363**

* Line section, 1 wattmeter, 1 wattmeter element (0-15 kW) and 1 wattmeter element (0-1.5 kW).

** Line section, 1 wattmeter, 1 wattmeter element (0-25 kW).

Ordering Information

RF Load Assembly (15/25 kW, 470-890 MHz).....MI-19198-A2

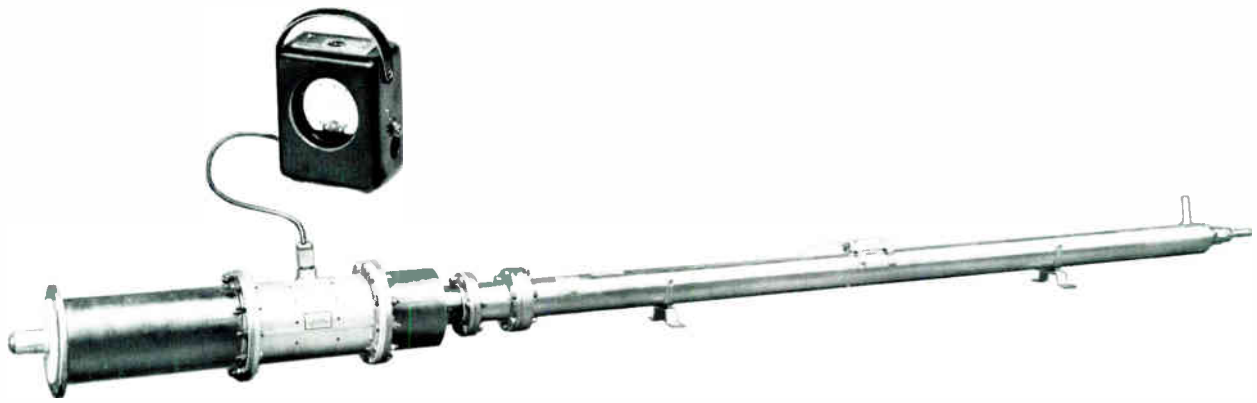

- Reads power directly in watts
- Reads incident or reflected power
- 10/25/50 kilowatt full scale readings

50 KW UHF RF Load and Wattmeter

Description

The ES-561408 50 Kilowatt RF Load and Wattmeter is a water cooled termination type unit for operation with RCA Type TTU-50 UHF Transmitters. The input is 6 $\frac{1}{8}$ -inch, 75 ohm (MI-19387) and may be directly connected to the combined visual transmitter output or the output of the filterplexer. With the aid of an MI-19387-4CH reducer transformer, the unit may be connected to either the aural or individual visual outputs which are 3 $\frac{1}{8}$ -inch, 50 ohm (MI-19089). A thermoswitch is also provided.

ES-561408 consists of a transformer, a ThruLine unit, a reducer and an MI-19198-A2 RF load. The input transformer is designed to match the 6 $\frac{1}{8}$ -inch, 75 ohm transmission line to the 50 ohm ThruLine unit. The ThruLine unit is supplied with three elements and a wattmeter to provide full scale readings of 10, 25 and 50 kilowatts. The individual elements may be turned 180 degrees to provide either incident or reflected power reading. The section reducer matches the 6 $\frac{1}{8}$ -inch ThruLine unit

to the 3 $\frac{1}{8}$ -inch input of the RF load. The transformer, ThruLine and reducer units are supplied as a complete matched and tuned assembly for a specified channel. The RF load

is supplied with all hardware required to mate with the reducer unit. The water flow requirements for 50 kilowatt operation may be found in the following specifications.

Specifications

Frequency Range	470 to 842 MHz
Power Rating (Avg. at 8000 ft. max. ele.)	50 kW
RF Input	6 $\frac{1}{8}$ -inch, 75 ohm coaxial line (MI-19387)
Ambient Temperature:	
Maximum	45°C
Minimum	5°C
Mounting	Horizontal, water output up
Coolant	Potable tap water 40°C max.
Water Requirements (typical)	9.7 gpm @ 10°C to 16.4 gpm @ 40°C
VSWR	1.1 Maximum
Dimensions (overall).....	114-13/32" long, 8 $\frac{1}{8}$ " (greatest diameter) (290.6 cm long, 20.64 cm greatest diameter)
Weight (approx.)	80 lbs. (36.28 kg.)

Accessory

Reducer TransformerMI-19387-4CH*

Ordering Information

50 kW UHF RF Load and WattmeterES-561408-CH*

* Specify channel in purchase order.

Index

	MI No.	Page
Adaptor, Type N to Type HN.....	19089-19	109
Amplifier, Distribution, Type TA-33.....	ES-556933	50
Amplitude Equalizer	34035	50
Analyzers:		
TV Sideband Response, Type BW-5C.....	ES-34010-C	57
TV Sideband Response, Type BWU-5C.....	ES-34009-C	57
Antennas:		
UHF TV Pylon.....	Custom	69
"Zee" Panel	Custom	89
"Vee-Zee" Panel	Custom	89
Cable, Coaxial RG-8/U	MI-74A	60
Carrier-Off Monitor	ES-27235	52
Chopper Relay	#211711	56
Connector, Anchor Insulator	19089-10A	109
Couplers:		
Directional, for use with MI-19089 Transmission Line	ES-34231-1, 2	60
Directional, for use with MI-27791 Transmission Line	ES-34231-1, 8	60
Directional, for use with MI-19387 Transmission Line	ES-34232-1, 2	60
Directional, for use with MI-27792 Transmission Line	ES-34232-1, 5	60
Console, Transmitter Control, Type TTC-5B	ES-561900	45
Demodulators:		
Visual Sideband, Type BW-4B (FCC)	ES-34048	55
Visual Sideband, Type BW-4B (CCIR)	MI-826557	55
Visual Sideband, Type BWU-4B (FCC)	ES-34049-B	55
Visual Sideband, Type BWU-5B (CCIR)	826559	55
Directional Coupler, For use with:		
MI-19089 Transmission Line	ES-34231-1, 2	60
MI-27791 Transmission Line	ES-34231-1, 8	60
MI-19387 Transmission Line	ES-34232-1, 2	60
MI-27792 Transmission Line	ES-34232-1, 5	60
Distribution Amplifier, Type TA-33	ES-556933	50
Envelope Delay Measuring Equipment:		
Type BW-8A (FCC)	34063	61
Type BW-8A1 (CCIR)	34068	61
Equalizer, Amplitude	34035	50
Exciter, Spare Group (for TTU-50C Transmitter)	ES-560281	36
Filters:		
Low Pass Video	27132-A	51
UHF Harmonic (Channels 14-43)	561549-L-CH	63
UHF Harmonic (Channels 44-83)	561549-H-CH	63
Filterplexers:		
2 kW UHF	19086-HM	65
12½ kW UHF	19086-J	65
30 kW UHF	19086-F	65
60 kW UHF Waveguide (Channels 14-43)	561550-CH	67
60 kW UHF Waveguide (Channels 44-83)	561551-CH	67

	MI No.	Page
Frequency and Modulation Monitors:		
115 Volt, 50 Hertz	Model H02-335-ER	53
115 Volt, 60 Hertz	Model 335-ER	53
230 Volt, 50 Hertz	Model H03-335-ER	53
Generator, Marker	WR-99A	56
Hangers, Transmission Line		107
Harmonic Filters:		
For UHF Channels 14-43	561549-L-CH	63
For UHF Channels 44-83	561549-H-CH	63
Low Pass Video Filter	27132-A	51
Marker Generator	WR-99A	56
Meter, Plate Current	21200-C1	56
Monitors:		
Carrier-Off	27235	52
Frequency and Modulation, 115V 50 Hz	Model H02-335-ER	53
Frequency and Modulation, 115V 60 Hz	Model 335-ER	53
Frequency and Modulation, 230 V 50 Hz	Model H03-335-ER	53
Monitoring Diodes:		
UHF	19364	64
VHF	19051-B	56
Mounting Frame	577300	50
Oscillator, TV Sweep	WR-69A	56
Oscilloscopes:		
General Purpose	WO-91B	60
Wide Band	TO-524AD	56
Phase Equalizer Equipment Complete	ES-34034-B	49
Plate Current Meter	21200-C1	56
Power Distribution Modules:		
For 115V, 60 Hz	556648-1	50
For 230V, 50 Hz	556648-2	50
Pressurizing Equipment		108
Pylon Antennas:		
TFU-6C	Custom	72
TFU-6J	Custom	72
TFU-24DL	Custom	73
TFU-24DM	Custom	73
TFU-27DJ	Custom	73
TFU-30J	Custom	74
TFU-25G	Custom	74
TFU-46K	Custom	74
TFU-24DAS	Custom	74
TFU-30JDA	Custom	74
Reducer, 50 Ohm 3 $\frac{1}{8}$ " to Type N	19089-17	109
Reducer Transformer	19387-4-CH	111
Relay, Chopper	#211711	56
RF Loads:		
1200 Watt (Including Wattmeter)	19197	109
15/25 kW UHF (470-890 MHz)	19198-A2	111
50 kW (Including Wattmeter)	ES-561408-CH	111
Sideband Response Analyzers:		
VHF Type BW-5C	ES-34010-C	57
UHF Type BWU-5C	ES-34009-C	57

	MI No.	Page
Switches, Transmission Line		108
Towers, Television Antenna	Custom	97
Transformer, Reducer	19387-4-CH	111
Transmission Line:		
3 $\frac{1}{8}$ " Bolt Flanged 50 Ohm	19089	105
6 $\frac{1}{8}$ " Bolt Flanged 75 Ohm	19387	105
3 $\frac{1}{8}$ " Universal 50 Ohm	27791-D	105
6 $\frac{1}{8}$ " Universal 75 Ohm	27792-D	105
9 $\frac{1}{16}$ " Universal 75 Ohm	27793-D	105
Transmission Line Hangers		107
Transmission Line Section (for mounting BW-5C Directional Coupler):		
3 $\frac{1}{8}$ " 51.5 Ohm Flanged Transmission Line	19313-48	60
3 $\frac{1}{8}$ " 51.5 Ohm Flanged Transmission Line	19313-49	60
3 $\frac{1}{8}$ " 50 Ohm Transmission Line	27912-12	60
Transmission Line Switches		108
Transmitter Control Console, Type TTC-5B	ES-561900	45
Transmitters:		
Type TTU-2A 2 kW UHF 208/240 V, 60 Hz	ES-560237	5
Type TTU-2A 2 kW UHF 380/415 V, 50 Hz	ES-560240	5
Type TTU-10A 10 kW 208/240 V, 60 Hz	ES-560243	13
Type TTU-10A 10 kW UHF 380/415 V, 50 Hz	ES-560246	13
Type TTU-30A 30 kW UHF 440/460/480 V, 60 Hz	ES-560250	21
Type TTU-30A 30 kW UHF 380/400/415 V, 50 Hz	ES-560253	21
Type TTU-50C 55 kW UHF 440/460/480 V, 60 Hz	ES-560275	29
Type TTU-50C 55 kW UHF 380/400/415 V, 50 Hz	ES-560277	29
Type TTU-50C1 55 kW UHF 440/460/480 V, 60 Hz	ES-560276	37
Type TTU-50C1 55 kW UHF 380/400/415 V, 50 Hz	ES-560278	37
Type TTU-150A 150 kW UHF	Custom	—
Tubes:		
Complete set of spares for TTU-2A	ES-560238	12
Complete set of spares for TTU-10A	ES-560244	20
Complete set of spares for TTU-30A	ES-560251	28
Complete set of spares for TTU-50C/50C1	ES-560279	36
Minimum set of spares for TTU-2A/10A	ES-560239	12
Minimum set of spares for TTU-30A/50C/50C1	ES-560252	28
Spares for Carrier-Off Monitor	27825	52
FCC spares for Carrier-Off Monitor	27831	52
Set of spares for BW-4B	34014	56
Set of spares for BWU-4B	34015	56
"Vee-Zee" Panel Antennas	Custom	89
Visual Sideband Demodulators:		
Type BW-4B (FCC)	ES-34048	55
Type BW-4B (CCIR)	826557	55
Type BWU-4B (FCC)	ES-34049-B	55
Type BWU-4B (CCIR)	826559	55
VoltOhmyst (Senior Model)	WV-98C	56
Wattmeters:		
RF Thruline (0-15 kW for MI-19198-A2)	27350	110
RF Thruline (0-25 kW for MI-19198-A2)	27363	110
Waveguide Filterplexers:		
60 kW for UHF Channels 14-42	561550	67
60 kW for UHF Channels 43-83	561551	67
"Zee" Panel Antennas	Custom	89



The Most Trusted Name in Television

RADIO CORPORATION OF AMERICA

BROADCAST AND COMMUNICATIONS PRODUCTS DIVISION, CAMDEN, N. J. 08102 • RCA INTERNATIONAL DIVISION, CENTRAL and TERMINAL AVENUES, CLARK, NEW JERSEY, U.S.A. 07066

UHF-62366

Tmk(s)® Marca(s) Registrada(s)

Printed in U.S.A.