

SPARTA ASC-305B
STEREO STUDIO CONTROL
AND REMOTE UNIT

MODEL

DESCRIPTION ASC-305B

The ASC-305B Stereo Studio Control and Remote Unit consists of a Studio Control Console (cabinet) two twelve-inch professional turntables, two TEP-3S Stereo Preamplifiers, an MCA-1 monitor-amplifier and the AS-30B Stereo Audio Console.

CONSOLE AS-30B

The AS-30B Console may be used separately from the ASC-305B cabinet by simply removing the quick-disconnect connectors from the rear panel. It may be battery-operated or the power supply may be easily removed also from the ASC-305B.

PREAMPLIFIERS

Preamplifiers are located on the lower shelf, one on each side, and feature separate level controls for left and right channel output. These are preset for proper level but may be changed if needed for new or different cartridges. Additional information, plus maintenance data is included in a later section.

MONITOR AMP, MCA-1:

An MCA-1 monitor amp is also located on the lower shelf near the operator's knee. A level switch supplies either Cue or Program audio to the monitor speaker located in the console cabinet.

Adequate power is available to drive an alternate, external 8 ohm speaker if desired. Appropriate schematics are included with the AS-30B schematics.

DESCRIPTION ASC-305B (Cont'd)

TURNTABLES

The ASC-305B may be equipped with either four-pole or synchronous motor driven turntables. Another section provides additional information.

TONE ARMS

The ASC-305B is supplied standard with SPARTA ST-220 Professional Stereo tone arms and are designed so highly accurate adjustment may be made visually for optimum overhand and tracking-force. Other tone-arm options are available.

FEATURES

Portable Cabinets:

Finish.....	Walnut wood grain & Dove bonded plastic laminate
Unit set-up Dimensions.....	Overall, including legs & lift leaf extended 34" high (28" to work surface) 51 1/2" wide, 25 3/4" deep.
Bench/Lid Dimensions.....	Legs installed 16 1/2" high, 49 1/2" wide, 19 1/2" deep.
Closed Case Dimension.....	Bench/Lid installed 14 1/2" high 51 1/2" wide, 19 1/2" deep.
Shipping Weight.....	185 Pounds

AS-30B Console:

9 stereo pairs 1 each for mixers 1 through 4 and 5 for mixer 5.

Standard equipment of the AS-30B as supplied with the ASC-305B includes a pair of microphone preamplifiers in channel 1, plus stereo equalized phono preamplifiers for inputs to channels 2 and 3.

TONE ARM

The SPARTA Model ST-220 Professional Stereo Tone Arm reflects the high quality and scientific design needed for the superior reproduction of phonograph records. It permits the use of lower tracking forces for which the latest cartridges are designed. The Tone arms can be precision balanced and are so designed that a highly accurate adjustment of the tracking force can be made visually. Some of the outstanding features are: All cartridges can be adjusted for correct overhang to insure optimum tracking. The plug-in head assembly is rigidly locked in place, but very easily removed when necessary. Precision ball-bearings are used throughout on all pivot surfaces.

ST-220 PROFESSIONAL STEREO TONE ARM

FOR BROADCAST APPLICATIONS

USING HIGH COMPLIANCE CARTRIDGES



FEATURES

- CONSTRUCTION:** Light alloy arm, with low-mass cartridge shell
- MOUNTING:** 7/8" diameter single hole, 1" long threaded shank
- ROTATION:** Miniature precision ball bearing
- LATERAL BALANCE:** Adjustable, to compensate for variations in center of gravity between various cartridges
- TRACKING FORCE ADJUSTABLE:** Movable weight, with locking screw, adjusts tracking force for any cartridge
- HEIGHT ADJUSTABLE:** Locking screws on shafts of arm and rest adjust height of arm from 40-60 mm (1-9/16" - 2-3/8")
- CARTRIDGE SHELL REMOVABLE:** Uses international standard 4 pin connector
- CONNECTING CABLE PLUG-IN:** 5' cable plugs into base of arm, has color-coded phono plugs and ground wire

SPECIFICATIONS

- TOTAL LENGTH 310 mm (12-13/32")
- EFFECTIVE LENGTH 220 mm (8-21/32")
- OVERHANG 15 mm (19/32")
- OFFSET ANGLE 22°
- LATERAL BALANCE Adjustable, all cartridges
- STYLUS PRESSURE ... Adjustable, 1-6 grams recommended, depending on cartridge
- TRACKING ERROR + 4°, - 1°

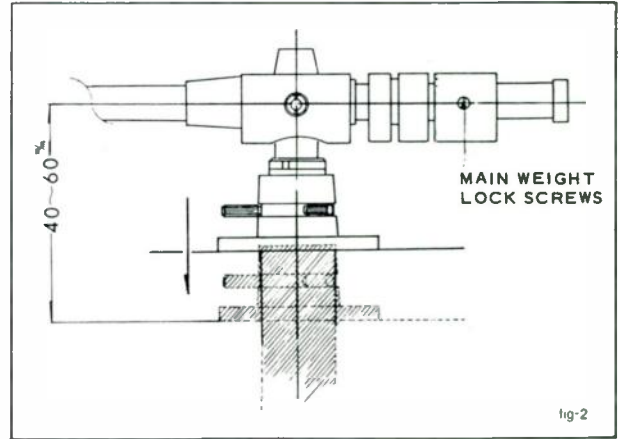

fig-2

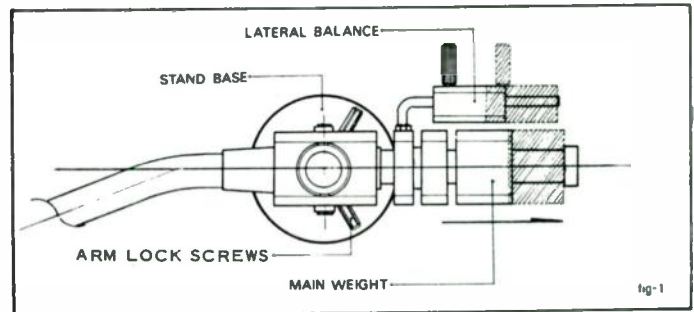
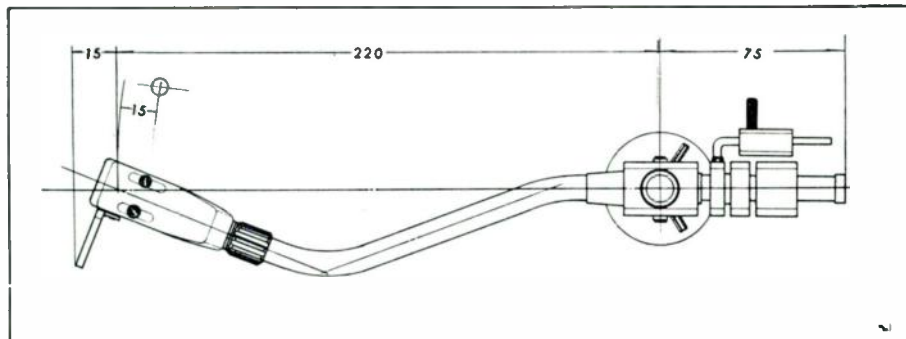

fig-1



TECHNICAL MANUAL
SPARTA
GT-12 TURNTABLE

INSTRUCTIONS FOR OPERATION 2 SPEED TRANSCRIPTION TURNTABLES

SPARTA Turntables are shipped completely assembled. Shipping materials such as blocks, cardboard, etc., should be removed and the table thoroughly checked for possible damage incurred in transit.

Connect 115V 60 cycle AC (unless otherwise ordered or specified) only to terminals marked in red.

INSTALLATION: The table should be solidly mounted to operating table or desk. DO NOT USE SPONGE RUBBER OR OTHER RESILIENT MATERIAL BETWEEN TURNTABLE CHASSIS AND MOUNTING SURFACE! This is especially important where reproducer arm is of such length that it cannot be mounted directly on the turntable chassis.

OPERATION AND ADJUSTMENTS: Turntable speed is controlled by 3 factors: (1) speed of motor in RPM, (2) diameter of motor pulley (capstan) (3) diameter of inside rim of turntable. Diameter of idler has no effect on table speed, hence no speed change occurs as idler wears. Speed change is made by placing speed change arm in one of the two slots, top for 33-1/3, and bottom for 45 RPM. A "Neutral" position is provided between the slots, and when not in use the shift arm should be left in neutral position to prevent "flats" on the idler.

Both of the slots have an adjustable stop which limits the travel of the arm. While a slight change can be made in table speed by adjusting these stops, their purpose is to limit the pressure between motor pulley-idler and table rim.

INITIAL ADJUSTMENT IS AS FOLLOWS: Screw in (clockwise) (45 RPM) screw until motor ceases to drive table, then back out screw slowly until just enough pressure is applied to give satisfactory acceleration. Best results will be realized by using the least possible pressure consistent with adequate driving power. Too much pressure will cause undue wear on the idler, cause incorrect speed and induce vibration.

LUBRICATION: MAIN TURNTABLE SHAFT: Main turntable shaft should be wiped clean with clean lintless cloth and bearing well should be cleaned with cloth wrapped around wooden dowl to remove gummy deposits of dirt and oil. Relubricate by applying lubriplate #3 Special Product Oil. If not available use S.A.E. 30 automotive oil. A small dab of Lubriplate should be applied to the ball on the end of turntable shaft. This lubrication procedure should be followed every two weeks -- every week if table is used in a 24 hour operation.

IDLER BEARING LUBRICATION: The idler bearing is made of oilite; a material consisting of small bronze particles pressed together with microscopic passages between them. These passages are impregnated with oil. This bearing material contains enough oil for several years of bearing life. Should the idler tend to become stiff on the shaft and not rotate freely, this would indicate that the bearing no longer has sufficient oil for lubrication. At this time the idler should be removed, the shaft and bearing wiped thoroughly with a clean lintless cloth and the bearing relubricated with a light oil such as 3 in 1 oil.

BODINE SYNCHRONOUS MOTOR: This motor is equipped with oil cups located on the side of top and bottom bearing. The bearings on these are of the solid bronze sleeve type, equipped with a felt wick to carry oil to the shaft. Ordinary lubrication at two month intervals with a couple of drops of oil per bearing is sufficient. Grade #10 non-detergent oil is recommended.

UNIVERSAL ELECTRIC FOUR POLE MOTOR: This motor comes equipped with oilite bearings and ordinarily needs no lubrication attention during its life. If the turntable is located in an unusually hot location it is possible for the oil in these bearings to change viscosity to the point where the motor shafts will be so stiff that the motor will have trouble starting. Under these conditions, the motor should be removed from the turntable, disassembled, and the bearing and shaft cleaned. The bearing then should be thoroughly saturated with a light oil such as 3 in 1. The motor then can be reassembled, reinstalled on table and table restored to further usage.

IDLER ADJUSTMENTS: Note that the motor is attached to its hanger with screws or bolts through elongated holes. If, due to wear, (reduction of diameter) of the idler, it becomes impossible to secure adequate driving power with the shift arm at the extreme left hand end of the speed selector slot, moving the motor toward the rim of the table will give correct driving pressure more toward the center of the speed change slot. If a new idler makes it impossible to obtain a "neutral", the motor is simply moved away from the table rim until a suitable arm position in the slot is obtained.

IDLER DRIVING SURFACE: It is extremely important that the driving surface of the idler and the inside rim of the turntable be kept clean of oil or other contaminating substances. During the first few weeks of operation, the idler driving surface and the inside rim of the table should be cleaned with methyl alcohol at weekly intervals. No further attention should be needed unless these areas are subject to oil overflow from the idler due to over-lubrication. If the idler or table rim becomes contaminated with oil, the only satisfactory solution is to clean the table and idler thoroughly with hot water and detergent.

NOISE, HUM, RUMBLE: Many pickups are subject to hum caused by the magnetic field of a motor. Before installing pickup arm on table, it is wise to move the pickup head to various locations on the platter, with the motor operating but with the idler in "neutral". This should help in locating the mounting position of the arm which will cause the least hum. Noise is divided into two classes, mechanical and electrical.

Noise that can be heard without amplifier or pickup in operation, can usually be traced to its source by comparing the noise with the speed of the motor, idler or table itself. If noise is constant at all speeds it probably originates in the motor. If it increases with table speed, but its frequency is greater than table speed, it can usually be traced to the idler. If the noise varies with table speed and has the same frequency, look for something on the table rim, such as oil, dirt or possibly a crack in the table casting. In the case of noise traced to the idler, look for dirt on idler driving surface, pits, or foreign material imbedded in idler driving surface. Check felt thrust bearing under idler to be sure idler is not riding directly on metal boss at bottom of idler shaft. Too much idler tension can cause idler to rise on its shaft and noise is heard as the idler contacts the idler retaining ring.

Rumble more or less constant at all table speeds can usually be traced to the capstan. Again, too much idler tension will aggravate rumble caused by an out of round or wobbly condition in the capstan, (motor pulley). Noise caused by "flats" in the idler will run out in a few minutes because of the "self-healing" nature of the neoprene used in the idlers. Put table in 45 RPM position and let run for a few minutes.

SPARTA ELECTRONIC CORPORATION will be glad to assist in any problems in connection with operation or maintenance of the tables. To insure a minimum of delay, please give as much information as possible in connection with the problem, such as serial number of table, date purchased, whether problem is new or of long standing, type of pickup and arm used, whether problem is different at different table speeds, whether it is only in evidence when idler is driving table, etc. The more information supplied, the easier it will be to provide suggestions to eliminate the difficulty.

SPARTA ELECTRONIC CORPORATION
5851 Florin-Perkins Road
Sacramento, California 95828

TURNTABLE
PARTS LIST (Replacement)

PART NO.	DESCRIPTION
890-2010	Platter
2015	Platter bearing assembly
2020	Shift knob and set screw
2025	Shift lever and nut
2035	Shift mechanism vertical compression spring and hardware
2040	Shift mechanism return spring
2045	Paddle switch assembly
2050	Paddle assembly microswitch
2055	Indicator lamp
2060	Capstan and set screws
2065	Idler wheel
2070	Idler wheel arm assembly
2075	Idler wheel adjusting screws
2080	Motor (sync.) and mounting hardware
2085	Sync motor end play adjustor
2090	Sync motor capacitor
2095	Motor capacitor mounting bracket
2100	Motor (4 pole) and mounting hardware
2105	Motor mounting plate
2110	Shock mounts (motor) and hardware
2115	Switch capacitor
2120	Terminal strip
2125	Grounding strap
012-0590	Microswitch

SERVICE MANUAL

SPARTA RIAA/ NAB
Equalized Preamplifiers
Model TEP 3S Stereo
Model TEP 3M Monaural

1971

TEP 3S, TEP 3M PHONO EQUALIZED PREAMPLIFIERS

SPECIFICATIONS

FREQ. RESPONSE: RIAA (NAB) within typical ± 0.5 db ($+ 1$ db max).

OUTPUT LEVEL, PROGRAM: β dbm into 600 ohms balanced,
adjustable to below -20 dbm.

OUTPUT LEVEL, MAX: $+10$ dbm (12 to 14 dbm typical)

DISTORTION: Less than 0.1% (0.03% typical) THD.

INPUT IMPEDANCE: 47K ohms. Can be changed.

SENSITIVITY: 5 millivolts for β dbm output at 1 KHz.

NOISE: 70 db below Program Level. More than 80 db below max. output.

HUM: Inaudible and virtually un-measurable. (Below noise)

SEPARATION: Stereo: 70 db typical (65 db min.)

SIZE: Width, 4.5". Height 2.6", Depth 6.5"

WEIGHT: 1 lb. 6 oz.

POWER: 110 to 125 VAC, 50-60 Hz., 0.25A

MOUNTING: Rubber feet plus two single-hole "Z"clamps.

INSTALLATION: Please Read Carefully!

As with all electronic instruments, best performance will be assured by following good wiring practices and proper installation procedures.

RCA type phono input connectors are provided plug a ground terminal for the turntable frame lead and tone-arm shell ground, if part of the tone-arm cable.

The tone-arm cable length should not exceed 30 inches, to avoid excessive shunt capacitance which could result in losses of the higher audio frequencies.

Output connections are via an Amphenol 91 series connector. When soldering the output cables, be certain not to leave excess solder on the pins which might distort the mating socket, and carefully remove any remaining flux or rosin before engaging the connector. Additional information will be found in the following:

DESCRIPTION section under "output".

A common cause of RFI in low-level audio equipment occurs when a connecting cable length represents a multiple of an electrical quarter-wave at the frequency of a nearby transmitter, and thereby acts as an antenna. Connecting cable lengths should be chosen slightly longer than required so they can be re-routed or shortened electrically by folding-over and tying the excess length. Always avoid excess cable lengths and never coil audio connecting cables.

In strong RF fields, these same conditions may apply to the AC power-cords in a system; excess or critical lengths should be avoided. In extreme circumstances it may be necessary to experiment by adding or removing various system grounds

INSTALLATION (cont'd)

to find the best combination.

The output circuit of the TEP-3 series is a transformerless para-phase inverter

which avoids the problems associated with cascaded output and input transformers.

This contributes significantly to the excellent equalization and freedom from ex-

taneous hum pickup of the TEP-3s. Please read the following description thoroughly

to obtain the maximum benefit from this feature.

DESCRIPTION:

The SPARTA TEP 3S (Stereo) and TEP 3M (mono) preamplifiers are completely self-contained and equalized for use with any modern variable-reluctance or magnetic cartridge. They offer a combination of capabilities and performance features rarely, if ever, found in other phono-equalized preamplifiers for broadcast use.

Most significant is the use of a dual (stereo) integrated-circuit (IC) in the amplifier proper. The extremely high open-loop gain (typ. 20,000) allows both the operating gain and equalization to depend solely on the characteristics of simple passive components, which provides inherent long-term stability and reliability. In addition, the s/n ratio of the IC is equal to or better than can be obtained in discrete designs, which leaves the noise performance primarily dependent upon the resistors used in the external circuitry.

Other preamplifiers are specified at 10 or 12 mv. input for rated output. But most modern, high-performance cartridges provide less than 10 mv. output at normal program level, with some as low as 5 mv. So the SPARTA TEP 3S and TEP 3M preamplifiers were designed with added gain for the newer low-output cartridges without compromising any other performance feature. An interesting side benefit comes about when gain is adjusted lower to accommodate high-output cartridges; The gain reduction also reduces the noise, resulting in further improvement of the already-excellent noise figure.

The input impedance of each channel is set at 47K ohms by an internal

DESCRIPTION: (cont'd)

resistor. This is the proper value for virtually all monaural and stereo cartridges, but can easily be changed, if need be, by referring to the schematic diagram. Care should be taken to use only deposited-film, low-noise resistors.

The self-contained power-supply is extremely well regulated and will maintain proper performance below 110V AC input. This results in an output hum-level that is virtually un-detectable and completely masked by normal "white" noise produced by various circuit resistances.

OPERATION:

Gain Adjustment: During final test at SPARTA, the gain (sensitivity) of the TEP 3S or TEP 3M is set for 0 dbm output with 10 mv. input. If they were set for higher sensitivity, then operation with a high output cartridge would provide more than 0 dbm output and seriously decrease the available headroom for program peaks. If the output level of your cartridge is unknown and you do not have an NAB test record plus the means to accurately measure the preamp output level, it is suggested that the gain controls be left at the factory setting.

With a test record and a suitable meter, the 1 KHz reference tone at 7 cm/sec velocity (lateral) can be played and the gain controls set for 0 dbm output across 600 ohms (774 mv.) or for -6 dbm (387 mv.) from either plus or minus output to ground (shield). This will assure the maximum program output level while maintaining a minimum of 10 db head room. Note that the 7cm/sec. lateral test tone will produce the same level in each channel of a stereo unit as a 5cm/sec left or right channel only tone will.

OPERATION (Cont'd)

Balance. Since a lateral test-tone should produce equal outputs from each half of a stereo cartridge, the method described automatically assures a balanced output from the preamp system, for the gains are being set also to compensate for any cartridge unbalance. Further tests may be made at other frequencies to determine if the system is retaining proper balance throughout the audio range.

Balance may also be set by playing a mono record and noting the console VU meters. Balance should be accomplished by reducing gain of the channel which is too high, which again insures that gains have not been increased to the detriment of the adequate headroom.

Input is made via a standard phone jack plus a separate front-panel ground stud.

The stud is provided for the separate tone-arm-shell ground lead which is often provided and is also the proper place to connect the turntable frame ground. Tone-arm to preamp cables should not be much longer than 30 inches since excessive capacitive loading will affect the cartridge high-frequency response.

Output is taken from the six-pin panel socket using the plug-in connector provided. Refer to the schematic diagram for proper connections, noting that pins 1 and 2 are not used on the TEP 3M (monaural) and taking care to note proper output phasing on the TEP 3S (stereo) as indicated by the polarity indications.

It should also be noted that outputs are true differential balanced-to-ground in the standard versions, and care must be taken that neither output is shorted to ground. If single-ended output is needed for testing purposes, it can be taken from either plus or minus output and ground, with the attendant 6db

OPERATION (Cont'd)

Output (cont'd)

reduction in overall output level.

Output connections are normally made with standard, twisted-pair shielded audio cable, although separate single shielded cables will work equally well. The source impedance of the TEP 3S/M is quite low, so cables of any reasonable length may be used. In the interest of RFI reduction, however, the cables should be no longer than required and the shields may be left floating at one end only, usually the source end, to prevent magnetic field pickup. The best arrangement can be determined experimentally for the individual installation. As stated earlier, hum is virtually non-existent in the TEP 3S/M. If hum is experienced in a final installation, it will most likely be due to pickup in the cartridge or tone-arm leads. This can be determined by shorting the preamp inputs with shorting-plugs. If the hum disappears, it was introduced before the preamp. Similarly, disconnecting the preamp output plug will determine if hum is coming through or from the preamp. If the output cable shield was originally connected to the preamp output shield terminal (3), it should be disconnected and the plug then reinserted to eliminate any ground-loops through the shield. Also, it is worthwhile to determine if the load (console) has a grounded center-tap on the primary of the input transformer. If so, this ground should be broken, so the input is isolated from any possible ground-loops.

Rumble filter. Both the TEP 3S and TEP3M preamps incorporate rumble suppression in the form of a controlled low-frequency characteristic as described in the Circuit Theory section. Response is shaped so as to be nearly 2 db down at 30 Hz and 3 db down at 20Hz., approaching a 12db-per-octave slope at the usual rumble frequencies. The suppression thus obtained is more than

OPERATION (Cont'd)

Rumble filter (cont'd)

adequate for essentially rumble-free operation with any reasonable turntable, without restricting low-frequency reproduction of program material.

High frequency filtering. As indicated earlier, the input impedance of the TEP 3S and TEP 3M preamplifiers is 47 K ohms. If a cartridge is terminated in a higher-than-optimum impedance, undesirable high-frequency peaking will result. If a lower value is used, however, the terminating resistor with the cartridge inductance will result in a rolloff of the higher frequencies. Filtering, then, can be obtained simply by providing a lower terminating resistance. The proper value is best determined by trial-and-error until the desired rolloff is obtained. A resistor may then be added directly across the input phone jack(s) without altering components on the circuit board.

MAINTENANCE - Circuit Theory:

Power Supply: The TEP 3S/M power supply is a hard-regulated design capable of supplying 30 to 33 VDC at 40 ma continuous. The output voltage is determined by the values and tolerances of Z22, R5 and R6. Since these are 5% tolerance components, it would theoretically be possible for the output voltage to fall between 29.1 and 33.9 volts. In final test, however, one of those components is changed, if required, to hold the voltage within proper limits. The maximum load current is determined primarily by the limits of the power transformer, T1.

Normal operation is as follows: The rectified DC supplied by T1 and diodes D1 and D2 provide a nominal 40 V DC across filter capacitor C2. This voltage will vary between mono and stereo units and also vary with input line voltage. Proper operation can be expected with as low as 34 to 36 volts, however, so long as this voltage is 4 or 5 volts higher than the expected output voltage.

When first turned on, the voltage from C2 causes current-flow through R2, R3 and the emitter-to-base junctions of Q2 and Q1. Q2 is a Darlington driver, or current-multiplier, so Q1 and Q2 may be considered as a single transistor with very high current-gain (h_{fe}).

Q1 will conduct very heavily, delivering current through the load until the output voltage rises to rated level. During this rise, Q3 has not been able to conduct because the emitter has been rising with the output voltage, but the base voltage has been lower than the emitter due to divider R5/R6. With Q3 not conducting, all of the current through R2 and R3 is being used to turn on Q1/Q2.

MAINTENANCE - Circuit Theory:

Power Supply (cont'd)

When the output reaches 22 volts, zener diode Z22 begins to conduct and prevents the emitter of Q3 from rising further. But Q3 still cannot conduct until its base voltage has risen 0.6 volts higher than its emitter. This cannot occur, due to divider R5/R6, until the output voltage reaches the proper level.

As the output voltage attempts to rise above normal, Q3 comes into conduction and draws current from R2/R3, which in turn decreases the drive current to Q2. Thus, a state of equilibrium is reached wherein any tendency of the output voltage to change will signal Q2 to cause an increase or decrease in base drive to Q2.

C1 protects diodes D1 and D2 from line transients. C3 prevents dc pulses from the power supply from reaching Q2 and appearing in the output and also causes a slow turn-on characteristic. R1 limits the peak current through the diodes at turn-on and also limits the power dissipation in Q1. C4 filters the zener noise and C5 improves the ac regulation by bypassing the attenuator R5/R6. There is a frequency in the several-hundred KiloHertz region where phase-shift through Q3, Q2 and Q1 would exceed 180 degrees. C6 reduces the loop gain of the regulator circuit to less than unity to prevent oscillation.

Troubleshooting. When servicing solid-state circuits, a knowledge of only a few characteristics of transistors plus the application of a little thought is usually all that is needed. For example (1) a normally-operating silicon transistor will always have a base voltage that is about 0.6 volts different than the emitter, i.e. the emitter-to-base junction must be forward-biased (0.25v for germanium). (2) The collector voltage will always lie between

MAINTENANCE - Circuit Theory:

Troubleshooting (cont'd)

the emitter voltage and the collector supply voltage. (3) If we short the emitter to the base, the transistor should turn off, so the collector will look like an open circuit and the collector voltage will rise towards the supply voltage.

Considering these factors, let us now apply them to several possible power supply malfunctions:

1. No output voltage.

a) Voltage across C2 higher than normal would indicate that Q1/Q2 is not conducting. If the voltage at Q2's base indicates that both Q1 and Q2 have normal forward bias, then collectors of Q1 and Q2 must be open. If the bias voltage of Q1 or Q2 is much more than 0.6v each, then either a base or an emitter must be open.

b) Voltage across C2 lower than normal would indicate excessive load current and suggest a shorted C6, in which case Q1 and R1 would be very hot. In this event, either Q1, Q2 or R1 would probably burn open and result in (a) above.

2. Output voltage high.

This would indicate that Q3 is not diverting current from R2/R3, allowing Q2/Q1 to turn on full. Check for normal zener voltage at the emitter of Q3 and then for normal base voltage at Q3. An open zener will raise the Q3 emitter, or an open R5 will lower the Q3 base -- either one will turn off Q3. If the emitter-to-base voltage of Q3 is normal, then Q3 must have an open collector.

3. Output Voltage low.

In all such cases, the first step is to determine the status of Q3 by

MAINTENANCE - Circuit Theory:

3. Output Voltage low; (cont'd)

measuring emitter and base voltages. Next, determine that Q3 is responding to the base voltage by shorting Q3 emitter to base -- the output voltage should rise. If it does rise, it almost certainly indicates a failure in the base divider such as an open R6 or shorted C5. If it does not rise it is very likely that Q3 has an emitter to collector short.

It can be seen by the examples given that the basic approach in transistor servicing is one of determining if the transistor has normal emitter-to-base bias, and then noting if the collector responds normally to a change of this bias, such as complete removal. This explains in part why most companies including SPARTA do not provide transistor sockets -- it is much too easy to determine if a transistor is operable without introducing the likelihood of intermittent socket contacts, quite aside from the added cost factor.

Preamplifier. The TEP 3S and TEP 3M preamplifiers utilize an integrated-circuit operational amplifier; a term which aptly describes its common useage in performing mathematical operations. And the characteristics which make it valuable in computers also make it ideal for use as an equalized preamp.

An "op-amp" is characterized by having differential input terminals; that is, a plus or non-inverting input and a minus or inverting input, and also by having extremely high open-loop gain capability as compared to its normal operating-level gain.

A signal applied to the plus, or non-inverting input, will appear amplified at the output terminal and in-phase with the input signal. The IC op-amp used in the TEP 3 series has a typical open-loop gain of 20,000, so the output will try to be 20,000 times larger than the input signal.

If the output signal is now connected back to the minus, or inverting input, the fed-back signal will act to cancel the input signal. Cancellation will only take place when the two input signals are equal in amplitude and phase (the necessary phase-inversion takes place at the minus, or inverting input), and so, if all the output also appears at the minus input, the output is forced to follow the original signal input and we have a unity-gain, voltage-follower.

Maintenance of the TEP 3 series preamps is made very easy by applying the principle just described to set the DC operating point of the IC amplifier, so that two simple DC voltage measurements are all that is required to

Maintenance (Contd)

assure the IC is operating properly and is capable of responding to the input signal.

Transistors and ICs do, of course, have frequency limitations, but these are included in the original circuit design. And any subsequent failure of a solid-state device will invariably affect both the AC and DC operation of the device. So again, if the IC will respond properly to the DC voltages used to set the operating-point, it will also respond properly to normal signal inputs.

Referring to the schematic diagram, when the circuit is first turned ON, capacitor C2 charges very rapidly to 8 volts or so, or one-half of the voltage at pin 14 of the IC, through divider R3/R2. This voltage also appears through R1 as an input voltage to the IC, so the output at pin 1 swings towards the supply as fast as it can charge C9. At the same time, the output voltage begins to charge C3 through R4, R6 and R7 (We will ignore D1 for the moment).

Because of the high value of R7, C3 will require nearly 40 seconds to charge to 8 volts, but once it does it will cancel the input voltage at pin 5, since the voltage of C3 is also present at the inverting input, pin 6 of the IC. The output voltage will now fall until it is equal to the voltage at pin 5 and a state of equilibrium is reached. Any attempt at deviation appears as an error-voltage at pin 6, and the full open-loop gain of the IC is used to hold the output in agreement with the plus input.

Maintenance (Cont'd)

Since the time-constant of C3/R7 is quite long, the voltage across C3 can only respond to the average, or very low frequencies in the output. At frequencies in the audio range, C3 appears as a near short-circuit so gain is no longer limited to one, or unity. Diode D1 is added so that at turn-on capacitor C3 can charge more rapidly through R4 up to 7.4 volts (the 8 volt reference less the 0.6 volt diode drop). As C3 continues to charge the diode drops out of conduction and plays no further part. This allows the circuit to turn on and stabilize in 10 seconds or less.

To assure that the IC is operating normally, it is only necessary to measure the voltage at pin 5 and then check to see that pin 1 has the same voltage.

If the output voltage is high, the next check is to see if this voltage is getting back to pin 6. Incidentally, these measurements must be made with a high-impedance VTVM or FETVM. If the voltage at pin 6 is also higher than pin 5, the IC is defective. Conversely, if the output is low, it can only be due to an external short or defective IC.

In the stereo TEP 3S these measurements must of course be made for both halves of the IC, using the appropriate pin numbers as indicated on the schematic. It should be noted that IC failures are quite rare, and it is worthwhile to be very sure before going to the expense and trouble of replacing one. If it does become necessary it should be removed very carefully to avoid damaging the PC board. Use of a solder-removing tool or wick is strongly recommended.

Audio operation of the IC amplifier is identical to the DC and low-frequency operation described with the exception of the gain changes allowed by the components in the external feedback network. For all frequencies in the audio range, capacitor C3 is essentially a short-circuit so that R4 now becomes part of a voltage-divider in the feedback path.

At the lowest audio frequencies, the gain is the highest, more than 60db, since the capacitors C6 and C7 have very little effect and the output signal must now be quite high in order to produce a cancelling signal through the feed-back network. As the input frequencies increase, however, more feedback occurs through C6 and C7 and the closed-loop gain decreases accordingly.

So it is apparent that the gain and frequency response are determined strictly by the values and tolerances in the feedback network, primarily R6, R7, C6 and C7. If it is suspected that the amplifier is not within the nominal 0.5 db of the RIAA/NAB curve, this should be carefully verified with an audio generator and output meter known to be accurate within 0.1 db over the audio range. It is not sufficient to rely upon a test record and playback cartridge, since even the best of these are subject to variations of plus or minus a db or more.

Rumble filtering is provided by capacitors C9 and C10 plus resistors R9 through R13. These components allow a rolloff of nearly 2 db at 30 Hz and 3 db at 20 Hz, with a curve approaching 12 db/octave below 20 Hz. In addition, C3 becomes ineffective at 12 to 15 Hz, allowing an even more rapid rolloff towards unity gain.

The output amplifier, Q4, is a paraphase inverter which supplies a balanced, differential output to the external 600 ohm load. The emitter signal is a replica of the base signal, but the collector signal is equal in amplitude and out of phase with the emitter. Therefore, the output amplifier provides a transformerless output with 6 db of added gain, without the weight, bulk, hum-pickup or frequency limitations associated with transformers. Several side-benefits of operational amplifiers are of incidental interest: If the open-loop gain were infinite, rather than just high, the application of negative feedback would reduce distortion to zero because the output would be forced to follow the input exactly. In the TEP 3s, the nominal open-loop gain is 86 db whereas the maximum closed-loop gain is slightly over 60 db. This assures a minimum of more than 20 db of feedback, which accounts for the extremely low distortion, typically 0.03%.

The same negative feedback has the effect of raising the input impedance in direct proportion, so that the actual input impedance of the preamplifier becomes that of the input terminating resistor, R1. This assures perfect termination for the cartridge simply by selecting the correct resistor.

Negative feedback also lowers the output impedance which provides a pure voltage drive for the equalizing components in the feedback network. This further assures that performance depends solely on the feedback components.

The end result is a preamplifier which is hum-free, and represents state-of-the-art performance in regards to noise, distortion and faithful reproduction.

TEP-3 OUTPUT CONNECTIONS

BALANCED

Pin 1	Right output (+)
Pin 2	Right output (-)
Pin 3	Common (See Note)
Pin 4	Left output (-)
Pin 5	Left output (+)

Note: In balanced lines the shield is normally left floating at the audio source and is connected to ground at the audio console. But, if RFI is experienced, it may be necessary to ground the shield at the TEP-3 also.

UNBALANCED

Pin 1	Right output
Pin 2	(not used)
Pin 3	Common Shield
Pin 4	(not used)
Pin 5	Left output

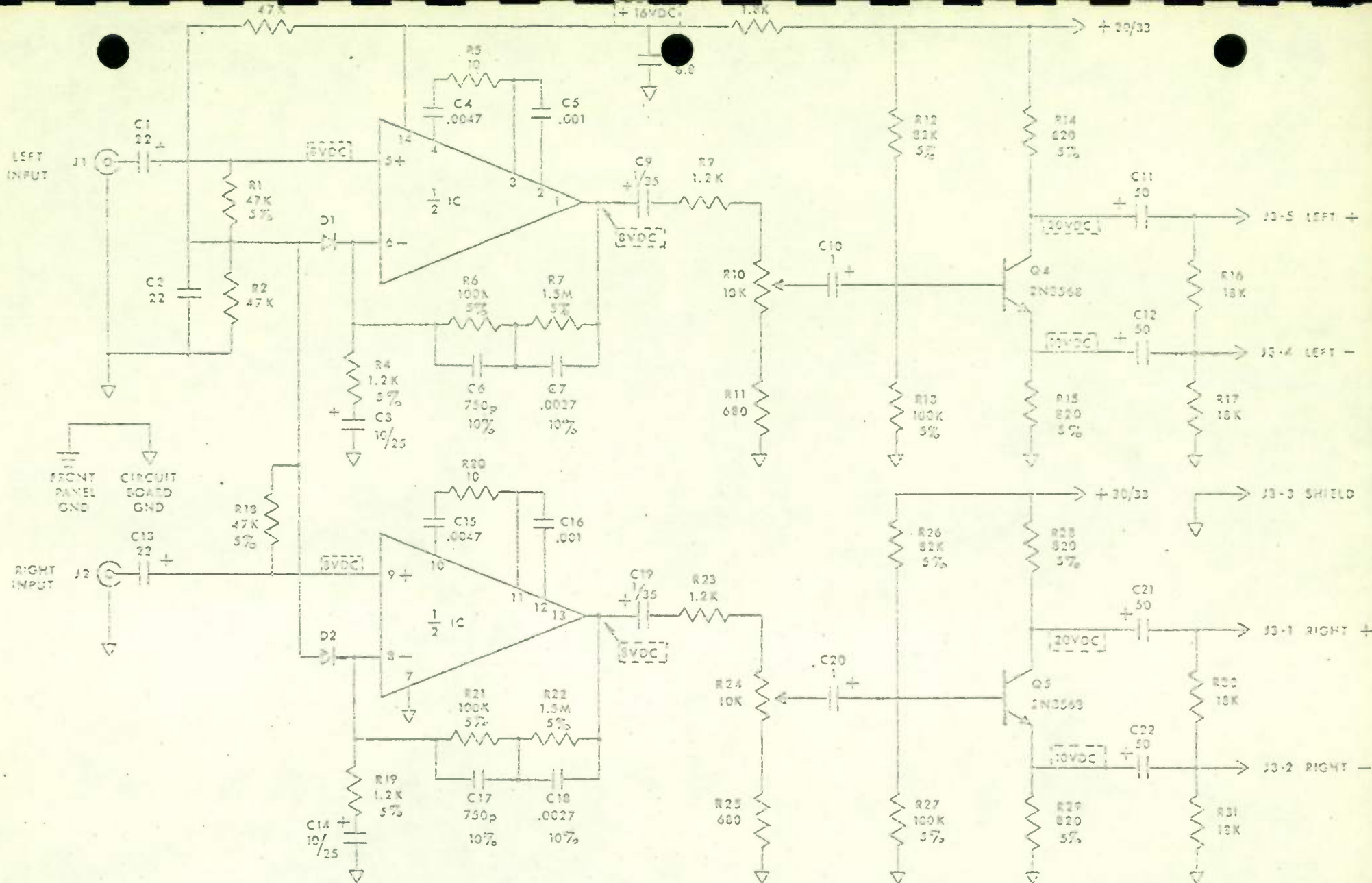

D1,2: 1N4001

I.C.: FSC MUA739
MOT MC 1003

Note: Right channel deleted in mono TEP3M version.

SPARTA ELECTRONIC CORP

TEP3S (STEREO)
TEP3M (MONO)
PHONO SIGNALIZED PREAMPLIFIER

Drawn	Checked	Date	Revised	By
SMU		3-14-70		

SPARTA AS-30B
AUDIO CONSOLE
TECHNICAL MANUAL

AS-30B CONSOLE

SPECIFICATIONS

- MIXERS:** Five
- INPUTS:** Nine stereo pairs; One each for Mixers 1 through 4 and five for Mixer 5, plus external AIR input.
Low-level; -55 db nominal from 150/250 ohms (50 ohm selected by jumper), standard on Mixer 1 (optional for Mixer 2).
Hi-level; -10 dbm nominal from 600 ohm source, standard on Mixers 2 through 5. See note 1.
AIR; Depends upon external monitor-amp.
- OUTPUTS:** Program; 8 dbm into balanced 600 ohms at \emptyset vu. 22 dbm max.
Audition; 8 dbm nominal into 600 ohms single-ended. (from 60 ohm source. See note 2).
Monitor; 1v nominal into hi-Z load.
Cue; 0.1v nominal into hi-Z load.
Phones; 1 mw nominal into 10K ohms.
- FREQ. RESPONSE:** All outputs less than 2db down, 20 Hz to 20 kHz.
- NOISE:** Below 65 db at \emptyset vu out with -55 db low level input
Below 75 db at \emptyset vu out with -10 dbm hi-level input
- DISTORTION:** All outputs less than 0.5% THD at normal operating levels.
Less than 1% THD at max outputs.
- CROSSTALK:** Below noise in all channels and modes
- POWER:** 117/234 vac, 50/60 Hz.
- SIZE:** W, 15 1/2"; H, 6 5/8"; D, 11 1/2".
- SHIPPING WT:** 24 lbs (incl. pwr. supply)
- MUTING:** Switch closure to rear-panel terminals from Mixers 1 to 3, closed in Aud. & Prog. modes for control of external DC relays.
- NOTE 1:** Hi-level inputs are balanced-bridging to allow individual termination of input lines at rear panel, if required. Permits constant line load plus use of high-impedance sources.
- NOTE 2:** Identical line amplifiers for Program and Audition outputs.

AS-30B CONSOLE

DESCRIPTION

GENERAL:

The AS-30B is a desk-type Stereo Audio Console featuring five mixing channels with push-button-selected multiple inputs for Mixer 5. As normally supplied, the first mixer includes low-level preamplifiers for 50 to 150 ohm microphones and the remaining four are supplied with high-level balanced input transformers. The input transformers for Mixer 2 are located on cards to allow replacement with another pair of low-level preamplifiers.

The high-level inputs are balanced bridging, which avoids the source loading of the typical 600 ohm input and greatly increases the flexibility of the console. In the very-rare instance where a 600 ohm termination is required, it is a simple matter to add a pair of 620 ohm resistors across the line at either the source or load end. Some sources, such as Ampex and TEAC, provide for this internally. When operating from sources intended for single-ended, high-impedance loads, the minus input terminals of the consoles are connected to the shield and the console now appears as a single-ended high-impedance (10K) load.

The Audition and Program Amplifiers in the AS-30B are identical and interchangeable. In the Audition side, the line-amplifier gain is determined by internal resistors and is set to provide approximately the same level output as the Program side with normal gain control settings. The audition output terminals are fed directly from the audition line amplifiers from a single-ended source impedance of 60 ohms. The audition output is then capable of driving multiple loads with little, if any attenuation.

The input-source selection for Mixer 5 is via a push-button assembly which allows more than one source to be selected simultaneously. This feature, if used judiciously, will permit more than one source to be mixed simultaneously on the one mixer pot. If this is attempted, the individual source levels must be adjusted externally but the console will not load either source. It must be considered, however, that each

of two sources will then be loaded by the other, and suitable isolation must be provided, if required.

INSTALLATION: Input and Output Connections, with the exception of the Mixer 1 XLR connectors, are made via rear-panel barrier strips. Spade lugs or fanning-strips are not required since the barrier strips are designed with captive plates to easily accommodate several stripped wires per terminal, either solid or stranded. Rear panel connections are clearly identified to facilitate installation without resorting to the manual or to a numbered diagram.

Audio connections are normally made with twisted-pair, shielded cable such as Belden 8737 (stranded) or 8739 (solid). Either may be used, although it is generally more satisfactory to use solid wire in a permanent installation where flexibility is not required since solid wire is easier to handle and less apt to inadvertently short to an adjacent terminal. Single-ended outputs and inputs can use the same type cable by simply clipping off the unused conductor. The input terminals include a ground connection for the cable shield and the transformer input windings are ungrounded or "floating". This prevents the possibility of setting up a severe ground-loop and also permits one side of the transformer input to be grounded for single-ended operation if desired. In like manner, the program line outputs are also isolated.

A central ground lug is provided on the rear panel for connection to the system master ground, and as heavy a gauge strap or braid as practical should be used.

AUDIO CONSOLE

INSTALLATION

GENERAL: Most input and output connections are made via rear-panel barrier strips. Spade lugs or fanning-strips are not required since the barrier strips are designed with captive plates to easily accommodate several stripped wires per terminal, either solid or stranded. Rear panel connections are all clearly identified to facilitate installation without resorting to the manual or to a numbered diagram.

Audio connections are normally made with twisted-pair, shielded cable such as Belden 8737 (stranded) or 8739 (solid). Either may be used, although it is generally more satisfactory to use solid wire in a permanent installation where flexibility is not required, since solid wire is easier to handle and less apt to inadvertently short to an adjacent terminal. Single-ended outputs and inputs can use the same cable by simply clipping off the unused conductor.

Both the high-level and low-level inputs are brought to isolated balanced input transformers. The input terminals include a ground connection for the cable shield and the transformer input windings are ungrounded, or "floating". This prevents the possibility of setting up a severe ground-loop and also permits one side of the transformer input to be grounded for single-ended operation if desired. In like manner, the program line output is also isolated.

A central ground lug is provided on the rear panel for connection to the system master ground, and as heavy a gage strap or braid as practical should be used.

Once the desired input and output audio connections are made, it is only necessary to complete the power connections, set the master and monitor gain controls to suitable levels and turn the console on. As a general rule, normal operating position for all level controls will be at approximately 10 o'clock. There is considerable reserve gain available in the program line amplifier and it is usually not advisable to turn both Master and Mixer gain controls to full clockwise at the same time. No harm will come from abnormal control settings, but the possibility would exist for decreased signal-to-noise ratio or increased distortion.

MONITOR AND CUE AMPS: The monitor and cue amplifiers are rated for an 8 ohm load, although they will operate equally well with a 4 ohm load. (or two 8 ohm speakers in parallel) with slightly increased power output capability. If the load is higher than 8 ohms, power output will be reduced accordingly since a given voltage level will then produce less current.

Both amplifiers are a direct-coupled transformerless design and do not require termination in the absence of a load. The load should never be less than 4 ohms, however, and if multiple speakers are to be used, it may be necessary to consider a series-parallel arrangement to provide 4 ohm minimum loading. A short circuit should be avoided at all costs.

When connecting speakers, it should be considered that eight watts RMS into 8 ohms requires a peak audio current of 1.4 amps. It is suggested that for moderate to long runs, an 18 gauge cable pair such as common, lamp or "zip-cord" be used to avoid power loss on audio peaks.

MUTING: As indicated in the General Description, the muting system is quite flexible. No external connections need be made other than to connect the speakers to the proper terminals as indicated on the rear panel. Jumpers must be connected internally on the relay board to activate the relays as required for the particular application. Each relay coil terminates at an eyelet with a short jumper wire attached and the relay will close if this wire is grounded.

The mixer 1, 2 and 3 pre-selector switches are wired so that a ground is made available at additional eyelets on the relay board corresponding to the input selected. This ground is only completed when the mixer control lever switch leaves the off position. In the A-15B Console, this lever switch selects the A & B inputs to each mixer and the "C" position does not exist so the corresponding terminals on the relay boards are not used.

The relay contacts brought to the rear panel for control of remote equipment are rated at 117 v. AC 5 amps; if used to control incandescent lamp loads, it should be noted that such lamps have a cold resistance of approximately 10% of their operating value. Unless provided with current limiting, lamp loads should be limited to 40 watts per relay to avoid damage from initial current surges. The relay contacts are completely isolated from the console proper and under no circumstances should power be applied to them from within the console to avoid shock hazard from the exposed Jones-connector blades.

CIRCUIT DESCRIPTION, SPARTA AUDIO CONSOLES

GENERAL. The description to follow is generally applicable to all SPARTA consoles, mono or stereo, and outlines the basic system of selecting, mixing and amplifying the usual program-sources plus the methods used to process auxiliary functions such as cue and monitor signals. Features applicable to specific consoles are then discussed elsewhere in the appropriate manual sections.

Microphone Preamplifiers. With a nominal gain of 55db. the output level from the preamp to the mixer potentiometer is typically -10 to 0 dbm. depending, of course, on the sound level and microphone used. In a normal situation, then, the preamplifier output is at essentially the same level as the high-level input signals, resulting in approximately the same mixer-level settings for normal operation. Preamp gain can be changed to accommodate unusual situations by referring to the preamplifier circuit description.

As normally supplied by SPARTA, the input transformer is wired for use with 150/250 ohm microphones. A transformer tap is provided for easy conversion to use with 30/50 ohm microphones.

All SPARTA Audio Consoles are supplied as standard with a microphone preamplifier in the first mixer position. The preamplifiers are interchangeable with high-level input cards, however, so additional microphone

CIRCUIT DESCRIPTION, GENERAL

preamplifiers may be incorporated, or alternately, all inputs may be high-level.

High-Level Inputs are brought to the primaries of input-isolation transformers which are suitably terminated and connected directly to the proper Mixer potentiometers. The primaries are floating (ungrounded) to allow single-ended connection and also to prevent the possibility of setting up undesired ground-loops or common-mode signals via the input cables.

Mixing takes place by feeding the output of each mixer potentiometer through a high-value series resistor (10K or 27K) to a common mixing bus, which in turn leads to a mixing amplifier. The mixing amplifier, which is usually located with the line amplifier, is specifically designed to have a very low input impedance, typically 100 ohms.

Since the Mixer feed resistors are so much higher in value, the mixer amp becomes a "current sink" and responds to the current in the feed resistors, which in turn is determined by the voltage available from the Mixer pots. The output of the mixer amp, then, is proportional to the sum of the currents at its input.

CIRCUIT DESCRIPTION, GENERAL

Mixer isolation is excellent with this system since the current from each feed resistor will follow the easiest path -- obviously into the mixer amp rather than to another Mixer pot. Changing one mixer-pot, then, will have relatively little effect upon the program level coming from another mixer-pot.

There is obviously a significant loss of program power in the mixer feed resistors, but the power levels are so low that it is a simple matter to recover the loss in the mixer amplifier. Mixer amp. gain is set to restore the program to substantially the same level as originally fed to the mixer pots, with the mixer-pots at their usual operating positions, about one o'clock.

Since a "current" mixer operates from a relatively high source impedance, it allows the use of high impedance mixer-pots. And since it is not critical of the precise source impedance, there is no need to resort to the bulk and cost of precision ladder attenuators.

Output of the mixer system is then fed to the Master gain control at essentially the same level as the original high-level program material. To test the entire mixer system, a -10 or 0 dbm signal is provided at a high-level input, the appropriate mixer pot is set at the normal operating position and the signal is viewed or measured across the Master gain control.

CIRCUIT DESCRIPTION, GENERAL

The Line Amplifier provides the final amplification between the Master gain control and the line output terminals. It must therefore recover the signal loss of the Master gain control, compensate for any losses in matching or isolation pads, and provide power-gain for driving the output line at rated level.

For a rated output of 8dbm into a 600 ohm line at zero VU, several factors must be considered: A minimum of 10 dbm of additional gain, without distortion, must be available to handle program peaks (headroom). Also, the output transformer must be isolated from the line with a pad, typically 4 db, to prevent interaction with line reactances. Finally, the line amplifier output-impedance must properly match the line transformer primary so the output terminals are a true 600 ohm source.

The line transformer must then handle a nominal level of 12dbm, and 22dbm on program peaks. The line amplifier must be capable of supplying 18dbm to the line plus the power-losses in the line pad, insertion loss in the transformer and internal loss necessary to obtain a proper impedance match. This is considered in detail in the line-amplifier section of the manual.

VU Meter. The standard VU meter contains rectifier diodes and consequently appears as a non-linear impedance to its signal source. To avoid introducing

CIRCUIT DESCRIPTION, GENERAL

distortion on the program-line, it is necessary to provide isolation between the meter and the line.

It is also necessary to attenuate the level to the meter so it can indicate \emptyset vu when the line is at 8dbm and finally, the attenuator must be so designed as to appear to the meter as a 3.9K ohm source to preserve the linearity of the meter indication.

This latter requirement accounts for the meter pad being a "T" configuration rather than a simple series resistor. In SPARTA consoles, the metering source is the line transformer output, ahead of the line pad, which allows an added 4 db of attenuation in the meter pad for increased isolation. A balanced "H" pad is not required since the meter need not be balanced to ground.

Cue. Common to all SPARTA consoles is a "Cue" position on each Mixer potentiometer. In the simplest case, program material from each mixer, through the cue switches and isolation resistors, is delivered to a rear-panel terminal for feed to an external cue amplifier. In more elaborate consoles, a cue level control, internal amplifier and optional-use internal speaker are provided.

Monitor. Although provisions for program-line monitoring vary in different SPARTA consoles, in all cases the source of program material is the output

CIRCUIT DESCRIPTION, GENERAL

stage of the program line amplifier. Since there are no active or non-linear components to follow, the monitor provides constant assurance of both level and quality, whereas the VU meter alone only indicates level.

CIRCUIT DESCRIPTION/MAINTENANCE

PREAMPLIFIER, 1018

The 1018 Preamplifier is supplied standard for operation with 150/250 ohm microphones and provides a nominal gain of 55db into a 600 ohm or higher load. A jumper is provided on the circuit board, either a wire or a low-value resistor, to accommodate 30/50 ohm microphones.

The 1018 Preamplifier differs from its predecessor, the 1008A, in several respects. The microphone transformer is a miniaturized PC-mounting type with extended high and low frequency response. The 1018 circuitry takes full advantage of the transformer's 80K secondary impedance to provide improved noise performance, expanded frequency response and excellent overload characteristics.

With normal microphone input levels, the output level to the mixer will be approximately 0 dbm. The maximum output level of the 1018 before clipping is in excess of 14 dbm, which assures more than adequate head-room in normal operation. In the event that microphones must be used, which provide unusually high output, a pad may be added in series with the microphone or a resistor in the 1018 may be changed in value to lower the preamp gain, as described later.

The input signal is amplified approximately 20db by the input transformer and then amplified a further 35db by transistors Q1 and Q2. The output signal from Q2 then passes through emitter-follower Q3 to provide the necessary low output impedance.

The emitter of Q2 is heavily bypassed to ground by capacitor C8; therefore the base impedance of Q2 is quite low, being essentially a forward-biased diode.

Most of the signal current from Q1 passes to the base of Q2, then, rather than through the much higher impedance of the collector resistor R3. This assures maximum current gain from Q1, although the voltage gain is relatively small.

The emitter of Q3 is not bypassed, however, so the base impedance of Q3 is relatively high compared to Q2's collector resistor R4. The signal current from Q2 must therefore cause a significant signal voltage across R4. This assures a maximum of voltage gain from Q2, and since Q3 is an emitter-follower this signal appears at the low impedance emitter of Q3.

A portion of the output signal determined by feedback attenuator R8/R9 appears at the emitter of Q1. Since Q1 and Q2 both invert the signals through them, the feed-back to the emitter of Q1 is in-phase with the signal input to the base of Q1. This constitutes negative feed-back, since the feed-back attempts to cancel the input signal. The open-loop gain (without feed-back) is extremely high, so the normal closed-loop gain is determined by the turns-ratio of the input transformer plus the ratio of R8 to R9. It can now be seen that changing the value of either R8 or R9 will change the gain of the amplifier proportionally. For example, if R9 were to be increased to 360 ohms, the voltage gain of the amplifier would decrease by 6db, since the output of the amplifier would only need to swing half as far to provide the same feed-back voltage to the emitter of Q1. Consequently, reasonable selection of gain can be obtained simply by selecting the value of R9.

The use of negative feedback to control gain via the input emitter also has the effect of raising the input impedance to Q1. This permits the use of a high-ratio

input transformer for added voltage-gain without added noise. Distortion is also lowered with negative feed-back since any difference between the input and output wave-forms appears as an error signal. Distortion in the 1018 is held well below 0.1%.

A stable operating-point, or "Q", is one of the most important characteristics of an amplifier because the maximum signal output without clipping and therefore the headroom is determined by the average DC voltage at the emitter of Q3. The emitter can move no higher than the supply voltage and no lower than ground, so the ideal operating-point, permitting maximum dynamic range, is logically somewhere near to one-half the supply voltage.

The emitter voltage of Q3 is set by the collector voltage of Q2 and since the collector current of Q2 is also the emitter current of Q2, any change in the collector voltage of Q2 also appears as an inverted change at the emitter of Q2. The bias current for Q1 is obtained through R6 from the emitter of Q2; therefore, any change of emitter voltage at Q2 results in a corrective change of bias current to Q1. This not only provides normal operating bias for Q1, but any change at Q2 is also fed-back to Q1, as an error signal to maintain the proper operating-point.

Maintenance: From the foregoing circuit description, it can be surmised that failure of any component involved in the DC biasing of the circuit, including leaky capacitors, will cause a shift in the operating-point of Q3. Stated in a more useful manner, if the emitter of Q3 is at a reasonable voltage, then all of the components involved must be functioning normally.

During trouble-shooting most components, including the transistors, can be removed from question simply by making two DC voltage measurements: First, the supply voltage at terminal 3, and second, the voltage at the emitter of Q3. When we consider that resistors may vary 5% or 10% and individual transistor gains may vary by a factor of 2 or more, it is reasonable to expect a possible variation of $\pm 20\%$ or so in the operating point. This, then, would indicate a reasonable voltage range for the emitter of Q3 of from approximately 10.5 to 15.5 volts. In the event of catastrophic failure of any of the resistors or transistors, or of excessive leakage or shorts in any of the capacitors, it will almost invariably result in a gross shift of the operating-point towards the supply or towards ground. If the operating-point is beyond the limit given but still capable of moving further in either direction, the amplifier will still be operative; it simply will not have as much dynamic range or head room.

If the operating point is found to be correct, but the amplifier gain is abnormally high or low, (which usually would be accompanied by high distortion) it would most likely be due to either an open capacitor or a defective input transformer. Transistor failure would normally not be a factor simply because, at audio frequencies, a transistor cannot tell the difference between AC and DC, so we would look for a component which could alter the signal gain without affecting the DC operating-point. Excessive noise can be due to almost any component. The most likely suspects would be the input transistor, Q1, followed by the resistors and capacitors associated with the first stage since noise generated there would be subject to the most amplification.

CIRCUITRY DESCRIPTION/MAINTENANCE

Mixer & Line Amps 1020

The 1020 board consists of two independent amplifiers; a mixer amp and a program line amp. The mixer amp is characterized by very low input and moderate output impedances and the program line amp by high input and low **output** impedances.

Mixer Amplifier: The input signals to the mixer amplifier are obtained from a group of mixer potentiometers and each one must be capable of being switched or adjusted in level without affecting the level coming from the others. The mixer amplifier is specifically designed for very low input Z (100 ohms) and is supplied signal currents from the mixers through high value resistors of 10K ohms or more. Each input current, then, follows the path of least resistance into the mixer amplifier, independent of the condition of the other mixing channels, thereby providing excellent isolation between mixer channels.

With a very low input Z and high source Z , the input signals take the form of a current which is a linear function of the source voltage. The unusually low distortion characteristics accrue in part because small changes of an already low input Z have virtually no effect on the signal input currents. Obviously, the voltage attenuation of the mixer system is quite high -- it is the input current which determines the output voltage of the mixer amplifier. The output impedance is sufficiently low to serve as a voltage-source for the Master gain control. The mixer amplifier therefore operates in the

Mixer Amplifier (cont'd)

"trans-impedance" mode; that is, the output voltage is a linear function of the input current, not the input voltage. A measure of voltage gain is not appropriate unless the input voltage is applied through a series feed resistor and the measured gain will then depend on the value of this resistor as well as the amplifier gain.

Circuit Operation: The first stage of the mixer amplifier Q1, is a conventional grounded-emitter amplifier with operating bias determined by current from the collector via R3. A decrease of collector voltage will cause a decrease of base current, resulting in a decrease of collector current which tends to raise the collector voltage. R3 then, forms a negative feedback path which assures that Q1's operating-point remains within a reasonable range. Normal operation of Q1 will be obtained at any collector voltage between approximately 5 and 20 volts.

Bias resistor R3 also performs a secondary function: Since signal voltage from Q1's collector is also fed back to the base, it is a negative-feedback path to the signal, as well. An input signal current to the base of Q1 is met by an opposing signal current from R3, with the result that R3 appears to the input signal as a shunt impedance much lower than the schematic value.

This contributes towards lowering the input impedance of the amplifier.

The second stage Q2, is biased in the same manner as Q1 by R5. Although R5 does have the effect of lowering the input impedance of Q2, it is not nearly so effective since the voltage gain of Q2 is limited by the un-bypassed

Circuit Operation: (cont'd)

emitter resistor R8; therefore, the relative feedback signal current is much lower.

The voltage gain of Q2 is determined by the ratio of resistor R8 to the collector load impedance R7. Consider Q2 as having a typical beta of 100, and no external load on the collector. The emitter resistor R8 carries the collector current plus the base current, but since the base current is only 1% of the collector current, we can assume the emitter and base currents to be the same for all practical purposes.

The emitter is not bypassed, so a change of voltage at the base results in an equal change at the emitter. This in turn changes both emitter and collector currents by the same amount. But the collector current is flowing through a resistor, R7, which is ten times larger than R8, so it must cause ten times the voltage-change. The voltage-gain of Q2, then, must simply be the ratio of R7 to R8, or ten. In normal application, Q2 is loaded by the Master gain control (5K ohms) so the AC collector load impedance is 1.75 K ohms instead of 2.7K resulting in a normal stage gain of approximately 6.5, or 16db. The unbypassed R8, then, forms a third negative-feedback path -- this time to fix the ac gain -- because the collector current through R8 produces an emitter voltage change which tends to cancel the input base voltage, thereby limiting the gain.

The collector voltage of Q2, like Q1, is not critical. The nominal signal level at the collector of Q2 is 0 dbm, or about 1 volt rms. If we allow for 12db of headroom, or 4 volts rms, the collector must be free to swing 12 volts peak-to-peak or 6 volts in either direction. So an operating-point between approximately 8 and 18 volts will assure normal operation.

Circuit Operation (cont'd)

The signal voltage at the emitter of Q2 is the same as at the base of Q2 and so is a second source of shunt negative feedback to the base of Q1. Only this time, the source is a low impedance (R8) permitting the feedback resistor R6 to be low, also. R6, then, is a fourth negative-feedback path and has the most significant effect in lowering the input Z of Q1.

In addition, the source for R6 is a voltage which is a fixed portion of the output voltage. Therefore, R6 also serves to set the gain of Q1.

When an input signal current is applied to Q1, the signal voltage at the emitter of Q2 can only rise to the point where the combined feedback currents from R3 and R6 approach cancellation of the input current, with the current through R6 being dominant.

Very low distortion results, typically 0.035%, since any difference of amplitude or phase between input and feedback currents appears as an error signal. The output voltage is therefore a linear reflection of the input current, which in turn is a linear function of voltage at the source end of the mixer feed resistors.

Gain of the mixer amplifier may be verified by applying an input signal current of 10 microamps through a minimum resistance of 2K ohms. Signal level at the collector of Q1 should be about 130 mv, and at the collector of Q2 nearly 850 mv with the output connected to the 5K Master gain pot. With no external load, the output should be nearer to 1.3v.

Circuit Operation (cont'd)

Do not be concerned by 10 or 20% gain variations, since many 10% resistors are used and are easily compensated for by the normal control settings.

Line Amplifier: The input stage, Q3 and Q4, is a differential comparator which performs three separate functions: First is signal amplification wherein Q3 operates in the transconductance mode; that is, the collector current is a function of base voltage. Second, a large proportion of the average dc voltage at the emitters of Q6 and Q7, which appears at the base of Q4, is compared to the base voltage of Q3 to stabilize the operating-points of the output transistors. And third, a small proportion of the output signal, which is fed back to the base of Q4, is compared to the input signal at the base of Q3, thereby setting the ac gain.

When power is first applied, C13 must be charged to one-half of the supply voltage through Q6, and to protect Q6 the charging-rate must be limited. Q6 cannot turn on until Q5 and hence Q3 begin to conduct. But Q3 cannot conduct any faster than C6 can charge, so C6 not only filters the bias current to Q3, but also controls the charge-rate of C13.

The ideal dc operating-point for the output transistors Q6 and Q7 is one half of the supply voltage, because this is the point at which the greatest peak-to-peak output-voltage swing, or headroom, is available. When first turned on, C6 charges and the base of Q3 is brought to 40% of the supply voltage. As C13 charges, the voltage common to the emitters of Q6 and Q7 rises towards the supply. Upon reaching one-half of the supply voltage, 80% of this (or 40% of the supply voltage) reaches the base of Q4 via dc divider R16, R15,

Line Amplifier: (cont'd)

R14 and R22.

These resistors form a dc divider because C11 prevents output signal currents from reaching Q4 via R15/R14. Thus the comparator Q3/Q4 compares the dc operating-point of the output to the base voltage of Q3, which is as stable as R9, R10 and R11 will allow. The dc gain of the amplifier, then, is very nearly unity, resulting in an extremely stable operating-point.

The ac, or signal gain, is determined in very similar fashion: The output signal is taken from the load end of C13 so the feedback signal is a true representation of the line output. At very low frequencies, both amplitude and phase of the output will change due to the rising reactance of C13. This change will appear as an error-signal when compared with the input, and allows the reserve open-loop gain of the amplifier to correct the error, thereby permitting use of a capacitor of reasonable size and value while maintaining clean, undistorted response to below the audio range.

The ac feedback path is via divider R14 and R15 and gain is set by the ratio of these two resistors. The junction of R15 and R16 is at ac ground so R16 plays no part at audio frequencies. It can be seen, however, that ac gain would drop to near unity if C11 were open or removed. The ac gain is therefore set at 11, or 21 db.

The collector impedance of Q3 is so high that R13 has no effect on gain. In the event of circuit failure, however, it serves to protect Q5 by limiting base current. D1 provides ambient temperature compensation for

Line Amplifier (Cont'd)

Q6 and Q7, while R17, R20 and R21 provide operating bias and thermal stability.

At maximum signal amplitudes Q6 and Q7 must approach saturation. Q6 can readily do so because its base current comes from Q5, and Q5's collector current is determined by its base current -- not its collector voltage. The base current to Q7, however, is dependent upon R18 and R19 and without C12 the base current would fall off as the base approached ground, resulting in clipping and/or distortion. With the junction of R18 and R19 "boot-strapped" from the output, R17 appears as a constant-current source to Q7 and the junction can be driven below ground.

R22 raises the source-impedance of the line amp, at the expense of nearly 6db of signal level, so as to provide a good match for the 60 ohm primary of the line output transformer. The transformer produces 10 db of voltage gain, which is followed by a 3 db loss in a resistive isolation pad. The rms signal voltage at the emitters of Q6 and Q7 is therefore the same as the rms voltage delivered to the external 600 ohm load.

If we assume a nominal β dbm voltage-level at the top of the Master gain control the 1020 line amplifier will produce 8 dbm (at β vu) into the output line with 13 db of gain left to recover the voltage loss in the Master gain control. This corresponds to normal operation at about the one-o'clock position.

Component failures, if they occur, will almost always result in a shift of operating-point. If the operating-points in the 1020 are normal, all of the components associated with dc operation must be normal, including transistors. So if an amplifier then has no ac gain, the logical suspects will be capacitors which may open without affecting dc operation. Capacitors C2, C8, and

Line Amplifier (cont'd)

C10 may safely be ignored at this time since they are only effective above the audio spectrum.

Noise or hiss, may be due to almost any component but those associated with Q1 or Q3 and Q4 would be most suspect since subsequent gain is the highest. Hum (120 Hz) would of course lead one to the power supply.

Distortion will be practically non-existent if normal dc and ac gain is obtained. The line amplifier, for example has an open-loop gain of more than 66 db, providing more than 45 db of feedback so that distortion is almost un-measurable. If distortion does arise, it will almost always be the result of transistor substitution.

WARRANTY

SPARTA ELECTRONIC CORPORATION warrants to the purchaser of SPARTA Electronic Products that any part thereof, which proves to be defective within one year from the date of shipment, will be repaired or replaced free of charge if returned to the factory prepaid. All returns must be specifically authorized by the factory prior to shipment.

SPARTA reserves the right to make changes in design and improvements upon its products without assuming any obligation to install the same upon any of its products theretofore manufactured.

High voltage transformers, modulation transformers, reactors and filter chokes carry an extended warranty of 50% of the replacement cost being allowed should failure occur during the second year. Electron tubes and silicon rectifiers bear only the warranty of the manufacturer thereof in effect at the time of shipment to Purchaser.

Accessories supplied by, but not manufactured by SPARTA ELECTRONIC CORPORATION, shall carry only such manufacturer's standard warranty and are specifically excluded from SPARTA ELECTRONIC CORPORATION's warranty.

This warranty is expressly in lieu of all other warranties express or implied and does not apply to normal wear and tear or damage resulting from shipment, misuse, unauthorized modifications, or any other modifications, or any other cause or condition except normal usage. Replacement parts supplied under this warranty carry only the unexpired portion of the original warranty.

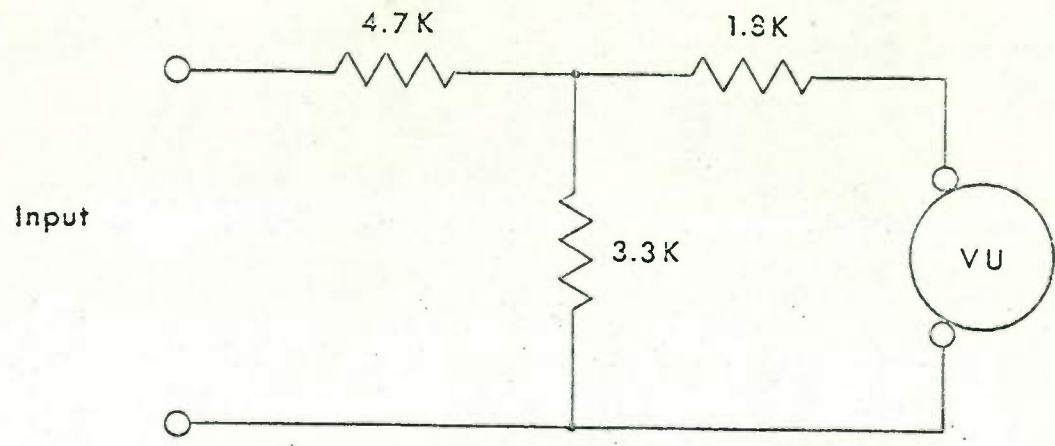

All resistors $\frac{1}{2}$ W, 5%

SPARTA ELECTRONIC CORP				
905 METER PAD				
Drawn	Checked	Date	Revised	Number

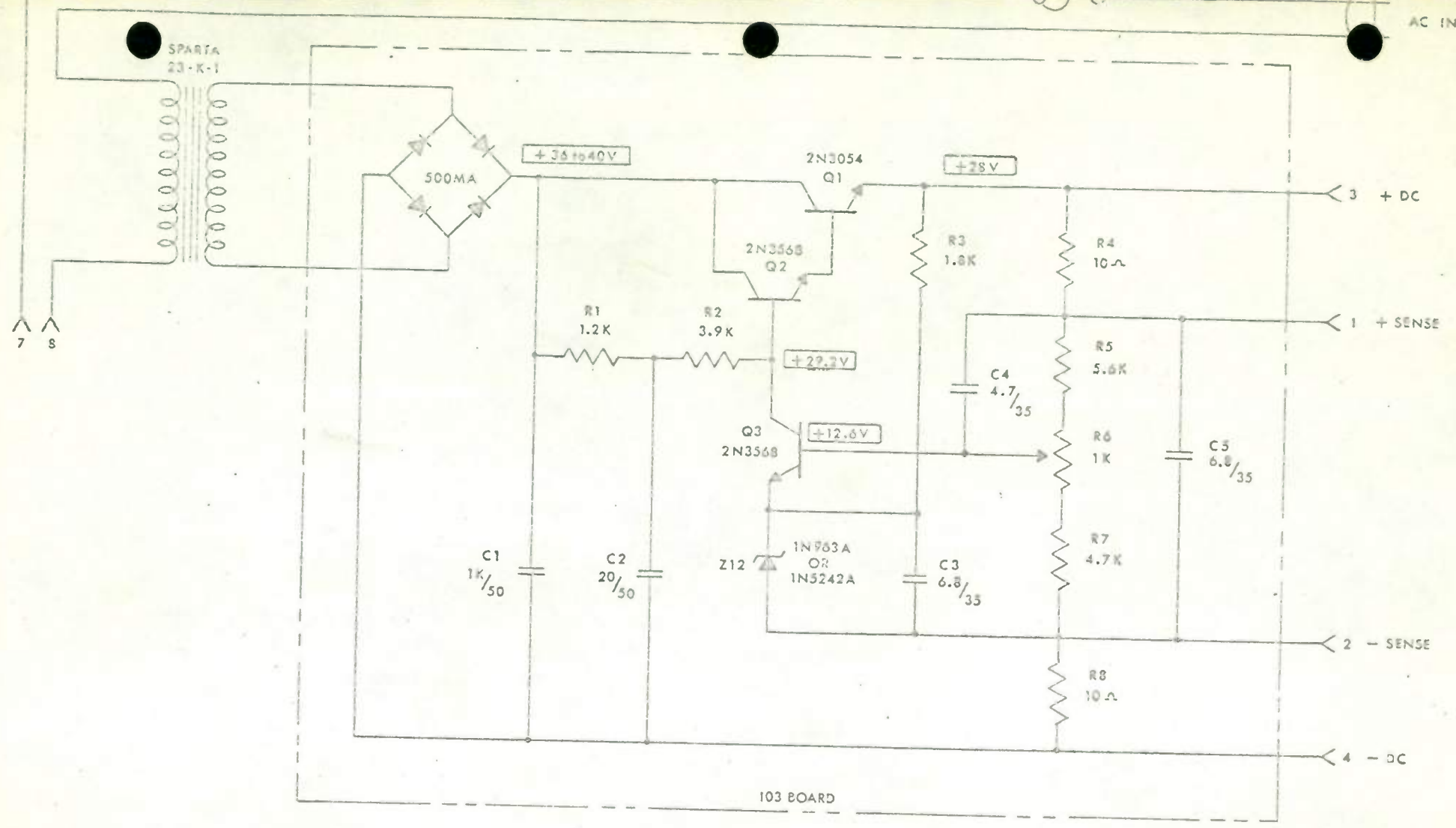

Output 28VDC
 DC volts refer to neg. buss
 Resistors 1/2w, 10%
 Capacitors in mfd

 SACRAMENTO, CALIFORNIA 95828 <small>A MEMBER OF COMPUTER EQUIPMENT CORPORATION</small>		TITLE	
		PS-6 POWER SUPPLY	
DRN	SCALE	DATE	SHT
APPD	DATE	DATE	OF
DWG NO.			S-107A

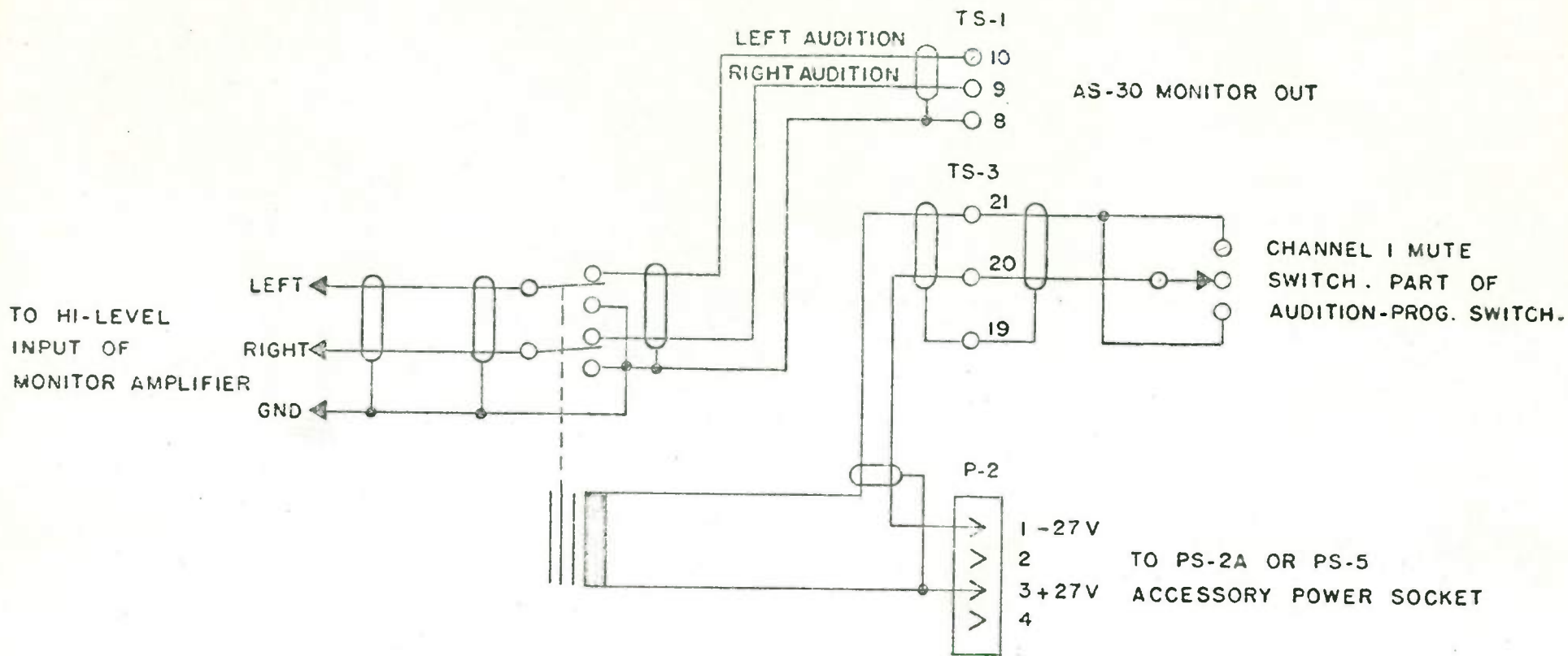

RELAY : 24VDC COIL
 GUARDIAN 640-2C-24DC;
 POTTER-BRUMFIELD GA IID;
 OR EQUIVALENT.

SPARTA ELECTRONIC CORP

AS-30 MUTING,
 CHANNEL I TYPICAL

DRAWN	CHECKED	DATE	NUMBER
SMU	<i>RPO</i>	2-7-68	ASA52

Ph - 13 to 10000
 Casocfe

change 1

5 R-0	—		
4 G-U	L+R	MIXTURE	OUT
3 L-R	L+R	ADDITION	OUT
2 R-C	L+R	AIR MIXTURE	IN
1 R-Y	CH 5-4	"	"
R-BL	CH 5-4	"	"
R-U	CH 5-3	"	"
R-Y	CH 5-2	"	"
R-R	CH 5-1	LEFT+RIGHT	CN-REAR
R-BL	CH 4	RIGHT	}
R-C	CH 4	LEFT	
R-U	CH 3	RIGHT	}
R-R	CH 3	LEFT	
R-0	CH 2	RIGHT	}
R-R	CH 2	LEFT	

REAR

NEWS ROOM COORDS CONNECTIONS
L TS

TS 1					
BL	+	PROGRAM	OUT	RIGHT	BALANCED
C-U	-				
3		GROUND			
DL	+	PROGRAM	OUT	LEFT	BALANCED
DL	-				
6		RIGHT	ADDITION	OUT	UN BALANCED
7		LEFT	ADDITION	OUT	
8		GROUND			
L-U		RIGHT	MONITOR	OUT	UN BALANCED
10		LEFT	MONITOR	OUT	UN BALANCED

CH1	-	MIC
CH2	-	++
CH3	-	CART UAC
CH4	-	RENDX

CH 5		
1		PHONE
2		ABC PATCH
3		CASSETTE
4		ABC
5		TONE

52

(RO)	1	+	}	CH 2	LEFT IN	BALANCED
	2	-				
	3	GROUND				
R-B	4	+	}	CH 2	RIGHT IN	
	5	-				
(PL-R)	6	+	}	CH 3	LEFT	RIGHT IN
	7	-				
	8	GROUND				
(BL-W)	9	+	}	CH 3	RIGHT	LEFT IN
	10	-				
(BL-G)	11	+	}	CH 4	LEFT	RIGHT IN
	12	-				
	13	GROUND				
(BL-B)	14	+	}	CH 4	RIGHT	LEFT IN
	15	-				
(BL-BR)	16	CH 5 - 1		LEFT	RIGHT IN	BALANCED
	17	CH 5 - 1		RIGHT	LEFT	
	18	GROUND				
(BL-Y)	19	CH 5 - 2		LEFT	RIGHT	
	20	CH 5 - 2		RIGHT	LEFT	
	21	GROUND				



NEWS ROOM / CONSOL
TS CONNECTIONS

TS 3

(R-W)	1	CH 5-3	LEFT	RIGHT	UN BALANCED
	2	CH 5-3	RIGHT	LEFT	"
	3	GROUND			
(R-B)	4	CH 5-4	LEFT	RIGHT	"
	5	CH 5-4	RIGHT	LEFT	"
	6	GROUND			
(R-Y)	7	CH 5-5	LEFT	RIGHT	"
	8	CH 5-5	RIGHT	LEFT	"
	9	GROUND			
	10	} C-E			
	11				
(R ± G)	12	} LEFT AIR MONITOR IN			
	13		GROUND		
	14		RIGHT AIR MONITOR IN		
	15	RELAY			
	16	GROUND			
	17	CH 2 MUTE			
	18	CH 2 MUTE			
	19	GROUND - SHIELD			
	20	} CH 1 MUTE			
	21		RELAY		

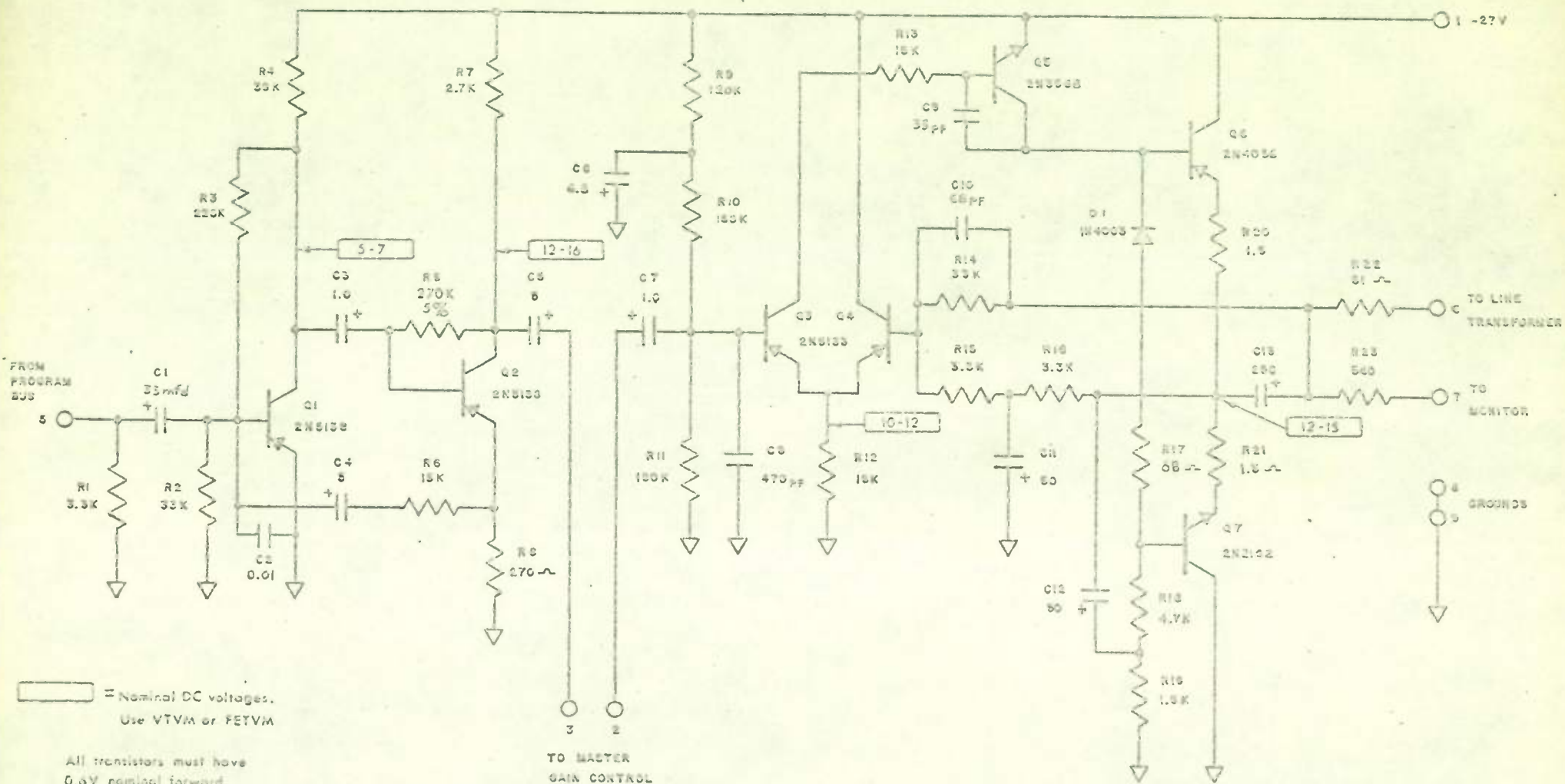

= Nominal DC voltages.
 Use VTVM or FEYVM

All transistors must have
 0.6V nominal forward
 emitter-to-base bias.

- △ ECR278
- △ ECR159, C9 was 10pf
- △ ECR177
- △ 130c170 ECR 150
- △ 15 JULY 70: ECR 114, Q5 WAS 2N3563
- △ 12 FEB 70: ECR 52
- △ 6 FEB 70: ECR 46

 ELECTRONIC CORPORATION SACRAMENTO, CALIFORNIA		TITLE 1020 PROGRAM LINE AMP & MIXER AMP	
DRWN. <i>JMM</i>	DATE 4-13-69	CHT OF	ORG. NO.
		S-2J	

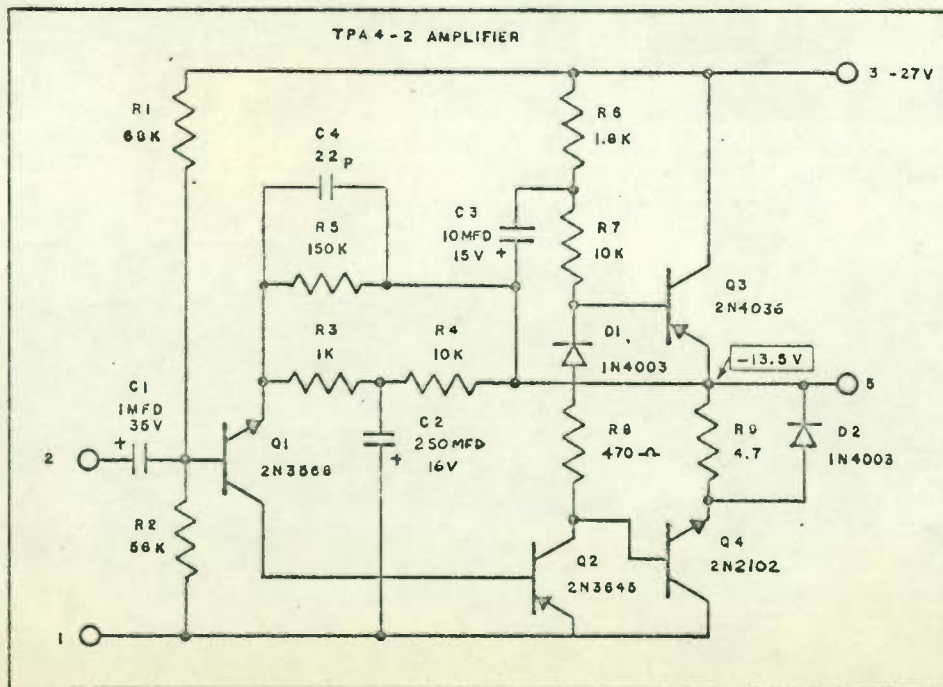
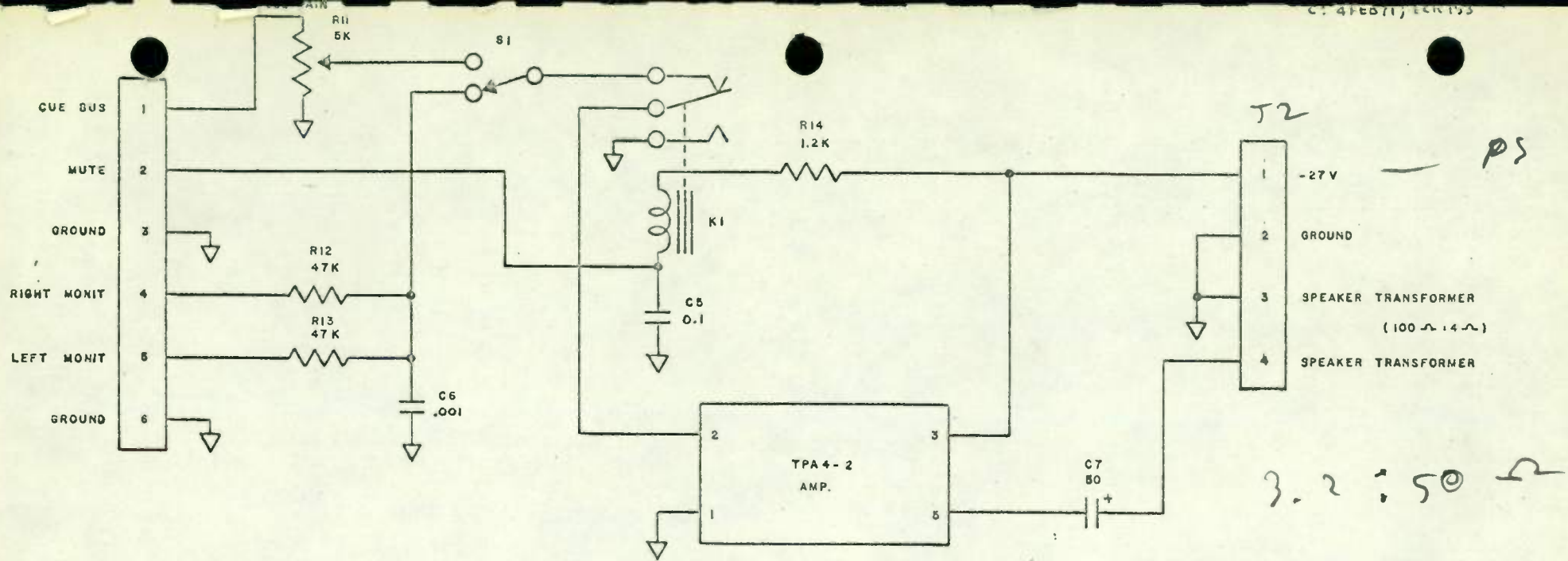

 ELECTRONIC CORPORATION SACRAMENTO, CALIFORNIA		TITLE	
		MCA-1 MONITOR/CUE AMP ASC-305	
DRWN. SMU	DATE	6-6-69	DWG. NO.
APPD.			SHT OF
			S-1C

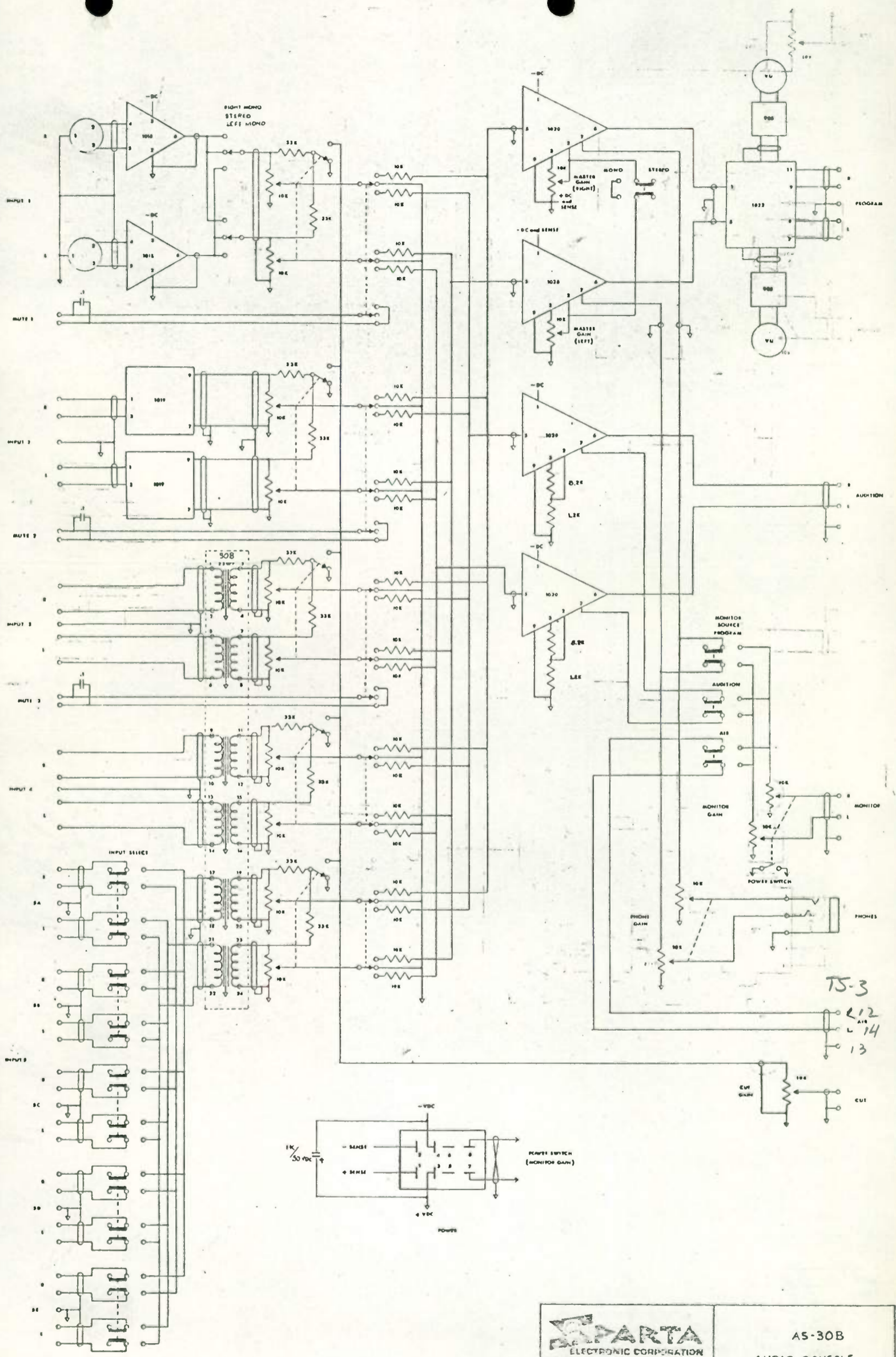

ECR 306
 ECR 235
 ECR 74

 SPARTA ELECTRONIC CORPORATION SACRAMENTO, CALIFORNIA 95828		AS-30B AUDIO CONSOLE
DWN <i>SMC</i> APPR <i>CRK</i>	DATE <i>6/20/70</i> SCALE DATE <i>6/22/70</i>	S-109 C

BUILDING CABLE

FROM: _____

TO: _____

<u>PAIR #</u>	<u>COLOR</u>	<u>CONN TO</u>	<u>CONN TO</u>
1	RD/BK		
2	WH/BK		
3	GN/BK		
4	BL/BK		
5	Y/BK		
6	BN/BK		
7	OR/BK		
8	WH/RD		
9	GN/RD		
10	BL/RD		
11	Y/RD		
12	BN/RD		
13	OR/RD		
14	WH/GN		
15	BL/GN		

SPECIAL NOTES: