

# INFORMATION

AS IT APPEARS  
IN THIS CATALOG

TITLE	Effective Date
<b>GENERAL</b>	
Quick Reference Catalog	10-1-54
Field Engineers	10-1-54
Tube Type Numbering System	
Distributors	11-15-54
Tube Replacement Chart	1-2-52
Price List	6-10-55
Vacuum Pump Price List	6-1-50
Application Bulletin No. 3	2-1-55
<b>TETRODES—PENTODES</b>	
4-65A	5-14-54
4-125A	7-15-54
4-250A	8-24-53
4-400A	1-15-55
4-1000A	6-2-52
4PR60A	3-22-54
4W20,000A	2-27-54
4X150 Tube Extractor	
4X150A	5-10-54
4X150D	
4X150G	3-15-53
4X250B	6-1-55
4X500A	2-15-51
4E27A/5-125B	8-15-52
<b>KLYSTRONS</b>	
1K015XA, G	7-22-54
3K20,000LA, F, K	8-17-53
3K50,000LA, F, K	8-17-53

TITLE	Effective Date
<b>TRIODES</b>	
2C39A	6-2-52
3C24	11-1-51
3W5000A3	8-23-53
3W5000F3	3-1-51
3X2500A3	6-2-52
3X2500F3	2-1-53
3X3000A1	2-1-52
3X3000F1	4-20-53
6C21	4-1-54
25T	2-1-51
35T	6-15-51
35TG	10-1-51
75TH	1-2-52
75TL	1-2-52
100TH	4-1-49
100TL	4-1-49
152TH	11-25-52
152TL	1-1-44
250TH	5-1-53
250TL	8-20-53
304TH	4-10-53
304TL	5-1-49
450TH	8-1-50
450TL	10-1-49
592/3-200A3	7-1-54
750TL	6-2-52
1000T	3-15-52
1500T	8-7-53
2000T	10-15-50

TITLE	Effective Date
<b>DIODES—RECTIFIERS</b>	
2-01C	10-20-53
2-25A	7-1-52
2-50A	7-1-52
2-150D	7-1-52
2-240A	7-1-52
2-2000A	7-1-52
250R	7-1-52
253	7-1-52
8020	2-1-52
KY21A	7-12-53
RX21A	7-12-53
866A/866	5-30-53
872A/872	12-1-46

TITLE	Effective Date
<b>OTHER PRODUCTS</b>	
Vacuum Capacitors	6-15-52
Variable Vacuum Capacitors	3-1-49
HV-1 Diffusion Pump	8-29-53
100IG Ionization Gauge	6-15-53
Preformed Contact Finger Stock	3-10-53
HR Connectors	10-15-54
Air System Sockets	
4-400A/4000	1-15-55
4-1000A/4000	See Tube Data Sheet
4X150A/4000	6-15-53

EITEL-McCULLOUGH, INC., SAN BRUNO, CALIFORNIA

(Effective 6-1-55)

**VACUUM TUBES**

1K015XA	\$ 180.00	4X150A	38.95
1K015XG	180.00	4X150D	38.95
2-01C	15.25	4X150G	54.00
2-25A	11.00	4X250B	42.50
2-50A	13.75	4X500A	121.00
2-150D	19.25	4X500F	93.50
2-240A	40.00	4X5000A	395.00
2-2000A	214.50	6C21	77.00
2C39A	24.00	KY21A	13.25
2C39B	27.50	RX21A	9.00
2X3000F	140.00	25T	11.00
3C24	12.00	35T	12.00
3K3000LA	2,470.00	35TG	16.00
3K3000LQ	2,360.00	75TH	16.00
3K20,000LA	2,975.00	75TL	16.00
3K20,000LF	2,975.00	100TH	18.25
3K20,000LK	2,975.00	100TL	18.25
3K50,000LA	4,200.00	152TH	32.00
3K50,000LF	4,200.00	152TL	32.00
3K50,000LK	4,200.00	250R	22.00
3K50,000LQ	4,200.00	250TH	33.00
3W5000A3	198.00	250TL	33.00
3W5000F3	198.00	253	20.50
3W10,000A3	957.00	304TH	60.50
3X2500A3	198.00	304TL	60.50
3X2500F3	198.00	450TH	77.00
3X3000A1	198.00	450TL	77.00
3X3000F1	198.00	592/3-200A3	30.25
4-65A	20.00	750TL	137.50
4-125A	30.25	866A	2.45
4-250A	41.25	872A	8.20
4-400A	60.50	1000T	137.50
4-1000A	132.00	1500T	220.00
4E27A/5-125B	35.75	2000T	275.00
4PR60A	90.00	8020 (100R)	15.00
4W300B	41.50		
4W20,000A	1,850.00		

**VACUUM CAPACITORS**

VC6-20	\$15.00	VC50-20	\$ 24.25
VC6-32	17.25	VC50-32	27.50
VC12-20	16.50	VVC60-20	66.00
VC12-32	20.00	VVC2-60-20	147.50
VC25-20	20.00	VVC4-60-20	284.00
VC25-32	23.25		

**HEAT DISSIPATING CONNECTORS**

HR-1	\$ .60	HR-6	\$ .80
HR-2	.60	HR-7	1.60
HR-3	.60	HR-8	1.60
HR-4	.80	HR-9	3.00
HR-5	.80	HR-10	1.60

**AIR SYSTEM SOCKETS**

4-400A/4000	\$16.00
4-400A/4001	12.00
4-400A/4006*	6.00
4-1000A/4000	22.50
4-1000A/4001	17.00
4-1000A/4006*	7.50
4X150A/4000	18.00
4X150A/4001	17.50
4X150A/4006*	.60
4X150A/4010	20.15
4X150A/4011	19.70

\*Replacement Chimneys

**PREFORMED CONTACT FINGER STOCK**

17/32"	- - - -	\$1.65/ft.
31/32"	- - - -	1.80/ft.
1-7/16"	- - - -	2.00/ft.

**VACUUM PUMP & GAUGE**

HV-1	\$125.00
Pump Oil - Qt.	5.00
100 IG	22.50

**VACUUM SWITCH**

VS-2	\$18.00
VS-5	24.00
VS-6	32.00
12V Coil	7.50
24V Coil	8.50

**TUBE EXTRACTOR**

Tube Extractor for 4X150A, 4X150D, 4X150G	\$ .55
--	--------

# general

---

## A QUICK GUIDE TO EIMAC PRODUCTS AND SERVICES OFFERED IN THIS CATALOG

### Including...

- Your nearest distributor of modern, fully guaranteed Eimac Vacuum tubes, vacuum capacitors, heat dissipating connectors, air-system sockets, preformed contact finger stock and vacuum switches.
- Your nearest Eimac Field Engineer, who stands ready to give you immediate engineering assistance, any information on deliveries and prices, or provide other information not found in the catalog.
- Eimac tube type numbering system.
- Tube Replacement Chart.
- Prices on Eimac products.

---

## IMPORTANT EIMAC "EXTRAS"

**Application Engineering.** The Eimac Application Engineering Department is available at all times for consultation. New tube operating techniques are continually being explored, tested and proved by Eimac application engineers, whose combined knowledge and experience are made available to you. Additional contributions by this Eimac department are its Application Bulletins, an expanding service which you get without obligation.

**Field Engineering.** Serving as an extension of the Application Engineering Department outside the Eimac plant, Eimac field engineers cover the United States, operate out of offices in major cities. They will help you personally with experimental work, problems of technique, etc. Engineers from the Eitel-McCullough plant in San Bruno are available, too, for field consultation throughout the country. As Eimac tubes are world renowned, the same services extend to various countries overseas through the Eimac export division.

Serving eight territories throughout the United States are top qualified men well equipped for electronic factory-field liaison. A phone call or letter to the Eimac field engineer covering your area will bring immediate engineering assistance or information on deliveries and prices. These men are in daily communication with the Eimac factories and have up-to-the-minute information available at their finger tips.

**HERB BECKER**  
1140 Crenshaw Blvd.  
Los Angeles 19, California  
Phone: Webster 1-1257

- ▶ **J. E. JOYNER, JR.**  
2524 Jenny Wren Lane, S. W.  
P. O. Box 341, Station A  
Atlanta, Georgia  
Phone: Amhurst 1101

**ROYAL J. HIGGINS CO.**  
10105 South Western Ave.  
Chicago 43, Illinois  
Phone: Cedarcrest 3-7388

**ADOLPH SCHWARTZ**  
One Exchange Place, Room 919  
Jersey City, New Jersey  
Phone: Delaware 3-2424

- ▶ **TIM COAKLEY SALES OFFICE**  
148 Needham St.  
Newton Highlands  
Boston 61, Massachusetts  
Phone: Decatur 2-4800

*For information concerning your electronic problems or needs solicit the services of these men without any obligation.*

**DAVE M. LEE CO.**  
2517 Second Ave.  
Seattle 1, Washington  
Phone: Main 5512

- ▶ **McLOUD & RAYMOND CO.**  
5528 East Colfax Ave.  
Denver 7, Colorado  
Phone: Fremont 3067

**CLYDE H. SCHRYVER SALES CO.**  
4550 Main St., Room 224  
Kansas City 5, Missouri  
Phone: Westport 4660

- ▶ **JACK YOUNT**  
1431 Pleasant Drive  
Dallas 17, Texas  
Phone: Express 0988

Export Agents  
**FRAZAR & HANSEN, LTD.**  
301 Clay St.  
San Francisco, California  
Phone: Exbrook 2-5112

120 Broadway  
New York 5, New York  
Phone: Worth 4-3454

225 West 23rd St.  
Los Angeles 7, Calif.  
Phone: Prospect 2538

**SEE REVERSE SIDE FOR SECTIONAL MAP**

# EIMAC FIELD ENGINEERS

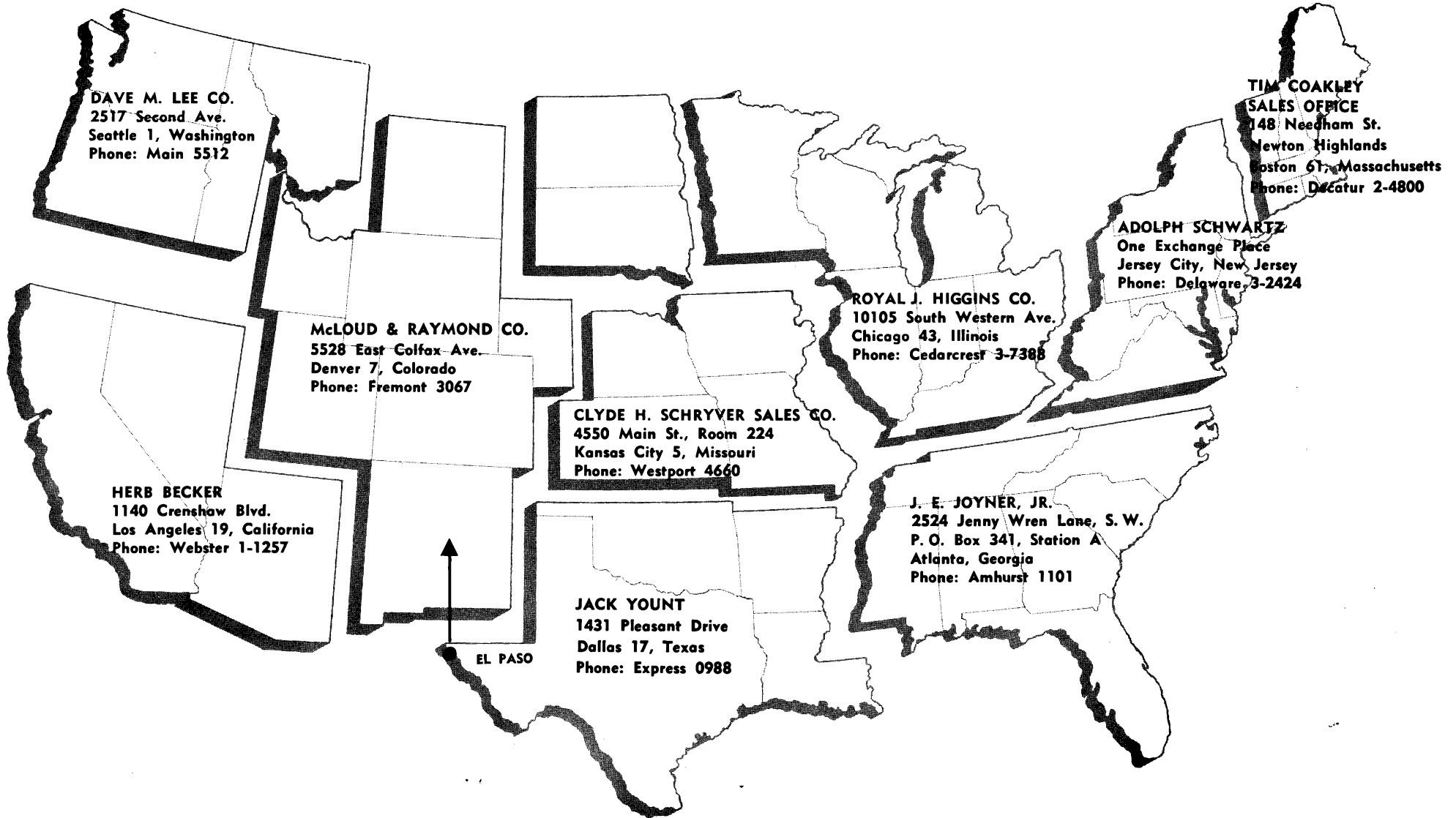

**Export Agents: FRAZAR & HANSEN, 301 Clay Street, SAN FRANCISCO, CALIF. Phone: Exbrook 2-5112**  
**120 Broadway, NEW YORK 5, N. Y. Phone: Worth 4-3454**  
**225 West 23rd Street, LOS ANGELES 7, CALIF. Phone: Prospect 2538**

Since 1945 all new tube types developed by Eitel-McCullough, Inc., have been given a type number chosen according to a coded numbering scheme. This system is designed to convey descriptive information about the tube.

To illustrate the method of coding and the information the type number conveys, a 2½ kw forced-air cooled Eimac triode, type number 3X2500A3, is broken down as follows:

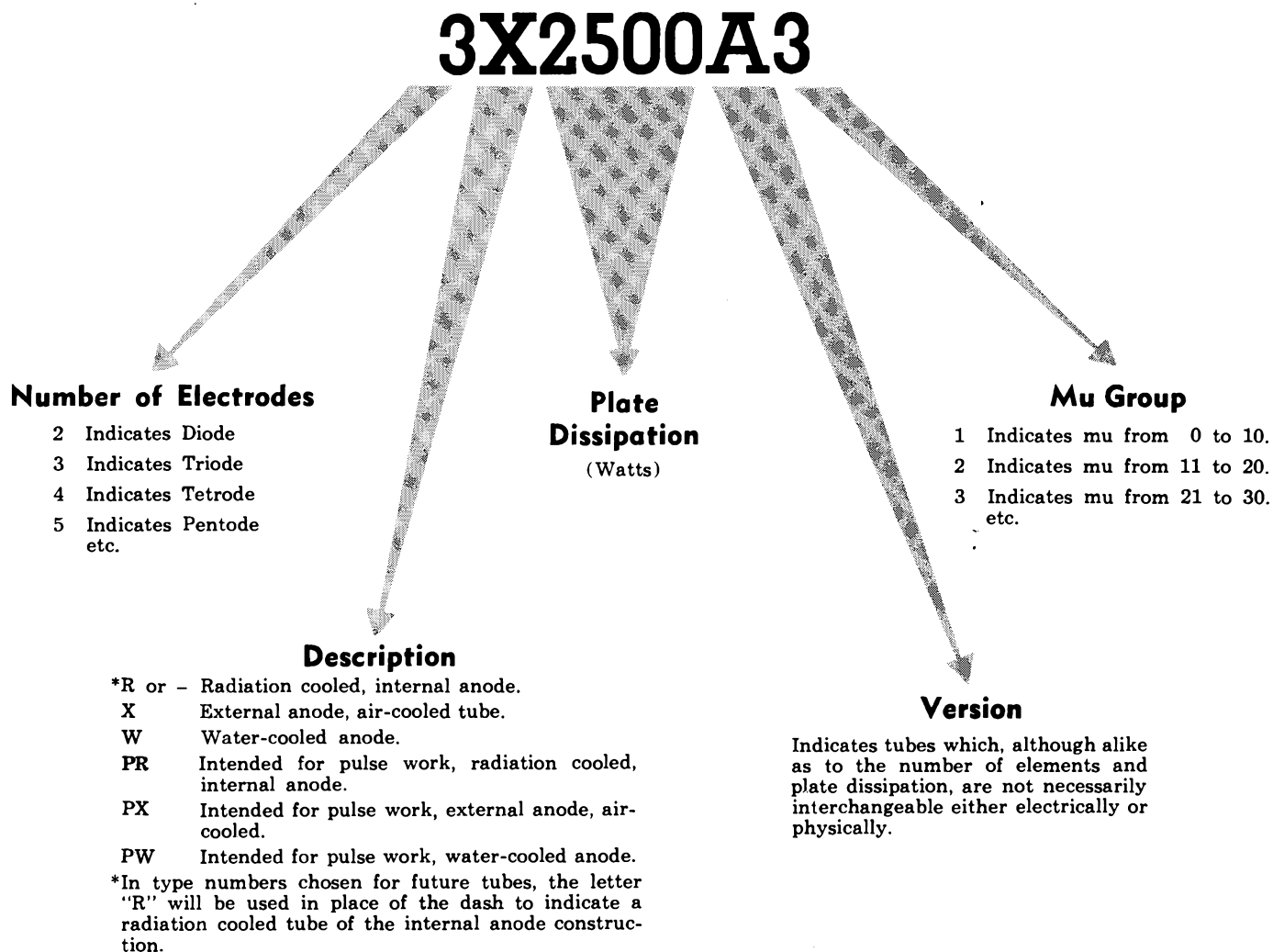

# Eimac Tube Type Numbering System for Velocity Modulated Tubes (Klystron, Travelling Wave, etc.)

To illustrate the method of coding and the information the type number conveys, the Eimac 5 kw output Klystron for the lowest third of the UHF television band, type number 3K20,000LA, is broken down as follows:

## 3K20,000LA

### Number of Cavities

This is the number of interaction regions along the beam. A reflex klystron would be considered to have one interaction space; a travelling wave tube with a distributed circuit would be considered as having "zero" cavities because there are no well defined interaction regions.

### Dissipation Rating (Watts)

### Type of Tube

K Klystron  
TW Traveling Wave  
PK Pulse Klystron  
ST Space Charge  
Travelling Wave Tube.

### Version

Indicates tubes which, although alike as to the number of interaction regions, type, dissipation and frequency band, are not necessarily interchangeable either electrically or physically.

### Frequency Band

Predominately an L-band tube  
Predominately an X-band tube  
etc.

# AN EIMAC DISTRIBUTOR IS NEAR YOU

For Your Assurance to Obtain the Most Modern, Guaranteed Eimac Tubes — Purchase Only from These Authorized Distributors

## ALASKA

### Anchorage

Yukon Radio Supply, Inc.  
Box 406

### Fairbanks

Yukon Radio Supply, Inc.  
655-6th Ave.  
P. O. Box 1385

### Juneau

Alaska Radio Supply, Inc.  
Box 2538

## ALABAMA

### Birmingham

Ack Radio Supply Co.  
2205-3rd Ave. North  
James W. Clary Co.  
1713 - 2nd Ave., South  
Forbes Distributing Co., Inc.  
2600 - 3rd Ave. South

### Gadsden

Southeastern Radio Parts Co.  
120 Chestnut St.

### Mobile

Forbes Electronic  
Distributors, Inc.  
57 N. Washington St.  
Harris Supply Co.  
10 N. Water St.  
PO Box 1009

### Montgomery

Nolin-McInnis, Inc.  
205 Commerce St.  
P. O. Box 2229  
Southeastern Radio Parts Co.  
210 N. Court St.

## ARIZONA

### Phoenix

Radio Parts of Arizona  
214 South 11th Ave.  
Radio Specialties &  
Appliance Corp.  
305 E. Roosevelt  
Western Radio & Engineering Co.  
1915 East Washington St.

### Tucson

Elliott Electronics, Inc.  
418 N. 4th Ave.  
P. O. Box 5081

## ARKANSAS

### Blytheville

Blytheville Radio Supply  
112 South First St.

### Ft. Smith

Wise Radio Supply  
1001 Towson Ave.

### Little Rock

Carlton Wholesale Radio, Inc.  
109 W. 9th St.  
P. O. Box 828

Southern Radio Supply  
1419 Main St.

David White Radio Supply Co.  
1222 Main St.

### Texarkana

Lavender Radio Supply Co., Inc.  
520 East Fourth

## CALIFORNIA

### Bakersfield

Valley Radio Supply  
716 Baker St.

### Burbank

Fred S. Dean Co.  
1500 W. Burbank Blvd.  
Valley Electronic Supply Co.  
1302 W. Magnolia Blvd.

### Fresno

Jack C. Arbuckle  
2330 Kern Ave.  
Kierulff & Co.  
725 "L" St.

### Glendale

Hagerty Radio Supply  
6826 San Fernando Road

### Los Angeles

Federated Purchaser, Inc.  
911 South Grand Ave.  
Henry Radio  
11240 West Olympic

Kierulff Electronics, Inc.  
820 West Olympic Blvd.

Radio Products Sales, Inc.  
1501 South Hill St.

Radio Specialties Co.  
1956 So. Figueroa St.

Radio Television Supply Co.  
341 W. 18th St.

Shelley Radio Co.  
2008 Westwood Blvd.

### Long Beach

Fred S. Dean Co.  
969 American Ave.

Larry Lynde Electronics  
1526 E. 4th St.

Scott Radio Supply, Inc.  
266 Alamitos Ave.

### Maywood

Kierulff & Company  
6058 Walker Ave.

### Oakland

W. D. Brill Co.  
198 10th St.

Elmar Electronics  
140 - 11th St.

### Palo Alto

Zack Radio Supply Co.  
225 Hamilton Ave.

### Pasadena

Dow Radio Supply Co.  
1759 E. Colorado St.

Electronic Supply Corp.  
2615 East Foothill Blvd.

### Sacramento

E. M. Kemp Co.  
1115 "R" Street

Sacramento Electric Supply Co.  
1219 "S" St.

### San Bernardino

Kierulff & Company  
1123 W. Base Line at "L" St.

### San Diego

Shanks & Wright  
2045 Kettner Blvd.

Western Radio & Television  
Supply Co.  
1415 India St.

### San Francisco

San Francisco Radio Supply Co.  
1284 Market St.

Zack Radio and Television  
1426 Market St.

### San Jose

Frank Quement, Inc.  
161 W. San Fernando St.

### Santa Ana

Radio & Television Equipment Co.  
207 Oak St.

### Santa Barbara

Channel Radio Supply Co.  
523 Anacapa St.

### Stockton

B. J. DeJarnatt Wholesale Co.  
515 N. Hunter St.

## COLORADO

### Colorado Springs

Murray Radio Co.  
9 East Vermijo

### Denver

Inter-State Radio & Supply Co.  
1200 Stout St.

Niles Phonograph & Radio Co.  
505-507-509 14th St.

Radio Products Sales Co.  
1237 - 16th St.

L. B. Walker Radio Co.  
854 Broadway

### Grand Junction

Radio & Electronic Supply Co.  
511 Ute

### Pueblo

L. B. Walker Radio Co.  
218 W. 8th St.

## CONNECTICUT

### Bridgeport

Hatry of Bridgeport, Inc.  
1700 Main St.

## Hartford

Hatry of Hartford, Inc.  
203 Ann St.

R. G. Sceli Co.  
1249 Main St.

## New Britain

United Radio Supply Co.  
47-53 East Main St.

## New Haven

Thomas H. Brown Co.  
15-25 Whiting St.

Congress Radio Co.  
207 Congress Ave.

Dale Electronic Distributors  
Div. of Dale-Connecticut, Inc.  
150 James St.

Hatry of New Haven, Inc.  
77 Broadway

## New London

Aikins Electronic Supply Co.  
428 Bank St.

## Stamford

Hatry of Stamford, Inc.  
97 Main St.

## Waterbury

The Bond Radio Supply  
439 W. Main St.

Hatry of Waterbury, Inc.  
89 Cherry St.

## DELAWARE

### Wilmington

Almo Radio Co.  
Cor. 6th & Orange St.

Radio Electric Service Co.  
3rd & Tatnall Sts.

## FLORIDA

### Ft. Lauderdale

Goddard Distributors  
2113-15 South Andrews Ave.

### Jacksonville

Kinkade Radio Supply  
1402 Laura St.

Southeast Audio Company  
930 W. Adams Street

### Lakeland

Radio Accessories Co.  
1050 South Florida Ave.

### Miami

Electronic Supply Co.  
61 N. E. 9th St.

Herman Radio Supply Co.  
1365 N.W. 23rd St.

Thurrow Distributors, Inc.  
2207 N.E. 2nd Ave.

### Orlando

Hammond-Adams, Inc.  
9 South Terry St.

### Pensacola

Grice Radio & Electronic  
Supplies  
360 E. Wright Street

### St. Petersburg

Cooper Radio Co.  
648 Second Ave., So.

### Tallahassee

Thurrow Distributors, Inc.  
739 North Monroe

### Tampa

Kinkade Radio Supply  
1707 Grand Central Ave.

Radio Accessories Co.  
137-9 So. Franklin St.

Thurrow Distributors, Inc.  
134-136 South Tampa St.

### West Palm Beach

Goddard Distributors, Inc.  
1309 North Dixie

## GEORGIA

### Albany

Specialty Distributing Co.  
104 Pine Ave.

### Atlanta

Specialty Distributing Co.  
425 Peachtree St., N. E.

Southeastern Radio Parts Co.  
400 W. Peachtree St.

The Yancey Company, Inc.  
1500 Northside Dr., N. W.

## Augusta

Specialty Distributing Co.  
644 Reynolds St.

## Columbus

Radio Sales & Service Co.  
1326 First Ave.

## Macon

Specialty Distributing Co.  
539 Arch St.

## Savannah

Specialty Distributing Co.  
411 E. B. Oughton St.

Southeastern Radio Parts Co.  
38 Montgomery St.

## HAWAII

### Honolulu, T. H.

Precision Radio Co.  
1372-74 So. King St.

Radio Wholesale & Supply Co.  
P. O. Box 3768

## IDAHO

### Boise

Craddock's Radio Supply  
1522 State St.

Kopke Electronics Co.  
119 Peasley St.

### Idaho Falls

Schwendiman's Wholesale  
Distributors  
380 E. Street

## ILLINOIS

### Belleville

Lurtz Electric Co.  
219 North Illinois St.

### Chicago

Allied Radio Corp.  
100 N. Western Ave.

Chicago Radio Apparatus  
Co., Inc.  
415 South Dearborn St.

Green Mill Radio Supply  
145 West 111th St.

Lukko Sales Corp.  
5024 Irving Park Rd.

Newark Electric Co.  
223 West Madison St.

Star Electronic Distributors, Inc.  
7736 South Halsted Street

Walker-Jimieson, Inc.  
311 South Western Ave.

### Decatur

York Radio Supply Corp.  
801 North Broadway

### Elgin

Fox Electric Supply Co.  
67-69 North State St.

### Peoria

Klaus Radio & Electric Co.  
707 Main St.

### Quincy

Cooper Supply Co.  
935 Main St.

### Rockford

H & H Electronic Supply, Inc.  
510 Kishwaukee St.

Art A. Johnson Sales & Service  
1117 Charles St.

Mid-West Associated Distributors  
506 Walnut St.

### Rock Island

Tri-City Radio Supply, Inc.  
1919 Fourth Ave.

### Springfield

Harold Bruce  
120 N. 1st St.

Wilson Supply Co.  
108 W. Jefferson St.

## INDIANA

### Anderson

Seyberts Radio Supply  
1331 Main St.

### Angola

Lakeland Radio Supply Co.  
South West & West Pleasant Sts.

### Evansville

Castrop's  
1014 West Franklin St.

EIMAC TUBES ARE THE COUNTERSIGN OF DEPENDABILITY IN ANY ELECTRONIC EQUIPMENT



Ohio Valley Sound Service  
11 N. W. Riverside Drive  
Wesco Radio Parts  
428-430 Pennsylvania St.

### Fort Wayne

Ft. Wayne Electronics  
Supply, Inc.  
223 East Main St.  
Pemberton Laboratories  
236 East Columbia at Barr St.  
Warren Radio Co.  
1716 South Harrison St.

### Indianapolis

Graham Electronics Supply, Inc.  
102 S. Pennsylvania St.  
Meunier Radio Supply Co.  
524 North Illinois  
Radio Distributing Co.  
1013 N. Capitol Ave.

### Lafayette

Holmes Radio Supply Co., Inc.  
217 Main St.

### Muncie

Muncie Electronic Supply  
305 North Madison  
Standard Radio Parts Co., Inc.  
718 South Walnut St.

### Peru

Clingaman Radio  
814 West Main St.

### Richmond

Radio & Television  
Distributing Co.  
717 South 5th St.

### South Bend

Collfax Co., Inc.  
802 South Main St.  
Radio Distributing Co.  
Monroe & Carroll Sts.

### Terre Haute

Archer & Evinger  
1216 Wamash Ave.  
Terre Haute Radio  
501 Ohio St.

## IOWA

### Cedar Rapids

Gifford Brown Inc.  
106-108 First St., S. W.

### Council Bluffs

World Radio Laboratories, Inc.  
3415 - 27 West Broadway

### Davenport

Tri-City Radio Supply, Inc.  
320 East 4th St.

### Des Moines

Gifford Brown, Inc.  
1216 Grand Ave.  
Radio Trade Supply Co.  
1224 Grand Ave.

### Dubuque

Boe Distributing Co.  
1605 Rockdale Road

### Sioux City

Dukes Radio Co.  
209 Sixth St.  
Power City Radio Co.  
408 Jones St.

### Waterloo

Farnsworth Radio & Television  
623 Jefferson St.  
Ray-Mac Radio Supply Co.  
200 Ballou St.

## KANSAS

### Hutchinson

Acme Radio Supply  
327 W. 4th St.  
Interstate Electronic Supply Corp.  
325 W. 4th St.

### Pittsburg

Pittsburg Radio Supply  
212 South Broadway

### Salina

Western Dist. Radio & Supply Co.  
227 North Santa Fe

### Topeka

Acme Radio Supply  
412 E. 10th St.

John A. Costelow Co. Inc.  
125 Kansas Ave.  
The Overton Electric Co. Inc.  
522 Jackson St.

### Wichita

Amateur Radio Equipment Co.  
1203 East Douglas  
Interstate Electronic  
Supply Corp.  
230 Ida, P. O. Box 1018  
Radio Supply Co.  
1125-27 East Douglas

## KENTUCKY

### Lexington

Electronic Distributors  
134 West 3rd St.  
Kentucky Radio Supply Co.  
376 East Main St.  
Radio Equipment Co.  
480 Skain St.

### Louisville

P. I. Burks & Co., Inc.  
911 West Broadway  
Universal Radio Supply Co.  
533 South Seventh St.

## LOUISIANA

### Alexandria

Central Radio Supply Co.  
509 Monroe St.

### Baton Rouge

Electronic Supply Co.  
1751-53 North 21st St.

### Lafayette

Ralph's Radio Electronic Supply  
3004 Cameron St.

### Lake Charles

Wholesale Radio Equipment Co.  
230 Bilboa St.

### Monroe

Hale & McNeil  
421 Walnut St.

### New Orleans

Columbia Radio & Supply Co.  
3940 Third Street  
Electronic Parts Corp.  
205-207 North Broad  
Radio Parts, Inc.  
807 Howard Ave.  
Shuler Supply Co.  
415 Dryades St.

### Shreveport

Inter-state Electric Co. of  
Shreveport, Inc.  
630 Spring Street  
Koelemay Sales Co.  
220 Crockett St.

## MAINE

### Auburn

Radio Supply Co. Inc.  
26 Cross St.

### Bangor

Radio Service Laboratory  
16 Salem Court

### Portland

Maine Electronic Supply Corp.  
13 Deer St.  
Radio Service Laboratory  
1004 Congress St.

## MARYLAND

### Baltimore

Henry O. Berman Co., Inc.  
12 E. Lombard St.  
Kann-Ellert Electronics, Inc.  
9 South Howard St.  
Radio Electric Service Co.  
5 North Howard St.  
Wholesale Radio Parts Co., Inc.  
3311 West Baltimore St.

### Cumberland

Zimmerland Wholesalers  
162 Bedford St.

### Hagerstown

114 E. Washington St.

### Salisbury

Almo Radio Co.  
219 Highland Ave.

## MASSACHUSETTS

### Boston

DeMambro Radio Supply Co.  
1111 Commonwealth Ave.  
General Electric Supply Corp.  
145 North Beacon  
Hatry & Young of Mass., Inc.  
811 Boylston St.  
The Louis M. Herman Co.  
885 Boylston Street  
A. W. Mayer Co.  
895 Boylston St.  
Radio Shack Corp.  
167 Washington St.  
Radio Wire Television, Inc.  
110 Federal St.

### Brockton

Ware Radio Supply Co.  
913 Center St.

### Cambridge

The Eastern Co.  
620 Memorial Drive  
Electrical Supply Corp.  
1739 Massachusetts Ave.

### Fitchburg

Hatry & Young of Fitchburg, Inc.  
390 Water St.

### Holyoke

Oakes Electrical Supply Co.  
271 Appleton St.  
Springfield Radio Co.  
93 High St.

### Lawrence

Hatry & Young of Lawrence, Inc.  
262 Lowell Street

### New Bedford

C. E. Beckman Co.  
11 Commercial St.

### Pittsfield

Pittsfield Radio Co.  
41 West St.

### Springfield

T. F. Cushing  
349 Worthington St.  
Hatry & Young  
of Springfield, Inc.  
169 Spring Street  
Regent Sales Inc.  
236 Chestnut St.  
Riga Electrical Corp.  
376 Worthington St.  
Soundco Electronic Supply Co.  
147 Dwight St.  
Springfield Radio Co.  
405 Dwight St.  
Westinghouse Electric Supply Co.  
46 Hampden St.

### Worcester

DeMambro Radio Supply Co., Inc.  
222 Summer Street  
Radio Electronic Sales Co.  
52 Chandler St.  
Radio Maintenance Supply Co.  
19 - 25 Central St.

## MICHIGAN

### Ann Arbor

Purchase Radio & Camera Shop  
605 Church Street  
Wedemeyer Electronic Supply Co.  
215 N. Fourth Ave.

### Battle Creek

Electronic Supply Corp.  
94 Hamblin Ave.

### Bay City

Kinde Distributing Co.  
504 Washington Ave.

### Detroit

M. N. Duffy & Co.  
2040 Grand River Ave., W.  
Radio Electronic Supply Co.  
1112 W. Warren Ave.  
Radio Specialties Co.  
456 Charlotte Ave.

### Flint

Shand Radio Specialties  
203 West Kearsley St.

## Grand Rapids

Radio Electronic Supply Co.  
505 Jefferson Ave., S. E.

### Jackson

Fulton Radio Supply Co.  
265 W. Cortland St.

### Kalamazoo

Electronic Supply Corp.  
906 East Michigan Ave.  
Ralph M. Ralston Co.  
201 N. Park St.

### Lansing

Wedemeyer Electronic Supply Co.  
2005 E. Michigan Ave.

### Larium

Northwest Radio

### Muskegon

Fitzpatrick Electric Supply Co.  
444 Irwin Ave. Cor. Wood  
Bell-Lourim Electronics, Inc.  
1839 Peck St.

### Pontiac

Electronic Supply Co.  
248 East Pike St.

## MINNESOTA

### Duluth

Lew Bonn Company  
228 E. Superior St.  
Northwest Radio  
123 East First St.

### Minneapolis

Lew Bonn Company  
1211 La Salle Ave.  
Electronic Center, Inc.  
107 - 3rd Ave. No.  
Northwest Radio & Electronic  
Supply Co.  
52 So. 12th St.  
Stark Radio Supply Co.  
71 S. Twelfth St.

### St. Paul

Lew Bonn Co.  
141 - 147 West Seventh St.  
Hall Electric  
566 North Robert St.

## MISSISSIPPI

### Jackson

Swan Distributing Co., Inc.  
342 N. Gallatin St. P.O. Box 3201

## MISSOURI

### Butler

Henry Radio  
211 North Main St.

### Cape Girardeau

Suedekum Electronic Supply Co.  
902 South Sprigg St.  
P. O. Box 221

### Joplin

4-State Radio & Supply Company  
201 Main St.

### Kansas City

Burstein-Applebee Company  
1012-14 McGee Street  
Continental Electric Co.  
1321 West 13th St.

Electro-Crafts  
1305 Swift, North  
Radiolab  
1612 Grand Ave.

### Poplar Bluff

Tri-State Radio & Supply Co.  
536 E. Pine Blvd.

### St. Joseph

Acme Radio Supply  
110 North 9th St.  
St. Joseph Radio & Supply Co.  
922-24 Francis St.

### St. Louis

Ar-Ka Engineering, Inc.  
1319 South Vandeventer  
Walter Ashe Radio Co.  
1125 Pine St.  
Interstate Supply Company  
26 South Tenth St.  
Radonics  
5040 Easton Ave.  
Van Sickle Radio Co.  
1113 Pine St.

**Springfield**

Reed Radio & Supply Co.  
805 Boonville Ave.

**MONTANA**

**Billings**

Electronic Supply Co.  
214 Eleventh St., West

**Butte**

Smith Supply Co.  
425 So. Arizona St.

**Helena**

D. N. Latus Co.  
1531 National

**Great Falls**

Geo. Lindgren Co.  
P. O. Box 966

**Missoula**

Northwest Distributors  
509 South Higgins Ave.

**NEBRASKA**

**Lincoln**

Hicks Radio Company  
1422 "O" Street

Leuck Radio Supply  
243 South 11th St.

**Omaha**

J. B. Distributing Co.  
1616 Cass St.

Omaha Appliance Co.  
18th & St. Mary's  
Radio Equipment Co.  
2852 Douglas St.

**Scottsbluff**

Joaquim Radio Supply, Inc.  
1913 Broadway - P. O. Box 67

**NEVADA**

**Reno**

Ed. Heim Radio & Electronics  
1185 Wells Ave.

**NEW HAMPSHIRE**

**Concord**

Evans Radio  
P. O. Box 312

**Dover**

American Radio Corp.  
Sixth and Chestnut Sts.

**Manchester**

DeMambo Radio Supply Co.  
1308 Elm Street

Radio Service Laboratory  
670 Chestnut St.

**NEW JERSEY**

**Atlantic City**

Almo Radio Co.  
4401 Ventnor Ave.

Radio Electric Service Co.  
406 North Albany

**Camden**

Almo Radio Co.  
1133-35-37 Haddon Avenue

Radio Electric Service of  
New Jersey, Inc.  
513-515 Cooper St.

**Newark**

Continental Sales Co., Inc.  
Bloomfield Ave. at North 11th St.

Federated Purchaser Corp.  
114 Hudson St. at Central Ave.

Aaron Lippman & Co.  
99-107 Newark St.

Radio Wire-Television, Inc.  
24 Central Ave.

Westinghouse Electric Supply Co.  
528 Ferry St.

**New Brunswick**

William Radio Supply Co.  
1861 Woodbridge Ave., Route 43

**Trenton**

Allen and Hurley  
25 South Warren St.

**NEW MEXICO**

**Albuquerque**

Radio Equipment Co.  
523 East Central Ave.

L. B. Walker Radio Co., Inc.  
114 W. Granite Ave.

**Roswell**

Supreme Radio Supply  
129 W. 2nd St.

**Santa Fe**

A-I Communications Supply Co.  
441 Cerrillos Road

**NEW YORK**

**Albany**

Fort Orange Distributing Co., Inc.  
904 Broadway

E. E. Taylor Co.  
465 Central Ave.

**Amsterdam**

Adirondak Radio Supply  
P. O. Box 88

**Binghamton**

Federal Radio Sales & Supply Co.  
188 State St.

**Brooklyn**

Peerless Electronics Distributors  
Corp.  
76 Willoughby St.

**Buffalo**

Dymac, Inc.  
2329 Main St.

Genesee Radio & Parts Company  
205 Genesee St.  
Radio Equipment Corp.  
147 Genesee St.

**Cortland**

C. A. Winchell Radio Supply Co.  
37 Central Ave.

**Fredonia**

Barker-Higbee, Inc.  
27 Water St.

**Hempstead**

Standard Parts Corp.  
277 No. Franklin St.

**Ithaca**

Stallman of Ithaca, Inc.  
123-131 South Tioga St.

**Jamaica**

Harrison Radio Corp.  
144 - 24 Hillside Ave.

Norman Radio Distributors, Inc.  
94-29 Merrick Road

Peerless Radio Distributors, Inc.  
92-32 Merrick Road

**New York City**

Arrow Electronics Co.  
82 Cortlandt St.

Electronics Center Inc.  
118 Duane St.

Federated Purchaser  
66 Dey St.

Harrison Radio Corp.  
225 Greenwich Street

Harvey Radio Co., Inc.  
103 W. 43rd St.

Hudson Radio & Television Corp.  
48 West 38th St.

Hudson Radio & Television Corp.  
212 Fulton St.

Midway Radio & Television Corp.  
60 West 45th St.

Milo Radio & Electronics Corp.  
200 Greenwich St.

Radio Wire-Television, Inc.  
100 Sixth Ave.

Sun Radio & Electronics Co., Inc.  
650 Sixth Ave.

Terminal Radio Corp.  
85 Cortlandt St.

**Rochester**

Hunter Electronics  
233 East Ave.

Masline Radio & Electronic  
Equipment Co.  
192-196 Clinton Ave., North

Rochester Radio Supply Co.  
114 St. Paul St.

**Syracuse**

W. E. Berndt  
655 S. Warren St.

Radio Supply Co.  
200 Walton St.

Stewart W. Smith, Inc.  
325 East Water St.

**Utica**

Beacon Electronics, Inc.  
411 - 419 Columbia St.

**Watertown**

Wolmar Distributors, Inc.  
Div. of Beacon Electronics, Inc.  
108 Lincoln Bldg.

**White Plains**

Westchester Electronic Supply Co.  
420 Mamaroneck Ave.

**NORTH CAROLINA**

**Asheville**

Freck Radio & Supply Co.  
38 Biltmore Ave.

**Charlotte**

Dixie Radio Supply Co., Inc.  
715 W. Morehead

Shaw Distributing Co.  
205 W. First St.

Southern Radio Corp.  
1625 West Morehead

**Greensboro**

Johannesen Electric Co.  
312 - 14 N. Eugene St.

Southeastern Radio Supply Co.  
404 North Eugene St.

**Raleigh**

Allied Electronics  
413 - 415 Hillsboro St.

Southeastern Radio Supply Co.  
415 Hillsboro St.

**Winston-Salem**

Dalton-Hege Radio Supply Co.  
924 W. 4th St.

**NORTH DAKOTA**

**Fargo**

Bristol Distributing Co.  
419 N. P. Ave.

Fargo Radio Service Co.  
515 Third Ave. N.

**OHIO**

**Akron**

Olson Radio Warehouse, Inc.  
73 East Mill St.

The Sun Radio Co.  
110 East Market St.

**Ashtabula**

Morrison's Radio Supply  
331 Center St.

**Canton**

Armstrong's Electronic Center  
1261 Cleveland Ave. Northwest

Wireless Radio & Television  
117-12th St., N. E.

**Cincinnati**

Chambers Electronic  
Supply Co., Inc.

1667-71 Central Parkway

Herrlinger Distributing Co.  
15th & Vine Sts.

Hughes-Peters Inc.  
1128 Sycamore St.

The Mytronic Co.  
121 West Central Parkway

The Schuster Electric Co.  
319-21 East 8th St.

Steinberg's Inc.  
633 Walnut St.

United Radio, Inc.  
1314 Vine St.

**Cleveland**

Northern Ohio Laboratories  
2073 W. 85th St.

Pioneer Radio Supply Corp.  
2115 Prospect Ave.

The Progress Radio Supply Co.  
415 Huron Rd.

Radio & Electronics Part Corp.  
3235 Prospect Ave.

Winteradio, Inc.  
1468 West 25th St.

**Columbus**

Hughes-Peters, Inc.  
111 - 117 East Long St.

Thompson Radio Supplies  
182 East Long St.

**Dayton**

Hughes-Peters, Inc.  
300 W. 5th at Perry

**Srepeco, Inc.**

314 Leo St.  
Stotts-Friedman Co.  
135 E. Second St.

**East Liverpool**

D & R Radio Supply  
631 Dresden Ave.

**Lima**

Lima Radio Parts Co.  
600 North Main St.

**Springfield**

Eberlie's Radio Supply  
522 West Main St.

Standard Radio—Springfield, Inc.  
119 West Main St.

**Steubenville**

D & R Radio Supply  
156 S. 3rd St.

**Toledo**

The H & W Auto Accessories Co.  
26 N. 11th St.

Lifetime Electronics  
1501-05 Adams St.

Warren Radio Co.  
1320 Madison Ave.

**Youngstown**

Radio Parts Co.  
230 Boardman St.

Ross Radio Company  
325 West Federal St.

**OKLAHOMA**

**Oklahoma City**

Radio Supply, Inc.  
924 W. Hudson

**Tulsa**

Electronic Supplies  
219 East First St.

Industrial Electronic Supply, Inc.  
1124 East Fourth St.

Oil Capital Electronics Corps.  
923 East 4th St.

Radio, Inc.  
1000 S. Main St.

S & S Radio Supply Co.  
721 S. Detroit St.

**OREGON**

**Eugene**

Carlson, Hatton & Hay, Inc.  
96 East 10th Ave.

United Radio Supply, Inc.  
179 W. 8th St.

**Medford**

Verl G. Walker Co.  
P. O. Box 1586

**Portland**

Central Distributors  
1135 S. W. Washington St.

Fleming & Company  
N. W. Broadway at Flanders

Harper-Meggee Co.  
1506 N W Irving St.

Lou Johnson Co., Inc.  
422 N. W. 8th Ave.

Northwest Radio Supply Co.  
717 S W Ankeny St.

Pacific Stationery  
Wholesale Radio Dept.  
414 S. W. Second Ave.

Portland Radio Supply Co.  
1300 W. Burnside St.

Stubbs Electric Co.  
33 N W Park Ave.

United Radio Supply, Inc.  
22 N. W. Ninth Ave.

**Salem**

Lou Johnson Company  
1051 South Commercial St.

**PENNSYLVANIA**

**Erie**

J. V. Duncombe Co.  
1011 West 8th St.

Warren Radio, Inc.  
12th & State Sts.

**Harrisburg**

Radio Distributing Co.  
915 South 13th St.

**Philadelphia**

A. C. Radio Supply Co.  
1537 W. Passyunk Ave.

**Almo Radio Co.**  
509 Arch St.  
**Almo Radio Co.**  
6205 Market St.  
**Almo Radio Co.**  
412-16 North 6th St.  
**Consolidated Radio Co.**  
612 Arch St.  
**Herbach & Rademan, Inc.**  
1205 Cuthbert St.  
**M&H Sporting Goods Co.**  
512 Market St.  
**Radio Electric Service Co.**  
N. W. Cor. 7th & Arch Sts.  
**Radio Electric Service Co. of Penna., Inc.**  
3412-14 Germantown Ave.  
**Albert Steinberg & Company**  
2520 North Broad St.  
**Eugene G. Wile**  
218 South 11th St.

#### Pittsburgh

**Cameradio**  
1121 Penn Ave.  
**Tydings Company**  
5800 Baum Blvd.

#### Reading

**George D. Barbey Co.**  
2nd and Penn Sts.

#### Scranton

**Fred P. Pursell**  
1221 - 27 N. Washington Ave.  
**Scranton Radio & Television Supply Co.**  
519-21 Mulberry St.

#### Uniontown

**Zimmerman Wholesalers**  
55 Morgantown St.

#### Wilkes-Barre

**Radio Service Co.**  
346 South Main St.

#### Williamsport

**Williamsport Radio Supply**  
518 W. Third St.

#### York

**York Radio & Refrigeration Parts**  
263 West Market St.

### RHODE ISLAND

#### Providence

**Wm. Dandreta & Co.**  
129 Regent Ave.  
**DeMambro Radio Supply Co.**  
90 Broadway  
**W. H. Edwards Co.**  
94 Broadway

### SOUTH CAROLINA

#### Charleston

**Radio Laboratories**  
215 King St.

#### Columbia

**Dixie Radio Supply Co., Inc.**  
1700 Laurel St.  
**McElhenny Co., Inc.**  
1215 Henderson St.  
**Southeastern Radio Parts Co.**  
1608 Gregg St.

#### Greenville

**Dixie Radio Supply Co., Inc.**  
22 South Richardson St.

#### Spartanburg

**McElhenny Co., Inc.**  
204 St. John St.

### SOUTH DAKOTA

#### Aberdeen

**Burghardt Radio Supply**  
P. O. Box 342

#### Sioux Falls

**Power City Radio Co.**  
209 South First Ave.

#### Watertown

**Burghardt Radio Supply**  
P. O. Box 41

### TENNESSEE

#### Bristol

**Roden Electrical Supply Co.**  
104 East State St.

#### Chattanooga

**Specialty Distributing Co.**  
135 Market St.

#### Jackson

**L. K. Rush Company**  
103 Highland St.

#### Kingsport

**Chemcity Radio & Electric Co.**  
1019 Bristol Highway

#### Knoxville

**Chemcity Radio & Electric Co.**  
12 Emory Park  
**Roden Electrical Supply Co.**  
808 North Central Ave.

#### Memphis

**Bluff City Distributing Co.**  
905 Union Ave.  
**Lavender Radio Supply Co., Inc.**  
180 South Cooper St.  
**W & W Distributing Co.**  
644 Madison Ave.

#### Nashville

**Braid Electric Co.**  
1100 Demonbreun St.  
**Electra Distributing Co.**  
1914 West End Ave.

### TEXAS

#### Abilene

**R. & R. Electronic Co.**  
802-4 Walnut St.

#### Amarillo

**R. & R. Electronic Co.**  
707 Adams St.  
**West Texas Radio Supply**  
1026 W. 6th St.

#### Austin

**The Hargis Co.**  
706 West 6th St.

#### Beaumont

**Montague Radio Distributing Co.**  
760 Laurel St.

#### Brownsville

**Electronic Equipment & Engineering Co.**  
1152 East Madison St.

#### Corpus Christi

**Electronic Equipment & Engineering Co.**  
805 South Staples St.  
**Wicks-DeVilbiss Co.**  
513-15 South Staples St.

#### Dallas

**Crabtree's Wholesale Radio**  
2608 Ross Ave.  
**Industrial Electronic Supply, Inc.**  
134 Leslie St.

**Ra-Tel, Inc.**  
2409 Ross Ave.

**Southwest Radio Supply**  
1820 N. Harwood St.

**Wilkinson Bros.**  
P. O. Box 1169

#### Denison

**Denison Radio Supply**  
310 W. Woodard St.

#### El Paso

**C. C. McNicol**  
811 North Estrella  
**Midland Specialty Co.**  
425 West San Antonio St.

**Reeves Radio Supply**  
720 North Stanton St.

#### Fort Worth

**Electronic Equipment Co.**  
917-19 Florence St.  
**Ft. Worth Radio Supply Co.**  
1201 Commerce St.  
**Scooter's Radio Supply Co.**  
509 Commerce St.  
**Bill Sutton's Wholesale Electronics**  
Commerce at 5th St.

#### Houston

**Busacker Electronic Equipment Co.**  
1721 Waugh Drive  
**Electronic Parts Co.**  
3508 Crawford St.  
**Geophysical Supply Co.**  
P. O. Box 2214

**Robert E. Franklin Co.**  
1905 Chartres St.  
**Gulf Coast Electronics**  
1110 Winbern St.

**R. C. & L. Hall, Inc.**  
1219 Caroline St.

**Harrison Equipment Co.**  
1422 San Jacinto St.

**Houston Radio Supply Co., Inc.**  
Clay at LaBranch

**Lenert Company**  
2213 Congress Ave.

**Sterling Radio Products Co.**  
1616 McKinney Ave.

**Straus-Frank Company**  
4000 Leeland Ave.

#### Laredo

**Guarantee Radio Supply Co.**  
1314 Iturbide St.

#### Lubbock

**R & R Supply Co., Inc.**  
706 Main St.

**West Texas Radio Supply**  
1007 Avenue Q

#### McAllen

**Rio Radio Supply Co.**  
P. O. Box 168

#### San Angelo

**Gunter Wholesale Co.**  
606 South Irving St.  
P. O. Box 1505

#### San Antonio

**Amateur Headquarters & Supply**  
P. O. Box 5086

**Beacon Hill Station**  
Electronics, Inc.

512 Broadway

**Mission Radio, Inc.**  
P. O. Box 2487

**Radio & Television Parts Co.**  
118-20 Seventh St.

**Rio Radio Supply Co.**  
818 San Pedro

**Straus-Frank Company**  
301 S. Flores St.

#### Tyler

**Lavender Radio Supply Co.**  
502 East Oakwood

#### Waco

**The Hargis Co., Inc.**  
1205 Washington Ave.

#### Wichita Falls

**Clark & Gose Radio Supply**  
1203 Indiana Ave.

**Mooney Radio Supply Co.**  
P. O. Box 969

### UTAH

#### Salt Lake City

**O'Laughlin's Radio Supply Co.**  
113 East Broadway

**S. R. Ross, Inc.**  
1212 South State St.

**Standard Supply Co.**  
531 South State St.

### VIRGINIA

#### Bristol

**Bristol Radio Supply Corp.**  
31 Moore St.

#### Norfolk

**Radio Equipment Co.**  
821 West 21st St.

**Radio Parts Distributing Co.**  
128 West Olney Road

**Radio Supply Company**  
711 Granby St.

#### Richmond

**The Arnold Company**  
2810 West Marshall St.

**Radio Supply Company**  
3302 West Broad St.

**Wyatt-Cornick, Inc.**  
Grace at 14th St.

#### Roanoke

**H. C. Baker Sales Co., Inc.**  
19 Franklin Road

### WASHINGTON

#### Bellingham

**Waitkus Supply Co.**  
110 Grand Ave.

#### Everett

**Pringle Radio Wholesale Co.**  
2514 Colby Ave.

#### Seattle

**Electronic Supply Corp.**  
6305 - 49th Ave., S. W.

**Harper-Meggee, Inc.**  
960 Republican St.

**Radio Products Sales Co., Inc.**  
1214 - 1st Ave.

**Seattle Radio Supply, Inc.**  
2117 - 2nd Ave.

**Western Electronic Supply Co.**  
717 Dexter Ave.

**Westlake Electronic Supply**  
511 Westlake Ave., North

**Herb E. Zobrist Co.**  
2121 Westlake Ave.

#### Spokane

**Columbia Electric & Mfg. Co.**  
South 123 Wall St.

**Harper-Meggee Co.**  
North 734 Division

**Northwest Electronics Co.**  
North - 102 Monroe St.

#### Tacoma

**C & G Radio Supply Co.**  
2502-6 Jefferson Ave.

**A. T. Stewart Co.**  
743 Broadway

#### Walla Walla

**Kar Radio & Electric Co.**  
12th & Pine Sts.

### WASHINGTON D. C.

**Capitol Radio Wholesalers**  
2120 - 14th St. N. W.

**Electronic Wholesalers, Inc.**  
2345 Sherman Ave. N. W.

**General Electric Supply Corp.**  
705 Edgewood St. N. E.

**Kenyon Radio Supply Company**  
2020 - 14th Street, N. W.

**Rucker Radio Wholesalers**  
1312 - 14th St., N. W.

**Southern Wholesalers, Inc.**  
707 Edgewood St. N. E.

**Sun Radio**  
938 "F" St. N. W.

### WEST VIRGINIA

#### Charleston

**Chemcity Radio & Electric Co.**  
103 Clendenin St.

#### Clarksburg

**Trenton Radio Co.**  
791 Pike St.

#### Huntington

**Electronic Supply, Inc.**  
422 Eleventh St.

**King & Irwin Inc.**  
-316 Eleventh St.

#### Morgantown

**Trenton Radio Company**  
300 Grant Avenue

#### Wheeling

**General Electronics Distributors, Inc.**  
26 Tenth St.

### WISCONSIN

#### Appleton

**Appleton Radio Supply Co.**  
1217 N. Richmond St.

**Valley Radio Distributors**  
518 N. Appleton St.

#### Madison

**Satterfield Radio Supply**  
326 W. Gorham St.

#### Marinette

**G. M. Popkey Co.**  
Main at 9th St.

#### Milwaukee

**Central Radio Parts Co.**  
1723 W. Fond du Lac Ave.

**Electro-Pliance Distributors, Inc.**  
2548 W. Lisbon Ave.

**Radio Parts Co., Inc.**  
536-538 West State St.

#### Wausau

**Radio Service & Supply Co.**  
615 Third St.

### WYOMING

#### Cheyenne

**Houge Radio & Supply Co.**  
2008 Carey Ave.

*Eitel-McCullough*  
**EITEL-McCULLOUGH, INC.**  
 SAN BRUNO, CALIFORNIA

**TUBE  
 REPLACEMENT  
 CHART**

Tubes in the column marked "TYPE REPLACED" should be replaced with "EIMAC TUBE TYPE" shown in the first column. Replacement with the EIMAC TUBE TYPE will require no reductions in voltages or power input or changes in mechanical connections.

Tubes under the heading "NEAR EQUIVALENT" can be replaced with EIMAC tubes provided changes are made in the electrical values or mechanical connections. Where an "X" appears in the "CHANGES REQUIRED" column some change is indicated.

**TRIODES**

Eimac Tube Type	Type Replaced	NEAR EQUIVALENT					
		Type	CHANGES REQUIRED				
			Ef	Bias	Socket	Plate Connector	Grid Connector
3C24	25TG 3-25D3 VT204 24G DR24G PE130A	3C28 TUF20 PE130B		X	X	X	X X X
2C39A	GE2C39A ML381 ML2C39A 2C39 3X100A11 2C38 ZP572 GL2C39						
3X2500A3		7C24 7C25 WL473	X X X		X X X	X X X	X X X
3X2500F3		492R	X		X	X	X
25T	3-25A3 3C24 24 PE130C	HY30Z NU30Z 809 GL809 NU809 WL809 1623 GL1623 NUI623		X X X X X X		X X X X X X X X	
35T	3-50A4 PE35T	HY40 T40 NU40T HY40Z TZ40 NU40TZ T55 811 DR811 GL811 NU811 WL811 812 812H DR812 GL812 NU812 WL812	X X X X X X X X X X X X X X X X X X X	X X X		X X X X X X X X X X X X X X X X X	
35TG	3-50D4	4C25 54 356A 808 DR808		X X	X	X X X X	X X X X
UH50	VT62 3-50G2 BW11 304B 834						



## TUBE REPLACEMENT CHART—TRIODES (Continued)

Eimac Tube Type	Type Replaced	NEAR EQUIVALENT					
		Type	CHANGES REQUIRED				
			Ef	Bias	Socket	Plate Connector	Grid Connector
75TH	3-75A3	HY51A NU51A HY51B HY51Z TW75 8005	X X X X X X	X		X X X X X X	X X X X X X
75TL	3-75A2 75T						
100TH	3-1000A4 VT218 RK38 DR100TH EE100TH	4C22 HF100 T125 254 810 GL810 WL810 227A 327A 327B	X X X  X X X  X	X X  X	X X X X X X X X X	X X X X X X X X X X	X X X X X X X X X X
100TL	RK36 3-100A2 50T	8000 VT127A	X		X X	X X	X X
152TH	3-150A3 152H						
152TL	3-150A2 152L 152T						
592/3-200A3	GL592						
527	3-300G4						
6C21	GL6C21						
250TH	3-250A4 VT220 RK63 454H	4C32 TW150 354E 354F WL463 PE530 GL592 8225	X X   X X X	X	X X	X X X X X X	X X X X X X X
250TL	3-250A2 VT130 150T 454L	4C34 HV18 KU23 DR200 EE200 HF200 NU200 T200 DR300 EE300 HF300 NU300 354C 354D WL460 806 GL806 WL806	X X X X X X X X X X X X X X X X X X X	X	X	X X X X X X X X X X X X X X X X X X	X X X X X X X X X X X X X X X X X X X
304TH	3-300A3 VT254 304H WL535						
304TL	3-300A2 VT129 304L 304T WL525						



## TUBE REPLACEMENT CHART—TRIODES (Continued)

Eimac Tube Type	Type Replaced	NEAR EQUIVALENT					
		Type	CHANGES REQUIRED				
			Ef	Bias	Socket	Plate Connector	Grid Connector
450TH	3-450A4 VT108 WL450 F450TH 854H E450TH	833 357A 833A DR833A GL833A ML833A WL833A	X X X X X X X		X X X X X X	X	X X X X X X
450TL	3-450A2 300T 854L						
750TL	3-750A2 1054L						
1000T	3-1000A4 1000UHF						
1500T	3-1500A3						
2000T	3-2000A3	HF3000 ZB3200	X X	X	X X	X X	X X

### TETRODES

Eimac Tube Type	Type Replaced	NEAR EQUIVALENT					
		Type	CHANGES REQUIRED				
			Ef	Bias	Socket	Plate Connector	Grid Connector
4PR60A	5D21 715C 4-60A 715A 715B						
4-65A		57	X			X	
4-125A	4D21 4D23 AT340 PE340	4E27 RK65 257 257B AT257C PE257C 813 VT144 GL813 ML813 NU813 WL813 8001		X  X X X X X X X X X X X	X X X X X X X X X X X X	X X X X X X X X X X X X	
4X150A		4X100A				X	
4-250A	5D22 5D24	363A GL592	X X	X	X X	X X	
4-400A	4-250A						
4X500A		RK6D22	X	X	X	X	X

### PENTODES

Eimac Type	Type Replaced
4E27A/5-125B	257 257B 8001 4E27 5-125B

### RECTIFIERS

Eimac Tube Type	Type Replaced	NEAR EQUIVALENT				
		Type	CHANGES REQUIRED			
			Ef	Eg	Socket	Plate Connector
2-25A	25R	3B24W WL579B	X X		X X	
2-50A	35R					
253	HK253	217C 317C	X X			
8020/100R		WL578 GL451 2-100A GL8020 DR8020 EE8020 R6174 100R				
866A/866		VT46A C866A C866 RCA866A UE966 WL866A/866 GL866A/866 NU866A/866 3096 UE966A F366A UX866 RK866 T866A/866 CE866A/866 3572 EE866A/866 CV32 836 3B28 3B27 3B25				

(Continued on Back Page)



## RECTIFIERS (Continued)

Eimac Tube Type	Type Replaced	NEAR EQUIVALENT					
		Type	CHANGES REQUIRED				
			Ef	Eg	Socket	Plate Con- nector	Grid Con- nector
2-150D	152RA						
250R	2-250A TR40M 371B DR371B NU371B						
2-2000A	2000R						
RX21A	RX21						
KY21A	KY21						
872A	VT42A 872 UE972 NU872A / 872 C872A F872A F353A RCA872A F353 T872A / 872 3070 GL872A CE872A WL872A / 872 F872B BB872A						

## CONDENSERS

Eimac Tube Type	Type Replaced	NEAR EQUIVALENT		
		Type	CHANGES REQUIRED	
			Connectors	Spacing
VC6-20	VC6			
VC12-20	VC12	GL1L21 GL1L25	X X	X X
VC25-20	VC25	GL1L22 GL136	X X	X X
VC50-20	VC50	GL1L23 GL1L38	X X	X X
VC6-32	VC6			
VC12-32	VC12			
VC25-32	VC25			
VC50-32	VC50			

## TUBE REPLACEMENT CHART—CROSS INDEX

Comparable types arranged in serial order of their dominant number.

FOR TYPE NO.	USE EIMAC	FOR TYPE NO.	USE EIMAC	FOR TYPE NO.	USE EIMAC	FOR TYPE NO.	USE EIMAC	FOR TYPE NO.	USE EIMAC
GL1L21	VC12-20	4E27	4E27A / 5-125B	VT108	450TH	AT340	4-125A	WL809	25T
GL1L22	VC25-20	5D21	4PR40A	TI25	100TH	PE340	4-125A	810	100TH
GL1L23	VC50-20	5D22	4-250A	VT127A	100TL	354C	250TL	GL810	100TH
GL1L25	VC12-20	5D24	4-250A	VT129	304TL	354D	250TL	WL810	100TH
GL1L36	VC25-20	6L6C21	4C21	PE130A	3C24	354E	250TH	811	35T
GL1L38	VC50-20	RK4D22	4X500A	PE130B	3C24	354F	250TH	DR811	35T
2C38	2C39A	7C24	3X2500A3	PE130C	25T	356A	35TG	GL811	35T
2-100A	100R	7C25	3X2500A3	VT130	250TL	357A	450TH	NU811	35T
2-250A	250R	BW11	UH50	VT144	4-125A	363A	4-250A	WL811	35T
GL2C39	2C39A	HV18	250TL	150T	250TL	371B	250R	812	35T
ML2C39	2C39A	TUF20	3C24	TW150	250TH	DR371B	250R	812H	35T
3-25A3	25T	KU23	250TL	152H	152TH	NU371B	250R	DR812	35T
3-25D3	3C24	24	25T	152L	152TL	ML381	2C39A	GL812	35T
3-50A3	35T	24G	3C24	152RA	2-150D	E450TH	450TH	NU812	35T
3-50D4	35TG	DR24G	3C24	152T	152TL	F450	450TH	WL812	35T
3-50G2	UH50	25TG	3C24	DR200	250TL	WL450	450TH	813	4-125A
3-75A2	75TL	HY30Z	25T	EE200	250TL	GL451	8020 / 100R	GL813	4-125A
3-75A3	75TH	NU30Z	25T	HF200	250TL	454H	250TH	ML813	4-125A
3-100A2	100TL	PE35T	35T	NU200	250TL	454L	250TL	NU813	4-125A
3-100A3	100TH	RK34	100TL	T200	250TL	WL460	250TL	WL813	4-125A
3-150A2	152TL	RK38	100TH	VT204	3C24	WL463	250TH	822S	250TH
3-150A3	152TH	HY40	35T	VT218	100TH	WL473	3X2500A3	833	450TH
3-250A3	250TL	HY40Z	35T	VT220	250TH	492R	3X2500F3	833A	450TH
3-250A4	250TH	NU40T	35T	227A	100TH	WL525	304TL	DR833A	450TH
3-300A2	304TL	NU40TZ	35T	HK253	253	PE530	250TH	GL833A	450TH
3-300A3	304TH	T40	35T	254	100TH	WL535	304TH	ML833A	450TH
3-300G4	52T	TR40M	250R	VT254	304TH	ZP572	2C39	WL833A	450TH
3-450A2	450TL	TZ40	35T	257	4E27A / 5-125B	WL578	8020 / 100R	834	UH50
3-450A4	450TH	50T	100TL	257B	4E27A / 5-125B	GL592	592 / 3-200A3	854H	450TH
3-750A2	750TL	HY51A	75TH	PE257B	4E27A / 5-125B	GL592	250TH	854L	450TH
3-1000A4	1000T	HY51B	75TH	AT257C	4E27A / 5-125B	715A	1000UHf	4PR40A	1000T
3-1500A3	1500T	HY51Z	75TH	PE257C	4E27A / 5-125B	715B	1054L	4PR60A	750TL
3-2000A3	2000T	NU51A	75TH	DR300	250TL	715C	1623	4PR60A	25T
3C24	25T	54	35TG	EE300	250TL	R6174	8020 / 100R	GL1623	25T
3C28	3C24	T55	35T	HF300	250TL	804L	450TL	NU1623	25T
3C34	25T	VT42	UH50	NU300	250TL	804	250TL	HF3000	2000T
3X100A11	2C39A	RK63	250TH	300T	450TL	GL806	250TL	8000	100TL
4C22	100TH	RK65	4-125A	304B	UH50	WL806	250TL	8001	4E27A / 5-125B
4C25	35TG	75T	75TL	304H	304TH	808	35TG	8005	75TH
4C32	250TH	TW75	75TH	304L	304TL	DR808	35TG	8020	8020 / 100R
4C34	250TL	DR100TH	100TH	304T	304TL	809	25T	DR8020	8020 / 100R
4D21	4-125A	EE100TH	100TH	327A	100TH	GL809	25T	EE8020	8020 / 100R
4D23	4-125A	HF100	100TH	327B	100TH	NU809	25T	GL8020	8020 / 100R

# PRICE

June 1, 1953

## VACUUM TUBES

TUBE TYPE	PRICE	TUBE TYPE	PRICE
2-01C	\$ 15.25	6C21	\$ 77.00
2-25A	11.00	KY21A	13.25
2-50A	13.75	RX21A	9.00
2-150D	19.25	25T	9.00
2-240A	66.00	35T	10.50
2-2000A	214.50	35TG	16.00
2C39A	34.00	75TH	13.25
3K20,000LA	2,975.00	75TL	13.25
3K20,000LF	2,975.00	100TH	18.25
3K20,000LK	2,975.00	100TL	18.25
3W5000A3	198.00	152TH	28.75
3W5000F3	198.00	152TL	28.75
3W10,000A3	957.00	250R	22.00
3X2500A3	198.00	250TH	33.00
3X2500F3	198.00	250TL	33.00
3X3000A1	198.00	253	20.50
4-65A	20.00	304TH	60.50
4-125A	30.25	304TL	60.50
4-250A	41.25	450TH	77.00
4-400A	60.50	450TL	77.00
4-1000A	132.00	592/3-200A3	30.25
4E27A/5-125B	35.75	750TL	137.50
4PR60A	90.00	866A	2.10
4W20,000A	1,850.00	872A	8.20
4X150A	48.00	1000T	137.50
4X150D	48.00	1500T	220.00
4X150G	54.00	2000T	275.00
4X500A	121.00	8020(100R)	15.00
4X500F	93.50		

## VACUUM CAPACITORS

TYPE	PRICE	TYPE	PRICE
VC6-20	\$15.00	VC50-20	\$ 24.25
VC6-32	17.25	VC50-32	27.50
VC12-20	16.50	VVC60-20	66.00
VC12-32	20.00	VVC2-60-20	147.50
VC25-20	20.00	VVC4-60-20	284.00
VC25-32	23.25		

## HEAT DISSIPATING CONNECTORS

TYPE	PRICE	TYPE	PRICE
HR-1	\$ .60	HR-6	\$ .80
HR-2	.60	HR-7	1.60
HR-3	.60	HR-8	1.60
HR-4	.80	HR-9	3.00
HR-5	.80	HR-10	1.60

## AIR SYSTEM SOCKETS

TYPE	PRICE
4-400A/4000	\$16.00
4-400A/4001	12.00
4-400A/4006*	6.00
4-1000A/4000	22.50
4-1000A/4001	17.00
4-1000A/4006*	7.50
4X150A/4000	18.00
4X150A/4001	17.50
4X150A/4006*	.60
4X150A/4010	20.15
4X150A/4011	19.70

\*Replacement Chimneys

## PREFORMED CONTACT FINGER STOCK

	PRICE
17/32" - - - -	\$1.65/ft.
31/32" - - - -	1.80/ft.
1 - 7/16" - - - -	2.00/ft.

## VACUUM PUMP & GAUGE

TYPE	PRICE
HV-1	\$125.00
Pump Oil - Qt.	5.00
100 IG	22.50

## VACUUM SWITCH

	PRICE
VS-2	\$13.25
12V Coil	11.75
24V Coil	12.50



# VACUUM PUMP

## PRICE LIST

June 1, 1950

### OIL DIFFUSION PUMP

A glass barrel, triple-jet, air-cooled vacuum pump of the oil-diffusion type. Ultimate vacuum of  $4 \times 10^{-7}$  mm of mercury. Speed without baffle approximately 67 liters per second. Simple to operate, requires no intricate adjustment or special tools for assembly. Heater voltage 110 volts. Current 1.7 amperes. Overall length below high-vac manifold  $16\frac{1}{2}$ ". Shipping weight 18 pounds. Complete assembly includes flanges and nipples for connecting to high-vac manifold and forepump system, together with necessary gaskets and complete operating instructions.

**PRICE \$125.00**

### PUMP OIL

An especially prepared petroleum product compounded to afford ultimate in high vacuum. Absence of "light ends" eliminates oil contamination to high vacuum system without use of liquid air or charcoal traps.

**PRICE, QT. \$5.00**

### ION GAUGE

Essentially a triode vacuum tube with a pure tungsten filament for measuring pressures from  $10^{-3}$  to less than  $10^{-8}$  mm of mercury. Constructed of "hard" glass for sealing to nonex glass vacuum systems.

**PRICE \$22.50**

EIMAC PART NO.	NO. REQ.	DESCRIPTION	PRICE EACH
D-3	2	Neoprene Gasket for 3" Coupling	\$ 1.65
4911	1	Jet Assembly	40.00
D-9	1	Neoprene Gasket for 1" Coupling	1.25
917	1	Pump Barrel Assembly	70.00
914	1	Manifold Adaptor	20.00
8911	1	Forevac Nipple	15.00
D-15	2	1" Insert	.45
D-22	2	3" Insert	.75
911	1	Baffle Assembly	8.50
7912	1	3" Flange Assembly*	25.00
7913	1	1" Flange Assembly*	10.00
D-10	6	Springs	.10

\*Each flange assembly includes necessary flanges, gaskets, inserts, bolts and hardware.

The Eimac HV-1 vacuum pump and its allied components have for many years been the standby for one of the most exacting of vacuum techniques—the evacuating of radio transmitting tubes on a production basis. They have also been thoroughly proven in many other fields of endeavor.

The Eimac engineering staff will gladly supply further information to assist in your employing the HV-1 to fulfill your vacuum requirements.

# PRICE

January 1, 1955

1K015XA	\$ 180.00	4X150D	41.50 \$ <del>48.00</del>
1K015XG	180.00	4X150G	54.00
2-01C	15.25	4X500A	121.00
2-25A	11.00	4X500F	93.50
2-50A	13.75	6C21	77.00
2-150D	19.25	KY21A	13.25
2-240A	40.00 <del>66.00</del>	RX21A	9.00
2-2000A	214.50	25T	9.00
2C39A	24.00	35T	10.50
3C24	12.00	35TG	16.00
3K20,000LA	2,975.00	75TH	13.25
3K20,000LF	2,975.00	75TL	13.25
3K20,000LK	2,975.00	100TH	18.25
3K50,000LA	4,200.00	100TL	18.25
3K50,000LF	4,200.00	152TH	28.75
3K50,000LK	4,200.00	152TL	28.75
3K50,000LQ	4,200.00	250R	22.00
3W5000A3	198.00	250TH	33.00
3W5000F3	198.00	253	20.50
3W10,000A3	957.00	304TH	60.50
3X2500A3	198.00	304TL	60.50
3X2500F3	198.00	450TH	77.00
3X3000A1	198.00	450TL	77.00
3X3000F1	198.00	592/3-200A3	30.25
4-65A	20.00	750TL	137.50
4-125A	30.25	866A	2.45
4-250A	41.25	872A	8.20
4-400A	60.50	1000T	137.50
4-1000A	132.00	1500T	220.00
4E27A/5-125B	35.75	2000T	275.00
4PR60A	90.00	8020(100R)	15.00
4W20,000A	1,850.00		
4X150A	41.50 <del>48.00</del>		

VC6-20	\$15.00	VC50-20	\$ 24.25
VC6-32	17.25	VC50-32	27.50
VC12-20	16.50	VVC60-20	66.00
VC12-32	20.00	VVC2-60-20	147.50
VC25-20	20.00	VVC4-60-20	284.00
VC25-32	23.25		

HR-1	\$ .60	HR-6	\$ .80
HR-2	.60	HR-7	1.60
HR-3	.60	HR-8	1.60
HR-4	.80	HR-9	3.00
HR-5	.80	HR-10	1.60

4-400A/4000	\$16.00
4-400A/4001	12.00
4-400A/4006*	6.00
4-1000A/4000	22.50
4-1000A/4001	17.00
4-1000A/4006*	7.50
4X150A/4000	18.00
4X150A/4001	17.50
4X150A/4006*	.60
4X150A/4010	20.15
4X150A/4011	19.70

\*Replacement Chimneys

17/32" - - - -	\$1.65/ft.
31/32" - - - -	1.80/ft.
1-7/16" - - - -	2.00/ft.

HV-1	\$125.00
Pump Oil - Qt.	5.00
100 IG	22.50

VS-2	\$18.00
VS-5	24.00
VS-6	32.00
12V Coil	7.50
24V Coil	8.50

Tube Extractor for 4X150A, 4X150D, 4X150G	\$ .55
--	--------

**THE APPLICATION OF CRYSTAL CONTROL TO DIATHERMY**

The obvious advantages of operating diathermy and r-f heating equipment within the frequency bands recently assigned for this service by the FCC makes the use of crystal control attractive, if economically feasible. This bulletin describes a 400 to 500-watt crystal-controlled diathermy unit employing an Eimac 4-250A tetrode as a power amplifier in the output stage. The unit provides for the necessary frequency stability, control of output, circuit simplicity and safety to both operator and patient. Due to the low driving power requirements of the 4-250A, a minimum of equipment is needed for adequate frequency control. The exciter unit consists mainly of receiving type tubes and small parts. The complete unit is no larger than many existing outmoded self-controlled oscillators serving the same purpose. As the frequency is controlled within a band assigned for diathermy use, shielding is not required to prevent interference with communication services.

**CIRCUIT**

The circuit (Fig. 5) employs a crystal having a fundamental frequency one-fourth the output frequency of 27.32 Mc. This scheme would be applicable to either of the other two assigned diathermy frequencies, 13.66 Mc. or 40.98 Mc., as crystals having fourth harmonics within this range are available.<sup>1</sup> The oscillator stage employs a 6AG7 operating as a Pierce oscillator in the grid-screen section, and doubling in the plate circuit. This is followed by a 6L6 doubler stage. With approximately 425 volts plate supply for these two tubes, the 6L6 easily delivers adequate grid excitation to the 4-250A.

The plate of the 4-250A is shunt-fed through an r-f choke, to allow d-c grounding of the plate tank circuit, as a safety measure. The maximum plate voltage applied to the 4-250A is 3000 volts. Power is taken from the output circuit via a matching network which allows an efficient transfer of energy for various forms of application. A small pilot lamp inductively coupled to the output leads indicates presence of maximum output to the patient, while a plate-current meter indicates the degree of loading.

The 4-250A does not require neutralization at the frequency on which this unit operates, if reasonable precautions are taken regarding by-passing and shielding. All r-f circuits preceding the 4-250A have been placed under the chassis, to prevent capacitive coupling around the power amplifier stage. The 6L6 in the doubler stage is of the metal-envelope type, with the envelope grounded via a short lead, to prevent capacitive coupling between the plate of the 4-250A and the plate of the 6L6. The filament and screen by-pass capacitors in the 4-250A stage are returned to ground by short, direct leads.

It has been found that the 4-250A plate circuit, once set for resonance, needs no further adjustment with changes in loading. The plate tank capacitor control might well be placed behind the panel out of immediate reach, as it is not required as an operating control.

## CONSTRUCTION

A wooden cabinet 16 by 22 by 48 inches houses the equipment. Space is available for the storage of cords and pads in a small cupboard below the control panel. Two chassis 17 by 13 by 3 inches, one for the r-f section, the other for the low and high power supplies, provide ample space for construction. The power supply chassis rests on cleats provided at the base of the unit, while the r-f section is situated behind the control panel to which it is attached. The two units may be removed through the rear of the cabinet, which is normally covered with a single partition. As air cooling of the 4-250A base structure is required, and envelope cooling is advisable, a unique ventilating system has been incorporated in the diathermy unit to provide both types of cooling. A 15 by 20 by 2 inch glass-type dust filter is located in the bottom of the cabinet, below the power supply. Air is drawn by a 6-inch fan through the filter, around the power supply chassis, up behind the storage space, and exhausted through a screened opening six inches in diameter behind the r-f section. The fan is centered in this opening but is attached to the side of the cabinet, allowing easy removal of the rear partition when desired. Air, in passing into the upper section of the cabinet, is also drawn under the r-f chassis and through the socket in sufficient quantity to provide adequate cooling of the 4-250A base structure. The r-f chassis does not completely block the flow of air into the upper section containing the fan and outlet opening, as the entire volume of air is not required to cool the tube base.

## CONTROLS

The output to the applicator pads is smoothly controlled by a continuously variable autotransformer in the high voltage transformer primary. Since the 4-250A screen voltage is obtained by means of a series dropping resistor from the plate supply, no separate control is required for screen voltage, and the voltage on the screen due to changes in the loading preliminary to or during treatment is self-regulating to the extent that no adjustment is necessary. The main controls for adjustment to the patient are a time switch as a guard against overdose due to unintentional duration of treatment, the autotransformer power adjustment, and the output load matching control. As a precaution against maladjustment, an overload relay protects the equipment. A reset button for the overload relay is provided on the control panel.

## RESULTS

The output has been found to be more than ample for normal therapeutic treatment. In many cases a smaller tube such as the Eimac 4-125A in the amplifier would deliver adequate power, with a resulting saving in the cost of the tube and certain components.

Tests on frequency stability indicate that there is no appreciable change in frequency either from varying load conditions or from drift due to temperature changes. The frequency drift during the first ten minutes from a cold start measured approximately 800 cycles at the output frequency of 27.32 Mc. The frequency shift from changes in loading and power was so slight as to be inconsequential. Stability of this sort is a great improvement over self-controlled oscillator devices, many of which shift frequency violently, often rendering whole bands of communications frequencies completely useless.

<sup>1</sup>The sixth harmonic, using the combination of 3X in the 6AG7 and 2X in the 6L6, would lower the crystal frequency still further, if desired and yet provide ample excitation for the 4-250A.

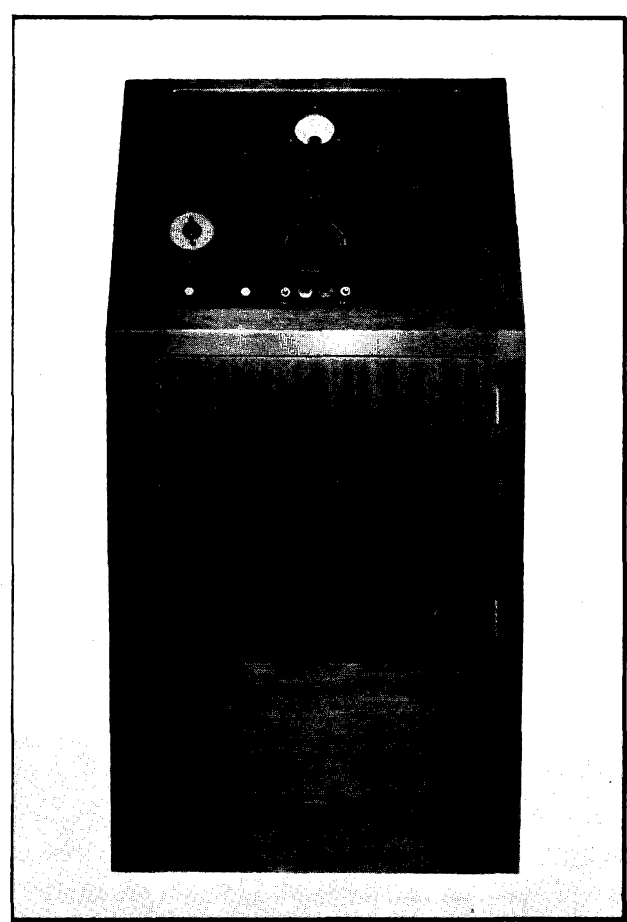

FIG. 1—Front view of the experimental crystal-controlled diathermy unit. Apparatus on the panel includes, autotransformer control, PA plate meter, output tuning control, interval timer, PA plate tuning control, output jacks, output indicator lamp, oscillator and doubler tuning controls (screwdriver adjustment), power switches and pilot lamps.

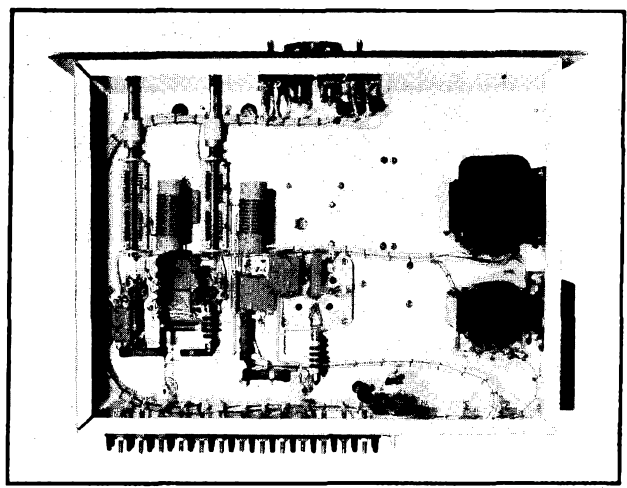

FIG. 4—Bottom view of the r-f section chassis. All r-f circuits preceding the 4-250A plate circuit are placed under the chassis, to prevent unwanted feedback around the power amplifier stage. Holes in the 4-250A socket allow adequate circulation of air through the tube base, with the aid of the exhaust fan above the chassis.

FIG. 2 Complete r-f section of the diathermy unit. The two tuning capacitors for the output network are visible at the upper left of the panel. One of the capacitors is used as a fixed padding capacitor, the other is adjustable from the front panel.

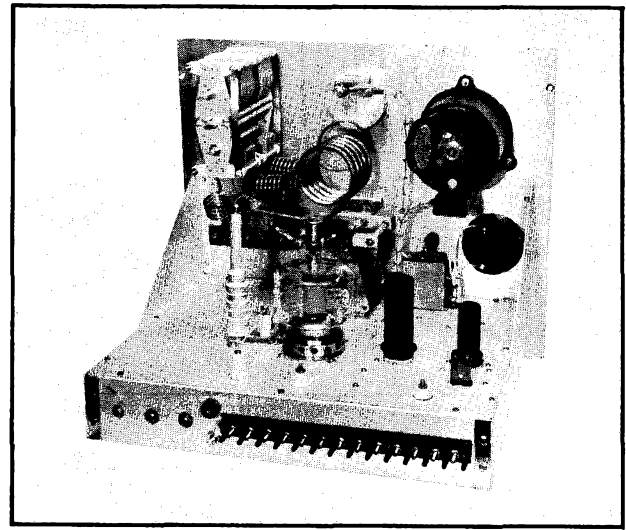
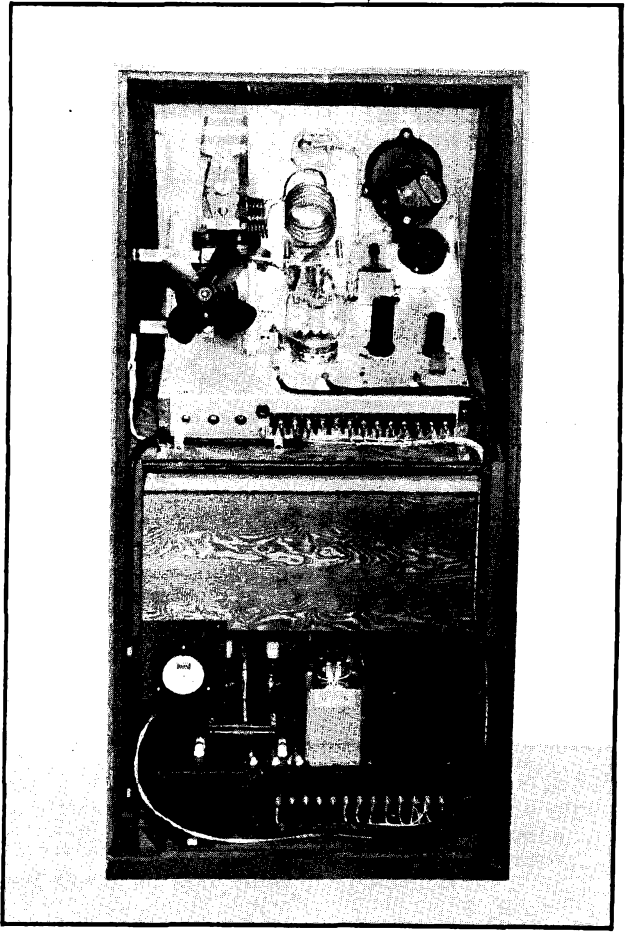

FIG. 3—Rear view of diathermy unit (rear partition removed). Removing the rear partition allows access to exciter-section metering jacks, fuses, and overload relay shunt. Note exhaust fan supported from left side of cabinet.





REVISED 1-19-53

**PULSE SERVICE NOTES**

In pulse service, where the "on-time" is small compared to the "off-time," Eimac tubes with their ample reserve of filament emission and freedom from internal insulators can be run to a much higher peak-power than is permissible in continuous services. In continuous service, the published voltage and current maxima of Eimac tubes are generally set at values considerably less than the inherent limitations of the design, due to the need to consider the average power dissipated on the anode, grids, and entire tube structure. In pulse service, it is usually reasonable to increase the applied electrode voltages and resulting pulse currents above the maximum values shown for continuous service on the data sheets.

Because of the wide variety of operating conditions in pulse service, it seems advisable to indicate possibilities of tube performance rather than specific operating conditions. It is the user's responsibility to see that no basic limitations of the tubes are exceeded and to introduce factors of safety according to the needs of the particular application.

The principal basic limitations of the tube are given below:

1. **Average Electrode Dissipation.** The dissipation limits of the electrodes are given on the tube data sheet and usually under Radio Frequency Power Amplifier or Oscillator Service. The dissipation must be average over a full repeated pulse cycle. The length of the applied pulse must not be so great that the temperature rises excessively on any one pulse. Pulse times as high as 0.1 second are often not unreasonable. Above about 0.1 seconds the rise in temperature of the electrodes rather than the average power during the pulse becomes the basic limitation and this type of service is discussed under Item 5, "Long Pulse Operation."

Usually, the average electrode dissipation is the product of the dissipation on the element during the on-time, multiplied by the duty cycle (ratio of on-time to a full cycle

time). This assumes that the pulse is essentially a square wave. The dissipation may be considerably greater if intermediate values of current between zero and the maximum value flow for appreciable time. Sometimes uneven heating of an element may be a further limitation. In the case of a radiation-cooled anode, this effect is apparent and the temperature of the hottest spot should not be allowed to exceed the normal maximum anode temperature.

2. **Envelope and Seal Temperatures.** The temperature requirements of the bulb and seals will be met if the ordinary cooling instructions are followed. In continuous radio frequency service, a limiting upper frequency is usually specified above which operation at reduced ratings or increased cooling is recommended. In pulse service above this frequency, care should be taken to see that the heating of the leads due to rf charging currents will not be greater than normal.
3. **Available Cathode Emission.** In continuous service, the tube currents are usually limited by dissipation of the electrodes and for convenience are given in terms of dc components read on a meter external to the tube. In pulse service, one needs to know the available total cathode emission in order to engineer the application. With thoriated tungsten filaments operating at rated voltage in Eimac tubes, the available emission throughout life is above 80 milliamperes per watt of filament power. By raising the filament voltage 10%, this figure can be approximately doubled. Above 10%, the emission will not be further increased, except for short periods of time due to the failure to maintain the optimum emitting surface conditions. With oxide coated cathodes, the available peak emission is not clearly defined or as easily generalized as in the case of thoriated tungsten fila-

When, in 1936, government engineers first tried Eimac tubes as pulsed oscillators, radar became a reality in the United States. The ability of standard Eimac tube types to withstand voltages many times in excess of their maximum CW ratings and to deliver high orders of emission current over relatively long periods of time made possible the attainment of the high peak power required for a practical radar system.

Throughout the years since 1936, the development of improved pulse equipment has been paced by new Eimac tubes and the continual improvement of existing types for better and more reliable operation under pulsed conditions.

**Important milestones in the use of Eimac tubes in pulse service are:**

Eimac 100T tubes used as pulsed VHF oscillators in the Navy's first radar tests at sea aboard the USS New York in 1938.

Eimac VT-127's, a modification of the 100T used as oscillators and Eimac 304T's used as modulators in the SCR-268, one of the Army's first radar sets.

Eimac 15E and 15R miniature transmitting tubes developed for and used as pulsed oscillators and high voltage rectifiers in ASB airborne search radar.

Eimac 327A and 227A tubes developed for use as pulsed oscillators in Navy search radar sets of the SC and SK series.

Eimac 527 tube developed for and used in SK-1M and SR radar for high-power search.

Eimac 1000T, later modified for mass production and designated 6C21, used as modulator for the Army's famous SCR-584 radar.

During World War II Eimac produced nearly 2 million tubes of its own design for pulse service. In the process of developing and producing these tubes Eimac has gained "know how" about the pulse operation of tubes which is unequalled in the vacuum tube industry. This knowledge has made it possible to develop new tubes having outstanding characteristics for pulse operation. Among these tubes are oscillators and amplifiers capable of delivering pulse powers from a few tens of kilowatts to megawatts and modulators which will key currents from a few amperes to hundreds of amperes.

Years of experience have been gained regarding the pulse capabilities of standard Eimac types. Some of this information is presented on the following pages. However, many pulse applications are so specialized in nature that they do not lend themselves to general rules or tabular presentation. If your problem is of this sort, avail yourself of the services of the Eimac Field Engineering Department.



ments. It appears that the available emission for pulse work in typical oxide coated cathodes used in Eimac tubes can conservatively be estimated as 500 ma. per watt of heater power. This figure assumes that the pulse duration is not over about 3 micro-seconds. There is some evidence that above 3 micro-seconds, the maximum usable space current may have to be reduced.

4. **VOLTAGE INSULATION.** The breakdown voltage of Eimac tubes is usually well above the values given for continuous service. The basic limit is related to the maximum instantaneous voltage applied to the anode of the tube at any instant. It is also somewhat affected by the regulation of the supply voltage and length of time the voltage is applied. The accompanying table is a rough guide to the values of dc anode voltage that can be applied to the tube.

5. **LONG PULSE OPERATION.** When the length of the applied pulse exceeds about 0.1 seconds (100 milliseconds) the power limitation is no longer the average power dissipated on the electrodes and one must consider the temperature rise of the electrodes (principally the grid wires) during the time the pulse is on. If the pulse duration is in excess of 2.5 seconds the tube must be treated as in continuous service and the normal data sheet ratings apply.

The maximum capabilities of a thoriated tungsten tube in pulse service when the pulse duration is between 0.1 seconds and 2.5 seconds can be computed by using the accompanying curve and table.

As long as the off-time between pulses is 5 seconds or more the pulse may be repeated even though the maximum tube capability for a given pulse length is utilized. Because the grid dissipation is the principal limitation, the curve and table give factors to compute the permissible grid dissipation during the pulse. The product of the two factors is the number of times the rated grid dissipation can be exceeded for a given pulse duration. The factor from the curve is to be used directly for the plate and screen dissipation.

When first running up the voltage on a tube in pulse service, or after the tube has been idle for some time occasional internal flash breakdowns in a tube are to be expected. The circuit should be designed so that the high rush of current and resulting high transient voltage surges will not be destructive to equipment. The transients, due to momentary breakdown of the insulation of the vacuum space, have very high frequency components. As a consequence, high voltages will develop across small lead inductances. Spark gaps, bypass capacitors and inductance filters are often used to dissipate or divert this energy into harmless channels.

Protective devices should be designed to remove the applied voltage quickly when a breakdown occurs. If overload protective action is fast, and the regulation of the source voltage poor enough, no damage to the tube will result and operation can be resumed.

No guarantee is made that the tube will not break down at the voltages given on the chart. It is estimated from considerable experience that these are approximately safe maximum values to be considered in design work.

▶ Indicates Revision

**MAXIMUM RATINGS FOR PULSED SERVICE**

Tube Type	MAXIMUM PLATE VOLTAGE			Max. Screen Voltage Kilovolts	Grid Factor Long Pulse Operation*
	RF Service Plate Pulsed Kilovolts	RF Service Grid Pulsed Kilovolts	Pulse Modulator Service Kilovolts		
▶ 2C39A	3.5	.....	.....	.....	.....
3C24	10	7.5	15	.....	.68
3X2500A3	15	10	25	.....	.68
▶ 3X2500F3	15	10	25	.....	.68
▶ 3W5000A3	15	10	25	.....	.68
▶ 3W5000F3	15	10	25	.....	.68
4E27A/5-125B	12	9	18	2.0	1.68
4-65A	10	7.5	15	2.0	.57
4-125A	12	9	18	2.0	1.87
4-250A	15	10	20	2.5	2.7
4-400A	15	10	20	2.5	2.7
4-1000A	20	15	30	2.5	1.54
4PR60A	.....	.....	20	1.5	.....
▶ 4X150A	2	.....	3	1.0	.....
▶ 4X150D	2	.....	3	1.0	.....
4X150G	2	.....	3	1.0	.....
4X500A	10	7.5	15	2.0	.95
4X500F	10	7.5	15	2.0	.95
6C21	20	15	30	.....	.....
15E	12.5	10	15	.....	.....
25T	10	7.5	15	.....	.77
35T	10	7.5	15	.....	.84
35TG	10	7.5	15	.....	.84
UH-50	5	4	7.5	.....	.....
75TH	12	9	17	.....	.67
75TL	12	9	17	.....	.62
100TH	15	10	20	.....	1.01
100TL	15	10	20	.....	1.11
152TH	12	9	18	.....	.71
152TL	12	9	18	.....	.65
250TH	18	15	25	.....	1.03
250TL	18	15	25	.....	.89
304TH	12	9	18	.....	.71
304TL	12	9	18	.....	.65
327A	20	15	30	.....	.....
450TH	20	15	30	.....	1.09
450TL	20	15	30	.....	1.0
527	20	18	30	.....	.....
592/3-200A3	18	15	25	.....	.80
750TL	20	15	30	.....	1.09
1000T	20	15	30	.....	1.1
1500T	20	15	30	.....	1.61
2000T	20	15	30	.....	1.8

\*Combine with factor taken from curve for various pulse duration times.

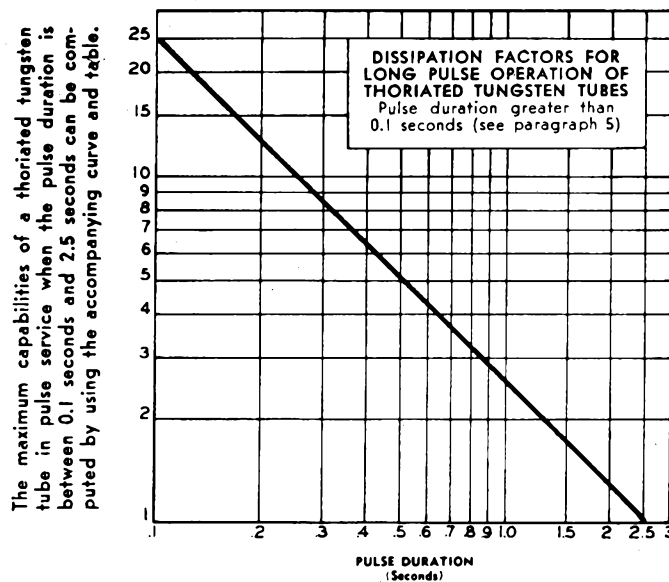



# PULSE

*Eimac*  
**TUBES**

## CLASS C AMPLIFIER CALCULATIONS WITH THE AID OF CONSTANT CURRENT CHARACTERISTICS

In calculating and predicting the operation of a vacuum tube as a class-C radio frequency amplifier, the considerations which determine the operating conditions are plate efficiency, power output required, maximum allowable grid and plate dissipation, maximum allowable plate voltage and maximum allowable plate current. The values chosen for these factors will depend both on the demands of a particular application and the tube selected to do the job.

The plate and grid currents of a class-C amplifier are periodic pulses, the durations of which are always less than 180 degrees. For this reason the average plate and grid currents, power output, driving power, etc., cannot be directly calculated but must be determined by a Fourier analysis from points selected along the line of operation as plotted on the constant-current characteristics. This may be done either analytically or graphically. While the Fourier analysis has the advantage of accuracy, it also has the disadvantage of being tedious and involved.

An approximate analysis which has proven to be sufficiently accurate for most purposes is presented in the following material. This system has the advantage of giving the desired information at the first trial. The system, which is an adaption of a method developed by Wagener<sup>1</sup>, is direct because the important factors, power output, plate efficiency and plate voltage may be arbitrarily selected at the beginning.

In the material which follows, the following set of symbols will be used. These symbols are illustrated graphically in Figure 1.

## Symbols

- $P_i$  = Plate power input
- $P_o$  = Plate power output
- $P_p$  = Plate dissipation
- $n$  = Plate efficiency expressed as a decimal
- $E_{bb}$  = D-c plate supply voltage
- $E_{pm}$  = Peak fundamental plate voltage
- $E_{bmin}$  = Minimum instantaneous plate voltage
- $I_b$  = Average plate current
- $I_{pm}$  = Peak fundamental plate current
- $I_{bmax}$  = Maximum instantaneous plate current
- $\theta_p$  = One-half angle of plate current flow
- $E_{cc}$  = D-c grid bias voltage (a negative quantity)
- $E_{c2}$  = D-c screen voltage

<sup>1</sup> W. G. Wagener "Simplified Methods for Computing Performance of Transmitting Tubes," Proc. I.R.E., Vol. 25, p. 47, (Jan. 1937).

(Reprinted from the Eimac News Industrial Edition, March 1945)

Indicates Revision 11-10-49

- $E_{gm}$  = Peak fundamental grid excitation voltage
- $e_{emp}$  = Maximum positive instantaneous grid voltage
- $I_c$  = Average grid current
- $i_{cmmax}$  = Maximum instantaneous grid current
- $P_d$  = Grid driving power (including both grid and bias losses)
- $P_g$  = Grid dissipation
- $\mu$  = Amplification factor of triode
- $\mu_{12}$  = Grid-screen amplification factor of tetrode

## Method

The first step in the use of the system to be described is to determine the power which must be delivered by the class-C amplifier. In making this determination it is well to remember that ordinarily from 5 to 10 per cent of the power delivered by the amplifier tube or tubes will be lost in well-designed tank and coupling circuits at frequencies below 20 Mc. Above 20 Mc. the tank and coupling circuit losses are ordinarily somewhat above 10 per cent.

The plate power input necessary to produce the required output is determined by the plate efficiency:

$$P_i = \frac{P_o}{n}$$

For most applications it is desirable to operate at the highest possible efficiency. High-efficiency operation usually requires less expensive tubes and power supplies, and the amount of artificial cooling needed is frequently less than for low-efficiency operation. On the other hand, high-efficiency operation often requires more driving power and higher operating plate voltages. Eimac triodes and tetrodes will operate satisfactorily at 80 per cent efficiency at the highest recommended plate voltages and at 75 per cent efficiency at medium plate voltages.

The first determining factor in selecting a tube or tubes for any particular application is the maximum allowable plate dissipation. The total plate dissipation rating for the number of tubes used must be equal to or greater than that calculated from

$$P_p = P_i - P_o$$

After selecting a tube or tubes to meet the power output and plate dissipation requirements it becomes necessary to determine from the tube characteristics whether the tube selected is capable of the required operation and, if so, to determine the driving power, grid bias and grid current.

The complete procedure necessary to determine the class-C-amplifier operating conditions is as follows<sup>2</sup>:

1. Select plate voltage, power output and efficiency.
2. Determine plate input from

$$P_i = \frac{P_o}{\eta}$$

3. Determine plate dissipation from

$$P_p = P_i - P_o$$

$P_p$  must not exceed maximum rated plate dissipation for tube or tubes selected.

4. Determine average plate current from

$$I_b = \frac{P_i}{E_{bb}}$$

$I_b$  must not exceed maximum rated plate current for tube selected.

5. Determine approximate  $i_{bmax}$  from

$$\begin{aligned} i_{bmax} &= 4.5 I_b \text{ for } \eta = 0.80 \\ i_{bmax} &= 4.0 I_b \text{ for } \eta = 0.75 \\ i_{bmax} &= 3.5 I_b \text{ for } \eta = 0.70 \end{aligned}$$

6. Locate the point on constant-current characteristics where the constant plate current line corresponding to the approximate  $i_{bmax}$  determined in step 5 crosses the line of equal plate and grid voltages ("diode line") in the case of triodes; or in the case of tetrodes where the plate current line turns rapidly upward. Read  $e_{bmin}$  at this point.<sup>3</sup>

7. Calculate  $E_{pm}$  from

$$E_{pm} = E_{bb} - e_{bmin}$$

8. Calculate the ratio  $\frac{I_{pm}}{I_b}$  from

$$\frac{I_{pm}}{I_b} = \frac{2\eta E_{bb}}{E_{pm}}$$

9. From the ratio of  $\frac{I_{pm}}{I_b}$  calculated in step 8 determine the ratio  $\frac{i_{bmax}}{I_b}$  from Chart 1.

10. Calculate a new value for  $i_{bmax}$  from ratio found in step 9.

$$i_{bmax} = (\text{ratio from step 9}) I_b$$

11. Read  $e_{cmp}$  and  $i_{cmax}$  from constant current characteristics for values of  $e_{bmin}$  and  $i_{bmax}$  determined in steps 6 and 10.

12. Calculate the cosine of one-half the angle of plate current flow from

$$\cos \theta_p = 2.3 \left( \frac{I_{pm}}{I_b} - 1.57 \right)^4$$

13. Calculate the grid bias voltage from

$$E_{cc} = \frac{1}{1 - \cos \theta_p} \left[ \cos \theta_p \left( \frac{E_{pm}}{\mu} - e_{cmp} \right) - \frac{E_{bb}}{\mu} \right], \text{ for triodes;}$$

$$\text{or } E_{cc} = \frac{1}{1 - \cos \theta_p} \left[ -e_{cmp} \cos \theta_p - \frac{E_{c2}}{\mu_{12}} \right], \text{ for tetrodes.}$$

14. Calculate the peak fundamental grid excitation voltage from

$$E_{gm} = e_{cmp} - E_{cc}$$

15. Calculate the ratio  $\frac{E_{gm}}{E_{cc}}$  for values of  $E_{cc}$  and  $E_{gm}$  found in steps 13 and 14.

16. Read ratio  $\frac{i_{cmax}}{I_c}$  from Chart 2 for ratio  $\frac{E_{gm}}{E_{cc}}$  found in step 15.

17. Calculate average grid current from ratio found in step 16 and value of  $i_{cmax}$  found in step 11.

$$I_c = \frac{i_{cmax}}{\text{ratio from step 16}}$$

18. Calculate approximate grid driving power from

$$P_d = 0.9 E_{gm} I_c^5$$

19. Determine grid dissipation from

$$P_g = P_d + E_{cc} I_c$$

$P_g$  must not exceed the maximum rated grid dissipation for the tube selected.

### Example

A typical application of this procedure is shown in the example below.

1. Desired power output..... 1250 watts  
Desired plate voltage..... 4000 volts  
Desired plate efficiency..... 75 per cent ( $\eta = 0.75$ )

$$2. \quad P_i = \frac{1250}{0.75} = 1670 \text{ watts}$$

$$3. \quad P_p = 1670 - 1250 = 420 \text{ watts}$$

Try type 450TL; Max.  $P_p = 450W$ ;  $\mu = 18$

$$4. \quad I_b = \frac{1670}{4000} = 0.417 \text{ ampere}$$

(Max.  $I_b$  for 450TL = 0.600 ampere)

5. Approximate  $i_{bmax} = 4.0 \times 0.417 = 1.67$  ampere

$$6. \quad e_{bmin} = 315 \text{ volts (see figure 2)}$$

$$7. \quad E_{pm} = 4000 - 315 = 3685 \text{ volts}$$

$$8. \quad \frac{I_{pm}}{I_b} = \frac{2 \times 0.75 \times 4000}{3685} = 1.63$$

$$9. \quad \frac{i_{bmax}}{I_b} = 3.45 \text{ (from Chart 1)}$$

$$10. \quad i_{bmax} = 3.45 \times 0.417 = 1.44 \text{ amperes}$$

$$11. \quad e_{cmp} = 280 \text{ volts}$$

$$i_{cmax} = 0.330 \text{ amperes}$$

(see figure 3)

$$12. \quad \cos \theta_p = 2.32 (1.63 - 1.57) = 0.139$$

$$13. \quad E_{cc} = \frac{1}{1 - 0.139} \left[ 0.139 \left( \frac{3685}{18} - 280 \right) - \frac{4000}{18} \right] = -270 \text{ volts}$$

$$14. \quad E_{gm} = 280 - (-270) = 550 \text{ volts}$$

$$15. \quad \frac{E_{gm}}{E_{cc}} = \frac{550}{-270} = -2.04$$

$$16. \quad \frac{i_{cmax}}{I_c} = 5.69 \text{ (from Chart 2)}$$

$$17. \quad I_c = \frac{0.330}{5.69} = 0.058 \text{ amperes}$$

$$18. \quad P_d = 0.9 \times 550 \times 0.058 = 28.7 \text{ watts}$$

$$19. \quad P_g = 28.7 + (-270 \times 0.058) = 13.0 \text{ watts}$$

(Max  $P_g$  for 450TL = 65 watts)<sup>6</sup>

<sup>2</sup> In the case of push-pull or parallel amplifier tubes the analysis should be carried out on the basis of a single tube, dividing  $P_i$ ,  $P_o$  and  $P_p$  by the number of tubes before starting the analysis and multiplying  $I_b$ ,  $I_c$  and  $P_d$  by the same factor after completing the analysis.

<sup>3</sup> In a few cases the lines of constant plate current will inflect sharply upward before reaching the diode line. In these cases  $e_{bmin}$  should not be read at the diode line but at the point where the plate current line intersects a line drawn from the origin through these points of inflection.

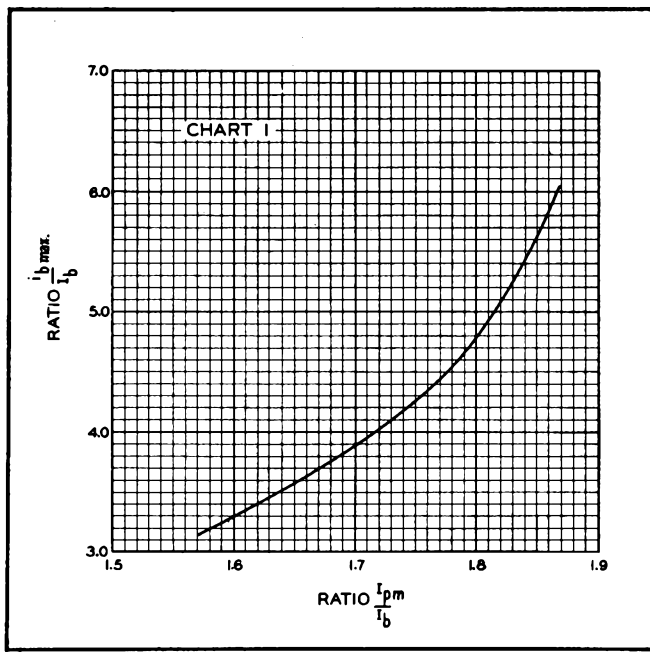

Chart 1

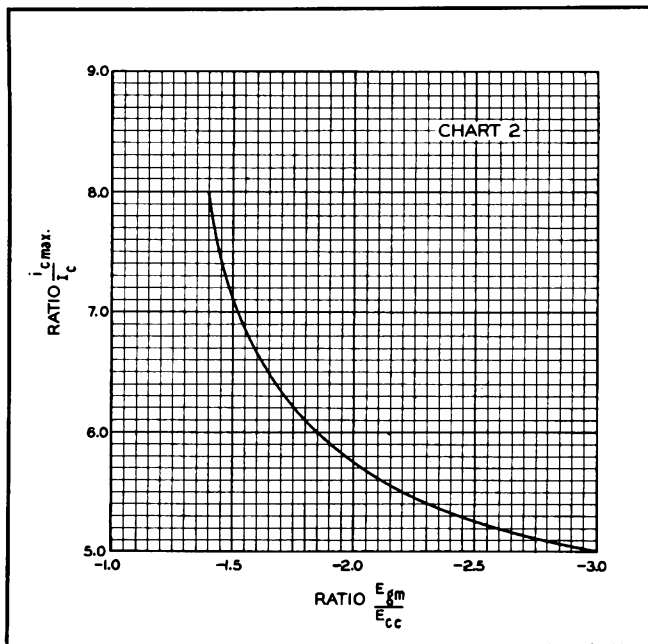

Chart 2

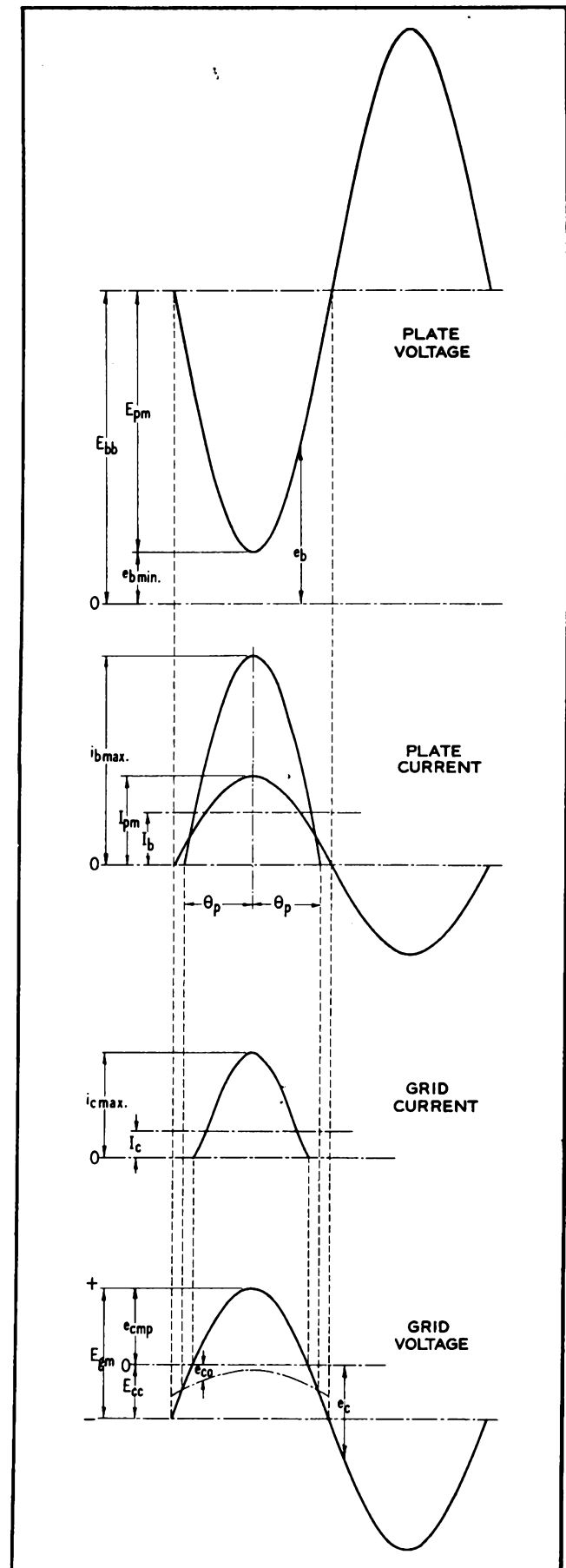

Figure 1. Symbols

4 If this calculation gives  $\text{Cos } \theta_p$  as zero or a negative quantity class-B operation is indicated and new operating conditions should be chosen on a basis of higher efficiency (less plate dissipation, more power output or less power input).

5 The calculated driving power is that actually used in supplying the grid and bias losses. Suitable allowance in driver design must be made to allow for losses in the coupling circuits between the driver plate and the amplifier grid.

6 "Vacuum Tube Ratings" Eimac News, Industrial Edition, Jan. 1945.

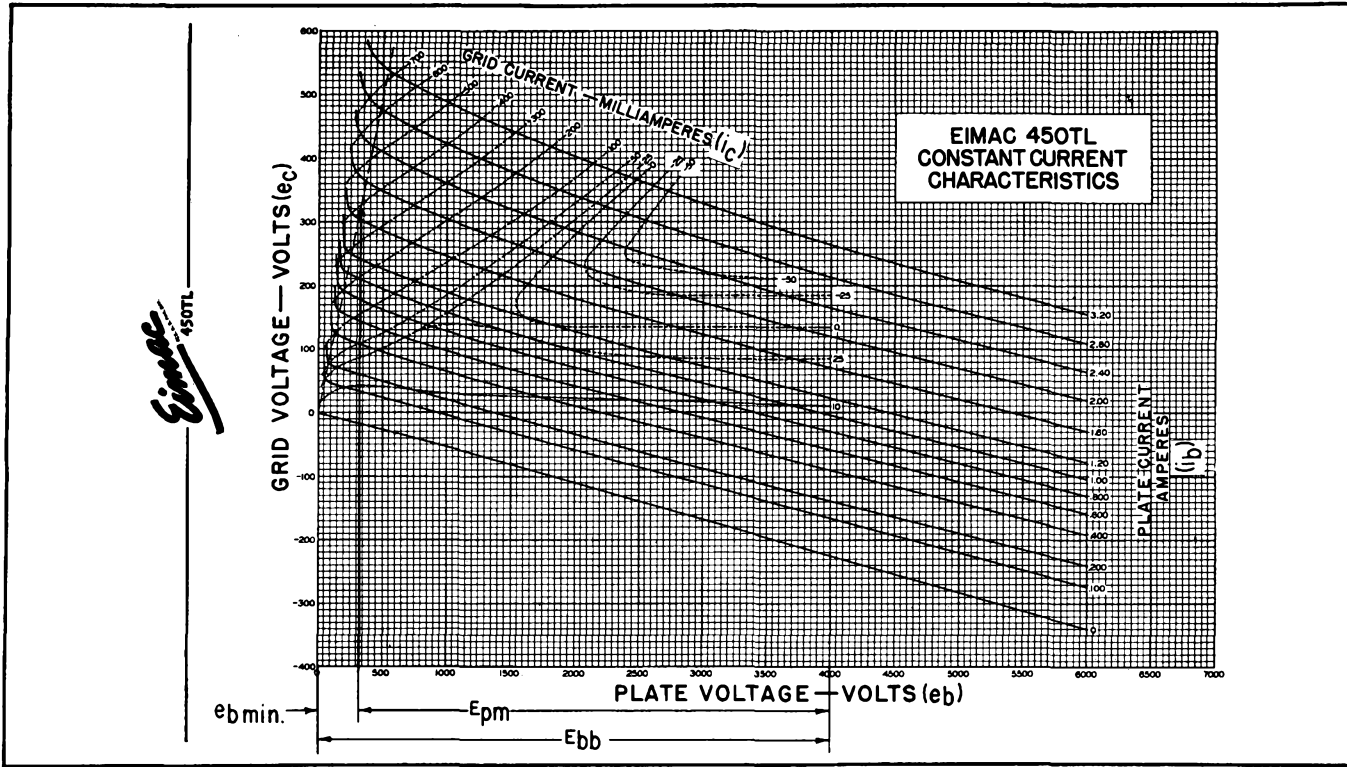

Figure 2. 450TL constant-current characteristics showing method of determining  $e_{bmin}$  and  $E_{pm}$  in steps 6 and 7 from value of  $i_b$  obtained in step 5.

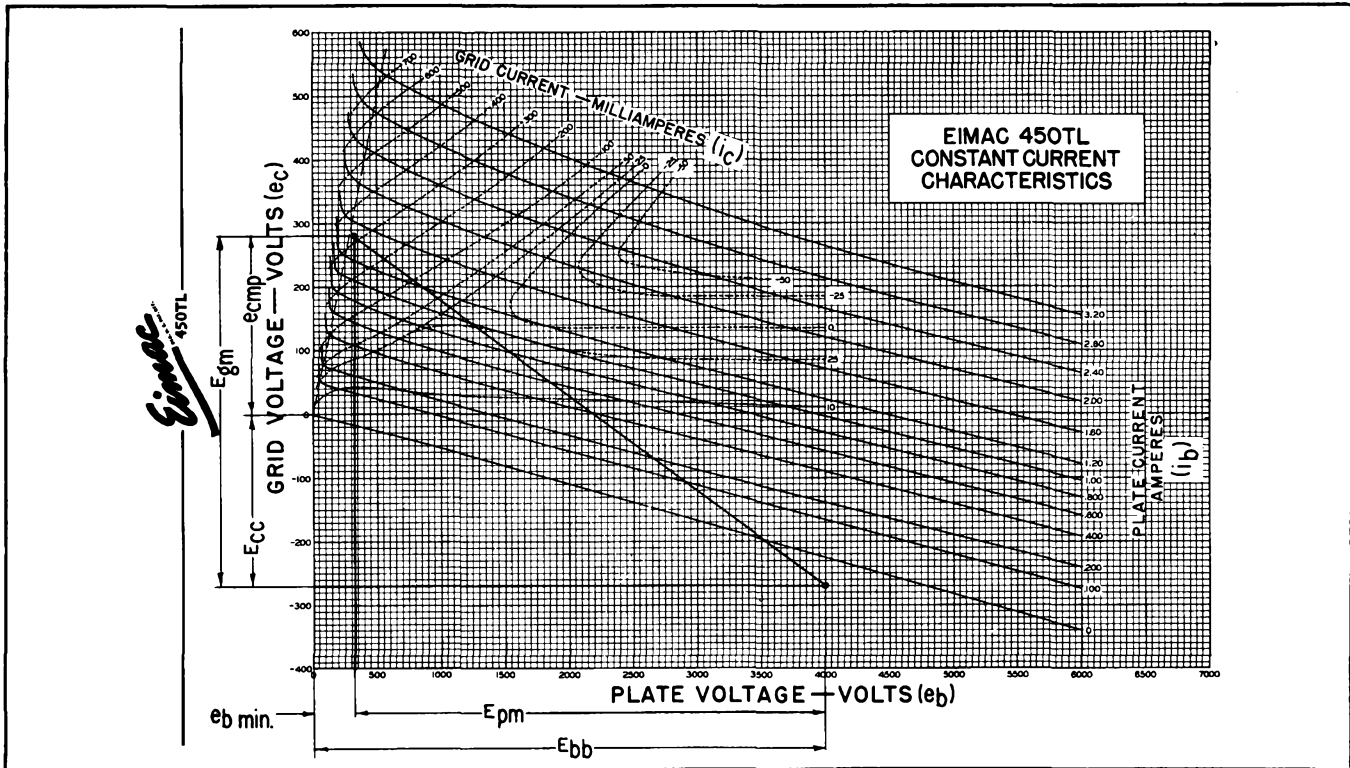
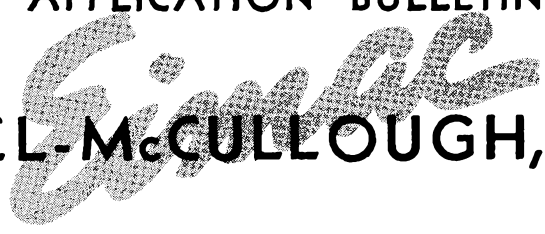

Figure 3. Method of determining  $e_{cmp}$  and  $i_c$  on 450TL constant-current characteristics from values of  $e_{bmin}$  and  $E_{pm}$  found in steps 6 and 7 and value of  $i_b$  found in step 10. The value of  $E_{cc}$  and  $E_{gm}$  from steps 13 and 14 and the operating line are also shown.

The information presented herein is based on data believed accurate, but no responsibility is accepted for the successful application of the systems or principles discussed. Likewise, no responsibility is assumed for patent infringement, if any, resulting from the application of this information. Permission to reprint this or other application bulletins will ordinarily be granted upon request.

# APPLICATION BULLETIN

# EITEL-McCULLOUGH, INC.



SAN BRUNO, CALIFORNIA

## NUMBER 5 TUBE PERFORMANCE COMPUTOR

DETAILED INSTRUCTIONS

### TUBE PERFORMANCE COMPUTOR FOR RF AMPLIFIERS (CLASS B, C, AND FREQUENCY MULTIPLIERS)

It is quite easy to make a close estimate of the performance of a vacuum tube in radio frequency power amplifier service, or an approximation in the case of harmonic amplifier service. Such estimates will give RF output power, DC input power, grid driving power and all DC current values.

These estimates can be made easily by using the Eimac Tube Performance Computor and the characteristic curves of a tube, plotted on plate voltage/grid voltage curves (constant current curves). Only the ability to multiply out figures taken from the curves by means of the computor is required.

By graphically laying out the trace of the plate and grid voltages as they rise and fall about the applied DC plate voltage and DC grid bias a clearer understanding is possible of the action taking place within a tube. With such an understanding the operating conditions can be altered readily to suit one's particular requirements.

#### Simple Action in Class C RF Amplifiers

In an amplifier a varying voltage is applied to the control grid of the tube. Simultaneously the plate voltage will vary in a similar manner, due to the action of the amplified current flowing in the plate circuit. In radio frequency applications with resonant circuits these voltage variations are smooth sine wave variations, 180° out of phase (as the grid voltage rises and becomes *more* positive, the plate voltage falls and becomes *less* positive) as indicated in Fig. 1. Note how these variations center about the DC plate voltage and the DC control grid bias.

Let us now see how such variations of the plate and grid voltages of a tube appear on the constant current curve sheet of a tube. In Fig. 2 these

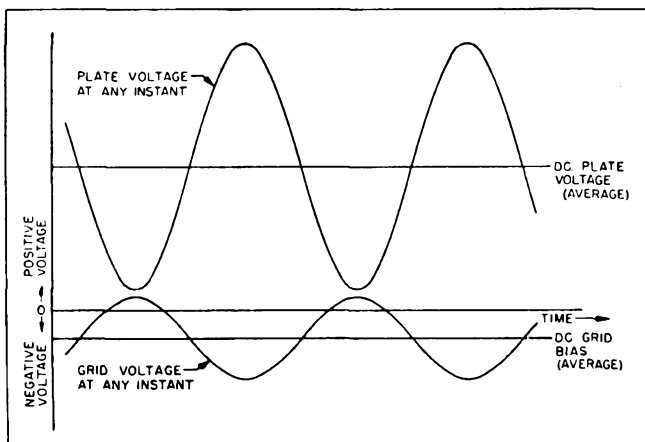

Figure 1

variations have been indicated next to the plate voltage and grid voltage scales of a typical constant current curve. At some instant of time, shown as "t" on the time scales, the grid voltage has a value which is the point marked "eg" on the grid voltage sine wave. At this same instant of time the plate voltage has a value which is the point "ep" marked on the plate voltage sine wave. If now one finds the point on the tube curve sheet corresponding to these values (where a line drawn from "eg" and a line drawn from "ep" cross) he will be at point A in Fig. 2. As the values of grid voltage "eg" and plate voltage "ep" vary over the RF cycle, the point A moves up and down a line, which in the case of the normal RF power amplifier is a straight line. This line is called the "Operating Line."

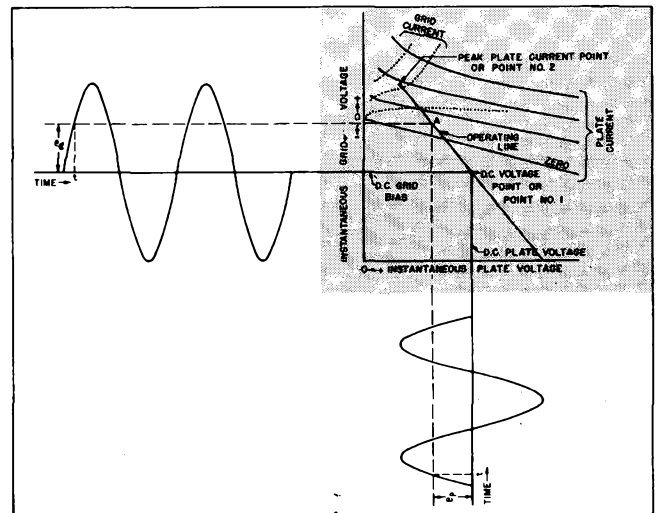

Figure 2

Any point on the operating line (when drawn on a curve sheet as in Fig. 2 or Fig. 4) tells the instantaneous values of plate current, screen current, and grid current which must flow when those particular values of grid and plate voltage are applied to the tube. Thus by reading off the values of the currents and plotting them against the time, t, one can obtain a curve of instantaneous values of plate and grid current. See Fig. 3.

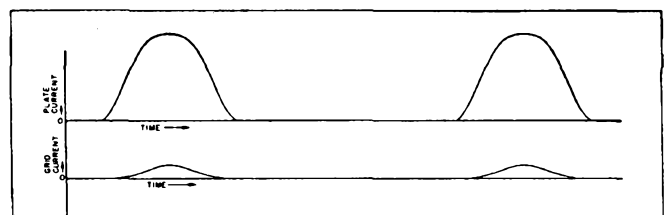

Figure 3

If we analyze the plate and grid current values shown, we can predict that they will cause a DC ammeter to show a particular reading. This is called the DC component of the current. Also, we can predict that if the plate current flows through a properly loaded resonant RF circuit a certain amount of radio frequency power will be delivered to that circuit. If the circuit is tuned to the fundamental frequency (same frequency as the RF grid voltage) the power delivered will be due to the fundamental (or principle radio frequency) component of plate current. If the circuit is tuned to a harmonic of the grid voltage frequency (for instance, two, or three times the frequency) the power delivered will be due to a harmonic component of the plate current.

The Eimac Tube Performance Computer gives us the means to make these simple calculations. It is a means with which to determine the DC component, the fundamental RF component, or the approximate harmonic component of the current flowing in a tube when the tube is operating as a radio frequency amplifier, and enables one to state what all meter readings will be and to predict the RF output power and the required driving power. With these factors known we are then able also to forecast what will happen if any of the operating conditions are changed.

#### **Use of the Eimac Tube Performance Computer**

The Eimac Tube Performance Computer is a simple aid to enable one to select suitable values from the characteristic curves of a tube, and by means of simple calculations to forecast the performance of the tube in radio frequency power amplifiers.

The basic steps are outlined under "Instructions" on the computer. This requires selecting DC plate and grid bias voltages, being guided by the typical operating values given on the technical data sheet for the tube type and by general experience. Next, a suitable "Operating Line" must be chosen on the constant current curves for the tube type (plotted on grid voltage/plate voltage scales).

The computer when properly placed over this operating line enables one to obtain instantaneous values of the currents flowing at every 15° of the electrical cycle. The formulas given on the computer were derived by Chaffee to give the various average and harmonic components of the resulting currents. Knowing these current component values and the radio frequency voltage values which are indicated by the use of the computer, one can readily calculate the complete performance of the tube.

The fundamental methods of making such computations, and the considerations necessary to stay within ratings of the tube types, and accomplish various forms of modulation have been covered in the literature.<sup>2,3,4,5,6,7</sup> The method for the case of harmonic amplifier service is approximate and should be used only for tetrode and pentode tubes, where the plate voltage has little effect on the amount of plate current flowing. A more exact method, showing that for harmonic operation the

operating line is a simple Lissajou figure, has been described by Brown.<sup>8</sup>

The results of using this computer for power amplifier service can be applied in combination with the other methods given in the literature to give good accuracy with simpler procedures. The resulting accuracy is well within the normal variation of tube characteristics due to the normal variation in manufacturing dimensions of a tube. Since the published tube curves are only typical of the characteristics to be expected from a particular tube type, the calculated performance is well within the values expected when different tubes of a given tube type are operated under the assumed conditions.

#### **Example Showing Detailed Use of the Eimac Tube Performance Computer Radio Frequency Power Amplifier, Class C (Telegraphy or FM)**

Let us say we have an Eimac 4-65A tetrode and want to make it work effectively. Also let us say we have a 2000 volt DC plate power supply available.

Within frequency limits, we know a tube should be able to run in class-C amplifier service with about 75% efficiency, or, in other words, to convert 75% of the DC plate input power into RF output power. The difference, or 25% of the input power, is dissipated or lost as heat on the plate of the tube. The DC plate input power is then about four times the power dissipated on the plate.

The 4-65A tetrode has a maximum rated plate dissipation of 65 watts, so, to illustrate performance near the maximum rating, we'll choose an input power four times the plate dissipation, or 260 watts per tube. At 2000 volts the plate current per tube must then be 130 ma. It is usual practice, in the case of tetrodes and the medium or low mu triodes in class-C amplifier service for the DC grid bias voltage to be roughly two or three times the grid voltage necessary to cut off the flow of plate current. By referring to the curves of the 4-65A we decide to use a DC grid bias voltage of -120 volts.

Let us now locate the "Operating Line" on the constant current curves of the 4-65A. See Fig. 4. First mark the point where the DC grid bias and DC plate voltage cross. The "Operating Line" must go through this point. Call it point No. 1. Next, we must decide what the peak value of plate current of the tube must be and how low we can let the instantaneous value of plate voltage go when the tube is passing this much current. This is necessary in order to locate the other end of the "Operating Line," point No. 2.

The peak value of plate current usually runs about four times the DC plate current. The minimum value of instantaneous plate voltage is usually set by the fact that if the voltage is too low the grid and screen currents will be needlessly high, and also little will be gained as far as output power is concerned. The minimum value of plate voltage is usually in the region where the plate constant current curves bend upward. See Fig.



4. (In the case of the triode this is near the "diode line" or line where the instantaneous grid and plate voltages are equal.) The practical procedure in calculating tube performance is to arbitrarily choose point No. 2 and complete the calculations. Then try other locations of point No. 2, complete the calculations, and compare the results.

In the case of the 4-65A let us choose a peak value of plate current about four times the DC plate current of 130 ma, or 500 ma. Let us choose a minimum instantaneous plate voltage of 250 volts and thus fix the upper end of the "Operating Line." Next, locate this point on the tube curves. This is point No. 2 on Fig. 4. (The plate currents which flow at various combinations of plate and grid voltages are shown by the plate current lines. The value of current for each line is noted. In-between values can be estimated closely enough for our purposes.) Now draw a straight line between points No. 1 and No. 2. This line is the "Operating Line" and shows the current and voltage values for each part of the RF cycle when current is being taken from the tube. (The non-conducting half of the RF cycle would be shown by extending this line an equal distance on the opposite side of point No. 1. However, there is little use in so doing because no current flows during this half of the cycle.)

The Eimac Tube Performance Computer can now be used to obtain the meter readings and power values from this "Operating Line." Place the com-

putor on the constant current curve sheet so that the "guide lines" of the computer are parallel with the operating line. Now slide the computer about without turning it until the line OG passes through the DC voltage point No. 1 and line OA passes through the peak current point No. 2. Make sure the guide lines are still parallel to the "Operating Line."

Note that the lines OB, OC, OD, OE and OF of the computer all cross over the "Operating Line."

At each point where the lines OA, OB, etc., cross the "Operating Line" we need to determine the instantaneous values of plate current and grid current (and screen current if a tetrode or pentode is used) which is flowing at that particular moment in the RF cycle. Later, from these key values of current, we will calculate the values of DC plate current and grid current (and screen current) as well as the RF components of the plate current.

At each of these points, where the instantaneous current values are to be determined, a mark should be made on the constant current curve sheet of the tube. By noting where this mark lies with respect to the plate current curves, one can estimate the value of plate current flowing at this part of the cycle. Next, the location of this mark with respect to the control grid curves is noted and a value of grid current is estimated. Finally, by referring the mark to the screen grid curves, if the tube is a tetrode or pentode, a value of screen current is noted. These current values should be listed for each

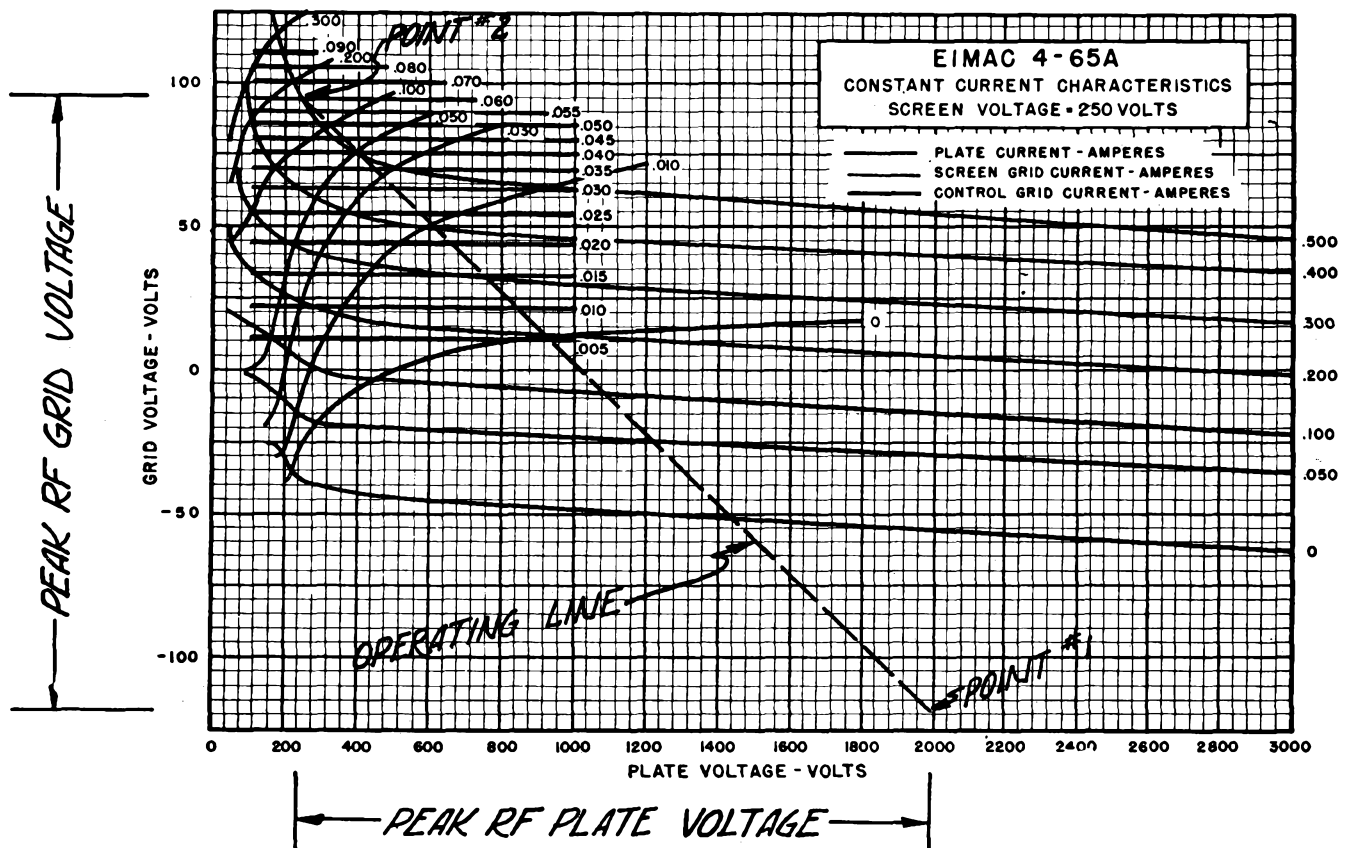

Figure 4

point where the lines OA, OB, etc., cross the operating line so that they can be combined later to calculate the various tube currents. At points where OF and OE cross, the current values are often zero.

Now in the example chosen, let us read off the instantaneous plate current values where these lines cross the "Operating Line." At the point where the line OA crosses the "Operating Line" the plate current is 500 ma. Where OB crosses the operating line the plate current can be estimated as 510 ma since the point is about 1/10 of the way from the 500 ma line to the 600 ma line. At OC the plate current is 460 ma, OD 290 ma, OE 75 ma, OF and OG 0 ma. Similarly we can estimate the instantaneous screen current at the crossing of OA and the "Operating Line" as 165 ma, and the instantaneous grid current at 60 ma. Values are read for the other crossings and written down. These values are put in simple columns for calculating:

Crossing of line	Simplified Name in Formulas	Instantaneous Values of Currents		
		Plate	Screen	Control Grid
OA	A	500 Ma	165 Ma	60 Ma
OB	B	510	100	50
OC	C	460	25	30
OD	D	290	5	14
OE	E	80	0	0
OF	F	0	0	0

Now in order to obtain the DC value of plate, screen, and control grid currents the formula (see computer) says to add up the above values but use only one-half of the A values (giving 250 ma for plate, 82 ma for screen, and 30 ma for grid), and then divide by 12, as follows:

DC Meter Reading = 1/12 (0.5 A+B+C+D+E+F)		
Plate	Screen	Control Grid
250 Ma	82 Ma	30 Ma
510	100	50
460	25	30
290	5	14
80		
<u>Total 1590 Ma</u>	<u>212 Ma</u>	<u>124 Ma</u>
DC Current = 1/12 Total =		
132 Ma	18 Ma	10 Ma

Now to calculate the RF output power it is necessary to use the formula for the peak RF current which is present in the tube plate current. Since we are using the tube as a straight RF power amplifier we use the formula for "Peak Fundamental RF" as shown on the computer. (If we were estimating the performance of a doubler or tripler we would use the formula for "Peak 2nd Harmonic RF" or "Peak 3rd Harmonic RF".)

From the computer we see that the formula for the peak fundamental RF current is:

1/12 (A+1.93 B+1.73 C+1.41 D+E+0.52 F)	
A = 500 = 500 Ma	
1.93 B = 1.93x 510 = 985	
1.73 C = 1.73x 460 = 796	
1.41 D = 1.41x 290 = 409	
E = 80 = 80	
<u>Total = 2770 Ma</u>	
Peak fundamental current = 1/12 Total	
= 2770/12 = 230 Ma	

We now have the various current values. In

order to calculate the powers involved it is necessary to know, not only the DC voltage values, but the greatest amount each voltage swings away from the DC value. This is known as the peak value of the RF voltage. Because the plate voltage swings from 2000 volts down to 250 volts the peak RF voltage is the difference, or 1750 volts. Similarly the grid voltage must rise and fall between the operating points No. 1 and No. 2, or from -125 volts to +95 volts. This is a peak swing of 220 volts and the peak RF grid voltage is 220 volts.

Let us now use the formulas for output power and driving power:

Output power = 1/2 peak RF plate current x peak RF plate voltage.

We found the peak RF plate current to be 230 ma or .230 amperes, and the peak RF plate voltage to be 1750 volts.

So; Output Power = 1/2 x .230 x 1750 = 201 watts,  
and Input Power = DC Plate Current x DC Plate Voltage  
= .132 x 2000 = 264 watts  
Plate Dissipation = DC Input Power - RF Output Power  
= 264 - 201 = 63 watts  
Efficiency = RF Output Power divided by  
DC Input Power  
= 201/264 = 76%

Driving Power = DC Grid Current x Peak RF Grid Voltage  
So the Driving Power = .010 x 220 = 2.2 watts

The power consumed by the bias source is simply the product of the DC grid current and the DC grid voltage, or .010 x 120 = 1.2 watts.

The difference between the driving power and the power consumed by the bias source is the power dissipated on the control grid, or 2.2 - 1.2 = 1.0 watts.

The power dissipated on the screen grid is simply the product of the DC screen current and the DC screen voltage, because the screen grid has no impedance between it and the DC screen supply. Thus it is .018 x 250 = 4.5 watts.

The performance of the tube can now be summarized:

DC Plate Voltage 2000 Volts	Driving Power	2.2 Watts
DC Screen Voltage 250 Volts	Grid Dissipation	1.0 Watts
DC Grid Voltage -120 Volts	Screen Dissipation	4.5 Watts
DC Plate Current 132 Ma	Plate Power Input	264 Watts
DC Screen Current 18 Ma	Plate Power Output	201 Watts
DC Grid Current 10 Ma	Plate Dissipation	63 Watts
Peak RF Grid Voltage	220 Volts	

## REFERENCES

1. E. L. Chaffee, "A Simplified Harmonic Analysis," Review Sci. Inst. 7, page 384, October 1936
2. H. P. Thomas, "Determination of Grid Driving Power in Radio Frequency Power Amplifiers," Proc. IRE, Vol. 21, pp. 1134-1141; August 1933
3. W. G. Wagener, "Simplified Methods for Computing Performance of Transmitting Tubes," Proc. IRE; January 1937
4. R. I. Sarbacher, "Graphical Determination of PA Performance," Electronics; December 1942
5. R. I. Sarbacher, "Performance of Self Biased Modulated Amplifier," Electronics; April 1943
6. "Class C Amplifier Calculations With The Aid of Constant-Current Characteristics," Eimac Application Bulletin Number 4
7. "Vacuum Tube Ratings," Eimac Application Bulletin Number 6
8. Robert H. Brown, "Harmonic Amplifier Design," Proc. IRE, Vol. 35 pp. 771-777; August 1947



TUBE  
PERFORMANCE  
COMPUTOR

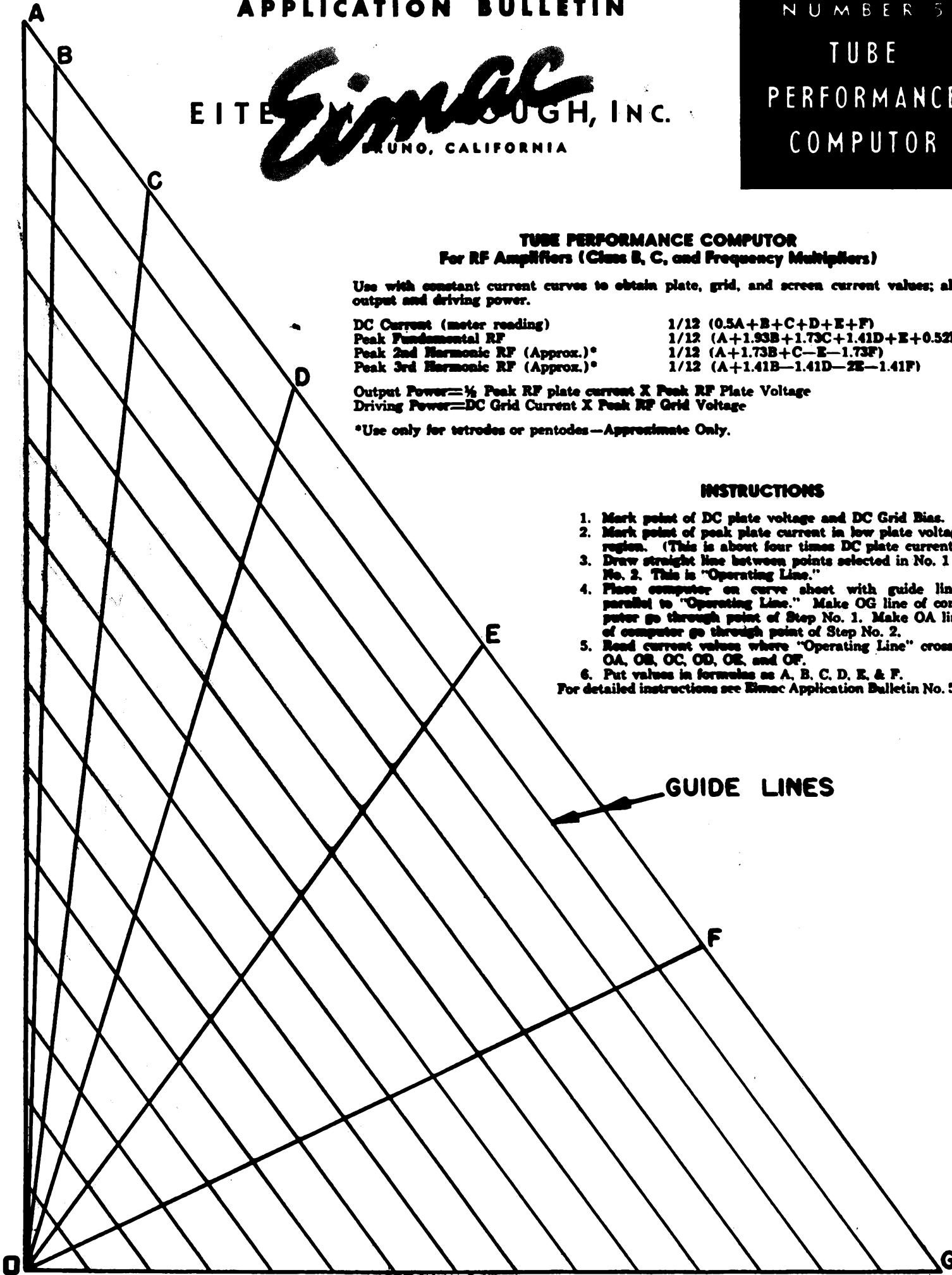

**TUBE PERFORMANCE COMPUTOR**  
For RF Amplifiers (Class B, C, and Frequency Multipliers)

Use with constant current curves to obtain plate, grid, and screen current values; also output and driving power.

DC Current (meter reading)	$1/12 (0.5A+B+C+D+E+F)$
Peak Fundamental RF	$1/12 (A+1.93B+1.73C+1.41D+E+0.52F)$
Peak 2nd Harmonic RF (Approx.)*	$1/12 (A+1.73B+C-E-1.73F)$
Peak 3rd Harmonic RF (Approx.)*	$1/12 (A+1.41B-1.41D-2E-1.41F)$

Output Power =  $1/2$  Peak RF plate current X Peak RF Plate Voltage  
Driving Power = DC Grid Current X Peak RF Grid Voltage

\*Use only for tetrodes or pentodes—Approximate Only.

**INSTRUCTIONS**

1. Mark point of DC plate voltage and DC Grid Bias.
  2. Mark point of peak plate current in low plate voltage region. (This is about four times DC plate current).
  3. Draw straight line between points selected in No. 1 & No. 2. This is "Operating Line."
  4. Place computer on curve sheet with guide lines parallel to "Operating Line." Make OG line of computer go through point of Step No. 1. Make OA line of computer go through point of Step No. 2.
  5. Read current values where "Operating Line" crosses OA, OB, OC, OD, OE, and OF.
  6. Put values in formulas as A, B, C, D, E, & F.
- For detailed instructions see Eimac Application Bulletin No. 5.

GUIDE LINES

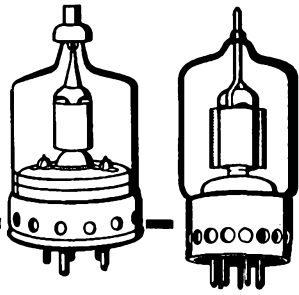

# tetrodes • pentodes ▶

---

## Look in the front pages for ...

- Your nearest distributor of modern, fully guaranteed Eimac Vacuum tubes, vacuum capacitors, heat dissipating connectors, air-system sockets, preformed contact finger stock and vacuum switches.
- Your nearest Eimac Field Engineer, who stands ready to give you immediate engineering assistance, any information on deliveries and prices, or provide other information not found in the catalog.
- Eimac tube type numbering system.
- Tube Replacement Chart.
- Prices on Eimac products.

---

## IMPORTANT EIMAC "EXTRAS"

**Application Engineering.** The Eimac Application Engineering Department is available at all times for consultation. New tube operating techniques are continually being explored, tested and proved by Eimac application engineers, whose combined knowledge and experience are made available to you. Additional contributions by this Eimac department are its Application Bulletins, an expanding service which you get without obligation.

**Field Engineering.** Serving as an extension of the Application Engineering Department outside the Eimac plant, Eimac field engineers cover the United States, operate out of offices in major cities. They will help you personally with experimental work, problems of technique, etc. Engineers from the Eitel-McCullough plant in San Bruno are available, too, for field consultation throughout the country. As Eimac tubes are world renowned, the same services extend to various countries overseas through the Eimac export division.

# Eitel-McCULLOUGH, INC.

SAN BRUNO, CALIFORNIA

# 4-65A

RADIAL-BEAM  
POWER TETRODE

MODULATOR  
OSCILLATOR  
AMPLIFIER

The Eimac 4-65A is a small radiation-cooled transmitting tetrode having a maximum plate-dissipation rating of 65 watts. The plate operates at a red color at maximum dissipation. Short, heavy leads and low interelectrode capacitances contribute to stable efficient operation at high frequencies.

Although it is capable of withstanding high plate voltages, the internal geometry of the 4-65A is such that it will deliver relatively high power output at a low plate voltage.

The quick-heating filament allows conservation of power during standby periods in mobile applications.

## GENERAL CHARACTERISTICS

### ELECTRICAL

Filament: Thoriated tungsten

Voltage	- - - - -	6.0 volts
Current	- - - - -	3.5 amperes
Grid-Screen Amplification Factor (Average)	- - - - -	5
Direct Interelectrode Capacitances (Average)		
Grid-Plate	- - - - -	0.08 $\mu\mu\text{f}$
Input	- - - - -	8.0 $\mu\mu\text{f}$
Output	- - - - -	2.1 $\mu\mu\text{f}$
Transconductance ( $I_b = 125 \text{ ma.}, E_b = 500 \text{ v.}, E_{c2} = 250 \text{ v.}$ )	- - - - -	4000 $\mu\text{mhos}$
Frequency for Maximum Ratings	- - - - -	150 Mc.

### MECHANICAL

Base	- - - - -	5-pin—Fits	} National HX-29 Socket Johnson 122-101 Socket Vertical, base down or up Convection and Radiation Eimac HR-6
Mounting	- - - - -		
Cooling	- - - - -		
Recommended Heat Dissipating Connector	- - - - -		
Maximum Over-all Dimensions			
Length	- - - - -		4.38 inches
Diameter	- - - - -		2.38 inches
Net Weight	- - - - -		3 ounces
Shipping Weight	- - - - -		1.5 pounds

### ▶ RADIO-FREQUENCY POWER AMPLIFIER AND OSCILLATOR

Class-C Telephony or FM Telephony

MAXIMUM RATINGS (Key-down conditions, per tube)

D-C PLATE VOLTAGE	- - - - -	3000 MAX. VOLTS
D-C SCREEN VOLTAGE	- - - - -	400 MAX. VOLTS
D-C GRID VOLTAGE	- - - - -	-500 MAX. VOLTS
D-C PLATE CURRENT	- - - - -	150 MAX. MA
PLATE DISSIPATION	- - - - -	65 MAX. WATTS
SCREEN DISSIPATION	- - - - -	10 MAX. WATTS
GRID DISSIPATION	- - - - -	5 MAX. WATTS

#### TYPICAL OPERATION

D-C Plate Voltage	- - - - -	600	1000	1500	2000	3000	volts
D-C Screen Voltage	- - - - -	250	250	250	250	250	volts
D-C Grid Voltage	- - - - -	-75	-80	-85	-90	-100	volts
D-C Plate Current	- - - - -	150	150	150	140	115	ma
D-C Screen Current*	- - - - -	40	40	40	40	22	ma
D-C Grid Current*	- - - - -	18	17	18	11	10	ma
Peak R-F Grid Voltage	- - - - -	170	175	180	190	170	volts
Driving Power*	- - - - -	3.1	3.0	3.2	2.1	1.7	watts
Screen Dissipation*	- - - - -	10	10	10	10	5.5	watts
Plate Power Input	- - - - -	90	150	225	280	345	watts
Plate Dissipation	- - - - -	45	55	60	65	65	watts
Plate Power Output	- - - - -	45	95	165	215	280	watts

\*Approximate values.

### ▶ PLATE-MODULATED RADIO-FREQUENCY AMPLIFIER

Class-C Telephony (Carrier conditions unless otherwise specified, 1 tube)

MAXIMUM RATINGS

D-C PLATE VOLTAGE	- - - - -	2500 MAX. VOLTS
D-C SCREEN VOLTAGE	- - - - -	400 MAX. VOLTS
D-C GRID VOLTAGE	- - - - -	-500 MAX. VOLTS
D-C PLATE CURRENT	- - - - -	120 MAX. MA
PLATE DISSIPATION	- - - - -	45 MAX. WATTS
SCREEN DISSIPATION	- - - - -	10 MAX. WATTS
GRID DISSIPATION	- - - - -	5 MAX. WATTS

#### TYPICAL OPERATION

D-C Plate Voltage	- - - - -	600	1000	1500	2000	2500	volts
D-C Screen Voltage	- - - - -	250	250	250	250	250	volts
D-C Grid Voltage	- - - - -	-120	-125	-125	-130	-135	volts
D-C Plate Current	- - - - -	120	120	120	120	110	ma
D-C Screen Current*	- - - - -	40	40	40	40	25	ma
D-C Grid Current*	- - - - -	15	16	16	16	12	ma
Screen Dissipation*	- - - - -	10	10	10	10	6.3	watts
Peak A-F Screen Voltage,							
100% Modulation	- - - - -	250	250	250	250	250	volts
Peak R-F Grid Voltage	- - - - -	215	220	220	225	215	volts
Driving Power*	- - - - -	3.2	3.5	3.5	3.6	2.6	watts
Plate Power Input	- - - - -	72	120	180	240	275	watts
Plate Dissipation	- - - - -	27	30	40	45	45	watts
Plate Power Output	- - - - -	45	90	140	195	230	watts

\*Approximate values.

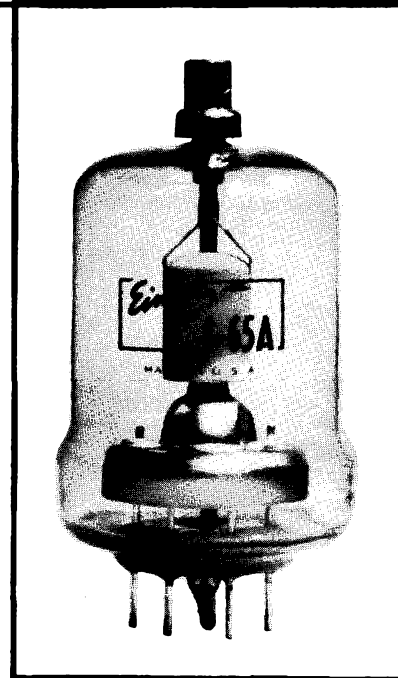



## APPLICATION

### MECHANICAL

**Mounting**—The 4-65A must be mounted vertically, base up or base down. The socket must provide clearance for the glass tip-off which extends from the center of the base. A flexible connecting strap should be provided between the plate terminal and the external plate circuit, and the Eimac HR-6 cooler (or equivalent) used on the tube plate lead. The socket must not apply lateral pressure against the base pins. The tube must be protected from severe vibration and shock.

Adequate ventilation must be provided so that the seals and envelope under operating conditions do not exceed 225°C. For operation above 50 Mc., the plate voltage should be reduced, or special attention should be given to seal cooling.

In intermittent-service applications where the "on" time does not exceed a total of five minutes in any ten minute period, plate seal temperatures as high as 250°C are permissible. When the ambient temperature does not exceed 30°C it will not ordinarily be necessary to provide forced cooling of the bulb and plate seal to hold the temperature below this maximum at frequencies below 50 Mc, provided that a heat-radiating plate connector is used, and the tube is so located that normal circulation of air past the envelope is not impeded.

### ELECTRICAL

**Filament Voltage**—The filament voltage, as measured directly at the filament pins, should be between 5.7 volts and 6.3 volts.

**Bias Voltage**—D-C bias voltage for the 4-65A should not exceed -500 volts. If grid-leak bias is used, suitable protective means must be provided to prevent excessive plate or screen dissipation in the event of loss of excitation.

**Grid Dissipation**—Grid dissipation for the 4-65A should not be allowed to exceed five watts. Grid dissipation may be calculated from the following expression:

$$P_g = e_{cmp} I_c$$

where  $P_g$  = Grid dissipation,  
 $e_{cmp}$  = Peak positive grid voltage, and  
 $I_c$  = D-c grid current.

$e_{cmp}$  may be measured by means of a suitable peak voltmeter connected between filament and grid.\*

**Screen Voltage**—The D-C screen voltage for the 4-65A should not exceed 400 volts except in the case of class-AB audio operation and Single Side Band R-F amplifier operation where it should not exceed 600 volts.

**Screen Dissipation**—The power dissipated by the screen of the 4-65A must not exceed 10 watts. Screen dissipation is likely to rise to excessive values when the plate volt-

age, bias voltage or plate load is removed with filament and screen voltages applied. Suitable protective means must be provided to limit screen dissipation to 10 watts in the event of circuit failure.

**Plate Voltage**—The plate-supply voltage for the 4-65A should not exceed 3,000 volts. Above 50 Mc. it is advisable to use a lower plate voltage than the maximum, since the seal heating due to R-F charging currents in the screen leads increases with plate voltage and frequency. See instructions on seal cooling under "Mechanical" and "Shielding."

**Plate Dissipation**—Under normal operating conditions, the plate dissipation of the 4-65A should not be allowed to exceed 65 watts in unmodulated applications.

In high-level-modulated amplifier applications, the maximum allowable carrier-condition plate dissipation is 45 watts.

Plate dissipation in excess of maximum rating is permissible for short periods of time, such as during tuning procedures.

### OPERATION

**Class-C FM or Telegraphy**—The 4-65A may be operated as a class-C FM or telegraph amplifier without neutralization up to 110 Mc. if reasonable precautions are taken to prevent coupling between input and output circuits external to the tube. In single ended circuits, plate, grid, filament and screen by-pass capacitors should be returned through the shortest possible leads to a common chassis point. In push-pull applications the filament and screen terminals of each tube should be by-passed to a common chassis point by the shortest possible leads, and short, heavy leads should be used to interconnect the screens and filaments of the two tubes. Care should be taken to prevent leakage of radio-frequency energy to leads entering the amplifier, in order to minimize grid-plate coupling between these leads external to the amplifier.

Where shielding is adequate, the feedback at frequencies above 110 Mc. is due principally to screen-lead-inductance effects, and it becomes necessary to introduce in-phase voltage from the plate circuit into the grid circuit. This can be done by adding capacitance between plate and grid external to the tube. Ordinarily, a small metal tab approximately 3/4" square and located adjacent to the envelope opposite the plate will suffice for neutralization. Means should be provided for adjusting the

\*For suitable peak V.T.V.M. circuits see, for instance, "Vacuum Tube Ratings," *Eimac News*, January 1945. This article is available in reprint form on request.

spacing between the neutralizing capacitor plate and the envelope. An alternate neutralization scheme for use above 110 Mc is illustrated in the diagram on page 4. In this circuit, feedback is eliminated by series-tuning the screen to ground with a small capacitor. The socket screen terminals should be strapped together as shown on the diagram, by the shortest possible lead, and the lead from the mid point of this screen strap to the capacitor, C, and from the capacitor to ground should be made as short as possible.

Driving power and power output under maximum output and plate voltage conditions are shown below. The power output shown is the actual plate power delivered by the tube; the power delivered to the load will depend upon the efficiency of the plate tank and output coupling system. The driving power is likewise the driving power required by the tube (includes bias loss). The driver output power should exceed the driving power requirements by a sufficient margin to allow for coupling-circuit losses. The use of silver-plated linear tank-circuit elements is recommended for all frequencies above 75 Mc.

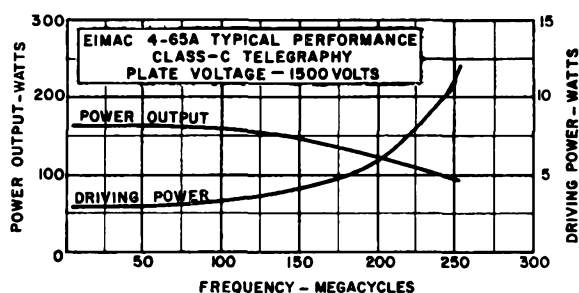

**Class-C AM Telephony**—The R-F circuit considerations discussed above under Class-C FM or Telegraphy also apply to amplitude-modulated operation of the 4-65A. When the 4-65A is used as a class-C high-level-modulated

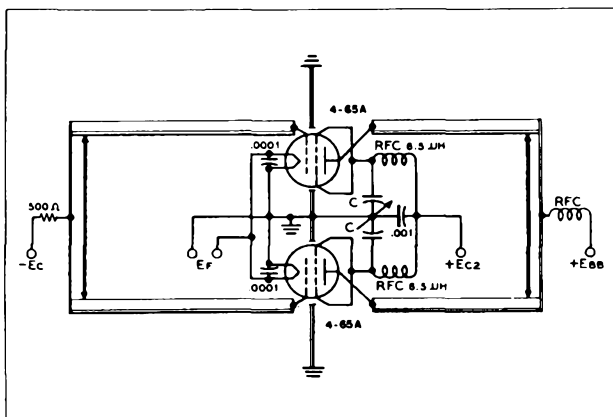

Screen-tuning neutralization circuit for use above 100 Mc. C is a small split-stator capacitor.

$$C(\mu\text{fd}) = \frac{640,000}{f^2 (\text{Mc.})}, \text{ approx.}$$

amplifier, both the plate and screen should be modulated. Modulation voltage for the screen is easily obtained by supplying the screen voltage via a series dropping resistor from the unmodulated plate supply, or by the use of an audio-frequency reactor in the positive screen-supply lead, or from a separate winding on the modulation transformer. When screen modulation is obtained by either the series-resistor or the audio-reactor methods, the audio-frequency variations in screen current which result from the variations in plate voltage as the plate is modulated automatically give the required screen modulation. Where a reactor is used, it should have a rated inductance of not less than 10 henries divided by the number of tubes in the modulated amplifier and a maximum current rating of two to three times the operating D-C screen current. To prevent phase-shift between the screen and plate modulation voltages at high audio frequencies, the screen by-pass capacitor should be no larger than necessary for adequate R-F by-passing.

For high-level modulated service, the use of partial grid-leak bias is recommended. Any by-pass capacitors placed across the grid-leak resistance should have a reactance at the highest modulation frequency equal to at least twice the grid-leak resistance.

**Class-AB<sub>1</sub> and Class-AB<sub>2</sub> Audio**—Two 4-65As may be used in a push-pull circuit to give relatively high audio output power at low distortion. Maximum ratings and typical operating conditions for class-AB<sub>1</sub> and class-AB<sub>2</sub> audio operation are given in the tabulated data.

Screen voltage should be obtained from a source having reasonably good regulation, to prevent variations in screen voltage from zero-signal to maximum-signal conditions. The use of voltage regulator tubes in a standard circuit should provide adequate regulation.

Grid bias voltage for class-AB<sub>2</sub> service may be obtained from batteries or from a small fixed-bias supply. When a bias supply is used, the D-C resistance of the bias source should not exceed 250 ohms. Under class-AB<sub>1</sub> conditions the effective grid-circuit resistance should not exceed 250,000 ohms.

The peak driving power figures given in the class-AB<sub>2</sub> tabulated data are included to make possible an accurate determination of the required driver output power. The driver amplifier must be capable of supplying the peak driving power without distortion. The driver stage should, therefore, be capable of providing an undistorted average output equal to half the peak driving power requirement. A small amount of additional driver output should be provided to allow for losses in the coupling transformer.

In some cases the maximum-signal plate dissipation shown under "Typical Operation" is less than the maximum rated plate dissipation of 4-65A. In these cases, with sine wave modulation, the plate dissipation reaches a maximum value, equal to the maximum rating, at a





## SHIELDING

The internal feedback of the tetrode has been substantially eliminated, and in order to fully utilize this advantage, it is essential that the design of the equipment completely eliminates any feedback external to the tube. This means complete shielding of the output circuit from the input circuit and earlier stages, proper reduction to low values of the inductance of the screen lead to the R-F ground, and elimination of R-F feedback in any common power supply leads.

Complete shielding is easily achieved by mounting the socket of the tube flush with the deck of the chassis as shown in the sketch on page 7.

The holes in the socket permit the flow of convection air currents from below the chassis up past the seals in the base of the tube. This flow of air is essential to cool the tube and in cases where the complete under part of the chassis is enclosed for electrical shielding, screened holes or louvers should be provided to permit air circulation. Note that shielding is completed by aligning the internal screen shield with the chassis deck and by proper R-F by-passing of the screen leads to R-F ground. The plate and output circuits should be kept above deck and the input circuit and circuits of earlier stages should be kept below deck or completely shielded.

## DIFFERENT SCREEN VOLTAGES

The published characteristic curves of tetrodes are shown for the commonly used screen voltages. Occasionally it is desirable to operate the tetrode at some screen voltage other than that shown on the characteristic curves. It is a relatively simple matter to convert the published curves to corresponding curves at a different screen voltage by the method to be described.

This conversion method is based on the fact that if all inter-electrode voltages are either raised or lowered by the same relative amount, the shape of the voltage field pattern is not altered, nor will the current distribution be altered; the current lines will simply take on new proportionate values in accordance with the three-halves power law. This method fails only where insufficient cathode emission or high secondary emission affect the current values.

For instance, if the characteristic curves are shown at a screen voltage of 250 volts and it is desired to determine conditions at 500 screen volts, all voltage scales should be multiplied by the same factor that is applied to the screen voltage (in this case—2). The 1000 volt plate voltage point now becomes 2000 volts, the 50 volt grid voltage point, 100 volts, etc.

The current lines then all assume new values in accordance with the  $3/2$  power law. Since the voltage was increased by a factor of 2, the current lines will all be increased in value by a factor of  $2^{3/2}$  or 2.8. Then all the current values should be multiplied by the factor 2.8. The 100 ma. line becomes a 280 ma. line, etc.

Likewise, if the screen voltage given on the characteristic curve is higher than the conditions desired, the voltages should all be reduced by the same factor that is used to obtain the desired screen voltage. Correspond-

ingly, the current values will all be reduced by an amount equal to the  $3/2$  power of this factor.

For convenience the  $3/2$  power of commonly used factors is given below:

Voltage Factor	.25	.5	.75	1.0	1.25	1.50	1.75
Corresponding Current Factor	.125	.35	.65	1.0	1.4	1.84	2.3
Voltage Factor	2.0	2.25	2.5	2.75	3.0		
Corresponding Current Factor	2.8	3.4	4.0	4.6	5.2		

## SINGLE SIDE BAND SUPPRESSED CARRIER OPERATION

The 4-65A may be operated as a class B linear amplifier in SSSC operation and peak power outputs of over 300 watts per tube may be readily obtained. This is made possible by the intermittent nature of the voice. If steady audio sine wave modulation is used, the single side band will be continuous and the stage will operate as a C-W class-B amplifier. With voice modulation the average power will run on the order of  $1/5$ th of this continuous power.

The same precautions regarding shielding, coupling between input and output circuits, and proper R-F by-passing must be observed, as described under Class-C Telegraphy Operation.

Due to the widely varying nature of the load imposed on the power supplies by SSSC operation, it is essential that particular attention be given to obtaining good regulation in these supplies. The bias supply especially, should have excellent regulation, and the addition of a heavy bleeder to keep the supply well loaded will be found helpful.

Under conditions of zero speech signal, the operating bias is adjusted so as to give a plate dissipation of 50 watts at the desired plate and screen voltages. Due to the intermittent nature of voice, the average plate dissipation will rise only slightly under full speech modulation to approximately 65 watts. At the same time, however, the peak speech power output of over 300 watts is obtained.

### SSSC TUNING PROCEDURE

Tuning the SSSC transmitter is best accomplished with the aid of an audio frequency oscillator and a cathode-ray oscilloscope. The audio oscillator should be capable of delivering a sine wave output of a frequency of around 800 to 1000 cycles so that the frequency will be somewhere near the middle of the pass-band of the audio system. Since successful operation of the class-B stage depends on good linearity and the capability of delivering full power at highest audio levels, the final tuning should be made under conditions simulating peak modulation conditions. If a continuous sine wave from the audio oscillator is used for tuning purposes, the average power at full modulation would be about five times that of speech under similar conditions of single side band operation and the final amplifier would be subjected to a heavy overload. One method of lowering the duty cycle of the audio oscillator to closer approxi-

mate speech conditions would be to modulate the oscillator with a low frequency.

An alternate method would be to use the continuous audio sine wave, making all adjustments at half voltages and half currents on the screen and plate, thus reducing the power to one quarter. The stand-by plate dissipation under these conditions should be set at about 10 watts. Following these adjustments, minor adjustments at full voltages and 50 watts of stand-by plate dissipation could then be made, but only allowing the full power to remain on for ten or fifteen second intervals.

The first step is to loosely couple the oscilloscope to the output of the exciter unit. The final amplifier with its filament and bias voltages turned on should also be coupled to the exciter at this time. With the audio oscillator running, adjust the exciter unit so that it delivers double side band signals. Using a linear sweep on the oscilloscope, the double side band pattern will appear on the screen the same as that obtained from a 100% sine wave modulated AM signal. Next vary the audio gain control so that the exciter can be checked for linearity. When the peaks of the envelope start to flatten out the upper limit of the exciter output has been reached and the maximum gain setting should be noted. The coupling to the final stage should be varied during this process and a point of optimum coupling determined by watching the oscilloscope pattern and the grid meter in the final stage.

Next, adjust the exciter for single side band operation and if it is working properly, the pattern on the oscilloscope will resemble an unmodulated AM carrier. The phasing controls should be adjusted so as to make the envelope as smooth on the top and bottom as possible. If the above conditions are satisfied, the exciter unit can be assumed to be operating satisfactorily.

Next, loosely couple the oscilloscope link to the output of the final amplifier and again adjust the exciter unit to give double side band output.

If the reduced duty cycle method is used, the following tuning procedure may be followed:

1. Cut the audio output to zero.
2. Apply 120 volts of bias to the 4-65A control grid.
3. Apply the operating plate voltage followed by the operating screen voltage.
4. Reduce bias voltage to obtain 50 watts of stand-by plate dissipation.
5. Increase audio gain, checking the oscilloscope pattern for linearity as in the case of the exciter, and adjust for optimum antenna coupling.
6. Re-adjust exciter unit for single side band operation.
7. Disconnect test signal and connect microphone.
8. Adjust the audio gain so that the voice peaks give the same deflection on the oscilloscope screen as was obtained from the test signal peaks.

If the alternate method is used with a 100% duty cycle from the audio oscillator, then step 3 should be to apply half voltages and the stand-by plate dissipation should be set at 10 watts.

After the audio oscillator is disconnected and step 8 completed at half voltages, the full voltages can then be applied and the stand-by plate dissipation adjusted for 50 watts.

It is essential that the microphone cable be well shielded and grounded to avoid R-F feedback that might not occur when the lower impedance audio oscillator is used as an audio source.

Typical operational data are given for SSSC in the first part of this data sheet.

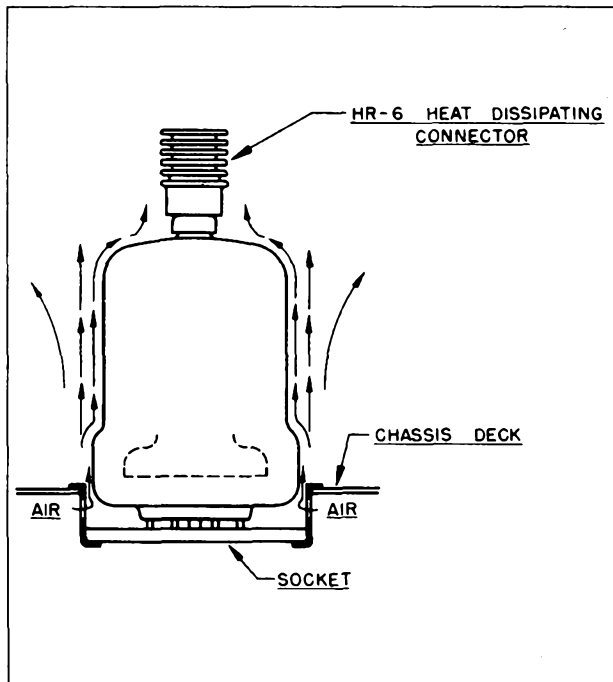

## COMPONENTS FOR TYPICAL CIRCUITS

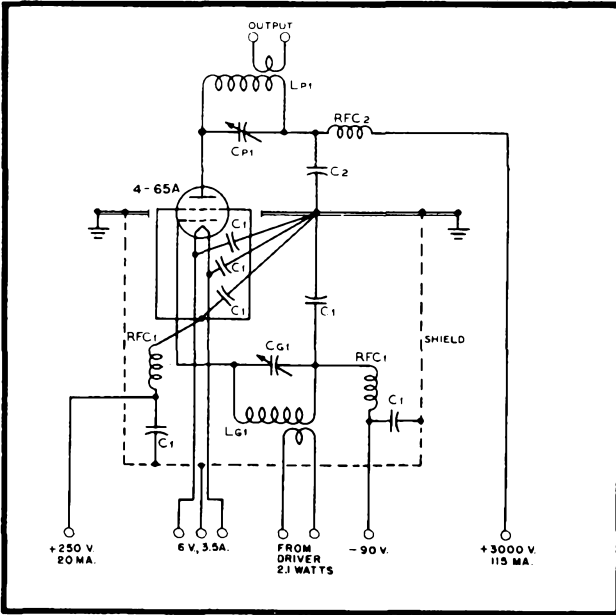

Typical radio-frequency power amplifier circuit, Class-C telegraphy, 345 watts input.

- L<sub>p1</sub>-C<sub>p1</sub>—Tank circuit appropriate for operating frequency; Q=12. Capacitor plate spacing=.200".
- L<sub>p2</sub>-C<sub>p2</sub>—Tank circuit appropriate for operating frequency; Q=12. Capacitor plate spacing=.200".
- L<sub>p3</sub>-C<sub>p3</sub>—Tank circuit appropriate for operating frequency; Q=12. Capacitor plate spacing=.375".
- L<sub>g1</sub>-C<sub>g1</sub>—Tuned circuit appropriate for operating frequency.
- L<sub>g2</sub>-C<sub>g2</sub>—Tuned circuit appropriate for operating frequency.
- C<sub>1</sub>—.002- $\mu$ fd. 500V Mica
- C<sub>2</sub>—.002- $\mu$ fd. 5000V Mica
- C<sub>3</sub>—.001- $\mu$ fd. 2500V Mica
- C<sub>4</sub>—.1- $\mu$ fd. 1000V paper
- C<sub>5</sub>—.1- $\mu$ fd. 600 V paper
- C<sub>6</sub>—16- $\mu$ fd. 450V Electrolytic
- C<sub>7</sub>—10- $\mu$ fd. 100V Electrolytic
- R<sub>1</sub>—53,000 ohms 200 watt—60,000 ohm adjustable
- R<sub>2</sub>—250,000 ohms 1 watt
- R<sub>3</sub>—5,000 ohms 5 watt
- R<sub>4</sub>—25,000 ohms 2 watts
- R<sub>5</sub>—26,500 ohms 200 watts—30,000 ohm adjustable
- R<sub>6</sub>—2,500 ohms 5 watts
- R<sub>7</sub>—750 ohms 5 watts
- RFC<sub>1</sub>—2.5 mhy. 125 ma. R-F choke
- RFC<sub>2</sub>—1 mhy. 500 ma. R-F choke
- T<sub>1</sub>—150 watt modulation transformer; ratio primary to secondary impedance approx. 1:1.1 Pri. impedance 15,000 ohms, sec. impedance 16,700 ohms.
- T<sub>2</sub>—5 watt driver transformer impedance ratio primary to 1/2 secondary 1.5:1.
- T<sub>3</sub>—300 watt modulation transformer; impedance ratio pri. to sec. approx. 2.4:1; Pri. impedance=20,000 ohms, sec. impedance=8,333 ohms.

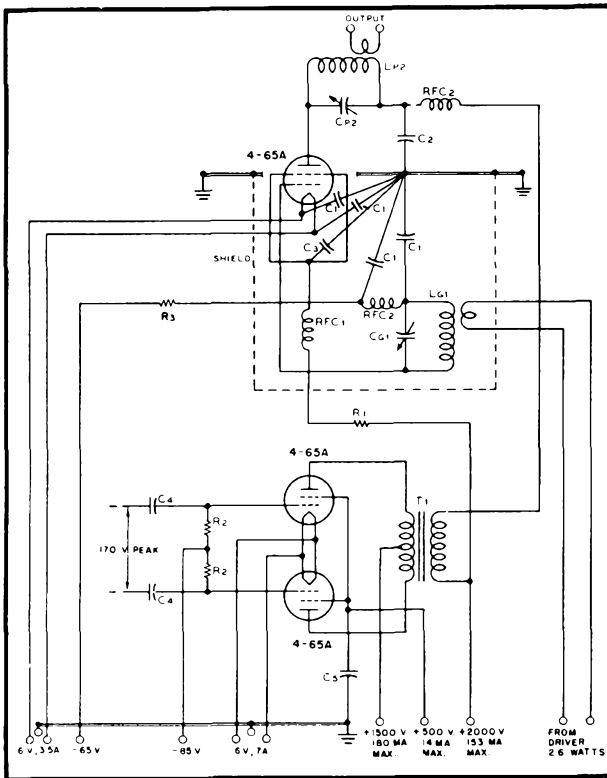

Typical high-level-modulated R-F amplifier, 240 watts plate input. Modulator requires zero driving power.

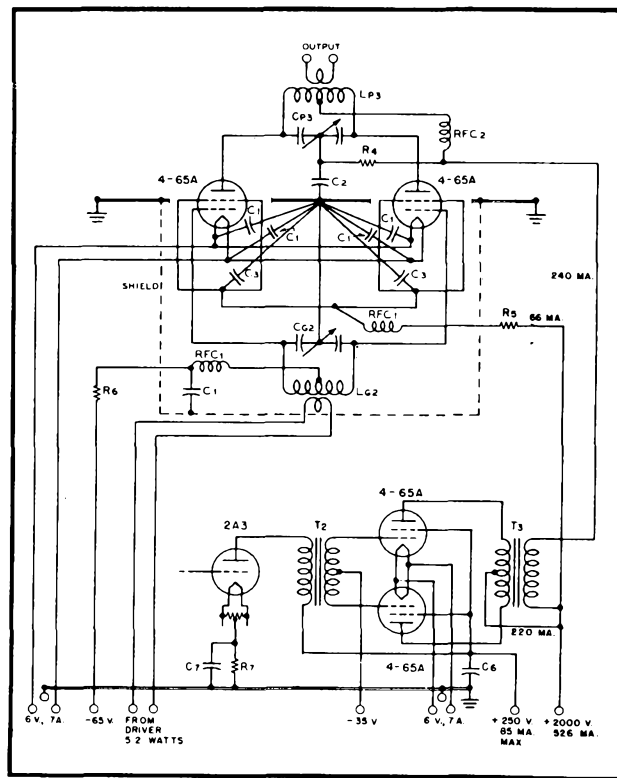

Typical high-level-modulated R-F amplifier circuit, with modulator and driver stages, 480 watts plate input.

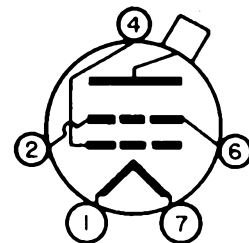
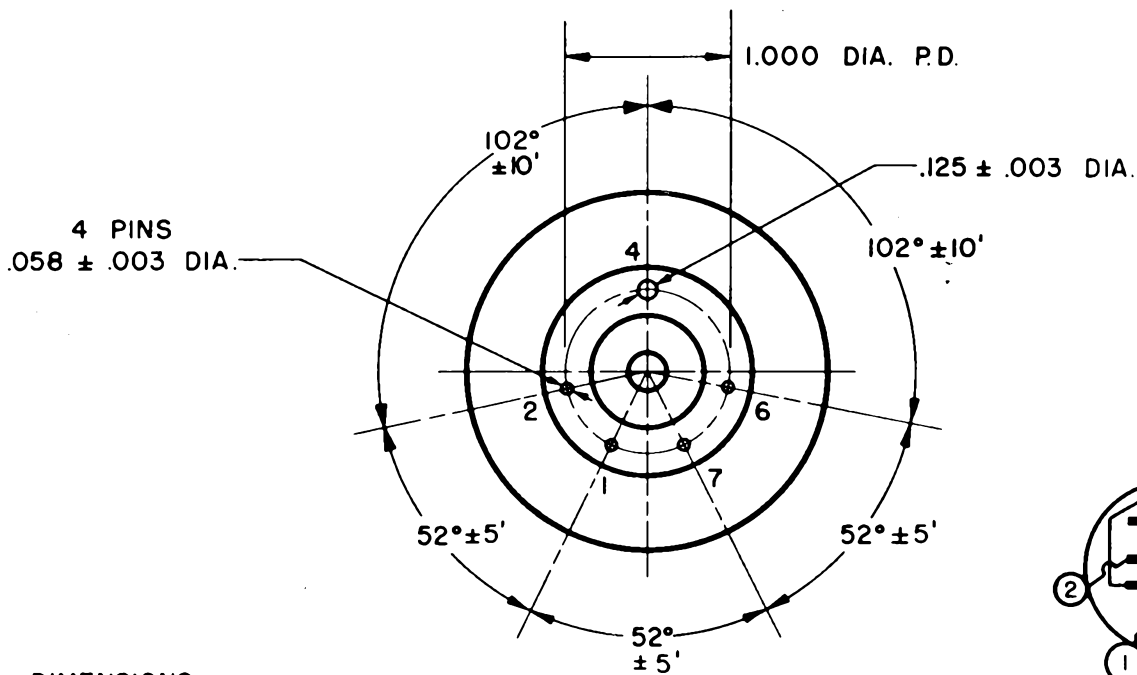
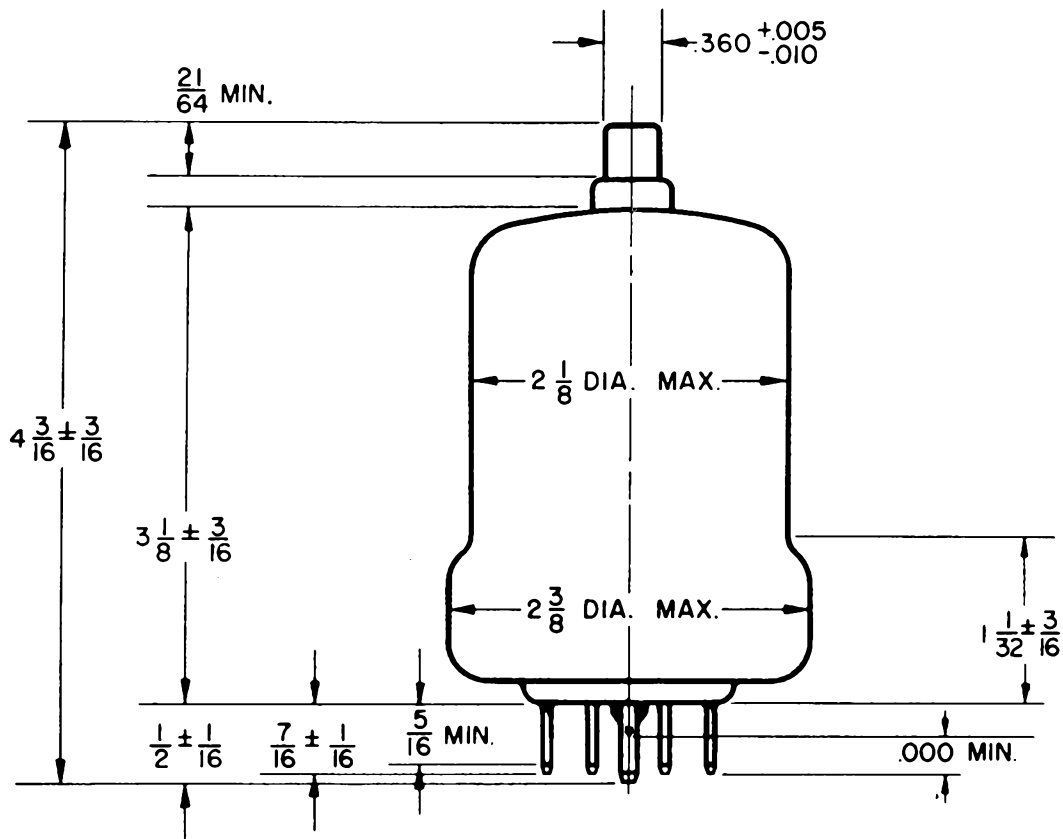

ALL DIMENSIONS  
IN INCHES

BOTTOM VIEW

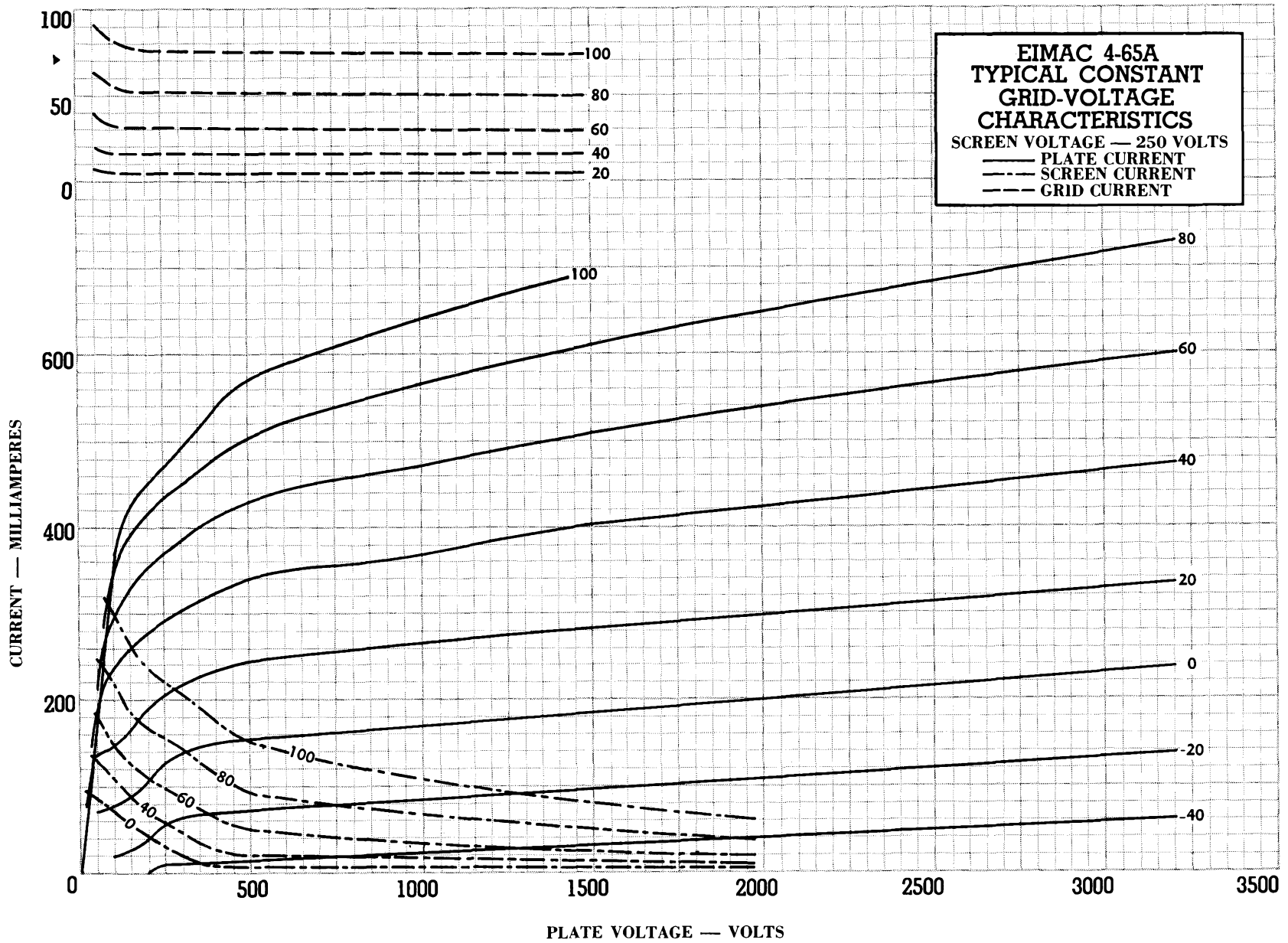

► Indicates change from sheet dated 1-30-53

**Eimac**  
4-65A

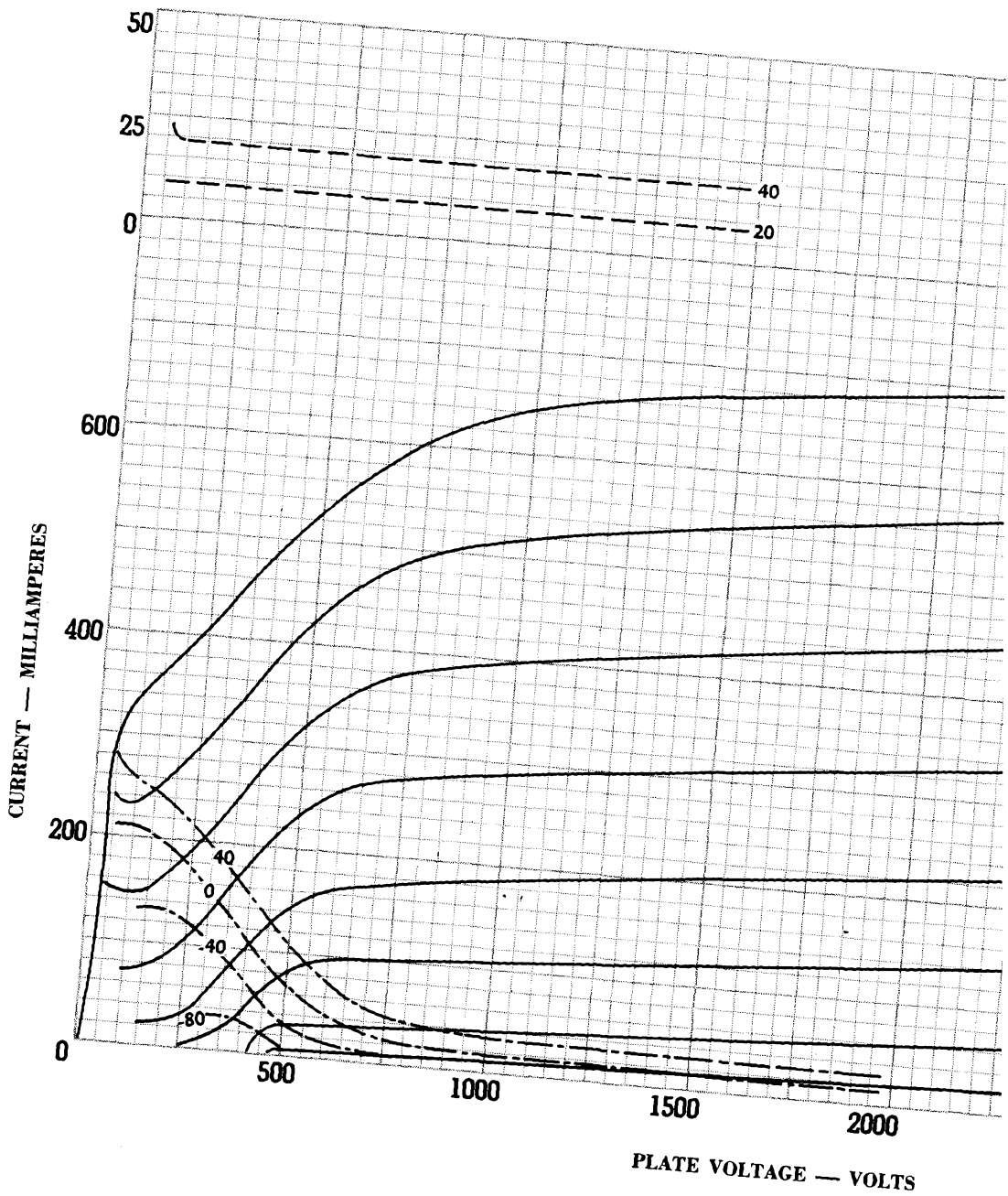

**EIMAC 4-65A  
TYPICAL CONSTANT  
GRID-VOLTAGE  
CHARACTERISTICS**  
SCREEN VOLTAGE—500 VOLTS

- PLATE CURRENT
- - - SCREEN CURRENT
- - - GRID CURRENT

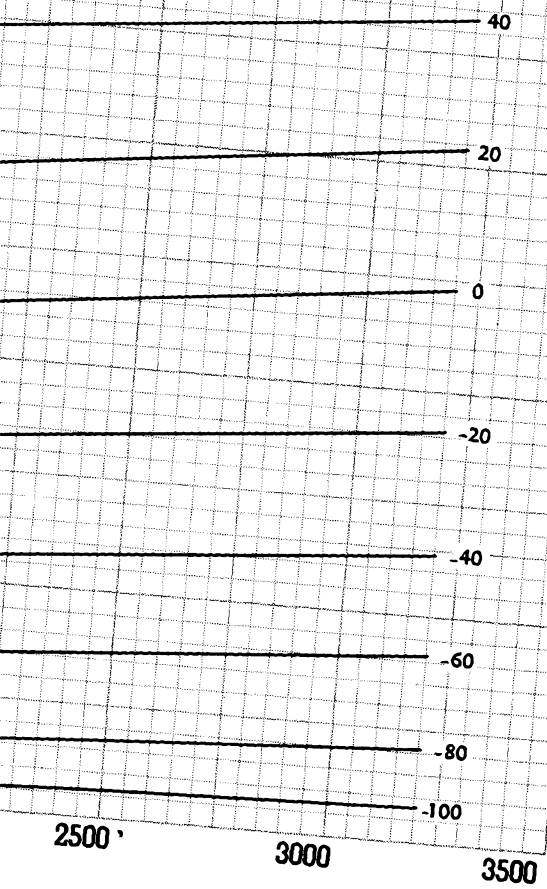

**Eimac**  
4-65A



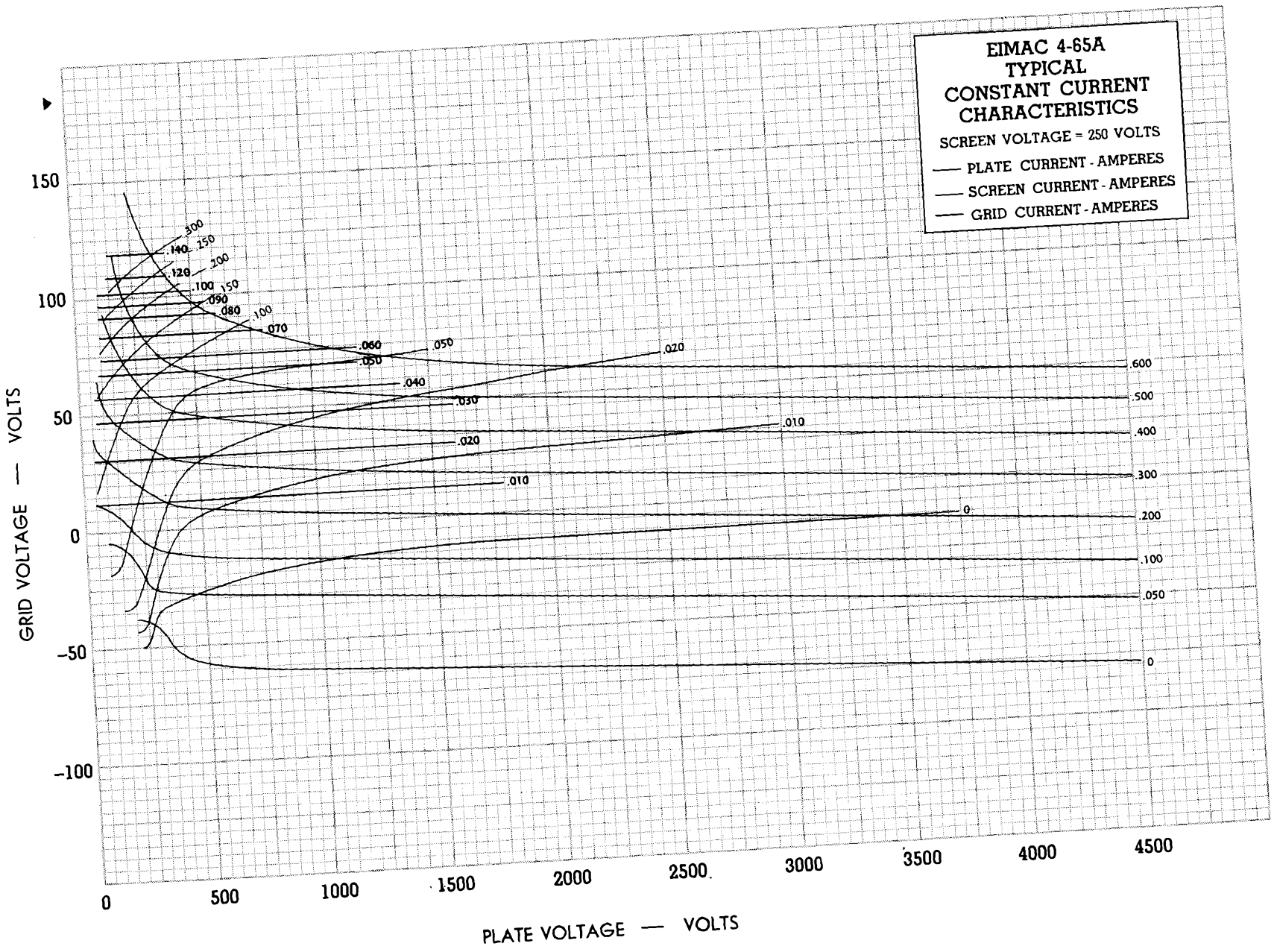

*Eimac*  
 4-65A

Printed in USA 5-17-80380

▶ Indicates change from sheet dated 1-30-53

## **4-125A**

### **ADDENDUM**

Typical operation of **HIGH-LEVEL MODULATED RADIO FREQUENCY AMPLIFIER**, page two, column two, should read as follows:

<b>Plate Dissipation</b>	<b>.</b>	<b>75</b>	<b>80 watts</b>
<b>Plate Power Output</b>	<b>.</b>	<b>225</b>	<b>300 watts</b>

*Eimac*  
**EITEL-McCULLOUGH, INC.**  
 SAN BRUNO, CALIFORNIA

# 4PR60A

RADIAL-BEAM  
 PULSE TETRODE  
 MODULATOR  
 AMPLIFIER

The Eimac 4PR60A is a high-vacuum tetrode intended for pulse-modulator service in circuits employing inductive or resistive loads. This tube unilaterally replaces the 715C and the 5D21.

▶ The 4PR60A has a maximum plate dissipation rating of 60 watts, is cooled by radiation and convection, and delivers pulse power output in the range of 300 kilowatts with one kilowatt of pulse driving power.

## GENERAL CHARACTERISTICS

### ELECTRICAL

Cathode: Oxide-coated, Unipotential	
Heater Voltage - - - - -	26.0 volts
Heater Current - - - - -	2.25 amperes
Minimum Heating Time - - - - -	3 minutes
Direct Interelectrode Capacitances (Average)	
Grid-Plate (without shielding) - - - - -	0.3 $\mu\mu\text{f}$
Input - - - - -	43.0 $\mu\mu\text{f}$
Output - - - - -	9.0 $\mu\mu\text{f}$

### MECHANICAL

Minimum Shock Test - - - - -	200g
Base - - - - -	Fits E. F. Johnson Co. Socket Number 122-234 or equivalent
Mounting Position - - - - -	Any
Cooling - - - - -	Radiation and Convection
Recommended Heat Dissipating Plate Connector - - - - -	Eimac HR-8
Maximum Over-all Dimensions	
Length - - - - -	6 inches
Diameter - - - - -	3 $\frac{1}{4}$ inches
Net Weight - - - - -	12 ounces
Shipping Weight - - - - -	1.75 pounds

### RATINGS

**MAXIMUM RATINGS—Pulse Modulator Service (Per Tube)**

D-C PLATE VOLTAGE - - -	20 MAX. KILOVOLTS
D-C SCREEN VOLTAGE <sup>1</sup> - - -	1.5 MAX. KILOVOLTS
D-C GRID VOLTAGE <sup>2</sup> - - -	-1.0 MAX. KILOVOLT
PEAK POSITIVE GRID VOLTAGE - - -	300 MAX. VOLTS
PEAK PLATE CURRENT - - -	18 MAX. AMPERES
PEAK POSITIVE PLATE VOLTAGE - - -	25 MAX. KILOVOLTS
PLATE DISSIPATION (AVERAGE) - - -	60 MAX. WATTS
SCREEN DISSIPATION (AVERAGE) - - -	8 MAX. WATTS
SEAL TEMPERATURES - - -	200 MAX. DEG. C

#### DUTY

For peak plate currents in excess of 5 amperes, the duty shall not exceed 0.001, and the product of peak current in amperes and pulse duration in microseconds shall not exceed 40. The tube shall not be operated for longer than 5 microseconds in any 100 microsecond interval.

For peak plate current values of less than 5 amperes, the pulse duration-current factor of 40 applies, and the plate dissipation rating of 60 watts determines the maximum permissible duty.

### TYPICAL OPERATION

#### Pulse Modulator (Per Tube)

D-C Plate Voltage - - - - -	15.8 20.0 kilovolts
Pulse Plate Current - - - - -	14.0 16.0 amperes
D-C Screen Voltage - - - - -	1.25 1.25 kilovolts
Pulse Screen Current* - - - - -	4.0 3.0 amperes
D-C Grid Voltage - - - - -	-600 -600 volts
Pulse Grid Current* - - - - -	1.1 1.1 amperes
Pulse Positive Grid Voltage - - - - -	100 100 volts
Duty - - - - -	.001 .001
Pulse Length - - - - -	2 2 $\mu\text{sec}$
Peak Positive Plate Voltage - - - - -	25 25 kilovolts
Peak Plate Current - - - - -	16 18 amperes
Pulse Power Input - - - - -	220 320 kilowatts
Pulse Power Output - - - - -	210 305 kilowatts
Plate Output Voltage - - - - -	15.0 19.0 kilovolts

<sup>1</sup>Screen grid series protective resistance shall be 20,000 ohms, minimum.

▶ <sup>2</sup>Control grid series resistance shall be 100,000 ohms, maximum.

\*Approximate values.



## APPLICATION

### MECHANICAL

**Mounting**—The 4PR60A may be mounted and operated in any position. A flexible connecting strap should be provided between the plate terminal and the external plate circuit.

The 4PR60A is designed to withstand 200g shocks of short duration transferred to the tube through clamps on the metal skirt. Such clamps must be shaped to fit the contour of the skirt and must be fastened to the tube before being tightened to the chassis in order that no distorting force will be applied. No lateral pressure or clamping action should be applied to the base pins or to any part of the tube other than the skirt. The skirt is internally connected to the cathode.

Adequate ventilation must be provided so that the seals and envelope under operating conditions do not exceed 200°C.

### ELECTRICAL

**Heater Voltage**—The heater voltage, as measured directly at the heater pins, should be the rated

value of 26.0 volts. Variations in heater voltage must be kept within the range from 23.4 to 28.6 volts.

**Screen Dissipation**—The average power dissipated by the screen of the 4PR60A must not exceed eight watts. A protective series resistance of not less than 20,000 ohms must be inserted in the screen-voltage supply circuit and the screen should be adequately by-passed directly to the cathode by means of a suitable capacitor.

**Plate Voltage**—The plate-supply voltage for the 4PR60A should not exceed 20 kilovolts. In circuits employing inductive loading, the peak instantaneous plate voltage should not exceed 25 kilovolts.

**Plate Dissipation**—Under normal operating conditions, the plate dissipation of the 4PR60A should not be allowed to exceed 60 watts. Plate dissipation in excess of maximum rating is permissible for short periods of time, such as during adjustment procedures. The 4PR60A should not be operated without a heat dissipating plate connector such as the recommended Eimac HR-8.

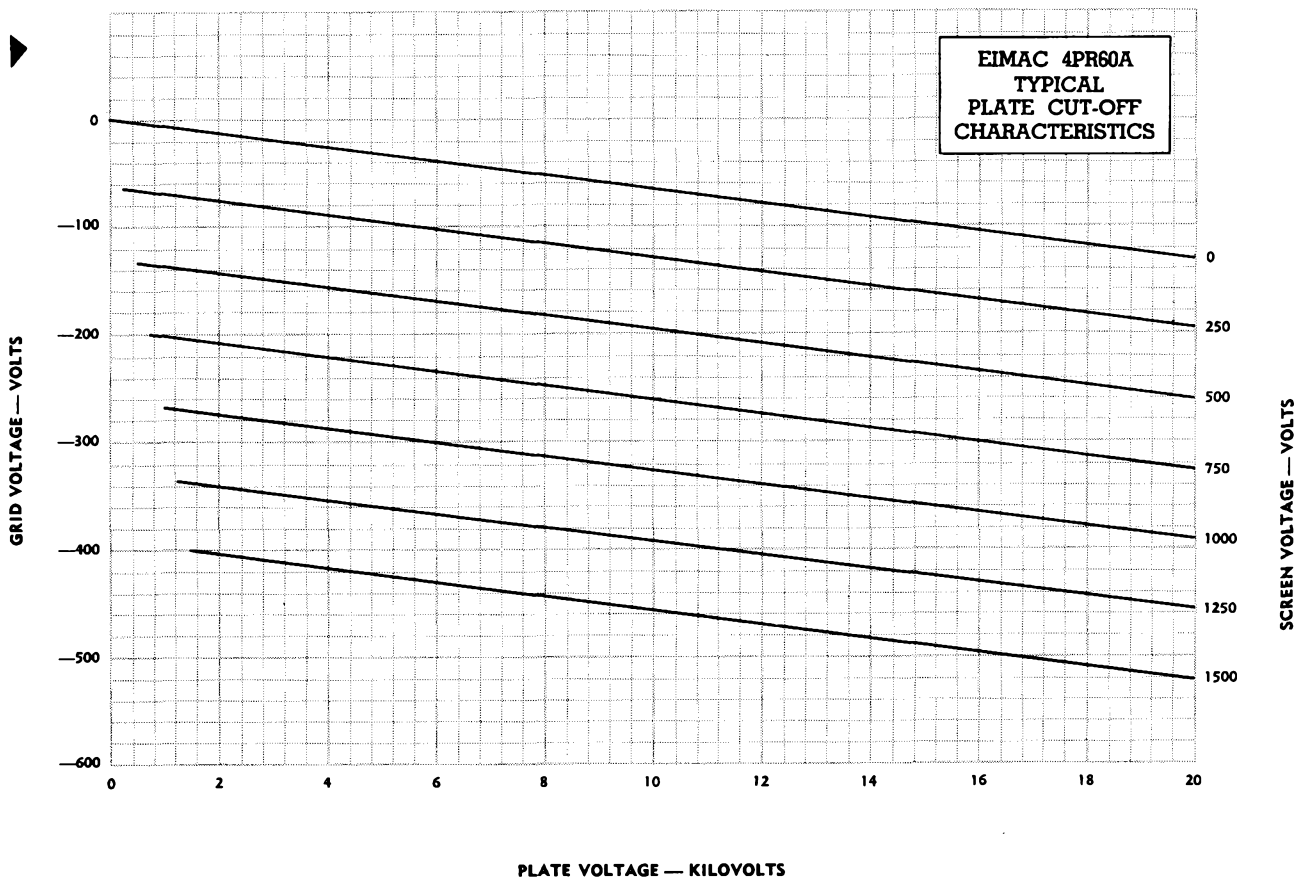

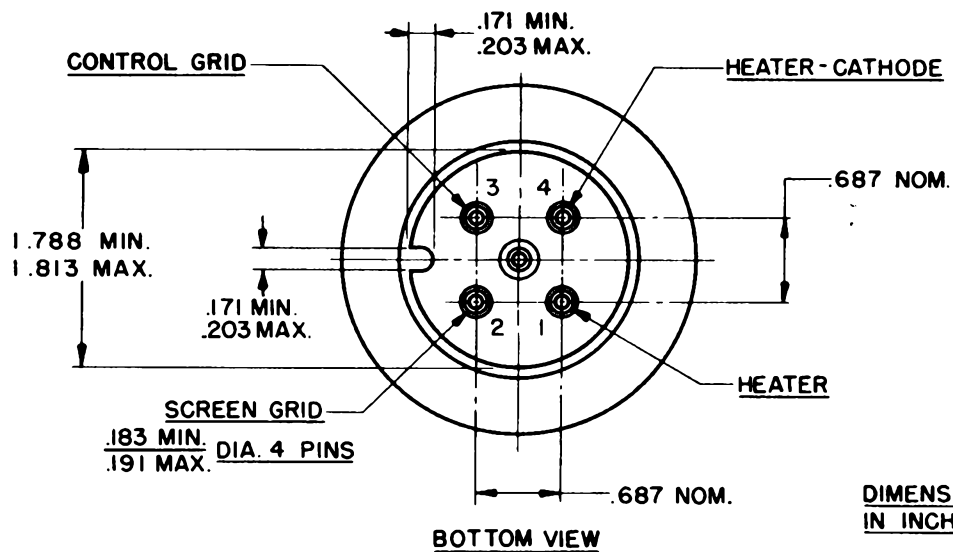
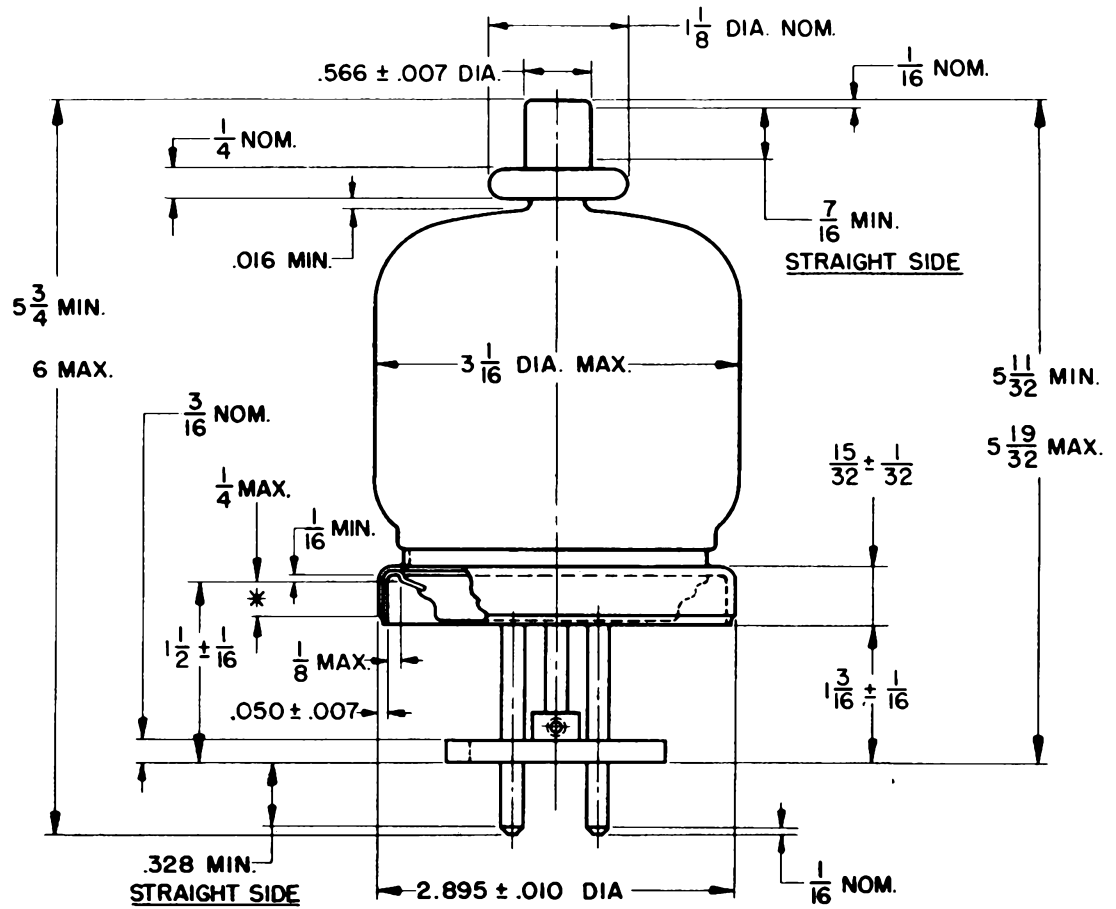

THE BASE SHALL BE CAPABLE OF ENTERING A GAUGE  $1/4$ " THICK HAVING 4 HOLES WHOSE DIA'S ARE  $.214$ " AND WHICH ARE LOCATED ON  $11/16$ " CENTERS AND A CENTER HOLE OF  $.250$ " DIA.

\*CYLINDRICAL SURFACE AVAILABLE FOR CLAMPING MUST NOT BE DEFORMED BY ACTION OF CLAMPS

DIMENSIONS IN INCHES

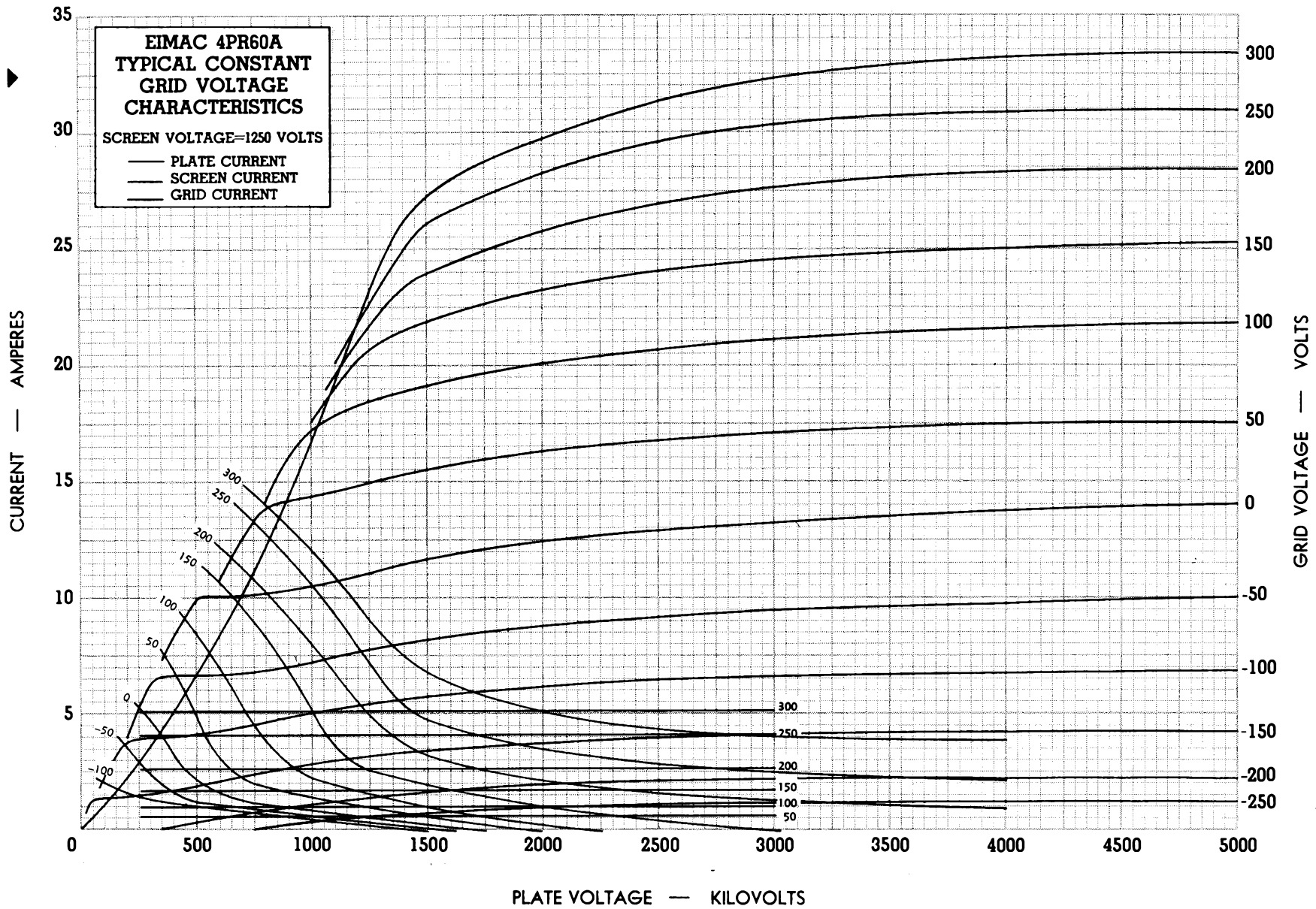

*Eimac*  
4PR60A

▶ Indicates change from sheet dated 8-15-52.

# EITEL-McCULLOUGH, INC.

SAN BRUNO, CALIFORNIA

## 4X150A

RADIAL-BEAM  
POWER TETRODE

These Data apply to type 4X150D which is identical to 4X150A except for the heater rating of 26.5 volts 0.57 ampere.

The Eimac 4X150A is a compact power tetrode intended for use as an amplifier, oscillator or frequency multiplier over a wide range of frequencies extending into the UHF region. It is cooled by forced air.

A single 4X150A operating in a coaxial-cavity amplifier circuit will deliver up to 140 watts of useful power output at 500 megacycles.

The maximum rated plate voltage for the 4X150A is 1250 volts, and the tube is capable of good performance with plate voltages as low as 400 volts. Its high ratio of transconductance to capacitance and its 150-watt plate dissipation rating make the 4X150A useful for wide-band amplifier applications.

The use of the Eimac 4X150A Air-System Socket, or a socket providing equivalent air-cooling facilities, is required.

### GENERAL CHARACTERISTICS

#### ELECTRICAL

Cathode: Oxide Coated, Unipotential			
Minimum Heating Time	- - - - -	30	seconds
Cathode-to-Heater Voltage	- - - - -	150	max. volts
Heater: Voltage	- - - - -	6.0	volts
Current	- - - - -	2.6	amperes
Grid-Screen Amplification Factor (Average)	- - - - -	-	5
Direct Interelectrode Capacitances (Average)			
Grid-Plate	- - - - -	0.03	$\mu$ uf
Input	- - - - -	15.5	$\mu$ uf
Output	- - - - -	4.5	$\mu$ uf
Transconductance ( $E_b=500v.$ , $E_{c2}=250v.$ , $I_b=200$ ma)	- - - - -	-	12,000 $\mu$ mhos
Frequency for Maximum Ratings	- - - - -	-	500 Mc

#### MECHANICAL

Base	- - - - -	-	9-pin, special
Recommended Socket	- - - - -	-	Eimac 4X150A Air-System Socket
Base Connections	- - - - -	-	See outline drawing
Mounting	- - - - -	-	Any position
Cooling	- - - - -	-	Forced air
Maximum Over-all Dimensions			
Length	- - - - -	-	2.47 inches
Diameter	- - - - -	-	1.65 inches
Seated Height	- - - - -	-	1.91 inches
Net Weight	- - - - -	-	5.2 ounces
Shipping Weight	- - - - -	-	1.6 pounds

Note: Typical operation data are based on conditions of adjusting the r-f grid drive to a specified plate current, maintaining fixed conditions of grid bias and screen voltage. It will be found that if this procedure is followed, there will be little variation in power output between tubes even though there may be some variation in grid and screen currents. Where grid bias is obtained principally by means of a grid resistor, to control plate current it is necessary to make the resistor adjustable.

## RADIO-FREQUENCY POWER AMPLIFIER OR OSCILLATOR

Class-C Telegraphy or FM Telephony  
(Key-down conditions, per tube)

#### MAXIMUM RATINGS

D-C PLATE VOLTAGE	-	1250 MAX. VOLTS
D-C SCREEN VOLTAGE	-	300 MAX. VOLTS
D-C GRID VOLTAGE	- -	-250 MAX. VOLTS
D-C PLATE CURRENT	-	250 MAX. MA
PLATE DISSIPATION	- -	150 MAX. WATTS
SCREEN DISSIPATION	-	12 MAX. WATTS
GRID DISSIPATION	- -	2 MAX. WATTS

TYPICAL OPERATION (Frequencies up to 165 Mc., per tube)						
D-C Plate Voltage	- - - - -	600	750	1000	1250	volts
D-C Screen Voltage	- - - - -	250	250	250	250	volts
D-C Grid Voltage	- - - - -	-75	-80	-80	-90	volts
D-C Plate Current	- - - - -	200	200	200	200	ma
D-C Screen Current	- - - - -	37	37	30	20	ma
D-C Grid Current	- - - - -	10	10	10	10	ma
Peak R-F Grid Voltage (approx.)	- - - - -	90	95	95	105	volts
Driving Power	- - - - -	0.7	0.7	0.7	0.8	watts
Plate Power Input	- - - - -	120	150	200	250	watts
Plate Power Output	- - - - -	85	110	150	195	watts

The performance figures for frequencies up to 165 Mc. are obtained by calculation from the tube characteristic curves and confirmed by direct tests. The driving power includes only power taken by the tube grid and the bias circuit. The driving power and output power do not allow for losses in the associated resonant circuits.

TYPICAL OPERATION (Single tube, 500-Mc., coaxial cavity)						
D-C Plate Voltage	- - - - -	600	800	1000	1250	volts
D-C Screen Voltage	- - - - -	250	250	250	250	volts
D-C Grid Voltage	- - - - -	-80	-80	-80	-80	volts
D-C Plate Current	- - - - -	200	200	200	200	ma
D-C Screen Current	- - - - -	7	7	7	7	ma
D-C Grid Current	- - - - -	10	10	10	10	ma
Driver Output Power (approx.)	- - - - -	10	10	10	10	watts
Power Input	- - - - -	120	160	200	250	watts
Useful Power Output	- - - - -	65	90	110	140	watts

These typical performance figures were obtained by direct measurement in operating equipment. The output power is useful power measured in a load circuit. The driving power is the total power taken by the tube and a practical resonant circuit. In many cases with further refinement and improved techniques better performance might be obtained.



## PLATE-MODULATED RADIO-FREQUENCY AMPLIFIER

Class-C Telephony (Carrier conditions, per tube)

### MAXIMUM RATINGS

D-C PLATE VOLTAGE	-	1000	MAX. VOLTS
D-C SCREEN VOLTAGE	-	300	MAX. VOLTS
D-C GRID VOLTAGE	-	-250	MAX. VOLTS
D-C PLATE CURRENT	-	200	MAX. MA
PLATE DISSIPATION	-	100	MAX. WATTS
SCREEN DISSIPATION	-	12	MAX. WATTS
GRID DISSIPATION	-	2	MAX. WATTS

### TYPICAL OPERATION (Frequencies up to 165 Mc.)

D-C Plate Voltage	-	400	600	800	1000	volts
D-C Screen Voltage	-	250	250	250	250	volts
D-C Grid Voltage	-	-90	-95	-100	-105	volts
D-C Plate Current	-	200	200	200	200	ma
D-C Screen Current	-	40	35	25	20	ma
D-C Grid Current	-	7	8	10	15	ma
Peak A-F Screen Voltage at crest of 100% Modulation	-	140	150	160	170	volts
Peak R-F Grid Input Voltage (approx.)	-	110	120	120	125	volts
Driving Power (approx.)	-	1	1	1.5	2	watts
Plate Dissipation	-	25	40	60	60	watts
Plate Power Input	-	80	120	160	200	watts
Plate Power Output	-	55	80	100	140	watts

## RADIO-FREQUENCY POWER AMPLIFIER

Class-B Linear, Television Visual Service (per tube)

### MAXIMUM RATINGS

D-C PLATE VOLTAGE	-	1250	MAX. VOLTS
D-C SCREEN VOLTAGE	-	400	MAX. VOLTS
D-C GRID VOLTAGE	-	-250	MAX. VOLTS
D-C PLATE CURRENT (AVERAGE)	-	250	MAX. MA
PLATE DISSIPATION	-	150	MAX. WATTS
SCREEN DISSIPATION	-	12	MAX. WATTS
GRID DISSIPATION	-	2	MAX. WATTS

### TYPICAL OPERATION (Frequencies up to 216 Mc., 5 Mc. bandwidth)

D-C Plate Voltage	-	750	1000	1250	volts
D-C Screen Voltage	-	300	300	300	volts
D-C Grid Voltage	-	-60	-65	-70	volts
During Sync-Pulse Peak:					
D-C Plate Current	-	335	330	305	ma
D-C Screen Current	-	50	45	45	ma
D-C Grid Current	-	15	20	25	ma
Peak R-F Grid Voltage	-	85	95	100	volts
R-F Driver Power (approx.)	-	7	8	9	watts
Useful Power Output	-	135	200	250	watts
Black Level:					
D-C Plate Current	-	245	240	230	ma
D-C Screen Current	-	20	15	10	ma
D-C Grid Current	-	4	4	4	ma
Peak R-F Grid Voltage (approx.)	-	65	70	75	volts
R-F Driver Power (approx.)	-	4.25	4.7	5.5	watts
Plate Power Input	-	185	240	290	watts
Useful Power Output	-	75	110	140	watts

## CLASS-AB OR -B POWER AMPLIFIER OR MODULATOR

MAXIMUM RATINGS (Per tube)

D-C PLATE VOLTAGE	-	1250	MAX. VOLTS
D-C SCREEN VOLTAGE	-	400	MAX. VOLTS
D-C PLATE CURRENT	-	250	MAX. MA
PLATE DISSIPATION	-	150	MAX. WATTS
SCREEN DISSIPATION	-	12	MAX. WATTS
GRID DISSIPATION	-	2	MAX. WATTS

### TYPICAL OPERATION

Class AB <sub>1</sub> (Sinusoidal wave, two tubes unless otherwise specified)						
D-C Plate Voltage	-	600	800	1000	1250	volts
D-C Screen Voltage	-	300	300	300	300	volts
D-C Grid Voltage (approx.)*	-	-44	-47	-47	-48	volts
Zero-Signal D-C Plate Current	-	160	120	120	115	ma
Max-Signal D-C Plate Current	-	380	380	380	390	ma
Zero-Signal D-C Screen Current	-	0	0	0	0	ma
Max-Signal D-C Screen Current	-	65	65	60	40	ma
Effective Load, Plate-to-Plate	-	3550	4625	5850	7200	ohms
Peak A-F Grid Input Voltage (per tube)	-	44	47	47	48	volts
Driving Power	-	0	0	0	0	watts
Max-Signal Plate Dissipation (per tube)	-	45	55	70	90	watts
Max-Signal Plate Power Output	-	140	195	240	310	watts

\*Adjust grid voltage to obtain specified zero-signal plate current. Maximum permissible grid circuit series resistance 100,000 ohms per tube.

### TYPICAL OPERATION

Class AB <sub>2</sub> (Sinusoidal wave, two tubes unless otherwise specified)						
D-C Plate Voltage	-	600	800	1000	1250	volts
D-C Screen Voltage	-	300	300	300	300	volts
D-C Grid Voltage**	-	-41	-43	-43	-44	volts
Zero-Signal D-C Plate Current	-	185	160	165	180	ma
Max-Signal D-C Plate Current	-	485	490	495	475	ma
Zero-Signal D-C Screen Current	-	0	0	0	0	ma
Max-Signal D-C Screen Current	-	85	75	70	65	ma
Effective Load, Plate-to-Plate	-	2600	3500	4600	5600	ohms
Peak A-F Grid Input Voltage (per tube)	-	47	48	49	50	volts
Max-Signal Peak Driving Power	-	0.15	0.15	0.15	0.15	watts
Max-Signal Nominal Driving Power (approx.)	-	75	75	75	75	mw
Max-Signal Plate Dissipation (per tube)	-	60	75	90	85	watts
Max-Signal Plate Power Output	-	170	240	315	425	watts

\*\*Adjust grid voltage to obtain specified zero-signal plate current.



## APPLICATION

### MECHANICAL

**Mounting**—The 4X150A may be mounted in any position. Use of the Eimac 4X150A Air-System Socket, or its equivalent, is required.

The tube will fit a standard "loktal" socket, but the use of such a socket prevents adequate air-cooling of the base of the tube. Use of the "loktal" socket is not recommended.

Connections to the terminals of all the electrodes except the plate are provided by the Air-System Socket. The anode-cooler assembly provides a terminal surface for the plate connection. For high-frequency applications a metal band or a spring-finger collet should be used to make good electrical contact with the cylindrical outer surface of the anode cooler. Points of electrical contact should be kept clean and free of oxidation to minimize r-f losses.

**Cooling**—The 4X150A requires sufficient forced-air cooling to keep the cooler core and the metal parts of the metal-to-glass seals from exceeding a maximum temperature of 150°C. The air flow must be started when power is applied to the heater, and must continue without interruption until all electrode voltages have been removed from the tube.

The Eimac Air-System Socket directs the air over the surfaces of the tube base, and through the anode cooler to provide effective cooling with a minimum air flow. Seven and one-half cubic feet of cooling air per minute must flow through the Air-System Socket and the anode cooler for adequate cooling. This corresponds to a total pressure drop of 0.6 inches of water through the socket and the anode cooler.

The air requirements stated above are based on operation at sea level and an ambient temperature of 20°C. Operation at high altitude or at high ambient temperatures requires a greater volume of air flow. The necessary design information for such conditions is contained in an article entitled "Blower Selection for Forced-Air-Cooled Tubes", by A. G. Nekut, in the August, 1950, issue of "Electronics."

One method of measuring temperature is provided by the use of the "Tempilaq", a temperature-sensitive lacquer, which melts when a given temperature is reached. Where forced-air cooling is employed, very thin applications of the lacquer must be used. This product is obtainable from the Tempil Corporation, 132 West 22nd St., New York 11, N. Y.

### ELECTRICAL

**Heater**—The heater should be operated as close to 6.0 volts as possible, but it will withstand heater-voltage variations as great as 10% without injury. Some variation in power output must be expected to occur with variations of the heater voltage.

**Cathode**—The cathode is internally connected to the four even-numbered base pins. All four corresponding socket terminals should be used for connection to the external circuit. The leads should be of large cross-section and as short and direct as possible to minimize cathode-lead inductance.

**Grid Dissipation**—Grid-circuit driving-power requirements increase with increasing frequency because of circuit losses other than grid dissipation. This becomes noticeable at frequencies near 30 Mc., and increases until

at 500 Mc. as much as 30 watts driving power may be required in ordinary circuits.

Despite the increased driving power required by the circuit as a whole at higher frequencies, the power actually consumed by the tube grid does not increase greatly. Satisfactory operation in stable amplifier circuits is indicated by d-c grid-current values below approximately 15 milliamperes.

**Screen Dissipation**—Bias- or plate-supply failure or unloaded-plate-circuit operation can cause the screen current and dissipation to rise to excessive values. Protection for the screen can be provided by an overload relay in the screen circuit, in addition to the usual plate-overload relay. Use of a screen-current milliammeter is advisable.

**Plate Dissipation**—The maximum-rated plate dissipation is 150 watts. The maximum-rated plate dissipation for plate-modulated applications is 100 watts under carrier conditions, which permits the plate dissipation to rise to 150 watts under 100% sinusoidal modulation.

Plate dissipation may be permitted to exceed the maximum rating momentarily, as, for instance, during tuning.

**UHF Operation**—Transit time effects, which occur at ultra-high frequencies in the 4X150A, can be minimized by adherence to the operating conditions suggested below:

1. Use a minimum d-c bias voltage, not over twice cut-off.
2. Apply only enough drive to obtain satisfactory plate efficiency.
3. Operate the screen at reasonably high voltage, but do not exceed the screen-dissipation rating. The circuit should be loaded to obtain screen-current values close to those given under "Typical Operation" at 500 Mc.
4. Fairly heavy plate loading is required. In general, low-voltage, high-current operation is preferable to operation at high voltage and low current. If conditions require a change to lighter plate loading, the drive should also be reduced to the minimum value for satisfactory operation at the new output level.
5. Parasitic oscillations are usually associated with excessive grid and screen current and are injurious to vacuum tubes. Similarly, tuned-plate circuits which accidentally become simultaneously resonant to harmonics and the fundamental frequency may also cause low efficiency and damage tubes.

**Plate Modulation**—Plate modulation can be applied to the 4X150A when it is operated as a class-C radio-frequency amplifier. To obtain 100% modulation, the d-c screen voltage must be modulated approximately 55%, in phase with the plate modulation. Self-modulation of the screen by means of a series resistor or reactor may not be satisfactory in this particular tetrode due to the screen-voltage, screen-current characteristics.

**Grid Resistance**—In class-A and -AB<sub>1</sub> amplifiers, where no grid current flows, the grid-bias voltage may be applied through a resistor. The maximum permissible series resistance per tube is 100,000 ohms.

**Special Applications**—If it is desired to operate this tube under conditions widely different than those given here, write to Eitel-McCullough, Inc., San Bruno, California, for information and recommendations.

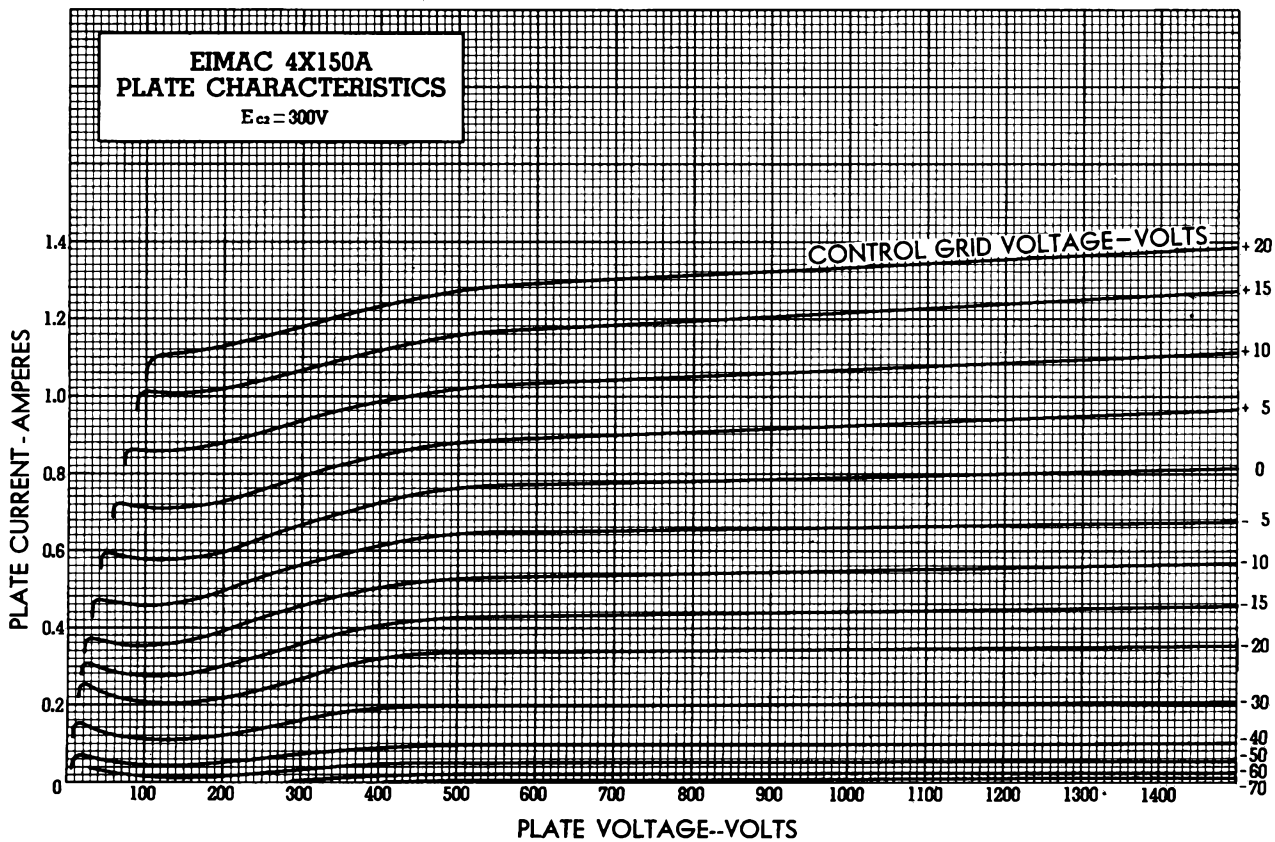
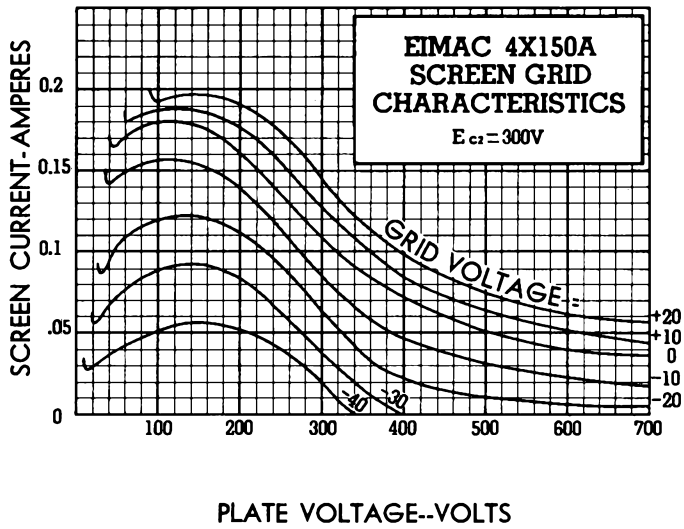
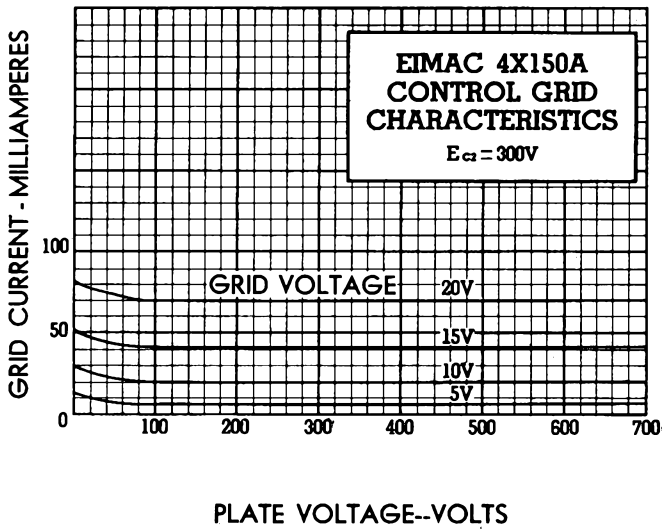

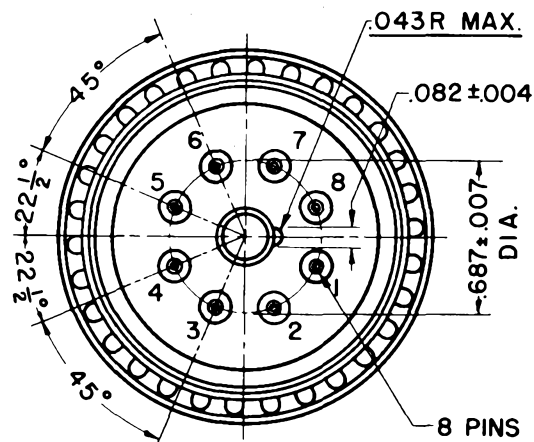
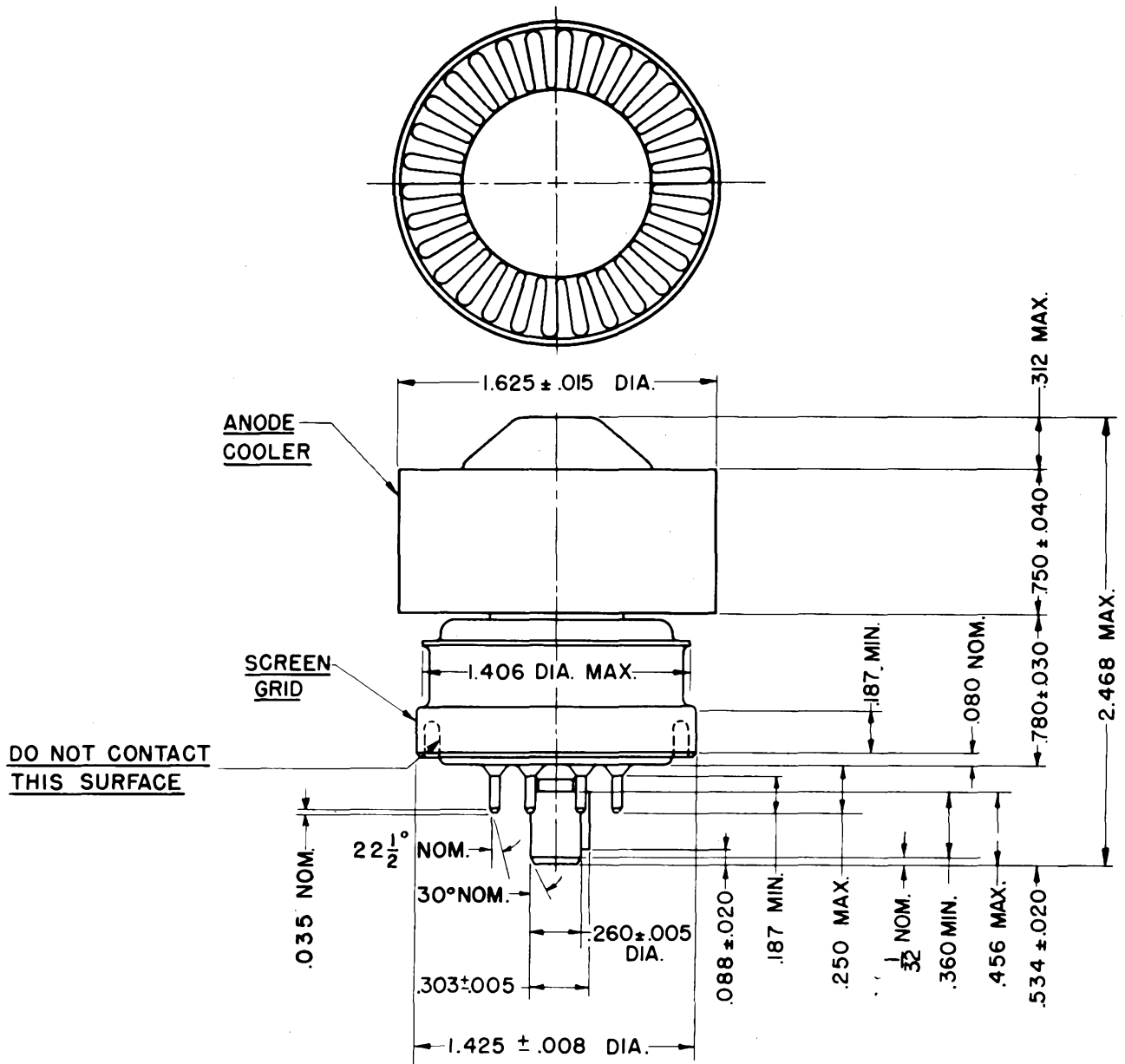

- PIN NO. 1 SCREEN GRID**
- PIN NO. 2 CATHODE**
- PIN NO. 3 HEATER**
- PIN NO. 4 CATHODE**
- PIN NO. 5 I.C. DO NOT USE FOR EXTERNAL CONNECTION**
- PIN NO. 6 CATHODE**
- PIN NO. 7 HEATER**
- PIN NO. 8 CATHODE**
- CENTER PIN-CONTROL GRID**

**DIMENSIONS  
IN INCHES**

**BOTTOM VIEW**

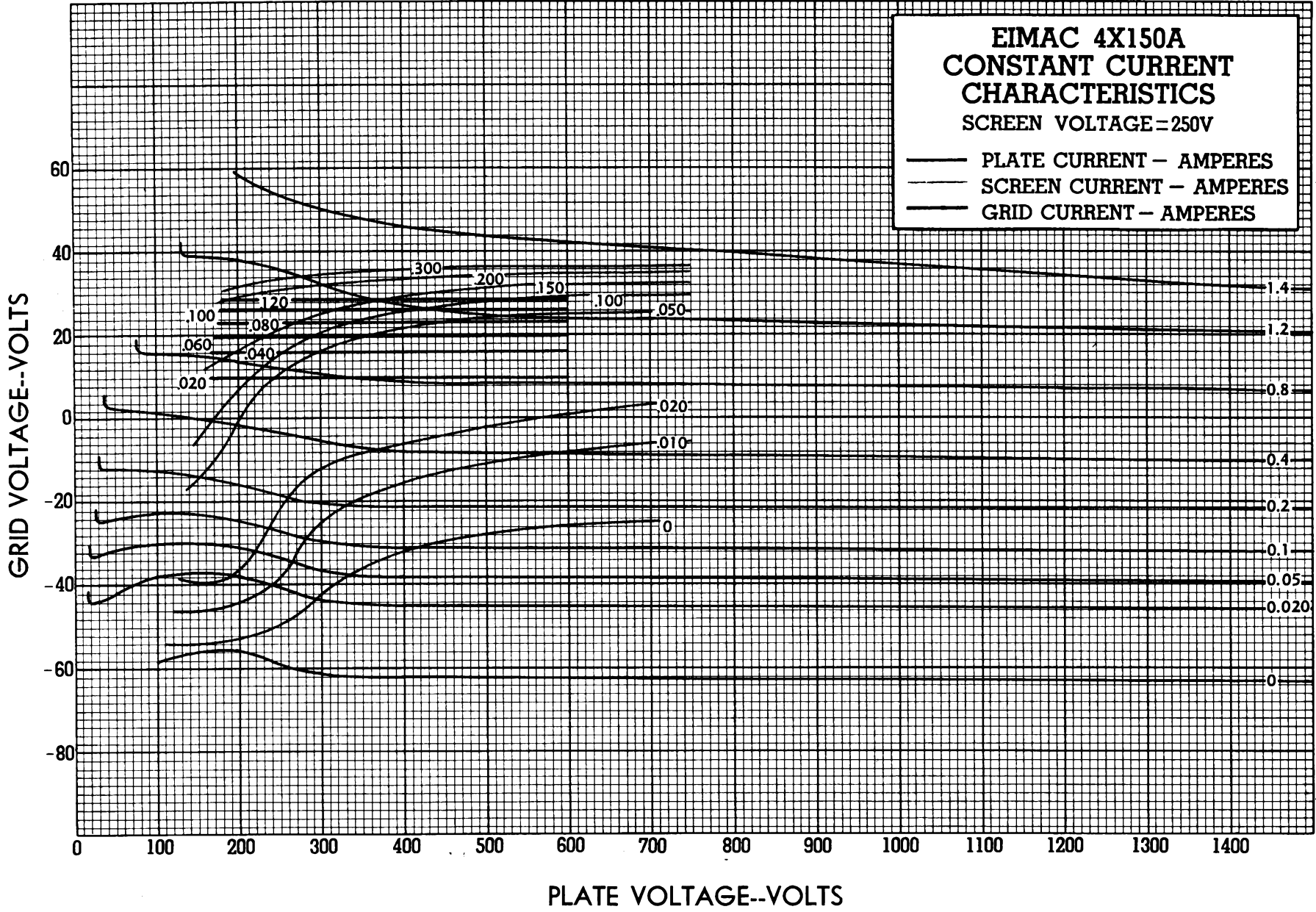

*Eimac*  
EITEL-McCULLOUGH, INC.  
SAN BRUNO, CALIFORNIA

**4X150D**  
RADIAL-BEAM  
POWER TETRODE

The Eimac 4X150D is the 26.5 volt version of the 4X150A. The 4X150D differs from the 4X150A only in the construction of its package-type heater which is integral with the cathode. The material in the 4X150A data sheet applies exactly to the 4X150D, except for its heater rating of 26.5 volts at 0.57 amperes.

Because of its package-type heater, wherein an insulating material encloses the heater and is bonded to the inner cathode surface, the Eimac 4X150D is suited for use in airborne or vehicular service having 28 volt electrical systems.

As with the 4X150A, the use of the Eimac 4X150A Air-System Socket, or a socket providing equivalent air-cooling facilities, is required for the 4X150D.

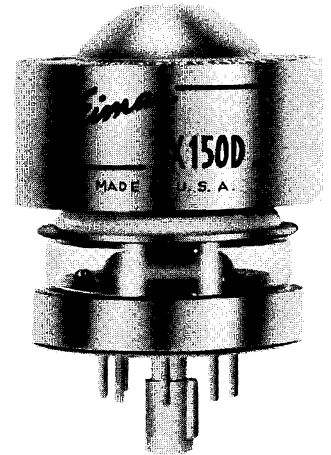

The Eimac 4X150A/4000 and 4X150A/4010 Air-System Sockets are designed to provide adequate air cooling and an efficient high-frequency circuit arrangement for the Eimac 4X150A and 4X150D tetrodes. The insulating materials used in their construction have very low r-f losses to well above 800 Mc., and are mechanically strong, non-porous, non-hygroscopic and substantially unaffected by temperatures up to 180° Centigrade. The contact fingers are of spring alloy and all metal parts are silver plated to reduce r-f losses.

The 4X150A/4000 Air-System Socket is characterized by having all connecting tabs insulated from the socket flange and skirt. This type socket is intended for use in circuits where the cathode of the tube is not at chassis potential.

The 4X150A/4010 Air-System Socket is characterized by having the four cathode connecting tabs (Numbers 2, 4, 6 and 8) riveted permanently to the socket skirt. This type socket is intended for use in circuits where the cathode of the tube is at chassis potential.

**MOUNTING**—If the tube and socket are to be used in a coaxial-line circuit, the Air-System Socket may be mounted directly on the end of the coaxial input line. The skirt of the socket fits over a cylinder of 1 5/8" outside diameter, and four mounting holes are provided (See Outline Drawings).

For chassis mounting, a 2 1/4" diameter hole should be cut into the deck and the socket secured by the three toe clamps provided.

**DO NOT DRILL THROUGH THE SOCKET FLANGE.**

**CONNECTIONS**—The control grid connection is on the axis of the socket and is provided with a No. 6-32 threaded hole for direct connection to a coaxial line or a terminal lug.

A low impedance path between screen grid and ground is provided by a bypass capacitor of from 2750  $\mu\mu\text{f}$   $\pm$  500  $\mu\mu\text{f}$  built into the socket flange.

**COOLING**—A pressurized chamber should be provided to introduce an air stream into the socket from the under side to cool the grid, cathode and screen seals. A heat-resistant chimney is provided to direct the air stream over the tube envelope and through the anode radiator.

If a coaxial-line circuit is used, the input line should be pressurized, while the output cavity should be made air tight to direct the air through the anode radiator of the tube.

For the specific cooling requirements of the 4X150A and 4X150D, see the paragraph on "Cooling" in the 4X150A Data Sheet.

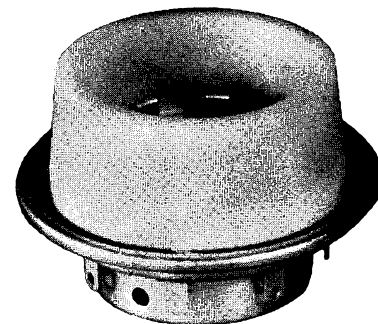

### SOCKET IDENTIFICATION

TYPE NUMBER	DESCRIPTION
4X150A/4000 - - - - -	4X150A Air-System Socket with Chimney
4X150A/4001 - - - - -	4X150A Air-System Socket less Chimney
4X150A/4006 - - - - -	4X150A Air-System Chimney Only
4X150A/4010 - - - - -	4X150A Air-System Socket—Grounded Cathode—with Chimney
4X150A/4011 - - - - -	4X150A Air-System Socket—Grounded Cathode—less Chimney

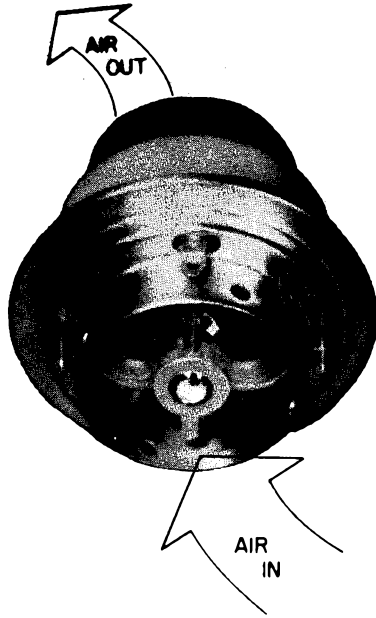

**4X150A/4000  
with 4X150A**

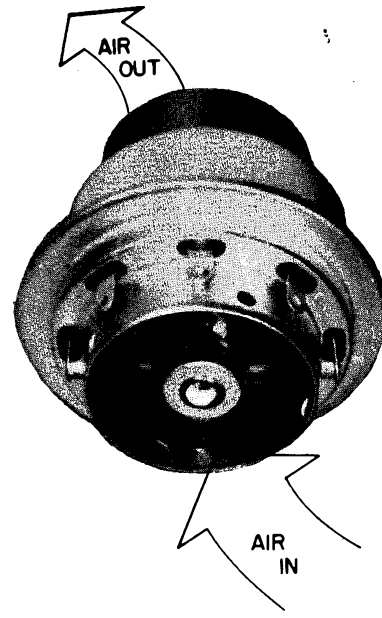

**4X150A/4010  
with 4X150A**

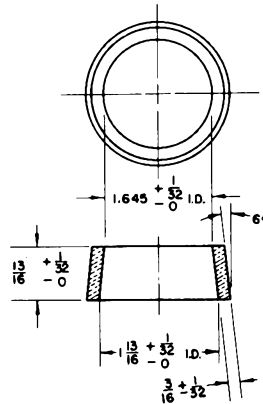

**4X150A/4006**

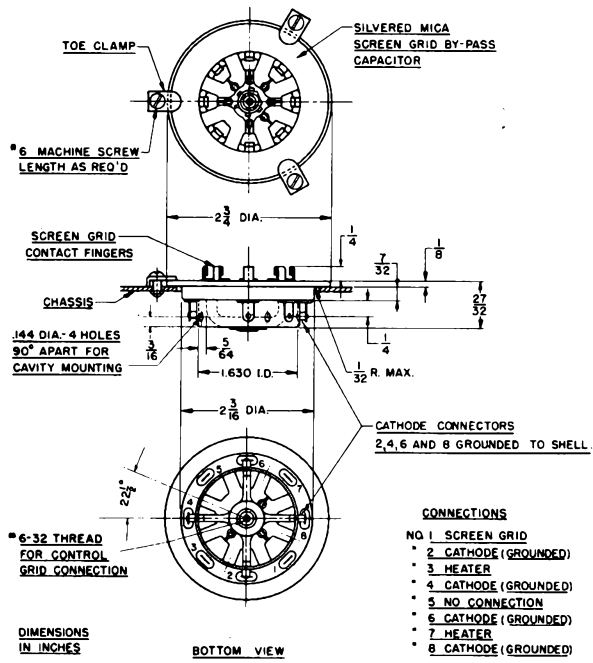
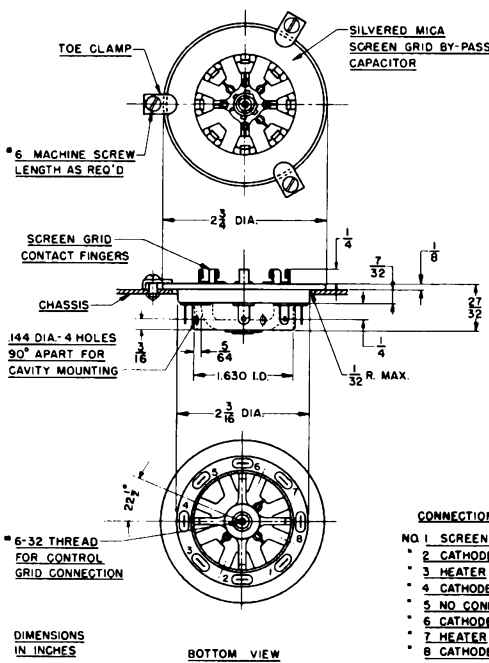

The Eimac 4X150G is an extremely compact external-anode tetrode intended for use as a radio-frequency amplifier, frequency multiplier, or oscillator at frequencies well into the UHF region or as an amplifier in any service requiring a high-gain tube capable of delivering high power-output at low plate-voltage. The combination of a high ratio of transductance to capacitance and a plate dissipation capability of 150 watts make the tube an excellent wide-band amplifier for video applications.

The cathode, grid and screen electrodes are mounted on conical and cylindrical supports giving a minimum of circuit discontinuities and lead inductance. The rugged cylindrical terminals, progressively larger in size, allow the tube to be inserted in coaxial line cavities. The screen support and terminal provide maximum isolation between the grid-cathode terminals and the plate circuit.

In amplifier service at 500 megacycles, output power of 140 watts per tube, with a stage power-gain of 14, can be obtained. At 1000 megacycles an output power of 50 watts per tube is obtained with a power-gain of five.

**GENERAL CHARACTERISTICS**

**ELECTRICAL**

Cathode: Coated Unipotential

Heater Voltage	- - - - -	2.5	volts
Heater Current	- - - - -	6.25	amperes
Minimum Heating Time	- - - - -	45	seconds

Screen-Grid Amplification Factor (Average) - - - - - 5.0

Direct Interelectrode Capacitances (Average)	Grounded Grid	Grounded Cathode
Feedback (without shielding)	- - less than 0.005	- - - 0.035 $\mu$ fd
Input	- - - - - 17.	- - - 27 $\mu$ fd
Output	- - - - - 4.5	- - - 4.5 $\mu$ fd

Transconductance ( $I_b=250$  ma.,  $E_b=500$ v.,  $E_{c2}=250$  V.) - - - - - 12,000  $\mu$ mhos

**MECHANICAL**

Cooling	- - - - -	Forced Air
Mounting position	- - - - -	Any
Maximum Over-all Dimensions		
Length	- - - - -	2 $\frac{3}{4}$ inches
Diameter	- - - - -	1.635 inches
Maximum Seated Height	- - - - -	1-27/32 inches
Net Weight	- - - - -	6 ounces
Shipping Weight (Average)	- - - - -	1.6 pounds

Note: Typical operation data are based on conditions of adjusting the r-f grid drive to a specified plate current, maintaining fixed conditions of grid bias and screen voltage. It will be found that if this procedure is followed, there will be little variation in power output between tubes even though there may be some variation in grid and screen currents. Where grid bias is obtained principally by means of a grid resistor, to control plate current it is necessary to make the resistor adjustable.

**RADIO-FREQUENCY POWER AMPLIFIER OR OSCILLATOR**

**Class-C Telegraphy or FM Telephony**  
 (Key-down conditions, per tube)

**MAXIMUM RATINGS**

D-C PLATE VOLTAGE	-	1250	MAX. VOLTS
D-C SCREEN VOLTAGE	-	300	MAX. VOLTS
D-C GRID VOLTAGE	- -	-250	MAX. VOLTS
D-C PLATE CURRENT	-	250	MAX. MA
PLATE DISSIPATION	- -	150	MAX. WATTS
SCREEN DISSIPATION	-	12	MAX. WATTS
GRID DISSIPATION	- -	2	MAX. WATTS

<b>TYPICAL OPERATION</b> (Frequencies up to 165 Mc. per tube)						
D-C Plate Voltage	- - - - -	600	750	1000	1250	volts
D-C Screen Voltage	- - - - -	250	250	250	250	volts
D-C Grid Voltage	- - - - -	-75	-80	-80	-90	volts
D-C Plate Current	- - - - -	200	200	200	200	ma
D-C Screen Current	- - - - -	37	37	30	20	ma
D-C Grid Current	- - - - -	10	10	10	10	ma
Peak R-F Grid Voltage (approx.)	- - - - -	90	95	95	105	volts
Driving Power	- - - - -	0.7	0.7	0.7	0.8	watts
Plate Power Input	- - - - -	120	150	200	250	watts
Plate Power Output	- - - - -	85	110	150	195	watts

The performance figures for frequencies up to 165 Mc. are obtained by calculation from the tube characteristic curves and confirmed by direct tests. The driving power includes only power taken by the tube grid and the bias circuit. The driving power and output power do not allow for losses in the associated resonant circuits.

<b>TYPICAL OPERATION</b> (Single tube, 500 Mc., coaxial cavity)						
D-C Plate Voltage	- - - - -	600	800	1000	1250	volts
D-C Screen Voltage	- - - - -	250	250	250	250	volts
D-C Grid Voltage	- - - - -	-80	-80	-80	-80	volts
D-C Plate Current	- - - - -	200	200	200	200	ma
D-C Screen Current	- - - - -	7	7	7	7	ma
D-C Grid Current	- - - - -	10	10	10	10	ma
Driver Output Power (approx.)	- - - - -	10	10	10	10	watts
Power Input	- - - - -	120	160	200	250	watts
Useful Power Output	- - - - -	65	90	110	140	watts

These typical performance figures were obtained by direct measurement in operating equipment. The output power is useful power measured in a load circuit. The driving power is the total power taken by the tube and a practical resonant circuit. In many cases with further refinement and improved techniques better performance might be obtained.

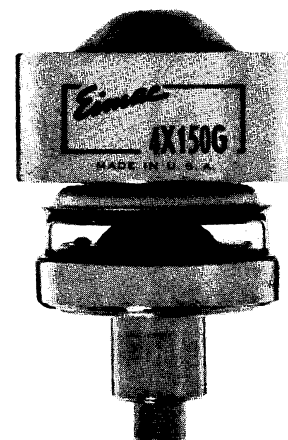



## PLATE-MODULATED RADIO-FREQUENCY AMPLIFIER

Class-C Telephony (Carrier conditions, per tube)

### MAXIMUM RATINGS

D-C PLATE VOLTAGE	-	1000	MAX. VOLTS
D-C SCREEN VOLTAGE	-	300	MAX. VOLTS
D-C GRID VOLTAGE	-	—250	MAX. VOLTS
D-C PLATE CURRENT	-	200	MAX. MA
PLATE DISSIPATION	-	100	MAX. WATTS
SCREEN DISSIPATION	-	12	MAX. WATTS
GRID DISSIPATION	-	2	MAX. WATTS

### TYPICAL OPERATION (Frequencies up to 165 Mc.)

D-C Plate Voltage	-	400	600	800	1000	volts
D-C Screen Voltage	-	250	250	250	250	volts
D-C Grid Voltage	-	—90	—95	—100	—105	volts
D-C Plate Current	-	200	200	200	200	ma
D-C Screen Current	-	40	35	25	20	ma
D-C Grid Current	-	7	8	10	15	ma
Peak A-F Screen Voltage at crest of 100% Modulation	-	140	150	160	170	volts
Peak R-F Grid Input Voltage (approx.)	-	110	120	120	125	volts
Driving Power (approx.)	-	1	1	1.5	2	watts
Plate Dissipation	-	25	40	60	60	watts
Plate Power Input	-	80	120	160	200	watts
Plate Power Output	-	55	80	100	140	watts

## RADIO-FREQUENCY POWER AMPLIFIER

Class-B Linear, Television Visual Service (per tube)

### MAXIMUM RATINGS

D-C PLATE VOLTAGE	-	1250	MAX. VOLTS
D-C SCREEN VOLTAGE	-	400	MAX. VOLTS
D-C GRID VOLTAGE	-	—250	MAX. VOLTS
D-C PLATE CURRENT (AVERAGE)	-	250	MAX. MA
PLATE DISSIPATION	-	150	MAX. WATTS
SCREEN DISSIPATION	-	12	MAX. WATTS
GRID DISSIPATION	-	2	MAX. WATTS

### TYPICAL OPERATION (Frequencies up to 216 Mc., 5-Mc. bandwidth)

D-C Plate Voltage	-	750	1000	1250	volts
D-C Screen Voltage	-	300	300	300	volts
D-C Grid Voltage	-	—60	—65	—70	volts

### During Sync-Pulse Peak:

D-C Plate Current	-	335	330	305	ma
D-C Screen Current	-	50	45	45	ma
D-C Grid Current	-	15	20	25	ma
Peak R-F Grid Voltage	-	85	95	100	volts
R-F Driver Power (approx.)	-	7	8	9	watts
Useful Power Output	-	135	200	250	watts

### Black Level:

D-C Plate Current	-	245	240	230	ma
D-C Screen Current	-	20	15	10	ma
D-C Grid Current	-	4	4	4	ma
Peak R-F Grid Voltage (approx.)	-	65	70	75	volts
R-F Driver Power (approx.)	-	4.25	4.7	5.5	watts
Plate Power Input	-	185	240	290	watts
Useful Power Output	-	75	110	140	watts

## PLATE PULSED RADIO FREQUENCY AMPLIFIER OR OSCILLATOR

### MAXIMUM RATINGS

PULSED PLATE VOLTAGE	-	7000	MAX. VOLTS
PULSED SCREEN VOLTAGE	-	1500	MAX. VOLTS
D-C GRID VOLTAGE	-	—500	MAX. VOLTS
MAXIMUM PULSE DURATION	-	5	MICROSECONDS
PULSED CATHODE CURRENT	-	7	MAX. AMPS
AVERAGE POWER INPUT	-	250	MAX. WATTS
PLATE DISSIPATION	-	150	MAX. WATTS
SCREEN DISSIPATION	-	15	MAX. WATTS
GRID DISSIPATION	-	2	MAX. WATTS

### TYPICAL PULSE OPERATION

Single tube oscillator, 1200-Mc.

Pulsed Plate Voltage	-	5	7	Kilovolts
Pulsed Plate Current	-	4.0	6.0	Amps.
Pulsed Screen Voltage	-	800	1000	Volts
Pulsed Screen Current	-	0.3	0.4	Amps.
D-C Grid Voltage	-	—200	—250	Volts
Pulsed Grid Current	-	0.5	0.6	Amps.
Pulse Duration	-	4	4	Microseconds
Pulse Repetition Rate	-	2500	1250	Per second
Peak Power Output	-	7	17	Kilowatts

## A P P L I C A T I O N

### MECHANICAL

**Mounting**—The 4X150G may be mounted in any position. The concentric arrangement of the electrode terminals permits the use of the 4X150G in coaxial line type circuits to advantage.

Connections to the contact surfaces should be made by means of spring-finger collets which have sufficient pressure to maintain a good electrical contact at all fingers. The presence of non-contacting, or intermittently-contacting, fingers may result in erratic circuit operation, particularly at very-high- or ultra-high-frequencies. Points of electrical contact should be kept clean and free of oxidation to minimize r-f losses.

**Cooling**—The 4X150G requires sufficient forced-air cooling to keep the cooler core and the metal parts of the metal-to-glass seals from exceeding a maximum

temperature of 150°C. The air flow must be started when power is applied to the heater, and must continue without interruption until all electrode voltages have been removed from the tube.

Effective cooling of the anode is accomplished by directing six cubic feet per minute of air through the anode cooler. This flow is obtained at a pressure drop across the cooler of approximately 0.25 inch of water column. The grid, cathode and heater terminals are cooled by high velocity air directed at the terminals and the connecting collets which aid in the removal of heat from the terminals by conduction. The volume required will depend upon the socket arrangement and should be adequate to keep the metal-to-glass seals below 150°C and the center heater terminal below 200°C.

The air requirements stated above are based on op-

eration at sea level and an ambient temperature of 20°C. Operation at high altitudes or at high ambient temperatures requires a greater volume of air flow. The necessary design information for such conditions is contained in an article entitled "Blower Selection for Forced-Air-Cooled Tubes," by A. G. Nekut, in the August, 1950, issue of "Electronics."

Temperature of the external parts of a tube may be measured with the aid of "Tempilaq," a temperature-sensitive lacquer manufactured by the Tempil Corporation, 11 West 25th Street, New York 10, N. Y.

### ELECTRICAL

**Heater**—The heater should be operated as close to 2.5 volts as possible, but it will withstand heater-voltage variations as great as 10% without injury. Some variation in power output must be expected to occur with variations of the heater voltage. In UHF operation of the 4X150G some advantage can be gained by operation of the heater at reduced voltages to compensate for cathode back-heating. Under conditions of operation for maximum power output at frequencies between 500 and 1000 Mc the heater voltage may be reduced to 2.4 volts. 2.3 volts is usually adequate for similar conditions at frequencies from 1000 to 1500 Mc.

**Grid Dissipation**—Grid-circuit driving-power requirements increase with increasing frequency because of losses other than grid dissipation. This becomes noticeable at frequencies above 150 megacycles and increases until at 500 Mc the required driving power may be as much as 15 watts in an ordinary circuit.

Despite the increased driving power required by the circuit as a whole at higher frequencies, the power actually dissipated at the tube grid does not increase greatly. Satisfactory operation in stable amplifier circuits is indicated by d-c grid-current values below approximately 15 milliamperes.

**Screen Dissipation**—Bias- or plate-supply failure or unloaded-plate-circuit operation can cause the screen current and dissipation to rise to excessive values. Protection for the screen can be provided by an overload relay in the screen circuit, in addition to the usual plate-overload relay. Use of a screen-current milliammeter is advisable.

**Plate Dissipation**—The maximum-rated plate dissipa-

tion is 150 watts. The maximum-rated plate dissipation for plate-modulated applications is 100 watts under carrier conditions, which permits the plate dissipation to rise to 150 watts under 100% sinusoidal modulation. Plate dissipation may be permitted to exceed the maximum rating momentarily, as, for instance, during tuning procedures.

**UHF Operation**—Transit-time effects, which occur at ultra-high frequencies in the 4X150G, can be minimized by adherence to the operating practices suggested below:

1. Use a minimum d-c bias voltage, not over twice cut-off.
2. Apply only enough drive to obtain satisfactory plate efficiency.
3. Operate the screen at reasonably high voltage, but do not exceed the screen-dissipation rating. The circuit should be loaded to obtain screen-current values close to those given under "Typical Operation" at 500 Mc.
4. Fairly heavy plate loading is required. In general, low-voltage, high-current operation is preferable to operation at high voltages and low currents. If conditions require a change to lighter plate loading, the drive should also be reduced to the minimum value for satisfactory operation at the new output level.
5. Parasitic oscillations are usually associated with excessive grid and screen currents and are injurious to vacuum tubes. Similarly, tuned-plate circuits which accidentally become simultaneously resonant to harmonics and the fundamental frequency may also cause low efficiency and resultant tube damage.

**Plate Modulation**—Plate modulation can be applied to the 4X150G when it is operated as a class-C radio-frequency amplifier. To obtain 100% modulation, the d-c screen voltage must be modulated in phase with the plate modulation. Self-modulation of the screen by means of a series resistor or reactor may not be satisfactory in this particular tetrode due the screen-voltage, screen-current characteristic.

**Grid Resistance**—In class-A and -AB<sub>1</sub> amplifiers, where no grid current flows, the grid-bias voltage may be applied through a resistor. The maximum permissible series resistance per tube is 100,000 ohms.

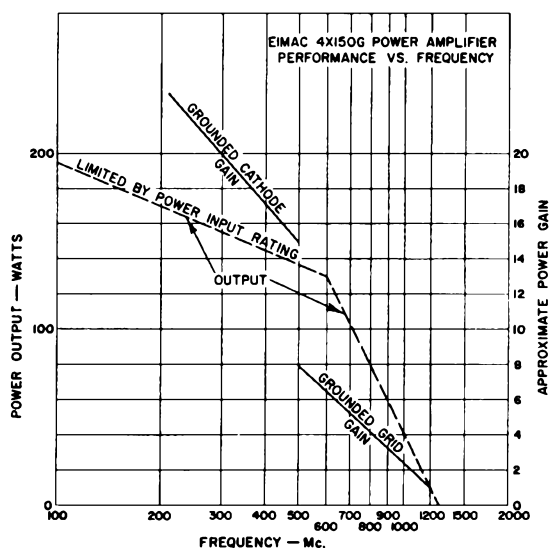
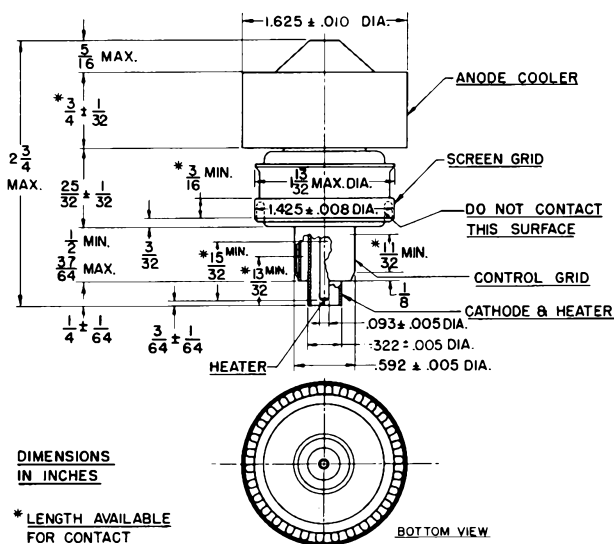

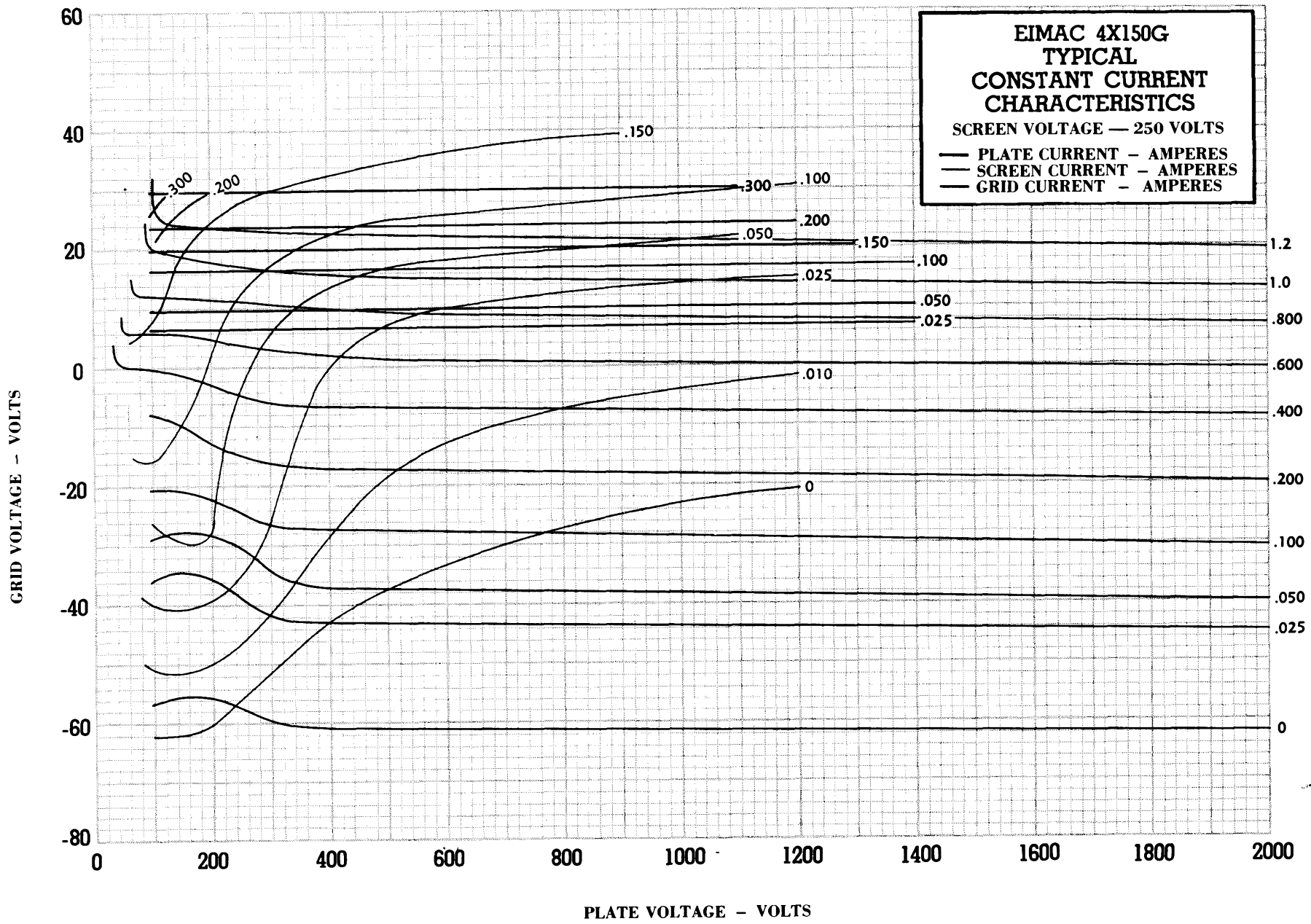

*EIMAC*  
4X150G

# TENTATIVE DATA



**4X250B**  
 RADIAL-BEAM  
 POWER TETRODE

The Eimac 4X250B is a compact, oxide-cathode, external-anode power tetrode, unilaterally interchangeable with the 4X150A in most applications, and is intended for use as an amplifier, oscillator or frequency multiplier over a wide range of frequencies extending into the UHF region. It is cooled by convection and forced air.

A single 4X250B in a coaxial-cavity amplifier circuit will deliver up to 300 watts of useful power output at 400 megacycles although this is not the upper frequency limit of the tube.

Outstanding features of the 4X250B are: 1. Simple air-cooling requirements. 2. A maximum plate-dissipation rating of 250 watts available for low-efficiency applications. 3. A maximum d-c plate voltage rating of 2000 volts at frequencies up to 400 Mc. The high transconductance of the 4X250B makes the tube useful at relatively low plate voltages. The high ratio of transconductance to inter-electrode capacitance and the 250-watt plate dissipation make the tube very useful for wide-band amplifier applications.

The use of the Eimac 4X150A Air-System Socket, or a socket providing equivalent air cooling characteristics, is required.

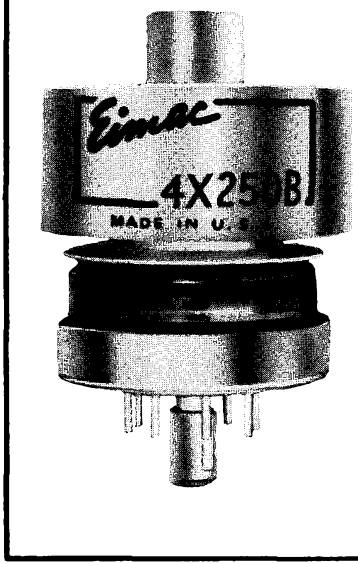

## GENERAL CHARACTERISTICS

### ELECTRICAL

Cathode: Oxide Coated, Unipotential			
Minimum Heating Time	- - - - -	30	seconds
Cathode-to-Heater Voltage	- - - - -	150	max. volts
Heater: Voltage	- - - - -	6.0	volts
Current	- - - - -	2.1	amperes
Grid-Screen Amplification Factor (Average)	- - - - -	- - -	5
Direct Interelectrode Capacitances (Average)			
Grid-Plate	- - - - -	0.04	μf
Input	- - - - -	18.5	μf
Output	- - - - -	4.7	μf
Transconductance ( $E_b=500v., E_{c2}=250v., I_b=200 ma$ )	- - - - -	- - -	12,000 μhos
Frequency for Maximum Plate Voltage Ratings	- - - - -	- - -	400 Mc

(All other Maximum Ratings applicable to 500 Mc)

### MECHANICAL

Base	- - - - -	- - - - -	- - - - -	- - - - -	9-pin, special
Recommended Socket	- - - - -	- - - - -	- - - - -	- - - - -	Eimac 4X150A Air-System Socket
Base Connections	- - - - -	- - - - -	- - - - -	- - - - -	See outline drawing
Mounting	- - - - -	- - - - -	- - - - -	- - - - -	Any position
Cooling	- - - - -	- - - - -	- - - - -	- - - - -	Convection and Forced air
Maximum Over-all Dimensions					
Length	- - - - -	- - - - -	- - - - -	- - - - -	2.59 inches
Diameter	- - - - -	- - - - -	- - - - -	- - - - -	1.65 inches
Seated Height	- - - - -	- - - - -	- - - - -	- - - - -	2.03 inches
Net Weight	- - - - -	- - - - -	- - - - -	- - - - -	4.0 ounces
Shipping Weight	- - - - -	- - - - -	- - - - -	- - - - -	1.6 pounds

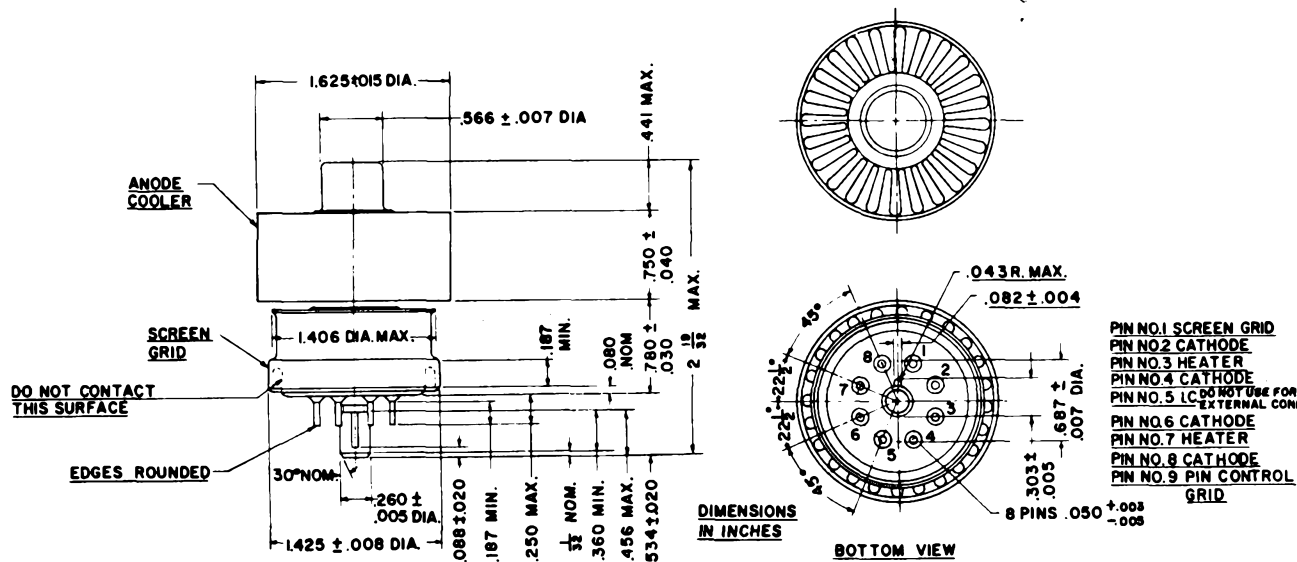

## RADIO-FREQUENCY POWER AMPLIFIER OR OSCILLATOR

Class-C Telephony or FM Telephony  
(Key-down conditions, per tube)

### MAXIMUM RATINGS

D-C PLATE VOLTAGE	- -	2000 MAX. VOLTS
D-C SCREEN VOLTAGE	- -	300 MAX. VOLTS
D-C GRID VOLTAGE	- -	-250 MAX. VOLTS
D-C PLATE CURRENT	- -	250 MAX. MA
PLATE DISSIPATION	- -	250 MAX. WATTS
SCREEN DISSIPATION	- -	12 MAX. WATTS
GRID DISSIPATION	- -	2 MAX. WATTS

### TYPICAL OPERATION (Frequencies up to 175 Mc, per tube)

D-C Plate Voltage	- - -	500	1000	1500	2000	volts
D-C Screen Voltage	- - -	250	250	250	250	volts
D-C Grid Voltage	- - - -	-90	-90	-90	-90	volts
D-C Plate Current	- - -	250	250	250	250	ma
D-C Screen Current	- - -	45	35	30	25	ma
D-C Grid Current	- - -	32	28	28	27	ma
Peak R-F Grid Voltage (approx.)	- - -	118	116	116	115	volts
Driving Power	- - - -	3.6	3.2	3.2	2.8	watts
Plate Power Input	- - -	125	250	375	500	watts
Plate Power Output	- - -	85	195	300	410	watts

## PLATE-MODULATED RADIO-FREQUENCY AMPLIFIER

Class-C Telephony (Carrier conditions, per tube)

### MAXIMUM RATINGS

D-C PLATE VOLTAGE	- -	1500 MAX. VOLTS
D-C SCREEN VOLTAGE	- -	300 MAX. VOLTS
D-C GRID VOLTAGE	- -	-250 MAX. VOLTS
D-C PLATE CURRENT	- -	200 MAX. MA
PLATE DISSIPATION	- -	165 MAX. WATTS
SCREEN DISSIPATION	- -	12 MAX. WATTS
GRID DISSIPATION	- -	2 MAX. WATTS

### TYPICAL OPERATION (Frequencies up to 175Mc, per tube)

D-C Plate Voltage	- - -	500	1000	1500	volts
D-C Screen Voltage	- - -	250	250	250	volts
D-C Grid Voltage	- - -	-100	-100	-100	volts
D-C Plate Current	- - -	200	200	200	ma
D-C Screen Current	- - -	45	35	25	ma
D-C Grid Current	- - -	22	19	17	ma
Peak R-F Grid Input Voltage	- - -	124	122	121	volts
Driving Power	- - - -	2.7	2.3	2.1	watts
Plate Power Input	- - -	100	200	300	watts
Plate Power Output	- - -	75	160	250	watts

## CLASS-AB POWER AMPLIFIER OR MODULATOR

### MAXIMUM RATINGS (Per tube)

D-C PLATE VOLTAGE	- -	2000 MAX. VOLTS
D-C SCREEN VOLTAGE	- -	400 MAX. VOLTS
D-C PLATE CURRENT	- -	250 MAX. MA
PLATE DISSIPATION	- -	250 MAX. WATTS
SCREEN DISSIPATION	- -	12 MAX. WATTS
GRID DISSIPATION	- -	2 MAX. WATTS

### TYPICAL OPERATION

Class-AB<sub>1</sub> Audio Amplifier (Sinusoidal wave, two tubes unless otherwise noted)

D-C Plate Voltage	- - - -	1000	1500	2000	volts,
D-C Screen Voltage	- - - -	350	350	350	volts
D-C Grid Voltage (approx.)*	- - - -	-50	-50	-50	volts
Zero-Signal D-C Plate Current	- - - -	200	200	200	ma
Max-Signal D-C Plate Current	- - - -	500	500	500	ma
Max-Signal D-C Screen Current	- - - -	50	40	30	ma
Effective Load, Plate-to-Plate	- - - -	3260	5760	8260	ohms
Peak A-F Grid Input Voltage (per tube)	- - - -	50	50	50	volts
Driving Power	- - - -	0	0	0	watts
Max-Signal Plate Dissipation (per tube)	- - - -	125	150	175	watts
Max-Signal Plate Power Output	- - - -	250	450	650	watts
Third-Harmonic Distortion	- - - -	4.5	4.5	4.5	pct

\*Adjust grid voltage to obtain specified zero-signal plate current

### TYPICAL OPERATION

Class-AB<sub>1</sub> R-F Linear Amplifier (Frequencies to 175 Mc, per tube)

D-C Plate Voltage	- - - -	1000	1500	2000	volts
D-C Screen Voltage	- - - -	350	350	350	volts
D-C Grid Voltage (approx.)*	- - - -	-50	-50	-50	volts
Zero-Signal D-C Plate Current	- - - -	100	100	100	ma
Max-Signal D-C Plate Current	- - - -	250	250	250	ma
Max-Signal D-C Screen Current	- - - -	25	20	15	ma
Peak R-F Grid Voltage	- - - -	50	50	50	volts
Driving Power	- - - -	0	0	0	watts
Max-Signal Plate Dissipation	- - - -	125	150	175	watts
Max-Signal Plate Power Output	- - - -	125	225	325	watts

\*Adjust grid voltage to obtain specified zero-signal plate current

Note: Typical operation data are based on conditions of adjusting the r-r grid drive to a specified plate current, maintaining fixed conditions of grid bias and screen voltage. It will be found that if this procedure is followed, there will be little variation in power output between tubes even though there may be some variation in grid and screen currents. Where grid bias is obtained principally by means of a grid resistor, to control plate current it is necessary to make the resistor adjustable.

## APPLICATION

### MECHANICAL

**Mounting**—The 4X250B may be mounted in any position. Use of the Eimac 4X150A Air-System Socket, or its equivalent, is recommended.

The tube will fit a standard "loktal" socket, but the use of such a socket in the usual way prevents adequate air-cooling of the base of the tube. Use of the "loktal" socket is not recommended.

Connections to the terminals of all the electrodes except the plate are provided by the Air-System Socket. The anode-cooler assembly provides a terminal surface for the plate connection. For high-frequency applications a metal band or a spring-finger collet should be used to make good electrical contact with the cylindrical outer surface of the anode cooler. Points of electrical contact should be kept clean and free of oxidation to minimize r-f losses.

**Cooling**—The 4X250B requires sufficient cooling air to prevent the temperature of the metal part of the metal-to-glass seals exceeding a maximum of 175°C. The temperature of the anode as measured at the base of the cooling fins must be maintained below its maximum of 250°C.

Under conditions of normal room temperatures and installation in the 4X150A Air-System Socket, the 4X250B requires no forced air during stand-by periods where only the heater power is on. Anode cooling air may be started and stopped simultaneously with the power on the anode. A quantity of 3.8 cubic feet per minute is required to cool the tube when operating at maximum-rated plate dissipation at 500 Mc. At this quantity of air the pressure drop across the cooler and the Air-System Socket is equal to approximately 0.25 inches of water column. At frequencies below 175 Mc and at 250 watts plate dissipation the quantity of air flow may be reduced to 3.6 cubic feet per minute, at which quantity the pressure drop is 0.23 inches of water column.

The air requirements stated above are based on operation at sea level and an ambient temperature of 20°C. Operation at high altitude or at high ambient temperatures requires a greater volume of air flow. The necessary design information for such conditions is contained in an article entitled "Blower Selection for Forced-Air-Cooled Tubes," by A. G. Nekut, in the August, 1950, issue of "Electronics."

One method of measuring temperature is provided by the use of "Tempilaq", a temperature-sensitive lacquer, which melts when a given temperature is reached. Where forced-air cooling is employed, very thin applications of the lacquer must be used. This product is obtainable from the Tempil Corporation, 11 West 25th St. New York 10, N. Y.

### ELECTRICAL

**Heater**—The heater should be operated as close to 6.0 volts as possible, but it will withstand heater-voltage variations as great as 10% for short durations without injury. Some variations in power output must be expected to occur with variations of the heater voltage.

**Cathode**—The cathode is internally connected to the four even-numbered base pins. All four corresponding socket terminals should be used for connection to the external circuit. The leads should be of large cross-

section and as short and direct as possible to minimize cathode-lead inductance.

**Grid Dissipation**—Grid-circuit driving-power requirements increase with frequency because of circuit losses other than grid dissipation. This becomes noticeable at frequencies near 100 Mc., and increases until at 500 Mc. as much as 20-25 watts driving power may be required in ordinary circuits.

Despite the increased driving power required by the circuit as a whole at higher frequencies, the power actually dissipated at the tube grid does not increase greatly. Satisfactory operation in stable amplifier circuits is indicated by d-c grid-current values below approximately 20 milliamperes.

**Screen Dissipation**—Bias- or plate-supply failure or unloaded-plate-circuit operation can cause the screen current and dissipation to rise to excessive values. Protection for the screen can be provided by an overload relay in the screen circuit, in addition to the usual plate-circuit overload relay. Use of a screen-current milliammeter is recommended.

**Plate Dissipation**—The maximum-rated plate dissipation is 250 watts. The maximum-rated plate dissipation for plate modulated applications is 165 watts under carrier conditions, which permits the plate dissipation to rise to 250 watts under 100% sinusoidal modulation.

Plate dissipation may be permitted to exceed the maximum rating momentarily, as, for instance, during tuning.

**UHF Operation**—Transit time and other effects, which occur at ultra-high-frequencies in the 4X250B, can be reduced to minimum values by compliance with the following suggested operating conditions:

1. Use a minimum value of d-c grid bias voltage.
2. Apply only enough grid drive to obtain satisfactory plate efficiency.
3. Operate the screen at reasonably high voltage, but do not exceed the screen dissipation rating.
4. Fairly heavy plate loading is required. In general, low-voltage, high-current operation is preferable to operation at high voltage and low current. If conditions require a change to lighter plate loading, the drive should also be reduced to the minimum value for satisfactory operation at the new output level.
5. Parasitic oscillations are usually associated with excessive grid and screen current and are injurious to vacuum tubes. Similarly, tuned-plate circuits which accidentally become simultaneously resonant to harmonics and the fundamental frequency may also cause low efficiency and damage tubes.

**Plate Modulation**—Plate modulation can be applied to the 4X250B when it is operated as a class-C radio-frequency amplifier. To obtain 100% modulation, the d-c screen voltage must be modulated in phase with the plate modulation. Self-modulation of the screen by means of a series resistor or reactor may not be satisfactory in this particular tetrode due to the screen-voltage, screen-current characteristics.

**Special Applications**—If it is desired to operate this tube under conditions widely different than those given here, write to Eitel-McCullough, Inc., San Bruno, California, for information and recommendations.

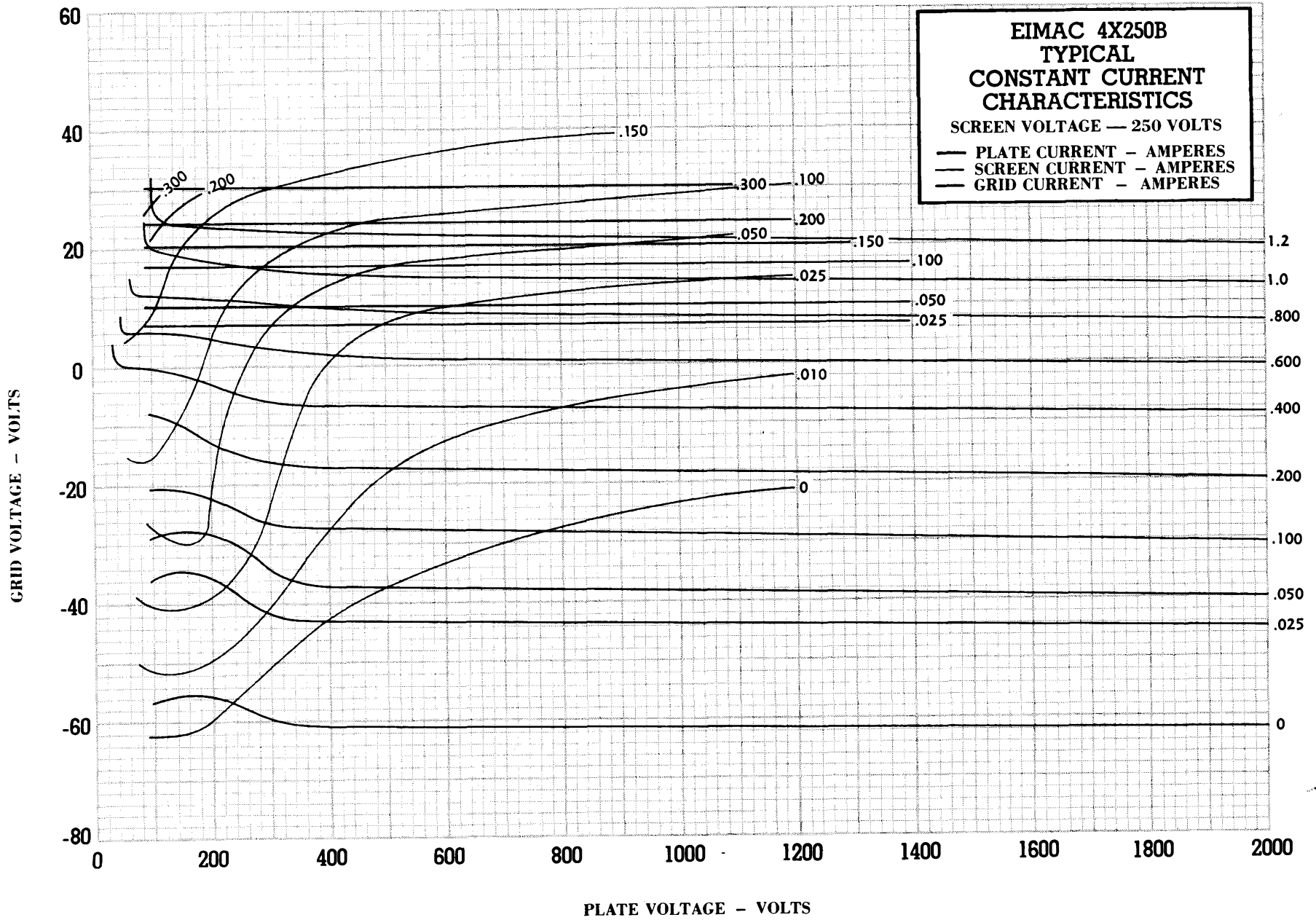

*Simplic*  
 THE SIMPLICITY OF  
 4X250B

# TENTATIVE DATA

*Eimac*  
**EITEL-McCULLOUGH, INC.**  
 SAN BRUNO, CALIFORNIA

**4X250F**  
 RADIAL-BEAM  
 POWER TETRODE

The Eimac 4X250F is a compact, oxide-cathode, external-anode power tetrode, unilaterally interchangeable with the 4X150D in most applications, and is intended for use as an amplifier, oscillator or frequency multiplier over a wide range of frequencies extending into the UHF region. It is cooled by convection and forced air.

A single 4X250F in a coaxial-cavity amplifier circuit will deliver up to 300 watts of useful power output at 400 megacycles although this is not the upper frequency limit of the tube.

Outstanding features of the 4X250F are: 1. Simple air-cooling requirements. 2. A maximum plate dissipation rating of 250 watts available for low-efficiency applications. 3. A maximum d-c plate voltage rating of 2000 volts at frequencies up to 400 Mc. The high transconductance of the 4X250F makes the tube useful at relatively low plate voltages. The high ratio of transconductance to inter-electrode capacitance and the 250-watt plate dissipation make the tube very useful for wide-band amplifier applications.

The use of an Eimac Air-System Socket or a socket providing equivalent air cooling characteristics, is required.

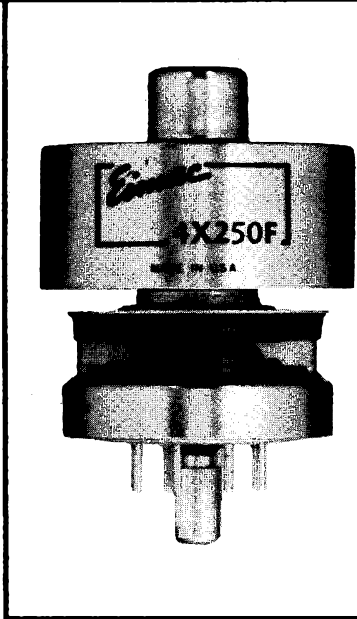

## GENERAL CHARACTERISTICS

### ELECTRICAL

Cathode: Oxide Coated, Unipotential							
Minimum Heating Time	-	-	-	-	-	30	seconds
Cathode-to-Heater Voltage	-	-	-	-	-	150	max. volts
Heater: Voltage	-	-	-	-	-	26.5	volts
Current	-	-	-	-	-	0.50	amperes
Grid-Screen Amplification Factor (Average)	-	-	-	-	-	-	5
Direct Interelectrode Capacitances (Average)							
Grid-Plate	-	-	-	-	-	0.04	μf
Input	-	-	-	-	-	18.5	μf
Output	-	-	-	-	-	4.7	μf
Transconductance (E <sub>b</sub> =500v., E <sub>c2</sub> =250v., I <sub>b</sub> =200 ma)	-	-	-	-	-	-	12,000 μhos
Frequency for Maximum Plate Voltage Ratings	-	-	-	-	-	-	400 Mc

(All other Maximum Ratings applicable to 500 Mc)

### MECHANICAL

Base	-	-	-	-	-	-	-	9-pin, special
Recommended Socket	-	-	-	-	-	-	-	Eimac Air-System Socket
Base Connections	-	-	-	-	-	-	-	See outline drawing
Mounting	-	-	-	-	-	-	-	Any position
Cooling	-	-	-	-	-	-	-	Convection and Forced air
Maximum Over-all Dimensions								
Length	-	-	-	-	-	-	-	2.59 inches
Diameter	-	-	-	-	-	-	-	1.65 inches
Seated Height	-	-	-	-	-	-	-	2.03 inches
Net Weight	-	-	-	-	-	-	-	4.0 ounces
Shipping Weight	-	-	-	-	-	-	-	1.6 pounds

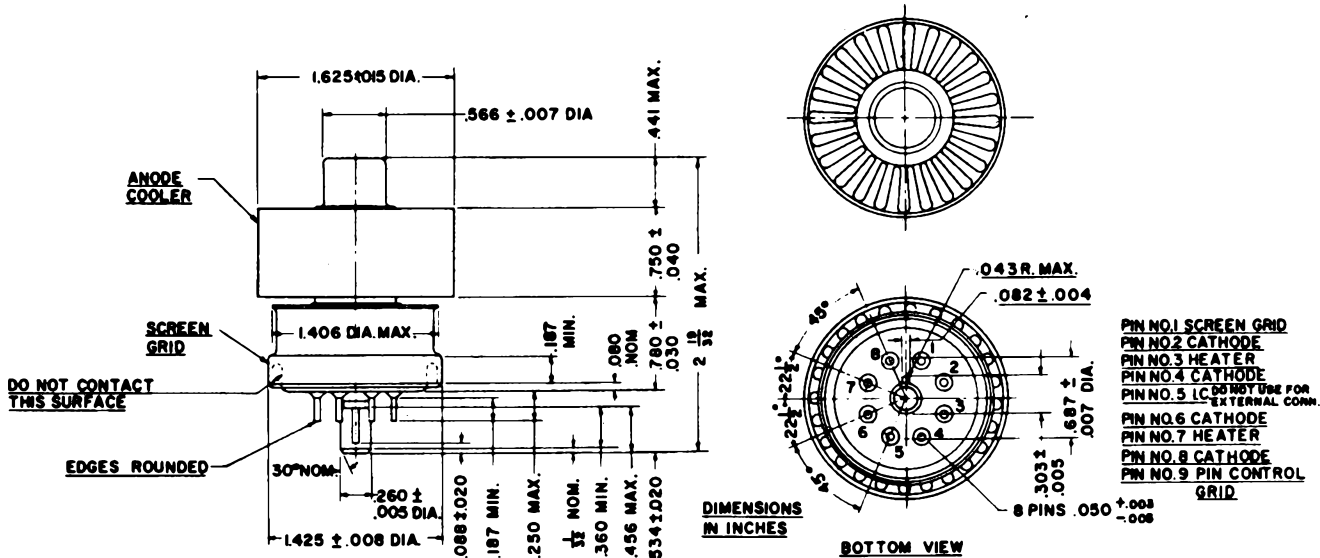



## RADIO-FREQUENCY POWER AMPLIFIER OR OSCILLATOR

Class-C Telephony or FM Telephony  
(Key-down conditions, per tube)

### MAXIMUM RATINGS

D-C PLATE VOLTAGE	- -	2000 MAX. VOLTS
D-C SCREEN VOLTAGE	- -	300 MAX. VOLTS
D-C GRID VOLTAGE	- -	-250 MAX. VOLTS
D-C PLATE CURRENT	- -	250 MAX. MA
PLATE DISSIPATION	- -	250 MAX. WATTS
SCREEN DISSIPATION	- -	12 MAX. WATTS
GRID DISSIPATION	- -	2 MAX. WATTS

### TYPICAL OPERATION (Frequencies up to 175 Mc, per tube)

D-C Plate Voltage	- - -	500	1000	1500	2000	volts
D-C Screen Voltage	- -	250	250	250	250	volts
D-C Grid Voltage	- - - -	-90	-90	-90	-90	volts
D-C Plate Current	- - -	250	250	250	250	ma
D-C Screen Current	- - -	45	35	30	25	ma
D-C Grid Current	- - -	32	28	28	27	ma
Peak R-F Grid Voltage (approx.)	-	118	116	116	115	volts
Driving Power	- - - -	3.6	3.2	3.2	2.8	watts
Plate Power Input	- - -	125	250	375	500	watts
Plate Power Output	- - -	85	195	300	410	watts

## PLATE-MODULATED RADIO-FREQUENCY AMPLIFIER

Class-C Telephony (Carrier conditions, per tube)

### MAXIMUM RATINGS

D-C PLATE VOLTAGE	-	1500 MAX. VOLTS
D-C SCREEN VOLTAGE	-	300 MAX. VOLTS
D-C GRID VOLTAGE	-	-250 MAX. VOLTS
D-C PLATE CURRENT	-	200 MAX. MA
PLATE DISSIPATION	- -	165 MAX. WATTS
SCREEN DISSIPATION	- -	12 MAX. WATTS
GRID DISSIPATION	- -	2 MAX. WATTS

### TYPICAL OPERATION (Frequencies up to 175Mc, per tube)

D-C Plate Voltage	- - -	500	1000	1500	volts
D-C Screen Voltage	- - -	250	250	250	volts
D-C Grid Voltage	- - -	-100	-100	-100	volts
D-C Plate Current	- - -	200	200	200	ma
D-C Screen Current	- - -	45	35	25	ma
D-C Grid Current	- - -	22	19	17	ma
Peak R-F Grid Input Voltage	-	124	122	121	volts
Driving Power	- - - -	2.7	2.3	2.1	watts
Plate Power Input	- - -	100	200	300	watts
Plate Power Output	- - -	75	160	250	watts

## CLASS-AB POWER AMPLIFIER OR MODULATOR

### MAXIMUM RATINGS (Per tube)

D-C PLATE VOLTAGE	-	2000 MAX. VOLTS
D-C SCREEN VOLTAGE	-	400 MAX. VOLTS
D-C PLATE CURRENT	-	250 MAX. MA
PLATE DISSIPATION	-	250 MAX. WATTS
SCREEN DISSIPATION	-	12 MAX. WATTS
GRID DISSIPATION	- -	2 MAX. WATTS

### TYPICAL OPERATION

Class-AB<sub>1</sub> Audio Amplifier (Sinusoidal wave, two tubes unless otherwise noted)

D-C Plate Voltage	- - - -	1000	1500	2000	volts,
D-C Screen Voltage	- - - -	350	350	350	volts
D-C Grid Voltage (approx.)*	- - - -	-50	-50	-50	volts
Zero-Signal D-C Plate Current	- - - -	200	200	200	ma
Max-Signal D-C Plate Current	- - - -	500	500	500	ma
Max-Signal D-C Screen Current	- - - -	50	40	30	ma
Effective Load, Plate-to-Plate	- - - -	3260	5760	8260	ohms
Peak A-F Grid Input Voltage (per tube)	- - - -	50	50	50	volts
Driving Power	- - - -	0	0	0	watts
Max-Signal Plate Dissipation (per tube)	- - - -	125	150	175	watts
Max-Signal Plate Power Output	- - - -	250	450	650	watts
Third-Harmonic Distortion	- - - -	4.5	4.5	4.5	pct

\*Adjust grid voltage to obtain specified zero-signal plate current

### TYPICAL OPERATION

Class-AB<sub>1</sub> R-F Linear Amplifier (Frequencies to 175 Mc, per tube)

D-C Plate Voltage	- - - -	1000	1500	2000	volts
D-C Screen Voltage	- - - -	350	350	350	volts
D-C Grid Voltage (approx.)*	- - - -	-50	-50	-50	volts
Zero-Signal D-C Plate Current	- - - -	100	100	100	ma
Max-Signal D-C Plate Current	- - - -	250	250	250	ma
Max-Signal D-C Screen Current	- - - -	25	20	15	ma
Peak R-F Grid Voltage	- - - -	50	50	50	volts
Driving Power	- - - -	0	0	0	watts
Max-Signal Plate Dissipation	- - - -	125	150	175	watts
Max-Signal Plate Power Output	- - - -	125	225	325	watts

\*Adjust grid voltage to obtain specified zero-signal plate current

Note: Typical operation data are based on conditions of adjusting the r-f grid drive to a specified plate current, maintaining fixed conditions of grid bias and screen voltage. It will be found that if this procedure is followed, there will be little variation in power output between tubes even though there may be some variation in grid and screen currents. Where grid bias is obtained principally by means of a grid resistor, to control plate current it is necessary to make the resistor adjustable.

## APPLICATION

### MECHANICAL

**Mounting**—The 4X250F may be mounted in any position. Use of an Eimac Air-System Socket, or its equivalent, is recommended.

The tube will fit a standard "loktal" socket, but the use of such a socket in the usual way prevents adequate air-cooling of the base of the tube. Use of the "loktal" socket is not recommended.

Connections to the terminals of all the electrodes except the plate are provided by the Air-System Socket. The anode-cooler assembly provides a terminal surface for the plate connection. For high-frequency applications a metal band or a spring-finger collet should be used to make good electrical contact with the cylindrical outer surface of the anode cooler. Points of electrical contact should be kept clean and free of oxidation to minimize r-f losses.

**Cooling**—The 4X250F requires sufficient cooling air to prevent the temperature of the metal part of the metal-to-glass seals exceeding a maximum of 175°C. The temperature of the anode as measured at the base of the cooling fins must be maintained below its maximum of 250°C.

Under conditions of normal room temperatures and installation in the Eimac Air-System Socket, the 4X250F requires no forced air during stand-by periods where only the heater power is on. Anode cooling air may be started and stopped simultaneously with the power on the anode. A quantity of 3.8 cubic feet per minute is required to cool the tube when operating at maximum-rated plate dissipation at 500 Mc. At this quantity of air the pressure drop across the cooler and the Air-System Socket is equal to approximately 0.25 inches of water column. At frequencies below 175 Mc and at 250 watts plate dissipation the quantity of air flow may be reduced to 3.6 cubic feet per minute, at which quantity the pressure drop is 0.23 inches of water column.

The air requirements stated above are based on operation at sea level and an ambient temperature of 20°C. Operation at high altitude or at high ambient temperatures requires a greater volume of air flow. The necessary design information for such conditions is contained in an article entitled "Blower Selection for Forced-Air-Cooled Tubes," by A. G. Nekut, in the August, 1950, issue of "Electronics."

One method of measuring temperature is provided by the use of "Tempilaq", a temperature-sensitive lacquer, which melts when a given temperature is reached. Where forced-air cooling is employed, very thin applications of the lacquer must be used. This product is obtainable from the Tempil Corporation, 11 West 25th St. New York 10, N. Y.

### ELECTRICAL

**Heater**—The heater should be operated as close to 26.5 volts as possible, but it will withstand heater-voltage variations as great as 10% for short durations without injury. Some variations in power output must be expected to occur with variations of the heater voltage.

**Cathode**—The cathode is internally connected to the four even-numbered base pins. All four corresponding socket terminals should be used for connection to the external circuit. The leads should be of large cross-

section and as short and direct as possible to minimize cathode-lead inductance.

**Grid Dissipation**—Grid-circuit driving-power requirements increase with frequency because of circuit losses other than grid dissipation. This becomes noticeable at frequencies near 100 Mc., and increases until at 500 Mc. as much as 20-25 watts driving power may be required in ordinary circuits.

Despite the increased driving power required by the circuit as a whole at higher frequencies, the power actually dissipated at the tube grid does not increase greatly. Satisfactory operation in stable amplifier circuits is indicated by d-c grid-current values below approximately 20 milliamperes.

**Screen Dissipation**—Bias- or plate-supply failure or unloaded-plate-circuit operation can cause the screen current and dissipation to rise to excessive values. Protection for the screen can be provided by an overload relay in the screen circuit, in addition to the usual plate-circuit overload relay. Use of a screen-current milliammeter is recommended.

**Plate Dissipation**—The maximum-rated plate dissipation is 250 watts. The maximum-rated plate dissipation for plate modulated applications is 165 watts under carrier conditions, which permits the plate dissipation to rise to 250 watts under 100% sinusoidal modulation.

Plate dissipation may be permitted to exceed the maximum rating momentarily, as, for instance, during tuning.

**UHF Operation**—Transit time and other effects, which occur at ultra-high-frequencies in the 4X250F, can be reduced to minimum values by compliance with the following suggested operating conditions:

1. Use a minimum value of d-c grid bias voltage.
2. Apply only enough grid drive to obtain satisfactory plate efficiency.
3. Operate the screen at reasonably high voltage, but do not exceed the screen dissipation rating.
4. Fairly heavy plate loading is required. In general, low-voltage, high-current operation is preferable to operation at high voltage and low current. If conditions require a change to lighter plate loading, the drive should also be reduced to the minimum value for satisfactory operation at the new output level.
5. Parasitic oscillations are usually associated with excessive grid and screen current and are injurious to vacuum tubes. Similarly, tuned-plate circuits which accidentally become simultaneously resonant to harmonics and the fundamental frequency may also cause low efficiency and damage tubes.

**Plate Modulation**—Plate modulation can be applied to the 4X250F when it is operated as a class-C radio-frequency amplifier. To obtain 100% modulation, the d-c screen voltage must be modulated in phase with the plate modulation. Self-modulation of the screen by means of a series resistor or reactor may not be satisfactory in this particular tetrode due to the screen-voltage, screen-current characteristics.

**Special Applications**—If it is desired to operate this tube under conditions widely different than those given here, write to Eitel-McCullough, Inc., San Bruno, California, for information and recommendations.

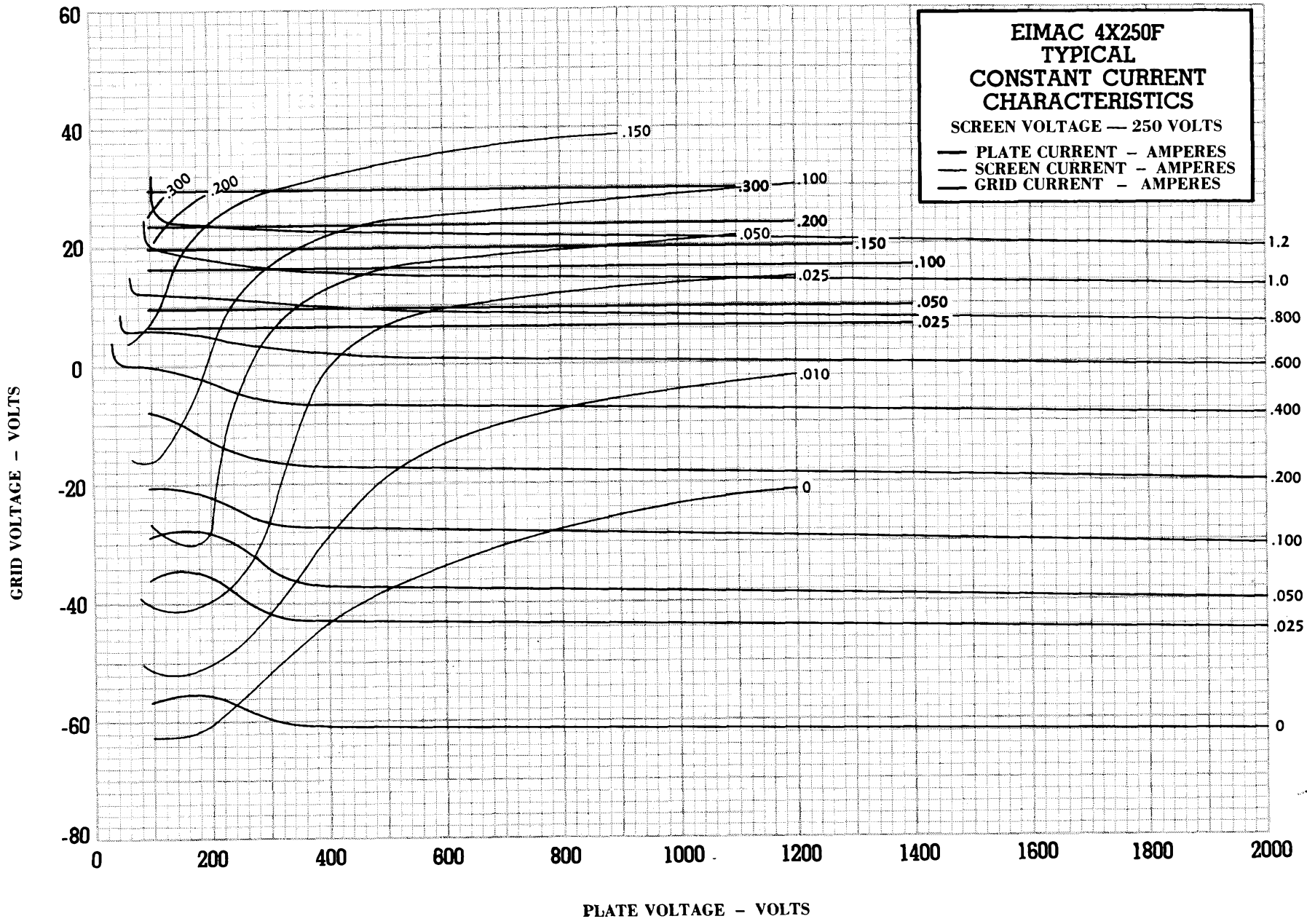

*Eimac*  
4X250F

# EITEL-McCULLOUGH, INC.

SAN BRUNO, CALIFORNIA

# 4X500A

**RADIAL-BEAM  
POWER TETRODE**

The Eimac 4X500A is an external-anode tetrode having a maximum plate dissipation rating of 500 watts. Its small size and low-inductance leads permit efficient operation at relatively large outputs well into the VHF region. The screen grid is mounted on a disc which terminates in a connector ring located between grid and plate, thus making possible effective shielding between the grid and plate circuits. The grid terminal is located at the center of the glass base to facilitate single-tube operation in coaxial circuits.

The combination of low grid-plate capacitance, low screen-lead inductance and functionally located terminals contributes to the stable operation of the 4X500A at high frequencies, making neutralization unnecessary in most cases and greatly simplifying it in others.

### GENERAL CHARACTERISTICS

#### ELECTRICAL

Filament: Thoriated Tungsten	
Voltage	5.0 volts
Current	13.5 amperes
Screen Grid Amplification Factor (Average) - - - - - 6.2	
Direct Interelectrode Capacitances (Average)	
Grid-Plate	0.05 $\mu\text{mfd}$
Input	12.8 $\mu\text{mfd}$
Output	5.6 $\mu\text{mfd}$
Transconductance ( $i_b=200 \text{ ma.}, e_b=2500 \text{ v.}, E_{c2}=500 \text{ v.}$ ) - - - - - 5200 $\mu\text{mhos}$	
Frequency for Maximum Ratings - - - - - 120 Mc.	

#### MECHANICAL

Maximum Overall Dimensions:	
Length	4.75 inches
Diameter	2.625 inches
Net Weight	1.17 pounds
Shipping Weight (Average)	6 pounds
Mounting Position	Vertical, base down or up
Cooling	Forced Air

At 500 watts plate dissipation, a minimum air-flow of 40 cubic feet per minute must be passed through the anode cooler. The pressure drop across the cooler at this rate of flow equals 1.4 inches of water. Forced-air cooling must be provided for the base and screen seals. Normally, suitable amounts of air may be obtained from a small centrifugal blower directed at the seals. In no case should the temperature of the metal-to-glass seals or the core of the anode cooler exceed 150°C. Cooling air specified above must be applied to the seals and the anode cooler prior to the application of filament power and continued for three minutes after power is removed from the filament.

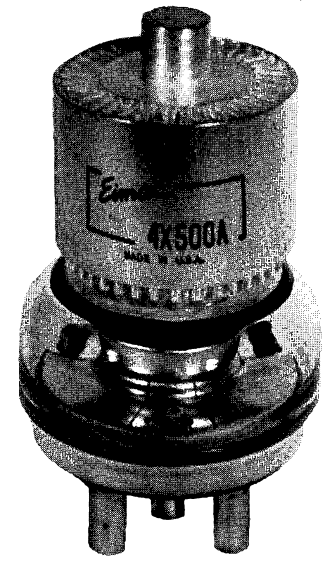

#### RADIO FREQUENCY POWER AMPLIFIER AND OSCILLATOR

Class-C FM or Telegraphy (Key-down conditions, 1 tube)  
MAXIMUM RATINGS (Frequencies up to 120 Mc.)

D-C PLATE VOLTAGE	4000 MAX. VOLTS
D-C SCREEN VOLTAGE	500 MAX. VOLTS
D-C GRID VOLTAGE	-500 MAX. VOLTS
D-C PLATE CURRENT	350 MAX. MA.
PLATE DISSIPATION	500 MAX. WATTS
SCREEN DISSIPATION	30 MAX. WATTS
GRID DISSIPATION	10 MAX. WATTS

#### TYPICAL OPERATION (Per tube, at 110 Mc.)

D-C Plate Voltage	2500	3000	4000	Volts
D-C Plate Current	310	310	315	Ma.
D-C Screen Voltage	500	500	500	Volts
D-C Screen Current	26	24	22	Ma.
D-C Grid Voltage	-150	-150	-150	Volts
D-C Grid Current	15	16	16	Ma.
Driving Power (approx.)	5	5	5	Watts
Useful Power Output (approx.)	475	600	835	Watts

#### RADIO FREQUENCY POWER AMPLIFIER

Class-B Linear Amplifier, Television Visual Service  
MAXIMUM RATINGS FOR TV (Frequencies up to 220 Mc.)

D-C PLATE VOLTAGE	3000 MAX. VOLTS
D-C PLATE CURRENT	350 MAX. MA.
D-C SCREEN VOLTAGE	500 MAX. VOLTS
PLATE DISSIPATION	500 MAX. WATTS
SCREEN DISSIPATION	30 MAX. WATTS
GRID DISSIPATION	10 MAX. WATTS

#### TYPICAL OPERATION

(Per tube at peak synchronizing level, 5-Mc. bandwidth, assumed load resistance 3,000 ohms per tube.)<sup>1</sup>

D-C Plate Voltage	1850	2400	Volts
D-C Screen Voltage	500	500	Volts
D-C Grid Voltage	-100	-100	Volts
D-C Plate Current	285	400 <sup>1</sup>	Ma.
D-C Screen Current (approx.)	20	35	Ma.
D-C Grid Current (approx.)	10	15	Ma.
Peak R-F Grid Voltage	140	185	Volts
Driving Power, 220 Mc. (approx.)	15	25	Watts
Plate Power Input	525	960	Watts
Power Output	300	600	Watts
<b>BLACK LEVEL</b>			
D-C Plate Current	215	300	Ma.
D-C Screen Current	2	3	Ma.
D-C Grid Current	2	5	Ma.
Plate Power Input	400	720	Watts
Plate Dissipation	230	380	Watts
Power Output	170	340	Watts

<sup>1</sup> Operating conditions at peak synchronizing level may be permitted for exceed maximum ratings of the tube because of the low duty factor. Maximum ratings apply to black level conditions.

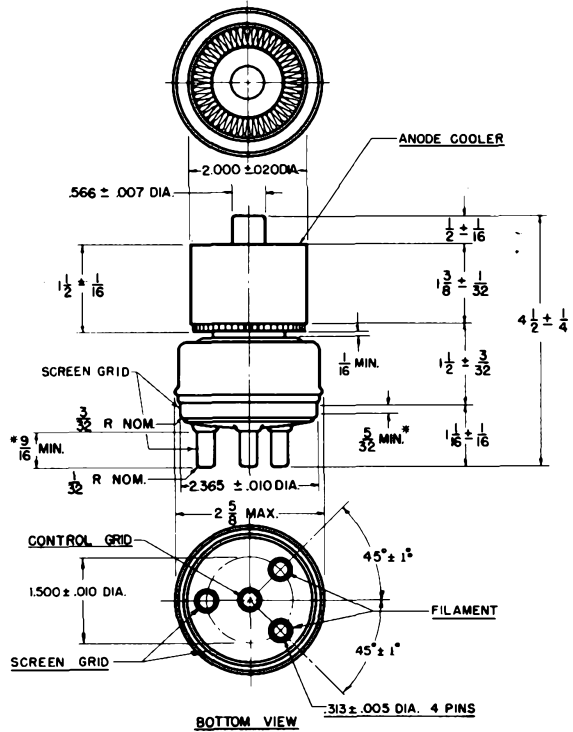
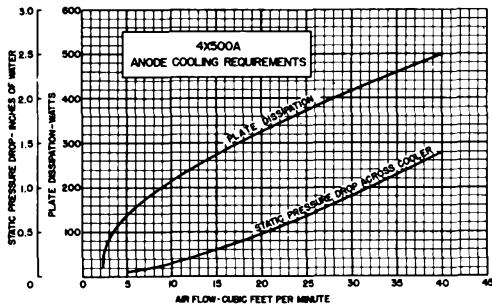
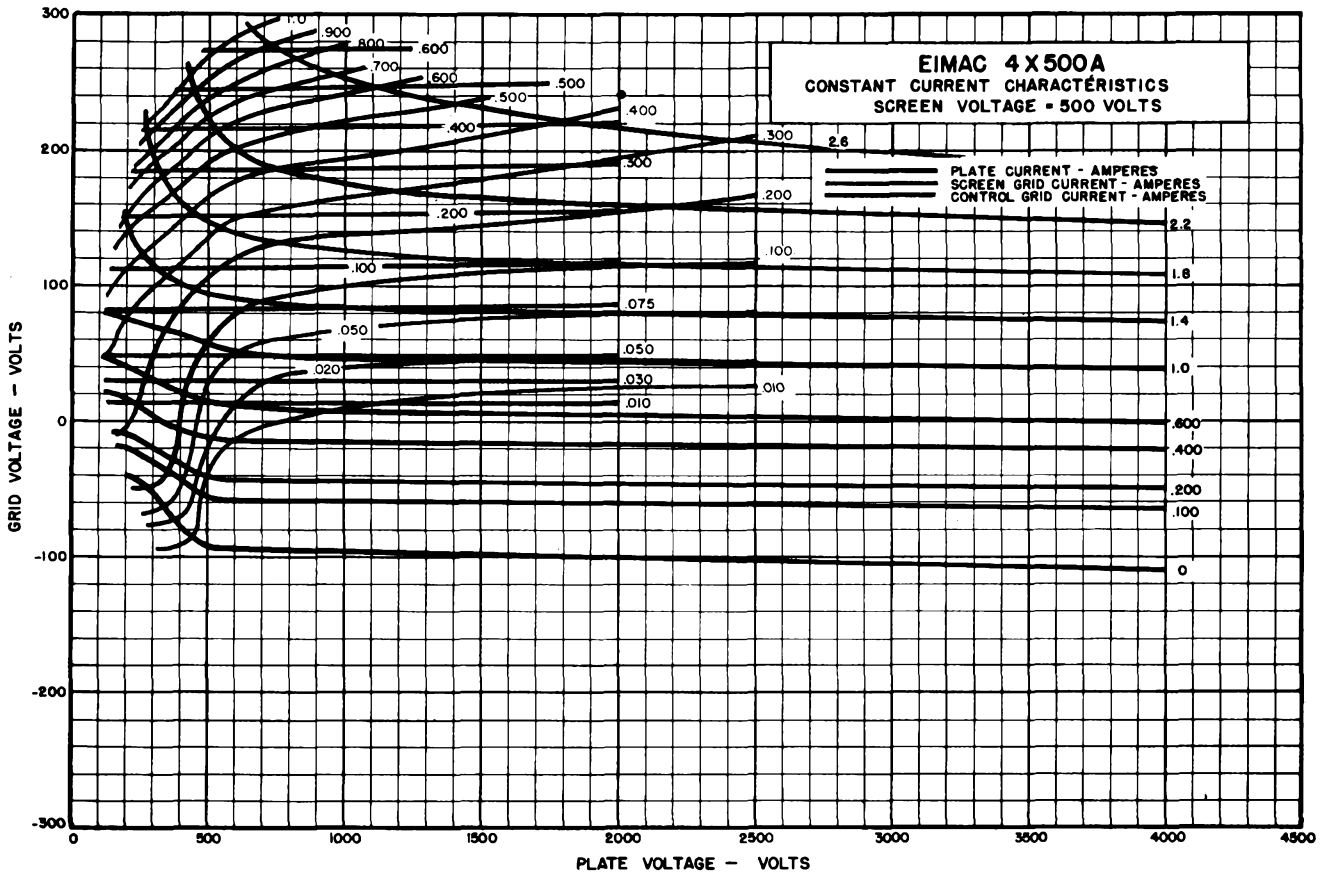

**DIMENSIONS  
IN INCHES**

**\* STRAIGHT SIDE  
AVAILABLE FOR  
CONTACT**

# EITEL-McCULLOUGH, INC.

SAN BRUNO, CALIFORNIA

## 4E27A / 5-125B

RADIAL-BEAM  
POWER PENTODE

MODULATOR  
OSCILLATOR  
AMPLIFIER

The Eimac 4E27A/5-125B is a power pentode intended for use as a modulator, oscillator or amplifier. The driving-power requirement is very low, and neutralization problems are simplified or eliminated entirely. The tube has a maximum plate-dissipation rating of 125 watts and a maximum plate voltage rating of 4000 volts at frequencies up to 75 Mc. Cooling is by convection and radiation. Type 4E27A/5-125B unilaterally replaces type 4E27.

The 4E27A/5-125B in class-C r-f service will deliver up to 375 watts plate power output with less than 2 watts driving power. It will deliver up to 75 watts of carrier for suppressor modulation.

Two 4E27A/5-125B's will deliver up to 300 watts maximum-signal plate power output in class AB<sub>1</sub> modulator service, 400 watts in class AB<sub>2</sub> with less than 1 watt driving power.

### GENERAL CHARACTERISTICS

#### ELECTRICAL

Filament: Thoriated tungsten	
Voltage	5.0 volts
Current	7.5 amperes
Grid-Screen Amplification Factor (Average)	5.0
Direct Interelectrode Capacitances (Average)	
Grid-Plate	0.08 $\mu$ fd
Input	10.5 $\mu$ fd
Output	4.7 $\mu$ fd
Transconductance ( $I_b=50$ ma., $E_b=2500$ v., $E_c=500$ v., $E_{c3}=0$ v.)	2150 $\mu$ mhos
Highest Frequencies for Maximum Ratings	75 Mc.

#### MECHANICAL

Base	7-pin, metal shell
Connections	See drawing
Socket*	E. F. Johnson Co. No. 122-237, or equivalent
Mounting Position	Vertical, base down or up
Cooling	Convection and radiation
Recommended Heat Dissipating Plate Connector	Eimac HR-5
Maximum Over-All Dimensions:	
Length	6.19 inches
Diameter	2.75 inches
Net Weight (Average)	6.0 ounces
Shipping Weight	2.0 pounds

\*See "Cooling" under Application Notes.

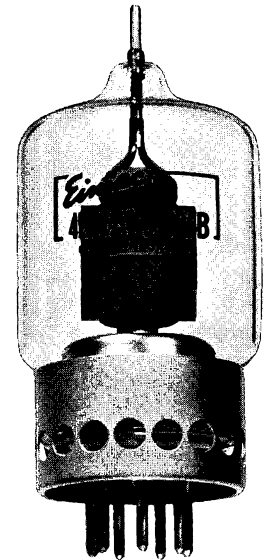

Note: Typical operation data are based on conditions of adjusting to a specified plate current, maintaining fixed conditions of grid bias, screen voltage, suppressor voltage and r-f grid voltage. It will be found that if this procedure is followed, there will be little variation in power output between tubes even though there may be some variation in grid, screen and suppressor currents. Where grid bias is obtained principally by means of a grid resistor, to control plate current it is necessary to make the resistor adjustable.

### RADIO-FREQUENCY POWER AMPLIFIER OR OSCILLATOR

Class-C Telegraphy or FM Telephony, Frequencies up to 75 Mc. (Key-down conditions, per tube)

#### MAXIMUM RATINGS

D-C PLATE VOLTAGE	4000 MAX. VOLTS
D-C SCREEN VOLTAGE	750 MAX. VOLTS
D-C GRID VOLTAGE	-500 MAX. VOLTS
D-C PLATE CURRENT	200 MAX. MA
PLATE DISSIPATION	125 MAX. WATTS
SUPPRESSOR DISSIPATION	20 MAX. WATTS
SCREEN DISSIPATION	20 MAX. WATTS
GRID DISSIPATION	5 MAX. WATTS

#### TYPICAL OPERATION

60 Suppressor Volts, 500 Screen Volts	
D-C Plate Voltage	1000 1500 2000 2500 3000 volts
D-C Grid Voltage	-120 -130 -150 -170 -200 volts
D-C Plate Current	167 200 200 184 167 ma
D-C Suppressor Current*	6 5 4 3 3 ma
D-C Screen Current*	11 11 11 7 5 ma
D-C Grid Current*	6 8 8 7 6 ma
Peak R-F Grid Input Voltage	170 200 222 240 260 volts
Driving Power*	1.0 1.6 1.8 1.7 1.6 watts
Grid Dissipation*	.3 .6 .6 .5 .6 watts
Screen Dissipation*	5.5 5.5 5.5 3.5 2.5 watts
Plate Dissipation	47 85 100 115 125 watts
Plate Power Input	167 300 400 465 500 watts
Plate Power Output	120 215 300 350 375 watts

#### TYPICAL OPERATION

Zero Suppressor Volts, 500 Screen Volts	
D-C Plate Voltage	1000 1500 2000 2500 3000 volts
D-C Grid Voltage	-170 -180 -200 -225 -250 volts
D-C Plate Current	145 180 200 184 167 ma
D-C Screen Current*	17 20 23 18 12 ma
D-C Grid Current*	6 8 11 9 7 ma
Peak R-F Grid Input Voltage	170 200 240 250 270 volts
Driving Power*	1.0 1.6 2.6 2.3 1.9 watts
Grid Dissipation*	.3 .6 1.0 .8 .5 watts
Screen Dissipation*	8.5 10 12 9 6 watts
Plate Dissipation	55 95 125 125 125 watts
Plate Power Input	145 270 400 460 500 watts
Plate Power Output	90 175 275 335 375 watts

#### TYPICAL OPERATION

Zero Suppressor Volts, 750 Screen Volts	
D-C Plate Voltage	1000 1500 2000 2500 3000 volts
D-C Grid Voltage	-170 -180 -200 -225 -250 volts
D-C Plate Current	160 200 200 184 167 ma
D-C Screen Current*	21 24 22 12 9 ma
D-C Grid Current*	3 6 6 4 3 ma
Peak R-F Grid Input Voltage	205 235 257 270 290 volts
Driving Power*	.6 1.4 1.5 1.1 .9 watts
Grid Dissipation*	.1 .4 .3 .2 .2 watts
Screen Dissipation*	16 18 17 9 7 watts
Plate Dissipation	45 85 100 115 125 watts
Plate Power Input	160 300 400 465 500 watts
Plate Power Output	115 215 300 350 375 watts

\*Approximate Values



**PLATE-MODULATED RADIO-FREQUENCY AMPLIFIER**

Class-C Telephony, Frequencies up to 75 Mc.  
(Carrier conditions, per tube, unless otherwise specified)

**MAXIMUM RATINGS**

D-C PLATE VOLTAGE	- - -	3200 MAX. VOLTS
D-C SCREEN VOLTAGE	- - -	750 MAX. VOLTS
D-C GRID VOLTAGE	- - -	-500 MAX. VOLTS
D-C PLATE CURRENT	- - -	160 MAX. MA
PLATE DISSIPATION	- - -	85 MAX. WATTS
SUPPRESSOR DISSIPATION	- - -	20 MAX. WATTS
SCREEN DISSIPATION	- - -	20 MAX. WATTS
GRID DISSIPATION	- - -	5 MAX. WATTS

**TYPICAL OPERATION**

Zero Suppressor Volts, 500 Screen Volts					
D-C Plate Voltage	- - - -	1000	1500	2000	2500 volts
D-C Grid Voltage	- - - -	-190	-195	-200	-205 volts
D-C Plate Current	- - - -	149	150	151	152 ma
D-C Screen Current*	- - - -	20	18	17	16 ma
D-C Grid Current*	- - - -	7	7	8	8 ma
Peak A-F Screen Voltage	- - - -				
(100% Modulation)	- - - -	350	350	350	350 volts
Peak R-F Grid Input Voltage	- - - -	260	265	270	275 volts
Driving Power*	- - - -	2	2	2	2 watts
Grid Dissipation*	- - - -	0.5	0.5	0.5	0.5 watts
Screen Dissipation*	- - - -	10	9	8.5	8 watts
Plate Dissipation	- - - -	64	72	80	85 watts
Plate Power Input	- - - -	149	225	300	380 watts
Plate Power Output	- - - -	85	153	220	295 watts

**SUPPRESSOR-MODULATED RADIO-FREQUENCY AMPLIFIER**

Class-C Telephony, Frequencies up to 75 Mc.  
(Carrier conditions, per tube, unless otherwise specified)

**MAXIMUM RATINGS**

D-C PLATE VOLTAGE	- - -	4000 MAX. VOLTS
D-C SCREEN VOLTAGE	- - -	750 MAX. VOLTS
D-C GRID VOLTAGE	- - -	-500 MAX. VOLTS
D-C PLATE CURRENT	- - -	200 MAX. MA
PLATE DISSIPATION	- - -	125 MAX. WATTS
SUPPRESSOR DISSIPATION	- - -	20 MAX. WATTS
SCREEN DISSIPATION	- - -	20 MAX. WATTS
GRID DISSIPATION	- - -	5 MAX. WATTS

**TYPICAL OPERATION**

D-C Plate Voltage	- - - -	1500	2000	2500	3000 volts
D-C Suppressor Voltage	- - - -	-220	-260	-305	-350 volts
Peak A-F Suppressor Voltage	- - - -				
(100% Modulation)	- - - -	220	260	305	350 volts
D-C Screen Voltage	- - - -	400	400	400	400 volts
Fixed D-C Screen Voltage	- - - -	610	645	650	610 volts
Screen Dropping Resistor <sup>1</sup>	- - - -	5500	9100	10,000	8300 ohms
D-C Grid Voltage	- - - -	-170	-180	-190	-200 volts
D-C Plate Current	- - - -	59	59	59	60 ma
D-C Screen Current*	- - - -	38	27	25	25 ma
D-C Grid Current*	- - - -	6	5	5	4 ma
Peak R-F Grid Input Voltage	- - - -	230	235	245	250 volts
Driving Power*	- - - -	1.4	1.3	1.2	1.2 watts
Grid Dissipation*	- - - -	.35	.25	.25	.20 watts
Screen Dissipation*	- - - -	15	11	10	10 watts
Plate Dissipation	- - - -	54	68	87	105 watts
Plate Power Input	- - - -	89	118	148	180 watts
Plate Power Output	- - - -	35	50	61	75 watts

<sup>1</sup>Adjust to stated d-c screen voltage.

**AUDIO-FREQUENCY POWER AMPLIFIER OR MODULATOR**

Class-AB, Sinusoidal Wave

**MAXIMUM RATINGS (Per Tube)**

D-C PLATE VOLTAGE	- - -	4000 MAX. VOLTS
D-C SCREEN VOLTAGE	- - -	750 MAX. VOLTS
D-C GRID VOLTAGE	- - -	-500 MAX. VOLTS
D-C PLATE CURRENT	- - -	200 MAX. MA
PLATE DISSIPATION	- - -	125 MAX. WATTS
SUPPRESSOR DISSIPATION	- - -	20 MAX. WATTS
SCREEN DISSIPATION	- - -	20 MAX. WATTS
GRID DISSIPATION	- - -	5 MAX. WATTS

**TYPICAL OPERATION (Two tubes unless otherwise specified)**  
Class-AB<sub>1</sub>

D-C Plate Voltage	- - - -	1500	2000	2500	volts
D-C Suppressor Voltage	- - - -	0	0	0	volts
D-C Screen Voltage	- - - -	500	500	500	volts
D-C Grid Voltage <sup>1</sup>	- - - -	-70	-80	-85	volts
Zero-Signal D-C Plate Current	- - - -	110	85	65	ma
Max-Signal D-C Plate Current	- - - -	205	210	220	ma
Zero-Signal D-C Screen Current*	- - - -	0	0	0	ma
Max-Signal D-C Screen Current*	- - - -	15	13	8	ma
Effective Plate-to-Plate Load	- - - -	13,700	18,000	20,000	ohms
Peak A-F Grid Voltage (per tube)	- - - -	70	80	85	volts
Max-Signal Driving Power*	- - - -	0	0	0	watts
Max-Signal Plate Power Input	- - - -	310	420	550	watts
Max-Signal Plate Power Output	- - - -	200	250	300	watts

<sup>1</sup>Adjust to stated zero-signal d-c plate current. The effective grid circuit resistance for each tube must not exceed 250,000 ohms.

**TYPICAL OPERATION (Two tubes unless otherwise specified)**  
Class-AB<sub>2</sub>

D-C Plate Voltage	- - - -	1500	2000	2500	volts
D-C Suppressor Voltage	- - - -	60	0	0	volts
D-C Screen Voltage	- - - -	500	500	500	volts
D-C Grid Voltage <sup>1</sup>	- - - -	-70	-80	-85	volts
Zero-Signal D-C Plate Current	- - - -	110	85	65	ma
Max-Signal D-C Plate Current	- - - -	365	295	250	ma
Zero-Signal D-C Screen Current*	- - - -	0	0	0	ma
Max-Signal D-C Screen Current*	- - - -	11	16	13	ma
Effective Plate-to-Plate Load	- - - -	7300	13,000	20,000	ohms
Peak A-F Grid Input Voltage (per tube)	- - - -	100	100	95	volts
Max-Signal Driving Power*	- - - -	0.5	0.3	0.2	watts
Max-Signal Plate Power Input	- - - -	550	590	625	watts
Max-Signal Plate Power Output	- - - -	300	350	400	watts

<sup>1</sup>Adjust to stated zero-signal d-c plate current.

\*Approximate values.

IF IT IS DESIRED TO OPERATE THIS TUBE UNDER CONDITIONS WIDELY DIFFERENT FROM THOSE GIVEN UNDER "TYPICAL OPERATION", POSSIBLY EXCEEDING THE MAXIMUM RATINGS GIVEN FOR CW SERVICE, WRITE EITEL-McCULLOUGH, INC., FOR INFORMATION AND RECOMMENDATIONS.

## APPLICATION

### MECHANICAL

**Mounting**—The 4E27A/5-125B must be mounted vertically, base down or up. The plate lead should be flexible, and the tube must be protected from vibration and shock.

**Cooling**—A heat dissipating connector (Eimac HR-5 or equivalent) is required at the plate terminal, and provision must be made for the free circulation of air through the socket and through the holes in the base. If the E. F. Johnson Co. 122-237 socket recommended under "General Characteristics" is to be used, the model incorporating a ventilating hole should be specified.

At high ambient temperatures, at frequencies above 75 Mc., or when the flow of air is restricted, it may become necessary to provide forced air circulation in sufficient quantity to prevent the temperature of the plate and base seals from exceeding 225°C. Forced movement of air across the tube seals and envelope is always beneficial, though not necessarily required.

Tube temperatures may be measured with the aid of "Tempilaq," a temperature-sensitive lacquer manufactured by the Tempil Corporation, 132 West 22nd Street, New York 11, N. Y.

### ELECTRICAL

**Filament Voltage**—For maximum tube life the filament voltage, as measured directly at the base pins, should be the rated value of 5.0 volts. Variations should be held within the range of 4.75 to 5.25 volts.

**Grid Voltage**—Although a maximum of -500 volts bias may be applied to the grid, there is little advantage in using bias voltages in excess of those listed under "Typical Operation," except in certain specialized applications.

When grid-leak bias is used, suitable protective means must be provided to prevent excessive plate dissipation in the event of loss of excitation, and the grid-leak resistor should be made adjustable to facilitate maintaining the bias voltage and plate current at the desired value from tube to tube.

In class-C operation, particularly at high frequency, both grid bias and grid drive should be only great enough to provide satisfactory operation at good plate efficiency.

**Screen Dissipation**—Decrease or removal of plate load, plate voltage or bias voltage may result in screen dissipation in excess of the 20 watt maximum rating. The tube may be protected by an overload relay in the screen circuit set to remove the screen voltage when the dissipation exceeds 20 watts.

Resistors placed in the screen circuit for the purpose of developing an audio modulating voltage on the screen in modulated radio-frequency amplifiers should be made variable to permit adjustment when replacing tubes.

**Plate Dissipation**—Plate dissipation in excess of the 125-watt maximum rating is permissible for short periods of time, such as during tuning procedures.

**Operation**—If reasonable precautions are taken to prevent coupling between the input and output circuits, the 4E27A/5-125B may usually be operated at frequencies up to 75 Mc. without neutralization. A conventional method of obtaining the necessary shielding between the grid and plate circuits is to use a suitable metal chassis with the grid circuit mounted below the deck and the plate circuit above. The tube socket should be mounted flush with the under side of the chassis deck, and spring fingers mounted around the socket opening should make contact between the chassis and the metal base shell of the tube. Power-supply leads entering the amplifier should be bypassed to ground and properly shielded. The output circuit and antenna feeders should be arranged so as to preclude any possibility of feedback to other circuits.

Feedback at high frequencies may be due to the inductance of leads, particularly those of the screen and suppressor-grids. By-passing methods and means of placing these grids at r-f ground potential are discussed in Application Bulletin Number Eight, "The Care and Feeding of Power Tetrodes," available from Eitel-McCullough, Inc., for twenty-five cents. Much of the material contained in this bulletin may be applied to pentodes.

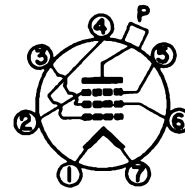
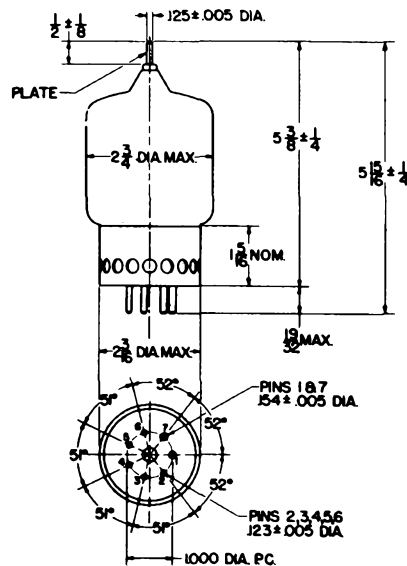

7BM



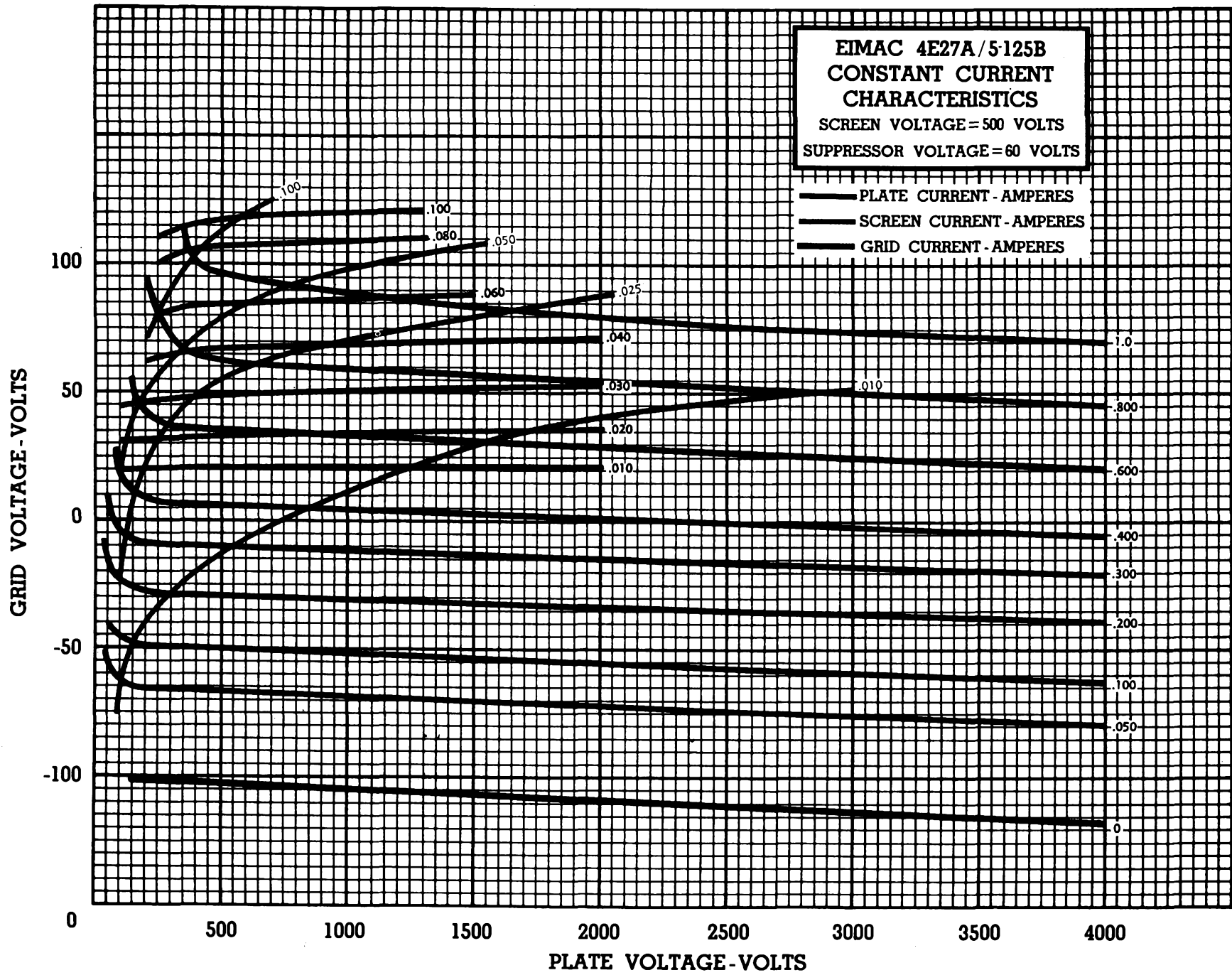

*Eimac*  
4E27A/5-125B

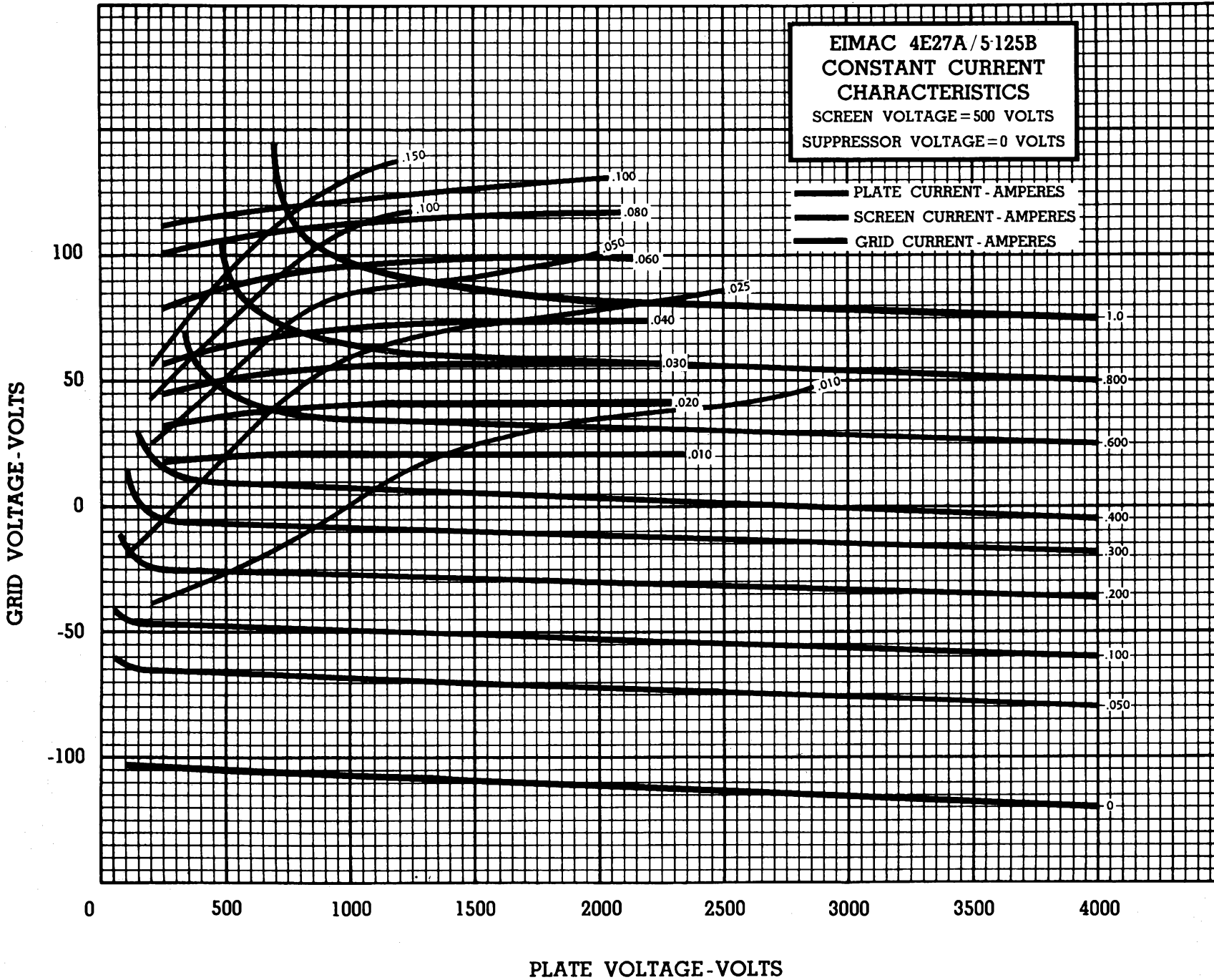

*Eimac*  
 4E27A/5-125B

CURRENT - MILLIAMPERES

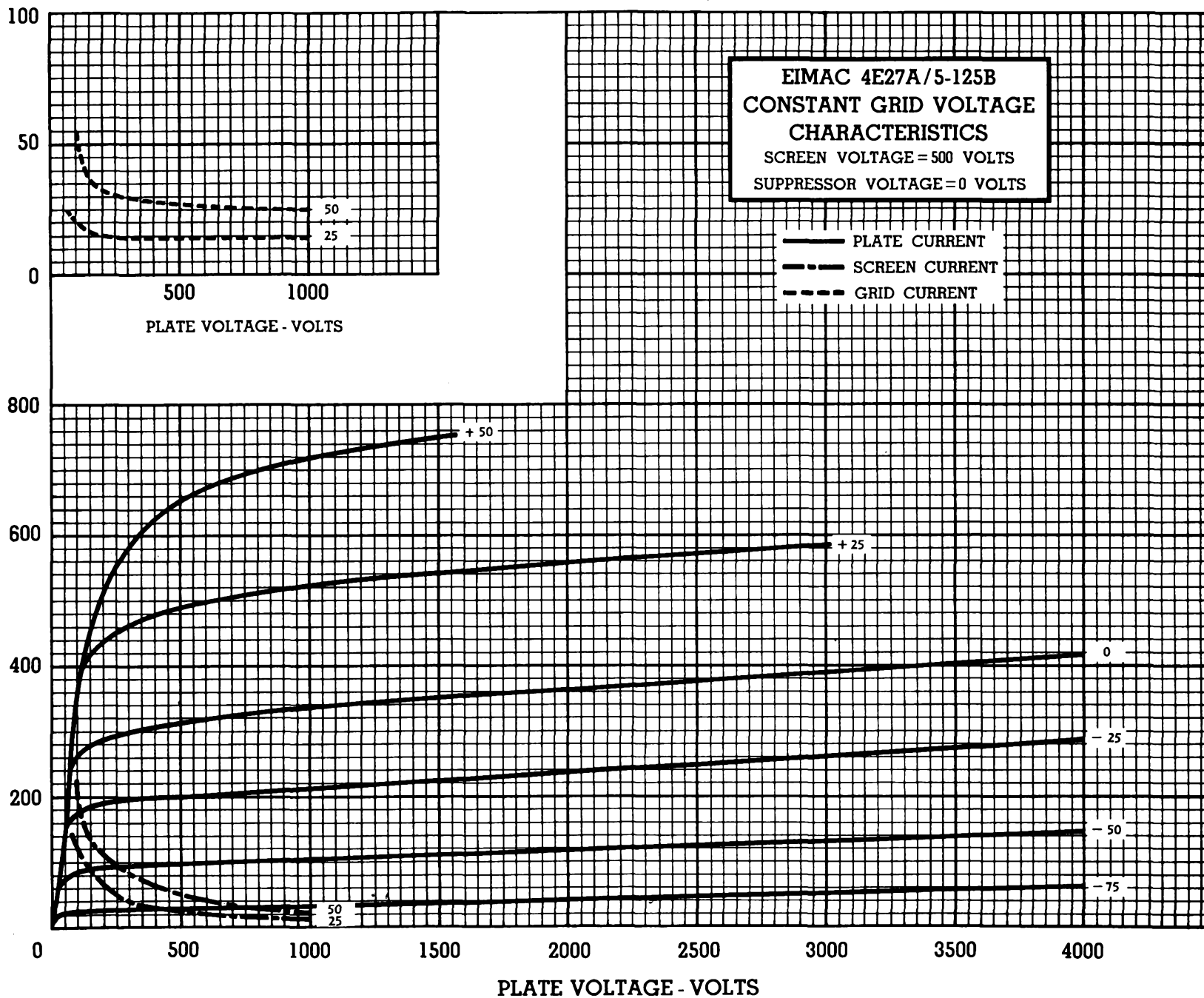



**E I M A C**  
 Division of Varian  
 SAN CARLOS  
 CALIFORNIA

**8166**  
**4-1000A**  
 RADIAL-BEAM  
 POWER-TETRODE  
 •  
 MODULATOR  
 OSCILATOR  
 AMPLIFIER

The EIMAC 8166/4-1000A is a radial-beam tetrode with a maximum plate dissipation rating of 1000 watts. Intended for use as an amplifier, oscillator, or modulator, the 8166/4-1000A is capable of efficient operation well into the VHF range.

In FM broadcast service on 110 Megahertz, two 8166/4-1000A tetrodes will deliver a useful output power of over 5000 watts.

Operating under class AB<sub>2</sub> modulator conditions with less than 10 watts of peak driving power, two of these tubes will deliver 3900 watts of output power.

In class AB<sub>1</sub>, a pair of 8166/4-1000A tetrodes will deliver 3800 watts of output power.

Cooling of the tube is accomplished by radiation from the plate and by circulation of forced-air through the base and around the envelope. Cooling can be simplified through the use of the EIMAC SK-500 Air-System Socket.

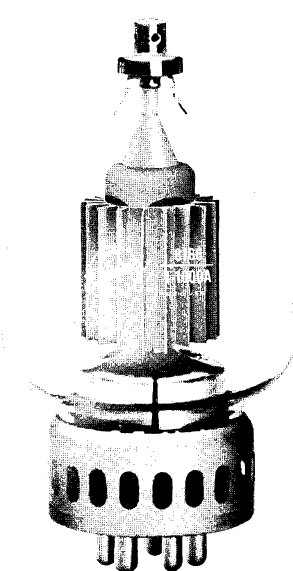

**GENERAL CHARACTERISTICS**

**ELECTRICAL**

	<i>Min.</i>	<i>Nom.</i>	<i>Max.</i>	
Filament: Thoriated tungsten				
Voltage - - - - -		7.5		volts
Current - - - - -	20.0		22.7	amperes
Amplification Factor (Grid to Screen)	6.1		7.7	
Direct Interelectrode Capacitances:†				
Grid-Plate - - - - -			0.35	μμf
Input - - - - -	23.8		32.4	μμf
Output - - - - -	6.8		9.4	μμf
Transconductance (I <sub>b</sub> =300 ma)		10,000		μmhos
Highest Frequency for Maximum Ratings			110	MHz

**MECHANICAL**

Base - - - - -				5-pin metal shell
Basing - - - - -				See drawing
Recommended Socket - - - - -				EIMAC SK-500 Air-System Socket
Operating Position - - - - -				Vertical, base up or down
Cooling - - - - -				Radiation and forced air
Recommended Heat-Dissipating Connector:				
Plate - - - - -				EIMAC HR-8
Maximum Over-all Dimensions:				
Length - - - - -				9.63 inches
Diameter - - - - -				5.25 inches
Net Weight (tube only) - - - - -				1.5 pounds
Shipping Weight - - - - -				12 pounds

†In Shielded Fixture



## RADIO FREQUENCY POWER AMPLIFIER AND OSCILLATOR

Class-C Telephony or FM Telephony

### MAXIMUM RATINGS (Key-down conditions, per tube to 110 MHz)

DC PLATE VOLTAGE	-	-	-	-	-	-	-	-	-	-	-	6000 VOLTS
DC SCREEN VOLTAGE	-	-	-	-	-	-	-	-	-	-	-	1000 VOLTS
DC GRID VOLTAGE	-	-	-	-	-	-	-	-	-	-	-	-500 VOLTS
DC PLATE CURRENT	-	-	-	-	-	-	-	-	-	-	-	700 MA
PLATE DISSIPATION	-	-	-	-	-	-	-	-	-	-	-	1000 WATTS
SCREEN DISSIPATION	-	-	-	-	-	-	-	-	-	-	-	75 WATTS
GRID DISSIPATION	-	-	-	-	-	-	-	-	-	-	-	25 WATTS

### TYPICAL OPERATION (Frequencies below 110 MHz, one tube)

DC Plate Voltage	-	-	-	-	-	-	-	-	-	-	-	3000	4000	5000	6000	volts
DC Screen Voltage	-	-	-	-	-	-	-	-	-	-	-	500	500	500	500	volts
DC Grid Voltage	-	-	-	-	-	-	-	-	-	-	-	-150	-150	-200	-200	volts
DC Plate Current	-	-	-	-	-	-	-	-	-	-	-	700	700	700	700	ma
DC Screen Current	-	-	-	-	-	-	-	-	-	-	-	146	137	147	140	ma
DC Grid Current	-	-	-	-	-	-	-	-	-	-	-	38	39	45	42	ma
Screen Dissipation	-	-	-	-	-	-	-	-	-	-	-	73	69	73	70	watts
Grid Dissipation	-	-	-	-	-	-	-	-	-	-	-	5	6	7	6	watts
Peak RF Grid Input Voltage (approx.)	-	-	-	-	-	-	-	-	-	-	-	290	290	355	350	volts
Driving Power (approx.)*	-	-	-	-	-	-	-	-	-	-	-	11	12	16	15	watts
Plate Input Power	-	-	-	-	-	-	-	-	-	-	-	2100	2800	3500	4200	watts
Plate Dissipation	-	-	-	-	-	-	-	-	-	-	-	670	700	690	800	watts
Plate Output Power	-	-	-	-	-	-	-	-	-	-	-	1430	2100	2810	3400	watts

\*Apparent driving power requirements increase above 30 MHz. At 110 MHz the driver should be capable of supplying 200 watts per tube to take care of feed-through, circuit losses, and radiation.

### TYPICAL OPERATION (110 MHz, two tubes, push-pull)

DC Plate Voltage	-	-	-	-	-	-	-	-	-	-	-	4000	5000	6000	volts
DC Screen Voltage	-	-	-	-	-	-	-	-	-	-	-	450	500	500	volts
DC Grid Voltage	-	-	-	-	-	-	-	-	-	-	-	-150	-160	-180	volts
DC Plate Current	-	-	-	-	-	-	-	-	-	-	-	1.15	1.25	1.25	amps
DC Screen Current	-	-	-	-	-	-	-	-	-	-	-	280	240	250	ma
DC Grid Current	-	-	-	-	-	-	-	-	-	-	-	80	80	100	ma
Screen Dissipation (per tube)	-	-	-	-	-	-	-	-	-	-	-	63	60	63	watts
Driving Power (approx.)	-	-	-	-	-	-	-	-	-	-	-	350	400	400	watts
Plate Input Power	-	-	-	-	-	-	-	-	-	-	-	4600	6250	7500	watts
Plate Dissipation (per tube)	-	-	-	-	-	-	-	-	-	-	-	650	850	900	watts
Useful Output Power	-	-	-	-	-	-	-	-	-	-	-	3000	4200	5200	watts

These 110 MHz typical performance figures were obtained by direct measurement in operating equipment. The output power is useful power measured in a load circuit. The driving power is that taken by the tube and a practical resonant circuit. In many cases with further refinement and improved techniques, better performance might be obtained.

## PLATE-MODULATED RADIO-FREQUENCY AMPLIFIER

Class-C Telephony (Carrier Conditions)

### MAXIMUM RATINGS (Per tube to 110 MHz)

DC PLATE VOLTAGE	-	-	-	-	-	-	-	-	-	-	-	-	-	-	-	-	5000 VOLTS†
DC SCREEN VOLTAGE	-	-	-	-	-	-	-	-	-	-	-	-	-	-	-	-	1000 VOLTS
DC GRID VOLTAGE	-	-	-	-	-	-	-	-	-	-	-	-	-	-	-	-	-500 VOLTS
DC PLATE CURRENT	-	-	-	-	-	-	-	-	-	-	-	-	-	-	-	-	600 MA
PLATE DISSIPATION	-	-	-	-	-	-	-	-	-	-	-	-	-	-	-	-	670 WATTS
SCREEN DISSIPATION	-	-	-	-	-	-	-	-	-	-	-	-	-	-	-	-	25 WATTS
GRID DISSIPATION	-	-	-	-	-	-	-	-	-	-	-	-	-	-	-	-	75 WATTS

†5500 Max. volts below 30 MHz.

### TYPICAL OPERATION (Frequencies below 110MHz, one tube)

DC Plate Voltage	-	-	-	-	-	-	-	-	-	-	-	3000	4000	5000	5500*	volts
DC Screen Voltage	-	-	-	-	-	-	-	-	-	-	-	500	500	500	500	volts
DC Grid Voltage	-	-	-	-	-	-	-	-	-	-	-	-200	-200	-200	-200	volts
DC Plate Current	-	-	-	-	-	-	-	-	-	-	-	600	600	600	600	ma
DC Screen Current	-	-	-	-	-	-	-	-	-	-	-	145	132	130	105	ma
DC Grid Current	-	-	-	-	-	-	-	-	-	-	-	36	33	33	28	ma
Screen Dissipation	-	-	-	-	-	-	-	-	-	-	-	72	66	65	52	watts
Grid Dissipation	-	-	-	-	-	-	-	-	-	-	-	5	4	4	3	watts
Peak AF Screen Voltage (100% modulation)	-	-	-	-	-	-	-	-	-	-	-	250	250	250	250	volts
Peak RF Grid Input Voltage	-	-	-	-	-	-	-	-	-	-	-	340	335	335	325	volts
Driving Power**	-	-	-	-	-	-	-	-	-	-	-	12	11	11	9	watts
Plate Input Power	-	-	-	-	-	-	-	-	-	-	-	1800	2400	3000	3300	watts
Plate Dissipation	-	-	-	-	-	-	-	-	-	-	-	410	490	560	670	watts
Plate Output Power	-	-	-	-	-	-	-	-	-	-	-	1390	1910	2440	2630	watts

\*5500 volt operation may be used below 30 MHz only.

\*\*Apparent driving power requirements increase above 30 MHz. At 110 MHz the driver should be capable of supplying 200 watts per tube to take care of feed-through, circuit losses, and radiation.

## AUDIO FREQUENCY POWER AMPLIFIER AND MODULATOR

Class-AB

### MAXIMUM RATINGS (Per tube)

DC PLATE VOLTAGE	-	-	-	-	-	-	-	-	-	-	-	-	-	-	-	-	6000 VOLTS
DC SCREEN VOLTAGE	-	-	-	-	-	-	-	-	-	-	-	-	-	-	-	-	1000 VOLTS
MAX-SIGNAL DC PLATE CURRENT	-	-	-	-	-	-	-	-	-	-	-	-	-	-	-	-	700 MA
PLATE DISSIPATION	-	-	-	-	-	-	-	-	-	-	-	-	-	-	-	-	1000 WATTS
SCREEN DISSIPATION	-	-	-	-	-	-	-	-	-	-	-	-	-	-	-	-	75 WATTS

### TYPICAL OPERATION Class-AB<sub>1</sub>

(Sinusoidal wave, two tubes unless otherwise specified)

DC Plate Voltage	-	-	-	-	-	-	-	-	-	-	-	4000	5000	6000	volts
DC Screen Voltage	-	-	-	-	-	-	-	-	-	-	-	1000	1000	1000	volts
DC Grid Voltage (approx.)*	-	-	-	-	-	-	-	-	-	-	-	-115	-125	-135	volts
Zero-Signal DC Plate Current	-	-	-	-	-	-	-	-	-	-	-	300	240	200	ma
Max-Signal DC Plate Current	-	-	-	-	-	-	-	-	-	-	-	1.05	1.00	0.95	amps
Zero-Signal DC Screen Current	-	-	-	-	-	-	-	-	-	-	-	0	0	0	ma
Max-Signal DC Screen Current	-	-	-	-	-	-	-	-	-	-	-	60	60	64	ma
Effective Load, Plate-to-Plate	-	-	-	-	-	-	-	-	-	-	-	7000	10,000	14,000	ohms
Peak AF Grid Input Voltage (per tube)	-	-	-	-	-	-	-	-	-	-	-	115	125	135	volts
Driving Power	-	-	-	-	-	-	-	-	-	-	-	0	0	0	watts
Max-Signal Plate Dissipation (per tube)	-	-	-	-	-	-	-	-	-	-	-	930	950	930	watts
Max-Signal Plate Output Power	-	-	-	-	-	-	-	-	-	-	-	2340	3100	3840	watts

\*Adjust to give stated zero-signal plate current. The DC resistance in series with the control grid of each tube should not exceed 250,000 ohms.

### TYPICAL OPERATION Class-AB<sub>2</sub>

(Sinusoidal wave, two tubes unless otherwise specified)

DC Plate Voltage	-	-	-	-	-	-	-	-	-	-	-	4000	5000	6000	volts
DC Screen Voltage	-	-	-	-	-	-	-	-	-	-	-	500	500	500	volts
DC Grid Voltage (approx.)*	-	-	-	-	-	-	-	-	-	-	-	-60	-70	-75	volts
Zero-Signal DC Plate Current	-	-	-	-	-	-	-	-	-	-	-	300	200	150	ma
Max-Signal DC Plate Current	-	-	-	-	-	-	-	-	-	-	-	1.20	1.10	.95	amps
Zero-Signal DC Screen Current	-	-	-	-	-	-	-	-	-	-	-	0	0	0	ma
Max-Signal DC Screen Current	-	-	-	-	-	-	-	-	-	-	-	95	90	65	ma
Effective Load, Plate-to-Plate	-	-	-	-	-	-	-	-	-	-	-	7000	11,000	15,000	ohms
Peak AF Grid Input Voltage (per tube)	-	-	-	-	-	-	-	-	-	-	-	140	145	130	volts
Max-Signal Peak Driving Power	-	-	-	-	-	-	-	-	-	-	-	11.0	11.0	9.4	watts
Max-Signal Nominal Driving Power (approx.)	-	-	-	-	-	-	-	-	-	-	-	5.5	5.5	4.7	watts
Max-Signal Plate Dissipation (per tube)	-	-	-	-	-	-	-	-	-	-	-	900	850	900	watts
Max-Signal Plate Output Power	-	-	-	-	-	-	-	-	-	-	-	3000	3800	3900	watts

\*Adjust to give stated zero-signal plate current.

Note: Typical operation data are based on conditions of adjusting the rf grid drive to a specified plate current, maintaining fixed conditions of grid bias and screen voltage. It will be found that if this procedure is followed there will be little variation in output power between tubes even though there may be some variation in grid and screen currents. Where grid bias is obtained principally by means of a grid resistor, it is necessary to make the resistor adjustable to control plate current.

IF IT IS DESIRED TO OPERATE THIS TUBE UNDER CONDITIONS WIDELY DIFFERENT FROM THOSE GIVEN UNDER "TYPICAL OPERATION," POSSIBLY EXCEEDING THE MAXIMUM RATINGS GIVEN FOR CW SERVICE, WRITE EIMAC DIVISION OF VARIAN ASSOCIATES, FOR INFORMATION AND RECOMMENDATIONS



## APPLICATION

### MECHANICAL

**Mounting** — The 4-1000A must be operated vertically. The base may be down or up. The recommended socket for this tube is the SK-500 Air-System Socket.

**Cooling** — Adequate forced-air cooling must be provided to maintain the base seal temperatures below 150°C and the plate seal temperature below 200°C. Cooling is simplified by the use of the EIMAC SK-500 Air-System Socket, and its SK-506 Air Chimney, which control the flow of air around the tube.

When the EIMAC SK-500 Air-System Socket is used, the following flow rates apply to sea level operation, with an ambient temperature of 25°C for the operating conditions described:

At 110 megahertz, with maximum rated plate dissipation, an air-flow rate of 35 cfm is required. The corresponding pressure drop as measured in the socket is 1.9 inches of water column.

At frequencies below 30 megahertz, an air-flow rate of 20 cfm provides adequate cooling. The corresponding pressure drop as measured in the socket is 0.6 inch of water column.

In the event that an Air-System Socket and Air Chimney are not used, air must be circulated through the base of the tube and over the envelope surface and the plate seal in sufficient quantities to maintain the temperatures below the maximum ratings. Seal-temperature ratings may require that cooling air be supplied to the tube if the filament is maintained at operating temperature during standby periods.

In any questionable situation, the only criterion for correct cooling practice is temperature. A convenient medium for measuring tube temperatures is a temperature-sensitive paint.

### ELECTRICAL

**Filament Voltage** — For maximum tube life the filament voltage, as measured directly at the filament pins, should be the rated voltage of 7.5 volts. Variations in filament voltage must be kept within the range of 7.13 to 7.87 volts.

**Bias Voltage** — The dc bias voltage for the 4-1000A should not exceed 500 volts. With grid-leak bias, suitable means must be provided to prevent excessive plate or screen dissipation in

the event of loss of excitation. The grid-resistor should be made adjustable to facilitate maintaining the bias voltage and plate current at the desired values from tube to tube. In the case of operation above 50 megahertz, it is advisable to keep the bias voltage as low as possible.

**Screen Voltage** — The dc screen voltage for the 4-1000A should not exceed 1000 volts. The screen voltages shown under "Typical Operation" are representative voltages for the type of operation involved.

**Plate Voltage** — The plate-supply voltage for the 4-1000A should not exceed 6000 volts in CW and audio applications. In plate-modulated telephony service above 30 megahertz, the dc plate-supply voltage should not exceed 5000 volts; however, below 30 megahertz, 5500-volts may be used.

**Grid Dissipation** — Grid dissipation for the 4-1000A should not be allowed to exceed 25 watts. Grid dissipation may be calculated from the following expression:

$$P_g = e_{\text{cmp}} I_c$$

where:  $P_g$  = Grid dissipation,  
 $e_{\text{cmp}}$  = Peak positive grid to cathode voltage  
 $I_c$  = DC grid current.

$e_{\text{cmp}}$  may be measured by means of a suitable peak voltmeter connected between filament and grid.

**Screen Dissipation** — The power dissipated by the screen of the 4-1000A must not exceed 75 watts. Screen dissipation is likely to rise to excessive values when the plate voltage, bias voltage, or plate load are removed with filament and screen voltages applied. Suitable protective means must be provided to limit screen dissipation to 75 watts in event of circuit failure.

**Plate Dissipation** — Under normal operating conditions, the plate dissipation of the 4-1000A should not be allowed to exceed 1000 watts.

In plate-modulated amplifier applications, the maximum allowable carrier-condition plate dissipation is 670 watts. The plate dissipation will rise to 1000 watts under 100 per-cent sinusoidal modulation.

Plate dissipation in excess of the maximum rating is permissible for short periods of time, such as during tuning procedures.



*Neutralization* — If reasonable precautions are taken to prevent coupling between input and output circuits, the 4-1000A may be operated up to the 10-megahertz region without neutralization. In the region between 10 megahertz and 30 megahertz, the conventional type of cross-neutralizing may be used with push-pull circuits. In single-ended circuits ordinary neutralization systems may be used which provide 180° out of phase voltage to the grid.

At frequencies above 30 megahertz the feedback is principally due to screen-lead-inductance effects. Feedback is eliminated by using series capacitance in the screen leads between the screen and ground. A variable capacitor of from 25 to 50  $\mu\mu\text{fds}$  will provide sufficient capacitance to neutralize each tube in the region of 100 megahertz. When using this method, the two screen terminals on the socket should be strapped together by the shortest possible lead. The lead from the mid-point of this screen strap

to the variable capacitor and from the variable capacitor to ground should have as little inductance as possible.

In general, plate, grid, filament, and screen-bypass or screen-neutralizing capacitors should be returned to rf ground through the shortest possible leads.

In order to take full advantage of the high power gain obtainable with the 4-1000A, care should be taken to prevent feedback from the output to input circuits. A conventional method of obtaining the necessary shielding between the grid and plate circuits is to use a suitable metal chassis with the grid circuit mounted below the deck and the plate circuit mounted above the deck. Power-supply leads entering the amplifier should be bypassed to the ground and properly shielded to avoid feedback coupling in these leads. The output circuit and antenna feeders should be arranged so as to preclude any possibility of feedback into other circuits.

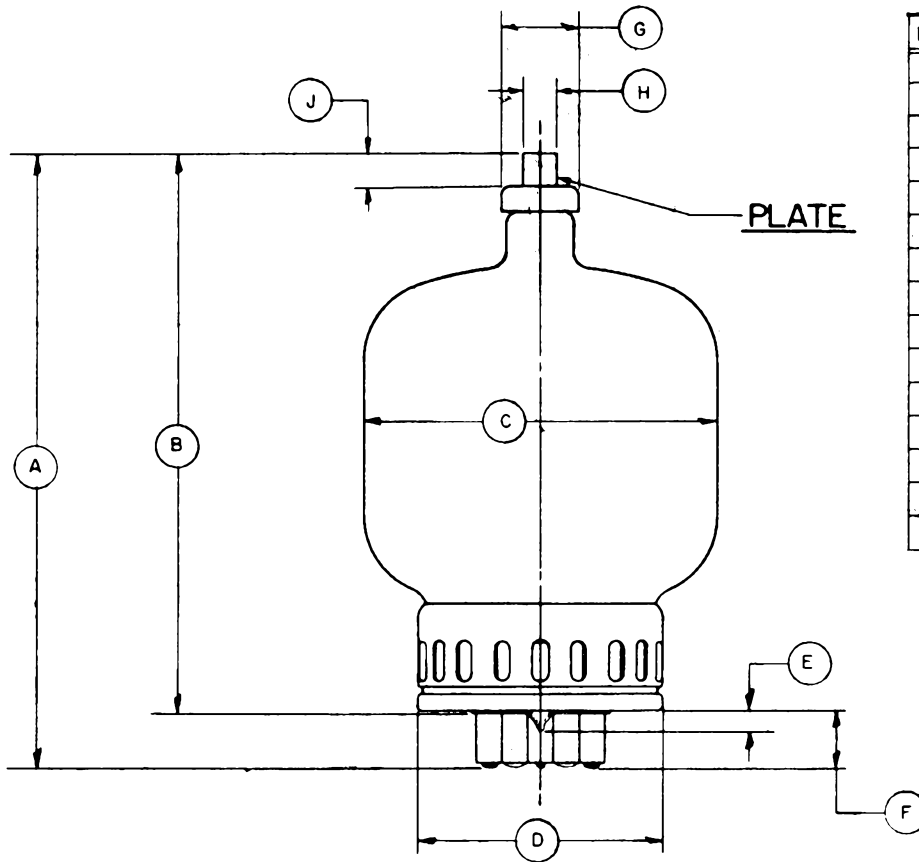

REF.	MIN.	NOM.	MAX.
A	8.875	9.250	9.625
B	6.000	8.375	8.750
C			5.250
D			3.625
E			.313
F	.825	.875	.925
G	1.110	1.125	1.140
H	.559	.566	.573
J	.484		
K		60°	
L		30°	
M		30°	
N	1.495	1.500	1.505
P	.371	.374	.377

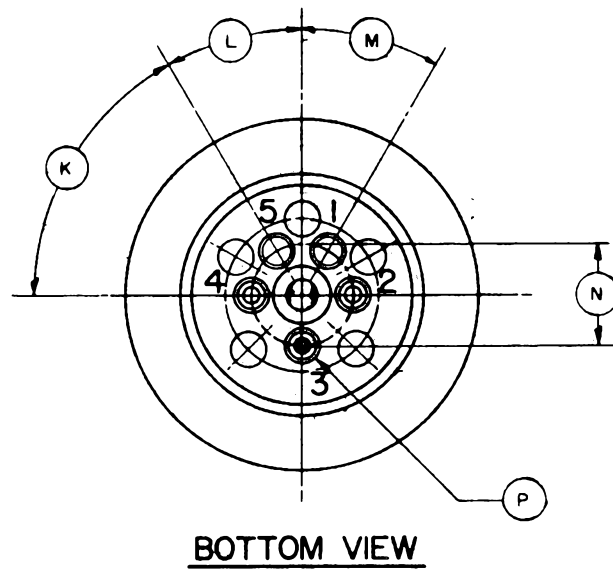
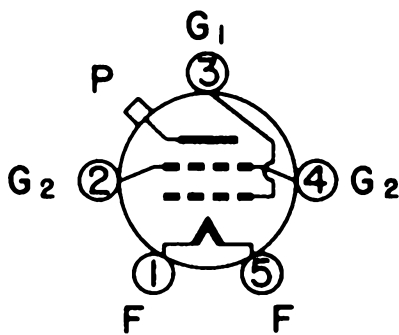

DIMENSIONS  
IN INCHES



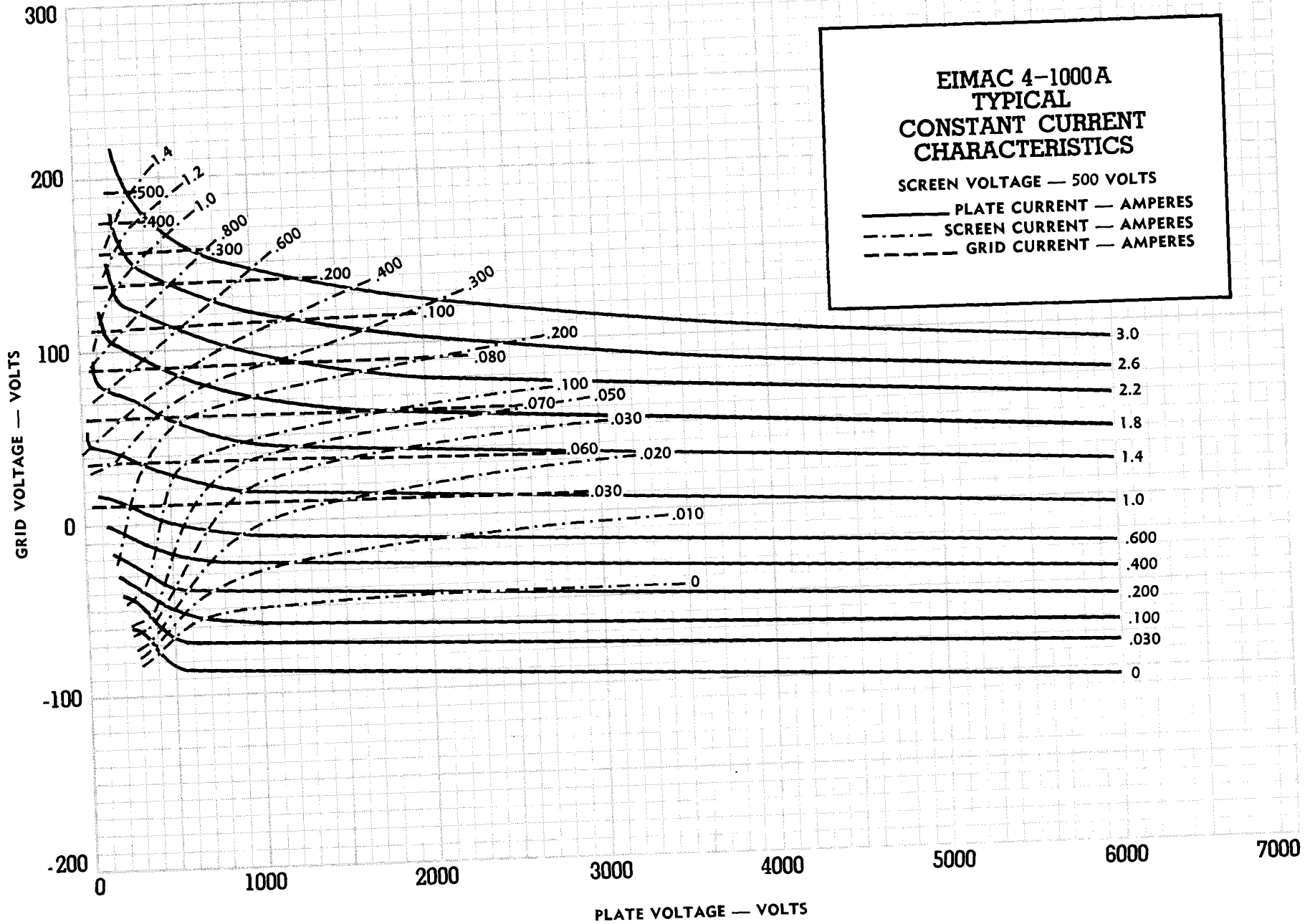

EIMAC  
4-1000A

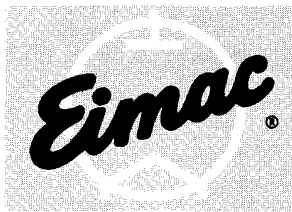

**E I M A C**  
 Division of Varian  
 S A N C A R L O S  
 C A L I F O R N I A

**8168**  
**4CX1000A**  
 CERAMIC  
 POWER TETRODE

The EIMAC 8168/4CX1000A is a ceramic/metal, forced-air cooled, radial-beam tetrode with a rated maximum plate dissipation of 1000 watts. It is a low-voltage, high-current tube specifically designed for Class-AB<sub>1</sub> rf linear-amplifier or audio-amplifier applications where its high gain may be used to advantage. At its rated maximum plate voltage of 3000 volts, it is capable of producing 1630 watts of peak-envelope output power. Two 8168/4CX1000As operating in Class-AB<sub>1</sub> will produce 3260 watts of audio power.

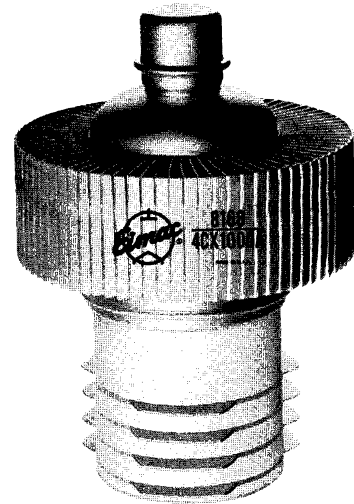

**GENERAL CHARACTERISTICS<sup>1</sup>**

**ELECTRICAL**

Cathode: Oxide Coated, Unipotential

Heater: Voltage . . . . . 6.0 ± 0.3 V  
 Current, at 6.0 volts . . . . . 9.0 A

Transconductance (Average):

I<sub>b</sub> = 1.0 Adc . . . . . 37,000 μmhos

Direct Interelectrode Capacitances (grounded cathode)<sup>2</sup>

Input . . . . . 81 pF  
 Output . . . . . 11.8 pF  
 Feedback . . . . . 0.015 pF

Direct Interelectrode Capacitances (grounded grid and screen)<sup>2</sup>

Input . . . . . 35.5 pF  
 Output . . . . . 12 pF  
 Feedback . . . . . 0.004 pF

Frequency of Maximum Rating:

CW . . . . . 110 MHz

1. Characteristics and operating values are based upon performance tests. These figures may change without notice as the result of additional data or product refinement. EIMAC Division of Varian should be consulted before using this information for final equipment design.

2. In Shielded Fixture.

**MECHANICAL**

Maximum Overall Dimensions:

Length . . . . . 4.80 in; 122 mm  
 Diameter . . . . . 3.37 in; 85.5 mm  
 Net Weight . . . . . 27 oz; 768 gm  
 Operating Position . . . . . Any



Maximum Operating Temperature:

Ceramic/Metal Seals .....	.250°C
Anode Core .....	.250°C
Cooling .....	Forced Air
Base .....	Special, breechblock terminal surfaces
Recommended Socket .....	EIMAC SK-800 Series
Recommended Chimney .....	EIMAC SK-806 Series

**RADIO FREQUENCY LINEAR AMPLIFIER**

**GRID DRIVEN**

Class AB<sub>1</sub>

MAXIMUM RATINGS:

DC PLATE VOLTAGE .....	3000 VOLTS
DC SCREEN VOLTAGE .....	400 VOLTS
DC PLATE CURRENT .....	1.0 AMPERE
PLATE DISSIPATION .....	1000 WATTS
SCREEN DISSIPATION .....	12 WATTS
GRID DISSIPATION .....	0 WATT

1. Adjust to specified zero-signal dc plate current.
2. Approximate value.

TYPICAL OPERATION (Frequencies to 30 MHz)

Class AB<sub>1</sub> Grid Driven, Peak Envelope or Modulation Crest Conditions

Plate Voltage .....	2000	2500	3000	Vdc
Screen Voltage .....	325	325	325	Vdc
Grid Voltage <sup>1</sup> .....	-60	-60	-60	Vdc
Zero-Signal Plate Current ...	250	250	250	mAdc
Single Tone Plate Current ...	890	885	875	mAdc
Two-Tone Plate Current ...	645	650	635	mAdc
Zero-Signal Screen Current ...	8	6	5	mAdc
Single-Tone Screen Current <sup>2</sup> ..	35	35	35	mAdc
Two-Tone Screen Current <sup>2</sup> ...	10	8	8	mAdc
Plate Output Power .....	930	1300	1630	W

**AUDIO FREQUENCY POWER AMPLIFIER OR MODULATOR**

Class AB<sub>1</sub>, Grid Driven(Sinusoidal Wave)

MAXIMUM RATINGS (Per Tube)

DC PLATE VOLTAGE .....	3000 VOLTS
DC SCREEN VOLTAGE .....	400 VOLTS
DC PLATE CURRENT .....	1.0 AMPERE
PLATE DISSIPATION .....	1000 WATTS
SCREEN DISSIPATION .....	12 WATTS
GRID DISSIPATION .....	0 WATT

TYPICAL OPERATION (Two Tubes)

Plate Voltage .....	2000	2500	3000	Vdc
Screen Voltage .....	325	325	325	Vdc
Grid Voltage <sup>1,2</sup> .....	-60	-60	-60	Vdc
Zero-Signal Plate Current ...	500	500	500	mAdc
Max Signal Plate Current ...	1.78	1.77	1.75	Adc
Zero-Signal Screen Current <sup>1</sup> ..	16	12	10	mAdc
Max Signal Screen Current <sup>1</sup> ..	70	70	70	mAdc
Plate Output Power .....	1860	2600	3260	W
Load Resistance (plate to plate) .....	2040	2850	3860	Ω

1. Approximate value.
2. Adjust to give stated zero-signal plate current.

NOTE: TYPICAL OPERATION data are obtained by calculation from published characteristic curves. Adjustment of the rf grid voltage to obtain the specified plate current at the specified bias, screen and plate voltages is assumed. If this procedure is followed, there will be little variation in output power when the tube is changed, even though there may be some variation in grid and screen current. The grid and screen currents which result when the desired plate current is obtained are incidental and vary from tube to tube. These current variations cause no difficulty so long as the circuit maintains the correct voltage in the presence of the variations in current. When grid drive is applied, the screen voltage required to obtain the specified value of plate current without drawing grid current may vary somewhat from the typical values shown.



## RANGE VALUES FOR EQUIPMENT DESIGN

	<u>Min.</u>	<u>Max.</u>	
Heater: Current at 6.0 volts . . . . .	8.1	9.9	A
Cathode Warmup Time . . . . .	3	---	min.
Interelectrode Capacitances <sup>1</sup> (grounded cathode connection)			
Input . . . . .	75	88	pF
Output . . . . .	10.8	12.8	pF
Feedback . . . . .	---	0.022	pF

1. In shielded fixture

## APPLICATION

### MECHANICAL

**COOLING** - Sufficient cooling must be provided for the anode and ceramic/metal seals to maintain operating temperatures below the rated maximum values:

Ceramic/Metal Seals	250°C
Anode Core	250°C

A flow rate of 25 cubic feet per minute will be adequate for operation at maximum rated plate dissipation at sea level and with inlet air temperatures up to 40°C. Under these conditions, 25 cfm of air flow corresponds to a pressure difference across the tube and socket of 0.2 inch of water column. Experience has shown that if reliable long-life operation is to be obtained, the cooling air flow must be maintained during standby periods when only the heater voltage is applied to the tube.

At higher altitudes and at VHF increased air flow will be required. For example, at an altitude of 10,000 feet, a flow rate of 37 cfm will be required and will be obtained with a pressure drop across tube and socket of 0.3 inch of water column. In selecting a blower for use at high altitudes, care must be taken to assure that the blower is designed to deliver the desired volume of air at the corresponding pressure drop and *at the particular altitude*.

In cases where there is any doubt regarding the adequacy of the supplied cooling, it should be borne in mind that operating temperature is the sole criterion of cooling effectiveness. Surface temperatures may be easily and effectively measured by using one of the several temperature-sensitive paints or sticks available from various chemical or scientific-equipment suppli-

ers. When these materials are used, extremely thin applications must be made to avoid interference with the transfer of heat from the tube to the air stream, which would cause inaccurate indications.

The 4CX1000A is tested for vibration (noise) from 10 Hz to 500 Hz. Vibration level is 10 G units peak 28 Hz to 500 Hz. Below 28 Hz vibration double amplitude is .25 inch.

The 4CX1000A is tested for shock, 50 G, 11 ms, three axes, after which the tube must be within specification for grid bias voltage and gas current.

### ELECTRICAL

**HEATER** - The rated heater voltage for the 4CX1000A is 6.0 volts. The voltage, as measured at the socket, should be maintained at this value to minimize variations in operation and to obtain maximum tube life. In no case should the voltage be allowed to exceed 5% above the rated value.

The cathode and one side of the heater are internally connected.

It is recommended that the heater voltage be applied for a period of not less than 3 minutes before other operating voltages are applied. From an initial cold condition, tube operation will stabilize after a period of approximately 5 minutes.

**GRID OPERATION** - The grid dissipation rating of the 4CX1000A is zero watts. The design features which make the tube capable



of maximum power operation without driving the grid into the positive region also make it necessary to avoid positive-grid operation.

Although the average grid-current rating is zero, peak grid currents of less than five-milliamperes as read on a five-milliamperemeter may be permitted to flow for peak-signal monitoring purposes.

**SCREEN OPERATION** - Tetrode tubes may exhibit reversed screen current to a greater or lesser degree depending on individual tube design. This characteristic is prominent in the 4CX1000A and, under some operating conditions, indicated negative screen currents in the order of 25 milliamperes may be encountered.

The maximum rated power dissipation for the screen grid in the 4CX1000A is 12 watts and the screen power should be kept below this level. The product of the peak screen voltage and the indicated dc screen current approximates the screen input power except when the screen current indication is near zero or negative. In the usual tetrode amplifier, where no signal voltage appears between cathode and screen, the peak screen voltage is equal to the dc screen voltage. Experience has shown that the screen will operate within the limits established for this tube if the indicated screen current, plate voltage and drive voltage approximate the "Typical Operation" values.

The screen supply voltage must be maintained constant for any values of negative and positive screen currents that may be encoun-

tered. Dangerously high plate currents may flow if the screen power supply exhibits a rising voltage characteristic with negative screen current. Stabilization may be accomplished in several different ways. A bleeder resistor may be connected from screen to cathode; a combination of VR tubes may be connected from screen to cathode; or an electron-tube regulator circuit may be used in the screen supply. It is absolutely essential to use a bleeder if a series electron-tube regulator is employed. The screen bleeder current should approximate 70 milliamperes to adequately stabilize the screen voltage. It should be observed that this bleeder power may be usefully employed to energize low-power stages of the transmitter.

**PLATE OPERATION** - The maximum rated plate dissipation power is 1000 watts. Except for brief periods during circuit adjustments, this maximum value should not be exceeded.

The top cap on the anode cooler may be used as a plate terminal at low frequencies or a circular clamp or spring-finger collet encircling the cylindrical outer surface of the anode cooler may be used at high frequencies.

**SPECIAL APPLICATIONS** - If it is desired to operate this tube under conditions different from those given here, write to the Power Grid Tube Marketing Department, EIMAC Division of Varian, San Carlos, California 94070, for information and recommendations.

DIM.	DIMENSIONAL DATA			
	INCHES		MILLIMETERS	
	MIN.	MAX.	MIN.	MAX.
A	3.335	3.365	84.71	85.47
B	0.807	0.817	20.50	20.75
C	1.870	1.900	47.50	48.26
D	2.250D	2.300D	57.15D	58.42D
E	2.195	2.380	55.75	60.45
F	3.410	3.550	86.61	90.17
G	4.600	4.800	116.84	121.92
H	0.965	0.988	24.51	25.10
J	0.690	0.710	17.53	18.03
K	0.415	0.435	10.54	11.05
L	0.140	0.165	3.56	4.19
M	0.020	0.030	0.51	0.76
N	0.700	0.800	17.78	20.32
P	0.314D	0.326D	7.98D	8.28D
R	55°	65°	55°	65°
S	115°	125°	115°	125°
T	0.470	0.530	11.94	13.46
U	0.025	0.048	0.63	1.22
V	0.045D	0.070D	1.14	1.78

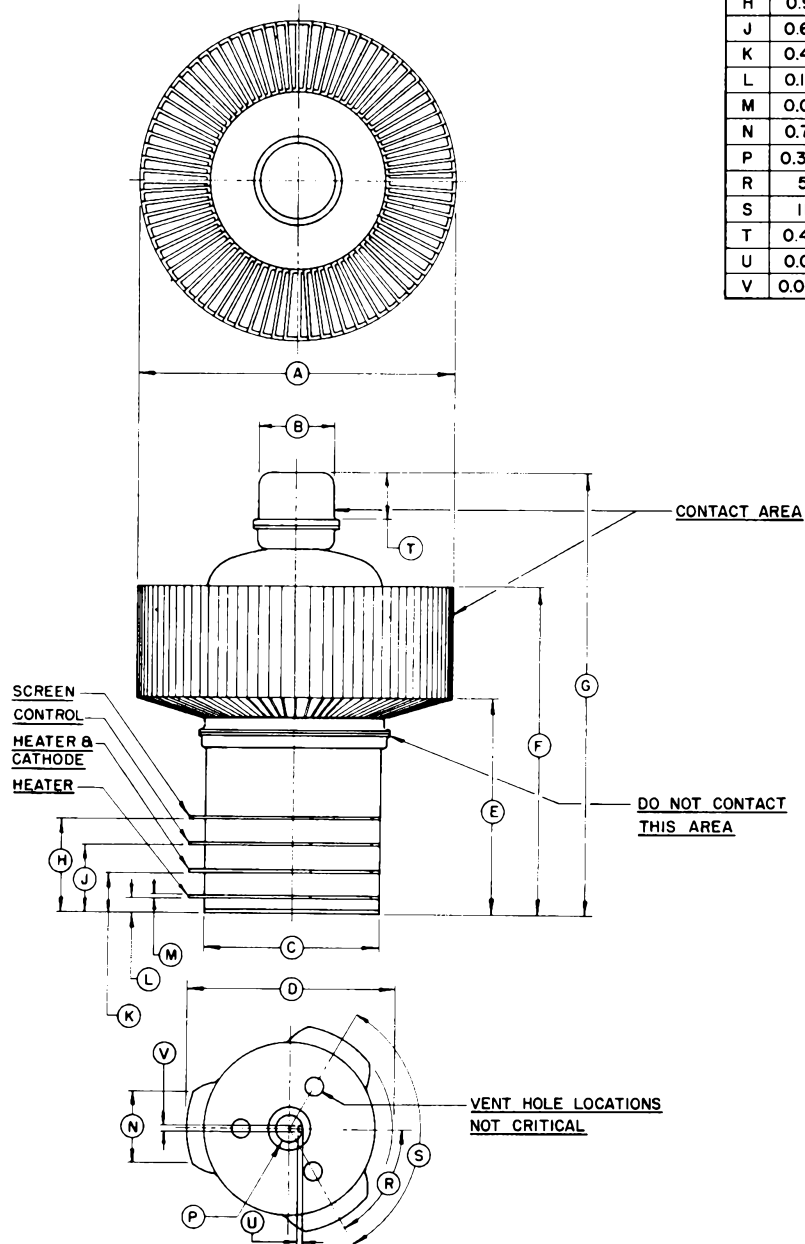

**EIMAC 4CX1000A**  
**TYPICAL**  
**CONSTANT CURRENT**  
**CHARACTERISTICS**  
 SCREEN VOLTAGE — 325 VOLTS  
 ——— PLATE CURRENT — AMPERES  
 - - - - SCREEN CURRENT — AMPERES

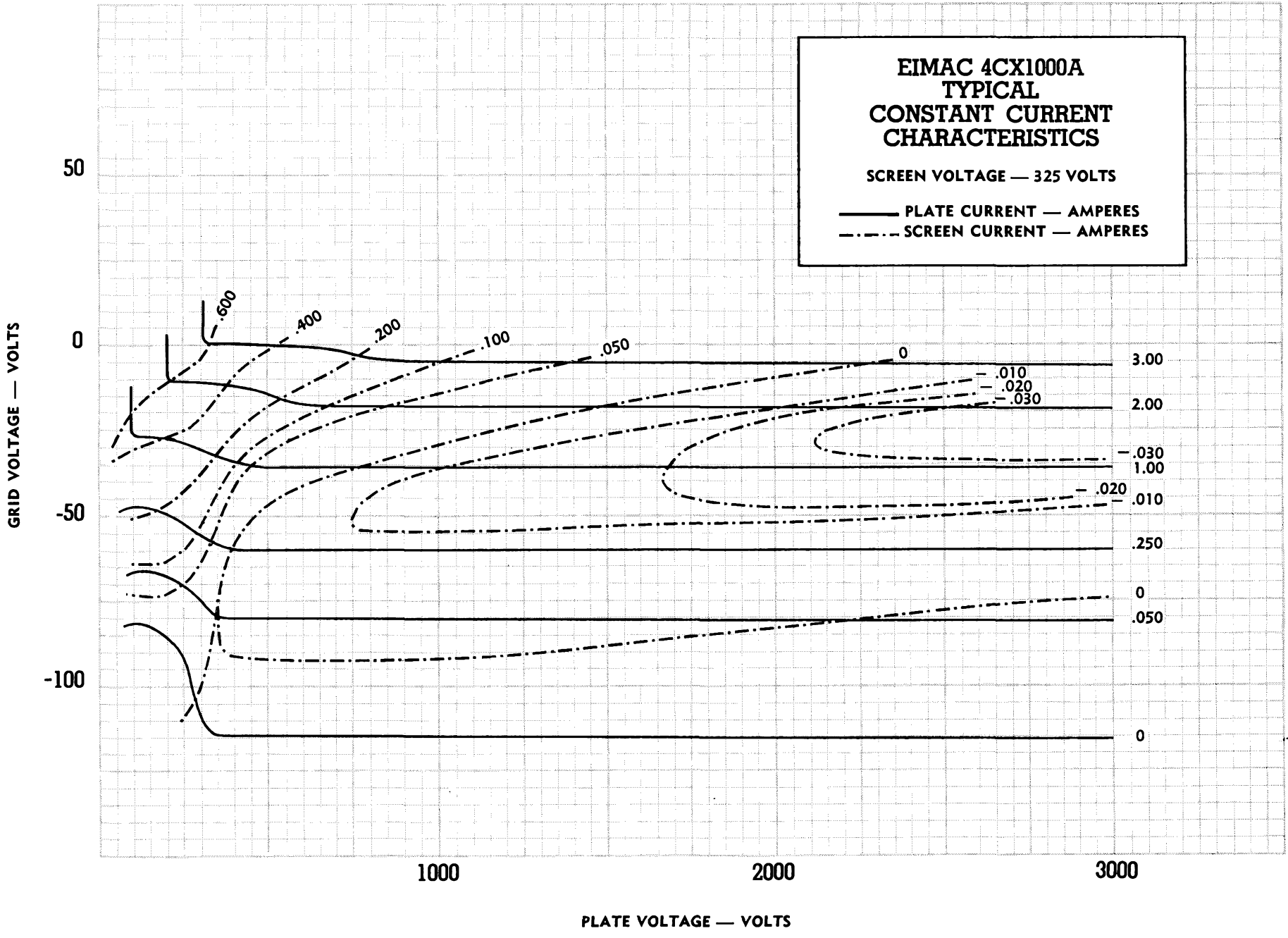

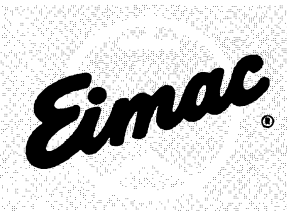

**E I M A C**  
 Division of Varian  
 SAN CARLOS  
 CALIFORNIA

**4CX1500B**  
 RADIAL BEAM  
 POWER TETRODE

JEDEC DESIGNATION

**8660**

The EIMAC 4CX1500B is ceramic and metal, forced-air cooled, radial beam tetrode with a rated maximum plate dissipation of 1500 watts. It is a low-voltage, high-current tube specifically designed for exceptionally low intermodulation distortion and low grid interception. The low distortion characteristics make the 4CX1500B especially suitable for radio-frequency and audio-frequency linear amplifier service.



**ELECTRICAL GENERAL CHARACTERISTICS**

	<u>Min.</u>	<u>Nom.</u>	<u>Max.</u>	
Cathode: Oxide Coated, Unipotential				
Heating Time - - - - -	3			min
Heater: Voltage - - - - -		6.0		V
Current - - - - -	9.0		11.0	A
Transconductance: ( $I_p=0.5$ amperes, $E_c=225$ volts)		30,000		umhos
Direct Interelectrode Capacitances, Grounded Cathode: *	<u>Min.</u>	<u>Nom.</u>	<u>Max.</u>	
Input - - - - -	75		88	pF
Output - - - - -	10.8		12.8	pF
Feedback - - - - -			.03	pF
Direct Interelectrode Capacitances, Grounded Grid and Screen: *				
Input - - - - -		38		pF
Output - - - - -		12		pF
Feedback - - - - -			0.005	pF

\* In Shielded Fixture

**MECHANICAL**

Base - - - - -	Special, breechblock terminal surfaces
Maximum Operating Temperatures:	
Ceramic-to-Metal Seals - - - - -	250°C
Anode Core - - - - -	250°C
Recommended Socket - - - - -	EIMAC SK-800 Series
Operating Position - - - - -	Any
Maximum Over-All Dimensions:	
Height - - - - -	4.8 in
Diameter - - - - -	3.37 in
Net Weight - - - - -	27 oz
Shipping Weight (Approximate) - - - - -	3 lbs

**RADIO-FREQUENCY LINEAR AMPLIFIER**

Class AB

MAXIMUM RATINGS

DC PLATE VOLTAGE - - - - -	3000 VOLTS
DC SCREEN VOLTAGE - - - - -	400 VOLTS
DC PLATE CURRENT - - - - -	.900 AMP
PLATE DISSIPATION - - - - -	1500 WATTS
SCREEN DISSIPATION - - - - -	12 WATTS
CONTROL GRID DISSIPATION - - - - -	1 WATT

\*Adjust to the specified Zero-Signal Plate Current.  
 \*\*The driving power specified includes the power dissipated in a 1000 ohm swamping resistor between the control grid and the cathode.  
 \*\*\*The intermodulation distortion products will be as specified or better for all levels from zero-signal to maximum output power and are referenced against one tone of a two equal tone signal.

**TYPICAL OPERATION (Frequencies below 30 MHz)**

Class AB<sub>2</sub>, Grid Driven, Peak Envelope or Modulation Crest Conditions

DC Plate Voltage - - - - -	2500	2750	2900	Volts
DC Screen Voltage - - - - -	225	225	225	Volts
DC Grid Voltage* - - - - -	-34	-34	-34	Volts
Zero-Signal DC Plate Current - - - - -	300	300	300	mA
Single-Tone DC Plate Current - - - - -	720	755	710	mA
Two-Tone DC Plate Current - - - - -	530	555	542	mA
Single-Tone DC Grid Current - - - - -	1.3	0.95	0.53	mA
Two-Tone DC Grid Current - - - - -	0.06	0.20	0.06	mA
Single-Tone DC Screen Current - - - - -	—7	—14	—15	mA
Two-Tone DC Screen Current - - - - -	—11	—11	—11	mA
Peak RF Grid Voltage - - - - -	46	45	41	Volts
Driving Power** - - - - -	1.5	1.5	1.5	Watts
Useful Output Power - - - - -	900	1100	1100	Watts
Resonant Load Impedance - - - - -	1900	1900	2200	Ohms
Intermodulation Distortion Products***				
3rd order - - - - -	—38	—40	—43	dB
5th order - - - - -	—47	—48	—47	dB



**AUDIO AMPLIFIER OR MODULATOR**Class AB<sub>1</sub>MAXIMUM RATINGS

DC PLATE VOLTAGE	- - -	3000 VOLTS
DC SCREEN VOLTAGE	- - -	400 VOLTS
DC PLATE CURRENT	- - -	.900 AMP
PLATE DISSIPATION	- - -	1500 WATTS
SCREEN DISSIPATION	- - -	12 WATTS
GRID DISSIPATION	- - -	1.0 WATTS

\*Approximate values.

\*\*Adjust grid bias to obtain listed zero-signal plate current.

TYPICAL OPERATION (Sinusoidal wave, 2 tubes unless noted)

DC Plate Voltage	- - -	2000	2500	2900	Volts
DC Screen Voltage	- - -	325	325	325	Volts
DC Grid Voltage**	- - -	-60	-60	-60	Volts
Zero-Signal DC Plate Current	-	500	500	500	mA
Max.-Signal DC Plate Current	-	1.68	1.69	1.69	Amps
Zero-Signal DC Screen Current*	-	30	25	20	mA
Max.-Signal DC Screen Current*	-	27	33	32	mA
Effective Load, Plate to Plate	-	1948	2715	3333	Ohms
Driving Power	- - -	0	0	0	Watts
Max.-Signal Plate Output Power	-	1604	2258	2774	Watts

NOTE: "TYPICAL OPERATION" data are obtained by calculation from the published characteristic curves and confirmed by direct tests. Adjustment of the grid bias to obtain the specified zero-signal plate current is assumed. When grid drive is applied, the screen voltage required to obtain the specified value of plate current without drawing grid current may vary somewhat from the typical values shown.

**APPLICATION**

**Cooling** — The maximum temperature rating for the anode core of the 4CX1500B is 250°C. Sufficient forced air circulation must be provided to keep the temperature of the anode at the base of the cooling fins and the temperature of the ceramic-to-metal seals to below 250°C. Air flow requirements to maintain seal temperature at 225°C in 50°C ambient air are tabulated below (for operation below 30 megahertz). Tube mounted in recommended socket and chimney.

Plate Dissipation watts	Sea Level		10,000 feet	
	Air Flow CFM	Pressure Drop inches water	Air Flow CFM	Pressure Drop inches water
1000	18	.23	24	.31
1500	34	.60	45	.80

\*Since the power dissipated by the heater represents about 60 watts and since grid plus screen dissipation can, under some conditions, represent another 13 watts, allowance has been made in preparing this tabulation for an additional 73 watts dissipation.

The blower selected in a given application must be capable of supplying the desired air flow at a back pressure equal to the pressure drop shown above plus any drop encountered in ducts and filters.

At other altitudes and ambient temperatures the flow rate must be modified to obtain equivalent cooling. The flow rate and corresponding pressure differential must be determined individually in such cases, using rated maximum temperatures as the criteria for satisfactory cooling.

**Heater** — The rated heater voltage for the 4CX1500B is 6.0 volts. The voltage, as measured at the socket, should be maintained at this value to minimize variations in operation and to obtain maximum tube life. In no case should the voltage be allowed to exceed 5% above or below the rated value.

The cathode and one side of the heater are internally connected.

It is recommended that the heater voltage be applied for a period of not less than 3 minutes before other operating voltages are applied. From an initial cold condition, tube operation will stabilize after a period of approximately 5 minutes.

**Intermodulation Distortion** — The Radio Frequency Linear Amplifier operating conditions including the distortion data are the results of actual operation in a neutralized grid-driven amplifier. Plots of IM distortion versus power output under two-tone conditions, as a function of zero-signal plate current, are included to illustrate the effect of this parameter upon distortion. Because the 4CX1500B has very low grid interception it is possible to drive the grid positive without any adverse effects upon the distortion level or upon the driver. Class AB<sub>2</sub> linear amplifier operation is therefore possible and recommended. It is also recommended that a low impedance driver be used and that the input of the 4CX1500B be swamped with a 1000 ohm resistor from grid to cathode so as to provide an almost constant load to the driver.

**Control-Grid Operation** — The control grid dissipation rating of the 4CX1500B is 1 watt. The design features which make the 4CX1500B such an extremely linear tube also contribute to very low grid interception. It will be found that the grid will be driven into the positive grid region in the typical operation of the tube. The grid current will usually be less than 1.0 milliamperere.

**Screen-Grid Operation** — Tetrode tubes may exhibit reversed screen current to a greater or lesser degree depending on individual tube design. This characteristic is prominent in the 4CX1500B and, under some operating conditions, indicated negative screen currents in the order of 35 milliamperes may be encountered.

The maximum rated power dissipation for the screen grid in the 4CX1500B is 12 watts and

the screen power should be kept below this level. The product of the peak screen voltage and the indicated dc screen current approximates the screen input power except when the screen current indication is near zero or negative. In the usual tetrode amplifier, where no signal voltage appears between cathode and screen, the peak screen voltage is equal to the dc screen voltage. Experience has shown that the screen will operate within the limits established for this tube if the indicated screen current, plate voltage and drive voltage approximate the "Typical Operation" values.

The screen supply voltage must be maintained constant for any values of negative and positive screen currents that may be encountered. Dangerously high plate currents may flow if the screen power supply exhibits a rising voltage characteristic with negative screen current. Stabilization may be accomplished in several different ways. A bleeder resistor may be connected from screen to cathode; a combination of VR tubes may be connected from screen to cathode; or an electron-tube regulator circuit may be used in the screen supply. It is absolutely essential to use a bleeder if a series electron-tube regulator is employed. The screen bleeder current should approximate 70 milliamperes to

adequately stabilize the screen voltage. It should be observed that this bleeder power may be usefully employed to energize low-power stages of the transmitter.

**Plate Operation** — The maximum rated plate dissipation power is 1500 watts. Except for brief periods during circuit adjustments, this maximum value should not be exceeded.

The top cap on the anode cooler may be used as a plate terminal at low frequencies or a circular clamp or spring-finger collet encircling the cylindrical outer surface of the anode cooler may be used at high frequencies.

Points of electrical contact with the anode cooler should be kept clean and free of oxide to minimize radio-frequency losses. The anode cooler should be inspected periodically and cleaned when necessary to remove any dirt which might interfere with effective cooling.

**Special Applications** — If it is desired to operate this tube under conditions different from those given here, write to the Power Grid Product Manager, EIMAC Division of Varian Associates, San Carlos, California, for information and recommendations.

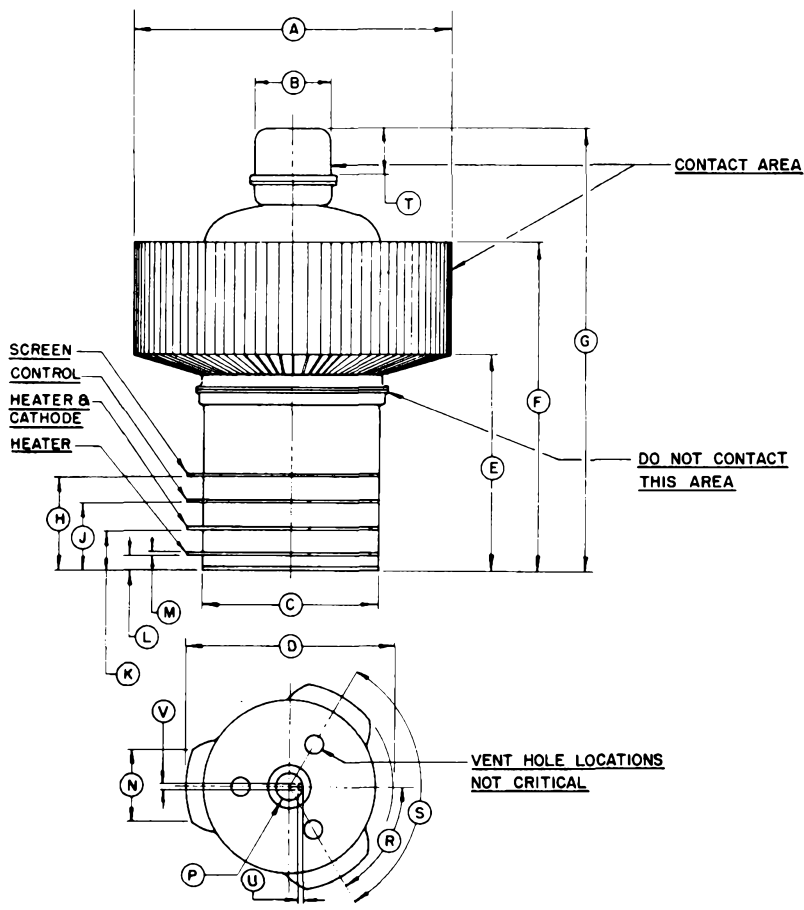

DIMENSION DATA			
REF.	NOM.	MIN.	MAX.
A		3.335	3.365
B		.807	.817
C		1.870	1.900
D		2.250 DIA.	2.300 DIA.
E		2.195	2.380
F		3.410	3.550
G		4.600	4.800
H		.950	1.000
J		.675	.725
K		.400	.450
L		.140	.170
M		.020	.030
N		.700	.800
P		.314 DIA.	.326 DIA.
R		55°	65°
S		115°	125°
T		.470	.530
U		.023	.043
V		.057 DIA.	.073 DIA.

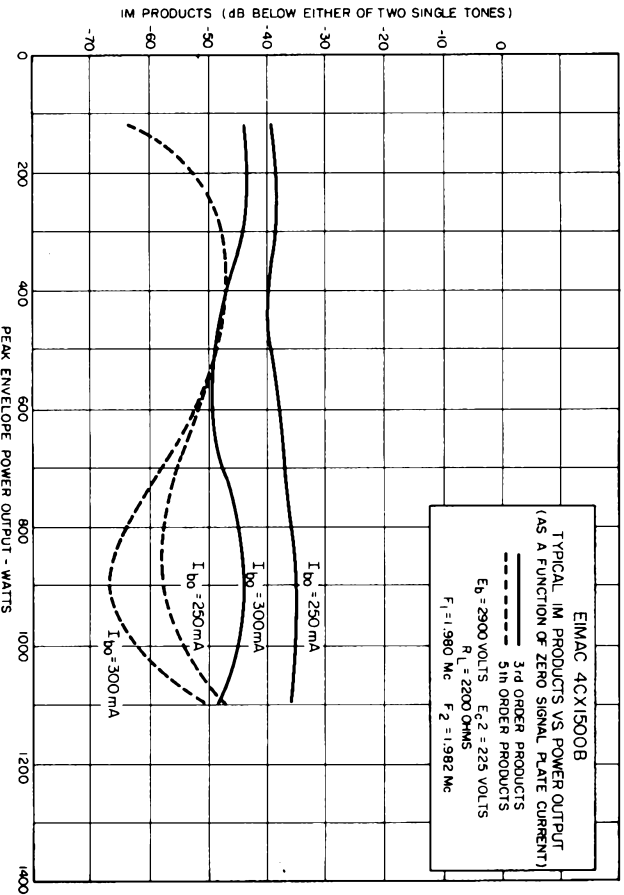
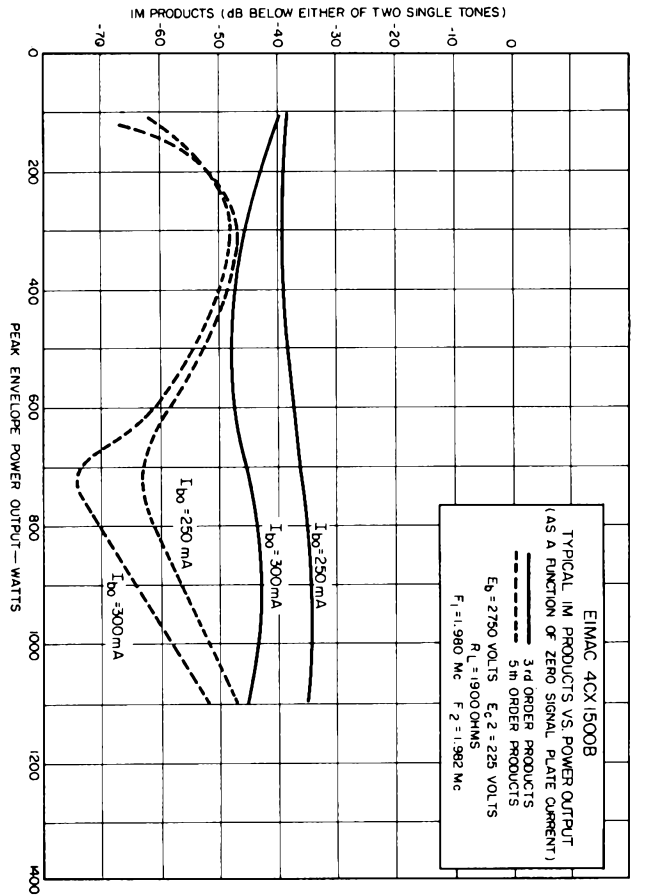
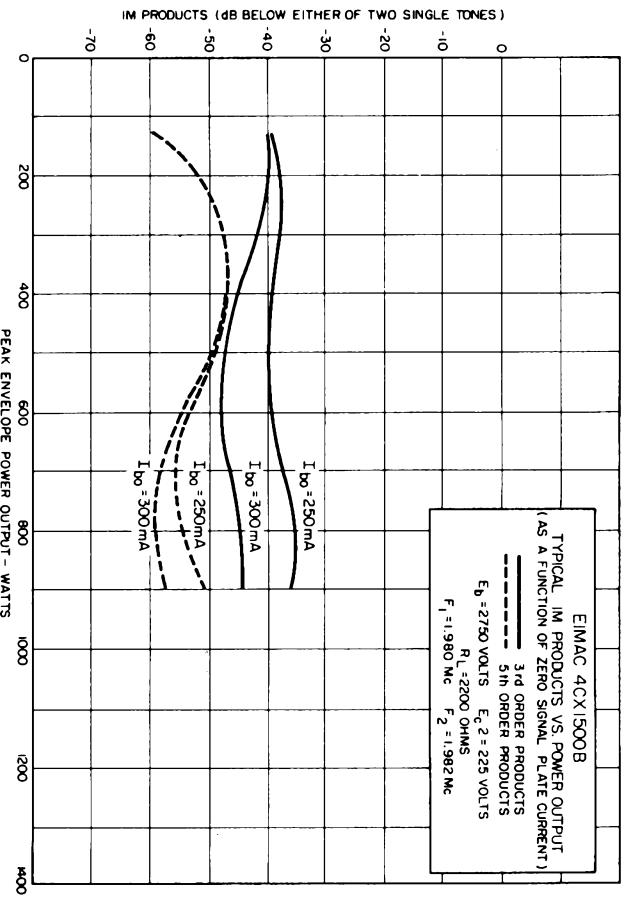
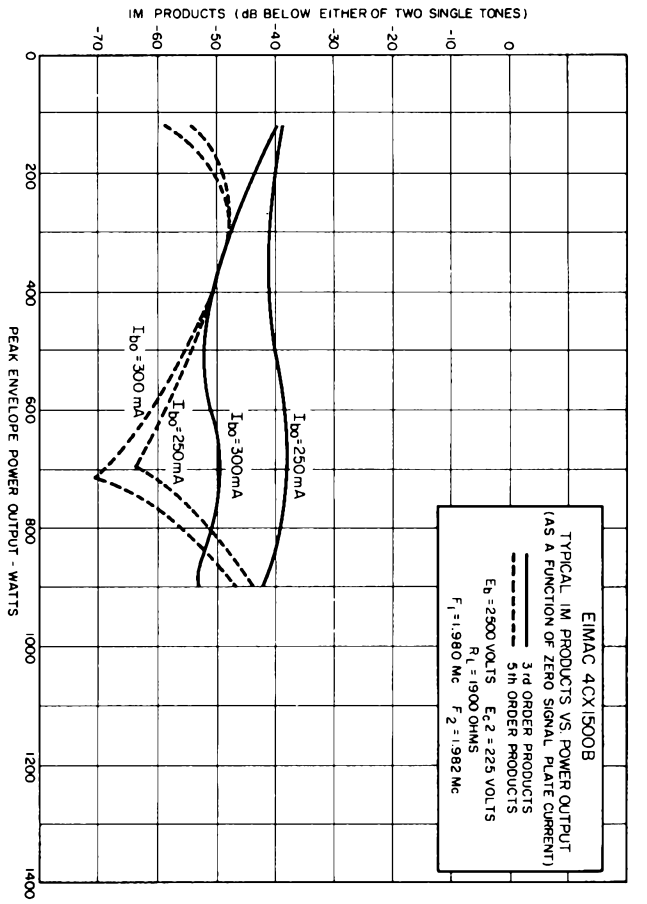

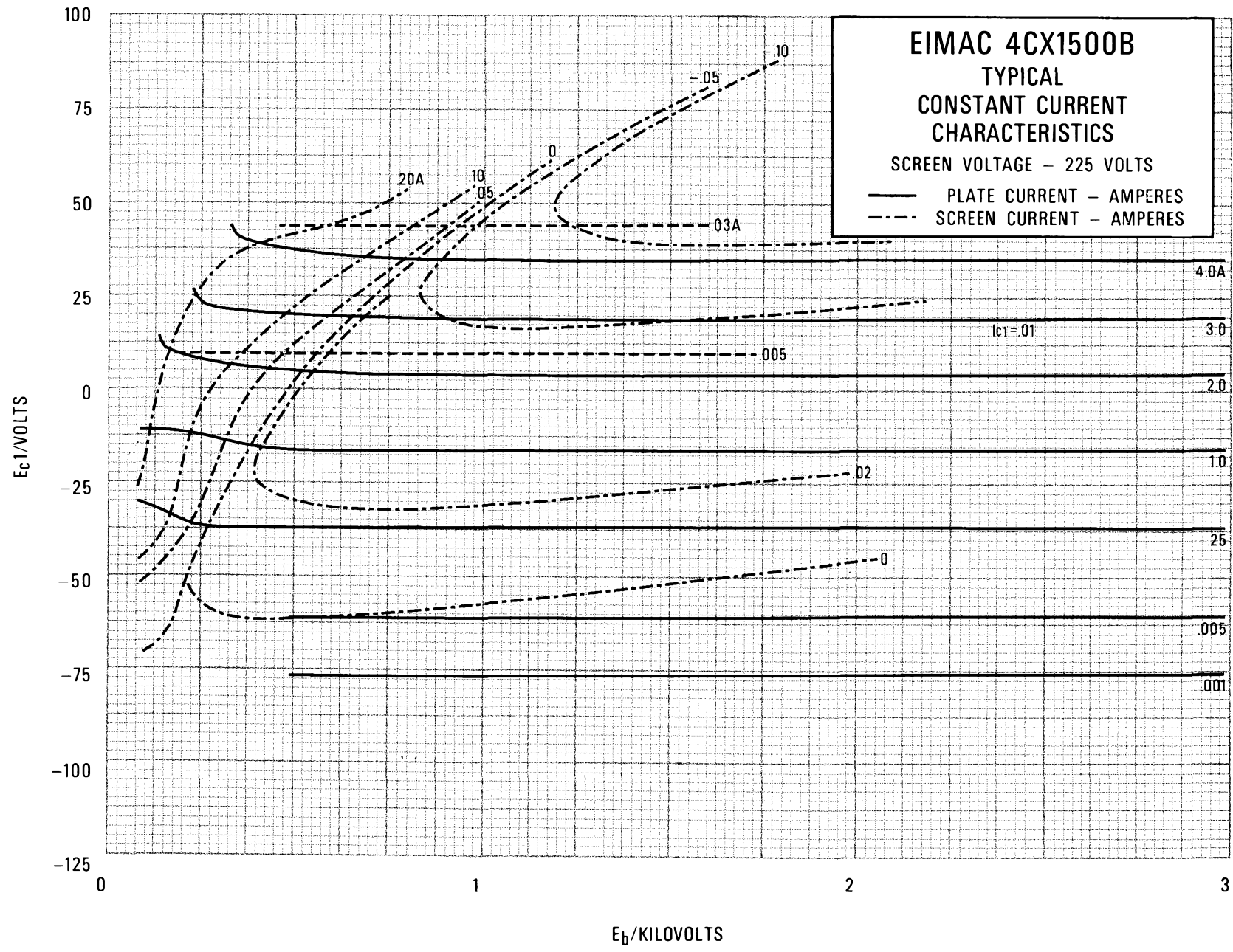

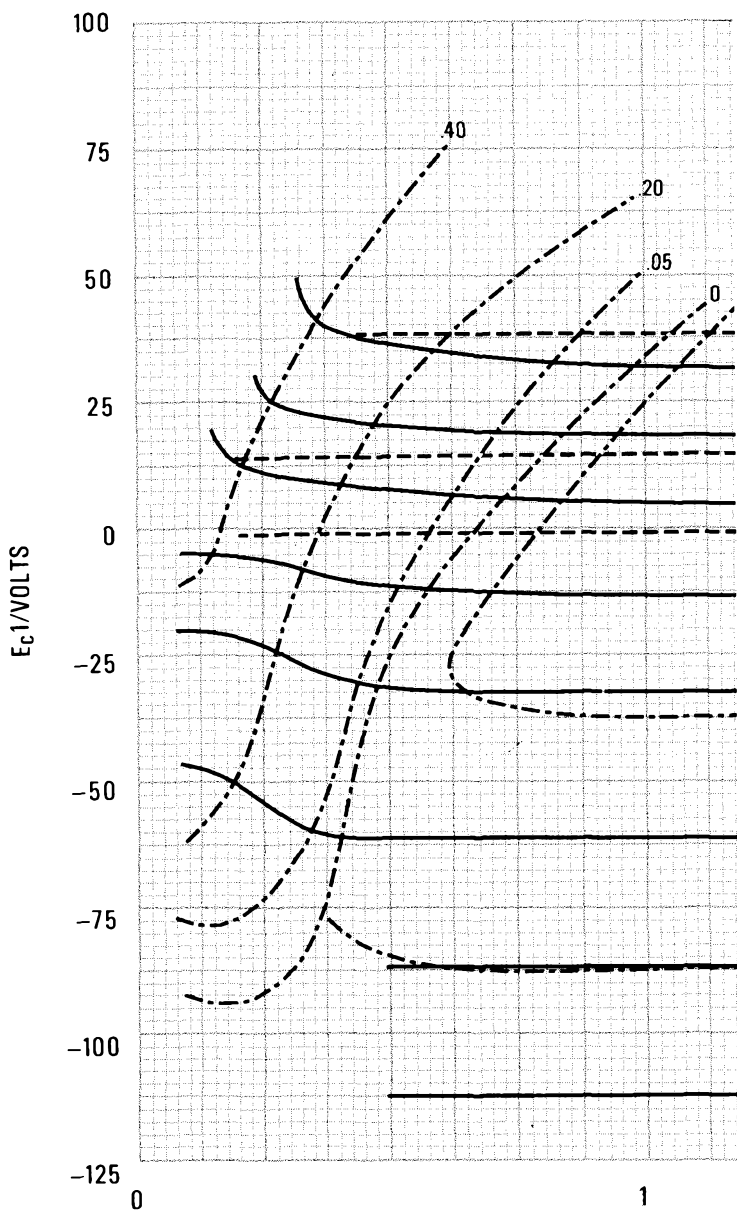

**EIMAC 4CX1500B**  
**TYPICAL**  
**CONSTANT CURRENT**  
**CHARACTERISTICS**  
 SCREEN VOLTAGE - 325 VOLTS  
 — PLATE CURRENT - AMPERES  
 - - - SCREEN CURRENT - AMPERES

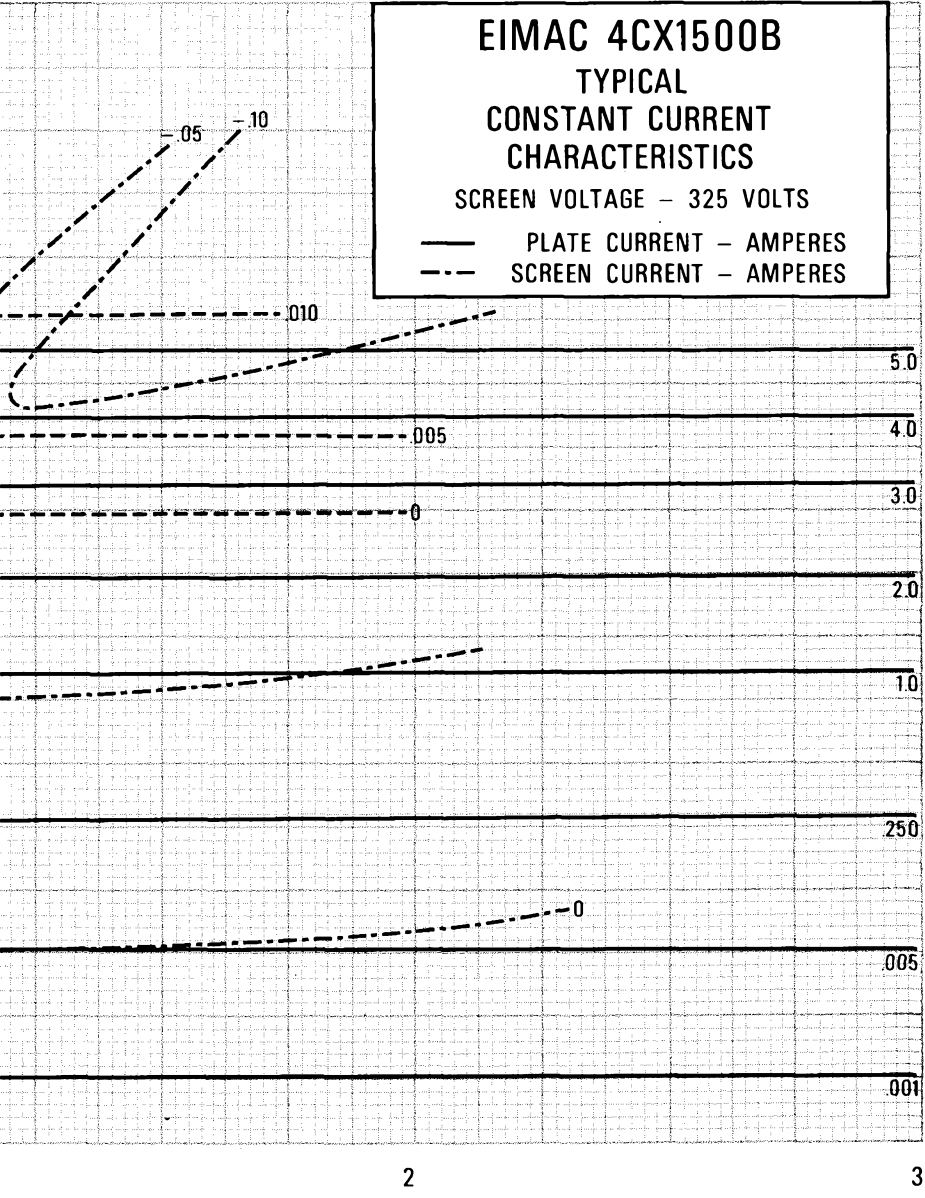

$E_b$ /KILOVOLTS

# TENTATIVE DATA

*Eimac*  
**EITEL-McCULLOUGH, INC.**  
 SAN BRUNO, CALIFORNIA

# 4W20,000A

**RADIAL-BEAM  
 POWER TETRODE**

The Eimac 4W20,000A is a high-power, water-cooled transmitting tetrode having a maximum plate dissipation rating of 20 kilowatts. This tube will operate efficiently as a power-amplifier at frequencies up to 250 Mc. A single 4W20,000A operating as a television visual r-f amplifier will deliver a synchronizing power output of 26 kilowatts at 216 Mc., with a 5-Mc. bandwidth.

The coaxial terminal arrangement of the tube is ideally suited for use in cavity circuits. The cathode is a unipotential thoriated tungsten cylinder of rugged construction, heated by electron bombardment.

## GENERAL CHARACTERISTICS

### ELECTRICAL

Cathode: Unipotential, thoriated tungsten. Heated by electron bombardment.	
▶ D-C Voltage (Approx.)	1400 volts
▶ D-C Current (Approx.)	1.8 amperes
Filament: Thoriated Tungsten, Helical	
Voltage	10 volts
Current (without cathode bombardment)	30 amperes
Current (with cathode bombardment)	25 amperes
Maximum allowable starting current	50 amperes
Direct Interelectrode Capacitances (Average)	
Grid-Plate	0.5 $\mu\mu\text{f}$
Input	125 $\mu\mu\text{f}$
Output	23 $\mu\mu\text{f}$
Screen-Grid Amplification Factor (Average)	5.5
Transconductance ( $I_b=6.6$ A., $E_b=3.0$ kV., $E_{c2}=1200$ V.)	75,000 $\mu\text{mhos}$

### MECHANICAL

Base	Special, Concentric
Mounting Position	Vertical, base down or up
Cooling	Water and Forced Air
Maximum Over-all Dimensions	
Length	15.2 inches
Diameter	5.0 inches
Net Weight	7.6 pounds
Shipping Weight	40 pounds

### RADIO FREQUENCY POWER AMPLIFIER MAXIMUM RATINGS (per tube)

D-C PLATE VOLTAGE	8 MAX. KV
D-C PLATE CURRENT	15 MAX. AMP
PLATE DISSIPATION	20 MAX. KW
SCREEN DISSIPATION	200 MAX. WATTS
GRID DISSIPATION	60 MAX. WATTS

### TYPICAL OPERATION

Class-C Telegraphy or FM Telephony (Per tube—220 Mc.)

D-C Plate Voltage	5000	6000	7000	volts
D-C Screen Voltage	1200	1200	1200	volts
D-C Grid Voltage	-350	-370	-400	volts
D-C Plate Current	3.6	3.6	3.4	amps
D-C Screen Current (approx.)*	167	167	167	ma
D-C Grid Current (approx.)	50	50	50	ma
Peak R-F Input Voltage	455	475	505	volts
Driving Power (approx.)*	750	780	830	watts
Screen Dissipation	200	200	200	watts
Plate Power Input	18	21.6	23.8	kw
Plate Dissipation	7.0	8.6	8.0	kw
Useful Power Output	9.2	11.5	13.0	kw

\*The performance figures listed above are obtained by calculation from the characteristic tube curves and confirmed by direct tests. The driving power and output power allow for losses associated with practical resonant circuits.

### TYPICAL OPERATION

Class-B Linear Amplifier—Television Visual Service  
 (Per tube, 5-Mc. Bandwidth up to 216 Mc.)

Peak Synchronizing Level	
Load Impedance	650 ohms
Effective Length of Plate Line	1/4 wave
D-C Plate Voltage	7000 volts
D-C Screen Voltage	1200 volts
D-C Control Grid Voltage	-150 volts
D-C Plate Current	6.0 amps
D-C Screen Current (approx.)	230 ma
D-C Control Grid Current (approx.)	90 ma
Peak R-F Grid Input Voltage	280 volts
Driving Power (approx.)	500 watts
Plate Power Input	42 kw
Plate Dissipation	16 kw
Useful Plate Power Output	26 kw
Black Level	
D-C Plate Current	4.5 amps
D-C Screen Current	100 ma
D-C Control Grid Current (approx.)	45 ma
Peak R-F Grid Input Voltage	220 volts
Driving Power (approx.)	300 watts
Plate Power Input	32 kw
Plate Dissipation	16.5 kw
Useful Power Output	15.5 kw

These 216 Mc. typical performance figures were obtained by direct measurement in test equipment. The output power is useful power measured in a load circuit. The driving power is that taken by the tube and a practical resonant grid circuit. These figures are subject to variation and in many cases, with further refinement and improved techniques, better performance might be obtained.



Note: Typical operation data are based on conditions of adjusting to a specified plate current, maintaining fixed conditions of grid bias, screen voltage, suppressor voltage and r-f grid voltage. It will be found that if this procedure is followed, there will be little variation in power output between tubes even though there may be some variation in grid, screen and suppressor currents. Where grid bias is obtained principally by means of a grid resistor, to control plate current it is necessary to make the resistor adjustable.

## APPLICATION

**Mounting**—The 4W20,000A must be mounted vertically. Base-down or base-up mounting is optional.

The co-axial contact surfaces provided for connection to the filament, cathode, grid, screen, and anode are of successively larger diameters to facilitate removal and replacement of tubes.

Cavity circuits may be designed around the dimensions shown in the outline drawing. At very high frequencies the points of contact between the tube and the external circuit will be required to carry high values of charging current. It is, therefore, essential that the contactors make firm and uniform contact between the terminal surfaces of the tube and the external circuit. Particular care should be taken that the contactors are not inadvertently forced out of shape, and that all contact surfaces are maintained free from dust or other foreign matter which would prevent uniform electrical connection. At VHF, poor contact by one finger of a multi-finger collet can result in local overheating which may damage the tube seals.

Although contact fingers or slotted collets are often made an integral part of cavity circuits, there is some advantage to reversing the plan by providing contact-finger assemblies which are designed to be clamped firmly to the terminal surfaces of the tube itself and to make sliding contact with the cavity as the tube is inserted. This arrangement facilitates replacement of worn or damaged contactors and tends to remove incidental local heating from the vicinity of the tube seals. Tubes held in reserve for emergency replacement may be fitted with contact-finger assemblies and water-line extensions to minimize lost time in making changes.

▶ **Cathode Heating Power**—The cathode of the 4W20,000A is a unipotential, thoriated tungsten cylinder, heated by electron bombardment of its inner surface. Bombardment is obtained by using the cylindrical cathode as the anode of a diode. A helical filament is mounted on the axis of the cathode cylinder to supply the bombarding electrons. A d-c potential of approximately 1400 volts is applied between the filament and the cathode cylinder, and the recommended cathode heating power of 2500 watts is obtained with approximately 1.8 amperes.

The inner filament is designed to operate under space-charge limited conditions so that the cathode temperature may be varied by changing the voltage applied between the inner filament and the cathode cylinder.

For maximum tube life the filament voltage, as measured directly at the filament terminals, and the cathode power should be held at their rated values. Variations in filament voltage should be held within the range of 9.5 to 10.5 volts, cathode power within the range of 2250 to 2750 watts.

Further increases in cathode efficiency will result in a decrease in the cathode bombardment power requirements. The cathode bombardment power supply should, therefore, be capable of providing a minimum of approximately 2000 watts.

**Caution:** It must be kept in mind that the filament is at a potential of 1400 volts d-c with respect to ground. The filament transformer and voltmeter must be adequately insulated for this voltage.

▶ **Grid Voltage Regulation**—The practice of designing grid voltage supplies to maintain adequate regulation under conditions of varying grid current is particularly desirable with the 4W20,000A. Because the cathode of the 4W20,000A is a complete cylinder, grid temperatures run higher than usual. For this reason, even with no excitation, control grid current reversal might conceivably be several milliamperes and safe design should allow for possible peaks on the order of 100 milliamperes.

▶ **Anode Cooling**—The water-cooled anode requires 6 gallons per minute of cooling water for the rated 20 kilowatts of plate dissipation. This corresponds to a pressure drop of 1 pound per square inch across the water jacket. The inlet water pressure must not exceed a maximum of 50 pounds per square inch.

The outlet water temperature must not exceed a maximum of 70°C under any conditions.

▶ **Seal Cooling**—The grid and screen tube contact surfaces and adjacent glass and ceramic must be cooled by high-velocity air which may be accomplished by means of ring manifolds. The quantity, velocity and direction of air must be adjusted to limit the maximum seal temperatures to 150°C.

IF IT IS DESIRED TO OPERATE THIS TUBE UNDER CONDITIONS WIDELY DIFFERENT FROM THOSE GIVEN UNDER "TYPICAL OPERATION", POSSIBLY EXCEEDING THE MAXIMUM RATINGS GIVEN FOR CW SERVICE, WRITE EITEL-McCULLOUGH, INC., FOR INFORMATION AND RECOMMENDATIONS.



The cathode and filament stem also require forced-air cooling in sufficient quantity so that the region on the cathode terminal opposite the glass of the grid terminal seal does not exceed a maximum of 150°C. The major portion of this air must be guided along the surface of the terminal sleeve. The remaining air flows through the nine holes inside the terminal sleeve, cools the filament stem and vents through the three holes in the tube base enclosed by the outer filament spring collet connection.

By employing a cathode collet such as is shown in the accompanying drawings, the

recommended cooling requirements will be fulfilled with an air flow of 25 cubic feet per minute at a static manifold pressure of 2 inches of water.

Tube temperatures may be measured with the aid of "Tempilaq", a temperature-sensitive lacquer manufactured by the Tempil Corporation, 11 West 25th St., New York 10, N. Y.

Air and water flow must be started before filament and cathode power are applied and maintained for at least two minutes after the filament and cathode power have been removed.

**4W20,000A/3W10,000A3**  
**SUGGESTED STEM AIR COOLING**

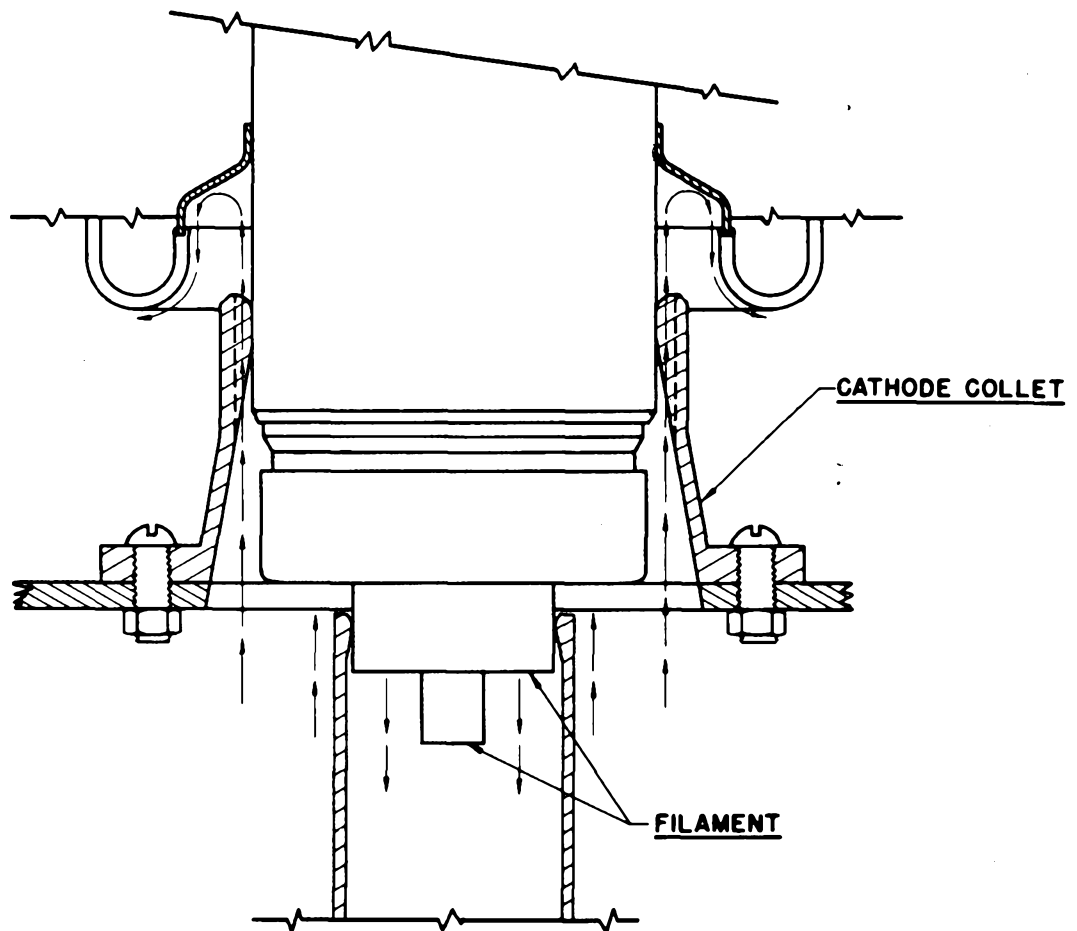

**4W20,000A/3W10,000A3**

**CATHODE COLLET**

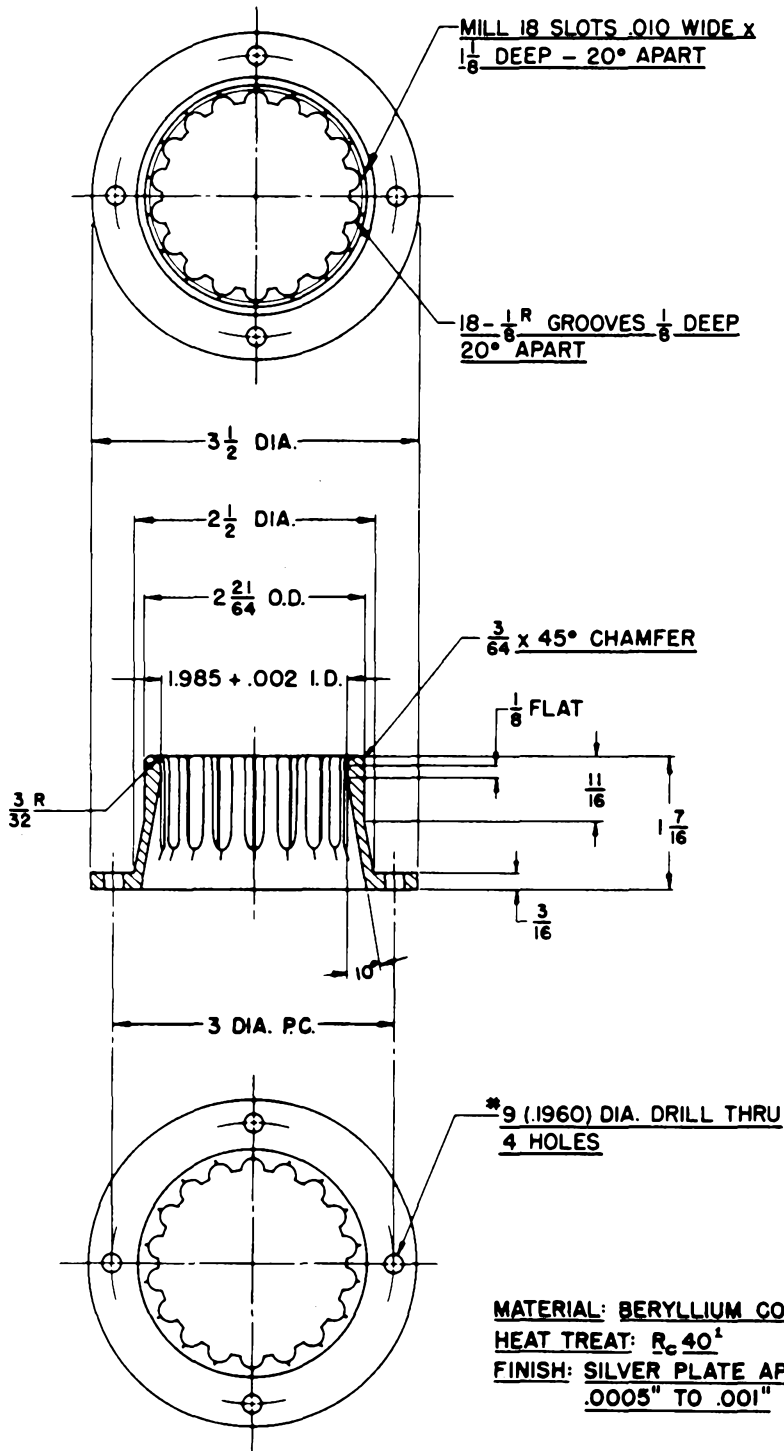

**MATERIAL: BERYLLIUM COPPER**  
**HEAT TREAT: R<sub>c</sub> 40<sup>1</sup>**  
**FINISH: SILVER PLATE APPROX.**  
**.0005" TO .001"**

<sup>1</sup> **385°C FOR APPROX. 5-6 HRS.**  
**IN NON-REDUCING ATMOSPHERE**

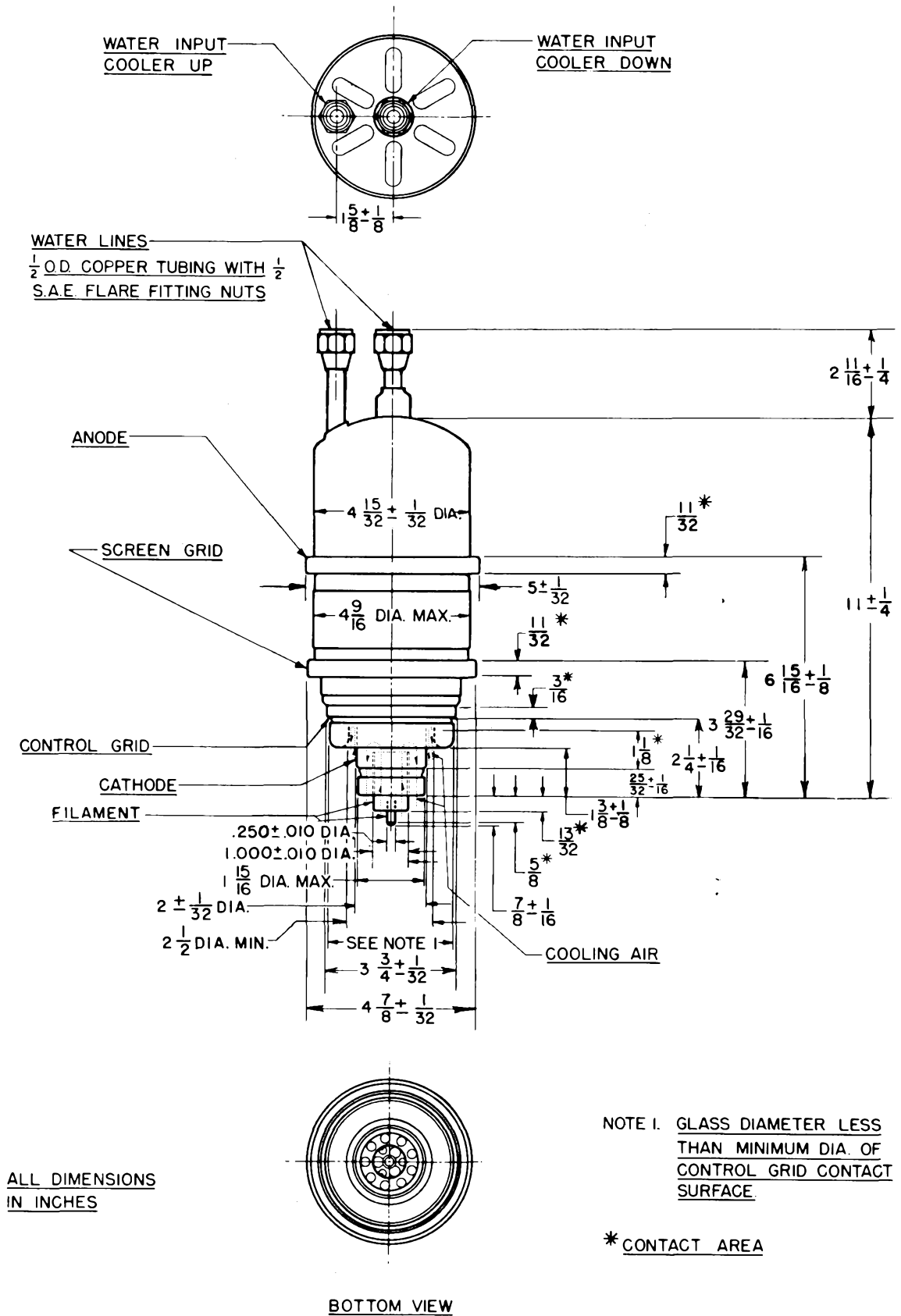

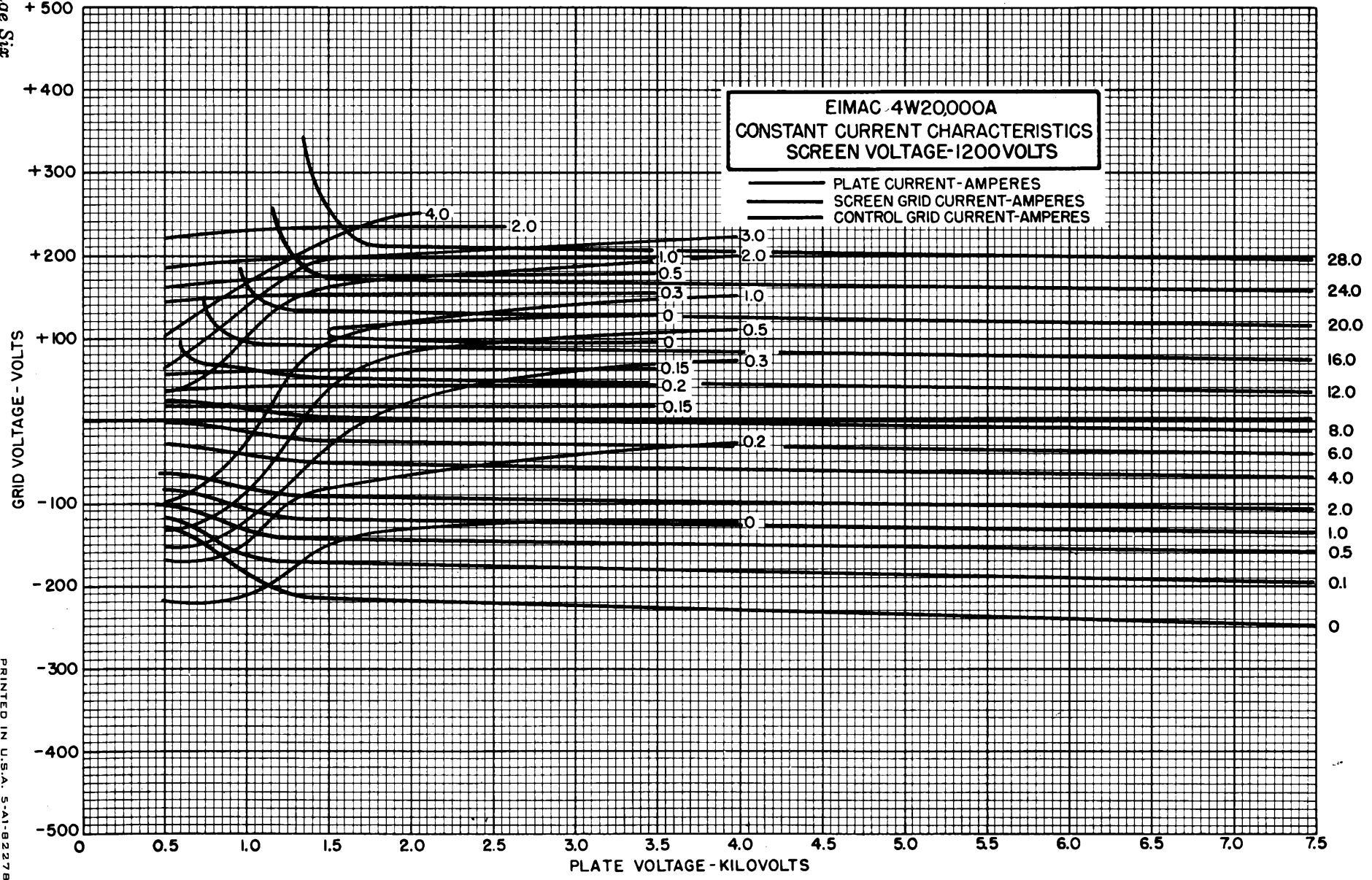

**TENTATIVE DATA**

**EITEL-McCULLOUGH, INC.**  
SAN BRUNO, CALIFORNIA

**1K015XA  
AND  
1K015XG  
KLYSTRONS  
•  
X-BAND  
OSCILLATORS**

The EIMAC 1K015XA and 1K015XG are ruggedized, integral-cavity, X-band, reflex klystrons intended for local oscillator service under conditions of severe shock, vibration or sustained acceleration.

The 1K015X type tubes are available with either coaxial output or waveguide output. The r-f terminal of the 1K015XA is a coaxial connector. For waveguide output, the r-f terminal of the 1K015XG is the Eimac transition section.

**GENERAL CHARACTERISTICS**

**ELECTRICAL**

Cathode: Coated Unipotential	
Heater Voltage	6.3 volts
Heater Current	0.80 amperes
▶ Frequency Range	(8400 thru 9600 Mc) 800 Mc
(See paragraph: Mechanical Tuning in Application)	

**MECHANICAL**

High Impact Shock*	100 g
▶ Axial Vibration Test (20-2000 cycles)*	10 g

Mounting (See Outline Drawing)	{ 1K015XA } { 1K015XG }	Three-hole flange and coaxial r-f terminal or
		In conjunction with an Eimac transition section mounts directly on a UG-39/U waveguide flange

Connections:

Heater	White wire at base
Heater and Cathode	Black wire at base
Resonator	Shell of tube
Repeller	White wire at top

Output (See Outline Drawings)	{ 1K015XA: Coaxial fitting, 1K015XG: UG-39/U waveguide flange
-------------------------------	--

\*The shock and vibration tests are applicable to both coaxial and waveguide outputs.

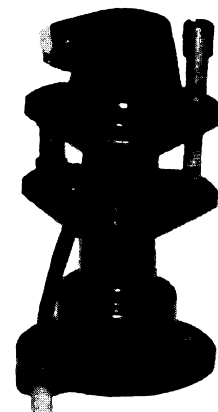

**1K015XA  
(Coaxial Output)**

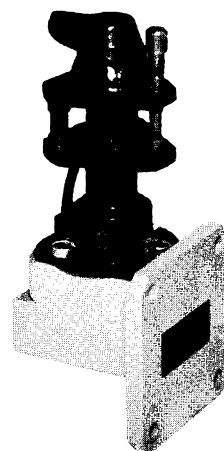

**1K015XG  
(Waveguide Output)**

Mounting Position	- - - - -	- - - - -	- - - - -	- - - - -	- - - - -	- - - - -	- - - - -	- - - - -	- - - - -	- - - - -	- - - - -	- - - - -	Any	
Cooling	- - - - -	- - - - -	- - - - -	- - - - -	- - - - -	- - - - -	- - - - -	- - - - -	- - - - -	- - - - -	- - - - -	- - - - -	Convection and Radiation	
Maximum Over-all Dimensions:													Coaxial Output	Waveguide Output
Length	- - - - -	- - - - -	- - - - -	- - - - -	- - - - -	- - - - -	- - - - -	- - - - -	- - - - -	- - - - -	- - - - -	- - - - -	2-3/8 inches	3-9/16 inches
Diameter	- - - - -	- - - - -	- - - - -	- - - - -	- - - - -	- - - - -	- - - - -	- - - - -	- - - - -	- - - - -	- - - - -	- - - - -	1-3/16 inches	—
Width	- - - - -	- - - - -	- - - - -	- - - - -	- - - - -	- - - - -	- - - - -	- - - - -	- - - - -	- - - - -	- - - - -	- - - - -	—	1-15/32 inches
Net Weight	- - - - -	- - - - -	- - - - -	- - - - -	- - - - -	- - - - -	- - - - -	- - - - -	- - - - -	- - - - -	- - - - -	- - - - -	1.5 ounces	6.5 ounces
Shipping Weight	- - - - -	- - - - -	- - - - -	- - - - -	- - - - -	- - - - -	- - - - -	- - - - -	- - - - -	- - - - -	- - - - -	- - - - -	4 ounces	8 ounces

**MAXIMUM RATINGS**

D-C RESONATOR VOLTAGE	- - - - -	- - - - -	- - - - -	- - - - -	- - - - -	- - - - -	- - - - -	- - - - -	- - - - -	- - - - -	- - - - -	- - - - -	350 MAX. VOLTS
RESONATOR DISSIPATION	- - - - -	- - - - -	- - - - -	- - - - -	- - - - -	- - - - -	- - - - -	- - - - -	- - - - -	- - - - -	- - - - -	- - - - -	15 MAX. WATTS
▶ D-C CATHODE CURRENT	- - - - -	- - - - -	- - - - -	- - - - -	- - - - -	- - - - -	- - - - -	- - - - -	- - - - -	- - - - -	- - - - -	- - - - -	50 MAX. MA
D-C REPELLER VOLTAGE													
Positive Limit	- - - - -	- - - - -	- - - - -	- - - - -	- - - - -	- - - - -	- - - - -	- - - - -	- - - - -	- - - - -	- - - - -	- - - - -	0 MAX. VOLTS
Negative Limit	- - - - -	- - - - -	- - - - -	- - - - -	- - - - -	- - - - -	- - - - -	- - - - -	- - - - -	- - - - -	- - - - -	- - - - -	500 MAX. VOLTS

**▶ TYPICAL OPERATION (With flat load)**

Mode	- - - - -	- - - - -	- - - - -	- - - - -	- - - - -	- - - - -	- - - - -	- - - - -	- - - - -	6 ¾	7 ¾	5 ¾	6 ¾
D-C Resonator Voltage	- - - - -	- - - - -	- - - - -	- - - - -	- - - - -	- - - - -	- - - - -	- - - - -	- - - - -	250	250	300	300 volts
D-C Cathode Current	- - - - -	- - - - -	- - - - -	- - - - -	- - - - -	- - - - -	- - - - -	- - - - -	- - - - -	36	36	47	47 mA
D-C Repeller Voltage	- - - - -	- - - - -	- - - - -	- - - - -	- - - - -	- - - - -	- - - - -	- - - - -	- - - - -	-110	-65	-170	-95 volts
Power Output	- - - - -	- - - - -	- - - - -	- - - - -	- - - - -	- - - - -	- - - - -	- - - - -	- - - - -	45	30	100	65 mW
Frequency	- - - - -	- - - - -	- - - - -	- - - - -	- - - - -	- - - - -	- - - - -	- - - - -	- - - - -	9000	9000	9000	9000 Mc/s
Electronic Tuning Range	- - - - -	- - - - -	- - - - -	- - - - -	- - - - -	- - - - -	- - - - -	- - - - -	- - - - -	40	55	40	60 Mc/s

**APPLICATION**

**Mounting**—The 1K015XA is provided with a three-hole base flange for solid mounting directly to the equipment chassis, to an insulating support or to the Eimac transition section to make the 1K015XG. No socket or tube clamp is necessary.

**Cooling**—No special provisions are ordinarily required for the cooling of the 1K015XA or 1K015XG. The resonator will dissipate 15 watts of power by radiation and convection in ambient temperatures up to 100°C.

**Resonator**—The resonator of the 1K015XA and 1K015XG is integral with the shell of the tube. For this reason it is often convenient to operate the resonator at chassis potential, with the repeller and cathode at appropriate negative potentials. The coaxial output connection also lends itself to d-c isolation of the resonator from chassis potential. All voltages given in the list of Maximum Ratings and in the Typical Operation data are measured with respect to the cathode of the tube.

**Cathode**—Heater voltage should be at the rated value of 6.3 volts. Variations should be kept within the range of 5.7 to 6.9 volts. The cathode is internally connected to one side of the heater. If the resonator is operated at chassis potential, the heater transformer must be insulated for the cathode-to-resonator potential.

▶ Indicates change from sheet dated 7-7-53

**Repeller**—There will be an optimum repeller voltage for any given output frequency, and the range of electronic tuning or frequency modulation under control of the repeller voltage will vary with output frequency and choice of repeller mode. These relations are shown for a typical tube in the accompanying curves.

Repeller voltages must be negative with respect to the cathode at all times.

► **Mechanical Tuning**—Mechanical tuning is accomplished by a single screw with a differential thread. Six full turns of the screw will tune the tube through a range of 800 Mc. The particular 800 Mc. range desired should be specified. Standard tuning range adjustment, unless otherwise specified, will be for 8600 to 9400 Mc.

**Output**—Curves illustrating the variation of power output with operating frequency for a typical tube are shown below. These curves assume a flat load and optimum repeller voltages at all frequencies. With a VSWR mismatch of 2 to 1, the power output will not fall below one-half the indicated power.

► **Frequency Stability**—Under axial vibration of 10g maximum acceleration, the spectrum width is less than 1.0 Mc. The frequency modulation response to vibration along other axes of the tube is approximately one-half that for the axial direction.

Frequency variations within the range of normal operating temperatures do not exceed  $\pm 0.1$  Mc/°C.

**Starting Time**—The 1K015XA and 1K015XG will be within  $\pm 10$  Mc of operating frequency in less than one minute after applying voltages.

### TYPICAL OPERATING CHARACTERISTICS 1K015XA AND 1K015XG

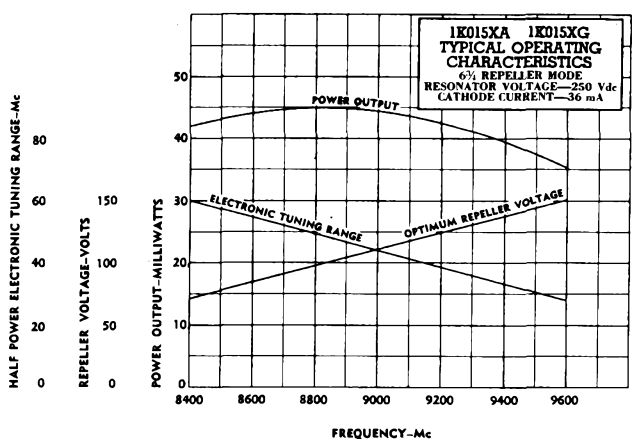
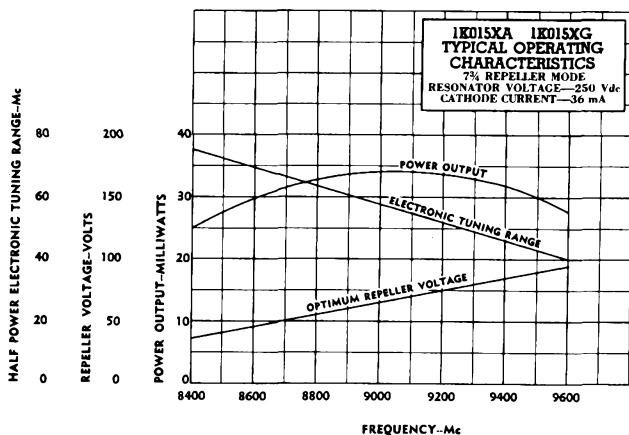
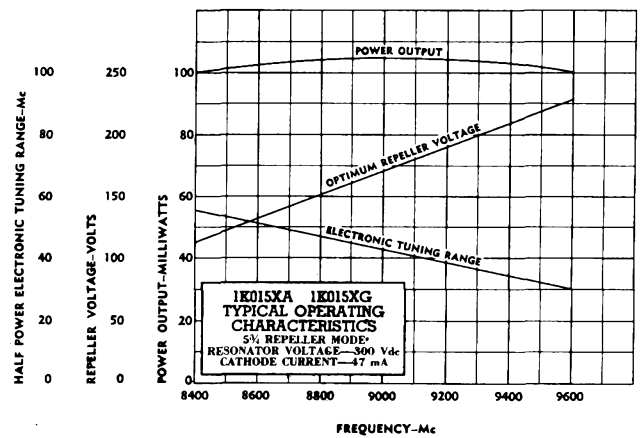
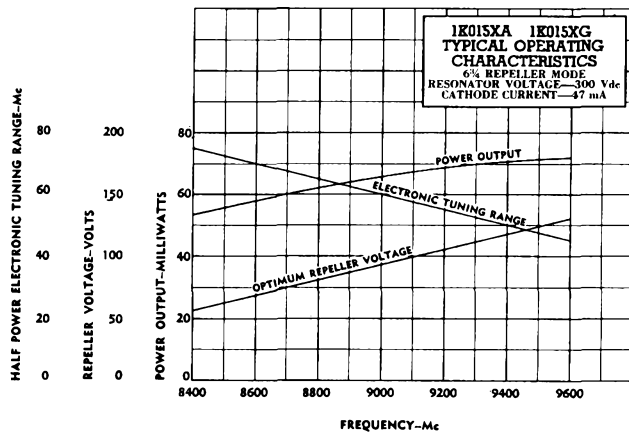

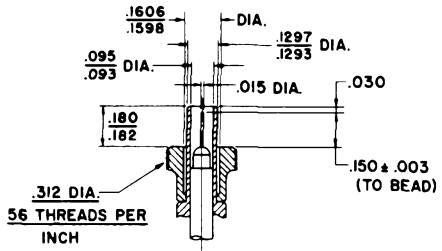

**CONNECTOR DETAIL**

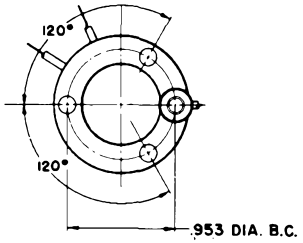
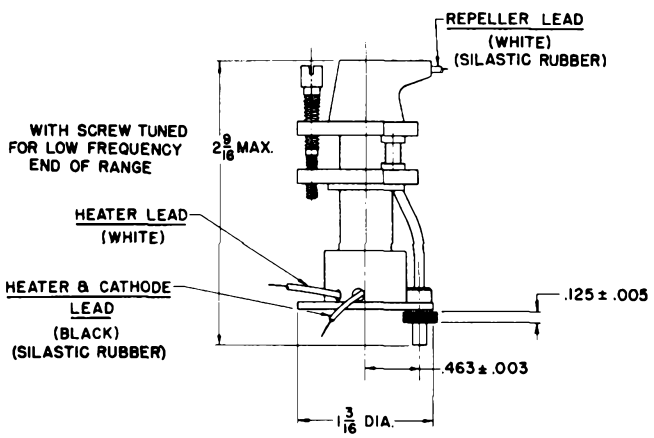

**BOTTOM VIEW**

**IKO15XA (COAXIAL OUTPUT)**

Printed in U.S.A. 2-4-81470



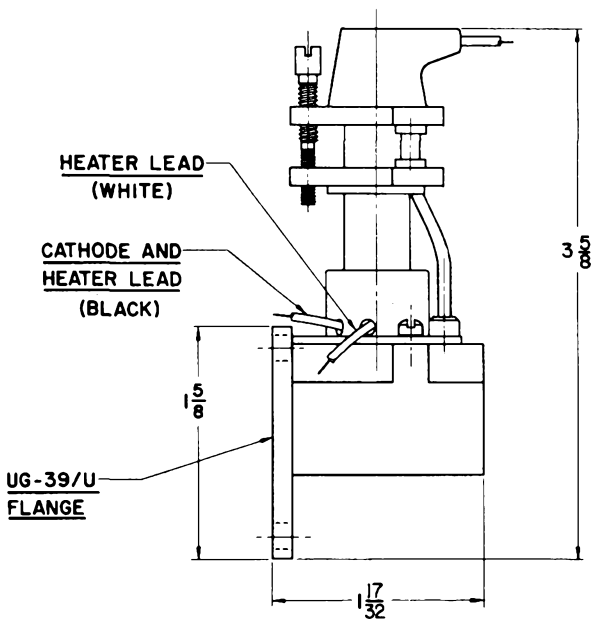
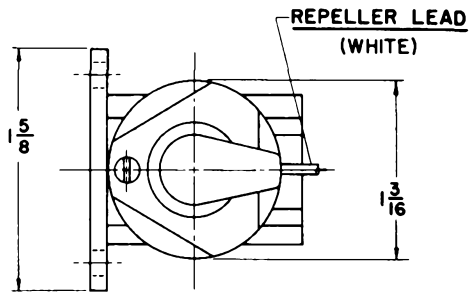

1K015XG (WAVEGUIDE OUTPUT)

# TENTATIVE DATA

**EITEL-McCULLOUGH, INC.**  
SAN BRUNO, CALIFORNIA

**3K20,000LA**  
**3K20,000LF**  
**3K20,000LK**  
**KLYSTRONS**  
**L-BAND**  
**AMPLIFIERS**

The Eimac 3K20,000LA, 3K20,000LF and 3K20,000LK klystrons are three cavity, magnetically focused power amplifiers intended primarily for UHF television broadcast service. Each klystron type, operating as a television visual r-f amplifier, will deliver 5.5 kW of peak synchronizing power output with a power gain of approximately 20 db. The cavities of the Eimac UHF television klystrons have ceramic windows and are completed by tuning boxes external to the tubes.

## NOMINAL TUNING RANGE

The UHF television band (470-890 Mc) is covered by the three tube types as follows:

TUBE TYPE NUMBER	MC.	CHANNEL
3K20,000LA	470-580	14-32
3K20,000LF	580-720	33-55
3K20,000LK	720-890	56-83

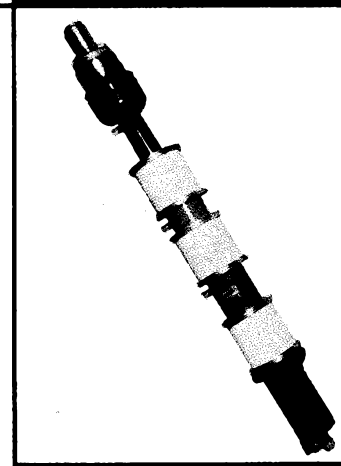

## GENERAL CHARACTERISTICS

### MECHANICAL

Mounting (See Outline Drawing)	Support from Mounting Flange		
Mounting Position	Axis Vertical		
Cooling	Water & Forced Air		
Connections:			
Filament	Flexible Leads		
Cathode	Cylindrical Strap		
Focus Electrode	Cylindrical Strap		
Cavities	Multiple Contact Fingers		
Collector	Cylindrical Strap		
Klystron Type	"A"	"F"	"K"
Maximum Overall Dimensions:			
Length	50	45	41 inches
Diameter	5/8	5/8	5/8 inches
Net Weight	42	37	35 pounds
Shipping Weight	160	150	145 pounds

### ELECTRICAL

Filament: Pure Tungsten		
Voltage	-	9.0 volts
Current (with cathode cold)	-	42 amperes
Current (with cathode at operating temperature)	-	39 amperes
Maximum Allowable Short Circuit Current of Filament Current Source	-	84 amperes
Cathode: Unipotential; heated by electron bombardment		
<b>MAXIMUM CATHODE RATINGS</b>		
DC VOLTAGE	-	2300 MAX. VOLTS
DC CURRENT	-	.75 MAX. AMPERES
DC POWER	-	1600 MAX. WATTS
Focus Electrode		
*Voltage (with respect to cathode)	-	0 to -500 volts
Magnetic Field: Axial (See Magnetic Circuit Schematic)		
Field Strength (approximately)	-	120 gauss
*May be varied over a range of 0 to -500 volts if beam current control is desired.		

## ULTRA HIGH FREQUENCY POWER AMPLIFIER MAXIMUM RATINGS

DC BEAM VOLTAGE	-	14.0 MAX. KILOVOLTS
DC BEAM CURRENT	-	1.7 MAX. AMPERES
COLLECTOR DISSIPATION	-	20.0 MAX. KILOWATTS

Note: Maximum beam voltage and beam current should not be applied without r-f excitation.

### TYPICAL OPERATION

<b>RF Linear Amplifier—Television Visual Service (In accordance with United States Federal Communications Commission Standards)</b>	
DC Cathode Bombarding Power	1400 watts
DC Cathode Bombarding Voltage (approximately)	2100 volts
DC Cathode Bombarding Current (approximately)	.66 amperes
DC Focus Electrode Voltage	0 volts
DC Beam Voltage	13 kilovolts
DC Beam Current	1.4 amperes
DC Collector Current (approximately) <sup>1</sup>	1.2 amperes
Peak Synchronizing Level (80% of saturation power)	
Driving Power (approximately) <sup>2</sup>	55 watts
Power Output	5.5 kilowatts
Efficiency	30 percent
<b>Black Level</b>	
Collector Dissipation (approximately) <sup>1</sup>	12.5 kilowatts
Driving Power (approximately) <sup>2</sup>	33 watts
Power Output	3.3 kilowatts
Efficiency	18 percent

<b>RF Amplifier—Television Aural Service</b>	
DC Cathode Bombarding Power	1400 watts
DC Cathode Bombarding Voltage	2100 volts
DC Cathode Bombarding Current	.66 amperes
DC Focus Electrode Voltage	0 volts
DC Beam Voltage	10.0 kilovolts
DC Beam Current	.95 amperes
DC Collector Current <sup>1</sup>	.8 amperes
Driving Power <sup>2</sup>	20 watts
Collector Dissipation (approximately) <sup>1</sup>	5.8 kilowatts
Power Output	2.75 kilowatts
Efficiency	29 percent

<sup>1</sup>Minor tube-to-tube variations may be expected.

<sup>2</sup>Total driving power includes losses inserted for broadband operation. The output power is useful power measured in a load circuit.

<sup>3</sup>The driving power is the total power required by the tube and a resonant circuit.

## APPLICATION

**Mounting**—The klystrons are provided with a mounting flange (See Outline Drawing) which may be used to support the tubes with either end up.

**Filament Operation**—For maximum tube life, the pure tungsten filament should be operated just above the emission limiting temperature. This temperature will be obtained with a filament voltage, as measured directly at the terminals, of approximately 9 volts.

**Cathode Heating Power**—The cathode is unipotential and heated by electron bombardment. A dc potential of approximately 2100 volts is applied between the filament and the cathode; and the recommended cathode heating power of 1400 watts is obtained with approximately .66 amperes. The filament is designed to operate under space-charge limited conditions. Cathode temperature is varied by changing the bombarding potential between the filament and the cathode.

**Cooling**—Forced air is used to cool the Electron Gun Structure and the Middle and Output Cavities. Only clean, well filtered air should be blown on the tube to avoid voltage breakdown due to dust accumulation. The temperature of the metal in the region of the metal-to-glass seals should not exceed 150°C. Tube temperatures may be measured with a temperature-sensitive paint, such as "Tempilaq", manufactured by the Tempil Corporation, 132 West 22nd Street, New York 11, N. Y.

Water is used to cool the Drift Tubes and the Collector Assembly. The cooling water should be of sufficient purity to prevent liming of the water system, and the use of a heat exchanger is recommended. The inlet water pressure of the Drift Tubes and the Collector Assembly should not exceed 40 pounds per square inch. The outlet water temperature must not exceed a maximum of 70°C. under any condition.

Air and water flow should be started before the filament and cathode power are applied and maintained for at least two minutes after the filament and cathode power have been removed.

Klystron Cooling Requirements for Typical Operating Conditions and Correct Magnetic Field Adjustment:

	Cooling Medium	Volume	Pressure Drop	Remarks
Input Drift Tube	*Water	1 gpm	1 psi	Total pressure drop if series connected with 5/16" tubing = 4 psi.
Short Drift Tube Jacket	*Water	1 gpm	1 psi	
Long Drift Tube Jacket	*Water	1 gpm	1 psi	
Output Drift Tube	Water	1 gpm	1 psi	
Collector Assembly	*Water	6 gpm	3 psi	
Electron Gun Structure	Filament Stem	Air	1-2 cfm	See Cooling Diagram
	Cathode Terminal	Air	90 cfm	
	Focus Electrode and Anode Seals	Air	90 cfm	
	Input Cavity	None		
Center Cavity	Air	15 cfm		
Output Cavity	Air	50 cfm		

\*Cooling water connections should be made as noted on Cooling Diagram.

**RF Contact Surfaces**—The means by which contact is made between the cavities and the tuning boxes is of

great importance. Two requirements which must be met to ensure proper electrical connections are as follows:

- (1) Contact to the tube cavities must be made only on the peripheral surface of the 1/4" cavity flanges as shown on the outline drawing.
- (2) Each individual finger of the collet or spring stock material must make positive contact to the cavity flange to prevent arcing.

**Magnetic Field**—An adjustable magnetic field is necessary to control and direct the beam throughout the length of the drift tube. The magnetic field should be capable of variation around the recommended field strength of 120 gauss. Typical magnetic circuit requirements for a 3K20,000LK are shown in the Magnetic Circuit Schematic. The current and adjustment of the pre-focusing coil are optimized under low beam voltage conditions and will require minor readjustment with changes in beam voltage. The current and location of the focusing coils should be capable of independent adjustment. Readjustment of the current of the focusing coils is necessary with changes in beam voltage. Beam transmission (collector current divided by the beam current as measured in the cathode return to beam power supply) will vary from 75% to 95%. Improper adjustment or misalignment of the magnetic field, as indicated by too low a value of beam transmission, may cause the beam to strike and overheat the drift tube walls.

### MAGNETIC FIELD COIL REQUIREMENTS

Tube Type	Number of Coils Required for Field Strength of Approximately 120 Gauss.		
	Pre-focusing Coil	Focusing Coils	
	375-750 ampere-turns per coil	1600-4800 ampere-turns per coil	0-1600 ampere-turns per coil
3K20,000LA	1	3	1
3K20,000LF	1	3	1
3K20,000LK	1	2	1

**CAUTION**—It is convenient to operate the r-f and collector portions of the tube at ground potential. Since the cathode and filament are operated at high negative potentials with respect to ground, filament and cathode power supplies and voltmeters must be adequately insulated for these high voltages. Protection must also be afforded to operating personnel.

**Protection**—It is recommended that the following protective devices be used:

- (1) Interlocks in air and water supplies.
- (2) Interlocks in magnetic field supply circuits.
- (3) Current overload in cathode bombardment supply circuit.
- (4) Current overload in beam current supply circuit.
- (5) Current overload in cavity current circuit.
- (6) Current limiting resistor of approximately 100 ohms in series with beam power supply to isolate tube from final capacitor of supply.

The filament and cathode bombardment voltages will normally be applied before the beam voltage. Cavity tuning or magnetic field adjustment should be made with reduced beam voltage (1/2 to 2/3 normal). Slight retuning and readjustment will be necessary when beam voltage is raised to full value.

"IMPERIAL FLEX FITTINGS" FOR  $\frac{1}{2}$ " O.D. TUBING.  
ALL OTHERS ARE "IMPERIAL FLEX FITTING" FOR  $\frac{5}{16}$ " O.D. TUBING.

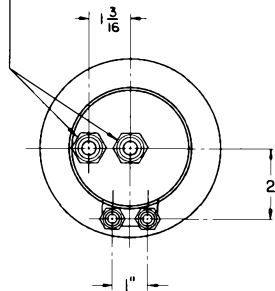

OUTPUT END VIEW

	A	B	C	D	E
3K20,000 LA	$48 \frac{11}{16}$	$30 \frac{1}{2}$	6	$4 \frac{7}{8}$	$2 \frac{3}{8}$
LF	$44 \frac{3}{16}$	26	5	$3 \frac{3}{4}$	2
LK	$40 \frac{3}{16}$	22	4	$3 \frac{1}{8}$	$1 \frac{5}{8}$

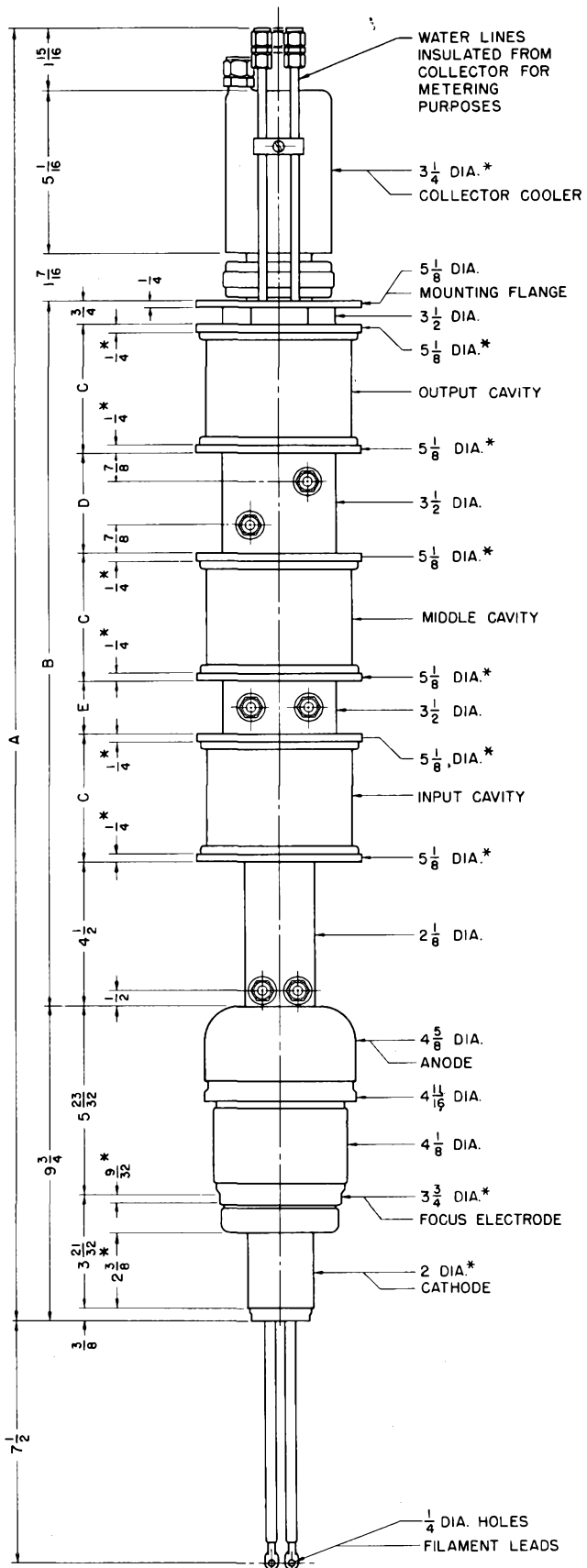

DIMENSIONS IN INCHES

\* CONTACT SURFACE



3K20,000LA  
 3K20,000LF  
 3K20,000LK

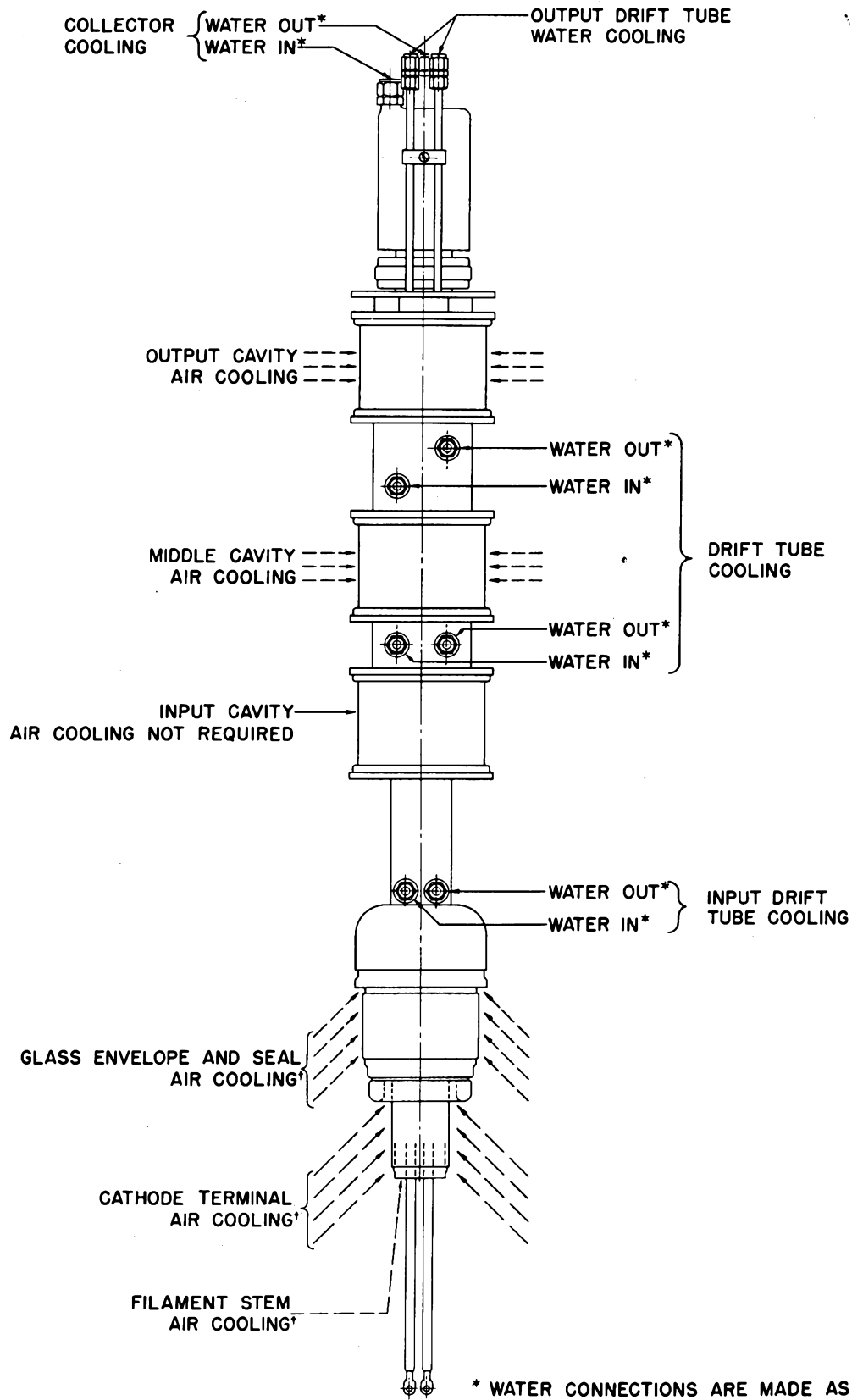

† THIS COOLING MAY BE SUPPLIED BY A SINGLE BLOWER THROUGH SUITABLE MANIFOLD & BAFFLES

\* WATER CONNECTIONS ARE MADE AS SHOWN WHEN TUBE IS MOUNTED WITH COLLECTOR UP WHEN TUBE IS MOUNTED WITH ANODE UP THE WATER CONNECTIONS MUST BE REVERSED.

**COOLING DIAGRAM**

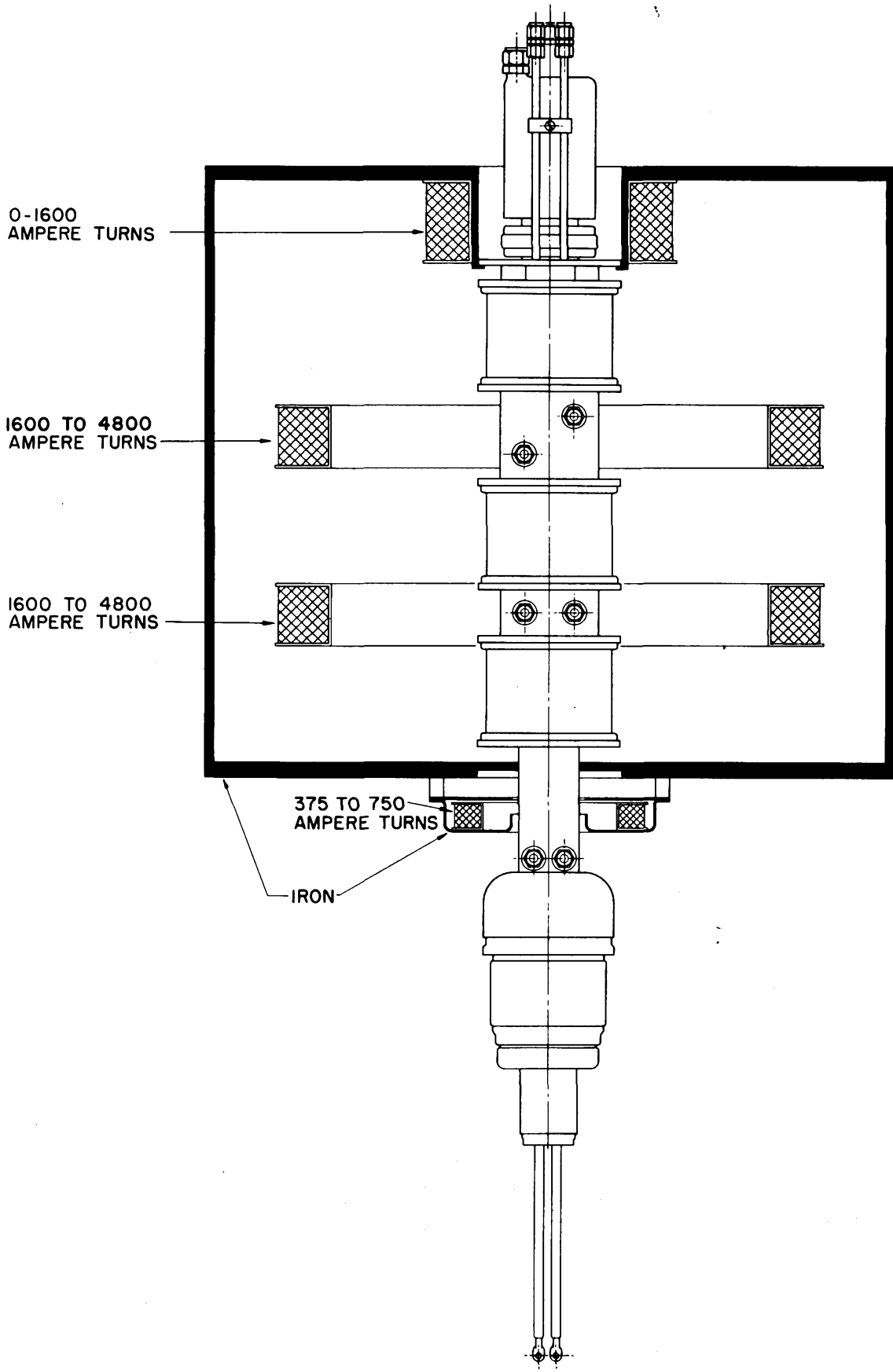

**MAGNETIC CIRCUIT SCHEMATIC FOR 3K20,000LK**

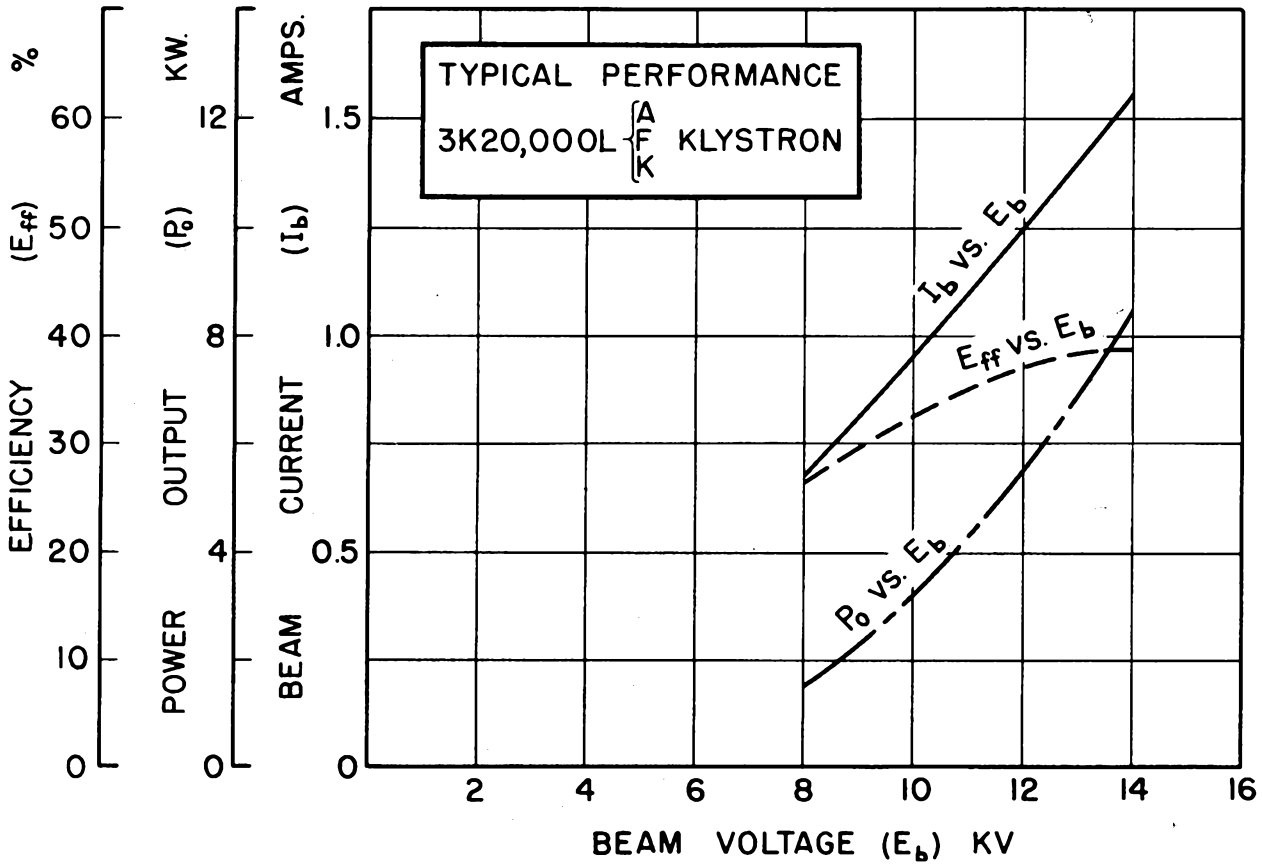

BEAM CURRENT, POWER OUTPUT AND EFFICIENCY VERSUS BEAM VOLTAGE

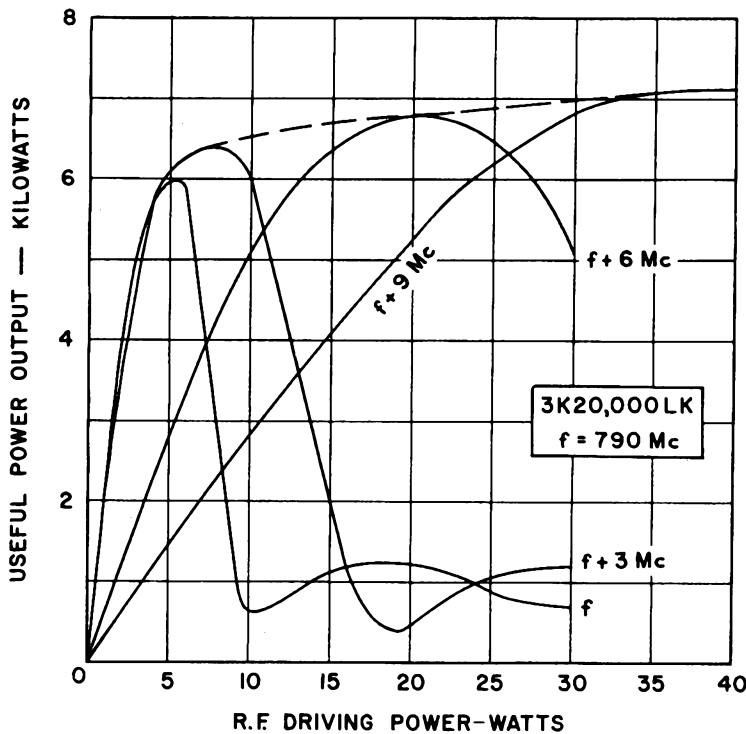

USEFUL POWER OUTPUT VS. R.F. DRIVING POWER

(MIDDLE CAVITY DETUNED; INPUT & OUTPUT CAVITIES TUNED TO DRIVE FREQUENCY)

# High-Power Klystrons at UHF\*

D. H. PREIST†, MEMBER, IRE, C. E. MURDOCK†, ASSOCIATE, IRE, AND J. J. WOERNER†

**Summary**—A brief history of high-power cw klystron development and a classification of types of klystron are followed by a description of the three-cavity, gridless klystron amplifier with magnetic focusing, in general terms, and the Eimac 5-kw klystron for UHF-TV in more detail. This tube has cavities which are partly outside the vacuum system and contain ceramic "windows." The advantages of the klystron over the conventional negative-grid type of tube are reviewed from the standpoint of performance, and the main operational features are noted.

## INTRODUCTION

IN VIEW OF the increasing activity above 450 mc for such purposes as television, it may be of value to review the means of generating transmitter power presently available.

Of outstanding interest in this field is the post-World War II development of power amplifier klystrons. Although the klystron principle was discovered as far back as 1939,<sup>1</sup> its application to high-power generation was delayed, largely because of the 1939–1945 war and the need to concentrate on those lines of development which appeared the most promising for military purposes. The ultimate possibilities of the klystron were appreciated by few, and although a great deal of fundamental research on electron beams was carried on in various places, development in the field of high-power cw tubes was confined mainly to one group in California,<sup>2,3</sup> and one group in France.<sup>4,5</sup> As a result of this work the basic principles have been extended, and much progress has been made in techniques of construction, culminating in the recent appearance of high-power klystrons for commercial purposes in the United States,<sup>2,6</sup> and an increasing awareness of the great advantages of this type of tube for stable amplification at high-power levels.

The object of this paper is to review, briefly, from the point of view of the potential user, the performance of a modern high-power klystron, and to describe the special peculiarities and methods of operation of this type of tube. A brief survey will also be made of the factors limiting the performance of a klystron, compared with the factors limiting the performance of conventional negative-grid tubes.

\* Decimal classification: R339.2×R583.6. Original manuscript received by the Institute, November 3, 1952.

† Eitel-McCullough, Inc., San Bruno, Calif.

<sup>1</sup> R. H. Varian and S. F. Varian, "A high frequency oscillator and amplifier," *Jour. Appl. Phys.*, vol. 10, p. 321; 1939.

<sup>2</sup> "High Power UHF Klystron," *Tele-Tech*, p. 60; October, 1952.

<sup>3</sup> W. C. Abraham, F. L. Salisbury, S. F. Varian, and M. Chodorow, "Transmitting Tube Suitable for UHF TV," paper presented at IRE National Convention; 1951.

<sup>4</sup> P. Guénard, B. Epsztein, and P. Cahour, "Klystron Amplificateur de 5 KW à large bande passante," *Ann. Radioelect.*, vol. VI, p. 24; 1951.

<sup>5</sup> R. Warnecke and P. Guénard, "Tubes à Modulation de Vitesse," Gauthier-Villards, Paris; 1951.

<sup>6</sup> J. J. Woerner, "A High Power UHF Klystron for TV Service," paper presented at IRE National Convention; 1952.

## KLYSTRON TYPES

Present-day klystrons fall into three categories:

### 1. Reflex Klystron Oscillators

Most of these have low efficiency (of the order of 1 per cent) and generate relatively low power, and are suitable for receivers, local oscillators, test equipment, and the like.

### 2. 2-Cavity Klystrons

These may be used as amplifiers, oscillators, or frequency multipliers; as amplifiers they are capable of power gains of about 13 db and efficiencies of about 20 per cent, at frequencies of the order of 1,000 mc.

### 3. 3-Cavity Klystrons

These are useful, principally, as amplifiers, and are capable of power gains of about 20 to 30 db, and efficiencies of 30 to 40 per cent, together with bandwidths of several mc, at frequencies of the order of 1,000 mc. Because of the superior amplifier performance given by this type of klystron, the other two types will not be dealt with further in this paper.

## 3-CAVITY GRIDLESS KLYSTRON AMPLIFIER WITH MAGNETIC FOCUSING

### A. Description

This type of tube, sometimes called a "cascade amplifier," is illustrated schematically in Fig. 1. It will be seen to consist of four essential parts:

#### 1. The Electron Gun

This has a source of electrons (the cathode), a means of accelerating the electrons to a high energy level (the anode), and a means of focussing the electrons into a parallel beam of high electron density emerging from the hole in the anode.

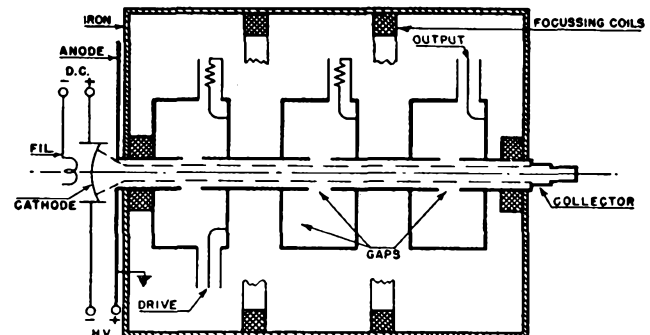

Fig. 1—Schematic diagram of 3-cavity klystron with magnetic focusing.



## 2. The RF Resonant Cavities and Drift Tubes

The first cavity is fed with RF energy from a driving source at low level. The second cavity is tuned to resonance, or near resonance, but is not fed with energy from outside. The function of these two cavities, in conjunction with the drift tubes, is to velocity-modulate the electron beam so as to produce "bunches" of electrons at the output cavity. The latter is tuned to resonance and coupled to the antenna, or other load, and serves to extract as much RF energy as possible from the "bunched" electron beam. Its function and operation are closely similar to those of the output circuit of a Class "C" amplifier using triodes or tetrodes.

## 3. The "Collector" Electrode

This collects the electrons after they have passed through the output cavity, and have given up part of their energy to the RF field, and thus to the load; because only about 30 per cent of the energy in the beam is converted to RF energy, this collector has to be capable of dissipating the remaining percentage, that is to say, 70 per cent of the product of the anode-cathode voltage and cathode current, when fully driven. (In practice the collector current is very slightly less than this because some electrons inevitably strike the anode and the drift-tube walls.) If the tube is used as a linear modulated amplifier, the collector will be required to dissipate 100 per cent of the input power under conditions of zero drive and zero output.

## 4. External Magnetic Circuit

This consists of suitably disposed electromagnets producing an axial magnetic field of controllable strength which tends to keep the beam parallel as it passes along the tube. Without this field the beam would expand because of the mutual repulsion of the electrons. The optimum field strength is fairly critical, and is not necessarily uniform along the length of the tube. It is usually prevented from penetrating the cathode, either by a metallic magnetic shield or by the use of a "bucking" coil, or by a combination of both.

## B. Performance and Operational Features of This Type of Klystron

The 3-cavity klystron is a tube capable of generating a much larger power output at uhf than the conventional negative-grid tube. The deterioration of performance as the frequency is raised is slight. The power gain of the klystron is very much larger than that of a tetrode. It may be worthwhile to review briefly the reasons for this.

Considering the factors limiting the power output of a triode or tetrode, aside from external circuit losses, one finds that basically they are the total cathode emission, the anode voltage, the interelectrode spacing, and

the RF loss in the materials used to make the electrodes and the envelope. Now the total cathode emission, assuming the best material is used and that a given life is required, depends on its area. This area is limited at uhf because the tube forms part of a resonant transmission line in which large changes of electric and magnetic field occur over distances which are small compared with the wavelength. Since nonuniform potentials between electrodes cause loss of efficiency, it is necessary to keep the electrode dimensions small compared with the wavelength; thus, the cathode area is limited, and has to be reduced as the wavelength is decreased. The anode voltage is limited by internal flash-arcs between electrodes. The electrode spacing must, however, be small enough to give small electron transit times, and must be decreased with the wavelength. The applied voltage must, therefore, be reduced also with the wavelength. Lastly, the RF losses in the tube materials increase as the wavelength decreases. All these factors added together give the well-known result that triodes and tetrodes get rapidly smaller as the wavelength decreases, and so does the power they will generate and the efficiency. In addition, the problem of manufacture becomes more and more serious, and ultimately becomes prohibitive. The two worst problems are caused by the small spacing between electrodes, of the order of 0.001 inch, and the mechanical weakness of the fine wire grids.

Considering now the power gain, this becomes less as the wavelength decreases because the tube requires more and more driving power to overcome the increasing electron transit-time effects, losses in materials, grid current, and (usually) inherent negative feedback.

In a klystron, on the other hand, some of these limitations do not occur at all, and others are less significant. The cathode area is not limited by the wavelength because it is outside the RF field. The anode-to-cathode spacing being of the order of 1 inch, extremely high anode voltages may be applied without internal flash-arcs; also, the cavity gap spacings may be about  $\frac{1}{2}$  inch in a 5-kw tube at 1,000 mc. Again, because gridless gaps may be used without serious loss of coupling between the beam and the resonant cavities, there are no problems of fabrication or heating of grid wires. Furthermore, because the collector is outside the RF field, it may be designed solely for the purpose of dissipating heat, and this becomes a minor problem in practice. The losses in the conductive tube materials are small because all the metal parts carrying RF current may be made of high-conductivity metal. (There is no loss comparable to the RF losses in a triode due to RF current flowing through lossy cathode material or fine resistive grid wires.) Therefore, the only limiting factor approached in klystrons giving adequate power for present commercial applications is the loss in the dielectrics. Some dielectrics are inevitable either in the form of windows in the cavities, as in the Eimac tube, or in the other type of tube with integral cavities, the window between the

output cavity and the load. If the power level is raised high enough, these dielectrics will ultimately break down, either by cracking due to heat or by flashing over the outside surface which is at atmospheric pressure; however, this does not occur in a well-designed tube at power levels that are presently interesting.

Considering the power gain of a klystron, this is governed almost entirely by the geometry and is limited only by the small RF losses in the input cavity and the beam loading of the cavity, which is small. The transit-time loading experienced with a triode becomes a factor of minor importance, and the negative feedback disappears since there is no coupling between the input and output cavities.

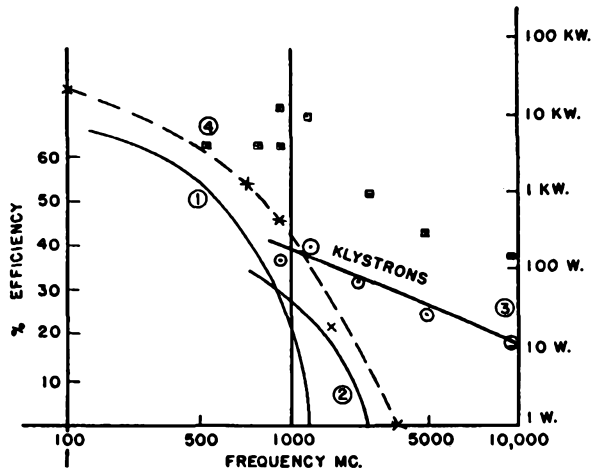

Fig. 2—Curve (1): Efficiency versus frequency for typical uhf tetrode—4X150G. (Plate dissipation 150 watts.)  
Curve (2): Efficiency versus frequency for typical uhf triode—2C39. (Plate dissipation 100 watts.)  
Curve (3): Typical efficiency of klystrons versus frequency (independent of output power). This is the efficiency at the optimum frequency for each tube.  
Curve (4) (dotted): Maximum power output of the largest commercially available negative-grid tube at various frequencies.  
Points  $\square$  cw power output of various klystrons (not the largest possible).

It is, therefore, apparent that the efficiency and power gain of a klystron will fall off relatively slowly, compared with a triode or tetrode, as the wavelength is reduced. This is illustrated by the curves in Fig. 2. It is also clear that the maximum size and power output of a klystron are not determined by the wavelength. It follows that the klystron is ideally suited to high-power generation at uhf and microwave frequencies, and out-classes the conventional type of tube in every respect, including ease of manufacture.

Turning now to a typical performance obtainable from a 3-cavity klystron, the results given by the Eimac tube may be taken as representative of this type of tube. This tube will generate 5 kw of RF power in the uhf television band with an efficiency of more than 30 per cent when fully driven. The over-all bandwidth is about 5 mc and the power gain, under television condi-

tions, is about 20 db. Salient features of operation are these:

The tuning of each of the 3 cavities is independent of the others since there is no feedback present. This makes for very simple lining-up procedure.

The output cavity is tuned to resonance at the mid-band frequency, and loaded for optimum performance by means of some variable coupling device external to the tube.

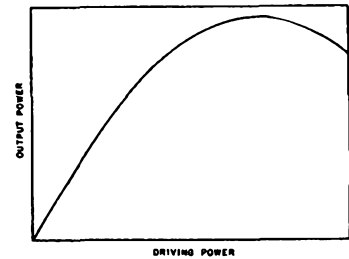

Fig. 3—Output power versus driving power for klystron.

A curve of power output against power input for this type of tube is a Bessel function of the first order and the first part of such a curve is very nearly linear. (See Fig. 3.) In television service, assuming that sync stretching is used in the driving stages, the klystron may be operated in such a way that the sync pulses drive the tube very nearly to the peak of the Bessel curve, so that the efficiency at sync pulse levels is nearly the fully driven efficiency.

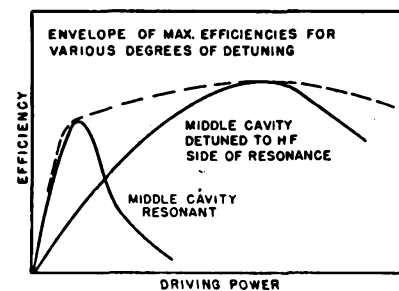

Fig. 4—Efficiency versus driving power, showing the effect of detuning the middle cavity.

The center cavity is detuned to a frequency slightly higher than the midband frequency, since this gives greater efficiency than resonant operation, and helps to broaden the pass band. This cavity may be loaded externally by resistance in some cases. This detuned operation requires greater driving power to the first cavity than resonant operation. (See Fig. 4.)

The input cavity may be either detuned on the low-frequency side of resonance or it may be tuned to resonance and loaded with external resistance in order to achieve the necessary bandwidth.

The relation between efficiency, power output, and anode voltage for a given tube is shown at Fig. 5. There is an optimum voltage for best efficiency because the voltage determines the speed of the electrons along the tube. Now a certain time is required for electron bunching to take place; this depends mainly on the frequency and determines the distance between the cavities. But this distance will be optimum for only one electron speed, and therefore only one voltage. Conversely, for a given voltage the relation between efficiency and frequency will also show a broad peak at a given frequency, and this fall-off at higher and lower frequencies will limit the useful frequency range of a given tube, even if the cavities are tunable over an indefinitely wide range.

The power input from the dc power supply feeding the anode of the tube is constant (about 1.5 amps at 13 kv), and independent of the drive voltage; therefore, the regulation of this power supply may be quite poor without adverse effects. Also, only simple circuits are necessary to reduce the hum to a low level. The filament may be heated by ac.

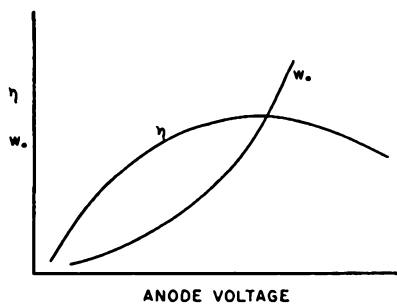

Fig. 5—Power output and efficiency versus anode voltage.

The magnetic field used for focussing the beam is simple to arrange, and relatively low in intensity, and consumes only a small amount of dc power in the coils. It must be made variable since the efficiency of the tube varies fairly rapidly with the field strength and reaches a maximum for an optimum setting of the magnetic field. The RF cavities, the drift tubes, and the anode are all in metallic contact and may be grounded. Thus,

there is no problem of by-passing and dc isolation in the output circuit compared to the by-passing problem with a triode or tetrode amplifier. The collector is usually insulated from the main part of the tube in order to facilitate monitoring of the current division between the collector and the drift tubes. The anode voltage supply is grounded on the positive side, and the negative side is connected to the cathode of the tube.

Considering now the over-all problem of design, construction, installation, and operation of a high-power uhf amplifier, and the difference between the problem with a conventional type of tube and with a klystron, it is evident that the klystron scores heavily in all respects. The burden imposed on the transmitter designer is lessened because the klystron with its cavities forms a complete amplifier stage in itself. Because of the absence of feedback in the klystron, the circuit design is greatly simplified, compared with the conventional amplifier design. Also, when using a conventional tube at uhf, the designer is usually faced with the very difficult problem of obtaining the maximum efficiency from a stage in which the tube is run to its limit, and only by very careful design can the desired performance be obtained from it. With klystrons, on the other hand, the problem is easier because there is usually a greater margin of performance, both in respect to output and power gain. Also, the construction of a klystron stage is simpler than the conventional stage, and, as we have seen, the operation is also simpler.

Fig. 1 shows the more or less conventional type of klystron construction involving integral cavities, namely, cavities which are an integral part of the vacuum system. A unique feature of the Eimac tube, hereinafter described, is that part of the cavities are external to the tube envelope so that simple mechanical tuning of the cavities over a wider band of frequencies is possible. The tube itself is also simplified.

### C. A Practical Example: Eimac UHF Klystron for TV

The photograph in Fig. 6 shows the Eimac uhf klystron, an example of a 3-cavity klystron in a form suitable for commercial manufacture, and now in produc-

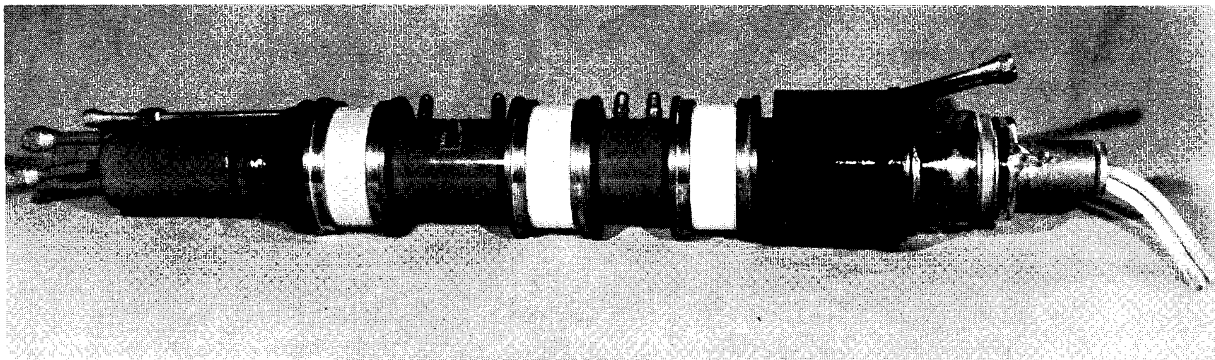

Fig. 6—The Eimac 5-kw uhf klystron for TV.

tion. Tube-cavity parts and drift-tube sections are shown in Fig. 7. Fig. 8 shows the tube and external cavities in a test setup.

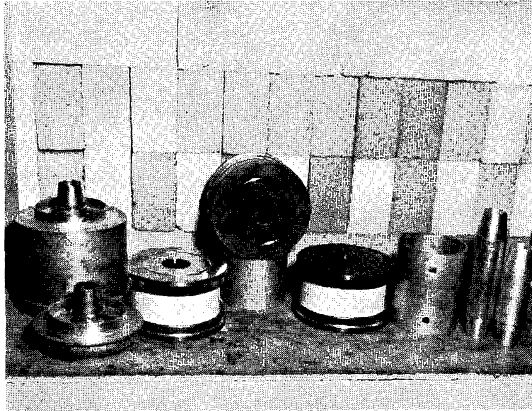

Fig. 7—Tube cavity parts and drift tube sections.



Fig. 8—The 5-kw klystron on test.

A feature of interest is the use of cavities which are tunable by means external to the vacuum system. This is made possible by use of ceramic "windows" which, if designed and fabricated correctly, will produce only a minor deterioration in the over-all performance of the tube because of their finite dielectric loss and high dielectric constant.

This means that part of each cavity is in vacuo and part is in air. The convenience of operating a tube of this type, compared with a tube in which the cavities

are entirely in vacuo, is considerable. In the first place, the mechanism for varying the resonant frequency is simple and may involve straightforward shorting bars with sliding contacts with negligible losses. These slidable devices are outside the vacuum system, as shown in Fig. 8. The tuning range of such a cavity is large. With a totally evacuated cavity it has not yet been found possible to use such a means of tuning, because sliding contacts in vacuo are generally unsatisfactory. Therefore, tuning has to be done by distortion of some flexible metallic membrane. Such a membrane introduces mechanical weaknesses into the tube structure which then has to be stiffened by an external frame. Also, the range of tuning is relatively small, and usually the tuning is done by varying the gap spacing, and therefore, its capacitance. This can be done only to a limited extent. If the gap is made too wide, the electron transit time will become an appreciable fraction of 1 RF cycle, causing inefficiency; on the other hand, if the gap is too small, the bandwidth will suffer (bandwidth varies roughly as  $1/c$ ). With a ceramic window cavity the tuning is done by varying the inductance of the cavity, the capacitance across the gap is fixed, and the gap can be set for optimum performance over the frequency band.

Another point of difference is that the mechanical forces required to tune a cavity by means external to the vacuum system are small, being determined only by friction, whereas with the other type of cavity the tuning mechanism has to withstand the forces caused by the operation of atmospheric pressure against the flexible metallic membrane.

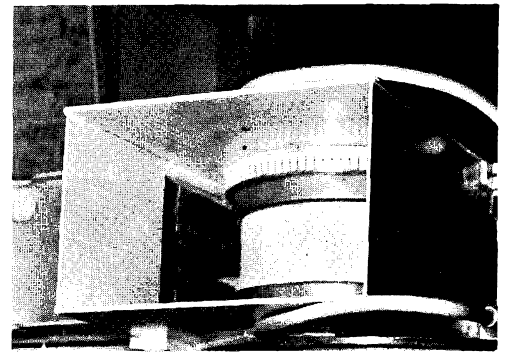

Fig. 9—Output cavity with one tuning plunger removed, showing ceramic and output coupling device.

Another desirable feature obtained with the ceramic windows is that the loading of the cavity may be accomplished outside the vacuum system, either by loops or a waveguide-to-cavity loading device, such as a quarter-wave transformer made from ridge waveguide. (See photograph of output cavity, Fig. 9.) The coupling may, therefore, be varied with ease. With a totally evacuated cavity it is very inconvenient to build in a variable load coupling, and it is common practice to use

a fixed loop; thus the benefit of variable coupling is lost.

Lastly, because of the relatively large frequency band that can be covered by a given klystron with ceramic windows, a smaller number of tube designs is required to cover a given frequency band, such as the uhf TV band. This simplifies the manufacturing problem and reduces the cost of the tube.

Another feature of interest is the use of a tantalum cathode heated by electron bombardment from a tungsten filament of relatively small size by means of a dc power supply (0.6 amps. at 2,000 volts) between the cathode and the filament. This constitutes a flexible system, and is much simpler to design and construct than a radiation-heated cathode.

#### CONCLUSIONS

The 3-cavity externally tunable klystron is excellently suited to high-power generation at uhf (and also at higher frequencies) because

1. it is relatively simple to manufacture,
2. it is easy to use and adjust,
3. the transmitter design and construction is simplified by its use,
4. its performance as an amplifier is greatly superior to other tube types.

It is likely that the future will see more and more such tubes in commercial service for an increasing variety of applications.

Reproduced from the PROCEEDINGS OF THE INSTITUTE OF RADIO ENGINEERS  
VOL. 41, NO. 1, JANUARY, 1953

#### NOTE

The appended reprint from the PROCEEDINGS OF THE INSTITUTE OF RADIO ENGINEERS describes early experimental klystron structures.

# TENTATIVE DATA

**EITEL-McCULLOUGH, INC.**  
SAN BRUNO, CALIFORNIA

**3K50,000LA**  
**3K50,000LF**  
**3K50,000LK**  
**KLYSTRONS**  
**L-BAND**  
**AMPLIFIERS**

The Eimac 3K50,000LA, 3K50,000LF and 3K50,000LK klystrons are three cavity, magnetically focused power amplifiers intended primarily for UHF television broadcast service. Each klystron type, operating as a television visual r-f amplifier, will deliver 12 kW of peak synchronizing power output with a power gain of approximately 20 db. The cavities of the Eimac UHF television klystrons have ceramic windows and are completed by tuning boxes external to the tubes.

### NOMINAL TUNING RANGE

The UHF television band (470-890 Mc) is covered by the three tube types as follows:

TUBE TYPE NUMBER	MC.	CHANNEL
3K50,000LA	470-580	14-32
3K50,000LF	580-720	33-55
3K50,000LK	720-890	56-83

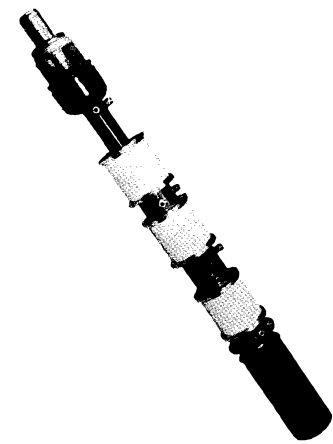

## GENERAL CHARACTERISTICS

### MECHANICAL

Mounting (See Outline Drawing)	Support from Mounting Flange		
Mounting Position	Axis Vertical		
Cooling	Water & Forced Air		
Connections:			
Filament	Flexible Leads		
Cathode	Cylindrical Strap		
Focus Electrode	Cylindrical Strap		
Cavities	Multiple Contact Fingers		
Collector	Cylindrical Strap		
Klystron Type	"A"	"F"	"K"
Maximum Overall Dimensions:			
Length	54	49	45 inches
Diameter	5 1/8	5 1/8	5 1/8 inches
Net Weight	53	48	46 pounds
Shipping Weight	185	175	170 pounds

### ELECTRICAL

Filament: Pure Tungsten		
Voltage	-	9.0 volts
Current (with cathode cold)	-	42 amperes
Current (with cathode at operating temperature)	-	39 amperes
Maximum Allowable Short Circuit Current of Filament Current Source	-	84 amperes
Cathode: Unipotential; heated by electron bombardment		
<b>MAXIMUM CATHODE RATINGS</b>		
DC VOLTAGE	-	2300 MAX. VOLTS
DC CURRENT	-	.75 MAX. AMPERES
DC POWER	-	1600 MAX. WATTS
Focus Electrode		
*Voltage (with respect to cathode)	-	0 to -500 volts
Magnetic Field: Axial (See Magnetic Circuit Schematic)		
Field Strength (approximately)	-	120 gauss
*May be varied over a range of 0 to -500 volts if beam current control is desired.		

## ULTRA HIGH FREQUENCY POWER AMPLIFIER

### MAXIMUM RATINGS

DC BEAM VOLTAGE	-	19.5 MAX. KILOVOLTS
DC BEAM CURRENT	-	2.56 MAX. AMPERES
COLLECTOR DISSIPATION	-	50.0 MAX. KILOWATTS

Note: Maximum beam voltage and beam current should not be applied without r-f excitation.

### TYPICAL OPERATION

RF Linear Amplifier—Television Visual Service (In accordance with United States Federal Communications Commission Standards)	
DC Cathode Bombarding Power	1400 watts
DC Cathode Bombarding Voltage (approximately)	2100 volts
DC Cathode Bombarding Current (approximately)	.66 amperes
DC Focus Electrode Voltage	0 volts
DC Beam Voltage	17.2 kilovolts
DC Beam Current	2.15 amperes
DC Collector Current (approximately) <sup>1</sup>	1.72 amperes
Peak Synchronizing Level (80% of saturation power)	
Driving Power (approximately) <sup>2</sup>	55 watts
Power Output	12.0 kilowatts
Efficiency	41 percent
Black Level	
Collector Dissipation (approximately) <sup>1</sup>	30 kilowatts
Driving Power (approximately) <sup>2</sup>	33 watts
Power Output	7.2 kilowatts
Efficiency	19 percent

RF Amplifier—Television Aural Service	
DC Cathode Bombarding Power	1400 watts
DC Cathode Bombarding Voltage	2100 volts
DC Cathode Bombarding Current	.66 amperes
DC Focus Electrode Voltage	0 volts
DC Beam Voltage	12.3 kilovolts
DC Beam Current	1.33 amperes
DC Collector Current <sup>1</sup>	1.06 amperes
Driving Power <sup>3</sup>	20 watts
Collector Dissipation (approximately) <sup>1</sup>	10 kilowatts
Power Output	6 kilowatts
Efficiency	36 percent

<sup>1</sup>Minor tube-to-tube variations may be expected.

<sup>2</sup>Total driving power includes losses inserted for broadband operation. The output power is useful power measured in a load circuit.

<sup>3</sup>The driving power is the total power required by the tube and a resonant circuit.



3K50,000LA  
3K50,000LF  
3K50,000LK

## APPLICATION

**Mounting**—The klystrons are provided with a mounting flange (See Outline Drawing) which may be used to support the tubes with either end up.

**Filament Operation**—For maximum tube life, the pure tungsten filament should be operated just above the emission limiting temperature. This temperature will be obtained with a filament voltage, as measured directly at the terminals, of approximately 9 volts.

**Cathode Heating Power**—The cathode is unipotential and heated by electron bombardment. A dc potential of approximately 2100 volts is applied between the filament and the cathode; and the recommended cathode heating power of 1400 watts is obtained with approximately .66 amperes. The filament is designed to operate under space-charge limited conditions. Cathode temperature is varied by changing the bombarding potential between the filament and the cathode.

**Cooling**—Forced air is used to cool the Electron Gun Structure and the Middle and Output Cavities. Only clean, well filtered air should be blown on the tube to avoid voltage breakdown due to dust accumulation. The temperature of the metal in the region of the metal-to-glass seals should not exceed 150°C. Tube temperatures may be measured with a temperature-sensitive paint, such as "Tempilaq", manufactured by the Tempil Corporation, 132 West 22nd Street, New York 11, N. Y.

Water is used to cool the Drift Tubes and the Collector Assembly. The cooling water should be of sufficient purity to prevent liming of the water system, and the use of a heat exchanger is recommended. The inlet water pressure of the Drift Tubes and the Collector Assembly should not exceed 50 pounds per square inch. The outlet water temperature must not exceed a maximum of 70°C. under any condition.

Air and water flow should be started before the filament and cathode power are applied and maintained for at least two minutes after the filament and cathode power have been removed.

Klystron Cooling Requirements for Typical Operating Conditions and Correct Magnetic Field Adjustment:

	Cooling Medium	Volume	Pressure Drop	Remarks
Input Drift Tube	*Water	1 gpm	1 psi	Total pressure drop if series connected with 5/16" tubing = 4 psi.
Short Drift Tube Jacket	*Water	1 gpm	1 psi	
Long Drift Tube Jacket	*Water	1 gpm	1 psi	
Output Drift Tube	*Water	1 gpm	1 psi	
Collector Assembly	*Water	15 gpm	3 psi	

Electron Gun Structure	Filament Stem	Air	1-2 cfm	See Cooling Diagram	
	Cathode Terminal	Air	90 cfm		
	Focus Electrode and Anode Seals	Air	90 cfm		
Input Cavity	-	None			
Center Cavity	-	Air	15 cfm		
Output Cavity	-	Air	50 cfm		

\*Cooling water connections should be made as noted on Cooling Diagram.

**RF Contact Surfaces**—The means by which contact is made between the cavities and the tuning boxes is of

great importance. Two requirements which must be met to ensure proper electrical connections are as follows:

- (1) Contact to the tube cavities must be made only on the peripheral surface of the 1/4" cavity flanges as shown on the outline drawing.
- (2) Each individual finger of the collet or spring stock material must make positive contact to the cavity flange to prevent arcing.

**Magnetic Field**—An adjustable magnetic field is necessary to control and direct the beam throughout the length of the drift tube. The magnetic field should be capable of variation around the recommended field strength of 120 gauss. Typical magnetic circuit requirements for a 3K50,000LK are shown in the Magnetic Circuit Schematic. The current and adjustment of the pre-focusing coil are optimized under low beam voltage conditions and will require minor readjustment with changes in beam voltage. The current and location of the focusing coils should be capable of independent adjustment. Readjustment of the current of the focusing coils is necessary with changes in beam voltage. Beam transmission (collector current divided by the beam current as measured in the cathode return to beam power supply) will vary from 75% to 95%. Improper adjustment or misalignment of the magnetic field, as indicated by too low a value of beam transmission, may cause the beam to strike and overheat the drift tube walls.

### MAGNETIC FIELD COIL REQUIREMENTS

Tube Type	Number of Coils Required for Field Strength of Approximately 120 Gauss.		
	Pre-focusing Coil	Focusing Coils	
	{ 375-750 ampere-turns per coil }	{ 1600-4800 ampere-turns per coil }	{ 0-1600 ampere-turns per coil }
3K50,000LA	- 1	3	1
3K50,000LF	- 1	3	1
3K50,000LK	- 1	2	1

**CAUTION**—It is convenient to operate the r-f and collector portions of the tube at ground potential. Since the cathode and filament are operated at high negative potentials with respect to ground, filament and cathode power supplies and voltmeters must be adequately insulated for these high voltages. Protection must also be afforded to operating personnel.

**Protection**—It is recommended that the following protective devices be used:

- (1) Interlocks in air and water supplies.
- (2) Interlocks in magnetic field supply circuits.
- (3) Current overload in cathode bombardment supply circuit.
- (4) Current overload in beam current supply circuit.
- (5) Current overload in cavity current circuit.
- (6) Current limiting resistor of approximately 100 ohms in series with beam power supply to isolate tube from final capacitor of supply.

The filament and cathode bombardment voltages will normally be applied before the beam voltage. Cavity tuning or magnetic field adjustment should be made with reduced beam voltage (1/2 to 2/3 normal). Slight retuning and readjustment will be necessary when beam voltage is raised to full value.

"IMPERIAL FLEX FITTINGS" FOR  
 $\frac{3}{4}$ " O.D. TUBING.  
ALL OTHERS ARE "IMPERIAL  
FLEX FITTINGS" FOR  $\frac{5}{8}$ " O.D.  
TUBING.

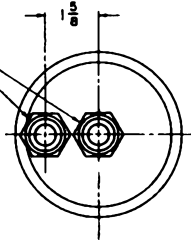

OUTPUT END VIEW

	A	B	C	D	E
3K50,000 LA	$53 \frac{3}{8}$	$31 \frac{1}{4}$	6	$4 \frac{7}{8}$	$2 \frac{3}{8}$
3K50,000 LF	$48 \frac{7}{8}$	$26 \frac{3}{4}$	5	$3 \frac{3}{4}$	2
3K50,000 LK	$44 \frac{7}{8}$	$22 \frac{3}{4}$	4	$3 \frac{1}{8}$	$1 \frac{5}{8}$

DIMENSIONS IN INCHES

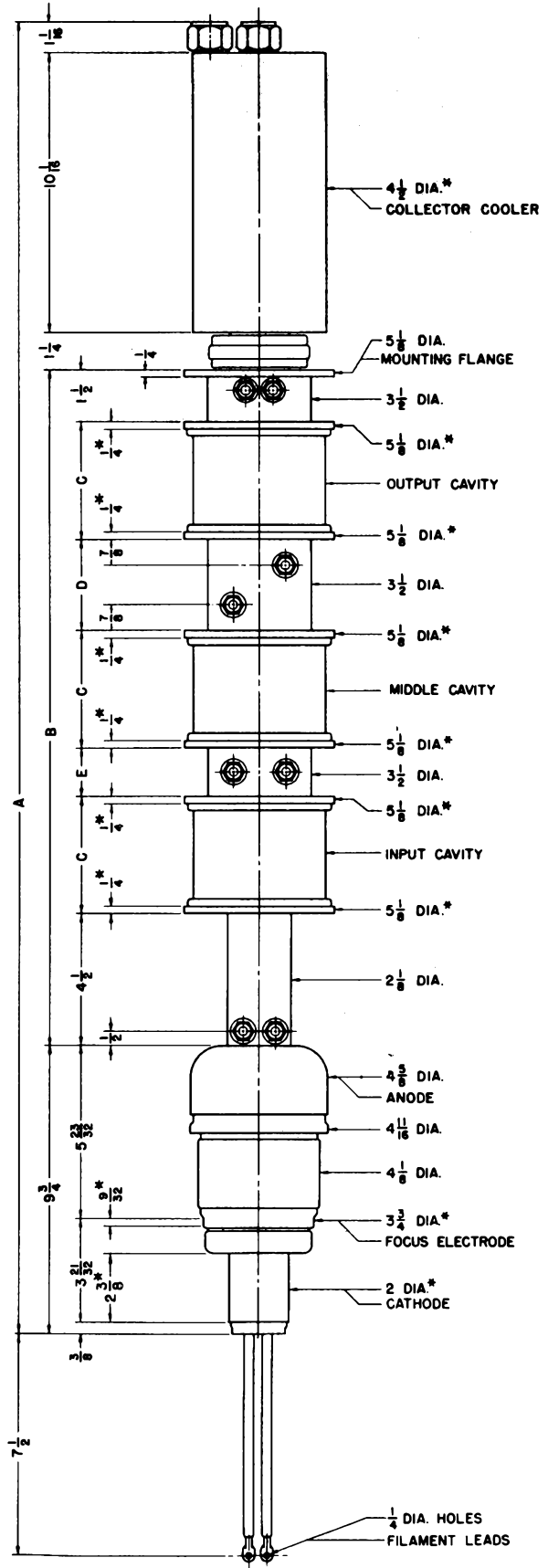

\*CONTACT SURFACE





3K50,000LA  
3K50,000LF  
3K50,000LK

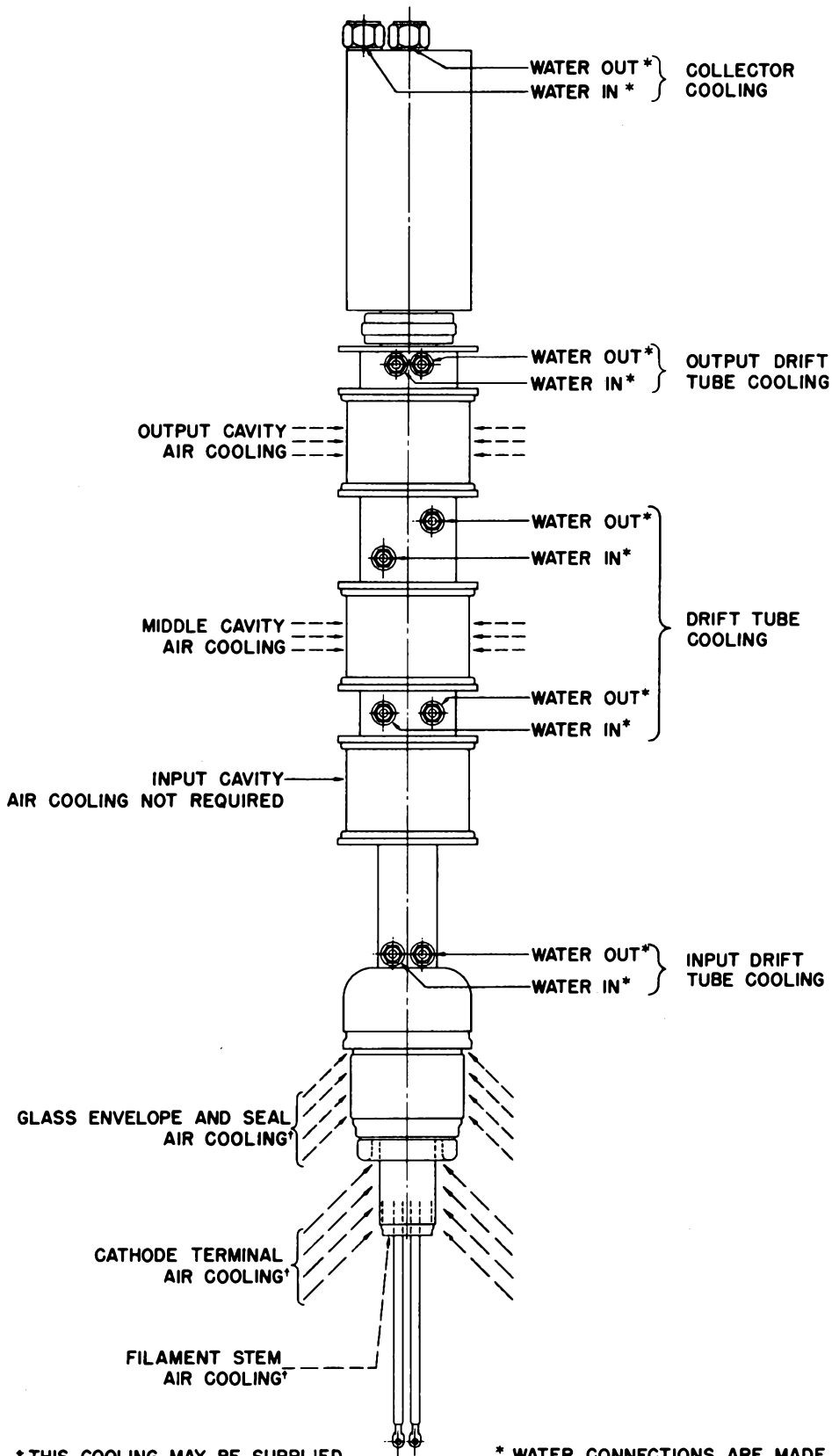

† THIS COOLING MAY BE SUPPLIED BY A SINGLE BLOWER THROUGH SUITABLE MANIFOLD & BAFFLES

\* WATER CONNECTIONS ARE MADE AS SHOWN WHEN TUBE IS MOUNTED WITH COLLECTOR UP WHEN TUBE IS MOUNTED WITH ANODE UP THE WATER CONNECTIONS MUST BE REVERSED.

**COOLING DIAGRAM**

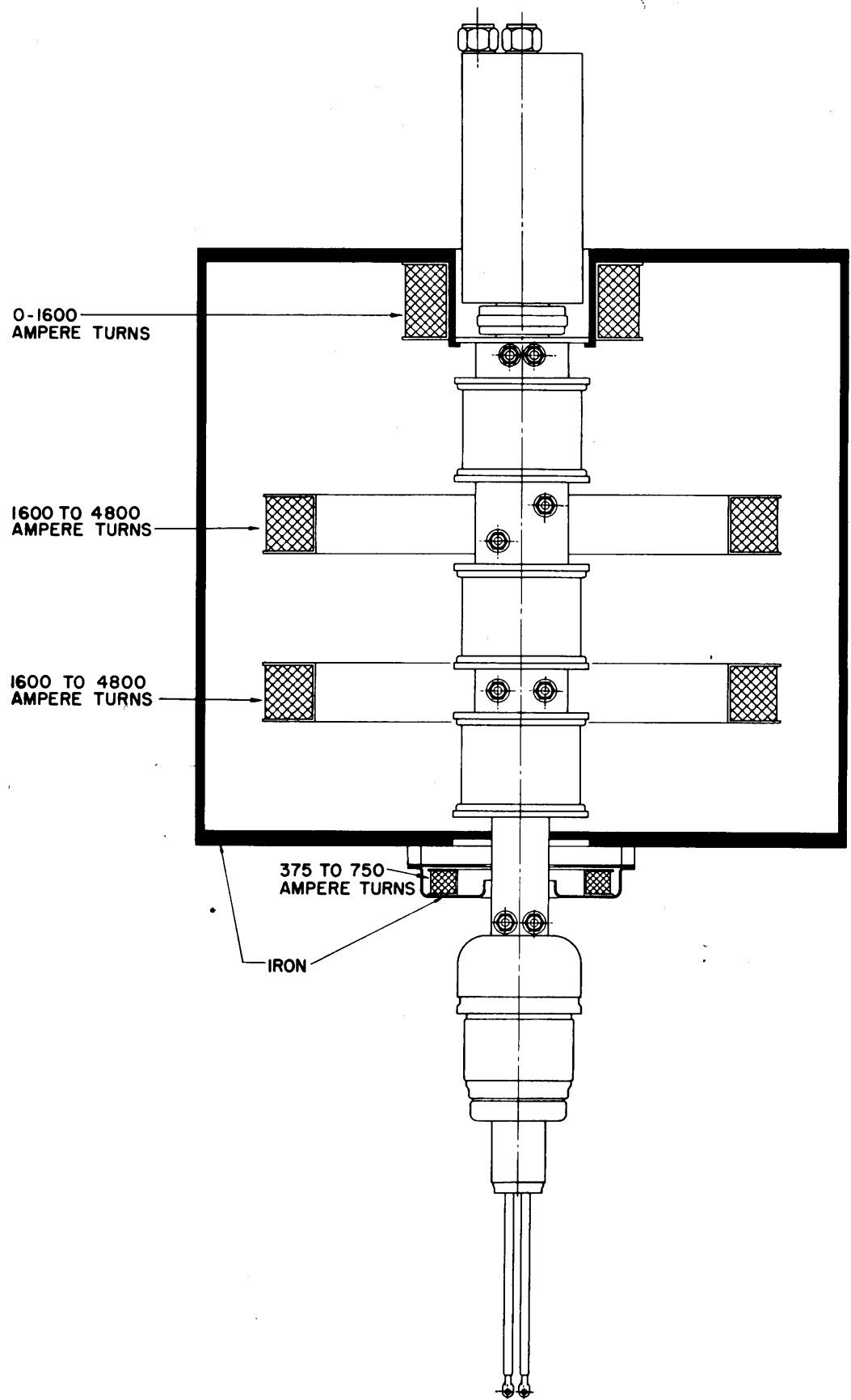

**MAGNETIC CIRCUIT SCHEMATIC FOR 3K50,000LK**

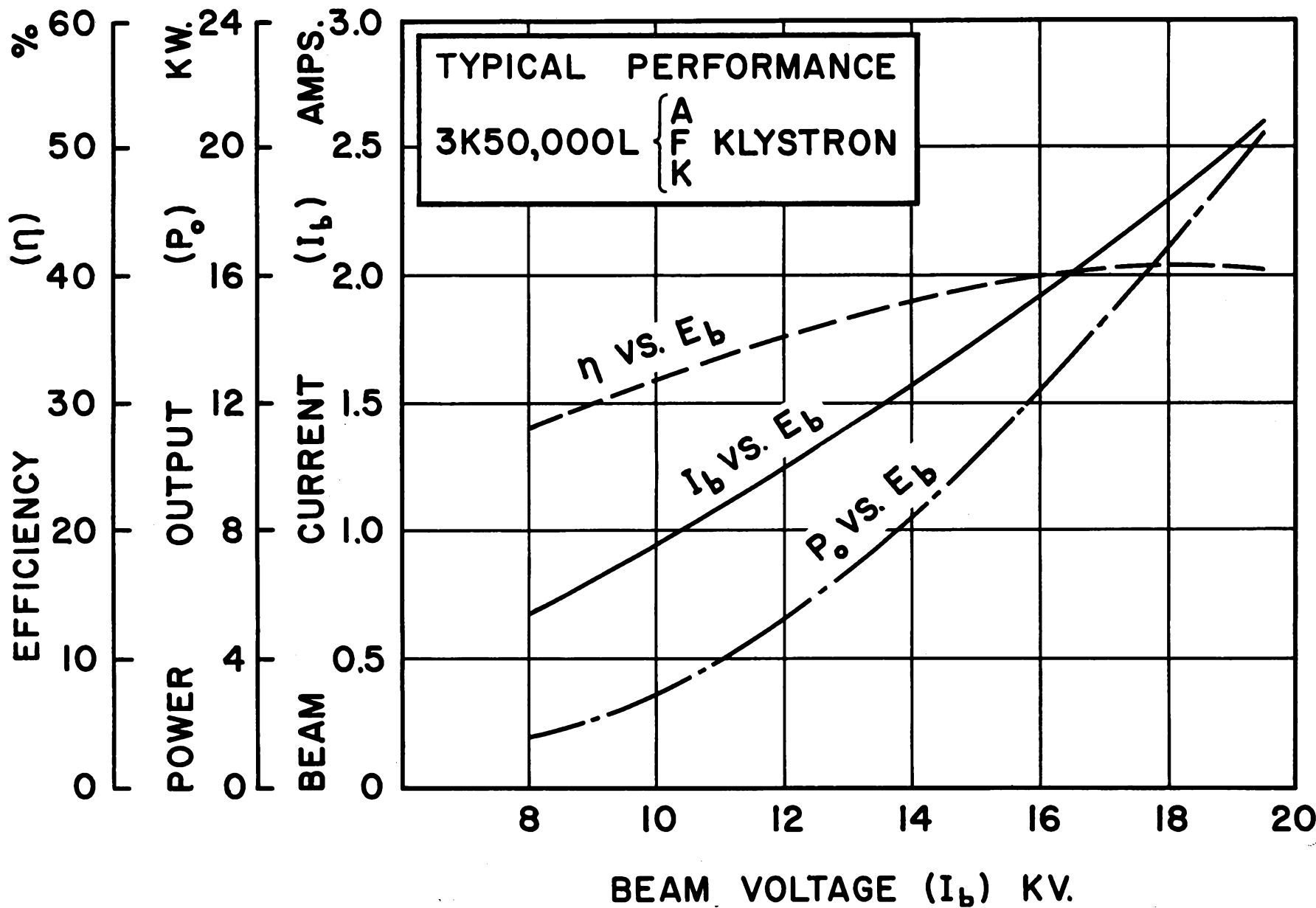

*Simmac*  
3K50,000LA  
3K50,000LF  
3K50,000LK

BEAM CURRENT, POWER OUTPUT AND EFFICIENCY VS. BEAM VOLTAGE

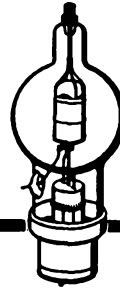

# triodes ▶

---

## Look in the front pages for ...

- Your nearest distributor of modern, fully guaranteed Eimac Vacuum tubes, vacuum capacitors, heat dissipating connectors, air-system sockets, preformed contact finger stock and vacuum switches.
- Your nearest Eimac Field Engineer, who stands ready to give you immediate engineering assistance, any information on deliveries and prices, or provide other information not found in the catalog.
- Eimac tube type numbering system.
- Tube Replacement Chart.
- Prices on Eimac products.

---

## IMPORTANT EIMAC "EXTRAS"

**Application Engineering.** The Eimac Application Engineering Department is available at all times for consultation. New tube operating techniques are continually being explored, tested and proved by Eimac application engineers, whose combined knowledge and experience are made available to you. Additional contributions by this Eimac department are its Application Bulletins, an expanding service which you get without obligation.

**Field Engineering.** Serving as an extension of the Application Engineering Department outside the Eimac plant, Eimac field engineers cover the United States, operate out of offices in major cities. They will help you personally with experimental work, problems of technique, etc. Engineers from the Eitel-McCullough plant in San Bruno are available, too, for field consultation throughout the country. As Eimac tubes are world renowned, the same services extend to various countries overseas through the Eimac export division.

▶ The Eimac 2C39A is a high-mu UHF transmitting triode with a plate-dissipation rating of 100 watts, designed for use as a power amplifier, oscillator, or frequency multiplier at frequencies to above 2500 Mc. The rugged construction, small size and unusually high transconductance of this tube make it ideal for compact fixed or mobile equipment. Its physical characteristics are particularly suitable for grid-isolation circuits and for cavity-type circuits.

The 2C39A in a class-C r-f grid-isolation circuit at 500 Mc. will deliver up to 27 watts useful power output with 6 watts driving power. As an r-f oscillator at 2500 Mc., the 2C39A will deliver a minimum of 12 watts useful power output.

**GENERAL CHARACTERISTICS**

**ELECTRICAL**

Cathode: Coated Unipotential	
Heater Voltage <sup>2</sup>	6.3 volts
Heater Current	1.0 ampere
Amplification Factor (Average)	100
Direct Interelectrode Capacitances (Average)	
Grid-Plate	1.95 $\mu\mu\text{f}$
Grid-Cathode	6.50 $\mu\mu\text{f}$
Plate-Cathode	0.035 $\mu\mu\text{f}$ max.
Transconductance ( $I_b=70\text{ma.}, E_b=600\text{v.}$ )	22,000 $\mu\text{mhos}$
Highest Frequency for Maximum Ratings	2500 Mc.

<sup>1</sup>See "Application".

▶ **MECHANICAL**

Base, Socket and Connections	See drawing
Mounting Position	Any
Cooling	Forced air
Maximum Temperature of Anode, Grid, Cathode and Heater Seals and Anode Cooler Core	175°C
Maximum Overall Dimensions:	
Length	2.75 inches
Diameter	1.26 inches
Net Weight	2.8 ounces
Shipping Weight (Average)	7 ounces

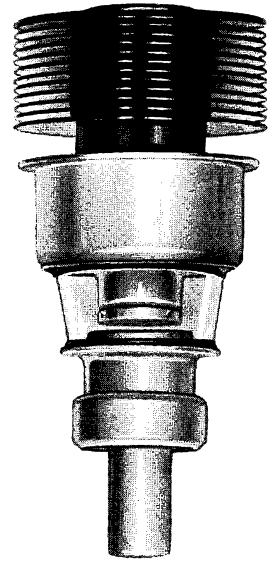

**RADIO-FREQUENCY POWER AMPLIFIER, OSCILLATOR OR MODULATOR**

MAXIMUM RATINGS (Per tube)

D-C PLATE VOLTAGE	1000 MAX. VOLTS
D-C CATHODE CURRENT	125 MAX. MA
D-C GRID VOLTAGE	-150 MAX. VOLTS
D-C GRID CURRENT	50 MAX. MA
HEATER VOLTAGE	SEE APPLICATION NOTES
INSTANTANEOUS PEAK POSITIVE GRID VOLTAGE	30 MAX. VOLTS
INSTANTANEOUS PEAK NEGATIVE GRID VOLTAGE	400 MAX. VOLTS
PLATE DISSIPATION	100 MAX. WATTS
GRID DISSIPATION	2 MAX. WATTS

TYPICAL OPERATION (Key-down conditions, per tube)  
 (Power-Amplifier Grid-Isolation Circuit, CW Operation, 500 Mc.)

D-C Plate Voltage	800 volts
D-C Grid Voltage	-20 volts
D-C Plate Current	80 ma
D-C Grid Current	32 ma
Driving Power (approx.) <sup>1</sup>	6 watts
Useful Power Output	27 watts

TYPICAL OPERATION

(R-F Oscillator, 2500 Mc.)<sup>2</sup>

D-C Plate Voltage	900 volts
D-C Grid Voltage	-22 volts
D-C Plate Current	90 ma
D-C Grid Current	27 ma
Useful Power Output	12 watts

**PLATE-MODULATED RADIO-FREQUENCY AMPLIFIER OR OSCILLATOR**

MAXIMUM RATINGS (Carrier conditions, per tube)

D-C PLATE VOLTAGE <sup>3</sup>	600 MAX. VOLTS
D-C GRID VOLTAGE	-150 MAX. VOLTS
D-C GRID CURRENT	50 MAX. MA
D-C CATHODE CURRENT	100 MAX. MA
PEAK INSTANTANEOUS POSITIVE GRID VOLTAGE	30 MAX. VOLTS
PEAK INSTANTANEOUS NEGATIVE GRID VOLTAGE	400 MAX. VOLTS
PLATE DISSIPATION	70 MAX. WATTS
GRID DISSIPATION	2 MAX. WATTS

TYPICAL OPERATION

(Plate-Modulated Radio-Frequency Power Amplifier Grid-Isolation Circuit, 500 Mc., Per Tube)

D-C Plate Voltage	600 volts
D-C Grid Voltage	-16 volts
D-C Plate Current	75 ma
D-C Grid Current	40 ma
Driving Power (approx.) <sup>1</sup>	6 watts
Useful Carrier Power Output	18 watts

<sup>1</sup>Driving power listed is the total power which must be supplied to a practical grid circuit at the frequency shown.

<sup>2</sup>These 2500-Mc. conditions conform to the minimum requirements of the JAN-1A specifications for the 2C39A.

<sup>3</sup>For less than 100% modulation, higher d-c plate voltage may be used if the sum of the peak positive modulating voltage and the d-c plate voltage does not exceed 1200 volts.

IF IT IS DESIRED TO OPERATE THIS TUBE UNDER CONDITIONS WIDELY DIFFERENT FROM THOSE GIVEN UNDER "TYPICAL OPERATION", POSSIBLY EXCEEDING THE MAXIMUM RATINGS GIVEN FOR CW SERVICE, WRITE EITEL-McCULLOUGH, INC., FOR INFORMATION AND RECOMMENDATIONS.

## APPLICATION

### MECHANICAL

**Mounting**—The 2C39A may be operated in any position. It should seat against the "anode flange" (see outline drawing), and any clamping action intended to hold the tube in its socket against vibration should also be applied to this flange. No seating or clamping pressure should be exerted against any other surface.

**Connections**—The tube terminals are in the form of concentric cylinders having graduated diameters, as illustrated in the outline drawing. Spring collets or fingers should be fitted to these cylindrical surfaces to make contact with the anode, grid, cathode and heater terminals. It is important to maintain good electrical contact by keeping these surfaces clean and by providing adequate contact area and spring pressure.

**Cooling**—Forced air must be supplied to the anode, grid, cathode and heater seals and to the anode cooler core in sufficient quantities to limit their temperatures to 175°C. A convenient accessory for the measurement of tube temperatures is "Tempilaq", a temperature-sensitive lacquer manufactured by the Tempil Corporation, 132 West 22nd St., New York 11, N. Y.

A suitable arrangement for an anode cooling cowl is shown in conjunction with the outline drawing. For operation at maximum rated dissipation, an air flow through this cowling of 12.5 cubic feet per minute is recommended; less cooling air may be used at low plate dissipations, provided only that seal and anode cooler core temperatures are not allowed to exceed 175°C.

At ambient temperatures greater than 25°C., or at altitudes higher than sea level, more air will be required to accomplish equivalent cooling. Further information on this subject is contained in an article by A. G. Nekut, "Blower Selection for Forced-Air Cooled Tubes", *Electronics*, August, 1950.

### ELECTRICAL

**Heater Voltage**—The heater of the 2C39A is designed to be operated at 6.3 volts, with variations

held within the range of 5.7 to 6.9 volts. This operating voltage is particularly recommended for pulse applications requiring in excess of 3.0 amperes of peak cathode current.

Tube life may be materially increased by operation of the heater at 5.3 volts, with variations held within the range of 4.8 to 5.8 volts. This operating voltage should be used whenever the peak cathode current is not required to exceed 3.0 amperes, and whenever transit-time effects contribute back heating to the cathode. Back heating is a function of frequency, grid bias and excitation (grid current), load impedance, power output and circuit design and adjustment.

**Cavity Circuits**—Information regarding the design of cavities suitable for the 2C39A is widely available. One source is the material on cavity design for the 2C38 and 2C39 contained in "Very High Frequency Techniques", Radio Research Laboratory Staff, McGraw-Hill Co., 1947, Vol. 1, Chapter 15, pp. 337-375.

**Operation**—Low-voltage, high-current operation is preferable to high-voltage, low-current operation, from the standpoint of optimum tube life.

An excellent indication of operating conditions is the ratio of grid current to plate current; when the 2C39A is operated with grid-current values greater than half those of the plate current, either the drive is excessive or the plate loading is too light for the excitation present. The tube should never be operated without a load, or lightly loaded, even for short periods of time, and drive should be held to the lowest value consistent with reasonable efficiency.

When grid-leak bias is used, suitable means must be provided to protect the tube against loss of excitation at plate voltages in excess of 800 volts, and the grid-leak resistor should be made variable to facilitate maintaining the bias voltage and plate current at the desired values when tubes are changed in the equipment.

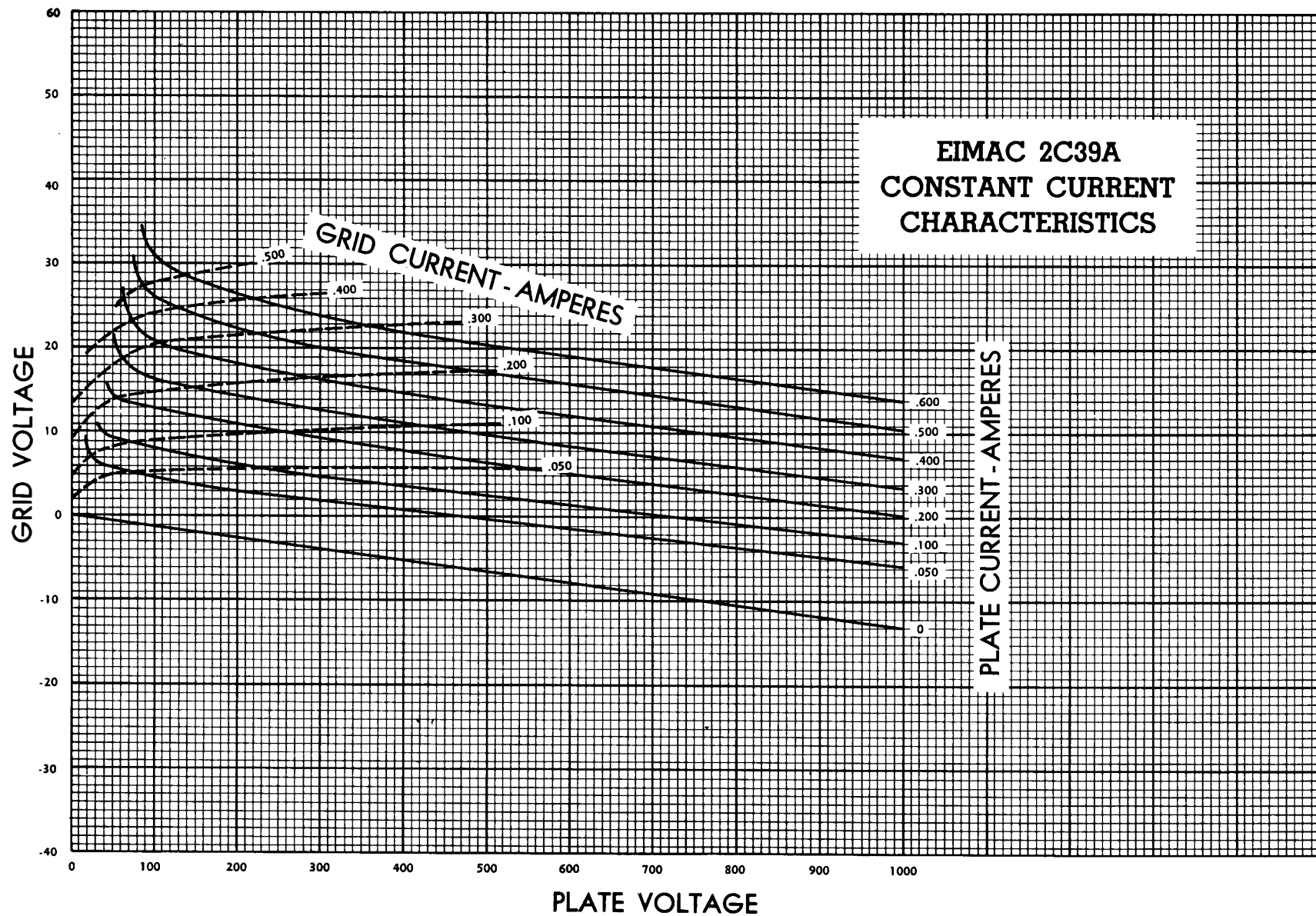

*Eimac*  
THE ELECTRON TUBE DIV.  
2C39A

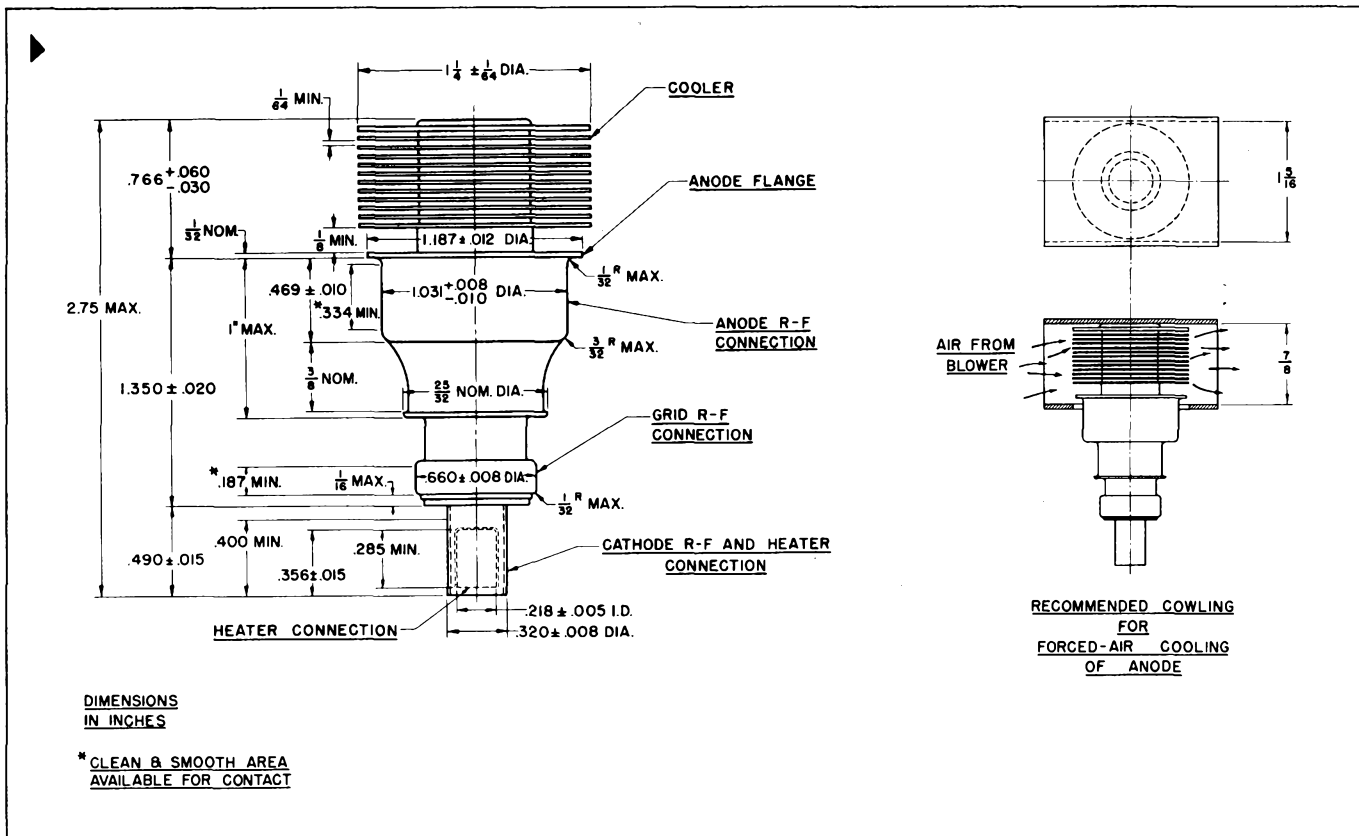
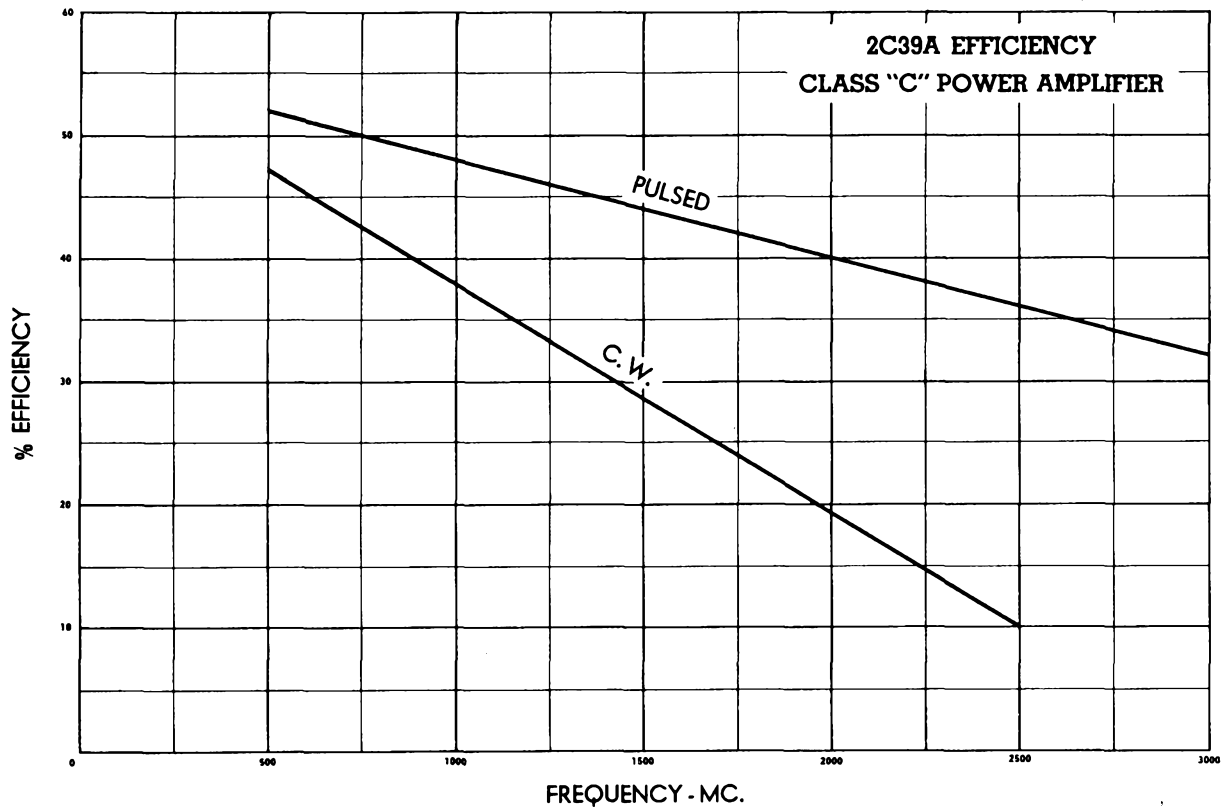



# EITEL-McCULLOUGH, INC.

SAN BRUNO, CALIFORNIA

## 3 C 2 4

MEDIUM-MU TRIODE  
MODULATOR  
OSCILLATOR  
AMPLIFIER

► The Eimac 3C24 is a medium-mu, power triode intended for use as an amplifier, oscillator or modulator. It has a maximum plate dissipation rating of 25 watts and can be operated at its maximum ratings at frequencies up to 60 megacycles.  
The 3C24 is cooled by radiation from the plate and by air circulation around the envelope. The plate operates at a visible red color at maximum rated dissipation.  
This tube is identical to the 25T except that the grid terminal is located at the side of the envelope instead of the base.

### GENERAL CHARACTERISTICS

#### ► ELECTRICAL

Filament: Thoriated tungsten	
Voltage	6.3 volts
Current	3.0 amperes
Amplification Factor (Average)	24
Direct Interelectrode Capacitances (Average)	
Grid-Plate	1.6 $\mu\mu\text{f}$
Grid-Filament	1.7 $\mu\mu\text{f}$
Plate-Filament	0.2 $\mu\mu\text{f}$
Transconductance ( $i_b=25 \text{ ma.}, E_b=1000 \text{ v.}$ )	2500 $\mu\text{mhos}$
Frequency for Maximum Ratings	60 Mc.

#### ► MECHANICAL

Base	UX Small 4-pin
Basing - Fits E. F. Johnson Co. No. 122-224, National Co. No. XC-4 or CIR-4, or equivalent socket	
Mounting	Vertical, base down or up
Cooling	Convection and Radiation

#### Recommended Heat Dissipating Connector:

Plate	HR-1
Grid	HR-1
Maximum Over-all Dimensions:	
Length	4.38 inches
Diameter	1.44 inches
Net Weight	1.5 ounces
Shipping Weight (Average)	1.0 pound

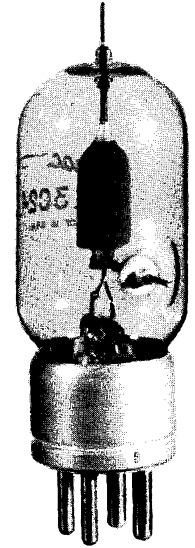

#### ► AUDIO FREQUENCY POWER AMPLIFIER AND MODULATOR

Class-B and AB

##### MAXIMUM RATINGS, PER TUBE

D-C PLATE VOLTAGE	2000 MAX. VOLTS
MAX-SIGNAL D-C PLATE CURRENT	75 MAX. MA.
PLATE DISSIPATION	25 MAX. WATTS
GRID DISSIPATION	7 MAX. WATTS

##### TYPICAL OPERATION, CLASS AB<sub>2</sub>

Sinusoidal wave, two tubes unless otherwise specified

D-C Plate Voltage	750	1000	1250	Volts
D-C Grid Voltage (approx.)*	-20	-30	-42	Volts
Zero-Signal D-C Plate Current	43	32	24	Ma.
Max-Signal D-C Plate Current	127	127	130	Ma.
Effective Load, Plate-to-Plate	12,000	17,000	21,400	Ohms
Peak A-F Grid Input Voltage (per tube)	110	120	135	Volts
Max-Signal Peak Driving Power	5.5	6.0	6.8	Watts
Max-Signal Nominal Driving Power (approx.)	2.8	3.0	3.4	Watts
Max-Signal Plate Power Output	60	85	112	Watts

\*Adjust to give stated zero-signal plate current.

#### ► PLATE MODULATED RADIO FREQUENCY AMPLIFIER

Class-C Telephony (Carrier conditions, per tube)

##### MAXIMUM RATINGS

D-C PLATE VOLTAGE	1600 MAX. VOLTS
D-C PLATE CURRENT	60 MAX. MA.
PLATE DISSIPATION	17 MAX. WATTS
GRID DISSIPATION	7 MAX. WATTS

##### TYPICAL OPERATION

D-C Plate Voltage	1000	1250	1600	Volts
D-C Plate Current	60	60	53	Ma.
D-C Grid Voltage	-120	-140	-170	Volts
D-C Grid Current	14	13	11	Ma.
Peak R-F Grid Input Voltage	235	255	280	Volts
Driving Power	3.3	3.3	3.1	Watts
Grid Dissipation	1.4	1.5	1.2	Watts
Plate Power Input	60	75	85	Watts
Plate Dissipation	13	15	17	Watts
Plate Power Output	47	60	68	Watts

The above figures show actual measured tube performance and do not allow for variations in circuit losses.

#### ► RADIO FREQUENCY POWER AMPLIFIER AND OSCILLATOR

Class-C Telegraphy or FM Telephony (Key-down conditions, per tube)

##### MAXIMUM RATINGS

D-C PLATE VOLTAGE	2000 MAX. VOLTS
D-C PLATE CURRENT	75 MAX. MA.
PLATE DISSIPATION	25 MAX. WATTS
GRID DISSIPATION	7 MAX. WATTS

##### TYPICAL OPERATION

D-C Plate Voltage	1000	1500	2000	Volts
D-C Plate Current	72	67	63	Ma.
D-C Grid Voltage	-70	-95	-130	Volts
D-C Grid Current	9	13	18	Ma.
Peak R-F Grid Input Voltage	170	195	245	Volts
Driving Power	1.3	2.2	4.0	Watts
Grid Dissipation	.9	1.3	2.1	Watts
Plate Power Input	72	100	125	Watts
Plate Dissipation	25	25	25	Watts
Plate Power Output	47	75	100	Watts

The above figures show actual measured tube performance and do not allow for variations in circuit losses.

**Simms**  
ELECTRONIC TUBE  
3C24

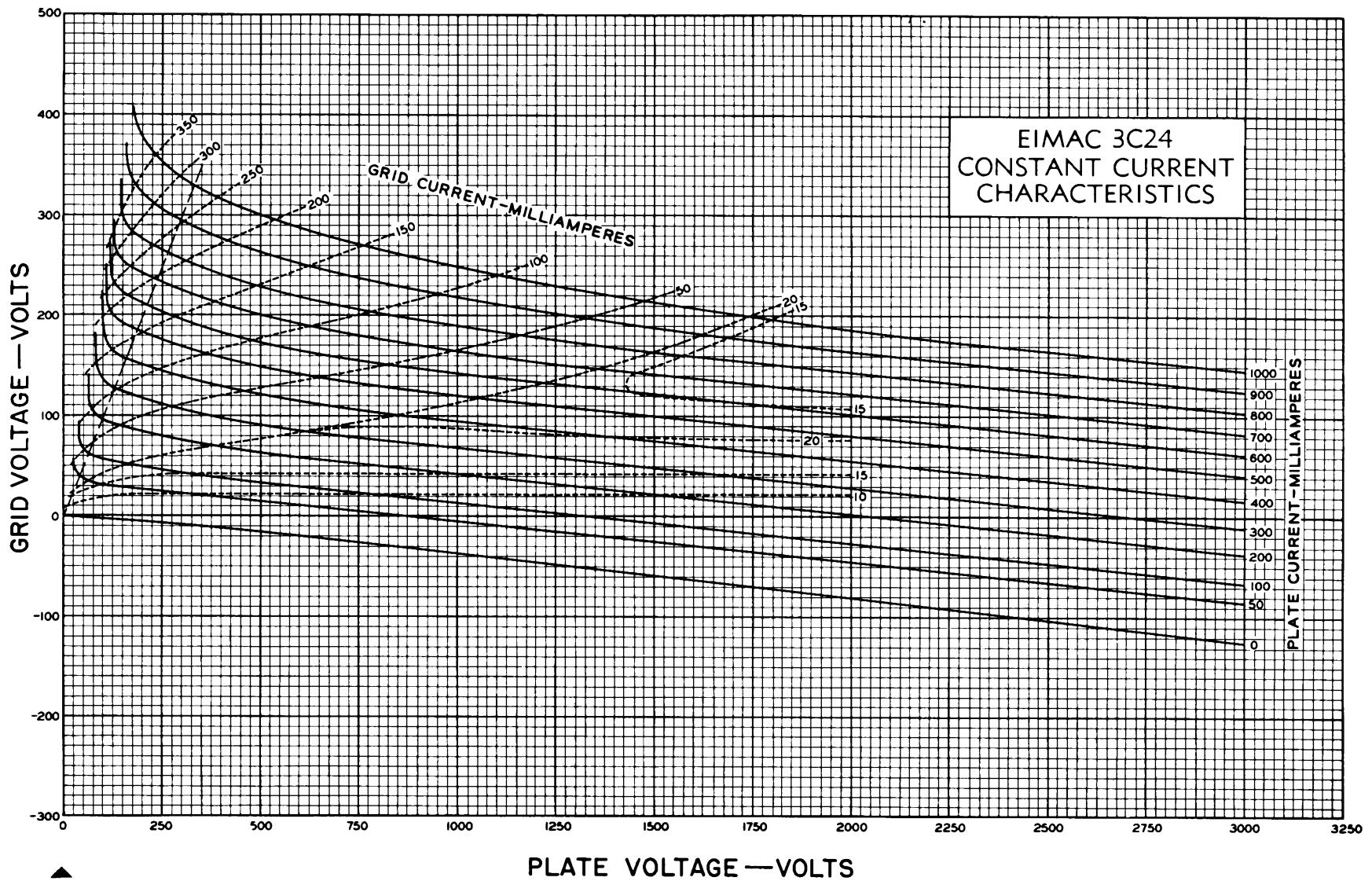

▲ Indicates change from sheet dated 8-15-44.

## DRIVING POWER vs. POWER OUTPUT

The three charts on this page show the relationship of plate efficiency, power output and grid driving power at plate voltages of 1000, 1500 and 2000 volts. These charts show combined grid and bias losses only. The driving power and power output figures do not include circuit losses. The plate dissipation in watts is indicated by  $P_p$ .

Points A, B, and C are identical to the typical Class C operating conditions shown on the first page under 1000, 1500, and 2000 volts respectively.

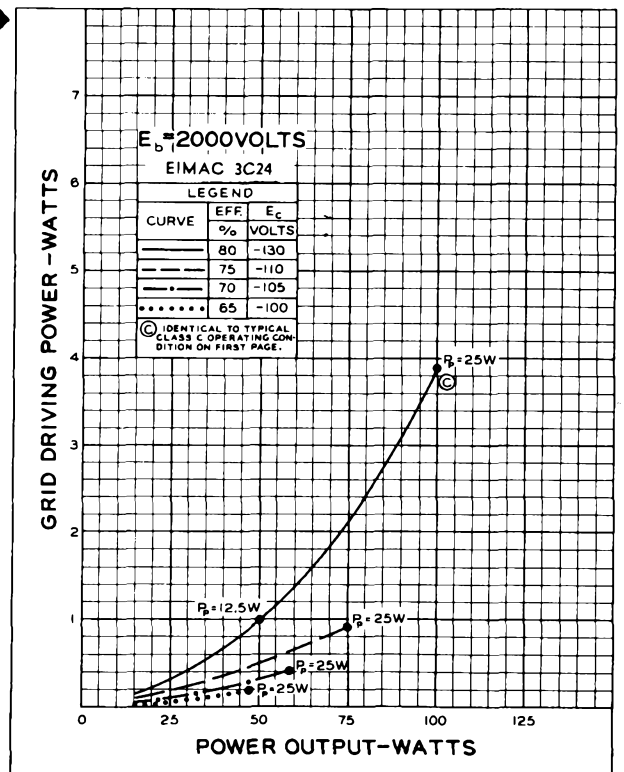
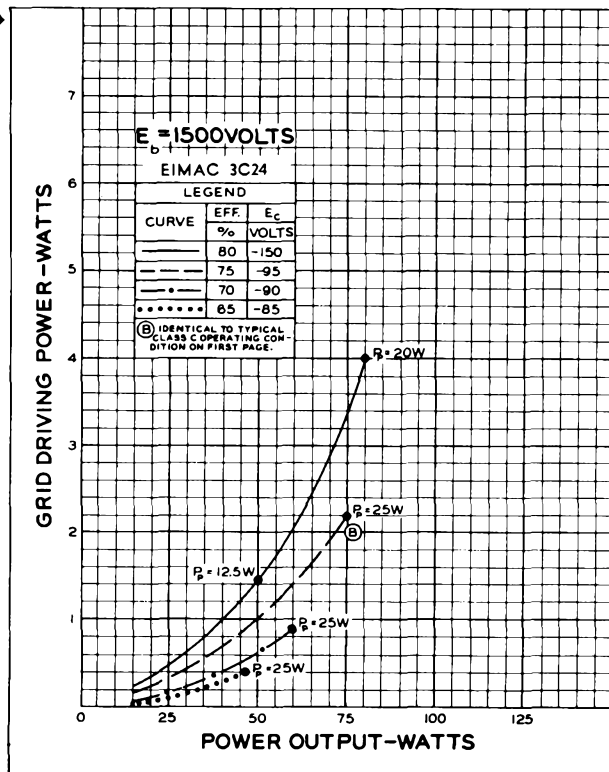
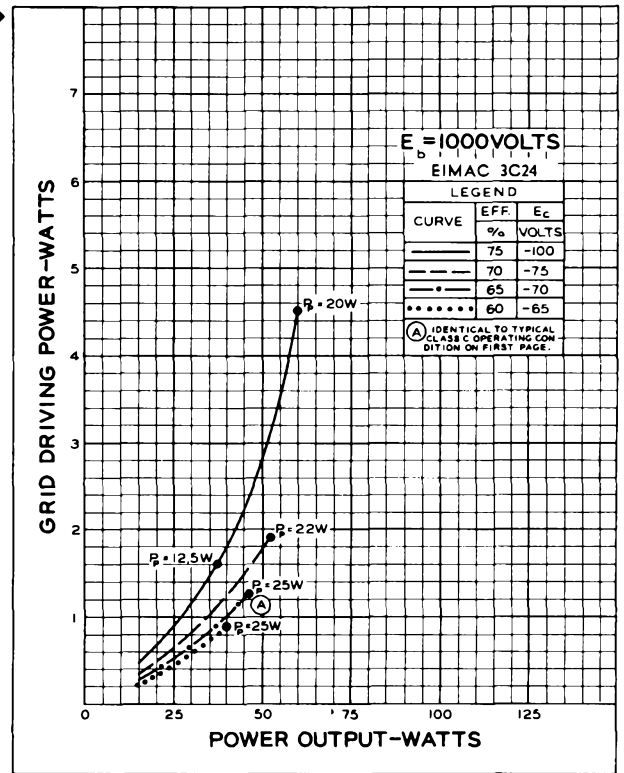

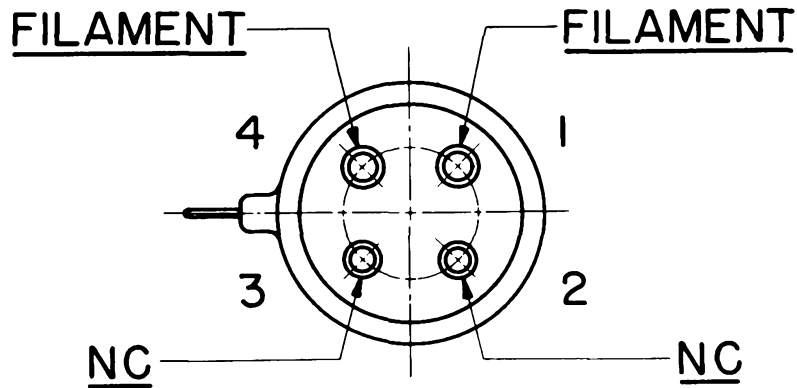
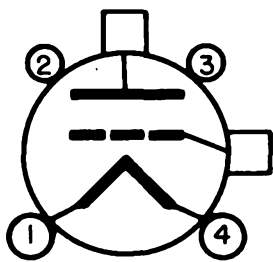
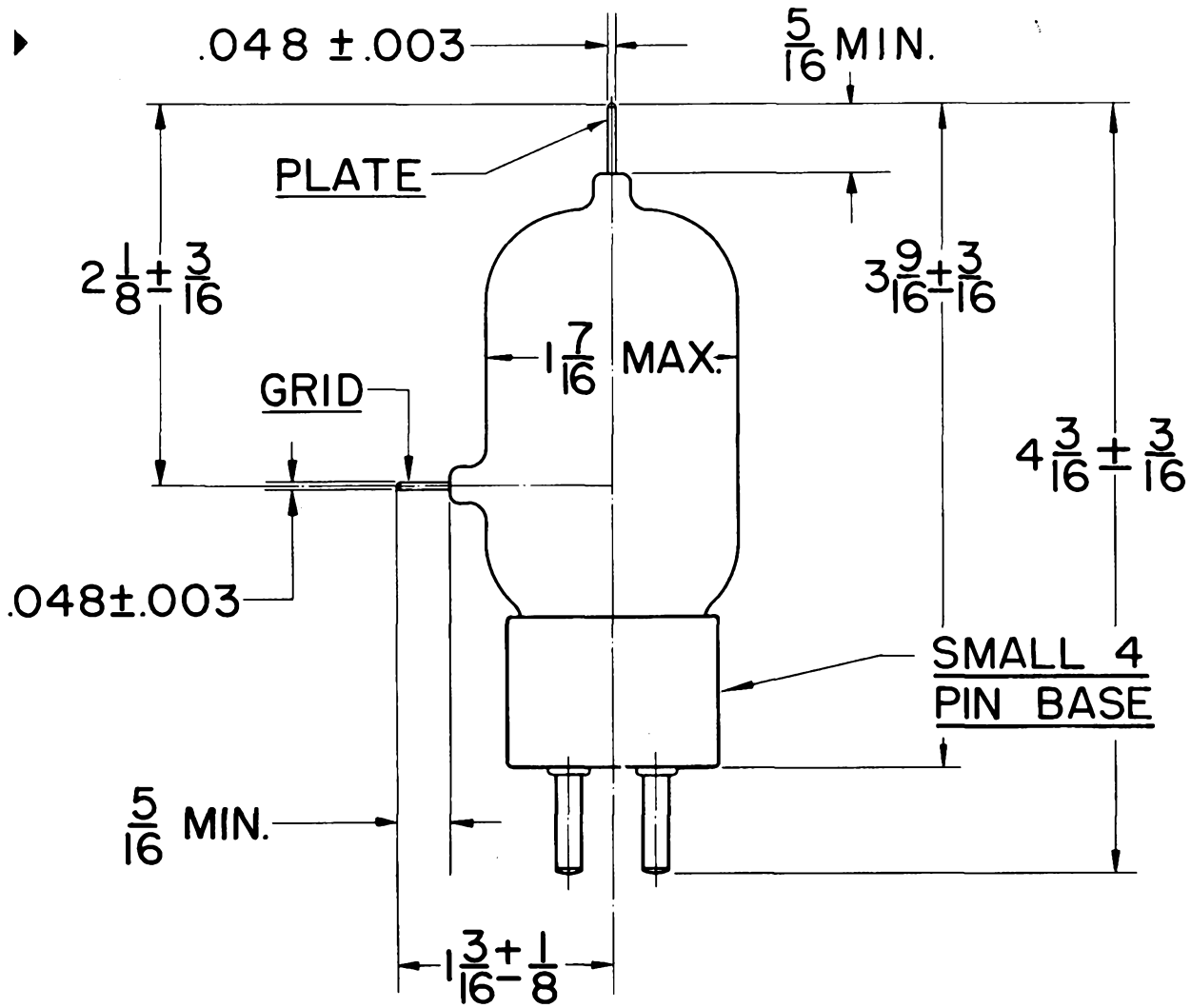

BOTTOM VIEW

*Eitel-McCullough*  
**EITEL-McCULLOUGH, INC.**  
 SAN BRUNO, CALIFORNIA

**3W5000A3**

MEDIUM MU TRIODE

The Eimac 3W5000A3 is a water-cooled, medium-mu transmitting triode with a maximum plate dissipation rating of 5000 watts. Relatively high power-output as an oscillator, amplifier or modulator may be obtained from this tube at low plate voltages. A single tube will deliver a radio frequency output of 7500 watts at 4000 volts at frequencies up to 110 Mc.

The tube has a rugged, low-inductance cylindrical filament-stem structure, which readily becomes a part of a linear filament-tank circuit for VHF operation. The grid provides thorough shielding between the input and output circuits for grounded-grid applications and is conveniently terminated in a ring between the plate and filament terminals.

NOTE: THE 3W5000A3 IS A WATER-COOLED VERSION OF THE AIR-COOLED 3X2500A3.

The plate dissipation of the 3W5000A3 is 5000 watts. Other ratings are the same as for the 3X2500A3 tube type.

The 3W5000A3 should be used where water cooling is preferred and for industrial applications or installations where reserve anode dissipation is desired.

**GENERAL CHARACTERISTICS**

**ELECTRICAL**

Filament: Thoriated tungsten	
Voltage	7.5 volts
Current	51 amperes
Amplification Factor (Average)	20
Direct Interelectrode Capacitances (Average)	
Grid-Plate	20 $\mu\mu\text{f}$
Grid-Filament	36 $\mu\mu\text{f}$
Plate-Filament	1.2 $\mu\mu\text{f}$
Transconductance ( $i_b=830 \text{ ma.}, E_b=3000\text{v.}$ )	20,000 umhos
Frequency for Maximum Ratings	75 Mc.

**MECHANICAL**

Base	see drawing
Mounting	Vertical, base down or up
Maximum Overall Dimensions:	
Length	12.56 inches
Diameter	3.63 inches
Net Weight	3.5 pounds
Shipping Weight (Average)	15 pounds
Cooling	Water and Forced Air

The water-cooled anode requires one gallon of cooling water per minute for the rated plate dissipation of 5 kilowatts. The outlet water temperature must not exceed a maximum of 70°C. under any conditions. The inlet water pressure must not exceed a maximum of 60 pounds per square inch. The pressure drop across the anode is negligible compared to the drop in the associated piping.

The grid-terminal contact surface and adjacent glass must be cooled by forced air. The quantity, velocity and direction must be adjusted to limit the maximum seal temperature to 150°C.

The filament stem structure also requires forced-air cooling. A minimum of 6 cubic feet per minute must be directed into the space between the inner and outer filament contacting surfaces.

Air and water flow must be started before filament power is applied and maintained for at least five minutes after the filament power has been removed.

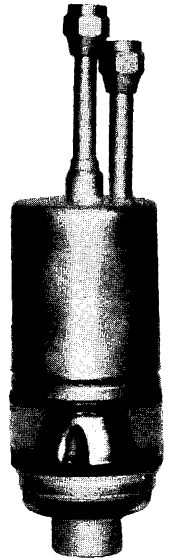

**RADIO FREQUENCY POWER AMPLIFIER OR OSCILLATOR**

(Conventional Neutralized Amplifier—Frequencies below 75 Mc.)

Class-C FM or Telegraphy (Key-down conditions, per tube)

**MAXIMUM RATINGS**

D-C PLATE VOLTAGE	6000 MAX. VOLTS
D-C PLATE CURRENT	2.5 MAX. AMPS
PLATE DISSIPATION	5000 MAX. WATTS
GRID DISSIPATION*	150 MAX. WATTS

**TYPICAL OPERATION** (Frequencies below 75 Mc., per tube)

D-C Plate Voltage	4000	5000	6000	Volts
D-C Plate Current	2.5	2.5	2.08	Amps
D-C Grid Voltage	-300	-450	-500	Volts
D-C Grid Current	245	265	180	Ma.
Peak R-F Grid Input Voltage	580	750	765	Volts
Driving Power (approx.)	142	197	136	Watts
Grid Dissipation	68	78	46	Watts
Plate Power Input	10,000	12,500	12,500	Watts
Plate Dissipation	2500	2500	2500	Watts
Plate Power Output	7500	10,000	10,000	Watts

\*See application notes.



3W5000A3

### RADIO FREQUENCY POWER AMPLIFIER

Grounded-Grid Circuit  
Class-C FM Telephony

MAXIMUM RATINGS (Frequencies between 85 and 110 Mc.)

D-C PLATE VOLTAGE	- - - -	4000 MAX. VOLTS
D-C PLATE CURRENT	- - - -	2.0 MAX. AMPS
D-C GRID CURRENT*	- - - -	200 MAX. MA.
PLATE DISSIPATION	- - - -	5000 MAX. WATTS
GRID DISSIPATION*	- - - -	150 MAX. WATTS

\*See application notes.

### TYPICAL OPERATION (110 Mc., per tube)

D-C Plate Voltage	- - - -	3700	4000	Volts
D-C Grid Voltage	- - - -	-450	-500	Volts
D-C Plate Current	- - - -	1.8	1.85	Amps
D-C Grid Current	- - - -	190	190	Ma.
Driving Power (approx.)	- - - -	1600	1900	Watts
Useful Power Output	- - - -	6850	7500	Watts

### PLATE MODULATED RADIO FREQUENCY AMPLIFIER

(Conventional Neutralized Amplifier—Frequencies below 75 Mc.)  
Class-C Telephony (Carrier conditions, per tube)

MAXIMUM RATINGS

D-C PLATE VOLTAGE	- - - -	5000 MAX. VOLTS
D-C PLATE CURRENT	- - - -	2.0 MAX. AMPS
PLATE DISSIPATION	- - - -	3350 MAX. WATTS
GRID DISSIPATION	- - - -	150 MAX. WATTS

TYPICAL OPERATIONS (Frequencies below 75 Mc., per tube)

D-C Plate Voltage	- - -	4000	4500	5000	Volts
D-C Plate Current	- - -	1.67	1.55	1.45	Amps
Total Bias Voltage	- - -	-450	-500	-550	Volts
Fixed Bias Voltage	- - -	-230	-325	-410	Volts
Grid Resistor	- - -	1500	1500	1400	Ohms
D-C Grid Current	- - -	150	120	100	Ma.
Peak R-F Grid Input Voltage	- - -	680	720	760	Volts
Driving Power (approx.)	- - -	102	86	76	Watts
Grid Dissipation	- - -	35	26	21	Watts
Plate Power Input	- - -	6670	6970	7250	Watts
Plate Dissipation	- - -	1670	1670	1670	Watts
Plate Power Output	- - -	5000	5300	5580	Watts

### AUDIO FREQUENCY POWER AMPLIFIER AND MODULATOR

Class B (Sinusoidal wave, two tubes unless otherwise specified)

MAXIMUM RATINGS

D-C PLATE VOLTAGE	- - - -	6000 MAX. VOLTS
MAX-SIGNAL D-C PLATE CURRENT, PER TUBE	- - - -	2.5 MAX. AMPS
PLATE DISSIPATION, PER TUBE	- - - -	5000 MAX. WATTS

TYPICAL OPERATION CLASS AB<sub>2</sub> (Two tubes)

D-C Plate Voltage	- - -	4000	5000	6000	Volts
D-C Grid Voltage (approx.)*	- - -	-150	-190	-240	Volts
Zero-Signal D-C Plate Current	- - -	0.6	0.5	0.4	Amps
Max-Signal D-C Plate Current	- - -	4.0	3.2	3.0	Amps
Effective Load, Plate to Plate	- - -	2200	3600	4650	Ohms
Peak A-F Grid Input Voltage (per tube)	- - -	340	360	390	Volts
Max-Signal Peak Driving Power	- - -	340	230	225	Watts
Max-Signal Nominal Driving Power (approx.)	- - -	170	115	113	Watts
Max-Signal Plate Power Output	- - -	11,000	11,000	13,000	Watts

\*Adjust to give stated zero-signal plate current.

### TYPICAL OPERATION CLASS AB<sub>2</sub> (Two tubes)

(Modulator service for 4000 and 5000 volt operation, to modulate one or two tubes, as shown under "Plate Modulated Radio Frequency Amplifier.")

D-C Plate Voltage	- - -	4000	5000	4000	5000	Volts
D-C Grid Voltage (approx.)*	- - -	-155	-200	-145	-190	Volts
Zero-Signal D-C Plate Current	- - -	0.4	0.4	0.6	0.5	Amps
Max-Signal D-C Plate Current	- - -	1.35	1.13	2.70	2.26	Amps
Effective Load, Plate to Plate	- - -	6600	10,000	3300	5000	Ohms
Peak A-F Grid Input Voltage (per tube)	- - -	240	275	285	310	Volts
Max-Signal Peak Driving Power	- - -	42	40	134	118	Watts
Max-Signal Nominal Driving Power (approx.)	- - -	21	20	67	59	Watts
Max-Signal Plate Power Output	- - -	3700	4000	7400	8000	Watts
Will Modulate R. F. Final Input of	- - -	6670	7250	13,340	14,500	Watts

\*Adjust to give stated zero-signal plate current.

### APPLICATION

**Filament Voltage** — The filament voltage, as measured directly at the tube, should be 7.5 volts with maximum allowable variations due to line fluctuation of from 7.1 to 7.9 volts.

**Bias Voltage**—There is little advantage in using bias voltages in excess of those given under "Typical Operation", except in certain very specialized applications. Where bias is obtained from a grid resistor, suitable protective means must be provided to prevent excessive plate dissipation in the event of loss of excitation.

**Plate Voltage**—The plate supply voltage for the 3W5000A3 should not exceed 6000 volts. In most cases there is little advantage in using plate-supply voltages higher than those given under "Typical Operation" for the power output desired.

In Class-C FM or Telegraphy service, a 0.1 henry choke, shunted by a spark gap, should be series connected between the plates of the amplifier tubes and the high voltage plate supply capacitor to offer protection from transients and surges. In plate modulated service, where a plate modulation transformer is used, the protective choke is not normally required.

**Grid Dissipation** — The power dissipated by the grid of the 3W5000A3 must never exceed 150 watts. Grid dissipation may be calculated from the following expression:

$$P_g = e_{cmp} I_c$$

where  $P_g$  = Grid dissipation,  
 $e_{cmp}$  = Peak positive grid voltage, and  
 $I_c$  = D-C grid current

$e_{cmp}$  may be measured by means of a suitable peak voltmeter connected between filament and grid. Any suitable peak v.t.v.m. circuit may be used (one is shown in "Vacuum Tube Ratings", Eimac News, January 1945. This article is available, in reprint form on request).

In equipment in which the plate loading varies widely, such as oscillators used for radio-frequency heating, care should be taken to make certain that the grid dissipation does not exceed the maximum rating under any condition of loading.

In VHF operation, particularly above 75 Mc., the d-c grid current must not exceed 200 ma. under any conditions of plate loading. With lightly loaded conditions the grid driving-power should be reduced so that the grid current does not exceed one-tenth of the plate current.

**DRIVING POWER vs. POWER OUTPUT**—The three charts on this page show the relationship of plate efficiency, power output and grid driving-power at plate voltages of 4000, 5000 and 6000 volts. These charts show combined grid and bias losses only. The driving power and power output figures do not include circuit losses. The plate dissipation in watts is indicated by Pp. Points A, B, and C are identical to the typical Class-C operating conditions shown on the first page under 4000, 5000 and 6000 volts respectively.

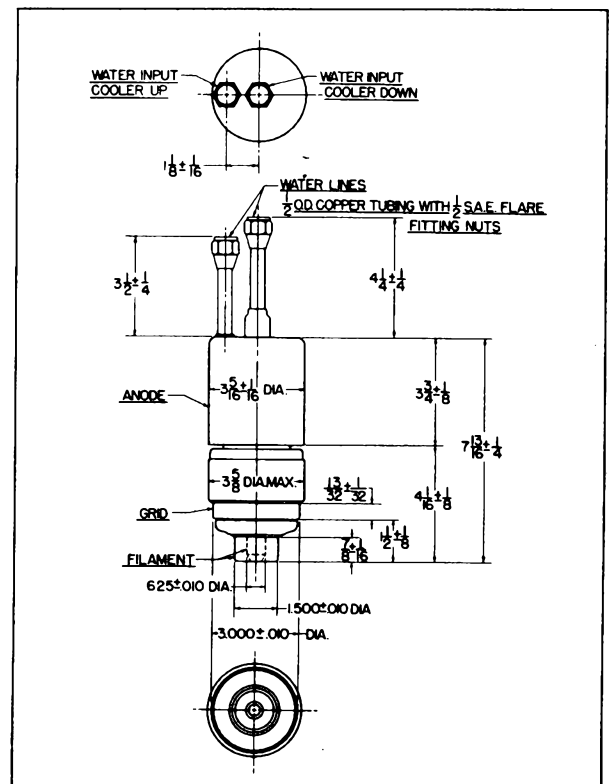
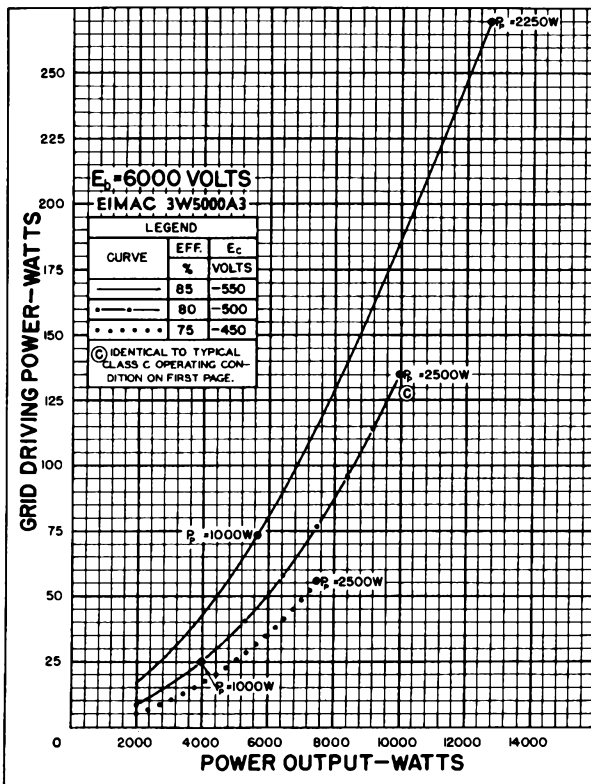
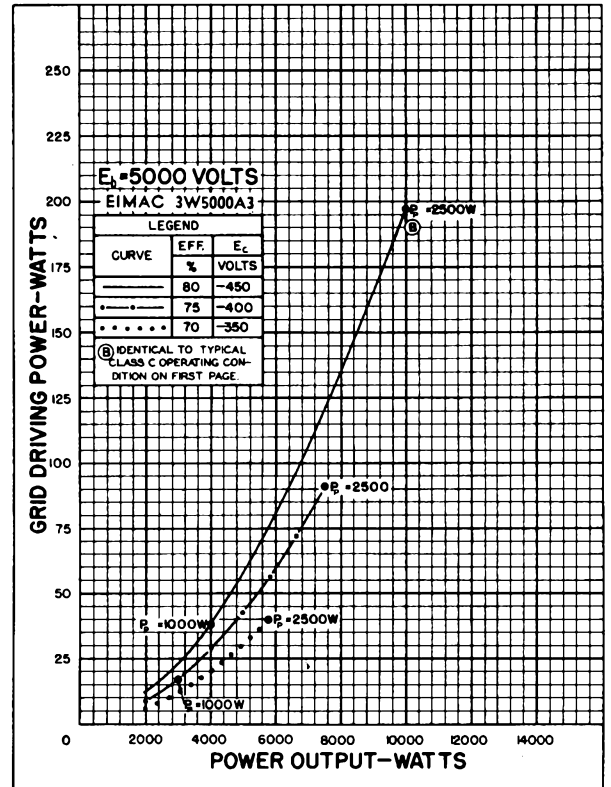
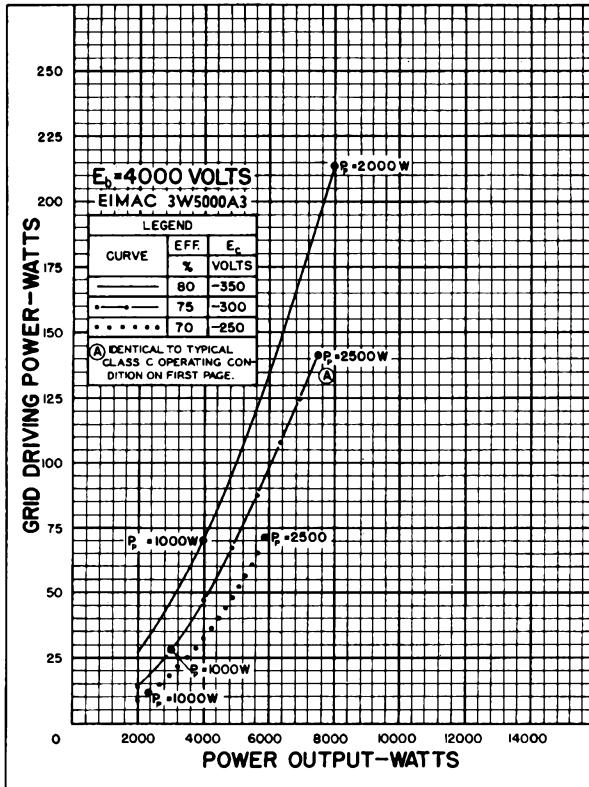

GRID VOLTAGE - VOLTS

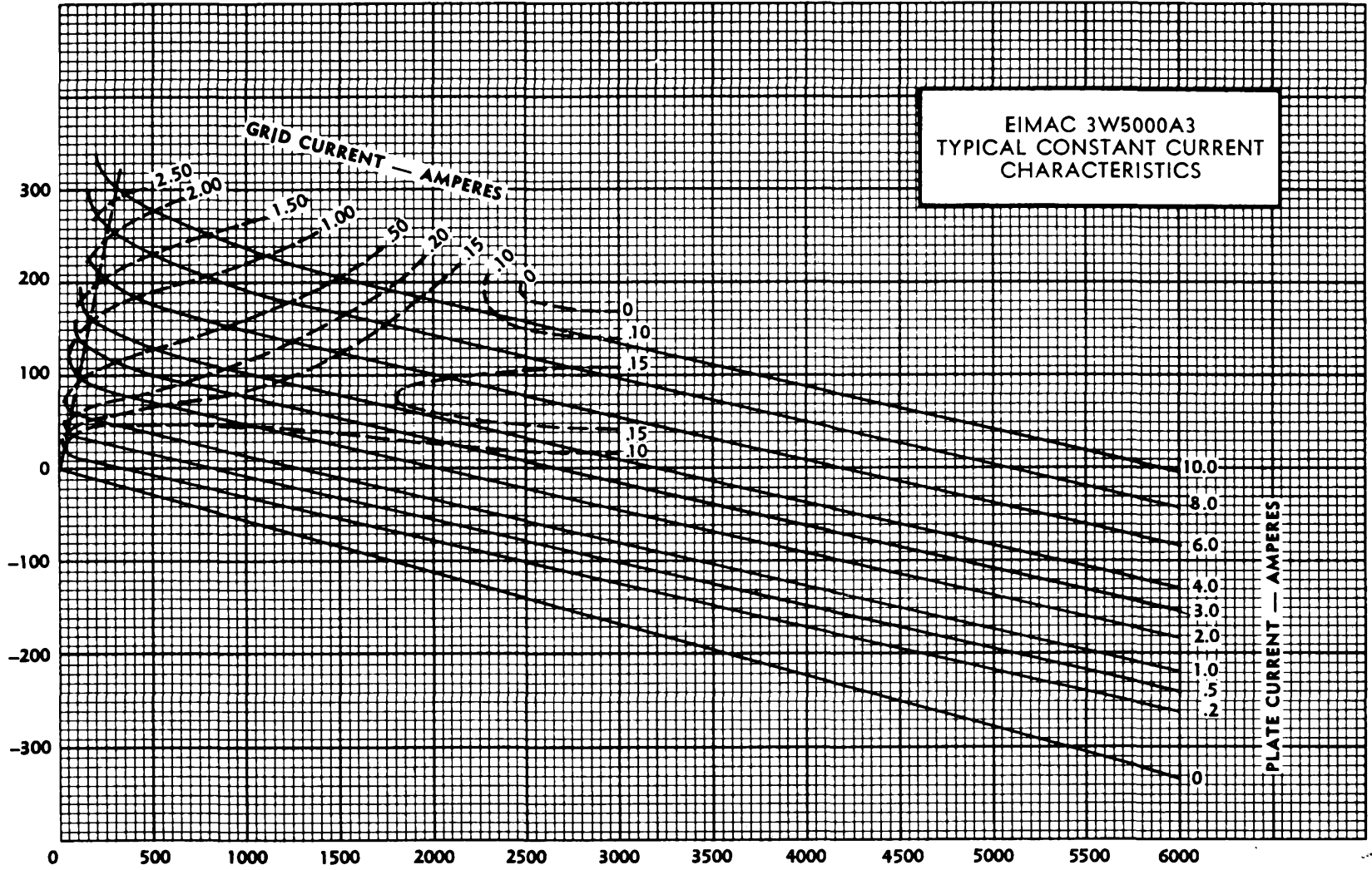



# TENTATIVE DATA

**EITEL-McCULLOUGH, INC.**  
SAN BRUNO, CALIFORNIA

# 3W5000F3

MEDIUM MU-TRIODE

The Eimac 3W5000F3 is a water-cooled, medium-mu power triode intended for amplifier, oscillator or modulator service. It has a maximum plate dissipation rating of 5000 watts and is capable of high output at relatively low plate voltages. A single 3W5000F3 will deliver a radio frequency plate power-output of 7500 watts at a plate voltage of 4000 volts.

The tube is equipped with flexible filament and grid leads which simplifies socketing and equipment design for industrial and communication frequencies below 30 Mc.

NOTE: THE 3W5000F3 IS A WATER-COOLED VERSION OF THE AIR-COOLED 3X2500F3.

The plate dissipation of the 3W5000F3 is 5000 watts. Other ratings are the same as for the 3X2500F3 tube type.

The 3W5000F3 should be used where water cooling is preferred and for industrial applications or installations where reserve anode dissipation is desired.

## GENERAL CHARACTERISTICS

### ELECTRICAL

Filament: Thoriated tungsten	
Voltage	7.5 volts
Current	51 amperes
Maximum allowable starting current	100 amperes
Amplification Factor (Average)	20
Direct Interelectrode Capacitances (Average)	
Grid-Plate	21 $\mu\text{uf}$
Grid-Filament	36 $\mu\text{uf}$
Plate-Filament	1.2 $\mu\text{uf}$
Transconductance ( $i_b=830 \text{ ma.}, E_b=3000\text{v.}$ )	20,000 $\mu\text{mhos}$
Frequency for Maximum Ratings	30 Mc.

### MECHANICAL

Base	see drawing
Mounting	Vertical, base down or up.
Maximum Overall Dimensions:	
Length (Does not include filament connectors)	12.56 inches
Diameter	3.63 inches
Net Weight	4.8 pounds
Shipping Weight (Average)	15 pounds
Cooling	Water and Forced Air

The water-cooled anode requires one gallon of cooling water per minute for the rated plate dissipation of 5 kilowatts. The outlet water temperature must not exceed a maximum of 70°C. under any conditions. The inlet water pressure must not exceed a maximum of 60 pounds per square inch. The pressure drop across the anode is negligible compared to the drop in the associated piping.

The grid-terminal contact surface and adjacent glass must be cooled by forced air. The quantity, velocity and direction must be adjusted to limit the maximum seal temperature to 150°C.

The filament stem structure also requires forced-air cooling. A minimum of 6 cubic feet per minute must be directed into the space between the inner and outer filament contacting surfaces.

Air and water flow must be started before filament power is applied and maintained for at least five minutes after the filament power has been removed.

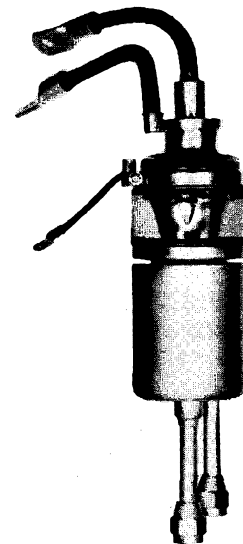

### RADIO FREQUENCY POWER AMPLIFIER OR OSCILLATOR

(Frequencies below 30 Mc.)

Class-C FM or Telegraphy

(Key-down conditions, per tube)

#### MAXIMUM RATINGS

D-C PLATE VOLTAGE	6000 MAX. VOLTS
D-C PLATE CURRENT	2.5 MAX. AMPS
PLATE DISSIPATION	5000 MAX. WATTS
GRID DISSIPATION	150 MAX. WATTS

#### TYPICAL OPERATION

(Frequencies below 30 Mc., per tube)

D-C Plate Voltage	4000	5000	6000	Volts
D-C Plate Current	2.5	2.5	2.08	Amps
D-C Grid Voltage	-300	-450	-500	Volts
D-C Grid Current	245	265	180	Ma.
Peak R. F. Grid Input Voltage	580	750	765	Volts
Driving Power (approx.)	142	197	136	Watts
Grid Dissipation	68	78	46	Watts
Plate Power Input	10,000	12,500	12,500	Watts
Plate Dissipation	2500	2500	2500	Watts
Plate Power Output	7500	10,000	10,000	Watts

(Effective 3-1-51) Copyright 1951 by Eitel-McCullough, Inc.

# TENTATIVE DATA

### PLATE MODULATED RADIO FREQUENCY AMPLIFIER

(Frequencies below 30 Mc.)

Class-C Telephony

(Carrier conditions, per tube)

#### MAXIMUM RATINGS

D-C PLATE VOLTAGE	- - - -	5000 MAX. VOLTS
D-C PLATE CURRENT	- - - -	2.0 MAX. AMPS
PLATE DISSIPATION	- - - -	3350 MAX. WATTS
GRID DISSIPATION	- - - -	150 MAX. WATTS

### TYPICAL OPERATION

(Frequencies below 30 Mc., per tube)

D-C Plate Voltage	- -	4000	4500	5000	Volts
D-C Plate Current	- -	1.67	1.55	1.45	Amps
Total Bias Voltage	- -	-450	-500	-550	Volts
Fixed Bias Voltage	- -	-230	-325	-410	Volts
Grid Resistor	- -	1500	1500	1400	Ohms
D-C Grid Current	- -	150	120	100	Ma.
Peak R. F. Grid Input Voltage	- - -	680	720	760	Volts
Driving Power (approx.)	- -	102	86	76	Watts
Grid Dissipation	- -	35	26	21	Watts
Plate Power Input	- -	6670	6970	7250	Watts
Plate Dissipation	- -	1670	1670	1670	Watts
Plate Power Output	- -	5000	5300	5580	Watts

### AUDIO FREQUENCY POWER AMPLIFIER AND MODULATOR

Class B (Sinusoidal wave, two tubes unless otherwise specified)

#### MAXIMUM RATINGS

D-C PLATE VOLTAGE	- - - -	6000 MAX. VOLTS
MAX-SIGNAL D-C PLATE CURRENT, PER TUBE	- - - -	2.5 MAX. AMPS
PLATE DISSIPATION, PER TUBE	- - - -	5000 MAX. WATTS

#### TYPICAL OPERATION CLASS AB<sub>2</sub> (Two Tubes)

D-C Plate Voltage	- - -	4000	5000	6000	Volts
D-C Grid Voltage (approx)*	- - -	-150	-190	-240	Volts
Zero-Signal D-C Plate Current	- - -	0.6	0.5	0.4	Amps
Max-Signal D-C Plate Current	- - -	4.0	3.2	3.0	Amps
Effective Load, Plate to Plate	- - -	2200	3600	4650	Ohms
Peak A-F Grid Input Voltage (per tube)	- - -	340	360	390	Volts
Max-Signal Peak Driving Power	- - -	340	230	225	Watts
Max-Signal Nominal Driving Power (approx.)	- - -	170	115	113	Watts
Max-Signal Plate Power Output	- - -	11,000	11,000	13,000	Watts

\*Adjust to give stated zero-signal plate current.

#### TYPICAL OPERATION CLASS AB<sub>2</sub> (Two Tubes)

Modulator service for 4000 and 5000 volt operation, to modulate one or two tubes, as shown under "Plate Modulated Radio Frequency Amplifier" (Page 1)

D-C Plate Voltage	-	4000	5000	4000	5000	Volts
D-C Grid Voltage (approx)*	- - -	-155	-200	-145	-190	Volts
Zero-Signal D-C Plate Current	- - -	0.4	0.4	0.6	0.5	Amps
Max-Signal D-C Plate Current	- - -	1.35	1.13	2.70	2.26	Amps
Effective Load, Plate to Plate	- - -	6600	10,000	3300	5000	Ohms
Peak A-F Grid Input Voltage (per tube)	- - -	240	275	285	310	Volts
Max-Signal Peak Driving Power	- -	42	40	134	118	Watts
Max-Signal Nominal Driving Power (approx.)	- - -	21	20	67	59	Watts
Max-Signal Plate Power Output	- -	3700	4000	7400	8000	Watts
Will Modulate one Tube R. F. Final Input of	- - -	6670	7250			Watts
Will Modulate two tubes R. F. Final Input of	- - -			13,340	14,500	Watts

\*Adjust to give stated zero-signal plate current.

### APPLICATION

**Filament Voltage** — The filament voltage, as measured directly at the tube, should be 7.5 volts with maximum allowable variations due to line fluctuation of from 7.12 to 7.87 volts.

**Bias Voltage**—There is little advantage in using bias voltages in excess of those given under "Typical Operation", except in certain very specialized applications. Where bias is obtained from a grid resistor, suitable protective means must be provided to prevent excessive plate dissipation in the event of loss of excitation.

**Plate Voltage**—The plate supply voltage for the 3W5000F3 should not exceed 6000 volts. In most cases there is little advantage in using plate-supply voltages higher than those given under "Typical Operation" for the power output desired.

In Class-C FM or Telegraphy service, a 0.1 henry choke, shunted by a spark gap, should be series connected between the plates of the amplifier tubes and the high voltage plate supply capacitor to offer protection from transients and surges. In plate modulated service, where a plate modulation transformer is used, the protective choke is not normally required.

**Grid Dissipation**—The power dissipated by the grid of the 3W5000F3 must never exceed 150 watts. Grid dissipation may be calculated from the following expression

$$P_g = e_{cmp} I_c$$

where  $P_g$  = Grid dissipation.

$e_{cmp}$  = Peak positive grid voltage, and

$I_c$  = D-C grid current

$e_{cmp}$  may be measured by means of a suitable peak voltmeter connected between filament and grid. Any suitable peak v.t.v.m. circuit may be used (one is shown in "Vacuum Tube Ratings", Eimac News, January 1945. This article is available in reprint form on request).

In equipment in which the plate loading varies widely, such as oscillators used for radio-frequency heating, care should be taken to make certain that the grid dissipation does not exceed the maximum rating under any condition of loading.

## DRIVING POWER vs. POWER OUTPUT

The three charts on this page show the relationship of plate efficiency, power output and grid driving power at plate voltages of 4000, 5000 and 6000 volts. These charts show combined grid and bias losses only. The driving power and power output figures do not include circuit losses. The plate dissipation in watts is indicated by  $P_p$ .

Points A, B, and C are identical to the typical Class C operating conditions shown on the first page under 4000, 5000 and 6000 volts respectively.

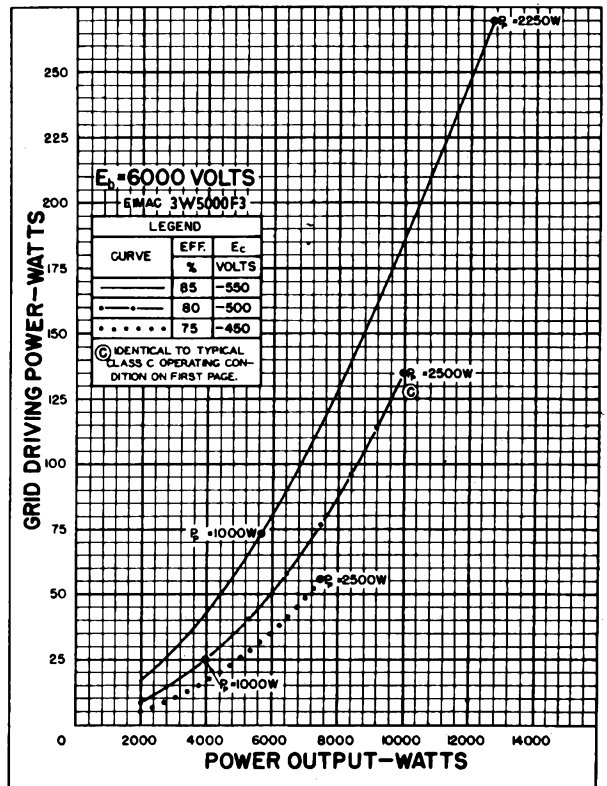
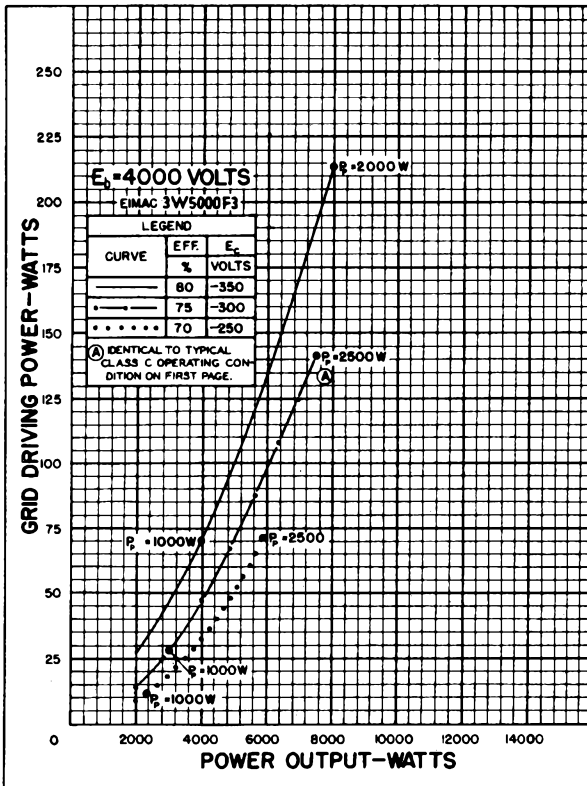
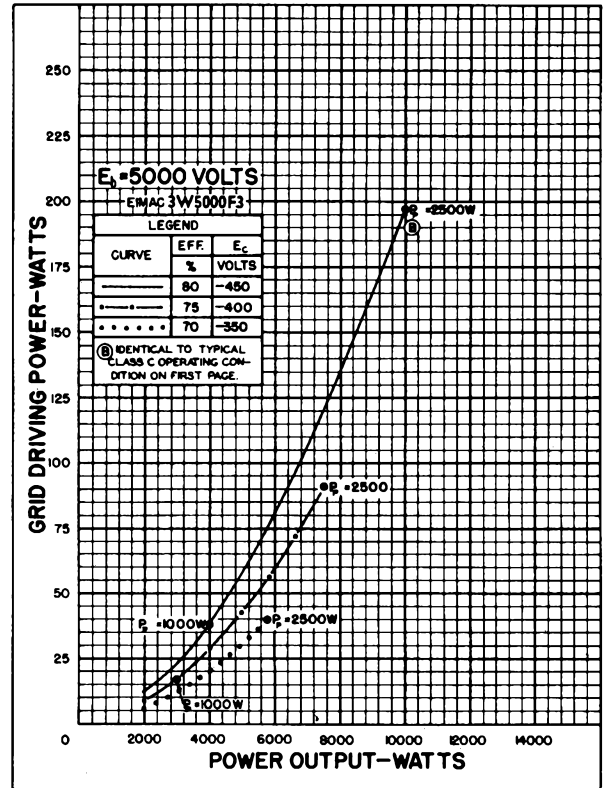

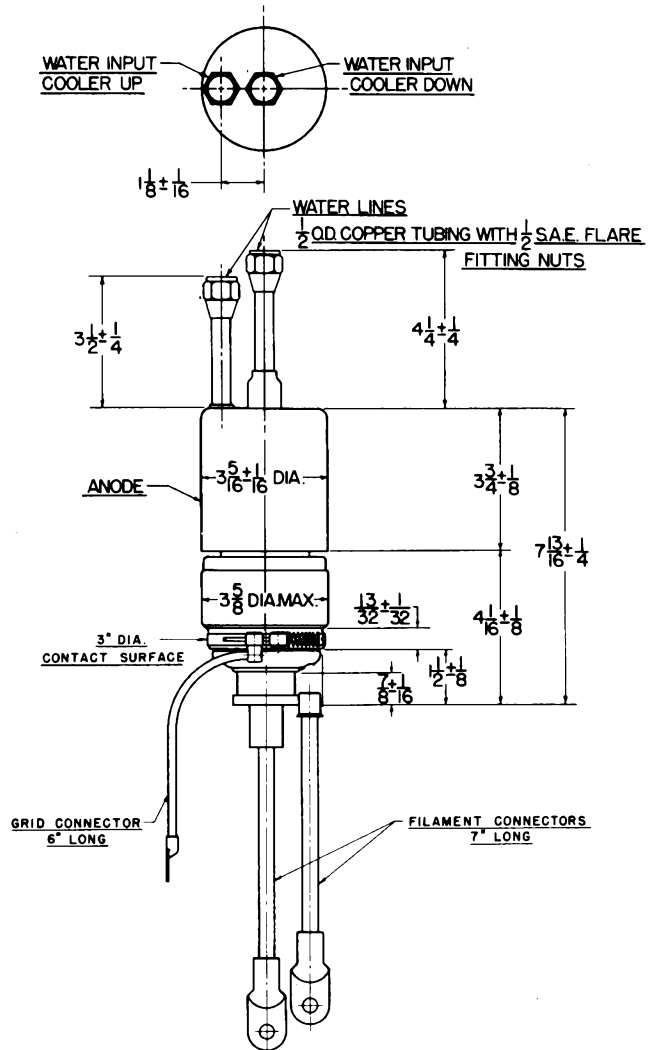
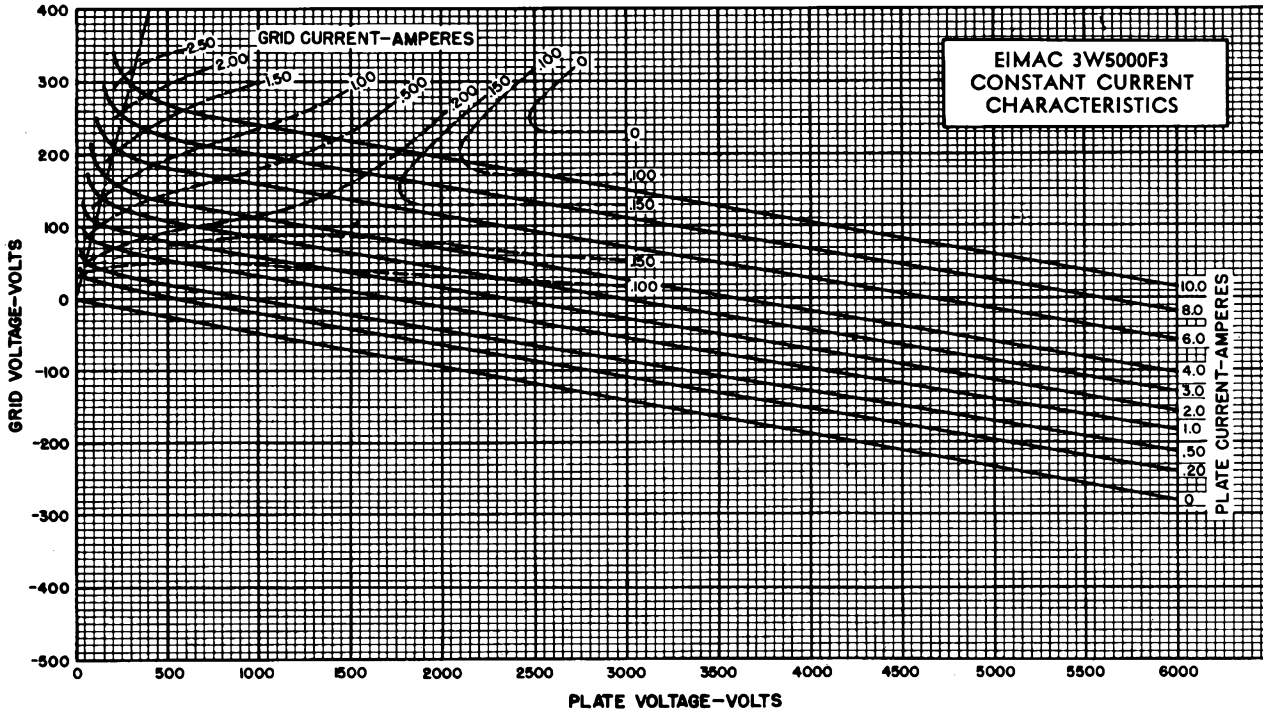

# EITEL-McCULLOUGH, INC.

SAN BRUNO, CALIFORNIA

# 3X2500A3

MEDIUM-MU TRIODE

The Eimac 3X2500A3 is a medium-mu, forced-air-cooled, external-anode transmitting triode with a maximum plate-dissipation rating of 2500 watts. Relatively high power output as an amplifier, oscillator or modulator may be obtained from this tube at low plate voltages. A single tube will deliver a radio-frequency output of 7500 watts at 4000 plate volts at frequencies up to 110 Mc., as well as at lower frequencies.

The tube has a rugged, low-inductance cylindrical filament-stem structure, which readily becomes part of a linear filament tank circuit for V.H.F. operation. The grid provides thorough shielding between the input and output circuits for grounded-grid applications, and is conveniently terminated in a ring between the plate and filament terminals. As a result of the use of unique grid- and filament-terminal arrangements, it is possible to install or remove the 3X2500A3 without the aid of tools.

The approved Federal Communications Commission rating for the 3X2500A3 as a plate-modulated amplifier is 5000 watts of carrier power.

## GENERAL CHARACTERISTICS

### ELECTRICAL

Filament: Thoriated tungsten	
Voltage	7.5 volts
Current	51 amperes
Amplification Factor (Average)	20
Direct Interelectrode Capacitances (Average)	
Grid-Plate	20 $\mu\mu\text{f}$
Grid-Filament	36 $\mu\mu\text{f}$
Plate-Filament	1.2 $\mu\mu\text{f}$
Transconductance ( $I_b = 830 \text{ ma.}, E_b = 3000 \text{ v.}$ )	20,000 $\mu\text{mhos}$
Highest Frequencies for Maximum Ratings	75 Mc.

### MECHANICAL

Base	see drawing
Mounting	Vertical, base down or up
Cooling	Forced air
Maximum Anode Cooler Core and Seal Temperatures	150°C
Maximum Over-All Dimensions:	
Length	9.0 inches
Diameter	4.156 inches
Net Weight	6.25 pounds
Shipping Weight (Average)	17 pounds

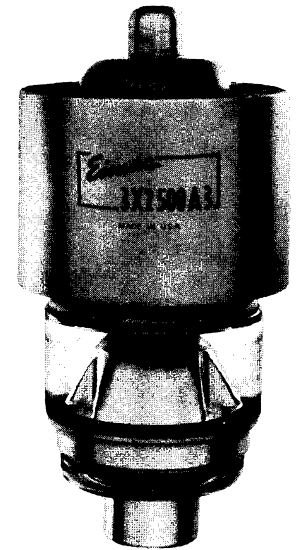

### RADIO-FREQUENCY POWER AMPLIFIER OR OSCILLATOR

(Conventional Neutralized Amplifier—Frequencies below 75 Mc.)  
Class-C FM or Telegraphy (Key-down conditions, per tube)

MAXIMUM RATINGS	
D-C PLATE VOLTAGE	6000 MAX. VOLTS
D-C PLATE CURRENT	2.5 MAX. AMPS
PLATE DISSIPATION	2500 MAX. WATTS
PLATE COOLER CORE TEMPERATURE	150 MAX. °C
GRID DISSIPATION*	150 MAX. WATTS

#### TYPICAL OPERATION (Frequencies below 75 Mc., per tube)

D-C Plate Voltage	4000	5000	6000	volts
D-C Plate Current	2.5	2.5	2.08	amps
D-C Grid Voltage	-300	-450	-500	volts
D-C Grid Current	245	265	180	ma
Peak R-F Grid Input Voltage	580	750	765	volts
Driving Power (approx.)	142	197	136	watts
Grid Dissipation	68	78	46	watts
Plate Power Input	10,000	12,500	12,500	watts
Plate Dissipation	2500	2500	2500	watts
Plate Power Output	7500	10,000	10,000	watts

### RADIO-FREQUENCY POWER AMPLIFIER

Grounded-Grid Circuit  
Class-C FM Telephony

MAXIMUM RATINGS (Frequencies between 85 and 110 Mc.)	
D-C PLATE VOLTAGE	4000 MAX. VOLTS
D-C PLATE CURRENT	2.0 MAX. AMPS
D-C GRID CURRENT*	200 MAX. MA
PLATE DISSIPATION	2500 MAX. WATTS
PLATE COOLER CORE TEMPERATURE	150 MAX. °C
GRID DISSIPATION*	150 MAX. WATTS

#### TYPICAL OPERATION (110 Mc., per tube)

D-C Plate Voltage	3700	4000	volts
D-C Grid Voltage	-450	-500	volts
D-C Plate Current	1.8	1.85	amps
D-C Grid Current	190	190	ma
Driving Power (approx.)	1600	1900	watts
Useful Power Output	6850	7500	watts

### PLATE-MODULATED RADIO-FREQUENCY AMPLIFIER

(Conventional Neutralized Amplifier—Frequencies below 75 Mc.)  
Class-C Telephony (Carrier conditions, per tube)

MAXIMUM RATINGS	
D-C PLATE VOLTAGE	5000 MAX. VOLTS
D-C PLATE CURRENT	2.0 MAX. AMPS
PLATE DISSIPATION	1670 MAX. WATTS
PLATE COOLER CORE TEMPERATURE	150 MAX. °C
GRID DISSIPATION	150 MAX. WATTS

#### TYPICAL OPERATIONS (Frequencies below 75 Mc., per tube)

D-C Plate Voltage	4000	4500	5000	volts
D-C Plate Current	1.67	1.55	1.45	amps
Total Bias Voltage	-450	-500	-550	volts
Fixed Bias Voltage	-230	-325	-410	volts
Grid Resistor	1500	1500	1400	ohms
D-C Grid Current	150	120	100	ma
Peak R-F Grid Input Voltage	680	720	760	volts
Driving Power (approx.)	102	86	76	watts
Grid Dissipation	35	26	21	watts
Plate Power Input	6670	6970	7250	watts
Plate Dissipation	1670	1670	1670	watts
Plate Power Output	5000	5300	5580	watts

IF IT IS DESIRED TO OPERATE THIS TUBE UNDER CONDITIONS WIDELY DIFFERENT FROM THOSE GIVEN UNDER "TYPICAL OPERATION", POSSIBLY EXCEEDING THE MAXIMUM RATINGS GIVEN FOR CW SERVICE, WRITE EITEL-McCULLOUGH, INC., FOR INFORMATION AND RECOMMENDATIONS.

## AUDIO-FREQUENCY POWER AMPLIFIER AND MODULATOR

Class B (Sinusoidal wave, two tubes unless otherwise specified)

MAXIMUM RATINGS	
D-C PLATE VOLTAGE	6000 MAX. VOLTS
MAX.-SIGNAL D-C PLATE CURRENT, PER TUBE	2.5 MAX. AMPS
PLATE DISSIPATION, PER TUBE	2500 MAX. WATTS
PLATE COOLER CORE TEMPERATURE	150 MAX. ° C

TYPICAL OPERATION CLASS AB<sub>2</sub> (Two tubes)

D-C Plate Voltage	4000	5000	6000	volts
D-C Grid Voltage (approx.)*	-150	-190	-240	volts
Zero-Signal D-C Plate Current	0.6	0.5	0.4	amps
Max.-Signal D-C Plate Current	4.0	3.2	3.0	amps
Effective Load, Plate to Plate	2200	3600	4650	ohms
Peak A-F Grid Input Voltage (per tube)	340	360	390	volts
Max.-Signal Peak Driving Power	340	230	225	watts
Max.-Signal Nominal Driving Power (approx.)	170	115	113	watts
Max.-Signal Plate Power Output	11,000	11,000	13,000	watts

TYPICAL OPERATION CLASS AB<sub>2</sub> (Two tubes)

(Modulator service for 4000 and 5000 volt operation, to modulate one or two tubes, as shown under "Plate Modulated Radio Frequency Amplifier.")

D-C Plate Voltage	4000	5000	4000	5000	volts
D-C Grid Voltage (approx.)*	-155	-200	-145	-190	volts
Zero-Signal D-C Plate Current	0.4	0.4	0.6	0.5	amps
Max.-Signal D-C Plate Current	1.35	1.13	2.70	2.26	amps
Effective Load, Plate to Plate	6600	10,000	3300	5000	ohms
Peak A-F Grid Input Voltage (per tube)	240	275	285	310	volts
Max.-Signal Peak Driving Power	42	40	134	118	watts
Max.-Signal Nominal Driving Power (approx.)	21	20	67	59	watts
Max.-Signal Plate Power Output	3700	4000	7400	8000	watts
Will Modulate R. F. Final Input of	6670	7250	13,340	14,500	watts

\*Adjust to give stated zero-signal plate current.

## APPLICATION

► **Cooling**—A minimum air flow of 120 cubic feet per minute must be passed through the anode cooler. The pressure drop across the cooler at this rate of flow equals 1.0 inch of water when the tube is cold, and increases with rising temperature to 1.25 inches when the plate dissipation attains its rated maximum value of 2500 watts.

A minimum air flow of 6 cubic feet per minute must also be directed into the filament stem structure between the inner and outer filament terminals. Cooling air in the above quantities must be supplied to the anode cooler and the filament seals before filament voltage is applied, and the air flow should be maintained for at least one minute after the filament power has been removed. Simultaneous removal of all power and air (as in case of power failure) will not ordinarily injure the tube, but it is not recommended as a standard operating practice. Anode-cooler-core, grid- and filament-seal temperatures must not exceed 150° C.

The figures above are for an ambient temperature of 20° C at sea level and do not include duct or filter losses. Further information regarding operation at higher ambient temperatures or higher altitudes is available in an article entitled "Blower Selection for Forced Air Cooled Tubes", by A. G. Nekut, in the August, 1950, issue of "Electronics".

**Filament Voltage**—The filament voltage, as measured directly at the tube, should be 7.5 volts with maximum allowable variations due to line fluctuation of from 7.12 to 7.87 volts.

**Bias Voltage**—There is little advantage in using bias voltages in excess of those given under "Typical Operation", except in certain very specialized applications. Where bias is obtained from a grid resistor, suitable protective means must be provided to prevent excessive plate dissipation in the event of loss of excitation.

**Plate Voltage**—The plate-supply voltage for the 3X2500A3 should not exceed 6000 volts. In most cases there is little advantage in using plate-supply voltages higher than those given under "Typical Operation" for the power output desired.

In Class-C FM or Telegraphy service, a 0.1 henry choke, shunted by a spark gap, should be series connected between the plates of the amplifier tubes and the high-voltage-plate-supply capacitor to offer protection from transients and surges. In plate-modulated service, where a plate-modulation transformer is used, the protective choke is not normally required.

**Grid Dissipation**—The power dissipated by the grid of the 3X2500A3 must never exceed 150 watts. Grid dissipation may be calculated from the following expression:

$$P_g = e_{\text{emp}} I_c$$

where  $P_g$  = Grid dissipation

$e_{\text{emp}}$  = Peak positive grid voltage, and

$I_c$  = D-C grid current

$e_{\text{emp}}$  may be measured by means of a suitable peak voltmeter connected between filament and grid. Any suitable peak v.t.v.m. circuit may be used (one is shown in "Vacuum Tube Ratings", Eimac News, January 1945. This article is available, in reprint form on request).

In equipment in which the plate loading varies widely, such as oscillators used for radio-frequency heating, care should be taken to make certain that the grid dissipation does not exceed the maximum rating under any condition of loading.

In VHF operation, particularly above 75Mc., the d-c grid current must not exceed 200 ma. under any conditions of plate loading. With lightly loaded conditions the grid driving power should be reduced so that the grid current does not exceed one-tenth of the plate current.

## DRIVING POWER vs. POWER OUTPUT

The three charts on this page show the relationship of plate efficiency, power output and approximate grid driving power at plate voltages of 4000, 5000 and 6000 volts. These charts show combined grid and bias losses only. The driving-power and power-output figures do not include circuit losses. The plate dissipation in watts is indicated by  $P_p$ . Points A, B, and C are identical to the typical Class C operating conditions shown on the first page under 4000, 5000 and 6000 volts respectively.

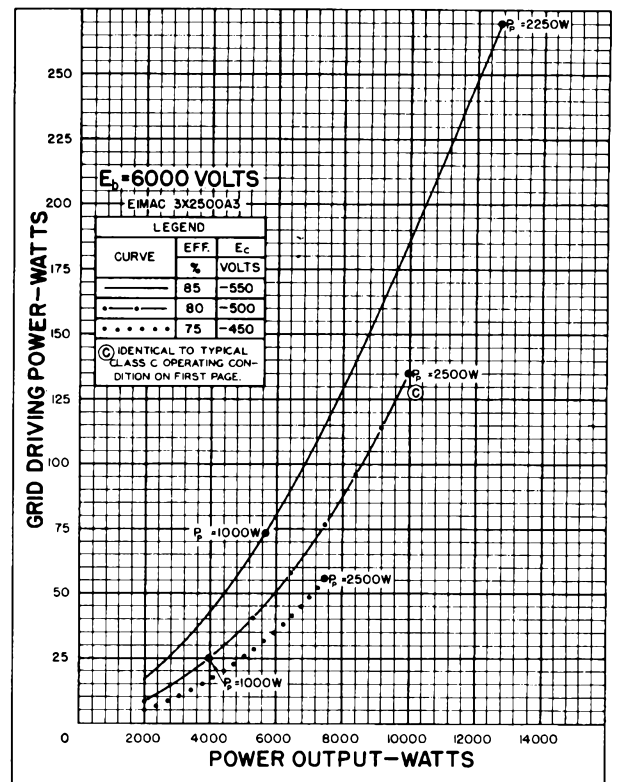
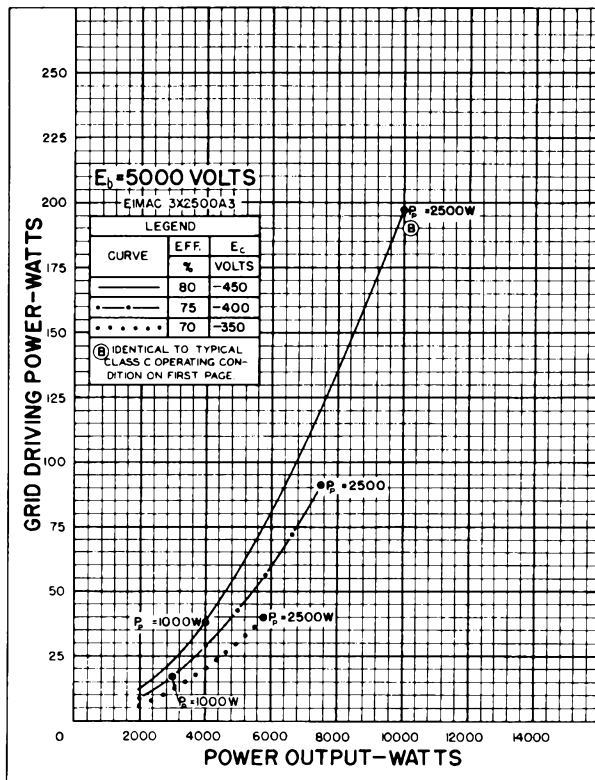
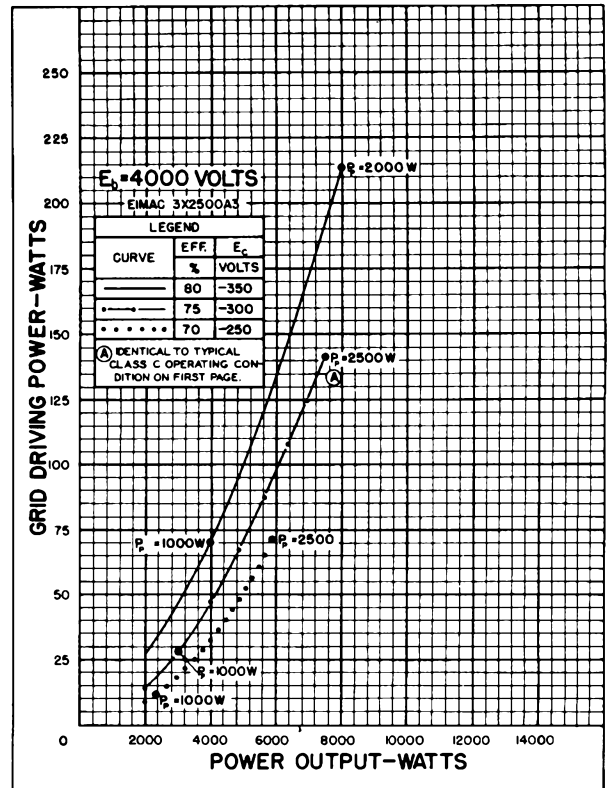

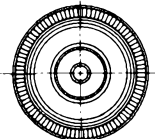
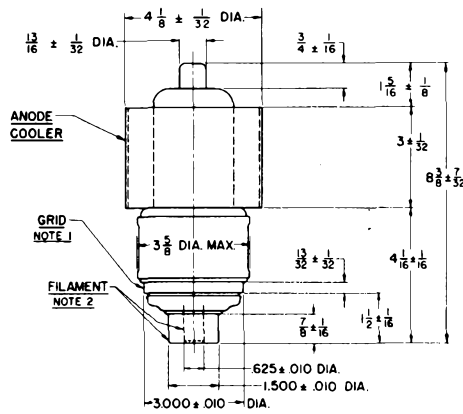
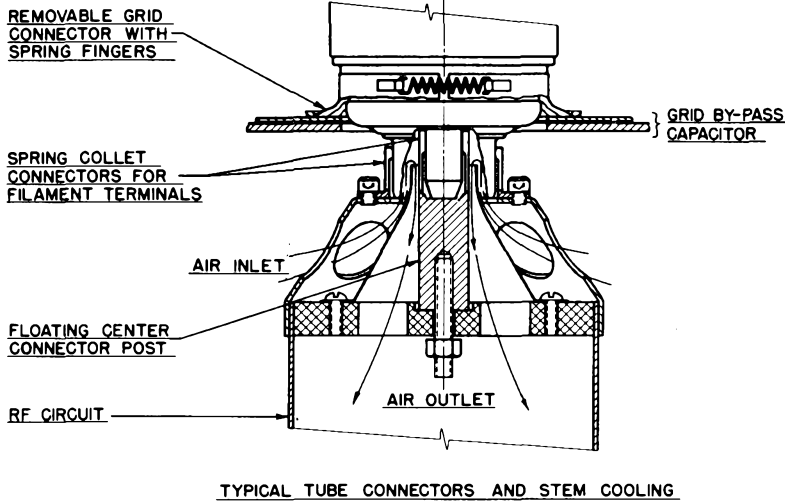
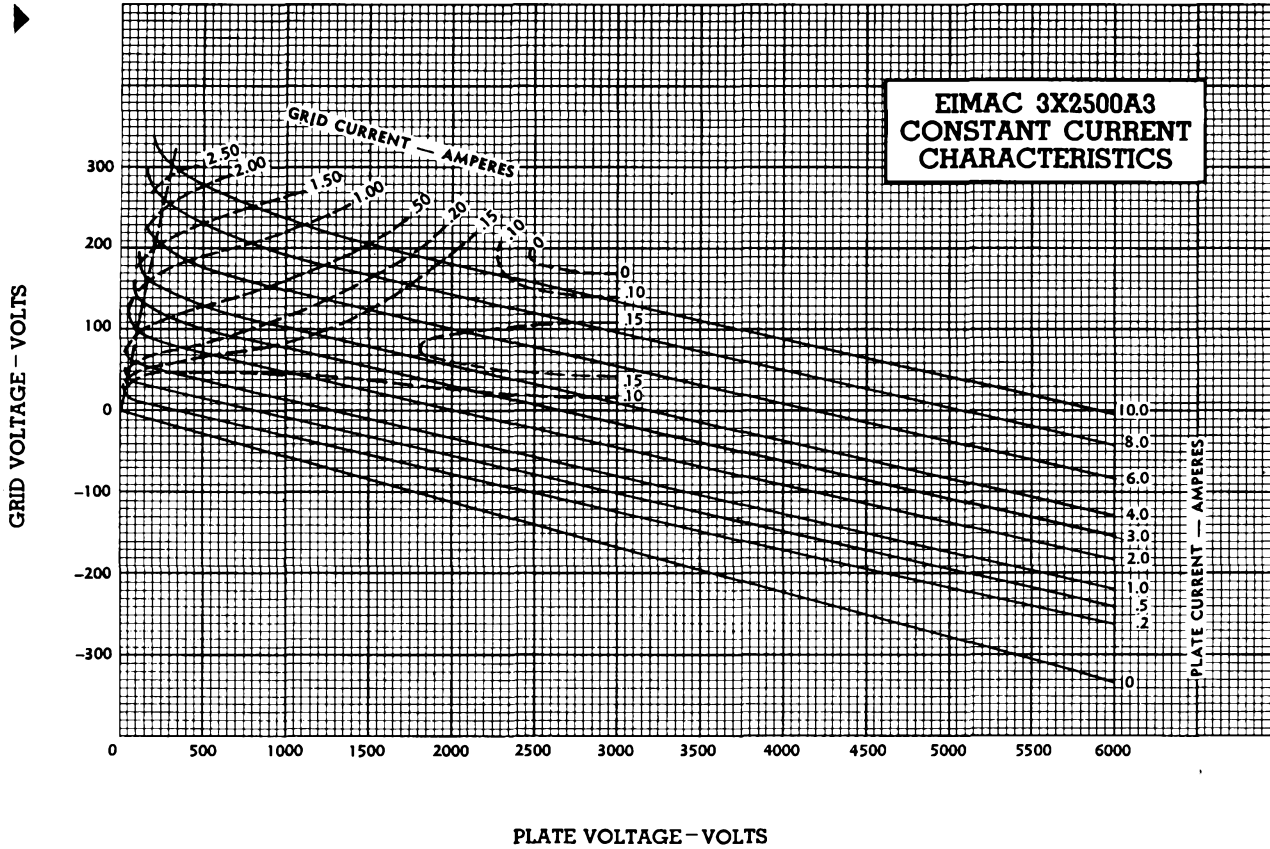

**NOTE 1**  
 040° MAXIMUM ROUNDOFF OF GRID CONTACT SURFACE WITH RESPECT TO AXIS DETERMINED BY ANODE AND OUTER FILAMENT CONTACT SURFACE.

**NOTE 2**  
 025° MAXIMUM ROUNDOFF OF INNER FILAMENT CONTACT SURFACE WITH RESPECT TO OUTER FILAMENT CONTACT SURFACE.

**DIMENSIONS IN INCHES**



The Eimac 3X2500F3 is a medium-mu, forced-air cooled, external-anode power triode intended for amplifier, oscillator and modulator service. It has a maximum plate dissipation rating of 2500 watts and is capable of high output at relatively low plate voltages. A single 3X2500F3 will deliver a radio frequency plate power-output of 7500 watts at a plate voltage of 4000 volts.

The tube is equipped with flexible filament and grid leads which simplifies socketing and equipment design for industrial and communication frequencies below 30 Mc.

The approved Federal Communications Commission rating for the 3X2500F3 as a plate modulated amplifier is 5000 watts of carrier power.



**GENERAL CHARACTERISTICS**

**ELECTRICAL**

Filament: Thoriated tungsten	
Voltage	7.5 volts
Current	51 amperes
Amplification Factor (Average)	20
Direct Interelectrode Capacitances (Average)	
Grid-Plate	20 $\mu\text{fd}$
Grid-Filament	36 $\mu\text{fd}$
Plate-Filament	1.2 $\mu\text{fd}$
Transconductance ( $i_b = 830 \text{ ma.}, E_b = 3000 \text{ v.}$ )	20,000 $\mu\text{mhos}$
Frequency for Maximum Ratings	30 Mc

**MECHANICAL**

Base	See Drawing
Mounting	Vertical, base down or up
Maximum Overall Dimensions:	
Length (does not include filament connectors)	9.0 inches
Diameter	4.156 inches
Net weight	7.5 pounds
Shipping weight (Average)	17 pounds
► Cooling	

A minimum flow of 120 cubic feet of air per minute must be passed through the anode cooler. The pressure drop across the cooler at this flow equals 1.0 inch of water. A minimum air-flow of 6 cubic feet per minute must also be directed toward the filament-stem structure, between the inner and outer filament conductors. Cooling air in the above quantities must be supplied to both anode cooler and filament seals before applying filament voltage and should be continued for one minute after the filament power is removed. Anode-cooler core, grid and filament seal temperatures must not exceed 150° C. These figures are for an ambient temperature of 20° C at sea level and do not include duct or filter losses.

**RADIO-FREQUENCY POWER AMPLIFIER OR OSCILLATOR**

► (Conventional Neutralized Amplifier—Frequencies below 30 Mc.)  
 Class-C FM or Telegraphy (Key-down conditions, per tube)  
**MAXIMUM RATINGS**  
 D-C PLATE VOLTAGE - - - - - 6000 MAX. VOLTS  
 D-C PLATE CURRENT - - - - - 2.5 MAX. AMPS  
 PLATE DISSIPATION - - - - - 2500 MAX. WATTS  
 PLATE COOLER CORE TEMPERATURE - - - - - 150 MAX. °C  
 GRID DISSIPATION\* - - - - - 150 MAX. WATTS  
 \* SEE APPLICATION NOTES.

**TYPICAL OPERATION (Frequencies below 30 Mc. per tube)**

D-C Plate Voltage	4000	5000	6000	volts
D-C Plate Current	2.5	2.5	2.08	amps
D-C Grid Voltage	-300	-450	-500	volts
D-C Grid Current	245	265	180	ma
Peak R-F Grid Input Voltage	580	750	765	volts
Driving Power (approx.)	142	197	136	watts
Grid Dissipation	68	78	46	watts
Plate Power Input	10,000	12,500	12,500	watts
Plate Dissipation	2500	2500	2500	watts
Plate Power Output	7500	10,000	10,000	watts

**PLATE-MODULATED RADIO-FREQUENCY AMPLIFIER**

► (Conventional Neutralized Amplifier—Frequencies below 30 Mc.)  
 Class-C Telephony (Carrier conditions, per tube)  
**MAXIMUM RATINGS**  
 D-C PLATE VOLTAGE - - - - - 5000 MAX. VOLTS  
 D-C PLATE CURRENT - - - - - 2.0 MAX. AMPS  
 PLATE DISSIPATION - - - - - 1670 MAX. WATTS  
 PLATE COOLER CORE TEMPERATURE - - - - - 150 MAX. °C  
 GRID DISSIPATION - - - - - 150 MAX. WATTS

**TYPICAL OPERATIONS (Frequencies below 30 Mc. per tube)**

D-C Plate Voltage	4000	4500	5000	volts
D-C Plate Current	1.67	1.55	1.45	amps
Total Bias Voltage	-450	-500	-550	volts
Fixed Bias Voltage	-230	-325	-410	volts
Grid Resistor	1500	1500	1400	ohms
D-C Grid Current	150	120	100	ma
Peak R-F Grid Input Voltage	680	720	760	volts
Driving Power (approx.)	102	86	76	watts
Grid Dissipation	35	26	21	watts
Plate Power Input	6670	6970	7250	watts
Plate Dissipation	1670	1670	1670	watts
Plate Power Output	5000	5300	5580	watts

IF IT IS DESIRED TO OPERATE THIS TUBE UNDER CONDITIONS WIDELY DIFFERENT FROM THOSE GIVEN UNDER "TYPICAL OPERATION," POSSIBLY EXCEEDING THE MAXIMUM RATINGS GIVEN FOR CW SERVICE, WRITE EITEL-McCULLOUGH, INC., FOR INFORMATION AND RECOMMENDATIONS.

**AUDIO-FREQUENCY POWER AMPLIFIER AND MODULATOR**

Class B (Sinusoidal wave, two tubes unless otherwise specified)

MAXIMUM RATINGS				
D-C PLATE VOLTAGE	-	-	-	6000 MAX. VOLTS
MAX.-SIGNAL D-C PLATE CURRENT, PER TUBE	-	-	-	2.5 MAX. AMPS
PLATE DISSIPATION, PER TUBE	-	-	-	2500 MAX. WATTS
PLATE COOLER CORE TEMPERATURE	-	-	-	150 MAX. °C
TYPICAL OPERATION CLASS AB <sub>2</sub> (Two tubes)				
D-C Plate Voltage	4000	5000	6000	volts
D-C Grid Voltage (approx.)*	-150	-190	-240	volts
Zero-Signal D-C Plate Current	0.6	0.5	0.4	amps
Max.-Signal D-C Plate Current	4.0	3.2	3.0	amps
Effective Load, Plate to Plate	2200	3600	4650	ohms
Peak A-F Grid Input Voltage (per tube)	340	360	390	volts
Max.-Signal Peak Driving Power	340	230	225	watts
Max.-Signal Nominal Driving Power (approx.)	170	115	113	watts
Max.-Signal Plate Power Output	11,000	11,000	13,000	watts

**TYPICAL OPERATION CLASS AB<sub>2</sub> (Two tubes)**

(Modulator service for 4000 and 5000 volt operation, to modulate one or two tubes, as shown under "Plate Modulated Radio Frequency Amplifier.")

D-C Plate Voltage	4000	5000	4000	5000	volts
D-C Grid Voltage (approx.)*	-155	-200	-145	-190	volts
Zero-Signal D-C Plate Current	0.4	0.4	0.6	0.5	amps
Max.-Signal D-C Plate Current	1.35	1.13	2.70	2.26	amps
Effective Load, Plate to Plate	6600	10,000	3300	5000	ohms
Peak A-F Grid Input Voltage (per tube)	240	275	285	310	volts
Max.-Signal Peak Driving Power	42	40	134	118	watts
Max.-Signal Nominal Driving Power (approx.)	21	20	67	59	watts
Max.-Signal Plate Power Output	3700	4000	7400	8000	watts
Will Modulate R. F. Final Input of	6670	7250	13,340	14,500	watts

\*Adjust to give stated zero-signal plate current.

**APPLICATION**

**Filament Voltage**—The filament voltage, as measured directly at the tube, should be 7.5 volts with maximum allowable variations due to line fluctuation of from 7.12 to 7.87 volts.

**Bias Voltage**—There is little advantage in using bias voltages in excess of those given under "Typical Operation," except in certain very specialized applications. Where bias is obtained from a grid resistor, suitable protective means must be provided to prevent excessive plate dissipation in the event of loss of excitation.

**Plate Voltage**—The plate-supply voltage for the 3X2500F3 should not exceed 6000 volts. In most cases there is little advantage in using plate-supply voltages higher than those given under "Typical Operation" for the power output desired.

In Class-C FM or Telegraphy service, a 0.1 henry choke, shunted by a spark gap, should be series connected between the plates of the amplifier tubes and the high-voltage-plate-supply capacitor to offer protection from transients and surges. In plate-modulated service, where a plate-modulation transformer is used, the protective choke is not normally required.

**Grid Dissipation**—The power dissipated by the grid of the 3X2500F3 must never exceed 150 watts. Grid dissipation may be calculated from the following expression:

$$P_g = e_{cmp} I_c$$

where  $P_g$  = grid dissipation,

$e_{cmp}$  = peak positive grid voltage, and

$I_c$  = d-c grid current.

$e_{cmp}$  may be measured by means of a suitable peak voltmeter connected between filament and grid. Any suitable peak v.t.v.m. circuit may be used (one is shown in "Vacuum Tube Ratings," Eimac News, January 1945. This article is available, in reprint form on request).

In equipment in which the plate loading varies widely, such as oscillators used for radio-frequency heating, care should be taken to make certain that the grid dissipation does not exceed the maximum rating under any condition of loading.

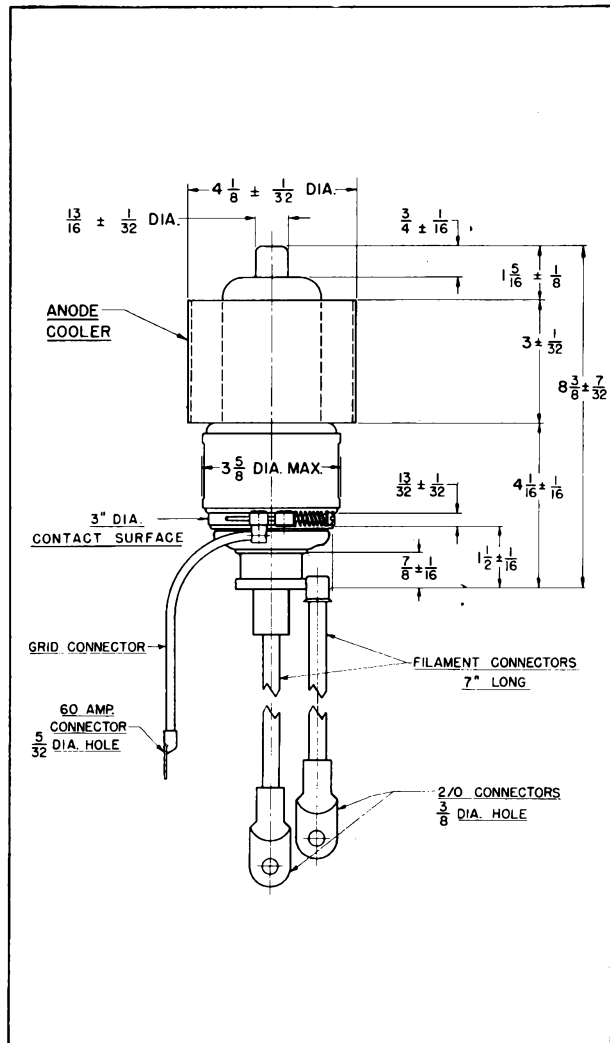

## DRIVING POWER vs. POWER OUTPUT

The three charts on this page show the relationship of plate efficiency, power output and grid driving-power at plate voltages of 4000, 5000 and 6000 volts. These charts show combined grid and bias losses only. The driving power and power output figures do not include circuit losses. The plate dissipation in watts is indicated by  $P_p$ .

Points A, B, and C are identical to the typical Class C operating conditions shown on the first page under 4000, 5000 and 6000 volts respectively.

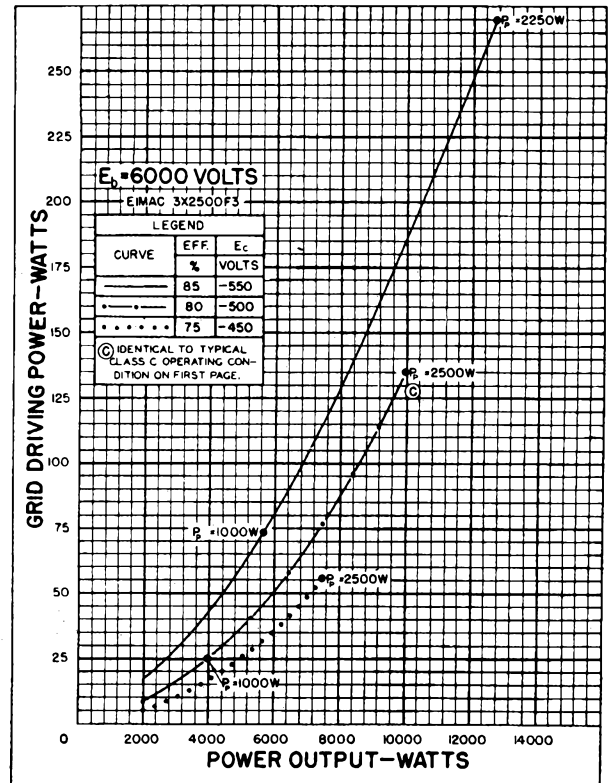
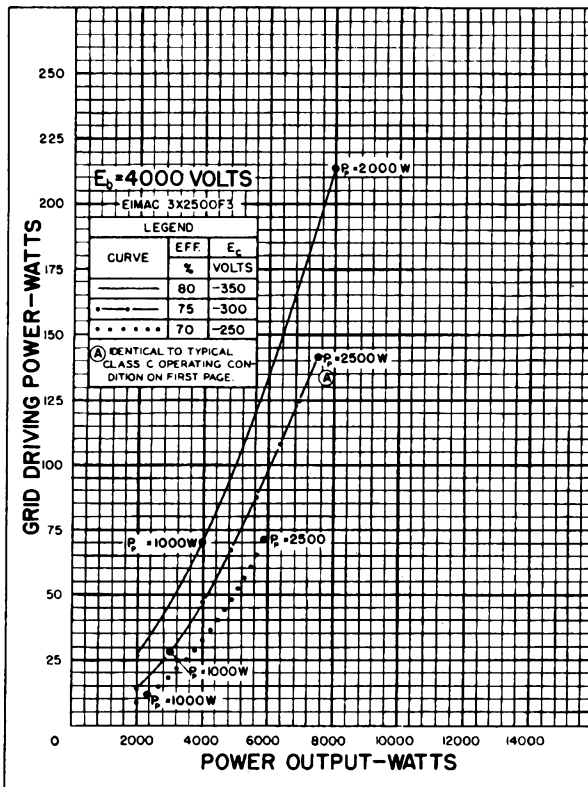
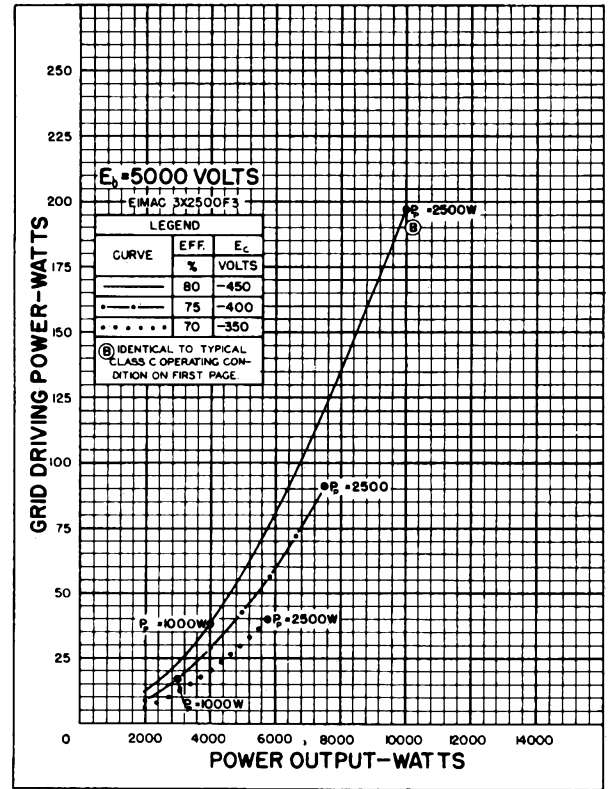

EIMAC 3X2500F3  
TYPICAL CONSTANT CURRENT  
CHARACTERISTICS

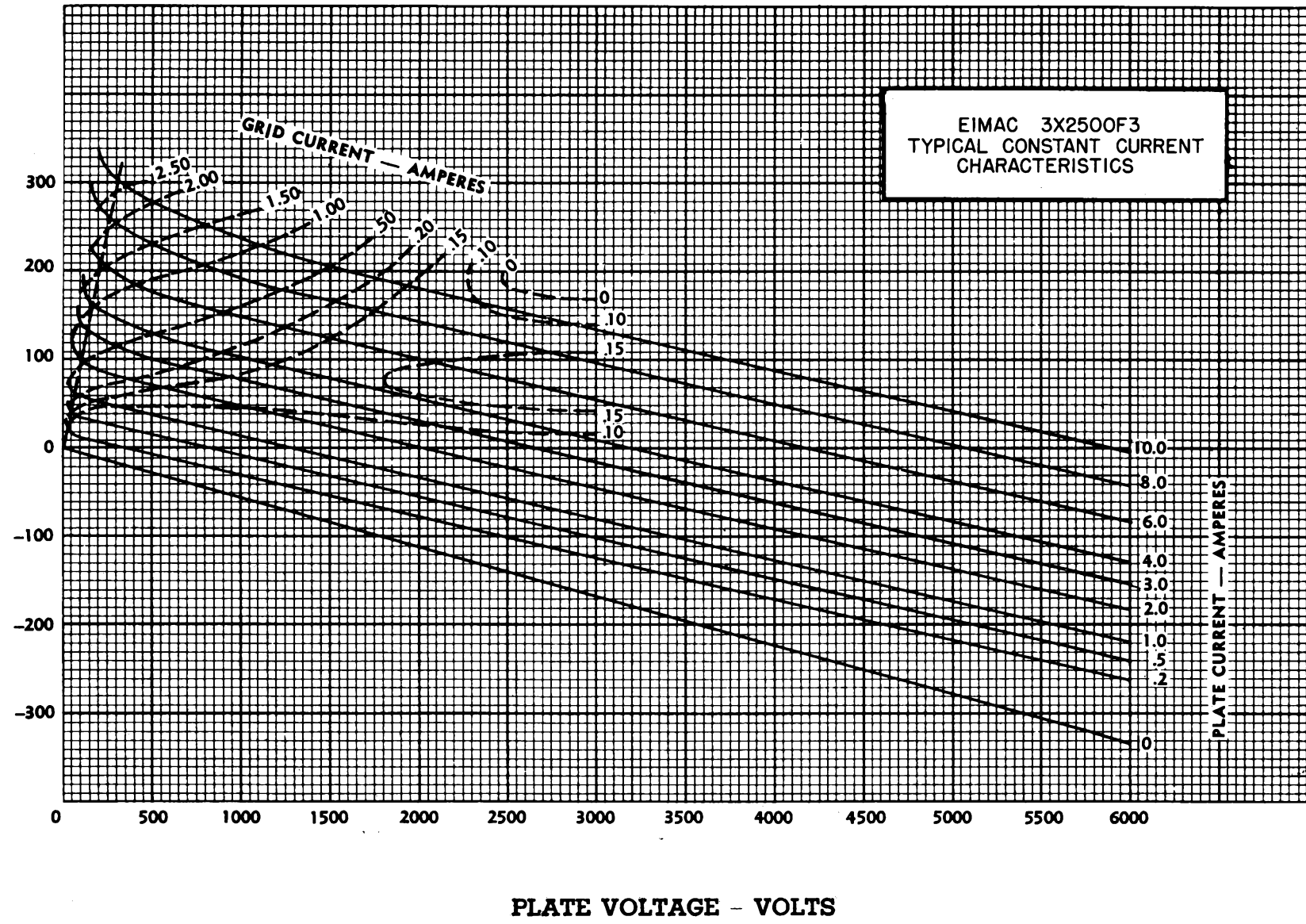

GRID VOLTAGE - VOLTS

PLATE VOLTAGE - VOLTS

Indicates Change from Sheet Dated 2-1-50

# Eitel-McCullough, Inc.

SAN BRUNO, CALIFORNIA

## 3X3000A1 LOW-MU TRIODE MODULATOR AMPLIFIER

The Eimac 3X3000A1 is a low-mu forced-air-cooled power triode intended for use as an audio amplifier or modulator. The maximum rated plate dissipation is 3000 watts.

Two 3X3000A1's in class-AB<sub>1</sub> audio service will deliver up to 10 kilowatts maximum-signal plate power output at 6000 plate volts without drawing grid current.

### GENERAL CHARACTERISTICS

#### ELECTRICAL

Filament: Thoriated Tungsten	
Voltage	7.5 volts
Current	51 amperes
Amplification Factor (Average)	5
Direct Interelectrode Capacitances (Average)	
Grid-Plate	17 $\mu\text{fd}$
Grid-Filament	29 $\mu\text{fd}$
Plate-Filament	2.5 $\mu\text{fd}$
Transconductance ( $I_b = 1.0 \text{ amp.}, E_b = 3000\text{v.}$ )	11,000 $\mu\text{mhos}$

#### MECHANICAL

Base	See outline drawing
Mounting Position	Vertical, base down or up
Cooling	Forced air
Maximum Temperatures:	
Grid and Filament Seals, Anode Cooler Core	150°C
Maximum Overall Dimensions:	
Length	9.0 inches
Diameter	4.16 inches
Net Weight	6.25 pounds
Shipping Weight (Average)	16 pounds



#### AUDIO FREQUENCY POWER AMPLIFIER OR MODULATOR

Class-AB<sub>1</sub>

##### MAXIMUM RATINGS (Per tube)

D-C PLATE VOLTAGE	6000 MAX. VOLTS
D-C PLATE CURRENT	2.5 MAX. AMPERES
PLATE DISSIPATION	3000 MAX. WATTS
GRID DISSIPATION	50 MAX. WATTS

TYPICAL OPERATION (Sinusoidal wave, two tubes unless otherwise specified)					
D-C Plate Voltage	3000	4000	5000	6000	volts
D-C Grid Voltage (approx.) <sup>1</sup>	-400	-860	-1080	-1300	volts
Zero-Signal D-C Plate Current	465	500	400	335	ma
Max-Signal D-C Plate Current	3.35	3.00	2.80	2.65	amps
Effective Load, Plate-to-Plate	1170	2160	3320	4560	ohms
Peak A-F Grid Input Voltage (per tube)	555	760	995	1250	volts
Max-Signal Driving Power (approx.)	0	0	0	0	watts
Max-Signal Plate Power Input	10,000	12,000	14,000	16,000	watts
Max-Signal Plate Dissipation (per tube)	3000	3000	3000	3000	watts
Max-Signal Plate Power Output	4000	6000	8000	10,000	watts
Total Harmonic Distortion <sup>2</sup>	2.7	1.8	2.6	2.1	per cent

<sup>1</sup>Adjust to stated Zero-Signal D-C Plate Current. Effective grid-circuit resistance must not exceed 200,000 ohms.

<sup>2</sup>At maximum signal without negative feedback.

#### APPLICATION

**Filament Voltage**—The filament voltage, as measured directly at the tube, should be the rated value of 7.5 volts. Variations should be held within the range of 7.12 to 7.87 volts.

**Cooling**—The 3X3000A1 requires an air-flow of 150 cubic feet per minute through the anode cooler. This corresponds to a pressure drop across the cooler of 2.2 inches of water. A flow of 6 cubic feet per minute must also be directed into the filament stem structure, between the inner and outer filament conductors.

The air-flow must be started when power is applied to the filament, and must continue without interruption

until all electrode voltages have been removed from the tube. It is advisable to permit the air-cooling system to operate for two minutes or more after the removal of power.

These air requirements are based upon operation at an ambient temperature of 20°C and at sea level.

Cooling conditions for the 3X3000A1 may be considered satisfactory if the temperature of the anode cooler core and of the metal parts of the metal-to-glass seals is not allowed to exceed 150°C. A convenient accessory for the measurement of these temperatures is "Tempilaq", a temperature-sensitive lacquer manufactured by the Tempil Corporation, 132 West 22nd St., New York 11, N. Y.

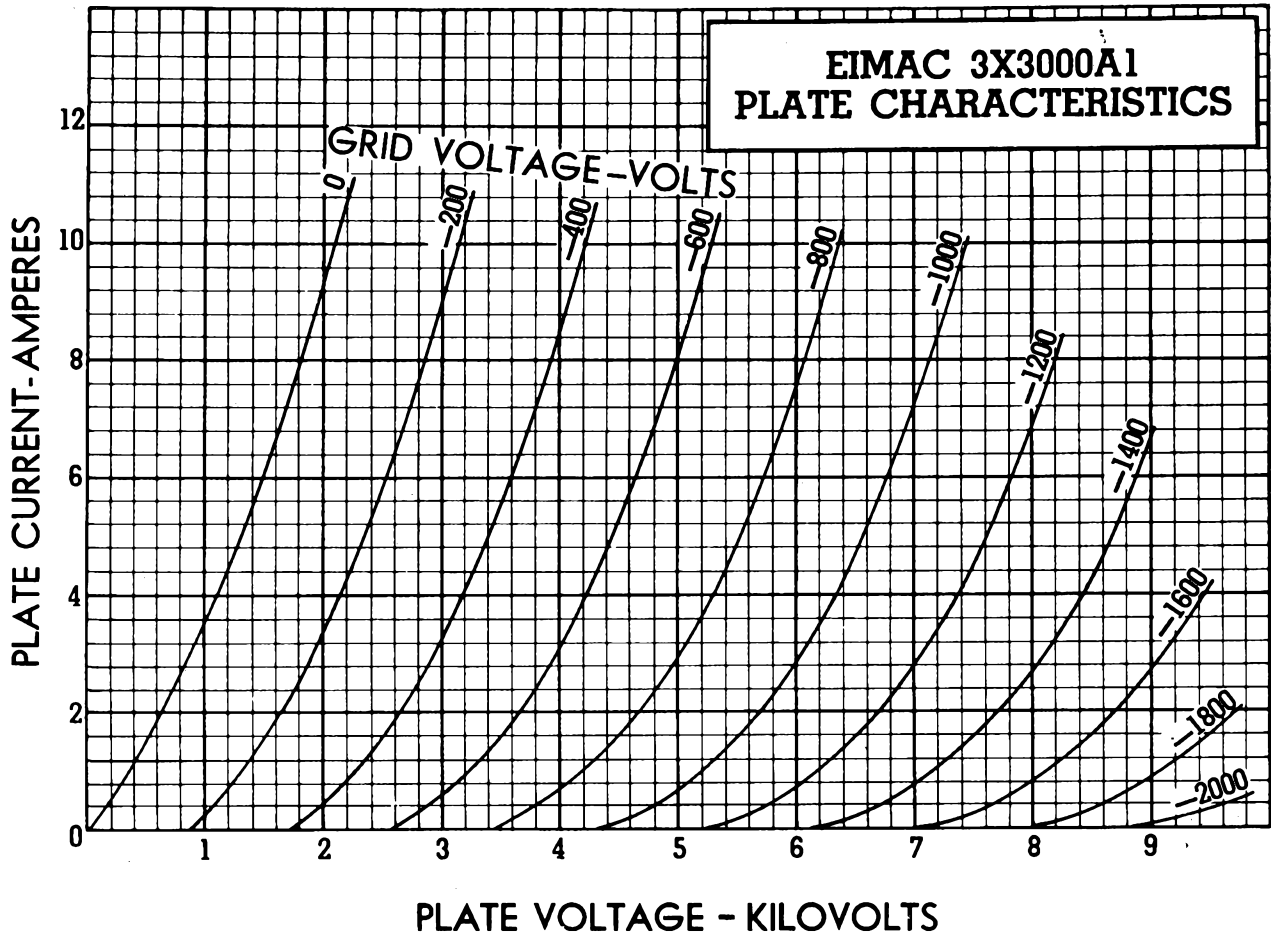

**NOTE 1**  
040" MAXIMUM RUNOUT OF GRID CONTACT SURFACE WITH RESPECT TO AXIS DETERMINED BY ANODE AND OUTER FILAMENT CONTACT SURFACE.

**NOTE 2**  
025" MAXIMUM RUNOUT OF INNER FILAMENT CONTACT SURFACE WITH RESPECT TO OUTER FILAMENT CONTACT SURFACE.

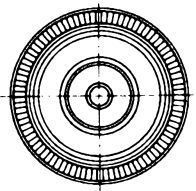
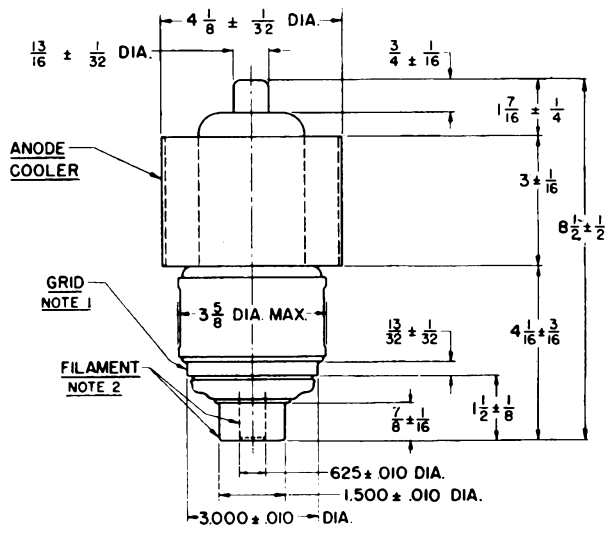

**BOTTOM VIEW**

**DIMENSIONS  
 IN INCHES**

*Eitel*  
**EITEL-McCULLOUGH, INC.**  
 SAN BRUNO, CALIFORNIA

**3X3000F1**

LOW-MU TRIODE

MODULATOR  
 AMPLIFIER

The Eimac 3X3000F1 is a low-mu forced-air-cooled power triode intended for use as an audio amplifier or modulator. The maximum rated plate dissipation is 3000 watts.

Two 3X3000F1's in class-AB<sub>1</sub> audio service will deliver up to 10 kilowatts maximum-signal plate power output at 6000 plate volts without drawing grid current.

**GENERAL CHARACTERISTICS**

**ELECTRICAL**

Filament: Thoriated Tungsten	
Voltage	7.5 volts
Current	51 amperes
Amplification Factor (Average) - - - - - 5	
Direct Interelectrode Capacitances (Average)	
Grid-Plate	17 $\mu\mu\text{fd}$
Grid-Filament	29 $\mu\mu\text{fd}$
Plate-Filament	2.5 $\mu\mu\text{fd}$
Transconductance ( $I_b = 1.0 \text{ amp.}, E_b = 3000\text{v.}$ )	11,000 $\mu\text{mhos}$

**MECHANICAL**

Base	See outline drawing
Mounting Position	Vertical, base down or up
Cooling	Forced air
Maximum Temperatures:	
Grid and Filament Seals,	
Anode Cooler Core	150°C
Maximum Overall Dimensions:	
Length	9.0 inches
Diameter	4.16 inches
Net Weight	7.5 pounds
Shipping Weight	17 pounds

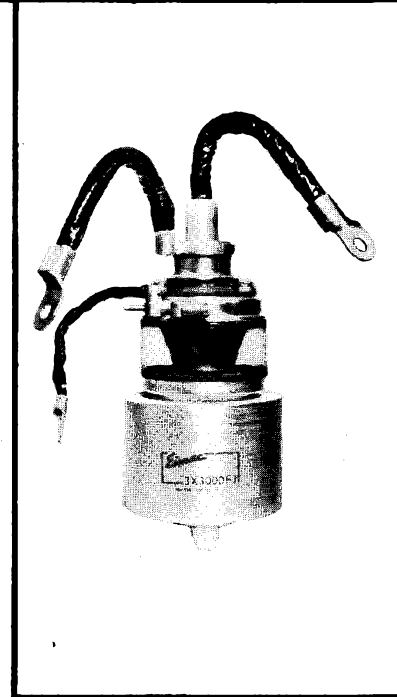

**AUDIO FREQUENCY POWER AMPLIFIER OR MODULATOR**

Class-AB<sub>1</sub>

MAXIMUM RATINGS (Per tube)

D-C PLATE VOLTAGE	6000 MAX. VOLTS
D-C PLATE CURRENT	2.5 MAX. AMPERES
PLATE DISSIPATION	3000 MAX. WATTS
GRID DISSIPATION	50 MAX. WATTS

TYPICAL OPERATION (Sinusoidal wave, two tube unless otherwise specified)				
D-C Plate Voltage	3000	4000	5000	6000 volts
D-C Grid Voltage (approx.) <sup>1</sup>	-600	-860	-1080	-1300 volts
Zero-Signal D-C Plate Current	665	500	400	335 ma
Max-Signal D-C Plate Current	3.35	3.00	2.80	2.65 amps
Effective Load, Plate-to-Plate	1170	2160	3320	4560 ohms
Peak A-F Grid Input Voltage (per tube)	555	760	995	1250 volts
Max-Signal Driving Power (approx.)	0	0	0	0 watts
Max-Signal Plate Power Input	10,000	12,000	14,000	16,000 watts
Max-Signal Plate Dissipation (per tube)	3000	3000	3000	3000 watts
Max-Signal Plate Power Output	4000	6000	8000	10,000 watts
Total Harmonic Distortion <sup>2</sup>	2.7	1.8	2.6	2.1 per cent

<sup>1</sup>Adjust to stated Zero-Signal D-C Plate Current. Can be expected to vary  $\pm 15\%$ . Effective grid-circuit resistance must not exceed 200,000 ohms.  
<sup>2</sup>At maximum signal without negative feedback.

**APPLICATION**

**Filament Voltage**—The filament voltage, as measured directly at the tube, should be the rated value of 7.5 volts. Variations should be held within the range of 7.12 to 7.87 volts.

**Cooling**—The 3X3000F1 requires an air-flow of 150 cubic feet per minute through the anode cooler. This corresponds to a pressure drop across the cooler of 2.2 inches of water. A flow of 6 cubic feet per minute must also be directed into the filament stem structure, between the inner and outer filament conductors.

The air-flow must be started when power is applied to the filament, and must continue without interruption

(Effective 4-20-53) Copyright 1953 by Eitel-McCullough, Inc.

until all electrode voltages have been removed from the tube. It is advisable to permit the air-cooling system to operate for two minutes or more after the removal of power.

These air requirements are based upon operation at an ambient temperature of 20°C and at sea level.

Cooling conditions for the 3X3000F1 may be considered satisfactory if the temperature of the anode cooler core and of the metal parts of the metal-to-glass seals is not allowed to exceed 150°C. A convenient accessory for the measurement of these temperatures is "Tempilaq", a temperature-sensitive lacquer manufactured by the Tempil Corporation, 132 West 22nd St., New York 11, N. Y.

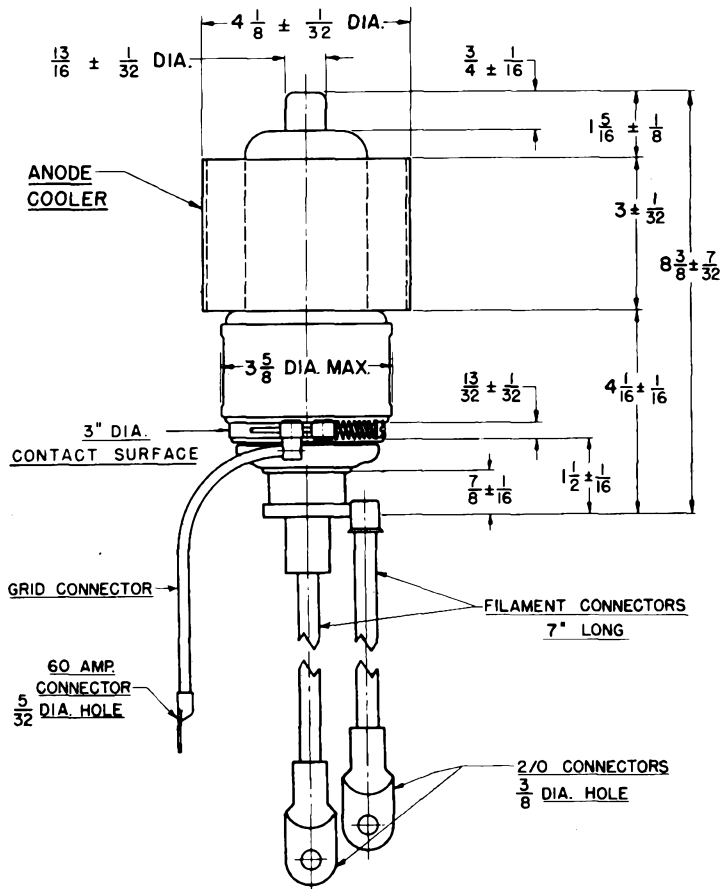
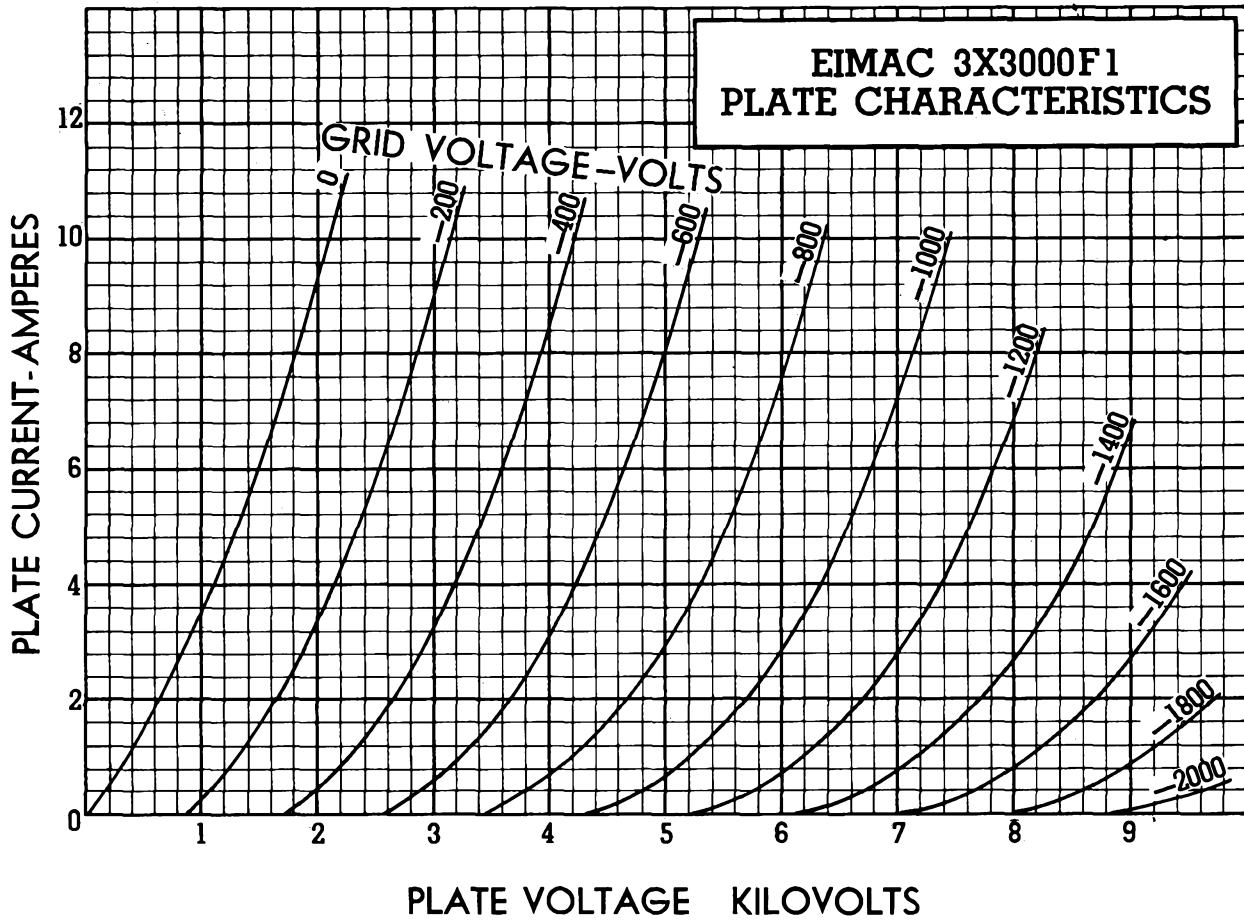



*Eimac*  
**EITEL-McCULLOUGH, INC.**  
 SAN BRUNO, CALIFORNIA

**6C21**  
 PULSE TRIODE  
 •  
 MODULATOR  
 AMPLIFIER

The Eimac 6C21 is a high-vacuum power triode designed for pulse-modulator service at d-c plate voltages up to 30 kilovolts and peak plate currents as high as 15 amperes.

The 6C21 is forced-air and radiation cooled, has a maximum plate-dissipation rating of 300 watts, and, in pulse modulator service, will deliver up to 375 kilowatts to a resistive load with 7.5 kilowatts of driving power.

**GENERAL CHARACTERISTICS**

**ELECTRICAL**

Filament: Thoriated Tungsten	
Voltage	8.2 volts
Current	17.0 amperes
Amplification Factor (Average)	30
Direct Interelectrode Capacitances (Average)	
Grid-Plate	4.3 $\mu\mu\text{f}$
Input	9.5 $\mu\mu\text{f}$
Output	0.7 $\mu\mu\text{f}$
Transconductance ( $I_b=100 \text{ ma.}, E_b=2000\text{v.}$ )	6100 $\mu\text{mhos}$

**MECHANICAL**

Base	50-watt jumbo 4-pin
Connections	See drawing
Socket	E. F. Johnson Co. 123-211, National Co. XM-50 or equivalent.
Mounting Position	Vertical, base down or up
Cooling	Forced Air and Radiation
Maximum Temperature of Grid & Plate Seals	225° C.
Recommended Heat Dissipating Plate and Grid Connectors	Eimac HR-8
Maximum Overall Dimensions:	
Length	12- $\frac{5}{8}$ inches
Diameter	5- $\frac{1}{8}$ inches
Net Weight	1.3 pounds
Shipping Weight	5.8 pounds

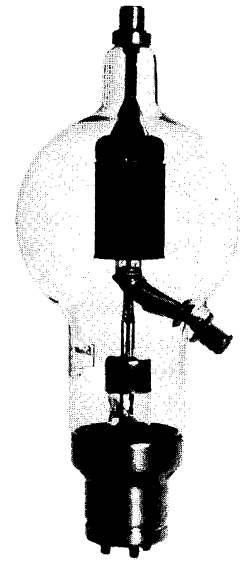

**MAXIMUM RATINGS**

Pulse Modulator Service (Per Tube)	
D-C PLATE VOLTAGE	30 MAX. KILOVOLTS
D-C GRID VOLTAGE	-2.0 MAX. KILOVOLTS
PEAK POSITIVE PLATE VOLTAGE	35 MAX. KILOVOLTS
PEAK POSITIVE GRID VOLTAGE	1.6 MAX. KILOVOLTS
PEAK PLATE CURRENT	15 MAX. AMPERES
AVERAGE GRID DISSIPATION	50 MAX. WATTS
AVERAGE PLATE DISSIPATION	300 MAX. WATTS

**TYPICAL OPERATION**

D-C Plate Voltage	28 kilovolts
D-C Grid Voltage	-1.5 kilovolts
Pulse Plate Current	15 amperes
Pulse Grid Current*	3.0 amperes
Pulse Positive Grid Voltage	1000 volts
Pulse Grid Driving Power*	7.5 kilowatts
Load: Resistive	1650 ohms
Duty	.002
Pulse Voltage Output	25 kilovolts
Pulse Power Input	420 kilowatts
Pulse Plate Dissipation	45 kilowatts
Pulse Power Output	375 kilowatts

\*Approximate values.

**APPLICATION**

**Mounting**—The 6C21 must be mounted vertically, base down or up. The leads to the plate and grid terminals should be flexible, and the tube must be protected from vibration and shock.

**Cooling**—Forced-air cooling of the filament stem structure is required. Base cooling requires a minimum air flow of 2½ cubic feet per minute directed through the tube base toward the filament press. If the hole in the socket is at least 1 inch in diameter and the manifold is the same diameter, a static pressure of ¼ inch of water is required at the manifold to provide the 2½ cubic feet per minute. Heat Dissipating Connectors (Eimac HR-8 or equivalent) must be used at the plate and grid terminals and unobstructed circulation of air around the tube is required in sufficient quantity to prevent the temperatures of grid and plate seals from exceeding 225°C. Forced ventilation of compartments or equipment in which the tube is located is always beneficial, though not necessarily required.

Tube temperatures may be measured with the aid of "Tempilaq", a temperature-sensitive lacquer manufactured by the Tempil Corporation, 132 West 22nd Street, New York 11, N. Y. For satisfactory results, Tempilaq must be sprayed on the surface to be measured in a thin coat, covering as small an area as will serve the purpose.

**ELECTRICAL**

**Filament Voltage**—For optimum tube life the filament voltage, as measured directly at the base pins, should be the rated value of 8.2 volts. Variations should be kept within the range of 7.9 to 8.5 volts. All four socket terminals should be used, with two placed in parallel for each filament connection.

**Plate Dissipation**—Under normal operating conditions, the plate dissipation should not be allowed to exceed the maximum rating of 300 watts. Plate dissipation in excess of the maximum rating is permissible for short periods of time, such as during adjustment procedures.

**Operation**—The 6C21 may be operated with inductive or resistive loads, provided only that the maximum ratings are not exceeded. The ratings listed for pulse modulator service are for operation at peak plate currents of 15 amperes and pulse lengths up to 100 milliseconds. Further information on pulse operation, such as tube limitations under long (100 milliseconds or more) pulse conditions, is contained in "Pulse Service Notes" obtainable from Eitel-McCullough, Inc., on request. If it is desired to operate the 6C21 under conditions widely different from those given for pulse modulator service, write Eitel-McCullough, Inc., for information and recommendations.

Useful information about pulse circuits may be obtained from such publications as "Pulse Generators", volume 5 of the MIT Radiation Laboratory Series, published by McGraw-Hill, 1948.

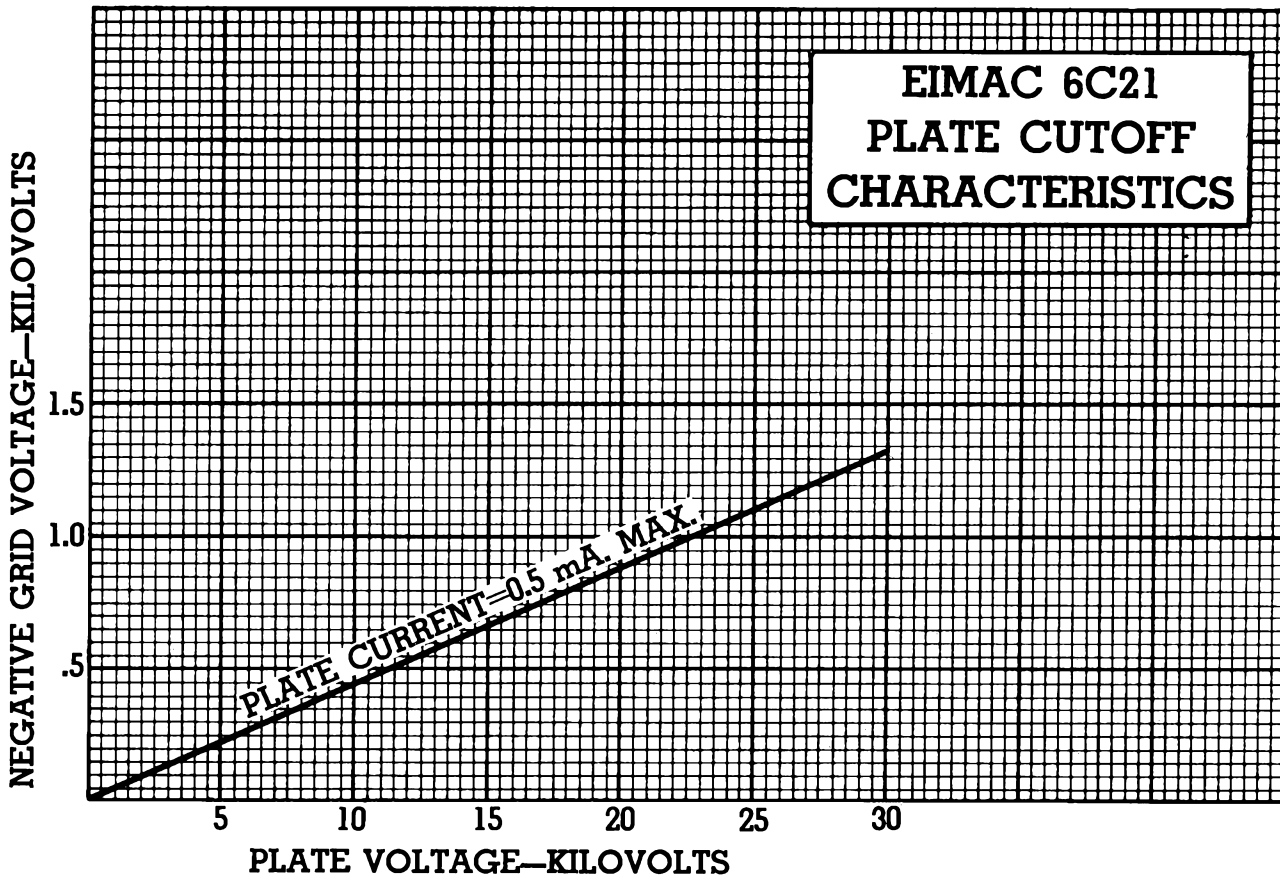

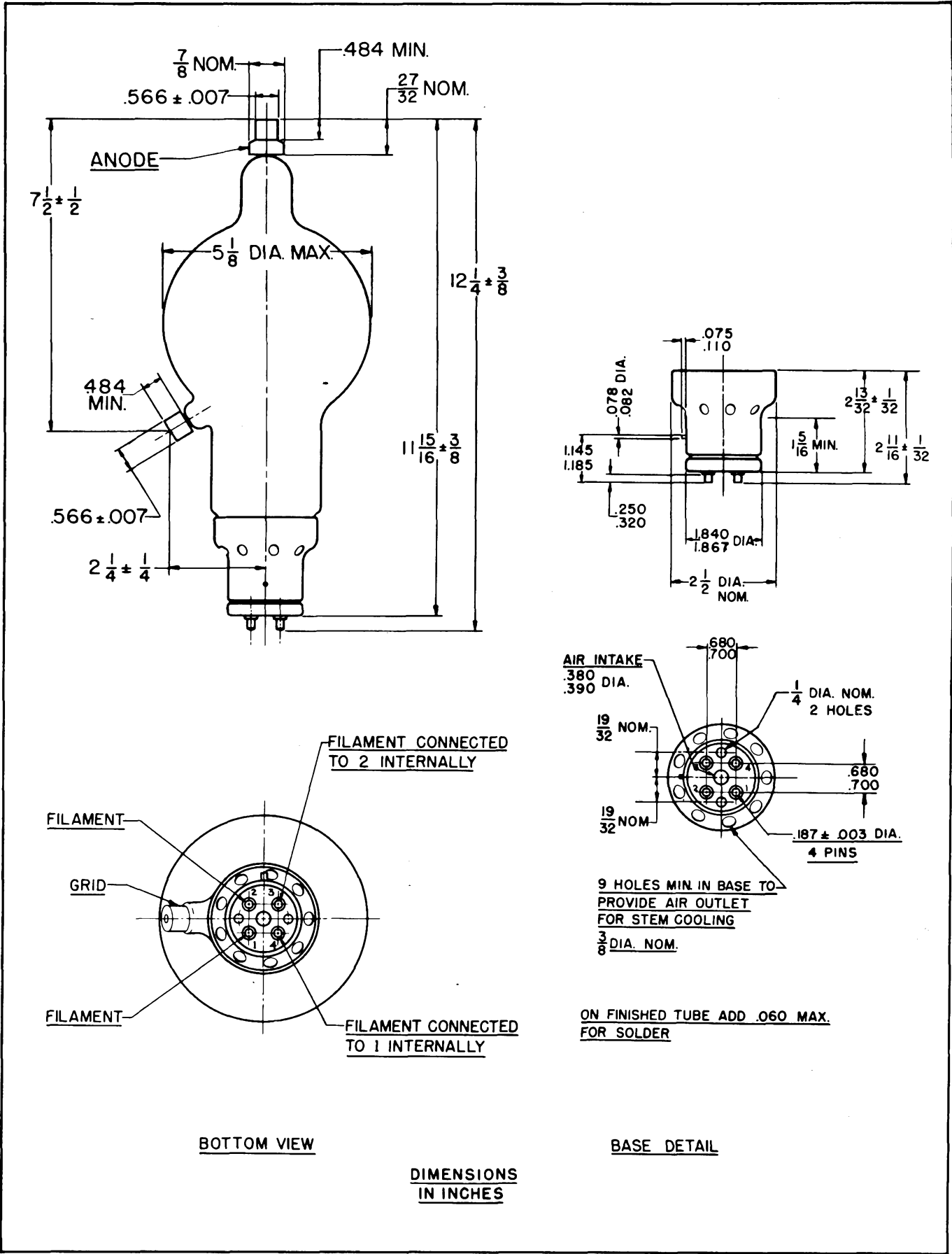
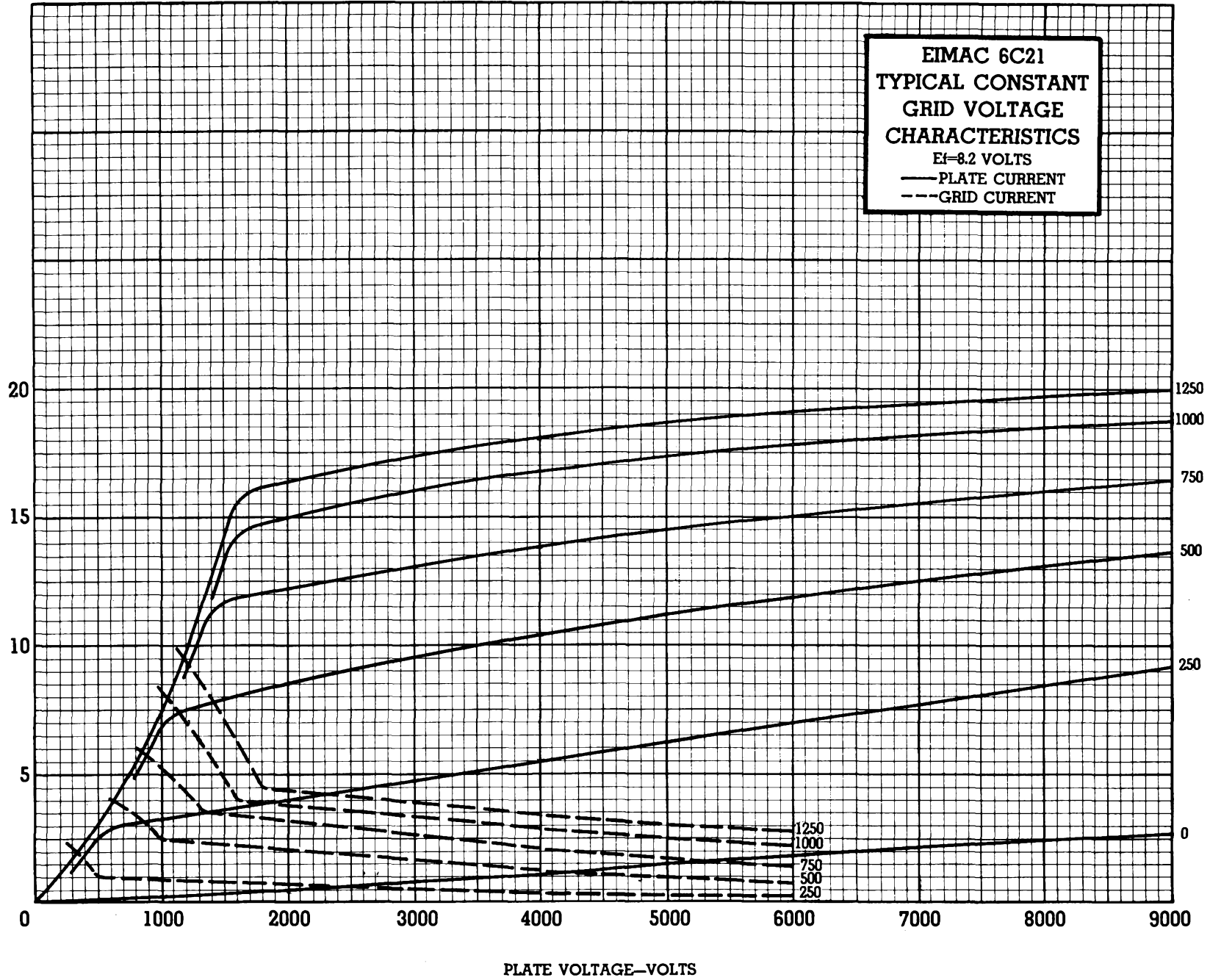

PLATE CURRENT—AMPERES  
GRID CURRENT—AMPERES



GRID VOLTAGE—VOLTS



# EITEL-McCULLOUGH, INC.

SAN BRUNO, CALIFORNIA

# 25T

MEDIUM-MU TRIODE  
 MODULATOR  
 OSCILLATOR  
 AMPLIFIER

► The Eimac 25T is a medium-mu, power triode having a maximum plate dissipation of 25 watts and is intended for use as an amplifier, oscillator or modulator. It can be used at its maximum ratings at frequencies as high as 60 Mc.

Cooling of the 25T is accomplished by radiation from the plate, which operates at a visible red color at maximum dissipation and by means of air convection around the envelope.

## GENERAL CHARACTERISTICS

### ► ELECTRICAL

Filament: Thoriated tungsten	
Voltage - - - - -	6.3 volts
Current - - - - -	3.0 amperes
Amplification Factor (Average) - - - - - 24	
Direct Interelectrode Capacitances (Average)	
Grid-Plate - - - - -	1.5 $\mu\mu\text{f}$
Grid-Filament - - - - -	2.2 $\mu\mu\text{f}$
Plate-Filament - - - - -	0.2 $\mu\mu\text{f}$
Transconductance ( $i_b=25$ ma., $E_b=1000$ v.) - - - - -	2500 $\mu\text{mhos}$
Frequency for Maximum Ratings - - - - -	60 Mc.

### ► MECHANICAL

Base - - - - -	Small 4-pin, RMA type A4-5
Basing (See outline drawing) - - - - -	RMA type 3G
Mounting - - - - -	Vertical, base down or up
Cooling - - - - -	Convection and Radiation
Recommended Heat Dissipating Connector:	
Plate - - - - -	HR-1
Maximum Overall Dimensions:	
Length - - - - -	4.38 inches
Diameter - - - - -	1.44 inches
Net Weight - - - - -	1.5 ounces
Shipping Weight (Average) - - - - -	1.0 pound

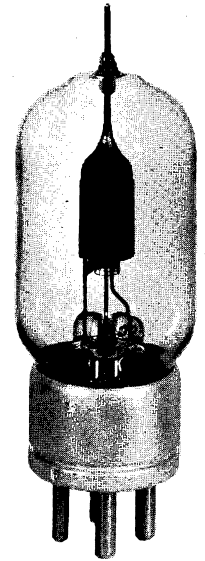

### ► AUDIO FREQUENCY POWER AMPLIFIER AND MODULATOR

Class-B

MAXIMUM RATINGS, PER TUBE

D-C PLATE VOLTAGE - - - - -	2000 MAX. VOLTS
MAX-SIGNAL D-C PLATE CURRENT - - - - -	75 MAX. MA.
PLATE DISSIPATION - - - - -	25 MAX. WATTS
GRID DISSIPATION - - - - -	7 MAX. WATTS

#### TYPICAL OPERATION, CLASS AB<sub>2</sub>

Sinusoidal wave, two tubes unless otherwise specified

D-C Plate Voltage - - - - -	750	1000	1250	Volts
D-C Grid Voltage (approx.)* - - - - -	-20	-30	-42	Volts
Zero-Signal D-C Plate Current - - - - -	43	32	24	Ma.
Max-Signal D-C Plate Current - - - - -	127	127	130	Ma.
Effective Load, Plate-to-Plate - - - - -	12,000	17,000	21,400	Ohms
Peak A-F Grid Input Voltage (per tube) - - - - -	110	120	135	Volts
Max-Signal Peak Driving Power - - - - -	5.5	6.0	6.8	Watts
Max-Signal Nominal Driving Power (approx.) - - - - -	2.8	3.0	3.4	Watts
Max-Signal Plate Power Output - - - - -	60	85	112	Watts

\*Adjust to give stated zero-signal plate current.

### ► PLATE MODULATED RADIO FREQUENCY AMPLIFIER

Class-C Telephony (Carrier conditions, per tube)

MAXIMUM RATINGS

D-C PLATE VOLTAGE - - - - -	1600 MAX. VOLTS
D-C PLATE CURRENT - - - - -	60 MAX. MA.
PLATE DISSIPATION - - - - -	17 MAX. WATTS
GRID DISSIPATION - - - - -	7 MAX. WATTS

#### TYPICAL OPERATION

D-C Plate Voltage - - - - -	1000	1250	1600	Volts
D-C Plate Current - - - - -	60	60	53	Ma.
D-C Grid Voltage - - - - -	-120	-140	-170	Volts
D-C Grid Current - - - - -	14	13	11	Ma.
Peak R-F Grid Input Voltage - - - - -	235	255	280	Volts
Driving Power - - - - -	3.3	3.3	3.1	Watts
Grid Dissipation - - - - -	1.4	1.5	1.2	Watts
Plate Power Input - - - - -	60	75	85	Watts
Plate Dissipation - - - - -	13	15	17	Watts
Plate Power Output - - - - -	47	60	68	Watts

The above figures show actual measured tube performance and do not allow for variations in circuit losses.

### ► RADIO FREQUENCY POWER AMPLIFIER AND OSCILLATOR

Class-C Telegraphy or FM Telephony (Key-down conditions, per tube)

MAXIMUM RATINGS

D-C PLATE VOLTAGE - - - - -	2000 MAX. VOLTS
D-C PLATE CURRENT - - - - -	75 MAX. MA.
PLATE DISSIPATION - - - - -	25 MAX. WATTS
GRID DISSIPATION - - - - -	7 MAX. WATTS

#### TYPICAL OPERATION

D-C Plate Voltage - - - - -	1000	1500	2000	Volts
D-C Plate Current - - - - -	72	67	63	Ma.
D-C Grid Voltage - - - - -	-70	-95	-130	Volts
D-C Grid Current - - - - -	9	13	18	Ma.
Peak R-F Grid Input Voltage - - - - -	170	195	245	Volts
Driving Power - - - - -	1.3	2.2	4.0	Watts
Grid Dissipation - - - - -	.9	1.3	2.1	Watts
Plate Power Input - - - - -	72	100	125	Watts
Plate Dissipation - - - - -	25	25	25	Watts
Plate Power Output - - - - -	47	75	100	Watts

The above figures show actual measured tube performance and do not allow for variations in circuit losses.

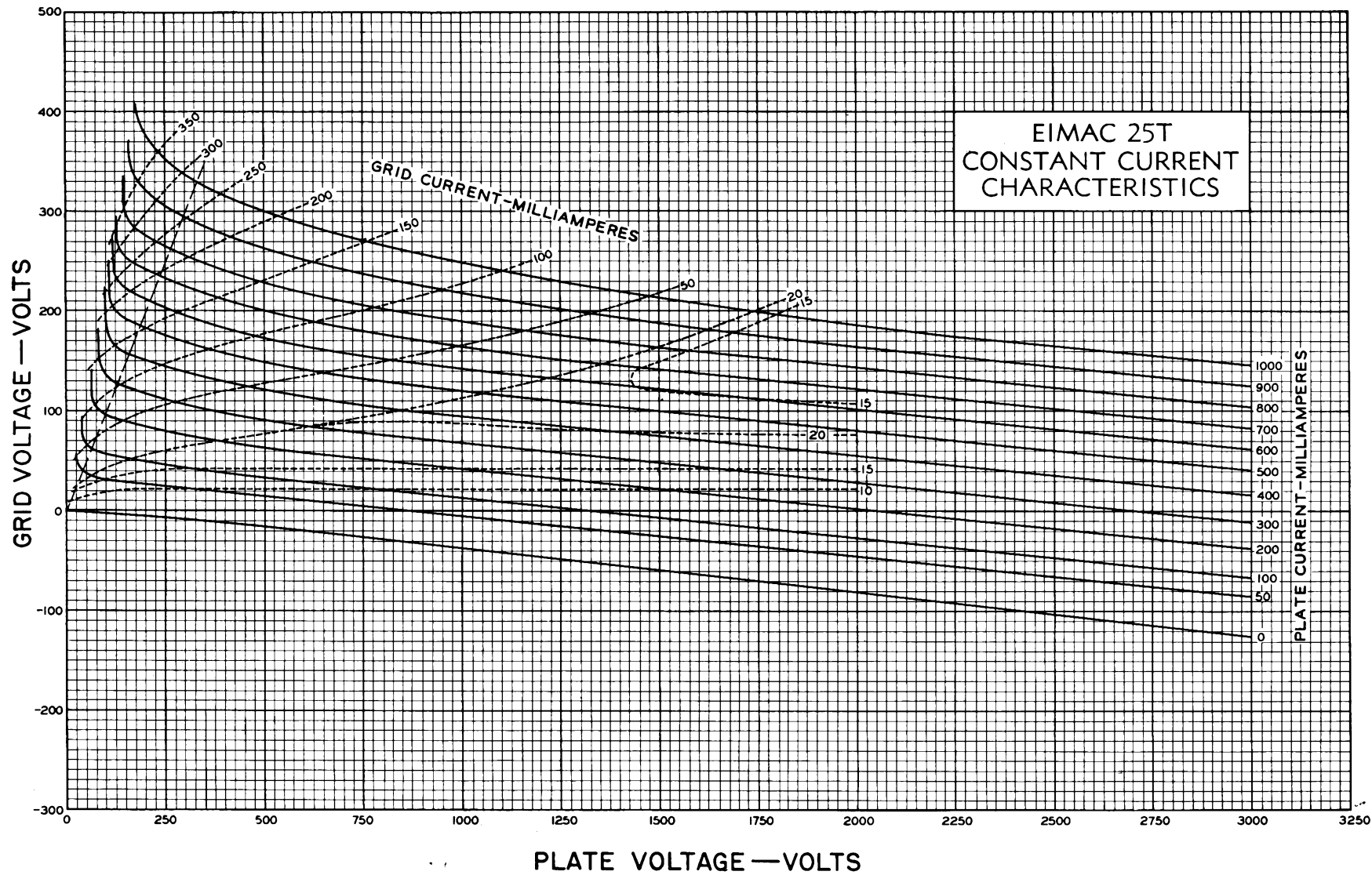

## DRIVING POWER vs. POWER OUTPUT

The three charts on this page show the relationship of plate efficiency, power output and grid driving power at plate voltages of 1000, 1500 and 2000 volts. These charts show combined grid and bias losses only. The driving power and power output figures do not include circuit losses. The plate dissipation in watts is indicated by  $P_p$ .

Points A, B, and C are identical to the typical Class C operating conditions shown on the first page under 1000, 1500, and 2000 volts respectively.

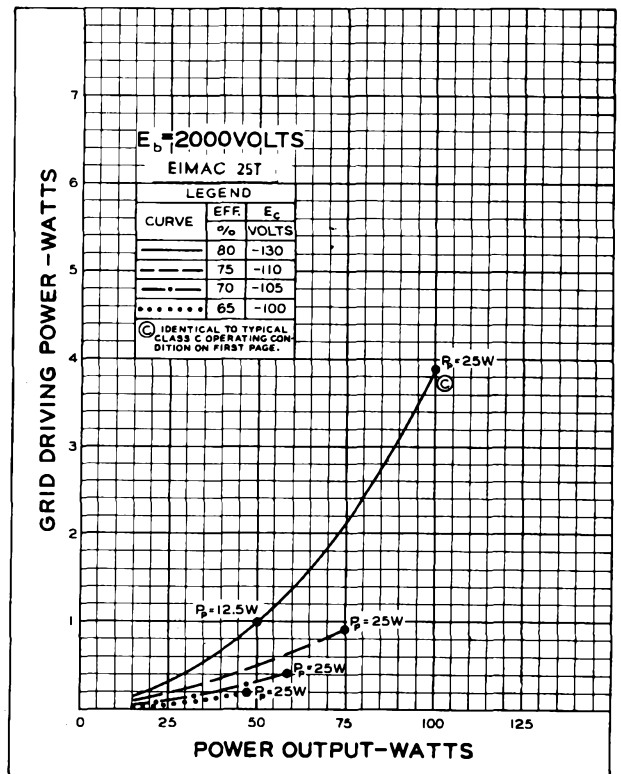
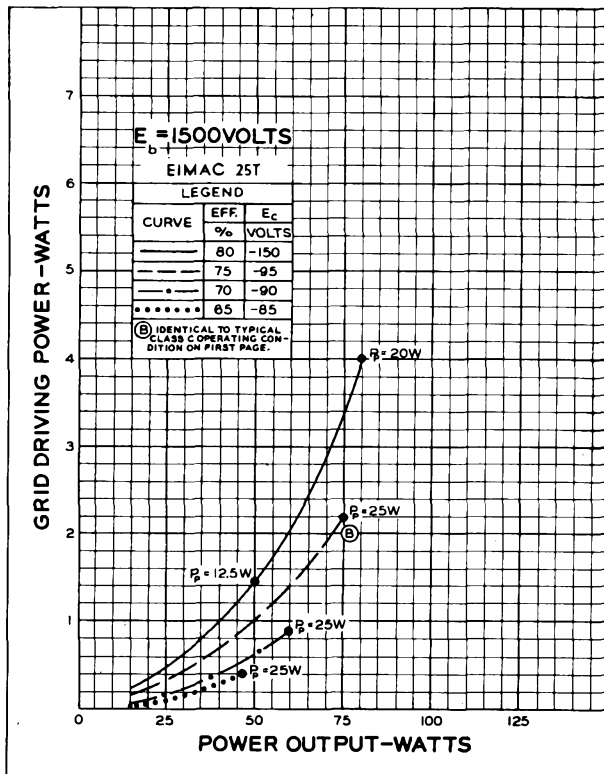
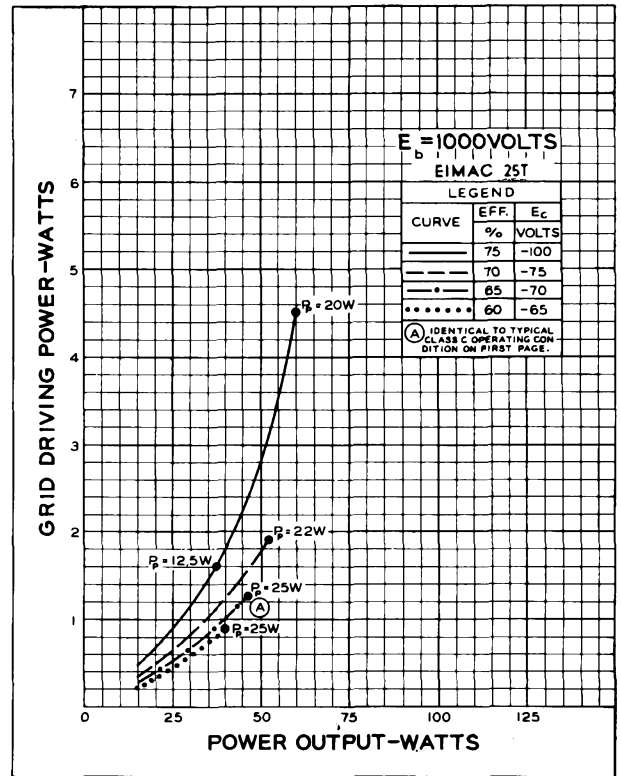

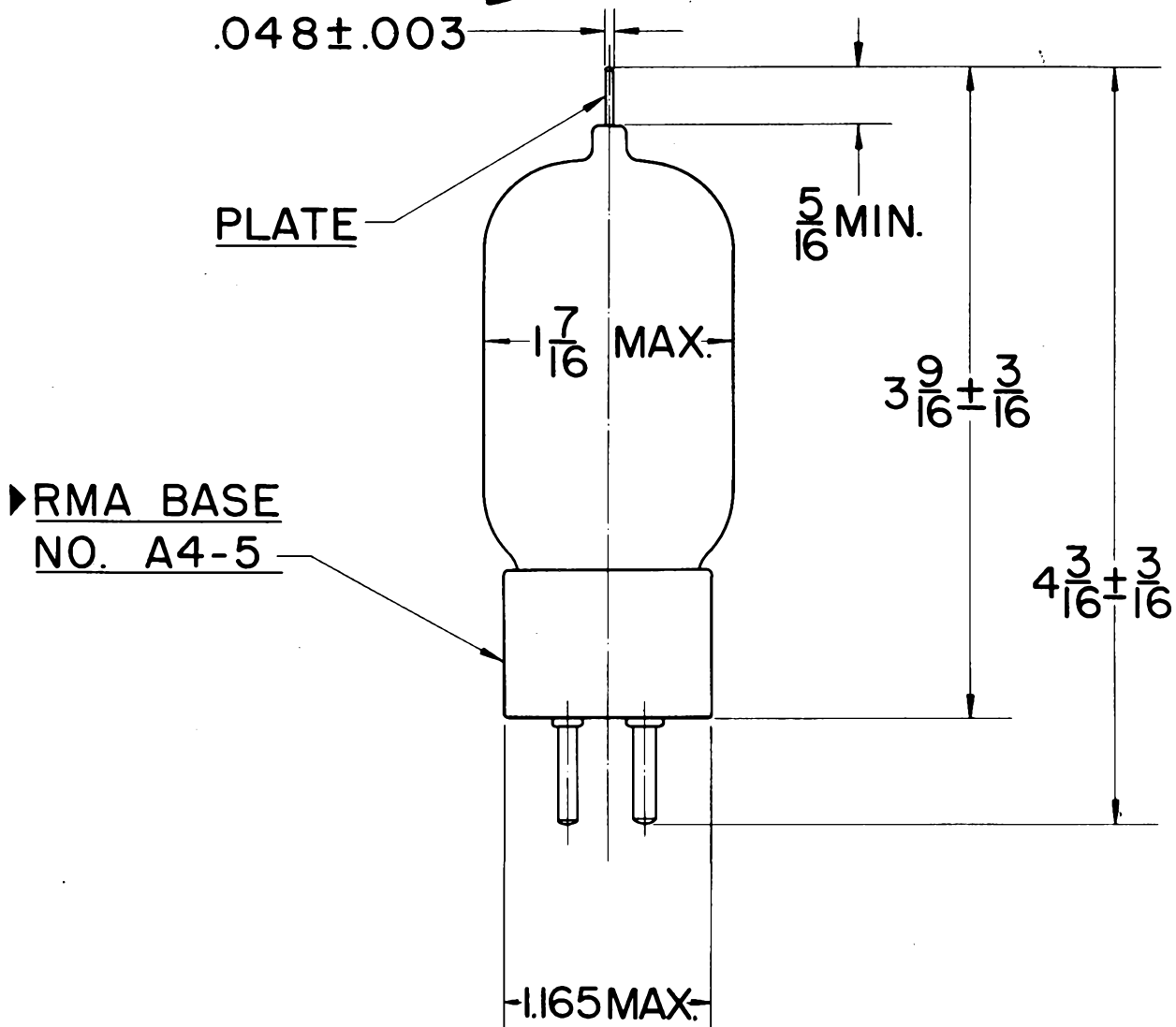

2 PINS  $.125 \pm .003$   
2 PINS  $.156 \pm .003$

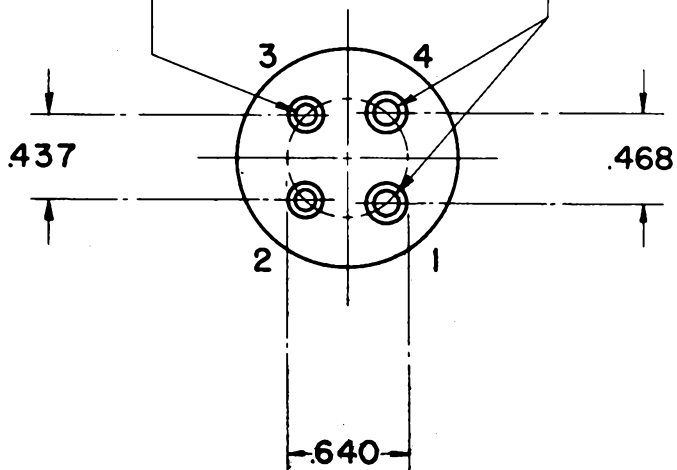
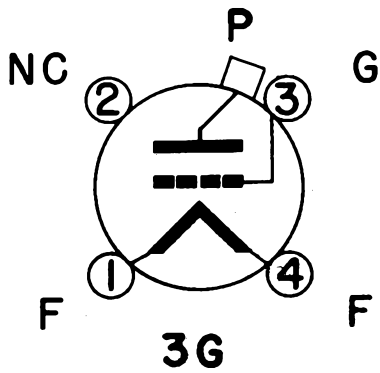



# EITEL-McCULLOUGH, INC.

SAN BRUNO, CALIFORNIA

# 35T

HIGH-MU TRIODE  
MODULATOR  
OSCILLATOR  
AMPLIFIER

▶ The Eimac 35T is a high-mu triode having a maximum plate dissipation of 50 watts. It is intended for use as an amplifier, oscillator or modulator, and can be used at its maximum ratings at frequencies up to 100 Mc.  
The 35T is cooled by radiation and by free circulation of air around the envelope. The plate operates at a visible red color at full dissipation.

## GENERAL CHARACTERISTICS

### ELECTRICAL

Filament: Thoriated tungsten		
Voltage	- - - - -	5.0 volts
Current	- - - - -	4.0 amperes
Amplification Factor (Average)	- - - - -	39
Direct Interelectrode Capacitances (Average)		
Grid-Plate	- - - - -	1.8 $\mu\text{fd}$
Grid-Filament	- - - - -	4.1 $\mu\text{fd}$
Plate-Filament	- - - - -	0.3 $\mu\text{fd}$
Transconductance ( $I_b=100 \text{ ma.}, E_b=2000\text{V}, E_c=-30\text{V}$ )	- - - - -	2850 $\mu\text{mhos}$
Frequency for Maximum Ratings	- - - - -	100 Mc.

### MECHANICAL

Base: UX Medium 4-pin. Fits E. F. Johnson Co. 122-224, or National XC-4 or CIR-4 sockets.

Basing - - - - - See outline drawing  
Mounting - - - - - Vertical, base down or up.  
Cooling - - - - - Convection and radiation.

Recommended Heat Dissipating Plate Connector - - - - -  
Maximum Overall Dimensions:

Length	- - - - -	5.5 inches
Diameter	- - - - -	1.8 inches
Net weight	- - - - -	2.5 ounces
Shipping weight (Average)	- - - - -	1.25 pounds

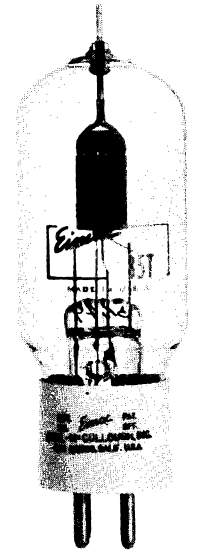

Eimac HR-3

### AUDIO FREQUENCY POWER AMPLIFIER AND MODULATOR

▶ Class-AB<sub>2</sub> (Sinusoidal wave, two tubes unless otherwise specified)

MAXIMUM RATINGS	
D-C PLATE VOLTAGE	- - - 2000 MAX. VOLTS
D-C PLATE CURRENT	- - - 150 MAX. MA.
PLATE DISSIPATION	- - - 50 MAX. WATTS
GRID DISSIPATION	- - - 15 MAX. WATTS

### TYPICAL OPERATION

D-C Plate Voltage	- - - - -	600	1000	1500	2000	Volts
D-C Grid Voltage (approx.)*	- - - - -	0	-8	-25	-40	Volts
Zero-signal D-C Plate Current	- - - - -	90	67	45	34	Ma.
Max-signal D-C Plate Current	- - - - -	300	240	200	167	Ma.
Effective Load Plate-to-Plate	- - - - -	4250	7900	16,200	27,500	Ohms
Peak A-F Input Voltage (per tube)	- - - - -	130	240	250	255	Volts
Peak Driving Power (approx.)	- - - - -	18	14	10	8	Watts
Nominal Driving Power (approx.)	- - - - -	9	7	5	4	Watts
Max-signal Plate Power Output	- - - - -	95	140	200	235	Watts

### RADIO FREQUENCY POWER AMPLIFIER AND OSCILLATOR

▶ Class-C Telegraphy or FM Telephony (Key-down conditions, per tube)<sup>1</sup>

MAXIMUM RATINGS	
D-C PLATE VOLTAGE	- - - 2000 MAX. VOLTS
D-C PLATE CURRENT	- - - 150 MAX. MA.
PLATE DISSIPATION	- - - 50 MAX. WATTS
GRID DISSIPATION	- - - 15 MAX. WATTS

### TYPICAL OPERATION

D-C Plate Voltage	- - - - -	1000	1500	2000	Volts
D-C Grid Voltage	- - - - -	-60	-120	-135	Volts
D-C Plate Current	- - - - -	125	125	125	Ma.
D-C Grid Current	- - - - -	40	40	45	Ma.
Peak R-F Grid Input Voltage	- - - - -	165	250	285	Volts
Driving Power (approx.)	- - - - -	7	9	13	Watts
Grid Dissipation	- - - - -	4.2	5.0	6.8	Watts
Plate Power Input	- - - - -	125	188	250	Watts
Plate Dissipation	- - - - -	38	47	50	Watts
Plate Power Output	- - - - -	87	141	200	Watts

### PLATE MODULATED RADIO FREQUENCY POWER AMPLIFIER

Class-C Telephony (Carrier conditions, per tube)<sup>1</sup>

MAXIMUM RATINGS	
D-C PLATE VOLTAGE	- - - 1600 MAX. VOLTS
D-C PLATE CURRENT	- - - 120 MAX. MA.
PLATE DISSIPATION	- - - 33 MAX. WATTS
GRID DISSIPATION	- - - 15 MAX. WATTS

### TYPICAL OPERATION

D-C Plate Voltage	- - - - -	750	1000	1500	Volts
D-C Grid Voltage	- - - - -	-100	-125	-150	Volts
D-C Plate Current	- - - - -	95	100	90	Ma.
D-C Grid Current	- - - - -	40	40	40	Ma.
Peak R-F Driving Voltage (approx.)	- - - - -	210	240	270	Volts
Driving Power (approx.)	- - - - -	9	10	11	Watts
Plate Dissipation	- - - - -	20	25	30	Watts
Plate Input	- - - - -	70	100	135	Watts
Plate Power Output	- - - - -	50	75	105	Watts

\*Adjust for stated zero-signal plate current.

<sup>1</sup>The performance figures listed under Typical Operation are for radio frequencies up to the VHF region and are obtained by calculation from the characteristic tube curves and confirmed by direct tests. The driving power given includes power taken by the tube grid and the bias circuit. The driving power and output power do not allow for losses in the associated resonant circuits. These losses are not included because they depend principally upon the design and choice of the circuit components.

**Simac**  
35T

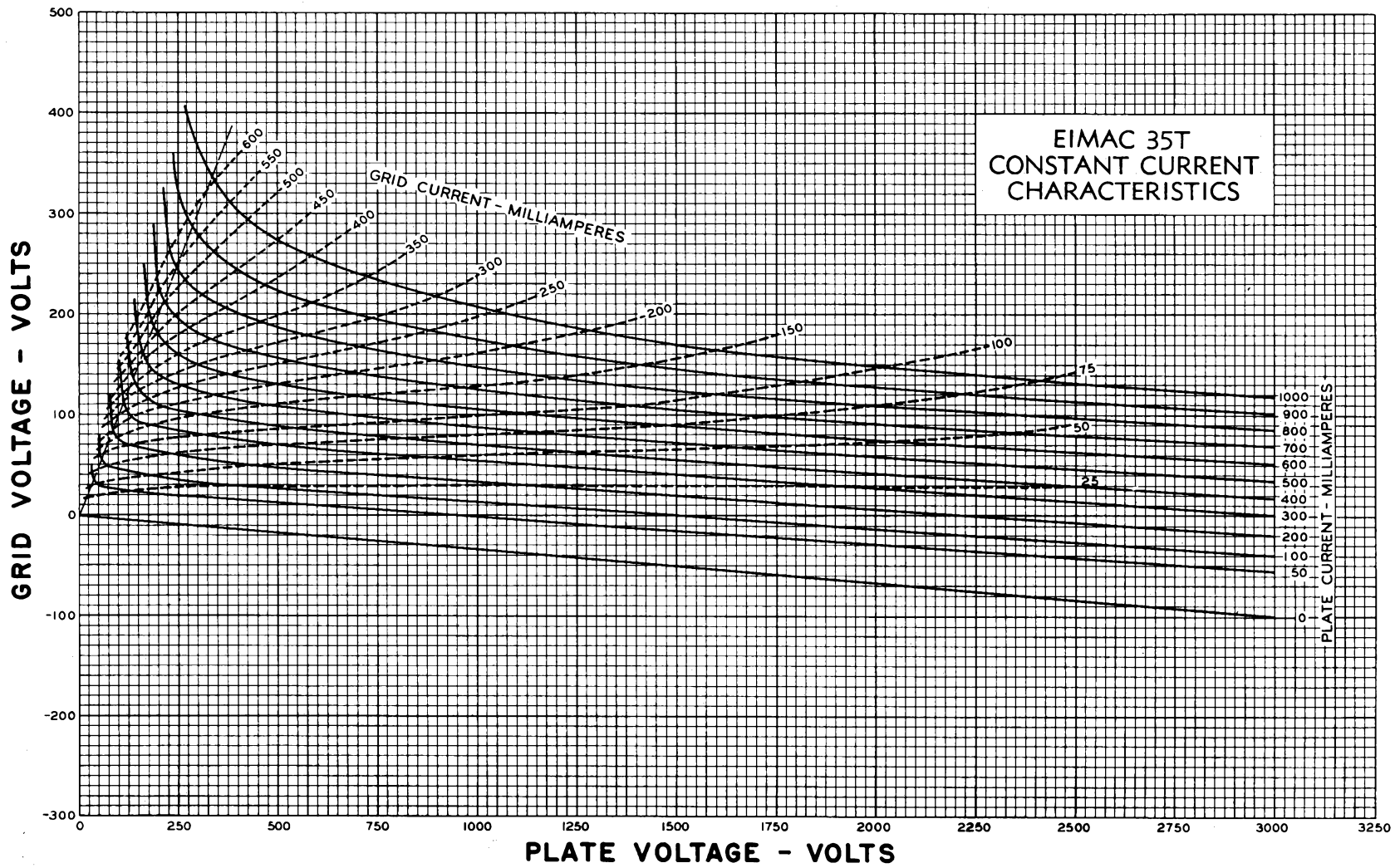

## DRIVING POWER vs. POWER OUTPUT

The three charts on this page show the relationship of plate efficiency, power output and grid driving power at plate voltages of 1000, 1500 and 2000 volts. These charts show combined grid and bias losses only. The driving power and power output figures do not include circuit losses. The plate dissipation in watts is indicated by  $P_p$ .

Points A, B, and C are identical to the typical Class C operating conditions shown on the first page under 1000, 1500, and 2000 volts respectively.

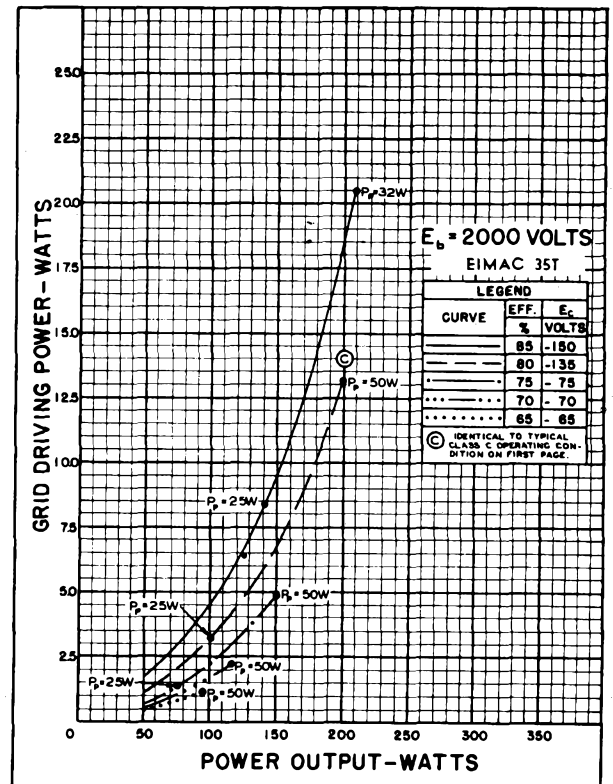
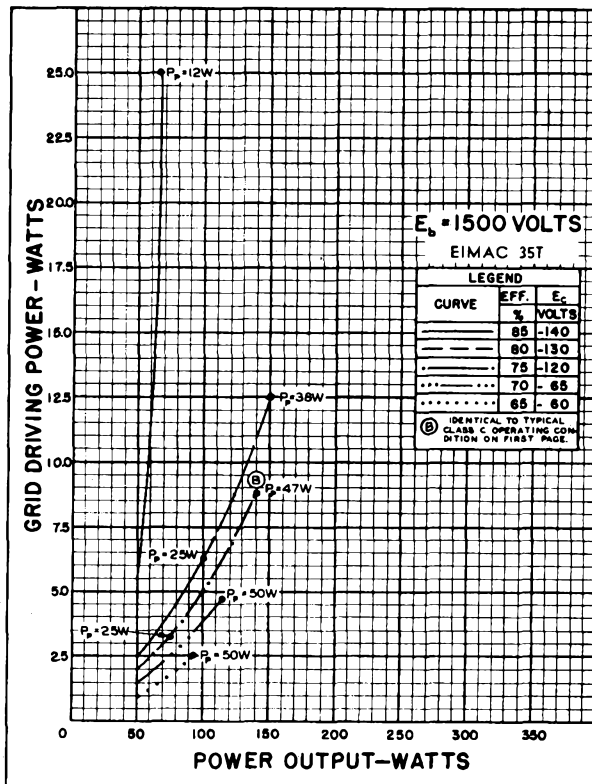
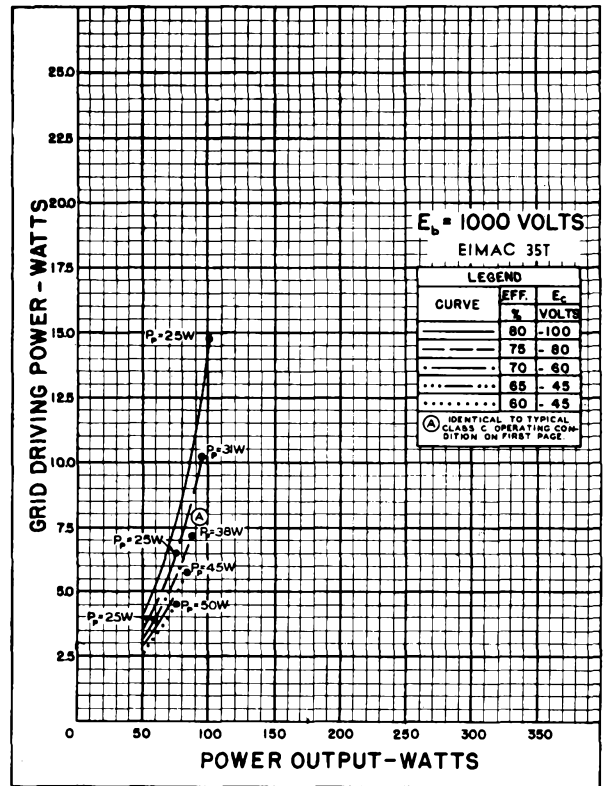

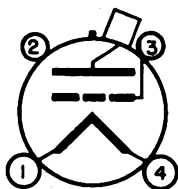
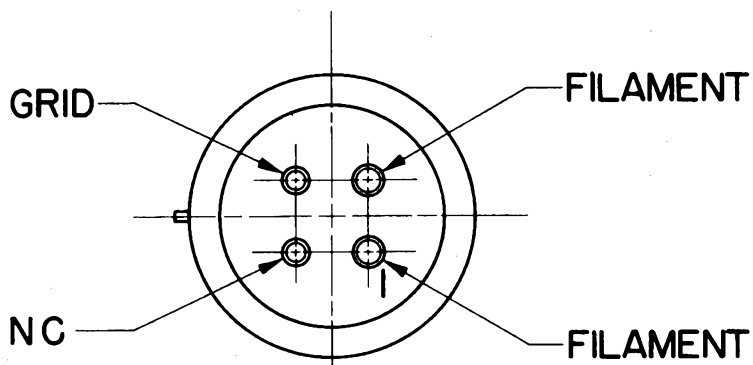
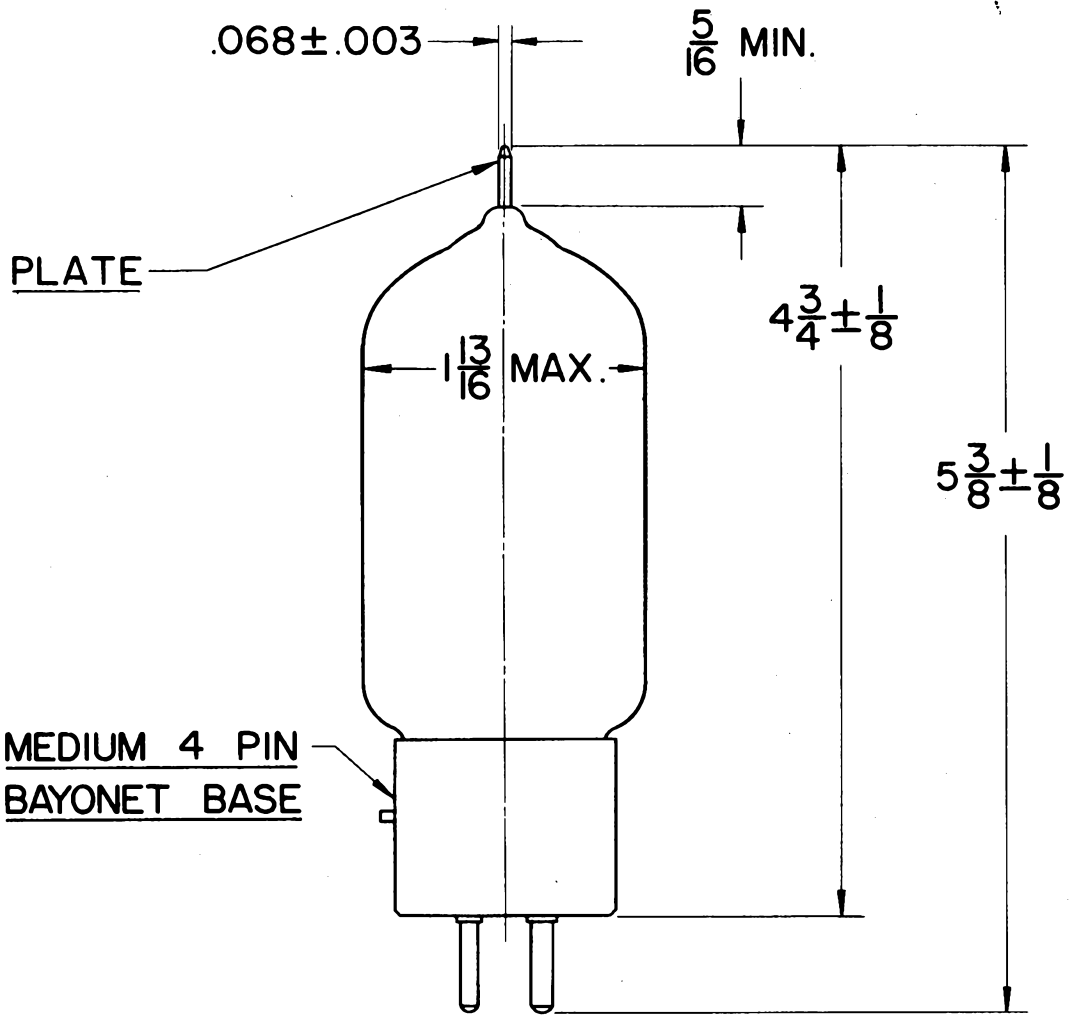

*Eimac*  
**EITEL-McCULLOUGH, INC.**  
 SAN BRUNO, CALIFORNIA

**35TG**

HIGH-MU TRIODE

MODULATOR  
 OSCILLATOR  
 AMPLIFIER

▶ The Eimac 35TG is a high-mu triode intended for use as an amplifier, oscillator, or modulator in applications particularly suited to the side grid connection. It is basically the same as the Eimac 35T except that the grid terminal is brought out at the side of the bulb. The 35TG has a maximum plate dissipation rating of 50 watts and delivers plate power output in the range of 100 to 200 watts at plate voltages of 1000 to 2000 volts. The tube can be operated at maximum ratings up to 100 Mc. Cooling is by radiation and the free circulation of air.

The 35TG in class-C r-f service will deliver up to 200 watts plate power output with 13 watts driving power. Two 35TG's in class-AB<sub>1</sub> modulator service will deliver up to 235 watts maximum signal plate power output with 8 watts driving power.

**GENERAL CHARACTERISTICS**

**ELECTRICAL**

Filament: Thoriated tungsten	
Voltage	5.0 volts
Current	4.0 amperes
Amplification factor (Average)	39
▶ Direct Interelectrode Capacitances (Average)	
Grid-Plate	1.6 $\mu\mu\text{fd}$
Grid-Filament	2.5 $\mu\mu\text{fd}$
Plate-Filament	0.25 $\mu\mu\text{fd}$
Transconductance ( $I_b=100$ ma., $E_b=2000$ v., $E_c=-30$ v.)	2850 $\mu\text{mhos}$
Frequency for Maximum Ratings	100 Mc.

▶ **MECHANICAL**

Base: Medium 4-pin bayonet. Fits E. F. Johnson Co. 122-224, National XC-4 or CIR-4 sockets, or equivalent.

Basing	See outline drawing
Mounting Position	Vertical, base down or up.
Cooling	Convection and radiation.
Recommended Heat Dissipating Plate and Grid Connectors	Eimac HR-3
Maximum Overall Dimensions:	
Length	5.5 inches
Diameter	1.8 inches
Net Weight	2.5 ounces
Shipping Weight (Average)	1.25 pounds

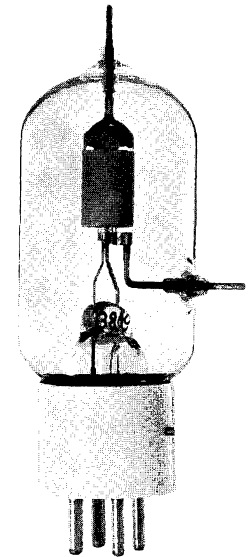

▶ **RADIO FREQUENCY POWER AMPLIFIER AND OSCILLATOR**

Class-C Telephony or FM Telephony  
 (Key-down conditions, per tube)

MAXIMUM RATINGS (Frequencies up to 100 Mc)

D-C PLATE VOLTAGE	2000 MAX. VOLTS
D-C PLATE CURRENT	150 MAX. MA
PLATE DISSIPATION	50 MAX. WATTS
GRID DISSIPATION	15 MAX. WATTS

TYPICAL OPERATION (Frequencies up to 30 Mc)<sup>1</sup>

D-C Plate Voltage	1000	1500	2000	Volts
D-C Grid Voltage	-60	-120	-135	Volts
D-C Plate Current	125	125	125	Ma
D-C Grid Current (approx.)	40	40	45	Ma
Peak R-F Grid Input Voltage (approx.)	165	250	285	Volts
Driving Power (approx.)	7	9	13	Watts
Grid Dissipation	4.2	5.0	6.8	Watts
Plate Dissipation	38	47	50	Watts
Plate Power Input	125	188	250	Watts
Plate Power Output	87	141	200	Watts

<sup>1</sup>The performance figures listed under Typical Operation are for radio frequencies up to the VHF region and are obtained by calculation from the characteristic tube curves and confirmed by direct tests. The driving power given includes power taken by the tube grid and the bias circuit. The driving power and output power do not allow for losses in the associated resonant circuits. These losses are not included because they depend principally upon the design and choice of the circuit components.

IF IT IS DESIRED TO OPERATE THIS TUBE UNDER CONDITIONS WIDELY DIFFERENT FROM THOSE GIVEN UNDER "TYPICAL OPERATION", AND WHICH POSSIBLY EXCEED MAXIMUM RATINGS, WRITE EITEL-McCULLOUGH, INC., FOR INFORMATION AND RECOMMENDATIONS.

## ▶ AUDIO FREQUENCY POWER AMPLIFIER OR MODULATOR

Class-AB<sub>2</sub>

MAXIMUM RATINGS (Per tube)

D-C PLATE VOLTAGE	- - -	2000 MAX. VOLTS
D-C PLATE CURRENT	- - -	150 MAX. MA
PLATE DISSIPATION	- - -	50 MAX. WATTS
GRID DISSIPATION	- - -	15 MAX. WATTS

TYPICAL OPERATION (Sinusoidal wave, two tubes unless otherwise specified)

D-C Plate Voltage	- - -	600	1000	1500	2000	Volts
D-C Grid Voltage (approx.)*	- - -	0	-8	-25	-40	Volts
Zero-Signal D-C Plate Current	- - -	90	67	45	34	Ma
Max-Signal D-C Plate Current	- - -	300	240	200	167	Ma
Effective Load Plate-to-Plate	- - -	4250	7900	16,200	27,500	Ohms
Peak A-F Grid Input Voltage (per tube)	- - -	115	120	125	130	Volts
Peak Driving Power (approx.)	- - -	18	14	10	8	Watts
Nominal Driving Power (approx.)	- - -	9	7	5	4	Watts
Max-Signal Plate Power Output	- - -	95	140	200	235	Watts

\*Adjust for stated zero-signal plate current.

## ▶ PLATE MODULATED RADIO FREQUENCY POWER AMPLIFIER

Class-C Telephony (Carrier conditions, per tube)

MAXIMUM RATINGS (Frequencies up to 100 Mc)

D-C PLATE VOLTAGE	- - -	1600 MAX. VOLTS
D-C PLATE CURRENT	- - -	120 MAX. MA
PLATE DISSIPATION	- - -	33 MAX. WATTS
GRID DISSIPATION	- - -	15 MAX. WATTS

TYPICAL OPERATION (Frequencies up to 30 Mc)<sup>1</sup>

D-C Plate Voltage	- - -	750	1000	1500	Volts
D-C Grid Voltage	- - -	-100	-125	-150	Volts
D-C Plate Current	- - -	95	100	90	Ma
D-C Grid Current (approx.)	- - -	40	40	40	Ma
Peak R-F Grid Input Voltage (approx.)	- - -	210	240	270	Volts
Driving Power (approx.)	- - -	9	10	11	Watts
Plate Dissipation	- - -	20	25	30	Watts
Plate Power Input	- - -	70	100	135	Watts
Plate Power Output	- - -	50	75	105	Watts

<sup>1</sup>The performance figures listed under Typical Operation are for radio frequencies up to the VHF region and are obtained by calculation from the characteristic tube curves and confirmed by direct tests. The driving power given includes power taken by the tube grid and the bias circuit. The driving power and output power do not allow for losses in the associated resonant circuits. These losses are not included because they depend principally upon the design and choice of the circuit components.

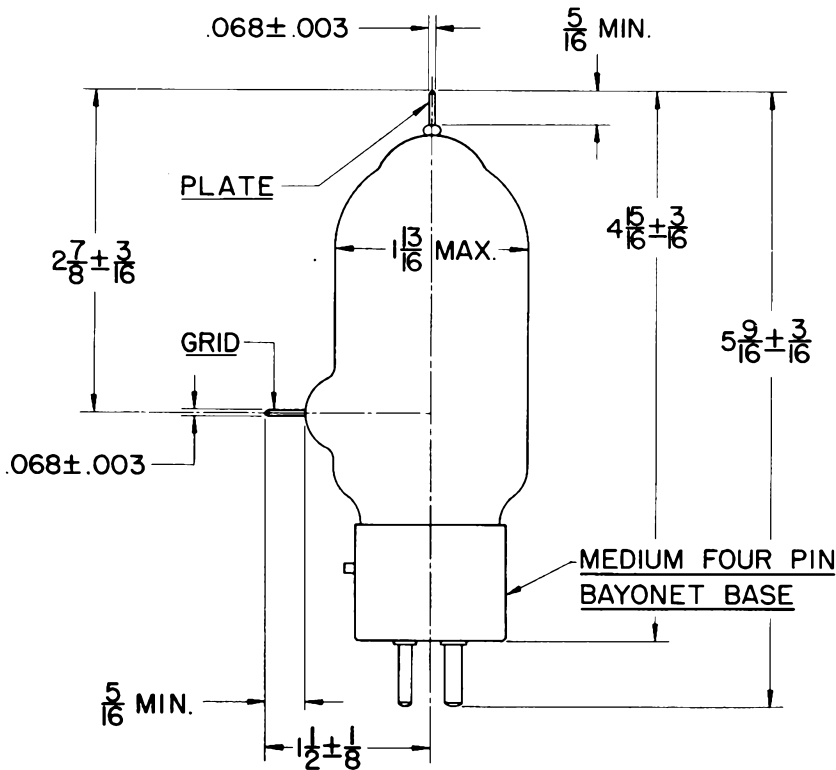

ALL DIMENSIONS IN INCHES

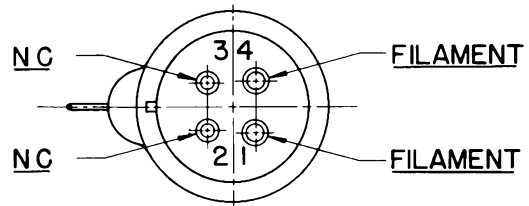
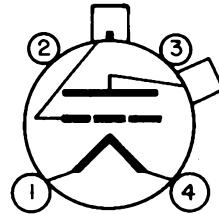

BOTTOM VIEW

## DRIVING POWER vs. POWER OUTPUT

The three charts on this page show the relationship of plate efficiency, power output and grid driving power at plate voltages of 1000, 1500 and 2000 volts. These charts show combined grid and bias losses only. The driving power and power output figures do not include circuit losses. The plate dissipation in watts is indicated by  $P_p$ .

Points A, B, and C are identical to the typical Class C operating conditions shown on the first page under 1000, 1500, and 2000 volts respectively.

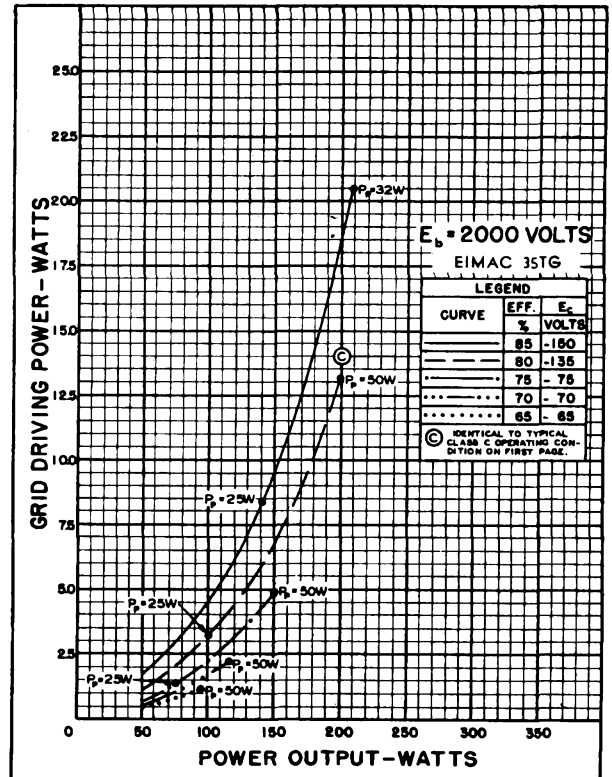
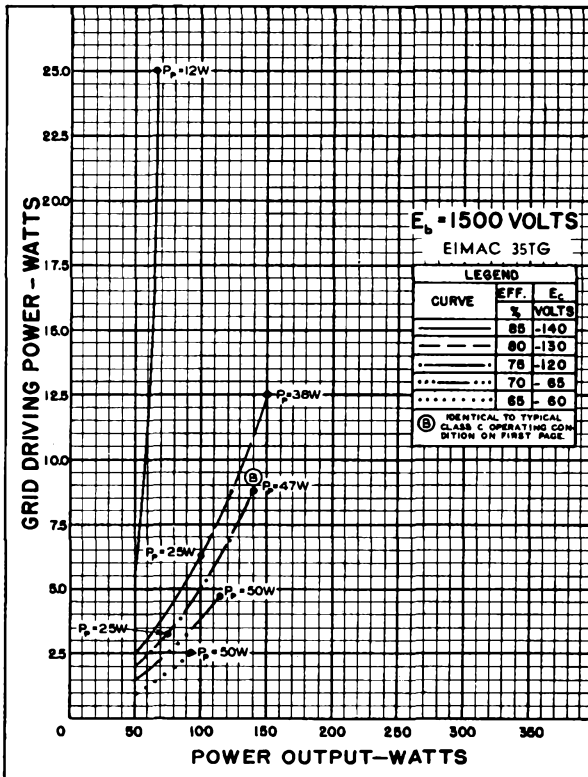
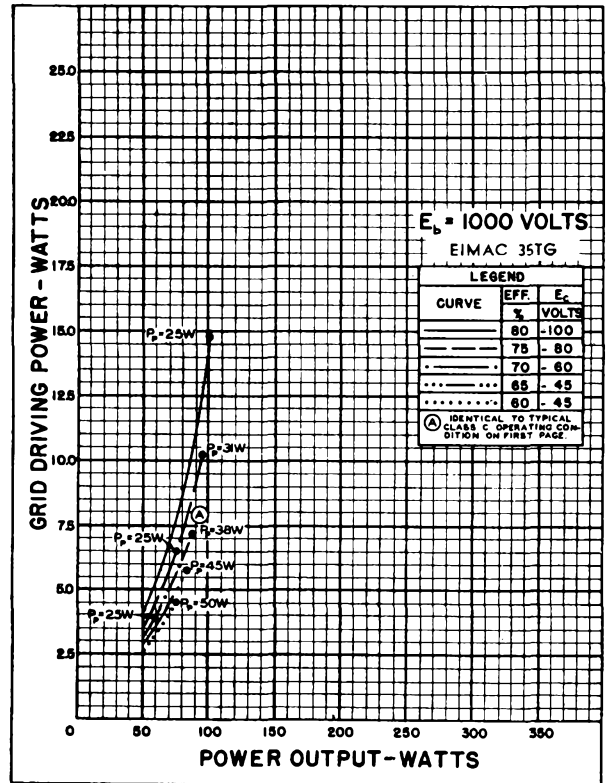



35TG

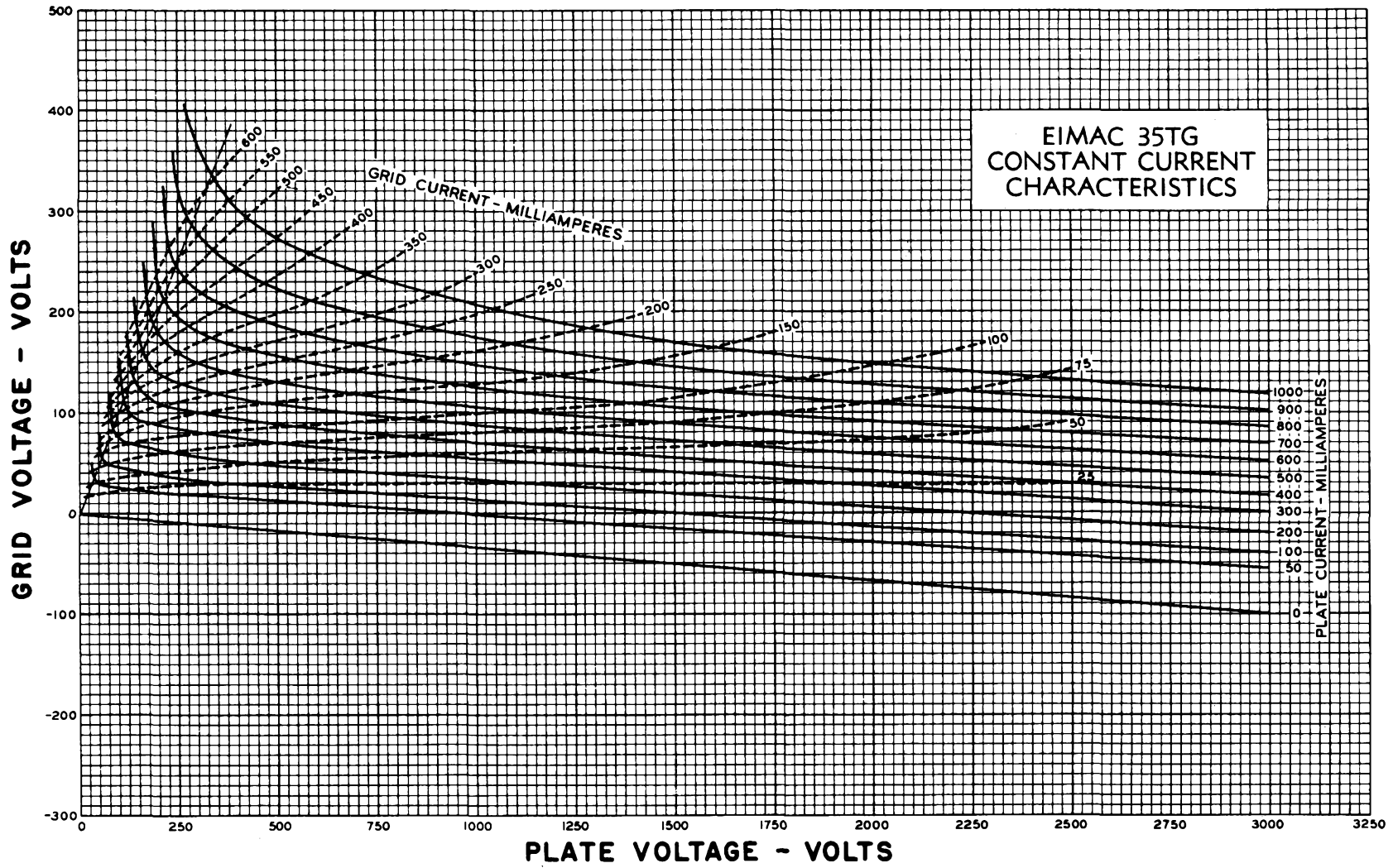



# EITEL-McCULLOUGH, INC.

SAN BRUNO, CALIFORNIA

# 75TH

MEDIUM-MU TRIODE  
MODULATOR  
OSCILLATOR  
AMPLIFIER

► The Eimac 75TH is a medium-mu power triode intended for use as an amplifier, oscillator, or modulator. It has a maximum plate dissipation rating of 75 watts and a maximum plate voltage rating of 3000 volts at frequencies up to 40 Mc. Forced-air cooling is not required in properly designed equipment operating at frequencies below 40 Mc.

The 75TH in Class-C R-F service will deliver up to 225 watts plate power output with 10 watts driving power. Two 75TH's in Class-B modulator service will deliver up to 300 watts maximum-signal plate power output with 3 watts driving power.

## GENERAL CHARACTERISTICS

### ELECTRICAL

Filament: Thoriated Tungsten	
Voltage - - - - -	5.0 volts
Current - - - - -	6.25 amperes
Amplification Factor (Average) - - - - -	20
Direct Interelectrode Capacitances (Average)	
Grid-Plate - - - - -	2.3 $\mu\mu\text{f}$
Grid-Filament - - - - -	2.7 $\mu\mu\text{f}$
Plate-Filament - - - - -	0.3 $\mu\mu\text{f}$
Transconductance ( $I_b=225$ ma., $E_b=3000$ v.) - - - - -	4150 $\mu\text{mhos}$
Highest Frequency for Maximum Ratings - - - - -	40 Mc

### MECHANICAL

Base - - - - -	Medium 4-pin bayonet
Basing - - - - -	See outline drawing
Socket - - - - -	Johnson type No. 122-224, National type No. XC-4 or CIR-4, or equivalent
Mounting Position - - - - -	Vertical, base down or up
Cooling - - - - -	Convection and radiation
Maximum Temperature of Plate and Grid Seals - - - - -	225°C
Recommended Heat Dissipating Connectors:	
Plate - - - - -	Eimac HR-3
Grid - - - - -	Eimac HR-2
Maximum Overall Dimensions:	
Length - - - - -	7.25 inches
Diameter - - - - -	2.81 inches
Net Weight - - - - -	3 ounces
Shipping Weight (Average) - - - - -	1.5 pounds

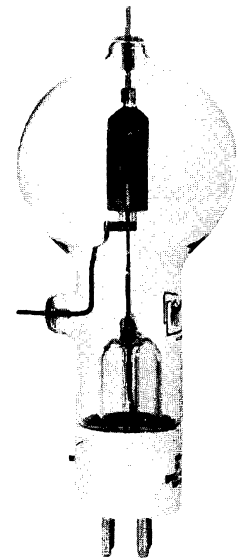

### RADIO FREQUENCY POWER AMPLIFIER AND OSCILLATOR

Class-C Telephony (Key-down conditions, 1 tube)

MAXIMUM RATINGS (Frequencies up to 40 Mc.)	
D-C PLATE VOLTAGE - - - - -	3000 MAX. VOLTS
D-C PLATE CURRENT - - - - -	225 MAX. MA.
PLATE DISSIPATION - - - - -	75 MAX. WATTS
GRID DISSIPATION - - - - -	16 MAX. WATTS

#### TYPICAL OPERATION (Frequencies up to 40 Mc.)

D-C Plate Voltage - - - - -	1000	1500	2000	volts
D-C Grid Voltage - - - - -	-80	-125	-200	volts
D-C Plate Current - - - - -	215	167	150	ma.
D-C Grid Current (approx.) - - - - -	35	23	32	ma.
► Peak R-F Grid Input Voltage (approx.) - - - - -	270	280	350	volts
Driving Power (approx.) - - - - -	9	6	10	watts
Plate Power Input - - - - -	215	250	300	watts
Plate Dissipation - - - - -	75	75	75	watts
Plate Power Output - - - - -	140	175	225	watts

### PLATE MODULATED RADIO FREQUENCY AMPLIFIER

Class-C Telephony (Carrier conditions, per tube)

MAXIMUM RATINGS (Frequencies up to 40 Mc.)	
D-C PLATE VOLTAGE - - - - -	2400 MAX. VOLTS
D-C PLATE CURRENT - - - - -	180 MAX. MA.
PLATE DISSIPATION - - - - -	50 MAX. WATTS
GRID DISSIPATION - - - - -	16 MAX. WATTS

#### TYPICAL OPERATION (Frequencies up to 40 Mc.)

D-C Plate Voltage - - - - -	1000	1500	2000	volts
D-C Grid Voltage - - - - -	-150	-200	-300	volts
D-C Plate Current - - - - -	135	115	110	ma.
D-C Grid Current (approx.) - - - - -	20	14	15	ma.
► Peak R-F Grid Input Voltage (approx.) - - - - -	300	330	440	volts
Driving Power (approx.) - - - - -	6	5	6	watts
Grid Dissipation - - - - -	3	2	2	watts
Plate Power Input - - - - -	135	175	220	watts
Plate Dissipation - - - - -	50	50	50	watts
Plate Power Output - - - - -	85	125	170	watts

### AUDIO FREQUENCY POWER AMPLIFIER AND MODULATOR

Class-B

MAXIMUM RATINGS (Per tube)	
D-C PLATE VOLTAGE - - - - -	3000 MAX. VOLTS
MAX-SIGNAL D-C PLATE CURRENT - - - - -	225 MAX. MA.
PLATE DISSIPATION - - - - -	75 MAX. WATTS
GRID DISSIPATION - - - - -	16 MAX. WATTS

#### TYPICAL OPERATION (Sinusoidal wave, two tubes unless otherwise specified)

D-C Plate Voltage - - - - -	1000	1500	2000	volts
► D-C Grid Voltage (approx.) <sup>1</sup> - - - - -	-30	-60	-90	volts
D-C Plate Current - - - - -	90	67	50	ma.
Max-Signal D-C Plate Current - - - - -	350	267	225	ma.
Effective Load, Plate-to-Plate - - - - -	5300	11,400	19,300	ohms
Peak A-F Grid Input Voltage (per tube) - - - - -	175	165	175	volts
Max-Signal Driving Power (approx.) - - - - -	7	4	3	watts
Max-Signal Plate Dissipation (per tube) - - - - -	75	75	75	watts
Max-Signal Plate Power Output - - - - -	200	250	300	watts
► Total Harmonic Distortion - - - - -	1.5	2.0	2.0	per cent

<sup>1</sup>Adjust to give stated zero-signal plate current.

IF IT IS DESIRED TO OPERATE THIS TUBE UNDER CONDITIONS WIDELY DIFFERENT FROM THOSE GIVEN UNDER "TYPICAL OPERATION", POSSIBLY EXCEEDING MAXIMUM RATINGS, WRITE EITEL-McCULLOUGH, INC., FOR INFORMATION AND RECOMMENDATIONS.

**APPLICATION**

**MECHANICAL**

**Mounting**—The 75TH must be mounted vertically, base down or up. The plate and grid leads should be flexible. The tube must be protected from vibration and shock.

**Cooling**—Heat Dissipating Connectors (Eimac HR-3 and HR-2) should be used at the plate and grid terminals of the 75TH. If the free circulation of air around the tube is restricted, a small fan or centrifugal blower should be used to provide additional cooling for the plate and grid seals.

Cooling requirements will be met if the temperature of the plate and grid seals is not allowed to exceed 225°C. One method of measuring these temperatures is provided by the use of "Tempilaq", a temperature-sensitive lacquer available from the Tempil Corporation, New York 11, N.Y.

**ELECTRICAL**

**Filament Voltage**—For maximum tube life the filament voltage, as measured directly at the base pins, should be the rated value of 5.0 volts. Variations must be kept within the range of 4.75 to 5.25 volts.

**Bias Voltage**—Although there is no maximum limit on the bias voltage which may be used on the 75TH, there is little advantage in using bias voltages in excess of those given under "Typical Operation," except in certain very specialized applications. Where bias is obtained by a grid leak, suitable protective means must be provided to prevent excessive plate dissipation in the event of loss of excitation.

**Plate Voltage**—The plate-supply voltage for the 75TH should not exceed 3000 volts. In most cases there is little advantage in using plate-supply voltages higher than those given under "Typical Operation" for the power output desired.

**Grid Dissipation**—The power dissipated by the grid of the 75TH must not exceed 16 watts. Grid dissipation may be calculated from the following expression:

$$P_g = e_{cmp} I_c$$

where  $P_g$  = Grid dissipation,

$e_{cmp}$  = Peak positive grid voltage, and

$I_c$  = D-c grid current.

$e_{cmp}$  may be measured by means of a suitable peak voltmeter connected between filament and grid<sup>1</sup>. In equipment in which the plate loading varies widely, such as oscillators used for radio-frequency heating, care should be taken to make certain that the grid dissipation does not exceed the maximum rating under any condition of loading.

**Plate Dissipation**—The plate of the 75TH operates at a visibly red temperature at its maximum rated dissipation of 75 watts. Plate dissipation in excess of the maximum rating is permissible only for short periods of time, such as during tuning procedures.

<sup>1</sup> For suitable peak v.t.v.m. circuits see, for instance, "Vacuum Tube Ratings", Eimac News, January, 1945. This article is available in reprint form on request.

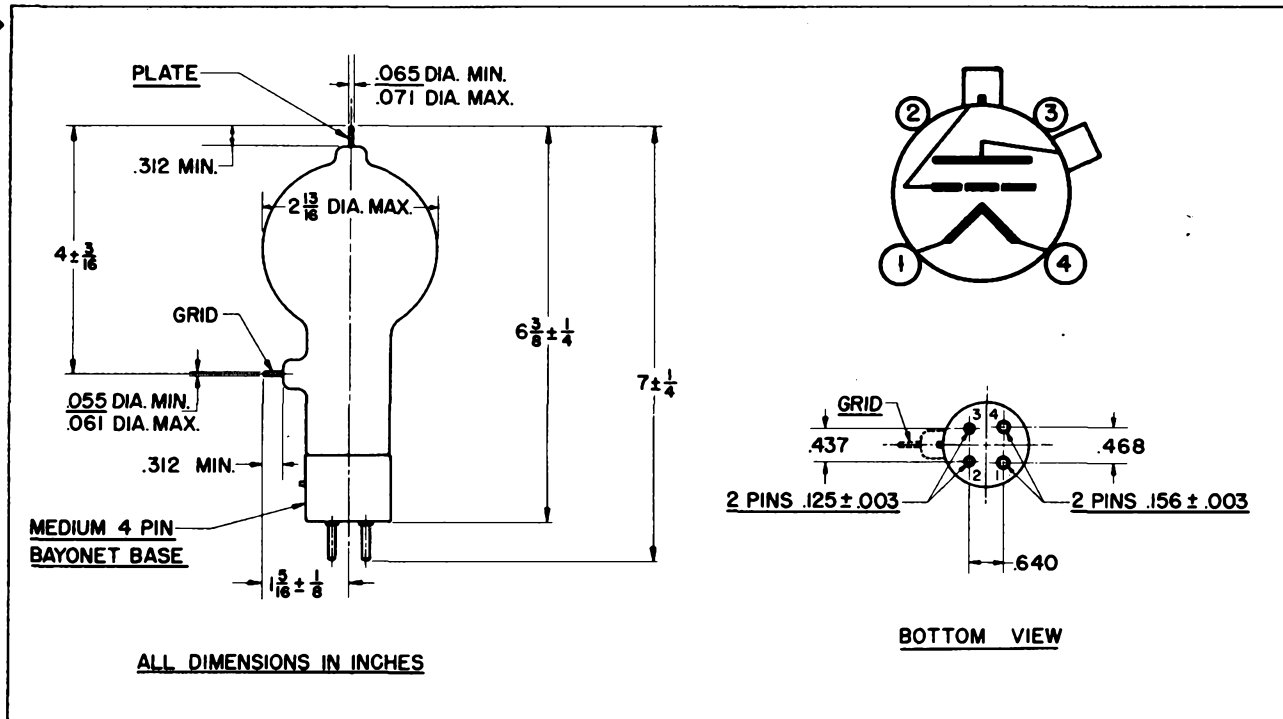

► Indicates change from sheet dated 7-1-44.

## DRIVING POWER vs. POWER OUTPUT

The three charts on this page show the relationship of plate efficiency, power output and grid driving power at plate voltages of 1000, 1500 and 2000 volts. These charts show combined grid and bias losses only. The driving power and power output figures do not include circuit losses. The plate dissipation in watts is indicated by  $P_p$ .

Points A, B, and C are identical to the typical Class C operating conditions shown on the first page under 1000, 1500, and 2000 volts respectively.

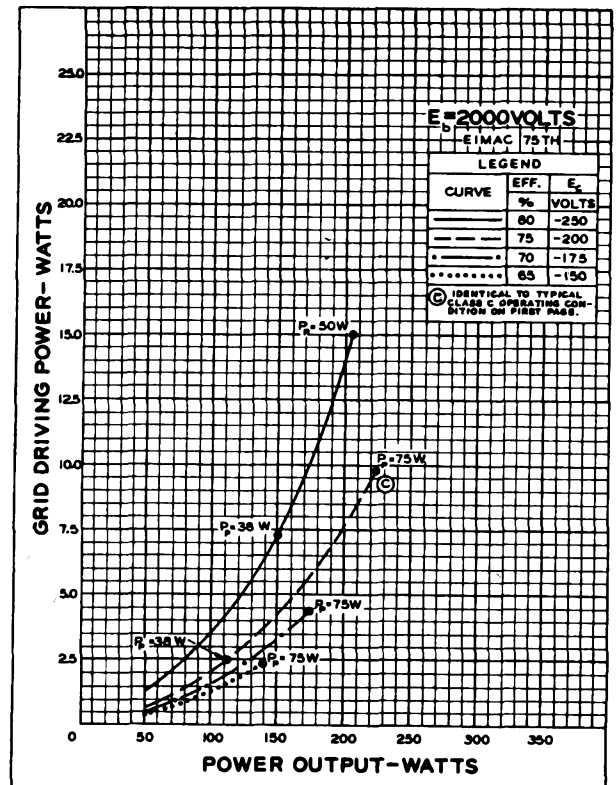
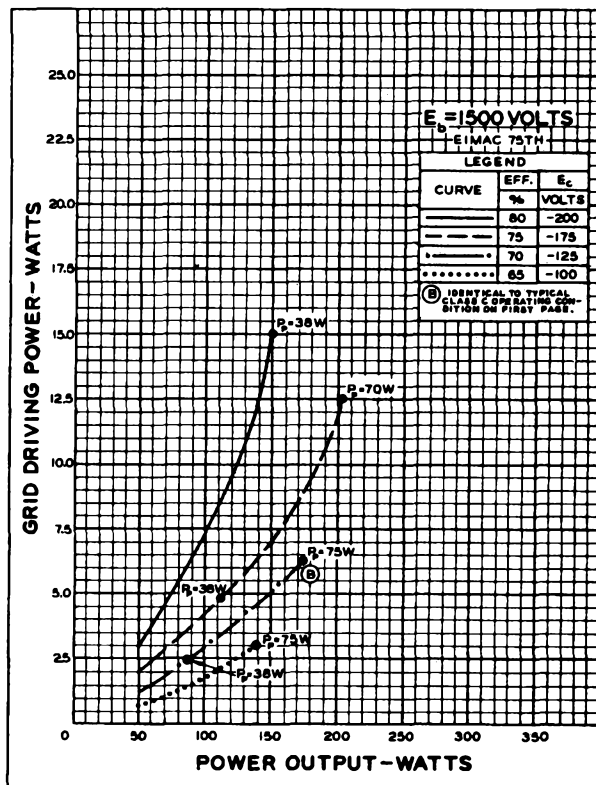
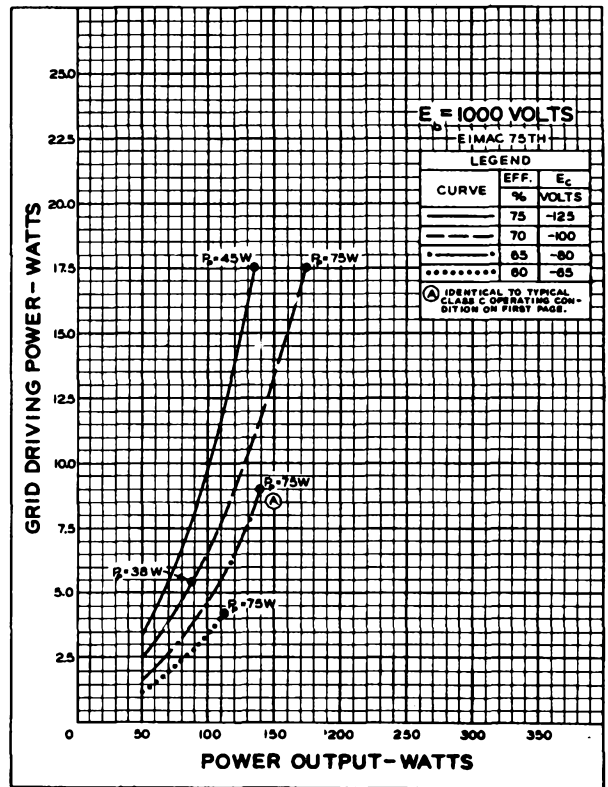

**Eimac**  
75TH

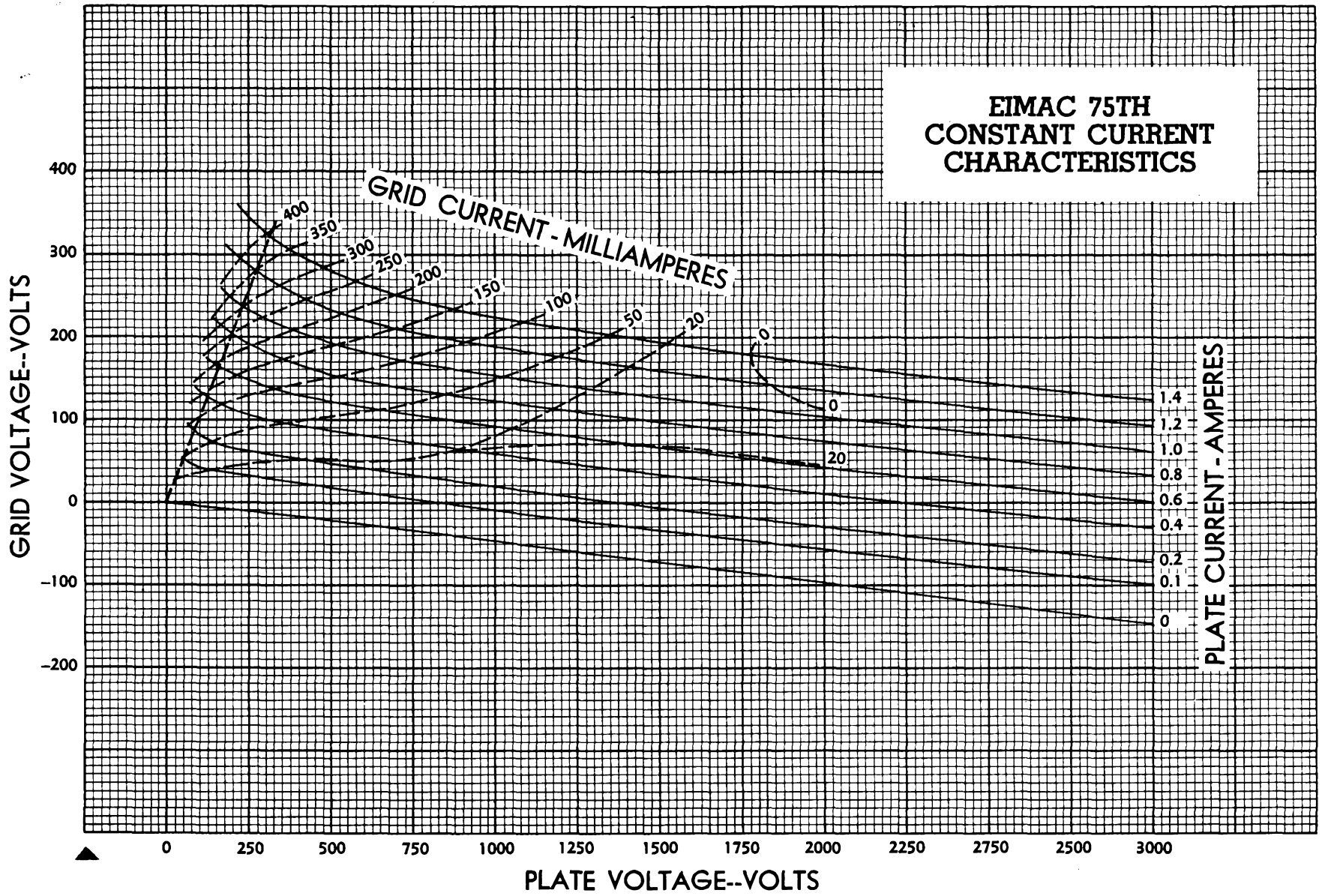

▲ Indicates change from sheet dated 7-1-44.  
Printed in U. S. A. 4-G-1-55522

# EITEL-McCULLOUGH, INC.

SAN BRUNO, CALIFORNIA

# 75TL

LOW-MU TRIODE  
 MODULATOR  
 OSCILLATOR  
 AMPLIFIER

The Eimac 75TL is a low-mu power triode intended for use as an amplifier, oscillator, or modulator. It has a maximum plate dissipation rating of 75 watts and a maximum plate voltage rating of 3000 volts at frequencies up to 40 Mc. Forced-air cooling is not required in properly designed equipment operating at frequencies below 40 Mc.

The 75TL in Class-C R-F service will deliver up to 225 watts plate power output with 8 watts driving power. Two 75TL's in Class-B modulator service will deliver up to 350 watts maximum-signal plate power output with 5 watts driving power.

## GENERAL CHARACTERISTICS

### ELECTRICAL

Filament: Thoriated tungsten		
Voltage	5.0	volts
Current	6.25	amperes
Amplification Factor (Average)	12	
Direct Interelectrode Capacitances (Average)		
Grid-Plate	2.4	$\mu\mu\text{f}$
Grid-Filament	2.6	$\mu\mu\text{f}$
Plate-Filament	0.4	$\mu\mu\text{f}$
Transconductance ( $I_b=225$ ma., $E_b=2500$ v.)	3350	$\mu\text{mhos}$
Highest Frequency for Maximum Ratings	40	Mc.

### MECHANICAL

Base	Medium 4-pin bayonet
Basing	See outline drawing
Socket	Johnson type No. 122-224, National type No. XC-4 or CIR-4, or equivalent
Mounting Position	
Cooling	Vertical, base down or up Convection and radiation
Maximum Temperature of Plate and Grid Seals	225°C
Recommended Heat Dissipating Connectors:	
Plate	Eimac HR-3
Grid	Eimac HR-2
Maximum Overall Dimensions:	
Length	7.25 inches
Diameter	2.81 inches
Net Weight	3 ounces
Shipping Weight (Average)	1.5 pounds

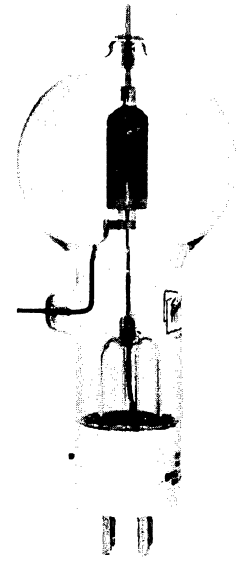

### RADIO FREQUENCY POWER AMPLIFIER AND OSCILLATOR

Class-C Telegraphy (Key-down conditions, 1 tube)

MAXIMUM RATINGS (Frequencies up to 40 Mc.)

D-C PLATE VOLTAGE	3000 MAX. VOLTS
D-C PLATE CURRENT	225 MAX. MA.
PLATE DISSIPATION	75 MAX. WATTS
GRID DISSIPATION	13 MAX. WATTS

TYPICAL OPERATION (Frequencies up to 40 Mc.)

D-C Plate Voltage	1000	1500	2000	volts
D-C Grid Voltage	-150	-250	-300	volts
D-C Plate Current	215	167	150	ma.
D-C Grid Current	28	22	21	ma.
Peak R-F Grid Input Voltage (approx.)	320	355	425	volts
Driving Power (approx.)	8	6	8	watts
Plate Power Input	215	250	300	watts
Plate Dissipation	75	75	75	watts
Plate Power Output	140	175	225	watts

### PLATE MODULATED RADIO FREQUENCY AMPLIFIER

Class-C Telephony (Carrier conditions, per tube)

MAXIMUM RATINGS (Frequencies up to 40 Mc.)

D-C PLATE VOLTAGE	2400 MAX. VOLTS
D-C PLATE CURRENT	180 MAX. MA.
PLATE DISSIPATION	50 MAX. WATTS
GRID DISSIPATION	16 MAX. WATTS

TYPICAL OPERATION (Frequencies up to 40 Mc.)

D-C Plate Voltage	1000	1500	2000	volts
Total Bias Voltage	-250	-370	-500	volts
Fixed Bias Voltage	-130	-260	-380	volts
Grid Resistor	7500	6000	6000	ohms
D-C Plate Current	135	130	130	ma.
D-C Grid Current (approx.)	16	18	20	ma.
Peak R-F Grid Input Voltage (approx.)	410	545	695	volts
Driving Power (approx.)	6	10	4	watts
Grid Dissipation	2	3	4	watts
Plate Power Input	135	195	260	watts
Plate Dissipation	50	50	50	watts
Plate Power Output	85	145	210	watts

### AUDIO FREQUENCY POWER AMPLIFIER AND MODULATOR

Class-AB<sub>1</sub>

MAXIMUM RATINGS (Per tube)

D-C PLATE VOLTAGE	3000 MAX. VOLTS
MAX-SIGNAL D-C PLATE CURRENT	225 MAX. MA.
PLATE DISSIPATION	75 MAX. WATTS

TYPICAL OPERATION (Sinusoidal wave, two tubes unless otherwise specified)

D-C Plate Voltage	1500	2000	volts
D-C Grid Voltage	-130	-190	volts
Peak A-F Grid Input Voltage (per tube)	130	190	volts
Zero-Signal D-C Plate Current	67	50	ma.
Max-Signal D-C Plate Current	143	130	ma.
Driving Power	0	0	watt
Effective Load, Plate-to-Plate	10,200	21,200	ohms
Max-Signal Plate Power Output	64	110	watts
Max-Signal Plate Dissipation (per tube)	75	75	watts
Total Harmonic Distortion	3.0	3.5	per cent

IF IT IS DESIRED TO OPERATE THIS TUBE UNDER CONDITIONS WIDELY DIFFERENT FROM THOSE GIVEN UNDER "TYPICAL OPERATION", POSSIBLY EXCEEDING MAXIMUM RATINGS, WRITE EITEL-McCULLOUGH, INC., FOR INFORMATION AND RECOMMENDATIONS.

### AUDIO FREQUENCY POWER AMPLIFIER AND MODULATOR

Class—AB<sub>2</sub>

#### MAXIMUM RATINGS (Per tube)

D-C PLATE VOLTAGE	- - - - -	3000 MAX. VOLTS
MAX-SIGNAL D-C PLATE CURRENT	- - - - -	225 MAX. MA.
PLATE DISSIPATION	- - - - -	75 MAX. WATTS
GRID DISSIPATION	- - - - -	13 MAX. WATTS

#### TYPICAL OPERATION (Sinusoidal wave, two tubes unless otherwise specified)

D-C Plate Voltage	- - - - -	1000	1500	2000	volts
D-C Grid Voltage <sup>1</sup>	- - - - -	-70	-130	-190	volts
Peak A-F Grid Input Voltage (per tube)	- - - - -	215	250	300	volts
Zero-Signal D-C Plate Current	- - - - -	100	67	50	ma.
Max-Signal D-C Plate Current	- - - - -	350	285	250	ma.
Max-Signal Avg. Driving Power (approx.)	- - - - -	7	6	5	watts
Max-Signal Peak Driving Power	- - - - -	26	23	19	watts
Effective Load, Plate-to-Plate	- - - - -	5300	11,000	18,000	ohms
Max-Signal Plate Power Output	- - - - -	200	280	350	watts
Max-Signal Plate Dissipation (per tube)	- - - - -	75	75	75	watts
Total Harmonic Distortion	- - - - -	2.0	4.5	6.0	per cent

<sup>1</sup>Adjust to give stated zero-signal plate current. The effective grid-circuit resistance for each tube must not exceed 250,000 ohms in class-AB<sub>2</sub> operation.

### APPLICATION

#### MECHANICAL

**Mounting**—The 75TL must be mounted vertically, base down or up. The plate and grid leads should be flexible. The tube must be protected from vibration and shock.

**Cooling**—Heat Dissipating Connectors (Eimac HR-3 and HR-2) should be used at the plate and grid terminals of the 75TL. If the free circulation of air around the tube is restricted, a small fan or centrifugal blower should be used to provide additional cooling for the plate and grid seals.

Cooling requirements will be met if the temperature of the plate and grid seals is not allowed to exceed 225°C. One method of measuring these temperatures is provided by the use of "Tempilaq", a temperature-sensitive lacquer available from the Tempil Corporation, New York 11, N.Y.

#### ELECTRICAL

**Filament Voltage**—For maximum tube life the filament voltage, as measured directly at the base pins, should be the rated value of 5.0 volts. Variations must be kept within the range of 4.75 to 5.25 volts.

**Bias Voltage**—Although there is no maximum limit on the bias voltage which may be used on the 75TL, there is little advantage in using bias voltages in excess of those given under "Typical Operation," except in certain very specialized applications. Where bias is obtained by a grid leak, suitable protective means must be provided to prevent excessive plate dissipation in the event of loss of excitation.

**Plate Voltage**—The plate-supply voltage for the 75TL should not exceed 3000 volts. In most cases there is little advantage in using plate-supply voltages higher than those given under "Typical Operation" for the power output desired.

**Grid Dissipation**—The power dissipated by the grid of the 75TL must not exceed 13 watts. Grid dissipation may be calculated from the following expression:

$$P_g = e_{cmp} I_c$$

where  $P_g$  = Grid dissipation,  
 $e_{cmp}$  = Peak positive grid voltage, and  
 $I_c$  = D-c grid current.

$e_{cmp}$  may be measured by means of a suitable peak voltmeter connected between filament and grid.<sup>2</sup> In equipment in which the plate loading varies widely, such as oscillators used for radio-frequency heating, care should be taken to make certain that the grid dissipation does not exceed the maximum rating under any condition of loading.

**Plate Dissipation**—The plate of the 75TL operates at a visibly red temperature at its maximum rated dissipation of 75 watts. Plate dissipation in excess of the maximum rating is permissible only for short periods of time, such as during tuning procedures.

<sup>2</sup>For suitable peak v.t.v.m. circuits see, for instance, "Vacuum Tube Ratings", Eimac News, January, 1945. This article is available in reprint form on request.

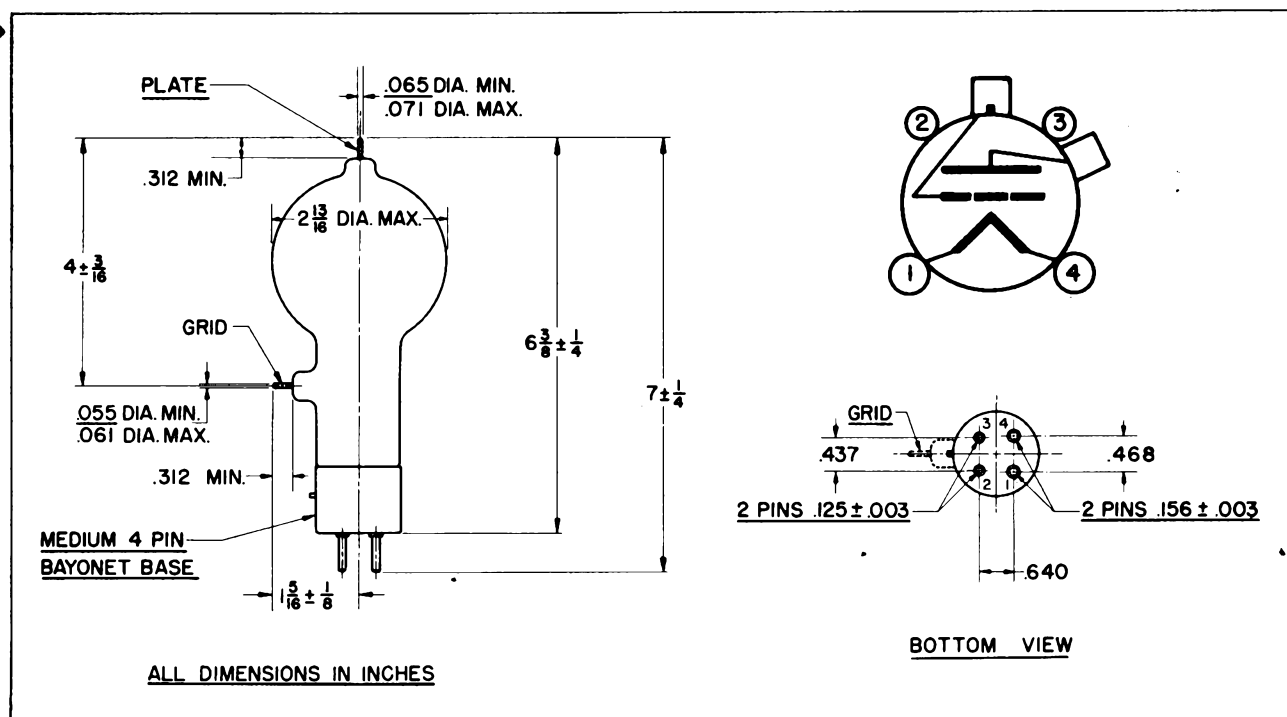

► Indicates change from sheet dated 4-1-46.

## DRIVING POWER vs. POWER OUTPUT

The three charts on this page show the relationship of plate efficiency, power output and grid driving power at plate voltages of 1000, 1500 and 2000 volts. These charts show combined grid and bias losses only. The driving power and power output figures do not include circuit losses. The plate dissipation in watts is indicated by  $P_p$ .

Points A, B, and C are identical to the typical Class C operating conditions shown on the first page under 1000, 1500, and 2000 volts respectively.

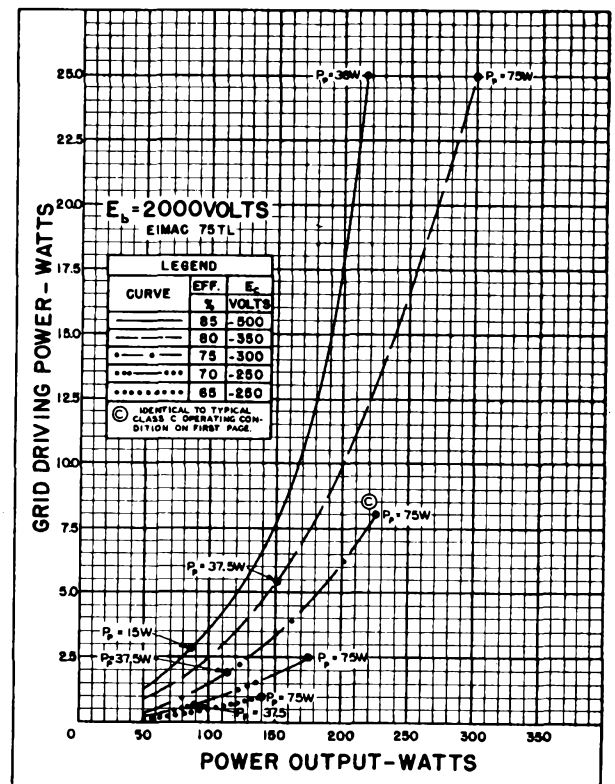
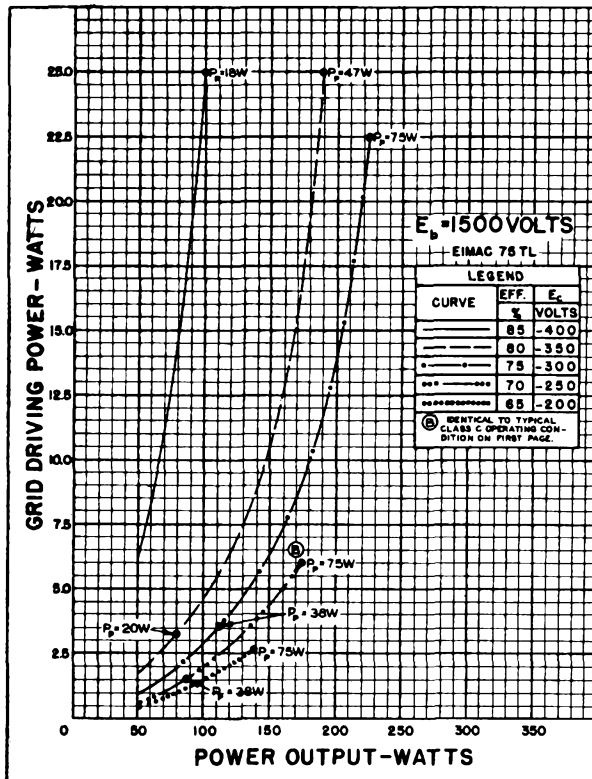
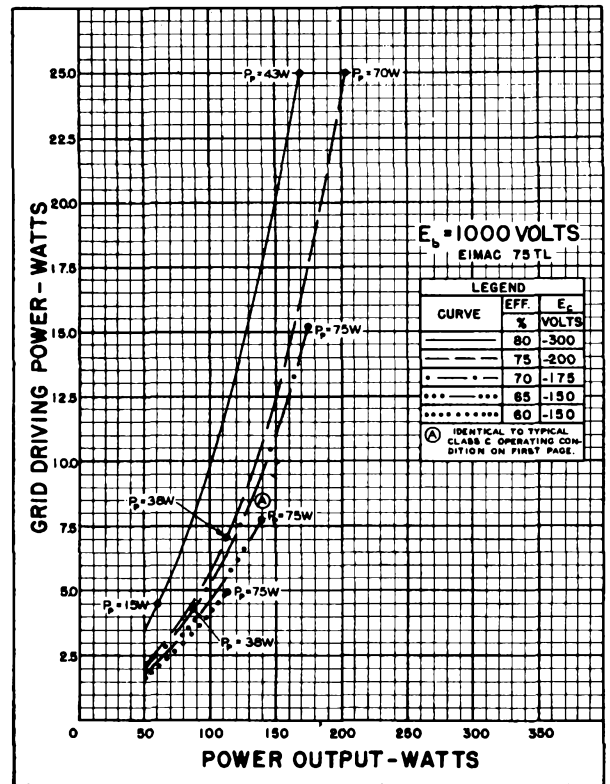

**Simul** 75TL

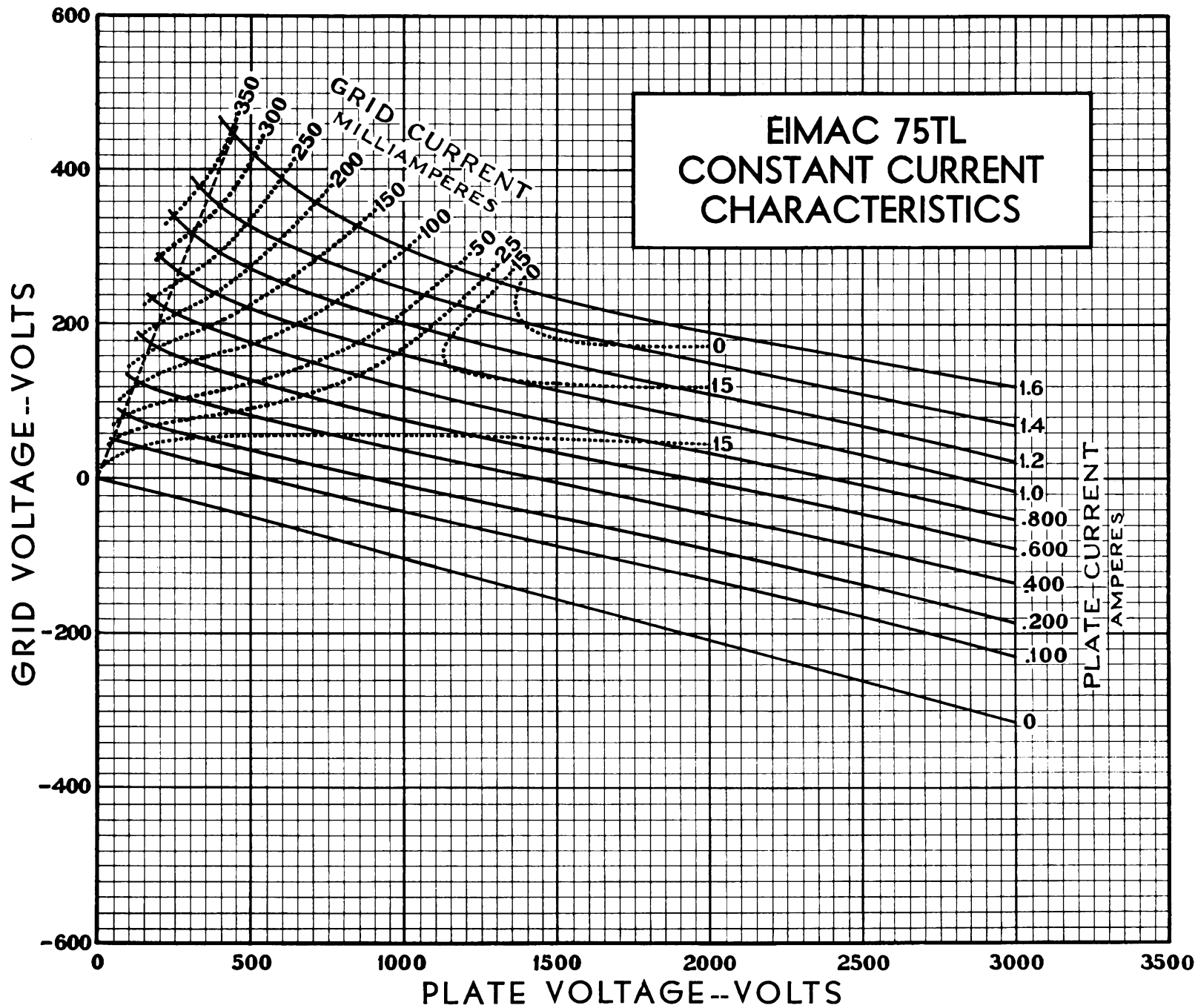



# EITEL-McCULLOUGH, INC.

SAN BRUNO, CALIFORNIA

## 100TH HIGH-MU TRIODE MODULATOR OSCILLATOR AMPLIFIER

The Eimac 100TH is a high-mu power triode having a maximum plate dissipation rating of 100 watts, and is intended for use as an amplifier, oscillator, or modulator. It can be used at its maximum ratings at frequencies as high as 40-Mc.

Cooling of the 100TH is accomplished by radiation from the plate, which operates at a visible red color at maximum dissipation, and by means of air circulation by convection around the envelope.

### GENERAL CHARACTERISTICS

#### ELECTRICAL

Filament:	Thoriated tungsten	
	Voltage - - - - -	5.0 volts
	Current - - - - -	6.3 amperes
▶ Amplification Factor (Average)		38
Direct Interelectrode Capacitances (Average)		
	Grid-Plate - - - - -	2.0 $\mu\mu\text{f}$
	Grid-Filament - - - - -	2.9 $\mu\mu\text{f}$
	▶ Plate-Filament - - - - -	0.3 $\mu\mu\text{f}$
▶ Transconductance ( $i_b=200$ ma., $E_b=3000$ v., $e_c=-5$ v.)		4500 $\mu\text{mhos}$
Frequency for Maximum Ratings - - - - -		40 Mc.

#### MECHANICAL

Base - - -	(Medium 4-pin bayonet, ceramic)	RMA type M8-078
Basing - - -		RMA type 2M
▶ Mounting - - - - -		Vertical, base down or up.
▶ Cooling - - - - -		Convection and Radiation.

#### ▶ Recommended Heat Dissipating Connectors:

Plate - - - - -		Eimac HR-6
Grid - - - - -		Eimac HR-2
Maximum Overall Dimensions:		
	Length - - - - -	7.75 inches
	Diameter - - - - -	3.19 inches
Net weight - - - - -		4 ounces
Shipping weight (Average) - - - - -		1.5 pounds

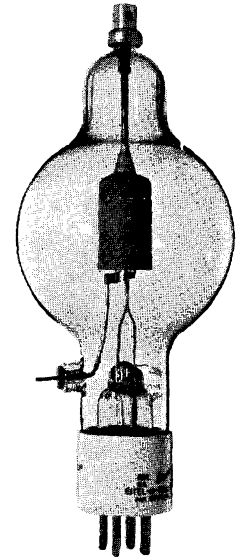

#### AUDIO FREQUENCY POWER AMPLIFIER AND MODULATOR

Class-AB: (Sinusoidal wave, two tubes unless otherwise specified)

##### MAXIMUM RATINGS

D-C PLATE VOLTAGE - - - - -	3000 MAX. VOLTS
MAX-SIGNAL D-C PLATE CURRENT, PER TUBE - - - - -	225 MAX. MA.
PLATE DISSIPATION, PER TUBE - - - - -	100 MAX. WATTS

#### ▶ TYPICAL OPERATION

D-C Plate Voltage - - - - -	1500	2000	2500	Volts
D-C Grid Voltage (approx.)* - - - - -	-20	-35	-50	Volts
Zero-Signal D-C Plate Current - - - - -	80	60	48	Ma.
Max-Signal D-C Plate Current - - - - -	320	280	250	Ma.
Effective Load, Plate-to-Plate - - - - -	8800	15,000	22,000	Ohms.
Peak A-F Grid Input Voltage (per tube) - - - - -	145	150	155	Volts
Max-Signal Peak Driving Power - - - - -	18	19	15	Watts
Max-Signal Nominal Driving Power (approx.) - - - - -	9	9.5	7.5	Watts
Max-Signal Plate Power Output - - - - -	280	360	425	Watts

\*Adjust to give stated zero signal plate current.

#### RADIO FREQUENCY POWER AMPLIFIER AND OSCILLATOR

Class-C Telegraphy or FM Telephony (Key-down conditions, per tube)

##### MAXIMUM RATINGS

D-C PLATE VOLTAGE - - - - -	3000 MAX. VOLTS
D-C PLATE CURRENT - - - - -	225 MAX. MA.
PLATE DISSIPATION - - - - -	100 MAX. WATTS
▶ GRID DISSIPATION - - - - -	20 MAX. WATTS

#### TYPICAL OPERATION

D-C Plate Voltage - - - - -	1500	2000	3000	Volts
D-C Grid Voltage - - - - -	-65	-80	-200	Volts
D-C Plate Current - - - - -	190	165	165	Ma.
D-C Grid Current - - - - -	48	39	51	Ma.
Peak R-F Grid Input Voltage - - - - -	230	230	385	Volts
Driving Power (approx.) - - - - -	10	8	18	Watts
Grid Dissipation - - - - -	7	5	10	Watts
Plate Power Input - - - - -	285	335	500	Watts
Plate Dissipation - - - - -	100	100	100	Watts
Plate Power Output - - - - -	185	235	400	Watts

#### ▶ PLATE MODULATED RADIO FREQUENCY AMPLIFIER

Class-C Telephony (Carrier conditions, per tube)

##### MAXIMUM RATINGS

D-C PLATE VOLTAGE - - - - -	2500 MAX. VOLTS
D-C PLATE CURRENT - - - - -	180 MAX. MA.
PLATE DISSIPATION - - - - -	65 MAX. WATTS
GRID DISSIPATION - - - - -	20 MAX. WATTS

#### TYPICAL OPERATION

D-C Plate Voltage - - - - -	1500	2000	2500	Volts
D-C Grid Voltage - - - - -	-150	-200	-250	Volts
D-C Plate Current - - - - -	160	150	140	Ma.
D-C Grid Current - - - - -	46	41	40	Ma.
Peak R-F Grid Input Voltage - - - - -	325	375	425	Volts
Driving Power (approx.) - - - - -	15	15.5	17	Watts
Grid Dissipation - - - - -	8	7.3	7	Watts
Plate Power Input - - - - -	240	300	350	Watts
Plate Dissipation - - - - -	65	65	65	Watts
Plate Power Output - - - - -	175	235	285	Watts

EIMAC 100TH  
CONSTANT CURRENT  
CHARACTERISTICS

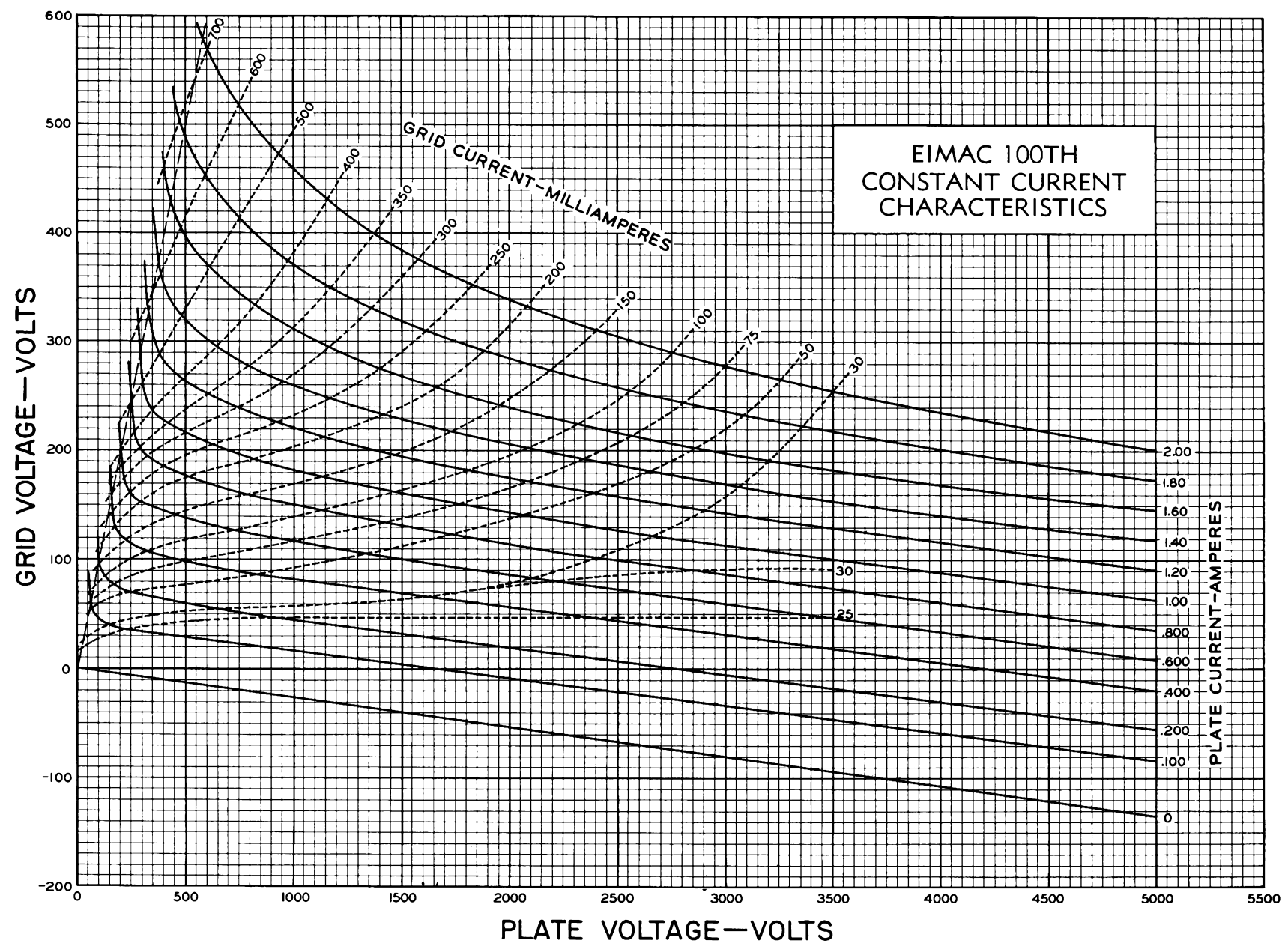

## DRIVING POWER vs. POWER OUTPUT

The three charts on this page show the relationship of plate efficiency, power output and grid driving power at plate voltages of 1500, 2000 and 3000 volts. These charts show combined grid and bias losses only. The driving power and power output figures do not include circuit losses. The plate dissipation in watts is indicated by  $P_p$ .

Points A, B, and C are identical to the typical Class C operating conditions shown on the first page under 1500, 2000, and 3000 volts respectively.

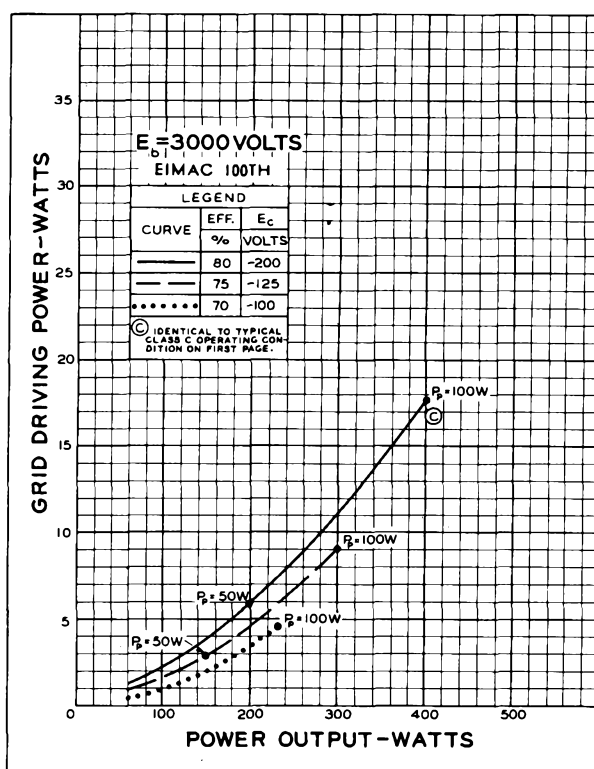
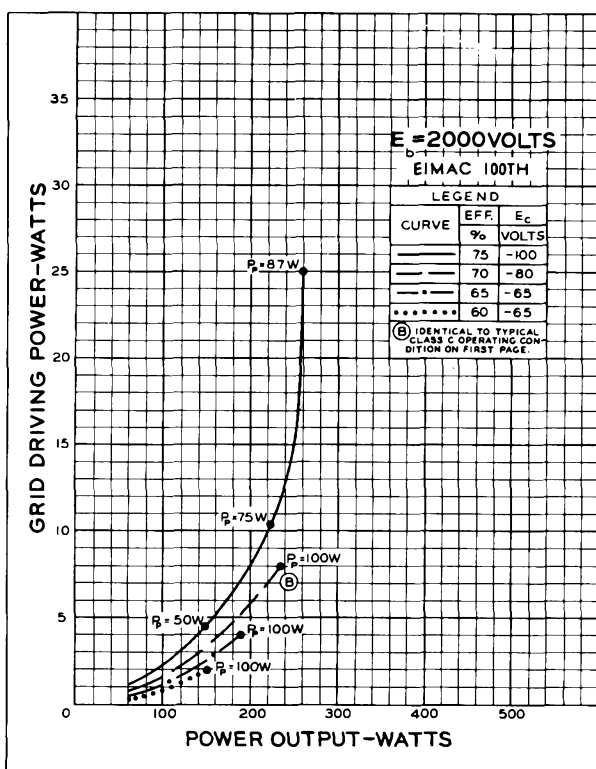
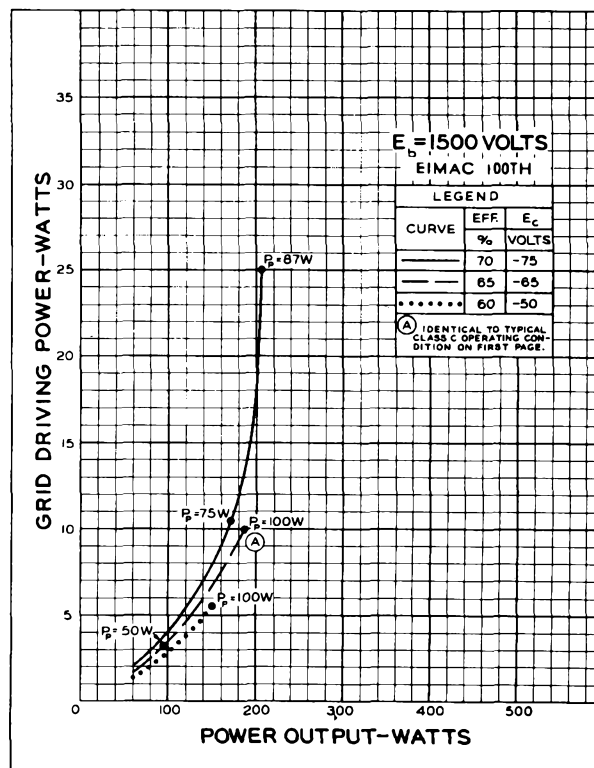

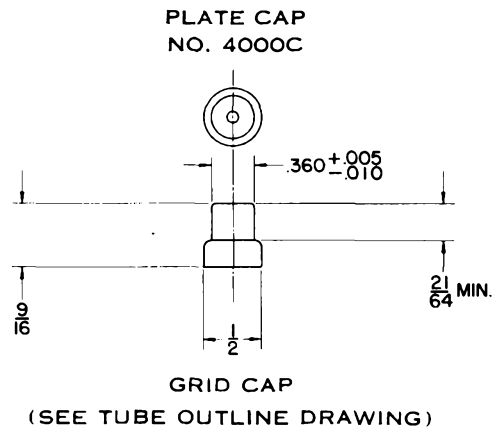
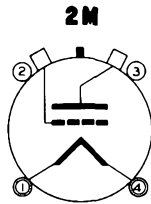
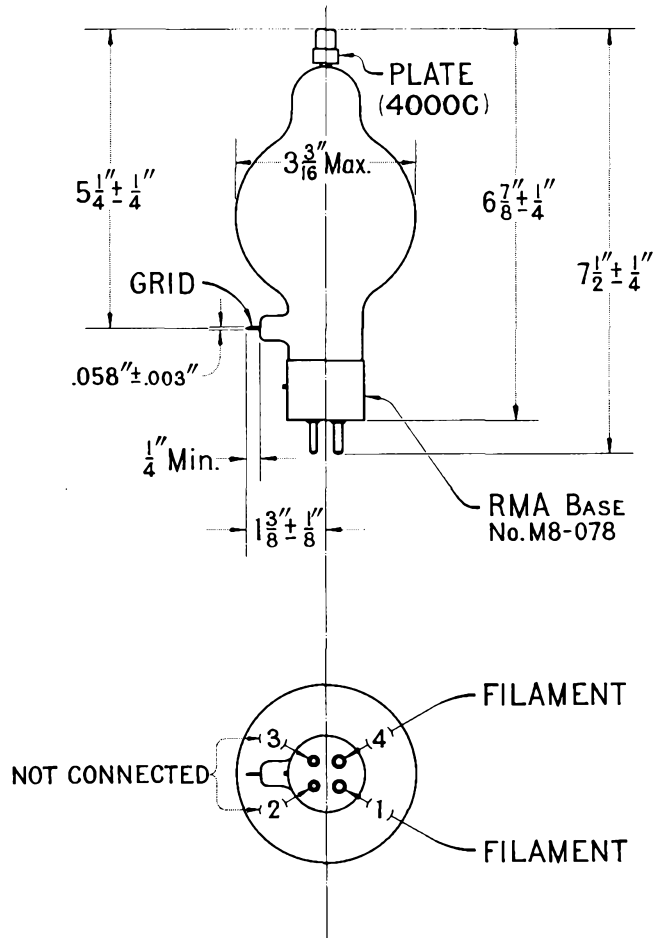

# Eitel-McCullough, Inc.

SAN BRUNO, CALIFORNIA

# 100TL

LOW-MU TRIODE  
MODULATOR  
OSCILLATOR  
AMPLIFIER

The Eimac 100TL is a low-mu power triode having a maximum plate dissipation rating of 100 watts, and is intended for use as an amplifier, oscillator or modulator. It can be used at its maximum ratings at frequencies as high as 40-Mc.

Cooling of the 100TL is accomplished by radiation from the plate, which operates at a visible red color at maximum dissipation, and by means of air circulation by convection around the envelope.

## GENERAL CHARACTERISTICS

### ELECTRICAL

Filament:	Thoriated tungsten	
	Voltage	5.0 volts
	Current	6.3 amperes
Amplification Factor (Average)		14
Direct Interelectrode Capacitances (Average)		
	Grid-Plate	2.0 $\mu\mu\text{f}$
	Grid-Filament	2.3 $\mu\mu\text{f}$
	Plate-Filament	0.4 $\mu\mu\text{f}$
▶ Transconductance ( $i_b=225$ ma., $E_b=3000$ v., $e_c=-90$ v.)		3000 $\mu\text{mhos}$
Frequency for Maximum Ratings		40 Mc.

### MECHANICAL

Base	(Medium 4-pin bayonet, ceramic)	RMA type M8-078
Basing		RMA type 2M
▶ Mounting		Vertical, base down or up.
▶ Cooling		Convection and Radiation.

#### ▶ Recommended Heat Dissipating Connectors:

Plate		Eimac HR-6
Grid		Eimac HR-2
Maximum Overall Dimensions:		
Length		7.75 inches
Diameter		3.19 inches
Net weight		4 ounces
Shipping weight (Average)		1.5 pounds

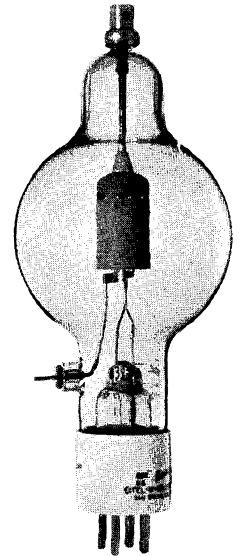

### AUDIO FREQUENCY POWER AMPLIFIER AND MODULATOR

Class-AB, (Sinusoidal wave, two tubes unless otherwise specified)

#### MAXIMUM RATINGS

D-C PLATE VOLTAGE	3000 MAX. VOLTS
MAX-SIGNAL D-C PLATE CURRENT, PER TUBE	225 MAX. MA.
PLATE DISSIPATION, PER TUBE	100 MAX. WATTS

#### ▶ TYPICAL OPERATION

D-C Plate Voltage	1500	2000	2500	Volts
D-C Grid Voltage (approx.)*	-65	-110	-145	Volts
Zero-Signal D-C Plate Current	80	60	48	Ma.
Max-Signal D-C Plate Current	320	280	250	Ma.
Effective Load, Plate-to-Plate	8800	15,000	22,000	Ohms
Peak A-F Grid Input Voltage (per tube)	235	270	290	Volts
Max-Signal Peak Driving Power	21	22	20	Watts
Max-Signal Nominal Driving Power (approx.)	10.5	11	10	Watts
Max-Signal Plate Power Output	280	360	425	Watts

\*Adjust to give stated zero signal plate current.

### RADIO FREQUENCY POWER AMPLIFIER AND OSCILLATOR

Class-C Telephony or FM Telephony (Key-down conditions, per tube)

#### MAXIMUM RATINGS

D-C PLATE VOLTAGE	3000 MAX. VOLTS
D-C PLATE CURRENT	225 MAX. MA.
PLATE DISSIPATION	100 MAX. WATTS
GRID DISSIPATION	15 MAX. WATTS

#### TYPICAL OPERATION

D-C Plate Voltage	1500	2000	3000	Volts
D-C Grid Voltage	-175	-225	-400	Volts
D-C Plate Current	190	165	165	Ma.
D-C Grid Current	37	28	30	Ma.
Peak R-F Grid Input Voltage	425	450	650	Volts
Driving Power (approx.)	14	11	20	Watts
Grid Dissipation	7.5	5	8	Watts
Plate Power Input	285	335	500	Watts
Plate Dissipation	100	100	100	Watts
Plate Power Output	185	235	400	Watts

### ▶ PLATE MODULATED RADIO FREQUENCY AMPLIFIER

Class-C Telephony (Carrier conditions, per tube)

#### MAXIMUM RATINGS

D-C PLATE VOLTAGE	2500 MAX. VOLTS
D-C PLATE CURRENT	180 MAX. MA.
PLATE DISSIPATION	65 MAX. WATTS
GRID DISSIPATION	15 MAX. WATTS

#### TYPICAL OPERATION

D-C Plate Voltage	1500	2000	2500	Volts
D-C Grid Voltage	-300	-400	-500	Volts
D-C Plate Current	160	150	140	Ma.
D-C Grid Current	32	31	31	Ma.
Peak R-F Grid Input Voltage	530	655	750	Volts
Driving Power (approx.)	17	20	23	Watts
Grid Dissipation	8	7.5	7.5	Watts
Plate Power Input	240	300	350	Watts
Plate Dissipation	65	65	65	Watts
Plate Power Output	175	235	285	Watts

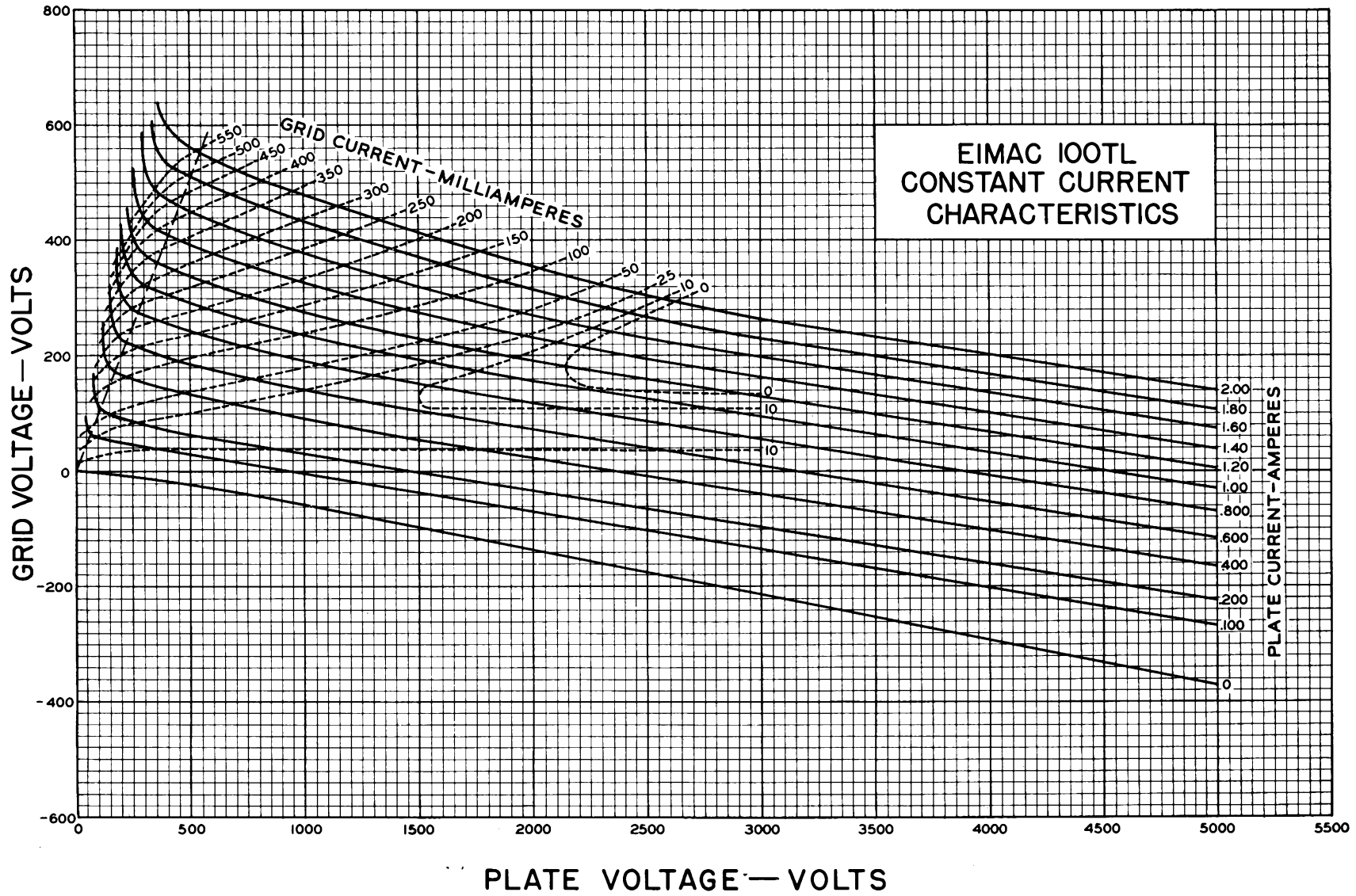

**Eimac**  
100TL

## DRIVING POWER vs. POWER OUTPUT

The three charts on this page show the relationship of plate efficiency, power output and grid driving power at plate voltages of 1500, 2000 and 3000 volts. These charts show combined grid and bias losses only. The driving power and power output figures do not include circuit losses. The plate dissipation in watts is indicated by  $P_p$ .

Points A, B, and C are identical to the typical Class C operating conditions shown on the first page under 1500, 2000, and 3000 volts respectively.

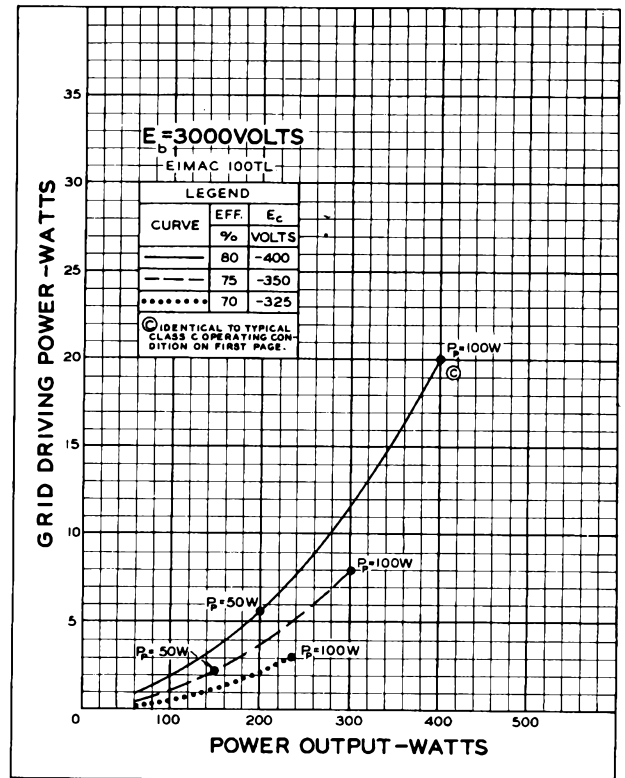
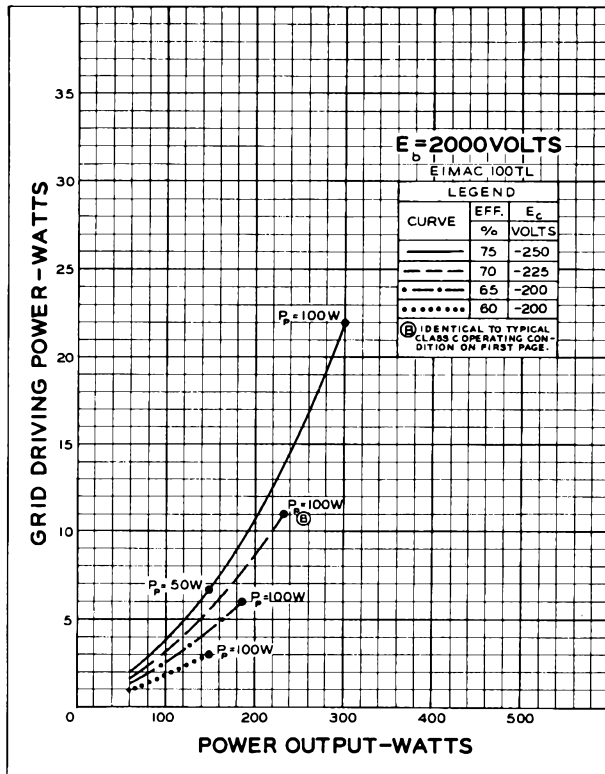
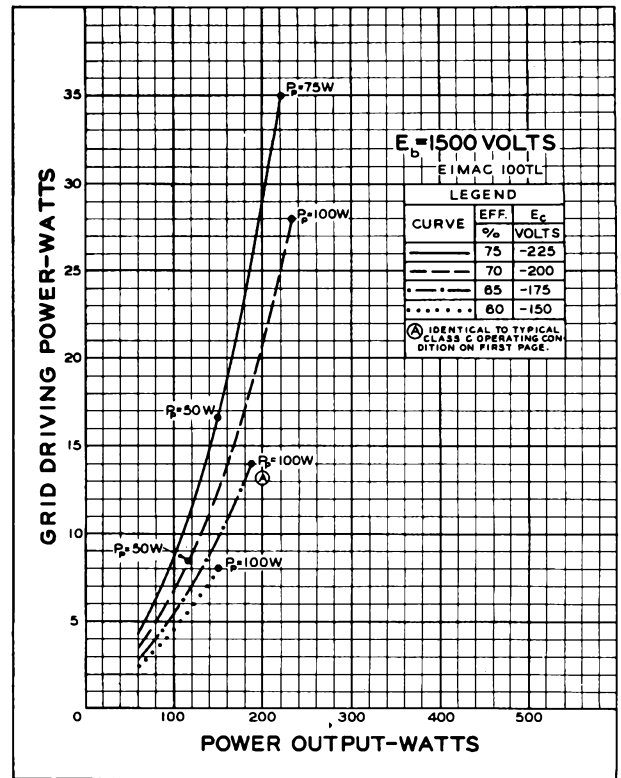

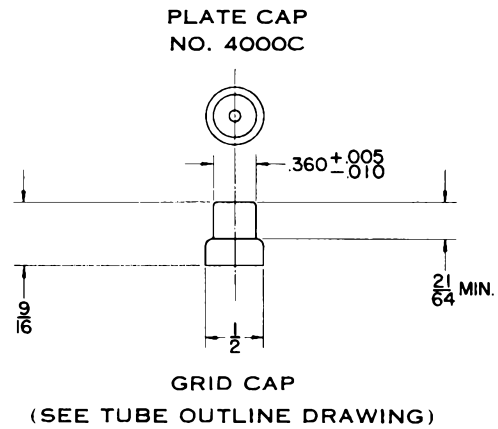
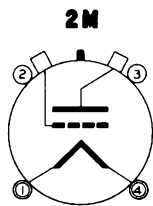
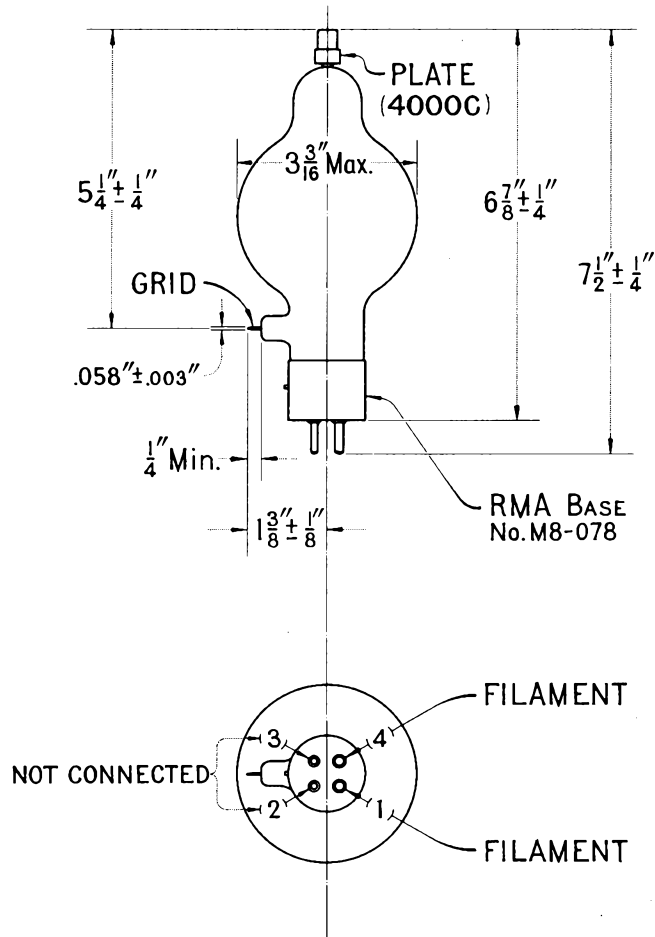



# EITEL-McCULLOUGH, INC.

SAN BRUNO, CALIFORNIA

# 152TH

MEDIUM MU TRIODE

MODULATOR  
OSCILLATOR  
AMPLIFIER

► The Eimac 152TH is a medium-mu power triode intended for use as an amplifier, oscillator or modulator. It has a maximum plate-dissipation rating of 150 watts and a maximum plate-voltage rating of 3000 volts at frequencies up to 40 Mc.

The 152TH in class-C r-f service will deliver up to 600 watts plate power output with 27 watts driving power. Two 152TH's in class-B modulator service will deliver up to 600 watts maximum-signal plate power output with 8 watts nominal driving power.

### GENERAL CHARACTERISTICS

#### ELECTRICAL

Filament: Thoriated Tungsten	
Voltage	5.0 or 10.0 volts
Current	12.5 or 6.25 amperes
Amplification Factor (Average)	
Direct Interelectrode Capacitances (Average)	20
Grid-Plate	4.8 $\mu\text{fd}$
Grid-Filament	5.7 $\mu\text{fd}$
► Plate-Filament	0.4 $\mu\text{fd}$
Transconductance ( $I_b=500 \text{ ma.}, E_b=3000 \text{ v.}$ )	
Highest Frequency for Maximum Ratings	8300 $\mu\text{mhos}$ 40 Mc

#### ► MECHANICAL

Base	Special 4-pin
Basing	See outline drawing
Socket	Johnson type No. 124-213 or equivalent
Mounting Position	Vertical, base down or up
Cooling	Convection and radiation
Maximum Temperature of Plate and Grid Seals	225° C
Recommended Heat-Dissipating Connectors:	
Plate	Eimac HR-5
Grid	Eimac HR-6
Maximum Over-all Dimensions:	
Length	7.63 inches
Diameter	2.57 inches
Net Weight	8 ounces
Shipping Weight	1.25 pounds

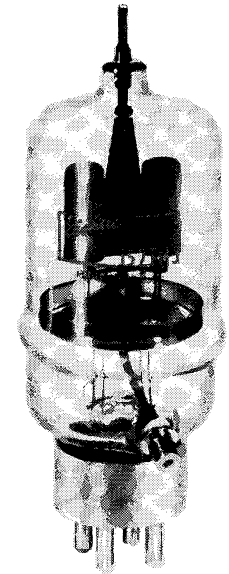

#### RADIO-FREQUENCY POWER AMPLIFIER OR OSCILLATOR

Class-C Telegraphy (Key-down conditions, one tube)  
MAXIMUM RATINGS (Frequencies up to 40 Mc.)

D-C PLATE VOLTAGE	3000 MAX. VOLTS
D-C PLATE CURRENT	450 MAX. MA
PLATE DISSIPATION	150 MAX. WATTS
GRID DISSIPATION	30 MAX. WATTS

#### TYPICAL OPERATION (Frequencies up to 40 Mc.)

D-C Plate Voltage	1500	2000	3000	volts
D-C Grid Voltage	-125	-200	-300	volts
D-C Plate Current	335	300	250	ma
D-C Grid Current*	58	75	70	ma
Peak R-F Grid Voltage	265	335	410	volts
Driving Power*	13	20	27	watts
Plate Power Input	500	600	750	watts
Plate Dissipation	150	150	150	watts
Plate Power Output	350	450	600	watts

#### ► PLATE-MODULATED RADIO-FREQUENCY AMPLIFIER

Class-C Telephony (Carrier conditions, per tube)  
MAXIMUM RATINGS (Frequencies up to 40 Mc.)

D-C PLATE VOLTAGE	2500 MAX. VOLTS
D-C PLATE CURRENT	350 MAX. MA
PLATE DISSIPATION	100 MAX. WATTS
GRID DISSIPATION	30 MAX. WATTS

#### TYPICAL OPERATION (Frequencies up to 40 Mc.)

D-C Plate Voltage	1000	1500	2000	2500	volts
D-C Grid Voltage	-150	-200	-300	-350	volts
D-C Plate Current	270	235	220	200	ma
D-C Grid Current*	40	28	30	30	ma
Peak R-F Grid Voltage	300	330	440	485	volts
Driving Power*	12	10	12	15	watts
Grid Dissipation*	6	4	4	4	watts
Plate Power Input	270	350	440	500	watts
Plate Dissipation	100	100	100	100	watts
Plate Power Output	170	250	340	400	watts

#### ► AUDIO-FREQUENCY POWER AMPLIFIER OR MODULATOR

Class-B  
MAXIMUM RATINGS (Per tube)

D-C PLATE VOLTAGE	3000 MAX. VOLTS
D-C PLATE CURRENT	450 MAX. MA
PLATE DISSIPATION	150 MAX. WATTS

#### TYPICAL OPERATION (Sinusoidal wave, two tubes unless otherwise specified)

D-C Plate Voltage	1500	2000	2500	volts
D-C Grid Voltage <sup>1</sup>	-65	-95	-125	volts
Zero-Signal D-C Plate Current	65	50	40	ma
Max-Signal D-C Plate Current	515	405	340	ma
Effective Load, Plate-to-Plate	6000	11,000	17,000	ohms
Peak A-F Grid Voltage (per tube)	165	175	195	volts
Max-Signal Peak Driving Power*	25	17	16	watts
Max-Signal Nominal Driving Power*	13	9	8	watts
Max-Signal Plate Power Input	775	810	850	watts
Max-Signal Plate Power Output	500	550	600	watts

\*Approximate values.

<sup>1</sup>Adjust to give stated Zero-Signal D-C Plate Current.

IF IT IS DESIRED TO OPERATE THIS TUBE UNDER CONDITIONS WIDELY DIFFERENT FROM THOSE GIVEN UNDER "TYPICAL OPERATION" POSSIBLY EXCEEDING THE MAXIMUM RATINGS GIVEN FOR CW SERVICE, WRITE EITEL-McCULLOUGH, INC., FOR INFORMATION AND RECOMMENDATIONS.

## ▶ APPLICATION

### MECHANICAL

**Mounting**—The 152TH must be mounted vertically, base down or up. The plate and grid leads should be flexible, and the tube must be protected from vibration and shock.

**Cooling**—Heat Dissipating Connectors (Eimac HR-5 and HR-6 or equivalent) must be used at the plate and grid terminals of the 152TH. Forced-air cooling is not required in properly designed equipment operating at frequencies below 40 Mc. If the free circulation of air around the tube is restricted, a small fan or centrifugal blower should be used to provide additional cooling.

The temperature of the plate and grid seals must not be allowed to exceed 225° C. One method of measuring these temperatures is by the use of "Tempilaq," a temperature-sensitive lacquer manufactured by the Tempil Corporation, 132 W. 22nd St., New York 11, N. Y.

### ELECTRICAL

**Filament Voltage**—The filaments of the 152TH may be operated either at 10.0 volts when connected in series or at 5.0 volts when connected in parallel (see basing diagram). For maximum tube life the filament voltage should be maintained at the rated value. Variations must not be allowed to exceed ± 5%.

**Bias Voltage**—When grid-leak bias is used, suitable protective means must be provided to prevent excessive plate dissipation in the event of loss of excitation, and the grid-leak resistor should be made adjustable to

facilitate maintaining the bias voltage and plate current at the desired value from tube to tube.

**Grid Dissipation**—The power dissipated by the grid of the 152TH must not exceed 30 watts. Grid dissipation may be calculated from the following expression.

$$P_g = e_{cmp} I_c$$

where  $P_g$  = grid dissipation,

$e_{cmp}$  = peak positive grid voltage, and

$I_c$  = d-c grid current.

$e_{cmp}$  may be measured by means of a suitable peak-reading voltmeter connected between filament and grid.<sup>1</sup> In equipment in which the plate loading varies widely, such as oscillators used for radio-frequency heating, care should be taken to make certain that the grid dissipation does not exceed the maximum rating under any condition of loading.

**Plate Dissipation**—The plates of the 152TH operate at a visibly red color at the maximum rated dissipation of 150 watts. Plate dissipation in excess of the maximum rating is permissible only for short periods of time, such as during tuning procedures.

<sup>1</sup>For suitable peak v.t.v.m. circuits see, for instance, "Vacuum Tube Ratings," Eimac News, January, 1945. This article is available in reprint form on request.

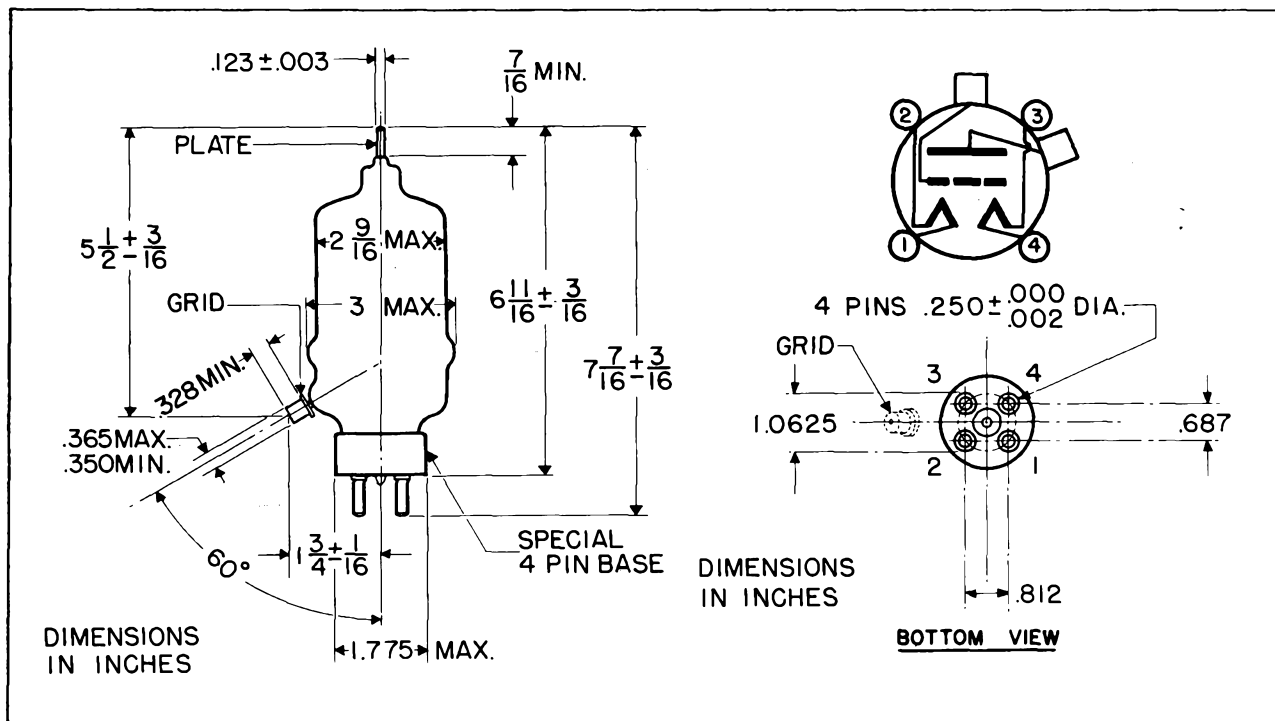

## DRIVING POWER vs. POWER OUTPUT

The three charts on this page show the relationship of plate efficiency, power output and grid driving power at plate voltages of 1500, 2000 and 3000 volts. These charts show combined grid and bias losses only. The driving power and power output figures do not include circuit losses. The plate dissipation in watts is indicated by  $P_p$ .

Points A, B, and C are identical to the typical Class C operating conditions shown on the first page under 1500, 2000, and 3000 volts respectively.

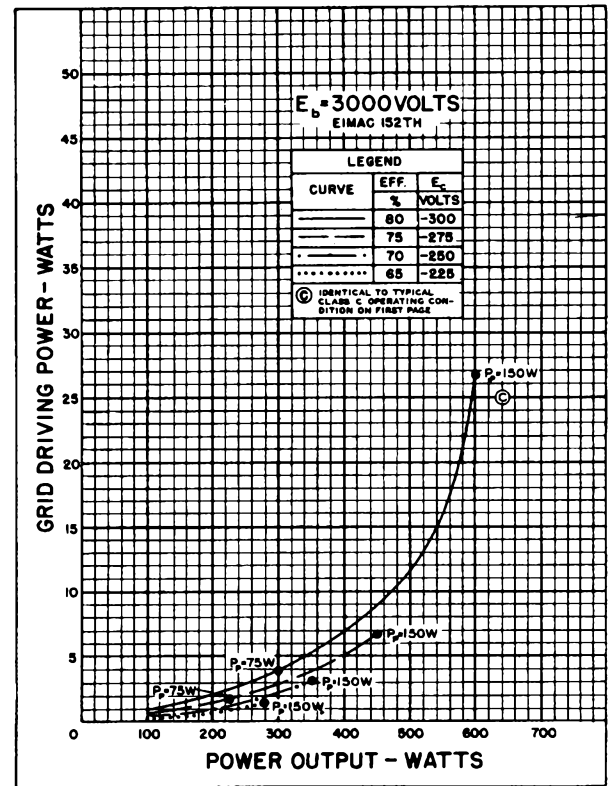
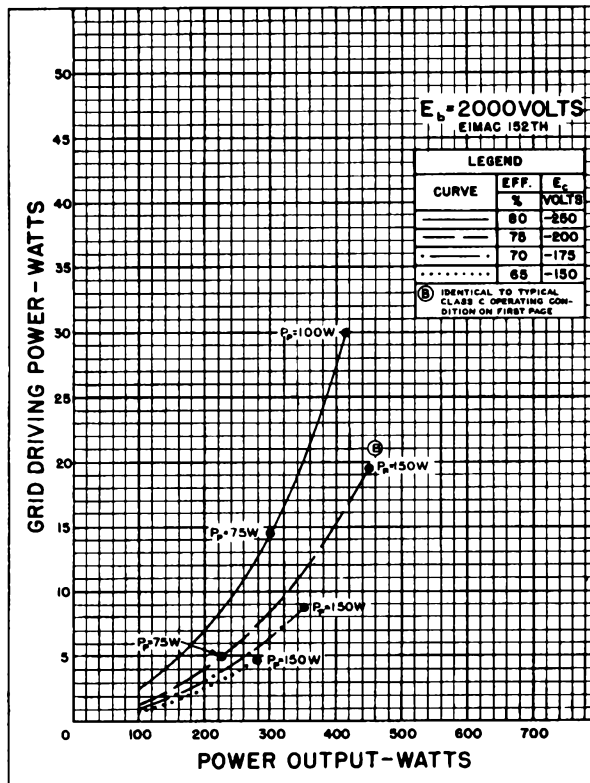
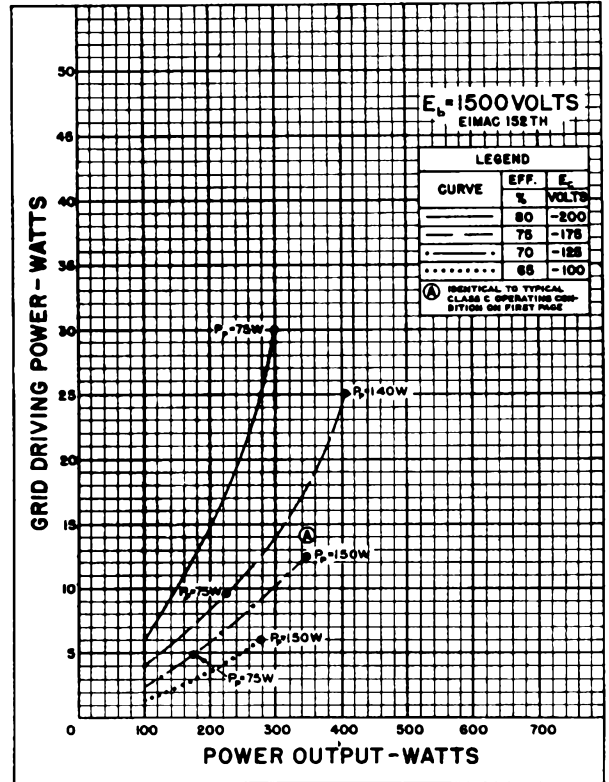

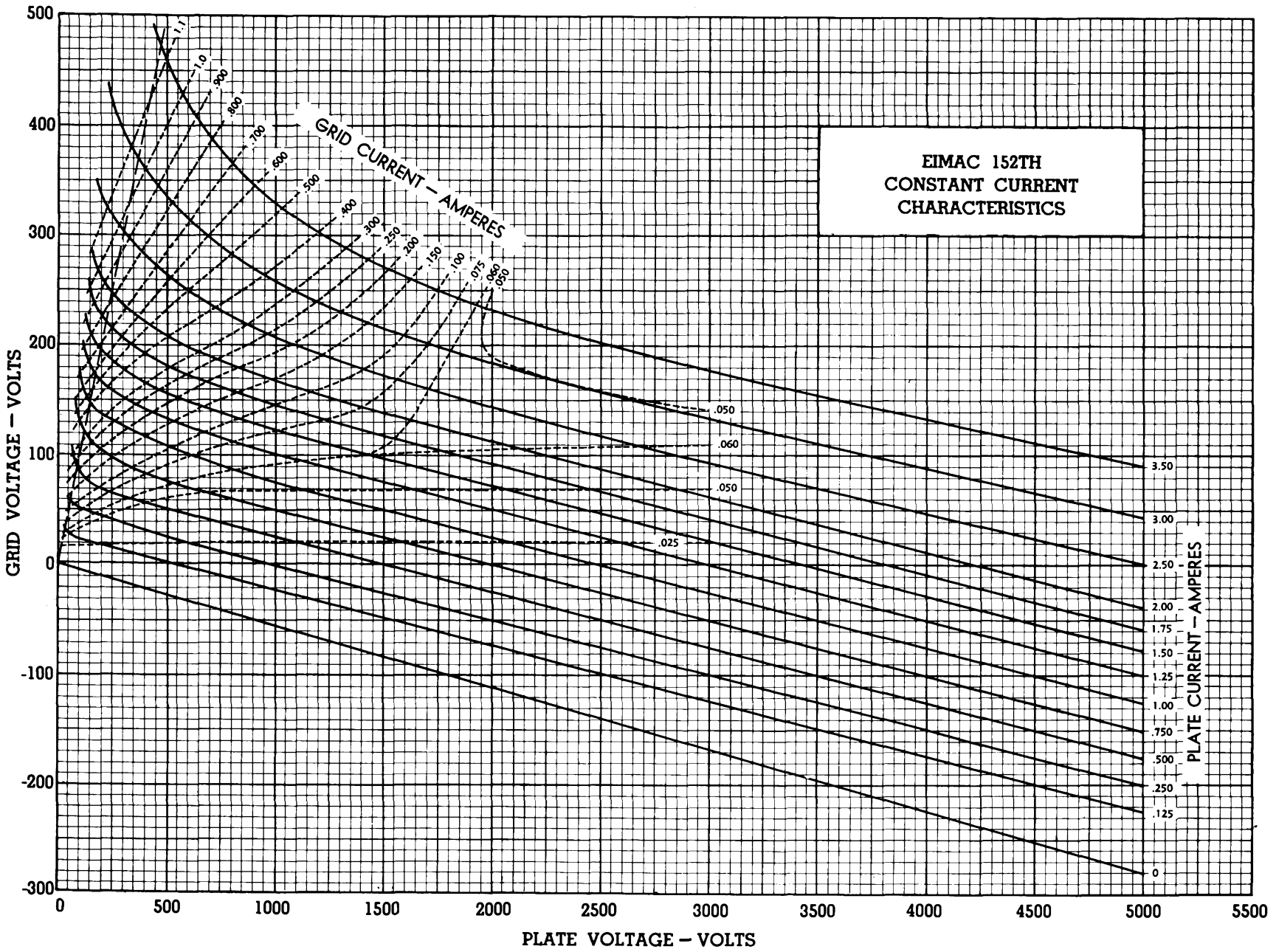

Printed in U. S. A. 2-F-43032

**Singer**  
152TH

# EITEL-McCULLOUGH, INC.

SAN BRUNO, CALIFORNIA

# 152TL

LOW-MU TRIODE  
 MODULATOR  
 OSCILLATOR  
 AMPLIFIER

## GENERAL CHARACTERISTICS

### ELECTRICAL

Filament: Thoriated tungsten	
Voltage - - - - -	5.0 of 10.0 volts
Current - - - - -	12.5 or 6.25 amperes
Amplification Factor (Average) - - - - -	12
Direct Interelectrode Capacitances (Average)	
Grid-Plate - - - - -	4.4 $\mu\mu\text{f}$
Grid-Filament - - - - -	4.5 $\mu\mu\text{f}$
Plate-Filament - - - - -	0.7 $\mu\mu\text{f}$
Transconductance ( $i_b = 500 \text{ ma.}, E_b = 3000 \text{ v.}, E_c = -85 \text{ v.}$ )	7150 umhos

### MECHANICAL

Base - - - - -	Special 4 pin, No. 5000B
Basing - - - - -	RMA type 4BC
Maximum Overall Dimensions:	
Length - - - - -	7.625 inches
Diameter - - - - -	2.563 inches
Net weight - - - - -	7 ounces
Shipping weight (Average) - - - - -	2.0 pounds

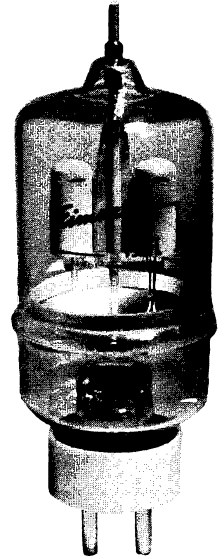

## AUDIO FREQUENCY POWER AMPLIFIER AND MODULATOR

### Class B

	ZERO GRID CURRENT OPERATION—2 TUBES			TYPICAL OPERATION 2 TUBES			MAX. RATING
	1500	2000	3000	1500	2000	3000	
D-C Plate Voltage - - - - -	1500	2000	3000	1500	2000	3000	3000 volts
Max.-Sig. D-C Plate Current, per tube*	•	•	•	•	•	•	450 ma.
Plate Dissipation, per tube*	•	•	•	•	•	•	150 watts
D-C Grid Voltage (approx.) - - -	-105	-160	-260	-105	-160	-260	volts
Peak A-F Grid Input Voltage - - -	210	320	520	500	620	675	volts
Zero-Signal D-C Plate Current - - -	135	100	65	135	100	65	ma.
Max.-Signal D-C Plate Current - - -	286	260	220	570	500	335	ma.
Max.-Signal Driving Power (approx.)	0	0	0	15	13	3	watts
Effective Load, Plate-to-Plate - - -	5100	10500	24000	5500	9000	20400	ohms
Max.-Signal Plate Power Output - - -	130	220	370	560	700	700	watts

\*Averaged over any sinusoidal audio frequency cycle.

## RADIO FREQUENCY POWER AMPLIFIER AND OSCILLATOR

### Class-C \*Telegraphy

(Key down conditions without modulation)

	TYPICAL OPERATION—1 TUBE			MAX. RATING
	1500	2000	3000	
D-C Plate Voltage - - - - -	1500	2000	3000	3000 volts
D-C Plate Current - - - - -	333	300	250	450 ma.
D-C Grid Current - - - - -	45	42	40	75 ma.
D-C Grid Voltage - - - - -	-250	-300	-400	volts
Plate Power Output - - - - -	350	450	600	watts
Plate Input - - - - -	500	600	750	watts
Plate Dissipation - - - - -	150	150	150	150 watts
Peak R. F. Grid Input Voltage, (approx.) - - -	400	455	550	volts
Driving Power, (approx.) - - - - -	16	18	20	watts

\*The above figures show actual measured tube performance, and do not allow for variations in circuit losses.

(Effective 1-1-44) Copyright, 1946 by Eitel-McCullough, Inc.

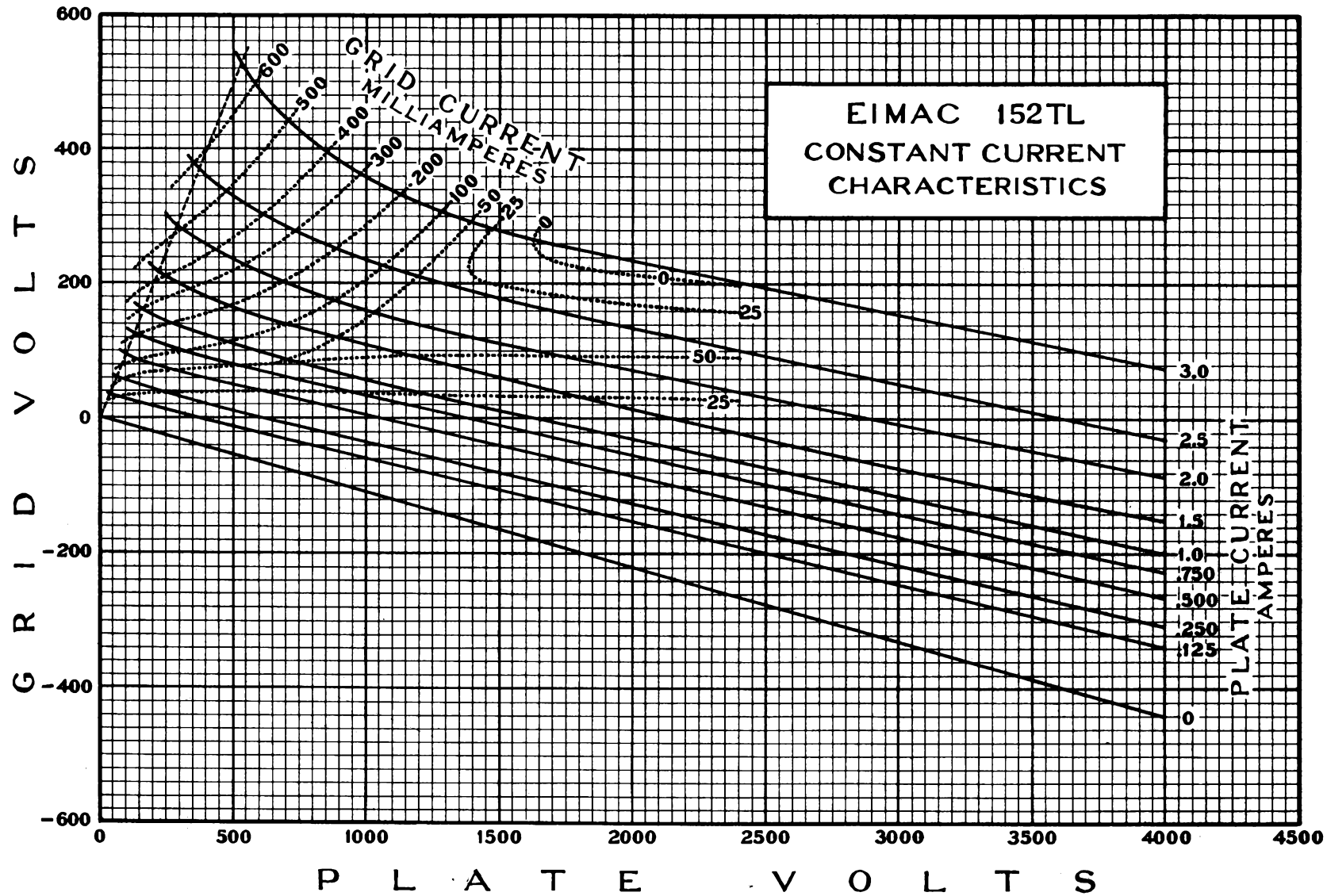

**Eimac**  
152TL

## DRIVING POWER vs. POWER OUTPUT

The three charts on this page show the relationship of plate efficiency, power output and grid driving power at plate voltages of 1500, 2000 and 3000 volts. These charts show combined grid and bias losses only. The driving power and power output figures do not include circuit losses. The plate dissipation in watts is indicated by  $P_p$ .

Points A, B, and C are identical to the typical Class C operating conditions shown on the first page under 1500, 2000, and 3000 volts respectively.

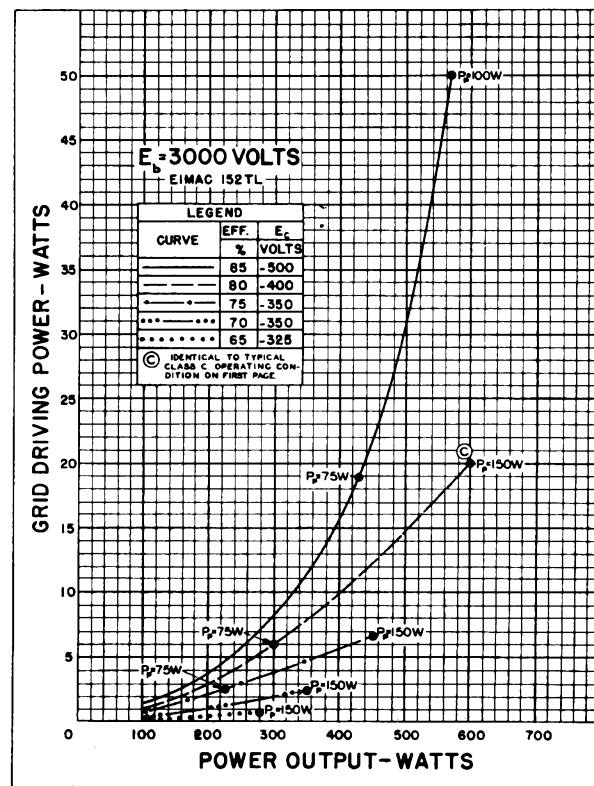
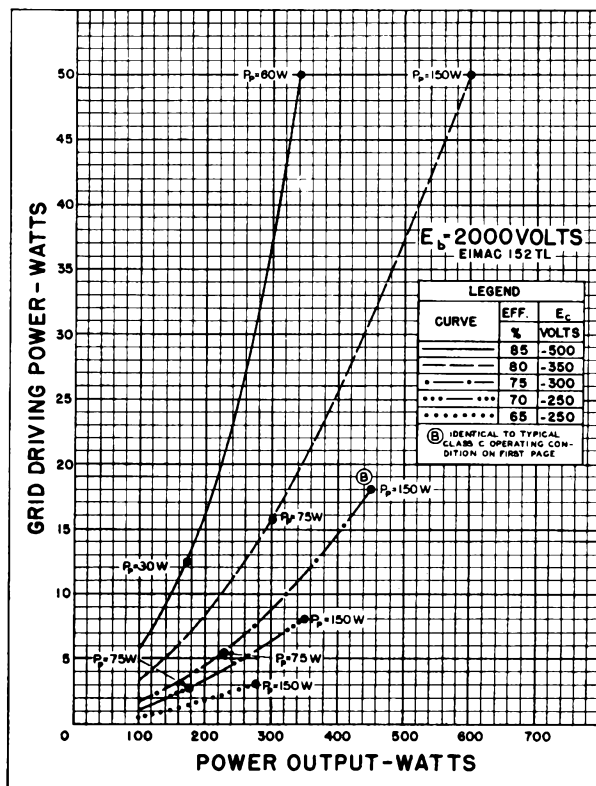
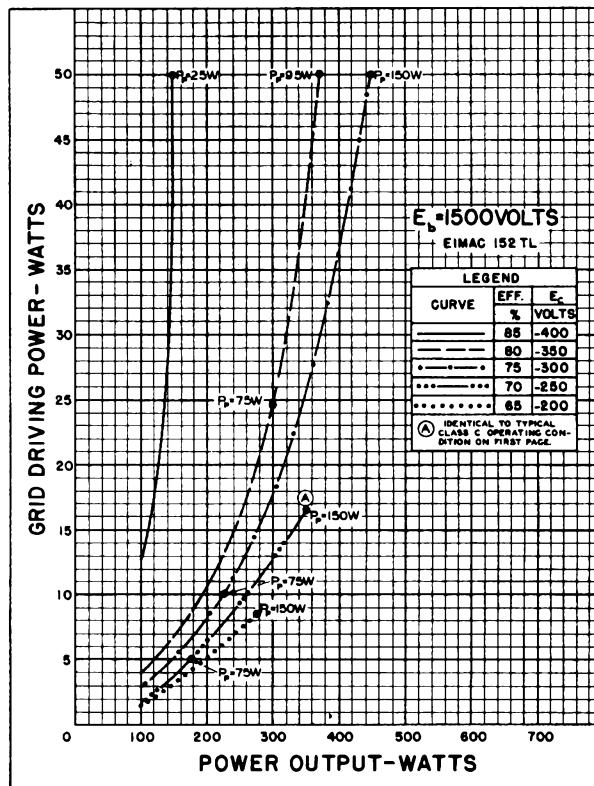

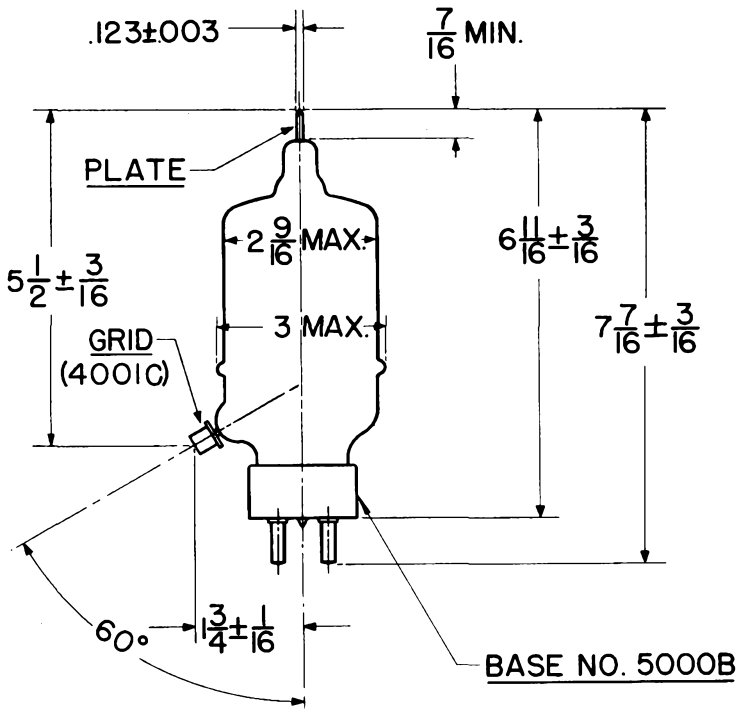
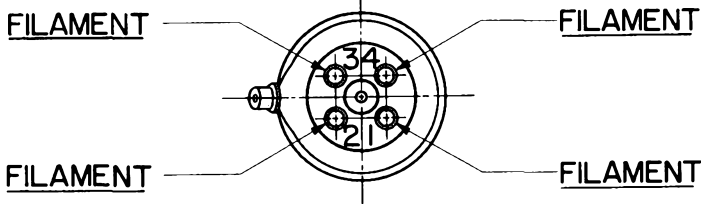
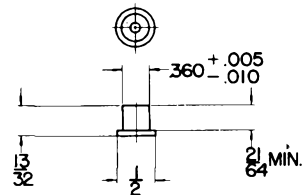
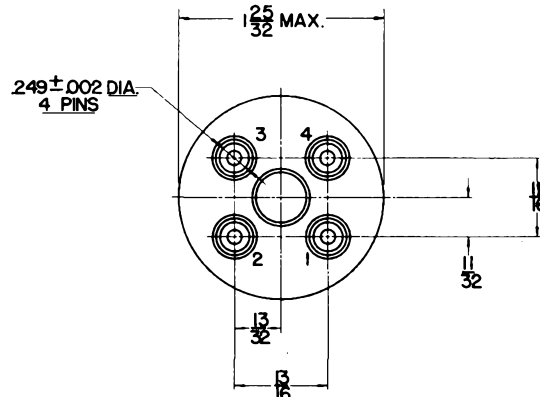
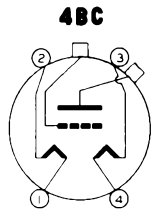
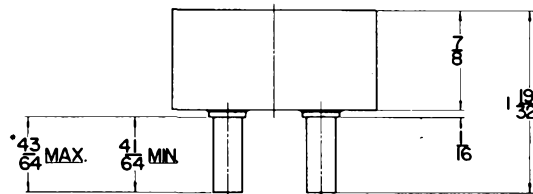

PLATE CAP  
 (SEE TUBE OUTLINE DRAWING)

GRID CAP  
 NO. 4001C



BASE NO. 5000B



\*ON FINISHED TUBE ADD .060 FOR SOLDER



# Eitel-McCullough, Inc.

SAN BRUNO, CALIFORNIA

# 304TH

MEDIUM-MU TRIODE  
MODULATOR  
OSCILLATOR  
AMPLIFIER

The Eimac 304TH is a medium-mu power triode intended for use as an amplifier, oscillator or modulator. It has a maximum plate-dissipation rating of 300 watts and a maximum plate-voltage rating of 3000 volts at frequencies up to 40 Mc.

The 304TH in class-C r-f service will deliver up to 1200 watts plate power output with 53 watts driving power. Two 304TH's in class-AB<sub>2</sub> modulator service will deliver up to 1400 watts maximum-signal plate power output with 14 watts nominal driving power.

## GENERAL CHARACTERISTICS

### ELECTRICAL

Filament: Thoriated Tungsten	
Voltage	5.0 or 10.0 volts
Current	25.0 or 12.5 amperes
Amplification Factor (Average) - 20	
Direct Interelectrode Capacitances (Average)	
Grid-Plate	10.2 μμf
Grid-Filament	13.5 μμf
Plate-Filament	0.7 μμf
Transconductance (I <sub>b</sub> = 1.0 amp., E <sub>b</sub> = 3000 v.) - 16,700 μμhos	
Highest Frequency for Maximum Ratings - 40 Mc	

### MECHANICAL

Base	Special 4-pin
Basing	See outline drawing
Socket	Johnson type No. 124-213 or equivalent
Mounting Position	
Cooling	Vertical, base down or up Convection and radiation
Maximum Temperature of Plate and Grid Seals	225° C
Recommended Heat-Dissipating Connectors:	
Plate	Eimac HR-7
Grid	Eimac HR-6
Maximum Over-all Dimensions:	
Length	7.63 inches
Diameter	3.56 inches
Net Weight	9 ounces
Shipping Weight	3.0 pounds

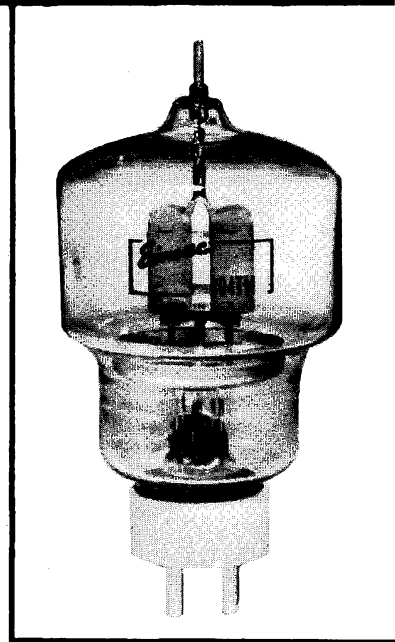

### RADIO-FREQUENCY POWER AMPLIFIER OR OSCILLATOR

Class-C Telegraphy (Key-down conditions, one tube)  
MAXIMUM RATINGS (Frequencies up to 40 Mc.)

D-C PLATE VOLTAGE	3000 MAX. VOLTS
D-C PLATE CURRENT	900 MAX. MA
PLATE DISSIPATION	300 MAX. WATTS
GRID DISSIPATION	60 MAX. WATTS

TYPICAL OPERATION (Frequencies up to 40 Mc.)

D-C Plate Voltage	1500	2000	3000 volts
D-C Grid Voltage	-125	-200	-300 volts
D-C Plate Current	865	600	500 ma
D-C Grid Current*	115	125	135 ma
Peak R-F Grid Voltage	250	325	395 volts
Driving Power*	25	39	53 watts
Grid Dissipation*	16	12	16 watts
Plate Dissipation	300	300	300 watts
Plate Power Input	1000	1200	1500 watts
Plate Power Output	700	900	1200 watts

### ▶ PLATE-MODULATED RADIO-FREQUENCY AMPLIFIER

Class-C Telephony (Carrier conditions, per tube)  
MAXIMUM RATINGS (Frequencies up to 40 Mc.)

D-C PLATE VOLTAGE	2500 MAX. VOLTS
D-C PLATE CURRENT	750 MAX. MA
PLATE DISSIPATION	200 MAX. WATTS
GRID DISSIPATION	60 MAX. WATTS

TYPICAL OPERATION (Frequencies up to 40 Mc.)

D-C Plate Voltage	1500	2000	2500 volts
D-C Grid Voltage	-200	-300	-350 volts
D-C Plate Current	420	440	400 ma
D-C Grid Current*	55	60	60 ma
Peak R-F Grid Voltage	330	440	485 volts
Driving Power*	18	26	29 watts
Grid Dissipation*	7	8	8 watts
Plate Dissipation	200	200	200 watts
Plate Power Input	700	880	1000 watts
Plate Power Output	500	680	800 watts

### ▶ AUDIO-FREQUENCY POWER AMPLIFIER OR MODULATOR

Class-AB<sub>2</sub>  
MAXIMUM RATINGS (Per tube)

D-C PLATE VOLTAGE	3000 MAX. VOLTS
D-C PLATE CURRENT	900 MAX. MA
PLATE DISSIPATION	300 MAX. WATTS

TYPICAL OPERATION (Sinusoidal wave, two tubes unless otherwise specified.)

D-C Plate Voltage	1500	2000	3000 volts
D-C Grid Voltage <sup>1</sup>	-65	-90	-150 volts
Zero Signal D-C Plate Current	265	200	135 ma
Max. Signal D-C Plate Current	1065	900	665 ma
Effective Load Plate-to-Plate	2840	4820	10,200 ohms
Peak A-F Grid Voltage (per tube)	165	175	210 volts
Max. Signal Peak Driving Power*	50	37	27 watts
Max. Signal Nominal Driving Power*	25	19	14 watts
Max. Signal Plate Power Input	1600	1800	2000 watts
Max. Signal Plate Power Output	1000	1200	1400 watts

\* Approximate values.  
<sup>1</sup> Adjust to give stated Zero-Signal D-C Plate Current.

IF IT IS DESIRED TO OPERATE THIS TUBE UNDER CONDITIONS WIDELY DIFFERENT FROM THOSE GIVEN UNDER "TYPICAL OPERATION," POSSIBLY EXCEEDING THE MAXIMUM RATINGS GIVEN FOR CW SERVICE, WRITE EITEL-McCULLOUGH, INC., FOR INFORMATION AND RECOMMENDATIONS.

**APPLICATION**

**MECHANICAL**

**Mounting**—The 304TH must be mounted vertically, base down or up. The plate and grid leads should be flexible, and the tube must be protected from vibration and shock.

**Cooling**—Heat Dissipating Connectors (Eimac HR-7 and HR-6 or equivalent) must be used at the plate and grid terminals of the 304TH. Forced-air cooling is not required in properly designed equipment operating at frequencies below 40 Mc. If the free circulation of air around the tube is restricted, a small fan or centrifugal blower should be used to provide additional cooling.

The temperature of the plate and grid seals must not be allowed to exceed 225° C. One method of measuring these temperatures is by the use of "Tempilaq," a temperature-sensitive lacquer manufactured by the Tempil Corporation, 132 W. 22nd St., New York 11, N. Y.

**ELECTRICAL**

**Filament Voltage**—The filaments of the 304TH may be operated either at 10.0 volts when connected in series or at 5.0 volts when connected in parallel (see basing diagram). For maximum tube life the filament voltage should be maintained at the rated value. Variations must not be allowed to exceed ± 5%.

**Bias Voltage**—When grid-leak bias is used, suitable protective means must be provided to prevent excessive plate dissipation in the event of loss of excitation, and the grid-leak resistor should be made adjustable to facilitate maintaining the bias voltage and plate current at the desired value from tube to tube.

**Grid Dissipation**—The power dissipated by the grid of the 304TH must not exceed 60 watts. Grid dissipation may be calculated from the following expression.

$$P_g = e_{cmp} I_c$$

where  $P_g$  = grid dissipation,  
 $e_{cmp}$  = peak positive grid voltage, and  
 $I_c$  = d-c grid current.

$e_{cmp}$  may be measured by means of a suitable peak-reading voltmeter connected between filament and grid.† In equipment in which the plate loading varies widely, such as oscillators used for radio-frequency heating, care should be taken to make certain that the grid dissipation does not exceed the maximum rating under any condition of loading.

**Plate Dissipation**—The plates of the 304TH operate at a visible red color at the maximum rated dissipation of 300 watts. Plate dissipation in excess of the maximum rating is permissible only for short periods of time, such as during tuning procedures.

†For suitable peak v.t.v.m. circuits see, for instance, "Vacuum Tube Ratings," Eimac News, January, 1945. This article is available in reprint form on request.

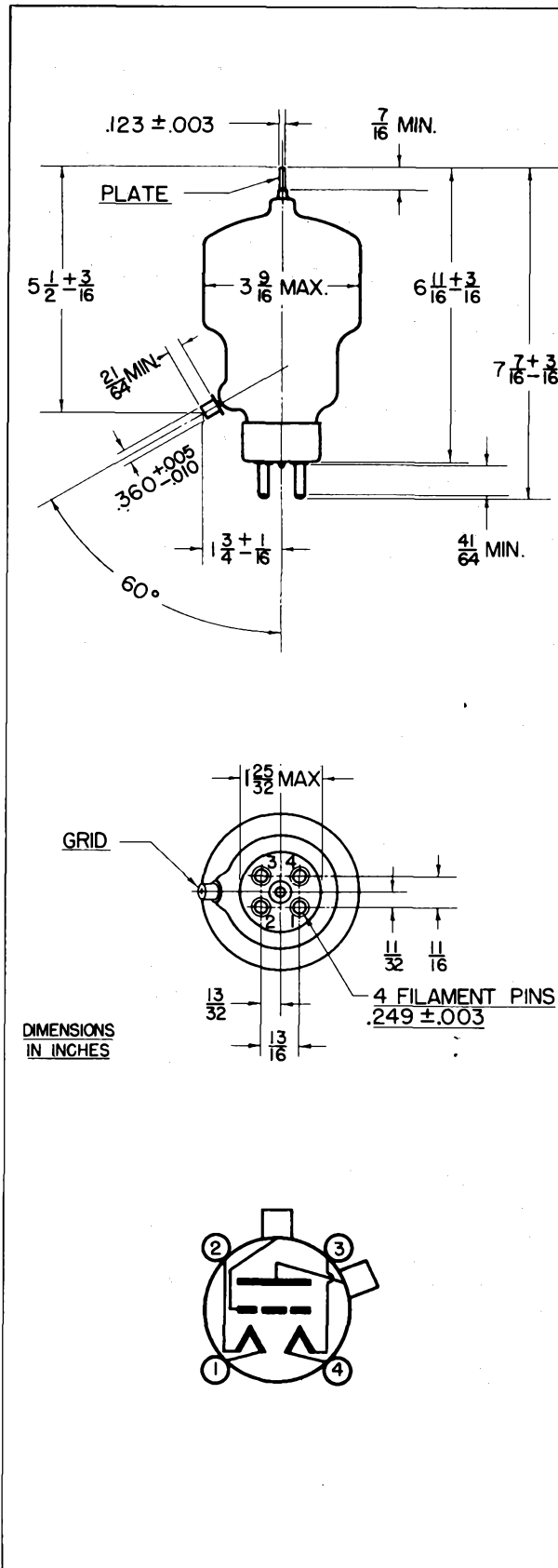

## DRIVING POWER vs. POWER OUTPUT

The three charts on this page show the relationship of plate efficiency, power output and approximate grid driving power at plate voltages of 1500, 2000 and 3000 volts. These charts show combined grid and bias losses only. The driving power and power output figures do not include circuit losses. The plate dissipation in watts is indicated by  $P_p$ .

Points A, B, and C are identical to the typical Class C operating conditions shown on the first page under 1500, 2000, and 3000 volts respectively.

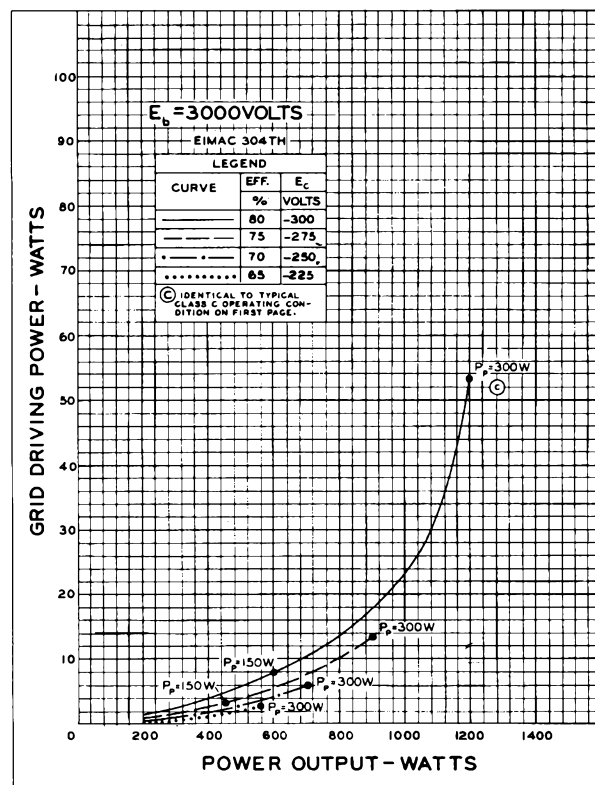
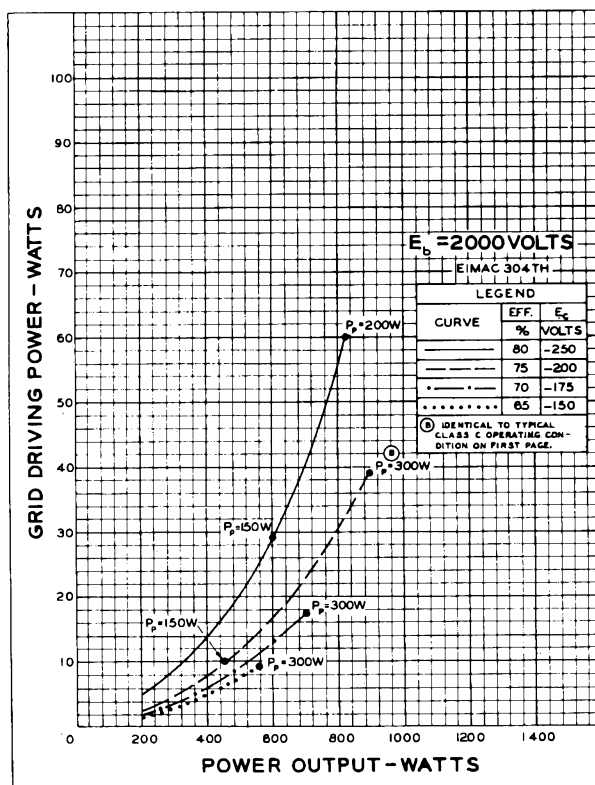
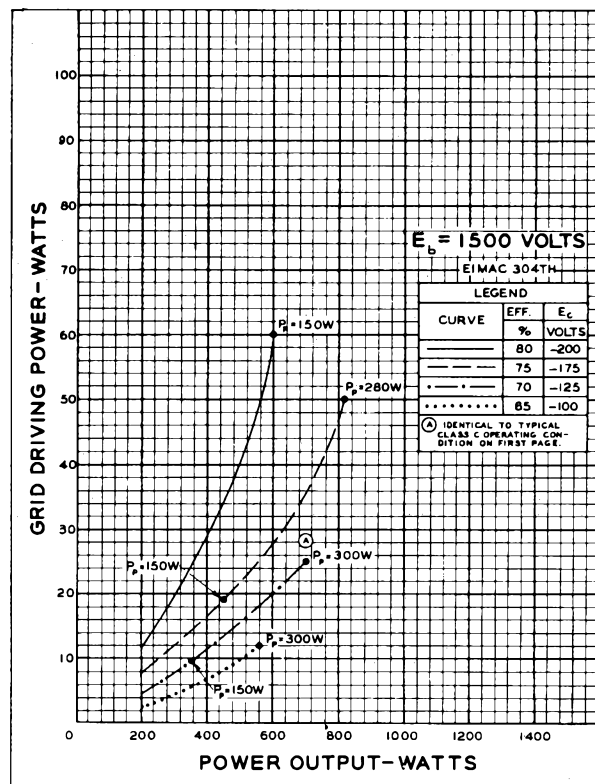

EIMAC 304TH  
TYPICAL CONSTANT CURRENT  
CHARACTERISTICS

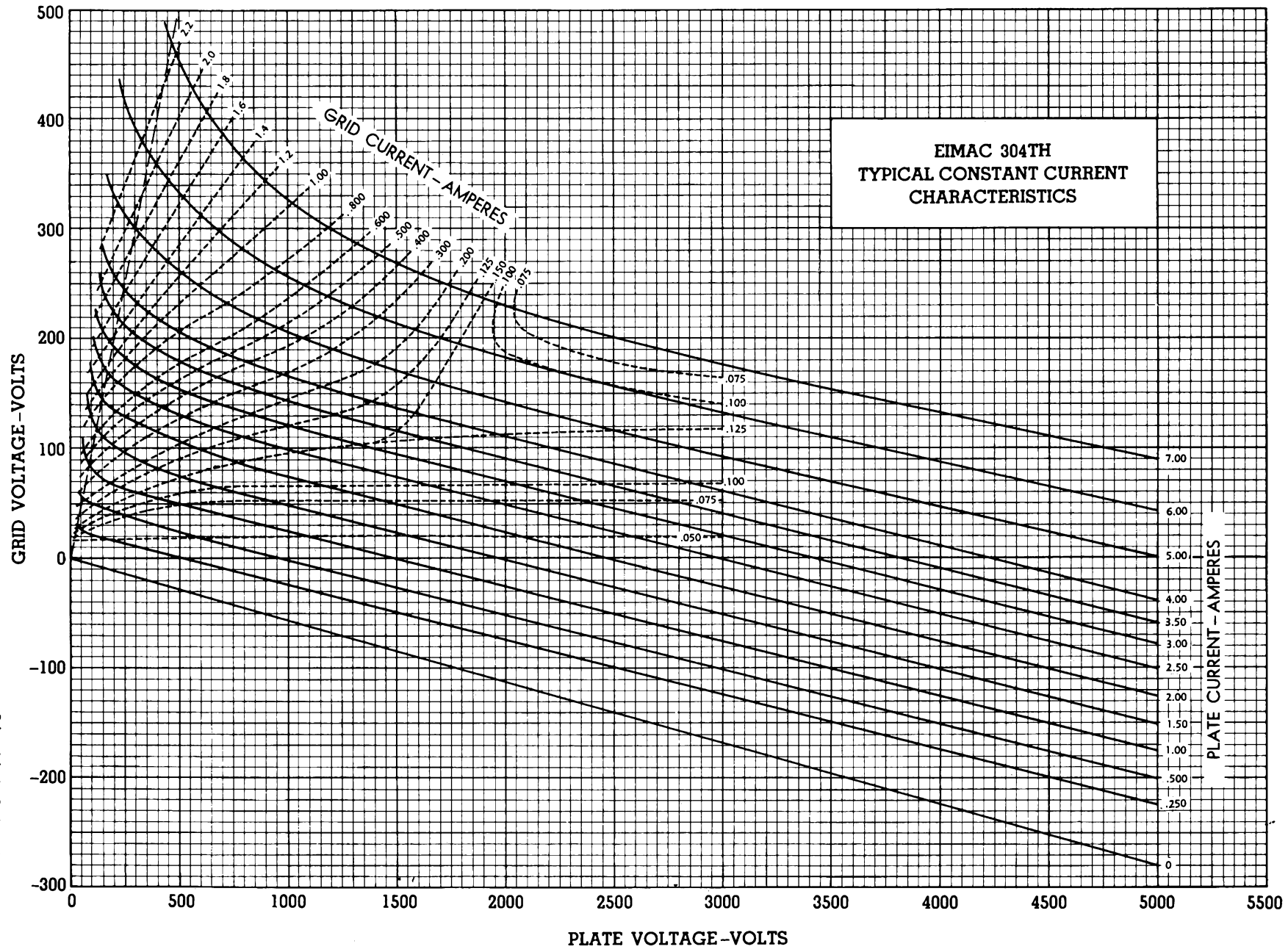

Printed in U. S. A. 2-FA-68148



# EITEL-McCULLOUGH, INC.

SAN BRUNO, CALIFORNIA

# 304TL

LOW-MU TRIODE  
 MODULATOR  
 OSCILLATOR  
 AMPLIFIER

The Eimac 304TL is a low-mu, power triode having a maximum plate dissipation rating of 300 watts, and is intended for use as an amplifier, oscillator or modulator, where maximum performance can be obtained at low plate voltage. It can be used at its maximum ratings at frequencies as high as 40-Mc.  
 Cooling of the 304TL is accomplished by radiation from the plate, which operates at a visible red color at maximum dissipation, and by means of air convection around the envelope.

## GENERAL CHARACTERISTICS

### ELECTRICAL

Filament: Thoriated tungsten	
Voltage	5.0 or 10.0 volts
Current	25.0 or 12.5 amperes
Amplification Factor (Average)	12
▶ Direct Interelectrode Capacitances (Average)	
Grid-Plate	8.6 $\mu\mu\text{f}$
Grid-Filament	12.1 $\mu\mu\text{f}$
Plate-Filament	.8 $\mu\mu\text{f}$
▶ Transconductance ( $i_b=1.0$ amp., $E_b=3000$ v., $e_c=-175$ v.)	16,700 $\mu\text{mhos}$
Frequency for Maximum Ratings	40 Mc.

### MECHANICAL

Base	Special 4 pin, No. 5000B
Basing	RMA type 4BC
▶ Mounting	Vertical, base down or up
▶ Cooling	Convection and Radiation
▶ Recommended Heat Dissipating Connectors:	
Plate	HR-7
Grid	HR-6
Maximum Overall Dimensions:	
Length	7.625 inches
Diameter	3.563 inches
▶ Net weight	9 ounces
▶ Shipping weight (Average)	2 pounds

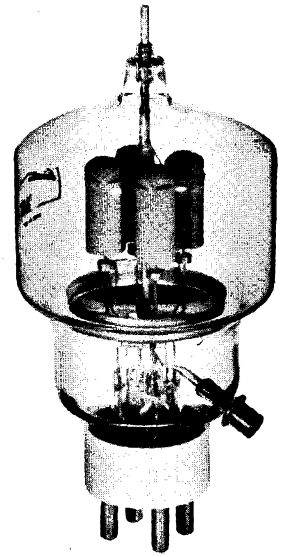

### AUDIO FREQUENCY POWER AMPLIFIER AND MODULATOR

Class B (Sinusoidal wave, two tubes unless otherwise specified)

#### MAXIMUM RATINGS

D-C PLATE VOLTAGE	3000 MAX. VOLTS
MAX-SIGNAL D-C PLATE CURRENT, PER TUBE	900 MAX. MA.
PLATE DISSIPATION, PER TUBE	300 MAX. WATTS

#### ▶ TYPICAL OPERATION, CLASS AB<sub>1</sub>

D-C Plate Voltage	1500	2000	2500	3000	Volts
D-C Grid Voltage (approx.)*	-118	-170	-230	-290	Volts
Zero-Signal D-C Plate Current	270	200	160	130	Ma.
Max-Signal D-C Plate Current	572	546	483	444	Ma.
Effective Load, Plate-to-Plate	2540	5300	8500	12,000	Ohms
Peak A-F Grid Input Voltage (per tube)	118	170	230	290	Volts
Max-Signal Peak Driving Power	0	0	0	0	Watts
Max-Signal Plate Power Output	256	490	610	730	Watts

\*Adjust to give stated zero-signal plate current. The effective grid circuit resistance for each tube must not exceed 250,000 ohms.

#### ▶ TYPICAL OPERATION, CLASS AB<sub>2</sub>

D-C Plate Voltage	1500	2000	2500	3000	Volts
D-C Grid Voltage (approx.)*	-118	-170	-230	-290	Volts
Zero-Signal D-C Plate Current	270	200	160	130	Ma.
Max-Signal D-C Plate Current	1140	1000	900	800	Ma.
Effective Load, Plate-to-Plate	2750	4500	6600	9100	Ohms
Peak A-F Grid Input Voltage (per tube)	245	290	340	390	Volts
Max-Signal Peak Driving Power	78	87	95	110	Watts
Max-Signal Nominal Driving Power (approx.)	39	44	48	55	Watts
Max-Signal Plate Power Output	1100	1400	1650	1800	Watts

\*Adjust to give stated zero-signal plate current.

(Effective 5-1-49) Copyright, 1949 by Eitel-McCullough, Inc.

### ▶ PLATE MODULATED RADIO FREQUENCY AMPLIFIER

Class-C Telephony (Carrier conditions, per tube)

#### MAXIMUM RATINGS

D-C PLATE VOLTAGE	2500 MAX. VOLTS
D-C PLATE CURRENT	700 MAX. MA.
PLATE DISSIPATION	200 MAX. WATTS
GRID DISSIPATION	50 MAX. WATTS

#### TYPICAL OPERATION (Power input limited to 500 and 1000 watts)\*

D-C Plate Voltage	2000	2000	2500	2500	Volts
D-C Plate Current	250	500	200	400	Ma.
Total Bias Voltage	-500	-500	-525	-550	Volts
Fixed Bias Voltage	-410	-275	-300	-300	Volts
Grid Resistor	3000	3000	12,500	5000	Ohms
D-C Grid Current	30	75	18	50	Ma.
Peak R-F Grid Input Voltage	615	690	620	715	Volts
Driving Power	18	52	11	36	Watts
Grid Dissipation	3	15	2	9	Watts
Plate Power Input	500	1000	500	1000	Watts
Plate Dissipation	90	190	75	170	Watts
Plate Power Output	410	810	425	830	Watts

\*The figures are for convenience in obtaining a 500 or 1000 Watt carrier input per tube to the modulated amplifier. The output figures do not allow for circuit losses.

#### TYPICAL OPERATION\*

D-C Plate Voltage	1500	2000	2500	Volts
D-C Plate Current	520	525	450	Ma.
Total Bias Voltage	-370	-500	-550	Volts
Fixed Bias Voltage	-160	-260	-440	Volts
Grid Resistor	2800	3000	2000	Ohms
D-C Grid Current	75	80	55	Ma.
Peak R-F Grid Input Voltage	545	695	720	Volts
Driving Power	41	55	40	Watts
Grid Dissipation	13	15	10	Watts
Plate Power Input	780	1050	1125	Watts
Plate Dissipation	200	200	200	Watts
Power Output	580	850	925	Watts

\*The figures are for one tube operating at maximum plate dissipation as a plate modulated Class C amplifier. The output figures do not allow for circuit losses.

(Continued on Next Page)

**RADIO FREQUENCY POWER AMPLIFIER  
 AND OSCILLATOR**

Class-C Telegraphy or FM Telephony  
 (Key-down conditions, per tube)

**MAXIMUM RATINGS**

D-C PLATE VOLTAGE	- - - -	3000 MAX. VOLTS
D-C PLATE CURRENT	- - - -	900 MAX. MA.
PLATE DISSIPATION	- - - -	300 MAX. WATTS
GRID DISSIPATION	- - - -	50 MAX. WATTS

**TYPICAL OPERATION\***

D-C Plate Voltage	- - - -	1500	2000	3000	Volts
D-C Grid Voltage	- - - -	-250	-300	-400	Volts
D-C Plate Current	- - - -	665	600	500	Ma.
D-C Grid Current	- - - -	90	85	80	Ma.
Peak R-F Grid Input Voltage	- - - -	430	480	575	Volts
Driving Power (approx.)	- - - -	33	36	40	Watts
Grid Dissipation	- - - -	11	11	8	Watts
Plate Power Input	- - - -	1000	1200	1500	Watts
Plate Dissipation	- - - -	300	300	300	Watts
Plate Power Output	- - - -	700	900	1200	Watts

\*The figures show actual measured tube performance, and do not allow for circuit losses.

► Indicates change from sheet dated 1-1-44

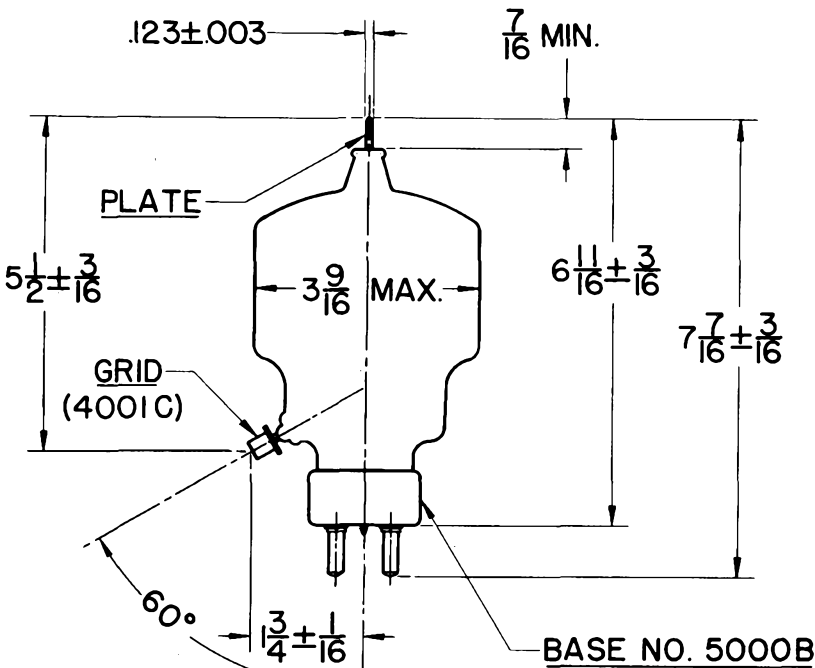

GRID CAP  
 NO. 4001C

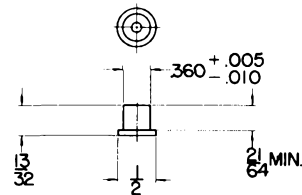

BASE NO. 5000B

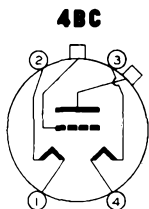
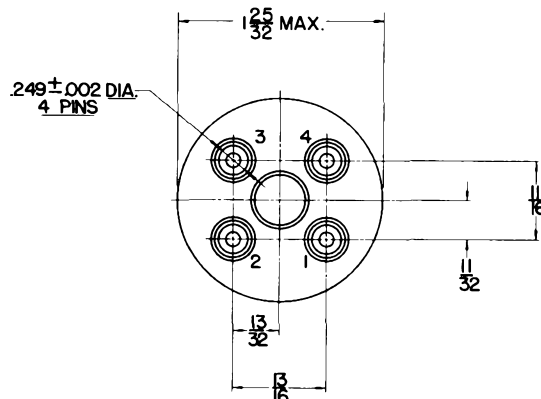
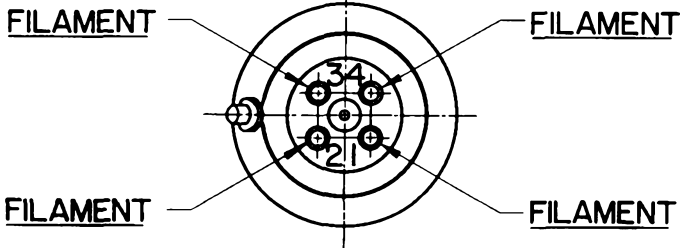
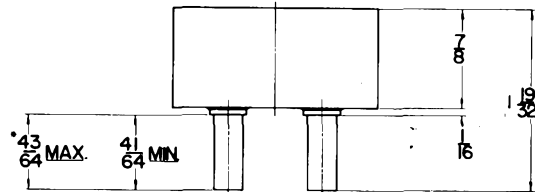

\*ON FINISHED TUBE ADD .060 FOR SOLDER

## DRIVING POWER vs. POWER OUTPUT

The three charts on this page show the relationship of plate efficiency, power output and grid driving power at plate voltages of 1500, 2000 and 3000 volts. These charts show combined grid and bias losses only. The driving power and power output figures do not include circuit losses. The plate dissipation in watts is indicated by  $P_p$ .

Points A, B, and C are identical to the typical Class C operating conditions shown on the first page under 1500, 2000, and 3000 volts respectively.

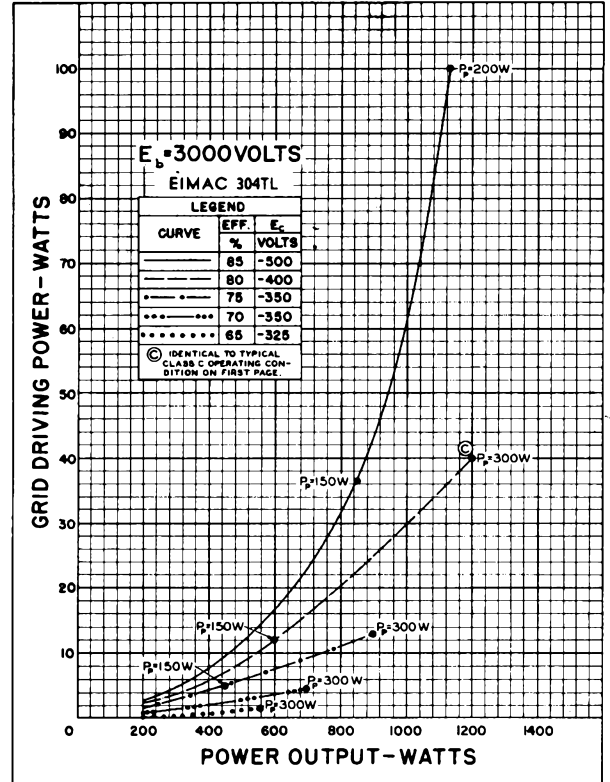
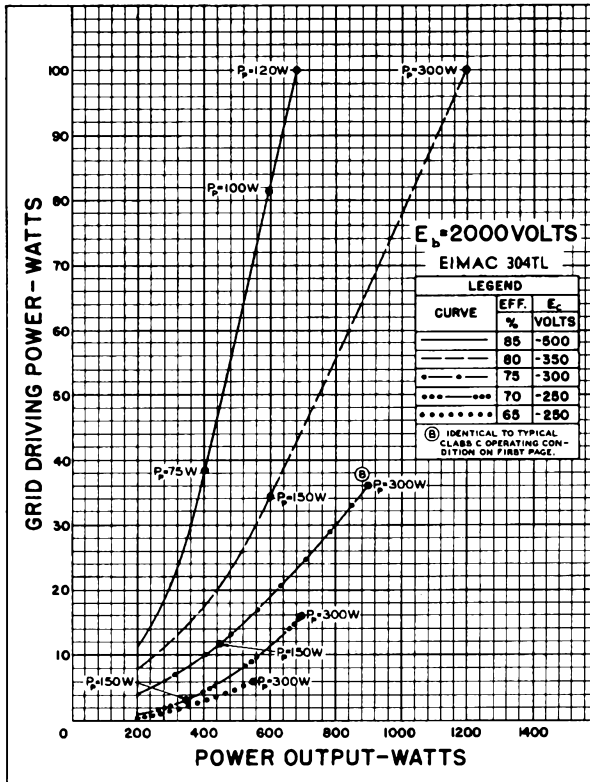
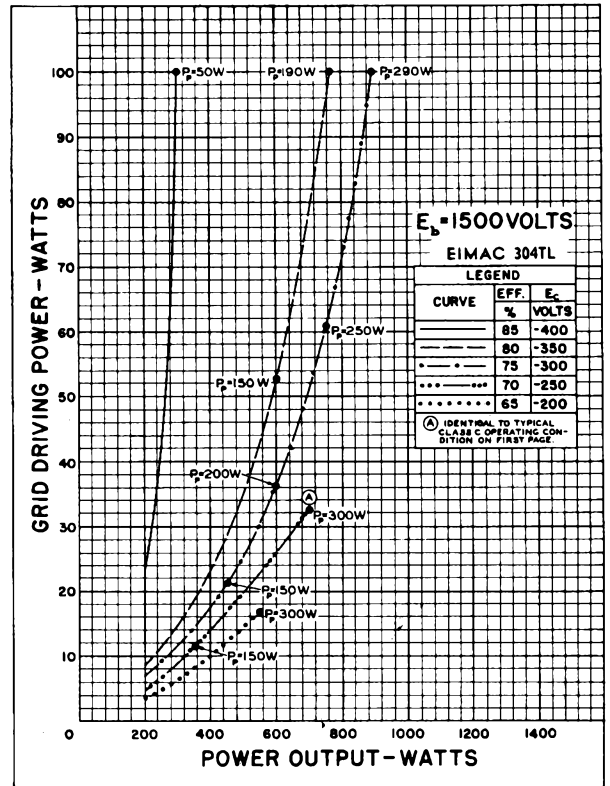

**Eimac** 304TL

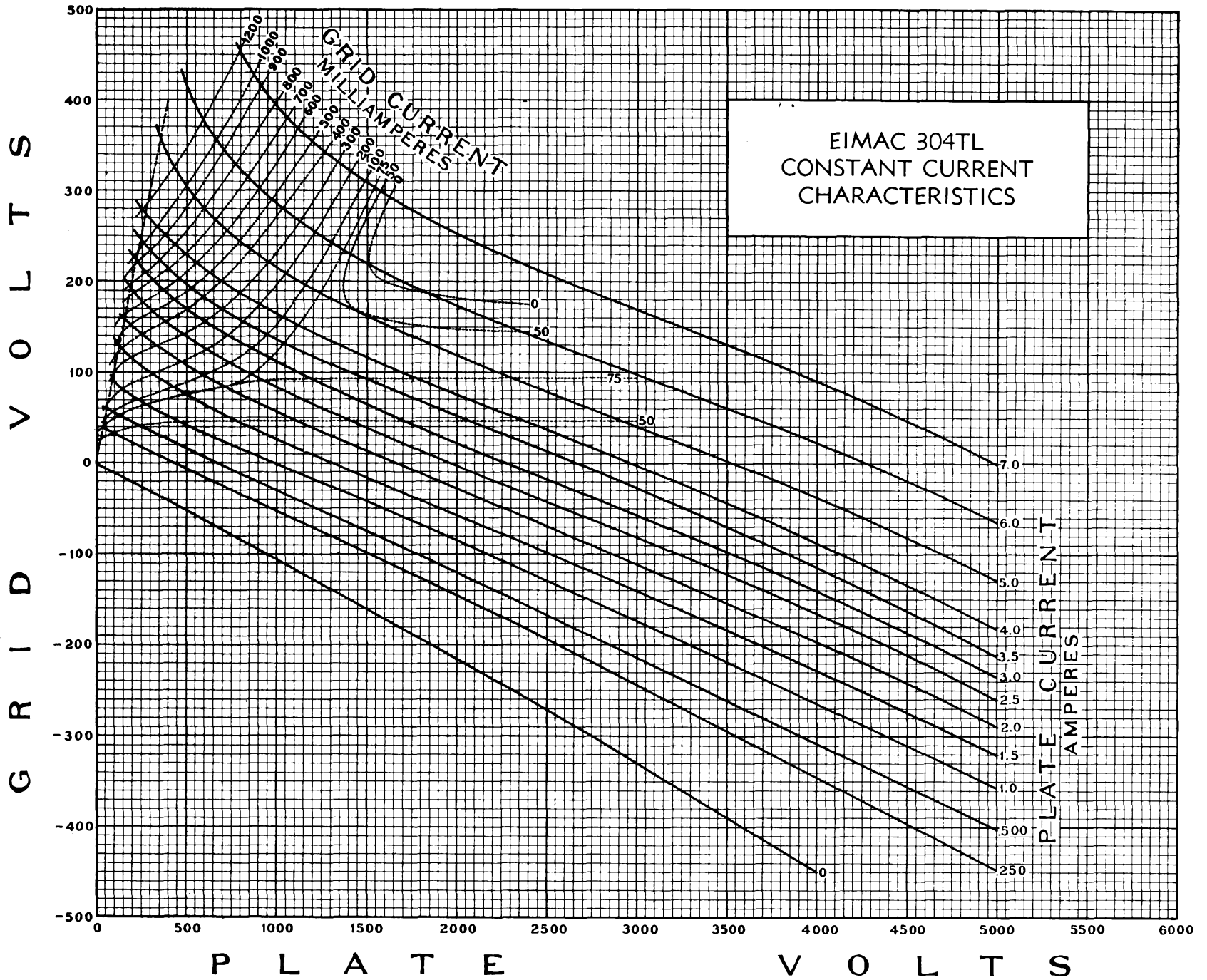



# EITEL-McCULLOUGH, INC.

SAN BRUNO, CALIFORNIA

# 450TH

HIGH-MU TRIODE  
MODULATOR  
OSCILLATOR  
AMPLIFIER

The Eimac 450TH is a high-mu power triode having a maximum plate dissipation rating of 450 watts, and is intended for use as an amplifier, oscillator and modulator. It can be used at its maximum ratings at frequencies as high as 40 Mc.

Cooling of the 450TH is accomplished by radiation from the plate, which operates at a visible red color at maximum dissipation, and by means of air circulation around the envelope.

## GENERAL CHARACTERISTICS

### ELECTRICAL

Filament: Thoriated tungsten	
Voltage	7.5 volts
Current	12.0 amperes
Note: Dual connections for each filament lead are provided within the base of the tube (see basing diagram). Corresponding socket terminals must be connected in parallel to provide proper distribution of filament and R-F charging currents.	
Amplification Factor (Average)	38
Direct Interelectrode Capacitances (Average)	
Grid-plate	5.0 $\mu\mu\text{fd.}$
Grid-Filament	8.8 $\mu\mu\text{fd.}$
Plate-Filament	0.8 $\mu\mu\text{fd.}$
Transconductance ( $i_b = 500 \text{ ma.}, E_b = 4000 \text{ v.}$ )	6650 $\mu\text{mhos}$
Frequency for maximum ratings	40 Mc.

### MECHANICAL

Base	Special 4 pin, No. 5002B
Basing	RMA type 4AQ
Mounting	Vertical, base down or up
Cooling	Radiation and air circulation

Note: Adequate ventilation or air cooling must be provided so that the seals and envelope do not exceed 200°C under operating conditions.

Socket Johnson Type No. 211 or National Type No. XM50 or equivalent.

Recommended Heat Dissipating Connectors:

Plate	Eimac HR-8
Grid	Eimac HR-8

Note: The grid terminal of the 450TH is now .560" in diameter. To accommodate existing equipment designed for the older style 450TH having .098" diameter grid terminals, an adapter pin is provided with the newer tubes. This adapter pin is threaded so that it may be removed from the grid terminal of the tube. The small grid terminal, if used, requires an HR-4 heat dissipating connector. (See outline drawing.)

Maximum Overall Dimensions:

Length	12.625 inches
Diameter	5.125 inches
Net weight	1.3 pounds
Shipping weight (Average)	5.6 pounds

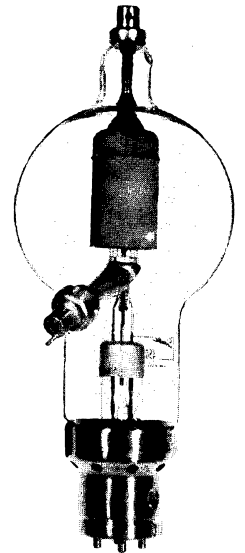

### AUDIO FREQUENCY POWER AMPLIFIER AND MODULATOR

Class AB<sub>2</sub> (Sinusoidal wave, two tubes unless otherwise specified)

#### MAXIMUM RATINGS

D-C PLATE VOLTAGE	6000 MAX. VOLTS
MAX-SIGNAL D-C PLATE CURRENT PER TUBE	600 MAX. MA.
PLATE DISSIPATION, PER TUBE	450 MAX. WATTS

#### TYPICAL OPERATION—2 TUBES

D-C Plate Voltage	3000	4000	5000	Volts
D-C Grid Voltage (approx.)*	-50	-85	-115	Volts
Zero-Signal D-C Plate Current	200	150	120	Ma.
Max-Signal D-C Plate Current	770	675	620	Ma.
Effective Load, Plate-to-Plate	7800	12,800	18,600	Ohms
Peak A-F Grid Input Voltage (per tube)	225	235	267	Volts
Max-Signal Peak Driving Power	40	34	40	Watts
Max-Signal Nominal Driving Power (approx.)	20	17	20	Watts
Max-Signal Plate Power Output	1400	1800	2200	Watts

\*Adjust to give stated zero-signal plate current.

### PLATE MODULATED RADIO FREQUENCY AMPLIFIER

Class-C Telephony (Carrier conditions, per tube)

#### MAXIMUM RATINGS

D-C PLATE VOLTAGE	4500 MAX. VOLTS
D-C PLATE CURRENT	500 MAX. MA.
PLATE DISSIPATION	300 MAX. WATTS
GRID DISSIPATION	80 MAX. WATTS

#### TYPICAL OPERATION, PER TUBE\*

D-C Plate Voltage	3000	4000	4500	Volts
D-C Plate Current	380	340	345	Ma.
Total Bias Voltage	-250	-300	-350	Volts
Fixed Bias Voltage	-100	-150	-175	Volts
Grid Resistor	2500	3500	3500	Ohms
D-C Grid Current	60	43	50	Ma.
Peak R-F Grid Input Voltage	490	525	585	Volts
Driving Power (approx.)	30	23	29	Watts
Grid Dissipation	14	10	12	Watts
Plate Power Input	1150	1360	1550	Watts
Plate Dissipation	300	300	300	Watts
Plate Power Output	850	1060	1250	Watts

\*The figures are for one tube operating at maximum plate dissipation as a plate modulated Class-C amplifier. The output figures do not allow for circuit losses.

## RADIO FREQUENCY POWER AMPLIFIER AND OSCILLATOR

Class-C Telegraphy or FM Telephony (Key-down conditions, per tube).

### MAXIMUM RATINGS

D-C PLATE VOLTAGE	6000 MAX. VOLTS
D-C PLATE CURRENT	600 MAX. MA.
PLATE DISSIPATION	450 MAX. WATTS
GRID DISSIPATION	80 MAX. WATTS

### TYPICAL OPERATION, PER TUBE\*

D-C Plate Voltage	3000	4000	5000	Volts
D-C Grid Voltage	-175	-200	-300	Volts
D-C Plate Current	500	450	450	Ma.
D-C Grid Current	95	85	90	Ma.
Peak R-F Grid Input Voltage	400	410	570	Volts
Driving Power (approx.)	35	35	46	Watts
Grid Dissipation	21	18	24	Watts
Plate Power Input	1500	1800	2250	Watts
Plate Dissipation	450	450	450	Watts
Plate Power Output	1050	1350	1800	Watts

\*The figures show actual measured tube performance and do not allow for circuit losses.

## APPLICATION

### MECHANICAL

**Mounting**—The 450TH must be mounted vertically, base up or base down. Flexible connecting straps should be provided from the grid and plate terminals to the external grid and plate circuits. The tube must be protected from severe vibration and shock.

**Cooling**—Provision should be made for ample circulation of air around the 450TH. In the event that the design of the equipment restricts natural circulation, the use of a small fan or centrifugal blower to provide additional cooling for the tube will aid in obtaining maximum tube life. Special heat-dissipating connectors (Eimac HR-8) are available for use on the plate and grid terminals. These connectors help to prolong tube life by reducing the temperature of the seals.

### ELECTRICAL

**Filament Voltage**—For maximum tube life the filament voltage, as measured directly at the filament pins, should be the rated value of 7.5 volts. Unavoidable variations in filament voltage must be kept within the range from 7.03 to 7.88 volts. All four socket terminals should be used, putting two in parallel for each filament connection.

**Bias Voltage**—Although there is no maximum limit on the bias voltage which may be used on the 450TH, there is little advantage in using bias voltages in excess of those given under "Typical Operation," except in certain very specialized applications. Where bias is obtained by a grid leak, suitable protective means must be provided to prevent excessive plate dissipation in the event of loss of excitation.

**Grid Dissipation**—The power dissipated by the grid of the

450TH must not exceed 80 watts. Grid dissipation may be calculated from the following expression:

$$P_g = e_{cmp} I_c$$

where  $P_g$  = Grid dissipation,

$e_{cmp}$  = Peak positive grid voltage, and

$I_c$  = D-c grid current.

$e_{cmp}$  may be measured by means of a suitable peak voltmeter connected between filament and grid. In equipment in which the plate loading varies widely, such as oscillators used for radio-frequency heating, care should be taken to make certain that the grid dissipation does not exceed the maximum rating under any conditions of loading.

**Plate Voltage**—Except in very special applications, the plate supply voltage for the 450TH should not exceed 6000 volts. In most cases there is little advantage in using plate-supply voltages higher than those given under "Typical Operation" for the power output desired.

**Plate Dissipation**—Under normal operating conditions, the power dissipated by the plate of the 450TH should not be allowed to exceed 450 watts. At this dissipation the brightness temperature of the plate will appear a visible red color. The value of this color is somewhat effected by light from the filament as well as from external sources. Plate dissipation in excess of the maximum rating is permissible for short periods of time, such as during tuning procedures.

\*For suitable peak v.t.v.m. circuits see, for instance, "Vacuum Tube Ratings," Eimac News, January, 1945. This article is available in reprint form on request.

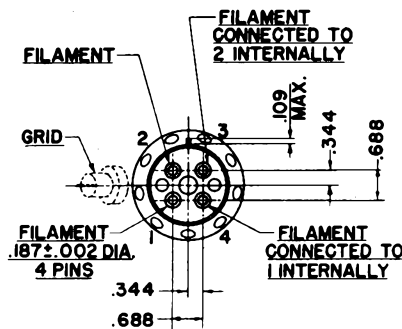
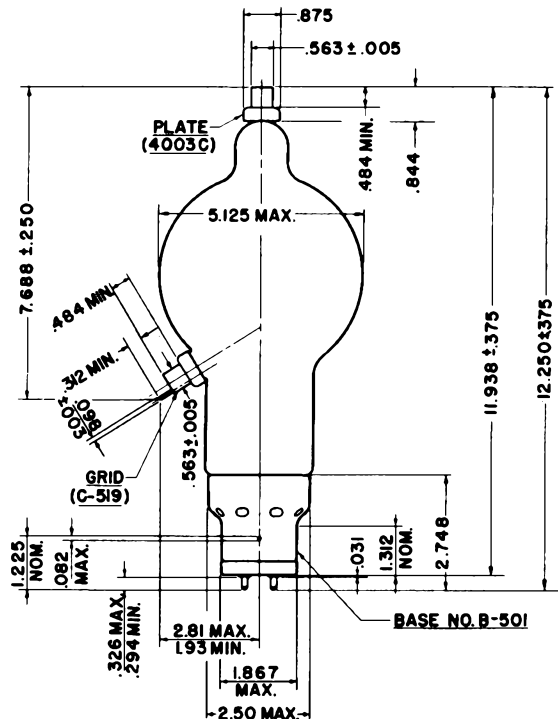

BOTTOM VIEW

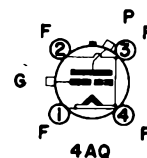

**NOTE:**—The grid terminal on the new 450TH and TL type tube is now .563" in diameter. To accommodate existing equipment which uses the 450TH or TL tubes with the old style .098" grid terminal, an adapter pin is provided. This adapter pin, if not needed, may be removed by unscrewing.

► Indicates change from sheet dated 10-1-49

## DRIVING POWER vs. POWER OUTPUT

The three charts on this page show the relationship of plate efficiency, power output and grid driving power at plate voltages of 3000, 4000, and 5000 volts. These charts show combined grid and bias losses only. The driving power and power output figures do not include circuit losses. The plate dissipation in watts is indicated by  $P_p$ .

Points A, B, and C are identical to the typical Class C operating conditions shown on the first page under 3000, 4000, and 5000 volts respectively.

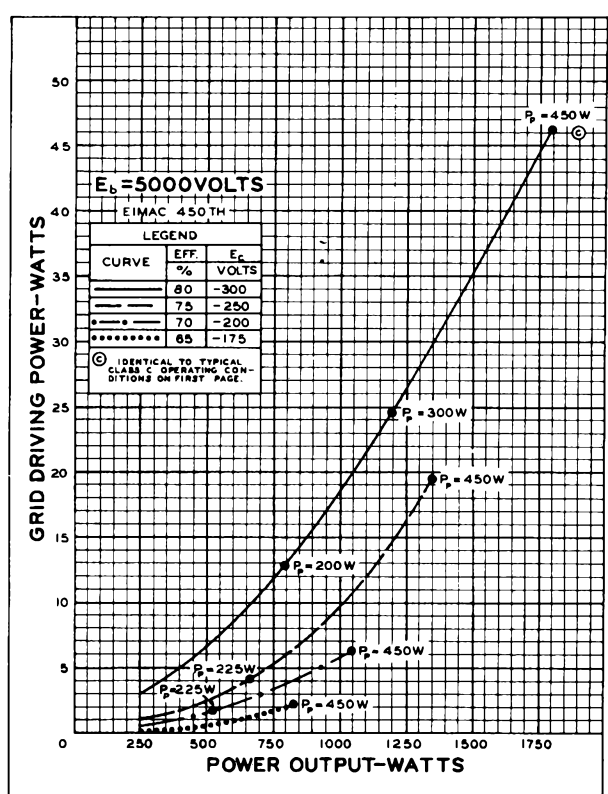
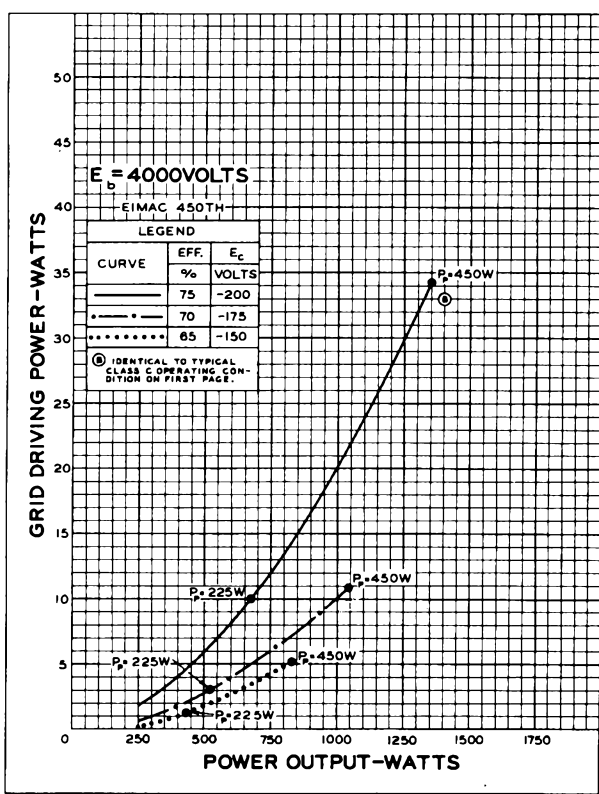
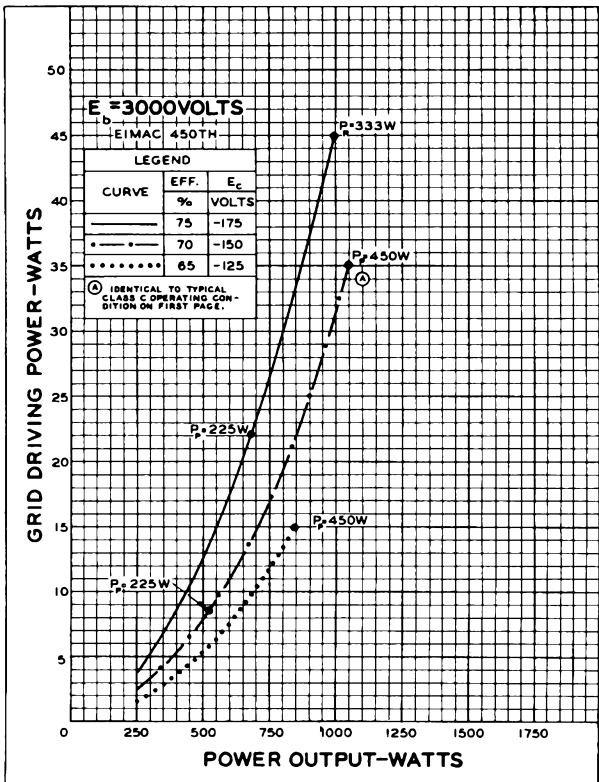

**Simul**  
450TH

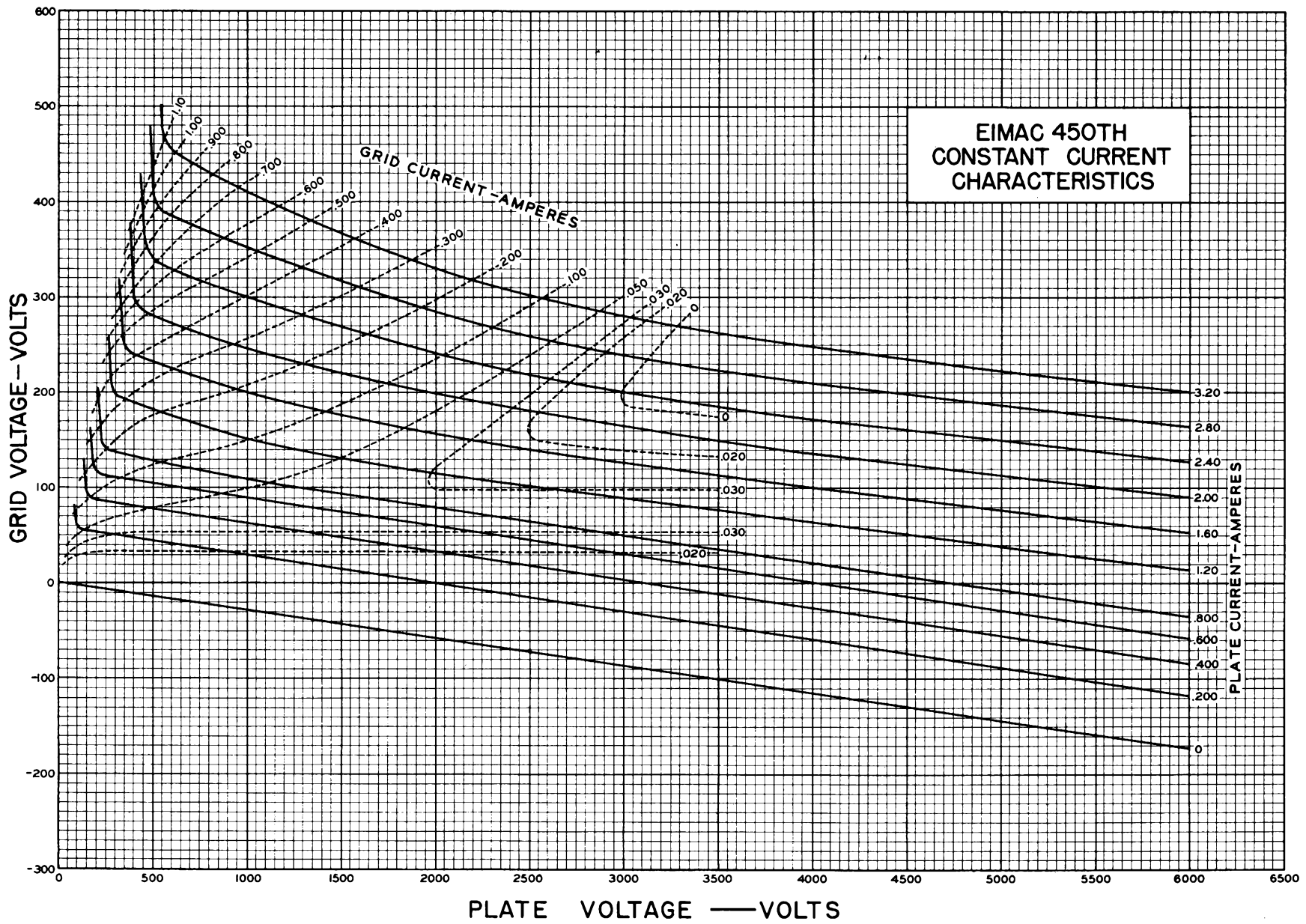

# EITEL-McCULLOUGH, INC.

SAN BRUNO, CALIFORNIA

# 450TL

MEDIUM-MU TRIODE  
MODULATOR  
OSCILLATOR  
AMPLIFIER

The Eimac 450TL is a medium-mu power triode having a maximum plate dissipation rating of 450 watts, and is intended for use as an amplifier, oscillator and modulator. It can be used at its maximum ratings at frequencies as high as 40-Mc.

Cooling of the 450TL is accomplished by radiation from the plate, which operates at a visible red color at maximum dissipation, and by means of air circulation around the envelope.

## GENERAL CHARACTERISTICS

### ELECTRICAL

Filament: Thoriated tungsten	
Voltage	7.5 volts
Current	12.0 amperes
Note: Dual connections for each filament lead are provided within the base of the tube (see basing diagram). Corresponding socket terminals must be connected in parallel to provide proper distribution of filament and R-F charging currents.	
Amplification Factor (Average)	18
Direct Interelectrode Capacitances (Average)	
Grid-Plate	4.5 $\mu\mu\text{f}$
Grid-Filament	6.8 $\mu\mu\text{f}$
Plate-Filament	0.8 $\mu\mu\text{f}$
Transconductance ( $i_b=500\text{ma}$ , $E_b=4000\text{v}$ , $e_c=-75\text{v}$ )	5000 $\mu\text{mhos}$
Frequency for Maximum Ratings	40-Mc.

### MECHANICAL

Base	Special 4 pin, No. 5002B
Basing	RMA type 4A $\phi$
Mounting	Vertical, base down or up
Cooling	Radiation and air circulation

Note: Adequate ventilation or air cooling must be provided so that the seals and envelope do not exceed 200°C under operating conditions.

Socket Johnson Type No. 211 or National Type No. XM50 or equivalent.

Recommended Heat Dissipating Connectors:

Plate	Eimac HR-8
Grid	Eimac HR-8

Note: The grid terminal of the 450TL is now .560" in diameter. To accommodate existing equipment designed for the older style 450TL having .098" diameter grid terminals, an adapter pin is provided with the newer tubes. This adapter pin is threaded so that it may be removed from the grid terminal of the tube. The small grid terminal, if used, requires an HR-4 heat dissipating connector. (See outline drawing.)

Maximum Overall Dimensions:

Length	12.625 inches
Diameter	5.125 inches
Net weight	1.3 pounds
Shipping weight (Average)	5.6 pounds

### AUDIO FREQUENCY POWER AMPLIFIER AND MODULATOR

Class AB<sub>2</sub> (Sinusoidal wave, two tubes unless otherwise specified)

MAXIMUM RATINGS

D-C PLATE VOLTAGE	6000 MAX. VOLTS
MAX-SIGNAL D-C PLATE CURRENT PER TUBE	400 MAX. MA.
PLATE DISSIPATION, PER TUBE	450 MAX. WATTS

TYPICAL OPERATION—2 TUBES

D-C Plate Voltage	3000	4000	5000	Volts
D-C Grid Voltage (approx.)*	-110	-175	-240	Volts
Zero-Signal D-C Plate Current	200	150	120	Ma.
Max-Signal D-C Plate Current	770	675	620	Ma.
Effective Load, Plate-to-Plate	7700	12,800	18,500	Ohms
Peak A-F Grid Input Voltage (per tube)	325	345	430	Volts
Max-Signal Peak Driving Power	40	33	56	Watts
Max-Signal Nominal Driving Power (approx.)	20	17	28	Watts
Max-Signal Plate Power Output	1400	1800	2200	Watts

\*Adjust to give stated zero-signal plate current.

### RADIO FREQUENCY POWER AMPLIFIER AND OSCILLATOR

Class-C Telephony or FM Telephony (Key-down conditions, per tube).

MAXIMUM RATINGS

D-C PLATE VOLTAGE	6000 MAX. VOLTS
D-C PLATE CURRENT	400 MAX. MA.
PLATE DISSIPATION	450 MAX. WATTS
GRID DISSIPATION	65 MAX. WATTS

TYPICAL OPERATION, PER TUBE\*

D-C Plate Voltage	3000	4000	5000	Volts
D-C Grid Voltage	-275	-400	-500	Volts
D-C Plate Current	500	450	450	Ma.
D-C Grid Current	65	53	54	Ma.
Peak R-F Grid Input Voltage	640	740	870	Volts
Driving Power (approx.)	38	35	42	Watts
Grid Dissipation	20	13	15	Watts
Plate Power Input	1500	1800	2250	Watts
Plate Dissipation	450	450	450	Watts
Plate Power Output	1050	1350	1800	Watts

\*The figures show actual measured tube performance and do not allow for circuit losses.

### PLATE MODULATED RADIO FREQUENCY AMPLIFIER

Class-C Telephony (Carrier conditions, per tube)

MAXIMUM RATINGS

D-C PLATE VOLTAGE	4500 MAX. VOLTS
D-C PLATE CURRENT	500 MAX. MA.
PLATE DISSIPATION	300 MAX. WATTS
GRID DISSIPATION	65 MAX. WATTS

TYPICAL OPERATION, PER TUBE\*

D-C Plate Voltage	3000	4000	4500	Volts
D-C Plate Current	380	340	345	Ma.
Total Bias Voltage	-400	-500	-550	Volts
Fixed Bias Voltage	-200	-250	-275	Volts
Grid Resistor	5000	7000	7500	Ohms
D-C Grid Current	40	36	36	Ma.
Peak R-F Grid Input Voltage	700	790	850	Volts
Driving Power	28	29	31	Watts
Grid Dissipation	12	11	11	Watts
Plate Power Input	1150	1360	1550	Watts
Plate Dissipation	300	300	300	Watts
Plate Power Output	850	1060	1250	Watts

\*The figures are for one tube operating at maximum plate dissipation as a plate modulated Class-C amplifier. The output figures do not allow for circuit losses.

Indicates change from sheet dated 9-1-44.

(Effective 10-1-49) Copyright 1949 by Eitel-McCullough, Inc.

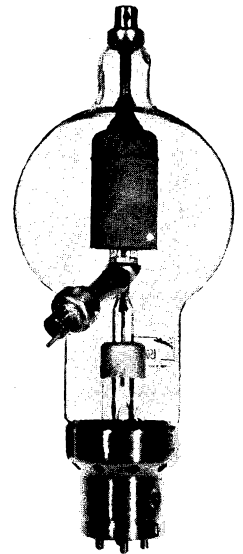

## APPLICATION

### MECHANICAL

**Mounting**—The 450TL must be mounted vertically, base up or base down. Flexible connecting straps should be provided from the grid and plate terminals to the external grid and plate circuits. The tube must be protected from severe vibration and shock.

**Cooling**—Provision should be made for ample circulation of air around the 450TL. In the event that the design of the equipment restricts natural circulation, the use of a small fan or centrifugal blower to provide additional cooling for the tube will aid in obtaining maximum tube life. Special heat-dissipating connectors (Eimac HR-8) are available for use on the plate and grid terminals. These connectors help to prolong tube life by reducing the temperature of the seals.

### ELECTRICAL

**Filament Voltage**—For maximum tube life the filament voltage, as measured directly at the filament pins, should be the rated value of 7.5 volts. Unavoidable variations in filament voltage must be kept within the range from 7.03 to 7.88 volts. All four socket terminals should be used, putting two in parallel for each filament connection.

**Bias Voltage**—Although there is no maximum limit on the bias voltage which may be used on the 450TL, there is little advantage in using bias voltages in excess of those given under "Typical Operation," except in certain very specialized applications. Where bias is obtained by a grid leak, suitable protective means must be provided to prevent excessive plate dissipation in the event of loss of excitation.

**Grid Dissipation**—The power dissipated by the grid of the 450TL must not exceed 65 watts. Grid dissipation may be calculated from the following expression:

$$P_g = e_{cnp} I_c$$

where  $P_g$  = Grid dissipation

$e_{cnp}$  = Peak positive grid voltage, and

$I_c$  = D-c grid current.

$e_{cnp}$  may be measured by means of a suitable peak voltmeter connected between filament and grid.<sup>1</sup> In equipment in which the plate loading varies widely, such as oscillators used for radio-frequency heating, care should be taken to make certain that the grid dissipation does not exceed the maximum rating under any conditions of loading.

**Plate Voltage**—Except in very special applications, the plate supply voltage for the 450TL should not exceed 6000 volts. In most cases there is little advantage in using plate-supply voltages higher than those given under "Typical Operation" for the power output desired.

**Plate Dissipation**—Under normal operating conditions, the power dissipated by the plate of the 450TL should not be allowed to exceed 450 watts. At this dissipation the brightness temperature of the plate will appear a red-orange in color. The value of this color is somewhat affected by light from the filament as well as from external sources. Plate dissipation in excess of the maximum rating is permissible for short periods of time, such as during tuning procedures.

<sup>1</sup> For suitable peak v.t.v.m. circuits see, for instance, "Vacuum Tube Ratings," Eimac News, January, 1945. This article is available in reprint form on request.

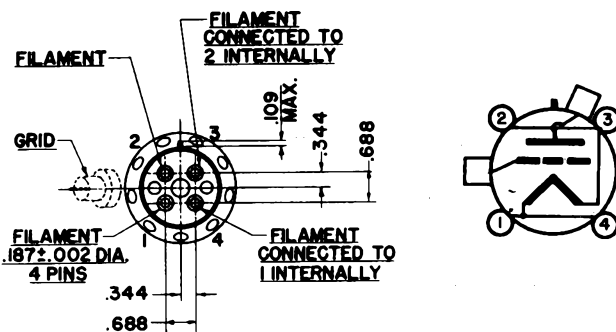
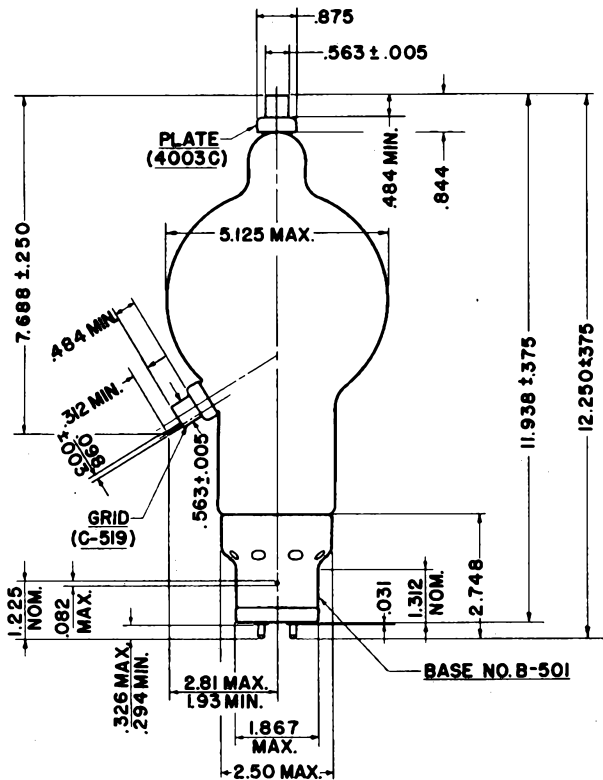

**NOTE:**—The grid terminal on the new 450TH and TL type tube is now .563" in diameter. To accommodate existing equipment which uses the 450TH or TL tubes with the old style .098" grid terminal, an adaptor pin is provided. This adaptor pin, if not needed, may be removed by unscrewing.

## DRIVING POWER vs. POWER OUTPUT

The three charts on this page show the relationship of plate efficiency, power output and grid driving power at plate voltages of 3000, 4000, and 5000 volts. These charts show combined grid and bias losses only. The driving power and power output figures do not include circuit losses. The plate dissipation in watts is indicated by  $P_p$ . Points A, B, and C are identical to the typical Class C operating conditions shown on the first page under 3000, 4000, and 5000 volts respectively.

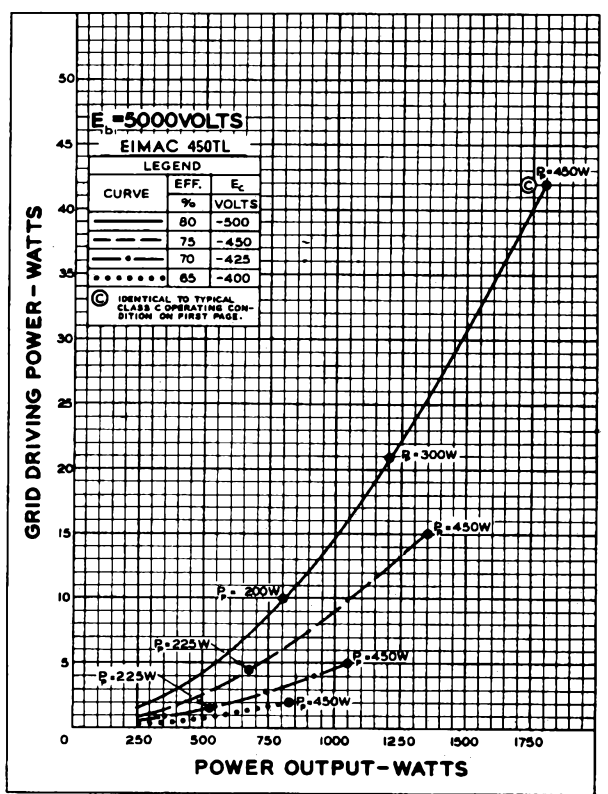
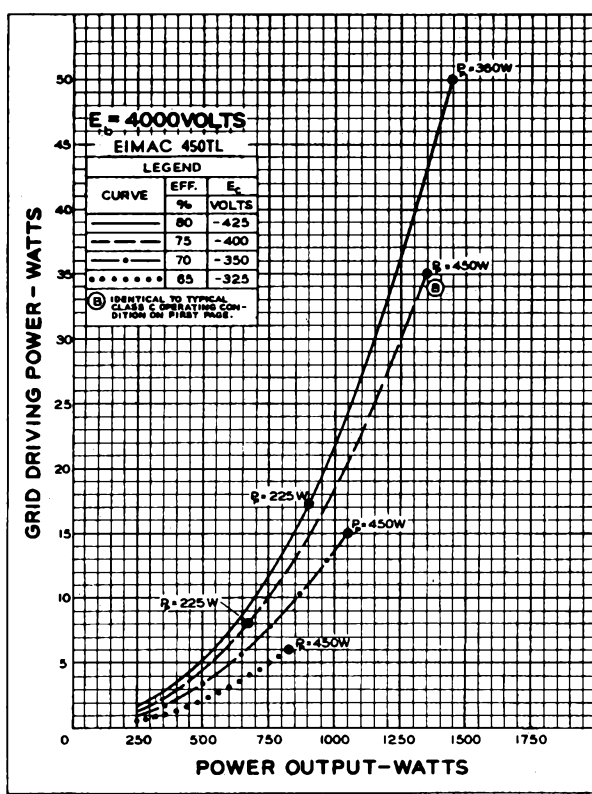
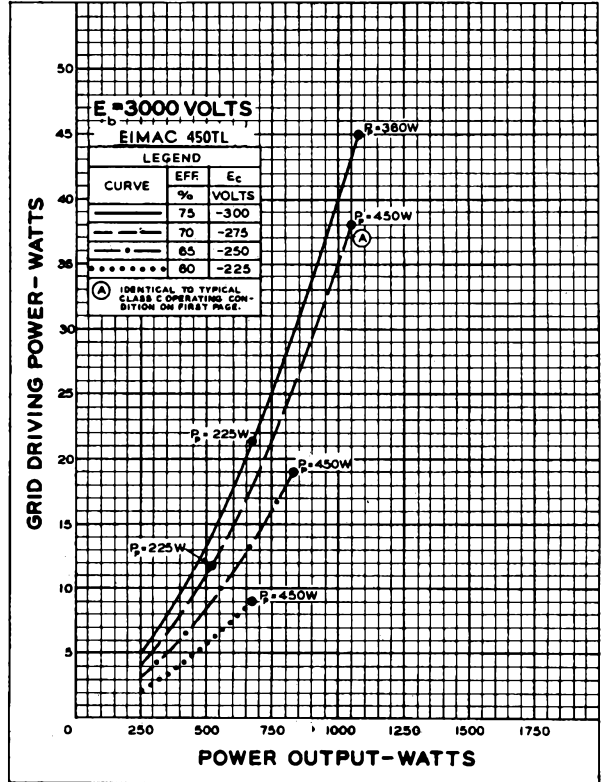

**Eimac**  
450TL

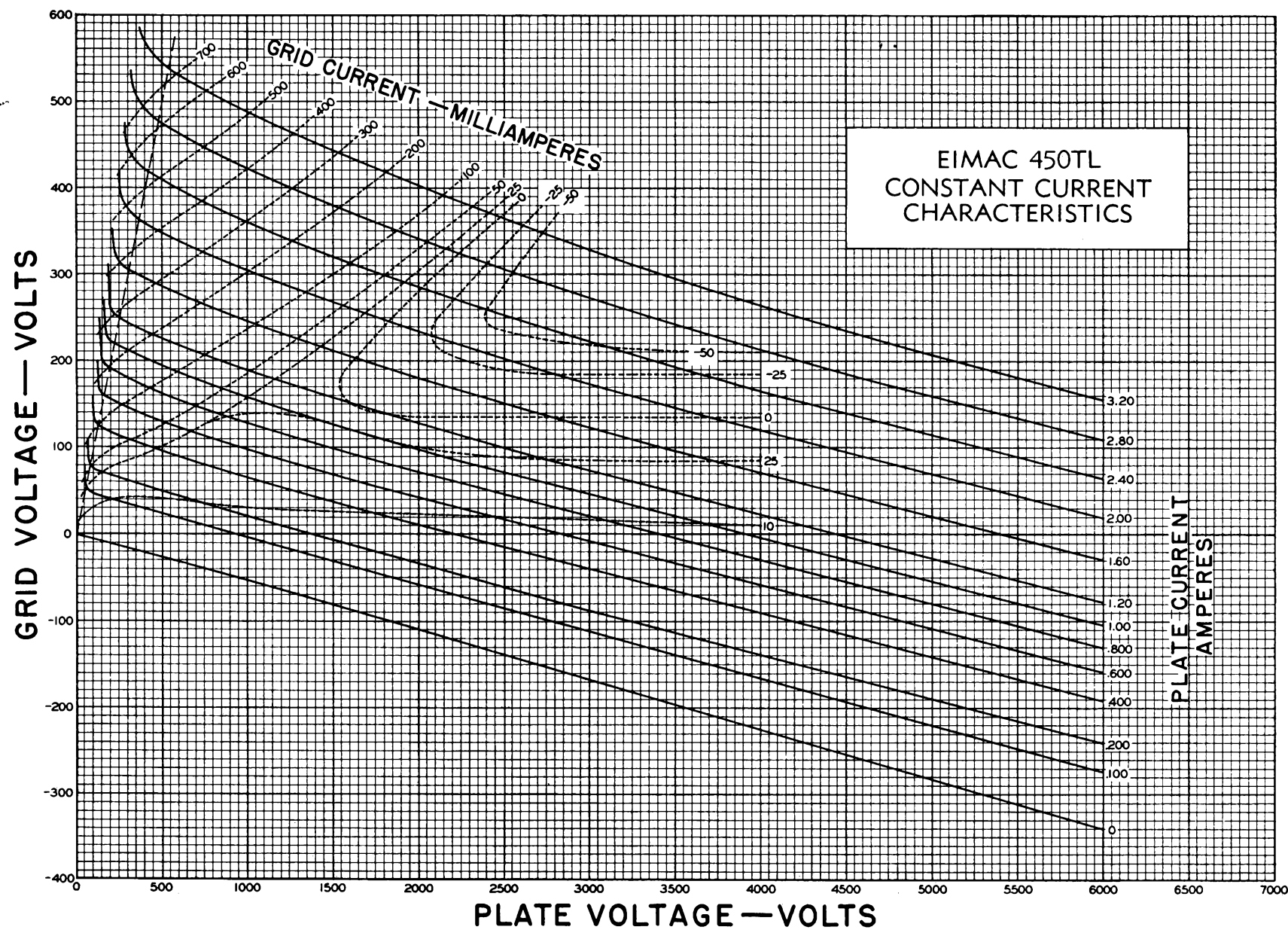



# EITEL-McCULLOUGH, INC.

SAN BRUNO, CALIFORNIA

## 592/3-200A3

MEDIUM-MU TRIODE

MODULATOR  
OSCILLATOR  
AMPLIFIER

The Eimac 592/3-200A3 is a medium-mu power triode having a maximum plate dissipation rating of 200 watts, and it is intended for use as a power amplifier, oscillator, or modulator. It can be used at its maximum ratings at frequencies as high as 150 Mc.

Cooling of the 592/3-200A3 is accomplished by radiation from the plate, which operates at a visible red color at maximum plate dissipation, and by means of forced-air circulation around the envelope.

### GENERAL CHARACTERISTICS

#### ELECTRICAL

Filament: Thoriated tungsten	
Voltage	10.0 volts
Current	5.0 amperes
Amplification Factor (Average)	25
Direct Interelectrode Capacitances (Average)	
Grid-Plate	3.3 $\mu\text{mf}$
Grid-Filament	3.6 $\mu\text{mf}$
Plate-Filament	0.29 $\mu\text{mf}$
Transconductance ( $I_b=200 \text{ ma.}, E_b=3000 \text{ v.}$ )	3600 $\mu\text{mhos}$
Frequency for Maximum Ratings	150 Mc.

#### MECHANICAL

Mounting	Vertical
Maximum Over-all Dimensions:	
Length	6.0 inches
Diameter	3-13/32 inches
Net Weight (approx.)	6 ounces
Shipping Weight (approx.)	1 1/2 pounds
Cooling	Radiation and Forced-Air
Recommended Heat Dissipating Connectors:	
Plate	Eimac HR-10
Grid	Eimac HR-5
Maximum bulb temperature	225° C
Maximum seal temperature	175° C

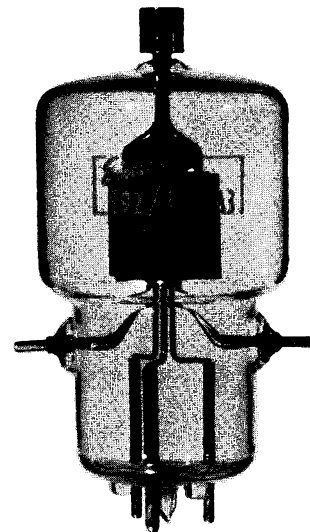

#### AUDIO FREQUENCY POWER AMPLIFIER AND MODULATOR—CLASS B

##### MAXIMUM RATINGS, PER TUBE

D-C PLATE VOLTAGE	3500 MAX. VOLTS
MAX-SIGNAL D-C PLATE CURRENT	250 MAX. MA.
PLATE DISSIPATION	200 MAX. WATTS
GRID DISSIPATION	25 MAX. WATTS

##### TYPICAL OPERATION

Sinusoidal wave, two tubes unless otherwise specified.

D-C Plate Voltage	2000	2500	3000	Volts
D-C Grid Voltage (approx.)*	-50	-70	-90	Volts
Zero-Signal D-C Plate Current	120	100	80	Ma.
Max-Signal D-C Plate Current	500	450	400	Ma.
Effective Load, Plate-to-Plate	8500	12,600	18,000	Ohms
Peak A-F Grid Input Voltage (per tube)	260	270	270	Volts
Max-Signal Peak Driving Power	50	52	40	Watts
Max-Signal Nominal Driving Power (approx.)	25	26	20	Watts
Max-Signal Plate Power Output	600	725	820	Watts

\*Adjust to give stated zero-signal plate current.

#### PLATE MODULATED RADIO FREQUENCY AMPLIFIER

Class-C Telephony (Carrier conditions, per tube)

##### MAXIMUM RATINGS

D-C PLATE VOLTAGE	2600 MAX. VOLTS
D-C PLATE CURRENT	200 MAX. MA.
PLATE DISSIPATION	130 MAX. WATTS
GRID DISSIPATION	25 MAX. WATTS

##### TYPICAL OPERATION

D-C Plate Voltage	2000	2500	Volts
D-C Plate Current	200	200	Ma.
D-C Grid Voltage	-250	-300	Volts
D-C Grid Current	35	35	Ma.
Peak R-F Grid Input Voltage	480	535	Volts
Driving Power	17	19	Watts
Grid Dissipation	8	9	Watts
Plate Power Input	400	500	Watts
Plate Dissipation	115	125	Watts
Plate Power Output	285	375	Watts

The output figures do not allow for circuit losses.

#### RADIO FREQUENCY POWER AMPLIFIER AND OSCILLATOR

Class-C Telegraphy or FM Telephony (Key-down conditions, per tube)

##### MAXIMUM RATINGS

D-C PLATE VOLTAGE	3500 MAX. VOLTS
D-C PLATE CURRENT	250 MAX. MA.
PLATE DISSIPATION	200 MAX. WATTS
GRID DISSIPATION	25 MAX. WATTS

##### TYPICAL OPERATION

D-C Plate Voltage	2000	2500	3000	3500	Volts
D-C Plate Current	250	228	222	228	Ma.
D-C Grid Voltage	-150	-180	-220	-270	Volts
D-C Grid Current	32	28	25	30	Ma.
Peak R-F Grid Input Voltage	380	400	440	505	Volts
Driving Power	12	11	11	15	Watts
Grid Dissipation	7	6	5.5	7	Watts
Plate Power Input	500	570	666	800	Watts
Plate Dissipation	200	200	200	200	Watts
Plate Power Output	300	370	466	600	Watts

The output figures do not allow for circuit losses.

## APPLICATION

### MECHANICAL

**Mounting**—The 592/3-200A3 must be mounted vertically, base down or base up. Flexible connecting straps should be provided from the grid and plate terminals to the external grid and plate circuits. The tube must be protected from severe vibration and shock.

**Cooling**—An air-flow of approximately 15 cubic feet per minute should be directed at the bulb from a 2 inch diameter nozzle located about three inches from the center line of the tube. The center line of the nozzle should be located about two inches down from the top of the plate terminal. The incoming air temperature should not exceed 50° C. Other methods of cooling may be used provided the maximum bulb and seal temperatures are not exceeded. An 8 inch, household-type fan located about 10 inches from the tube is one alternate method. Special heat-dissipating connectors (Eimac HR-5 and HR-10, or equivalent, for grid and plate terminals respectively) should be used with this tube. These connectors help to prolong tube life by reducing the temperature of the metal-glass seals.

### ELECTRICAL

**Filament Voltage**—For maximum tube life, the filament voltage, as measured directly at the filament pins, should be the rated value of 10.0 volts. Unavoidable variations in filament voltage must be kept within the range of 9.5 to 10.5 volts.

**Bias Voltage**—There is little advantage in using bias voltages in excess of those given under "Typical Operation" except in certain very specialized applications. Where bias is obtained by a grid leak, suitable protective means must be provided to prevent excessive plate dissipation in the event of loss of excitation.

**Grid Dissipation**—The power dissipated by the grid of the 592/3-200A3 must not exceed 25 watts. Grid dissipation may be calculated from the following expression:

$$P_g = e_{cmp} I_c$$

where  $P_g$  = grid dissipation,  
 $e_{cmp}$  = peak positive grid voltage, and  
 $I_c$  = d-c grid current.

$e_{cmp}$  may be measured by means of a suitable peak-reading voltmeter connected between filament and grid.\*

**Plate Voltage**—Except for special applications, the plate supply voltage for the 592/3-200A3 should not

exceed 3500 volts. In most cases there is little advantage in using plate-supply voltages in excess of those given under "Typical Operation" for the power output desired.

**Plate Dissipation**—Under normal operating conditions, the power dissipated by the plate of the 592/3-200A3 should not exceed 200 watts. At this dissipation the brightness temperature of the plate will appear a red-orange in color. The value of this color is somewhat affected by light from the filament, as well as from external sources. Plate dissipation in excess of the maximum rating is permissible for short periods of time, such as during tuning procedures.

\*For suitable peak v.t.v.m. circuits see, for instance, "Vacuum Tube Ratings," Eimac News, January, 1945. This article is available in reprint form on request.

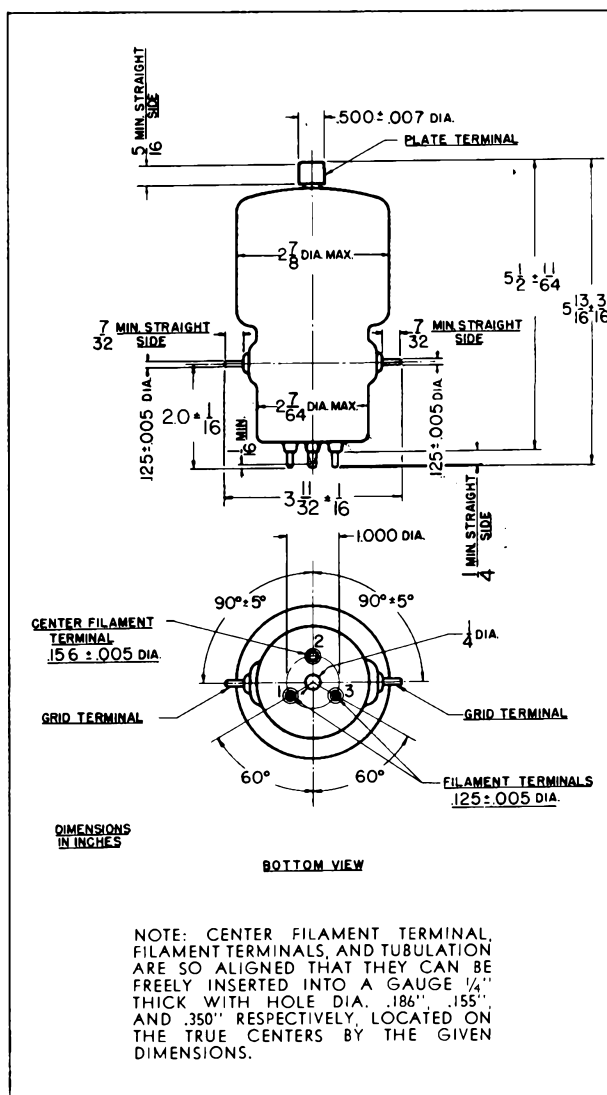

## DRIVING POWER vs. POWER OUTPUT

The four charts on this page show the relationship of plate efficiency, power output and grid driving power at plate voltages of 2000, 2500, 3000 and 3500 volts. These charts show combined grid and bias losses only. The driving power and power output figures do not include circuit losses. The plate dissipation in watts is indicated by  $P_p$ .

Points A, B, C, and D are identical to the typical Class C operating conditions shown on the first page under 2000, 2500, 3000 and 3500 volts respectively.

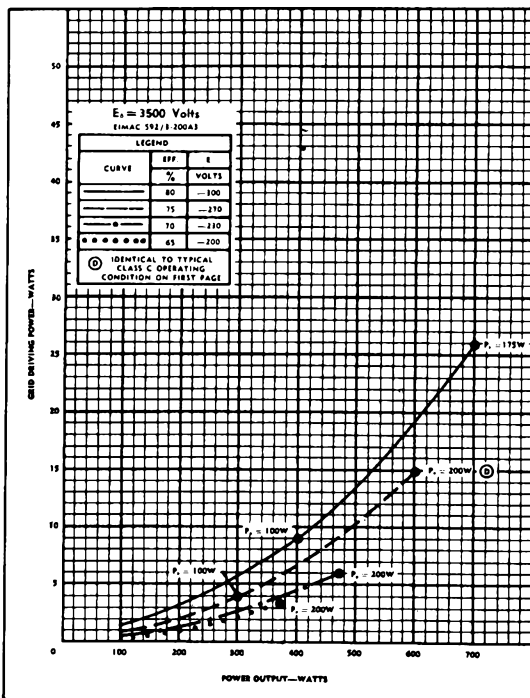
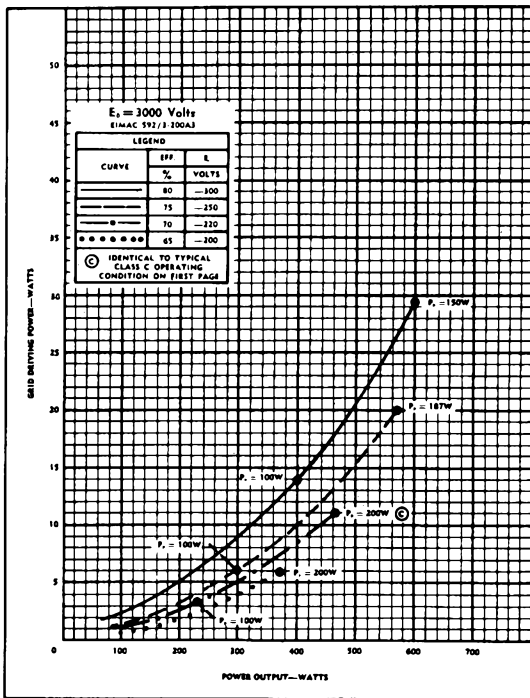
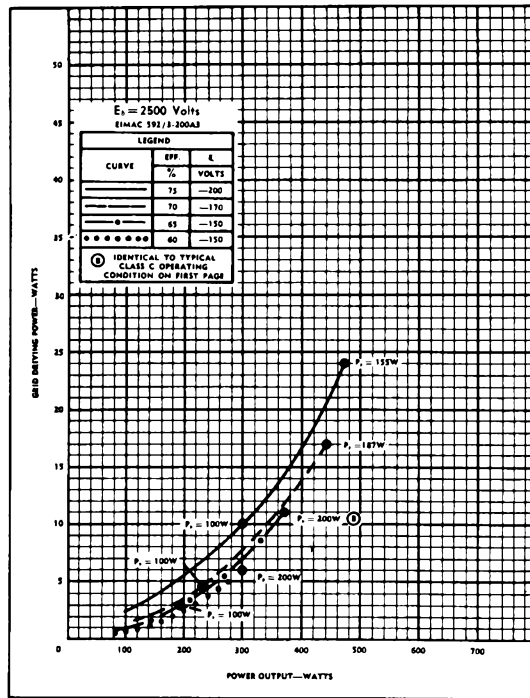
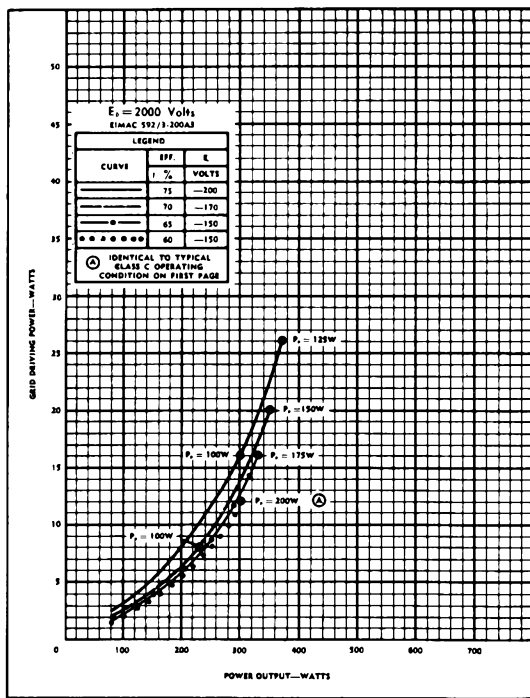

**EIMAC 592/3-200A3  
CONSTANT CURRENT  
CHARACTERISTICS**

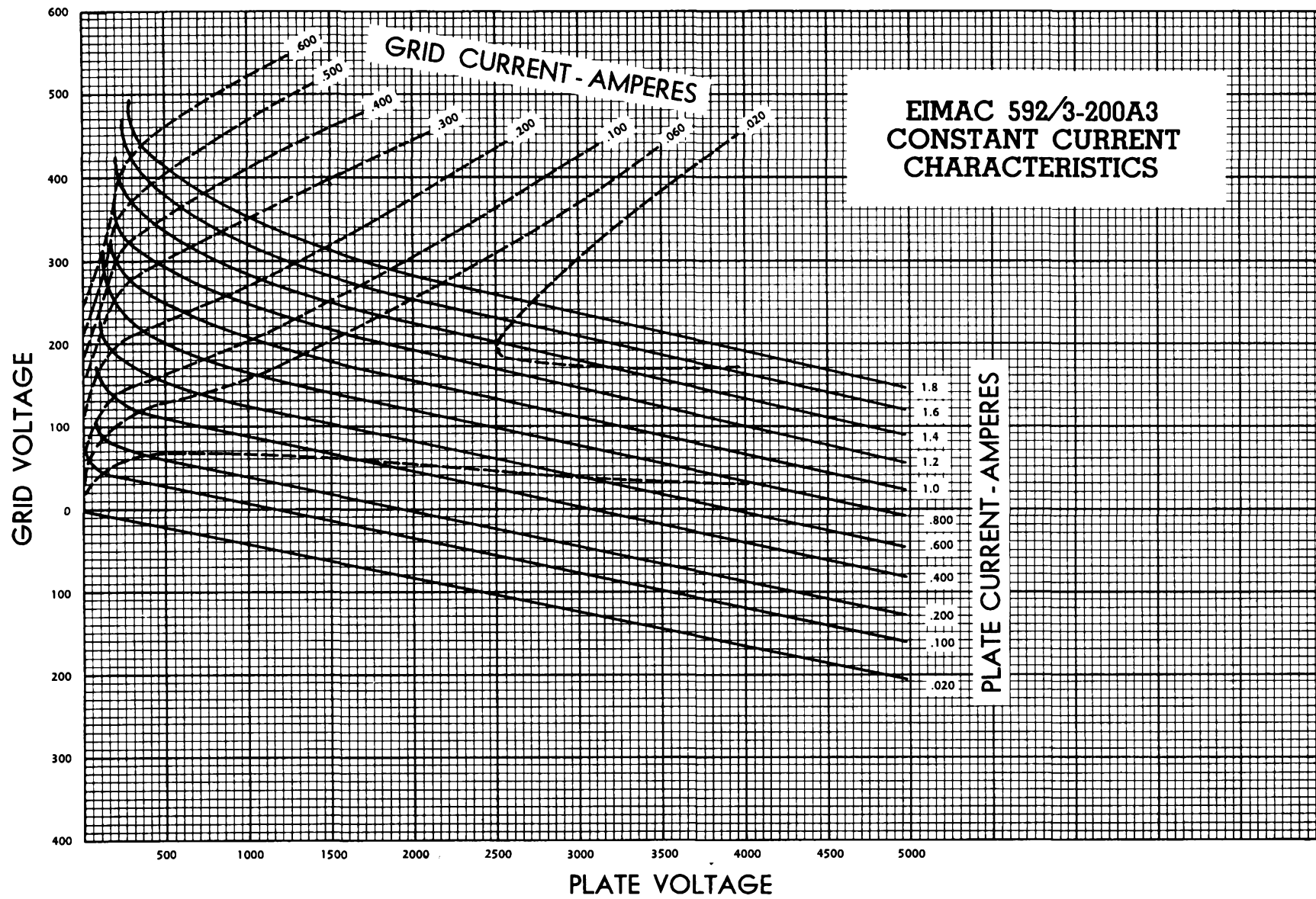

**Eimac**  
592/3-200A3

# EITEL-McCULLOUGH, INC.

SAN BRUNO, CALIFORNIA

# 750TL

MEDIUM-MU TRIODE  
 MODULATOR  
 OSCILLATOR  
 AMPLIFIER

▶ The Eimac 750TL is a medium-mu power triode intended for use as an amplifier, oscillator, or modulator. It has a maximum plate dissipation rating of 750 watts and a maximum plate voltage rating of 10,000 volts at frequencies up to 40 Mc. The 750TL is cooled by air-circulation and radiation.

The 750TL in class-C r-f service will deliver up to 3000 watts plate power output with 125 watts driving power. Two 750TL's in class-AB<sub>2</sub> modulator service will deliver up to 3500 watts maximum-signal plate power output with 46 watts driving power.

## GENERAL CHARACTERISTICS

### ELECTRICAL

Filament: Thoriated Tungsten	
Voltage	7.5 volts
Current	21.0 amperes
Amplification Factor (Average)	15
Direct Interelectrode Capacitances (Average)	
Grid-Plate	5.8 μμf
Grid-Filament	8.5 μμf
Plate-Filament	1.2 μμf
▶ Transconductance (I <sub>b1</sub> =250ma., E <sub>b1</sub> =5000v.)	3500 μmhos
▶ Highest Frequency for Maximum Ratings	40 Mc

### MECHANICAL

Base	Special 4-pin
Connections	See outline drawing
Socket	Johnson type No. 124-214 or equivalent
Mounting Position	Vertical, base down or up
Cooling	Air-circulation and radiation
Recommended Plate and Grid Heat Dissipating Connectors	Eimac HR-8
Maximum Overall Dimensions:	
Length	17.0 inches
Diameter	7.13 inches
Net Weight (Average)	2.9 pounds
Shipping Weight (Average)	13 pounds

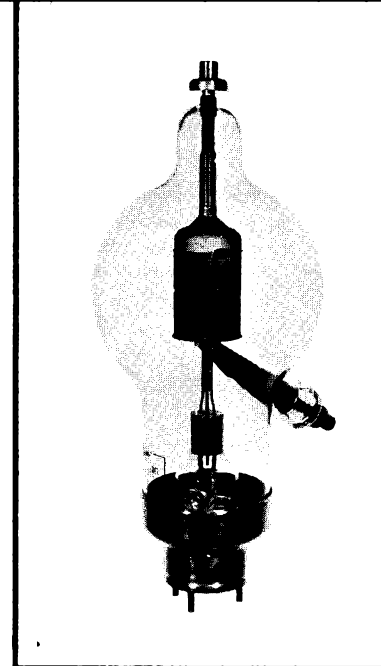

### ▶ AUDIO-FREQUENCY POWER AMPLIFIER OR MODULATOR

Class-AB<sub>2</sub> (Sinusoidal wave)

MAXIMUM RATINGS (Per tube)

D-C PLATE VOLTAGE	10,000 MAX. VOLTS
D-C PLATE CURRENT	1000 MAX. MA
PLATE DISSIPATION	750 MAX. WATTS
GRID DISSIPATION	100 MAX. WATTS

TYPICAL OPERATION (Two tubes unless otherwise specified)

D-C Plate Voltage	4000	5000	6000	volts
D-C Grid Voltage <sup>1</sup>	-230	-320	-390	volts
Zero-Signal D-C Plate Current	250	200	166	ma.
Max-Signal D-C Plate Current	950	860	834	ma
Effective Load, Plate-to-Plate	8270	12,300	16,300	ohms
Peak A-F Grid Voltage (per tube)	490	560	650	volts
Max-Signal Driving Power*	38	28	46	watts
Max-Signal Plate Power Input	3800	4300	5000	watts
Max-Signal Plate Power Output	2300	2800	3500	watts

<sup>1</sup>Adjust to stated zero-signal plate current.

### ▶ RADIO-FREQUENCY POWER AMPLIFIER OR OSCILLATOR

Class-C Telegraphy or FM Telephony (Key-down conditions, per tube)

MAXIMUM RATINGS (Frequencies up to 40 Mc.)

D-C PLATE VOLTAGE	10,000 MAX. VOLTS
D-C PLATE CURRENT	1000 MAX. MA
PLATE DISSIPATION	750 MAX. WATTS
GRID DISSIPATION	100 MAX. WATTS

TYPICAL OPERATION (Frequencies up to 40 Mc.)

D-C Plate Voltage	3000	4000	5000	6000	volts
D-C Grid Voltage	-350	-450	-550	-700	volts
D-C Plate Current	713	625	600	625	ma
D-C Grid Current*	120	90	90	105	ma
Peak R-F Grid Voltage	805	885	985	1040	volts
Driving Power*	97	83	86	125	watts
Grid Dissipation*	55	40	38	50	watts
Plate Power Input	2140	2500	3000	3750	watts
Plate Power Output	1390	1750	2250	3000	watts

### ▶ PLATE-MODULATED RADIO-FREQUENCY AMPLIFIER

CLASS-C TELEPHONY (Carrier conditions, per tube)

MAXIMUM RATINGS (Frequencies up to 40 Mc.)

D-C PLATE VOLTAGE	8000 MAX. VOLTS
D-C PLATE CURRENT	800 MAX. MA
PLATE DISSIPATION	500 MAX. WATTS
GRID DISSIPATION	100 MAX. WATTS

TYPICAL OPERATION (Frequencies up to 40 Mc.)

D-C Plate Voltage	3000	4000	5000	6000	volts
D-C Grid Voltage	-500	-650	-800	-950	volts
D-C Plate Current	415	400	400	415	ma
D-C Grid Current*	55	60	55	60	ma
Peak R-F Grid Voltage	830	985	1150	1330	volts
Driving Power*	45	50	60	75	watts
Grid Dissipation*	15	15	16	20	watts
Plate Power Input	1250	1600	2000	2500	watts
Plate Power Output	750	1100	1500	2000	watts

\*Approximate values

IF IT IS DESIRED TO OPERATE THIS TUBE UNDER CONDITIONS WIDELY DIFFERENT FROM THOSE GIVEN UNDER "TYPICAL OPERATION", POSSIBLY EXCEEDING THE MAXIMUM RATINGS GIVEN FOR CW SERVICE, WRITE EITEL-McCULLOUGH, INC., FOR INFORMATION AND RECOMMENDATIONS.

**APPLICATION**

**MECHANICAL**

**Mounting**—The 750TL must be mounted vertically, base down or up. The plate and grid leads should be flexible. The tube must be protected from vibration and shock.

**Cooling**—Heat Dissipating Connectors (Eimac HR-8 or equivalent) must be used at the plate and grid terminals of the 750TL. Unobstructed circulation of air around the tube is required in sufficient quantity to prevent the seal temperatures from exceeding 225°C. Forced ventilation of compartments or equipment in which the tube is located is usually desirable. Forced movement of air across the tube seals and envelope is always beneficial, though not necessarily required.

Tube temperatures may be measured with the aid of "Tempilaq", a temperature-sensitive lacquer manufactured by the Tempil Corporation, 132 West 22nd Street, New York 11, N. Y.

**ELECTRICAL**

**Filament Voltage**—For maximum tube life the filament voltage, as measured directly at the filament pins, should be the rated value of 7.5 volts. Variations should be kept within the range of 7.5 to 7.85 volts. All four socket terminals should be used, placing two in parallel for each filament connection.

**Bias Voltage**—Although there is no maximum limit placed on the bias voltage which may be used with the 750TL, there is little advantage in using bias voltages in

excess of those given under "Typical Operation", except in certain very specialized applications.

When grid-leak bias is used, suitable protective means must be provided to prevent excessive plate dissipation in the event of loss of excitation, and the grid-leak resistor should be made adjustable to facilitate maintaining the bias voltage and plate current at the desired value from tube to tube.

**Grid Dissipation**—Grid dissipation may be calculated from the following expression:

$$P_g = e_{emp} I_c$$

where:  $P_g$  = Grid dissipation,  
 $e_{emp}$  = Peak positive grid voltage, and  
 $I_c$  = D-C grid current.

$e_{emp}$  may be measured by means of a suitable peak voltmeter connected between filament and grid.<sup>1</sup> In equipment in which the plate loading varies widely, such as oscillators used for radio-frequency heating, care should be taken to make certain that the grid dissipation does not exceed the maximum rating of 100 watts under any conditions of loading.

**Plate Dissipation**—Under normal operating conditions, the plate dissipation of the 750TL should not be allowed to exceed the maximum rating. Plate dissipation in excess of the maximum rating is permissible for short periods of time, such as during tuning procedures.

<sup>1</sup>For suitable peak v.t.v.m. circuits see, for instance, "Vacuum Tube Ratings", Eimac News, January, 1945. This article is available in reprint form on request.

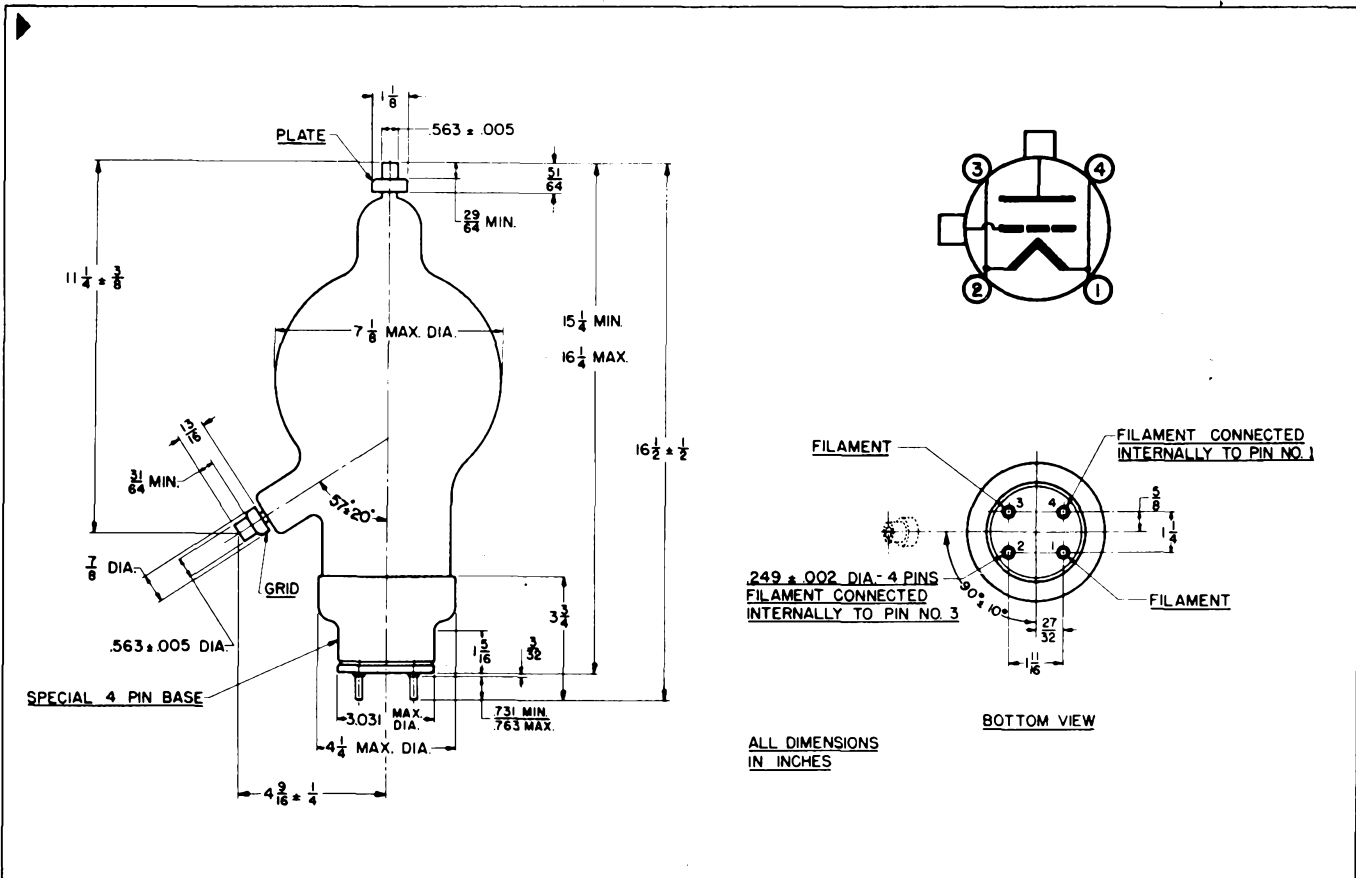

## DRIVING POWER vs. POWER OUTPUT

The three charts on this page show the relationship of plate efficiency, power output and approximate grid driving power at plate voltages of 4000, 5000 and 6000 volts. These charts show combined grid and bias losses only. The driving power and power output figures do not include circuit losses. The plate dissipation in watts is indicated by  $P_p$ . Points A, B and C are identical to the typical Class-C operating conditions shown on the first page under 4000, 5000 and 6000 volts, respectively.

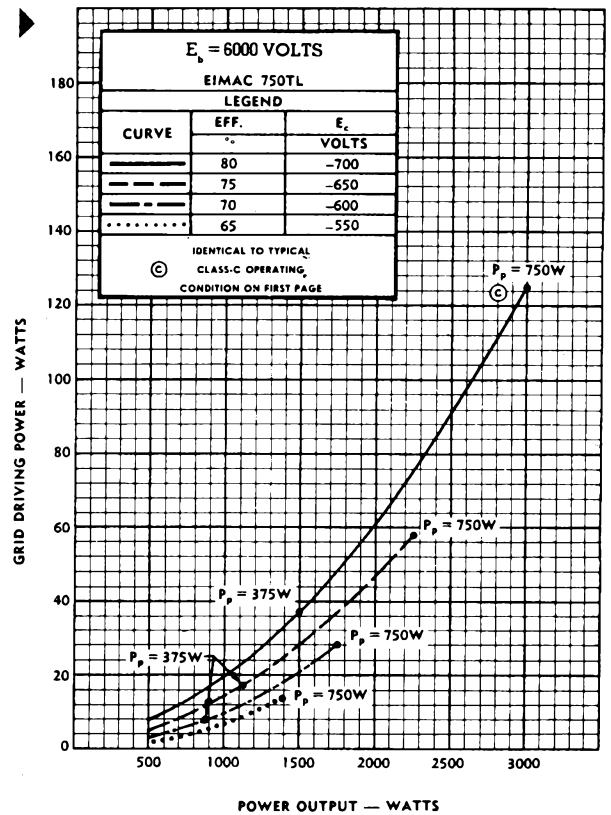
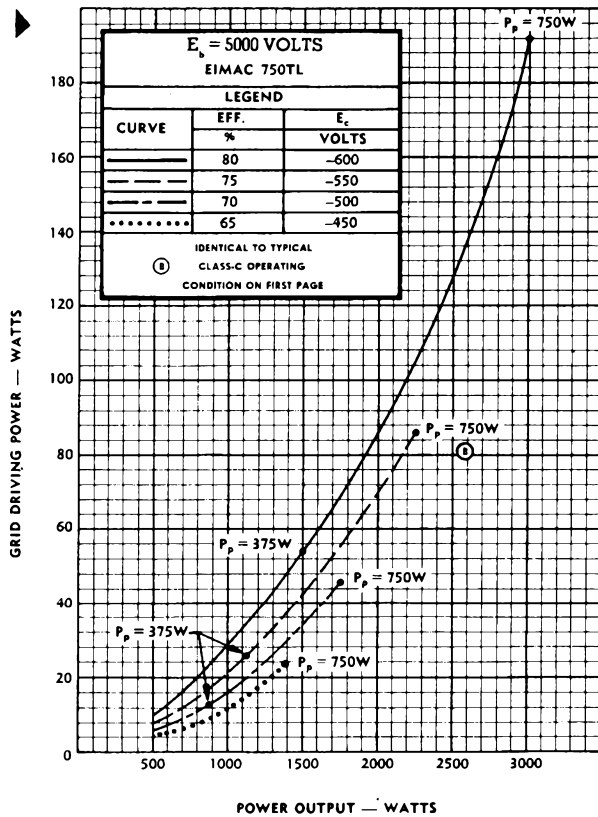
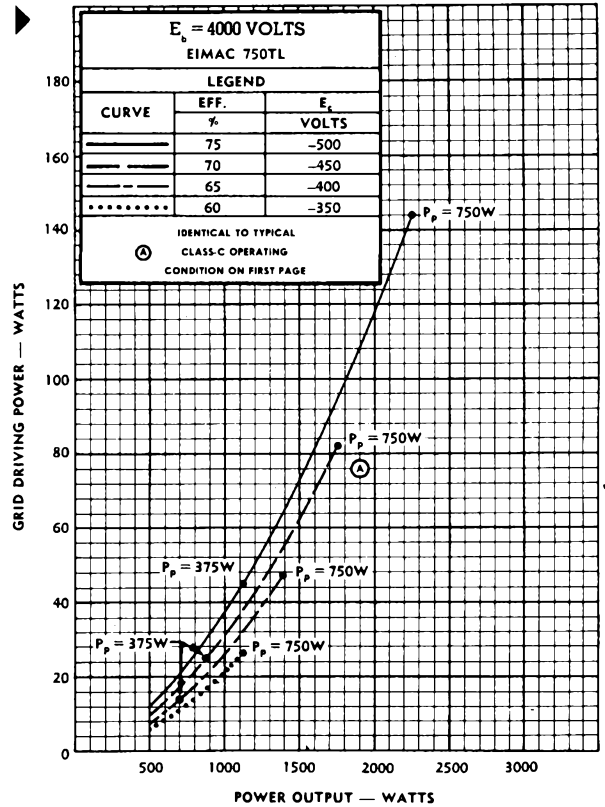

***Simul***  
750TL

GRID VOLTAGE - VOLTS

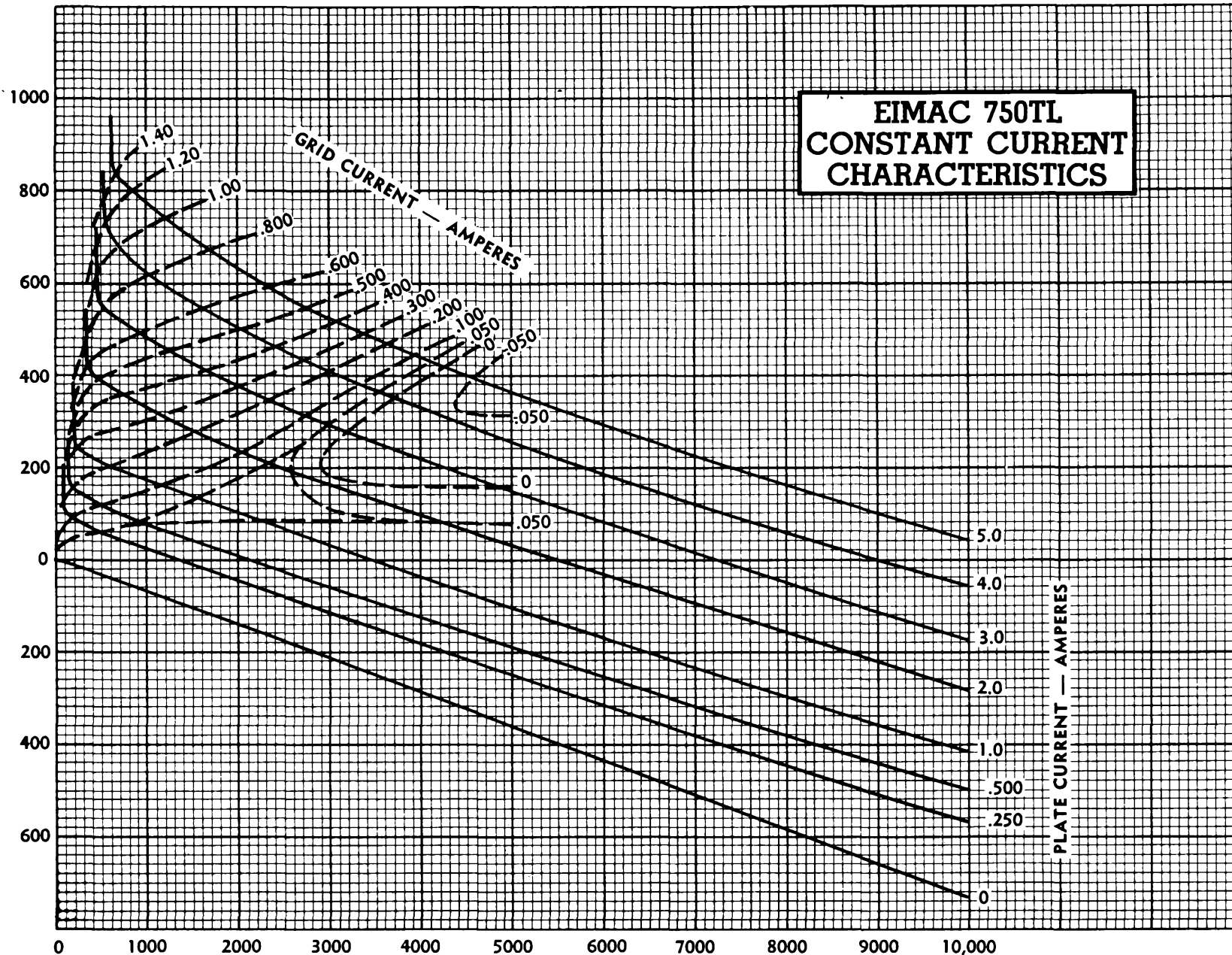

PLATE VOLTAGE - VOLTS



# EITEL-McCULLOUGH, INC.

SAN BRUNO, CALIFORNIA

# 1000T

HIGH-MU TRIODE  
MODULATOR  
OSCILLATOR  
AMPLIFIER

▶ The Eimac 1000T is a high-mu power triode intended for use as a modulator, oscillator, or amplifier. The tube has a maximum plate dissipation rating of 1000 watts, and a maximum plate voltage rating of 7500 volts at frequencies up to 50 Mc. Cooling is by forced air and radiation.

The 1000T in Class-C r-f service will deliver up to 3000 watts plate power output with 60 watts driving power. Two 1000T's in Class AB<sub>2</sub> modulator service will deliver up to 4600 watts maximum-signal plate power output with 60 watts driving power.

## GENERAL CHARACTERISTICS

### ELECTRICAL

▶ Filament: Thoriated Tungsten	
Voltage	7.5 volts ± 5%
Current	15.5 amperes
Amplification Factor (Average)	35
Direct Interelectrode Capacitances (Average)	
Grid-Plate	5.1 μμf
Grid-Filament	9.3 μμf
Plate-Filament	0.5 μμf
Transconductance (I <sub>b</sub> = 750ma., E <sub>b</sub> = 6000v.)	9050 μmhos
Highest Frequency for Maximum Ratings	50 Mc

### MECHANICAL

Base	50-watt jumbo 4-pin with air-conduction pipe
Connections	See outline drawing
Socket	Johnson type No. 123-211 or equivalent
Mounting Position	Vertical, base down or up
Cooling	Forced air and radiation
Maximum Temperature of Grid and Plate Seals	225°C
Recommended Grid and Plate Heat Dissipating Connectors	Eimac HR-9
Maximum Dimensions:	
Seated Height	12.3 inches
Diameter	5.13 inches
Net Weight	1.25 pounds
Shipping Weight (Average)	6.25 pounds

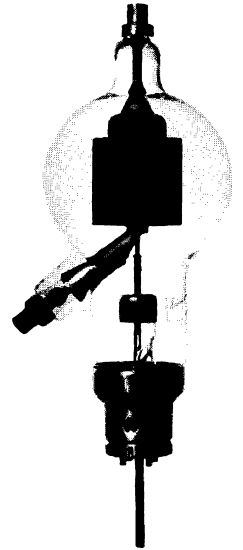

### AUDIO-FREQUENCY POWER AMPLIFIER OR MODULATOR

Class-AB<sub>2</sub>  
MAXIMUM RATINGS (Per tube)

D-C PLATE VOLTAGE	7500 MAX. VOLTS
D-C PLATE CURRENT	750 MAX. MA
PLATE DISSIPATION	1000 MAX. WATTS
GRID DISSIPATION	80 MAX. WATTS

TYPICAL OPERATION (Sinusoidal wave, two tubes unless otherwise specified)

D-C Plate Voltage	4000	5000	6000	volts
D-C Grid Voltage <sup>1</sup>	-85	-125	-160	volts
Zero-Signal D-C Plate Current	335	270	220	ma
Max-Signal D-C Plate Current	1.25	1.14	1.05	amps
Effective Load, Plate-to-Plate	6250	9200	13,300	ohms
Peak A-F Grid Voltage (per tube) <sup>1</sup>	260	290	335	volts
Max-Signal Driving Power*	35	37	60	watts
Max-Signal Plate Power Input	5000	5700	6300	watts
Max-Signal Plate Power Output	3000	3700	4600	watts

<sup>1</sup>Adjust to stated Zero-Signal Plate Current.

### RADIO-FREQUENCY POWER AMPLIFIER OR OSCILLATOR

Class-C Telephony or FM Telephony (Key-down conditions, per tube)  
MAXIMUM RATINGS (Frequencies up to 50 Mc.)

D-C PLATE VOLTAGE	7500 MAX. VOLTS
D-C PLATE CURRENT	750 MAX. MA
PLATE DISSIPATION	1000 MAX. WATTS
GRID DISSIPATION	80 MAX. WATTS

TYPICAL OPERATION (Frequencies up to 50 Mc.)

D-C Plate Voltage	3000	4000	5000	6000	volts
D-C Grid Voltage	-150	-150	-225	-350	volts
D-C Plate Current	750	713	667	667	ma
D-C Grid Current*	90	100	87	110	ma
Peak R-F Grid Voltage	350	365	420	610	volts
Driving Power*	30	33	33	60	watts
Grid Dissipation*	21	19	14	25	watts
Plate Power Input	2250	2850	3335	4000	watts
Plate Power Output	1350	1850	2335	3000	watts

### PLATE-MODULATED RADIO-FREQUENCY AMPLIFIER

Class-C Telephony (Carrier conditions, per tube)  
MAXIMUM RATINGS (Frequencies up to 50 Mc.)

D-C PLATE VOLTAGE	6000 MAX. VOLTS
D-C PLATE CURRENT	600 MAX. MA
PLATE DISSIPATION	665 MAX. WATTS
GRID DISSIPATION	80 MAX. WATTS

TYPICAL OPERATION (Frequencies up to 50 Mc.)

D-C Plate Voltage	4000	5000	6000	volts
D-C Grid Voltage	-300	-400	-500	volts
D-C Plate Current	600	600	600	ma
D-C Grid Current*	80	90	95	ma
Peak R-F Grid Voltage	540	660	775	volts
Driving Power*	45	60	75	watts
Grid Dissipation*	20	24	25	watts
Plate Power Input	2400	3000	3600	watts
Plate Power Output	1735	2335	2935	watts

\*Approximate values

IF IT IS DESIRED TO OPERATE THIS TUBE UNDER CONDITIONS WIDELY DIFFERENT FROM THOSE GIVEN UNDER "TYPICAL OPERATION", POSSIBLY EXCEEDING THE MAXIMUM RATINGS GIVEN FOR CW SERVICE, WRITE EITEL-McCULLOUGH, INC., FOR INFORMATION AND RECOMMENDATIONS.

## APPLICATION

### MECHANICAL

**Mounting**—The 1000T must be mounted vertically. The base may be either down or up. The leads to the plate and grid terminals should be flexible, and the tube must be protected from vibration and shock.

**Cooling**—The envelope and seals of the 1000T require forced-air cooling. Air-conduction pipes are provided in the base of the tube and in the HR-9 plate and grid Heat-Dissipating Connectors. Two cubic feet of air per minute supplied to each of these pipes will satisfy the cooling requirements of the seals. An 8- or 10-inch fan located approximately a foot from the tube will provide sufficient cooling air for the envelope. Air must be supplied to the tube when plate and grid voltages are applied, and must be continued until these voltages are removed. In some cases, particularly in locations where the ambient temperature is high, or where the free circulation of air is impeded, cooling air must be supplied when filament voltage is applied, and continued for two or more minutes after all voltages are removed.

The temperature of the grid and plate seals must not be allowed to exceed 225°C. A convenient accessory for the measurements of these temperatures is "Tempilaq", a temperature-sensitive lacquer manufactured by the Tempil Corporation, 132 W. 22nd St., New York 11, N. Y.

### ELECTRICAL

**Filament**—All four socket terminals should be used, putting two in parallel for each filament connection.

**Bias Voltage**—The maximum limit on bias voltages which may be used with the 1000T is considerably above those listed in "Typical Operation." Where bias is obtained by a grid leak, suitable protective means must be provided to prevent excessive plate dissipation in the event of loss of excitation.

**Plate Voltage**—The rated maximum d-c plate voltage of 7500 volts applies at frequencies up to 50 Mc. Above that frequency the tube must be operated at lower d-c voltages. In most cases there is little advantage in using plate supply voltages higher than those given under "Typical Operation" for the power output desired.

**Grid Dissipation**—Grid dissipation may be assumed to be the product of the d-c grid current and the peak positive cathode-to-grid voltage. This assumption is sufficiently accurate for the purpose of determining that the 1000T is operating within its maximum rated grid dissipation of 80 watts.

**Plate Dissipation**—Under normal operating conditions, the power dissipated by the plate of the 1000T should not be allowed to exceed 1000 watts. Plate dissipation in excess of the maximum rating is permissible for short periods of time, such as during tuning procedures.

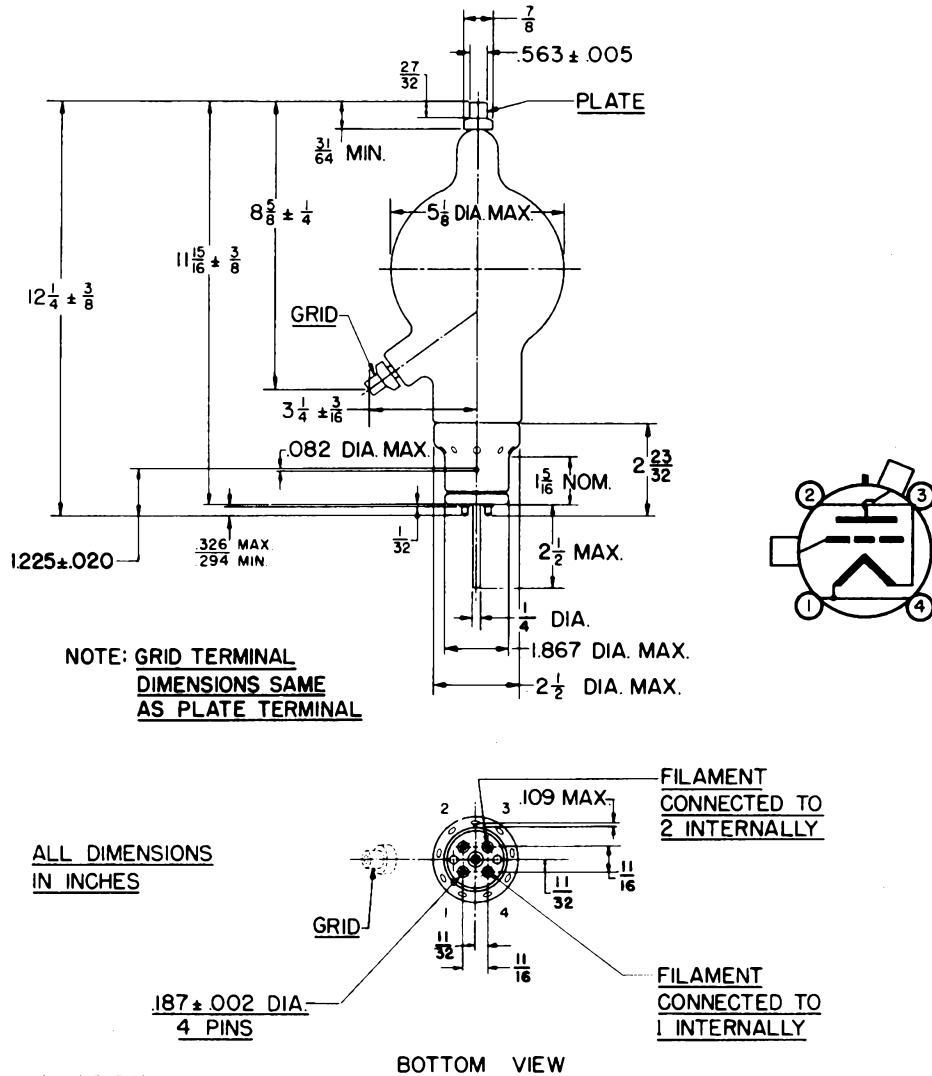

## DRIVING POWER vs. POWER OUTPUT

The three charts on this page show the relationship of plate efficiency, power output and grid driving power at plate voltages of 4000, 5000 and 6000 volts. These charts show combined grid and bias losses only. The driving power and power output figures do not include circuit losses. The plate dissipation in watts is indicated by  $P_p$ . Points A, B, and C are identical to the typical Class C operating conditions shown on the first page under 4000, 5000, and 6000 volts respectively.

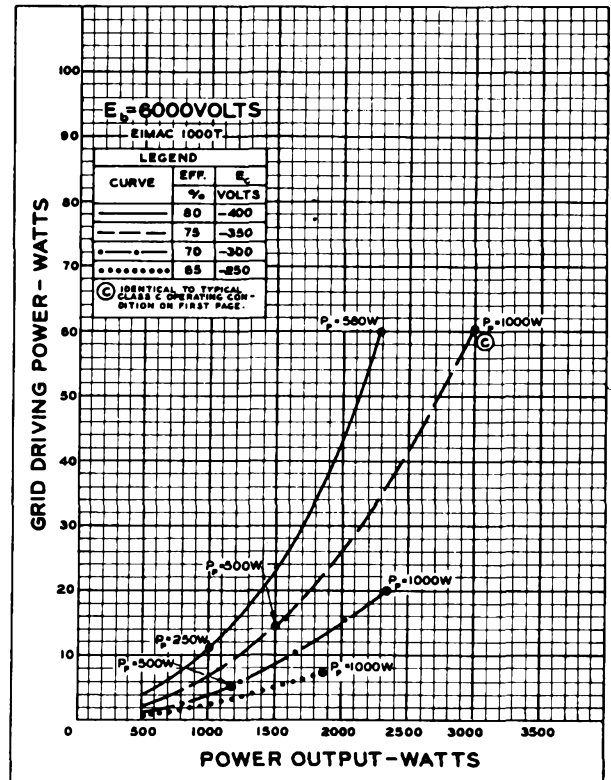
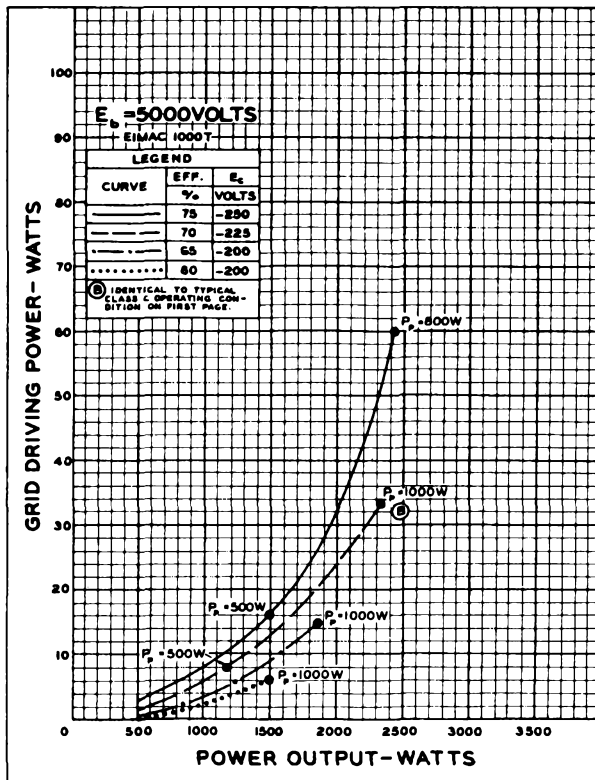
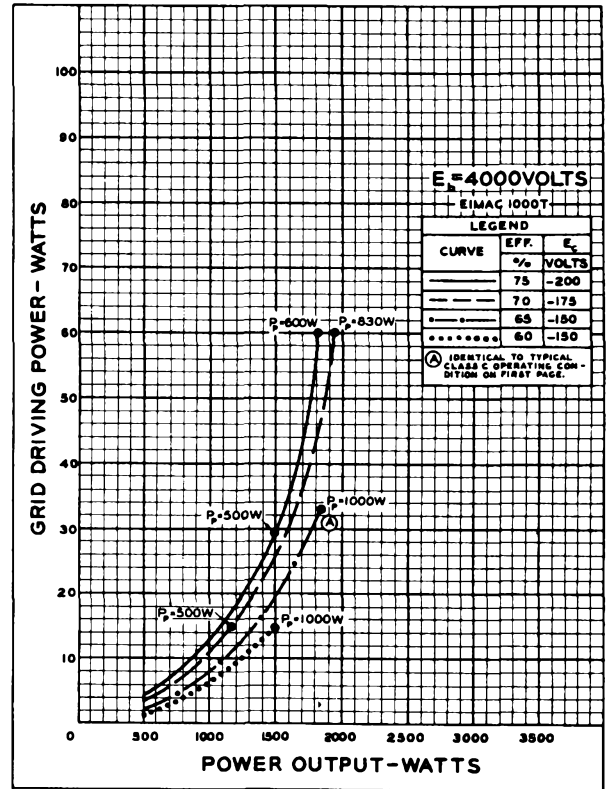

**Eimac**  
1000T

GRID VOLTAGE-VOLTS

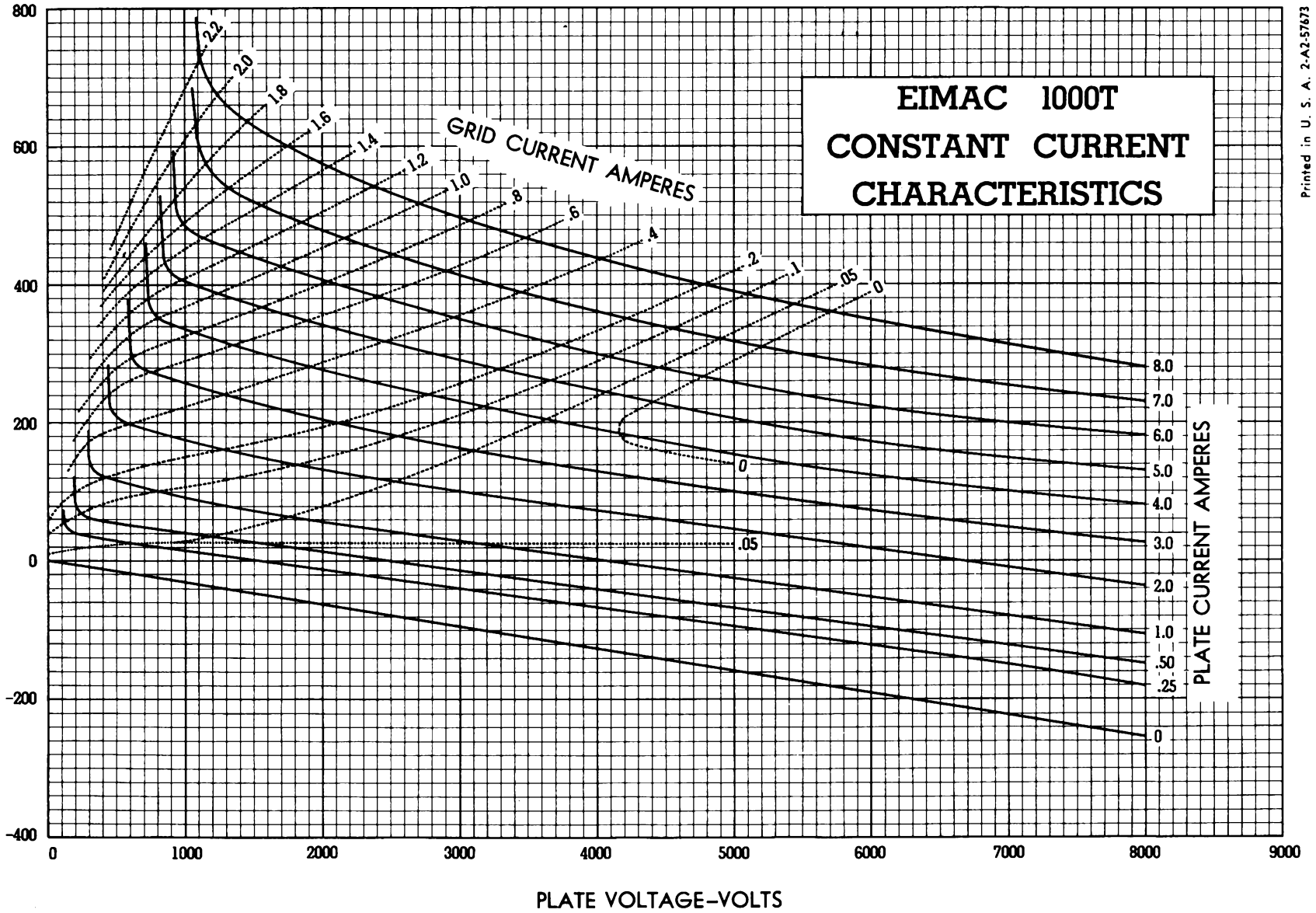

# EITEL-McCULLOUGH, INC.

SAN BRUNO, CALIFORNIA

# 1500T

MEDIUM-MU TRIODE

MODULATOR  
OSCILLATOR  
AMPLIFIER

The Eimac 1500T is a medium-mu power triode intended for use as an amplifier, oscillator or modulator. It has a maximum plate-dissipation rating of 1500 watts and a maximum plate-voltage rating of 8000 volts at frequencies up to 40 Mc.

The 1500T in class-C r-f service will deliver up to 4500 watts plate power output with 85 watts driving power. Two 1500T's in class-B modulator service will deliver up to 7000 watts maximum-signal plate power output with 115 watts nominal driving power.

## GENERAL CHARACTERISTICS

### ELECTRICAL

Filament: Thoriated tungsten	
Voltage	7.5 volts
Current	24.0 amperes
Amplification Factor (Average)	24
Direct Interelectrode Capacitances (Average)	
Grid-Plate	7.2 $\mu\text{mf}$
Grid-Filament	9.9 $\mu\text{mf}$
Plate-Filament	1.5 $\mu\text{mf}$
Transconductance ( $i_b = 1.25 \text{ amp.}, E_b = 6000 \text{ v.}$ )	10,000 $\mu\text{mhos}$

### MECHANICAL

Base	Special 4-pin
Basing	See outline drawing
Socket	Johnson type No. 124-214 or equivalent
Mounting Position	Vertical, base down or up
Cooling	Radiation and forced air
Maximum Temperature of Plate and Grid Seals	225°C
Recommended Heat-Dissipating Connectors:	
Plate	Eimac HR-8
Grid	Eimac HR-8
Maximum Overall Dimensions:	
Length	17.0 inches
Diameter	7.13 inches
Net Weight	3.0 pounds
Shipping Weight	13 pounds

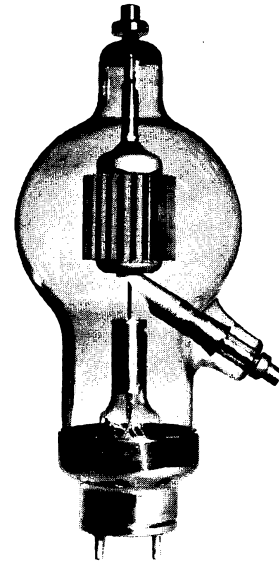

### RADIO-FREQUENCY POWER AMPLIFIER AND OSCILLATOR

Class-C Telegraphy (Key-down conditions, one tube)

MAXIMUM RATINGS (Frequencies below 40 Mc.)

D-C PLATE VOLTAGE	8000 MAX. VOLTS
D-C PLATE CURRENT	1.25 MAX. AMPS.
PLATE DISSIPATION	1500 AX. WATTS
GRID DISSIPATION	125 MAX. WATTS

TYPICAL OPERATION (Frequencies below 40 Mc.)

D-C Plate Voltage	5000	6000	7000	volts
D-C Grid Voltage	-375	-600	-500	volts
D-C Plate Current	1.00	1.00	1.00	amps
D-C Grid Current	150	165	110	ma
Grid Dissipation*	59	61	30	watts
Peak R-F Grid Input Voltage (approx.)	850	1100	885	volts
Driving Power*	115	160	85	watts
Plate Power Input	5000	6000	6000	watts
Plate Dissipation	1500	1500	1500	watts
Plate Power Output	3500	4500	4500	watts

### PLATE-MODULATED RADIO-FREQUENCY AMPLIFIER

Class-C Telephony (Carrier conditions, per tube)

MAXIMUM RATINGS (Frequencies up to 40 Mc.)

D-C PLATE VOLTAGE	6500 MAX. VOLTS
D-C PLATE CURRENT	1.00 MAX. AMPERE
PLATE DISSIPATION	1000 MAX. WATTS
GRID DISSIPATION	125 MAX. WATTS

TYPICAL OPERATION (Frequencies up to 40 Mc.)

D-C Plate Voltage	4000	5000	6000	volts
D-C Grid Voltage <sup>1</sup>	-450	-550	-450	volts
D-C Plate Current	750	700	665	ma
D-C Grid Current*	85	75	70	ma
Peak R-F Grid Voltage	840	950	1050	volts
Driving Power*	48	67	70	watts
Grid Dissipation*	30	24	25	watts
Plate Power Input	3000	3500	4000	watts
Plate Dissipation	1000	1000	1000	watts
Plate Power Output	2000	2500	3000	watts

### AUDIO-FREQUENCY POWER AMPLIFIER AND MODULATOR

Class-B (Sinusoidal wave, two tubes unless otherwise specified)

MAXIMUM RATINGS

D-C PLATE VOLTAGE	8000 MAX. VOLTS
MAX-SIGNAL D-C PLATE CURRENT, PER TUBE	1.25 MAX. AMPS.
PLATE DISSIPATION, PER TUBE	1500 MAX. WATTS
GRID DISSIPATION, PER TUBE	125 MAX. WATTS

TYPICAL OPERATION

D-C Plate Voltage	4000	5000	6000	volts
D-C Grid Voltage <sup>2</sup>	-95	-145	-190	volts
Zero-Signal D-C Plate Current	500	400	330	ma
Max-Signal D-C Plate Current	1.88	1.72	1.65	amps
Effective Load, Plate-to-Plate	4150	6150	8200	ohms
Peak A-F Grid Input Voltage (per tube)	485	535	570	volts
Max-Signal Avg. Driving Power*	95	105	115	watts
Max-Signal Plate Dissipation	1500	1500	1450	watts
Max-Signal Plate Power Output	4500	5600	7000	watts

\*Approximate values.

<sup>1</sup>Bias should be obtained by means of an adjustable grid-leak resistor.

<sup>2</sup>Adjust to give stated Zero-Signal D-C Plate Current.

IF IT IS DESIRED TO OPERATE THIS TUBE UNDER CONDITIONS WIDELY DIFFERENT FROM THOSE GIVEN UNDER "TYPICAL OPERATION", POSSIBLY EXCEEDING THE MAXIMUM RATINGS GIVEN FOR CW SERVICE, WRITE EITEL-McCULLOUGH, INC., FOR INFORMATION AND RECOMMENDATIONS.

## APPLICATION

### MECHANICAL

**Mounting**—The 1500T must be mounted vertically, base up or base down. Flexible leads should be provided between the grid and plate terminals and the external grid and plate circuits. The tube must be protected from vibration and shock.

► **Cooling**—Forced-air cooling is required on the envelope and also in the base of the tube. Envelope cooling may be accomplished by locating an ordinary 8- or 10-inch fan about one foot from the tube and directing the air at the middle of the envelope.

Base cooling requires an air flow of  $2\frac{1}{2}$  cu. ft. per min. directed up through the bottom of the base toward the filament press. The base of the tube is provided with a 1-inch diameter hole for this purpose. If a socket is used with a 1-inch diameter matching hole and the manifold is of the same diameter, a static pressure of less than 0.1 inch of water is required at the manifold to provide the  $2\frac{1}{2}$  cu. ft. per min.

One type of socket provides a  $\frac{1}{4}$  inch diameter pipe for the air inlet to the base. With this type of socket a static pressure of  $5\frac{1}{2}$  inches of water is required at the pipe to obtain the necessary  $2\frac{1}{2}$  cu. ft. per min. volume.

Suitable electrical interlocks should be provided to remove the plate and filament voltages in the event that the supply of cooling air is interrupted.

### ELECTRICAL

**Filament Voltage**—The filament voltage, as measured directly at the filament pins, should be between 7.125 and 7.875 volts. All four socket terminals should be used by employing two for each connection to filament supply. See base diagram and outline drawing.

**Bias Voltage**—There is little advantage in using bias voltages in excess of those given under "Typical Operation," except in certain very specialized applications. Where bias is obtained by a grid leak resistor, suitable protective means must be provided to prevent excessive plate dissipation in the event of loss of excitation. The grid-leak resistor should be adjustable to facilitate maintaining the bias voltage and plate current at the desired values from tube to tube.

**Grid Dissipation**—The power dissipated by the grid of the 1500T must not exceed 125 watts. Grid dissipation may be calculated from the following expression:

$$P_g = e_{cmp} I_c$$

where  $P_g$  = Grid dissipation,  
 $e_{cmp}$  = Peak positive grid voltage, and  
 $I_c$  = D-c grid current.

$e_{cmp}$  may be measured by means of a suitable peak voltmeter connected between filament and grid.<sup>1</sup> In equipment in which the plate loading varies widely, such as oscillators used for radio-frequency heating, care should be taken to make certain that the grid dissipation does not exceed the maximum rating under any condition of loading.

**Plate Dissipation**—The plate is a red-orange color when dissipating 1500 watts. Under normal operating conditions, the power dissipated by the plate of the 1500T should not be allowed to exceed the maximum rating. Plate dissipation in excess of the maximum rating is permissible for short periods of time, such as during tuning procedures.

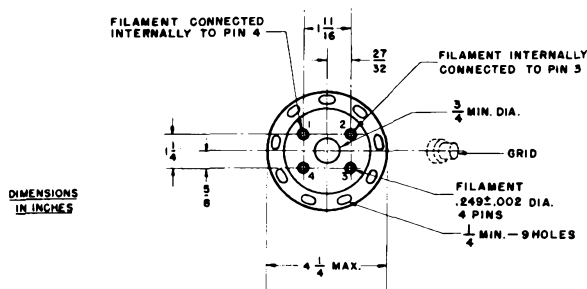
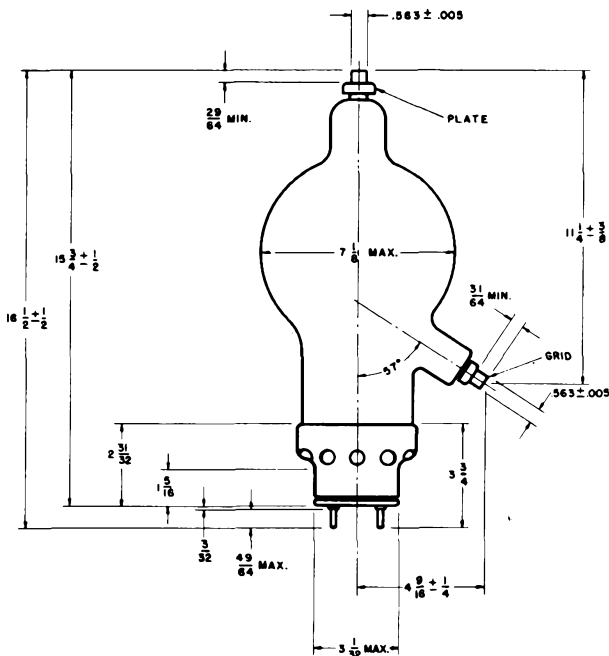

<sup>1</sup>For suitable peak v.f.v.m. circuits see, for instance, "Vacuum Tube Ratings," Eimac News, January, 1945. This article is available in reprint form on request.

## DRIVING POWER vs. POWER OUTPUT

The three charts on this page show the relationship of plate efficiency, power output and approximate grid driving power at plate voltages of 5000, 6000, and 7000 volts. These charts show combined grid and bias losses only. The driving power and power output figures do not include circuit losses. The plate dissipation in watts is indicated by Pp. Points A, B, and C are identical to the typical Class C operating conditions shown on the first page under 5000, 6000, and 7000 volts respectively.

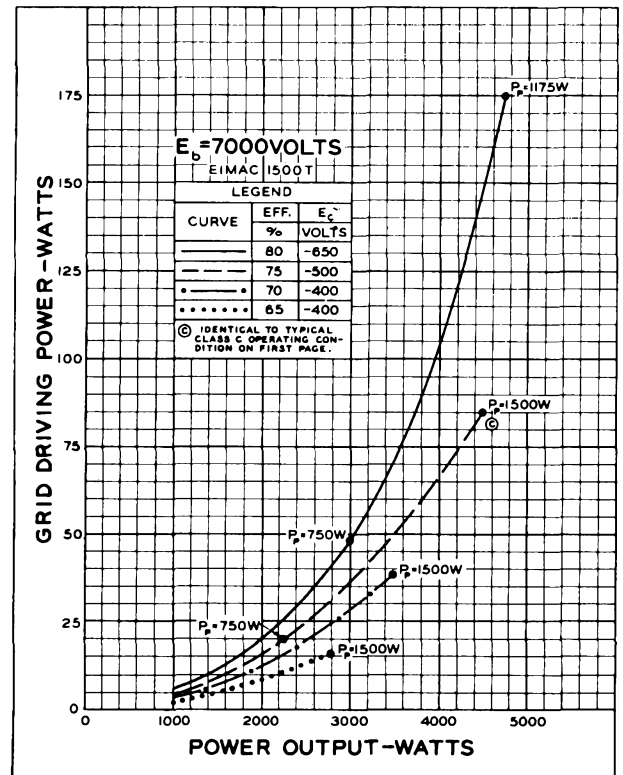
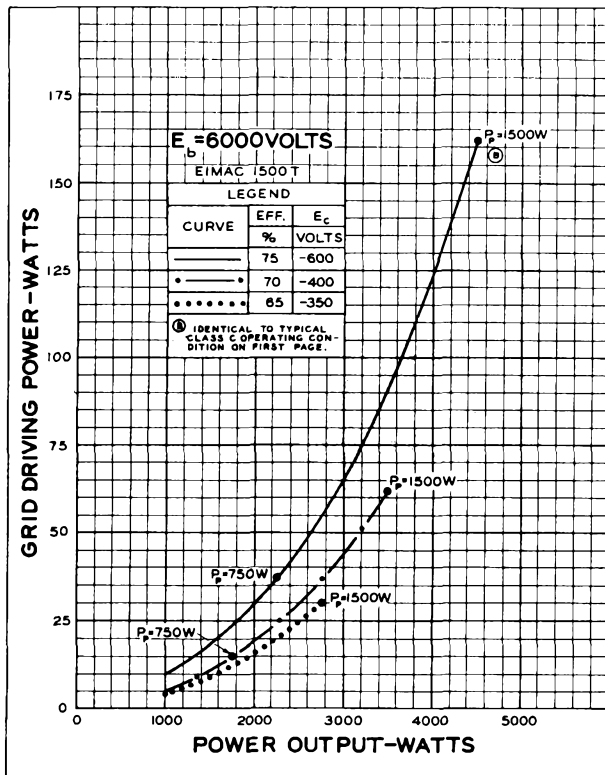
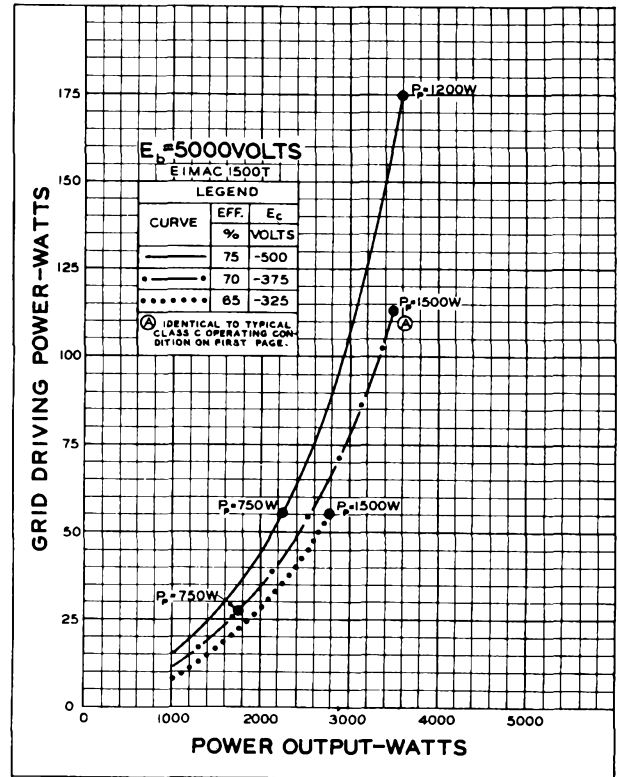

**EIMAC 1500T  
CONSTANT CURRENT  
CHARACTERISTICS**

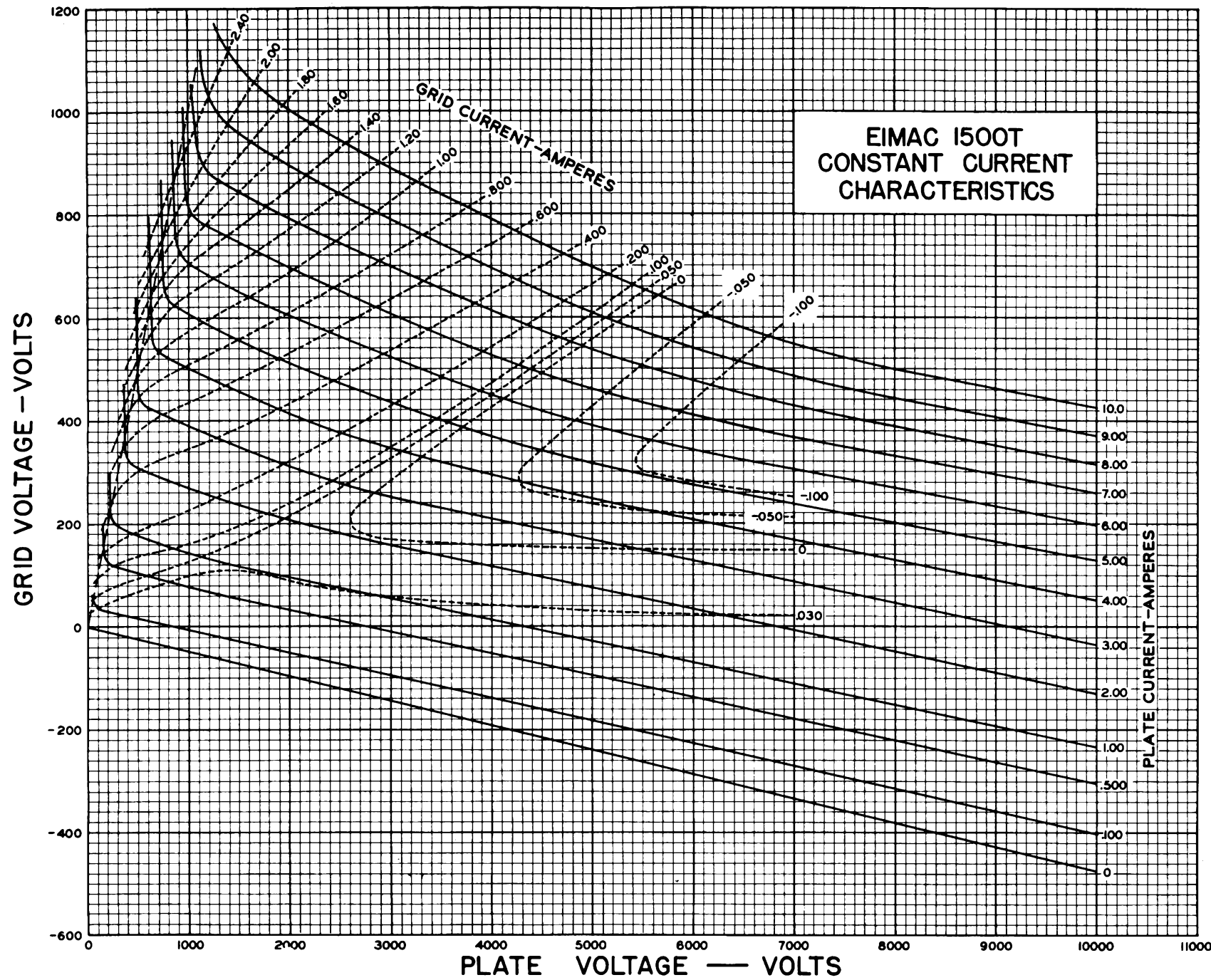



# EITEL-McCULLOUGH, INC.

SAN BRUNO, CALIFORNIA

# 2000T

MEDIUM-MU TRIODE

MODULATOR  
OSCILLATOR  
AMPLIFIER

The 2000T is a medium-mu, high-vacuum transmitting triode intended for amplifier, oscillator and modulator service. It has a maximum plate dissipation rating of 2000 watts. Cooling of the 2000T is accomplished by radiation from the plate, which operates at a visibly red temperature at maximum dissipation, and by means of forced air circulation around the envelope and at the seals.

## GENERAL CHARACTERISTICS

### ELECTRICAL

Filament: Thoriated Tungsten	
Voltage	10.0 volts
Current	23.5 amperes
Note: Dual connections for each filament lead are provided within the base of the tube (see basing diagram). Corresponding socket terminals must be connected in parallel to provide proper distribution of filament and R-F charging currents.	
Amplification Factor (Average)	23
Direct Interelectrode Capacitances (Average)	
Grid-Plate	8.5 $\mu\text{mfd.}$
Grid-Filament	12.7 $\mu\text{mfd.}$
Plate-Filament	1.7 $\mu\text{mfd.}$
Transconductance ( $i_b = 1.75 \text{ amp.}, E_b = 6000 \text{ v.}$ )	11,000 $\mu\text{mhos}$
Frequency for Maximum Ratings	40 Mc.

### MECHANICAL

Base	Special 4-pin, No. 5006B
Basing	RMA type 48D
Mounting	Vertical, base down or up
Cooling	Radiation and forced air
Recommended Heat Dissipating Connectors:	
Plate	Eimac HR-8
Grid	Eimac HR-8
Maximum Overall Dimensions:	
Length	17.75 inches
Diameter	8.125 inches
Net weight	3.5 pounds
Shipping weight (Average)	13 pounds

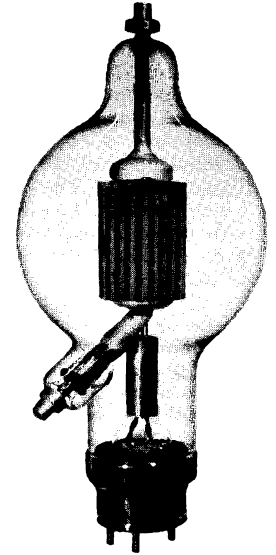

### AUDIO FREQUENCY POWER AMPLIFIER AND MODULATOR

Class AB, (Sinusoidal wave, two tubes unless otherwise specified)

#### MAXIMUM RATINGS

D-C PLATE VOLTAGE	8000 MAX. VOLTS
MAX-SIGNAL D-C PLATE CURRENT, PER TUBE	1.75 MAX. AMPS.
PLATE DISSIPATION, PER TUBE	2000 MAX. WATTS

#### TYPICAL OPERATION—2 TUBES

D-C Plate Voltage	4000	5000	6000	7000	Volts
D-C Grid Voltage (approx.)*	-140	-180	-230	-280	Volts
Zero-Signal D-C Plate Current	400	400	400	300	Ma.
Max-Signal D-C Plate Current	2.30	2.20	2.00	1.80	Amps
Effective Load, Plate-to-Plate	3400	5000	7000	9200	Ohms
Peak A-F Grid Input Voltage (per tube)	500	520	580	600	Volts
Max-Signal Peak Driving Power	300	280	380	350	Watts
Max-Signal Nominal Driving Power (approx.)	150	140	190	175	Watts
Max-Signal Plate Power Output	5200	7000	8000	8600	Watts

\*Adjust to give stated zero-signal plate current

### RADIO FREQUENCY POWER AMPLIFIER AND OSCILLATOR

Class-C Telegraphy or FM Telephony (Key-down conditions, per tube)

#### MAXIMUM RATINGS (Frequencies below 40 Mc.)

D-C PLATE VOLTAGE	8000 MAX. VOLTS
D-C PLATE CURRENT	1.75 MAX. AMPS.
PLATE DISSIPATION	2000 MAX. WATTS
GRID DISSIPATION	150 MAX. WATTS

#### TYPICAL OPERATION, PER TUBE\* (Frequencies below 40 Mc.)

D-C Plate Voltage	5000	6000	7000	Volts
D-C Grid Voltage	-350	-500	-600	Volts
D-C Plate Current	1.35	1.35	1.15	Amps.
D-C Grid Current	175	165	120	Ma.
Peak R-F Grid Input Voltage	840	1000	1060	Volts
Driving Power (approx.)	140	160	115	Watts
Grid Dissipation	85	82	55	Watts
Plate Power Input	6750	8000	8000	Watts
Plate Dissipation	2000	2000	2000	Watts
Plate Power Output	4750	6000	6000	Watts

\*The performance figures listed under Typical Operation are for radio frequencies up to the VHF region and are obtained by calculation from the characteristic tube curves and confirmed by direct tests. The driving power given includes power taken by the tube grid and the bias circuit. The driving power and output power do not allow for losses in the associated resonant circuits. These losses are not included because they depend principally upon the design and choice of the circuit components.

### PLATE MODULATED RADIO FREQUENCY AMPLIFIER

Class-C Telephony (Carrier conditions, per tube)

#### MAXIMUM RATINGS (Frequencies below 40 Mc.)

D-C PLATE VOLTAGE	6000 MAX. VOLTS
D-C PLATE CURRENT	1.4 MAX. AMPS.
PLATE DISSIPATION	1350 MAX. WATTS
GRID DISSIPATION	150 MAX. WATTS

#### TYPICAL OPERATION, PER TUBE\* (Frequencies below 40 Mc.)

D-C Plate Voltage	4000	5000	6000	Volts
D-C Plate Current	1.25	1.20	1.13	Amps.
Total Bias Voltage	-600	-700	-800	Volts
Fixed Bias Voltage	-300	-330	-375	Volts
Grid Resistor	1500	2000	2500	Ohms
D-C Grid Current	200	185	170	Ma.
Peak R-F Grid Input Voltage (approx.)	1140	1240	1320	Volts
Driving Power (approx.)	228	230	225	Watts
Grid Dissipation	108	100	88	Watts
Plate Power Input	5000	6000	6750	Watts
Plate Dissipation	1350	1350	1350	Watts
Plate Power Output	3650	4650	5400	Watts

\*The performance figures listed under Typical Operation are for radio frequencies up to the VHF region and are obtained by calculation from the characteristic tube curves and confirmed by direct tests. The driving power given includes power taken by the tube grid and the bias circuit. The driving power and output power do not allow for losses in the associated resonant circuits. These losses are not included because they depend principally upon the design and choice of the circuit components.

## APPLICATION

### MECHANICAL

**Mounting**—The 2000T must be mounted vertically, base up or base down. Flexible connecting straps should be provided between the grid and plate terminals and the external grid and plate circuits. The tube must be protected from severe vibration and shock.

▶ **Cooling**—Forced-air cooling is required on the envelope and also in the base of the tube. Envelope cooling may be accomplished by locating an ordinary 8- or 10-inch fan about one foot from the tube and directing the air at the middle of the envelope.

Base cooling requires an air flow of 2½ cu. ft. per min. directed up through the bottom of the base toward the filament press. The base of the tube is provided with a 1-inch diameter hole for this purpose. If a socket is used with a 1-inch diameter matching hole and the manifold is of the same diameter, a static pressure of less than 0.1 inch of water is required at the manifold to provide the 2½ cu. ft. per min.

One type of socket provides a ¼ inch diameter pipe for the air inlet to the base. With this type of socket a static pressure of 5½ inches of water is required at the pipe to obtain the necessary 2½ cu. ft. per min. volume.

Suitable electrical interlocks should be provided to remove the plate and filament voltages in the event that the supply of cooling air is interrupted.

### ELECTRICAL

▶ **Filament Voltage**—For maximum tube life the filament voltage, as measured directly at the filament pins, should be the rated value of 10 volts. Unavoidable variations in filament voltage must be kept within the range from 9.5 to 10.5 volts. All four socket terminals should be used, putting two in parallel for each filament connection.

**Bias Voltage**—Although there is no maximum limit on the bias voltage which may be used on the 2000T there is

little advantage in using bias voltages in excess of those given under "Typical Operation," except in certain very specialized applications. Where bias is obtained by a grid leak, suitable protective means must be provided to prevent excessive plate dissipation in the event of loss of excitation.

**Plate Voltage**—The plate supply voltage for the 2000T should not exceed 8000 volts. In most cases there is little advantage in using plate-supply voltages higher than those given under "Typical Operation" for the power output desired.

**Grid Dissipation**—The power dissipated by the grid of the 2000T must not exceed 150 watts. Grid dissipation may be calculated from the following expression:

$$P_g = e_{cmp} I_c$$

where  $P_g$  = Grid dissipation,  
 $e_{cmp}$  = Peak positive grid voltage, and  
 $I_c$  = D-c grid current.

$e_{cmp}$  may be measured by means of a suitable peak voltmeter connected between filament and grid. In equipment in which the plate loading varies widely, such as oscillators used for radio-frequency heating, care should be taken to make certain that the grid dissipation does not exceed the maximum rating under any condition of loading.

**Plate Dissipation**—Under normal operating conditions, the power dissipated by the plate of the 2000T should not be allowed to exceed 2000 watts. Plate dissipation in excess of the maximum rating is permissible for short periods of time, such as during tuning procedures.

<sup>1</sup>For suitable peak v.t.v.m. circuits see, for instance, "Vacuum Tube Ratings," Eimac News, January, 1945. This article is available in reprint form on request.

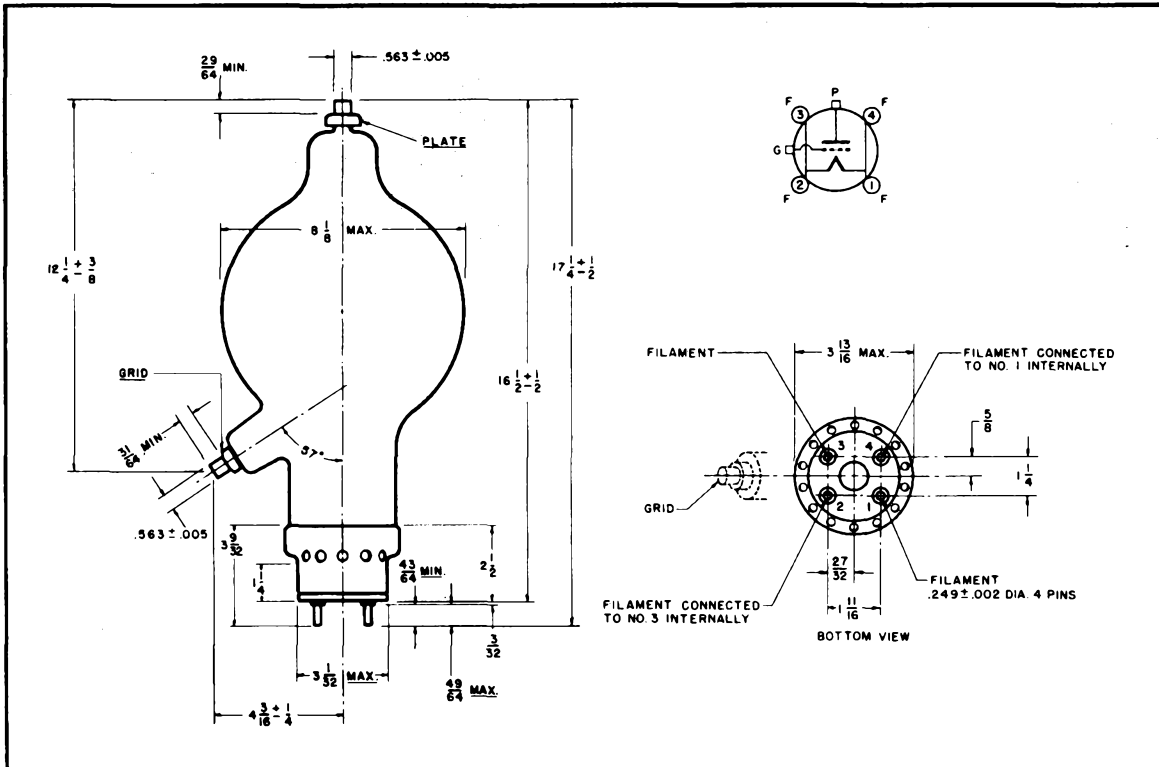

## DRIVING POWER vs. POWER OUTPUT

The three charts on this page show the relationship of plate efficiency, power output and grid driving power at plate voltages of 5000, 6000, and 7000 volts. These charts show combined grid and bias losses only. The driving power and power output figures do not include circuit losses. The plate dissipation in watts is indicated by  $P_p$ .

Points A, B, and C are identical to the typical Class C operating conditions shown on the first page under 5000, 6000, and 7000 volts respectively.

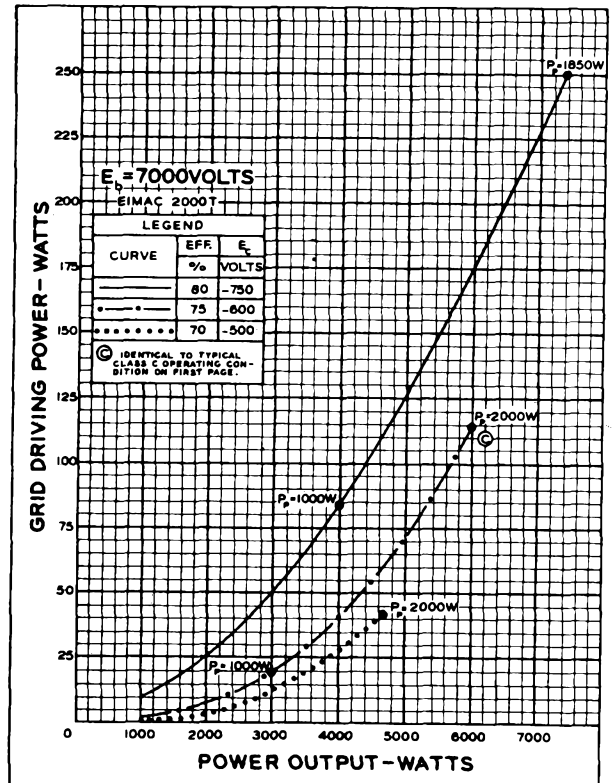
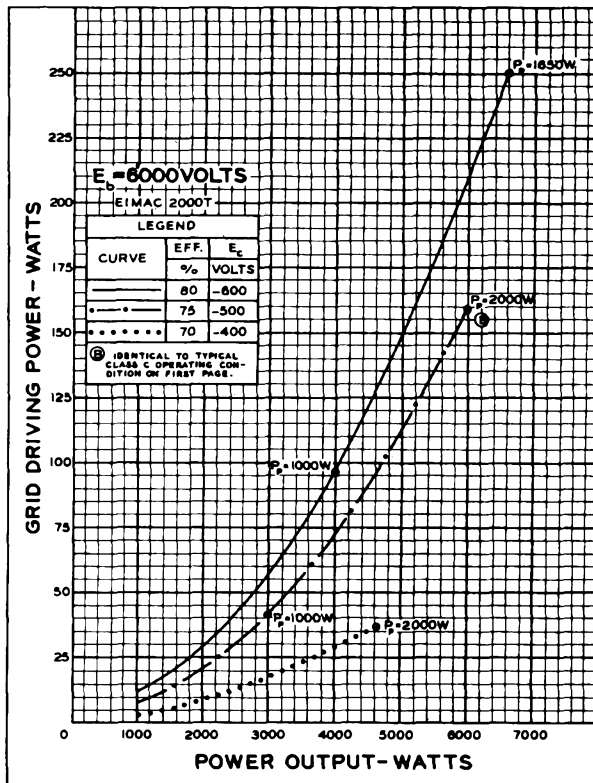
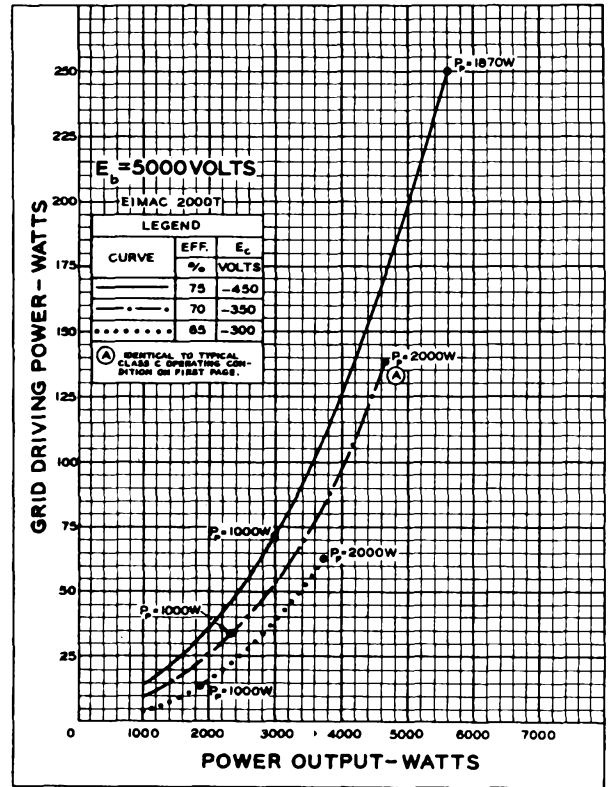

**Sima**  
ELECTRONIC TUBES  
2000T

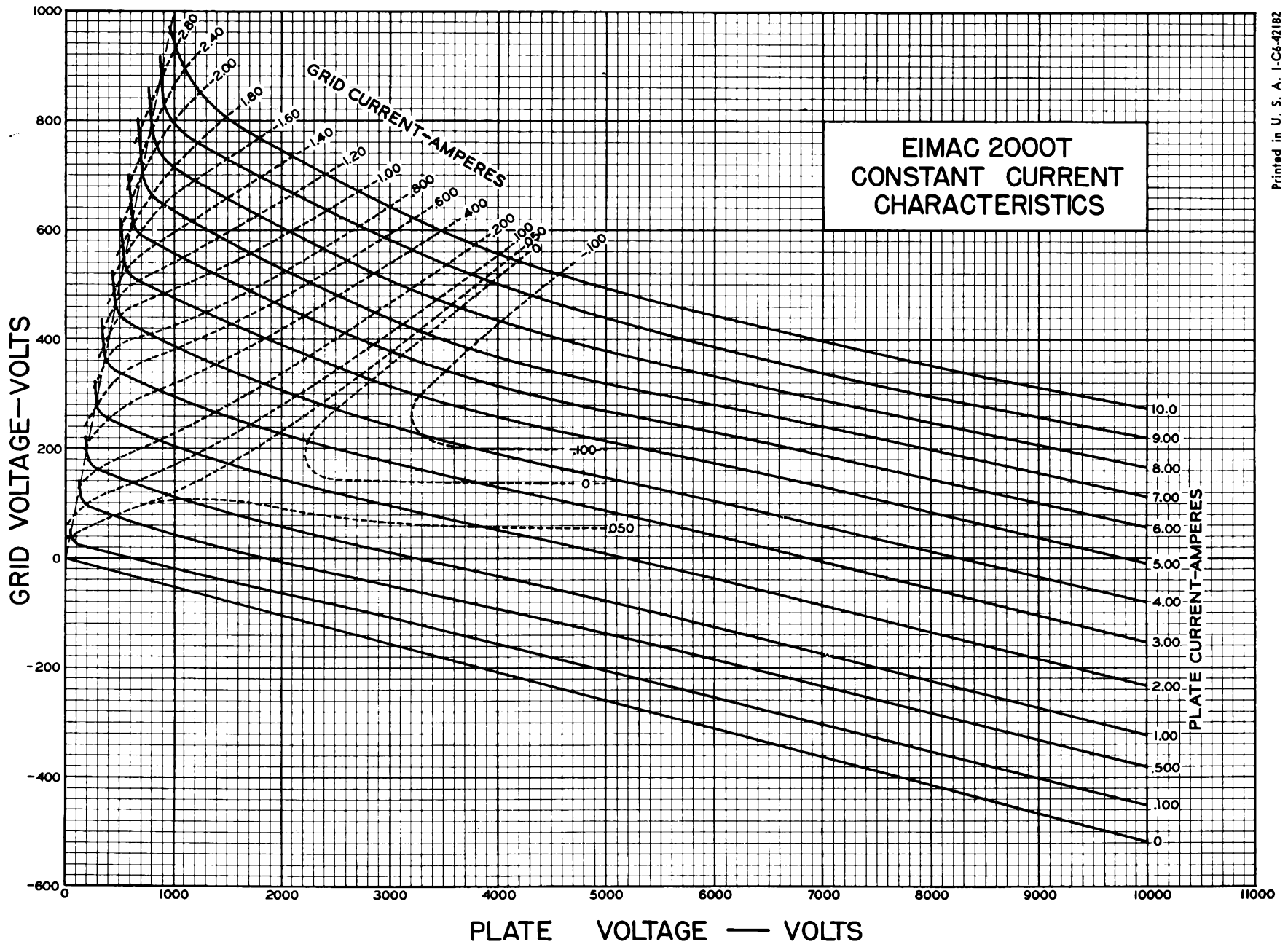

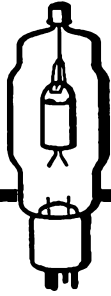

# diodes • rectifiers ▶

---

## Look in the front pages for ---

- Your nearest distributor of modern, fully guaranteed Eimac Vacuum tubes, vacuum capacitors, heat dissipating connectors, air-system sockets, preformed contact finger stock and vacuum switches.
- Your nearest Eimac Field Engineer, who stands ready to give you immediate engineering assistance, any information on deliveries and prices, or provide other information not found in the catalog.
- Eimac tube type numbering system.
- Tube Replacement Chart.
- Prices on Eimac products.

---

## IMPORTANT EIMAC "EXTRAS"

**Application Engineering.** The Eimac Application Engineering Department is available at all times for consultation. New tube operating techniques are continually being explored, tested and proved by Eimac application engineers, whose combined knowledge and experience are made available to you. Additional contributions by this Eimac department are its Application Bulletins, an expanding service which you get without obligation.

**Field Engineering.** Serving as an extension of the Application Engineering Department outside the Eimac plant, Eimac field engineers cover the United States, operate out of offices in major cities. They will help you personally with experimental work, problems of technique, etc. Engineers from the Eitel-McCullough plant in San Bruno are available, too, for field consultation throughout the country. As Eimac tubes are world renowned, the same services extend to various countries overseas through the Eimac export division.

*Eimac*  
**EITEL-McCULLOUGH, INC.**  
 SAN BRUNO, CALIFORNIA

**2-01C**  
 INSTRUMENT  
 DIODE

The Eimac 2-01C is a small, closely-spaced, low-capacitance, high-vacuum diode designed for use through ultra-high frequencies. In measurement work, it is well suited to mounting in a probe and will maintain accuracy in the order of  $\pm 1$  decibel up to 700 megacycles. It is useful as an indicator at frequencies as high as 3000 megacycles.

The 2-01C has a maximum d-c current rating of 1.0 milliamperere and a maximum peak inverse voltage rating of 1000 volts. Cooling is by convection and radiation.

**GENERAL CHARACTERISTICS**

**ELECTRICAL**

Cathode—Coated Unipotential			
Heater Voltage	- - - - -	5.0	volts
Heater Current	- - - - -	0.34	amperes
Direct Interelectrode Capacitance	- - - - -	0.7	$\mu\mu f$
Zero Signal Voltage (11 Megohm Load)			
Minimum	- - - - -	0.6	volts
Maximum	- - - - -	1.4	volts
Resonant Frequency (Approximately)	- - - - -	2800	mc
Plate Resistance ( $E_b=12$ volts)			
Average	- - - - -	8000	ohms
Maximum	- - - - -	25,000	ohms
Peak Inverse Anode Voltage (Maximum)	- - - - -	1000	volts
D-C Plate Current (Maximum)	- - - - -	1.0	ma
Plate Dissipation (Maximum)	- - - - -	0.1	watt



Actual Size

**MECHANICAL**

Length	- - - - -	1.75	inches	Net Weight	- - - - -	0.2	ounce
Diameter	- - - - -	0.56	inches	Shipping Weight	- - - - -	1.0	pound

**INPUT CHARACTERISTICS**

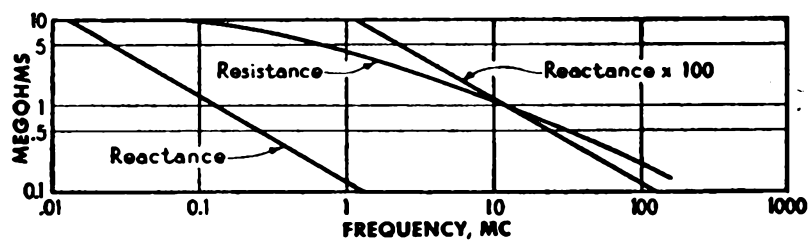

**RESPONSE**

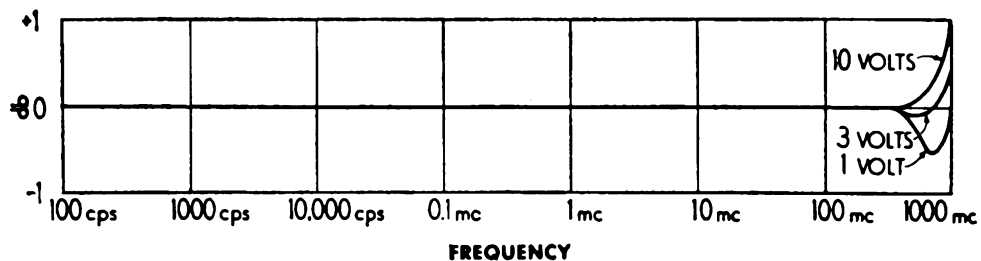

Input Impedance and Frequency Response of an Eimac 2-01C operating in a Hewlett-Packard Model 410B Vacuum Tube Voltmeter. Reproduced from Hewlett-Packard Catalog No. 21-A, 1952.

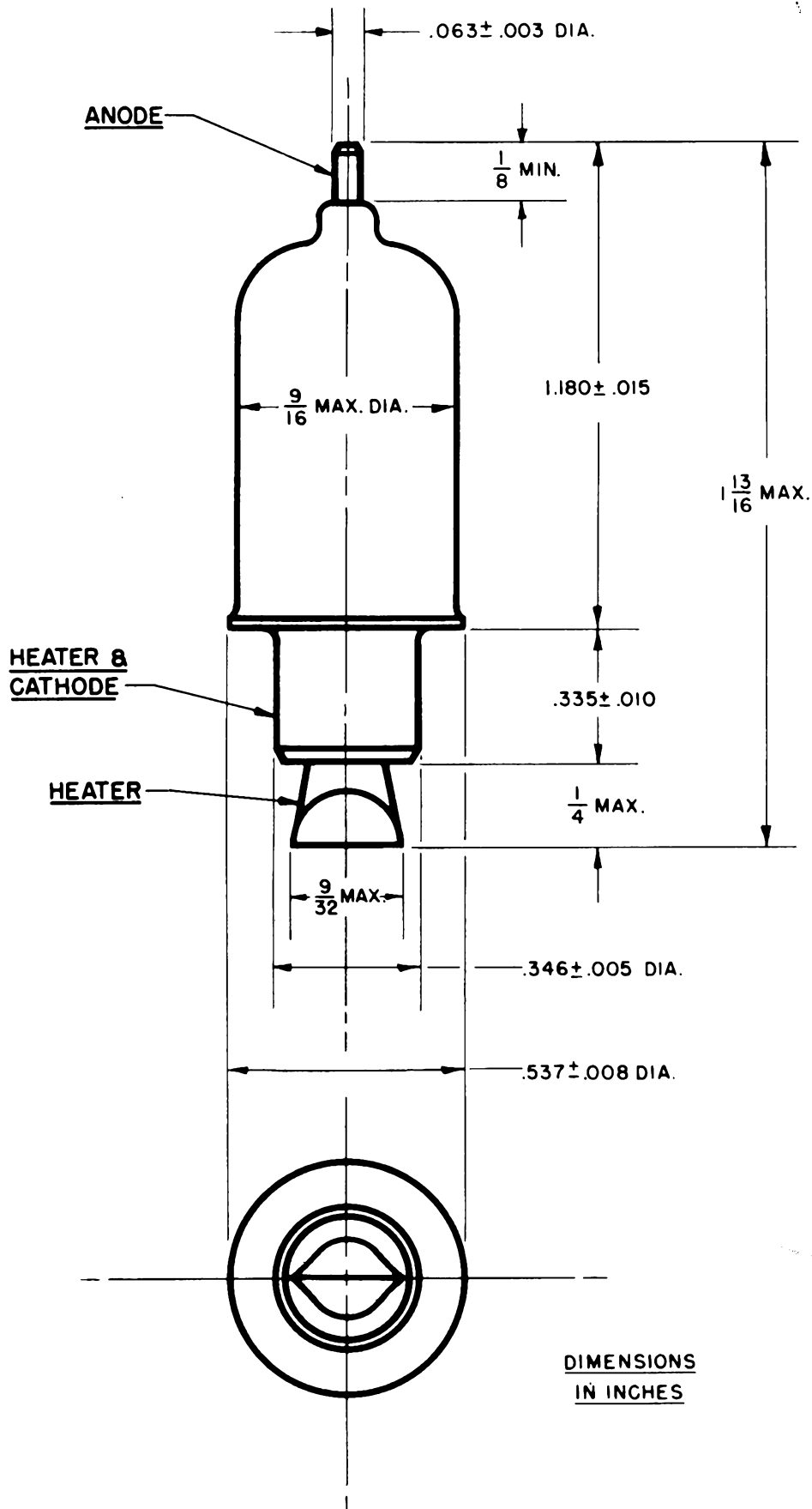

*Eimac*  
**EITEL-McCULLOUGH, INC.**  
 SAN BRUNO, CALIFORNIA

**2-25A**  
 HIGH-VACUUM  
 RECTIFIER

The Eimac 2-25A diode is a high-vacuum rectifier intended for use in rectifier units, voltage multipliers, or in special applications, whenever conditions of extreme ambient temperatures, high operating frequency, high peak inverse voltages, or the production of high-frequency transients would prevent the use of gas-filled rectifier tubes.

The 2-25A has a maximum d-c current rating of 50 milliamperes and a maximum peak inverse voltage rating of 25,000 volts. Cooling is by convection and radiation.

A single 2-25A will deliver 40 milliamperes at 10,000 volts to a capacitor-input filter with 8800 volts single-phase supply. Four 2-25A's in a bridge circuit will deliver 100 milliamperes at 15,600 volts to a choke-input filter with 17,600 volts single-phase supply.

### GENERAL CHARACTERISTICS

#### ELECTRICAL

Filament: Thoriated Tungsten

Voltage	-	-	-	-	-	-	-	-	-	6.3	volts
Current	-	-	-	-	-	-	-	-	-	3.0	amperes

#### MECHANICAL

Base	-	-	-	-	-	-	-	-	-	-	-	Small 4-pin
Basing	-	-	-	-	-	-	-	-	-	-	-	Refer to outline drawing
Socket	-	-	-	-	-	-	-	-	-	-	-	Refer to discussion under "Application"
Mounting Position	-	-	-	-	-	-	-	-	-	-	-	Vertical, base down or up
Cooling	-	-	-	-	-	-	-	-	-	-	-	Convection and radiation
Maximum Temperature of Plate Seal	-	-	-	-	-	-	-	-	-	-	-	225°C
Recommended Heat Dissipating Plate Connector	-	-	-	-	-	-	-	-	-	-	-	Eimac HR-1
Maximum Overall Dimensions:												
Length	-	-	-	-	-	-	-	-	-	-	-	4.38 inches
Diameter	-	-	-	-	-	-	-	-	-	-	-	1.44 inches
Net Weight	-	-	-	-	-	-	-	-	-	-	-	1.2 ounces
Shipping Weight (approx.)	-	-	-	-	-	-	-	-	-	-	-	1.0 pound

#### MAXIMUM RATINGS (Per tube)

PEAK INVERSE PLATE VOLTAGE	-	-	-	-	-	-	-	-	-	25,000	MAX. VOLTS
PLATE DISSIPATION	-	-	-	-	-	-	-	-	-	15	MAX. WATTS
D-C PLATE CURRENT <sup>1</sup>	-	-	-	-	-	-	-	-	-	50	MAX. MA
PEAK PLATE CURRENT	-	-	-	-	-	-	-	-	-	1.0	MAX. AMPERE

<sup>1</sup>Averaged over one cycle for each tube. Applies only when the rectifier is coupled to the load by a choke-input filter incorporating the "critical" value (or larger) of input inductance. For maximum d-c current ratings under this and other load conditions see discussion under "Application".

### APPLICATION

#### MECHANICAL

**Mounting**—The 2-25A must be mounted vertically with the base either down or up. The lead to the plate terminal of the tube should be flexible.

The small 4-pin base fits an E. F. Johnson Co. No 122-224, a National Co. No. XC-4 or CIR-4, or an equivalent socket. In some circuits, particularly those of the voltage multipliers illustrated in Fig. 2, it may be necessary to mount the socket on stand-off insulators, or on a sheet of insulating material, to provide adequate insulation to ground.

**Cooling**—The 2-25A is cooled by convection and radiation. Clearance should be provided around the glass envelope adequate for the free circulation of air. An Eimac HR-1 Heat Dissipating Connector or equivalent is required on the plate terminal.

The maximum temperature at the plate seal must not exceed 225°C. A convenient accessory for measuring this temperature is "Tempilaq", a temperature-sensitive lacquer available from the Tempil Corporation, 132 W. 22nd St., New York 11, N. Y.

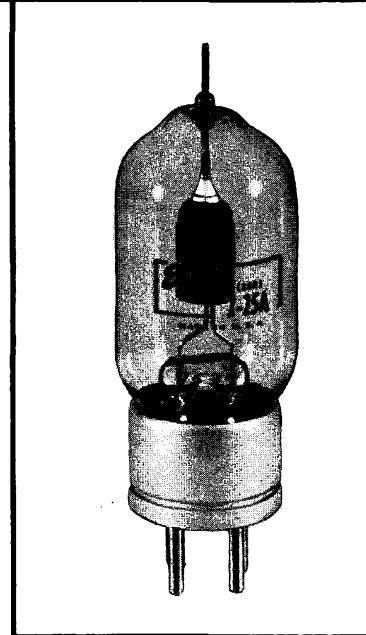



## APPLICATION (Continued)

### ELECTRICAL

**Filament Operation**—For maximum tube life, the filament voltage, as measured at the base pins, should be the rated value of 6.3 volts. Variations must be kept within the range from 6.0 to 6.6 volts. In applications which require the diode to deliver high peak currents, it is important to maintain the filament voltage at the rated value.

**CAUTION SHOULD BE OBSERVED WHEN MEASURING RECTIFIER FILAMENT VOLTAGE. THE FILAMENT CIRCUIT MAY BE AT HIGH POTENTIAL.**

The thoriated-tungsten filament of the 2-25A reaches operating temperature in a fraction of a second after application of voltage. Plate voltage may be applied simultaneously with filament voltage.

**Plate Operation**—With low room illumination, the plate of the 2-25A begins to show color as the maximum plate dissipation rating of 15 watts is approached. The maximum peak inverse voltage rating of 25,000 volts should not be exceeded at any time.

**Performance**—The accompanying table shows some maximum performance capabilities of the 2-25A when used as a power-supply rectifier.

2-25A MAXIMUM-PERFORMANCE CAPABILITIES

Circuit Type	Capacitor-Input Filter		Choke-Input Filter	
	A-C Input Voltage (volts rms)	D-C Output Voltage (volts)	D-C Output Current (ma)	D-C Output Current (ma)
Single-Phase, Half-Wave	8800	10,000	40	.....
Single-Phase, Full-Wave	8800 <sup>1</sup>	10,000	80	7900
Single-Phase, Bridge	17,600	20,000	80	15,800

<sup>1</sup>One-half the transformer secondary voltage.

**Maximum D-C Current Ratings**—Plate dissipation rather than peak current usually limits the d-c current which the 2-25A is capable of delivering to the load. Because the plate dissipation associated with a given d-c current depends upon the amount of ripple and its wave-shape, circuit conditions will determine the maximum d-c current rating of the tube.

**Choke-Input Filter**—The maximum d-c current rating of the 2-25A is 50 milliamperes when the load incorporates a choke-input filter with the "critical" value (or larger) of input inductance ( $L_1$  in Fig. 1):

$$L_o = \frac{R_{eff}}{18.8f} \quad \text{for full-wave single-phase rectifiers,}$$

$$L_o = \frac{R_{eff}}{75f} \quad \text{for half-wave three-phase rectifiers,}$$

$$L_o = \frac{R_{eff}}{660f} \quad \text{for full-wave three-phase rectifiers,}$$

where:  $L_o$  = "critical" value of input inductance (henries),  
 $f$  = supply-line frequency (cycles per second),

$$R_{eff} = \frac{\text{Load voltage (volts)}}{\text{Load current (amps)}}$$

Choke-input filters are not normally used with single-phase half-wave rectifiers.

**Capacitor-Input Filter**—The 2-25A is particularly suitable for power-supply applications demanding high voltage at low current. Under these conditions capacitor-input filter circuits become desirable. The maximum d-c current rating of the 2-25A when no input choke is incorporated in the filter depends upon

the total series resistance of the capacitor-charging circuit relative to the effective load resistance seen by each tube. The circuit diagrams and tabulation in Fig. 2 are so arranged and labeled that this required series resistance may be found for a wide range of load conditions. This may be done by determining the value of the following quantities:

$E_c$  is the filter-input d-c voltage. While this is usually the entire load voltage, in the case of voltage multipliers it is the load voltage divided by the multiplication factor.

$I_p$  is the d-c current per tube. This is the entire load current only in the case of the simple half-wave rectifier or half- or full-wave multiplier. In the case of full-wave center-tapped or bridge rectifiers,  $I_p$  is half the load current.

$R_c$  is the total charging-circuit resistance. A certain minimum value of charging-circuit resistance is necessary to limit the peak value of current to which the tubes will be subjected under given load conditions. This required minimum depends upon the d-c current per tube ( $I_p$ ), and has been tabulated in Fig. 2 as a percentage of the effective load resistance per tube ( $E_c/I_p$ ). The total charging-circuit resistance involves the internal resistance of the rectifier tube,  $R_p$ , the added series resistor,  $R_s$ , and the equivalent internal resistance of the a-c voltage supply,  $R_i$ .

$R_p$  is the plate resistance of the 2-25A, which may be taken as 1200 ohms.

$R_i$  is the equivalent internal resistance of the supply. This may be taken as the regulation of the high-voltage supply expressed as a decimal multiplied by the load resistance used in measuring this regulation.

$R_s$  is the series resistor which must be inserted in the charging circuit to bring the total charging-circuit resistance ( $R_c$ ) up to the required minimum. Its value may be found from the formula associated with each of the circuits of Fig. 2. This resistor must be inserted in such a position in the circuit that it protects all tubes.

Tubes may be operated in parallel to increase the output capability in a given circuit. When two tubes are placed in parallel at each place where one is shown in the circuits of Fig. 2, the plate resistance ( $R_p$ ) will be half as great and the maximum allowable load current twice as great as indicated.

**Peak Inverse Voltage**—The peak inverse voltage rating of the 2-25A is 25,000 volts. In single-phase power-supply rectifier circuits the peak inverse voltage to be used in design is the peak a-c supply voltage (1.41 times  $E_{rms}$  in Fig. 2) in the case of bridge circuits, and twice this value in the case of half- and full-wave rectifiers and voltage multipliers. Peak inverse voltage in three-phase operation depends upon the circuit employed, and will be found listed in the handbooks.

**Special Applications**—The ratings given for capacitor-input filter circuits assume values of input capacitance large enough to hold the ripple to a low value. In special applications where a larger percent ripple is tolerable, and filter capacitance is low, the 2-25A is capable of larger d-c output currents.

As a unidirectional conductor in d-c circuits where the current is continuous and the percent ripple is moderate, the maximum current rating of the 2-25A is 90 milliamperes.

The plate characteristic curve for the 2-25A serves as a guide to special applications. The maximum plate dissipation rating of 15 watts, the maximum peak inverse voltage rating of 25,000 volts, and the maximum peak plate current of 1.0 ampere must not be exceeded.

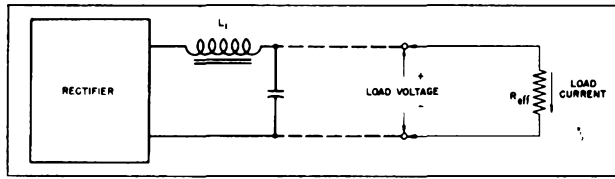
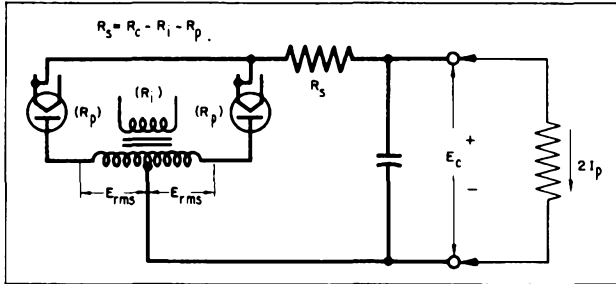
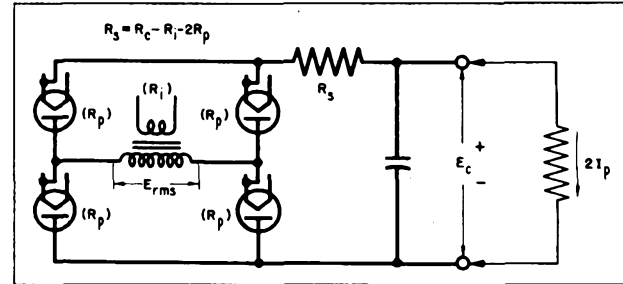

Fig. 1. Rectifier with Choke-Input Filter



a. Full-Wave Center-Tapped Rectifier



b. Full-Wave Bridge Rectifier

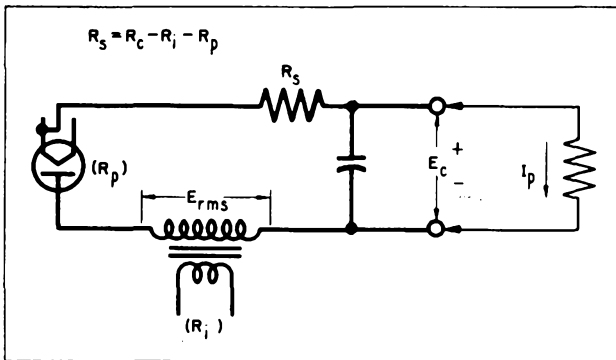

c. Half-Wave Rectifier

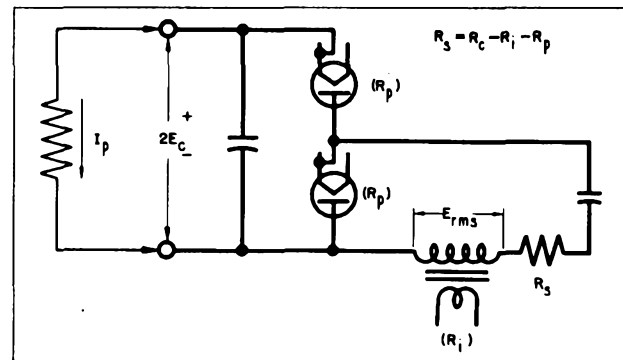

d. Half-Wave Voltage Doubler

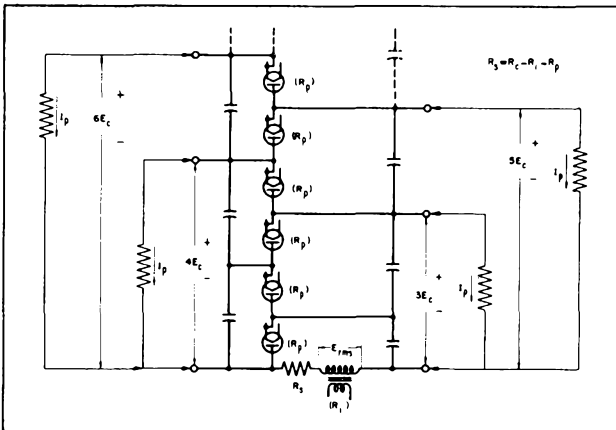

e. Half-Wave Voltage Multiplier (with common ground when  $R_s$  is inserted on the "high" side of  $E_{rms}$ )

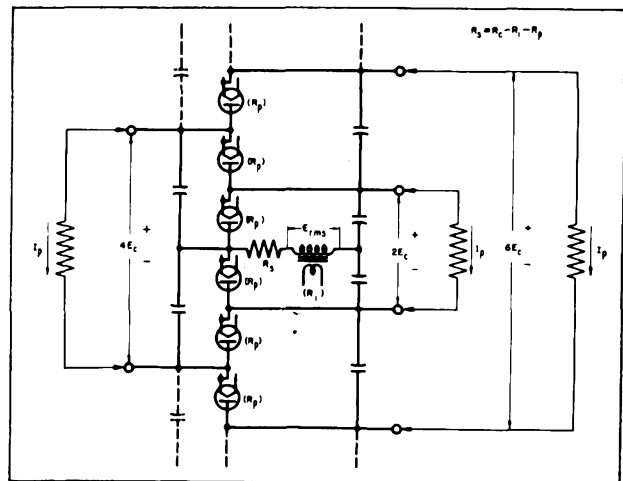

f. Full-Wave Voltage Multiplier

Eimac 2-25A Maximum D-C Current Ratings for R-C Filter Applications								
D-C Plate Current ( $I_p$ )	35.0	37.5	40.0	42.5	45.0	47.5	50.0	milliamperes per tube
Total Charging-Circuit Resistance ( $R_c$ )	1.3	2.0	3.4	5.5	9.0	16	27	percent of Effective Load Resistance per Tube ( $E_c/I_p$ )
A-C Supply Voltage ( $E_{rms}$ )	0.80	0.83	0.88	0.94	1.05	1.23	1.50	times Filter-Input D-C Voltage ( $E_c$ )
Peak Inverse Voltage ( $1/2$ these values for circuit b.)	2.3	2.4	2.5	2.7	3.0	3.5	4.3	times Filter-Input D-C Voltage ( $E_c$ )

Fig. 2. Eimac 2-25A Basic R-C Circuits (for any one of the indicated loads)

$R_1$  = Equivalent resistance of voltage source.

$R_p$  = 1200 ohms (600 ohms for two tubes in parallel)

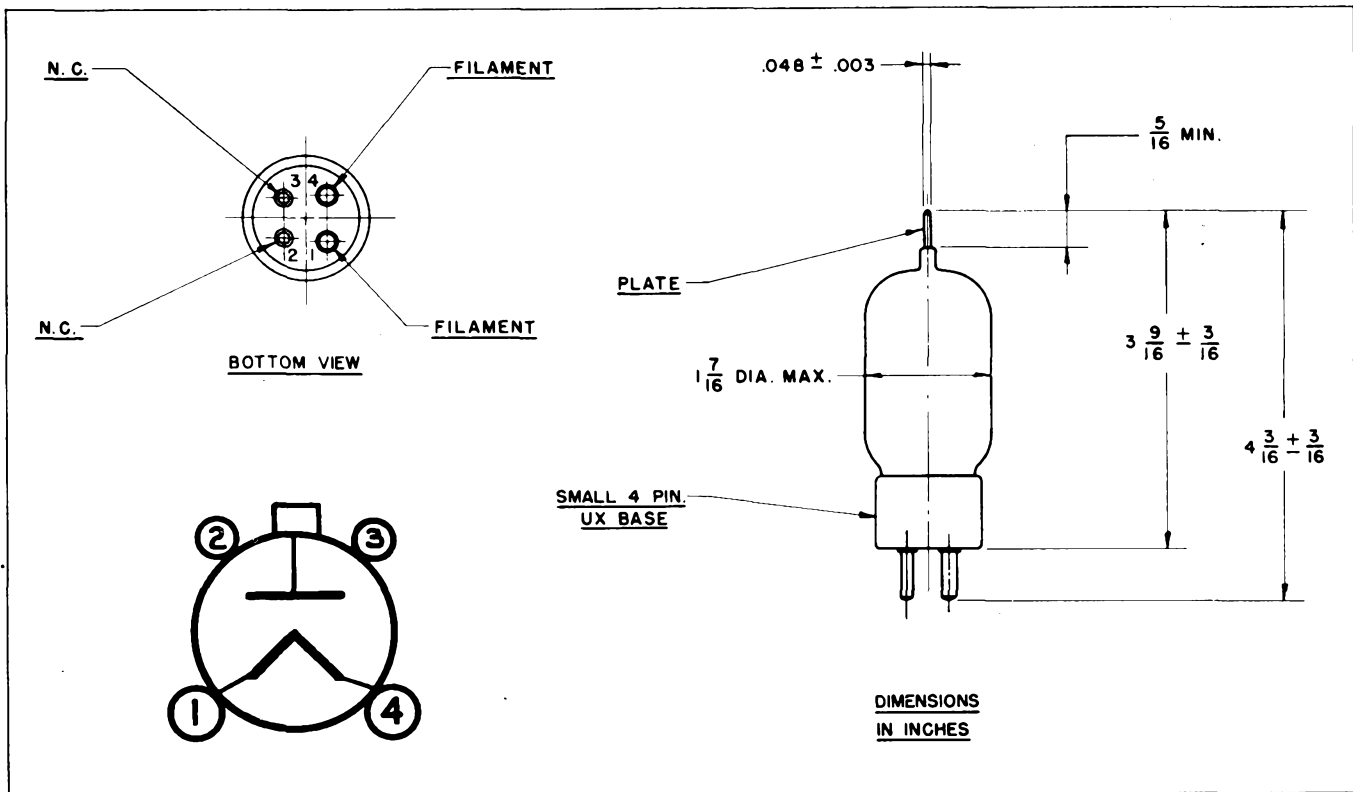
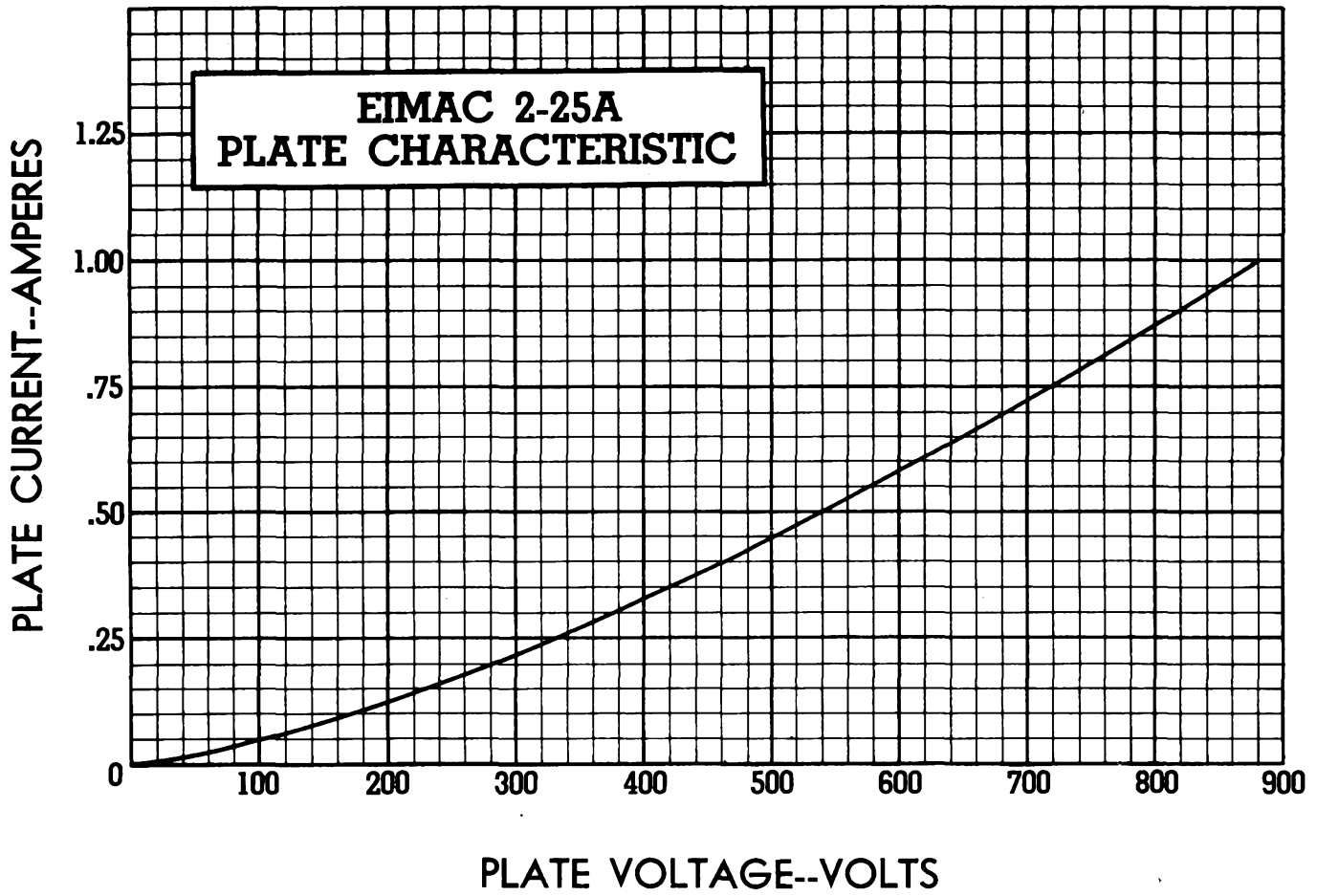

*Eimac*  
**EITEL-McCULLOUGH, Inc.**  
 SAN BRUNO, CALIFORNIA

**2-50A**  
 HIGH-VACUUM  
 RECTIFIER

The Eimac 2-50A diode is a high-vacuum rectifier intended for use in rectifier units, voltage multipliers, or in special applications, whenever conditions of extreme ambient temperatures, high operating frequency, high peak inverse voltages, or the production of high-frequency transients would prevent the use of gas-filled rectifier tubes.

The 2-50A has a maximum d-c current rating of 75 milliamperes and a maximum peak inverse voltage rating of 30,000 volts. Cooling is by convection and radiation.

A single 2-50A will deliver 60 milliamperes at 12,500 volts to a capacitor-input filter with 10,600 volts single-phase supply. Four 2-50A's in a bridge circuit will deliver 150 milliamperes at 19,000 volts to a choke-input filter with 21,200 volts single-phase supply.

**GENERAL CHARACTERISTICS**

**ELECTRICAL**

Filament: Thoriated Tungsten	
Voltage	5.0 volts
Current	4.0 amperes

**MECHANICAL**

Base	Medium 4-pin bayonet
Basing	Refer to outline drawing
Socket	Refer to discussion under "Application"
Mounting Position	Vertical, base down or up
Cooling	Convection and radiation
Maximum Temperature of Plate Seal	225°C
Recommended Heat Dissipating Plate Connector	Eimac HR-3
Maximum Overall Dimensions:	
Length	5.50 inches
Diameter	1.82 inches
Net Weight	2.5 ounces
Shipping Weight (approx.)	1.0 pound

**MAXIMUM RATINGS (Per tube)**

PEAK INVERSE PLATE VOLTAGE	30,000 MAX. VOLTS
PLATE DISSIPATION	30 MAX. WATTS
D-C PLATE CURRENT <sup>1</sup>	75 MAX. MA
PEAK PLATE CURRENT	1.0 MAX. AMPERE

<sup>1</sup>Averaged over one cycle for each tube. Applies only when the rectifier is coupled to the load by a choke-input filter incorporating the "critical" value (or larger) of input inductance. For maximum d-c current ratings under this and other load conditions see discussion under "Application".

**APPLICATION**

**MECHANICAL**

**Mounting**—The 2-50A must be mounted vertically with the base either down or up. The lead to the plate terminal of the tube should be flexible.

The medium 4-pin base fits an E. F. Johnson Co. No. 122-224, a National Co. No. XC-4 or CIR-4, or an equivalent socket. In some circuits, particularly those of the voltage multipliers illustrated in Fig. 2, it may be necessary to mount the socket

on stand-off insulators, or on a sheet of insulating material, to provide adequate insulation to ground.

**Cooling**—The 2-50A is cooled by convection and radiation. Clearance should be provided around the glass envelope adequate for the free circulation of air. An Eimac HR-3 Heat Dissipating Connector or equivalent is required on the plate terminal.

The maximum temperature at the plate seal must not exceed 225°C. A convenient accessory for measuring this temperature



## APPLICATION (Continued)

is "Tempilaq" a temperature-sensitive lacquer available from the Tempil Corporation, 132 W. 22nd St., New York 11, N. Y.

### ELECTRICAL

**Filament Operation**—For maximum tube life, the filament voltage, as measured at the base pins, should be the rated value of 5.0 volts. Variations must be kept within the range from 4.75 to 5.25 volts. In applications which require the diode to deliver high peak currents, it is important to maintain the filament voltage at the rated value.

CAUTION SHOULD BE OBSERVED WHEN MEASURING RECTIFIER FILAMENT VOLTAGE. THE FILAMENT CIRCUIT MAY BE AT A HIGH POTENTIAL.

The thoriated-tungsten filament of the 2-50A reaches operating temperature in a fraction of a second after application of voltage. Plate voltage may be applied simultaneously with filament voltage.

**Plate Operation**—With low room illumination the plate of the 2-50A begins to show color as the maximum plate dissipation rating of 30 watts is approached. The maximum peak inverse voltage rating of 30,000 volts should not be exceeded at any time.

**Performance**—The accompanying table shows some maximum performance capabilities of the 2-50A when used as a power-supply rectifier.

2-50A MAXIMUM-PERFORMANCE CAPABILITIES

Circuit Type	Capacitor-Input Filter			Choke-Input Filter	
	A-C Input Voltage (volts rms)	D-C Output Voltage (volts)	D-C Output Current (ma)	D-C Output Voltage (volts)	D-C Output Current (ma)
Single-Phase, Half-Wave	10,600	12,500	60	.....	.....
Single-Phase, Full-Wave	10,600 <sup>1</sup>	12,500	120	9500	150
Single-Phase, Bridge	21,200	25,000	120	19,000	150

<sup>1</sup>One-half the transformer secondary voltage.

**Maximum D-C Current Ratings**—Plate dissipation rather than peak current usually limits the d-c current which the 2-50A is capable of delivering to the load. Because the plate dissipation associated with a given d-c current depends upon the amount of ripple and its wave-shape, circuit conditions will determine the maximum d-c current rating of the tube.

**Choke-Input Filter**—The maximum d-c current rating of the 2-50A is 75 milliamperes when the load incorporates a choke-input filter with the "critical" value (or larger) of input inductance ( $L_o$  in Fig. 1):

$$L_o = \frac{R_{eff}}{18.8f} \quad \text{for full-wave single-phase rectifiers,}$$

$$L_o = \frac{R_{eff}}{75f} \quad \text{for half-wave three-phase rectifiers,}$$

$$L_o = \frac{R_{eff}}{660f} \quad \text{for full-wave three-phase rectifiers,}$$

where:  $L_o$  = "critical" value of input inductance (henries),  
 $f$  = supply-line frequency (cycles per second),

$$R_{eff} = \frac{\text{Load voltage (volts)}}{\text{Load current (amps)}}$$

Choke-input filters are not normally used with single-phase half-wave rectifiers.

**Capacitor-Input Filter**—The 2-50A is particularly suitable for power-supply applications demanding high voltage at low current. Under these conditions capacitor-input filter circuits become desirable. The maximum d-c current rating of the 2-50A

when no input choke is incorporated in the filter depends upon the total series resistance of the capacitor-charging circuit relative to the effective load resistance seen by each tube. The circuit diagrams and tabulation in Fig. 2 are so arranged and labeled that this required series resistance may be found for a wide range of load conditions. This may be done by determining the value of the following quantities:

$E_c$  is the filter-input d-c voltage. While this is usually the entire load voltage, in the case of voltage multipliers it is the load voltage divided by the multiplication factor.

$I_p$  is the d-c current per tube. This is the entire load current only in the case of the simple half-wave rectifier or half- or full-wave multiplier. In the case of full-wave center-tapped or bridge rectifiers,  $I_p$  is half the load current.

$R_c$  is the total charging-circuit resistance. A certain minimum value of charging-circuit resistance is necessary to limit the peak value of current to which the tubes will be subjected under given load conditions. This required minimum depends upon the d-c current per tube ( $I_p$ ), and has been tabulated in Fig. 2 as a percentage of the effective load resistance per tube ( $E_c/I_p$ ). The total charging-circuit resistance involves the internal resistance of the rectifier tube,  $R_p$ , the added series resistor,  $R_s$ , and the equivalent internal resistance of the a-c voltage supply,  $R_i$ .

$R_p$  is the plate resistance of the 2-50A, which may be taken as 1000 ohms.

$R_i$  is the equivalent internal resistance of the supply. This may be taken as the regulation of the high-voltage supply expressed as a decimal multiplied by the load resistance used in measuring this regulation.

$R_s$  is the series resistor which must be inserted in the charging circuit to bring the total charging-circuit resistance up to the required minimum. Its value may be found from the formula associated with each of the circuits of Fig. 2. This resistor must be inserted in such a position in the circuit that it protects all tubes.

Tubes may be operated in parallel to increase the output capability in a given circuit. When two tubes are placed in parallel at each place where one is shown in the circuits of Fig. 2, the plate resistance ( $R_p$ ) will be half as great and the maximum allowable load current twice as great as indicated.

**Peak Inverse Voltage**—The peak inverse voltage rating of the 2-50A is 30,000 volts. In single-phase power-supply rectifier circuits the peak inverse voltage to be used in design is the peak a-c supply voltage (1.41 times  $E_{rms}$  in Fig. 2) in the case of bridge circuits, and twice this value in the case of half- and full-wave rectifiers and voltage multipliers. Peak inverse voltage in three-phase operation depends upon the circuit employed, and will be found listed in the handbooks.

**Special Applications**—The ratings given for capacitor-input filter circuits assume values of input capacitance large enough to hold the ripple to a low value. In special applications where a larger percent ripple is tolerable, and filter capacitance is low, the 2-50A is capable of larger d-c output currents.

As a unidirectional conductor in d-c circuits where the current is continuous and the percent ripple is moderate, the maximum current rating of the 2-50A is 145 milliamperes.

The plate characteristic curve for the 2-50A serves as a guide to special applications. The maximum plate dissipation rating of 30 watts, the maximum peak inverse voltage rating of 30,000 volts, and the maximum peak plate current of 1.0 ampere must not be exceeded.

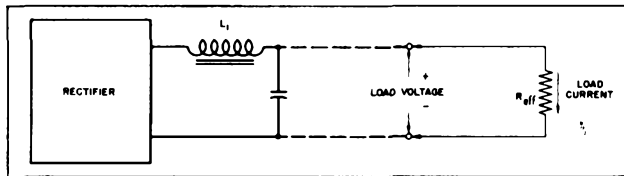
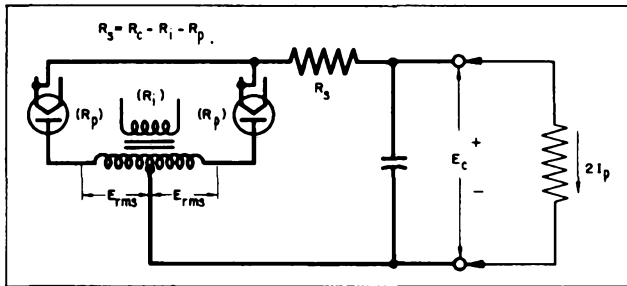
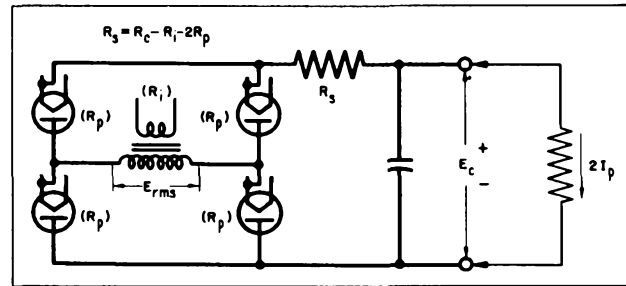

Fig. 1. Rectifier with Choke-Input Filter



a. Full-Wave Center-Tapped Rectifier



b. Full-Wave Bridge Rectifier

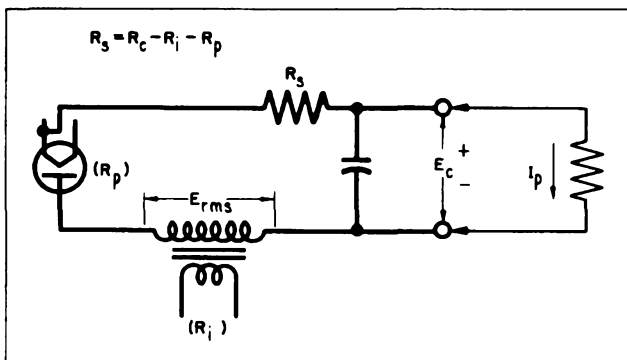

c. Half-Wave Rectifier

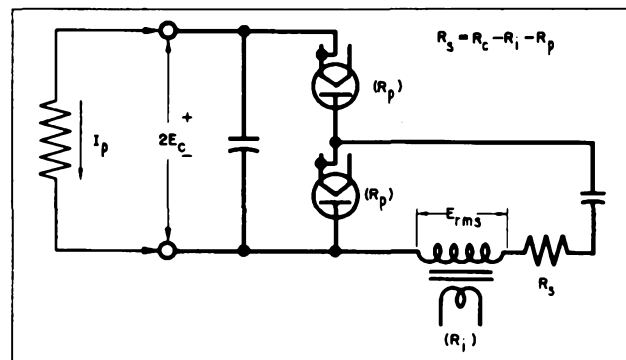

d. Half-Wave Voltage Doubler

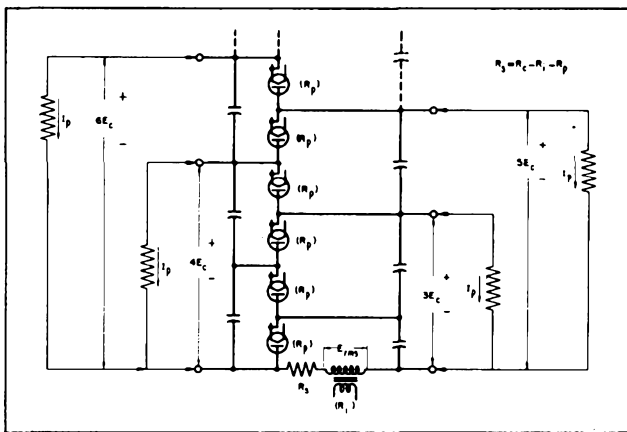

e. Half-Wave Voltage Multiplier (with common ground when  $R_s$  is inserted on the "high" side of  $E_{rms}$ )

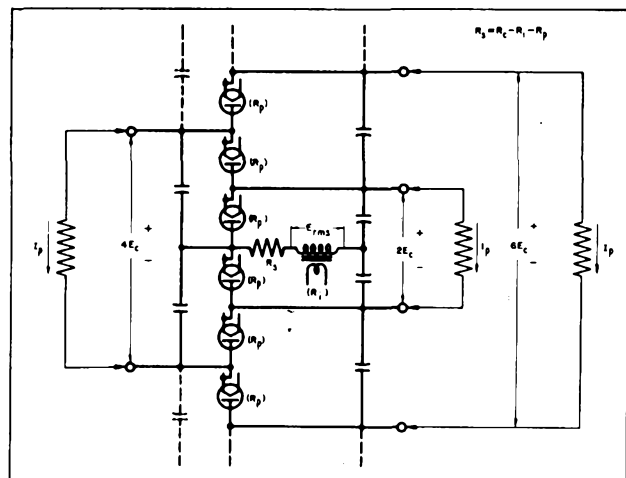

f. Full-Wave Voltage Multiplier

Eimac 2-50A Maximum D-C Current Ratings for R-C Filter Applications						
D-C Plate Current ( $I_p$ )	55	60	65	70	75	milliamperes per tube
Total Charging-Circuit Resistance ( $R_c$ )	1.3	2.4	4.7	8.5	17	percent of effective Load Resistance per Tube ( $E_c/I_p$ )
A-C Supply Voltage ( $E_{rms}$ )	0.80	0.85	0.92	1.04	1.28	times Filter-Input D-C Voltage ( $E_c$ )
Peak Inverse Voltage ( $1/2$ these values for circuit b.)	2.3	2.4	2.6	3.0	3.7	times Filter-Input D-C Voltage ( $E_c$ )

Fig. 2 Eimac 2-50A Basic R-C Circuits (for any one of the indicated loads)

$R_i$  = Equivalent resistance of voltage source

$R_p$  = 1000 ohms (500 ohms for two tubes in parallel)

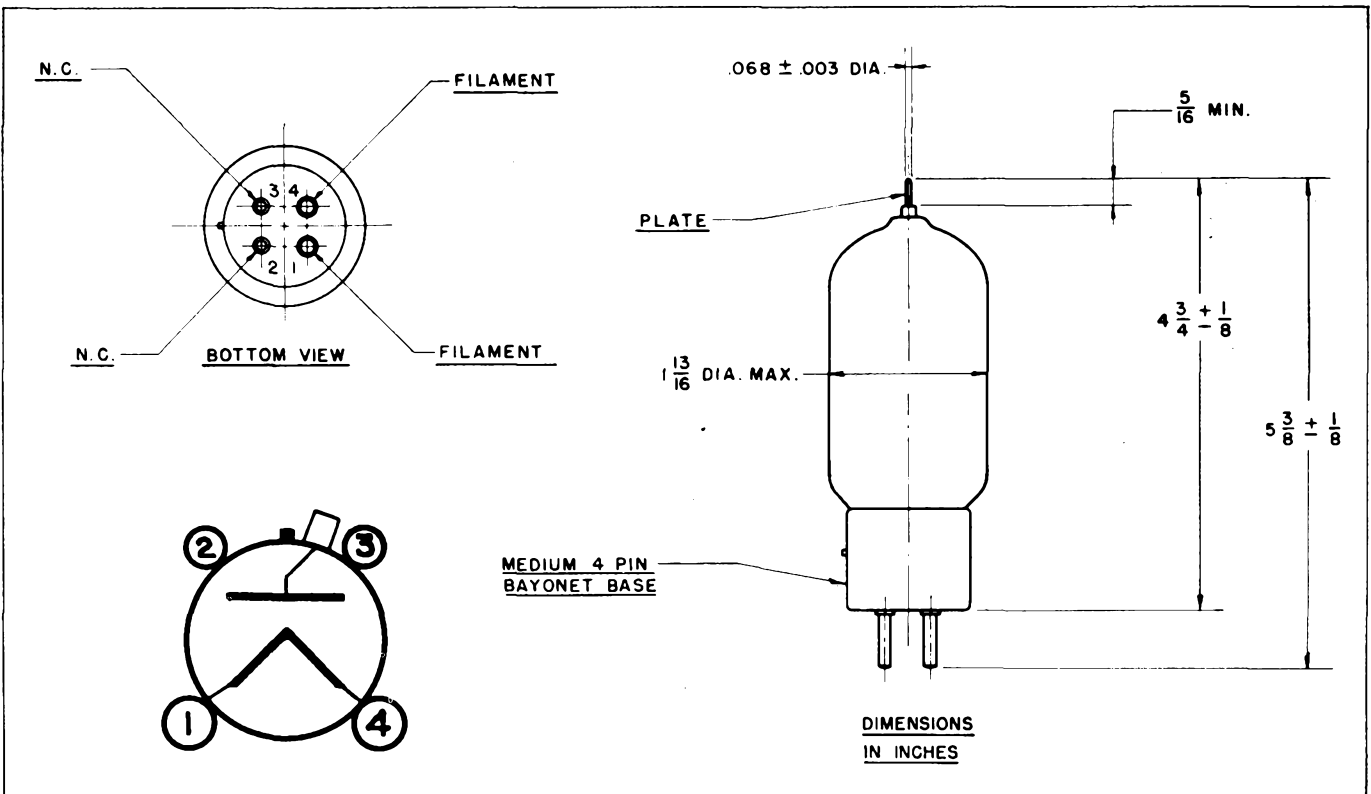
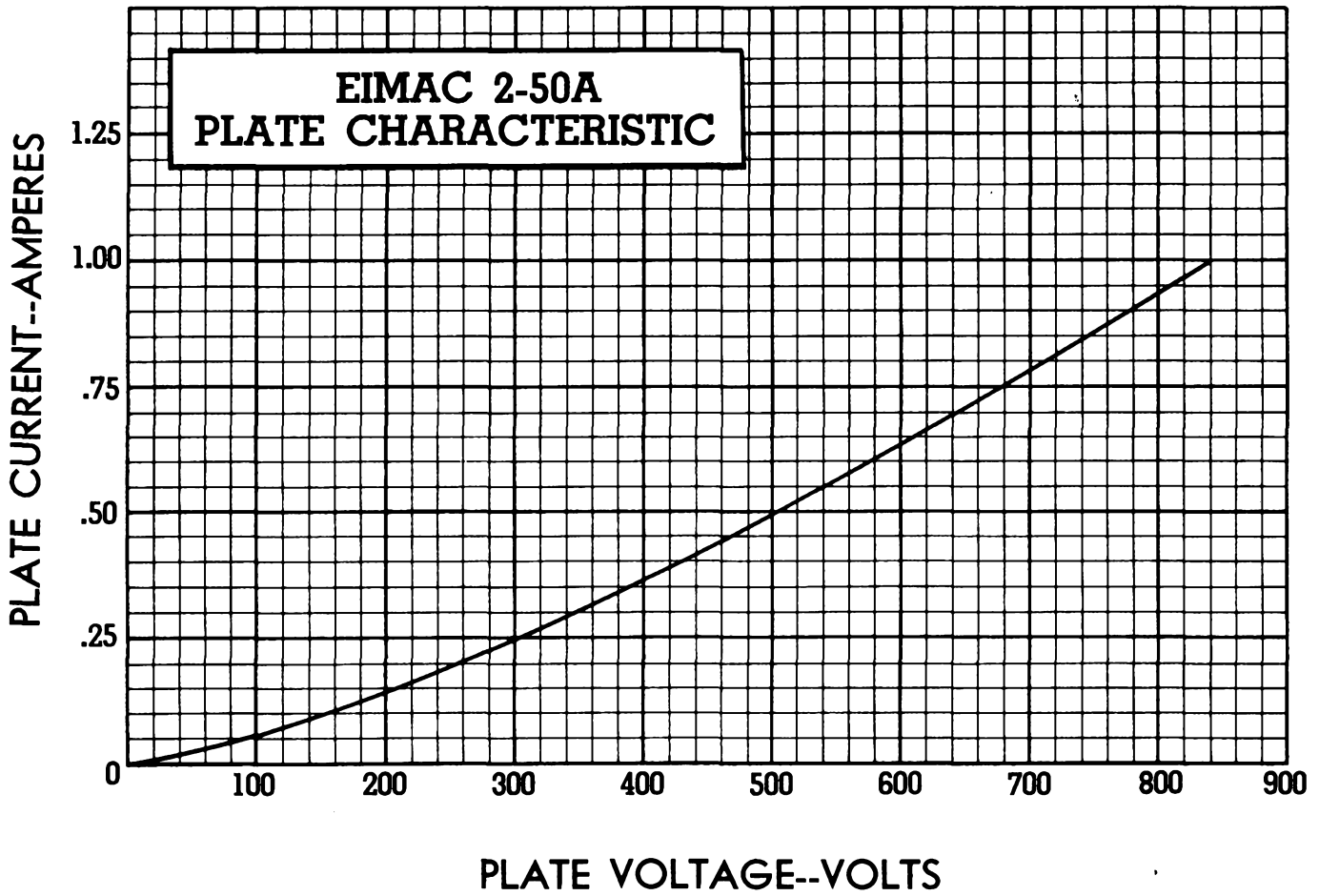





## APPLICATION (Continued)

is "Tempilaq", a temperature-sensitive lacquer available from the Tempil Corporation, 132 W. 22nd Street, New York 11, N. Y.

### ELECTRICAL

**Filament Operation**—For maximum tube life, the filament voltage, as measured at the base pins, should be the rated value of 5.0 volts. Variations must be kept within the range from 4.75 to 5.25 volts. In applications which require the diode to deliver high peak currents, it is important to maintain the filament voltage at the rated value.

**CAUTION SHOULD BE OBSERVED WHEN MEASURING RECTIFIER FILAMENT VOLTAGE. THE FILAMENT CIRCUIT MAY BE AT HIGH POTENTIAL.**

The thoriated-tungsten filament of the 2-150D reaches operating temperature in a fraction of a second after application of voltage. Plate voltage may be applied simultaneously with filament voltage.

**Plate Operation**—With low room illumination, the plate of the 2-150D begins to show color as the maximum plate dissipation rating of 90 watts is approached. The maximum peak inverse voltage rating of 30,000 volts should not be exceeded at any time.

**Performance**—The accompanying table shows some maximum performance capabilities of the 2-150D when used as a power-supply rectifier.

2-150D MAXIMUM-PERFORMANCE CAPABILITIES

Circuit Type	Capacitor-Input Filter			Choke-Input Filter	
	A-C Input Voltage (volts rms)	D-C Output Voltage (volts)	D-C Output Current (ma)	D-C Output Voltage (volts)	D-C Output Current (ma)
Single-Phase, Half-Wave	10,600	11,800	200	.....	.....
Single-Phase, Full-Wave	10,600 <sup>1</sup>	11,800	400	9500	500
Single-Phase, Bridge	21,200	23,600	400	19,000	500

<sup>1</sup>One-half the transformer secondary voltage.

**Maximum D-C Current Ratings**—Plate dissipation rather than peak current usually limits the d-c current which the 2-150D is capable of delivering to the load. Because the plate dissipation associated with a given d-c current depends upon the amount of ripple and its wave-shape, circuit conditions will determine the maximum d-c current rating of the tube.

**Choke-Input Filter**—The maximum d-c current rating of the 2-150D is 250 milliamperes when the load incorporates a choke-input filter with the "critical" value (or larger) of input inductance ( $L_o$  in Fig. 1):

$$L_o = \frac{R_{eff}}{18.8f} \quad \text{for full-wave single-phase rectifiers,}$$

$$L_o = \frac{R_{eff}}{75f} \quad \text{for half-wave three-phase rectifiers,}$$

$$L_o = \frac{R_{eff}}{660f} \quad \text{for full-wave three-phase rectifiers,}$$

where:  $L_o$  = "critical" value of input inductance (henries),  
 $f$  = supply-line frequency (cycles per second),

$$R_{eff} = \frac{\text{Load voltage (volts)}}{\text{Load current (amps)}}$$

Choke-input filters are not normally used with single-phase half-wave rectifiers.

**Capacitor-Input Filter**—The 2-150D is particularly suitable for power-supply applications demanding high voltage at low current. Under these conditions capacitor-input filter circuits become desirable. The maximum d-c current rating of the 2-150D

when no input choke is incorporated in the filter depends upon the total series resistance of the capacitor-charging circuit relative to the effective load resistance seen by each tube. The circuit diagrams and tabulation in Fig. 2 are so arranged and labeled that this required series resistance may be found for a wide range of load conditions. This may be done by determining the value of the following quantities:

$E_c$  is the filter-input d-c voltage. While this is usually the entire load voltage, in the case of voltage multipliers it is the load voltage divided by the multiplication factor.

$I_p$  is the d-c current per tube. This is the entire load current only in the case of the simple half-wave rectifier or half- or full-wave multiplier. In the case of full-wave center-tapped or bridge rectifiers,  $I_p$  is half the load current.

$R_c$  is the total charging-circuit resistance. A certain minimum value of charging-circuit resistance is necessary to limit the peak value of current to which the tubes will be subjected under given load conditions. This required minimum depends upon the d-c current per tube ( $I_p$ ), and has been tabulated in Fig. 2 as a percentage of the effective load resistance per tube ( $E_c/I_p$ ). The total charging-circuit resistance involves the internal resistance of the rectifier tube,  $R_p$ , the added series resistor,  $R_s$ , and the equivalent internal resistance of the a-c voltage supply,  $R_j$ .

$R_p$  is the plate resistance of the 2-150D, which may be taken as 300 ohms.

$R_j$  is the equivalent internal resistance of the supply. This may be taken as the regulation of the high-voltage supply expressed as a decimal multiplied by the load resistance used in measuring this regulation.

$R_s$  is the series resistor which must be inserted in the charging circuit to bring the total charging-circuit resistance up to the required minimum. Its value may be found from the formula associated with each of the circuits of Fig. 2. This resistor must be inserted in such a position in the circuit that it protects all tubes.

Tubes may be operated in parallel to increase the output capability in a given circuit. When two tubes are placed in parallel at each place where one is shown in the circuits of Fig. 2, the plate resistance ( $R_p$ ) will be half as great and the load maximum allowable load current twice as great as indicated.

**Peak Inverse Voltage**—The peak inverse voltage rating of the 2-150D is 30,000 volts. In single-phase power-supply rectifier circuits the peak inverse voltage to be used in design is the peak a-c supply voltage (1.41 times  $E_{rms}$  in Fig. 2) in the case of bridge circuits, and twice this value in the case of half- and full-wave rectifiers and voltage multipliers. Peak inverse voltage in three-phase operation depends upon the circuit employed, and will be found listed in the handbooks.

**Special Applications**—The ratings given for capacitor-input filter circuits assume values of input capacitance large enough to hold the ripple to a low value. In special applications where a larger percent ripple is tolerable, and filter capacitance is low, the 2-150D is capable of larger d-c output currents.

As a unidirectional conductor in d-c circuits where the current is continuous and the percent ripple is moderate, the maximum current rating of the 2-150D is 500 milliamperes.

The plate characteristic curve for the 2-150D serves as a guide to special applications. The maximum plate dissipation rating of 90 watts, the maximum peak inverse voltage rating of 30,000 volts, and the maximum peak plate current of 3.0 amperes must not be exceeded.

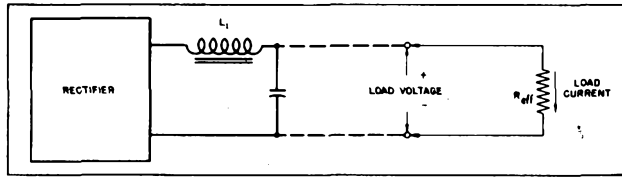
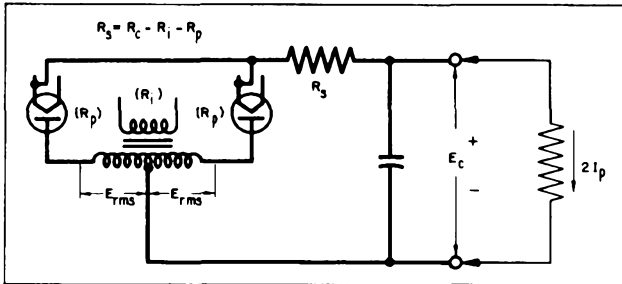
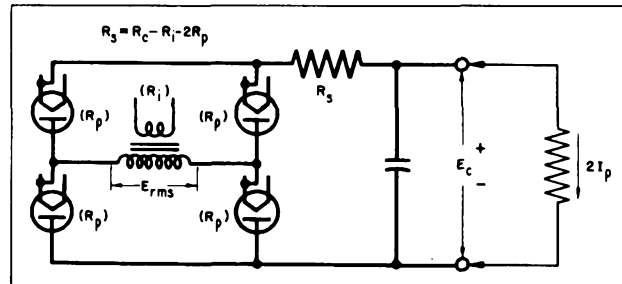

Fig. 1. Rectifier with Choke-Input Filter



a. Full-Wave Center-Tapped Rectifier



b. Full-Wave Bridge Rectifier

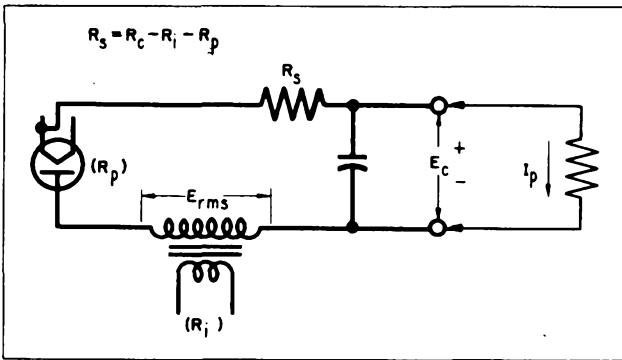

c. Half-Wave Rectifier

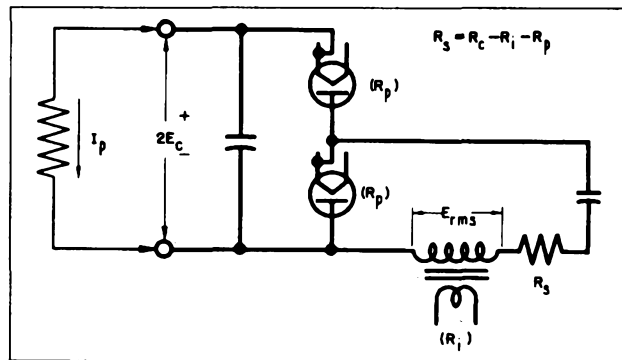

d. Half-Wave Voltage Doubler

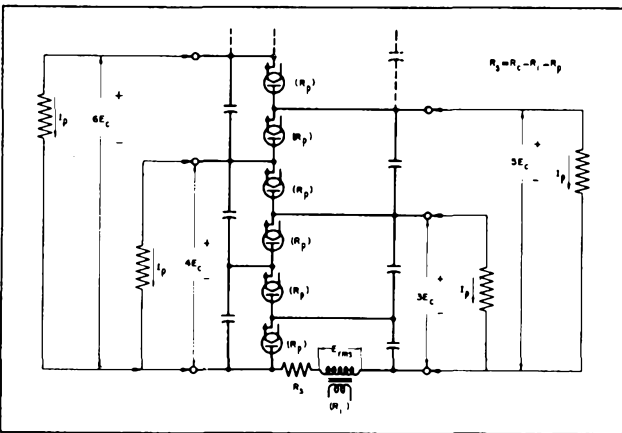

e. Half-Wave Voltage Multiplier (with common ground when  $R_s$  is inserted on the "high" side of  $E_{rms}$ )

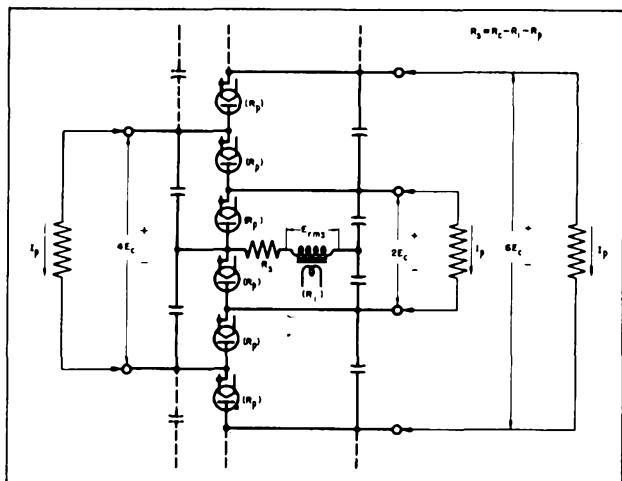

f. Full-Wave Voltage Multiplier

Eimac 2-150D Maximum D-C Current Ratings for R-C Filter Applications						
D-C Plate Current ( $I_p$ )	150	175	200	225	250	milliamperes per tube
Total Charging-Circuit Resistance ( $R_c$ )	0.7	1.6	3.9	9.6	27	percent of Effective Load Resistance per Tube ( $E_c/I_p$ )
A-C Supply Voltage ( $E_{rms}$ )	0.78	0.82	0.90	1.07	1.50	times Filter-Input D-C Voltage ( $E_c$ )
Peak Inverse Voltage ( $1/2$ these values for circuit b.)	2.2	2.4	2.6	3.0	4.3	times Filter-Input D-C Voltage ( $E_c$ )

Fig. 2 Eimac 2-150D Basic R-C Circuits (for any one of the indicated loads)

$R_i$  = Equivalent resistance of voltage source

$R_p$  = 300 ohms (150 ohms for two tubes in parallel)

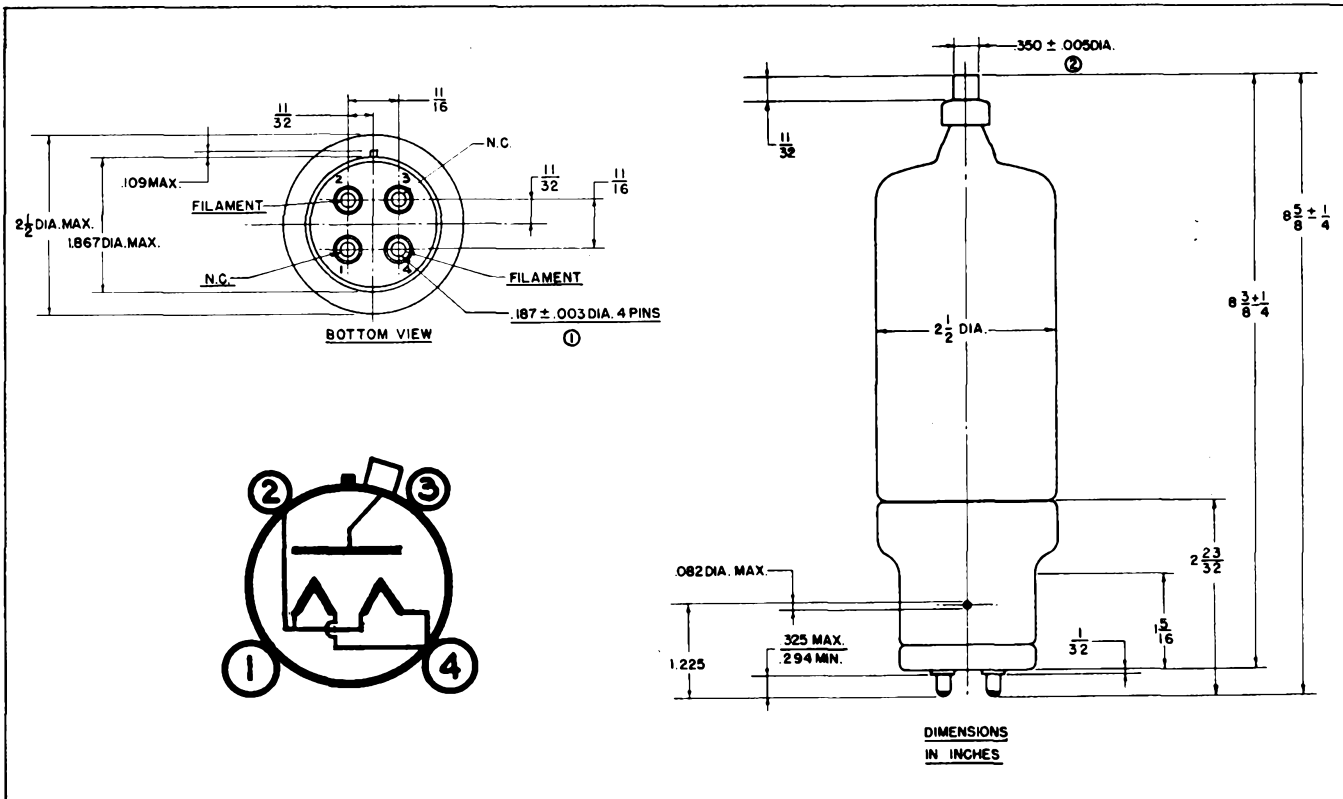
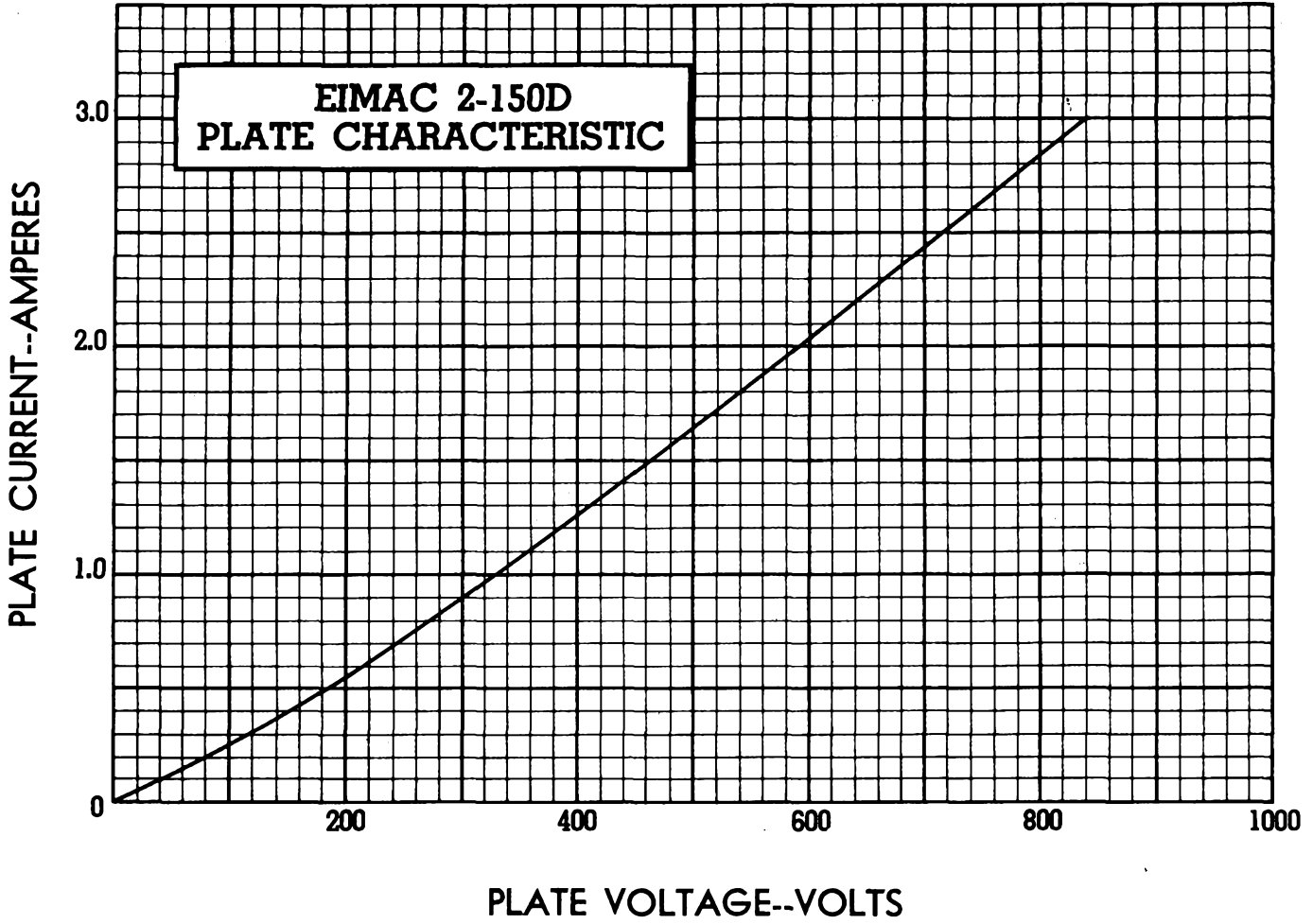

*Eimac*  
**EITEL-McCULLOUGH, INC.**  
 SAN BRUNO, CALIFORNIA

**2-240A**

**HIGH-VACUUM  
 RECTIFIER**

The Eimac 2-240A is a high vacuum diode rectifier intended for use in rectifier units, voltage multipliers, or in special applications, whenever conditions of extreme ambient temperatures, high operating frequency, high peak inverse voltages, or the production of high-frequency transients would prevent the use of gas-filled rectifier tubes.

The 2-240A has a maximum d-c current rating of 500 milliamperes and a maximum peak inverse voltage rating of 40,000 volts. Cooling is by convection and radiation.

A single 2-240A will deliver 320 milliamperes at 16,000 volts to a capacitor-input filter with 14,000 volts single-phase supply. Four 2-240A's in a bridge circuit will deliver 1.0 ampere at 25,000 volts to a choke-input filter with 28,000 volts single-phase supply.

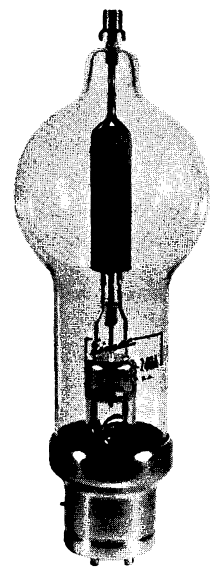

**GENERAL CHARACTERISTICS**

**ELECTRICAL**

Filament: Thoriated Tungsten

Voltage	-	-	-	-	-	-	-	-	-	7.5	volts
Current	-	-	-	-	-	-	-	-	-	12.0	amperes

**MECHANICAL**

Base	-	-	-	-	-	-	-	-	-	-	50-watt jumbo 4-pin bayonet
Basing	-	-	-	-	-	-	-	-	-	-	Refer to outline drawing
Socket	-	-	-	-	-	-	-	-	-	-	Refer to discussion under "Application"
Mounting Position	-	-	-	-	-	-	-	-	-	-	Vertical, base down or up
Cooling	-	-	-	-	-	-	-	-	-	-	Convection and radiation
Maximum Temperature of Plate Seal	-	-	-	-	-	-	-	-	-	-	225°C
Recommended Heat Dissipating Plate Connector	-	-	-	-	-	-	-	-	-	-	Eimac HR-6
Maximum Over-all Dimensions:											
Length	-	-	-	-	-	-	-	-	-	-	11.2 inches
Diameter	-	-	-	-	-	-	-	-	-	-	3.82 inches
Net Weight	-	-	-	-	-	-	-	-	-	-	10 ounces
Shipping Weight (approx.)	-	-	-	-	-	-	-	-	-	-	3 pounds

**MAXIMUM RATINGS (Per tube)**

PEAK INVERSE PLATE VOLTAGE	-	-	-	-	-	-	-	-	-	40,000	MAX. VOLTS
PLATE DISSIPATION	-	-	-	-	-	-	-	-	-	150	MAX. WATTS
D-C PLATE CURRENT <sup>1</sup>	-	-	-	-	-	-	-	-	-	500	MAX. MA
PEAK PLATE CURRENT	-	-	-	-	-	-	-	-	-	4.0	MAX. AMPERES

<sup>1</sup>Averaged over one cycle for each tube. Applies only when the rectifier is coupled to the load by a choke-input filter incorporating the "critical" value (or larger) of input inductance. For maximum d-c current ratings under this and other load conditions see discussion under "Application".

**APPLICATION**

**MECHANICAL**

**Mounting**—The 2-240A must be mounted vertically with the base either down or up. The lead to the plate terminal of the tube should be flexible.

The 50-watt jumbo 4-pin bayonet base fits an E. F. Johnson Co. No. 123-211, a National Co. No. XM-50, or an equivalent socket. In some circuits, particularly those of the voltage multipliers illustrated in Fig. 2, it may be necessary to mount

the socket on stand-off insulators, or on a sheet of insulating material, to provide adequate insulation to ground.

**Cooling**—The 2-240A is cooled by convection and radiation. Clearance should be provided around the glass envelope adequate for the free circulation of air. An Eimac HR-6 Heat Dissipating Connector or equivalent is required on the plate terminal.

The maximum temperature at the plate seal must not exceed

## APPLICATION (Continued)

225°C. A convenient accessory for measuring this temperature is "Tempilaq", a temperature-sensitive lacquer available from the Tempil Corporation, 132 W. 22nd St., New York 11, N. Y.

### ELECTRICAL

**Filament Operation**—For maximum tube life, the filament voltage, as measured at the base pins, should be the rated value of 7.5 volts. Variations must be kept within the range from 7.15 to 7.85 volts. In applications which require the diode to deliver high peak currents, it is important to maintain the filament voltage at the rated value. All four socket terminals should be used, placing two in parallel for each filament connection.

**CAUTION SHOULD BE OBSERVED WHEN MEASURING RECTIFIER FILAMENT VOLTAGE. THE FILAMENT CIRCUIT MAY BE AT HIGH POTENTIAL.**

The thoriated-tungsten filament of the 2-240A reaches operating temperature in a fraction of a second after application of voltage. Plate voltage may be applied simultaneously with filament voltage. All four socket terminals should be used, putting two in parallel for each filament connection.

**Plate Operation**—With low room illumination, the plate of the 2-240A begins to show color as the maximum plate dissipation rating of 150 watts is approached. The maximum peak inverse voltage rating of 40,000 volts should not be exceeded at any time.

**Performance**—The accompanying table shows some maximum performance capabilities of the 2-240A when used as a power-supply rectifier.

Circuit Type	2-240A MAXIMUM-PERFORMANCE CAPABILITIES				
	A-C Input Voltage (volts rms)	Capacitor-Input Filter D-C Output Voltage (volts)	Choke-Input Filter D-C Output Current (amperes)	Capacitor-Input Filter D-C Output Voltage (volts)	Choke-Input Filter D-C Output Current (amperes)
Single-Phase, Half-Wave	14,000	16,000	0.320	.....	.....
Single-Phase, Full-Wave	14,000 <sup>1</sup>	16,000	0.640	12,500	1.00
Single-Phase, Bridge	28,000	32,000	0.640	25,000	1.00

<sup>1</sup>One-half the transformer secondary voltage.

**Maximum D-C Current Ratings**—Plate dissipation rather than peak current usually limits the d-c current which the 2-240A is capable of delivering to the load. Because the plate dissipation associated with a given d-c current depends upon the amount of ripple and its wave-shape, circuit conditions will determine the maximum d-c current rating of the tube.

**Choke-Input Filter**—The maximum d-c current rating of the 2-240A is 500 milliamperes when the load incorporates a choke-input filter with the "critical" value (or larger) of input inductance ( $L_1$  in Fig. 1):

$$L_0 = \frac{R_{eff}}{18.8f} \text{ for full-wave single-phase rectifiers,}$$

$$L_0 = \frac{R_{eff}}{75f} \text{ for half-wave three-phase rectifiers,}$$

$$L_0 = \frac{R_{eff}}{660f} \text{ for full-wave three-phase rectifiers,}$$

where:  $L_0$  = "critical" value of input inductance (henries),  
 $f$  = supply-line frequency (cycles per second),

$$R_{eff} = \frac{\text{Load voltage (volts)}}{\text{Load current (amps)}}$$

Choke-input filters are not normally used with single-phase half-wave rectifiers.

**Capacitor-Input Filter**—The 2-240A is particularly suitable for power-supply applications demanding high voltage at low cur-

rent. Under these conditions capacitor-input filter circuits become desirable. The maximum d-c current rating of the 2-240A when no input choke is incorporated in the filter depends upon the total series resistance of the capacitor-charging circuit relative to the effective load resistance seen by each tube. The circuit diagrams and tabulation in Fig. 2 are so arranged and labeled that this required series resistance may be found for a wide range of load conditions. This may be done by determining the value of the following quantities:

$E_c$  is the filter-input d-c voltage. While this is usually the entire load voltage, in the case of voltage multipliers it is the load voltage divided by the multiplication factor.

$I_p$  is the d-c current per tube. This is the entire load current only in the case of the simple half-wave rectifier or half- or full-wave multiplier. In the case of full-wave center-tapped or bridge rectifiers,  $I_p$  is half the load current.

$R_c$  is the total charging-circuit resistance. A certain minimum value of charging-circuit resistance is necessary to limit the peak value of current to which the tubes will be subjected under given load conditions. This required minimum depends upon the d-c current per tube ( $I_p$ ), and has been tabulated in Fig. 2 as a percentage of the effective load resistance per tube ( $E_c/I_p$ ). The total charging-circuit resistance involves the internal resistance of the rectifier tube,  $R_p$ , the added series resistor,  $R_s$ , and the equivalent internal resistance of the a-c voltage supply,  $R_i$ .

$R_p$  is the plate resistance of the 2-240A, which may be taken as 200 ohms.

$R_i$  is the equivalent internal resistance of the supply. This may be taken as the regulation of the high-voltage supply expressed as a decimal multiplied by the load resistance used in measuring this regulation.

$R_s$  is the series resistor which must be inserted in the charging circuit to bring the total charging-circuit resistance up to the required minimum. Its value may be found from the formula associated with each of the circuits of Fig. 2. This resistor must be inserted in such a position in the circuit that it protects all tubes.

Tubes may be operated in parallel to increase the output capability in a given circuit. When two tubes are placed in parallel at each place where one is shown in the circuits of Fig. 2, the plate resistance ( $R_p$ ) will be half as great and the maximum allowable load current twice as great as indicated.

**Peak Inverse Voltage**—The peak inverse voltage rating of the 2-240A is 40,000 volts. In single-phase power-supply rectifier circuits the peak inverse voltage to be used in design is the peak a-c supply voltage (1.41 times  $E_{rms}$  in Fig. 2) in the case of bridge circuits, and twice this value in the case of half- and full-wave rectifiers and voltage multipliers. Peak inverse voltage in three-phase operation depends upon the circuit employed and will be found listed in the handbooks.

**Special Applications**—The ratings given for capacitor-input filter circuits assume values of input capacitance large enough to hold the ripple to a low value. In special applications where a larger percent ripple is tolerable, and filter capacitance is low, the 2-240A is capable of larger d-c output currents.

As a unidirectional conductor in d-c circuits where the current is continuous and the percent ripple is moderate, the maximum current rating of the 2-240A is 800 milliamperes.

The plate characteristic curve for the 2-240A serves as a guide to special applications. The maximum plate dissipation rating of 150 watts, the maximum peak inverse voltage rating of 40,000 volts, and the maximum peak plate current of 4.0 amperes must not be exceeded.

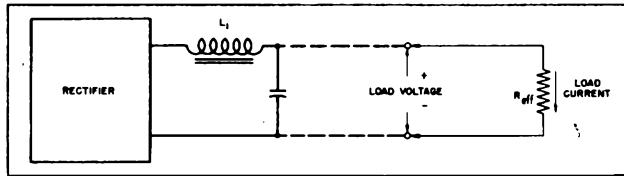
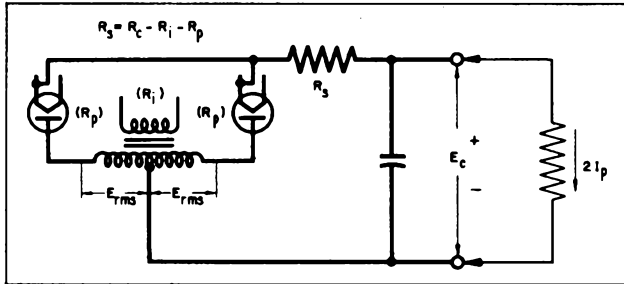
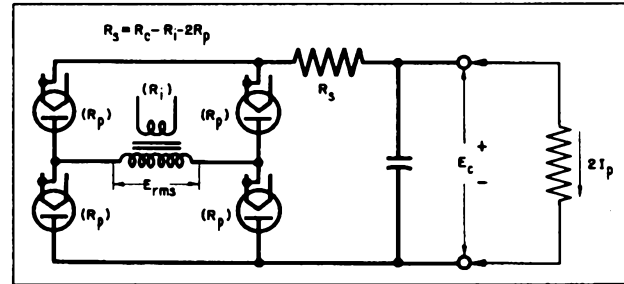

Fig. 1. Rectifier with Choke-Input Filter



a. Full-Wave Center-Tapped Rectifier



b. Full-Wave Bridge Rectifier

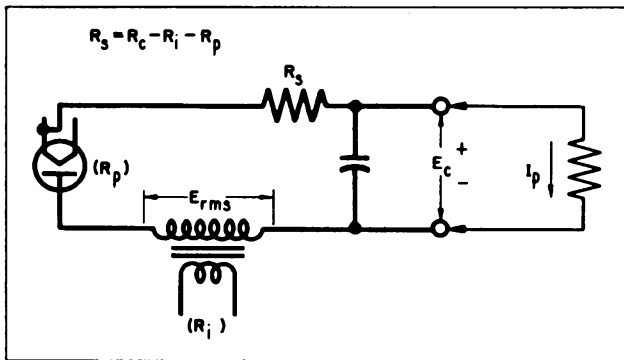

c. Half-Wave Rectifier

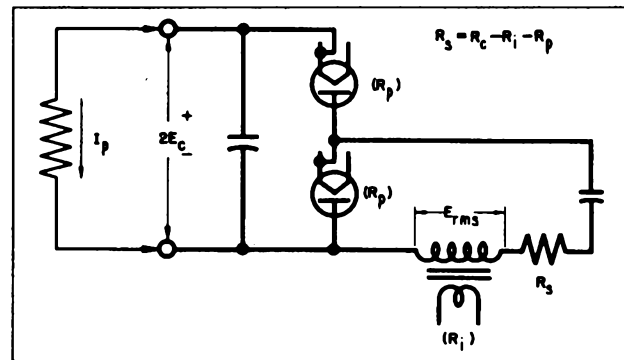

d. Half-Wave Voltage Doubler

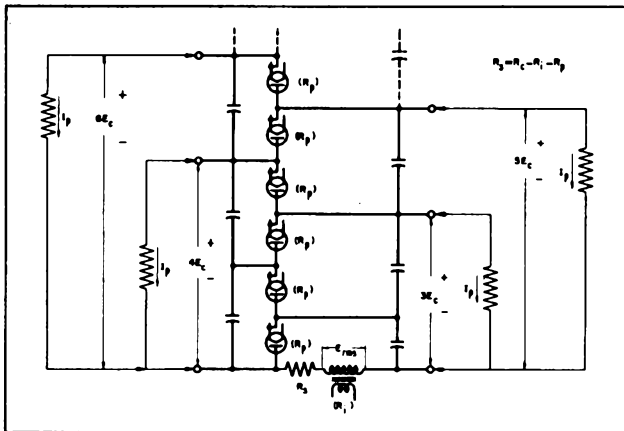

e. Half-Wave Voltage Multiplier (with common ground when  $R_s$  is inserted on the "high" side of  $E_{rms}$ )

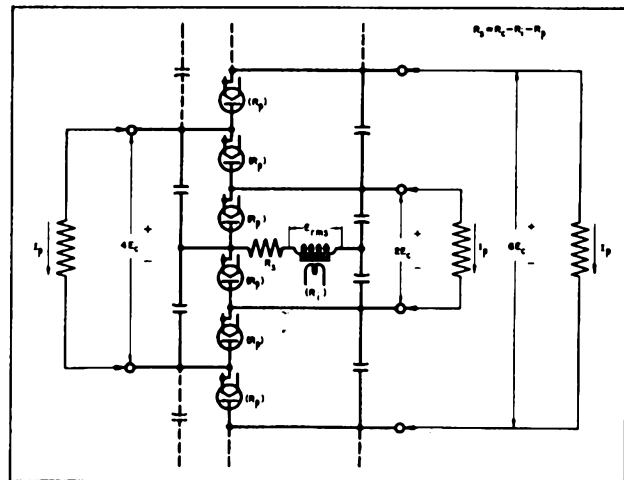

f. Full-Wave Voltage Multiplier

Eimac 2-240A Maximum D-C Current Ratings for R-C Filter Applications								
D-C Plate Current ( $I_p$ )	280	300	320	340	360	380	400	milliamperes per tube
Total Charging-Circuit Resistance ( $R_c$ )	1.0	1.8	3.0	5.0	7.5	12	20	percent of Effective Load Resistance per Tube ( $E_c/I_p$ )
A-C Supply Voltage ( $E_{rms}$ )	0.80	0.83	0.87	0.94	1.01	1.14	1.33	times Filter-Input D-C Voltage ( $E_c$ )
Peak-Inverse Voltage ( $1/2$ these values for circuit b.)	2.3	2.4	2.5	2.7	2.9	3.2	3.8	times Filter-Input D-C Voltage ( $E_c$ )

Fig. 2 Eimac 2-240A Basic R-C Circuits (for any one of the indicated loads)

$R_i$  = Equivalent resistance of voltage source

$R_p$  = 200 ohms (100 ohms for two tubes in parallel)

PLATE CURRENT--AMPERES

# EIMAC 2-240A PLATE CHARACTERISTIC

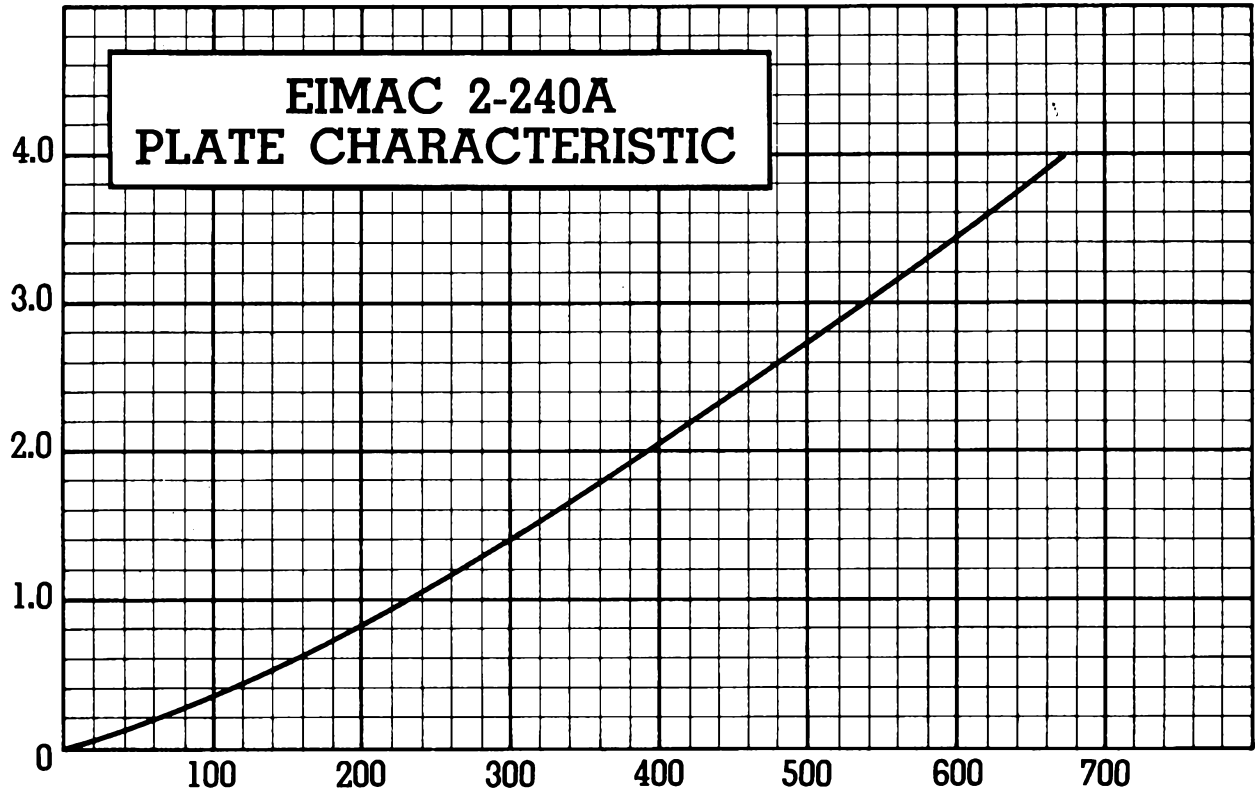
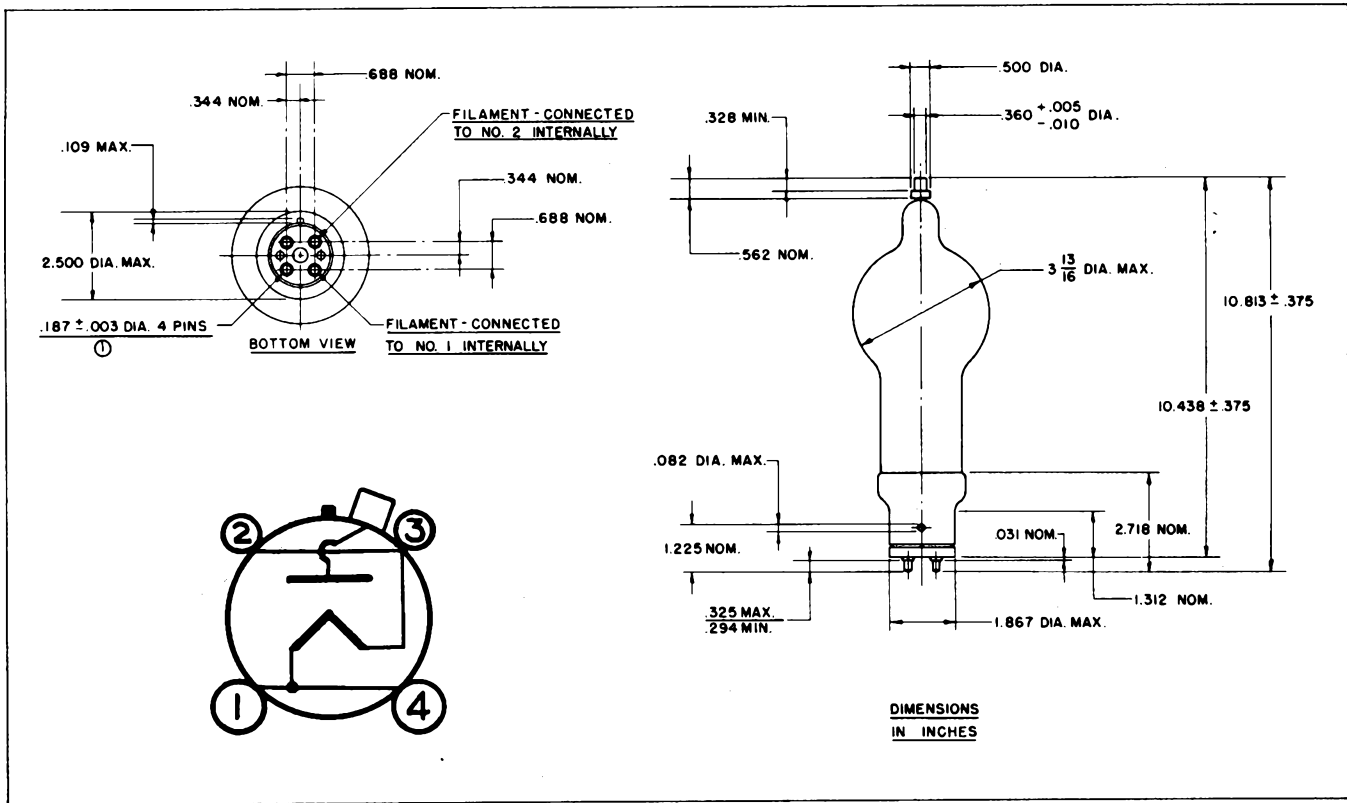

PLATE VOLTAGE--VOLTS



*Eimac*  
**EITEL-McCULLOUGH, INC.**  
 SAN BRUNO, CALIFORNIA

**2-2000A**  
 HIGH-VACUUM  
 RECTIFIER

The Eimac 2-2000A is a high-vacuum diode rectifier intended for use in rectifier units, voltage multipliers, or in special applications, whenever conditions of extreme ambient temperatures, high operating frequency, high peak inverse voltages, or the production of high-frequency transients would prevent the use of gas-filled rectifier tubes.

The 2-2000A has a maximum d-c current rating of 750 milliamperes and a maximum peak inverse voltage rating of 75,000 volts. Cooling is by forced air, convection, and radiation.

A single 2-2000A will deliver 600 milliamperes at 31,500 volts to a capacitor-input filter with 26,500 volts single-phase supply. Four 2-2000A's in a bridge circuit will deliver 1.50 amperes at 47,600 volts to a choke-input filter with 53,000 volts single-phase supply.

**GENERAL CHARACTERISTICS**

**ELECTRICAL**

Filament: Thoriated Tungsten

Voltage	-	-	-	-	-	-	-	-	-	10.0	volts
Current	-	-	-	-	-	-	-	-	-	25.0	amperes

**MECHANICAL**

Base	-	-	-	-	-	-	-	-	-	-	-	Special 4-pin
Basing	-	-	-	-	-	-	-	-	-	-	-	Refer to outline drawing
Socket	-	-	-	-	-	-	-	-	-	-	-	Refer to discussion under "Application"
Mounting Position	-	-	-	-	-	-	-	-	-	-	-	Vertical, base down or up
Cooling	-	-	-	-	-	-	-	-	-	-	-	Forced air, convection, and radiation
Maximum Temperature of Plate Seal	-	-	-	-	-	-	-	-	-	-	-	225°C
Recommended Heat Dissipating Plate Connector	-	-	-	-	-	-	-	-	-	-	-	Eimac HR-8
Maximum Over-all Dimensions:												
Length	-	-	-	-	-	-	-	-	-	-	-	17.8 inches
Diameter	-	-	-	-	-	-	-	-	-	-	-	8.13 inches
Net Weight	-	-	-	-	-	-	-	-	-	-	-	3 pounds
Shipping Weight (approx.)	-	-	-	-	-	-	-	-	-	-	-	13 pounds

**MAXIMUM RATINGS (Per tube)**

PEAK INVERSE PLATE VOLTAGE	-	-	-	-	-	-	-	-	-	75,000	MAX. VOLTS
PLATE DISSIPATION	-	-	-	-	-	-	-	-	-	1200	MAX. WATTS
D-C PLATE CURRENT <sup>1</sup>	-	-	-	-	-	-	-	-	-	750	MAX. MA
PEAK PLATE CURRENT	-	-	-	-	-	-	-	-	-	12	MAX. AMPERES

<sup>1</sup>Averaged over one cycle for each tube. Applies only when the rectifier is coupled to the load by a choke-input filter incorporating the "critical" value (or larger) of input inductance. For maximum d-c current ratings under this and other load conditions see discussion under "Application".

**APPLICATION**

**MECHANICAL**

**Mounting**—The 2-2000A must be mounted vertically with the base either down or up. The lead to the plate terminal of the tube should be flexible.

The special 4-pin base fits an E. F. Johnson Co. No. 124-214 or an equivalent socket. In some circuits, particularly those of the voltage multipliers illustrated in Fig. 2, it may be necessary to mount the socket on stand-off insulators, or on a sheet of insulating material, to provide adequate insulation to ground.

**Cooling**—The 2-2000A is cooled by forced air, convection, and radiation. Forced air is required for cooling of the filament seals. If an E. F. Johnson Co. No. 124-214 socket is used, air at a static pressure of 4 inches of water measured at the inlet of the 1/4-inch cooling tube in the socket will provide sufficient base cooling. The base of the tube is provided with a 1-inch diameter hole. If a socket is used with a 1-inch diameter matching hole and the manifold is of the same diameter, a static pressure of less than 0.1 inch of water will be required. Clearance should be provided around the glass envelope adequate

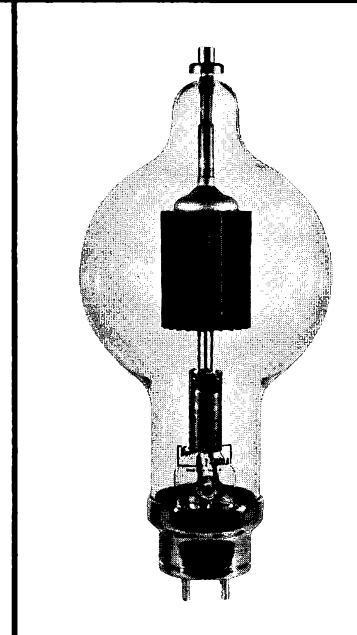



## APPLICATION (Continued)

for the free circulation of air. An Eimac HR-8 heat Dissipating Connector or equivalent is required on the plate terminal.

The maximum temperature at the plate seal must not exceed 225°C. A convenient accessory for measuring this temperature is "Tempilaq", a temperature-sensitive lacquer available from the Tempil Corporation, 132 W. 22nd St, New York 11, N. Y.

### ELECTRICAL

**Filament Operation**—For maximum tube life, the filament voltage, as measured at the base pins, should be the rated value of 10.0 volts. Variations must be kept within the range from 9.5 to 10.5 volts. In applications which require the diode to deliver high peak currents, it is important to maintain the filament voltage at the rated value. All four socket terminals should be used, putting two in parallel for each filament connection.

**CAUTION SHOULD BE OBSERVED WHEN MEASURING RECTIFIER FILAMENT VOLTAGE. THE FILAMENT CIRCUIT MAY BE AT HIGH POTENTIAL.**

The thoriated-tungsten filament of the 2-2000A reaches operating temperature in a fraction of a second after application of voltage. Plate voltage may be applied simultaneously with filament voltage.

**Plate Operation**—The plate of the 2-2000A operates at dull red color at the maximum plate dissipation rating of 1200 watts. The maximum peak inverse voltage rating of 75,000 volts should not be exceeded at any time.

**Performance**—The accompanying table shows some maximum performance capabilities of the 2-2000A when used as a power-supply rectifier.

Circuit Type	2-2000A MAXIMUM-PERFORMANCE CAPABILITIES			Capacitor-Input Filter		Choke-Input Filter	
	A-C Input Voltage (volts rms)	D-C Output Voltage (volts)	D-C Output Current (amperes)	D-C Output Voltage (volts)	D-C Output Current (amperes)	D-C Output Voltage (volts)	D-C Output Current (amperes)
Single-Phase, Half-Wave	26,500	31,500	0.600	.....	.....	.....	.....
Single-Phase, Full-Wave	26,500 <sup>1</sup>	31,500	1.20	23,800	1.50	.....	.....
Single-Phase, Bridge	53,000	63,000	1.20	47,600	1.50	.....	.....

<sup>1</sup>One-half the transformer secondary voltage.

**Maximum D-C Current Ratings**—Plate dissipation rather than peak current usually limits the d-c current which the 2-2000A is capable of delivering to the load. Because the plate dissipation associated with a given d-c current depends upon the amount of ripple and its wave-shape, circuit conditions will determine the maximum d-c current rating of the tube.

**Choke-Input Filter**—The maximum d-c current rating of the 2-2000A is 750 milliamperes when the load incorporates a choke-input filter with the "critical" value (or larger) of input inductance ( $L_1$  in Fig. 1):

$$L_o = \frac{R_{eff}}{18.8f} \quad \text{for full-wave single-phase rectifiers,}$$

$$L_o = \frac{R_{eff}}{75f} \quad \text{for half-wave three-phase rectifiers,}$$

$$L_o = \frac{R_{eff}}{660f} \quad \text{for full-wave three-phase rectifiers,}$$

where:  $L_o$  = "critical" value of input inductance (henries),

$f$  = supply-line frequency (cycles per second),

$$R_{eff} = \frac{\text{Load voltage (volts)}}{\text{Load current (amps)}}$$

Choke-input filters are not normally used with single-phase half-wave rectifiers.

**Capacitor-Input Filter**—The 2-2000A is particularly suitable for power-supply applications demanding high voltage at low cur-

rent. Under these conditions capacitor-input filter circuits become desirable. The maximum d-c current rating of the 2-2000A when no input choke is incorporated in the filter depends upon the total series resistance of the capacitor-charging circuit relative to the effective load resistance seen by each tube. The circuit diagrams and tabulation in Fig. 2 are so arranged and labeled that this required series resistance may be found for a wide range of load conditions. This may be done by determining the value of the following quantities:

$E_c$  is the filter-input d-c voltage. While this is usually the entire load voltage, in the case of voltage multipliers it is the load voltage divided by the multiplication factor.

$I_p$  is the d-c current per tube. This is the entire load current only in the case of the simple half-wave rectifier or half- or full-wave multiplier. In the case of full-wave center-tapped or bridge rectifiers,  $I_p$  is half the load current.

$R_c$  is the total charging-circuit resistance. A certain minimum value of charging-circuit resistance is necessary to limit the peak value of current to which the tubes will be subjected under given load conditions. This required minimum depends upon the d-c current per tube ( $I_p$ ), and has been tabulated in Fig. 2 as a percentage of the effective load resistance per tube ( $E_c/I_p$ ). The total charging-circuit resistance involves the internal resistance of the rectifier tube,  $R_p$ , the added series resistor,  $R_s$ , and the equivalent internal resistance of the a-c voltage supply,  $R_i$ .

$R_p$  is the plate resistance of the 2-2000A, which may be taken as 400 ohms.

$R_i$  is the equivalent internal resistance of the supply. This may be taken as the regulation of the high-voltage supply expressed as a decimal multiplied by the load resistance used in measuring this regulation.

$R_s$  is the series resistor which must be inserted in the charging circuit to bring the total charging-circuit resistance up to the required minimum. Its value may be found from the formula associated with each of the circuits of Fig. 2. This resistor must be inserted in such a position in the circuit that it protects all tubes.

Tubes may be operated in parallel to increase the output capability in a given circuit. When two tubes are placed in parallel at each place where one is shown in the circuits of Fig. 2, the plate resistance ( $R_p$ ) will be half as great and the maximum allowable load current twice as great as indicated.

**Peak Inverse Voltage**—The peak inverse voltage rating of the 2-2000A is 75,000 volts. In single-phase power supply rectifier circuits the peak inverse voltage to be used in design is the peak a-c supply voltage (1.41 times  $E_{rms}$  in Fig. 2) in the case of bridge circuits, and twice this value in the case of half- and full-wave rectifiers and voltage multipliers. Peak inverse voltage in three-phase operation depends upon the circuit employed, and will be found listed in the handbooks.

**Special Applications**—The ratings given for capacitor-input filter circuits assume values of input capacitance large enough to hold the ripple to a low value. In special applications where a larger percent ripple is tolerable, and filter capacitance is low, the 2-2000A is capable of larger d-c output currents.

As a unidirectional conductor in d-c circuits where the current is continuous and the percent ripple is moderate, the maximum current rating of the 2-2000A is 1500 milliamperes.

The plate characteristic curve for the 2-2000A serves as a guide to special applications. The maximum plate dissipation rating of 1200 watts, the maximum peak inverse voltage rating of 75,000 volts, and the maximum peak plate current of 12 amperes must not be exceeded.

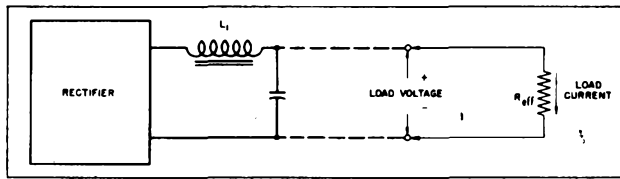
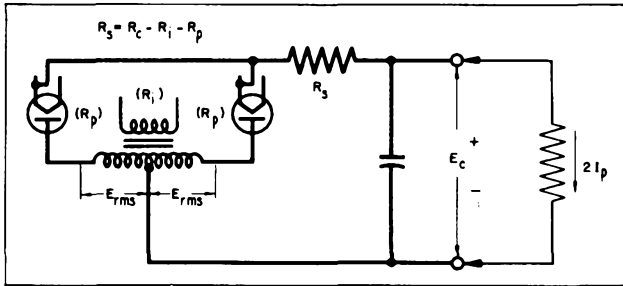
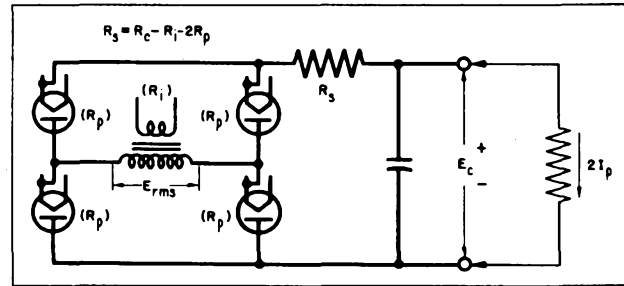

Fig. 1. Rectifier with Choke-Input Filter



a. Full-Wave Center-Tapped Rectifier



b. Full-Wave Bridge Rectifier

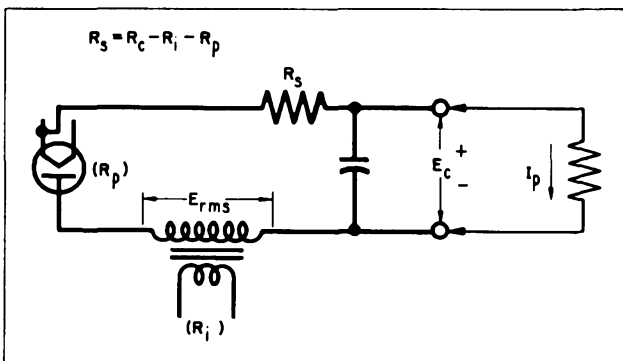

c. Half-Wave Rectifier

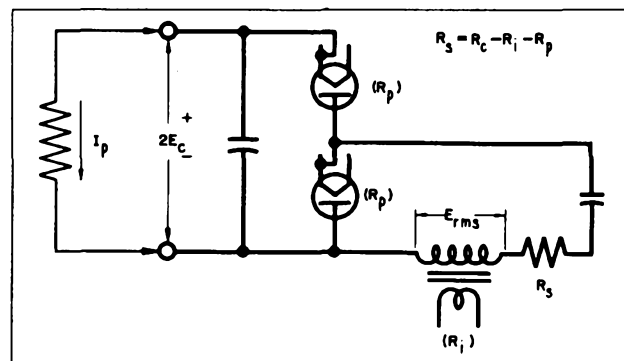

d. Half-Wave Voltage Doubler

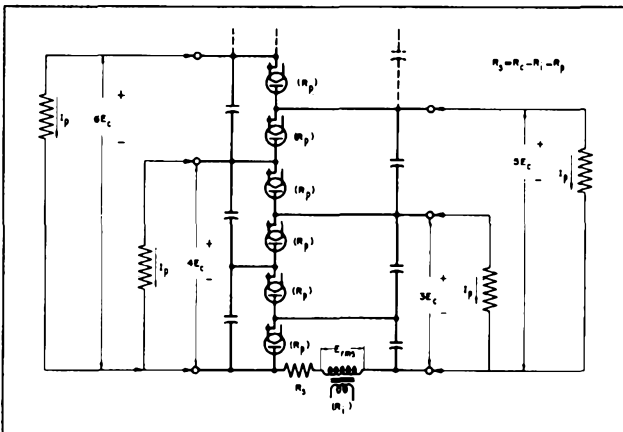

e. Half-Wave Voltage Multiplier (with common ground when  $R_s$  is inserted on the "high" side of  $E_{rms}$ )

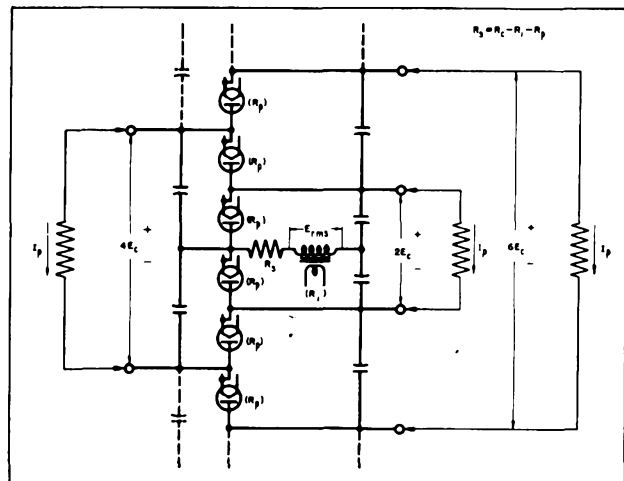

f. Full-Wave Voltage Multiplier

Eimac 2-2000A Maximum D-C Current Ratings for R-C Filter Applications						
D-C Plate Current ( $I_p$ )	550	600	650	700	750	milliamperes per tube
Total Charging-Circuit Resistance ( $R_c$ )	1.1	2.1	3.8	7.0	13	percent of Effective Load Resistance per Tube ( $E_c/I_p$ )
A-C Supply Voltage ( $E_{rms}$ )	0.80	0.84	0.90	1.00	1.16	times Filter-Input D-C Voltage ( $E_c$ )
Peak Inverse Voltage ( $1/2$ these values for circuit b.)	2.3	2.4	2.6	2.8	3.3	times Filter-Input D-C Voltage ( $E_c$ )

Fig. 2 Eimac 2-2000A basic R-C Circuits (for any one of the indicated loads)

$R_i$  = Equivalent resistance of voltage source

$R_p$  = 400 ohms (200 ohms for two tubes in parallel)

PLATE CURRENT--AMPERES

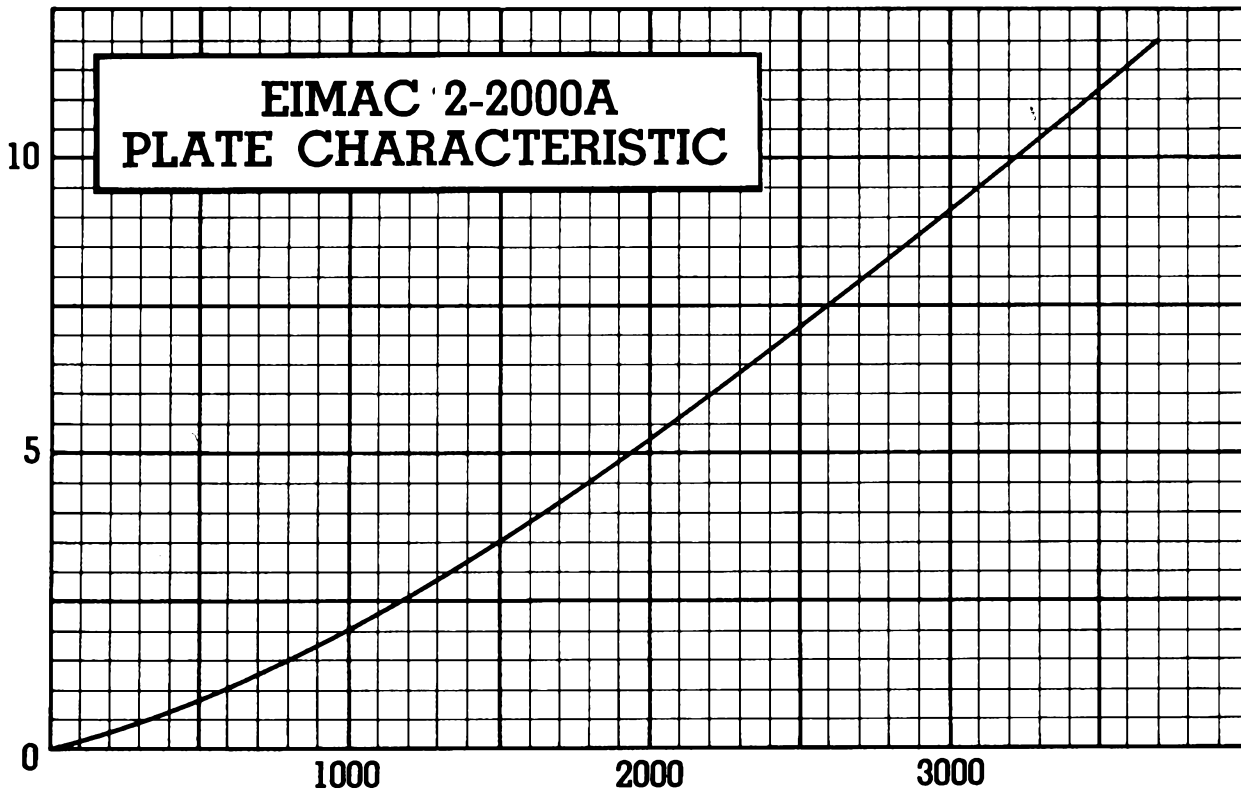
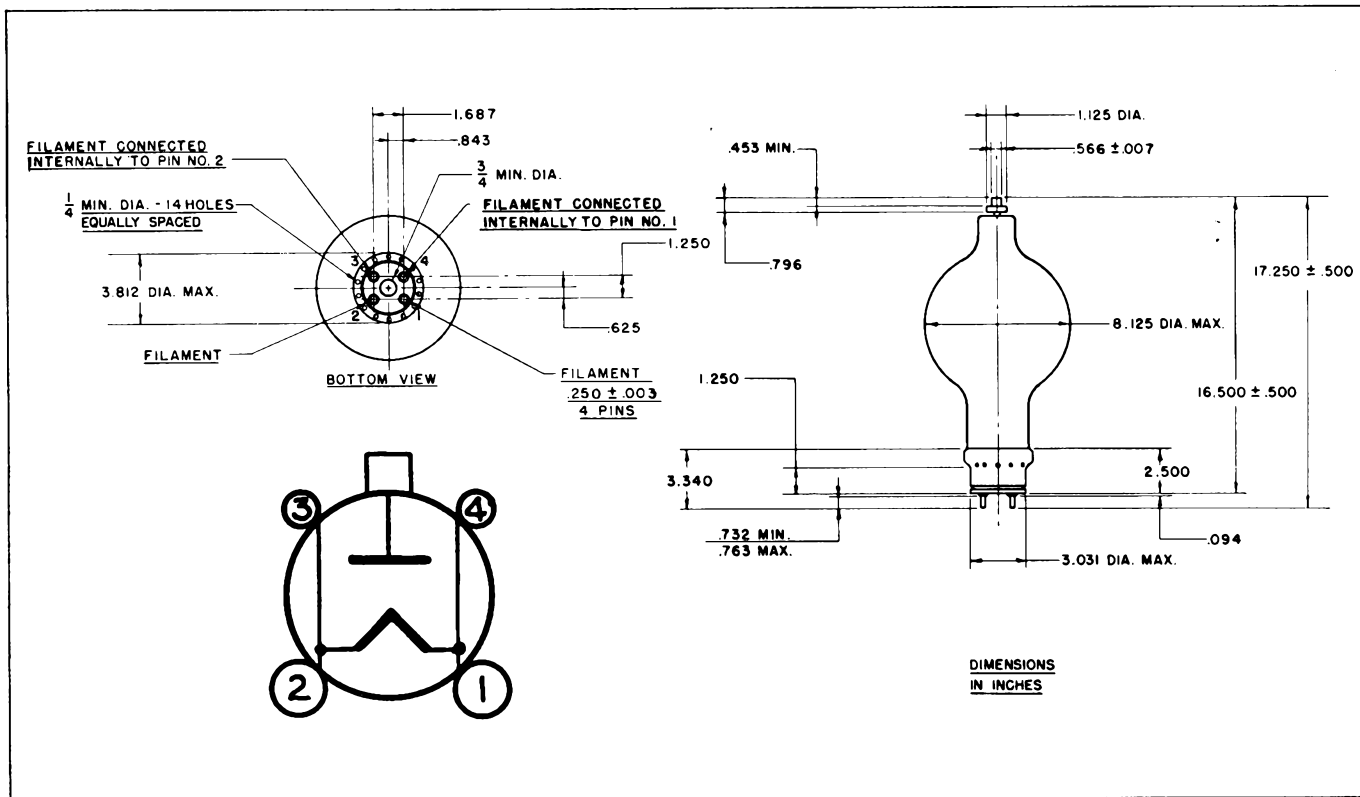

PLATE VOLTAGE--VOLTS



*Eimac*  
**EITEL-McCULLOUGH, INC.**  
 SAN BRUNO, CALIFORNIA

**250R**  
 HIGH-VACUUM  
 RECTIFIER

The Eimac 250R is a high-vacuum diode rectifier intended for use in rectifier units, voltage multipliers, or in special applications, whenever conditions of extreme ambient temperatures, high operating frequency, high peak inverse voltages, or the production of high-frequency transients would prevent the use of gas-filled rectifier tubes.

The 250R has a maximum d-c current rating of 250 milliamperes and a maximum peak inverse voltage rating of 60,000 volts. Cooling is by convection and radiation.

A single 250R will deliver 160 milliamperes at 24,000 volts to a capacitor-input filter with 21,000 volts single-phase supply. Four 250R's in a bridge circuit will deliver 500 milliamperes at 38,000 volts to a choke-input filter with 42,000 volts single-phase supply.

**GENERAL CHARACTERISTICS**

**ELECTRICAL**

Filament: Thoriated Tungsten

Voltage	-	-	-	-	-	-	-	-	-	5.0	volts
Current	-	-	-	-	-	-	-	-	-	10.5	amperes

**MECHANICAL**

Base	-	-	-	-	-	-	-	-	-	-	50-watt jumbo 4-pin bayonet
Basing	-	-	-	-	-	-	-	-	-	-	Refer to outline drawing
Socket	-	-	-	-	-	-	-	-	-	-	Refer to discussion under "Application"
Mounting Position	-	-	-	-	-	-	-	-	-	-	Vertical, base down or up
Cooling	-	-	-	-	-	-	-	-	-	-	Convection and Radiation
Maximum Temperature of Plate Seal	-	-	-	-	-	-	-	-	-	-	225°C
Recommended Heat Dissipating Plate Connector	-	-	-	-	-	-	-	-	-	-	Eimac HR-6
Maximum Over-all Dimensions:											
Length	-	-	-	-	-	-	-	-	-	-	10.13 inches
Diameter	-	-	-	-	-	-	-	-	-	-	3.82 inches
Net Weight	-	-	-	-	-	-	-	-	-	-	10 ounces
Shipping Weight (approx.)	-	-	-	-	-	-	-	-	-	-	3 pounds

**MAXIMUM RATINGS (Per tube)**

PEAK INVERSE PLATE VOLTAGE	-	-	-	-	-	-	-	-	-	60,000	MAX. VOLTS
PLATE DISSIPATION	-	-	-	-	-	-	-	-	-	150	MAX. WATTS
D-C PLATE CURRENT <sup>1</sup>	-	-	-	-	-	-	-	-	-	250	MAX. MA
PEAK PLATE CURRENT	-	-	-	-	-	-	-	-	-	2.5	MAX. AMPERES

<sup>1</sup>Averaged over one cycle for each tube. Applies only when the rectifier is coupled to the load by a choke-input filter incorporating the "critical" value (or larger) of input inductance. For maximum d-c current ratings under this and other load conditions see discussion under "Application".

**APPLICATION**

**MECHANICAL**

**Mounting**—The 250R must be mounted vertically with the base either down or up. The lead to the plate terminal of the tube should be flexible.

The 50-watt jumbo 4-pin bayonet base fits an E. F. Johnson Co. No. 123-211, a National Co. No. XM-50, or an equivalent socket. In some circuits, particularly those of the voltage multipliers illustrated in Fig. 2, it may be necessary to mount the

socket on stand-off insulators, or on a sheet of insulating material, to provide adequate insulation to ground.

**Cooling**—The 250R is cooled by convection and radiation. Clearance should be provided around the glass envelope adequate for the free circulation of air. An Eimac HR-6 Heat Dissipating Connector or equivalent is required on the plate terminal.

The maximum temperature at the plate seal must not exceed

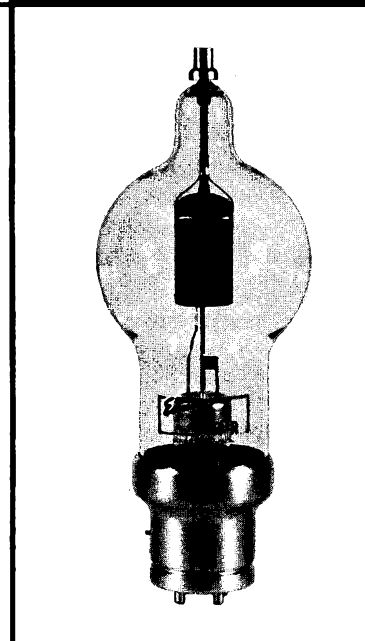

## APPLICATION (Continued)

225°C. A convenient accessory for measuring this temperature is "Tempilaq", a temperature-sensitive lacquer available from the Tempil Corporation, 132 W. 22nd St., New York 11, N. Y.

### ELECTRICAL

**Filament Operation**—For maximum tube life, the filament voltage, as measured at the base pins, should be the rated value of 5.0 volts. Variations must be kept within the range from 4.75 to 5.25 volts. In applications which require the diode to deliver high peak currents, it is important to maintain the filament voltage at the rated value.

**CAUTION SHOULD BE OBSERVED WHEN MEASURING RECTIFIER FILAMENT VOLTAGE. THE FILAMENT CIRCUIT MAY BE AT HIGH POTENTIAL.**

The thoriated-tungsten filament of the 250R reaches operating temperature in a fraction of a second after application of voltage. Plate voltage may be applied simultaneously with filament voltage.

**Plate Operation**—With low room illumination, the plate of the 250R begins to show color as the maximum plate dissipation rating of 150 watts is approached. The maximum peak inverse voltage rating of 60,000 volts should not be exceeded at any time.

**Performance**—The accompanying table shows some maximum performance capabilities of the 250R when used as a power-supply rectifier.

250R MAXIMUM-PERFORMANCE CAPABILITIES

Circuit Type	Capacitor-Input Filter		Choke-Input Filter		
	A-C Input Voltage (volts rms)	D-C Output Voltage (volts)	D-C Output Current (ma)	D-C Output Voltage (volts)	D-C Output Current (ma)
Single-Phase, Half-Wave	21,000	24,000	160	.....	.....
Single-Phase, Full-Wave	21,000 <sup>1</sup>	24,000	320	19,000	500
Single-Phase, Bridge	42,000	48,000	320	38,000	500

<sup>1</sup>One-half the transformer secondary voltage.

**Maximum D-C Current Ratings**—Plate dissipation rather than peak current usually limits the d-c current which the 250R is capable of delivering to the load. Because the plate dissipation associated with a given d-c current depends upon the amount of ripple and its wave-shape, circuit conditions will determine the maximum d-c current rating of the tube.

**Choke-Input Filter**—The maximum d-c current rating of the 250R is 250 milliamperes when the load incorporates a choke-input filter with the "critical" value (or larger) of input inductance ( $L_0$  in Fig. 1):

$$L_0 = \frac{R_{eff}}{18.8f} \quad \text{for full-wave single-phase rectifiers,}$$

$$L_0 = \frac{R_{eff}}{75f} \quad \text{for half-wave three-phase rectifiers,}$$

$$L_0 = \frac{R_{eff}}{660f} \quad \text{for full-wave three-phase rectifiers,}$$

where:  $L_0$  = "critical" value of input inductance (henries),  
 $f$  = supply-line frequency (cycles per second),

$$R_{eff} = \frac{\text{Load voltage (volts)}}{\text{Load current (amps)}}$$

Choke-input filters are not normally used with single-phase half-wave rectifiers.

**Capacitor-Input Filter**—The 250R is particularly suitable for power-supply applications demanding high voltage at low current. Under these conditions capacitor-input filter circuits be-

come desirable. The maximum d-c current rating of the 250R when no input choke is incorporated in the filter depends upon the total series resistance of the capacitor-charging circuit relative to the effective load resistance seen by each tube. The circuit diagrams and tabulation in Fig. 2 are so arranged and labeled that this required series resistance may be found for a wide range of load conditions. This may be done by determining the value of the following quantities:

$E_c$  is the filter-input d-c voltage. While this is usually the entire load voltage, in the case of voltage multipliers it is the load voltage divided by the multiplication factor.

$I_p$  is the d-c current per tube. This is the entire load current only in the case of the simple half-wave rectifier or half- or full-wave multiplier. In the case of full-wave center-tapped or bridge rectifiers,  $I_p$  is half the load current.

$R_c$  is the total charging-circuit resistance. A certain minimum value of charging-circuit resistance is necessary to limit the peak value of current to which the tubes will be subjected under given load conditions. This required minimum depends upon the d-c current per tube ( $I_p$ ), and has been tabulated in Fig. 2 as a percentage of the effective load resistance per tube ( $E_c/I_p$ ). The total charging-circuit resistance involves the internal resistance of the rectifier tube,  $R_p$ , the added series resistor,  $R_s$ , and the equivalent internal resistance of the a-c voltage supply,  $R_i$ .

$R_p$  is the plate resistance of the 250R, which may be taken as 750 ohms.

$R_i$  is the equivalent internal resistance of the supply. This may be taken as the regulation of the high-voltage supply expressed as a decimal multiplied by the load resistance used in measuring this regulation.

$R_s$  is the series resistor which must be inserted in the charging circuit to bring the total charging-circuit resistance up to the required minimum. Its value may be found from the formula associated with each of the circuits of Fig. 2. This resistor must be inserted in such a position in the circuit that it protects all tubes.

Tubes may be operated in parallel to increase the output capability in a given circuit. When two tubes are placed in parallel at each place where one is shown in the circuits of Fig. 2, the plate resistance ( $R_p$ ) will be half as great and the maximum allowable load current twice as great as indicated.

**Peak Inverse Voltage**—The peak inverse voltage rating of the 250R is 60,000 volts. In single-phase power-supply rectifier circuits the peak inverse voltage to be used in design is the peak a-c supply voltage (1.41 times  $E_{rms}$  in Fig. 2) in the case of bridge circuits, and twice this value in the case of half- and full-wave rectifiers and voltage multipliers. Peak inverse voltage in three-phase operation depends upon the circuit employed, and will be found listed in the handbooks.

**Special Applications**—The ratings given for capacitor-input filter circuits assume values of input capacitance large enough to hold the ripple to a low value. In special applications where a larger percent ripple is tolerable, and filter capacitance is low, the 250R is capable of larger d-c output currents.

As a unidirectional conductor in d-c circuits where the current is continuous and the percent ripple is moderate, the maximum current rating of the 250R is 400 milliamperes.

The plate characteristic curve for the 250R serves as a guide to special applications. The maximum plate dissipation rating of 150 watts, the maximum peak inverse voltage rating of 60,000 volts, and the maximum peak plate current of 2.5 amperes must not be exceeded.

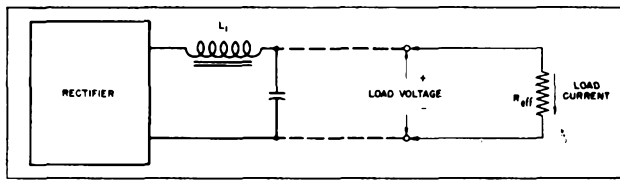
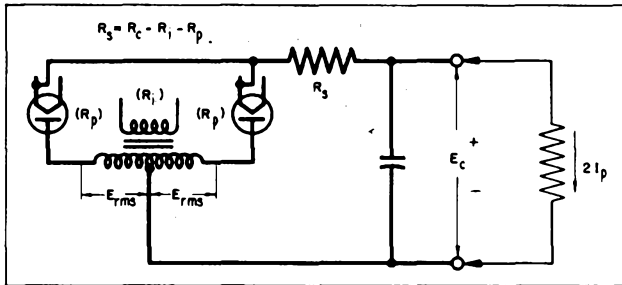
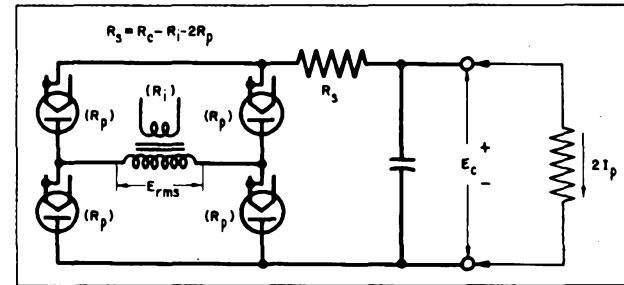

Fig. 1. Rectifier with Choke-Input Filter



a. Full-Wave Center-Tapped Rectifier



b. Full-Wave Bridge Rectifier

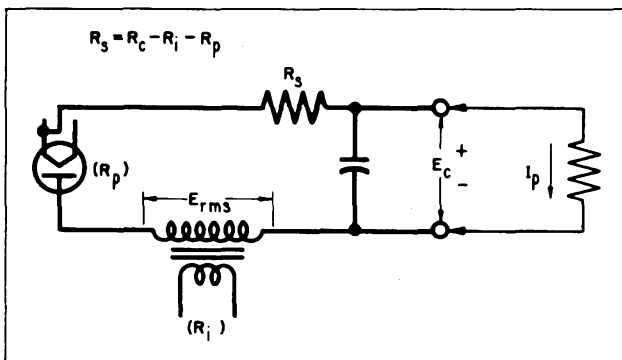

c. Half-Wave Rectifier

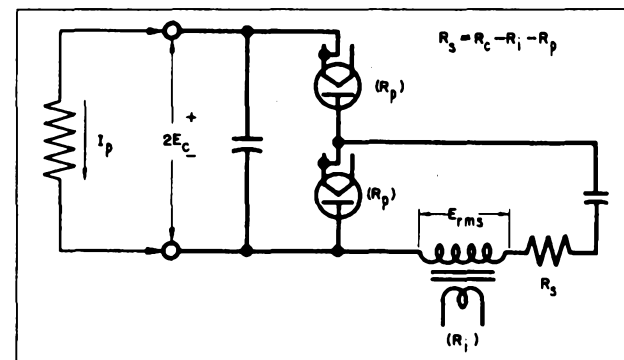

d. Half-Wave Voltage Doubler

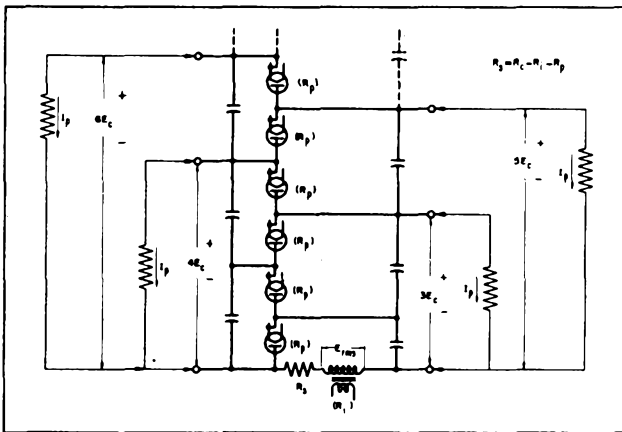

e. Half-Wave Voltage Multiplier (with common ground when  $R_s$  is inserted on the "high" side of  $E_{rms}$ )

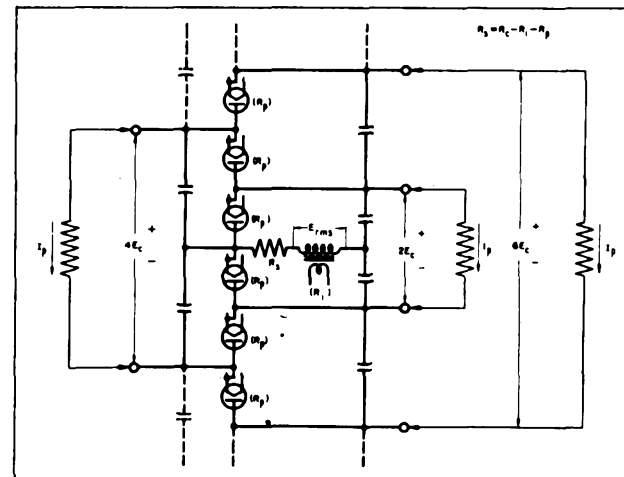

f. Full-Wave Voltage Multiplier

Eimac 250R Maximum D-C Current Ratings for R-C Filter Applications								
D-C Plate Current ( $I_p$ )	140	150	160	170	180	190	200	milliamperes per tube
Total Charging-Circuit Resistance ( $R_c$ )	1.2	1.9	3.0	4.8	7.6	12	19	percent of Effective Load Resistance per Tube ( $E_c/I_p$ )
A-C Supply Voltage ( $E_{rms}$ )	0.80	0.83	0.87	0.93	1.01	1.14	1.33	times Filter-Input D-C Voltage ( $E_c$ )
Peak Inverse Voltage ( $1/2$ these values for circuit b.)	2.3	2.4	2.5	2.7	2.9	3.2	3.7	times Filter-Input D-C Voltage ( $E_c$ )

Fig. 2 Eimac 250R Basic R-C Circuits (for any one of the indicated loads)

$R_i$  = Equivalent resistance of voltage source

$R_p$  = 750 ohms (375 ohms for two tubes in parallel)

PLATE CURRENT--AMPERES

**EIMAC 250R  
PLATE CHARACTERISTIC**

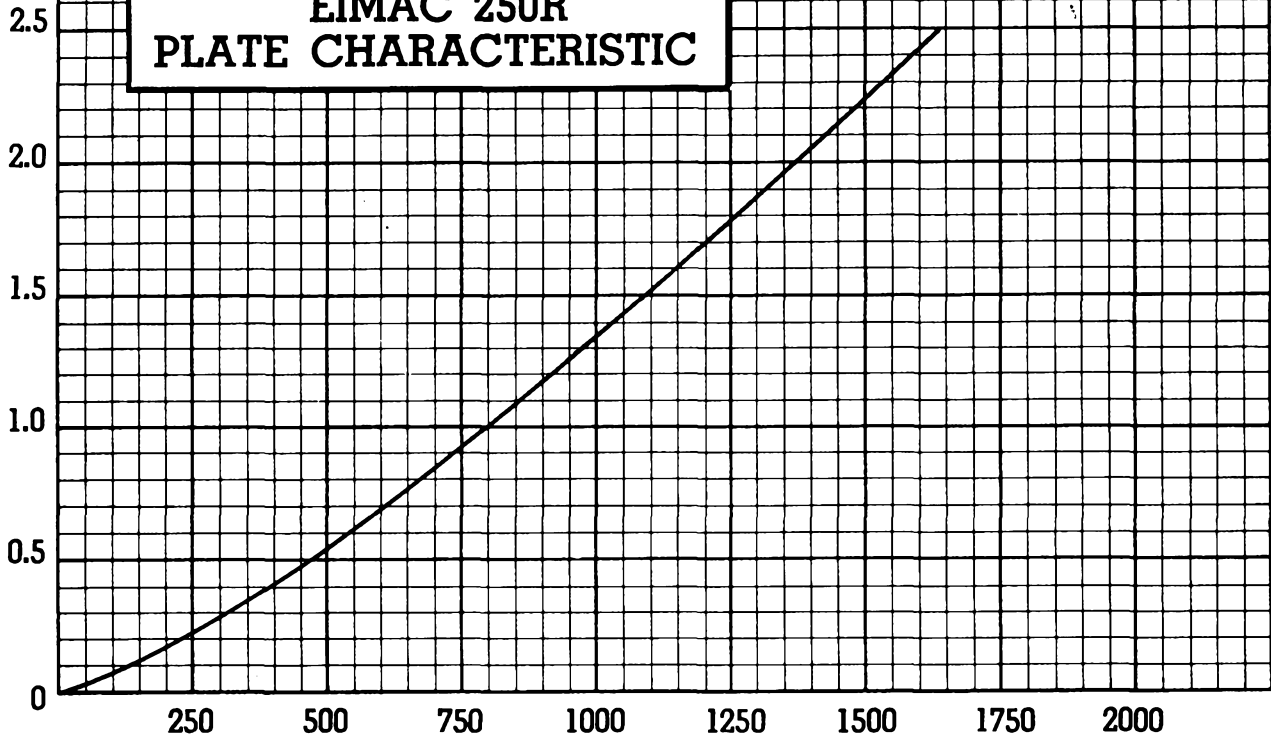
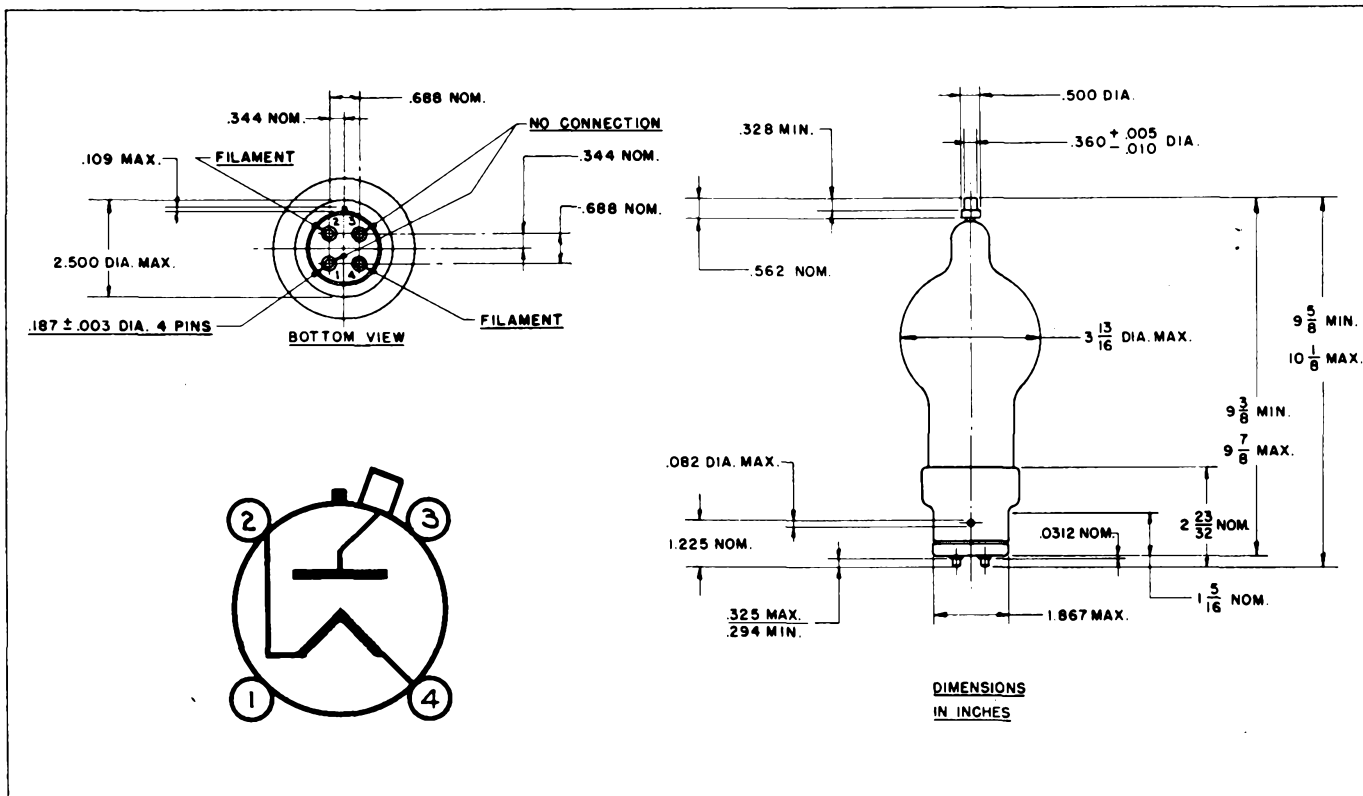

PLATE VOLTAGE--VOLTS



The Eimac 253 is a high-vacuum diode rectifier intended for use in rectifier units, voltage multipliers, or in special applications, whenever conditions of extreme ambient temperatures, high operating frequency, high peak inverse voltages, or the production of high-frequency transients would prevent the use of gas-filled rectifier tubes.

The 253 has a maximum d-c current rating of 350 milliamperes and a maximum peak inverse voltage rating of 15,000 volts. Cooling is by convection and radiation.

A single 253 will deliver 210 milliamperes at 5640 volts to a capacitor-input filter with 5300 volts single-phase supply. Four 253's in a bridge circuit will deliver 700 milliamperes at 9500 volts to a choke-input filter with 10,600 volts single-phase supply.

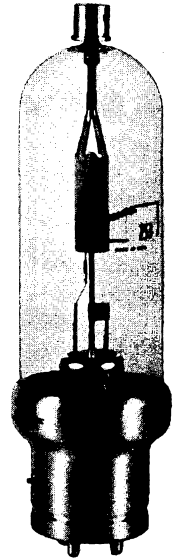

## GENERAL CHARACTERISTICS

### ELECTRICAL

Filament: Thoriated Tungsten

Voltage	-	-	-	-	-	-	-	-	-	5.0	volts
Current	-	-	-	-	-	-	-	-	-	10.0	amperes

### MECHANICAL

Base	-	-	-	-	-	-	-	-	-	50-watt jumbo 4-pin bayonet	
Basing	-	-	-	-	-	-	-	-	-	Refer to outline drawing	
Socket	-	-	-	-	-	-	-	-	-	Refer to discussion under "Application"	
Mounting Position	-	-	-	-	-	-	-	-	-	Vertical, base down or up	
Cooling	-	-	-	-	-	-	-	-	-	Convection and Radiation	
Maximum Temperature of Plate Seal	-	-	-	-	-	-	-	-	-	225°C	
Recommended Heat Dissipating Plate Connector	-	-	-	-	-	-	-	-	-	Eimac HR-8	
Maximum Over-all Dimensions:											
Length	-	-	-	-	-	-	-	-	-	8.75	inches
Diameter	-	-	-	-	-	-	-	-	-	2.50	inches
Net Weight	-	-	-	-	-	-	-	-	-	7	ounces
Shipping Weight (approx.)	-	-	-	-	-	-	-	-	-	1	pound

### MAXIMUM RATINGS (Per Tube)

PEAK INVERSE PLATE VOLTAGE	-	-	-	-	-	-	-	-	-	15,000	MAX. VOLTS
PLATE DISSIPATION	-	-	-	-	-	-	-	-	-	100	MAX. WATTS
D-C PLATE CURRENT <sup>1</sup>	-	-	-	-	-	-	-	-	-	350	MAX. MA
PEAK PLATE CURRENT	-	-	-	-	-	-	-	-	-	2.5	MAX. AMPERES

<sup>1</sup>Averaged over one cycle for each tube. Applies only when the rectifier is coupled to the load by a choke-input filter incorporating the "critical" value (or larger) of input inductance. For maximum d-c current ratings under this and other load conditions see discussion under "Application".

## APPLICATION

### MECHANICAL

**Mounting**—The 253 must be mounted vertically with the base either down or up. The lead to the plate terminal of the tube should be flexible.

The 50-watt jumbo 4-pin bayonet base fits an E. F. Johnson Co. No. 123-211, a National Co. No. XM-50, or an equivalent socket. In some circuits, particularly those of the voltage multipliers illustrated in Fig. 2, it may be necessary to mount the

socket on stand-off insulators, or on a sheet of insulating material, to provide adequate insulation to ground.

**Cooling**—The 253 is cooled by convection and radiation. Clearance should be provided around the glass envelope adequate for the free circulation of air. An Eimac HR-8 Heat Dissipating Connector or equivalent is required on the plate terminal.

The maximum temperature at the plate seal must not exceed 225°C. A convenient accessory for measuring this tem-



## APPLICATION (Continued)

perature is "Tempilaq", a temperature-sensitive lacquer available from the Tempil Corporation, 132 W. 22nd Street, New York 11, N. Y.

### ELECTRICAL

**Filament Operation**—For maximum tube life, the filament voltage, as measured at the base pins, should be the rated value of 5.0 volts. Variations must be kept within the range from 4.75 to 5.25 volts. In applications which require the diode to deliver high peak currents, it is important to maintain the filament voltage at the rated value.

**CAUTION SHOULD BE OBSERVED WHEN MEASURING RECTIFIER FILAMENT VOLTAGE. THE FILAMENT CIRCUIT MAY BE AT HIGH POTENTIAL.**

The thoriated-tungsten filament of the 253 reaches operating temperature in a fraction of a second after application of voltage. Plate voltage may be applied simultaneously with filament voltage.

**Plate Operation**—With low room illumination, the plate of the 253 begins to show color as the maximum plate dissipation rating of 100 watts is approached. The maximum peak inverse voltage rating of 15,000 volts should not be exceeded at any time.

**Performance**—The accompanying table shows some maximum performance capabilities of the 253 when used as a power-supply rectifier.

Circuit Type	253 MAXIMUM-PERFORMANCE CAPABILITIES				
	A-C Input Voltage (volts rms)	Capacitor-Input Filter D-C Output Voltage (volts)	Choke-Input Filter D-C Output Current (ma)	Choke-Input Filter D-C Output Voltage (volts)	Choke-Input Filter D-C Output Current (ma)
Single-Phase, Half-Wave	5300	5640	210	.....	.....
Single-Phase, Full-Wave	5300 <sup>1</sup>	5640	420	4750	700
Single-Phase, Bridge	10,600	11,280	420	9500	700

<sup>1</sup>One-half the transformer secondary voltage.

**Maximum D-C Current Ratings**—Plate dissipation rather than peak current usually limits the d-c current which the 253 is capable of delivering to the load. Because the plate dissipation associated with a given d-c current depends upon the amount of ripple and its wave-shape, circuit conditions will determine the maximum d-c current rating of the tube.

**Choke-Input Filter**—The maximum d-c current rating of the 253 is 350 milliamperes when the load incorporates a choke-input filter with the "critical" value (or larger) of input inductance ( $L_0$  in Fig. 1):

$$L_0 = \frac{R_{eff}}{18.8f} \text{ for full-wave single-phase rectifiers,}$$

$$L_0 = \frac{R_{eff}}{75f} \text{ for half-wave three-phase rectifiers,}$$

$$L_0 = \frac{R_{eff}}{660f} \text{ for full-wave three-phase rectifiers,}$$

where:  $L_0$  = "critical" value of input inductance (henries),  
 $f$  = supply-line frequency (cycles per second),

$$R_{eff} = \frac{\text{Load voltage (volts)}}{\text{Load current (amps)}}$$

Choke-input filters are not normally used with single-phase half-wave rectifiers.

**Capacitor-Input Filter**—The 253 is particularly suitable for power-supply applications demanding high voltage at low current. Under these conditions capacitor-input filter circuits be-

come desirable. The maximum d-c current rating of the 253 when no input choke is incorporated in the filter depends upon the total series resistance of the capacitor-charging circuit relative to the effective load resistance seen by each tube. The circuit diagrams and tabulation in Fig. 2 are so arranged and labeled that this required series resistance may be found for a wide range of load conditions. This may be done by determining the value of the following quantities:

$E_c$  is the filter-input d-c voltage. While this is usually the entire load voltage, in the case of voltage multipliers it is the load voltage divided by the multiplication factor.

$I_p$  is the d-c current per tube. This is the entire load current only in the case of the simple half-wave rectifier or half- or full-wave multiplier. In the case of full-wave center-tapped or bridge rectifiers,  $I_p$  is half the load current.

$R_c$  is the total charging-circuit resistance. A certain minimum value of charging-circuit resistance is necessary to limit the peak value of current to which the tubes will be subjected under given load conditions. This required minimum depends upon the d-c current per tube ( $I_p$ ), and has been tabulated in Fig. 2 as a percentage of the effective load resistance per tube ( $E_c/I_p$ ). The total charging-circuit resistance involves the internal resistance of the rectifier tube,  $R_p$ , the added series resistor,  $R_s$ , and the equivalent internal resistance of the a-c voltage supply,  $R_i$ .

$R_p$  is the plate resistance of the 253, which may be taken as 300 ohms.

$R_i$  is the equivalent internal resistance of the supply. This may be taken as the regulation of the high-voltage supply expressed as a decimal multiplied by the load resistance used in measuring this regulation.

$R_s$  is the series resistor which must be inserted in the charging circuit to bring the total charging-circuit resistance up to the required minimum. Its value may be found from the formula associated with each of the circuits of Fig. 2. This resistor must be inserted in such a position in the circuit that it protects all tubes.

Tubes may be operated in parallel to increase the output capability in a given circuit. When two tubes are placed in parallel at each place where one is shown in the circuits of Fig. 2, the plate resistance ( $R_p$ ) will be half as great and the maximum allowable load current twice as great as indicated.

**Peak Inverse Voltage**—The peak inverse voltage rating of the 253 is 15,000 volts. In single-phase power-supply rectifier circuits the peak inverse voltage to be used in design is the peak a-c supply voltage (1.41 times  $E_{rms}$  in Fig. 2) in the case of bridge circuits, and twice this value in the case of half- and full-wave rectifiers and voltage multipliers. Peak inverse voltage in three-phase operation depends upon the circuit employed, and will be found listed in the handbooks.

**Special Applications**—The ratings given for capacitor-input filter circuits assume values of input capacitance large enough to hold the ripple to a low value. In special applications where a larger percent ripple is tolerable, and filter capacitance is low, the 253 is capable of larger d-c output currents.

As a unidirectional conductor in d-c circuits where the current is continuous and the percent ripple is moderate, the maximum current rating of the 253 is 500 milliamperes.

The plate characteristic curve for the 253 serves as a guide to special applications. The maximum plate dissipation rating of 100 watts, the maximum peak inverse voltage rating of 15,000 volts, and the maximum peak plate current of 2.5 amperes must not be exceeded.

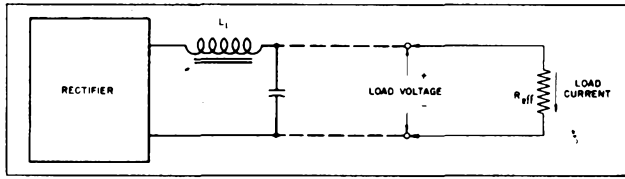
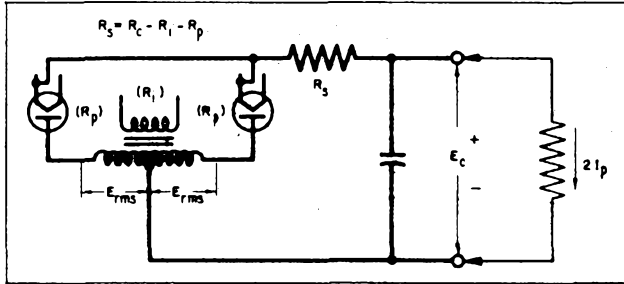
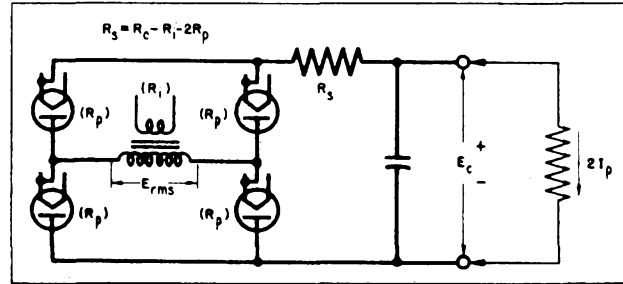

Fig. 1. Rectifier with Choke-Input Filter



a. Full-Wave Center-Tapped Rectifier



b. Full-Wave Bridge Rectifier

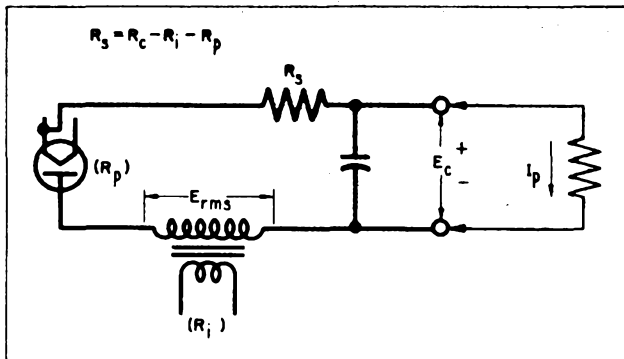

c. Half-Wave Rectifier

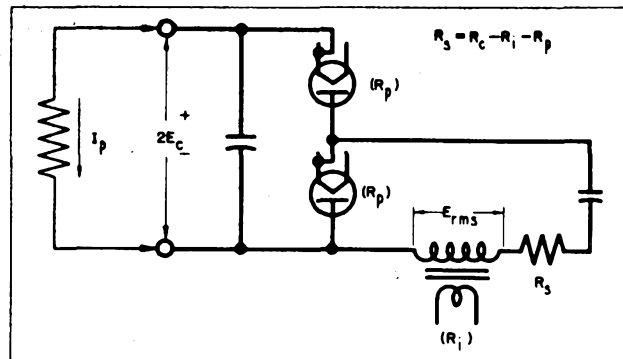

d. Half-Wave Voltage Doubler

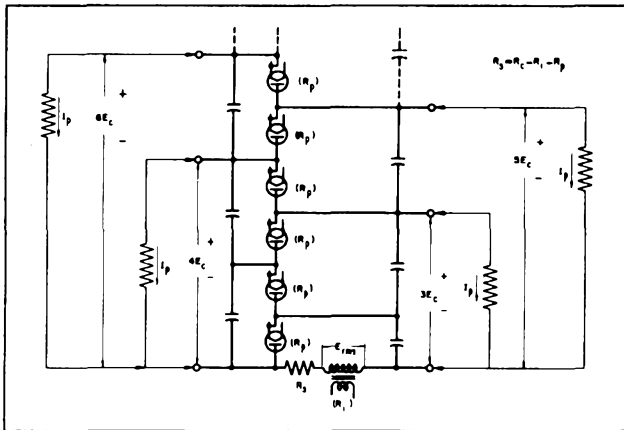

e. Half-Wave Voltage Multiplier (with common ground when  $R_s$  is inserted on the "high" side of  $E_{rms}$ )

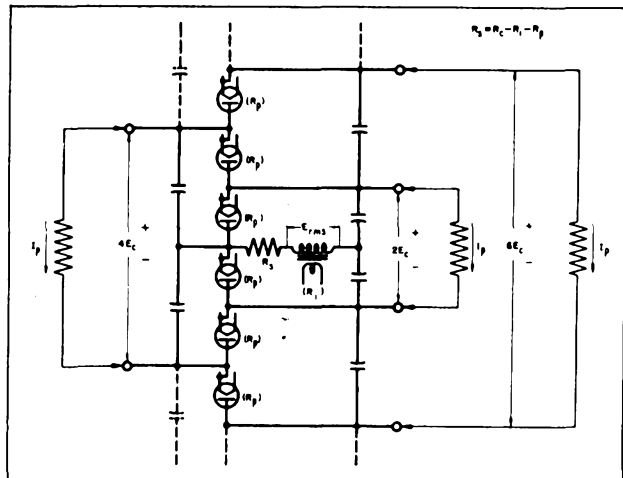

f. Full-Wave Voltage Multiplier

Eimac 253 Maximum D-C Current Ratings for R-C Filter Applications						
D-C Plate Current ( $I_p$ )	170	190	210	230	250	milliamperes per tube
Total Charging-Circuit Resistance ( $R_c$ )	1.1	2.3	5.0	10	27	percent of Effective Load Resistance per Tube ( $E_c/I_p$ )
A-C Supply Voltage ( $E_{rms}$ )	0.80	0.85	0.94	1.08	1.50	times Filter-Input D-C Voltage ( $E_c$ )
Peak Inverse Voltage ( $1/2$ these values for circuit b.)	2.3	2.4	2.7	3.1	4.3	times Filter-Input D-C Voltage ( $E_c$ )

Fig. 2 Eimac 253 Basic R-C Circuits (for any one of the indicated loads)

$R_1$  = Equivalent resistance of voltage source

$R_p$  = 300 ohms (150 ohms for two tubes in parallel)

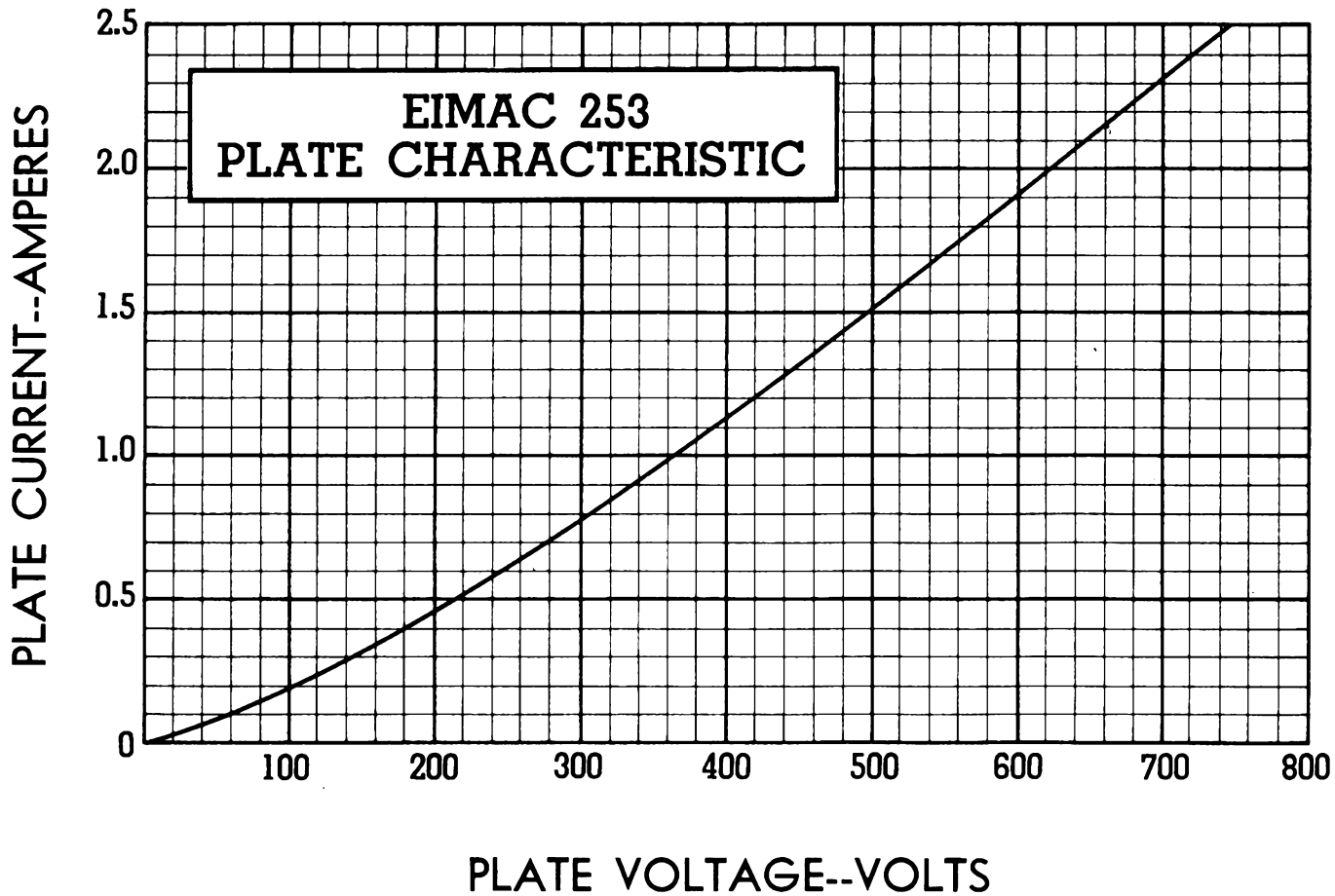
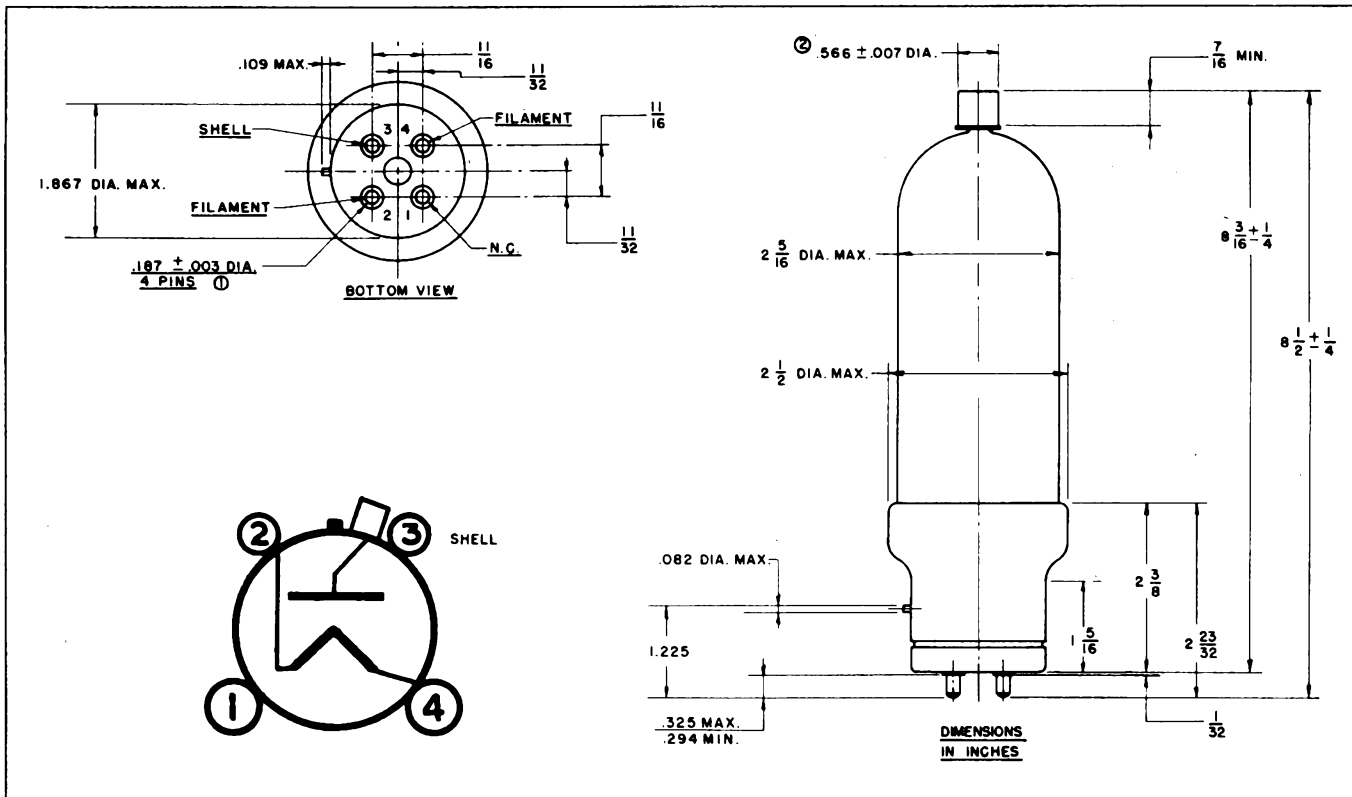

PLATE VOLTAGE--VOLTS



*Eimac*  
**EITEL-McCULLOUGH, INC.**  
 SAN BRUNO, CALIFORNIA

**8020**

(100R)

**HIGH-VACUUM  
 RECTIFIER**

The Eimac 8020(100R) diode is a high-vacuum rectifier intended for use in rectifier units, voltage multipliers, or in special applications, whenever conditions of extreme ambient temperatures, high operating frequency, high peak-inverse voltages, or the production of high-frequency transients would prevent the use of gas-filled rectifier tubes.

The 8020 has a maximum d-c current rating of 100 milliamperes and a maximum peak-inverse voltage rating of 40,000 volts. Cooling is by convection and radiation.

A single 8020 will deliver 80 milliamperes at 17,000 volts to a capacitor-input filter with 14,000 volts single-phase supply. Four 8020's in a bridge circuit will deliver 200 milliamperes at 25,000 volts to a choke-input filter with 28,000 volts single-phase supply.

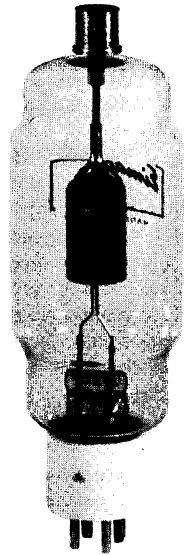

**GENERAL CHARACTERISTICS**

**ELECTRICAL**

Filament: Thoriated Tungsten

Voltage	-	-	-	-	-	-	-	-	-	-	-	5.0	volts
Current	-	-	-	-	-	-	-	-	-	-	-	6.5	amperes

**MECHANICAL**

Base	-	-	-	-	-	-	-	-	-	-	-	-	-	Medium 4-pin bayonet
Basing	-	-	-	-	-	-	-	-	-	-	-	-	-	Refer to outline drawing
Socket	-	-	-	-	-	-	-	-	-	-	-	-	-	Refer to discussion under "Application"
Mounting Position	-	-	-	-	-	-	-	-	-	-	-	-	-	Vertical, base down or up
Cooling	-	-	-	-	-	-	-	-	-	-	-	-	-	Convection and radiation
Maximum Temperature of Plate Seal	-	-	-	-	-	-	-	-	-	-	-	-	-	225°C
Recommended Heat Dissipating Plate Connector	-	-	-	-	-	-	-	-	-	-	-	-	-	Eimac HR-8
Maximum Overall Dimensions:														
Length	-	-	-	-	-	-	-	-	-	-	-	-	-	8.00 inches
Diameter	-	-	-	-	-	-	-	-	-	-	-	-	-	2.32 inches
Net Weight	-	-	-	-	-	-	-	-	-	-	-	-	-	4 ounces
Shipping Weight (approx.)	-	-	-	-	-	-	-	-	-	-	-	-	-	1 pound

**MAXIMUM RATINGS (Per tube)**

PEAK-INVERSE PLATE VOLTAGE	-	-	-	-	-	-	-	-	-	-	-	-	40,000 MAX. VOLTS
PLATE DISSIPATION	-	-	-	-	-	-	-	-	-	-	-	-	60 MAX. WATTS
D-C PLATE CURRENT <sup>1</sup>	-	-	-	-	-	-	-	-	-	-	-	-	100 MAX. MA
PEAK PLATE CURRENT	-	-	-	-	-	-	-	-	-	-	-	-	1.5 MAX. AMPERE

<sup>1</sup>Averaged over one cycle for each tube. Applies only when the rectifier is coupled to the load by a choke-input filter incorporating the "critical" value (or larger) of input inductance. For maximum d-c current ratings under this and other load conditions see discussion under "Application".

**APPLICATION**

**MECHANICAL**

**Mounting**—The 8020 must be mounted vertically with the base either down or up. The lead to the plate terminal of the tube should be flexible.

The medium 4-pin bayonet base fits an E. F. Johnson Co. No. 122-224, a National Co. No. XC-4 or CIR-4, or an equivalent socket. In some circuits, particularly those of

the voltage multipliers illustrated in Fig. 2, it may be necessary to mount the socket on stand-off insulators, or on a sheet of insulating material, to provide adequate insulation to ground.

**Cooling**—The 8020 is cooled by convection and radiation. Clearance should be provided around the glass envelope adequate for the free circulation of air. An Eimac HR-8

## APPLICATION (Continued)

Heat Dissipating Connector or equivalent is required on the plate terminal.

The maximum temperature at the plate seal must not exceed 225°C. A convenient accessory for measuring this temperature is "Tempilaq", a temperature-sensitive lacquer available from the Tempil Corporation, 132 W. 22nd St., New York 11, N. Y.

### ELECTRICAL

**Filament Operation**—For maximum tube life, the filament voltage, as measured at the base pins, should be the rated value of 5.0 volts. Variations must be kept within the range from 4.75 to 5.25 volts. In applications which require the diode to deliver high peak currents, it is important to maintain the filament voltage at the rated value.

**Caution should be observed when measuring rectifier filament voltage. The filament circuit may be at high potential.**

The thoriated-tungsten filament of the 8020 reaches operating temperature in a fraction of a second after application of voltage. Plate voltage may be applied simultaneously with filament voltage.

**Plate Operation**—With low room illumination, the plate of the 8020 begins to show color as the maximum plate dissipation rating of 60 watts is approached. The maximum peak-inverse voltage rating of 40,000 volts should not be exceeded at any time.

**Performance**—The accompanying table shows some maximum performance capabilities of the 8020 when used as a power-supply rectifier.

Circuit Type	8020 MAXIMUM PERFORMANCE CAPABILITIES					
	A-C Input Voltage (volts rms)	Capacitor-Input Filter		Choke-Input Filter		
		D-C Output Voltage (volts)	D-C Output Current (ma)	D-C Output Voltage (volts)	D-C Output Current (ma)	
Single-Phase, Half-Wave	14,000	17,000	80	—	—	
Single-Phase, Full-Wave	14,000 <sup>1</sup>	17,000	160	12,500	200	
Single-Phase, Bridge	28,000	34,000	160	25,000	200	

<sup>1</sup>One-half the transformer secondary voltage.

**Maximum D-C Current Ratings**—Plate dissipation rather than peak current usually limits the d-c current which the 8020 is capable of delivering to the load. Because the plate dissipation associated with a given d-c current depends upon the amount of ripple and its wave-shape, circuit conditions will determine the maximum d-c current rating of the tube.

**Choke Input Filter**—The maximum d-c current rating of the 8020 is 100 milliamperes when the load incorporates a choke-input filter with the "critical" value (or larger) of input inductance ( $L_1$  in Fig. 1):

$$L_o = \frac{R_{eff}}{18.8f} \quad \text{for full-wave single-phase rectifiers,}$$

$$L_o = \frac{R_{eff}}{75f} \quad \text{for half-wave three-phase rectifiers,}$$

$$L_o = \frac{R_{eff}}{660f} \quad \text{for full-wave three-phase rectifiers,}$$

where:  $L_o$  = "critical" value of input inductance (henries),  
 $f$  = supply-line frequency (cycles per second),

$$R_{eff} = \frac{\text{Load voltage (volts)}}{\text{Load current (amps)}}$$

Choke-input filters are not normally used with single-phase half-wave rectifiers.

**Capacitor-Input Filter**—The 8020 is particularly suitable for power-supply applications demanding high voltage at low current. Under these conditions capacitor-input filter

circuits become desirable. The maximum d-c current rating of the 8020 when no input choke is incorporated in the filter depends upon the total series resistance of the capacitor-charging circuit relative to the effective load resistance seen by each tube. The circuit diagrams and tabulation in Fig. 2 are so arranged and labeled that this required series resistance may be found for a wide range of load conditions. This may be done by determining the value of the following quantities:

$E_c$  is the filter-input d-c voltage. While this is usually the entire load voltage, in the case of voltage multipliers it is the load voltage divided by the multiplication factor.

$I_p$  is the d-c current per tube. This is the entire load current only in the case of the simple half-wave rectifier or half- or full-wave multiplier. In the case of full-wave center-tapped or bridge rectifiers,  $I_p$  is half the load current.

$R_c$  is the total charging-circuit resistance. A certain minimum value of charging-circuit resistance is necessary to limit the peak value of current to which the tubes will be subjected under given load conditions. This required minimum depends upon the d-c current per tube ( $I_p$ ), and has been tabulated in Fig. 2 as a percentage of the effective load resistance per tube ( $\frac{E_c}{I_p}$ ). The total charging circuit resistance involves the internal resistance of the rectifier tube,  $R_p$ , the added series resistor,  $R_s$ , and the equivalent internal resistance of the a-c voltage supply.

$R_p$  is the plate resistance of the 8020, which may be taken as 1000 ohms.

$R_i$  is the equivalent internal resistance of the supply. This may be taken as the regulation of the high-voltage supply expressed as a decimal multiplied by the load resistance used in measuring this regulation.

$R_s$  is the series resistor which must be inserted in the charging circuit to bring the total charging-circuit resistance up to the required minimum. Its value may be found from the formula associated with each of the circuits of Fig. 2. This resistor must be inserted in such a position in the circuit that it protects all tubes.

Tubes may be operated in parallel to increase the output capability in a given circuit. When two tubes are placed in parallel at each place where one is shown in the circuits of Fig. 2, the plate resistance ( $R_p$ ) will be half as great and the maximum allowable load current twice as great as indicated.

**Peak-Inverse Voltage**—The peak-inverse voltage rating of the 8020 is 40,000 volts. In single-phase power-supply rectifier circuits the peak-inverse voltage to be used in design is the peak a-c supply voltage (1.41 times  $E_{rms}$  in Fig. 2) in the case of bridge circuits, and twice this value in the case of half- or full-wave rectifiers and voltage multipliers. Peak-inverse voltage in three-phase operation depends upon the circuit employed, and will be found listed in the handbooks.

**Special Applications**—The ratings given for capacitor-input filter circuits assume values of input capacitance large enough to hold the ripple to a low value. In special applications where a larger percent ripple is tolerable and filter capacitance is low, the 8020 is capable of larger d-c output currents.

As a unidirectional conductor in d-c circuits where the current is continuous and the percent ripple is moderate, the maximum current rating of the 8020 is 200 milliamperes.

The plate characteristic curve for the 8020 serves as a guide to special applications. The maximum plate dissipation rating of 60 watts, the maximum peak-inverse voltage rating of 40,000 volts, and the maximum peak plate current of 1.5 ampere must not be exceeded.

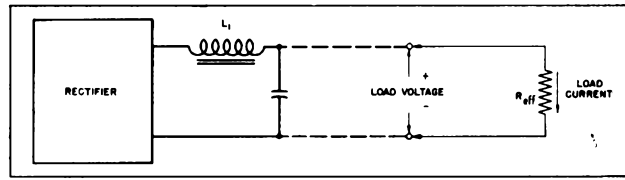
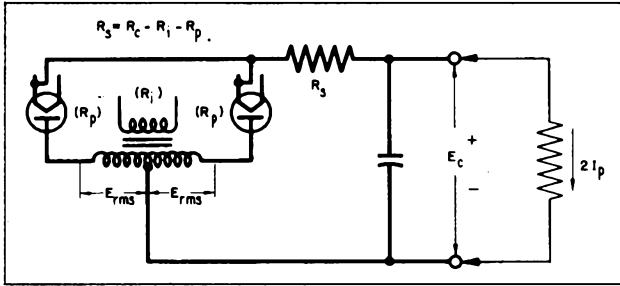
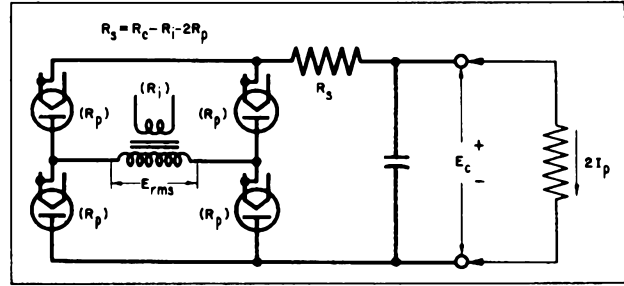

Fig. 1. Rectifier with Choke-Input Filter



a. Full-Wave Center-Tapped Rectifier



b. Full-Wave Bridge Rectifier

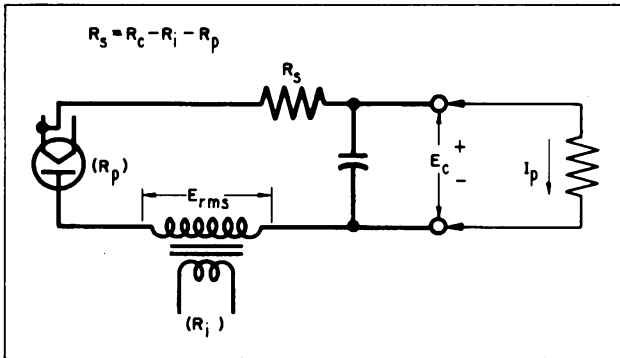

c. Half-Wave Rectifier

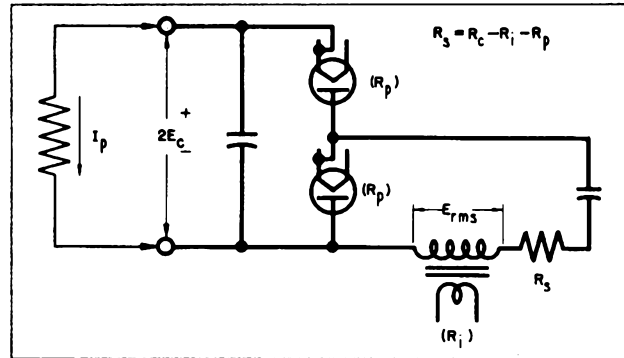

d. Half-Wave Voltage Doubler

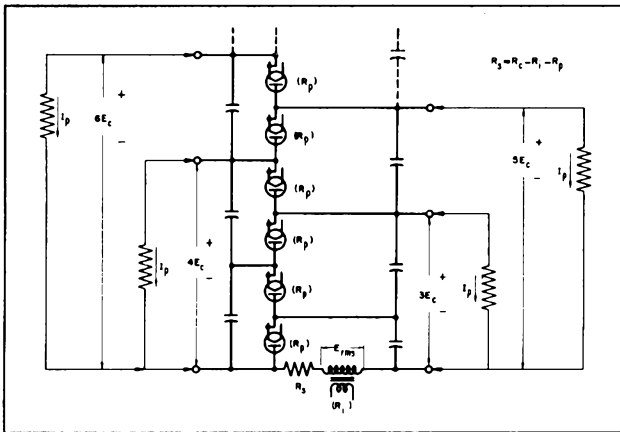

e. Half-Wave Voltage Multiplier (with common ground when  $R_s$  is inserted on the "high" side of  $E_{rms}$ )

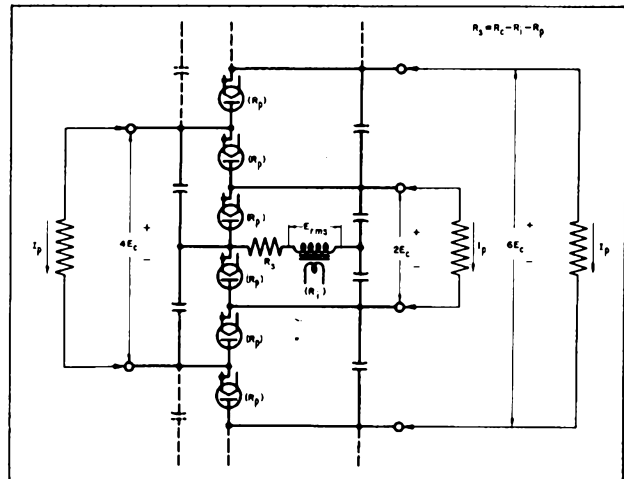

f. Full-Wave Voltage Multiplier

Eimac 8020 Maximum D-C Current Ratings for R-C Filter Applications								
D-C Plate Current ( $I_p$ )	70	75	80	85	90	95	100	milliamperes per tube
Total Charging-Circuit Resistance ( $R_c$ )	0.8	1.2	1.8	3.0	4.7	7.6	12	percent of Effective Load Resistance per Tube ( $\frac{E_c}{I_p}$ )
A-C Supply Voltage ( $E_{rms}$ )	0.78	0.80	0.83	0.87	0.92	1.01	1.14	times Filter Input D-C Voltage ( $E_c$ )
Peak-Inverse Voltage	2.2	2.3	2.4	2.5	2.6	2.9	3.2	times Filter Input D-C Voltage ( $E_c$ )

Fig. 2. Eimac 8020 Basic R-C Circuits (for any one of the indicated loads)

$R_i$  = Equivalent resistance of voltage source

$R_p$  = 1000 ohms (500 ohms for two tubes in parallel)

PLATE CURRENT--AMPERES

# EIMAC 8020 (100R) PLATE CHARACTERISTICS

1.6  
1.2  
0.8  
0.4  
0

200 400 600 800 1000 1200 1400

PLATE VOLTAGE--VOLTS

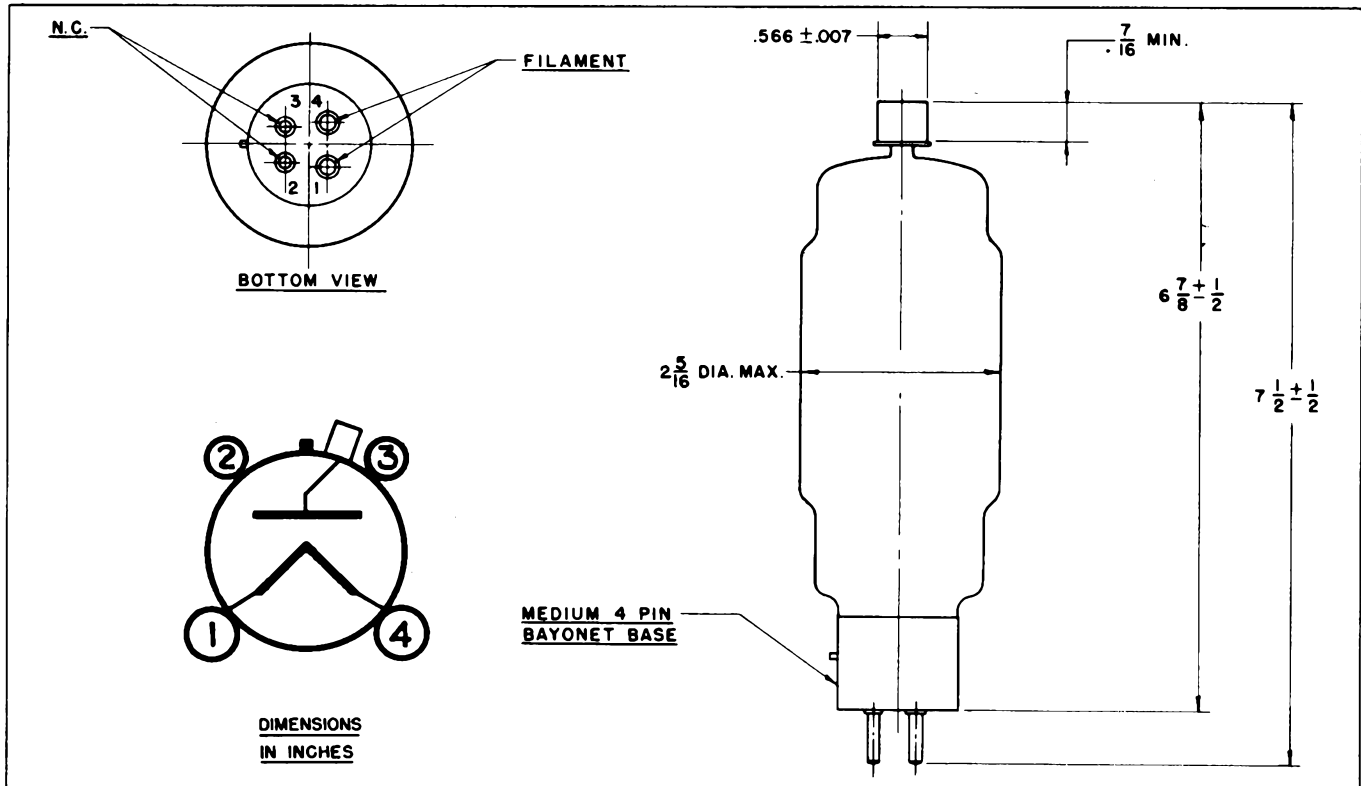

*Eimac*  
**EITEL-McCULLOUGH, INC.**  
 SAN BRUNO, CALIFORNIA

**KY21A**  
 GRID-CONTROLLED  
 MERCURY  
 VAPOR  
 RECTIFIER

The Eimac KY21A is a grid-controlled mercury vapor rectifier. A pair of KY21A's in a conventional single phase full wave circuit will supply a d-c power output of 5 kilowatts (3500 volts at 1.5 amperes) with a choke input filter.

**GENERAL CHARACTERISTICS**

**ELECTRICAL**

Filament: Coated	
Voltage - - - - -	2.5 volts
Current - - - - -	10 amperes
Filament Heating Time (minimum) - - - - -	30 seconds
Tube Voltage Drop (average) - - - - -	15 volts
Ionization Time (approximately) - - - - -	10 $\mu$ seconds
Deionization Time (approximately) - - - - -	1000 $\mu$ seconds

**MECHANICAL**

Base* - - - - -	Medium, 5 Pin
Basing - - - - -	See Outline Drawing
Maximum Overall Dimensions	
Length - - - - -	8.0 inches
Diameter - - - - -	2.25 inches
Net Weight - - - - -	5 ounces
Shipping Weight - - - - -	1 pound

**MAXIMUM RATINGS (single tube)**

Peak Inverse Anode Voltage - - - - -	11,000 max. volts
Peak Forward Anode Voltage - - - - -	5,500 max. volts
Peak Anode Current - - - - -	3 max. amperes
Average Anode Current - - - - -	.75 max. amperes
Supply Frequency - - - - -	150 max. C.P.S.
Temperature Limits, Condensed Mercury - - - - -	20° to 60° Centigrade 65° to 140° Fahrenheit

\*In order to carry the ten amperes of filament current the adjacent pins have been connected in parallel within the base. Similar connections should be made on the socket.



**APPLICATION**

**MECHANICAL**

**Mounting**—The KY21A must be mounted vertically, base down.

**Cooling**—Since the cooling of the KY21A is accomplished by radiation and convection, provision should be made for adequate air circulation around the tube. The temperature of the condensed mercury within the KY21A should be maintained at 40 degrees plus or minus 5 degrees Centigrade for best performance. To measure the condensed mercury temperature a thermocouple or small thermometer may be attached to the envelope in the area designated on the outline drawing, using a very small amount of putty.

**ELECTRICAL**

CAUTION SHOULD BE OBSERVED IN MEASURING THE FILAMENT VOLTAGE, AS THE FILAMENT CIRCUIT MAY BE AT A HIGH D-C POTENTIAL.

**Filament Voltage**—For maximum tube life the filament voltage, as measured directly at the filament pins, should be held at the rated value of 2.5 volts. Variations in filament voltage must be kept within the range of 2.4 to 2.6 volts. The filament of the KY21A should be allowed to reach operating temperature before the plate voltage is applied. Under normal conditions, a delay of approximately 30 seconds will be required. Under conditions where the tube is to be operated in extremely cold or extremely warm temperatures some external method of maintaining proper ambient temperature must be provided.

When a KY21A is first installed, the filament should be operated at rated voltage for approximately ten minutes with no plate voltage applied, in order that the mercury may be properly distributed. It will not be necessary to repeat this procedure unless the mercury is spattered on the filament and plate during subsequent handling.

**Shielding**—Extreme care must be exercised in preventing r-f electromagnetic and electrostatic fields from entering the circuits incorporating the KY21A. Tube "hold-off" characteristics will be materially affected in the presence of r-f fields.

**Grid Circuit**—The KY21A is prevented from conducting by placing a negative potential on the grid. The relationship between negative grid control voltage and anode voltage is shown in the characteristic curve. The ratio of d-c plate voltage to control voltage varies from about 87:1 at 1000 volts to 130:1 at 3500 volts. The use of slightly higher than the minimum voltage for hold-off is recommended. It may be convenient to supply 100 to 150 volts of bias from a small pack. This grid voltage is satisfactory for all normal plate voltages. It will usually be advisable to protect the grid of the KY21A by means of a current limiting resistor of approximately 10,000 ohms.



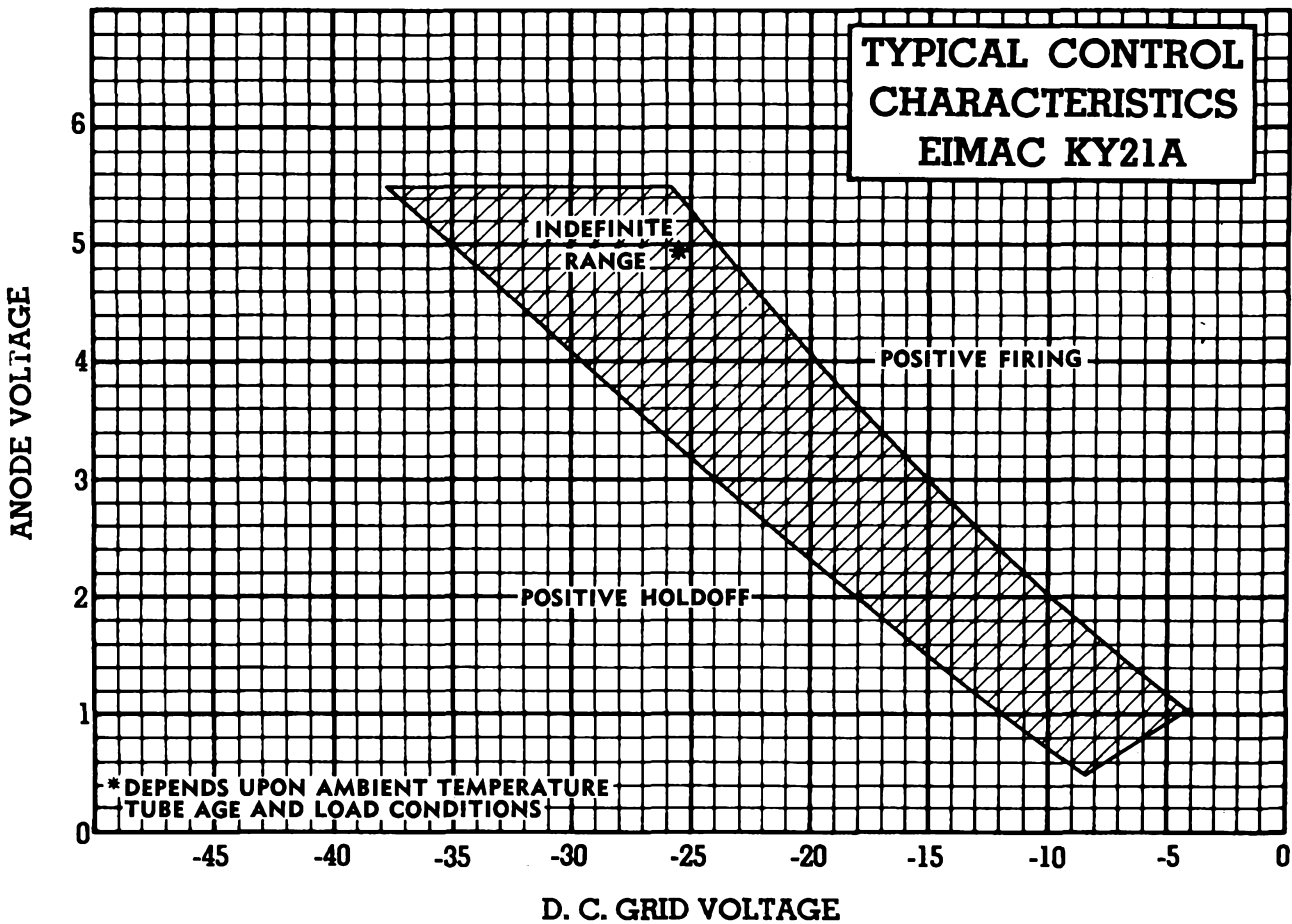
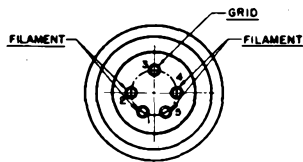
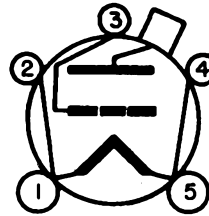
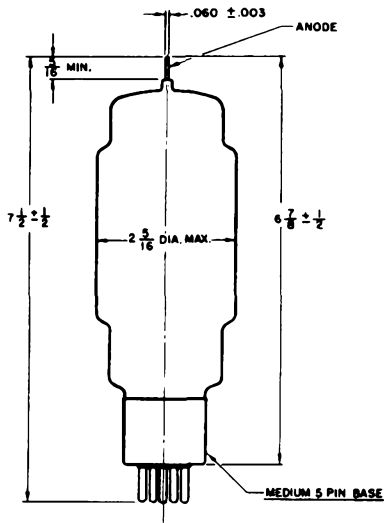

# Eitel-McCULLOUGH, Inc.

SAN BRUNO, CALIFORNIA

# RX21A

**MERCURY  
VAPOR  
RECTIFIER**

The Eimac RX21A is a half-wave mercury vapor rectifier incorporating features which enable it to withstand high peak inverse voltages and to conduct at relatively low applied voltages. The shielded ribbon filament, edgewise-wound, provides a large emission reserve and long life.

## GENERAL CHARACTERISTICS

### ELECTRICAL

Filament: Coated		
Voltage	- - - - -	2.5 volts
Current	- - - - -	10 amperes
Tube Voltage Drop (approx.)	- - - - -	15 volts

### MECHANICAL

Base <sup>1</sup>	- - - - -	Medium, 5-pin
Basing	- - - - -	See base connection diagram
Maximum Overall Dimensions:		
Length	- - - - -	8.0 inches
Diameter	- - - - -	2.25 inches
Net Weight	- - - - -	5 ounces
Shipping Weight	- - - - -	1 pound

### MAXIMUM RATINGS (single tube)

PEAK INVERSE ANODE VOLTAGE <sup>2</sup>	- - - - -	11,000 MAX. VOLTS
PEAK ANODE CURRENT	- - - - -	3 MAX. AMPERES
AVERAGE ANODE CURRENT	- - - - -	.75 MAX. AMPERES
SUPPLY FREQUENCY	- - - - -	150 MAX. C. P. S.
CONDENSED-MERCURY TEMPERATURE RANGE <sup>3</sup>	- - - - -	20-60 °C

<sup>1</sup>In order to carry the ten amperes of filament current the adjacent pins have been connected in parallel within the base. Similar connections should be made in the socket.

<sup>2</sup>Temperatures in excess of 60° C limit the peak-inverse rating to 5,000 volts with a corresponding reduction in permissible RMS supply voltages to one-half those listed in the table.

<sup>3</sup>Operation at 40° plus or minus 5° C is recommended.



## APPLICATION

### MECHANICAL

**MOUNTING**—The RX21A must be mounted vertically, base down.

**COOLING**—Provisions should be made for adequate air circulation around the tube, because cooling is accomplished by convection. The temperature of the condensed-mercury in the RX21A should be kept within the ranges given under "MAXIMUM RATINGS". This temperature should be maintained at 40 degrees plus or minus 5 degrees C for most satisfactory operation of the tube. To measure the condensed-mercury temperature a thermocouple or small thermometer may be attached to the bulb in the area designated on the outline drawing, using a very small amount of putty. A condensed-mercury temperature lower than the recommended value raises the voltage at which the tube becomes conducting and tends to reduce the life of the filament. A temperature higher than recommended lowers the voltage at which the tube becomes conducting and tends to increase the life of the filament, but reduces the peak inverse voltage rating of the tube. When it is necessary to use a shield around the RX21A care must be taken to insure adequate ventilation and maintenance of normal condensed-mercury temperature.

### ELECTRICAL

**CAUTION SHOULD BE OBSERVED IN MEASURING THE FILAMENT VOLTAGE, AS THE FILAMENT CIRCUIT MAY BE AT A HIGH D-C POTENTIAL.**

**FILAMENT VOLTAGE**—For maximum tube life, the filament voltage as measured directly at the filament pins, should be held at the rated value of 2.5 volts. Unavoidable variations in filament voltage must be kept within the range of 2.4 to 2.6 volts. A filament voltage less than the minimum recommended value may cause a high tube voltage drop, with consequent bombardment of the filament and eventual loss of emission. A filament voltage higher than the recommended maximum value will also decrease the life of the filament.

The plate-circuit return of each tube should preferably be connected to the center tap of the transformer winding supplying the filament voltage. This precaution is recommended to insure uniform starting voltage for each tube when several are used in a given circuit.

The filament of the RX21A should be allowed to reach operating temperature before the plate voltage is applied. Under normal conditions, a delay of approximately 30 seconds will be required. The delay time should be increased if there is any evidence of arc-back within the tube. In radio transmitter applications the filament should be kept at its rated voltage during "standby" periods to avoid delay due to warm-up. It is desirable to use a protective relay in the plate circuit to prevent the application of plate voltage before the filament has reached operating temperature. This relay should have a time delay adjustable up to a maximum of one minute.

When an RX21A is first installed, the filament should be operated at normal voltage for approximately ten minutes with no plate

voltage applied, in order that the mercury may be properly distributed. It will not be necessary to repeat this procedure unless the mercury is spattered on the filament and plate during subsequent handling.

**SHIELDING**—Electromagnetic and electrostatic fields tend to cause the mercury vapor to break down, are detrimental to tube life and make proper operation difficult. Consequently, the RX21A should be isolated from such fields as exist around a transmitter or other similar equipment. When the tubes are located in the region of such fields, shielding with adequate ventilation should be used around the tubes. R-f filtering should also be employed when the tubes are affected by r-f voltages.

**FILTERING**—A "choke input" filter will allow the greatest usable d-c output current to the load. When using a section of filter between rectifier and load, to prevent exceeding the maximum peak current of 3 amperes, a suitable maximum value for the first capacitor should be determined. Determination of this capacitance should be made under conditions simulating those to be used in service.

The relationship of voltage input, inductance, and capacitance is one in which a higher operating voltage requires greater input inductance, and less following capacitance to keep the peak STARTING current from exceeding 3 amperes. This is for the usual case where the supply is controlled by an on-off switch.

Where the rectifier plate voltage is started by a control which gradually raises the voltage from zero or a small amount to the desired operating value, starting current need not ordinarily be considered, and the characteristics of the filter may be based on preventing excessive peak current under normal operating conditions.

In the single phase circuits (1 and 3), if the current drawn by the load is reduced or varies under operating conditions to values less than approximately 70% of the indicated maximum d-c load current, a swinging (input) choke will supply the necessary additional inductance to prevent the voltage from rising, and will afford proper filtering over a much greater current range.

Where a larger value of inductance is desirable to obtain additional filtering, the subsequent capacitance may be proportionately increased to aid in still further filtering without excessive peak starting and operating current. Still lower ripple may of course be obtained by added sections of filter.

When "condenser input" filter is used, the peak current will be relatively high in respect to the usable load current, and the voltage across the capacitor may be as high as 1.4 times the nominal RMS voltage of the transformer.

For parallel operation of RX21A rectifiers, suitable resistors or small inductors may be used in series with each plate lead to permit equal loading and starting characteristics. The inductors aid in reducing the peak current, and are more desirable due to their low d-c resistance. An approximate value for suitable resistors is 50 ohms, and for inductors, approximately one-third henry each.

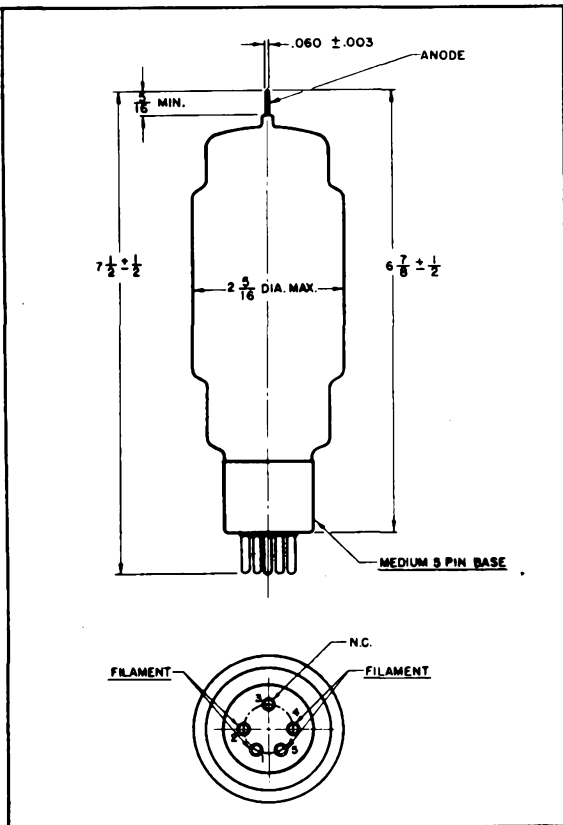
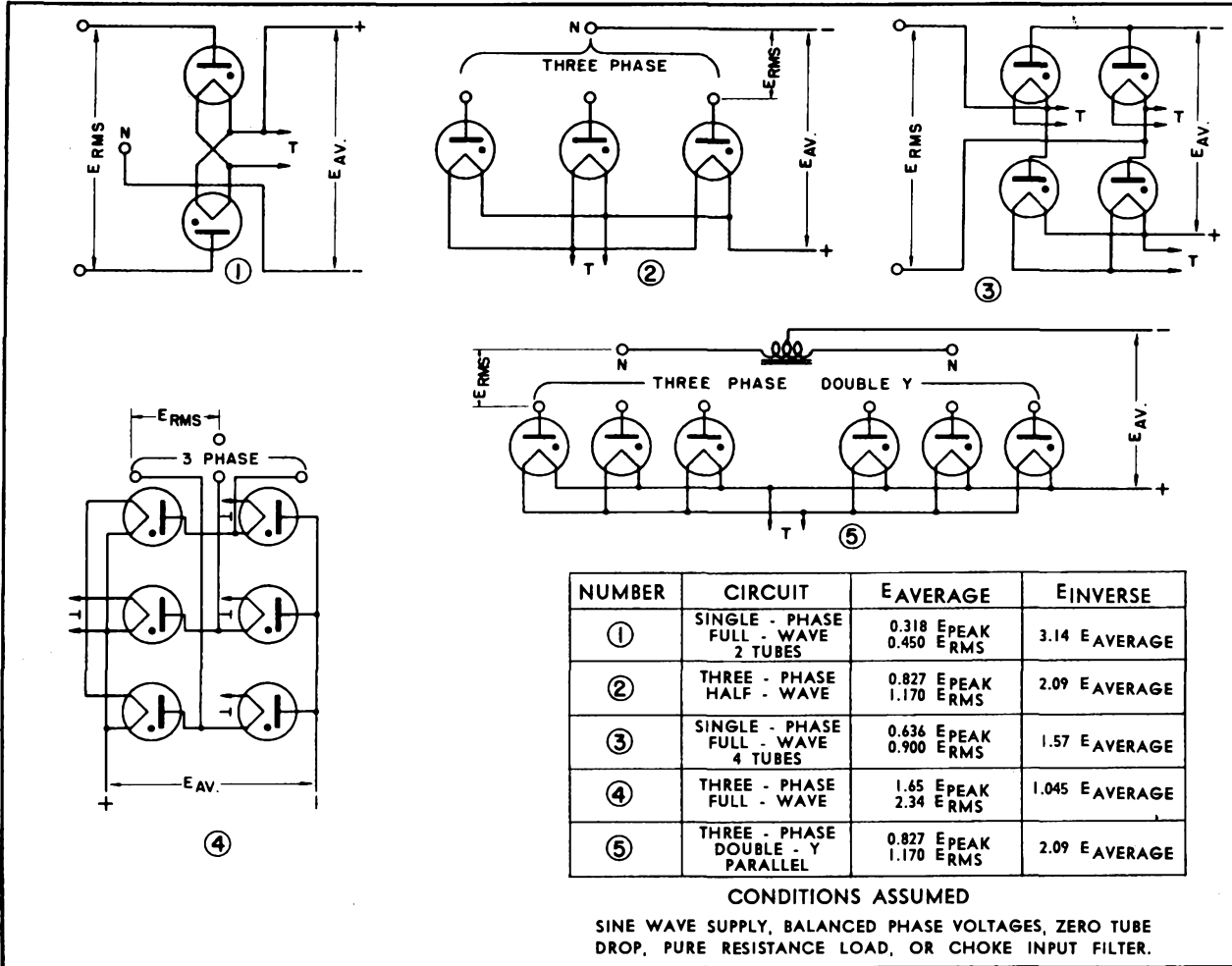

CIRCUIT	INPUT VOLTS* MAX. A-C (RMS)	APPROX. D-C OUTPUT VOLTS TO FILTER	MAX. D-C CURRENT OUTPUT (Amperes)
①	3890 per tube	3510	1.5
②	4490 per leg	5270	2.25
③	7780 total	7020	1.5
④	4490 per leg	10,520	2.25
⑤	4490 per leg	5270	4.5

\*For use under the conditions of the 11,000 volt peak inverse rating. If the RX21A is to be used under frequency and/or temperature condition such that the peak inverse voltage is limited to 5500 volts, the a-c input voltage and d-c output voltage values in the table should be multiplied by a factor of 0.5 to give new values for the 5500 volt condition.



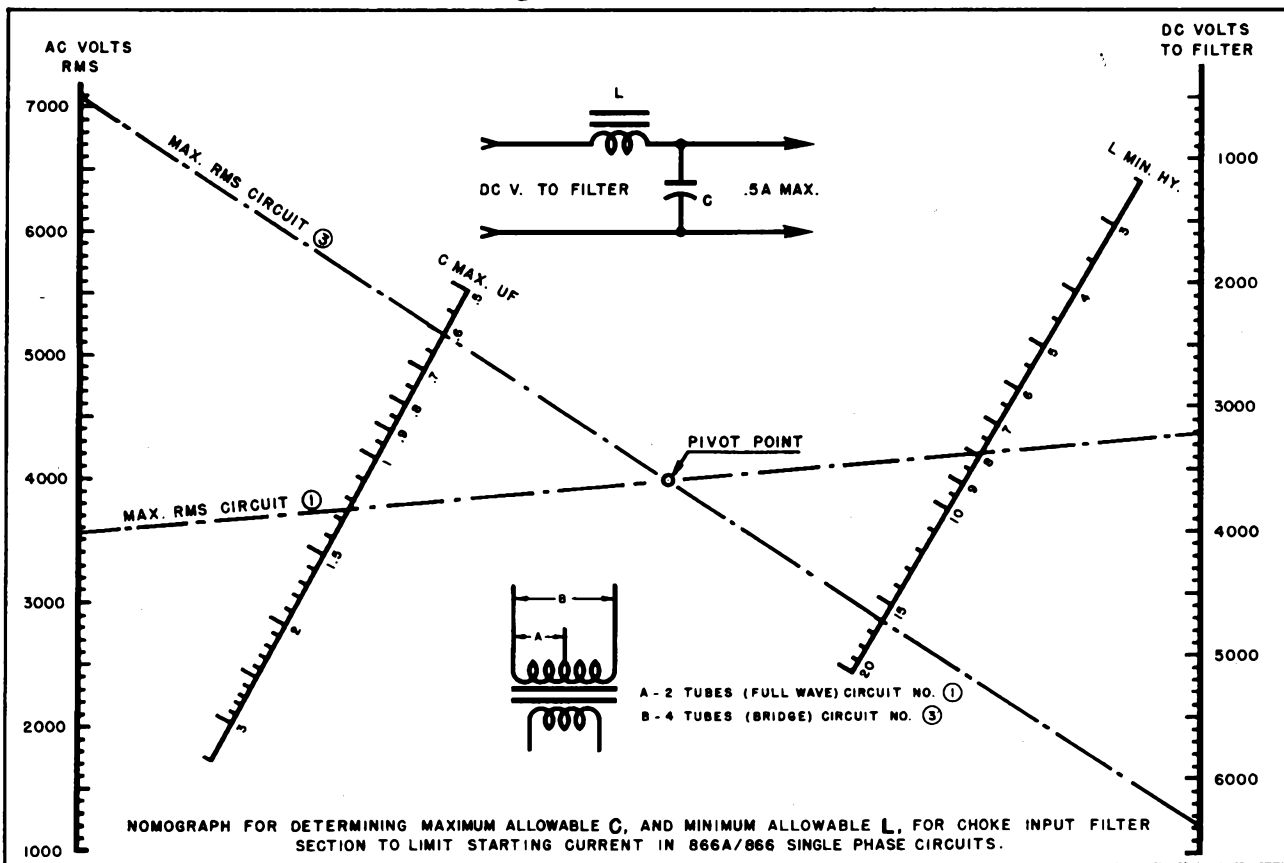

NUMBER	CIRCUIT	E AVERAGE	E INVERSE	I AVERAGE
①	SINGLE - PHASE FULL - WAVE 2 TUBES	0.318 E MAXIMUM 0.450 E RMS	3.14 E AVERAGE	0.636 I MAXIMUM
②	THREE - PHASE HALF - WAVE 3 TUBES	0.827 E MAXIMUM 1.170 E RMS	2.09 E AVERAGE	0.827 I MAXIMUM
③	SINGLE - PHASE FULL - WAVE 4 TUBES	0.636 E MAXIMUM 0.900 E RMS	1.57 E AVERAGE	0.636 I MAXIMUM
④	THREE - PHASE FULL - WAVE 4 TUBES	1.65 E MAXIMUM 2.34 E RMS	1.045 E AVERAGE	0.955 I MAXIMUM
⑤	THREE - PHASE DOUBLE - Y PARALLEL 4 TUBES	0.827 E MAXIMUM 1.170 E RMS	2.09 E AVERAGE	1.91 I MAXIMUM

**CONDITIONS ASSUMED**  
 (1) SINE WAVE SUPPLY (2) BALANCED PHASE VOLTAGES (3) ZERO TUBE DROP  
 (4) PURE RESISTANCE LOAD (5) NO FILTER USED

CIRCUIT	A-C INPUT VOLTS** (RMS)	MAX. D-C OUTPUT VOLTS TO FILTER	CHOKE INPUT ONE-SECTION FILTER		MAX. D-C LOAD CURRENT amperes
			MIN. CHOKE (L) henrys	MAX. CONDENSER (C) uf	
THREE-PHASE HALF-WAVE CIRCUIT 2	per leg				
	4080	4780	3.2	1.4	0.75
	3000	3510	2.2	2.0	0.75
	2000	2340	1.4	3.0	0.75
THREE-PHASE FULL-WAVE CIRCUIT 4	per leg				
	4080	9570	1.8	0.5	0.75
	3000	7020	1.4	0.7	0.75
	2000	4680	0.9	1.2	0.75
THREE-PHASE DOUBLE-Y PARALLEL CIRCUIT 5	per leg				
	4080	4780	2.0	0.5	1.5
	3000	3510	1.5	0.7	1.5
	2000	2340	1.0	1.1	1.5
SINGLE PHASE FULL-WAVE (2 tubes) CIRCUIT 1*	per tube				
	3535	3950	—	—	0.25
	3000	3390	—	—	0.25
	2000	2260	—	—	0.25
	1500	1700	—	—	0.25

\* With condenser input to filter.  
 \*\* For use under the conditions of the 10000-volt peak inverse rating. If the 866-A/866 is to be used under frequency and/or temperature conditions such that the peak inverse voltage is limited to 5000 volts, the a-c input voltage and d-c output voltage values in the table should be multiplied by a factor of 0.5 to give new values for the 5000-volt conditions.

**BOTTOM VIEW OF SOCKET CONNECTIONS**

ST 19 BULB

ZONE WHERE CONDENSED MERCURY TEMPERATURE SHOULD BE MEASURED

MEDIUM 4-PIN BAYONET BASE

● = GAS-TYPE TUBE

**TUBE MOUNTING POSITION**  
 VERTICAL - BASE DOWN ONLY



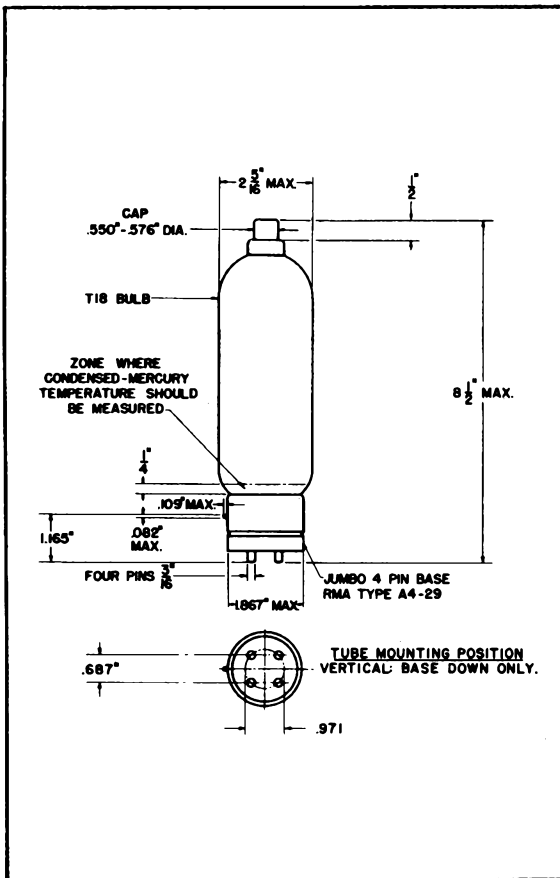
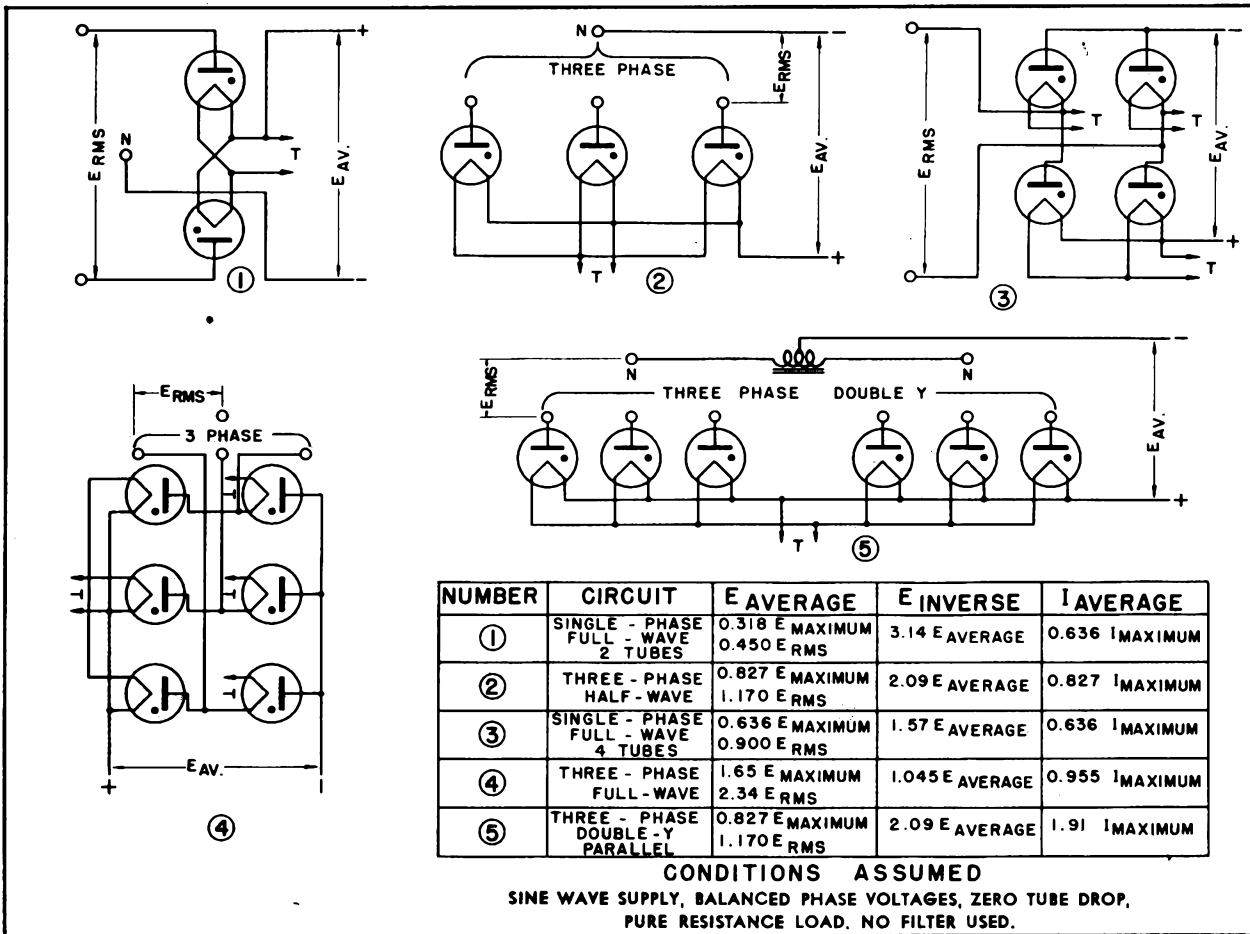

CIRCUIT	INPUT VOLTS/ MAXIMUM A-C (RMS)	APPROX. D-C OUTPUT VOLTS TO FILTER	MAXIMUM D-C OUTPUT CURRENT AMPERES
1	3535 per tube	3180	2.5
2	4080 per leg	4780	3.75
3	7070 total	6360	2.5
4	4080 per leg	9570	3.75
5	4080 per leg	4780	7.5

<sup>1</sup> Max. peak inverse voltage of 10,000 volts.

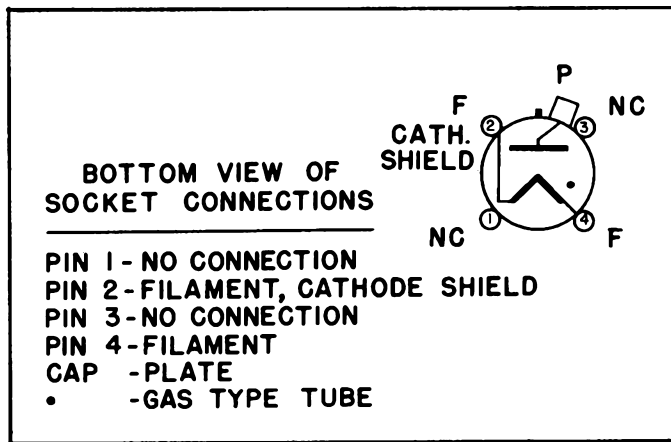

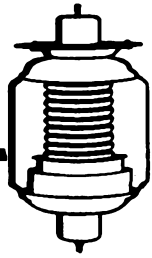

# other products ▶

---

## Look in the front pages for ...

- Your nearest distributor of modern, fully guaranteed Eimac Vacuum tubes, vacuum capacitors, heat dissipating connectors, air-system sockets, preformed contact finger stock and vacuum switches.
- Your nearest Eimac Field Engineer, who stands ready to give you immediate engineering assistance, any information on deliveries and prices, or provide other information not found in the catalog.
- Eimac tube type numbering system.
- Tube Replacement Chart.
- Prices on Eimac products.

---

## IMPORTANT EIMAC "EXTRAS"

**Application Engineering.** The Eimac Application Engineering Department is available at all times for consultation. New tube operating techniques are continually being explored, tested and proved by Eimac application engineers, whose combined knowledge and experience are made available to you. Additional contributions by this Eimac department are its Application Bulletins, an expanding service which you get without obligation.

**Field Engineering.** Serving as an extension of the Application Engineering Department outside the Eimac plant, Eimac field engineers cover the United States, operate out of offices in major cities. They will help you personally with experimental work, problems of technique, etc. Engineers from the Eitel-McCullough plant in San Bruno are available, too, for field consultation throughout the country. As Eimac tubes are world renowned, the same services extend to various countries overseas through the Eimac export division.



*Eimac*  
**EITEL-McCULLOUGH, INC.**  
 SAN BRUNO, CALIFORNIA

# HR HEAT DISSIPATING CONNECTORS

Eimac HR Heat Dissipating Connectors are used to make electrical connections to the plate and grid terminals of Eimac tubes, and, at the same time, provide efficient heat transfer from the tube element and glass seal to the air. The HR connectors aid materially in keeping seal temperatures at safe values. However, it is sometimes necessary to forced-air-cool the connector by means of a small fan or blower. In such cases the air flow should be parallel with the fins of the connector.

Designed for use on the larger tubes, the HR-9 Heat Dissipating Connector is provided with an air duct to conduct the cooling air directly to the glass seal.

HR Heat Dissipating Connectors are machined from solid dural rod, and are supplied with the necessary machine screws. The table below lists the proper connectors for use with each Eimac tube type.

TUBE	PLATE CONNECTORS	CONNECTOR GRID	TUBE	PLATE CONNECTORS	CONNECTOR GRID
2-25A	HR-1	.....	75TH-TL	HR-3	HR-2
2-50A	HR-3	.....	100R	HR-8	.....
2-150D	HR-6	.....	100TH-TL	HR-6	HR-2
2-240A	HR-6	.....	VT127A	HR-3	HR-3
2-2000A	HR-8	.....	152TH-TL	HR-5	HR-6
3C24	HR-1	HR-1	250TH-TL	HR-6	HR-3
4-65A	HR-6	.....	250R	HR-6	.....
4-125A	HR-6	.....	253	HR-8	.....
4-250A	HR-6	.....	304TH-TL	HR-7	HR-6
4-400A	HR-6	.....	327A	HR-4	HR-3
4-1000A	HR-8	.....	450TH-TL	HR-8	HR-8*
4E27A/5-125B	HR-5	.....	592/3-200A3	HR-10	HR-5
4PR60A	HR-8	HR-8			
6C21	HR-8				
KY21A	HR-3	.....	750TL	HR-8	HR-8
RX21A	HR-3	.....	866A	HR-8	.....
25T	HR-1	.....	872A	HR-8	.....
35T	HR-3	.....	1000T	HR-9	HR-9
35TG	HR-3	HR-3	1500T	HR-8	HR-8
UH50	HR-2	HR-2	2000T	HR-8	HR-8

\*The grid terminal of the 450TH-TL type tube is now .560" in diameter. To accommodate existing equipment designed for the older style 450TH-TL having .098" diameter grid terminals, an adapter pin is provided with the newer tubes. This adapter pin is threaded so that it may be removed from the grid terminal of the tube. The small grid terminal requires an HR-4 connector.

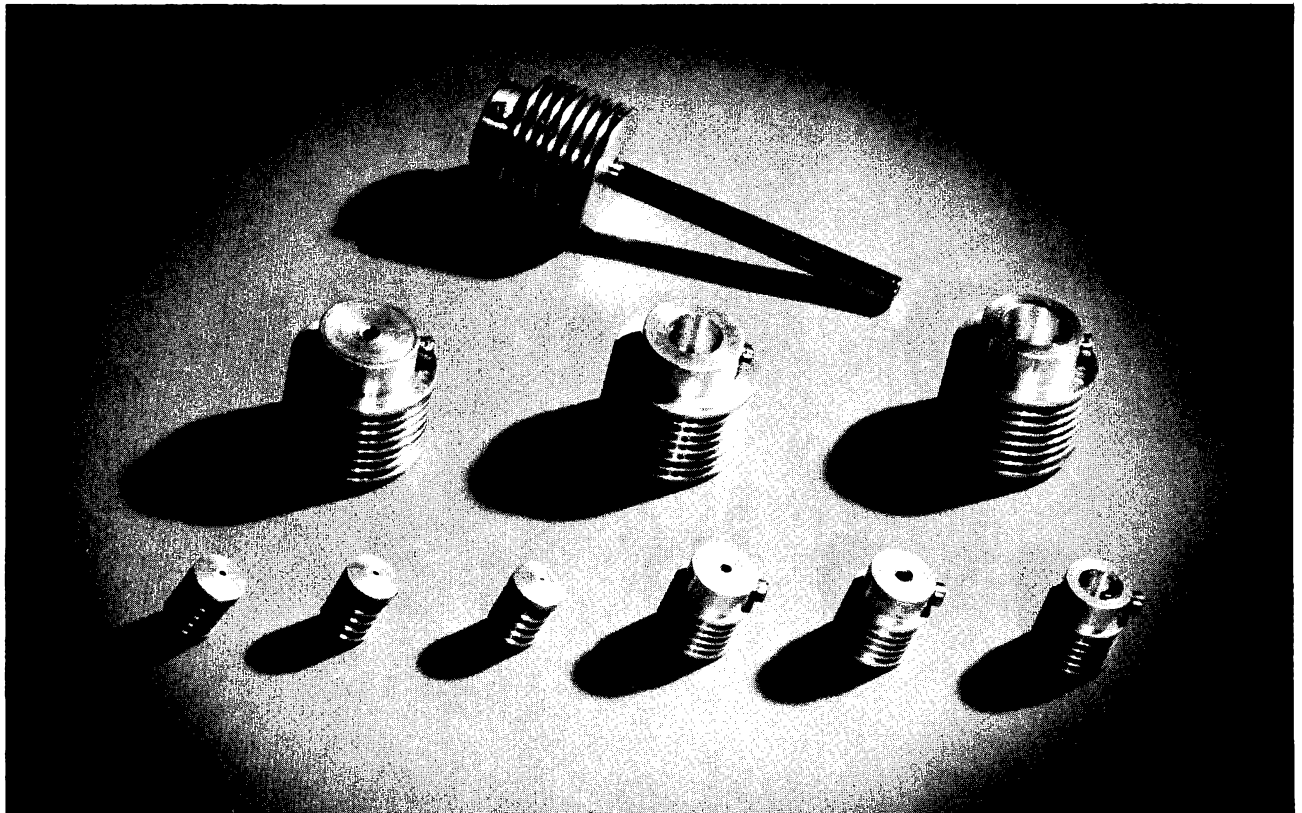

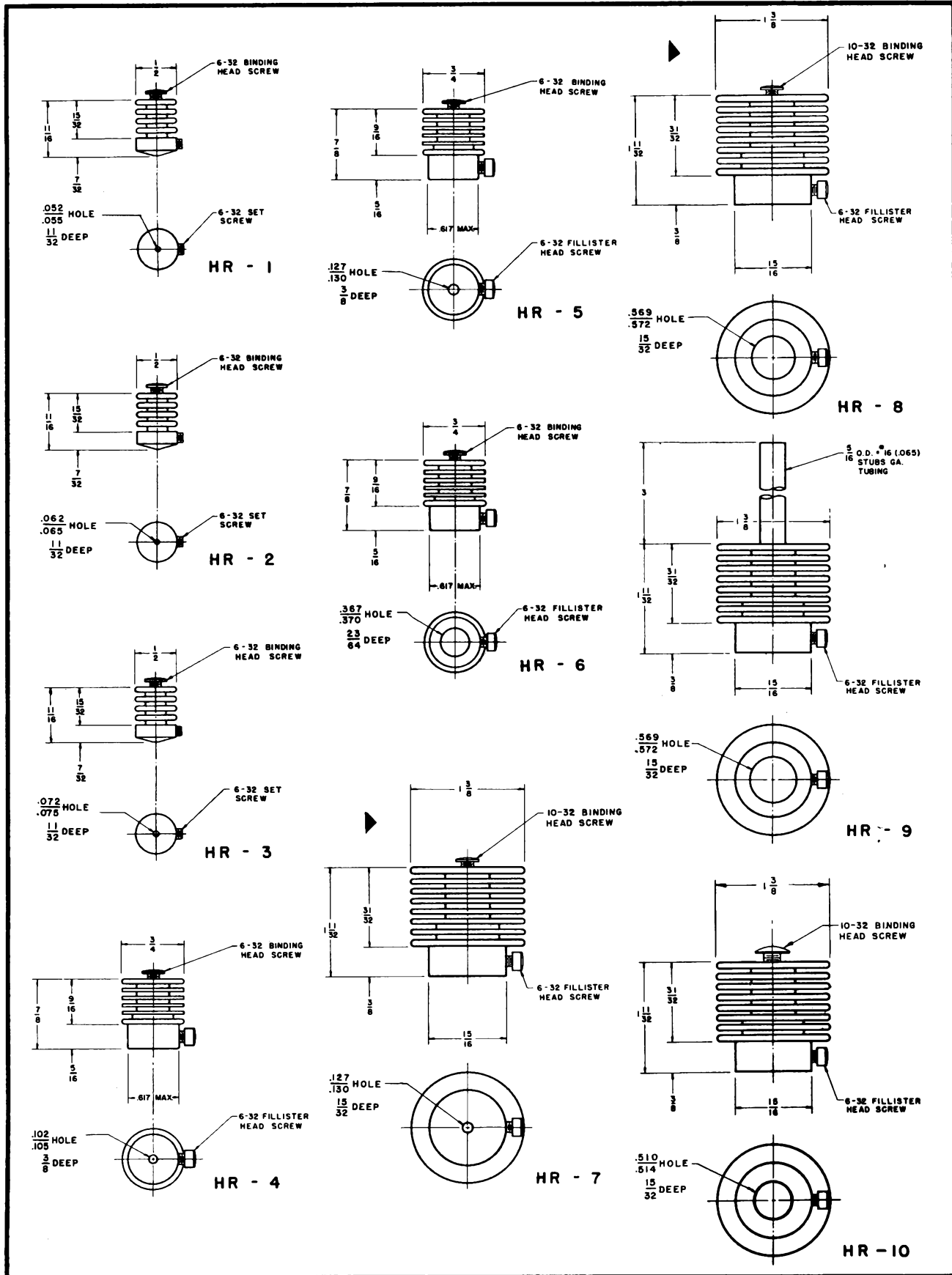

# Eimac

## 4X150 TUBE EXTRACTOR

**4X150  
Tube Extractor**



**4X150  
Tube Extractor  
in Application**



The Eimac 4X150 tube extractor may be used as pictured for inserting or extracting the 4X150A, 4X150D and 4X150G from normal or deep cavities. The prongs of the extractor are placed through the radiator of the tube and permit quick handling of tubes. The spring steel construction allows the tube to be gripped firmly without scoring the cavity walls. Only normal cavity wall clearance is required.

(Note: This sheet should be inserted immediately preceding the 4X150A data sheet in your catalog.)

**EITEL-McCULLOUGH, INC.**  
San Bruno, California

# EITEL-McCULLOUGH, INC.

SAN BRUNO, CALIFORNIA

# VACUUM CAPACITORS

VC50-32	VC50-20
VC25-32	VC25-20
VC12-32	VC12-20
VC6-32	VC6-20

Eimac vacuum capacitors are small, vacuum-dielectric units intended principally for use as all or part of the plate tank capacitance in radio-frequency amplifiers or oscillators. They are also frequently used as high-voltage coupling and by-pass capacitors at high frequencies and as high-voltage neutralizing capacitors, when used in conjunction with small high-voltage variable capacitors having a small capacitance range. The use of a vacuum as a dielectric permits the construction of a comparatively small, lightweight capacitor for a given voltage rating and capacitance. In addition, the effects of dust and atmospheric conditions on the capacitor are eliminated by sealing the plates within a glass envelope.

These capacitors are manufactured in two maximum peak voltage ratings, 32,000 and 20,000 volts, and in capacitances of 6, 12, 25 and 50 uufd. All types have a maximum current rating of 28 amperes. Each of the capacitors may be operated at its full maximum voltage rating at any frequency below that at which the rms current through the capacitor is 28 amperes. Above this frequency, the r-f voltage across the capacitor must be reduced as the frequency increases, to prevent the current from exceeding the maximum rating. The graphs below show the maximum peak r-f voltage which may be applied to each type of capacitor at frequencies between 100 kilocycles and 50 megacycles. Curves are also shown which indicate the rms current flowing through the capacitor under maximum r-f voltage conditions at any frequency between 100 kilocycles and 50 megacycles. Where both r-f and d-c voltages are applied to the capacitor, the sum of the peak r-f and d-c voltages must not exceed the peak voltage rating of the capacitor.

Eimac vacuum capacitors are provided with terminals which allow the use of standard 60-ampere fuse clips for mounting. These clips must be kept clean and must at all times make firm and positive contact with the capacitor terminals. Failure to maintain a low-resistance contact to the capacitor terminals may result in excessive heating and permanent damage to the capacitor seals.

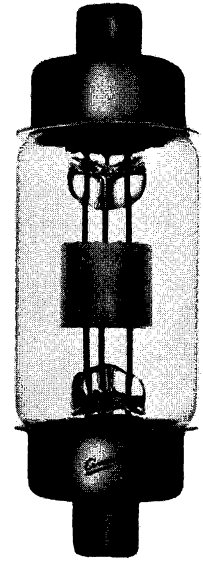

## VC50-32

Capacitance\* . . . . . 50  $\mu\text{fd}$ .  
 Max. Peak Voltage . . . . . 32,000 volts  
 Max. RMS Current . . . . . 28 amps.

## VC50-20

Capacitance\* . . . . . 50  $\mu\text{fd}$ .  
 Max. Peak Voltage . . . . . 20,000 volts  
 Max. RMS Current . . . . . 28 amps.

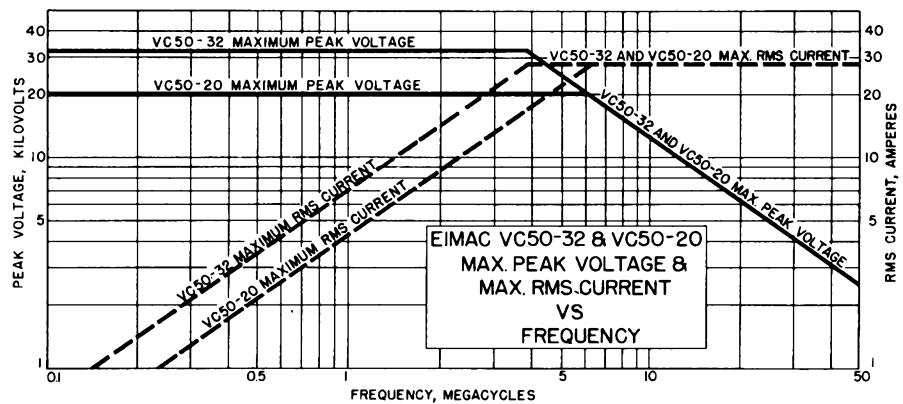

## VC25-32

Capacitance\* . . . . . 25  $\mu\text{fd}$ .  
 Max. Peak Voltage . . . . . 32,000 volts  
 Max. RMS Current . . . . . 28 amps.

## VC25-20

Capacitance\* . . . . . 25  $\mu\text{fd}$ .  
 Max. Peak Voltage . . . . . 20,000 volts  
 Max. RMS Current . . . . . 28 amps.

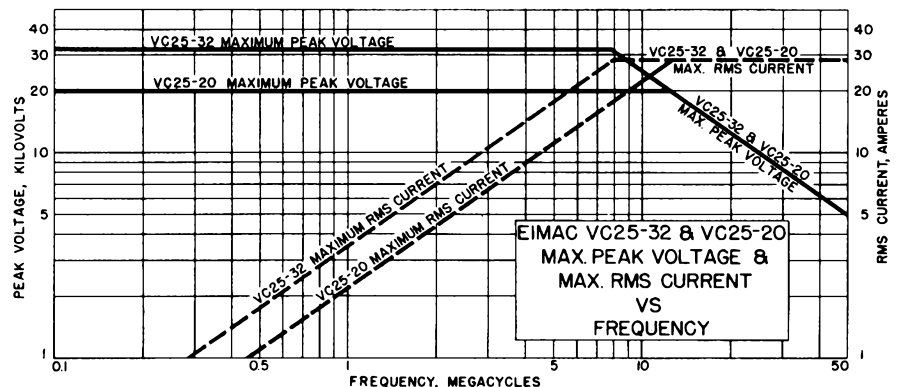

### VC12-32

Capacitance\* . . . . . 12  $\mu\mu\text{fd.}$   
 Max. Peak Voltage . . . . . 32,000 volts  
 Max. RMS Current . . . . . 28 amps.

### VC12-20

Capacitance\* . . . . . 12  $\mu\mu\text{fd.}$   
 Max. Peak Voltage . . . . . 20,000 volts  
 Max. RMS Current . . . . . 28 amps.

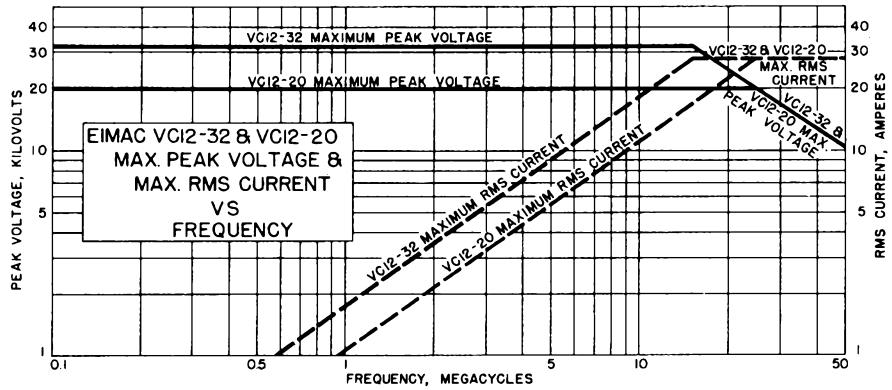

### VC6-32

Capacitance\* . . . . . 6  $\mu\mu\text{fd.}$   
 Max. Peak Voltage . . . . . 32,000 volts  
 Max. RMS Current . . . . . 28 amps.

### VC6-20

Capacitance\* . . . . . 6  $\mu\mu\text{fd.}$   
 Max. Peak Voltage . . . . . 20,000 volts  
 Max. RMS Current . . . . . 28 amps.

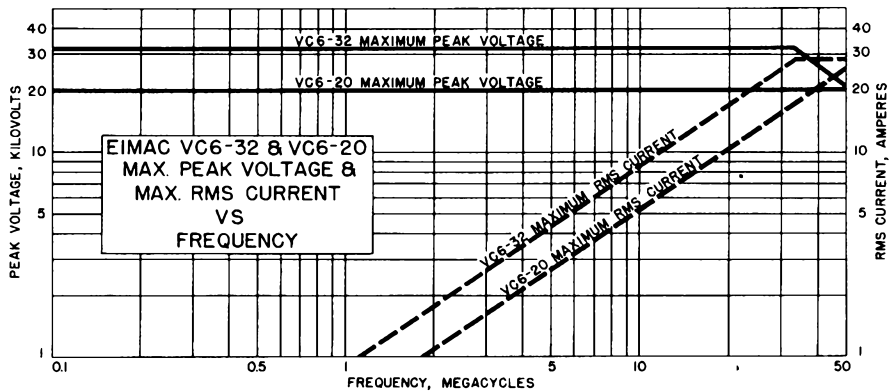

\*Tolerances:

VC50-32, VC50-20 . . . . .  $\pm 1 \mu\mu\text{fd.}$ ; VC25-32, VC25-20 . . . . .  $\pm 1 \mu\mu\text{fd.}$ ; VC12-32, VC12-20 . . . . .  $\pm 1 \mu\mu\text{fd.}$ ; VC6-32, VC6-20 . . . . .  $\pm 0.5 \mu\mu\text{fd.}$

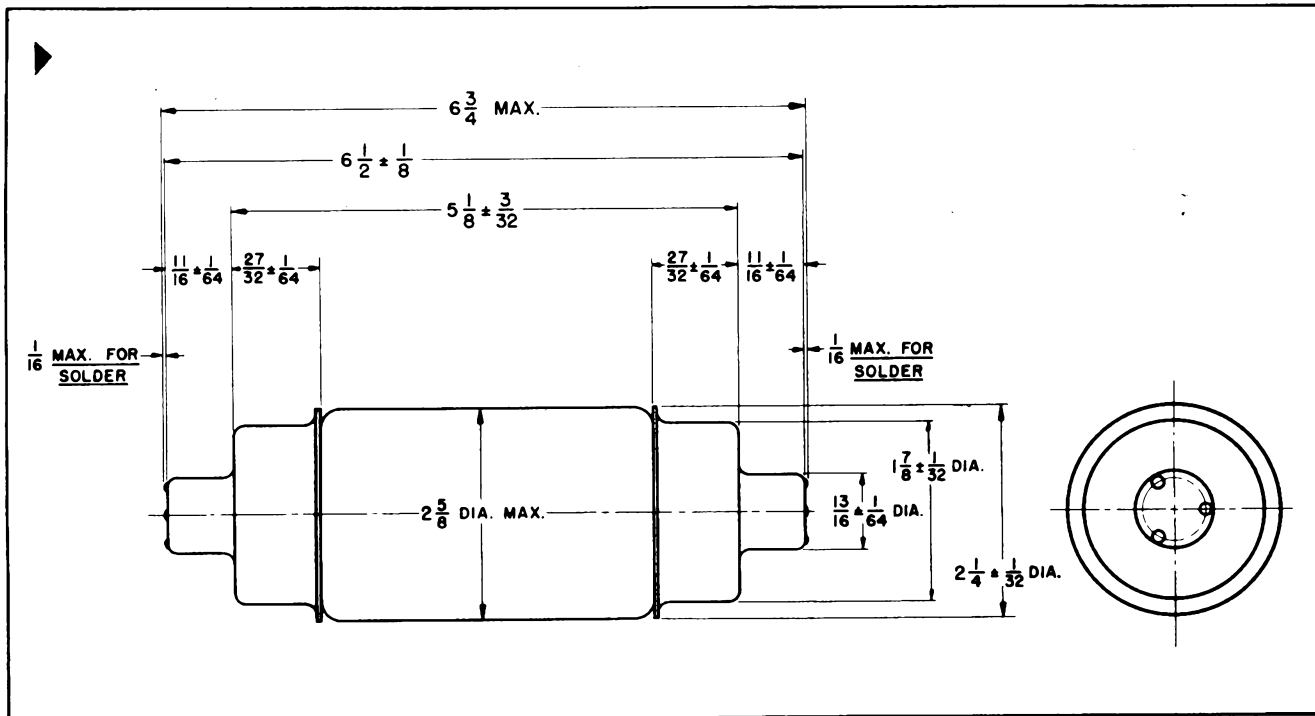

## TYPES VVC 60-20 VVC2-60-20 VVC4-60-20

### GENERAL

Eimac variable vacuum capacitors are intended principally for use as plate tank capacitors in radio frequency amplifiers and oscillators. The use of vacuum for the dielectric permits close spacing of the electrodes giving concentrated capacitance at high voltage. The variable vacuum capacitors are compact, lightweight, and eliminate the effects of dust and atmospheric conditions.

The basic capacitor unit (VVC60-20) has an RF peak voltage rating of 20,000 volts and a maximum current rating of 40 amperes RMS. Ganged multiple unit capacitors are available using two units (VVC2-60-20) or four units (VVC4-60-20). These multiple unit capacitors include a single mounting plate, gear train, and single tuning shaft. One end of each unit capacitor mounts on the common plate and one end is free. Thus the multiple capacitor may be connected with the units in parallel, as two series capacitors for "split-stator" work, or as multiple capacitors with one terminal common.

The capacitors may be operated at a maximum voltage rating at any frequency provided the current rating is not exceeded. Above a particular frequency the maximum current rating becomes the limitation and voltage values less than the maximum must be used. Curves are given for each capacitor showing maximum allowable current (RMS) vs. frequency.

The capacitance variation is linear with respect to shaft rotation with the complete range being covered in seventeen revolutions of the shaft. Reference should be made to the tuning curve for each capacitor. A return to previously-indexed settings is positive. The variable vacuum capacitors have a low temperature coefficient resulting in a negligible change in capacitance due to variation in temperature. The actual coefficient values are given for each capacitor combination.

### MOUNTING

The VVC60-20 is provided with a mounting plate on one end, which also serves as an electrical

connection. If the circuit is such that one side of the capacitor is grounded, the mounting plate can be fastened directly to the panel or chassis. Four eyelets to accommodate No. 8-32 machine screws are provided on the mounting plate. If a single or multiple unit is to be ungrounded the mounting should be on insulators and the tuning shaft broken with an insulating coupling and the dial portion of the shaft grounded.

The other end of the capacitor is provided with a large terminal that permits the use of a simple clamp or collet connector. This connector should be mounted flexibly to prevent undue mechanical strain being put on the capacitor seals. The connector must be kept clean and must at all times make a firm and positive contact with the capacitor terminal. Failure to maintain a low resistance contact to the capacitor terminal may result in excessive heating and permanent damage to the capacitor seals.

The multiple unit capacitor is designed so that it may be mounted readily on the chassis or from a panel. The mounting plate serves as one electrical connection and can be mounted directly at ground potential or insulated above ground.

The capacitors require normal circulation of air to keep the metal-to-glass seals below the maximum permissible temperature when carrying large values of current. In cases where the air flow is restricted or the ambient temperature is above room temperature a measurement of the seal temperature should be made. Adequate cooling must be provided to keep the metal of the metal-to-glass seals below 150° centigrade.

The low-torque tuning mechanism provides easy hand-operation of a dial directly on the shaft of either the single or multiple-unit capacitors. The capacity of type VVC vacuum condensers may be controlled by an electric tuning motor providing a minimum of two inch-pounds of torque per unit. The use of positive-action limit switches or a slip-coupling is recommended to avoid forcing the mechanism when it reaches the limit of its travel in either direction.

**VVC 60-20**  
**VARIABLE**  
**VACUUM**  
**CAPACITOR**

*Eimac*  
**EITEL-McCULLOUGH, INC.**  
 SAN BRUNO, CALIFORNIA

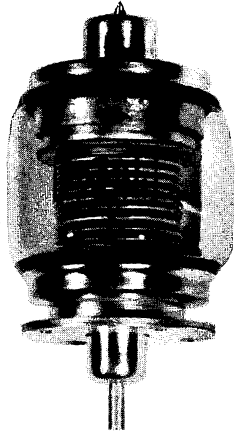

The VVC60-20 is a single unit variable vacuum capacitor.

**CHARACTERISTICS**

**ELECTRICAL**

Capacitance	
Maximum .....	60 mmfd
Minimum .....	10 mmfd
Number of revolutions (See Curve) .....	17 turns
Maximum Peak R.F. Voltage.....	20 kilovolts
Maximum Current (RMS).....	40 amperes
(See derating curve vs frequency)	
Temperature Coefficient.....	+ .004 mmfd/°C

**MECHANICAL**

Mounting .....	See Outline Drawing
Cooling .....	Air Convection
Maximum Seal Temperature.....	150°C.
Maximum Overall Dimensions	
Length .....	5-11/16"
Diameter .....	3- 1/16"
Net Weight .....	1 lb. 6 oz.
Shipping Weight (average) .....	2 lb.

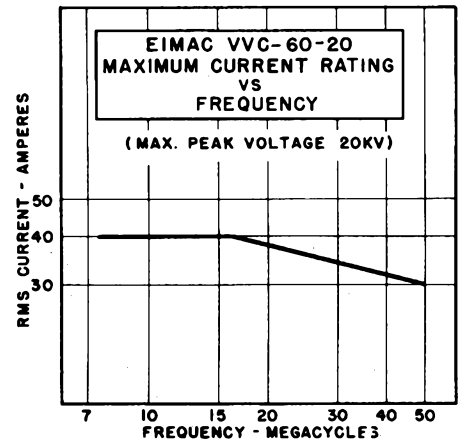
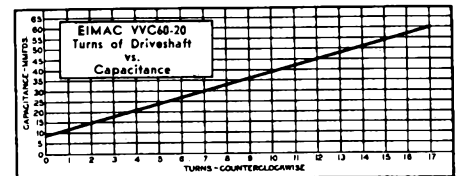
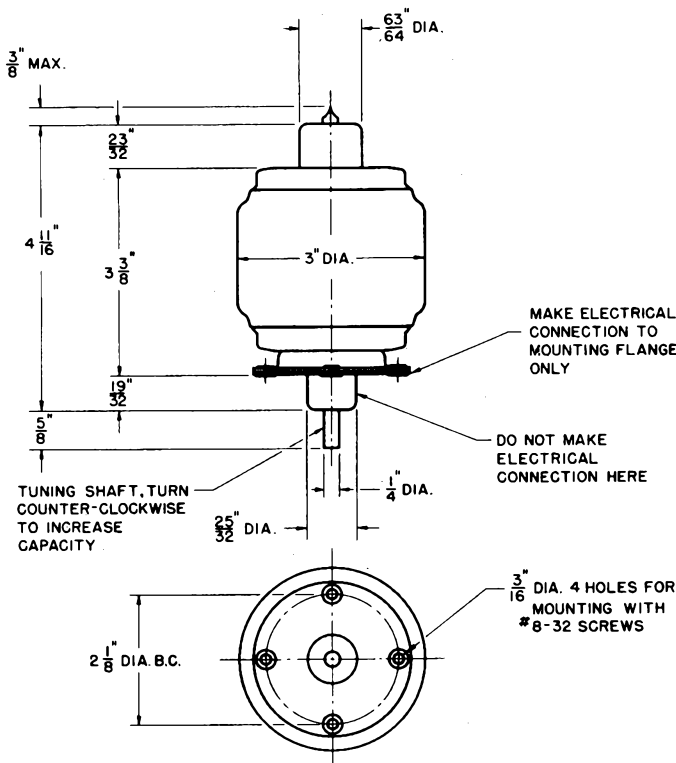

The VVC2-60-20 is a dual unit variable vacuum capacitor consisting of two VVC60-20 units in a convenient gang mounting.

**CHARACTERISTICS**

**ELECTRICAL**

	Parallel	Split Stator
Capacitance		
Maximum .....	120	30 mmfd
Minimum .....	20	5 mmfd
Number of revolutions (See Curves)	17	17 turns
Maximum Peak R.F. Voltage.....	20	40 kilovolts
Maximum Current (RMS) .....	80	40 amperes
(See derating vs frequency)		
Temperature Coefficient .....	+ .008	+ .002 mmfd/°C

**MECHANICAL**

Mounting .....	See Outline Drawing
Cooling .....	Air Convection
Maximum Seal Temperature.....	150°C
Maximum Overall Dimensions	
Depth .....	6-9/32"
Height .....	3-1/8"
Width .....	8-1/8"
Net Weight .....	4 lbs.
Shipping Weight (approx.).....	8 lbs.

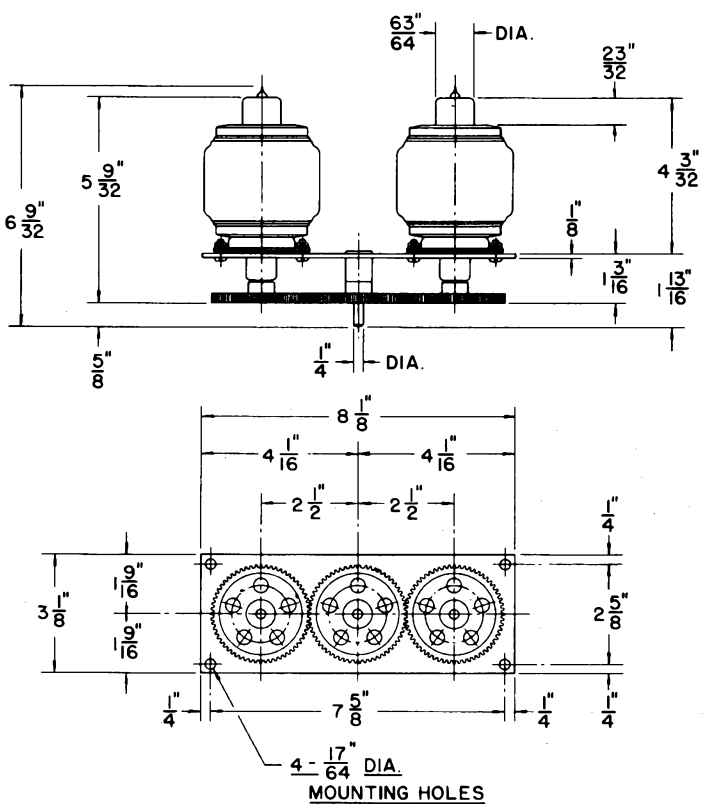
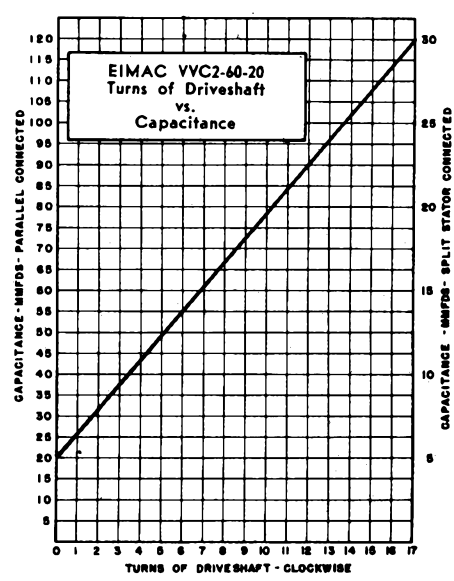
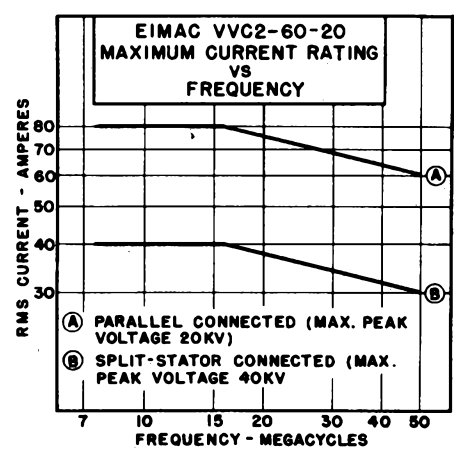
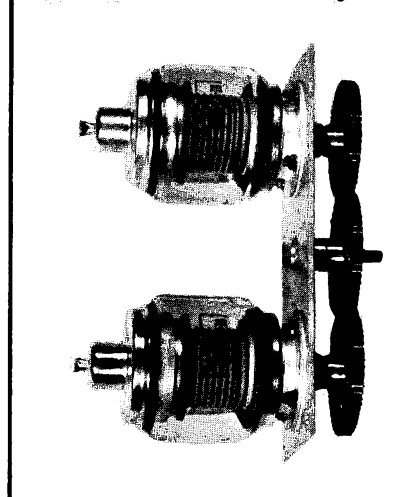



**VVC4-60-20**  
**VARIABLE**  
**VACUUM**  
**CAPACITOR**

*EIMAC*  
**EITEL-McCULLOUGH, INC.**  
 SAN BRUNO, CALIFORNIA

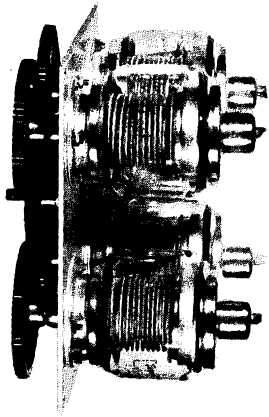

The VVC4-60-20 is a four unit variable vacuum capacitor consisting of four VVC60-20 units in a convenient gang mounting.

**CHARACTERISTICS**

**ELECTRICAL**

	Parallel	Split Stator	
Capacitance			
Maximum .....	240	60	mmfd
Minimum .....	40	10	mmfd
Number of revolutions (See Curves)	17	17	turns
Maximum Peak R.F. Voltage.....	20	40	kilovolts
Maximum Current (RMS).....	160	80	amperes
(See derating curve vs frequency)			
Temperature Coefficient .....	+0.016	+0.004	mmfd/°C

**MECHANICAL**

Mounting .....	See Outline Drawing
Cooling .....	Air Convection
Maximum Seal Temperature.....	150°C
Maximum Overall Dimensions	
Depth .....	6- 9/32"
Height .....	7-13/16"
Width .....	7-13/16"
Net Weight .....	8 lbs.
Shipping Weight (approx.) .....	14 lbs.

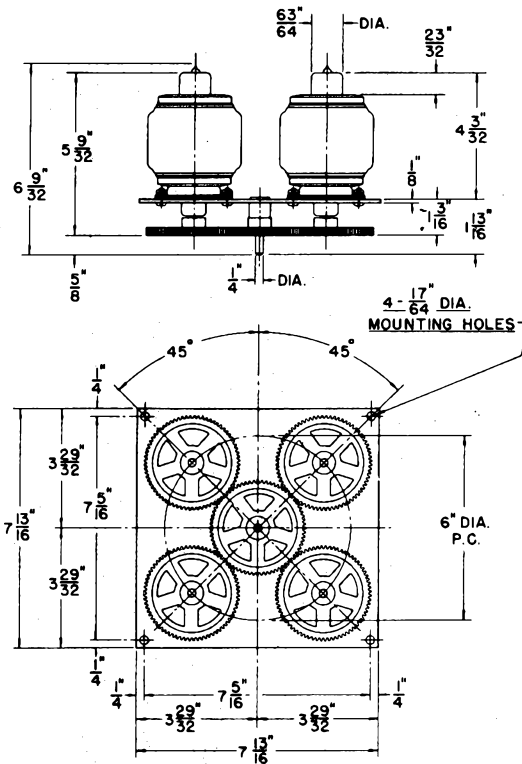
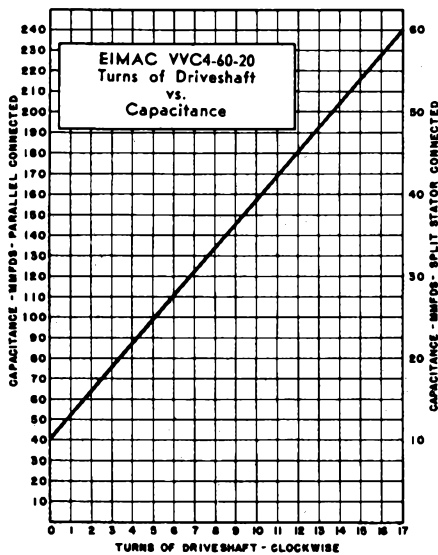
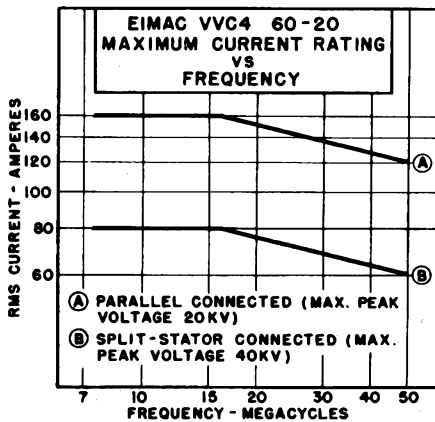

**EITEL-McCULLOUGH, INC.**  
 SAN BRUNO, CALIFORNIA



# HV-1 DIFFUSION PUMP

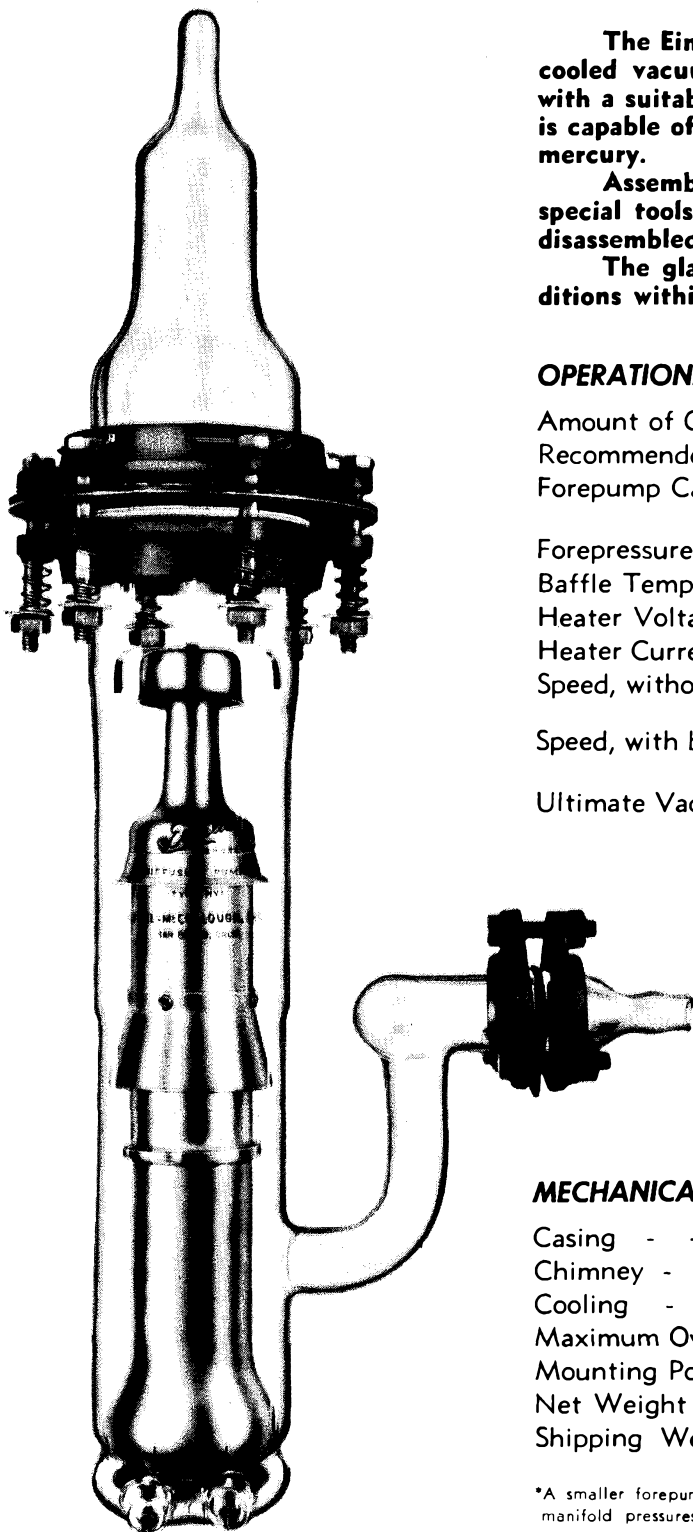

The Eimac HV-1 Diffusion Pump is a fast, triple-jet, air-cooled vacuum pump of the oil-diffusion type. When used with a suitable mechanical forepump and Eimac type A oil it is capable of reaching an ultimate vacuum of  $4 \times 10^{-7}$  mm of mercury.

Assembly of the pump is a simple operation, requiring no special tools or intricate adjustments. It can be completely disassembled for cleaning in five minutes or less.

The glass construction permits rapid inspection of conditions within the pump.

### OPERATIONAL DATA

Amount of Oil	- - - - -	150 milliliters
Recommended Oil	- - - - -	Eimac Diffusion Pump Oil, Type A
Forepump Capacity*	- - - - -	0.1 to 2.0 liters per second at 0.001 mm of mercury, or less
Forepressure (maximum)	- - - - -	0.02 mm of mercury
Baffle Temperature	- - - - -	35° C or lower
Heater Voltage	- - - - -	100 to 110 volts
Heater Current (at 110 volts)	- - - - -	1.7 amperes
Speed, without baffle (approx.)*	- - - - -	67 liters per second at $4 \times 10^{-4}$ to $4 \times 10^{-6}$ mm Hg
Speed, with baffle (approx.)*	- - - - -	32 liters per second at $4 \times 10^{-4}$ to $4 \times 10^{-6}$ mm Hg
Ultimate Vacuum, at 25° C (approx.)	- - - - -	$4 \times 10^{-7}$ mm Hg when using recommended oil.

### MECHANICAL DATA

Casing	- - - - -	Pyrex Glass
Chimney	- - - - -	3 Jet, Aluminum
Cooling	- - - - -	Air
Maximum Overall Dimensions	- - - - -	See Outline Drawing
Mounting Position	- - - - -	-Vertical, boiler down
Net Weight	- - - - -	6 pounds
Shipping Weight	- - - - -	18 pounds

\*A smaller forepump may be used, but this will reduce the pumping speed at the higher manifold pressures.

**OPERATION**

The principle upon which the oil-diffusion pump operates may be explained as follows. The drawing on page three illustrates the accepted theory. Gas to be removed from the high-vacuum system enters the pump at the top, whence it moves into the region of the upper jet. Emerging from this jet is a stream of oil vapor which is generated by the electrically-heated oil boiler at the bottom of the pump. Molecules of the unwanted gas diffuse into this stream of oil vapor and are carried down and out toward the cooler glass-wall of the pump. Upon reaching the glass-wall, the oil vapor condenses to a film of liquid oil which runs down the wall and returns to the boiler. The gas molecules are forced downward by the oil vapor and gas above them and come under the influence of the middle jet, where they are again forced down toward the bottom of the pump by a stream of oil vapor.

in the system are to be avoided wherever possible. A short length of small-bore tubing can cause a considerable reduction in pumping speed.

Pumping speed is also affected by the capabilities of the forepump. The forepump must be able to remove the gas from the system while maintaining the required low pressure at its end of the diffusion pump.

Increased pumping speed may be obtained by operating several HV-1 units in multiple. The number of units which may effectively be used in multiple will be determined by the ability of the forepump to produce the required forepressure, and the ability of the manifold and tubulations to handle the desired pumping speed.

The HV-1 is capable of reaching an ultimate vacuum of  $4 \times 10^{-7}$  mm of mercury. To reach this low pressure, however, it is essential to avoid any contaminant in the high-vacuum system. Water, even in small amounts, or

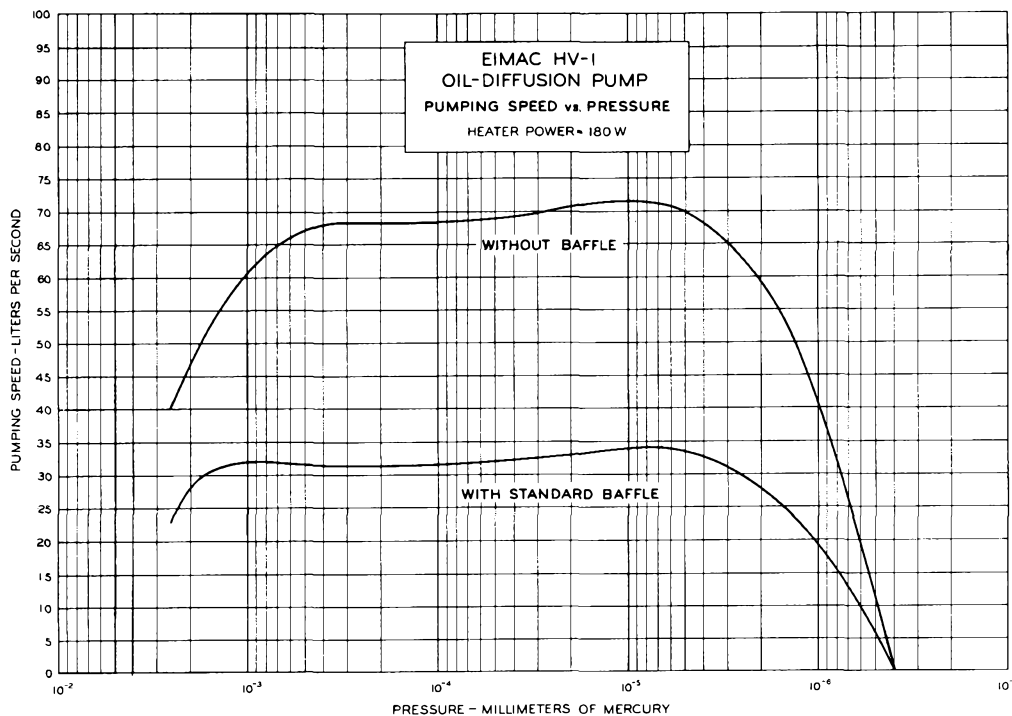

The curves at the left show the gas handling capabilities of the HV-1 over a range of pressures both with and without a baffle. These curves apply when a forepump with the required capacity is used. The rapid loss in pumping speed at the higher pressures is due to the inability of the forepump to handle the necessary volume of gas. With a larger forepump, the pumping speed would be maintained out to higher pressures.

The process of "packing" the molecules of gas down toward the bottom of the pump is again repeated at the bottom jet. During pumping, as the manifold pressure drops, the amount of oil issuing from the lower jet is sufficient to form a visible ring of oil on the wall of the pump at a point well below the bottom skirt. In this region the concentration of gas is great enough to raise the pressure to a point which will allow a mechanical forepump to effectively remove the gas from the system.

To prevent small amounts of oil vapor from finding their way back into the high-vacuum side of the system, a baffle is often employed between the diffusion pump and the high-vacuum system. In the HV-1 this baffle is a pair of aluminum discs which are kept relatively cool by the pump cooling fan. Oil vapor reaching the baffle condenses and is returned to the boiler. The baffle reduces the pumping speed by about one-half. If there are several bends in the high-vacuum manifold between the pump and the space to be evacuated, the baffle may be dispensed with, as the bends will serve to collect the oil vapor. However, the bends will also reduce the pumping speed. This is well illustrated in the curves. Constrictions

any hygroscopic matter should be carefully excluded. When so located as to be affected by heat, rubber is particularly objectionable, and a poor ultimate vacuum is likely to result if rubber gaskets are used in the diffusion pump. For this reason, Neoprene gaskets are supplied with the HV-1.

In systems employing stop-cocks, valves or gaskets, it is necessary that the stop-cock, valve or gasket lubricant have the minimum possible vapor pressure, because poor lubricants can easily destroy the high-vacuum capabilities of the pump.

**APPLICATION**

The HV-1 diffusion pump must be mounted securely, but not too rigidly. A satisfactory method of mounting consists of 1 X 1 X  $\frac{1}{8}$  inch angle shaped and drilled to pass four of the six spring loaded bolts used to join the large flanges at the top of the barrel (see illustration). When the desired manifold has been sealed to the manifold adapter (914 on outline drawing), the pump is prepared for operation (after cleaning thoroughly as specified under "CLEANING") in accordance with the following procedure:

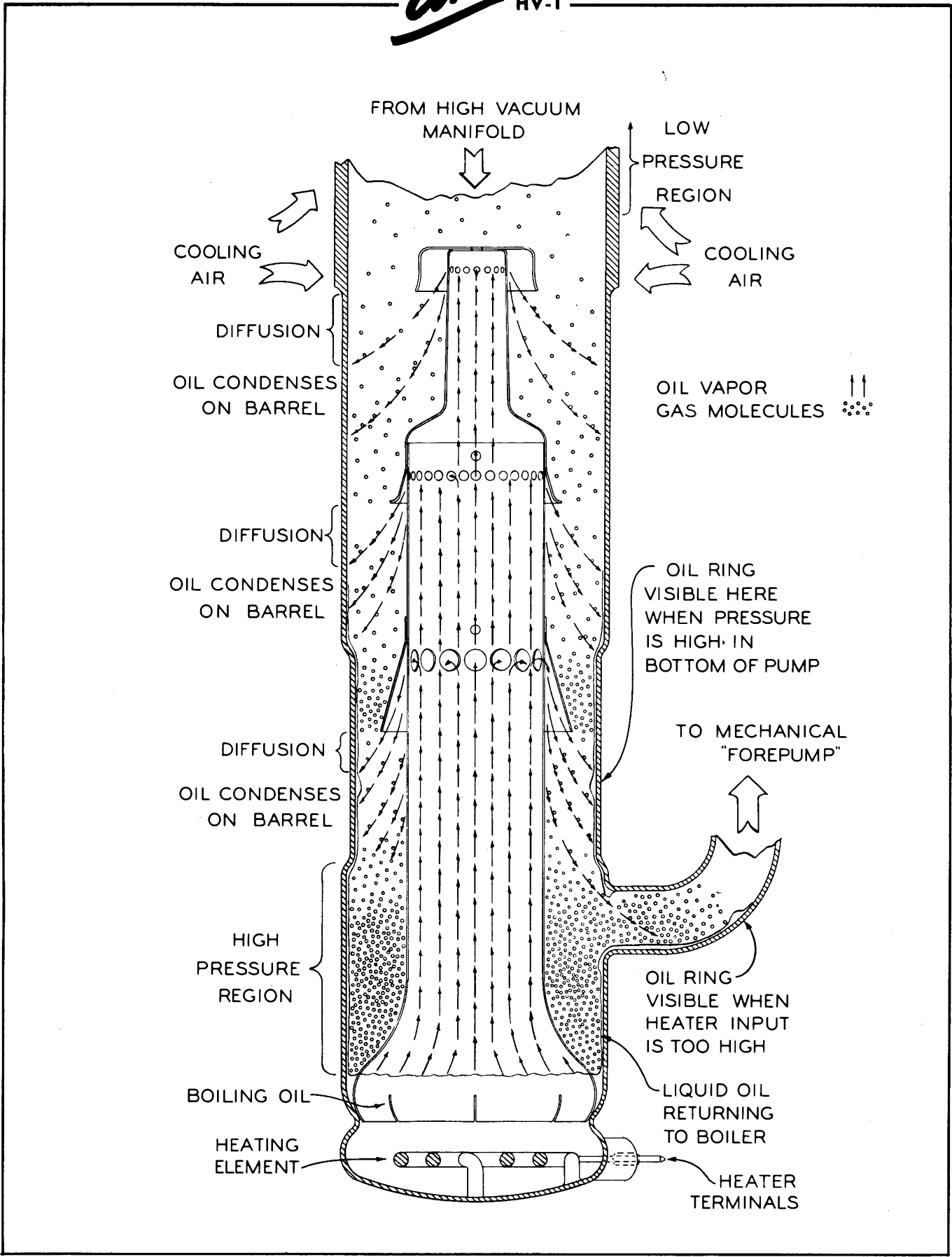

1. Pour 150 milliliters of Eimac Diffusion Pump Oil, Type A, into the pump barrel (917).
2. Insert the aluminum jet assembly (4911) into the pump barrel.
3. Assemble the pump carefully, moistening both sides of each gasket with pump oil, or with a thin layer of heavy-grade "Celvacene," or equivalent grease.
4. Install the pump in its mounting.  
**IMPORTANT: DO NOT START DIFFUSION PUMP HEATER UNTIL FOREPUMP IS IN OPERATION AND SYSTEM IS FREE OF LEAKS, TO AVOID PREMATURE HIGH TEMPERATURE AND DECOMPOSITION OF THE OIL.**
5. After making certain that the forepump is connected to the nipple (8911) through the suitable flexible coupling (vacuum-hose or vacuum type bellows), start the forepump motor. Check the manifold with a Tesla or other high-voltage, high-frequency spark coil for leaks **BEFORE CONTINUING.**

The Tesla coil, with a flexible wire probe may be used to indicate the presence of leaks above the baffle. It is also valuable in estimating pressure in the manifold during the early stages of evacuation. **CAUTION:** Too high a voltage may puncture the manifold at its weak points, i. e. where the glass may be very thin or at a seal-off tubulation. A rough indication for a suitable Tesla voltage is that which will produce a corona of about one-eighth inch on the end of a No. 14 B & S probe wire, visible in the dark only, and a stringy spark not over five-eighths inch to a grounded metal surface.

If the system is known to be free of leaks, the forepump and HV-1 may be started together. However, to protect the system and its oil, the manifold first should be checked with the Tesla coil, with the HV-1 "off." When the cold oil stops bubbling and the pink glow is seen to be diminishing at a normal rate, the system may be assumed to be reasonably tight and the HV-1 may be started.

6. Connect the oil heater terminals via a switch to the source of power. The oil heater voltage should be set to between 100 and 110 volts for best results. An adjustable resistor or an auto transformer of the tapped or continuously variable types is recommended. The current at 110 volts is approximately 1.7 amperes.
7. The baffle assembly and upper end of the pump barrel should be kept cool (35° C or lower) by a small fan or blower (see illustration).

**OIL**—Eimac Type A Diffusion Pump Oil is a special petroleum product carefully processed by Eitel-McCullough, Inc. to afford the high-vacuum desired in diffusion pump work. The ultimate vacuum attainable for Type-A oil is on the order of  $10^{-7}$  mm Hg. Its boiling-point at pressures on the order of  $10^{-2}$  mm Hg is 135° C.

One noteworthy property of this oil is that under normal conditions, no particles of condensed oil will be found deposited in the high-vacuum manifold. This lack of condensation is indicative of the absence of "light ends." Such products of distillation usually must be barred from the high vacuum system by the use of liquid air or charcoal traps which invariably reduce the speed of any system and require extensive maintenance.

**VACUUM GAGES**—To properly evaluate the vacuum conditions at the manifold, a sensitive gage in the desired range is necessary. There are many systems used for this purpose, the most sensitive in the high-vacuum spectrum being the Ionization (or Ion) gage. Its range of usefulness extends from approximately 5 microns to a region in the upper experimental vacuum limits on the order of  $10^{-8}$  microns ( $5 \times 10^{-3}$  to  $10^{-9}$  mm Hg). Recently, tubes and circuits have been developed which con-

tribute to the high stability of this instrument. The Eimac type 100-IG Ion Gage tube is designed to give the maximum internal leakage path, thus avoiding erratic readings due to possible contamination from the system.

**LEAKS**—If the system does not "clean-up" in a reasonable time, considering the nature and size of the manifold and connected chambers, a leak may be looked for by means of the Tesla coil. The probe should be run over the entire surface of the glass work involved. A "fast" leak will be indicated where sparks concentrate at a point on the glass and a pinkish glow takes place within the evacuated space.

Where a slow leak is suspected, before "bake-out" and where the vacuum is high but still not satisfactory, a solvent such as carbon tetrachloride may be applied to the manifold surface, but not to the Neoprene gaskets, with an atomizer, a wad of cotton or brush. If a leak is found, the Tesla voltage will cause a marked bluish glow while the solvent is entering the aperture, or the ion gage reading will indicate increased pressure.

After "bake-out" or when the manifold is too hot for the application of liquids, illuminating gas or hydrogen may be applied to the surface from an unlighted torch. Gas entering the hole will effect the ionization gage reading immediately. A very small leak may be found in this way. If there are no leaks, the manifold and pump assembly is ready for use<sup>2</sup>.

With the manifold at high vacuum, no ionization will be apparent from the effects of a Tesla probe held on the manifold (above the baffle). Below the baffle on the barrel of the HV-1 pump the probe will cause fluorescence of the oil vapors as well as a visible disturbance of the oil flow below the jets. The probe when touched to the HV-1 outlet will show a faint blue-violet glow. If these first two conditions are obtained, but a pinkish glow is present in the outlet, the mechanical pump and its coupling should be checked.

For new oil, or after an oil change, the pump will require about 24 hours of operation to condition the oil for optimum performance. Approximately 15 minutes heating time is required for the HV-1 to reach full efficiency from a cold start.

#### PRECAUTIONS

1—The vacuum system should not be opened "to air" when the diffusion pump is hot, to prevent oxidation of the pump oil. 2—If at any time a white vapor is visible in the HV-1, both pumps should be immediately shut off. The vapor is an indication of forepump failure or a very rapid leak. If the oil has become dark, the system may require complete cleaning. 3—Ground leads should be provided on both flange couplings to prevent the Tesla voltage from puncturing the Neoprene gaskets.

#### CLEANING

Diffusion pumps in continuous use should be cleaned at approximately one-month intervals. The materials and facilities required for cleaning are: Carbon tetrachloride and pentane (or acetone). An oven capable of temperatures up to 500° C will allow complete removal of carbonaceous deposits. The oven should be provided with an air inlet and outlet to allow the products of oxidation to be carried off. An accurate temperature control and indicator are advisable to prevent mishap to the glass parts. Where an oven is not available, steel wool, water and some abrasive cleanser such as diatomaceous earth

<sup>1</sup> "Bake-out" consists of surrounding the manifold and work to be evacuated with an oven. The temperature is then raised and held just under the annealing point for the "softest" glass being used in the system (approximately 500 degrees C for Pyrex). The temperature is maintained for thirty minutes to an hour, or at least until the new glass in the system shows no fluorescence on application of the Tesla voltage. This "cleans up" the glass-ware to a point where it will not normally release further gas. An accurate thermocouple type temperature indicator and heater control are advisable to prevent mishaps to the system during "bake-out."

<sup>2</sup> Contamination in the system such as decomposed oil, or a source of high vapor pressure in the load will give "virtual leaks" or unfavorable maximum vacuum readings.

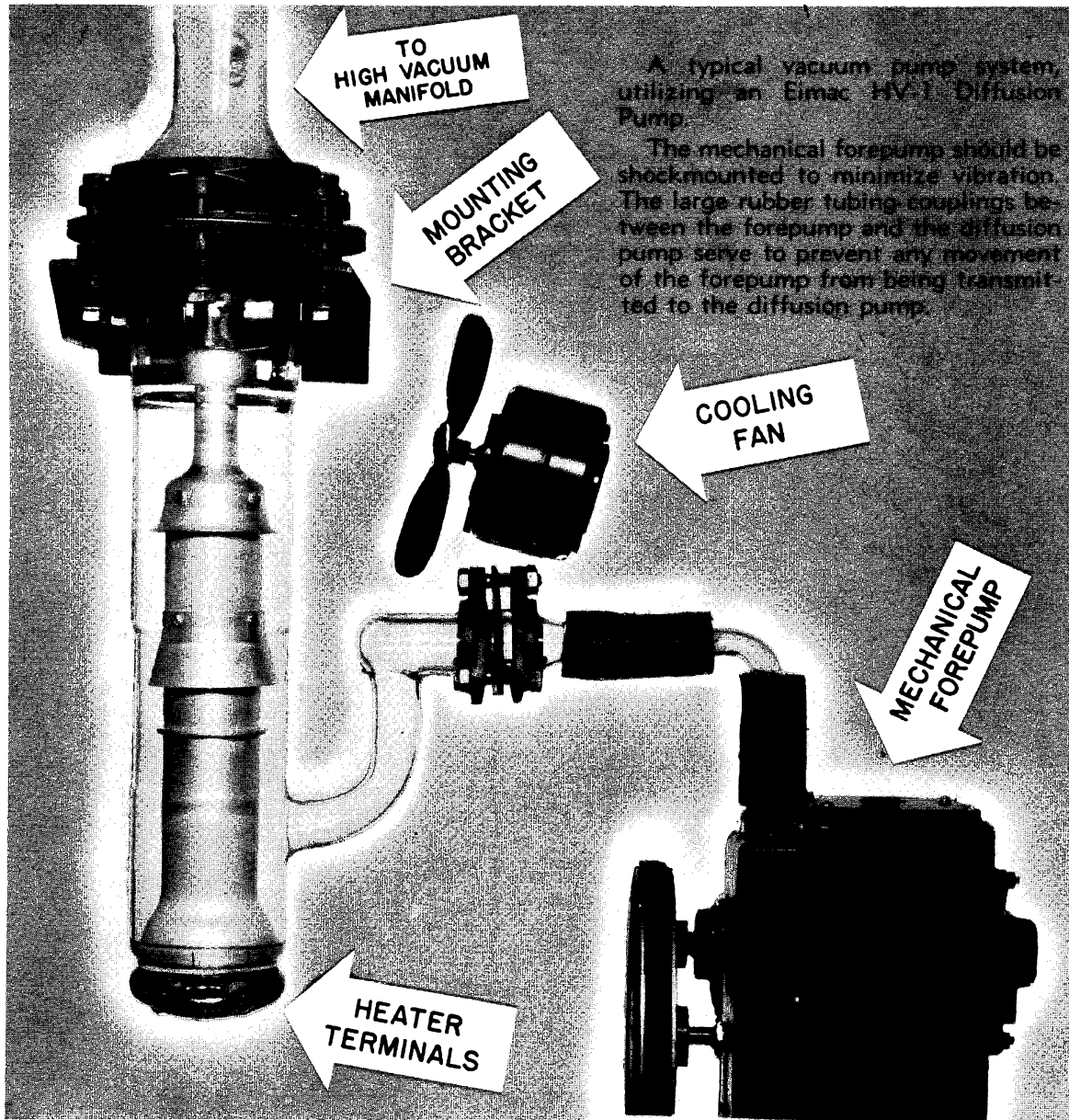

A typical vacuum pump system, utilizing an Eimac HV-1 Diffusion Pump.

The mechanical forepump should be shockmounted to minimize vibration. The large rubber tubing couplings between the forepump and the diffusion pump serve to prevent any movement of the forepump from being transmitted to the diffusion pump.

may be used. The procedure is given in the following paragraphs.

**GLASS HOUSING BARREL**—New housings should be given a rinse with a cup of pentane or acetone and then warm-air dried. (CAUTION: pentane and acetone are inflammable. Keep away from open flames.) Used, dirty housings should have the excess of oil fluid rinsed out with two or three flushings of about one cup (per rinse) of carbon tetrachloride. The last rinse may be saved for the first wash of the following pieces. To remove adhering carbonaceous matter after draining, the housing should be baked out in an oven up to 500° C. If the housing is not too caked, a rinse with pentane or acetone and gentle drying with warm air (in place of baking out in the oven) is sufficient.

**ALUMINUM JET ASSEMBLY**—The jet assembly may be cleaned at the same time that the glass housing barrel is cleaned by inserting the assembly into the glass housing, pouring in the rinse solution and closing the top opening with a stopper. Agitate the solution by tilting and shak-

ing the pump so that all parts are well washed over. Always remove the stopper and jet assembly after washing, prior to draining, baking or air drying. To further remove hard carbonaceous material, the assembly, less baffle, should be placed in an annealing oven and heated carefully to 475° C, then allowed to cool slowly in air.

**BAFFLE**—The baffle should be disassembled and all parts rinsed three times with pentane or acetone; the last two rinsings must be with clean solution. Follow with warm-air drying.

▶ **NEOPRENE GASKETS**—Wash the gaskets in pentane or alcohol, then dry in oven at 110° C for 30 minutes.

**GLASS MANIFOLDS**—Use the same procedure as for the glass housing barrel when feasible. However, usually washing with pure water and alcohol, followed by warm-air drying, may be sufficient because there is less formation of carbonaceous matter here than in the case of the pump housing.

▶ Indicates change from sheet dated 6-1-50.

**EIMAC HV-1 DIFFUSION PUMP**

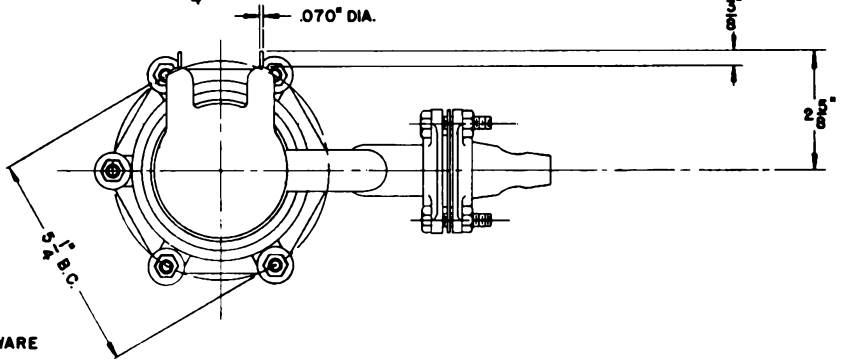
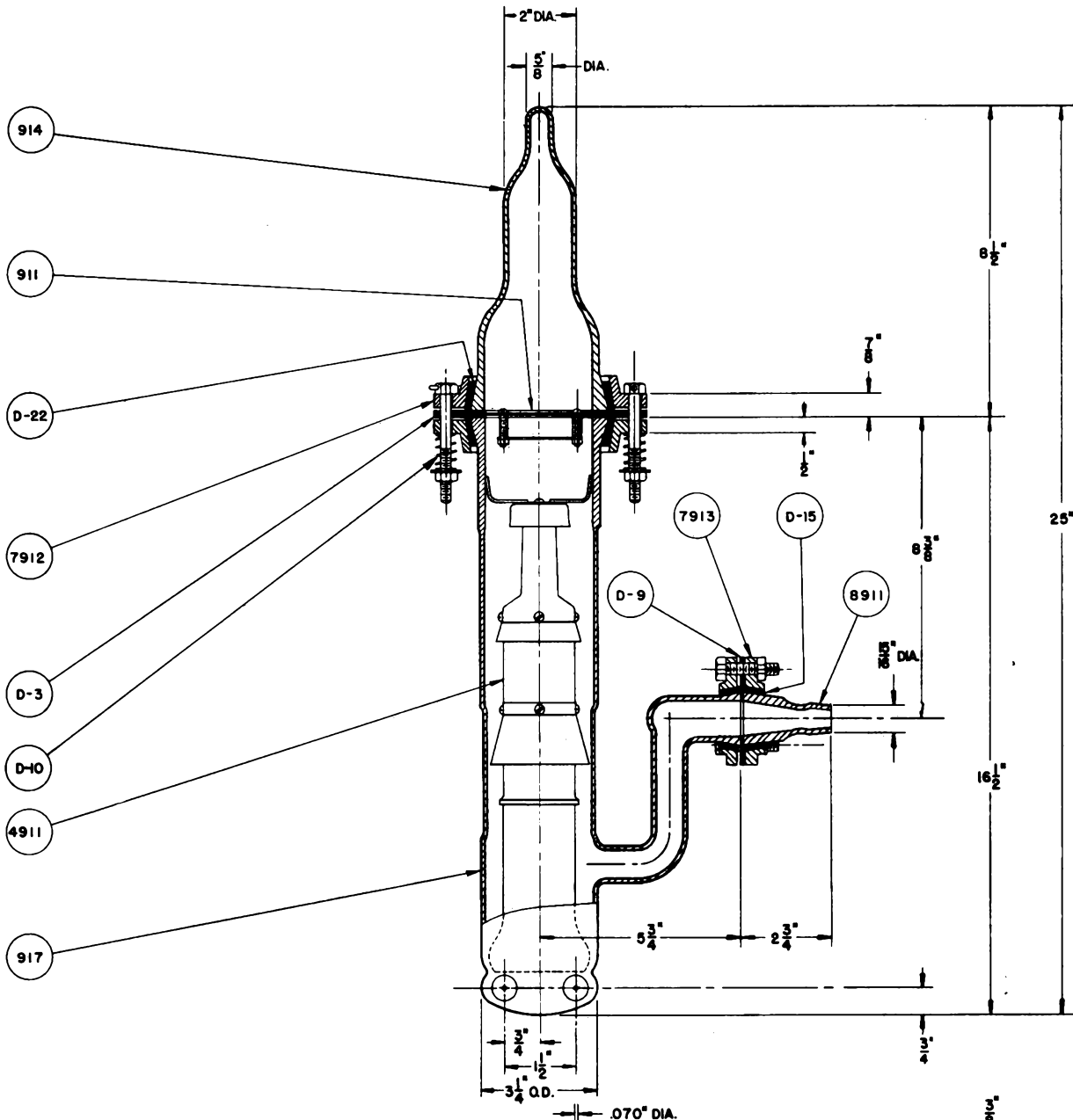

PART NO.	NO REQ'D	ITEM
D-3	2	NEOPRENE GASKET- 3" COUPLING
D-9	1	NEOPRENE GASKET- 1" COUPLING
D-10	6	SPRINGS
D-15	2	1" INSERT
D-22	2	3" INSERT
911	1	BAFFLE ASSEMBLY
914	1	MANIFOLD ADAPTOR
917	1	PUMP BARREL ASSEMBLY
4911	1	JET ASSEMBLY
7912	1	3" METAL FLANGE ASSEMBLY *
7913	1	1" METAL FLANGE ASSEMBLY *
8911	1	FORE-VAC NIPPLE

\* EACH FLANGE ASSEMBLY INCLUDES NECESSARY FLANGES, GASKETS, INSERTS, BOLTS AND HARDWARE

*Eimac*  
**EITEL-McCULLOUGH, INC.**  
 SAN BRUNO, CALIFORNIA

**100 IG**  
 IONIZATION  
 GAUGE  
 TRIODE

The Eimac 100 IG ionization gauge is designed for use in high vacuum exhaust systems, and will measure pressures from approximately  $10^{-3}$  millimeters of mercury to less than  $10^{-8}$  millimeters of mercury. The Nonex glass envelope can be sealed directly to exhaust systems employing Nonex or Kovar-sealing glass and can be sealed to Pyrex by means of a graded seal.

The 100 IG is a triode vacuum tube consisting of a pure tungsten filament and molybdenum grid and plate. No insulators are used within the tube, and the envelope is designed to provide long leakage paths between the plate and other tube elements.

Positive ion current indications are obtained with either a sensitive galvanometer or a vacuum tube amplifier. A typical circuit employing an Eimac 100 IG ionization gauge triode and a vacuum tube voltmeter is shown below.

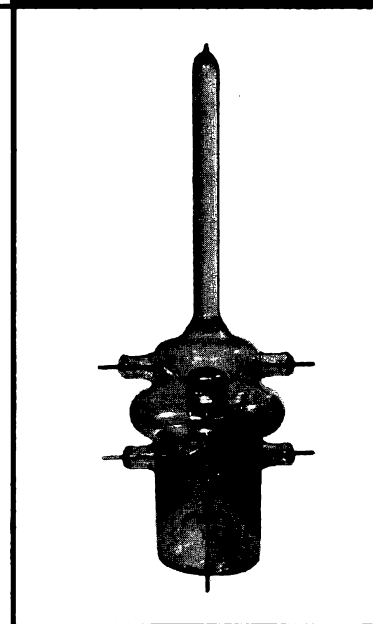
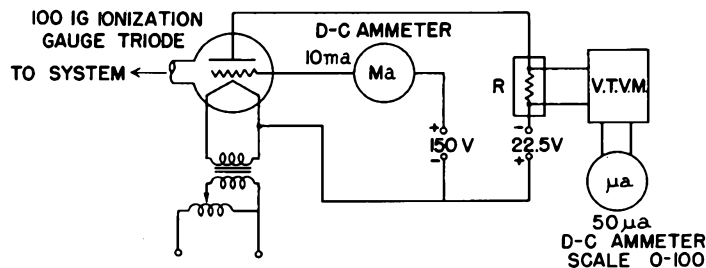

The filament temperature of the 100 IG must be low enough so that the emission is temperature-limited. With a good vacuum, the filament voltage will be between 2.0 and 4.0 volts, and the filament current will be approximately 8.0 amperes. With a poor vacuum, it will be necessary to increase the filament voltage to approximately 7.5 volts, and the current will be about 12 amperes. (The tube should not be operated long at high filament voltage.)

**CAUTION:** Filament voltage should not be applied until vacuum has been obtained as indicated by a spark coil glow test.

If grid voltage is obtained from a rectified a-c power supply and if the line voltage is not stable, it will be desirable to employ a gaseous regulator tube. A positive voltage of 150 volts with respect to the filament and current of 5 milliamperes is standard for the 100 IG.

The recommended plate voltage is -22.5 volts with respect to the filament. A plate voltage from -20 to -45 volts will give satisfactory operation, but plate voltages of 0 to -20 volts will result in low and incorrect plate currents.

In order to fully realize the capabilities of the 100 IG, it will be necessary to make "R" in the above figure variable. One circuit that has been employed with success is a group of 6 resistors and a rotary switch arranged so that only one resistor is across the input to the vacuum tube voltmeter at a time. By selecting resistors that increase by a factor of 10, the 0-100 scale microammeter will change calibration by the same factor, and will be convenient to read. With resistance values of 500, 5K, 50K, 500K, 5 megohms and 50 megohms, the maximum (full scale meter deflection) input voltage to the vacuum tube voltmeter will be  $\frac{1}{2}$  volt.

The calibration of the gauge depends upon the composition of the gas in the system. For dry air the pressure is given by the following formula:

$$\text{Pressure (mm. of Hg)} = I_p (3.3 \times 10^{-5})$$

where  $I_p$  . . . . . = Plate current in microamperes  
 when Grid Voltage . . . = +150 volts  
 Grid Current . . . . . = .005 amperes  
 Plate Voltage . . . . . = -22.5 volts

A bake-out of the tube at 450° Centigrade and outgassing of the tube elements is necessary whenever the exhaust system has been opened to air or the elements need cleaning. Outgassing is accomplished by heating the grid and plate to a dull cherry red by either r-f induction or by direct electron bombardment. Recommended outgassing voltages for the 100 IG are as follows:

Filament Outgassing Voltage (approximately)	8 volts
Plate Outgassing Voltage	800 volts
Plate Outgassing Current	120 ma

The grid and a 1000 ohm resistor is placed in series with the plate during outgassing. The recommended outgassing time is approximately five minutes, or until the pressure in the exhaust system has become stabilized.



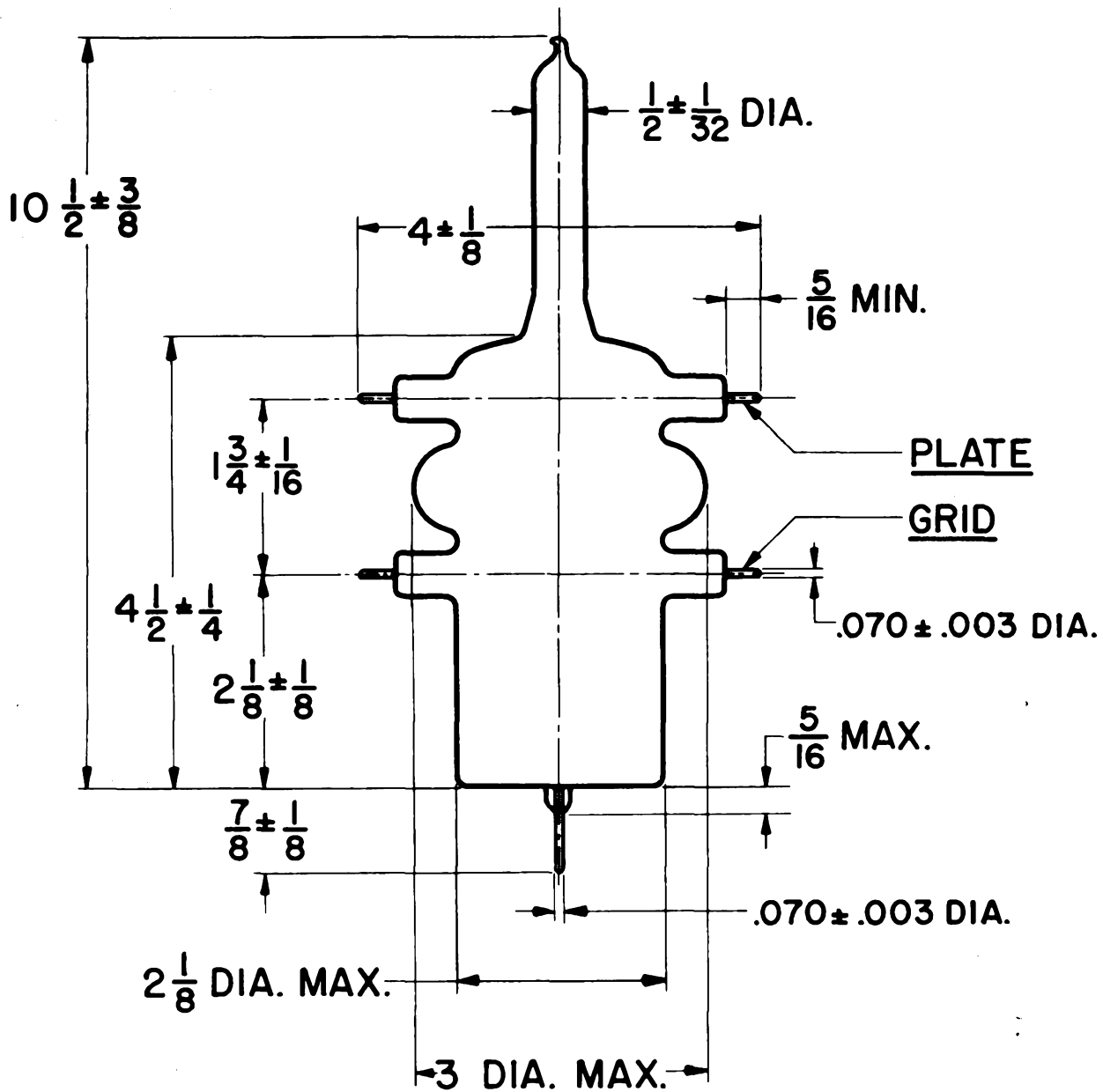

**DIMENSIONS**  
**IN INCHES**

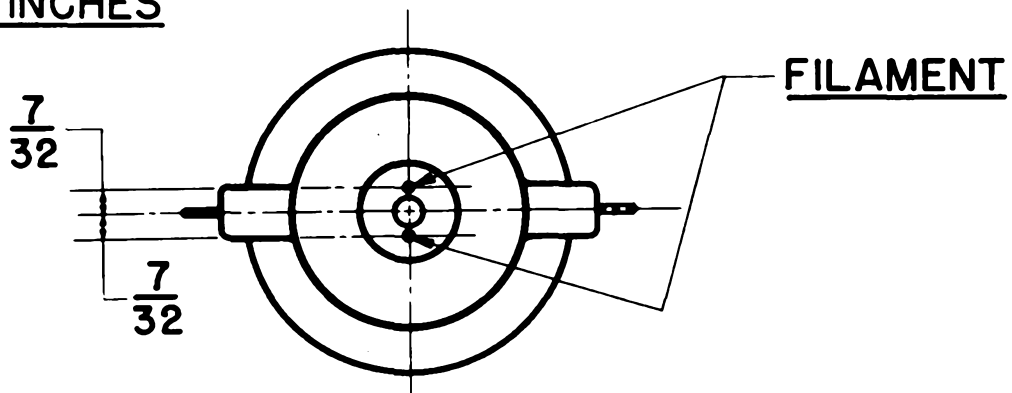

## PREFORMED CONTACT FINGER STOCK

► Eimac Preformed Contact Finger Stock is a prepared strip of spring material slotted and formed into a series of fingers designed to make sliding contact.

Eimac Finger Stock is an excellent means of providing good circuit continuity when using components with adjustable or moving contact surfaces. It is especially suitable for making connections to tubes with coaxial terminals, or to moving parts, such as long-line and cavity type circuits; and it is also useful in acting as an electrical "weather-strip" around access doors to equipment cabinets.

The material is a heat treated alloy; and is silver plated for better r-f conductivity. No further forming of the material should be attempted. Eimac Finished Finger Stock has a minimum radii of curvature of  $\frac{1}{2}$ " for the 17/32" type, and  $\frac{3}{4}$ " for both the 31/32" and 1 - 7/16" types. It may be secured by any suitable mechanical means or by soft soldering.

Eimac Finger Stock can be obtained to order in a raw state (punched, formed, unplated and not heat treated). The Raw Finger Stock can be formed to different shapes by the user but it then must be carefully heat treated. Finished Finger Stock receives a closely controlled and uniform heat treatment as follows: 375°-385°C. for 5 hours in a neutral gas atmosphere. No special cooling considerations are necessary, except those required to avoid oxidation. Eitel-McCullough will not undertake to heat treat or plate Raw Finger Stock after being further formed by a customer. For further information concerning the heat treatment of the Finger Stock material, Alloy No. 720, write the supplier of the material:

General Plate Division  
 Metals and Control Corporation  
 Attleboro, Massachusetts

Standard lengths of either Raw or Finished Finger Stock are 1 foot, 2 feet and 3 (maximum) feet. Some small variation about the standard lengths should be expected.

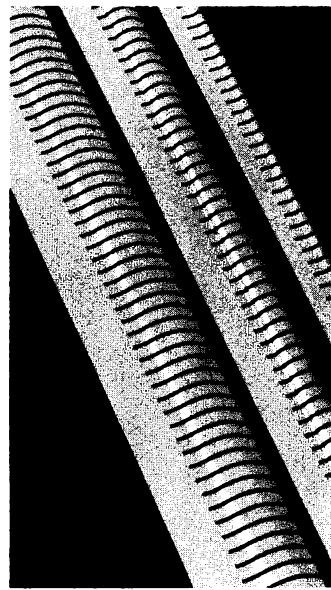

Eimac Tubes and Contact Surfaces for which Finger Stock is especially suitable.	PLATE	GRID	SCREEN GRID	CATHODE
<b>3W10,000A3</b>	1 - 7/16	31/32		17/32
<b>3W5000A3</b>	1 - 7/16	17/32		
<b>3W5000F3</b>	1 - 7/16	17/32		
<b>3X3000A1</b>	1 - 7/16	17/32		
<b>3X3000F1</b>	1 - 7/16			
<b>3X2500A3</b>	1 - 7/16	17/32		
<b>3X2500F3</b>	1 - 7/16			
<b>4X500A</b>	31/32		31/32	
<b>4X500F</b>	31/32			
<b>4X150A</b>	17/32		17/32	
<b>4X150D</b>	17/32		17/32	
<b>4X150G</b>	17/32		17/32	
<b>2C39A</b>	17/32			

► Indicates change from sheet dated 9-15-51.

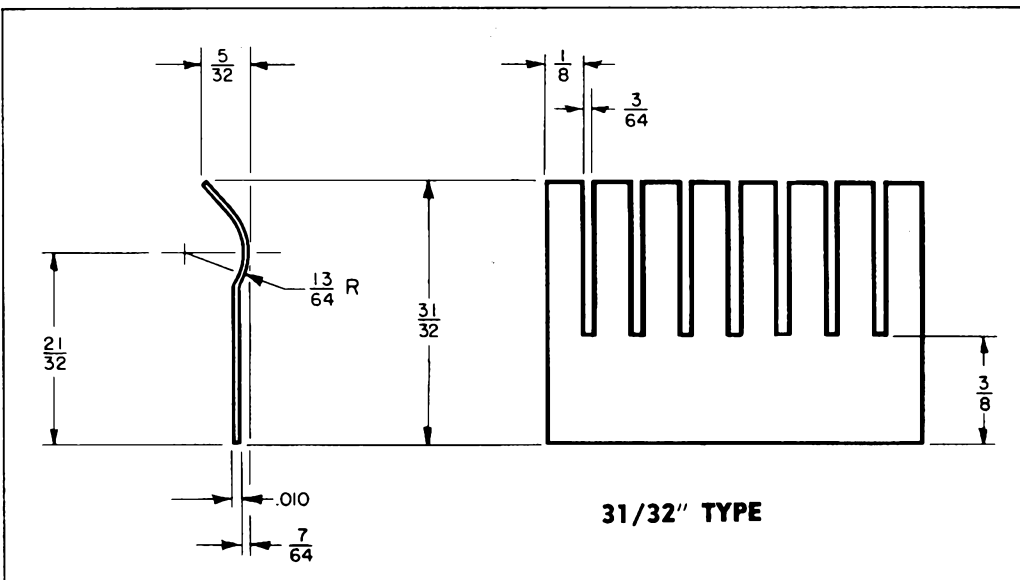
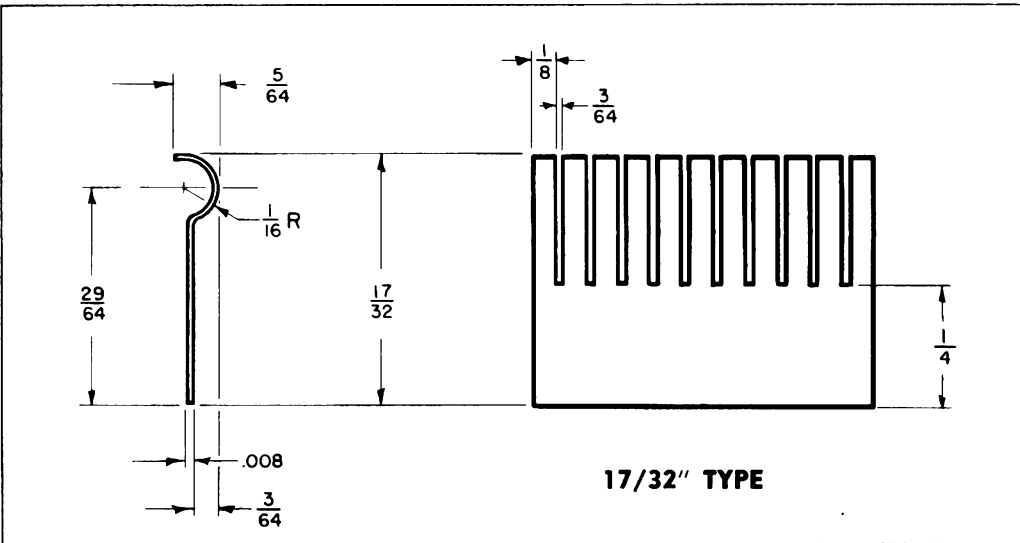
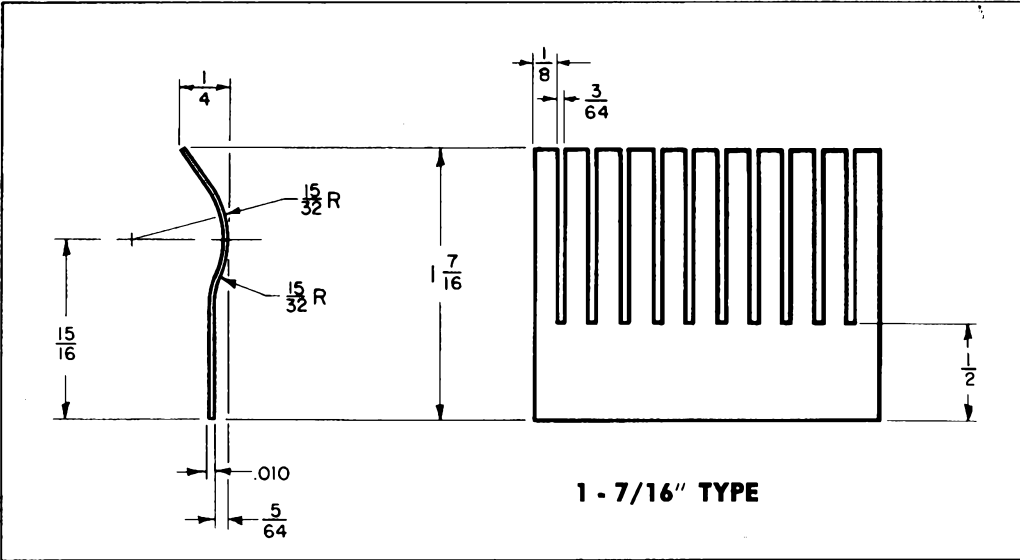

NOTE—The above dimensions should be regarded as carrying normal manufacturing tolerances because of variations in the shearing, forming and heat-treating processes.