

Mercury



TUBE TESTER

INSTRUCTION MANUAL

MODEL 1100B

MERCURY
ELECTRONICS CORP.

manufacturers of quality electronic products

TABLE OF CONTENTS

<i>Item</i>	<i>Page Number</i>
Introduction	3
The Panel and Controls	3
Test Procedure	4
A. Preliminary	4
B. Regular Shorts Test – Cathode Shorts	4
C. Additional Shorts Tests – Screen Shorts	5
D. Quality Test.....	6
Service Notes	7
A. Sample Tests.....	7
B. General Rules.....	8
C. Troubleshooting Hints.....	9
Parts List.....	10
Circuit Diagram.....	11

MERCURY ELECTRONICS CORP.
MINEOLA, NEW YORK

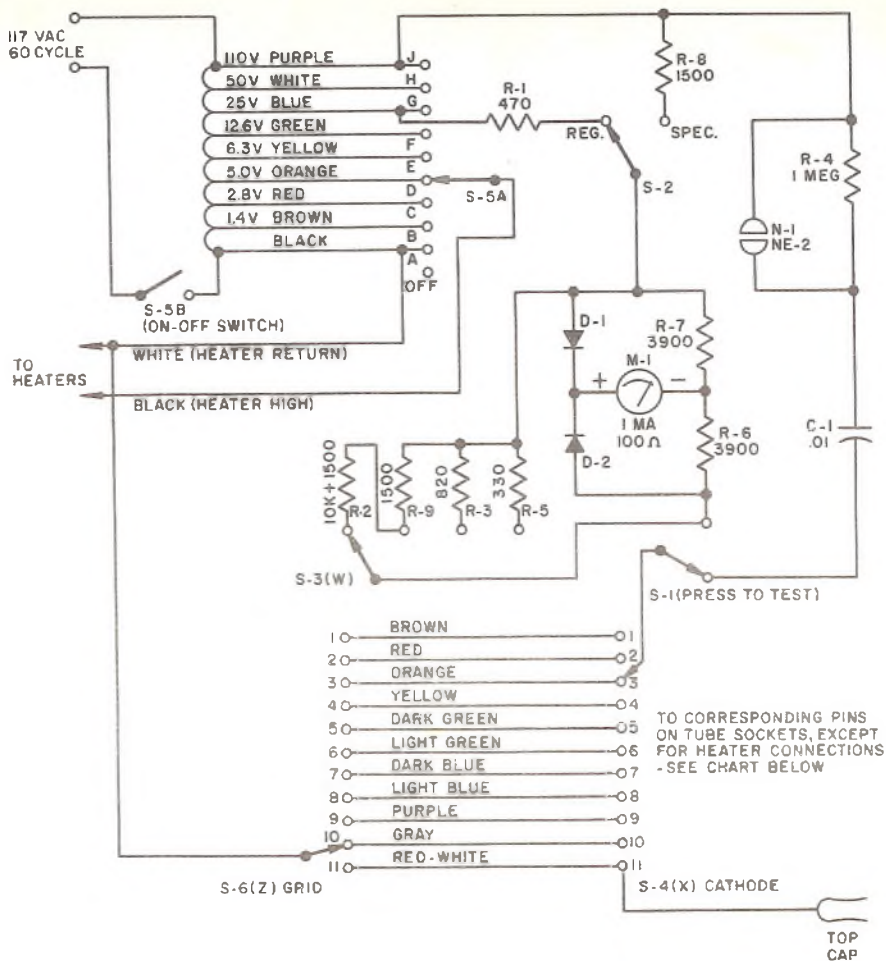

HEATER CONNECTION CHART

SOCKET NO.	1	2	3	4	5	6	7	8	9	10	11	12	13
HIGH PIN NO.	5	2	5	7	8	8	3	8	12	12	5	4	7
RETURN PIN NO.	4	1	4	2	7	2	1	1	1	10	4	3	1

SCHEMATIC - MODEL 1100A TUBE TESTER

MODEL 1100A
REPLACEMENT PARTS LIST

Description	Part No.	Price
1 Meg Ohm Resistor ½w, 10%	1-0-45	\$.05
10 K Ohm Resistor, ½w, 10%	1-0-33	.05
3.9 K Ohm Resistor, ½w, 10%	1-0-20	.05
1.5 K Ohm Resistor, ½w, 10%	1-0-40	.05
820 Ohm Resistor, ½w, 10%	1-0-41	.05
470 Ohm Resistor, ½w, 10%	1-0-10	.05
330 Ohm Resistor, ½w, 10%	1-0-49	.05
.01 Mfd. 600V. Capacitor	3-1-18	.15
Power Transformer	10-1-9	2.67
Meter Rectifier	18-1-1	.41
Meter	11-1-20	5.25
SPDT Slide Switch	6-1-1	.13
SPDT Spring Return	6-1-2	.23
4 Position Slide Switch	6-1-7	.38
1 Pole 12 Position Rotary Switch	6-2-27	1.26
2 Pole 10 Position Rotary Switch	6-2-28	1.17
Knob	15-1-14A	.11
Line Cord	22-1-3	.39
Grid Clip	27-1-3	.23
NE-2 Neon Lamp	17-1-2	.17
Case and Cover	14-2-13	5.04
7 Pin Straightener	8-2-4	.06
9 Pin Straightener	8-2-3	.06
Jewel, Clear	16-1-11C	.04

INTRODUCTION

The Model 1100A is a compact, ultra-modern tube tester designed for maximum performance in high-speed testing of practically all tube types used in radio, television, high-fidelity, and industrial equipment.

The Model 1100A uses the time-proven principle of Dynamic Cathode Emission for Quality test. Shorts and leakage between any internal elements are shown by the panel indicator lamp. All sections of multi-section tubes are tested separately.

Circuitry is designed for simple and safe testing of all tubes. When following proper test procedure, it is impossible to burn out a tube in the Model 1100A. Tubes listed on the Tube Chart include a complete coverage of Hi Fi, industrial and foreign types.

THE PANEL AND CONTROLS

1. SOCKETS

There are thirteen sockets in Model 1100A which provide all heater pin arrangements in use today. Socket types include the 7-pin, 9-pin and 10-pin miniatures, plus Octal, Loctal, Nuvistor, Novar and Compactron 12-pin.

2. METER

The 3½ inch meter has a 3-color GOOD-WEAK-BAD scale for tube quality testing. A diode test line shows diode QUALITY to be good for all meter readings over the start of this line.

3. SPEC.-REG. SWITCH (Special-Regular)

This slide switch is always left in the REG. (lower) position unless the symbol (S) appears in the column W of the tube chart, in which case the switch is moved up to SPEC. position.

4. ROTARY SWITCHES X, Y and Z

Switch X is a 12-position switch that connects the proper pin element to the meter.

Switch Z is a 12-position switch that connects the proper pin element to the return circuit.

Switch Y is a 10-position heater switch, and also serves as the main power switch.

5. SWITCH W

This switch has four positions which provide the proper limiting resistance for the QUALITY test.

6. "PRESS FOR QUALITY" SWITCH

This is a spring-return slide switch normally in the upper position for SHORTS test. It is used only to get QUALITY readings on the meter.

7. SHORTS-GRID LEAKAGE INDICATOR

This clear-view neon indicator shows a short or leakage of any type between any two pins of a tube. It is sensitive to 2 megohms.

8. Pin Straighteners are provided for miniature 7-pin and 9-pin tubes.

TEST PROCEDURE

A. Preliminary

1. Be sure to set controls before inserting the tube in its socket. In this way, damage will be avoided due to excessive heater voltage being applied to the tube.
2. Check for SHORTS and LEAKAGE before testing for QUALITY. Do not test a tube for QUALITY if the SHORTS-GRID LEAKAGE indicator glows when the tube is inserted in its socket, or else damage to the tube or tube tester circuitry may result.

B. Regular Shorts Test - Cathode Shorts

1. Plug the line cord into the power line. Power is turned on when you advance switch Y from the OFF position.
2. Set controls X, Y, Z, and W, as directed on the Tube Chart alongside the listing of the tube you wish to test. If this tube is listed more than once, the test must be performed again for each additional listing. This provides a test of each section in multi-section tubes.
3. The slide switch marked SPEC.-REG. should always remain at the REG (lower) position, unless the symbol (S) appears in column W of your Tube Chart. Where (S) appears, use the SPEC. (upper) position of this switch.

C. Trouble Shooting Hints

No meter movement on QUALITY tests -

1. Controls X or Z set wrong
2. No line power
3. Defective meter
4. Defective meter rectifier
5. Current limiting resistor burned open (try another position of switch W)

Meter goes off scale -

1. Controls X or Z set wrong
2. Tube under test is shorted
3. Switch W set wrong

Continuous Short Indication

1. Controls X and Z at same setting
2. Shorted .01 mfd. condenser

General Information

1. The Model 1100A is an unusually trouble-free and reliable circuit. With proper use it will never overheat, burn out, damage tubes under test or give misleading test results.
2. The panel is insulated, and has no shock hazard.

Diode Test, type 1B3

1. See listing in Tube Chart
2. Set X at position 11
3. Set Y at position B
4. Set Z at position 12
5. Set W at position B, noting symbol (S) at this listing
6. Set SPEC.-REG. switch at SPEC.
7. Plug tube into socket 4, connect top cap
8. Observe SHORTS-GRID LEAKAGE indicator
9. If no shorts are indicated, press QUALITY switch, and read tube QUALITY on meter – any reading over the start of the "DIODES O.K." line means tube QUALITY is good.
10. Release QUALITY switch and return SPEC.-REG. switch to REG. Note that the G-2 SHORT column is blank because type 1B3 has no screen.

B. General Rules

1. If a tube element is connected to two or more base pins, any one of these pins may be used to contact that element.
Example: 6CZ5 G-1 may be contacted at either pin 3 or pin 6.
2. Do not leave both X and Z at the same setting, or you will automatically get a dead SHORT indication. As long as QUALITY switch is not pressed, a short indication will do no damage.
3. If you press the QUALITY switch when the indicator shows a short, you may damage the meter or rectifier in the tube tester, as a result of excessive current flow.

4. Plug the tube into the designated socket and allow ten seconds for warm-up.
5. Observe the neon indicator. Any glow shows that there is a SHORT or LEAKAGE between cathode and heater or between cathode and grid.

C. Additional Shorts Tests

This section shows how to find rare types of SHORTS. You will seldom need to use this procedure, unless you suspect that the tube malfunctioning is due to a rare type of SHORT.

1. By using switches X and Z, a short between any two elements in a tube can be found, as follows:
2. Use base diagram of tube as given in popular handbooks available free or at nominal cost from any tube jobber.
3. Set switch X to the number corresponding to one of the base pins to be tested.
4. Set switch Z to the number corresponding to the other base pin to be tested.
5. Observe SHORT-GRID LEAKAGE indicator. If glow occurs, there is a SHORT or LEAKAGE between the two base pins being tested.
6. EXAMPLE - to check for a SHORT between plate and screen of type 6BQ6, set X at position 4 (pin 4 is screen), and set Z at position 11 (plate of 6BQ6 is top cap, which is position 11 of this switch)
7. EXAMPLE - to find a short between plate and control grid of triode 6AB4: the base diagram shows Plate (P) is pin 1, and control grid (G-1) is pin 6. Setting X to 1 and Z to 6 will catch any short between these two elements.

Screen (G-2 Short) Test

- 1 Refer to the Tube Chart column labeled G-2-SHORT.
2. Move the designated switch (either X or Z) to the position given in that column.
3. Any glow in the SHORTS indicator means G_1 is shorted to G_2 and the tube should be replaced.

D. Quality Test

- 1 If tube showed a short in preceding test, do not test for quality, or damage to tube or tester might result. The tube is bad and should be replaced.
- 2 If tube shows n shorts, press the QUALITY test slide switch and read tube QUALITY on meter.
3. Tubes have good QUALITY if meter pointer comes to rest anywhere in the green area of the 3 color meter scale. If tube is a diode, it will have "*" written next to its listing on the tube chart. Any QUALITY reading above the start of the "DIODES O.K." line means the diode is good. The diode line starts at 25 on the numerical meter scale.
4. If more than one listing of a tube appears on the tube chart, it is a multi-section tube and a test must be made separately for each section.
5. The tube test is now completed except for a screen (G-2 Short) test that may be desired. This test is described in the following steps:

SERVICE NOTES

Sample Tests

Pentode type 6AC7

1. See listing in Tube Chart
2. Set X at position 5
3. Set Y at position E
4. Set Z at position 4
5. Set W at position A

NOTE: Since there is no symbol (S) next to this listing, the SPEC.-REG. switch must be at REG. position.

6. Plug tube into socket 4
7. Observe SHORTS-GRID LEAKAGE indicator
8. If no shorts are indicated, press QUALITY switch and read tube quality on meter.
9. Release QUALITY switch. Refer to G-2 SHORT listing on Tube Chart, and move switch X to position 6. If indicator glows, tube has G 1 to G-2 short.

Directly heated cathode type 1R5

1. See listing in Tube Chart.
2. Set X at position 4
3. Set Y at position B
4. Set Z at position 12
5. Set W at position B
(SPEC.-REG. Switch remains at REG.)
6. Plug tube into socket 13
7. Observe SHORTS-GRID LEAKAGE indicator.
8. If no SHORTS are indicated, press QUALITY switch, and read tube QUALITY on meter.
9. Release QUALITY switch. Refer to G-2 SHORT listing on Tube Chart, and move switch Z to position 3. If indicator glows, tube has a G-1 - G-2 short.