

THORDARSON



EST. 1957
BY 1968

No. 114

SEATTLE BUSINESS GUIDE



Pioneers — Forty Years of Transformer Manufacturing

THE THORDARSON Electric Manufacturing Company built transformers long before they were applied to radio transmission and reception. The early "spark" transmitters depended upon THORDARSON high voltage transformers to produce the roaring, crackling discharge which characterized early radio transmission.

WITH the development of vacuum tubes, THORDARSON devised audio coupling transformers. The early receiver manufacturers such as Kennedy, Zenith, Silver-Marshall, and others used THORDARSON Transformers in their sets.

THE first entirely A. C. operated receivers using Type 112 tubes employed THORDARSON Transformers.

WITH the development of the heater type tubes THORDARSON made the power equipment, B eliminator chokes, and audio transformers.

TODAY THORDARSON Transformers and Chokes are found in the finest quality radio receivers and in the best custom-built public address systems. THORDARSON make all the parts, except the wire, from raw material in one plant. Features which have characterized THORDARSON products are uniform quality, which has never been sacrificed for any reason; conservative rating, which has insured long, satisfactory service; and a special process of transformer impregnation, which withstands the most severe conditions of climate, humidity, and salt sea air.

THORDARSON is particularly proud of the performance record of its products under adverse conditions. Not satisfied to rest upon laurels, THORDARSON is constantly developing new products in its research laboratory. Satisfied customers are the proof of THORDARSON'S position in the electrical industry. Ask any "old timer" in radio what the most dependable make of transformer is and he will invariably reply—"THORDARSON."

THORDARSON ELECTRIC MFG. CO.

TRANSFORMERS FOR EVERY PURPOSE

TRADE THORDARSON

500 W. HURON ST. COR. KINGSBURY

CHICAGO

To Friends of the Thordarson Company in Every Part of the World

If I were a young man again, I know of no more desirable profession in which to get started than the Radio Service Business. Since radio began, I have followed with keen interest the lives of many men associated with the radio industry. The most successful began at the foundation of radio and worked themselves up, from service and engineering, into manufacturing and industrial organizations.

Radio service is one of the few occupations which combines professional skill and merchandising. It brings you into direct contact with a wide variety of clients. You learn their tastes, their reactions, their habits -- in short you come to know the public. Your mind develops an alertness which no amount of secluded study can equal. You perfect yourself in the technique of radio engineering. With all this you combine merchandising. You constantly sell your service and the material which must necessarily accompany radio service. A good radio service merchant can step into almost any executive position in the radio industry and do a good job. I know this because I have selected such men from the field and placed them in responsible positions. They have never failed to live up to my expectations! Men of this calibre have written the balance of this Guide. It is of value to you and is worthy of careful study. These men have served their apprenticeship in radio service -- their experience is your experience. The Servicemen's Guide contains only items which they believe are of immediate value to you.

The contents of this Guide are proof that Thordarson is closely in touch with your problems. We are always seeking new ways in which to cooperate with you and help you. If you like this Servicemen's Guide, we shall endeavor to issue supplements from time to time as we discover additional items of interest to you. We want you to succeed. Everything we can do to help you will be done.

Thank you, and God bless you,

C. H. Thordarson,

Chester H. Thordarson, President
THORDARSON ELECTRIC MFG. CO.

TRANSFORMER SPECIALISTS SINCE 1895



Table of Contents

- Page 2
PIONEERS, Forty Years of Transformer Manufacturing
- Page 3
A MESSAGE, From Radio's First Serviceman
- Page 5
AUDIO CIRCUITS—Eight Systems Worth Studying
- Page 6
INDUCTANCE MEASURING by Scientific Methods
- Page 7
TRANSFORMER IMPEDANCE Matching by Ratio Tables
- Page 8
TRANSMISSION LINES, "T" Pads and Ratio Charts
- Page 9
**Neon Output Indicator
A Handy Probing Light
Audio Neutralizing
R. M. A. Color Code**
- Page 10
DECIBELS, Graphic Illustration of Decibel Relations
- Page 11
Db. and Mu, Simplified Method of Using Decibels in Practical Applications
- Page 12
TEMPERATURE RISE OF TRANSFORMERS and Relation of Core Size to Volt-Amperes
- Page 13
FUNDAMENTAL POWER SUPPLY CIRCUITS and How They Differ
- Page 14
RESONANCE CURVES of Tuned Chokes Under Load: Method of Measurement
- Page 15
GETTING STARTED, Planning a Radio Business
- Page 16
TROUBLE SHOOTING, A Methodical Procedure to Follow
- Page 17
A. F. OSCILLATOR, The Octone Generator. A Soldering Iron Pilot. Polarity of Auto Batteries
- Page 18
CONDENSER CAPACITY TESTER. Checks Mfds. and Leakage
- Page 19
ASSEMBLY OF CAPACITY TESTER You Can Make This Tester Yourself!
- Page 20
WHAT WOULD YOU DO? Three Business Problems
- Page 21
ALL-STAR JR., Profit and Pleasure from This Remarkable Radio Receiver
- Page 22-23
TUBE TABLES, New and Interesting Tube Data with Db. Gain and Power Consumption
- Page 24
RECTIFIER TABLES, Socket Layout Connections and Tube Circuits

© 1935—THORDARSON ELEC. MFG. CO.

Reproduction of contents permitted providing credit is given the THORDARSON ELECTRIC MFG. CO.

Audio Systems

CIRCUIT A

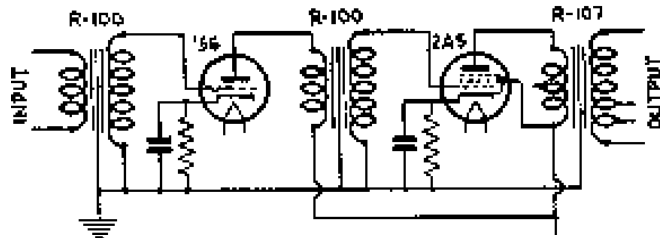

A good, straight, audio amplifier circuit. The center tap of the R-107 transformer is ignored in this circuit. From 45 to 55 Db. gain may be secured from this circuit with 3 to 4 watts power output. Fair quality.

CIRCUIT B

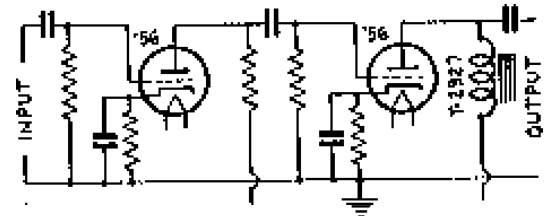

Voltage amplifier, primarily for condenser microphone or one of the newer crystal, ribbon, or dynamic microphones preceding a power amplifier. Brings signal level up about 25 to 28 Db. Good quality.

CIRCUIT C

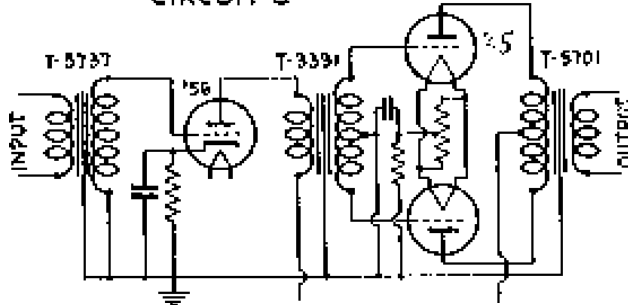

Straight audio into push-pull. Improved by use of 56 and 45 tubes over original 27 and 71A tubes used in early radio sets. Secures 20 to 25 Db. gain with about 4 watts output. Tone quality excellent.

CIRCUIT D

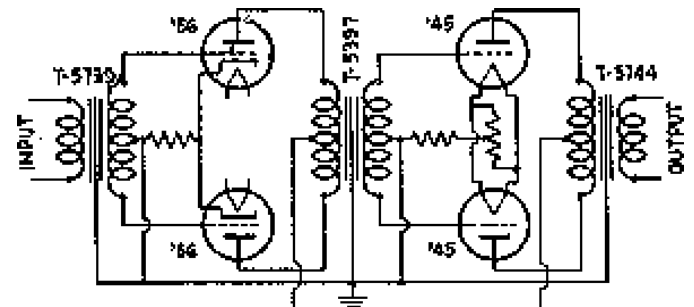

Double push-pull, a circuit with amazing handling capacity and freedom from distortion. Probably the best low power circuit in use. About 25 Db. gain with 4 to 5 watts power output.

CIRCUIT E

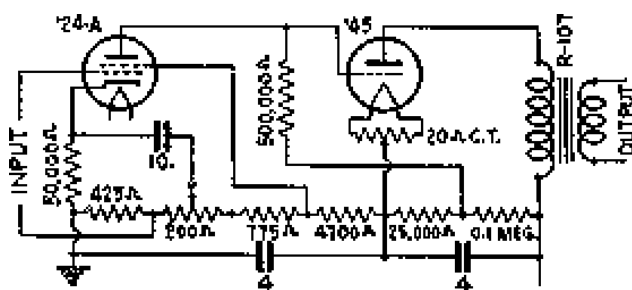

Basic Loftin-White direct coupled amplifier. Resistance values are rather critical and are given to assist servicemen in making repairs. About 45 Db. gain and good quality possible up to 3 watts.

CIRCUIT F

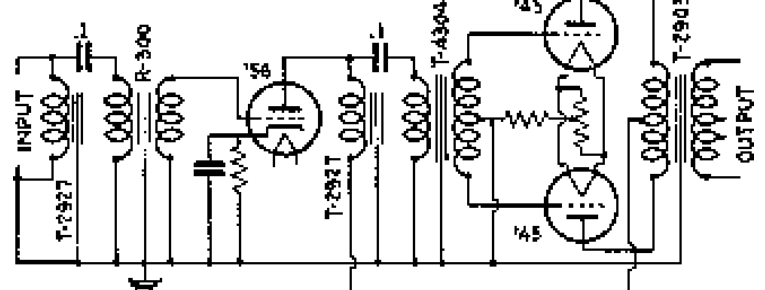

Tone compensating circuit. Different values of coupling condensers change frequency response. Primarily for use where bass notes must be overemphasized to compensate for a small speaker baffle. About 25 Db. gain.

CIRCUIT G

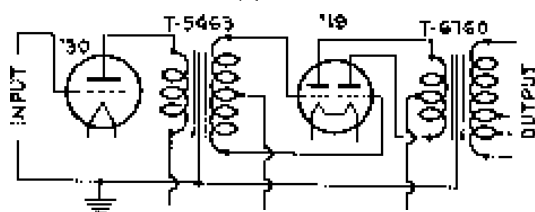

A battery operated Class B amplifier widely used in two-volt rural sets. Will deliver 2 watts with heavy duty B batteries as power supply. About 40 Db. gain with good quality on full volume.

CIRCUIT H

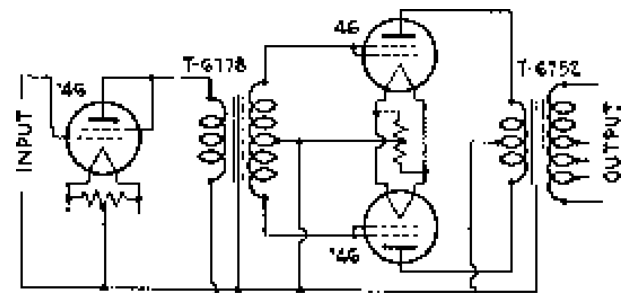

Good design in Class B utilizing the dual grid 46 tubes, first as a triode-driver and in push-push as a power output. Will deliver 20 watts if supplied from a good power pack. Only about 22 Db. gain.

Scientific Inductance Measuring

The actual inductance of iron cored filter chokes is largely dependent upon the working conditions under which a choke is used. It is well known that the amount of direct current passed through the choke affects its inductance, but it is not widely known that the applied A. C. voltage also affects the actual inductance.

The copper resistance of a choke is usually small compared with its inductive reactance, and in many measurements it is neglected. However, the core losses are usually large enough to show a marked difference between the apparent inductance and the actual inductance. The core losses consist of eddy currents circulating within the molecules of the iron and around the paths set up by the magnetic lines of force. The hysteresis losses are due to the tendency of iron, when magnetized, to hold its magnetic polarity and hence reluctantly reverse its polarity as the current reverses its phase. In well-designed chokes, laminated iron reduces the eddy currents, and special alloys of iron, having the least reluctance magnetically, reduce the hysteresis losses, hence, the difference in cost between an efficient, well-designed choke and an indifferently designed choke. The difference can be detected by measurement and by the hum level when used in the filter circuit of an amplifier's power supply.

The THORDARSON Laboratory employs an interesting and accurate inductance measuring circuit.

The diagram illustrates the method employed in the measurement of iron

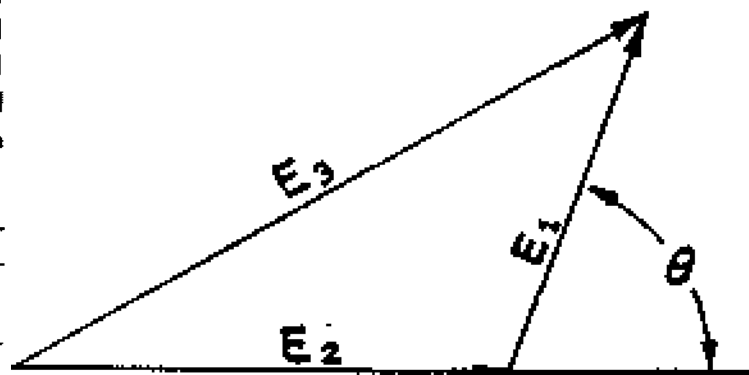
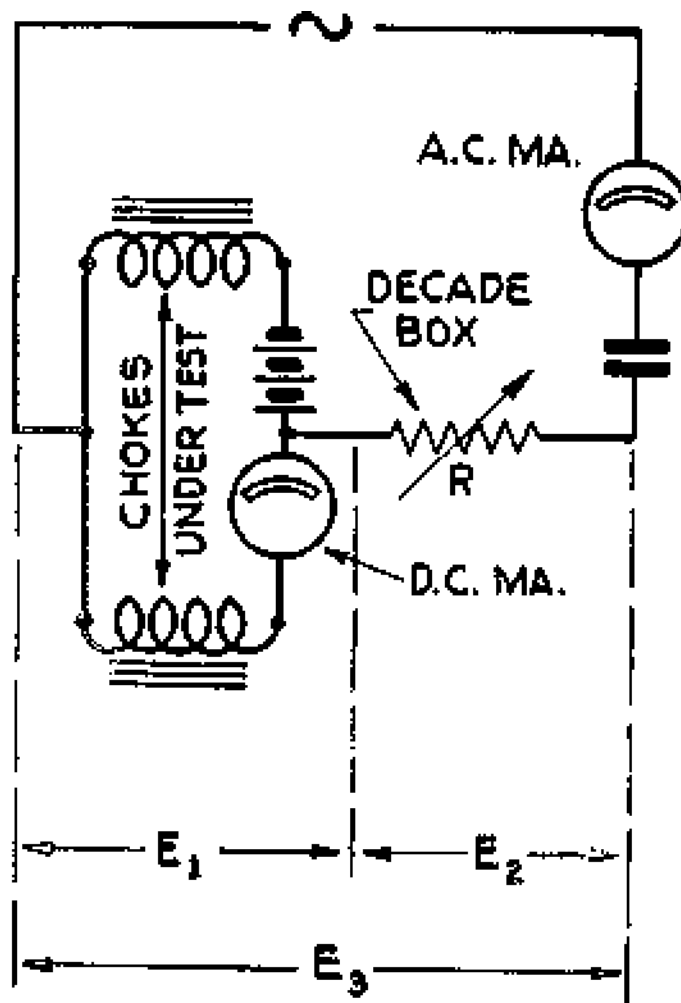

cored inductances under conditions equivalent to normal working conditions.

Two identical chokes are measured at once. Heavy storage batteries are used to provide any voltage between 2 and 200 for the equivalent of the steady D. C. flowing through the choke. The resistance R is a non-inductive precision resistance box. A well regulated alternator supplies the A. C. component through a 10 Mfd. paper dielectric condenser with less than 1/4 of 1% power factor. The measurements are made with a vacuum tube voltmeter. Of course, the frequency supplied by the alternator is equivalent to the ripple frequency of a full wave rectifier, or 120 cycles for the average choke used on a 60 cycle power supply. The V-T voltmeter is calibrated in R. M. S. values.

The simple method of calculation is with a vector diagram wherein a distance of 1/4 inch equals one volt. With a compass the lengths equivalent to the three voltages, E₁, E₂, E₃, are plotted in the form illustrated. The acute angle formed by E₁ and an extension of E₂ is measured with a protractor and recorded in degrees. From the tables of "sines" in a trigonometry, the sine of the acute angle is determined. The formula for actual inductance is:

$$L = \frac{R \text{ (in ohms)} E_1}{\pi f E_2} \text{Sine } \theta$$

where f is the frequency of the alternator and R is the resistance of the standard.

The Wheatstone Bridge

The method of inductance measurement given above is much too slow for production testing. It is employed as a laboratory method of establishing a standard. After the actual inductance of a choke is determined, it is substituted as the known value K, in a Wheatstone Bridge. Thereafter production chokes are matched to the standard of the same type on the bridge. Repeated tests have indicated that this is the most accurate method of rapidly testing a large number of inductances of the same type.

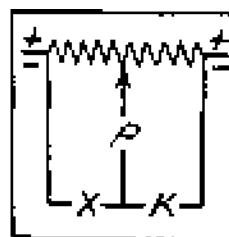

It is possible to make comparative measurements of chokes of unknown or questionable inductance rating with the aid of the Wheatstone Bridge described on Page 18 as a Condenser and Capacity Leakage Tester; however, the results will not be equivalent to the accurate method of test under load outlined above. The difference in air-gaps of different chokes makes their performance under load quite different from their no-load characteristic. All THORDARSON inductances are measured under actual working conditions.

Determination of Transformer Ratios

Voice Coil Impedance

An empirical formula has been evolved which simplifies the calculation of voice coil impedance. It is 1.5 times the D. C. resistance of the coil and hum bucking winding.

To measure the D. C. resistance of a voice coil, it must be disconnected from its transformer. Connect a 4½ volt C battery in series with a 1000 or 2000 ohm rheostat and an 0-15 milliammeter. One side of the milliammeter and one end of the battery connect to the voice coil. With an 0-5 or 0-10 1000 ohm per volt voltmeter, read the voltage across the voice coil when the rheostat has been adjusted to pass 100 milliamperes through the voice coil. If the voltage is 1.2 with 100 mils., the resistance from ohms' law would be 10 times the voltage reading. If the reading is 0.5 volts, the resistance is 5 ohms.

For every combination of power tube and speaker there is a ratio of winding which will transfer the output of the tube to the speaker with the greatest possible efficiency. While this ratio is not extremely critical, a transformer should be used which has a ratio of windings reasonably close to the theoretically perfect ratio. For all standard conditions, the tube data sheets on pages 22 and 23 will provide the recommended plate load impedance data which should govern your selection of a transformer.

In the table below, the intersection of a vertical voice coil impedance value with a horizontal output load impedance value gives the ideal value or ratio of transformer for coupling the tube and voice coil. If tubes are used in parallel, divide the load for stated power output by the number of tubes in parallel. If tubes are used in push-pull, use twice the value of load for stated power output of a single tube or the manufacturer's recommended load.

Chart for Matching Speaker Voice Coils to Standard Power Tubes
 Figures in Squares = Correct Transformer Ratio

Load for Stated Power Output in Ohms	VOICE COIL IMPEDANCE IN OHMS (1.5 x D. C. Resistance)														
	1	2	3	4	5	6	7	8	9	10	12	14	16	18	20
1,500	39	28	23	19	18	16	14.5	13.6	12.8	12.2	11.1	10.3	9.7	9.1	8.6
2,000	45	32	26	22.3	20	18.2	16.9	15.8	14.9	14.1	12.8	12	11.2	10.5	10
3,000	55	39	32	27	24.5	22.3	20.7	19.3	18.2	17.3	15.8	14.6	13.6	12.8	12.2
4,000	64	45	37	32	28.2	25.8	23.9	22.3	21.1	20	18.2	16.9	15.8	14.8	14.1
5,000	71	50	41	35	32	28.8	26.7	25	23.5	22.3	20.3	18.8	17.6	16.6	15.8
6,000	78	55	45	39	35	32	29.1	27.3	25.8	24.5	22.3	20.6	19.3	18.2	17.3
7,000	84	59	48	42	38	34	32	29.3	28	26.4	24.1	22.3	20.9	19.7	18.7
8,000	90	64	52	45	40	37	34	32	29.5	28.2	25.8	23.9	22.3	21	20
9,000	95	67	55	47	43	39	36	34	32	29.5	27.3	25.3	23.7	22.3	21.2
10,000	100	71	58	50	45	41	38	35	33	32	29	27	25	23.5	22.3
12,000	110	78	63	55	49	45	42	39	37	35	32	29	27.5	25.8	24.5
14,000	118	84	68	59	52	48	45	42	39	38	34	32	29.5	27.3	26.4
16,000	127	89	73	64	57	51	48	45	42	40	36.5	34	32	30	28.5
18,000	134	95	78	67	60	55	51	47	45	42.5	39	36	34	32	30
20,000	141	100	82	71	64	58	54	50	47	45	41	38	35.5	34	32

Method of Coupling Several Speakers to a Transmission Line

Determine the impedance of each speaker voice coil by multiplying its D. C. resistance by 1.5.
 Determine the number of speakers to be attached to the line.

Determine the desired distribution of volume.
 For uniform distribution of volume, select the transformer ratio for each speaker from the chart. Thus for three speakers, each with different voice coil impedances, select the transformer ratios under each voice coil

impedance in the line designated for three speaker outlets.

For half volume on two duplicate speakers and full volume on one speaker of the same or different impedance: In the line for two speaker outlets, select a transformer to match the single speaker and one to match an impedance equal to one half the impedance of the duplicate speakers, which should be connected with voice coils in parallel.

Chart for Matching Speaker Voice Coils to Standard Transmission Lines
 Assuming a 500-Ohm Line Circuit, Figures in Squares = Correct Transformer Ratio

Total Number of Spkr. Outlets	Voice Coil Impedance in Ohms (1.5 x D. C. Resistance)														
	1	2	3	4	5	6	7	8	9	10	12	14	16	18	20
1	22	16	13	11	10	9	8	8	7	7	7	6	6	5	5
2	33	22	18	16	14	13	12	11	11	10	9	8	8	7	7
3	39	27	22	19	17	16	14	14	13	12	11	10	10	9	9
4	45	33	26	22	20	18	17	16	15	14	13	12	11	11	10
5	50	36	29	25	22	20	19	18	17	16	15	13	13	12	11
6	55	39	33	28	25	22	21	19	18	17	16	15	14	13	12
7	59	42	34	30	27	24	22	21	20	19	17	16	15	14	13
8	64	45	37	33	29	26	24	22	21	20	18	17	16	15	14
9	67	48	39	34	30	28	26	24	22	21	19	18	17	16	15
10	71	50	41	36	33	29	27	25	24	22	20	19	18	17	16

Chart for Matching Standard Power Tubes in any Arrangement to Standard Transmission Lines

Load for Stated Power Output in Ohms	Desired value of line impedance (Figures in squares = correct transformer ratio)				
	125	250	500	750	1,000
1,500	3.4	2.4	1.7	1.4	1.2
2,000	4	2.8	2	1.6	1.4
3,000	4.9	3.5	2.4	2	1.7
4,000	5.6	4	2.8	2.3	2
5,000	6.3	4.4	3.1	2.5	2.2
6,000	6.9	4.9	3.4	2.8	2.4
7,000	7.4	5.1	3.7	3	2.6
8,000	8	5.6	4	3.3	2.8
9,000	8.4	6	4.2	3.4	3
10,000	8.9	6.3	4.4	3.7	3.1
12,000	9.7	6.9	4.8	4	3.4
14,000	10.5	7.4	5.2	4.3	3.7
16,000	11.3	8	5.6	4.6	4
18,000	12	8.4	6	4.8	4.2
20,000	12.6	8.9	6.3	5.2	4.4

Method of Individual Speaker Volume Control on a Transmission Line

An individual T pad, capable of dissipating the same audio power as the speaker is expected to handle, should be connected between the transmission line and the individual speaker's transformers. The following table gives the size T pad for each speaker on the various transmission lines.

Total Number of Spkr. Outlets	Desired value of line impedance (Figures in squares = constant resistance of T pad in ohms)				
	125	250	500	750	1,000
1	125	250	500	750	1,000
2	250	500	1,000	1,500	2,000
3	375	750	1,500	2,250	3,000
4	500	1,000	2,000	3,000	4,000
5	625	1,250	2,500	3,750	5,000
6	750	1,500	3,000	4,500	6,000
7	875	1,750	3,500	5,250	7,000
8	1,000	2,000	4,000	6,000	8,000
9	1,125	2,250	4,500	6,750	9,000
10	1,250	2,500	5,000	7,500	10,000



Handy Probing Light

A piece of fiber tubing 5 or 6 inches long and 1/2 inch in diameter, a radio pilot light socket, a multiple outlet plug, and at least 8 feet of light, flexible, wire cord, will provide a very handy probing light.

The source of power for the light may be a small radio C battery or a dynamic speaker output transformer mounted on a three-hole fixture-plug, as illustrated. These speaker output transformers come in different ratios, which range between 60:1 and 20:1. If the primary is connected to 120 volts A. C., the secondary voltage will be between 2 and 6 volts, suitable for a standard radio pilot light. A binding of leather or tape with some bus-bar braces will hold the transformer on the fixture socket to which the apparatus under test may be connected. Use Transformer T-3399.



Neon Output Indicator

A transformer and Neon 1/4 watt 110 volt lamp are the essential parts of a practical output indicator for use while making tests with a service oscillator or audio oscillator. The use of a potentiometer permits the operator to adjust the output until the bulb will only flash when the output voltage is at its peak value. The theory of operation is that the transformer steps the potential across the speaker voice coil windings up to a value sufficient to flash the Neon bulb. The flexible wires on T-3399 go to the potentiometer.

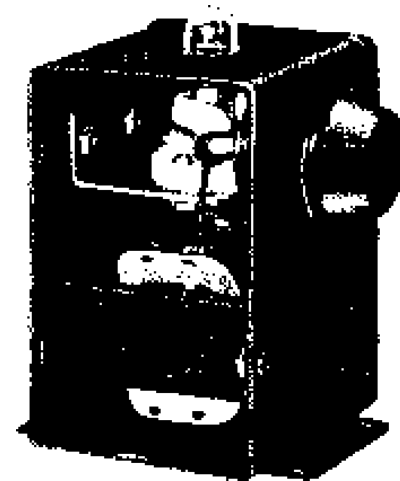

Method of Neutralizing Single and Push-Pull Output Stage to Secure High Fidelity

For Push-Pull Output Stage: Two 0.00001 Mfd. mica condensers, rated for at least 1000 volts, are required. Connect these condensers as in circuit diagram B.

For Single Power Tube Stage: Substitute a push-pull output transformer for the straight output transformer; connect one 0.00001 Mfd. condenser between the grid of the tube to the terminals of the output transformer, which is not connected to the plate of the tube. The center tap is connected to B plus. Connections are made as in circuit diagram A.

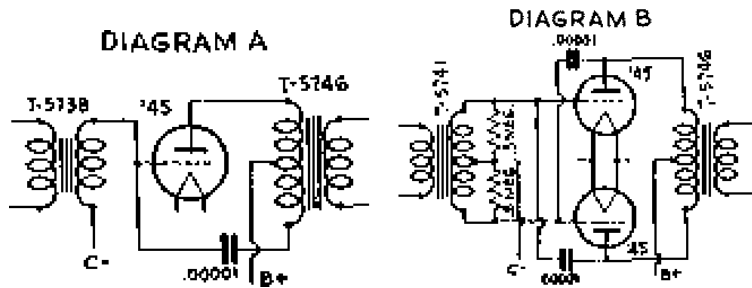

Complete Parts List

- 1 T-3399 Thorndarson Transformer
- 1 279 Electrad Potentiometer
- 1 GE 1/4 Watt Neon Glow Lamp, 110 Volt
- 1 Porcelain Candelabra Socket
- 24 Inch Test Leads, Hook-up Wire, etc.
- 1 Metal or Wood Case

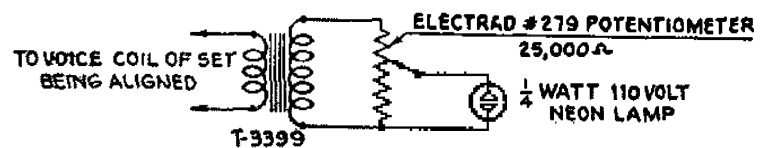

R. M. A. Color Code

For Fixed Condensers, Unit, Micro-Microfarads

First Dot	Second Dot	Third Dot
Black 0	Black 0	Brown 0
Brown 1	Brown 1	Red 00
Red 2	Red 2	Orange 000
Orange 3	Orange 3	Yellow 0000
Yellow 4	Yellow 4	Green 00000
Green 5	Green 5	Blue 000000
Blue 6	Blue 6	Purple 0000000
Purple 7	Purple 7	Gray 00000000
Gray 8	Gray 8	White 000000000
White 9	White 9	

For Resistors, Unit, Ohms

Body Color	End Color	Dot Color
Black 0	Black 0	Brown 0
Brown 1	Brown 1	Red 00
Red 2	Red 2	Orange 000
Orange 3	Orange 3	Yellow 0000
Yellow 4	Yellow 4	Green 00000
Green 5	Green 5	Blue 000000
Blue 6	Blue 6	Purple 0000000
Purple 7	Purple 7	Gray 00000000
Gray 8	Gray 8	White 000000000
White 9	White 9	

Copyright by
ELECTRONICS
 330 W. 42d St.
 New York, N. Y.

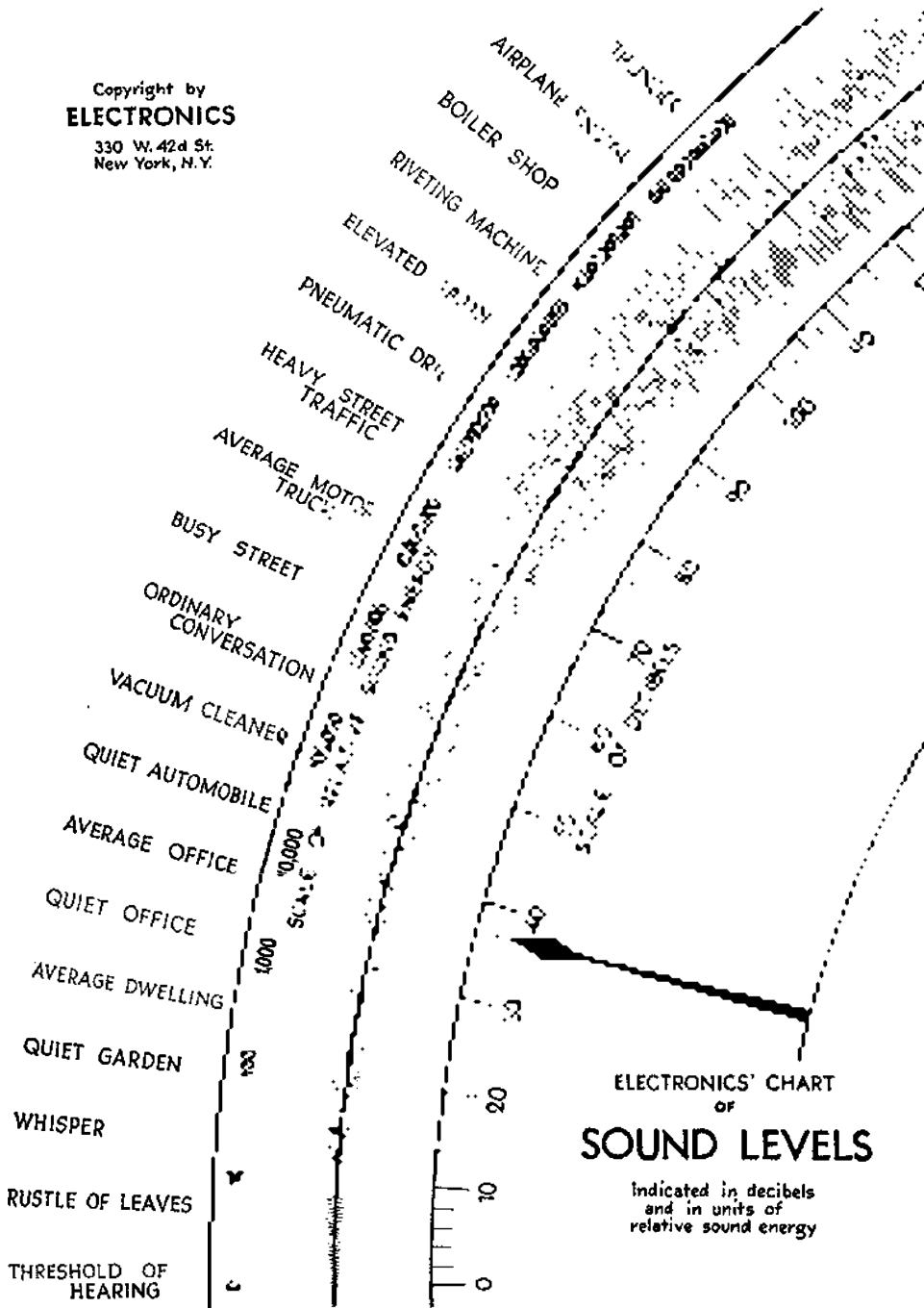

How to Measure Gain of Power in Audio Amplification

The human ear is less sensitive to a change in volume of sound as the intensity of the sound increases. Thus a thunderclap might represent several million times the audio power of a watch ticking, yet our ears can stand the tremendous volume of thunder and at the same time detect a watch ticking. Scientists have discovered that the ear's response to changes in sound intensity follows mathematical rules.

Relative audio powers may be expressed as power ratios. For instance, if the output power of an amplifier is 10 watts and the input power is 1 watt, we have increased the power level of the signal through the amplifier 10 times. The output power divided by the input power gives the ratio of signal increase.

But our ears do not respond according to power ratios. So we have to change these ratios to sound units or decibels. Don't be frightened by this term decibel—it is no more difficult to handle than ohms, watts, or any of the other terms you use every day in radio service. An easy method of thinking in decibels is expressed thus: In terms of power gain in an amplifier—

- A power ratio of 1 is a 0 decibel gain
- A power ratio of 10 is a 10 decibel gain
- A power ratio of 100 is a 20 decibel gain
- A power ratio of 1,000 is a 30 decibel gain
- A power ratio of 10,000 is a 40 decibel gain
- A power ratio of 100,000 is a 50 decibel gain
- A power ratio of 1,000,000 is a 60 decibel gain
- A power ratio of 10,000,000 is a 70 decibel gain

Studying this series of relations, you can quickly see that the number of times 10 would have to be multiplied by itself equals the significant figure of the decibel gain. But each decibel gain figure is 10 times the significant figure. Therefore, any gain ratio even though it is a billion, which is 10 multiplied by itself 9 times, needs only to have the 9 multiplied by 10 to secure the decibel gain which in this case would be 90. Those who prefer the logarithmic method of calculating decibels use the formula:

$$\text{Db.} = 10 \text{ Log}_{10} \frac{\text{Power output}}{\text{Power input}}$$

Relation of Mu and Actual Voltage Gain to Decibels

The static value of Mu is given in all standard tube characteristic charts. The actual voltage gain of a tube in an audio amplifier is less than the theoretical Mu because part of the gain is always lost across the plate load resistance. In the Cunningham-Radiotron Manual, Series RC-12, a formula appears on page 10 by which the actual voltage gain of a tube may be calculated. This is:

$$\text{Actual voltage amplification equals } \frac{\text{Mu} \times \text{Plate Load}}{\text{Plate Load} + \text{Plate Resistance}}$$

The table following gives the theoretical gain in Db. for several values of Mu and also the Db. gain for actual voltage amplification as derived from the above formula. Thus for a tube with an actual voltage amplification which is less than the rated Mu, the column headed Audio Decibel Gain may be used.

Voltage Gain or Mu	Equivalent Decibel Gain	Audio Decibel Gain	Voltage Gain or Mu	Equivalent Decibel Gain	Audio Decibel Gain
1	0	0	12.5	21.9	15.9
2	6	5	15	23.5	17.5
3	9.4	8	20	26	20
4	12	10	25	28	21.9
5	14	11.5	100	40	33.9
6	15.6	12.5	200	46	35
7	16.9	13.5	500	54	37.5
8	18.1	14	1000	60	40
9	19	14.4	1500	63.5	42
10	20	14.8			

If the serviceman will think in terms of Db. rather than in Mu or voltage gain, he will find that it is much easier to make calculations. The overall Db. gain of an amplifier is the sum of the Db.

gain figures for each tube. Any coupling device between tubes merely transfers but does not increase power, hence there is no Db. gain except that secured by the tubes. If you are in favor of doing your own mathematics, figure the actual voltage amplification of each tube, find the logarithm of that figure in a log table having a base of 10, and multiply the logarithm by 20 to obtain the exact Db. gain.

A practical method of using this information may be applied to an amplifier. You may wish to know the probable amplification in Db. of an amplifier. Suppose this amplifier had a 57 tube working into a 56 through a resistance coupling, and that tube coupled through a 1 to 2 ratio transformer to a 2A5. Then with the tube chart on pages 22 and 23, which gives the Db. gain of each type of tube in an audio amplifier, add the Db. gain of a 57 to a 56 to a 2A5, thus 42 + 16 + 35, or 93 Db. Of course, if the amplifier works some of its tubes at a lower gain level by reducing the voltage or using low plate resistance for the sake of stability or hum elimination, and consequently does not carry a Db. rating as high as figures indicate might be possible, that is no reflection upon the amplifier. In calculating the gain of push-pull or parallel tubes, assume the Mu of one of the tubes and from the above chart or the tube chart, use the audio decibel gain for that value of Mu. The mathematical analysis of this appears in the formula for actual voltage amplification—with parallel tubes, the net plate resistance is one-half that of a single tube, but in good design, the plate load is made one-half also, hence the gain remains the same as for a single tube. The same reasoning holds true for push-pull tubes where the plate to plate impedance is twice that of a single tube. (See tube manufacturers' recommendations for push-pull plate impedance.)

Temperature Rise of Transformers

DON'T BURN YOUR FINGERS! The most important factor in radio power transformer design is the allowable temperature rise under rated load. A transformer will serve its purpose for many years if it is not subjected to excessive heat. The heat generated in a transformer is due to two causes: the copper loss is the power which is dissipated by the resistance of the wire to the electrical current; the iron loss is due to eddy currents and hysteresis characteristics of the core material. In ideal design, the no-load watt loss due to each of these factors is about equal. Under load, transformers pass much more current than under no load. Consequently, more power is consumed by the resistance of the copper and the reluctance of the core material to the magnetic flux.

THORDARSON'S method of measuring temperature rise of transformers may be of interest to radio servicemen. The resistance of all windings is first measured very accurately with a precision Wheatstone Bridge. The transformer is then placed upon the heat test bench and operated under conditions similar to those which are applied in a radio power circuit. Resistors duplicate the effect of full load operation. A synchronized alternator is used to supply the power at any frequency desired.

Section Under Test	T-5002	Brand B	Brand C
No Load—Watts.....	3.2	10	5.75
No Load—M. A.....	100	390	240
Full Load—Watts.....	44	47.5	43.5
Full Load—M. A.....	400	500	425
Pri. Volts.....	115	115	115
Pri. Heat Rise.....	27.7°C	71.8°C	54.3°C
Sec. No. 1—Volts @ 2 amps.....	4.97	4.62	4.62
Sec. No. 1—Heat Rise.....	36.5°C	70°C	52.5°C
Sec. No. 2—Volts @ 5 amps.....	2.48	2.4	2.35
Sec. No. 2—Heat Rise.....	26.7°C	79.5°C	64°C
Sec. No. 3—D. C. Volts @ .040 amps..	320	290	298
Sec. No. 3—Heat Rise.....	26.3°C	67.2°C	52.2°C
Core Temp. Rise.....	21°C	58°C	45°C
Core Section—Sq. In.....	1.17	.75	.87

Sensitive thermo couples are used to measure core temperature and accurate thermometers check room temperature. After eight hours of full load operation, the resistance of all windings is measured while the transformer is still hot. Well-known formulas give the increase in resistance of copper wire per degree centigrade increase of temperature. Hence, the actual temperature within the transformer of each winding can be accurately determined. Engineering design and underwriters' requirements limit

the temperature rise of a transformer to 40°C. As room temperature is usually in the vicinity of 25°C, this means that a transformer should not exceed an actual temperature of 65°C. (35°C. below the boiling point of water.) This temperature will not cause a sensation of burning when a human hand is placed upon the core of the transformer. In good transformer design, the temperature of all the windings should be approximately equal. However, due to conduction of heat by the core and radiation of heat in the air—due to the large exposed surface of the transformer—the middle windings are sometimes a few degrees warmer than the other sections of the transformer.

The heat rise measurements of the THORDARSON T-5002 Transformer and two competitive transformers of equivalent rating are given in the accompanying chart. This data tells its own story. When you use a THORDARSON-built transformer, you have the finest engineering in the world back of its design.

Relation of Transformer Core Size to V.A. (Watts) Capacity To Determine Watt Capacity of a Radio Power Transformer

The iron content of a well-designed radio power transformer has a direct relation to the power handling capacity of the transformer. Many other factors affect the relationship between iron and power handling capacity, such as air-gaps in the core assembly, which lower the rating; allowable temperature rise, which should never exceed 40°C.; design of the transformer which should reduce heating from eddy currents to a minimum; and the quality of iron which should be expressly for transformers and offer the least possible heating from hysteresis losses. Taking all these factors into consideration, the THORDARSON Laboratory has compiled a chart, graphically illustrating the relation between transformer core area and the secondary A. C. volt-ampere rating. As the power load of a radio set is not pure resistance, volt-amperes are approximately equal to 80% of the primary watts. In transformer design it is possible to compensate for small core section by increasing the number of turns

on each winding; usually the space is inadequate without materially reducing the size of wire which results in excessive heating.

The Wasteless Shell Type Transformer is the type in which the core is stamped out like a letter E and the open side of the core is completely filled by laminated stampings. Some transformers are assembled from two letter E stampings interleaving in such a manner that only half the core area is effective in the return magnetic path. Deduct one-third from the measured core area of

such a transformer to determine its power handling capacity from this chart. In the Wasteless Type Lamination the cross section of the center bar of the E would be hard to measure, but it is equal to the sum of the cross sections of the top and bottom leg of the E. Assume a transformer with a 1 1/4" core width and the top and bottom leg each 1/2" high. 1/2"x1 1/4" plus 1/2"x1 1/4" equals 1.55 square inches. Locate 1.55 on the core area side of the chart. It intersects the curve at 70 V.A. This is approximately 80% of the total power consumption in watts.

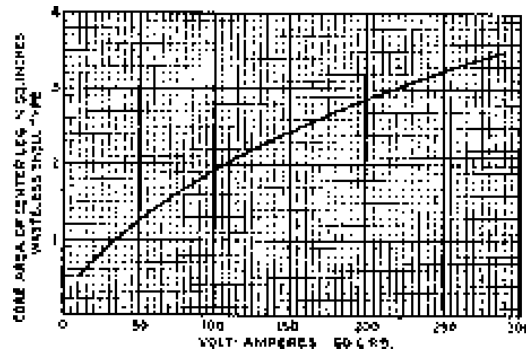

Fundamental Power Supply Circuits

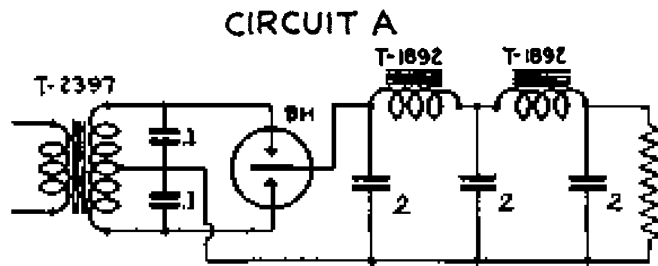

Filamentless gaseous tube rectifier—the first in all-electric sets. The 0.1 Mfd. buffer condensers and the first 2 Mfd. condenser must be rated for 600 volts or else.

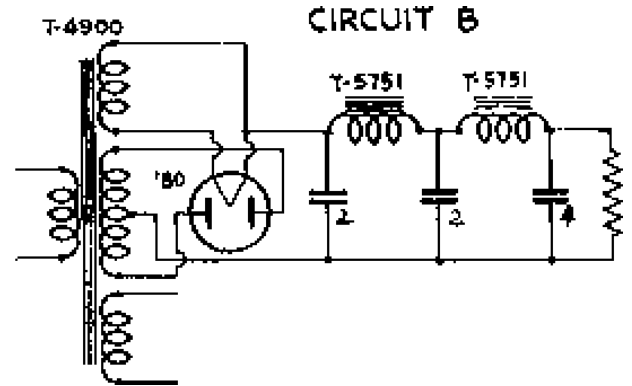

Brute-force twin-choke system using the popular 80 type tube. This is a rugged and dependable type of B power supply with a very pure D. C. output.

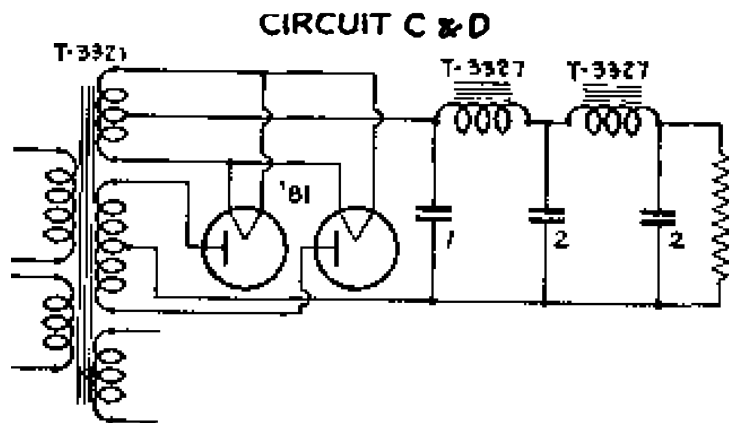

High voltage power supply. One tube is sometimes omitted in half-wave systems, necessitating double the filter capacity for hum elimination.

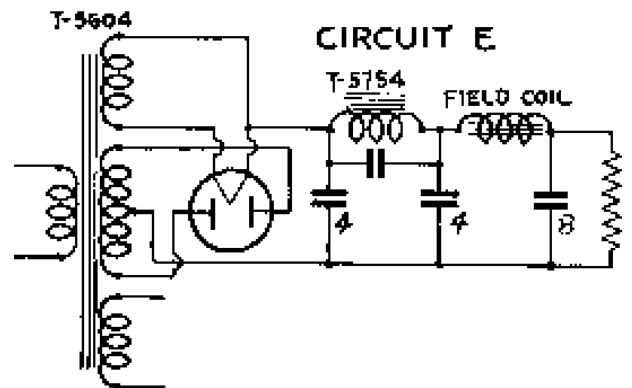

Popular modern circuit using any of the full-wave rectifiers. First choke is tuned to double the supply frequency. The speaker field serves as the second choke.

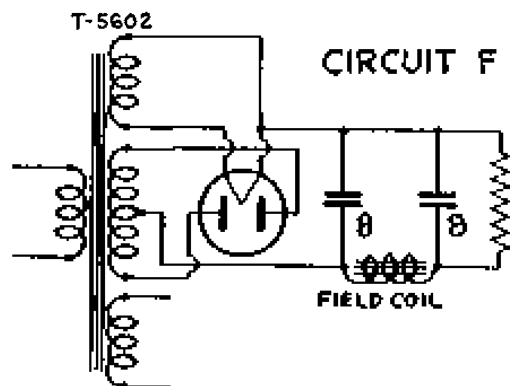

Typical midget set power supply system where low-frequency response of set is not sufficient to amplify the 60 or 120 cycle hum usually encountered.

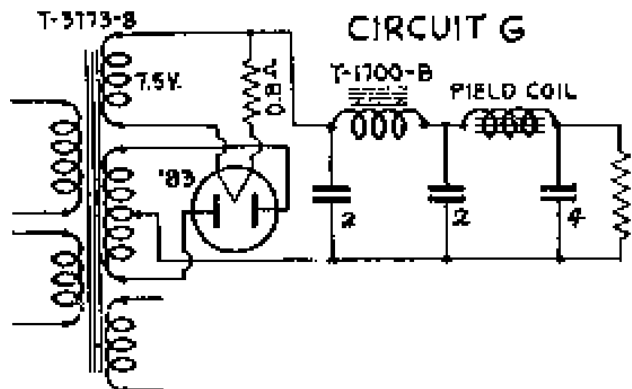

Circuit suggests method of changing C and D into a modern hook-up with a lower priced rectifier tube and a speaker field supply. Very practical.

Tuning Filter Chokes for Hum Suppression

The inductance of filter chokes varies with any change of direct current flowing through the coil. This is because the presence of the direct current magnetically saturates the iron core of the choke. THORDARSON Choke Coils have a small gap to relieve this condition of saturation. This broadens the saturation curve to a certain extent and permits tuning of the choke to the 120 cycles necessary to relieve the most intense and annoying amount of hum encountered in 60 cycle rectified power filters.

In the accompanying chart, the tuning curves for popular THORDARSON Choke Coils permit the experimenter or serviceman to select the right capacity to tune the choke to 120 cycles, which is the ripple frequency of a full-wave rectifier on a 60 cycle power supply.

Determine with a good D. C. milliammeter the amount of direct current flowing through the choke with a receiver or amplifier adjusted for low volume. For currents between 50 and 175 milliamperes, select a point on the horizontal base line of the chart equal to the D. C. in milliamperes. At the intersection of the vertical line with the curve of any particular choke, trace over to the vertical figures. This is the capacity in microfarads which should be connected across the choke. If a fixed condenser slightly below this value is bridged in parallel with a variable trimmer condenser, the adjustment may be made with a rectifier type meter in the amplifier's output to indicate the least trace of hum.

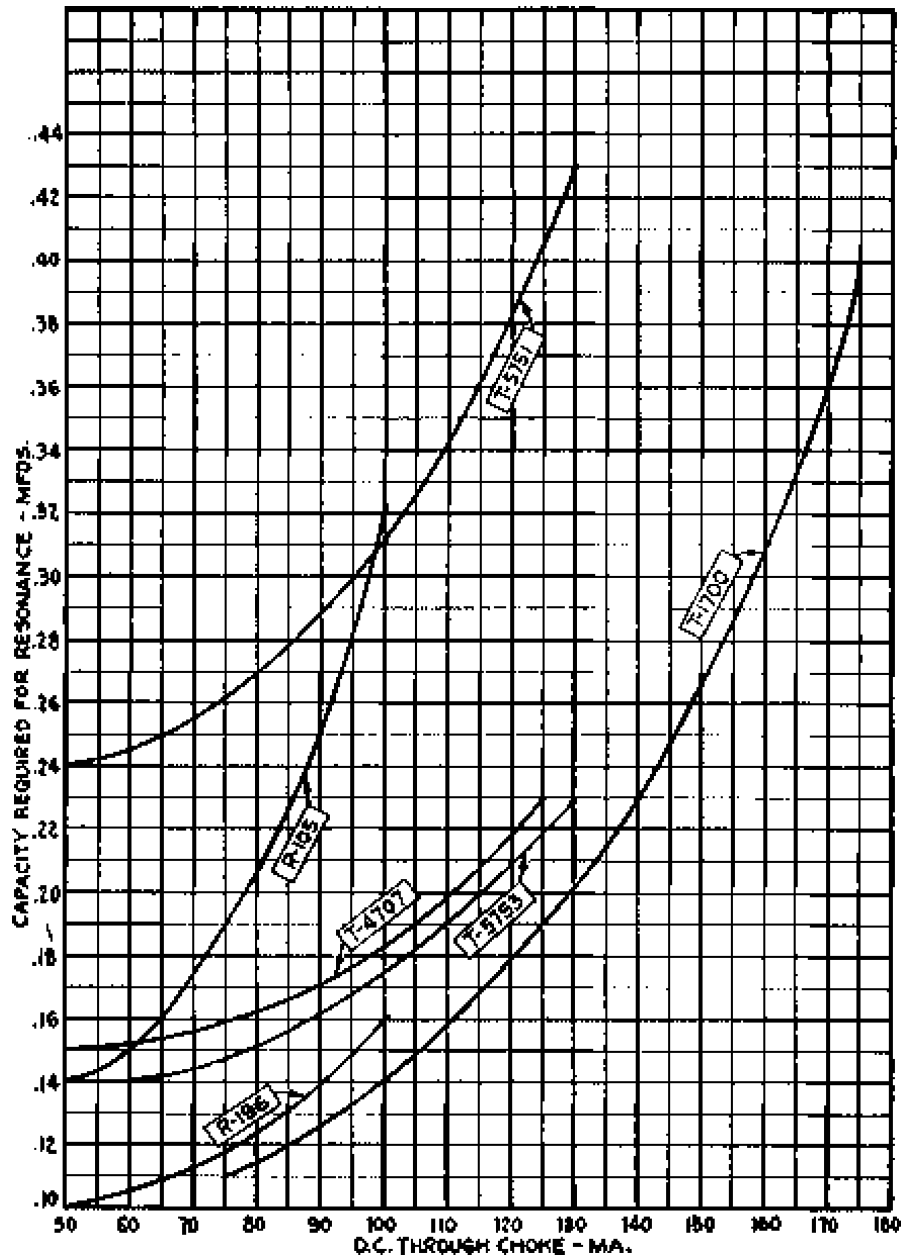

Method of Measurement

This interesting circuit is used to determine the resonant frequency of chokes in the THORDARSON Laboratory. A D. C. saturation current is passed through the choke under test. Two high inductance chokes are in series with the unit under test. 120 cycle A. C. is applied through a blocking condenser of 8 Mfd. (paper), and a precision variable decade condenser box is shunted across the choke. The capacity at any given direct current saturation which causes the lowest reading on A. C. ammeter (I. A. C.) determines the point on the curve in the above chart.

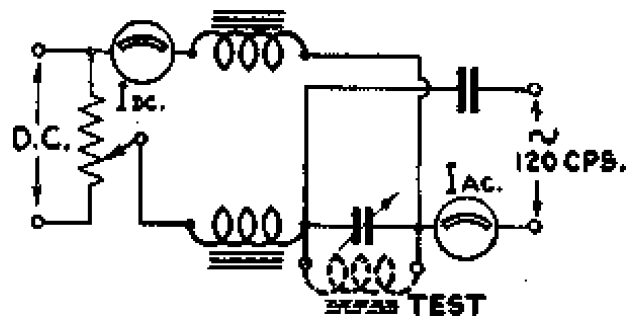



Planning a Radio Business

Your Market

A preliminary survey of your market will do more to establish a radio service business on a firm foundation than any amount of hit or miss advertising. Determine first your logical trading area.

Make a house-to-house canvass to learn how many radio sets are in the community you expect to serve. You can anticipate an average of two calls per year on each receiver. As all servicemen charge at least \$1.00 to \$1.50 per call, you should take in a minimum of \$2.00 for labor for every radio set in your trading area within a year. Thus, if there are 1,000 radio sets within your trading area, you have a possible market for at least \$2,000.00 worth of service per year.

For Future Tube Sales

While making your survey, observe the types of tubes employed in the receivers in the homes you visit. If you do not have an opportunity to look in the set, you can usually identify the make and type of the receiver and from your service manuals determine the tubes required. From these records you can compile a list of the tubes your customers will likely require for replacement purposes in these sets.

Tubes rarely give more than one year of satisfactory service. Customers, however, retain tubes as long as three or four years. Hence, you can anticipate selling at least one-fourth of the total number of tubes your customers now have in service, per year.

Note the condition of the aerial installation on each set. New aerials are profitable to install and improve the reception of programs.

The Old "Oil"

This preliminary call presents an excellent opportunity to make friends with your prospective customers. Leave a card with your name and address to help them remember your visit. Follow up this visit with a penny postcard to each address (the names of the residents can be secured from your local directory) thanking the party for the courtesy extended to you when you called. This leaves a good impression in the customer's mind and enhances your opportunity of getting his business. A number of servicemen have their pictures printed on cards of this type.

Publicity

Get acquainted with the editor of the newspaper which serves your community. Supply him with a good photograph of yourself; tell him you are starting in the radio

business. Most editors are very kind to prospective advertisers starting in business, and you can most likely secure some free publicity which will assist you in getting started. As soon as your picture appears, go to the advertising manager of the paper and ask him to prepare an advertisement for you, employing the same picture. Have the advertising manager save the "mat" containing your picture and ad in case you wish to use it at some later time. After your ad appears, go to the editor again and offer to supply him with articles of interest to local radio users. These you can write up at your leisure.

For example, you can explain in one article why stations fade; in another, the proper type of lightning protection on an aerial; and in still another article, how to identify defective tubes or short circuits.

One serviceman in an Indiana city supplied his local newspaper with articles of this nature every day for over two years. Needless to say, he commanded the largest service business in the city as a result of this publicity. Always ask the newspaper to print your name as the author of these articles, which you supply to them free. This will establish a reputation for you as a skilled technician whom the newspaper respects as a capable serviceman.

Initial Investment

In planning a store or shop, the first and most important purchase is tools. You will not need many tools, but it will pay you to buy the best quality you can afford. The next most important equipment consists of meters, a tube tester, an all-wave oscillator, and service manuals. If you are located on a street with any appreciable traffic, endeavor to purchase a Neon sign stating "Radio Repair" or "Radio Service" in brilliant red, and let it run day and night. You will need a small stock of tubes, probably not over 50 or 75 of the types used by most of your prospective customers. It is not advisable to lay in a large stock of parts until you know the requirements of your trade.

Success ???

Your future success will depend largely upon the quality of the material you sell and the satisfaction which results from your workmanship. Always consider that the customer is right, regardless of how unreasonable his demands may be. You will often have to do a job over in order to please a customer, but you will find that honest effort will be rewarded by an ever increasing and profitable business.

A Method of Service Procedure

A systematic method for radio servicemen to follow in testing a defective receiver is to:

1—Turn on the set and observe if any peculiar pink or purple haze gathers around the plates of the rectifier tube. This is an immediate indication of power pack trouble, except in mercury vapor rectifiers. If the haze appears immediately, turn off the set.

2—If there is apparent trouble in the power pack, measure the resistance from the cathode or filament terminal of the rectifier tube to the chassis. If the value of resistance is less than 5,000 ohms, it is very probable that a condenser in the filter circuit is defective. If the resistance is over 5,000 ohms, check the tube for a possible defect first, then check the power transformer secondary.

A simple method of making this test is to measure the resistance from each plate terminal of the rectifier socket to the chassis. If these resistances differ by more than 50 ohms, it is an indication of trouble within the transformer.

If in the initial test the tubes did not light at all, the trouble probably lies in the power switch or the primary of the transformer. (If there is a fuse in the circuit, test it!)

3—To test the primary of the transformer, remove the A. C. plug from its socket and measure the resistance from one terminal of the plug to the other with your ohmmeter. With the switch turned on, this resistance should not be over 50 ohms and is usually in the neighborhood of 5 or 6 ohms. If you fail to get a circuit on this test and the switch is all right, it is probable that the transformer primary is open—a trouble which usually necessitates replacing the entire transformer.

4—On rare occasions, a filter choke coil will develop a short to the chassis. A good method of test for this trouble is to disconnect the speaker field and measure the resistance from the filament or cathode terminal of the rectifier to one of the plate terminals. With the speaker field disconnected, this test should indicate no circuit or a resistance of at least 1 megohm.

5—If the power supply circuit of the receiver is not at fault, the next test should be made at the speaker. A slight residual hum of a dynamic speaker should vibrate the cone if the output transformer and speaker voice coil are performing properly. If this slight hum cannot be detected, test with a pair of headphones across the primary of the output transformer.

An audio oscillator is the most satisfactory source of signal for a test of this nature. It may be connected to the grid of the tube preceding the power stage in the receiver. If no signal is heard from the primary of the output transformer, remove the power tube and test from the grid terminal of the power tube socket to the cathode terminal or ground. If signals are not heard in this test, the trouble is obviously between the point of test and the audio oscillator. This may be a defective audio transformer or a defective resistance coupler.

One of the most difficult troubles in this portion of the circuit exists when there is a slight leakage in the coupling condenser in a resistance-coupled stage. There is one good method of testing for this trouble, and that is to remove the original coupling condenser and substitute an .01 Mfd. test condenser in the circuit.

An older method of determining this trouble involves the older type service analysis instrument which measured the plate current of the power tube. Any leakage in the coupling condenser always causes an excessive plate current in the power tube.

6—There are three general methods of tracing down trouble in the R.F. and I.F. portions of a receiver. Roughly the methods are as follows: First, voltage analysis, which includes measuring the plate current and voltages on each terminal of the tubes.

The second method is a test of the resistance of each circuit of the receiver with the power turned off. The readings are compared to the manufacturer's service data sheet, or in the case of a receiver without adequate service data, the judgment of the serviceman determines the approximate values which should exist in each circuit.

The third method requires a modulated oscillator and either headphones or a good rectifier type output meter. This method follows the same system outlined for testing the power and audio portion of the receiver with the audio portion of the modulated oscillator, and then continues through the R.F. and I.F. stages with the modulated oscillator producing the frequency signals for which the set is designed. This latter method lends itself to a simultaneous tube test made by substituting a new tube for each of the original tubes in the receiver. Any improvement will be detected by an increased reading on the output meter while a constant signal is supplied to the antenna and ground terminal of the receiver by the modulated oscillator.



Audio Frequency Oscillator

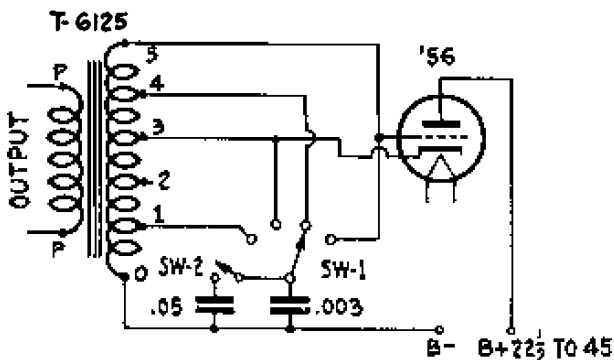

HIGH RANGE
 SW-2 OPEN
 .003
 1 - 3000 C.P.S.
 3 - 2000 "
 4 - 1500 "
 5 - 900 "

LOW RANGE
 SW-2 CLOSED
 .003 + .05
 1 - 900 C.P.S.
 3 - 550 "
 4 - 400 "
 5 - 300 "

The Octone Generator

Eight different audio frequencies for radio and amplifier testing! Suitable for all manner of bridge measurements at audio levels!

The Octone Generator is a simplified audio oscillator for home construction by radio servicemen, experimenters, and students. It employs one or two 22½ volt No. 4156 Burgess batteries. If a 56 type tube is used, a T-5061 THORDARSON Filament Lighting Transformer may be used, deriving its power from 110-115 volt 50-60 cycle A. C. lines. A type 76 tube may be operated from either a 6 volt storage battery or a 6 volt T-6185 transformer, with equal satisfaction.

Most of the parts will be found in the surplus equipment of radio servicemen. Values are given on the diagram.

An interesting use of the audio oscillator is in testing a P. A. system for acoustic feedback. A headphone should be connected to the output of the Octone Generator and placed near the microphone of the P. A. system. By varying the tone of the Generator and adjusting the position of the speakers, feedback can be reduced to a minimum. A "Christmas tree" flasher button in the primary circuit of the filament transformer will cause the Generator to produce a wavering tone which is easy to identify and work with during P. A. adjustments.

A Soldering Iron Pilot

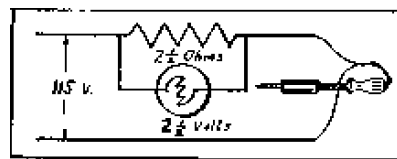

An excellent pilot light for a soldering iron may be made by inserting a small resistance in series with the power supply line to the soldering iron outlet. Across this resistance a standard 2½ volt pilot light bulb may be connected to indicate when the soldering iron is connected. The size of the resistance is determined by the power consumption of the soldering iron. In the case of a 100 watt iron, which draws approximately 1 ampere of current, a resistance of 2½ ohms capable of passing 1 ampere will cause a voltage drop of approximately 2½ volts.

A short section of wire from an old radio filament rheostat or from an old electric toaster will serve as a resistance. The wire may be wound on a strip of bakelite or on a round pencil, from which it may be removed in the form of a spiral spring.

The drop in voltage will not seriously cut the efficiency of the soldering iron but does provide ample current for the pilot light. The pilot will only light when the soldering iron is drawing current through the circuit. (See diagram.) By experimenting with various resistances, it is possible to make simple pilot lights for flatirons, toasters, percolators, and other household appliances, which may otherwise be left connected for a long time.

Polarity of Auto Batteries

This handy chart of battery polarity in the leading makes of automobiles will indicate correct connections to make when testing auto-radios removed from cars. It is also helpful when preparing a new auto-radio for installation.

Positive Side Grounded to Chassis		Negative Side Grounded	
Auburn	LaSalle	Buick	Nash
Austin	Marmon	Chevrolet	(1960, 970)
Cadillac	Nash	Cunningham	Oldsmobile
Chrysler	(980, 990)	DeVaux	Pontiac
Cord	Packard	Duesenberg	Reo
DeSoto	Peerless	Durant	Stutz
Dodge	Pierce-Arrow	Essex	Willys-Knight
Ford	Plymouth	Hudson	Willys-Overland
Franklin	Rockne	Lincoln	
Graham	Studebaker		
Hupmobile			

Condenser Capacity and Leakage Tester—

An economical capacity and leakage tester is the most logical service instrument to construct. THORDARSON engineers have perfected a design which is simple and economical to build and which may be assembled from standard parts available from radio parts distributors.

Condensers, by their very nature, are the most vulnerable parts in a radio receiver. A method of testing the two principal factors which affect their performance is essential in good radio service work. Condenser testers have been offered on the market in two styles: one measuring the reactance to alternating current as an indication of capacity; and the other measuring the leakage, irrespective of capacity as an indication of merit.

Both methods used to test condensers are important—THORDARSON design combines an efficient leakage tester with a bridge method of balancing the reactance of one condenser against another for a comparative measurement. While the accuracy of this test depends largely upon the comparison standard, the possibility of error in selecting a standard unit of capacity is no

greater than the error occasioned by a slight drift of voltage or frequency while using a metered type capacity tester. The standard units of capacity should be checked against two meter-type capacity testers. The leakage test further reduces possibility of error in capacity.

The Wheatstone Bridge principle is employed in the capacity measuring portion of this tester. The calibrated potentiometer indicates the ratio between an unknown condenser's capacity and the capacity of the known standard built into the tester. The scale is calibrated both in ratio and in actual units of capacity in microfarads. The test voltage may be any power source of 60 cycles or more at 115 volts or less. Thus an audio oscillator may supply the testing signal. Headphones are the simplest and most satisfactory means of identifying the potentiometer position which cancels all current in the phones. The Neon lamp in series with any direct current source over 90 volts tests leakage. If this potential is secured from the set in which the condenser is used, the test is actually under working conditions!

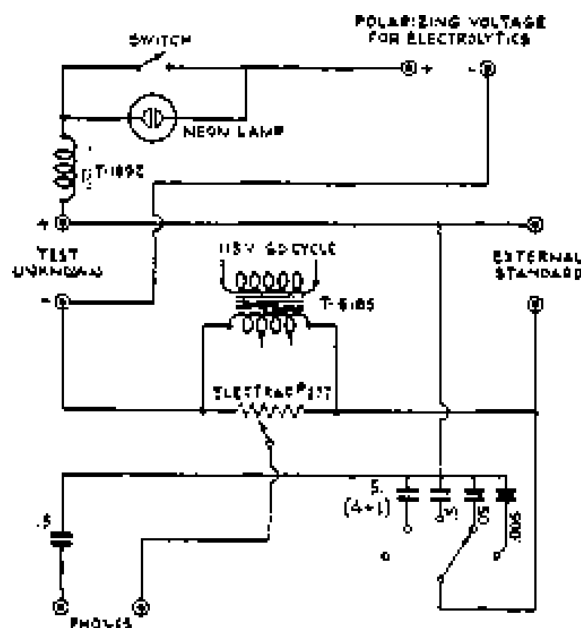
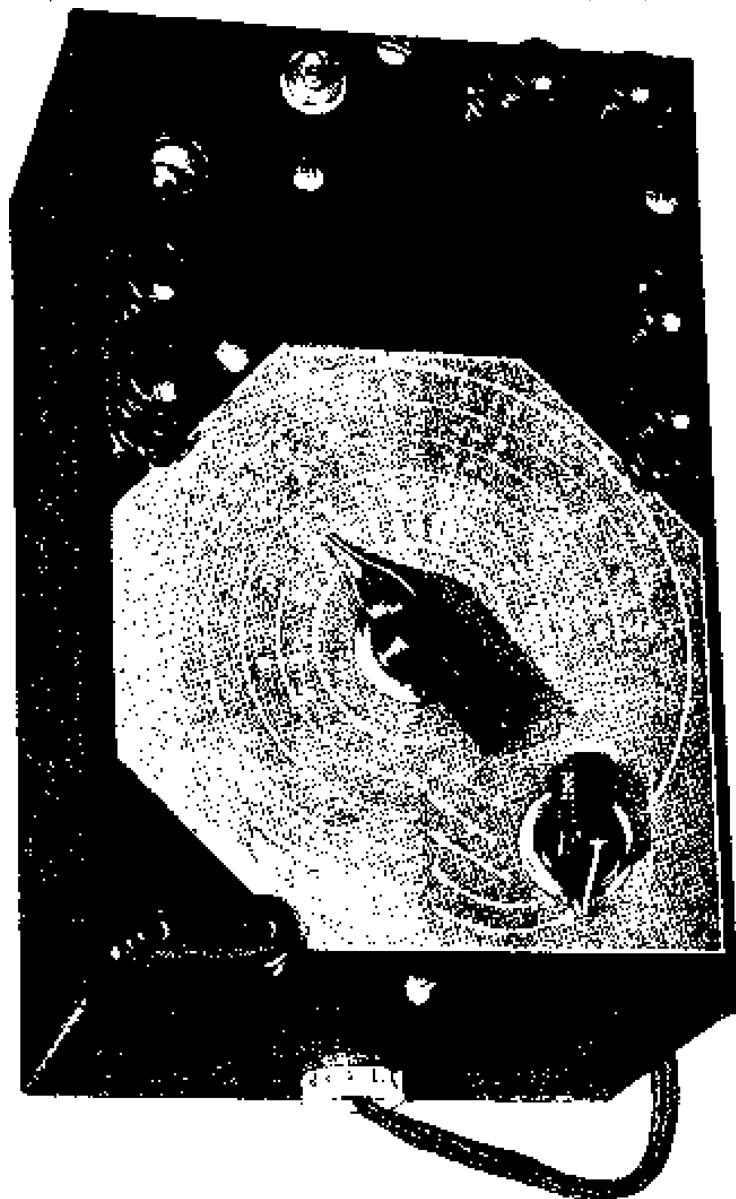

Essential Parts List

The transformer T-6185, made by THORDARSON, is the heart of the tester. The THORDARSON Choke T-1892 permits accurate capacity tests while the leakage test is on. Other important parts are Electrad No. 277, 4000 ohm potentiometer, and the following Aerovox Condensers: one 4 Mfd., 400 S; one 1 Mfd., 400 S; two 0.5 Mfd., type 484; one 0.05 Mfd. type 484; one 0.005 Mfd., type 484—all 400 volt rating. Six binding posts, two phone-tip-jacks, one 1 1/4" bar knob, one 2 1/4" bar knob, one single pole single throw switch, one 1/4 watt Neon bulb, one miniature socket, one Yaxley No. 1316 selector switch... A 5 1/2" x 8 1/2" panel on a metal or wood case 4 1/2" deep will adequately house the unit.

« « You Can Make This Tester Yourself!

The actual assembly of the condenser tester presents no difficulties to a man engaged in radio service work requiring capacity measurements. Certain features will be pointed out which will simplify calibration and use of this instrument.

When all connections have been made and the dial covered with a piece of celluloid, connect a pair of phones. Take two 1000-ohm resistors which test alike and connect one to each pair of binding posts at the top of the scale. Adjust the small knob to the ratio position. Turn the shaft of the potentiometer with your fingers until the least possible sound is heard in the phones, then attach the bar knob with the pointer indicating 1 on the outside scale.

Remove the resistors and test a paper condenser of 0.5 Mfd. rating, which you are quite certain is correctly marked. If this condenser matches your internal standard, the pointer should point at 0.5 Mfd. on the middle scale, when the least hum is heard in the phones.

The condensers recommended for standards were purchased in a group of assorted condensers from a parts distributor. They tested exact capacity. Electrolytic condensers obviously cannot be used as standards.

Testing electrolytic condensers! The first test is for leakage. Here the polarity markings on the diagram must be observed and followed. A source of polarizing voltage from the rectifier tube of the radio should be connected. Any D. C. potential between 90 volts and the maximum D. C. working voltage of the condenser may be used. Upon completing the circuit, the Neon bulb will glow brightly. If the condenser under test is good and has low leakage, the light in the bulb will become dim or die out entirely in ten or fifteen seconds. Then the switch shunting the light may be closed and the condenser measured for capacity. If the positive lead is opened, the condenser may be tested in the set under its actual working voltage.

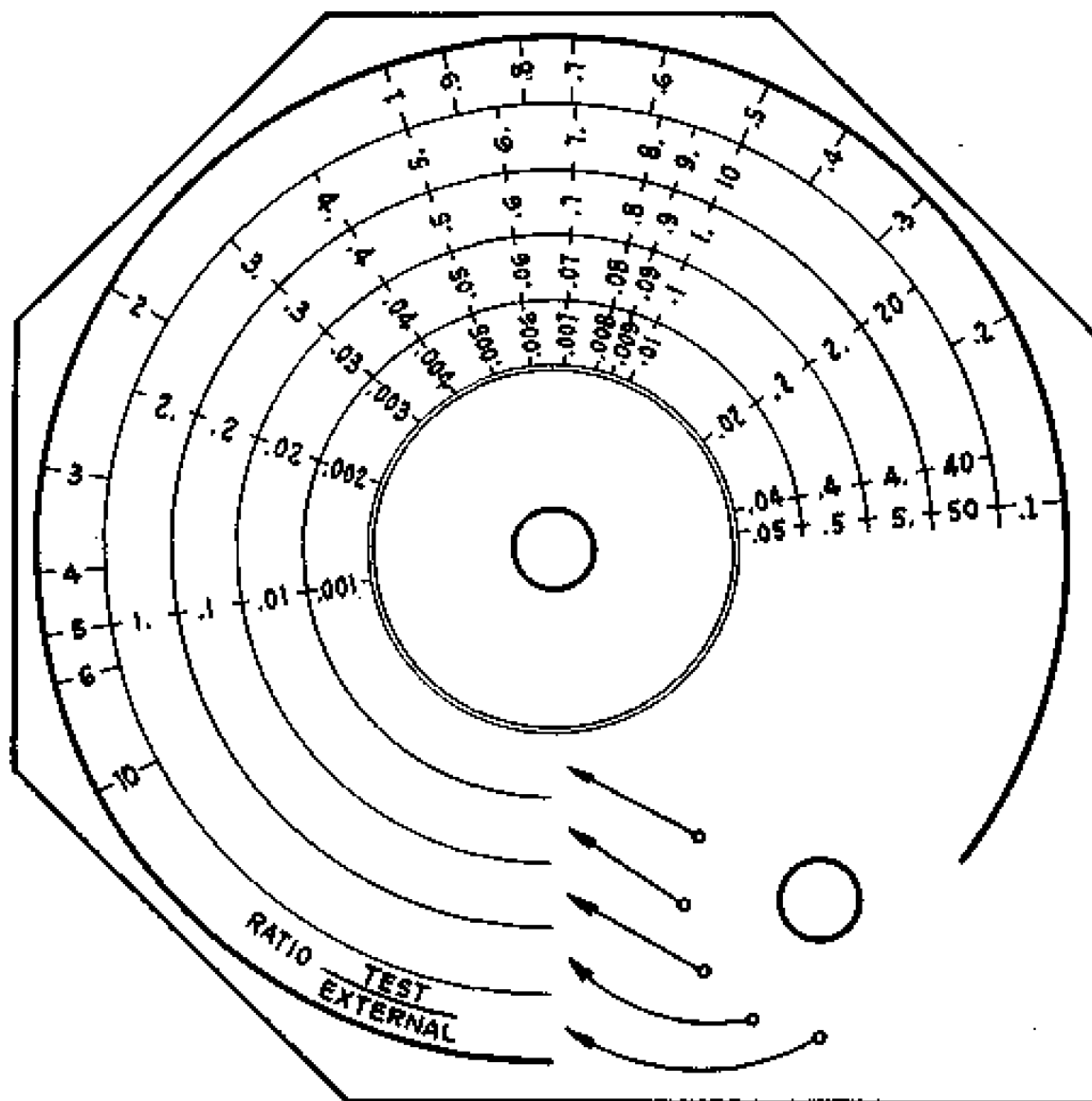

Scale Calibrated for Electrad No. 277 Potentiometer.

What Would You Do?

Chiseling

Jack Nevins made it a policy to quote free estimates on repair jobs to customers who had at some previous time called him for service. When Dan Hutchinson called him to look over an Apex 42 model Jack had serviced a year before, the trouble was quickly located as a burned-out filter condenser, the one microfarad unit following the speaker field circuit, and Jack observed that the volume control, a 400-ohm potentiometer, had several frayed turns of wire and should be replaced. Figuring mentally a one microfarad, 400-volt condenser at \$1.00, a new volume control at \$1.25, and \$2.00 for labor, Jack quoted his client \$4.25 for the complete job, guaranteeing that the set would work satisfactorily when it was repaired.

The customer replied that while he would rather have Jack do the work, having rendered satisfactory service in the past, another firm had offered to repair the set for \$2.00 and Mr. Hutchinson said he couldn't afford to pay Jack twice that much.

Jack Nevins was quite certain he knew who quoted the low price, having observed the card of a rival service concern in the set, and rather than let his competitor get the job, he offered to meet his price.

After getting the set to the shop, Jack had his assistant call the other company, and outlining the trouble, ask for an estimate. The reply was that the job would run between \$5.00 and \$6.00. This led Jack to think his customer had tricked him in obtaining the low price and determined to retaliate by installing a condenser rated at 150 volts and merely soldering the volume control instead of replacing it. He then returned the set and obtained his \$2.00 fee.

What was wrong about Jack Nevins' actions on this service job?

In quoting a price, whether giving an exact list of the parts you intend to use or mentally determining that certain parts of a given quality will be used, you are morally obligated to supply that quality. If the customer insists on a lower price that would make the job unprofitable if you used the originally planned merchandise in making the repair, and you decide to do the job with inferior parts within the price range determined upon, you must inform the customer of that fact. The best way to win out over a price haggling customer is to agree to his price request, but explain that such a price forces you to use inferior material—always let the customer know he is getting only what for which he chooses to pay.

The Old Army Game

A telephone call came to Ray Myer's Radio Shop and the voice on the wire asked, "How cheap can I get a good set of tubes for my Sparton Model 931 radio—it uses six type 484, two type 482-B, and one type 280?"

Now Myer carried those tubes in stock, but shrewdly figuring that the customer had called other shops for estimates, determined to obtain the business—and quickly figuring the cost of six type 56 tubes that could be substituted for the 484 Cardon brand by reducing the voltage with the adjustment on the back of the set—figuring type 71A tubes in place of the 482-B power tubes—and adding the cost of the type '80, he replied, "We can supply first quality standard tubes for \$6.60. For our 50 cent testing charge, we will deliver and install these tubes, adjusting the voltage of your set to suit the tubes and give you maximum service."

The customer accepted Myer's price and had the tubes installed.

Shortly thereafter, an R. F. by-pass condenser burned out and after shopping around, the owner of the set hired a young serviceman to inspect the trouble. The serviceman blamed the trouble on the tubes that were used, explaining that the manufacturer's specifications called for the original type of tube.

The customer then requested that Myer make the repair free, having sold tubes unsuited for the radio. This Myer refused to do. How would you have handled this case?

Ray Myer should have quoted both the price of the specified original tubes and the price of the standard tubes that could be substituted, giving the customer the option. It is always well to explain to a customer when changing from one type of tube to another, that the cheaper substitute tubes may cause a greater strain on certain parts of the set. Under the circumstances, it would have been a good policy for Myer to assume the customer was right and replace the burned out by-pass condenser, then suggest installing the regular tubes at the full price with a reasonable allowance for the old tubes. The good will of a customer is more important than the cost of a minor repair job.

Kidding Yourself

Henry Cashmere learned his service profession, like most of the old timers, from magazines, sound reasoning, and practical experience. Some of the lessons came hard—to the customers.

Dr. Stone's radio was one of those mysterious brands that circulated freely during the period of conversion from battery operation to electric power. During that period eight or ten inches were not considered a long path for common grid return leads to associate in the shaft of a tuning condenser. Hence, when a bearing at the end of the condenser nearest to the one grounding lead became dirty, the R. F. currents had to skip down to the other bearing and then back along the frame of the condenser to the ground lead, as this chassis had a wood base.

Henry worked three conscientious hours, puttering, cussing, and reasoning this trouble out. Eventually, extra pigtail leads between each condenser section solved the problem and Henry felt a little guilty about running up the bill with this time charge that was really due in part to his lack of knowledge. Dr. Stone's bill was only for an hour and a half labor.

Hearing of Dr. Stone's satisfaction, a neighbor with the same type of set and the same trouble came to Henry with his set. Instantly recognizing the trouble, Henry waited until the customer left his shop, then made the necessary repair in about fifteen minutes. Fearing to anger Dr. Stone by charging the neighbor less, Henry made the same charge.

What is wrong about Henry Cashmere's policy? What would you do?

Feeling as he did about Dr. Stone's set did not change the fact that considerable time had been spent on it and if Henry had been working for a dealer who paid on the basis of a 40-hour working week, the three hours' effort would have been charged up to the doctor. It is important to be fair to yourself and charge for your time. If lack of experience causes you to use more time than justified, your rate should be less, as the customer is entitled to a fair amount of results for a given expenditure. The regular minimum charge should have been made for the second customer, for if Henry had ten or twelve more people with the same type of set come in for the same repair, it would be obviously unfair to make them all pay for his lack of knowledge in fixing Dr. Stone's radio. It is no crime to displease a customer—but it is unfair to overcharge him.

★ BUILD YOUR OWN ★
ALL-STAR JR
 ★ ALL-WAVE Superheterodyne ★

Service Data

A. C. line voltage, 115, 60 cycles. D. C. volt measurements made with a 0-50-250-500 voltmeter with 1000 ohms per volt resistance. All measurements from tube socket terminals to chassis, which serves as a common ground.

6A7 socket terminals: Plate, 215; Grids 3&5, 100; Grid 2, 155; Grid 1, 14; Cathode, 0; Top Cap, 0.

6F7 socket terminals: Plate, 215; Pentode Screen, 100; Triode Plate, 10; Triode Grid, 2; Cathode, 4 1/2.

77 socket terminals: Plate, 100; Screen, 10; Suppressor, 5; Cathode, 5; Top Cap, 0.

42 socket terminals: Plate, 205; Screen, 215; Grid, 0; Cathode, 14.

80 socket terminals: Plate, 325 A. C.; Heater, 305.

Voltage readings may vary 10% without affecting the performance of the receiver. However, heater voltages should not exceed 6.5 on the R. F. and A. F. tubes, and should not exceed 5 volts on the filament of the 80 tube.

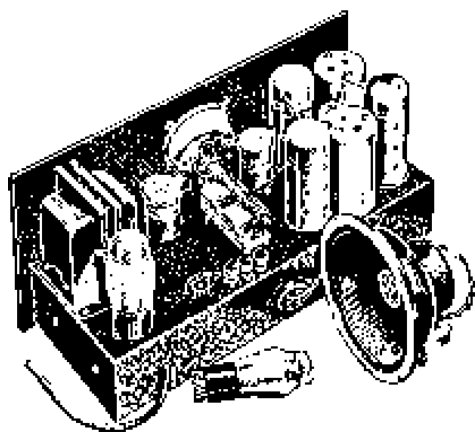

For Profit and Pleasure

When Junior Earns His Way

Custom-built receivers formed a large part of the radio serviceman's activities in the early days of radio. A conscientious serviceman could build a better radio than a customer could buy elsewhere. With the improvement in manufacture of parts came the inevitable quantity production of low-priced receivers, forcing the serviceman out of the custom-building market. Because of keen individual competition, manufacturers permitted their quality of material and workmanship to be sacrificed on a price market. Design has been improved so much that this makes little difference on the broadcast market, but in the high-frequency band, precision hand work means better distance and superior performance.

Servicemen can sell these specialized ALL-STAR JUNIOR Receivers to the multitude of enthusiastic short-wave listeners who lack the tools and the courage to tackle a new job, but who desire the truly amazing results obtainable.

Not only can the parts and labor of assembly be sold, but a doublet antenna system, tubes, and a cabinet will add to the initial profit.

Build the ALL-STAR JUNIOR yourself—offer to help (at your usual service fee) anyone else who wants to build his own. If he likes your set, sell it at a profit and build another. After the first assembly, you will find the sets can be wired in two or three hours. If your customer wants to buy his own parts, offer to complete the assembly for a flat rate. (At least \$10.00.) The sponsors have dozens of letters from servicemen who have built ALL-STAR Receivers for resale. Many have sold more than ten of these receivers. You, too, can increase your earnings by building these splendid receivers.

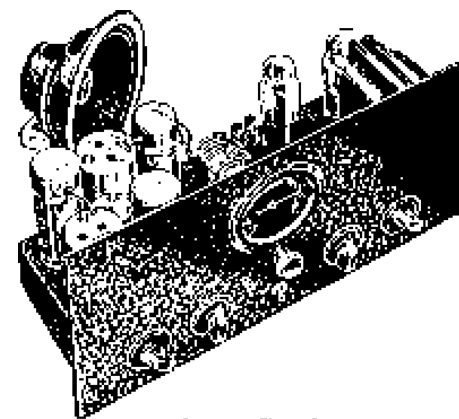

Armchair Explorers

Seek new trails through the ether! Listen to voices and strange music beyond the seas. Follow the planes and ships to adventures and thrills as they battle the forces of nature. Catch the staccato orders of police patrols, the nervous chatter of code, and the homely jargon of amateurs joshing each other from one continent to another. Come home if you wish to your native broadcast stations—the world is at your fingertips, the dial of your ALL-STAR JUNIOR.

The ALL-STAR JUNIOR is a five-tube superheterodyne, all-wave, all-electric band-spread receiver, which can be assembled by anyone familiar with a screw driver, pliers, and soldering iron. It tunes over a wave band of 10 to 550 meters, equivalent to a frequency range of 30 megacycles to 545 kilocycles. The volume and tone quality of reception are equal to the higher priced factory-built American broadcast sets.

The outstanding feature of the JUNIOR, which is not found in commercial receivers, is the beat-frequency-oscillator which permits locating and tuning in far distant stations, even though there is no audible sound modulating the station's carrier wave . . . as a period between announcements which is often as long as ten minutes at foreign stations.

Write to THORDARSON for free details about this radio and how to build it.

Tube data which directly affects the selection of transformers has been compiled in this convenient form. Other tube data may be obtained from the tube manufacturers' bulletins.

Type	Fig. No.	Fil. Volts	Fil. Amps.	Fil. Watts	Max. Plate Volts	Max. Plate M. A.	Max. Screen Volts	Screen M. A.	Max. Volt. Gain or Mu	Audio Db. Gain	May Be Used as	Ohms Load for Stated Power Output	Power Output in Watts
1A6	26	2	0.06	.12	180	1.3	67.5	2.4	Pent Grid Converter
1C6	26	2	0.12	.24	180	2.8	67.5	0.1	P. P. Amp.	3-5000	15-10
2A3	1	2.5	2.5	6 1/4	300	40	4.2	10	P. A. Pentode	7000	3
2A5	15A	2.5	1.75	4.4	250	34	250	6.5	220	35	Hi-Mu Triode
2A6	13	2.5	0.8	2	250	0.8	50	26	Mixer-Osc.
2A7	20	2.5	0.8	2	250	3.5	100	2.2	P. A. Dual-Triode	5000	4-10
2B6	Spec	2.5	2 1/4	5.6	350	45	26.4	22	Det.-Amp.
2B7	21	2.5	0.8	2	250	9	125	2.3	730	37	Diode-Det.
2S-4S	23	2.5	1	2.5	P. A. Pentode	8000	1.4
6A4	6	6.3	0.3	1.9	180	22	180	3.9	100	34	Mixer-Osc.
6A7	20	6.3	0.3	1.9	250	3.5	100	2.2	Cas. P. A. Dual-Tri.	7000	4-10
6B5	6.3	0.8	5.04	300	45	300	6	58	28	Det.-Amp.
6B7	21	6.3	0.3	1.9	250	9	125	2.3	730	37	3-Grid
6C6	11	6.3	0.3	1.9	250	2.3	100	1	1500	42	R. F. Amp.
6D6	11	6.3	0.3	1.9	250	7.5	100	1.75	1280	41	I. F. Pentode
6D7	Spec	6.3	0.3	1.9	250	2.3	100	1	1500	42	R. F. Pentode
6E7	Spec	6.3	0.3	1.9	250	7.5	100	1.75	1160	40	Triode-Pentode
6F7	27	6.3	0.3	1.9	250	6.5	100	1.5	900	39	Det.
00-A	1	5	0.25	1 1/4	45	1.5	Bat.-Amp.	20,000	0.02
01-A	1	5	0.25	1 1/4	135	3	8	14	P. A. Triode	10,200	1.6
10	1	7.5	1 1/4	9.3	425	18	8	14	Drycell Det.
11-12	12-1	1.1	1/4	0.3	135	3	6.6	13	Det.-Amp.	9400	0.05
12A	1	5	1/4	1 1/4	180	7.7	8.5	14	Class B Only	10,000	1.9
19	25	2	0.26	0.5	135	8	Drycell P. A.	6500	0.11
20	1	3.3	.132	.43	135	6.5	3.3	9	R. F. Amp.
22	4	3.3	.132	.43	135	3.7	67.5	1.3	160	34	R. F. Amp.
24A	9	2.5	1.75	4.4	275	4.5	90	1.7	630	38	R. F.-A. F. Amp.	15,000	0.02
26	1	1.5	1.05	1.15	180	6.2	8.3	14	Det.-Amp.	18,500	0.025
27	8	2.5	1.75	4.4	275	5.2	9	14.5	Drycell-Amp.	20,000	0.01
30	1	2	0.06	.12	180	3.1	9.3	14.6	Drycell-P. A.	5700	0.375
31	1	2	0.13	.26	180	12.3	3.8	9.5	R. F. Amp.
32	4	2	0.06	.12	180	1.7	67.5	0.4	780	39	P. A. Pentode	6000	1.4
33	6	2	0.26	.52	180	22	180	5	90	31	R. F. Amp.
34	4A	2	0.06	.12	180	2.8	67.5	1	620	38	R. F.-A. F. Amp.
35-51	9	2.5	1.75	4.4	275	6.5	90	2.5	420	37	R. F. Amp.
36	9	6.3	0.3	1.9	250	3.2	90	1.7	595	38	Det.-Amp.
37	8	6.3	0.3	1.9	250	7.5	9.2	14.5	P. A. Pentode	10,000	2.5
38	9A	6.3	0.3	1.9	250	22	250	3.8	120	34	R. F. Amp.
39-44	9A	6.3	0.3	1.9	250	5.8	90	1.4	1050	40	Voltage Amp.
40	1	5	0.25	1 1/4	180	0.2	30	22

SERVICEMEN'S GUIDE



The Audio Db. gain figures are based upon extensive measurements in THORDARSON'S Laboratory. Future developments may increase these values to 20 times the logarithm of Mu, an ideal condition.

Type	Fig. No.	Fil. Volts	Fil. Amps.	Fil. Watts	Max. Plate Volts	Max. Plate M. A.	Max. Screen Volts	Screen M. A.	Max. Volt. Gain or Mu	Audio Db. Gain	May Be Used as	Ohms Load for Stated Power Output	Power Output in Watts
41	15A	6.3	0.4	2.5	250	32	250	5.5	150	34.5	P. A. Pentode	7600	3.4
42	15A	6.3	0.7	4.3	250	34	250	6.5	220	35	P. A. Pentode	7000	3
43	15A	25	0.3	7.5	135	34	135	7	80	27	P. A. Pentode	4000	2
45	1	2.5	1.5	3.7	275	36	3.5	9	P. A. Triode	4600	2
46	7	2.5	1.75	4.4	250	22	5.6	12	P. A. Triode	6400	1.25
47	6	2.5	1.75	4.4	250	31	250	6	150	34.5	P. A. Pentode	7000	2.7
48	15	30	0.4	12	125	56	100	9.5	28	22	Tetrode	1500	2.5
49	7	2	0.12	.25	135	6	4.5	10.5	P. A. Triode	11,000	0.17
50	1	7.5	1.25	9.3	450	55	3.8	9.5	P. A. Triode	4350	4.6
52	14	6.3	0.3	1.9	100	42	Tetrode	9400	3.5
53	24	2.5	2	5	300	6	25	21.9	V. A. Triode	10,000	1
55	13	2.5	1	2.5	250	8	8.3	14	Det.-Amp.	2000	3.5
56	8	2.5	1	2.5	250	5	13.8	16	Det.-Amp.	19,000	0.03
57	11	2.5	1	2.5	250	2	100	0.5	1500	42	R. F.-A. F. Amp.
58	11	2.5	1	2.5	250	8.2	100	2	1280	41	R. F.-Amp.
59	18	2.5	2	5	250	26	6	12.5	P. A. Triode	5000	1.25
59	18	2.5	2	5	250	35	250	9	100	33.9	P. A. Pentode	6000	3
59	18	2.5	2	5	400	8	Class B	6000	20
71A	1	5	0.25	1 1/4	180	20	3	8	P. A. Triode	4800	0.79
75	13	6.3	0.3	1.9	250	0.4	50	26	Diode-Triode
76	8	6.3	0.3	1.9	250	5	13.8	16	Det.- Amp.
77	11	6.3	0.3	1.9	250	2.3	100	0.5	1500	42	R. F. Amp.
78	11	6.3	0.3	1.9	250	10.5	125	2.6	990	40	R. F. Amp.
79	19	6.3	0.6	3.8	250	8	Class B	14,000	8
85	13	6.3	0.3	1.9	250	8	8.3	14	Diode-Triode	2000	0.35
87	11	6.3	0.4	2.5	250	2	100	1	1250	41	R. F. Pentode
88	11	6.3	0.4	2.5	250	8.2	100	3	1280	41	R. F. Pentode
89	14	6.3	0.4	2.5	250	32	4.7	11	A. F. Triode	5500	0.9
89	14	6.3	0.4	2.5	250	32	250	5.5	125	34	P. A. Pentode	6750	3.4
89	14	6.3	0.4	2.5	180	8	Class B	9400	3.5
181	Spec	3	1.75	5 1/4	180	20	5	11.5	Sparton P. A.	7000	1.5
401	Spec	3	1	3	180	6	8.7	14.3	Kellogg Triode	14,000	0.03
482B	1	5	1.25	6 1/4	250	18	5	11.5	P. A. Triode	4500	1.4
483	1	5	1.35	6 3/4	250	25.3	3.3	8.5	P. A. Triode	3900	1.6
485	8	3	1.25	3 3/4	90	5	12.5	15.9	Sub. for 484
586	1	7.5	1.25	9.3	450	55	3.8	9.5	Same as 50	4350	4.6
864	1	1.1	0.25	.3	135	3.5	8.2	14	Porta. Osc.
955	Spec	6.3	0.16	1	180	4.5	25	21.9	H. F. Det.-Osc.
WUNA	Spec	6.3	0.4	2.5	250	7	9	14.4	Dual Mike Mix
WUN	Spec	2.5	1.0	2.5	250	7	9	14.4	Dual Mike Mix

TUBE SYMBOLS AND BOTTOM VIEWS OF SOCKET CONNECTIONS

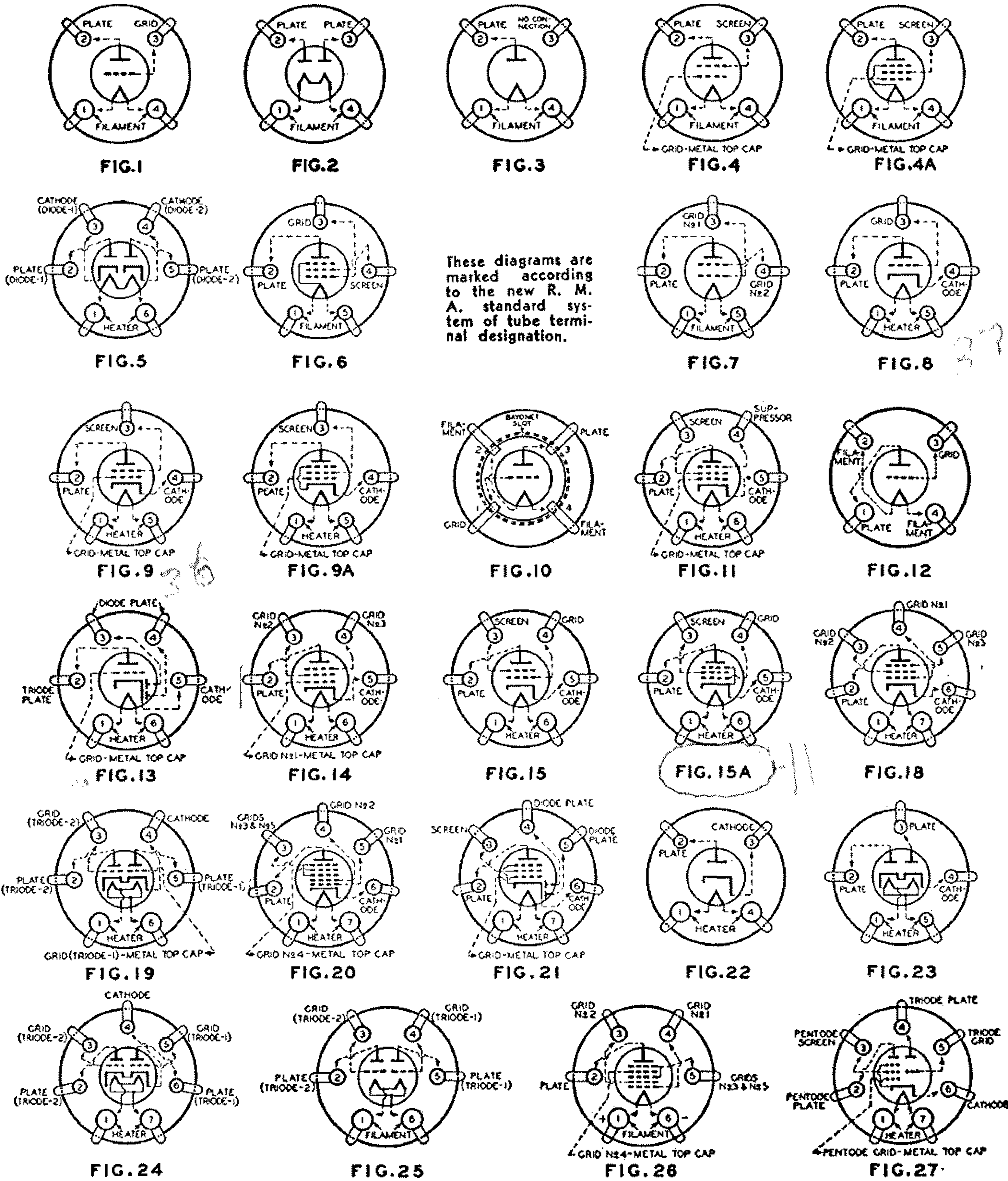

Rectifiers

Type	Fig.	Fil. V.	Fil. A.	Fil. W.	A.C. Volts Per Plate	D.C. Current Max.	Type	Fig.	Fil. V.	Fil. A.	Fil. W.	A.C. Volts Per Plate	D.C. Current Max.
5Z3	2	5	3	15 W.	500 V.	250 Ma.	81	3	7.5	1.25	9 1/2 W.	700 V.	85 Ma.
12Z3	22	12.6	0.3	3 3/4 W.	250 V.	60 Ma.	82	2	2.5	3	7 1/2 W.	500 V.	125 Ma.
25Z5	5	25	0.3	7 1/2 W.	125 V.	100 Ma.	83	2	5	3	15 W.	500 V.	250 Ma.
1-v	22	6.3	0.3	1.89 W.	350 V.	50 Ma.	84	23	6.3	0.5	3 1/4 W.	350 V.	50 Ma.
80	2	5	2	10 W.	400 V.	110 Ma.							

THORDARSON ELECTRIC MFG. CO.
 500 W. HURON ST.
 CHICAGO, ILL.