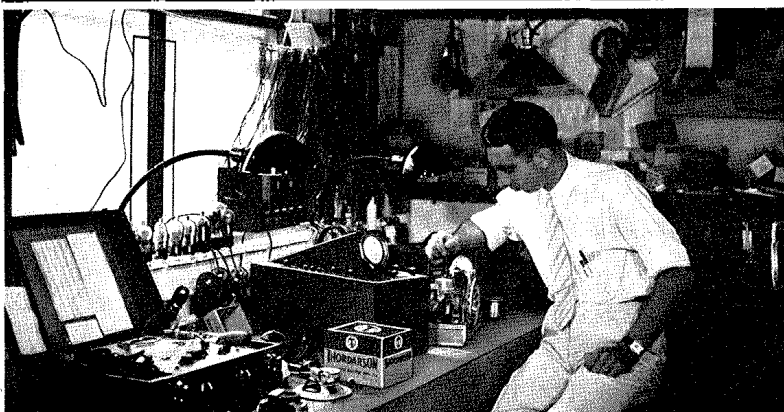


THORDARSON



No. 342-B

RADIO SERVICING GUIDE

PRICE 15c

THORDARSON ELECTRIC MFG. CO. . . CHICAGO

SUN RADIO CO.
227 FULTON ST.
(COR. BROADWAY ST.)
New York City



The Story of Thordarson

Proud of its heritage and standing at the doorway of fifty years devoted to progressive growth, the THORDARSON ELECTRIC MANUFACTURING COMPANY has played a major part in the great modern drama of radio. The distinction of being the oldest and largest exclusive transformer manufacturer in the world is THORDARSON'S. C. H. Thordarson, the founder and head of the company, first fabricated transformers for the use of physicists throughout the world. As a young man, Thordarson founded his business with the rugged, individualistic precepts of his Icelandic forebears. So precise are his manufacturing requirements, that every part used in the manufacture of his transformers then and today, copper wire excepted, is fabricated in the THORDARSON plant which occupies an entire city block.

The first transformers built by THORDARSON were used in the early efforts of engineers pioneering wireless communication. Later, such immortal heroes as Heaton, who first sent a distress signal from a sinking ship, used THORDARSON transformers for high frequency spark transmission. The advent of the vacuum tube and the tremendous advancement in communication made possible by the inventions of DeForest, Armstrong and countless others developed a great demand for audio transformers. THORDARSON was among the first to meet this need and grow with its development. After C. W. had been perfected the growth of radio became one of the wonders of modern science. Marching forward with radio, strongly conscious of the pioneering instinct which made its name respected in all electrical and radio fields, THORDARSON has been largely responsible for the development of radio transformers. From the clumsy, noisy, non-shielded unit of early days to the present efficient design.

Pioneer manufacturers such as Kennedy, Argus, Zenith, Sparton and others called on THORDARSON for their first audio transformers. With the creation of A. C. operated sets and the famous type 112 tube, the name of THORDARSON was readily recognized as the logical source of supply in the component transformers. Heater tubes, a later development, called on THORDARSON to develop the necessary power supplies in the form of compact power transformers.

Today, the huge THORDARSON factory in Chicago turns out transformers to fit every known need. Aside from its splendid research laboratories and staff of preeminent radio engineers, it boasts the world's most complete private library specializing in electrical and radio technical subjects.

Any THORDARSON customer will tell you the reason for the company's success. It is the word of mouth testimony by thousands of satisfied customers who make up the widespread THORDARSON family.



EARLY SPARK
TRANSFORMER

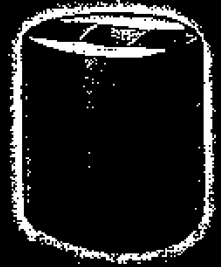
EARLY AUDIO
FREQUENCY
TRANSFORMER

TRU-FIDELITY

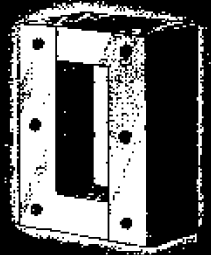


Table of Contents

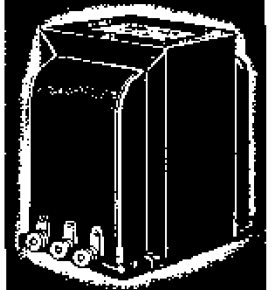
The Story of Thordarson	2
A Direct Reading Vacuum Tube Voltmeter	4
Adding a Tuning Indicator to any Receiver	6
How to Make and Use Output Indicators and Align Receivers	8
Condensed Underwriters' Specifications for Radio Receivers	10
Bias Resistor Charts	11
Relation of Transformer Core Size to V. A. (Watts) Capacity	13
Phone-Radio Oscillator	14
Elimination of Code Interference	15
Installing Piezo-Electric Crystal Pickup Units	16
Auto Installation Hints	18
Radio Interference From Neon Signs	21
Improving the Fidelity of Any Receiver	22
Simplified Radio Math Formulas	26
Tube Data	29
Octal Base Tubes — Socket Connections	31
Tube Symbols and Bottom Views of Socket Connections	32
Rectifier Tables	32



COIL



CORE



CASE





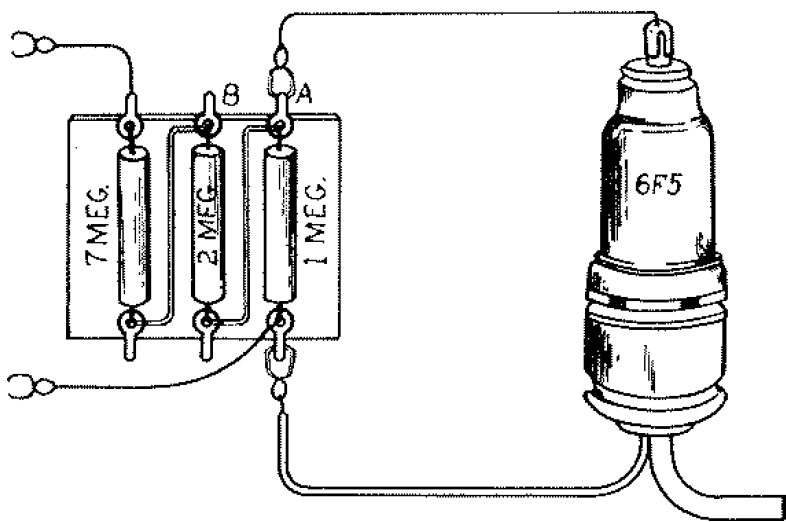
A Direct Reading—Vacuum Tube Voltmeter

The vacuum tube voltmeter is ideal for measuring, as this device draws virtually no power from the circuit being analysed. As the calibration remains substantially constant from low audio to radio frequencies, the instrument can be calibrated by using a stepdown transformer with an A.C. voltmeter across the secondary as a source of input voltage to the device.

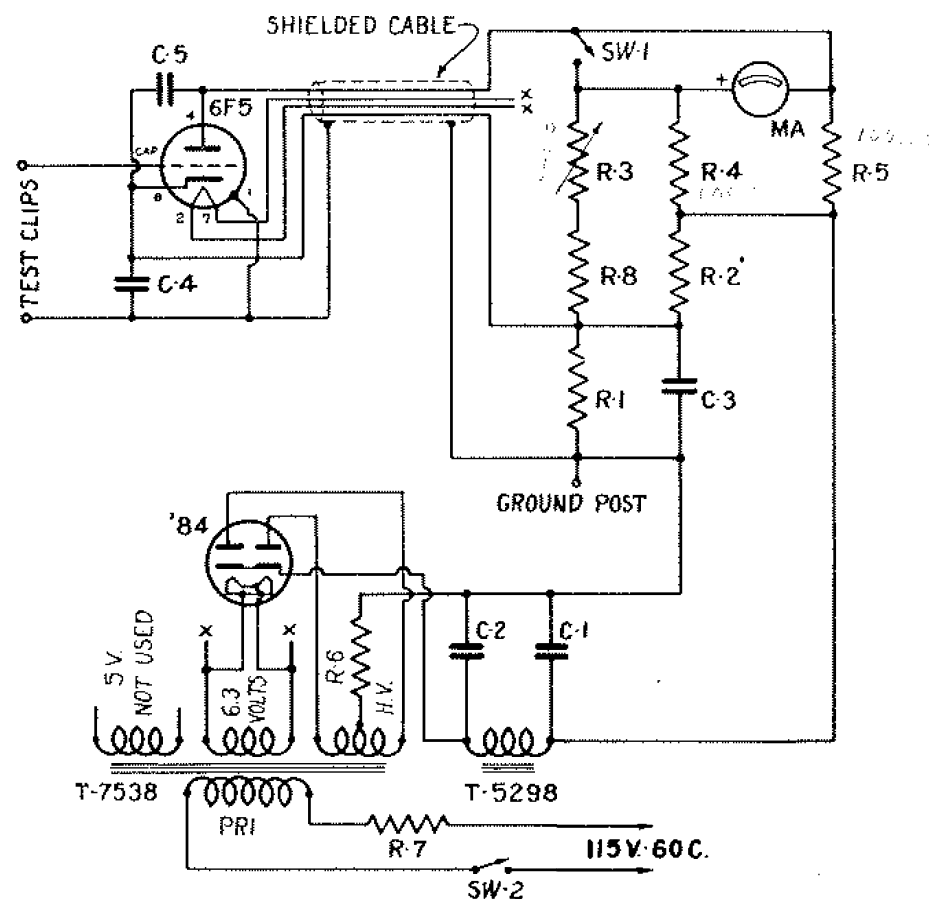
be made. The circuit consists of a bridge arrangement, with the vacuum tube acting as one arm of the bridge.

With no voltage input to the voltmeter (grid of tube shorted), R₃ is adjusted so that the meter reads zero, indicating a balance. A voltage impressed on the grid of the measuring tube will change the plate resistance of that tube, and will unbalance the bridge. The amount

FIG - 2



The range of this V.M. is approximately 2.3 volts R.M.S. without any multiplier. By using a multiplier as shown in Figure 2, the range can be increased to about 22 volts. The meter should be calibrated on each step of the multiplier if accurate readings are to

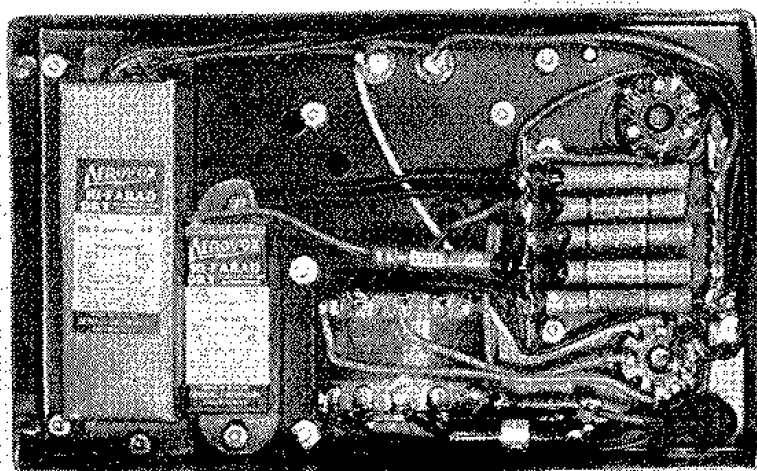
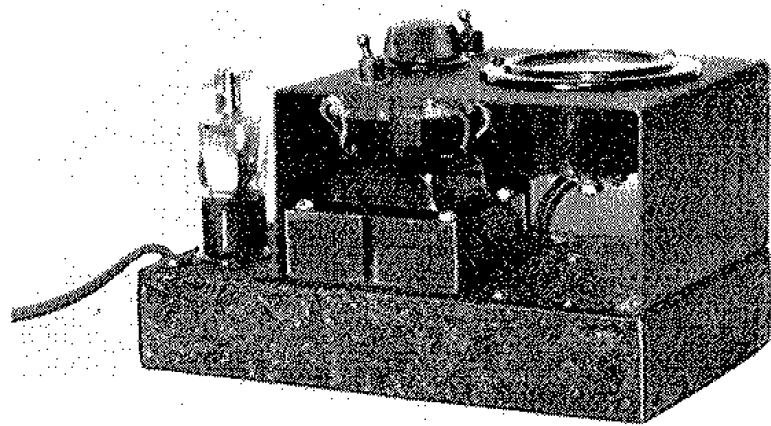


of unbalance is indicated by the milliammeter and the instrument can be calibrated so the meter will directly show the voltage impressed on the grid of the 6F5 tube.

The experimental model was built on a metal base 8 1/2" x 5 1/8" x 1 3/4" deep. The meter and controls were mounted on a metal "U" 6 1/4" x 5 1/8" x 3" high. Layout and construction are clearly shown in the photographs. The Amphenol socket for the 6F5 was connected to the end of a 4 wire shielded rubber covered cable, and the "postage stamp" condensers C₄ and C₅ connected at the socket. A six inch lead is soldered to the metallic cable shielding, and the base placed over the condensers and socket bottom. Socket terminals 3, 5 and 6 should be removed to make room for the condensers, as they are not used.

In the model, the other end of the cable was attached to a six prong plug for convenience, although this is not necessary. A small battery clip should be attached to the ground wire at the 6F5 socket and another to a grid clip which attaches to the cap of the tube.

In the setup shown in circuit of Figure 1, the voltmeter is connected to the line and the power applied by closing SW₂ after the meter has been shorted by means of SW₁. The two test clips should be connected together and after tubes have warmed up, SW₁ opened and R₃ adjusted so the meter reads zero. SW₁ should



always be closed before test clips are moved to prevent injury to the meter. For the same reason, the voltmeter should never be used across circuits that do not provide a D.C. return. The voltmeter is connected across the 2.5 volt winding of the transformer in circuit of Figure 1, and a calibration made by plotting the reading on the milliammeter against that of the A.C. voltmeter. A sample curve is shown in Figure 10. The loading resistor must be across the secondary of the filament transformer during calibration to minimize errors due to wave form distortion in the calibrating voltage.

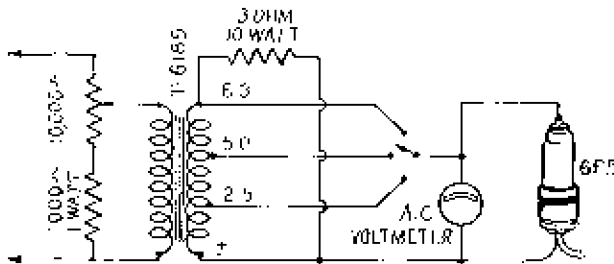


FIG. 1

If the multiplier is to be used, each step of it should be calibrated in the same way, using proportionately higher voltages.

The vacuum tube voltmeter has many uses in radio service work, only a few will be indicated here. A frequent use of the voltmeter is as an output meter. It is connected across the voice coil of the speaker, and the alignment of the receiver circuits carried out in the usual manner.

In receivers employing AVC, the voltmeter may be connected between the grid return of one of the controlled tubes to the ground. In this position, the meter may be used to align the circuits, adjusting for maximum voltage reading. The AVC operation of the receiver may be checked by varying the input from the test oscillator and noting if bias voltage increases with increase in signal input. Faulty operation may be due to defective tubes, resistors or leaky bypass condensers.

Leaky coupling condensers in resistance coupled audio stages will usually cause distortion. In the circuit of Figure 4 the plate supply voltage flows through resistor R, through C if the latter is leaky, and returns to ground through the grid resistor. The voltage drop due to this current through the grid resistor opposes the cathode bias resulting in the operating bias becoming too low. To check for a leaky condenser, connect the vacuum tube voltmeter from grid of V_2 to ground, and apply plate voltage to the amplifier. With no signal applied to the amplifier, there will be no voltage reading if the condenser is good.

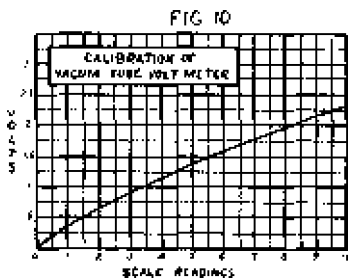


FIG. 10

The voltmeter can be used also in measuring the power output of an audio amplifier. A load resistor of proper value is used to replace the speaker, and the voltage across the load resistor measured with a steady signal applied to the amplifier. The power output will be

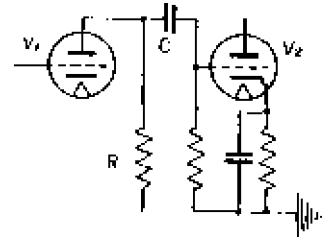


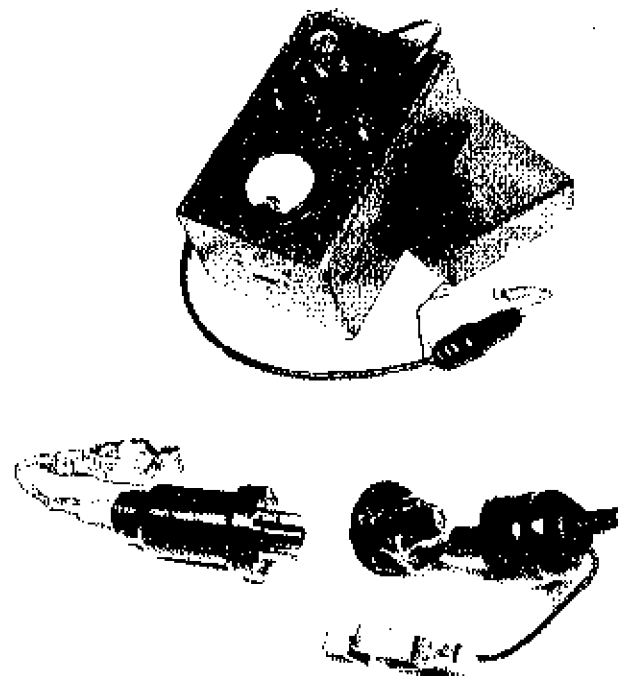
FIG. 4

$$P. O. = \frac{(\text{output voltage})^2}{\text{Load resistance (ohms)}}$$

In many cases where an R.F. coil of a tuned R.F. receiver is burned out, it is desirable to rewind the coil if replacements are difficult to secure. The rewind coil can be matched to the other coils by coupling a test oscillator to the primary of a good coil and tuning the secondary with a variable condenser, connecting the vacuum tube across the coil as a resonance indicator. The inductance of the repaired coil should be varied until resonance occurs at the same condenser setting used on the good coil. Coupling between the test oscillator and the coil should be very loose to avoid detuning effects.

In a receiver which is inoperative, due to R.F. circuit defects, such as shorted coils or condensers, the faulty stage can be quickly located by coupling a test oscillator to the antenna post and connecting the

Continued on Page 31





Adding a Tuning Indicator to Any Receiver

Many radio programs are spoiled by faulty tuning. Few listeners are gifted with an ear for tonal qualities and can rarely tune a receiver to the exact point of resonance with a careless twist of the dial. Electrical means of indicating resonance have been introduced so that the eye may aid the ear.

The type of receiver determines the type of resonance indicator needed. Receivers may be divided into two broad classes for the selection of proper resonance indi-

polarity of the meter. If grid-leak and condenser detection is used, the meter reading will **DECREASE** with resonance. If the self-bias (power) type of detector is employed, the meter reading will **INCREASE** with resonance.

Choose the meter to fit the receiver. First measure the plate current of the detector tube with a standard milliammeter. Then a standard tuning meter should be used having a maximum range which just exceeds the maximum plate current of the detector tube.

In some of the older receivers, a more expensive tuning meter is needed, as these receivers employ detector tubes which operate on low values of plate current — from about 500 microamperes to 2 milliamperes. Meters that show this value of current are, of course, more expensive than meters indicating from 5 to 10 milliamperes.

Your local jobber has standard tuning meters in stock which come complete with an escutcheon to fit individual requirements. Select a wide escutcheon as it will cover up a rough cut in the wall of the cabinet made in mounting the meter.

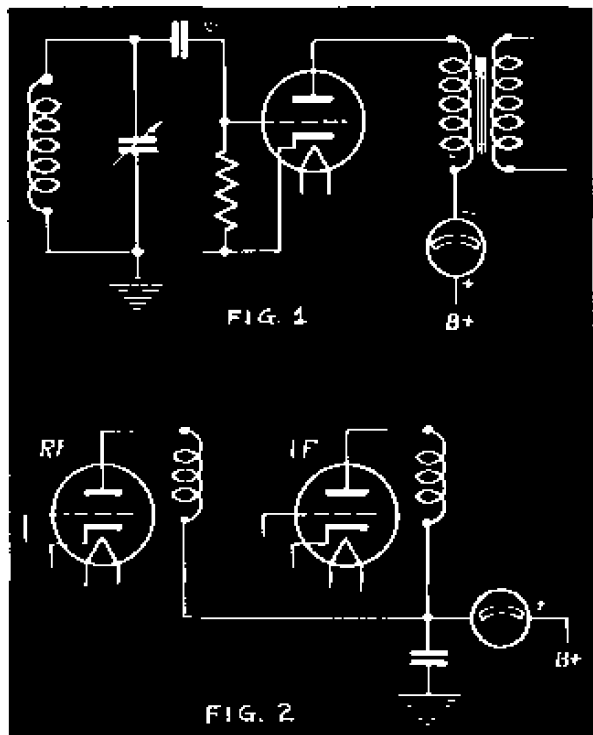
To most radio men, the mounting of a tuning meter is a problem. If the work is done right, however, the job is greatly simplified. A sharp half inch wood chisel, brace and bitt, are the most practical implements to use. Choose the spot where the meter is to be mounted avoiding unnecessary thickness in cutting through the cabinet wall. Place the meter over the selected spot and trace its outline on the panel with a pencil.

The next step is most important. The modern receiver cabinet is made of veneer (strips of wood glued together). These strips are very thin so that rough handling may split them, so care must be exercised in starting the hole. After the pencil outline is made, place the cutting point of the chisel on the outline and by lightly tapping the tool point of the chisel on the outline cut your circle until the first ply or strip is cut through. Next bore a hole with the brace and bitt in the center of the outlined space and continue to cut through the cabinet wall with the chisel in the same manner as above. Be sure to hold the chisel so that if it slips it will fall towards the hole in the center. This prevents scratching. After the rough hole is cut, use a sharp pocket knife to smooth off any ragged edges.

Some tuning meters come equipped with pilot lights. In using these meters, connect the leads to a filament circuit. The pilot light should be mounted on a bracket so that the light from it falls on the rear of the tuning meter scale.

If the receiver employs A.V.C., connect the tuning meter as shown in Fig. 2. Here the meter is in series with the plate circuits of several tubes. It must, therefore, be capable of measuring the maximum plate current of these tubes. Note particularly that the meter is **NOT** a part of the plate load for either tube. (Do not connect the meter between the plate of the tube and its load).

The new 6E5, a small cathode-ray tube commonly called the "Electric Eye" or "Magic Eye" may be used



cators — those with and without A.V.C. In an A.V.C. receiver, the plate currents of the R.F. and I.F. tubes decrease with resonance. This means that a meter may be connected in series with either the plate or cathode circuits to indicate resonance, minimum reading on the meter indicating the perfect resonance.

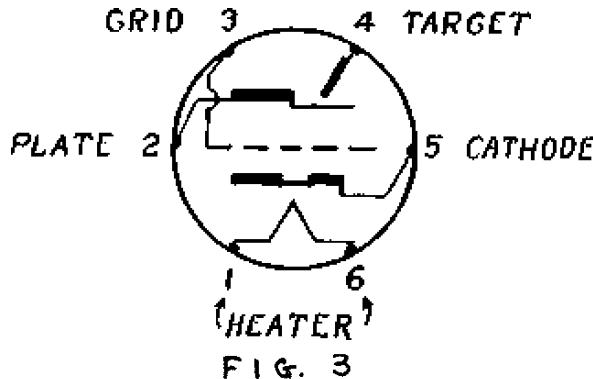
In non-A.V.C. receivers, resonance does not cause a noticeable change in the plate current of any tubes except the detector. Therefore, the tuning meter should be connected in series with either the plate or cathode circuit of the detector. The plate circuit is preferable, as the resistance of the meter need not be considered. On the other hand, if the meter is connected in the cathode circuit, its resistance (unless it is very low) will cause the grid voltage to increase since an additional voltage drop is created in the cathode circuit when the plate current increases.

Fig. 1 shows the recommended method of connecting a tuning meter for non-A.V.C. receivers. Note the



as a resonance indicator on any A.V.C. circuit. Fig. 3 shows the bottom view of the socket for this tube.

The tube is so arranged that under normal conditions (no signal, zero grid bias) a fluorescent pattern equal to about 100 degrees appear on the screen of the tube. This is similar to the glow seen on the screen of a



cathode-ray tube in an oscillograph. This effect is shown in Fig. 4. These tubes are so connected that as the A.V.C. voltage begins to take effect (showing an approach to resonance) the width of the shaded area on the screen will DECREASE. The narrower the shaded area, the nearer the point of resonance — provided the contacts of the circuit have been chosen correctly. With improper connection, the pattern may close up entirely or blur. This may be prevented by limiting the negative voltage applied to the grid of the 6E5 tube. R3 of Fig. 5 controls the value of the negative grid voltage.

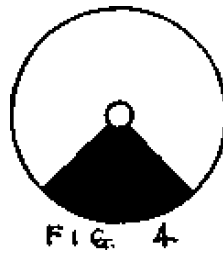
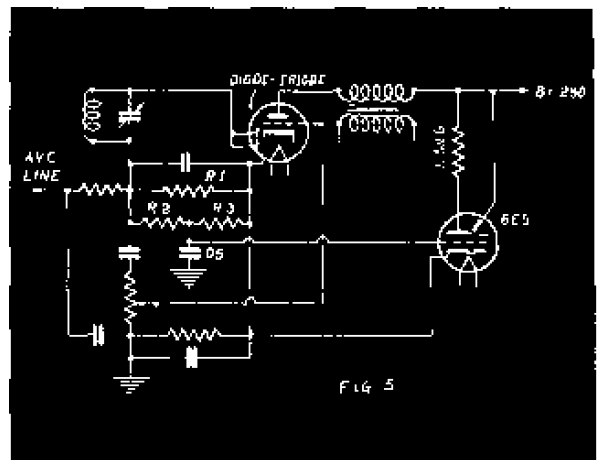


Fig. 5 shows the tube connected to an ordinary diode circuit. The plate and target of the 6E5 should be connected together by means of a 1 megohm resistor. The target terminal should then be

connected to approximately 250 volts positive. The cathode of 6E5 should connect to the cathode of the diode tube.

R1 may be load resistor for any diode type of circuit. It is to be shunted by R2 and R3. These two resistors should be chosen with two purposes in view. (1) To have a high enough value so that the parallel effect across R1 will not be noticeable. This means that from 3 to 6 megohms total are required. (2) R2 should be so chosen that when the receiver is tuned to the strongest local signal, the pattern on the 6E5 will not close or blur. Because of differences in design, individual receivers will require R3 to have any value between 200,000 ohms and 1 megohm. One should start with 200,000 ohms and increase the value of R3 until the desired effect is achieved.

These tubes should be mounted horizontally so that the end of the tube shows through the cabinet wall. Regular kits with the tube escutcheons are recommended. When making a hole in the cabinet wall for the end of the tube, the same precautions should be observed as for tuning meters. All leads to the tube should be kept as short as possible.



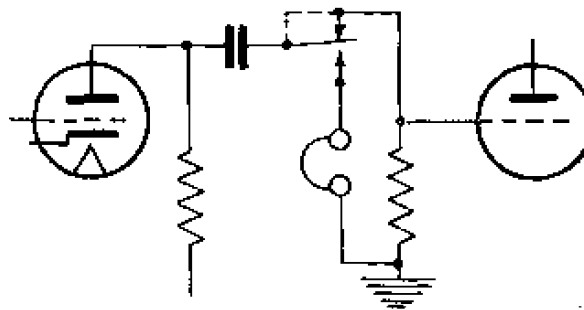
Adding Headphones to Radio Receivers

There are many receiver installations where the addition of a headphone connection is an easy and profitable job for the serviceman. In many homes, some member of the family is hard of hearing and requires headphones for complete enjoyment of broadcast programs. In other cases, it is desirable to listen to late programs without disturbing others in the home.

The circuit shows the manner of connecting the phones across the grid resistor of the power stage. The tube preceding may be

either the first audio tube or a duo-diode detector. A switch is used to cut the phones in or out of the circuit. If the connection shown by the dotted line is made,

both the speaker and phones will be energized. If omitted, the speaker will be silent while the phones are in operation. Either an open circuit jack or phone tip jacks may be installed in the receiver for attaching the phones. The latter have one terminal grounded so there is no possibility of a shock in handling the phones.





How to Make and Use Output Indicators and Align Receivers

Any device giving an indication of the power output of a radio receiver may be used to indicate the condition of the tuned stages in the receiver. Thus if a trimmer condenser capacity is decreased or increased the power will change. Maximum output indicates the peak of resonance.

The "output meter" ordinarily is nothing more than an A. C. voltmeter. It is usually of the low current, high impedance, copper-oxide rectifier type, which is not affected by changes in frequency and will give a full scale deflection with little current.

A magnetic vane type of A. C. voltmeter generally requires more current than is available at the terminals of some tubes and it loses its sensitivity if used with frequencies other than 60 cycles per second. This is the frequency for which it was designed, so it is not recommended for use on an output meter.

Other A. C. voltmeters, which give a reasonable deflection when connected across the speaker terminals, (or any pair of terminals to be described later) may be

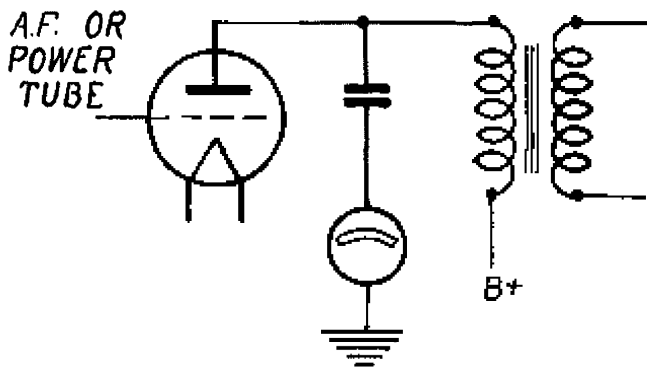


FIG. 1

used, including those of the "hot-wire", "thermo-couple", "vacuum tube", "rectifier", and even some "magnetic vane" types.

A trial will tell you if the A. C. voltmeter you have will serve. If D. C. is present in the circuit to which you wish to connect your A. C. voltmeter, then include a 1 mfd. or larger size, fixed condenser, in series with the meter, to exclude the D. C. (See Figure 1). Reduce the volume control and connect the meter to any pair of terminals in the audio frequency amplifier where sufficient A. C. from the signal is produced.

More voltage may exist across one pair of terminals than across others, therefore, select terminals where the meter deflects to some convenient point on the scale when the signal is tuned in. Next raise the volume control as it is needed to keep the deflection at or near the center of the meter scale.

There are other meters and devices which may be used as output indicators. A low range milliammeter may be connected in series with the detector plate circuit. See Fig. 2. If the detector is the biased type, the trimmer condensers should be adjusted for maximum meter reading. If the grid-leak and condenser system

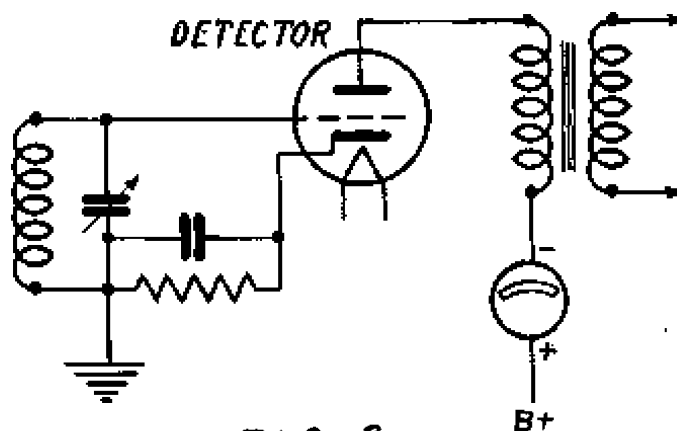


FIG. 2

of detection is employed, the trimmer condensers should be adjusted for minimum reading.

Another useful output indicator is shown in Fig. 3. This consists of a T3399 output transformer, a 1/4 watt 110 volt neon bulb and a 25,000 ohm potentiometer. The voice coil winding of the transformer is connected across the voice coil of the speaker. The potentiometer across the other winding is adjusted until the neon bulb just begins to glow. It will be very sensitive to changes in output. As the tuning circuits are brought nearer to resonance (by adjusting the trimmers), the neon bulb will grow brighter. The object is to adjust all the trimmers for the most brilliant glow of the bulb with the potentiometer at lowest possible setting.

Whatever the type of output indicator, it must be connected across two terminals. These may be the voice coil of the speaker, the secondary of one of the coupling transformers, the primary of a coupling transformer, from plate to plate of the push-pull tubes, or from plate to chassis of any audio or second detector tube.

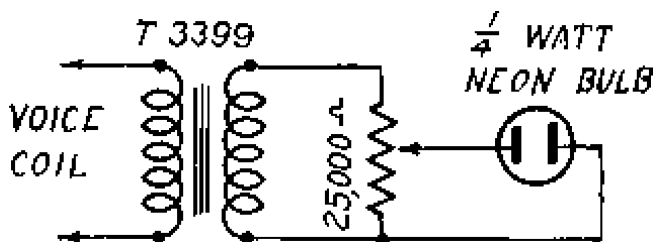


FIG. 3

Those servicemen who have a cathode ray oscillograph may connect its vertical terminals across any of the above pair of terminals where there is sufficient voltage to give a deflection for use as an output meter, since this instrument will also give vertical deflections when A. C. voltages are amplified by the receiver.

The "output meter" serves the same purpose as the "tuning meter" which the customer watches when tuning in the station (mentioned in another part of this book.) With its use you can always determine the point of



resonance when you adjust the main tuning control or any of the trimmers used in the tuning circuits. A signal generator and output meter should always be employed when adjusting tuned circuits.

The steady signal produced by a signal generator allows you better adjustment than the varying signal obtained from a broadcast station, therefore, the use of a signal generator will be specified in these instructions.

Bear in mind that the signal generator and the output meter are added conveniences because more dependable adjustments can be made in less time through their use, and there will be no question when each adjustment has been properly made.

In other words, with a signal generator you can adjust the frequency output until the characteristic buzzing signal is heard. If you were using a broadcast signal you would have to guess or wait until you could identify the station to determine the frequency. If you use a broadcast signal, you may find that you have synchronized the trimmers to bring in one station on the main tuning dial where another should be received.

Alignment Procedure for T.R.F. Receivers

Connect the two leads from a signal generator (the modulated oscillator) to the antenna and ground binding posts of the receiver. Remove the antenna so that broadcast signals will not interfere with the reading on the output meter. The ground is left connected to keep hum at a low level and to stabilize the receiver so there will be little chance for the circuits to oscillate.

Connect the output meter across a pair of terminals as explained previously where a reading will be indicated when the steady signal is tuned in. Turn on the receiver and turn its volume control to maximum. Set the variable condensers of the receiver to receive the highest frequency (or some convenient value between 1200 KC and 1500 KC) by turning the receiver tuning knob so the condenser plates are almost entirely out of mesh. Start the signal generator and adjust its R. F. frequency selector knob so that it will produce the loudest sound in the speaker, without changing the "volume control" or "output control" or "attenuator" which controls the volume only. The purpose of this adjustment is to tune the signal generator and the receiver to resonance, or to point which is as near resonance as the present alignment of the receiver will permit.

A reading will now be indicated on the output meter in addition to a steady sound from the speaker. Now adjust the "volume control" (sometimes marked "output" or "attenuator") on the signal generator so the reading on the output meter will show a convenient deflection. Try to get an adjustment near the half scale position so you can readily watch decreased as well as increased reading when altering the adjustments. If necessary, change the setting of the volume control on the receiver to aid you in getting this deflection. A T.R.F. receiver should be adjusted at 600, 1000 and 1400 K.C. for the best results.

This is done by setting the receiver dial at 1000 K.C. if calibrated, and the test oscillator set at the same frequency. The trimmers on each stage are now

adjusted for maximum output, starting with the detector stage and working forward to the antenna stage. As the receiver is brought into alignment it may be necessary to reduce the output of the test oscillator to prevent the meter from going off scale. The receiver should now be checked at 1400 and 600 K.C. for alignment. If one of the rotor plates in each section is cut in segments, these segments may be bent to give highest output at all three settings.

Notice that small changes in the setting of any volume or tuning control produce small differences in sound which are difficult to distinguish. These changes are readily noticed on the meter. This is why the meter is preferable to listening to the sound alone.

Trimmer condensers are used to eliminate moving the condenser rotor during the aligning procedure, and are connected in parallel with the main tuning condensers. Trimmer condensers should not be confused with "neutralizing condensers". Remember that one terminal of a "neutralizing condenser" may at times connect to either terminal of the main tuning condenser; neutralizing condensers are not connected in parallel with the main tuning condenser.

Furthermore, neutralizing condensers are seldom used with screen grid tubes, or with triode tubes of the filament or heater type, which have suppressor resistors connected in the grid circuit. These simple distinctions should be noted because many receivers may not have trimmers, whereas other sets may not have "neutralizing condensers".

Learn how these two types of condensers are connected since the procedures for their adjustment are opposite. This is necessary because some manufacturers call a "neutralizing condenser" by the name of "balancing condenser" while another manufacturer may call a "trimmer" a "balancing condenser".

Most trimmers are located on the main tuning condenser gang and are adjusted by means of a slotted screw or a hexagon head nut. These are reached through holes which are punched in the shields which cover the main tuning condensers. Screwdrivers or socket wrenches when used for turning these adjustments should be of insulated material with little or no metal present. These special tools are recommended because the metal found in ordinary tools of this type will change the capacity of the circuit making it difficult to adjust for correct maximum output.

Neutralizing the R.F. Circuits

Where triode tubes are used in R. F. stages there is a tendency for the stages to act as "undesired signal generators." This tendency must be prevented. The usual practice is to connect either a resistor in the grid circuit of the R. F. stage or to feed back energy from some other circuit by means of the conventional neutralizing circuit. This tendency to act as an "oscillator" is more pronounced when the main tuning condenser is adjusted to receive the higher broadcast frequencies.

To "neutralize" the circuits, align the stages properly so that the greatest output from the signal generator is indicated on the output meter. The signal generator and output meter are left connected, to



produce the greatest output at a setting, preferably near 1400 KC. Stop the filament current flow to the R. F. tube which is located ahead of the detector, leaving the rest of the circuits connected in the regular manner, including one side of the filament circuit of the tube in which we are interested.

The usual practice is to use a special adapter which opens one filament connection only. The same thing can be accomplished by insulating one filament prong. Another stunt is to use a tube which has one filament prong cut off. In every case, the other filament prong must make good contact to the filament circuit so that the natural capacity of the tube will be present.

Having stopped the filament current, adjust the neutralizing condenser in this last R. F. stage until the least deflection is shown on the output meter. Sometimes the circuit is already partly neutralized so little or no reading is shown; and in this case, it will be found that the least sound in the loudspeaker will allow you to get the proper adjustment.

Re-establish the filament or heater current in this stage and note now that maximum output again is obtained. Then stop the filament current flow in the R.F. tube ahead of the just adjusted stage. Again carry out a similar procedure for getting the least output

while adjusting the neutralizing condenser in this stage.

Some servicemen have the impression that neutralizing can be carried out by leaving the tube heated and that it is not necessary to stop the filament current in the one tube neutralized. A good neutralizing job requires that the filament or heater current be stopped.

Superhetrodyne Tuning Adjustments

First feed the correct I. F. from the signal generator into the 1st detector circuit and connect an output indicator as already described. Get a rough adjustment for all I. F. trimmers, then repeat the adjustment to get the greatest peak for each trimmer. This does not refer to band pass circuits since these are best adjusted with the aid of an oscillograph.

The R. F. and oscillator trimmers on the gang condenser are usually called high frequency trimmers. These are next adjusted at 1400 K.C. for best results. As a rule, no adjustment is necessary at 600 K.C. unless the oscillator tube employs a low frequency padder condenser. In this case feed 600 K.C. to the input of the receiver and set the receiver dial to 600 K.C. Adjust the low frequency padder for greatest output at a 600 K.C. setting for both the receiver and signal generator.

Condensed Underwriter's Specifications for Radio Receivers

Below, are given for the guidance of Radio Servicemen, Condensed Underwriter's specifications for Radio receivers, taken from the "National Electrical Code Handbook" by Abbot, published by McGraw-Hill Book Co., 330 West 42nd Street, New York, N. Y.

Antenna and Counterpoise.

(3702-a) Outdoor antenna and counterpoise conductor sizes shall be not less than No. 14 if of copper or No. 17 if of copper-clad steel, bronze, or other high-strength corrosion-resistive material.

(3702-a) Outdoor antenna and counterpoise shall be securely supported and constructed in a workmanlike manner. Insulators used in antenna or counterpoise conductors shall have a mechanical strength greater than the conductors which they support.

(3207-b) Antenna and counterpoise conductors outside buildings shall not cross over the conductors of electric supply or trolley circuits of more than 250 volts to ground and shall be kept well away from all such conductors so as to avoid the possibility of accidental contacts; they shall not be attached to poles or similar structures carrying such electric supply conductors.

It is recommended that antenna and counterpoise conductors be so installed as not to cross over or under electric supply conductors of less than 250 volts.

(3702-c) Antenna and counterpoise, where in proximity to the conductors of electric supply circuits of less than 250 volts to ground or of signal circuits, shall be constructed and installed in a strong and durable manner and shall be so located as to provide sufficient clearance, which shall not be less than 2 ft. to prevent accidental contact, by sagging or swinging,

with wires of other circuits or branches of trees.

(3702-d) Splices and joints in antenna span shall be made with approved splicing devices or by such other means as will not appreciably weaken the conductors.

In some cases the antenna is almost unavoidably so located that in case of a break in the wire it may come in contact with electric light or power wires. For this reason, the wire should be of sufficient size to have considerable mechanical strength and the joints should be as reliable as the wire. Joints will have sufficient mechanical strength if properly made with the standard double tube connectors used in telephone and telegraph work, though a good soldered joint is easily made and is certain to provide adequate electrical conductivity.

Lead-in Conductors.

(3702-f) Lead-in conductors from outdoor antenna to protective devices shall be of copper, copper-clad steel, bronze, or other high strength material. Where the length of such lead-in conductors between the point of attachment to the antenna and the first building attachment is greater than 35 ft. and no intermediate supports are provided, the conductors shall be not less than No. 14 if of copper or of No. 17 if of copper-clad steel, bronze, or other high strength material. Where the length of the lead-in between the point of attachment to the antenna and the first building attachment is less than 35 ft. or intermediate supports are provided so that the distance between points of support is less than 35 ft., smaller lead-in conductors may be used but shall not be smaller than No. 19 or its equivalent if of copper, or No. 20 or its equivalent if of bronze or, where the lead-in consists

Continued on Page 28



CHART

BIAS RESISTOR CHART

Most present-day receivers and amplifiers operate on a self-bias arrangement — that is, a resistor is connected in series with the cathode or center tap of filament (depending on the type of tube) to give the required grid bias voltage. The plate current of the tube is forced to flow through this resistor — thus a voltage drop occurs across it. That end of the resistor next to the cathode is positive and the other end which is connected to ground or to the chassis is negative. The grid return of the tube is usually connected to the ground. In some instances the grid return may go through several A.V.C. filter resistors before it reaches the ground. This does not affect the grid voltage, for theoretically there should be no grid current except in Class B or Class AB amplifiers. Since grid voltage is that voltage existing between cathode and grid, it follows that if the grid return is connected to the negative end of the cathode resistor, the grid voltage will be equal to the voltage drop across the resistor.

The value of the bias resistor may be calculated by using the following formula:

$$R = \frac{E_g}{I_k}$$

where E_g equals the required grid voltage and I_k the total cathode current. I_k also includes any screen grid current or any bleeder current that may be introduced into the cathode circuit due to the design of the receiver.

Let us consider the 2A3 tube. A grid voltage of 45 volts is required for 250 volts on the plate. The total cathode current in this case is 60 milliamperes. R then is equal to —

$$\frac{45}{.06} = 750 \text{ ohms.}$$

Another example:

Let us consider a 6K7 tube. A negative grid voltage of 3 volts is required for 250 volts on the plate. The plate current is 10.5 ma. and the screen current is 2.6 ma. This makes a total cathode current of $10.5 + 2.6 = 13.1$ ma. R in this case equals —

$$\frac{3}{.0131} = 229 \text{ ohms.}$$

A 229 ohm resistor is not standard, so the next highest standard value is used which in this case is 250 ohms.

As there are so many types of tubes in use, it would require considerable time for each serviceman to calculate all values. In view of this, the table below gives the bias resistor values for most of the standard tubes.

Type	Use	Plate Volts Ep	Grid Volts Eg	Screen Volts Esg	Cathode Current Ma. Ik	Resistor Value Ohms	Rating Watts
01A	Amp.....	135	-9	3.0	3000	.5
		90	-4.5	2.5	2000	.5
	Bias Det.....	135	-13.5	0.2	65000	.5
		90	-7.5	0.2	40000	.5
1A4	Amp.....	180	-3	67.5	3.0	1000	.5
1A6	Pent. Conv.....	180	-3	67.5	5.5	500	.5
		135	-3	67.5	5.9	500	.5
1B4	Amp.....	180	-3	67.5	2.1	1500	.5
	Biased Det.....	180	-6	0.2	30000	.5
		135	-4.5	0.2	22500	.5
1B5/25S	Res. Coup. Volt Amp.	135	-3	0.8	3750	.5
1C6	Pent. Conv.....	180	-3	67.5	8.7	350	1.
		135	-3	67.5	7.25	400	1.
1F4	Power Amp.....	135	-4.5	135	10.6	420	1.
2A3	Power Amp. (1).....	250	-45	60	750	10
		300	-62	80	800	20
2A5	See Type 42.....						
2A6	See Type 75.....						
2A7	See Type 6A7.....						
2B7	See Type 6B7.....						
6A3	Power Pent.....	250	-45	60	750	5.
		325	-68	80	850	20.
6A4/LA	Power Amp.....	180	-12	180	25.9	450	1.
		165	-11	165	22.9	500	1.
		135	-9	135	15.8	600	.5
		100	6.5	100	9.1	700	.5
6A6	Power Amp. Class A..	294	-6	7.0	850	.5
		250	-5	6.0	850	.5
6A7	Pent. Conv.....	250	-3	100	10.4	300	.5
		100	-1.5	50	8.3	200	.5
6A8	Pent. Conv.....	250	-3	100	0.7	300	.5
		100	-1.5	50	4.55	300	.5
6B7	Volt Amp. Pent.....	250	-3	125	11.3	250	.5
		250	-3	100	7.5	400	.5
		180	-3	75	4.3	750	.5
	R.F., I.F.....	100	-3	100	7.5	400	.5
		180	-2.1	25	0.6	4000	.5
		135	-1.95	20	0.4	5000	.5
100	-2.15	20	0.23	10000	.5		
6C5	Amp.....	250	-8	8	8.0	1000	.5
6C6	Biased Det.....	250	-4.3	100	0.43	10000	.5
		250	-1.95	50	0.65	3000	.5
		100	-1.83	30	0.183	10000	.5
		100	-1.16	12	0.063	18000	.5
		100	-1.16	12	0.063	18000	.5
	Amp.....	250	-3	100	2.5	1200	.5
		180	-1.3	30	0.5	2500	.5
		135	-1.25	25	0.33	3500	.5
		100	-1.05	20	0.31	3500	.5
		100	-1.05	20	0.31	3500	.5
6D6	Amp.....	250	-3	100	10.2	300	.5
		250	-10	100	3.5	3000	.5
	Superhet. Mixer.....	250	-10	100	3.5	3000	.5



CHART — Continued

Type	Use	Plate Volts Ep	Grid Volts Eg	Screen Volts Esg	Cathode Current Ma. Ik	Resistor Value Ohms	Rating Watts
6E6	Power Amp.	250	-27.5	...	36	750	5.
		180	-20	...	23	850	2.
6F5	Volt Amp.	250	-2	...	1.1	1800	.5
6F6	Power Amp. Class A	315	-22	315	50	400	5.
		250	-16.5	250	40.5	400	2.
		250	-20	...	31	650	2.
		375	-26	250	70	350	5.
6F6	Class AB Push-Pull	350	-38	...	50	730	10.
		350	-38	...	50	730	10.
6F7	Superhet. Conv. Triode	250	-10	100	3.4	1700	.5
		250	0.1 Meg. Leak	...	2.4
6F7	Diode Det. and A-F. Amp.	250	-3	100	0.6	5000	.5
		250	-3	100	0.6	5000	.5
6J7	Biased Det.	250	-4.3	100	0.43	10000	.5
		250	-2	50	0.65	3000	.5
		250	-1.7	33	0.21	8000	.5
		250	-3	100	2.5	1200	.5
6K7	Amp.	100	-1.5	100	2.5	600	.5
		250	-3	125	13.1	250	.5
6K7	Amp.	250	-3	100	8.7	350	.5
		180	-3	75	5.0	600	.5
		90	-3	90	6.7	450	.5
6L7	Mixer	250	-6	150	14.9	500	.5
		250	-3	100	11	350	.5
6L7	Amp.	250	-3	100	10.8	300	.5
6Q7	Res. Coup. Volt Amp.	250	-2.5	...	0.37	7000	.5
6R7	Res. Coup. Volt Amp.	250	-6.5	...	0.65	10000	.5
10	Class A Amp.	425	-40	...	18	2000	2
		350	-32	...	16	2000	2
		250	-23.5	...	10	2250	1
12-A	Class A Amp.	180	-13.5	...	7.7	2000	.5
		135	-9	...	6.2	1500	.5
12-A	Biased Det.	90	-4.5	...	5.0	1000	.5
		180	-20	...	0.2	100000	.5
12A5	Power Amp. Pent.	180	-27	180	42	650	5
12A7	Power Amp. Pent.	135	-13.5	135	10.8	1250	.5
15	Det. Osc.	135	-1.5	67.5	2.15	700	.5
18	See Type 42
20	Power Amp.	135	-22.5	...	6.0	3750	.5
		90	-16.5	...	2.8	6000	.5
22	Amp. R.F.	135	-1.5	67.5	5.0	300	.5
		135	-1.5	45	2.3	600	.5
21A	Amp.	250	-3	90	5.7	500	.5
		180	-3	90	5.7	500	.5
21A	Biased Det.	275	-5	20-45	0.15	33000	.5
26	Amp.	180	-14.5	...	6.2	2500	.5
		135	-10	...	5.5	2000	.5
		90	-7	...	2.9	2500	.5
27	Amp.	250	-21	...	5.2	4000	.5
		180	-13.5	...	5.0	2700	.5
		135	-9	...	4.5	2000	.5
		90	-6	...	2.7	2200	.5
27	Biased Det.	275	-33	...	0.2	150000	.5
		250	-30	...	0.2	150000	.5
30	Amp.	180	-13.5	...	3.1	4000	.5
		135	-9	...	3.0	3000	.5
		90	-4.5	...	2.5	2000	.5
		180	-18	...	0.2	75000	.5
		135	-13.5	...	0.2	65000	.5
30	Biased Det	90	-9	...	0.2	40000	.5

CHART — Continued

Type	Use	Plate Volts Ep	Grid Volts Eg	Screen Volts Esg	Cathode Current Ma. Ik	Resistor Value Ohms	Rating Watts
31	Power Amp.	180	-30	...	12.3	2500	1.
		135	-22.5	...	8.0	2500	.5
32	Amp.	180	-3	67.5	2.1	1500	.5
		135	-3	67.5	2.1	1500	.5
		180	-1	30	0.36	3000	.5
		180	-6	...	0.25	25000	.5
32	Biased Det.	135	-4.5	...	0.25	20000	.5
33	Power Amp. Pent.	180	-18	180	27	650	.5
		135	-13.5	135	17.5	750	.5
34	Amp. R.F.	180	-3	67.5	3.8	850	.5
		135	-3	67.5	3.8	850	.5
		180	-3	67.5	3.8	850	.5
34	Superhet. Mixer	180	-5	67.5	2.8	2000	.5
		135	-5	67.5	2.8	2000	.5
		67.5	-5	67.5	2.8	2000	.5
35/51	Amp. R.F.	250	-3	90	9.0	350	.5
		180	-3	90	8.8	350	.5
		250	-7	90	6.2	1250	.5
36	Amp.	250	-3	90	3.6	850	.5
		180	-3	90	3.5	850	.5
		135	-1.5	67.5	3.2	500	.5
		100	-1.5	55	2.2	750	.5
37	Amp.	250	-18	...	7.5	2400	.5
		180	-13.5	...	4.3	3000	.5
		135	-9	...	4.1	2200	.5
		90	-6	...	2.5	2400	.5
		250	-28	...	0.2	100000	.5
37	Biased Det.	180	-20	...	0.2	100000	.5
		135	-15	...	0.2	75000	.5
		90	-10	...	0.2	50000	.5
		90	-10	...	0.2	50000	.5
38	Power Amp. Pent.	250	-25	250	25.8	1000	2
		180	-18	180	16.4	1100	1
		135	-13.5	135	10.5	1300	5
		100	-9	100	8.2	1100	.5
39/44	Amp.	250	-3	90	7.2	400	.5
		180	-3	90	7.2	400	.5
		90	-3	90	7.2	400	.5
		250	-7	90	3.5	2000	.5
		180	-7	90	3.4	2000	.5
41	Power Amp. Pent.	250	-18	250	37.5	500	2
41	Power Amp. Pent.	180	-13.5	180	21.5	650	1
		135	-10	135	14.7	700	.5
		100	-7	100	10.6	650	.5
		100	-7	100	10.6	650	.5
42	Power Amp. Class A	315	-22	315	51.5	450	5
		250	-16.5	250	41.5	400	2
		250	-20	...	33	600	2
		375	-26	250	62	400	5
42	Class AB Push-Pull	350	-38	...	56	700	10
43	Power Amp. Pent.	180	-20	135	48	400	5
		135	-20	135	41	500	2
		95	-15	95	24	600	1
45	Power Amp.	275	-56	...	36	1500	10
		250	-50	...	34	1500	5
		180	-31.5	...	31	1000	5
46	Class A Driver	250	-33	...	22	1500	2
47	Power Amp. Pent.	250	-16.5	250	37	450	2
48	Power Amp. Tet.	125	-22.5	100	64	350	5
		95	-20	95	64	350	5
49	Power Amp. Class A. Tri.	135	-20	...	6.0	3500	.5
50	Power Amp.	450	-84	...	55	1500	10
		400	-70	...	55	1250	10
		350	-63	...	45	1500	10
		300	-54	...	35	1500	5
53	See Type 6A6
55	See Type 85
56	See Type 76
57	See Type 6C6



CHART — Continued

Type	Use	Plate Volts Ep	Grid Volts Eg	Screen Volts Esg	Cathode Current Ma. Ik	Resistor Value Ohms	Rating Watts
58	See Type 6D6						
59	Power Amp. Class A Tri.	250	-28		26	1000	2
	Power Amp. Class A Pent.	250	-18	250	44	400	2
71A	Power Amp.	180	-40.5		20	2000	2
		135	-27		17.3	1500	1
		90	-16.5		10	1500	.5
75	Res. Coup. Volt. Amp.	250†	-1.35		0.4	3500	.5
		180†	-1.3		0.24	5000	.5
		135†	-1.1		0.09	11000	.5
	Impedance Coup.	250	-2		0.8	2500	.5
76	Amp.	250	-13.5		5.0	2700	.5
	Biased Det.	250	-20		0.2	100000	.5
77	Amp.	250	-3	100	2.9	1000	.5
		100	-1.5	60	2.1	700	.5
	Biased Det.	250	-4.3	100	0.43	10000	.5
		250	-1.95	50	0.65	3000	.5
		250	-1.95	36	0.155	12500	.5
78	Amp.	250	-3	125	13.1	250	.5
		250	-3	100	8.7	350	.5
		180	-3	75	5.0	600	.5
		90	-3	90	6.7	450	.5
79	Power Amp. Class A Tri.	250	-1.5		0.5	3000	.5
85	Amp. (Trans. Coup.)	250	-20		8.0	2500	.5
		180	-13.5		6.0	2250	.5
		135	-10.5		3.7	2800	.5
	Amp. (Res. Coup.)	180	-7		0.47	15000	.5
		135	-7		0.31	20000	.5
		100	-5		0.23	20000	.5
89	Power Amp. Class A Tri.	250	-31		32	1000	5
		180	-22.5		20	1250	2
		160	-20		17	1250	1
	Class A Pent.	250	-25	250	37.5	750	5
		180	-18	180	23	750	1
		135	-13.5	135	16.2	850	.5
99	Amp.	90	-4.5		2.2	2000	.5
	Biased Det.	90	-10.5		0.2	50000	.5
182B	Power Amp.	250	-35		20	1750	2
183	Power Amp.	250	-65		20	3250	5
210T	See Type 10						
485	Amp.	180	-9		5.8	1600	.5
864	Amp.	135	-9		3.5	2500	.5
		90	-4.5		2.9	1500	.5
	Biased Det.	135	-15		0.2	75000	.5
		90	-10.5		0.2	50000	.5

All of the above data holds for a single tube. For push-pull stages, the bias resistor value is one-half that of one tube. The power rating, however, must be multiplied by two.

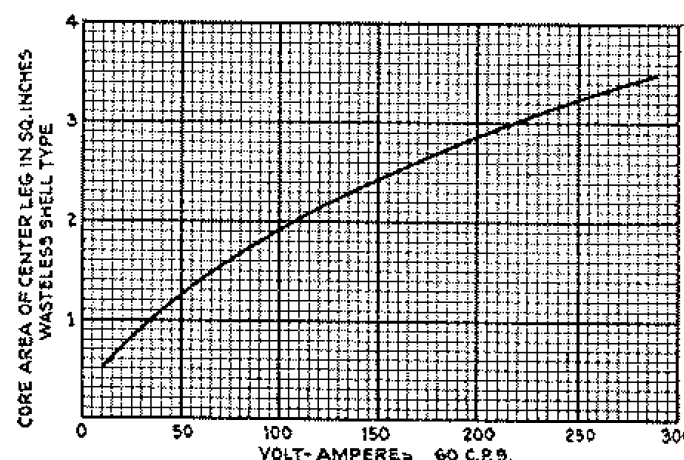
The same principle holds for two or more R.F. or I.F. tubes, which obtain their grid voltage from a common resistor. The value of a resistor for such a combination is found by dividing the resistor value of one tube by the number of tubes. If bleeder current is involved in the cathode circuit, the power rating may be found by multiplying the voltage by the current or by squaring the voltage and dividing by the resistance value. Another way to get the power rating is to square the current and multiply by the resistance value. This figure should be multiplied by three to obtain wattage rating of resistor to be used.

Relation of Transformer Core Size to V. A. (Watts) Capacity

To Determine Watt Capacity of a Radio Power Transformer

The iron content of a well-designed radio power transformer has a direct relation to the power handling capacity of the transformer. Many other factors affect the relationship between iron and power handling capacity, such as air-gaps in the core assembly, which lower the rating; allowable temperature rise, which should never exceed 40°C.; design of the transformer which should reduce heating from eddy currents to a minimum; and the quality of iron which should be expressly for transformers and offer the least possible heating from hysteresis losses. Taking all these factors into consideration, the THORDARSON Laboratory has compiled a chart, graphically illustrating the relation between transformer core area and the secondary A.C. volt-ampere rating. As the power load of a radio set is not pure resistance, primary watts are approximately equal to 80% of the volt-amperes. In transformer design it is possible to compensate for small core section by increasing the number of turns on each winding; usually the space is inadequate without materially reducing the size of wire which results in excessive heating.

The Wasteless Shell Type Transformer is the type in which the core is stamped out like a letter E and the open side of the core is completely filled by laminated stampings. Some transformers are assembled from two letter E stampings interleaving in such a manner that only half the core area is effective in the return magnetic path. Deduct one-third from the measured core area of such a transformer to determine its power handling capacity from this chart. In the Wasteless Type Lamination the cross section of the center bar of the E would be hard to measure, but it is equal to the sum of the cross sections of the top and bottom leg of the E. Assume a transformer with a 1 1/4" core width and the top and bottom leg each 1 1/2" high. 1/2" x 1 1/4" plus 1/2" x 1 1/4" equals 1.55 square inches. Locate 1.55 on the core area side of the chart. It intersects the curve at 70 V.A. This is approximately 80% of the total power consumption in watts.





Phono-Radio Oscillator

A ready market exists for the sale of units that permit the use of phonograph pickups with a radio receiver. The unit described operates from any 110 volt A.C. or D.C. line and requires no internal connection to, or change in, the circuit of the receiver. It can be easily built by any serviceman and is ideal for demonstration of receivers in noisy locations.

The circuit, shown in Figure 1, consists of an electron coupled oscillator, suppressor modulated, with a transformerless power supply.

The photographs show the arrangement of the parts on a base 5" x 6" x 2" deep, although the layout may be changed to suit individual requirements.

Standard parts are used with the exception of coils L₁ and L₂.

L₁ is wound on a piece of tubing 1" in diameter by 2 1/2" long. It consists of 98 turns of No. 26 enamelled wire, tapped at 39 turns from the bottom. The coil shield is 2" in diameter by 3 3/4" high.

C₂ is mounted inside L₁, with the grid lead projecting out the top of the shield. L₂ is a 80 millihenry R.F. choke, with 10 turns of No. 26 D.C.C. wound between the coil and terminal board.

All parts must be insulated from the chassis.

After wiring, the voltages should be checked at the tube terminals; the voltage readings of the experimental model follow:

	2	3	4	5	CAP
6C6	30	30	0	0	0
25Z5	0	150	150	0	-

Usually, a wire from one of the output posts of the oscillator with a few turns wrapped around the antenna lead in will give sufficient signal input to the receiver.

In extreme cases, the two output posts must be connected to the ground and antenna posts of the receiver,

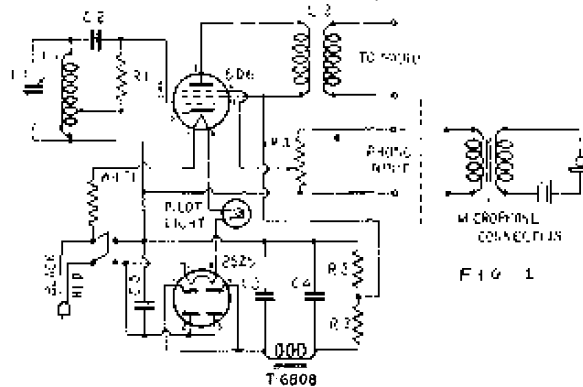


FIG. 1

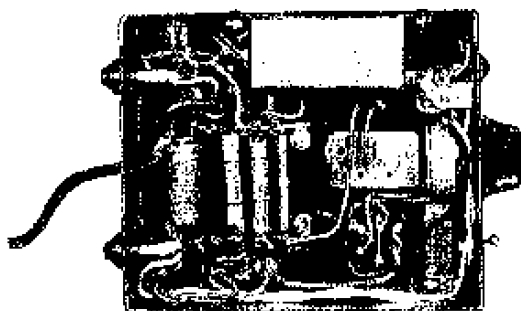
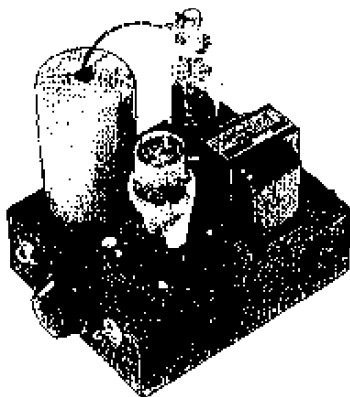
using a switch to cut in regular antenna for broadcast reception. The coupling between oscillator and receiver should be as loose as possible.

The phono pickup can be connected to the input posts, the power being applied to the oscillator and the receiver. The latter should be tuned to a point where no broadcast signal is heard, then the small trimmer condenser adjusted until the oscillator is operating at the same frequency. The gain control R₄ controls only the percentage of modulation, not the R.F. output of the oscillator, so coupling should be adjusted for best results.

A microphone can be connected into the oscillator by the circuit shown to the right of the dotted line on Figure 1.

Parts Used

- 1 Thordarson T-6808 choke
- R₁ 50,000 ohm
- R₂ 2,500 ohm
- R₃ 7,500 ohm
- C₃, C₄ Dual 8-8 mfd. 200 volt cardboard electrolytic condenser
- C₅ 0.1 mfd. 400 volt tubular condenser
- 1 290 ohm Cordohm resistance cord
- R₄ 100,000 ohm potentiometer
- 1 Double pole, double throw toggle switch
- C₁ 250 mmfd. padding condenser
- 1 pc. tubing 1" diameter, 2 1/2" long
- 2 six prong sockets
- 4 binding posts or pin jacks (insulated type)
- 1 2.5 volt pilot light and mounting
- L₂ 80 millihenry R.F. choke
- C₂ .00025 mfd. mica condenser
- 1 shield can 2" diameter by 3 3/4" high
- 1 metal base 5" x 6" x 2" deep





Elimination of Code Interference

Code signal interference has many causes, the most common being (1) harmonics of the code signal carriers falling within the broadcast or other receiving band, (2) image interference due to inadequate pretuning, (3) direct I.F. pickup due to exposed circuits or undesirable input coupling to the I.F. amplifier, (4) cross modulation due to demodulation of signals prior to their introduction into the first detector. By analyzing the nature of the interference it is possible to completely eliminate undesirable interference.

Beyond accurate adjustment of all tuned circuits for the highest possible selectivity nothing can be done about the reception of upper harmonics of code signal carriers if these fall within the frequency range of the receiver. Except in rare cases of powerful stations very near the point of reception, practically all harmonic energy is eliminated from the wave as it is transmitted. For this reason such interference is fortunately quite rare.

Image interference can ordinarily be identified as it is tunable and confined generally to the high frequency end of the receiving band. Signals caused by image interference are received independently of other carriers and may fall directly on a desired signal or between stations. Reception of these signals may be prevented by increasing the selectivity of the tuning stages preceding the first detector, (1) by adding one or more tuned R.F. stages, (2) decreasing interstage coupling, or (3) taking both steps. In many instances this method of adjustment alone will answer the purpose.

If the I.F. amplifier has a high peak frequency, it is subject to direct amplification of any signal that might reach its input. This type of interference is not tunable but its intensity may vary with the tuning of the receiver. Proper shielding of the I.F. amplifier will go a long way toward preventing this trouble.

For the correction of interference identified as cross modulation, a "Variable Mu" or "Super Control" type of R.F. amplifier tube should be used, in stages preceding the first detector. This prevents rectification of strong signals in the R.F. stage which is the principal cause of cross modulation. Thus, in this case, the modulation of one carrier cannot be superimposed on any other carrier. Interference due to cross modulation always accompanies another carrier, and hence is always tunable. The intensity of the interference in this case is proportionate to that of the desired signal.

There are two common circuits used to correct general code interference. One is a high pass filter as in Fig. 1. It may be seen that the series inductive reactance increases with frequency. The coupling condenser has a negative decreasing reactance characteristic with frequency.

The result is that with proper choice of constants for the circuit, all frequencies below 500 K.C. are cut off, eliminating any interference in this region, but still allowing broadcast and higher frequencies to be received. For Fig. 1, L_1 and L_2 should be two separate shielded coils, having an inductance of approximately 245 microhenries each. Condenser C should be of the trimmer type, having a capacity of from 90 to 250 mmfd.

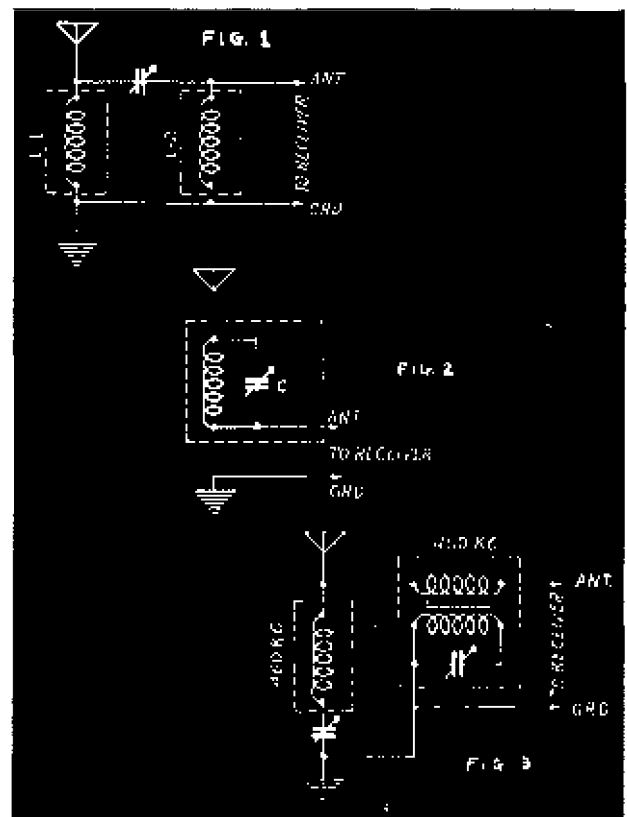
Condenser C is adjusted so that signals at the low frequency end of the broadcast band (550 K.C.) are not effected, but all lower frequency signals are cut off.

The second circuit called the wave trap is used to eliminate a band of frequencies with 460 K.C. at the center with a fairly broad characteristic. Since one tuned circuit is always somewhat broad in tuning, this will eliminate practically all of the ordinary undesired interference.

A parallel resonance circuit is placed in series with the antenna for this purpose as in Fig. 2. One winding of a 465 KC I.F. transformer with trimmer may be used for this purpose. After connection, a signal generator is connected to the antenna and ground and a frequency of 460 KC is fed to the input of the receiver. The trimmer C is adjusted for minimum signal as indicated by the output meter or other indicating device.

For extreme cases of elimination from a nearby powerful interfering station, the wave elimination system as shown in Fig. 3 is recommended. Here the two tuned circuits are adjusted for minimum signal of any undesired interference in, below or above the regular receiving band. For general purpose interference they may both be tuned to 460 KC or one may be tuned to 420 KC and the other to 480 KC.

Any of these methods will be found effective in the correction of signal interference.





Installing Piezo-Electric Crystal Pickup Units

In using Piezo electric or crystal pickups the main problem is making proper circuit connections for greatest effectiveness. The D.C. resistance of any pickup must be taken into account to avoid errors in connecting them in radio circuits.

Because of the low D.C. resistance of some types of magnetic pickups and microphones, they may be used either in the plate or cathode circuits successfully. The resistance of a magnetic pickup is often suitable as a cathode self-bias unit or may easily be adapted to so operate, while supplying a signal voltage. A carbon microphone may often carry the cathode current of an

audio amplifier and function in the same way, while supplying a signal voltage.

Piezo-electric pickup devices cannot be used in this manner as they have very high resistance and must not carry D.C. The signal potentials are built up across the Piezo-electric unit which is a good dielectric — and the fact that fairly high voltages can be produced with almost no mechanical effort indicates a very high impedance existing across the terminals. This averages around 75,000 ohms.

This impedance value suggests a direct connection to the grid input of audio amplifier circuits. For an analysis, let us inspect the connection shown in Fig. 1. It is a simplified typical diode detector circuit with the pick-up connected directly across the manual volume control. The pick-up produces a signal voltage comparable in value to the rectified audio voltage developed across the volume control, R_1 , at full volume of the receiver. With this connection, however, the pickup will affect the receiver practically as though a small capacity were shunted across R_1 (100 mmfd. approx.) and will not affect the A.V.C. action of the receiver or the detection of signals. Regular reception will not be interrupted with this connection and the only way to amplify the pickup output alone is to turn the dial to a dead spot of the receiver.

This has many disadvantages. The noise level will still exist if no "Q action circuit" is used in the receiver. Removal of the diode detector tube from its socket will solve this problem, but it is not a convenient method. Shorting the grid to ground by means of a switch is a step in the wrong direction, because this would shunt the audio input (A to G) with the .1 meg. resistor — thus reducing the effectiveness of the pick-up. While enough amplification may follow the input to compensate for this loss, it is not always the case, and the frequency response will possibly be affected as well.

There are many ways to block the radio reception while the pick-up is in use. Several which will involve the least disturbance are, (1) shorting the antenna and ground posts, (2) changing any R.F. or I.F. plate circuit,

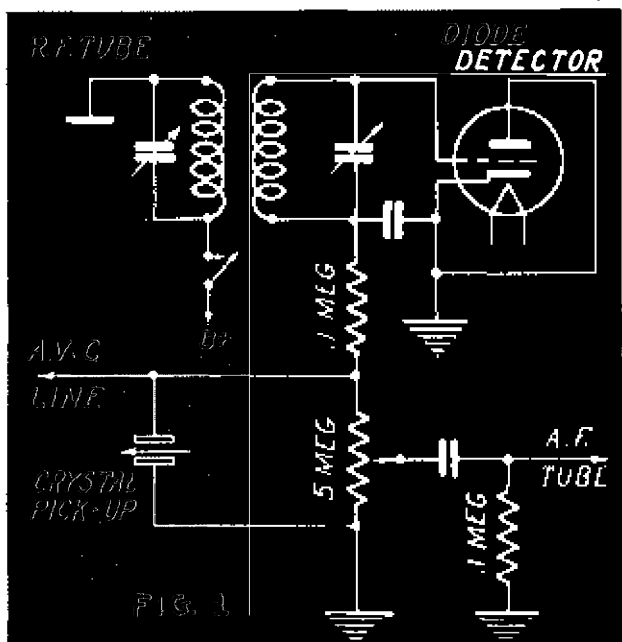


FIG. 1

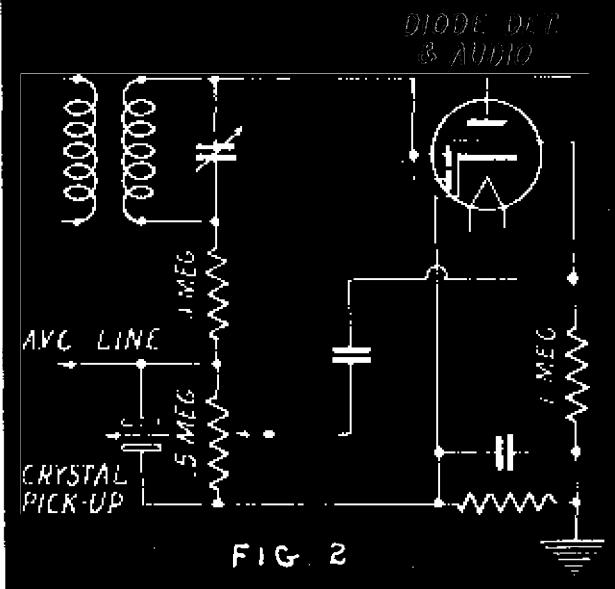


FIG. 2

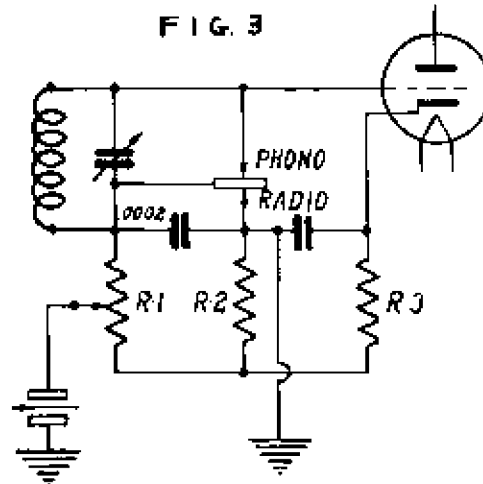


FIG. 3



(3) shorting any I.F. transformer winding, (4) opening the oscillator plate circuit. Use the method found most convenient. A single pole throw switch may be used. Be sure not to ground any high voltage circuit.

In Fig. 2 we have another widely used circuit in which connections for a crystal pickup unit are the same. Here we cannot remove the diode detector tube even though convenient; because it also includes the first A.F. tube.

For earlier sets using power detection, the circuit of Fig. 3 is recommended. A single pole double throw switch is used for the complete changeover. When turned to Radio, the proper detector bias is placed in the circuit by the drop across R_2 plus R_3 and the pickup is not used. When turned to Phono, the tuning coil and condenser are shorted and the bias is reduced to a value appropriate for an audio amplifier, as the grid is biased by the drop across R_3 only. R_1 is .5 meg. and a small capacity, C , .0002 mfd. tends to stabilize the circuit.

Other problems in such installations arise in transferring the signal voltage from the pickup or microphone to the points shown in the receiver. An ordinary twisted double wire line sharply attenuates any signal if fed from an impedance widely separated from its own impedance. Each line has a definite impedance to which it will respond most favorably. This value depends upon the physical construction of the line, size of wire, spacing of wire, whether or not it is shielded, nature of shield, etc. The longer this line, the more effectively it attenuates the signal voltage from the pickup.

Remember, if any wire is used besides the leads supplied with the pickup, matching transformers at the pickup and at the set are recommended. This circuit, using a shielded line, is shown in Fig. 4. Note that there are no isolated units—all parts are grounded. This aids considerably in keeping the noise at a minimum. Isolated parts invariably pick up charges which must leak off, causing noise. The leads from the pickup to the input transformer, T7083 of Fig. 4, should be as short as possible and not twisted. Do not attempt to shield these leads—a shield would reduce the pickup output materially.

The shielded line may be as long as 1,000 feet without noticeable decrease in efficiency. If more than 20 feet long, it should be grounded at several intermediate points.

If a volume control at the pickup point is preferred to

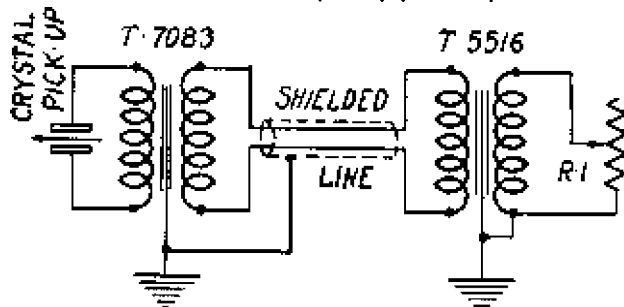


FIG. 4

one at the receiver, the circuit of Fig. 5 is recommended. For an open wire line, Fig. 6 will be found suitable.

In connecting a crystal pickup to a phonograph oscillator having an open grid input such as the RCA RK-24, the grid circuit must be completed in some way. Connections are made as in Fig. 7, showing only the parts concerned. The pickup volume control must be used here, as the oscillator has no means of volume control. In some cases, the receiver volume control may be depended upon, in which event, a 500,000 ohm resistor must be placed across A to G (Fig. 7) to close the grid circuit.

Do not attempt to operate a crystal pickup or microphone in parallel with a magnetic pickup or other microphone type. Two crystal units may be used in parallel, but combinations of units without the proper transformers will not work satisfactorily.

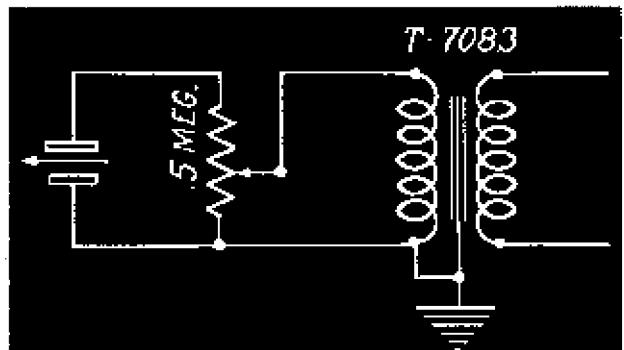


FIG. 5

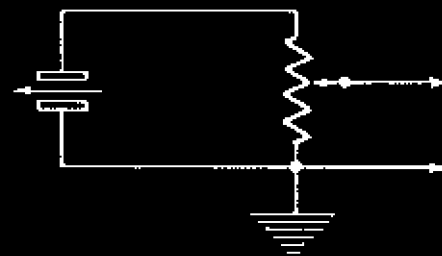


FIG. 6

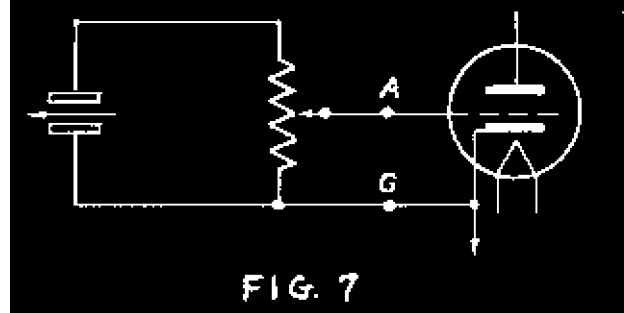


FIG. 7



Auto Installation Hints

When installing and servicing automobile radio receivers, servicemen are confronted by difficulties not found in ordinary home radio installation. Receivers and speakers must be mounted, ignition interference is a problem, and in older model cars, an "interference free" antenna system must be erected.

Servicemen should be properly prepared before attempting to profitably handle auto installation and service jobs. Tools and supplies are of paramount importance.

For installation work, an electric or large hand drill is absolutely necessary. The drill is used for mounting receivers and speakers or in obtaining short direct leads to ground or chassis connections. Bond shielded leads directly to the frame of the car by drilling a small hole in the frame and fastening the leads to the chassis or frame by means of clamps, nuts and bolts. The chuck of the drill should be capable of handling any size of bitt from $\frac{1}{8}$ to $\frac{3}{8}$ of an inch. A $\frac{3}{4}$ inch chuck is usually used. Because of breakage, keep a good

supply of bits on hand. Radio men find a reamer a useful tool for enlarging holes.

Many auto radio installations have been unsatisfactory because of poorly soldered joints. Soldering to large surfaces of metal — which always tends to cool an ordinary soldering iron, often is the cause. You will find that it pays to check every connection after soldering. A 200 watt iron is not too large, although best results are obtained with a small blow-torch. As there is danger in using a torch around a car, it is wise to keep a fire extinguisher handy, or a large bucket of sand.

Never use water — it spreads the flame.

A flexible steep tape is needed for measuring the distance between mounting parts. Always keep your wire leads short. Remember! — the longer the leads — the greater the chances of picking up interference.

Two types of tape are required: gum rubber and friction tape on the outside. Don't skimp, especially if the taped joint is exposed to heat from the engine.

Rosin core solder should always be used, and the surfaces to be soldered made absolutely bright. There are three fundamental rules to follow when soldering. (1) Be sure the surfaces are clean. (2) Use plenty of solder. (3) Be sure that both surfaces are hot enough to melt solder. If you will observe these rules, you need have no worry about your soldered connections.

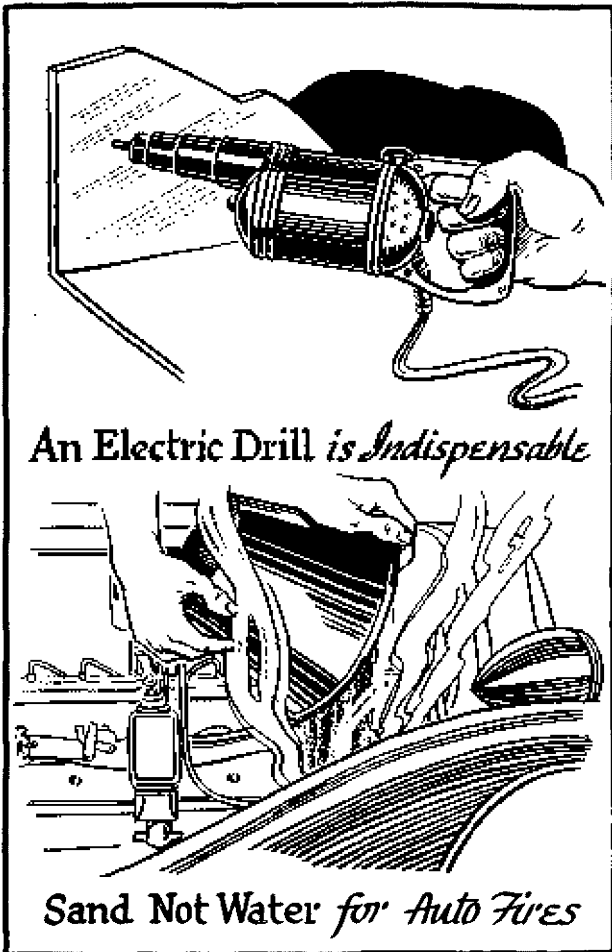
In regard to supplies, several kits of suppressor resistors and auto condensers should be available at all times. You can never tell when you are going to need one or more of these.

A good rule to follow in wiring is to ground the shield of every piece that you use. Either use wire that is already shielded or put copper braid around the wire yourself. Keep a sufficient supply of copper braid on hand at all times. By doing this you will be able to shield all high tension and other leads if necessary. In making grounds, always measure the resistance from your connection to the chassis (the part of the car you will use as a ground). The modern car uses wood, rubber and fiber in the body construction as well as metal. There should always be a low resistance from your connection to the chassis (frame of the car) thus insuring perfect ground.

A drilling template comes with new receivers and shows you where to drill the mounting holes. If you are installing an old receiver or one without a drilling template, measure the distance between the mounting studs, and make up a template from cardboard or a similar material.

Suppression of Ignition Interference

Auto receiver design has reached the point where suppressor resistors are no longer needed to overcome ignition interference.





Manufacturers have overcome this problem — (1) by designing an antenna input circuit that cuts out all frequencies above and below the broadcast band, keeping interference out of the input of the receiver. (In general, present day interfering frequencies are not within the broadcast band). (2) By inserting low resistance — high inductance chokes in all power supply leads and by-passing these with suitable condensers. (3) By laying out the receiver wiring systematically to reduce transfer of energy between wiring. (4) Improved methods of shielding both wiring and the entire receiver and speaker. (5) Obtaining the cooperation of auto manufacturers to reduce transfer of interfering frequencies due to incorrect placement of auto wiring and parts.

On all older cars and receivers you must use suppressor resistors and special auto condensers, to minimize ignition interference. In the past high value resistors were used for suppression but today resistors of from 5,000 to 11,000 ohms are used. These resistances are a special type guaranteed not to interfere with the electrical function of the ignition system. The condensers used are sealed in metal containers and are also of a special type. These condensers usually have a capacity of 1 mfd.

A suppressor resistance will be required for each spark plug. To install these, remove the high tension lead from the top of each plug. Remember — remove but one lead at a time and reconnect the lead before starting on the next plug. A misplaced ignition wire will change the firing order of the motor so that the car will backfire or not start.

Modern suppressors have spade terminals or special connections on the ends of the unit to permit easy wire connections. Place the split terminal of the suppressor on the spark plug and slip the original spark plug lead on the free end of the suppressor.

It is necessary, at times, to use what is known as the splice-in-type of suppressor which has screw terminals at each end. To connect it in series with the spark plug lead, cut the wire and "screw on" or turn the suppressor into the two ends of the wire which you have cut. The suppressor will then be in series with the spark plug lead. To get best results, this type of suppressor should be located in a horizontal position and connected as near the spark plug as possible.

Make certain that good contact is made between the wires and the screws. Wrap soft gum rubber tape around each end of the suppressor, and wrap this in turn with friction tape. This insures a permanent connection.

Cars equipped with dual ignition, (two spark plugs to each cylinder) require a suppressor for each spark plug.

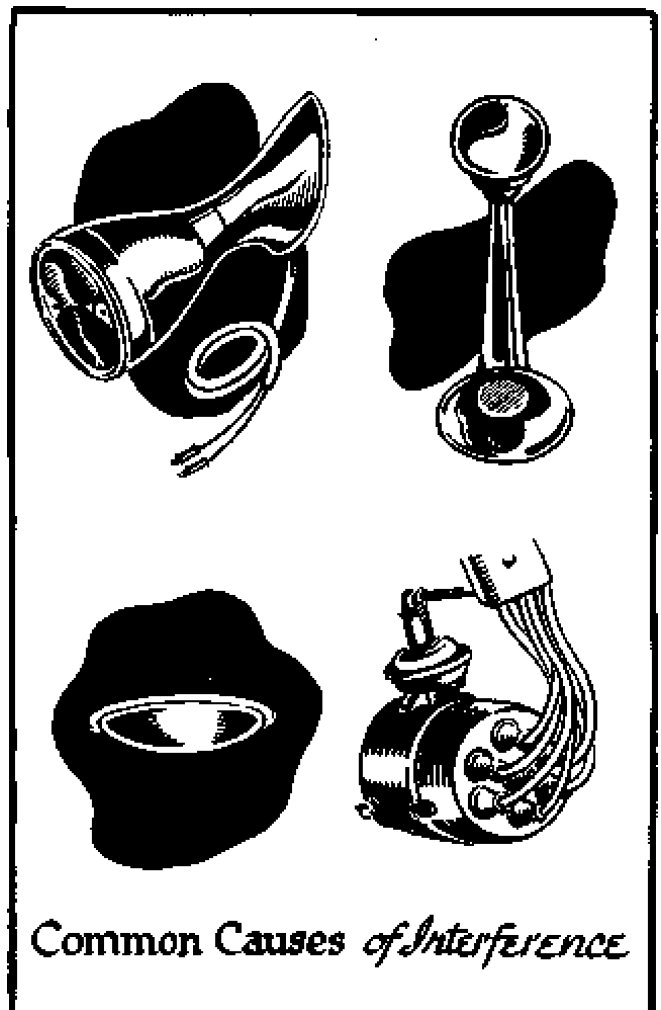
One suppressor which is different from the others and easily recognized is required for the distributor. In the case of a plug-in type of distributor cap, plug the split end of the distributor suppressor into the socket from which the center high tension lead has been removed, then insert the center high tension lead in the free end of the distributor suppressor.

For the cap type distributor, use the splice-in type suppressor, to be connected in series with the high tension lead from the rotor arm. Locate the suppressor as near the distributor as possible. If two ignition coils are used, a suppressor is required for each coil.

Use of Condensers

Two or more condensers are used in every installation. One condenser is always used on the generator and one on the ammeter. Each condenser should have a mounting hole to accommodate a small screw. The screw which holds down the cover on the small cut-out relay of the generator may be used to mount the generator condenser. However, before mounting the condenser, scrape the connections clean, as the mounting lug is in reality the ground lead for the condenser. The single wire lead should connect to that side of the cut-out relay to which the lead from the generator connects.

The ammeter condenser should be located as near the ammeter as convenient. Connect it across the battery side of the ammeter and the ground. Find a screw near the ammeter which is long enough to permit mounting the condenser, or drill a hole for a mounting



Common Causes of Interference



screw in the instrument panel or the cowl. Be sure that direct metallic contact is made to the chassis or frame of the car.

Extra capacity may be needed in the dome light, stop light, horn or other auto accessory wires. Connect the condenser in each case between the accessory wire and the chassis or the frame of the car. Use from .25 mfd. to 1 mfd.

To determine which accessory wire is causing the most interference, turn on the radio and start the motor of the car, then temporarily connect a condenser between each accessory wire and ground. You will find one or more positions which reduce interference to a minimum. When you have found this connection, mount and connect the condenser permanently in the circuit.

A condenser is sometimes needed between the battery side of the ignition coils and the frame of the car. One should always be tried in this position when you have excessive interference.

Further Interference Elimination Notes

There will be times when it is necessary to know whether the interference is being picked up from the antenna or at the point where the antenna connects to the receiver. To check, disconnect the antenna. If the interference stops, it is being picked up by the antenna. If it continues, it is being picked up by the receiver. If the receiver is picking up the interference, check all ground and condenser connections. The receiver should not pick up interference if the manufacturer's instructions have been followed, and all ground connections properly made and the radio wires kept out of the motor compartment.

If you have antenna pick up of motor interference, be sure that the antenna lead is properly shielded from the receiver to the antenna. Also see that this shield is properly grounded. If you still have interference, the rotor arm of the distributor should be "peened" in order that the gap between it and the contacts in the distributor head may be reduced. Extreme caution should be used to prevent damaging the distributor. The gap between the arm and the contacts should be about .001 inch maximum (use a machinist gauge). Care must be taken to see that the rotor does not touch any of the contacts. Building up the rotor arm with solder (to reduce the gap) will not work as the solder burns away.

In order to "peen" the rotor arm, place it on a flat steel block (or other hard surface) and hammer the end of it carefully with a small machinist's hammer. This operation should be repeated until there is just sufficient clearance for the rotor to turn without touching the contacts. In hammering out the rotor, you may force it out of shape. To overcome this, dress the end of the rotor with a file to its original shape.

In order to judge the correct amount of lengthening of the rotor arm, place a heavy chalk mark on each of the contacts. After the arm has been hammered out, reassemble the distributor and turn the motor over (with

the hand crank) so that the arm makes a complete revolution. Remove the cap of the distributor and examine the end of the arm for traces of chalk. If a mark is found, examine the contacts to determine the one which is too closely spaced, then file the rotor arm enough to clear the contacts. If the distributor head is "off center" it should be replaced.

If the rotor continues to touch the contacts, file off about .001 inch and recheck. If the rotor is double ended, both ends should be treated in this manner. However, the operation should be complete on one end before proceeding to work on the other.

If you still have interference, remove the high tension lead between the coil and distributor. With the radio operating, turn on the ignition switch and turn the motor over several times with the starter. A "clicking" sound in the speaker indicates that part of the interference, at least, is coming from the low tension circuit or breaker points on the distributor. To overcome this, remove the primary lead running from the ignition coil to the breaker points and replace it with a piece of No. 10 shielded low tension cable. The shield of this cable should be grounded in at least two places. The connections, of course, should be as short as possible. It may be necessary to replace the lead from the switch to the ignition coil with No. 10 shielded low tension cable. Make sure the shielding is well grounded, also check the leads to the switch or distributor for grounding.

A by-pass condenser should never be used on the distributor side of the coil as it will affect the operation of the motor. Sometimes the interference comes from the high tension secondary circuit of the ignition system. Remember, all low tension wires running parallel to or in the field of the high tension circuits act as carriers. Therefore, they should be moved and the high tension leads rerouted. In many cases where a manifold is used to house both low and high tension wires, removing the low tension wires from the manifold will be sufficient to prevent the pickup of interference from the high tension wires.

Where the ignition coil is mounted on the instrument panel or elsewhere under the cowl, one of two methods may be followed. First, you may shield the high tension lead from the coil to the distributor. Do this by covering the lead with cloth and running copper braid over the cloth. Then ground the copper braid to the frame of the coil at one end and to the motor block or high tension manifold at the other. This lead should be direct from the coil to the motor compartment. If necessary, drill a hold in the dash to shorten the lead.

Occasionally if you move the ignition coil (or coils) into the motor compartment, pickup is eliminated. Mount the coil on the motor block as near as possible to the distributor, making sure that a good ground contact is made. If you mount the coil above the motor, make sure the coil will stay comparatively cool in the location selected. When the coil is moved, use new primary leads, which should be of No. 10 shielded low tension cable. Keep these wires away from the high tension leads and ground the shields.

Often a good electrical contact between the motor



block, dash and frame of the car will eliminate a great deal of interference. In case of doubt, measure the resistance. A positive contact between motor, dash and instrument panel can be made by connecting these units together with short pieces of copper braid. This type of bonding is nearly always necessary on cars having the motor mounted in rubber. In such cases, the copper braid from the motor block must be long enough to allow for vibration.

All wires, rods or pipes running from the motor compartment through the dash may radiate interference. Each of these should be grounded to the dash. Use heavy flexible copper braid in making the connection to ground. In many cases the steering column must also be grounded to the dash.

Sometimes interference may be caused by loose wires in the electrical system of the car. Connections to all lights, the horn, cigar lighter etc., should be checked to see that the contacts are clean and the connections tight.

Any metal parts of the car making imperfect or intermittent contact with the metal case of the receiver or associated equipment will also cause noises in the speaker. To prevent such interference, the choke rod, wires, speedometer cables, copper tubes, etc., should be kept away from the receiver housing. All shielded cables should be fastened firmly to the frame of the car so that they will not make poor or intermittent contact with other metal parts.

Cars having high tension wiring near the bottom of the engine compartment have a large amount of interference introduced through the wood toe boards. The passenger transfers this interference to the antenna through his body. A grounded screen on the under side of the toe board will eliminate this interference.

The ignition system of the car must be kept in good condition. Plugs that are fouled or have improperly adjusted gaps will affect the operation of the receiver as well as that of the car. Burned or improperly adjusted breaker points can also cause untold trouble.

Electrical disturbances from nearby power lines or other electrical equipment should not be confused with ignition interference. Such disturbances will be heard whether or not the motor is running. Ignition interference should always be checked in a location free from electrical disturbances.

Radio Interference From Neon Signs

Gaseous tube signs may cause severe radio interference if improperly constructed or installed. Due to the high voltages required to operate this type of sign, an electrostatic charge tends to collect on the surface of the glass tubing. It is the leakage of this charge or defective insulation causing an arc to ground which usually causes radio disturbance.

To determine if the transformer is defective, it should be operated first with no connection to the secondary, then with the two secondary terminals connected to-

gether (short circuited). If interference is experienced in either case, the transformer is defective and should be replaced. *The high voltage of neon transformers is dangerous, so be sure the transformer is turned off before making any connections.*

With the transformer eliminated as a source of interference, faulty tubing, or leaky insulation of connecting cables or insulators must next be checked.

NOTE: *The radiation may be introduced into the receiver, either through the antenna circuit or through the power supply lines. If it is due to the latter, shorting the antenna post to ground will not reduce the interference. The following suggestions, if followed out, will eliminate the difficulty in most cases. A receiver should be set up where the efficacy of each step can be noted.*

If the tubing electrodes fit into porcelain housings, minute cracks or dirty surfaces may provide a conducting path to the metal surface of the sign. If the high tension cables come in contact with metal, a similar effect may occur which can be prevented by supporting the conductors on suitable insulators.

Modern encased neon transformers have the secondary center tap grounded to the case. It is important that both the transformer case and the complete sign enclosure be connected to a good ground.

If the interference is being radiated through the power lines, a filter consisting of R. F. chokes and bypass condensers connected between the sign transformer and the line should reduce the disturbance in the receiver greatly.

The static charge on the tubing is usually concentrated at sharp bends or at strictures in the tubing. They may be found by running the hand lightly over the tubing while in operation. The disturbance in the receiver will increase when the hand is at one of the points of static potential. A few turns of bare copper wire should be twisted around the tubing at each of these points and these wires connected together to reduce the charge on the tubing. In some cases, connecting these wires to ground will be helpful.

Some paints used to "black out" the electrodes contain a metallic pigment. If the paint touches the lead wires of the electrode, a conducting path may be formed which will cause noise in the receiver when current passes through it. Removing the paint within $\frac{1}{4}$ " of the live leads, or replacing paint with black lacquer will remove this difficulty.

The static charge on the tubing varies with the voltage applied. The transformer operating the sign may have much higher secondary voltage than required. Replacing it with a lower voltage transformer will usually reduce radio interference. If the transformer has too low a secondary voltage, the sign will flicker, especially if the primary voltage drops. Flickering will usually cause severe radio interference.

Where a number of separate sections are operated in series from one transformer, interference can often be reduced by operating each individual section from a proportionately lower voltage transformer.



Improving the Fidelity of Any Receiver

Nearly every design factor of a receiver contributes in some way to its fidelity. The selectivity of the R. F. and I. F. circuits affects the degree of selective attenuation of audio frequencies before demodulation, the detector characteristics determine its output fidelity and the audio amplifier and speaker have a major effect on fidelity. A composite graph has been prepared for Fig. 1 showing the nature of the effect each of the factors have on fidelity.

The horizontal scale represents audibility in arbitrary units. Do not attempt to draw any comparison between any two curves as each may be quite a different scale from any other. Just observe the nature of the effect which each item has on the fidelity as a whole.

Remember also that the ideal which we wish to approach is the line marked zero. Note the sharp heterodyne at 10KC which drops out any station heterodyne.

Curve A represents the qualitative effect of a tuned circuit on fidelity. It is not advisable to alter the one or two R. F. tuned stages in order to reduce the selectivity (improve fidelity) of a receiver as selectivity at this point in the circuit is highly desirable for other reasons. The R. F. circuits alone in the average superheterodyne receiver, can not introduce enough selectivity to affect the fidelity. However if the receiver is not a superheterodyne the R. F. circuits must be broadened—or made less selective to gain more fidelity. To correct this effect we may load the tuned circuit with series or shunt resistance as in Fig. 2, or increase their coupling and stagger them. Any of these things will increase the overall circuit decrement

thus reducing the attenuation or loss of the high frequencies.

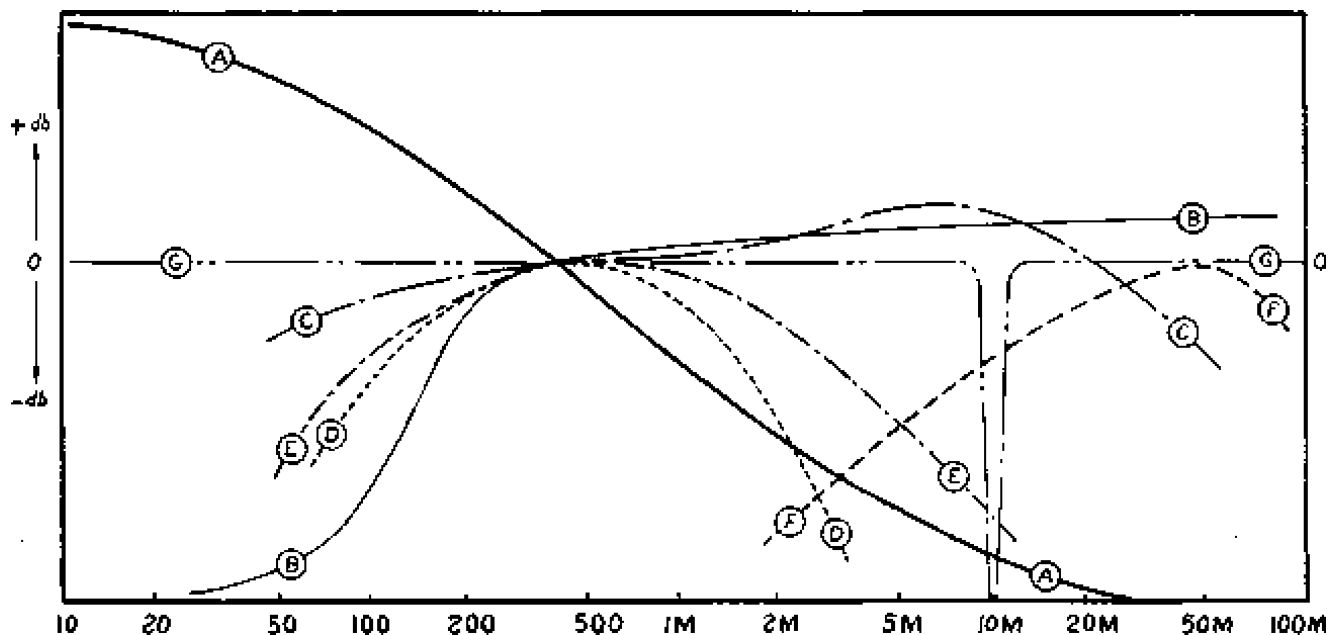
It is best to make fidelity improvements in the I. F. amplifier when the circuit is a superheterodyne. The effect of the tuned R. F. circuits to minimize cross-modulation, image interference or station interference will thus not be disturbed.

For broadening out the tuning of an I. F. amplifier so that it will freely pass a band 15 or 20 KC wide we can introduce losses by using series resistance as in Fig. 3a or preferably by using a separate coil to which resistors are coupled as in Fig. 3b. In this system, a third winding is placed between the primary and secondary and fitted with a variable series resistance so that the degree of band spreading may be altered. A copper or other metal disc interposed between the primary and secondary as in Fig. 3c will broaden the resonance characteristics of the I. F. circuit. A variable or movable core containing some iron is used with a control knob in some cases for the setting of any desired band pass characteristics within wide limits. See Fig. 3d.

Detectors

For the purpose of any analysis of detectors we must assume that their input circuits are supplied with a carrier (R. F. or I. F.) modulated with the signal with no selective attenuation. Moreover any detector must be able to handle signals modulated at various percentages from 75 up to 100.

Considering first the design factors of a grid leak-condenser detector, the value of the signal input volt-



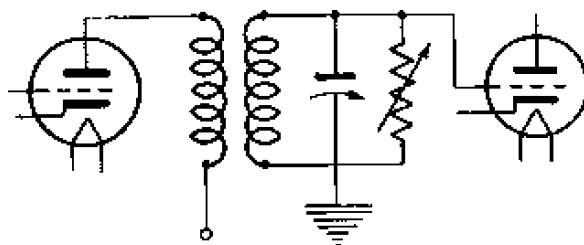


age is of major importance. If the audio amplifier has enough gain to adequately handle a small output, such a detector may be used. As long as the detector input voltage remains below 1 or 2 volts high fidelity may be expected but if it is supplied with greater signal input voltages the type of detection should be changed to a power type or a diode. Finally the grid leak must be low enough to allow for stable operation. A value of 2 megohms should not ordinarily be exceeded. The plate load needs no R. F. filter and must match or exceed the detector tube A. C. plate resistance at audio frequencies.

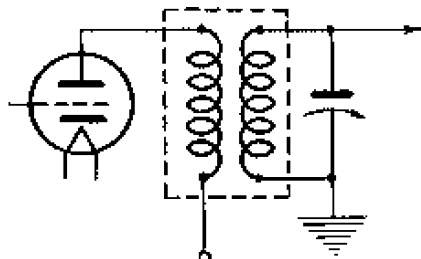
A typical power detector circuit is shown in Fig. 4a. The cathode resistance must be chosen to bias the tube higher than the maximum signal peak to be received. A good plate filter should be used and if the fidelity of the receiver is to be extended beyond 10 KC a tuned trap adjusted to 10 KC as in Fig. 4b must be used. This will give the sharp dip in the circuit characteristics as in Fig. 1 at the intersection of the line marked 0 DB and the 10 KC line.

The diode detector has excellent high fidelity char-

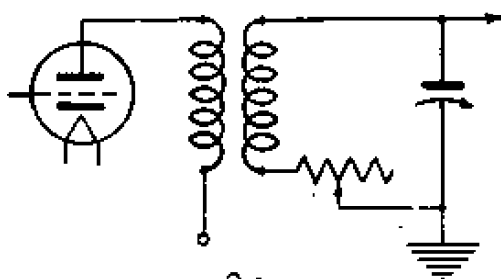
acteristics when used properly. Ordinary improvised diode detectors of various types supplying single stage amplifiers are shown diagrammatically in Fig. 5. For 100% modulation and maximum amplitude the full current range of the diode is used. Its characteristics are curved as shown in Fig. 6, being more pronounced in distortion effects as the load is increased. On the other hand the load must be large enough to allow it to handle as high a modulation percentage as possible. This property of a diode is bettered as the AC load and DC load approach a unit ratio. In Fig. 5d R1 is regarded as a D. C. load whereas R2 is an A. C. load, C being neglected because of its large size. R1 must be low enough to allow high percentage modulated signals to be detected with minimum distortion (50,000 to 100,000 ohms) and high enough not to load the diode and tuned circuit excessively. For an approach to unity ratio of R1/R2, the parallel resistance of R2 and all of the loads on R1 such as the A.V.C.



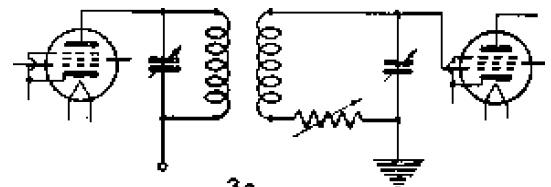
2a



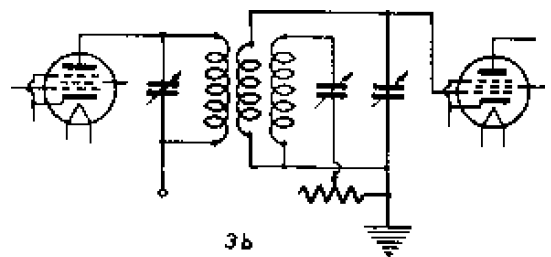
2b



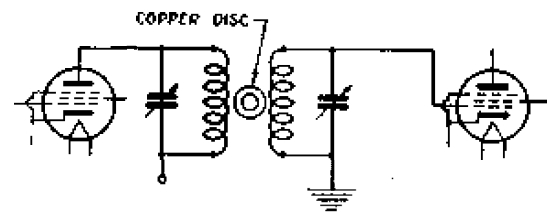
2c



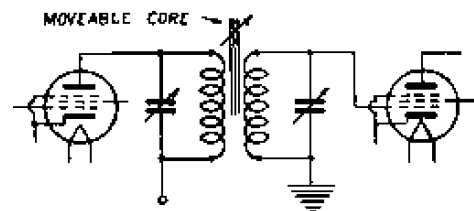
3a



3b



3c



3d



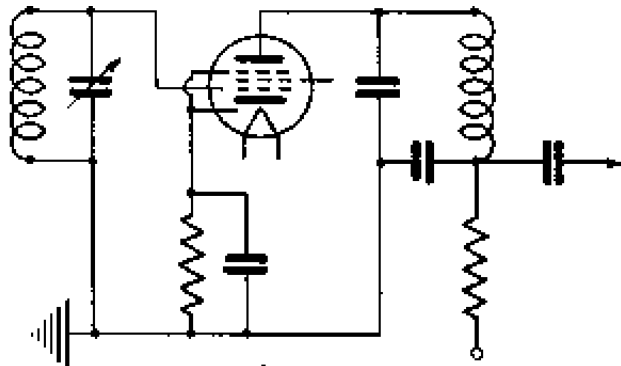
bleeder, and resistor (not shown), should simulate that of R1.

A detector system for feeding push-pull resistance coupled stage without a phase inverter tube is shown in Fig. 7. A 6H6 tube or the equivalent may be used.

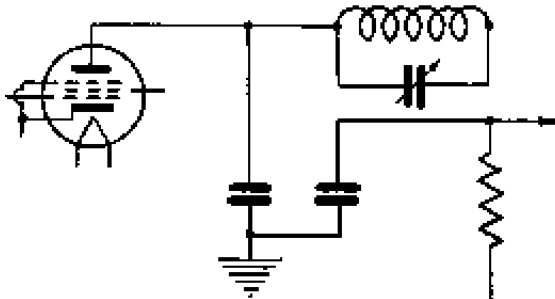
We now come to the audio amplifier which is highly important in connection with high fidelity reproduction.

Curve B Fig. 1 shows the characteristic of a condenser-resistor grid input coupling system of a modern audio amplifier as in Fig. 8. If the condenser is large enough (up to .01 mfd. or larger) and the resistor large (1 or 2 megs.) as compared to the grid input impedance, good fidelity will be obtained. Increasing the condenser size shifts the steep part of the curve Fig. 1 to the left and if this is down to 30 or 40 cycles good

fidelity is obtained. The upper part of the curve needs no attention as it is practically straight. Curve C shows roughly the amplifying characteristics of a transformer operated with a minimum D. C. component. Its decrease to the left of the 400 cycle line is due to its impedance at these frequencies being small as compared to the tube A. C. plate resistance. Past 400 cycles the curve would rise steadily if it were not for losses due to hysteresis, leakage, capacity and load, or regulation characteristics. The lower part of the curve can be improved through the use of high quality transformers having large iron cores, short flux paths, uniform maximum core cross section, minimum window area, high quality core material, and adequate wire sizes. The upper section of the curve may be reduced in amplitude by loading, as in Fig. 9.



4 a



4 b

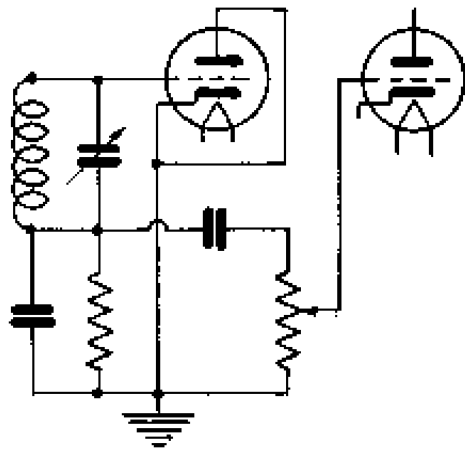


FIG. 5 a

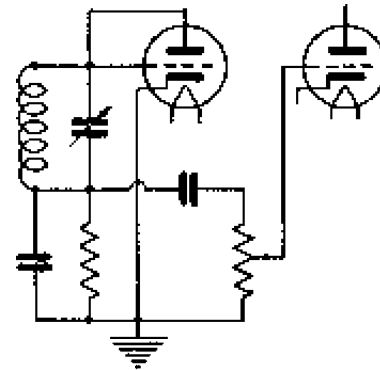


FIG. 5 b

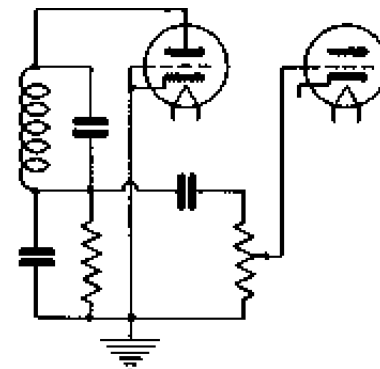


FIG. 5 c

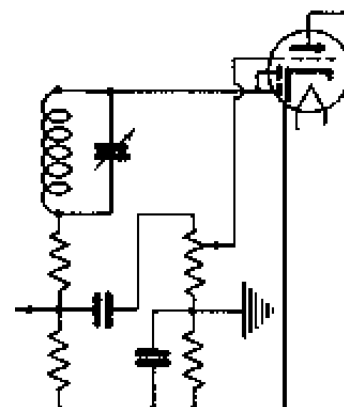


FIG. 5 d



.1 to 1 meg. will serve the average purpose. A further improvement may be made in the connection of transformers for the elimination of direct current flow which has the effect shown in Fig. 10. Fig. 11 shows the circuit.

R should be about 50,000 ohms and C about 0.1 mfd. The primary of the transformer and C form a series resonant circuit. Increasing the capacity of C shifts the resonance to a lower frequency, so by proper selection of C, the desired effect can be obtained.

Class B circuits may be eliminated from this discussion as they are not fundamentally high fidelity circuits as applied to broadcast reception. The best fidelity is obtained from them when they are furnishing maximum power.

A tone control or output by-pass unit will have the effect of Curve D as shown in Fig. 1. The high

frequency response can be greatly improved by elimination of all tone controls or compensators.

The average speaker characteristic is shown in curve E Fig. 1. Since more power is required to reproduce low frequencies we can simply supply more power to the speaker, but to prevent the proportional increase from accentuating the high frequency end a tone control is sometimes used. However, the only satisfactory answer to the problem is to use two speakers. One is designed to reproduce low frequencies and the other is for high ones. The high frequency speaker is called a tweeter and has characteristics as in F of Fig. 1. A high frequency speaker may be added to any receiver for high fidelity reproduction.

All resonance points of a speaker diaphragm or frame or receiver cabinet must be eliminated by treatment fitting the nature of the trouble.

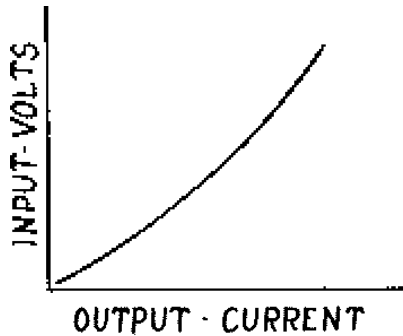


FIG. 6.

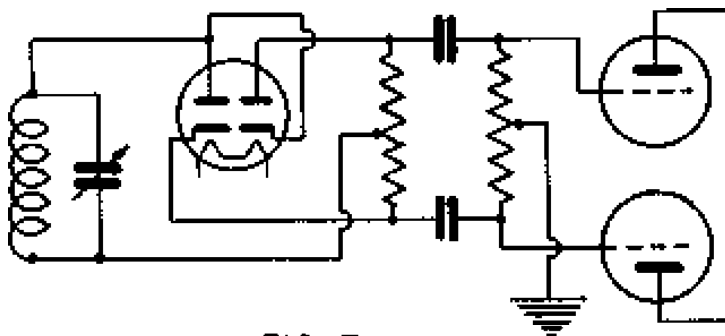


FIG. 7

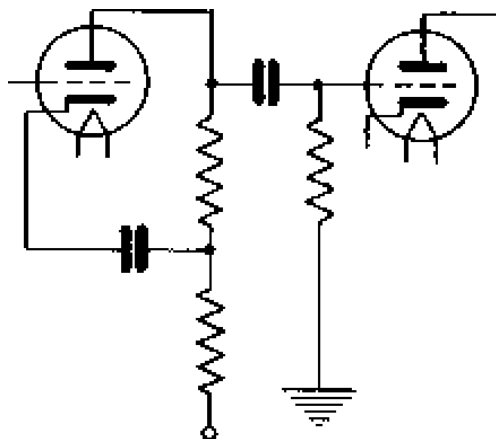


FIG - 8

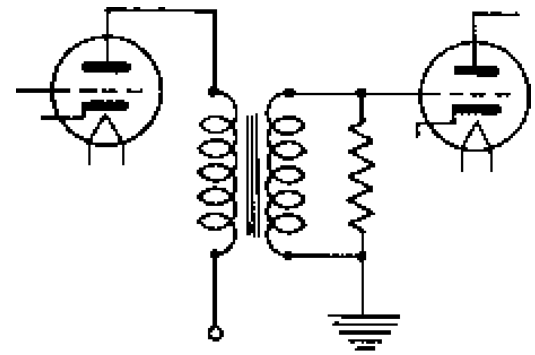


FIG 9

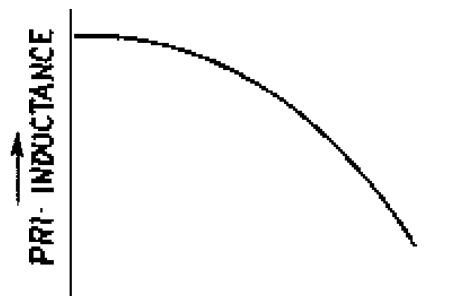


FIG. 10

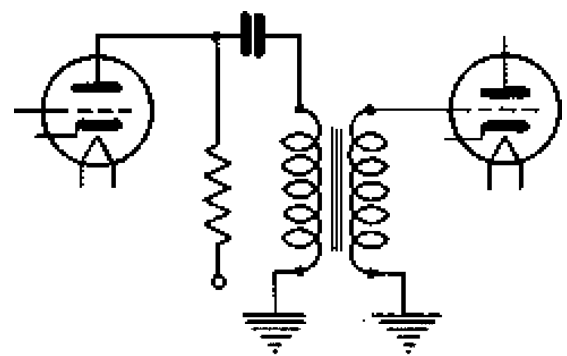


FIG. 11



Simplified Radio Math Formulas

Servicemen and experimenters often find need of mathematics in their work. The following formulas are given to aid those who must do work of this nature. These are standard formulas, or formulas which are derived from a fundamental formula. Since space does not permit, no attempt will be made to explain how each of these are used.

Ohms Law for D.C.

- E = Voltage
- I = Current — Amperes
- R = Resistance — ohms
- P = Power — watts
- G = Conductance — mhos

$$E = I \times R \quad \sqrt{PR} = \frac{P}{I} \quad \frac{I}{G}$$

$$I = \frac{E}{R} \quad \frac{P}{\sqrt{R}} \quad \frac{P}{E} \quad EG$$

$$R = \frac{E}{I} \quad \frac{E^2}{P} \quad \frac{P}{I^2} = \frac{1}{G}$$

$$G = \frac{1}{E} = \frac{I^2}{P} = \frac{P}{E^2} = \frac{1}{R}$$

Ohms Law for A.C.

- X = Reactance — ohms
- X_c = Capacitive reactance — ohms
- X_L = Inductive reactance — ohms
- Z = Impedance — ohms
- R = Resistance — ohms
- L = Inductance in henries
- C = Capacity in farads
- F = Frequency — cycles per second
- 2π = 6.28

$$X = \frac{E}{I}, \quad E = IX, \quad I = \frac{E}{X}$$

$$X_c = \frac{1}{2\pi FC}, \quad X_L = 2\pi FL$$

$$Z = \sqrt{R^2 + X^2} \quad \text{or} \quad Z = \sqrt{R^2 + (X_L - X_c)^2}$$

$$\text{Or } Z = \sqrt{R^2 + (2\pi FL - \frac{1}{2\pi FC})^2}$$

$$\text{Or } Z = \frac{E}{I}, \quad E = IZ, \quad I = \frac{E}{Z}$$

$$I = \frac{E}{\sqrt{X^2 + R^2}}, \quad E = I \sqrt{X^2 + R^2}$$

$$I = \frac{E}{\sqrt{(X_L - X_c)^2 + R^2}}$$

$$E = I \sqrt{(X_L - X_c)^2 + R^2}$$

Resistor Formulas

Resistors in Series = R₁ + R₂ + R₃, etc.

Resistors in Parallel —

- R_t = Total resistance
- R₁ = One value of R
- R₂ = Another value of R

$$R_t = \frac{R_1 \times R_2}{R_1 + R_2} \quad \text{for two resistors}$$

$$R_1 = \frac{R_t R_2}{R_2 - R_t}, \quad R_2 = \frac{R_t R_1}{R_1 - R_t}$$

For three or more resistors —

$$R_t = \frac{1}{\frac{1}{R_1} + \frac{1}{R_2} + \frac{1}{R_3} + \frac{1}{R_4}} \quad \text{etc.}$$

Shunt Multiplier Resistor for Current Meter —

- R_s = Shunt Resistor
- R_m = Resistance of meter
- I_t = Total current
- I_m = Meter current

$$R_s = \frac{R_m}{\frac{I_t}{I_m} - 1} \quad I_m = \frac{R_s I_t}{R_m + R_s} \quad I_t = I_m \frac{(R_m + R_s)}{R_s}$$

$$R_m = R_s \frac{(I_t - I_m)}{I_m}$$

Series Multiplier Resistor for Voltmeter —

- R_s = Series resistor
- R_m = Resistance of meter
- E = New voltage range
- E_m = Original voltage range of meter

$$R_s = R_m \left(\frac{E}{E_m} - 1 \right)$$

Condenser Formula

C_t = Total Capacity
For Condensers in parallel

$$C_t = C_1 + C_2 + C_3, \text{ etc.}$$

For Condensers in Series

$$C_t \text{ for two condensers} = \frac{C_1 C_2}{C_1 + C_2}$$

$$C_1 = \frac{C_t C_2}{C_2 - C_t}, \quad C_2 = \frac{C_t C_1}{C_1 - C_t}$$

C_t for three or more =

$$\frac{1}{\frac{1}{C_1} + \frac{1}{C_2} + \frac{1}{C_3}} \quad \text{etc.}$$



Resonance Formulas

Resonance Formulas —

- F = Frequency in Kilocycles
- L = Inductance in Microhenries
- C = Capacity in Microfarads

$$F^2 = \frac{25330}{LC}, \quad L = \frac{25330}{F^2C}, \quad C = \frac{25330}{F^2L}$$

Gain of Amplifier Stage

- G = Gain
- Mu = Amplification factor
- RI = Plate load
- Rp = Internal A.C. plate resistance of tube

$$G = Mu \frac{RI}{RI + Rp}$$

Impedance of resistor and either capacitive or inductive reactance in parallel.

$$Z = \frac{XR}{\sqrt{R^2 + X^2}}$$

If R and Z are known —

$$X = \frac{ZR}{\sqrt{R^2 - Z^2}}$$

If Z and X are known —

$$R = \frac{XZ}{\sqrt{X^2 - Z^2}}$$

Various units are used in Radio work, and it is often necessary to change from one form to another. The table given below will aid in changing quickly from one unit to another.

MULTIPLY	BY	TO GET
Amperes	× 1,000,000,000,000	Micro-microamperes
Amperes	× 1,000,000	Microamperes
Amperes	× 1,000	Milliamperes
Cycles	× .000001	Megacycles
Cycles	× .001	Kilocycles
Farads	× 1,000,000,000,000	Micro-microfarads
Farads	× 1,000,000	Microfarads
Henries	× 1,000,000	Microhenries
Henries	× 1,000	Millihenries
Kilocycles	× 1,000	Cycles
Kilowatts	× 1,000	Watts
Megacycles	× 1,000,000	Cycles
Mhos	× 1,000,000	Micromhos
Mhos	× 1,000	Millimhos
Microamperes	× .000001	Amperes
Microfarads	× .000001	Farads
Microhenries	× .000001	Henries
Micromhos	× .000001	Mhos
Micro-ohms	× .000001	Ohms
Microvolts	× .000001	Volts
Micro-microfarads	× .000000000001	Farads
Micro-micro-ohms	× .000000000001	Ohms
Milliamperes	× .001	Amperes
Millihenries	× .001	Henries
Millimhos	× .001	Mhos
Millivolts	× .001	Volts
Milliwatts	× .001	Watts
Ohms	× 1,000,000,000,000	Micro-micro-ohms
Ohms	× 1,000,000	Micro-ohms
Ohms	× 1,000	Milliohms
Volts	× 1,000,000	Microvolts
Volts	× 1,000	Millivolts
Watts	× 1,000,000	Microwatts
Watts	× .001	Kilowatts



Condensed Underwriter's Specifications for Radio Receivers

Continued from Page 10

of two or more conductors which are twisted together or are parallel and enclosed in the same covering or are concentric, the mechanical strength of the combination shall not be less than that of No. 19 if of copper, or No. 20 if of bronze. Lead-in conductors shall be securely attached to the antenna, to the building, and to intermediate supports.

(3007-g) Lead-in conductors from the first building attachment to the building entrance shall, except as specified in the following paragraph, be installed and maintained so that they cannot swing closer to the conductors of other electric circuits than the following distances:

- Circuits of 0 to 600 volts..... 2 ft.
- Circuits exceeding 600 volts..... 10 ft.

Where all conductors involved are supported so as to insure a permanent separation and the other electric circuits concerned do not exceed 150 volts to ground, the clearance may be reduced but shall not be less than 4 in. unless separated by a continuous firmly fixed non-conductor which will maintain permanent separation. In this latter case the non-conductor shall be in addition to any insulating material on the wires.

Lead-in Protective Devices.

(3702-h) Unless protected throughout the distance from the antenna to the building entrance by a metallic shield which is permanently and effectively grounded, each conductor of a lead-in from an outdoor antenna shall be provided with an approved protective device (lightning arrester) which will operate at a voltage of 500 volts or less, properly connected and located either inside the building at some point between the entrance and the set (or transformer where one is used in connection with the antenna system) which is convenient to ground or outside the building. The protector shall be located as near as practicable to the point of entrance of the lead-in conductor into the building and shall not be placed in the immediate vicinity of combustible material or where exposed to flammable gases or dust or flying of combustible material.

Protective Grounding.

(3702-i) The grounding conductor from the protective device may be bare and shall be of copper, copper-clad steel, bronze, or other corrosion-resistive material and shall not be smaller than No. 14 copper or No. 17 copper-clad steel or bronze if outside the building, or No. 18 if wholly inside the building.

(3702-i, j, k) The protective grounding conductor shall be run in as straight a line as possible from the protective device to a good permanent grounding. It may be run either inside or outside the building and shall be guarded where exposed to mechanical injury.

(3702-j) An approved ground clamp shall be used where the protective grounding conductor is connected to a pipe.

Conductors inside Building.

(3702-l) Conductors inside buildings shall be securely fastened in a workmanlike manner, and, shall not come nearer than 2 in. to the conductors of any

other electric supply or signal circuit not in conduit unless separated therefrom by some continuous and firmly fixed non-conductor, such as porcelain tubes or approved flexible tubing, making a permanent separation. This non-conductor shall be in addition to any regular insulating covering on the wire.

All possibility of a cross between a light or power wire and any wire connected to the receiving set must of course be guarded against. It is also well understood that for reasons pertaining to the operation of the set, it is better to keep all radio wiring separated much more than 2 in. from light or power wires, especially if the two wires are parallel.

(3702-n) Under conditions noted in subparagraphs 1, 2, 3, 4, and 5 below, wiring for radio systems, public address systems, or speech-amplifier systems may be grouped in the same conduit, armored cable, electrical metallic tubing, metal raceway, pull box, junction box, cabinet, or flexible cord.

1. Power-supply conductors are introduced solely for supplying the equipment to which the other conductors are connected.

2. Flexible cords are of types P, K, S, or SJ or other type especially approved for the purpose in which conductors other than power-supply conductors are insulated individually or collectively in groups by insulation at least equivalent to that on the power-supply conductors.

3. Conductors other than power-supply conductors are permissible in sizes not smaller than No. 26, provided they are not conductively connected to the power supply and are equipped with current-limiting means so that the maximum power under any condition will not exceed 150 watts.

4. Conductors other than power-supply conductors run in conduit, armored cable, electrical metallic tubing, metal raceway, pull box, junction box, or cabinet with power-supply conductors are insulated individually or collectively in groups by insulation at least equivalent to that of the power-supply conductors or the power-supply and other conductors are separated by a lead sheath or other continuous metallic covering.

5. Terminals for the power-supply conductors and the other conductors provide spacings of all other terminals from the power terminals at least as great as the spacing between power terminals of opposite polarities and also suitable means are provided to guard against connecting other conductors to the power-supply terminals.

The foregoing provisions permit the use of an outlet box and receptacle for the power supply, antenna, and ground wire for a radio receiver, provided that standard 600-volt rubber-covered wire is used for the antenna or lead-in and ground wire. A four-conductor cable may be used for connection from the outlet to the receiver, if the cable is Type P, K, S, or SJ with each conductor insulated for 600 volts and if a receptacle and plug are used which are so designed that the plug can be inserted in only one position.



RADIO SERVICING GUIDE



Tube data which is most frequently used has been compiled in this convenient form.
Other tube data may be obtained from the tube manufacturer's bulletins.

Type	Fig. No.	Fil. Volts	Fil. Amps.	Fil. Watts	Max. Plate Volts	Max. Plate M. A.	Max. Screen Volts	Screen M. A.	Max. Volt. Gain or Mu	May Be Used as	Ohms Load for Stated Power Output	Power Output in Watts
1A4	4	2.0	.06	0.12	180	2.3	67.5	0.7	720	R. F. Amp.		
1A6	26	2	.06	0.12	180	1.3	67.5	2.4		Pent Grid		
1B4	4	2.0	.06	0.12	180	1.7	67.5	0.4		R. F. Amp.		
1B5/255		2.0	.06	0.12	135	0.8			20	Diode-Triode		
1C6	26	2	.12	.24	180	2.8	67.5	0.1		Converter		
2A3	1	2.5	2.5	6 1/4	300	40			4.2	P. P. Amp.	3-5000	15-10
2A5	15A	2.5	1.75	4.4	250	34	250	6.5	220	P. A. Pentode	7000	3
2A6	13	2.5	0.8	2	250	0.8			50	Hi-Mu Triode		
2A7	20	2.5	0.8	2	250	3.5	100	2.2		Mixer-Osc.		
2B6	Spec	2.5	2 1/4	5.6	350	45			26.4	P. A. Dual-Triode	5000	4-10
2B7	21	2.5	0.8	2	250	9	125	2.3	730	Det.-Amp.		
2S-4S	23	2.5	1	2.5						Diode-Det.		
6A4	6	6.3	0.3	1.9	180	22	180	3.9	100	P. A. Pentode	8000	1.4
6A6	24	6.3	0.8	5.0	300	6			25	V. A. Triode	10,000	1
6A7	20	6.3	0.3	1.9	250	3.5	100	2.2		Mixer-Osc.		
6A8	*	6.3	0.3	1.9	250	3.3	100	3.2		Mixer Osc.		
6B5		6.3	0.8	5.0	300	45	300	6	58	Cas. P. A. Dual-Tri.	7000	4-10
6B7	21	6.3	0.3	1.9	250	9	125	2.3	730	Det.-Amp.		
6C5	*	6.3	0.3	1.9	250	8			20	V. A. Triode	10,000	.3
6C6	11	6.3	0.3	1.9	250	2.3	100	1	1500	3-Grid		
6D6	11	6.3	0.3	1.9	250	7.5	100	1.75	1280	R. F. Amp.		
6D7	Spec	6.3	0.3	1.9	250	2.3	100	1	1500	I. F. Pentode		
6E5	Spl.	6.3	0.3	1.9	250	.24				Tuning Ind.		
6E7	Spec	6.3	0.3	1.9	250	7.5	100	1.75	1160	R. F. Pentode		
6F5	*	6.3	0.3	1.9	250	0.9			100	V. A. Triode	100,000	
6F6	*	6.3	0.7	4.4	315	42	315	8	200	P. A. Pentode	7,000	5
6F7	27	6.3	0.3	1.9	250	6.5	100	1.5	900	Triode-Pentode		
6H6	*	6.3	0.3	1.9						Twin Diode		
6J7	*	6.3	0.3	1.9	250	2	100	0.5	1500	3 Grid		
6K7	*	6.3	0.3	1.9	250	10.5	125	2.6	990	3 Grid		
6L6	*	6.3	0.9	5.7	300	55	200	5	135	Beam P. A.	5,000	6.5
6L7	*	6.3	0.3	1.9	250	3.3	150	8.3		Mixer Amp.		
6N7	*	6.3	0.8	5.0		Same as 6A6						
6Q7	*	6.3	0.3	1.9	250	1.1			70	Diode Triode	100,000	
6R7	*	6.3	0.3	1.9	250	9.5			16	Diode Triode	10,000	0.28
00-A	1	5	0.25	1 1/4	45	1.5				Det.		
01-A	1	5	0.25	1 1/4	135	3			8	Bat.-Amp.	20,000	0.02
10	1	7.5	1 1/4	9.3	425	18			8	P. A. Triode	10,000	1.6
11-12	12-1	1.1	1/4	0.3	135	3			6.6	Drvcell Det.		
12A	1	5	1/4	1 1/4	180	7.7			8.5	Det.-Amp.	9400	0.05
19	25	2	0.26	0.5	135	B				Class B Only	10,000	1.9
20	1	3.3	.132	.43	135	6.5			3.3	Drvcell P. A.	6500	0.11
22	4	3.3	.132	.43	135	3.7	67.5	1.3	160	R. F. Amp.		

* Metal Tubes.



RADIO SERVICING GUIDE



Type	Fig. No.	Fil. Volts	Fil. Amps.	Fil. Watts	Max. Plate Volts	Max. Plate M. A.	Max. Screen Volts	Screen M. A.	Max. Volt. Gain or Mu	May Be Used as	Ohms Load for Stated Power Output	Power Output in Watts
24A	9	2.5	1.75	4.4	275	4.5	90	1.7	630	R. F. Amp.
25A6	*	25	0.3	7.5	180	38	135	7.5	100	P. A. Pentode	5,000	2.75
26	1	1.5	1.05	1.15	180	6.2	8.3	R. F.-A. F. Amp.	15,000	0.02
27	8	2.5	1.75	4.4	275	5.2	9	Det.-Amp.	18,500	0.025
30	1	2	0.06	.12	180	3.1	9.3	Drycell-Amp.	20,000	0.01
31	1	2	0.13	.26	180	12.3	3.8	Drycell-P. A.	5700	0.375
32	4	2	0.06	.12	180	1.7	67.5	0.4	780	R. F. Amp.
33	6	2	0.26	.52	180	22	180	5	90	P. A. Pentode	6000	1.4
34	4A	2	0.06	.12	180	2.8	67.5	1	620	R. F. Amp.
35-51	9	2.5	1.75	4.4	275	6.5	90	2.5	420	R. F.-A. F. Amp.
36	9	6.3	0.3	1.9	250	3.2	90	1.7	595	R. F. Amp.
37	8	6.3	0.3	1.9	250	7.5	9.2	Det.-Amp.
38	9A	6.3	0.3	1.9	250	22	250	3.8	120	P. A. Pentode	10,000	2.5
39-44	9A	6.3	0.3	1.9	250	5.8	90	1.4	1050	R. F. Amp.
40	1	5	0.25	1 1/4	180	0.2	30	Voltage Amp.
41	15A	6.3	0.4	2.5	250	32	250	5.5	150	P. A. Pentode	7600	3.4
42	15A	6.3	0.7	4.3	250	34	250	6.5	220	P. A. Pentode	7000	3
43	15A	25	0.3	7.5	135	34	135	7	80	P. A. Pentode	4000	2
45	1	2.5	1.5	3.7	275	36	3.5	P. A. Triode	4600	2
46	7	2.5	1.75	4.4	250	22	5.6	P. A. Triode	6400	1.25
47	6	2.5	1.75	4.4	250	31	250	6	150	P. A. Pentode	7000	2.7
48	15	30	0.4	12	125	56	100	9.5	28	Tetrode	1500	2.5
49	7	2	0.12	.25	135	6	4.5	P. A. Triode	11,000	0.17
50	1	7.5	1.25	9.3	450	55	3.8	P. A. Triode	4350	4.6
52	14	6.3	0.3	1.9	100	42	Tetrode	9400	3.5
53	24	2.5	2	5	300	6	25	V. A. Triode	10,000	1
55	13	2.5	1	2.5	250	8	8.3	Det.-Amp.	20,000	0.35
56	8	2.5	1	2.5	250	5	13.8	Det.-Amp.	19,000	0.3
57	11	2.5	1	2.5	250	2	100	0.5	1500	R. F.-A. F. Amp.
58	11	2.5	1	2.5	250	8.2	100	2	1280	R. F.-Amp.
59	18	2.5	2	5	250	26	6	P. A. Triode	5000	1.25
59	18	2.5	2	5	250	35	250	9	100	P. A. Pentode	6000	3
59	18	2.5	2	5	400	B	Class B	6000	20
71A	1	5	0.25	1 1/4	180	20	3	P. A. Triode	4800	0.79
75	13	6.3	0.3	1.9	250	0.4	50	Diode-Triode
76	8	6.3	0.3	1.9	250	5	13.8	Det.-Amp.	19,000	0.3
77	11	6.3	0.3	1.9	250	2.3	100	0.5	1500	R. F. Amp.
78	11	6.3	0.3	1.9	250	10.5	125	2.6	990	R. F. Amp.
79	19	6.3	0.6	3.8	250	B	Class B	14,000	8
85	13	6.3	0.3	1.9	250	8	8.3	Diode-Triode	2000	0.35
87	11	6.3	0.4	2.5	250	2	100	1	1250	R. F. Pentode
88	11	6.3	0.4	2.5	250	8.2	100	3	1280	R. F. Pentode
89	14	6.3	0.4	2.5	250	32	4.7	A. F. Triode	5500	0.9
89	14	6.3	0.4	2.5	250	32	250	5.5	125	P. A. Pentode	6750	3.4
89	14	6.3	0.4	2.5	180	B	Class B	9400	3.5

For data on rectifier tubes, see page 32



Type	Fig. No.	Fil. Volts	Fil. Amps.	Fil. Watts	Max. Plate Volts	Max. Plate M.A.	Max. Screen Volts	Screen M.A.	Max. Volt. Gain or Mu	May Be Used as	Ohms Load for Stated Power Output	Power Output in Watts
181	Spec	3	1.75	5 1/4	180	20	5	Sparton P. A.	7000	1.5
401	Spec	3	1	3	180	6	8.7	Kellogg Triode	14,000	0.03
482B	1	5	1.25	6 1/4	250	18	5	P. A. Triode	4500	1.4
483	1	5	1.35	6 3/4	250	25.3	3.3	P. A. Triode	3900	1.6
485	8	3	1.25	3 3/4	90	5	12.5	Sub. for 484		
586	1	7.5	1.25	9.3	450	55	3.8	Same as 50	4300	4.6
864	1	1.1	0.25	.3	135	3.5	8.2	Porta. Osc.		
955	Spec	6.3	0.16	1	180	4.5	25	H. F. Det. Osc.		
WUNA	Spec	6.3	0.4	2.5	250	7	9	Dual Mike Mix		
WUN	Spec	2.5	1.0	2.5	250	7	9	Dual Mike Mix		

Octal Base Tubes — Socket Connections

Octal base tubes all fit the standard octal sockets. The pin connections are consecutively numbered from one to eight in a clockwise direction viewed from bottom of

socket starting with the first pin to the left of locating key. The following table shows the socket connections for all standard metal, metal-glass and octal based glass tubes.

PIN POSITIONS AND NUMBERS

	1	2	3	4	5	6	7	8
5W4	S	F	P	P	F
5Z4	S	H	P2	P1	K & H
6A8	S	H	P	G3 & G5	G1	G2	H	K
6C5	S	H	P	G	H	K
6F5	S	H	P	H	K
6F6	S	H	P	G2	G1	H	K & G3
6H6	S	H	P2	K2	P1	H	K1
6J7	S	H	P	G2	G3	H	K
6K7	S	H	P	G2	G3	H	K
6L6	S	H	P	G2	G1	H	K
6L7	S	H	P	G2 & G4	G3	H	K & G5
6N7	S	H	P2	G2	G1	P1	H	K
6Q7	S	H	P	D1	D2	H	K
6R7	S	H	P	D1	D2	H	K
6X5	S	H	P2	P1	H	K
25Z6	S	H	P2	K2	P1	H	K1

A Direct Reading Vacuum Tube Voltmeter

Continued from Page 5

vacuum tube voltmeter to the grid of each stage successively until the inoperative stage is found. This will be indicated by absence of R.F. voltage at the grid of the following tube. There will be a slight detuning effect due to the "tube inter-element capacities" of the vacuum tube voltmeter, but not enough to have a great effect on the reading.

If the instrument is used on circuits which do not provide a D.C. path between the two test clips, false readings will result.

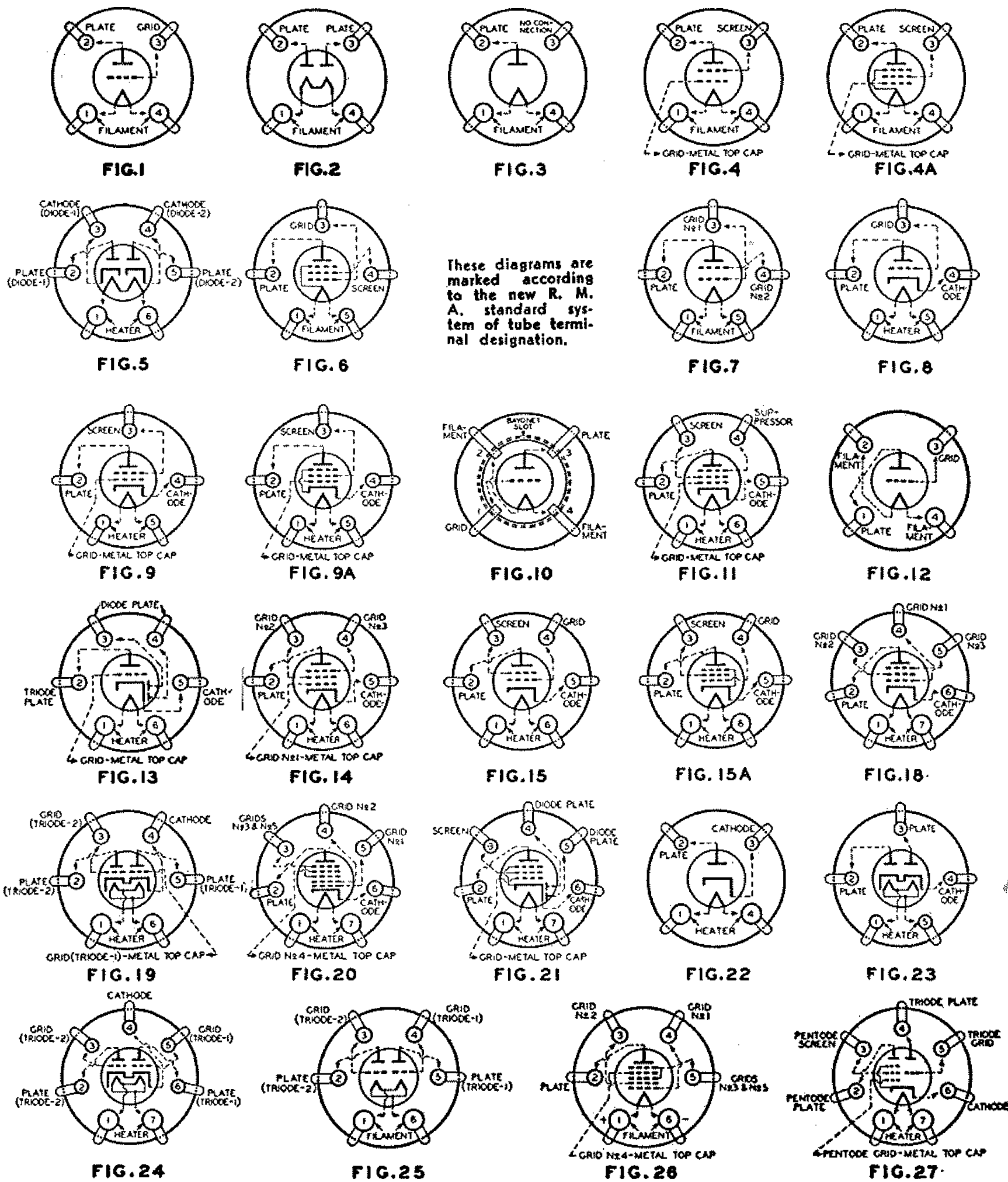
There are an infinite number of tests and measurements which can be made with the vacuum tube voltmeter, many of which will suggest themselves to the user.

A more sensitive meter, such as a microammeter, may be used as an indicating device but will be less rugged for ordinary use and will reduce the maximum voltage readings. A "soft" or gassy 6F5 tube will give erratic readings if the resistance in the grid circuit is high (as when multiplier is used), due to shift in bias voltage.

PARTS LIST

R ₁ — 100 ohm 1 watt	R ₆ — 20,000 ohm 1 watt	MA — 0.1 milliammeter
R ₂ — 15,000 ohm 1 watt	C ₁ — Dual 8.8 mfd 450	T-7538 — Power transformer
R ₃ — 10,000 ohm wire wound potentiometer	C ₂ — volt dry electrolytic	T-5298 — Choke
R ₄ — 10,000 ohm 1 watt	C ₃ — 25 mfd 25 volt electrolytic	2 — S.P.S.T. switches
R ₅ — 100,000 ohm 1 watt	C ₄ — .0005 mfd mica	1 — 6F5 tube
R ₆ — 12,500 ohm 1 watt	C ₅ — "Postage stamp type"	1 — 84 tube
R ₇ — 125 ohm 5 watt		Sockets, cable, case, etc.

TUBE SYMBOLS AND BOTTOM VIEWS OF SOCKET CONNECTIONS



Rectifiers

Type	Fig.	Fil. V.	Fil. A.	Fil. W.	A.C. Volts Per Plate	D.C. Current Max.	Type	Fig.	Fil. V.	Fil. A.	Fil. W.	A.C. Volts Per Plate	D.C. Current Max.
5W4	*	5.0	1.5	7½ W.	350 V.	110 Ma.	1-v	22	6.3	0.3	1.89 W.	350 V.	50 Ma.
5Z3	2	5	3	15 W.	500 V.	250 Ma.	80	2	5	2	10 W.	400 V.	110 Ma.
5Z4	*	5.0	2.0	10 W.	400 V.	125 Ma.	81	3	7.5	1.25	9½ W.	700 V.	85 Ma.
6X5	*	6.3	0.6	3¾ W.	350 V.	75 Ma.	82	2	2.5	3	7½ W.	500 V.	125 Ma.
12Z3	22	12.6	0.3	3¾ W.	250 V.	60 Ma.	83	2	5	3	15 W.	500 V.	250 Ma.
25Z5	5	25	0.3	7½ W.	125 V.	100 Ma.	84	23	6.3	0.5	3¼ W.	350 V.	50 Ma.
25Z6	*	25	0.3	7½ W.	125 V.	85 Ma.							

* — Metal Tubes.

THORDARSON ELECTRIC MFG. CO.
500 W. HURON ST. CHICAGO, ILL.