

INFORMATION
FOR THE
CARE AND OPERATION
OF THE
106-A
RADIO TELEPHONE
BROADCASTING EQUIPMENT
1 KW

Western Electric Company

OCTOBER, 1926

S. Adams

Copyright 1926
by the
Western Electric Company, Inc.

PRINTED IN U. S. A.

S. Adams

INTRODUCTION

The 106-A Radio Telephone Broadcasting Equipment comprises all apparatus necessary for a broadcasting station having a power output of one kilowatt with the exception of the antenna and ground systems. If conditions necessitate placing the transmitter more than one thousand feet from the studio additional speech input equipment will be required. Under such circumstances a 5-A Speech Input Equipment should be used at the radio station, the 1-E Speech Input Equipment being installed at the studio and the two equipments connected by telephone line.

The apparatus comprising the 106-A Radio Telephone Broadcasting Equipment is grouped with reference to function, into three classes of equipment which serve the general purposes outlined below.

1. The 6-A Radio Transmitter (pages 68 to 74) in conjunction with the motor generators and control circuits operates to deliver to the antenna circuit one kilowatt of unmodulated energy at any desired frequency between 500 and 1500 kilocycles per second.

2. The 1-E Speech Equipment (page 89) serves to convert sound energy in the studio into electrical energy and to amplify and control it so as to modulate the output of the radio transmitter in accordance therewith.

3. The 6204-D Radio Receiving Outfit (pages 121, 129 and 133) furnishes the means when required of listening for distress or other signals while the station is operating.

In the pages which follow suggestions and directions for adjusting and operating the 106-A equipment are presented for the guidance of the purchaser.

PREFACE

This Instruction Bulletin has been prepared to enable the operator of the 106-A Radio Telephone Broadcasting Equipment to familiarize himself with the component parts of the apparatus and also to furnish him with sufficient information for the successful operation and care of the equipment.

Ordering information is supplied in the back of the bulletin to facilitate accurate reference to various parts of the equipment, through apparatus designations, when corresponding with the Graybar Electric Company (in the U. S. A.), the Northern Electric Company, Limited (in Canada), or the International Standard Electric Corporation (in other foreign countries).

LIST OF DRAWINGS

Code No.	Unit	Drawing	Page
106-A	R. T. B. Equipment		
	Wiring Diagram	ESX-308419	66
6-A	Radio Transmitter		
	Schematic of Power Equipment	ESX-308487	67
	Schematic Issue 4	ESR-307849	76
	Schematic Issue 5	ESR-307849	77
	Schematic Issue 7	ESR-307849	78
	Typical Water Circulating System	ESO-308612	83
	Typical Water Circulating System	ESO-309899	86
KS-3070	Pressure Regulator		
	Modified Schematic	ESA-308177	85
1-E	Speech Input Equipment		
	Schematic	ESX-308402	90
8-B	Speech Input Amplifier		
	Schematic	ESO-304581	94
	Wiring Diagram	ESR-304971	95
518-B	Volume Indicator Panel		
	Simplified Circuit	ESA-271195	98
	Wiring Diagram	ESO-271196	99
18-B	Amplifier		
	Schematic	ESL-306365	102
	Wiring Diagram	ESO-306449	103
514-A	Meter Panel		
	Wiring Diagram	ESL-259576	105
534-A	Signal and Control Panel		
	Schematic	ESO-272220	108
	Wiring Diagram	ESO-272098	109
6045-A	Telephone Set		
	Circuit Label 522-A Sub. Set	ESL-272562	111
D-76814	Extension Panel		
	Wiring Diagram	ESO-272145	114
536-B	Battery Supply Panel		
	Wiring Diagram	ESL-302270	117
KS-2805	Battery Charging and Switching Panel		
	Schematic	ESL-305070	119
	Wiring Diagram	ESR-305061	120

Code No.	Unit	Drawing	Page
6204-D	Radio Receiving Outfit		
	Schematic	ESO-312816	123
4-D	Radio Receiver		
	Schematic	ESO-308830	124
6004-C	Radio Receiving Outfit		
	Schematic	ESO-307765	126
4-C	Radio Receiver		
	Circuit Label	ESO-305683	127
4-B—4-C	Radio Receiver		
	Wiring	ESO-303676	128

LIST OF PHOTOGRAPHS

Code No.	Unit	Photograph	Page
106-A	R. T. B. Equipment Assembly	22853	65
6-A	Radio Transmitter		
	Front View	25453	68
	Front View (Open)	25452	69
	Left Side (Screens Off)	25454	70
	Rear View (Door Off)	25457	71
	Rear View (Upper Section)	25450	72
	Right Side (Screens Off)	25455	73
	Right Side (Upper Section)	25451	74
KS-5054	Motor Generator	22734	79
KS-5055	Motor Generator	22733	80
100-A	Electrolytic Condenser	22737	81
125-A	Retard Coil	22736	82
KS-3070	Pressure Regulator	22735	84
226-A	Relay	23298	87
KS-3068	Water Pump	25445	88
1-E	Speech Input Racks	23117-C	89
373-W	Microphone Transmitter	26068	91
387-W			
8-B	Speech Input Amplifier		
	Front View	21425	92
	Rear View	26101	93
518-B	Volume Indicator Panel		
	Front View	21435	96
	Rear View	26100	97
18-B	Monitoring Amplifier		
	Front View	26103	100
	Rear View	26102	101
514-A	Meter Panel	21448	104
534-A	Signal and Control Panel		
	Front View	21436	106
	Rear View	21440	107
6045-A	Telephone Set.	21449	110
D-76814	Extension Panel		
	Front View	22882	112
	Rear View	22884	113

Code No.	Unit	Photograph	Page
536-A	Battery Supply Panel (Modified)	23255-C	115
536-B	Battery Supply Panel	22963-C	116
KS-2805	Battery Charging and Switching Panel	21445	118
4-D	Radio Reciever		
	Front View	25448	121
	Open View	25694	122
4-C	Radio Receiver	21437	125
2-B	Tuning Unit		
	Front View	25449	129
	Rear View	25446	130
2-A	Tuning Unit		
	Front View	22129	131
	Rear View	21442	132
20-A	Filter		
	Front View	21434	133
	Rear View	21444	134

TABLE OF CONTENTS

INTRODUCTION

CHAPTER I	Page
6-A RADIO TRANSMITTER	1
A. GENERAL DESCRIPTION	1
B. TRANSMITTER CIRCUITS	2
1. Oscillator	2
2. Modulator and Speech Amplifier	2
3. Power Amplifier	3
4. Antenna	4
5. Monitoring Rectifier	5
6. Power Supply	5
a. Filament	5
1. 100-A Condenser	5
2. 125-A Retardation Coil	7
b. Negative Grid Voltage	7
c. Plate	7
7. Protection	7
a. Switches and Relays	7
b. Fuses	8
C. METHOD OF ADJUSTMENT	9
Table 1	10
Table 2	15
Table 3	15
Table 4	16
Table 5	18
Recapitulation	18
CHAPTER II	
1-E SPEECH INPUT EQUIPMENT	20
A. GENERAL DESCRIPTION	20
1. 387-W and 373-W (Microphone) Transmitters	20
2. 8-B (Speech Input) Amplifier	21
3. 518-B (Volume Indicator) Panel	21
4. 18-B (Monitoring) Amplifier	23
5. 514-A (Meter) Panel	23
6. 534-A (Signal and Control) Panel	23

	Page
7. 6045-A Telephone Set	24
8. D-76814 (Extension) Panel	25
9. 547-B (Microphone) Panel	25
10. 536-A (Battery Supply) Panel (Modified)	25
536-B (Battery Supply) Panel	25
11. KS-2805 Battery Charging and Switching Panel ..	25
 CHAPTER III	
RADIO RECEIVING OUTFIT	
A. GENERAL DESCRIPTION 6204-D RADIO RE- CEIVING OUTFIT	26
1. 4-D Radio Receiver	26
2. 2-B Tuning Unit	27
3. 20-A Filter	28
B. GENERAL DESCRIPTION 6004-C RADIO RE- CEIVING OUTFIT	28
1. 4-C Radio Receiver	28
2. 2-A Tuning Unit	29
3. 20-A Filter	30
 CHAPTER IV	
AUXILIARY EQUIPMENT	
A. WATER CIRCULATING SYSTEM	31
1. Water Pump	32
2. Radiator	33
3. Expansion Tank	33
 CHAPTER V	
OPERATING PROCEDURE	
A. RADIO TRANSMITTER	34
B. SPEECH INPUT EQUIPMENT	34
1. Studio Operation	34
Switch Settings	36
2. Control Room Operation	35
Current Table	35
3. Broadcasting from Remote Points	37
4. Monitoring	37
C. OPERATING ROUTINE	38
Routine prior to each Broadcasting Period	38
Routine during Program	39
D. RADIO RECEIVING OUTFIT	39
1. 6204-D Radio Receiving Outfit	39
2. 6004-C Radio Receiving Outfit	41

CHAPTER VI	Page
MAINTENANCE	43
A. DAILY ROUTINE	43
B. WEEKLY ROUTINE	43
C. ADDITIONAL ROUTINE	44
D. 100-A CONDENSERS	44
E. RELAYS	48
F. STORAGE BATTERIES	49
CHARGING RATES	50
CHAPTER VII	
LOCATION OF TROUBLE	52
A. TRANSMITTER	53
1. Overloading	53
2. Reduced Radiation	53
B. SPEECH INPUT EQUIPMENT	54
1. Amplifiers	54
2. Signal and Control Circuits	55
3. Radio Frequency Feed Back	55
4. Power Supply Circuit	56
C. RADIO RECEIVING OUTFIT	56
CHAPTER VIII	
ENGINEERING SERVICE	57
CHAPTER IX	
ORDERING INFORMATION	57
CAPACITIES	57
FUSES	58
INDUCTANCES	58
METERS	59
RELAYS	60
RESISTANCES	60
TRANSFORMERS	62
CHAPTER X	
SPARE PART EQUIPMENT	63
A. SPARE PARTS SUPPLIED	63
B. OPTIONAL SPARE PARTS	63

CHAPTER I

6-A RADIO TRANSMITTER

A. GENERAL DESCRIPTION

The 6-A Radio Transmitter (pages 68 to 74) is designed for broadcasting service and is rated at 1 kilowatt, which means that the power delivered to the antenna when not modulating is 1 kilowatt. Special attention has been given to the design of the audio frequency circuits so that the transmission of frequencies between 30 cycles and 7000 cycles is practically the same.

The vacuum tubes employed are one 211-D, two 212-D, one 228-A and one 205-D Vacuum Tubes.

The 211-D Tube is used as a "Speech Amplifier" and one 212-D Tube is used as a "Modulator", both of these tubes acting as audio frequency amplifiers.

The other 212-D Tube is used as an "Oscillator", the output of this oscillator being modulated by the audio frequency output from the modulator.

The 228-A Vacuum Tube is used as a "Power Amplifier". The grid of this tube is driven by the output of the oscillator tube and delivers its power to a tuned output circuit.

The antenna is capacitatively coupled to the output circuit and in this way derives its power indirectly from the power amplifier. This coupling is such that the radiation of harmonics of the radio frequency from the antenna circuit is effectively suppressed.

The 228-A Vacuum Tube is of the water-cooled anode type, while all of the others are radiation cooled.

The 205-D Vacuum Tube is used as a rectifier. It is coupled to the antenna circuit to such a degree that the audio frequency output from it may be used to operate a loud speaker for the purpose of observing the quality of transmission from the broadcasting station.

The power for operating the 6-A Radio Transmitter is derived from two motor-generator sets. One set KS-5054 (page 79) is composed of a motor driving the 2000-volt generators. The two generators are connected in series and supply power at 4000 volts to the 228-A Vacuum Tube and power at 2000 volts, which is reduced to 1500 volts, for the two 212-D Tube. The other motor-generator set KS-5055 (page 80) is composed of a motor driving one 250-volt generator and one 24 volt generator. The 24-volt generator furnishes power for the filament circuits of all the vacuum tubes. The 250-volt generator supplies the constant negative voltage for the vacuum tube grids as well as the field excitation for the 2000-volt generators and power for some control circuits.

Installed near these motor-generator sets are the necessary switches, fuses and motor starters for remote control and also the filter coil and condensers for smoothing the output of the 24-volt generator. The motor-generator sets are controlled from push-button switches mounted on the radio transmitter.

B. TRANSMITTER CIRCUITS

A schematic circuit of the radio transmitter is shown on pages 76, 77 and 78 (See also page 67). The operation of the various parts of the circuit is as follows:

1. Oscillator

The oscillator tube is indicated as V_3 . Its plate circuit derives its power from the 2000-volt generator (page 67) which is connected to Terminals 16 and 28. This voltage is reduced to the proper value by the series resistance R_9 and the current is supplied to the plate through the modulating choke coils L_2 , meter M_7 and the high frequency choke coils L_5 and L_{14} .

Plate current supplied to the oscillator tube is indicated by M_7 , the meter on the panel marked "Oscillator Plate Current". The frequency at which the oscillator operates is determined by the circuit composed of the inductance L_6 and the condensers C_4 and C_9 . The frequency is varied entirely by the adjustment of L_6 . Large changes in L_6 are made by means of a tap on the coil which is accessible from the rear of the transmitter. (L_6 is the coil to the right looking into the rear.) Small changes are made by means of a slider, which covers three turns at one end of the coil and is controlled from the front panel by the handwheel marked "Frequency." Turns are added by turning the indicator from 0 to 3.

The oscillatory circuit derives its power from the plate circuit of V_3 , through condenser C_2 , and the grid excitation for V_3 is obtained from the oscillatory circuit through condenser C_3 . The direct current flowing in the grid circuit is indicated by meter M_8 , which is marked "Oscillator Grid Current" on the front panel. The resistance R_{17} , which is bridged across a portion ($C_{4.1}$) of the oscillatory circuit, acts as a load on the oscillator and serves as a potentiometer for applying the proper input voltage to the power amplifier. The radio frequency current flowing through R_{17} is indicated by M_6 , which is marked "Oscillator Load Current" on the front panel.

2. Modulator and Speech Amplifier

The audio frequency input to the transmitter passes through the resistance network R_{15} and transformer T_1 . It is amplified by the speech amplifier V_1 and the modulator V_2 . The audio frequency output voltage of V_2 is developed across the choke coils L_2 , through which the plate power for both modulator and oscillator is obtained, and is thus impressed on the oscillator V_3 , modulating its radio frequency output.

Plate current for V_1 passes through R_{11} and is indicated by M_5 , marked on the panel "Speech Ampl. Plate Current." The plate current of V_2 is indicated by M_9 , marked on the panel "Modulator Plate Current."

M_{10} indicates the direct current flowing in the grid circuit of V_2 . It is marked "Modulator Grid Current" on the panel. This meter is provided to serve as an indication of overload at the input of the modulator. The input to the transmitter should be kept low enough to prevent frequent indications on this meter as will be explained later.

The necessary constant negative grid voltage required for the operation of V_1 and V_2 is obtained from a potentiometer R_5 connected across the 250-volt generator. Noise from this source is prevented by the filter, consisting of the choke coil L_{16} , and condenser C_{13} .

The four taps on the potentiometer R_5 are provided so that a slightly different negative grid voltage may be supplied when modulator tubes having different plate-filament impedances are used. The 212-D Tubes are divided into four classes numbered from 1 to 4 depending on the plate-filament impedance classification into which they fall. This classification of tubes is not in any way a graduation of quality and no one of these classes has advantages over another. The tapped portion of R_5 is accessible from the rear of the transmitter and is marked "Modulator Tube".

The flexible lead should be connected to the terminal number corresponding to the number indicating the impedance classification of the modulator tube.

3. Power Amplifier

The power amplifier tube V_4 derives its plate current from the 4000-volt Terminals 16 and 27, through the low frequency choke coil L_3 , and the high frequency choke coil L_{11} . The current is indicated by M_2 , which is marked on the front panel "Power Amplifier Plate Current."

The switch D_1 is provided in the filament circuit V_4 for the purpose of reversing the direction of current through the filament at intervals of either one day or one month. By operating in this way the increased current flowing in the filament due to plate current is not always at the same end of the filament and an increase in filament life is obtained.

The constant negative grid voltage is applied to this tube from the 250-volt generator through the high frequency choke coils L_{10} . Noise from this source is prevented by the filter, consisting of coil L_{15} and condenser C_{19} .

The direct current flowing in the grid circuit is indicated by M_1 , which on the front panel is marked "Power Ampl. Grid Current".

The radio frequency voltage for grid excitation is obtained through condenser C_5 from a tap on R_{17} . These taps are accessible from the rear of the transmitter. They are numbered from 1 to 12 on transmitters bearing serial

numbers up to and including #144. On subsequent sets the potentiometer has been modified to include 25 taps, the lower numbers indicating the lower input voltages.

The tuned output circuit called the closed circuit consists of inductance L_7 and condensers C_7 and C_{10} is the "Coupling Condenser", the reactance of which is used for coupling the closed circuit to the antenna circuit. Its capacity is large compared with C_7 so that tuning is mainly accomplished through varying L_7 and C_7 . Particular values of L_7 and C_7 are used in order that the vacuum tube V_4 may work into the proper load impedance. The selection of these values is explained later. Changes in C_7 , which is mounted across the rear of the transmitter just above R_{17} , are made by means of links which connect different condensers into the circuit. Large changes in L_7 , which is the coil mounted to the left looking into the rear of the transmitter, are made by means of taps accessible from the rear. Small changes are made by means of a slider on the coil, which covers three turns and is adjustable from the front panel. The control wheel is marked "Closed Circuit Inductance" and turning the indicator from 0 toward 3 increases the inductance. The current flowing in the closed circuit is indicated by M_3 , which is marked "Closed Circuit Current" on the panel.

Power is obtained from the plate circuit of V_4 , through the condenser C_6 . C_6 is connected to L_7 through the upper tap on L_7 . This tap is placed as nearly as possible on the same turn as the lower (tuning) tap. Changes from this are explained later in instructions for tuning.

4. Antenna

The antenna circuit is coupled to the closed circuit through the capacity C_{10} which is common to both circuits. The circuit is tuned by means of the inductance L_8 , mounted in the top of the transmitter. Large changes in inductance are made by means of the tap which is connected to the antenna insulator. Small changes are made by means of a slider which covers three turns and is controlled from the front of the panel. The control wheel is marked "Antenna Inductance" and turning the pointer from 0 to 3 increases the inductance.

The current in the antenna circuit is indicated by M_4 , which is the meter marked "Antenna Current". Adjustments of C_{10} are made to obtain the proper degree of coupling as explained later. The condensers comprising C_{10} are mounted near the top of the transmitter along the left side looking into the rear and changes in capacity are made by means of the links.

The radio transmitter was primarily designed to operate with a ground connection or a grounded counterpoise, but an insulated counterpoise may be used if necessary. A terminal for this connection is provided at the top and

the required changes in connections are indicated on pages 67, 76, 77, and 78. The capacity of the counterpoise to the ground should be not less than 5000 mmf. in order to keep its voltage to ground below 1000. Engineering recommendations should be obtained if the use of an insulated counterpoise is thought desirable. See page 57.

5. Monitoring Rectifier

The Vacuum Tube V_5 (205-D) is used as a rectifier for monitoring purposes. It is coupled to the antenna circuit by means C_{17} , which is connected across the coupling condenser C_{10} , or, in certain cases described later, between the counterpoise and ground.

The high frequency input to V_5 is taken from a tap on C_{17} and is applied through condenser C_8 . C_{17} is near the top of the transmitter and to the left looking into the rear. The input to the rectifier is decreased as the tap on C_{17} is moved to the right when looking at the transmitter from the rear.

The output of the rectifier tube passes through transformer T_2 , the winding of relay S_3 and thence to terminals 22 and 23 for connection to monitoring circuits. Proper volume is obtained by adjustment of the tap on C_{17} . Contacts of relay S_3 are arranged to close local signal light circuits through terminals 20 and 21 affording visual indication that the transmitter is in operation.

6. Power Supply Circuits

a. *Filament Circuits.* Power for heating the filaments is supplied at terminals 4 and 26. The filament voltage of the 228-A Vacuum Tube is held at 22 volts and is indicated by meter M_{13} marked "Filament Voltage" on the panel. The filaments of all the other tubes are operated, with suitable series resistances, in parallel with the filament of the 228-A Tube. The voltage is adjusted by means of R_{22} the field rheostat of the 24 volt generator. The hand-wheel for controlling it is marked "24 Volt Generator".

A filter composed of one 125-A Retard Coil (page 82) and two 100-A Condensers is used to reduce the commutator ripple in the current which heats the filaments of the vacuum tubes, thus reducing the noise in the carrier from this source.

The 100-A Condenser (page 81) is of the electrolytic type. This type is used on account of the large capacity obtained in a relatively small space.

When properly installed this condenser should give no trouble and little maintenance is required, however, due to lack of general familiarity with this type of equipment the following rather lengthy and complete information is given.

1. **100-A Condenser** The 100-A Condenser is an electrolytic cell deriving its high capacity from a thin film which is formed electrochemically on the

positive corrugated aluminum electrode. This film maintains itself when the aluminum electrode is the anode in a suitable condenser fluid. The electrostatic capacity is obtained from the film which serves as a dielectric between the conducting condenser fluid on one side and the metal of the aluminum anode on the other. The flat negative electrode serves only as a means of passing current into and from the condenser fluid.

Each condenser consists of a glass jar filled to a specified level with condenser fluid, in which are submerged two aluminum electrodes mounted rigidly on a porcelain cover which insulates the electrodes and terminal posts from each other. A layer of oil covers the condensers fluid to prevent evaporation.

These condensers must operate only on direct current circuits and within their normal voltage range which is from 19 to 33 volts. They are designed for operation on a 24 volt circuit.

The fluid used is non-combustible, non-poisonous and will not injure the skin or clothing. It must not be contaminated by being placed in dirty containers or containers that have ever held storage battery electrolyte. Condenser fluid and aluminum of special purity are used and every effort is made to prevent impurities from getting into the cell. Organic impurities are especially to be guarded against if the cell is to have long life. A touch of the finger on one of the electrodes or a drop of perspiration in the fluid may introduce organic matter sufficient to do harm.

High and low temperatures are not good for the condenser. The condenser fluid freezes at the same temperature as water, and even before freezing, crystals may form to the detriment of the cell. High operating temperatures shorten the life of the condenser so that it is desirable to operate them in as cool a place as possible, observing of course, the precaution referred to in regard to low temperatures. It is safe to operate the condenser at temperatures up to 105° F, but the life of the fluid at this temperature is only about one-third as long as the life to be obtained by operating at 75° F. It is advisable, therefore, to install the condenser in a place where there is a free circulation of cool air and the temperature may be maintained between 40° and 105° F.

To maintain the dielectric film it is advisable to keep the condenser connected constantly across its rated potential; but it must be connected across a circuit of its rated potential for at least 1 hour each week to prevent danger of failure. It should not be moved or jarred unnecessarily. If not disturbed and the temperature does not run above 105° F or below 40° F no difficulties should be encountered.

Complete and specific information for the installation of these condensers is furnished with them and should be followed carefully when placing the condensers in service for the first time or when renewing the condenser fluid. This information is summarized on page 44.

2. **125-A Retard Coil** The 125-A Retard Coil (page 82) is used in the filament circuit of the vacuum tubes for the purpose of suppressing the ripples in the D. C. supply. The coil has a laminated silicon steel core of the shell type and cast iron end housings to protect the windings and also provide suitable means for mounting.

The coil consists of two conductors wound along side of each other, the flexible terminals of which are brought out through bushed holes in one of the end plate housings.

As installed the coils are connected in parallel by strapping terminals 1 & 3 and 2 & 4, which are in turn connected in series in the positive side of the filament generator line.

b. **Negative Grid Voltage** A negative grid voltage of 250 is required for the 228-A Vacuum Tube. It is obtained from the 250 volt generator through terminals 2 and 25. This voltage is indicated by meter M_{12} , marked "Grid Voltage" and is kept constant by field rheostat R_{21} , the controlling hand-wheel of which is marked "250 Volt Generator".

The lower voltages required for the grids of the speech amplifier and modulator tubes are taken from the potentiometer R_5 , as previously mentioned.

c. **Plate Circuit** Power for the plate circuit of the 228-A Vacuum Tube is obtained from the 4000 volt terminals 16 and 27, and its voltage is indicated by M_{11} which is marked "Plate Voltage" on the panel. Power for the plate circuits of the other vacuum tubes is obtained from the 2000 volt terminals 16 and 28. The voltages of both 2000 volt generators are controlled simultaneously by means of rheostat R_{23} , the handwheel of which is marked "4000-Volt Generator". Consequently, when M_{11} indicates 4000 volts, 2000 volts will be obtained on terminals 16 and 28 and 4000 volts will be obtained on terminals 16 and 27. These generators obtain field excitation from the 250 volt generator through terminals 5 and 6.

7. Protection

a. **Switches and Relays** In order to protect the operator, switches are provided which shut down the motor-generator sets whenever the rear door is opened or whenever the door in front of the vacuum tubes is dropped.

For the protection of the vacuum tubes a number of relays are provided and the circuits are interlocked as follows:

Relay S_1 is a time delay relay. It is mounted near the bottom of the panel on the left-hand side and is marked "4000 V. Time Delay Relay". This relay is energized whenever the filament voltage is applied. Its contacts are in series with the operating coil of relay S_4 which controls the field circuit of the high voltage generators. An interval of 10 to 20 seconds is required for the time delay relay to operate so that it is assured that the vacuum tubes will have had this amount of time to become warmed up before the high voltage is applied.

Relay S_2 is an overload relay mounted near the bottom of the panel on the right-hand side and marked "Plate Overload Relay". It is connected in the negative lead of the high voltage generators so that excessive load in this circuit trips it open thereby deenergizing S_4 which in turn opens the field circuit of the generators, removing the high voltage. It is necessary to reset relay S_2 by hand once the contacts have been tripped open.

The magnetic switches S_4 and S_5 are mounted at the rear of the transmitter just above the fuse blocks. S_4 is to the left and its contacts control the field circuit of the high voltage generators. S_5 is the one to the right and its contacts control the field circuit of the 24-volt generator. Both of these switches obtain their operating currents from the 250-volt generator. Consequently, if the 250-volt generator is not supplying voltage to the radio transmitter, it would be impossible to close them so the danger of applying plate voltage to the tubes without having grid voltage is obviated.

It is necessary also to protect against applying power to the water-cooled tube (228-A) without having cooling water circulating around the anode. This is accomplished by inserting in the control circuit of S_5 a relay which, in some transmitters is controlled by the pressure at the inlet of the cooling system, and in other transmitters is controlled by the rate of flow of water in the system.

If the water pressure or rate of flow varies abnormally due to obstruction in the intake, discharge or other portion of the circulating system, the relay will operate to open the control circuit of S_5 . S_5 will in turn open the field circuit of the 24 volt generator, thus removing the power from the filament circuit. With the removing of voltage from the filament circuit the time delay relay S_1 will be deenergized and its contacts will open the control circuit of S_4 which, in turn, opens the field circuit of the high voltage generators, thus removing the plate power from the transmitter. This same protection is, of course, obtained upon attempting to start the transmitter with the cooling water supply shut off.

b. **Fuses** The fuses used in all of the transmitter circuits are mounted in the rear of the transmitter just above the terminal boards. The capacities of the fuses used in the various places are as follows:

Used in Positions	Amperes	Volts	Catalog Number
F_1	3	250	91125
F_2	3	250	91125 (Graybar
F_3	3	250	91125
F_4	3	250	91125 Electric
F_5	65	250	91149
F_6	50	250	91143 Catalog
F_7	20	250	91136

F ₈	3	250	91125 1926-7)
F ₉	3	250	91125
F ₁₀	2	2500	2760 Western Electric Yearbook 1924.
F ₁₁	2	2500	2760 Western Electric Yearbook 1924.
F ₁₂	2	2500	2760 Western Electric Yearbook 1924.

C. METHOD OF ADJUSTMENT OF RADIO TRANSMITTER

It is essential that the unmodulated power delivered to the antenna be not greatly in excess of 1 kilowatt, otherwise the radio transmitter will not properly deliver the peaks of power required when modulated. The power adjustment provided allows, under most conditions, unmodulated power considerably in excess of 1 kilowatt to be delivered to the antenna, but the transmitter should not be operated overloaded for the reason just noted.

Before it is possible to properly adjust the transmitter it is therefore necessary to determine the value of antenna current which dissipates 1000 watts in the antenna. This current depends upon the value of the antenna resistance, at the operating wave length, and for any output the following formula for antenna current should be used:

$$\text{Antenna Current} = \sqrt{\frac{\text{Antenna Power}}{\text{Antenna Resistance (at operating wave length)}}$$

The antenna resistance may be obtained from any proper method of measurement and if not otherwise obtainable may be determined by substituting a dummy antenna in place of the real antenna and adjusting its known constants until the condition of operation of the transmitter, including its adjustments, is the same on both the real and dummy antenna. Under these conditions the resistance of the dummy antenna is approximately equal to the resistance of the real antenna.

Having determined the antenna current which it is desired to obtain and assuming that the equipment has been completely installed with fuses and vacuum tubes in circuit, the following procedure should be followed.

NOTE These instructions also cover adjustments of the transmitter when determining antenna resistance by the dummy antenna method.

An approximate setting for condensers C_7 and C_{10} and inductances L_7 and L_6 should be made, depending on the wave length to be used and the resistance of the antenna, using as a guide table #1.

NOTE On transmitters bearing serial numbers prior to #144 the coupling condenser C_{10} consists of four units of values .04—.02—.01—.005 MF. All subsequent transmitters are modified to include five units of values .02—.02—.01—.005—.0025 MF. It will therefore be necessary to select the nearest value divisible by .005 from those noted in table #1 for transmitters bearing serial numbers 143 and under.

TABLE I

Approximate Tuning Adjustment For 6-A Radio Transmitter

Freq. (KC)	Wave Length (Meters)	Ant. Resis. (Ohms)	Tuning Capac. (MF)	Coupling Capac. (MF)	Closed Cir. Ind. (Turns)	Plate Tap (Turns)	Osc. Tap (Turns)
<i>1000 W. ATTS</i>							
1500	200	6	.00075	.0175	8	7	8
		10	.00075	.0125	8	7	8
		15	.00075	.0125	8	7	8
		20	.00075	.0100	8	7	8
<i>750 W. ATTS</i>							
		6	.00075	.0175	8	8	8
		10	.00075	.015	8	7	8
		15	.00075	.0125	8	8	8
		20	.00075	.0100	8	8	8
<i>500 W. ATTS</i>							
		6	.00075	.02	8	8	8
		10	.00075	.0175	8	8	8
		15	.00075	.015	8	8	8
		20	.00075	.0125	8	8	8
<i>1000 W. ATTS</i>							
1000	300	6	.0015	.0225	9	9	12
		10	.0015	.0175	9	9	12
		15	.00125	.015	9	8	12
		20	.0015	.0125	9	9	12

TABLE I (Cont.)

Approximate Tuning Adjustment For 6-A Radio Transmitter

Freq. (KC)	Length Wave (Meters)	Ant. Resis. (Ohms)	Tuning Capac. (MF)	Coupling Capac. (MF)	Closed Cir. Ind. (Turns)	Plate Tap (Turns)	Osc. Tap (Turns)
<i>750 W. ATTS</i>							
		6	.00125	.0225	9	9	12
		10	.00125	.0175	9	9	12
		15	.00125	.015	9	9	12
		20	.00125	.0125	9	9	12
<i>500 W. ATTS</i>							
		6	.00125	.0250	9	9	12
		10	.00125	.020	9	9	12
		15	.00125	.0175	9	9	12
		20	.00125	.015	9	9	12
<i>1000 W. ATTS</i>							
750	400	6	.002	.03	10	10	18
		10	.002	.025	10	10	18
		15	.002	.02	10	10	18
		20	.002	.0175	10	10	18
<i>750 W. ATTS</i>							
		6	.00175	.03	10	10	18
		10	.00175	.025	10	10	18
		15	.00175	.02	10	10	18
		20	.00175	.0175	10	10	18
<i>500 W. ATTS</i>							
		6	.0015	.0325	10	10	18
		10	.0015	.030	10	10	18
		15	.00175	.025	10	10	18
		20	.00175	.02	10	10	18
<i>1000 W. ATTS</i>							
500	600	6	.00275	.0475	14	14	31
		10	.00275	.040	14	14	31
		15	.00325	.0350	14	14	31
		20	.00300	.0300	14	14	31

TABLE I (Cont.)

Approximate Tuning Adjustment For 6-A Radio Transmitter

Freq. (KC)	Wave Length (Meters)	Ant. Resis. (Ohms)	Tuning Capac. (MF)	Cou- ling Capac. (MF)	Closed Cir. Ind. (Turns)	Plate Tap (Turns)	Osc. Tap (Turns)
<i>750 WATTS</i>							
		6	.0025	.0475	14	14	31
		10	.00275	.040	14	14	31
		15	.003	.0350	14	14	31
		20	.003	.0275	14	14	31
<i>500 WATTS</i>							
		6	.00225	.0475	14	14	31
		10	.00225	.040	14	14	31
		15	.003	.0375	14	14	31
		20	.0025	.0300	15	15	31

In the lower left-hand corner at the rear of the transmitter the taps on resistance R_5 are marked "1, 2, 3 and 4" on the small panel marked "Modulator Tube." The flexible lead should be connected to the tap numbered to correspond with the number on the modulator tube which indicates its impedance classification. See page 3.

Disconnect the slider below R_{17} at the rear of the transmitter, which connects C_5 to R_{17} .

Before applying power to the transmitter the cooling water should be started circulating.

The motor-generator sets may be started by operating the top button on the "Master Control" switch. This starts both motor-generator sets at the same time. "The Plate Voltage" switch should be in the off position, i. e. with black button depressed.

The voltage supplied to the filament should now be adjusted by means of the rheostat at the left of the front panel marked "24 Volt Generator" to indicate a filament voltage of 22. The voltage of the 250 volt generator should be adjusted by means of the rheostat in the center of the front panel to indicate a grid voltage of 250. The grid voltage must be advanced to full 250 volts in order to close the field magnetic switch S_4 .

The "4000 V. Time Delay Relay" should operate with the filament voltage of 22, otherwise the knurled nut at the bottom should be adjusted until it

does. Turning the adjustment to the right raises the plunger and accelerates the action. The needle valve in the top of the relay should be adjusted so that the contacts will close from 10 to 20 seconds after the filament voltage has been applied to the transmitter. Turning the knurled screw to the right closes the valve and retards the action.

This relay having functioned and with the contacts of the plate overload relay closed, it is possible now to close the field circuit of the high voltage generators by operating the top button of the "Plate Voltage" switch. The plate voltage should be adjusted to 4000 volts by means of the field rheostat mounted on the right of the panel.

The oscillator should now be operating at a wave length approximately that desired. Operation will be indicated by the following readings:

Oscillator Load Current5 ampere
Oscillator Plate Current	280-320 milliamperes
Oscillator Grid Current	40- 60 milliamperes
*Modulator Plate Current	80-120 milliamperes
Modulator Grid Current	0
Power Amplifier Grid Current	0
Power Amplifier Plate Current1-4 ampere
Speech Amplifier Plate Current	30- 40 milliamperes

*Due to the circuit used, fluctuations of small amplitude will be noted in the reading of the modulator plate current meter when the transmitter is not being modulated. This condition in no way affects the performance and may accordingly be disregarded.

Meter indications considerably outside of the above limits indicate an abnormal condition which should be corrected before proceeding further.

The wave length at which the oscillator is operating should be measured by suitable means and corrected to the proper value by the adjustment of L_6 . If the desired value cannot be obtained by means of the adjustment marked "Frequency" on the front of the panel it will be necessary to move the tap on L_6 accessible from the rear. The final adjustment is, of course, obtained by means of the handwheel marked "Frequency."

Remove the plate voltage by means of the push-button switch and connect the slider below R_{17} to tap 1 on R_{17} . Apply the plate voltage by means of the push-button switch and tune the output of the power amplifier by adjusting L_7 until the closed circuit current is a maximum but not more than 15 amperes. If a current greater than 15 amperes is obtained when the circuit is tuned it may be left untuned temporarily to keep the current below this value. Coarse adjustments of L_7 are made by moving the taps, and fine adjustments are made by means of the handwheel marked "Closed Circuit Inductance."

NOTE The taps should be kept connected to the same turn on L_7 at this time.

Tune the antenna circuit by adjusting L_8 until the antenna current becomes a maximum. Coarse adjustment of L_8 is made by means of a tap connecting to the antenna insulator and fine adjustment is made through the handwheel marked "Antenna Inductance."

Tuning the antenna circuit will probably decrease the closed circuit current so that the closed circuit may be retuned to increase its current. Regardless of the value of the antenna current, the closed circuit current and the power amplifier plate current should be adjusted to the values given in Table II, page 15. This adjustment should follow the procedure given in Tables III and IV, pages 15 and 16 and such adjustments should be made *one at a time*. The frequency should be checked and the antenna power adjusted after each change in capacitance before any further change is made.

For a given antenna power the power amplifier plate current is a measure of the plate circuit impedance. For the various antenna powers different impedances and different operating plate currents are used. With the proper coupling as shown by the closed circuit current, and the proper amplifier plate current, the plate circuit impedance will be of the correct value. If currents other than those given in Table II are used, either the modulation or the efficiency will suffer. Allowable limits of current are given in this table within which the operation is satisfactory but adjustment should be made to give as nearly as possible the exact values.

The operation of "tuning" the 6-A Transmitter is one of wave length setting and adjusting for the correct plate circuit impedance and coupling to be used with the desired power in the antenna. The procedure to be used in setting the wave length is covered by these Instructions while the settings required for wave length, coupling and plate circuit impedance are given in Table I.

The "plate circuit impedance" referred to is the impedance offered to the radio frequency voltage by the circuit composed of L_7 - C_7 and C_{10} with the coupled antenna circuit. (See ESR-307849) (pages 76, 77 and 78)

If the instructions in Tables III and IV are followed the proper impedance and coupling will be obtained. Some further explanation of the function of the tuning and coupling condensers seem necessary. First, a change in either tuning or coupling condenser (followed by a retuning of inductances L_7 and L_8) changes both the closed circuit current and the power amplifier plate current. However, the coupling condenser affects the closed circuit current more than it does the plate current so that *the closed circuit is adjusted (for large variations) by the coupling condenser*. The reverse effect holds for the tuning condenser. *The tuning condenser should be adjusted for large variations in the plate current*.

There are two methods of increasing the plate circuit impedance. One is to increase the reactance of the condenser branch, i. e., decrease the value of the tuning condenser and the other is to loosen the coupling, i. e., increase coupling condenser C_{10} . The two methods have the same effect on the plate current (a decrease) but the first method decreases the closed circuit current while the latter increases it. For a *decrease* in impedance the reverse holds true; the tuning condenser may be increased, or the coupling condenser may be decreased. The amplifier plate current is increased in both cases. The closed circuit current is increased in the first case and decreased in the second.

It will be found that large changes in either C_{10} or C_7 condensers require a change in the taps on the tuning inductance L_7 . (Both taps are moved together.) This tap change will amount to one or two turns and must be obtained by trial. The following data indicates the directions the tap change will take in order to bring the circuit again in tune:

TABLE II

<i>Antenna Power</i>	<i>Power Amplifier Plate Current</i>	<i>Closed Circuit Current</i>
1000 watts	.85 amp. (limits+zero) — .10)	14 amps. (limits+1.0) — 1.0)
750 watts	.70 amp. (limits+.05) — .05)	12 amps. (limits+1.0) — 1.0)
500 watts	.53 amp. (limits+.10) — .03)	10 amps. (limits+1.0) — 1.0)

TABLE III

(See Table IV)

<i>INDICATION</i>	<i>ADJUSTMENT</i>
Plate* current high and Closed circuit current high	Decrease tuning condenser C_7 .
Plate current high and Closed circuit current low	Decrease coupling (increase C_{10}).
Plate current low and Closed circuit current low	Increase tuning condenser C_7 .
Plate current low and closed circuit current high	Increase coupling (decrease C_{10}).

*The power amplifier plate current is referred to.

TABLE IV

<i>INDICATION</i>	<i>ADJUSTMENT</i>
Plate current OK and Closed circuit current high	Decrease C_{10} then see Table III.
..... low	Increase C_{10} then see Table III.
Closed circuit current OK and Plate current high	Decrease C_7 then see Table III.
..... low	Increase C_7 then see Table III (or decrease plate tap turns.)
<i>Capacity Change (large changes only)</i>	<i>Tap Change</i>
Increase in C_7	Decrease turns
Decrease in C_7	Increase turns
Increase in C_{10}	Decrease turns
Decrease in C_{10}	Increase turns

In cases where one current (Table II) is within the prescribed limits and the other one is not, the procedure in Table IV should be followed as the first operation. This will either bring both currents within the limits or will enable Table III to be used for the second adjustment.

When adjustments are made in this manner it is desirable to keep a record of current indications for the various capacities used. This record may have the following form:

C_7	C_{10}	Current	Plate Current	Power
Value of	Value of	Closed Cir.	Power Amp.	Antenna
.....
.....
.....
.....

The setting giving currents nearest to the exact values of Table II may then be chosen.

The frequency should now be readjusted to the correct value. The closed circuit inductance (L_7) should be adjusted to give the minimum Power Amplifier plate current and the antenna inductance (L_8) should be adjusted to give a maximum antenna current. The output of the transmitter may now be adjusted to give the antenna current corresponding to the desired power output by moving the connection of R_{17} to the proper tap. The output is increased as the connection is moved from tap 1 toward tap 12 on transmitters bearing serial

numbers up to and including #144. On subsequent sets the potentiometer has been modified to include 25 taps, the lower range of which permits power settings between 500 and 1000 watts. The photograph on page 72 shows the modified potentiometer. After the connection has been made to approximately the correct position, the frequency should again be adjusted to the correct value, the closed circuit inductance should be adjusted to give minimum Power Amplifier plate current and the antenna inductance should be adjusted to give a maximum antenna current.

With an antenna current of the proper value the closed circuit current should fall within the limits noted in Table II.

If the closed circuit current is less than the value noted, readjustment should be made using a larger capacity in C_{10} . C_{10} is the coupling capacity mounted near the top at the left-hand side of the transmitter looking into the rear and links are provided for changing the capacity.

If the closed circuit current is greater a readjustment should be made using a smaller capacity in C_{10} . With all adjustments made the power amplifier plate current should be in accordance with the value noted in Table II.

If the plate current is high, a readjustment should be made with a smaller capacity in C_7 . C_7 is the tuning capacity mounted across the rear of the transmitter and the links are provided for changing the capacity. If the plate current is low, a readjustment should be made with a larger capacity in C_7 . If the correct value of amplifier plate current cannot be obtained with the taps connected to the same turn on L_7 , the value of C_7 , which gives the nearest higher value of power amplifier plate current, should be used. Then, readjustment should be made with the tap on the upper slider (which connects to the plate circuit of V_4 through C_6) moved the necessary amount nearer the front panel than the tap on the lower slider (which connects to the tuning capacity C_7), to bring the plate current to the correct value. In a very few cases it will be necessary to do this and the effect of lowering the plate tap is always to decrease the plate circuit impedance without greatly affecting the closed circuit current. This effect is taken advantage of in the last part of Table IV. However, this change should not be made unless it is otherwise impossible to obtain the correct adjustment.

The above adjustments are more or less interdependent as previously stated, so that for instance in changing C_{10} to adjust the closed circuit current there will be a secondary effect changing the power amplifier plate current which may make necessary a change in L_7 and C_7 to bring the power amplifier plate current within limits.

In the process of tuning care should be taken to see that everything is properly adjusted to the correct frequency before determining from the meter indications the adjustment to be made next.

The general rule is to adjust closed circuit current by changing C_{10} and to adjust power amplifier plate current by changing L_7 and C_7 when the desired power output is being delivered to the antenna.

RECAPITULATION

1. For the first trial setting use the values of tuning condenser, tuning inductance and oscillator inductance as given in Table I. As it is desirable, however, to start with too loose a coupling and gradually to tighten it, *an initial value of C_{10} larger by .005 mf than the value given in Table I should be used.*

2. Adjust for the desired wave length and antenna power as specified. It is best to start with a low plate voltage and a low potentiometer tap until the set is approximately tuned. The plate voltage and potentiometer tap may then be increased without causing excessive currents to flow.

3. Tune for maximum antenna current and minimum amplifier plate current. Compare the closed circuit current and the plate current with Table II and determine into which class of Table III or IV the correction in condenser setting falls.

4. Perform the indicated change using the smallest condenser unit available until the antenna current, closed circuit current and power amplifier plate current are correct (refer to Table II).

5. Check all meter indications with Table V.

When finally adjusted the meter indications should fall within the following limits. This table applies to all wave lengths from 200 to 600 meters inclusive:

TABLE V

<i>Antenna Power (Watts)</i>	<i>1000</i>	<i>750</i>	<i>500</i>
Speech Amplifier Plate Current	30-40 ma.*	30-40 ma.	30-40 ma.
Antenna Current	Proper value for desired power in the antenna. See formula.		
Closed Circuit Current	13-15 a.	11-13 a.	9-11 a.
Power Amplifier Plate Current	.75-.85 a.	.65-.75 a.	.5-.63 a.
**Power Amplifier Grid Current	Less than 100 ma.		
Modulator Grid Current	0	0	0
Modulator Plate Current	70-120 ma.	70-120 ma.	70-120 ma.
Oscillator Grid Current	40-60 ma.	40-60 ma.	40-60 ma.

Oscillator Plate Current	280-340 ma.	280-340 ma.	280-340 ma.
Oscillator Load Current	.4-.6 a.	.4-.6 a.	.4-.6 a.
Filament Voltage	22	22	22
Plate Voltage	4000	4000	4000
Grid Voltage	250	250	250

The function of the modulator grid current meter is to indicate overloading of the modulator tube. After overloading begins there is a gradual deterioration of quality as the load is increased and for good results the load should not be such as to give frequent indications of modulator grid current.

When the transmitter is operating in conjunction with the speech input equipment, the operating level (maintained through observation of the volume indicator) should be slightly below the level which gives grid current as indicated by the meter on the transmitter.

*ma = millamperes
a. = amperes

**Note: With certain adjustments a negative indication of grid current may be observed. This is normal and without significance.

CHAPTER II

1-E SPEECH INPUT EQUIPMENT

A. GENERAL DESCRIPTION

The 1-E Speech Input Equipment (page 89) provides the necessary apparatus for picking up the sound waves of music or speech, converting them into electrical currents and amplifying these currents to a sufficient volume to drive the radio transmitter. The operation of this apparatus will ordinarily require two attendants, one in the studio to care for the microphone and another in the control room to care for the amplifiers and to maintain the output volume at the proper level to operate the radio transmitter. A communication system of signals and telephones is provided between the studio and control room to facilitate the operation of the station. The greater part of the apparatus is mounted on two racks in the control room. Arrangement of this apparatus may be changed to meet the needs of the individual installation.

1. 387-W & 373-W (Microphone) Transmitters

The external appearance of the types 387-W and 373-W Microphone Transmitters is identical, the difference being internal changes to the carbon buttons. The microphone is mounted in a housing and equipped with a cord and plug as shown on page 91. It is used in the studio to pick up the sound waves and convert them into electrical currents for broadcasting, and is designed for high quality reproduction of all frequencies in the audible range. Its output volume is necessarily low requiring amplification to a volume level suitable for driving the radio transmitter. In the microphone, a thin diaphragm stretched between two heavy metal rings vibrates with the sound waves in the studio. Attached to this diaphragm at its center are two carbon buttons. The two buttons are connected in series and to the primary of the input transformer of the 8-B Amplifier. Their midpoint is grounded to the transmitter ring and to the main ground through a third lead from the microphone. Current is supplied to the microphone from the filament battery between a midpoint on the input transformer and the grounded transmitter ring. The microphone is equipped with a cord and plug to facilitate rapid replacement and change from one position to another when several receptacles are provided in the studio. The microphone circuit is run in lead covered wire in iron conduit from the amplifier and terminates in one or more outlet receptacles located in the baseboard of the studio.

2. 8-B (Speech Input) Amplifier

This amplifier (pages 92 and 93) is used to amplify the feeble currents from the microphone sufficiently to drive the radio transmitter. It is mounted on a rack in the control room and has three stages of amplification. The first stage uses a 102-D Vacuum Tube and the second and third stages use 205-D Vacuum Tubes. A jack panel is provided on the amplifier for measuring the filament and plate currents of the tubes. Jacks are also provided for measuring the current supplied to the two carbon buttons of the microphone. They are connected in the leads from the input transformer which forms a part of this amplifier. Rheostats for controlling the filament current of the tubes and the microphone current are provided. A key for switching the microphone on and off is also provided. The gain of this amplifier is controlled by a 22 point potentiometer which operates on the first two stages to vary the gain gradually from minimum to maximum.

3. 518-B (Volume Indicator) Panel

The 518-B Panel (pages 96 and 97) indicates the volume level of the program material (speech, music, etc.) supplied by the 8-B Amplifier to the radio transmitter. This panel gives reading in terms of a unit known as the "Transmission Unit" (usually written TU) and used in telephone engineering to measure amounts of electrical power. Such power can also be measured in watts but the TU is generally used because of its convenience from a technical standpoint. Power measurements in TU are measured with reference to an arbitrarily selected value known as "Zero Level". The 518-B Panel is calibrated on the basis that zero level is 0.006 watt. An amount of power less than this is prefixed by the negative (—) if measured in TU.

For the benefit of those not familiar with the Transmission Unit the following description is included:

Gain, loss and output level, are measured in terms of a unit called the Transmission Unit (written TU). In the case of gain or loss, the TU is used to express the ratio of the powers at the output of the system, due to a change in the circuit conditions, such as an adjustment of the potentiometer control, or the insertion or removal of amplifiers, transformers, etc. When used in this sense it does not give any idea as to the level or loudness of the sounds involved but merely indicates the *change* in loudness. As it cannot be accurately defined or described without the use of mathematics, the following table is printed, which will give the reader a quantitative idea of the relation which exists between TU's and the power ratios.

TU	Power Ratio	TU	Power Ratio
1	1.26	10	10
2	1.6	20	100
3	2.0	30	1,000
4	2.5	40	10,000
5	3.2	50	100,000
6	4.0	60	1,000,000
7	5.0	70	10,000,000
8	6.3	80	100,000,000
9	8.0	90	1,000,000,000

By reference to an arbitrarily selected value known as the normal or zero level, the number of units above or below zero is used to indicate the actual loudness of the sound. When used in this sense, the number of units is not directly proportional to the electrical power involved (as it would be if the measurements were made in watts) but is roughly proportional to the sensation produced upon the ear. A difference of one TU in the power supplied to a telephone receiver represents approximately the smallest change in the volume of sound which the normal ear can detect.

There are other uses to which the Transmission Unit is applied, but an understanding of these is not necessary to the proper operation of the Speech Input Equipment.

Further information, and the mathematical definition, can be obtained from the paper by W. H. Martin, entitled "The Transmission Unit" printed in the Journal of the American Institute of Electrical Engineers for June, 1924.

The 518-B Panel uses a 102-D Vacuum Tube which requires a filament current of .95 ampere and a plate potential of 130 volts. Indication of the power being measured is given by a sensitive galvanometer in the plate circuit of the vacuum tube. A rheostat and a key are provided to control the filament current and a potentiometer controls the negative bias voltage of the tube. The negative bias should be so adjusted that the galvanometer needle gives a permanent deflection of five divisions when there is no input to the volume indicator panel. The grid circuit is energized by the output of the 8-B Amplifier. In this circuit is a level measuring key for large steps and a level measuring switch for small steps calibrated in transmission units. The large steps are 0, +16 and +30 TU and the small ones are each 2 TU and cover a range of 20 TU (-10 to +10 TU). When the galvanometer needle swings to 30 divisions about once in 10 seconds during the transmission of speech the volume level at the input to the transmitter is the algebraic sum of the key and switch settings. In other words, volume level may be measured by adjusting the key and

switch until the desired deflection of 30 divisions about once in 10 seconds is obtained and taking the algebraic sum of the settings as the reading. For example, if the setting of the key is +16 and the reading of the dial switch is -4, the energy level measured is 16-4 or 12 TU.

During broadcasting this instrument is used as a guide to volume adjustment rather than as a measuring device as explained under Monitoring (page 37).

4. 18-B (Monitoring) Amplifier

This amplifier (pages 100 and 101) is designed to drive a 540-CW Loud Speaking Telephone with sufficient volume of sound for monitoring. The amplifier obtains its input from the output of the 8-B Amplifier or from the output of the rectifying tube V_5 in the radio transmitter depending upon the position of the monitoring transfer key in the 534-A Panel which provides a means of switching between these sources for purposes of comparison. One 205-D Vacuum Tube is used in the single stage of amplification provided. Volume is controlled by potentiometer. As in the case of the 8-B Amplifier there are jacks for measuring filament and plate currents and a rheostat for controlling the filament current.

5. 514-A (Meter) Panel

The meter panel (page 104) provides facilities for measuring filament, plate and microphone currents in the different circuits of the speech input equipment. Three meters are provided with two cords and a non-locking key. The 0-4 ammeter with a cord and small plug is used for measuring filament currents in the different tube circuits. The other cord with the large plug is connected to the other two ammeters through the key. In the normal position the 0-100 milliammeter is connected to the cord and plug but when the non-locking key is depressed the 0-10 milliammeter is connected in its place. This plug fits the jacks in the plate circuits of the tubes and the microphone circuits while it will not enter the filament jacks. Plugging into a plate circuit jack gives a reading on the 0-100 milliammeter. If this reading is below 5 milliamperes it may be read more accurately by pressing the button and reading on the 0-10 milliammeter. This meter is provided for reading the plate current in the 102-D Vacuum Tube only.

6. 534-A (Signal and Control) Panel

This panel (pages 106 and 107) is the control room terminal of the signal and control system between the control room and the studio.

The amplifier input transfer key has three positions. One position is used

to connect the 8-B Amplifier input circuit to the studio microphone; a second position to a microphone in the control room and the middle position is used for connection to the extension panel and thence to a telephone line when it is desired to transmit a program from a distant point.

A monitoring transfer key is provided for switching the input to the (monitoring) 18-B Amplifier either to the monitoring rectifier in the radio transmitter or to the output of the 8-B Amplifier. This provides a convenient means of comparing the quality of the radiated program with that of the input to the radio transmitter.

The ready signal key marked "RADIO TRANSMITTER" is provided to signal the studio when everything is in readiness for transmission. This key is in series with relay S_3 and controls the green light on the 6045-A Telephone Set in the studio. When radiation of the carrier starts relay S_3 closes. The radio room BROADCAST lamp will light when the ready signal key is turned on provided the amplifier input transfer key is thrown to the radio room position. This red light means that all sounds in the control room are being broadcast. If the keys are thrown to the studio position the green light in the studio will burn showing that everything is in readiness for broadcasting. The studio operator then turns a key (described under the 6045-A Telephone Set) and the circuits are in readiness for broadcasting from the studio. Turning this key lights a red lamp in the studio and the white studio broadcast lamp on the 534-A Panel signaling both operators that the studio is broadcasting.

A hand telephone is provided for talking to the studio operator. A lamp signal and a buzzer are provided for telephone signaling and a key is provided to turn the buzzer off when not wanted. A push button is used to signal the studio.

7. 6045-A Telephone Set

This telephone set (page 110) is the signal and control unit for the studio. It has a ready signal lamp marked "RADIO" which lights when the control room operator has everything in readiness for broadcasting from the studio. The studio operator then turns the microphone key marked "STUDIO TRANS." on, thereby connecting the output of the 8-B Amplifier to the radio transmitter by the operation of the broadcast control relay on the 534-A Panel, and the studio then is ready for broadcasting. The studio "BROADCAST" lamp lights as a warning that everything said in the studio is being broadcast. A hand telephone is provided for intercommunication between operators. The telephone set is equipped with a light marked "INTERPHONE", a buzzer signal and a push button marked "SIGNAL" for calling. A key marked "BUZZER" is provided to open the buzzer circuit when it is not wanted. The

buzzer is automatically disconnected by the microphone key whenever that key is turned on thus making it impossible to buzz into the microphone.

8. D-76814 (Extension) Panel

This panel (pages 112 and 113) is equipped with facilities for connecting the input circuit of the 8-B Amplifier to one of nine telephone lines by means of a patching cord. A key and 20 ohm resistance are connected from the -12 volt battery to terminal #12 on the 534-A Panel for operating the broadcast control relay. A resistance network of about 20 TU equivalent, with a key to short circuit it, is connected between terminals 25 and 26 of the 534-A Panel and one of the jacks. The other nine jacks are for connection to nine telephone lines.

9. 547-B (Microphone) Panel

This panel carries a receptacle for the radio room microphone which is connected to the radio room position on the 534-A Panel.

10. 536-A (Modified) or 563-B (Battery Supply) Panels

These panels (pages 115 and 116) are interchangeable and provide switches and fuse protection for battery circuits to the various units of the speech input equipment. The fuse is in the same circuit with the switch directly above it and a designation strip between them indicates the circuit controlled and protected by each.

11. KS-2805 (Battery Charging and Switching) Panel

This panel (page 118) is arranged with charging and operating positions for 350 volt plate battery in five sections, two 12 volt batteries and one 8 volt battery. The five sections of plate battery of 70 volts each are charged in parallel with a lamp in series with each section. When the power supply is alternating current, Tungar rectifiers are used for charging the batteries. Safety door switches are provided to sectionalize the 350 volt battery when the door of the panel is open.

CHAPTER III

RADIO RECEIVING OUTFIT

A. GENERAL DESCRIPTION

6204-D RADIO RECEIVING OUTFIT

The No. 6204-D Radio Receiving Outfit is a complete equipment for radio reception, intended primarily for use at broadcasting stations, and in it is included an electrical filter which eliminates practically all interference from the station at which it is employed. The outfit operates over a frequency range of 375 to 1500 kilocycles. This corresponds to a wave length range of 800 to 200 meters.

The distance from which reception is practical cannot be stated definitely because it is influenced by such factors as geographical location, effectiveness of the receiving antenna, power of the transmitting stations and local interference. In the 6204-D Radio Receiving Outfit special attention has been given to the response-frequency characteristic with the result that virtually uniform amplification is obtained for the audio frequencies ordinarily transmitted. It is sensitive enough when used with a good antenna to meet the requirements of a broadcasting station making possible the reception of distress signals under average conditions from several hundreds of miles. Its exceptional frequency characteristic makes it very valuable in monitoring at the studios the signals radiated from the station when the transmitter is located remote from the studios, or in listening critically to the broadcasting of competitive stations.

1. No. 4-D Radio Receiver

The No. 4-D Radio Receiver operates on the principle of double detection and intermediate frequency amplification. It has two stages of intermediate frequency amplification and one stage of audio frequency amplification. No interstage jacks are provided. However, the amplification control switch (page 121), provides a means of securing the proper regulation of the volume produced by the set.

Six Western Electric No. 215-A Vacuum Tubes are used in this radio receiver. These tubes are connected in series and are operated from the 8 volt storage battery.

Tuning is accomplished by means of the tuning condenser and the oscillator condenser, shown on page 121. There are two settings of the oscillator condenser and one setting of the tuning condenser, that correspond to any given

frequency within the range of this outfit. It is generally immaterial which of the two settings of the oscillator condenser is used, but in most cases the interference will be less with one setting than with the other. The condenser settings for stations using a low frequency will be on the lower portion of the scales, and for stations using a high frequency the settings will be on the upper portion of the scales.

The filament rheostat controls the battery supply to the filaments of the vacuum tubes.

The telephone headset supplied with this outfit is provided with a cord to which is attached a plug that fits the "OUT" jack of the radio receiver.

When the 6204-D Radio Receiving Outfit is used at the studios for monitoring signals radiated from the associated remotely located transmitter, the output of the radio receiver is frequently wired to the input of the 18-B Amplifier through the monitoring transfer key of the 534-A Panel. This arrangement gives loud speaker volume to the received signal and provides means of comparison between the signals as delivered to the line connecting the studio with the radio transmitter and the signals radiated by the radio transmitter.

2. No. 2-B Tuning Unit

The No. 2-B Tuning Unit, shown on pages 129 and 130 is used to couple the No. 4-D Radio Receiver to the antenna. The tuning unit is mounted in a separate cabinet, which should be located close to the radio receiver in order that the connecting leads to the receiver may be as short as possible. This precaution will avoid the introduction of undesirable capacity resulting from leads of appreciable length.

The No. 2-B Tuning Unit consists essentially of a primary circuit coupled to a secondary circuit through variable coupling. (See page 123). In addition to the antenna terminal and the ground terminal, the primary circuit contains a variometer for tuning the antenna, a two point antenna switch for cutting the variometer in or out of the circuit—thus making the antenna either tuned or untuned—and two fixed condensers, arranged to provide a means of utilizing antennae of different electrical characteristics. The connection to this unit is made, on the side of the cabinet, to one of the terminals marked "LONG," "MEDIUM" or "SHORT," while the ground is attached to the "GRD" terminal.

Because of the many factors that effect the constants of an antenna, it is difficult to classify any given antenna as long, medium or short. In making the connection to this unit, it is best to try the "MEDIUM" terminal first and note how high and low frequency stations are received. If high frequency stations cannot be tuned in, while the "MEDIUM" terminal is being utilized, the connection should be shifted to the "LONG" terminal. If low frequency stations

cannot be tuned in, the connection should be shifted to the "SHORT" terminal. If both high and low frequency stations can be tuned in well, the connection should be left on the "MEDIUM" terminal.

The coupling transformer, which inductively joins the primary and secondary circuits, serves also as a means of controlling both the sensitivity and the selectivity of the receiver. The adjustment of the coupling (See page 129) is effective with the antenna tuned or untuned. The maximum selectivity is obtained with minimum coupling and the maximum sensitivity is obtained with maximum coupling. Shunted across the secondary of the coupling transformer is a fixed condenser so arranged with a two point switch that it may be cut in or out of the circuit. With this switch it is possible to secure two frequency ranges; 375 to 600 kilocycles, and 475 to 1500 kilocycles.

In connecting the tuning unit to the radio receiver, the three terminals, on the right hand side of the tuning unit, should be connected to the three terminals on the input terminal block in the radio receiver, connecting together the top terminals of each, the middle terminals and the bottom terminals, respectively.

3. 2-A Tuning Unit

The 20-A filter shown on pages 133 and 134 eliminates from the receiver practically all electrical energy of the frequency at which the associated broadcasting station is operated thereby reducing interference to a minimum. This apparatus is connected between the antenna and the 2-B Tuning Unit and is equipped with brackets for mounting it against a wall or beneath a table. It should be located close to the radio receiver and tuning unit. The adjustment of the filter is described on page 76.

B. GENERAL DESCRIPTION

6004-C RADIO RECEIVING OUTFIT

This receiving outfit, shown schematically on page 126 is a complete equipment for radio reception intended primarily for use at broadcasting stations. It is an earlier design than the 6204-D Radio Receiving Outfit described above. While it is slightly more sensitive than the latter design this increased sensitivity is obtained at some sacrifice in quality. It employs the 4-C Radio Receiver, with the 2-A Tuning Unit for tuning the antenna and the 20-A Filter for eliminating the transmitter frequency.

1. 4-C Receiver

The 4-C receiver (page 125) is a double-detection receiver employing six 215-A Vacuum Tubes. It is designed for operation with a loop antenna but may be adapted for use with an outside antenna by the addition of a 2-A Tuning Unit.

The first tube is used in an oscillator circuit, which is adjusted to a frequency 45 kilocycles above or below the received frequency. The oscillator output and the received signal are applied together to the grid of the second tube, which is a detector. The output of this detector is amplified by two amplifier stages at 45 kilocycles when it is again detected to produce the modulation frequency of the received signal. The last tube is used as an audio frequency amplifier. The output from the last tube is obtained directly from the plate of the tube through the jack on the front of the panel or from terminals on the back. The output circuits must carry the DC plate current of the tube, which is about .001 ampere.

The filaments of all of the tubes are connected in series. The filament current, supplied by an 8-volt battery, is controlled by a filament rheostat on the panel. A 45-volt dry battery is used for the plate supply to the oscillator, the amplifier tubes and the first detector. A mid-tap of $22\frac{1}{2}$ volts is used to supply the second detector tube.

Ammeter jacks marked "Test" are placed in the plate circuits of the oscillator and the first detector for testing purposes. The jack marked "Det." is connected to the plate circuit of the second detector so that the output circuit plug can be plugged in it to obtain the output from the detector directly. Plugging into this jack opens the interstage transformer at the plate of the detector. The amplifier control key short-circuits the second 45 kilocycle amplifier stage, when it is thrown to the position marked "1," and puts it in the circuit at the position marked "2." The amplification control switch controls a shunt resistance across the primary of the input transformer to the first amplifier tube.

The tuning condenser is used to tune the input circuit to the received radio frequencies and the oscillator condenser is used to tune the oscillator to a frequency about 45 kilocycles different from the received radio frequency.

2. No. 20-A Filter

The 2-A Tuning Unit (pages 131 and 132) is used for connecting the antenna to the 4-C Radio Receiver. It is a variable coupler with a secondary having a middle tap. The three secondary taps are connected to the loop terminals on the receiver. The primary is tuned with a loading coil and a variable condenser in the antenna circuit. Coupling to the secondary is controlled by a knob with an indicator on the front of the panel and an aperiodic-tuned switch is provided which connects the antenna to either the tuned circuit just described when on the point marked "T" or to the primary coupling coil alone when on the point marked "A." The aperiodic connection is used for preliminary tuning of the receiving set, after which more selectivity can be obtained by tuning the primary circuit.

3. 20-A Filter

The 20-A filter is used with both the 6204-D and 6004-C Radio Receiving Outfits. This unit is described on page 28.

CHAPTER IV

AUXILIARY EQUIPMENT

A. WATER CIRCULATING SYSTEMS

Water circulating systems are provided for dissipating the heat developed in the operation of the 228-A Vacuum Tube. This heat, unless dissipated as rapidly as produced, will become so intense as to destroy the tube within a short time. For this reason each system is fitted with a device which automatically removes all power from the 228-A Vacuum Tube whenever the water flow is materially reduced due to obstruction in the system or for other reasons. In some transmitters this protection is afforded by the use of a pressure gauge (page 84), the indicating needle of which makes contact with stationary contacts in the event of excessive increases or decreases of pressure. Other transmitters utilize a Venturi Tube in conjunction with a 226-A Relay. This relay is a device containing an electric contact operated by the motion of two opposed metal bellows. The operation of the relay is as follows: Two different pressures established at two separate points in the Venturi Tube by the water flow in the system are transmitted through tubular connections to the metal bellows. The difference in pressure established in the bellows causes one to expand and the other to contract closing or opening a contact through the medium of a multiply lever and a push rod. The relay is shown on page 87.

Page 83 and page 86 show typical water systems, the former utilizing the pressure gauge, the latter the Venturi Tube and 226-A Relay. Each page shows two systems. Figure 1 in each instance utilizes the house water supply, discharging into the sewer. Figure 2 on each page illustrates closed circulating systems with provision for emergency operation from the house water supply. A closed system filled with distilled or other pure water must be provided for localities in which the local water is unsatisfactory for use in the transmitter. A closed system is obviously desirable in localities in which the cost of water is exceptionally high.

Full instructions for the use of the systems, the setting of the valves, etc., is given on page 83 and page 86.

NOTE When using the house water supply with a system employing a pressure gauge, valve "M" (see page 83) should be adjusted to indicate a pressure of 15 to 20 pounds on the gauge. The stationary contacts of the gauge should be set 5 to 10 pounds on each side of the normal position of the movable arm.

The transmitter schematics shown on pages 76,77 and 78 apply respectively to cases in which the pressure gauge (page 76 and the 226-A Relay (pages 77 and 78) are used. The relay is indicated on pages 67, 77 and 78 by S₆.

Just inside the transmitter in front of the two 212-D Vacuum Tubes are the controlling handles for two valves in the bottom of the transmitter. The valves are in the inlet and outlet of the water circulating system in the transmitter. These must, of course, be open during operation of the transmitter and are closed for the purpose of changing water-cooled tubes.

A strainer is provided in the water line ahead of the pressure regulator and vacuum tube water jacket. This is accessible by removing the front panel at the bottom of the transmitter (see page 69) and should be cleaned at suitable intervals. A second strainer which is located at the pump, page 88, is accessible for cleaning by removing the cap which forms the bottom of the cup-shaped housing. A pet-cock has been threaded into the hex shaped boss on this cap to allow for venting at this point and in some cases it will be found necessary to first remove the pet-cock due to insufficient clearance between it and the pump base to allow for unthreading the strainer housing cap. Where this condition exists it is recommended that the pet-cock be replaced by a plug. Both strainers should be frequently and regularly cleaned.

1. Water Pump

The water pump is a suction type, high pressure, single stage pump of rugged, compact and simple construction. It has but one moving part, this being a disk or wheel called the impeller. The shaft to which this impeller is fastened revolves in two outboard radial ball bearings assembled to take thrust, thus avoiding metal to metal contact, friction and wear. Both suction and discharge openings are in the periphery. Vanes in the periphery of the impeller extend into the water channel, the shoulders of which, on account of their proximity to the flat surfaces of the impeller, cause a water seal to be formed, thus increasing and maintaining the pressure in the channel.

A strainer is installed at the "inlet" of the pump to prevent foreign material, which might find its way into the piping system during installation or thereafter, from entering the channel or damaging the vanes. This should be inspected and cleaned frequently. (Page 88)

The pump is direct connected to a motor through a noiseless flexible coupling, both pump and motor being mounted on the same base. For A. C. operation the ½ H. P. motor is thrown directly on the line. For D. C. operation an enclosed counter e. m. f. automatic starter is furnished.

2. Radiator

The radiator is a standard hot-water radiator of 99 square feet of radiating surface, consisting of 22 sections, 38 inches high and overall length of 3 feet, 8 inches. It is tapped for one inch pipe, top and bottom, opposite ends and fitted with air valve and key. Air should be released at frequent intervals if it shows a tendency to collect. As supplied the radiator is finished in black asphaltum.

3. Expansion Tank

A galvanized iron tank twelve inches in diameter and twenty inches high with a capacity of ten gallons is installed in an elevated position to allow for expansion in the cooling system and furnish sufficient head. The tank is equipped with a gauge glass and a bracket for mounting on the wall.

CHAPTER V

OPERATING PROCEDURE

A. RADIO TRANSMITTER

The antenna switch should be set in the operating or ungrounded position when it is desired to operate the set. At all other times the antenna should be grounded through this switch to protect against lightning.

Before applying power to the transmitter the cooling water should be started circulating, if the local house supply is used. Installations using the closed circulating system have the pump connected to the automatic starter of the KS-5055 motor-generator. The motor-generators are started by operating the top button of the "Master Control" switch. (If much time has elapsed since last broadcasting it is generally best to start the motor-generator sets with the Plate Voltage Switch open.)

The filament and grid voltages should be adjusted to 22 and 250 volts respectively by varying the rheostats on the front of the panel.

The plate voltage is applied by operating the top button of the "Plate Voltage" switch. The plate voltage should be adjusted to 4000 volts by varying the "4000 Volt Generator" field rheostat.

When radiation of the carrier starts a check should be made to assure that the transmitter is operating on the assigned frequency and that the antenna current is normal. The readings of all the instruments should be contrasted against those noted on page 18 to assure proper operation before starting the program.

B. SPEECH INPUT EQUIPMENT

1. Studio Operation

The studio manager is in direct charge of the program, while it is being broadcast and he is in personal contact with the artist or speaker furnishing the program. He is also in contact by telephone and signals with the control room operator and a certain routine should be established regarding his use of the signals and controls on the 6045-A Telephone Set mounted in the studio. The studio transmitter key on the 6045-A Telephone Set should normally remain in the "Off" position, except when music or speech is being broadcast. The studio microphone should not be moved or jarred in any way while this key is in the "On" position or without advising the operator so that the micro-

phone battery circuit may be opened by him. If the former precaution is neglected unpleasant sounds may be broadcast and if battery is not removed from the microphone before moving or jarring its life may be seriously impaired.

A program cannot be broadcast until the ready signal lamp marked, "Radio" is lighted. This light means that the radio transmitter and other speech input circuits are in readiness to broadcast. Under this condition when the studio transmitter key is turned on, the red lamp marked, "Broadcast" will light, signifying that any sounds produced in the studio are being broadcast. The button marked "Signal" calls the control room operator to the interphone. The lamp marked, "Interphone" is operated by the control room operator when he wishes to talk to the studio manager. The buzzer key when "On" connects a buzzer in the box in parallel with the interphone lamp when no program is being broadcast. The buzzer is automatically disconnected when the studio transmitter key is "On".

2. Control Room Operation

The control room operator is responsible for the operation of the speech input equipment. He must get all of his circuits in readiness before each program and continually watch the quality and volume of the output of the radio transmitter during the program. Before each program he should adjust the filament circuits of the amplifiers, adjust the current supply to the microphone and measure the plate current of each tube. The current in the various circuits should be within the limits given in the following table:

<i>Unit Circuit</i>	<i>Current</i>
518-B Filament	.95 amp.
*518-B Plate Circuit	5 divisions
8-B Plate Circuit No. 1	.0005 - .001 amp.
8-B Plate Circuit No. 2	.005 - .008 amp.
8-B Plate Circuit No. 3	.015 - .028 amp.
8-B Filament No. 1	.95 amp.
8-B Filament No. 2 and No. 3	1.6 amp.
18-B Filament	1.6 amp.
18-B Plate Circuit	.015 - .028 amp.
8-B Transmitter No. 1	20 - 30 Mils
8-B Transmitter No. 2	20 - 30 Mils

* An indication of this plate current is read on the galvanometer mounted on the panel and adjustment is made by the potentiometer marked, "C Voltage".

The program will be obtained from one of three places, the station's studio, the control room, or an outside point. Each of these will require slightly different operation in the control room.

The apparatus is made ready for a program from the station's studio by making the following settings of switches a few minutes in advance of the program. The last operation should be to turn the key in the 534-A panel marked, "Radio Transmitter" to the "On" position. This lights a signal lamp in the studio telling the studio manager that the circuits are ready.

<i>Unit</i>	<i>Control</i>	<i>Setting</i>
536-B Panel	Receiver Switch	On
536-B "	8-B Amplifier Filament Switch	On
536-B "	518-B Filament Switch	On
536-B "	18-B Amplifier Filament Switch	On
536-B "	534-A Panel Switch	On
536-B "	518-B Panel 130 V. Switch	On
536-B "	8-B Amplifier 350 V. Switch	On
518-B "	Filament Key	On
518-B "	Level Measuring Key	Zero
518-B "	Level Measuring Switch	Operating Level
8-B Amplifier	Output Transformer Key	Coil Out
8-B "	Filament Key	On
8-B "	Microphone Key (Marked, "Trans.")	On
8-B "	Amplification Control Switch	Determined by Experience
18-B "	Filament Switch	On
18-B "	Amplification Control	Determined by Experience
534-A Panel	Monitor	Radio Output
534-A "	Amplifier	Studio
	Input Key (Marked, "Transmitter")	
534-A "	Buzzer Key	To suit Operator
534-A "	Radio Signal (Marked, "Radio Transmitter")	On (Last Key to be Set)

Caution

Unbalanced currents in the two buttons of the microphone may be caused by opening the microphone circuit with any other switch than the microphone key on the 8-B Amplifier. This key is shunted by a condenser for the purpose of protecting the microphone from an inductive kick due to opening the circuit. The microphone circuit should always be opened by this key before changing the amplifier input transfer key on the 534-A Panel or before turning off the

battery supply switch to the 8-B Amplifier on the 536-B Panel. As a further safeguard the microphone current should be reduced by turning the controlling rheostat to minimum position before opening the circuit. The microphone in use should never be disconnected by means of the baseboard plug until after the microphone key is turned off. (If a microphone becomes unbalanced it can frequently be corrected by shaking it slightly with the current off.) Observing these precautions will greatly increase the life of the microphone.

The control room position for the microphone will ordinarily be used only for short announcements or testing. The apparatus is set as for the studio except that the amplifier input transfer key on the 534-A Panel is set to the position marked, "Radio Room."

3. Broadcasting from Remote Point

For broadcasting a program from some distant point the speech input must come in over a pair of telephone wires to the control room where it is again amplified before it goes to the radio transmitter.

The control room apparatus will be set as for broadcasting from the studio except that the microphone key on the 8-B Amplifier will be off, the amplifier input transfer key on the 534-A Panel will be in the "Extension" position, and the input key on the extension panel will now operate the broadcast control relay. The artificial line on the extension panel will ordinarily be in the circuit in order that a sufficiently high volume level on the incoming telephone lines may be used to minimize the effect of line noises and yet leave an ample margin for control in the 8-B Amplifier.

The white light marked "Broadcast Studio" no longer indicates when broadcasting is in progress.

4. Monitoring

Two means of monitoring are provided to assist the operator in properly adjusting the speech input amplifier. They are the 540-CW Loud Speaking Telephone and the volume indicator. The loud speaking telephone is connected to the output of the 18-B Amplifier which furnishes sufficient power to drive it. The input of the 18-B Amplifier may be connected either to the output of the monitoring rectifier in the radio transmitter or to the output of the 8-B Amplifier depending on the position of the monitoring transfer key on the 534-A Panel. Normally monitoring should be done at the output of the monitoring rectifier as a means of judging the quality of the broadcast program. By operating the transfer key, however, and listening to the loud speaking telephone in both positions a comparison of the quality of the program at the input and output of the radio transmitter is obtained. When making this com-

parison it is very important that the volume of sound output from the loud speaking telephone be the same on both occasions. Before making any comparison, therefore, the input of the monitoring rectifier should be adjusted until its output is at the same level as that of the 8-B Amplifier. It may also be pointed out that quality cannot be satisfactorily judged when much reverberation is present. Monitoring is necessarily done in the control room and improved transmission may be expected if this room is treated acoustically.

The volume indicator is a better guide to proper adjustment of the volume level of the input to the radio transmitter. As already recorded in the table of current readings on page 35, the filament current should be adjusted to .95 ampere and the plate current reading on the galvanometer to 5 scale divisions by means of the grid voltage potentiometer while there is no input to the unit. The level measuring switch and key must be set according to a predetermined level at which the program is to be supplied to the radio transmitter and the volume adjusted by the amplification control on the 8-B Amplifier. This level should be 2 to 4 TU below the level that causes the modulator grid current meter on the panel of the radio transmitter to show a tendency to move. Current indication on this meter is a sure sign of overloading.

During broadcasting the volume indicator galvanometer needle will follow the fluctuations of the program currents and for the louder tones should reach a deflection of 30 divisions but should rarely go over 30. Smaller deflections may be disregarded. These results will usually be obtained by an experienced operator with one adjustment of the amplification control of the 8-B Amplifier for each number. It is ordinarily undesirable to change the amplification adjustment during a number as this impairs the expression of the artist, however, slight adjustments may be necessary during numbers in which unusually loud or faint passages are rendered.

C. OPERATING ROUTINE

ROUTINE PRIOR TO EACH BROADCASTING PERIOD

1. Check the current balance in the microphones (the Nos. 387-W and 373-W Transmitters) and the adjustments on the No. 18-B Amplifier and No. 8-B Amplifier. Make sure they fall within the operating limits given in the table.
2. Check the adjustments on the No. 6-A Radio Transmitter making sure they fall within the operating limits given in the table on page 18.
3. Check the position of all switches and keys on the Speech Input Equipment. Make sure they are set in accordance with the table on page 36.
4. Obtain a copy of the program. This will be of value in adjusting the amplification control potentiometer on the No. 8-B Amplifier and in the general operation of the set.

ROUTINE DURING PROGRAM

1. Watch continuously all the meters connected permanently in the circuit to see that the operating currents or voltages remain within the prescribed limits.
2. Check the microphone currents every half hour or so. Whenever possible, this checking should be done during the intermission between numbers when the amplifier is disconnected from the radio transmitter.
3. Check the heating of the motor-generator sets (especially at the bearings) every half hour.

D. RADIO RECEIVING OUTFIT

1. 6204-D Radio Receiving Outfit

The No. 4-D Radio Receiver should always be operated with the panel in the vertical position, as shown on page 121. This is important because the No. 215-A Vacuum Tubes used in this radio receiver are not intended to be operated in the horizontal position.

To put the radio receiver in operation close battery supply key on 536-B Panel, press the panel lock buttons on the sides of the cabinet and then open the panel sufficiently to view the vacuum tubes. Now turn the filament rheostat knob from the "OFF" position in the direction indicated to increase current. The rheostat should be turned only until the filaments of the tubes light to a yellow-red. Close the panel and proceed with the tuning.

To tune the radio receiver to a particular station, set the "AMPLIFICATION CONTROL", at "9". Turn the two point antenna switch on the No. 2-B Tuning Unit to the "UNTUNED" position. Turn the other two point switch on the tuning unit to the frequency range over which reception is desired. Now set the pointer of the coupling knobs at maximum and slowly turn the tuning and oscillator condensers of the radio receiver. The tuning condenser should be turned so that the pointer advances over the scale only a few divisions at a time. For every setting of the tuning condenser the oscillator condenser should be turned so that the pointer passes over a considerable number of scale divisions. After the signal has been obtained, turn the two point antenna switch to "TUNED" position and then turn the antenna tuning knob on the tuning unit until maximum signal intensity is obtained.

The selectivity can now be improved by reducing the coupling, and the tuning can be refined by readjusting the two condensers on the radio receiver and the antenna tuning knob on the tuning unit. This is important in order to secure good quality of reception. Do not attempt to reduce the volume by manipulation of the condensers. This will throw the receiver out of tune and will im-

pair the quality of reception. The receiver should always be tuned as accurately as possible, and the volume should be controlled by means of the amplification control switch. Raising the setting of this switch increases the amplification of the receiver.

After the receiver is in operation and reception is satisfactory, the filament rheostat should be turned back to a point at which a change in volume occurs. It should then be advanced about 30 degrees to insure operation well above the point effecting volume. If operated lower the quality may be seriously impaired.

This receiver is not designed to operate a loud speaker without the use of an additional outside stage of amplification. To obtain a given volume from a loud speaker when the receiver is used in conjunction with a monitoring amplifier it is preferable to utilize all of the amplification available from the monitoring amplifier and only a portion of that available from the radio receiver rather than utilize only a portion of the amplification available in the monitoring amplifier and all the amplification available in the radio receiver. This method of operation improves the quality of reception as it prevents needless overloading of the detector and places the heavy load on that portion of the combination designed to carry it.

When the outfit is not in use, the filament rheostat knob should be turned to the "OFF" position in order to conserve the life of the batteries and the vacuum tubes.

The adjustment of the 20-A Filter must be made while the station is broadcasting or while its carrier wave is being transmitted.

To adjust the filter, tune the receiving outfit to the frequency of the station at which it is being used. It will probably be necessary to use the minimum sensitivity obtainable in order to avoid overloading the receiver. Place the antenna switch of the tuning unit in the untuned position and use a moderate amount of coupling. Loosen the locking screws which are located in the slots of the dials (See page 133) and listen, by means of the headset, to the output of the radio receiver. The dial, adjacent to the ground terminal, should now be turned by means of a screw-driver inserted in the slot in the center until the interference from the associated station is reduced as much as possible. Repeat this procedure with the other dial until the interference is at a minimum, then lock both dials in place by tightening the locking screws.

This filter unit requires no manipulation during reception because it is permanently adjusted to the correct wave length at the time of installation. If, however, a change is made in the operating wave length of the broadcasting station at which it is used, or if the receiving antenna is altered, it will generally be found necessary to change the adjustment of the filter.

2. 6004-C Radio Receiving Outfit

The No. 4-C Radio Receiver should always be operated with the panel vertical as the No. 215-A Vacuum Tubes used in this radio receiver are not intended to be operated in a horizontal position.

To put the radio receiver in operation, open the panel (by pressing the buttons on the sides of the cabinet near the top) sufficiently to view the vacuum tubes and turn the filament rheostat knob from the "OFF" position in the direction indicated to increase the current. The rheostat should be turned only far enough so that the filaments of the tubes light to a yellow red. Close the panel and proceed with the tuning.

To tune the radio receiver to a particular station set the "Intermediate Frequency Amplifier Switch" at "2" and the "Amplification Control" at "5". Turn the two point switch on the No. 2-A Tuning Unit to the contact marked "A". This makes the primary circuit aperiodic. Then set the coupling knob at maximum and turn the tuning and oscillator condensers of the No. 4-C Radio Receiver slowly. The tuning condenser should be turned so that the pointer advances only a few graduations at a time. For every setting of the tuning condenser the oscillator condenser should be turned so that the pointer passes over a considerable number of graduations in order to find both settings of the oscillator condenser. After the signal has been obtained, turn the switch on the No. 2-A Tuning Unit to the contact marked "T" and turn the primary tuning knob on the tuning unit until maximum signal intensity is obtained. Now reduce the coupling, as this improves the selectivity and the tuning may be refined by readjusting all three condensers. This is important if good quality is desired. Do not attempt to reduce the volume by manipulation of the condensers. This will throw the receiver out of tune and impair the quality of the reception. The radio receiver should always be tuned as accurately as possible and the volume controlled as explained below.

The volume may be controlled by varying the intermediate frequency amplification. One or two stages of intermediate frequency amplification may be employed as desired by setting the "Intermediate Frequency Amplifier Switch" at "1" or "2". With the switch set at "2", the volume will be considerably greater than with the switch set at "1". A finer regulation of volume can be obtained by adjustment of the "Amplification Control". This finer regulation operates when employing either one or two stages of intermediate frequency amplification. To avoid the possibility of overloading it is advisable, whenever possible, to operate with the Frequency Amplifier Switch at "1" rather than at "2".

The headset is provided with a cord and a plug which may be inserted either in the jack marked "DET" or the jack marked "OUT". If the plug is inserted in the jack marked "DET", the stage of audio frequency amplification

is cut out and the volume of sound will be considerably less than if the plug is inserted in the jack marked "OUT".

To obtain a given volume from a loud speaker when the receiver is used in conjunction with a monitoring amplifier it is preferable to utilize all of the amplification available from the monitoring amplifier and only a portion of that available from the radio receiver rather than utilize only a portion of the amplification available in the monitoring amplifier and all the amplification available in the radio receiver. This method of operation improves the quality of reception as it prevents needless overloading of the detector and places the heavy load on that portion of the combination designed to carry it.

For filter adjustment instructions see page 40.

CHAPTER VI

MAINTENANCE

For best operation the 106-A Radio Telephone Broadcasting Equipment must be kept free from dust and dirt. High pressure air is recommended for cleaning the apparatus inside the enclosures, but a soft clean cloth can be used with good results. Waste and oily cloth should never be used. Lemon oil is recommended as a polish for the front of the panel units. It should be used sparingly and wiped off with a clean cloth.

A. DAILY ROUTINE

1. As far as possible, anticipate tube failures and make the required tube replacements. Tube failure may be guarded against to some extent by keeping a record of the length of time the tubes are in use and by observing the conditions of the elements contained inside of the tube. The plate or grid may have become warped or the filament may have sagged, due to excessive heat, in such a manner as to increase the probability of these parts short-circuiting while the apparatus is in operation.

2. Check the specific gravity of the storage batteries and recharge when necessary. The various makes of batteries should be charged according to the instructions furnished by the manufacturer of the battery in use. (See page 50.)

3. Clean the commutators of the high and low voltage generators with a rag to remove oil and dust. This will help to keep the generator noise at a minimum. *Caution: Be sure there is no voltage on these machines at this time.*

4. Clean the oil and dust from the motor-generator set.

B. WEEKLY ROUTINE

Once a week the following routine should be followed in addition to the daily routine:

1. Clean the commutators of the high voltage and low voltage generators with *fine* sandpaper, applied lightly. Do not use emery cloth or crocus cloth for this purpose. Wipe dust and grease off the brush holders, especially on the high voltage generator. *Be sure there is not voltage on these machines at this time.*

2. Wipe dust and dirt off all exposed apparatus. This includes the motor generator sets, the radio receiver, the speech input equipment and its meters.

and the radio transmitter together with the apparatus and meters mounted on it. Bellows should be used to blow out all inaccessible places. Many cases of trouble will be prevented by keeping the equipment clean.

3. Inspect the condition of the brushes on the motor-generator sets and replace when necessary. The brushes should be replaced when they have been worn so short that there is danger of the brush spring resting on the brush holder.

4. Check the voltage of the plate battery used on the No. 18-B Amplifier, the No. 8-B Amplifier and the radio receiver. If the voltage of the radio receiver battery is allowed to fall much below 40 volts, the quality of the speech or music may be impaired.

5. Test the voltage of the "C" battery of the No. 18-B Amplifier. If the voltage measures less than twenty-four volts, the battery should be replaced.

Test the voltage of the "C" battery of the No. 8-B Amplifier. If the voltage measures less than twenty-four volts the battery should be replaced.

6. Check the lubrication of the motor-generator sets, and make sure that the oil rings rotate properly. Any good grade of machine oil may be used.

7. Check the store of tubes and other spare parts. Have all spares readily accessible and clearly classified. It is important to permit no confusion of serviceable and unserviceable material. Such confusion may cause unnecessary delays in broadcasting at the time trouble arises. A list of spare parts furnished with the equipment will be found under the heading "SPARE PART EQUIPMENT" page 63.

8. Inspect and clean strainers in water system.

C. ADDITIONAL ROUTINE

Once a month test all nuts, bolts and screws and tighten loose ones if any are found. Also check connections and if any loose contacts are found tighten or resolder them. Cases of trouble can often be prevented by such tests.

Two or three times a year lower the antenna and clean the dust, dirt and soot off the insulators. Inspect contacts and tighten the nuts and bolts, if any are used on antenna fittings. It is important that the antenna insulators should be cleaned periodically, especially in locations where there is much smoke in the air. Where smoke exists, soot collects on the insulators and produces high resistance ground leaks which will reduce the radiation efficiency of the station.

D. 100-A CONDENSERS

The best treatment for the 100-A Condensers is to not disturb them any more than is absolutely necessary and if they are operated at normal temperatures at their rated voltage, little or no maintenance is required. However,

abnormal conditions may, in certain cases, occur so that some attention is required.

The oil above the condenser fluid should remain clear and the aluminum plates at the terminals where they emerge from the liquid should remain clean and free from corrosion.

Corrosion of the positive plates is the most serious trouble that may develop. It may be recognized by the appearance of a gray flaky growth on the corrugated electrode under the condenser fluid, particularly on the positive plate supports just below the oil line. When the growths are down between the plates where they cannot be seen readily, the corrosion is sometimes detected by a grayish deposit of material that breaks loose from the corrosive growths and collects in the bottom of the glass jar.

When corrosion appears in a condenser nothing should be done unless the fuse blows with which the condenser is connected in the circuit. Provided the fuse does not blow, a corroded condenser performs satisfactorily from a circuit standpoint and actually has greater capacity than an uncorroded unit. It would not be uncommon to obtain more than two years service from a condenser after it has started to corrode. If the fuse blows, however, a short circuit has occurred in the condenser which it is necessary to remove. To do this the electrode should be withdrawn through the oil raising the lid as instructed in connection with renewing condenser fluid. If the short circuit has been caused by the accumulation of corrosion products between the plates forcing the positive plate into contact with the negative, the corrosion should be removed between the plates with a clean metal (preferably of aluminum) or glass rod. Then the position of the positive plate should be adjusted so that it hangs free from the negative.

NOTE The corrosion products are of themselves non-conducting and a short circuit can be caused only by the positive electrode actually touching the negative.

If the short circuit has been caused by the positive electrode supports being eaten through allowing one end of an element to drop and short circuit against the cross-piece of the negative electrode assembly, the remaining support of the affected electrode must be cut off above the oil with a pair of shears and the entire element removed from the condenser assembly.

NOTE The reduction in capacity caused by the loss of one electrode is offset to a great extent by the increase in capacity which normally occurs in a corroded condenser.

Before the electrodes are put back in service they should be rinsed thoroughly in distilled water or condenser fluid and placed back in service using fresh fluid and oil.

Precautions should be taken to keep the hole in the cover plugged with a cork and have the groove of the cover set properly over the rim of the glass jar, the paraffin in the groove maintaining a seal. Unless the air space above the oil is sealed to prevent air circulation, salt crystals from the evaporation of creeping condenser fluid will form on the supports above the oil. This white salt growth, which may appear on either the positive or negative plate supports, is harmless and must not be confused with the injurious gray corrosive growth which, when it occurs, appears only on the positive plates and only below the oil layer.

The condenser must operate only on direct current circuits and at not more than its rated potential of 33 volts. If the condenser is allowed to remain disconnected from the circuit for more than one week, there is danger that the film on the positive plate may deteriorate. If it becomes necessary to disconnect the condenser for periods of more than one week, it is desirable to keep the film in condition by connecting the condenser across a circuit of normal operating voltage for one or two hours each week that the cell is out of service.

Observe the color of the condenser fluid occasionally. It should be clear and its level should be about $\frac{5}{8}$ " above the aluminum plates. When the color of the fluid turns from clear to a hazy or milky white during operation it is an indication that the fluid should be renewed. This condition should occur only after considerable use and when it is noticed a period of three or four months can elapse without injury to the condenser before the fluid is renewed. However, it is advisable to renew the fluid as quickly as convenient, particularly during the summer months. Because of the more favorable conditions under which the condenser fluid can be shipped, it is advisable, in general, to renew the fluid during the summer months rather than during the winter. When condenser fluid is received which has, in all probability been exposed to freezing temperatures in shipment, it is necessary to make sure that the salts that have crystallized out are dissolved back into solution before the fluid is used. For this reason, the solution should be warmed up to room temperature (70° F to 100° F is satisfactory) and vigorously shaken before opened.

Condenser fluid is shipped in glass containers and may be stored in these containers for extended periods without deteriorating provided the containers are kept tightly corked and not subjected to extreme temperatures. The fluid should not be used after the date stamped on the label of the shipping container. Instructions for using condenser fluid are given on this label.

The fluid should not be stored in metal containers under any circumstances.

When necessary to renew the condenser fluid the following materials are necessary.

- Three gallons of fresh condenser fluid.
- Fresh supply of oil for protecting layer.

Abundant supply of fresh rinsing water.
Supply of clean cloths (not waste).
One aluminum funnel.
One cork stopper.

All of the above except the rinsing water and clean cloths may be obtained by ordering

One "I-A Condenser Filling Unit"

for each condenser in which it is desired to renew the fluid.

The process of renewing the fluid is as follows:

After disconnection from the circuit, remove the electrodes from the cell by raising the porcelain cover and drawing the electrodes through the oil. The cover rests on paraffin and it may be necessary to tap the lid gently upward to loosen it. This should be done carefully, using a small wooden block to absorb the impact of the light blows.

Rinse the electrodes thoroughly with clean fresh water; and when the greater part of the oil that adheres to the electrodes has been removed, rinse finally with condenser fluid (use not more than 1 quart). The most favorable results can be obtained in rinsing by grasping the porcelain lid to which the electrodes are fixed, and holding the aluminum electrodes under a faucet, letting cold water flow freely over the aluminum surfaces. The final rinse with condenser fluid can be done by pouring the rinsing liquid over the aluminum plates from a clean glass, porcelain or aluminum cup. After the final rinse, the electrodes may be set aside to dry. *DO NOT USE SOAP IN CLEANING THE ELECTRODES OR THE GLASS JAR.*

Pour the old condenser fluid and the oil from the glass and wash the jar inside and out with water (hot water preferably) using a clean cloth as a swab to remove the oil. Rinse with water and rub the jar inside and out with a clean dry cloth. Then rinse thoroughly with fresh water and complete the rinsing with about one quart of condenser fluid. Permit the jar to drain thoroughly by inverting, but do not dry with a cloth after the final rinse. If the cell is to be placed in dry storage, distilled water instead of condenser fluid should be used for rinsing and the cell should be protected from dust and dirt during the time it is stored.

The condenser fluid is supplied in glass containers. Remove the bottles from their cases and clean the outside thoroughly with a cloth before pouring out any of the fluid.

When the jars and electrodes are dry, fill each jar with condenser fluid to the *bottom* of the black line on the jar. The fresh condenser fluid when poured from the container should be clear and colorless. Precautions should

be taken to prevent dirt being blown into the fluid while the jars are being filled. If any small particles are floating on the surface of the fluid, remove them with the stem of the funnel which is supplied for pouring oil into the condenser.

Place the jars in their permanent position with the level marks in view. Lower the electrodes carefully into the fluid so as not to wet the terminals above the fluid surface. Raise and lower the electrodes carefully several times to thoroughly wet the immersed portion with the fluid. Make sure that each cover is seated evenly on the paraffin packing ring. The level of the condenser fluid should be $\frac{5}{8}$ " above the condenser plates and approximately even with the top of the black line after the electrodes are immersed.

Colorless mineral oil is furnished with the set of renewals, each container holding enough for one condenser. After the electrodes are immersed, the layer of oil approximately $\frac{1}{2}$ " thick, is carefully poured on the top of the condenser fluid and the cork fitted snugly into the hole. It is desirable to coat the cork with paraffin by using a hot soldering iron to melt a small piece of paraffin or wax placed on top of the cork. The condensers are now ready to be connected in the circuit, the positive lead to the terminal of the condenser marked + and the negative to the terminal marked —. In a battery room, the terminals of the condensers should be painted with acid resisting paint after the connections have been made.

In case of damage by accident, the following parts, complete, may be obtained (no other combination of parts should be ordered):

Glass Jar for 100-A Condenser

Electrode and Cover Assembly for 100-A Condenser.

E. RELAYS

Experience has shown that dirty contacts constitute one of the chief sources of relay trouble due to dust collecting on the contacts in spite of the individual or group covers. Abrasives, such as fine files or emery cloth should never be used on contacts. In cases of badly pitted contacts crocus cloth may be used but the contacts should be cleaned as outlined after such use.

For cleaning contacts a small quantity of carbon tetrachloride of highest purity and some hard wood tooth picks, flat on one end, are required. A drop or two of the liquid should be deposited on the relay contacts, they being held slightly separated. The point of a tooth pick may be used for this purpose. The flat end of the tooth pick should then be dipped in the liquid to a depth of about one quarter of an inch and rubbed back and forth two or three times between the contacts which should now be closed with a slight pressure on the flat sides of the tooth pick. The liquid will soften any deposit that may have

collected on the contacts and the rubbing will remove it. Then with the contacts again held slightly open they should be flushed with a little of the liquid taken up on the clean point of the tooth pick (not the end used for rubbing). This will wash off any loose particles that remain. The tooth pick should not be reused for cleaning another set of contacts, otherwise the deposit removed from one contact might be left in the liquid and later deposited on the other contacts. Care should be taken to keep the liquid from coming in contact with the rubber studs or insulators as far as is practicable as carbon tetrachloride has an injurious effect on rubber if applied frequently.

The tools necessary for maintaining "B" and "E" type relays together with their application and ordering information of each, are noted herein for the customers information.

Tool #265—For cleaning and burnishing contacts of relays and jacks.

Tool #259—For adjusting relay springs.

In using this spring tensioning tool the slot in the end of the tool should be slipped over the spring to be tensioned near its front end and then slid back about $\frac{1}{4}$ to $\frac{1}{2}$ inch from the heel of the spring. In this position a slight turn to the left or right will increase or decrease the spring tension. Excessive turning of the spring tensioning tool should be avoided, since such practice is apt to disturb the tension of adjacent springs and particularly in the case of springs adjacent to the armature, to bend the armature hinge plates.

Other tools which will be found of use in connection with speech input maintenance are the following:

Tool #116—For removing #2 Type Signal Lamps.

Tool #146—For removing #2 Type Lamp Caps.

In order to assure unretarded action of the valves of the Type PQ Time Delay Relays it is recommended that Neatsfoot Oil be applied to the bellows once every three months or oftener if necessary.

F. CARE OF STORAGE BATTERIES

Inspection tests should be made to determine when the "A" and "B" batteries need recharging, and when they need additions of water.

ALL BATTERIES SHOULD BE CHARGED AT LEAST ONCE A MONTH WHETHER OR NOT THEY HAVE BEEN SUBJECTED TO ANY DISCHARGE.

To determine the condition of the battery, readings of the specific gravity in pilot cells should be taken with a hydrometer. One cell in the filament battery, and one cell in each of the 15 sections of the plate battery should be selected as pilot cells.

CHARGING RATES

Type	Charging Rate "A" Battery	Fully Charged Specific Gravity
LXL-13	9 Amperes	1275
LXL-9	6 Amperes	1275
LXL-5	3 Amperes	1275
	"B" Battery	
LR-2	.5 Amperes	1200

The significance of the specific gravity readings is shown by the following table:

	"A" Battery Type LX Exide	"B" Battery Type LR Exide
Full capacity available	1275	1200
$\frac{3}{4}$ " "	1250	1175
$\frac{1}{2}$ " "	1225	1150
$\frac{1}{4}$ " "	1200	1125
Fully discharged	1175	1100

In order that the batteries shall be kept in readiness to give satisfactory service, the various batteries should be recharged whenever the specific gravity of their respective pilot cells reaches 1225 for the Type LX Exide or 1150 in the case of the Type LR Exide.

The batteries may, of course, be completely discharged, if the equipment has to be used so steadily that there is no opportunity for charging them before this condition is reached. In such cases, the batteries should be recharged as soon as possible.

Add distilled water preferably just before a charge, but often enough to keep the plates covered at all times. Add slowly and carefully, bringing the electrolyte well above the plates but not high enough to touch the lower end of the filling tubes. Particular attention should be given to the pilot cells, in which the level of electrolyte should be kept approximately constant at all times.

Enough electrolyte should be drawn into the barrel of the hydrometer syringe to float the hydrometer, but it should not touch the side or top of the barrel. Return to the cell all of the electrolyte withdrawn for a reading. Do not read immediately after adding water or before the water is mixed in by charging. The specific gravity of the electrolyte will rise during charge. Gassing will start after the cells are partly charged, and will become particularly noticeable toward the end of the charge. The specific gravity of the electrolyte

in the cells should be read periodically during the charge, which may be considered complete when the reading shows no increase for two or three consecutive hourly readings.

Once every six months, the specific gravity of all the cells should be read after a full charge. If any cell of the "A" battery reads below 1235, or differs by 50 points or more from the others, a further charge should be given to the battery, continuing until the low cells show no further rise. If any cell continues to show a difference of 50 or more points from the others or still remains below 1235, special attention at a service station may be required.

In the case of the "B" battery, if the inspection mentioned discloses any cell with a specific gravity below 1150 a further charge should be given until the low cells show no further rise. If any cell still remains below these respective figures, special attention at a service station may be required.

Keep batteries clean and dry. Frequently wipe off all parts of the batteries and the rack with a rag moistened with bicarbonate of soda solution to neutralize any electrolyte that may collect.

Keep all filling plugs tightly in place except when adding water or taking specific gravity readings.

Keep connections clean and tight.

Never bring a lighted match or other exposed flame near batteries.

Never allow metals or other impurities of any kind to get into the cells.

If battery is installed in a cabinet or closet, keep this ventilated when charging.

Melted vaseline should be applied to all battery terminals with a brush, to assure a thin coating, and prevent the accumulation of corrosion and verdigris. The batteries should be wiped clean frequently and the vaseline renewed.

CHAPTER VII

LOCATION OF TROUBLE

If routine maintenance tests are made regularly and carefully, very few cases of trouble will occur. However, when trouble does arise, the one thing that counts for most is experience. To the new operator, simple troubles are often baffling, while to the experienced operators, the cause is obvious. An operator may spend hours hunting for a simple case of trouble the first time it occurs and find it immediately the second time it occurs. It is simply a case of recognizing the relation between effect and cause.

These suggestions of the location of trouble are written primarily for the person who operates the equipment for the first time. As experience in operating the equipment accumulates, the operator will become more and more able to immediately recognize from the symptoms the cause of the trouble and will have less need for these suggestions.

It is not possible to anticipate every case of trouble that may arise and to provide a plan for its location. It is our purpose, however, to make certain general suggestions which will be of aid in every case of trouble and to give a few examples of the application of these methods which we hope will suggest the proper procedure in the cases of trouble that are bound to arise from time to time in spite of the most vigilant maintenance.

Troubles in the 106-A Radio Telephone Broadcasting Equipment will usually be found due to improper operation of some of the switches, keys or adjustments and the first thing to do in all cases of trouble is to carefully inspect the adjustments of all of the circuits. After this it is well to eliminate any units that are not operating properly. Currents in the circuits provided with jacks should be within the limits as shown on page 35. If the trouble is not readily found, a more thorough test of the units must be made.

In most cases a search for trouble can best be made by isolating the part which functions improperly from those parts which operate in a normal manner. It is usually best to start with the power supply and work out. Obviously the search must be made systematically, the best method being the process of elimination.

Do not use a buzzer in checking amplifier circuits because of the danger of magnetizing the coils which would result in impairing the quality of transmission. The use of a high resistance telephone in series with a flashlight battery serves to indicate circuit continuity. In this connection care should be taken to distinguish between the click of the receiver when the contact is first

made (due to capacity effect) and the click due to the passage of current as the circuit opens and closes. The former usually occurs only on the first making of the contact. Subsequent contacts result in weak clicks. When the source of the trouble is located in one or two or more interconnected circuits, each of these may be tested separately by temporarily disconnecting it from others. An electrical soldering iron will be found convenient for such temporary circuit changes.

If the cause of the trouble is obvious no suggestions are needed.

If the cause of trouble is *not* obvious it is of utmost importance that the search be made systematically. It is generally possible to immediately isolate the trouble, that is, to locate it in some one unit of the equipment such as the motor-generator, the radio transmitter, the radio receiver, the speech input equipment, the studio signal and control equipment or the microphone. Frequently it is possible to still further isolate the trouble, as for example in the radio transmitter, it is possible to determine whether it is in the oscillator, modulator or speech amplifier circuits; or in the motor-generator set whether it is in the motor, the low voltage generator or the high voltage generator. Before starting on any elaborate set of tests, check the position of all keys and switches and make sure that they are in the correct position.

A. TRANSMITTER

1. Overloading

The margin of safety in designing the 6-A Radio Transmitter has been made ample to allow for the proper and continued operation of this equipment at the rated power output of 1 K.W. It should be realized, however, that the instantaneous power output during modulation is considerably greater than 1 K.W. To allow for the power peaks during modulation the water cooled tube has been accordingly made sufficiently rugged to deliver several kilowatts.

It is apparent that the greatest precautions must be used to prevent overloading the transmitter in order to assure continuity of operation and a high order of transmission. The degree of freedom from trouble, to be enjoyed, is dependent directly upon the care taken in closely adhering to this condition.

Fuse protection throughout the transmitter allows for promptly locating such troubles as may arise and through intimate knowledge of the various circuits the operator may reduce interruption in programs to a minimum.

2. Reduced Radiation

Reduced radiation, indicated by reports from radio listeners, if accompanied by reduced antenna current, usually indicates that connections in the antenna lead or ground have corroded introducing a high resistance in the an-

tenna ground system. Inspection of all contacts in this system should be made and imperfect contacts eliminated.

Another cause of reduced radiation is soot coated insulators which provide high resistance paths between antenna and ground. The antenna should be lowered and the insulators cleaned or replaced.

If reduced radiation is unaccompanied by change in antenna current it is probably due to a seasonal or atmospheric condition which will eventually right itself.

B. SPEECH INPUT EQUIPMENT

1. Amplifiers

The troubles most commonly encountered in amplifiers are noise in the output, either regular or intermittent, and "singing". In most cases these troubles can be traced to the grid bias batteries, commonly known as "C" batteries. When these batteries are low in voltage, the plate current in the tubes is generally excessive but it is wise to remove all batteries from the battery box and check each one separately with the portable voltmeter furnished with the equipment. Investigate the possibility of a poorly soldered connection between the brass spring contacts and zinc shells of the batteries as intermittent noise is sometimes traceable to this cause. Batteries which show reduced voltage should be discarded and replaced by new ones. It is advisable to polish the contacts of the batteries before inserting them in the battery box.

Troubles which occur less frequently are open circuits, short circuits and loose connections; symptoms of these troubles depend largely on their location. Open circuits and short circuits usually can be repaired very easily when they are located. The ease with which they are located depends largely on the operator's experience in tracing trouble in apparatus of this kind. The best procedure is to use the circuit diagrams of the apparatus unit in question as a guide in tracing the trouble to its source by the process of elimination. Testing can best be done by using a high resistance telephone receiver in series with a flashlight battery for determining the continuity or discontinuity of circuits. If the trouble appears only when using the meters, it may be that "opens" have developed in the meter cords where they enter the plugs or elsewhere.

Loose connections are usually more difficult to locate because at the time of the test, they may be making momentary contact. They can frequently be detected by moving the wiring back and forth while listening to the telephone receiver.

Noises are often traceable to loose or high resistance contacts on the low voltage batteries commonly known as "A" batteries. These contacts should receive regular inspection.

Occasionally noise from the amplifier manifests itself in the form of a steady hum or other regular sound. This is often traceable to inductive interference from the power lines or electrical machinery. Ordinarily it is picked up by the microphone circuits and in this case may be readily isolated from the amplifier. Interference of this nature may be eliminated by proper shielding and grounding.

Intermittent interruption of plate or filament current in the vacuum tube circuits may indicate poor tube contacts. Remove the tube and polish the spring contacts with fine sandpaper and if necessary bend up the contacts in the socket to improve the connection.

One form of amplifier noise, due to vibration of the elements of the vacuum tubes through acoustic or mechanical coupling, is known as "microphonic effect". It is occasionally observed when the monitoring loud speaker is operated at a high level when close to the tubes. When excessive mechanical vibration is transferred to the tubes some form of cushioning should be employed to reduce it.

2. Signal and Control Circuits

Trouble in these circuits will often be indicated by the failure of a lamp to light properly. This may be due to a burned-out filament, or it may be a bad spring contact on one of the keys. By operating the keys and studying the circuit, the trouble can usually be located. If the trouble seems to be in one of the keys it may be found by operating the key while watching the contacts. The trouble should be definitely located before any change is made as a changed connection is often very hard to find.

Note that the large "Broadcast" lamps on the 534-A Panel and on the 6045-A Telephone Set are used in series with the relay on the 534-A Panel which connects the 8-B Amplifier to the radio transmitter so that if they burn out it is not possible to operate this relay through them.

3. Radio Frequency Feed Back

One particularly baffling trouble manifests itself as "singing", which is a sustained high pitched note, audible at the output of the 8-B Amplifier, the radio transmitter or any receiving set. This radio frequency feed back occurs only when the radio transmitter is operating in conjunction with the speech input equipment and in extreme cases it may trip the circuit breaker in the plate circuits of the transmitter.

Singing is caused by insufficient or defective shielding, grounding or both in the microphone or interconnecting circuits. It usually shows itself at the time of installation rather than later but if it arises suddenly it is probably

incident to the breaking of a ground connection somewhere. It may invariably be corrected by additional grounding, shielding or both after the offending circuit is isolated.

When the defective grounding or shielding occurs in filament circuits the condition is indicated by noise in the carrier. Additional grounding and shielding is the proper remedy in this case also.

4. Power Supply Circuits

Troubles in the speech input supply circuits can usually be located very quickly with the aid of a DC voltmeter.

C. RADIO RECEIVING OUTFIT

A gradual decrease in the volume of reception indicates that the filament or plate batteries are becoming exhausted. Examine the vacuum tubes. If the filaments of the vacuum tubes cannot be made to glow at a yellow-red color by adjustment of the rheostat, the decreased volume is caused by an exhausted filament battery and this battery should be recharged. If the filaments can be made to glow at the above brilliancy and the volume of reception is still unsatisfactory, the plate batteries are probably exhausted and should be replaced.

A sudden cessation of reception probably indicates that a vacuum tube has been burned out. Examine the vacuum tubes. If they are extinguished, one of them is probably burned out. The filaments of the tubes are connected in series and if one is burned out all the tubes will fail to light. To determine which tube is burned out, test each tube in succession by replacing it with a new one and noting whether all the tubes then light.

NOTE: To insure continuous service from the radio receiver it is recommended that at least three spare No. 215-A Vacuum Tubes be kept on hand to be used as replacements.

If difficulties other than those mentioned above are experienced, examine the receiver cord, the wiring to the batteries and the connections between the radio receiver, the tuning unit and the filter for loose or broken connections.

The location of the various parts of the No. 4-D Radio Receiver is shown on page 122. The connecton diagram of the various units comprising the No. 6204-D Radio Receiving Outfit is shown on pages 123 and 124.

The location of the various parts of the No. 4-C Radio Receiver is shown on page 125. A schematic of the connections between the various units comprising the No. 6004-C Radio Receiving Outfit is shown on pages 126, 127 and 128.

CHAPTER VIII

ENGINEERING SERVICE

In case it is impossible to locate the cause of the trouble with the aid of the foregoing suggestions or should the purchaser desire to avail himself of engineering services, the matter should be referred to the nearest Branch House of the Graybar Electric Company, and authorization for such service placed with them.

In Canada this service may be obtained through the Northern Electric Company, Limited, and through the International Standard Electric Corporation in other foreign countries.

CHAPTER IX

ORDERING INFORMATION

All orders for replacement apparatus should be placed with the nearest branch house of the Graybar Electric Company (in the U. S. A.), the Northern Electric Company, Limited (in Canada), or the International Standard Electric Corporation (in other foreign countries), and should clearly indicate the name and code number or other designation of the apparatus desired. This information may be found on the apparatus itself and in most cases it also appears on the drawings. As a further aid a list of the apparatus assembled in the 6-A Radio Transmitter is included and will be found on the following pages:

ORDERING INFORMATION

For Apparatus Mounted in 6-A Radio Transmitter

Apparatus Designation	No. of Units	Information to be furnished with order	Unit Value
Capacities			
C-1	1	82-A Condenser	1 MF
C-2	1	UC-1852 Faradon Condenser	.005
C-3	1	UC-2253 Faradon Condenser	.0025
C-4.1	1	UC-2318 Faradon Condenser	.002
C-4.2	1	UC-2318 Faradon Condenser	.002
C-5	1	UC-1852 Faradon Condenser	.005
C-6	1	UC-1816 Faradon Condenser	.010
C-7.1	1	UC-2316 Faradon Condenser	.0005

C-7.2	1	UC-2303 Faradon Condenser	.00025
C-7.3	1	UC-2316 Faradon Condenser	.0005
C-7.4	1	UC-1886 Faradon Condenser	.001
C-7.5	1	UC-1886 Faradon Condenser	.001
C-8	1	UC-1852 Faradon Condenser	.005
C-9	1	UC-2317 Faradon Condenser	.0035
C-10.1	1	UC-1896 Faradon Condenser	.020
C-10.2	1	UC-1896 Faradon Condenser	.020
C-10.3	1	UC-1849 Faradon Condenser	.010
C-10.4	1	UC-2223 Faradon Condenser	.005
C-10.5	1	UC-2390 Faradon Condenser	.0025
C-11.1	3	95-B Condensers	1 MF
C-11.2	3	95-B Condensers	1 MF
C-12	1	82-A Condenser	1 MF
C-13	1	117-A Condenser	1 MF
C-14	1	117-A Condenser	1 MF
C-15	3	KS-3042 Condensers	2.8 MF
C-16	1	95-A Condenser	1 MF
C-17	1	UC-2297 Faradon Condenser	.002-.040
C-18	1	119-A Condenser	.5 MF
C-19	9	21-AA Condensers	1 MF

Fuses

A list will be found on page 8 of the text.

Inductances

Apparatus Designation	No. of Units	Information to be furnished with order
L-2.1	1	D-78395 Retard Coil
L-2.2	1	D-78395 Retard Coil
L-3	1	126-A Retard Coil
L4.1	1	5-B Choke Coil
L4.2	1	5-B Choke Coil
L5	1	Choke Coil per detail #1 on drawing ESO-307474
L6	1	Inductance Coil per drawing ESR-307463
L7	1	Inductance Coil per drawing ESR-307675
L8	1	Inductance Coil per drawing ESR-307459
L9.1	1	5-B Choke Coil

L9.2	1	5-B Choke Coil
L10.1	1	5-B Choke Coil
L10.2	1	5-B Choke Coil
L11	1	Choke Coil per detail #1, drawing ESO-307473
L12	1	Choke Coil per detail #7, drawing ESL-307925
L13.1	1	5-B Choke Coil
L13.2	1	5-B Choke Coil
L14	1	Choke Coil per detail #1, drawing ESL-307925
L15	1	64-A Retard Coil
L16	1	75-B Retard Coil
L17	1	Choke Coil per detail #1, drawing ESL-308363
L18.1	1	5-B Choke Coil
L18.2	1	5-B Choke Coil

Meters

Apparatus Designation	No. of Units	Information to be furnished with order
M1	1	Weston Model #301 D. C. Milliammeter scale 0-100 ma.
M2	1	Weston Model #301 D. C. Ammeter Scale 0-1.5 amperes
M3	1	Weston Model #425 Thermoammeter Scale 0-20 amperes (Thermocouple of same serial number to be furnished with meter)
M4	1	Weston Model #425 Thermoammeter Scale 0-15 amperes (Thermocouple of same serial number to be furnished with meter)
M5	1	Weston Model #301 D. C. Milliammeter Scale 0-100 ma.
M6	1	Weston Model #425 Thermoammeter Scale 0-1 ampere (Thermocouple of same serial number to be furnished with meter)
M7	1	Weston Model #301 D. C. Milliammeter Scale 0-500 ma.
M8	1	Weston Model #301 D. C. Milliammeter Scale 0-100 ma.
M9	1	Weston Model #301 D. C. Milliammeter Scale 0-300 ma.
M10	1	Weston Model #301 D. C. Milliammeter Scale 5-0-10 ma.

M11	1	Weston Model #431 (per KS-3064) D. C. Voltmeter 0-5000 volts furnished with metal case.
M12	1	Weston Model #431 D. C. Voltmeter Scale 0-400 volts furnished with metal case
M13	1	Weston Model #431 D. C. Voltmeter Scale 0-30 volts furnished with metal case

Relays

Apparatus Designation	No. of Units	Information to be furnished with order
S1	1	G. E. Co. "PQ-6" Instantaneous One Circuit Contacts, circuit opening, hand reset relay, coil to carry continuously 1.5 ampere DC and calibrated to operate at 1.0-1.5-2.0 and 3.0 amperes
S2	1	G. E. Co. "PQ" Definite time delay relay to operate on 22 volts DC constantly applied, closing one circuit with a delay of 10 to 15 seconds and equipped with quick release valve per SL-1893427-G-1.
S3	1	B-36 Relay
S4	1	Magnetic Switch C-R 4002 A-2 similar to catalog #1772583-G-3 except equipped with 5 ampere blowout coil, the operating coil to operate continuously at 250 volts DC.
S5	1	Magnetic Switch C-R 4002 A-2 similar to catalog #1772583-G-3 except equipped with 5 ampere blowout coil, the operating coil to operate continuously at 250 volts DC.
S6	1	226-A Relay (furnished only on transmitters numbered 119 or higher)

Resistances

Apparatus Designation	No. of Units	Information to be furnished with order
R1	1	W.-L. "CM" 4 ohm $\pm 5\%$ Resistance with tab terminals
R2	1	W.-L. "CM" 1.34 ohm $\pm 5\%$ Resistance with tab terminals

R3	1	W.-L. "CM" 1.34 ohm \pm 5% Resistance with tab terminals
R4	1	W.-L. "CM" 1500 ohm \pm 10% Resistance with tab terminals
R5.1	1	W.-L. "CM" 79 ohm \pm 1% Resistance with tab terminals
R5.2	1	W.-L. "CM" 9 ohm \pm 5% Resistance with tab terminals (taps at 3 ohms and 6 ohms \pm 5% each section)
R5.3	1	W.-L. "CM" 112 ohm \pm 1% Resistance with tab terminals
R5.4	1	W.-L. "CM" 112 ohm \pm 1% Resistance with tab terminals
R9.1	1	W.-L. "D" 500 ohm \pm 5% Resistance with clamp terminals
R9.2	1	W.-L. "D" 500 ohm \pm 5% Resistance with clamp terminals
R11	1	W.-L. "CM" 25000 ohm \pm 5% Resistance with tab terminals tapped at 9000 ohms \pm 5% (9000 ohm section marked R11.1-16000 ohm section marked R11.2)
R13	1	W.-L. "CM" 48000 ohm Resistance with tab terminals
R14		(Part of L14 assembly)
R15.1	1	18-P Resistance
R15.2	1	18-P Resistance
R15.3	1	18-AR Resistance
R15.4	1	18-P Resistance
R15.5	1	18-P Resistance
R15.6	1	18-AP Resistance
R16	1	W. L. "B" 5000 ohm \pm 10% Resistance
R17.1	1	62-B Resistance
R17.2	1	62-A Resistance
R17.3	1	62-A Resistance
R18	1	W.-L. "O" 1000 ohm \pm 10% Resistance with tab terminals
R19	1	W.-L. "BM" 11 ohm \pm 5% Resistance with tab terminals
R20	1	Weston External Resistance Box per Weston drawing CD-52719 furnished with model #431 Voltmeter Scale 0-5000 volts per KS-3064

*R21	1	W.-L. Field Rheostat for 250-V Generator— M.G. set KS
*R22	1	W.-L. Field Rheostat for 24-V Generator— M.G. set KS
*R23	1	W.-L. Field Rheostat for High Voltage Gen- erator M.G. set KS
R24.1	1	38-W Resistance
R24.2	1	38-W Resistance
R24.3	1	38-W Resistance
R25	1	Weston Miniature Precision Resistor per Weston drawing CD-46882 to be ordered with model 431 (M) DC Voltmeter scale 0-400 volts

*Specify KS number which is stamped on the base of motor-generator set.

Transformers

T1	1	233-C Input Transformer
T2	1	D-79629 Output Transformer

CHAPTER X

SPARE PART EQUIPMENT

A. The following is a list of spare parts supplied with the 106-A Radio Telephone Broadcasting Equipment.

- 1—788 Cord
- 3—728 Cords (one each red, white, and green) 1 foot long, equipped with
- 6—110 Plugs
- 10—35-F Fuses, $\frac{1}{2}$ ampere
- 10—35-B Fuses, 3 amperes
- 6—62-B Fuses
- 4—2-F Lamps
- 2—Lamps per W. E. List #12052 or 6-8 volt, 2 candle power, double contact, bayonet bases, Mazda 64
- 2—62-A Resistances
- 1—62-B Resistance
- 3—387-W Transmitters
- 2—102-D Vacuum Tubes
- 5—205-D Vacuum Tubes
- 2—211-D Vacuum Tubes
- 2—212-D Vacuum Tubes
- 6—215-A Vacuum Tubes
- 2—228-A Vacuum Tubes
- *1—G. E. Co. Tungar Bulb Cat. No. 189048
- *1—G. E. Co. Tungar Bulb Cat. No. 189049

*Furnished only when power supply for charging is A. C.

B. The following list of apparatus is suggested as an additional complement of spare parts for this equipment. Any or all items, if desired, shall be ordered separately.

- 1—Armature for the Center 2000 Volt Generator of KS-5054 Motor-Generator Set
- 1—Armature for the End 2000 Volt Generator of the KS-5054 Motor-Generator Set
- 1—Complete Set of Brushes for the KS-5054 Motor-Generator Set

- 1—Complete Set of Brushes for the KS-5055 Motor Generator Set
- 2—82-A Condensers
- 2—95-B Condensers
- 1—Faradon UC-1896 Condenser
- 1—Faradon UC-2223 Condenser
- 1—Faradon UC-1849 Condenser
- 1—Faradon UC-2316 Condenser
- 1—Faradon UC-2303 Condenser
- 1—Faradon UC-1886 Condenser
- 1—KS-3042 Condenser
- 1—Ward-Leonard Type CM Resistance with "Tab" Terminals 4
Ohms \pm 5%
- 1—Ward-Leonard Type CM Resistance with "Tab" Terminals 1.34
Ohms \pm 5%
- 2—Ward-Leonard Type DM Resistance with "Tab" Terminals 500
Ohms \pm 5%
- 2—Ward-Leonard Type CM Resistance with "Tab" Terminals 112
Ohms \pm 1%
- 1—Ward-Leonard Type CM Resistance with "Tab" Terminals 79
Ohms \pm 1%
- 1—Ward-Leonard Type CM Resistance with "Tab" Terminals 9
Ohms \pm 5% with taps at 3 Ohms and 6 Ohms Each Section
 \pm 5%
- 1—Ward-Leonard Type CM Resistance with "Tab" Terminals 25,000
Ohms \pm 5% with Tap at 9000 Ohms \pm 5%
- 1—Ward-Leonard Type CM Resistance with "Tab" Terminals 1500
Ohms \pm 10%
- 1—Ward-Leonard Type CM Resistance with "Tab" Terminals 48,000
Ohms \pm 5%
- 1—Ward-Leonard Type BM Resistance with "Tab" Terminals 5000
Ohms \pm 10%
- 1—Ward-Leonard Type BM Resistance with "Tab" Terminals 11
Ohms \pm 5%

INSTRUCTION BULLETIN #255

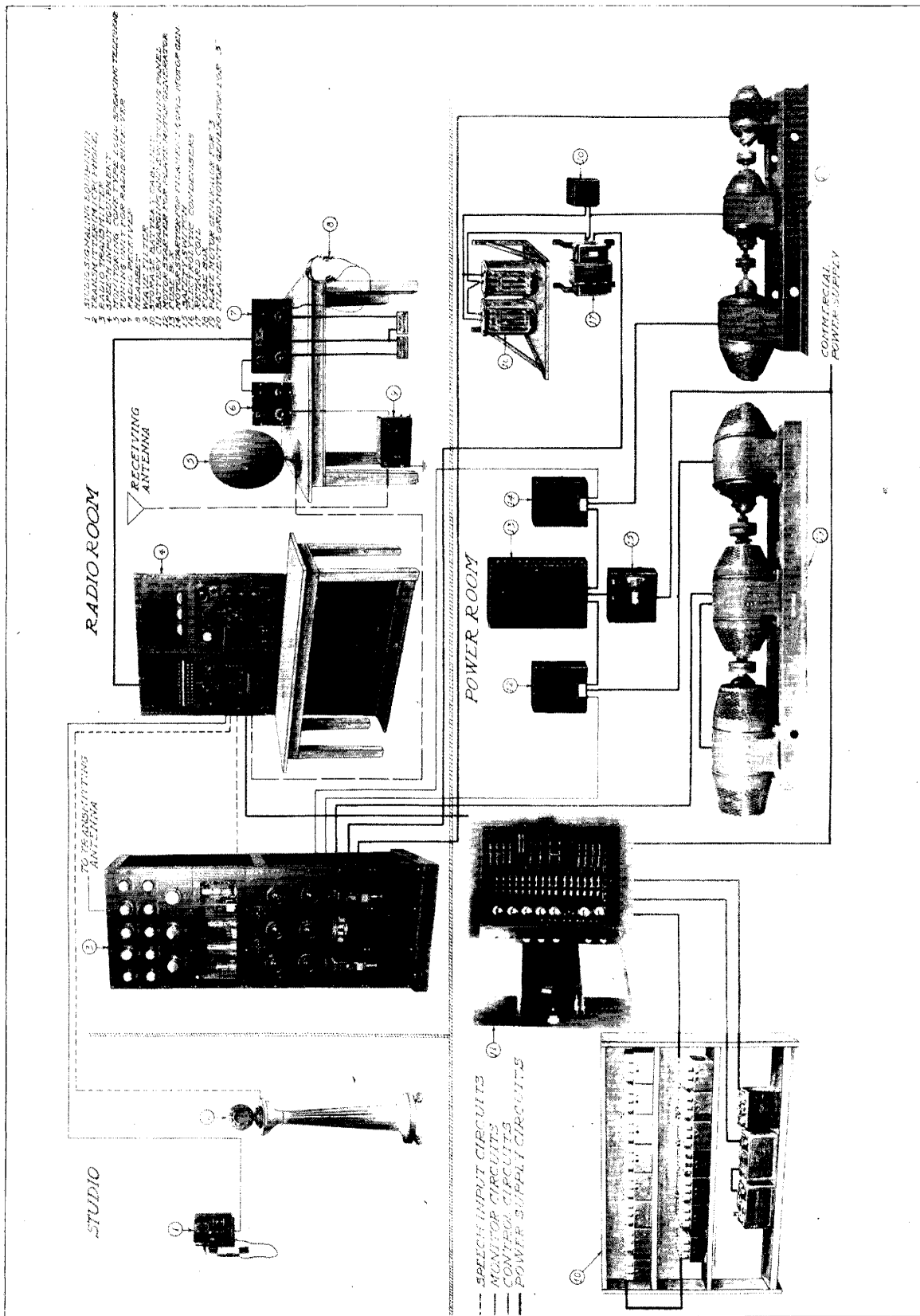

106-A R. T. B. EQUIPMENT ASSEMBLY—22853

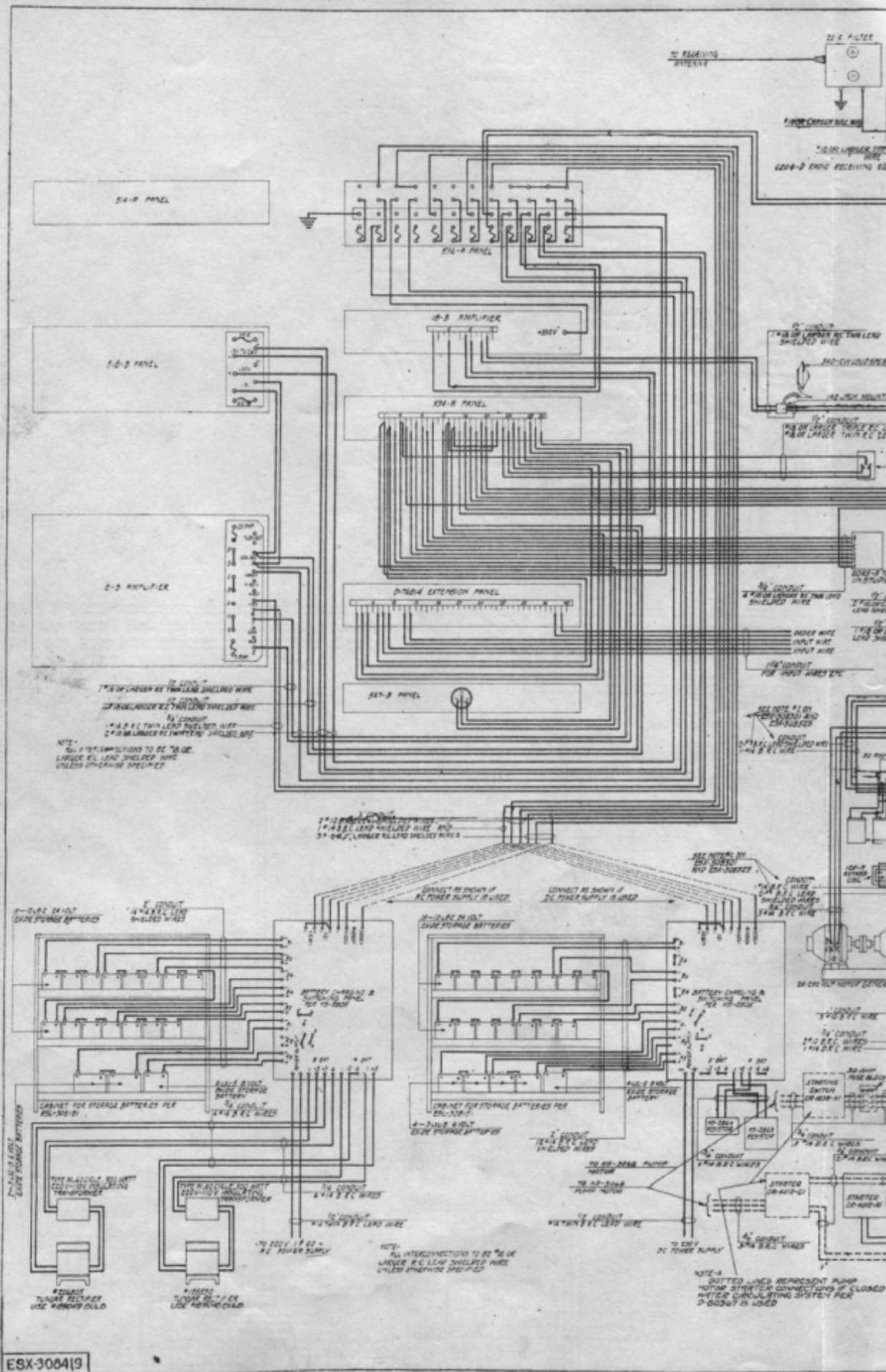

54-B PANEL

50-B PANEL

50-A AMPLIFIER

50-B PANEL

50-B AMPLIFIER

50-A EXTENSION PANEL

50-B PANEL

NOTE: 1/4\"/>

1/4\"/>

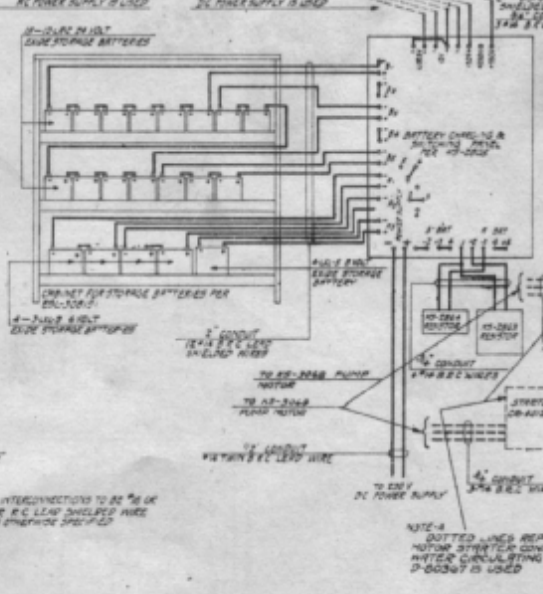
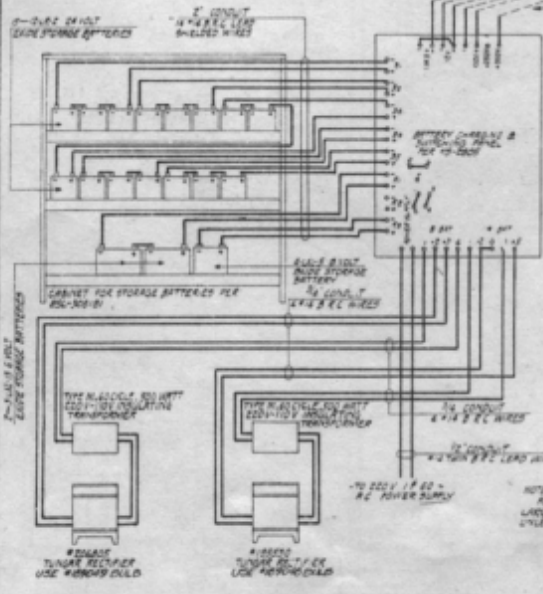

TO 234-A PANEL TERMINAL 19
 TO 234-A PANEL TERMINAL 17
 TO 234-A PANEL TERMINAL 18
 TO 234-A PANEL TERMINAL 19

TO BE USED WITH ALL G-R RADIO TRANSMITTERS
 SUPPLIED UP TO AND INCLUDING SERIAL NUMBER 114,
 AND OMITTED THEREAFTER

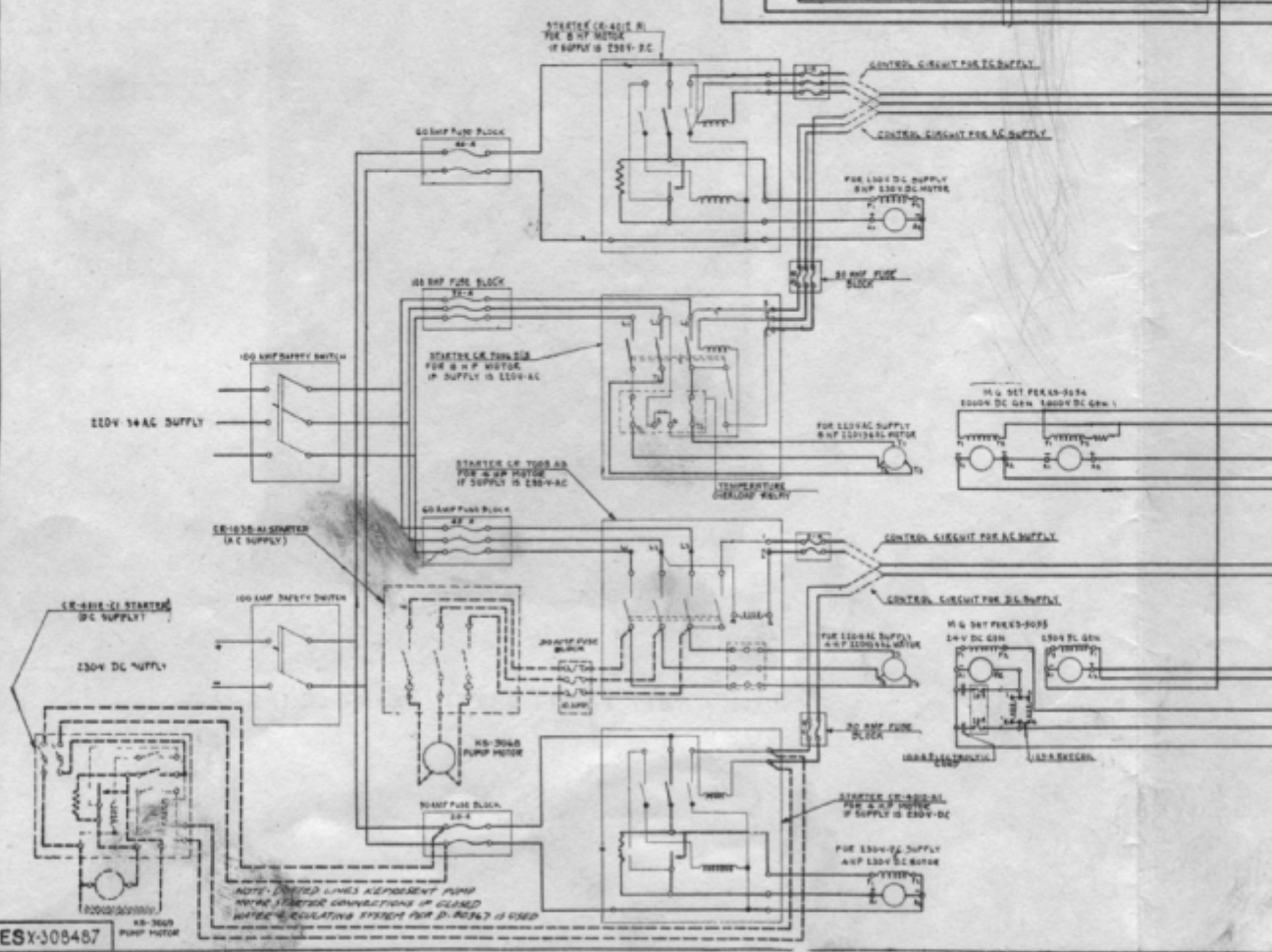
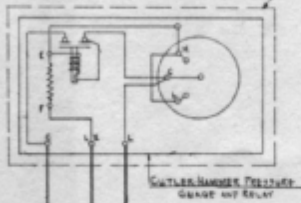

ESX-308487

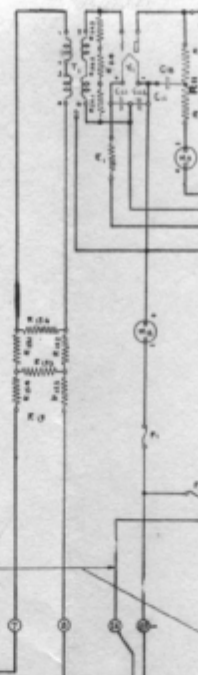

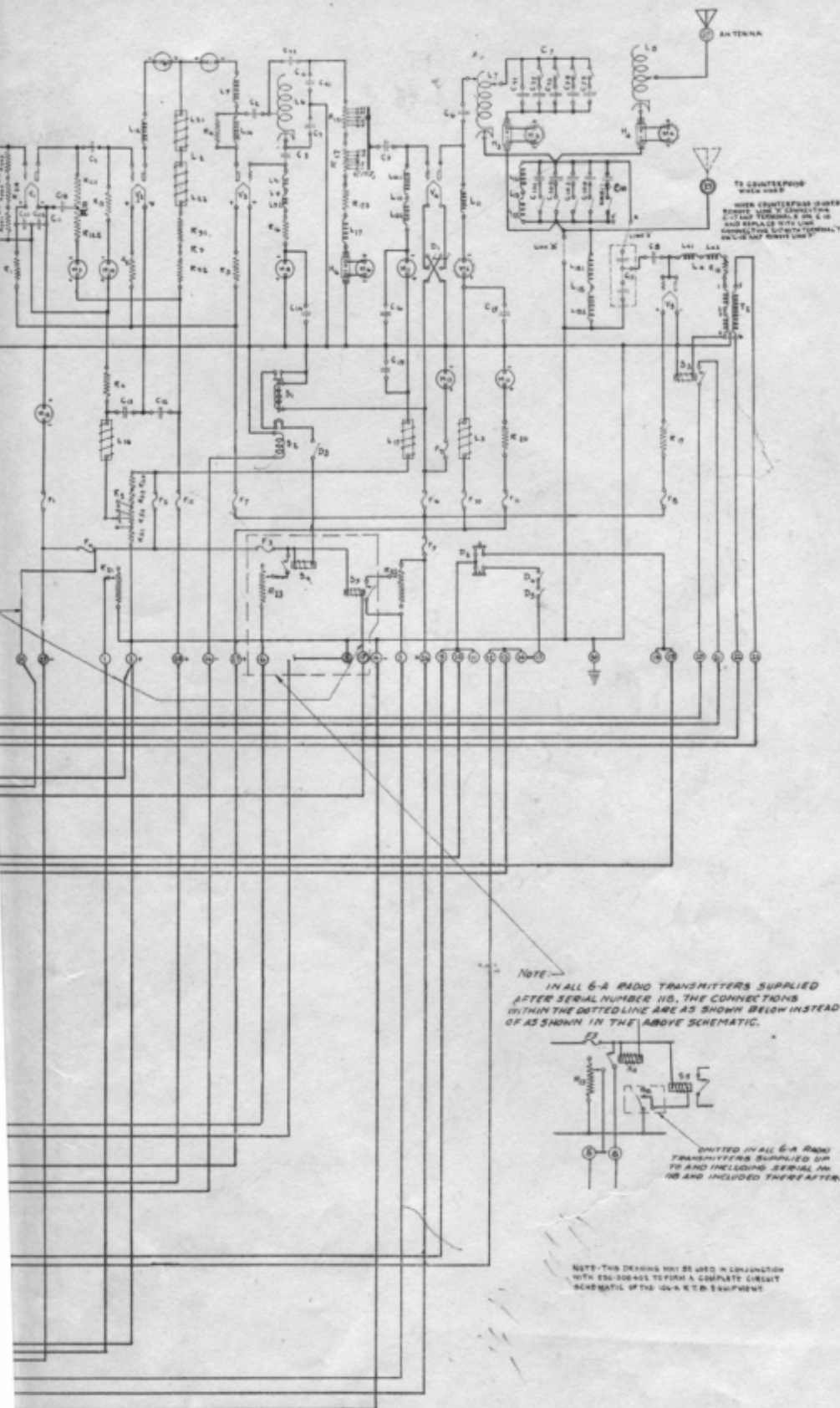

TO COUNTERPOISE LEADS
WITH WIRE

WITH COUNTERPOISE LEADS
REMOVE WIRE Y CONNECTION
C-1 AND TERMINAL Y ON 6-10
AND REPLACE WITH LEAD
ACCORDING TO WIRE TERMINAL
Y IN LEAD RIGHT UNIT

Note
IN ALL 6-A RADIO TRANSMITTERS SUPPLIED
AFTER SERIAL NUMBER 108, THE CONNECTIONS
WITHIN THE DOTTED LINE ARE AS SHOWN BELOW INSTEAD
OF AS SHOWN IN THE ABOVE SCHEMATIC.

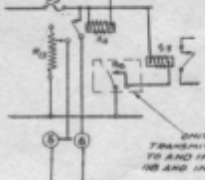

SHIPPED IN ALL 6-A RADIO
TRANSMITTERS SUPPLIED UP
TO AND INCLUDING SERIAL NO.
108 AND INCLUDED THEREAFTER

Note: This drawing may be used in conjunction
with ESX-308481 to form a complete circuit
schematic of the 106-A R.T.B. equipment

TRANSMITTER AND POWER EQUIPMENT SCHEMATIC—ESX-308487

GROUND SYSTEM REF. ESX-308480
CONDUIT-120-V-AC REF. ESX-308201
CONDUIT-120-V-DC REF. ESX-308729
WIRING DIAGRAM REF. ESX-308419
SCHEMATIC THE SLE REF. ESX-308402

106-A RADIO TELEPHONE
BROADCASTING EQUIPMENT
TRANSMITTER AND POWER
EQUIPMENT SCHEMATIC
SCALE

106-A
106-B
106-C
106-D
106-E
106-F
106-G
106-H
106-I
106-J
106-K
106-L
106-M
106-N
106-O
106-P
106-Q
106-R
106-S
106-T
106-U
106-V
106-W
106-X
106-Y
106-Z

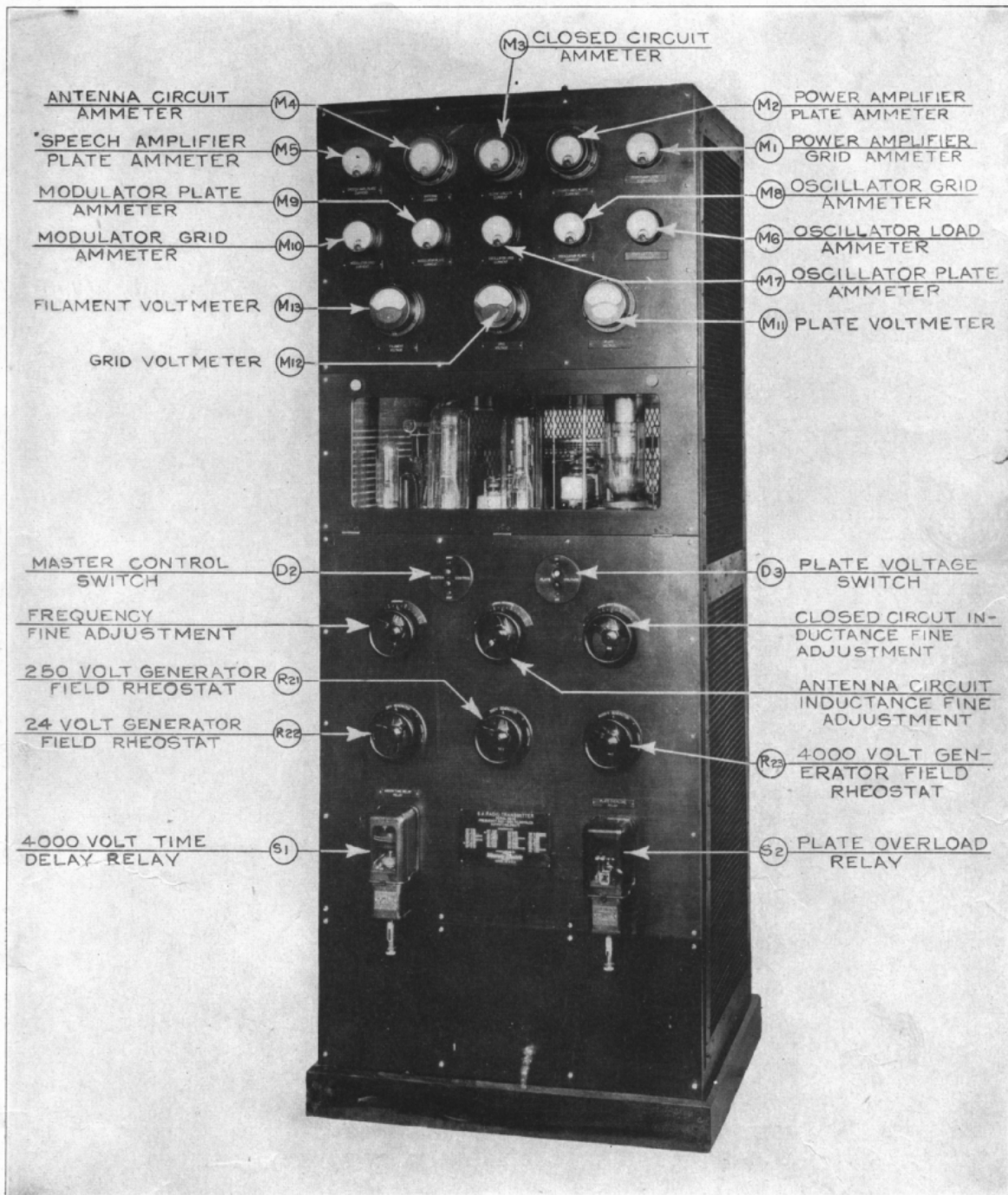

6-A RADIO TRANSMITTER FRONT VIEW—25453

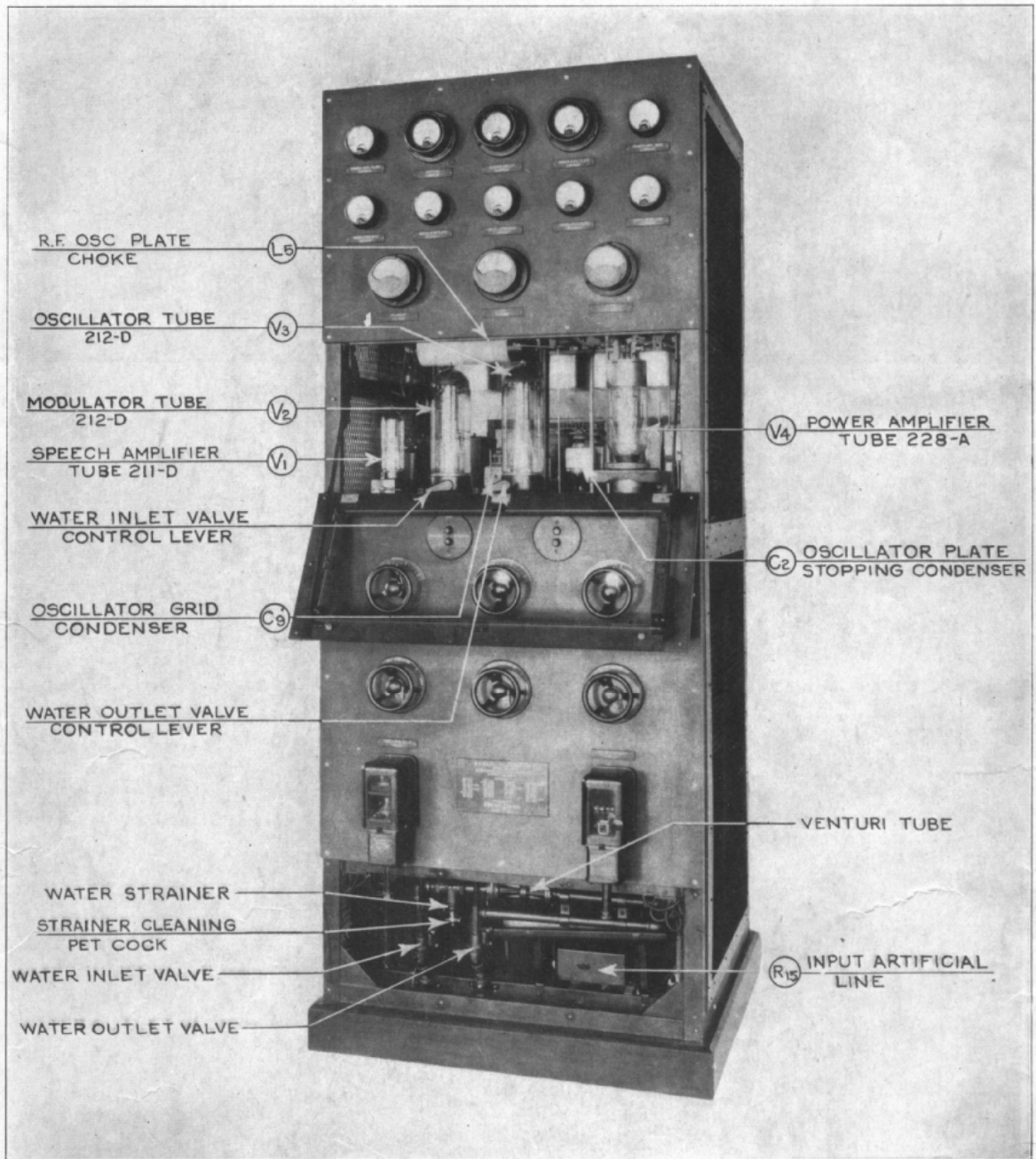

6-A RADIO TRANSMITTER FRONT VIEW (OPEN)—25452

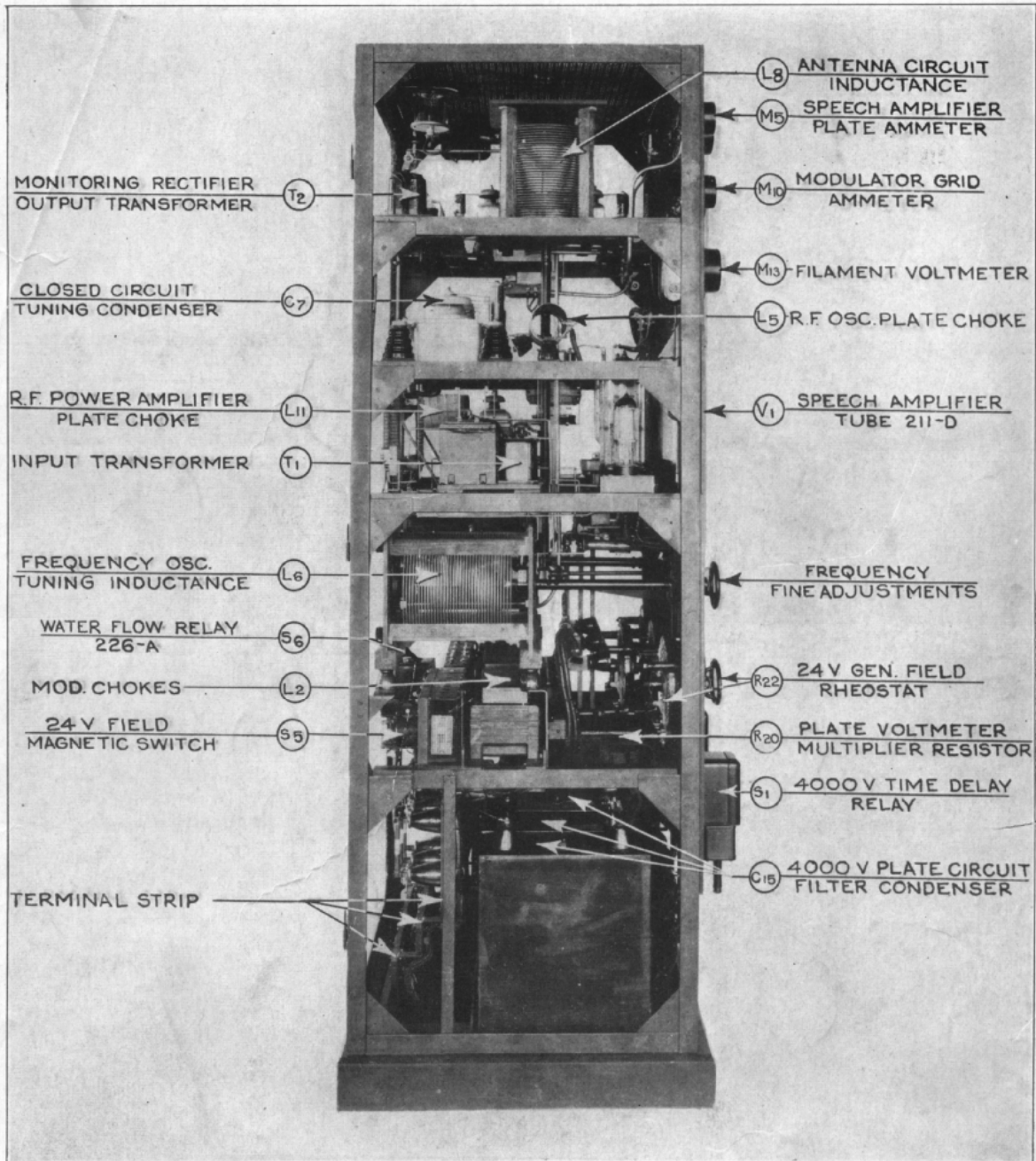

6-A RADIO TRANSMITTER LEFT SIDE (SCREENS OFF)—25454

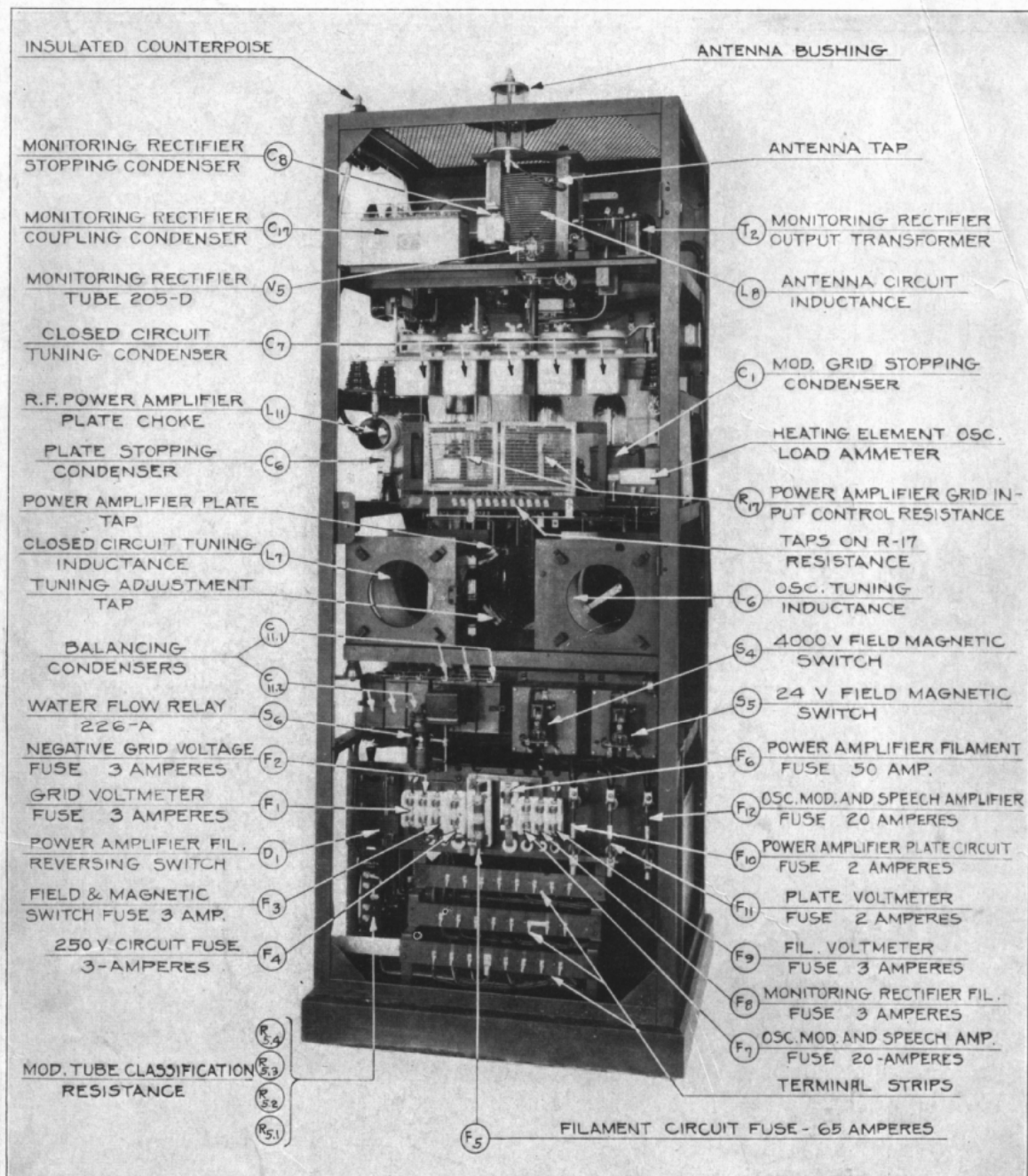

6-A RADIO TRANSMITTER REAR-25457

CLOSED CIRCUIT TUNING
CONDENSERS

C7

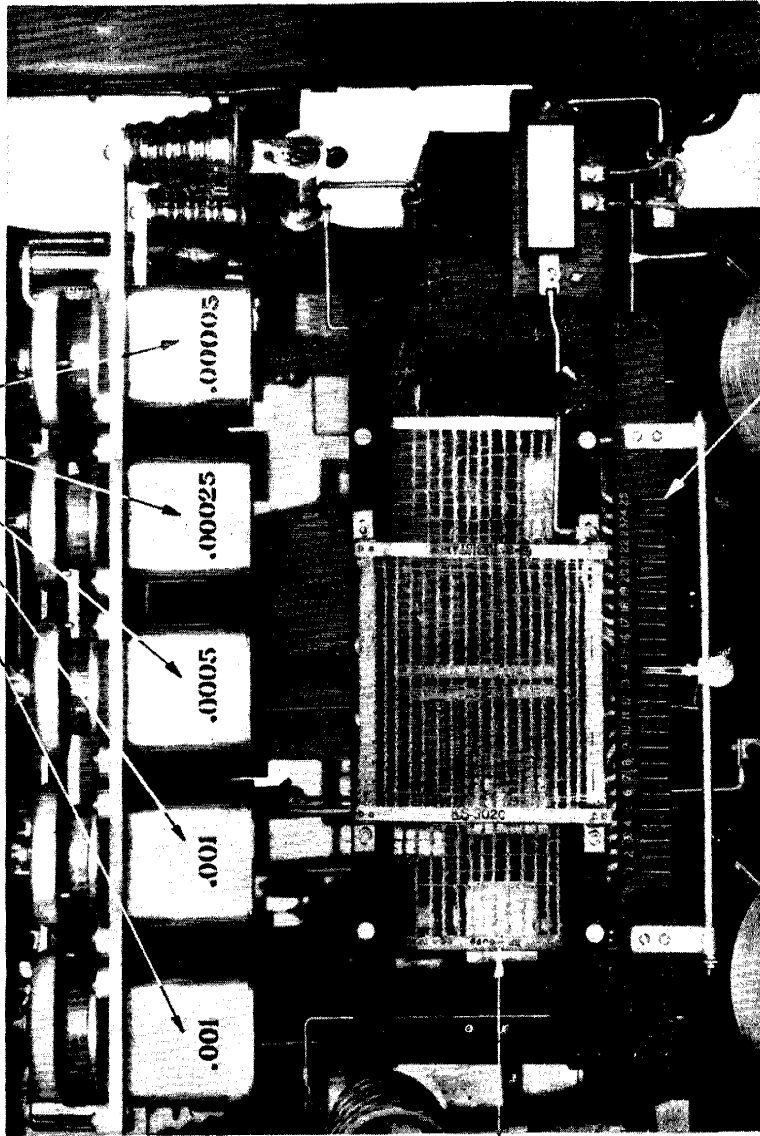

R17 POWER AMPLIFIER GRID INPUT CONTROL
RESISTANCE - 500-1000 WATT OUTPUT

TAPS ON R17 RESISTANCE

6-A RADIO TRANSMITTER REAR VIEW (UPPER SECTION) - 25450

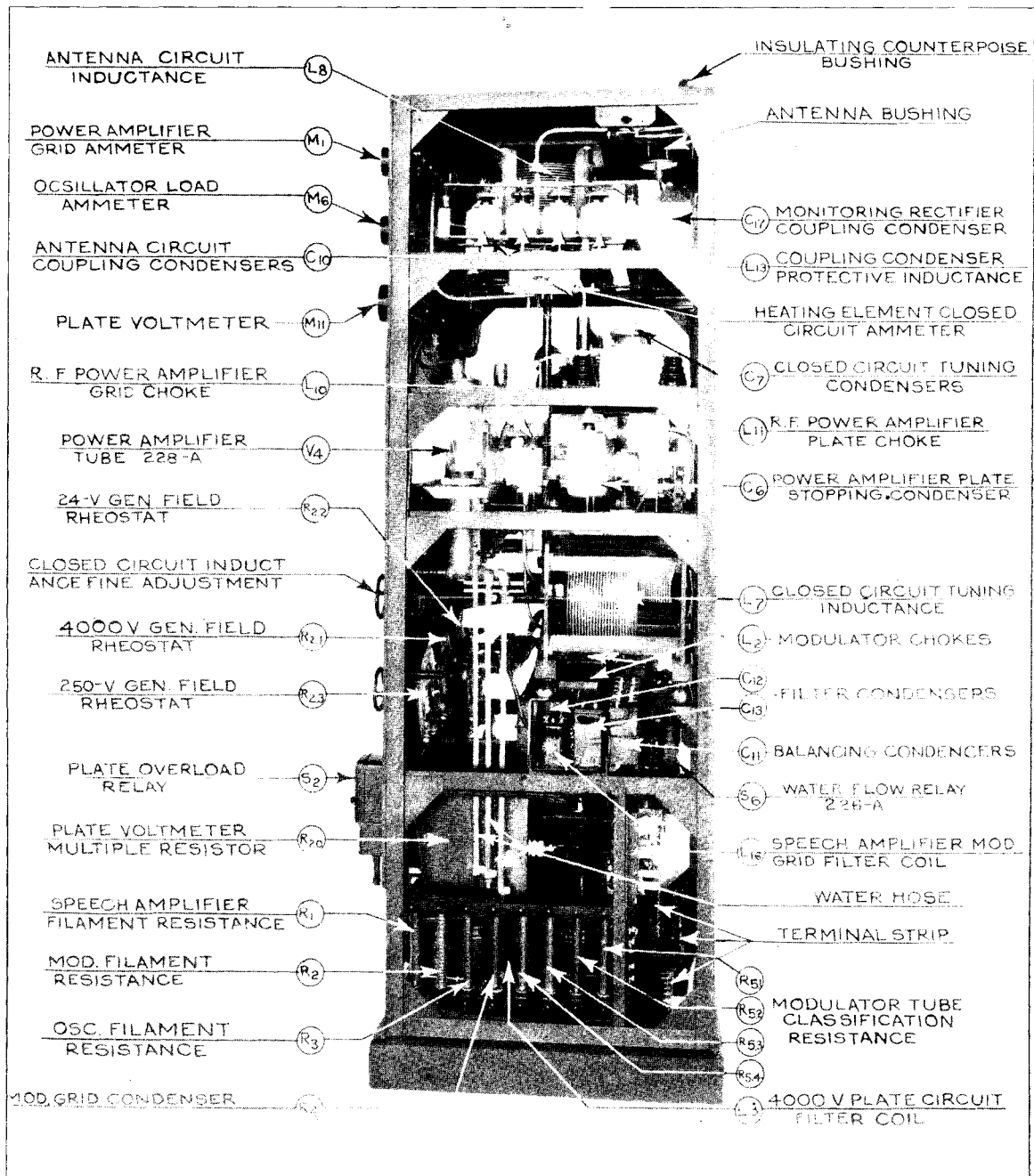

6-A RADIO TRANSMITTER RIGHT SIDE (SCREENS OFF)—25455

ANTENNA CIRCUIT
INDUCTANCE L8

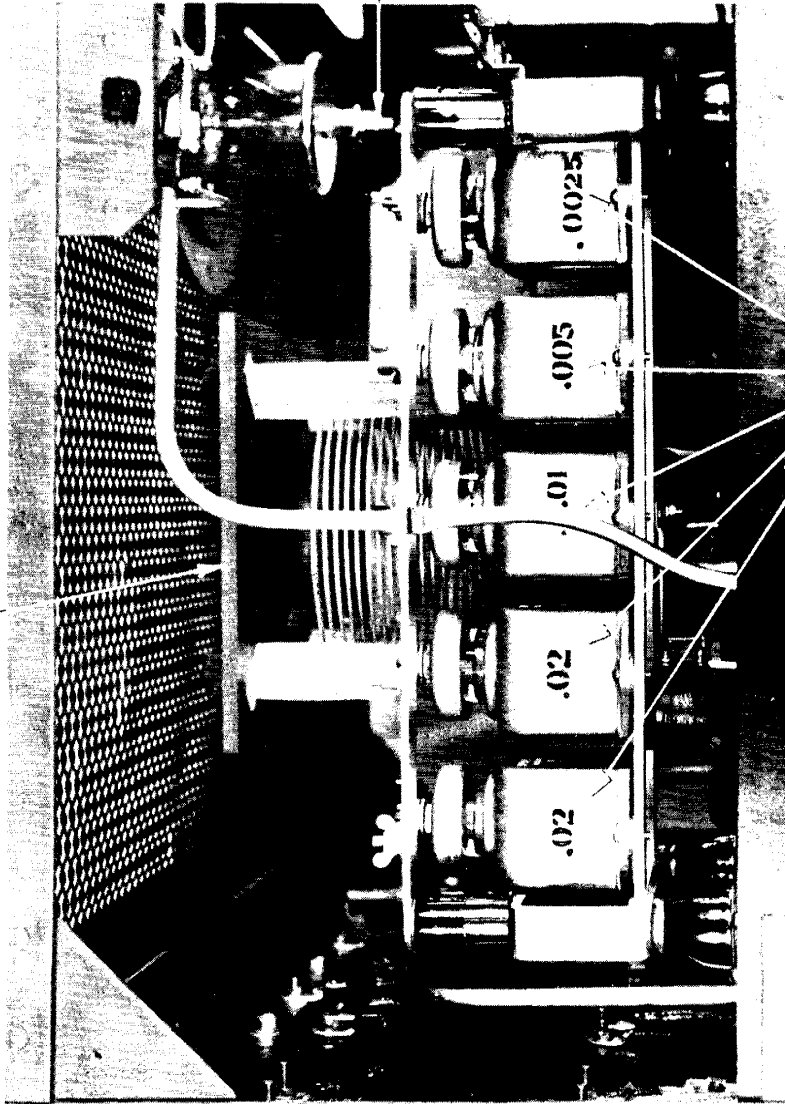

ANTENNA
BUSHING

ANTENNA CIRCUIT COUPLING
CONDENSERS

6-A RADIO TRANSMITTER RIGHT SIDE (UPPER SECTION)—25451

NOTE

Pages 76, 77 and 78 each show the Schematic Wiring Diagram of the 6-A Radio Transmitter. These diagrams vary in the following details:

Page 76 shows the 6-A Transmitter equipped with the Pressure Relay and Resistance R_{23} connected to Terminal 6.

Page 77 shows the 6-A Transmitter equipped with type 226-A Relay and Resistance R_{23} connected to ground through Terminal 30.

Page 78 shows the 6-A Transmitter connected in the same manner as page 77 with the following additions:—

R_{17} has been modified to include 25 taps for adjustment of power output between 500 and 1000 watts.

C_{10} has been modified to include five condenser units of the following values:—.02, .02, .01, .005, .0025.

The modifications noted, with the exception perhaps of R_{23} , can be readily discerned and should be used as a guide in applying the schematic wiring diagram to any particular transmitter. In the case of R_{23} this change is incorporated in all transmitters serial #119 and higher.

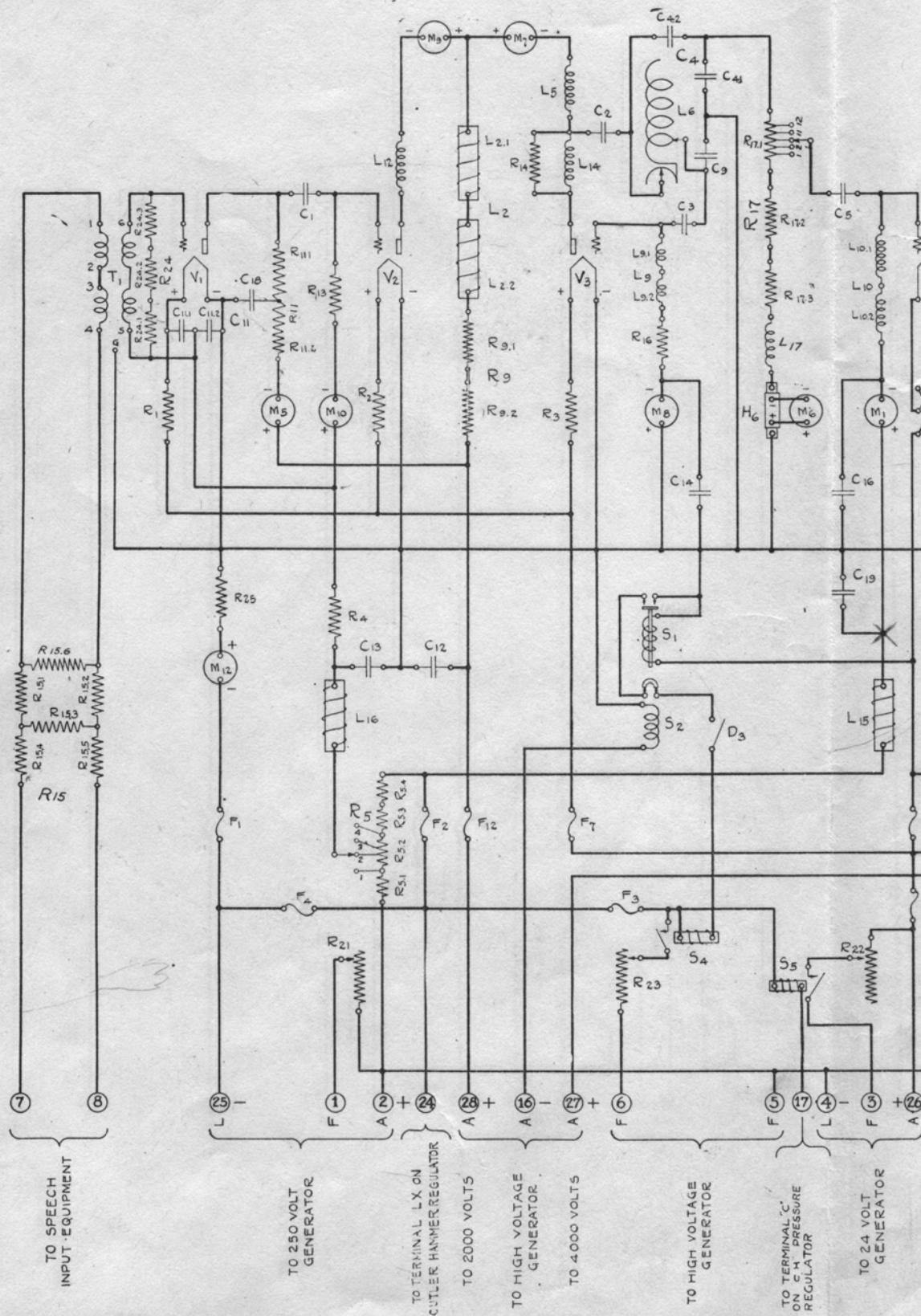

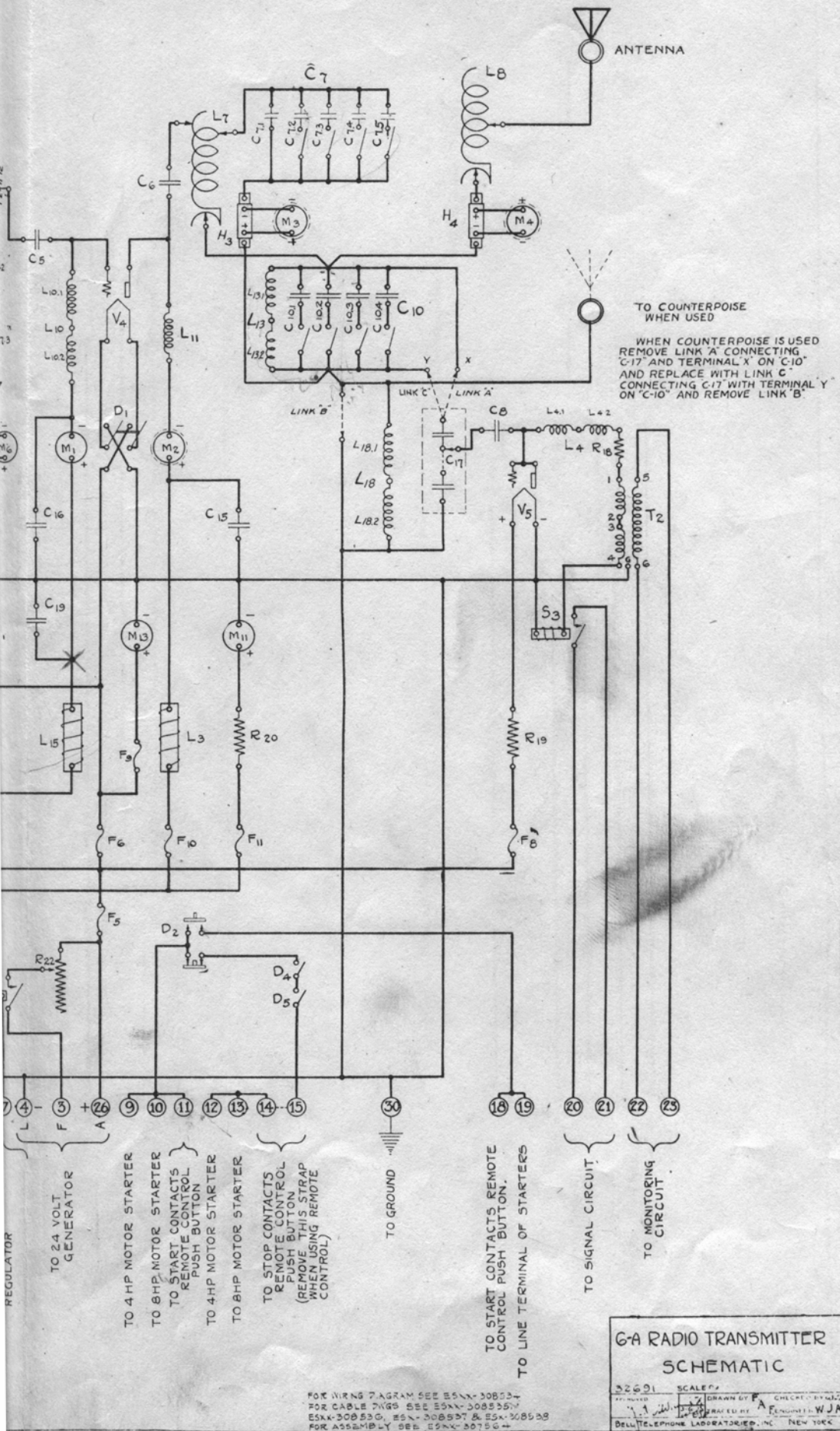

6-A RADIO TRANSMITTER SCHEMATIC

FOR WIRING DIAGRAM SEE ESK-30853
 FOR CABLE DIAGS SEE ESK-30853
 ESK-30853G, ESK-30853T & ESK-30853B
 FOR ASSEMBLY SEE ESK-30756-4

32591 SCALE: 1/2"
 DRAWN BY: CHICK
 CHECKED BY: WJA
 BELL TELEPHONE LABORATORIES, INC. NEW YORK

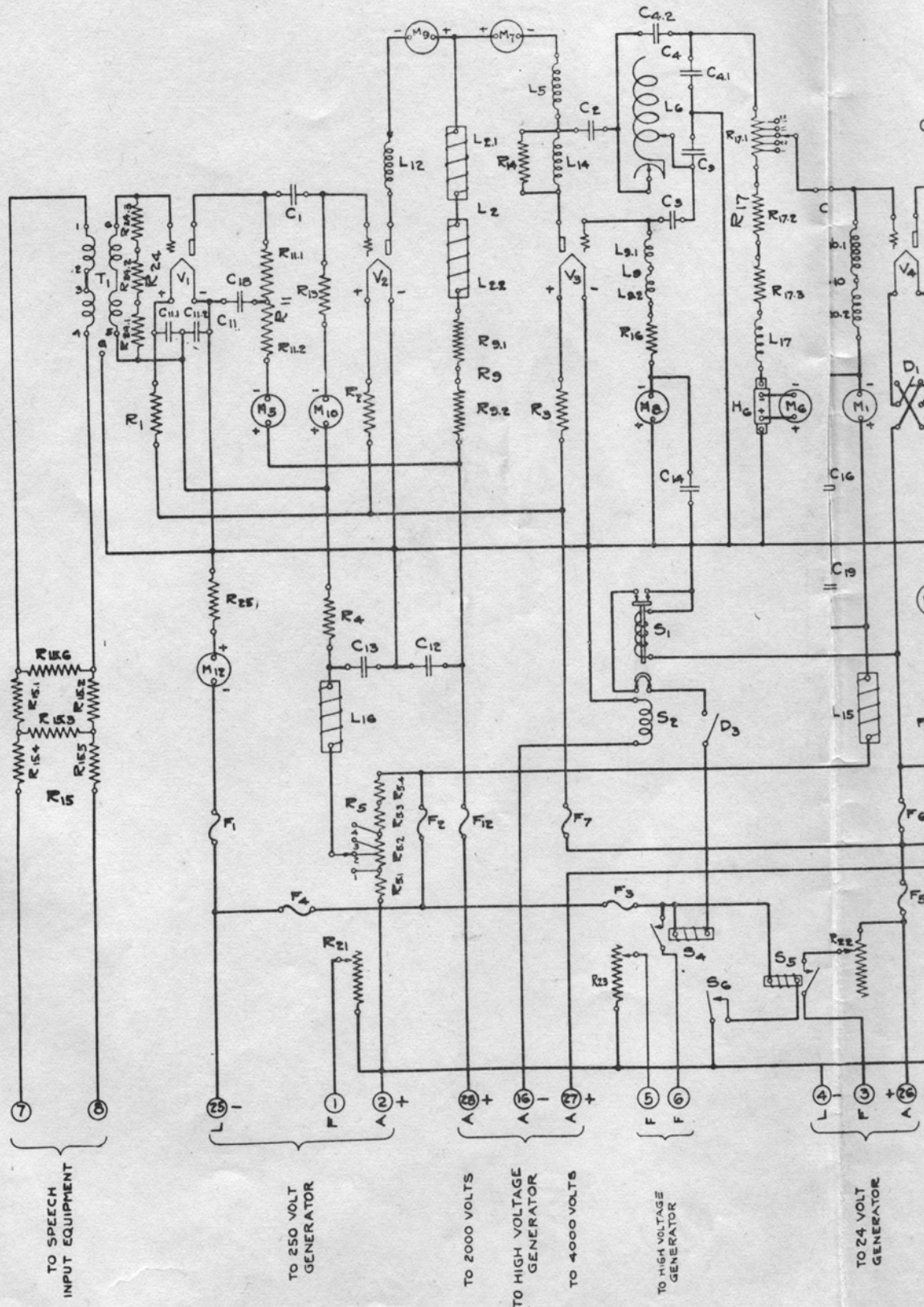

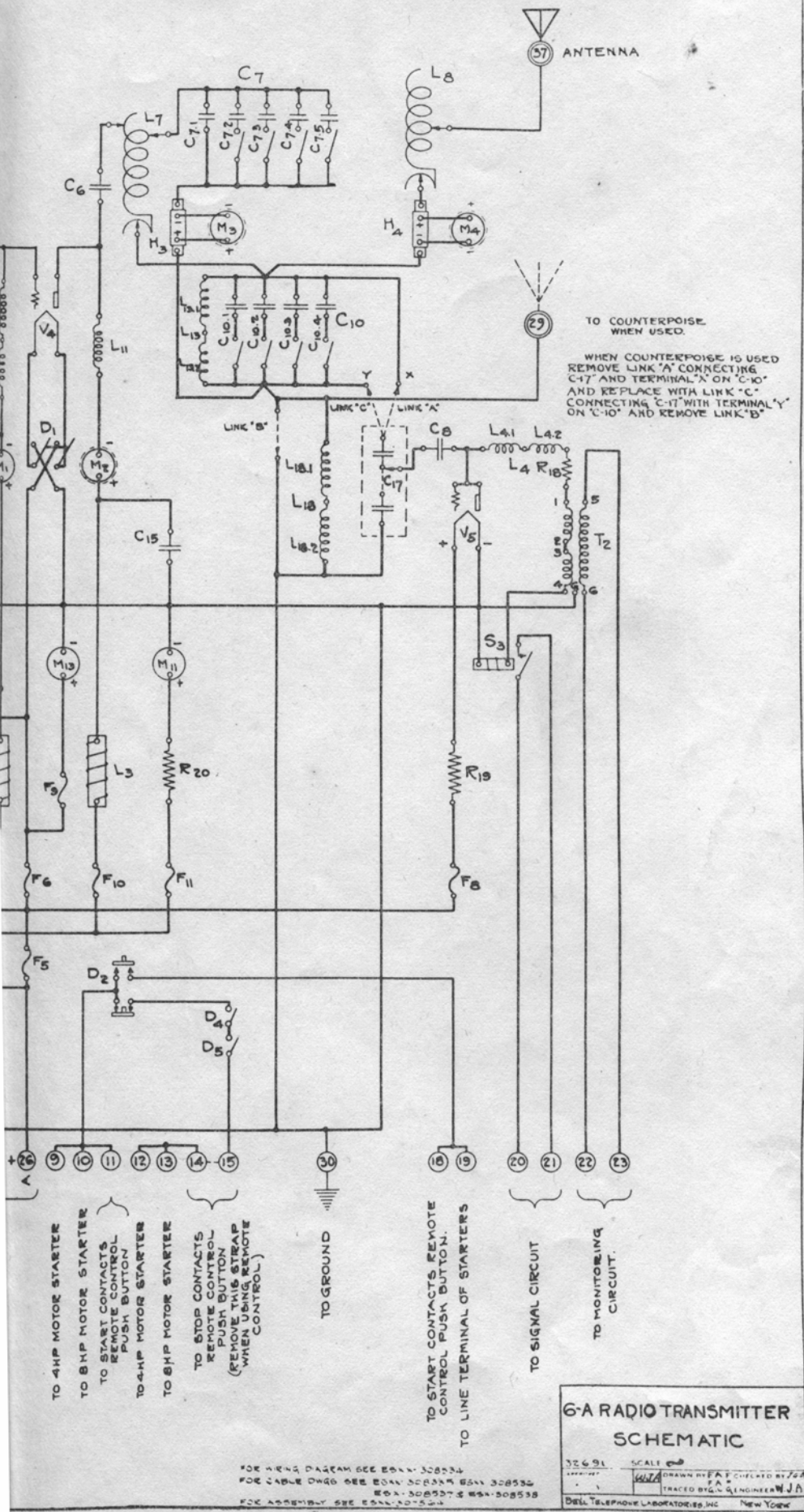

TO COUNTERPOISE WHEN USED.

WHEN COUNTERPOISE IS USED REMOVE LINK 'A' CONNECTING C-17 AND TERMINAL 'X' ON 'C-10' AND REPLACE WITH LINK 'C' CONNECTING 'C-17' WITH TERMINAL 'Y' ON 'C-10' AND REMOVE LINK 'B'

TO 4HP MOTOR STARTER
 TO 8HP MOTOR STARTER
 TO START CONTACTS REMOTE CONTROL PUSH BUTTON
 TO 4HP MOTOR STARTER
 TO 8HP MOTOR STARTER
 TO STOP CONTACTS REMOTE CONTROL PUSH BUTTON (REMOVING LAMP STRIP WHEN IN REMOTE CONTROL)

TO START CONTACTS REMOTE CONTROL PUSH BUTTON.
 TO LINE TERMINAL OF STARTERS

TO SIGNAL CIRCUIT
 TO MONITORING CIRCUIT.

6-A RADIO TRANSMITTER SCHEMATIC

32691 SCALE 1/8" = 1"

DESIGNED BY E. A. F. CHECKED BY J. G. W. J. A.
 TRACED BY G. G. QUINCY W. J. A.

DELL TELEPHONE LABORATORIES, INC. NEW YORK

FOR WIRING DIAGRAM SEE BOM 308534
 FOR CABLE DWG SEE BOM 308535 BOM 308536
 BOM 308537 & BOM 308538
 FOR ASSEMBLY SEE BOM 308539

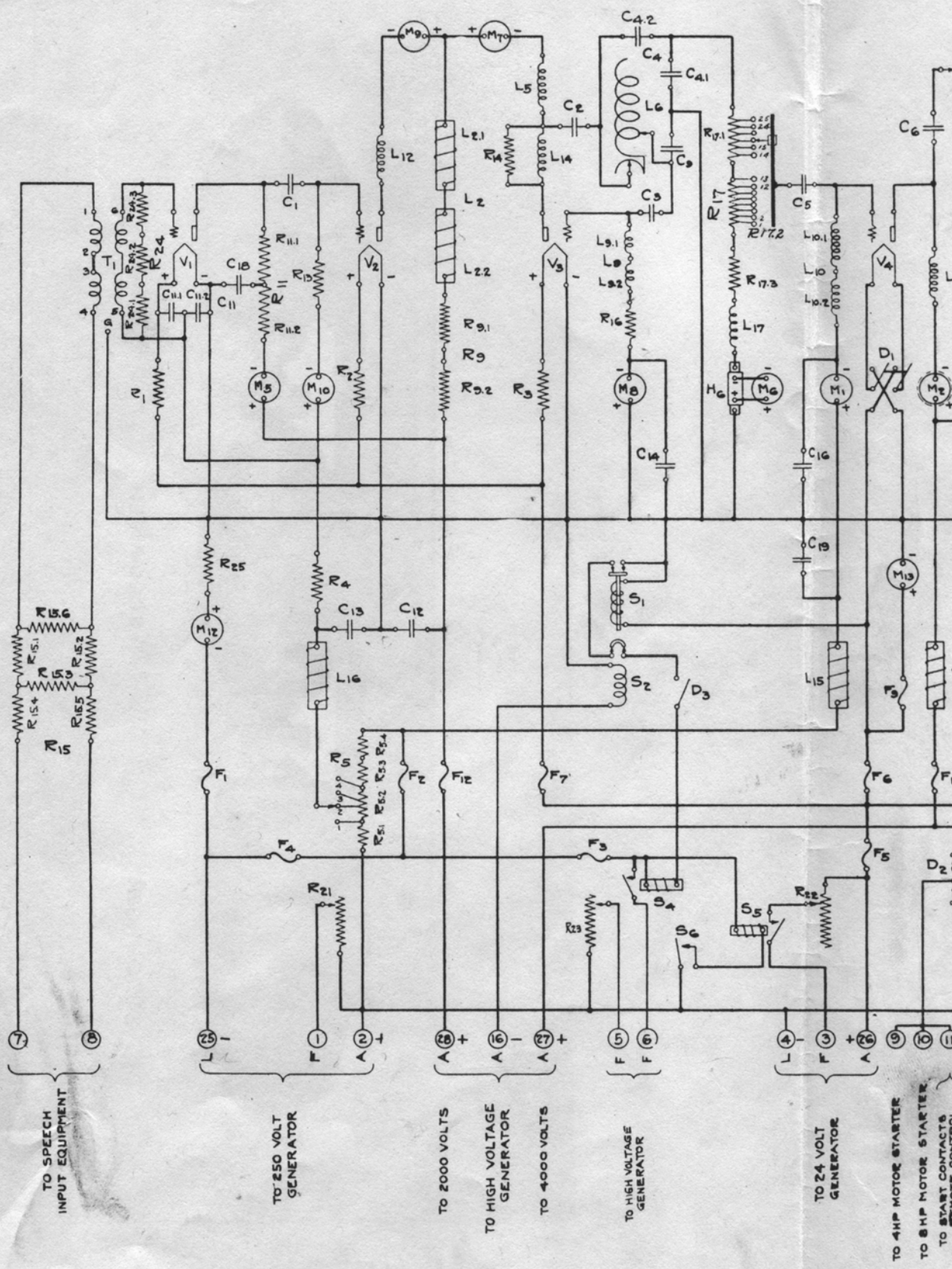

E6R307849

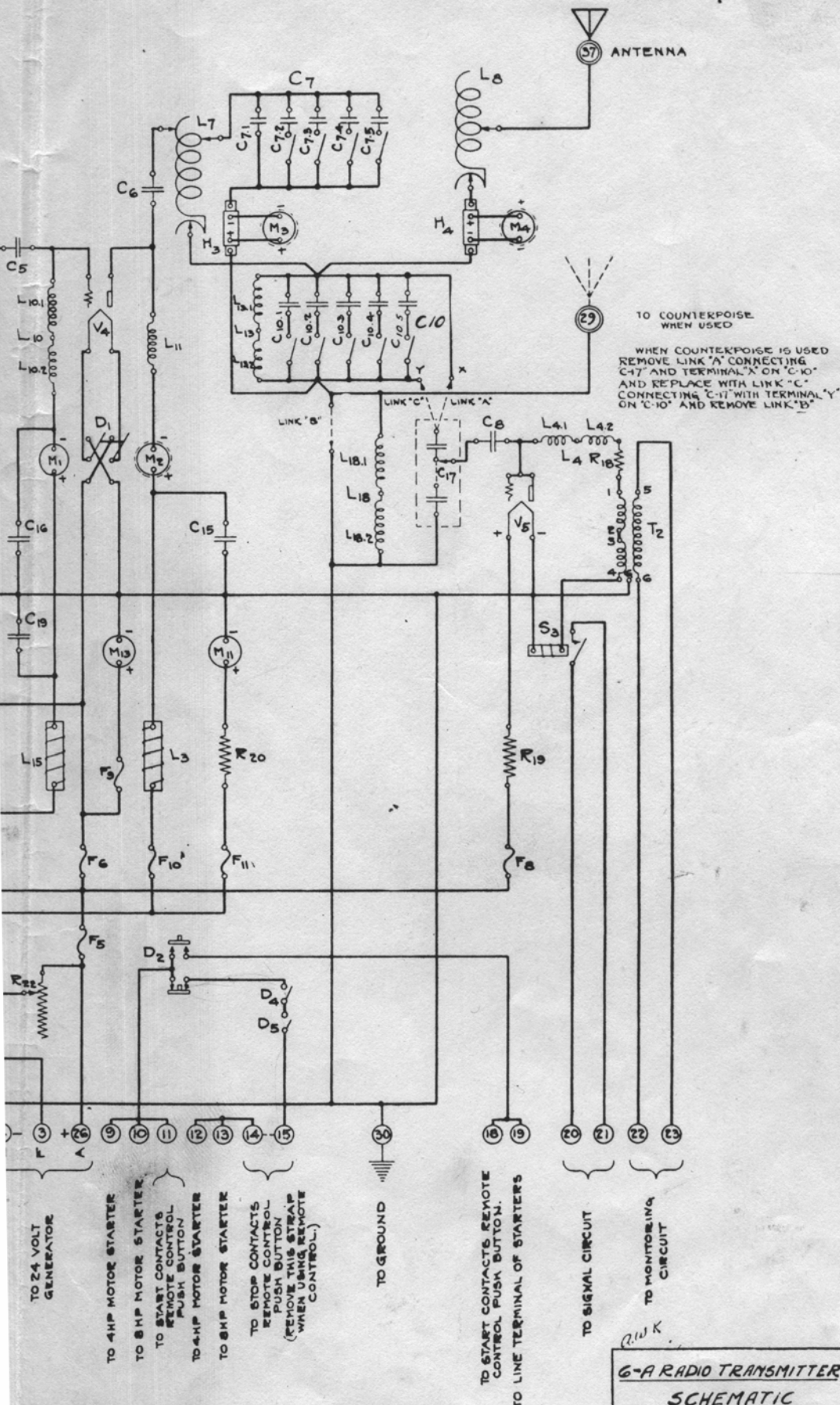

TO COUNTERPOISE WHEN USED

WHEN COUNTERPOISE IS USED REMOVE LINK 'A' CONNECTING C-7 AND TERMINAL 'X' ON 'C-10' AND REPLACE WITH LINK 'C' CONNECTING 'C-7' WITH TERMINAL 'Y' ON 'C-10' AND REMOVE LINK 'B'

TO 24 VOLT GENERATOR

TO 4HP MOTOR STARTER

TO 8HP MOTOR STARTER

TO START CONTACTS REMOTE CONTROL PUSH BUTTON

TO 4HP MOTOR STARTER

TO 8HP MOTOR STARTER

TO STOP CONTACTS REMOTE CONTROL PUSH BUTTON (REMOVING THIS STRAP WHEN USING REMOTE CONTROL)

TO GROUND

TO START CONTACTS REMOTE CONTROL PUSH BUTTON.

TO LINE TERMINAL OF STARTERS

TO SIGNAL CIRCUIT

TO MONITORING CIRCUIT

6-A RADIO TRANSMITTER SCHEMATIC

FOR WIRING DIAGRAM, SEE ESNL 308534
 FOR CABLE DWG., SEE ESNL 308535, ESNL 308536
 L.A. 30770 ESNL 308537 & ESNL 308538
 FOR ASSEMBLY SEE ESNL 307364

33360	SCALE 0"
40.3	W.A. HENNING
	DESIGNED BY TELE. CHECKER BELL
	DESIGNED BY SCHUMER W.A.
	BELL TELEPHONE LABORATORIES, INC.

MOTOR

2000-V GEN.

2000-V GEN.

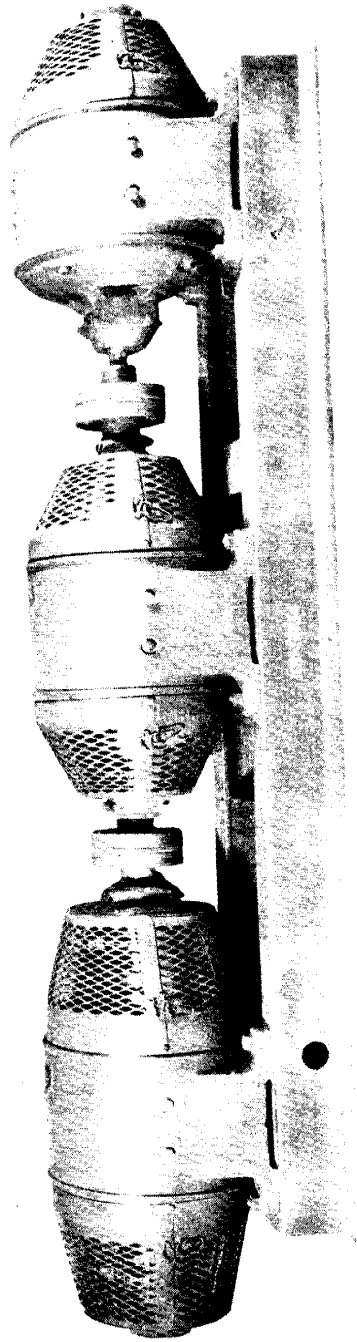

KS-5054 MOTOR GENERATOR—22734

MOTOR

24-V GEN.

250-V GEN.

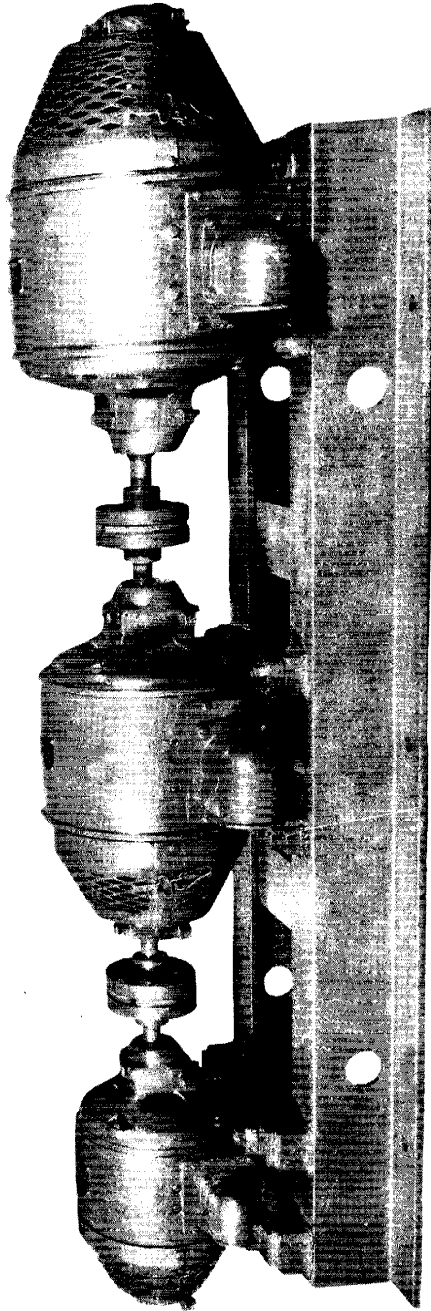

KS-5055 MOTOR GENERATOR—22733

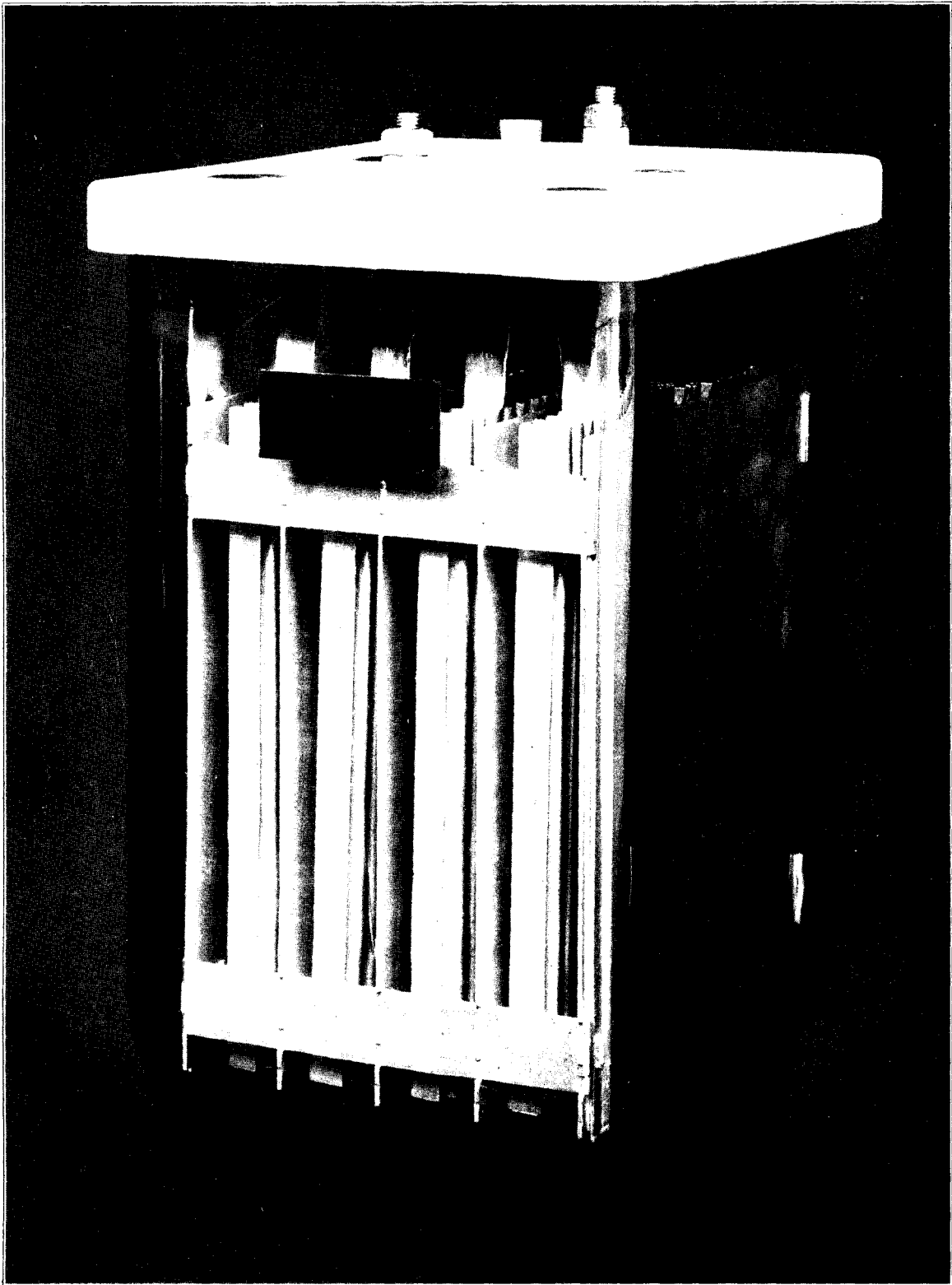

100-A ELECTROLYTIC FILTER CONDENSER—22737

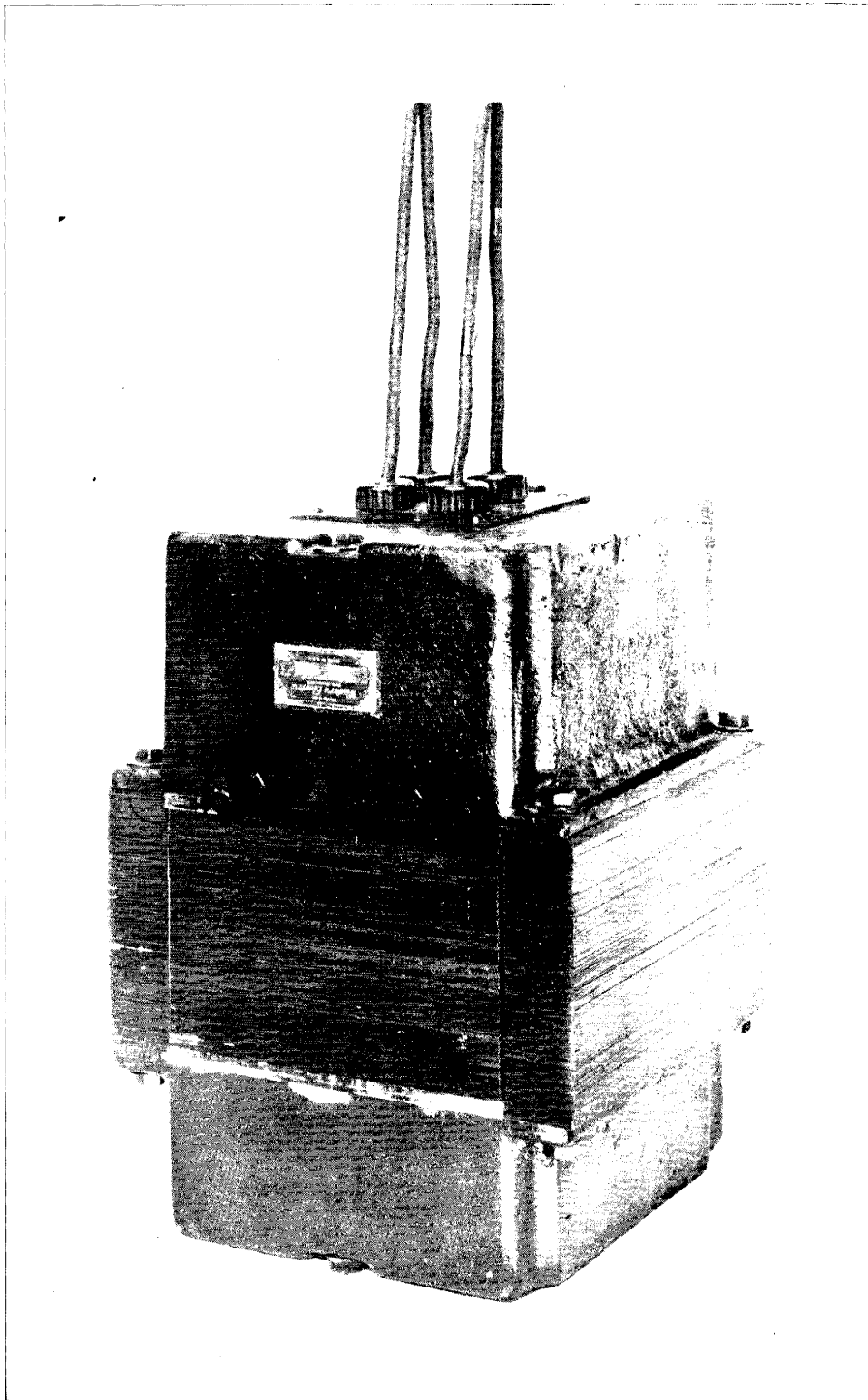

125-A RETARD COIL—22736

SYSTEMS FOR CONTROLLING OF WATER SYSTEMS SHOWN IN FIGURE 2

	A	B	C	D	E	F	G	H
WATER SUPPLY	OPEN	OPEN	OPEN	OPEN	OPEN	OPEN	OPEN	OPEN
WATER FLOW	OPEN	OPEN	OPEN	OPEN	OPEN	OPEN	OPEN	OPEN
WATER PRESSURE	OPEN	OPEN	OPEN	OPEN	OPEN	OPEN	OPEN	OPEN
WATER TEMPERATURE	OPEN	OPEN	OPEN	OPEN	OPEN	OPEN	OPEN	OPEN
WATER QUALITY	OPEN	OPEN	OPEN	OPEN	OPEN	OPEN	OPEN	OPEN
WATER PHOSPHORUS	OPEN	OPEN	OPEN	OPEN	OPEN	OPEN	OPEN	OPEN
WATER PHOSPHORUS	OPEN	OPEN	OPEN	OPEN	OPEN	OPEN	OPEN	OPEN
WATER PHOSPHORUS	OPEN	OPEN	OPEN	OPEN	OPEN	OPEN	OPEN	OPEN
WATER PHOSPHORUS	OPEN	OPEN	OPEN	OPEN	OPEN	OPEN	OPEN	OPEN
WATER PHOSPHORUS	OPEN	OPEN	OPEN	OPEN	OPEN	OPEN	OPEN	OPEN
WATER PHOSPHORUS	OPEN	OPEN	OPEN	OPEN	OPEN	OPEN	OPEN	OPEN
WATER PHOSPHORUS	OPEN	OPEN	OPEN	OPEN	OPEN	OPEN	OPEN	OPEN
WATER PHOSPHORUS	OPEN	OPEN	OPEN	OPEN	OPEN	OPEN	OPEN	OPEN
WATER PHOSPHORUS	OPEN	OPEN	OPEN	OPEN	OPEN	OPEN	OPEN	OPEN

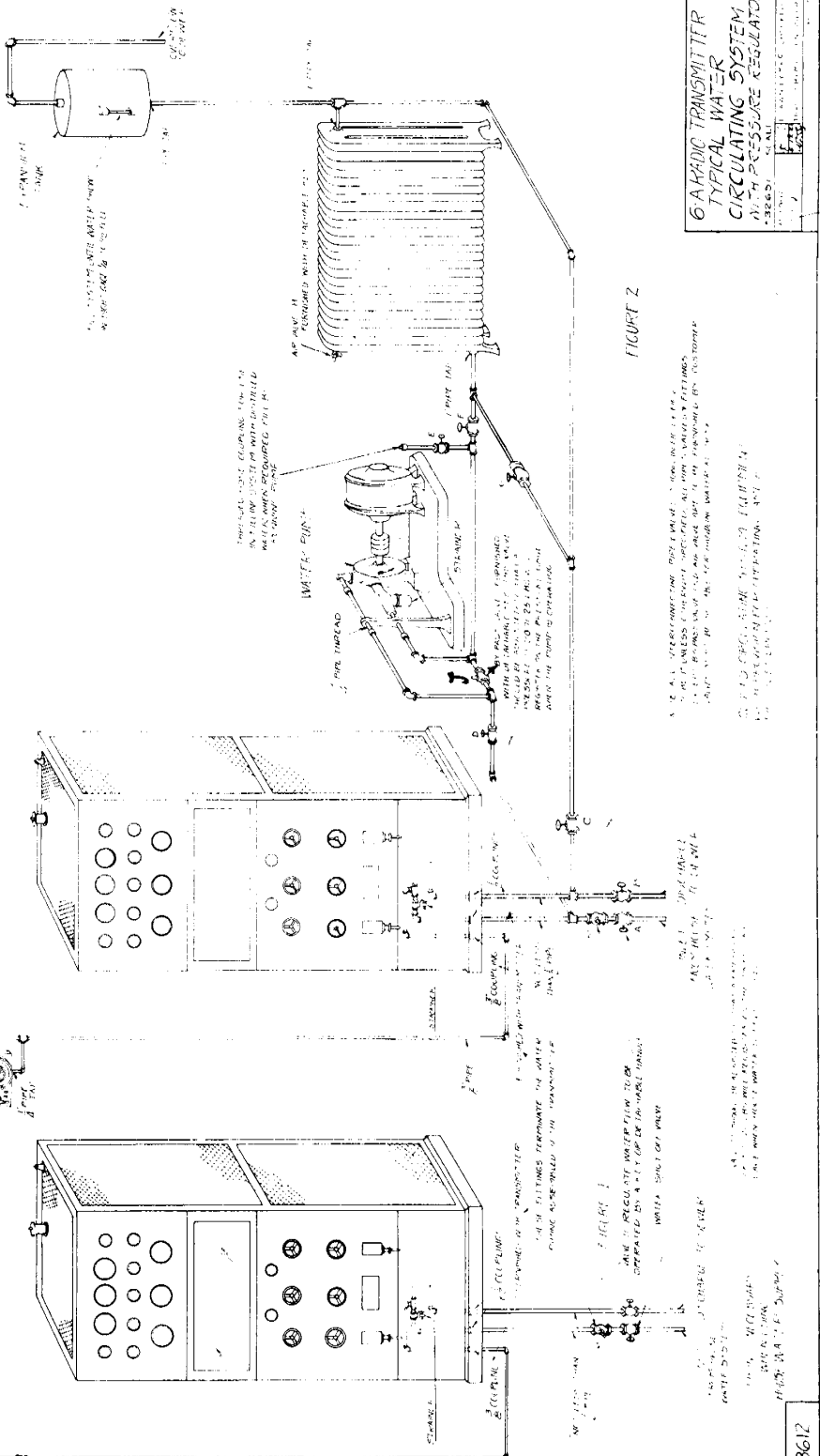

FIGURE 2

THIS SYSTEM IS A TYPICAL EXAMPLE OF A WATER SYSTEM WHICH IS OPERATED BY A PRESSURE REGULATING VALVE. THE WATER FLOW IS CONTROLLED BY A WATER FLOW CONTROL VALVE. THE WATER LEVEL IS CONTROLLED BY A WATER LEVEL CONTROL VALVE. THE WATER METER IS USED TO MEASURE THE WATER FLOW. THE WATER FILTER IS USED TO REMOVE ANY DEBRIS FROM THE WATER. THE WATER DISTRIBUTION SYSTEM IS USED TO DELIVER THE WATER TO THE POINTS OF USE. THE STEAMING UNIT IS USED TO HEAT THE WATER. THE WATER PUMP IS USED TO CIRCULATE THE WATER THROUGH THE SYSTEM.

GAMADO TRANSMITTER
TYPICAL WATER
CIRCULATING SYSTEM
WITH PRESSURE REGULATOR

ES0 308612

TYPICAL WATER CIRCULATING SYSTEM—ES0 308612

ADJUSTABLE CONTACTS

MOVABLE ARM

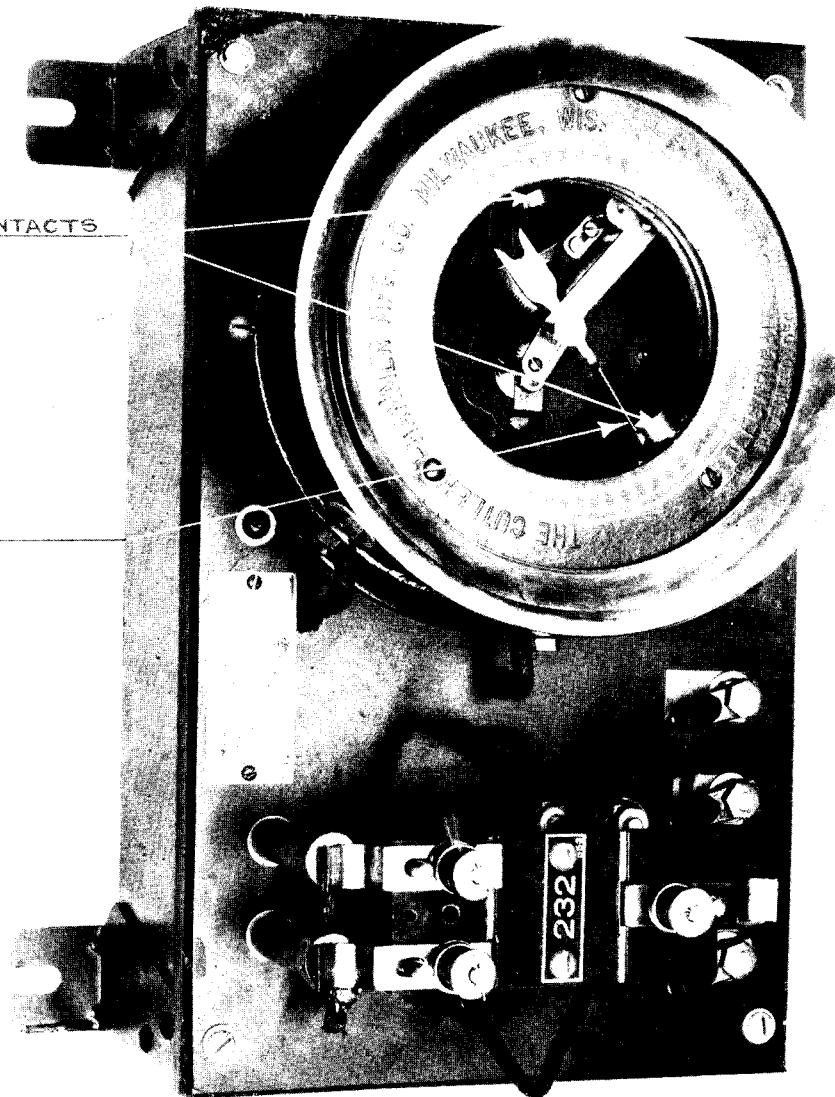

KS-3070 PRESSURE REGULATOR—22735

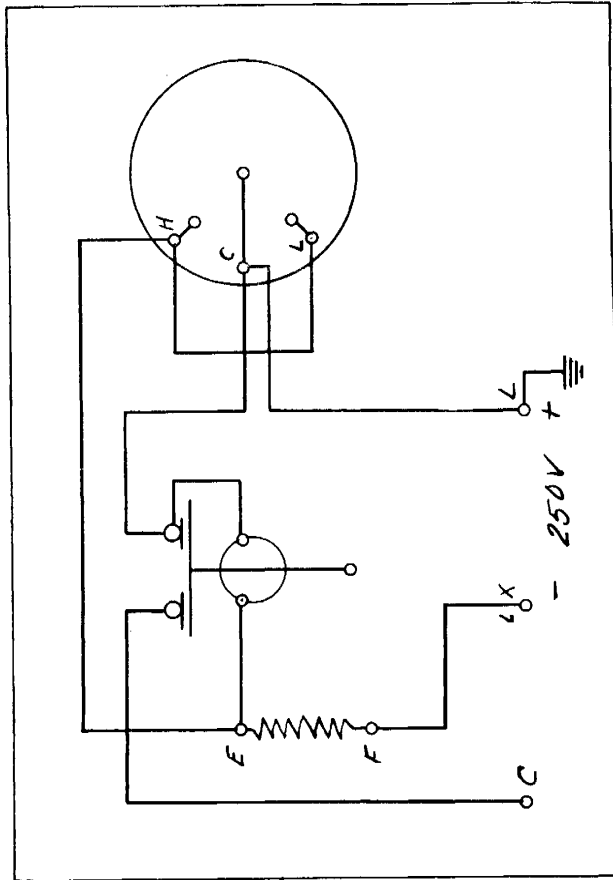

6-A RADIO TRANSMITTER
 MODIFIED SCHEMATIC FOR
 CUTLER HAMMER PRESSURE REGULATOR

32691 SCALE

APPROVED: *[Signature]* DRAWN BY: *[Signature]* CHECKED BY: *[Signature]*
 TRACED BY: *[Signature]* ENGINEER: H. V.
 BELL TELEPHONE LABORATORIES, INC. NEW YORK

CUTLER HAMMER PRESSURE REGULATOR—ESA-308177

INSTRUCTION TABLE FOR OPERATION OF VALVES SHOWN IN FIGURE 2

	A	B	C	D	E	F	G	H
WHEN OPERATING ON HOUSE WATER SUPPLY	OPEN	OPEN	CLOSE	CLOSE	CLOSE	CLOSE	CLOSE	CLOSE
WHEN OPERATING AS CLOSED CIRCUIT SYSTEM	CLOSE	CLOSE	OPEN	OPEN	OPEN	OPEN	OPEN	OPEN
TO DRAIN SYSTEM	OPEN	OPEN	CLOSE	CLOSE	CLOSE	CLOSE	CLOSE	CLOSE
TO FILL WITH DISTILLED WATER	CLOSE	CLOSE	CLOSE	CLOSE	OPEN	CLOSE	CLOSE	CLOSE
WHEN CLEANING STRAINER ON WATER PUMP	CLOSE	CLOSE	CLOSE	CLOSE	CLOSE	CLOSE	CLOSE	CLOSE
WHEN CLEANING STRAINER ON TRANSMITTER	CLOSE	CLOSE	CLOSE	CLOSE	CLOSE	CLOSE	CLOSE	CLOSE

** OPEN UNTIL EXPANATOR IS FULL

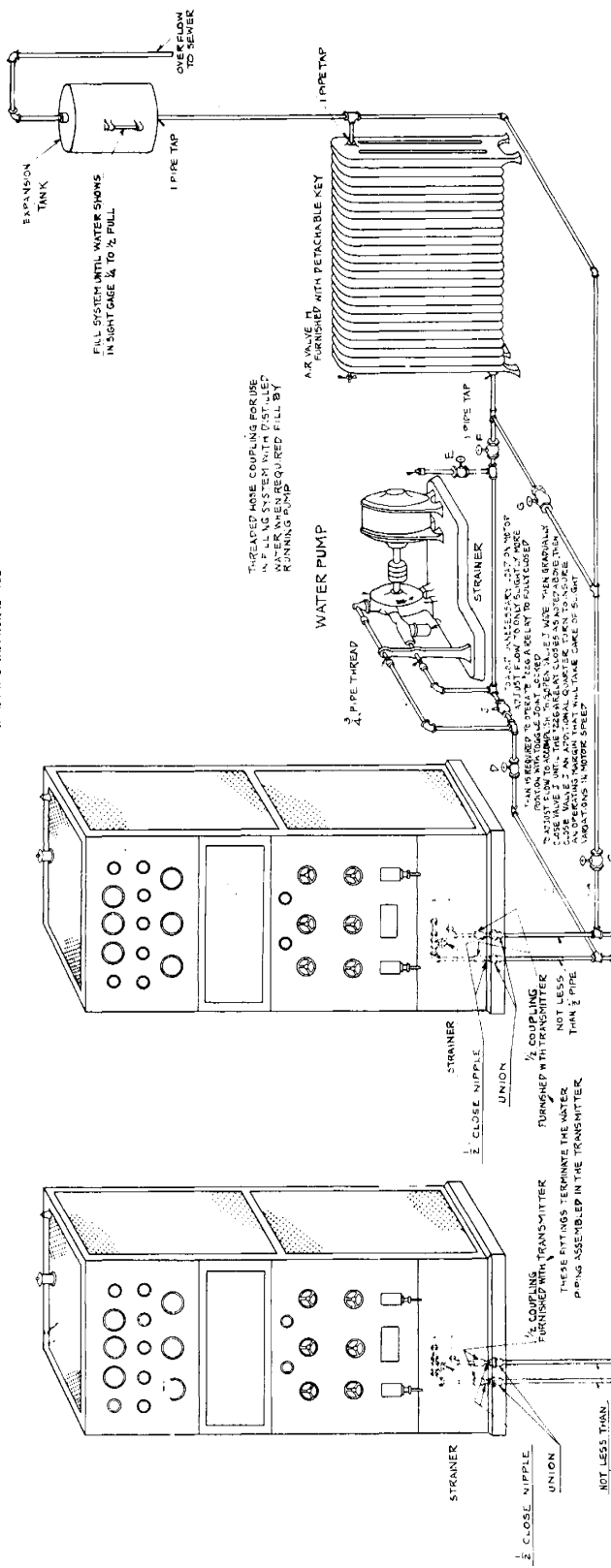

6-A RADIO TRANSMITTER
 TYPICAL WATER
 CIRCULATING SYSTEM
 WITH 226-A RELAY

EXPANDED FROM FIG. 2, 1937
 REVISIONS: 1, 2, 3, 4, 5, 6, 7, 8, 9, 10, 11, 12, 13, 14, 15, 16, 17, 18, 19, 20, 21, 22, 23, 24, 25, 26, 27, 28, 29, 30, 31, 32, 33, 34, 35, 36, 37, 38, 39, 40, 41, 42, 43, 44, 45, 46, 47, 48, 49, 50, 51, 52, 53, 54, 55, 56, 57, 58, 59, 60, 61, 62, 63, 64, 65, 66, 67, 68, 69, 70, 71, 72, 73, 74, 75, 76, 77, 78, 79, 80, 81, 82, 83, 84, 85, 86, 87, 88, 89, 90, 91, 92, 93, 94, 95, 96, 97, 98, 99, 100, 101, 102, 103, 104, 105, 106, 107, 108, 109, 110, 111, 112, 113, 114, 115, 116, 117, 118, 119, 120, 121, 122, 123, 124, 125, 126, 127, 128, 129, 130, 131, 132, 133, 134, 135, 136, 137, 138, 139, 140, 141, 142, 143, 144, 145, 146, 147, 148, 149, 150, 151, 152, 153, 154, 155, 156, 157, 158, 159, 160, 161, 162, 163, 164, 165, 166, 167, 168, 169, 170, 171, 172, 173, 174, 175, 176, 177, 178, 179, 180, 181, 182, 183, 184, 185, 186, 187, 188, 189, 190, 191, 192, 193, 194, 195, 196, 197, 198, 199, 200, 201, 202, 203, 204, 205, 206, 207, 208, 209, 210, 211, 212, 213, 214, 215, 216, 217, 218, 219, 220, 221, 222, 223, 224, 225, 226, 227, 228, 229, 230, 231, 232, 233, 234, 235, 236, 237, 238, 239, 240, 241, 242, 243, 244, 245, 246, 247, 248, 249, 250, 251, 252, 253, 254, 255, 256, 257, 258, 259, 260, 261, 262, 263, 264, 265, 266, 267, 268, 269, 270, 271, 272, 273, 274, 275, 276, 277, 278, 279, 280, 281, 282, 283, 284, 285, 286, 287, 288, 289, 290, 291, 292, 293, 294, 295, 296, 297, 298, 299, 300, 301, 302, 303, 304, 305, 306, 307, 308, 309, 310, 311, 312, 313, 314, 315, 316, 317, 318, 319, 320, 321, 322, 323, 324, 325, 326, 327, 328, 329, 330, 331, 332, 333, 334, 335, 336, 337, 338, 339, 340, 341, 342, 343, 344, 345, 346, 347, 348, 349, 350, 351, 352, 353, 354, 355, 356, 357, 358, 359, 360, 361, 362, 363, 364, 365, 366, 367, 368, 369, 370, 371, 372, 373, 374, 375, 376, 377, 378, 379, 380, 381, 382, 383, 384, 385, 386, 387, 388, 389, 390, 391, 392, 393, 394, 395, 396, 397, 398, 399, 400, 401, 402, 403, 404, 405, 406, 407, 408, 409, 410, 411, 412, 413, 414, 415, 416, 417, 418, 419, 420, 421, 422, 423, 424, 425, 426, 427, 428, 429, 430, 431, 432, 433, 434, 435, 436, 437, 438, 439, 440, 441, 442, 443, 444, 445, 446, 447, 448, 449, 450, 451, 452, 453, 454, 455, 456, 457, 458, 459, 460, 461, 462, 463, 464, 465, 466, 467, 468, 469, 470, 471, 472, 473, 474, 475, 476, 477, 478, 479, 480, 481, 482, 483, 484, 485, 486, 487, 488, 489, 490, 491, 492, 493, 494, 495, 496, 497, 498, 499, 500, 501, 502, 503, 504, 505, 506, 507, 508, 509, 510, 511, 512, 513, 514, 515, 516, 517, 518, 519, 520, 521, 522, 523, 524, 525, 526, 527, 528, 529, 530, 531, 532, 533, 534, 535, 536, 537, 538, 539, 540, 541, 542, 543, 544, 545, 546, 547, 548, 549, 550, 551, 552, 553, 554, 555, 556, 557, 558, 559, 560, 561, 562, 563, 564, 565, 566, 567, 568, 569, 570, 571, 572, 573, 574, 575, 576, 577, 578, 579, 580, 581, 582, 583, 584, 585, 586, 587, 588, 589, 590, 591, 592, 593, 594, 595, 596, 597, 598, 599, 600, 601, 602, 603, 604, 605, 606, 607, 608, 609, 610, 611, 612, 613, 614, 615, 616, 617, 618, 619, 620, 621, 622, 623, 624, 625, 626, 627, 628, 629, 630, 631, 632, 633, 634, 635, 636, 637, 638, 639, 640, 641, 642, 643, 644, 645, 646, 647, 648, 649, 650, 651, 652, 653, 654, 655, 656, 657, 658, 659, 660, 661, 662, 663, 664, 665, 666, 667, 668, 669, 670, 671, 672, 673, 674, 675, 676, 677, 678, 679, 680, 681, 682, 683, 684, 685, 686, 687, 688, 689, 690, 691, 692, 693, 694, 695, 696, 697, 698, 699, 700, 701, 702, 703, 704, 705, 706, 707, 708, 709, 710, 711, 712, 713, 714, 715, 716, 717, 718, 719, 720, 721, 722, 723, 724, 725, 726, 727, 728, 729, 730, 731, 732, 733, 734, 735, 736, 737, 738, 739, 740, 741, 742, 743, 744, 745, 746, 747, 748, 749, 750, 751, 752, 753, 754, 755, 756, 757, 758, 759, 760, 761, 762, 763, 764, 765, 766, 767, 768, 769, 770, 771, 772, 773, 774, 775, 776, 777, 778, 779, 780, 781, 782, 783, 784, 785, 786, 787, 788, 789, 790, 791, 792, 793, 794, 795, 796, 797, 798, 799, 800, 801, 802, 803, 804, 805, 806, 807, 808, 809, 810, 811, 812, 813, 814, 815, 816, 817, 818, 819, 820, 821, 822, 823, 824, 825, 826, 827, 828, 829, 830, 831, 832, 833, 834, 835, 836, 837, 838, 839, 840, 841, 842, 843, 844, 845, 846, 847, 848, 849, 850, 851, 852, 853, 854, 855, 856, 857, 858, 859, 860, 861, 862, 863, 864, 865, 866, 867, 868, 869, 870, 871, 872, 873, 874, 875, 876, 877, 878, 879, 880, 881, 882, 883, 884, 885, 886, 887, 888, 889, 890, 891, 892, 893, 894, 895, 896, 897, 898, 899, 900, 901, 902, 903, 904, 905, 906, 907, 908, 909, 910, 911, 912, 913, 914, 915, 916, 917, 918, 919, 920, 921, 922, 923, 924, 925, 926, 927, 928, 929, 930, 931, 932, 933, 934, 935, 936, 937, 938, 939, 940, 941, 942, 943, 944, 945, 946, 947, 948, 949, 950, 951, 952, 953, 954, 955, 956, 957, 958, 959, 960, 961, 962, 963, 964, 965, 966, 967, 968, 969, 970, 971, 972, 973, 974, 975, 976, 977, 978, 979, 980, 981, 982, 983, 984, 985, 986, 987, 988, 989, 990, 991, 992, 993, 994, 995, 996, 997, 998, 999, 1000

FIGURE 2

NOTE: ALL INTERCONNECTING PIPE & VALVES SHOWN IN FIG. 1 & FIG. 2 TO BE 1/2" UNLESS OTHERWISE SPECIFIED. ALL PIPE VALVES & FITTINGS MUST BE OF THE TYPE SPECIFIED IN THE LIST OF MATERIALS. VALVES MUST BE SUITABLE FOR HAND AND WATER AT 150°F.

CLOSED CIRCULATING SYSTEM EQUIPMENT
 IN EMERGENCY

ESO-309899

TYPICAL WATER CIRCULATING SYSTEM WITH 226-A RELAY—ESO-309899



226-A RELAY—23298

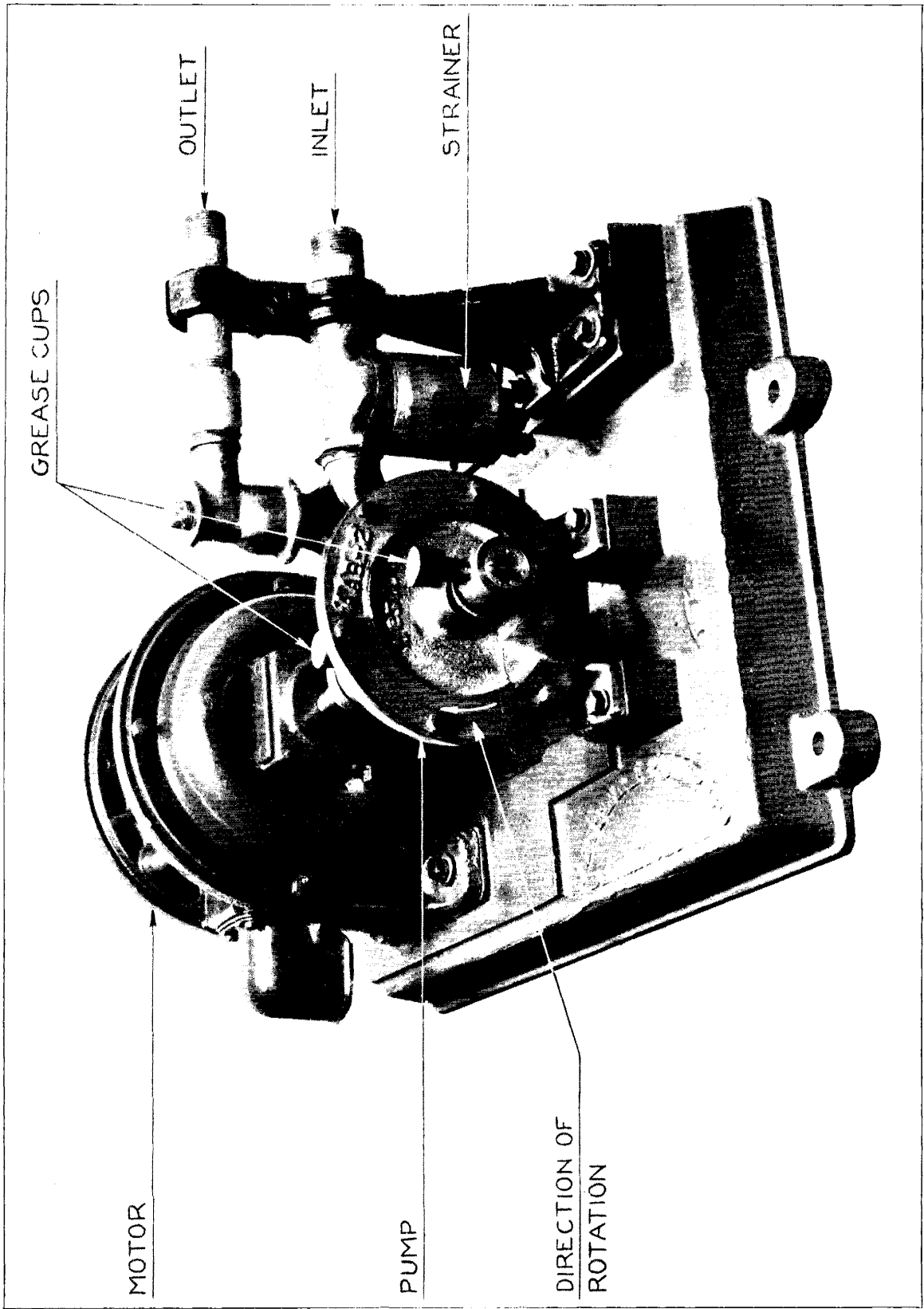

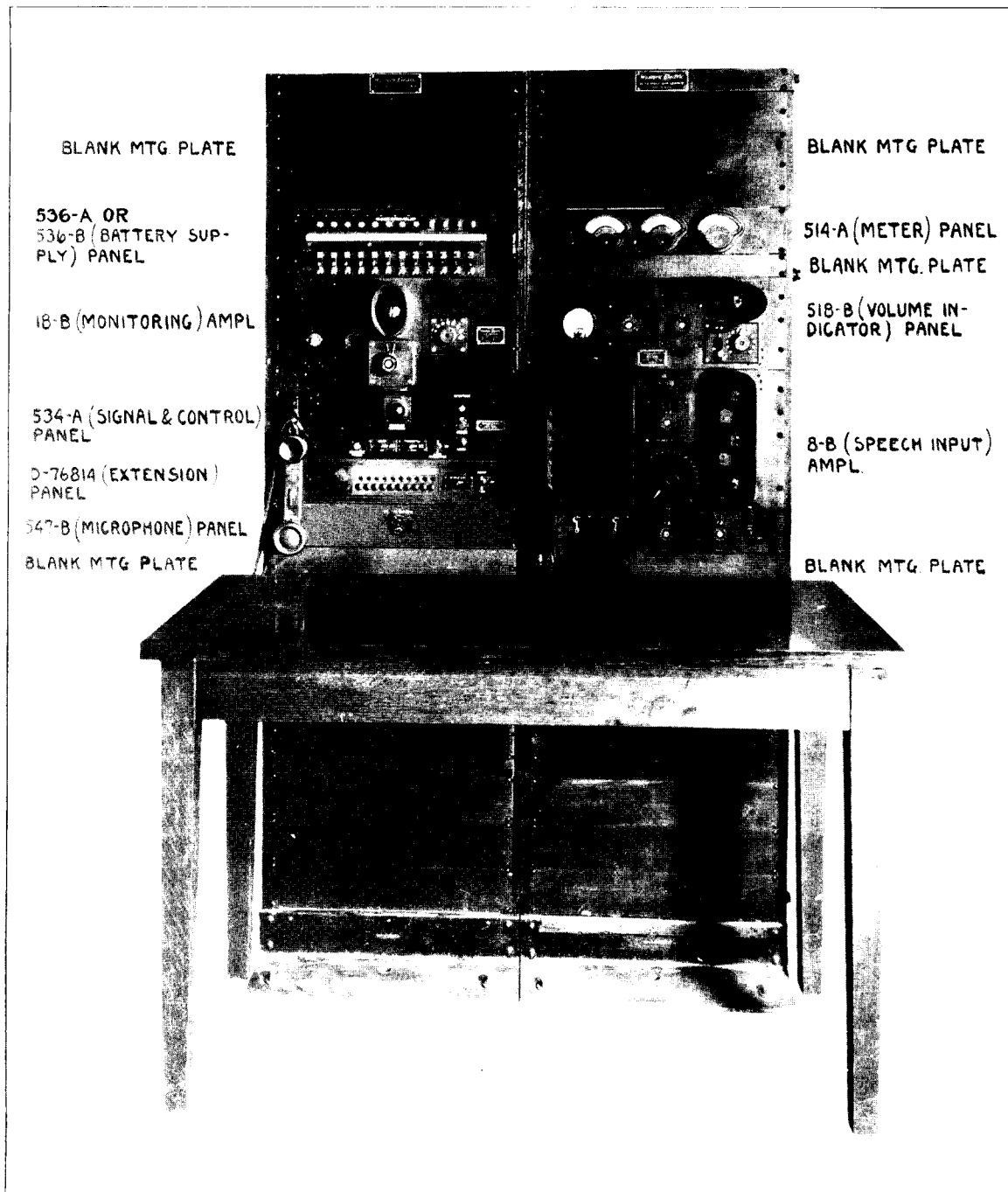

1-E SPEECH INPUT RACKS—23117-C

WHITE OR GREEN TRACER
CORD TERMINAL

BROWN CORD TERMINAL

GREEN OR WHITE
TRACER CORD
TERMINAL

COMMON LEAD



373-W-387-W MICROPHONE TRANSMITTER-26068

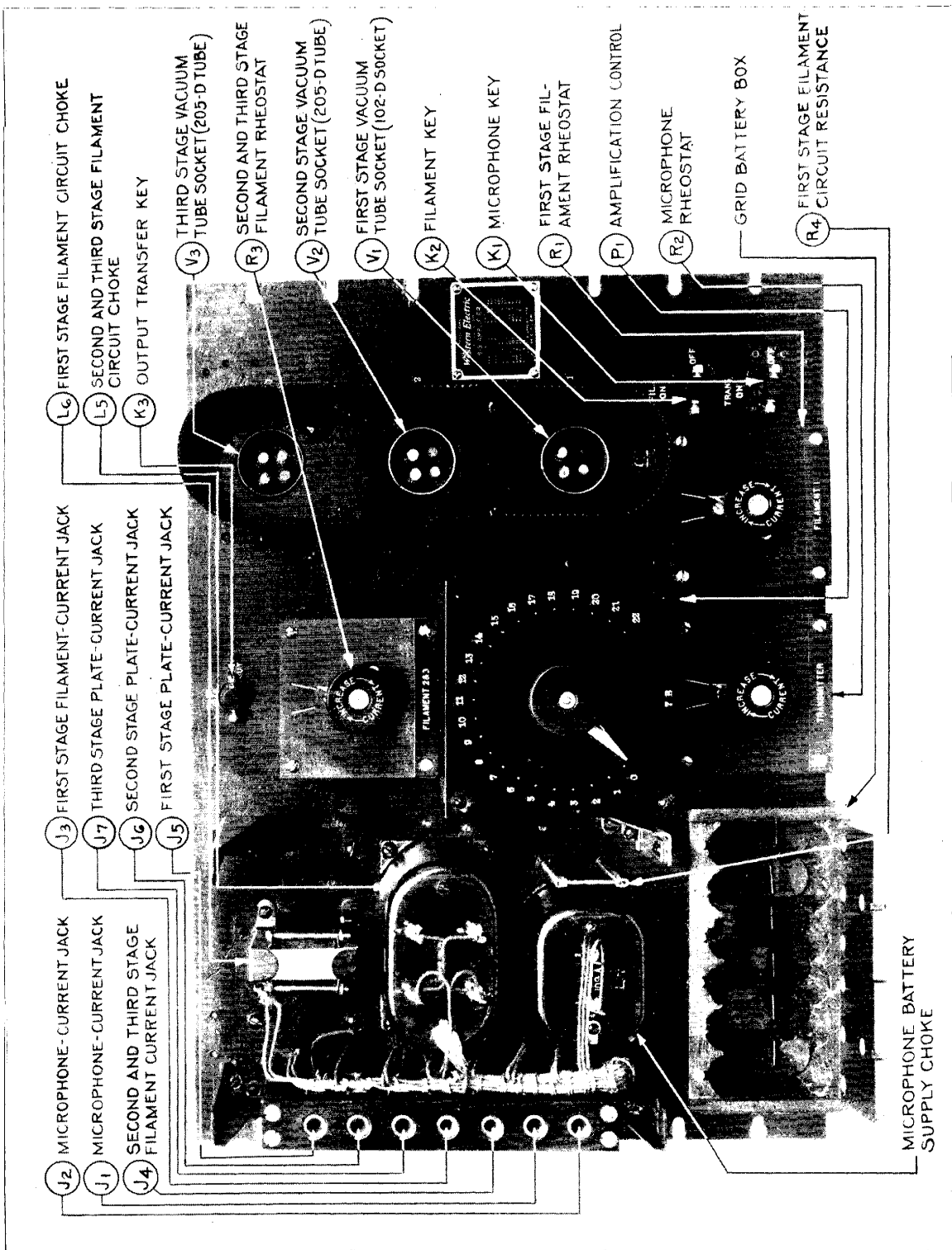

8-B SPEECH INPUT AMPLIFIER FRONT VIEW-21425

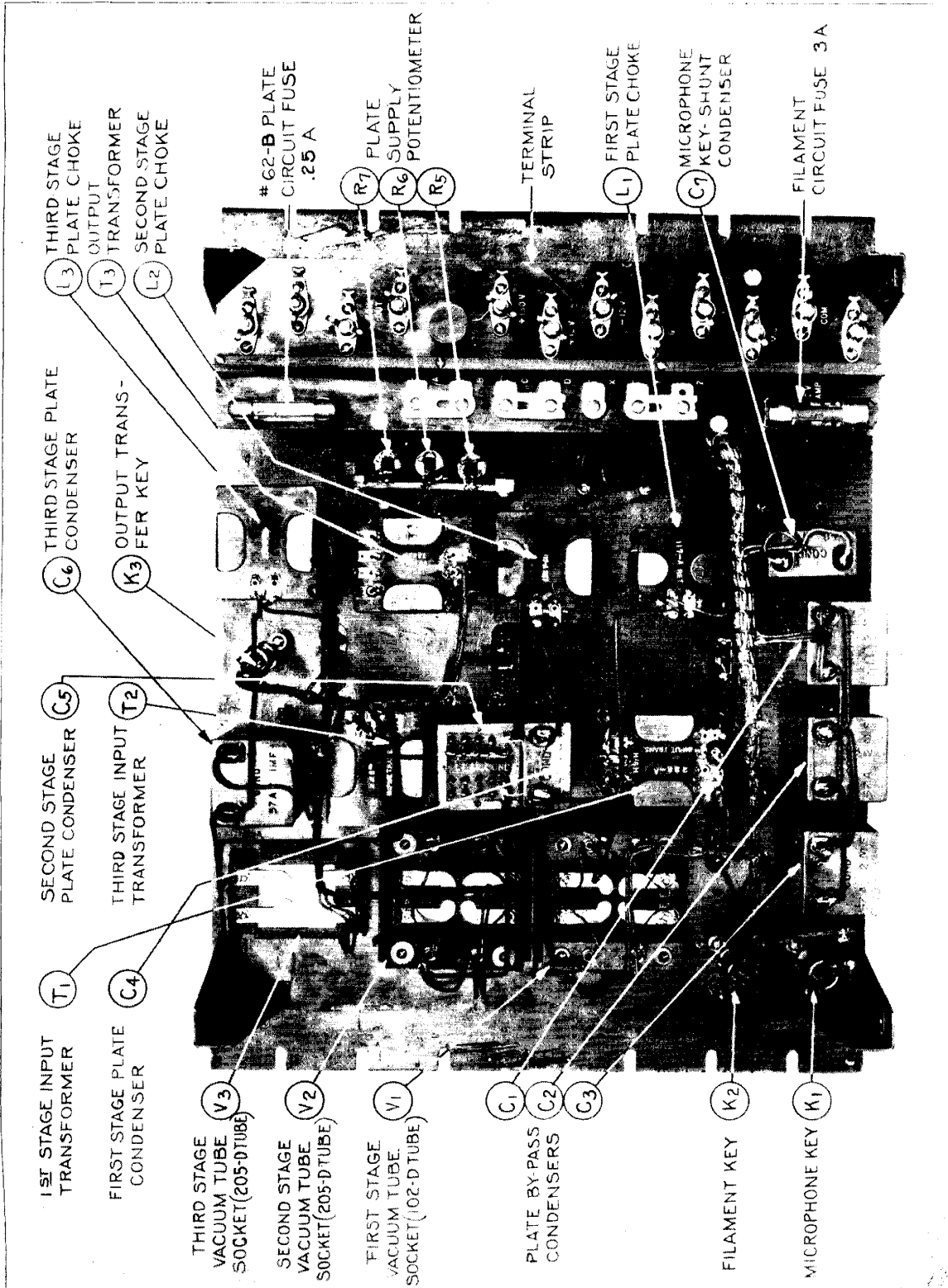

8-B SPEECH INPUT AMPLIFIER REAR VIEW—26101

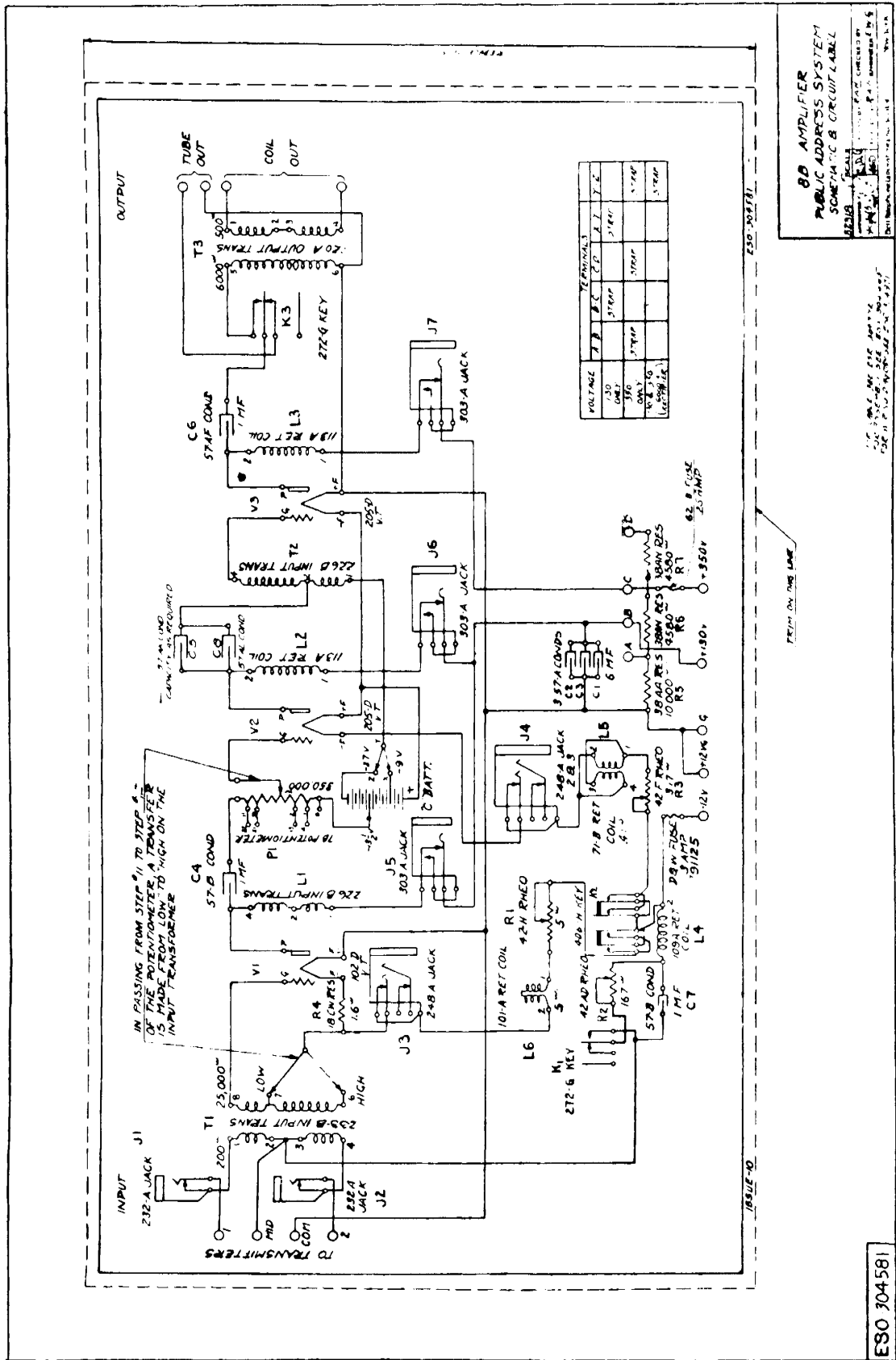

VOLTAGE	A	B	C	GROUND	TERMINALS	A	Z	Z	Z
130					57AF				
350					272-G				
450					272-G				
4500					272-G				
4500					272-G				

8-B AMPLIFIER PUBLIC ADDRESS SYSTEM SCHEMATIC CIRCUIT LABEL

ES0 304581

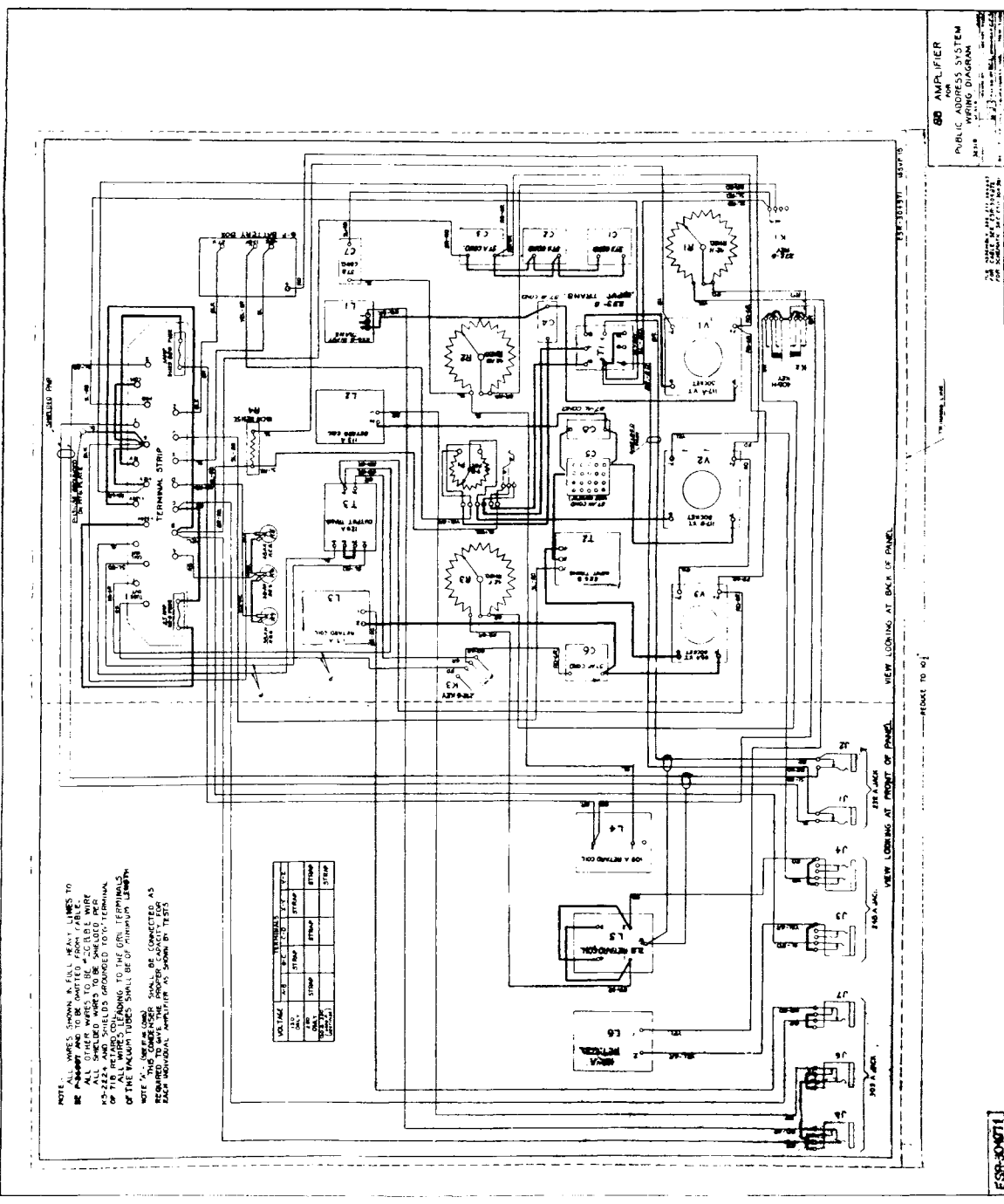

8-B AMPLIFIER
 FOR
 PUBLIC ADDRESS SYSTEM
 WIRING DIAGRAM

8-B SPEECH INPUT AMPLIFIER WIRING DIAGRAM—ESR-304971

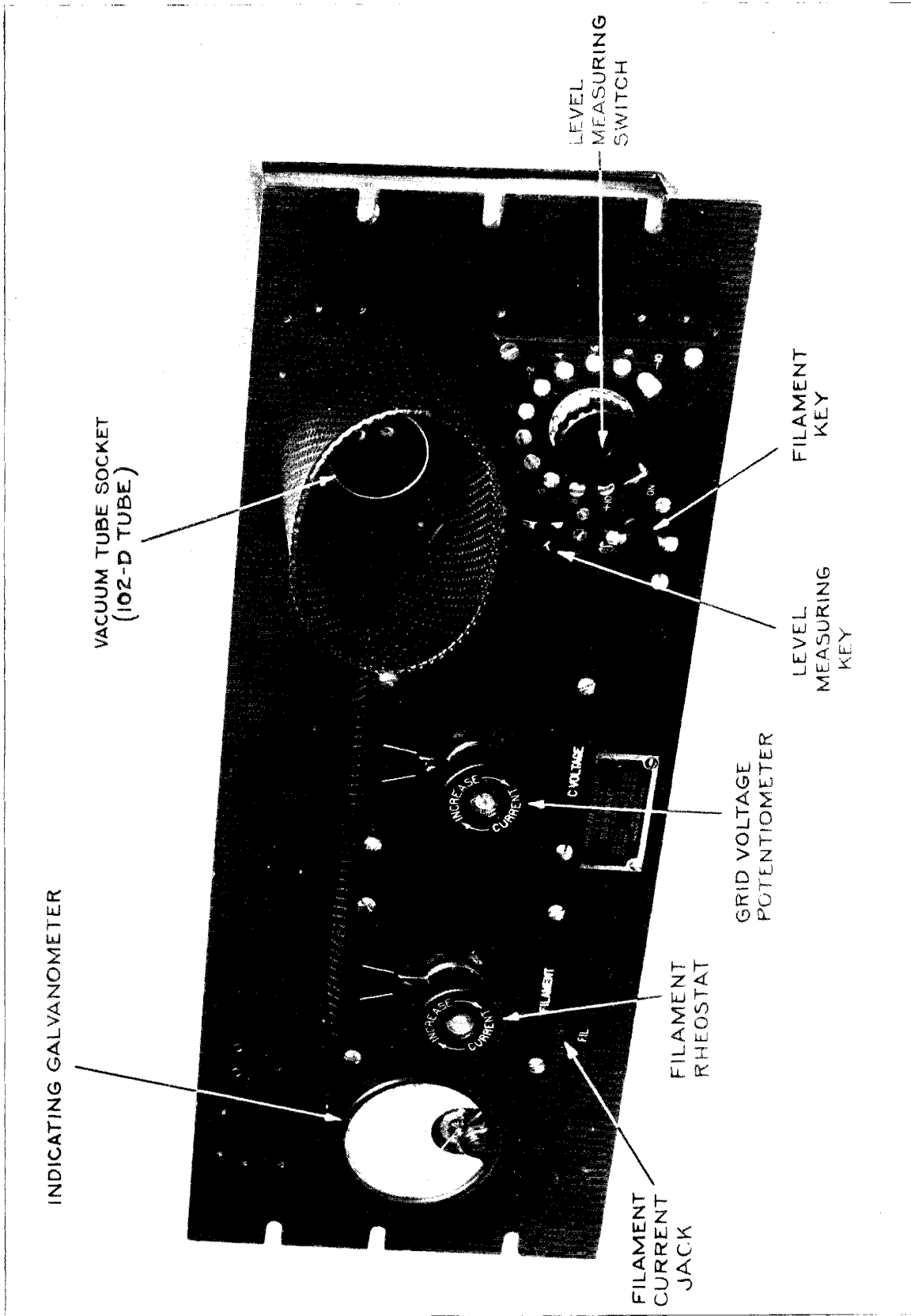

518-B VOLUME INDICATOR PANEL, FRONT VIEW- 21435

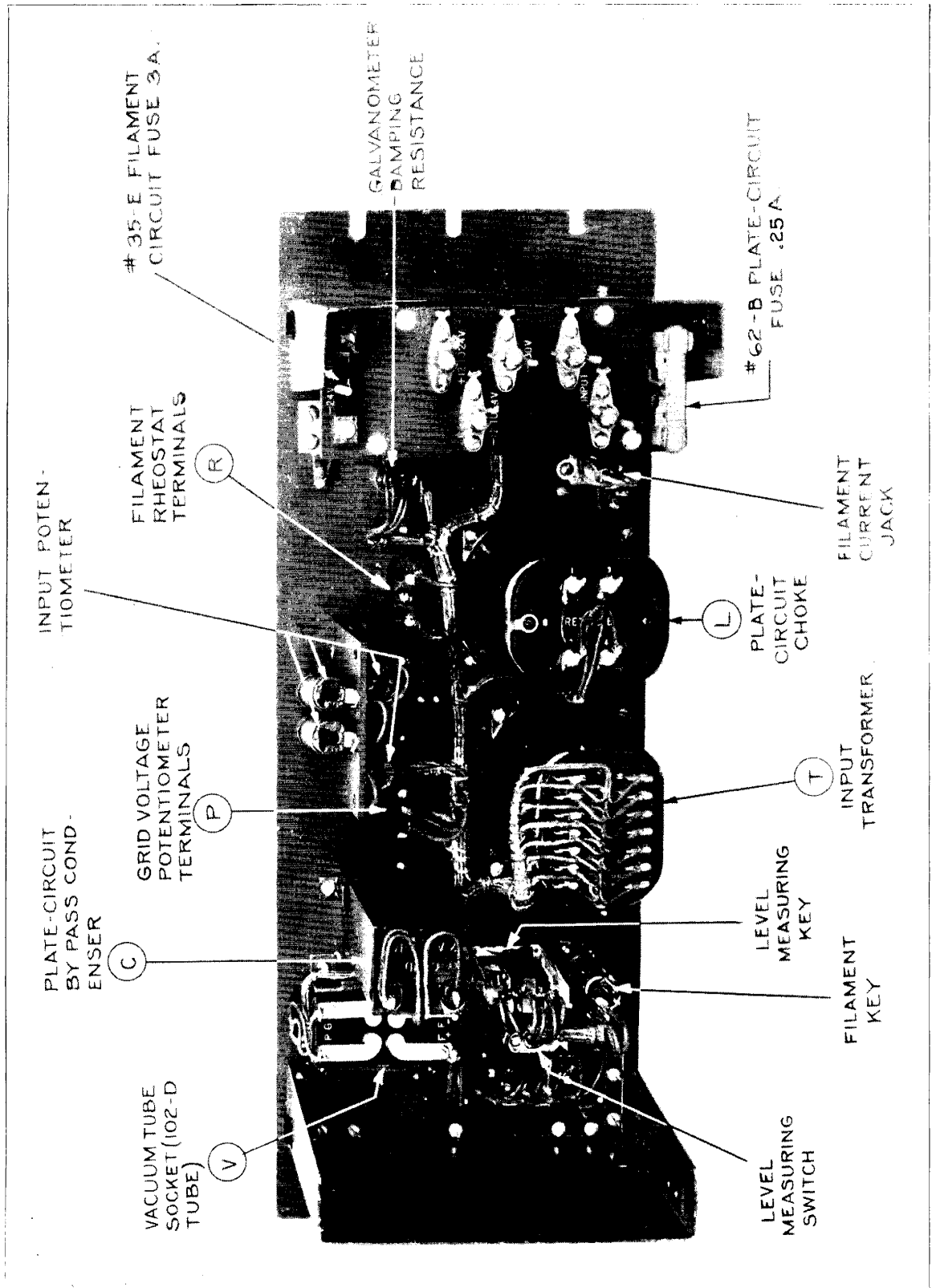

518-B VOLUME INDICATOR PANEL, REAR VIEW—26100

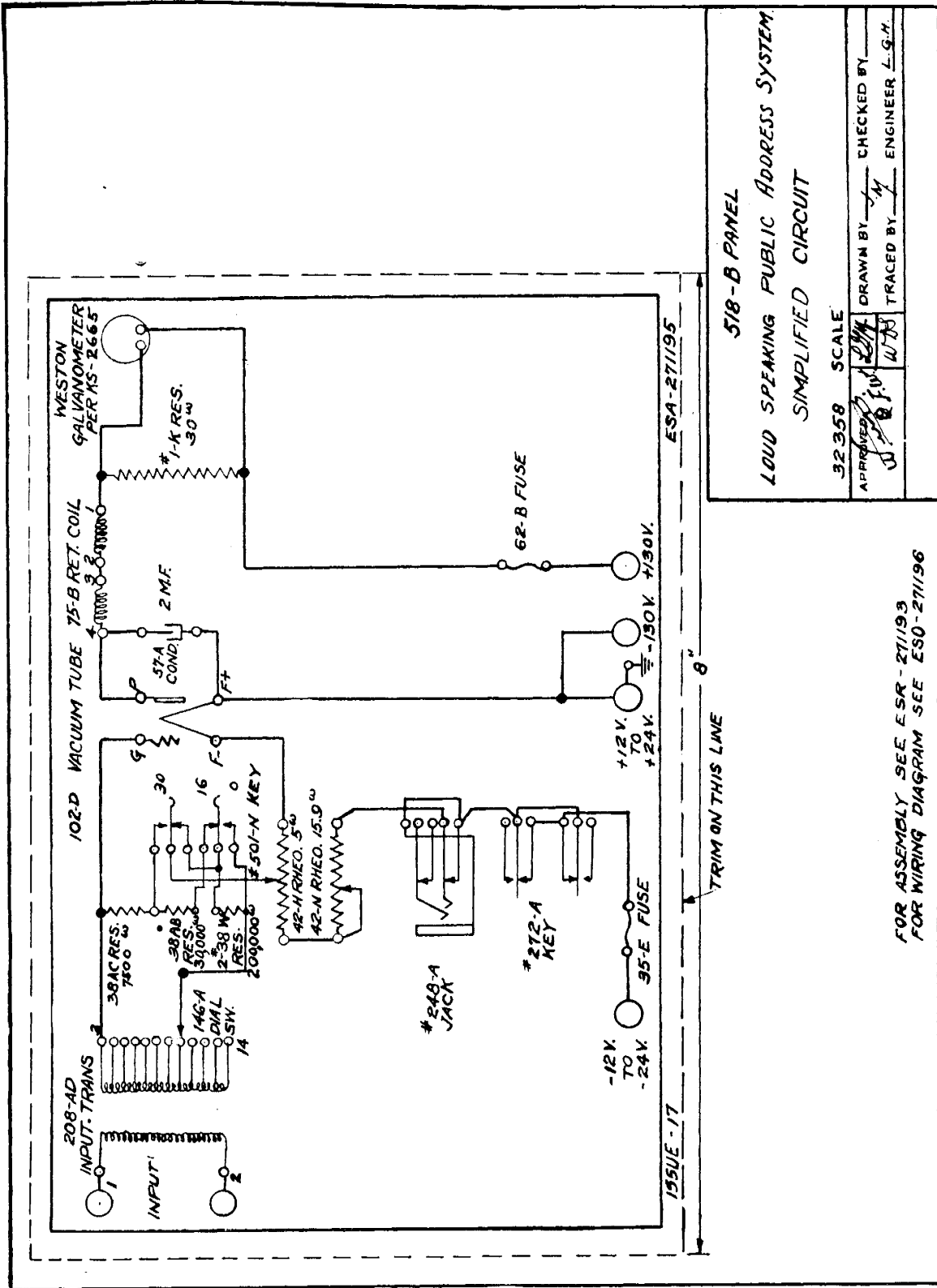

518-B PANEL
 LOUD SPEAKING PUBLIC ADDRESS SYSTEM
 SIMPLIFIED CIRCUIT

32358 SCALE

APPROVED BY *[Signature]* DRAWN BY *[Signature]* CHECKED BY *[Signature]*
 TRACED BY *[Signature]* ENGINEER L.G.H.

FOR ASSEMBLY SEE ESR-271193
 FOR WIRING DIAGRAM SEE ESO-271196

518-B VOLUME INDICATOR PANEL SIMPLIFIED CIRCUIT—ESA-271195

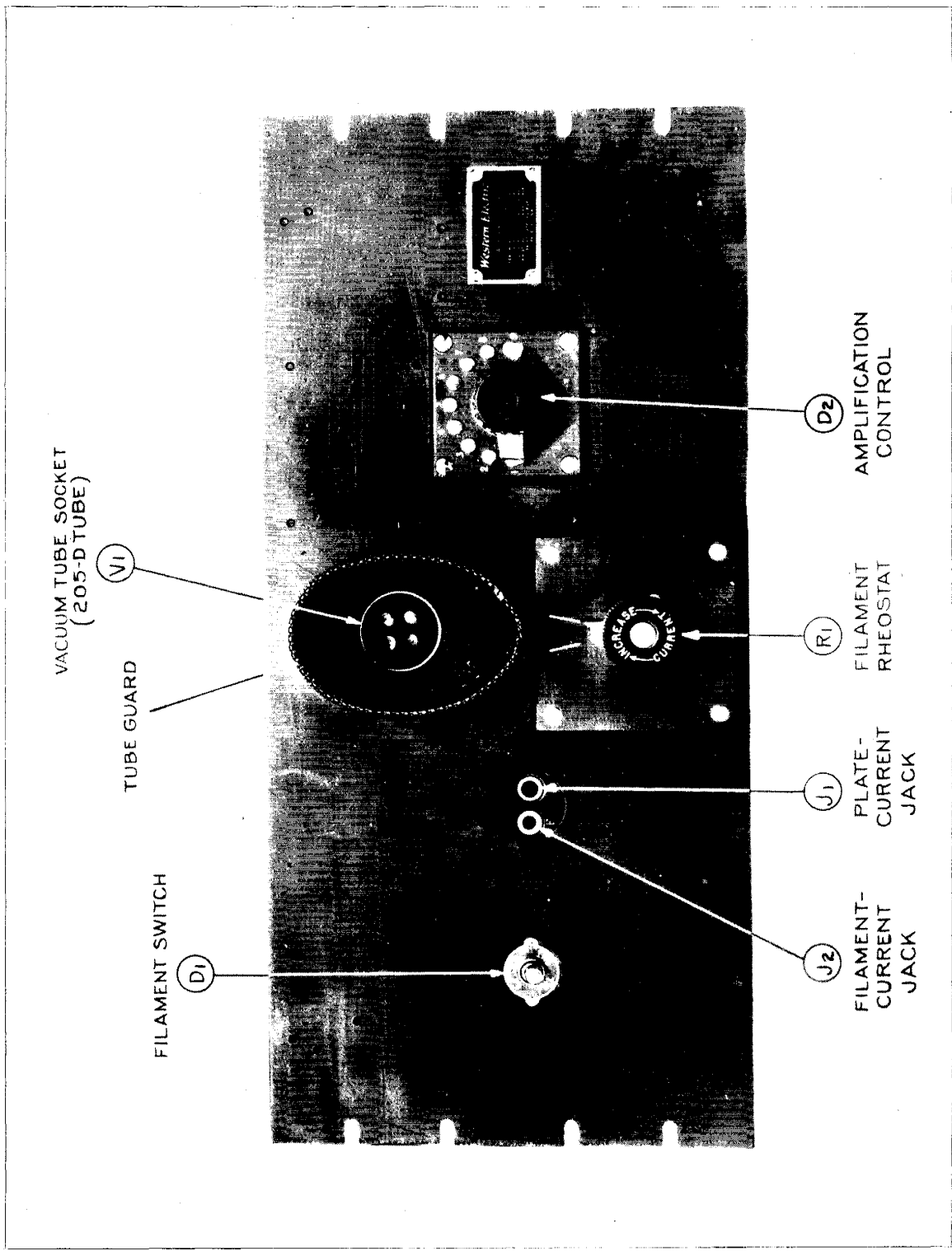

18-B MONITORING AMPLIFIER FRONT VIEW—26103

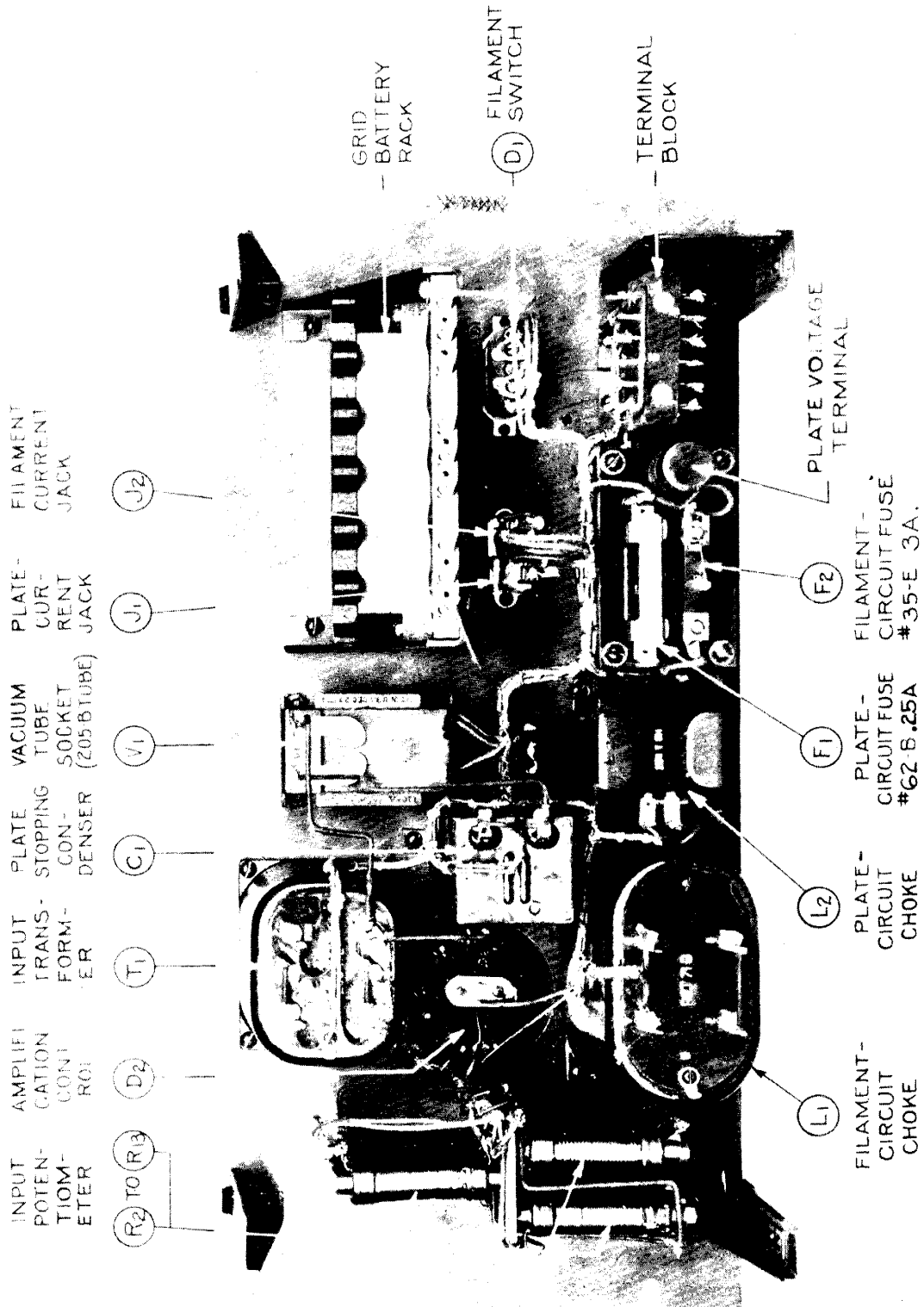

18-B MONITORING AMPLIFIER REAR VIEW—26102

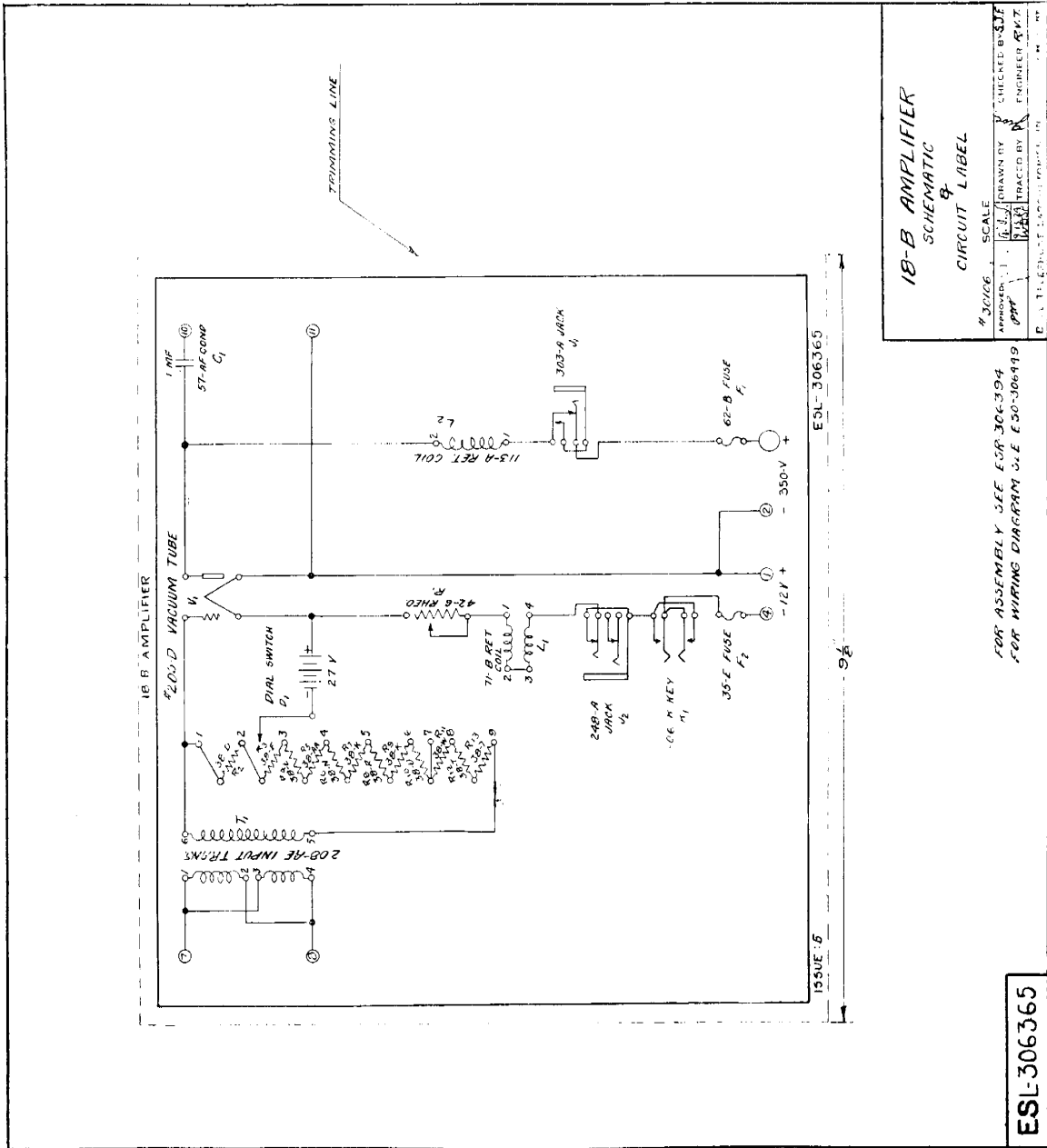

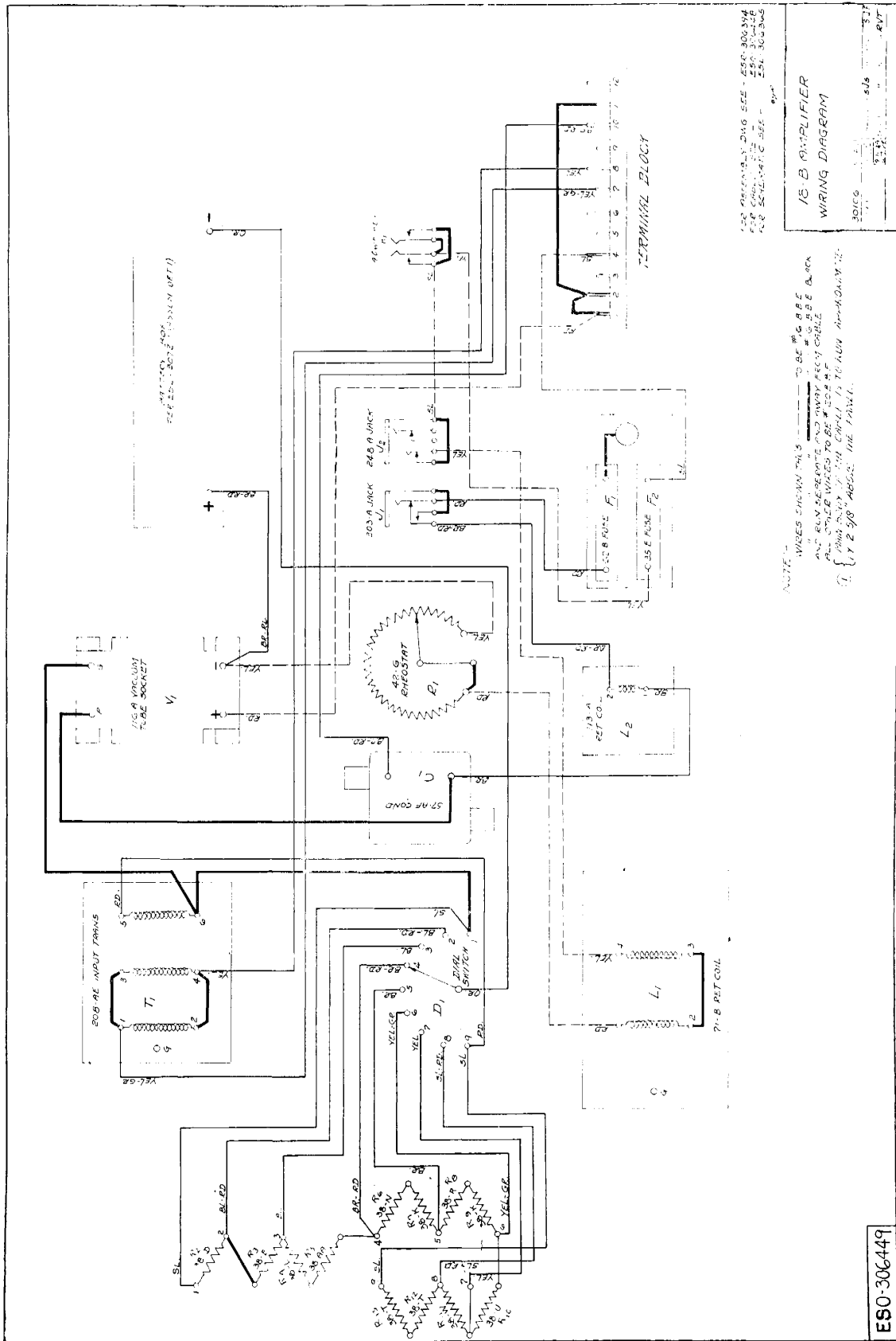

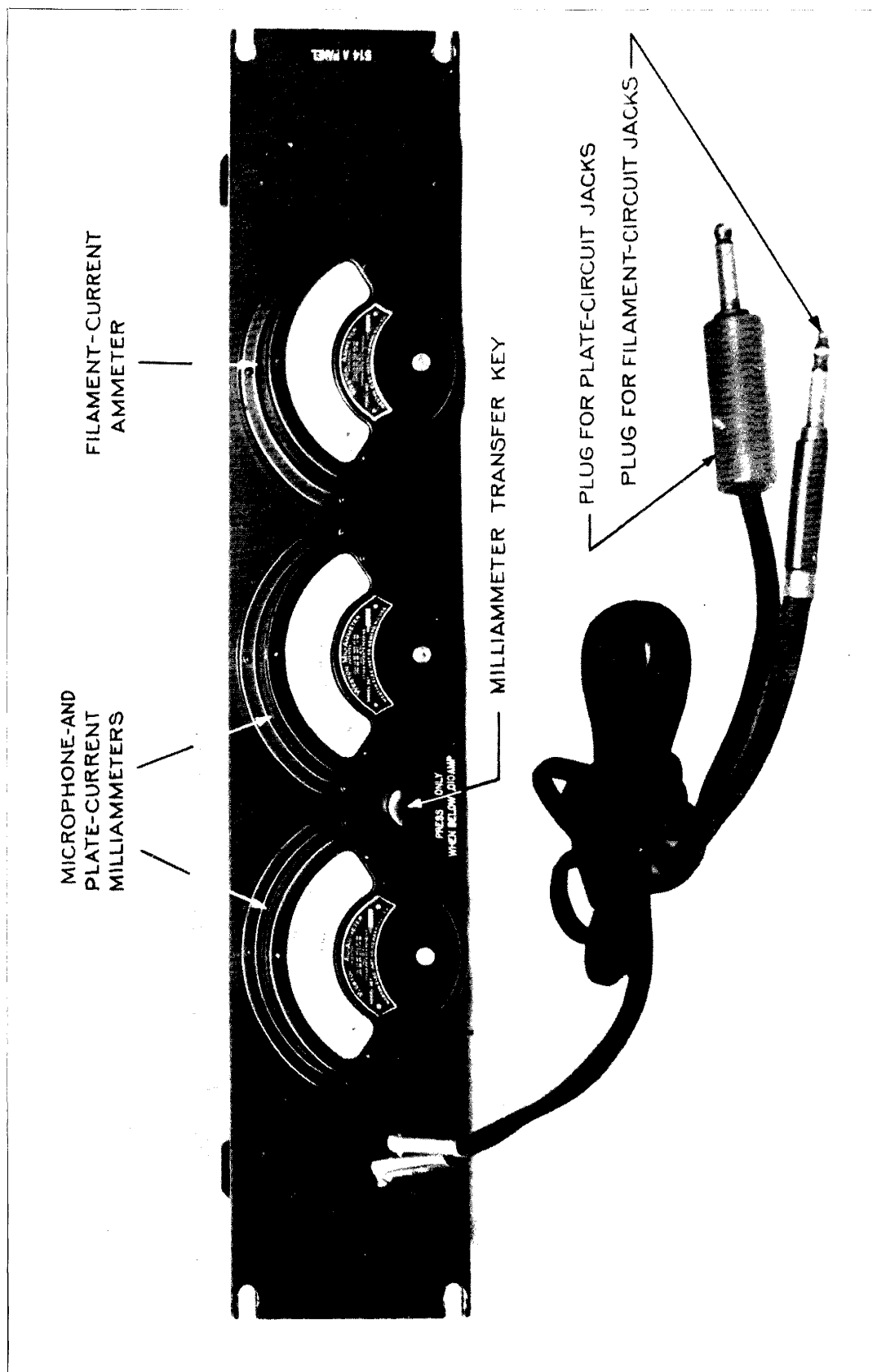

514-A METER PANEL--21448

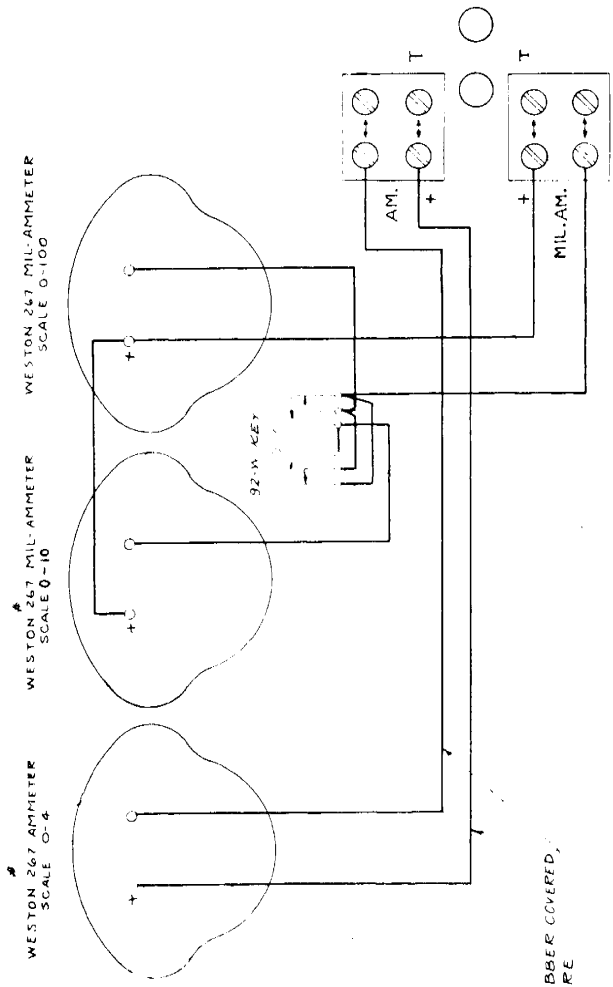

USE #14 PARAKELL RUBBER COVERED,
TINNED COPPER WIRE

VIEW LOOKING AT BACK OF PANEL

FOR ASSEMBLY SEE ESR-259562
LOUD SPEAKING PUBLIC
ADDRESS SYSTEM
519A PANEL
WIRING DIAGRAM

31320 SCALE
DRAWN BY JJC CHECKED BY JJC
DATE 12-2-53
MAILED BY JJC ENGINEER 6.6.71
V. Stern Electric Company, Incorporated N. Y. Eng. Dept.

ESL-259576

514-A METER PANEL WIRING DIAGRAM—ESL-259576

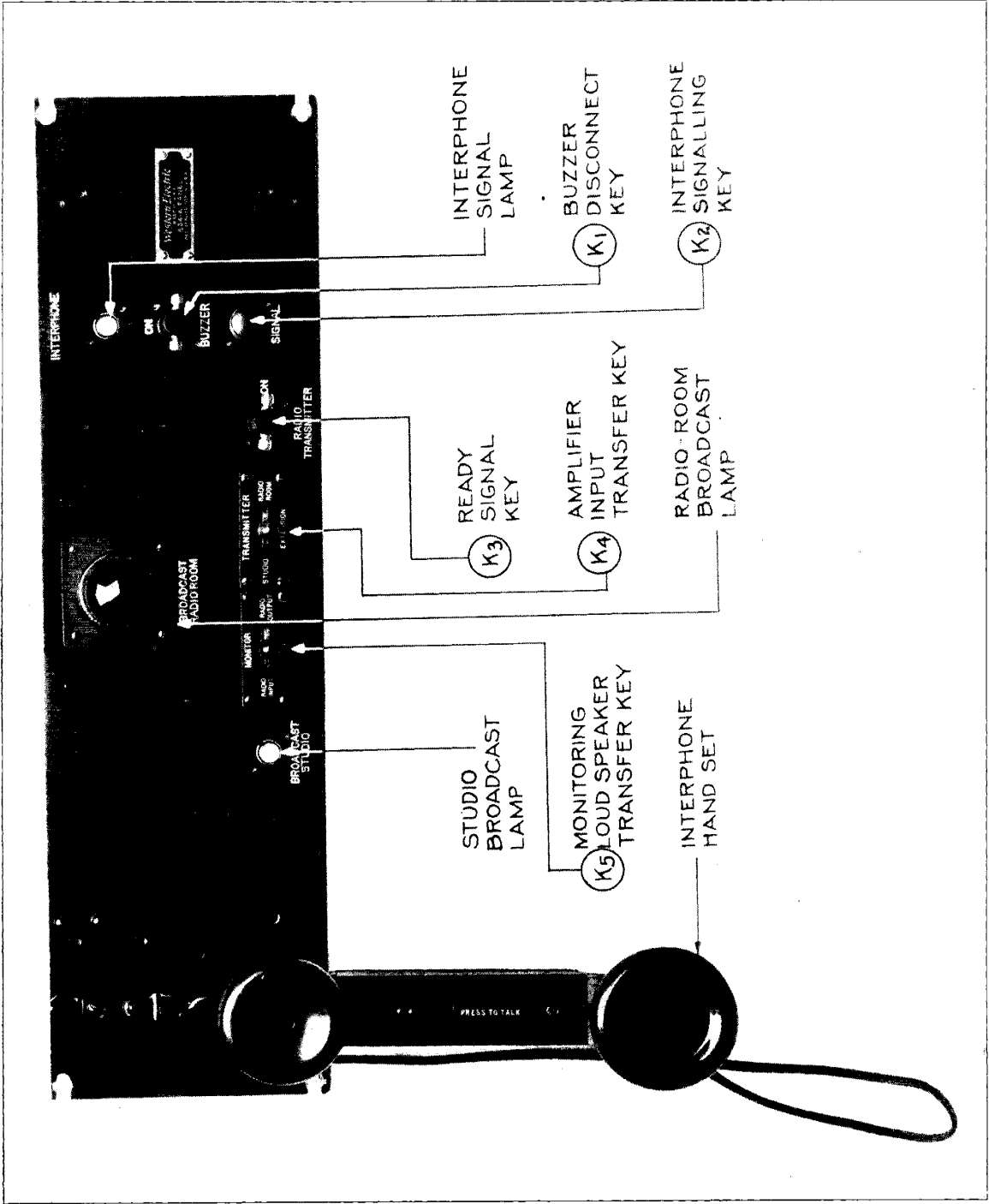

534-A SIGNAL AND CONTROL PANEL FRONT VIEW-21436

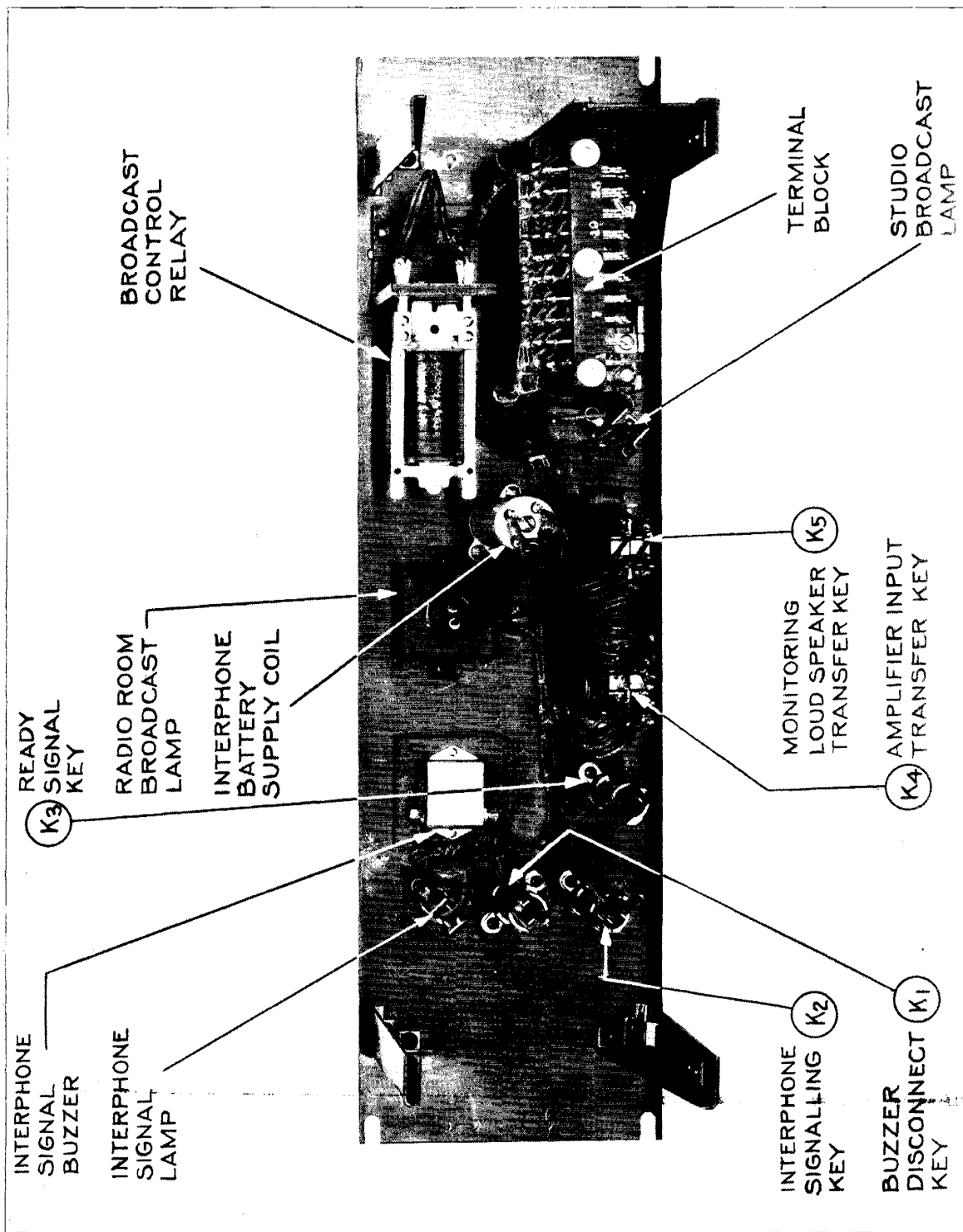

534-A SIGNAL AND CONTROL PANEL REAR VIEW-21440

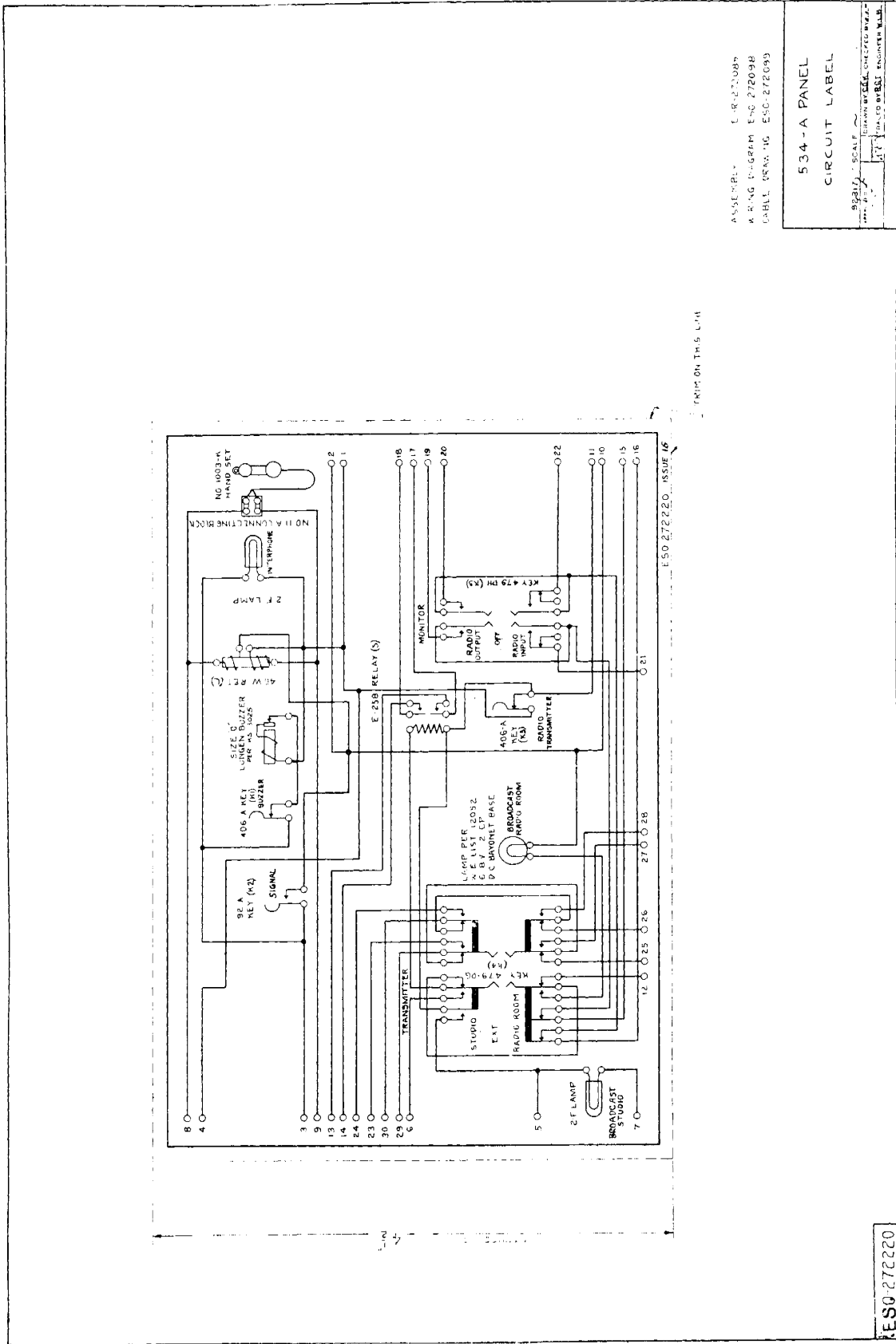

ASSEMBLER: CAR-272087
 DRAWING ENGINEER: ENC-272098
 CABLE DRAWING: ENC-272099

534-A PANEL
 CIRCUIT LABEL

SCALE: 1" = 100' (SEE DRAWING)
 DRAWN BY: [Signature]
 CHECKED BY: [Signature]
 APPROVED BY: [Signature]

534-A SIGNAL AND CONTROL PANEL SCHEMATIC--ISSUE 16

ES0-272220

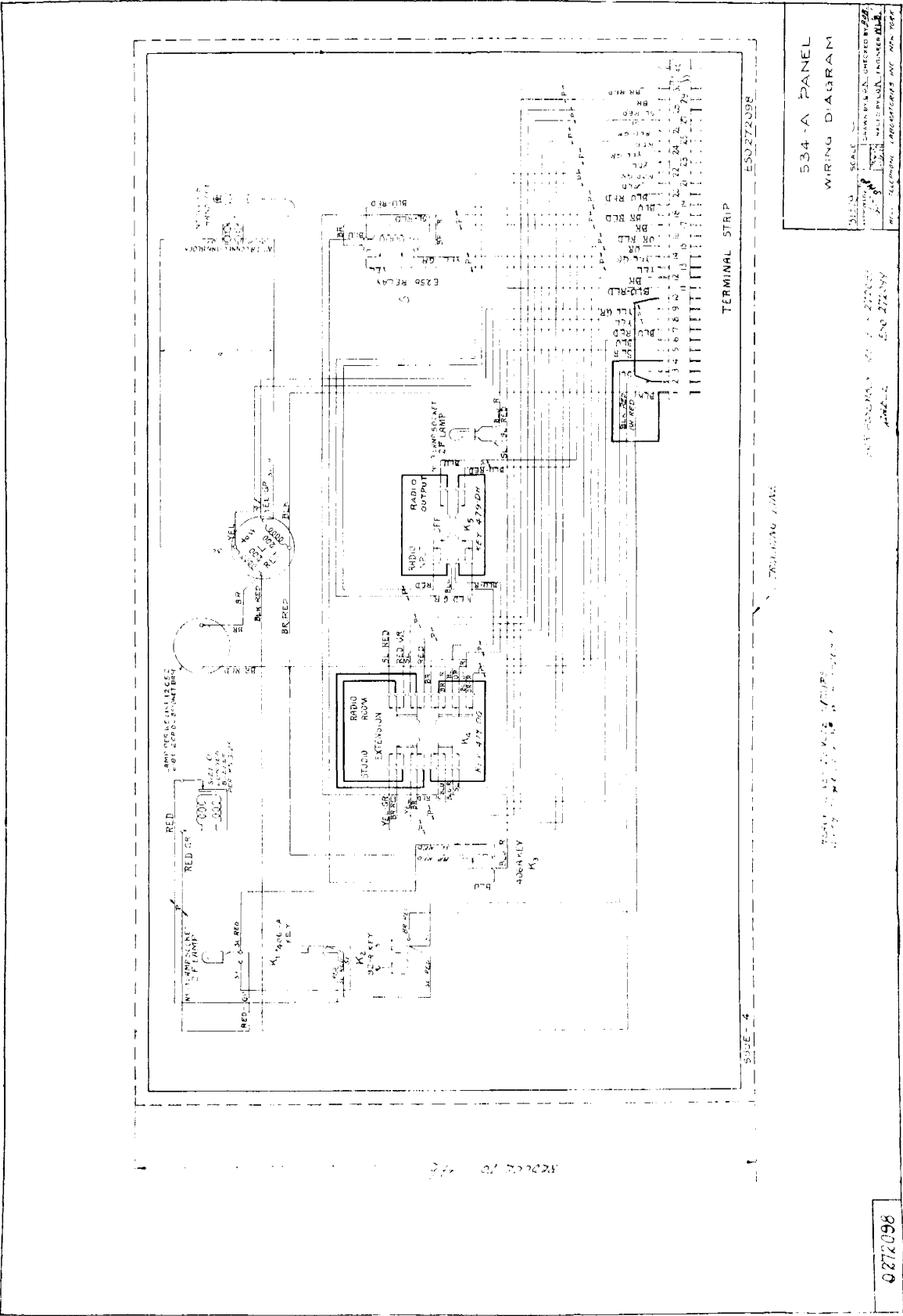

534-A PANEL
 WIRING DIAGRAM

SCALE: 1/8" = 1'-0"

DATE: 12/1/50
 DRAWN BY: J. L. BROWN
 CHECKED BY: R. L. BROWN
 TITLE: 534-A PANEL WIRING DIAGRAM
 PROJECT: 534-A PANEL

WIRING LINE

TERMINAL STRIP

SCALE - 4

534-A SIGNAL AND CONTROL PANEL WIRING DIAGRAM—E50-272098

0272098

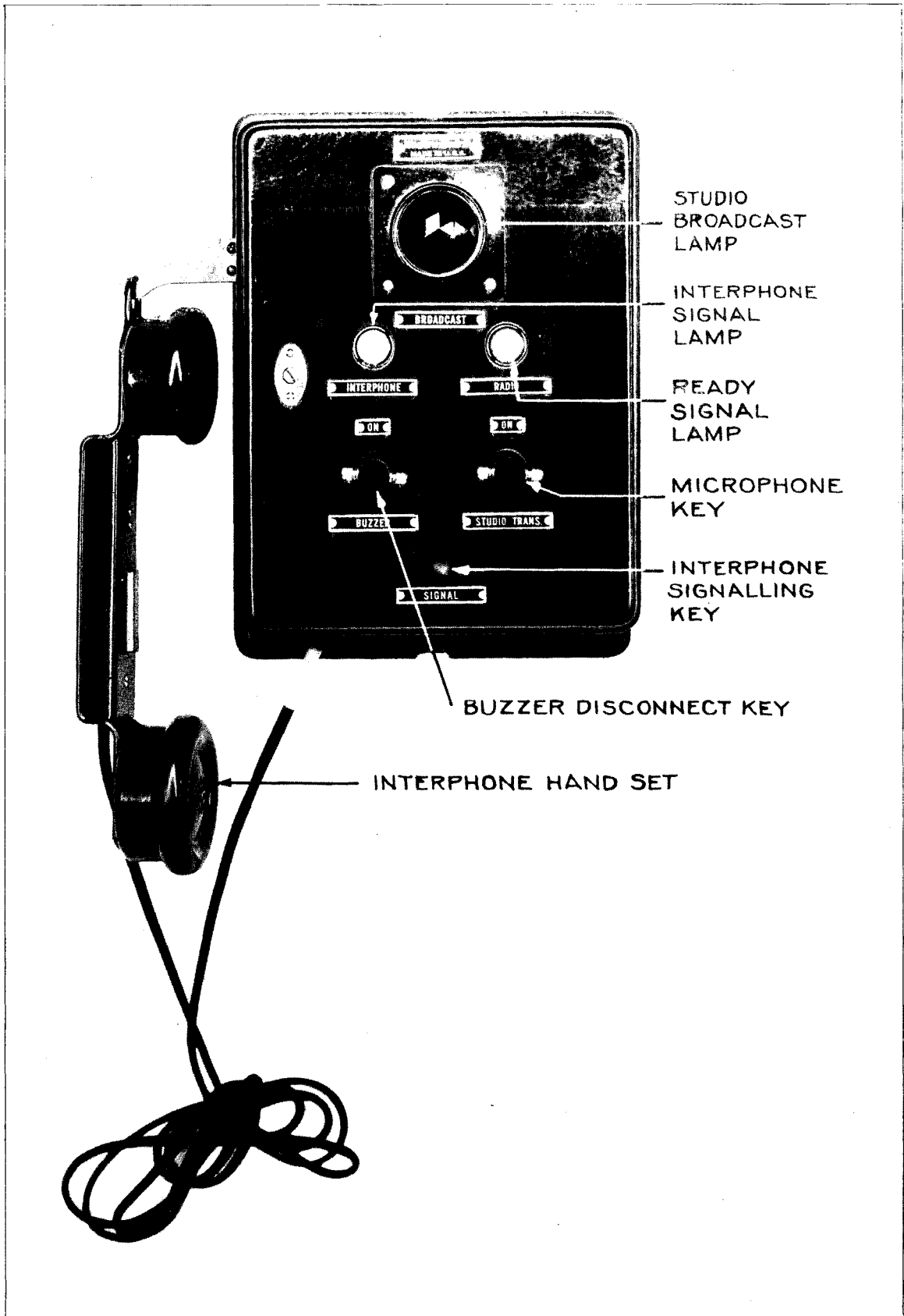

6045-A TELEPHONE SET—21449

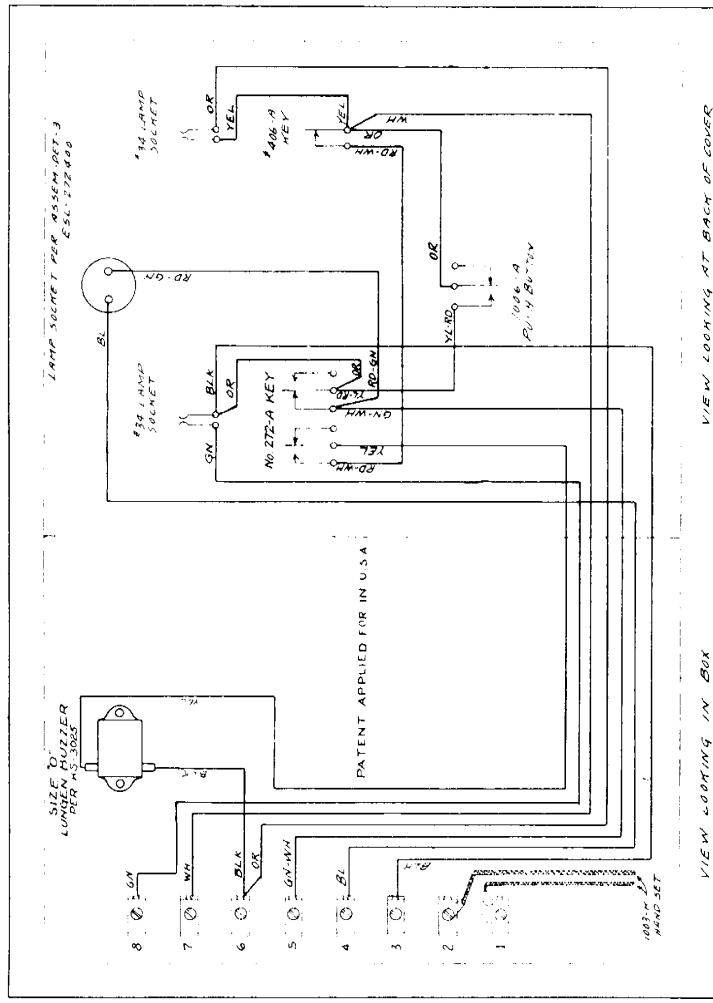

NOTE: WIRE WITH #22 SPECIAL TANNED INS. SINGLE LAMP CORD PER MS 1604

FOR ASSEMBLY SEE ESO-272560

522-A SUBSCRIBERS SET
FOR
RADIO BROADCASTING STUDIO
CIRCUIT LABEL

SCALE: 3/8"=1"

DESIGNED BY: J. J. JONES

CHECKED BY: A. E. B. ENGINEER, E. E. M.

TRACED BY: A. F. B. ENGINEER, E. E. M.

NEW YORK

ESL-272562

6045-A TELEPHONE SET CIRCUIT LABEL 522-A SUB. SET--ESL-272562

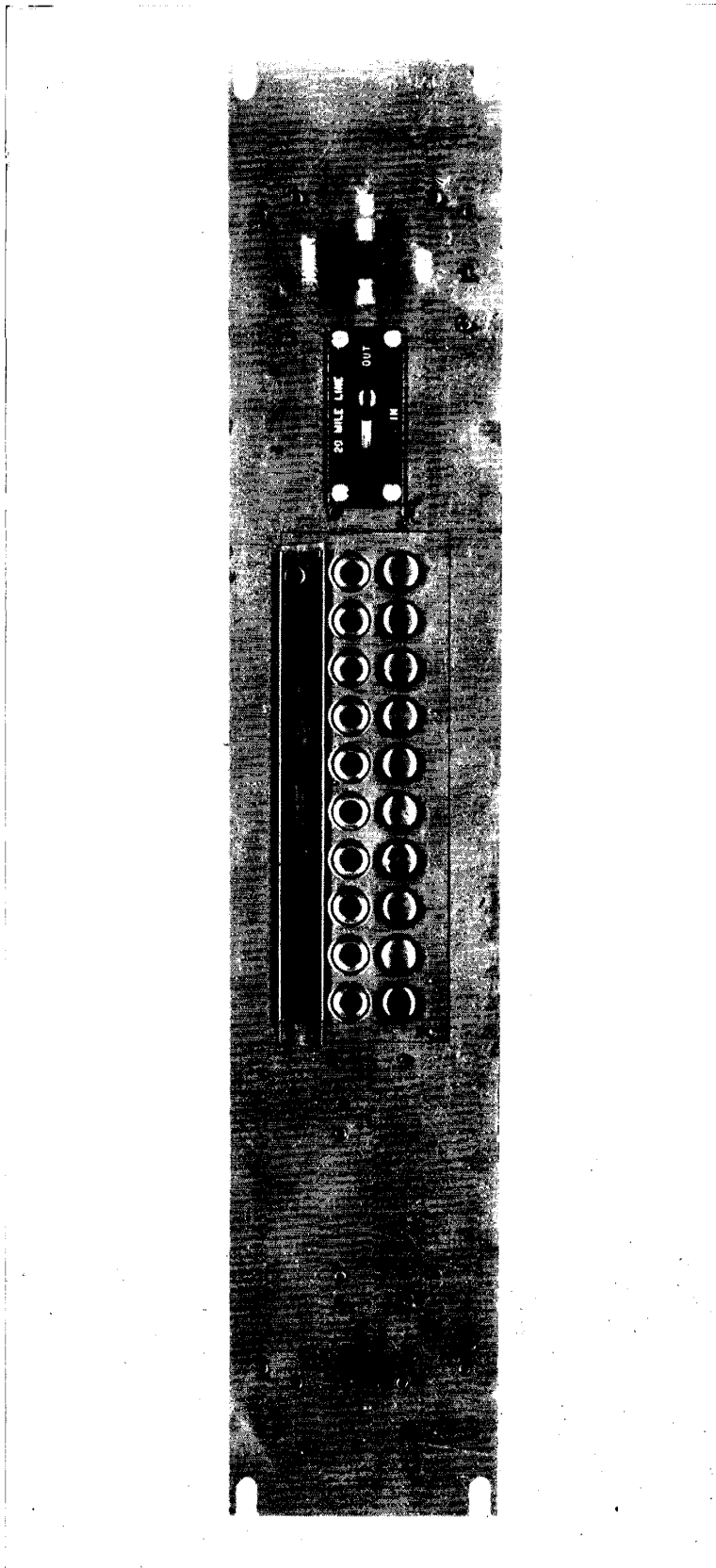

D-76814 EXTENSION PANEL FRONT VIEW-22882

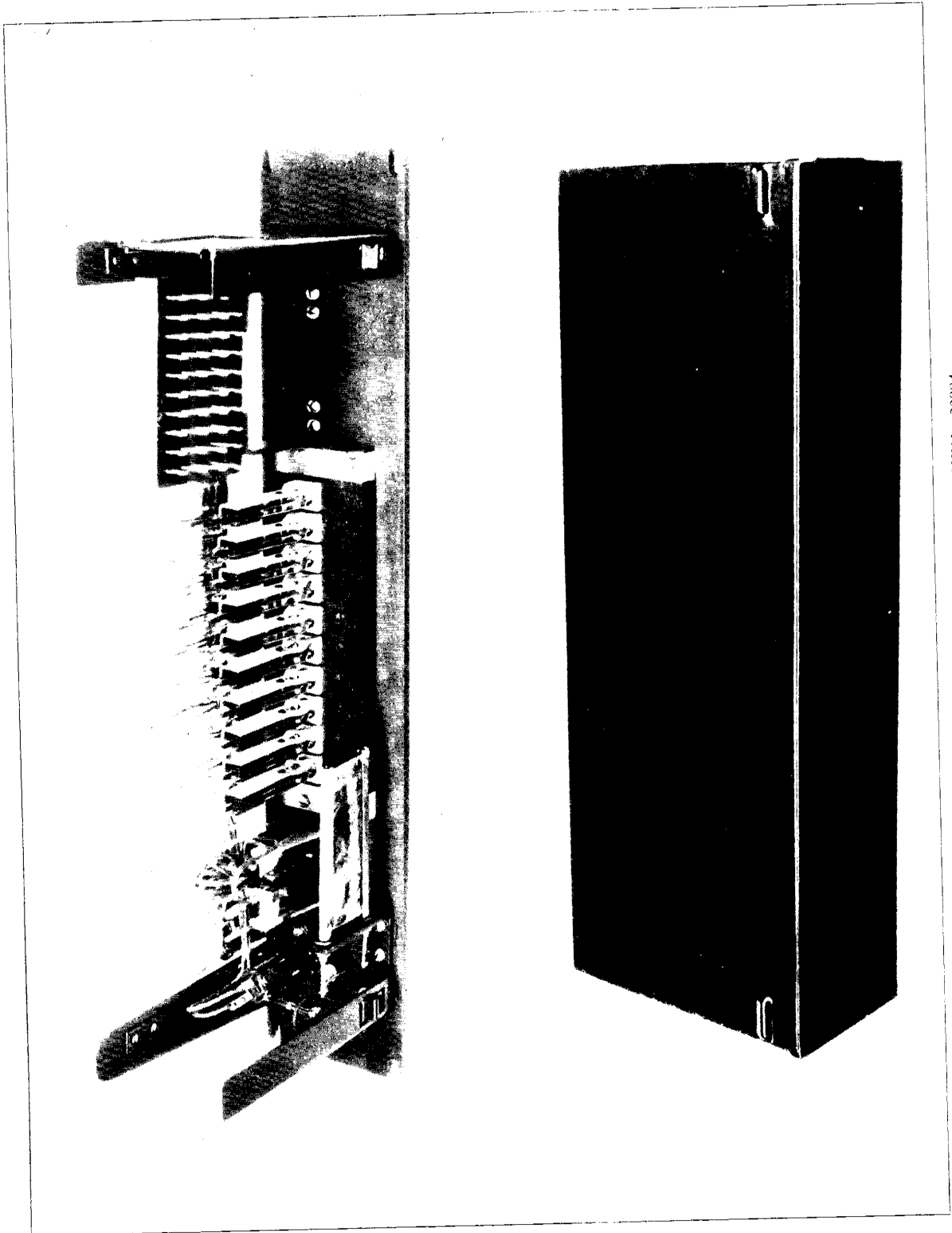

D-76814 EXTENSION PANEL REAR VIEW-22884

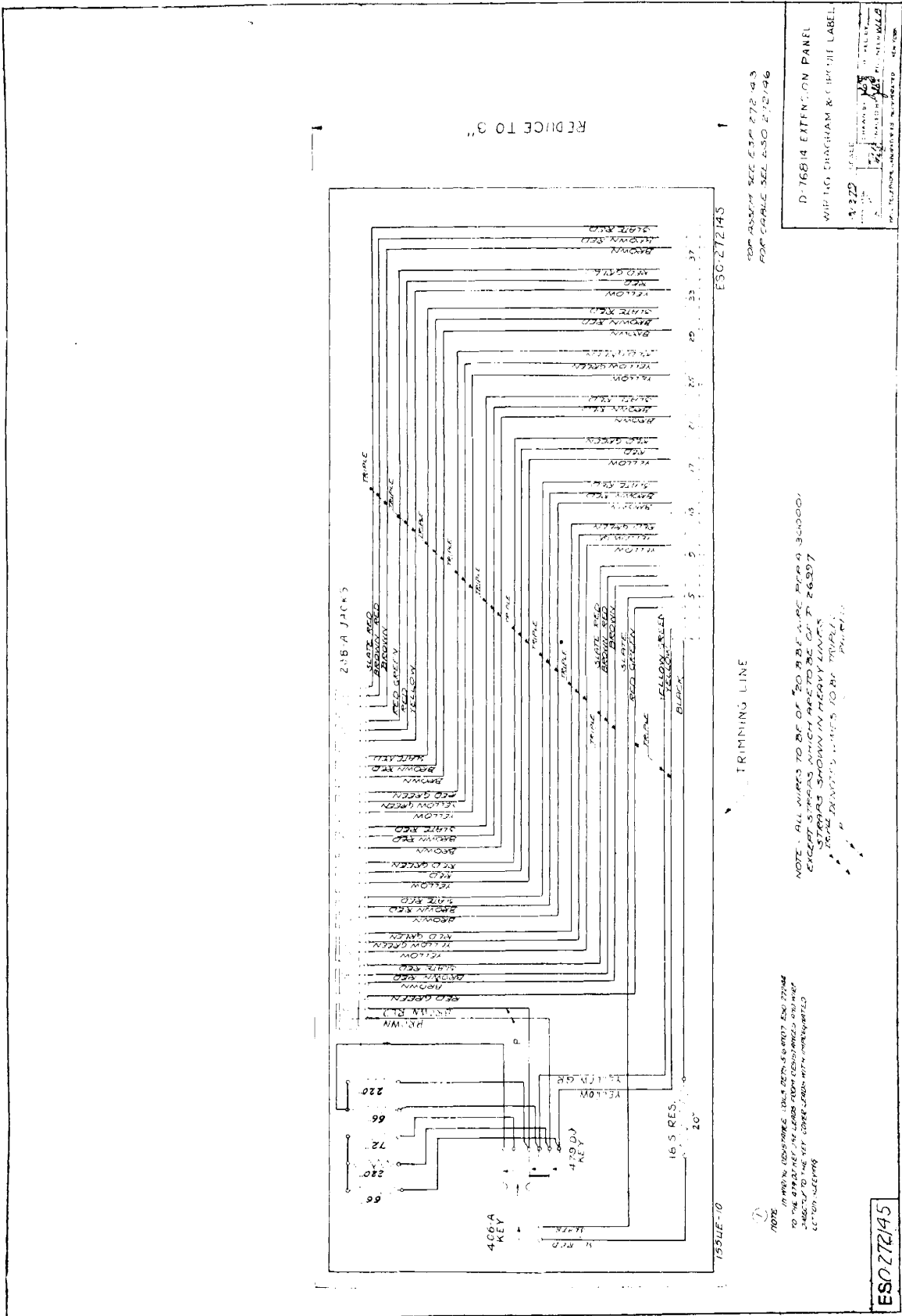

REDUCE TO 3"

TOP BOARD SEC 234 272-43
FOR CABLE SEE 272/46

D-7684 EXTENSION PANEL
WIRING DIAGRAM & CIPHER LABEL

9-22-50

REVISIONS

NO.	DATE	BY	REASON
1	9-22-50

TRIMMING LINE

NOTE: ALL WIRES TO BE OF 18 AWG UNLESS OTHERWISE SPECIFIED.
EXCEPT STRIPAS WHICH ARE TO BE OF 20 AWG.
STRIPAS SHOWN IN HEAVY LINES.
CIPHER LABELS ARE TO BE TRIMMED.

NOTE: IN THIS WIRING, ALL WIRE IS 18 AWG UNLESS OTHERWISE SPECIFIED.
ALL WIRE IS TO BE STRIPPED TO THE 1/2\"/>

ES0272/45

D-7684 EXTENSION PANEL WIRING DIAGRAM—ES0-272/45

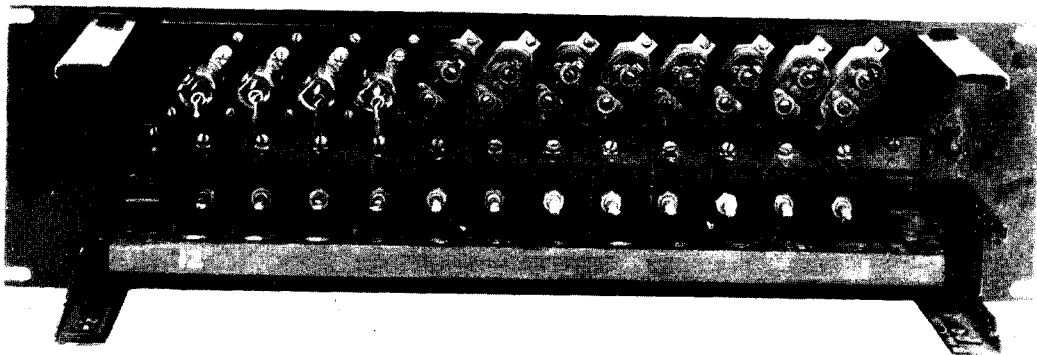
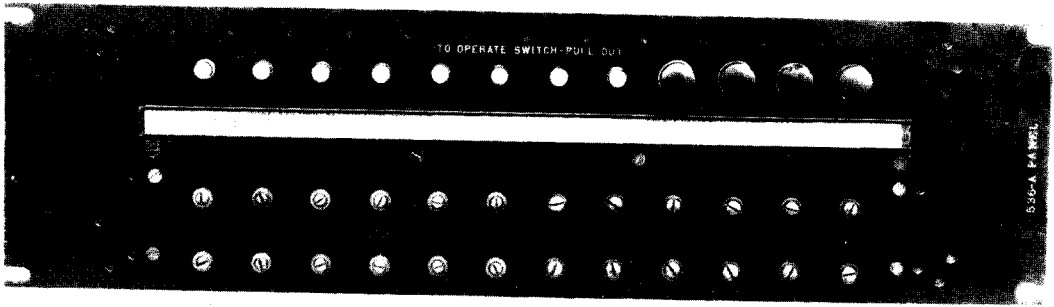

536-A BATTERY SUPPLY PANEL (MODIFIED)—23255-C

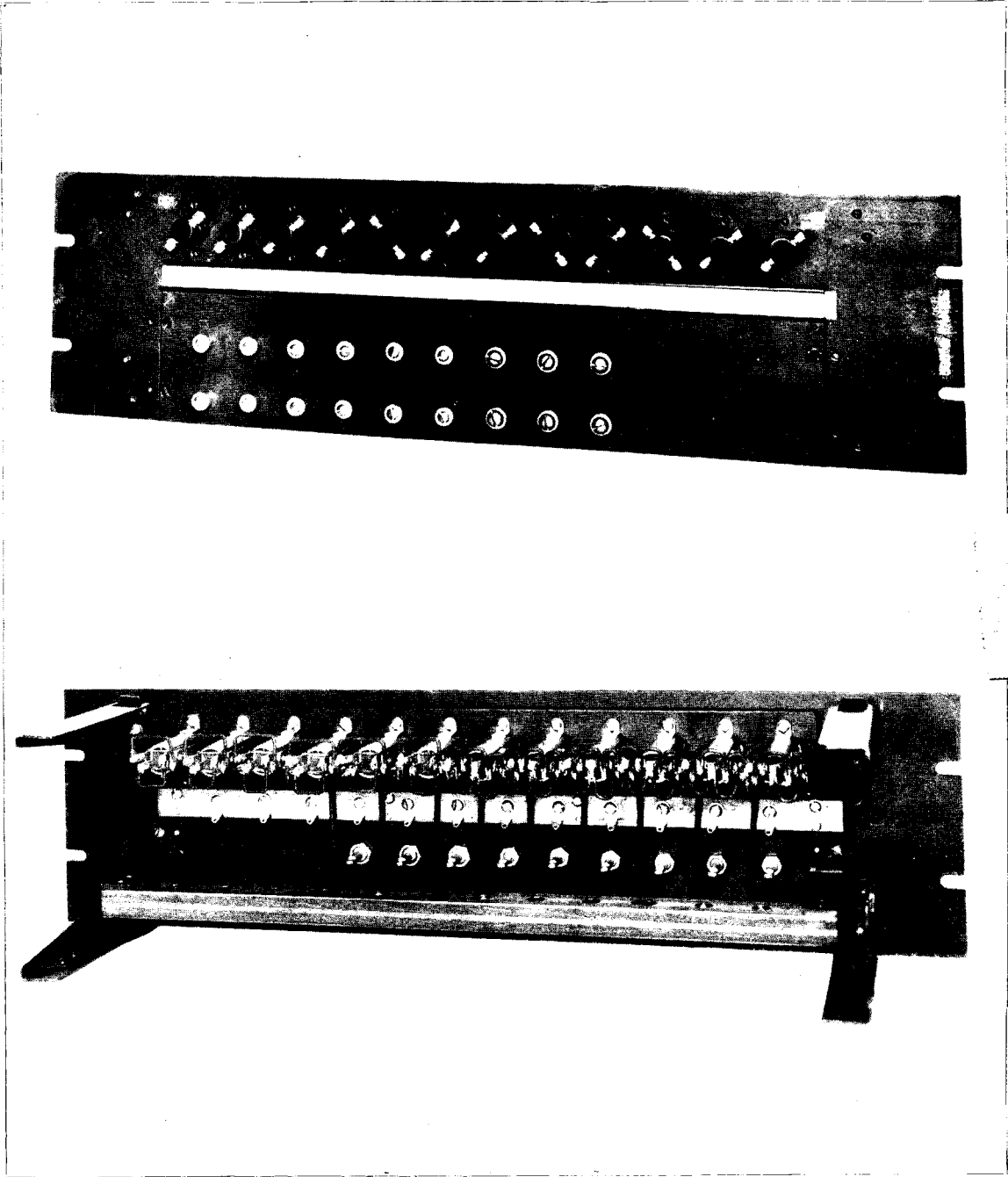

536-B BATTERY SUPPLY PANEL—22963-C

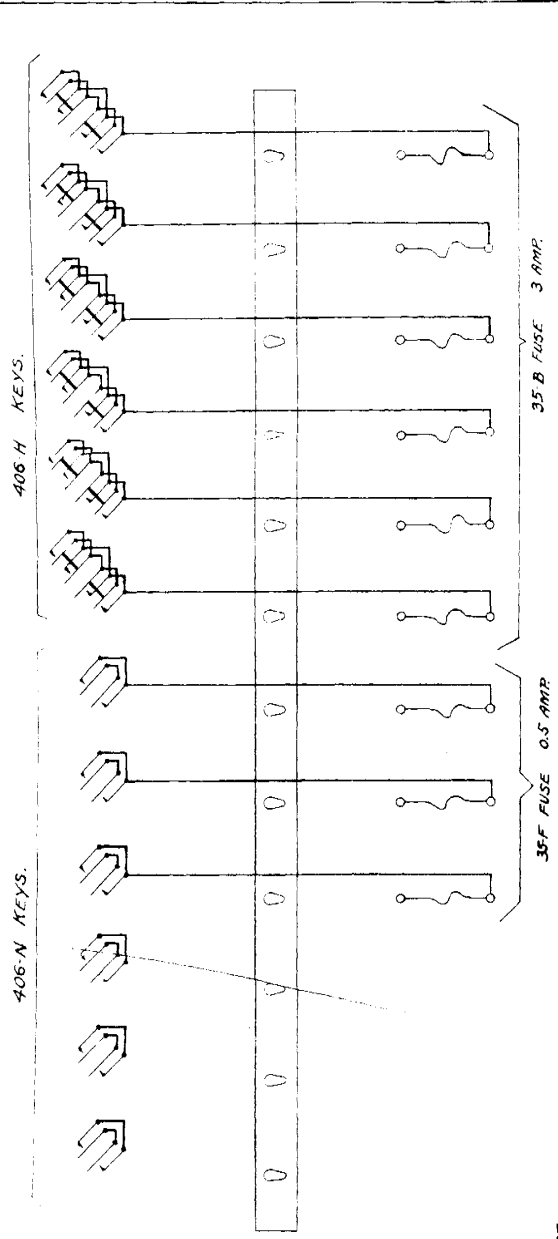

NOTE
 STRAPPING BETWEEN TERMINALS OF 406
 TYPE KEYS SHALL BE PER P. 2699.
 ALL OTHER WIRING TO BE BLACK #16 BBE
 WIRE PER A. 300001.

NOTE - A
 STRAPS SHALL BE SOLDERED CLOSE
 TO BODY OF KEYS TO LEAVE HOLES
 IN SPRINGS OPEN FOR EXTERNAL
 WIRING

APPROVED
 FOR ASSEMBLY SEE ESR-302269

536-B PANEL
 RADIO BROADCASTING EQUIPMENT
 BATTERY SUPPLY AND FUSE PANEL
 WIRING DIAGRAM

32344 SCALE
 APPROVAL: [Signature] DRAWN BY: [Signature] CHECKED BY: [Signature]
 R.A. [Signature] TRACED BY: [Signature] ENGINEER: E.V.T.
 BELL TELEPHONE LABORATORIES NEW YORK

ESL-302270

536-B BATTERY SUPPLY PANEL WIRING DIAGRAM—ESL-302270

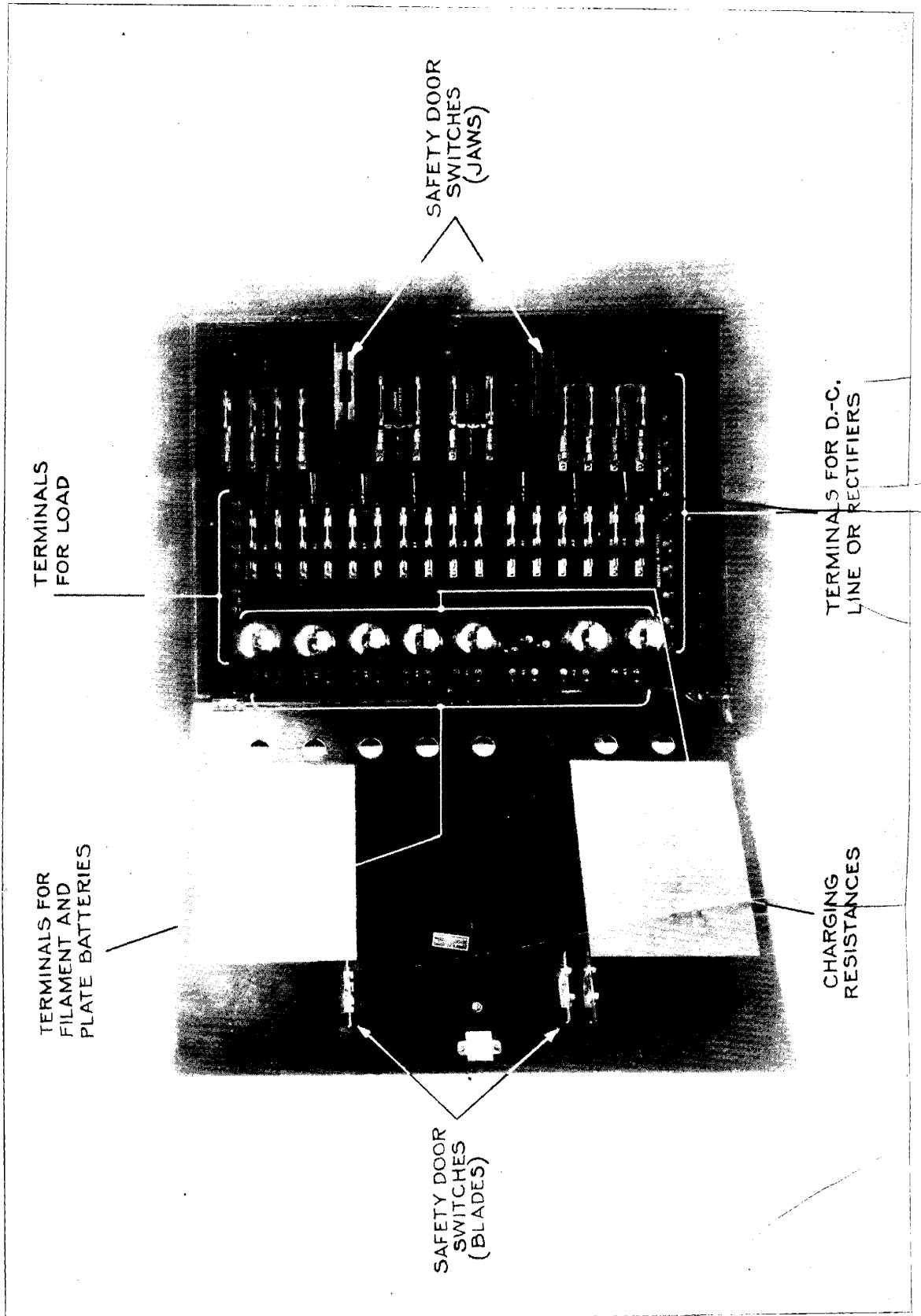

TERMINALS FOR LOAD

TERMINALS FOR FILAMENT AND PLATE BATTERIES

SAFETY DOOR SWITCHES (JAWS)

SAFETY DOOR SWITCHES (BLADES)

TERMINALS FOR D-C. LINE OR RECTIFIERS

CHARGING RESISTANCES

KS-2805 BATTERY CHARGING AND SWITCHING PANEL--21445

SWITCHING PANEL KS 2805
FOR
#2A-PUBLIC ADDRESS SYSTEM
SCHEMATIC

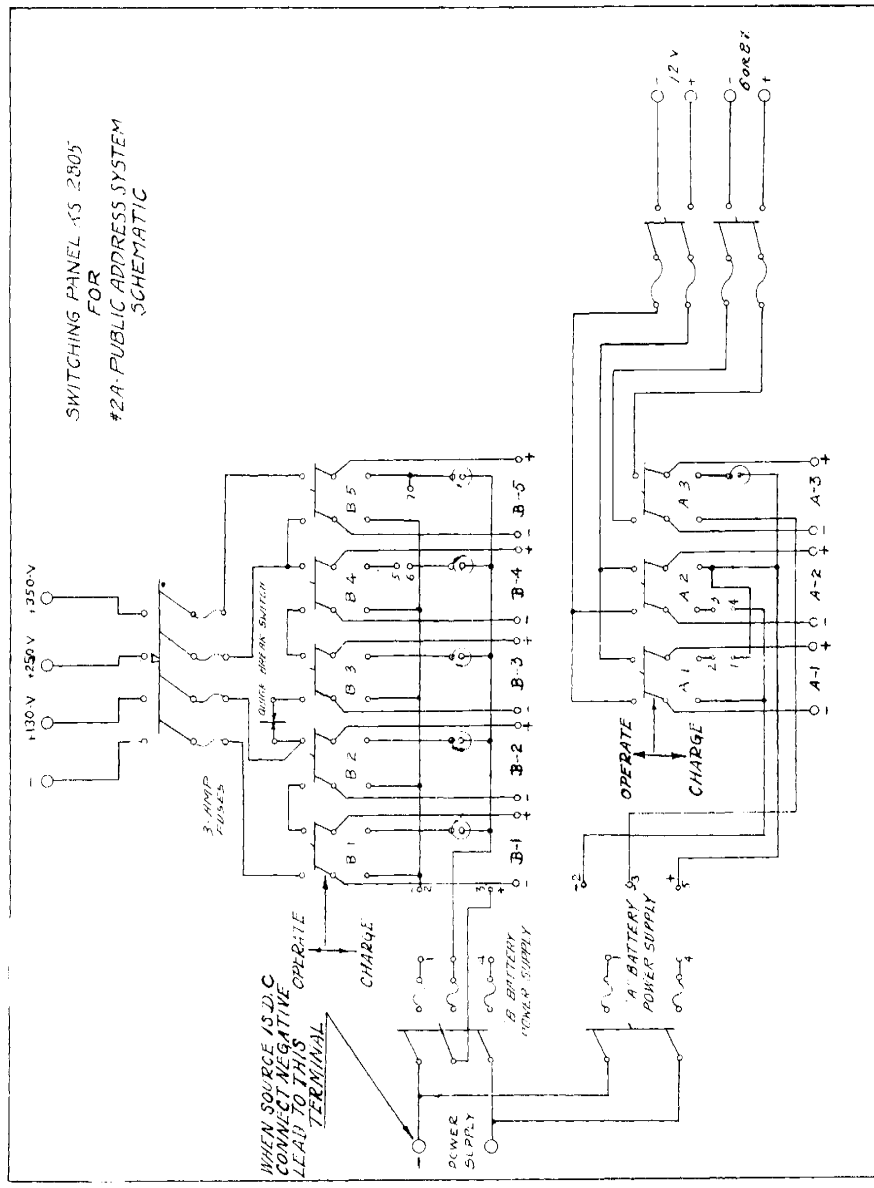

E5L - 305070

BATTERY CHARGING & SWITCHING
PANEL KS 2805
#2A-PUBLIC ADDRESS SYSTEM
SCHEMATIC

32614 SCALE
APPROVED BY: [Signature]
DRAWN BY: P.C.S. CHECKED BY: W.S.D.
TRACED BY: P.C.S. ENGINEER/CAH
ELECTRONIC LABORATORIES, INC. NEW YORK

FOR ASSEMBLY SEE ESR 305060
FOR WIRING SEE ESR 305061

ISSUE 10

E6L 305070

KS-2805 BATTERY CHARGING AND SWITCHING PANEL SCHEMATIC—E5L-305070

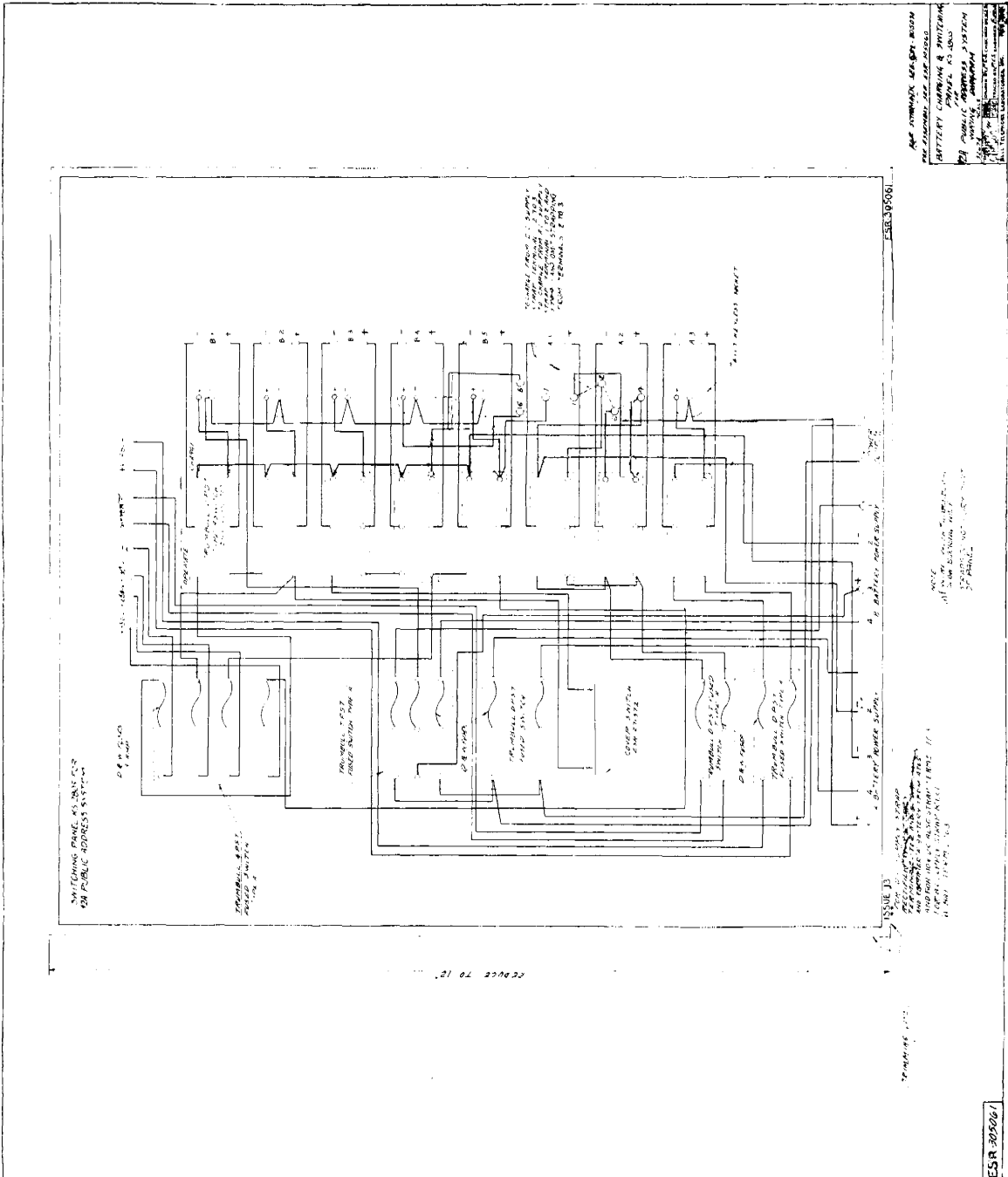

KS-2805 BATTERY CHARGING AND SWITCHING PANEL WIRING DIAGRAM—ESR-305061

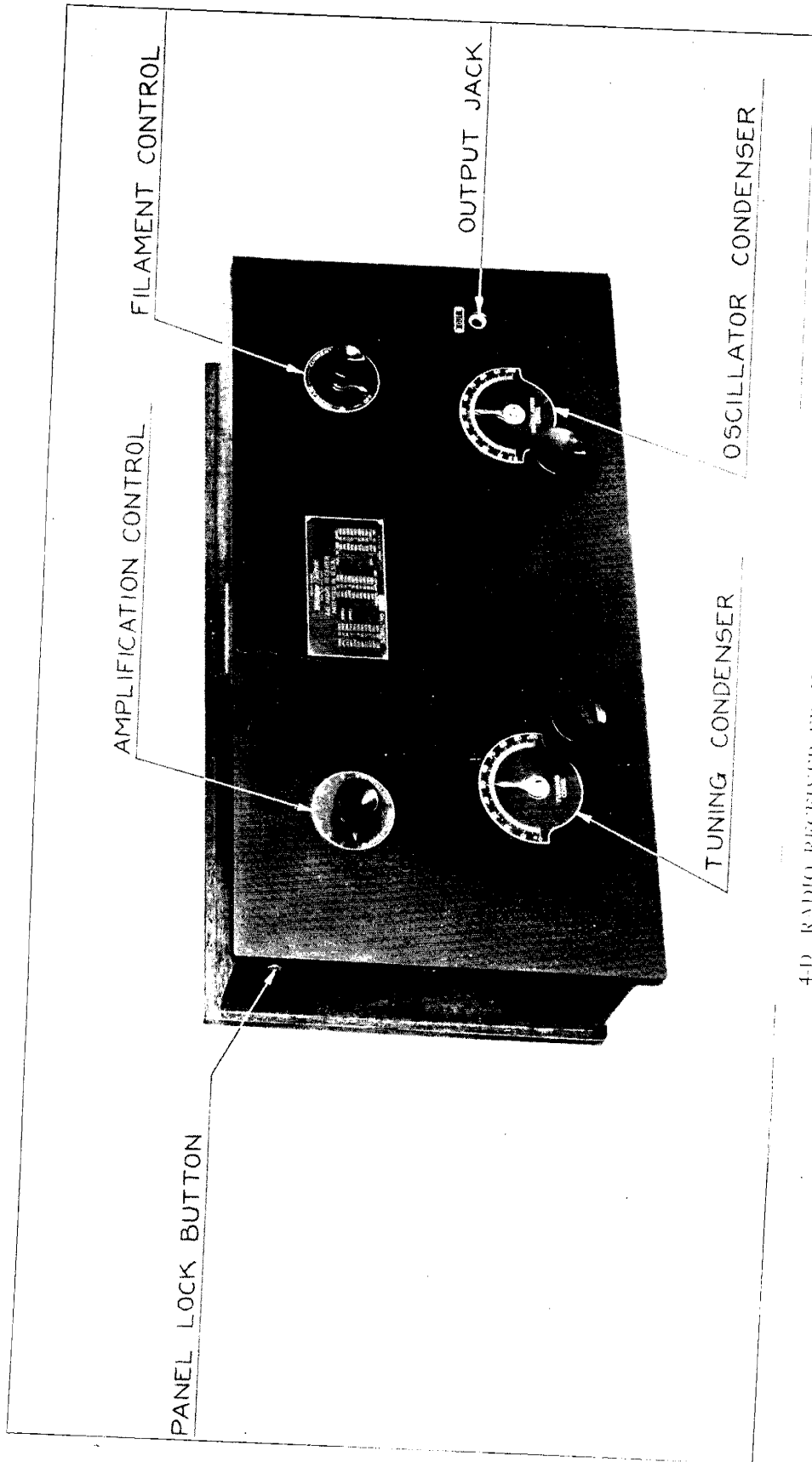

4-D RADIO RECEIVER FRONT VIEW—2548

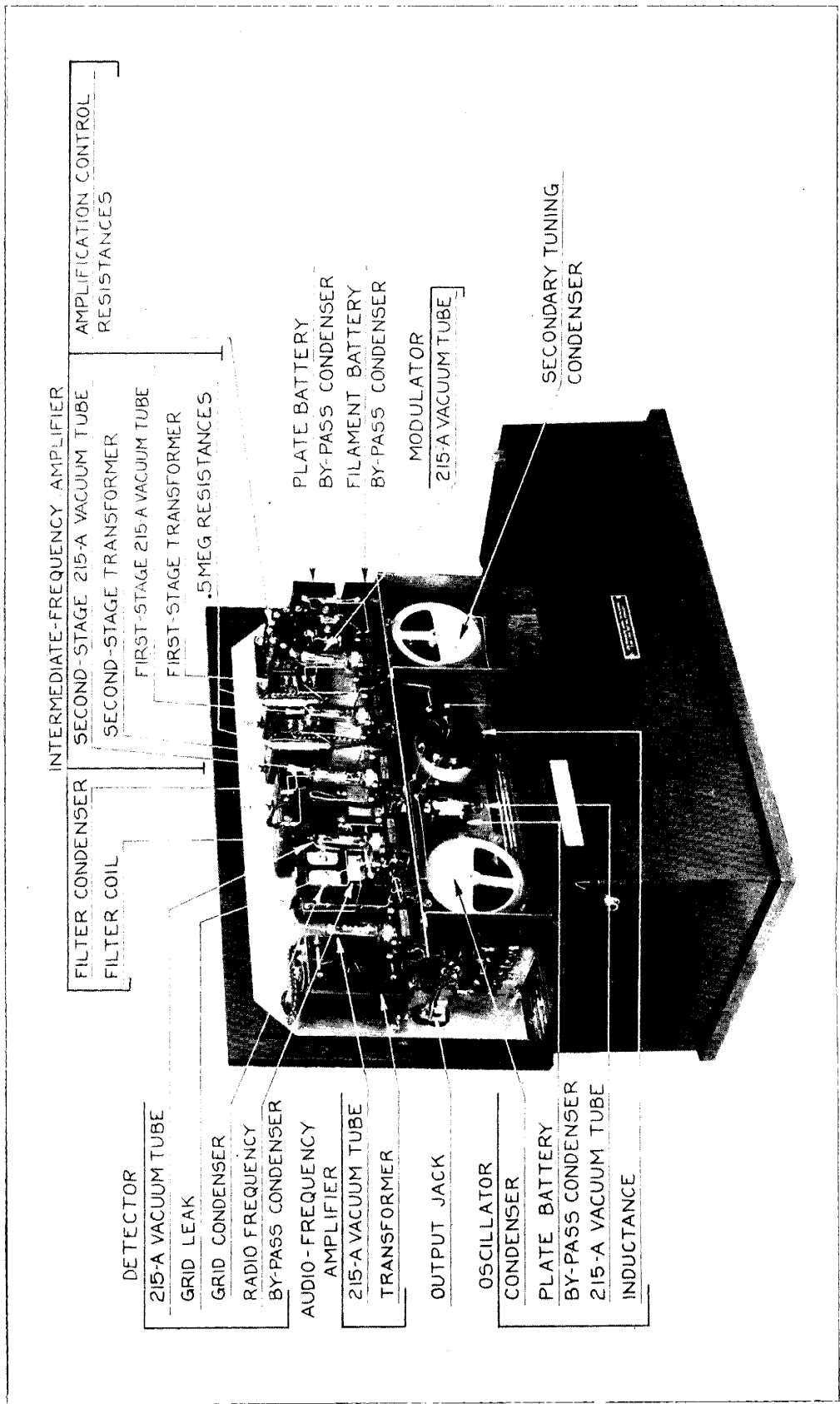

4-D RADIO RECEIVER OPEN VIEW—25694

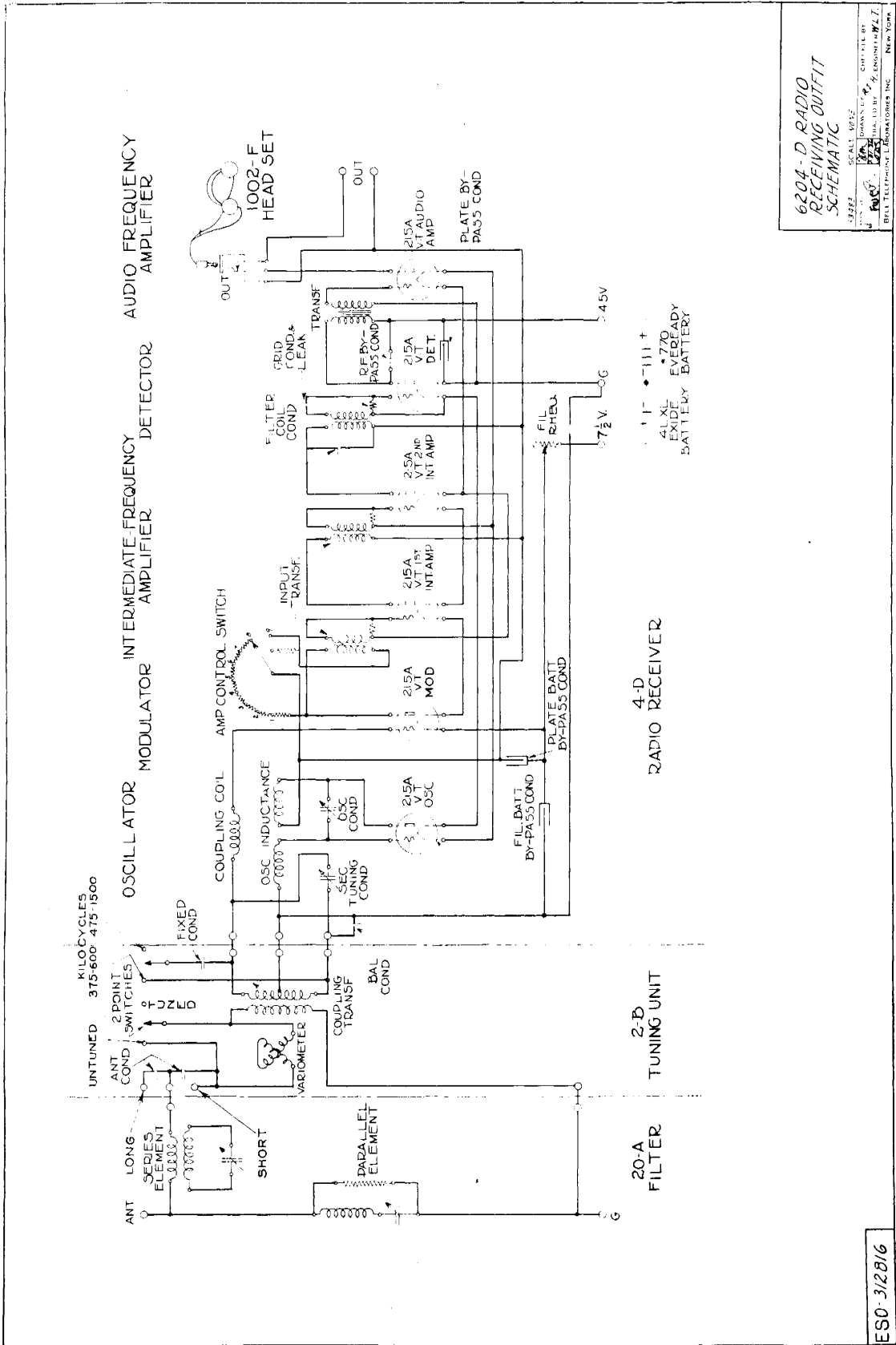

6204-D RADIO RECEIVING OUTFIT SCHEMATIC

SCALE: 100%
 DRAWN BY: [Signature]
 CHECKED BY: [Signature]
 DESIGNED BY: [Signature]
 BEL TELEPHONE LABORATORIES INC. NEW YORK

6204-D RADIO RECEIVING OUTFIT SCHEMATIC--ESO-312816

ESO-312816

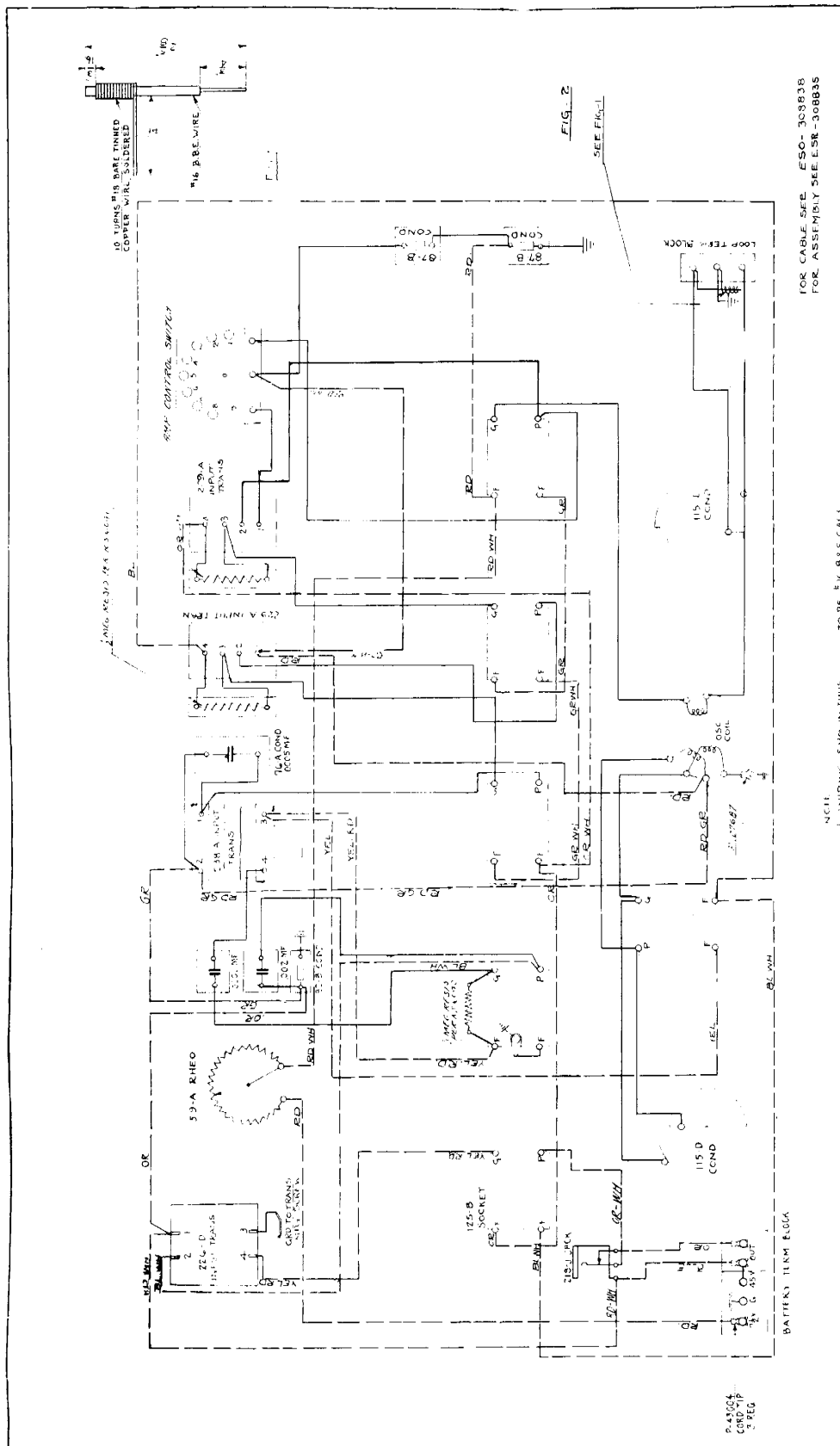

FOR CABLE SEE ESO-308830
FOR ASSIGNMENT SEE ESR-308835

4-D RADIO RECEIVER WIRING DIAGRAM

- NOTE
1. WIRING SHOWN THUS — TO BE 16 B & S GAGE BARE TINNED COPPER WIRE.
 2. WIRING SHOWN THUS — TO BE IN CABLE.
 3. ALL GRID WIRES TO BE SOLDERED TO SHIELDING.
 4. WHITE BAKELITE WIRE PASS THROUGH SHIELDING INSULATED WITH 1/8" VARNISHED TUBING.

37644 SCALE
DRAWN BY S. RICHARDS
CHECKED BY E. S. HALL
BELL TELEPHONE LABORATORIES, INC. NEW YORK

ESO-308830

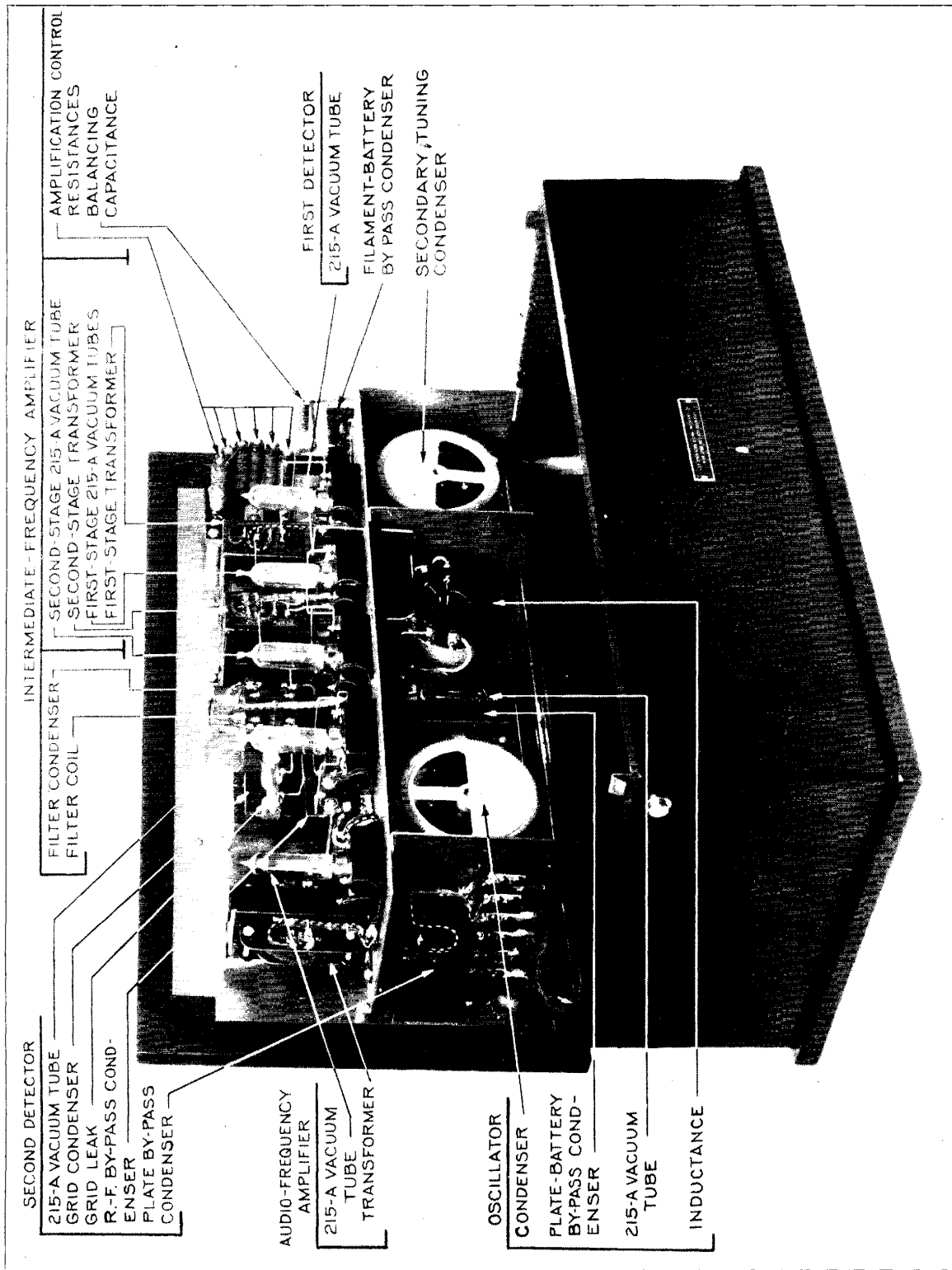

4-C RADIO RECEIVER--21437

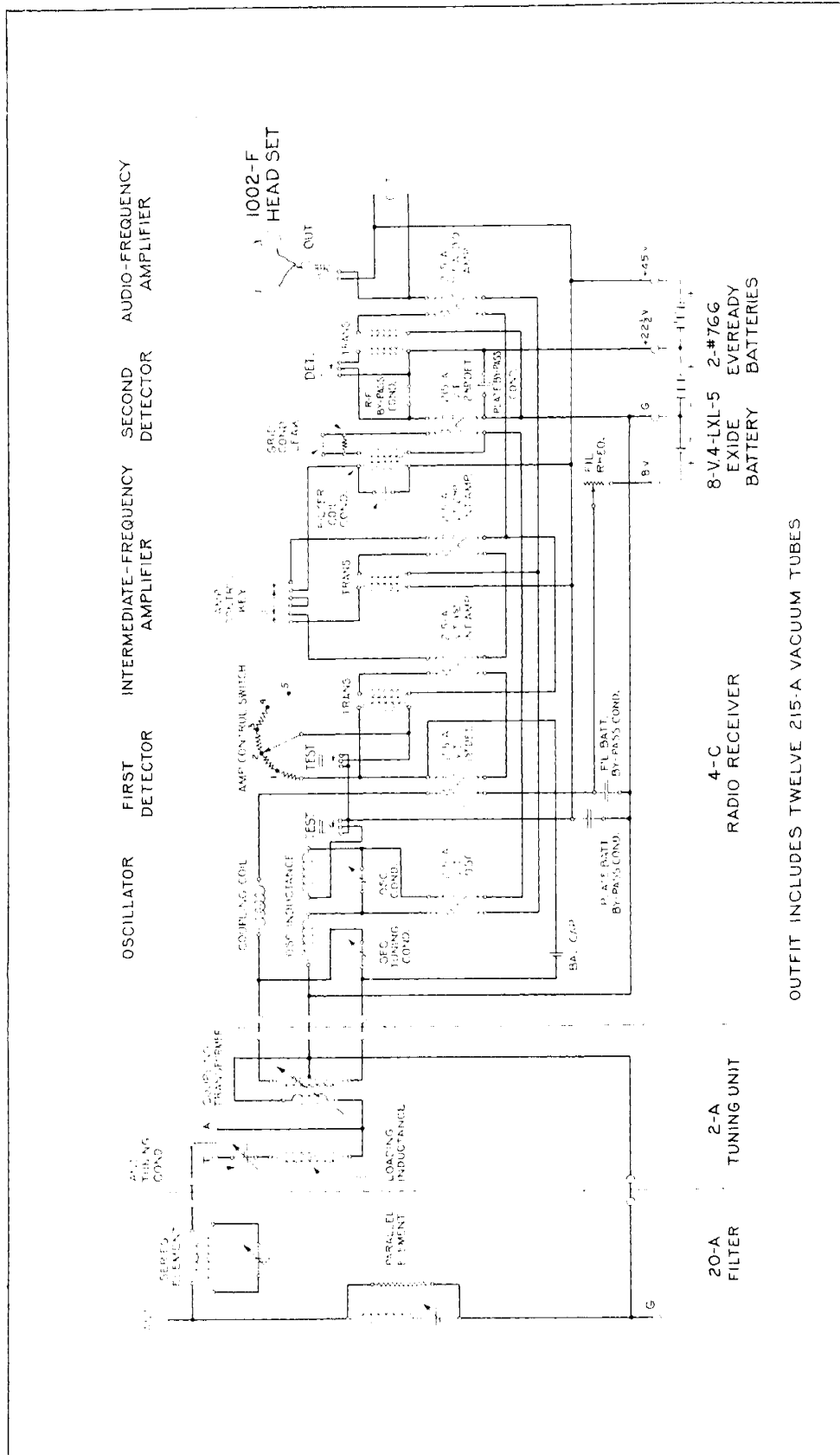

6004-C RADIO
RECEIVING OUTFIT
- SCHEMATIC -

U.S. GOVERNMENT PRINTING OFFICE: 1944
RADIO ENGINEERING LABORATORY, INC., NEW YORK

8-V-4-LXL-5 2-#76G
EXIDE EVEREADY
BATTERY BATTERIES

4-C
RADIO RECEIVER

20-A
FILTER

OUTFIT INCLUDES TWELVE 215-A VACUUM TUBES

ESO-307765

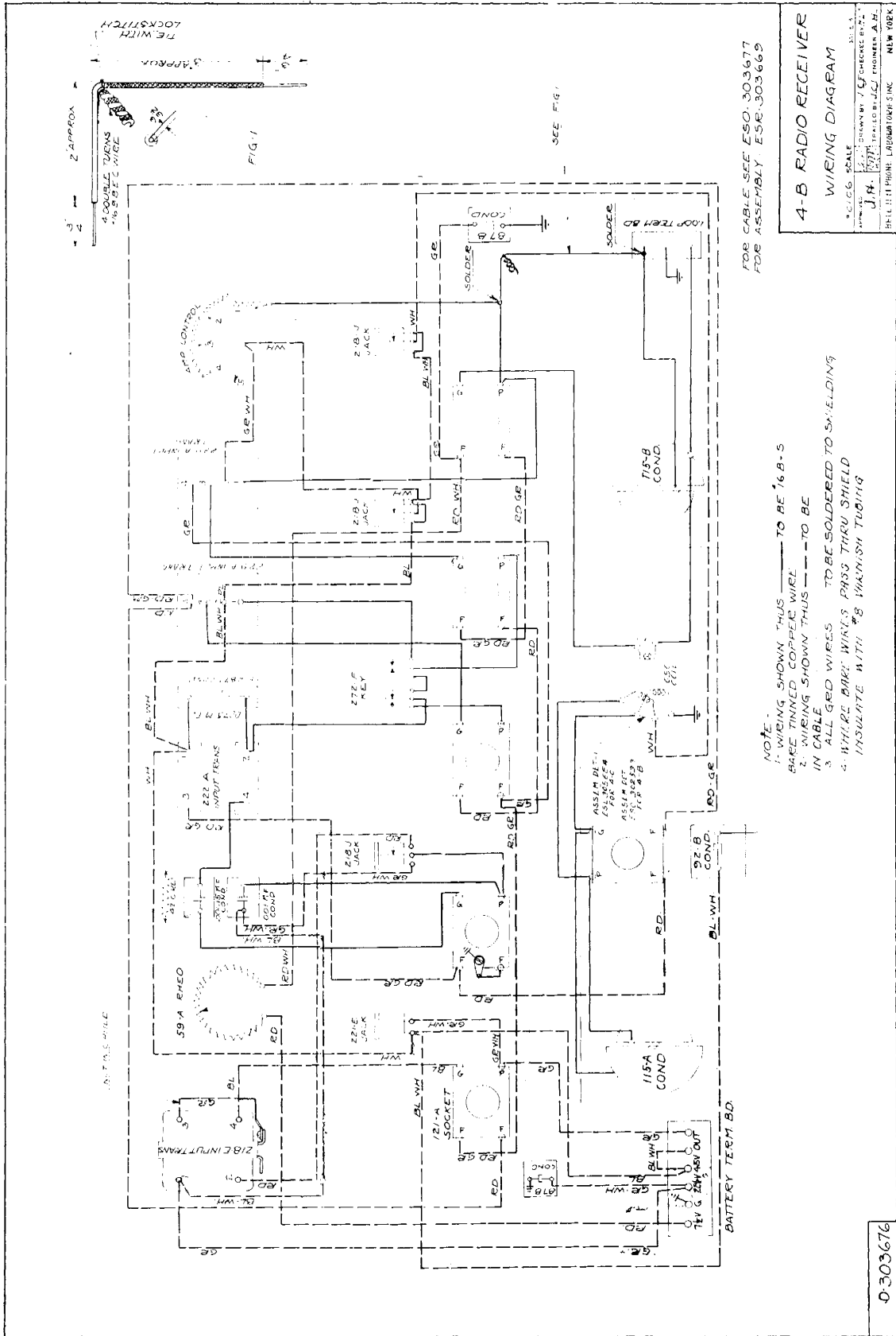

FOR CABLE SEE ESO-303677
FOR ASSEMBLY ESR-303669

**4-B RADIO RECEIVER
WIRING DIAGRAM**

SCALE: 1/8" = 1'
DRAWN BY: J. H. [Signature]
CHECKED BY: J. H. [Signature]
DESIGNED BY: J. H. [Signature]
APPROVED BY: J. H. [Signature]
DATE: [Blank]
NEW YORK

NOTE:
1. WIRING SHOWN THUS TO BE 16.8-5 BARE TINNED COPPER WIRE
2. WIRING SHOWN THUS TO BE IN CABLE
3. ALL GND WIRES TO BE SOLDERED TO SHIELDING
4. WHERE BARE WIRES PASS THRU SHIELD INSULATE WITH #8 WAXWASH TUBING

4-B 4-C RADIO RECEIVER WIRING—ESO-303676

0-303676

TWO POINT SWITCHES

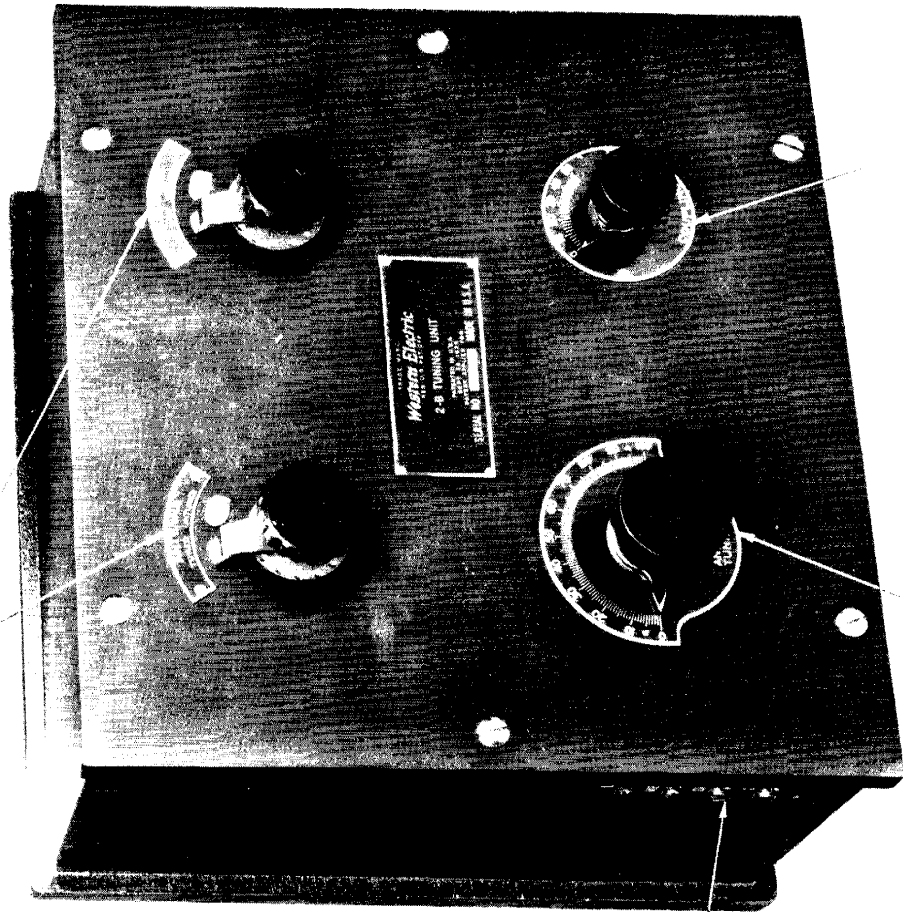

TERMINAL

ANTENNA TUNING VARIOMETER

COUPLING

2-B TUNING UNIT FRONT VIEW—25449

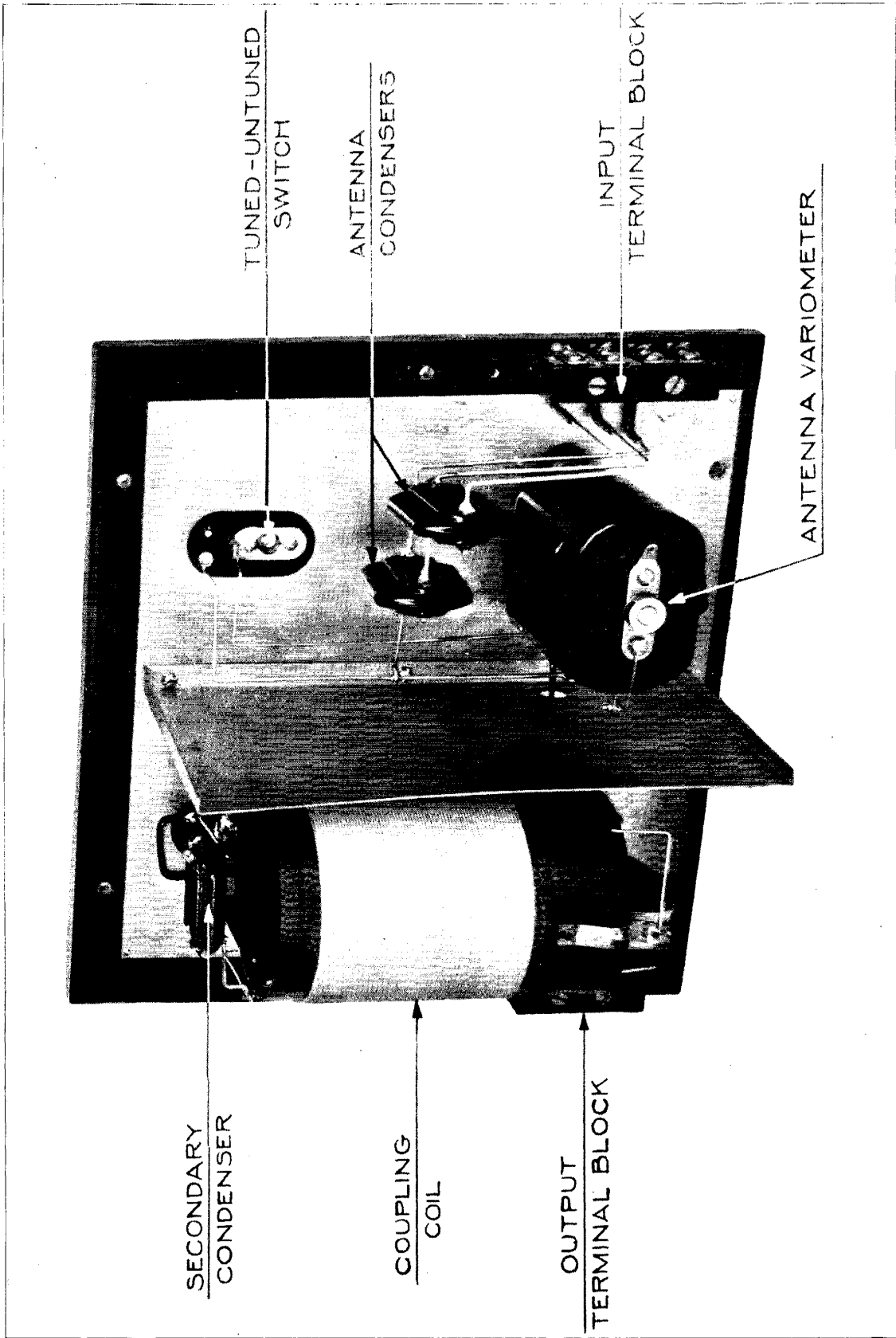

2-B TUNING UNIT REAR VIEW—25446

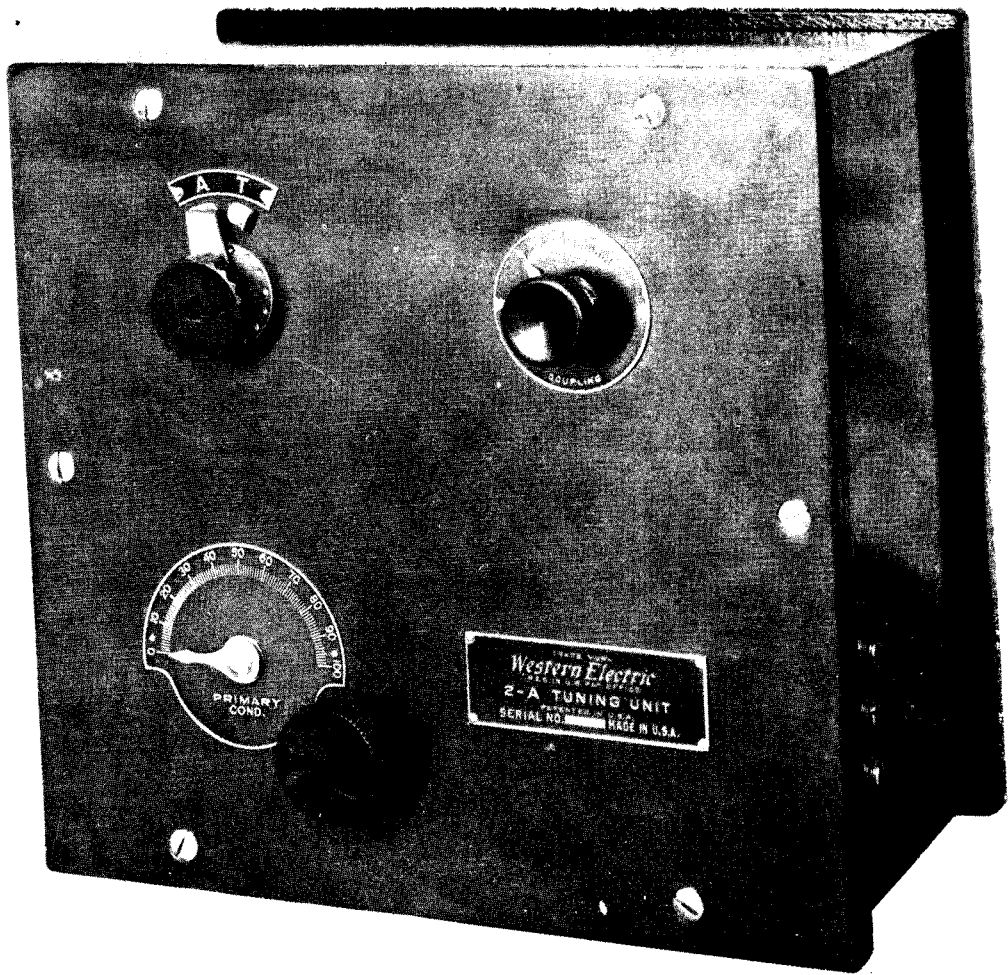

2-A TUNING UNIT FRONT VIEW—22129

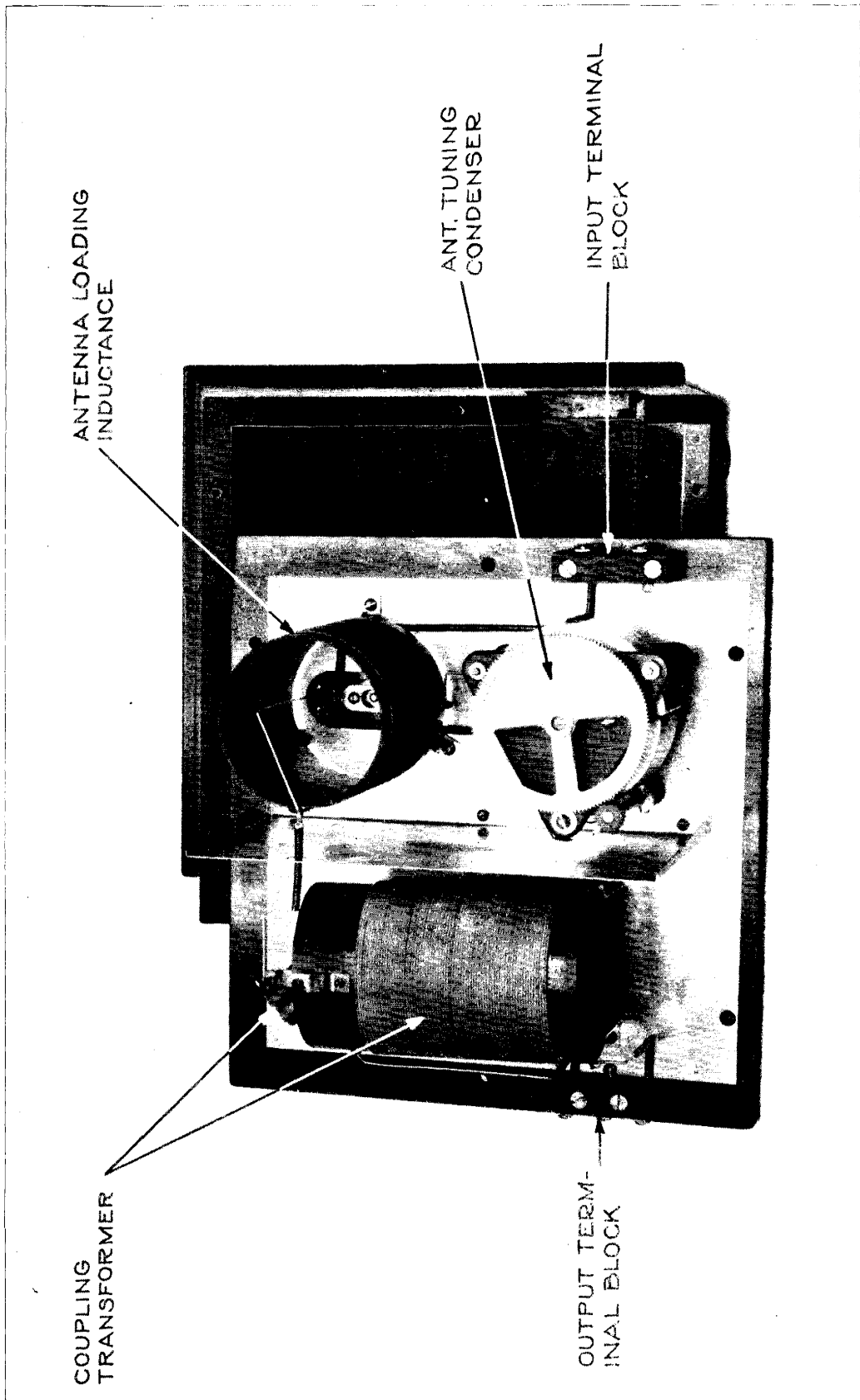

2-A TUNING UNIT REAR VIEW-2142

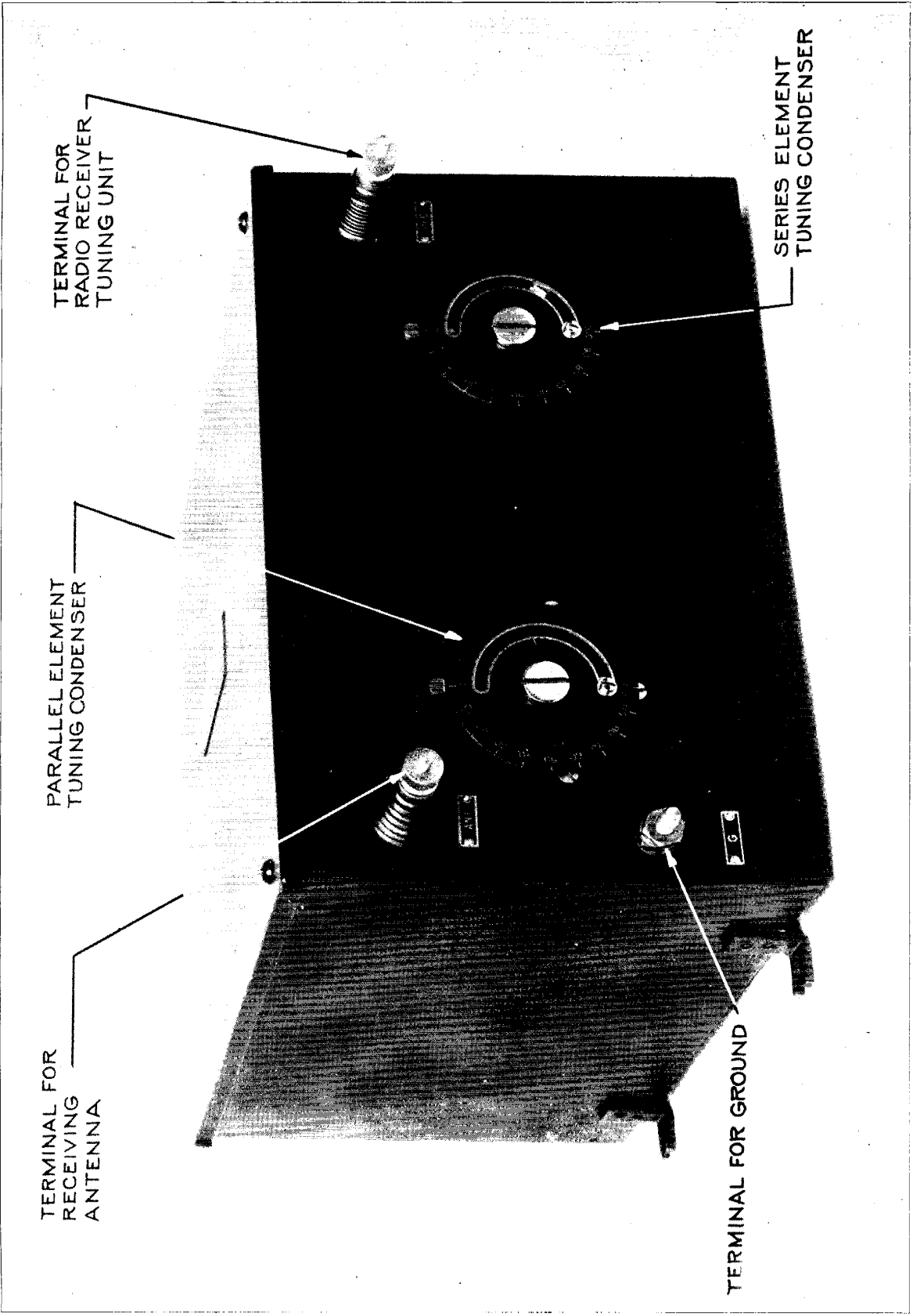

TERMINAL FOR
RADIO RECEIVER
TUNING UNIT

PARALLEL ELEMENT
TUNING CONDENSER

TERMINAL FOR
RECEIVING
ANTENNA

SERIES ELEMENT
TUNING CONDENSER

TERMINAL FOR GROUND

20-A FILTER FRONT VIEW - 21484

TERMINAL FOR
RADIO RECEIVER
TUNING UNIT

TERMINAL FOR
RECEIVING
ANTENNA

SERIES
ELEMENT
TUNING
CONDENSER
INDUCTANCE

PARALLEL
ELEMENT
TUNING
CONDENSER
INDUCTANCE

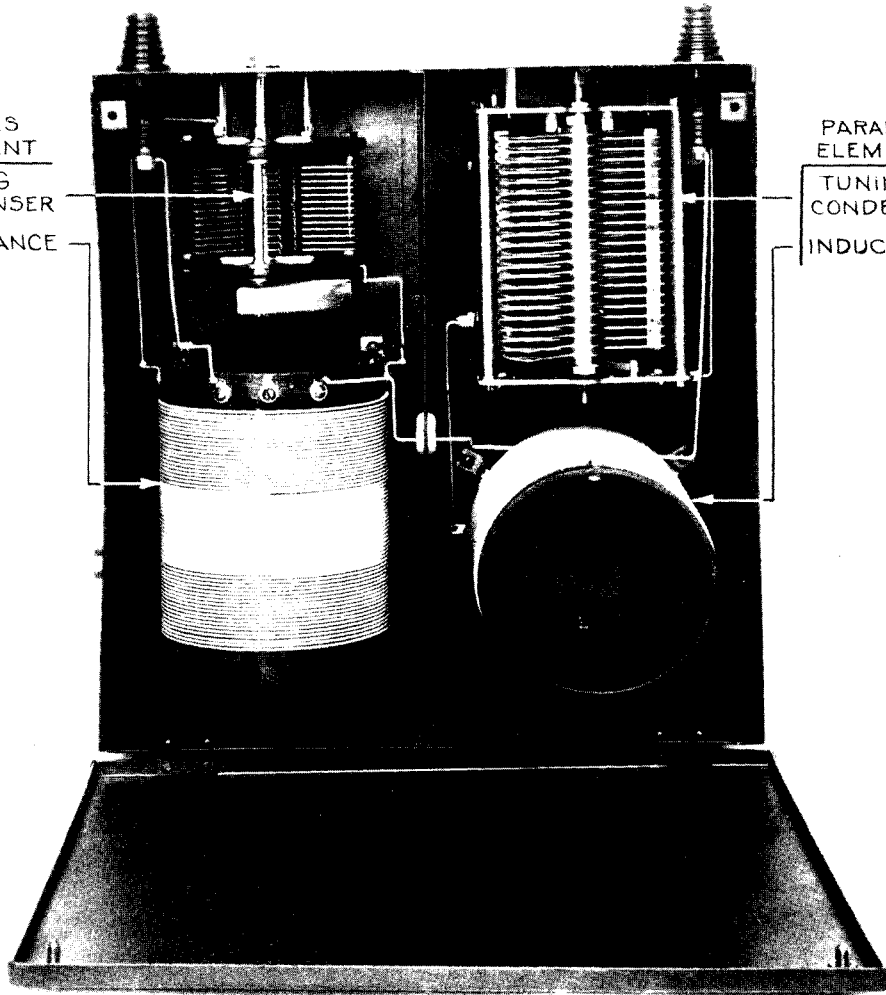

20-A FILTER REAR VIEW—21444

DISTRIBUTOR IN THE UNITED STATES

Graybar

ELECTRIC COMPANY, INC.

SUCCESSOR TO SUPPLY DEPARTMENT *Western Electric*

Albany
Asheville
Atlanta
Baltimore
Birmingham
Boston
Brooklyn
Buffalo
Charlotte
Chicago
Cincinnati
Cleveland

Columbus
Dallas
Davenport
Dayton
Denver
Detroit
Duluth
Grand Rapids
Harrisburg
Hartford
Houston
Indianapolis

Jacksonville
Kansas City
Los Angeles
Memphis
Miami
Milwaukee
Minneapolis
Nashville
Newark
New Haven
New Orleans
New York

Norfolk
Oakland
Omaha
Philadelphia
Pittsburgh
Portland
Providence
Reading
Richmond
St. Louis
St. Paul
Salt Lake City

San Antonio
San Francisco
Savannah
Seattle
Spokane
Syracuse
Tacoma
Tampa
Toledo
Worcester
Youngstown

A NATIONAL ELECTRICAL SERVICE

DISTRIBUTOR FOR CANADA AND NEWFOUNDLAND

NORTHERN ELECTRIC COMPANY, LIMITED

Plant and General Offices
121 Shearer Street, Montreal, P. Q.

Branch Houses

Halifax
Quebec
Montreal

Ottawa
Toronto
London

Hamilton
Windsor
Winnipeg

Regina
Calgary
Vancouver

FOREIGN DISTRIBUTORS

International Standard Electric Corporation

Formerly International Western Electric Company, Incorporated

25 Broad Street

New York, U. S. A.

Foreign Associated and Allied Companies

ARGENTINA—

Cia Standard Electric Argentina
(Formerly Cia Western Electric
Argentina) Casilla de Correo 49,
(Street Address, Paseo Colon
185), Buenos Aires.

AUSTRALIA—

Standard Telephones and Cables
(Australasia) Ltd. (Formerly
Western Electric Co., (Australia)
Ltd.) Harvard House, 192 Castle-
reagh Street, (P. O. Box 525),
Sydney, N. S. W.

AUSTRIA—

Verriegelte Telefon und Tele-
graphenfabrik, A. G. Czernia
Nissl & Co., Dresdner Strasse,
No. 75, Vienna, XX 2.

BELGIUM—

Be 11 Telephone Manufacturing
Co., 18 Rue Bondewyns, Antwerp.

BRAZIL—

International Standard Electric
Corp. (Formerly International
Western Electric Co., Inc.) Caixa
Postal 219, (Street Address, Rua
dos Ourives 91-D) Rio de Janeiro.

CHINA—

China Electric Co., Ltd., 1 Piao
Chang-ku Cha-dao, Peking.
China Electric Co., Ltd., 1-C
Kukiang Road (P. O. Box 289),
Shanghai.

CZECHO-SLOVAKIA—

Hekaphon-Standard Electric
(Formerly — Hekaphon Western
Electric), Prague—Vrsovice 664.

EGYPT—

Standard Telephones and Cables,
Ltd., (Formerly Western Electric
Co., Ltd.), 26 Sharia El Mauakh
(P. O. Box 2034), Cairo.

ESTHONIA—

A. E. Reinke, Sales Representa-
tive, International Standard Elec-
tric Corp. (Formerly Interna-
tional Western Electric Co., Inc.),
Vene Tanav 17, Reval.

FRANCE—

Le Materiel Telephonique, 46
Avenue de Breteuil, Paris.

GREAT BRITAIN—

Standard Telephones and Cables,
Ltd. (Formerly Western Electric
Co., Ltd.), Connaught House,
Aldwych, London, W. C. 2.

HOLLAND—

Bell Telephone Manufacturing
Co., Scheldestraat 160-162, The
Hague.

HUNGARY—

United Incandescent Lamps &
Electrical Co., Ltd., Ujpest 4
(near Budapest).

INDIA—

Standard Telephones and Cables,
Ltd. (Formerly Western Electric
Co., Ltd.), C-2 Clive Building,
(P. O. Box 413) Calcutta.

ITALY—

Standard Elettrica Italiana (For-
merly Western Electric Italiana),
Via Vittoria Colonna, No. 9,
Milan, 25.

JAPAN—

Nippon Electric Co., Ltd., 2 Mita
Shikokumachi, Shiba-Ku, Tokyo.

LATVIA—

A. E. Reinke, Sales Representa-
tive, International Standard Elec-
tric Corp. (Formerly Interna-
tional Western Electric Co., Inc.),
Rainis Boulevard 11, Riga.

NEW ZEALAND—

Standard Telephones and Cables
(Australasia), Ltd. (Formerly
Western Electric Co., (Australia)
Ltd.), P. O. Box 638, Wellington.

NORWAY—

Standard Electric Aktieselskap
(Formerly Western Electric Norsk
Aktieselskap), Drammensveien 20,
Oslo.

POLAND—

Standard Electric Co. W. Polsee,
Sp. z o.o., (Formerly Western
Electric Co., Ltd., W. Polsee.)
Warsaw, Matejki, 7.

SOUTH AFRICA—

Standard Telephones and Cables,
Ltd. (Formerly Western Electric
Co., Ltd.), Cam Buildings, Sim-
monds Street (South) (P. O. Box
1571), Johannesburg.

SPAIN—

Standard Electrica S/A (For-
merly Telefonos Bell, S/A),
Avenida de Pi y Margall No. 5,
(Apartado No. 12,325), Madrid.

STRAITS SETTLEMENTS—

Standard Telephones and Cables,
Ltd. (Formerly Western Electric
Co., Ltd.), 1 Orchard Road,
Singapore.

SWITZERLAND—

Bell Telephone Manufacturing
Co., 10 Bubenberplatz, Berne.

S. Adams

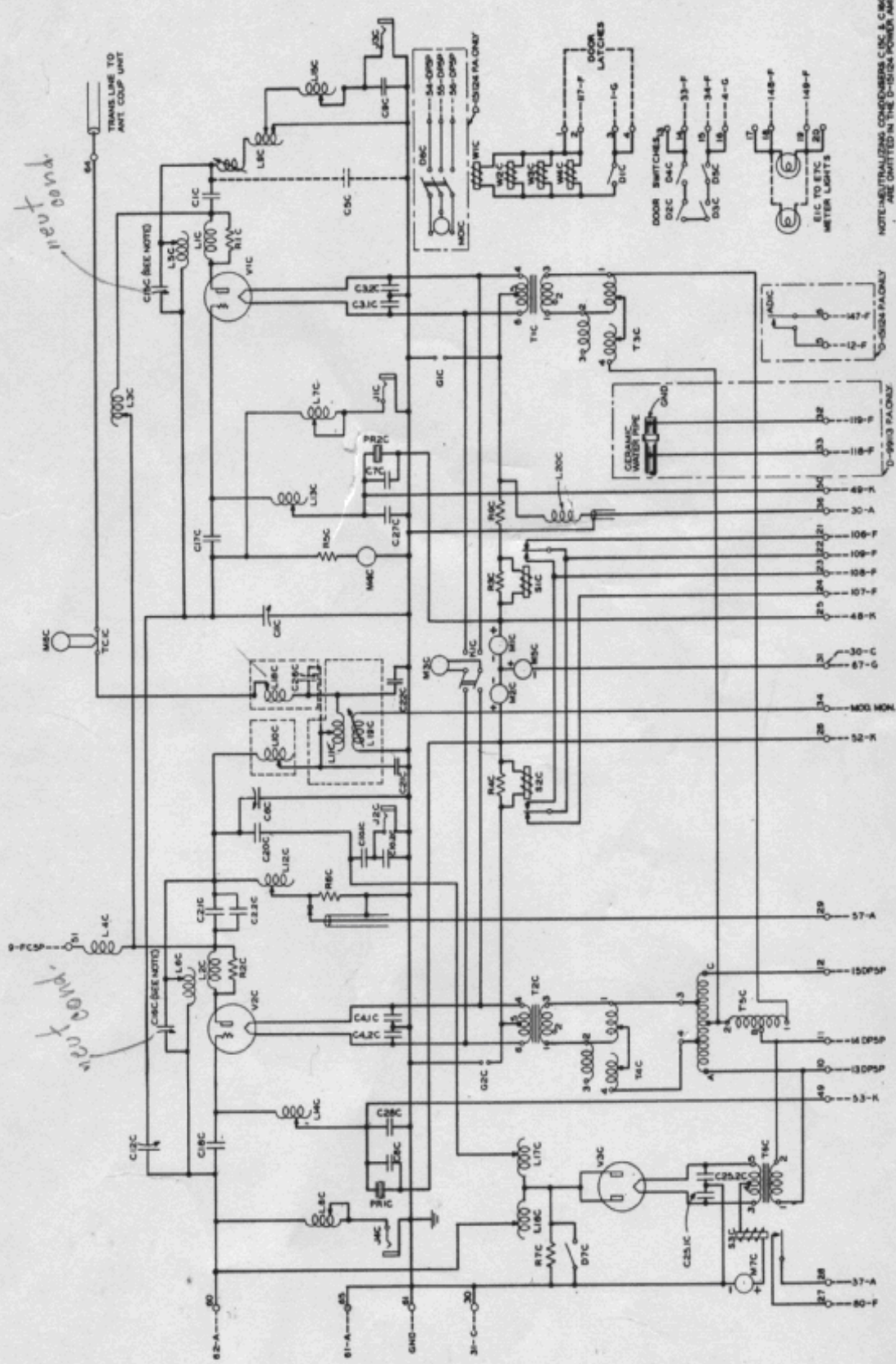

FIGURE 8—Unit C-D-99113 (or D-151124) Power Amplifier