

**ELEMENTS
OF SPEECH INPUT SYSTEMS
(STUDIO APPLICATIONS)**

Western Electric



Photograph courtesy OWI and Electronics Industries

*Master
Control*

HEART OF THE
PROGRAM
DISPATCHING
SYSTEM

Western Electric

The Program Production Unit . . . 6

*The Master Dispatching
Equipment 12*

*The Principle
of Stabilized Feedback 15*

Key to Circuit Symbols 16

*Index to Western Electric
Speech Input Components 18*

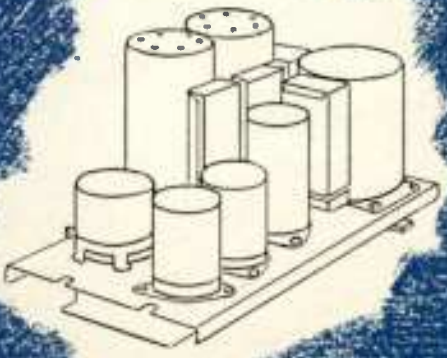
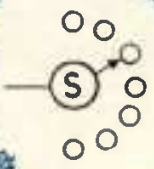

Foreword . . .

Refinements in radio broadcasting techniques which substantially increase the operating demands on both network and individual studio facilities have focused attention anew on that vitally important portion of the broadcasting plant – the Speech Input equipment.

To attempt to point out specific deviations from previous practice which are inherent in the use of these new techniques would, in most instances, lead the engineer onto controversial ground. Moreover, such a discussion would be meaningless to the newcomer to radio who may lack background in basic speech input principles.

Instead, it is our purpose here to review in outline form the principal components and effects produced in a typical modern speech input system for both AM and FM broadcasting, so that the neophyte may gain a broad perspective of how such systems operate and so that the expert may draw from it such information regarding new developments as he may find applicable to his own problems.

Elements of Speech Input Systems

AN OUTLINE of the Components,
Organization and Characteristics
of a Typical Audio System for High
Fidelity Broadcasting.

THE fundamental purpose of a Speech Input or Audio System for broadcasting is to convert sound into electrical energy and to prepare this energy for effective transmission over telephone lines or through the air in such a manner that the original sound can be faithfully reproduced at many distant points.

Basic components required for achieving this objective include:

1. A microphone, or converting element.
2. A succession of vacuum tube amplifier stages, provided with progressively greater power handling capacity to raise the initially low level of converted sound energy in terms of units of gain and volume called decibels (db).
3. Control, checking and stabilizing devices, which are applied throughout the amplification process (a) to maintain proper strength and balance among all outgoing program elements and (b) to overcome noise and prevent tone distortion.
4. A means of transferring the prepared program energy to the circuit of the transmitting element with a minimum loss of signal strength and quality.

Qualified Transmission Experts

During the course of many years of practical experience in the allied fields of wire and radio sound transmission, Bell Telephone Laboratories and

Western Electric have developed fundamental Audio circuits and circuit components in which optimum performance is combined with the greatest economy in equipment outlay. The advent of Frequency Modulation offered a further opportunity to apply an exceptional understanding of wide-frequency band transmission to the new, high fidelity requirements of the radio industry, with the result that standard units now in the line transmit the full 30 to 15,000 cycle audio range faithfully, and are in every way suited to both FM and AM broadcasting.

For purposes of demonstration, we have summarized in this booklet certain basic Western Electric ideas regarding the components, desirable operating characteristics and functions of a typical Speech Input Installation, including both the basic, or Program Production Unit and the Master Dispatching Equipment. Most of these concepts have at various times been incorporated into systems designed for major U. S. broadcasting stations and an analysis of them will be helpful to an understanding of all Western Electric Audio System Equipment.

Program Production and Dispatching

Figure 1 outlines the basic structure of a typical six input studio Program Production Unit and shows the relative positions of the various recommended

inputs, amplifiers, networks and controls. In Figure 2 are diagramed the units commonly found in a Master Dispatching Circuit through which the program normally passes on its way to the transmitting element. Figures 1A and 2A demonstrate the successive energy levels of program input as it progresses through each section of this typical system – the depressions indicating the losses which occur, because of the nature of the circuit elements, or which are inserted deliberately to provide a margin of level control. The scale at the left of each of the last two drawings is graduated in dbm (decibel level referred to power rating in milliwatts) – the modern standard unit for measuring program energy level in Audio frequency circuits. This unit coincides approximately in amount with the minimum amount of change in volume the trained listener can detect. For convenience a zero reference level has been arbitrarily set at 1 milliwatt. Values above this level are indicated in +dbm; values below are prefixed by a minus sign.

Program Production Unit



The initial component in any Audio system is, of course, the MICROPHONE, of which two are shown as input sources in Figure 1, Page 21 (Channels 1 and 2). Microphones in common use for broadcasting, employ a movable element arranged to follow those vibrations in air which produce the sensation of sound when they act upon the ear. This element is usually a conducting coil or ribbon suspended so as to move freely in a magnetic field and which, as it moves, generates an electrical voltage across its terminals. Energy produced solely by the vibrations of sound waves is, of course, infinitesimally small. Engineers define it as in the order of .000055 watt for sound of normal conversational intensity originating at a distance of three feet from the Microphone. Referring to Figure 1A, it will be noted that, translated into terms of program level, this converted sound energy normally enters our typical Production Unit from one or more microphone sources located in an associated studio at approximately –62 dbm. Recorded program material which, by means of records, wire or tape, has been held in storage follow-

ing its original conversion into electrical energy, is introduced into the system from one or more REPRODUCERS (Figure 1, Page 21, Channels 3 and 4) at approximately the same low energy level. At the foot of Figure 1, two additional input sources are shown in the form of Incoming Program Transmission lines, dispatched from points outside of the studio (Channels 5 and 6). Since the normal level of transmission from remote points is about +8 dbm, the input from these sources normally enters the studio equipment at a relatively high level.

Program Blending

A most desirable objective obviously, is to merge the active input channels in our system into one, so that succeeding volume-producing and control operations can be applied to the blended program material with the greatest efficiency and the least amount of equipment. The program level at the output of the microphone and reproducer channels, however, is so low that the further energy losses which are apt to occur during the merging process would expose the transmission to noise generated in the circuit elements by interacting electro-magnetic fields or thermionic activity. Since disturbances in a speech input system are likely to be cumulative in effect, i.e., become disproportionately magnified as successive stages of amplification are applied, it is extremely important at this initial stage to offset these effects by amplifying the transmission before these disturbances can become detrimental. Accordingly, a series of PRE-MIXING AMPLIFIERS, is employed, equivalent in number to the low level input sources on the chart, each of which raises the energy level in its particular channel by approximately 40 db.

In our system, the amount of increase, or "gain" as it is called, of each amplifier unit is always a fixed quantity unless subjected to further control. However, in these early stages of program preparation, this fixed gain may occur over different ranges extending to the maximum and minimum levels defined in Figures 1A and 2A by the dotted curves. It is important therefore that a Pre-Mixing Amplifier possess the ability to handle a higher output power than that called for under normal transmission conditions. An adequate margin of power handling capacity is accordingly provided in these, as well as in other types of amplifiers



Western Electric Custom Built desk type Program Production equipment for FM or AM broadcasting. This type of equipment is suited for installation in standard functional arrangements, or can be assembled to suit individual station requirements.

described herein, to permit faithful performance at the highest anticipated levels of program energy. Harmonic distortion, which otherwise might be produced by overloading the circuit, is thus held, in these units, to less than 1%. By the same token, output noise encountered in a more marked degree at points below normal input levels is reduced to a minimum by use of proper shielding against the action of surrounding magnetic fields and careful selection and construction of vacuum tubes and other component parts.

Returning to Figure 1A, it will be noted that the levels of the incoming program lines have been dropped to approach those of the other program sources as they emerge from the Pre-Mixing Amplifiers. A portion of this overall drop in the line channels is produced automatically through the action of LINE EQUALIZERS which serve to compensate for attenuation occurring in the higher audio frequencies during the course of long lines transmission—and of LINE REPEATING COILS which isolate the audio equipment from direct current potentials

built up over the line and aid in matching the impedances of the two circuits. The remaining portion of this loss however, is achieved by the use of adjustable volume controls or Line Pads. These latter circuit elements also possess frequency stabilization characteristics which are discussed in greater detail in a later section on impedance stabilization.

Level Controls and Indicators



At this point, all input sources are at about -22 dbm, and a sufficient level margin has been assured to permit joining the channels into a properly balanced, common output. The first step in this joining process is accomplished in the MIXER LEVEL CONTROLS, which provide variable loss characteristics for each channel so as to afford a means for rapid level adjustment. To show how this works, let us assume, for example, that Input Channel 1 carries the voice of a featured soprano, who is



Western Electric's 25 Type Speech Input Console, incorporating two complete main amplifier channels capable of simultaneous operation on different programs. Also built into the main housing are a separate monitoring amplifier, a seven channel mixing circuit, four pre-mixing amplifiers and switching and control circuits for dual channel operation.

accompanied by an orchestra on Input Channel 2. In order to keep the singer's voice at a listening level proportionate to that of the orchestra, a loss greater than that occurring in Channel 1 is deliberately inserted on Channel 2. In this manner, an apparent gain is produced on Channel 1 so that the two channel levels can be blended into a realistic and naturally proportioned reproduction of the original program. Moreover, when desirable, special dramatic effects can be developed in the Mixer Level Controls which contribute substantially to the realism of the finished program. Intensive rehearsal, involving the artists, Control Engineer, and Program Producer, usually precedes the transmission of the final program to determine proper sound intensities, distances from microphones and the extent of the losses to be inserted in each channel in order to produce the desired results. Should actual transmitting conditions cause variations in the anticipated input levels, the range of adjustment in the Mixer Level Controls should be adequate to permit compensation by rapid read-

justment of the amount of loss provided for each program source.

Passing into the MIXING NETWORK, the six channels are merged into one by means of a complex circuit in which all branches (both input and output) are terminated and their impedances matched so that the transmission remains independent of the settings of the individual input controls. This procedure also operates to prevent frequency discrimination and excessive loss of program energy.

The action taking place in the Mixing Network causes some energy loss however (about 18 db for this particular circuit) and brings the average program level down to approximately -54 dbm (only 8 dbm above the level of the original input from the microphones). Hence, to bring the volume up to the point at which it is safe to apply further controls, a BOOSTER AMPLIFIER is required. For this purpose the same type of two-stage amplifier may be used as for the Pre-Mixing Amplifier, since the allotted gain (approximately 40 db)

and power handling capacity of this unit is usually adequate for this application.

While at first glance it might appear that the gain provided by the Booster Amplifier might just as well be supplied by adding an equivalent amount of amplification either to the preceding Pre-Mixing Amplifiers or to the Main Amplifier, which is the next major unit in the system, so that the Booster stage could be omitted entirely, experience has proved that this is seldom practical either from an economic or performance standpoint. For example, if more gain were added to the Pre-Mixing Amplifiers, each of the four pre-amplifying units in our illustration (Fig. 1) would increase substantially in both size and cost. In systems employing a larger number of microphone input channels, this cost factor would greatly over-shadow the outlay for the single extra unit represented by the Booster Amplifier. On the other hand, if this gain were to be added to the Main Amplifier, a further

dilemma would arise. The Master Level Control, if located at the output of the Mixing Network, might reduce the transmission below the level of safety from thermionic disturbance. Conversely, if this control were to be applied at the output of the Main Amplifier, electronic interference might be induced in the low level mixer circuits as a result of the normal desirability for a close physical association between the Master and Mixer Level Controls.

On leaving the Booster Amplifier, the program enters the MASTER LEVEL CONTROL at about +14 dbm. The Master Level Control, like the Mixer Level Controls, may be adjusted as a result of rehearsal experience to produce a fixed level drop at various points during the program in order to take into account fluctuations in the amount of energy received from the Booster Amplifier (Figure 1A shows an inserted loss of about 14 db). By regulating the extent of the drop which is actually used

For the smaller broadcasting station, or for semi-permanent "remotes" in large systems, the Western Electric 23 type equipment answers a need for a single compact unit containing program production facilities for one or two studios.





Close up of Volume Indicator Meter, standardized for broadcast use. The upper row of figures shows program level in terms of percentage of optimum transmission requirements. The lower row of figures is calibrated in vu, above and below the 100% reference point.

above or below the prescribed level, as the input energy of the combined program elements rises or falls while the studio is on the air, it is possible to assure a reasonably uniform output at all times to the MAIN AMPLIFIER.

The Main Amplifier is designed to produce the full amount of additional amplification needed to meet the requirements of main transmission lines following energy drains to a variety of checking, stabilizing and monitoring circuits which are fed from its output. Hence its power handling capacity must be somewhat greater than that of the preceding units in the circuit. Western Electric Main Amplifiers are designed to supply gains of from 45 to 70 db, and to provide a maximum output power of .6 watts, the power equivalent of approximately +28 dbm. Necessary safeguards are provided against harmonic and frequency distortion through the use of Stabilized Feedback—a feature commonly employed in Western Electric amplifiers to prevent the generation of spurious harmonics and to help maintain a flat frequency response throughout a 15,000 cycle range.

At +12½ dbm, which serves, in our studio system, as the reference point upon which all of the foregoing level-producing and control operations are based, the program enters the ISOLATING NETWORK through which the transmission is distributed to various wayside destinations, as well as to the outgoing studio line, properly matched

and at the desired level. One branch of this network leads to the VOLUME INDICATOR which is inserted to provide a visual check on the program level at this highest or reference point. The Volume Indicator translates rapidly varying program energy levels (dbm) into units designated as "vu"—numerically equivalent to dbm but differing in that the dynamic characteristics of the measuring mechanism are taken into account to provide a practical and uniform system of observation during the transmission.

Monitoring Facilities

A simultaneous aural indication of program quality is provided by means of a MONITOR LOUD SPEAKER located in the Control Engineer's Booth, operated from a line coming from another branch of the Isolating Network, and feeding through a MONITOR LEVEL CONTROL. The Monitor Level Control functions on the same principle as the Master Level Control to provide a uniform and comfortable listening level within the booth. In order to deliver the required volume to the Monitor Loud Speaker, a MONITOR AMPLIFIER is employed possessing an overall gain of from 35 to 63 db, and which should be capable of an output power of from 5 to 20 watts without noticeable distortion. In addition to monitoring the main transmission, this amplifier should have adequate gain and power capacity to permit listening in directly on other incoming program lines, as well as other circuits requiring separate monitoring. For this reason a sufficient loss should be inserted in that branch of the Isolating Network which leads to the Monitor Amplifier and in the leads to other sources to be monitored to permit switching among the inputs of these relatively low level sources without frequent adjustment of the Monitor Level Control.

A CUE AND TALKBACK LOUDSPEAKER located in the associated studio may also be connected to the booth monitoring circuit to allow oral control over the actions of performers, and to facilitate cueing by allowing the performers to hear the close of the program preceding their own. Operation of a loudspeaker in the same room with a live microphone can be prevented by loudspeaker cut-off relays interlocked with "Mike On" Keys for both booth and studio loudspeakers. As a further oper-



Photograph courtesy Station WTM

Part of a Master Dispatching System showing a custom built Master Control Desk and one of the equipment racks (extreme left). The desk incorporates level and switching controls, indicating circuits, monitoring and communication facilities. The racks contain amplifying, line circuit, auxiliary and maintenance equipment. Built by the Western Electric Company.

ating convenience, a keying system can be arranged for remote line cueing to permit switching between the three conditions of monitoring on remote lines, receiving cue from the master control point and feeding cue to the remote lines.

Impedance Stabilization

Still another branch of the Isolating Network consists of an IMPEDANCE STABILIZATION PAD which, in addition to performing other valuable functions, brings down the level in the main transmission circuit to about +8 vu. This, it will be recalled, is the level required for most outgoing transmission lines. The loss in the network branch feeding the Volume Indicator is adjusted so that the meter will read at the normal indication (0 vu or 100% at approximately $\frac{3}{4}$ full meter scale) when +8 vu is being fed to the outgoing transmission line.

The Impedance Stabilization Pad is another direct outgrowth of Bell System research in telephone line transmission. It was discovered during the course of developing the long lines system, that the circuits involved contain not only resistance, but capacitive and inductive reactance to a degree which, if uncontrolled, changes energy distribution with variations in frequency. To correct this condition, Bell Laboratories engineers devised new circuit elements for the telephone plant which have been adapted for use in high quality Audio systems to stabilize the impedances of matching circuits uniformly over the entire 30 to 15,000 cycle range. By inserting such a Pad, in association with a LINE REPEATING COIL, at this point in the system, it is possible to effect the transfer of program energy from the primary, or Production Unit to the Master Dispatching Equipment — or, in the case of a simple one studio installation, to the main transmission line — with a minimum amount of alteration or loss of program quality.

The Master Dispatching Equipment



Constantly under the control of the Studio Engineer, the program passes out of the Production Unit into the Output Switching and Compensating Circuits of the Master Dispatching Equipment—an intricate and complex network which, in our illustration (Figure 2), is capable of receiving the outputs from five studio systems such as the one just described and of feeding program from any three of these separately or simultaneously over three outgoing lines.

The design of the Output Switching and Compensating Circuits is a matter for individual consideration during which such factors as the following should be taken into account:

- (a) Number of Incoming Program Production lines.
- (b) Number of Outgoing Program Dispatching lines.
- (c) Number of simultaneous transmission paths for different programs.
- (d) Frequency with which switching operations will occur.
- (e) Rapidity with which switchovers must be made.
- (f) Number of simultaneous switchovers at peak operation.

- (g) Desirable provisions for light load hour operation.
- (h) Physical arrangement of facilities and point at which Switching Control is to be located.
- (i) Possible extension of Switching Control to satellite locations.
- (j) Facilities for pre-setting for one or more program periods in advance of any given transmission period, so that a number of unit switchovers can be accomplished by the operation of a single switch.
- (k) Coordination signals between Program Dispatching and Program origination points.
- (l) Coordination with other dispatchers using the same transmission lines.
- (m) Facilities for emergency operation—for locating and correcting operating troubles—and routine test equipment to aid in maintenance.
- (n) Other considerations peculiar to the individual location.

Since the output switching requirements for small stations, intermediate stations and networks obviously will differ widely in respect to these circuits, a detailed discussion of the subject is not within the scope or purpose of this survey. One fundamental premise, however, should be recognized in this connection. Regardless of the total number of program originating and dispatching lines there may be, it is, of course, desirable to arrange for transmitting program from any production source to any one, or group, or to all of the outgoing lines.



Photograph courtesy Station WTMJ

Typical Main Control Panel for relay type output switching system. This panel contains line level indicators and level controls and is capable of serving nine studios and six outgoing lines. Pre-setting switches enable the succeeding program dispatching condition to be established ahead of schedule so that the actual switchover can be performed by the operation of a single master key. Lamps indicate pre-set and "on the air" conditions.

It is also usually desirable to feed program from *different sources to different lines simultaneously*, depending on the number of transmission paths which are built into the system. However, each outgoing line can accept program from only one source at a time without sacrificing proper program control. Hence where program elements are to be originated simultaneously at more than one point, they should be combined in a Program Production Unit before being transmitted to the Program Dispatching System.

Program Sampling

At the entrance to the Master Dispatching System, individual program samples may be drawn off to a House Monitor Bus System through which they can be switched to various other points in studios and offices for observation purposes. In taking a program off a studio transmission line, no discernible loss in line level results, since bridging circuits are used with high impedance differentials. However, an extremely low level is produced in the bridging circuit and, in order to bring the program up to the level required for most monitor bus systems, an ISOLATION AMPLIFIER is required. In addition to performing its normal amplifying function, the Isolation Amplifier, as the name implies, serves to isolate the main line from electronic disturbances developing in the House Monitor Switching System. The choice of units for use as Isolation Amplifiers depends on the input power levels which they will be required to accept, and the bus levels which they will be called upon to supply. Frequently units of the Pre-Mixing Amplifier type will suffice. However, for higher level buses serving many listening stations, an amplifier should be employed which can handle considerably higher power loads. Monitor Amplifiers, Monitor Level Controls, and Monitor Loudspeakers are located at each observation point and are connected to the outputs of each branch of the House Monitor Switching System to maintain suitable volume levels for each individual listening point.

Program Distribution

Meanwhile, energy losses have occurred in the three main transmission paths of our typical system due to the terminating, matching and dispatch-

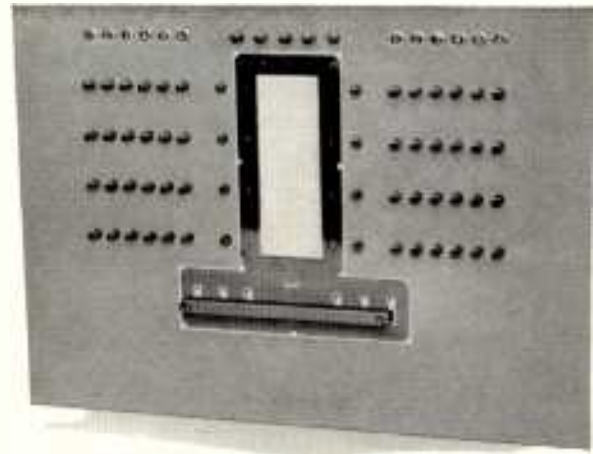

Output Switching Control Panel using manually operated keys for program dispatching. Duplicate key banks are provided to allow pre-setting for the succeeding dispatching condition. The lever type master key (lower center) is used for switching between the two banks.

ing operations which have taken place in the Output Switching and Compensating Circuits. A corresponding gain of from 40 to 70 db is accordingly supplied in each circuit by means of LINE AMPLIFIERS.

Uniform frequency response and a high degree of stability are of especial importance in a Line Amplifier, since it is called upon to handle programs emanating from many different points in response to rapid switch-overs at the Master Dispatching Desk. Each Line Amplifier is provided with an associated LINE LEVEL CONTROL to facilitate adjusting successive incoming programs or program elements to a uniform volume level. Output power capable of exceeding the +8 vu level requirement of long distance telephone lines is another requisite for this type of unit in order to compensate for further energy loss due to subsequent stabilizing and line equalization operations.

Now ready to leave the studio, the transmission on each line is subjected to a final visual and aural check by means of Volume Indicators and Monitor Loudspeakers — (Note Isolation Amplifiers connected to outputs of Line Amplifiers in Figure 2). The transfer from the Speech Input circuit to the circuit of the transmitting element is then accomplished in much the same manner as from the Studio Production Unit to Master Control.

Impedance Stabilization Pads prepare the transmission for the transfer by stabilizing variable

impedance elements and preventing non-uniform distribution of program energy throughout the required audio frequency range. Line Repeating Coils then isolate the circuits against direct current potentials and deliver suitably matched and faithful electrical interpretations of the prepared program material to lines which carry it out to remote transmitter stations or onto wire networks, ready for broadcasting over the air.

System Applications

From the foregoing outline, it will be apparent that, in the case of an audio system installation, "the whole is indeed greater than the sum of its parts." High-quality program preparation depends not only on the individual characteristics of microphones, reproducers, amplifiers, etc., but on experi-

enced planning and careful integration of the units that make up such systems so as to meet most effectively and economically the performance requirements of the station or network in which the system is to be used.

For this reason, not one but several Western Electric equipments are, in most instances, offered for each type of audio service.

The "Index to Speech Input Equipment" appearing on page 18 will serve to indicate the diversity of the standard Western Electric line.

An examination of the electrical and mechanical characteristics of specific units in consultation with a local Western Electric distributor will enable the broadcasting engineer to proceed with confidence in the selection and assembly of the equipment best suited to his individual needs.

One of the units of Bell Telephone Laboratories, Murray Hill, N. J. In this, the largest research organization in the world devoted to the science of communications, many of the outstanding developments in Speech Input Equipment were pioneered.



The Principle of Stabilized Feedback

Another Famous Bell System "First" in Electronics

In the early days of vacuum tube amplifiers it was recognized that more gain could be obtained if some of the output was fed back as additional input; but the result if the process was carried too far was "singing." Stable operation, it was commonly supposed, required a net loss in the loop form by amplifier and feedback circuit. It was also believed that feedback in reversed phase afforded no advantage compensating its accompanying reduction in net gain.

The paradox of amplifier design was announced, however, in the early 1930's by Harold S. Black. His work in Bell Laboratories had led him to an epoch-making invention in electronics. He showed that many remarkable properties inhere in amplifier operation with a negative feedback which reduces the gain. Following his technique, one designs an amplifier for more amplification than is required; and then, by properly sacrificing some of this potential gain, one obtains amazing constancy of amplification and stability of operation.

The resultant amplifier has increased linearity of characteristic with a substantial reduction in harmonics. Tube noises are greatly reduced. There is improvement in phase distortion, in the gain-load characteristic and in the amplifier's impedance relationships. These important advantages are obtained economically without excessive refinements in the designs of tubes and in the constancy of their power supplies.































































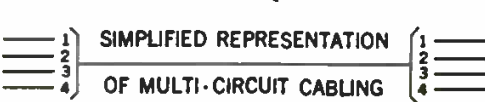

Stabilized Feedback also facilitates the equalization (within reasonable limits) of frequency distortion due to apparatus in the direct path of the signal current. Previously it had been necessary to introduce a network of inverse characteristic. In construction, such networks range from difficult to impractical. With Stabilized Feedback, however, they are unnecessary because usually the desired result can be produced by inserting in the feedback circuit apparatus with the characteristics which are to be equalized, and then properly increasing the amount of feedback.

The stability of this type of amplifier is well illustrated by long carrier-current circuits in coaxial or other cable. They permit the operation of hundreds of high-gain repeaters in tandem. The gains can be made so independent of ordinary variables that insuring the stability of the circuit is essentially a matter of regulating against transmission variations in the line itself.

Black's invention has been widely utilized wherever constancy of amplification with freedom from distortion is a requirement—that is, in practically all types of communication circuits, audio-frequency, carrier and radio.

Extensive use has been made of the Stabilized Feedback principle in the design of Western Electric amplifiers for Speech Input applications.

SYMBOL KEY SHEET

<p> RECTIFIER</p> <p> PRE-MIXING AMPLIFIER</p> <p> BOOSTER AMPLIFIER</p> <p> MAIN AMPLIFIER</p> <p> LINE AMPLIFIER</p> <p> SPEAKER AMPLIFIER</p> <p> ISOLATION AMPLIFIER</p> <p> GENERAL PURPOSE AMPLIFIER</p> <p> LOUDSPEAKER WITH AMPLIFIER</p> <p> LOUDSPEAKER</p> <p> POWER SUPPLY (Heaters and Plates)</p> <p> BUZZER</p> <p> PATCHING CORD WITH PLUGS</p> <p> SINGLE CORD WITH PLUG</p> <p> OR  REPEATING COIL</p> <p> CONTROL OR INDICATING CIRCUITS</p> <p> PROGRAM OR TALKING CIRCUITS</p> <p> OR  TERMINATING CIRCUITS</p> <p> CHAIR</p> <p> DIRECTION OF TRANSMISSION</p> <p> DIAL FOR OPERATING DIAL SELECTOR EQUIPMENT</p> <p> EQUALIZER</p> <p> ADJUSTABLE VOLUME OR LEVEL CONTROL</p> <p> ADJUSTABLE GAIN CONTROL</p> <p> LAMP</p> <p> OR  KEY (Contacts Unoperated Position)</p> <p> DOUBLE CIRCUIT JACKS (4 Jacks) WITH CIRCUIT NORMALED THROUGH</p> <p> DOUBLE CIRCUIT JACKS (2 Jacks) UNTERMINATED</p> <p> DOUBLE CIRCUIT JACKS (2 Jacks) TERMINATED</p> <p> SINGLE JACK</p> <p> COMBINED DROP SIGNAL AND JACK</p> <p> PAD</p> <p> OR  MICROPHONE</p> <p> OR  RELAY (Contacts Unoperated Position)</p> <p> TRANSCRIPTION TURNTABLE</p>	<p> TRANSDUCER</p> <p> TALK-BACK</p> <p> ROTARY MULTIPOINT SWITCH</p> <p> INTERLOCKED MULTIBUTTON PUSH KEY</p> <p> INTERLOCKED RELAY SYSTEM</p> <p> VOLUME INDICATOR</p> <p> NETWORK</p> <p> CUSTOM BUILT SPEECH INPUT CONSOLE</p> <p> 25 TYPE SPEECH INPUT CONSOLE</p> <p> 23 TYPE SPEECH INPUT CONSOLE</p> <p> INDICATES FUTURE CIRCUITS OR EQUIPMENT OR EQUIPMENT NOT INCLUDED IN CURRENT PROPOSAL</p> <p> CIRCUIT LOOPED THROUGH POSITION OF FUTURE EQUIPMENT</p> <p> SIMPLIFIED REPRESENTATION OF MULTI-CIRCUIT CABLING</p> <p> INDICATES ALTERNATIVE CONNECTIONS</p> <p> DOT INDICATES TERMINAL OR CONNECTION, LACK OF DOT INDICATES NO CONNECTION</p> <p> INDICATES SERIES CONNECTION</p> <p> INDICATES PARALLEL CONNECTION</p> <p> INDICATES SERIES PARALLEL CONNECTION</p> <p> HIGH PASS FILTER</p> <p> LOW PASS FILTER</p> <p> POSITIVE D.C. SIGNAL SUPPLY</p> <p> NEGATIVE D.C. SIGNAL SUPPLY</p> <p> D.C. SIGNAL SUPPLY</p> <p> A.C. POWER SOURCE</p> <p> CLOCK</p>
---	---

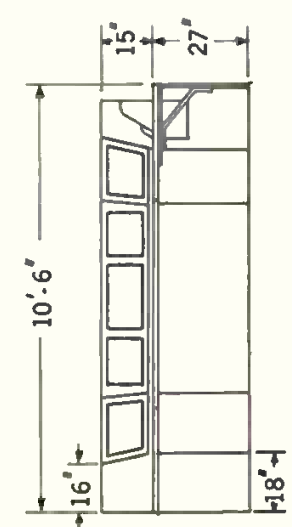
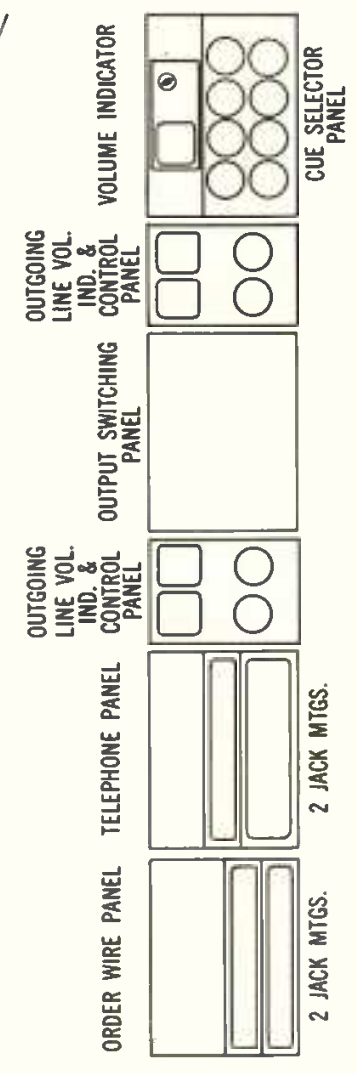
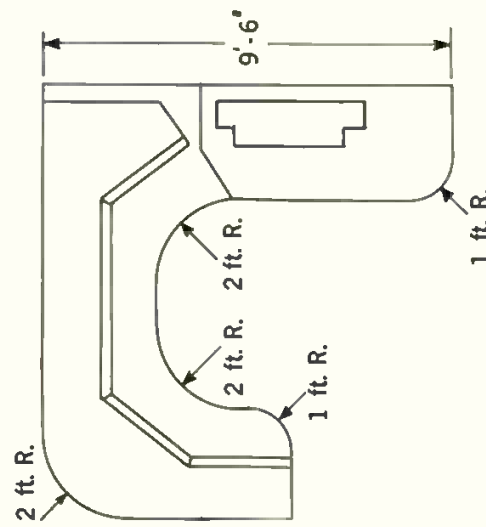
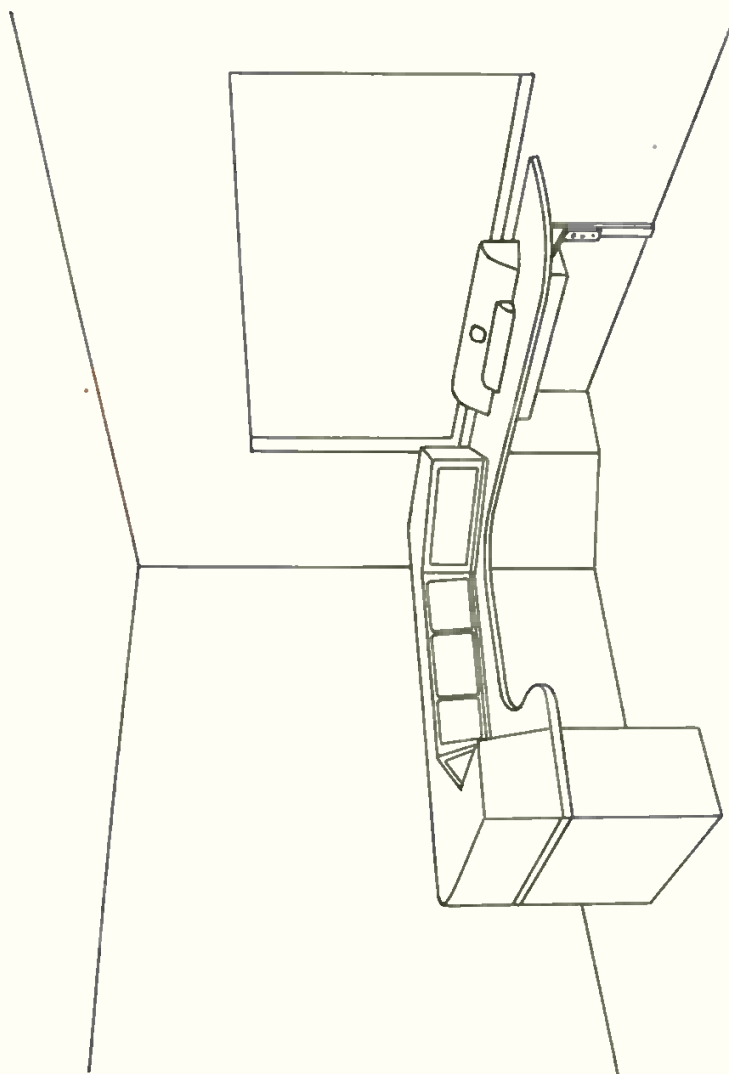

**TYPICAL MASTER DISPATCHING DESK AND EQUIPMENT
INCLUDING ASSOCIATED STUDIO AND PROGRAM PRODUCTION UNIT
FOR LIGHT LOAD HOUR OPERATION**

Index to Speech Input Components

by

Western Electric

	PAGE REFERENCE
BOOSTER AMPLIFIERS	8
EQUALIZERS	7
IMPEDANCE STABILIZATION PADS (Made to Order)	11
ISOLATING NETWORKS (Made to Order)	10
ISOLATION AMPLIFIERS	13
LEVEL (GAIN) CONTROLS (Not furnished separately)	7, 9, 10, 13
LINE AMPLIFIERS	13
LOUDSPEAKERS (Cue and Talkback)	10
MAIN AMPLIFIERS	10
MICROPHONES	6
MIXING NETWORKS (Made to Order)	8
MONITOR AMPLIFIERS	10, 13
MONITOR LOUDSPEAKERS	10, 13
OUTPUT SWITCHING PANELS	12, 13
REPEATING COILS	7, 14
REPRODUCERS	6
STUDIO CONSOLES	7, 8
VOLUME INDICATORS	10

Also

- | | |
|--------------------------|---------------------------------|
| HEADSETS | PORTABLE SPEECH INPUT EQUIPMENT |
| JACKS AND JACK MOUNTINGS | LIMITING AMPLIFIERS |
| MICROPHONE ACCESSORIES | RECTIFIERS |
| MOUNTING PLATES | VACUUM TUBES |
| ORDER WIRE PANELS | |

Ask your distributor for individual bulletins or other information on the items listed above. A Distributor listing appears on the inside back cover of this bulletin.

For Quality Performance
"Look for the name – Western Electric"

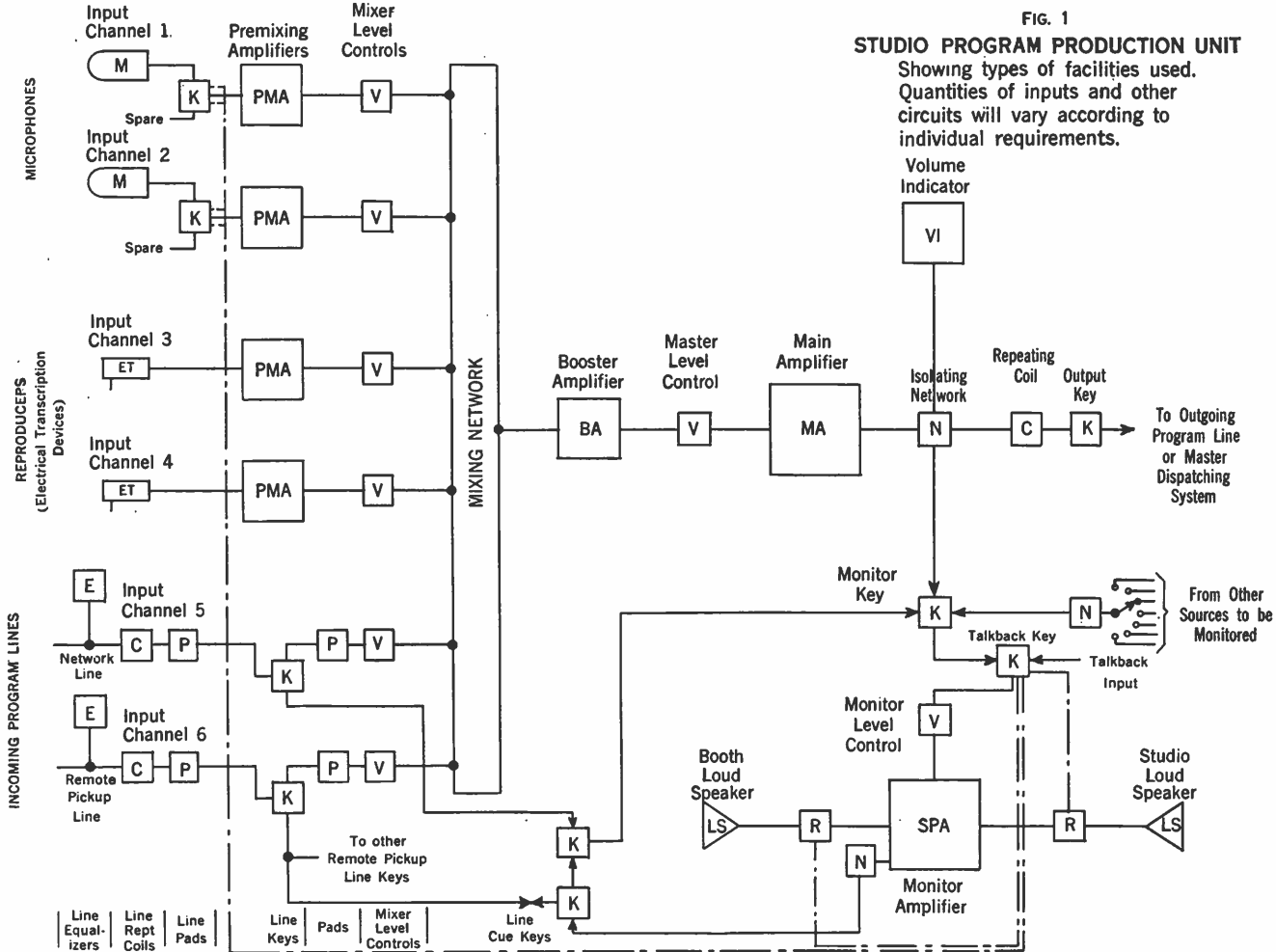

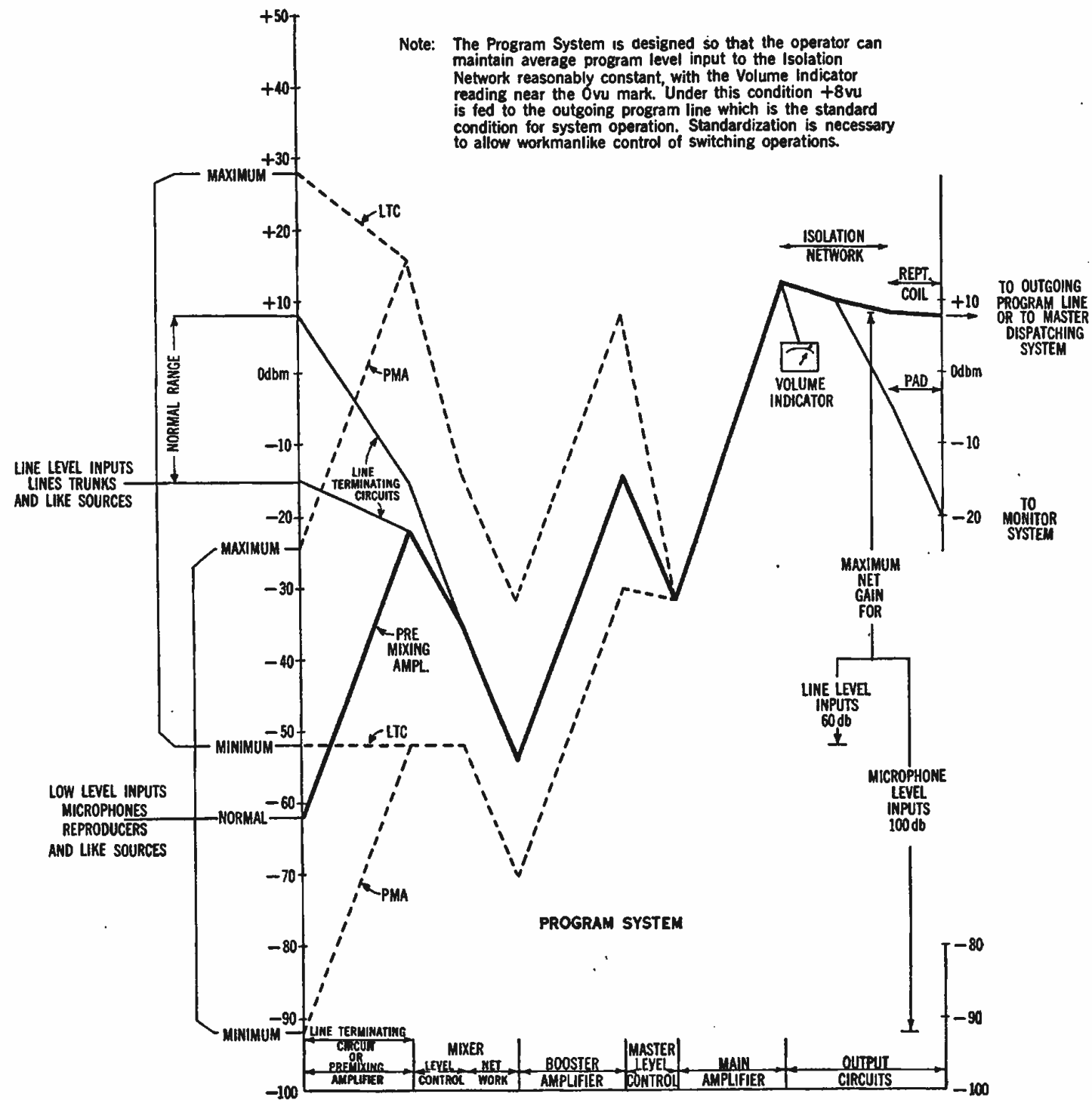

TYPICAL
LEVEL DIAGRAM
STUDIO
PROGRAM PRODUCTION
UNIT
STUDIO SPEECH INPUT
SYSTEM

WESTERN ELECTRIC CO. INC.
FIG. 1A

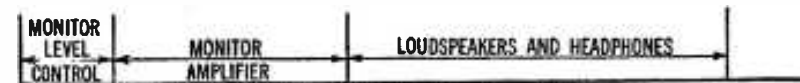
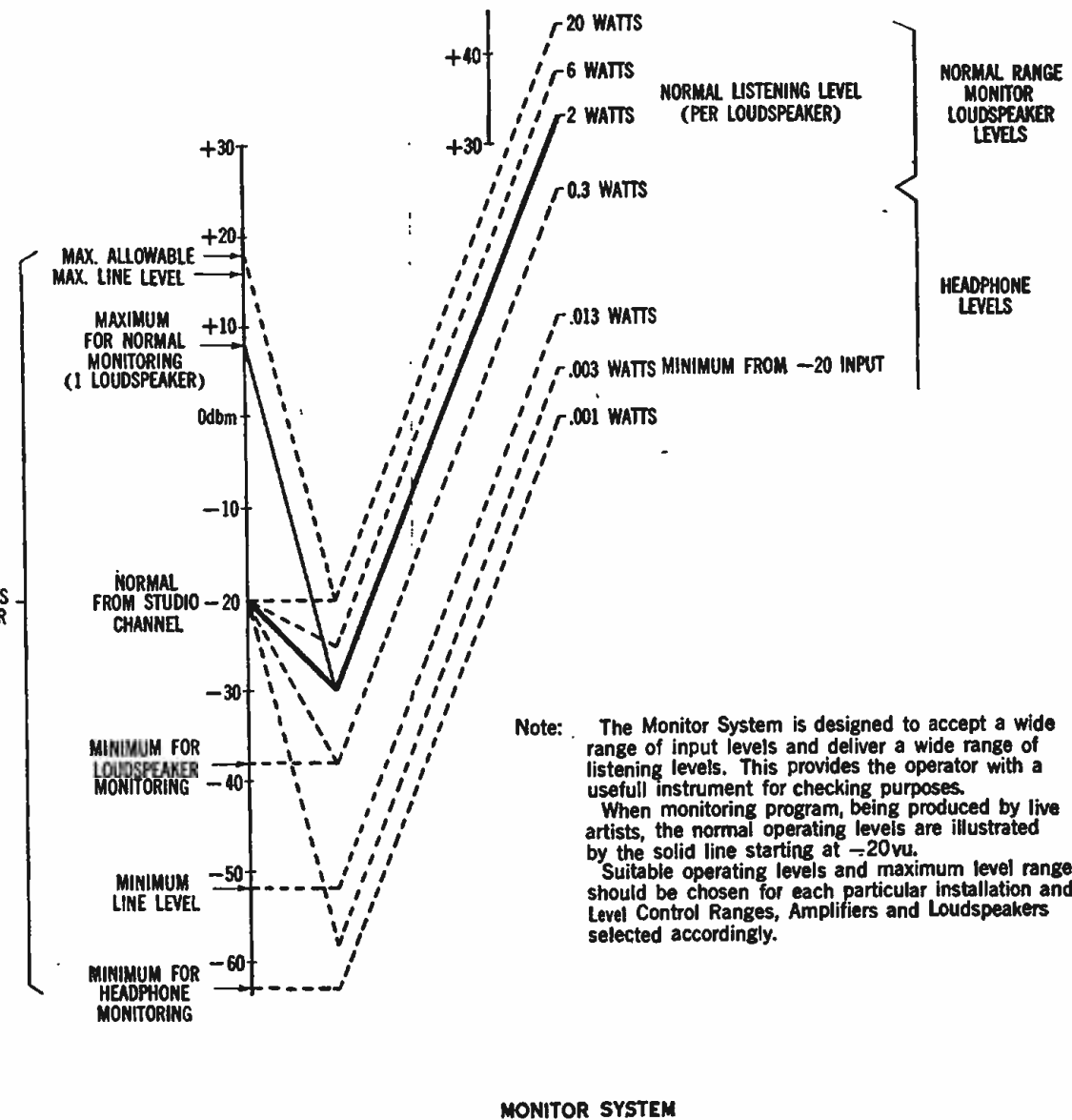

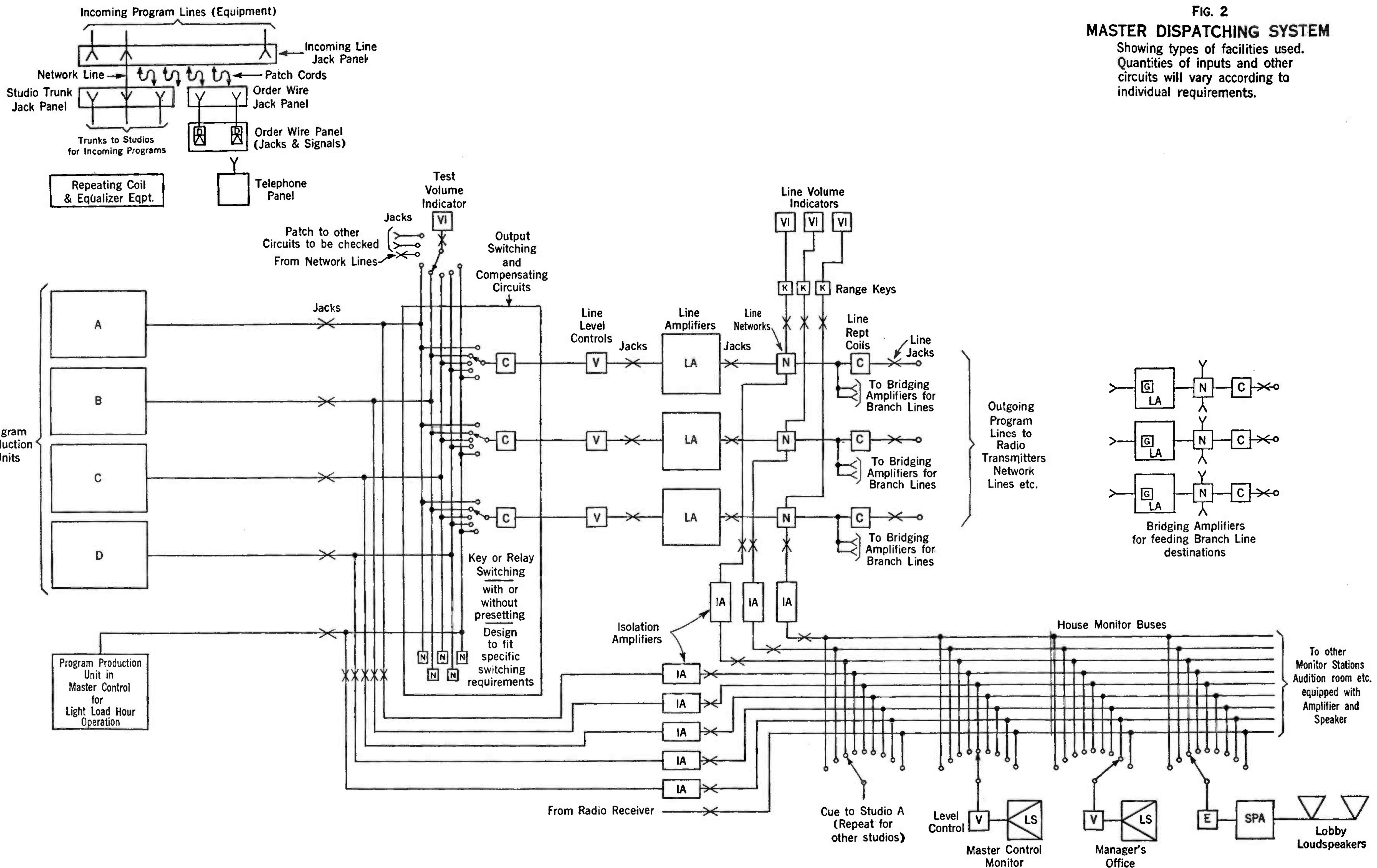
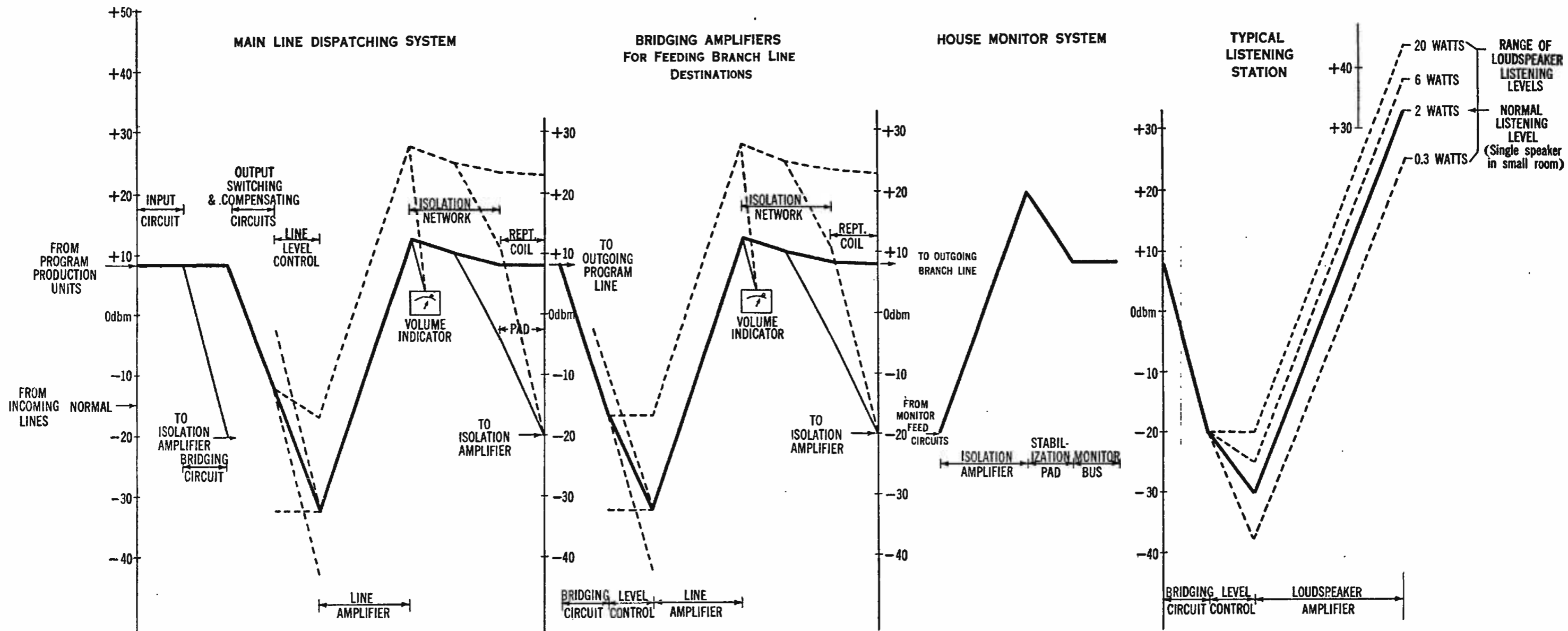

FIG. 2
MASTER DISPATCHING SYSTEM
 Showing types of facilities used.
 Quantities of inputs and other
 circuits will vary according to
 individual requirements.



Note: The Master Dispatching System is designed for operation at normal levels. The Line Gain Control provides a means of adjustment for abnormal operating conditions, for example,

- (a) Receipt of abnormal level from Program Production Unit.
- (b) Emergency operation direct from Incoming Program Line.
- (c) Requirement for abnormally high level feed to Outgoing Program Line.

**TYPICAL
LEVEL DIAGRAM
MASTER DISPATCHING SYSTEM
STUDIO SPEECH INPUT EQUIPMENT**

**WESTERN ELECTRIC CO., INC.
FIG. 2A**

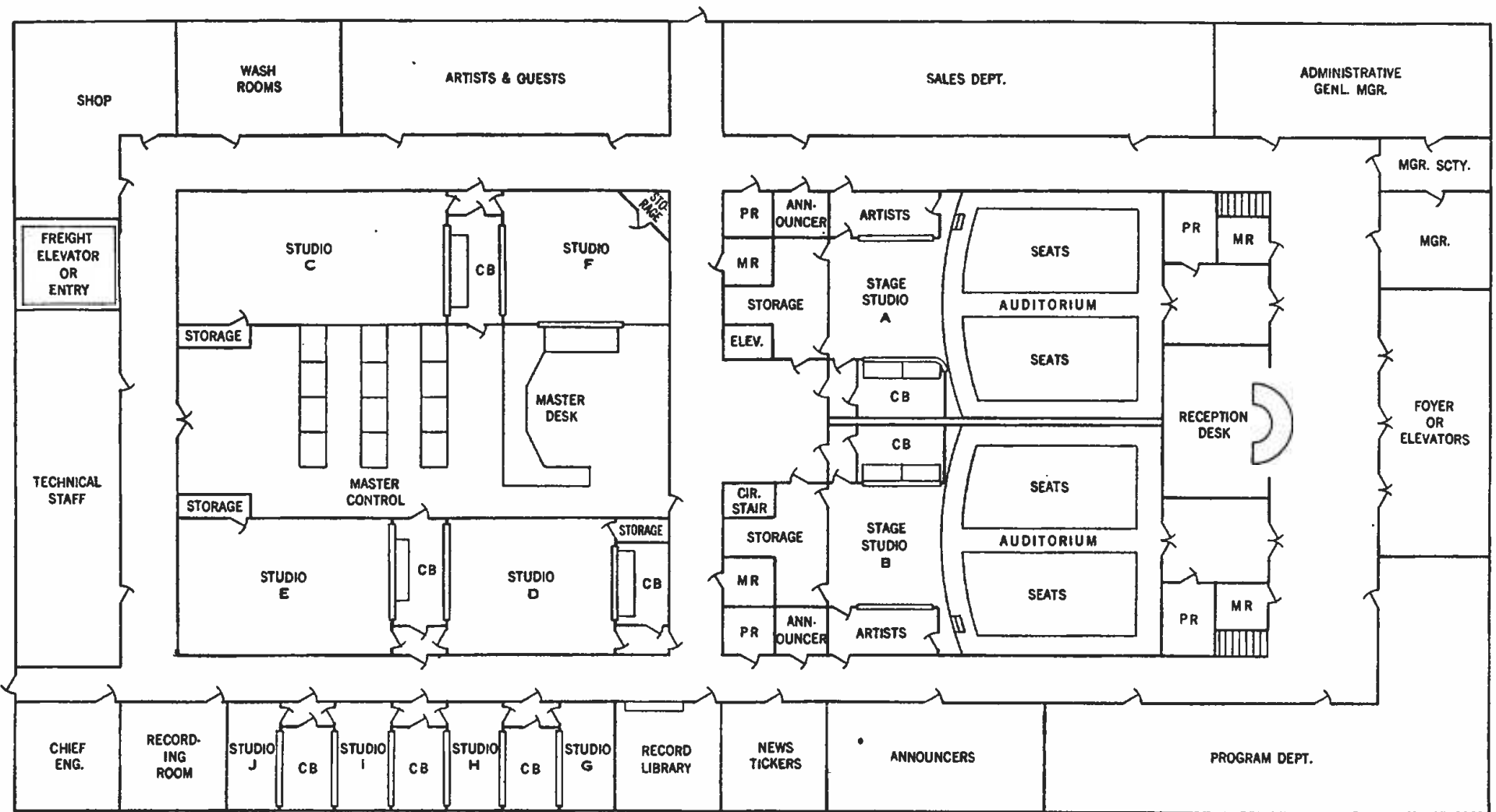

TYPICAL FLOOR PLAN FOR BROADCASTING STUDIO FACILITIES

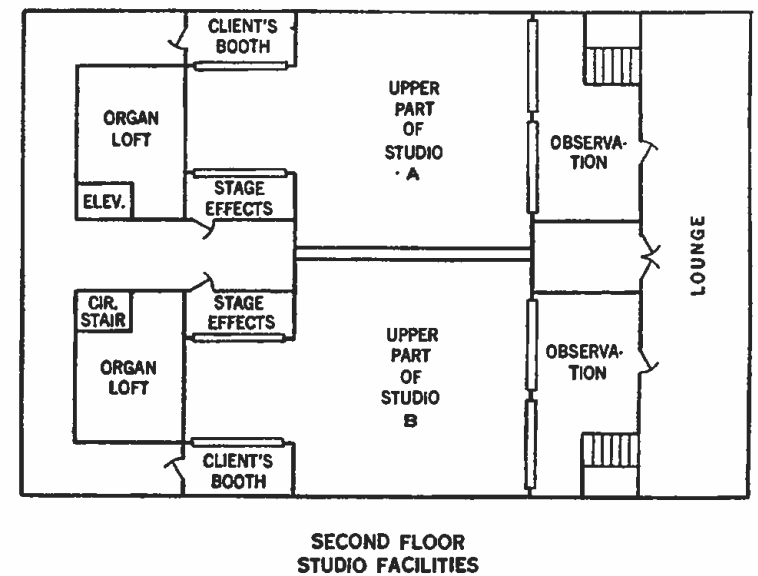
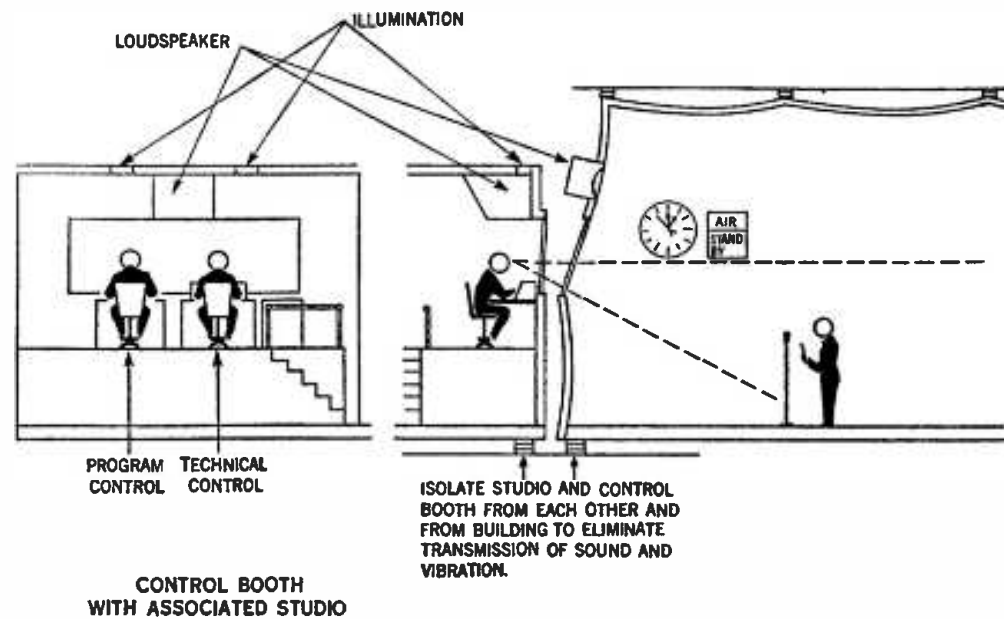

DISTRIBUTOR IN THE UNITED STATES

Graybar

ELECTRIC COMPANY

Executive Offices: 420 Lexington Avenue, New York 17, N. Y.

ALABAMA
Birmingham

ARIZONA
Phoenix

CALIFORNIA
Los Angeles
Oakland
Sacramento
San Diego
San Francisco

COLORADO
Denver

CONNECTICUT
Hartford
New Haven

DIST. OF COLUMBIA
Washington

FLORIDA
Jacksonville
Miami
Orlando
Tampa

GEORGIA
Atlanta
Savannah

ILLINOIS
Chicago
Peoria

INDIANA
Hammond
Indianapolis

IOWA
Davenport
Des Moines

KANSAS
Wichita

KENTUCKY
Louisville

LOUISIANA
New Orleans

MAINE
Portland

MARYLAND
Baltimore

MASSACHUSETTS
Boston
Springfield
Worcester

MICHIGAN
Detroit

Flint
Grand Rapids
Lansing

MINNESOTA
Duluth
Minneapolis
St. Paul

MISSOURI
Kansas City
St. Louis

NEBRASKA
Omaha

NEW JERSEY
Newark

NEW YORK
Albany
Buffalo
New York
Rochester
Syracuse

NO. CAROLINA
Asheville
Charlotte

Durham
Winston-Salem

OHIO
Akron
Cincinnati
Cleveland
Columbus
Dayton
Toledo
Youngstown

OKLAHOMA
Oklahoma City
Tulsa*

OREGON
Portland

PENNSYLVANIA
Allentown
Harrisburg
Philadelphia
Pittsburgh
Reading

RHODE ISLAND
Providence

SO. CAROLINA
Columbia

TENNESSEE
Chattanooga
Knoxville
Memphis
Nashville

TEXAS
Beaumont
Corpus Christi*
Dallas
Fort Worth
Houston
San Antonio

UTAH
Salt Lake City

VIRGINIA
Richmond
Roanoke
Norfolk

WASHINGTON
Seattle
Spokane
Tacoma

WISCONSIN
Milwaukee

*Sales Office

A NATIONAL ELECTRIC SERVICE

DISTRIBUTOR FOR CANADA AND NEWFOUNDLAND

Northern Electric Company

LIMITED

General Offices: 1620 Notre Dame Street, W. Plant: 1261 Shearer Street,
Montreal, P. Q., Canada

TWENTY-THREE BRANCHES FROM COAST TO COAST

