

\$1.00

COMMUNICATIONS

a merger of
RADIO ENGINEERING
...
COMMUNICATION &
BROADCAST ENGINEERING
...
THE BROADCAST ENGINEER

FEBRUARY
1938

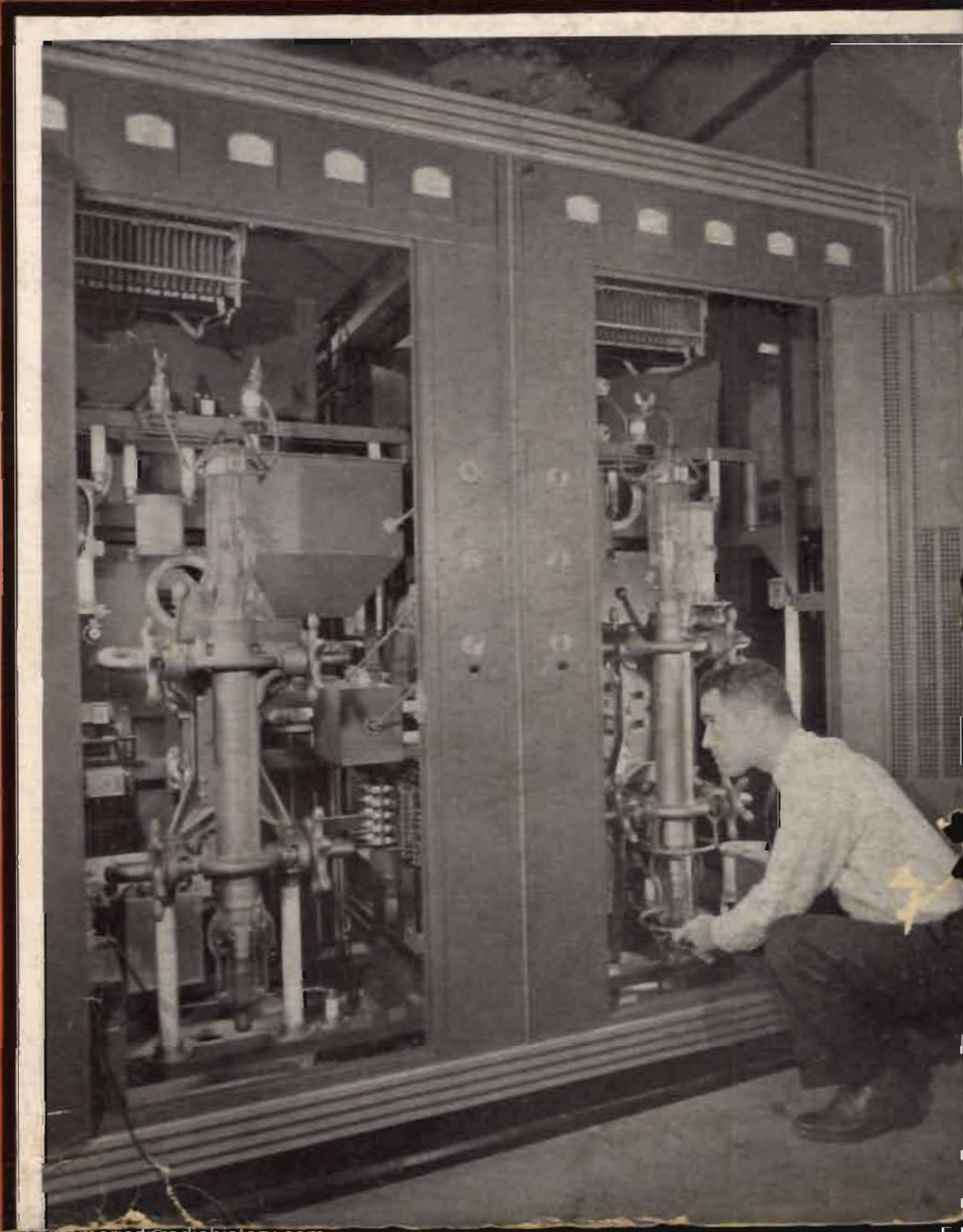



Modern Engineering

Amperex tubes are not fashioned along design and engineering principles of a previous decade.

Independent research and experiment has resulted in the application of new engineering principles and an advanced concept of vacuum tube mathematics, to the design of the exclusive Amperex types, and to the redesigning of the older models.

The unquestioned leadership of Amperex in the design and production of U.H.F. tubes such as the HF 100, 200, 300, 849H, the popularity of the redesigned older models and the wide acceptance of the newly designed water-cooled line, containing structural and design improvements and refinements which enhance their efficiency and increase their longevity, are mainly due to this modern engineering.

AMPEREX ELECTRONIC PRODUCTS, Inc.

79 WASHINGTON STREET

BROOKLYN, NEW YORK

Changes in antenna structure

design have come fast

insulate yours from the beginning with

**LAPP
LAPP**

In scarcely more than 10 years the radio industry has seen a rapid succession of different antenna structure designs. Starting in 1925, when Lapp developed the first tower footing insulator, porcelains by Lapp have been supporting and protecting antenna structures. All the way from sectionalizing insulators designed to eliminate re-radiation and distortion effects, in the old two-tower horizontal antenna arrangement, to giant base insulators that support on a single point radiators over 1,000 feet in height, Lapp units have been giving dependable service.

One of the present tendencies is to use an antenna feeding circuit that produces a zero potential at the radiator base, eliminating the necessity for base insulators. What the next development will be is unpredictable. Possibly a still further improved antenna tuning circuit will again require an insulated antenna; if so, those structures built this year without insulators will be obsoleted. They must continue in inefficient operation or must, at high expense, be insulated.

It's wise and economical to insulate every new antenna structure—with Lapp.

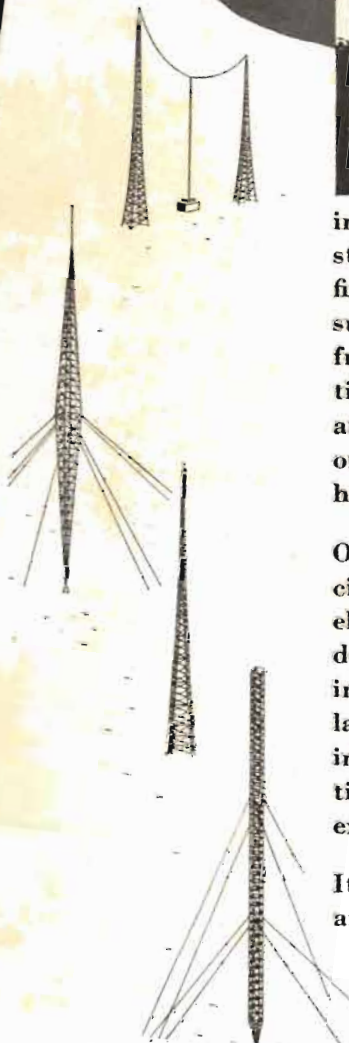

LAPP INSULATOR CO., INC.

**LAPP
INSULATORS**

LE ROY - N.Y. - U.S.A.

COMMUNICATIONS

Member of Audit Bureau of Circulations

RAY D. RETTENMEYER • Editors • W. W. WALTZ

CONTENTS FOR FEBRUARY

Cover Illustration: W. H. Doherty, of the Bell Telephone Laboratories, inventor of the High-Efficiency circuit employed in WHAS's new 50-kilowatt Western Electric transmitter, inspecting the power-amplifier stage of the equipment under test at Whippany, N. J. (See page 20.)

	Page
With the Editors	4
The NAB Convention	9
Losses in A-F Coils	10
Amplifier Expansion Circuits	11
..... By Aaron Nadell	
Tuned Impedance of I-F Transformers	12
Modulation Suppression	14
..... By Hans Roder	
A Crystal-Controlled Pack Transmitter	18
..... By Don Langham	
Radio Station WHAS, Louisville, Kentucky	20
New Research Tools	22
Veteran Wireless Operators Association News	24
Over the Tape	26
"The Offset-Head Crystal Pickup"	28
..... By David G. Knapp	
Book Reviews	32
Telecommunication	40
The Market Place	42
Index of Advertisers	48

VOLUME 18

NUMBER 2

BRYAN S. DAVIS
President

JAMES A. WALKER
Secretary

Published Monthly by the
BRYAN DAVIS PUBLISHING CO., INC.

19 East 47th Street
New York City
New York Telephone: PLaza 3-0483

SANFORD R. COWAN
Manager

PAUL S. WEIL
Advertising Manager

A. B. CARLSEN
Circulation Manager

Chicago Office—608 S. Dearborn St.
Telephone: Wabash 11903.



Wellington, New Zealand—Te Aro Book Depot.
Melbourne, Australia—McGill's Agency.

Entered as second class matter October 1, 1937, at the Post Office at New York, N. Y., under the act of March 3, 1879. Yearly subscription rate: \$2.00 in the United States and Canada, \$3.00 in foreign countries. Single copies: twenty-five cents in United States and Canada, thirty-five cents in foreign countries.

DOHERTY CIRCUIT INCREASES AMPLIFIER EFFICIENCY BY MORE THAN 100%!

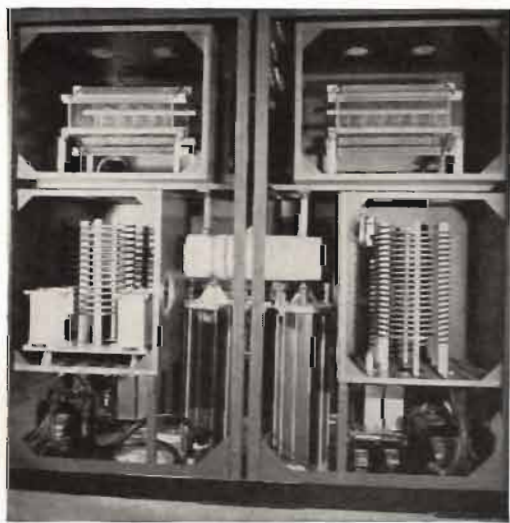

Rear view of the new 50 KW amplifier which employs the Doherty high efficiency circuit.

The famous Doherty Circuit—developed by Bell Telephone Laboratories—increases the efficiency of the power amplifier stage from the usual 30% to over 60%.

In the past, approximately $\frac{2}{3}$ of the plate power supplied to radio frequency amplifier tubes was lost by dissipation.

Today, the Doherty Circuit—used in Western Electric's new radio transmitters—greatly reduces plate dissipation, which minimizes tube cooling requirements. It makes possible the use of smaller circuit elements, saving space—gives increased stability and greater ease of adjustment—reduces outlay for auxiliary equipment—results in marked operating economies.

For full details on these pace-setting Western Electric transmitters with the Doherty Circuit, write to Graybar, Graybar Building, New York.



Distributors:
Graybar Electric Company.
In Canada:
Northern Electric Co., Ltd.
In other foreign countries:
International Standard Electric Corp.

Western Electric

RADIO TELEPHONE BROADCASTING EQUIPMENT

WITH THE EDITORS

NAB CONVENTION

THE SIXTEENTH ANNUAL Convention of the National Association of Broadcasters, which is being held at the Hotel Willard, Washington, D.C., on February 14, 15 and 16, promises to be the largest gathering in the history of the organization.

The major problem confronting the NAB members at this gathering will be that of reorganization of the association. Since the reorganization report submitted to the membership a few weeks ago met with practically no opposition, it is anticipated that the plan will be put into effect promptly.

All broadcasters are urged to attend this meeting. The importance of the gathering can hardly be over-stressed.

FACSIMILE BROADCASTING

AS PREDICTED, considerable interest is now being shown in facsimile. This is especially true of the broadcasters, some thirteen experimental licenses having been granted by the Federal Communications Commission. The results of these field tests should be of great interest, and we believe that they will prove that facsimile, as an auxiliary broadcasting service, is practical.

RADIO EXCISE TAX

THE RMA CAMPAIGN in Congress to secure repeal or substantial reduction of the federal radio excise tax met with a friendly and apparently sympathetic reception by the House Ways and Means Committee at the public hearing held in Washington, D. C., on January 20. Leslie Muter, President of RMA, and other industry leaders seemed greatly encouraged and will continue their efforts to secure tax relief.

In urging repeal or reduction of the radio tax, the RMA contended that the radio tax was a burden on the greatest agency of mass communications; that its repeal or reduction would increase sales, employment and spread the utility of radio to about 4,000,000 more

American homes; that radio is no longer a luxury; and that the price has been greatly reduced and it was now in universal use.

Also asked by RMA was exemption of police, aircraft, marine, public address and all other commercial radio, together with administrative changes to relieve manufacturers, especially of parts and accessories, not only of the tax but of accounting and collection difficulties.

Certainly radio has passed out of the luxury stage. Repeal of the tax would seem the logical move.

CRAVEN'S REPORT ON BROADCASTING

COMMISSIONER FRANK R. MCNINCH, of the Federal Communications Commission, has made public Commissioner T. A. M. Craven's report on the social and economic aspects of radio broadcasting presented at the Informal Engineering Hearing which began October 5, 1936.

Although the report is quite long, it is interesting to note the opinion expressed in regards to "Super-Power." The report says, in part:

"The factor involved in the use of super-power is that a small group of licensees operating on frequencies which have been assigned to them by the Federal Government would have control of radio facilities capable of reaching the entire nation. Unless care were exercised in the regulation of these licensees, the possibility exists of having granted a few people, from natural resources of the Federal Government, the control of a system of mass communication having untold potentialities of being utilized to influence public opinion. Hence it seems that in the determination of the question of super-power must also come the consideration of the ability of the Federal Government to control these facilities, both from the standpoint of individual licensees as well as combinations thereof, in such a manner that they will operate always in the interest of the public. . . ."

The twin forces that move modern industry to greater volume, better profit margins, more stable employment and that higher standard of living which is the social justification for a profit in our individual undertakings, are scientific research and consumer advertising.

. . . C. H. WELLING

THE FEVER THAT CURES

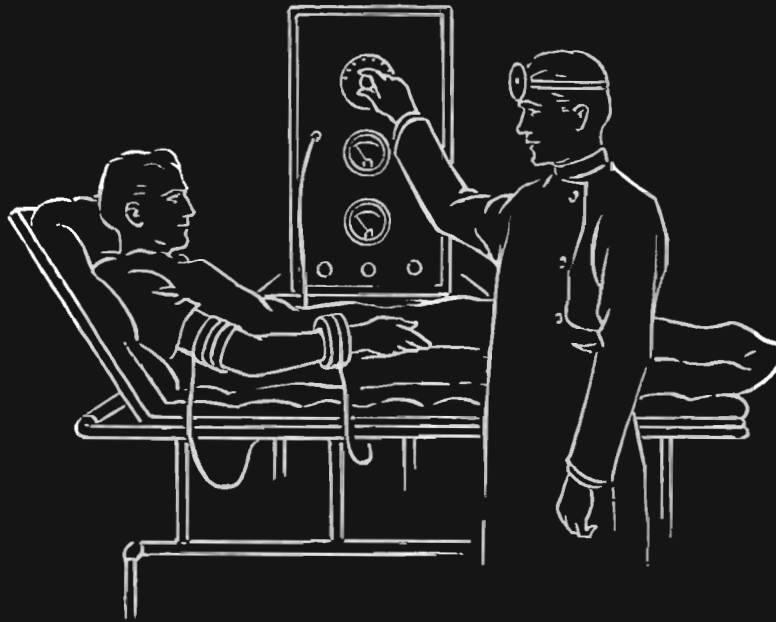

IN THE new science of electrotherapy, the medical profession relies on instruments that respond with the precision of a surgeon's skilled hands. The fever that cures — produced in the patient's body by high frequency currents—must be carefully controlled by dependable instruments. There can be no compromise with quality in the construction of the equipment which generates and controls the currents. The manufacturers of equipment for electrotherapy meet the physician's needs by the greatest care in the design of their product and in the selection of materials.

For the high frequency circuits they find in

Isolantite* the insulation they need — strong, precisely made, *dependable in operation* — an insulation uniform in quality, supplied to meet exacting specifications. The technical cooperation of Isolantite engineers is a valuable aid in the formulation of insulator designs for every type of service.

* Registered Trade-name for the products of Isolantite, Inc.

ISOLANTITE INC.

CERAMIC INSULATORS

Factory: Belleville, N. J. • Sales Office: 233 Broadway, New York, N. Y.

Consistent Leadership by
AMPERITE
 achieves another new development...
THE ACOUSTIC COMPENSATOR (Pat. Pend.)

An exclusive Amperite feature, available in new Models RBHk (High Impedance) and RBMk (200 ohms)



3 IMPORTANT USES

1. The Acoustic Compensator enables you to lower or raise the response of the microphone by the mere flip of the finger: Not a volume control—operation is similar in principle to the sliding panels in broadcast studios.
2. Makes the Velocity immediately adjustable to close talking or distant pickup.
3. Immediately adjustable to any room condition... or any type of job or occasion.

Increasing the quality, without increasing the price, is the keynote of the Amperite sales policy. In the new Amperite Velocity, with the Acoustic Compensator, the P.A. Industry has the last word in microphone perfection at a competitive price.

MODELS RBHk, RBMk, with acoustic compensator. Frequency range 40 to 11,000 CPS. Output, -65 db. Complete with switch, cable connector and 25' of cable. **\$42.00 LIST**

MODELS RBHn, RBMn, without acoustic compensator **\$42.00 LIST**

NEW! AMPERITE CONTACT MICROPHONE

A contact mike without distortion. Ideal for use on all string instruments. Flatters an ordinary fiddle by giving it the volume and depth of a "Strad"; makes a small piano sound like a "Grand". Unusual high output—can be used on radio sets. No string changes, no drilling. Attached without tools. Operates with either high or low gain amplifiers. Frequency response, 40 to 8000 cps. Output, -40 db. 25' of cable. **MODEL KTH (Hi-imp): KTL (200 ohms).....\$22.00 LIST**
KTH or KTL with foot-operated volume control...\$30.00 LIST

NEW! AMPERITE "HAND-1-MIKE"

The smallest velocity made... but has an output equal to larger types, -68 db. Frequency range 60 to 7500 cps. Excellent for close talking, and can be used as hand, desk, or stand microphone. Unusually rugged. Size of head, 1" x 3/4" x 2 1/4". **MODELS HDH (Hi-imp): HDL (200 oms); with switch, \$22.00 LIST**

AN EXCELLENT VELOCITY AT \$22.00 LIST

P.A. Men, you do not have to sacrifice quality on a "low-cost" job. This fine velocity, built to Amperite standards, is excellent for both speech and music. Gives flat response without peaks over entire audible range. Reduces feedback. Frequency range 60 to 7500 cps. Output, -68 db. Unusually rugged, not affected by temperature, pressure or humidity. Triple shielded, fitted with shock absorber and swivel bracket. **MODEL RAH (Hi-imp.) with 12' of cable; MODEL RAL (200 ohms) with 8' of cable..... ONLY \$22.00 LIST**

BROADCASTING STUDIOS, please note : New Output, -56 db.

The new Amperite Studio Velocity, model SR80n, has -56 db. output, highest in studio velocities available today. The SR80n is now accepted as the finest microphone for studio and recording: (Two weeks' free trial to established studios). Frequency range 40 to 15000 CPS. Triple shielded, fitted with switch (optional), cable connector, and 25' of cable. **MODEL SR80Hn (Hi-imp): SR80n (200 ohms).....\$80.00 LIST**



SALES AIDS FOR THE P.A. MAN
 Amperite offers the following co-operation to P.A. Men

1. FREE: Window Decal advertising your Sound Service. Size 5 1/4 x 3 1/4, finished in 4 striking colors.
2. FREE: Window Display, 11x17.
3. Special Sound Equipment Letterheads. Samples and prices on request.

Write for these valuable sales helps, and new Illustrated Bulletins, today!

AMPERITE Co. 581 BROADWAY, N. Y. U. S. A. CABLE ADDRESS ALKEM, NEW YORK

"Better Systems Specify Amperite"

VELOCITY **AMPERITE** MICROPHONES

Announcing...

BAKELITE POLYSTYRENE LOW-LOSS MATERIAL

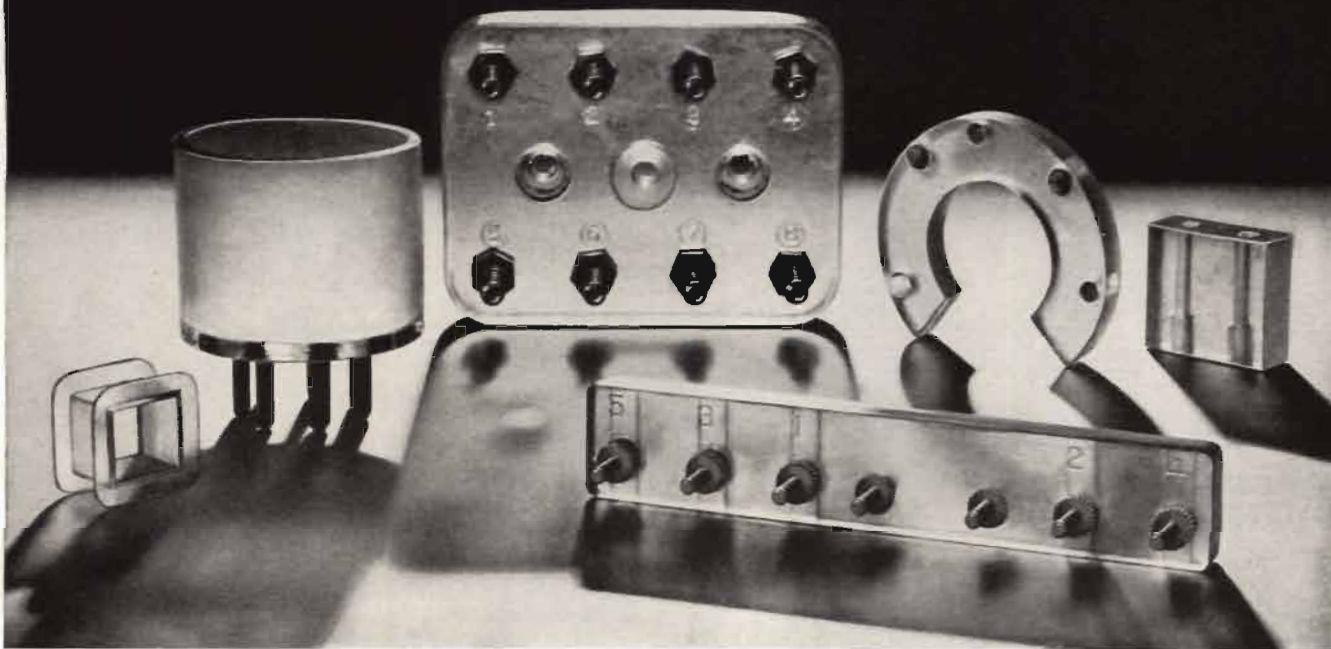

Advantageous applications of Bakelite XMS-10023 Material include: coil forms, tube bases, terminal blocks, spacing washers, connector blocks.

AFTER exhaustive research and development in its laboratories, Bakelite Corporation now contributes to electrical science and industry a superior thermo-plastic material for low-loss purposes.

Possessing the extraordinary properties in a molded plastic, of a power factor of less than .0002 at frequencies of 60 to 1,000,000 cycles, and a dielectric constant of 2.60 at the same frequencies, this new Bakelite Polystyrene molding material offers marked advantages for

many electrical products and equipment parts. Its dielectric strength is more than 500 volts per mil; its resistivity, over 10^8 megohm centimeters; and its arc-resistance, 240 to 250 seconds.

In addition to these electrical advantages, Bakelite XMS-10023 material provides the important merits of: uniformity in molding; freedom from crazing or other surface difficulties; permanence of dimension at temperatures under 100°F; and high resistance to water,

acids and alkalis. Its durability and toughness are indicated by its A.S.T.M. Impact Strength of .16 foot pounds, and flexural strength of more than 7000 pounds per square inch.

Opportunities for the improvement of high-frequency apparatus through application of this new Bakelite molding material are practically unlimited. We invite electrical engineers and manufacturers to write for further data on Bakelite Polystyrene Low-Loss material.

BAKELITE CORPORATION, 247 PARK AVENUE, NEW YORK, N.Y.
BAKELITE CORPORATION OF CANADA, LIMITED, 163 Dufferin Street, Toronto, Canada West Coast: Electrical Specialty Co., Inc., 316 Eleventh Street, San Francisco, Cal.

BAKELITE

The registered trade mark shown above distinguishes materials manufactured by Bakelite Corporation, under the capital "B" in a circle, from other materials. The symbol "B" in a circle is a registered trademark of Bakelite Corporation.

PLASTICS HEADQUARTERS

Visit the Bakelite Travelcade, an exposition of "Modern Plastics for Modern Living", Museum of Science and Industry, Rockefeller Center, New York City, March 1 to 31

COMMUNICATIONS FOR FEBRUARY 1938 • 7



PIONEER OF THE AIR

FOUNDED IN 1919, the Radio Corporation of America has completed 18 years of pioneering effort to develop and improve the uses of radio.

Starting "from scratch," RCA has created a world-wide communications system with direct circuits between the United States and 42 foreign countries, and with ships at sea. It has created a nation-wide broadcasting system of endless cultural possibilities, now rapidly expanding its services by short-wave to all the world. It has created essential instruments for the radio transmission and reception of sound, of code messages, and of facsimile reproductions, and for the recording and reproduction of sound on records and on

motion picture film. It has created countless radio devices indispensable to modern science, industry, medicine, telephony, and public safety. It has created the basis for a system of electronic television, forecasting the day when radio sight, added to sound, will perform a useful public service.

Today the Radio Corporation of America is owned by nearly a quarter of a million stockholders in 48 states. No one person owns as much as $\frac{1}{2}$ of 1% of its stock. Achievements of the past 18 years are a tribute to the American tradition of service in the public interest through private initiative and ownership.

RCA presents the "Magic Key" every Sunday, 2 to 3 P.M., E.S.T., on NBC Blue Network.



RADIO CORPORATION OF AMERICA

RADIO CITY • NEW YORK, U. S. A.

NATIONAL BROADCASTING COMPANY

• RCA MANUFACTURING COMPANY, INC.

RCA COMMUNICATIONS, INC. • RCA INSTITUTES, INC. • RADIOMARINE CORP. OF AMERICA

COMMUNICATIONS

FOR FEBRUARY, 1938

THE NAB CONVENTION

February 14-16
At the Hotel Willard
Washington, D. C.

THE SIXTEENTH ANNUAL Convention of the National Association of Broadcasters, which will be held at the Hotel Willard in Washington, D. C., from February 14 through 16, will probably be the largest convention in the history of the organization. While the final program for the gathering has not been announced, it is expected that most of the sessions will be concerned with the business of reorganization of the group.

Highlights of the reorganization plan call for the appointment of a paid President with broad authority, the appointment of a Secretary-Treasurer as administrative officer, appointment of Directors of public relations, labor rela-

James W. Baldwin, Managing Director, NAB.



FCC Commissioner T. A. M. Craven.

tions, education, law, research and engineering. The office of Managing Director, now held by James W. Baldwin, will probably be abolished. Further, a budget in the vicinity of \$250,000 has been proposed, the annual dues being based upon the income of the member stations.

The Committee on Reorganization which drafted the new plan is made up of Edwin W. Craig, WSM, author of the plan, Philip G. Loucks, attorney, John Shepard, 3rd, Yankee Network, Edward Allen, WLVA, Walter J. Damm, WTMJ, and E. Craney, KGIR.

According to E. M. Spence, Chairman of the Convention, the tentative plans for the gathering include:

MONDAY, FEBRUARY 14

Call to order by President John Elmer, WCBM.

Address of Welcome to be delivered by Commissioner George Allen.

Address of the President, John Elmer.

Guest speakers include Senator Burton K. Wheeler, Montana, Chairman of Senate Interstate Commerce Committee, and Frank R. McNinch, Chairman of the Federal Communications Commission. These speakers will be followed

John Elmer, WCBM, President, NAB.



by the report of James W. Baldwin, Managing Director, and the report of the Reorganization Committee.

TUESDAY, FEBRUARY 15

Completion of reorganization business.

Address of Commissioner T. A. M. Craven of the Federal Communications Commission.

Annual Banquet.

WEDNESDAY, FEBRUARY 16

Completion of unfinished business.

Reports of various committees: Engineering, State, Radio Research, and Sales Managers.

Following adjournment of the Convention, the Board of Directors will meet to appoint a temporary executive until such time as the new president has been selected.

LOSSES IN A-F COILS

IN DESIGNING electrical communication equipment, it is frequently necessary to select low-loss inductance coils for use in tuned circuits and filters. Experimental data accumulated over a period of several years at the General Radio Company have shown that a set of formulae derived by means of approximations of limited validity hold very well in practice. These expressions, according to L. B. Arguimbau in *The General Radio Experimenter*, are so simple that they have been of considerable assistance in selecting the best type of coil for a particular use.

This discussion will be limited to measurements in the frequency range between 10 and 10,000 cycles and to frequencies far removed from resonance. For iron-core coils it will be assumed that the voltages are very low in order that hysteresis may be neglected in comparison to eddy-current losses. Most of the measurements have been made on iron-core coils (with and without air gap) and multi-layer a-f coils of the type usually met in filter practice.

With these restrictions it has been found that all coils may be represented by the equivalent circuit shown in Fig. 1, where R_0 is the d-c resistance and R_e is a resistance due to eddy currents and is independent of frequency.

This is based on the following considerations: A conductor placed in the magnetic field of a coil may be considered a terminated secondary winding. As long as the circulating currents are mainly determined by the resistance of the path rather than by its inductance the termination impedance is resistive, and the secondary circuit will reflect a resistance in parallel with the primary winding. In particular, the circulatory currents may exist in an iron core and may include induced currents set up in the wire itself, usually spoken of as skin effect.

In many applications the reactance to resistance ratio, known as "Q," serves as a convenient factor of merit. From the simplicity of the equivalent circuit

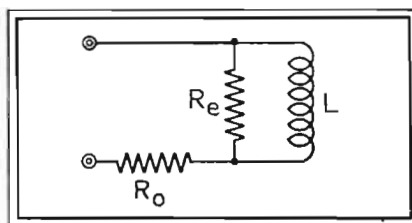

Fig. 1. Equivalent circuit of a coil.

shown in Fig. 3, it might be expected that the curve of Q versus frequency for any coil would be given by a fairly simple expression. The application of ordinary circuit theory to Fig. 1 gives the approximate results:

$$X = 2\pi fL$$

$$R = R_0 + \frac{(2\pi fL)^2}{R_e}$$

which gives for Q,

$$Q = \frac{2\pi fL}{R} = \frac{1}{\frac{R_0}{2\pi fL} + \frac{2\pi fL}{R_e}}$$

which has a maximum value, Q_m , of

$$Q_m = \frac{\pi f_m L}{R_0} \dots \dots \dots (1)$$

Fig. 3. Showing frequency for maximum Q of coil of Fig. 2.

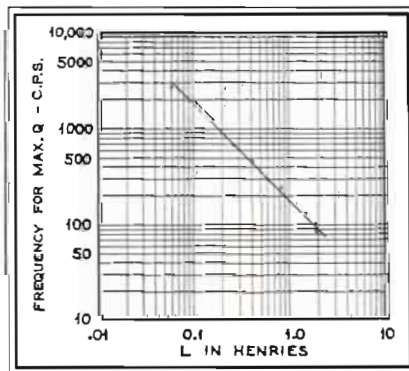

or

$$Q_m = \frac{1}{2} \sqrt{\frac{R_e}{R_0}} \dots \dots \dots (2)$$

at a frequency

$$f_m = \frac{\sqrt{R_0 R_e}}{2\pi L} \dots \dots \dots (3)$$

where,

f_m is the frequency of maximum Q. At any other frequency, f , the corresponding value of Q (denoted by Q_f) is

$$Q_f = \frac{2Q_m}{\frac{f}{f_m} + \frac{f_m}{f}} \dots \dots \dots (4)$$

It will be noticed that this expression is symmetrical with respect to

$$\frac{f}{f_m} \text{ and } \frac{f_m}{f}$$

and will give a curve shape which is invariant on logarithmic paper.

To tabulate available Q data, it is sufficient to plot the point of maximum Q and use a standard template for drawing the curve (this template may be obtained by replotting a curve of Fig. 2 on standard logarithmic paper).

In iron-core coils, the eddy-current losses in the copper are usually negligible in comparison to those in the core so that, for a given core and volume of copper, wire size has little influence on Q. One interesting point to be noted for iron-core coils is that the maximum Q for a given structure but with various air gaps is very nearly constant. This can be explained by the fact that the core may be regarded as a single-turn secondary of constant termination. This reflects a given shunt resistance across the winding regardless of its inductance. Since the copper resistance is constant, it follows that the ratio of shunt eddy-current to series copper resistance must be constant and hence from expression

(Continued on page 35)

AMPLIFIER EXPANSION CIRCUITS

By AARON NADELL

EXPANSION has just begun to creep into the public-address field; it is promised, at least, in connection with talking pictures, and has had a preliminary but hesitant introduction into the home radio receiver. Two entirely different circuits are used at the present time, each subject to minor modifications in the hands of different designers. They may be distinguished here as tube expansion and variable-resistance expansion. Tube expansion seems to be the most popular, one reason for which may possibly be that it lends itself very readily to double duty as an audio avc system, only a d-p, d-t switch being needed to make the same circuit perform the double duty.

TUBE EXPANSION

Fig. 1 gives the circuit of a volume expander plus compressor, or "componder," as its manufacturer calls it, used in one of the latest RCA public-address systems. The circuits of Fig. 1 constitute the voltage amplifier (MI-4288), the expander being that portion which is below the horizontal dotted line. Fig. 2 gives the expander circuit alone.

The basic action will be readily apparent on studying these drawings; a portion of the output of the first 1612 tube is detoured, amplified in another 1612, and rectified by a 6H6. The d-c thus obtained will vary in strength proportionately with the input signal. It is applied as a supplementary bias to one of the grids of the output tube. If the polarity of this supplementary bias

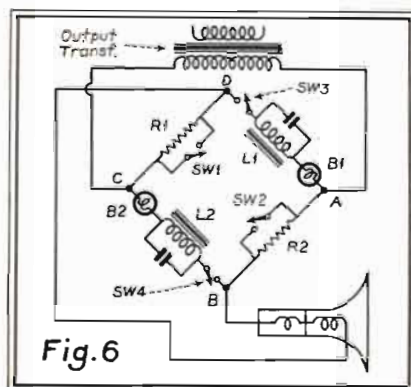

Fig. 6
Illustrating the variable-resistance method of expansion.

Curves showing sound pressures at various frequencies.

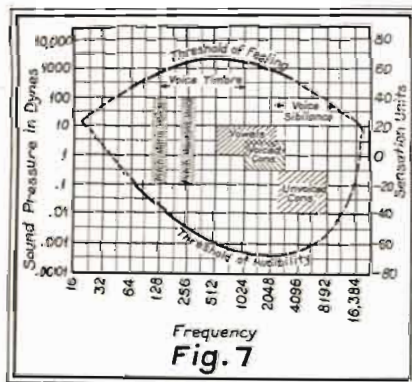

Fig. 7

is such that the gain of the output tube increases with the strength of the original signal, the circuit acts as an expander; if the polarity is reversed, and

increased signal strength diminishes the gain of the output tube, the circuit serves as a compressor, or avc. The d-p, d-t switch needed to make the circuit perform either function is shown at the lower right of Fig. 1; the potentiometer that governs the extent of "componder" action being drawn just to the left of it.

That arrangements similar to those of Figs. 1 and 2 can readily be built into a production p-a amplifier, so as to become an integral and scarcely distinguishable part of the unit, is shown in Fig. 3, some of the circuit details of which differ from those just examined. The drawing represents a 60-watt amplifier of Lafayette Radio Manufacturing Company. The polarity reversing switch, shown almost in the exact center of the drawing, is triple pole. The 6H6 rectifier is drawn just below it. Part of the output of the 6N7 mixer tube is tapped off (just below the 50,000-ohm plate resistor) and coupled through a 0.01-mfd condenser and a controlling .5-megohm potentiometer to the control grid of a 6J7 (drawn just left of the 6H6). Only the right-hand side of the 6H6 takes part in the action, the other half being reserved to operate the 6G5 volume indicator. The rectified output is applied to the middle grid of the 6L7 voltage amplifier.

Expansion circuits very similar to the above now find a separate market as independent units, sold to be attached to existing public-address equipment.

A volume expansion and compression circuit used in one p-a system.

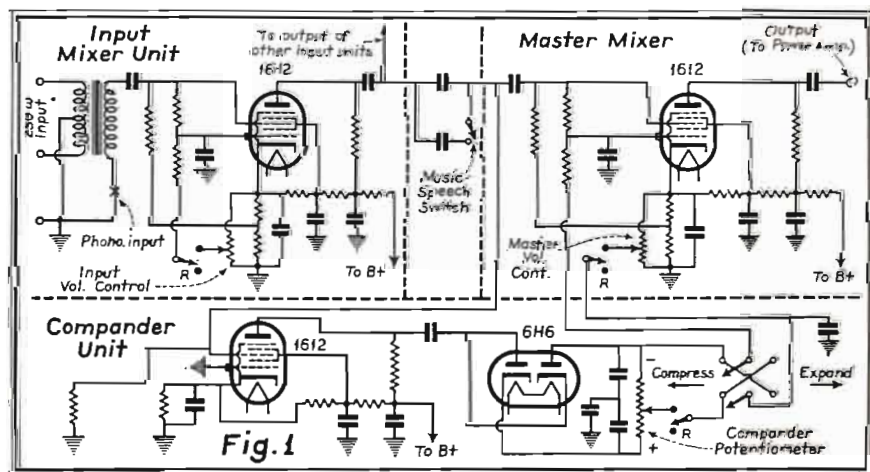

Fig. 1

The expander circuit of Fig. 1.

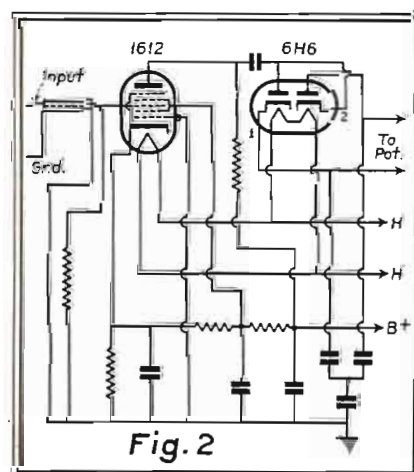
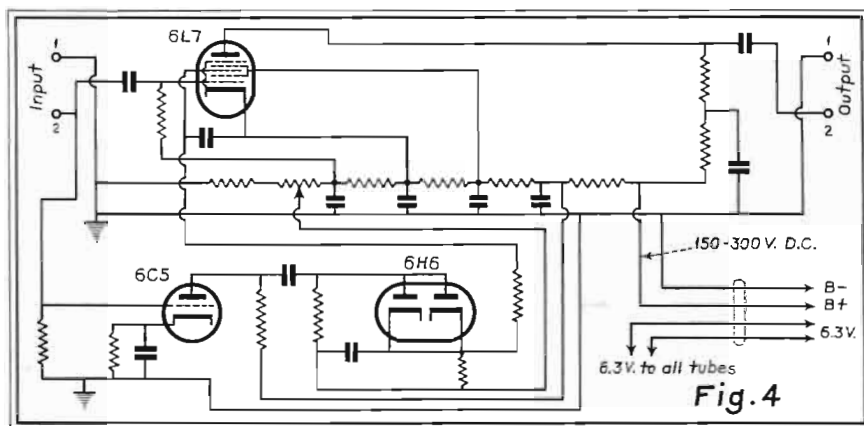

Fig. 2



Circuit of unit designed to be attached to existing p-a equipment.

Two such units, products of David Bogen Co., are shown in Figs. 4 and 5. They are pure expanders; compression or avc is not included. It will be noted that the 6H6 acts as a half-wave rectifier receiving plate excitation from the B+ circuits; a potentiometer in the B supply serving to govern the extent of expander action used.

The units of Figs. 4 and 5 are introduced into existing p-a equipment between the phono pickup or other sound source and the amplifier input. As such, they can be used for phonograph reproduction in connection with a home radio receiver, as well as for p-a, provided that the a-c stages and speaker of the receiver can handle the peak power. The two circuits are identical except that Fig. 4 is designed to receive its plate and filament power from the amplifier with which it functions, while Fig. 5 includes an a-c/d-c power supply built around a 25Z6, and consequently

can be added to existing equipment by any user whatever.

A similar circuit is used by Operadio Mfg. Co., in their Model 885 power amplifier, serving both as expander and (Continued on page 39)

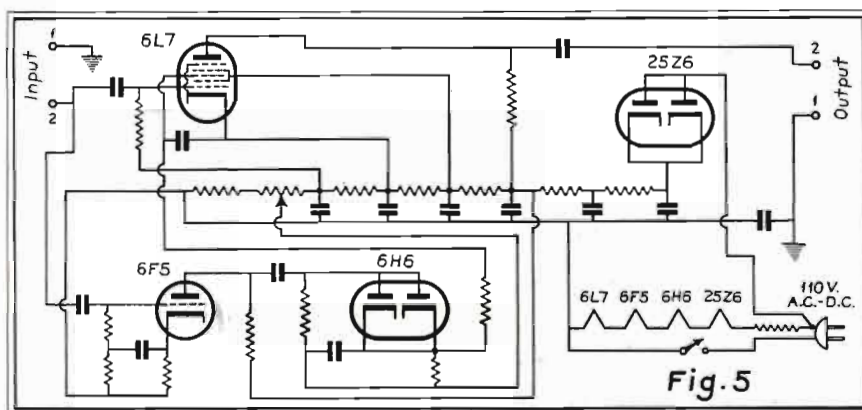

Circuit diagram of another unit similar to that of Fig. 4.

Circuit diagram of amplifier employing volume expansion.

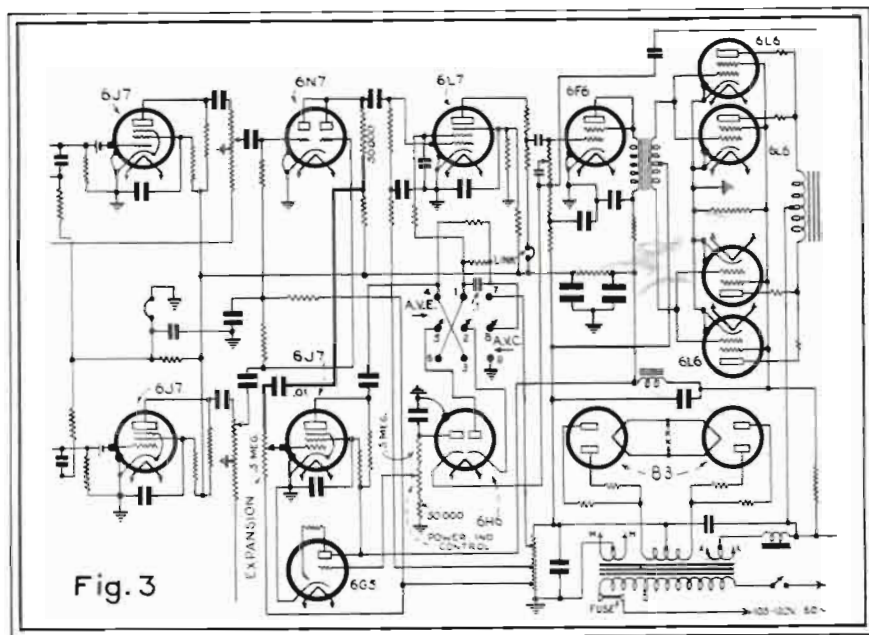

Fig. 3

TUNED IMPEDANCE OF I-F TRANSFORMERS*

THE BASIC electrical properties of a coil are its resistance R and its inductance L . At any frequency f the coil will have a reactance X and may be tuned to resonance at this frequency by a capacity C . The ratio of X/R or Q is accepted as a figure of merit of the coil since the voltage step-up of a resonant circuit is dependent upon Q , and the selectivity or bandwidth is a function of $1/Q$. The tuned-circuit impedance of a parallel-resonant circuit is another important constant as this is the load seen by the tube. It is usually expressed as Z and is equal to XQ .

The accompanying chart of Q , Z , C , and L has been designed to show at a glance important constants of an i-f coil. The chart has been constructed for a frequency of 455 kc which is now considered the standard intermediate frequency. As measured on the usual

commercial coil-measuring instruments the values of Q and C are read directly; L and C are plotted on the same axis of the chart so that L can be read directly from this axis. If a straight edge is laid across the chart connecting Q and C , it will intersect the middle axis at Z , the tuned-circuit impedance.

To obtain the approximate load impedance which an i-f tube looks into when driving the usual double-tuned i-f transformer, it is necessary to measure the Q of the primary with the secondary coupled and tuned to resonance. The trimmer of the primary should be disconnected from the "high" side when a capacitance within the measuring instrument is used to resonate the primary. If the transformer feeds a diode, the diode should also be connected to the secondary, loaded, and the cathode heated. The loading effect of an amplifier tube is negligible at this frequency and need not be considered.

*Material prepared by Engineering Department, Hygrade Sylvania Corporation.

TUNED IMPEDANCE OF I-F TRANSFORMERS

$$Z = 2\pi f L Q$$

FREQUENCY = 455 K.C.

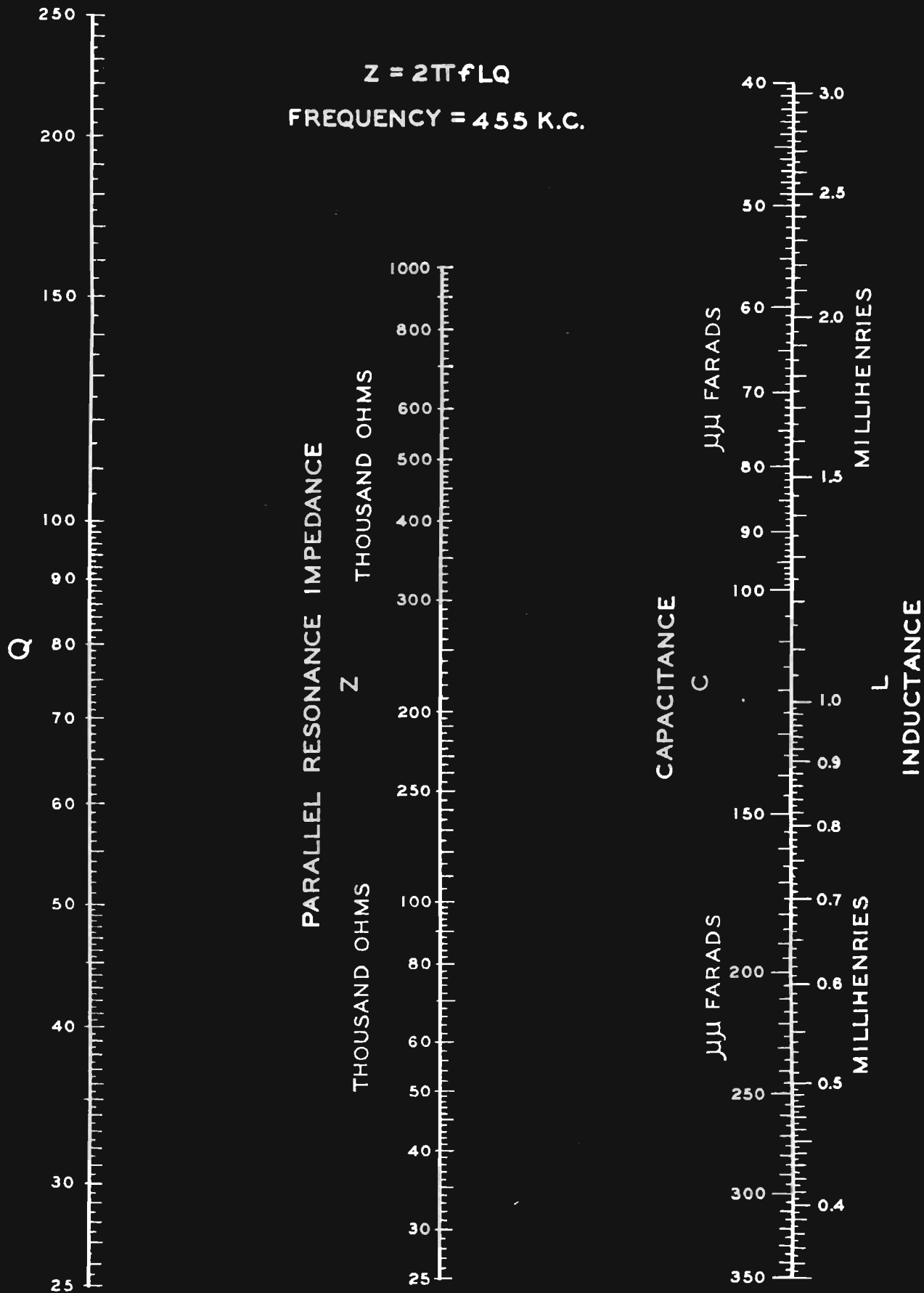

MODULATION

of a Weak Signal

By HANS RODER

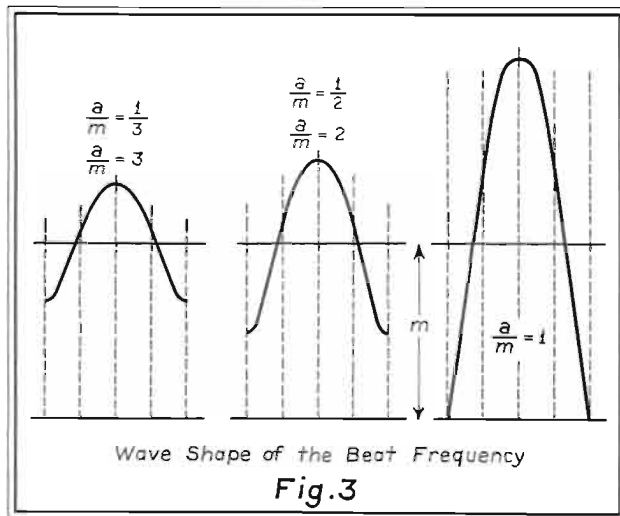

THERE APPEARED during the years from 1928 to 1933 a series of articles, in the well known English periodical *The Wireless Engineer*, which dealt with an interesting phenomenon, namely, the apparent demodulation of a weak signal by a stronger one.¹⁻¹⁰ In the American usage, the term "demodulation" is given a meaning different from that implied in the above articles; it therefore seems preferable to speak instead of "modulation compression." Some authors call it the "masking effect."¹¹⁻¹⁴

Modulation compression is not only an interesting theoretical phenomenon, but also has practical significance because it affects the effective selectivity of a radio set. In consideration of this fact and others, the IRE Standards Committee has recently recommended the "two-signal" testing method. Yet, the fundamentals of this phenomenon from a physical standpoint do not seem to be widely known nor understood, and no compre-

hensive treatment has so far been published in the literature.

In an earlier paper, the author has called attention to the fact that two distinct and independent magnitudes are involved in every problem of detection of a modulated signal.¹⁵ These are: the envelope of the r-f detector input signal and the rectification characteristic. The latter, on the other hand, is the result of two factors: the detector tube characteristic and the detector load characteristic. The audio output will depend on what combination of r-f envelope, tube characteristic and load characteristic is chosen. We shall keep this fact in mind as we proceed and begin first with the determination of the r-f envelope.

We assume two radio signals, one of which is unmodulated

$$e_1 = mE \sin \omega_0 t, \quad (1)$$

and a second one which shall be modulated:

$$e_2 = E(1 + k \sin at) \sin \omega_0 t \quad (2)$$

One will note from these expressions that

$$m = \text{ratio of } \frac{\text{unmodulated carrier}}{\text{modulated carrier}}$$

We put

$$\omega_2 - \omega_0 = b = \text{beat frequency} \quad (3)$$

$$1 + k \sin at = a,$$

whereby k represents the percentage modulation of signal

e_2 and $\alpha = 2\pi f_0$, with $f_0 =$ audio frequency. A sinusoidally variable magnitude like e_1 is most simply represented by the projection of vector of length mE , rotating counterclockwise with a velocity ω_0 into a fixed projection axis. It is, however, in our case more convenient to hold the vector mE fixed and let the projection axis rotate in clockwise direction (Fig. 1). The second signal e_2 , is similarly represented in the same diagram by a vector of length aE , rotating at an angular

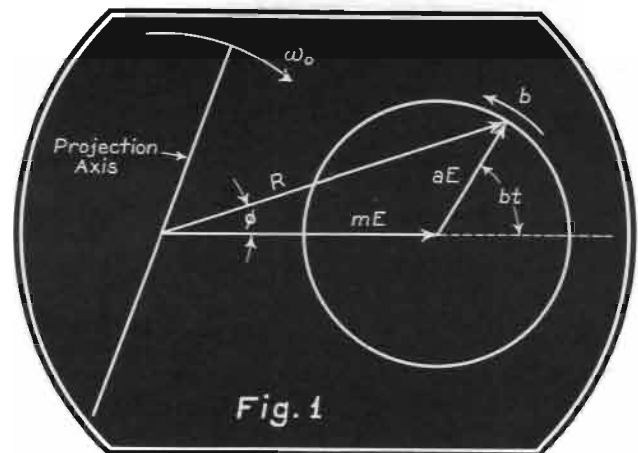

velocity of $\omega_2 - \omega_0 = b$ relative to the vector mE . The vector sum

$$R = mE + aE$$

represents the instantaneous value of the resulting envelope of $e_1 + e_2$ and it is this function for which we want to solve.

From an inspection of Fig. 1 we note that R assumes a maximum if $bt = 0$; we then have

$$R_{\max} = (m + a) E = (m + 1 + k \sin at) E.$$

If

$$bt = \frac{1}{2} \pi,$$

R becomes a minimum with

$$R_{\min} = (m - a) E = (m - (1 + k \sin at)) E.$$

The curves R_{\max} and R_{\min} are shown in Fig. 2. Between these two curves, R varies rapidly back and forth; the frequency of this variation equals b , which is the beat

SUPPRESSION

By a Stronger One

GENERAL ELECTRIC CO.

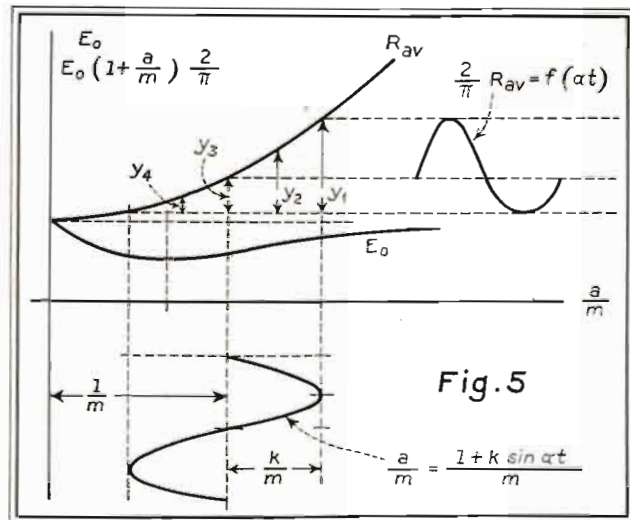

frequency. Fig. 2 shows how the r-f envelope R varies during 1 audio cycle. The curves R_{max} and R_{min} are the upper and lower envelope for the beat frequency. We see that we have to deal with three frequencies in this problem: the audio frequency $\alpha/2\pi$ (say 200 cycles), the beat frequency $b/2\pi$ (say 10,000 cycles) and the r-f (say 1,000,000 cycles—not shown in Fig. 2).

Next, let us consider in detail the change which R undergoes during 1 cycle of beat frequency. The vector

These assumptions mean that the capacitor C is so large that its electrical charge has no time to leak off during 1 cycle of the radio or of the beat frequency. On the other hand, it is small enough to permit its potential to follow variations at low audio-frequency rate. The result is that the potential across the capacitor C will follow the curve R_{max}' (Fig. 2) which is not much different from R_{max} , as far as the fundamental audio component is concerned. In other words, the output will correspond to the envelope of the beat-frequency peaks. The audio component of the output is proportional to $k \sin \alpha t$; this means that *no modulation compression* has taken place. The percent modulation, however, which was k percent before, is now reduced; it equals $\frac{k}{1+m}$.

We note from these considerations that the elimina-

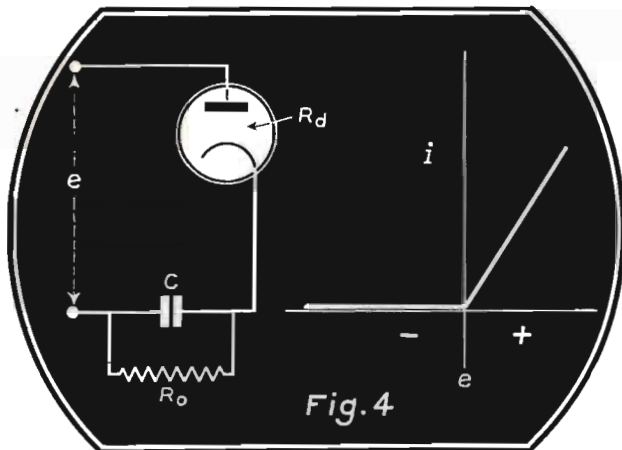

aE rotates with the angular velocity b . If we let a be constant during one revolution, we can readily determine R from the vector-diagram of Fig. 1. Three different types of "beat curves," determined graphically, for different values of a/m , are plotted in Fig. 3. We also could calculate R from the relation

$$R = E \sqrt{m^2 + a^2 + 2am \cos bt} \quad (4)$$

which follows from the vector-diagram of Fig. 1.

Knowing the r-f envelope we have to study how this envelope will be transformed into d-c and audio current by means of a rectifier. We consider the diode circuit shown in Fig. 4; we assume the diode characteristic to be a broken straight line. For the CR-load circuit of the diode we must consider two different cases.

Case 1

- The CR-network shall have
- very low impedance for the radio frequency,
 - very low impedance for the beat frequency,
 - very high impedance for the audio frequency.

tion of the beat frequency in the detector load circuit, produces an output which is equivalent to that resulting from the addition of two signals, e_1 and e_2 , of equal r-f (equation (1) and (2)). Provided the carriers are in phase, the resulting envelope equals R_{max} . The resulting audio output is $k \sin \alpha t$ and the percentage modulation equal to $\frac{k}{1+m}$. These results follow from a consideration of Fig. 1.

Case 2

We find a quite different result if we make the CR-network such that it represents

- a very low impedance for the radio frequency,
- a very high impedance for the beat frequency,
- a very high impedance for the audio frequency.

This means that the capacitor C is small enough to permit its potential to follow any variations at audio-frequency or beat-frequency rate, while it is still too large to let its potential follow the r-f.

The potential variations across the capacitor C are now an exact reproduction of the r-f envelope R . The current flowing through resistor R_o , Fig. 4, will consist not only of an audio component, α , and its harmonics, but also of the beat frequency b and its harmonics, as well as some sum and difference frequencies. The beat frequency and the combination frequencies are located at the upper limit of the audible spectrum or beyond that limit. These components are of no further interest;

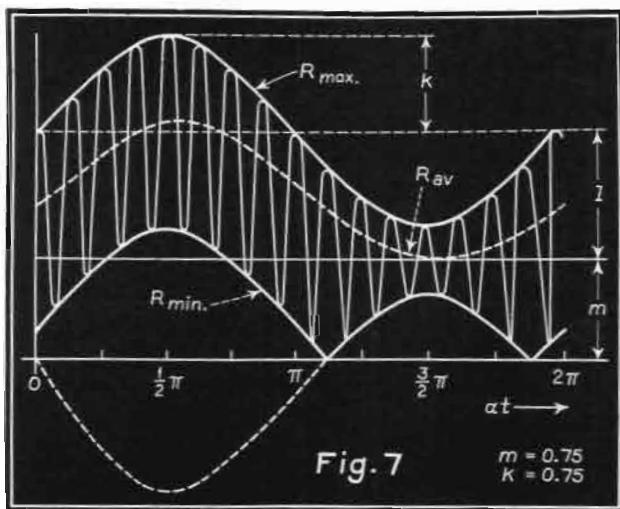

By simple algebraic transformation we can write equation (4) as follows

$$R = E(a + m) \sqrt{1 - \frac{4a/m}{\left(1 + \frac{a}{m}\right)^2} \sin^2(1/2 bt)}$$

By substitution into (6)

$$R_{av} = E m \frac{2}{\pi} \left(1 + \frac{a}{m}\right)$$

$$\int_0^{\pi/2} \sqrt{1 - \frac{4a/m}{\left(1 + \frac{a}{m}\right)^2} \sin^2(1/2 bt)} d(1/2 bt)$$

Fig. 2

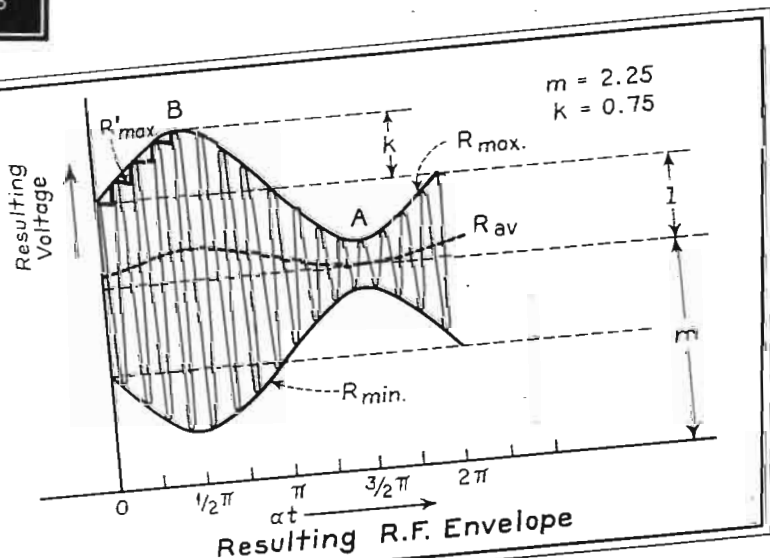
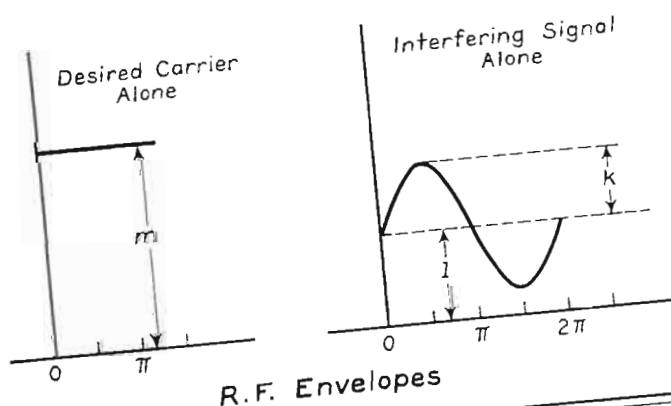

they are sharply attenuated in the audio system and in the loudspeaker, since most sets do not pass more than about 6000 cycles. We wish, however, to know what fundamental audio component is contained in R . If we denote by k_1 the amplitude of the fundamental audio component and apply Fourier's harmonic analysis to the function R , we get

$$k_1 = \frac{1}{\pi} \int_{-\pi}^{\pi} R \sin \alpha t d(\alpha t) \quad (5)$$

Substituting now equation (3) into (4) and equation (4) into (5) produces a complicated function which cannot be evaluated in straightforward manner.

However, the fact that the audio frequency is very much lower than the beat frequency offers a possibility for an attack to obtain at least an approximate solution. The variation of $\sin \alpha t$ during one cycle of beat frequency is so small that $\sin \alpha t$ may be considered constant during the time $2\pi/b$. During this time, the average value of R is

$$R_{av} = \frac{1}{2\pi} \int_0^{2\pi} R d(bt) = \frac{1}{\pi} \int_0^{\pi} R d(bt) \quad (6)$$

We have to determine R_{av} as a function of time during 1 full cycle of audio frequency α ; the fundamental audio component of R_{av} is the quantity k_1 we want to find.

The integral is of the form

$$\int_0^{\pi/2} \sqrt{1 - v^2 \sin^2 \phi} d\phi;$$

it will be recognized as the complete elliptic integral of the second kind. For the modulus v we have

$$v = \frac{2\sqrt{\frac{a}{m}}}{1 + \frac{a}{m}}$$

v must always be smaller than 1. This condition is met because we note that the right-hand term is always smaller than unity, regardless whether a/m is smaller or greater than 1. This means that our results will not be limited to small ratios of interfering versus desired carrier, but will hold for any ratio. Furthermore, we note that the above expression for v is symmetrical with respect to 1; or, by way of an example: $a/m = 1/5$ and $a/m = 5$ yield equal values for v , and subsequently equal values for the integral.

The evaluation of the integral is simple if $a/m = 1$.

Then $v = 1$ and

$$\int_0^{\pi/2} \sqrt{1 - \sin^2 \phi} d\phi = 1.$$

For the other values of a/m we have to refer to published tables for elliptic integrals for computation of the integral.¹⁶ We put

$$\int_0^{\pi/2} \sqrt{1 - \frac{4a/m}{(1+a/m)^2} \sin^2(1/2bt)} d(1/2bt) = E_0$$

and

$$R_{av} = Em \frac{2}{\pi} (1 + a/m) E_0 \quad (7)$$

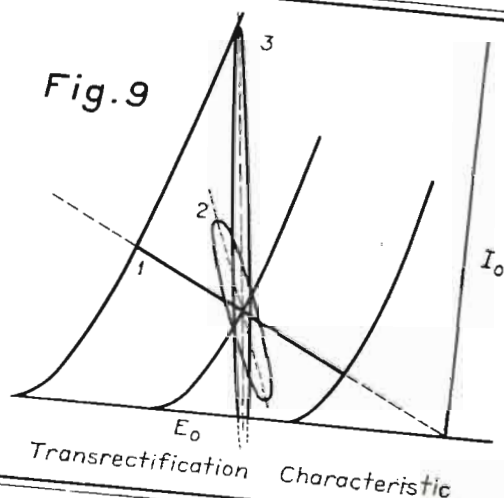
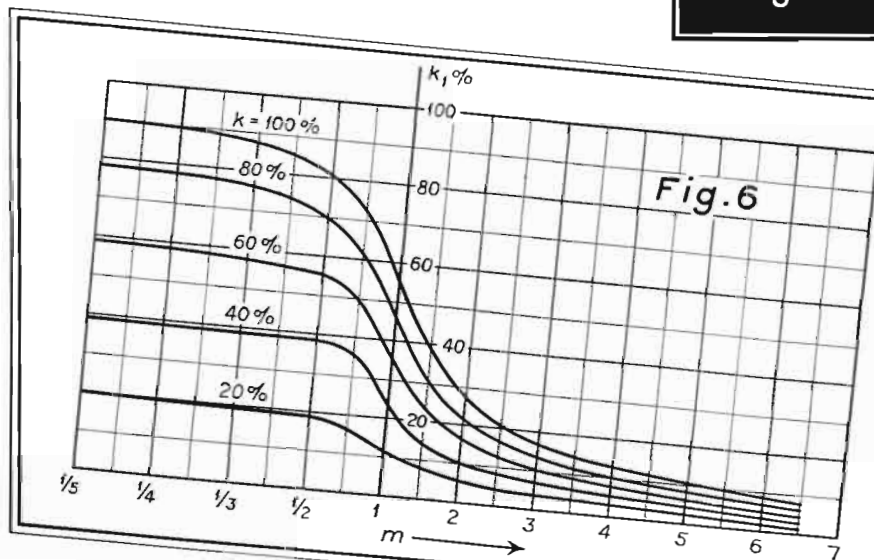
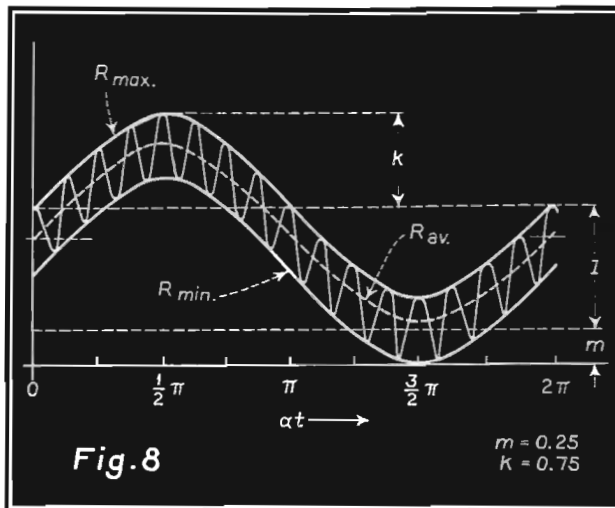

In Fig. 5 the functions

$$E_0 \text{ and } \frac{2}{\pi} (1 + a/m) E_0$$

are plotted versus a/m .

The magnitude a/m is a function of audio frequency (equation (3)). We have

$$\frac{a}{m} = \frac{1 + k \sin at}{m}$$

and this term is always positive if the factor of percentage modulation, k , is equal to or smaller than 100%. By simple graphical construction—shown in Fig. 5—we obtain the resulting R_{av} as a function of frequency αt . This curve is shown in Fig. 2. It is seen that the amplitude variation of R_{av} is very much less than that of R_{max} ; this difference in amplitude variation represents the “modulation suppression”. The procedure of determining R_{av} versus αt is perfectly analogous to that used for determining the output voltage of an amplifier, whose operating characteristic corresponds to R_{av} , for sinusoidal grid input voltage. The fundamental harmonic component of the periodic function

$$R_{av} = f(\alpha t)$$

is the desired magnitude k , i.e., the fundamental audio

component of the output. For finding this component, a number of graphical methods is available. With an approximate method due to W. Kleen¹⁷, we obtain for the fundamental component

$$k_1 = \frac{1}{3} (y_1 + y_2 - y_3) \quad (8)$$

The significance of the y_1 , y_2 and y_3 is shown in Fig. 5.

We now have the final solution of the problem we started out to study. The results hold for any carrier ratio m , but for $m > 5$ another method is more convenient. Equation (4) can be transferred into

$$R = mE \sqrt{1 + \frac{a}{m} \left(\frac{a}{m} + 2 \cos bt \right)}$$

If a/m is small, the root can be expanded into a fast converging series which was previously derived by P. Vigoureux and also by E. B. Moullin^{18, 7}:

$$R = mE \left(1 + \frac{1}{2^2} \left(\frac{a}{m} \right)^2 + \left(\frac{1}{2} \right)^2 \frac{1}{4^2} \left(\frac{a}{m} \right)^4 + \left(\frac{1.3}{2.4} \right)^2 \frac{1}{6^2} \left(\frac{a}{m} \right)^6 + \dots \text{ terms containing } bt \right)$$

(Continued on page 45)

A CRYSTAL-CONTROLLED PACK TRANSMITTER

By **DON LANGHAM**

Engineering Department
WFBL

THE FIRST consideration in designing the pack transmitter illustrated here was to provide crystal control with a minimum of apparatus and tuning controls. Since the weight and dimensions of pack transmitters must be kept at a minimum, certain conditions were imposed. The r-f section was to have no more than three tuning controls. The output was to be two watts, and the antenna $\frac{1}{4}$ -wave long. The frequency of this particular pack was to be 37.6 megacycles, and if full advantage of crystal control was to be realized the maximum allowable frequency drift would be approximately 20 cycles per mc per degree Centigrade.

Since a fundamental crystal is impractical at this frequency, doubling was necessary. A crystal to fulfill the conditions was readily obtainable, ground for 18.8 mc at 70° C.

R-F SECTION

A great deal of experimenting with various circuits and tube combinations resulted in the layout shown in diagram. The use of 2-volt tubes allowed a minimum of battery drain and weight. The total filament current is .76 ampere.

The oscillator and doubler were combined through the use of a 19 twin triode. This tube in a conventional cir-

cuit performed dependably, the output at the second harmonic being sufficient to easily drive the final when properly coupled. Any attempt to bias the oscillator resulted in decreased output and apparently had no effect on the stability.

Choosing a tube for the final was somewhat more difficult. Two problems were confronted. First, unless a thoroughly shielded screen-grid tube was used, neutralizing was necessary. Since the only 2-volt tubes of this type are the 32 or 1B4, we preferred to work out the neutralizing problem using a power-amplifier pentode such as the 1F4. The driver requirements for this tube were light and a reasonable amount of output could be expected.

Experiment showed us that only a very small neutralizing capacity was required to eliminate undesirable self-oscillations. About 6 inches of twisted strap wire sufficed.

Having eliminated this tuning control, the next step was to do away with the tuned-grid circuit and link coupling. Capacity coupling was discarded. In order to obtain sufficient excitation from the doubler an efficient transfer must

occur. This finally was accomplished by winding a grid coil with a natural frequency somewhat below the operating frequency. Then with fairly close coupling to the doubler tank the number of turns were reduced until maximum transfer was attained. This method proved very satisfactory.

Although there was nothing unorthodox about the circuit itself, the usual vagaries of ultra-high frequencies were experienced.

AUDIO SECTION

With an input to the final of 4.5 watts, the audio power required for complete plate modulation was approximately 2.3 watts. The tentative tube line-up to furnish this included a 19 in Class "B" as modulator, a 30 driver and a 32 preamplifier. Some doubt was entertained as to whether sufficient amplification would be obtained from the preamplifier when using a low-level microphone, but careful adjustment resulted in ample gain.

Supply voltage to all tubes was 225. The Class "B" modulator was operated at zero bias, giving greater output. The 30 was operated with 13.5 volts bias. However, the key to optimum results lay in the screen voltage to the 32, the value of which was found to be quite

Circuit diagram of the ultra-high-frequency transmitter.

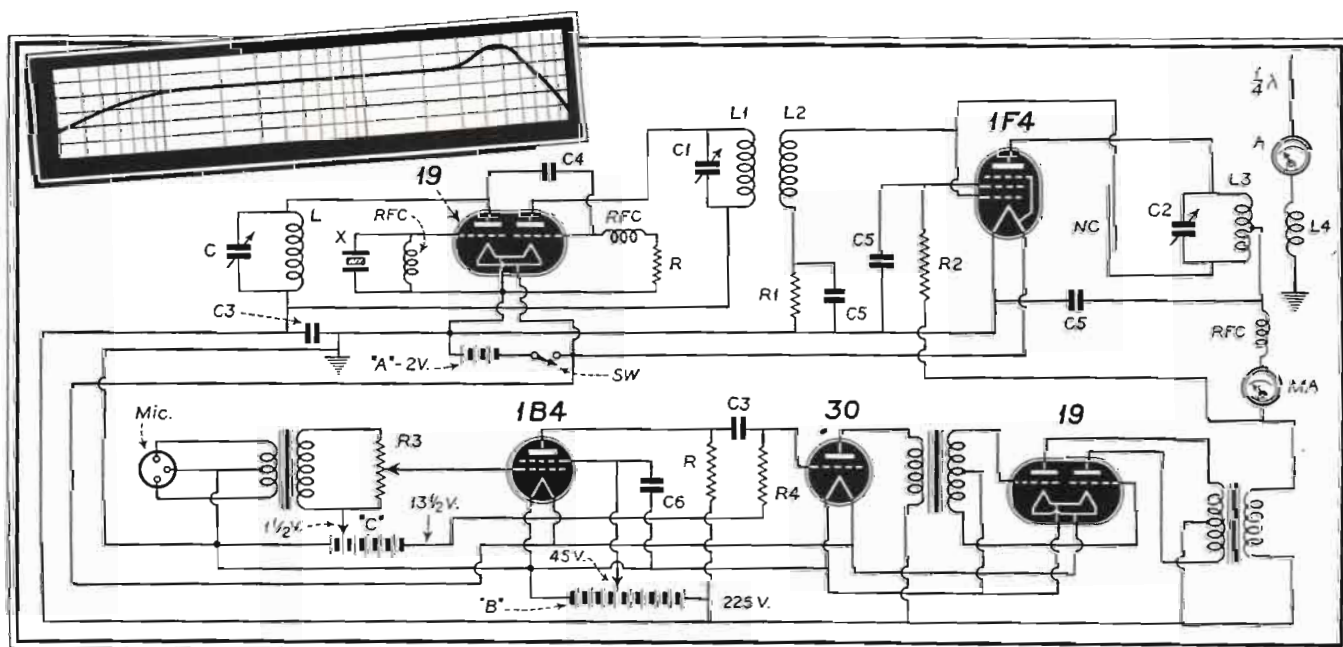

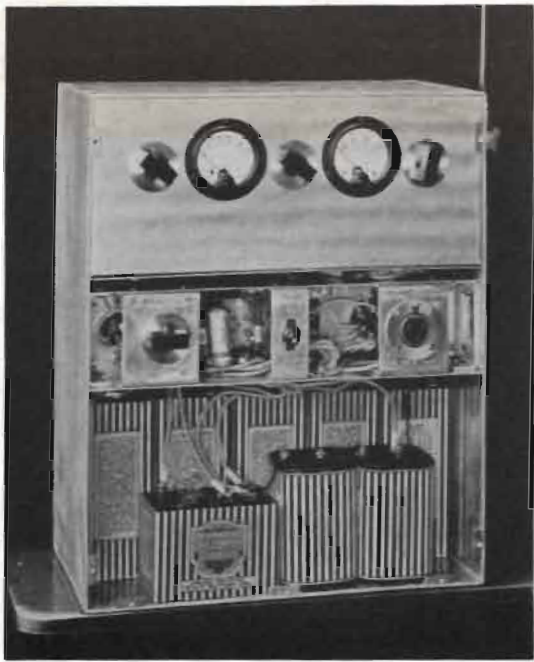

The pack transmitter with front cover removed.



Front view of the crystal-controlled unit.

critical. In this case it should be 45 volts.

CONSTRUCTION

Construction details were worked out last, since they depended to a great extent on the amount of "pruning" possible.

In order to obtain the required service hours from the plate batteries at a drain of approximately 100 ma, it was necessary to use medium size B batteries. Five of these side by side measured 13 inches and determined the width.

With a depth and height of 7 inches the battery compartment accommodated all batteries nicely, including 2 dry cells and the midget 22½-volt C battery. An additional height of 9 inches was sufficient to house the r-f and audio units with no space wasted. The r-f section was laid out on a shelf with a one-inch sub-compartment for all resistors, fixed condensers, chokes, etc. The audio components were mounted on a dish type chassis 3 x 13 x 2 inches.

The case was built of ¼-inch aluminum with back, sides and bottom welded into one piece. The top was removable for access to the r-f compartment. An independent, semi-false front was fashioned to allow all controls to protrude flush through cut-outs. In this way ready access could be obtained to batteries and the audio unit. It is likely that 3/32-inch aluminum would prove as serviceable and reduce weight.

The holder for the "fish-pole" type antenna was mounted on the top side of the case adjacent to the final amplifier.

Total weight of the pack was approximately 35 pounds.

The antenna was a quarter-wave rod grounded to the case through a

coupling coil. A little experimenting with the antenna length and coupling coil provided the proper loading to the final with an average antenna current of .2 ampere and approximately 20-ma plate current.

The microphone cord had some effect on the tuning and when too long introduced feedback into the audio system, but with a cord of about 5 feet no difficulties were experienced from this source.

Service tests on the batteries showed that a continuous run of 3 to 4 hours was possible before B replacement was necessary. This was deemed sufficient for any likely broadcast. A pair of "lit-

tle six" batteries supplied filaments approximately 12 hours. Since tube and battery life was of secondary importance, 225 volts was applied to all plates, an overload absorbed by the tubes without untoward degeneration.

A 1B4 preamplifier tube was later substituted for the 32 with a slight increase in gain.

Reception of the pack under actual, severe operating conditions was gratifying, the stability of the signal permitting the use of a superhet if desired. Mobile use over hilly terrain had no effect on the carrier except the usual "shadow" effect.

"PLANE TIME" SIGNALS

WHILE "RAILROAD TIME" has been made synonymous with accurate time-keeping, "airplane time" bids fair to become a new symbol of standard time synchronization.

Regulation of its coast-to-coast and border-to-border air schedules on Naval Observatory time signals broadcast by its own nation-wide radio chain hourly is being established by United Air Lines' technical engineers over the New York-Chicago-California and Seattle-San Diego airways.

The airline engineers are making installation to flash observatory-checked time signals every hour to its airport radio stations at Chicago, San Francisco and other principal cities.

J. R. Cunningham, United's chief of communications, stated that with pilots of all planes in flight required to report their positions and the weather aloft every half-hour, the new time-signal system is important to regulate plane-ground communication.

Top view of transmitter with cover removed.

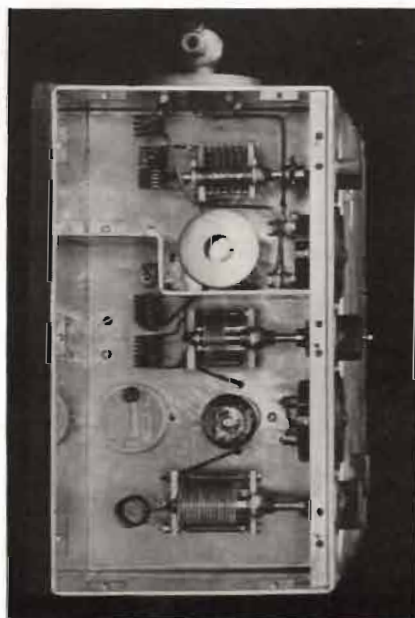

A view of the modulating amplifier of the new 50-kilowatt transmitter of WHAS.

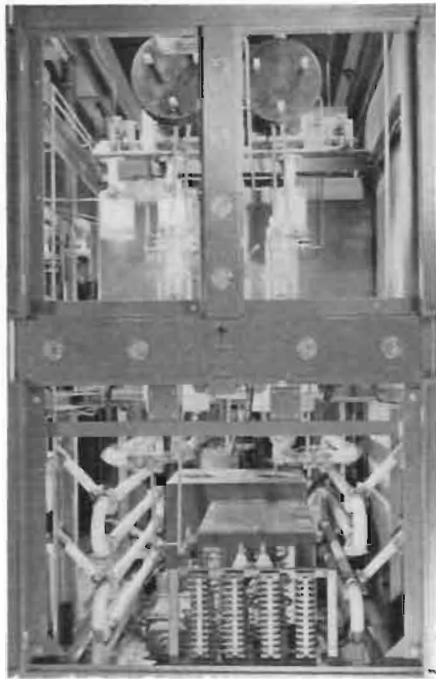

Engineers inspecting WHAS's new Western Electric transmitter.

RADIO STATION WHAS



Rear view of the oscillator amplifier in the new transmitter.

One of the two 100-kilowatt final amplifier power tubes used in the Doherty circuit.

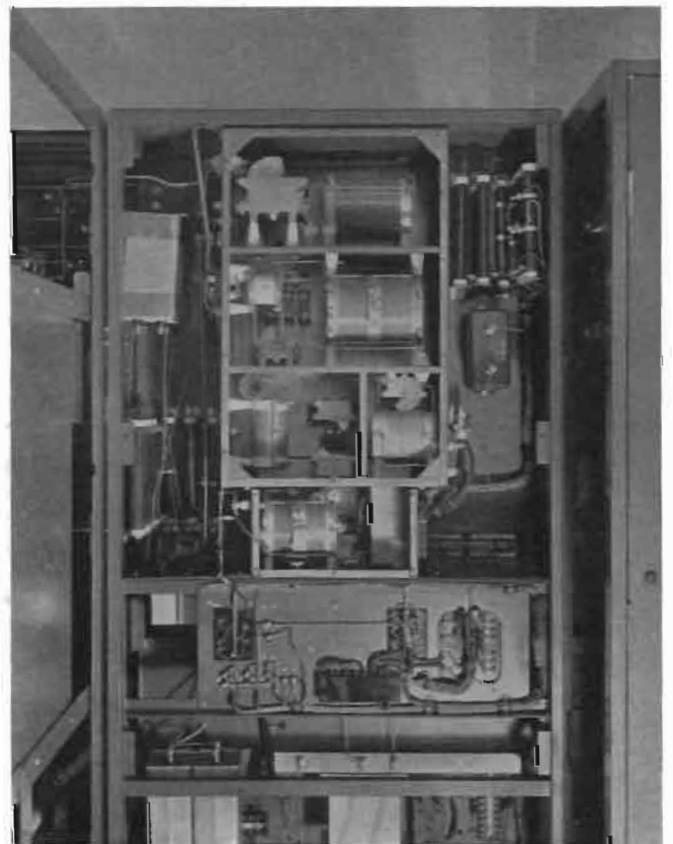



View of nitrogen filled coaxial transmission line and 650-foot Blaw-Knox radiator.

The power control cabinet at WHAS's new 50-kilowatt transmitter.

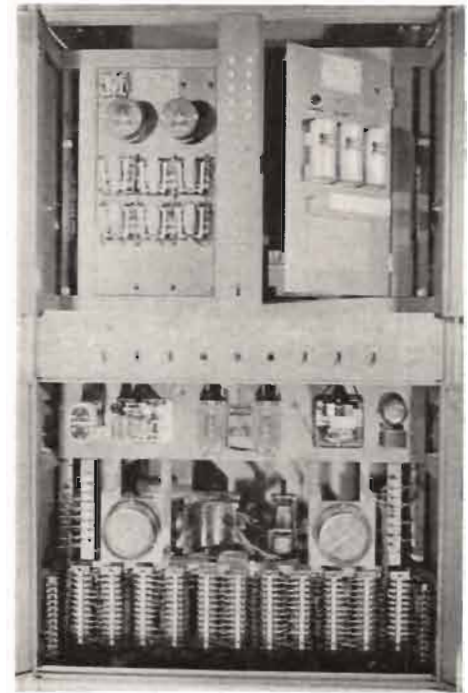

LOUISVILLE, KENTUCKY

Front view of the two final output amplifiers, showing 100-kw tubes.

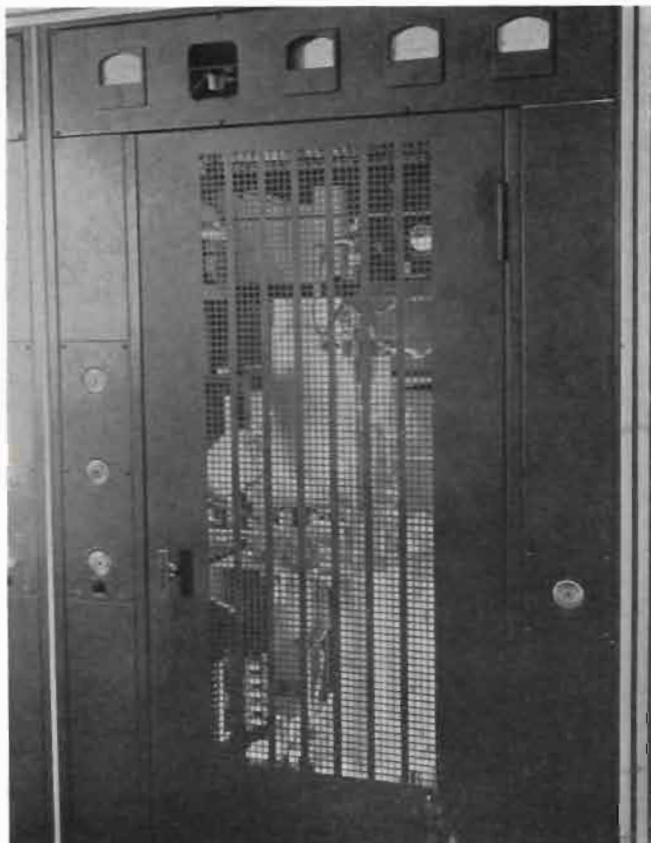

Station speech-input bay, with automatic program amplifier, microphone and monitoring loudspeaker.

NEW RESEARCH TOOLS

CYCLOTRONS, electrostatic generators, neutron producers, atom smashers, and high-voltage generators, are the terms used in describing the types of new equipment for physical research. Undoubtedly, some time will elapse before the academic and theoretical results obtainable from these devices are adapted widely in the electrical and communications industries. Like all developments of the past, however, the full ramifications of a given discovery, growing with the demands of an increasingly complex civilization, are rarely known or foreseen by the initial workers. It is significant, in this case, that the now famous Van der Graaff generators have passed from the Round Hill Laboratories, through stages as an exhibition piece (Paris Exposition) to the Westinghouse Research Laboratories where the academic possibilities may unfold more rapidly into commercial realities.

The pear-shaped tank, now in construction at Pittsburgh, employs the Van der Graaff d-c generator and a forty-foot vacuum tube in a sixty-five-foot structure for the production of 5,000,000 volts. Details of its building have had wide publicity.

Meanwhile, parts are being made at Round Hill for the voltage extension of the present set-up¹. The cascade² accelerating tube, recently completed,³ rests on a twenty-four-foot I-beam of bakelite-impregnated plywood extending horizontally between the generator terminals and consists of four rigid sixty-five-inch sections joined by flexible bellows. Each section has twelve porcelain cylinders and eleven steel electrodes, all clamped between heavy steel end plates by means of six plywood tension rods. The porcelain cylinders have external corrugations and are twelve inches in diameter. The electrodes consist of focusing cylinders three inches in diameter spaced with $\frac{1}{2}$ -inch gaps and held coaxially in the tube by diaphragms, the edges of which protrude slightly between the porcelain cylinders. Vacuum joints are made reliably tight by lead gaskets painted with Glyptal. The tube and I-beam are shielded against radial fields by seven rings consisting of tractor inner tubes coated with "Aquadag" and electrically connected to the tube at every sixth diaphragm. Voltage distribution is con-

trolled by corona points attached to the edges of all diaphragms.

Cyclotrons, following the initial work of Lawrence and Livingston⁴ in California, are being constructed by various universities throughout the country. The adoption of these magnetic accelerators for electrons into industrial laboratories is pending. The latest one, as completed at Princeton,⁵ has over-all dimensions of 7 x 9 feet, weighs more than 82,000 pounds, and provides fields in excess of 14,000 gauss.

Similarly, with the discovery of neutrons, investigators in various parts of the country have been concerning themselves with the construction of neutron generators. The production of high vacuums and voltages, involving the related precautions for leakage and insulation, are the chief problems of design—a fact that will be appreciated from Fig. 1 showing a typical generating tower with a 600-kv vacuum tube. Steel and porcelain are the main build-

ing materials in this fifteen-foot structure. The vacuum tube of surface-sealed porcelain is shielded at its midpoint against radial fields with a graphited hoop following the practices of Van de Graaff. The tower at the right is similarly protected.

POLICE TRANSMITTER

AN ULTRA-HIGH-FREQUENCY police-radio transmitter of advanced design for use in the band between 30 and 42 megacycles is being introduced by the Western Electric Company. The power output is a full 25 watts (unmodulated) and 38 watts during modulation. This transmitter, designed by Bell Telephone Laboratories, is the first to appear incorporating the new "signal boosting" amplifier circuit, which permits operation at an unusually high percentage of modulation without risk of exceeding the predetermined maximum on peaks.

The audio-frequency amplifier consists of four stages, with a total gain of approximately 100 db and an audio output conservatively rated at 25 watts.

(Continued on page 41)

¹Phys. Rev. 51, 1013 (1937).

²Phys. Rev. 40, 45, 50, 55 (1930-1936).

³R.S.L., 9, 19 (1938).

Fig. 1. 600-kv vacuum tube built at Memorial Hospital (New York City) with the cooperation of the W.P.A.



⁴Phys. Rev. 49, 761, (1936).

⁵Phys. Rev. 35, 66, (1930).

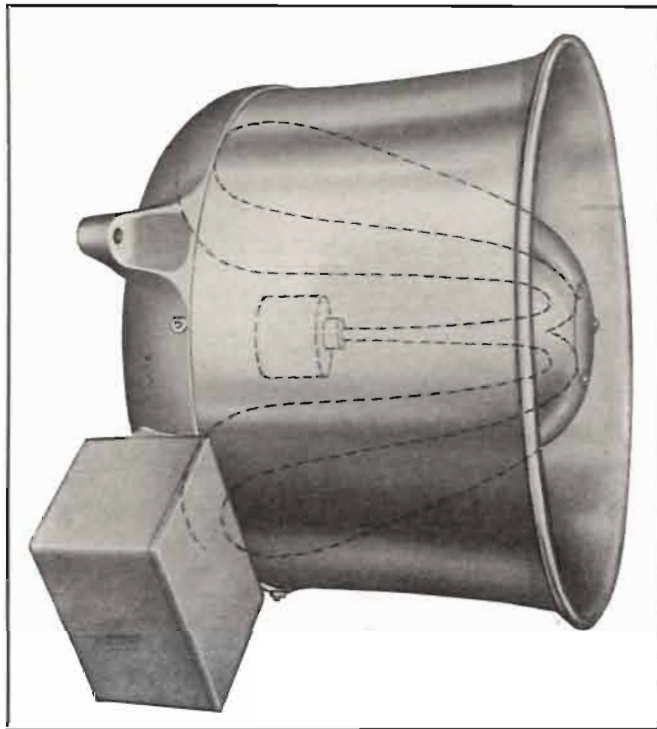

The New RACON MARINE SPEAKER*

The following represent a few of the Steamships which are being equipped with RACON MARINE SPEAKERS on all embarkation decks:

United States Lines

S.S. "California"
S.S. "Pennsylvania"
S.S. "Virginia"
S.S. "Manhattan"
S.S. "Washington"
S.S. "Pres. Harding"
S.S. "Pres. Roosevelt"

Furness Steamship Lines

S.S. "Eastern Prince"
S.S. "Northern Prince"
S.S. "Southern Prince"
S.S. "Western Prince"

Munson Steamship Lines

S.S. "American Legion"
S.S. "Southern Cross"
S.S. "Pan American"
S.S. "Western World"
S.S. "Munargo"

Southern Pacific Lines

S.S. "Dixie"

Merchants & Miners Transp. Co.

S.S. "Alleghany"
S.S. "Berkshire"
S.S. "Chatham"
S.S. "Dorchester"
S.S. "Fairfax"

AGWI Steamship Lines

S.S. "Oriente"
S.S. "Coamo"
S.S. "Yucatan"
S.S. "Siboney"
S.S. "Borinquen"
S.S. "San Jacinto"
S.S. "Shawnee"
S.S. "Cherokee"
S.S. "Troquois"
S.S. "Algonquin"
S.S. "Seminole"
S.S. "Orizaba"

Eastern Steamship Lines

S.S. "Acadia"
S.S. "St. John"
S.S. "Yarmouth"
S.S. "Evangeline"
S.S. "Robert E. Lee"
S.S. "George Washington"

Grace Steamship Lines

S.S. "Santa Barbara"
M.S. "Santa Clara"
S.S. "Santa Elena"
M.S. "Santa Inez"
S.S. "Santa Lucia"
S.S. "Santa Maria"
S.S. "Santa Marta"
S.S. "Santa Paula"
M.S. "Santa Rita"
S.S. "Santa Rosa"

Matson Steamship Lines

S.S. "Lurline"

Export Steamship Lines

S.S. "Excalibur"
S.S. "Excambion"
S.S. "Exeter"
S.S. "Exochorda"

Colombian Lines

S.S. "Haiti"

United Fruit Lines

S.S. "Antigua"
S.S. "Chiriqui"
S.S. "Petén"
S.S. "Oquirigua"
S.S. "Sixaola"
S.S. "Talamanca"
S.S. "Tolosa"
S.S. "Ulua"
S.S. "Veragua"

Savannah Lines

S.S. "City of Birmingham"
S.S. "City of Chattanooga"

*The only loud-speaker approved for outdoor use on ships by the Bureau of Marine Inspection and Navigation — and used by ALL companies making emergency loud speaker installations.

The latest speaker in Marine Practice. A compact re-entrant type of horn, 14" in diameter, 10" deep, having a base of heavy aluminum casting and heavy aluminum spinning. Uses a Driving Unit of the latest type made of Alnico Steel and Armco Iron, resulting in the most efficient unit of its size ever developed. The Driving Unit and connections are all enclosed making a completely waterproof speaker, not affected by temperature or weather, including use on sea even during storms.

Used as a LOUDSPEAKER and as a MICROPHONE, will pick up sound outdoors from distances up to 100 feet with very small amplifying gain, and will deliver 100 db. of sound 10 feet from the horn with an input of one watt.

Makes an ideal speaker not only for Marine work, but also for general PA use as well, where highly concentrated sound for great distances is required.

WEIGHT 25 POUNDS — Code REDIM

Technical Data and Prices on Request

RACON ELECTRIC CO., INC.

224 Fourth Avenue, New York City



VETERAN WIRELESS OPERATORS ASSOCIATION NEWS



W. J. McGONIGLE, President

RCA Building, 30 Rockefeller Plaza, New York, N. Y.

H. H. PARKER, Secretary

GREETINGS

WE EXTEND our most cordial greetings to the members of the National Association of Broadcasters in convention assembled in Washington, D. C., February 14, 15 and 16, and best wishes for a most successful gathering.

PURPOSE

WE HEREWITH publish our "Aims and Purposes" for the information of the many readers of COMMUNICATIONS who have not had the opportunity of becoming acquainted with our Association:

(a) To foster and extend an *esprit de corps* among wireless operators.

(b) To afford opportunity for social intercourse, and to promote a fraternal and comradely sentiment between and among its members.

(c) To recognize meritorious service rendered by wireless operators on land, at sea, or in the air, by the erection of memorials and by the bestowal of testimonials, medals, scholarships, or other suitable awards.

(d) To acquaint the public with the work, traditions and ideals of wireless operators and to perform and encourage any other purely fraternal activity or activities adjudged helpful to the wireless profession.

MEDAL

WE TAKE a great deal of pleasure in announcing that, this year, our Association will present the "Marconi Memorial Gold Medal of Valor"—so named to honor the memory of the celebrated inventor of the wireless telegraph—"For outstanding accomplishments in the art of radio communication while a member of the First and Second Byrd Antarctic Expeditions and particularly for resourcefulness, courage and exceptional ability in effecting the safe navigation of the Air Exploration Party back to its base on January 3, 1934, wholly by radio bearings with inadequate equipment and under extremely trying circumstances," to Lieut. Carl O. Petersen, USNR.

The Medal will be presented to Lieut. Petersen on the evening of February 11, 1938, at the Hotel Astor on the occasion of our Thirteenth Annual Dinner-Cruise, a complete report of which will be published on this page in the March issue.

Lieut. Petersen numbers among his previous honors a Congressional Gold Medal, the Leif Erikson Medal and a Testimonial Scroll, all for his work on the First Byrd Expedition. For his outstanding work on the Second Byrd Expedition Lieut. Petersen has been awarded a Second Congressional Medal, a Distinguished Flying Cross and now the "Marconi Memorial Medal of Valor."

The second Congressional Medal of Honor was presented to Lieut. Petersen



Lieut. Carl O. Petersen.

on December 2, 1937, by Mayor F. H. LaGuardia at the City Hall in New York City, with Admiral Byrd present, and following the presentation ceremonies they were guests of Admiral Byrd at the Biltmore Hotel in New York City.

The Medal was inscribed: "Presented to Officers and men of the Second Byrd Antarctic Expedition to express the very high admiration in which the Congress and the American people hold their heroic and undaunted accomplishments for Science, unequalled in the history of Polar Exploration." Only members of the Ice Party received this Medal, and Lieut. Petersen alone received his from the Mayor on this occasion.

Admiral Byrd congratulated him as follows: "With this Medal goes a reiteration of my enduring appreciation for your splendid contribution to the Expedition, and my heartiest congratulations for this honor that the nation has done you. Sincerely yours, Dick Byrd."

Lieut. Petersen was recently elected Vice-President of the American Polar Society.

CAIRO

OUR ASSOCIATION is well represented at the Cairo Conference: A. J. Costigan, a Director of our organization and Traffic Manager of the Radio Marine Corporation of America, is representing that company at the Conference; Fred Meinholtz, a former Secretary of our Association and Director of Communications of the New York Times, is representing the Times; Haraden Pratt, Vice-President and Chief Engineer of the Mackay Radio Telegraph Company, represents his company; Loyd Briggs, Manager of the London office of RCA Communications and our London Chapter

Chairman, is representing RCA Communications; Captain S. C. Hooper, United States Navy, Honorary Member, represents the Navy. There will be a simultaneous Dinner in Cairo on February 11 under the Chairmanship of A. J. Costigan. A complete report later.

TESTIMONIALS

SEVERAL TESTIMONIAL SCROLLS will be awarded at the 13th Annual Dinner-Cruise for outstanding radio performance. The recipients' names and the inscriptions will be included in this page, next issue.

HONOLULU

H. F. MCINTOSH, Honolulu Chapter Secretary, reports:

"Chairman Maddams and I got together and decided upon a membership drive, the results of which were fairly satisfactory. Out of forty-five letters sent out we received fourteen applications for membership and six or seven promises of signing up in the very near future. There are quite a number of men eligible for membership in the Association among the inhabitants of these islands. We are a much scattered bunch, though, what with transmitting and receiving stations located in places that only the fellows who chose their location can find them, and it is, therefore, not always possible or convenient for members at these stations to dash into Honolulu for meetings. There are some Navy men who have evinced an interest in joining and we expect to hear from them soon.

"I am enclosing a money order to cover the enclosed fourteen applications. We are looking forward to the coming Dinner-Cruise on February 11, although plans are still in the tentative stage. Many of our old stand-bys have left the islands and we shall miss them. There will be some new faces among us and we expect to have our usual good time.

"Please note that three complete Year Book groups 1932-1938 are desired. (Anyone desiring a complete set may obtain them by sending fifty cents to the Secretary.—HHP)

"I am sorry to say that we lost a prospective member when the plane 'Samoan Clipper' was destroyed in the South Pacific just a few days ago. Just the day before the clipper sailed from here I had a chat with T. J. Findley, L. D. Paulson and another Pan American Airways man, and all three of them expressed a desire to join our Association. Paulson and Findley were alternate flight operators on the 'Samoan Clipper'—Findley was making the flight and he took an application blank along with him, promising to fill it out and return it to me in a few days. The news of the loss of the plane and the lives of all on board came as a severe shock to those of us who had known Findley. He was a

(Continued on page 38)

Let CLAROSTAT

Solve

YOUR RESISTANCE PROBLEM

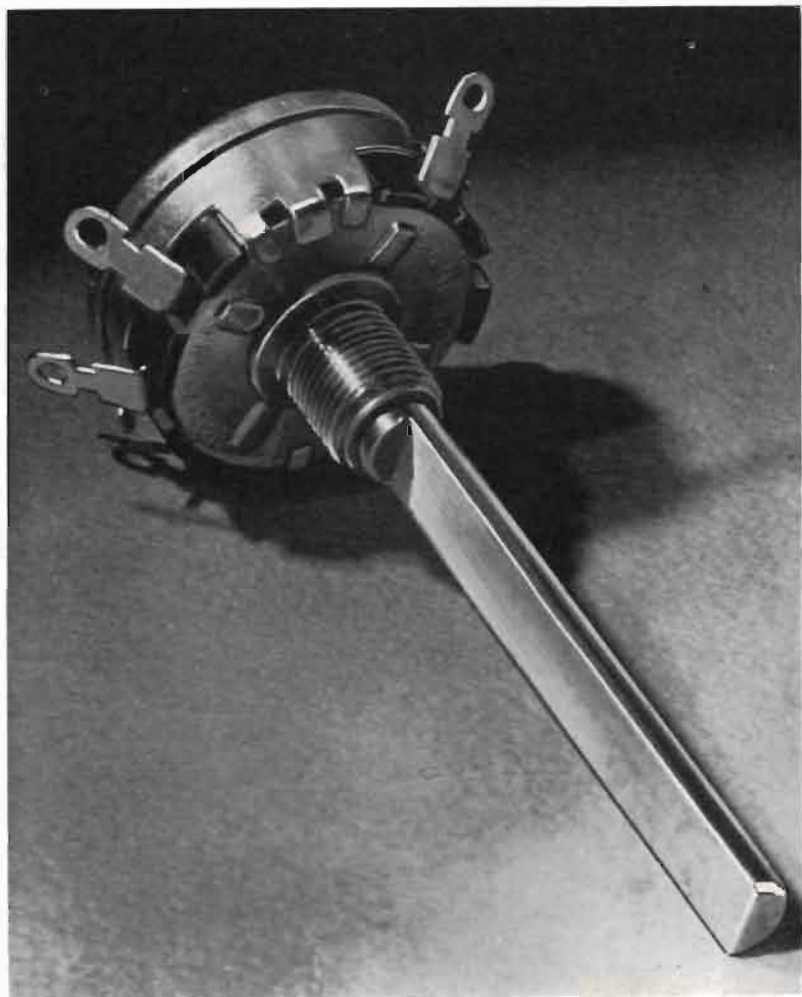

Clarostat Series 37 (Composition-Element) Controls are available in the widest range of resistance values, all standard tapers, choice of shafts, switches, etc.

Also offered in the tapped type (shown at left) for such functions as diode bias method of controlling volume and as a tone compensator in audio control system.

Series 37 also includes special controls for automobile receivers with various kinds of special shafts—full-length slotted, end-slotted (shown below), double-milled, etc.

So just state your control requirements. We'll fit the Series 37 to your exact needs. Samples cheerfully submitted to quantity users. Like-wise quotations and specifications.

● THERE'S more than just extreme compactness involved in the CLAROSTAT Midget (Series 37) Control. Actually, it's an entirely *new* design, *new* production technique, *new* standard of performance. ● No other control ever reflected such a background of experience, specialized engineering, and willingness to replace existing production machinery and methods, regardless of cost, in order to produce a *provably better* product. ● And in tens of thousands of assemblies, CLAROSTAT Series 37 Controls are already confirming these statements.

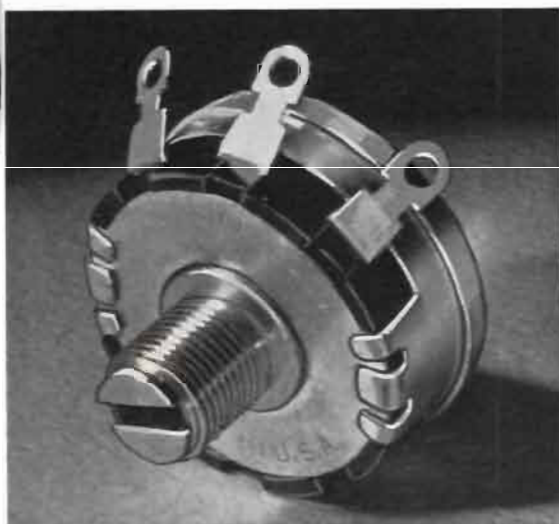

CLAROSTAT Manufacturing Co., Inc.



285-287 NORTH SIXTH STREET
BROOKLYN, NEW YORK, U.S.A.

• OFFICES IN PRINCIPAL CITIES •

OVER THE TAPE . . .

NEWS OF THE COMMUNICATIONS FIELD

DAWES & DUNN ELECTED TO RCA BOARD OF DIRECTORS

General Charles G. Dawes, former Vice-President of the United States, author of the Dawes Plan, and subsequently Ambassador to the Court of Saint James; and Gano Dunn, noted scientist, engineer, administrator and President of The J. G. White Engineering Corporation, were elected to the Board of Directors of the Radio Corporation of America at the regular meeting of the Board held January 28, it was announced by David Sarnoff, the President. They fill vacancies due to the recent deaths of Frederick Strauss, banker, and Newton D. Baker, former Secretary of War.

Mr. Sarnoff further announced that at the meeting of the National Broadcasting Company Board, held the same day, Dr. James Rowland Angell, former President of Yale University, and now in charge of educational program development for the NBC, was elected a Director of that company. General Dawes and Gano Dunn were also elected as Directors of the NBC.

INDUSTRIAL CAPACITOR MANUAL

A new edition of the Aerovox Industrial Capacitor Manual is now offered by Aerovox Corporation, 70 Washington St., Brooklyn, N. Y. This handy manual deals with ratings, required capacities, power factors and other engineering and servicing aspects of motor-starting capacitors. Simple self-calculating charts are included for figuring out the necessary mathematical problems. A copy of this manual may be had from the local Aerovox jobber or from the Aerovox Corporation direct.

ARCTURUS REPRESENTATIVE SAILS

Charles I. Robbins, Foreign Sales Representative of the Arcturus Radio Tube Company, Newark, N. J., left for Europe on January 27th. His itinerary will carry him into every country in Europe, including the Scandinavian countries, the Near East and Asia.

ANDREW LITERATURE

Two new bulletins have recently been issued by Victor J. Andrew, 7221 South Francisco Ave., Chicago, Illinois. One bulletin (72) deals with semi-flexible coaxial cables while the other one (816) covers coupling units for shunt-excited radiators. Both bulletins are available on request.

L. C. LOSHBOUGH DIES

L. C. Loshbough, for the past 12 years Chicago representative of the Global Division of the Carborundum Company, Niagara Falls, N. Y., died December 31st, 1937 at his home, 6925 East End Avenue, Chicago, Ill. Mr. Loshbough was well regarded in the radio industry, being rated as one of the early comers to that field. Mrs. Loshbough has been appointed to The Global Division of The Carborundum Company to carry on in the radio field the work which was so capably handled by her husband.

OUTSTANDING ENGINEER

Dr. Chauncey Guy Suits, of the General Electric Company, has been chosen as America's outstanding young electrical engineer for 1937 by Eta Kappa Nu, honorary electrical engineering association. Dr. Suits was selected from a list of 60 candidates of less than 35 years of age nominated by leading industrialists and educators. Three other men, Leonard L. Carter, of the Anacosta Wire & Cable Co., Philo T. Farnsworth, Farnsworth Television, Inc., and Clifford A. Faust, Ohio Brass Company, were cited for honorable mention.

NATIONAL CARBON APPOINTMENTS

R. P. Tolles, former assistant manager of the Eastern Division of National Carbon Company, Inc., has been promoted to the management of the Pacific Coast Division, with headquarters in San Francisco. At the same time, the corporation announces that C. O. Kleinsmith, Sales Manager of the Atlanta District, has been transferred to the New York office, where he will serve as Assistant Manager of the Eastern Division.

NEW TECH REPRESENTATIVE

The appointment of Henry P. Segel, of Segel Sound, Incorporated, Gardner, Massachusetts, as representative for New England, is announced by Tech Laboratories, 7 Lincoln St., Jersey City, N. J. Segel Sound, Incorporated, have discontinued their manufacturing business, and are specializing in the sale of sound equipment.

CANADIAN CUTLER-HAMMER, LTD.

Cutler-Hammer, Inc., of Milwaukee, Wisconsin, as part of its foreign trade activities, announces that a company known as Canadian Cutler-Hammer Limited has been organized for the purpose of manufacturing Cutler-Hammer motor and generator control products for the Canadian market. The Company will be a subsidiary of the Amalgamated Electric Corporation Limited which will provide the manufacturing facilities. The new Company's headquarters address will be 384 Pape Avenue, Toronto 6, Canada.

PODOLSKY JOINS SPRAGUE

Leon Podolsky is now associated with Sprague Products Company, North Adams, Massachusetts, as Research and Sales Engineer. Mr. Podolsky was formerly Research Engineer of the Wirt Company of Philadelphia.

DIRECTORY OF CHEMISTS

The 1938 Directory (fourth edition) of the members of the Association of Consulting Chemists and Chemical Engineers, Inc., has just been issued. In addition to the usual data expected in a directory, this one contains valuable details about the work these leading consultants are especially prepared to undertake. Copies of this directory may be secured from the above organization at 50 East 41st Street, New York City.

COHAN EMBARKS FOR CAIRO

E. K. Cohan, CBS Director of Engineering, has sailed (Saturday, January 15) on the *Ile de France* on the first step of his journey to Cairo, Egypt, where he will represent Columbia at the World Telecommunications Conference in February. Accompanying him on the 5,500-mile journey is Haraden Pratt, Vice-President and Chief Engineer of the Mackay Radio and Telegraph Co., and President of the Institute of Radio Engineers.

THORDARSON PROMOTIONS

Charles P. Cushway, General Sales Manager of the Thordarson Electric Mfg. Company, 500 West Huron Street, Chicago, Illinois, has announced several promotions in the Sales Department. Roy E. Davy, formerly Chief Sales Engineer, has been advanced to the newly created position of Industrial Sales Engineer, while Jerome H. Kleker becomes Chief Sales Engineer, in addition to his present duties in the Sound Division. Douglas ("Doug") Fortune, W9UVC, has been promoted from the engineering staff to the Sales Engineering Department, in charge of amateur activities. Leland S. Hicks is Sales Engineer in the Replacement Transformer Division.

GEORGE J. IRVING DIES

George J. Irving, Sales Promotion Manager and Sales Correspondent of The Webster Company of Chicago, died suddenly on December 22, 1937. Mr. Irving had been ailing for some time, due to recurring effects of injuries received in action during the World War.

RADIO PARTS SHOW

Large advance reservations for booths insure another successful National Radio Parts Trade Show at Chicago next June. Early and voluntary booth reservations have been received in unusual number and further indication of interest lies in the fact that a large percentage of exhibitors who had single booths in past trade shows are now making reservations for double space.

The Exhibition Hall in the Stevens Hotel, where the parts show will be held June 8-11, inclusive, will be laid out as a city, to be known as Radio Parts City. Each street, avenue, and boulevard will be named in honor of a deceased outstanding figure in the development of radio, such as Marconi, Ampere, Edison, etc.

Arrangements for various meetings to be held in conjunction with the show are being made by Ken Hathaway, Manager for the Show Corporation, operated jointly under the sponsorship of RMA and the Sales Managers Clubs of Chicago and New York. The joint meeting of the latter will be held Thursday morning, June 9. There will be technical lectures and sessions for service men conducted by the Chicago chapter of the Radio Service Men's Association, and a meeting of the Chicago section of IRE also is planned, together with meetings of parts distributors' organizations.

(Continued on page 37)



Specs and Dates

AEROVOX research, engineering and production facilities—probably unexcelled in this industry—are closely interlocked for just one purpose: to meet your most critical specifications and delivery dates.

- So name your needs. We shall meet them.

AEROVOX
CORPORATION
75 Washington St. Roseland, N. Y.
in CANADA, AERVOX-CANADA, Limited, Hamilton, Ont.



ALADDIN

Announces a Perfected
AUTOMATIC
Push-Button TUNER



Designed for STABILITY and Elimination of Frequency Drift

The remarkable simplicity of operation and excellent performance of this New ALADDIN Automatic Push-Button Tuner can be attributed to the following exclusive ALADDIN combination of features:

EASE OF ADJUSTMENT—Only ONE adjustment per station is required and it is easily made from the FRONT of the panel. Note illustration shows these adjustments are located exactly above the push-buttons, allowing simple, speedy access for station selection, even by the layman.

STABILITY OF OPERATION—Inductance tuning is used throughout in combination with stabilized fixed condensers. This provides a greater degree of tuning stability, elimination of frequency drift, and better uniformity of operation on any band. A new type coil-switch assembly insures accurate tracking in all positions.

PRECISION WORKMANSHIP AND QUALITY MATERIALS—Great care, engineering skill and quality materials, comparable to those used in the fabrication of fine precision instruments, are used in the making of this ALADDIN tuning mechanism.

MANUFACTURERS—Increase the sales appeal of your receivers, use ALADDIN Automatic Tuning in your 1938 models.

DEALERS—Insist upon ALADDIN Automatic Tuning in your new receiver lines. Its simplicity of operation enables your customer to make station changes himself.

For complete details,
WRITE, TELEGRAPH or CABLE

Aladdin Radio Industries, Inc.
462 W. Superior St., Chicago, Ill., U.S.A.
Cable Address: "ALADDIN"

Licensee of Johnson Laboratories, Inc.

These devices manufactured under one or more of the following U. S. Letters Patents

1,887,380,	1,940,226,	1,978,568,
1,978,599,	1,978,600,	1,982,689,
1,997,453,	2,002,500,	2,082,590,
2,018,626,	2,028,534,	2,032,914,
2,035,439,	2,051,012,	2,059,393,
2,082,589,	2,082,595,	2,094,189,
		2,095,420.

Other patents pending.



"THE OFFSET-HEAD CRYSTAL PICKUP"

IN CONNECTION with the article, "The Offset-Head Crystal Pickup" by J. R. Bird and C. M. Chorpening, which appeared in "Radio Engineering" for March, 1937, an approximate formula was given for the optimum value (for most nearly constant tracking error) of Q, the ratio of overhang to arm length. The exact formula may easily be developed as follows:

In Fig. 1 (Fig. 3 of the original article) construct a line connecting the center of the spindle with the tip of the needle (shown by heavy dotted line). This line forms the base of a triangle having its apex at the swivel point on which the arm turns. Of the three angles of this triangle, one (the one at the needle point) is the complement of θ , the uncompensated tracking angle. Applying the law of cosines to this triangle,

$$(L - D)^2 = L^2 + R^2 - 2LR \cos(90^\circ - \theta)$$

$$90^\circ - \theta = \arccos \frac{L^2 + R^2 - (L - D)^2}{2LR}$$

We assume the optimum condition to be that which yields the same tracking angle at both ends of the sound track. Obviously, the two values of R must give the same values of $\cos(90^\circ - \theta)$, therefore we may express the above condition in the equation

$$\frac{L^2 + R_1^2 - (L - D)^2}{2LR_1} = \frac{L^2 + R_2^2 - (L - D)^2}{2LR_2}$$

$$R_1 [L^2 + R_2^2 - (L - D)^2] = R_2 [L^2 + R_1^2 - (L - D)^2]$$

$$(L - D)^2 = L^2 - R_1 R_2$$

Now, by definition

$$Q = \frac{D}{L}$$

Fig. 1.

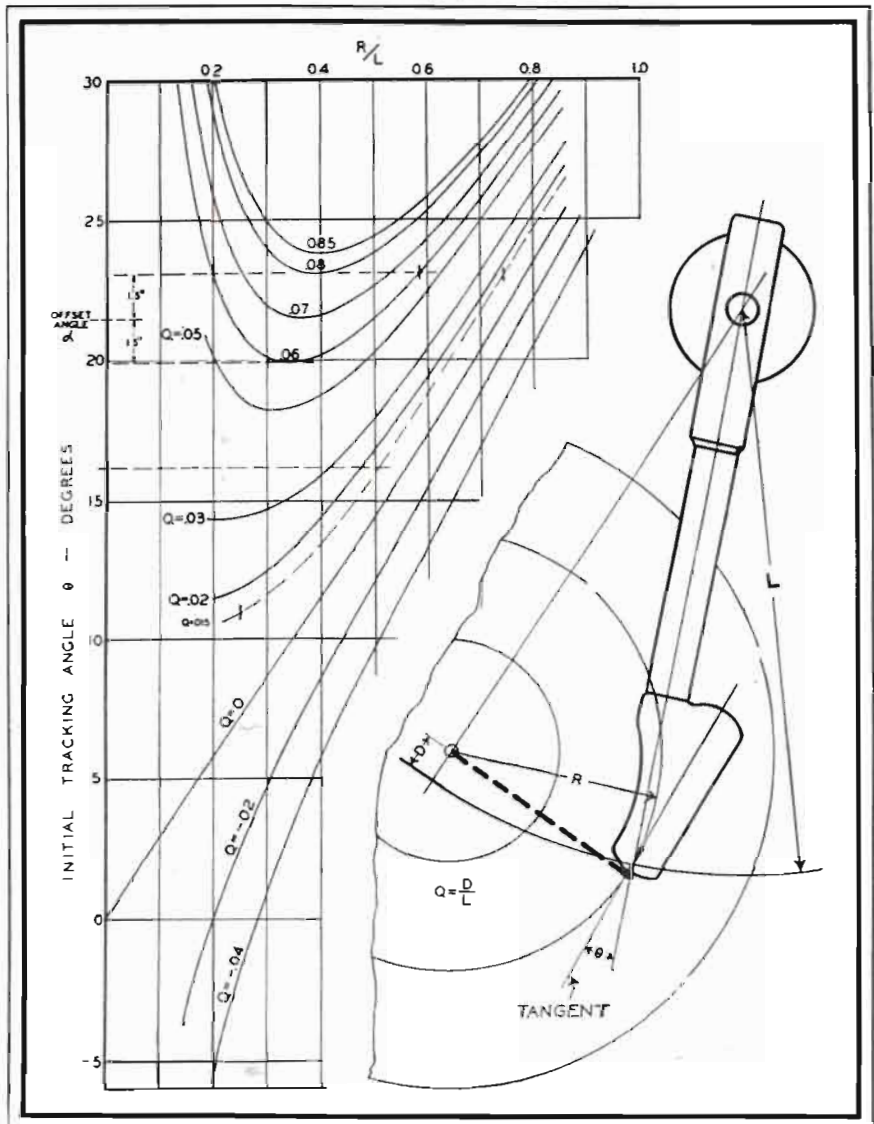

$$= 1 - \frac{L-D}{L}$$

hence

$$Q_{opt} = 1 - \frac{\sqrt{L^2 - R_1 R_2}}{L}$$

$$= 1 - \sqrt{1 - \frac{R_1 R_2}{L^2}}$$

This is the exact expression for the optimum overhang ratio. It is apparent that $R_1 R_2$ cannot exceed L^2 for any practicable instrument, hence we may use the binomial theorem if it is desired to obtain an approximate expression suitable for rapid computation. Since the exponent of the binomial is $\frac{1}{2}$, there are an infinite number of terms, but the first four will suffice. The result of this process is

$$Q_{opt} = \frac{R_1 R_2}{2L^2} + \frac{R_1^2 R_2^2}{8L^4} + \frac{R_1^3 R_2^3}{16L^6} + \frac{5 R_1^4 R_2^4}{128L^8} + \dots$$

In the original article only the first term of this expression was given. The error involved, however, was only about $\frac{1}{64}$ inch in D for a $10\frac{1}{4}$ -inch arm. Two or three terms would certainly be adequate for any conceivable requirements.

DAVID G. KNAPP

Allen B. DuMont inspecting a new $13\frac{1}{2}$ -inch television tube which he has recently developed. The rounded sides provide the strength to withstand the atmospheric pressure on the highly evacuated glass bulb.



FOR RECORDING STUDIOS THAT CAN AFFORD THE BEST



THE PRESTO STATIONARY RECORDER

Experienced recording engineers, those who are expected to get results *every time*, appreciate the refinements, the extra factors of safety and convenience, included in this Presto recording turntable.

Now that you know that instantaneous recording is a profitable fast growing business—give your engineer the best in equipment and be certain of producing the kind of records that keep your studios busy and make money for you.

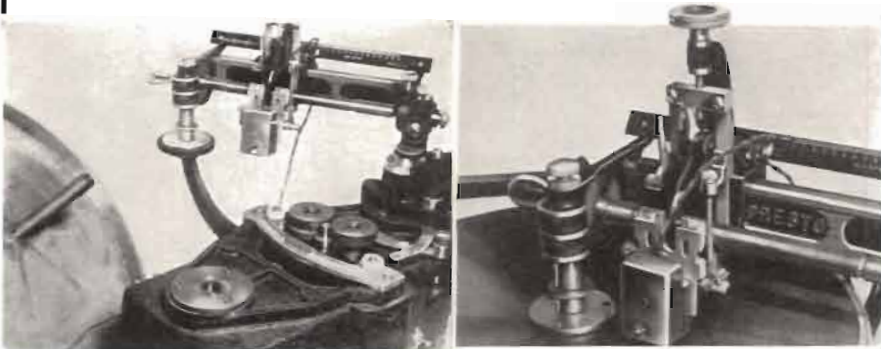

A heavy duty, constant speed motor drives a perfectly balanced cast iron turntable at the rim—the point of greatest leverage — providing ample power for recording and assuring absolutely steady speed. You can change speed from 78 to $33\frac{1}{3}$ RPM in less than 2 seconds.

Note the cam levers for lowering the cutting head and engaging the feed screw, the heavy guide bar for the cutter carriage, the scale indicating elapsed recording time, the quick adjustments of the cutting needle angle and pressure.

Send for the Presto catalog giving full technical description
Visit our demonstration at the NAB Convention

PRESTO RECORDING CORPORATION
145 W. 19th ST., NEW YORK

OUR A-1 REPRODUCING TABLE

The Ultimate in Lateral Reproduction

Especially Designed for
BROADCASTING
STATIONS

Featuring the
DYNAMIC PRINCIPLE
WITH
ASSOCIATED NETWORKS

In Addition to
OUTSTANDING AND
EXCLUSIVE
MECHANICAL FEATURES

For complete information
write for our latest
"Sound Apparatus Bulletin"
on
A MODERN REPRODUCING
SYSTEM

**SOUND APPARATUS
COMPANY**

150 West 46th Street
New York City

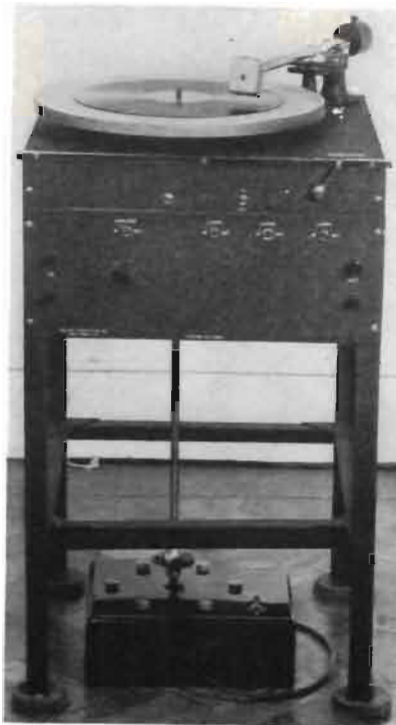

FOREIGN RADIO TRADE NAMES AND BRANDS

At the request of RMA, a survey of trade names and brands of radio sets appearing on foreign markets has been made by the Electrical Division of the U. S. Bureau of Foreign and Domestic Commerce. The survey covered capitals of twenty-eight countries where the federal bureau has offices and a total of 103 American names were found in the foreign markets as compared with fifty-two trade names or brands from sources other than U. S. and their own domestic manufacture. Many European manufacturers employ a separate trade name for each model in their lines. Other summarized results of the government survey were as follows:

"The largest number is reported from Belgium, where 159 domestic makes are listed, imported sets number 26, of which 16 are American. The United Kingdom has 84 domestic names listed, and 29 American sets are reported to be on sale. Information as to imported sets other than American is as yet incomplete. Brazil, reporting 62 American makes, leads in this respect, with 6 other imported and 9 domestic. Argentina shows 48 American, 4 others imported, and 25 domestic.

"The Dutch 'Philips' and German 'Telefunken' from among the foreign makes were reported from the greatest number of markets. Much of the trade in these two makes is actually produced in several branch factories in as many countries. British GEC and Marconi, Austrian Hornophone, and German Korting, Nora, Mende, and Blaupunkt (sometimes sold under the name 'Blue Spot') also have wide distribution.

"Although this survey was made primarily to obtain information regarding possible infringement of American trade names by foreign companies, only one case was reported where such infringement was evident. This case is being appropriately investigated."

Inasmuch as the foreign offices of the federal bureau were instructed to report strictly on the basis of local markets, and to seek information only regarding those sets merchandised through retail outlets in the cities in which these foreign offices are located the results may be of value to American firms in determining the aggressiveness of their foreign representatives. Any American firm desiring information as to which of the 26 reporting offices found their sets featured will be furnished a list on request. Such a list can be provided only to the manufacturer or exporter of the brand in question. Address the Electrical Division at Washington direct or through the nearest District or Cooperative Office of the Bureau.

TARIFF REDUCTION IN BRITISH TREATY

Radio apparatus is included among a large number of articles for proposed tariff reductions in the new reciprocal trade agreement now under negotiation between the State Department and the British Government. Probable opposition by the radio industry because of the "most favored nation" clause in the British and Japanese treaties, which would grant similar tariff concessions and reductions to Japanese imports, will be considered soon by the RMA Board of Directors. The State Department's announcement on January 8, of formal notice of negotiation on the proposed trade treaty with Great Britain, details the articles under negotiation, including radio, all electrical, and many other manufactures

PARTS LIKE THESE



SMALL STAMPINGS—WIRE FORMS
SPRINGS—VARIOUS TYPES
WASHERS—PLAIN, SPRING, SPECIAL
have solved countless design and manufacturing problems. Let us know what yours is. Design consultant services at your disposal. It will pay you to inquire.

M. D. HUBBARD, Pres.

P. M. HUBBARD

J. A. HUBBARD, Secy.

M. D. Hubbard Spring Company

672 CENTRAL AVE., PONTIAC, MICH.

and agricultural products. It states that the U. S. tariffs would not necessarily be reduced but that the State Department would be willing to consider concessions on the articles listed. The Canadian, Australian, and New Zealand tariff rates will not be included in the negotiations. Public hearings on the treaty for the United Kingdom and British Colonies will open March 14.

"MOLDED DUREZ"

"Molded Durez" is the title of a booklet depicting the part that plastics are playing in radio manufacture. Better than twenty models of table radios are being molded of Durez. Two of these Durez cabinets have won awards in the national contest conducted by *Modern Plastics*. Copies of the booklet may be secured from General Plastics Inc., North Tonawanda, New York.

BOGEN CATALOG

A new catalog describing the Bogen Centralized School Systems has just been issued by David Bogen Co., Inc., 663 Broadway, New York City. Copies may be obtained by writing to the company at the address above.

CISE

The Transformer Corporation of America, 69 Wooster St., New York City, has formed an organization of sound and p-a men, known as the Clarion Institute of Sound Engineering. This organization to which, it is said, only qualified sound and p-a men will be admitted, will function to give direct factory connections to its members for the purchase of Clarion equipment. Other advantages claimed for the organization include engineering advice to members, assigned territories, etc.

DETROIT IRE ELECTION

The Detroit Section of the Institute of Radio Engineers has announced the election of the following officers for the year 1938: Chairman, Emery H. Lee, Inspector in Charge of Radio for the Nineteenth District; Vice-Chairman, Frank S. Kaserman; Secretary, Richard J. Schaefer.

Meetings are held on the third Friday of each month, generally in the Conference Room of the Detroit News. Visitors are welcome at all times and through the efforts of Program Chairman Lynn Smeby, Chief Engineer of WXYX, Ed. Denstaedt, Supervisor of Radio for the Detroit Police Department, A. B. Buchanan, Operating Engineer for the Detroit Edison Company, H. L. Byerlay, Professor of Communication Engineering, Lawrence Institute of Technology (to mention a few of the well known members) interesting programs are always arranged.

CZECHOSLOVAKIAN TREATY

The RMA has requested the State Department to include concessions for the radio industry in the reciprocal trade treaty now being negotiated with representatives of the Czechoslovakian Republic. Data has been submitted for the RMA by Chairman S. T. Thompson of the Association's Export Committee and Bond Geddes, Executive Vice-President in Washington, together with a statement received by the RMA from the Czechoslovakian Association of Radio Merchants. It appears that the Czechoslovakian merchants are extremely favorable to the importation of American radio, two foreign manufacturing firms now supply 70 percent of radio imported by Czechoslovakia.

New!



FERRANTI

AERO TRANSFORMERS

A complete line of Miniature Transformers of decided interest to the entire Communications and Electronics industry. Weighing but little and extremely small (photo is actual size), Ferranti Aero series is ideal for aircraft, portable and compact installations of all types.



Actual Size

40 UNITS IN ALL including

- audio chokes
- interstage transformers
- bridging transformers
- voice frequency transformers
- line to line mixing transformers
- output to line transformers
- input from line transformers

USABLE RANGE 20 to 20,000 c.p.s.
OPERATING LEVEL -80 to +22 db.

WRITE

for complete descriptive literature and technical information on the entire Aero line

Ferranti Electric Inc.

R. C. A. BUILDING, NEW YORK, N. Y.

RECOGNITION—the REWARD FOR ACCOMPLISHMENT

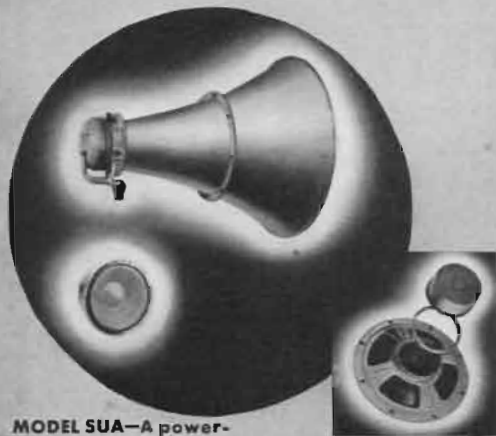

MODEL SUA—A powerful exponential unit with 3½" voice coil—the ultimate in air column sound projectors.

COUPLING RING UNIT ASSEMBLY Assures Permanent Voice Coil Alignment and Simplifies Cone Replacement.

CINAUDAGRAPH CORPORATION, with its extensive background of engineering experience and modern manufacturing facilities, has earned leadership recognition for the industry. This is because its line of speakers is outstanding in performance, quality of materials and workmanship. CINAUDAGRAPH Speakers are styled and built to meet today's requirements—they are sold on a competitive price basis.

VISIT WITH US
AT THE
WILLARD HOTEL
9TH FLOOR
FEBRUARY 13-14-15-16



CINAUDAGRAPH CORPORATION
Speaker Division • Stamford, Conn.

A complete line of Magic Magnet Speakers ranging in size from 5 to 18 in.

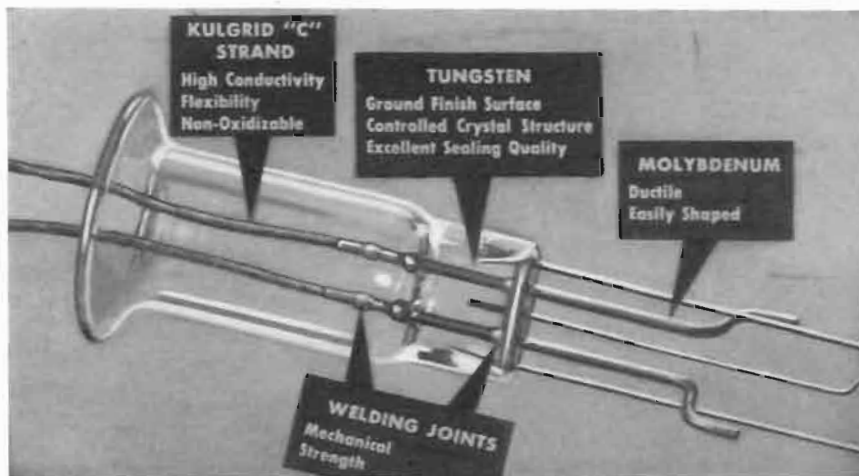

HARD GLASS STEM
MADE WITH
CALLITE LEAD-IN WIRES
of Tungsten • Molybdenum • Kulgrid

The **TUNGSTEN** in Callite Hard Glass Welds is specially processed to give a compact fibrous structure, free from longitudinal cracks and is centerless ground to eliminate surface imperfections.

The **KULGRID "C" STRAND** has none of the objectionable features of regular copper strand. Kulgrid "C" does not oxidize. Therefore, no oxide flakes off to deposit in the tube press as is the case with copper strand. Kulgrid "C" is flexible and does not become brittle. It welds more readily to tungsten than ordinary copper strand and forms a strong joint. *Accept no inferior substitutes.*

Pure metals of best quality are used for any third component part.

CALLITE PRODUCTS DIVISION

EISLER ELECTRIC CORPORATION

542-39th STREET

UNION CITY, N. J.

A. S. T. M. STANDARDS ON ELECTRICAL INSULATING MATERIALS, prepared by Committee on Electrical Insulating Material, published by American Society for Testing Materials, 260 North Broad Street, Philadelphia, Pennsylvania, 373 pages, heavy paper covers, price \$2.00.

In addition to the current Report of Committee D-9 on electrical insulating materials, this compilation includes all of the thirty-seven A. S. T. M. specifications and test methods covering the various types of insulating materials. These standards, given in their latest approved form, are grouped in the following manner: insulating varnishes, paints, lacquers, etc.; molded insulating materials; plates, tubes, and rods; mineral oils; ceramic products (porcelain, glass); solid filling and treating compounds; electrical tests; papers and fabrics; mica products; rubber products and textile materials.

In addition to these specifications, there are two proposed standards covering tests for neutralization number of petroleum products and specifications for rubber insulating blankets.

Of particular interest in the edition are the three discussions on significance of tests involving dielectric strength tests, resistivity tests, and impact tests, prepared by three prominent technologists.

THE RADIO AMATEUR'S HANDBOOK, prepared by the Headquarters Staff of the American Radio Relay League, published by the American Radio Relay League, West Hartford, Connecticut, 564 pages, price paper bound \$1.00 in U. S. A., \$1.25 elsewhere, buckram bound \$2.50.

The 1938 edition of *The Radio Amateur's Handbook* is an even more comprehensive treatment of the amateur short-wave field than its fourteen predecessors. The new volume contains 564 pages, approximately 290,000 words, 600 illustrations, 75 charts and tables, and 111 practical equations and formulas.

New chapters have been added in this edition. One is a thorough treatment of workshop practice, covering the problems faced in working with raw material, assembling and wiring the component parts of station equipment. Constructional details on work benches, operating tables and transmitter racks are given. Another new chapter is devoted to the increasingly important field of portable and emergency equipment. De-

signs are given for representative forms of emergency gear, with special attention paid to the power problem.

The chapters on fundamentals have been entirely re-written, with a new method of presentation. A new chapter on fundamental principles is aimed at those individuals, young or old, who have absolutely no knowledge whatsoever of electrical and radio phenomena but who demand a painless introduction to the subject. For the more advanced worker there has been included a chapter of definitions, values and computations useful in amateur work.

While *The Radio Amateur's Handbook* is intended primarily for amateurs, it will often be found a valuable reference for the radio engineer.

EXPERIMENTAL RADIO, by R. R. Ramsey, Professor of Physics, Indiana University, published by Ramsey Publishing Company, Bloomington, Indiana, fourth edition, 196 pages, 167 figures, price \$2.75 post-paid.

An excellent manual containing 132 experiments in elementary audio and radio-frequency work, particularly adaptable for a college student's course. These experiments cover a wide field beginning with fundamental methods in the measurement of circuit constants and progressing to vacuum-tube characteristics, oscillatory circuits, detection, audio amplification and associated subjects. Some of the other more interesting experiments delve into the principles of radio transmitters and receivers, modulation, filters and television.

The author gives directions for conducting each experiment in an indirect and interesting manner and furnishes only a brief outline of the pertinent theory. However, numerous references are given for a more detailed explanation of the principles involved which the reader is expected to consult.

ELECTRONIC MUSIC INSTRUMENTS

WHILE RADIO and communication workers are concentrating their energies on the development of high-fidelity reception of the widest possible spectrum of sound, musical engineers are expanding music scales in ranges heretofore thought impracticable. The electronic organ has received much publicity in this regard. More recently, interior decorators have made a vogue of small musical instruments, resulting in attempts to improve volume and tone within limited sounding space. Having succeeded somewhat with electrical organs and pianos of small proportions, engineers are now extending the operation principles to guitars and violins.

(Continued on page 34)

FOR *Specialized* NEEDS

IN DB MEASUREMENT

... choose from more than a dozen WESTONS

Keeping pace with today's exacting requirements for *specialized* power level indication, WESTON now offers more than a dozen different instruments for DB measurement, each one "engineered-from-bedrock" to meet the precise needs of one or more types of service.

Newest of the group is the multi-range Model 695 type 11, a medium speed instrument with a constant impedance network maintaining 20,000 ohms at the terminals for all ranges. Voltage ranges are 2, 5, 8, 20, 50, 80 and 200 volts, with associated DB values. The high, constant impedance reduces the effect of the instrument on the circuit to a negligible value, and at the same time all ranges will track on the same volt and DB scales. The broad coverage of this instrument with its high, constant impedance and high accuracy has led to its widespread application in the measurement of audio frequency signals of all kinds.

Why risk basing your choice of power level indicators on anything less than the full range of instruments now available? A new WESTON bulletin, "Power Level Indicators," brings complete *modern* specifications. Weston Electrical Instrument Corporation, 618 Frelinghuysen Avenue, Newark, New Jersey.



Model 695
WESTON
Constant Impedance
DB
Meter

WESTON

Instruments



ANNOUNCING

A new . . . and improved
FORM FITTING TUBE SHIELD
by **GOAT**
will be ready soon

Watch these pages for
further details.



GOAT RADIO TUBE PARTS, INC.

314 Dean Street
Brooklyn, N. Y.

ELECTRONIC INSTRUMENTS

(Continued from page 33)

B. F. Meissner, initial worker in this field, holds the fundamental patents. By his method, a narrow conductor supported on insulators is placed beneath each string. The conductor is separated from the string by sufficient distance to prevent contact at maximum vibration. A high voltage across the wire and conductor provides a polarizing voltage of variable value per vibration. This oscillating voltage is amplified to a peak output of 60 watts, the gain being controlled by a swell pedal not unlike the conventional piano control. Other keyboard devices regulate volume and tone in gradations actually superior to that of concert model pianos.

Such a system is particularly sensitive to external electrical disturbances and, accordingly, requires extra precaution for shielding. Current practice specifies painting the interior walls of the piano cabinet with aqueous dispersions of graphite in the colloidal state. Conducting films formed in this manner are easily grounded.

The same principle of amplifying a string's vibration is being used in the violin and guitar. In the latter instrument, the shielding can be accomplished with a metal case and ground connection, though for the violin this is not satisfactory for tonal reasons. If the interior wood case of the violin can be graphite-treated like the electrical piano, grounding must be effected through the operator's body. Types of conducting surfaces for wood, simulating present violin finishes, are being investigated. Each type of electrical instrument discussed above is a commercial reality, further improvements being the subject of present experimentation.

Oscillating circuits intended for the production of musical tones have also been developed recently in Germany. A typical one-tube hook-up consists of a bias battery and potentiometer in series between the cathode, grid, and transformer secondary. When the musician presses a leather-covered conductor along its length, the amount of bias voltage connected to the grid may be controlled. The grid bias in turn controls the amount of plate current flowing through the primary transformer and this in turn changes the inductance of both windings by saturating the transformer core. Such an inductance change influences frequency operation, the oscillation being sustained by the connection between the plate and grid circuit through the transformer. The output of the plate circuit is then amplified.

In a two-tube circuit the change in bias influences the duration of each



"The standard by which others are judged and valued"

A pick-up for every need, delivering wider range and greater stability than you can secure elsewhere at the price, listing from... **\$750 to 26000**
Complete literature on request

AUDAX COMPANY 500 Fifth Ave., New York
"Creators of High Grade Electrical and Aconstical Apparatus Since 1915"

current pulse through the tube. This in turn controls the frequency of the thyatron in the anode circuit. The resulting voltage across the resistance-capacitance combine is amplified by the next tube. The volume of the instrument is controlled by a carbon-button microphone connected in series with the final output.

LOSSES IN A-F COILS

(Continued from page 10)

(2) Q_m must stay the same. Experimental results check fairly closely with the relationship given by (3) which shows that the frequency of maximum Q varies inversely with the inductance as the air gap is varied.

Fig. 2 shows the characteristics of an audio-transformer core as the air gap in the magnetic circuit is varied. It will be noticed that the maxima are practically independent of the magnitude of the gap. With no gap, the maximum Q is about 50 and occurs at a frequency of 90 cycles. With a 0.125-inch air gap the maximum Q is 45. With a gap of 0.95 inch the maximum Q stays about the same, at 42, even though the gap corresponds to a total removal of the center leg.

Fig. 3 shows the frequency at which Q is a maximum for the same core as a function of the inductance in accordance with equation (3).

Fig. 4 gives the loci of points of maximum Q for several types of coils. Curve B corresponds to the data of Fig. 2 and Curve A shows the characteristics of another type of iron core.

Curve C gives the locus of Q_m points for a set of multi-layer air-core coils of given mechanical form but varying wire size. It will be noticed that the larger wire sizes have lower maxima as might be expected from the larger dimensions of the individual eddy-current circuits. The straight line drawn through the three experimental points are drawn in accordance with equation (1), with a unit slope corresponding to what would be expected of the variation of Q_m with the frequency at which the maximum occurs when ratio of L/R_s is held constant, as it is with a given geometry and weight of copper.

Tests made on high-frequency dust cores show that at audio frequencies the effective series resistance of a coil is virtually unchanged as the core is brought into the field, but the inductance is increased, and the Q increases directly as the inductance. The particular case is more complicated than the previous ones because essentially the coil may be thought of as consisting of two parts, first an air-core coil of the type previously considered and, second,

(Continued on page 36)

SPEECH INPUT COMPONENTS



EQUALIZER

MODEL 3A—The UTC universal equalizer will equalize telephone lines, recording systems, pickups and cutters, microphones and all other broadcast equipment. It is accurately calibrated and quickly adjustable for both low and high frequency equalization. Low frequency controls permit maximum equalization at 25, 50 or 100 cycles with zero to 25 DB control. The high frequency end permits maximum equalization at 4,000, 6,000, 8,000, or 10,000 cycles with zero to 25 DB control.

Net price to broadcast stations and recording studios.....\$85

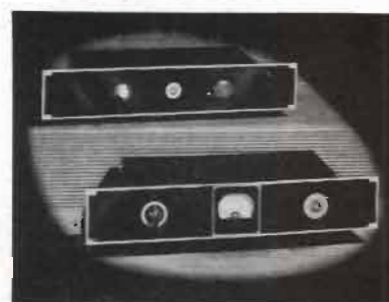

STUDIO PREAMPLIFIER

MODEL 5A—The UTC 5A preamplifier can be used as a two stage, three stage or four stage amplifier. The relative gains under these respective conditions are 55 DB, 77 DB and 100 DB. A tri-alloy shielded input transformer plus additional design features developed in the UTC Laboratories effect extremely low hum level. The frequency response is uniform from 30 to 14,000 cycles and the power output is plus 7 DB. A switch and milliammeter are provided to permit checking plate current of all tubes.

POWER SUPPLY

MODEL 6A—This is a highly filtered power supply for use with the 5A preamplifier. 250 Volts at 15 ma is provided and 6 Volts at 1.2A.

The Model 5A-6A unit is supplied complete, wired and calibrated with tubes, net\$125

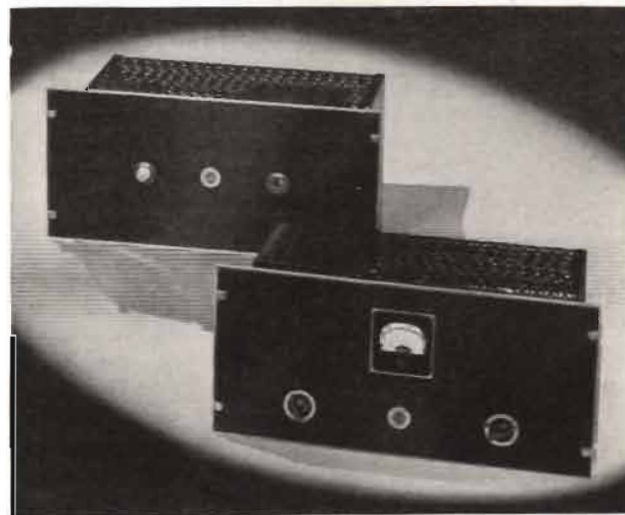

STUDIO-MONITORING AMPLIFIER

MODEL 7A—With MODEL 8A POWER SUPPLY—This amplifier is suitable for all medium power broadcast applications including driver service. It provides 15 or 25 watts power output using pushpull 2A3's or 300 A's. Three pushpull stages effect 85 DB gain with hum level 50 DB below normal output. A switch and meter are provided on the audio panel to check plate current of all tubes, and a control is provided to balance the plate current of the output tubes. The power supply panel incorporates a pilot light and fuse. The frequency response of this unit is uniform from 30 to 14,000 cycles. The model 7A-8A unit is supplied complete, wired and calibrated, with tubes, net.....\$160

UNITED TRANSFORMER CORP.

72 SPRING STREET NEW YORK, N. Y.

EXPORT DIVISION: 100 VARICK STREET NEW YORK, N. Y. CABLES: "ARLAB"

JUST COMPLETED . . . AFTER YEARS OF PREPARATION

VAN NOSTRAND'S Scientific Encyclopedia

This great new work presents, for the first time in one volume, all the knowledge of science known to date. In authority, in completeness, in sheer physical size it surpasses any similar volume ever published. If your work, study or reading is concerned with any branch of science, this is the volume you need.

Thumb-Notch Index

The Instant Question-Answerer for
**LABORATORY & SHOP WORKERS
MECHANICS · HOME SCIENTISTS
AND STUDENTS**

7 1/4 x 10 3/4 ins.

10,000 Entries • 1200 Illustrations
1500 Pages • Extensive Cross References

12 VOLUMES IN ONE!

Every Science Completely Covered
for Amateur and Professional

Chemistry: Elements and compounds, reactions, occurrence, production, industrial uses; agriculture and food chemistry.

Physics: Mechanics, heat, light, sound, electricity, magnetism, X-rays; applications.

Mathematics: From fundamentals to calculus and differential equations; practical applications.

Astronomy: Planets, telescope, spectrometer, etc.; maps.

Zoology: Single cell life, insects, mollusks, worms, birds, fish, reptiles, mammals.

Medicine: Anatomy and systems of the body; diseases; drugs; latest researches.

Mechanical Engineering: From fundamentals to automobiles, locomotives, steam, gas, gasoline, diesel engines.

Civil Engineering: Motors, generators, lighting, radio, television, etc., explained, illustrated.

This is only a partial list—**Geology, Botany, Navigation, Chemical Engineering**—every branch of science covered in detail.

BY EXPERTS!

Authorities of such universities as Columbia, Rose Polytechnic, Princeton, Lehigh, Amherst, etc. Absolutely authoritative.

SAVE 10%—Pre-Publication Price

This volume, now on the press, will sell for \$10 or more. By placing your reservation now, however, you may have it at the special pre-publication price of only \$8.95—payable in easy monthly installments. Send no money now. Just mail the coupon.

SEND NO MONEY—READ IT FREE

See this volume without expense or obligation. We will send it to you for free examination. Read it, use it for 10 days. If satisfied, pay the special low pre-publication price of only \$8.95 or return it and owe nothing. Mail the coupon at once.

MAIL THIS COUPON—Send No Money Unless You Wish

D. VAN NOSTRAND CO., Inc. (Com. 2-38)
236 Fourth Avenue, N. Y.

Send Van Nostrand's SCIENTIFIC ENCYCLOPEDIA, complete in one volume, 1500 pages, bound in sturdy fabricoid. Within 10 days I will either return it or pay you the special pre-publication price of \$8.95 in the following installments: \$2.95 as first payment, and \$2.00 monthly for three months.

Name

Address

City and State

Reference

Address

For free catalog of best books of practical instruction and technical information, check here. If you do not want the Scientific Encyclopedia cross out paragraph above.

LOSSES IN A - F COILS
(Continued from page 35)

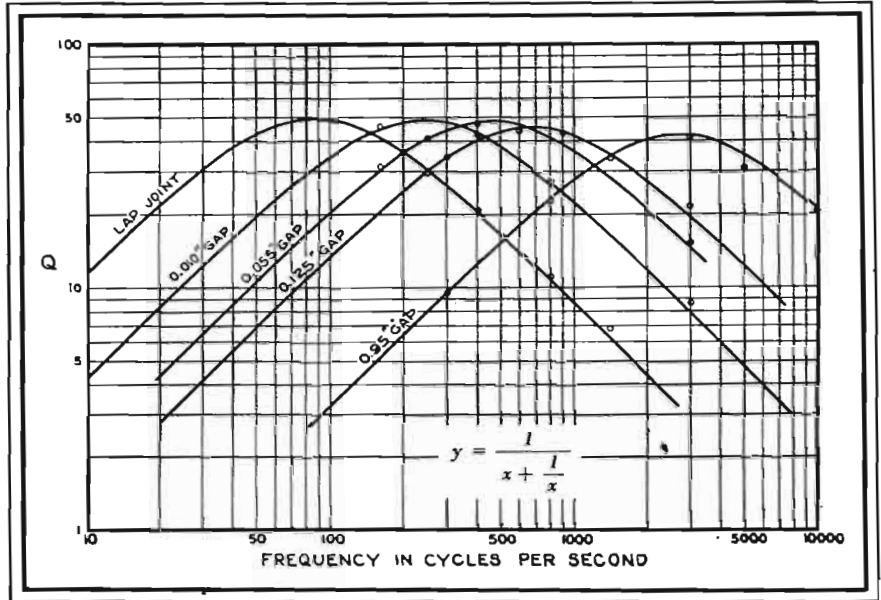

Fig. 2. Frequency characteristic of Q for an iron-core coil with various air gaps.

a loss-free inductance. As the amount of iron in the field is varied, such a structure will have a vertical locus, that is, the maximum Q will vary, but the frequency at which it occurs will be unchanged.

One application of these ideas about Q may be noted. In constant-K low-pass filters it is frequently desirable to keep the attenuation within the transmitted band very nearly constant. It is often stated that, in order to achieve this, Q should be very high. Actually the change of attenuation is due almost entirely to the shunt component of the loss. To assure constant transmission, a coil should be operated at frequencies

well below that which makes Q a maximum; in this region the effective series resistance is constant, and the loss, which is almost entirely governed by this effective series resistance, is also constant.

Another application is in oscillator coil design. To assure constant output as a tuning condenser is varied, the equivalent parallel resistance should be constant, because this resistance is equal to the anti-resonant impedance of the coil and represents the loading on the tube. Constant parallel resistance is achieved when the coil is operated at frequencies well above the frequencies of maximum Q.

Fig. 4. Loci of maximum Q points for various coil types.

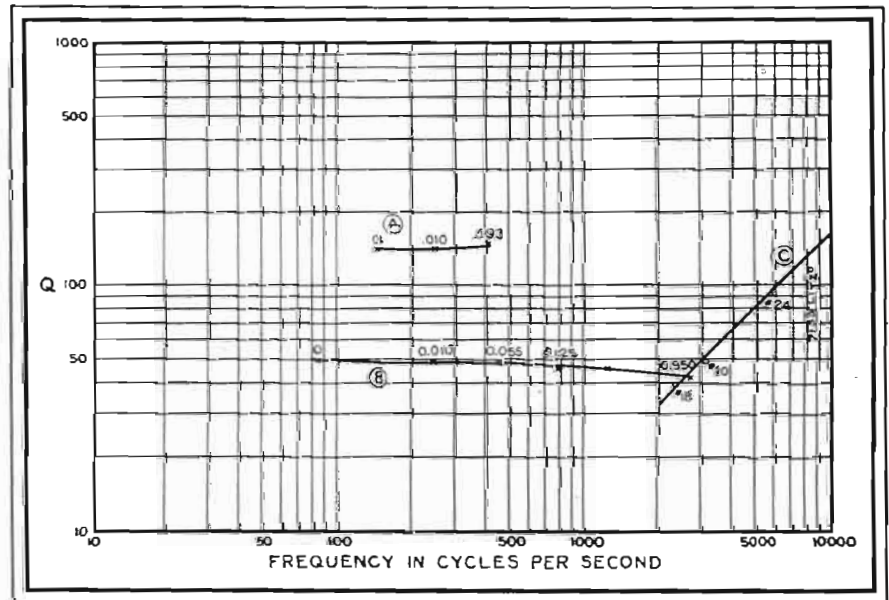

OVER THE TAPE

(Continued from page 26)

MANUFACTURERS' REPRESENTATIVE

Harold I. Danziger, 130 East 40 Street, New York City, is now a manufacturer's representative. Mr. Danziger was formerly Vice-President of Danziger Jones, Inc., and later Vice-President and General Manager of the Condenser Corporation of America. More recently he was associated with the engineering and production departments of Sprague Specialties Co. Among the many lines handled by Mr. Danziger will be the Henry L. Crowley line of ceramics in the states of New Jersey, New York, Connecticut, Rhode Island and Massachusetts.

CINAUDAGRAPH CHICAGO OFFICE

Cinaudagraph Corporation, Stamford, Connecticut, have announced the opening of their Chicago offices in the Northwest Tower Building, 2018 W. North Avenue. Mr. Roy W. Augustine is Cinaudagraph's midwestern representative.

UNITED ELECTRONICS BULLETIN

Complete descriptions and engineering information on the United line of transmitting and rectifying tubes is contained in a new 55-page bulletin issued by the United Electronics Company, 42 Spring Street, Newark, N. J. Copies of this bulletin may be secured by writing to the above organization.

NIAA CONFERENCE

The National Industrial Advertisers Association will hold its Sixteenth Annual Conference in Cleveland, Ohio, September 21-23, according to an announcement made by Stanley Knisely, Advertising Manager of the Republic Steel Corporation. Mr. Knisely as Vice-President of the association heads its committee for conference program and arrangements.

ALDEN PRODUCTS BULLETINS

Alden Products Company, 715 Center Street, Brockton, Mass., have recently issued two interesting bulletins. One bulletin covers detachable pilot lamp sockets, while the second is concerned with "Flat Wave" extension cable for power and doublet antennas. These bulletins are available from the above organization.

"ELEKTROAKUSTISCHES TASHHENBUCK"

Announcement has been made of the publication of "Elektroakustisches Tashhenbuck" by Georg Neumann and Company, Berlin, Germany. This book features the measurement of cutting heads by light method, the definition of *phone* as a unit of loudness, and pertinent information required in the electro-acoustical field, together with their practical applications. Further particulars may be secured from Sound Apparatus Company, 150 West 46 Street, New York City.

ACME ELECTRIC LITERATURE

The Acme Electric and Manufacturing Co., 1444 Hamilton Ave., Cleveland, Ohio, have made available literature on the following equipment: Acme Voltrols, for laboratory and factory testing; Acme insulation breakdown testers; variable voltage adjusters, for over-seas operation of electrical equipment where the voltage differs from the American standard; transformers, for high-intensity mercury-vapor lamps; and Autopaks, for lighting neon signs from 6-volt storage batteries.

(Continued on page 38)

YOUR RECORDING REQUIREMENTS DEMAND

- Turntable Performance at 33 1/3 RPM equal to that of the finest transcription tables.
- High Recording Levels to reduce surface noise in the playback
AND
- Quality acceptable for "high fidelity" broadcast purposes, as well as auditions.



THE NEW FAIRCHILD RECORDER with

Center Drive turntable and Synchronous Motor guarantees that "fourteen minutes and twenty-nine seconds" of recorded disc will play back in exactly the same time.

Crystal Cutter Head, by Fairchild, puts a higher signal level on the record, thereby reducing surface noise materially

AND

Fairchild users expect and *get* quality that meets the highest broadcast requirements.

IT SOUNDS AS GOOD AS IT LOOKS

1. Precision in design and performance.
2. Sufficient Mass and consequent inertia to completely neutralize any tendency to "resonance" in the cutter head.
3. Equal spacing of grooves (avoids "echo") at 90, 110, 130, or 150 lines per inch and easily varied depth of cut, from inside or outside without extra feed screws or parts—the "last word" in flexibility.

For further information address



SOUND EQUIPMENT DIVISION

FAIRCHILD AERIAL CAMERA CORP.

88-06 Van Wyck Blvd., Jamaica, Long Island, N. Y.

Complete Satisfaction

with

LEHIGH VERTICAL RADIATORS

(Insulated or Grounded)

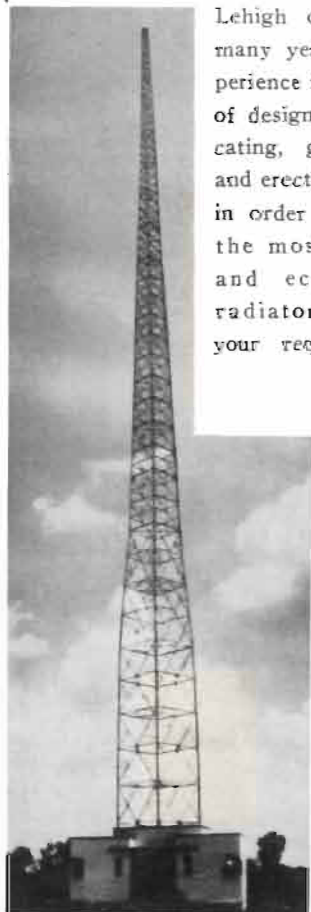

Lehigh offers you many years of experience in the field of designing, fabricating, galvanizing and erecting of steel in order to obtain the most efficient and economical radiator to meet your requirements.

485 ft.
Shunt-
excited
Lehigh
Antenna
at WJBO
Baton
Rouge,
La.

RADIO DIVISION
LEHIGH STRUCTURAL STEEL CO.
11 BATTERY PLACE, NEW YORK, N. Y.
PLANT AT ALLESTOWN, PA.
Office in Portland, Ore.

in January

over 950 new paid
subscriptions re-
ceived for

COMMUNICATIONS

truly the fastest grow-
ing magazine in the
field.

OVER THE TAPE

(Continued from page 37)

UTAH APPOINTMENTS

G. Hamilton Beasley, President of Utah Radio Products Co., has announced a number of new appointments. Oden F. Jester has assumed the post of General Sales Manager. E. L. Barrett, associated with Utah's engineering division for nine years, has been elected to the position of Vice-President in charge of Development and Research Engineering. William F. Dumke, who has supervised plant production for the past eight years, was appointed Vice-President in charge of Production and Plant Supervision. Austin W. Ellmore now occupies the position of Chief Engineer, while H. S. Neyman is in charge of the general offices in addition to his duties as secretary and treasurer. John Burress is in charge of purchases. B. J. Clarke has tendered his resignation as Vice-President but continues as a member of the board.

POINSETTIA BULLETIN

Poinsettia, Inc., Pitman, New Jersey, have recently issued an 8-page bulletin on sound recording equipment and master waxes. Those interested in securing this bulletin should write to the above organization.

FEDERAL TELEGRAPH CONTRACT

The order for 42 aviaional combination radiotelephone and radio range beacon signal transmitters at 36 stations of the Bureau of Air Commerce of the Department of Commerce is in manufacture at the plant of Federal Telegraph Company, Newark, N. J. This material, according to Admiral Luke McNamee, President of Federal Telegraph, is to replace and modernize radiotelephone and beacon equipment along principal air routes. The new stations will incorporate the numerous recent advancements which have resulted from intensive development work on radio aids to air navigation.

It is expected, Admiral McNamee says, that the first series of beacons will be installed by late May, and that all of the 36 stations will be in service by March of next year.

VWOA NEWS

(Continued from page 24)

mighty fine chap and a fitting companion to those other fine radio men who died at their posts of duty on land, at sea, and in the air.

"On behalf of the Honolulu Chapter, I should like to inquire into the matter of having Findley's name inscribed upon the Memorial statue in Battery Park, New York City. It is a matter of concern to our members and we will appreciate it if the proper Committee is advised."

A splendid report and congratulations on the success of your membership campaign, HFM. Please be assured that the proper committees will be advised.

MIAMI

V. H. C. EBERLIN, 2nd, Secretary of the Miami Chapter, reports:

"We're meeting on Tuesday January 25 to complete final plans for what portends to be our biggest and best Cruise. We haven't yet elected for 1938 and so soon as we do we will forward the results to you.

"We'll forward a complete report on our Third Annual Cruise in Miami shortly after the 11 and in the meantime consider coming south and stay with us—lots of room, and the dogs are running in fine form at present."

PERSONALS

Arthur J. Costigan, Traffic Manager of Radiomarine Corporation of America, has spent much time in Washington recently working with the committee preparing for the International Radio Convention to be held in Cairo, Egypt, early next year. Better study up on hieroglyphics, AIC, before you go! . . . H. H. Parker has done a fine job as Association Secretary this past year-MC. . . A. F. "Steve" Wallis, Mackay Commercial Representative, recently signed up George E. Orgera, recently appointed Mackay Marine Chief Operator. George is a real veteran going back to the early days of radio. Glad to welcome him into the fold. . . All of the activity in the Maritime Commission keeps Charles "Jerry" Guthrie, Radio Supervisor of the New York office, very busy. He always finds time, though, to attend Directors and Membership meetings. . . To MacIlvain Ross, a veteran of long standing, our appreciation for his generous gesture. . . Uda B. Ross, formerly Radio Editor of the New York Telegram before the merger and now Manager for the Western Electric Company of Chile and the Western Electric Company of Cuba with headquarters in Santiago, Chile, and incidentally our gracious host on a visit to Santiago in '33, is in New York for a month or so. His territory embraces the entire west coast of South America. His efforts have resulted in many theatres in the territory mentioned being equipped with Western Electric "talkie" movie equipment. . .

Thanks to Dr. E. A. Cyriax, owner and operator of amateur radio station W2DI, for his kind greetings. Always glad to hear from you EAC. . . An interesting letter from W. H. Barlow, Instructor in the Operating Department, Radio Division of the Coyne Electrical School in Chicago, in which he invites comments from some of the real oldtimers concerning the aims and purposes of our Association and also concerning conditions in the radio operating business generally. We thank him for his proffer of support and aid, if required. . .

W. H. Martin of San Diego, Calif., is now connected with the electrical department of the Harold Lloyd Studios, Inc. He was recently down Texas way with the Exposition in Dallas. Quite an interesting life you're leading WHM. Come to New York some time and see us. . . Belatedly we acknowledge receipt of a photostatic copy of Radio Operators License issued to James Ashton Greig at the Brooklyn Navy Yard by E. Stuart Tucker, Gunner, U. S. Navy on Nov. 19, 1913—over 24 years ago. He spent some time aboard the *Maracaibo* of the Red D Line (so did this writer, incidentally—though some time later) and is at present Advertising Manager of the Ohmite Manufacturing Company in Chicago. Glad to send Mr. Grieg an application and we look forward to welcoming him into the fold. . . Our greetings to Musayuki Hisamoto, Japanese residing in Boston, graduate of the Electrical Engineering course at Massachusetts Institute of Technology and recent addition to our membership roll. . . Glad to know that Fred Klingenschmitt of Amy, Aceves and King is up and about again after his recent illness. Hope to see you at the Astor on the 11th, Fred.

AMPLIFIER
EXPANSION
CIRCUITS

(Continued from page 12)

compressor, and is said to provide a maximum expansion of 18 db and 15 db maximum compression.

VARIABLE-RESISTANCE EXPANSION

A radically different circuit is shown in Fig. 6, in which the expander action depends upon the nature of the temperature-resistance curve of the two small bulbs, B-1 and B-2. When switches 3 and 4 are closed, loudspeaker input depends upon the degree of unbalance of the Wheatstone bridge. Since the resistance of the bulb filaments will increase with a rise in the current flowing through them, it follows that the degree of bridge unbalance will grow more pronounced with increase of signal strength. The values of the resistors, R-1 and R-2, must of course be chosen with reference to the critical bend in the temperature-resistance curve of the bulbs used.

Opening switches 3 and 4, and closing the switches around the resistors, cuts the expander out of circuit, and the loudspeaker then functions in the ordinary way. The switches are, of course, ganged in practice.

Some of the circuits based on this principle employ ganged potentiometers in place of the bridge resistors, as means of controlling the extent of expander action.

Time delay, which is needed in all expanders, and which is secured in the tube type by suitable choice of circuit constants, is naturally provided in this case by the inherent temperature lag of the bulb filaments.

Fig. 6, in which the bulb arms of the bridge include audio filters, represents this form of expander as used by the Crosley Radio Corporation. In other variants, the filters are omitted. Their use in this circuit is based upon the well-known curve of Fig. 7, in which it will be noted that low-frequency sound drops below audibility (so far as the human ear is concerned) while higher frequencies of the same intensity can still be heard without difficulty. Thus, it will be seen that a sound pressure of more than 0.1 dyne is needed to make 64 cycles audible, while 8,000 cycles can be heard with a pressure of less than 0.005 dyne. The filters shown in Fig. 6 alter the audio-frequency response of the expander, and give the results such that at maximum output volume the response is flat, but at lesser levels of output the extreme low frequencies are progressively enhanced.

UNEQUALLED DEPENDABILITY UNDER THE MOST SEVERE CONDITIONS



Cement Coated POWER WIRE WOUND RESISTORS



INTERNATIONAL RESISTANCE COMPANY

415 NORTH BROAD STREET, PHILADELPHIA, PA.

Factories or Licensees in Canada, England, France, Germany, Italy, Denmark and Australia

MAKERS OF RESISTANCE UNITS OF MORE TYPES, IN MORE SHAPES, FOR MORE APPLICATIONS THAN ANY OTHER MANUFACTURER IN THE WORLD



Frequency Measuring Service



Many stations find this exact measuring service of great value for routine observation of transmitter performance and for accurately calibrating their own monitors.

MEASUREMENTS WHEN YOU NEED THEM MOST

at any hour every day in the year

R.C.A. COMMUNICATIONS, Inc.

Commercial Dept.

A RADIO CORPORATION OF AMERICA SERVICE

66 BROAD STREET

NEW YORK, N. Y.

TELECOMMUNICATION

PANORAMA OF PROGRESS IN COMMUNICATIONS

WOR U-H-F TRANSMITTER

WOR will make its entry into the realms of the ultra-high frequencies when its new short-wave transmitter starts operation from the 44th floor of 1450 Broadway overlooking Times Square.

The new equipment, under the call letters W2XJI, will transmit Mutual network and WOR programs, but because of the characteristics of ultra-high-frequency signals, its reception will be effective primarily within a 40-mile radius.

A 45-foot antenna pole was hoisted 44 stories from the street to serve as a radiator for the new 100-watt RCA transmitter. This necessitated an adroit bit of engineering to lift the 1,000-pound mast nearly 600 feet, without mishap, from the crowded sidewalk of Broadway.

A number of frequencies are available, including 31.6, 35.6, 38.6 and 41-megacycle channels. Operation at first will be limited to eight hours each day.

P-A SYSTEM FOR WESTMINSTER ABBEY

WESTMINSTER ABBEY, historic shrine of the British Commonwealth, resting place of her kings and heroes, is being wired for sound. The impression made by the extensive public-address system which was installed for the Coronation ceremony in May was so favorable that

The new Lehigh vertical radiator installed at radio station WJBO, Baton Rouge, Louisiana. This shunt-excited antenna is 485 feet high.



work is now progressing on a permanent installation. The system for the Coronation and for permanent installation is supplied and installed by Standard Telephones & Cables, Ltd., manufacturing subsidiary in London of the International Telephone and Telegraph Corporation.

Six microphones and 70 amplifiers are

involved. The system is regarded as one of the most complete and most modern in use anywhere. Special installation problems are being met in the placing of the loudspeakers. It has been possible to locate most of them so that they are invisible to the audience, but where this might impair the performance of the equipment, the speakers have been finished to match exactly their surroundings.

Without amplification, services are almost entirely inaudible in some parts of the Abbey.



A tubular metal hoop, 5 feet in diameter, is now being tested by United Air Lines to eliminate static from ground station reception of plane-ground radio signals. Here a United Air Lines stewardess is shown with the device which was developed in the company's experimental laboratories.

SHORT-WAVE TRANSMITTER

PROVIDING a world outlet for the 1939 Golden Gate International Exposition, the General Electric Company is scheduled to begin work at once on a short-wave transmitter at Belmont, Calif., according to J. A. Cranston, Commercial Vice-president of the company.

This 25-kilowatt station, the first short-wave transmitter west of the Mississippi, will have directional antennas of the latest type, with beams directed to the Far East and South America. Concentrating the transmitter output within an angle of 30 degrees, these antennas will provide a signal gain of approximately 300 percent over the ordinary antenna.

POLICE TRANSMITTER

(Continued from page 22)

The automatic gain device incorporated in this amplifier maintains the modulation at a high percentage almost independent of the speech level introduced at the microphone. Since radio coverage depends upon the average percentage of modulation, this device insures a maximum of efficiency and provides consistent communication with the cars cruising at a distance where only momentary "peaks" emitted by the ordinary transmitter of this same power rating could be heard.

Sufficient audio amplification is provided in this Type 22 transmitter to permit the use of a high-fidelity dynamic microphone, with the result that the voice of a police radio dispatcher reaches the patrol cars with broadcast station clarity. The high-quality voice transmission thus accomplished is valuable, not merely for its pleasing effect, but for its intelligibility.

This transmitter is arranged for simplex operation on a single carrier frequency in common with the transmitters used in the police cars, or for duplex operation involving one frequency for the headquarters transmitter and another frequency for the radio car transmitters. The voice-frequency range of the new unit is 100 to 10,000 cycles within plus or minus 2 db, and the harmonic distortion is confined to less than 8 percent rms audio harmonics.

A quartz plate is used for control, having a frequency stability of better than .025 percent of assigned frequency throughout a temperature range from minus 20° to plus 60° Centigrade.

The design is such that all control and audio circuits may be extended a reasonable distance for remote control. The special input circuits of this transmitter will accommodate a variety of types of microphones, such as the popular "salt shaker" dynamic, the double-button carbon and the single-button handset. Direct-current power supply for carbon microphones is an incorporated feature of the transmitter and provision is also made for connection to a remote speech-input telephone line. The radio-frequency output circuit may be connected directly to a 70-ohm, 3/8-inch diameter concentric transmission line for efficient feed to the antenna.

The operator in charge of this equipment knows whenever the power is on, for a red pilot light on the face of the unit indicates that it is ready for operation. By means of a conveniently located key, he may transmit a warning tone to attract attention at the receivers and indicate that a message is about to follow.

FOR UNFAILING



PERFORMANCE!

"THIS receiver is truly an extraordinarily fine instrument," says Stanley Wolff, Chief Operator, New York Herald Tribune wireless station. Mr. Wolff adds, "The 'Super-Pro' is at all times exceedingly quiet, bringing in the weakest stations with not only extreme clarity, but marked regularity for 16 hours a day, even though the receiver is located on the top floor of the building, next to all sorts of electrical machinery."

Such exceptional performance is only obtainable with a receiver that is precision engineered. The outstanding features of the "Super-Pro" include: two pre-selector stages on all bands, providing abso-

lute image rejection; variable selectivity—3 to 16 kc.; fractional micro-volt sensitivity; direct tuning calibration within 1/2%, and electrical band spread; 16 tubes, 8 metal and 8 glass.

The "Super-Pro" is a high fidelity receiver, available in three tuning ranges, viz.—7 1/2 to 240, 15 to 360, and 15 to 2000 meters, less 60-120 M. and 560-1000 M. bands. Write for bulletin.

HAMMARLUND MFG. CO., INC. C-2
424-438 W. 33rd St., New York City

Please send me "Super-Pro" bulletin.

Name

Address

City..... State.....



HAMMARLUND

Waxes Compounds Varnishes

FOR INSULATION
OF CONDENSERS

Transformers, coils, power packs, pot heads, sockets, wiring devices, wet and dry batteries, etc. Also WAX SATURATORS for braided wire and tape. WAXES for radio parts. Compounds made to your own specifications if you prefer.

● ZOPHAR
MILLS, INC.

Founded 1846
120—26th Street
Brooklyn, N. Y.

SUPERIOR

Playback
Needles



BUILT

on the

BALL-BEARING Principle

Ball-bearings are practically frictionless—silent and non-wearing on contacting surfaces. Similarly SUPERIOR Needle's rounded point keeps scratch-level and groove-wear at their lowest. Retention of high frequencies is close to 100%. Tone is natural, brilliant, distinct.

Write for details.

Also MELOGRAPH Needles
SAPPHIRE Needles
STEEL Cutting Needles

RECOTON

Corporation

178 Prince Street, New York City

THE MARKET PLACE

NEW PRODUCTS FOR THE COMMUNICATIONS FIELD



PLUGGIN PAPER CONDENSER

A "Pluggin" compact paper condenser in cylindrical aluminum container, measuring $1\frac{1}{2}$ " in diameter x $2\frac{1}{4}$ " in height, is a late development. This condenser is supplied in various capacities and in single and multiple sections to operate at potentials up to 1,000 volts d-c working. A feature of this condenser is its method of sealing, which is said to allow the condenser to be immersed in saturated brine solution for long periods without harming the electrical qualities of the condenser in any way. These condensers are fitted with standard UX four-prong bases. When these condensers are used in portable or marine equipment, special clamps are supplied which prevent the condenser from jarring loose from the socket.

For further information write to *Tobe Deutschmann Corp.*, Canton, Mass.—COMMUNICATIONS.

MICAMOLD CONDENSER

A small mica condenser molded in bakelite, is now being offered. The condenser section is made up of metal plates that are integral with the lead terminals and mica films. The assembly is rigidly clamped in a steel channel. The new unit is said to have an excellent "Q" factor and the capacity is stable under working conditions. Any capacity from 2.5 mmfd to 50 mmfd can be supplied with a minimum tolerance of plus or minus 1 mmfd.

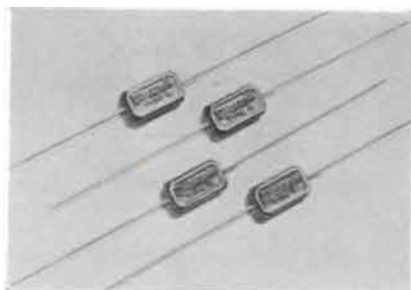

Further information may be secured from *Micamold Radio Corporation*, 1087 Flushing Ave., Brooklyn, N. Y.—COMMUNICATIONS.

TUBE SHIELD

Users of Goat form-fitting tube shields will be interested to learn that an improved design is in the offing. It is said that the new shields will incorporate features which will probably find a ready acceptance. Further details will soon be available from *Goat Radio Tube Parts, Inc.*, 314 Dean Street, Brooklyn, N. Y.—COMMUNICATIONS.

TACO ANTENNA

A new antenna system, designed to permit directional reception effects with the directivity controlled by the set operator, has been announced by the *Technical Appliance Corp.*, 17 E. 16 St., New York City.—COMMUNICATIONS.

MALLORY CONDENSERS

A new line of Mallory condensers, types TX and TZ, for radio-transmitter and high-power amplifier application has been announced.

Mallory TX transmitting condensers are housed in compact rectangular metal cans, finished with a black crackle enamel that matches the other standard transmitter components. Two ceramic stand-off terminal insulators are provided.

Mallory TZ condensers are dual-purpose units, designed for use in either transmitter filters or heavy-duty power-amplifier circuits. These condensers are supplied in round aluminum cans having threaded necks for inverted mounting. Upright mounting can be employed by using a standard ring bracket.

Both types are impregnated with Mallory Compound, a new substance developed after two years of research. The high dielectric constant of Mallory Compound is said to be combined with unusual resistance to heat, thereby providing a good power factor and stable d-c resistance.

Further details may be secured from *P. R. Mallory & Co., Inc.*, Indianapolis, Ind.—COMMUNICATIONS.

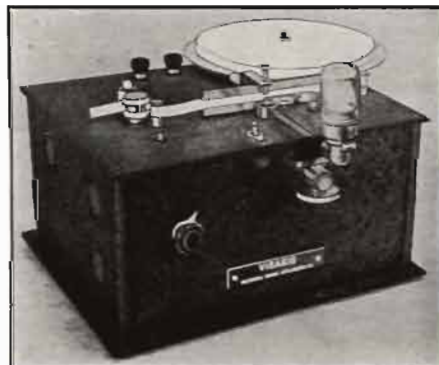
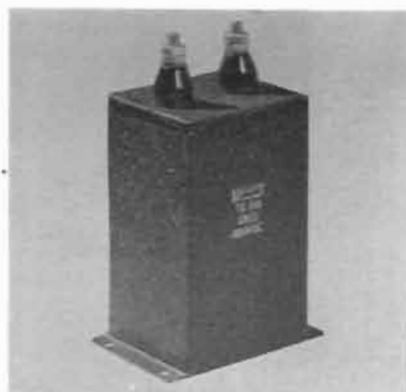

RADIO-TELEGRAPH RECORDER

An improved Visasig radio-telegraph recorder, Model V-5, has recently been made available. This new model is said to record effectively at a speed of 200 words per minute. Audio-frequency band-pass filters allow recording through interference, while low-pass filters are used for weak signals when the noise level is high. Both filters are switch controlled.

Complete literature on this new model recorder may be secured by writing to *Universal Signal Appliances*, 64 West 22 Street, New York City.—COMMUNICATIONS.

RHEOSTAT DIALS

Specially designed dial plates are available for Ohmite vitreous enameled rheostats, to provide easy and accurate setting of the rheostat—a large $5\frac{1}{2}$ " size for Ohmite rheostat Models N, R, and U—and a smaller $2\text{-}3/16$ " size for Models H, J, K, and L. The plates are brass and etched black. The dials are calibrated numerically and read directly in percentages of resistance in the circuit. Areas instead of lines indicate the zero and the one hundred positions, enabling the dials to be used on rheostats with slightly different angles of rotation. A sturdy $3\frac{1}{4}$ " knob (for $3/8$ " shaft) of black bakelite with a brass insert is also available and may be had with a pointer as shown, for use with $5\frac{1}{2}$ " dial, or without pointer when so desired. Various knobs for $1/4$ " shafts for use with the small dials are also available. *Ohmite Manufacturing Company*, 4827 Florence St., Chicago, Ill.—COMMUNICATIONS.

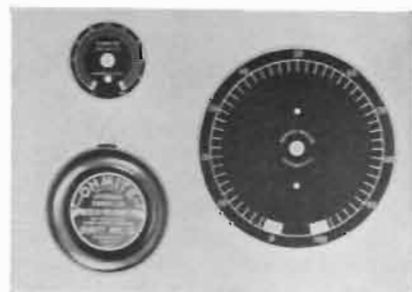



**BLILEY
CRYSTALS**

are manufactured for all frequencies from 20 Kc. to 30 Mc. Precision holders and ovens are available for standard and special applications. . . . Bliley Broadcast Frequency Crystals are approved by the Federal Communications Commission.

BLILEY ELECTRIC COMPANY
UNION STATION BUILDING ERIE, PA.

COLONIAL

FAST-EFFICIENT-COMPACT WIRE STRIPPER

**DOUBLE EDGE
BLADES
NO SPRINGS**

Here are the **FEATURES:**

1. Centrifugal action on double edge blades. No springs whatever.
2. Dialed micrometer adjustment screw, for exact gauge, for stripping all kinds and sizes of wire.
3. Disc clutch and lever connected and under positive control of micrometer adjustment.
4. Reversible type switch on motor, with ball bearings throughout.
5. Foot pedal and lever counterbalanced.
6. Face plate, bushed for all sizes of insulation, leads wire direct to center of stripping blades.

Take Advantage of Free Trial Offer — Or Write for Circulars and Prices.

PYRAMID PRODUCTS COMPANY
2224-C So. State Street
Chicago, Ill.

Also Manufacturers of
E-Z HAND and BENCH TYPE Wire Strippers



**10-DAY
FREE TRIAL**

Try This Stripper in your own plant. Send us your wire samples and specifications so that we may accurately gauge your needs before shipping machine and instructions.

Modest or Pretentious—



WHETHER it be a single room (as above) or an elaborate suite, you will find Hollenden guest rooms modern and up-to-the-minute in decorations, equipment and furnishings. We are completing a modernizing program which make Hollenden guest rooms as fine as any to be found in Cleveland. The location is ideal, the service excellent, the food of the best and the prices moderate. Select the Hollenden on your next trip to Cleveland.

HOTEL HOLLENDEN

A DeWitt Operated Hotel **CLEVELAND** R. F. Marsh, Mgr.

HIGH FREQUENCY AND ULTRA-HIGH FREQUENCY PORTABLE TRANSMITTER

TYPE HFM



- 10 watts nominal output over entire range.
- 7000 to 60,000 Kc. with single crystal.
- Lower frequencies to order.
- Completely self-contained.
- A1, A2 and A3 emission.
- Operates from 6v. D.C. or 110 A.C. supply. Power equipment available for either.
- Anti-noise microphone for mobile operation.
- Portable receiving equipment to work with above.

We have helped many with their portable and mobile communication problems. Write, stating your requirements, and we will advise on available or custom built units.

**PORTABLE PACK
M.O.P.A. UNIT
TYPE PTR-19-M**
2-WATT TRANSMITTER AND A RECEIVER-MONITOR

Write for Bulletin C-38

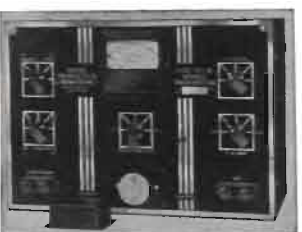
RADIO TRANSCEIVER LABS.
8627 - 115th Street
Richmond Hill New York



AERO TRANSFORMERS

A complete line of miniature transformers known as the Aero Series has been announced. These units are light in weight but extremely small in size. They are suitable for aircraft and other portable and compact installations.

The overall dimensions of these new transformers including reversible mounting arrangement are only 1 1/4" x 1 1/4" x 1 1/2" high. These transformers use nickel-iron alloys as their core material. Coils are designed with a moisture-proof construction for use in marine and aeronautical service.

Transformers have a usable range of from 20 to 20,000 cps and it is interesting to note that Aero units are available in input, interstage, output, bridging and mixing types. These new units have an operating level of from minus 80 to plus 22 db and a special group is included which is capable of passing plate current when used over the voice range.

Complete descriptive literature and technical information is available from *Ferranti Electric, Inc.*, 30 Rockefeller Plaza, New York City.—COMMUNICATIONS.

MICROPHONE STAND

The new Astatic Type "G," "grip-to-talk," microphone desk stand, designed for airway ground stations, inter-communication systems and amateur radio operators, is equipped with a bar actuated multiple contact switch and socket connector to fit any Astatic crystal microphone, including Models T-3, D-104, K-2 and D-2. The switch automatically operates under 10-ounce pressure on the grip which moves only 1/16 of an inch to work a relay and cut in the microphone. When the relay is not employed, the mechanism becomes a simple shorting switch. This stand is 8 3/4" high with a 5 1/2" diameter base and weighs 1 1/4 pounds. The handle is finished in heavy chrome plate and the base black.

Additional information may be secured from the *Astatic Microphone Laboratory, Inc.*, 830 Market St., Youngstown, Ohio.—COMMUNICATIONS.



MOLYBDENUM WIRE, ROD AND SHEET

Molybdenum, widely used for parts of electronic tubes and lamps, has been announced in the forms of round wire and rod, and in sheets.

The wires and rods are from one-thousandth of an inch to three-quarters of an inch in diameter. The sheets are up to several inches in width and from 2 1/2 to 30 thousandths inch thick. This product is unique in its resistance to high temperatures, at the same time being workable with relative ease.

Further information is available from *Westinghouse Electric & Mfg. Co.*, East Pittsburgh, Pa.—COMMUNICATIONS.



MULTI-MATCH TRANSFORMERS

Three additions to the C. H. T. multi-match series of transformers have been announced.

Two of these units, T-15D82 and T-15D83, are multi-match drivers for coupling a 500-ohm line to any Class B grids. Both have ratios of from 1:0.75 to 1:3.15, from primary to one-half secondary. T-15D82 is capable of handling 15 watts of audio power, while T-15D83 will handle up to 30 watts.

The third transformer, T-15D84, is a multi-match driver for coupling 6L6's as drivers to any Class B grids. This transformer has a special tertiary winding to give 16.6 percent inverse feedback to the 6L6's, which is said to make it possible to use their high-gain characteristics without the poor regulation which is inherent in these tubes when used as drivers. Ratios of from 1.5:1 to 3.5:1 are available with an audio capacity of 30 watts.

These units are products of the *Thordarson Electric Mfg. Co.*, 500 West Huron St., Chicago, Ill.—COMMUNICATIONS.

WRAPPING PAPER

There has recently been placed on the market a new sheet of wrapping paper which is both absorbent and tough when wet. This new paper is manufactured by *H. P. Smith Paper Co.*, 1130 W. 37th St., Chicago, who, we understand, invite those interested to write for samples.—COMMUNICATIONS.

CORNELL-DUBILIER CAPACITORS

The Cornell-Dubilier Type DH Dykanol capacitors are said to be designed to operate efficiently under any humidity and temperature conditions. Their light weight and compactness make them suitable for use in aircraft, submarine and marine radio equipment. These capacitors are impregnated and filled with Dykanol, a non-inflammable and non-explosive chlorinated-diphenol impregnating compound. The Type DH series is available in a capacity range from .05 to 2 mfd, at voltages of 400, 600 and 1000, d-c.

The Type DH series are manufactured by *Cornell-Dubilier Electric Corp.*, 1005 Hamilton Blvd., South Plainfield, N. J.—COMMUNICATIONS.



TRANSMICA CAPACITORS

The accompanying illustration shows a high-voltage, heavy current-carrying unit of the Transmica line of mica dielectric



transmitting capacitors. Like the Transoil and Solarex lines, the Transmica units are tested individually. Full specifications may be secured by writing to *Solar Manufacturing Corp.*, 599 Broadway, New York City.—COMMUNICATIONS.

MULTIPLE OSCILLATOR

A multiple oscillator, aligned with Polyiron cores, and contained in a compact housing, is shown in the accompanying illustration. This unit is for use in pre-selected tuning systems and by virtue of the Polyiron adjusting method is said to obviate drift. The following ranges are obtained with the individual coils which cover the broadcast band:

- A coil: 1520-830 kc
- B coil: 1520-830 kc
- C coil: 1250-740 kc
- D coil: 1220-670 kc
- E coil: 970-580 kc
- F coil: 770-540 kc

For further information, write to *Aladdin Radio Industries, Inc.*, 466 West Superior St., Chicago.—COMMUNICATIONS.

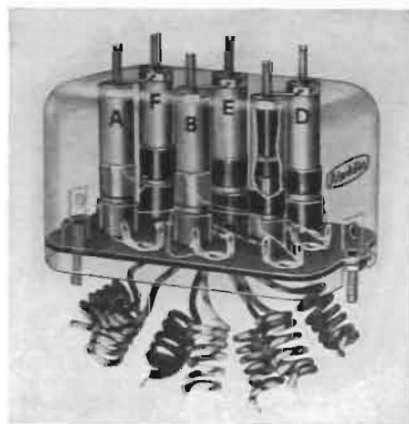

Mr. Engineer—

YOU'LL FIND a big sales advantage when you include the Brush "Hushatone" (pillow speaker) in your new model midget radio. It's easy to modify your output circuit to accommodate this popular accessory.

In the home the "Hushatone" is ideal for use in bed, on a couch or a comfortable chair.

In hospitals and sanitariums it has a natural use. Convalescents and bedridden patients welcome the "Hushatone" because of the pleasure and convenience it gives them.

Get in your order today and gain a definite sales advantage.



The **BRUSH DEVELOPMENT Co.**
3318 PERKINS AVE., CLEVELAND, OHIO

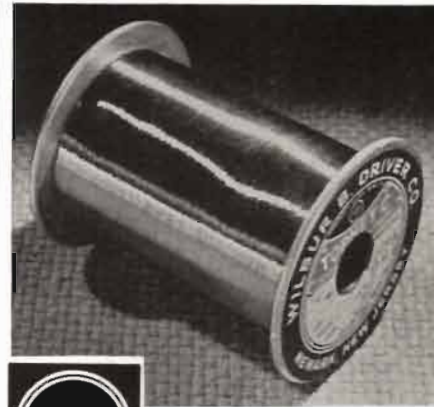

"TOPHET C" meets mechanical and corrosion-resistant specifications.

High specific resistance for compact resistors and controls.

Bare or insulated. Tangle-proof spooling.



Tophet

Pronounced TOF-FET—the always-uniform nickel-chrome alloy which bears the initials and endorsement of the pioneer. Made by alloy specialists for resistance-device specialists.

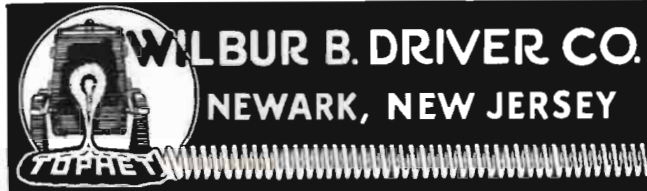

MODULATION SUPPRESSION

(Continued from page 17)

$$= mE \left(1 + \frac{1}{4} \left(\frac{a}{m} \right)^2 + \frac{1}{64} \left(\frac{a}{m} \right)^4 + \frac{1}{256} \left(\frac{a}{m} \right)^6 + \dots + \text{terms containing } bt \right)$$

After substituting a from equation (3) and writing down only the terms containing $\sin \alpha t$ we get

$$R = mE \left[\dots + \sin \alpha t \left(\frac{1}{4} \frac{1}{m^2} \cdot 2k + \frac{1}{64} \frac{1}{m^4} \left(4k + 4 \cdot \frac{3}{4} k^3 \right) + \frac{1}{256} \frac{1}{m^6} \left(6k + 20 \cdot \frac{3}{4} k^3 + 6 \cdot \frac{10}{16} k^5 \right) + \dots \right) + \dots \right] \quad (9)$$

As one will notice from this equation the modulation suppression is given by

$$k_1 = \frac{1}{2m} k$$

for large values of m .

By means of the equations (8) and (9), the factor k_1 , which is a measure for the modulation suppression, can be determined. This has been done and the results are plotted in Fig. 6. It is seen that for equal carriers

($m = 1$), the ratio k_1/k is approximately .58; this ratio drops rapidly as m is increased. Even for $m < 1$ there is an appreciable modulation-suppression effect. For $m > 1$, the ratio k_1/k is practically independent of the percentage modulation, k . For $m < 1$, the term k_1/k depends somewhat on both m and k ; for instance: at $m = \frac{1}{2}$ and $k = 20\%$, the ratio k_1/k is .95; for $m = \frac{1}{2}$ and $k = 100\%$, the ratio is 0.81.

In Figs. 7 and 8, the r-f envelopes are shown which result for $m < (1 + k)$. By comparing the amplitude variation of R_{av} versus that of R_{max} one will notice that in both cases "modulation compression" has taken place.

With the above data on hand the phenomenon of "modulation suppression" can now be readily explained.

During a time interval in which $(1 + k \sin \alpha t)$ is small in comparison with m , the beat-frequency waveform will be nearly sinusoidal—Fig. 3, left—as during interval A in Fig. 2. The average value of the r-f envelope, R_{av} , is practically equal to m , and the suppression of the modulation is nearly perfect. During the interval B in Fig. 2 $(1 + k \sin \alpha t)$ approaches the value of m ; this results for the beat-frequency waveform into a non-sinusoidal envelope similar to that shown in Fig. 3, right. The average value of the r-f envelope during 1 beat is then somewhat greater than m . This fact is responsible for the slight variation of R_{av} at audio-frequency rate. If the beat-frequency waveform was sinusoidal (as is nearly the case for large values of m)

(Continued on page 46)

MODULATION SUPPRESSION

(Continued from page 45)

then the modulation compression would be 100% complete whenever $m > (1 + k \sin \alpha t)$.

As has been said before and as is evident from these considerations, the phenomenon of modulation suppression can only take place if the rectifier load circuit is capable of following potential variations at beat-frequency rate. The case we have studied was a limit case, namely the condition under which the diode load network behaves alike against the modulation frequency α and against the beat frequency b . In practical cases, however, this condition does not hold, because generally the impedance of the diode network is very much smaller for the beat than for the audio frequency.

In order to study what is happening for medium diode load impedance for the beat frequency, we must consider the mechanism of diode rectification somewhat more in detail.¹⁹⁻²²

The beat-frequency waveform has the harmonic components $b, 2b, 3b, \dots$ whose amplitudes depend upon the ratio a/m , if a and m are the amplitudes of the two frequencies beating against each other.¹⁸ If a is a modulated r-f voltage, then a/m will vary sinusoidally, producing the r-f envelope R (Fig. 2) which has the component frequencies:

a	b	$2b$	$3b$
2α	$b \pm \alpha$	$2b \pm \alpha$.
3α	$b \pm 2\alpha$	$2b \pm 2\alpha$.
.	$b \pm 3\alpha$	$2b \pm 3\alpha$.

This r-f envelope is supplied to the diode rectifier, Fig. 4. The transrectification diagram of the diode is shown in Fig. 9, in which d-c output current is plotted versus d-c output voltage, with the r-f peak voltage being parameter. If the r-f envelope R with its multitude of component frequencies is applied to the diode, we note that the low-frequency components, $\alpha, 2\alpha$, will operate along the load line l , while the high-frequency components, $b, b \pm \alpha, 2b, \dots$, will operate over ellipses 2, on account of the by-passing effect of the capacitor C . The result is that the high-frequency components are sharply reduced in amplitude, perhaps in some cases practically eliminated. The components $\alpha, 2\alpha$ are reproduced; these components, however, constitute what was called above the function R_{av} . In other words, modulation suppression takes place just the same, even if the beat-frequency components are partially short circuited by the diode load circuit.

However, this last statement is too broad; it holds only if $m \gg (1 + k)$. If the "beat modulation" is high (i.e., if R_{min} approaches the zero-axis—Fig. 2 is an illustration of this case) and if the diode load impedance is low for the b -frequencies, then we will obtain a narrow, steep operating ellipse, like 3 in Fig. 9. The lower portion of this ellipse intersects the $I_a = 0$ axis; in other words, it is cut off. This means that during intervals of high "beat modulation"—interval B in Fig. 2—the envelope R cannot fall as low as R_{min} . The result is that R_{av} must increase, resulting in a decrease of modulation suppression. In other words, if the load impedance is low, the diode tends to treat the beat frequency the same as it treats the r-f, namely it begins

rectifying it. We thus note that there is a continuous transition from Case 2—high diode load impedance for the beat frequency—to the previously treated Case 1 in which we had zero diode load impedance at the beat frequency. However, in most practical applications $m \gg (1 + k)$, making the question of high or low diode load impedance relatively unimportant.

In reviewing now our study of the problem of modulation suppression we note the following features:

(1) Modulation suppression is a direct consequence of the fact that the heterodyne envelope is not sinusoidal and that the d-c component of the heterodyne envelope is depending upon the relative amplitude of the two interfering carriers.

(2) The extent to which modulation suppression can take place depends upon the value which the diode load impedance has for the beat frequency. If the load impedance is zero, the beat frequency will be rectified and no modulation suppression can take place. To get the full effect of modulation suppression, the diode load impedance for the beat frequency should be about the same order as for the audio frequency.

BIBLIOGRAPHY

- 1—R. T. Beatty, "Apparent Demodulation of a Weak Station by a Stronger One," *WE-EW* 5, 300, 1928.
- 2—S. Butterworth, "Apparent Demodulation of a Weak Station by a Stronger One," *WE-EW*, 6, 619, 1929 (Nov.).
- 3—F. M. Colebrook, "A Further Note on Apparent Demodulation," *WE-EW* 8, 409, 1931 (Aug.).
- 4—G. W. O. Howe, "Mutual Demodulation and Allied Problems," *WE-EW* 8, 405, 1931 (Aug.).
- 5—E. V. Appleton and D. Boohariwalla, "Mutual Interference of Wireless Signals in Simultaneous Detection," *WE-EW* 9, 136, 1932 (March).
- 6—E. Mallet, "Apparent Demodulation," *WE-EW*, Vol. 9, 248, 1932 (May).
- 7—E. B. Moullin, "The Detection by a Straight Line Rectifier of Modulated and Heterodyne Signals," *WE-EW*, Vol. 9, 378, 1932 (July).
- 8—F. M. Colebrook, "Letter to the Editor," *WE-EW*, Vol. 9, 394, 1932 (July).
- 9—E. V. Appleton, "Letter to the Editor," *WE-EW*, Vol. 9, 394, 1932 (July).
- 10—M. V. Callender, "A Note on Demodulation Under Practical Conditions," *WE-EW*, Vol. 9, 480, 1933 (Sept.).
- 11—M. V. Callender, "Problems in Selective Reception," *Proc. IRE*, Vol. 20, Page 1427, 1932 (Sept.).
- 12—C. B. Aiken, "Detection of Two Modulated Waves Which Differ Slightly in Frequency," *Proc. IRE*, 19, 120, 1931 (Jan.).
- 13—C. B. Aiken, "Detection of Two Modulated Waves Which Differ Slightly in Frequency," *Proc. IRE*, 20, 569, 1932 (March).
- 14—C. B. Aiken, "Theory of Detection of Two Modulated Waves by a Linear Rectifier," *Proc. IRE*, 21, 601, 1933 (April).
- 15—H. Roder, "Some Notes on Demodulation," *Proc. IRE*, Vol. 20, Pg. 1947, 1932 (Dec.).
- 16—Jahnke und Emde, *Funktionen—Tafeln*.
- 17—W. Kleen, "Output and Distortion of Output Tubes," *Telefunken-Rohre*; Heft 2, 58, 1934 (Sept.).
- 18—F. M. Colebrook, "The Frequency Analysis of the Heterodyne Envelope," *WE-EW* 9, 195, 1932 (April).
- 19—R. Urtel, "Diode Rectification," *Telefunken-Zeitung*, No. 64, Pg. 30, 1933 (Aug.).
- 20—W. B. Lewis, "The Detector," *WE-EW*, Vol. 9, Pg. 487, 1932 (Sept.).
- 21—C. E. Kilgour and J. M. Glessner, "Diode Detection Analysis," *Proc. IRE*, Vol. 21, 930, 1933 (July).
- 22—K. Wilhelm, "Diode Rectification," *Telefunken-Rohre*, No. 8, 196, 1936 (Nov.).

GET RID OF "EXPENSIVE" DIRT!

IDEAL

**JUMBO "3 IN 1"
ELECTRIC CLEANER**
Blows—Vacuums—
Sprays

Dirt wears out machinery—causes trouble with delicate electrical instruments, is a "short" hazard. Keep your Plant and Electrical equipment clean with Ideal Cleaner. Has power to spare—yet is gentle enough to use around most electrical instruments, apparatus, and wiring. Creates high-velocity, dry-air stream at low pressure. Gets dust in corners and "hard-to-clean" places. Portable—Easy to handle—Weights 14 lbs.



Ask About Free Trial
IDEAL COMMUTATOR DRESSER COMPANY
1062 PARK AVENUE SYCAMORE, ILLINOIS

COMPLETE ELECTRIC PLANTS

NEW 1938 MODELS

**OPERATE
RADIOS AND TRANSMITTERS**

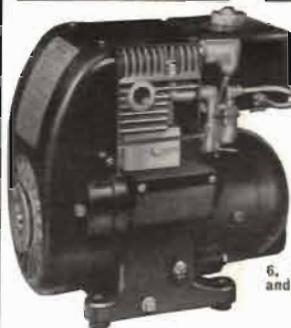

ONAN A.C. PLANTS furnish same current as city lines, 110 volt, 60 cycle. Ideal for operating PUBLIC ADDRESS SYSTEMS, SOUND CARS, MOTION PICTURE EQUIPMENT, PORTABLE NEWSCASTERS or for EMERGENCY STANDBY.

Standard Sizes 350 to 5000
Watts A.C.

6, 12, 32 and 110 volt D.C. Models, \$57.50 and up. Also combination A.C.-D.C. Units.

Write for details.

D. W. ONAN & SONS

359 ROYALSTON AVE.

MINNEAPOLIS, MINN.

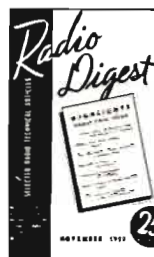

**Sensation
OF THE RADIO FIELD!**

It's the ONLY magazine with the best from ALL branches of radio, except business and entertainment.
Digests, extracts, reprints from QST, Radio, All Wave Radio, Radio News, Electronics, Service, Communications, Bell System and R.C.A. papers, house organs, over seas journals.
Twelve issues for \$2.50 in U.S.A., Canada, and Pan-American countries. Elsewhere, \$3.00 or 12s. 6d. Sample copy, 25c.
RADIO DIGEST
7460 Beverly Blvd. Los Angeles

IF

You are an experienced radioman;
You are ambitious to get ahead rapidly in Radio;

You realize the necessity of a directed training in the engineering principles of Radio, but are unable to take advantage of college training,

• Then--

send for our new illustrated book "A Tested Plan." It will give you complete details of an advanced home study course in Practical Radio Engineering written for the experienced Radioman.

Capitol Radio Engineering Institute

14th and Park Rd., N.W. Dept. CO-2 WASHINGTON, D. C.
29 Broadway, New York City

USED LABORATORY EQUIPMENT

Weston — G.R. — L&N — G.E., Etc.

Meters — Bridges — Torsion balances — Inductors.
Decade boxes — Analytical balances — Oscillographs.
Tubular rheostats — Signal generators — Condensers.

Write for new list

Louis J. Winslow

200 PENNSYLVANIA AVENUE

HILLSIDE, N. J.

RADIO IN ITS ENTIRETY!



"B-A" serves the trade with every need in radio—complete 160-page catalog of nationally known radio receivers, public address, parts, supplies and equipment. Orders shipped same day received.

BURSTEIN-APPLEBEE CO.
1012-14 MCGEE ST. KANSAS CITY, MO.



UP-TO-DATE CATALOG AVAILABLE

**"THE CRYSTAL SPECIALISTS SINCE 1925"
PIEZO-ELECTRIC CRYSTALS**

GUARANTEED Accurate to BETTER than .01%

SCIENTIFIC RADIO SERVICE

Send for FREE Booklet and Price List!

UNIVERSITY PARK - - - - - HYATTSVILLE, MD.

CHAS. EISLER'S
EQUIPMENT HAS PRODUCED

MILLIONS

spot welders up to 250 KVA, butt, and arc welders, get in touch with us. Write for our "college and glass working laboratory units" catalog.

EISLER ENGINEERING CO.

750 S. 13TH STREET (Near Ave. Ave.)

NEWARK, N. J.

FOREMOST IN THE ELECTRONICS FIELD FOR OVER 20 YEARS!

Charles Eisler's equipment for the production of radio and electronic tubes, incandescent lamps, X-Ray and cathode ray tubes, photoelectric cells, and neon signs has met the severest demands of industry in operating at maximum production and minimum cost. If you are in the market for any of the above or allied equipment including electric

36 years experience
in PERMANENT MAGNETS

We make Permanent Magnets for All Purposes Stamped, Formed and Cast, Chrome, Tungsten, Cobalt and ALNICO** (cast or sintered) under G. E. license

**THOMAS & SKINNER
STEEL PRODUCTS CO.**
1113 E. 23rd ST. • INDIANAPOLIS

LAMINATIONS FOR RADIO TRANSFORMERS
TOOLS • DIES • HEAT TREATING • STAMPINGS



**"TOPS"
FOR RADIO WORK**

Gardiner Rosin-Core Solder is outstanding for high tensile strength, consistent performance and economy. Quick setting flux of pure water white resin—no solvent added—permits faster, cleaner work by expert or amateur.

Costs less than even ordinary solders because produced by modern methods and equipment of our own development. Gardiner Solders are available in various alloys and core sizes and in gauges as small as 1/32 of an inch, 1, 5 and 20-lb. spools.

Eastern Sales Office and Warehouse

DAVID M. KASSON & CO., 264 Canal St., New York



4819 S. CAMPBELL AVE.

CHICAGO, ILL.

FERRIS

SIGNAL GENERATORS

A wide variety, from the big laboratory standard to the smallest practical unit for production testing.

FOR { *Design
*Research
*Production
*Development
*Servicing
*Testing

Submit your problems to us
—we're always ready to help.

FERRIS INSTRUMENT CORP.
Boonton, N. J.

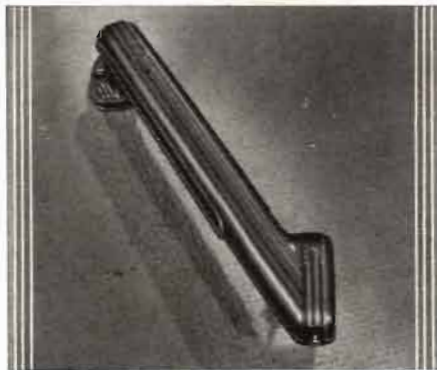

The ARM that Rests on a Cushion

In the new streamlined Model 0-7 pickup, Astatic Engineers have incorporated Axial Cushioning, insulating the playing arm from its supporting base to reduce motor noise and speaker pickup feedback. Other features include Offset Head design to reduce tracking error, easier needle loading, and shorter mounting possibilities.

LIST PRICE NOW \$10.00
Write for Literature

ASTATIC

ASTATIC MICROPHONE LABORATORY, Inc.
Dept. M-6 Youngstown, Ohio
Licensed Under Brush Development Co. Patents

Advertising Index

A	
Aerovox Corp.	27
Aladdin Radio Industries, Inc.	28
Amperex Electronic Products, Inc.	6
Inside Front Cover	
Amperite Co.	6
Astatic Microphone Laboratory, Inc.	48
Andah Co.	34
B	
Bakelite Corp.	7
Billey Electric Co.	43
Brush Development Co. The.	45
Burstein-Applebee Co.	47
C	
Callite Products Division.	32
Capitol Radio Engineering Inst.	47
Cinaudagraph Corp.	32
Claroostat Mfg. Co., Inc.	25
D	
Driver Co., Wilbur B.	45
E	
Eisler Engineering Co.	47
F	
Fairchild Aerial Camera Corp.	37
Ferranti Electric, Inc.	31
Ferris Instrument Corp.	48
G	
Gardiner Metal Co.	47
General Radio Co.	Third Cover
Goat Radio Tube Parts, Inc.	34
H	
Hammarlund Mfg. Co.	41
Hubbard Spring Co., M. D.	30
I	
Ideal Commutator Dresser Co.	47
International Resistance Co.	39
International Derrick & Equip. Co.	48
Isolantite, Inc.	5
L	
Lapp Insulator Co., Inc.	1
Lehigh Structural Steel Co.	38
Littelfuse Labs.	48
O	
Onan & Sons, D. W.	47
P	
Presto Recording Corp.	29
Pyramid Products Co.	43
R	
RCA Communications, Inc.	39
RCA Mfg. Co., Inc.	Back Cover
Racon Electric Co., Inc.	23
Radio Corp. of America.	8
Radio Digest	47
Radio Transceiver Co.	43
Recoton Corp.	41
S	
Scientific Radio Service.	47
Sound Apparatus Co.	30
T	
Thomas & Skinner Steel Prod. Co.	47
U	
United Transformer Corp.	35
V	
Van Nostrand Co., Inc., D.	36
W	
Western Electric Co.	3
Weston Elec. Instrument Corp.	33
Winslow, Louis J.	47
Z	
Zophar Mills, Inc.	41

VERTICAL RADIATORS

engineered and constructed by





■ The facilities and experience of this organization in both the engineering and construction of radio broadcasting radiators assure the efficiency of your radiator. Compare the cost of radiators on the basis of field strength—you will find IDECO offers highest efficiency per dollar invested. Write for special data information and prices.



THE INTERNATIONAL DERRICK & EQUIPMENT CO.
DIVISION OF INTERNATIONAL TRADE CORPORATION
Columbus, Ohio

RADIO RECEIVER FUSES



3 AG 250 Volt
Approved By Underwriters' Laboratories

DEFINITE NEW POINTS OF MERIT EXCLUSIVE WITH LITTELFUSE.

Rosin-Coated—breaks clean instantly.

Pure Zinc—safer on overloads.

Diagonal Alignment—accurate in any position.

Locked Caps—no cement to loosen.

Nickel-plated Caps—bright, clean.

Right Price—buy service.



CLEAN, BRIGHT, NICKEL-PLATED CAPS.

PURE ZINC.

WIRE 'ROSIN-COVERED'

ACCURATE DIAGONAL ALIGNMENT.

RATING PLAINLY MARKED ON CAPS.

'LOCKED' ASSEMBLY—SOLDER 'WETS' WIRE AND CAP.

SECOND TO NONE — WHY GAMBLE?

Std. Pkg. 100. Wt. 1 lb.

Cat. No.	Rating.
1040	1A 250V
1041	1½ 250V
1042	2A 250V
1043	3A 250V

3 AG FUSE MOUNTING
Extractor Fuse Post. Made entirely of black Bakelite. No exposed parts. Shock proof. Write

LITTELFUSE LABORATORIES
4242 Lincoln Ave., Chicago, Ill.

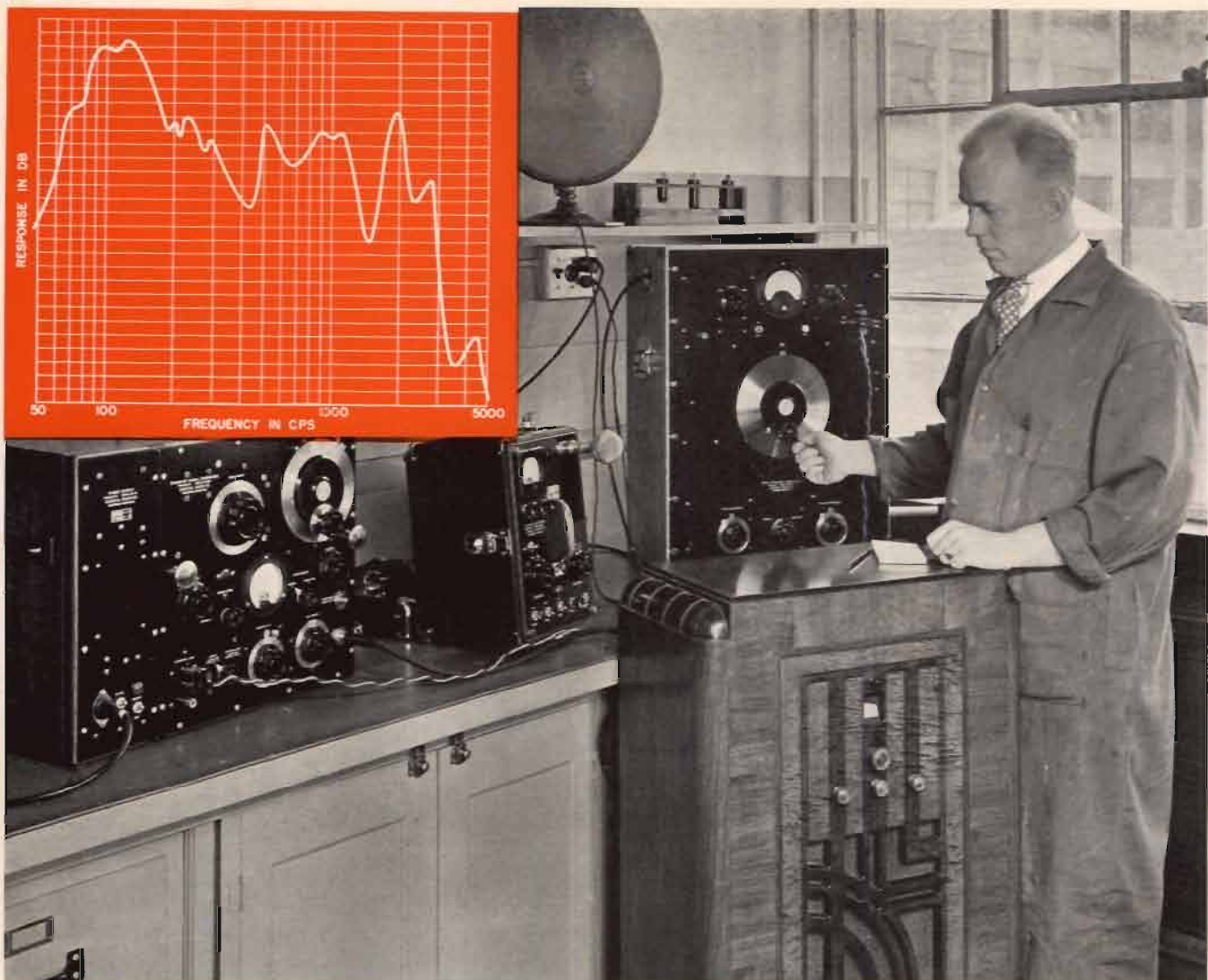

NEW DETECTOR FOR ACOUSTIC MEASUREMENTS

The G-R Type 759-A Sound Level Meter has many features which make it an excellent detector in acoustical measurements. Some of its radio and phonograph uses include:

RADIO RECEIVERS

- Acoustic Fidelity
- Power-line Hum
- Internal Noise
- Signal-to-Noise Ratio
- Inductive Interference

PHONOGRAPHS

- Gear Noise
- 120-cycle Hum
- Needle Scratch
- Filters and Cabinet Design
- Cabinet Vibration
- Cabinet Resonance
- Production Quality Tests

Both flat and weighted networks are included so that the G-R Sound Level Meter can be used for both objective measurements of acoustic fidelity and measurements of extraneous noises weighted for the effect on the human ear. Placed in any test position relative to the loudspeaker, its db indicator will register accurately the sound level at that position.

Features

1. Standardized in terms of ASA standards.
2. Linear meter scale in db.
3. Linear meter scale in db.
4. Three separate weighting networks.
5. Unusual sensitivity.
6. Wide range: 24 to 130 db above 10^{-16} watts per sq. cm.
7. Portable, small in size, and weighs only 23½ lbs.
8. Inexpensive: complete with batteries and ready for immediate operation, only..



Write for Bulletin 241
for Information

\$195.00



GENERAL RADIO COMPANY, Cambridge, Mass.

**IN BROADCASTING—
IT'S RCA ALL THE WAY
FROM MICROPHONE
TO LOUDSPEAKER**

**RCA GIVES YOU A COMPLETE LINE OF BROADCAST EQUIPMENT
FOR EVERY PURPOSE—IN THE STATION OR STUDIOS**

RCA equipment gives you more for your money because years of experience in every phase of radio . . . progressive research and sound engineering . . . modern factory facilities and skilled workers . . . a cooperative and friendly field organization

—all these important factors combine to produce first-class products at reasonable prices.

That's why it will pay you to follow the lead of hundreds of other stations—go RCA All The Way for *better broadcasting.*

Use RCA Transmitting Tubes, the tubes which help reduce operating costs



Broadcast Equipment

RCA MANUFACTURING CO., INC., GARDEN, N. J. • A Service of the Radio Corporation of America

NEW YORK: 1270 SIXTH AVENUE • CHICAGO: 589 E. ILLINOIS STREET • ATLANTA: 490 PEACHTREE STREET, N. E.
DALLAS: 2211 COMMERCE STREET • SAN FRANCISCO: 170 NINTH STREET • HOLLYWOOD: 1016 N. SYCAMORE AVENUE