

# COMMUNICATIONS

a merger of  
RADIO ENGINEERING  
...  
COMMUNICATION &  
BROADCAST ENGINEERING  
...  
THE BROADCAST ENGINEER

SEPTEMBER  
1938

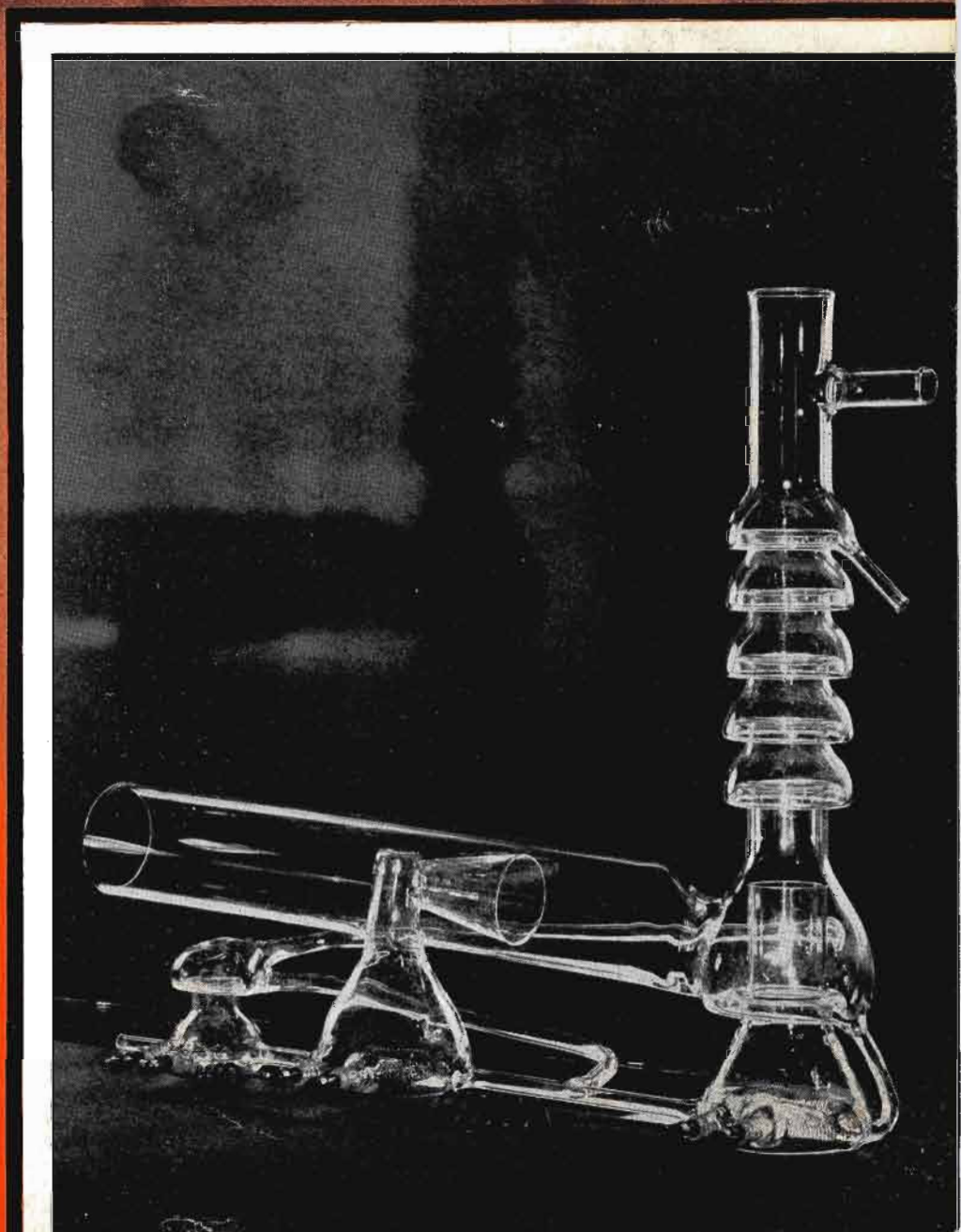



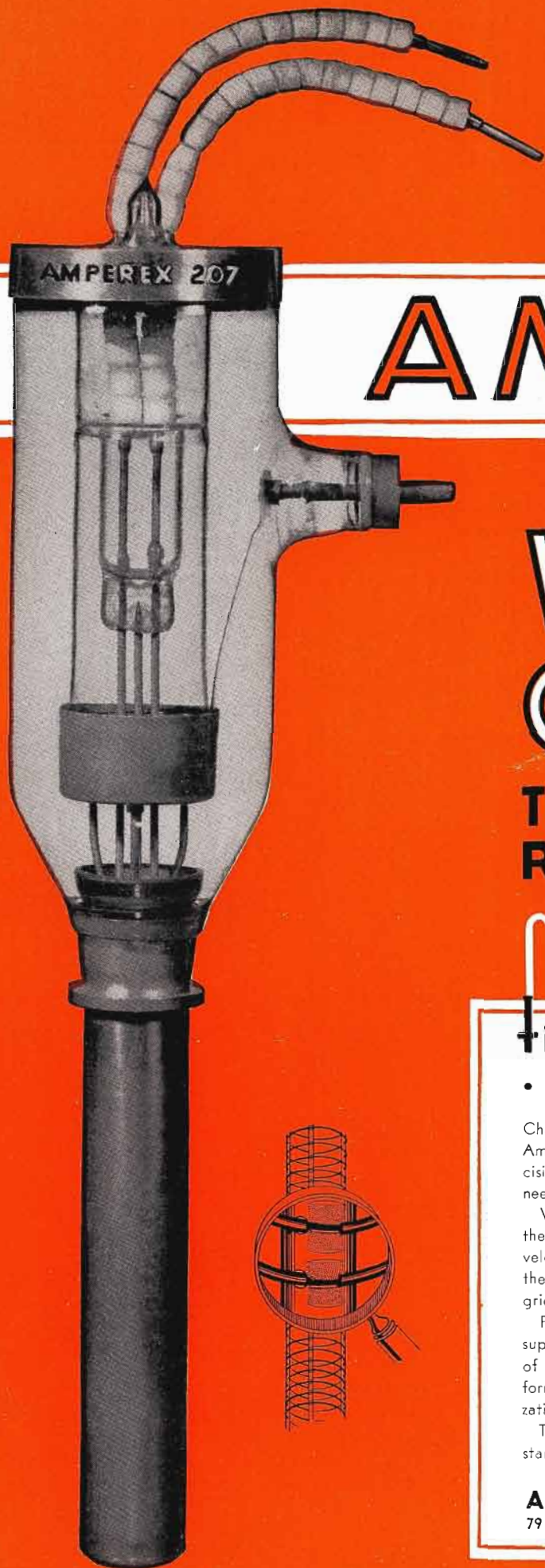

# AMPEREX

## WATER COOLED TRANSMITTING and RECTIFYING TUBES

**fine craftsmanship . . .  
. . . expert workmanship**

Characterize every element which enters into the construction of Amperex Water Cooled tubes. The painstaking thoroughness, precision and skill with which these elements are designed and engineered is best illustrated by the grid.

Welding, the customary method of attaching the fine grid wire to the supporting rods, is entirely eliminated. The intense heat developed in this process results in the formation of oxide films on the wires (a source of grid emission) and in the crystallization of grid wire and rod at the point of junction.

For the Amperex grids, a machine was developed which slots the supporting moly rods at accurate intervals determined by the pitch of the grid. The grid wire is securely swaged into these notches, forming a strong rugged grid free from brittleness due to crystallization and free from surface contamination because of any oxidation.

This minute attention to detail is a contributing factor to the outstanding performance of Amperex tubes.

**AMPEREX ELECTRONIC PRODUCTS, INC.**  
79 WASHINGTON STREET                      BROOKLYN, NEW YORK

# COMMUNICATIONS

Registered U. S. Patent Office  
Member of Audit Bureau of Circulations

RAY D. RETTENMEYER  
Editor

## CONTENTS FOR SEPTEMBER

Cover Illustration: A newly developed, three-compartment, two-jet, high-vacuum pump. Photo. Courtesy Distillation Products, Inc.

	Page
With the Editors.....	2
Theory and Design of Progressive Universal Coils By A. A. Joyner and V. D. Landon	5
Coupling Networks, Part I..... By W. L. Everitt	12
A Mutual Conductance Meter..... By C. B. Aiken and J. F. Bell	19
Developments in Television.....	20
Portable Field Intensity Meter..... By J. V. Cosman	22
Book Reviews.....	24
Notes and Comment.....	25
Over the Tape.....	26
Veteran Wireless Operators Association News.....	31
Purchasing Directory.....	32
The Market Place.....	52
Index of Advertisers.....	56

VOLUME 18

NUMBER 9

BRYAN S. DAVIS  
President

JAMES A. WALKER  
Secretary

Chicago Office—608 S. Dearborn St.  
Telephone: Wabash 1903.

Published Monthly by the  
BRYAN DAVIS PUBLISHING CO., INC.

19 East 47th Street  
New York City  
New York Telephone: PLaza 3-0483



SANFORD R. COWAN  
Manager

PAUL S. WEIL  
Advertising Manager

A. GOEBEL  
Circulation Manager

Wellington, New Zealand—Te Aro Book Depot.  
Melbourne, Australia—McGill's Agency.

*Entered as second class matter October 1, 1937, at the Post Office at New York, N. Y., under the act of March 3, 1879. Yearly subscription rate: \$2.00 in the United States and Canada, \$3.00 in foreign countries. Single copies: twenty-five cents in United States and Canada, thirty-five cents in foreign countries.*

COMMUNICATIONS FOR SEPTEMBER 1938 • 1



# WITH THE EDITORS

---

## TELEVISION

DURING the past few weeks, much interest has been centered in television . . . not only from the standpoint of experimental work in this country, but also due to developments abroad, some of which may point the way toward the future of television.

On September 12, the Radio Manufacturers Association submitted their proposed television transmission standards to the Federal Communications Commission for approval. Early action on the matter is not anticipated.

Also, considerable interest has been evidenced in a newly announced television kit for experimenters. This kit, marketed by the Garod Radio Corporation of New York, uses a 5-inch cathode-ray tube and is said to conform to the RMA standards. Further data on this receiver will be found elsewhere in this issue.

In addition, rumor, from what is usually a reliable source, has it that beginning the first of the year one of our larger "mail-order" houses will also place television kits on the market. We would assume, of course, that these kits will be restricted to only those areas which have experimental television stations.

NBC has been doing some interesting outdoor pickup work of both day and night scenes, making use of their mobile relay transmitter operating on a frequency of 177 megacycles. The tests were reported to be quite satisfactory.

Abroad, there have been some rather startling developments, especially in Germany. Some of their developments, we believe, will have considerable influence on television in this country. Further information on the progress abroad will be found on following pages.

## ROCHESTER FALL MEETING

THIS YEAR'S Rochester Fall Meeting will be held on November 14, 15 and 16 at the Sagamore Hotel in Rochester, N. Y. An interesting program of technical sessions as well as entertainment has been promised. Tentative plans for the technical meetings call for papers on the subjects of television, frequency modulation, loudspeakers, radio

interference, ultra-high-frequency tubes . . . to mention a few. More details later.

## POLICE FACSIMILE

WE HAVE often pointed out the many and varied uses to which facsimile transmission and reception could be applied. Hence, we learn with more than passing interest that certain police officials in the Middle West are seriously contemplating its use. We believe that someday radio facsimile will prove itself an invaluable aid to the efficient operation of most state and local police systems.

## SMPE CONVENTION

DETROIT, MICHIGAN, will be the scene of the twenty-third Fall, 1938, Convention of the Society of Motion Picture Engineers. The dates are October 31 to November 2, inclusive, the place being the Hotel Statler. We understand that a comprehensive program of interesting papers and technical presentations is being arranged.

## APCO CONVENTION

AND, WHILE on the subject of conventions, we should again like to remind the APCO members of their gathering in Houston, Texas, on October 19, 20, 21 and 22. Headquarters for the convention will be the Texas State Hotel. From all indications this will be the largest meeting in the history of the APCO.

## PRESENTING . . .

TO DATE relatively little has been published on progressive universal coils. Hence, we believe, the article "Theory and Design of Progressive Universal Coils," by A. A. Joyner and V. D. Landon, will be of considerable interest . . . especially since a practical design procedure is presented.

ALSO, of special interest in this issue is the paper by W. L. Everitt on "Coupling Networks." This is Part I of the paper presented at last year's Broadcast Engineering Conference at Ohio State University. It will be found to be quite complete and practical.

# Announcing!

**the greatest  
SINGLE  
IMPROVEMENT  
in the history of  
instantaneous re-  
cording equipment**



**PRESTO 6-D RECORDING TURNTABLE EQUIPPED WITH  
AUTOMATIC EQUALIZER**

## THE NEW PRESTO AUTOMATIC RECORDING EQUALIZER\*

It does a job no human skill can duplicate. It compensates smoothly and accurately for the progressive attenuation of high frequencies on 33 1/3 rpm recordings and as it varies the equalization it keeps the output of the recording amplifier at a constant level. It makes the quality of your 15-minute recordings the same from beginning to end . . . no hollow, tubby quality near the center of the record due to loss of highs . . . no shrill rasping reproduction at the outside due to over-equalization. And it's completely automatic in operation . . . requires no attention from the operator during recording.

This new device can be installed on your Presto recorder in less than ten minutes. Simply loosen two screws and clamp the slider unit onto the over head feed mechanism.

Plug the cables into the control box, connect to the 500 ohm input of your recording amplifier and your equipment is ready to make the finest instantaneous recordings you ever heard.

Price of Presto automatic recording equalizer complete \$156.00 net to broadcasting stations. (F.O.B. New York)

\*Patents pending.

**Place Your Order Today and  
Be Certain of Prompt Delivery.**

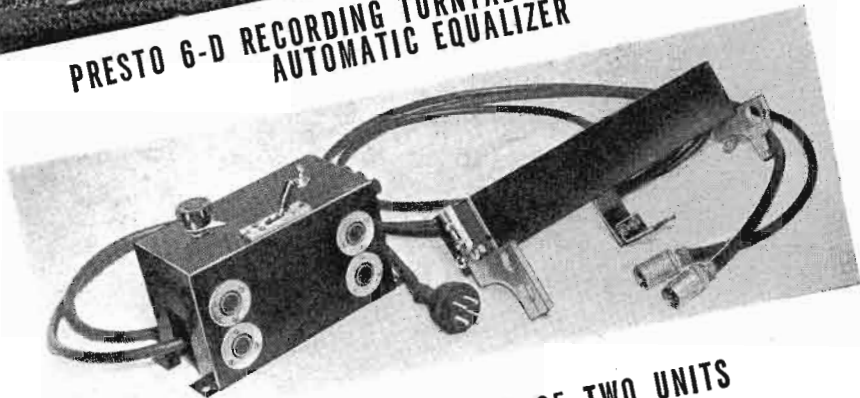

### THE NEW EQUALIZER CONSISTS OF TWO UNITS

1. A control box containing the tuned circuit which can be adjusted to peak at either 6000 or 8000 cycles, receptacles for the cables from two slider units, a cable connecting to the amplifier input and a changeover switch to connect the unit to either of two turntables.
2. A slider type, variable resistance network which engages with the cutting head mounting and moves across the surface of the disc with the cutting head. One resistor adjusts the slope of the amplifier curve to compensate for the changing groove radius. The second, a T pad, controls the amplifier gain in steps of 1/4 db. to compensate for the insertion loss of the equalizer.

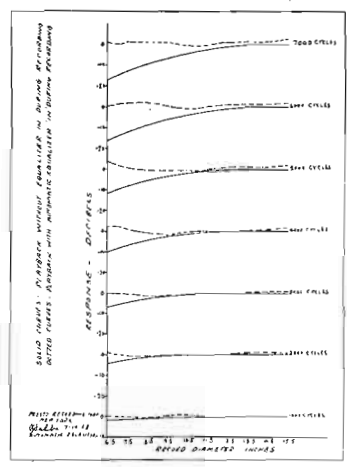

various groove radii. Dotted lines show the correction made by the Presto. Solid curves show the losses of high frequencies for Automatic Frequency Equalizer. Note that throughout the portion of the record used in making 15 minute transcriptions, the frequency response is uniform within 2 db. up to 7,000 cycles. Without equalization the loss at a groove radius of 3 1/2" is 15 db. at 7,000 cycles and over 8 db. at 4,000 cycles. The Presto 1-B high fidelity cutting head was used in making the records for measurement.

**PRESTO RECORDING CORPORATION  
147 W. 19th ST.**



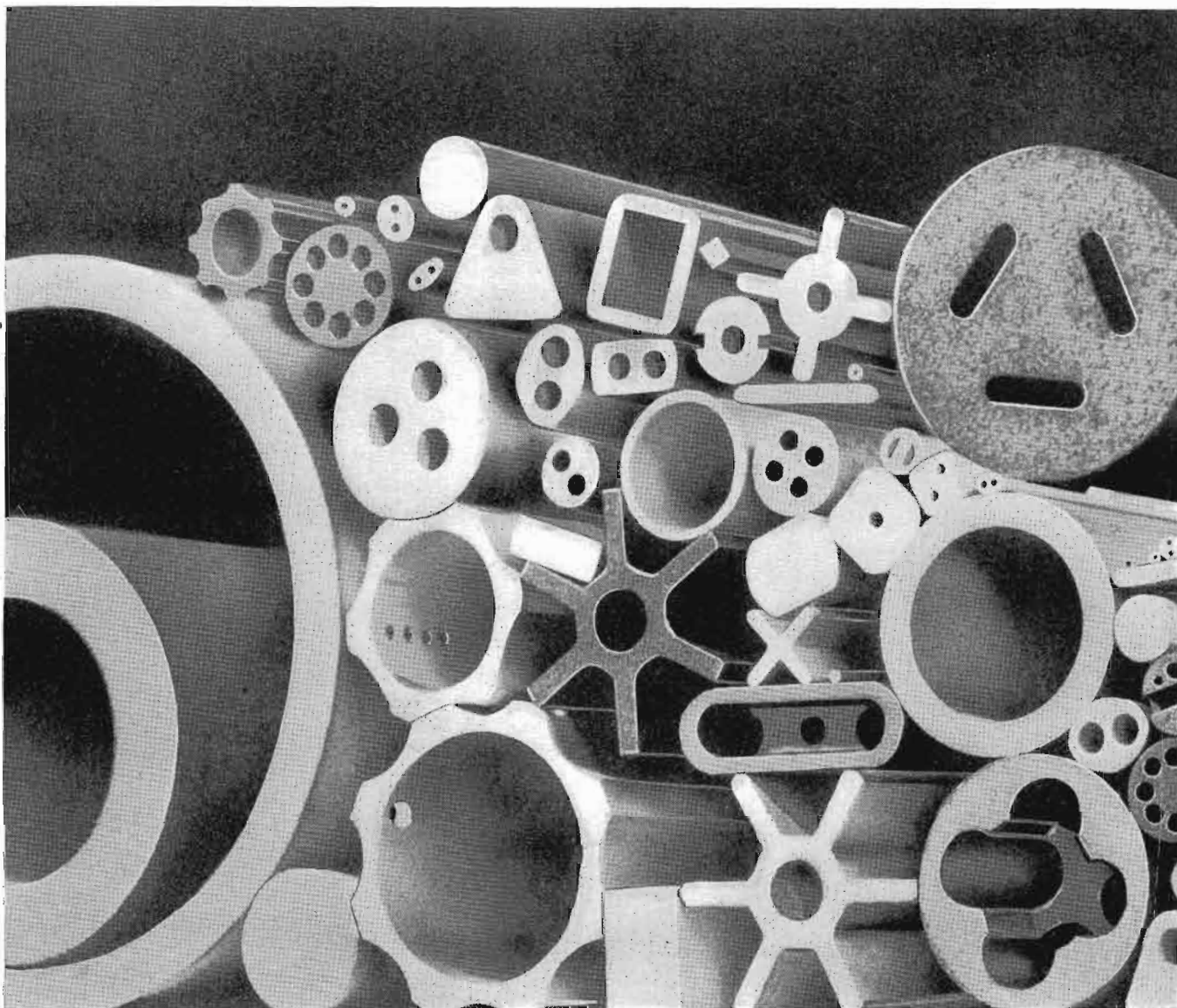

The above shapes are a few of the many varieties possible by our extrusion process.

By our automatic pressing method, we are also able to fabricate Alsimag into many intricate shapes,

Our engineers, from their vast experience with the highly technical, electrical and radio fields, can offer many positive suggestions and assistance for your ceramic problems. Address your inquiries either to us, direct, or to our branch offices, shown below,

**AMERICAN** *Lava Corporation*

CHATTANOOGA, TENN.

SALES OFFICES

New York  
Boston  
Washington

Philadelphia  
Chicago  
Cleveland

St. Louis  
San Francisco  
Los Angeles

# COMMUNICATIONS

FOR SEPTEMBER, 1938

## Theory and Design of PROGRESSIVE UNIVERSAL COILS

By **A. A. JOYNER & V. D. LANDON**

RCA MANUFACTURING CO., INC.  
Camden

THE TYPE of coil discussed in this paper is comparatively new. It made its first appearance in this country a year or two ago. It was used in Europe by the N. V. Philips Company some time before that. The point of origin is unknown. Coils of this type have been used in receivers in this country for about a year.

Various examples of experimental coils are illustrated in Figs. 1-8. The coils are wound on a special machine similar to that used for the common "universal" winding. The essential difference is that in winding the progressive universal the coil's form is moved slowly longitudinally during the winding operation. The resulting coil combines many of the features of both the universal and the solenoid. It is also similar to the bank windings in many respects. The advantage of this type of winding lies in the relatively high  $Q$  and low distributed capacity which may be obtained in a coil of moderate size.

For the most part the early coils were designed by cut and try methods which were found to be very tedious. The purpose of this paper is to organize a design procedure so that suitable progressive

List of Symbols-	
$C$	- Approximate crosses per turn (nearest integer or mixed no.)
$C^1$	- Accurate crosses per turn
$\Delta$	- $C^1 - C$
$N$	- Number of turns between a wire and its support
$T$	- Amplitude of wire guide motion (throw)
$w$	- Wire diameter
$d$	- Longitudinal motion of coil form per turn
$P$	- Perimeter of coil form
$E$	- Length of one excursion of wire
$N_1$	- Smaller $N$ number
$N_2$	- Larger $N$ number
$M_1$	- Turns per winding cycle = $N_1 + N_2$
$M_2$	- Turns per winding cycle = $2N_1 + N_2$
$\Delta_1$	- $\Delta$ corresponding to $N_1$
$\Delta_2$	- $\Delta$ corresponding to $N_2$

universal coils may be designed for any given purpose with a minimum of effort.

### OBTAINING A PATTERN

#### (1) Factors Determining the Pattern.

In designing coils of this type a proper choice of winding pitch, cam throw and number of crosses per turn must be made if a neat, mechanically strong coil with a definite pattern is to be obtained. To promote an understanding of how a pattern is obtained,

these coils may be compared to the simple universal winding.

(a) *The pattern of a universal coil*—In winding a universal coil, the exact number of crosses per turn  $C^1$  is adjusted to a value just larger (or smaller) than a simple integer or mixed number  $C$ . The difference,  $C^1 - C (= \Delta)$  is adjusted to a critical value such that each turn of wire lies adjacent to, and touching a preceding turn.  $C$  (the approximate integral number of crosses per turn) is chosen for minimum tendency to slip. The proper value depends on the diameter and width of the coil.

(b) *The pattern of the progressive universal*—With the progressive universal coil the longitudinal motion of the coil form makes necessary a new value of  $\Delta$ . When using a symmetrical motion of the wire guide it is impossible to have consecutive turns touching on both forward and backward excursions of the wire guide. In general, with a simple pattern, a given turn touches and is supported by an adjacent preceding turn on either the forward excursion or the backward excursion but not both. Support on the forward (downhill) excursion is illustrated in Fig. 1. Sup-

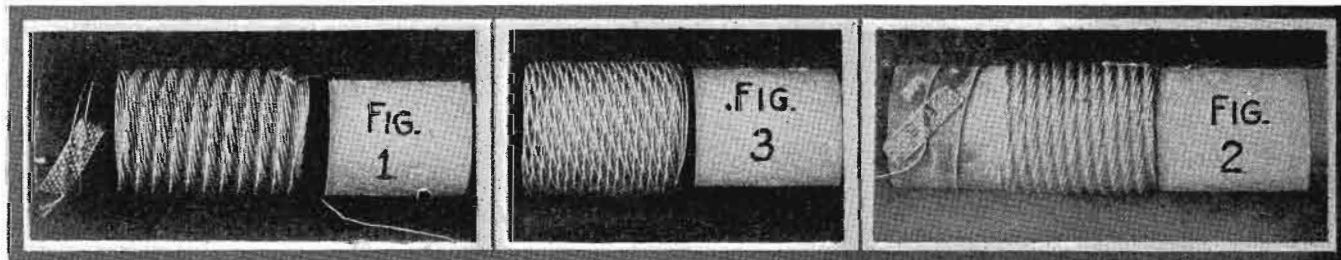



port on the backward excursion is illustrated in Fig. 2.

The to and fro motion of the wire guide makes corners or bends in the wire. The locus of the corners of adjacent wires forms a ridge which winds around the coil in a continuous spiral. This produces a neat pattern which is mechanically strong and uniform in appearance. It should be noted that when  $\Delta$  is positive ( $C^1 > C$ ), support is obtained on the backward (uphill) excursion and the direction of rotation of the spiral ridge is opposite to that of the wire. With negative values of  $\Delta$  ( $C^1 < C$ ) support is obtained on the forward (downhill) excursion and the ridge rotates in the same direction as the wire.

(c) *Types of support*—If the adjacent wires, which are used for support, are consecutive turns ( $C$  an even integer) the coil is called type 1 and there are  $C/2$  distinct spiral ridges.

If adjacent wires are not consecutive turns but are wound 2, 3, 4 or  $N$  turns apart, then the coil is called type 2, 3, 4 or  $N$ . Fig. 3 shows an example of a type 2 coil which is obtained when  $C$  is odd.

For the higher type numbers,  $C$  will be a mixed number but  $NC/2$  must be an integer as  $NC/2$  is equal to the number of distinct spiral ridges (the throw reverses on a different ridge  $C/2$  times per turn for  $N$  turns and then repeats).

(d) *Kind of wire guide motion*—In universal machines the wire guide customarily travels with a uniform velocity, reversing direction instantaneously at the end of the throw. In the progressive universal machines used by the authors, the wire guide executes simple harmonic motion (a sine wave). For simplicity the theoretical discussion which follows is based on uniform velocity. It has been determined experimentally that no change in the formulation is required when changing from one type of motion to the other.

**(2) The Simple Patterns (Type 1 or 2)**

Let  $w$  = wire dia.

$d$  = longitudinal movement of coil form per turn.

If  $w/d$  is less than unity a solenoid should be used. If  $w/d$  is greater than one but less than two the coil should preferably be made type 1 or 2.

(a) *The value of  $\Delta$* —A formula will now be developed expressing the rela-



tionship which is required if good support is to be obtained.

Fig. 9 is a diagrammatic representation of a certain turn of wire and the  $N$ th preceding turn.  $T$  = the throw = the amplitude of the the wire guide movement.  $Nd$  is the longitudinal distance moved by the coil form while making  $N$  turns.  $N\Delta T$  is the uncompleted portion of the last throw after exactly  $N$  turns (starting from beginning of a throw. It can be seen by inspection that:

$$\frac{N\Delta + Nd}{2} = \frac{w}{2} + Nd$$

$$N\Delta T = w + Nd$$

$$\Delta = \frac{w + Nd}{NT}$$

There is a slight error in that  $w$  is taken as the longitudinal distance between centers of the wires (measured in a direction parallel to the axis of the coil). Since the throw is only 1/7 of the excursion this error is very small.

Another slight error is caused by the line labelled  $Nd$ . This distance is in reality  $Nd + \frac{\Delta}{C}$ . This is a very small

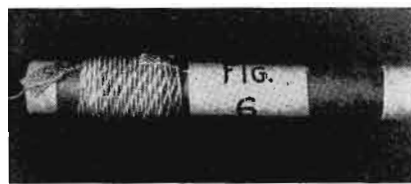

error because  $\frac{\Delta}{C}$  is very small compared to  $N$ .

If a similar analysis is carried out for support on the backward excursion instead of on the forward excursion, the same expression is obtained except that the sign is negative. Hence:

$$\Delta = \pm \frac{w + Nd}{NT} \dots\dots\dots(1)$$

Note that when starting a new design the values of  $w$  and  $d$  are usually given.  $N$  may be arbitrarily assigned a value 1, 2 or 3. This leaves two unknowns  $\Delta$  and  $T$  and but one equation indicating an indefinitely large number of possible solutions. This is actually the case. Either  $T$  or  $\Delta$  may be assigned arbitrarily and a corresponding value may be found for the other, so that support will occur and a uniform pattern will be obtained. However, certain other considerations assist in determining the optimum throw.

(b) *Factors determining the throw*—It has been determined experimentally that the distributed capacity of a coil is reduced by decreasing the throw.

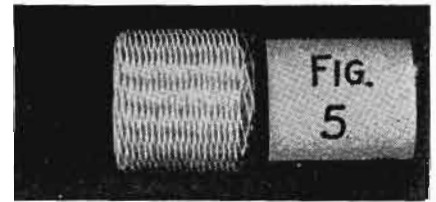

Hence, wherever low capacity is important the throw should be kept to a minimum. However, if the throw is reduced below a certain value it becomes difficult to obtain a uniform pattern. This limit is usually about:

$$T_{MIN} = 4w \times w/d = 4 \frac{w^2}{d} \dots\dots\dots(2)$$

Having decided on a value for  $T$ ,  $\Delta$  may be solved for by the use of (1).

(c) *The value of  $C$* —It should be noted that equation (1) (expressing the necessary condition for obtaining a pattern) does not involve  $C$ . This brings out the rather surprising fact that to keep a pattern no change in  $\Delta$  or  $T$  is required by a change in  $C$ . The value of  $C$  itself is chosen for minimum tendency to slip. There are two types of slippage: slippage on the coil form due to  $C$  being too large, and slippage when crossing another wire due to insufficient angle of attack ( $C$  too small).

The length of one excursion of the wire is  $E = P/C^1$ . ( $P$  = perimeter of coil form). It was experimentally determined that  $E$  should be about  $7T$ , hence  $C^1 = P/7T$ . This is not very critical, however. Acceptable coils have been wound between the limits

$$P/10T < C^1 < P/4T$$

If  $C^1$  is about  $P/4T$  the wire will slip on the coil form. If slippage is consistent a coil of uniform pattern may result anyway. There is some question about the consistency of this sort of pattern because of the dependence placed on the uniformity of the coefficient of friction of the coil form.

The factors controlling slippage are not thoroughly understood but there is some indication that  $C^1 = P/8T$  is best because there is practically no slippage.  $C = P/6T$  is almost as good because there is a small uniform slippage.  $C^1 = P/7T$  sometimes appears to be poorer than  $C^1 = P/6T$  because the slippage which occurs is not uniform. This seems to be a matter for further experimentation on each specific design as an undue amount of time would be required to obtain a consistent solution for the general case. The matter is somewhat in the hands of chance since  $C^1$  is nearly equal to  $C$  and  $C$  must be an integer. The procedure is to choose the nearest integer to  $P/7T$  for the value of  $C$  regardless of whether this figure lies nearest to  $P/6T$ ,  $P/7T$  or  $P/8T$ . In



general, a rough surface coil form facilitates winding. An occasional pattern is found which winds beautifully on a form covered with scotch tape, but cannot be wound without such a sticky surface.

If a given value of  $C^1$  gives a good pattern, another good value can be obtained without changing  $\Delta$  or  $T$  by simply adding or subtracting 2 from the previous value. As long as the new value lies between the limits  $P/4T$  and  $P/10T$  a fairly uniform pattern will usually be obtained. This operation

$$\text{changes the value of } \frac{NC}{2} \text{ by unity thus}$$

adding or subtracting one spiral ridge but leaving the general form and appearance of the pattern unchanged. Thus the same pattern ( $N$ ,  $\Delta$  and  $T$  unchanged) may be wound on several coil forms of different diameters by simply changing the value of  $C$  to keep it in the neighborhood of  $P/7T$  as  $P$  is changed by the change in diameter.

(3) The Composite Patterns.

(a) *General conditions when  $w/d > 2$* —When  $w/d > 2$  the spiral ridges overlap regardless of the value of the throw. Equation (2) is still a good approximation of the minimum value which can be assigned to  $T$  and still obtain good patterns. In general, when  $w/d > 2$ , the throw is greater than when  $w/d < 2$  since  $w/d$  appears in the formula for the minimum throw. The larger value of the throw is favorable for the use of more complicated patterns though theoretically the simple patterns may still be used.

(b) *The linear pattern*—An interesting variation in the appearance of the coil is obtained by making the decimal portion of  $C^1$  a simple fraction.

When this is done the phase of the winding repeats itself exactly after a number of turns equal to the denominator of the fraction (or twice that value if the total number of crosses is odd for that number of turns). The fact that the same phase recurs, results in pattern lines running parallel to the axis of the coil. The spiral ridges are still present but may be so much less prominent as to be unnoticed.

For such coils of type 1 or 2, if the decimal portion of  $C^1$  is a simple fraction,  $\Delta$  must also be a simple fraction, since  $C$  is integral.

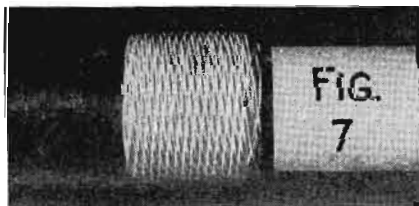

For example:

$$\begin{aligned} N &= 1 \\ C &= 2 \\ \text{let } \Delta &= \pm .250 \\ \text{then } C^1 &= 2.250 \text{ or } 1.750 \end{aligned}$$

The throw can now be adjusted to obtain a pattern.

Since

$$\Delta = \frac{W + Nd}{NT}; T = \frac{W + Nd}{N\Delta}$$

The pattern repeats every 8 turns.

For coils of higher type numbers than 2,  $C$  is a simple marked number but  $NC/2$  is always integral. In this case the decimal part of  $C^1$  is a simple fraction without  $\Delta$  being a simple fraction. This is an advantage in that the pattern may be made to repeat after a smaller number of turns without using an unduly large value for  $\Delta$ .

For example:

$$\begin{aligned} \text{Let } N &= 3, C = 3\text{-}1/3, NC/2 = 5 \\ C^1 &= 3\text{-}3/7, T = .094, \\ \Delta &= .095 \end{aligned}$$

The pattern repeats every 7 turns.

(c) *The composite character of linear patterns*—Consider also the following data:

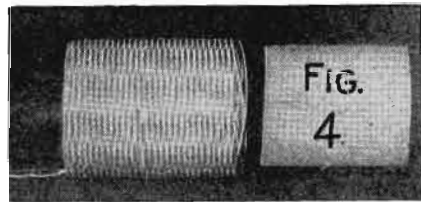

$$\begin{aligned} N &= 4, C = 3.5, NC/2 = 7 \\ C^1 &= 3\text{-}3/7, T = .114 \\ \Delta &= -.071 \end{aligned}$$

This is almost the same coil, though theoretically a slightly different throw is required. In the first example each turn is supported by lying against the third preceding turn on the backward or uphill excursion of the wire guide. In the second example each turn is supported by lying against the fourth preceding turn on the downhill or forward excursion, since  $\Delta$  is negative in this case. A compromise value of the throw may be found which will give fair support for both patterns provided the two values of throw required are not too widely different. The resulting coil will have three patterns, a set of spirals going in each direction (5 in one and 7 in the other) and a set of lines lengthwise of the coil (12 in number) giving a dodecagonal appearance. This linear pattern results from the fact that the phase of the winding repeats exactly after seven turns. This coil is illustrated in Fig. 4.

In all composite windings (having two  $N$  numbers) like the above, the

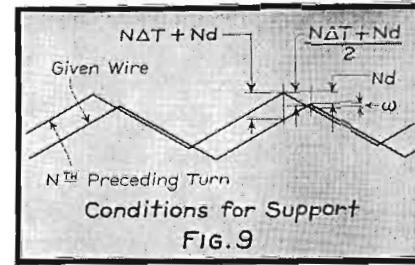

number of turns required to obtain repetition of phase is called  $M_1$ . The number of lengthwise lines is  $M_1 C^1/2$ . (The bend in the wire occurs on a new line  $C^1/2$  times per turn for  $M_1$  turns and then repeats.)

A close examination of coils of this sort shows that turns having a corner on a certain longitudinal line are supported by turns having corners on adjacent longitudinal lines. The linear distance between lines is evidently the perimeter divided by the number of lines or

$$\frac{C^1 E}{M_1 C^1/2} = \frac{2E}{M_1} = N_1 \Delta_1 E = N_2 \Delta_2 E$$

Hence

$$N_1 \Delta_1 = \frac{2}{M_1} = N_2 \Delta_2$$

Now the throw required for support is

$$T = \frac{w + N_1 d}{N_1 \Delta_1} = \frac{w + N_1 d}{2/M}$$

Also

$$T = \frac{w + N_2 d}{N_2 \Delta_2} = \frac{w + N_2 d}{2/M}$$

This shows that the best compromise for double support occurs when  $N_1$  and  $N_2$  are nearly equal. This may be considered as evidence in favor of consecutive  $N$  numbers. It is true that ( $N_1 = 2, N_2 = 3$ ) and ( $N_1 = 3, N_2 = 4$ ) wind fairly well, but for higher values of consecutive  $N$  numbers, good support is prevented by regularly spaced wires crossing between a given wire and its support. When  $N_2$  is approximately equal to  $2N_1$ , there is a tendency for these crossing wires to group together in pairs giving a space between groups when contact may be obtained between the given wire and its support. This is illustrated in Fig. 5.

If the throw of a linear composite coil is adjusted to give perfect type  $N_1$  support, then a given turn tends to be spaced from its  $N_2$  support by a distance  $(N_2 - N_1) d$ , except for slippage.

(d) *Non-linear composite patterns*—In linear patterns like the above, perfect support cannot be obtained on both forward and backward excursions. This is because of the arbitrary choice of  $N_1 \Delta_1 = N_2 \Delta_2$  so as to get a linear

pattern. It is only necessary to change  $C^1$  very slightly to obtain theoretically perfect support on both forward and backward excursions. It is only necessary that

$$T = \frac{w + N_1 d}{N_1 \Delta_1} = \frac{w + N_2 d}{N_2 \Delta_2}$$

or

$$\frac{\Delta_2}{\Delta_1} = \frac{N_1}{N_2} \frac{w + N_2 d}{w + N_1 d}$$

Knowing also that—

$$\Delta_2 + \Delta_1 = C_1 - C_2$$

we can solve for

$$\Delta_1, \Delta_2 \text{ and } C^1.$$

A coil designed in this manner is not linear but is still a composite. Theoretically at least, there are three sets of spirals, one for  $N_1$ , another for  $N_2$  and another (spiraling much more slowly) for  $M_1$ . The  $M_1$  spiral pattern, formed by the slow processing of the formerly linear pattern, is most prominent. This sort of pattern is illustrated in Fig. 6.

(e) *Table of linear composite patterns*—Table I gives possible number combinations leading to practical linear composite patterns.

In designing a coil for production the first operation is to obtain the preferred value for  $M_1$  using the formula:

$$M_1 = 4 \frac{w}{d}$$

This formula means that among the successful experimental coils,  $M$  had that average value. However, acceptable coils have been obtained with values for  $M_1$  ranging from  $M_1 = 3w/d$  to  $M_1 = 7w/d$ .

The next operation is to find the preferred value for  $C^1$  using the formula:

$$C^1 = \frac{P}{7T}; T = 4w \frac{w}{d}$$

The third operation is to choose from the table those values of  $C^1$  and  $M$  which are the nearest approximation to the

preferred values. Two or more sets of values should be chosen for trial. The value of  $T$  should be recalculated, using the formula:

$$T = \frac{w + N_2 d}{2/M_1}$$

Improved uniformity of winding can sometimes be obtained by readjusting  $T$  experimentally.

(f) *To avoid interference from  $M_1$ th turn*—When  $N_2$  is much greater than  $N_1$  in a non-linear composite, the rate of precession of the  $M_1$  pattern may get unduly great. When this occurs a given turn lies over the  $M_1$ th preceding turn, spoiling the pattern. This effect does not occur if

$$T = \frac{M_1 d - w}{M_1 \Delta_{M_1}} <$$

where  $\Delta_{M_1}$  is the difference between the  $C_1$  used and that required for a linear pattern.

If the pattern calls for a throw larger than the above equation, it will not wind properly. This is seldom a limitation.

(g) *Review of linear pattern*—In the linear pattern discussed above certain turns of wire (spaced  $M_1$  turns apart) have the same phase, so that the corners in the wires make a straight line running parallel to the axis of the coil. There are  $M_1 C^1 / 2$  such parallel lines. The turns forming corners on one line are supported by the turns having corners on adjacent lines. Support wires for the downward (forward) excursion are on one side and for the upward (backward) excursion on the other side. Consider two lines down a coil as identifying the turns of wire which form corners on those lines. A given turn in line number 1 is supported by a turn in the adjacent line number 2 on the upward excursion. This same given turn in line number 1 gives support on the downward excursion, to the next wire wound in line number 2.

(h) *The  $M_2$  linear pattern*—In the  $M_2$  pattern there are two  $N$  numbers

just as in the  $M_1$  pattern. Support on one excursion is obtained from the adjacent line just as described above. However, the support wires for the larger  $N$  number do not form a corner in the adjacent line but in the second adjacent line from that of the wire supported. This results in the following additional differences:

$$M_2 = 2N_1 + N_2 \quad (\text{while } M_1 = N_1 + N_2)$$

$$N_1 \Delta_1 = \frac{2}{M_2} \quad \text{but} \quad N_2 \Delta_2 = 4/M_2$$

$$T = (w + N_1 d) \frac{M_2}{2} \quad (\text{same as in } M_1)$$

$$= (w + N_2 d) \frac{M_2}{4} \quad (\text{note the four})$$

It is now possible to solve for the conditions which call for the same throw for both  $N_1$  and  $N_2$  support.

$$(w + N_1 d) \frac{M_2}{2} = (w + N_2 d) \frac{M_2}{4}$$

$$2w + 2N_1 d = (w + N_2 d)$$

$$\frac{w}{d} = N_2 - 2N_1$$

The same condition may be expressed in a different way, as follows:

$$M_2 = N_2 + 2N_1 = \frac{w}{d} + 4N_1$$

$$N_1 = \frac{M_2}{4} - \frac{w}{4d}$$

If this condition is met, then the throw theoretically required for each type of support is the same. The ideal condition of equal throw requirements is one which can never quite be met for  $M_1$  coils and yet some very neat and acceptable  $M_1$  coils have been wound. Hence it is obvious that with  $M_2$  coils it is not necessary to meet the condition of the last equation very accurately to obtain acceptable patterns.

An  $M_2$  pattern may always be obtained from an  $M_1$  pattern as follows:

$M_1$	$N_1$	$N_2$	$C^1_{MIN}$		$M_1$	$N_1$	$N_2$	$C^1_{MIN}$		$M_1$	$N_1$	$N_2$	$C^1_{MIN}$	
			Fraction	Decimal				Fraction	Decimal				Fraction	Decimal
5	2	3	4/5	.8	12	5	7	10/12	.8333	-	7	8	4/15	.2666
7	2	5	6/7	.8571	13	2	11	12/13	.923	16	3	13	10/16	.6250
-	3	4	4/7	.5714	-	3	10	8/13	.615	-	5	11	6/16	.3750
8	3	5	6/8	.750	-	4	9	6/13	.462	-	7	9	14/16	.8750
9	2	7	8/9	.888	-	5	8	10/13	.769	17	2	15	16/17	.942
-	4	5	4/9	.444	-	6	7	4/13	.308	-	3	14	12/17	.707
10	3	7	6/10	.60	14	3	11	10/14	.7142	-	4	13	8/17	.471
11	2	9	10/11	.90909	-	5	9	6/14	.4285	-	5	12	14/17	.824
-	3	8	8/11	.7272	15	2	13	14/15	.933	-	6	11	6/17	.353
-	4	7	6/11	.5454	-	4	11	8/15	.533	-	7	10	10/17	.588
-	5	6	4/11	.3636	$C^1 = 2K \pm C^1_{MIN}$ where K is any integer			-	-	-	8	9	4/17	.2353



# The **AMPERITE**

## ACOUSTIC COMPENSATOR

*gives you*

## HIGH OR LOW PITCH

WITH THE SAME MICROPHONE

**BIGGER PROFITS** To be ahead of competition, and realize a larger profit on each job, you must offer added value in new features. Realizing this, *Amperite* gives you *The Acoustic Compensator . . . at no extra cost to you!*

This is an exclusive feature which enables you to (1) lower or raise the response of the microphone; (2) adjust for close talking or distant pickup; (3) adapt microphone to varied conditions.

### THESE 4 MODELS HAVE THE ACOUSTIC COMPENSATOR

**MODEL RBHk** (hi-imp); **RBMk** (200 ohms) Frequency range 40 to 11000 CPS. Output -65 db. . . . Chrome or Gunmetal . . \$42.00 LIST

**NEW! MODEL RSHk** (hi-imp); **RBSk** (200 ohms) Frequency range 60 to 8000 CPS. Output -68 db. . . . Chrome or Gunmetal . . \$32.00 LIST

All of the above are complete with Acoustic Compensator, Switch, Cable Connector, and cable.

NOTE: Roth Sound Service writes. . . "Your mikes are certainly rugged. I've used them in rain, wind, and on the hottest days, but they've always stood up perfectly".

PUSH UP TO INCREASE HIGHS; PUSH DOWN TO INCREASE LOWS

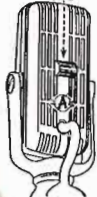

### IMPROVES ANY "LOW-COST" INSTALLATION ON 4 COUNTS!

P.A. Men, you can improve those "price" jobs by using the popular *Amperite* Model **RAH** (or **RAL**). You will get better results because: (1) it is excellent for both speech and music; (2) has flat response without undesirable peaks; (3) reduces feedback; (4) stands up under rain, wind, heat, and rough handling . . . Frequency range 60 to 7500 CPS. Output -68 db. **MODEL RAH** (hi-imp); with 12' of cable; **MODEL RAL** (200 ohms) with 8' of cable. . . . \$22.00 LIST

### MAKE EXTRA SALES WITH CONTACT MIKES...\$12.00 LIST

Professional and amateur musicians are delighted with the *Amperite* Contact Microphone. It "makes an ordinary violin sound like a Strad" . . . gives a small piano the tone of a grand. And yet, there is no distortion. No unnatural effects. No "fingering noises" . . . Frequency response 40 to 9000 CPS. Output -40 db. 20' of cable.

Models listed below can be used on most radio sets since 1935 and on all P.A. Systems. They operate with either high or low gain amplifiers. Installation is simple . . . no changes in strings or instruments . . . attached without tools.

- MODEL SKH** (Hi-imp); **SKL** (200 ohms) \$12.00 LIST
- SKH** or **SKL** with foot-operated volume control . . . . . \$20.00 LIST
- Professional Model KTH** (or **KTL**) . . . . . \$22.00 LIST

### A COMPACT VELOCITY for hand or stand

Though only a little larger than a match box, this *Amperite* Velocity has the features of the larger microphones. Good for speech and music. Designed for use on stand, but also makes an excellent hand microphone with comfortable pistol grip.

Frequency response 60 to 7500 CPS. Output -70 db. Complete with switch, cable connector, and 25' of cable.

- MODEL ACH** (hi-imp); or **ACL** (200 ohms) . . . . . \$25.00 LIST



*Sales Aids for the P. A. Man* *Amperite* offers the following co-operation to P.A. Men.

- (1.) FREE Window Decal advertising your Sound Service, Size 5 1/4 x 9 1/4, finished in 4 striking colors.
- (2.) FREE Window Display, 11 x 17.
- (3.) Special Sound Equipment Letterheads. Samples and prices on request.
- (4.) FREE use of cut for printing business cards, etc.

Write for these valuable sales helps, and new Illustrated Bulletins, today!

**AMPERITE Co.** 561 BROADWAY, N. Y. U. S. A. CABLE ADDRESS ALKEM, NEW YORK

*"Better Systems Specify Amperite"*



VELOCITY **AMPERITE** MICROPHONES





# AEROVOX CAPACITY and RESISTANCE Bridge

## What It Does . . .

This instrument not only provides for the widest range of capacitance and resistance tests, but it also offers a choice of measuring devices for other purposes, as follows:

### CAPACITY BRIDGE

Measures capacity 100 mmfd. (.0001) to 100 mfd. in 6 ranges; leakage; power factor to 50%, etc., of condensers *under actual working conditions.*

### RESISTANCE BRIDGE

Measures resistance values of resistors, and electrical equipment and circuits. 10 ohms to 1 meg-ohm in 5 ranges.

### INSULATION RESISTANCE

Measures this important factor in condensers and other devices. Meter is calibrated directly in megohms. Reads up to 10,000 megohms.

### VACUUM-TUBE VOLTMETER

Consists of amplifier stage and grid-leak detector. Measures minute values 0-2 volts.

### VOLTMETER

Available for voltage readings. 0-60 v., 0-300 v., 0-600 v. at 1,000 ohms per volt. *May be used externally.*

### MILLIVOLTMETER

Meter terminals brought out directly. Range: 60 mv. at 60 ohms or 1 ma. *Can be used with external shunts.*

### MILLIAMMETER

Meter can be read in milliamperes. 0-6 ma., 0-60 ma. *May be used externally.*

### VARIABLE POWER SUPPLY

Available directly at terminals. 15 to 600 volts *continuously variable over entire range.*

- As leading manufacturers of good condensers, AEROVOX has deemed it necessary to evolve a more critical and conclusive yardstick of condenser quality. Originally developed for its own laboratory use, the AEROVOX Capacity and Resistance Bridge has been redesigned into a simplified, portable instrument for use by all radio workers. A sufficiently large production schedule has brought the cost down to well within the reach of the serious radio man.
- Regardless what test equipment you may already have, this is one instrument you cannot afford to be without, if you must really *know* condensers.
- Literature on request.
- Your local AEROVOX jobber can show and demonstrate this instrument.



## AEROVOX CORPORATION

70 WASHINGTON STREET, BROOKLYN, N. Y.

Sales Offices in All Principal Cities





## LIST OF ILLUSTRATIONS

Figure	Description	w	d	T	Form Dia.	C <sup>1</sup>	N <sub>1</sub>	N <sub>2</sub>	M <sub>1</sub>	M <sub>2</sub>	Δ <sub>1</sub>	Δ <sub>2</sub>	Gears
1	-Δ Support	.011	.0083	.140	7/8	3.860	1				-.14		75/40 × 72/70
2	+Δ Support	.011	.0083	.125	7/8	4.190	1				+.19		90/43 × 1/1
3	Type 2 Pattern	.011	.0055	.125	7/8	2.912	2				-.088		116/80 × 1/1
4	Linear Pattern	.011	.0055	.100	7/8	3 <sup>3</sup> /7	3	4	7		+0.095	-.071	120/70 × 1/1
5	Linear Pattern N <sub>2</sub> = 2N <sub>1</sub>	.011	.004	.156	7/8	3.40	3	7	10		+0.067	-.028	119/70 × 1/1
6	Spiral Composite	.010	.00278	.165	3/8	1.5336	4	9			+0.034	-.022	70/72 × 71/90
7	M <sub>2</sub> Pattern	.010	.004	.125	7/8	3 <sup>5</sup> /13	3	7		13	+0.052	-.043	88/52 × 1/1
8	M <sub>2</sub> I.F. Transformer	.010	.00278	.156	3/8	1 <sup>9</sup> /17	4	9		17	+0.029	-.026	52/119 × 70/40

$$M_2 = M_1 + N_1$$

$$C_{2(MIN)}^1 = \frac{C_{1(MIN)}^1 M_1 + 2k}{M_1 + N_1}$$

where k is that integer which makes C<sub>2</sub><sup>1</sup> nearest C<sub>1</sub><sup>1</sup>, where C<sub>2</sub><sup>1</sup> and C<sub>1</sub><sup>1</sup> are the proper value of crosses per turn of M<sub>2</sub> and M<sub>1</sub> patterns respectively. As pointed out above, values should preferably be so chosen that N<sub>2</sub> is slightly greater than 2N<sub>1</sub>. Fig. 7 illustrates an M<sub>2</sub> pattern.

(i) An M<sub>2</sub> pattern i-f transformer design—An illustration is given in Fig. 8 of an M pattern coil which is suitable for use as an i-f transformer for 460 kc. The Q of this coil is 134 compared to 129 obtained with the same size wire wound into a 4 pi universal coil such as is often used.

### CONDENSED DESIGN PROCEDURE

(1) Instructions for designing simple coils (w/d < 2).

(a) Calculate the throw from the following formula:

$$T = 4w \frac{w}{d}$$

(b) Calculate the preferred value of C and N

$$C = \frac{P}{7T}$$

Choose the nearest integer to the above value for C. If this integer is even, N = 1; if odd, N = 2.

(c) Substitute the above values for T and N in the following equation to obtain Δ.

$$\Delta = \frac{w + Nd}{NT}$$

Then

$$C^1 = C \pm \Delta.$$

(d) The gears are so chosen that the ratio of revolutions of the cam (which governs the throw) to the winding mandril is C<sup>1</sup>/2. Detailed instructions for the choice of gears is given in the Ap-

pendix. If the accurate value desired cannot be obtained, due to lack of proper gears an approximate value may be chosen and T recalculated according to the following equation:

$$T = \frac{w + Nd}{N \Delta}$$

(Use the value of Δ determined by the gear train actually used.)

(2) Instructions for designing linear composite coils (w/d > 2).

(a) The formula for the minimum usable throw is the same as for the simple patterns.

$$T = 4w \frac{w}{d}$$

(b) The formula for the preferred value of C is the same as for simple coils.

$$C = \frac{P}{7T}$$

However, the value used need not be integral.

(c) The preferred value of M<sub>1</sub> is found from the formula

$$M_1 = \frac{w}{d}$$

(d) Table I is then searched for the values of C<sup>1</sup> and M<sub>1</sub> which come closest to the above values.

(e) The calculation of gears is the same as for simple coils. See Appendix for details.

(f) The throw is recalculated by the formula:

$$T = (w + N_2 d) \frac{M_1}{2}$$

(3) Instructions for spiral composite patterns.

If the improved appearance of the linear pattern is not considered important the non-linear composite should be used as it gives perfect support for both forward and backward excursions.

(a) Calculate all values as for a linear pattern.

(b) Solve the following simultaneous equations for Δ<sub>1</sub> and Δ<sub>2</sub>.

$$\frac{\Delta_2}{\Delta_1} = \frac{N_1}{N_2} = \frac{w + N_2 d}{w + N_1 d}$$

$$\Delta_1 + \Delta_2 = \pm (C_1 - C_2)$$

where C<sub>1</sub> is the nearest (mixed number) number of crosses per turn which would cause a repetition of phase in N<sub>1</sub> turns, C<sub>2</sub> is the nearest mixed number causing repetition in N<sub>2</sub> turns.

Then

$$C^1 = C_1 + \Delta_1 = C_2 - \Delta_2$$

(unless C<sub>1</sub> > C<sub>2</sub> in which case the signs are reversed).

(c) Recalculate the throw

$$T = \frac{w + N_1 d}{N_1 \Delta_1} = \frac{w + N_2 d}{N_2 \Delta_2}$$

(d) If above value exceed the following:

$$T = \frac{M d - w}{M \Delta_M}$$

then the coil is impractical and something else should be tried. This is seldom a limitation.

(e) Recalculate the gears.

(4) Design of M<sub>2</sub> Coils.

The relative values of M<sub>2</sub> and M<sub>1</sub> patterns have not been completely determined. It is probably best to try both types to determine which is best suited to the particular problem.

(a) Solve for C<sub>1</sub><sup>1</sup> as in M<sub>1</sub> pattern, preferably choosing N<sub>1</sub> slightly less than

$$\frac{N_2}{2}$$

(b) Solve for C<sub>2</sub><sup>1</sup> as follows:

$$C_{2(MIN)}^1 = \frac{C_{1(MIN)}^1 M_1 + 2k}{M_1 + N_1}$$

where k is that integer which makes C<sub>2</sub><sup>1</sup> nearest C<sub>1</sub><sup>1</sup>.

(Continued on page 50)

# COUPLING NETWORKS\*

## Part I

By **W. L. EVERITT**

Professor of Electrical Engineering  
OHIO STATE UNIVERSITY

### GENERAL REQUIREMENTS

ONE OF THE fundamental problems of electrical engineering appears when a generator or supply network is to deliver power to a load or utilizing network, and the power which is to be delivered must be set at some fixed value. It is usually the case that the impedance of the load will not be the proper value to absorb the desired power from the generator when a direct connection is made between the two elements. Assuming that the generator is capable of delivering the desired power, a coupling or four-terminal network is then required whose characteristics are such that when one pair of terminals is connected to the generator and another pair of terminals is connected to the load, the desired power will be delivered to the load.

Coupling networks may be classified in many ways and there will be occasion to make these classifications from time to time. One classification which might be made is:

- (A) Coupling networks which dissipate power
- (B) Coupling networks which do not dissipate power.

An objection can be raised to this classification as all physical networks dissipate power. The classification is made on the basis of design rather than complete realization. In Group A, the design intentionally includes dissipative elements. Examples of this group are pads and attenuation equalizers. They are usually used at low power levels where efficiency is not important, and at audio frequencies. Group B networks are designed on the basis of pure reactances and the structure which results is then examined to determine to what extent a network using realizable reactances will depart from the ideal. It is this group which will be discussed in this paper.

The principle of the use of reactance networks is that when a four-terminal network containing only reactances has a load connected to one pair of terminals, then the impedance measured at the other pair of terminals will, in general, be different. However, since the network cannot dissipate power, any power delivered to the input terminals must be transferred to the load to be dissipated. By proper design the input impedance of the network at one pair of terminals, when terminated at the other pair in a dissipative load, can be made anything desired, and so any power which the generator is capable of delivering can be absorbed from the generator and in turn transferred to the load.

It should be recognized that an impedance-transforming network does not necessarily make the impedance presented to the generator equal to that of the generator's even when maximum power is desired. Every generator has a load which will absorb the maximum power which

it is capable of delivering, but this capability may be limited by other considerations than its open-circuited voltage and internal impedance. For instance one of the most common limitations is the effect of the load upon the heat dissipation in the generator. This is particularly true of rotating machines and Class B or C radio-frequency amplifiers. The determination of the required load impedance is outside the province of this paper. It will be assumed that the impedance which should be presented to the generator is known and the purpose of the coupling network is to present such an impedance at one pair of terminals when the actual load is connected to the other pair of terminals.

It is useful in designing the network under these conditions to assume a generator whose impedance is the conjugate of the impedance to be presented to the actual generator and then make a design which will produce a conjugate match at the input terminals. (The conjugate of an impedance is another impedance whose resistance is equal to and whose reactance is opposite to that of the first impedance. A conjugate match occurs whenever the impedances looking in opposite directions, at a two-terminal junction, are conjugate to each other.) This assumption is useful because of the following theorem:

*Theorem: If a group of four-terminal networks containing only pure reactances are arranged in tandem to connect a generator to a load, then if at any junction there is a conjugate match of impedances, there will be a conjugate match of impedances at every other junction in the system.*

This theorem is illustrated in Fig. 1. The proof is simple. If there is a conjugate match at any pair of terminals, say B-B', then the maximum possible power is being transferred from the network on the left to the network on the right. If there should not be a conjugate match at some other pair of terminals, say C-C' then a proper modification of the network to the right would cause a greater amount of power to be transferred to it. But since the networks do not dissipate power this would require that a greater amount of power should be transferred across the terminals B-B'. Since this is impossible the assumption that there is not a conjugate match at the terminals C-C' is erroneous and so such a match must exist.

This theorem is useful because it shows that in a sequence of reactance networks, an adjustment can be made in any one of the networks so as to present the proper impedance at the junctions A-A'. Such a sequence ordinarily exists in coupling a radio transmitter to an antenna. One network would be placed at the base of the antenna, a transmission line would constitute a second network, and a third coupling network is used between the transmitter and the line. A change in adjustment at one point may be compensated for by an

\*Presented before the Broadcast Engineering Conference at The Ohio State University, February 7-18, 1938.



adjustment at another point. The only matter which must be investigated is whether the losses due to the physical nature of the actual elements will increase unduly by such changes and it can be shown that the loss does not increase appreciably for small mismatches of a transmission line.

### TWO-ELEMENT OR L NETWORKS

The basic networks for changing impedances may be designed to change a resistive load into another pure resistance. These basic networks may then be modified easily to take care of loads containing reactive components. The simplest case would be to shunt the load with a reactance as shown in Fig. 2-a. The input impedance would then be

$$Z_{in} = \frac{j R_1 X_1}{R_1 + j X_1} = \frac{R_1 X_1^2}{R_1^2 + X_1^2} + \frac{j R_1^2 X_1}{R_1^2 + X_1^2} \quad \dots \dots \dots (1)$$

The input resistance is now a lower value than  $R_1$  by the ratio  $\frac{X_1^2}{R_1^2 + X_1^2}$  and there is a reactive component

to the input impedance. This reactive component could be neutralized by a series element  $X_2$  shown in Fig. 2-b if it has the value

$$X_2 = - \frac{R_1^2 X_1}{R_1^2 + X_1^2} \quad \dots \dots \dots (2)$$

Hence the two-element network of Fig. 2-b can be used to change any resistance  $R_1$  into a lower value  $R_2$  by a proper selection of  $X_1$  and  $X_2$ .

If a generator with a resistance  $R_2$  is connected at the terminals 3-4 there will be a conjugate match. Hence there must also be a conjugate match at the terminals 1-2. This shows that the network can be used to transform resistance in either direction. For instance, if the same values of  $R_2$ ,  $X_1$  and  $X_2$  are used in Fig. 3 as in Fig. 2-b, then the impedance looking into the terminals 1-2 will be equal to  $R_1$ . It will be observed that Fig. 3 is a simple anti-resonant circuit.

From equation (1)

$$R_2 = \frac{R_1 X_1^2}{R_1^2 + X_1^2} \quad \dots \dots \dots (3)$$

The value of  $X_1$  for either Fig. 2-b or Fig. 3 can be solved from eq. (3).

$$X_1 = \pm \frac{R_1 R_2}{\sqrt{R_1 R_2 - R_2^2}} \quad \dots \dots \dots (4)$$

If this is substituted in eq. (2) the corresponding expression for  $X_2$  becomes

$$X_2 = \mp \sqrt{R_1 R_2 - R_2^2} \quad \dots \dots \dots (5)$$

If  $R_1$  is very much larger than  $R_2$  (say 100 times) then a simple approximation is

$$X_1 \approx X_2 \approx \sqrt{R_1 R_2} \quad \dots \dots \dots (6)$$

Fig. 1. Circuit used for illustrating theorem on opposite page.

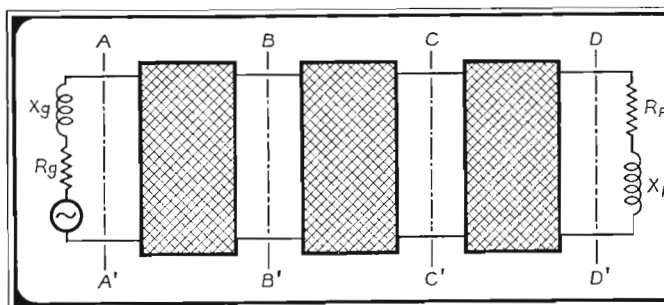

### COUPLING NETWORK FEATURES

The two-element structure is the simplest and most efficient type of impedance-transforming network. However more complicated structures are frequently used. This is because the coupling network can be used to provide other features in addition to its impedance-transforming function. Usually these extra functions determine the actual configuration of the network. In purchasing an automobile the average man makes his selection not on the basis of the engine, the most important feature, but takes into consideration the accessories which are provided. This is justified because of the uniform high quality of the fundamental design of cars on the market. Similarly coupling-network configurations may be selected because of the auxiliary functions which they can perform in addition to impedance transformation.

In general, for each additional function which is to be performed, at least one additional network element must be included. Some of the functions which can be performed by a reactance network in addition to impedance transformation are

- (1) Phase shift between generator voltage and load current
- (2) Discrimination against unwanted frequencies
- (3) Elimination of undesirable coupling due to the presence of a third conductor such as the ground.

As the functions of a network increase, the need for accurate design by computation rather than cut and try methods increases. If impedance transformation only is desired, manual adjustment is frequently sufficient as there are only two variables required in the network to adjust the two components (reactance and resistance) of the impedance to be presented. If the variable elements have the proper range the adjustment can be made by changing the first variable continuously while the second is held fixed, then changing the second by a fixed amount and repeating the variation of the first and so continuing the process by modifying the second variable in increments. If three variables are present the process is much more complicated for a cut and try process, and when there are more than three variables the use of manual adjustments without computation is almost hopeless. At the same time it must be realized that most computations do not take everything into account. For instance, the distributed capacity of inductances, the capacities of all elements to ground or to shields is usually neglected. Hence after a network is computed and set up some minor adjustments must be made by cut and try processes. This means that meters must be provided to indicate when the proper conditions are achieved, and there must be at least as many indications in the meters as there are variables to be adjusted. For example, if a given impedance is to be presented to a Class C amplifier by coupling to a load, a d-c plate-current meter and a radio-frequency tank-current meter

Fig. 2. Simple circuits used to illustrate how loads may be changed.

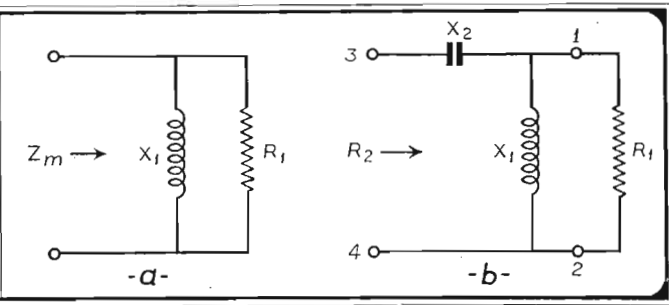

might be used since the impedance has two variables (resistance and reactance). Consider the case of Fig. 4. Imagine the typical operating conditions for the amplifier have been determined by inserting a resistor at the point marked X with the coupled network removed. Then the desired power would be delivered to this resistor, which would not be a useful place for dissipation.

If now the useful power is to be delivered to  $R_2$ , the original dummy resistor should be removed and the coupling network introduced. By proper adjustment the coupling network can reflect the same resistance into the tank circuit as was supplied by the original dummy resistor. If the d-c meter  $A_1$  and the radio-frequency meter  $A_2$  read the same value, this will indicate that the impedance presented to the tube in the second case is the same as in the first and the power which was originally delivered to the dummy will be delivered to  $R_2$  except for any losses which are introduced due to the physical nature of the reactances used.

One meter may sometimes be used to indicate two variables. For instance the radio-frequency meter  $A_2$  might be dispensed with. If  $A_1$  reads a *minimum* as  $C_1$  is adjusted and this minimum is the same magnitude in both cases, then the fact that it is a minimum indicates that a *resistive* load is being presented to the tube, and the fact that the current is the same in both cases indicates that the same *magnitude* of resistance is being presented to the tube in both cases. Hence irrespective of the configuration of the coupling network the same power will be delivered by the tube and unless excessive losses are occurring in the network this power will be delivered efficiently to the load.

Besides the additional functions which may dictate more complicated networks for impedance transformation, another consideration which enters is the ease of adjustment. In order to adjust the network of Figs. 2-b and 3, a variable inductor and a variable condenser are required. Under certain conditions variable condensers are more convenient than variable inductors and under other conditions the reverse is true. By the use of three or more elements in the network, the two adjustable members may both be condensers or both inductors.

### THREE-ELEMENT NETWORKS

The three-element coupling network is one of the most versatile and widely used. The three elements may be arranged in either a T or a  $\pi$  section. Since there are three variables, three characteristics may be controlled, and these characteristics are respectively the resistance and reactance of the input impedance and the phase shift between the voltage at the sending end and the current at the receiving end. The control of the phase shift is of importance in a directional array where the phase relations between the currents in the antenna elements must be fixed.

Again the fundamental method of design will assume that the terminating impedance is a pure resistance and the impedance to be presented to the generator is a pure resistance. The method of design can then be made by the method of image impedances.<sup>1,2</sup> The image impedances of a network are defined as follows: For every four-terminal network there are two impedances, called image impedances, each associated with a given pair of terminals, such that if either image impedance is connected to the pair of terminals with which it is associated the input impedance at the other pair of terminals will be the image impedance associated with that pair of terminals. An example of image impedances is shown in Figs. 2b and 3 where the two values are  $R_1$  and  $R_2$ .

In addition to the two image impedances a four-terminal network has another characteristic  $\theta$ , called the image transfer constant, which is defined by the relation

$$e^\theta = \sqrt{\frac{E_1 I_1}{E_2 I_2}} \dots\dots\dots (7)$$

In the general case  $\theta$  is a complex number as the vector volt-amperes at the sending end will be shifted in both magnitude and phase by the network. However in the simple case where the network is made of pure reactances and is intended to transform one resistance into another resistance, then the volt-amperes supplied to the sending end will equal in magnitude the volt-amperes delivered to the load and the term  $e^\theta$  will represent only a shift in phase. This is equivalent to saying that  $\theta$  is a pure imaginary number.

The equations for a general T or  $\pi$  section such as those shown in Fig. 5 are as follows,<sup>1,2</sup> where  $Z_{11}$  is the image impedance associated with terminals 1-2 and  $Z_{12}$  is the image impedance associated with the terminals 3-4.

$$\text{T Section } Z_1 = \frac{Z_{11} \cosh \theta - \sqrt{Z_{11} Z_{12}}}{\sinh \theta} \dots\dots\dots (8)$$

$$Z_2 = \frac{Z_{12} \cosh \theta - \sqrt{Z_{11} Z_{12}}}{\sinh \theta} \dots\dots\dots (9)$$

$$Z_3 = \frac{\sqrt{Z_{11} Z_{12}}}{\sinh \theta} \dots\dots\dots (10)$$

$$\pi \text{ Section } Z_A = \frac{Z_{11} Z_{12} \sinh \theta}{Z_{12} \cosh \theta - \sqrt{Z_{11} Z_{12}}} \dots\dots\dots (11)$$

$$Z_B = \sqrt{Z_{11} Z_{12}} \sinh \theta \dots\dots\dots (12)$$

$$Z_C = \frac{\sqrt{Z_{11} Z_{12}} \sinh \theta}{Z_{11} \cosh \theta - \sqrt{Z_{11} Z_{12}}} \dots\dots\dots (13)$$

In the case which is being discussed  $Z_{11}$  and  $Z_{12}$  are pure resistances and  $\theta$  is a pure imaginary number.

$$\text{Let } \begin{aligned} Z_{11} &= R_1 \\ Z_{12} &= R_2 \\ \theta &= jB \end{aligned}$$

Equations 8 to 13 then reduce to

$$\text{T Section } Z_1 = -j \frac{R_1 \cos B - \sqrt{R_1 R_2}}{\sin B} \dots\dots\dots (8a)$$

$$Z_2 = -j \frac{R_2 \cos B - \sqrt{R_1 R_2}}{\sin B} \dots\dots\dots (9a)$$

$$Z_3 = \frac{-j\sqrt{R_1 R_2}}{\sin B} \dots\dots\dots (10a)$$

$$\pi \text{ Section } Z_A = j \frac{R_1 R_2 \sin B}{R_2 \cos B - \sqrt{R_1 R_2}} \dots\dots\dots (11a)$$

$$Z_B = j \sqrt{R_1 R_2} \sin B \dots\dots\dots (12a)$$

$$Z_C = \frac{j \sqrt{R_1 R_2} \sin B}{R_1 \cos B - \sqrt{R_1 R_2}} \dots\dots\dots (13a)$$

If the impedance ratio  $r$  is defined as  $r = R_1/R_2$

a certain similarity may be shown between the equations

<sup>1</sup>Everitt, W. L., "Output Networks for Radio-Frequency Power Amplifiers" *Proc. I.R.E.* Vol. 19, p. 725, 1931.  
<sup>2</sup>Everitt, W. L., "Communication Engineering" 2nd ed., McGraw Hill Book Co.



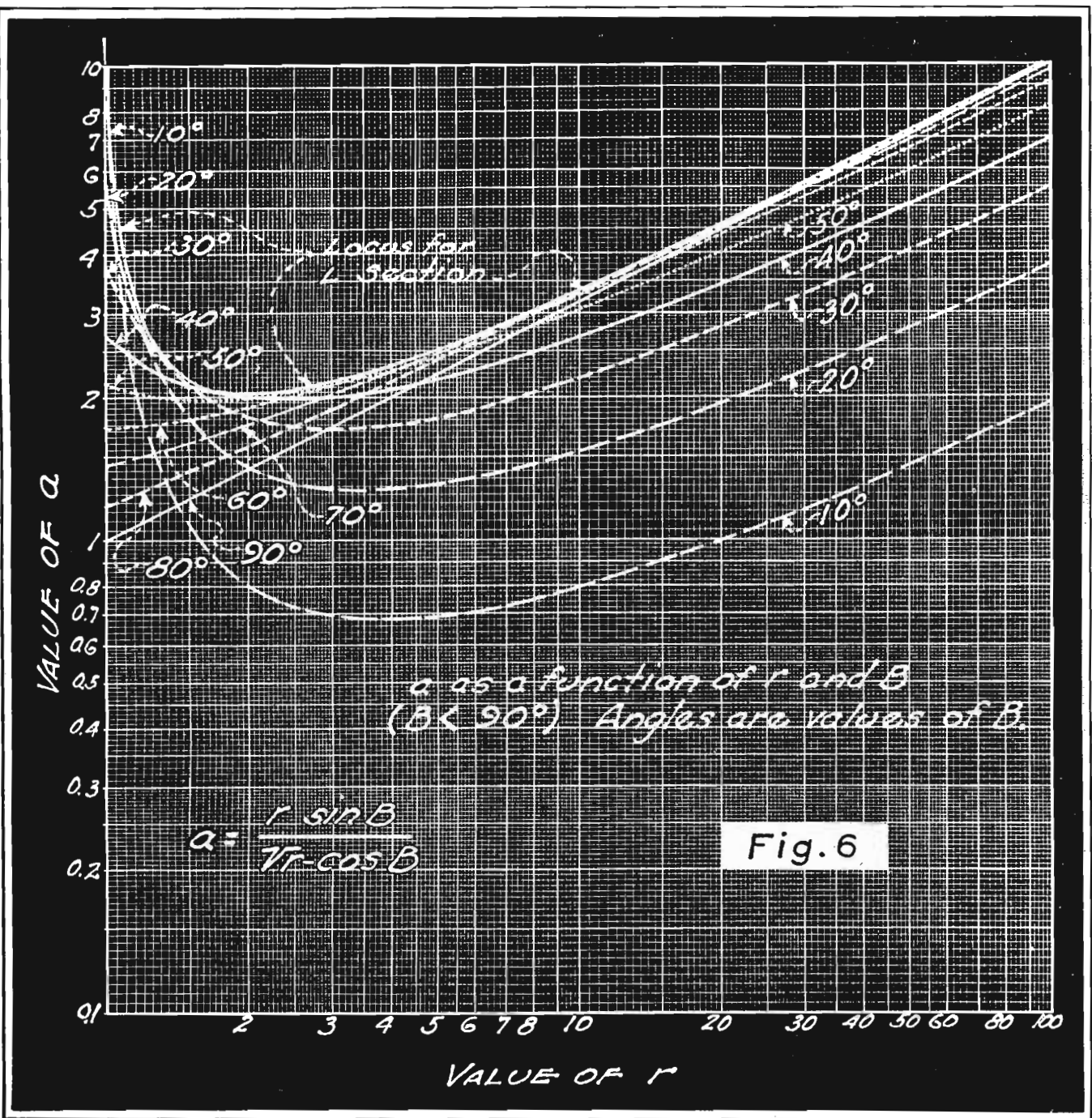
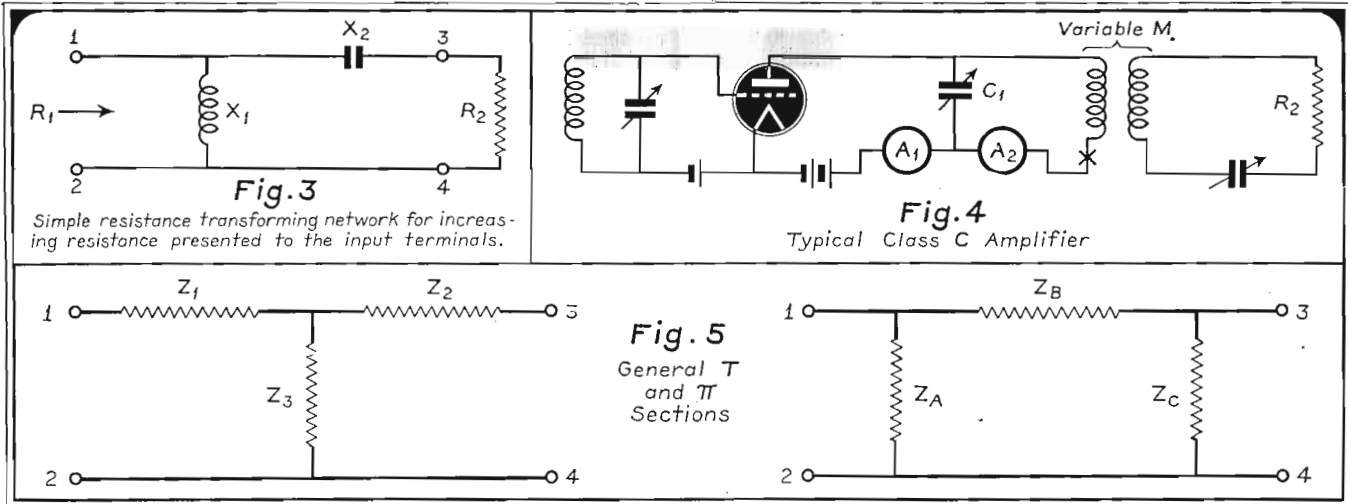

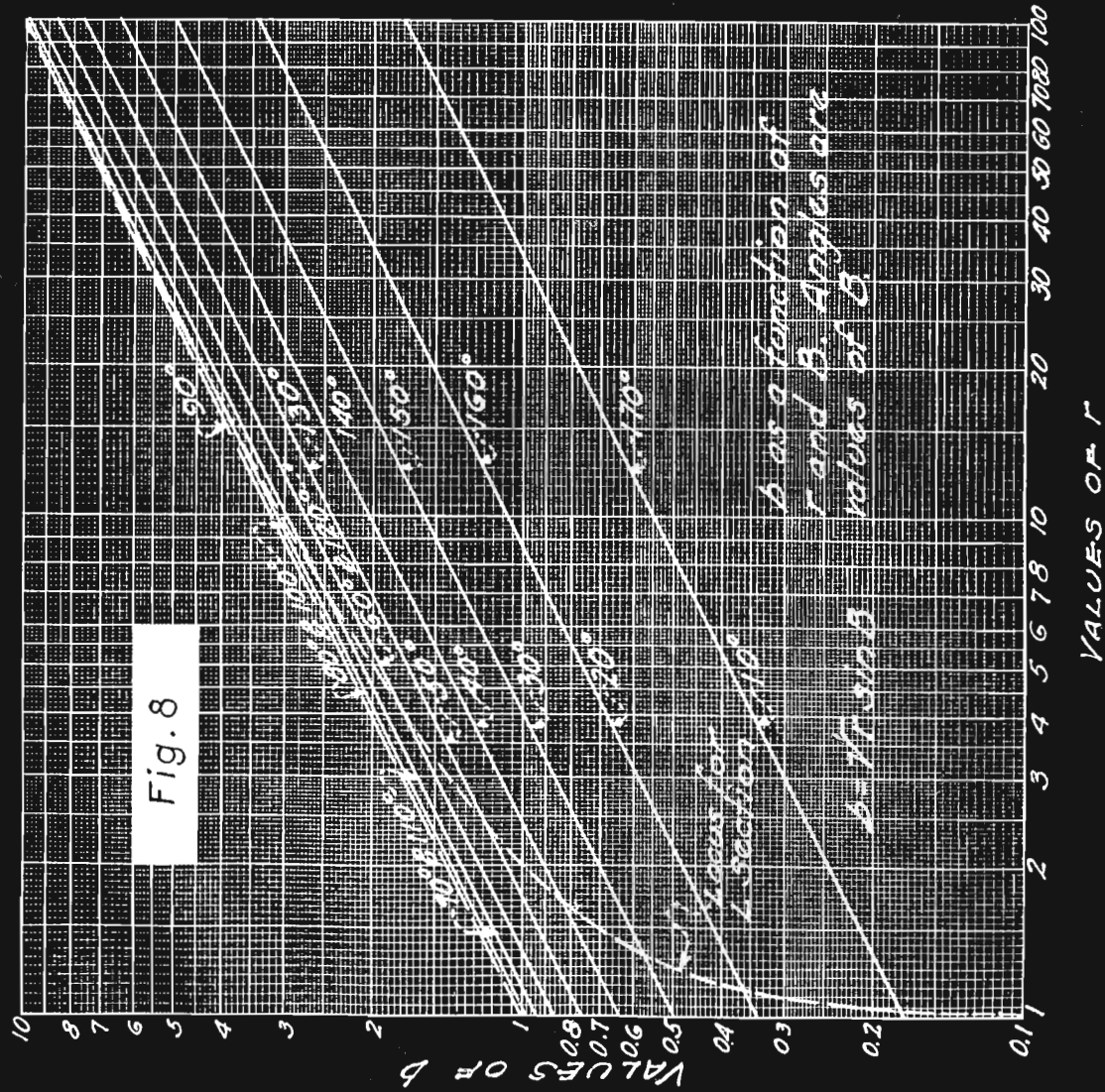
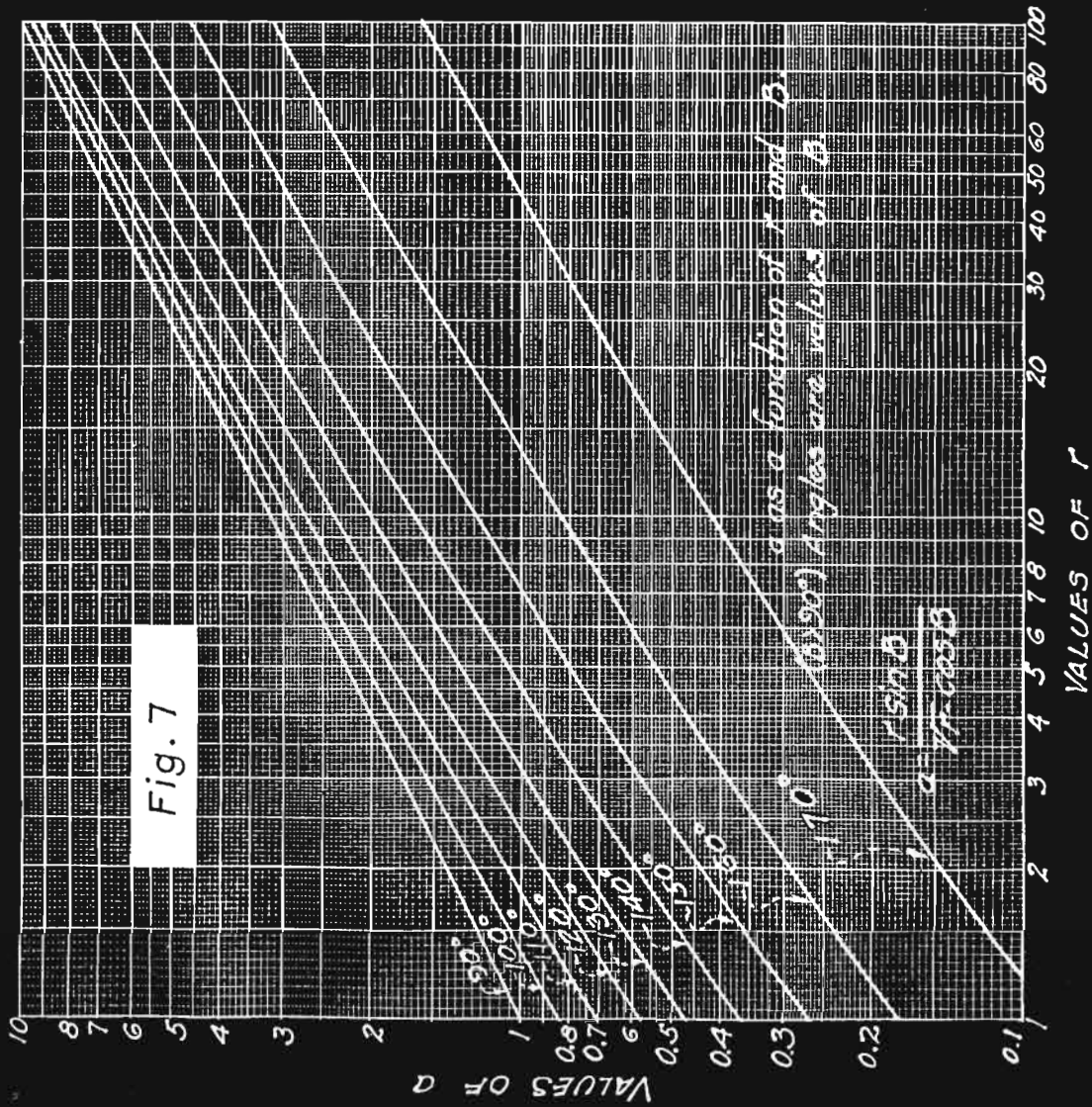



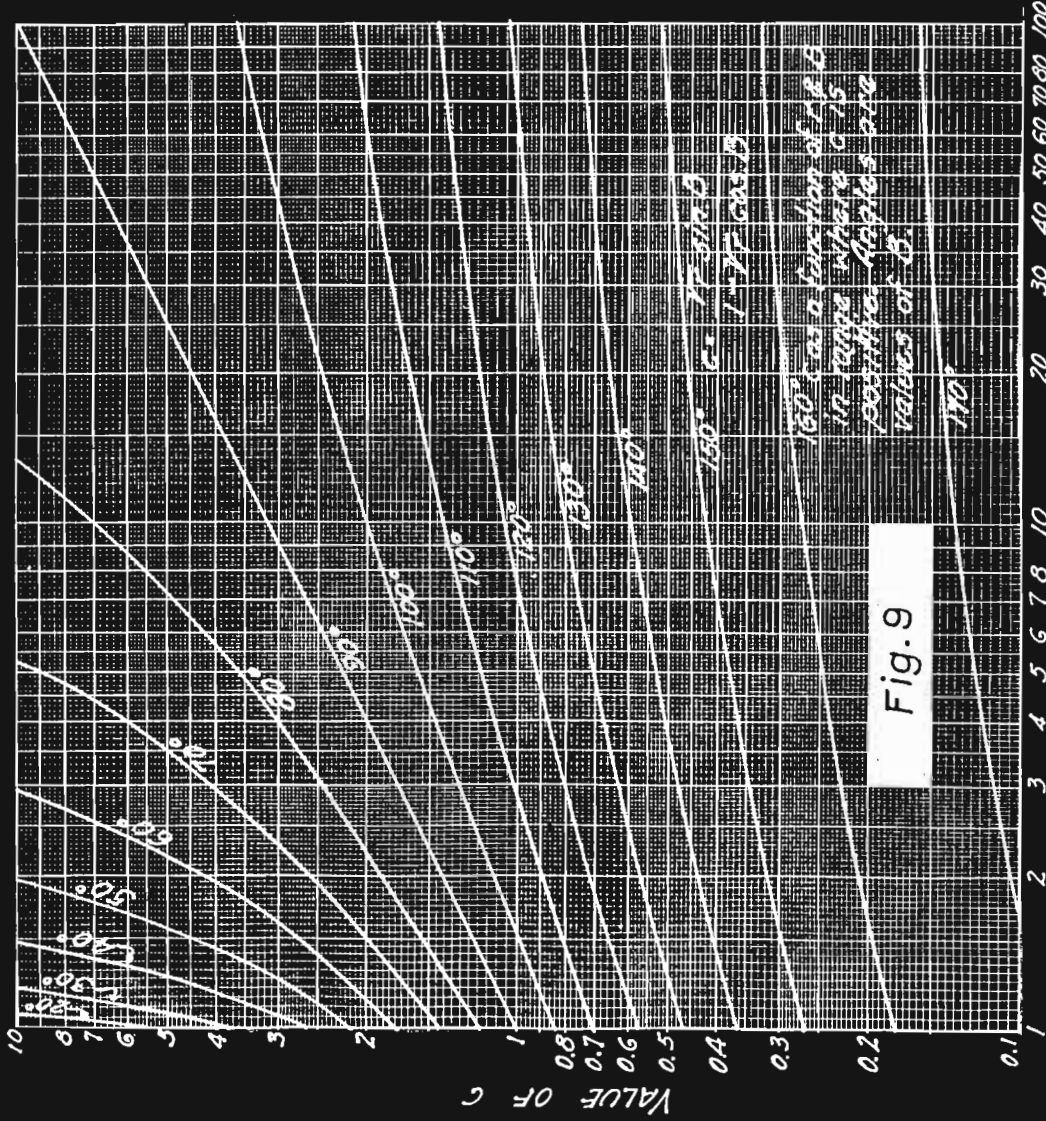

VALUE OF  $r$

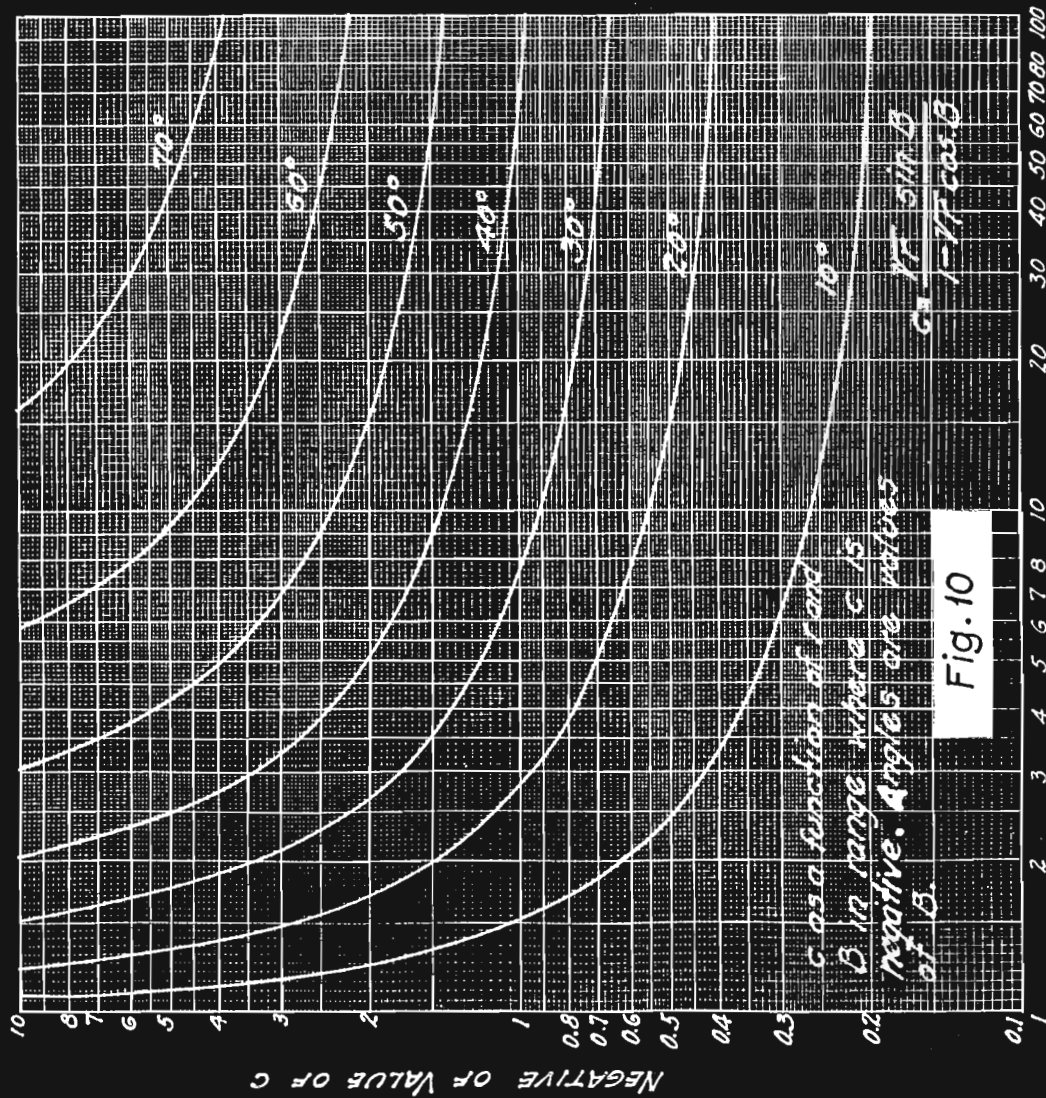

VALUE OF  $r$

for the elements of the T and  $\pi$  sections. Equations (8a) to (13a) may be written

$$\text{T Section } Z_1 = jR_1 \frac{(1 - \sqrt{r} \cos B)}{\sqrt{r} \sin B} \dots\dots\dots (8b)$$

$$Z_2 = jR_1 \frac{(\sqrt{r} - \cos B)}{r \sin B} \dots\dots\dots (9b)$$

$$Z_3 = \frac{-jR_1}{\sqrt{r} \sin B} \dots\dots\dots (10b)$$

$$\pi \text{ Section } Z_A = -jR_2 \frac{r \sin B}{\sqrt{r} - \cos B} \dots\dots\dots (11b)$$

$$Z_B = jR_2 \frac{\sqrt{r} \sin B}{\sqrt{r} \sin B} \dots\dots\dots (12b)$$

$$Z_C = -jR_2 \frac{1 - \sqrt{r} \cos B}{1 - \sqrt{r} \cos B} \dots\dots\dots (13b)$$

If now the following functions are defined

$$a = \frac{r \sin B}{\sqrt{r} - \cos B} \dots\dots\dots (14)$$

The functions given by Eqs. (14), (15) and (16) have been plotted and are shown in Figs. 6, 7, 8, 9, and 10. Only values of  $r$  greater than unity have been considered since  $R_1$  can always be considered as greater than  $R_2$ , due to the fact that the network can make a transformation in either direction. Under these conditions  $a$  and  $b$  are always positive numbers if  $B$  is a positive angle but  $c$  may be either negative or positive depending on the values of  $r$  and  $B$ . If  $B$  is a negative angle the magnitude of  $a$ ,  $b$  and  $c$  will be the same as for a positive angle but the signs will be reversed. Hence the charts of Figs. 6 to 10 may be used to design any T or  $\pi$  section for any angle of retardation or advancement up to 180 degrees. The corresponding values of reactance are shown in Fig. 11. These constitute all the three element reactance networks which may be used for the transformation of resistance. The resistance  $R_1$  is associated with the terminals 1-2 and the resistance  $R_2$  with the terminals 3-4, i.e., if a load resistance  $R_o$  is connected to 3-4 the input impedance at the terminals 1-2 will be equal to  $R_1$  and vice versa.

The chart of Fig. 8 illustrates the requirements for sufficient coupling. In the T section  $X_3$  is sometimes

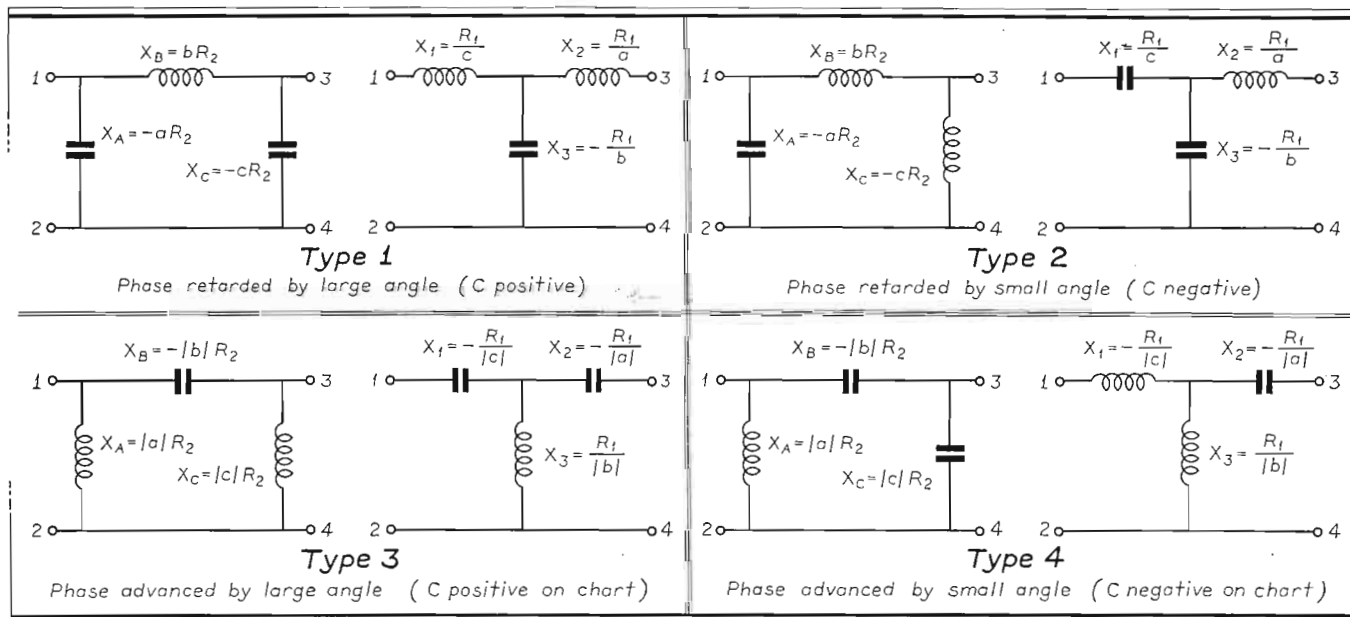

Fig. 11. The three-element reactance networks which may be used for the transformation of resistance.

$$b = \sqrt{r} \sin B \dots\dots\dots (15)$$

$$c = \frac{\sqrt{r} \sin B}{1 - \sqrt{r} \cos B} \dots\dots\dots (16)$$

Eqs. (8b) to (13b) will become

$$\text{T Section } Z_1 = \frac{j R_1}{c} \dots\dots\dots (8c)$$

$$Z_2 = \frac{j R_1}{a} \dots\dots\dots (9c)$$

$$Z_3 = \frac{R_1}{j b} \dots\dots\dots (10c)$$

$$\pi \text{ Section } Z_A = \frac{a R_2}{j} \dots\dots\dots (11c)$$

$$Z_B = j b R_2 \dots\dots\dots (12c)$$

$$Z_C = \frac{c R_2}{j} \dots\dots\dots (13c)$$

called the mutual reactance. In Fig. 8 it is seen that there is a maximum value of  $b$  for each value of  $r$ . Since  $|X_3| = R_1/b$  there is a minimum value of reactance. Any value of  $b$  less than this maximum or value of  $|X_3|$  greater than this minimum may be used to obtain the desired impedance transformation. When  $|X_3|$  exceeds this minimum value the network is said to have sufficient coupling.

It is also apparent that  $X_B$  in the  $\pi$  network plays a role similar to that of  $X_3$  in the T network, except that in this case the term "sufficient coupling" implies that  $X_B$  is less than an allowable maximum.

In some applications one of the reactance elements has a fixed value, and the value of the other two elements must be determined. This may be done by determining the value of  $a$ ,  $b$ , or  $c$  which corresponds to the fixed element. The appropriate chart is then used to determine the corresponding phase shift for the impedance ratio desired. There will be two possible phase shifts and either may be chosen.

(Continued on page 50)



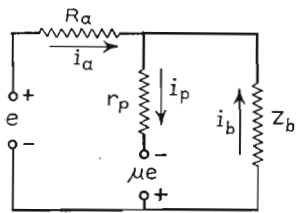

Fig. 2

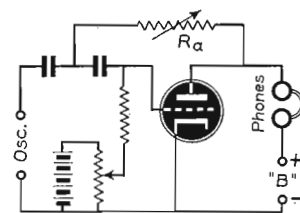

Fig. 1

# A MUTUAL CONDUCTANCE METER

By C. B. AIKEN & J. F. BELL

THERE ARE MANY circuits for measuring the mutual conductance of small high-vacuum thermionic tubes, ranging from complicated and expensive bridges down to simple tube checkers that merely indicate "good" or "bad." The cost and complexity of the former make them unsuited for certain applications, while many of the latter are not accurate enough for laboratory use. A mutual conductance meter has been developed for service in the communication laboratories at Purdue that is reasonably simple and is capable of making accurate measurements of the mutual conductance of all the standard thermionic receiver tubes.

## THE FUNDAMENTAL CIRCUIT

The simplified schematic circuit is shown in Fig. 1.<sup>1</sup> Alternating current is impressed, through blocking condensers, upon the input of the triode under test, and the variable resistance  $R_a$  is adjusted until the signal heard in the head telephones is reduced to zero. This condition of balance is obtained when

<sup>1</sup>A direct-current circuit of this sort was published by E. V. Appleton in the *Wireless World*, Vol. 6, p. 458, 1918.

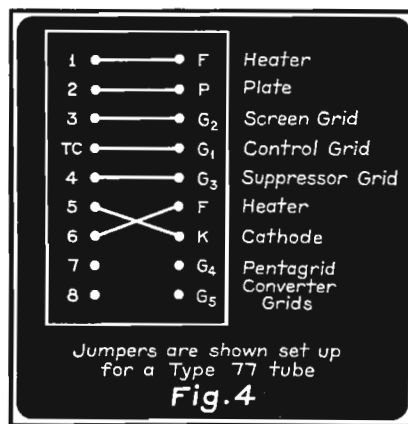

Arrangement of the jacks.

$$g_m = 1/R_a \quad (1)$$

The balance is independent of the impedance in the plate circuit of the tube and only one calibrated element is required, namely  $R_a$ . These points are of great advantage in testing a wide variety of tubes, since no special provision must be made for tubes of very high or very low plate resistance. Furthermore, the telephones can be

shunted with a low-resistance choke coil so that troubles caused by direct-current voltage drop in the plate circuit are reduced to a minimum. This is an important consideration when testing tubes that draw large amounts of current. Multi-electrode tubes can, of course, be measured with the same fundamental circuit, it being necessary merely to supply the proper voltages to the dynamically inactive electrodes.

The equivalent circuit of Fig. 1 is shown in Fig. 2 with only the alternating-current quantities indicated. The equations of this circuit are:

$$e = Z_a i_a - Z_b i_b \quad (2)$$

$$\mu e = r_p i_p + Z_b i_b \quad (3)$$

$$i_p = i_a + i_b \quad (4)$$

The solution of these equations for  $i_b$ , the current through the load impedance, gives.

$$i_b = \frac{e(\mu Z_a - r_p)}{Z_a r_p + Z_a Z_b + Z_b r_p} \quad (5)$$

from which it follows that the balance condition is that specified by (1), since  
(Continued on page 24)

Circuit diagram of the mutual conductance meter.

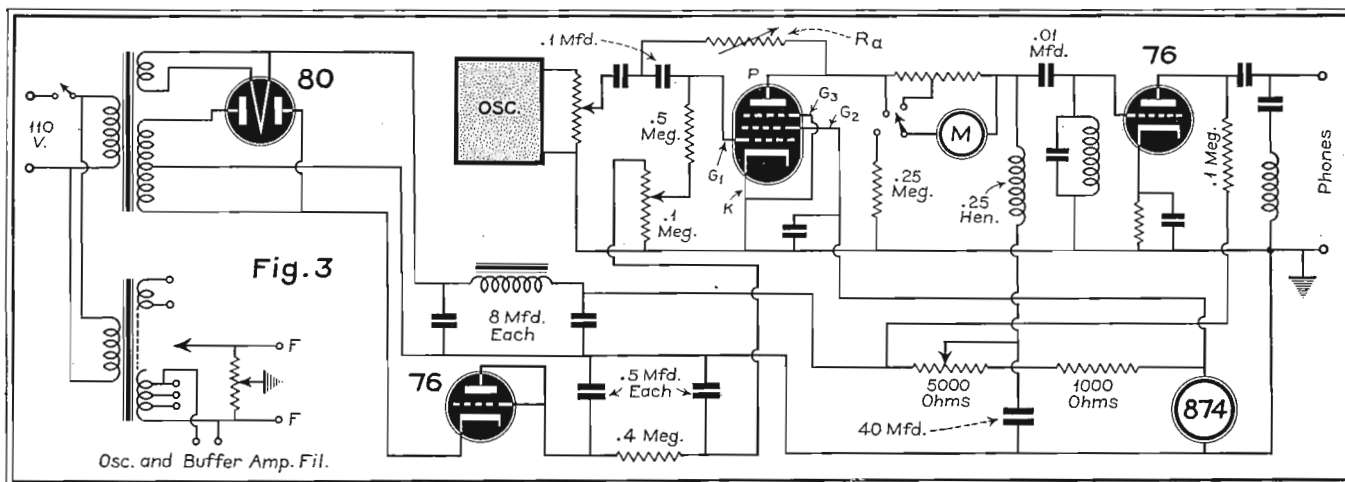

# DEVELOPMENTS

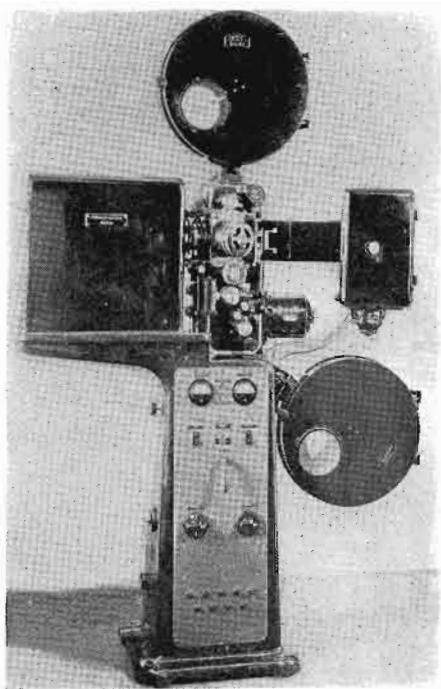

(1) A Farnsworth type disector tube film scanner as manufactured by the Fernseh A. G. It is possible to scan four pictures with this device.

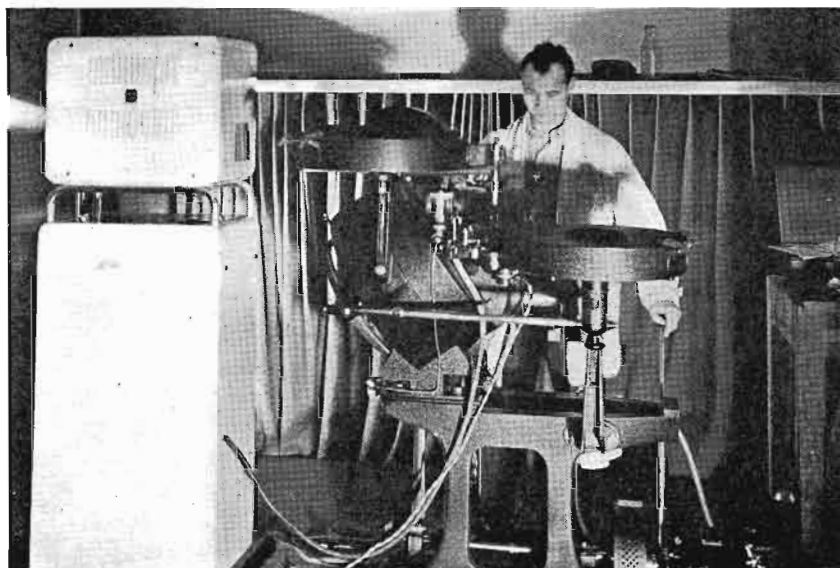

(2) The Karrelous cathode-ray tube scanner, projection type. This device, developed by Dr. Karrelous for Telefunken, produces one of the best pictures.

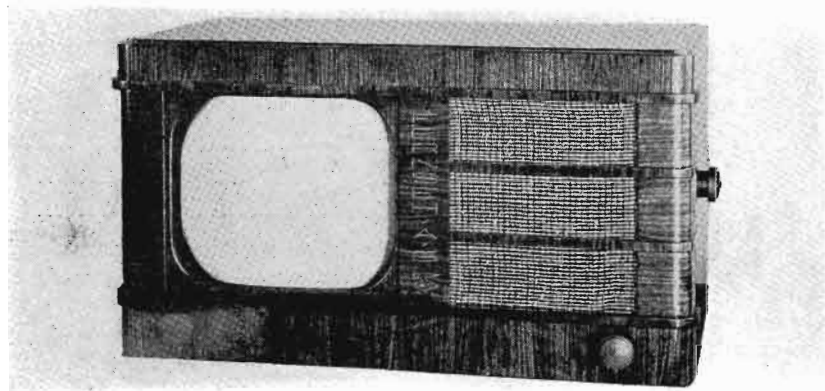

(3) A small all-wave and television receiver built by Fernseh.

With the exception of 8 and 9, the photos on this and the following page are published through the courtesy of National Union's Television Expert, Marshall P. Wilder, who recently returned from an extensive European Tour.

(4) This is a photograph of a projection television image. The photograph was made from the moving screen, not the tube end. The picture was 10 by 12 feet.

(5) Another view of receiver at (3). It is 22 inches long 14 inches deep, 12 inches high. The screen diameter of the tube is 11 inches, giving a 10 by 9 inch picture. The price is around \$200.

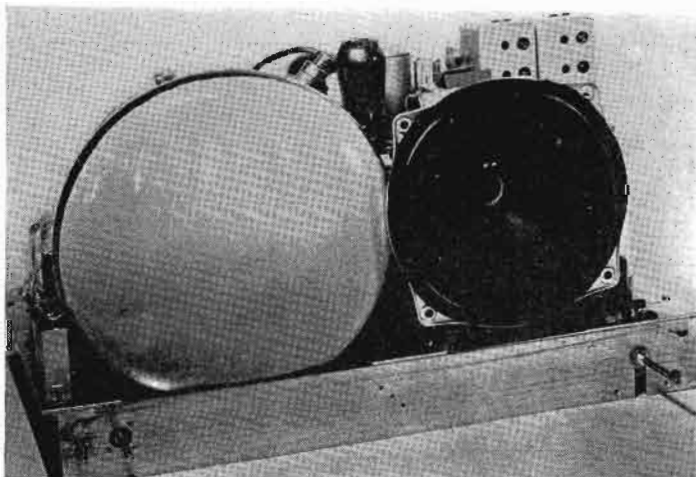



# IN TELEVISION

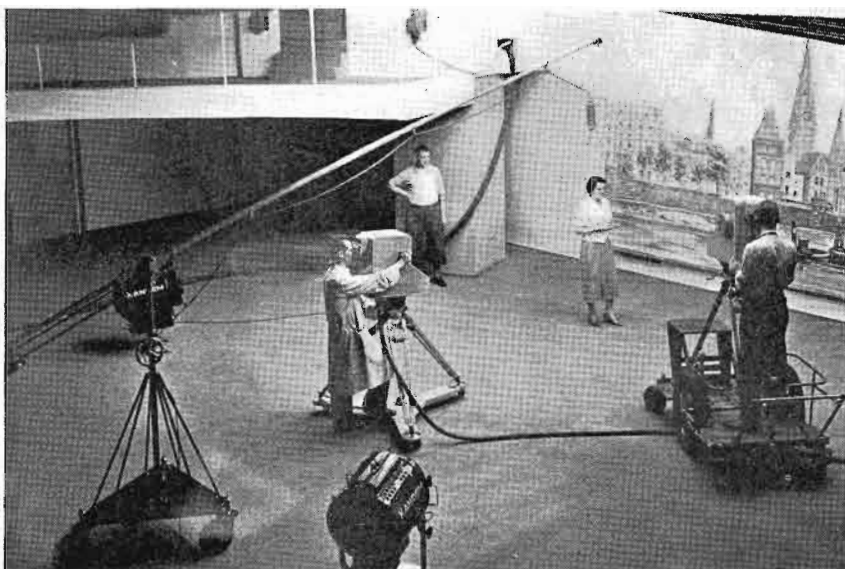

(7) Two television cameras of the storage type, manufactured by the Telefunken company, being used during the radio exhibition in Berlin for direct pickup.

(8) Recently announced in this country by the Garod Radio Corporation is a television kit for experimenters, amateurs, and service men. This receiver has been designed to conform with the RMA television standards, and is furnished complete with tubes, including the five-inch cathode-ray tube.

(9) The Garod receiver has been so designed that it can be mounted into the cabinet shown here. Normally the unit is without sound.

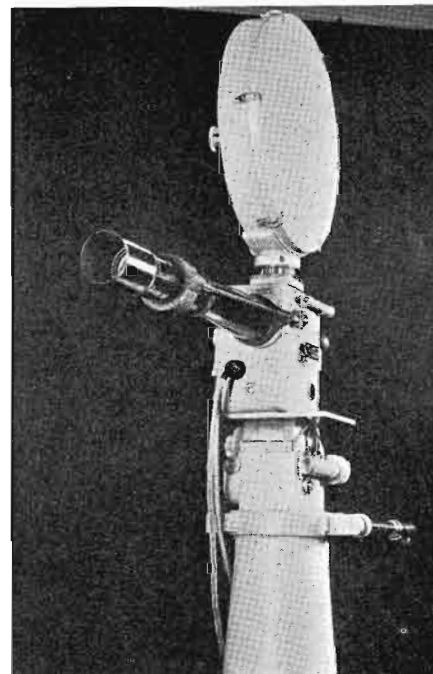

(6) A camera which uses special film that may be processed, dried, and ready for use in scanner shown in (1), eighty seconds after a photo is taken. It is manufactured by Fernseh, A. G.

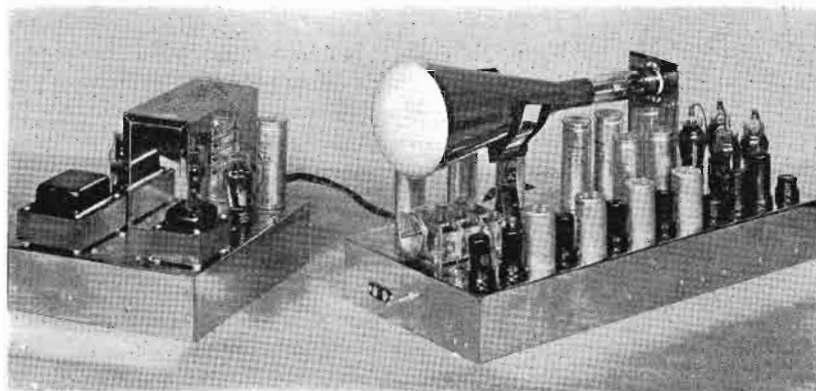

(10) Telefunken monitor unit and control table being used at the Berlin Radio Exhibition. These units generate standard synchronizing focus of the necessary sweep potential used by pickup tubes in (7).

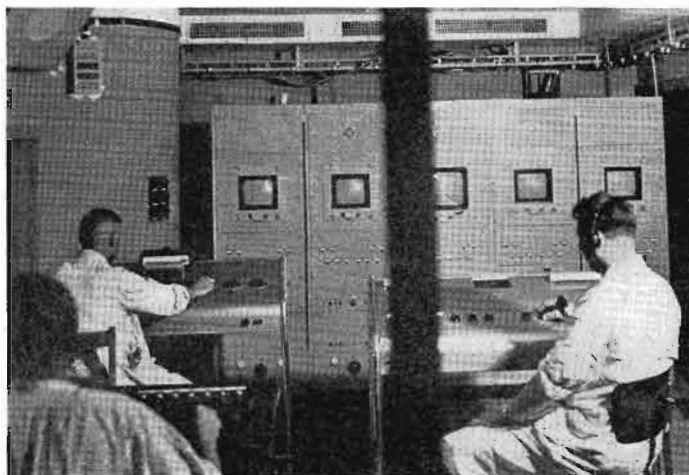

# PORTABLE FIELD

By J. V. COSMAN

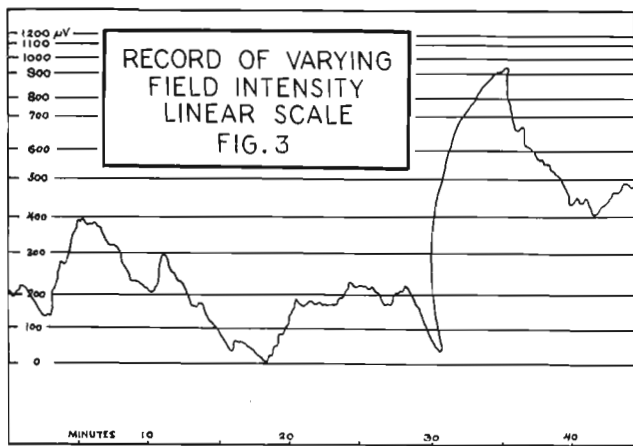

A NEW COMPLETE portable field-intensity meter has been made commercially available during the past month. Its weight, including self-contained batteries, loop and headset, is approximately 28 pounds.

The field-intensity meter is unique in a number of respects in addition to its light weight and small size. It has, for example, built-in coils with a band-change switch to cover the frequency range from 180 to 7000 kilocycles in four steps. Separate shielded loops are required for the four ranges of 180-420 kilocycles; 550-1600 kilocycles; 1550-3600 kilocycles; and from 3500 to 7000 kilocycles.

The method of measurement consists of inserting in series with a loop antenna a fixed calibrating voltage and comparing it with the induced field voltage by means of a sensitive vacuum-tube voltmeter; the latter comprises a superheterodyne receiver with a linear first detector and a resistance-type voltage attenuator connected between the detector and intermediate amplifier. A linear diode voltmeter is used to measure

the calibrating voltage, and, by throwing a switch, the same indicating meter in conjunction with a second diode measures the receiver output. In the latter usage, the voltmeter serves to span the gaps between successive steps of the voltage attenuator. The value of the calibrating voltage is automatically held within a limited range of variation by a special circuit arrangement. The set is arranged to facilitate making the output indicator reading identical with the reading of the diode voltmeter across the calibrating oscillator. In this way the value of the calibrating voltage may be lumped into a coefficient of the loop antenna, even though it varies within limits.

Fig. 1 shows a block diagram of the field intensity meter. The set ready for use is shown in Fig. 2.

One of the several important uses of a field-intensity set is for making a printed record of varying field intensities, such as, for example, fields received from distant broadcasting stations at night. In some cases the range of vari-

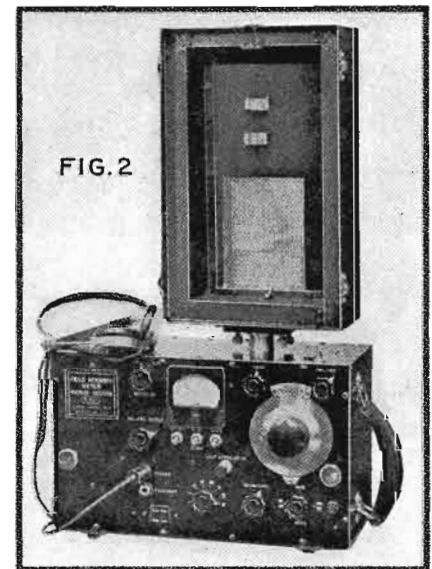

FIG. 2  
The field intensity meter set up for use.

A block diagram of the field strength measuring set.

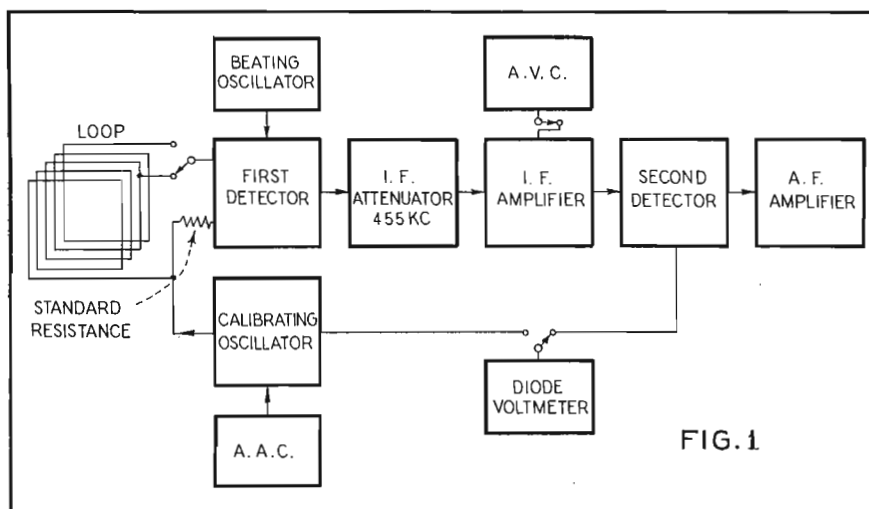

FIG. 1

ation of such received fields is less than 10 to 1, in which case a linear scale on the recording meter is desirable, while in other instances the range of field-intensity variation may be as much as 100 to 1, which requires a semi-logarithmic scale on the recording millimeter. To facilitate the making of such measurements, which are frequently utilized in broadcast practice, a jack has been provided for connection to a 500-ohm 5-milliamper recording meter such as the Esterline-Angus Model AW. A switch is provided for changing the scale of the recorder when so connected from linear to logarithmic as desired.

When the recorder switch is in the linear position the recorder current is obtained from the plate circuit of the output tube, and varies with the bias supplied by the diode element used as the second detector. When the recorder switch is in the logarithmic position, the recorder current is obtained from



# INTENSITY METER

FEDERAL TELEGRAPH CO.

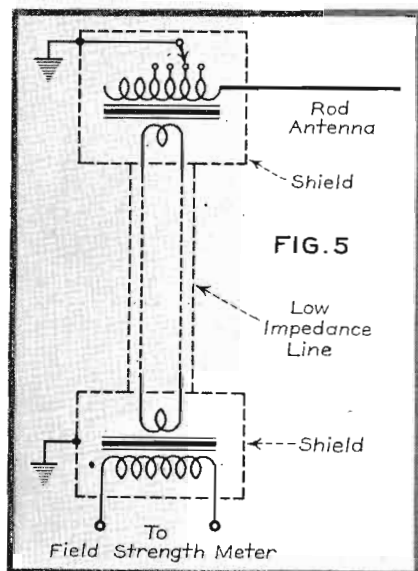

Diagram of the antenna adaptor.

the plate circuit of the first i-f tube; in this position, an avc circuit is placed in operation which causes variation of the d-c plate current in approximate logarithmic relation to the received signal intensity.

Fig. 3 shows a sample linear recording of a received varying field, while Fig. 4 shows a sample recording with the switch in the logarithmic position.

In many cases it has, in the past, been desirable to use a field-intensity meter in an automobile or an airplane in such a manner that observations could be made while the vehicle was in motion. This requirement automatically rules out the loop antenna for this use because of its directional properties, and has led to the development of an antenna adaptor to permit the use of a vertical rod antenna. A 54-inch rod antenna supported on the upper door hinge of a closed automobile has proved to be non-directional within a few percent, and to lend itself readily to making of measurements

in a moving automobile when the antenna adaptor is used. The antenna adaptor comprises two transformers, a tap switch and a shielded transmission line, as shown in Fig. 5.

Having available apparatus for measuring field intensities in a moving automobile, it is then a simple and logical step to arrange the field-intensity meter to operate a recording milliammeter which is geared to the speedometer so that the recorder chart moves about one inch per mile. The recorder seems to give the clearest record when operated with a semi-logarithmic scale which is readily obtainable as explained above. The marked variations of received field caused by overhead wires and other conductors may be clearly shown by this use, and, in many cases, the effects may be averaged by use of the continuous record operated by the speedometer connection.

The range of field intensities measurable with the Federal set is from approximately 20 microvolts per meter to about 8 volts per meter. The set may

be operated intermittently from self-contained dry A and B batteries, or, for sustained use, a vibropack may be substituted in the space otherwise occupied by the dry batteries, thus allowing the set to be operated by a single 6-volt storage battery. For automobile use a storage battery is normally used separate from the regular car battery.

Bureau of Standards certification of the obtainable accuracy of the set has indicated an accuracy within 5 percent when a fixed loop constant is used. A fixed loop constant is allowable with this set because of the use of the shielded unbalanced loop with consequent reduction of the loop error.

Also, the tuning controls are ganged so that the desired signal may be tuned in by movement of one main tuning dial. Trimmers are provided on the loop and the calibrating oscillator condensers for fine adjustment.

The unit is of relatively light weight but of sufficiently rugged construction to withstand the rough use that field intensity meters usually receive.

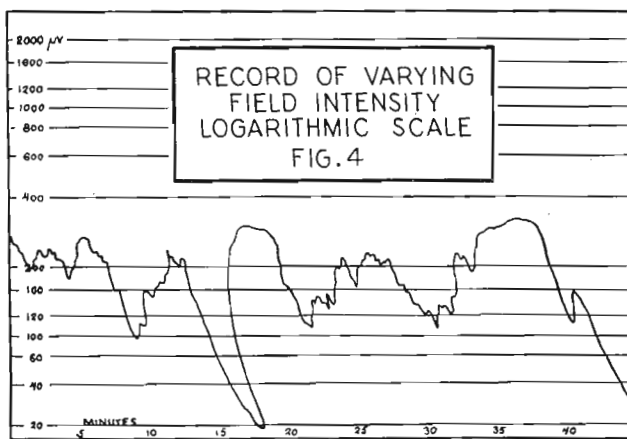

A typical record of a field measured in an automobile.

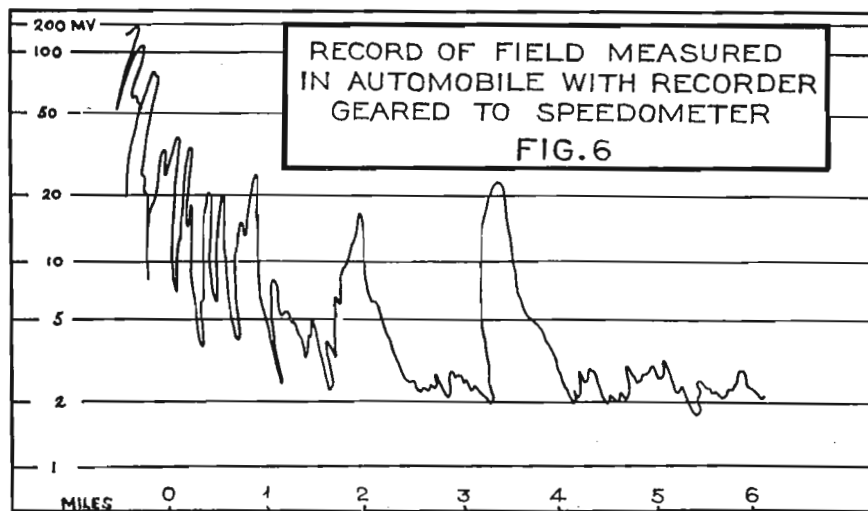

# BOOK REVIEWS

*THE RADIO ANTENNA HANDBOOK*, by the technical staff of "Radio," published by Radio, Ltd., 7460 Beverly Blvd., Los Angeles, California, second edition, stiff paper covers, 112 pages, 6" by 9", price, 75c in U. S., elsewhere 85c.

In this compilation of antenna data, emphasis is laid upon practical aspects, although the functions of the antenna and its associated equipment are discussed at some length. It has been written specifically for amateurs and others using high frequencies, and whenever possible computations are avoided through the use of tables, graphs, charts, etc.

A good idea as to the contents of the book may be gained from the following chapter heads: "Fundamentals," "Choosing an Antenna," "Feeding the Antenna," "Transmission Lines," "Harmonic Operation," "Coupling to the Transmitter," "Directive Properties of Antennas," "Directable Arrays," "U.H.F. Antennas," "Receiving Antennas," and "Supporting the Antenna."

All in all the book contains a good deal of practical information and it is to be recommended.

*THE RADIO NOISE REDUCTION HANDBOOK*, by the technical staff of "Radio," published by Radio, Ltd., 7460 Beverly Blvd., Los Angeles, California, 44 pages, paper covers, price in U. S. 35c, elsewhere 40c.

This book contains a great deal of practical information on the reduction of the two general types of radio noise, i. e., static and man-made electrical interference. The material contained in this volume is presented in a concise and logical order.

The book begins with an analysis of the various types of interference and explains how they may be identified. This is followed by data on noise balancing systems, giving circuits and the results which may be expected.

The third chapter has been devoted to the various types of noise limiters. This section covers the theory of noise limiters and gives circuits and data on the various types of noise limiters, such as the Dickert automatic noise limiter, the Watzel noise limiter, the Nicholson noise reducing circuit, etc.

Other parts of the book contain information on suppressing noise at its source, analyzing the type of interference, and descriptions of some new circuits.

For those interested in the reduction of noise, this book should prove to be

of considerable value. It is recommended.

*FOUNDATIONS OF WIRELESS*, by A. L. M. Sowerby, published by Iliffe & Sons, Ltd., Dorset House, Stamford Street, London, S. E. 1, England, second edition, 272 pages, price, 4/6 net, by post 4/11.

*Foundations of Wireless* has been thoroughly revised for the second edition and brought up to date by the addition of new matter on negative feedback, automatic tuning and automatic selectivity control.

The object of this elementary text book on receivers is to give the reader an understanding of the way a receiving set operates. Starting from the simple elementary conceptions, it deals first with the separate components of a set, later combining them to form simple circuits. Tubes are dealt with in detail, and some usual methods of performance-analysis are discussed. The process of detection is treated in adequate detail and shown to be the point about which the whole design of a receiver revolves.

*WIRELESS SERVICING MANUAL*, by W. T. Cocking, published by Iliffe & Sons, Ltd., Dorset House, Stamford Street, London, S. E. 1, England, third edition, 241 pages, price, 5/ net, by post 5/5.

The success of this book for service engineers has been such that this third edition has been published. It incorporates considerable additional material.

This book deals with testing apparatus and explains methods of locating and curing faults in receivers. Ganging, automatic volume control, instability, distortion, hum, local interference, etc., are all treated separately.

This edition contains additional information on short-wave receivers, and on methods of operating extension loudspeakers. The reference material includes base connections for British, Continental and American tubes.

*TELEVISION ENGINEERING*, by J. C. Wilson, published by Pitman Publishing Corp., 2 West 45 Street, New York City, price, \$10.00.

*Television Engineering* is an important contribution to the library of engineering treatises. Mr. Wilson has succeeded notably in presenting the fundamentals of present day television in a readable as well as a theoretical manner. His review of the principles of optics, the detailed derivation of formu-

lae and the extensive appendix make this a valuable compendium for practicing television engineers. The chapters dealing with actual equipment in use today seem to fall short of the high standard of excellence set in the earlier part of the book but this is due more to the rapidity of obsolescence of the equipment described rather than the author's unfamiliarity with the subject.

While we would be loath to recommend this book to the layman for general reading, it is this reviewer's honest opinion that this volume is a useful addition to any engineering library.

## CONDUCTANCE METER

(Continued from page 19)

$$g_m = \mu/r_p$$

If we solve for  $i_a$  and divide the result into the driving voltage  $e$ , there results the effective input impedance of the device, exclusive of the grid leak. This turns out to be

$$Z_{in} = \frac{Z_a + Z_{pb}}{1 + g_m Z_{pb}} \dots\dots\dots (6)$$

in which  $Z_{pb}$  is the alternating-current impedance of  $r_p$  and  $Z_p$  in parallel. It is evident from this expression that the input impedance may be rather low. Thus in the case of a type 2A3 tube, the plate resistance is normally 800 ohms, and if high-impedance headphones or a buffer amplifier is used,  $Z_{pb}$  will be about this value. If  $g_m = 0.005$  mhos, the input impedance calculated from (6) is 200 ohms. This is about as low an input impedance as is likely to be encountered and the oscillator should be designed to deliver several volts into this impedance.

## CIRCUIT DETAILS OF THE MEASURING DEVICE

Fig. 3 shows the circuit diagram of the instrument which has been used in the Purdue laboratories. The oscillator and input buffer amplifier employ a single dual-purpose tube. The circuits of this portion of the apparatus have not been shown, since they may be of any conventional type or they may be entirely omitted and a signal supplied from a suitable external audio-frequency oscillator of reasonably good wave form.

In order to reduce to a minimum the inevitable complexity resulting from the great variety of tubes that must be handled, the screen voltage is held constant at 90 volts by a type 874 gas regulator tube.

A single milliammeter is used to give plate-current ranges of 10 and 100 mil-

(See opposite page)



# NOTES AND COMMENT

## Design

## Production

### MICROPHONIC TUBES

ONE OF THE MOST exasperating problems which faces everyone working with high-gain amplifiers is the matter of selecting least microphonic tubes for input stages or pre-amplifiers. There are any number of elaborate checks for this condition but the good old method of tapping the tube and noting the result, when properly applied, is undoubtedly the simplest and is often a practical one for those not connected with tube manufacturing.

When battery-operated tubes are employed, the problem of picking the least troublesome tubes is most difficult. One method which has worked out very well is to connect an output meter and pair of phones in the output circuit of the amplifier. The tube is then tapped with a rubber-faced mallet, not just in one spot as so many of us do, but first on the side and then on the top. A tube may seem ok when tapped on the side, yet show up as bad when tapped on the top, and vice versa.

To make the test, tap the tube and note the output-meter reading and also the sound in the phones. A high reading on the output meter does not necessarily denote a bad tube unless it is accompanied by a sustained "Bon-n-g" in the phones. A good tube will yield a short, highly-damped response in the phones, regardless of the meter reading. The best tube is the one which gives the lowest meter reading and a sound in the phones which dies out quickly.

### ZERO-BIAS CLASS A AMPLIFIER

THE DIAGRAM of Fig. 1 shows the circuit of an extremely simple and compact little preamplifier which has found much use around WOI the last few months. By using low plate voltage it was possible to do away with grid bias entirely. It can be used for minute grid swing only, but works very well on the output of a dynamic microphone.

Amplifier chassis, batteries for 20 to 30 hours operation, input and output plugs, and headphone jack occupy 125 cubic inches and weigh 7 pounds. The amplifier has a gain of 25 db. The chassis is mounted on felt and the amplifier is so immune to vibration that, when a misdirected basket ball crashed into it during a sports interview last

winter, no sound due to microphonics was heard in the program.

Its use is limited to remotes where a quiet, short line to the control room is available, and where no moni-

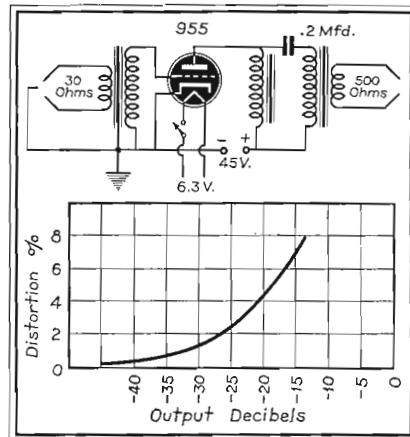

**Fig. 1. Circuit diagram and distortion-output curve of the small preamplifier described by W. E. Stewart.**

toring of the program is necessary. It was also found to be useful as a booster on a field microphone at football games when the line between the microphone and broadcasting booth became wet, and too noisy for use at microphone level.

W. E. STEWART  
Chief Engineer  
WOI

### A MUTUAL CONDUCTANCE METER

(Continued from opposite page)

liamperes full scale and a plate-voltage range of 0-250 volts. The grid bias may be measured externally if desired by connecting a high-resistance voltmeter to the terminals provided on the pin jack panel. Ordinarily, however, the desired operating condition may be secured by observing plate voltage and plate current.

Although the balance is independent of the load impedance, there is an optimum value determined by a compromise between high sensitivity and apparent sharpness of balance. If a tube having a high plate resistance is being tested, and a high load impedance is used, a slight

amount of stray pickup from the oscillator may occur in the high-impedance plate circuit that will obscure the balance. Experiments showed that 1000 ohms was a good value for the apparatus which has been constructed. With an external oscillator a higher value might be used.

The output of the tube under test is fed to an output buffer amplifier, in the grid of which is a parallel resonant circuit tuned to 700 cycles, the oscillator frequency. In the plate mesh of the buffer amplifier is a series-resonant circuit tuned to 1400 cycles. These two filters greatly reduce the harmonic content of the signal supplied to the headphones and make it possible to obtain a sharp balance since harmonics generated in the tube do not balance.

Some trouble was experienced with rhythmic fluctuations in the power-supply voltage caused by hunting of synchronous machinery. Since mutual conductance varies with the electrode voltages, there is a tendency for a fluttering signal to appear at balance. This effect was greatly reduced by employing 40 mfd of electrolytic condensers in the plate return of the tube under test. This large capacitance in conjunction with the series impedance of the power-supply circuit exerted a marked smoothing action on the power-line voltage fluctuations.

The model which has been built for the laboratory uses a 3-dial decade conductance, adjustable in steps of 1000, 100, and 10 micromhos, respectively. Thus the range of the balance extends from 10 to 11,000 micromhos. A tapered potentiometer can be used, but if excessive scale crowding is to be avoided the available range of  $g_m$  will be limited. However, if a 1000-ohm tapered potentiometer is used in series with a 250-ohm fixed resistance, it is possible to cover a range from 4000 down to 800 micromhos without serious crowding of the scale in any part of the dial. A much wider range can be covered by using two tapered resistances of suitable values ganged together on the same shaft. In this case a double scale would, of course, be necessary.

Provision for measuring a wide variety of tubes is made by using only enough sockets to take care of the

(Continued on page 50)

# OVER THE TAPE . . .

## NEWS OF THE COMMUNICATIONS FIELD

### EICOR, INC.

Just announced but already set up and ready to do business is Eicor, Inc., with plant and offices at 515 S. Laflin St., Chicago. Heading this company is Mr. Joe Nader, President and Chief Engineer, while the office of Vice-President and Sales Manager is held by R. D. Wright. Both have had many years' experience in the field of dynamotors, converters, gas electric plants and other rotary electrical apparatus in which the firm will specialize.

### FINCH LABS PURCHASE PLANE

Following encouraging experiments with facsimile transmissions to airplanes in flight, W. G. H. Finch, President of the Finch Telecommunications Laboratories, Inc., has increased the engineering staff at his Bendix, N. J., plant and has announced the purchase of a single motored monoplane to continue facsimile tests. Experimental facsimile tests between airplane and ground are said to have been so successful that it is soon expected to be used by both commercial air lines and military aircraft.

### SOUND APPARATUS BULLETIN

Volume 14, Number 2 of the Sound Apparatus Bulletin has just made its appearance. This leaflet describes an interesting new type of record-cutting mechanism. To secure copies of the bulletin, write to the Sound Apparatus Co., 150 W. 46 St., New York City.

### COMMERCIAL RADIO INSTITUTE BULLETIN

Commercial Radio Institute, 38 W. Biddle Street, Baltimore, Maryland, have recently issued an attractive and interesting bulletin describing the Institute and giving an outline of their courses, facilities, etc. This bulletin may be secured by writing to the above organization.

### ERPI PRESIDENT

T. Kennedy Stevenson was elected President and a Director of Electrical Research Products, Inc., a subsidiary of Western Electric Company at a special meeting of the board of directors of the former company held on September 1. He succeeds the late Whitford Drake who died on August 24.

Mr. Stevenson has been associated with the Western Electric Company for 24 years. For the last 10 years he has been Comptroller of manufacture of that Company. He was also Comptroller of the Nassau Smelting & Refining Company, another Western Electric subsidiary.

### RELAY BULLETIN

The Advance Electric Company, 1260 West 2nd St., Los Angeles, California, have made available an interesting bulletin describing and illustrating their line of a-c and d-c, heavy-duty, break-in, keying and other relays. This bulletin will be sent free to those who request it from the above organization.

### C. A. LAISE DIES

Mr. Clemens A. Laise, President of the Eisler Electric Corp., of Union City, N. J., died at his home on Sunday, September 28. Mr. Laise, who has served as the president of the Eisler organization since 1930, was born in Philadelphia, Pa., October 4, 1885. His death is to be deeply regretted.

### UNIVERSITY LABS. MOVE

The University Laboratories, manufacturers of horns and permanent-magnet speakers are moving their factory and sales offices from 191 Canal Street, New York City. The new offices are located at 195 Christie Street, New York City.

### BOSCH SELL POLICE DIVISION

The United American Bosch Corporation, announce that they have sold their Police Radio Division to Fred M. Link of New York City. Since the Bosch Company is retiring from the radio business it was not possible for them to continue this activity. Mr. Link takes over the current Bosch inventory and Mr. Morris Metcalf, formerly Vice-President of the Bosch Company, who has been in charge of this department for many years, will be associated with Mr. Link.

### GOLDSTEIN JOINS BERNARD

Jack Goldstein, who held positions in radio receiver factories as production engineer, has joined the staff of H. J. Bernard, manufacturer of electronic test equipment, in the same capacity. Mr. Goldstein was formerly in the instrument field under the trade name of Radio Design Company. The Bernard factory is at 319 Third Avenue, Brooklyn, N. Y.

### AUDAK CATALOG SHEETS

Literature giving detailed specifications of the new Audax line of Microdyne pickups—Relayed Frequency type as well as the new Compensated Microdyne type—in the form of sheets suitable for catalog insertion are now available. Additional literature is now on the press and will be released within a few days. Copies may be obtained by writing to Audak Company, 500 Fifth Ave., New York City.

### IDEAL BULLETIN

The Ideal Commutator Dresser Co., 1231 Park Ave., Sycamore, Illinois, have recently released a bulletin on Ideal "Thermo-Grips." This bulletin covers their complete line of electric soldering tools. It may be obtained by writing to the above organization.

### AEROVOX EMERGENCY STOCK

An emergency stock of all standard types of condensers set up in the middle west, is now available to jobbers for the prompt filling of their orders during the Aerovox C.I.O. strike in the Brooklyn plant. There will be no shortage and no delay in taking care of jobber business, so reports the Aerovox management.

### AMERICAN LAVA PURCHASES AMERICAN CERAMICS

The American Lava Corporation of Chattanooga, Tennessee, has acquired all equipment and good will of the American Ceramics & Specialties Corporation of Jackson, Michigan, and will remove the equipment to its Laboratory and works at Chattanooga. Carl R. Hower, Vice-President and Manager, and O. D. Riseden, Production Engineer, will be retained in Sales and Engineering capacities with the American Lava Corporation.

### CLAROSTAT BULLETIN

A handy numerical listing of Clarostat exact-duplicate controls and their corresponding standard controls, where the latter can be satisfactorily substituted, is now available in a 4-page bulletin just released by Clarostat Mfg. Co., Inc., 285-7 N. Sixth St., Brooklyn, N. Y. Once the correct exact duplicate type is determined the new listing can be used in substituting a standard control.

### LOEWENBERG BULLETIN

A 4-page bulletin is now available on the Models A and B Photrix universal photometer, a new photoelectric light meter, which may be used for measuring illumination, light transmission and absorption, for testing motion-picture screens, etc. This bulletin may be secured by writing to Dr. F. Loewenberg, 10 East 40th Street, New York City.

### EISLER CATALOG

The Eisler Engineering Company, 756 South 13th Street, Newark, New Jersey, have issued a new catalog, No. 38-T, 24 pages, with about 100 illustrations showing "Transformers in the Making," and a complete line of distribution transformers, spot-welding transformers and many types of special and standard transformers used in various industries. In the same catalog is shown a complete line of special welding machines from 1 kva to 400 kva with air and water-cooled transformers, electric welders, foot, air and motor-operated.

### BLILEY CATALOG

Radio engineers dealing with frequency control of transmitters, receivers, monitors, test equipment, or similar apparatus will be interested in the new Bliley catalog now being distributed. Precision quartz crystals and mountings for all frequencies from 20 kc to 30 mc are listed and described. A quick reference table gives immediate information regarding the type of crystal, the crystal characteristics, and the type of holder available for any frequency within the range in which quartz crystals are supplied. Of special interest are the high-frequency crystal units, types MO2 and MO3, for frequencies from 7.5 mc to 30 mc. Copies of this new catalog can be obtained from the Bliley Electric Company, Union Station Building, Erie, Pennsylvania. Just ask for Catalog G-10.

(Continued on page 31)



# Station Power



Shown above is a busy scene in the main office of RCA Communications, located in the heart of downtown New York, 66 Broad Street. This is one of the many services of the Radio Corporation of America.

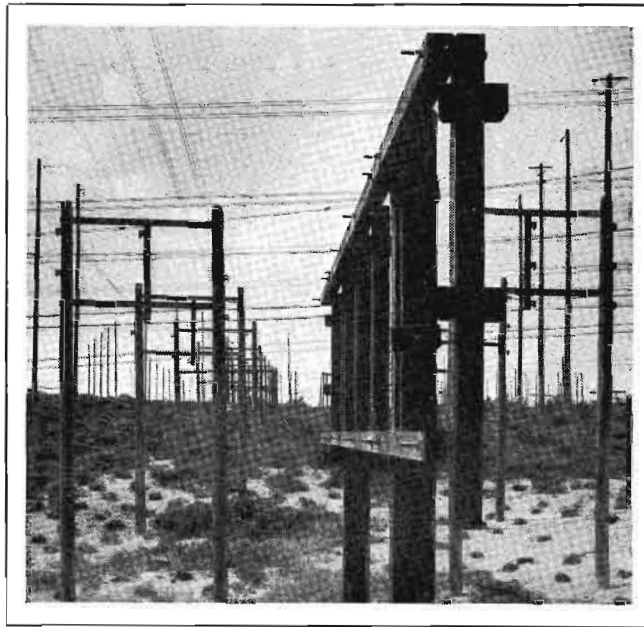

At the Riverhead, Long Island, receiving station of RCA Communications are scores of antennas. This is the point of reception of European features that are heard on hundreds of American radio stations.

**T**HE POWER of a broadcasting station is not measured in kilowatts alone, but in ability to hold an audience. The world-wide communications services of RCA may seem to have little connection with the power of broadcasting stations. But when power is considered in terms of audience rather than kilowatts the connection is clear. All radio broadcasting stemmed from communications. RCA research in this field has

constantly led to improvements in transmitting radio programs... more power to stations.

In the home no radio program is better than the radio receiver. RCA research has been responsible for a large part of the steady improvement in home receivers. This research is of a practical nature that not only improves instruments but makes them available at low prices. All of which means... more power to stations.



**Radio Corporation of America**

RADIO CITY, NEW YORK

RCA Manufacturing Company, Inc.  
RCA Communications, Inc.

RCA Institutes, Inc.

National Broadcasting Company  
Radiomarine Corporation of America

COMMUNICATIONS FOR SEPTEMBER 1938 • 27

# SHAKEPROOF

*announces*

# SEMS

TRADE MARK

The Patented

# PRE-ASSEMBLED LOCK

CONSIDER THESE  
IMPORTANT ADVANTAGES

## COST CONTROL

SAVES  
ASSEMBLY  
OVERHEAD



SAVES  
ASSEMBLY  
LABOR



PREVENTS  
LOST LOCK  
WASHERS



## PRODUCT CONTROL

ASSURES CORRECT  
WASHER FOR EACH  
TYPE OF SCREW  
HEAD



ASSURES A  
LOCK WASHER  
UNDER EVERY  
SCREW







**CAN'T DROP OFF!**

# WASHER AND SCREW

- SAVES TIME... ● SAVES MONEY...
- PROTECTS PRODUCT PERFORMANCE

U. S. PATENT Nos. 1,782,387—1,788,735—1,850,242—1,963,800—2,113,424—2,113,425. Other United States and foreign patents pending.



## SHAKEPROOF LOCK WASHER COMPANY

*Distributor of Shakeproof Products Manufactured by Illinois Tool Works*

2509 North Keeler Avenue, Chicago, Illinois

IN CANADA: Canada Illinois Tools, Ltd., Toronto, Ont.

Copyright 1938 Illinois Tool Works



Let CLAROSTAT

Solve

YOUR RESISTANCE PROBLEM

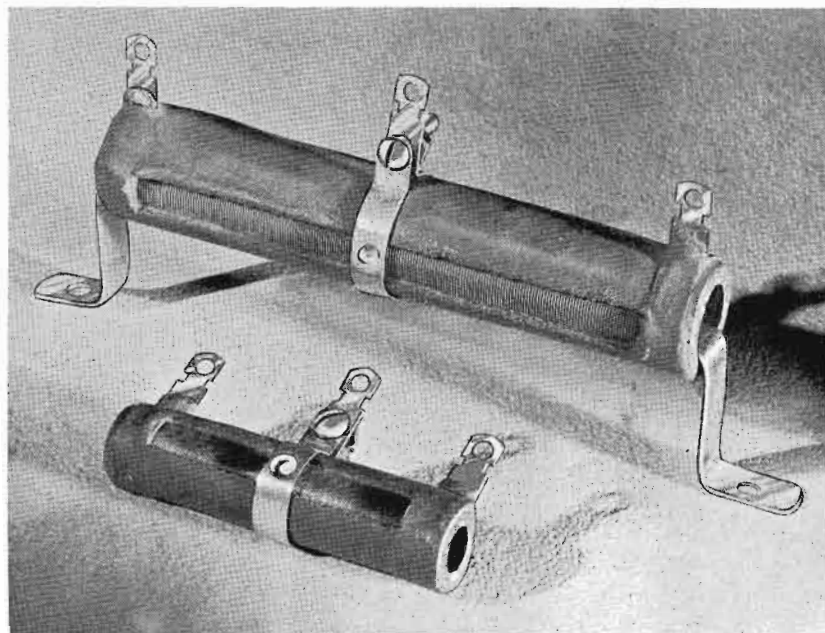

## Precision Resistors

● CLAROSTAT now offers you the *only ceramic-jacketed, fully-sealed* precision wire-wound resistors in the PR series. Just the thing for instrument makers seeking precision resistance values. Likewise for advanced laboratory workers. Standard tolerances of 1% on stock items. Tolerances as low as 1/10th of 1% on special order.

## Power WIRE-WOUND Resistors

FIXED—ADJUSTABLE—TAPPED

● WITH wire-winding experience, skill and equipment second to none, CLAROSTAT took years to introduce power resistors. Why? Simply because CLAROSTAT sought to provide a provably better power resistor, rather than to clutter the market with just another brand. You are invited to judge the results.

Characteristic green finish for ready identification. Inorganic cement coated. No blistering or cracking even at red heat. Varnish coated for extreme humidity conditions. Fixed and adjustable types. In 10, 20, 25, 40, 60, 80, 100, 160 and 200 watt ratings. From 1 to 100,000 ohms.

### Submit that Problem . . .

- No matter what your resistance or control requirements may be, send along your problem for engineering collaboration, samples, quotations. Be sure our loose-leaf engineering data is in your working library. Otherwise, copy on request.

Five different types to choose from. Widest choice of terminals, such as pigtailed, round-head screw binding posts, knurled-nut binding posts, soldering lugs, both terminals at end, etc. Some units mount by screw slipped through center hole.



Each unit, wound on ceramic spool and encased in ceramic sleeve. Enamelled resistance wire non-inductively wound in slots or sections. Thoroughly impregnated, sealed, aged. Ceramic sleeve provides full protection to winding.

Widest range of resistance values—0.1 ohm to 3 megohms. 1/2 to 2 watt ratings. Maximum voltage, 250 to 1000. A superior line of precision resistors, yet competitively priced. Descriptive bulletin available on request.



**CLAROSTAT** Manufacturing Co. INC.



285-287 NORTH SIXTH STREET  
BROOKLYN, NEW YORK, U.S.A.

• OFFICES IN PRINCIPAL CITIES •





# VETERAN WIRELESS OPERATORS ASSOCIATION NEWS



W. J. McGONIGLE, President

RCA Building, 30 Rockefeller Plaza, New York, N. Y.

H. H. PARKER, Secretary

## FALL

WITH THE COMING of Fall we look forward to a renewal of activities in all our Chapters and anticipate including news of them in this page. Of course the big event of the season is the annual simultaneous cruises of all the chapters on Saturday, February 11th, 1939. However, we urge Chapter officers to institute a program of activity leading up to the big event to assure a record turnout of our members and friends on that evening in all parts of the world. A "Smoker" or "Beefsteak" party might be successfully held by some of our chapters between now and then. Remember—nothing tried, nothing gained.

## NEW YORK

THE FIRST MEETING of the New York group will be held on the first Monday in October, the third, 1938, and cards will be sent the local members notifying them of the exact time and place. George Clark promises all the "Lager" we can consume in return for our participation in his quest for information concerning the application of a radio tuning element about the time of the World War. So all of you technical experts and circuit wizards turn out and see if George's money holds out as long as your information. It's in connection with receivers then in use and those of us operating during that period more than likely know something about the subject. It should be interesting to both those of us who have information and those who just listen. So we'll see you then, October 3rd, 1938, a Monday evening.

## PERSONALS

J. R. POPPELE, Chief Engineer of WOR, has been extremely active recently sending in names of prospective members and included among his suggestions is the name of Dick Stoddart, radioman of the Hughes Round the World Flight, for an Association Award. The nomination will be turned over to the Awards Committee for their consideration. Among the prospective members JR sent in we just received the application of D. K. de Neuf, an executive of Press Wireless, who started with the Radiomarine Corp. in marine radio in 1925 and subsequently served with the Matson and Dollar Steamship Companies, then for several years with RCAC in point-to-point in San Francisco and Honolulu and for the past eight years with Press Wireless in New York, Havana and San Francisco. We welcome Mr. de Neuf to our Association. . . . Geo. P. Smith, Jr., is mighty busy these days whipping the amusement concessions of the New York World's Fair 1939 into shape. GPS is in charge of the amusement concessions and has had

his photograph published several times in recent weeks in the New York *World Telegram* with models of the features to be included in the final layout. Mr. Smith is well qualified for his work as for many years he has been in charge of concessions at Bear Mountain Park and at other resorts featuring numerous entertainment ideas. Best of luck GPS and we'll look you up when we go out to look the Fair over. . . . We hope you all had a nice vacation. . . . Remember—the Secretary is still waiting for your dues (unless you have a 1938 card). Send them in now and make his job more pleasant. . . .

Welcome to the return to the fold of Robert E. Dalton, S. S. *Veragua*. An old timer now sailing the blue Caribbean for the Unifruitco. . . . L. A. McClelland is "Going to Town" on a one-man membership drive. Thanks LAM—more members—a stronger and more interesting association. . . . At long last a letter from one of our Charter members, Gilson Willets, and along with his letter a new member, John Masiello, formerly USN and now connected with the Los Angeles Bureau of Water and Power. Glad to have you in the VWOA, JM, and the increase in membership from the LA district seems to call for much interesting activity on the coast. . . . Then the secretary's attention was called to a communication from Tom Appleby, Lt. Comdr., USNRF. We know you will read this Tom and we want you in the association. . . . T. B. Linklater, Canadian National Telegraphs, becomes a Veteran Member.

New members within the year: George B. Riley, WOR Transmitter; Charles Singer, WOR Plant Supervisor; George Robinson, WOR, and much time in the old Morgan Line; Seth Gamblin, WOR; Raymond O'Neill, WOR, Marine operating, Geophysical exploration and Broadcasting; Ralph Willey, WOR; Edmund Franke, WOR; John E. Morse, WOR; John J. Keel, WOR; Raymond W. Rodgers, Jr., WOR Making WOR Transmitter 100% VWOA. Credit for this due H. A. Steinberg. . . .

Also New Members: Thomas J. Barry of Portland, Me., Police Dept. Hope to meet you socially not officially OM.

From the Honolulu Chapter we have: Robert Lee Richards, RCA; Warner Hobby of the Pan American Airways; W. Breuer, Pan Am. Airways; A. P. Davis, USN Retired, now Inter Island Airways; Lee R. Dawson, FCC; F. E. Connelly, Naval Radio Wailupe; F. T. Bowen, same; C. W. Gordon, US Air Corps, Wheeler Field; W. W. Hofmann, RCA Kahuku. Splendid work Honolulu.

. . . . Send in fifty cents for a copy of the Marconi Memorial Year Book. That just about covers cost of mailing. It's really quite interesting. . . . Carl O. Petersen delivered an interesting lecture on

radio at the South Pole at the recent Hudson Division Convention at the Astor Hotel in New York City.

## OVER THE TAPE

(Continued from page 26)

### RCA PROMOTIONS

Elevation of Eugene W. Ritter, as General Manager of the RCA Manufacturing Company's Harrison Plant, replacing J. C. Warner, deceased; and of D. F. Schmit, to succeed Mr. Ritter as Manager of Research and Engineering at the Company's tube making plant, was announced by Robert Shannon, Vice-President and General Manager.

Mr. Ritter has been associated with radio vacuum-tube manufacturing, engineering and research since 1925. D. F. Schmit also dates his association with vacuum-tube engineering to the early days of radio, in 1923.

### MUTUAL OFFICERS, DIRECTORS

All officers and directors of the Mutual Broadcasting System were reelected at the annual meeting of the stockholders and directors of the network in the Chicago offices of Mutual recently. Officers reelected were: President, W. E. Macfarlane; Chairman of the Board, Alfred J. McCosker; First Vice-President, T. C. Streibert; Executive Secretary and Treasurer, E. M. Antrim. Directors reelected: Alfred J. McCosker, T. C. Streibert, Jack I. Straus, W. E. Macfarlane, E. M. Antrim, E. W. Wood, Jr., and Fred Weber.

### MICKEL RECEIVES APPOINTMENT

Harry F. Mickel, for 12 years employed by RCA Victor in specialized engineering and sales capacities, has been appointed Manager of the RCA Police Radio Section, it is announced by James L. Schwank, Manager of the Engineering Products Division. Mr. Mickel succeeds P. A. Anderson, resigned.

### WESTINGHOUSE MICARTA PRODUCTS

A 4-page leaflet, published by Westinghouse Electric & Manufacturing Company, lists the standard sizes, colors and finishes of Micarta plate and tabulates the physical and electrical properties and applications of Micarta plate, Micarta rod, channels, angles and tubing. The physical and electrical properties include such items as punching, machining, strength, dielectric volts/mil, and dielectric constant.

Copies of this leaflet, Descriptive Data 63-020, may be secured from the nearest office of Westinghouse Electric & Manufacturing Company, or from headquarters at East Pittsburgh, Pennsylvania.

# Purchasing Directory

The following pages contain information which we believe will be of assistance and value to all executives, engineers and purchasing agents in the field.

The companies listed are recognized sources of supply whose products and services have acquired a highly commendable reputation.

In presenting this data COMMUNICATIONS assumes no responsibility for omissions. We have attempted to supply comprehensive and accurate information in a usable form. Any omissions are unintentional and should be called to our attention.

## FINCH FACSIMILE SYSTEM PATENTED & PAT'S PEND'G.

### LEADS THE WAY

**FIRST** to open the NEW field in "Home" Facsimile broadcasting.

**FIRST** SYSTEM placed in actual operation by the MAJORITY of MAJOR Facsimile broadcasting stations.

**FIRST** to PERFECT automatic, fully visible, continuous feed "HOME" recorders, requiring neither liquids nor carbon transfer sheets.

**FIRST** to develop an Automatic selective synchronizing method which permits "HOME" Facsimile recording in all AC or DC power areas.

**FIRST** to open the NEW field in Facsimile broadcasting for Aircraft, Police and other Mobile services.

The FINCH laboratories are open to licensed broadcasters for demonstration, by appointment.

**FINCH**  
TELECOMMUNICATIONS LABS., Inc.  
37 W. 57th ST., NEW YORK CITY  
PLAZA 5-6570

### Acoustic Material and Treatment

Armstrong Cork Products Co., Lancaster, Pa.  
Celotex Co., Chicago, Ill.  
Electrical Research Products, Inc., New York City.  
Insulite Co., Minneapolis, Minn.  
International Balsa Corp., Jersey City, N. J.  
Johns-Manville Co., New York City.  
National Gypsum Co., Buffalo, N. Y.  
Northwest Magnesite Co., Pittsburgh, Pa.  
Union Fibre Co., Winona, Minn.  
Upson Co., Lockport, N. Y.  
U. S. Gypsum Co., Chicago, Ill.

### Amplifiers, P-A and Sound Equipment

Audio Products Co., Los Angeles, Calif.—amplifiers, speech-input equipment.  
Bell Sound Systems, Inc., Columbus, Ohio—p-a and inter-communicating systems.  
BURSTEIN-APPLEBEE, 1012 McGee St., Kansas City, Mo.—amplifiers and p-a equipment.  
COLLINS RADIO CO., 2920 First Ave., Cedar Rapids, Iowa—amplifiers, speech-input equipment.  
Daniel Electrical Labs., New York City—amplifiers.  
Electro-Acoustic Products Co., Fort Wayne, Ind.—amplifiers.  
Electronic Design Corp., Chicago, Ill.—amplifiers, p-a systems.  
Electronic Sound Labs., Inc., Hollywood, Calif.—amplifiers, p-a & intercommunicating systems.  
GATES RADIO & SUPPLY CO., Quincy, Ill.—amplifiers, speech-input equipment.  
LANSING MFG. CO., 6900 S. McKinley Ave., Los Angeles, Calif.—sound systems.  
Morlen Electric Co., Inc., New York City—amplifiers, p-a equipment.  
Operadio Mfg. Co., St. Charles, Ill.—sound equipment.  
Philco Radio & Television Corp., Philadelphia, Pa.—amplifiers, intercommunicating systems.  
RCA MANUFACTURING CO., INC., Camden, N. J.—amplifiers, p-a & intercommunicating systems.  
Radio Receptor Co., Inc., 251 W. 19 St., New York City—sound equipment.

### MONEY SAVING FACTS . . . about PERMANENT MAGNETS



• Not a catalog, but a practical description of little-known factors governing the use of magnetic energy and magnetic materials. This new, fact-revealing manual should be in your files. Cleans up many perplexing problems. Loaded with practical facts that may point the way to design improvements, weight reductions, savings in materials and labor, and more satisfactory operation of apparatus. Available, without charge, to industrial organizations requesting it on their business letterhead. Write for your copy today.  
THE INDIANA STEEL PRODUCTS CO.  
135 S. La Salle St., Chicago, Ill.  
Largest Exclusive Manufacturer of Permanent Magnets

## NOW! National Union TELEVISION Tube Types Advanced Design! Superior Quality! Priced for Experimenters!

### 2203 MONOTRON

First satisfactory picture signal source. Spot small enough for 441 line definition. Pattern designed for complete test of transmitter quality. Electro-static focus and deflection. Non-magnetic deflection plates. Constant signal output. Ceramic mounted gun. **\$16.50**  
Net

### 2005 5-inch VIDEOTRON

Designed for television reception. Super quality as oscillograph. Non-magnetic deflection plates. Perfect trapizium correction. Fine trace for 441 line definition. Good modulation characteristics. Employs screen grid. No defocusing at extremes of sweep. Sensitivity to .56/mm/volt. High brilliance. Extra long life. Clean sharp focus. **\$22.50**  
Net

### 2109 9-inch VIDEOTRON

For magnetic deflection. Ceramic mounted gun mica spring supported to obviate possibility of knocking it off center. Double getter flashed for highest vacuum, longest life. Fine trace for 441 line definition. Screen material produces black and white pictures. No defocusing at extremes of sweep. Forty degrees of light contrast due to special processing of fluorescent screen. High brilliance. **\$50.00**  
Net

For Technical Data Write: NATIONAL UNION RADIO CORP., Newark, N. J.



**RADIOTONE, INC.**, 7356 Melrose Ave., Hollywood, Calif.—amplifiers.  
**Radolek Co.**, Chicago, Ill.—amplifiers.  
**Raytheon Mfg. Co.**, Waltham, Mass.—amplifiers.  
**Remler Co., Ltd.**, San Francisco, Calif.—amplifiers & intercommunicating systems.  
**Sound Products**, Hollywood, Calif.—p-a systems.  
**SOUND PROJECTS CO.**, 3140 N. Walton Ave., Chicago, Ill.—amplifiers, p-a systems.  
**Sound Systems, Inc.**, Cleveland, Ohio—amplifiers.  
**Stromberg-Carlson Tel. Mfg. Co.**, Rochester, N. Y.—sound equipment, amplifiers.  
**SUNDT ENGINEERING CO.**, 4238 Lincoln Ave., Chicago, Ill.—p-a equipment.  
**Thordarson Elec. Mfg. Co.**, Chicago, Ill.—amplifiers.  
**United Sound Eng. Co.**, St. Paul, Minn.—p-a & intercommunicating systems.  
**UNITED TRANSFORMER CORP.**, 72 Spring St., New York City—amplifiers.  
**UNIVERSAL MICROPHONE CO., LTD.**, Inglewood, Calif.—intercommunicating systems.  
**THE WEBSTER CO.**, 3825 W. Lake St., Chicago, Ill.—sound & intercommunicating systems, amplifiers.  
**Webster Electric Co.**, Racine, Wisc.—amplifiers.  
**WESTERN ELECTRIC CO.**, 195 Broadway, New York City—p-a equipment.  
**WHOLESALE RADIO SERVICE CO., INC.**, 100 Sixth Ave., New York City—sound systems, amplifiers.  
**WILCOX ELECTRIC CO.**, 1014 W. 37 St., Kansas City, Mo.—amplifiers, p-a equipment.

### Antennas, Antenna Erection, Antenna Arrays

**American Bridge Co.**, Pittsburgh, Pa.—antenna towers.  
**Victor J. Andrew**, Chicago, Ill.—filters, coupling equipment.  
**Bendix Radio Corp.**, Washington, D. C.—antenna arrays.  
**Blaw-Knox Co.**, Pittsburgh, Pa.—vertical radiators.  
**General Electric Co.**, Schenectady, N. Y.—tower-lighting chokes.  
**Hartenstine-Zane Co., Inc.**, New York City—antenna installation.  
**INTERNATIONAL DERRICK & EQUIP. CO.**, 875 Michigan Ave., Columbus, Ohio—vertical radiators.  
**E. F. Johnson Co.**, Waseca, Minn.—coupling equipment.  
**LEHIGH STRUCTURAL STEEL CO.**, 17 Battery Pl., New York City—vertical radiators.  
**JOHN E. LINGO & SON, INC.**, Camden, N. J.—vertical radiators.  
**Premax Products**, Niagara Falls, N. Y.—vertical radiators—amateur.  
**RCA MANUFACTURING CO., INC.**, Camden, N. J.—antenna surveys.  
**Radio Receptor Co.**, New York City—directional array phasing.  
**Hector R. Skifter**, St. Paul, Minn.—Antenna surveys.  
**Truscon Steel Co.**, Youngstown, Ohio—vertical radiators.  
**Washington Institute of Technology**, Washington, D. C.—directional antennas and exciter systems.

### Ceramics & Insulators

**AMERICAN LAVA CORP.**, Cherokee Blvd. & Mfg'r's. Rd., Chattanooga, Tenn.—ceramic, steatite and porcelain insulators.  
**Corning Glass Works**, Corning, N. Y.—glass insulators.  
**HENRY L. CROWLEY & CO.**, 1 Central Ave., West Orange, N. J.—ceramic insulators.  
**Demuth Glass Works, Inc.**, Brooklyn, N. Y.  
**Electronic Mechanics, Inc.**, New York City—mycalex insulators.  
**General Ceramics**, 30 Rockefeller Plaza, New York City.  
**ISOLANTITE, INC.**, 233 Broadway, New York City—ceramic insulators of all types.  
**LAPP INSULATOR CO., INC.**, LeRoy, N. Y.—porcelain insulators of all types.  
**Locke Insulator Corp.**, Baltimore, Md.—porcelain insulators.  
**Owens-Illinois Glass Co.**, Newark, Ohio—glass insulators.  
**MICA INSULATOR CO.**, 200 Varick St., New York City—mica insulators.  
**Mycalex Corp. of America**, New York City—mycalex insulators.  
**Stupakoff Laboratories, Inc.**, Pittsburgh, Pa.—ceramic insulators.

### Coils and Coil Machinery, Iron Cores

**ALADDIN RADIO INDUSTRIES, INC.**, 466 W. Superior St., Chicago, Ill.—coils.  
*(Continued on page 34)*

**WHAT — ?  
PRICE — ?  
POWER — ?**

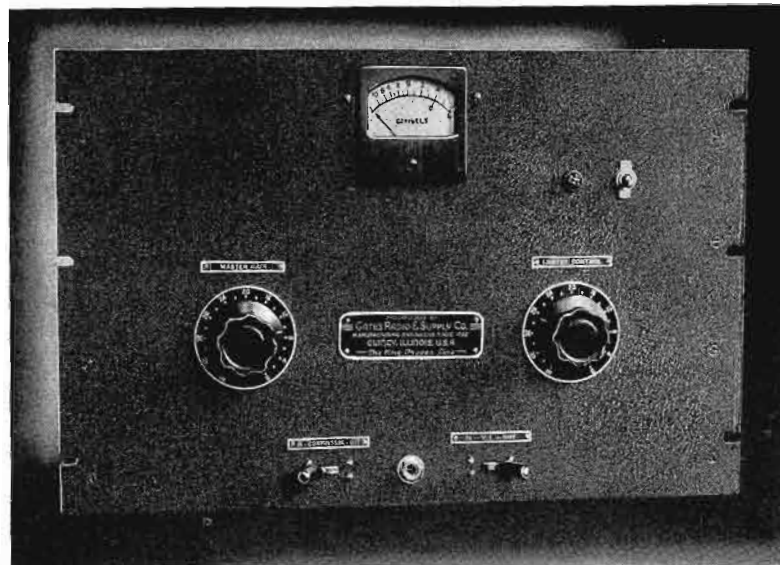

**W**HAT are you paying for carrier power, Mr. Broadcaster? What have you paid for a power increase? Don't tell us, because we know the figure was mighty generous. We can tell you how to give that signal more punch, however, and at a mighty low cost.

The Gates 27-C Peak Limiting Amplifier has been regularly bringing us unsolicited reports of as much as double wallop after its installation, yet the cost is less than one-sixth that of a good 1500-foot tower or a mere fraction the cost of a new transmitter. Its power consumption is 150 watts.

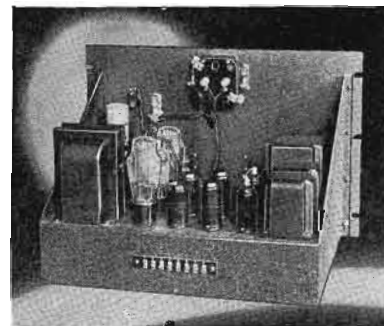

REAR VIEW

Now we do not say the 27-C takes the place of a new tower or a new transmitter, but what it will add to an old or new transmitter in direct signal increase makes these other investments proportionately very expensive.

Yes—if you are looking for more listeners, a wider radius, less hash in your secondary area as well as an excellent protection against over-modulation you will be looking into the new Gates 27-C Peak Limiting Amplifier.

*Write for catalog bulletin CM27 today*

**GATES RADIO & SUPPLY CO.**  
 MANUFACTURING ENGINEERS SINCE 1922  
**QUINCY, ILLINOIS, U.S.A.**  
 CABLE ADDRESS (GATESRADIO)

*The Time Proven Line*

**"Tell Smith to be sure and get figures from LINGO for that new radiator"**



**T**ODAY in hundreds of stations there is an amazing increase of interest among engineers and station managers in LINGO Vertical Tubular Steel Radiators . . . a new realization that LINGO Radiators give a higher performance value than any other type of antenna yet attained!

**Here's the Radiator that meets your particular needs—**

● After you investigate the amazing story of LINGO efficiency and economy, you will probably realize that here, indeed, are new standards that vitally affect you. And if you are like many other alert radiomen you will want to do something about it. You will want to take advantage of this new high in efficiency and new low in cost.

Send complete information on location, power and frequency of station . . . and we can show you how LINGO "Tube" Radiators can meet your particular needs, and also quote complete prices in advance for both construction and erection.

**Write Today**

for illustrated folder:

*"New Standards for Vertical Radiators"*

**JOHN E. LINGO & SON, INC.**  
Dept. C 9 Camden, N. J.

**LINGO**  
VERTICAL  
**TUBULAR STEEL**  
RADIATORS

Coils, Inc., Providence, R. I.—coils.  
**HENRY L. CROWLEY & CO., INC.**, 1 Central Ave., W. Orange, N. J.—r-f and i-f cores  
**FERROCART CORP. OF AMERICA**, Hastings-on-Hudson, N. Y.—r-f and i-f cores.  
Greyhound Equipment Co., Brooklyn, N. Y.—coils.  
**GUTHMAN & CO., INC., EDWIN I.**, Chicago, Ill.—coils.  
Halldorson Co., The, Chicago, Ill.—coils.  
**HAMMARLUND MFG. CO.**, 424 W. 33 St., New York City—coils.  
Meissner Mig. Co., Mt. Carmel, Ill.—coils.  
J. W. Miller & Co., Los Angeles, Calif.—coils.  
**PRECISION INDUCTANCE CORP.**, 591 Broadway, New York City—coil windings.  
**F. W. SICKLES CO.**, 300 Main St., Springfield, Mass.—coils.  
Teleradio Engineering Corp., New York City—coils.  
**UNITED TRANSFORMER CORP.**, 72 Spring St., New York City—coils.  
Universal Winding Co., Providence, R. I.—coil winding machines.

**Condensers—Fixed**

**AEROVOX CORP.**, 70 Washington St., Brooklyn, N. Y.  
American Condenser Corp., Chicago, Ill.  
**CENTRALAB**, 900 E. Keefe Ave., Milwaukee, Wis.  
**CONTINENTAL CARBON, INC.**, 13900 Lorain Ave., Cleveland, Ohio.  
**CORNELL-DUBILIER ELEC. CORP.**, South Plainfield, N. J.  
**HENRY L. CROWLEY & CO., INC.**, 1 Central Ave., W. Orange, N. J.  
Curtis Condenser Corp., Cleveland, Ohio.  
**TOBE DEUTSCHMANN CORP.**, Canton, Mass.  
Dumont Electric Co., Inc., New York City.  
Erie Resistor Corp., Erie, Pa.  
The Magnavox Co., Inc., Fort Wayne, Ind.  
**P. R. MALLORY & CO., INC.**, 3029 E. Washington St., Indianapolis, Ind.  
Micamold Radio Corp., Brooklyn, N. Y.  
J. W. Miller & Co., Los Angeles, Calif.  
Morrill & Morrill, New York City.  
The Muter Co., Chicago, Ill.  
**NATIONAL UNION RADIO CORP.**, Newark, N. J.  
Sangamo Electric Co., Springfield, Ill.  
**SOLAR MFG. CORP.**, 599 Broadway, New York City.  
Sprague Specialties, Inc., North Adams, Mass.  
Underwood Elec. & Mfg. Co., Chicago, Ill.

**Condensers—Variable**

Audio Products Co., Los Angeles, Calif.  
The Allen D. Cardwell Mig. Corp., Brooklyn, N. Y.  
DeJur-Amsco Corp., Shelton, Conn.  
General Instrument Co., Elizabeth, N. J.  
**GENERAL RADIO CO.**, 30 State St., Cambridge, Mass.  
**GUTHMAN & CO., INC., EDWIN I.**, Chicago, Ill.  
**HAMMARLUND MFG. CO., INC.**, 424 W. 33 St., New York City.  
E. F. Johnson Co., Waseca, Minn.  
National Co., Inc., Malden, Mass.  
Radio Condenser Co., Camden, N. J.  
Reliance Die & Stamping Co., Chicago, Ill.

**Crystals, Crystal Holders, Etc.**

**BLILEY ELECTRIC CO.**, 200 Union Station Bldg., Erie, Pa.  
Commercial Radio Equipment Co., Kansas City, Mo.  
Fridgen Crystal Labs., Bellefonte, Pa.  
Hipower Crystal Co., Chicago, Ill.  
Hollister Crystal Co., Merriman, Kansas.  
Peterson Radio Co., Council Bluffs, Iowa.  
Precision Crystal Labs., Inc., Springfield, Mass.  
Precision Piezo Service, Baton Rouge, La.  
Premier Crystal Labs., Inc., New York City.  
**SCIENTIFIC RADIO SERVICE**, 124 Jackson Ave., University Park, Md.  
**STANDARD PIEZO CO.**, 126 Cedar St., Carlisle, Pa.  
**THE VALPEY CRYSTALS**, Box 321, Holliston, Mass.

**Frequency Measuring & Monitoring Equipment & Services**

Bendix Radio Corp., Washington, D. C.—frequency monitors, meters.  
Commercial Radio Equipment Co., Kansas City, Mo.—frequency monitors

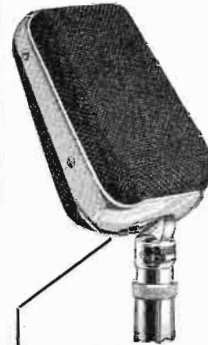

SELF-LOCKING  
TILTING  
HEAD

**Cannot be Acoustically Overloaded**

**NEW MULTI-UNIT Dual Diaphragm Crystal Microphone**

For night club and public address installations. Maximum amplification without feedback. Made in two models. MU-2 constructed with two dual diaphragm crystal units using four diaphragms. MU-4 uses four dual diaphragm crystal units and eight diaphragms. Black and chrome. Complete with three-prong interchangeable locking connector and 25-ft. cable.

List Prices

MU-2, \$29.50 :: MU-4, \$39.50



**MICROPHONE LABORATORY, INC.**

Dept. M-13, Youngstown, Ohio  
Licensed Under Brush Development Co. Patents

**KILOVOLTMETERS and KILOVOLT METER MULTIPLIERS**

Furnished to any specifications that may be encountered in the communication field. We are specialists in high voltage measurement.



Compact, highly insulated, high voltage multipliers readily adapted for broadcasting station transmitters, intermediate voltage power transmission and electron tube development.

Send for Bulletin 700-S

**SHALLCROSS MFG. CO.**  
Collingdale, Pa.



Donnelley Monitoring Service, Lake Bluff, Ill.  
**DOOLITTLE & FALKNER, INC.**, 7421 S. Loomis Blvd., Chicago, Ill.—frequency monitors.  
**GENERAL RADIO CO.**, 30 State St., Cambridge, Mass.—frequency standards, meters and monitors.  
**LAMPKIN LABS.**, Bradentown, Fla.—frequency meter.  
 Fred M. Link Co., New York City—frequency monitors.  
 Peterkin Radio Labs., Detroit, Mich.—frequency measurements.  
 Premier Crystal Labs., Inc., New York City—frequency meters.  
**RCA COMMUNICATIONS, INC.**, 66 Broad St., New York City—frequency measuring service.  
**RCA MANUFACTURING CO., INC.**, Camden, N. J.—frequency monitors.  
**STANDARD PIEZO CO.**, 126 Cedar St., Carlisle, Pa.—frequency meters, monitors, measuring service.  
 Washington Institute of Technology, Washington, D. C.—frequency monitoring.  
**WESTERN ELECTRIC CO.**, 195 Broadway, New York City—frequency monitors.

### Fuses

Jefferson Electric Co., Bellwood, Ill.  
**SUNDT ENGINEERING CO.**, 4238 Lincoln Ave., Chicago, Ill.

### Insulation—Molded and Laminated Plastics

**AMERICAN INSULATOR CORP.**, New Freedom, Pa.—molders.  
 Auburn Button Works, Inc., Auburn, N. Y.—molders.  
**BAKELITE CORPORATION**, 247 Park Ave., New York City.  
 Brandywine Fibre Products Co., Wilmington, Del.—laminated.  
 Chicago Molded Products Corp., Chicago, Ill.—molders.  
 Continental Diamond Fibre Co., Newark, Del.—laminated.  
**HARRY DAVIES MOLDING CO.**, 1428 N. Wells St., Chicago, Ill.—molders.  
 Erie Resistor Corp., Erie, Pa.—molders.  
 Formica Insulation Co., Cincinnati, Ohio.—laminated.  
 Franklin Fibre-Lamitex Corp., Wilmington, Del.—laminated.  
 General Electric Co., Schenectady, N. Y.—laminated.  
**GENERAL PLASTICS, INC.**, 100 Walek Rd., N. Tonawanda, N. Y.  
**MICA INSULATOR CO.**, 200 Varick St., New York City.—laminated.  
 Mitchell-Rand Insulation Co., Inc., New York City.  
 Nat'l Vulcanized Fibre Co., Wilmington, Del.—laminated.  
 Resinox Corp., Terre Haute, Ind.  
 Richardson Co., The, Cincinnati, Ohio—molders, laminated.  
**SYNTHANE CORPORATION**, Oaks, Pa.—laminated.  
**TAYLOR FIBRE CO.**, Norristown, Pa.—laminated.

### Laminations and Stampings

Aluminum Goods Mfg. Co., Manitowoc, Wis.  
 The American Rolling Mill Co., Middletown, Ohio.  
**M. D. HUBBARD SPRING CO.**, 613 Central Ave., Pontiac, Mich.  
 Hunter Pressed Steel Co., Lansdale, Penn.  
**THOMAS & SKINNER STEEL PRODUCTS CO.**, 1113 E. 23 St., Indianapolis, Ind.  
 F. R. Zierick Mfg. Works, New York City.

### Magnets

**CINAUDAGRAPH CORP.**, Stamford, Conn.  
 Crucible Steel Co. of America, New York City.  
**INDIANA STEEL PRODUCTS CO.**, 135 S. La Salle St., Chicago, Ill.  
 Taylor Wharton Co., Highbridge, N. J.  
**THOMAS & SKINNER STEEL PRODUCTS CO.**, 1113 E. 23 St., Indianapolis, Ind.

### Meters, Measuring Laboratory and Test Equipment

**AEROVOX CORP.**, 70 Washington St., Brooklyn, N. Y.—condenser & resistor bridge.  
 (Continued on page 36)

## ON THE Mainliner TOO



United Air Line's entire fleet of 53 transport planes operated over the company's New York — Chicago — California, and Seattle — San Diego airways.

IS EQUIPPED WITH UNITED ELECTRONIC GRAPHITE ANODE TUBES.

On the new 1938 type Mainliners, flying from coast to coast overnight—as it is on all flights—the pilot is in constant touch with his dispatcher by means of his radio transmitter.

UNITED ELECTRONICS TYPE 361-A is playing its part in the daily flying of 50,000 miles over United Air Line system, on which UNITED has flown 125,000,000 miles—an international record.

UNITED ELECTRONIC TRANSMITTING TUBES are always found in such places as the U. S. Bureau of Air Commerce, Lighthouse Service, Coast Guard, Signal Corp and other governmental departments where careful precision and expert craftsmanship are prime considerations.

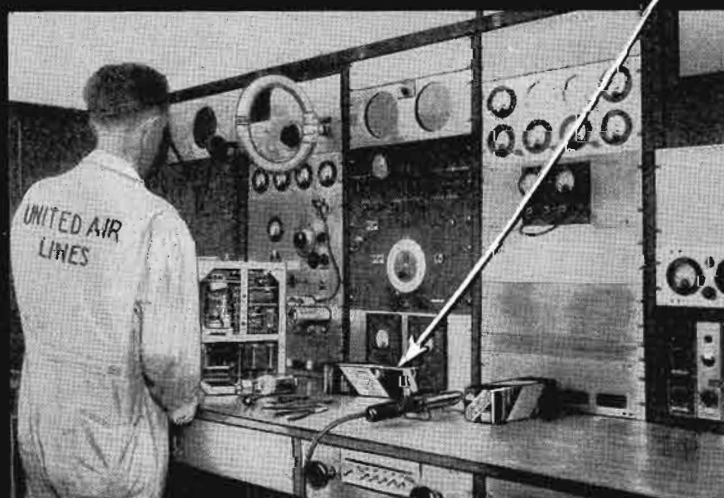

## UNITED ELECTRONICS COMPANY

42 Spring Street

Cable "UNELCO"

Newark, N. J.

# TAYLOR

**CUSTOM BUILT**

# TUBES

Have Approval for Broadcast Purposes

The Federal Communication Commission has approved these TAYLOR TUBES for broadcast purposes.

High Level Modulation or Plate Modulation in Last Radio Stage

TYPE	WATTS	TYPE	WATTS
T55	50	T155	125
841A	50	HD203A	125
203A	75	T200	250
211	75	204A	250
211C	75	814	250
Type 822		250 Watts	

Low Level Modulation or Last Radio Stage as Linear Power Amplifiers

TYPE	WATTS	TYPE	WATTS
203A	25	HD203A	50
211	25	T200	75
211C	25	204A	75
841A	25	814	75
Type 822		75 Watts	

Taylor Tubes can really "take it." The best test for any transmitting tube is "day after day" operation in actual work where the tube must be right twenty-four hours a day. TAYLOR TUBES have successfully passed the exhaustive test of actual performance in many of the worlds largest broadcast and police Transmitters. NOW TAYLOR SCORES AGAIN announcing a better 872-A which delivers true "More Watts Per Dollar" value.

## 872-A NEWER BETTER HEAVY DUTY



Half Wave Rectifier Tube has an entirely new design which has proven through actual operation its overwhelming superiority. Tube uses Speer Carbon Shield and Anode. Abusive life tests during the past eighteen months have convinced everyone who knows tube values that the TAYLOR 872-A sets a new standard in value and performance. Get a supply of these startling, new, heavy duty, half wave rectifiers at your Distributors. Every Taylor Tube carries an absolute guarantee of satisfactory long life, performance.

**NEW LOW PRICE** \$12.00

**TAYLOR TUBES, INC.**  
"More Watts Per Dollar"  
2341 Wabansia Ave.,  
Chicago, Ill.

Acme Electric & Mfg. Co., Cuba, N. Y.—insulation breakdown testers.  
**AMERICAN TRANSFORMER CO.**, 175 Emmet St., Newark, N. J.—transformer testing sets.  
 Victor J. Andrew, Chicago, Ill.—r-f ammeters, antenna impedance measuring sets.  
**BALLANTINE LABORATORIES**, Boonton, N. J.—electronic voltmeter.  
**ALFRED W. BARBER**, 35-33 172nd St., Flushing, N. Y.—impedance meters.  
 Bendix Radio Corp., Washington, D. C.—field intensity meters, tube and set testers.  
**BOONTON RADIO CORP.**, Boonton, N. J.—Q-meter, QX-checker, converter test oscillator, b-f generator.  
**THE BRUSH DEVELOPMENT CO.**, 3311 Perkins Ave., Cleveland, Ohio—oscilloscope units, high-speed pen recorder.  
 Burton-Rogers Co., Boston, Mass.—meters.  
 Clough-Brengle Co., Chicago, Ill.—signal generators, b-f oscillators, oscillographs, microvolts, frequency modulators, tube and set testers, v-t voltmeters, condenser & resistor bridges, decibel meters, etc.  
**TOBE DEUTSCHMANN CORP.**, Canton, Mass.—condenser & resistor testers, a-f graphic recorder.  
**DOOLITTLE & FALKNER, INC.**, 7421 S. Loomis Blvd., Chicago, Ill.—field-intensity meter, frequency monitors.  
**ALLEN B. DUMONT LABS., INC.**, 2 Main Ave., Passaic, N. J.—cathode-ray oscillographs. The Esterline-Angus Co., Indianapolis, Ind.—graphic recording instruments.  
**FEDERAL TELEGRAPH CO.**, Newark, N. J.—field-strength meter.  
**FERRANTI ELECTRIC, INC.**, 30 Rockefeller Plaza, New York City—electrostatic voltmeters.  
**FERRIS INSTRUMENT CORP.**, Boonton, N. J.—signal generators, microvolts, radio noise and field-strength meters, r-f calibrators.  
 General Electric Co., Schenectady, N. Y.—cathode-ray oscilloscopes, meters.  
**GENERAL RADIO CO.**, 30 State St., Cambridge, Mass.—heterodyne frequency meters, frequency monitors, stroboscopes, sound-level meters, standard signal generators, bridges, meters, oscillators.  
**THE HICKOCK ELEC. INST. CO.**, 10514 Dupont Ave., Cleveland, Ohio—meters, cathode-ray oscillographs.  
**LAMPKIN LABORATORIES**, Bradenton, Florida—micrometer frequency meter.  
 Leeds & Northrup Co., Philadelphia, Pa.—bridges, galvanometers, etc.  
**JOHN MECK INSTRUMENTS**, 160 N. May St., Chicago, Ill.—sound-level meters, signal generators, capacity meters, tube checkers.  
**MONARCH MFG. CO.**, Chicago, Ill.—signal generators, multivibrators, output meters, inductance & capacity bridges, v.t. voltmeters, db meters.  
 The Muter Co., Chicago, Ill.—resistance bridges, decade boxes.  
**RCA MANUFACTURING CO., INC.**, Camden, N. J.—field-strength meters, frequency monitors, modulation monitors, cathode-ray oscillographs, b-f oscillators, meters, etc.  
 Radio Engineering Labs., Inc., Long Island City, N. Y.—wavemeters.  
 Rawson Elec. Instrument Co., Cambridge, Mass.—ammeters, voltmeters, fluxmeters, multi-meters, electrostatic voltmeters, etc.  
 Roller-Smith Co., New York City—indicating and graphic instruments.  
 Sensitive Research Instrument Corp., New York City—meters.  
**SERVICE INSTRUMENTS, INC.**, 404 Fourth Ave., New York City—Chanalyst.  
**SHALLCROSS MFG. CO.**, Collingdale, Pa.—resistance and Wheatstone bridges, megohmeters, megohm voltmeters, milliohmeters, decade boxes.  
**SHURE BROTHERS**, 225 W. Huron St., Chicago, Ill.—acoustic laboratory equipment.



## NEW 1938 EDITION

Here's the only complete Handbook for students, amateurs, operators, and inspectors. It covers the entire field of radio in 1,000 pages with hundreds of illustrations and diagrams. It is actually a complete course of training in radio operation and a complete reference book for everyone in the field. It gives instantly the answer to every question about principles, methods, and apparatus of radio transmitting and receiving.

# THE RADIO MANUAL

The author, G. E. Sterling, is Assistant Chief, Field Section, Engineering Dept., Federal Communications Commission. The book is bound in durable flexible Fabrikoid.

### EXAMINE THIS BOOK FREE

D. VAN NOSTRAND CO., 250 Fourth Ave., New York  
 Send me on approval THE RADIO MANUAL. Within 5 days after I receive the book, I can return it and owe nothing. If I keep it, I will send you \$2.00 as first payment and I will pay \$2.00 monthly thereafter for 2 months—\$6.00 in all. (5% discount for cash.) C-9-38

Name .....

Address .....

City..... State.....

Reference .....

Address .....



## Frequency Measuring Service

Many stations find this exact measuring service of great value for routine observation of transmitter performance and for accurately calibrating their own monitors.

MEASUREMENTS WHEN YOU NEED THEM MOST

at any hour every day in the year

**R.C.A. COMMUNICATIONS, Inc.**

Commercial Dept.

A RADIO CORPORATION OF AMERICA SERVICE

66 BROAD STREET

NEW YORK, N. Y.



**SOLAR MFG. CORP.**, 599 Broadway, New York City—capacitor analyzers.

**SOUND APPARATUS CO.**, 150 W. 46 St., New York City—power-level recorder.

**STANDARD PIEZO CO.**, 126 Cedar St., Carlisle, Pa.—frequency meters.

**SUNDT ENGINEERING CO.**, 4238 Lincoln Ave., Chicago, Ill.—neobeam oscilloscope.

Tech Laboratories, 7 Lincoln St., Jersey City, N. J.—output meter volume indicators, special bridges.

**TELEVISO CO.**, 341-57 N. Pulaski Rd., Chicago, Ill.—microvolters, b-f oscillators.

**TRIPLETT ELECTRICAL INSTRUMENT CO.**, Bluffton, Ohio.—measuring instruments, test equipment.

Triumph Mfg. Co., Chicago, Ill.—cathode-ray oscillographs, oscillators, signal generators, meters.

United Sound Eng. Co., St. Paul, Minn.—oscillators, oscillographs.

**UNIVERSAL SIGNAL APPLIANCES**, 64 W. 22nd St., New York City—automatic tape recorders.

**WESTERN ELECTRIC CO.**, 195 Broadway, New York City—cathode-ray oscillographs, field-intensity meters, sound-level meters, etc.

Westinghouse Elec. & Mfg. Co., Pittsburgh, Pa.—instruments and meters.

**WESTON ELECTRICAL INST. CORP.**, 612 Frelinghuysen Ave., Newark, N. J.—ohmmeters, voltmeters, oscillators, volt-ohm-milliammeters, power-level indicators, output meters, etc.

### Microphones, Microphone Stands, Cutting Heads, Pickups, and Accessories

**AMERICAN MICROPHONE CO., INC.**, 1915 S. Western Ave., Los Angeles, Calif.—microphones, stands and accessories.

**AMPERITE COMPANY**, 561 Broadway, New York City—microphones and stands.

**ASTATIC MICROPHONE LAB., INC.**, 830 Market St., Youngstown, Ohio—microphones & accessories, pickups.

Atlas Sound Corp., Brooklyn, N. Y.—microphone stands.

**AUDAK COMPANY**, 500 Fifth Ave., New York City—pickups.

Beacon Microphone Co., Akron, Ohio.—microphones.

Bruno Laboratories, Inc., New York City, microphones, pickups.

**BRUSH DEVELOPMENT CO., INC.**, 3316 Perkins Ave., Cleveland, Ohio—microphones, microphone stands, pickups.

Bud Radio, Inc., Cleveland, Ohio—microphone stands.

Carrier Microphone Co., Inglewood, Calif.—microphones.

Daniel Electrical Labs., New York City—microphones.

**EASTERN MIKE-STAND CO.**, 56 Christopher Ave., Brooklyn, N. Y.—microphone stands.

Electro-Voice Mfg. Co., Inc., South Bend, Ind.—microphones & stands.

**FAIRCHILD AERIAL CAMERA CORP.**, Van Wyck Blvd., & Jamaica Ave., Jamaica, N. Y. pickups.

Garrard Sales Corp., New York City—pickups.

M. A. Gerrett Corp., Milwaukee, Wis.—microphone stands.

**LANSING MFG. CORP.**, 6900 S. McKinley Ave., Los Angeles, Calif.—pickups.

**RCA MANUFACTURING CO., INC.**, Camden, N. J.—microphones, pickups.

**RANGERTONE, INC.**, 201 Verona Ave., Newark, N. J.—recording heads.

Seairland Products Co., Kansas City, Mo.—microphones.

**SHURE BROTHERS**, 225 W. Huron St., Chicago, Ill.—microphones & stands, pickups.

**SOUND APPARATUS CO.**, 150 W. 46 St., New York City—recording & reproducing arms.

Transducer Corp., New York City—microphones.

The Turner Co., Cedar Rapids, Iowa.—microphones.

Unit Reproducers Corp., Rochester, N. Y.—pickups.

**UNIVERSAL MICROPHONE CO., LTD.**, Inglewood, Calif.—microphones, stands, accessories, cutting heads.

Upco Engineering Labs., New York City—pickups, cutting heads.

**WESTERN ELECTRIC CO.**, 195 Broadway, New York City—microphones.

Westinghouse Electric & Mfg. Co., Pittsburgh, Pa.—microphones.

(Continued on page 38)



## THE BRUSH S-16 PICKUPS GIVE *Life Insurance on Records*

★ With the Brush S-16 pickups, it is possible to accomplish hundreds of playbacks from direct recording acetate records before objectionable scratch is experienced. Were this feat attempted by pickups other than the Brush high fidelity type, complete ruination of the acetate recording would result.

★ Other features of this pickup include:

1. True reproduction with needle pressures as low as three-quarters of an ounce, and needle pressures conveniently adjustable in three positions up to two ounces for satisfactory reproduction under adverse conditions.
2. Permanent point, whose life is greater than 10,000 playings on shellacked pressings and after this time can be easily and economically replaced.
3. Perfect tracking with adjustable arm length from 12" to 16" and once adjusted for a particular turntable will remain fixed.
4. The arm swivel member is engaged by two combination thrust and radial ball bearings, permitting remarkably free movement of the arm.
5. Single set screw adjustment permitting height of arm variations from three-quarter inch to one and one-half inches, accommodating most any turntable.

This sort of protection and performance should be interesting to the recording enthusiast and every recording and broadcast engineer. Write for complete details.

**THE BRUSH DEVELOPMENT CO.**  
3316 Perkins Avenue  
CLEVELAND, OHIO

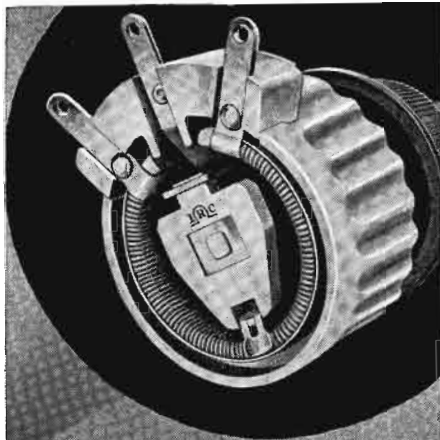

## DISSIPATE HEAT....

*Almost twice as fast!*

The 25 watts rating on the new IRC All Metal Rheostat means exactly what it implies: Use it *anywhere* up to its full rated load! Get more watts per dollar!

Temperature rise at full load is about half that of conventional rheostats, thanks to efficient utilization of the unique heat dissipating properties of aluminum. At full rotation and measured at the hottest spot, this rise is only 140° C. The full 25 watts may be applied across as little as one-quarter of the winding area with only a minor temperature of 20° C.

The IRC All Metal Rheostat is no larger in size—costs no more. Section VI of IRC Engineering Data on request—or send details of your application for our recommendation and sample unit.



## ALL METAL RHEOSTATS

**INTERNATIONAL RESISTANCE COMPANY**

415 N. Broad Street, Philadelphia, Pa.  
In Canada: 187 Duchess Street, Toronto, Ontario

## Power Supplies, Rectifiers, Voltage Regulators, Motors, Etc.

Acme Electric & Mfg. Co., Cuba, N. Y.—voltage regulators.

THE ALLIANCE MFG. CO., Alliance, Ohio—fractional horse power motors.

AMERICAN TRANSFORMER CO., 175 Emmett St., Newark, N. J.—rectifiers, voltage regulators.

AMPEREX ELECTRONIC PRODUCTS, INC., 79 Washington St., Brooklyn, N. Y.—rectifiers (tube).

The B-L Electric Mfg. Co., St. Louis, Mo.—copper sulphide magnesium rectifiers, battery chargers & eliminators, d-c power units.

Carter Motor Co., Chicago, Ill.—dynamotors, genomotors, converters.

COLLINS RADIO CO., 2920 First Ave., Cedar Rapids, Iowa—power supplies.

CONTINENTAL ELECTRIC CO., 715 Hamilton Ave., Geneva, Ill.—mercury-vapor rectifiers.

Delco Appliance Div. Rochester, N. Y.

Eicor, Inc., Chicago, Ill.—dynamotors, converters.

Eitel-McCullough, Inc., San Bruno, Calif.—rectifiers (tube).

Electric Specialty Co., Stamford, Conn.—generators, dynamotors, rotary converters.

Electronic Labs., Inc., Indianapolis, Ind.—polarity changers, power supplies & converters, vibrators.

Electronic Products, Los Angeles, Calif.—rectifiers (tube).

Federal Telegraph Co., Newark, N. J.—mercury-vapor rectifiers.

FERRANTI ELECTRIC, INC., 30 Rockefeller Plaza, New York City—rectifiers.

GATES RADIO & SUPPLY CO., Quincy, Ill.—power supplies.

General Electric Co., Schenectady, N. Y.—motor-generators, regulators.

HEINTZ & KAUFMAN, LTD., So. San Francisco, Calif.—portable engine generators, rectifiers.

International Tel. & Tel. Corp., New York City—scintum rectifiers.

Janette Mfg. Co., Chicago, Ill.—motors, motor-generator sets, rotary converters.

Kato Engineering Co., Mankato, Minn.—motors.

LEAR DEVELOPMENTS, INC., Roosevelt Field, Mineola, L. I., N. Y.—portable power supplies.

Fred M. Link Co., New York City—dynamotor and vibrator power units.

P. R. MALLORY & CO., INC., 3029 E. Washington St., Indianapolis, Ind.—vibrators, dry disc rectifiers.

Meissner Mfg. Co., Mt. Carmel, Ill.—vibrators.

D. W. ONAN & SONS, 43 Royalston Ave., Minneapolis, Minn.—electric generating plants.

Pauley-James Corp., Chicago, Ill.—vibrators.

Pioneer Gen-E-Motor Corp., Chicago, Ill.—dynamotors, genomotors, rotary converters.

The Radiart Corp., Cleveland, Ohio.—vibrators.

Raytheon Mfg. Co., Waltham, Mass.—voltage regulators, rectifiers, power supplies, battery chargers & eliminators.

Roller-Smith Co., New York City—voltage regulators.

SOLA ELECTRIC CO., 2525 Clybourn ave., Chicago, Ill.—voltage compensators.

STANDARD ELECTRICAL PRODUCTS CO., 317 Sibley St., St. Paul, Minn.—miniature motors.

SUNDT ENGINEERING CO., 4238 Lincoln Ave., Chicago, Ill.—surge protectors, arc suppressors.

TAYLOR TUBES, INC., 2341 Wabansia Ave., Chicago, Ill.—rectifiers (tube).

UNITED ELECTRONICS CO., 42 Spring St., Newark, N. J.—mercury rectifier tubes.

UNITED TRANSFORMER CORP., 72 Spring St., New York City—rectifiers, voltage regulators.

UTAH RADIO PRODUCTS CO., 812 Orleans St., Chicago, Ill.—vibrators.

### WHEN YOU CHANGE YOUR ADDRESS

Be sure to notify the Subscription Department of COMMUNICATIONS at 19 E. Forty-seventh St., New York City, giving the old as well as the new address, and do this at least four weeks in advance. The Post Office Department does not forward magazines unless you pay additional postage, and we cannot duplicate copies mailed to the old address. We ask your cooperation.

## Par-Metal

### RACKS and PANELS FOR BROADCAST USE



● Professional in design, construction and finish. Accurately machined to assemble with any rack or panel equipment. Complete line of metal accessories. Fully illustrated and described in our new catalogue No. 39. Send for your copy. It's free.

*Designed by Engineers for Engineers*

**PAR-METAL PRODUCTS CORP.**

3524 41st Street, Long Island City, N. Y.

On the Job—  
On Frequency!

## QUARTZ CRYSTALS

by

**STANDARD PIEZO CO.**  
CARLISLE, PA.

Overwhelming choice of the airlines and other discriminating commercial users.

• • •  
*South American Distributors Wanted*



WARD LEONARD ELECTRIC CO., Mt. Vernon, N. Y.—voltage regulators.  
 WESTERN ELECTRIC CO., 195 Broadway, New York City—rectifiers.  
 Westinghouse Electric & Mfg. Co., Bloomfield, N. J.—tube rectifiers.

## Recording and Transcription Equipment, Records, Etc.

Acoustic Consultants, Inc., New York City—magnetic tape recorders.  
 Harry Acton & Co., New York City—cutting & playback needles.  
**THE ALLIANCE MFG. CO.**, Alliance, Ohio—motors & turntables.  
 Allied Phono. & Record Mfg. Co., Hollywood, Calif.—recording blanks.  
 Allied Recording Products Co., New York City—recording equipment and needles.  
 Cellutone Record & Mfg. Co., Los Angeles, Calif.—recording blanks, styli, recording microscopes.  
 Electrical Research Products, Inc., New York City—lateral and vertical recording and reproducing equipment.  
 Electronic Sound Labs., Inc., Hollywood, Calif.—recording equipment.  
 Emar Instrument Corp., New York City—recording & reproducing equalizers, monitoring systems.  
**FAIRCHILD AERIAL CAMERA CORP.**, Van Wyck Blvd., & Jamaica Ave., Jamaica, L. I., N. Y.—portable and studio recorders.  
 Federal Recorder, New York City—recorders and discs.  
 Garrard Sales Corp., New York City—phonograph motors & assemblies, record changers, turntables, needles.  
**GATES RADIO & SUPPLY CO.**, Quincy, Ill.—transcription equipment.  
 M. A. Gerrett Corp., Milwaukee, Wis.—needles.  
 Holloway Co., New York City—recorders, turntables.  
 Mirror Record Corp., New York City—recording discs, needles.  
 Nash Radio Products Co., St. Louis, Mo.—record lube.  
 Phonograph Needle Supply Co., Providence, R. I.—needles.  
 Poinsettia, Inc., Pitman, N. J.—recording equipment & supplies.  
**PRESTO RECORDING CORP.**, 139 W. 19 St., New York City—recording discs, recording & reproducing equipment, needles, turntables.  
**RCA MANUFACTURING CO., INC.**, Camden, N. J.—transcription equipment, needles.  
 Radio Engineering & Mfg. Co., Jersey City, N. J.—turntables, transcription reproducers.  
**RADIOTONE, INC.**, 7356 Melrose Ave., Hollywood, Calif.—recorders, turntables, etc.  
**RANGERTONE, INC.**, 201 Verona Ave., Newark, N. J.—needles and recording accessories.  
**RECOTON CORP.**, 178 Prince St., New York City—needles.  
 Remler Co., Ltd., San Francisco, Calif.—transcription turntables.  
**SOUND APPARATUS CO.**, 150 W. 46 St., New York City—recording & reproducing machines, disc material, needles, recording microscopes, motors, equalizers, filters, etc.  
 Sound Products, Hollywood, Calif.—record players.  
**SOUND PROJECTS CO.**, 3140 N. Walton Ave., Chicago, Ill.—record players.  
 Sound Systems, Inc., Cleveland, Ohio—turntables.  
**UNIVERSAL MICROPHONE CO., LTD.**, Inglewood, Calif.—recording machines, discs, needles, etc.  
**UNIVERSAL SIGNAL APPLIANCES**, 64 W. 22 St., New York City—automatic tape recorders for code.  
**THE WEBSTER CO.**, 5622 Bloomingdale Ave., Chicago, Ill.—phonograph motors and assemblies.  
**WILCOX ELECTRIC CO.**, 1014 W. 37 St., Kansas City, Mo.—recording amplifiers.

## Relays

Advance Electric Co., Los Angeles, Calif.  
 Allen-Bradley Co., Milwaukee, Wis.  
 Allied Control Co., Inc., New York City.  
 American Automatic Electric Sales Co., Chicago, Ill.  
**L. S. BRACH MFG. CO.**, 55 Dickerson St., Newark, N. J.  
 Cinema Engineering Co., Hollywood, Calif.  
 Hugh H. Eby, Inc., Philadelphia, Pa.  
**GUARDIAN ELECTRIC CO.**, 1623 W. Walnut St., Chicago, Ill.  
 Heineken Machinery Corp., New York City.  
 Leach Relay Co., Los Angeles, Calif.  
 The Muter Co., Chicago, Ill.  
 Roller-Smith Co., New York City.  
 Sigma Instruments, Inc., Belmont, Mass.  
**STANDARD ELECTRICAL PRODUCTS CO.**, 317 Sibley St., St. Paul, Minn.  
 Struthers Dunn, Inc., Philadelphia, Pa.  
 United Cinephone Corp., Long Island City, N. Y.  
 (Continued on page 40)

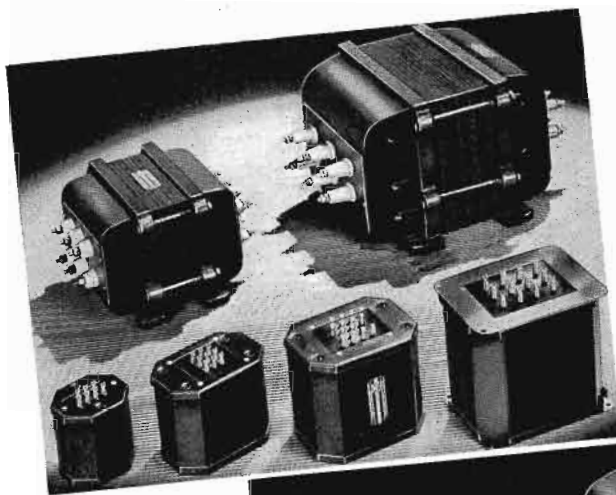

## VARIMATCH TRANSFORMERS

For every PA and amateur application.



## POWER SUPPLY COMPONENTS

For every commercial and broadcast application.

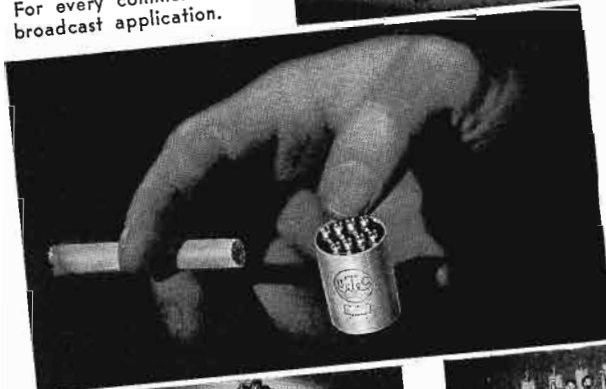

## OUNGER UNITS

One ounce audios for all low level applications.

## LINEAR STANDARD

Audio and power components from -100 Db. to 200 Kw.



## VARITRAN VOLTAGE CONTROLS

The ideal control for light, heat, line voltage, rectifier output.



DESCRIBED IN OUR NEW BULLETIN PS-403

## UNITED TRANSFORMER CORP.

72 SPRING STREET NEW YORK, N. Y.

EXPORT DIVISION • 100 VARICK STREET NEW YORK, N. Y. CABLES: "ARLAB"

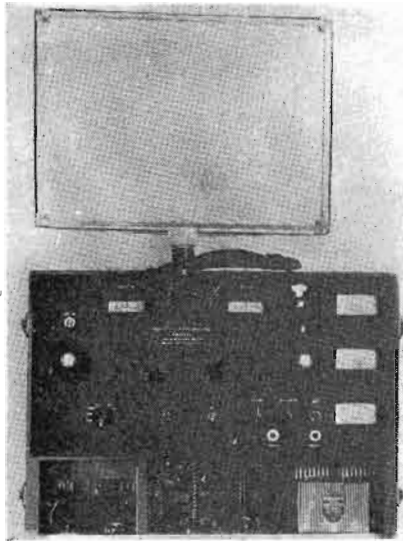

## FIELD INTENSITY METER

**T**HE Model RA Field Intensity Meter represents a long desired achievement. It fills the need for a precision instrument that is thoroughly reliable and efficient. The Model RA has been made compact and easily portable without sacrificing any of its outstanding operating characteristics. We will gladly send our bulletin, which describes the Model RA in detail, upon receipt of your request.



We offer you the services of a staff of Radio Transmission Engineers and Consultants who will make complete location and field intensity surveys as well as antenna resistance measurements and solutions of special design problems.



**We are Manufacturing Engineers and can supply**

1. Concentric Transmission Lines
2. U H F Monitors
3. Special Transmitters and Receivers

*and other radio transmitting equipment and supplies*

There are some territories in which we need representatives.

WRITE FOR DETAILS



**DOOLITTLE**  
and  
**FALKNOR** INC.  
7421 S. LOOMIS BLVD., CHICAGO, ILL.

WARD LEONARD ELECTRIC CO., 31 South St., Mt. Vernon, N. Y.  
WESTON ELECT. INST. CORP., 612 Frelinghuysen Ave., Newark, N. J.

## Resistors, Attenuators, Controls, Etc.

**AEROVOX CORP.**, 70 Washington St., Brooklyn, N. Y.—carbon resistors, fixed & adjustable wire-wound resistors.  
**Allen-Bradley Co.**, Milwaukee, Wis.—fixed and variable resistors.  
**Atlas Resistor Co.**, New York City—wire-wound tubular resistors.  
**Audio Products Co.**, Los Angeles, Calif.—attenuators.  
**The Carborundum Co.**, Niagara Falls, N. Y.—fixed resistors.  
**CENTRALAB**, 900 E. Keefe Ave., Milwaukee, Wis.—fixed & variable resistors.  
**Chicago Tel. Supply Co.**, Elkhart, Ind.—volume & tone controls.  
**Cinema Engineering Co.**, Hollywood, Calif.—resistors, attenuators.  
**CLAROSTAT MFG. CO., INC.**, 285 N. 6 St., Brooklyn, N. Y.—volume & tone controls, fixed wire resistors, attenuators, T & L pads, p-a controls, resistor tubes.  
**COLLINS RADIO CO.**, 2920 First Ave., Cedar Rapids, Iowa—attenuators.  
**CONTINENTAL CARBON, INC.**, 13900 Lorain Ave., Cleveland, Ohio—carbon & wire-wound resistors, suppressors.  
**THE DAVEN CO.**, 158 Summit St., Newark, N. J.—volume controls, attenuators.  
**Erie Resistor Corp.**, Erie, Pa.—carbon resistors.  
**FERRANTI ELECTRIC, INC.**, 30 Rockefeller Plaza, New York City—attenuators.  
**GENERAL RADIO CO.**, 30 State St., Cambridge, Mass.—resistors.  
**Hardwick, Hindle, Inc.**, Newark, N. J.—fixed & adjustable resistors, rheostats.  
**INTERNATIONAL RESISTANCE CO.**, 401 N. Broad St., Philadelphia, Pa.—metallized resistors, volume controls, attenuators, power rheostats, wire-wound resistors, precision resistors.  
**Lectrohm, Inc.**, Cicero, Ill.—fixed & variable enameled resistors, wire-wound resistors.  
**Leeds & Northrup Co.**, Philadelphia, Pa.—precision resistors, resistance standards.  
**P. R. MALLORY & CO., INC.**, 3029 E. Wash. St., Indianapolis, Ind.—volume control, rheostats, potentiometers, wire-wound resistors.  
**Micamold Radio Corp.**, Brooklyn, N. Y.—resistors, ballast tubes.  
**Morrill & Morrill**, New York City—resistors.  
**The Muter Co.**, Chicago, Ill.—resistors, plug-in resistors.  
**OHMITE MANUFACTURING CO.**, 4835 W. Flournoy St., Chicago, Ill.—rheostats, resistors, precision resistors, line-cord resistors, T & L pads, dummy antennas.  
**PRECISION RESISTOR CO.**, 334 Badger Ave., Newark, N. J.—precision wire-wound resistors, potentiometers, power resistors.  
**Remler Co., Ltd.**, San Francisco, Calif.—attenuators.  
**SHALLCROSS MFG. CO.**, Collingdale, Pa.—wire-wound resistors, surge resistors.  
**Speer Carbon Co.**, St. Marys, Pa.—carbon & wire-wound resistors.  
**Stackpole Carbon Co.**, St. Marys, Pa.—carbon resistors, volume & tone controls.  
**States Co.**, The, Hartford, Conn.—non-inductive resistors.  
**Tech Laboratories**, 7 Lincoln St., Jersey City, N. J.—attenuators, resistors.  
**UTAH RADIO PRODUCTS CO.**, 820 Orleans St., Chicago, Ill.—resistors, volume controls.  
**WARD LEONARD ELECTRIC CO.**, 31 South St., Mt. Vernon, N. Y.—wire-wound resistors, rheostats.  
**S. S. White Dental Mfg. Co.**, The, New York City—molded resistors, flexible shafts.  
**Wirt Co.**, Philadelphia, Pa.—resistors.

## Screws

**American Screw Co.**, Providence, R. I.  
**Continental Screw Co.**, New Bedford, Mass.  
**Corbin Screw Corp.**, New Britain, Conn.  
**Elastic Stop Nut Corp.**, Elizabeth, N. J.  
**National Screw & Mfg. Co.**, Cleveland, Ohio.  
**Parker-Kalon Corp.**, New York City.  
**Russell, Burdall & Ward Bolt & Nut Co.**, Port Chester, N. Y.  
**SHAKEPROOF LOCK WASHER CO.**, 2533 N. Keeler Ave., Chicago, Ill.

## Sockets, Jacks, Plugs, Switches, Terminal Strips, Etc.

**Adlen Mfg. Co.**, Brockton, Mass.  
**American Phenolic Corp.**, Chicago, Ill.  
**American Radio Hardware Co., Inc.**, N. Y. C.

## STUDIO QUALITY IN A PORTABLE RECORDER

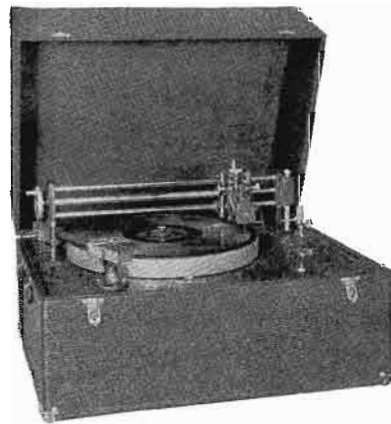

Recording technicians are amazed at the perfect studio quality of work produced on the **RADIOTONE PR-16** Portable Recorder. This 16-inch, dual-speed Recorder has numerous features that make it most flexible as well as giving it most faithful reproduction. Write today for facts.

*Radiotone Inc.*

7356 Melrose Ave., Hollywood, Cal.  
620 N. Michigan Ave., Chicago, Ill.

## Waxes Compounds Varnishes

FOR INSULATION  
OF CONDENSERS

Transformers, coils, power packs, pot heads, sockets, wiring devices, wet and dry batteries, etc. Also **WAX SATURATORS** for braided wire and tape. **WAXES** for radio parts. Compounds made to your own specifications if you prefer.

● **ZOPHAR MILLS, INC.**

Founded 1846  
120—26th Street  
Brooklyn, N. Y.



Bastian Brothers Co., Rochester, N. Y.  
 Birnbach Radio Corp., New York City.  
 Bud Radio, Inc., Cleveland, Ohio—sockets, jacks, plugs.  
**CENTRALAB**, 900 E. Keefe Ave., Milwaukee, Wis.—wave change & tone switches.  
 Chicago Tel. Supply Co., Elkhart, Ind.—switches, jacks, plugs.  
 Cinch Mfg. Corp., Chicago, Ill.—sockets, plugs.  
**CONTINENTAL ELECTRIC CO.**, 715 Hamilton Ave., Geneva, Ill.—vacuum power switches.  
**THE DAVEN CO.**, 158 Summit St., Newark, N. J.—rotary switches.  
 Hugh H. Eby, Inc., Philadelphia, Pa.—sockets, plugs, switches, binding posts, terminal strips.  
**A. W. FRANKLIN MFG. CO.**, 175 Varick St., New York City—sockets, terminal strips.  
 The Gamewell Co., Newton Falls, Mass.—cam-level switch.  
**HAMMARLUND MFG. CO.**, 424 W. 33 St., New York City—sockets.  
**IDEAL COMMUTATOR DRESSER CO.**, 1062 Park Ave., Sycamore, Ill.—connectors.  
 Insuline Corp. of America, New York City—radio parts.  
 E. F. Johnson Co., Waseca, Minn.—sockets, plugs, jacks.  
**HOWARD B. JONES**, 2300 Wabansia Ave., Chicago, Ill.—plugs, connectors, sockets, terminal panels, jacks.  
**P. R. MALLORY & CO., INC.**, 3029 E. Washington St., Indianapolis, Ind.—switches.  
 Meissner Mfg. Co., Mt. Carmel, Ill.—sockets, switches.  
 The Muter Co., Chicago, Ill.—switches.  
 Oak Manufacturing Co., Chicago, Ill.—switches, sockets.  
**OHMITE MANUFACTURING CO.**, 4835 W. Flournoy St., Chicago, Ill.—switches.  
**SHALLCROSS MFG. CO.**, Collingdale, Pa.—tap switches.  
 Struthers Dunn, Inc., Philadelphia, Pa.—limit switches.  
**TECH LABORATORIES**, 7 Lincoln St., Jersey City, N. J.—switches.  
 Technical Devices Corp., Bloomfield, N. J.  
**UTAH RADIO PRODUCTS CO.**, 820 Orleans St., Chicago, Ill.—plugs, switches, jacks.  
**WHOLESALE RADIO SERVICE CO.**, 100 6th Ave., New York City—parts.

## Solder, Soldering Irons, Etc.

**L. S. BRACH MFG. CO.**, 55 Dickerson St., Newark, N. J.—solder, soldering irons.  
 Drake Elec. Works, Inc., Chicago, Ill.—soldering irons and solder pots.  
 Electric Soldering Iron Co., Deep River, Conn.—electric soldering irons, temperature control for welding irons.  
**GARDINER METAL CO.**, 4820 S. Campbell Ave., Chicago, Ill.—rosin and acid core solders—wire, bar.  
**IDEAL COMMUTATOR DRESSER CO.**, 1062 Park Ave., Sycamore, Ill.—electric soldering tools.  
 Kester Solder Co., Chicago, Ill.—solder.  
 The Ruby Chemical Co., Columbus, Ohio—solder, soldering & tinning flux.  
 Sta-Warm Electric Co., Ravenna, Ohio—electric soldering irons, solder pots, wax pots and pouring heaters.

## Speakers, Headphones, Horns, Etc.

Arlavox Mfg. Co., Chicago, Ill.—speakers.  
 Atlas Sound Corp., Brooklyn, N. Y.—speakers, speaker baffles, enclosures, speaker trumpets, supports and fixtures.  
**BRUSH DEVELOPMENT CO.**, 3311 Perkins Ave., Cleveland, Ohio—tweeters, headphones.  
 C. F. Cannon Co., Springwater, N. Y.—headphones.  
 Chicago Tel. Supply Co., Elkhart, Ind.—headphones.  
**CINAUDAGRAPH CORP.**, Stamford, Conn.—speakers, horns.  
 Fox Sound Equip. Corp., Toledo, Ohio—speakers.  
**JENSEN RADIO MFG. CO.**, 6601 S. Laramie Ave., Chicago, Ill.—speakers.  
**LANSING MFG. CO.**, Los Angeles, Calif.—radio, p-a and theatre speakers.  
 The Magnavox Co., Inc., Ft. Wayne, Ind.—speakers.  
 Operadio Mfg. Co., St. Charles, Ill.—speakers.  
**OXFORD-TARTAK RADIO CORP.**, 915 W. Van Buren St., Chicago, Ill.—speakers, horns, baffles, field exciters, etc.  
 Quam-Nichols Co., Chicago, Ill.—speakers.  
**RCA MANUFACTURING CO., INC.**, Camden, N. J.—speakers, horns.  
**RACON ELEC. CO., INC.**, 52 E. 19 St., New York City—speakers, baffles, horns, tweeters, woofers, sound chambers.  
 The Rola Co., Cleveland, Ohio—speakers.  
 (Continued on page 42)

# LEAR AIRCRAFT Radio Equipment

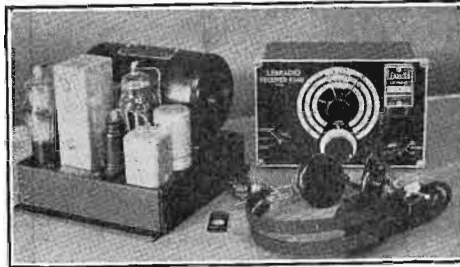

## ● LEARADIO CRYSTAL CONTROLLED RECEIVER

The R-3-AB is the first receiver with crystal holder plug provided on face of receiver with a crystal switch, allowing crystal locked reception of any frequency on any of the three bands—Beacon, Broadcast and Communication.

The tuning section, separated from amplifier section, reduces size and weight.

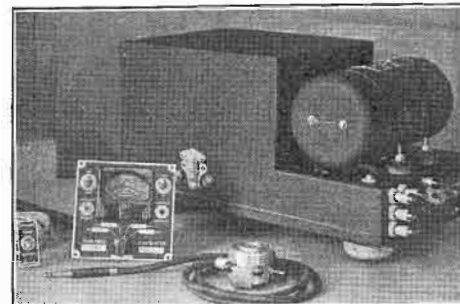

## ● LEARADIO UT-6 SIX-FREQUENCY TRANSMITTER

Furnishes pilot almost instantaneous choice of transmission on six frequencies. No adjustments—simple to operate and install. 30 to 40 watts. Compact and light-weight (28 lbs.).

Interphone, sidetone. Excellent voice and MCW. Built to meet Army, Navy and Department of Commerce specifications.

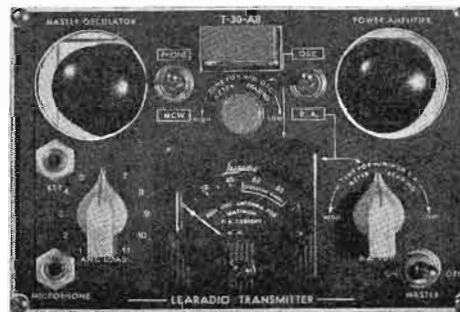

## ● LEARADIO T-30-AB TRANSMITTER

Remote, crystal controlled. 30 watts on phone or MCW. Weighs 19 lbs. A complementary unit to the R-3-AB receiver, the combination of which weighs only 28 pounds, complete with cables.

Advanced performance, minimum weight and low price.

## ● LEARADIO PORTABLE GROUND STATION

Designed and produced for aircraft and mining operations in the South Seas. Complete from portable doublet antenna reels to spare tubes and tool kit. Gasoline engine generator—three separate transmitters—three-band receiver—one common dynamotor and power supply. We study YOUR needs and supply 100 per cent satisfactory rig. We test under your field conditions.

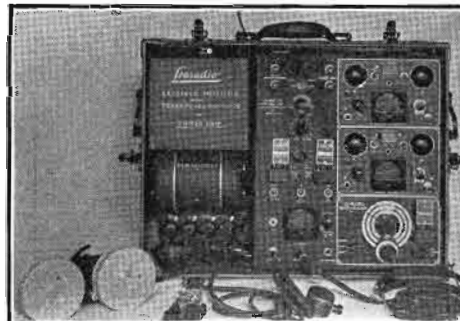

## ● NEW LEARADIO COMPASS AND AUTOMATIC DIRECTION FINDER

Something really fine, better performance in all respects, more sensitive, more accurate, more selective, more stable, easier to tune, wider tuning range (180 to 405 KC and 500 to 6700 KC), less affected by extreme temperatures, humidity etc. Better protected from corrosion. Less weight, smaller size, new dynamotor operation—and, best of all, bearing accuracy is unaffected by maladjustment. Automatic loop orientation is a new Learadio feature. Write for details and performance figures on the new Learadio ARC-6.



**GROUND STATIONS  
 AUXILIARY POWER PLANTS  
 AIRCRAFT RADIO  
 PORTABLE RADIOS  
 ULTRA HIGH FREQUENCY**

Ask for further data. Whatever your requirements for aircraft communication or direction finding equipment, investigate LEARADIO before deciding. We carry a complete line of tuning units, insulators, wire, switches, relays, etc.

**Engineering, Installation and Service on  
 All Types of Aircraft Radio**

## LEAR DEVELOPMENTS

**ROOSEVELT FIELD**

**INCORPORATED**

**MINEOLA, N. Y.**

Export Dept., 17 State Street, New York, N. Y.—Cable Address: LEARVELOP  
 Telephones: GARDEN CITY 2840 — VIGILANT 4-6380 (Direct N. Y. Wire)





## PILOT LIGHT ASSEMBLIES

*Do the Job Better, Faster and More Economically!*

Drake Pilot and Jewel Light Assemblies are built to highest standards . . . yet cost no more than ordinary types. . . Drake offers you a more complete selection of . . . Standard Types . . . Special Types . . . "Underwriters Approved" Types . . . Bayonet, Screw and Bracket Types . . . Jewel Types . . . and hundreds of others. Send for Free Catalog.

**★ENGINEERS:** Drake Assemblies are designed with a safety factor adequate to meet varying conditions in the field. Materials are finest grade. Our engineers will cooperate with you on your Pilot Light problems . . . no obligation.

**DRAKE MANUFACTURING CO.**  
1711 W. Hubbard St., Chicago, U.S.A.

**Compressed Nitrogen Condenser** TYPE 174

**IMPROVED**

Neoprene gaskets  
Corona shields  
Safety gap  
Increased break-down voltage



RATINGS: (at 1 mc.)  
PEAK VOLTS 40,000  
R. M. S. AMPERES 80

**HEINTZ AND KAUFMAN**  
SOUTH CALIFORNIA  
SAN FRANCISCO U.S.A.

Unit Reproducers Mfg. Co., Rochester, N. Y.—speakers.  
University Labs., New York City—speakers, horns, etc.  
**UTAH RADIO PRODUCTS CO.**, 820 Orleans St., Chicago, Ill.—speakers.  
**WESTERN ELECTRIC CO.**, 195 Broadway, New York City—speakers, horns, etc.  
Wright-DeCoster, Inc., St. Paul, Minn.—speakers.

## Transformers, Chokes, Reactors, Filters, Etc.

Acme Elec. Mfg. Co., Cuba, N. Y.—transformers.  
**AMERICAN TRANSFORMER CO.**, 175 Emmet St., Newark, N. J.—All types of transformers, reactors, etc.  
Anaconda Wire & Cable Corp., Muskegon, Mich.  
Arlavox Mfg. Co., Chicago, Ill.—transformers.  
Barker & Williamson, Ardmore, Pa.—transmitting inductances.  
Chicago Transformer Corp., Chicago, Ill.—transformers.  
**COLLINS RADIO CO.**, 2920 1st Ave., Cedar Rapids, Iowa—equalizers.  
**CONTINENTAL CARBON, INC.**, 13900 Lorain Ave., Cleveland, Ohio—filters.  
Coto-Coil Co., Inc., Providence, R. I.—chokes, inductors.  
**TOBE DEUTSCHMANN CORP.**, Canton, Mass.—filters.  
Dongan Elec. Mfg. Co., Detroit, Mich.—transformers, filters.  
**DOOLITTLE & FALKNER, INC.**, 7421 S. Loomis Blvd., Chicago, Ill.—transformers, chokes, filters.  
**FERRANTI ELECTRIC, INC.**, 30 Rockefeller Plaza, New York City—transformers, reactors, equalizers, filters.  
Franklin Transformer Mfg. Co., Minneapolis, Minn.—transformers, filters, reactors.  
Freed Transformer Co., New York City—transformers.  
General Transformer Corp., Chicago, Ill.—transformers.  
The Halldorson Co., Chicago, Ill.—transformers, reactors.  
**HAMMARLUND MFG. CO., INC.**, 424 W. 33 St., New York City—transformers.  
Jefferson Electric Co., Bellwood, Ill.—transformers, chokes.  
E. F. Johnson Co., Waseca, Minn.—inductors.  
Kenyon Transformer Co., Inc., New York City—transformers, reactors, chokes.  
J. W. Miller Co., Los Angeles, Calif.—coils, chokes, filters.  
**OHMITE MANUFACTURING CO.**, 4835 W. Flournoy St., Chicago, Ill.—chokes.  
Phelps Dodge Copper Prod. Corp., Los Angeles, Calif.—transformers.  
Raytheon Mfg. Co., Waltham, Mass.—transformers.  
**SOLA ELECTRIC CO.**, 2525 Clybourn Ave., Chicago, Ill.—transformers.  
**STANDARD ELECT. PROD. CO.**, 317 Sibley St., St. Paul, Minn.—transformers.  
Standard Transformer Co., Chicago, Ill.—transformers.  
Teck Laboratories, 7 Lincoln St., Jersey City, N. J.—equalizers.  
Technical Appliance Corp., New York City—filters.  
Thordarson Electric Mfg. Co., Chicago, Ill.—transformers, chokes.  
**UNITED TRANSFORMER CORP.**, 72 Spring St., New York City—transformers, reactors, equalizers, X-ray and television transformers.  
**UTAH RADIO PRODUCTS CO.**, 820 Orleans St., Chicago, Ill.—transformers.  
Westinghouse Elec. & Mfg. Co., Pittsburgh, Pa.—transformers, reactors.  
Whisk Laboratories, New York City—balancing and power filters.

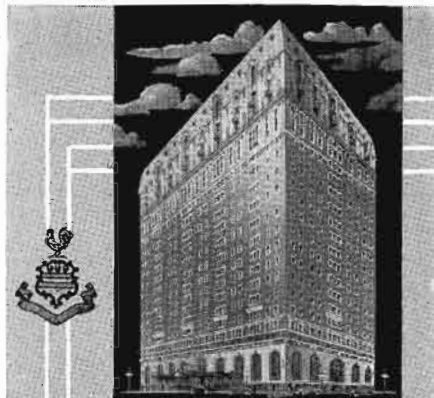

*Prestige*

The Blackstone is world-famous as an address of distinction in Chicago. Here graceful living is enjoyed by the discriminating traveler.

*"Where Elegance Is Not Extravagance"*

A. S. KIRKEBY,  
Managing Director

**The Blackstone**  
MICHIGAN AVENUE · CHICAGO



**HOTEL CHELSEA** ON THE BOARDWALK ATLANTIC CITY, N. J.

**AS FRIENDLY AS YOUR HOME**

**OFFERS EVERYTHING YOU HAVE THE RIGHT TO EXPECT IN A RESORT HOTEL**

Each member of the family will find diversion . . . Concerts and dinner music by artists of the Phila. Orchestra • Luncheon served guests in bathing attire on our open air dining terrace • Restricted beach • Bathing from rooms • Dancing • Bar • Sundecks • Social Director • Kindergarten • Noted cuisine.

Rates for Room, Bath, Meals, Based as Low as (on a weekly stay, per person, 2 in a room)

**\$6.30**  
**DAILY**



## Transmission Lines

Victor J. Andrew, Chicago, Ill.  
**COLLINS RADIO CO.**, 2920 1st Ave., Cedar Rapids, Iowa.  
 Communication Products, Inc., Jersey City, N. J.  
**DOOLITTLE & FALKNER, INC.**, 7421 S. Loomis Blvd., Chicago, Ill.  
**ISOLANTITE, INC.**, 233 Broadway, New York City.  
 E. F. Johnson Co., Waseca, Minn.  
 General Cable Corp., New York City.  
 Transducer Corp., New York City.  
**WESTERN ELECTRIC CO.**, 195 Broadway, New York City.

## Transmitting Equipment —Broadcast, Aeronautical, Marine, Police; High-Frequency Receivers & Associated Apparatus

Victor J. Andrew, Chicago, Ill.—custom built communication equipment.  
 Barker & Williamson, Ardmore, Pa.—transmitting inductances, band-switching devices, custom-built transmitters, etc.  
 Bendix Radio Corp., Baltimore, Md.—high-frequency transmitters, synchronizers, modulation monitors, etc.  
 Cinema Engineering Co., Hollywood, Calif.—sound, communication equipment.  
**COLLINS RADIO CO.**, 2920 1st Ave., Cedar Rapids, Iowa—broadcast, aeronautical, marine and police transmitters; broadcast amplifiers and speech-input equipment; volume limiting amplifiers, line equalizers, etc.  
 Commercial Radio Equip. Co., Kansas City, Mo.—broadcast amplifiers, preamplifiers.  
**THE DAVEN CO.**, 158 Summit St., Newark, N. J.—speech-input control apparatus, mixer panels, line equalizers.  
**DOOLITTLE & FALKNER, INC.**, 7421 S. Loomis Blvd., Chicago, Ill.—broadcast, aircraft, police transmitters, police receivers, special equipment to specifications.  
 Electronic Sound Labs, Inc., Hollywood, Calif.—radio transmitters.  
**FEDERAL TELEGRAPH CO.**, Newark, N. J.—transmitters.  
**FINCH TELECOMMUNICATIONS LABS., INC.**, 37 W. 57 St., New York City—facsimile transmitters and receivers.  
**GATES AMERICAN CORP.**, Quincy, Ill.—broadcast, airport and police transmitters; broadcast studio and remote equipment.  
 General Electric Co., Schenectady, N. Y.—aircraft and police transmitters and receivers, high-frequency apparatus.  
**GENERAL RADIO CO.**, 30 State St., Cambridge, Mass.—frequency and modulation monitors, power-level indicators, volume controls.  
**HAMMARLUND MFG. CO.**, 424 W. 33 St., New York City—communication receivers.  
 Harvey Radio Labs., Cambridge, Mass.—police radio systems, marine radio-telephonic installations, airport ground stations, general communication equipment.  
**HEINTZ & KAUFMAN, LTD.**, San Francisco, Calif.—radio transmitters.  
 Howard Radio Co., Chicago, Ill.—communication receivers.  
 Charles F. Jacobs, New York City—antenna spreaders, r-f feedline separators.  
 E. F. Johnson Co., Waseca, Minn.—“Q” antennas, antenna equipment, broadcast equipment.  
**LEAR DEVELOPMENTS, INC.**, Roosevelt Field, Mineola, L. I., N. Y.—aircraft transmitters, receivers, direction finders, ground stations, antenna reels, antenna insulators.  
 Fred M. Link Co., New York City—police transmitters, receivers; special radio products.  
 National Co., Inc., Malden, Mass.—communication receivers.  
**PAR-METAL PRODUCTS CORP.**, 3525 41 St., Long Island City, N. Y.—relay racks, rack and panel equipment.  
**RCA MANUFACTURING CO., INC.**, Camden, N. J.—broadcast transmitters, marine radio equipment, aviation and police radio, television equipment.  
 Radio Engineering Labs., Inc., Long Island City, N. Y.—police, aircraft, marine and fire radio equipment.  
 Radio Eng. & Mfg. Co., Jersey City, N. J.—portable transmitting equipment, amplifiers.  
 Radio Frequency Labs., Inc., Boonton, N. J.—aircraft transmitters and receiving equipment.  
 Radio Receptor Co., Inc., 251 W. 19 St., New York City—transmitters, aeronautical and marine radio equipment.  
 (Continued on page 44)

# SIMPLEX *backlash eliminating* RECORDER

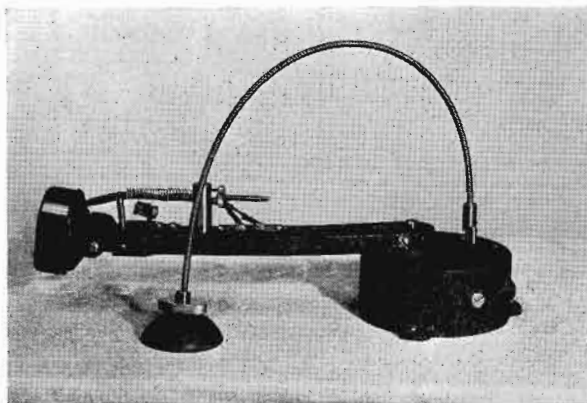

This unique, precision-made cutting unit, completely self-contained, embodies many features not to be found in higher priced recorders. It is designed for easy installation on all types of turntables. It is simple to operate, efficient and foolproof.

All grooves are cut uniformly 1/100 inch apart to permit high-intensity levels. Will feed inside out or outside in. When the flexible shaft is attached to a separate phonograph motor having a speed regulator, the number of grooves to be cut per inch may be changed to any number, even while recording.

Backlash is eliminated by the exclusive, automatic gear train buffer system which may be manually adjusted for special purposes. Adjustments for needle pressure and degree of cutting angle are incorporated. Models for cutting 12" and 16" records are available.

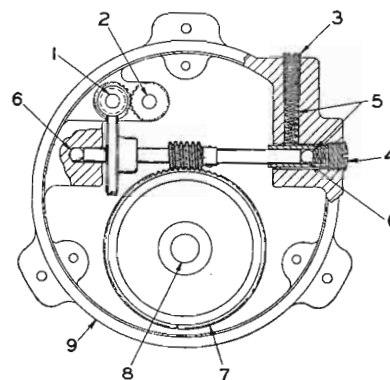

### Features of the Recorder Mechanism

- |  |                                      |
|--|--------------------------------------|
| 1. To flexible shaft and turntable (feeding outside in). | 4. Axial take-up screw (adjustable). |
| 2. To flexible shaft and turntable (feeding inside out). | 5. Compression springs.              |
| 3. Radial take-up screw (adjustable).                    | 6. Hardened thrust balls.            |
|  | 7. Precision worm gear.              |
|  | 8. Recorder arm shaft.               |
|  | 9. Oil packed housing.               |

Complete technical data sent upon request.

**SOUND APPARATUS Co.**  
 150 West 46th St., New York, N. Y.

# FERROCART

**Cores for permeability tuned push-button systems**

featuring:

1. Low frequency drift
2. Easy adjustment
3. Compact and economical
4. Close tolerance

■ Prompt deliveries of any large quantity of cores in various permeabilities as well as of high Q or high permeability for antenna, r-f and oscillator coils. Also standard designs of screw cores, pot cores, etc.

*Inquiries invited.*

## FERROCART

CORPORATION OF AMERICA  
Hastings-on-Hudson, N. Y., U. S. A.

**BUILT TO DO A BETTER P. A. JOB**

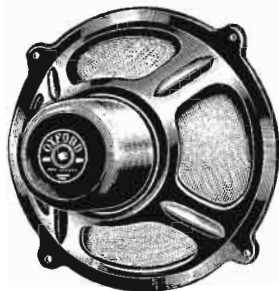

## IMPROVED OXFORD PERMAG SPEAKERS

Stepped-up in sensitivity, and otherwise improved in construction—Oxford Permag (Permanent Magnet) Speakers specially developed for Public Address and Intercommunicating Systems now enable sound engineers to do a better job at no more cost. Available in convenient stock sizes from 3 inches to 14 inches—or special units designed to meet specifications. Write today for complete information.

New York Office: 27 Park Pl., New York

**OXFORD-TARTAK**  
RADIO CORPORATION  
915 W. VAN BUREN ST. • CHICAGO, U. S. A.

**RADIO TRANSCEIVER LABS.**, 8627 115th St., Richmond Hill, N. Y.—high-frequency transmitters and receivers, u-h-f portable and pack transmitters and receivers.  
**Sound Products**, Hollywood, Calif.—aircraft and police radio, ship radio-telephone transmitters.  
**TELEVISO CO.**, 341-57 N. Pulaski Rd., Chicago, Ill.—broadcast transmitters, blind-landing aids.  
**Transmitter Equipment Mfg. Co., Inc.**, New York City—transmitters for broadcast, police, fire, marine and aviation services; police, fire, marine receivers.  
**WESTERN ELECTRIC CO.**, 195 Broadway, New York City—broadcast, police, marine and aviation radio equipment; speech-input units, amplifiers, etc.  
**Westinghouse Elec. & Mfg. Co.**, Baltimore, Md.—transmitting equipment.  
**WHOLESALE RADIO SERVICE CO.**, 100 6th Ave., New York City—transmitting equipment.  
**WILCOX ELECTRIC CO.**, 1014 W. 37 St., Kansas City, Mo.—airline and police radio equipment; broadcast amplifiers; speech-input equipment.

## Tube Machinery

**Distillation Products, Inc.**, Rochester, N. Y.—vacuum pumps.  
**EISLER ENGINEERING CO.**, 750 S. 13 St., Newark, N. J.—complete equipment for the production of radio and electronic tubes.  
**Kahle Engineering Corp.**, North Bergen, N. J.

## Tube Parts & Materials, Shields

**Aluminum Goods Mfg. Co.**, Manitowoc, Wis.—tube shields, special stampings.  
**The American Brass Co.**, Waterbury, Conn.—tube parts.  
**American Electro Metal Corp.**, Lewiston, Me.—tube parts and materials.  
**AMERICAN LAVA CORP.**, Chattanooga, Tenn.—ceramic, steatite, porcelain tube parts.  
**Brandywine Fibre Products Co.**, Wilmington, Del.—spacers, ferrules, bushings, grommets from fibre.  
**CALLITE PRODUCTS DIVISION**, 542 39th St., Union City, N. J.—tungsten and molybdenum rods, sheets, wire, contacts, grids, coils, supports, etc.; fluorescent tubing and materials; precious metal contacts.  
**Corning Glass Works**, Corning, N. Y.—glass.  
**HENRY L. CROWLEY CO.**, West Orange, N. J.—ceramic parts.  
**DeMuth Glass Works, Inc.**, Brooklyn, N. Y.—glass envelopes.  
**Driver-Harris Co.**, Harrison, N. J.—alloy wires.  
**WILBUR B. DRIVER CO.**, 150 Riverside Ave., Newark, N. J.—filament wire, carbonized plates for radio tubes.  
**Fansteel Metallurgical Corp.**, North Chicago, Ill.—tube parts and materials.  
**GOAT RADIO TUBE PARTS, INC.**, 314 Dean St., Brooklyn, N. Y.—tube shields, parts; grid cap clips; stampings.  
**International Nickel Co., Inc.**, New York City—nickel, nickel alloys.  
**King Laboratories, Inc.**, Syracuse, N. Y.—getters.  
**Newark Wire Cloth Co.**, Newark, N. J.—wire cloth.  
**Speer Carbon Co.**, St. Marys, Pa.—graphite anodes.  
**Summerill Tubing Co.**, Bridgeport, Pa.—seamless tubing.

## OVER THE TAPE

(Continued from page 31)

### MACQUARIE BROADCASTING SERVICES

Macquarie Broadcasting Services Pty. Ltd., has been formed with a capitalization of one million dollars, according to announcement by R. E. Denison.

Sir Hugh Denison is chairman of the board, with the other directors including R. E. Denison, N. L. Shaw, Frederick Daniell, C. Don Service and S. S. Crick. Mr. Daniell will serve as executive director of the board and George Millar as secretary.

The new group owns and operates stations 2GB and 2UE in Sydney. It has also formed a cooperating network group to include: 2CA, Canberra; 2GB and 2UE, Sydney; 2WL, South Coast; 2HR, Swan Hill; 4BH, Brisbane; 5DN, Adelaide; 5RM, Renmark; 6PR, Perth and 6KG, Kalgoorlie.

Dr. Ralph L. Power, Los Angeles radio counsellor, who has been the American representative for 2GB, Broadcasting Service Assn. and American Radio Transcription Agencies the past five years, has been reappointed by the Macquarie organization.

### PAR-METAL CATALOG

The Par-metal Products Corp. of 3529 41st Avenue, Long Island City, L. I., N.Y., are presenting a new catalog covering a complete line of rack and panel equipment. The catalog may be obtained from the manufacturer by addressing Department CM-98.

### UTC BULLETINS

Bulletin R-20A, now available from the United Transformer Corp., is a manual covering the UTC line of radio set replacement transformers. Another bulletin, S-10A, deals with the UTC special series transformer components, amplifier kits and transmitter kits. Both bulletins may be secured by writing to the above organization at 72 Spring St., New York City.

### TURNER BULLETIN

"Turner Sound Equipment" is a new bulletin just released by The Turner Company, Cedar Rapids, Iowa. This bulletin is devoted to the Turner line of crystal and dynamic microphones, microphone stands, cables, and accessories. Write to the above organization for Bulletin No. 40.

(Continued on page 49)

**NEW PORTABLE PLAY-BACK**



Plays 10, 12, 16 inch records. Operates on AC-DC current at dual speeds.

### ATTENTION

Radio Stations, Advertising Agencies, Program Producers—Use this machine to sell prospects on their own ground. Its completeness and simple operation together with its new low price makes it desirable for everyone.

See Your Dealer or Write

## SOUND PROJECTS COMPANY

3140 WEST WALTON STREET

CHICAGO



**SUPERIOR TUBING CO.**, Norristown, Pa.—seamed and seamless tubing in various metals and alloys.  
**SWEDISH IRON & STEEL CORP.**, 17 Battery Pl., New York City—metal in various forms for tube parts.

### Tubes—Receiving, Transmitting, Photo- electric Cells, Cathode- Ray, Etc.

**AMPEREX ELECTRONIC PRODUCTS, INC.**, 79 Washington St., Brooklyn, N. Y.—water and air-cooled transmitting.  
**Arcturus Radio Tube Co.**, Newark, N. J.—receiving.  
**Champion Radio Works, Inc.**, Danvers, Mass.—receiving.  
**CONTINENTAL ELECTRIC CO.**, Geneva, Ill.—photoelectric cells, mercury-vapor rectifiers.  
**ALLEN B. DUMONT LABS, INC.**, 2 Main Ave., Passaic, N. J.—cathode-ray.  
**Eitel-McCullough, Inc.**, San Bruno, Calif.—transmitting.  
**Electronic Products**, Los Angeles, Calif.—mercury-vapor, gaseous discharge and special vacuum.  
**Federal Telegraph Co.**, Newark, N. J.—transmitting.  
**HEINTZ & KAUFMAN, LTD.**, S. San Francisco, Calif.—transmitting.  
**Hygrade-Sylvania Corp.**, New York City—receiving, cathode-ray.  
**Hytron Corp.**, Salem, Mass.—receiving.  
**The Ken-Rad Tube & Lamp Corp.**, Owensboro, Ky.—receiving.  
**Dr. F. Loewenberg**, New York City—photoelectric cells.  
**NATIONAL UNION RADIO CORP.**, 57 State St., Newark, N. J.—receiving, cathode-ray, photocells.  
**RCA MANUFACTURING CO., INC.**, Harrison, N. J.—transmitting, receiving, cathode-ray.  
**Raytheon Production Corp.**, New York City—receiving.  
**TAYLOR TUBES, INC.**, 2341 Wabansia Ave., Chicago, Ill.—transmitting.  
**Triad Mfg. Co., Inc.**, Pawtucket, R. I.—receiving.  
**Tung-Sol Lamp Works, Inc.**, Newark, N. J.—receiving.  
**UNITED ELECTRONICS CO.**, 42 Spring St., Newark, N. J.—transmitting and industrial control.  
**WESTERN ELECTRIC CO.**, 195 Broadway, New York City—transmitting, cathode-ray.  
**Westinghouse Elect. & Mfg. Co.**, Bloomfield, N. J.—industrial electronic tubes, photocells.  
**WESTON ELECT. INST. CORP.**, 612 Frelinghuysen Ave., Newark, N. J.—photocells.

### Tubing, Spaghetti: Varnished Cloth, Mica

**Acme Wire Co.**, New Haven, Conn.—varnished cambric, silk, paper.  
**Bentley Harris Mfg. Co.**, Conshohocken, Pa.  
**WILLIAM BRAND & CO.**, 276 4th Ave., New York City—mica films, tubing and saturated sleeving, varnished cloth, paper and tape.  
**Insulation Manufacturers Corp.**, Chicago, Ill.—varnished tubing and saturated sleeving.  
**Mica Insulator Co.**, New York City—varnished cloth, mica.

### Tubing—Paper

**PARAMOUNT PAPER TUBE CO.**, 801 Glasgow Ave., Chicago, Ill.  
**Precision Paper Tube Co.**, Chicago, Ill.

### Tuning Controls, Dials, Etc.

**ALADDIN RADIO INDUSTRIES, INC.**, 466 W. Superior St., Chicago, Ill.—push-button tuners.  
**THE ALLIANCE MFG. CO.**, Alliance, Ohio—push-button tuning motors.  
**Aluminum Goods Mfg. Co.**, Manitowoc, Wis.—dials.  
**American Emblem Co., Inc.**, Utica, N. Y.—dials, scales, escutcheons, nameplates.  
**Crowe Name Plate & Mfg. Co.**, Chicago, Ill.—dials, nameplates.

(Continued on page 46)

# USE-RATIO\* HIGH SHELF-IDLENESS LOW...

\* Use-Ratio . . . the ratio of meter hours in actual measurement to total hours in the working day.

## Multi-Range Test Instruments BY WESTON

By meeting many, widely varied test requirements these multi-range WESTON test instruments come close to *continuous* service. Compact and dependable, they are ideal for all routine production needs. But even where there is no "regular" berth in the production line they can be kept busy in many ways . . . *performance check-ups on plant equipment . . . inspection of purchased parts . . . preliminary production tests, or regular production tests where runs are short and circuits subject to change . . . trouble shooting . . . standardization studies . . . research work.*

Take the new WESTON Model 765 Volt-Milliammeter, for example. It provides 10 DC voltage ranges at a sensitivity of 20,000 ohms per volt, and 10 AC voltage ranges at a sensitivity of

1000 ohms per volt; from 1.5 volts to 1500 volts full scale . . . 10 decibel ranges providing measurements from -18 DB to +58 DB . . . 12 DC current ranges available at the throw of a switch, permitting readings from 1 microampere to 15 amperes inclusive. Obviously, the use-ratio of an instrument of such broad utility will be high . . . its shelf-idleness low.

Other WESTON multi-range instruments offer equally flexible service, and should be considered not only for their high use-ratio, but for their dependability and economy as well. Available with or without portable carrying cases. Let us send you all the facts. Write to . . . Weston Electrical Instrument Corporation, 612 Frelinghuysen Avenue, Newark, New Jersey.



## "300" SERIES

### A COMPLETE NEW LINE OF SMALL PLUGS—SOCKETS

#### 2 CONTACTS TO 33 CONTACTS

PLUGS WITH CAPS      PLUGS WITH BRACKETS  
 SOCKETS WITH CAPS      SOCKETS WITH BRACKETS

*Ask for Bulletin 300*

### HOWARD B. JONES

2300 WABANSIA AVENUE, CHICAGO, ILLINOIS

# Announcing

**A NEW LINE OF SHIELDS TO FIT T-9 BULBS FOR BANTAM and 50 MIL. 1.4 VOLT SERIES TUBES**

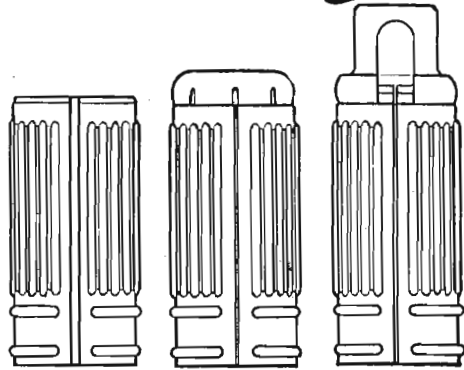

This new series rounds out the Goat Line of form-fitting tube shields, designed in close cooperation with the country's leading tube engineers, they will give you maximum efficiency in the purposes they serve.

*We will be pleased to send Bulletins, samples and prices to recognized manufacturers.*

**FEATURES:**  
Sturdy Construction  
Convenient Grounding  
Complete Shielding  
Modern Appearance  
Magnetic Shielding  
Easy Assembly  
Space Saving  
Economy



**GOAT RADIO TUBE PARTS, INC.**

(A DIVISION OF THE FRED GOAT CO., EST. 1893)

**314 DEAN ST., BROOKLYN, N. Y.**

## UNIVERSAL GAIN SET

A universal gain measuring instrument for rapid and accurate measurement of overall gain, frequency response, and power output of audio amplifiers.

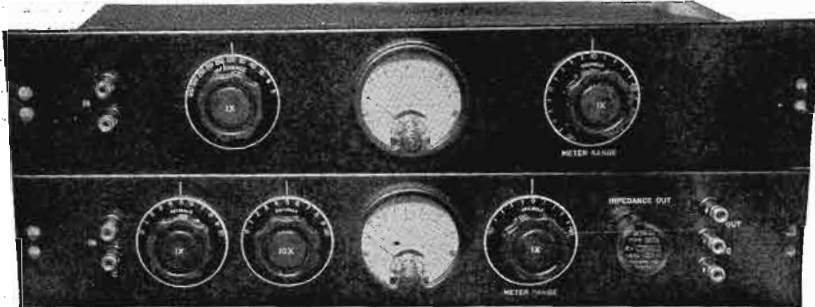

*Illustrated above: Type 685—complete set—width 19", height 7" (overall)—for standard rack mounting. Also available in portable carrying case at slight additional cost.*

*Individual panels available.  
Type 688—Load Panel—top, above.  
Type 683—Transmitter Panel—bottom, above.*

Type 685 assembly is a compact instrument for rapid, accurate measurement of audio amplifiers, transmission systems, and attenuation networks over the audio range. All networks, meters, and associated apparatus thoroughly shielded, carefully balanced, matched for uniform accuracy over a wide frequency range.

- **ATTENUATION RANGE** +10 db to -120 db in steps of 1 db.
- **POWER MEASURING RANGE** -20 db to +36 db.
- **LOAD IMPEDANCE** Eleven values, ranging from 5 to 600 Ohms, are available.
- **OUTPUT IMPEDANCES** may be changed from Balanced to Unbalanced, and to any loss and impedance required by means of plug-in type matching networks.
- **FREQUENCY RANGE** 20 to 17,000 cycles.
- **ACCURACY OF ATTENUATION CONTROLS** ±1%.

**THE DAVEN COMPANY**

158-160 SUMMIT STREET

Phone MArket 2-2468

NEWARK, N. J.

Centralabs, Milwaukee, Wis.  
**HARRY DAVIES MOLDING CO.**, 1428 N. Wells St., Chicago, Ill.—knobs, dials.  
 DeJur-Amsco Corp., Shelton, Conn.—push-button units, dials.  
 Delco Appliance Division, Rochester, N. Y.  
**DIAL LIGHT CO. OF AMERICA**, 136 Liberty St., New York City—pilot lights, pilot-light sockets, jewel assemblies.  
**DRAKE MFG. CO.**, 1713 W. Hubbard St., Chicago, Ill.—dial and jewel light assemblies.  
**A. W. FRANKLIN MFG. CO.**, 175 Varick St., New York City—push-button tuners.  
**P. R. MALLORY & CO., INC.**, 3029 E. Washington St., Indianapolis, Ind.—station selector switches, dial and panel lights.  
 Meissner Mfg. Co., Mt. Carmel, Ill.—push-button units, dials, remote-control units.  
 The Muter Co., Chicago, Ill.—push-button selector switches.  
**NATIONAL UNION RADIO CORP.**, 57 State St., Newark, N. J.—radio panel lamps.  
 Oak Manufacturing Co., Chicago, Ill.—push-button units.  
**OHMITE MANUFACTURING CO.**, 4835 W. Flournoy St., Chicago, Ill.—dials and knobs.  
 Premier Crystal Labs., Inc., New York City—pilot-light indicators.  
 Sprague Specialties, Inc., N. Adams, Mass.—push-button units.  
 F. W. Stewart Mfg. Corp., Chicago, Ill.—remote-control units.  
 Tung-Sol Lamp Works, Inc., Newark, N. J.—radio panel lamps.  
**UTAH RADIO PRODUCTS CO.**, 812 Orleans St., Chicago, Ill.—tuning motors.

### Varnishes, Lacquers, Compounds, Waxes, Etc.

Acheson Colloids Corp., Port Huron, Mich.  
**BAKELITE CORPORATION**, 247 Park Ave., New York City.  
 Candy & Co., Inc., Chicago, Ill.  
 E. I. Du Pont De Nemours & Co., Wilmington, Del.  
**GENERAL PLASTICS, INC.**, N. Tonawanda, New York.  
 Glyco Products, Inc., New York City.  
 Insulation Manufacturers Corp., Chicago, Ill.  
 Maas & Waldstein, Newark, N. J.  
**MICA INSULATOR CO.**, 200 Varick St., New York City.  
 The Zapon Co., Stamford, Conn.  
**ZOPHAR MILLS, INC.**, 120 26th St., Brooklyn, N. Y.

### Washers

**M. D. HUBBARD SPRING CO.**, 613 Central Ave., Pontiac, Mich.  
**SHAKEPROOF LOCK WASHER CO.**, 2533 N. Keeler Ave., Chicago, Ill.  
 Thompson-Bremer & Co., Chicago, Ill.  
 Wrought Washer Mfg. Co., Milwaukee, Wis.

### Wire—Antenna, Hook-Up, Magnet, Etc.

Acme Wire Co., New Haven, Conn.  
 Alpha Wire Corp., New York City.  
 American Electric Cable Co., Holyoke, Mass.  
 Anaconda Wire & Cable Co., Chicago, Ill.  
 Belden Mfg. Co., Chicago, Ill.  
 Cornish Wire Co., Inc., 30 Church St., New York City.  
 Crescent Insulated Wire & Cable Co., Trenton, N. J.  
 General Cable Corp., New York City.  
**HOLYOKE WIRE & CABLE CORP.**, 230 Main St., Holyoke, Mass.  
 Lenz Electric Mfg. Co., Chicago, Ill.  
 Phelps Dodge Copper Products Corp., Los Angeles, Calif.  
 Wheeler Insulated Wire Co., Bridgeport, Conn.

### Wire—Resistance

Driver-Harris Co., Harrison, N. J.  
**WILBUR B. DRIVER CO.**, 150 Riverside Ave., Newark, N. J.  
**HOLYOKE WIRE & CABLE CORP.**, 230 Main St., Holyoke, Mass.  
 Hoskins Mfg. Co., Detroit, Mich.



LONGER

LIFE

and

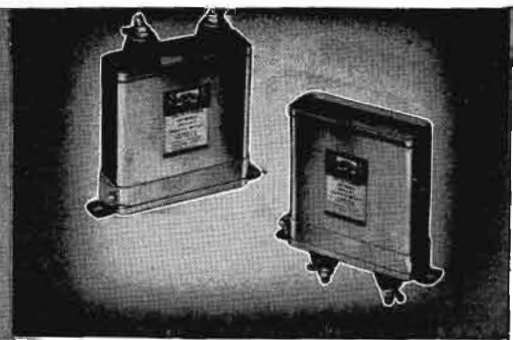

**TYPE TJU** Fireproof Dykanol Transmitting Capacitors. Dykanol (chlorinated diphenyl) impregnated and filled and hermetically sealed in sturdy steel containers. Supplied with adequate glazed porcelain or bakelite terminal (according to rating) insulators and universal mounting strap. Rigidly tested and conservatively rated.

**GREATER DEPENDABILITY WITH CORNELL-DUBILIER CAPACITORS**

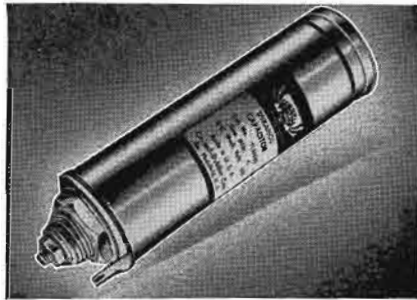

**TYPE TLA** Dykanol Filter Capacitors. Encased in cylindrical aluminum containers these capacitors are used with high fidelity P.A. amplifiers, power supplies for S.W. portable transmitters and transceivers. Substantially made the Type TLA will withstand transient voltages as well as high peak voltage surges.



**TYPE DY** Dykanol Capacitors. Designed for operation under severe tropical and humidity conditions. These capacitors are required to stand a test that calls for immersion in boiling water. Extensively used by manufacturers of aircraft, submarine and marine equipment. Available in single, dual and multiple capacity combinations.

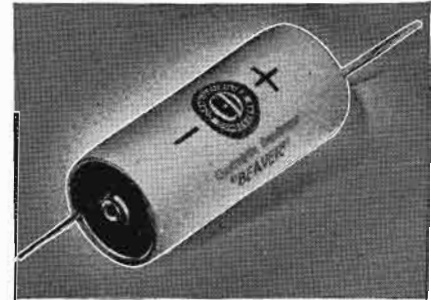

**TYPE BR** "Blue Beavers." The Type BR etched foil dry electrolytics are hermetically sealed, vented and encased in round aluminum containers with a protective outside sleeving. These capacitors eliminate drilling of chassis, use of pal nuts, washers and minimize assembly operations as well as save space and afford quick wiring.



**TYPE 59** Mica Transmitting Capacitors. Encased in a ceramic tube with cast aluminum end-terminals. Series, series-parallel or any other combination, can be obtained by bolting terminal ends together. These capacitors are used as neutralizers, padders, in tank circuits and wherever low capacity at high voltages is required.

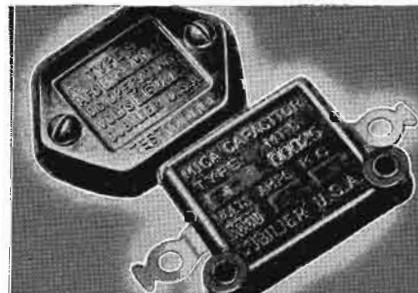

**TYPES 9 AND 4** Mica Receiving-Transmitting Capacitors. Effectively used for R. F. bypass, high voltage D.C. blocking, low power tank capacitors, padders, coupling functions, audio and video purposes. Utilizing the exclusive C-D stack assembly process, these units are constructed of the finest India ruby mica and foil.



**TYPES 6 AND 15** Mica Transmitting Capacitors. Designed to fulfill needs of low power transmitters, S.W. and portable equipment. These units are hermetically sealed in molded bakelite cases. Type 15 is enclosed in low loss mica base bakelite case. Low absorption value of case allows operation of units at high humidities.

MICA - PAPER - DYKANOL  
**CORNELL-DUBILIER**  
ELECTRIC CORPORATION  
South Plainfield, New Jersey  
Cable Address: CORDU  
WET & DRY ELECTROLYTIC

**MAIL COUPON FOR NEW FREE CATALOG** C9  
CORNELL - DUBILIER ELECTRIC CORP.  
1005 HAMILTON BOULEVARD, SO. PLAINFIELD, N. J.  
Rush to me copy of Catalog 160   
Put my name on list for house organ   
Name.....  
Address.....  
City..... State.....



# COMMUNICATIONS---the fastest moving magazine in a fast growing industry!

To the Publisher of

## COMMUNICATIONS

19 E. 47th St., N. Y. C.

Please enter annual subscriptions (12 issues) for each of the undersigned for which payment is enclosed at the rate of \$1.00 each. (This rate applies only on 4 or more subscriptions when classifications are given.) Foreign Subscriptions are \$2.00 each.

Name .....  
 Address .....  
 City-State .....  
 Classification .....  
 Employed by .....

Name .....  
 Address .....  
 City-State .....  
 Classification .....  
 Employed by .....

Name .....  
 Address .....  
 City-State .....  
 Classification .....  
 Employed by .....

Name .....  
 Address .....  
 City-State .....  
 Classification .....  
 Employed by .....

● Our slogan is "You will read it first in COMMUNICATIONS." And all the important news about all phases of the radio and communications industry *has* appeared in COMMUNICATIONS first.

This is a fast moving age—Communications a fast moving industry! It already tops the billion-dollar-a-year figure and it's still growing. The men responsible for this progress are subscribers to COMMUNICATIONS as it is their source of obtaining accurate and complete technical information while it is still "hot."

You and your associates can obtain a year's subscription to COMMUNICATIONS (12 issues) for only \$1.00 each by using the Group Subscription Plan. Here's how:

A regular yearly subscription to COMMUNICATIONS costs \$2.00—but when four or more men sign up at one time, each one is entitled to the half-price rate. (Foreign subscribers on the "G-S-P" only pay \$2.00 each.)

It is easy to get three or more of your associates to join a Group with you. Hundreds of leading engineers and technicians have subscribed year after year on that basis. Use the convenient form on this page. Fill in the names, tear out and mail today with your check or money order. Renewals and extensions are acceptable also.

**COMMUNICATIONS • BRYAN DAVIS PUB. CO., Inc.**



**OVER THE TAPE**  
(Continued from page 44)

**BAKELITE BULLETIN**

Bakelite Corporation, 247 Park Avenue, New York City, have recently made available an attractive 4-page bulletin announcing Bakelite Cellulose-Acetate. This new product is a rainbow-hued thermoplastic material for injection and compression molding. A copy of this bulletin may be secured from the above organization.

**ALLEGHENY LUDLUM STEEL CORP.**

The Allegheny Steel Company and the Ludlum Steel Company have announced the formation of the Allegheny Ludlum Steel Corporation. Pending further announcements, the business of the new company will be handled through present channels.

**ALLIED CATALOG**

Allied Radio Corporation, 833 West Jackson Blvd., Chicago, has just released its new 1939 radio catalog. The new 180-page catalog features many new developments in radio receivers, service instruments, amateur-experimenter equipment, public-address equipment, and radio parts.

**BOOKLET ON RIDER CHANALYST**

Service Instruments, Incorporated, 404 Fourth Avenue, New York City, has published a 16-page booklet on the Rider Chanalyst, the new test instrument which was announced to the industry in June. This new booklet is illustrated with numerous diagrams and explanations on the new test instrument.

**LEEDS & NORTHRUP CATALOG**

A new 8-page catalog describing the "Thermionic Amplifier for Voltage Measurements in High-Resistance Circuits" has just been released. This instrument adapts any potentiometer of suitable range for glass electrode measurements and other measurements of potential in high-resistance circuits. A copy of Catalog E-00A will be sent on request. Write to Leeds & Northrup Company, 4934 Stenton Ave., Philadelphia, Pennsylvania.

**ANDREW BULLETIN**

Victor J. Andrew, 6429 S. Laverne Ave., Chicago, Illinois, has just released Bulletin 87 on antenna coupling units. This bulletin will be sent free on request.

**JANETTE BULLETINS**

Janette Manufacturing Company, 556-558 West Monroe St., Chicago, Illinois, have just made available two interesting bulletins. Bulletin 228 covers the Janette line of generators, motor generators, rotary converters, speed reducers, etc. The second bulletin, No. 13-10, deals with rotary converters for radios and sound apparatus. Both are available from the above organization.

**AUTOMATIC ELECTRIC CATALOG**

A 48-page catalog giving complete information on the Automatic line of electrical control apparatus, including relays, stepping switches, impulse senders, lever, turn and push keys, lamps and lamp sockets, plugs and jacks, as well as other remote-control accessories, is available. Write to the American Automatic Electric Sales Company, 1033 West Van Buren Street, Chicago, Illinois, for Catalog 4071-B.

**CONTACT CALLITE**

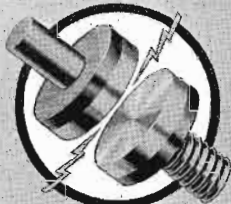

**FOR CONTACTS**

**FOR VIBRATORS  
RELAYS AND OTHER  
Electronics  
Devices**

**TUNGSTEN**

AND

**MOLYBDENUM**

RIVETS AND SCREWS  
● SILVER & PLATINUM  
● SPECIAL ALLOYS  
● PRECIOUS METAL  
LAMINATED  
SILVER AND PLATINUM ON  
BASE METALS

**...AND CONTACT  
CALLITE FOR...**

**TUNGSTEN**

... Rod, Sheets, Wire & Special Shapes  
... For Hard Glass Welds

**MOLYBDENUM**

... Rod, Sheet, Wire & Special Shapes  
... For Grids, Round or Flat  
... For Grids, Supports, Heating Elements  
... For Hard Glass Welds

**KULGRID**

... Kulgrid KK—A New Special Alloy Grid Wire  
—High Tensile Strength —Reduces Grid  
& Elongation Emission  
Write for Samples  
... Kulgrid "C" Tungsten Welds—For Hard  
Glass Leads

**CAL-LOX Fluorescent Materials**

with  
Measured Characteristics  
... for all applications

**CALLITE PRODUCTS DIVISION**

EISLER ELECTRIC CORPORATION

542-39th STREET

UNION CITY, N. J.

**NOT THE LARGEST...**

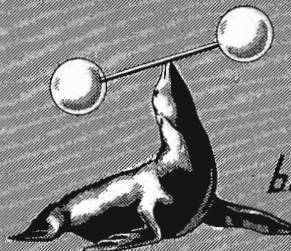

but

*finely trained*

**for QUALITY and SERVICE**

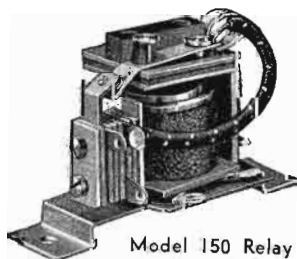

Model 150 Relay

When ordering specify current, voltage or resistance of coil, contact combination and load through contacts.

There may be larger manufacturers of RELAYS . . . but GUARDIAN gives you exactly what you want when you want it. Hard to believe, maybe, but orders are frequently shipped the same day—and built to customers specifications too.

**RELAYS by Guardian**

THE KIND YOU WANT . . .  
AS YOU REQUIRE THEM . . .  
SHIPPED WITHOUT DELAY . . .

The orders of every customer "rate" equally here—attention is not concentrated on one or two big customers. No matter who you are, or the size of your order, you'll get good service—fast service—from Guardian.

Relay illustrated is the Series 150. Hundreds of other types, and variations, available.

Write for our catalog C, or send specifications and let us quote.

**GUARDIAN  ELECTRIC**

1623 W. WALNUT STREET

CHICAGO, ILLINOIS

## PROGRESSIVE COILS

(Continued from page 11)

(c) Solve for the throw two ways:

$$T_1 = (w + N_1 d) \frac{M_2}{2}$$

$$T_2 = (w + N_2 d) \frac{M_2}{4}$$

If the two values are different, use the larger value.

(5) *w/d* greater than 5.

If *w/d* is greater than 5 the progressive universal winding appears to be impractical.

### APPENDIX

The machine used by the authors for winding these coils is arranged so that the number of revolutions of the cam per coil-form revolution is controlled by four gears so arranged that:

$$\frac{\text{Cam Rev.}}{\text{Coil Rev.}} = \frac{g_1}{g_2} \times \frac{g_3}{g_4} = \frac{g_1 g_3}{g_2 g_4} \dots \dots (13)$$

Where  $g_1, g_2, g_3$  and  $g_4$  are the number of teeth on the gears respectively.

Now one revolution of the cam produces two crossovers of the wire, so that the gear ratio is actually calculated to be  $C^1/2$ . The gears must be selected then from those available so that when they are substituted in eq. (13) the resulting ratio is equal to  $C^1/2$ . In the case

of linear patterns this relation must be exact, but this is usually not difficult as the ratio is always a simple fraction. In the case of composite spirals, however, the required accuracy is of the order of .1% and this sometimes entails a rather tedious process of computation if the available gears are limited. In the case of simple spiral patterns the accuracy requirement is not quite so rigid, since *T* may be adjusted slightly to preserve the relation

$$T = \frac{w + N d}{N \Delta}$$

For spiral composite patterns *c* is, in general, an irrational number (that is, a decimal which never comes out even). Although the accuracy required is quite high, no difficulty will be encountered in meeting it if a large number of gears are available. In general, it is desirable to have a group of gears which have consecutive numbers of teeth. The ratio obtained from two consecutive gears is slightly greater (or less) than unity. Adding one tooth to each gear changes the ratio an exceedingly small amount, hence the following procedure:

1. Choose  $g_1$  and  $g_2$  so that  $g_1/g_2$  is about 1% less than the required value of  $C^1/2$ .
  2. Choose that pair of consecutive gears having a ratio nearest to  $C^1/2 \times g_2/g_1$ .
- If a group of consecutive gears are

not available, suitable gears may (eventually) be found by the following method:

1. Choose at random  $g_1$  and  $g_2$ .
2. On a slide rule, set unity of scale

B opposite the value  $\frac{C^1}{2} \times \frac{g_2}{g_1}$  on scale

A. Search for a pair of integers which are directly opposite each other on the two scales.

3. Check to see if corresponding gears are available.

4. If unsuccessful change  $g_1$  and/or  $g_2$  and repeat until proper gears are found.

## CONDUCTANCE METER

(Continued from page 25)

different prong arrangements and furnishing a set of pin jacks on which connections can be set up for connecting any electrode to any one of the nine points in the measuring circuit. The arrangement of the jacks is indicated in Fig. 4. Each jack in the left-hand row is numbered and connected to all of the socket contacts designated by a corresponding number in the RMA tube-socket numbering system. The jacks in the right-hand row are marked with the conventional symbols for the tube elements and connected to the appropriate points in the measuring circuit.

## COUPLING NETWORKS

(Continued from page 18)

two elements may then be determined from the remaining charts.

When the terminating impedance contains reactance as well as resistance the charts may still be used. The procedure is extremely simple when a T section is used. In that case the network is first designed to transform the resistance in the termination to the desired value. The  $X_2$  arm is then modified by including an additional reactance of the right sign and magnitude to neutralize the reactance of the terminating impedance. The total reactance required for this arm may be supplied by a single reactor.

In case a  $\pi$  network is desired, the simplest method is to design a T network first in the manner described in the preceding paragraph and then obtain the equivalent section by the relations<sup>2</sup>

$$X_A = \frac{X_1 X_2 + X_2 X_3 + X_1 X_3}{X_2}$$

$$X_B = \frac{X_1 X_2 + X_2 X_3 + X_1 X_3}{X_3}$$

$$X_C = \frac{X_1 X_2 + X_2 X_3 + X_1 X_3}{X_1}$$

The charts may also be used to design an L section. In an L section the phase shift is determined by the impedance ratio and cannot be selected at will. Such an L

section is a special case of either the T or  $\pi$  section and corresponds to the situation where  $c = \infty$ . It is seen by eq. (16) that this occurs if

$$\cos B = 1/\sqrt{r} \dots \dots \dots (17)$$

In this case eq. (14) reduces to

$$a = \frac{r}{\tan B} = \frac{r}{\sqrt{r-1}} \dots \dots \dots (18)$$

$$b = \tan b = \sqrt{r-1} \dots \dots \dots (19)$$

In an L section the phase may be advanced or retarded but the shift is always less than  $90^\circ$  as  $\cos B$  must be a positive number.

The values of  $a$  and  $b$  corresponding to eq. (18) and (19) are plotted on Figs. 6 and 8. It will be observed that the value of  $a$  for the L section is the maximum value that  $a$  has for a given value of  $r$ . This may readily be proven from eq. (14). The maxima of  $a$  for a fixed value of  $r$  is obtained as follows

$$\frac{\delta a}{\delta B} = \frac{(\sqrt{r} - \cos B) r \cos B - r \sin^2 B}{(\sqrt{r} - \cos B)^2} = 0$$

This reduces to

$$\cos B = 1/\sqrt{r}$$

This is identical with eq. (17) and so the maximum value of  $a$  occurs in the case of an L section.

(To be concluded)



## The 57-D VOLUME LIMITING AMPLIFIER

for BROADCAST, POLICE, and AIRLINE STATIONS

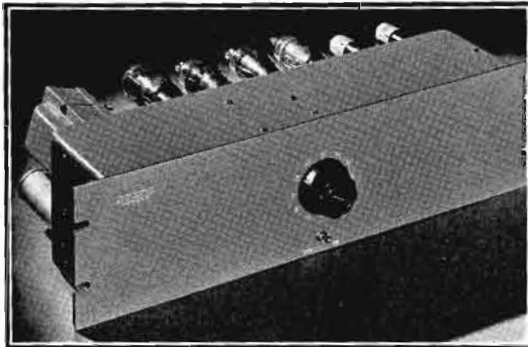

### SPECIFICATIONS

**FREQUENCY RESPONSE:**  $\pm 1$  db from 30 to 10,000 cycles with or without compression and at any setting of gain control.  
**GAIN:** 55 db.  
**NOISE LEVEL:** 60 db below zero level (.006) at full gain.  
**DISTORTION:** Less than 1/2% at any amount of compression below 20 db and at any output level below +20 db.  
**IMPEDANCE:** Provision for any impedance of 17, 50, 125, 200, 250, 333, 500 ohms input and output.  
**COMPRESSION:** May be set to come in at any level between -20 db and +20 db out of amplifier.  
 Timing: .010 second for complete action of gain reducing function. .250 second for recovery of gain after signal drops below compression level.  
**POWER:** A.C. operated. 110 volts, 60 cycles, 60 watts.  
**FINISH:** Chassis finished in aluminum lacquer; Panel finished in W.E. gray but may be supplied in any standard color.  
**PRICE:** \$155.00 f.o.b. Kansas City, Mo.

### WILCOX ELECTRIC COMPANY

1014 West 37th Street

Kansas City, Mo.

## MICROPHONE STANDS

A TYPE FOR EVERY NEED.

SPECIAL ATTENTION TO REQUIREMENTS OF SOUND EQUIPMENT MANUFACTURERS.

Write for complete catalogs to

**EASTERN MIKE STAND COMPANY**

56 Christopher Ave., Brooklyn, N. Y.

## BROADCAST ENGINEERS

Let us help you out the next time you want some needed Radio Parts, Tubes, Meters, Racks, Panels, Chassis, etc. . . . **IN A HURRY!** Engineers and laboratory technicians know that **SUN DELIVERS!** Phone, Write or Wire!

### SUN RADIO COMPANY

212 FULTON ST. Dept. C-9 NEW YORK, N. Y.

### SWITCHBOARD WIRE

General Electric Deltabeston switchboard wire insulated with a new type of synthetic compound which makes possible bending at sharp angles without rupture has been announced by the G-E appliance and merchandise department. The new product is approved by the Underwriters' Laboratories for switchboard and panel board wiring in continuous operation at 90 degrees Centigrade, and is also adaptable for use in the manufacture of new products and for maintenance work. It is stocked in sizes which range from No. 16 to No. 8, and larger sizes will be made available on order.

Further information may be secured from the Appliance and Merchandise Department,

General Electric Co., Bridgeport, Conn.—COMMUNICATIONS.

### CRYSTAL PICKUP

The Model X-78A-3, shown in the ac-

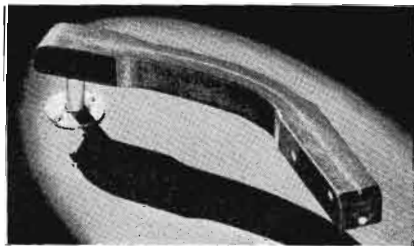

companying illustration, is a new design in the Webster Electric line incorporating a solid wood tone arm in walnut finish and the new "standard" rubber sealed cartridge. A metal outer shell serves as an electromagnetic or electrostatic shield. This construction is said to offer a high degree of protection against moisture and a greater safety factor against breakage. Leads are brought directly out of the cartridge. They are licensed under patents of the Brush Development Laboratories.

Complete information on these units may be secured from the *Webster Electric Company*, Racine, Wisconsin.—COMMUNICATIONS.



### LOCKHEED PLANE OHMITE-EQUIPPED

Hughes' dash around the world in his LOCKHEED Plane adds another "case history" to the service-record of Ohmite Vitreous-Enameled Rheostats and Resistors. Their ability to withstand overloads and abuse, shock and vibration, heat and humidity, has made Ohmite resistance units standard equipment on such major airways as Pan-American, United Air Lines, and others, both here and abroad—as well as in the general radio and communication fields. Send for New Catalog 17 today, or let Ohmite Engineers suggest the right units for your exact needs.



### OHMITE MANUFACTURING CO.

4857 W. Flournoy Ave., Chicago, U. S. A.

**OHMITE** ★

Rheostats  
Resistors  
Tap Switches ★

## Have YOU a right to succeed in Radio?

CREI technical training insures your future.

Professional radiomen—you can acquire the necessary additional ability for success by home-study training in your spare time. The CREI courses in Practical Radio Engineering are practical—and have been thoroughly tested and proved in all branches of the industry. New developments demand the services of highly skilled technicians. Training NOW can mean thousands of dollars to you in years to come.

### CAPITOL RADIO ENGINEERING INSTITUTE

Dept. CO-9

3224 16th St., N.W., Washington, D. C.



Free!

Just off the press. New illustrated booklet, "A Tested Plan for a Future in Practical Radio Engineering." Write for your copy at once!

# THE MARKET PLACE

NEW PRODUCTS FOR THE COMMUNICATIONS FIELD

## SEMS

"Sems"—a pre-assembled Shakeproof Lock Washer and standard machine screw—is the latest addition to Shakeproof's line of metal fastening products. This new patented assembly unit is said to save time and money by reducing labor costs; speeding up production and eliminating such waste as lost lock washers. Also Sems offer a means for better product control because each screw is equipped with the correct size of lock washer for its particular type of head. And, as the lock washer cannot drop off, no screw can be applied without having a lock washer under the head. Preliminary tests on Sems in both large and small production plants indicate not only immediate cost savings, but faster and better production as well.

For literature describing Sems in detail, write to *Shakeproof Lock Washer Co.*, 2501 North Keeler Avenue, Chicago, Illinois.—COMMUNICATIONS.

## MINIATURE TUBES

Information and data have been released on several types of miniature tubes measuring  $1\frac{1}{8}$  inches from top of glass envelope to bottom of base with a bulb diameter of  $9/16$  inch. These new miniature tubes have been named "Bantam, Jr.s." They have a drain of 0.070 ampere at 1.4 filament volts. They are available in a triode, input pentode, and output pentode.

Further information may be secured from the *Hytron Corporation*, Salem, Massachusetts.—COMMUNICATIONS.

## FIBERGLAS

The Owens-Illinois Glass Co. have introduced Fiberglas, an inorganic electrical insulation. This material, pure glass, is available in both staple and continuous form. Either form is converted into yarn and thread from which tape, braid and cloth are fabricated. It is said to possess the following advantages: superior electrical properties, will not burn, non-hygrosopic, high tensile strength, requires less space, resistant to acid, oil and corrosive vapors, and has high thermal conductivity and permanence.

A bulletin describing this material is available from the *Mitchell-Rand Insulation Co., Inc.*, 51 Murray St., New York City.—COMMUNICATIONS.

## NASH RECORD-LUBE

The Nash record-lube is a new product which is said to reduce the wear and surface tension on all types of electrical transcriptions and phonograph records. It is an oil base lubricant which has been specially treated to repel dust and at the same time reproduce all frequencies without any appreciable loss.

Manufactured by *Nash Radio Products Company*, 5437 Lisette Street, St. Louis, Mo. A catalog sheet 28A will be mailed upon request.—COMMUNICATIONS.

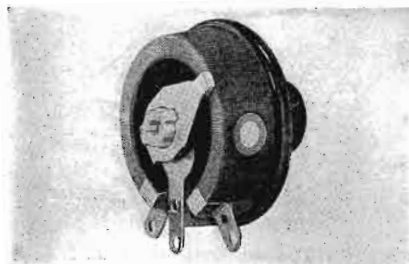

Above: Ohmite rheostat.

Below: Shakeproof's "Sems."

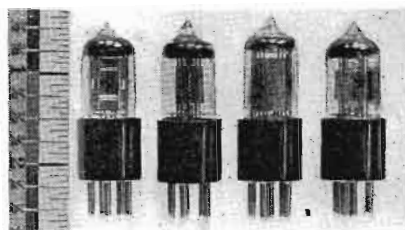
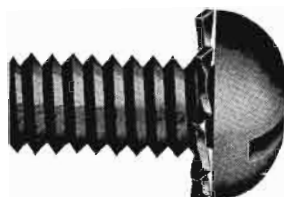

Above: Hytron tubes.

Below: Clarostat cord.

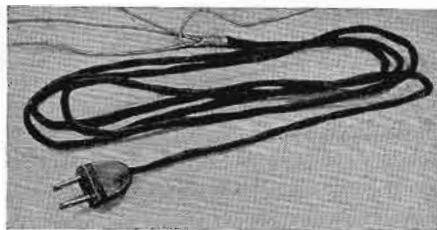

Below: Eisler spot welder.

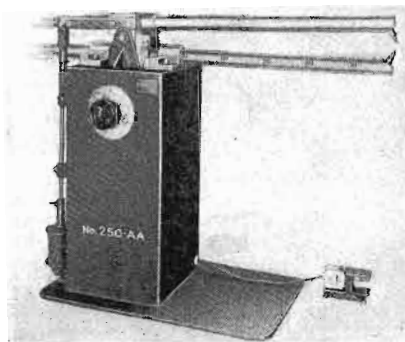

## OHMITE RHEOSTAT

A 75-watt power rheostat-potentiometer is now made available by Ohmite. This new unit has been added to the Ohmite line to provide manufacturers and engineers with a more complete range of low-power rheostats for their particular applications.

The new Model "G" incorporates the outstanding features of the other Ohmite models. It has the protection of Ohmite vitreous enamel which covers and separates the individual turns of wire, binding the entire assembly rigidly to the porcelain core. The entire shaft and bushing assembly is insulated from the electrical circuit by a ceramic driving hub. The rheostat can be mounted directly upon metal panels without further insulation.

Special constructional features such as: tapered windings, off positions, toggle switches, cages, and tandem mountings can be supplied. *Ohmite Manufacturing Company*, 4835 Flournoy Street, Chicago, Illinois.—COMMUNICATIONS.

## VOLTAGE-DROPPING CORDS

A line of voltage-dropping power cords either for initial or for replacement use with a-c/d-c sets is announced by Clarostat. Each cord is made up of three conductors enclosed in heavy braided covering, and including the resistance winding. These power cords are said to operate coolly and safely. The tie cord at chassis end removes strain on conductors proper. Color coded, the three conductors furnish plate voltage for rectifier tube, as well as reduced voltage for tube filaments. Eight types cover all standard 110-volt a-c/d-c set needs. Another type provides voltage reduction from 220 to 110 volts.

For additional information write to *Clarostat Mfg. Co., Inc.*, 285-287 N. 6th St., Brooklyn, N. Y.—COMMUNICATIONS.

## UNIVERSAL SPOT WELDER

Eisler has placed on the market a universal long horn spot welder for deep sheet metal work. The novel feature of the machine is that both horns, the upper and lower, can be lengthened or shortened to the desired type and size of work. The horn adjustment makes it possible to weld light and heavy work and deep metal parts. Markings on the horn represent the kva ratings. When the horn is placed on the 25 mark it represents 25 kva, when the horn is readjusted to 50 it represents 50 kva. The spot welders are made with many different styles of welding tips, in the unit shown the water cooling goes through the entire arm. The Eisler spot welders are made foot, air or motor operated. They will weld from 30 to 150 spots per minute, depending on the type of work.

Complete information on the Eisler spot welders may be obtained from the *Eisler Engineering Co.*, 750 South 13 Street, Newark, N. J.—COMMUNICATIONS.



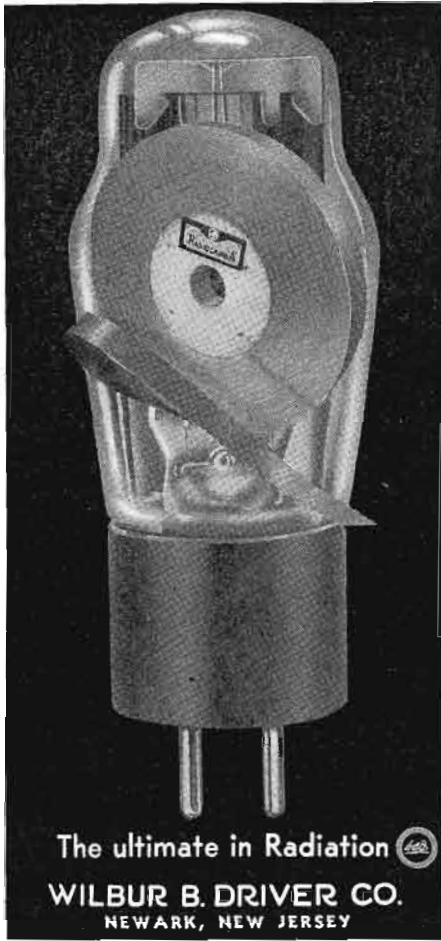

The ultimate in Radiation  
**WILBUR B. DRIVER CO.**  
 NEWARK, NEW JERSEY

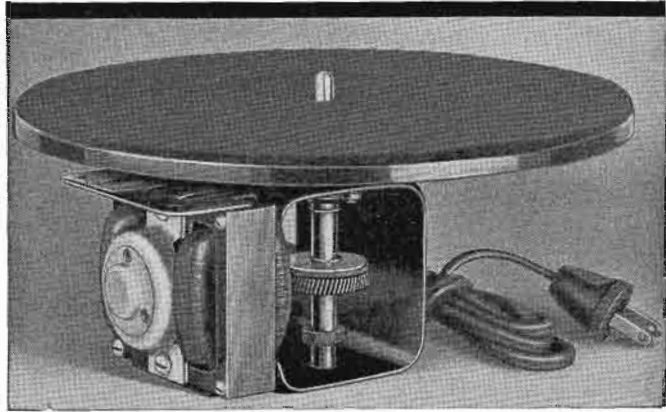

## Investigate This New "EVEN SPEED" PHONOGRAPH MOTOR

The new Alliance Self-starting "Even Speed" motor maintains proper record speed without the need of a governor, regardless of variations in record drag, line voltage or operating temperature.

Large bearings with ample oil reserves and laminated bakelite helical cut gears assure smooth, silent operation and long life. Motor design allows free ventilation and cooler operation. Motor dimensions are: Length  $4\frac{1}{8}$ " ; Width  $3\frac{3}{4}$ " ; Depth to bottom of motor board  $2\frac{1}{8}$ " ; bottom of motor to top of spindle  $4\frac{1}{2}$ ". Turn-table and motor (110 volt—60 cycle) furnished complete with rubber spools for mounting. Available with 9"—10" or 12" turn-tables.

For full information and prices write  
**ALLIANCE MANUFACTURING CO., ALLIANCE, OHIO**



**THIS RELAY**



- Bulletin 81  
Intermediate duty
- Bulletin 106  
Light duty
- Bulletin 131  
Heavy duty
- Bulletin 251  
Sensitive type
- Bulletin 351  
Thermal time relay
- Bulletin 362  
Motor driven time relay

## must be **DEPENDABLE**

Every user of a relay points to his application as the one place where dependability is paramount. The fact is, a relay is a control device and therefore the functioning of the entire equipment with which it is used, depends upon the relay. Ward Leonard recognizes the responsibility placed upon relays today and produces both relays and relay control assemblies that are the utmost in dependability, positive function and long life. Send for bulletins of interest.

**WARD LEONARD**  
**ELECTRIC COMPANY**

SOUTH STREET, MOUNT VERNON, N. Y.

ELECTRIC CONTROL DEVICES SINCE 1892

**A COMPLETE LINE  
 OF PRECISION  
 QUARTZ CRYSTALS  
 HOLDERS and OVENS  
 20 KC. TO 30 MC.**

*Write for Catalog G-10*

**BLILEY ELECTRIC COMPANY**

UNION STATION BUILDING

ERIE, PA.



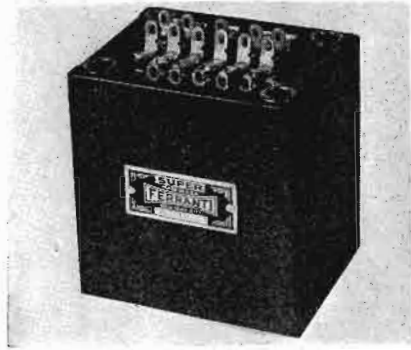

#### INPUT TRANSFORMER

Ferranti has announced a new input transformer to be known as the A216X. This transformer utilizes core type, hum bucking core and coil construction which in turn is encased in a multi-shielded or nested outer enclosure. The transformer, by virtue of this special construction, is said to be suitable for operations as low as -80 db. Electrostatic shields are provided between primary and secondary windings which makes it possible to use this new transformer in the input circuit of high-gain amplifiers and thus eliminate inductive or capacitive pickup due to stray fields.

For further information write to *Ferranti Electric, Inc.*, 30 Rockefeller Plaza, New York City.—COMMUNICATIONS.

#### ELECTRIC ETCHER

A new tool for marking permanent identification is the Ideal electric marker. The marker cuts owner's name, sizes, numbers, models and other information on steel, iron, bronze, glass, bakelite, ceramics, composition and other surfaces. Operates at a speed of 7,200 cutting strokes a minute. It is manufactured by the *Ideal Commutator Dresser Company*, 4025 Park Avenue, Sycamore, Illinois.—COMMUNICATIONS.

#### ELECTROLYTIC CONDENSER

A compact dry electrolytic condenser in a 1-inch diameter can, with simple ring mounting is shown in illustration. It is said that high capacity values can be packed into the small diameter aluminum can which varies in height according to its contents. Single, double and triple sections are available, as well as popular capacities and working voltages.

The hermetically-sealed unit is designed for ring mounting, upright or inverted, and any height above or below the chassis platform. The etch ratio of the section is said to be substantially lower than is generally the practice today in compact electrolytics. The new condenser is known as the new B type.

This condenser is a product of the *Aerovox Corporation*, 70 Washington Street, Brooklyn, N. Y.—COMMUNICATIONS.



#### NEW AMPERITE VELOCITY

The acoustic compensator is now being supplied as standard equipment on the lower priced Amperite models such as the RSHK

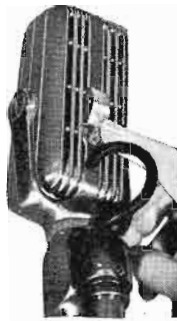

and RBSK. The new RSHK and RBSK will also come equipped with cable connector and switch.

The acoustic compensator makes the microphone immediately adjustable to close or distance pickup. By merely pushing the compensator up the pitch is raised. By lowering the compensator the pitch is lowered. Variations in room conditions are said to be easily compensated for with the acoustic compensator.

Not to be confused with a tone control, the acoustic compensator is a mechanical shutter that gradually closes the back of the microphone. An air cushion is formed behind the ribbon which changes its operation from velocity to pressure. In other words, it really changes the velocity to a dynamic microphone.

Additional information may be secured from the *Amperite Co.*, 561 Broadway, New York City.—COMMUNICATIONS.

#### CENCO ORDER BOOK

The Fall 1938-Spring 1939 Cenco order book, for science supplies for the instruction of physics, chemistry and biology, is now available. Write to *Central Scientific Company*, 79 Amherst Street, Boston, Mass.

#### FIELD STRENGTH METER

An instrument for the measurement of the field intensity of antennas on frequencies from 1,750 to 60,000 kc has just been introduced. This instrument employs a diode tube rectifier powered from a single dry cell mounted in the case. A wave-change switch for six bands and a phone jack for monitoring are provided. A damped square case meter indicates the relative radio-frequency field. This instrument is manufactured by *Radio Transceiver Laboratories*, 8627 115th Street, Richmond Hill, New York City.—COMMUNICATIONS.

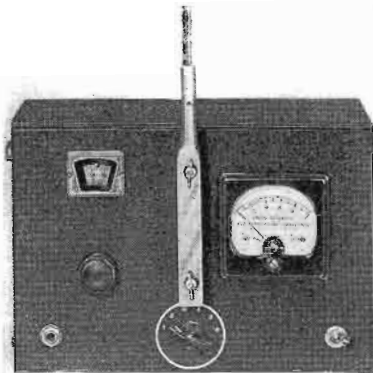

#### CORNELL-DUBILIER CAPACITORS

Hermetically sealed in round aluminum containers, the Type TLA Cornell-Dubilier capacitors are impregnated and filled with fireproof Dykanol. The capacitors are suited for operating in high-power amplifiers and medium-powered transmitters. Physical size and shape of the containers of these capacitors simulate electrolytic capacitors, allowing for simple and neat assembly into power unit. Complete details appear in new catalog, No. 161, free on request, from *Cornell-Dubilier Electric Corp.*, South Plainfield, N. J.—COMMUNICATIONS.

#### IMPULSE RELAY

Advance Electric announces a new impulse relay, Type 900, of very compact design. This unit is available as a single-pole-single-throw, double-pole-single-throw, double-pole-double-throw and four-pole-single-throw relay. Pure silver contacts are used in the switch assembly, rated from 100 to 1,000 watts. Coils are obtainable for all a-c and d-c voltages.

Additional information is available from the *Advance Electric Company*, 1260 W. 2nd St., Los Angeles, Calif.—COMMUNICATIONS.

#### ANTENNA LOADING INDUCTANCE

An electrical, remote-controlled, motor-driven antenna loading inductance has been developed by Learadio. This unit is necessary where a small fixed antenna is required to be tuned to a wide range of frequencies for transmitting purposes. A motor is provided which rotates the inductance coil, allowing a roller contact to increase or decrease the inductance by shorting out more or less turns, in accordance with the direction of rotation.

This antenna loading inductance is a product of *Lear Developments, Inc.*, Bldg. 31, Roosevelt Field, Mineola, L. I., New York.—COMMUNICATIONS.

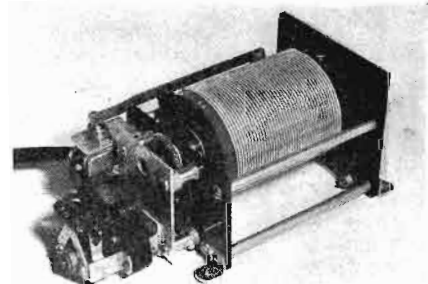



**36 years experience**  
**in PERMANENT MAGNETS**

We make Permanent Magnets for All Purposes Stamped, Formed and Cast. Chrome, Tungsten, Cobalt and **ALNICO\*\*** (cast or sintered) under G. E. license

**THOMAS & SKINNER**  
**STEEL PRODUCTS CO.**  
 1113 E. 23rd ST. - INDIANAPOLIS

LAMINATIONS FOR RADIO TRANSFORMERS  
 TOOLS - DIES - HEAT TREATING - STAMPINGS

**Be a TELEVISION EXPERT**



FIRST National's modernistic method of training is new and different. 75 profusely illustrated lessons in addition to **COMPLETE APPARATUS** for over 100 Radio and Television experiments will be given you—prepare you for employment in good pay Radio-Television field. You will also be qualified for the examination for your first class Radio-Telephone Operator's License. Get the facts! **FREE**—Write now for free 24-page booklet "Vision" describing this training.

**FIRST NATIONAL TELEVISION**

(Training Division)

Dept. C-9 Fidelity Bldg., Kansas City, Mo.

**TAYLOR** **VULCANIZED FIBRE**  
**PHENOL FIBRE**  
**TAYLOR INSULATION**

**TAYLOR FIBRE CO., Norristown, Pa.**

Radio Equipment...  
 for BROADCAST STATIONS -- LABORATORIES -- ENGINEERS  
*Call or write.*

We Carry at all times a most complete line of **PUBLIC ADDRESS EQUIPMENT**

**80 Cortlandt Street, New York, N. Y.**

**TERMINAL Radio Corporation**

BARclay 7-0622 — Cable Address: TERMRADIO

**VALPEY**  
**Frequency control units**  
 AMATEUR—COMMERCIAL—SPECIAL APPLICATIONS  
 Write for our new catalogue  
**THE VALPEY CRYSTALS**

Box 321 Holliston, Mass.

College Standards **ENGINEERING** Accredited Courses

... distinguished university faculty insures academic standards of instruction and scholarship... accredited Home Study courses in Radio and Electrical Engineering parallel college curricula... formal instruction is based upon standard college textbooks... credits are transferable to colleges for advanced standing... descriptive bulletin available upon request—Newton Institute of Applied Science, 2021-L Raymond-Commerce Bldg., Newark, N. J.

... the Graduate Division provides formal instruction in advanced engineering and higher mathematics for professional engineers.

**HOME STUDY ON THE COLLEGE LEVEL**

**PILOT LIGHTS**

**NEW TYPE No. 100**  
 1-inch Jewel Assembly  
 Uses Mazda S6 lamp removable from front of assembly. Can be furnished with smooth or faceted jewels. — Colors optional. Extremely low price.

Write for complete catalogue

MANUFACTURED BY  
**DIAL LIGHT CO. OF AMERICA**  
 National Sales Agents  
**F. EDWIN SCHMITT SALES CO.**  
 132 Liberty Street, New York, N. Y.

**GARDINER**  
**SOLDER**

**Famous FOR ECONOMY**

Throughout the radio industry Gardiner Rosin-Core Solder has an outstanding reputation for savings in both time and material. Its uniform water white rosin flux... no solvent added... permits cleaner work by both expert and inexperienced help. Its high tensile strength insures lasting bonds. Yet, due to modern production methods and tremendous demand, Gardiner Solder costs less than even ordinary kinds. Made in various alloys and core sizes and in gauges as small as 1/32 of an inch. Available in 1, 5 and 20-lb. spools.

Eastern Sales Office and Warehouse:  
**DAVID M. KASSON & CO., 401 Broadway, New York**

**Gardiner METAL CO.**

4819 S. CAMPBELL AVENUE, CHICAGO, ILL.

**MICROMETER FREQUENCY METER** for checking transmitters —up to 56 mc.

**LAMPKIN LABORATORIES - BRADENTON, FLORIDA**

**CHAS. EISLER'S** FOREMOST IN THE ELECTRONICS FIELD FOR OVER 20 YEARS!  
**EQUIPMENT HAS PRODUCED MILLIONS** Charles Eisler's equipment for the production of radio and electronic tubes, incandescent lamps, X-Ray and cathode ray tubes, mercury switches, photo-electric cells, and neon signs has met the severest demands of industry in operating at maximum production and minimum cost. If you are in the market for any of the above or allied equipment including electric spot welders up to 250 KVA, butt, and arc welders, get in touch with us. Write for our "college and glass working laboratory units" catalog.

**EISLER ENGINEERING CO.**  
 750 S. 13th STREET (Near Avon Ave.) NEWARK, N. J.

**PIEZO-ELECTRIC CRYSTALS**  
 GUARANTEED Accurate to BETTER than .01%  
 Send for FREE Booklet and Price List!  
**SCIENTIFIC RADIO SERVICE**  
 "The Crystal Specialists Since 1925"  
 UNIVERSITY PARK - HYATTSVILLE, MD.

**R. F. and I. F. COILS—RADIO CABINETS**  
 TEXTILE COVERED AND LITZ WIRE  
 TRIMMER AND PADDER CONDENSERS

Write for literature—submit specifications.

**E. I. GUTHMAN & CO., INC.**  
 400 SO. PEORIA STREET CHICAGO, ILL.

**Protect Fragile Equipment**  
From the Ravages of Dirt!

**IDEAL JUMBO**  
"3-in-1" Cleaner

Clean delicate instruments thoroughly, but gently with the Jumbo Cleaner! Does not disturb sensitive balance or exact adjustments.

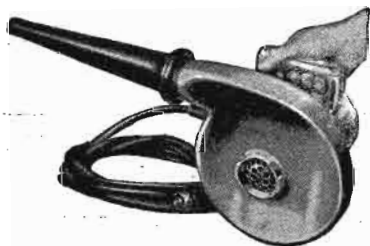

**Blows, Vacuums, Sprays**

High velocity, DRY AIR stream quickly and safely removes all dust and dirt from instruments, machinery, wiring systems, etc. Reduces "shorts" and corrosion. ★ In great demand by broadcasting stations and communication offices. Portable — weighs only 14 lbs.

*Sent on free trial.*

**Ideal Commutator Dresser Co.**  
1062 Park Avenue, Sycamore, Illinois



**CETRON**  
**PHOTOCELLS**

SET A  
STANDARD  
BY WHICH  
ALL PHOTO TUBES  
ARE JUDGED

76 DIFFERENT TYPES  
AVAILABLE

OUR ENGINEERING DEPARTMENT IS ALWAYS READY TO ASSIST YOU IN YOUR DEVELOPMENTS.

*Write for Literature*

**Continental Elec. Co.**  
Hamilton and Richards Streets  
GENEVA, ILL.

**Advertising Index**

A	
Aerovox Corp. ....	10
Alliance Mfg. Co. ....	53
American Lava Corp. ....	4
Amperex Electronic Products, Inc. ....	Inside Front Cover
Amperite Co. ....	9
Astatic Microphone Laboratory, Inc. ....	34
B	
Billie Electric Co. ....	53
Brush Development Co., The. ....	37
C	
Callite Products Division ....	49
Capitol Radio Engineering Inst. ....	51
Clarostat Mfg. Co., Inc. ....	30
Continental Electric Co. ....	56
Cornell-Dubilier Elec. Corp. ....	47
D	
Daven Co., The ....	46
Dial Light Co. of America ....	55
Doolittle & Falknor, Inc. ....	40
Drake Mfg. Co. ....	42
Driver Co., Wilbur B. ....	53
E	
Eastern Mike Stand Co. ....	51
Eisler Engineering Co. ....	55
F	
Ferrocarril Corp. of America. ....	44
Finch Telecommunications Labs., Inc. ....	32
First National Television. ....	55
G	
Gardiner Metal Co. ....	55
Gates Radio & Supply Co. ....	33
General Radio Co. ....	Inside Back Cover
Goat Radio Tube Parts, Inc. ....	46
Guardian Electric Co. ....	49
Guthman Co., E. I. ....	55
H	
Heintz & Kaufman, Ltd. ....	44
I	
Ideal Commutator Dresser Co. ....	56
Indiana Steel Products Co., The. ....	32
International Resistance Co. ....	38
J	
Jones, Howard B. ....	45
L	
Lampkin Labs. ....	55
Lear Developments, Inc. ....	41
Lingo & Son, Inc., John F. ....	34
N	
National Union Radio Corp. ....	32
Newton Inst. of Applied Science. ....	55
O	
Ohmite Mfg. Co. ....	51
Oxford-Tartak Co. ....	44
P	
Par-Metal Products Corp. ....	38
Precision Apparatus Co. ....	56
Presto Recording Corp. ....	3
R	
R. C. A. Communications, Inc. ....	36
RCA Mfg. Co., Inc. ....	Back Cover
Radio Corporation of America. ....	27
Radiotone, Inc. ....	40
S	
Scientific Radio Service. ....	55
Shakeproof Lock Washer Co. ....	28-29
Shallcross Mfg. Co. ....	34
Sound Apparatus Co. ....	43
Sound Projects Co. ....	44
Standard Piezo Co. ....	38
Sun Radio Co. ....	56
T	
Taylor Fibre Co. ....	55
Taylor Tubes, Inc. ....	36
Terminal Radio Corp. ....	55
Thomas & Skinner Steel Prod. Co. ....	55
U	
United Electronics Co. ....	35
United Transformer Corp. ....	39
V	
Valpey Crystals, The. ....	55
Van Nostrand Co., D. ....	36
W	
Ward Leonard Electric Co. ....	53
Weston Elec. Instrument Corp. ....	45
Wholesale Radio Service Co., Inc. ....	56
Wilcox Electric Co. ....	51
Z	
Zophar Mills, Inc. ....	40

POPULAR LABORATORY MODEL  
**PRECISION**  
SERIES 842 L



A.C.-D.C.-VOLT-OHM-DECIBEL  
MILLIAMMETER-AMMETER

With 2500 Volt A.C.-D.C. Range  
And 1000 M.A. and 10 AMP. RANGES

- FIVE AC VOLTAGE RANGES at 1000 ohms per volt: 0-10; 0-50; 0-250; 0-1000; 0-2500 volts.
- FIVE DC VOLTAGE RANGES at 1000 ohms per volt: 0-10; 0-50; 0-250; 0-1000; 0-2500 volts.
- SIX DC CURRENT RANGES: 0-1; 0-10; 0-50; 0-250 MA; 0-1/0-10 AMPS.
- FOUR RESISTANCE RANGES: 0-400 ohms (20 ohms center) SHUNT METHOD. 0-100,000 ohms (800 ohms center). 0-1 Megohm (8000 ohms center). 0-10 Megohms (80,000 ohms center).

NOTE: Provisions for mounting ohmmeter power supply (4½ and 45v batteries) on inside of case. No external connections necessary.

- FIVE DECIBEL RANGES FROM -10 TO +63DB: 0DB; +14DB; +28DB; +40DB; +48DB.
- FIVE OUTPUT RANGES: 0-10; 0-50; 0-250; 0-1000; 0-2500 volts.

842-L—Size 7½ x 8½ x 4. Housed in walnut finished wood case with carrying handle. Less Batteries and Test Leads. Net. **\$21.95**

**Precision Apparatus Corp.**  
821 East New York Ave., Brooklyn, N. Y.  
EXPORT DIVISION:  
458 BROADWAY, NEW YORK, U. S. A.  
CABLES: "MORHANEX"

**TWO GOOD REASONS**

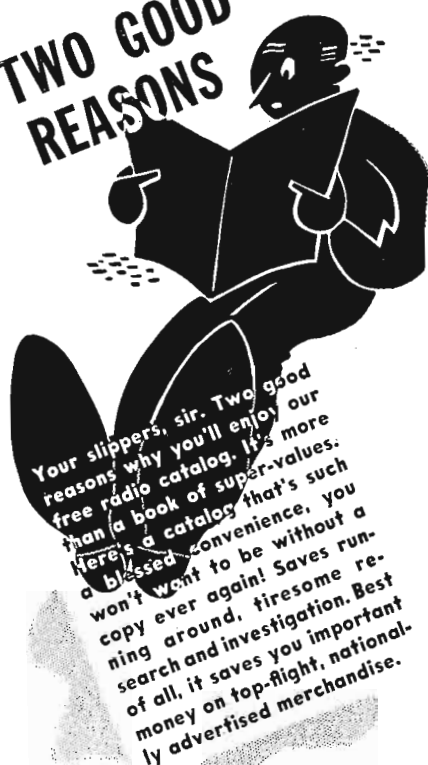

**WHOLESALE RADIO SERVICE CO. INC.**  
100 SIXTH AVE., NEW YORK, N. Y.  
CHICAGO, ILL. • ATLANTA, GA. • BOSTON, MASS.  
BRONX, N. Y. • NEWARK, N. J. • JAMAICA, L. I.



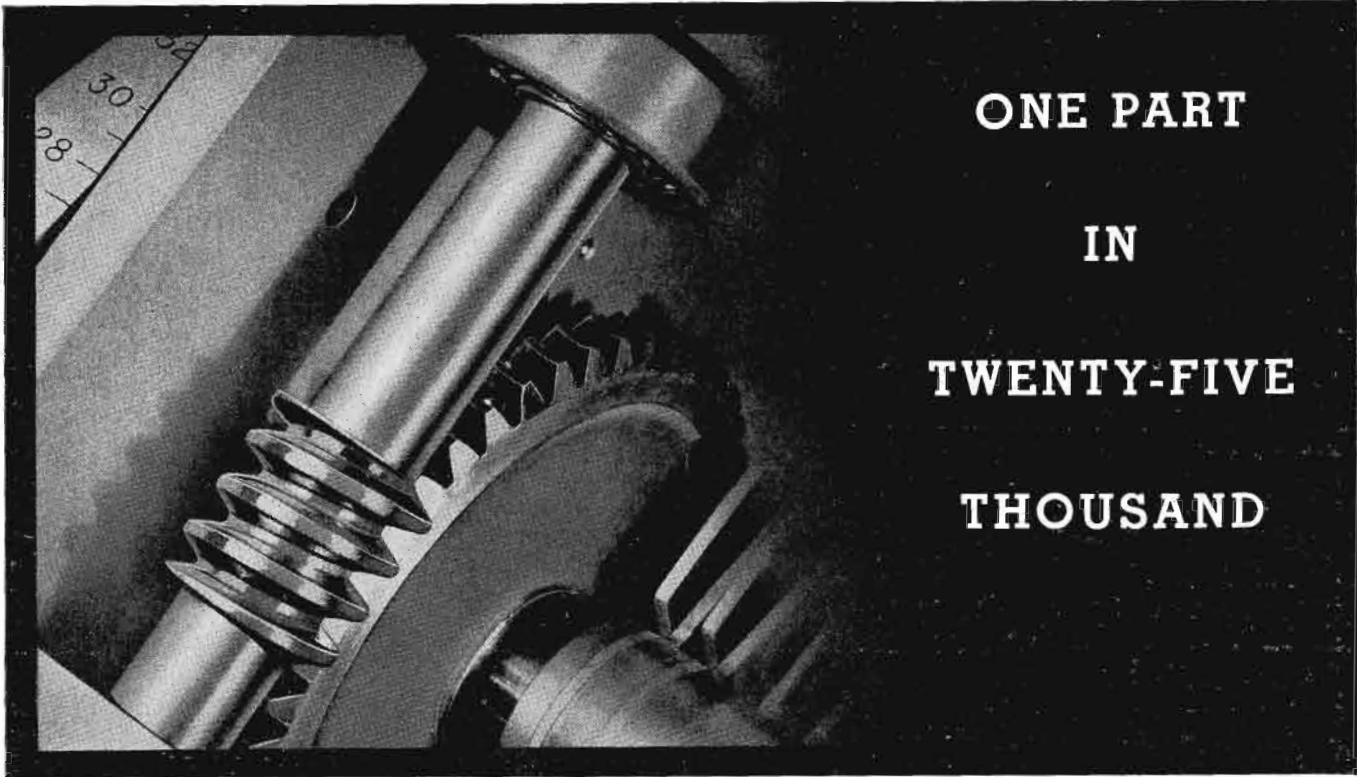

ONE PART  
IN  
TWENTY-FIVE  
THOUSAND

**P**RECISION variable air condensers for use as standards of capacitance have been manufactured by General Radio Company since 1919. The current Type 722 Precision Condensers are generally accepted by the leading laboratories throughout the world as *the* variable standard of capacitance.

The Type 722 condensers can be reset to 1 part in 25,000, an accuracy comparable to that obtained only in the finest type of precision machine. To secure this accuracy of setting, exceedingly close mechanical tolerances are held throughout.

A 50-to-1 worm drive equipped with a 3½-inch dial is used for the fine setting adjustment. Backlash in the drive is kept at a very low minimum (less than one-half worm division) by cutting the worm and worm-shaft from an integral steel shaft, thus eliminating eccentricity due to set screws and misfit. The worm shaft is held to a tolerance of 0.0004 inch; the radial eccentricity of the worm gear is held to less than 0.002 inch. The main rotor shaft is held to a radial tolerance of 0.0005 inch and its bearing surfaces to 0.0002 inch. Ball bearings are used on the worm and main rotor shafts.

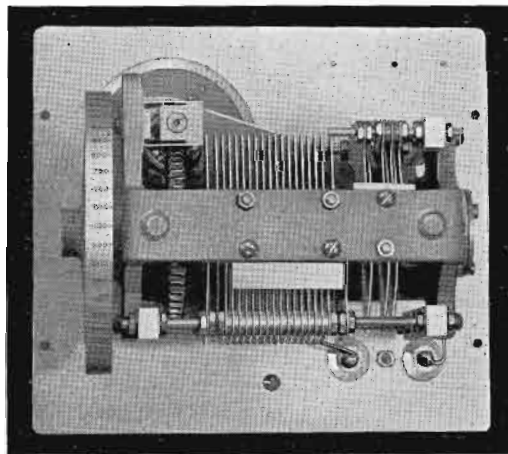

To take full advantage of the mechanical refinements of the worm drive, correspondingly important electrical and mechanical design features are incorporated in the other parts of these condensers. The main shaft, rotor and stator plates, tie rods and heavy cast frame are all fabricated from aluminum alloy. A remarkably low temperature coefficient of capacitance of only 0.0022 per cent per degree C. (22 parts per million) results from this construction.

Small, properly placed, waxed Isolantite bars insulate the rotor and stator plates. A Figure of Merit ( $R_{\omega}C^2$ ) of  $0.04 \times 10^{-12}$  at 1,000 cycles is thus secured.

After assembly the completed condensers pass through a number of aging cycles to relieve strains set up . . . strains which otherwise would not appear until years later. The condensers are then calibrated in our laboratories to an accuracy considerably better than that at which they are rated.

Type 722 Precision Condensers are stocked in three mounted and one unmounted models; prices range between \$85.00 and \$110.00.

General Radio Company, 30 State Street, Cambridge, Massachusetts  
Branches in New York and Los Angeles

• **WRITE FOR BULLETIN 310**

PRECISION RADIO APPARATUS SINCE 1915





# Parade of Progress

## PROVES WORTH OF RCA POLICY!



"To provide you with the finest in transmitting tubes, at the lowest possible cost," is a creed with RCA. And these recent RCA accomplishments are the result!

### BROADCAST ECONOMY

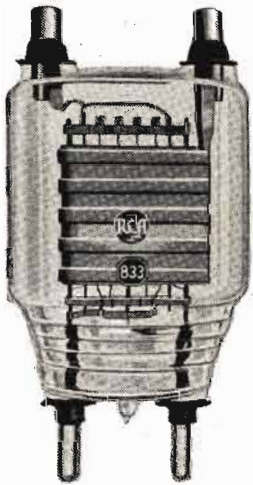

The RCA 833 combines high efficiency with economy. Two of these tubes, each rated at 500 watts by E. C. C. may be used as final r-f stage in 1 kw. transmitters.



Another RCA achievement in money-saving design is the air-cooled power tube available in two types — 891-R and 892-R. These tubes provide the design advantages of water-cooled tube construction, eliminate the expense water cooling incurs.

### HIGH POWER U.H.F. TRANSMISSION

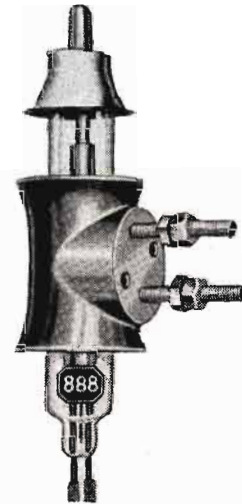

In the field of water-cooled tubes RCA offers the 887 and 888 which make possible the opening with adequate power of the enormous territory between 3 and 1 1/4 meters. These tubes are rated at 1200 watts max. input for wave lengths down to 1 1/4 meters. Power input and output capability for 1 1/4 meters is many times that of any other tube available.

### LINE OF SIGHT TRANSMISSION

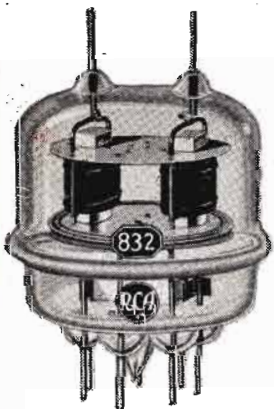

The RCA 832 gives exceptional performance at frequencies from 100 to 300 MC. Is designed primarily for use as a push-pull U.H.F. power amplifier with maximum ratings at wave lengths as short as two meters. With reduced ratings it may be operated at wave lengths down to one meter. Excellent for use in transmitters intended for line of sight communication.

### TELEVISION AMPLIFIERS



With interest in television mounting steadily, RCA engineers designed the 1852 and 1853 primarily for use in the picture channel amplifier circuit of television receivers. While these are not transmitting tubes they are an important RCA contribution to the industry and as such, belong in this parade of progress.

### ULTRA-HIGH FREQUENCY APPLICATION

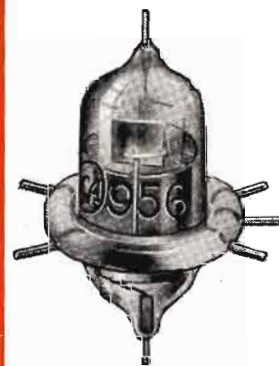

RCA's sensational acorn family, used chiefly by amateurs, is an outstanding advance in ultra-high frequency communication. Illustrated here is the RCA 956, a super-control r-f pentode which controls gain in r-f and permits a reduction in cross modulation. Other members of the acorn family are the RCA 954 and 955.

RCA presents the Magic Key, Sundays, 2 to 3 P. M., E. D. S. T., on the NBC Blue Network.

IT PAYS  
TO BUY...



# Radio Tubes

First in metal  
foremost in glass  
finest in performance

RCA MANUFACTURING CO., INC., CAMDEN, N. J. • A Service of the Radio Corporation of America