

# COMMUNICATIONS

a merger of  
RADIO ENGINEERING

...

COMMUNICATION &  
BROADCAST ENGINEERING

...

THE BROADCAST ENGINEER

OCTOBER  
1938

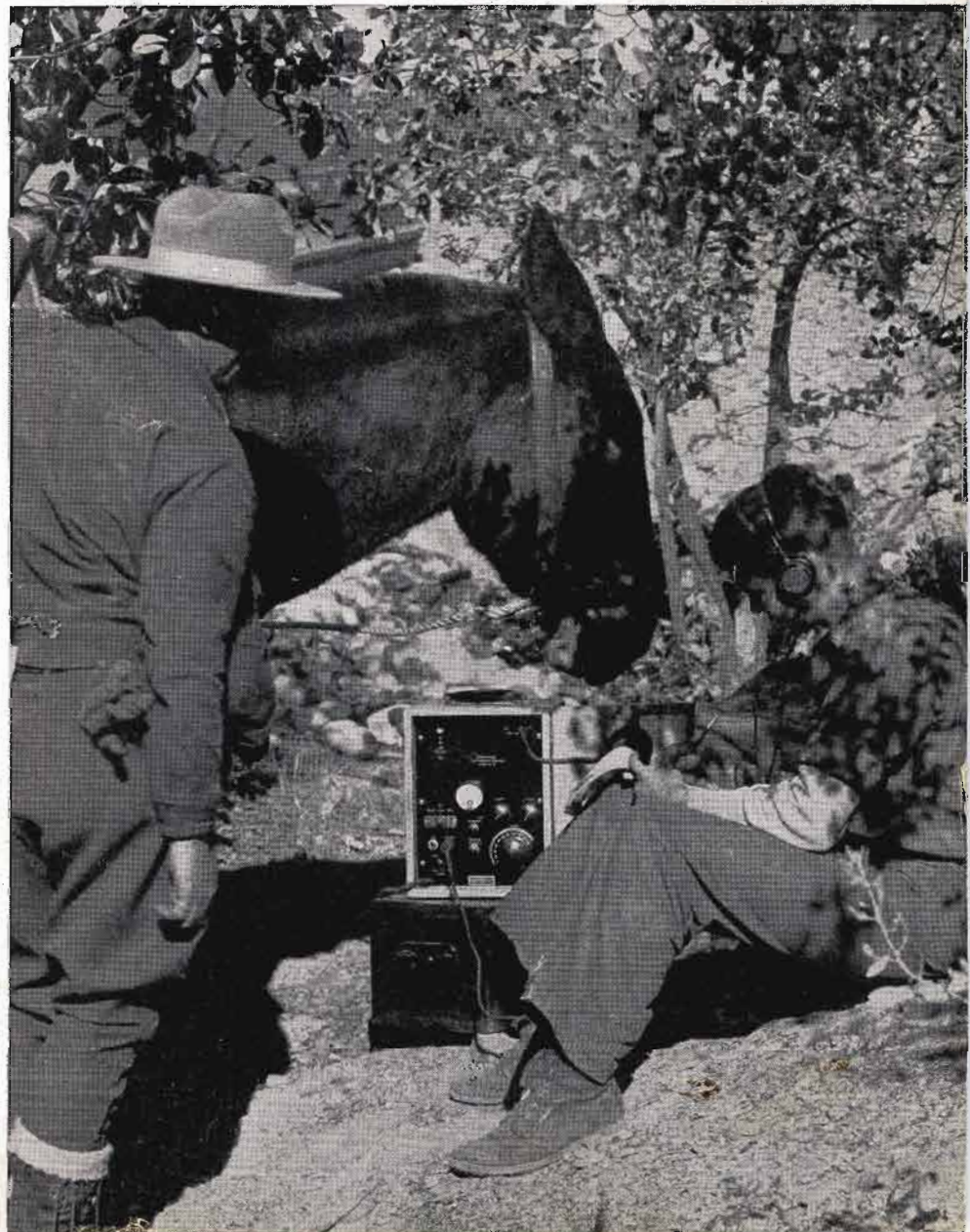



**SOLAR**

GIVES

YOU

*more*

FOR YOUR MONEY

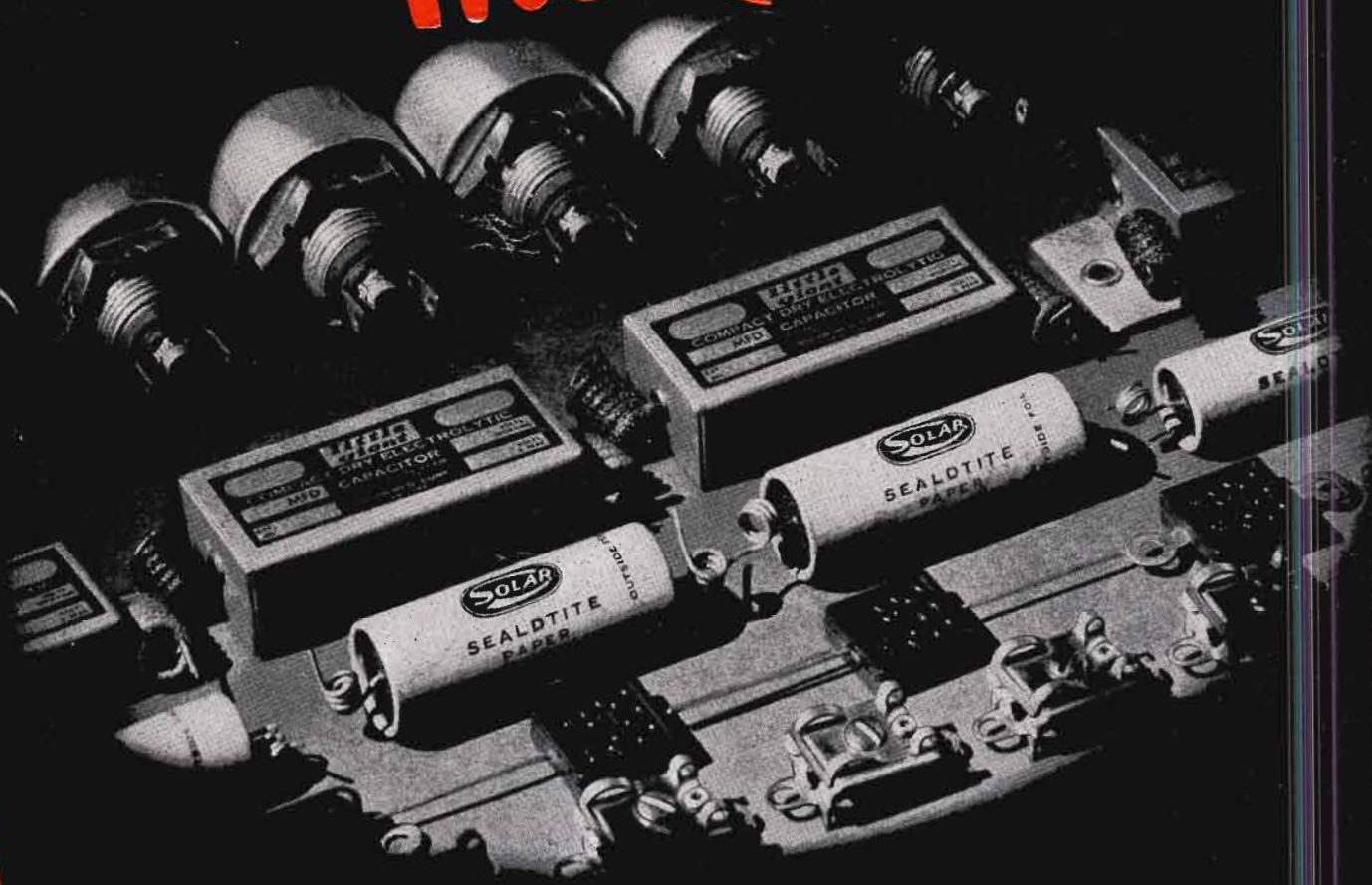

*Condensers* are much alike mechanically... but behind SOLAR Capacitors there is something more... the broad and deep experience of our laboratory and plant personnel. This powerful hidden ingredient makes the marked difference in PERFORMANCE which benefits the Radio and Electrical industries. Standardize on SOLAR... QUALITY ABOVE ALL

**SOLAR MFG. CORP., 599-601 BROADWAY, NEW YORK, N. Y.**

*Catalogs upon request*

# The New Collins 26C Limiting Amplifier

is a superb job of engineering. For one thing, it uses an entirely new, different and reliable automatic gain control circuit.

We cannot begin to talk about the many features of the 26C within the space of this page, so we suggest that you get the 26C Bulletin and settle down for an interesting fifteen minutes of enlightenment.

Then get a 26C for your station. It will do a real job for you.

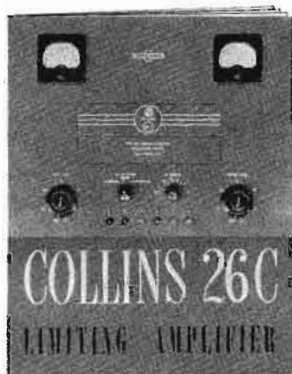

**COLLINS RADIO COMPANY**  
CEDAR RAPIDS, IOWA  
NEW YORK, N. Y.: 11 WEST 42 ST.

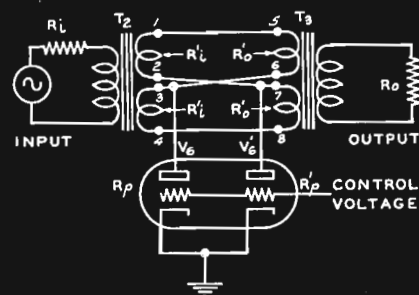

Fig. 1

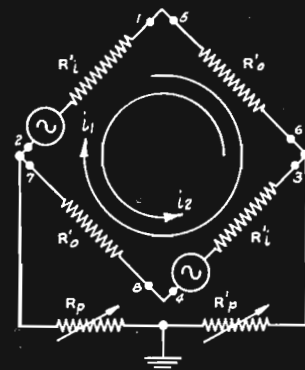

Fig. 2

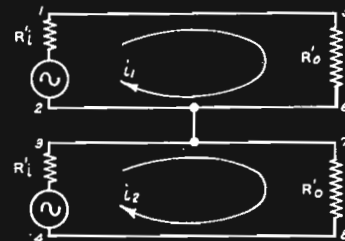

Fig. 3

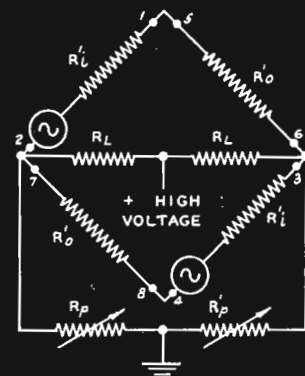

Fig. 4

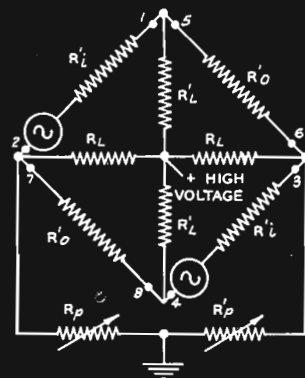

Fig. 5

# COMMUNICATIONS

Registered U. S. Patent Office  
Member of Audit Bureau of Circulations

RAY D. RETTENMEYER  
Editor

## CONTENTS FOR OCTOBER

Cover Illustration: CCC boy being instructed in the use of two-way portable radio. Klamath National Forest, California. In 5 years the number of short-wave radio sets in use in the woods and mountains of the United States National Forests has increased from 300 to 2300. Photo by U. S. Forest Service.

	Page
With the Editors .....	4
Exponential Transmission Line, Part I .....	7
By Charles R. Burrows	
An Automatic Direction Finder .....	10
Book Reviews .....	11
Coupling Networks, Part II .....	12
By W. L. Everitt	
A D'Arsonval Reproducer for Lateral Recordings	
By George W. Downs, Jr., and William Miller	19
Mystery Control .....	20
By Robert G. Herzog	
Flightray .....	22
Over the Tape .....	23
Veteran Wireless Operators Association News .....	24
Aircraft Direction Finding .....	33
AVC by Noise .....	33
Radio Altimeter .....	34
The Market Place .....	36
Index of Advertisers .....	40

VOLUME 18

NUMBER 10

BRYAN S. DAVIS  
President

JAMES A. WALKER  
Secretary

Chicago Office—608 S. Dearborn St.  
Telephone: Wabash 1903.

Published Monthly by the  
BRYAN DAVIS PUBLISHING CO., INC.

19 East 47th Street  
New York City  
New York Telephone: PLaza 3-0483



SANFORD R. COWAN  
Manager

PAUL S. WEIL  
Advertising Manager

A. GOEBEL  
Circulation Manager

Wellington, New Zealand—Te Aro Book Depot.  
Melbourne, Australia—McGill's Agency.

*Entered as second class matter October 1, 1937, at the Post Office at New York, N. Y., under the act of March 3, 1879. Yearly subscription rate: \$2.00 in the United States and Canada, \$3.00 in foreign countries. Single copies: twenty-five cents in United States and Canada, thirty-five cents in foreign countries.*



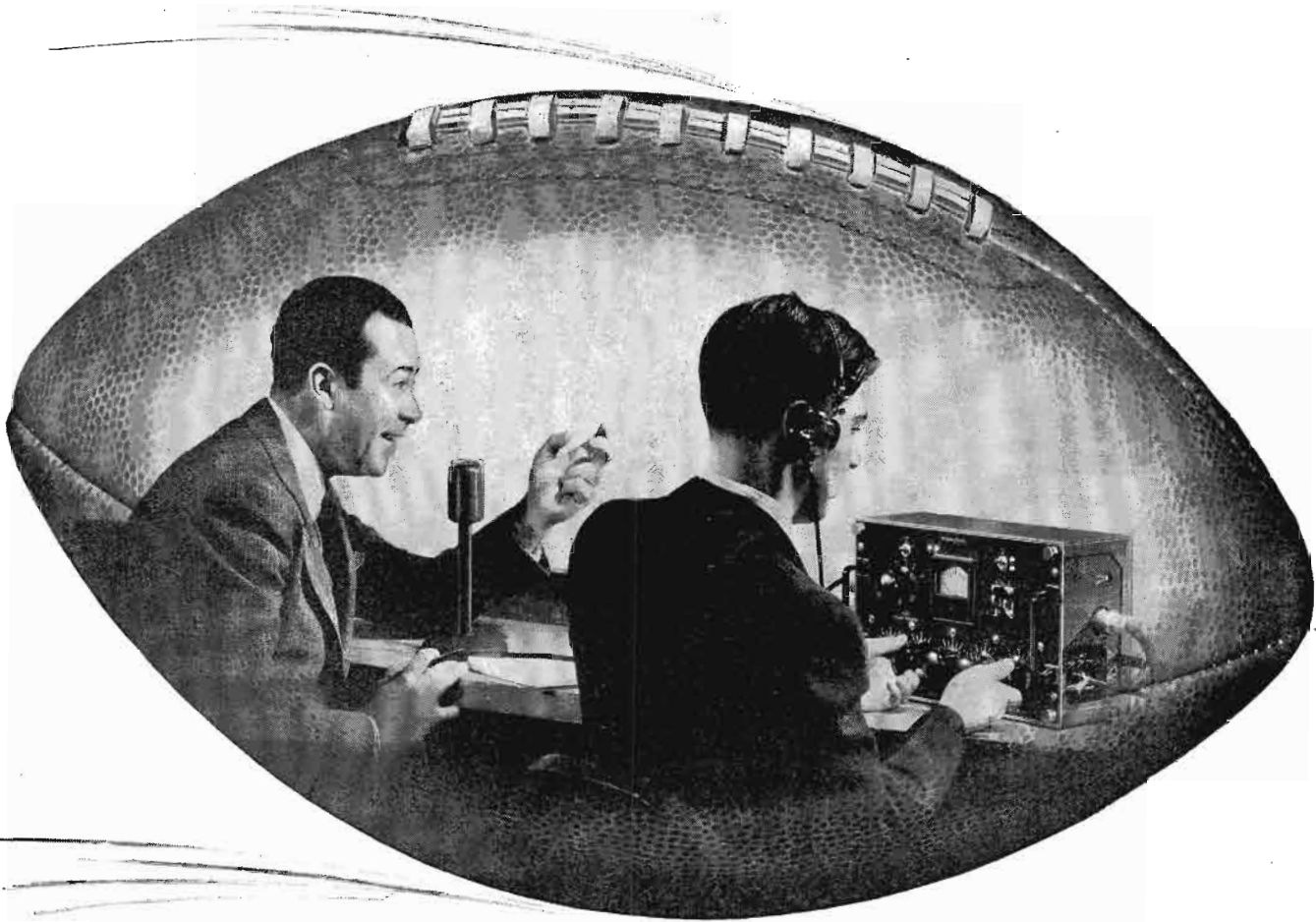

# It SCORES on every play!

## THE 22 TYPE PORTABLE SPEECH INPUT

### Outstanding Features:

- 1 Stabilized Feedback assures high fidelity.
- 2 Frequency characteristic flat within  $\pm 1$ db. from 30 to 10,000 cycles.
- 3 Maximum gain of amplifier approx. 92 db.
- 4 Maximum of control and flexibility through use of parallel mixing circuits for 4 mikes plus master gain control.
- 5 Operates from 115 volt 50/60 cycle AC supply or batteries.
- 6 Completely factory-wired and tested.

Distributors: Graybar Electric Co., Graybar Bldg., New York.  
 In Canada and Newfoundland: Northern Electric Co., Ltd.  
 In other countries: International Standard Electric Corp.

From kick-off to final whistle, this Western Electric equipment scores with operators and listeners. It's easily handled, rugged, designed for fast set-up — and it gives high fidelity that your listeners have a right to expect.

Both 22B and 22C equipments operate from AC supply or batteries — give you 4 mike mixers and main gain control. They're ideal for football pick-ups, political rallies, remotes of every kind.

Ask Graybar for all the facts on this high quality low cost equipment.

# Western Electric



RADIO TELEPHONE BROADCASTING EQUIPMENT

# WITH THE EDITORS

---

## RADIO CENSORSHIP

MUCH ATTENTION has been given to a recent decision of the Federal Communications Commission that cited WTCN for hearing because of its broadcast of Eugene O'Neill's Pulitzer prize play "Beyond the Horizon." The play, it seems, contains a few expressions which the Commission, with the exception of *Commander T. A. M. Craven*, felt should not be used in a radio broadcast.

The radio industry is much concerned over the decision, despite the fact that the FCC have voted to reconsider the case. Radio censorship by the Government is not wanted, and we do not believe it will be tolerated in this country. In this connection it is interesting to note the attitude expressed by Neville Miller, President of the National Association of Broadcasters, in an address delivered shortly after he took office:

"Any threat to gather the freedom of radio unto the bosom of a government, of a bureaucracy, or of a monopoly must be resisted. . . . Any invasion of our free competitive system of American broadcasting from any quarter whatsoever will meet with all the resistance at my command, and I believe as well with the determined resistance of the people who own and use the thirty million radio sets operative throughout America."

In our opinion, the American listening public is the real and logical censor of broadcasting . . . a condition that is in line with the true principle of democracy.

## AIRCRAFT RADIO AIDS

DURING THE PAST few weeks there has been much interest in radio aids for aircraft.

Among the interesting developments is a system designed for locating the exact position of an aircraft in flight. This direction finding system utilizes the signal from the plane's radio transmitter used for regular ground communication work.

Also of importance is a new type of direction finder for use on the plane. This instrument is entirely automatic in opera-

tion and furnishes the pilot with continuous bearings through 360 degrees.

Flight tests and demonstrations have been conducted on a new type of radio altimeter which measures the time taken for an ultra-high-frequency radio signal to be reflected from the ground back to the plane. This device is useful in that it gives the distance of the airplane above the surrounding terrain, rather than above sea level.

Another development is a combined indicator designed to simplify some of the problems of instrument flight and landing. When used as a flight instrument, the device shows on one dial the directional gyro, the artificial horizon, the turn indicator, the ball bank indicator and cruising altitude; as a landing aid, it gives the directional gyro, artificial horizon, turn indicator, glide path, runway localizer, ball bank, marker light signals and minimum air speed warning.

Additional data on all these developments will be found on following pages of COMMUNICATIONS.

## DON'T FORGET . . .

THE DATES of the Rochester Fall Meeting at the Hotel Sagamore, Rochester, N. Y. . . . November 14, 15 and 16. An interesting program has been planned with papers on the subjects of television, frequency modulation, loudspeakers, radio interference, ultra-high-frequency tubes, etc. The complete program will appear in our November issue.

## SPECIAL RECEIVERS

RADIO RECEIVER manufacturers might possibly find an additional outlet for their receivers if they were to build sets with special period and modernistic cabinets to be retailed exclusively by furniture stores. These models would have considerable sales appeal since they would be designed to go with specific sets of furniture, and sold at list price they would afford very little competition to regular dealers.

LESS THAN 7½% OF THE  
COST OF YOUR NEW  
RADIATOR  
WILL BE FOR

*Insulation*

## GIVE IT THE SECURITY OF INSULATION BY LAPP

If you are planning a 400-foot antenna structure, a self-supporting radiator will probably be recommended. The erected cost of the structure will approximate \$8,600. Insulation with four Lapp push-pull units will cost \$640, less than 7½% of the total investment. In a guyed radiator the ratio of base insulator-to-structure cost will be substantially less.

And if you are planning such a structure, it is because you expect to

achieve finer transmission quality. Is it not a wise investment, then, to give your radiator the security of insulation by Lapp? For then, and only then, would you have the assurance of complete electrical insulation, what-

ever your transmission equipment, whatever your antenna feeding circuit.

Ask for Lapp Bulletin No. 137. It tells the story of Lapp tower footing and guy insulators and porcelain water coils.

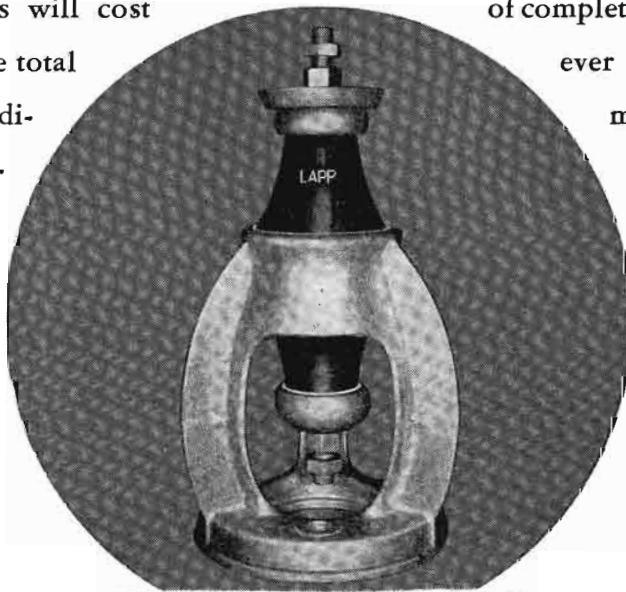

**LAPP**  
INSULATORS

LAPP INSULATOR CO. INC.

LE ROY - N.Y. - U.S.A.



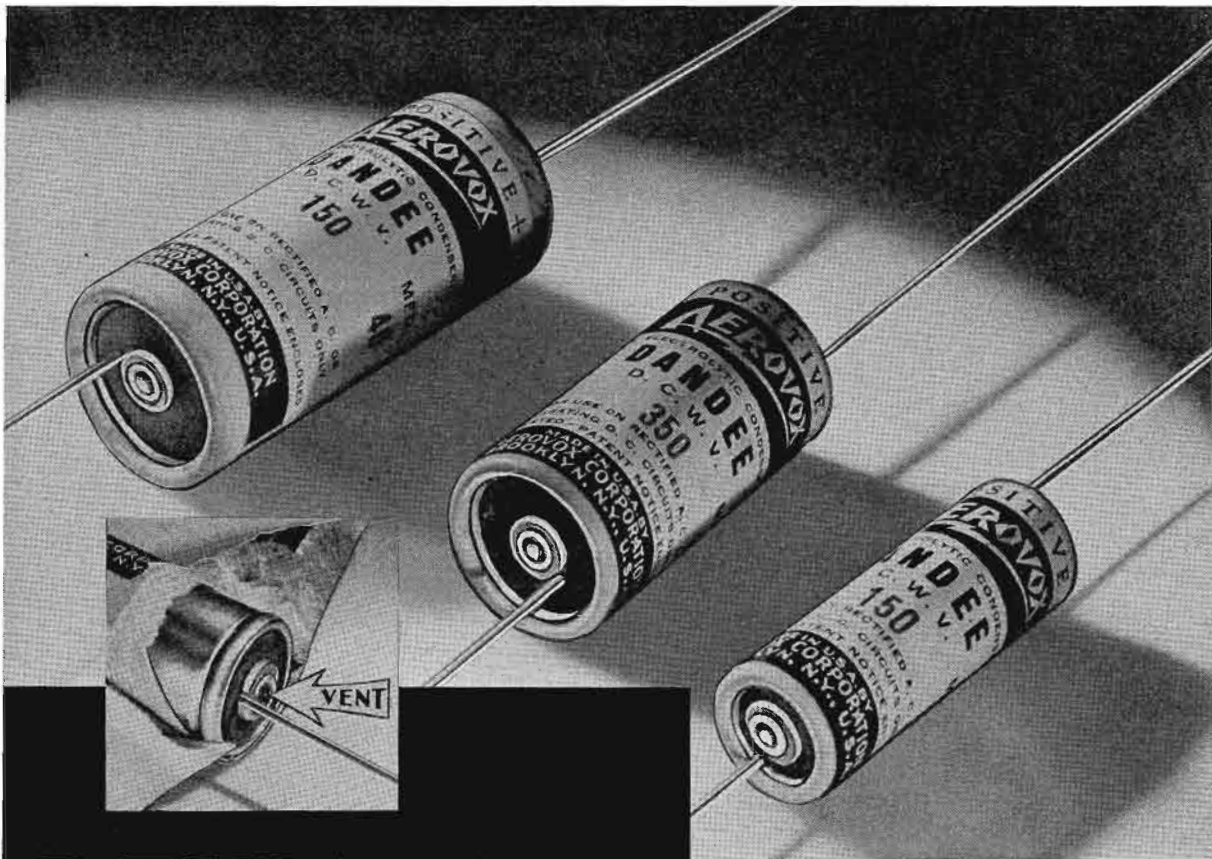

**DANDEE...**  
*in NAME and*  
*in FACT*

● IT remained for AEROVOX engineers to introduce the proper venting of these tiny electrolytics, thereby eliminating the troubles and hazards experienced with earlier types. And this adequate venting, plus other refinements, has made the DANDEE the logical choice for use in compact, low-cost, reasonable-life assemblies such as AC-DC receivers. ● Samples and quotations cheerfully submitted to designers and manufacturers.

*featuring...*

● Extreme compactness. No larger than usual paper tubular. Yet packs from 4 to 40 mfd. depending on voltage.

● Full rated capacity and working voltage. Remarkable life.

● Dry electrolytic section. Hermetically sealed in aluminum can. Insulated by paper jacket.

● Ends of jacket spun over aluminum can rim. No chance for "shorts" if leads are bent close to can. Jacket can't slip off.

● Polarity-indicating red and black end disks. Fully vented design.

**AEROVOX CORPORATION**

70 WASHINGTON STREET, BROOKLYN, N. Y.

Sales Offices in All Principal Cities



# COMMUNICATIONS

FOR OCTOBER, 1938

## EXPONENTIAL TRANSMISSION LINE

Part I

By **CHARLES R. BURROWS**  
BELL TELEPHONE LABORATORIES

THE EXPONENTIAL LINE may be defined as an ordinary transmission line in which the spacing between the conductors (or conductor size) is not constant but varies in such a way that the distributed inductance and capacity vary exponentially with the distance along the line; that is, the impedance ratio for two points a fixed distance apart is independent of the position of these two points along the line. A disturbance is propagated down an exponential transmission line in the same manner as it would be down a uniform line with the additional effect that the voltage is increased by the square root of the change in impedance level and the current is decreased by the reciprocal of this quantity.

The exponential line has the properties of a high-pass impedance transforming filter. The cutoff frequency depends upon the rate of taper. As the frequency is increased the transfer con-

stant<sup>1</sup> approaches the propagation constant of the equivalent uniform line. At sufficiently low frequencies the only effect of the line is to connect the input to the load.

Above cutoff the magnitudes of the characteristic impedances at any point are approximately equal to the nominal characteristic impedance<sup>1</sup> at that point but their phase angles (in radians) differ by an amount which at the higher frequencies is equal to the cutoff frequency divided by the frequency in question. The ratio of input impedance to the input impedance level<sup>1</sup> of an exponential line terminated in a resistance equal to the impedance level at the out-

put always remains within the range from  $1 - f_c/f$  to  $1/(1 - f_c/f)$  for frequencies,  $f$ , greater than the cutoff frequency,  $f_c$ . For a 2:1 transformation this means that the input impedance remains within  $\pm 6\%$  of the desired value for all frequencies above that for which the line is a wavelength long. For a 4:1 transformation under the same conditions the irregularities are twice as great.

A transforming network having deviations from the ideal of the order of  $\pm(f_c/f)^2$  may be made by connecting an inductance in parallel with the low-impedance terminal and a capacity in series with the high-impedance terminal. The magnitudes of these reactances are such that their impedances are equal to the impedance levels of the line at their respective ends at the cutoff frequency. Or expressed in another way the capacity is equal to  $2/(k-1)$  times the electrostatic capacity of the line and the inductance is the same factor times the

<sup>1</sup>See appendix for definition of terms.

**Fig. 2**  
Impedance diagram comparing the forward looking characteristic impedance with various terminal impedances. The numbers give the frequency relative to cutoff. The arrows are the vectors  $Z - Z_1^*$  which are a measure of the magnitude of the reflection.

**A. Step-up line.**  
Curve 1 - Forward looking characteristic impedance,  
 $Z_1 = Z_1 e^{-j \sin^{-1}(f_c/f)}$ ,  $f > f_c$   
 $Z_1 = Z_1 [-j(f_c/f)(1 + \sqrt{1 - f_c^2/f^2})]$ ,  $f_1 > f$   
Curve 2 - Resistance termination,  $Z_1 = Z_1$ ;  
Curve 3 - Capacity resistance termination,  $Z_1 = Z_1(1 - jf_c/f)$ ;  
Curve 4 - Capacity, resistance and inductance termination adjust-

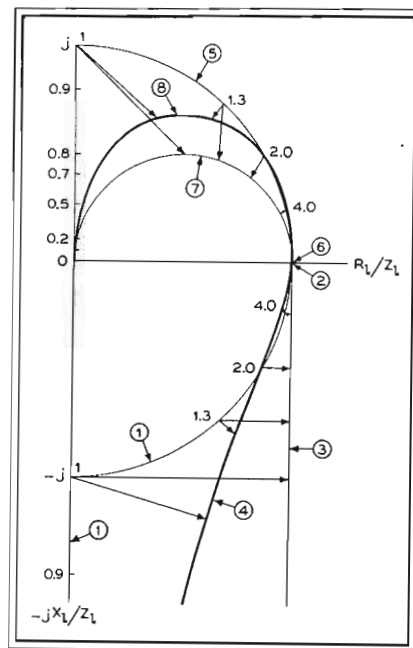

ed for no reflection at twice the cutoff frequency and at infinite frequency;

**B. Step-down line.**  
Curve 5 - Forward looking characteristic impedance,  
 $Z_1 = Z_1 e^{+j \sin^{-1}(f_c/f)}$ ,  $f > f_c$   
 $Z_1 = Z_1 [+j(f_c/f)(1 - \sqrt{1 - f_c^2/f^2})]$ ,  $f_1 > f$   
Curve 6 - Resistance termination  
 $Z_1 = Z_1$ ;  
Curve 7 - Inductance resistance termination  
 $Z_1 = Z_1/(1 - jf_c/f)$ .  
Curve 8 - Inductance, resistance and capacity termination adjusted for no reflection at twice the cutoff frequency and at infinite frequency.

total loop inductance of the line where  $k$  is the impedance transformation ratio of the line.

Fig. 1 shows the theoretical input impedance—frequency characteristics for 2 to 1 set-up and step-down exponential lines. Curve 1 is for the line with a resistance termination. At low frequencies the input impedance is equal to the load impedance while at high frequencies the line approaches an ideal transformer. Curve 2 is the input impedance of the line terminated with the appropriate resistance-reactance combination. The improvement in the input-impedance characteristic for frequencies above the cutoff frequency is evident. At the lower frequencies the input impedance does not approach the terminal reactance but approaches the reactance of the capacity of the line in parallel with the series terminal capacity for the step-up line and the reactance of the inductance of the line in series with the shunt terminal inductance for the step-down line. The improvement is not as great as apparent from the figures because the phase angle is not improved proportionally. This is easily remedied by completing the impedance transforming network with the appropriate reactance at the input. The resulting input impedance is shown in curve 3. In the "pass" frequency range the maximum reactive component is of the same order of magnitude as the deviation of the impedance from the ideal.

Besides its application as an impedance transforming network, the exponential line may be used as a "resistance" load of constant known impedance that has a high capacity for dissipating power. As such it is capable of dissipating more power in the same length of line than the uniform line. If  $x$  is the maximum attenuation in nepers that can be obtained with a uniform line without overheating, the same length of exponential line will have an attenuation of  $(e^{2x} - 1)/2$  nepers.

Exponential lines of the proper length have properties similar to half-wave and quarter-wave uniform lines. The input impedance of an exponential line an even number of quarter-wavelengths long is equal to the load impedance times the impedance transformation ratio of the line. When the length of the line differs from an odd multiple of a quarter-wavelength by an amount that depends upon the frequency and load impedance, the input impedance is equal to the product of the terminal impedance levels divided by the load impedance.

#### MATHEMATICAL FORMULATION

The telegraph equations for the exponential line may be solved by the same methods employed in the problem of a uniform line. The resulting equations for the voltage and current at any point along the line are

$$v_x = Ae^{-\left(\frac{\delta}{2}\right)x} + Be^{+\left(\frac{\delta}{2}\right)x} = Ae^{-\left(\frac{\delta}{2}\right)x} \left[ 1 + \frac{B}{A} e^{2\Gamma x} \right] \quad (1)$$

and

$$i_x = \frac{A}{Z_0} \frac{\Gamma - \frac{\delta}{2}}{\Gamma} e^{-\left(\frac{\delta}{2}\right)x} - \frac{B}{Z_0} \frac{\Gamma + \frac{\delta}{2}}{\Gamma} e^{+\left(\frac{\delta}{2}\right)x} \quad (2)$$

$$= \frac{A}{Z_0} \frac{\Gamma - \frac{\delta}{2}}{\Gamma} e^{-\left(\frac{\delta}{2}\right)x} \left[ 1 - \frac{B}{A} \frac{\Gamma + \frac{\delta}{2}}{\Gamma - \frac{\delta}{2}} e^{2\Gamma x} \right]$$

where

$$\delta = \frac{\log_e z/z_0}{x} = \frac{\log_e y_0/y}{x} = \frac{\log_e Z/Z_0}{x} \text{ is the rate of taper,}$$

$$Z_x = \sqrt{z/y} = Z_0 e^{\delta x}$$

is the surge or nominal characteristic impedance of the exponential line at the point  $x$  which is equal to the characteristic impedance of the uniform line that has the same distributed constants as this line has at the point  $x$ ,

$$\gamma = \sqrt{zy} = \sqrt{z_0 y_0}$$

is the propagation constant of any uniform line that has the same distributed constants as this line at any point. It is independent of the point along the

line to which it is referred, and

$$\Gamma = \sqrt{\gamma^2 + \delta^2/4} = \alpha + j\beta$$

is the transfer constant of the exponential line.

$+\gamma$  and  $+\Gamma$  refer to the values of the indicated roots that are in the first quadrant.

If these equations are compared with those for a uniform transmission line it is found that the propagation constant is  $\Gamma - \delta/2$  for voltage waves travelling in the positive  $x$  direction and  $\Gamma + \delta/2$  for voltage waves travelling in the negative  $x$  direction. For current waves the corresponding propagation constants are  $\Gamma + \delta/2$  and  $\Gamma - \delta/2$ . In the terminology of wave filters,  $\Gamma$  is the transfer constant and  $\delta$  is the impedance transformation constant.  $\delta/2$  is the voltage transformation constant and  $-\delta/2$  is the current transformation constant. The real and imaginary parts of  $\Gamma$ ,  $\alpha$  and  $\beta$ , are the attenuation and phase constants respectively.

An important parameter is

$$v = j \frac{\delta}{2\gamma}$$

which for a non-dissipative line is the ratio of the cutoff frequency to the frequency, as can be seen if we write the transfer constant as

$$\Gamma = \gamma \sqrt{1 - v^2}$$

where the indicated root is in the fourth quadrant. For a non-dissipative line  $v$  is real and the transfer constant is real or imaginary depending on whether  $v^2$  is greater than or less than unity. Hence the exponential line is a high-pass filter whose cutoff frequency,  $f_c$ , is that frequency for which  $v^2 = 1$ . The transfer constant is then less than that for a uniform line by the factor  $\sqrt{1 - v^2}$  so that both phase velocity and wavelength are larger for the exponential line than for the uniform line by the reciprocal of this factor.

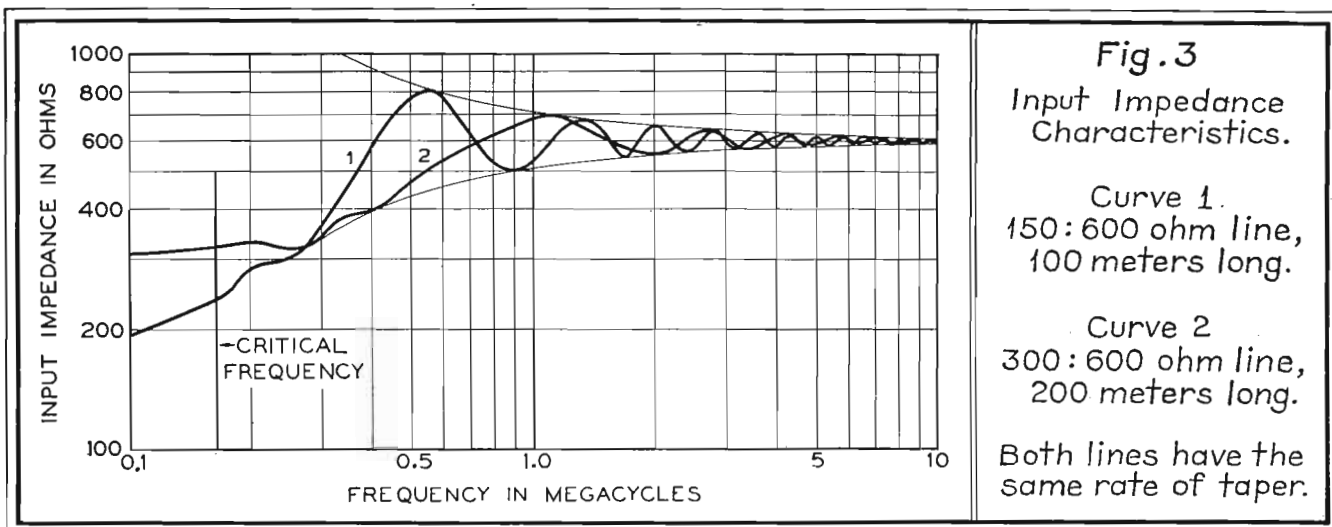



If we terminate this line at  $x = 1$  with an impedance  $Z_1 = v_1/i_1$ , the ratio of the reflected to direct voltage wave is found to be

$$\frac{B}{A} = - \frac{1 - (Z_1/Z_0)(\sqrt{1-v^2} + jv)}{1 + (Z_1/Z_0)(\sqrt{1-v^2} - jv)} e^{-2\Gamma l} \quad (3)$$

where the coefficient of the exponential is the *voltage reflection coefficient*.

There will be no reflection if

$$Z_1 = \frac{Z_0}{(\sqrt{1-v^2} + jv)} = Z_0 + \dots \quad (4)$$

which becomes  $Z_1 e^{-j \sin^{-1} v}$  above the cut off frequency for non-dissipative lines. This is the magnitude of the forward-looking *characteristic impedance* at  $x = 1$  as can be seen by dividing the first term of (1) by the first term of (2). Curve 1 of Fig. 2 gives the char-

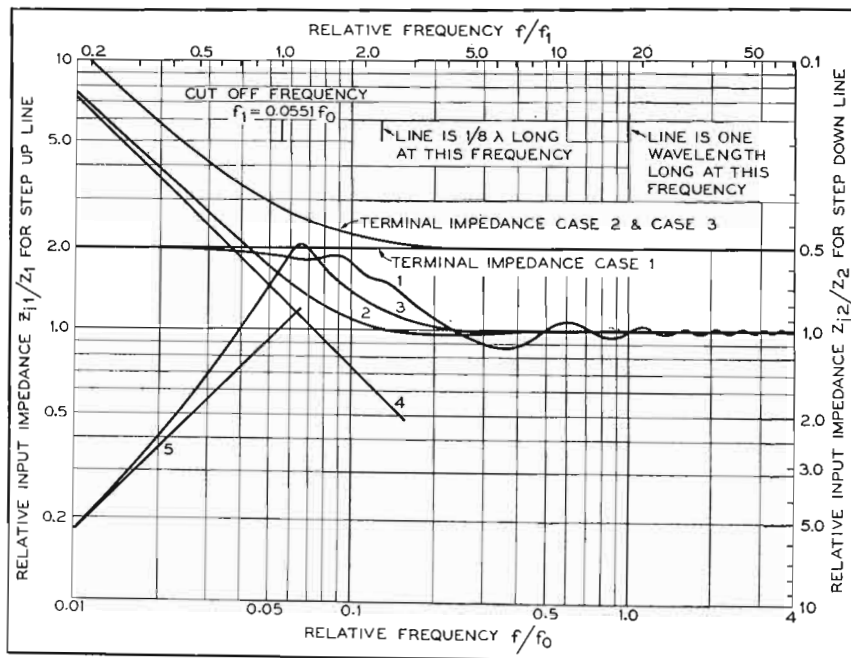

**Fig. 1**

Input impedance characteristics of 1:2 exponential lines. Left ordinate scale refers to step-up line. Right ordinate scale refers to step-down line.

Curve 1 - Resistance termination.

Curve 2 - With capacity equal to twice the electrostatic capacity of the line in series with the same resistance,  $Z_2 = Z_0 (1 - jf_1/f)$  for step-up line, or with an inductance equal to twice the total inductance of the line in shunt with the same resistance  $Z_1 = Z_0 / (1 - jf_1/f)$  for step-down line.

Curve 3 - Termination as for curve 2 with inductance equal to twice the total inductance of the line in parallel with input to the line,  $Z_1 = Z_0 / (1 - jf_1/f)$  for step-up line, or termination as for curve 2 with capacity equal to twice the static capacity of line in series with input to the line,  $Z_{12} = Z_0 (1 - jf_1/f)$ .

Curve 4 - Asymptotic value of impedance of capacity of line in parallel with termination for case 2 for step-up line, or asymptotic value of impedance of inductance in series with termination for case 2 for step-down line.

Curve 5 - Impedance of shunt inductance added at input for case 3 for step-up line, or impedance of capacity added in series at input for case 3 for step-down line.

acteristic impedance of a non-dissipative exponential line looking toward the high impedance end as a function of frequency. At infinite frequency the characteristic impedance is a resistance equal to the nominal characteristic impedance but as the frequency is decreased the phase angle of the characteristic impedance changes so that its locus is the circular arc. At and below cutoff it is a pure reactance. If the load is a resistance equal to the nominal characteristic impedance at the terminal, curve 2, there will be no reflection at infinite frequency, but as the frequency is lowered there will be an increasing impedance mismatch with its accompanying reflected wave.

This reflection may be materially reduced by inserting a condenser in series with the resistance load as shown by curve 3. Further improvement results from more complicated networks. Curve 4 shows the effect of adding an inductance in shunt with the resistance load of the resistance-capacity combination. The arrows indicate the resulting

impedance mismatch which is a measure of the reflected wave.

The characteristic impedance looking toward the low-impedance end is the inverse of that looking in the other direction as shown by curve 5. Shunting the resistance load with an inductance gives the impedance curve 7. Adding a capacity element gives curve 8.

Division of (1) by (2) and substitution of the result of (3) gives the following ratio for the impedance looking into the line at the point  $x$  to the impedance level at that point,

$$\frac{Z_x}{Z_0} = \frac{K(\sqrt{1-v^2} - jv + 1 + [K\sqrt{1-v^2} + jv] - 1)e^{-2\Gamma(1-x)}}{K + jv + \sqrt{1-v^2} - [K\sqrt{1-v^2} + jv]e^{-2\Gamma(1-x)}} \quad (5)$$

where  $K = Z_1/Z_0$  is the ratio of the load impedance to the impedance level at the terminal. Here as before the indicated root is in the fourth quadrant.

#### NETWORK CHARACTERISTICS

Three parameters are required to specify the characteristics of an exponen-

tial line of negligible loss: (1) the cut-off frequency,  $f_1$ , (2) the length of the line which is perhaps best specified as the frequency,  $f_0$ , = velocity of light/length of line, for which the line is one wavelength long, and (3) the impedance level at some point along the line. We will designate the impedance levels at the low and high-impedance ends of the line by  $Z_1$  and  $Z_2$  respectively, and their ratio  $Z_2/Z_1$  by  $k$ .

When the line is terminated in a resistance equal to the impedance level at the output (5) reduces to

$$\frac{Z_1}{Z_0} = k \cos 2\xi e^{2j\xi} \frac{1 + j \tan \xi k^{-\cos 2\xi}}{1 - j \tan \xi k \cos 2\xi}, v > 1 \quad (6)$$

$$\frac{Z_1}{Z_0} = e^{-2j\xi} \frac{1 + \tan \xi e^{j(2\xi + \frac{\pi}{2} - \eta)}}{1 + \tan \xi e^{j(-2\xi - \frac{\pi}{2} - \eta)}}, v < 1 \quad (7)$$

for frequencies below and above cutoff respectively. Here  $\eta = -j2\Gamma l$  is twice the electrical length of the line in radians,  $\sin 2\xi = 1/v$ ,  $\sin 2\xi = v$  and  $\cos 2\xi$  is ratio of the electrical length of the line to that of a uniform line of the same physical length. For the step-down line the corresponding ratios are the reciprocal of the above expressions. These ratios are plotted in Fig. 1.

When  $f = 0$ ,  $Z_1 = kZ_0 = Z_2 = Z_0$  and the only effect of the line is to connect the load to the input. Above cutoff the magnitude of the input impedance oscillates about the nominal characteristic impedance and the phase angle oscillates about the value

$$-2\xi \quad (\sim -f_1/f \text{ for } f \gg f_1)$$

which goes from  $-\pi/2$  to 0 as the frequency increases indefinitely from cut-

(Continued on page 26)

Fig. 1. The automatic direction finder installed in a plane.



Indicating head of the D-F may be operated by both pilots.

## AN AUTOMATIC DIRECTION FINDER

AFTER SEVERAL MONTHS of intensive flight tests in scheduled air transport service in an American Air Lines Douglas, a new radio aid to air navigation known as the Sperry-RCA automatic direction finder has been announced by the Sperry Gyroscope Company. This direction finder, a result of combined research between the engineers of the Sperry Gyroscope Company and the RCA Manufacturing Company, not only performs the usual functions of an instrument of this type but does it automatically and continuously without diverting the attention of the pilot from any other activity.

The Sperry-RCA automatic direction finder requires only that the pilot tune

to a station. The pointer on the instrument has an arrow on one end and indicates immediately the exact bearing of the station, and furthermore continues to give the bearing even up to the point of passing over the station. One of the most valuable features of the instrument is emphasized because, in addition to having indicated the bearing of the station, it immediately shows the pilot when he has passed over the station and gives positive information to confirm the "cone of silence" which he may have received if he has been flying on the regular radio beam. The cone of silence has been recognized as rather negative information because, as the term implies, it is a momentary absence of signal.

Aside from locating the bearings of any station or obtaining a "fix" for the airplane, the instrument provides a radio means of obtaining a drift or "crab" angle at any given time. In other words, a pilot may tune a station toward which he is flying and observe whether or not the heading of the airplane is constantly changing. It is only necessary then to turn the airplane to the right or left and note the difference between the actual heading of the plane and the direction of the station when the bearing is not changing to know the amount of drift or "crab" angle that the plane must take to make allowance for the wind. When flying along one of the regular beams, any station to the right or left of the course may be tuned in, and the pointer will then give immediate indication as to how far along the beam the plane has progressed. It has also been found that the automatic feature makes it possible to obtain bearings when radio conditions due to static are so bad as to make it virtually impossible to obtain a null or "no signal" if operating the ordinary type of hand-operated loop.

The automatic direction finder equipment consists of tear-drop housed shielded loops, sense antenna, receiver, and control and indicating unit arranged to furnish the pilot with continuous bearings throughout 360 degrees. These bearings are indicated by a pointer moving in the horizontal plane against a 360-degree scale. This pointer is connected by flexible shaft to the loop assembly, which is in turn fitted with a motor controlled by the receiver output. The

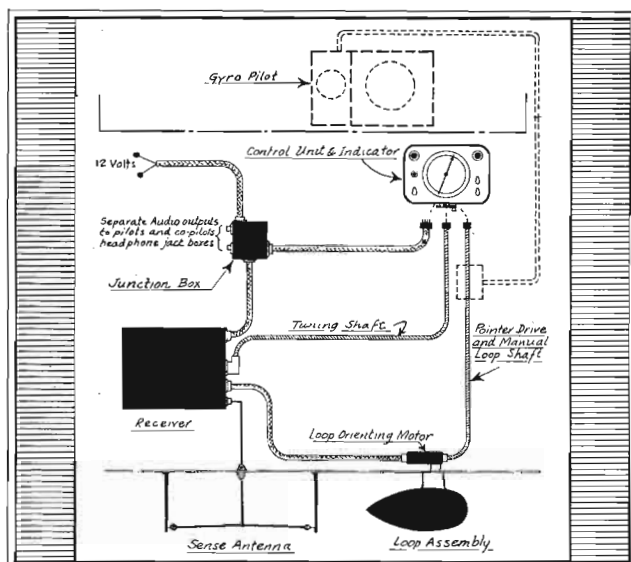

Fig. 3. A typical installation layout. The equipment consists of tear drop housed shielded loops, sense antenna, receiver, and control and indicating unit. Pilot is furnished with continuous bearings throughout 360 degrees.



action of the motor control circuits brings the loop to a null on the station to which the receiver is tuned, and this null is continuously and automatically maintained without 180° ambiguity, irrespective of any maneuvers which the ship may perform.

When the direction finder is operated under precipitation static conditions, the sense antenna may be disconnected, and a second shielded loop substituted therefor. Automatic operation will be provided as before, except that a line of bearing is given instead of the single-direction non-ambiguous bearing furnished when the sense antenna is connected. The second loop, used to replace the sense antenna, is mounted in the streamlined housing with the null loop, and is fixed on the motor operated shaft at right angles to the null loop. As a result of this arrangement, continuous headphone signal is provided by the pickup of the second loop, which is maintained at a position of maximum intensity on the reference station.

The control and indicating head has been designed to mount on the throttle column where it may be operated and observed conveniently by both pilots. An installation of a test model in the cockpit of an American Air Lines plane is shown in Fig. 1. In Fig. 2 is shown the layout of the production design of the control, while a typical installation layout is shown in Fig. 3.

The face of the instrument is mounted horizontally so that azimuth readings are shown in the plane in which they are actually measured. This helps the pilot to orient himself by visualizing the location of the station, with respect to the ship he is flying, as being in the direction of the arrow head relative to the miniature airplane shown on the face of the instrument. Navigation scales have been provided to permit ready determination of relative, magnetic or true bearings without the necessity for calculation.

Quadrantal error is automatically compensated for by a cam mechanism in the base of the control head. This cam may be cut to any shape to correct for errors introduced by different ships' structures. Provision has been made for easy substitution of the correct cam at the time of installation.

The azimuth indicating needle has a maximum speed of 30 degrees per second in seeking the desired stations, and comes to rest on the correct bearing without overshoot or hunting. Successive bearings on strong signals in the absence of noise will be reproduced to within one-half degree.

Flexible shaft connections carry tuning and pointer drives to the control unit.

The drive shaft from loop to pointer serves a dual function; in automatic

**Fig. 2. The control and indicator unit. This unit combines all the controls, indications and navigation scales. With this unit the taking of cross bearings, either true or magnetic, has been simplified.**

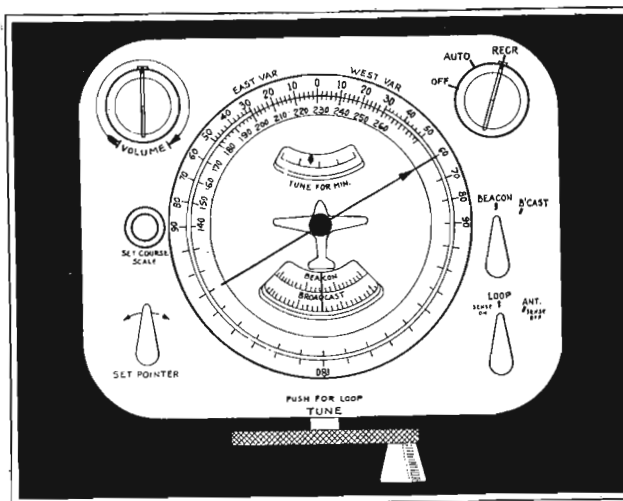

direction finding operation this shaft is driven by the loop motor during orientation at a ratio of 36 to 1 to the loop, but during manual aural null operation and in Gyropilot control the loop is manually oriented through this same shaft, driven by the tuning knob, which has been clutched in to engage the loop drive mechanism. In addition to this arrangement for manual loop orientation the "Set Pointer" switch provides a motor drive for rapid right or left orientation of the loop. This reversing switch can operate the loop drive motor only when the selector switch is in the "Recr" position, so that it cannot interfere with automatic direction finding.

A tuning meter is provided to assist in precise tuning and to serve as a rough guide to signal strength.

Illumination is indirect and a dimmer control knob protrudes from the under side of the control unit, where it is out of sight but may be reached conveniently. Lamps may be replaced without disturbing the cover of the control unit.

The receiver and power supply are in one unit which fits in a 7½" × 10½" × 19½" full depth rack section. Two power supply assemblies are available, one for 10.5-15.0 volts d-c power supply and the other for 105-125 volts single-phase 775-825 cycle ground return supply. The construction provides for easily substituting one power supply for the other. The entire receiver construction has been arranged for easy servicing and replacement of units. For example, r-f coil assemblies are in unit form including coils, trimmers and band switch sections.

A power-supply switch is provided on the front panel, having three positions as follows:

- (1) Normal operation.
- (2) Manual aural null direction finding and reception using plate supply at 180 volts from ship's dynamotor instead of from receiver.
- (3) Manual aural null direction finding and reception using auxiliary vibrator, and 12-volt battery. A motor-driven

function selector and band-change switch is provided, and controlled by switch knobs on the control unit.

The loop antenna system comprises a molded bakelite streamlined housing in which is rotatably mounted a pair of shielded crossed loops. A motor at the base of the loop support throat casting is geared to the loop shaft at ratio to provide a maximum loop searching speed of 30° per second. Special attention has been given to the design of this motor to insure its requiring a minimum of maintenance in service. The loop cable is at medium impedance, giving good gain combined with reasonable permissible cable length.

The service tests and pilot training in the technique for operating this new automatic direction finder have been conducted under the supervision of J. G. Flynn, Jr., Superintendent of Communications of American Air Lines and Chairman of the Subcommittee for Radio Direction Finding of the Radio Technical Committee for Aeronautics.

#### BOOK REVIEWS

**PHOTOELECTRIC CELL APPLICATIONS**, by R. C. Walker and T. M. C. Lance, published by Pitman Publishing Corp., 2 West 45 Street, New York City, third edition, 336 pages, price \$4.00.

This book describes the practical applications of photoelectric cells in television, talking pictures, electrical alarms, counting devices, and the like. Much water has passed under the bridge since the second edition was published, not only as the result of new applications, but also as a result of technical advances.

Besides the introductory portion, which is mostly of a historical nature, other chapters have been devoted to the methods of use, to counting, timing and mechanical handling devices, to alarms, indicators and safety devices, as well as to the use of photoelectric cells in advertising, sound reproduction, photo-

(Continued on page 28)

# COUPLING NETWORKS\*

## Part II

By **W. L. EVERITT**

Professor of Electrical Engineering

OHIO STATE UNIVERSITY

### DISSIPATION OF POWER IN THREE-ELEMENT NETWORKS

THE LOSS of these networks cannot always be neglected due to the fact that the resistance of the inductors is not entirely negligible. It will now be shown that the loss of the network depends only upon the  $Q$  of the coils, the transformation ratio  $r$  and the angle of phase shift  $B$ . It does not depend upon whether the phase is advanced or retarded or upon whether there are two inductors and one condenser or two condensers and one inductor in the network.

In the following derivations the approximation will be made that the *currents* in the various network branches are not appreciably affected by the dissipation of the elements. Therefore, the currents will be computed by assuming the networks have no dissipation. These currents will in turn be used to compute the power dissipated. This approximation is warranted for any networks where the total efficiency is of the order of 90 percent or higher and gives a great simplification to the functions.

Consider first the Type 1  $\pi$  network of Fig. 11, whose currents and vector diagram are shown in Fig. 12.

$$I_B^2 = I_1^2 + I_A^2 = \frac{E_1^2}{R_1^2} + \frac{E_1^2}{X_A^2}$$

Now

$$X_A = aR_2 = \frac{aR_1}{r} \quad \therefore \quad I_B^2 = \frac{E_1^2}{R_1^2} \left[ 1 + \frac{r^2}{a^2} \right]$$

Let  $Q$  be the ratio of reactance to resistance in the coils and let the dissipation in the condensers be negligible. Then the power dissipated is

$$P_{\text{lost}} = I_B^2 \frac{X_B}{Q} = I_B^2 \frac{bR_1}{rQ} = \frac{E_1^2}{R_1} \left[ \frac{1}{r} + \frac{r}{a^2} \right] \frac{b}{Q}$$

The power delivered to the network is

$$P_{\text{input}} = \frac{E_1^2}{R_1} \quad \therefore \quad \frac{P_{\text{lost}}}{P_{\text{input}}} = \left[ \frac{1}{r} + \frac{r}{a^2} \right] \frac{b}{Q}$$

Let  $\delta$  be defined by the relation

$$\frac{P_{\text{lost}}}{P_{\text{input}}} = \frac{\delta}{Q} \quad \dots \dots \dots (20)$$

For the Type 1 network let  $\delta$  be designated by  $\delta_1$ . Then

$$\delta_1 = \left[ \frac{1}{r} + \frac{r}{a^2} \right] b \quad \dots \dots \dots (21)$$

Consider next the Type 2  $\pi$  network. In this type the currents will be the same as in the Type 1 network.

\*Presented before the Broadcast Engineering Conference at The Ohio State University, February 7-18, 1938.

but there will also be dissipation in  $X_c$  as this element is inductive. Furthermore  $c$  is a negative number.

$$I_c = \frac{E_2}{X_c}$$

The power dissipated in  $X_c$  will be

$$P_{\text{lost}} = \frac{I_c^2 X_c}{Q} = \frac{E_2^2}{X_c Q} = - \frac{r E_1^2}{c R_2 Q} = - \frac{E_1^2}{c R_1 Q}$$

The total power lost in this network will be

$$P_{\text{lost}} = \frac{E_1^2}{R_1 Q} \left[ \left( \frac{1}{r} + \frac{r}{a^2} \right) b - \frac{1}{c} \right]$$

Let the  $\delta$  for Type 2 be designated by  $\delta_2$ . Then

$$\frac{P_{\text{lost}}}{P_{\text{input}}} = \left[ \left( \frac{1}{r} + \frac{r}{a^2} \right) b - \frac{1}{c} \right] \frac{1}{Q}$$

$$\delta_2 = \left[ \left( \frac{1}{r} + \frac{r}{a^2} \right) b - \frac{1}{c} \right] = \delta_1 - \frac{1}{c} \quad \dots \dots \dots (22)$$

This may be simplified since

$$\frac{1}{r} + \frac{r}{a^2} = \frac{1}{r} + \frac{(r - \cos B)^2}{r \sin^2 B}$$

$$\left( \frac{1}{r} + \frac{r}{a^2} \right) b = \frac{\sin^2 B + r - 2\sqrt{r} \cos B + \cos^2 B}{\sqrt{r} \sin B}$$

$$= \frac{r - 2\sqrt{r} \cos B + 1}{\sqrt{r} \sin B}$$

$$= \frac{\sqrt{r} - \cos B}{\sin B} + \frac{1 - \sqrt{r} \cos B}{\sqrt{r} \sin B}$$

$$= \frac{r}{a} + \frac{1}{c}$$

$$\therefore \quad \delta_2 = \frac{r}{a} \quad \dots \dots \dots (23)$$

Consider next the Type 3  $\pi$  network. Again the currents are the same as in Type 1, but the dissipation occurs in  $X_A$  and  $X_C$  as these are the inductive elements.

$$P_{\text{lost}} = \frac{I_A^2 X_A}{Q} + \frac{I_C^2 X_C}{Q} = \left[ \frac{E_1^2 r}{a R_1} + \frac{E_1^2}{c R_1} \right] \frac{1}{Q}$$

$$\frac{P_{\text{lost}}}{P_{\text{input}}} = \left[ \frac{r}{a} + \frac{1}{c} \right] \frac{1}{Q}$$

$$\therefore \quad \delta = \frac{r}{a} + \frac{1}{c} \quad \dots \dots \dots (24)$$



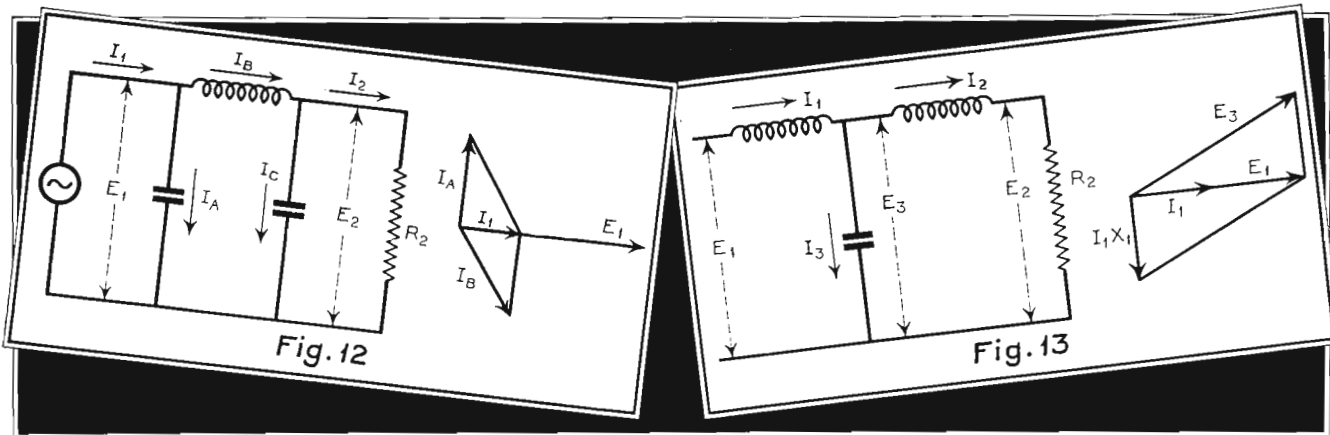

Currents and vector diagram of a pi network.

Currents and vector diagram of a T network.

By eqs. (22) and (23)

$$\delta_1 = \frac{r}{a} + \frac{1}{c}$$

Therefore the factor  $\delta$  is the same for both Type 1 and Type 3  $\pi$  networks.

In the Type 4  $\pi$  network power is dissipated in the reactance  $X_A$ .

$$P_{\text{lost}} = \frac{I_A^2 X_A}{Q} = \frac{E_1^2 r}{a R_1 Q}$$

$$\frac{P_{\text{lost}}}{P_{\text{input}}} = \frac{r}{a Q}$$

$$\delta = \frac{r}{a} = \delta_2$$

Therefore the factor  $\delta$  is the same for both Type 2 and Type 4 networks.

The currents and vector diagram for the T network are shown in Fig. 13. For the Type 1 configuration

$$I_1 = \frac{E_1}{R_1}$$

$$I_2 = \frac{E_2}{R_2} = \frac{E_1 \sqrt{r}}{R_1}$$

$$P_{\text{lost}} = I_1^2 \frac{X_1}{Q} + I_2^2 \frac{X_2}{Q} = \frac{E_1^2}{R_1} \left[ \left( \frac{1}{c} + \frac{r}{a} \right) \frac{1}{Q} \right]$$

$$\frac{P_{\text{lost}}}{P_{\text{input}}} = \left[ \frac{1}{c} + \frac{r}{a} \right] \frac{1}{Q} = \frac{\delta_1}{Q}$$

For the Type 2 T network

$$I_2 = \frac{E_1 \sqrt{r}}{R_1}$$

$$P_{\text{lost}} = \frac{I_2^2 X_2}{Q} = \frac{E_1^2}{R_1} \frac{r}{a Q}$$

$$\frac{P_{\text{lost}}}{P_{\text{input}}} = \frac{\delta_2}{Q}$$

For the Type 3 T network

$$E_3^2 = I_1^2 X_1^2 + E_1^2$$

$$= E_1^2 \left[ 1 + \frac{X_1^2}{R_1^2} \right] = E_1^2 \left[ 1 + \frac{1}{c^2} \right]$$

$$P_{\text{lost}} = \frac{I_3^2 X_3}{Q} = \frac{E_3^2}{X_3 Q} = \frac{E_1^2}{R_1} \left[ 1 + \frac{1}{c^2} \right] \frac{b}{Q}$$

$$\frac{P_{\text{lost}}}{P_{\text{input}}} = \left[ 1 + \frac{1}{c^2} \right] \frac{b}{Q}$$

$$\delta = \left[ 1 + \frac{1}{c^2} \right] b \dots \dots \dots (25)$$

Now

$$1 + \frac{1}{c^2} = 1 + \frac{(1 - \sqrt{r} \cos B)^2}{r \sin^2 B}$$

$$= \frac{r \sin^2 B + 1 - 2\sqrt{r} \cos B + r \cos^2 B}{r \sin^2 B}$$

$$= \frac{\sin^2 B + r - 2\sqrt{r} \cos B + \cos^2 B}{r \sin^2 B}$$

$$= \frac{1}{r} + \frac{(\sqrt{r} - \cos B)^2}{r \sin^2 B}$$

$$= \frac{1}{r} + \frac{r}{a^2}$$

Therefore

$$\frac{P_{\text{lost}}}{P_{\text{input}}} = \left[ \frac{1}{r} + \frac{r}{a^2} \right] \frac{b}{Q} = \frac{\delta_1}{Q}$$

For the Type 4 T network

$$P_{\text{lost}} = \frac{I_1^2 X_1}{Q} + \frac{I_3^2 X_3}{Q} = \frac{E_1^2 X_1}{R_1^2 Q} + \frac{E_3^2}{X_3 Q}$$

$$= \frac{E_1^2}{R_1} \left[ -\frac{1}{c} + \frac{r}{a} + \frac{1}{c} \right] \frac{1}{Q}$$

$$= \frac{E_1^2}{R_1} \frac{r}{a Q}$$

$$\frac{P_{\text{lost}}}{P_{\text{input}}} = \frac{r}{a Q} = \frac{\delta_2}{Q}$$

It is seen from the above analyses that the efficiency of the network is implicitly determined by the impedance ratio and angle of phase shift and not by the choice between T and  $\pi$  networks nor between advancing and retarding networks. In all cases  $\delta_1$  applies to those networks with the larger phase shifts and  $\delta_2$  to the networks with the smaller phase shifts.

The functions  $\delta_1$  and  $\delta_2$  have been plotted in Figs. 14 and 15. These functions show that the loss increases with an increasing transformation ratio  $r$ . They also show that very small or very large angles of phase shift

produce a high loss and the minimum loss occurs for the L sections of Figs. 2-b and 3 (pp. 13, 15, September, COMMUNICATIONS).

The loss may sometimes be reduced by using two sections in tandem instead of one. If the loss is not too great the value of  $\delta$  for a two-section network will equal the sum of the two  $\delta$ 's of the individual sections. As an example of the saving consider the rather extreme case of a network which is to have a value of  $r = 100$  and a phase shift  $B = 170^\circ$ . The corresponding value of  $\delta$  for a single section will be 69. An equivalent network could be designed with two sections, each with a value of  $r = 10$ , and a phase shift of  $85^\circ$ . The value of  $\delta$  for each section would then be 3.3 or a total for the two sections of 6.6. The power lost in the two sections would then be less than one-tenth that of a single section. Another design would be to make one of the sections an L section in order to reduce the number of elements. For one L section is  $r = 10$ , the phase

rent in Antenna B is to lag that in Antenna A by  $90^\circ$  and their magnitude is equal. From the charts given by Brown the computed self-impedance of each antenna is

$$Z_{11} = Z_{22} = 37 + j 22 \text{ ohms}$$

The mutual impedance between the two antennas is

$$Z_{12} = 21 - j 14$$

Since tower structures do not exactly reproduce theoretical values which are computed for a vertical wire about a perfect earth, it would be preferable to check these values by actual measurement. However they will serve the purpose for illustration.

The two antennas themselves constitute a four-terminal network, and it is necessary to compute the apparent impedance at the base of each antenna when both antennas are excited. This apparent impedance is the vector ratio of the applied voltage to the antenna current at the base of the antenna and it is this impedance

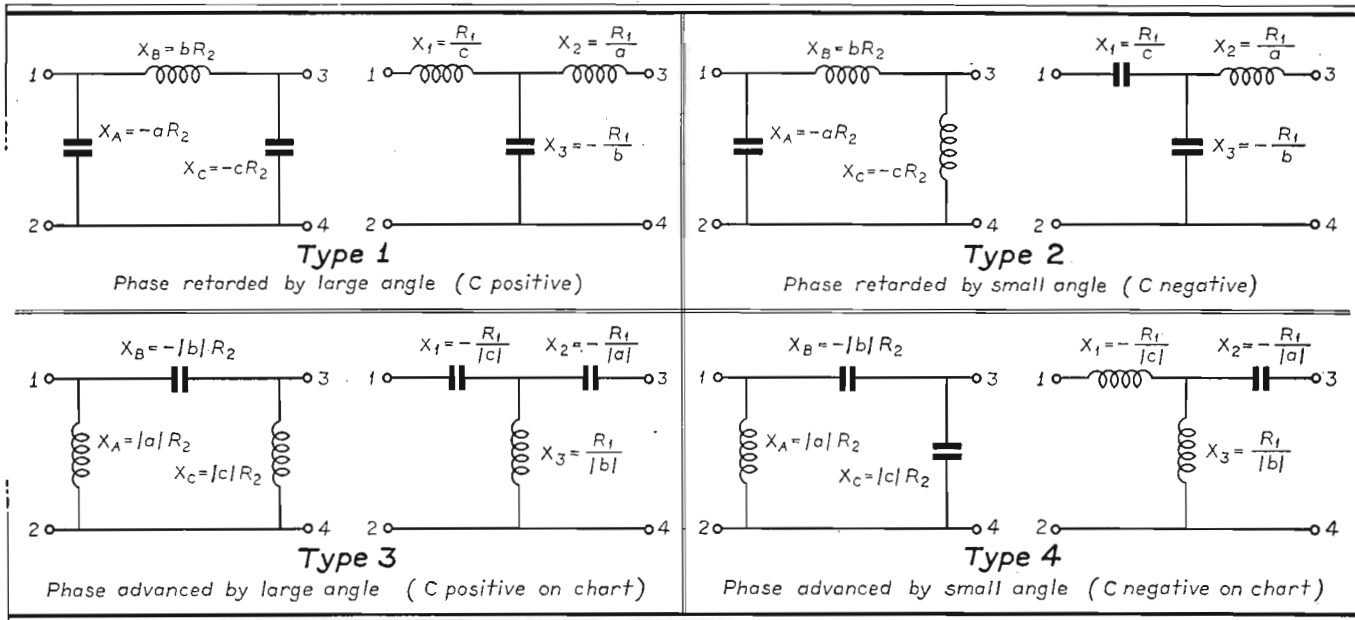

Fig. 11. The three-element reactance networks which may be used for the transformation of resistance.

shift would be  $72^\circ$ , and  $\delta = 2.95$ . The other section should then have a phase shift of  $98^\circ$  so that if  $r = 10$  its  $\delta$  would be 3.8. This would give a total  $\delta$  of 6.75 which would still be small in comparison with the value of 69 for one section.

#### APPLICATION OF DESIGN TO AN ANTENNA ARRAY

As an example of the use of the charts consider the case of two antennas one-quarter wavelength apart and driven with equal currents ninety degrees out of phase with each other.

The first data which must be secured is the self and mutual impedance of the antennas. These values may be measured if the antennas have been constructed or theoretical values may be obtained by computation or charts<sup>3</sup>.

Assume that there are two antennas, each one-quarter wavelength high, separated by a distance of one-quarter wavelength and driven  $90^\circ$  out of phase. They are to be supplied by 70-ohm concentric feeders. The transmitter is designed to feed a 70-ohm line. A possible arrangement is shown in Fig. 16. Assume that the cur-

rent must be transformed to match the line. The equivalent network is shown in Fig. 17. The apparent impedance is determined as follows:

$$E_A = I_A Z_{11} + I_B Z_{12} \dots \dots \dots (26)$$

$$E_B = I_A Z_{12} + I_B Z_{22} \dots \dots \dots (27)$$

For this case

$$\begin{aligned} I_A &= j I_B \\ \therefore E_A &= I_A (Z_{11} - j Z_{12}) \\ E_B &= I_B (Z_{22} + j Z_{12}) \end{aligned}$$

The apparent impedance of Antenna A is

$$Z_A = \frac{E_A}{I_A} = Z_{11} - j Z_{12} = 37 + j22 - j21 - 14 = 23 + j1 \text{ ohms}$$

The impedance of Antenna B is

$$Z_B = \frac{E_B}{I_B} = Z_{22} + j Z_{12} = 37 + j22 + j21 + 14 = 51 + j43 \text{ ohms}$$

Network No. 1 must therefore transform the impedance  $23 + j1$  into a resistance of 70 ohms. An L

<sup>3</sup>G. H. Brown, "Directional Antennas," *Proc. I. R. E.*, Vol. 25, pp. 78-145, Jan., 1937.



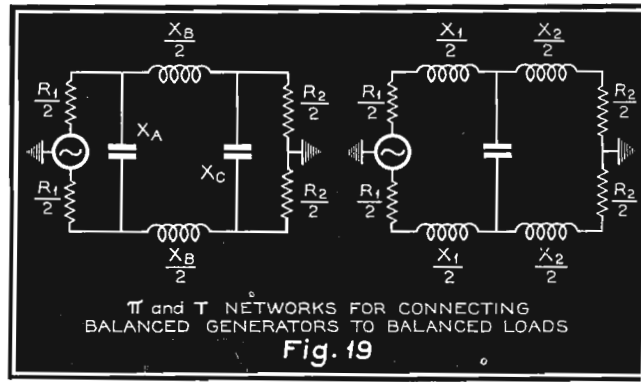
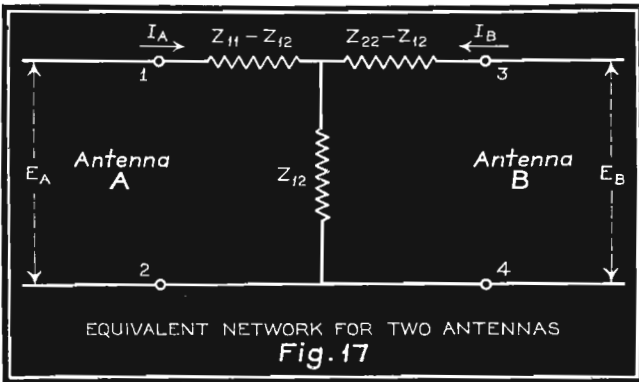

### LOSS FUNCTION FOR THREE TERMINAL NETWORK

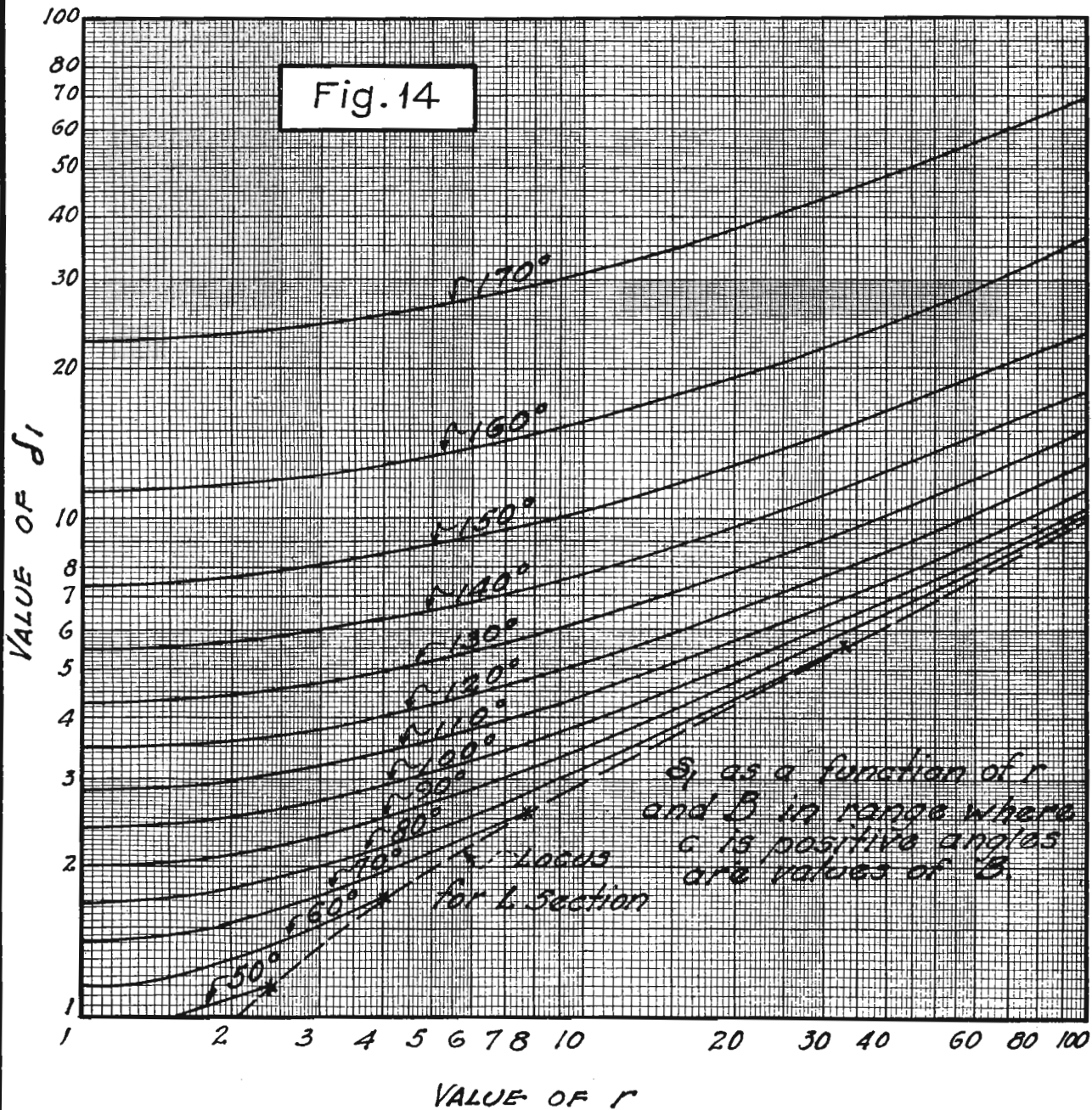

section might be used. This L section will be designed first to transform the resistance. For this case

$$r = \frac{70}{23} = 3.04$$

From the charts of Fig. 6 and 8 (pp. 15, 16, Sept., COMMUNICATIONS) or from Eqs. (17), (18) and (19)

$$\begin{aligned} a &= 2.12 \\ b &= 1.43 \\ B_1 &= 55^\circ \end{aligned}$$

Therefore the values of network 1 for a resistance match would be

$$\begin{aligned} X_A &= -a R_2 = -2.12 \times 23 = -48.8 \text{ ohms} \\ X_B &= b R_2 = 1.43 \times 23 = 32.9 \text{ ohms} \end{aligned}$$

Since the load has a positive reactance of one ohm, the value of  $X_B$  in the actual network would be reduced by one ohm, and the network shown in Fig. 18-a will be obtained.

Network No. 2 must transform the impedance  $51 + j43$  into a resistance of 70 ohms. Assume that an L section is to be used. For this case,

$$r = 70/51 = 1.37$$

From the charts (or equations)

$$\begin{aligned} a &= 2.25 \\ b &= 0.61 \\ B_2 &= 31^\circ \end{aligned}$$

Therefore for a resistance match

$$\begin{aligned} X_A &= -a R_2 = -2.25 \times 51 = -114.8 \text{ ohms} \\ X_B &= b R_2 = 0.61 \times 51 = 31.1 \text{ ohms} \end{aligned}$$

Since the load already has an inductive reactance of 43 ohms, the value of  $X_B$  in the actual network should be a capacitive reactance of  $43 - 31.1$  or 11.9 ohms. The network is shown in Fig. 18-b.

The next problem is to design Networks Nos. 3 and 4. The following conditions must be met.

(1) The input impedances of the two networks viewed from the transmitter must be such that each

Networks used in Fig. 16.

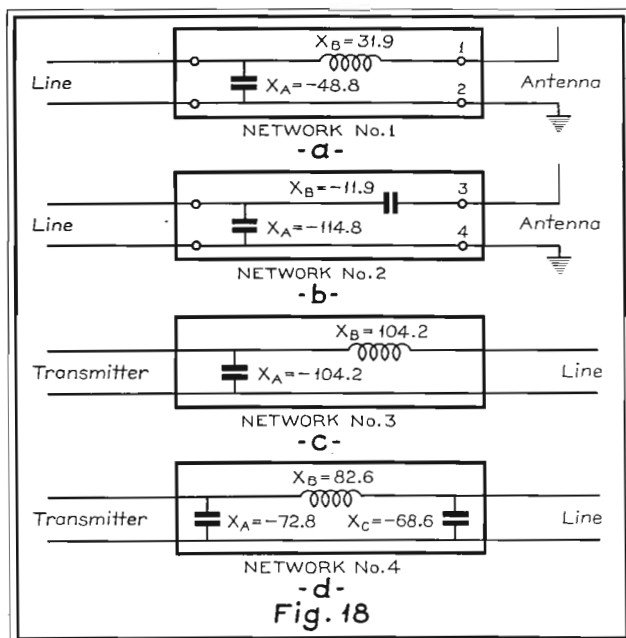

Fig. 18

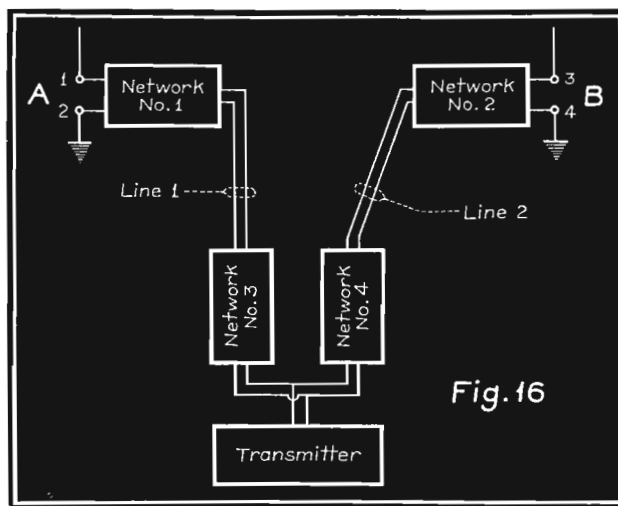

Fig. 16

Typical directional antenna system.

network will absorb the proper amount of power for its appropriate antenna.

(2) The two networks in parallel must present a resistance of 70 ohms to the transmitter.

(3) The phase shifts must be such that the total phase shift in the networks and line supplying Antenna B will be  $90^\circ$  greater than the total phase shift in the networks and line supplying Antenna A.

Since the magnitudes of the currents in the two antennas are equal, the power supplied to the two antennas will have the ratio of the apparent resistances as computed for both antennas in operation

$$\frac{P_A}{P_B} = \frac{23}{51}$$

Let  $R_3$  be the image impedance of Network 3 at the input (transmitter) terminals and  $R_4$  be the image impedance of Network 4 at the input terminals. Then since the input terminals are in parallel and so have equal applied voltages the ratio of these resistances should be

$$\frac{R_3}{R_4} = \frac{P_B}{P_A} = \frac{51}{23} = 2.22 \dots \dots \dots (28)$$

In order to meet condition 3

$$\frac{1}{R_3} + \frac{1}{R_4} = \frac{1}{70} \dots \dots \dots (29)$$

Combine Eqs. (28) and (29)

$$\frac{1}{R_3} + \frac{2.22}{R_3} = \frac{1}{70}$$

$$R_3 = 3.22 \times 70 = 225 \text{ ohms}$$

$$R_4 = \frac{225}{2.22} = 101.2 \text{ ohms}$$

Network No. 3 may also be an L network if desired. For this case

$$r = 225/70 = 3.22$$

$$a = 2.16$$

$$b = 1.49$$

$$B_3 = 56^\circ$$

$$\therefore X_A = -2.16 \times 70 = -151.2 \text{ ohms}$$

$$X_B = 1.49 \times 70 = 104.2 \text{ ohms}$$

and the network of Fig. 18-c is obtained.

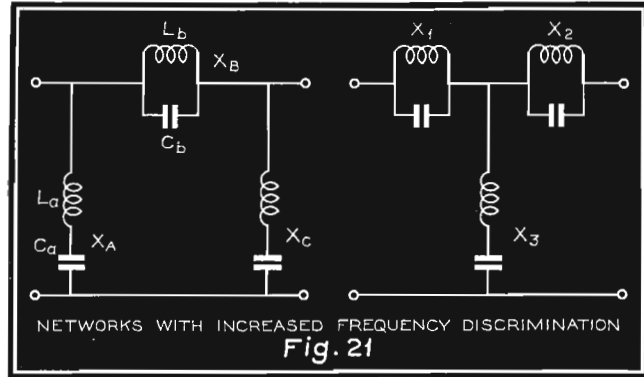
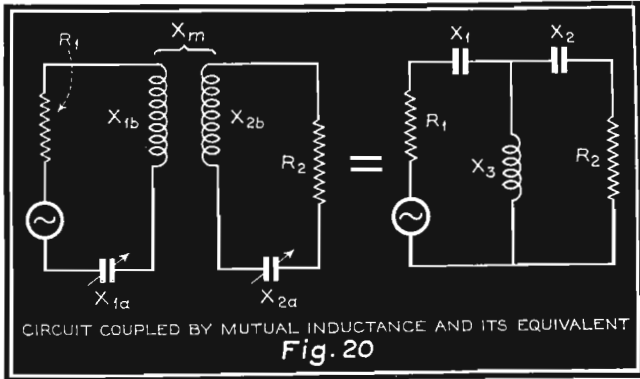

### LOSS FUNCTION FOR THREE TERMINAL NETWORK

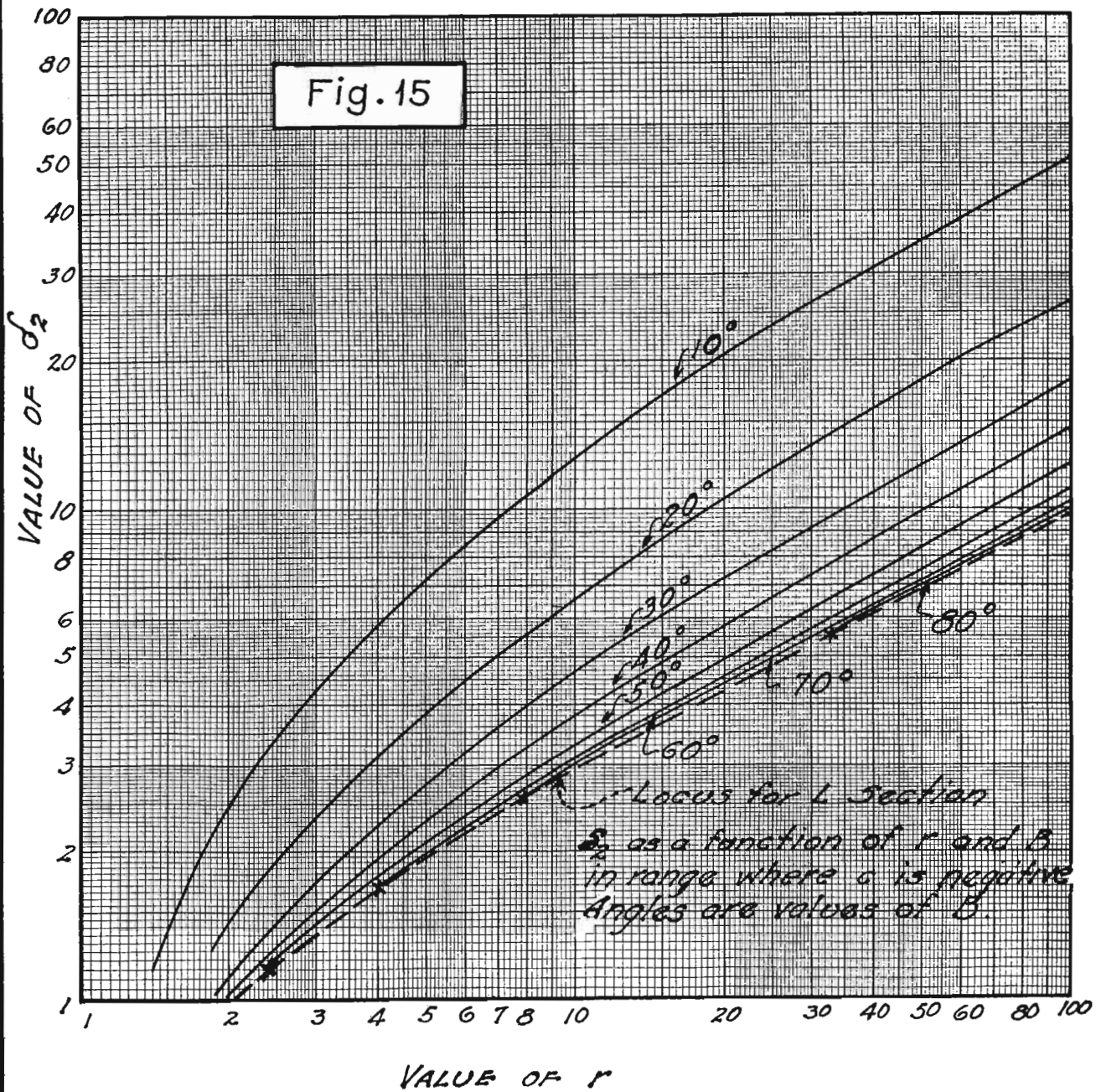



Assume in this problem that the line between Networks 4 and 2 is 70 electrical degrees longer than the line between Networks 3 and 1.

Then the total phase shift in Networks 1 and 3 must be 20° less than the total shift in Networks 2 and 4. This gives the equation

$$B_1 + B_3 + 20^\circ = B_2 + B_4$$

Therefore the phase shift of Network 4 will be

$$B_4 = B_1 + B_3 + 20^\circ - B_2 = 55^\circ + 56^\circ + 20^\circ - 31^\circ$$

$$B_4 = 100^\circ$$

The value of  $r$  will be

$$r = \frac{101.2}{70} = 1.45$$

From the charts

$$a = 1.04$$

$$b = 1.18$$

$$c = 0.98$$

$$\therefore X_A = -1.04 \times 70 = -72.8 \text{ ohms}$$

$$X_B = 1.18 \times 70 = 82.6 \text{ ohms}$$

$$X_C = -0.98 \times 70 = -68.6 \text{ ohms}$$

This network is shown in Fig. 18-d. It is apparent that all the network elements must be reduced to in-

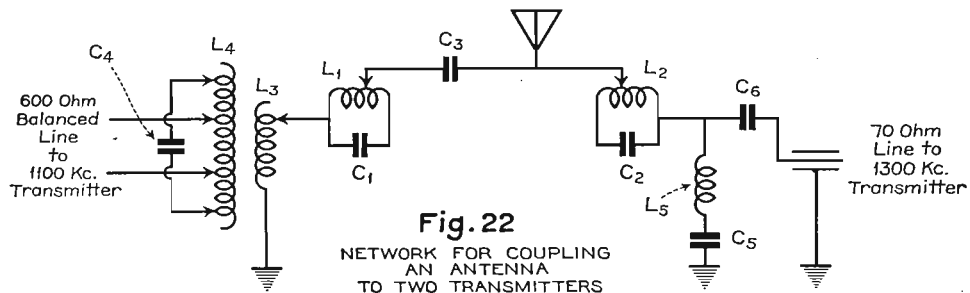

Fig. 22

NETWORK FOR COUPLING AN ANTENNA TO TWO TRANSMITTERS

ductances in microhenries and capacitances in microfarads when the frequency is specified to complete the design.

### EFFECT OF BALANCE ON COUPLING NETWORK DESIGN

When both the load and supply networks have similar conditions of balance the T and  $\pi$  configurations are quite satisfactory. The most common situations are where the systems are either grounded on one side or are balanced to ground. If the load and generator are both balanced to ground the design is the same as for the system which is grounded on one side, but in setting up the network, the series elements ( $X_B$  of the  $\pi$  section or  $X_1$  and  $X_2$  of the T section) must be divided in two and one half connected in each side of the line. This is illustrated in Fig. 19.

If the conditions of balance are different in the generator and load the most convenient type of coupling network will make use of mutual inductance. Examples where this is necessary are

- (1) Coupling a single ended Class C amplifier to a balanced line
- (2) Coupling a push pull Class C amplifier to a grounded line
- (3) Coupling a balanced line to a grounded antenna
- (4) Coupling any line to an antenna with a counterpoise
- (5) Coupling a balanced line to an unbalanced line.

### NETWORKS USING MUTUAL INDUCTANCE

The equations for the circuit coupled by mutual inductance are identical to those of a T section and so the charts may be used. For the equations refer to Fig. 20. In these networks the following equations should hold for an equivalence

$$X_m = X_3 = R_1/b \dots\dots\dots (29)$$

$$X_{1a} + X_{1b} = X_1 + X_3 = R_1 \left( \frac{1}{b} - \frac{1}{c} \right) \dots\dots\dots (30)$$

$$X_{2a} + X_{2b} = X_2 + X_3 = R_1 \left( \frac{1}{b} - \frac{1}{a} \right) \dots\dots\dots (31)$$

$X_{1b}$  and  $X_{2b}$  are selected to provide sufficient mutual reactance  $X_m$  and  $X_{1a}$  and  $X_{2a}$  are then determined from the total required by Eqs. (30) and (31).

Mutual inductance also provides one of the most convenient methods for varying a load. The driving point impedance presented to the generator is

$$Z'_{11} = Z_{11} + \frac{\omega^2 M^2}{Z_{22}}$$

where  $Z_{11}$  is the impedance of the primary circuit exclusive of the generator and  $Z_{22}$  is the impedance of the

secondary circuit. If the primary and secondary are both tuned to resonance

$$Z_{22} = R_2$$

and the impedance reflected into the primary will be equal to  $\frac{\omega^2 M^2}{R_2}$ . By adjusting  $M$ , this reflected resistance

may be varied over a wide range. For example in Fig. 4 if the secondary is tuned to resonance, then the mutual reactance may be increased until the proper meter readings are obtained and the reflected resistance will then equal that of the original dummy resistor.

Tuning the primary and secondary of an inductively coupled circuit to resonance corresponds to the case where

$$a = b = c$$

Hence the phase shift will always be 90° for this case. Adjusting the mutual inductance for the proper transformation with primary and secondary tuned to resonance will give

$$a = b = c = \sqrt{r}$$

If some phase shift other than 90° is required, the individual circuits should not be tuned to resonance.

### FREQUENCY DISCRIMINATION IN COUPLING CIRCUITS

When a circuit should provide frequency discrimination, it must be investigated further. In general the

(Continued on page 22)

# A D'ARSONVAL REPRODUCER

## for Lateral Recordings

By **GEORGE W. DOWNS, Jr. & WILLIAM MILLER**

LANSING MANUFACTURING CO.

CONSULTANT

IN ATTEMPTING to design and construct a new pickup the authors decided first to adopt a generating system with the desired characteristics, and then to construct the system with a single degree of freedom while keeping it so light that the force required to actuate this mechanism could not under any circumstances exceed the permissible maximum.

When selecting a generating system, the characteristics of available recordings must be considered. At the present time most lateral discs are cut with a constant maximum amplitude up to approximately 250 cycles. Above this frequency, cutting is done with a constant maximum velocity. Recently there has sprung up a certain amount of agitation for recording by this latter method over the entire band. Some companies also indulge in pre-equalization, i. e., increased level on the higher frequencies to permit playback with a drooping characteristic so as to offset noise.

Since the largest portion of the band is recorded constant velocity, it is desirable to use a generating system which will give constant voltage output with constant velocity actuation. Two well known electro-mechanical transducers with this characteristic are available. The first of these, the variable reluctance type, has been in common use. Another type of moving-coil generator, the D'Arsonval system, is used in galvanometers and indicating meters. In this arrangement the coil moves about an axis near or actually in the plane of the coil. Thus the moment of inertia is greatly reduced. The flux is passed

Closeup view of the pickup head.

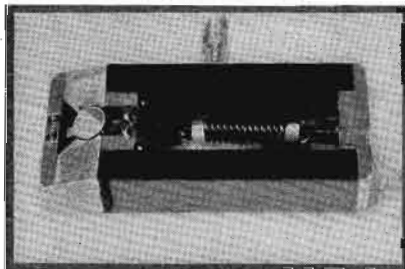

COMPARISON OF MECHANICAL CHARACTERISTICS			
No	DESCRIPTION	UNITS	D'ARSONVAL PICKUP
1	$\Delta F$ Incremental Force	Dynes	$4.9 \cdot 10^4$
2	$\Delta D$ Incremental Deflection	Centimeters	.0316
3	$K = \text{Force Constant} = \frac{\Delta F}{\Delta D}$	$\frac{\text{Dynes}}{\text{Centimeters}}$	$1.54 \cdot 10^6$
4	$F_R = \text{Frequency of Resonance}$	$\frac{\text{Cycles}}{\text{Second}}$	1275
5	$M_e = \text{Effective Mass} = \frac{K}{2\pi F_R}$	Grams	.024

through the plane of the coil transverse to the axis of rotation. There are two poles external to the coil and a permeable core within the coil. This system is admirably adapted for use in a lateral pickup.

The original design and construction was carried out by one of the writers, Mr. Miller. The design decided upon was a D'Arsonval type generator with permanent stylus. To make much improvement over existing pickups it is necessary to use a permanent point as the mass of the setscrew and chuck would be prohibitive. Two materials are commonly used as permanent styli, sapphire and diamond. Diamond styli are a little more expensive and much more difficult to polish. Sapphire, while a little softer than diamond, can be finished quite successfully and is probably the most satisfactory. However, either can be used.

The system consists of a cone machined from duralumin with the coil wound around the base and a stylus in the apex. The cone is about 6 mm in diameter and 5 mm in altitude. The walls of the cone are about .04 mm thick with the inside wall truncated to provide a boss in which to mount the stylus. At the base of the cone there is a cylindrical section with a groove in which the coil is wound. The suspension, a ribbon .1 mm by 2 mm, is passed through a slot in the cylindrical portion. This ribbon is under a spring tension of approximately 7 kg. The magnetic struc-

ture consists of two poles covering about 90 degrees each of the coil's surface, and a soft iron core located within the coil but fastened mechanically to the pole structure. Two bars of permanent-magnet material excite the magnetic circuit. The flux density in the gaps is about 5 kilogausses. The normal mode of vibration, which is actuated by lateral motion of the stylus, causes the moving system to rotate about an axis in the plane of the ribbon. This mode of vibration has a natural frequency of about 1300 cycles. The second mode is about an axis through the needle point and places the suspension in shear. The stiffness of the ribbon is many times as high in this mode as in torsion. It has not been possible, experimentally, to excite this mode, although the system has been driven with large amounts of power up to 40 kc.

In one experimental test a small drop of oil was placed between the cone and the central core. It was then impossible to find the natural frequency of the system as it was considerably over damped. None of the tests made indicated any effect on the response resulting from this resonance. The damping neither improved nor harmed this characteristic, and since this increases the force required to actuate the device, it was thought best not to add any damping to the system but to permit the record to determine the movement of the point.

The cone itself weighs .022 gram and the stylus .0024 gram. The weight of the coil is a function of the output desired as the output is roughly propor-

(Continued on page 35)

Showing the pickup head in use.



# MYSTERY CONTROL

By **ROBERT G. HERZOG**

Editor  
SERVICE

SEVERAL of the current Philco receivers employ a novel type of remote tuning called Mystery Control. These receivers can be tuned automatically to any one of eight stations, and the volume adjusted to any desired level, from a remote box which is about 6 by 8 by 4 inches. This control box is entirely self contained. There are no wires to it from the receiver or from the power lines.

To tune a station (once the receiver is turned on manually, and the band switch set to "remote") it is only necessary to spin a telephone type dial to a stop and then release it. Within 15 seconds the receiver will retune itself to the station dialed. If the volume is too loud or too soft, soft and loud positions are provided on the dial. The set can also be turned off from the remote box.

## CONTROL BOX

The control box is, essentially, a battery-operated oscillator. It is designed so that it is normally off and is turned on only during the dialing operations. The moulded dial has ten positions; eight station and loud and soft volume positions. This dial is connected to a pulsing mechanism which times the return of the dial so that connection is

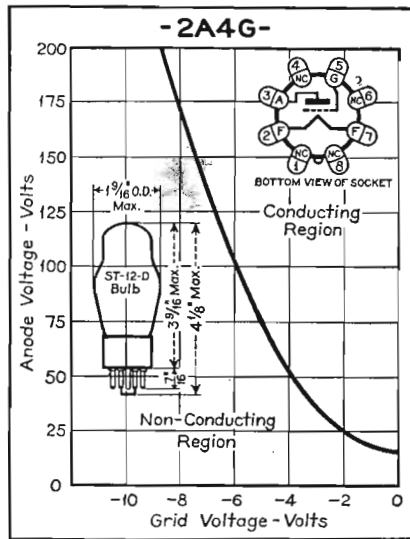

Fig. 3. The  $E_g-E_a$  characteristic of the Raytheon thyratron rectifier.

made to the several dial points at regular intervals.

As soon as the dial is rotated the filament of the type 30 oscillator tube is connected to its supply. As the dial returns the oscillator grid return is connected, intermittently, to the filament. This will set up an oscillation or pulse in the primary inductor (Fig. 1) for each contact on the pulser mechanism.

As the dial comes to rest it again disconnects the tube's filament supply. Thus, for any particular position dialed, a given number of pulses are radiated from the primary inductor.

To increase volume, the position at the extreme right is dialed and the end stop depressed until the volume reaches the desired level. The dial returns to its original position and, as it does so, sets up two pulses in the primary inductor. Depressing the end stop keeps the oscillator functioning and maintains the signal in the primary inductor on the second pulse.

To reduce volume, the second position from the right is dialed and the end stop held depressed until the volume reaches the desired level. This maintains the signal in the primary inductor on the third pulse. If the end stop is held down for a longer period the set will turn itself off.

## CONTROL AMPLIFIER

A large coil or loop is located at the bottom of the receiver cabinet (secondary inductor, Fig. 2). This coil is tuned to the frequency of the oscillator in the control box by means of a trimmer located inside a cylindrical cardboard box in one corner of the loop. This loop or secondary inductor acts as

Fig. 2. The control amplifier and station selector circuit located in the receiver.

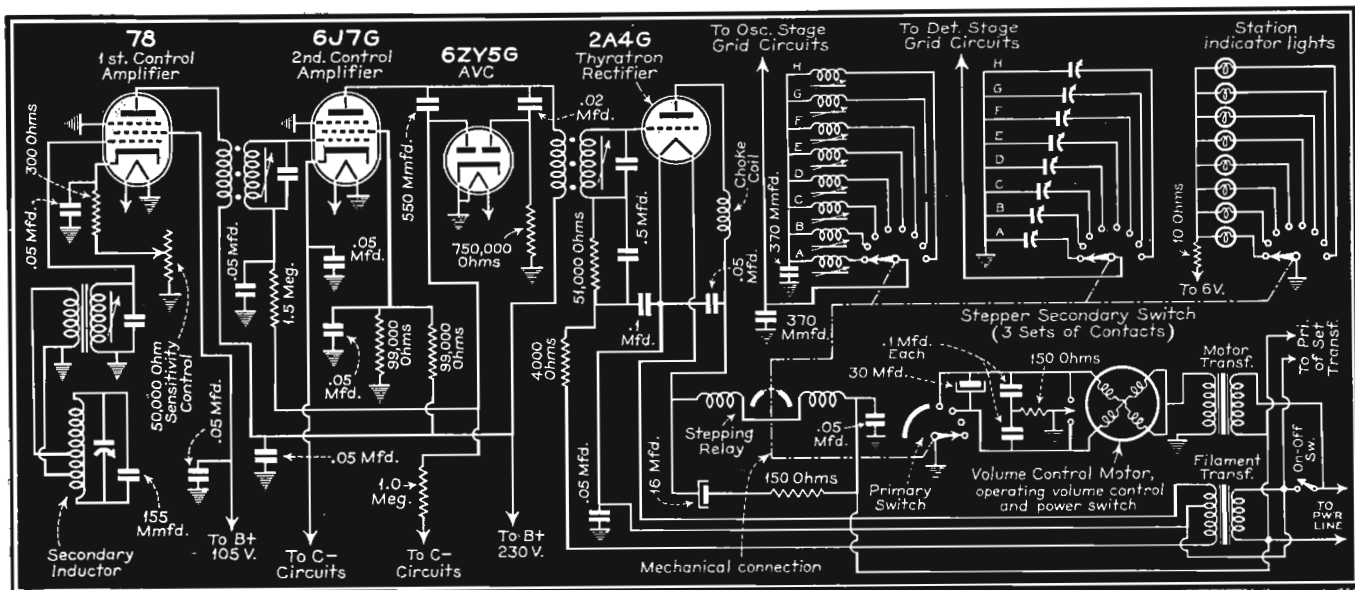



the antenna to receive the pulses from the primary inductor in the battery-operated control box.

These pulses are amplified first by a type 78 tube and further by a type 6J7G tube (Fig. 2). A 6ZY5G diode is used as avc tube to maintain an even input to the 2A4G thyratron rectifier output stage throughout a wide range of signal strength. The second diode is used as a limiter to dampen strong peaks, which might cause the thyratron tube to continue firing over too long a period.

#### THYRATRON RECTIFIER

The output stage of the control amplifier is an argon-filled thyratron rectifier. This tube is similar to a conventional gas-filled rectifier into which a grid has been placed. A rectifier passes current during the entire portion of the a-c cycle in which the plate is positive with respect to the cathode. A grid inserted between the plate and cathode would permit current flow only during that portion of the cycle in which the grid has the proper bias. If both grid and plate voltages are taken from the same a-c source their phase difference could be arranged so that the grid would permit current flow during the

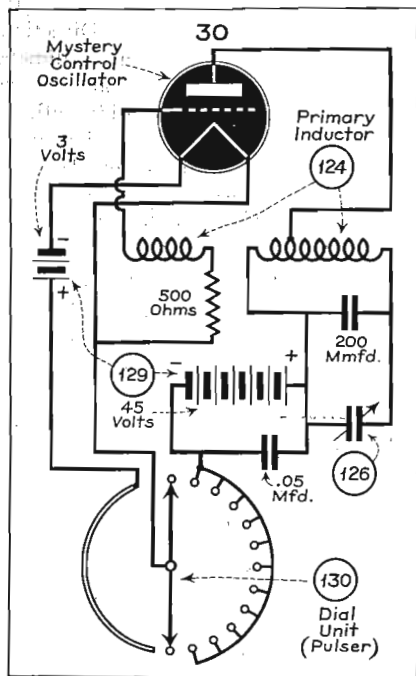

Fig. 1. Circuit of the Philco Mystery Control unit.

entire half cycle in which the plate is positive with respect to the cathode, so that no plate current would flow, or somewhere between these limits.

A type 2A4G thyratron rectifier is used in the Philco control amplifier. The  $E_g-E_p$  characteristic curve is given in Fig. 3. Ratings and other characteristics follow:

Filament Voltage:.....2.5 v

Filament current:.....2.5 amp  
 Maximum anode voltage (instantaneous)  
 Forward .....200 v  
 Inverse .....200 v  
 Maximum voltage between any  
 2 electrodes.....250 v

the primary switch. This switch controls the volume-control motor and shorts the voice coil to ground in the station selecting positions. A muting switch, which connects the plates of the

Fig. 4. Stepper assembly which operates station selector switch and volume control.

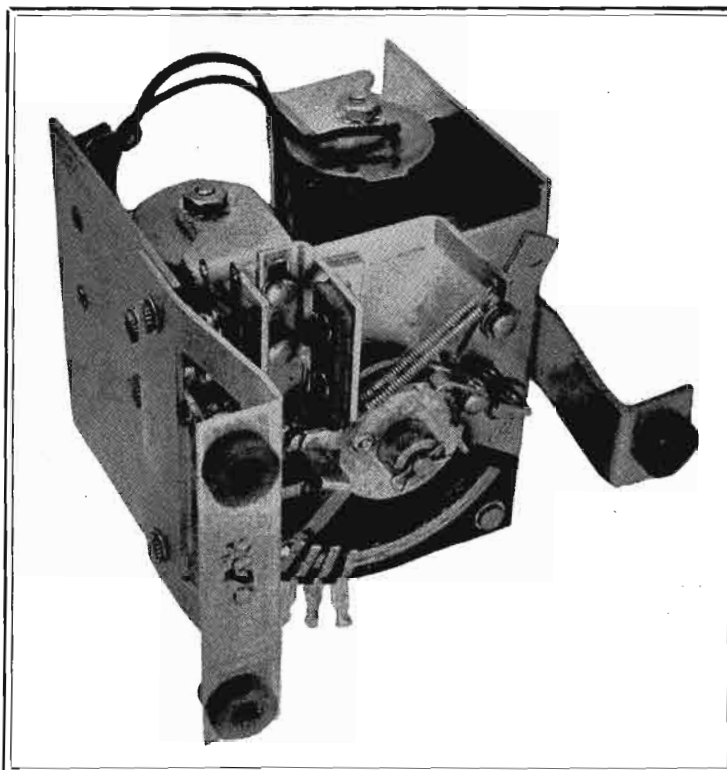

Maximum Anode current  
 Peak .....1.25 amp  
 Average .....0.10 amp  
 Maximum averaging time...45 sec  
 Tube voltage drop.....15 v  
 Cold starting time.....2 sec

The grid bias for the 2A4G, used in the control amplifier, is taken from the secondary of the tube's filament transformer. The plate supply is taken directly from the a-c lines. With the plate and grid voltages thus out of phase, no plate current will flow until the signal from the control amplifiers is sufficient to overcome the bias and supply the proper potential to fire the tube. Once operation has begun it is characteristic of this tube to continue firing throughout the remaining portion of the a-c cycle in which the plate is positive with respect to the cathode, regardless of any change in the grid voltage.

The plate current of the 2A4G flows through and energizes the holding relay and permits operation of the stepping relay as discussed below.

#### STEPPER ASSEMBLY

The stepper assembly houses a holding and a stepping relay. When the thyratron lights, the holding relay closes and the stepping relay pushes a ratchet as many times as the pulses sent out by the pulser in the control box.

There is a primary and a secondary ratchet. The stepper relay operates the primary ratchet which is connected to

output tubes together is closed during the station selecting operation. The set, of course, is playing during changes in volume, but is muted as the secondary ratchet returns to its home position, and climbs to the station dialed.

The station selecting switch assembly is located beneath the chassis but is driven by the stepper assembly. There are three groups of contacts operated by the switch. One group switches the oscillator coils, the second group switches the antenna padding condensers and the third group of switches lights the pilot lamps indicating the station dialed.

#### VOLUME CONTROL

The volume control and on-off switch are motor driven. The motor has an automatic clutch which releases and drops back as soon as the volume control is released by the stepper primary switch. This prevents over-shooting when changing volume and stops the gear train, which drives the volume control, immediately when the end stop is released on the control box. There is also a clutch in the volume control itself, so that the mechanism will not jam if the end stop lever is held down after the set is shut off.

The primary switch is a single-pole, double-throw switch which connects the desired winding in the volume control  
 (Continued on page 29)

**COUPLING NETWORKS**  
(Continued from page 18)

retarding networks (Types 1 and 2 of Fig. 11) will provide best discrimination against frequencies higher than those for which they are designed and the advancing networks (Types 3 and 4) will provide best discrimination against frequencies lower than those for which they are designed. The greater the phase shift the greater will be the discrimination.

Discrimination is fundamentally due to a variation in reactance, with frequency, of the network arms. This variation can be accentuated if the arms are constructed with two opposite types of reactance elements in series or parallel instead of a single element. The charts or equations are then used, but the required reactance is obtained with two elements, the proper element predominating by the desired amount. Fig. 21 shows possible networks designed in this way. The insertion loss of such a network may be made extremely high at three frequencies above the frequency for which it is designed to operate. These three frequencies would be the anti-resonant frequency or frequencies of the series arms and the resonant frequency or frequencies of the shunt arms. Suppose for example that a shunt arm composed of  $L_a$  and  $C_a$  in series is to have a reactance  $X_A$  at  $\omega = \omega_1$  and is to provide a high insertion loss at  $\omega = \omega_2$ . Then two simultaneous equations will determine the value of  $L_a$  and  $C_a$ .

$$\omega_1 L_a - \frac{1}{\omega_1 C_a} = X_A \quad \dots \dots \dots (32)$$

$$\omega_2 L_a - \frac{1}{\omega_2 C_a} = 0 \quad \dots \dots \dots (33)$$

Solving these gives the result

$$L_a = \frac{\omega_1 X_A}{\omega_1^2 - \omega_2^2} \quad \dots \dots \dots (34)$$

$$C_a = \frac{\omega_1^2 - \omega_2^2}{\omega_1 \omega_2^2 X_A} \quad \dots \dots \dots (35)$$

If  $X_A$  is a capacitive or negative reactance,  $\omega_2$  must be greater than  $\omega_1$  for a physical solution, while if  $X_A$  is a positive reactance  $\omega_2$  must be less than  $\omega_1$ .

On the other hand if a series arm composed of  $L_b$  and  $C_b$  in parallel is to have a reactance  $X_B$  at  $\omega = \omega_1$  and is to produce a high insertion loss at  $\omega = \omega_2$  then

$$\frac{\omega_1 L_b}{1 - \omega_1^2 L_b C_b} = X_B \quad \dots \dots \dots (36)$$

$$\omega_2 L_b = \frac{1}{\omega_2 C_b} \quad \dots \dots \dots (37)$$

This gives

$$L_b = \frac{\omega_2^2 - \omega_1^2}{\omega_1 \omega_2^2} X_B \quad \dots \dots \dots (38)$$

$$C_b = \frac{\omega_1}{(\omega_2^2 - \omega_1^2) X_B} \quad \dots \dots \dots (39)$$

(Continued on page 30)

THE SPERRY GYROSCOPE COMPANY has been engaged for some time in the development of a combined indicator designed to simplify some of the problems of instrument flight and landing. This development has been directed towards a reduction in the number of instruments on the modern aircraft instrument panel by combining the more essential indications on the face of a single indicator. The apparatus makes use of a cathode-ray tube as the indicator upon the lu-

**FLIGHTRAY**

minous screen of which the various indications are assembled in a standard pattern. In this manner the pilot is presented, on the face of a single instrument, with all the information needed for instrument flight or landing. This multiple indicator has been named the "Flightray."

The Flightray reproduces indications

from the following standard instruments: Artificial Horizon, Directional Gyro, Turn Indicator and Altimeter. In addition to these it may also be used to show position on the glide path and localizer radio beam for instrument landing. It is equally adaptable to any of the ground systems proposed for instrument landings, while at the same time retaining its usefulness as a combined indicator for route flying.

(Continued on page 30)

**The Sperry Flightray which may be used as a flight and landing instrument.**

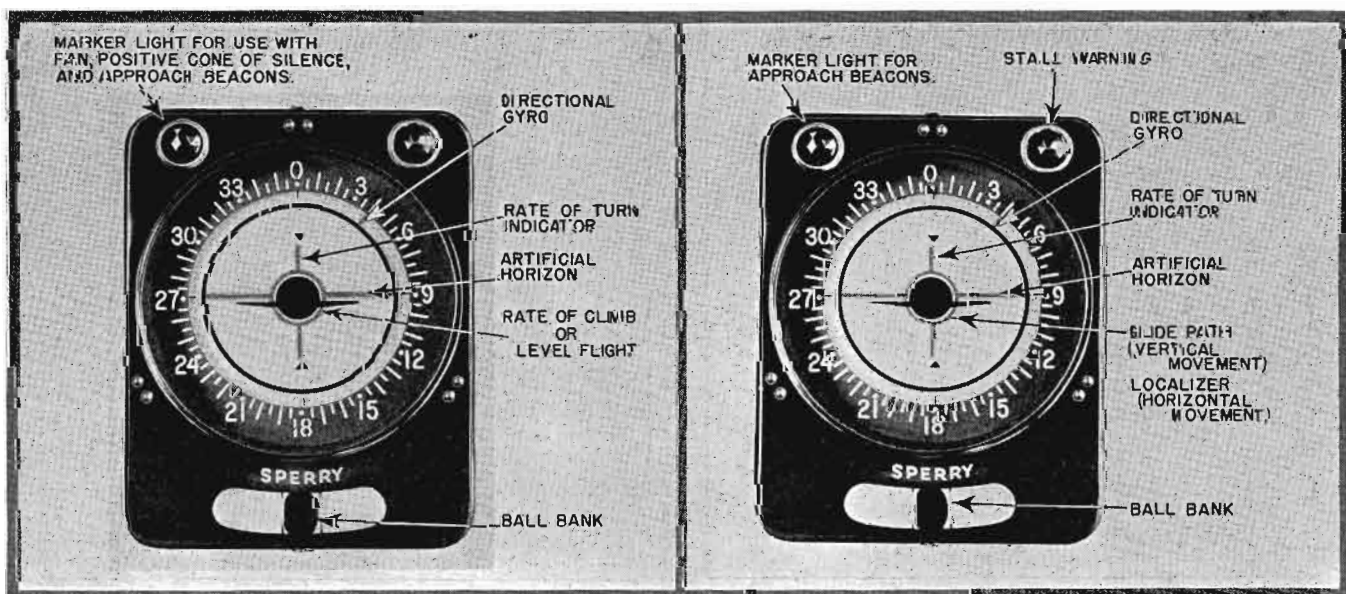

# OVER THE TAPE . . .

## NEWS OF THE COMMUNICATIONS FIELD

### RCA PROMOTIONS

Edward F. McGrady, Vice-President, and for the past year the Director of Labor Relations, of the Radio Corporation of America, was elected to the Board of Directors of the corporation to fill the vacancy created by the recent death of Mr. James R. Sheffield, it was announced by David Sarnoff, President. At a subsequent meeting of the Board of R. C. A. Communications, Inc., an RCA subsidiary, Mr. McGrady also was elected a director of this company.

### CLAROSTAT BULLETINS

A growing collection of engineering bulletins covering practically all types of resistors and resistance devices, is being made available to designers and builders of radio and electrical equipment, by Clarostat Mfg. Co., Inc., 285-7 North Sixth St., Brooklyn, N. Y. Additional bulletins are being issued from time to time. A loose-leaf binder with an entire set of bulletins to date, may be had for the asking.

### BALLANTINE BULLETIN

Ballantine Laboratories, Inc., Boonton, N. J., have issued Bulletin No. 2 which gives a full technical description of their new electronic voltmeter, Model 300. To secure a copy of this publication, write to the above organization.

### IDEAL LITERATURE

Ideal Commutator Dresser Co., Sycamore, Ill., have recently published a number of interesting bulletins. One of these bulletins is devoted to the Ideal line of wire strippers, wire cutters, solder and solderless lugs. Other bulletins cover a new "Select-O-Speed" transmission and electric engraving tools. These bulletins may be obtained by writing to the above organization.

### BRACH CATALOG

L. S. Brach Mfg. Corp., 55 Dickerson St., Newark, N. J., have announced their annual radio parts catalog No. 1038-R. This new catalog describes the latest designs of home and multiple antenna systems and accessories. New auto aerials of all types are shown, as well as other accessories. To secure a copy write to the above organization.

### CREI BULLETIN

The Capitol Radio Engineering Institute, 3224 16th St., N. W., Washington, D. C., have recently published a 48-page booklet giving much data on the Institute, including a brief history, courses, equipment, personnel, employment, etc. To secure a copy, write to the above organization.

### JENSEN CATALOG

Covering a great variety of sizes, types and models, Jensen's new 16-page speaker catalog contains much information for speaker buyers. This catalog is free on request. Write to Jensen Radio Mfg. Co., 6601 S. Laramie Ave., Chicago, Ill.

### PURCHASING DIRECTORY ADDITIONS

In our Purchasing Directory Section of the September, 1938, issue of COMMUNICATIONS, the following names were unintentionally omitted:

*Amplifier Company of America*, 37-45 W. 20th St., New York City—amplifiers, p-a and speech-input equipment.

*Jefferson-Travis Radio Mfg. Corp.*, 198 Milburn Ave., Baldwin, N. Y.—police, fire and marine radio telephone equipment.

*Precision Apparatus Corp.*, 821 East New York Ave., Brooklyn, N. Y.—laboratory and test equipment.

*Transformer Corp of America*, 69 Wooster St., New York City—amplifiers and sound equipment.

### WARD LEONARD BULLETIN

Ward Leonard Electric Co., Mount Vernon, N. Y., have just issued a four-page bulletin on their line of wire-wound fixed resistors, adjustohm resistors, vitrohms ring type rheostats, plaque resistors, and a parasitic suppressor. To secure a copy of this data sheet, write to the above organization for Circular 507.

### CATALOG ON CONDENSERS

Listings of all standard items of the extensive Aerovox condenser line, with the most popular types of carbon and wire-wound resistors as well, are provided in the handy form of the new Aerovox condensed catalog. Containing the same general pages as those provided through United Catalog service, the new catalog also features three pages of exact-duplicate replacement condenser listings and two pages of exact-duplicate motor-starting capacitor replacements. A copy may be had either through the local jobber or direct from Aerovox Corporation, 70 Washington St., Brooklyn, N. Y.

### RADIART BULLETIN

A recently issued, 4-page bulletin describes the Radiart "Vipower" units. Technical data, curves and circuits are given. Write to The Radiart Corp., 133 St. at Shaw Ave., Cleveland, Ohio, for Bulletin 835-C.

### DUMONT CATALOG

Allen B. Du Mont Laboratories, Inc., 2 Main Ave., Passaic, N. J., has released a 1938-1939 catalog. Cathode-ray tubes, oscillographs and accessory apparatus are covered. To secure a copy write to the above organization.

### ANDREW BULLETIN

Victor J. Andrew, 6429 S. Lavergne Ave., Chicago, Ill., has made available an engineering bulletin on remote-indicating antenna ammeters. Descriptive data and specifications are given.

### BOONTON BULLETIN

The Type 140-A beat-frequency generator is described in a 4-page bulletin now available from the Boonton Radio Corp., Boonton, N. J. A description and specifications of the unit are given.

### FOREIGN TRADE CONVENTION

The Twenty-Fifth National Foreign Trade Convention for 1938 will be held at the Hotel Commodore, New York City, from October 31 through November 2. All engaged in the promotion of oversea commerce are invited to attend. The afternoon of November 2 will be devoted to simultaneous group meetings by industries.

### UTC CATALOG

"Transformer Components" is the title of a new 15-page catalog which covers the UTC line of transformers, voltage-control units, and transmitter and amplifier kits. It may be obtained either from local jobber or from the United Transformer Corp., 72 Spring Street, New York City.

### SPAULDING DATA SHEET

Spaulding Fibre Co., Inc., 310 Wheeler St., Tonawanda, N. Y., have recently issued a bulletin entitled "New Standards for Spaulding Armite." This data sheet gives specifications on Spaulding Armite, a thin insulation (fish paper) for electrical and mechanical uses. A copy may be secured from the above organization.

### REMCO CATALOG

The Radio Engineering and Mfg. Co., 26 Journal Square, Jersey City, N. J., have made available Catalog No. 288. This catalog gives data on the Remco line of transcription and record reproducers, portable field amplifiers, meter enclosures, crystal couplers, frequency measuring equipment, a 1000-watt broadcast transmitter, etc.

### PATENT DECISION

The manufacturers of radio receiving sets, and the makers of inductance devices used in such sets, will be interested in a decision rendered on August 1st by the United States Court of Appeals of the Seventh Circuit in the patent litigation between Johnson Laboratories, Inc. and Aladdin Radio Industries, Inc. on the one hand, and Meissner Manufacturing Company on the other, as well as between Ferrocarril Corporation of America on the one hand, and Johnson Laboratories, Inc. and Aladdin Radio Industries, Inc. on the other hand, declaring that none of the claims in Johnson's patents, which were the object of several years of litigation, were infringed and they were held invalid, also that the Johnson and Aladdin Companies are guilty of unfair competition in trade by reason of threats of infringement suits made against the customers of Ferrocarril and Meissner. These cases were heard twice by the United States Court of Appeals and a petition by Johnson for a rehearing was denied in October. Attorneys for Johnson were Pennie, Davis, Marvin and Edmonds and for Ferrocarril, who defended Meissner Manufacturing Company, were Wilkinson, Huxley, Byron and Knight. Johnson began suit in August, 1938, against Andrea Radio Corporation in the Eastern District Court of New York and Henry Crowley & Company the New Jersey District, and in their answer, Crowley entered counter suit against Johnson.





# VETERAN WIRELESS OPERATORS ASSOCIATION NEWS



W. J. McGONIGLE, President

RCA Building, 30 Rockefeller Plaza, New York, N. Y.

H. H. PARKER, Secretary

## IN MEMORIAM

IT IS WITH deep regret and a feeling of great loss that we record the passing of one of the true pioneers of our profession, Chairman of the Boston Chapter of our Association at the time of his death, the late Harry R. Chetham. Always active in the affairs of our organization his loss will be felt by our entire membership and by his associates in the Boston group in particular.

He was born forty-eight years ago in Central Falls, R. I., and became interested in radio as a boy when he built a crude coherer set and spark coil transmitter. This equipment, including other things which he built while radio was in its infancy, is in the National Smithsonian Institution in Washington.

Twenty-five years ago he installed a radio transmitting and receiving station on Penikese Island in Buzzard's Bay, then inhabited by a leper colony. For this outstanding feat he was awarded a Testimonial Scroll by our Association.

At the time of the sinking of the *Titanic* he was commended for his work in receiving messages from the stricken vessel and he later received the world famous message from the rescue ship *Carpathia*, "Major Archie Butt not among the survivors."

He was in charge of construction at the United States Naval School at Harvard University at the outbreak of the World War. In November, 1914, he deciphered secret radio messages which resulted in the capture of a German radio station at Sayville, L. I. In August, 1918, he intercepted flashlight messages from a hotel room on the Maine Coast and brought about the capture of a German agent who was signalling to a submarine.

In 1922 he picked up an SOS message from an English steamship breaking up on Peaked Hill Bar, Cape Cod, from which fifty-four men were rescued. He also brought aid to other steamers in distress, among them the *City of Bangor* and the *Cormorant*.

In later years he was instructor in several schools teaching radio to police and fire department personnel and perhaps as an individual was instrumental in more persons obtaining government radio licenses of various grades than any other person not continuously employed as an instructor.

On several examinations for Chief Radio Operator in the Police Department of his home town, Somerville, Mass., he obtained perfect scores. For several years preceding his death he served as Chief Radio Operator of the Somerville Police Radio in addition to his work as instructor.

We offer our deepest sympathies and condolences to his family.

## MARCONI MEMORIAL SCHOLARSHIP

J. R. POPPELE, Chairman of our Scholarship Committee and Secretary and Chief Engi-

neer of the Bamberger Broadcasting Service, Inc., and the Radio Quality Group, Inc., submits the following details concerning the Marconi Memorial Scholarship.

The Marconi Memorial Scholarship is awarded each year by the Veteran Wireless Association in one of the areas in which they maintain a chapter. The scholarship of \$880 covers the full tuition and matriculation fee for R. C. A. Institute General Course in Radio Engineering. This course requires a period of two years for completion.

The order of rotation of the award among the various chapters is determined by the membership of the individual chapters. For example, the award for 1939 will be made by the chapter having the greatest paid membership as of January 1st of that year. The 1940 award will go to the chapter having second highest membership as of January 1st of 1940 and so on until each chapter has had the honor of making the award. In no case, however, shall the award be made by the same chapter for two consecutive years.

For the New York City chapter all high schools within a circle whose center is Times Square and whose radius is 50 miles shall be eligible to enter a contestant. In other cities where VWOA chapters exist, this circle shall be extended until it encompasses a number of high schools near to that in the New York City 50-mile radius area.

The contestant entered by the various high schools shall be required to submit to a competitive examination based on mathematics and physics; forms for which shall be obtained from a disinterested testing service providing this type of material.

## NOVEMBER MEETING

THE NOVEMBER MEETING of the New York group will be held at 6 p. m., Monday, November 7, 1938, at the Castle Garden Cafe, 62 Pearl Street, New York City. New York members please try to attend.

## CANADA

AN INTERESTING LETTER from Leonard C. Parkes, Engineer in Charge Radio Station CKSO, Ontario, Canada. He states:

"In brief, I started as wireless operator in VF2, United States Marine Aviation in 1923. After serving four years in the Marines I joined the Canadian Marconi Company, working at the factory, and the following year on the Lakes for the same firm. In 1928 joined CKCL, Toronto, as Transmitter Engineer for seven years. In 1935 came up to install CKSO and since that time have served as Engineer in Charge.

"I shall be glad to hear regarding requirements for membership in your Association and if my application should receive your favor, I have hopes of possibly hearing from some of the boys I used to know

in the Marines. I was at NFV with Grenlie and James, who accompanied Byrd on his Polar explorations."

Glad to hear from you, LCP, and we surely will look with favor on your application. Our Canadian membership is slowly but surely growing, much to our pleasure.

## PERSONALS

AMONG THOSE PRESENT at the first, and very successful, meeting of the New York group were: A. F. Parkhurst, early pioneer in commercial radio and in years past Superintendent for Tropical Radio in New York and more recently an executive of General Motors now residing in New York; Fred Meinholtz, New York Times Communications Superintendent, and Mr. De Neuf an executive of Press Wireless, Inc.; Mr. Steadman, an early member of the personnel of Tropical Radio; Carl Petersen, Marconi Memorial Medal of Valor Gold Medal recipient with Mr. Griswold, also of Paramount News; V. P. Villandre, Radiomarine Chief Operator; C. D. Guthrie, Maritime Commission Radio Supervisor; "Bob" Frey, Bull Steamship Line Radio Supervisor; "Bill" Simon, our worthy treasurer, of Tropical Radio with "Bob" Pheysey, and Messrs. Mathers and Davis of the same company; our VP, "Steve" Wallis, Mackay Radio Commercial Manager; our hard working Secretary, H. H. Parker; our President, "Bill McGonigle; our Junior Past President, George H. Clark; E. T. Jones, a real oldtimer—first editor of *Radio News* and now in charge of advertising of Engineering Products of RCA Manufacturing Company at Camden; "Dick" Egolf of RCA Communications; H. T. Hayden, our membership Chairman, Ward Leonard, Sales Engineer; A. F. Rehbein, Radio Supervisor of the American Hawaii-Air Lines; "Steve" Kovacs and his inseparable companion Alexander Vadas; Frank Orth of CBS and Sam Kay (not the orchestra leader); "Bill" Gillule of Mackay Radio Marine Department; Paul Girard also of the Marine Dept. of Mackay Radio; Paul K. Trautwein our former Treasurer, Pres. of the Mirror Record Corp.; Mr. Davis of the Engineering Staff of WOR; and some others. All in all a very successful meeting.

## DUES

A FEW of us have not yet remitted for 1938. Will you please look through your effects and if you have not a 1938 membership card send two dollars to the Secretary and get one. Your cooperation will be appreciated.

## DINNER CRUISE

REMEMBER: Saturday Evening, February 11th, 1939, is the date. Contact your local officers for details of your Chapter Cruise. We'll be looking for you. See you then!

# Let CLAROSTAT

# Solve

## YOUR RESISTANCE PROBLEM

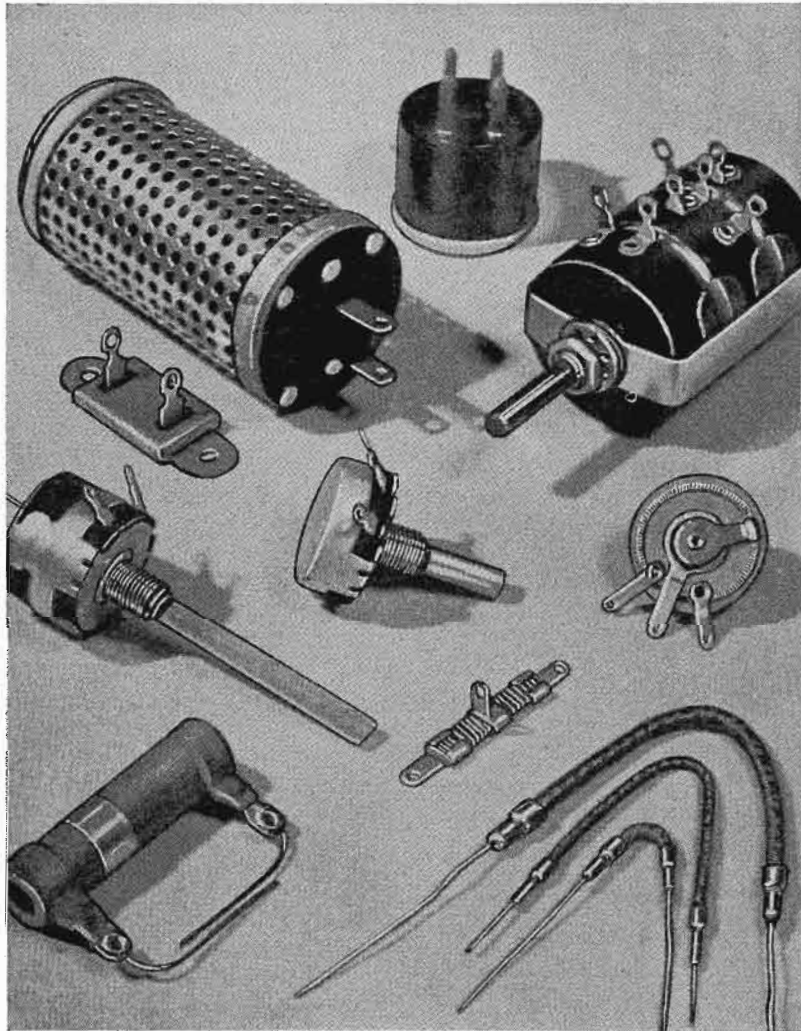

● CLAROSTAT—"The House of Resistors"—manufactures a remarkably complete line of resistors, controls and resistance devices. This assures you getting the unit best fitted for your particular job. Remember: CLAROSTAT plays no favorite types; does not ask you to improvise; positively discourages makeshifts. So let CLAROSTAT study your problem, provide adequate engineering collaboration, and finally apply the *right* unit at the *right* price.

### ... with PERFECTED CONTROLS

The entirely new Midget or Series M Midget composition-element control has been designed from scratch, to meet present-day critical circuit requirements. Will prove a revelation in accuracy, smoothness, immunity to moisture, and long life. Meanwhile, CLAROSTAT Wire-Wound or Series W Controls have long since been accepted as standard for critical circuits. A type for every need—dual and triple tandem units, T-pads, L-pads, faders, hum balancers, attenuators, etc.

### ... with VOLTAGE DIVIDERS

CLAROSTAT wire-wound metal-clad strip resistors are available in any resistance values and with any number of taps. The exclusive bakelite-molded metal-jacketed units are establishing new standards of performance. Also line-dropping resistors, cords, metal-tube-type resistors, voltage-regulating ballasts, etc.

### ... with FIXED RESISTORS

Wire-winding facilities second to none enable CLAROSTAT to provide any kind of fixed, dependable, accurate resistors. Tens of millions of CLAROSTAT Flexible Resistors are used in radio sets today. Also exposed strip resistors, tapped resistors, etc.

### ... with POWER RESISTORS

Only recently, following years of research and experimentation, has CLAROSTAT introduced an entirely new and provably better power resistor. The wire winding is protected by an inorganic cement. These green (for positive identification) resistors can be overloaded, heated to high temperature, and dipped in cold water, over and over again. They won't crack. Nor will they change in resistance value. Positively outstanding performance. Fixed and adjustable types. 10 to 200 watts.

### ... with PRECISION

CLAROSTAT now offers a line of precision resistors with a wide choice of terminals. Permanently accurate. Any resistance values. Also other precision resistors such as plug-in units, strips, etc., to your exact requirements.

Write...

- Place your resistance problem before our engineers for suggestions, specifications, samples, quotations. Be sure our loose-leaf data book is in your working library.



## CLAROSTAT Manufacturing Co. INC.



285-287 NORTH SIXTH STREET  
BROOKLYN, NEW YORK, U.S.A.

• OFFICES IN PRINCIPAL CITIES •





## Better Contacts

are made by

# CALLITE

**W**HATEVER your need for contacts or contact materials of tungsten, molybdenum, silver, platinum and their alloys, we are in a position to fulfill your requirements. Contact points must be accurate for the reliable operation of the devices in which they are used. Callite contacts are engineered from start to finish to give dependability and long life. Rigid control and supervision over every phase of manufacture insures your getting a product of unsurpassed characteristics. Our laboratories check daily the performance of these contacts under operating conditions, thereby maintaining the prescribed high standards of quality. Let us help solve your problems.

**CALLITE PRODUCTS DIVISION**  
542 39TH STREET UNION CITY, N. J.

## Announcing Walco **SAPPHIRE** CUTTING NEEDLES

*Far superior to any cutting needle now on the market because*

1. **Absolute uniformity**—Point is .002 radius, guaranteed accurate to 1/10,000th inch.
2. **Perfect cutting edge**—all other needles we can find show chipped edges under microscope.
3. **Longer life**—Walco Sapphire Needles will cut 2 to 10 times as many records, depending on conditions.

Send for bulletin in which microphotos and shadowgraphs show clearly the reasons for definite superiority of Walco Sapphire Needles

**ELECTROVOX COMPANY**  
424 MADISON AVENUE NEW YORK CITY  
Cable Address: Walvox



**DEALERS  
WANTED**

**Introductory Offer**—On your 1st order we will ship free with each cutting needle one Walco Sapphire Playback needle, the only needle which can't injure acetate.

LIST PRICE \$5.00 each • RESHARPENING \$1.30 net

## EXPONENTIAL TRANSMISSION LINE

(Continued from page 9)

off. The variation of the input impedance with frequency is shown for two lines of different length but the same rate of taper in Fig. 3. The magnitude of the oscillations depends only on the rate of taper and decreases with increase in frequency. The impedance varies between  $(1 + f_1/f)$  and  $1/(1 + f_1/f)$ . The positions of the maxima and minima, however, are determined by the length of the line. They occur respectively at those frequencies for which the line is approximately  $1/8$  of a wavelength more than an even or an odd number of quarter wavelengths long. The phase angle is usually negative but has a small positive value when the line is approximately a half wavelength long.

The locations of these maxima and minima are the same as would result from terminating a uniform line in an impedance whose magnitude is the same as the characteristic impedance but has a small reactive component. This suggests adding a compensating reactance to the resistance load. From (3) the best single reactive element is found to be a condenser whose impedance is equal to the impedance level at the cut-off frequency. This gives a value of  $K = 1 - jv$  which when substituted in (5) shows that the input impedance is to a first approximation a constant times the terminal impedance. To correct for the reactive component of the input impedance an inductance having an impedance  $jZ_0/v$  which is equal to the input impedance level at cutoff is shunted across the input. The resulting impedance transforming network consists of an exponential line with a series capacity at the high-impedance end and a shunt inductance at the low-impedance end. When terminated in a resistance load at either end equal to the impedance level at that end the input impedance, to a first approximation, is a resistance equal to the impedance level at the input end. In fact the deviations of the input impedance from the ideal, for transmission in one direction is just the reciprocal of that for transmission in the other direction.

The magnitudes of the series capacity and shunt inductance that give the improved network may be expressed in terms of the electrostatic capacity and loop inductance of the line. Simple calculation shows that the required series capacity is equal to  $2/(k-1)$  times the electrostatic capacity of the line and the required shunt inductance is equal to the same factor times the total inductance of the line.

There is an interesting relationship

between these terminations and a simple high-pass filter. The LC product of the shunt and series arms of the filter resonates at  $f_1$ . If an ideal transformer with transformation ratio  $k$  is inserted between the shunt inductance and the series capacity, the capacity becomes  $C/k$  and the new LC resonates at  $f_1\sqrt{k}$ . This is the same frequency at which the series capacity and shunt inductance that are added to the terminations of the exponential line resonate. Furthermore the reactance of the shunt inductance is equal to the impedance level at the cut-off frequency and the reactance of the series capacity is equal to the impedance level at the cutoff frequency exactly as in the case of the high-pass filter.

By using the exponential line it is possible to construct a network with properties that no network with lumped circuit elements possesses, namely, a high-pass transforming filter.

#### APPENDIX

The exponential line is a "non-uniform" line so that the terms "characteristic impedance" and "surge impedance" of an exponential line are not synonymous. The terms "surge impedance"<sup>2</sup> and "nominal characteristic impedance"<sup>3</sup> may be used synonymously for the characteristic impedance of the uniform line that has the same distributed constants as the non-uniform line at the point in question. Expressed as functions of the distributed "constants" of the line they are the square root of the ratio of the distributed series impedance to the distributed shunt admittance at the point along the line in question. It will be expedient to refer to the nominal characteristic impedance as the impedance level at the point in question. Schelkunoff<sup>4</sup> has defined the characteristic impedances as the ratio of voltage to current at the point in question for each of the two travelling waves of which the steady state condition is composed. At each point an exponential line has two characteristic impedances which are different and depend upon the frequency as well as the position along the line.

(See following page)

<sup>2</sup>The term "surge impedance" is defined by A. E. Kennelly on page 73 of "The Applications of Hyperbolic Functions to Electrical Engineering Problems" (McGraw-Hill 1916) as follows: "The surge impedance of the line is not only the natural impedance which it offers everywhere to surges of the frequency considered, but it is also the initial impedance of the line at the sending end". Hence the "surge impedance" should be independent of the configuration of the line except at the point in question and in particular it should be equal to that for a uniform line constructed so as to have the same dimensions everywhere as the non-uniform line has at the point in question.

<sup>3</sup>The word nominal as used here has the same meaning as in "nominal iterative impedance" as used by K. S. Johnson in "Transmission Circuits for Telephone Communication" (Van Nostrand 1925).

<sup>4</sup>S. A. Schelkunoff, "The Impedance Concept and Its Application to Problems of Reflection, Refraction, Shielding and Power Absorption," *Bell System Technical Journal*, 17, 17-48, January, 1936.



MILLER 100-LR

### REPRODUCER for LATERAL RECORDINGS

**The Lansing  
Manufacturing Co.  
believe this to be  
the best  
reproducer  
made.**

**You are invited  
to subject it  
to the most  
exacting  
tests.**

Perfectly flat response over entire recording frequency range permitting predetermined equalization. Reproduction so perfect that the Miller 100-LR is an excellent standard for calibrating frequency records and cutting heads.

Moving coil of D'Arsonval principle operates in a magnetic gap of uniform flux density. Output voltage is directly proportional to needle point movement velocity.

Permanent characteristics and consistent performance. It is not affected by humidity or temperature changes.

Double action lever-type arm designed for tangential tracking. It is fitted with a micrometer weight adjustment allowing weight at the needle point to be set any place between 6 and 30 grams.

Permanent sapphire needle point finely ground and polished by the makers of the finest watch jewels.

Lower needle point impedance than any other commercial pick-up. Effective mass at needle point only 24 milligrams.

Unlimited life insured for both acetate and processed discs by the combination of low needle point impedance, sapphire point, and micrometer weight adjustment.

Indestructible alumulite finish.

Write for Bulletin 9-C

**LANSING MANUFACTURING CO.**  
6900 McKinley Ave. Los Angeles, Calif., U. S. A.





**WRTD** chief engineer,  
**DAVID BAIN**, writes:

"We could write pages of praise concerning our Lingo Radiator, but suffice it to say that a few of the many advantages we have found are; low first cost; low upkeep; freedom from lightning static discharges, physical and electrical stability, better current distribution and many others.

On the whole, we are more than satisfied with our radiator and would not hesitate in recommending it unreservedly. The fact that we are planning on buying two more Lingo poles for a directional array in the event that our proposed power increase is granted, is a recommendation in itself."

## FACTS

—not just figures  
of speech!

Here is proof of the facts that we have been repeating in these very columns. We publish Mr. Bain's letter because we honestly believe every alert engineer should read it . . . and then be glad to know MORE about this amazing, new-type Radiator that bases its records of high efficiency and low cost on FACTS . . . and not just "figures of speech"!

Write for detailed folder—"New Standards for Vertical Radiators." Sent FREE on request. Be sure to state location, frequency and power of station.

**JOHN E. LINGO & SON, Inc.**  
Dept. C-10, Camden, N. J.

**LINGO**  
VERTICAL  
TUBULAR STEEL  
RADIATORS

Because of the change of impedance level, the propagation constants for the voltage and current differ, so that it is convenient to consider the transfer constant<sup>5</sup> which may be defined as half the sum of the voltage and current propagation constants.

<sup>5</sup>Compare with the definition of "image transfer constant" as given by K. S. Johnson in "Transmission Circuits for Telephone Communication."

(To be concluded)

## BOOK REVIEWS

(Continued from page 11)

telegraphy, television and scientific instruments. In addition a chapter has been devoted to miscellaneous applications of photocells. References are also given at the end of each chapter.

For engineers and those interested in the application of light sensitive devices, this book is to be recommended.

R. D. R.

*ELEMENTARY SURVEY OF PHYSICS*, by Arthur E. Haas and Ira M. Freeman, published by E. P. Dutton & Co., Inc., 300 Fourth Ave., New York City, 203 pages, price, \$1.90.

This book gives a concise survey of the field of physics. It is non-mathematical and elementary in nature. The fundamentals of the subject are reviewed, and a statement of the newer developments is given. It has been written to provide a "cultural" discussion of scientific research in physics.

The book has been divided into four parts on mechanics and physics, heat, optics, and electricity. Included in the appendices is a discussion of "Physics and Civilization," a special supplement for pre-medical students, as well as a mathematical appendix.

This book is recommended for those who want to keep abreast with the developments in physics and who need an up-to-date non-mathematical reference book.

R. D. R.

*WIRELESS SERVICING MANUAL*, by W. T. Cocking, published by Iliffe and Sons, Ltd., Dorset House, Stamford Street, London, S. E. 1, England, fourth (revised) edition, 1938, 288 pages, price 5/ net, by post 5/5.

Although the author did not consistently adhere to his policy, he has, in general, arranged the material according to the symptomatic manifestations of defects rather than in the traditional way of describing the functional operation of various circuits and listing the possible defects that may occur therein. This arrangement results in the book being of unusual utility to the man engaged in repairing radio receivers. It

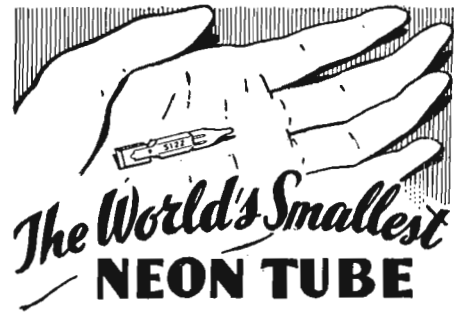

Measures only 1" x 1/4". Used in Littelfuse Tattelite—has thousands of other applications. Glows on only .0005 ampere current. Minimum operating voltage 90 D.C., 65 A.C., one milliamper maximum on steady loads. Now in use on remote control switches, test equipment, pilot lights, tests "B" batteries, open circuits, fuses, live lines, polarity, static, etc.



### INDICATOR TATTELITE

Same size and uses same base as a miniature switchboard lamp. Limiting resistor is in mounting. For 90 to 250 volts D.C.—65 to 250 volts A.C.

Write for  
FOLDER

Tells about Tattelite Products—solves many of your worst problems. Write

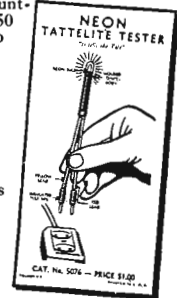

**LITTELFUSE INCORPORATED**  
4242 Lincoln Avenue Chicago, Illinois

MAYBE  
the trouble is with your  
NEEDLE ?

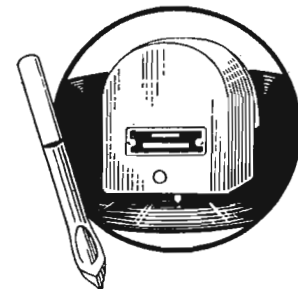

Next time you experience difficulty with your recordings, check up on your needle. RECOTON Steel Cutting Needles assure you Sapphire performance at very low cost. Made of superior tempered steel, highly polished to cut a clean groove with minimum scratch. For acetate and celluloid.

**RECOTON**  
CORPORATION

178 Prince St., New York City

is to be hoped that other authors in this field adopt a similar plan of arrangement.

This book should prove of interest not only to the service man, but also to the engineer who is interested in the radio export trade, for, among other things, it gives a listing of American, British, and Continental vacuum tube bases. In using the same diagram for both the British octal and the American octal base the author tends to give the impression that British and American octal tubes of equivalent type are interchangeable. His brief statement, "Actually, the pin spacing and size of the spigot are slightly different," would dispel any such illusion from an Englishman's mind due to the large amount of publicity this point has received in England. For the benefit of American readers the author might have added that not only will the British octal tube not fit into an American octal socket, and vice versa, but also that the internal wiring from electrodes to pins is very different.

Tabulated in one of the appendixes are inductance, capacitance, and resistance values which may be used in various circuits as a first approximation when specific information regarding the correct value for a particular receiver is lacking.

The author devotes a chapter to a description of defects that may occur in television receivers.

The present fourth edition has been enlarged by the addition of about fifty pages of new material. D. B.

### MYSTERY CONTROL

(Continued from page 21)

motor to increase or decrease volume. In parallel with this switch there is a single-pole, double-throw switch connected to the manual volume control. This switch is mounted directly below the receiver dial bezel.

#### RANGE

The normal range of the mystery control is within a circle of the receiver with a radius of about 25 feet. A sensitivity control is provided in the cathode of the type 78 control amplifier, however, to fit a wide range of operating conditions. Normally, sufficient precautions are taken in the amplifier and remote control circuits to greatly reduce the possibility of electrical interference. There is little possibility of interference affecting the receivers if the sensitivity control is kept down to the first half of its total movement.

In some installations, however, owing to the presence of large metal ob-

(Continued on page 31)

# Believe it or not...

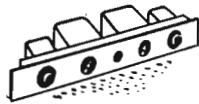

Unexcelled laboratory and engineering facilities plus dependability in production and performance have made **UTC** a standard source of supply for special transformers.

One organization was discouraged because they discovered that the development on which they were working required unheard of low frequency response. To solve their problem, UTC made a transformer **down only 2DB at .5 cycles per second.**

WOR liked our 3A universal **equalizer** but wanted **automatic level compensation\*** so that changing the equalization would not require a corresponding change in gain setting. UTC delivered... and it's a honey.

Phase shift, while of secondary importance in most commercial applications, was a bugaboo to one organization. UTC developed a transformer unit having a **phase shift of 4 degrees from 20 cycles to 2000 cycles.**

It is relatively simple to produce a 1 mhy. coil having a high Q at 10 kc. A coil having approximately **1 hy.** inductance and operating at this frequency is quite a problem. Through special design UTC supplied this coil with a **Q of 90 at 10 kc.** Similar design results in a Q of almost 200 at 1000 cycles.



UTC has supplied transformers for television service covering a range of 30 cycles to 2,000,000 cycles.



Due to the large external fields from dimmer reactors in a theatre amplifier installation, hum pickup was a terrific problem. The **UTC LS-10X** tri-alloy shielded input proved the answer.



If you have a special problem write to the UTC Engineering Staff. Our standard products are described in the new compact PS-403 Bulletin. Ask for your copy

\* Now the standard UTC 3AX equalizer.

## UNITED TRANSFORMER CORP.

72 SPRING STREET

NEW YORK, N. Y.

EXPORT DIVISION 100 VARICK STREET NEW YORK, N. Y. CABLES: "ARLAB"

# Everything in RELAYS

FROM THIS TO THIS

Two products from the same plant . . . one a simple contact switch . . . the other an intricate assembly of many electric control units, with 5 different types of relays, stepping relays, shutter control relays, time delay relays, interlocking relays, a 12-point multi-connector plug, and a dozen or more metal stampings, cams and special forms. Every part is made in Guardian's own factory . . . designed by Guardian Engineers . . . and assembled compactly in a space scarcely half the area of this page. Here is a convincing example of the astonishing variety of the work we do.

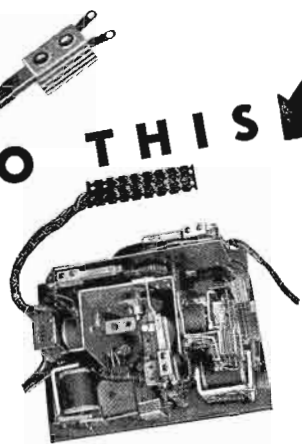

Whether YOUR electrical control problem is simple or complex . . . you'll find the correct solution in Guardian Engineering Service and in Guardian-built equipment. WRITE US today. Get our Big New Relay Catalog "C." Or ask us to make specific recommendations to fit your special requirements.

**GUARDIAN G ELECTRIC**  
 1623 W. WALNUT STREET CHICAGO, ILLINOIS

## COUPLING NETWORK

(Continued from page 22)

If  $X_B$  is a positive reactance,  $\omega_2$  must be greater than  $\omega_1$  while if it is a negative reactance  $\omega_2$  must be  $< \omega_1$ .

Eqs. (34), (35), (38) and (39) may be applied to any network after the values of reactance at the operating frequency have been determined.

An inductively coupled network inherently provides a high frequency discrimination as the primary and secondary circuits contain both capacitance and inductance. It is this combination, rather than the use of mutual inductance which provides the discrimination, and a similar result can be obtained with T or  $\pi$  networks with combinations such as are shown in Fig. 21.

### EXAMPLE OF NETWORK WITH HIGH FREQUENCY DISCRIMINATION

As an example of a rather complicated coupling network consider the circuit shown in Fig. 22. This network was designed with the following requirements in mind:

- (1) A single antenna is to be excited by two broadcast transmitters at 1,300 and 1,100 kilocycles.
- (2) The coupling of each transmitter to the antenna must be capable of adjustment without reacting on the coupling of the other transmitter.
- (3) Transmitter A at the higher frequency is designed to operate into a grounded 70-ohm concentric line while Transmitter B at the lower frequency is designed to operate into a 600-ohm line balanced to ground.
- (4) The frequency discrimination must be high. If this is not provided, the output of one transmitter will be rectified by the final stage of the second transmitter and will in turn modulate this transmitter output so that

cross talk will result.

Limits of space forbid the detailed computation of the constants of the circuit of Fig. 22, but some of the features will be pointed out.

$L_1C_1$  is anti-resonant at 1,300 kilocycles and so provides a high impedance to the left of the antenna at this frequency. Hence adjustments on the 1,300-kilocycle coupling are not disturbed by changes in the 1,100-kilocycle coupling.

Similarly  $L_2C_2$  is anti-resonant at 1100 kilocycles and isolates the network to the right when adjustments are being made on the coupling to the 1,100-kc transmitter.

Since  $L_1C_1$  will be inductive at 1,100 kilocycles,  $C_3$  is provided to resonate the antenna at 1,100 kilocycles.

As the 1,100-kilocycle transmitter feeds a balanced line, inductive coupling must be provided in this case by  $L_4$  and  $L_3$ .

The outside turns of  $L_4$  together with  $C_4$  provide a shunt resonant path at 1300 kilocycles to give additional discrimination against this frequency.

Similarly, on the right,  $L_5$  and  $C_5$  provide a shunt resonant path at 100 kilocycles to give additional discrimination against this frequency.

Since  $L_5C_5$  is an inductive reactance at 1,300 kilocycles and  $L_2C_2$  is a capacitive reactance at the same frequency, the network containing these arms and  $C_6$  is essentially the Type 3 T network of Fig. 11 and is designed accordingly.  $L_1-C_1$ ,  $L_2-C_2$  and  $L_5-C_5$  are then obtained by means of eqs. (34), (35), (38) and (39).

It has been shown that reactance coupling networks are very versatile and their adaptability to perform different functions is limited only by the complexity which is permitted. Only typical cases were shown and the ingenious designer will find many more applications.

## FLIGHT RAY

(Continued from page 22)

During September and October of 1937 flight tests were conducted at Indianapolis, Indiana, with the first experimental indicator, utilizing the instrument landing facilities made available by the Bureau of Air Commerce and the RCA Manufacturing Company at that airport. Many trial landings were made under the hood, using solely the indications as shown on the face of the single indicator. After successful preliminary tests it was shown to a small group of people representative of the aircraft industry. Their service and counsel were then solicited with a view towards insuring the best course for future development.

The results obtained and comments were sufficiently favorable to warrant continued development by the Sperry Gyroscope Company, and accordingly the apparatus has been considerably improved. It is expected that it will soon be ready for further flight tests and pilot training during the coming fall.

### THEODORE H. NAKKEN

An inquiry has been received for Mr. Theodore H. Nakken. It would be appreciated if Mr. Nakken would communicate directly with the Editor of COMMUNICATIONS, 19 E. 47 St., New York City, N. Y.

## MYSTERY CONTROL

(Continued from page 29)

jects around or near the receiver chassis, it will be necessary to increase the sensitivity of the control frequency amplifiers owing to the absorption of the metal surfaces. When this occurs, it will very likely be found that the same metal objects are shielding the receiver from excess static which would normally interfere with the control circuits in a high setting of the sensitivity control.

### CONTROL FREQUENCIES

Mystery Control receivers are designed to operate on a control frequency somewhere between 350 and 400 kc. The purpose of a variety of control frequencies is to assure freedom from interference between the circuits of two sets operated in close proximity to each other. A 20-kc difference is recommended between control frequencies of sets that are operated in the same room.

In homes or apartment houses the distance between receivers will determine the difference in frequencies that is necessary. When the control frequencies are 10 kc apart, receivers will not interfere with each other so long as their remote control cabinet is kept a minimum of 10 feet away from the second receiver. By having the control frequencies differ by 20 kc, the second cabinet can be placed anywhere, even on top of the first cabinet.

The procedure for setting up stations on the Mystery Control receivers is similar to the procedure followed in setting up Philco electric-automatic tuning models. The eight stations, however, are automatically dialed by the remote unit instead of by push buttons.

### IDEA IN DISC LABELS

Aerogram Corp., Hollywood recording studios and producers of custom built shows, has devised a novel and unique idea in its new label for wax program productions. With a combination background of light blue and white, including the usual directions and space for serial and program numbers, the firm has added a brand new angle in the form of a stroboscope. Ordinarily, this device, which is employed to test the accuracy of the turntable speed, is a separate cardboard and as a general rule it is of large size. Aerogram has incorporated the stroboscope as an integral part of the label as part of the outer edge. The label thus serves a twofold purpose, for program identification and also a measuring device to check the turntable for speed accuracy.

### CORRECTION

In our advertisement in September Communications reference is made to a 1500-foot tower. This is incorrect and should have read 150-foot tower. Sorry for the mistake.

**GATES RADIO & SUPPLY CO.**  
QUINCY, ILLINOIS, U. S. A.

# "THAR'S GOLD— In them thar hills" BUT ARE YOU GETTING IT ? ?

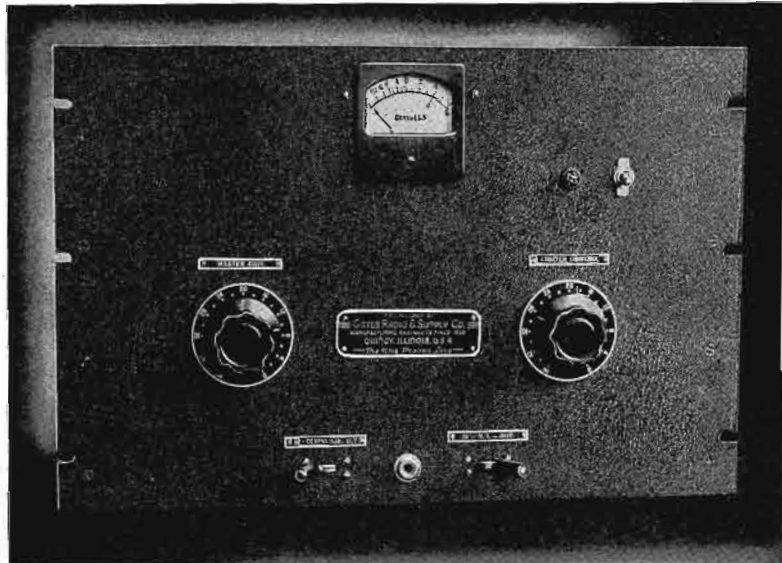

Yes Sir, Mr. Broadcaster, there are plenty of good American dollars in some of those very hills where your signal may now be questionable, where at night a beat gets the best of it or where in areas of man-made static other louder stations have the preference.

You can boost that signal at a mighty small cost by installing the 27-C Peak Limiting Amplifier and improve your quality at the same time, as the Gates 27-C Limiter does not flatten off the peaks or create odd

sounds under compression. Yes the 27-C Limiter is the only equipment of its kind employing a dual compression system and the only equipment that has a self contained power supply that is so compact—all on a 12 1/4" rack panel.

"We are now competing in signal strength with California stations," writes a prominent 250-watter from Idaho after installing the 27-C; in fact we can send you the story of many stations that have boosted their signal the Gates 27-C Limiter way.

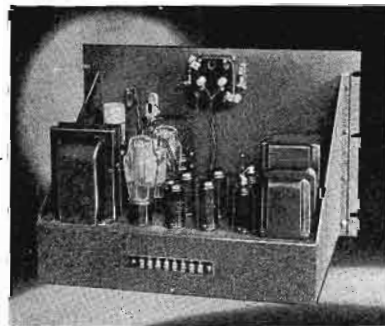

REAR VIEW

For Police and Aircraft stations, Gates has a special model at reduced prices where voice is used only.

Write for Bulletin CM20 Today.

# GATES RADIO & SUPPLY CO.

MANUFACTURING ENGINEERS SINCE 1922

QUINCY, ILLINOIS, U.S.A.

CABLE ADDRESS (GATESRADIO)

⚡ The Time Proven Line ⚡



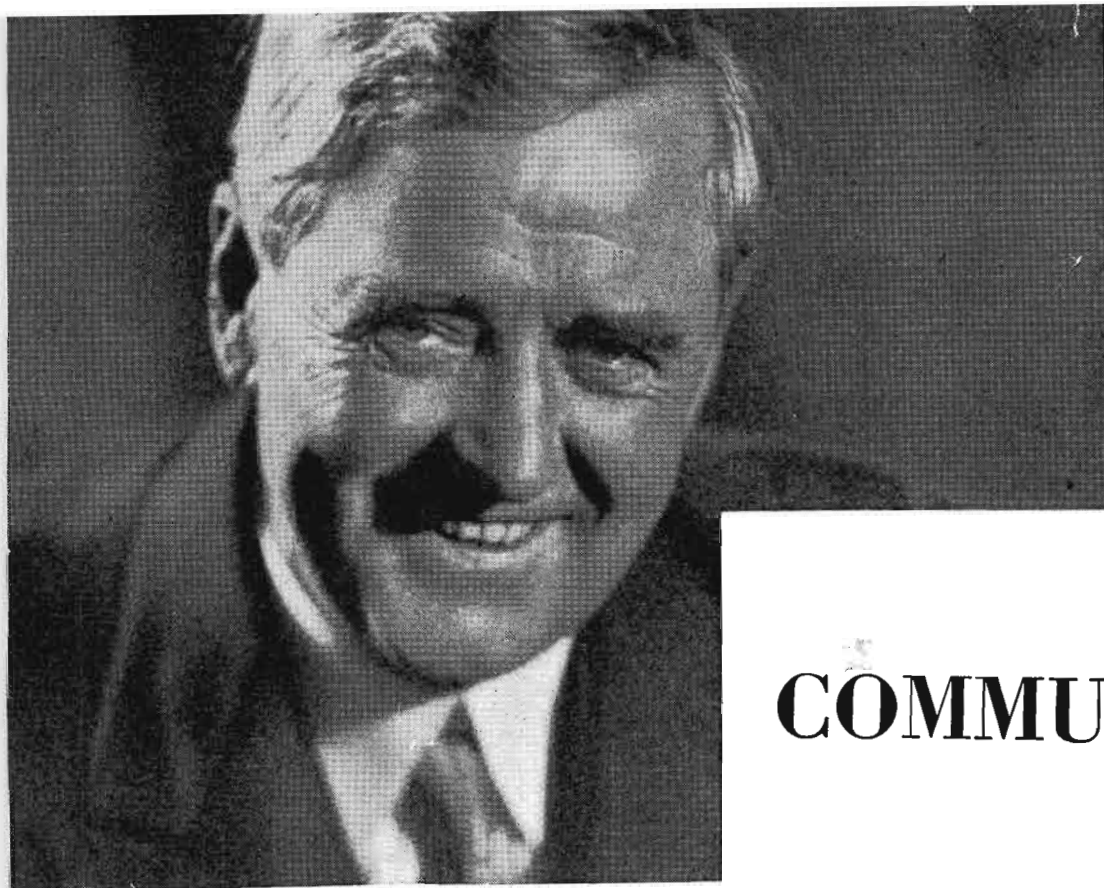

# COMMUNICATIONS\*

*“The act of imparting information”—“To make known”\**

**TEAR THIS OUT**

**COMMUNICATIONS,  
19 East 47th Street,  
New York City**

Gentlemen:

I remit \$ ..... herewith. Please enter 1 year subscriptions for the following:

Name .....  
Address .....  
City-State .....  
Occupation .....  
Employed by .....

Name .....  
Address .....  
City-State .....  
Occupation .....  
Employed by .....

Name .....  
Address .....  
City-State .....  
Occupation .....  
Employed by .....

Name .....  
Address .....  
City-State .....  
Occupation .....  
Employed by .....

**AND MAIL TODAY**

Actually the magazine COMMUNICATIONS does just that . . . for the men engaged in every phase of the Art.

The Radio and Communications Industries are definitely progressive. Engineers in the field depend on information regarding new developments and scientific advances. That's where COMMUNICATIONS fits in. It imparts such vital information essential to progress month after month. Twelve big important issues each year.

To keep abreast of the times in radio receiver manufacture; television; facsimile; recording; marine, aeronautical and police radio operation, etc., you can't afford to miss a single copy.

If you are a radio, broadcast, communications or industrial engineer, executive, department head or factory technician you can secure a year's subscription to COMMUNICATIONS (twelve issues) for only \$1.00 by using the Group Subscription Plan.

Regularly a yearly subscription to COMMUNICATIONS is \$2.00—but in groups of four or more, the subscription rate is only \$1.00 each per year. Your occupation must be stated.

Use the convenient form printed herewith. Your co-workers will sign up with you at the half-price rate if you tell them about the "G.S.P." All the important news about every phase of radio and communications appears *first* in COMMUNICATIONS. Sign up your group today.

*\* As defined in Funk & Wagnalls' STANDARD DICTIONARY*

**COMMUNICATIONS: 19 E. 47th ST.,  
NEW YORK, N. Y.**



When mailing a check (or money order) for a group of subscriptions, use this convenient form.

### AIRCRAFT DIRECTION FINDING

A TINY SPECK of green light moving on a screen of frosted glass shows airline dispatchers the exact direction of approaching planes, according to an announcement by Paul Goldsborough, president of Aeronautical Radio, Inc., following recent tests of a new development for locating airplanes in flight. Even though visibility is completely masked out by fog or blinding rainstorms, the new device, which operates by radio waves, enables airport personnel to follow the oncoming plane and, by return radio telephone, to guide its pilot to the field.

This unique contribution to air navigation was developed by Bell Telephone Laboratories for the Western Electric Company. When used in connection with the Civil Aeronautics Authority's beacon system, the new instrument will enable airline operators to ascertain the location of their aircraft at any time.

The system provides for indication on any of ten wavelengths which may be selected remotely. As each pilot talks, the spot of light moves instantly to its correct position on the circular screen of a cathode-ray tube. Compass markings inscribed around the screen's edge enable the airport dispatcher to give the pilot his exact bearings by return radio telephone. A pick-up antenna of special design is employed and this may be situated at any remote point. Connection between the antenna and the dispatcher is made over a single telephone line.

### AVC BY NOISE

A NOVEL method for automatically controlling loudspeaker outputs in large auditoriums equipped with p-a systems or regulating the loudspeaker volume in theatres, in order to override audience noise, is described in a recent issue of the *Wireless World*.

A schematic of the arrangement is shown in Fig. 1. It will be noted that a microphone is placed at some suitable point in the theatre. This microphone is used to provide an avc voltage which

Fig. 1. Arrangement for controlling loudspeaker outputs.

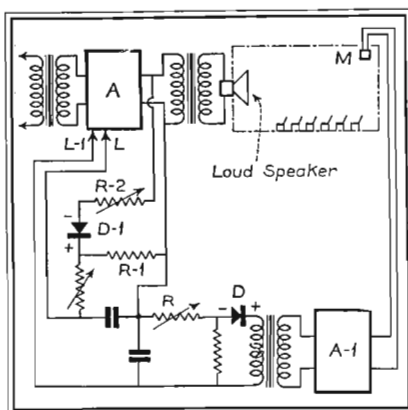

# NEW

OHMITE

*Vacuum-Type*

# DUMMY ANTENNA

*Resistor*



Patents Pending

**MODEL D-100**

**100 WATTS**

1. Built like a vacuum-tube, with four-prong base. Mounts in standard tube socket.
2. Power easily determined from R.F. ammeter reading.
3. 73 ohm value — to match concentric and twisted pair lines. Available also in higher resistances.
4. 100 watt rating. Easily combined in series, parallel and series-parallel groups for increased power capacity or other required resistances.
5. Unique non-inductive, non-capacitive design maintains the resistance (and impedance) constant to within a very few percent at any frequency up to 14 megacycles, and even beyond.

★

**TO CHECK  
R. F. POWER  
and Tune Up to  
Peak Efficiency  
Easily! Accurately!**

Another "first" for Ohmite — a new, compact "Vacuum-Type" Dummy Antenna Resistor with the convenience and efficiency you've always wanted. Provides a simple, accurate, dependable means of checking transmitter output and efficiency in amateur, aviation communication, police and broadcast services. Permits checking stage by stage, if desired. Insures tuning up for peak operating efficiency. Eliminates the creating of interference during periods of tuning-up and adjustment. The Model D-100 is a 100 watt unit — built like a vacuum-tube — mounts in a standard tube socket. Transmitter output is easily determined from R.F. ammeter reading. 73 ohm and other resistance values.

List Price . . . . \$5.50

For complete information, write today for D-100 data.

## OHMITE MANUFACTURING COMPANY

4857 West Flournoy Street,

Chicago, Ill., U. S. A.

*Be Right with* **OHMITE**  
RHEOSTATS \* RESISTORS \* TAP SWITCHES

## "300" SERIES

### A COMPLETE NEW LINE OF SMALL PLUGS-SOCKETS

**2 CONTACTS TO 33 CONTACTS**

PLUGS WITH CAPS      PLUGS WITH BRACKETS  
SOCKETS WITH CAPS      SOCKETS WITH BRACKETS

*Ask for Bulletin 300*

### HOWARD B. JONES

2300 WABANSIA AVENUE, CHICAGO, ILLINOIS





# ASTATIC

PIONEER  
MANUFACTURERS  
OF QUALITY  
CRYSTAL DEVICES

★ ★ ★ ★ ★ ★ ★

## New! MULTI-UNIT DUAL DIAPHRAGM CRYSTAL MICROPHONE



Designed especially for high class public address and recording purposes, Astatic's new MULTI-UNIT Microphone provides maximum amplification without feedback and cannot be acoustically overloaded. Made in two models: MU-2 with two dual diaphragm crystal units and four diaphragms, and MU-4 with four dual diaphragm crystal units and eight diaphragms. Black and chrome. Complete with interchangeable locking connector and 25-ft. cable.

### LIST PRICES

MU-2—\$29.50      MU-4—\$39.50

(See your Astatic Jobber  
or Write for Literature)

★ ★ ★ ★      ★ ★ ★ ★

## ASTATIC

Microphone Laboratory, Inc.

Youngstown, Ohio

Licensed Under Brush Development Co. Patents

## Protect Fragile Equipment From the Ravages of Dirt!

### IDEAL JUMBO "3-in-1" Cleaner

Clean delicate instruments thoroughly, but gently with the Jumbo Cleaner! Does not disturb sensitive balance or exact adjustments.

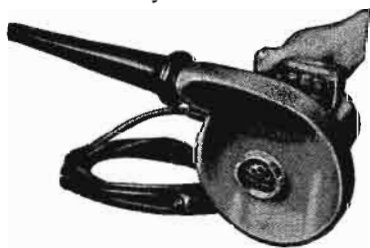

### Blows, Vacuums, Sprays

High velocity, DRY AIR stream quickly and safely removes all dust and dirt from instruments, machinery, wiring systems, etc. Reduces "shorts" and corrosion.

★ In great demand by broadcasting stations and communication offices. Portable — weighs only 14 lbs.

Sent on free trial.

**Ideal Commutator Dresser Co.**

1062 Park Avenue, Sycamore, Illinois

in turn controls the output from the loudspeaker.

The sound energy picked up by the microphone is fed to amplifier A-1. The output of A-1 is rectified at D and the resulting voltage fed through the variable resistance R to the biasing resistance R-1. Since the microphone will pick up normal sounds, a balancing voltage is applied through the shunt circuit containing resistance R-2, detector D-1 and the common resistance R-1. In practice, this balancing voltage is made somewhat larger than the normal pickup voltage from the microphone.

When any prolonged noise, such as laughter or applause, occurs, the voltage from the microphone builds up across R-2 in excess of the balancing voltage, and applies an AVC bias through the leads L and L-1 to the grid of one of the tubes in the main amplifier A. The loudspeaker output is thus increased until the disturbance is over, when normal conditions are restored.

### RADIO ALTIMETER

AN INSTRUMENT which gives airplane pilots their height above the ground over which the plane is flying was demonstrated October 10 by the Western Electric Company and United Air Lines. Claimed to be the first successful altimeter showing terrain clearance, the new device operates by radio, using the shortest wave ever employed for aviation purposes, officials of the companies stated.

Following additional service tests, which are planned for the near future, the new altimeter will be installed on all United planes and will be made available to the industry generally.

The principle employed in the present device is the result of research work done in Bell Telephone Laboratories. Basically it involves the transmission of a radio signal from the airplane, the reception of the signal as reflected from the earth, the measurement of the elapsed time between the transmission and the reception, and the translation of this time interval into a direct reading of the plane's altitude in feet as shown on a meter. Due to its use of an ultra-high frequency the new altimeter is entirely free from static interference.

In addition to the regular meter, the device may also be equipped with a red signal light which will automatically flash a warning when the plane descends below a safe predetermined altitude.

Extended flight tests of the new development are being made over regular airways by engineers of Bell Telephone Laboratories in a special Boeing twin-engined airliner assigned by United for service testing.



## Prestige

The Blackstone  
is world-famous  
as an address of  
distinction in  
Chicago. Here  
graceful living  
is enjoyed by  
the discrimi-  
nating traveler.

*"Where Elegance  
Is Not Extravagance"*

A. S. KIRKEBY,  
Managing Director

**The Blackstone**  
MICHIGAN AVENUE · CHICAGO

### WHEN YOU CHANGE YOUR ADDRESS

Be sure to notify the Subscription Department of COMMUNICATIONS at 19 E. Forty-seventh St., New York City, giving the old as well as the new address, and do this at least four weeks in advance. The Post Office Department does not forward magazines unless you pay additional postage, and we cannot duplicate copies mailed to the old address. We ask your cooperation.

## D'ARSONVAL REPRODUCER

(Continued from page 19)

tional to the mass of the winding. With a winding weighing .060 gram, an output level of approximately -40 db is given.

The force constant was measured by fastening a fine thread to the apex of the stylus and a small cylindrical mirror to the side of the cone. A line filament lamp and a scale were placed at conjugate foci of the cylindrical mirror. Weights were hung on the thread and the deflections measured. From these data the force constant in dyne centimeters per radian and in dynes per centimeter at needle point were measured. The natural frequency of the system was measured by passing a constant current through the moving coil and measuring voltage across the terminals of the moving coil as the frequency was varied. At resonance, a maximum in voltage is noted. Using these data (force constant and natural frequency) the moment of inertia and the effective mass at the needle point were computed.

The tone arm design was the result of considerable experimentation and argument. The first experimental model had a horizontal hinge just back of the pickup head. Using this system, both counterweights and spring suspension were tried. Finally an arm which had pivots located near the center of the distance between the needle and the vertical axis was used. This system with a spring suspension proved to be the most satisfactory. One objection to this system was the lack of enough freedom to permit sufficient vertical movement of the arm in placing it on, or removing it from, the record. This difficulty was overcome by placing another horizontal pivot near the vertical axis to permit further mobility. This pivot does not function when the needle is on the record.

Optical tests made on the records indicate certain deviations which were evident in the measurements made with the pickup. Nothing in any of the tests made, indicated the presence of any deviation from a uniform flat response in the pickup.

It is quite probable that no change in the response, over the audio range, would result if the mass of the system were increased by a factor of at least five, but record wear would increase as the force on the sides of the groove is proportional to the effective mass of the system. It is possible to build a less massive unit that will require still less force. This unit would be more costly, more delicate and have less output. The pickup described here is a compromise between these factors and seems to be a practical solution of the problem.

## SIMPLIFY 33 1-3 RPM RECORDING WITH THE PRESTO AUTOMATIC EQUALIZER



When you use the new Presto automatic equalizer you can start cutting a 15 minute transcription then forget about it until the end of the program. The equalizer automatically takes care of the frequency response from beginning to end and at the same time holds your audio level absolutely constant.

The equalizer moves with the cutting head carriage. It is always in position to give you a flat response to 6,000 cycles or better, wherever you start cutting.

With the automatic equalizer you can make excellent 33 $\frac{1}{3}$  RPM recordings on the economical 8-inch and 10-inch discs . . . almost impossible with manually operated equalizers.

*A Presto technical representative will give you a demonstration of this new equalizer at your station. He will attach it to your Presto recorder in ten minutes without disturbing your present equipment in any way. Let him show you this amazing new improvement. There is no obligation whatsoever.*

**PRESTO RECORDING CORPORATION, 145 W. 19th ST., NEW YORK CITY**



### Frequency Measuring Service

Many stations find this exact measuring service of great value for routine observation of transmitter performance and for accurately calibrating their own monitors.



**MEASUREMENTS WHEN YOU NEED THEM MOST**

*at any hour every day in the year*

**R.C.A. COMMUNICATIONS, Inc.**

*Commercial Dept.*

**A RADIO CORPORATION OF AMERICA SERVICE**

**66 BROAD STREET**

**NEW YORK, N. Y.**



# THE MARKET PLACE

NEW PRODUCTS FOR THE COMMUNICATIONS FIELD

## PARASITIC SUPPRESSOR

A new type of parasitic suppressor is shown in the accompanying illustration. It is known as the Model 507-622. Complete details on this suppressor are contained in circular 507. Write to *Ward Leonard Electric Company*, Mount Vernon, N. Y.—COMMUNICATIONS.

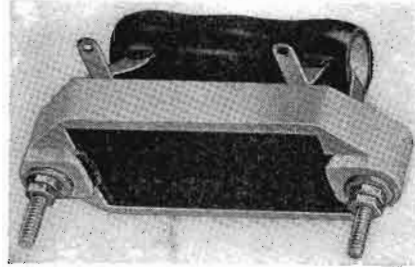

Ward Leonard parasitic suppressor.

## CORNELL-DUBILIER CAPACITOR

Announcement has been made by Cornell-Dubilier of the introduction of the TQ series of transmitting capacitors. Hermetically sealed in round drawn aluminum containers, these capacitors are impregnated and filled with non-explosive and non-inflammable Dykanol. The TQ series are available in ratings from 1 mfd, 600 v. to 2 mfd, 2000 v. d-c. Complete details appear in catalog No. 161 now available from *Cornell-Dubilier Electric Corp.*, South Plainfield, N. J.—COMMUNICATIONS.

Cornell-Dubilier capacitors.

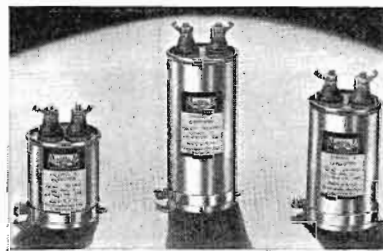

## SOUND EFFECTS UNIT

Gates has announced a sound effects equipment consisting of a special design cabinet with motor board containing three motors and four special designed pickups. Complete fading, touch type switch and motor control and the use of a 30-watt amplifier with 15-inch speaker is said to assure good operation as to tone or volume obtainable.

The first unit of this series was installed in the new St. Louis radio station KXOK under the supervision of Fred Grimwood, consulting engineer for that station, and the KXOK dramatic department.

Full information can be had on this unit by writing *Gates Radio & Supply Co.*, Quincy, Illinois.—COMMUNICATIONS.

## A-F RELAY

A sensitive audio-frequency relay has been announced by Sigma. The response of this new instrument to weak electrical impulses is said to render it especially useful as the pickup device for a remote-controlled circuit. It is also adaptable, by microphone connection, to alarm systems, counters, and sound-actuated controls. Sigma audio frequency relays are available in two types: the AF-1, with adjustable magnetic shunt for control of sensitivity; and the AF-2, with variable hairspring for sensitivity adjustment. The sensitivity ranges are the same for both types.—*Sigma Instruments, Inc.*, 388 Trapelo Road, Belmont, Mass.—COMMUNICATIONS.

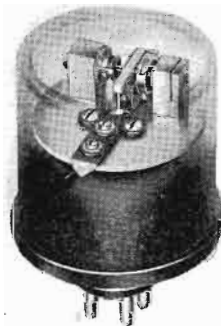

Sigma relay.

## RCA-813.



## N. U. VIDEOTRON

National Union has announced the addition of a 9" Videotron television picture tube to its present line of television tube types. The new Videotron has been assigned type number 2109. It is an electromagnetic deflection type with 9" medium persistence screen.

Features of the tube include a ceramic mounted gun, supported by mica springs to lessen possibility of knocking it off center, double getter flashing for high-vacuum and long life, fine trace for 441-line definition, a specially processed fluorescent screen which is said to produce black and white pictures with forty degrees of light contrast, high brilliance and no defocusing at extremes of sweep. *National Union Radio Corporation*, 57 State St., Newark, N. J.—COMMUNICATIONS.

## CUTTING NEEDLE

A new Walco Sapphire cutting needle has been announced to the recording industry. These needles are said to be absolutely uniform . . . dimensions guaranteed to 1/10,000 of an inch. Complete information may be secured from *Electrovox Company*, 424 Madison Avenue, New York City.—COMMUNICATIONS.

## RCA TUBES

In the accompanying illustration is shown a new transmitting beam power amplifier designated as RCA-813. Designed according to principles involving the use of directed electron beams, the 813 has high-power sensitivity and is capable of giving 260 watts output in typical Class C telegraph service. Full power output can be obtained at frequencies as high as 30 megacycles. This tube is said to make an excellent power amplifier for the final stage of high-power amateur transmitters in which quick band change without neutralizing adjustments is often desired. It is also said to be an excellent high-power frequency multiplier capable of giving high harmonic output with unusually high efficiency.

Also announced by RCA are six new octal-glass tube types as follows: RCA-1A5-G, power amplifier pentode; RCA-1A7-G, pentagrid converter; RCA-1C7-G, power amplifier pentode; RCA-1H5-G, diode high-mu triode; RCA-1N5-G, r-f amplifier pentode; RCA-6W7-G, triple-grid detector amplifier. The first five of these tubes are intended for use in low-drain, battery-operated receivers; the filaments of these tubes are designed so that they may be operated satisfactorily when connected directly across a 1.5-volt dry battery. The sixth tube is of the 6.3-volt, 0.150-ampere heater type and is intended for use with other tubes having the same heater rating in power-line-operated receivers.

Additional information on all these tubes may be secured from *RCA Radiotron Division, RCA Manufacturing Co., Inc.*, Harrison, N. J.—COMMUNICATIONS.

## WAX BLANKS

Universal Microphone has started to manufacture and distribute wax blanks packed in special cases for shipment. They are used to record originals for masters to produce pressings. They will be made in 13½ and 17-inch diameter sizes, weighing 11 and 7 pounds respectively. Universal's booklet, "Practical Wax Recording," contains full instructions. Write to *Universal Microphone Co.*, Inglewood, Calif.—COMMUNICATIONS.



The heart of the 280 tube  
**WILBUR B. DRIVER CO.**  
 NEWARK, NEW JERSEY

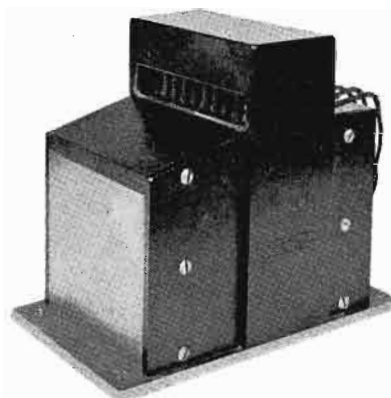

CUSTOM BUILT  
**MULTIPLE GALVANOMETERS**  
 FOR  
**OSCILLOGRAPHS**

High sensitivity, D'Arsonval type, electrically damped by permanent magnets in frequencies up to 500 cps. Higher frequencies are oil damped. Can be supplied with ANY number of elements. Elements are individually removable. Each element carries an optically precise aluminized mirror of the correct curvature to focus at the distance specified by the customer. These galvanometers are extremely compact. The illustration shows a ten element 100 cycle galvanometer which is only 3 inches wide and weighs but 7½ pounds.

GALVANOMETERS                      DESIGNING AND  
 GEOPHYSICAL APPARATUS          DEVELOPING OF  
 VIBRATION RECORDERS          SCIENTIFIC INSTRUMENTS

**WILLIAM MILLER**  
 PASADENA

11 STATE STREET                      PASADENA, CALIF.

**A COMPLETE LINE  
 OF PRECISION  
 QUARTZ CRYSTALS  
 HOLDERS and OVENS  
 20 KC. TO 30 MC.**

*Write for Catalog G-10*

**BLILEY ELECTRIC COMPANY**  
 UNION STATION BUILDING                      ERIE, PA.

**AMPEREX  
 CARBON ANODE  
 TRANSMITTING TUBES**

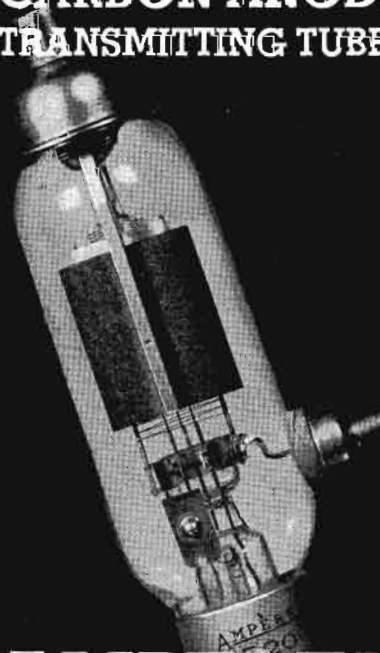

**AMPEREX**  
 ELECTRONIC PRODUCTS, Inc.  
 79 WASHINGTON ST., BROOKLYN, N. Y.

### POLICE-RADIO EQUIPMENT

A new line of low-priced, ultra-high-frequency transmitters and receivers has been announced by the General Electric. The new units are a 25-watt station transmitter, a 15-watt mobile transmitter, a superheterodyne station receiver, and a superheterodyne mobile receiver. They are for use in the 30- to 42-megacycle band by police departments, power companies, transit companies, and other services. Further information may be secured from the *General Electric Co.*, Schenectady, N. Y.—COMMUNICATIONS.

### SOLAR CONDENSER

In the accompanying illustration is shown Solar's new type of dual unit which is said to have extended the utility of the Minicap dry electrolytic capacitor to practically all commonly used values. Complete literature descriptive of Minicap and other Solar products may be had upon request. Write to *Solar Mfg. Corp.*, 599 Broadway, New York City.—COMMUNICATIONS.

### TATTELITES

"Tattelite" pocket-size testers can be used for locating live or open circuits, blown fuses, defective condensers and resistors, tell whether current is a-c or d-c, indicate grounded lines, and approximate voltage. Tattelites utilize a small neon bulb, which glows on only 1/10,000 ampere current. It is housed in an injection molded Tenite case with a limiting resistor in series. Test tips are insulated to prevent shorts in testing. To secure further information write to *Littelfuse Laboratories, Inc.*, 4238 Lincoln Ave., Chicago, Ill.—COMMUNICATIONS.

### PHOTOELECTRIC CONTROL

Model 50 photoelectric relay complete with light source is a general-purpose control suitable for many photoelectric applications. It operates only on 110-volt 60-cycle a-c current. The internal telephone type relay contacts s-p-d-t carries a load of 2 amperes, 110-volt, 60-cycle a-c non-inductive. Model 50 requires a minimum of three F. C. on the photocell.

The control has one RCA 6J5 amplifier tube and one UCC photocell 1105. The light source included with the equipment is furnished with a 32 c. p. automobile type bulb and will operate the control at a distance of twenty-five feet.

The Model 50 photoelectric relay is a product of *United Cinephone Corporation*, 43-37 33rd St., at Queens Blvd., Long Island City, N. Y.—COMMUNICATIONS.

### United Cinephone control.

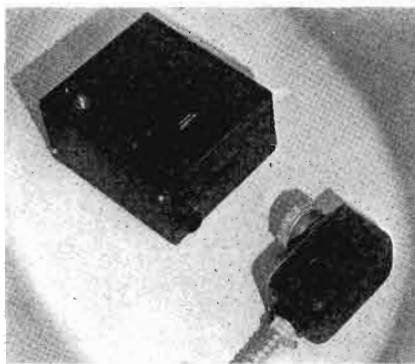

Right: IRC resistor.



Below: Solar condensers.

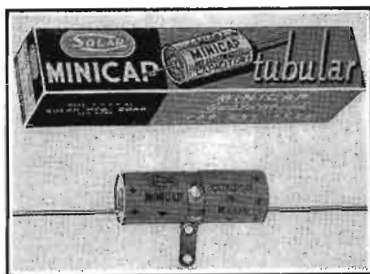

### ULTRA-HIGH-FREQUENCY RESISTORS

Excellent characteristics at ultra-high frequencies of 75 megacycles and up are said to be obtained in the newly developed IRC Type MP high-frequency power resistors through an adaptation of the IRC metallized coating applied to a ceramic tube. These new resistors are suited for transmitter dummy loads and rhombic antenna terminations. Also, due to their non-inductive characteristic, they are said to operate effectively as part of the measuring circuit in high-voltage surge generators and other devices providing steep wave fronts.

A new IRC Resistance Engineering Data Folder, No. 2, describing these new high frequency power resistors, as well as other IRC "Metallized" resistors types, will gladly be sent on request to the manufacturers, *International Resistance Company*, 401 North Broad Street, Philadelphia, Pa.—COMMUNICATIONS.

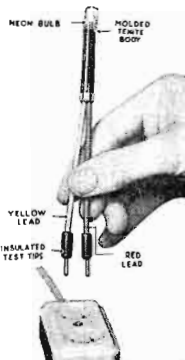

Above: Littelfuse tattelite.

Below: Radio City multi-tester.



Above: Jardur watch

Below: Lafayette amplifier.



### MULTI-PURPOSE WATCH

The watch shown in the accompanying illustration has been designed to serve a number of uses and should be of interest to broadcast engineers, announcers, program directors, and others. It is a 15-jewel unit with a non-magnetic Swiss movement. It may be used as a regular wrist watch, a stop watch, a time-out watch, telemeter, and tachometer. Literature is available from *Jardur Import Co.*, 21 West 19 St., New York City.—COMMUNICATIONS.

### A-C/D-C MULTIMETER

The new a-c/dc multi-tester, shown in the accompanying illustration, is equivalent to 22 different instruments, it is said. The meter, Model 444, has a 3 1/2-inch D'Arsonval movement accurate within 2%, and a large multicolored dial scale. The four a-c voltmeter ranges up to 1,000 volts are suited for measuring output, filament, line and power-transformer voltages. The four ohmmeter ranges go up to 1/2 megohm and to as low as .01 ohm. At 1,000 ohms per volt, four d-c voltages ranges cover up to 1,000 volts. Four decibel readings range from minus 12 to plus 54 db. The three current ranges are 1, 10 and 100 milliamperes.

This instrument is manufactured by *Radio City Products Company*, 88 Park Place, New York City.—COMMUNICATIONS.

### LAFAYETTE SOUND SYSTEMS

Over 50 coordinated sound systems and 40 amplifiers are included in the 1939 line of Lafayette sound equipment just announced by Wholesale Radio. For a number of years the Lafayette line has been expanding until now it includes amplifiers and coordinated systems to meet every sound reinforcement requirement from a compact 5-watt restaurant order unit to complete theatre and stadium sound systems adequate to provide coverage of up to 100,000 people.

Readers may have gratis the complete 188-page catalog by writing to *Wholesale Radio Service Co., Inc.*, at 100 Sixth Avenue, New York City.—COMMUNICATIONS.

## EVERYTHING IN RADIO!

### A COMPLETE SOURCE FOR YOUR RADIO NEEDS!

Our immense stock of radio sets, parts and supplies enables you to purchase your entire needs on one order. The big BA catalog is an encyclopedia of the Radio Industry. You will find all your Nationally Known Favorites shown in this book and it's **Free** for the asking. BA service is better than ever—practically every order shipped the day received.

Write for Big New Wholesale Catalog

**BURSTEIN-APPLEBEE CO.** 1012-14 MCGEE STREET  
KANSAS CITY, MISSOURI



## "TOPS" FOR RADIO WORK

Gardiner Rosin-Core Solder is outstanding for high tensile strength, consistent performance and economy. Quick acting flux of pure water white rosin—no solvent added—permits faster, cleaner work by expert or amateur. Costs less than even ordinary solders because produced by modern methods and equipment of our own development. Gardiner Solders are available in various alloys and core sizes and in gauges as small as 1/32 of an inch. 1, 5 and 20-lb. spools.

Eastern Sales Office and Warehouse

DAVID M. KASSON & CO., 401 Broadway, New York



## CHAS. EISLER'S EQUIPMENT HAS PRODUCED MILLIONS

Including electric spot welders up to 250 KVA, butt, and arc welders, got in touch with us. Write for our "college and glass working laboratory units" catalog.

### EISLER ENGINEERING CO.

750 S. 13th STREET (Near Avon Ave.)

NEWARK, N. J.

FOREMOST IN THE ELECTRONICS FIELD FOR OVER 20 YEARS! Charles Eisler's equipment for the production of radio and electronic tubes, incandescent lamps, X-Ray and cathode ray tubes, mercury switches, photo-electric cells, and neon signs has met the severest demands of industry in operating at maximum production and minimum cost. If you are in the market for any of the above or allied equipment

## PIEZO Electric Crystals Exclusively

Quality crystals for all practical frequencies supplied SINCE 1925. Prices quoted upon receipt of your specifications.

Our Pledge: QUALITY FIRST

### SCIENTIFIC RADIO SERVICE

UNIVERSITY PARK

HYATTSVILLE, MD.

Radio Equipment... for BROADCAST STATIONS -- LABORATORIES -- ENGINEERS  
Call or write.

We Carry at all times a most complete line of PUBLIC ADDRESS EQUIPMENT  
80 Cortlandt Street, New York, N. Y.



BARclay 7-0622 — Cable Address: TERMRADIO

## BROADCAST ENGINEERS

Let us help you out the next time you want some needed Radio Parts, Tubes, Meters, Racks, Panels, Chassis, etc. . . . IN A HURRY! Engineers and laboratory technicians know that SUN DELIVERS! Phone, Write or Wire!

### SUN RADIO COMPANY

212 FULTON ST. Dept. C-9 NEW YORK, N. Y.

## Academic Standards ENGINEERING Accredited Curricula

Newton Accredited Engineering (parallels college curricula) aims to provide thorough training in the basic scientific principles of engineering. Specifically designed for high school graduates seeking professional engineering (Radio, Electrical, Civil, Mechanical) careers. Cultural subjects serve to broaden the student's perspective and develop his capacity for dealing with economic problems of engineering. University faculty—formal instruction based upon standard college texts. Credits transferable to colleges. Graduate courses include higher mathematics and advanced physics. Bulletin sent upon request. Newton Institute of Applied Science, 2021-Y Raymond-Commerce Building, Newark, New Jersey.

HOME STUDY ON THE COLLEGE LEVEL

## VALPEY Frequency control units

AMATEUR—COMMERCIAL—SPECIAL APPLICATIONS

Write for our new catalogue

### THE VALPEY CRYSTALS

Box 321

Holliston, Mass.

## I. R. E. CONVENTION—ROCHESTER—NOV. 14-15-16

Your customers and prospects—engineers and executives—will all be on hand. Greet them with your sales message in the "big" carefully read

**NOVEMBER**  
Convention Issue

## COMMUNICATIONS

Advertising Forms Close November 2nd





*gives you*  
**HIGH OR LOW PITCH**  
 WITH THE SAME MICROPHONE

With the flip of a finger you can now (1) lower or raise the response of the microphone. . . (2) adjust the microphone for most desirable response for close talking or distant pickup. . . (3) adjust the system to any "taste", room condition, or equipment.

MODELS RBHk, RBMk, with Acoustic Compensator, frequency range 40 to 11000 cps, output, -65 db., complete with switch, cable connector and 25' of cable. . . . \$42.00 LIST

**NEW! MODEL RSHk (hi-imp); RBSk (200 ohms) Frequency range 60 to 8000 C.P.S. Output -68db. . . . Chrome or Gun-metal . . . . \$32.00 LIST**

**NEW LOW PRICE CONTACT "MIKE"**  
 ModelSKH (hi-imp); SKL (200ohms) \$12.00 LIST

MODELS RAH-RAL, excellent for speech and music. Reduce feedback. . . . \$22.00 LIST

Write for Complete Illustrated Bulletins and Valuable Sales Helps.

**AMPERITE Co.** 561 BROADWAY, N. Y.  
 Cable Address: Alkem, New York

**AMPERITE** Velocity **MICROPHONE**

**FINE WIRE, RIBBON, FOIL**

OF  
 "CLOSER-THAN-COMMERCIAL"  
 TOLERANCES

★  
 Obtainable in  
 Pt, Au, Ag, Ni, Cu, Fe, Al,  
 or any special alloys

★  
 BARE WIRES drawn to .0006" diameter  
 RIBBON rolled to less than .0001" thick  
 FOIL rolled to less than .0005" thick

★  
**FILAMENT WIRE  
 AND RIBBON**

CLOSE SCIENTIFIC CONTROL OF CHEMICAL COMPOSITION AND PHYSICAL CHARACTERISTICS. High purity; exact size, weight and elongation; high tensile strength; accurate torsional properties, resistance and temperature co-efficient of resistance.

★  
 Specialists in Precise Control of specifications for difficult alloys for:

- FILAMENTS
- GALVANOMETER SUSPENSIONS
- RESISTANCE and FUSE WIRES

**SIGMUND COHN**

44 GOLD ST. NEW YORK  
 SINCE 1901

**Advertising Index**

A	
Aerovox Corp. . . . .	6
Amperex Electronic Products, Inc. . . . .	37
Amperite Co. . . . .	40
Astatic Microphone Laboratory, Inc. . . . .	34
B	
Biiley Electric Co. . . . .	37
Burstein-Applebee Co. . . . .	39
C	
Callite Products Division. . . . .	26
Clarostat Mfg. Co., Inc. . . . .	25
Cohn, Sigmund . . . . .	40
Collins Radio Co. . . . .	1
D	
Driver Co., Wilbur B. . . . .	37
E	
Eisler Engineering Co. . . . .	39
Electrovox Co. . . . .	26
G	
Gardiner Metal Co. . . . .	39
Gates Radio & Supply Co. . . . .	31
General Radio Co. . . . . Inside Back Cover	
Guardian Electric Co. . . . .	30
I	
Ideal Commutator Dresser Co. . . . .	34
J	
Jones, Howard B. . . . .	33
L	
Lansing Mfg. Co. . . . .	27
Lapp Insulator Co., Inc. . . . .	5
Lingo & Son, Inc., John E. . . . .	28
Littelfuse, Inc. . . . .	28
M	
Miller, William . . . . .	37
N	
Newton Inst. of Applied Science. . . . .	39
O	
Ohmite Mfg. Co. . . . .	33
P	
Presto Recording Corp. . . . .	35
R	
R. C. A. Communications, Inc. . . . .	35
RCA Mfg. Co., Inc. . . . . Back Cover	
Radiotone, Inc. . . . .	40
Recoton Corp. . . . .	28
S	
Scientific Radio Service. . . . .	39
Solar Mfg. Corp. . . . . Second Cover	
Sun Radio Co. . . . .	39
T	
Terminal Radio Corp. . . . .	39
U	
United Transformer Corp. . . . .	29
V	
Valpey Crystals, The. . . . .	39
W	
Western Electric . . . . .	3
Z	
Zophar Mills, Inc. . . . .	40

**STUDIO QUALITY IN A PORTABLE RECORDER**



Recording technicians are amazed at the perfect studio quality of work produced on the RADIO-TONE PR-16 Portable Recorder. This 16-inch, dual-speed Recorder has numerous features that make it most flexible as well as giving it most faithful reproduction. Write today for facts.

**Radiotone Inc**  
 7356 Melrose Ave., Hollywood, Cal.  
 620 N. Michigan Ave., Chicago, Ill.

**Waxes  
 Compounds  
 Varnishes**

FOR INSULATION  
 OF CONDENSERS

Transformers, coils, power packs, pot heads, sockets, wiring devices, wet and dry batteries, etc. Also WAX SATURATORS for braided wire and tape. WAXES for radio parts. Compounds made to your own specifications if you prefer.

● **ZOPHAR  
 MILLS, INC.**

Founded 1846  
 120-26th Street  
 Brooklyn, N. Y.





# VARIACS

*for* A-C VOLTAGE CONTROL

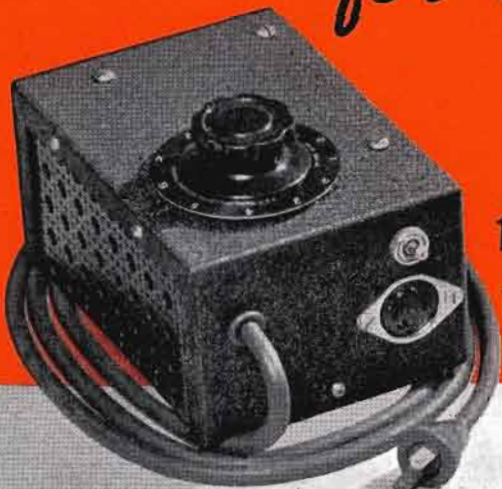

- ★ SMOOTHNESS OF A RHEOSTAT
  - ★ EFFICIENCY OF A TRANSFORMER
  - ★ OUTPUT VOLTAGES ABOVE LINE
- 18 MODELS ..... 860 WATTS TO 2 KW

WRITE FOR NEW BULLETIN 312

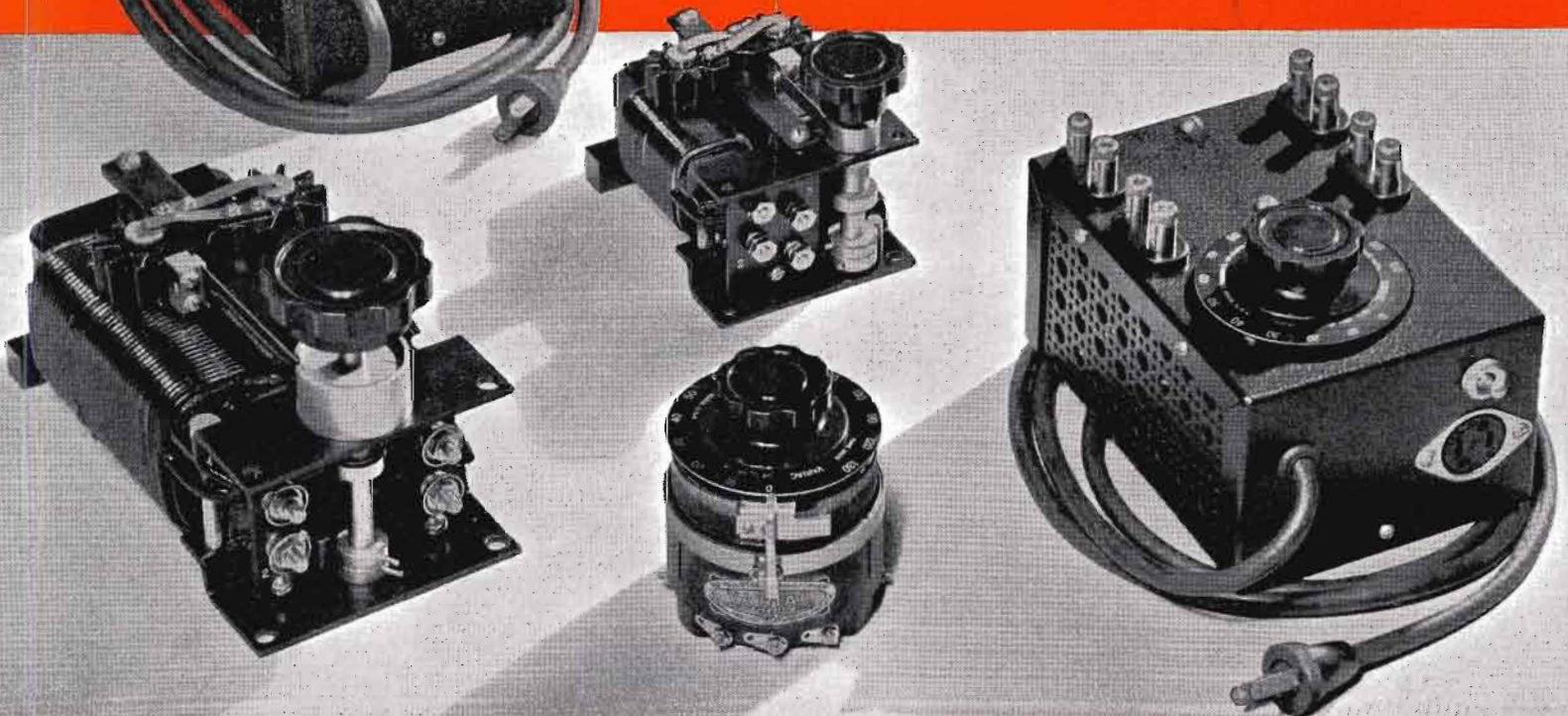

**GENERAL RADIO COMPANY**

**CAMBRIDGE  
MASSACHUSETTS**



# New RCA 5-DX Transmitter

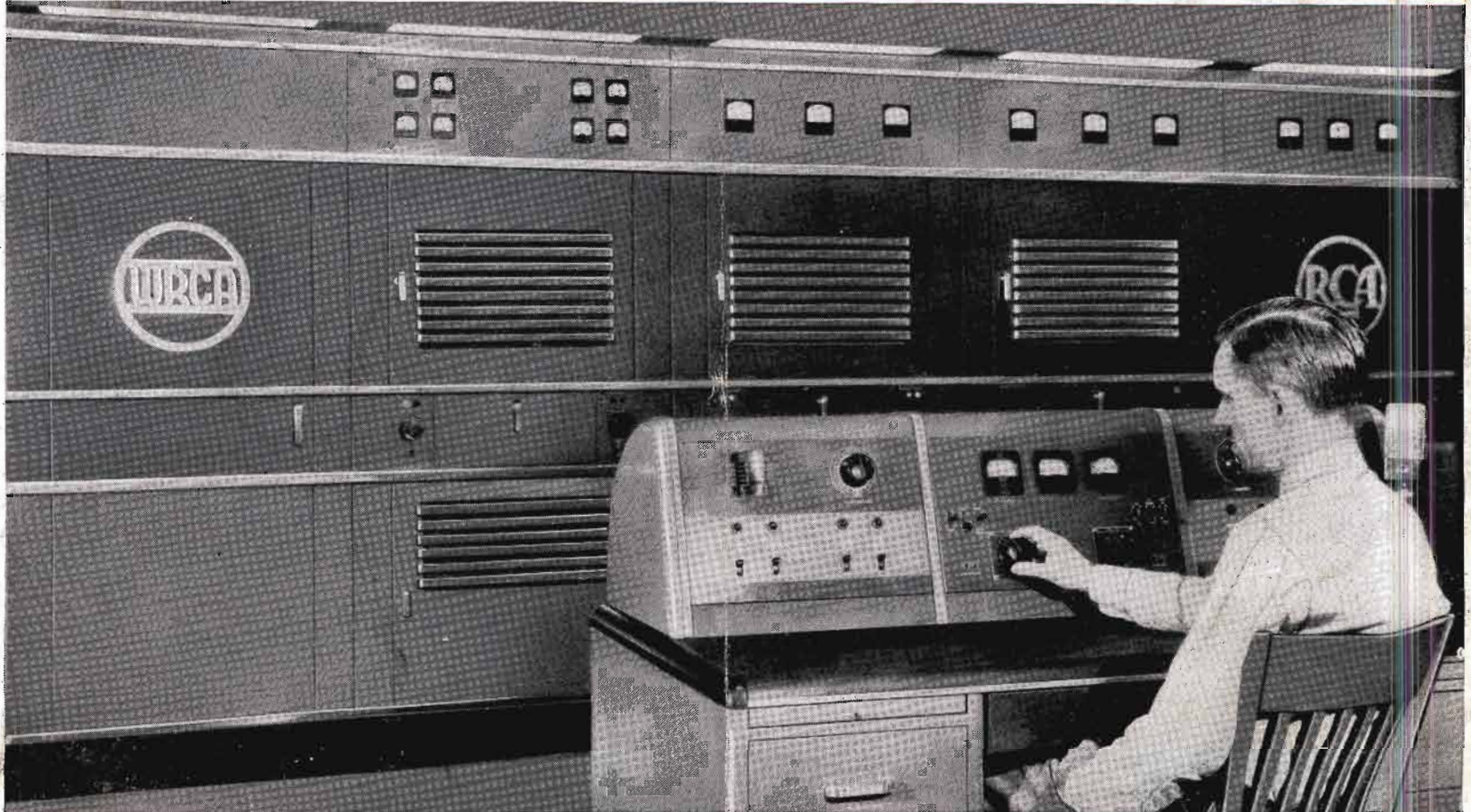

**Offers a  
New Standard  
of Value!**

*Here's Proof!*

5-DX, a new version of RCA's famous 5-D Transmitter with new operating conveniences:  
**Finger-tip Control      Smart, Modern Styling      Unified Front Panel Enclosure**

Plus the features which have won such wide acceptance among the broadcasters:  
**Lowest Operating Cost      No Water Cooling of Tubes      Simple Circuit—Easy to Adjust**  
**Vertical Chassis Construction      Complete Reliability      High Fidelity Transmission**

**T**RULY the 5-DX equipment represents a new standard of value in transmitters. This apparatus is the familiar RCA 5-D equipped with a new Unified Front Panel and Operating Console—containing all of the features which have made the 5-D so popular, plus new conveniences and additional terminal equipment. Write to the nearest office for highlights on the 5-DX.

Use RCA Radio Tubes in your station—for finer performance

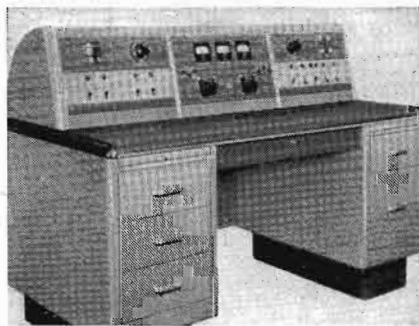

The 5-DX Operating Console—smart, streamlined—contains V1 and monitoring amplifier, controls for transmitter and speech input equipment.

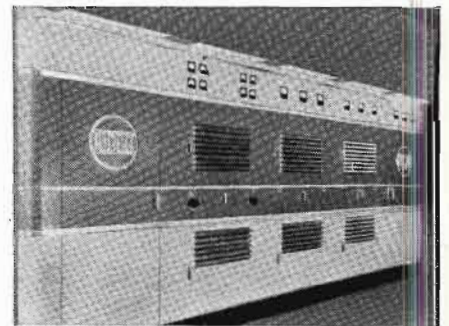

Modern Unified Front Panel of the 5-DX makes installation much easier. It is also an economy factor in designing your transmitter house.



*Broadcast Equipment*

RCA MANUFACTURING CO., INC., CAMDEN, N. J. • A Service of the Radio Corporation of America

New York: 1270 Sixth Ave. • Chicago: 589 E. Illinois St. • Atlanta: 490 Peachtree St., N. E. • Dallas: Santa Fe Building • San Francisco: 170 Ninth St. • Hollywood: 1016 N. Sycamore Ave.