

COMMUNICATIONS

**THE 20th ANNIVERSARY
OF WGY**

**NEW METHODS OF
PROGRAM SWITCHING**

**REVIEW OF IRE PAPERS
AT 1942 NEW YORK CITY
CONVENTION**

**JANUARY
1942**



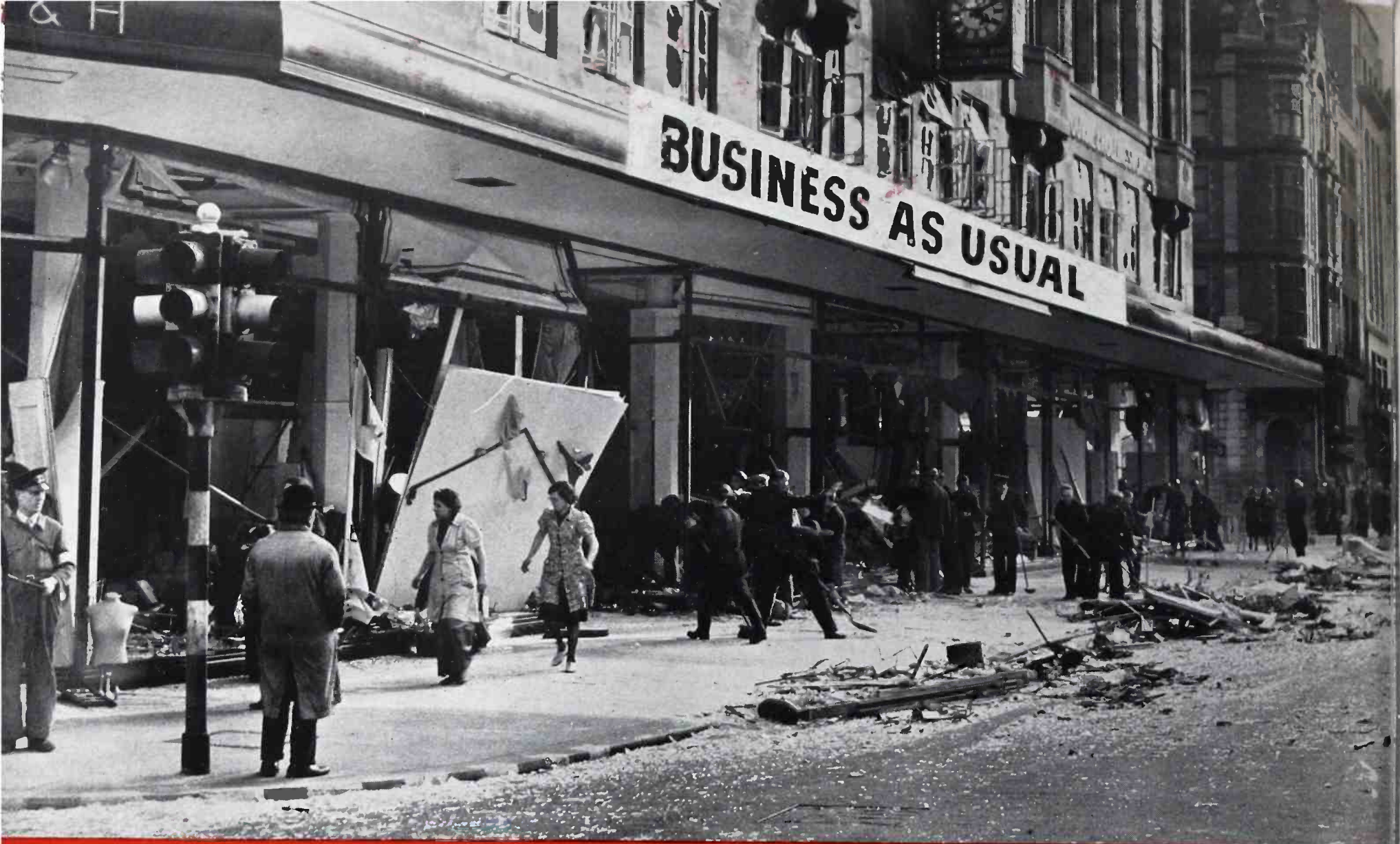

In a world at war



BUSINESS AS USUAL? . . . Hardly! We'd say that it's a "topsy-turvy" business, at best.

Unprecedented requirements for our military services . . . as well as for the armies and navies of our allies . . . have transformed our normal surpluses into acute shortages.

However, despite many severe curtailments, our regular clients have not been unduly inconvenienced, and every possible effort is being made to continue serving them.

You can help us expedite such deliveries by scheduling your requirements for the future, NOW . . . and by forwarding priorities extension certificates, whenever these are available.

AMPEREX ELECTRONIC PRODUCTS

79 WASHINGTON STREET

BROOKLYN, NEW YORK



SAFEGUARDING THE COMMUNICATIONS OF NATIONAL DEFENSE

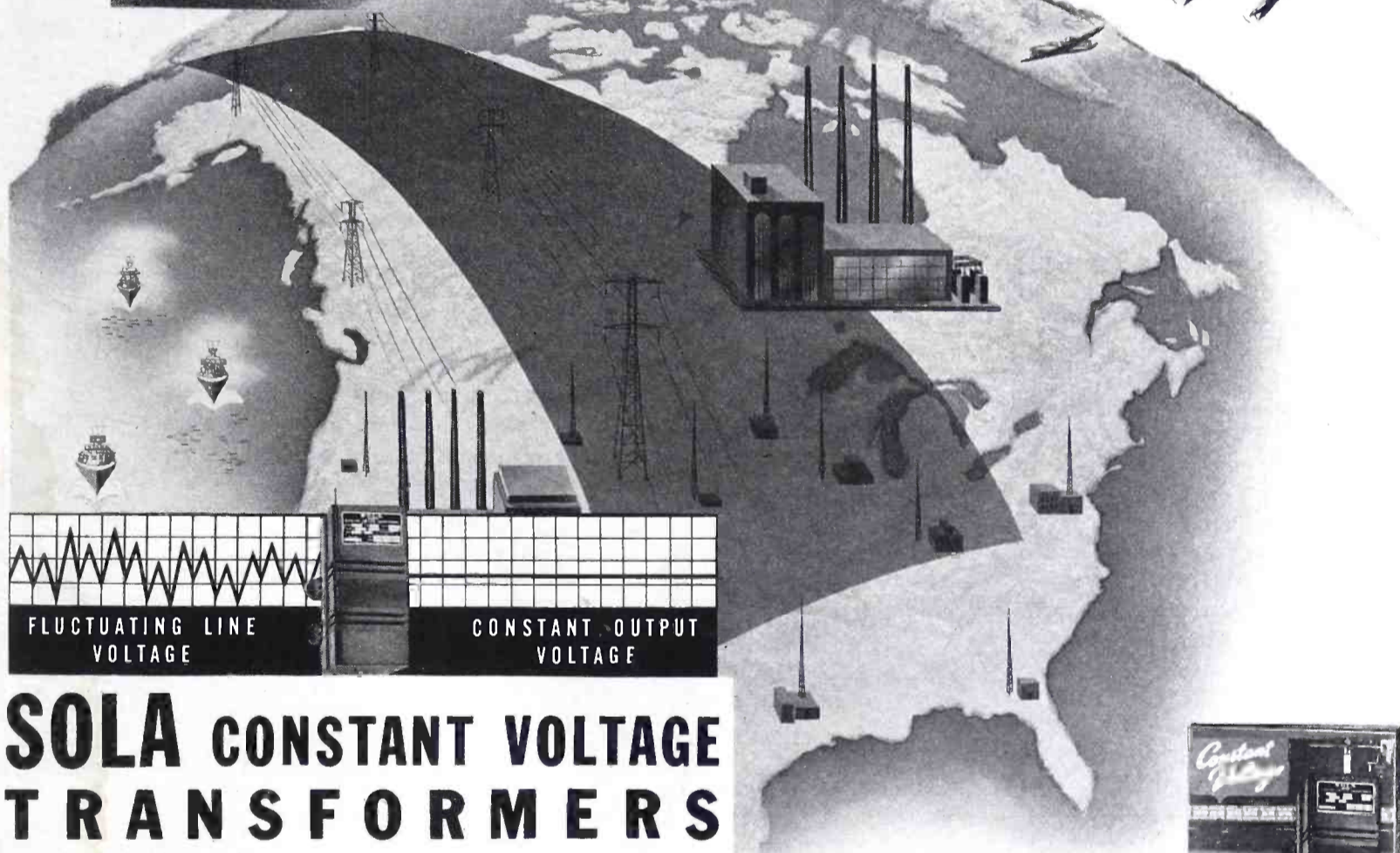

SOLA CONSTANT VOLTAGE TRANSFORMERS

Radio communication in all its phases needs the protection of constant voltage to—

- 1—insure dependable operation under emergency conditions.
- 2—protect vital equipment against damage by line surges.
- 3—eliminate the necessity of constant supervision.

The enormous demands placed on power stations by the national defense program are already making the maintenance of stable line voltages an overwhelming problem. Success or failure of a communications system may depend upon protection against line surges, or abnormal voltage levels.

Manufacturers of defense communication equipment can provide protection against these contingencies by building CONSTANT VOLTAGE into their products.

Sola CONSTANT VOLTAGE TRANSFORMERS will deliver a perfectly stabilized output voltage, even though line voltages vary as much as 30%. No moving parts. Instantaneous in action. Self-protecting against overload or short circuit.



Sola CV TRANSFORMERS are already at work in the national defense programs of the—
ARMY • NAVY • AIR CORPS
COAST GUARD and C.A.A.

SOLA ELECTRIC COMPANY, 2525 Clybourn Ave., Chicago, Ill.

COMMUNICATIONS

Including Television Engineering, Radio Engineering, Communication & Broadcast Engineering, The Broadcast Engineer. Registered U.S. Patent Office.
Member of Audit Bureau of Circulations.

JANUARY, 1942

VOLUME 22 NUMBER 1

We See...

WAR AND THE BITING program that must go with it, has come. And along has come, too, that hoodwinker "rumor." In the past weeks, we have seen and heard a fury of "tall tales" that unfortunately were not taken too lightly by many. There is no doubt that official orders are being issued rapidly, and that in this war effort, we will be forced to forego many "as usual" plans. But it is folly to gage your important activities on the mere say-so of rumor mongers. Some of these "carriers" may not mean harm; some may be deliberate. Be safe and sure and follow official instructions . . . instructions that may come from your broadcast associations, engineering societies, Government bodies themselves, or *reliable* newspapers or magazines.

"NO PRIORITIES ON CREATIVE ENGINEERING" was the title of an interesting Westinghouse advertisement we saw recently . . . an advertisement that spoke of stoves and refrigerators, but may have just as well referred to all of us . . . to 130,000,000 Americans. Now, more than ever before, with all the human endurance we can muster, we must create and develop. If a shortage occurs, we cannot, we must not stop. Alternates must be whipped into action . . . alternates which in many instances have already proven superior. If equipment breaks down and complete new equipment is not available, wailing will not help. Get individual parts that are available to assist in making the repair. If the exact duplicates are not available, you can always make suitable circuit corrections to justify an alternate installation.—L. W.

COVER ILLUSTRATION

Inspection of quartz crystal, before a strong arc light, in the newest GE crystal laboratory. In this test, needles, fractures, etc., are discovered. Later inspections include x-ray orientation of crystal face to assure low temperature drift, and uniform thicknesses within 0.00002 in. and flat within 0.0000001 in., so that they may be used as frequency resonators as well as oscillators.

TRANSMITTER DEVELOPMENT

Broadcast-Program Switching and Preselection P. B. Murphy	5
WGY Celebrates Its 20th Year	8

RECEIVER DESIGN AND APPLICATION

Design Data on A-C/D-C Battery Portables James J. Adams	11
---	----

ENGINEERING CONVENTION RESUME

A Report on the 1942 I R E Convention Lewis Winner	
Two Course Radio Range with Sector Identification	14
Color Television	15
A Stabilized F-M System	16
Loop Antennas for Aircraft	16
A Wide Range, Linear, Unambiguous Electronic Phasemeter	21
Vacuum Tubes As Variable Impedance Elements	21
500 MC Automatic Relay Systems	29
An Interference Analysis	29
Signal-to-Noise Analysis	32
Crystal Controlled Oscillator	32

MATERIALS AND THEIR APPLICATIONS

Plastic Properties Elliott Marshall	20
---	----

MONTHLY FEATURES

The Industry Offers	18
Veteran Wireless Operators Association News	22
News Briefs of the Month	24
Book Reviews	30
Advertising Index	36

Published Monthly by the Bryan Davis Publishing Co., Inc.

BRYAN S. DAVIS, President

PAUL S. WEIL, Advertising Director

F. WALEN, Secretary

A. GOEBEL, Circulation Manager

Advertising and Editorial offices, 19 East 47th Street, New York City, Telephone PLaza 3-0483. Chicago office, 608 South Dearborn Street, Chicago, Ill., Telephone Wabash 1903. Wellington, New Zealand, Te Aro Book Department. Melbourne, Australia, McGill's Agency. Entire Contents Copyright 1942, Bryan Davis Publishing Co., Inc. Entered as second-class matter October 1, 1937, at the Post Office at New York, N. Y., under the act of March 3, 1879. Yearly subscription rate: \$2.00 in the United States and Canada, \$3.00 in foreign countries. Single copies; twenty-five cents in United States and Canada, thirty-five cents in foreign countries.

INSULATION HIGHLIGHTS

PROGRESSIVE ENGINEERING characterizes the design of Columbia Broadcasting System's new 50 KW shortwave stations, WCBX and WCRC, at Brentwood, L. I., soon to be placed in operation. Facilities of the stations are planned for efficient shortwave transmission of programs to Latin America and Europe. Because of present-day conditions, improved reception in these parts of the world of programs from the United States is considered essential.

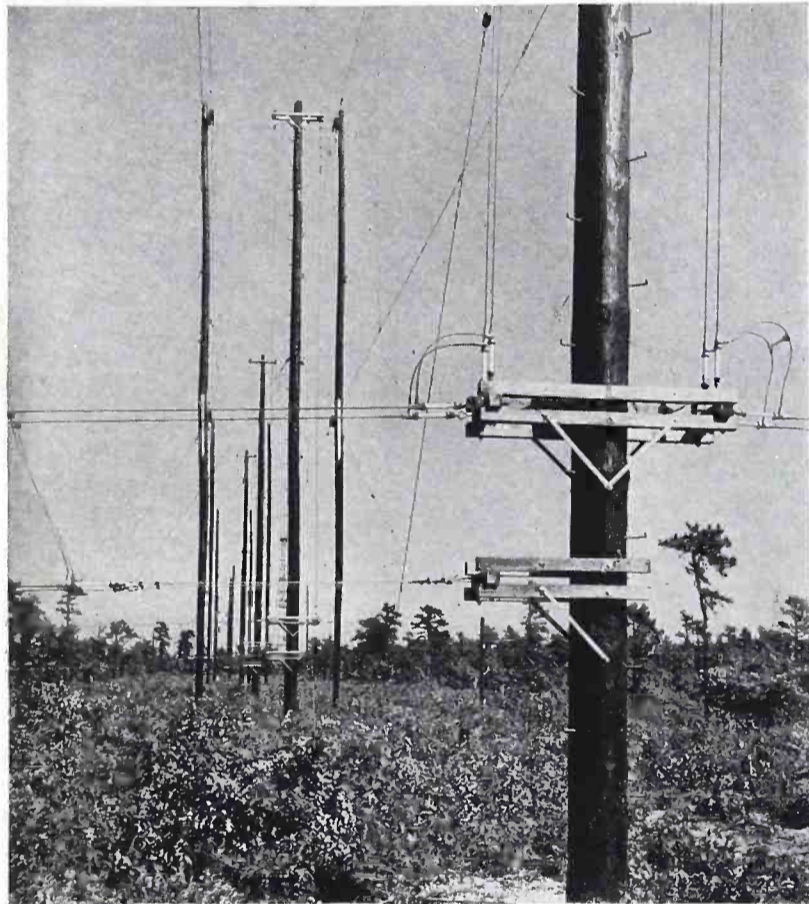

(Above) 13 DIRECTIONAL ANTENNAS are provided at the new stations, and several of them are of the four-section type shown here. Isolantite* strain insulators are extensively used in the construction of these antennas. These insulators find wide application in the radio and communications fields, because of their high mechanical strength and electrical efficiency.

**Registered trade-name for the products of Isolantite Inc.*

ISOLANTITE

CERAMIC INSULATORS

ISOLANTITE INC. FACTORY: BELLEVILLE, NEW JERSEY
SALES OFFICE: 233 BROADWAY, NEW YORK, N. Y.

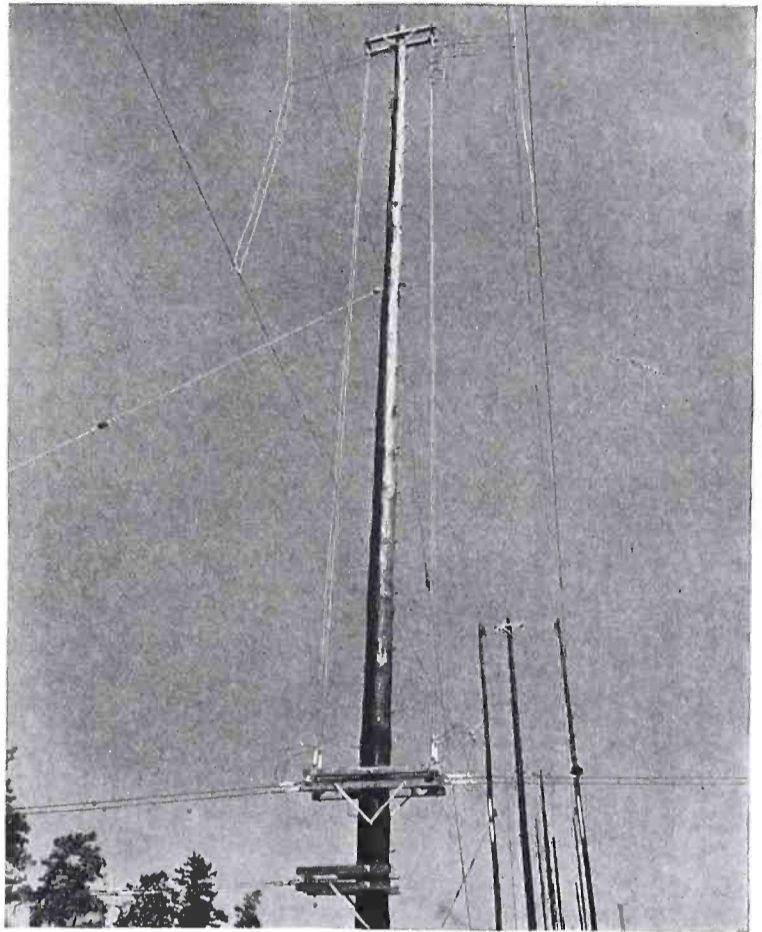

(Above) CONSTRUCTION DETAILS of the antennas are shown here. Horizontal wires at left near base of pole provide means for tuning the antennas through the medium of variable line shunts.

(Below) ISOLANTITE STRAIN INSULATORS are used also on lead-in wires from antennas to the building which houses the transmitting equipment built by Federal Telegraph Company. Transmitters can be quickly switched from one antenna to another, to maintain most efficient transmission at different times of day.

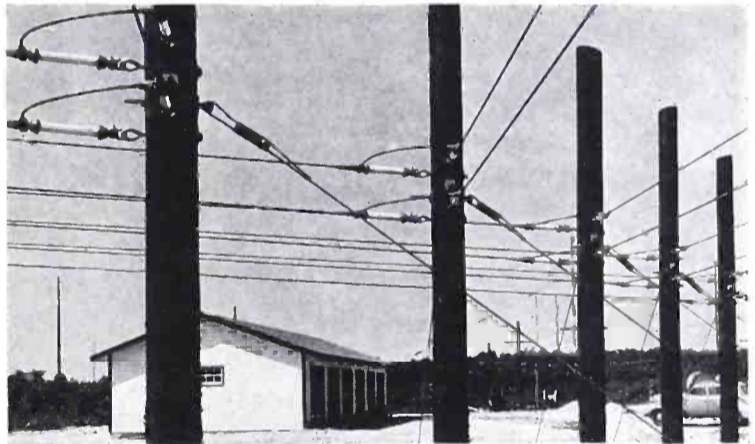

(Below) SPECIAL FITTINGS used on Isolantite strain and other types of Isolantite insulators at the new stations were designed and tested by engineers of Mackay Radio and Telegraph Company and the Columbia Broadcasting System. These fittings were manufactured by Burndy Engineering Company.

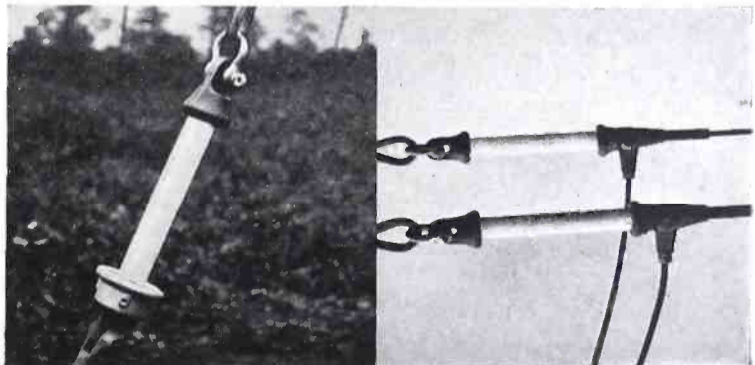



You Can Put Your Finger On Parts Like These At Your Mallory Distributor

Mallory makes it easy for you to get essential electronic parts . . . the ones you need for:

- Test or experimental work in your engineering department, research laboratories, pilot plants or proving grounds.
- Replacements in plant equipment.
- Efficient operation of some device you plan to put into production.

Distributors carefully selected by Mallory—253 of them—are ready to serve you promptly. These conveniently located Mallory Distributors keep adequate warehouse stocks. Their representatives

are well trained and able to help solve your problems. Want a rectifier? Condenser? Resistor? Switch? Electronic hardware? Your Mallory Distributor is the man to see.

For handy reference, you'll want the Mallory catalog . . . perhaps several copies for members of your organization. This catalog gives terse, factual information on Mallory parts used in the aeronautical, automotive, electrical, geophysical, radio and other industries. Use this catalog as your buying guide . . . depend on your Mallory Distributor as your supplier . . . for your industrial electronic needs.



Write today for free catalog covering entire line of Mallory Approved Precision Products.

P. R. MALLORY & CO. Inc.
MALLORY

P. R. MALLORY & CO., Inc.
INDIANAPOLIS INDIANA
Cable Address—PELMALLO

COMMUNICATIONS

LEWIS WINNER, Editor

Broadcast-Program

SWITCHING AND PRESELECTION

by P. B. MURPHY

Switching Development Department
Bell Telephone Laboratories

SINCE the days when the only thing in the way of a broadcast network was a single telephone line connecting a microphone to a radio transmitter, the Bell System has steadily improved and extended the circuits and added many new facilities to take care of the growing needs of the radio broadcasting industry. With the rapid expansion of the program networks, provisions for rearranging circuits at switching points have been in particular the subject of almost continuous study and development. As long as the number of switches at any one point was small, the attendant could listen for cues indicating the end of a program, and then operate the proper keys or change connections with patching cords. As the number of possible switches increased, however, the probability of errors increased, and various switching equipments were provided to meet the requirements at particular points. During this period the situation was being studied to determine whether

Figure 1
The switching panels with the new units for rapid and effective program control, that is now in use in the NBC station at Omaha, Nebraska. The cue panel shown at the right contains a control unit for each intersection and multiple, and is equipped with "white" lamps of the system.

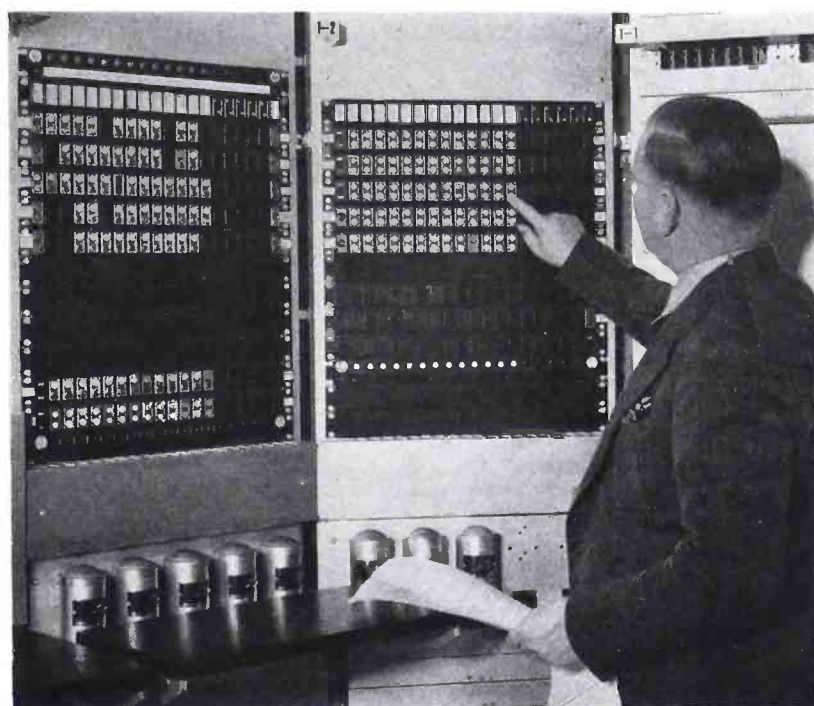

a switching system could be designed that would take care of all existing as well as probable future requirements. As a result, a system has been designed and tested both in the laboratory and in commercial installations, that seems to meet all existing requirements, and to be capable of expansion without fundamental change to meet all the future requirements that can be fore-

seen at the present time.

At any major switching point there will be a number of program circuits. Some of these will be lines to local broadcasting stations, and the others will be program trunks running over various toll routes in all directions. For each program, certain of these lines and trunks will be connected together as part of some "network." There are a number of such networks; some of them cover the entire country, and others may be less extensive in scope. At any one time all stations associated with any one network are broadcasting the same program, but the network is not a permanent structure. For the next program it may include a different set of stations. The basic problem of program switching thus consists in the rearrangements for each program of all trunks and lines at each switching point into the desired network. For purposes of visualization the situation could be represented by a rectangular lattice with each vertical line representing a program line or trunk, and each horizontal line representing a par-

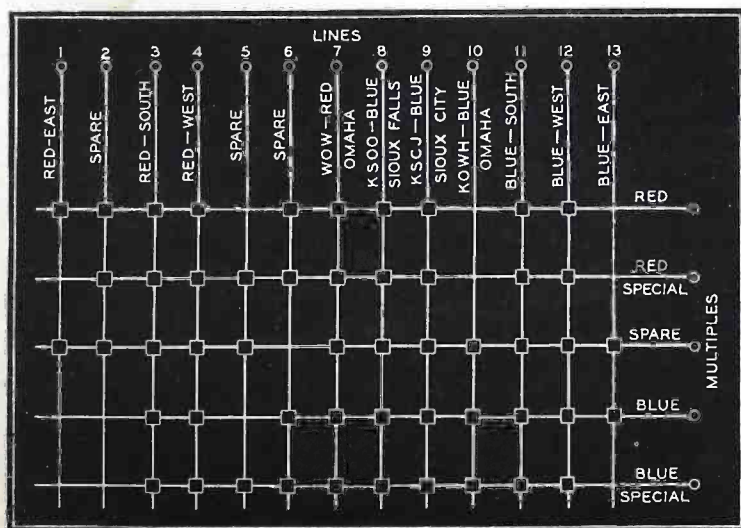

Figure 2
The network of the Omaha switching arrangement. Each intersection of vertical and horizontal line represents a point where switching may be done. In this installation, only those sections shown in the rectangles are now equipped.

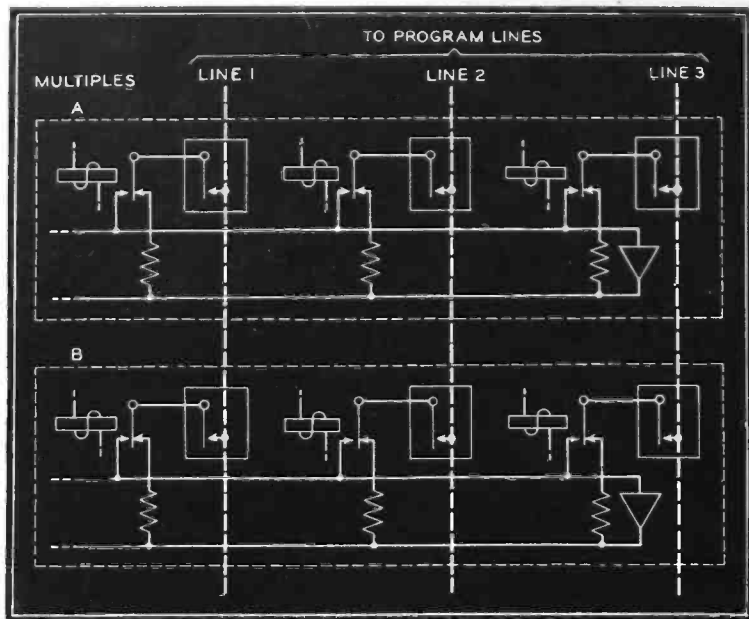

Figure 3
How the actual switching is completed is shown here in detail. In this installation, "G" type bridges and 14C amplifiers are used.

ticular network, which for each program will connect certain of the lines together.

Such a lattice for the National Broadcasting Company at Omaha, where the first installation of the new switching unit was made, is shown on Figure 2. Each intersection of vertical and horizontal line represents a point where switching may be done, but for this particular installation, only those intersections included in a small rectangle are actually equipped.

The actual switching accomplished at each intersection is indicated in greater detail in Figure 3. The horizontal grouping circuits are called "multiples." Several types have been used in the past, but the one shown is that using "G" type bridges and 14C amplifiers. Each line in these multiples is arranged on a reversible basis to the amplifier bridge circuit so that it may be connected to the input of the amplifier and serve as a program source, or to one of the bridge legs to receive a program from another point. This control of direction of transmission has already been described,* and is entirely independent of the changes made in the connection of lines to networks at the various switching points.

Since one of the objectives of this development was to reduce operating error by relieving the attendant of the necessity of performing a large number of operations in the few seconds between programs, it was desirable to secure some form of preselection. It should be possible, in other words, to set up the connections desired for each program period during the preceding period, when there would be plenty of time to recheck carefully all the preselections made so as to avoid the possibility of error. These preselection switches, of course, would not actually reconnect the program circuits, but

would merely set up paths through relays so that the switch could be made at the desired moment by a simple push-button operation. The method adopted employs a preselection key at the positions corresponding to the small rectangles of Figures 2 and 3, with white and red lamps associated with each key; a white light would indicate that a preselection had been made, and a red light, that the actual switch had been consummated.

To serve as this preselection key, the unit shown in Figure 6 was developed. It is called the 36A control unit, and in its front section houses a white and a red lamp. This front block is mounted between guides, within which it is free to move, although normally held in the forward position by springs. When it is pressed in, a spring contact is closed, and this contact is used to set up the preselection path. These control units are mounted on a panel in the form of a rectangular lattice like Figure 2, each vertical column corresponding to a program circuit and each horizontal row to a multiple. The panel used by the National Broadcasting Company at Omaha is shown at the left of the photograph (Figure 1).

Associated with each of these units is a circuit shown in simplified form in Figure 4. When the control unit is pressed in, contact C is closed. This operates relay A, lights the white lamp, and establishes a path to the L relay, which will make the actual switch when the proper time comes. There are a number of other relays associated with this circuit, but their arrangement is not essential to an understanding of the main operating procedure.

At some place in the office where these control panels are located are monitors, who listen to the various programs to make sure that the circuits are all operating correctly. There is one of these monitors for each network, and since it is the monitors that hear the cues indicating the end of the programs, it is desirable to have them operate the keys that make the various switching changes. Each monitor has a cue key, and when he operates this key, all the switching changes pertaining to his network that have been set up on the preselection panel will be made.

The end of a program does not necessarily mean that switching changes are to be made, however. Frequently a particular set of stations may be grouped together for a number of periods. Also, all the programs may not end at exactly the same time, and the complex arrangements between program circuits and networks frequently require that certain programs have preference with respect to certain lines. A certain line associated with multiple "A," for example, may be scheduled to be changed to multiple "B" at the end of the period. Three possible preferences may exist, however. It may be desired to hold this line associated with the A network until its program has ended, even though the new program on the B network starts before this. As a second possibility, it may be desired to change the line to multiple B as soon as the new program begins, even though the program on the A multiple has not

Figure 4
A simplified circuit diagram of a circuit associated with the control unit that further facilitates the consistency of operation.

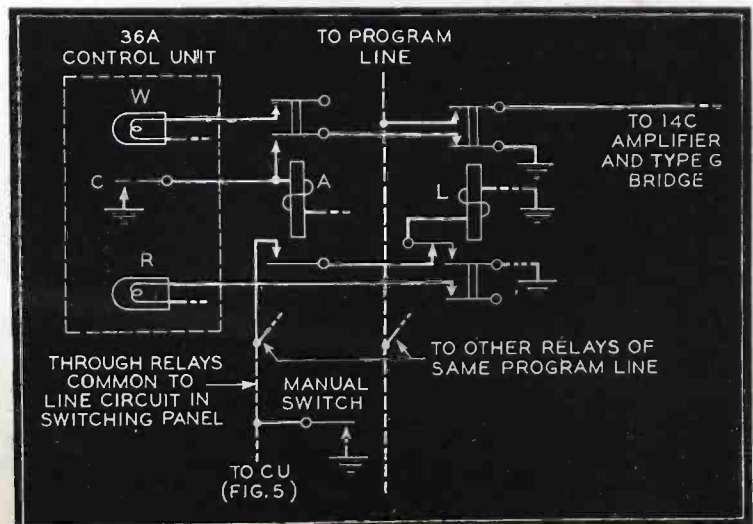

*Record No. 2269—Bachelet.

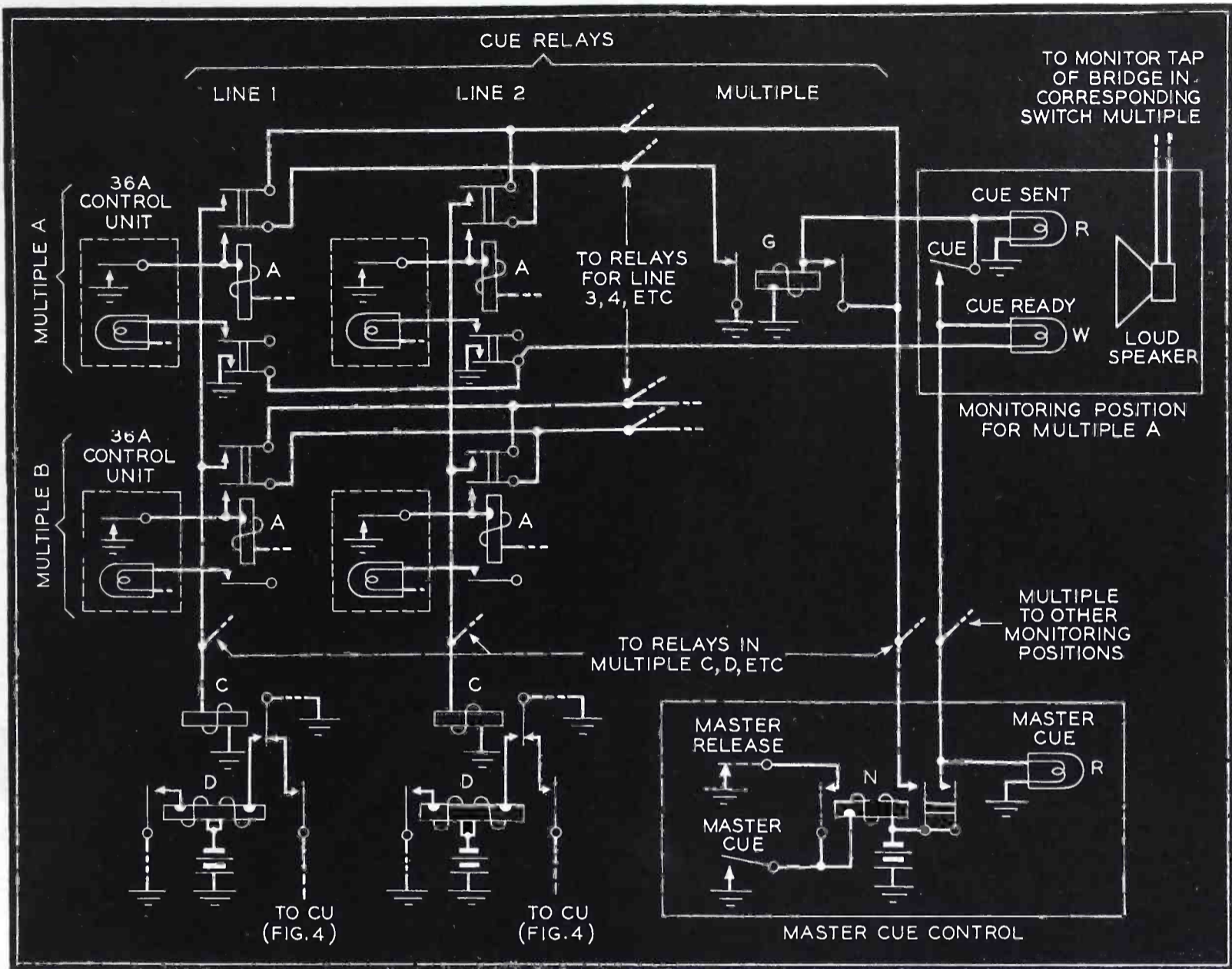

Figure 5
The circuits that are associated with the cue and monitor panels.

ended. The third possibility is a combination of both of these; it may be desired to hold the line associated with the A network at least until its program has ended, and then to connect it to the B network, but not until the new program on the B network is ready to begin. To permit control of such situations, which are often very important at the large switching points, a "cue" control panel is also provided. This panel likewise uses the 36A control units, and in appearance is very similar to the preselection panel. The cue panel at Omaha is shown at the right in Figure 1.

On the cue panel there is a 36A control unit for each intersection of line and multiple as on the preselection panel, but these control units are equipped with white lamps only. After the attendant has set up all his preselections and carefully checked them with his schedule, he goes to the cue panel and presses the control units there for all the controlling cues. Assume, for example, that program line 1, now as-

sociated with multiple A, is to be connected to multiple B at the end of the period, but that the connection is to be held on multiple A until that program is completed regardless of whether the new program on multiple B has begun or not. On the preselection panel the control unit at the intersection of line 1

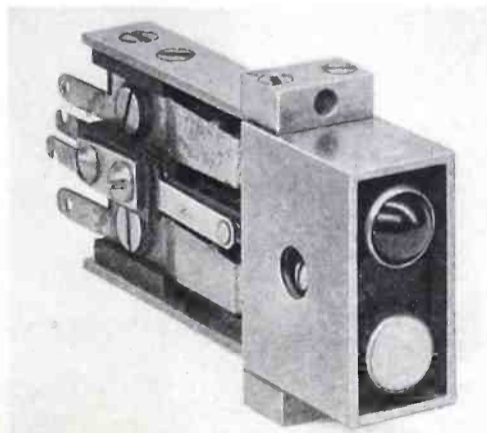
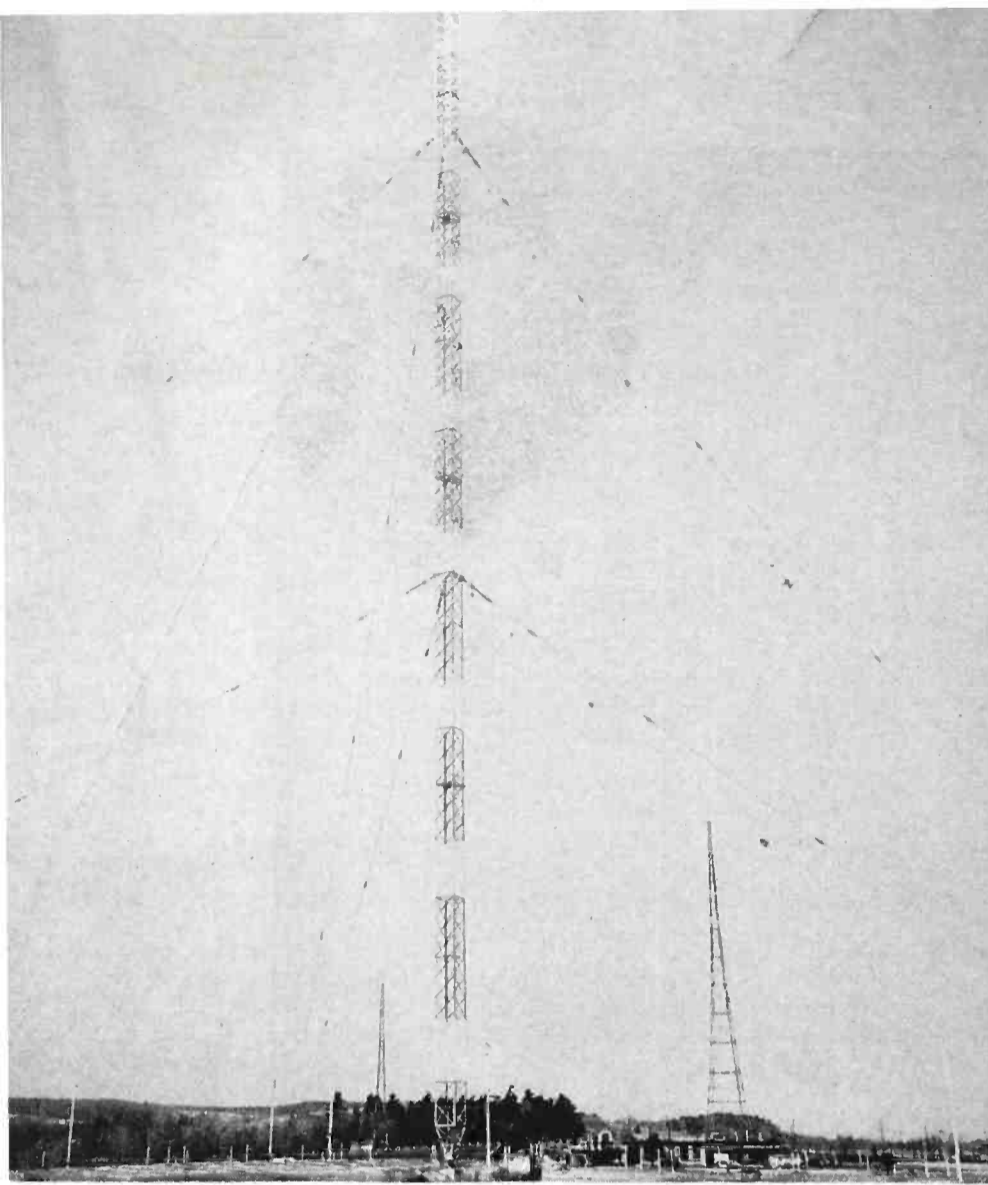

Figure 6
The key unit used in preselection of program switches.

and multiple B has been operated, but on the cue panel, the attendant will press the cue lamp at the intersection of line 1 and multiple A. This will set up circuits that will not change the connection of line 1 until the program on multiple A is completed.

The circuits associated with the cue panel are shown in simplified form in Figure 5. The pressing of a control unit operates an A relay and lights a white lamp as on the preselection panel. After all the required control units have been operated, the attendant will compare the lighted lamps with his instruction sheet to make sure everything is correct, but nothing further will be done until shortly before the end of the program period. He then presses a master cue key. This operates the N relay, which lights a red master cue lamp at the cue panel and white cue lamps at the monitor positions of multiples that have white lamps lighted at the cue panel. It also operates a "C" relay for each line that has a lighted

(Continued on page 32)



Latest 625 vertical radiator antenna. Older antenna supporting tower in background.



One of the pairs of towers for WGY's first transmitter in 1922.

WGY CELEBRATES ITS 20TH YEAR

[On Monday February 20th, WGY celebrates its 20th year on the air. During this span of years, a wealth of WGY-GE engineering developments, that made and are still making broadcasting history, were introduced. A few of those

outstanding contributions that have played an important role in this epochal achievement, are recorded on these pages.]

February 20, 1922. First program,

7:45 p.m., Monday.

October 13, 1922, first broadcast of Pallaphotophone record.

January, 1922, first use anywhere of

World's first 200 kw transmitter at WGY. The six tubes shown at right are forerunners to the GL-862.

The first application of a water cooled tube, in 1922 transmitter, a forerunner to GL-207.

Dr. W. R. G. Baker at 1922 WGY transmitter, as transmitter engineer. Today he is vice-president.

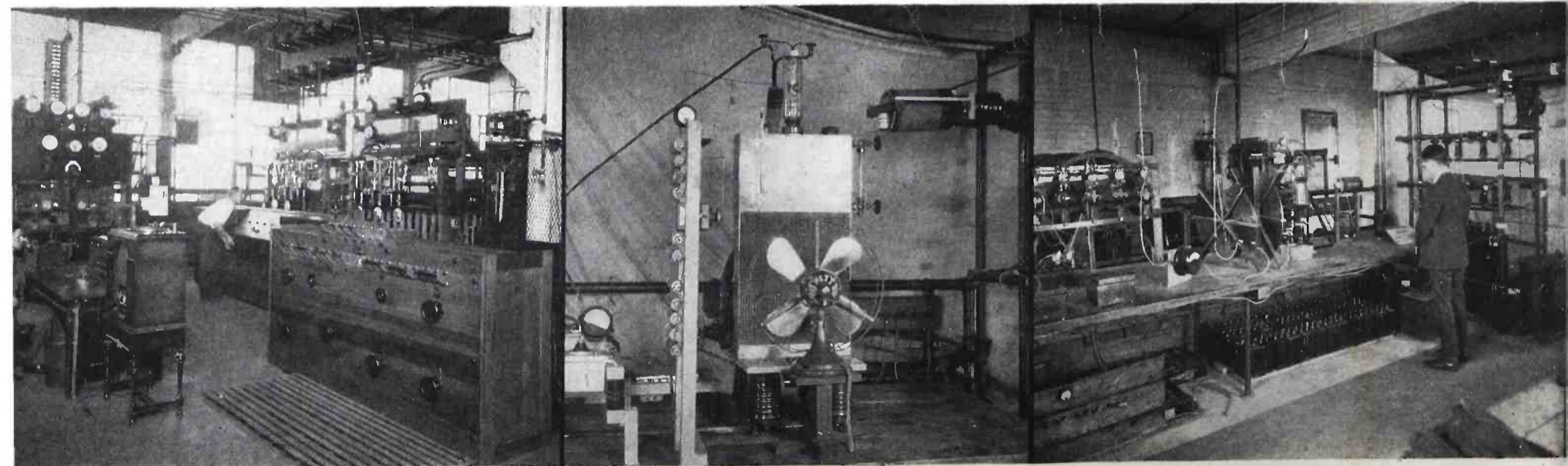

metal, water-cooled modulator tube.

August 7, 1923, first use anywhere of condenser microphone.

October 21, 1923, first use of portable, short wave low power transmitter to relay church service three miles to WGY control room.

July 26, 1925, first transmission using 50,000 watts in the antenna.

September 19, 1925, first use of crystal control on broadcast transmitter for regular program service.

May 25, 1925, description from air via short wave transmitter in U. S. Army planes of Gar Wood's motor boat race down the Hudson River, New York.

November 22, 1925, first program of New York State network, originated by WGY in association with stations in Buffalo, Rochester, and Syracuse. First program originated in Syracuse.

August 4, 1927, first use of so-called super-power of 100,000 watts in the antenna.

February 21, 1928, WGY broadcast the first two-way communication with England in a working arrangement between the BBC and GE engineers.

May 10, 1928, WGY adopted its first television schedule, transmitting at late hours.

August 22, 1928, WGY broadcast the first remote television pickup. Television cameras erected in the Assembly Chamber in Albany picked up action of Governor Alfred E. Smith during address accepting the Democratic Presidential nomination.

September 11, 1928, WGY established another television first, with the first broadcast of a televised play... Somerset Maugham's "The Queen's Messenger." The voice on this broadcast was carried by way of WGY and the picture signals were carried via W2XAF. Three cameras were used, one for each actor and a third for props (only two actors appeared in the play).

In the WGY laboratory, Dr. Irving Langmuir (left), inventor of the high vacuum tube, and Dr. William D. Coolidge (right), director of the GE research laboratory, discussing electronics with Professor J. J. Thomson, the English physicist, who discovered the electron. It was through the efforts of these outstanding scientists that we have many of the vital methods used so successfully in broadcasting today. Dr. Coolidge's research in x-ray tube design and its attendant phenomena brought him worldwide fame. Dr. Langmuir's tube developments established standards of design and practice that today are considered legion in schools and industry as well.



Dr. Charles P. Steinmetz broadcasting from one of the radio studios of WGY in March, 1922. This was one of the rare appearances of Dr. Steinmetz before a microphone. Acknowledged universally as one of the immortals of science, Dr. Steinmetz devoted his life to a variety of studies. Among his contributions were the solution of perplexing high voltage problems in electrical transmission, analyses of behavior of transient electrical currents, etc.



October 21, 1928, first broadcast anywhere of two-way communication with Sydney, Australia.

November 2, 1928, three way talks between Schenectady, Sydney and Bandoeng, Java carried on WGY.

March 9, 1930, first broadcast using 200 kilowatts in the antenna.

June 30, 1930, first broadcast of voice transmission around the world. W2XAD sent signal to Huizen, Holland, which was retransmitted to Ban-

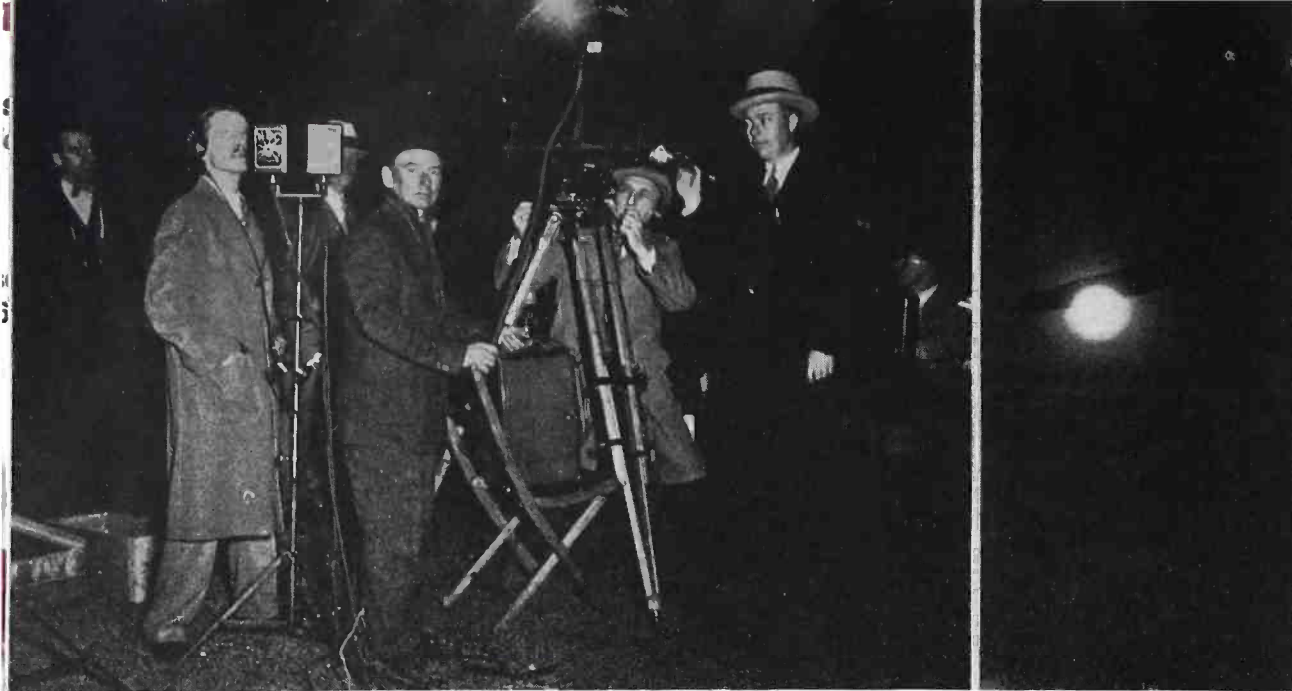

Equipment on roof of GE laboratory, for receiving light beam from U.S.N. dirigible Los Angeles flying over Schenectady, that placed WGY's 1932 transmitter on the air.

doeng, Java and again retransmitted to Sydney, Australia and finally picked up in Schenectady.

February 18, 1930, television signal transmitted by W2XAF to Sydney and retransmitted there and picked up on return.

March 11, 1930, WGY initiated for NBC networks two way communication, between the then Commander Richard E. Byrd, Russel Owen and others at Dunedin, New Zealand, and Adolph Ochs, publisher of the New York Times; Martin Rice of General Electric and Mr. Sulzberger, also of the Times.

May 19, 1932, new WGY transmitter put into service by a whistle blown aboard the U. S. dirigible Los Angeles, flying over Schenectady. The whistle signal produced by Chester H. Lang, broadcasting manager of GE, was carried over a beam of light, which hit a target at the top of the IGE building. The signal operated a relay which took the old transmitter off the air and put the new one on.

1932, WGY became an NBC affiliate as a managed and operated station of NBC. This affiliation existed until 1940, when GE resumed operation and management.

1938, new building was opened to house new WGY studios and FM studios. Old WGY building now houses international station studios of WGEO and WGEA.

Developments during past years . . . have covered a wide variety of apparatus, tubes and instruments for

high and ultra high frequencies, television and frequency modulation. At

present, there are transmissions in both aural and visual channels and on ultra high, high, and broadcast bands on transmitters that have been developed in WGY land.

In 1941 WGEO, international transmitter at Schenectady, was granted the use of the greatest power output to a single antenna of any high-frequency broadcast station in the United States . . . 100 kw.

A special tube, GL-880, was developed to facilitate operation at these high frequencies and large outputs. Two of the tubes in push-pull develop an output of 50 kw at such frequencies, an output which is more efficient than that previously obtained with parallel operation of previous tubes.

An early WGY broadcast originating in the library of Thomas Alva Edison, with (left to right) John W. Lieb, president of the New York Edison Company; E. W. Rice, former president of GE; Thomas Edison; George Morrison, GE vice-president, and Gerard Swope, president of GE at that time.

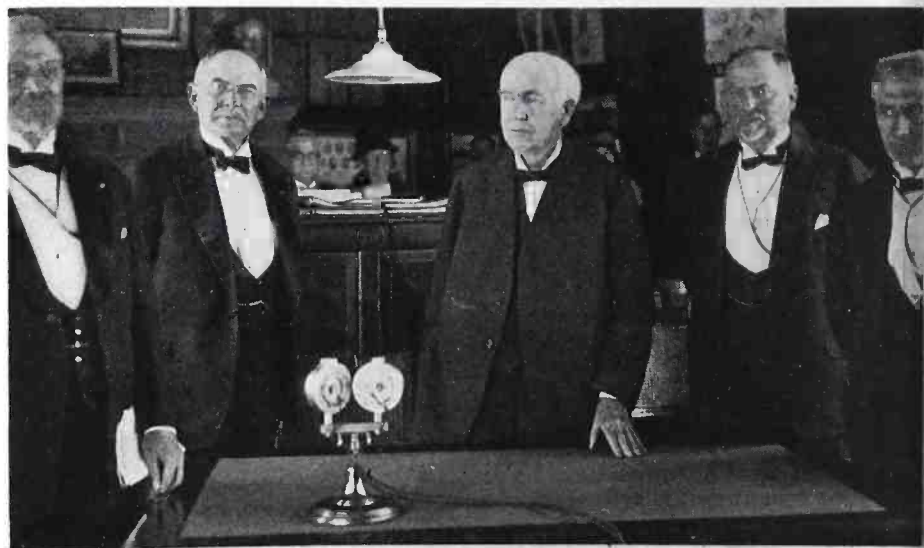

Jackie Coogan speaking into the Pallophotophone, in 1923, with C. A. Hoxie, who developed the instrument, directing the juvenile wonder of that period. This machine was the earliest attempt to record sound on standard size motion picture film, and was the forerunner to the present RCA sound recording system.

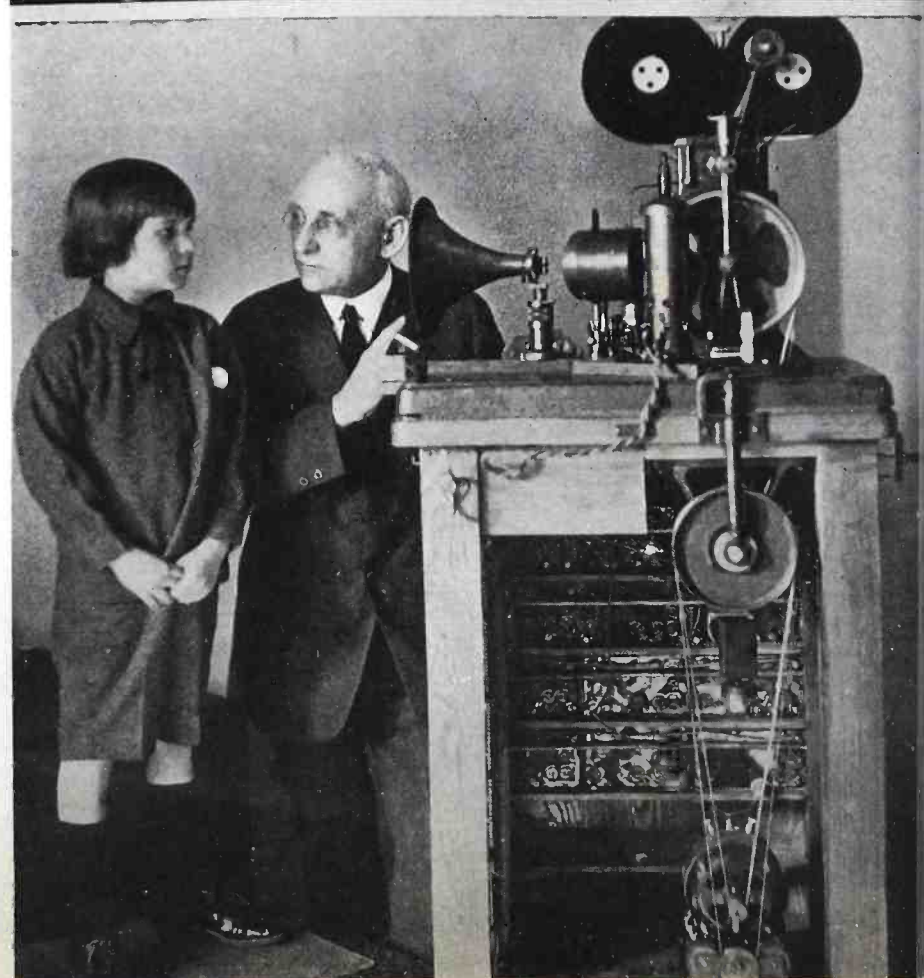

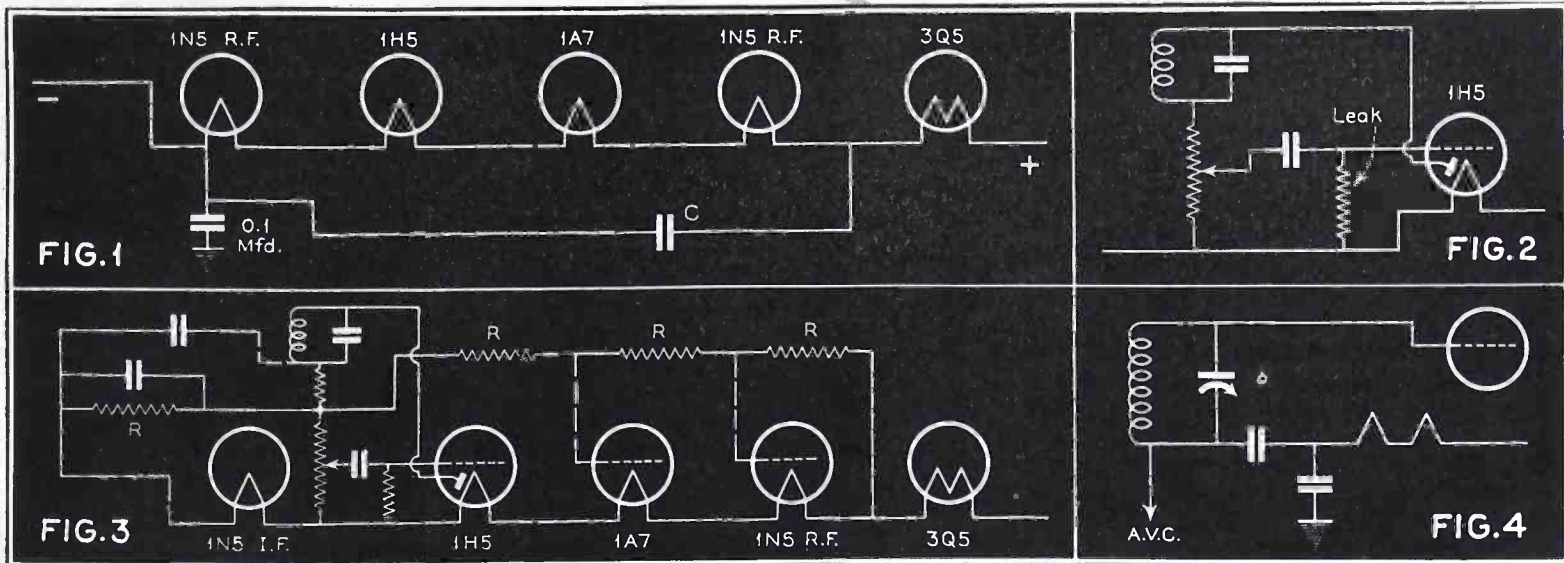

Design Data on **A-C/D-C BATTERY PORTABLES**

by **JAMES J. ADAMS**

Engineering Department, Zenith Radio Corp.

THE construction of battery portable and farm sets for use on a-c or d-c, too, has provoked many design complications due to the necessity of series filaments. Let us consider a receiver, for instance, using an 1N5 or 1LN5 r-f, 1A7 or 1LA6 converter, 1N5 or 1LN5 i-f, 1H5 or 1LH4 detector and first a-f, 3Q5 output and a rectifier tube. The B battery voltage would be 90, and the A voltage would be 9. The r-f stage would be tuned or untuned, with a 0.1 mfd. condenser from A-B to chassis ground.

The output tube in such a receiver is usually placed at the positive end of the string in order to get its grid bias from the rest of the string. This is not good practice, since the plate current of the output tube must flow through the rest of the filaments, causing audio feedback. However, this can be overcome. From the standpoint of i-f stability, it is best to have the i-f tube at the negative end of the string. This, of course, makes it impossible to put a-v-c on the i-f tube, the i-f tube, however, seldom being on a-v-c in these sets. A by-passed 15-megohm resistor in the grid return will

help prevent overload. In order to be able to have a-v-c on the converter and r-f tubes, the detector tube should be more negative than the converter and r-f tubes. Accordingly, the 1H5 seems to be best when next positive after the i-f tube, and for stability reasons it is best to have the converter more negative with respect to the r-f tube. This also makes it possible to put more a-v-c on the converter than on the r-f tube. A good sequence of tubes is shown in Fig. 1.

In such a circuit, the diode load should return to the side of the detector filament that the diode is on, so that there is no (or very little) positive or negative bias on the diode. If the diode is on the negative end of the detector filament there will be audio regeneration due to the output plate current flowing through the detector filament. If the diode is put on the positive end of the detector filament by reversing the filament connections there will be audio degeneration. Voltage due to the output current gets on the 1H5 grid since the center point of the filament is the reference point for the grid while the grid returns through the audio coupling con-

denser and the volume control to the diode end of the filament.

It makes no difference where the leak returns (Figure 2) because it is usually 5 to 15 megohms and is large compared to the impedance of the coupling condenser and the volume control to its tap. If an electrolytic condenser (C) of 200 mfd. is connected from the negative filament of the 3Q5 to the negative of the string, the regeneration or degeneration is very small. However, if a smaller value of C is used, such as 40 mfd., it is best to put the diode at the negative end of the 1H5 filament. This will give some regeneration on the lows which will result in some low frequency boost if it does not get too great; if too great, the set will appear microphonic. There would be no audio feedback if the diode could be put at the center of the filament, and the diode load returned to the center of two equal resistors across the 1H5 filament, but this would be very hard to do. Any method of isolating the diode from the audio grid to put them at their proper places causes a violent loss of gain.

The condenser C can also be used as the A hum filter since hum in the out-

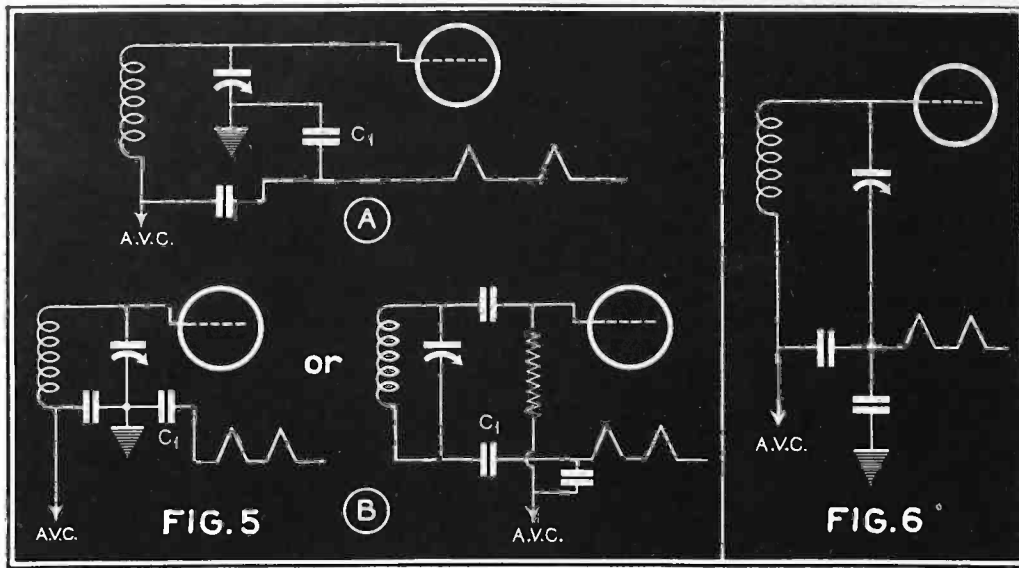

Portable receiver design with objectional features are shown in Figure 5. In Figure 6 is shown a method of obtaining effective stabilization of the i-f's.

put filament is not troublesome. If C is formed at the proper voltage there will be no trouble of blowing out filaments with this arrangement by removing and replacing tubes.

Modulation hum is likely to occur in improperly designed sets. The most critical point is the screen of the r-f tube. If its current is filtered from B+ with about 33,000 ohms and a 10-mfd. electrolytic it will probably be removed. If there is a flutter filter it can also be used to filter this screen. The condenser C of about 200 mfd. is also needed since at high levels these sharp cutoff tubes are good modulators for they are either drawing grid current or amplifying through their grid-to-plate capacities because of the large signal and high a-v-c bias. Anything flowing down the filament series string will be modulated on the carrier. Without a fairly high value of C the output plate current flowing down the string will be modulated in the first tubes, tending to cause a microphonic condition. Without a fairly high value of C there is another phenomenon, high level tweet; a high frequency tweet as the signal is tuned through resonance. It appears to be mainly output plate current flowing to chassis ground through capacity from output plate to chassis and then up the string. It can be made much worse by putting capacity from output plate to chassis.

In applying a-v-c it is desirable to keep the zero signal bias normal on each tube regardless of the position of the volume control. This can be done by connecting four equal series resistors (Figure 3) across the four lower tubes in the string and returning each grid and the diode to the point on the divider that corresponds to its proper return point on the filament string.

The four 4.7 megohm resistors provide the correct zero signal bias on each

grid and the diode, regardless of the position of the volume control. The arrangement gives two-thirds a-v-c on the converter and one-third a-v-c on the r-f tube. Partial a-v-c can be put on the i-f tube also by putting the 1H5 at the bottom of the string with its diode end positive. Mr. Benin of the Zenith Engineering Department introduced an idea to increase overall stability by isolating the gang from chassis and connecting it to a-v-c (Figure 4). This does away with the r-f and other r-f currents flowing through a condenser, which is part of the first tuned circuit, or between the first grid and its filament.

The other methods are inferior for the reasons described below and illustrated in Fig. 5.

In A, C₁ carries i-f and other r-f currents and is in the first tuned circuit. In B (left), C₁ carries i-f and other r-f currents and is between the first grid and its filament. In B (right), the gang is connected to the filament which is one side of the line in a-c or d-c oper-

ation. Underwriters will not pass this.

Stabilizing the i-f's in these sets is difficult. The problem is made more difficult by underwriter requirements on the amount of impedance from line to chassis and exposed parts. Stabilization depends a great deal on the placement of parts and capacities to ground. Each arrangement is different. The diode bypass condensers and a-v-c condensers provide greater efficiency sometimes when connected to negative filament or to their own filaments (Figure 6). With the above filament string, plate currents of the various tubes do not flow through filaments of tubes in a more sensitive position, except through the condenser C to the plus end of the string and then down the string. Because some of this current passes through C, some of the filaments must be by-passed. An r-f by-pass from the negative filament of the converter to negative of the string is usually necessary. Oftimes there is coupling from the plate of the i-f tube to the converter plate through capacity of each to ground. This is regenerative coupling and can be eliminated by putting a 1000 ohm resistor from the plate return of the i-f tube to B+ and an .05 mfd. condenser from the plate return to ground. This is especially true in miniature i-f's where the coils are close to the grounded cans. In larger i-f's, where both transformers are capacity aiding (grid inside and plate outside), the capacities from the two plates to ground are also many times high. It is usually best practice to have both transformers aiding, since a small movement of a grid or plate wire in a transformer connected in bucking position can change the gain considerably. This may cause additional microphonics in a set, where this condition is already bad. The selectivity curve is not as symmetrical with both transformers aiding, but this

(Continued on page 31)

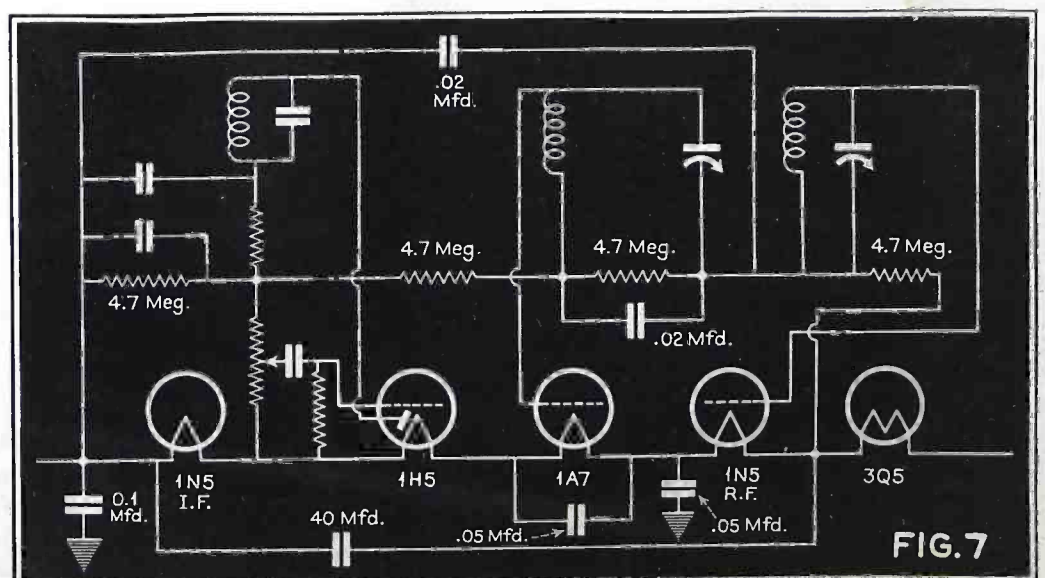

A receiver design that afforded an i-f stability of 3%, and average i-f sensitivity of 63 uv.



Radio...all out for Victory

Research and invention have placed radio in the first line of battle

COMMUNICATION—rapid communication—is a vital necessity, on land, at sea and in the air. RCA research and engineering developments in both radio and electronics are strengthening—and will further fortify—the bulwarks of our communications system. At Princeton, New Jersey, the new RCA Laboratories—the foremost center of radio research in the world—are under construction.

★ ★ ★

International circuits, operating on short and long waves, have made the United States the communication center of the world. Today, R.C.A. Communications, Inc., conducts direct radiotelegraph service with 49 countries.

★ ★ ★

Production of radio equipment is essential for news and timely information, for military and naval communications, for dissemination of news among foreign countries. The "arsenal of democracy" has a radio voice unsurpassed in range and efficiency. In the RCA Manufacturing Company's plants, workers have pledged themselves to "beat the promise," in production and delivery dates of radio equipment needed for war and civilian defense.

★ ★ ★

American life and property at sea are being safeguarded by ship-and-shore stations.

The Radiomarine Corporation of America has equipped more than 1500 American vessels with radio apparatus and is completely engaged in an all-out war effort.

★ ★ ★

Radio broadcasting is keeping the American people informed accurately and up-to-the-minute. It is a life-line of communication reaching 55,000,000 radio sets in homes and automobiles. It stands as the very symbol of democracy and is one of the essential freedoms for which America fights. The National Broadcasting Company—a service of RCA—and its associated stations, are fully organized for the coordination of wartime broadcasting.

★ ★ ★

New radio operators and technicians must be trained for wartime posts. RCA Institutes, the pioneer radio school of its kind in the United States, has more than 1,200 students enrolled and studying in its New York and Chicago classrooms.

★ ★ ★

When war came and America took its place on the widespread fighting front, radio was At the Ready . . . with radio men and radio facilities prepared to answer the call to duty "in the most tremendous undertaking of our national history."

David Sarnoff

PRESIDENT



Radio Corporation of America

RADIO CITY, NEW YORK

The Services of RCA: RCA Manufacturing Co., Inc. • RCA Laboratories • R.C.A. Communications, Inc. National Broadcasting Company, Inc. • Radiomarine Corporation of America • RCA Institutes, Inc.

A Report on the 1942 IRE CONVENTION

by LEWIS WINNER
Editor

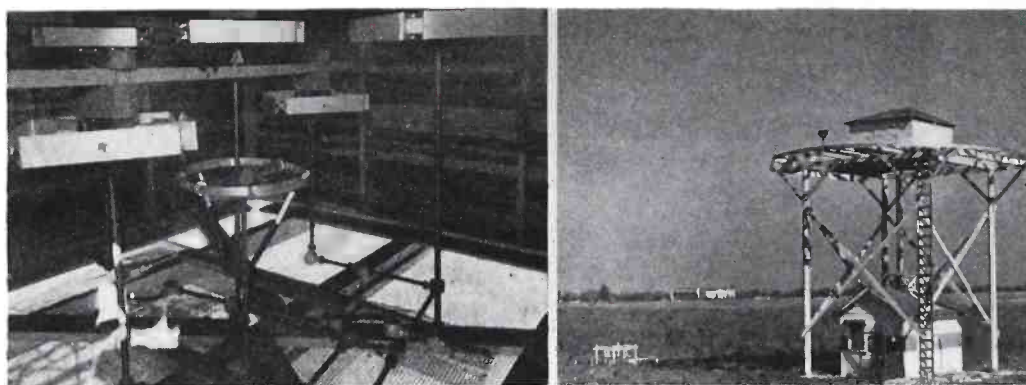

Figure 1.
At left, complete antenna installation of the radio range, with visual loops at top and aural loops at bottom. At right, complete transmitting installation.

TWO COURSE RADIO RANGE WITH SECTOR IDENTIFICATION

SO that an airplane pilot may know his location with respect to a pre-determined course, it is essential that he have reliable aural and visual indication with a radio range. In addition, it is very desirable to be able to identify quickly and positively the sector in which the airplane is, at any given time. That is, he should know whether he is East or West of an East-West radio range, with such vital information being available regardless of the terrain over which he is flying. The distortive effects of mountains, ore deposits or even mineral deposit water paths must not alter this reception.

A radio range system that provides a combination of such performance characteristics was recently developed for and in collaboration with the radio development section of the Civil Aeronautics Administration by the laboratory division of the International Telephone and Radio Manufacturing Corporation.

Described by A. G. Kandoian of the International Laboratory, this unusual system employs a group of three loop radiators that provide two overlapping mirror image patterns modulated at 90 and 150 cycles respectively. A cross pointer, the vertical pointer of which is actuated by a 90 and 150 cycle modulation provides the pilot with the neces-

sary information for orienting his plane.

A second set of radiators similar but at right angles to the first group, provides the keyed signal for aural sector identification, explained Mr. Kandoian. Except for the carrier radiation which is common to both the aural and visual signals, the two systems are entirely independent.

Operation of Range

The operation of the two-course radio range with sector identification is illustrated in Figure 2. The course extends directly East-West. The course-indicating instrument goes off scale approximately 10 degrees either side of the course. Within the indicating range of the instrument, the pointer indication is approximately proportional to the deviation from the exact "on course." It would therefore be perfectly possible, continued Mr. Kandoian, for the pilot to fly not only "on course" but say 5 degrees North or South of the course, if he so desired. The aural signals which are repeated at 30 second intervals, identify the radio range station to the pilot, and also define his position with respect to the station. The first two letters ID are the station identification, while the E or the W which follows indicates that the airplane is East or West of the station.

By virtue of an ultra high frequency

bridge circuit which is used in the visual antenna system, the total carrier power of the whole system is confined to the center loop antenna, thus providing substantially circular horizontal radiation for the carrier, said Mr. Kandoian.

Transmitting Equipment

The transmitting equipment consists of three primary units. There is, first, a 300 watt 125 mc transmitter; second, a mechanical modulator which provides 90 and 150 cycle modulation, and third, a side band generator which provides the 1020 cycle keyed sector and station identification signals. These units and associated transmission line equipment are installed in the house shown on the ground in Figure 1, right.

A special marker array, shown at the left of the main structure in Figure 1 is fed from an auxiliary 40 watt transmitter, which is removed in frequency from the main transmitter by approximately 20 kc. This signal has no modulation and serves merely to radiate carrier straight up, to steady the cross-pointer indicator in the airplane, when the plane is flying at high vertical angles with respect to the transmitting equipment.

The receiver designed for this radio range is the Western Electric Type RUM, a crystal controlled 125 mc super-heterodyne. A more recent Western Electric Receiver Type 32A has also

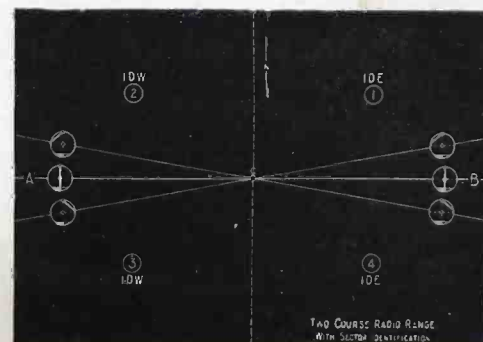

Figure 2.

Diagrammatic explanation of operation of radio range.



Figure 3.

been used in flight checks with very satisfactory results. The course indication is provided by a Weston cross-pointer instrument, the vertical pointer of which is utilized for this purpose. The receiving loop antenna on the airplane is similar to the type used for instrument landing.

Collaborating with Mr. Kandoian in this interesting project was Andrew Alford, also of the engineering department of International Telephone and Radio.

COLOR TELEVISION

THE effectiveness and value of black and white television is dominant. And the addition of color provides that quantity of the unusual that gives it a new force of dynamic importance. Even as a crude development some years ago, color television was immediately accepted as a major contribution to aural transmission. Today, commendable true-to-life color transmission is possible, thanks to the pioneering developments of Dr. Peter C. Goldmark and his associates J. N. Dyer, E. R. Piore and J. M. Hollywood of CBS.

CBS System

The CBS color television system as discussed by Dr. Goldmark is a sequential additive system in which picture fields are repeated in three primary colors. The first stage of development was the application of the optical and electronic formula to the practical problem of creating a picture in full color. This consisted of scanning a colored image, breaking it down into a television line structure, transmitting it through an

electrical circuit, reassembling the hundreds of thousands of electrical impulses into a color replica of the original subject. This was done by developing special pick-up or scanning equipment, using it to scan a glass slide containing a full color photograph and transmitting this picture to a specially constructed receiving set in which the image appeared as a picture approximately $2\frac{1}{2} \times 3$ inches in size. The success of this experiment verified the soundness of the theoretical data on which the process is based.

The second stage of development involved adding motion to color, to determine if the optical and electrical systems were capable of transmitting and reproducing motion picture film without a breakdown or separation of color. This required the special construction of an experimental film scanner. The third developmental stage consisted of adapting a standard black and white television receiver with a 9-inch tube to receive color, and substituting it for the specially constructed color receiver used in the first stage of the experiments.

Film Scanning

In operation, a color motion picture is run through a film scanner. Between the film and an electronic pickup tube there is a rotating disc containing red, green, and blue filters in that order. When the red filter is in front of the tube only those parts of the picture which contain red register in the pickup tube. When the green filter is in front of the tube only those parts of the picture which contain green (and this includes yellow) register in the tube. Similarly with the blue filter. Then the three filters (red, green and blue) are balanced to give the effect of pure white when the picture is white.

Synchronized with the disc in front of the pickup tube is a similar disc in front of the receiver tube. In other words, at the instant when the red filter is in front of the pickup tube, a red filter is in front of the receiver tube. The same holds for the green and blue.

Method of Scanning

The scanning method differs somewhat from that used in most black and white systems. For a 6 mc. television band, each color field interval is 1/120th second, using a single interlaced scanning system with 375 lines 60 frames per second. The minimum flicker frequency is 1/40th of a second, which permits a picture brightness of (on white) 2.6 fc. without perceptible flicker.

Artificially scanned photographs of typical subjects were shown, and compared with similar photographs taken on 8 and 16 mm. film. It was apparent that

in an idealized television system detail intermediate between that obtainable on 8 and 16 mm. film should be obtained in a 6 mc. television channel.

An analysis of the color characteristics of the system showed that the problems encountered and the results obtainable are similar to those of present-day color photography. Satisfactory color characteristics require careful attention to the light source, pickup tubes and filters, as well as to the receiving equipment. Fluorescent lamps have simplified the problems of studio lighting by making it possible to obtain a close approach to actual daylight conditions.

Color Television Receivers

Color television receivers have been developed for seven, nine and twelve inch tubes. The additional components that a color television receiver requires are the filter disc with its driving and synchronizing means, a cathode ray tube with a short decay screen (like some types used in black and white receivers) and some additional hum filtering and magnetic shielding. The filter disc is usually slightly more than twice the diameter of the cathode ray tube bulb, and for any given mechanical arrangement the filter shape can be determined graphically.

The orthicon type color television camera is suitable for studio or outdoor use. A camera which is in regular use in the CBS studios is shown in Figure 3. The orthicon is mounted horizontally,

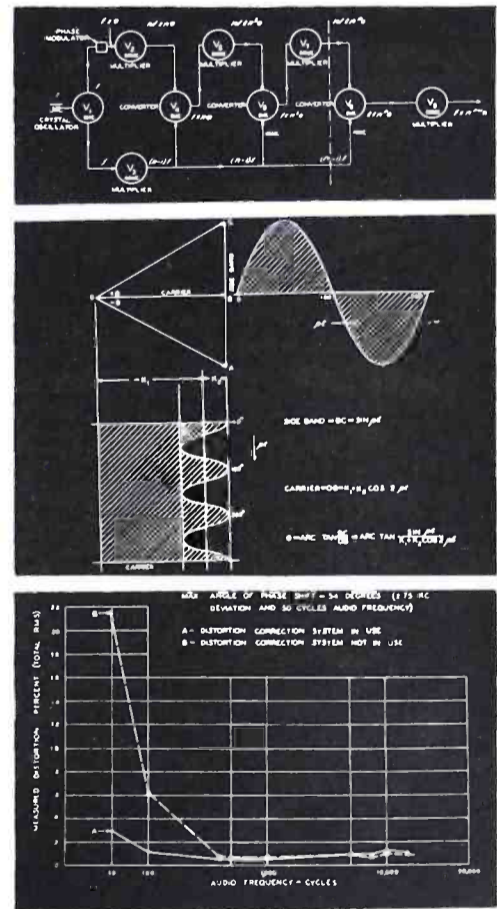

Figures 4, 5 and 6.

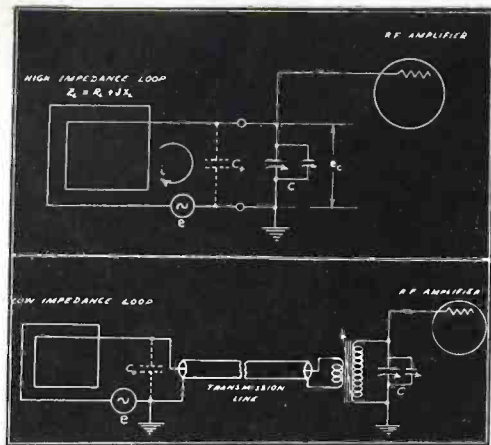

Figures 7 and 8.

with a filter drum rotating directly in front of the mosaic. A front surface stationary mirror within the drum reflects the optical image from the lens through the filter and on to the mosaic. The signals from the orthicon studio camera or a dissector film camera are fed to the color mixer in the control desk. The color mixer is a form of electronic switch which switches the video signal to individual gain and brightness controls in the proper sequence during the blanking intervals. By this means the gain and brightness of each color component may be controlled separately.

A STABILIZED F-M SYSTEM

IN f-m where wide band high frequency transmission is characteristic, it is essential that the center frequency be high. An ideal solution to this problem may be found in the direct crystal control of the center frequency, according to Roger J. Pieracci of the Collins Radio Company, who described such a system. This control, he said, is possible, if the f-m signals can be generated without extreme complexity of equipment or difficulty in securing suitable fidelity. When using this direct method of crystal control, it is necessary to use a phase modulator in f-m signal generation.

A relatively high phase multiplication factor from crystal to operating frequency and yet a low frequency multiplication factor from crystal to operating frequency would provide an acceptable phase modulator, he added.

Wide Angle Phase Shift

In the system described a wide angle of phase shift with low attendant distortion is afforded, thus reducing the phase multiplication factor required, said Mr. Pieracci. If the maximum phase angle is increased from 30 to 60 degrees, the phase multiplication may be cut in half, thus requiring the use of fewer multipliers and effecting a 6 db improvement in random noise, continued Mr. Pieracci.

In Figure 4 is illustrated a plan of a

system with a low frequency multiplication factor of high order.

To prevent undesired harmonics of the oscillator frequency from appearing at the input circuits of the converter, said Mr. Pieracci, care must be exercised in the mechanical arrangement and electrical design of the multiplier circuits. When distortion appears, an irregularity in phase characteristic appears. This repeats itself each time the required voltage vector completes one revolution about the undesired voltage vector. These slight irregularities resembling cogs appear in the demodulated a-f wave; and thus the term "cogging" has been applied to this effect, said Mr. Pieracci.

Distortion Corrective System

The mechanics of the distortion corrective system by vector representation of the carrier and side bands are illustrated in Figure 5. Here we can see that the side bands are added at an angle of 90 degrees with their amplitude varied in accordance with the a-f. In this instance, explained Mr. Pieracci, the carrier is also amplitude modulated simultaneously at twice the a-f, in such a manner that approximately a linear relation obtains between side band amplitude and angle of phase shift.

In Figure 6 the measured distortion characteristics are shown. Curve A shows the distortion produced when the correction system is in use, while B shows the rise in distortion due to the removal of the correction system. Distortion at 50 cycles was reduced from 21 percent to 3 percent.

LOOP ANTENNA FOR AIRCRAFT

IN aircraft loop design, there are three important requisites. First, it must be extremely portable and efficient in such form. Then, it must possess accurate direction finding properties, and last it should be electrostatically

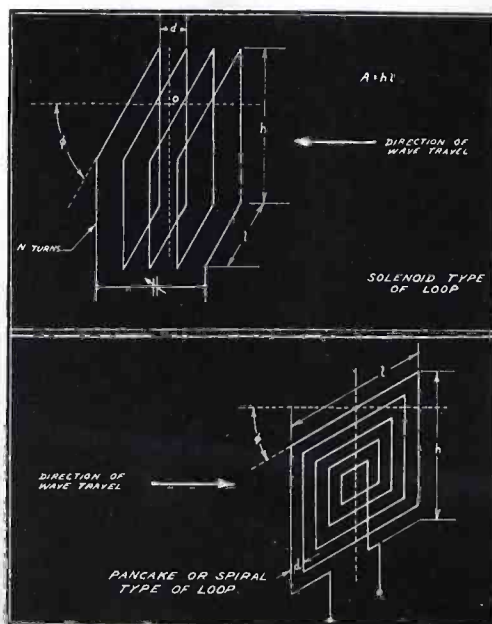

Figures 9 and 10.

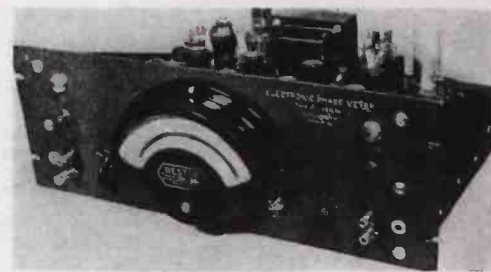

Figure 11 (see page 21).

ally shielded so as to decrease precipitation or snow static. In addition, there are physical design problems prompted by the plane structure that must be guarded. For instance, when the loop is mounted away from the fuselage, it is placed into the air stream where it causes a drag on the plane and is in addition subjected to distortive force. Thus, it has been shown that a toroidal shaped shielded loop 12 inches outside diameter with a cross sectional diameter of 1½ inches presents a drag of about 15 pounds when it is so rotated that the maximum projected area is in the air stream. This represents a seven horsepower loss at a 180 mile speed, said Mr. George F. Levy of the United Air Lines, in his discussion of Loops and Aircraft. Other problems are the rotating and indicating mechanisms. In the case of high impedance loops, for instance, it is extremely important that the parallel capacity represented by the gear box be as small as possible, and the effective "Q" be as high as possible, continued Mr. Levy.

High and Low Impedance Loops

Both high and low impedance loop systems are used. The high impedance loop (Figure 7) has sufficient inductance to permit its being tuned to the incoming frequency by a condenser connected directly across it. To realize the advantages of this type of loop, it should be fed directly into an r-f amplifier located very close to the loop. Then the output of the amplifier may be connected to the rest of the receiver through a low impedance low loss transmission line, explained Mr. Levy.

A low impedance loop (Figure 8) may be coupled to a receiver via a low impedance line without an intervening amplifier with a matching transformer at the receiver input.

Two Types of Loop Windings

There are two types of loop windings, said Mr. Levy. One is the solenoid type (Figure 9) in which all the turns have the same area, and the other is the pancake or spiral wound type (Figure 10) in which the areas of successive turns decrease towards the center of the winding.

In a solenoid loop, said Mr. Levy, each successive turn is displaced in space from the preceding turn by distance, (Continued on page 21)

FM STATION MONITORING IS EASY

with this G-E *multi-purpose*^{*} unit



Distortion is prevented by careful adjustments on a G-E wide-band oscilloscope.

Approved by the F. C. C.

With this new monitor, General Electric has removed one more hurdle from your path to FM. You will find this self-contained, multi-purpose^{*} instrument one of the most valuable units in your FM station. It provides:

- ★ Direct reading of center-frequency deviation (with or without modulation)†
- ★ Direct reading of modulation percentage†
- ★ Instant calibration against a precision crystal standard
- ★ Adjustable modulation-limit flasher†
- ★ High fidelity output for audio monitor†

All tubes and crystal units can be reached easily through the top of the cabinet. Removing chassis assembly from cabinet allows complete access to all panels and wiring.

In FM, more precise measuring techniques are a necessity. This instrument is custom-built for your requirements. Order your monitor now through the nearest G-E office, or direct from General Electric, Radio and Television Dept., Schenectady, New York.

†Provision has been made for remote console operation.

Some of the FM Pioneers Who Have Already Bought G-E Monitors

John L. Booth Broadcasting Co., Detroit, Mich.
 Capitol Broadcasting Co., Inc., Schenectady, N. Y.
 Columbia Broadcasting System, New York, N. Y., and Chicago, Ill. (Five units; three of these for "S-T" service)
 Don Lee Broadcasting System, Los Angeles, Cal.
 FM Radio Broadcasting Co., Inc., New York, N. Y.
 General Electric Co., Schenectady, N. Y. (Three units; one of these for "S-T" service, and one for television sound)
 Gordon Gray, Winston-Salem, N. C.
 The Journal Co., Milwaukee, Wis.
 Johan Lagercrantz, Stockholm, Sweden

Royal Miller, Sacramento, Cal.
 Midland Broadcasting Co., Kansas City, Mo.
 Moody Bible Institute, Chicago
 News Syndicate Co., New York
 Radio Engineering Laboratories, Long Island City, N. Y.
 San Diego City Schools, San Diego, Cal.
 Standard Broadcasting Co., Los Angeles, Cal. (Two units; one of these for "S-T" service)
 University of Illinois, Urbana, Ill.
 Walker-Downing Radio Corporation, Pittsburgh, Pa.
 WFIL Broadcasting Corporation, Philadelphia, Pa.
 WGN, Inc., Chicago, Ill.
 Yankee Network, Paxton, Mass., and Mt. Washington, N. H.



FM Broadcast Transmitters
250 to 50,000 Watts



Relay Transmitters



Receivers for Home
and "S-T" Service



FM Police and Emergency
Transmitters and Receivers



Tubes

FOR ALL YOUR FM NEEDS

GENERAL ELECTRIC

160-18A-6911

THE INDUSTRY OFFERS

SHURE'S SUPER-CARDIOID

A new "Super-Cardioid" broadcast dynamic microphone is announced by Shure Brothers, 225 West Huron St., Chicago. This new Series "556" introduces a polar pattern that is said to be twice as unidirectional as the cardioid, from the standpoint of receiving front sounds and rejecting rear sounds, yet has wide-angle front pick-up. Decreases pick-up of reverberation energy and random noise 73%. The axial polar pattern is symmetrical at all frequencies.

Frequency response is said to be from 40 to 10,000 cycles.

This new unit employs a patented Shure "Uniphase" single-unit construction which eliminates the necessity of using two dissimilar microphone elements in one microphone for obtaining true unidirectional operation.

The Super-Cardioid is available in three models: Model 556A for 35-50 ohm circuits, Model 556B for 200-250 ohm circuits; Model 56C, high impedance.



* * *

WESTINGHOUSE INDICATING LAMP

For general indicating or signal purposes on switchboards, control desks, and panel boards, a new indicating lamp, Minalite, is now being made by Westinghouse Electric and Manufacturing Company. The lamp has a rectangular-shaped lens designed for extreme angular visibility. Receptacle is made of one-piece moulded material and is suitable for mounting on panels 1/16 to 2 inches thick. Resistors as part of the unit are used for line voltage ratings between 50 and 250 volts.

Pressure type leaf spring contacts establish connections with the slide base telephone lamp having a rating of .032-.038 amperes, 24 volts. The rectangular lens assembly is held in place by steel spring clips engaging in retaining grooves of the receptacle.

* * *

EMERSON'S LONG-LIFE PHONO NEEDLE

A new long-life phonograph needle guaranteed for 4,000 plays without the necessity for changing has been introduced by Emerson Radio. Features are flexible shank, platinum metal tip, etc.

GIANT-SCREEN OSCILLOGRAPH NOW AVAILABLE

An oscillograph using a Du Mont 20-inch diameter intensifier-type cathode-ray tube with medium-persistence green screen, and a final accelerating potential of 6000 volts for a high-intensity spot of good resolving power affording a highly-detailed trace, even in well-illuminated rooms, has been developed at the Allen B. Du Mont Labs in Passaic, N. J. The instrument consists of the 20-inch cathode-ray tube; amplifiers for signal deflection along both X- and Y-axes, and for Z-axis or intensity-modulation signals, a linear-time-base generator; and associated power and control circuits.

Newly developed circuits are employed in both the X- and Y-axis signal amplifiers, providing direct coupling from input terminals to deflection plates when such connections are desired, or the more conventional capacitive coupling. The input circuits employ high-impedance compensated stepped attenuators, thermionic impedance transformers, and distortionless continuously-variable amplitude controls. The two-stage amplifiers are phase-inverting and self-balancing, and d-c positioning is used to provide instantaneous control of spot location. The deflection-signal voltages are balanced above ground and are connected to the deflection plates through jumpers on the rear terminal board, and thus external signal sources can be used for direct deflection if desired.

A linear-time-base generator is available to provide X-axis deflection over a wide frequency range. The time-base voltage, which can be locked to either positive or negative phase of one of several synchronizing signals available, can provide recurrent sweeps for general use or single sweeps for transient studies. Time calibration by means of intensity modulation is provided for by a Z-signal amplifier. Either positive or negative phase of the signal used is available for blanking or intensifying the fluorescent trace.

A beam switch is provided to permit stand-by operation of the oscillograph. It serves to switch the bias on the grid of the cathode-ray tube from normal operating values to a value which will cut off the beam, without disturbing the settings of other controls. In this manner the spot can be turned off with the instrument in "stand-by" condition, thereby avoiding the long concentration of the spot at a given point, which might cause "burning" or discoloration of the screen.

The instrument is completely self-contained and can be operated from a single-phase source of 50- to 60-cycle power at 115 volts r.m.s. Power consumption is approximately 350 watts. The metal gray wrinkle-finish cabinet measures approximately 28 inches wide, 36 inches deep, and 60 inches high, is mounted on rubber-tired locking casters, and weighs 325 pounds.

* * *

VULCANIZED FIBRE SURFACE MATERIAL

A vulcanized fibre surface on laminated phenolic material is now available from N. S. Baer, Hillside, N. J. It is suited where there is an arcing condition, the vulcanized fibre quenching the arc without carbonizing or tracking. The phenol fibre is said to give the necessary rigidity and moisture resistant qualities. The material can be punched, sawed, drilled or tapped.

G-E'S UHF POWER AMPLIFIER

A new ultra-high-frequency power amplifier, the 6L 8J10-R, has been announced by the Radio and Television Department of the General Electric Company, Schenectady, New York.

This tube has a coated cathode heated by electron bombardment from an auxiliary filament. Anode and cathode are fitted with coolers for forced-air cooling.

The parallel plane electrodes are closely spaced to facilitate neutralization. Grid plate capacitance is 1.5 micro-microfarads, grid cathode capacitance is 2.3 micro-microfarads, and plate cathode capacitance is 0.07 micro-microfarads. Low lead inductance is provided by the disk-type terminals.

When used as a class C radio-frequency amplifier, the tube has a maximum d-c plate voltage of 1350. Maximum plate current is 150 milliamperes; maximum plate input, 100 watts; and maximum plate dissipation, 50 watts. The tube has an amplification factor of 30.



* * *

IRC POSITIVE PRESSURE CONTACT BAND

Corroded contact bands with resulting damage to resistance windings are said to be eliminated by a new positive pressure contact band now supplied on all adjustable IRC power wire wound resistors of 25 watts and up.

This new IRC Band consists of a silver contact button mounted on a heat-resistant stainless steel spring that is spot welded to outer band surface. Thus, it is said, no matter how much the band itself may be tightened, pressure of the contact button on the wire does not vary. Its silver finish is an effective safeguard against corrosion or oxidation. Throughout, the bands are specifically designed for use under high temperatures.

In addition to being supplied on all IRC adjustable power wire wound resistors in the 25, 50, 80, 100 and 200-watt sizes, the new bands are available separately. They are made in 9/16", 3/4" and 1 1/8" diameters.

IRC resistor data bulletin No. IV-A
(Continued on page 28)



Here's the answer to Your problem of...

WHICH WIRE TO USE?

Any one of several different types of insulated wire *might do* for your definite requirement—yet only one certain wire is *best* for that use. The wire you use in the equipment you build should be that "best" wire—especially today when so much is dependent upon the successful operation of your product.

Lenz engineers know insulated wire—how it is made, how it will perform, which wire is best suited for your need. They are ready to help you solve your problem—with a line of insulated wire of various types to suit a wide variety of conditions.



Call a Lenz wire specialist for consultation—their services are without obligation and samples are gladly submitted without charge.

ELECTRICAL CORDS, WIRES AND CABLES

LENZ ELECTRIC MFG. CO. 1751 N. Western Ave., CHICAGO, ILL.

ENJOYING ITS 36TH YEAR OF SUCCESSFUL BUSINESS

PLASTIC PROPERTIES

by ELLIOTT MARSHALL

AS an alternate or substitute there is little doubt that plastics has the right of way these days. Its flexibility of application has made it one of the "number-one" essentials of the day. Of course, material and production problems still plague the industry, but notwithstanding, plastics has had and will have even greater industrial acceptability as the days go on.

In a recent paper before the Society of the Plastics Industry by J. B. Johnson, Chief of Materials Laboratory of the Army Air Corps, many of the reasons for this intense swing were effectively illustrated. For instance, in a chart showing the desired minimum values for mechanical properties at 160° F., 75° F., and -65° F., values were selected on the basis of experience with wood and metals. In other words, a plastic showing such characteristics as outlined could be used on an equal basis with metal and with only minor changes in design.

Clear plastics, made without the use of opaque fillers thus do not have all of the sturdy mechanical properties,

and can be used on instrument panels and other points where small injection molded parts are effective, said Mr. Johnson.

High mechanical properties are offered by the resin filler combinations which, of course, are the phenol-formaldehyde-wood compositions. Since, however, this material is difficult to obtain now for civilian applications, fabrics, paper and textile fibres, both natural and synthetic, have received more study since they produce mixtures which are easily molded, according to Mr. Johnson. All structural parts should have equal strength in all directions in the plane of application of loads, whether that application be small or large. Accordingly any fabrics which are laminated should have equal strength in the warp and filling. Fibres must be arranged in alternate layers at right angles to each other. In addition, any molecular orientation of synthetic fibres must be balanced, continued Mr. Johnson.

A material of low density may have a relatively low specific tensile strength. Yet due to the thicker sections which

may be incorporated, this material may produce a structure which will carry greater bending and twisting loads, than one prepared from a fabric with higher specific strength, but of high density which requires the use of thin sections that are subject to elastic instability.

In testing for fatigue properties, two types of test specimens may be used, according to Mr. Johnson. One is the R. R. Moore rotating beam type and the Krouse type for plate and sheet. The operating speed of the rotating beam machines are 3450 or 10,000 rpm and of the Krouse machine 1725 rpm.

The table below shows the mechanical properties of a variety of plastics, based on tests at one of the leading laboratories of the country. This cross section of plastics offers an interesting illustration of the many possible applications of plastics where alternates for metal are essential. Although the electrical characteristics of these plastics are not shown, their properties are sufficiently well known to afford a combination of data useful in selecting the correct alternate in design work.

Plastic	Specific Gravity	Tensile Properties						Modulus of Elasticity p.s.i. × 10 ³	Vickers Pyramid Hardness 2.5 Kg. Load	Ultimate Compressive Strength p.s.i.	Bending Modulus of Rupture p.s.i.	Fatigue Limit p.s.i.		
		Yield Strength 0.2% Offset p.s.i.		Ultimate Strength p.s.i.		Elongation per cent in 2 inches						78°F.	-38°F.	
		78°F.	-38°F.	78°F.	-38°F.	78°F.	-38°F.							
Methyl Methacrylate	1.18	5,000	8,100	8,000	14,400	5	3	380	650	18	12,100	11,400	2,000	4,800
Polystyrene	1.05	4,700	7,600	1	1	469	554	21	15,200
Cellulose Acetobutyrate	1.20	2,100	4,000	3,300	8,900	57	20	117	310	5
Cellulose Acetate	1.28	3,700	8,800	5,700	16,000	40	3	219	625	10	4,900	1,000
Polyvinyl Acetal	1.10	5,450	7,840	6,830	12,400	140	10	230	400	12
Vinyl Chloride—Acetate Copolymer	1.35	6,300	9,200	9,500	16,400	25	5	450	560	16	15,500
Molded Phenolic—no filler	1.36	10,000	10,400	1	1	28	23,600	14,000	4,200
Molded Phenolic — cotton fiber filler	1.33	17,000	25,000	30,000	2	1	2,380	2,600	29,500
Laminated Phenolic, Grade L	1.34	8,000	16,800	12,100	19,300	4	3	1,210	1,860	34	25,000	21,400	5,000	6,600
Laminated Phenolic, Grade C	1.34	8,100	14,800	14,900	17,500	3	2	1,300	1,700	36	27,600	21,400	4,700
Laminated Phenolic, Grade XX	1.34	12,700	17,700	16,700	19,700	2	1	1,560	2,140	40	23,600	18,400	5,200
Impregnated 50% Compressed Laminated Maple	1.37	32,800	7,500

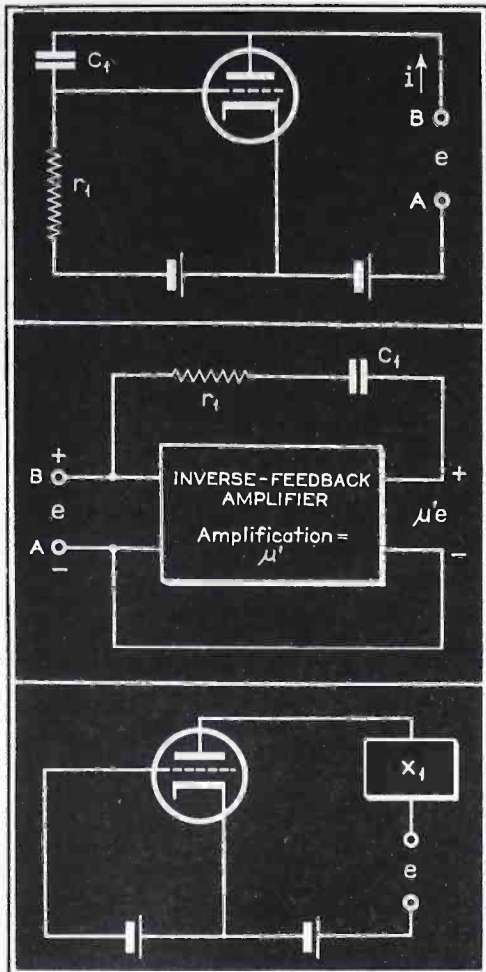

Figures 12, 13 and 14.

which may be equal to the diameter of the wire or greater than the diameter if the loop is space wound. Thus for all positions of the loop, except for where ϕ equals zero, the voltages developed in the successive turns will have a slight phase difference existing between them. Because of the capacity existing between turns a displacement current will flow across the coil. This will eventually pass through the tuning condenser and produce a signal. With this type of loop, said Mr. Levy, the polar characteristic is distorted from the theoretical pattern by three effects. One is the displacement current effect; another is the antenna effect, and the last is the shape effect.

In the other type of winding, the pancake or spiral winding, the polar pattern is also distorted by two effects, said Mr. Levy. They are the antenna effect and the winding pitch effect.

The solenoid type of winding is suitable for low impedance loops having a toroidal gap-type shield, while a pancake type of winding may also be employed in a low impedance loop, although it has constructional difficulties. Often two types of windings are employed, according to Mr. Levy, when several shallow pancakes are wound adjacent to each other and connected in series. This type of winding will have a polar characteristic very similar to the normal solenoid type especially when the inner and outer diameters of the windings are almost the same. In the case of low impedance loops using both wind-

ings, continued Mr. Levy, the Q over the aircraft beacon band of 200 to 400 kc will remain fairly constant. In high impedance loops, the pancake and combination windings were found to be most effective, according to Mr. Levy, the straight solenoid winding being too large for practical application.

A WIDE RANGE, LINEAR, UNAMBIGUOUS ELECTRONIC PHASEMETER

MOST methods of measuring phase involve null balances, or are fundamentally inaccurate in certain regions of phase difference, or cannot tell lead from lag, or require input voltages to maintain accurately constant, or have some combination of these defects. Thus it has become necessary to develop a phasemeter (Figure 11) consisting essentially of two sets of terminals and a meter with a property of reading phase angle from zero to 360° on a linear scale without any ambiguity as to quadrant, without regard to the frequency or magnitudes of the input voltages and without requiring an adjustment or null balance for easy reading, according to J. E. Shepherd, formerly of Harvard University.

These results were achieved, said Mr. Shepherd, by means of an electronic switch or trigger circuit which is triggered on one side at a given point in the cycle of one of the test voltages and on the other side at the corresponding point of the other test voltage. Suitable wave-squaring amplifiers and derivative circuits in the two channels assure that the triggering action will occur at the proper point and in the cycle of each of the test voltages. The meter current is then proportional only to the

power supply voltage, the trigger circuit resistors and the fraction of the total cycle during which the trigger circuit is triggered, in one direction, continued Mr. Shepherd. By these means an instrument can be easily made which will measure phase angle satisfactorily within a range of frequencies from 30 cycles to 15,000 cycles, while either or both input voltages may vary from .01 to 500 volts, without appreciably affecting the reading of the indicating meter.

This instrument has been found to be very convenient in student laboratory work and research problems in which the phase angle is studied as a function of some parameter such as frequency, explained Mr. Shepherd. The phasemeter can be connected to the input and output terminals of a filter or amplifier, for example, and the phase characteristics may be thus quickly determined as the input frequency is varied over the entire a-f range. This instrument has been used up to frequencies as high as 30 mc by heterodyning two r-f test voltages against a single r-f oscillator. The only requirement on the stability of the local oscillator is that the beat note remain in the range between 30 cycles and 15,000 cycles.

VACUUM TUBES AS VARIABLE IMPEDANCE ELEMENTS

BECAUSE of their application in automatic tuning and f-m. circuits in which tubes are used to produce a variable reactance, have achieved great popularity. However, the use of tubes to produce effective reactance, the magnitude of which may be controlled by voltage is only one aspect in the study of the application of tubes in
(Continued on page 29)

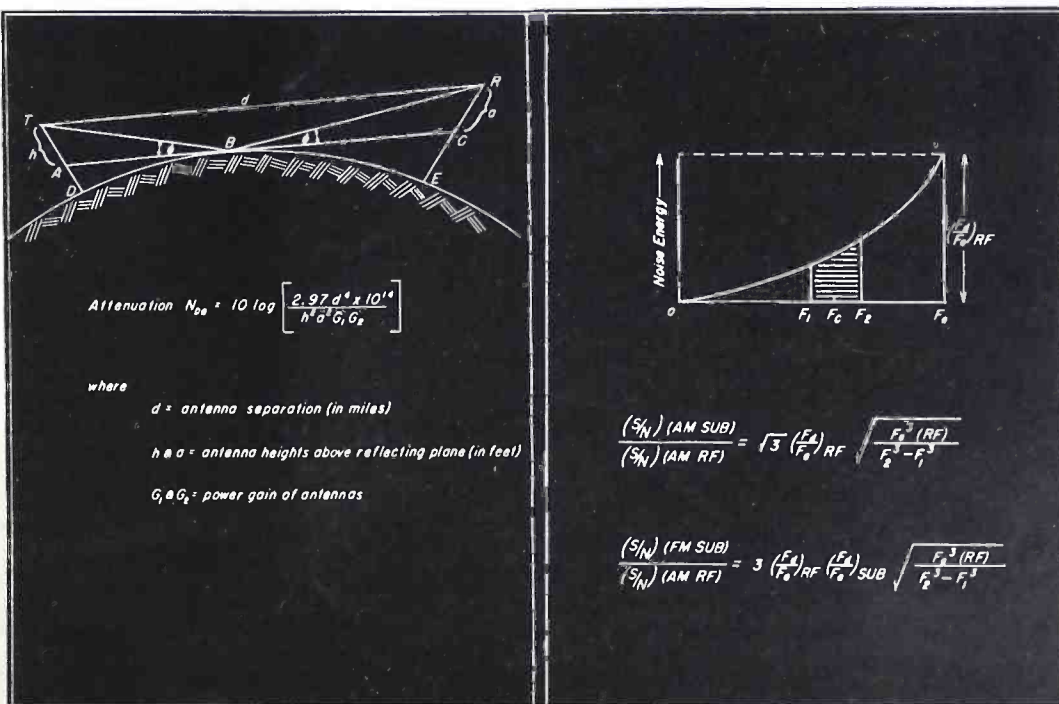

Figures 15 and 16 (See page 29).



VETERAN WIRELESS OPERATORS ASSOCIATION NEWS

W. J. McGONIGLE, President

RCA BUILDING, 30 Rockefeller Plaza, New York, N. Y.

GEORGE H. CLARK, Secretary

OUR Association will celebrate its Seventeenth Anniversary with a dinner-cruise at the Hotel Astor in New York City, and in other cities throughout the nation, on Saturday evening, February 21, 1942. This year's cruise will be the occasion of a special tribute by our Association to the heroic efforts of the radiomen in the various armed forces of our country.

We urge you to be present and add your tribute to the magnificent job being done by the present-day wirelessmen of the Army, Navy, Marine Corps and the Coast Guard and the wirelessmen of the American merchant marine. Remember, it is Saturday, February 21, 1942. Tickets, \$4.40.

RADIO MANPOWER

In a nationwide broadcast over the Blue Network of the National Broadcasting Company, on January 5, 1942, our Association sponsored an appeal to all radiomen to respond to the "Call to Arms."

George Hicks, announcer for NBC, opened the broadcast with the following: "In the public interest, the

National Broadcasting Company presents at this time a discussion program under the heading 'Radio Manpower Needed.' During the next fifteen minutes you will hear several speakers whose purpose it is to bring home to all of us the importance of professional and amateur radiomen and the nation's need of their services now. The first speaker is William J. McGonigle, president of the Veteran Wireless Operators' Association, who in addition to his own talk, will present other authoritative speakers on this subject of the need for radio manpower now."

Our prexy spoke of the fine spirit of service of all radiomen and the splendid part played by them in previous emergencies with particular tribute to the Army radiomen at Corregidor Island, the Navy radiomen at Pearl Harbor and the radiomen of the United States Marines at Wake Island. Mr. McGonigle then introduced Rear Admiral Randall Jacobs, an anti-submarine expert, who did notable work in the evacuation of Americans from the flooded Yangste Valley China. He is

now serving as Chief of the Bureau of Navigation in the Navy Department.

Admiral Jacobs, speaking from Washington, delivered a most inspiring appeal to radiomen to make their services available to the Navy. He spoke of the special ratings available to men trained in the radio art and the possibilities of rapid advancement and closed with "And the Navy needs them NOW." Then the program was switched to New York for our prexy's introduction of a pioneer of the Signal Corps of the Army, and a veteran of the last war who was designated by Major General Dawson Olmstead, Chief Signal Officer of the Army, to represent the Army, Colonel Otis K. Sadtler. He is now Chief of Army Communications in the Office of the Chief Signal Officer.

Speaking from the Washington studios of the National Broadcasting Company, he made an eloquent appeal to those able to serve in the armed forces of our country. He said in part: "There is also a big job to do for you radiomen who are ineligible for active military duty because of age, physical defects, or other lawful reasons. Your services are needed immediately in a civilian capacity, such as a radio operator at a corps area and other headquarters of the Army. Such volunteer radio operators would release the enlisted radio men for military duties." (Details of these positions can be obtained from the Civil Service Commission office in your local community.)

Mr. George W. Bailey, number one radio amateur in the United States, was then introduced by our president in New York. Mr. Bailey is now serving as Chairman of the Amateur Committee of the DCB and as Chairman of the Radio Section of the Office of Scientific Personnel in the National Research Council in Washington. Mr. Bailey stressed the need for the efforts of the vast army of amateurs throughout the country in the armed forces. He pointed out that already over ten thousand radio amateurs are in the Service. The program was concluded by an appeal from our president for the registration with our Association of all veteran wirelessmen who are still compe-

(Continued on page 28)



(Official U. S. Navy Photograph)

Left to right: G. W. Bailey of National Academy of Sciences; Rear Admiral R. Jacobs, Chief of Bureau of Navigation, and Colonel O. E. Sadtler of the Army Air Corps.



At Your Service...

★ UTC PLANT No. 2

Added manufacturing and engineering facilities that assure a continuance of UTC's fine performance record.

★ The LATEST UTC CATALOG

Incorporating a most complete line of transformers for communications, acoustic, instrument and industrial applications.

WRITE FOR YOUR COPY

UNITED TRANSFORMER CO.

150 VARICK STREET



NEW YORK, N. Y.

EXPORT DIVISION: 100 VARICK STREET NEW YORK, N. Y. CABLES: 'ARLAB'

NEWS BRIEFS OF THE MONTH . . . —

NAVY WANTS MORE RADIO LOCATER MEN

The Navy offers an exceptional chance to "get in on the ground floor" of radio locator applications, for detecting planes and other craft. Enlistment of radio technicians for specialized training and duty in connection with this new device is now under way.

In order to secure men who have had practical radio experience, first enlistments are being made in the rating of Radioman Second Class, Naval Reserve. This rating pays \$72 per month, plus complete clothing, food, lodging, medical and dental care, and all other Naval benefits. Married men receive an additional \$1.15 per day dependency allowance.

Applicants must (a) be male citizens between the ages of 17 and 50, (b) be a high school graduate, (c) hold or have held an Amateur Class A or B license, or, if no amateur experience, be actively engaged in radio repair or service work or have had experience with transmitting or receiving equipment.

Men selected will be sent to a Naval Training School for an intensive eight months course in mathematics and radio theory and its application to the locator devices. Pending completion of the Navy's new Radio Material School on Treasure Island in San Francisco Bay, students will attend the Radio Training School at Noroton Heights, Conn. (if enlisted, east of the Mississippi River) or Los Angeles, Calif. (if enlisted, west of the Mississippi River). When the Treasure Island school is ready to receive students, it is expected transfers will be made to that point.

Students who successfully complete the course of instruction may be recommended by the Officer-in-Charge of the School for advancement in rating up to and including Chief Radioman (at \$99 monthly, plus allowances).

This training and duty in connection with the new and secret radio locators will prove especially attractive to the man who wishes to make radio his profession, since it embraces a branch of the radio science which will have many commercial applications when the emergency is over.

All Navy Recruiting Stations are prepared to provide any additional details that interested, qualified radiomen may desire.

BROOKLYN POLYTECH ADDS WAR ENGINEERING COURSES

In recognition of the need under the existing emergency for the specialized training of graduate research workers the Graduate Division of Brooklyn Polytechnic Institute will conduct a series of intensive graduate courses in engineering science and management defense training. The first series, scheduled for completion in eight weeks of two two-hour evening sessions, beginning late in January, will comprise four courses and a seminar on ultra-short waves under the direction of Dr. Ernst Weber, research professor of electrical engineering.

Approved by the U. S. Department of Education under its defense training program, the courses will be the first to be offered in the United States at the graduate level on this phase of high frequency phenomena, in which the main emphasis of all defense research in radio communication centers.

An advanced training course in the

chemistry of powder and explosives has also been instituted. It is open to male students with three years of college chemistry, including one year of organic chemistry, who desire training as inspectors in powder and armament production. Courses will be under the direction of Professor Raymond E. Kirk, head of the department of chemistry. Both day and evening courses will be offered, requiring six and twelve weeks, respectively, for completion.

Four other defense training courses covering advanced work in aircraft jig and fixture design, aircraft lofting, tool design and die design to be given evenings only for fifteen weeks also have been scheduled.

U. S. MARITIME NEEDS MEN

The United States Employment Service of the Social Security Board, and the 1,500 State employment offices affiliated with it, have been charged with the task of securing applicants for free training courses leading to jobs in our merchant marine. Thousands of young men must be trained by the U. S. Maritime Commission during the next two years. Young men from 18 to 23 are needed to serve on U. S. merchant ships. Free training. Pay while learning to be a deck man, radio operator, steward or engineer. Free transportation, clothing, food and quarters. Jobs at high wages available after training. Ask for information at any State employment office, or write the United States Maritime Commission, Washington, D. C.

BOONTON RADIO CATALOG

A 32-page loose-leaf catalog has just been issued by the Boonton Radio Corporation, Boonton, New Jersey. The popular Q meters, QX checkers and many other new measuring instruments are illustrated and described in an effective manner.

NEW SOLA CATALOG WITH ENGINEERING DATA

Engineers will find a variety of useful transformer data in the new Sola catalog recently released by the Sola Electric Company, 2525 Clybourn Avenue, Chicago, Ill. Vector diagrams, load characteristic tables, power factor charts and other associated information have been included to assist in constant voltage circuit design.

ELLISON TO A.N.A. BOARD

Paul S. Ellison was elected to membership on the Board of Directors, Association of National Advertisers, at the recent Annual Fall Meeting.

He has been constantly active in the A. N. A. ever since he became advertising manager of the Brunswick-Balke-Collender Company in 1926.

Recently Mr. Ellison was promoted to position of Director of Advertising of the Hygrade Sylvania Corporation. At the present time he also is acting chairman of the A. N. A. Membership Committee and a member of the A. N. A. Display Committee.

WELLS JOINS UNIVERSAL

William W. Wells, U. of Washington graduate and the last three years with the

Colonial Radio Corp., Buffalo, in the research lab. and later as head of the testing department, has been appointed production manager for the output of the new defense orders at Universal Microphone Co., Inglewood, Cal.

UTC ISSUES NEW CATALOG

All types of audio and power transformers, filters, chokes, etc., are described and illustrated in the latest Transformer Component catalog released by the United Transformer Co., 150 Varick Street, New York City. The catalog also has a full-page reactance-frequency chart, decibels vs. voltage and power charts, transmitter circuits, tube combination tables, filter graphs, etc.

SOLAR'S MICA CAPACITOR CATALOG

Eighteen types of mica capacitors are described and illustrated in a colorful new 32-page Mica Capacitor catalog 12, section E, that has been issued by the Solar Manufacturing Corporation, Bayonne, New Jersey. Copies are available upon letterhead request.

NEW BEARING CATALOG ISSUED

Radial, pivot and special bearings in miniature precision sizes, are effectively described in a new catalog, number 41, just issued by Miniature Precision Bearings, Keene, New Hampshire. The smallest radial ball bearings in the world are shown and described in this new booklet.

NEW RCA INDUSTRIAL PA FOLDERS

Industrial adaptations of intercommunication systems have been effectively analyzed in a new series of folders, prepared by the Industrial Division, RCA Mfg. Co., Camden, N. J. Featured in these bulletins are interesting sound level charts.

CERAMICON BULLETIN

A bulletin describing the physical and electrical characteristics of Erie Ceramicon, is now available from Erie Resistor Corp., 640 W. 12th St., Erie, Pa. These small fixed capacitors with a ceramic dielectric, having coated plates of pure silver fired on at a high temperature provide compensation for frequency drift caused by temperature changes in other components. Their ability to perform this service is due to the fact that their capacity is inherently stable and their temperature coefficient is definite and entirely reproducible. The new bulletin on Erie Ceramicon gives the capacities available in various temperature coefficients ranging from + .00012 mmf/mm²°C to — .00075 mmf/mm²°C.

DON LEE-RCA TELEVISION PATENT INTERCHANGE CONSUMMATED

Consummation of a television patent interchange agreement between the Don Lee Broadcasting System and the Radio Corporation of America covering Don Lee broadcasting system patents of Harry R. Lubcke, director of television of that

organization, and include synchronization, scanning, cathode-ray tubes, and the transmission of motion pictures as well as living subjects by television, for both transmission and reception.

Agreement calls for a non-exclusive non-transferable license to RCA from Don Lee in return for a similar license for certain Don Lee equipment and a monetary consideration. Don Lee retains ownership of the patents and is free to license other organizations in the television field.

* * *

E. K. BARNES RETURNS TO UNIVERSAL

After an absence of three years, E. K. Barnes has rejoined the laboratory staff of the Universal Microphone Co., Inglewood, Cal. Author of a book on home recording, he was at one time assistant manager of KHJ, Los Angeles.

* * *

D'ALELIO APPOINTED G-E PLASTICS CHEMIST

Dr. G. Frank D'Alelio will serve as chemist of the General Electric plastics department. In his new post Dr. D'Alelio will be directly responsible for the direction and supervision of the plastics department with headquarters at One Plastics Avenue, Pittsfield, Mass.

* * *

E. E. LEWIS RCA V-P

Edward E. Lewis has been elected vice-president of the RCA Manufacturing Company. He will direct the activities of the Company's Finance and Accounts Divisions, and will continue in his former capacity as director of the Priorities Division.

* * *

SIESEL HEADS CROLITE PRODUCTION

William M. Siesel will direct the enlarged Crolite plant and expanded production activities. Siesel was formerly associated with the Elastic Stop Nut Corporation and the Wright Aeronautical Corporation.

* * *

BICKELHAUPT NOW V-P OF A. T. & T.

Carrol O. Bickelhaupt has been elected vice-president of the American Telephone and Telegraph Company, with special duties on National Defense matters.

* * *

SYLVANIA WAR EDITORIAL

An effective editorial entitled "This Is Our War," covering the importance of radio, appeared on the front page of the Sylvania News.

* * *

HIGH-FREQUENCY IRON CORE DATA

Facts, figures and curves dealing with the electrical and mechanical characteristics of various high-frequency powdered iron materials and cores has just been released by Henry L. Crowley & Co., Inc., 1 Central Ave., West Orange, N. J. The information is in loose-leaf form so that it may be added to from time to time as new powdered iron materials and new core shapes are made available. Due to the highly technical and specialized nature of the data, it is being made available only to engineers engaged in professional radio or allied work, writing in on their business stationery.

* * *

ASTATIC TO PUBLISH REPLACEMENT MANUAL

The Astatic Corporation will publish a
(Continued on page 26)

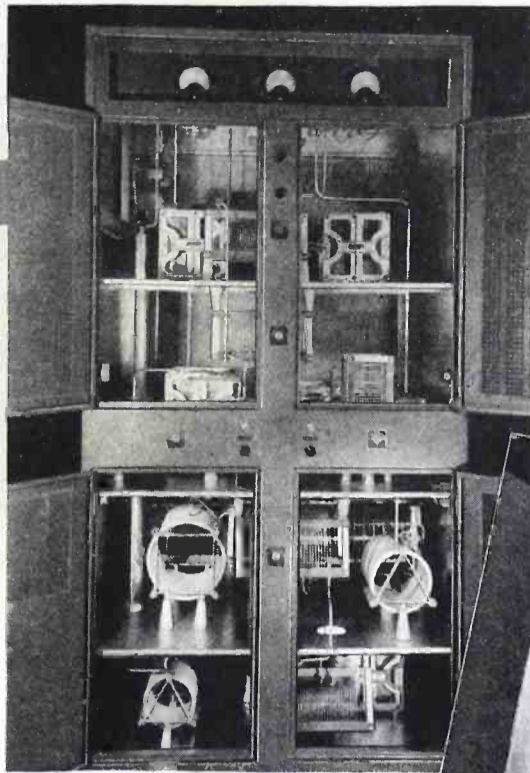

Phasing Unit supplied to WTMJ, Milwaukee Journal, Milwaukee, Wis. This unit was designed and built to meet their particular needs and specifications.

Antenna Coupling Unit for WTMJ, Milwaukee Journal, Milwaukee, Wis. Three such units were required.

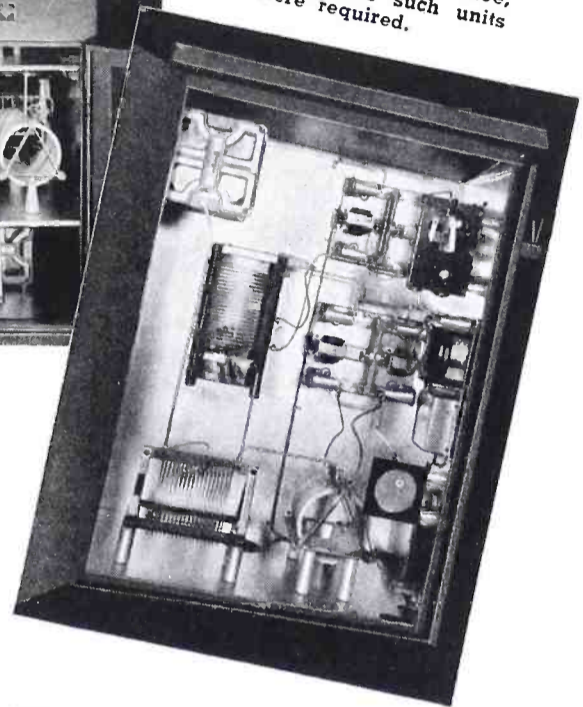

PRECISION ENGINEERING *at your service*

FOR YEARS Johnson Engineers have been designing and building precision apparatus to exacting specifications. They are prepared to design and build YOUR Phasing and Antenna Coupling Equipment to meet YOUR requirements. Write for a list of Johnson installations, or, better yet, send your specifications for recommendations and quotations. If you have other problems a letter from you will bring their help with no obligation on your part.

ASK FOR CATALOG 967E



E. F. JOHNSON CO

WASECA, MINNESOTA

EXPORT: 25 WARREN ST., NEW YORK, N. Y.

"MANUFACTURERS OF RADIO TRANSMITTING EQUIPMENT"

TO BUILD SPECIAL UNITS MORE EASILY

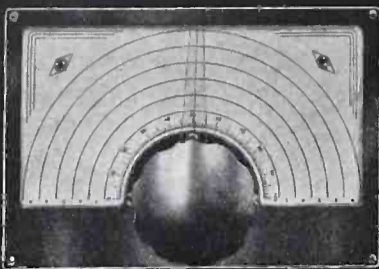

A DIAL DESIGNED FOR INDIVIDUAL CALIBRATION

TYPE ACN DIAL

- Dial bezel acts as drilling template.
- Blank scales for direct calibration.
- Index holes in pointer for pricking calibration points.
- Scale removable without dismounting mechanism.
- Employs Velvet Vernier Drive Unit.

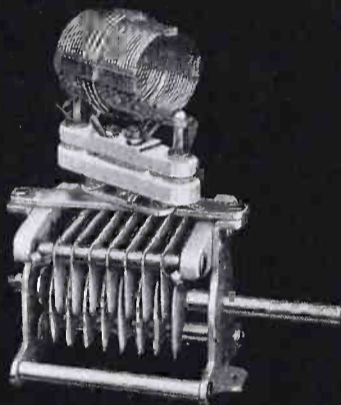

A UNIT COMBINATION OF COIL AND CONDENSER

TYPE AR-16 COIL & TMK CONDENSER

- Plug-in coils fit swivel mount.
- Air-spaced coils or plain coil forms available.
- Low loss construction throughout.
- Rigid condenser frame for permanent calibration.
- Condenser mounts on panel, chassis or standoff insulators.
- Condenser capacities to 250 mmf.



AN INSULATED COUPLING THAT WORKS AROUND CORNERS

TYPE TX-12

- Isolantite insulation.
- High quality flexible shafting.
- Fits 1/4" shafts.

NATIONAL COMPANY, INC.

MALDEN  MASS.

Phonograph Pickup Cartridge Replacement Manual for the convenience of jobbers, dealers, and radio servicemen. The use of this manual will afford the selection of the proper pickup cartridge for replacements.

* * *

W. C. WHITE DIRECTOR OF NEW G-E ELECTRONICS LAB.

William C. White has been appointed director of an electronics laboratory in which will be centralized General Electric's advance development activities.

Mr. White is a pioneer and authority in vacuum tube development work, and was engineer in charge of the vacuum tube division of the radio and television department of the company. He has been succeeded in this post by O. W. Pike as engineer, with R. W. Larson as assistant engineer.

* * *

ROLLER-SMITH APPOINTS NEW JOBBER

The Roller-Smith Company, Bethlehem, Pa. announces the appointment of the Electrical Jobber Equipment Company, 501 Fourth Avenue, South, Minneapolis, Minnesota, as its sales agent. The Electrical Jobber Equipment Company will handle the entire Roller-Smith line of products which include switchgear, oil, and air circuit breakers, and electrical instruments.

* * *

NEW PLASTICS MOLDING PROCESS

An interesting field of industrial, packaging and display applications, long restricted by excessive die costs and lately by priorities, is opened by a new molding process announced by Walco Plastics Company, 356 Glenwood Avenue, East Orange, New Jersey.

Utilizing newly discovered principles, the Walco process molds thermoplastic sheets in a variety of compound curves and angles that range in design from bomber noses or one-piece radio cabinets to seamless boxes or giant perfume bottle displays.

Materials which can be molded by the Walco process include acetate, methacrylate, ethyl cellulose and vinyl resin sheets, according to the requirements of any specific product. The dimensions of any seamless article are limited only by the size of the thermoplastic sheet, which ranges up to 40" x 60" in area and from .005" to .5" in thickness. Even larger sheets may be formed for national defense production, and there is a wide choice of transparent, translucent and opaque colors.

* * *

HYGRADE WINS SAFETY AWARD

A bronze plaque was awarded the Hygrade Sylvania Corporation by the National Safety Council in recognition of the excellent safety record marked up by the machine shop of the Emporium, Pennsylvania tube factory, for the year of July 1, 1940, to June 30, 1941. During that period, there were no lost time accidents.

The trophy was an award of the Metals Section of the National Safety Council. It was the first such honor won by the company in a national contest.

* * *

ROBERT M. KALB NOW ASSISTANT CHIEF ENGINEER OF KELLOGG

Robert M. Kalb, who for thirteen years was research engineer of the Bell Telephone Laboratory of New York, has just been appointed Assistant Chief Engineer of the Kellogg Switchboard & Supply Company of Chicago.

HARRINGTON APPOINTED

Lord Manufacturing Company, Erie, Pa., announces the appointment of George P. Harrington as sales and engineering representative for mid-western states. Mr. Harrington will represent Lord Bonded Rubber products in the mid-western states with headquarters at 844 N. Rush Street, Chicago, Illinois.

* * *

HALLICRAFTER'S NEW CATALOG

The 1942 catalog of Hallicrafters receiving, transmitting and radiophone equipment, recently released describes nine communications receivers and illustrates many popular models.

Three amateur transmitters described have outputs of 25, 100 and 450 watts and provide both phone and c.w. operation. All include band-switching of exciter circuits and operate on desired bands from 10 to 160 meters while one also includes 5-meter operation. Each is completely self-contained except that the 450-watt model has the speech amplifier and remote control equipment in a separate table-mounting cabinet for maximum operating convenience.

The marine radiophones range from a low-power, 3-channel model for harbor craft to a 50-watt ocean-going model which provides 5 transmitting and 6 receiving channels, all crystal controlled. Receiving channels are switch selected, as are the transmitting channels in all except the low-power model which includes a manually tuned receiver. A 110-18,000 kc. marine receiver and a compact radio compass round out the line of marine equipment.

* * *

RADEX MOVES

Radex Corporation has moved into larger quarters at 1308-22 Elston Ave., Chicago, Ill.

* * *

HARVEY-WELLS EXPANDS

Harvey-Wells Communications, Inc., Southbridge, Mass., have recently purchased the Precision Crystal Laboratories of Springfield, Massachusetts.

* * *

LEAR AVIA CLOSING N. Y. OFFICE

Because of centralization of activities in connection with National Defense, Lear Avia closed its New York office located at 30 Rockefeller Plaza on December 30, 1941. Sidney Nesbitt, Sales Manager, will henceforth be located at Lear Avia, Inc., Piqua, Ohio. Lazarre Gelin, Export Manager, will be located at 24 State Street, New York, N. Y., and Henry W. Roberts, Director of Public Relations, will be located at Lear Avia, Inc., Roosevelt Field, Mineola, N. Y.

* * *

NICKEL ALLOY SPRINGS DISCUSSED

"Relaxation Resistance of Nickel Alloy Springs" was the subject of a paper recently presented before the 62nd annual meeting of the American Society of Mechanical Engineers in New York City, by B. B. Betty, E. C. MacQueen of the Metallurgical Laboratory, and Carle Rolle of Technical Service Group, Development and Research Division, International Nickel Co.

In his presentation of the paper, Mr. Betty stated that as a result of a series of tests the authors determined the extent to which coil springs of several high nickel alloys, namely, Monel, K-Monel, Z-Nickel, and Inconel, retained their load-bearing capacity at elevated temperatures. Successive test temperatures from 300° F. to 700° F. were used, and there was established the range of temperatures over

which the above alloys, when relaxation is a criterion, may be applied.

* * *

McNAIRY PROMOTED

J. W. McNairy, who has been associated in various engineering and manufacturing capacities with the General Electric Company for 24 years, has been appointed assistant manager of the Bridgeport Works of the General Electric Company.

Mr. McNairy is holder of 39 patents, and twice recipient of G-E's Charles A. Coffin award.

Mr. McNairy's Coffin awards were granted in connection with the invention and development of an electrically-operated flow meter, and a high-speed air circuit breaker for railway feeder circuits.

* * *

ANGLE RE-ELECTED A N A DIRECTOR

Wesley M. Angle, president, Stromberg-Carlson Tel. Mfg. Co., Rochester, N. Y., has been re-elected as a director of the National Association of Manufacturers, to serve for the year 1942. Mr. Angle has been a member of the N. A. M.'s committee on employment relations.

* * *

UNIVERSAL'S NEW DEPARTMENT

Universal Microphone Co., Inglewood, Cal., has inaugurated a new department for stripping and re-coating of aluminum base recording blanks.

* * *

W. H. MILTON, JR., NAMED GE PLASTICS MANAGER

William H. Milton, Jr., has been named manager of the plastics department of the General Electric Company, Pittsfield, Mass., succeeding G. H. Shill, who becomes assistant to the manager of the appliance and merchandise department with headquarters in Bridgeport, Conn.

* * *

NEW GE SYNTHETIC PHENOL PLANT

Plans for the construction of a new \$1,000,000 plant in Pittsfield, Mass., by the General Electric Company, for the manufacture of synthetic phenol were announced recently by W. H. Milton, Jr., newly appointed manager of the G-E plastic department. This action is being taken at the request of the O. P. M. to counteract the shortage of phenol.

* * *

ATLAS APPOINTS NEW REPS

R. C. Reinhardt, sales manager of the Atlas Sound Corp., Brooklyn, N. Y., announces the appointment of Bruce L. MacPherson, 1919 Wells Street, Fort Wayne, to cover Indiana. L. D. Lowery, 401 N. Broad Street, Philadelphia, Pa., will cover Philadelphia; eastern Philadelphia; southern New Jersey; Maryland; Washington, D. C.; Delaware, and Virginia.

* * *

TURNER APPOINTS FOR CHICAGO

The Ralph T. Brengle Sales Company, 605 West Washington Blvd., Chicago, has been appointed sales representative for Turner microphones and accessories and the Turner line of vibrators, in the Chicago area.

* * *

BAKER JOINS RAINBO

Percival J. Baker, for the past twenty years a general accountant in Los Angeles, has become office manager of the Rainbo Record Co., manufacturers of instantaneous recording discs.

NEW SHURE BROADCAST DYNAMIC SUPER * CARDIOID

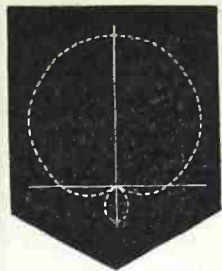

A New Concept
of Directional
Performance for
Broadcast Service



NEW — Wide Angle Pick-up—yet
Twice as Unidirectional
as the Cardioid

NEW — Single Moving-Coil Highly
Immune to Mechanical
Vibration and Wind Noises

NEW — Improved "Ultra"
Wide-Range Response
from 40 to 10,000 cycles

Model 556A for 35-50
ohms, Model 556B for
200-250 ohms, and Model
556C high impedance . . .
at only \$75.00 list.

* Patented by Shure Brothers

Now Available for Immediate Delivery

The newest, most advanced microphone available today for Broadcast service. The "Super-Cardioid" pattern first developed by Shure Engineers, together with the patented Shure Uni-phase* single-unit construction makes the big difference. It has the most unidirectional pattern in the limaçon family. It is twice as unidirectional as the Cardioid, from the standpoint of receiving front sounds and rejecting rear sounds, yet has wide-angle front pick-up. Decreases

pick-up of reverberation energy and random noise 73%. Improved frequency response assures full reproduction of music, crisp reproduction of speech. The axial polar pattern is symmetrical at all frequencies. It's the ideal answer for studio and remote microphone problems.

Broadcast Engineers: You can have the "Super-Cardioid" for 30-day free test in your station without obligation. Write us today.

SHURE BROTHERS, 225 W. Huron Street, Chicago, U. S. A.

"Microphone Headquarters"

SHURE

New York's Largest Available Stock of
RADIO and ELECTRONIC EQUIPMENT
 At Our NEW ADDRESS
85 CORTLANDT STREET

FOR BETTER SERVICE to our patrons, under present conditions, we have consolidated our large stocks of radio parts and equipment from our two New York Stores into one huge new shop at 85 Cortlandt Street—12,000 square feet on one great floor. This move will enable us to furnish prompt and complete deliveries of essential merchandise, and at the same time enable us to cooperate in the National Effort most effectively.

Visit our new, modern home and see the very latest innovations in radio merchandising. See for yourself the tremendous stock under one roof. And be convinced that here is your most dependable service of supply in the radio field.

For your convenience we are maintaining an uptown store for radio sets, phonographs and records only at 70 West 45th Street under the management of Jack Haizen.

Make Terminal your headquarters for everything in radio.

TERMINAL RADIO CORP.
85 CORTLANDT ST. • NEW YORK CITY
 TELEPHONE: WOrth 2-4416

T-PADS

For Speech Input Equipment

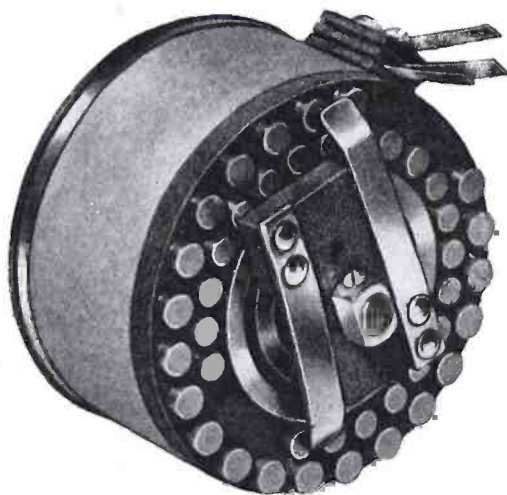

A complete line of speech input controls, Time tested—second to none—at Competitive prices.

Embody years of engineering and production experience. Hundreds of satisfied customers. No exaggerated claims . . . but what we make will give you lasting and trouble-free service.

Also light and heavy duty tap switches—special control to your specs.

• Write for bulletin 411. Complete catalogue upon request.

TECH LABORATORIES
 7 Lincoln Street Jersey City, N. J.

VWOA NEWS

(Continued from page 22)

tent at copying Continental code. The mail response was nationwide, from Maine to Florida and Virginia to California.

We now repeat that request to all veteran wirelessmen, particularly those now serving in non-vital industries. There is NOW an urgent need for your services, and as our nation's war effort develops more of the younger radiomen will be members of the various field forces. The entire mail response has been turned over to the government agencies interested and those writing should receive word in the very near future. REGISTER your qualifications with VWOA at Radio City, N. Y. We are most grateful for the response thus far. In the words of our Commander-in-Chief, "IT CAN BE DONE—WE WILL DO IT."

CONGRATULATIONS

Our sincere congratulations to Mr. Arthur F. Van Dyck, a life member of our Association, who assumed the presidency of the Institute of Radio Engineers at their recent convention in New York City.

THE INDUSTRY OFFERS

(Continued from page 18)

describing this development, is available from the International Resistance Company, 401 North Broad St., Philadelphia, Pa.

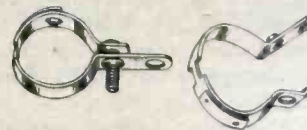

* * *

METAL DUPLICATING WITHOUT DIES

A method of making small metal parts in limited quantities is made possible by the use of a "DI-ACRO" bender, brake and shear, made by the O'Neil-Irwin Mfg. Co., 322 8th Ave. S., Minneapolis, Minn. These precision machines are said to be accurate to .001".

Bends can be of varying radii. Three machines comprise a system of almost unlimited possibilities for metal duplicating without dies, yet retaining die accuracy. The bender also handles round, half-round, square or flat wire, round or square tube, rod, etc. All the machines are adapted for either right or left hand operation.

* * *

OVERTRAVEL TYPE ACROSAP SWITCH

An overtravel type switch has recently been placed in production by Acro Electric Co., 3174 Fulton Rd., Cleveland, Ohio. Overtravel of at least 1/16" is provided, though the amount of this used for actuation remains at 1/1000", as in the standard pin plunger type.

All other features are the same as in the pin plunger type switch and include the new principle of the rolling spring. It also provides high operating frequency and high contact pressure.

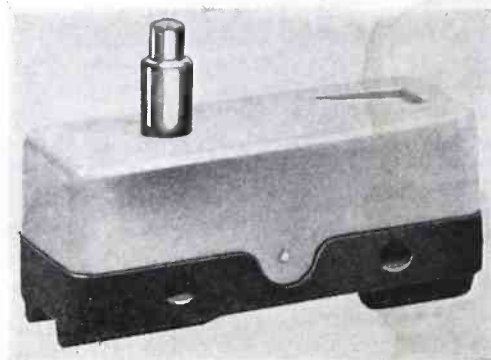

LITTELFUSE'S SPARE FUSE HOLDER AND PULLER

To facilitate changing fuses in close quarters; replacing a blow fuse in a twinkling, and giving notice on inspection that another spare is required, a Spare Fuse Holder & Puller combined is now being made by Littelfuse, Incorporated, 4797 Ravenswood Ave., Chicago.

The fuse in circuit goes through one end of the soft rubber rectangular holder, between the clips. Above, and at right angle, is an opening in the holder for the spare fuse. When inserted, the caps of the spare fuse project beyond the holder affording an easy grip for two fingers.

When the fuse in circuit blows, all the operator has to do is to pull and reverse the holder. This puts the spare fuse in circuit and brings the blown fuse on top

IRE CONVENTION REPORT

(Continued from page 21)

in the same position that the spare was in before. One end of the Littelfuse Holder & Puller is painted red. Until a fuse change is necessary, the red end is underneath, out of sight. When a reverse is made, putting the spare fuse in circuit, the red end is brought into full view on top. Windows in the Spare Fuse Holder & Puller keep the elements of both fuses in view at all times.

The device is made in two sizes—No. 1422 ($\frac{1}{2}$ " x $\frac{1}{2}$ " x $1\frac{5}{16}$ " long for 4 A G fuses, and No. 1378 ($\frac{5}{8}$ " x $\frac{5}{8}$ " x $1\frac{3}{8}$ " long) for 5 A G fuses.

* * *

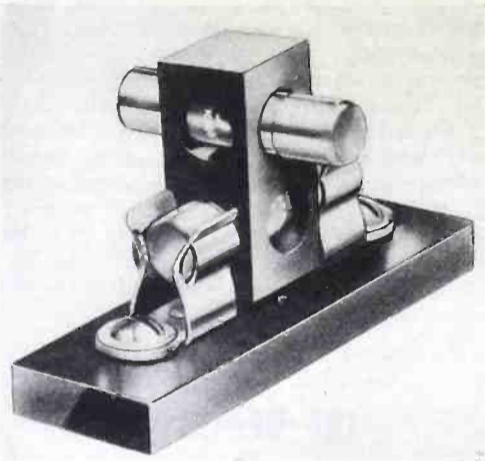

* * *

SHALLCROSS' UNIVERSAL BRIDGE

A new measuring instrument, a Universal Bridge, for measurement of resistances from one to 1,111,110 ohms, with a selection of tolerance percentages from 0.25% to 10% has been developed by the Shallcross Mfg. Co., Collingdale, Pa. The plus and minus tolerances may be set individually and independently of each other. The actual resistance of the units under test can also be measured.

The working standard may consist of 6 decades totaling 1,111,110 ohms, variable in one ohm increments—or any other range dictated by the user's particular requirements. This instrument is completely self contained. For measuring low resistances, there is a standard No. 6 dry cell; for higher resistances, an AC operated rectifier tube. The galvanometer has a sensitivity of one microampere per millimeter division.



* * *

COAXIAL VERTICAL ANTENNA

A $\frac{1}{2}$ -wave Coaxial Vertical Antenna, both transmitting and receiving, has been announced by the Wunderlich Radio Company, Chicago, Ill. It is shipped cut for operating frequency and requires no matching network and no tuning. May be had from 30 to 200 megacycles.

A $\frac{7}{8}$ " copper transmission line coming (Continued on page 34)

changing the phase angle of an impedance. For in this plane are the application of tubes for the production of negative resistance and of effective capacitive reactance without the use of capacitance or of inductive reactance without the use of inductance, said Herbert J. Reich, Professor of Electrical Engineering, the University of Illinois.

Parallel Circuit

A parallel type of circuit in which a vacuum tube may be used to change the magnitude or phase of an impedance is shown in Figure 12. It is also possible to vary the phase angle by the grid bias of this tube. This circuit has its principle application in automatic tuning and in f-m. Although triodes are shown in Figure 12, the plate and grid may be replaced by any two electrodes of a multielectrode tube, if the control electrode is maintained sufficiently negative to prevent the flow of electrons to it. As a matter of fact, said Professor Reich, the plate and grid may be replaced by the screen and suppressor respectively of a pentode, with the plate and first grid voltages being maintained constantly. In Figure 13 we have another type of circuit that may be used in changing the phase angle or magnitude of an impedance. This is done by a use of inverse feed-back and with a low impedance in the final stage of the amplifier. In this way the voltage amplification u' is made independent of r_1 and c_1 throughout the frequency range in which the circuit is to be used.

Variation of Phase Angle

In a third type of circuit, the phase angle of an impedance may be varied, as shown in Figure 14. Since the plate resistance of the tube may be adjusted by means of the voltage of one or more grids, the effective reactance and resistance between A and B may be controlled by a voltage, continued Professor Reich. This circuit does not have a variety of applications since it does not give an inductive reactance when x_1 is capacitive. This is because it does not afford a negative effective resistance since the effective capacitance is always less than the capacitance of x_1 . In addition, the effective shunting resistance cannot be infinite.

By the use of an inverse-feedback amplifier, said Professor Reich, it is possible to obtain very large effective capacitance or very low negative resis-

tance, the magnitudes of which may be varied by means of the amplifier gain.

500 MC RELAY SYSTEMS

PROBLEMS involved in design of a system operating above 500 megacycles in a point-to-point relay network, was analyzed by J. Ernest Smith of RCA Communications. Particular reference was made to experiments in which television signals were successfully transmitted through several unattended radio repeaters without demodulation and remodulation in the repeater equipment.

Interesting formulae and illustrative diagrams representing the methods adapted to achieve these data, are shown in Figures 15 and 16.

In Figure 15, a typical radio relay configuration is shown wherein T and R are, respectively, transmitting and receiving points. The formula represents the loss in one link of the radio relay chain which must be off-set by the gain of one repeater.

The shaded area of Figure 16 is a band pass channel representing only a portion of the total modulation spectrum. The formulae give the signal-to-noise ratios in two double modulation cases; namely, (1) when the sub-carrier is amplitude modulated and the radio frequency carrier is amplitude modulated, and (2) when the sub-carrier is frequency modulated and the radio frequency carrier is amplitude modulated.

AN INTERFERENCE ANALYSIS

MANY interesting studies on the generation of combination signals in the presence of strong fields of broadcast stations have been made lately, particularly since the advent of higher power stations. Analyses have been made in various parts of the country with specific emphasis on those sections where the sum frequency have fallen in some band of popular usage. Such was the instance of study of signal generation of stations WILL and WDWS in the area of Champaign and Urbana, Illinois, by A. James Ebel, Chief Engineer of station WILL of the University of Illinois. In his talk on the Source of Spurious Radiations in the Field of Two Strong Signals, he pointed out that the sum of the signal generated by 5,000 watt WILL (580 kc) and 250 watt WDWS (1370 kc*)

(Continued on page 30)

BOOK REVIEWS

PRINCIPLES OF ELECTRON TUBES

By **Herbert J. Reich**, Professor of Electrical Engineering, University of Illinois. . . . 670 pp. . . . New York: McGraw Hill Book Co. . . . \$5.00.

For the student or engineer interested chiefly in the electron tube as a working tool and its corresponding industrial application this volume will prove most helpful. From a treatment of electron dynamics in the first section the student is brought step by step through the development of cathode theory and practice, basic plate circuits, grid and multi-grid control problems, to a capable exposition of the series expansion method of vacuum tube analysis. Graphical solution of vacuum tube problems is more thoroughly developed than in most texts as is the treatment of equivalent circuits.

Basic amplifier problems are posed and clarified, together with practically all the types of vacuum tube circuits to be met with in practice. Methods of analysis are illustrated for the solution of the various circuit applications.

The field of glow and arc discharge tubes is likewise very thoroughly covered and includes the theory of conduction in gases as well as a study of methods of control and of problems that may be met in practice. Similar treatment is made of photosensitive tubes and cells illustrated by many diagrams of possible circuit applications.

A short section on rectifiers and filter requirements and a description and analysis of the basic circuits of elementary electron tube instruments complete the volume. The bibliography covers over one hundred items and provides references in every field touched in the text.

Taken as a whole the volume is unusually complete and logical in the development of its subject and provides a solid groundwork upon which to base the field of industrial electronics.—*JRS*

THE RADIO HANDBOOK (8th . . . 1942 Edition)

By the Editors of Radio. . . . 640 pp. . . . Santa Barbara, Calif.: Editors and Engineers, Ltd. . . . \$1.75 (cloth bound).

The Radio Handbook is a general compilation of information on the practical aspects of radio. Its content can be divided into three classifications: (1) basic theory of electricity, radio, vacuum tubes, and antennas, written from the standpoint of practice rather than from the engineering viewpoint, (2) constructional information on the building of a wide variety of types of high frequency u.h.f. transmitters and receivers for phone and c.w. use, coupled with information on the construction of many useful pieces of test equipment, (3) tube characteristic

tables, references charts and graphs, and a collection of formulas useful to the practicing radioman.

The Radio Handbook is an effective compilation of all types of transmitting, receiving and special-purpose tubes. Both transmitting and receiving tubes are listed in the order of their assigned number.

There are 27 chapters, arranged as follows: Introduction to Amateur Radio; Fundamental Electrical and Radio Theory; Vacuum Tube Theory; Radio Receiver Theory; Radio Receiving Tube Characteristics; Radio Receiver Construction; Transmitter Theory; Radiotelephony Theory; Frequency Modulation; Transmitting Tubes; Transmitter Design; Exciters and Low Powered Transmitters; Medium and High Power R. F. Amplifiers; Speech and Modulation Equipment; Power Supplies; Transmitter Construction; U.H.F. Communication; U.H.F. Receivers and Transceivers; U.H.F. Transmitters; Antenna Theory and Operation; Directive Antenna Arrays; U.H.F. Antennas; Transmitter Adjustment; Test and Measuring Equipment; Workshop Practice; Broadcast Interference, and Radio Mathematics and Calculations. There are also the three additional sections in the back of the book devoted to Appendix, Buyer's Guide, and Index. Illustrations and diagrams . . . 577 . . . with 41 tables.—*OR*

RADIO AMATEUR'S HANDBOOK (1942)

By the Headquarter's Staff of the ARRL. . . . 552 pp. . . . West Hartford, Conn.: American Radio Relay League, Inc. . . . \$1.00 (paper bound) . . . \$2.50 (buckram bound).

The general plan of the book has been revised to meet the growing need for a simple and nonmathematical text on the theory, design and operation of radio communication equipment, as well as to provide the constructional information on amateur equipment. To this end the Handbook is divided into two main parts, following the customary introductory chapters on what amateur radio is and how to go about becoming an amateur.

The first section, consisting of nine chapters, is devoted to the essential electrical fundamentals, the principles of vacuum tubes and their operation, methods of generating power, transmitter keying, methods of modulation and adjustment of modulated transmitters, radio reception, means of obtaining power supply, principles of wave propagation, and antenna systems.

The second part, dealing with construction of equipment, has eight main chapters on the subjects of receivers, transmitters, modulation equipment, u-h-f receivers and transmitters, portable and emergency equipment, antennas, and measuring gear.

The chapter on transmitter construction has undergone revision and coordinates power supply and r.f. equipment. Twenty

transmitter units are described.

A discussion of the various types of portable and emergency power supplies is given in the chapter of that name, as well as a tabulation of the commercial units available and a description of a 35-watt a-c/d-c power supply for portable emergency use.

The u-h-f section covers u-h-f receiving equipment including converters for use in conjunction with communications receivers.

A chapter on measurements and measuring equipment covers frequency measurements in all its phases—absorption frequency meters, Lecher wires, heterodyne frequency meters, secondary standards, etc.

In addition to the two main parts of the book described above, there are four additional chapters on workshop practice, tube characteristics and miscellaneous data, operating a station, and radio regulations. Tube tables, complete RMA color code data for all types of radio equipment, new charts and tables of miscellaneous useful information and a chapter on regulations with a table showing all U.S. frequency assignments from 10 m-c to 300 m-c by services are also included. There are approximately 680 illustrations and over 100 charts and tables.—*OR*

IRE REPORT

(Continued from page 29)

happen to fall in the 1.8 mc amateur band.

All measurements were made with a portable loop battery receiver with a-v-c removed and an output meter installed instead. In the tests, it was found that metal structures in or about the area under study exhibited a trace of the combination signal. For instance, a 140 foot galvanized windmill tower grounded to a buried grid of wires was one of the points at which traces of the signal could be found.

Generally speaking, said Mr. Ebel, it was found that most spurious radiations, in the field of two strong signals, are generated in the receiving antenna system. This is particularly true in an AC receiver that is not grounded for the electrical distribution ground systems are excellent rectifiers. An antenna system balanced against a ground, either using a loop or matched transmission, seems to be a solution, said Mr. Ebel. In conclusion, Mr. Ebel said that the possibility of a receiving antenna generating combination signals of a nonlinear element acting as a secondary source of these signals, depends on the extent of the nonlinearity of the impedance, the effective heights of the conductors, and the impedance of the conductor at the combination frequency as well as the field product. Thus, the field product cannot always be used as a criterion for the occurrence of objectional interference from such a source.

* WDWS now operates on 1400 kc, as a result of the frequency shift ordered under the North American Regional Broadcasting Agreement. Thus the difference frequency now appears at 820 kc.

(Continued on page 32)

PORTABLE DESIGN

(Continued from page 12)

is less important than the other considerations.

It is best to set the coupling of the second transformer to $W_{10} W_2$ (ratio of band width at 10 times down to band width at 2 times down) = about 2.5. Then the coupling of the first transformer should be adjusted to the same value on a vacuum tube voltmeter. Stabilization should be then added in the form of filament by-passes and filters until the correct degree of stabilization is obtained. In one design it was possible to get an i-f stability averaging 3%, having an average i-f sensitivity of 63 uv (Figure 7).

The i-f's on this type of set should be trimmed through the antenna coil, or the loop, or a dummy loop. Trimming at the converter grid makes a difference in trimming, depending on where the low potential end of the generator is connected. After some stability is reached, the i-f should be trimmed from the antenna or loop. Then, with the generator on the converter grid, the negative point which gives the same trimming as overall should be found. This may be the converter negative filament, negative of the string, or some other negative point. Readings of i-f sensitivity and selectivity should be taken at this point. If the i-f is trimmed at the converter grid with the negative of the generator to an arbitrary negative point, the overall sensitivity of the set may not be maximum, and may be far from maximum. In addition, the signals may be swishy because the i-f's are off trim. This makes the i-f tube grid-to-plate feedback worse.

In stabilizing these sets an indication of the points that need by-passing can be arrived at by putting the generator between different negative points (chassis, filament points, a-v-c points) and noting where the maximum sensitivity at i-f is obtained.

It is best to use fairly low inductance i-f's (1.8 mh. maximum) for stability, because of other couplings adding to the grid-to-plate coupling of the i-f tube.

In the miniature i-f's using powdered iron pots, it is best to have the axes of the cores parallel instead of in a line, for two reasons. First, if they are in line, the pots form a good shield and the coupling will be almost entirely capacity, which varies considerably. If they are parallel, there is an opening where the cores fit together, which allows the magnetic field to radiate. Second, for capacity aiding, the plate and grid are both inside, cutting down capacity coupling. Units made this way are very uniform. The i-f plate filter to

Bliley CRYSTAL UNITS



*Engineered Reliability
— Guaranteed Accuracy . . .*

BLILEY precision-made Crystal Units are supplied for all frequencies from 20Kc. to 30Mc. Catalog G-12 contains complete information.

BLILEY ELECTRIC COMPANY
UNION STATION BUILDING ERIE, PA.

JONES 500 SERIES PLUGS AND SOCKETS

Designed for 5,000 volts and 25 amperes. All sizes polarized to prevent incorrect connections, no matter how many sizes used on a single installation. Fulfills every electrical and mechanical requirement. Easy to wire and instantly accessible for inspection. Sizes: 2, 4, 6, 8, 10, and 12 contacts. Send for a copy of Bulletin 500 for complete information. Write today.

HOWARD B. JONES

2300 WABANSIA AVENUE, CHICAGO

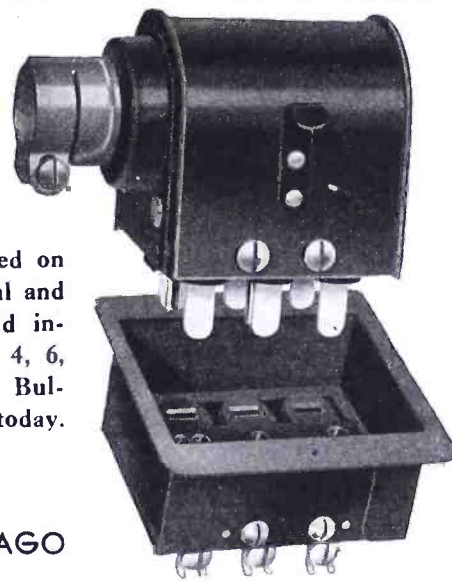

ground helps a lot with these small units.

The one-volt line of tubes and their lock-in equivalents have very sharp cut-offs so that the B drain will be small. It is very hard to get good high level characteristics with these tubes because it is difficult to apply a-v-c to them and get satisfactory results. However, the saving in B current far overshadows this difficulty. It is important to remember that the miniature one-volt line of

tubes have remote cutoff characteristics and thus very high current consumption, especially at 67.5 volts B, which is now widely used in miniature portables. Dropping the 1T4 screen lowers the current drain with some loss of gain and uniformity.

There are many possible combinations that can be used in these sets, but the arrangement discussed will give good performance with little possibility of troubles occurring.

NEW PROGRAM SWITCHING METHOD

(Continued from page 7)

white lamp on the cue panel. Relay C, in turn, operates relay "D," thus establishes a path to the L relays of the preselection circuit over which the switch will ultimately be made, and holds itself operated through another winding.

When a monitor hears a cue indicating the end of a program period, he operates his cue key if his white "cue ready" lamp is lighted. This lights the red "cue sent" lamp at the monitor's position, and the G relay associated with his multiple on the cue panel. The operation of G releases all operated A relays of that multiple, and these, in turn, release their associated C relays. Since the D relays of all lines involved in the switch were operated by the previous operation of their associated C relays and were locked in through their own contacts, the release of the C relays closes ground to the CU leads of the associated line circuits of the preselection panel. These ground connections operate a group of relays not shown on Figure 4, and these first release all operated L relays associated with their lines, and then, either immediately or after a three-second interval, depending on the circuits involved, operate all L relays associated with preselected A relays. The operation of L releases the A relay, extinguishes its white lamps, and lights the red lamp on the preselection panel.

To illustrate the usefulness of the cue panel, consider the situation where line 1, connected to multiple A, is to be transferred to multiple B for the next program, but the transfer is not to be made until the program on multiple A is completed. On the preselection panel the control unit at the intersection of line 1 and multiple B will be operated, and on the cue panel, the control unit at the intersection of line 1 and multiple A. When the attendant operates his master cue key, the C relay of line 1 (Figure 5) will be operated through the contacts of the A cue relay of line 1 for multiple A, which has been operated through the cue control unit. When the monitor on B multiple hears the cue indicating the end of his program, assuming this finishes before the program on the A multiple, he operates his cue key. This will have no effect on any of the relays of line 1 because the cue relay at the intersection of line 1 and multiple B is not operated. When the monitor of multiple A operates his cue key at the end of his program, however, the C relay of line 1 will be re-

leased, and line 1 will be switched to multiple B as preselected.

Had it been desired to hold line 1 with network A until that program had ended, and then not connect it to network B until the new program on that network was ready to begin, a double cue would have been set up. The cue control units at the intersections of line 1 and networks A and B would both have been operated. This would prevent the actual switching of the lines until the desired conditions had been fulfilled, because the C relay of line 1 will not release until the cue keys for both multiples A and B have been operated.

With this equipment the proper preselections and cues may be set up and checked at leisure during the program period. Shortly before the end of the period the attendant operates his master cue key, which lights white lamps at all monitor positions that are involved in program switches. As the monitors with lighted cue-ready lamps hear the cue indicating the ends of their programs, they operate their cue keys. The white lights on the cue panel go out as the monitors for the various multiples operate their cue keys, and thus indicate to the attendant that the cues have been attended to. The white lights on the preselection panel go out, and the red lamps light, as the actual line switch is made following the operation of a monitor's cue key for the



Figure 7
At post, at one of the monitoring positions.

multiple in which the cue lamp was lighted.

The system is very flexible in that the number of lines or multiples may be readily increased without interfering with existing wiring. When all positions are filled in one panel, additional panels may be added either above or at one side of it. Since all operations are performed by momentary contact closures, the circuit is readily adaptable to remote control, and certain installations of this type have been made. Experience in the field indicates that the design objectives of this new equipment have been very satisfactorily met.

IRE REPORT

(Continued from page 30)

SIGNAL TO NOISE ANALYSIS

An elementary analysis of the effect of the various sources of fluctuation noise on signal-to-noise ratio, particularly on u-h-f radio receivers was given by E. W. Herold of RCA Manufacturing Co. In this discussion, it was pointed out that the signal-to-noise ratio depends on the antenna noise; in addition, when bandwidth is not a consideration, it depends on the ratio of equivalent noise resistance to input resistance of the first tube, and, when bandwidth is a major consideration, on the product of input capacitance and equivalent noise resistance. Mr. Herold also showed how the coupling from antenna to first tube is an important variable in receiver design and how an optimum coupling may be found, which results in an improvement in signal-to-noise ratio. This optimum condition is often considerably different from the adjustment for maximum gain and, by its use, the noise induced in the grid becomes relatively unimportant. The noise from the second stage of the receiver was also evaluated. Discussed, also, was the thermal noise from a wideband interstage circuit that may be made negligible by concentrating all the damping on the secondary side.

CRYSTAL CONTROLLED OSCILLATOR

The results of a theoretical and experimental investigation of two types of bridge-stabilized oscillators incorporating a thermal device for amplitude control as developed in Bell Labs were also discussed. One circuit employing resistances and capacitances in the frequency-determining network and well adapted to low-frequency operation, and the other circuit using an inductance-capacitance network which adapts itself to the higher-frequency range was described.

IT BENDS EVERYTHING!

It's the "DI-ACRO" Bender No. 1, which together with "DI-ACRO" Brake and Shear turn out small quantities of metal parts in a hurry — "Metal Duplicating without Dies."

"DI-ACRO" Bender works wonders with Angles — Channel — Rod — Round or Square Tube — Round, Half-round, Square or Flat Wire and Strip Stock. TWO-WAY OPERATION —

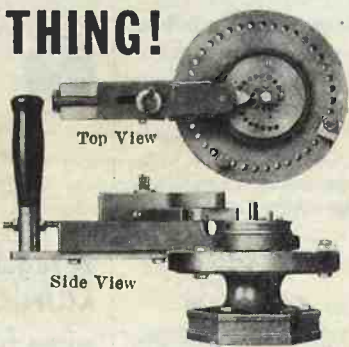

right or left. It's a money-saving die substitute.



Write for Catalog
"METAL DUPLICATING WITHOUT DIES"
O'NEIL-IRWIN MFG. CO. 322 8th Ave. So., Minneapolis, Minn.

CRYSTALS by HIPOWER

The Hipower Crystal Company, one of America's oldest and largest manufacturers of precision crystal units, is able to offer the broadcaster and manufacturer attractive prices because of their large production and the exclusive Hipower grinding process. Whatever your crystal need may be, Hipower can supply it. Write today for full information.

HIPOWER CRYSTAL CO.

Sales Division—205 W. Wacker Drive, Chicago
Factory—2035 Charleston Street, Chicago, Ill.

AMATEUR



COMMERCIAL

UNCONDITIONALLY
GUARANTEED

WRITE US
FOR PRICES

CRYSTALS EXCLUSIVELY SINCE 1934

PETERSEN RADIO CO., Council Bluffs, Iowa

EVERY REFLEX SPEAKER
Has a special place in
NATIONAL DEFENSE SOUND SYSTEMS
If: It's **SUPER POWER** Speech Projection
If: It's **ULTRA COMPACT** Police Emergency Sound
If: It's Outdoor **"BLACKOUT"** Sound Systems or
If: It's Indoor **DEFENSE FACTORY** call systems
UNIVERSITY has a specially designed model for every defense installation.
FOR SOUND NATIONAL DEFENSE specify
UNIVERSITY LABS
195 Chrystie St. New York City

MANUFACTURERS

Thousands of technical engineers associated with the radio, television, broadcast, recording and two-way communications fields—commercial and governmental—want to read about your new products in COMMUNICATIONS. Send complete data to the editor.

OHMITE STEPS UP PRODUCTION OF Rheostats · Resistors · Tap Switches

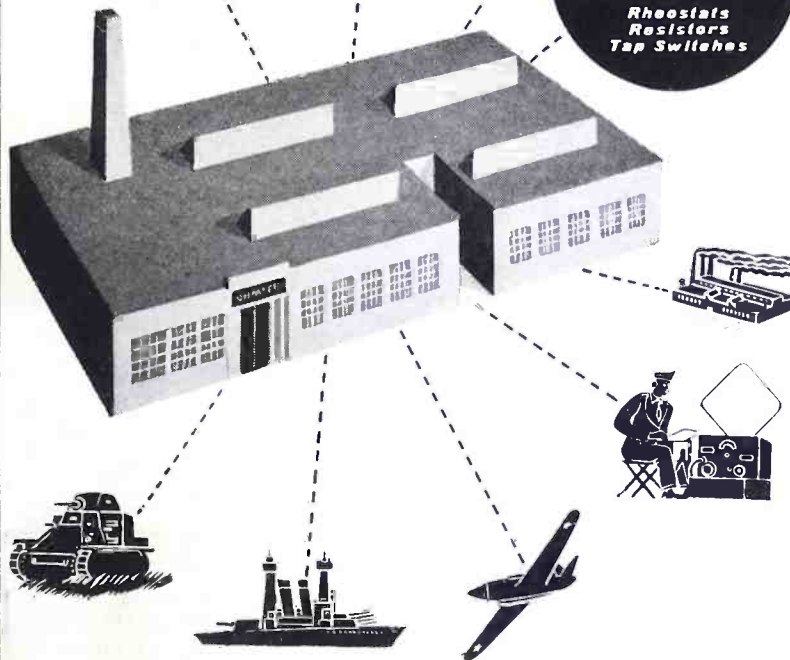
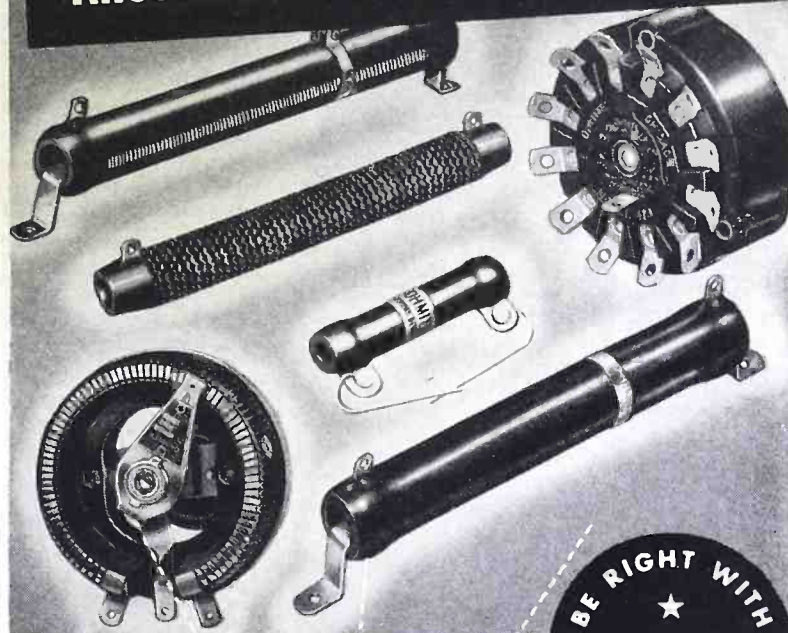

Ohmite is ready for the job ahead. Expanded factory facilities are operating day and night with increased momentum to produce more units, more quickly for Industry and the Armed Forces, for the planes, tanks, ships and other equipment the Nation needs for Victory.

The design and construction of Ohmite Rheostats, Resistors, Chokes and Tap Switches insure utmost dependability. The wide variety and extensive range of types and sizes in stock or special units make it easier to answer your exact needs. Ohmite engineers are glad to help you.

Send for 96-page Catalog and Engineering Manual No. 40.

Most complete, helpful guide in the selection and application of resistance units. Write on company letterhead for your copy.



OHMITE MANUFACTURING CO., 4869 Flournoy St., Chicago, U. S. A.

OHMITE *Marches with the Nation!*

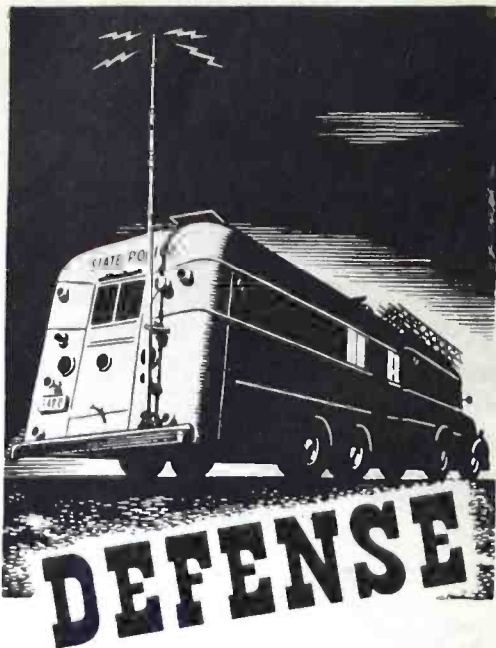

In Mobile Police Service

PREMAX ANTENNAS are doing their bit in police service—the special telescoping adjustable verticals for mobile broadcasting stations—the special police type on prowler cars.

Get the special bulletin illustrating standard Antennas and Mountings.

Premax Products

Division Chisholm-Ryder Co., Inc.
4213 Highland Ave., Niagara Falls, N. Y.

AMERICA IS PROTECTED



POWER by PINCOR

- ★ DYNAMOTORS ★ D. C. MOTORS
- ★ CONVERTORS ★ POWER PLANTS
- ★ GENERATORS ★ GEN-E-MOTORS

Power Supply **PINCOR** Products Equipment

PIONEER GEN-E-MOTOR

CHICAGO, ILLINOIS
Export Address: 25 Warren Street, N. Y., N. Y.
Cable: SIMONTRICE, New York

(Continued from page 29)

from the transmitter-receiver is coupled to the line section supplied with the antenna. The inner conductor of the line is electrically continuous with and feeds energy to the top $\frac{1}{4}$ -wave whip section. A gas-tight end bushing is assembled at the center, which protects the line from breathing moisture, thus preventing high loss and line failure.

* * *

POWER PLANTS FOR $7\frac{1}{2}$ TO 15 KW

Power plants are now available in $7\frac{1}{2}$ and 10 kw sizes at 1200 or 1800 rpm and in 15 kw sizes at 1800 rpm from the Kato Eng. Co., Mankoto, Minn.

These models are available with either self-excited or with separate exciter attached. The self-excited type can be made self-cranking by connecting to 18 or 24 volts of battery.

The driven end of Katolight armatures on all four cylinder plants is carried on a pilot bearing which keeps armature core centered up or concentric with engine crankshaft. Torque is transmitted from engine to armature through heavy driving pins which are set in rubber bushings with metal liners.

Engine is of the four-cylinder, 4-cycle, watercooled type with radiator, fan and centrifugal pump. Includes exhaust and muffler, governor with variable speed control, pressure lubrication system with gear type pump and pressure gauge, oil filter, gasoline carburetor, screen type air-cleaner, 12-gallon fuel tank, 7 qt. oil capacity, 4-gallon water capacity, gasoline filter, high tension magneto with impulse starter coupling, spark plugs, ignition cables and switch all enclosed in heavy gauge sheet steel housing. Shielded for radio operation.

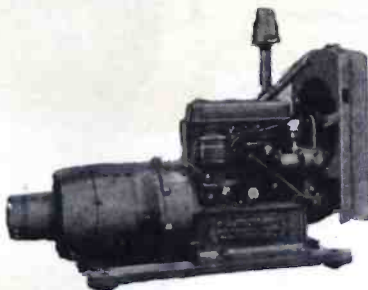

* * *

LOW POWER CONCENTRIC TRANSMISSION LINE TERMINATIONS

Concentric disc resistors now being supplied by the International Resistance Company, Philadelphia, Pa., are said to afford pure resistance loading of low power concentric transmission lines.

Available in a variety of sizes and resistance values, these concentric disc resistors have a minimum of inductance and capacity.



* * *

ARMORED POWER RHEOSTAT

An armored type 25 watt power rheostat is now made by Clarostat Mfg. Co., Inc., Brooklyn, N. Y. The front face of the unit has an ear or locking pin, which en-

You and your associates can obtain a year's subscription to **COMMUNICATIONS** (12 issues) for only \$1.00 each by using the Group Subscription Plan.

A regular yearly subscription to **COMMUNICATIONS** costs \$2.00 — but when four or more men sign up at one time, each one is entitled to the half-price rate. (Foreign subscribers on the Group Plan only pay \$2.00 each.)

COMMUNICATIONS

19 E. 47th St., N. Y. C.

Please enter annual subscriptions (12 issues) for each of the undersigned to which payment is enclosed at the rate of \$1.00 each. (This rate applies only on 4 or more subscriptions when occupations are given.) Foreign Subscriptions are \$2.00 each.

Name

Street

City-State

Occupation or title

Employed by

Nature of business

(State if Manufacturer, Broadcast Station, etc.)

Product

Name

Street

City-State

Occupation or title

Employed by

Nature of business

(State if Manufacturer, Broadcast Station, etc.)

Product

Name

Street

City-State

Occupation or title

Employed by

Nature of business

(State if Manufacturer, Broadcast Station, etc.)

Product

Name

Street

City-State

Occupation or title

Employed by

Nature of business

(State if Manufacturer, Broadcast Station, etc.)

Product

gages in a hole or indentation in the panel or mounting surface, preventing the turning of the entire unit when the knob is turned. A 3/8" bushing and nut provide the one-hole mounting.

This power rheostat is said to employ an unique insulated metal core to support the winding which is imbedded in a special inorganic cement. Maximum heat dissipation is obtained even when a portion of the winding is cut in. Even at one-third total resistance, the unit dissipates a full 25 watts. Made for 1 to 5000 ohms.



* * *

HEWLETT-PACKARD VACUUM TUBE VOLTMETER

A vacuum tube voltmeter, Model 400A, that affords measurements up to 1 megacycle has been developed by Hewlett-Packard Co., 481 Page Mill Road, Palo Alto, Calif. It is said that there are no adjustments to make or check before taking a reading, the high input impedance

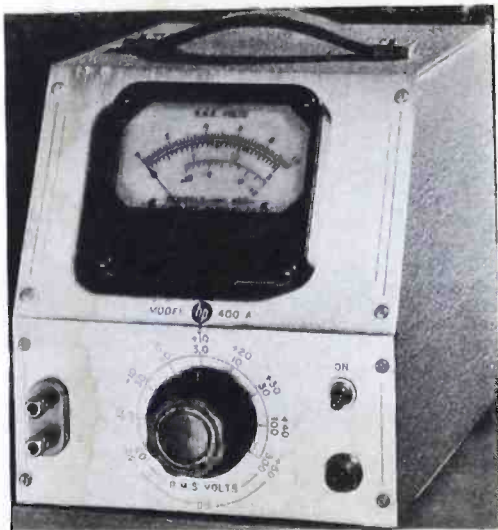

will not affect the circuit being measured, and a large overload will not damage the instrument.

This instrument has a frequency range from 10 cps to 1 megacycle. Nine voltage ranges are provided with full scale sensitivities from .03 volts to 300 volts. The voltage scale is linear and a decibel scale based on 600 ohms and 1 milliwatt is provided. The reading of the meter is independent of line voltage and tube characteristics.

* * *

HIGH-FREQUENCY IRON CORES AVAILABLE IN SIZES AND SPECIAL SHAPES

In addition to automatic high-speed molding machinery for turning out the usual pressed pieces, Henry L. Crowley & Co., West Orange, N. J., is said to be using a new and exclusive fabricating process for a still wider variety of lengths and shapes. L-shape cores, discs, spools, rings, tubes and other shapes are being made, in addition to the huge output of cores and cuts and plungers for the coils and permeability tuners of radio sets.

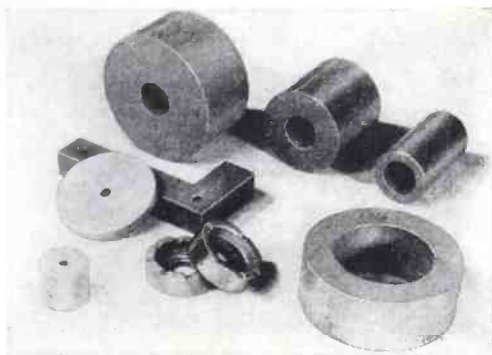

NEW FULL WAVE VARITRAN

A new Varitran designed for low voltage rectifiers, for plating equipment, battery chargers, etc., has just been announced by United Transformer Co., 150 Varick St., N. Y. City. In this construction an insulated secondary is provided with two contacts moving in opposite directions from the secondary center tap. In this way the DC voltage can be varied.

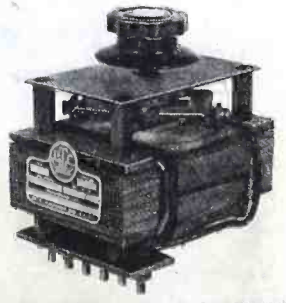

BOONTON FREQUENCY MODULATED GENERATOR

TYPE 150-A Series

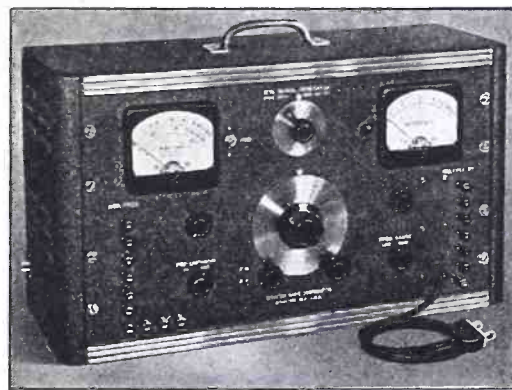

Here is a signal generator developed specifically for use in the design of FM equipment. Built into it are the features requested by FM engineers. Both Frequency and Amplitude Modulation available separately or simultaneously. All controls direct reading. Expanded scale meters. Power line regulation optional.

Brief Specifications:

Output from 0.1 μ V to 0.1 Volt with attenuator, and 0.1 Volt to 1 Volt with special tap.

Deviation from zero to 200 KC Internal AF-100, 400, 1K, 4K and 10K cycles.

RMA Pre-emphasis circuit.

Vernier F Control for selectivity.

Frequency Ranges

Type 150A	41-50mc and 1-10mc
Type 151A	30-40mc and 1-7mc
Type 152A	20-28mc and .5-5mc

New Catalog B now available.

BOONTON RADIO CORP.
Boonton, New Jersey, U. S. A.



"Cobanic"

is used as a cathode in Mercury Vapor Rectifiers meeting the specifications of the U. S. Navy.

WILBUR B. DRIVER CO.

NEWARK, NEW JERSEY

LAMINATIONS

for Output TRANSFORMERS
of Highest Permeability

Standard stocks in a wide range of sizes for Audio, Choke, Output and Power Transformers. Write for dimension sheets.

permanent MAGNETS

ALNICO (Cast or Sintered)

COBALT-CHROME-TUNGSTEN

Cast, formed or stamped permanent magnets for all purposes. Engineering cooperation backed by 38 years experience in magnet making.

TOOLS » DIES » STAMPINGS
HEAT TREATING

Thomas & Skinner
Steel Products Co.

1113 E. 23rd St. Indianapolis, Ind.



WAXES AND COMPOUNDS

FOR
INSULATION and WATERPROOFING
of ELECTRICAL and RADIO
COMPONENTS

● such as transformers, coils, power packs, pot heads, sockets, wiring devices, wet and dry batteries, etc. Also WAX SATURATORS for braided wire and tape and WAXES for radio parts. The facilities of our laboratories are at your disposal to help solve your problems.

Zophar MILLS, Inc.
FOUNDED 1846
120 - 26th ST., BROOKLYN, N. Y.

Index of Advertisers

	Page
A	
Amperex Electronic Products.....	Inside Front Cover
B	
Bliley Electric Co.....	31
Boonton Radio Corp.....	35
D	
Daven Co., The.....	20
Driver Co., Wilbur B.....	35
G	
General Electric Co.....	17
General Radio Co.....	Inside Back Cover
H	
Hipower Crystal Co.....	33
I	
Isolantite, Inc.....	3
J	
Johnson Co., E. F.....	25
Jones, Howard B.....	31
L	
Lapp Insulator Co., Inc.....	Back Cover
Lenz Electric Mfg. Co.....	19
M	
Mallory & Co., Inc., P. R.....	4
N	
National Co., Inc.....	26
O	
Ohmite Mfg. Co.....	33
O'Neil-Irwin Mfg. Co.....	33
P	
Petersen Radio Co.....	33
Premax Products.....	34
Pioneer Genemotor.....	34
R	
Radio Corporation of America.....	13
S	
Shure Brothers.....	27
Sola Electric Co.....	1
T	
Tech Laboratories.....	28
Terminal Radio Corp.....	28
Thomas & Skinner Steel Prods. Co...	36
U	
United Transformer Co.....	23
University Labs.....	33
Z	
Zophar Mills.....	30

A GRACIOUS HOST
FROM COAST TO COAST



The Gotham



The Drake

The Blackstone



The Town House



Bellevue Biltmore

A. S. KIRKEBY, Managing Director

**KIRKEBY
HOTELS**

Manufacturers—

If you need engineers or technicians, make known your requirements in

COMMUNICATIONS

The type of men you want will read your advertisement.

MAKING CONDENSERS

DIRECT READING



Fig. 1. The Obsolete Type 222-M Condenser

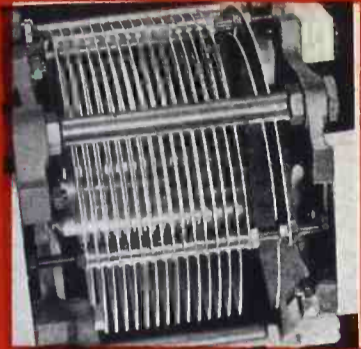

Fig. 2. Adjusting Plates of the Type 222-M



Fig. 3. The Improved Type 722 Condenser

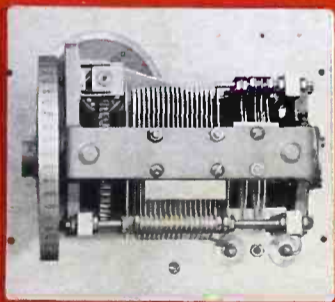

Fig. 4. Dual Sections of the Type 722-D

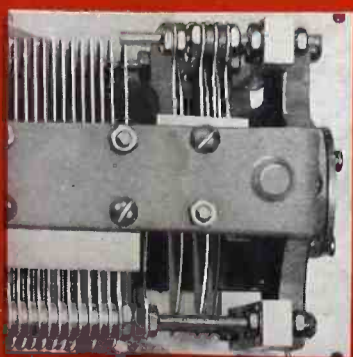

Fig. 5. Special Stator Plate and Low-Capacitance Sections of the Type 722-D Condenser

A VARIABLE AIR CONDENSER with semi-circular rotor and stator plates can be made to have remarkable linearity over about 80 per cent of a half turn. When used with calibration curves or charts, the accuracy obtained is so high that for many years manufacturers were discouraged from attempting to make condensers direct reading.

This phase of condenser development is now over. Most new condensers have direct-reading scales calibrated to an accuracy as good as was formerly obtained with calibration curves.

The first step in making a condenser direct reading was taken with the now obsolete Type 222 (Fig. 1). The worm was cut with double threads giving $12\frac{1}{2}$ turns for $\frac{1}{2}$ turn of the rotor. The number of plates were adjusted to make the capacitance increment per turn about $100 \mu\text{mf}$. Ten turns (or 80 per cent of the available motion) would then correspond to $1,000 \mu\text{mf}$.

The scale markings were chosen to indicate capacitance taken out of the circuit. Adjusting plates were provided to make the capacitance per turn exactly $100 \mu\text{mf}$ (Fig. 2). Since the stator plates were supported at three points, the stator adjusting plate could be warped to make up for irregularities in the main stack.

With this construction it was possible to adjust the condenser so that it was direct reading in capacitance difference from the zero mark with an accuracy of $1 \mu\text{mf}$ or 0.1%, whichever was greater.

The Type 722 Precision Condenser (Fig. 3) was developed as an improvement on the Type 222. Most of the changes . . . ball bearings . . . integral-cut worm . . . cast-aluminum frame . . . worm shaft at right angles to the panel . . . have no immediate bearing on the direct-reading problem.

In the Type 722-D the function of the drum and dial are transposed (Fig. 4). Twenty-five turns of the worm produce a half turn of the rotor plates. The dial is divided into 250 divisions; the usable portion of the condenser then has 5,000 divisions; one μmf covers 5 divisions on the $1,000 \mu\text{mf}$ condenser.

The stator plate at the right of the stack (Fig. 5) is used to make the capacitance per turn exactly $50 \mu\text{mf}$. Since only two stator supports are used, this plate can be tipped to correct for slight irregularities in the main stack. As this plate cannot be warped, a special stator plate, cut out in the middle, is used at the left end of the stack (Fig. 4). This plate increases the capacitance per turn at the ends.

Zero capacitance is altered by bending the flat plate which extends from the frame. By means of these various adjustments the large section of this condenser is made direct reading in total capacitance to $1 \mu\text{mf}$ or 0.1% between $100 \mu\text{mf}$ and $1,000 \mu\text{mf}$. A small section is provided also. This has one-tenth the capacitance of the larger. It is adjusted by similar means to be direct reading in total capacitance to $0.2 \mu\text{mf}$ or 0.1% between 25 and $100 \mu\text{mf}$.

By appropriately shaping the rotor and stator plates, these precision condensers can be adapted to use in a large number of direct-reading instruments. Plates A (Fig. 6) are standard semi-circular plates; stator B is the compensating plate used to increase the capacitance per turn at the end of the calibration; stator C is used in the low capacitance stack to decrease zero capacitance. Pair D give a logarithmic scale over a three-to-one range when used in a tuned oscillator; pair E will give a linear scale for frequency, and a semi-logarithmic scale for capacitance. Plates F are used in a beat-frequency oscillator to give a scale covering three decades.

The fundamental mechanical and electrical problems in making condensers direct-reading having been solved, it is now possible to design a condenser which can be made direct-reading in almost any one of the many related quantities which the condenser may control in a circuit or an instrument.

Fig. 6. Some Typical Condenser Plate Shapes

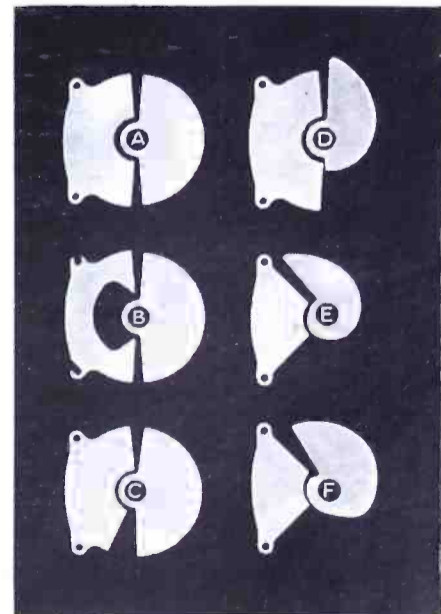

THIS GIANT BASE INSULATOR SUPPORTS
ONE CORNER OF THE NEW WABC TOWER

THE SERVICE RECORD
OF 21,000 COMPRESSION
CONES IS YOUR
MARGIN OF SAFETY
IN SPECIFYING "LAPP"
FOR ANTENNA
STRUCTURE INSULATORS



SINCE Lapp engineers conceived the compression cone of electrical porcelain as the most suitable design for radio antenna structure insulators, more than 21,000 of these cones have gone into service. They range from tiny 3" cones for pipe masts to the large units shown above and recently installed in the new WABC transmitter. And, in the history of these insulators, covering more than 20 years, we have never heard of a tower failure due to failure of a Lapp porcelain part. This record, we submit, is adequate reason for confidence on your part as you specify "Lapp" for tower footing insulators. Lapp Insulator Co., Inc., LeRoy, New York.

Specify

LAPP

FOR SECURITY IN ANTENNA STRUCTURE INSULATORS