

# COMMUNICATIONS

INCLUDING "RADIO ENGINEERING" AND "TELEVISION ENGINEERING"



FEBRUARY

- ★ FACSIMILE TRANSMITTING EQUIPMENT
- ★ MEASURING V-H-F RADIATION PATTERNS WITH MINIATURE ANTENNAS
- ★ BROOKHAVEN, LONG ISLAND, POLICE 72-76/152-762 MC 2-WAY F-M SETUP

1948

# get out

...get out the distortion  and variations in your incoming line voltages

with  **SORENSEN ELECTRONIC REGULATORS**

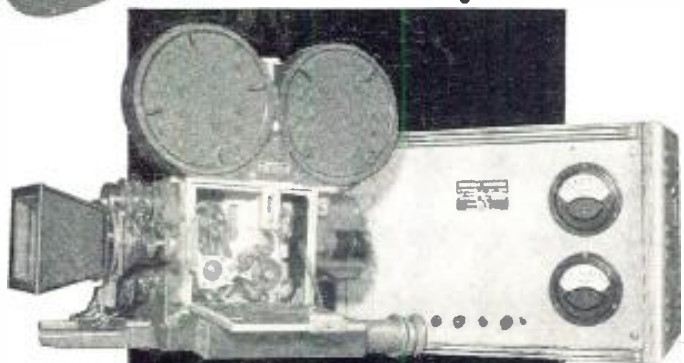

● This Nobatron is being used to test battery operated Movietone News cameras. Nobatrons provide a source of DC voltages at high currents previously available only with batteries.

The Nobatron maintains a regulation accuracy of 0.25%, ripple voltage (RMS max) of 1% and has a recovery time of 1/5 of a second.

● Wherever you use line voltage for precision operations, whether it be in the test laboratory or on the assembly line, a Sorensen unit can provide regulation accuracies to 2/10 of 1% with quick recovery time.

Arrange to have a Sorensen engineer analyze voltage regulation requirements in your plant. He can select one of the standard units or suggest a special design to handle your unusual applications.

*Take a look at this Performance!*

**Write** today for your copy of the new Sorensen catalog. It contains schematics, curves, application data and a special section on "Principles of Operation."

● Represented in all domestic and foreign principal cities.

Address of Sorensen office in your area furnished on request.

- 1 Wide input voltage range: 95 to 125 volts or 190 to 250 volts.
- 2 Low harmonic distortion: less than 5% in basic models, and 2% in "S" models.
- 3 Insensitive to input line frequencies between 50 and 60 cycles.
- 4 Power factor variations from 70% lagging to 90% leading have little effect on regulation accuracy.
- 5 Recovery time of 0.1 seconds under the most adverse input and load conditions.
- 6 Regulation accuracies from 0.1% to 0.5% depending upon model chosen.



The FIRST line of standard ELECTRONIC AC Voltage Regulators and Nobatrons

# SORENSEN

& COMPANY, INC. • STAMFORD, CONNECTICUT

PROFESSIONAL PERFORMANCE—that keeps the original sound alive!

# *Ride 'em without Rumble!*

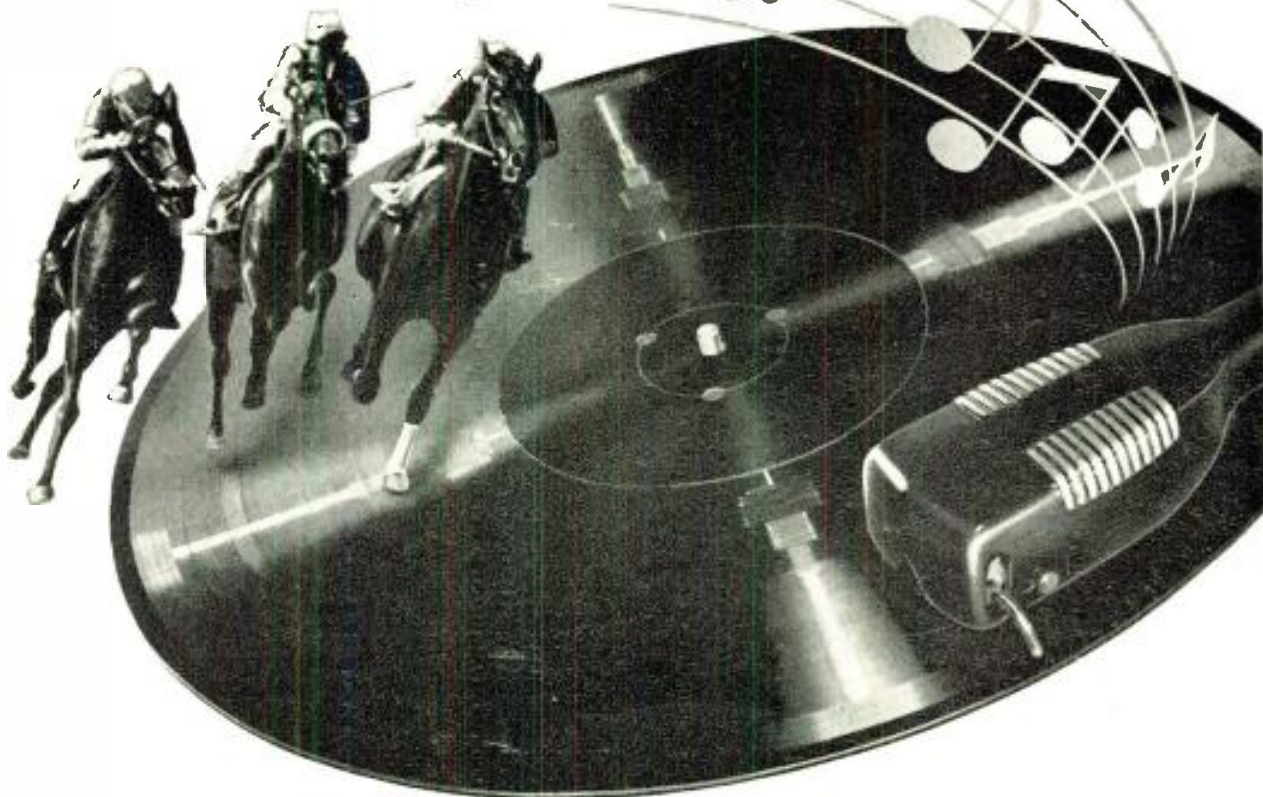

## *— on a turntable free of vibration*



The pounding of hooves may be sweet music to the ears of a race jockey. But to a disc jockey—whose program's success depends upon the undistorted high fidelity of his transcriptions—any extraneous mechanical noise leaves his listeners at the starting post. They just won't ride with him!

Fairchild engineers have succeeded in eliminating the last bit of extraneous mechanical noise—in the newly redesigned Unit 524 Transcription Turntable. Turntable noise, rumble and vibration are non-existent because of the unique method of mounting the drive—at the bottom of the cabinet... the use of a specially designed rubber coupling to connect the drive and synchronous motor which are spring-mounted and precision-aligned in a single heavy casting... the use of sound-stopping mechanical filters on the hollow drive shaft to reduce the transmission of vibration from the drive mechanism to the turntable... and the use of a heavy, webbed cast aluminum turntable mount at the top of the cabinet.

In addition to freedom from rumble, Fairchild offers you a wider frequency range and lower distortion content with its Unit 542 Lateral Dynamic Pickup, with a stylus mounting that allows the tip to follow the minute indentations engraved in the groove from 30 to 10,000 cycles and beyond, with a minimum of distortion. Want more details about sound equipment that really keeps the original sound alive? Address: 88-06 Van Wyck Boulevard, Jamaica 1, New York.



- Transcription Turntables*
- Studio Recorders*
- Magnetic Cutterheads*
- Portable Recorders*
- Lateral Dynamic Pickups*
- Unitized Amplifiers*



 *Fairchild* CAMERA  
AND INSTRUMENT CORPORATION

# COMMUNICATIONS

Including Television Engineering, Radio Engineering, Communication & Broadcast Engineering, The Broadcast Engineer. Registered U. S. Patent Office.

**LEWIS WINNER**  
Editor

**F. WALEN**  
Assistant Editor

Bryan S. Davis, President  
Paul S. Weil, Vice Pres.-Gen. Mgr.  
F. Walen, Secretary  
A. Goebel, Circulation Manager

Cleveland Representative:  
James C. Munn  
2253 Delaware Dr., Cleveland 6, Ohio  
Telephone: Erlview 1726

Pacific Coast Representative:  
Brand & Brand  
1052 W. Sixth St., Los Angeles 14, Calif.  
Telephone Michigan 1732  
315 Montgomery St., San Francisco 4, Calif.  
Telephone Douglas 4475

Wellington, New Zealand: Te Aro Book Depot.  
Melbourne, Australia: McGill's Agency.

Entered as second-class matter Oct. 1, 1937 at the Post Office at New York, N. Y., under the Act of March 3, 1879. Subscription price: \$2.00 per year in the United States of America and Canada; 25 cents per copy. \$3.00 per year in foreign countries; 35 cents per copy.

### COVER ILLUSTRATION

Sergeant Richard Cunneen, Brookhaven, Long Island, police headquarters dispatcher, at the control desk of the 2-way 1-m radio system recently installed. Remote-control console in the background is connected to the relay station in police chief's office on the floor below. (See page 6, this issue for complete details on the system).

### POLICE COMMUNICATIONS

Brookhaven, Long Island, Police 72-76/152-162 Mc 2-Way F-M System. P. R. Kendal 6  
*Eight Police and Two Detectives' Cars, and Jeep and Three Boats, Equipped With 2-Way 30-Watt 155.49-mc Units. Patrol 443 Square Miles.*

### TAXICAB 2-WAY SYSTEMS

Two-Way Taxicab Radio Systems.....Samuel Freedman 8  
*Equipment Features, Channel Problems and Solutions, Installation and Servicing Procedures.*

### FACSIMILE

Facsimile Transmitter at the Miami Herald, Florida.....Ralph G. Peters 12  
*Equipment Includes Scanner Amplifier, Limiter-Line Amplifier, Pulse Generator, Recorder Amplifier and Modulator.*

### MEASUREMENT TECHNIQUES

Effectiveness of Bypass Capacitors at V-H-F.....John F. Price 18  
*Qualitative and Quantitative Tests at 30 and 100 Mc on Paper, Tubular, Postage Stamp, Mica Molded, Mica Silvered and Button-Mica Types Reveal Capacitive and Inductive Factors To Be Considered in Selection of Capacitors.*

### F-M ANTENNAS

Measuring F-M Antenna Patterns with Miniature Antennas M. A. Honnell and J. D. Albright 20  
*Simple Setup Used to Measure Vertical V-H-F Radiation Patterns. Antennas Being Scaled Down to Microwave Dimensions, for Convenience in Pattern Measurement.*

### TRANSMITTING TUBES

Tube Engineering News..... 24  
*Design and Application Notes on TV Image Dissector, and Blowers Used for Cooling External Anode, Glass Envelope of Radiation-Cooled Anode Type Tubes, etc.*

### SOUND ENGINEERING

Noise Measurements.....Robert L. Morgan 28  
*Relation of Reference Levels, Sound Level Ranges, Use of Sound Meters, Microphone Positioning.*

### MONTHLY FEATURES

News and Views.....Lewis Winner 5  
Veteran Wireless Operators' Association News..... 16  
The Industry Offers..... 34  
News Briefs of the Month..... 38  
Advertising Index..... 40

Entire contents Copyright 1948, Bryan Davis Publishing Co., Inc.



Published monthly by Bryan Davis Publishing Co., Inc.  
52 Vanderbilt Avenue, New York 17, N. Y. Telephone Murray Hill 4-0170



advanced design of **KELLOGG** system gives you

# Mobile Radio-Telephone at its finest



**Efficient, economical, trouble-free operation to meet your every need**

You're probably aware of the many advantages that your own mobile radio-telephone system can provide: Speeded up communications, increased efficiency throughout your operations, better service to your customers.

Now two great names in the field of communications, Philco and Kellogg, are cooperating to bring you the benefits of this modern communication method at its most advanced stage.

Amazing compactness, new standards of operating efficiency, design and construction that assure trouble-free operation suggest that you investigate Kellogg Mobile Radio-Telephone before you invest in equipment. Check the many advantages listed below. Write for full information on how Kellogg Mobile Radio-Telephone can serve you in your line of business or industry.

### Check These Advanced Features:

- The Kellogg Mobile Radio-Telephone Equipment conforms to both the present and proposed requirements of the Federal Communications Commission and the Radio Manufacturers Association.
- "Private Line" service over a party line system—no listening in by any other mobile station.
- Advanced circuit design and components assure interference-free communication because of superior rejection of unwanted signals in adjacent channels.
- Uniform volume level regardless of strength of incoming signal.
- Positive modulation control, preventing distortion.
- Unexcelled performance over wide ranges of temperature and humidity.
- Drawer type, plug-in chassis permitting quick, easy maintenance service to subscribers.
- Very low stand-by drain from power source. Easily adaptable to various power sources.
- Rugged shock-proof mounting assures long, trouble-free life of the equipment.

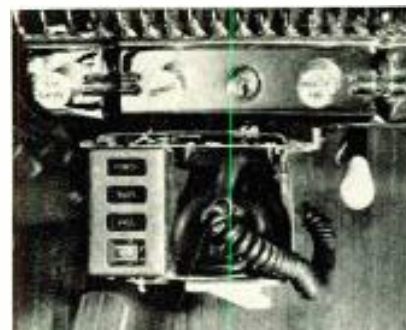

Control unit in vehicle is easily accessible and highly compact.

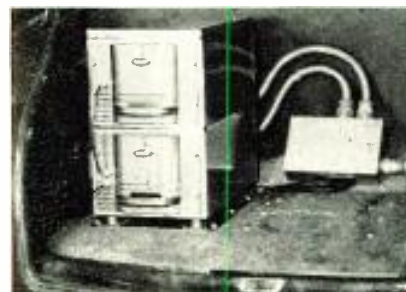

Mobile transmitter and receiver require minimum space in vehicle.



Drawer-type, plug-in chassis makes maintenance easy and fast.

WRITE FOR FULL INFORMATION TODAY



Distributed Nationally by

# KELLOGG

SWITCHBOARD & SUPPLY CO.  
6650 South Cicero Ave., Chicago 38, Illinois



# Jensen

## "SECTOR" CABINET

### WITH Bass Reflex\*

for 8-inch Speakers

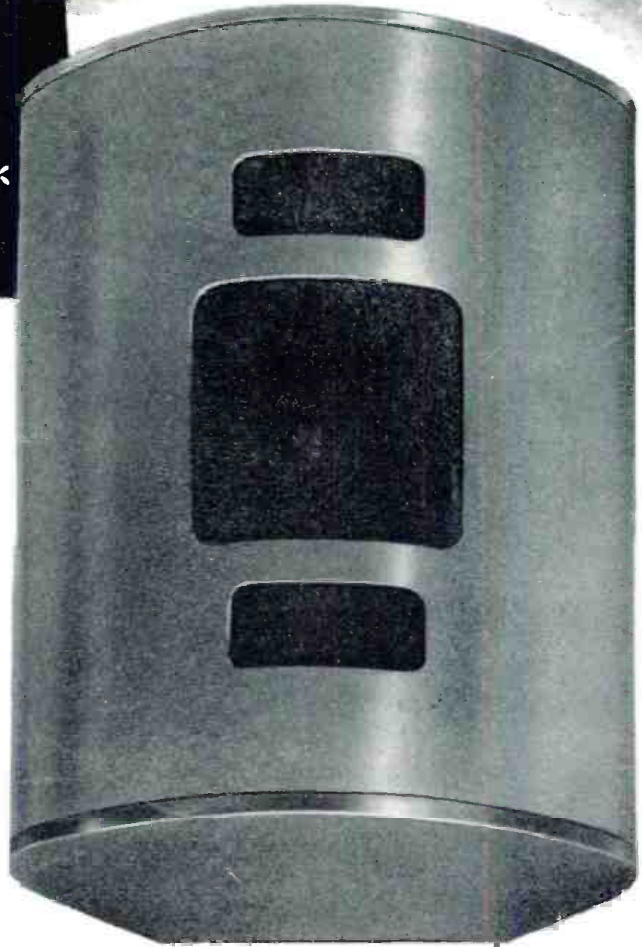
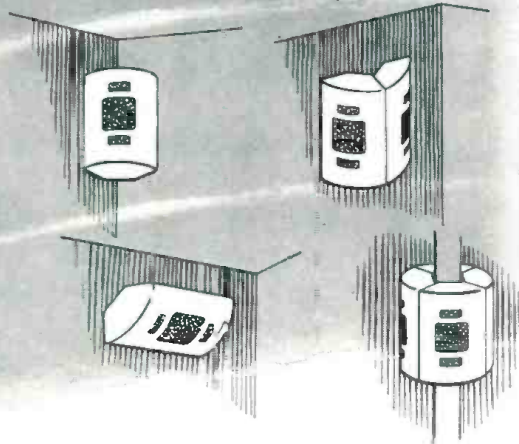

Model H-81 Sector Cabinet (ST-141) List Price \$22.50

They fit anywhere—in 90-degree corners—flat on walls—or in clusters to give wide-angle distribution. Perfectly adapted for nearly all interior sound installations, because of their economy, small size and, above all, the high quality performance of JENSEN speakers in Bass Reflex enclosures. Use with any JENSEN 8-inch speaker. Model P8-SH is recommended for high fidelity as required by many wired music installations.

Type H Sector Cabinets are built around a frame of solid wood with wood composition replacing the conventional plywood panels.

Finish is brown opaque lacquer although covering colors may be applied on the job if desirable to match environment. Size: Height 22½", width 17¾", depth 8½" Furnished with mounting brackets and screws.

#### JENSEN MANUFACTURING COMPANY

6603 South Laramie Avenue, Chicago 38

in Canada: Copper Wire Products, Ltd., 11 King St., W., Toronto

\*Trade Mark Registered

#### OTHER Jensen CABINETS

— BASS REFLEX —



IMPERIAL TYPE D  
D-151 (15-inch)  
D-121 (12-inch)



UTILITY TYPE B  
B-151 (15-inch)  
B-121 (12-inch)  
B-81 (8-inch)

PERI-DYNAMIC



WALL TYPE J  
J-61 (6-inch)

# Jensen

## SPEAKERS

### WITH ALNICO 5



Designers and Manufacturers  
of Fine Acoustic Equipment

# COMMUNICATIONS

LEWIS WINNER, Editor

FEBRUARY, 1948

## Growing Fast

A NOTABLE RECORD of expansion in 2-way mobile services was disclosed at the recent General Mobile Radio Service FCC hearings in Washington. Testimony revealed that close to 13,000 taxicabs had been licensed for 2-way operation and nearly 10,000 were authorized to be equipped. At the close of the year, there were approximately 2,000 applications for 2-way setups. It was also indicated that around 500 taxicab land stations had been licensed, over 400 were under construction, around 150 applications were on file, and 2-way applications for over 1,000 mobile vehicles are being received monthly.

Over 40,000 vehicles have been licensed for truck, bus, cab, Bell telephone and miscellaneous highway or urban radio service. Taxicab use represents approximately 65% of this total or about 25,000 units.

An analysis of the general and miscellaneous common carrier systems revealed that over 2,300 mobile units were equipped for 152 to 162-mc and twenty-five for 30 to 44-mc service, the latter for urban and the former for highway services such as doctor's calling systems, etc., while over 7,500 mobile units were being used on 152 to 162-mc and about 5,000 were being used for 30 to 40-mc operation by the Bell system for common carrier work.

The FCC hearings also revealed that most of the bus radio activity, at the present, is concentrated in Illinois and Michigan, while truck activity is confined to Kentucky, Illinois, Wyoming, Nebraska and Colorado.

Authorized i-m a-m tv broadcast stations are also on the increase, with California and Texas leading the parade. At this writing, 228 have applied for broadcast authorizations in California; 129 a-m, 87 i-m and 12 tv. Texas has 223 authorizations; 153 a-m, 66 i-m and 4 tv. Pennsylvania follows with 184 authorizations, of which 98 are for a-m, 80 for i-m and 6 for tv. Next comes New York with 178, which includes 89 a-m, 79 i-m and 10 tv. North Carolina is next with 132, including 86 a-m, 45 i-m and 1 tv. Ohio follows along

with 128, which includes 53 a-m, 66 i-m and 9 tv authorizations.

There are 3,119 broadcast authorizations on record, of which 1,969 are for a-m, 1,063 for i-m and 87 for tv, and the list is still growing!

## Bandwidths And Channels

THE USE of the 20 or 40-ke bandwidth in the 30 to 40 or the proposed 44 to 50-mc bands has been quite a debated topic during the past months.

In the main, mobile service users feel that 20-ke channels are not satisfactory.

Reporting on tests made on 20 and 40-ke band widths, at an RTPB meeting, D. E. Noble of Motorola said that a 40-ke receiver using a *triangular* type pass band gave 50 to 100% more range than a 20-ke model. The tests were made in mobile units receiving signals from a 1/2 to 1-watt fixed transmitter within line of sight. Noble indicated that because of intermodulation effects, it was believed there would be no effective increase in the number of useable channels in a given area by adopting the 20-ke bandwidth.

Budelman of Link Radio stated that laboratory tests indicated that intermodulation and blocking from adjacent channels were the limiting factors for channel utilization in the same area rather than i-f selectivity. It was emphasized that the RMA concept of channel, the useable channel and guard bands, be used instead of the FCC definition which is the spectrum occupied by transmitter radiation.

The 44 to 50-mc and 72 to 76-mc channel problem, recently probed in FCC Washington hearings, was effectively analyzed by D. E. Noble during his testimony. He pointed out that the 72 to 76-mc channel, which the FCC proposes to assign to the aeronautical marker beacon services should be retained for mobile service and that all adjacent channels used by television be assigned to mobile services for land and mobile work. He stated that engineering research will prove that television services will not be disturbed by this arrangement.

## Versatility Plus

DESIGNING a high-power transmitter demands the ultimate in resourcefulness, according to Dave Miller, assistant chief engineer of J. H. Bunnell. In designing the 20-kw Bunnell transmitter, Miller reports it was necessary to study, among other things, plumbing, chemistry (for insulation purposes and galvanic and other forms of corrosion), air conditioning (to calculate heat removal by blowers from the transmitter), and central power station techniques for handling the 70 kva of three-phase power to feed the transmitter. It was also necessary to conduct a bit of research into control systems, become thoroughly familiar with relays, contact problems, armature design, insulation, cabinet ventilation and other factors so that the transmitter would be easy and safe to operate. Quite a job!

## Dates To Remember

A HOST OF IMPORTANT conferences and meetings are scheduled for the next few months in the east, middle west and Pacific coast.

The outstanding meeting of the year will be the IRE National Convention at the Hotel Commodore and Grand Central Palace, March 22nd to March 25th. On April 24th, at Cincinnati, there'll be a one-day Spring meeting session of the IRE at the Engineering Society Headquarters Building, during which television will be a featured subject. The annual RMA-IRE Spring Meeting on transmitters again will be held in Syracuse, from April 26th to 28th at the Hotel Syracuse.

The 26th Annual NAB Convention will be held this year in Los Angeles at the Biltmore Hotel, from May 17th to May 21st, with two days devoted to engineering, May 20th and 21st.

The New England IRE Meeting will again be held in Cambridge on May 22nd.

The West Coast group of the IRE will meet in Los Angeles during a 3-day session from September 30th to October 2nd.

Looks as if there'll be plenty to listen to during the next few months.—L. W.

# Brookhaven, Long Island, Police

## 72-76 / 152-162-mc 2-Way F-M System



Two horizontal-polarized dipoles and triple skirt antenna at the central station doghouse on Selden Hill.

Taking a meter reading at the central station installation on Selden Hill.



Eight Police Cars, Two Detectives' Cars, Jeep and Three Boats Equipped with Two-Way 30-Watt 155.49-mc Units Patrol 443 Square Miles. Relay Stations Operating on 73.22 and 155.49-mc Link Headquarters to Mobile Units and Dispatcher's Offices.

by **P. R. KENDALL**

Field Engineer  
Motorola, Inc.

WITH THE HELP of a unique two-way f-m communications system fifty-four police officers cover 443 square miles of the Town of Brookhaven, L. I., the largest township in the state of New York. It is unique because it is 100 per cent radio, no land wires being used for remote control.

### **Terrain Characteristics**

Brookhaven boundaries run from the Atlantic Ocean on the south to Long Island Sound on the north, and include more than 30 miles of beach. Between these natural and man-made boundaries lie forty hamlets and villages and hundreds of summer homes ranging from small cottages to sumptuous mansions. Much of the territory is sparsely-settled terrain running from flat beach on the south to hills-jutting 350' high in the middle and on the north.

### **Patrol Equipment**

Patrolling this heterogeneous territory of water, beach and hills are fourteen radio-equipped vehicles. Eight police cars and two detectives' cars cover the interior, a jeep patrols the beach, and three boats patrol the bay and sound.

The system gives solid uninterrupted coverage over a radius of thirty-five miles and it is possible to cover eighteen to twenty miles between cars.

### **The Two-Channel System**

In studying the Brookhaven communications problem it was found that land wires for remote control could not be used. To cover the broken terrain, obviating numerous dead spots behind hills, the highest point in Brookhaven, Selden Hill, had been selected as the central station site. To reach the hill, six airline miles from headquarters, land wires would have to travel two or

Adjusting horizontally polarized home-made dipole antenna in the attic of Town Hall. Antenna cable leads to the radio relay equipment in the Chief of Police's office which via a short wire is connected to the remote-control console in the dispatcher's office on the ground floor.







Talking to headquarters over the two-way system.

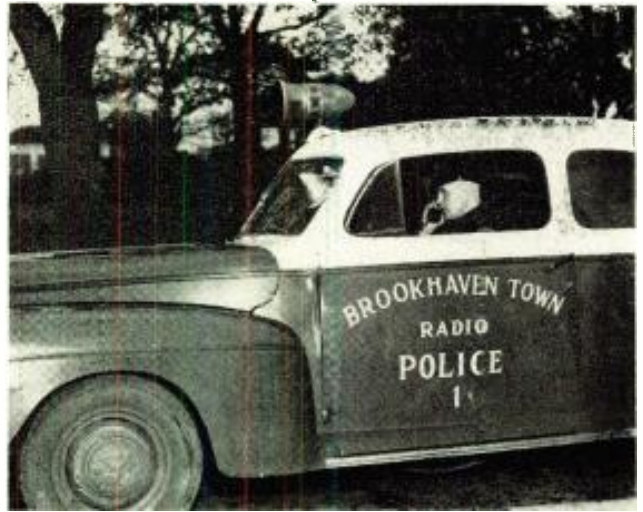

Brookhaven Police radio-equipped car.

more times that distance over sharply rolling, heavily wooded country. In winter these lines would be subjected to storms sometimes approaching hurricane force and be constantly threatened with damage from falling timber. Maintenance under these conditions would be excessively difficult and interruptions would undoubtedly come when the need for communications would be most urgent.

To overcome this problem and insure full coverage, even during static-filled storms, a two-channel radio relay system was developed.

#### 15-Watt Transmitter

Signals from a 15-watt transmitter at Police Headquarters in Patchogue, operating on 73.22 mc, are beamed via a simple dipole directional antenna to a receiver on Selden Hill. A squelch

relay on this receiver turns on a 50-watt transmitter operating on 155.49 mc, and radiates to 30-watt mobile units.

#### 74.5-mc Circuit

Signals from the mobile transmitters are picked up on Selden Hill by a 155.49-mc receiver with a squelch relay which activates a transmitter operating on 74.5 mc. This transmitter relays signals to the dispatcher's office.

#### Antennas Used

Antennas for the 72-mc relay circuit are simple home-made dipoles, horizontally polarized. The Headquarters antenna is in the attic of Town Hall.

The 160-mc antenna on Selden Hill is a triple-skirt colinear coaxial. In-

stallation of this antenna proved an interesting technical point. Before it was installed, a quickly-prepared simple coaxial dipole fed with RG-8/U copalene cable was put into temporary service. Field tests revealed eighteen miles to be the talk-out limit, and twenty to twenty-two miles the talk-back limit. Had this temporary antenna functioned properly talk-out and talk-back distances would have been equal.

#### Antenna Tests

Following installation of the present triple-skirt antenna, fed with  $\frac{7}{8}$ " copper dry air filled line, a second set of tests were conducted over the same route and under almost identical conditions. Talk-out and talk-back of equal strengths were conducted over a distance of 27 miles.

Chief of Police, Edward N. Bridge, at headquarters with the two-way relay equipment setup. System is connected by wire to the dispatcher's remote control console on the floor below.



Setup aboard shore patrol boat operating in Long Island Sound, Long Island.





(Left)  
Federal transmitter-receiver unit, in taxi trunk compartment.



(Right)  
Wilcox Electric transmitter-receiver in trunk compartment of taxicab.

# Two-Way Taxicab Radio Systems

IN THE INITIAL installment of this series, the economic aspects of 2-way taxicab systems were analyzed. In this presentation, equipment features, current channel problems and system installation problems are discussed.

## Technical Cab Radio Advances

Current two-way equipment has been engineered more carefully and expertly than the prewar 30 to 40-mc types.

All operations are f-m and on the 152 to 162-mc band. The reduced wavelength is now sufficiently short to make feasible the *hatpin* type of antenna located on the center of the roof. There, the antenna enjoys an increased horizon and a uniformly maximum efficiency in every direction. Prewar, the antenna was usually mounted on the rear bumper or at the rear of the vehicle slightly above the bumper or fender. It then had a directional characteristic, working as much as 4 to 1 better in the direction where most of the car metal stood between the antenna and the central station. This counterpoise effect is now available in all directions, with the antenna mounted atop the roof approximately at center.

The higher frequency reduces the tendency for sky wave abnormal ranges part of the time which may produce interference and confusion hundreds or thousands of miles away.

The wavelength is becoming suffi-

by **SAMUEL FREEDMAN**<sup>1</sup>

Engineer, Electronics Division  
De Mornay-Budd, Inc.

ciently short so that lumped inductance may be replaced by a resonant line or distributed inductance.

## Frequency Multiplication

Equipment utilizes more frequency multiplication to reach the higher frequency with quartz crystals of convenient thickness. The multiplication used varies from 32 to 96 times, as compared to 32 times in most prewar cases on the 30 to 40-mc band. A multiplication of 48 times the crystal frequency is the most popular method employed, and is usually achieved with one quadrupler, one tripler and two doublers.

Power output has been reduced partly by necessity because of the increased frequency multiplications and reduced tube efficiencies at higher frequency, and partly by choice to conserve battery drain. The transmitter power output, quoted by sixteen manufacturers varies from 2½ to 30 watts; see table I, page 11, and table which appeared in December article.

The number of tubes have been increased, but they are miniature and inexpensive in type. The transmitter may average one more tube, while the receiver may employ three to four more tubes than prewar. The number of tubes employed in the transmitter

varies between six and twelve, and in the receiver it varies between eleven and seventeen. The 6AK5 has become the most popular tube used, chiefly for the receiver stages. At least 75% of the manufacturers prefer this tube in the receiver r-f stages, as well as in several other stages. The 2E24, 2E25 or 2E26, 2E30 and 5516 are used most frequently in the driver and final amplifier stages of the transmitter.

Receiver battery consumption varies from 4.6 to 10 amperes. This represents little change from the prewar models.

The transmitter battery consumption varies from 21 to 58 amperes depending on the power rating of the transmitter and the number of frequency multiplication stages. It also depends on the number and type of the special features incorporated in the equipment. Many models use instant-heating tubes in the transmitter. In one model transmitter on standby consumes only .6 ampere for filament heaters.

Several have developed some distinctive type of selective calling or radio privacy system to facilitate dispatching of very large taxicab fleets. Most types work on the principle of keeping all cab loudspeakers dead until the central station actuates the receiver. Some systems further assure communication privacy by patented provisions which keeps all taxicab receivers dead except the one or ones who have their microphone off the

<sup>1</sup>Author of book, *Two-Way Radio*.

<sup>2</sup>COMMUNICATIONS; December, 1947.

## Part II. Equipment Features. Channel Problems and Possible Solutions. Installation and Servicing Procedures. Future of Taxicab Radio Systems.

hook. Various modifications of this technique have been developed. Further developments are continuing in this direction by many.

### Additional Features

Another model utilizes a synchro-cycle circuit which enables receiver to chase transmitter as latter drifts in frequency up to a maximum of 15 kc drift. Receiver locks on signal received from transmitters tuning itself automatically.

In another 2-way unit a *lockout* system is used so that only cab with microphone off hook can receive message at discretion of central station dispatcher.

An anti-stickup is a feature of another model wherein any sounds can be picked up by microphone and heard by the entire radio system in the event of foul play.

The price is no more, in some cases even less, than prewar equipment. This is true despite higher labor and

material costs existing today, and the fact that the equipment contains more tubes and circuits.

Control cables are simplified or reduced to only one or two between the controls and the equipment.

The operators of radio equipment in the vehicle no longer require a license or permit. Only the central station operator requires a permit or the keeping of a log. The service man still must hold a radiotelephone second or first class license.

All equipment is now much easier to inspect and service. Some units are of drawer type of construction. Most units have convenient provisions for exchange of units.

The receivers use more tuned circuits, running as high as twelve, and have better selectivity than the prewar versions. Every receiver offered is capable of a signal rejection of at least

1,000,000 to 1, when the undesired signal is one channel removed.

The discriminator tube has been eliminated in some receivers by the substitution of two 1N34 crystals, reducing battery consumption.

### Problems In Taxicab Radio

The most serious cab-radio problem is that of channel space. All taxicab operations in the United States today are being conducted on the same channel. This is only feasible where the cities are small, far apart and where only one taxicab organization exists in one community. This has seldom been the case to date. The situation is naturally aggravated, in large cities and great metropolitan areas surrounding them. It is further aggravated by the fact that taxicabs are very active, with each vehicle able to handle several assignments per hour. The traffic volume per vehicle may be as much as five times greater than that of a police car. Even with careful planning, well disciplined operators, faultless techniques, short messages, minimum call-up or acknowledgment and other considerations, at least six seconds are required to transmit an assignment to a taxicab. It is estimated that the maximum number of taxicabs which can be handled on one channel is between 75 and 100.

The FCC has recognized the problem and its responsibility in this con-

Circuit of the Bendix receiver-transmitter.

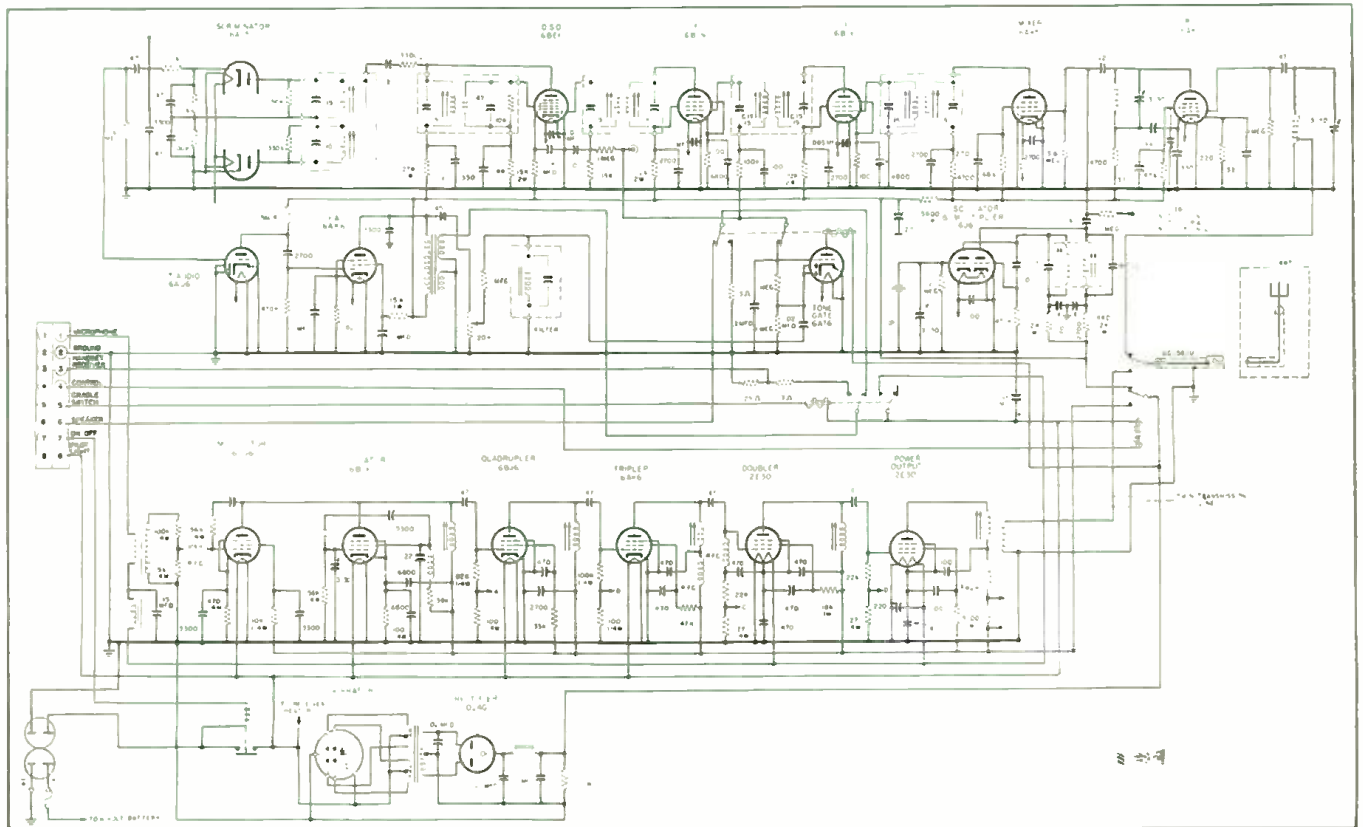

nection, and held a hearing recently to review frequency allocations for land transportation services. It is generally anticipated that many additional channels will be made available for cab radio operations.

Channel allocation will have to vary with locality and conditions. It will be necessary to consider the number of taxicabs in a single fleet in a single city or community. There should be one channel minimum per 100 taxicabs.

The number of separate taxicab fleets in one area is another factor. Each fleet should receive different frequencies than that of its competitor or competitors.

Finally there is the problem of the suburban or adjacent cities and communities which might be close enough to interfere with each other or with vehicles in the main metropolis. Thus each community should have separate frequencies.

This would be the optimum allocation of frequencies. It is obvious that the number of channels necessary in the case of our very largest cities would be excessive. A solution may be in providing a limited number of clear taxicab channels on a national basis plus a large number of additional channels on a shared basis. For example, forestry and marine frequencies can in many cases be used because the cities or communities may be remote from areas where such services exist.

#### Metropolitan Area Problems

New York City still remains an unsolved problem with no two-way taxicab radio provided. There are 14,500 taxicabs in New York operating as many small free-lance fleets, the largest of which is about 700 taxicabs. The drivers work on 42½% commission and are expected to complete 100 paid miles per shift or 200 paid miles for two shifts at the rate of twenty cents per mile. Dead mileage must be met out of the extra toll collected for the first quarter-mile. The rates are twenty cents for the first quarter mile and five cents for each additional quarter mile. To function on that basis, the drivers pay little attention to outlying areas. Instead, they concentrate in the midtown area, terminals or on principal thoroughfares. Cab operators are reluctant to take on the expense and organization of a central station dispatching system which two-way radio would require. A system capable of covering the entire city may



W.E. f-m telephone service system, installed by Bell System.

also be costly. It is here where the Bell system involving radio tolls may be more feasible. With such a system passengers would pay an extra charge for special pickup service similar to that used in a limited way by the Airport Taxi Service in Washington, D. C.

Taxicabs have been able to make satisfactory earnings without two-way radio because of city ordinances which limit the number of taxicabs. A consolidated dispatching and radio system serving all or most of the vehicles from one master point could solve the problem for the populated boroughs, such as Manhattan, Bronx and Brooklyn. Two-way systems could now be used quite effectively in the less-populated areas of New York, such as Staten Island and Queens.

#### Servicing

Another problem is servicing of equipment in smaller communities where or when a properly qualified and licensed person is not available. Schools have already recognized this need and are offering correspondence and residence courses on receivers and transmitters and first-class radiotelephone procedure. One school<sup>2</sup> is developing men with a 96-week resident school training.

It has been found that one full time service man is required for every 30 to 50 two-way radio stations. The higher figure should be the case with taxicabs who are within reach because they operate within the same city and usually from the same garage. On that basis there already exists a need for nearly 1,000 full-time service men. The number of service men that will eventually be required for installation and service is staggering when it is realized that there are fully 30,000,000

<sup>2</sup>De Forest Training, Chicago.

vehicles of all kinds—railroads, trucks, buses, taxicabs, automobiles, secondary vessels and aircraft which can utilize two-way radio.

#### Equipment . . . Operating Costs

The total equipment bill for initial installation for the taxicab field past, present and early future is approximately \$35,000,000. The annual parts and tube replacement bill, exclusive of service men salaries, is approximately \$2,000,000 per year. In the case of systems comprising 100 vehicles or more the overall servicing and maintenance cost for labor and materials will average about \$7.50 per month, assuming that parts are purchased at net prices.

Probably 90% of all taxicab business is pick-up type and on 5% of the streets in the modern city or community. It is reasonable to assume that there is enough business existing in the remaining 95% secondary areas to utilize double the number of taxicabs now in service. The development of this additional business is dependent on the full use of two-way radio in conjunction with a central office dispatching system. This dispatching system must operate on the basis of telephone request for taxicab service from the general public.

#### Emergency Uses of Taxicab Radio

Public agencies such as police, fire, utility, health and public works departments are particularly happy to see two-way radio in taxicabs. Since there are from 5 to 20 times more taxicabs than police radio cars in the average city, the two-way cabs can serve as *roving call boxes* for emergency contacts, without cost to the taxpayers. Cabs are in a position to report fires, accidents, street obstructions and to cooperate with the law.

With the advent of two-way systems, cab operation has become more important than ever, and destined to attract intelligent men to this otherwise ordinary occupation. Two-way communications is now paying off in a record-breaking manner by greatly improving the ratio between operating revenues and operating expenses for the fleet owner, more salary commissions for the drivers and excellent service for the public under all, rather than certain conditions.

**Right: Data on seven models of two-way mobile equipment used for taxicab radio service.**

Detail	Raytheon (Belmont)	Harvey Radio (541-542)	Link	Comco (Model 210)	Temco (30-FMT/FMR)	Federal (FT-25)	Wilcox (358A)	
Number of Tubes (Receiver)	12	14	13	16	13	17	13	
Number of Tubes (Transmitter)	9	9	6	8	8	10	8	
Number of Tubes (Total)	21	23	19	24	21	27	21	
Receiver Tube Lineup	1st R-F, 6AK5 2nd R-F, 6AK5 Converter, 6BE6 Tripler, 6AK5 Oscillator, 616 1st I-F, 6BA6 2nd I-F, 6BA6 Limiter, 6AC6 Discriminator, 6AL5 Squelch Amplifier, 6AQ6 1st Audio and Squelch, 6AQ6 Output, 6AK6	1st R-F, 6AK5 2nd R-F, 6AK5 1st Detector, 6AK5 1st I-F, 6AK5 2nd I-F, 6AK5 4th I-F, 6AK5 Oscillator, 6AK5 Multiplier, 6AK5 Noise Amplifier, 6C4 Squelch, 6AQ6 2nd Audio, 6AQ6 Output, 6AO5	R-F, 6AK5 1st Mixer, 6AK5 1st I-F, 7AG7 2nd Mixer, 7AG7 Oscillator-Multiplier, 7AG7 1st Limiter, 7AG7 2nd (5000 Kc) I-F, 7AG7 Discriminator, 7A6 1st Limiter, 7AG7 2nd Limiter, 7AG7 Noise Rectifier, 7A6 Squelch and Audio, 7F7 Audio Output, 7B5	R-F, 6AK5 1st Mixer, 6AK5 2nd Mixer, 6AK5 1st I-F, 9001 2nd I-F, 9001 3rd I-F, 9001 1st Limiter, 9001 2nd Limiter, 9001 Discriminator, 6AQ6 Discriminator, 6AQ6 Audio Amplifier, 616 7AG6 Oscillator-1st Doubler, 9001 2nd Doubler, 9001 3rd Doubler, 9001 4th Doubler, 9001	R-F Amplifier, 6AK5 1st Mixer, 6AK5 Multiplier, 6AK5 Oscillator, 7AG7 30-Mc I-F, 7AG7 2nd Mixer, 7AG7 4.4-Mc I-F, 7AG7 1st Limiter, 7AG7 2nd Limiter, 7AG7 Discriminator, 7A6 Noise Rectifier, 7A6 1st Audio and Squelch, 7F7 Output, 7C5	1st R-F, 6AK5 2nd R-F, 6AK5 Mixer (10-7 mc out put), 6AK5 I-F local oscillator, 6AK5 Multiplier, 6AK5 1st I-F (10.7 mc), 6AK5 2nd I-F I-F, 6AG5 Converter, 6BE6 2nd I-F (1.7 mc), 6AK5 1st Limiter (1.7 mc), 6AK5 2nd Limiter, 6AG5 Discriminator, 6AL5 Carrier switch tube (squelch), 2J21 Recd. Amplifier (in Selecto-Call models), 6AK5 1st A-F, 6AQ6 Output, 6V6GT Rectifier, 6X5GT or 0Z4 [Model 143A]	1st R-F, 6AK5 2nd R-F, 6AK5 1st mixer, 6AK5 Oscillator, 6AK5 1st I-F I-F, 6AK5 2nd R-F, 6AK5 1st mixer, 6AK5 Oscillator, 6AK5 Multiplier, 6AK5 2nd I-F I-F, 6AG5 Converter, 6BE6 2nd I-F I-F, 6AG5 1st Limiter, 6AG5 2nd Limiter, 6AG5 Discriminator, 6AL5 Carrier switch tube (squelch), 2J21 Recd. Amplifier (in Selecto-Call models), 6AK5 Noise Rectifier, 1N35 1st A-F, 6AQ6 Output, 6V6GT Rectifier, 6X5GT or 0Z4 [Model 143A]	1st R-F, 6AK5 2nd R-F, 6AK5 1st mixer, 6AK5 Oscillator, 6AK5 1st I-F I-F, 6AK5 2nd R-F, 6AK5 1st mixer, 6AK5 Oscillator, 6AK5 Multiplier, 6AK5 2nd I-F I-F, 6AG5 Converter, 6BE6 2nd I-F I-F, 6AG5 1st Limiter, 6AG5 2nd Limiter, 6AG5 Discriminator, 6AL5 Carrier switch tube (squelch), 2J21 Recd. Amplifier (in Selecto-Call models), 6AK5 Noise Rectifier, 1N35 1st A-F, 6AQ6 Output, 6V6GT Rectifier, 6X5GT or 0Z4 [Model 143A]
Transmitter Tube Lineup	Oscillator, 616 Modulator, 6AK6 1st Tripler, 6BA6 2nd Tripler, 6AK6 1st Doubler, 6AQ5 2nd Doubler, 6C4 Power Amplifier, 832A	Oscillator, 6AQ6 A-F, Amplifier, 6AQ6 Modulator, 6AQ6 Multiplier, 6AK5 Multiplier, 2E30 Multiplier, 2E30 Driver, 5516 P-p Amplifier, 5516	Oscillator-Phase Modulator, 7F7 1st Doubler, 7C7 Quadrupler, 7C5 2nd Doubler, 7C5 3rd Doubler, 2E26 Tripler-Power Amplifier, 829B	Oscillator-Audio Amplifier, 3A5 Modulator, 12E25 Quadrupler, 2E25 Tripler, 2E25 Driver-Doubler, 2E25 Power Amplifier, 3D23	Oscillator, 7C7 Modulator, 7A8 Quadrupler, 7AG7 Tripler, 7C5 Doubler, 7C5 2E26 Amplifier, 829B	Oscillator, 2E30 Modulator, 6AK5 Doubler, 2E30 1st Tripler, 2E30 2nd Tripler, 2E30 3rd Tripler, 2E30 Doubler, 2E30 Output, 832A	Oscillator, 6AK6 Modulator, 2 6BE6s 1st Tripler, 2E30 2nd Tripler, 2E30 3rd Tripler, 2E30 Doubler, 2E30 Output, 832A	Oscillator, 6AK6 Modulator, 2 6BE6s 1st Tripler, 2E30 2nd Tripler, 2E30 3rd Tripler, 2E30 Doubler, 2E30 Output, 832A
Transmitter Power Output	15 watts	36 watts	15 watts	15 watts	30 watts	25 watts	15 watts	
Multiplication of Transmitter Crystal Frequency	$3 \times 3 \times 2 \times 2 = 36$ times	(Optionally) 48 times	$2 \times 4 \times 2 \times 2 \times 3 = 96$ times	$4 \times 3 \times 2 \times 2 = 48$ times	$4 \times 3 \times 2 \times 2 = 48$ times	54	54	
Receiver Sensitivity For 20-db Signal-to-Noise Ratio	Below 1 microvolt for 50-milliwatt output	$\frac{1}{2}$ microvolt	$\frac{1}{2}$ microvolt	$\frac{1}{2}$ microvolt	$\frac{1}{2}$ microvolts	1 microvolt	Better than 1 microvolt	
Receiver Selectivity	60 db down at 120-ke off center frequency	85-db rejection on alternate channels	85 db at alternate channel (120 ke)	40 db at 80 kc; 60 db at 105 kc	6 db down 25 kc; 20 db down 55 kc; 40 db down at 110 kc	60 db 40 db at 120 kc; 60 db at 200 kc	40 db at 120 kc; 60 db at 200 kc	
Receiver Audio Output	1 watt	1 watt	1 watt	700 milliwatts	$\frac{1}{2}$ watts to 6-8-ohm voice coil	1.5 watts, 10% distortion; 2 watts, maximum	1 watt (less than 10% distortion)	
Squelch Operating Voltage	1 microvolt	.2 microvolt	.2 microvolt	.5 microvolt	Electron operated relay and biased audio amplifier	Receiver can be turned on in presence of blanketing noise; adjustable by pot. Responses only to signals in proper channel	.3 microvolt	



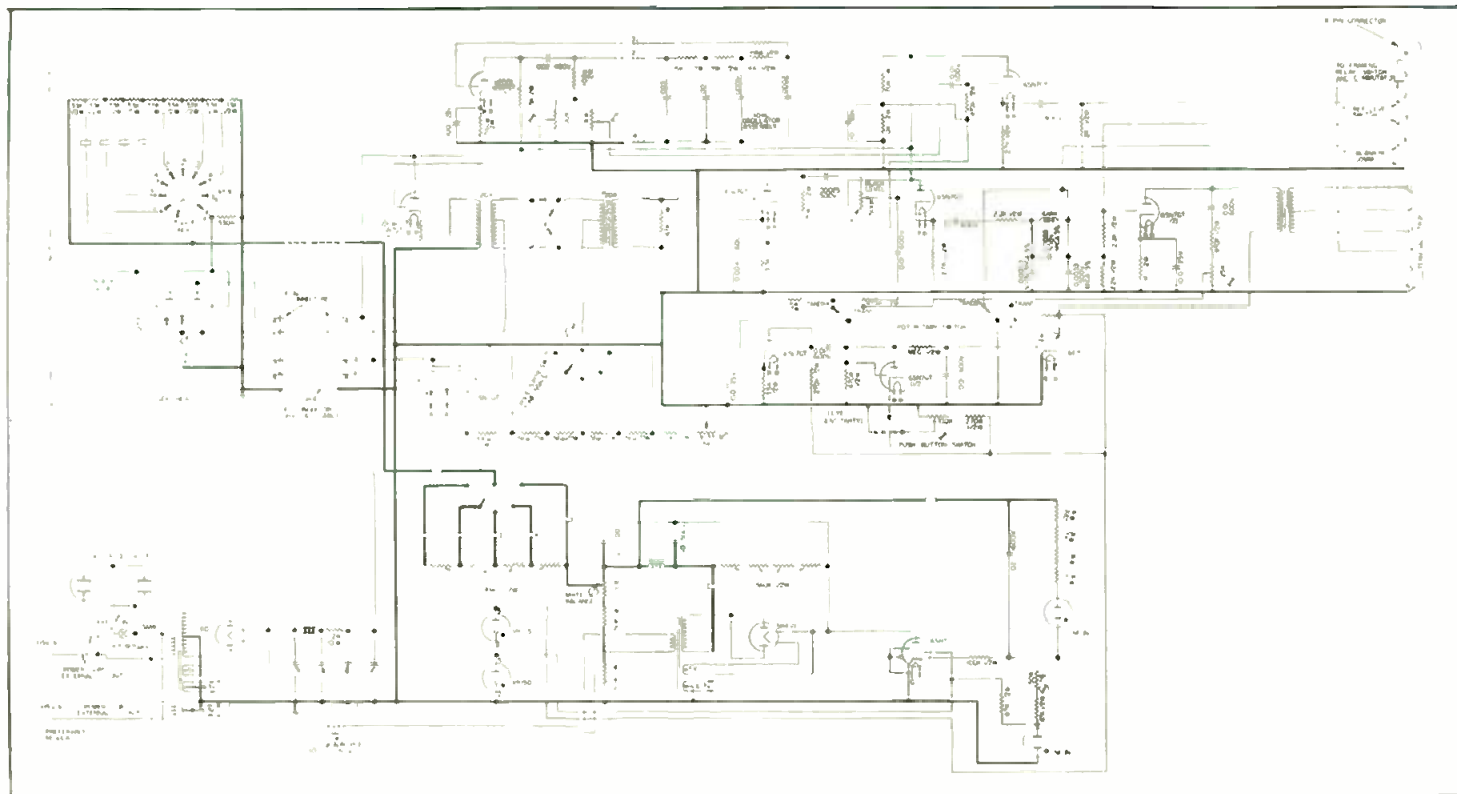

Figure 1  
Schematic of the scanner amplifier used in facsimile transmitter.

scanned in a spiral 1.105" wide and with a 1.105" pitch.

In this manner the scanner produces electrical signals representative of the optical density, or shade, of the copy as it is scanned. These signals are then fed to the scanner amplifier.

The blanking commutator at the left end of the drum shaft shorts out the signals in the scanner amplifier during  $\frac{1}{8}$  of each revolution of the drum, while the part of the drum circumference used for securing the copy holder is being scanned. On the driven sleeve there is another commutator which is used in bringing the driven sleeve to the correct angular position or phase with respect to a pulse-generator drum.

The scanner amplifier supplies power to the scanner, and uses the signals from the scanner to modulate a 10-ke subcarrier. The modulated subcarrier is amplified to +10-dbm level into a balanced 600-ohm load.

The signal from the scanner amplifier is further amplified by the limiter-amplifier.

The amplifier has two inputs. Signals applied to one of these inputs are amplified linearly. Signals applied to the other input are amplified with a limiting characteristic, whereby the output is zero for signals up to a particular value and nearly constant for levels above that value.

Signals from both the linear and limiting amplifiers are applied to a common output.

Both inputs and the output of this

amplifier operate with 600-ohm balanced circuits.

#### Pulse Generator

The equipment also employs a pulse generator which has a special scanning unit shock mounted on the horizontal chassis. In this scanning unit a drum about 4" in diameter and 1" long is rotated continuously, a speed of 360 rpm being maintained by a synchronous motor. A lamp, optical system, and phototube are arranged so that the drum circumference is interposed directly in the light path; one end of the drum is open to allow this. A part of the circumference is cut out and the opening covered with a piece of film on which are printed station call letters or other information to be transmitted as a page-separation signal. The printing is transparent with opaque background.

The light beam is restricted by a slot in the phototube housing parallel to the axis of the drum, with the slot extending from one end of the drum to the other and a little beyond. The light beam is also restricted by a disc with twelve radial slots. The disc is located between the housing and drum with its shaft perpendicular to the drum shaft. The clearances between the drum circumference and the disc, and between the disc and housing are both small. The light path is through

the intersection of the slot in the housing and a slot in the disc.

Scanning the drum from end to end is accomplished by rotating the disc through an angle of  $30^\circ$ , which is the spacing between the slots. The disc is rotated at one-half rpm by a synchronous motor. A cam-operated micro-switch automatically stops the disc after  $30^\circ$  rotation.

In the position where the disc stops, one of the slots is just past the end of the drum so that light reaches the phototube except when a  $15^\circ$  tab, which projects beyond the end of the drum, interrupts the light once each revolution of the drum. Immediately adjacent to this projection, the drum has a segment of  $15^\circ$  cut out. Therefore light reaches the phototube during this  $15^\circ$  of the drum's rotation regardless of the position of the scanning disc.

The output from the phototube keys a 10-ke subcarrier either on, when the light is interrupted, or off when the light reaches the phototube. As a result, the pulse generator, while the scanning disc is stationary, produces a single pulse for  $15^\circ$  of each drum revolution. This pulse is transmitted simultaneously with a facsimile signal from one of the scanners, the pulse being timed to occur during the interval when the copy-holder clamp of the scanner drum is being scanned and the scanner signal is being shorted by the blanking commutator on the scanner. The pulse generator output is mixed with the signal from one of the scan-

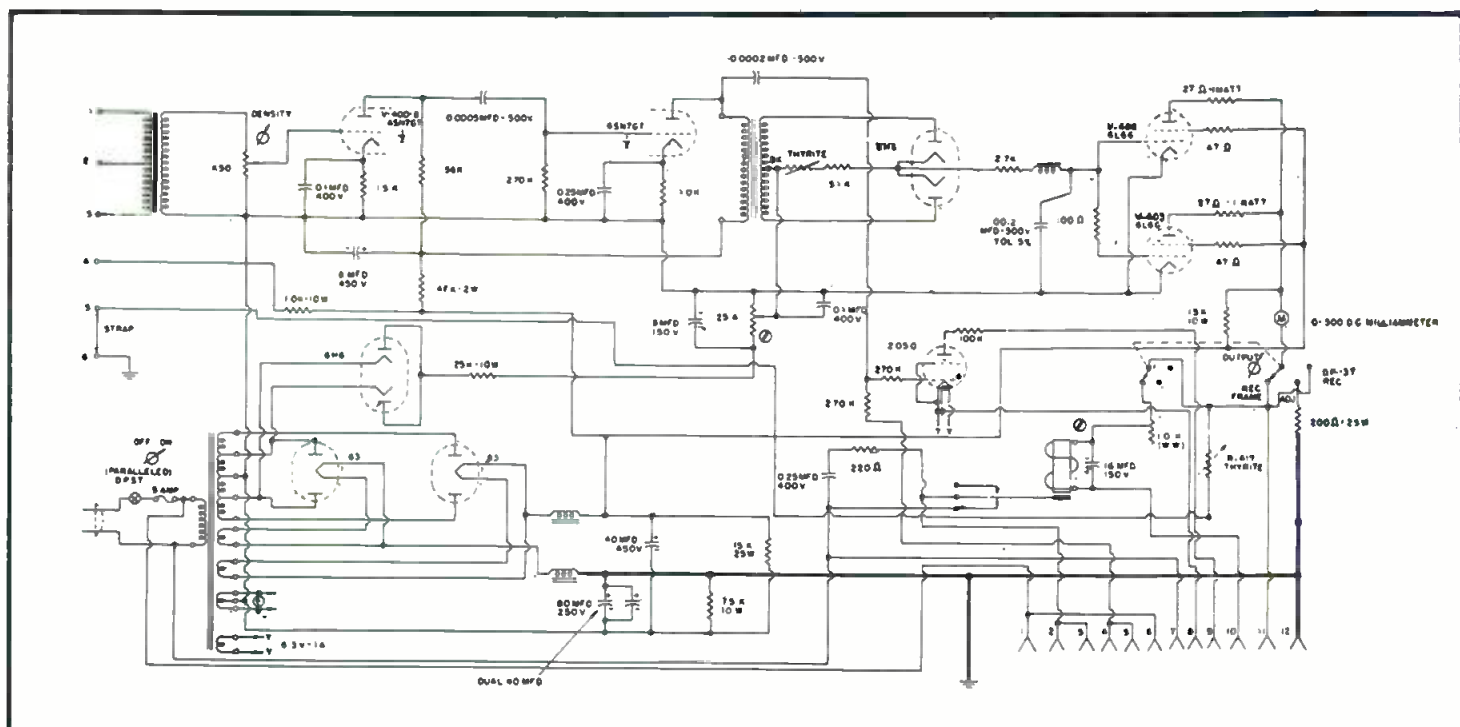

Figure 3  
The recorder amplifier.

ning channels in a mixing attenuator, which is mounted inside the right wing of the console. When the disc is rotated to transmit the page-separation signal after concluding a page from one of the scanners, the 10-kc subcarrier is transmitted continuously except for a 15° interruption once each revolution of the drum, and for whatever interruptions result from scanning across the page-separation signal. The subcarrier with 15° interruption serves to phase recorders automatically.

On the drum shaft there is also mounted a commutator which has a 6° conducting segment, having an angular position such that it contacts two brushes at the same time that the drum tab interrupts the light beam to produce the subcarrier pulse. These two brushes are connected so as to furnish a d-c pulse with each revolution of the drum. These pulses serve to phase the scanners, or, in other words, bring the scanner drums into the correct angular position relative to the pulse generator drum.

### Recorder Amplifier

A recorder amplifier amplifies the signal, rectifies it, and supplies current corresponding to the signal to mark paper in the recorder. A gain control (*density*) varies the amplification and, thereby, the marking current. This unit also supplies power to the recorder motor, and has a relay to interrupt the power when necessary to phase the recorder.

The recorder has a humidifier compartment which holds a roll of chemi-

cally-heated recording paper and keeps it moist, and rollers for guiding and feeding the paper. The paper passes over a drum with a raised helix, and the recording current flows from a printer blade above the paper through the paper to the helix. The paper then passes over a heater for drying the paper and intensifying the recording. A synchronous motor drives the helix drum and feedroller by means of a series of gears.

The blackening of the spot where the current flows through the paper is a function of the magnitude of the current. Metal from the printer blade is transferred to the paper by electrolytic action in proportion to the magnitude of the marking current. This metal then combines with the electrolyte to produce a mark of corresponding density. This process gradually consumes the marking edge of the printer blade.

The contrast is accentuated when the paper passes over a heater which dries the paper, the temperature of the heater being controlled by a thermal switch.

The motor has a synchronous speed of 1,800 rpm. The gearing is such that the drum rotates at 360 rpm and the paper advances at a rate of 3.43 inches per minute. Thus the recorder produces 105 lines per inch.

The drum speed is the same as that

<sup>2</sup>Phototube is of the multiplier type in which the current from light sensitive cathode is successively amplified by secondary emission at the dynode electrodes. A balance control varies this voltage and thereby the output from the phototube.

<sup>3</sup>This logarithmic characteristic is very desirable for facsimile transmission.

of the scanner drum, and the paper feed corresponds to the carriage motion on the scanner, with the result that the marking is in exactly the same order as the scanning of the transmitted copy.

### Phototube and Modulator Operation

A phototube<sup>2</sup> (Figure 1) receives light reflected from an area of the drum about the 1,105" square. The phototube is supplied from a regulated supply.

Output from the phototube appears across a 330,000-ohm resistor which is connected between the anode or collector electrode, and ground. In this application no potential is applied to the anode. While the output is much lower than would be obtained with a positive potential on the anode, it is proportional to the logarithm<sup>3</sup> of the illumination on the cathode over a considerable range. It has been found that the output at the upper end of this range is about .6 volt.

The output is applied to the grid of a 6SN7GT which is connected as a cathode follower.

V<sub>302</sub> (6SN7GT) has its grid grounded, plate connected directly to the same plate supply as V<sub>301</sub> (6SN7GT) and a 5,000-ohm variable resistance in its cathode. This permits adjusting the voltage from the V<sub>302</sub> cathode to ground to equal the voltage from the V<sub>301</sub> cathode to ground for a particular value of phototube output applied to the V<sub>301</sub> grid.

The cathode of this tube and the cathode of V<sub>302</sub> are connected to the



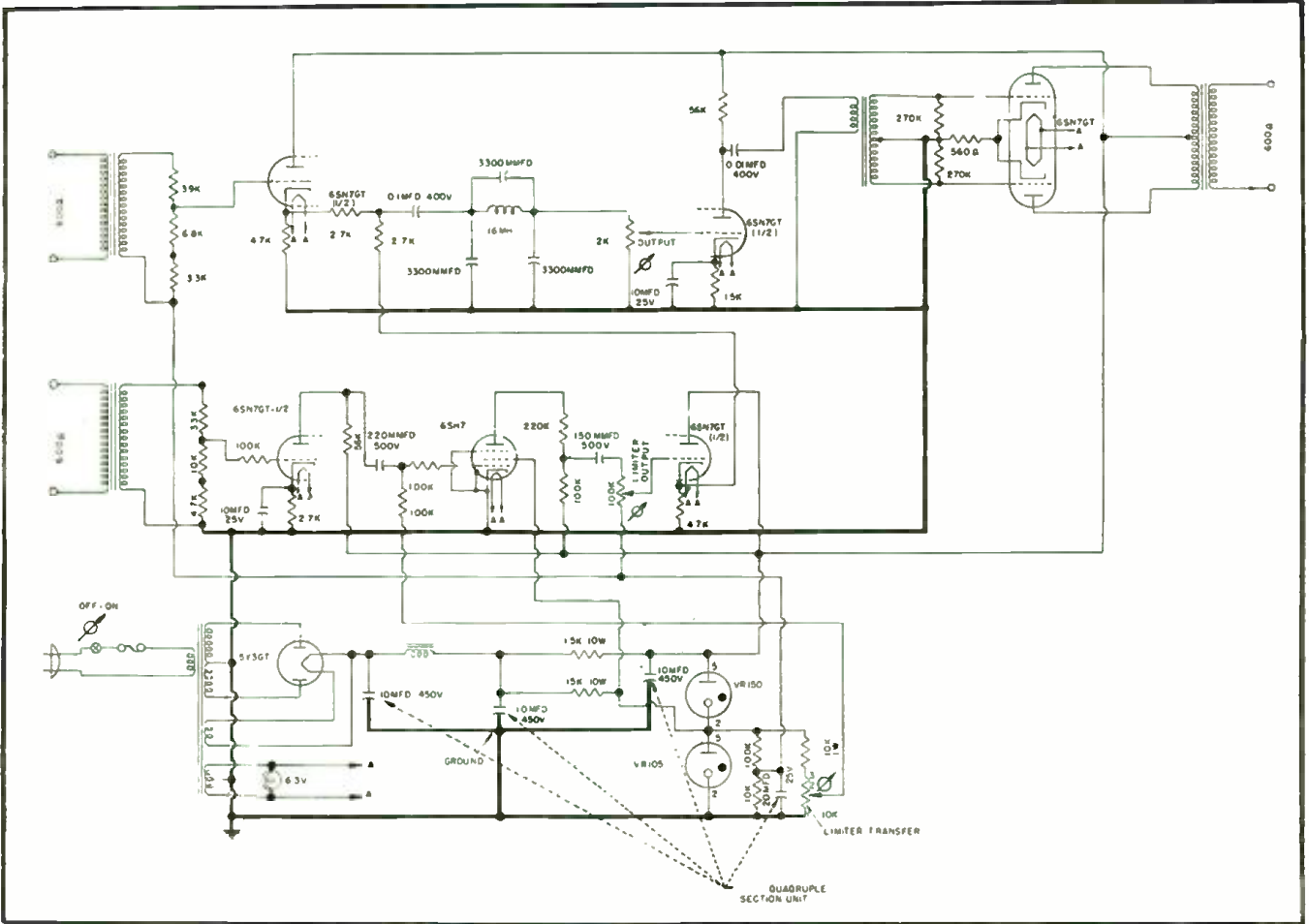

Figure 4  
Limiter-line amplifier schematic.

center taps of transformers,  $T_{3a1}$  and  $T_{3a2}$ , respectively, which with CR200 comprise a ring modulator. The 10-ke subcarrier is applied at the primary of  $T_{3a1}$  and the modulated output appears across  $T_{3a2}$ . For equal  $V_{b1}$  and  $V_{b2}$  cathode voltages, no voltage is applied to the modulator between the  $T_{3a1}$  and  $T_{3a2}$  center taps, and the output from the modulator is a minimum.

This inversion to produce maximum output from the modulator for minimum phototube output is necessary because maximum signal causes the recorders, which are reproducing the original copy, to mark black.

The 5,000-ohm variable,  $R_{WTR}$ , is adjusted for minimum output with a 2-pole 5-position switch,  $S_{201}$ , in a 0 position, and an output of .6 volt from the phototube. Thereafter, when the *white balance* control is adjusted to balance on the whitest area of individual pieces of the copy, the phototube output is automatically set to .6 volt which insures the logarithmic output-illumination characteristics.

### Pulse Generator

In this unit (Figure 2) the phototube is resistance coupled to the grid (5) of a 6J6 which acts as a d-c amplifier and

phase inverter. The voltage on the grid (6) is adjusted to set the output of the d-c amplifier with no illumination on the phototube. The output from the 6J6 (plate-to-plate) is amplified further in a 6SN7GT, the output being applied between the center taps of the transformers.

Diodes, 6H6, are connected between  $T_{3a2}$  and  $T_{3a1}$ , so that when the plate of one section of the 6SN7GT is positive with respect to the other, the diodes are conducting. This completes the circuit between the transformers,  $T_{3a2}$  and  $T_{3a1}$ , so that 10 ke is transmitted through these transformers to a 6SN7GT amplifier. Conversely, when the plate of the 6SN7GT is positive with respect to the other section, the diodes are non-conducting and the 10 ke is blocked from the amplifier.

### Recorder Amplifier and Recorder

The plate supply is operated with negative off ground so that the recorder printer blade, which is in a plate circuit, can be grounded. Otherwise, insulation of the recording paper

as well as the printer blade would be necessary.

A *thyrite* resistor (Figure 3),  $R_{A2}$ , is shunted between the helix and printer blade. This has the property of having a high resistance at low voltages which decreases as the voltage is raised. In this application it serves to complete the plate circuit of  $V_{b2}$  and  $V_{b1}$ , if the circuit between the helix and printer blade is open, so that screen current does not become excessive and to prevent a high voltage across the paper which could otherwise occur if the paper became dry. This might cause sparking through the paper. The resistance is high enough so that the thyrite has no effect for normal recording.

### Phasing of Scanner

It is necessary to have a definite angular relation between the drums on the pulse generator and the scanners. Both pulse generator and scanner drums are driven at 360 rpm by synchronous motors supplied by a common source of 60-cycle power. The motors may lock into synchronism with any one of twenty possible angular relations between the drums, differ-

(Continued on page 33)



# VETERAN WIRELESS OPERATORS ASSOCIATION NEWS

W. J. McGONIGLE, President

RCA BUILDING, 30 Rockefeller Plaza, New York, N. Y.

GEORGE H. CLARK, Secretary



Haraden Pratt, who is now second vice president of the VWOA.

THE COMMUNICATIONS INDUSTRY is well represented on the 1948 VWOA officers' roster and board of directors.

Our prexy, William J. McGonigle is with the New York Telephone Company. First vice president, A. J. Costigan is vice president of Radiomarine Corp. of America and second vice president Haraden Pratt is vice president and chief engineer of Mackay Radio and Telegraph Co. Genial secretary W. C. Simon is general manager of the Tropical Radio Service Corp., a subsidiary of United Fruit Company. Assistant secretary H. T. Hayden, Jr., is with Ward Leonard Electric, C. D. Guthrie, VWOA treasurer, was formerly with the U. S. Maritime Commission and is now retired.

On the board of directors are George H. Clark of RCA; Jack Poppele, chief engineer and vice president of WOR and TBA president; Fred Muller, captain U. S. N. R., in addition to Bill Simon, A. J. Costigan, C. D. Guthrie, Bill McGonigle and Haraden Pratt.

### Annual VWOA Meeting

THERE WAS QUITE a turnout at the annual VWOA meeting at the Fireplace Inn in New York City. Among those present were G. H. Clark,

Lucien E. Bondiaux, V. P. Villandre, W. Jablon, C. D. Guthrie and son, Rod Chipp, H. T. Hayden, Jr., Earl Nelson, R. J. Iversen, Roscoe Kent, Frank Melville, George T. Duvall H. L. Cornell, Dave Carruthers, R. D. Davis, Ben Beckerman, Charles Cooke, as well as, of course, Bill McGonigle and Bill Simon.

George Duvall reported that he is as busy as, with television work these days, but he doesn't mind it. . . . Frank Melville is also quite active with his school where television, i-m and commercial radio courses are given. . . . R. J. Iversen is still clearing the air lanes for the New York Times. . . . Walt Jablon has gone over to Espy where he'll be vice president in charge of sales. Walt was with Hammarlund for 18 years. . . . Florida kept C. Seid away from the meeting. Hope you're having a good time CS. . . . F. McDermott couldn't make it because of quite an important event, visiting with his son and family for the first time in seven years. . . . Jack O'Keefe wanted to come but his activities at French Cables kept him away. . . . An evening watch kept M. G. Carlir away from the annual meeting. . . . Orth of CBS was on night duty and couldn't come either. . . . W. J. Barkley, executive vice president of Collins Radio, was out on

VWOA veteran George E. Sterling, who has been appointed a FCC commissioner. GES was formerly FCC chief engineer.



William C. Simon, who was reelected secretary of the VWOA.

the west coast and couldn't attend but wrote in to say that he'll be at the dinner cruise on February 28th. . . . Ludwig Aranson, president of Radio Reception was called out of town and sent his regrets on the night of the annual meeting. . . . Jack Poppele had made arrangements to come to the meeting but was called away at the last moment. . . . Ed. G. Raser had hoped to drop in at the meeting but just couldn't make it. He reports that Bud Waite, Jr., recently returned from his second trip to Little America, is now in Churchill, Canada on a special mission for the Signal Corps. Bud was at Bikini during the atom bomb test in charge of communications detail. . . . Francis J. Herrmann reported that he couldn't attend the annual meeting but he'll be at the annual dinner cruise. . . . Bill Stedman had a night shift program to take care of on the eve of the meeting.

### The Annual Dinner Cruise

COMPLETE DETAILS on the Annual Dinner Cruise, which will be held at the Hotel Astor, on February 28th, are now in the mails. Members are urged to mail in their reservations for tables promptly. There'll be quite a crowded program of activities and many surprises. Hope we'll be seeing you!



POLICE



FIRE



TAXIS



BUSES



UTILITIES

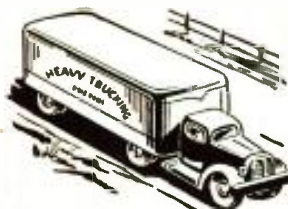

TRUCKING

# STOP

**Wasting Minutes!  
Wasting Mileage!  
Wasting Money!**

## Equip Your Fleet with Federal's MOBILE 2-WAY FM RADIO TELEPHONE

What do you do when you want to get in touch with one of your drivers while he's on the job? And how can he contact you? Without mobile radio, a moving vehicle is practically isolated from all contact with the outside world—and any other method of relaying messages between cars and headquarters wastes time and mileage, and costs plenty of money!

Now, with Federal's Mobile 2-way FM radio, you can keep in instant touch with any car, at any time,—for dispatching, re-routing, checking up on any job. The added efficiency of completely coordinated operation will save the cost of the radio equipment many times over!

Of course, the return on the investment depends on the equipment used—its operating economy, service life and maintenance cost. And that's where Federal's high standards of quality and workmanship can pay long-term dividends. Before you select your mobile radio equipment, check these outstanding features. Write to Federal for complete information. Dept. I 610.

### FEDERAL FEATURES

- **Effective Squelch Action**—receiver muted until called
- **Low Current Drain**—receiver standby, 6.0 amp. Transmitter standby, 30 to 44 Mc, 2.1 amp; 152 to 162 Mc, 0.415 amp.
- **Small Size**—less than one cubic foot
- **Interchangeable Units**—transmitter and receiver sections slide out for fast servicing
- **Low Maintenance Expense**—highest quality components throughout
- **Single Cable**—from dashboard control to transmitter-receiver unit.

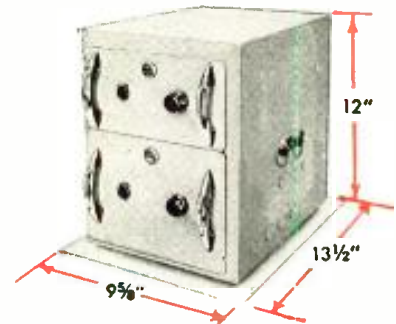

**TRY THESE FOR SIZE**—choice of vertical or horizontal arrangement for most efficient use of available mounting space.

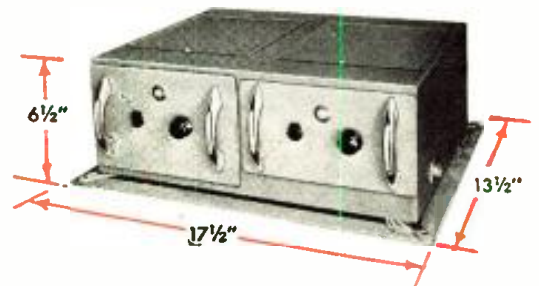

*Federal Telephone and Radio Corporation*

100 KINGSLAND ROAD, CLIFTON, NEW JERSEY

In Canada:—Federal Electric Manufacturing Company, Ltd., Montreal, P. Q.  
Export Distributors:—International Standard Electric Corp. 67 Broad St., N. Y.



KEEPING FEDERAL YEARS AHEAD... is IT&T's world-wide research and engineering organization, of which the Federal Telecommunication Laboratories, Nutley, N. J., is a unit.

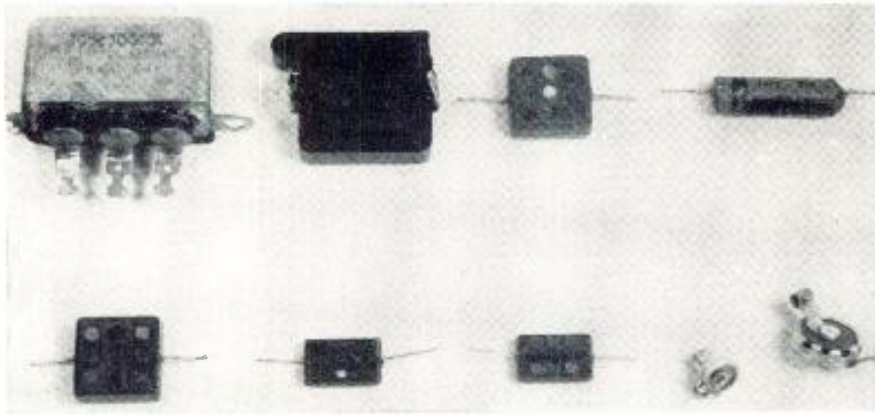

Figure 2  
Nine types of bypass capacitors that were checked by Price.

# Effectiveness of Bypass Capacitors at V-H-F

IN A VACUUM-TUBE AMPLIFIER STAGE operating at v-h-f, occasionally there is an unexplainable loss of gain and a large minimum bandwidth. This can be due to improper bypassing of the plate, screen or cathode returns in the amplifier stage. The amount of capacity used to bypass these returns is seemingly adequate from the value of the capacitance inscribed on the case. However, at very high frequencies, certain capacitors have resistive and reactive components that make the effective impedance quite large and, in some cases, the equivalent circuit of this capacity is an inductance. Manufacturers realize this and strive in capacitor development to make their units small and use a dielectric of good quality, thus minimizing the change in capacity with frequency. Even with excellent design, however, there is a limit to the frequency at which a bypass capacitor can be effectively used. In some cases this frequency limit is lower than the operating frequency of the amplifier stage in which it is used.

This design pit-fall can be overcome with the aid of a high-frequency Q-meter, with which it is possible to determine, in advance, the effectiveness of a bypass capacitor. In this method, the capacitor under test is connected in series with the *low* side of an inductance, the combination connected to the inductance terminals of the Q-meter, and then the combination is tuned to resonance with the meter's capacitor. From Figure 1, it will be noted that if the bypass is an effective one, the Q-reading on the

meter, and the variation in capacity of the instrument's capacitor will not change from that of the inductance alone applied to the inductance terminals of the Q-meter. However, if this is not the case, the capacitor under test may have a resistive component, as well as an appreciable reactive component that changes the Q-reading and the capacity required to tune the combination to the desired frequency.

\*Care must be exercised in the insertion of the capacitor in series with the inductance so as not to introduce strays. The most satisfactory arrangement is to build a jig, using metal strips and polystyrene. The capacitor under test can be mounted by soldering it to lugs, and reference values for Q and capacity can be made by simply shorting the terminals where the capacitor is attached.

\*\*The amount of inductance to be used at the test frequency is determined by the capacity value of the bypass. If the value is, say, 500 mmfd, then the inductance should be such that it can be tuned to resonance with a capacity of a value no larger than 1/20 of the bypass capacity or 25 mmfd. This will allow certain assumptions that will simplify a quantitative determination of the test capacitor's components.

Figure 1  
Schematic circuit of the test procedure used by Price to evaluate bypass-capacitor effectiveness at v-h-f.

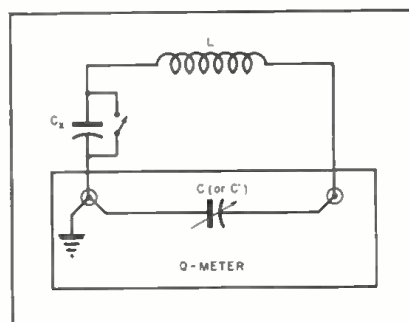

Since the capacitor under test can be inserted and shorted out in a manner that minimizes strays,\* one can qualitatively check the capacitor in the following way:

- (1) With the test capacitor shorted out, the amount of capacity needed to tune the inductance\*\* to resonance is recorded. Next, the value of the Q-reading on the meter is recorded.
- (2) The short is removed from the test capacitor and the new value of capacity needed to tune the inductance to resonance as well as the new value of Q is recorded.

In determining the effectiveness of a bypass capacitor, qualitatively, two points must be considered:

(1) If the amount of capacity required to tune the combination of coil and test capacity to resonance was *more* than the amount of capacity needed to tune the coil alone to resonance (at the same frequency, of course), then the test capacitor is acting as capacitance. (2) If, on the other hand, the capacity needed to tune the combination was *less* than the amount of capacity needed to tune the coil alone, then the test capacitor is acting as an inductance at the test frequency.

Data on just how much capacitance or inductance the test capacitor represents appears in the following quantitative discussion.

The fact that the capacitor is behaving as such is not sufficient to permit one to say it is satisfactory at the test frequency. The matter of the

# Qualitative and Quantitative Tests at 30 and 100-Mc on Paper, Tubular, Postage Stamp, Mica Molded, Mica Silvered and Button Mica Types Reveal Capacitive and Inductive Factors to Be Considered in Selection of Capacitors for V-H-F. H-F Q Meter and Simple Set of Equations Used in Checking Method.

by JOHN F. PRICE

Research Engineer  
Engineering Research Associates, Inc.  
Washington, D. C.

resistive component has to be determined.

The resistive component can be found from the loss in  $Q$  when the test capacitor is inserted. If the circuit  $Q$  changes appreciably (say more than 20%), then the resistive component is too high for effective bypassing\*\*\* at the test frequency.

### Quantitative Check

In conducting a quantitative check, let us assume the test capacitor had been subjected to a qualitative test and the values of tuning capacity and indicated  $Q$  recorded. Then, let

- $Q$  = the  $Q$  of circuit of the coil alone applied to the inductance terminals of the  $Q$ -meter.
- $Q'$  = the  $Q$  of the series combination of coil and test capacitor.
- $R$  = the resistance of the circuit of the coil alone (at the test frequency).

- $R'$  = the resistance of the test capacitor alone (at the test frequency.)
- $C$  = The amount of capacity needed to tune the coil to resonance.
- $C'$  = the amount of capacity needed to tune the series combination of the coil and test capacitor to resonance.
- $W$  =  $6.28 \times$  the test frequency.
- $L$  = the inductance of the coil.

Since

$$Q = \frac{WV L}{R} \text{ and } W^2 L = \frac{1}{WC}$$

at resonance, then

$$Q = \frac{WV L}{R} = \frac{1}{W^2 C R} \text{ or } R = \frac{1}{W^2 C Q} \quad (1)$$

$R$  can then be found, because  $W$ ,  $C$  and  $Q$  can be determined from the dials on the  $Q$ -meter if the distributed capacity can be neglected. It is not  $R$  we are after but  $R'$ , which can be

\*\*\*It will be recalled that circuit  $Q$  should be maximized in a v-h-f amplifier, as high circuit  $Q$  yields high gain and greater signal-to-noise discrimination.

found in the following manner:  
If

$$Q = \frac{1}{WRC}$$

after inserting the test capacitor

$$Q' = \frac{1}{W(R+R')C} \quad (\text{If } C \text{ does not change appreciably}) \quad (2)$$

$C$  will not change much if the coil is large enough to require a value of  $C$  to tune it that is considerably smaller than the capacity of the test capacitor. Then, solving (1) and (2) for  $R'$ , thus eliminating  $R$ , we get

$$R' = \frac{1}{WC} \left( \frac{1}{Q'} - \frac{1}{Q} \right) \quad (3)$$

The actual change in  $C$  is small compared to the term in parenthesis and hence equation (3) holds.

The magnitude and direction of the change in  $C$  is important, however, as the effective capacitance (or inductance) of the test capacitor can be found from these values.

If the capacitor is behaving as an inductance,  $C$  will be *greater* than  $C'$ , and, since the test frequency is held constant,

$$W^2 LC = 1 = W^2 (L + L') C',$$

where  $L'$  is the inductance of the capacitor. And, since

$$L = \frac{1}{W^2 C}$$

then

$$L' = \frac{1}{W^2} \left( \frac{1}{C'} - \frac{1}{C} \right) \quad (4)$$

When  $C$  is *less* than  $C'$  then the test capacitor is behaving as a capacitance

(Continued on page 32)

Capacitor	Rated Capacity	Cap. or Ind. at 30mc	Cap. or Ind. at 100 mc	Resistance		30-mc Data				100-mc Data			
				30 mc	100 mc	Q	Q'	C mmfd	C' mmfd	Q	Q'	C mmfd	C' mmfd
Paper	.1 mfd	.04 μh	.01 μh	295 ohm	262 ohm	206	153	31.2	29.9	240	134	20.3	18.3
Mica	.001 mfd	.0013 mfd	.....	.000 ohm	.....	206	206	31.2	32.0	Inductive*			
Mica Postage Stamp	.01 mfd	.004 μh	.002 μh	020 ohm	.011 ohm	209	204	31.2	31.1	236	228	20.3	19.9
Paper Tubular	.001 mfd	.0016 mfd	.....	.262 ohm	.....	204	155	31.2	31.8	Inductive and Resistive			
Mica Silvered	.003 mfd	.001 mfd	.002 μh	.000 ohm	.012 ohm	206	206	31.2	31.3	241	232	20.3	20.0
Mica Molded	.0001 mfd	100 mmfd	93 mmfd	.316 ohm***	.094 ohm	206	140	31.2	46.9	242	182	20.3	26.0
Mica Molded	.0005 mfd	495 mmfd	.....	.007 ohm	.....	207	190	31.2	33.2	Inductive and Resistive			
Small Button Mica (Silver)	.0005 mfd	518 mmfd	610 mmfd	.028 ohm	.003 ohm	207	200	31.2	33.2	232	230	20.3	21.0
Large Button Mica (Silver)	.002 mfd	**	.002 mfd	.000 ohm	.001 ohm	207	207	31.2	31.2	235	234	20.3	20.5

\*Data taken on only one-half on the inductive types.  
\*\*Indicates capacity is greater than .002, but error in reading the dial was as great as  $C' - C$ .  
\*\*\*This value obtained by using a value  $\frac{L' - L}{2}$  for  $C$  in calculating for  $R'$ .

Tabulated results of tests made on nine sample capacitors

# Measuring F-M Antenna Patterns With Miniature Antennas

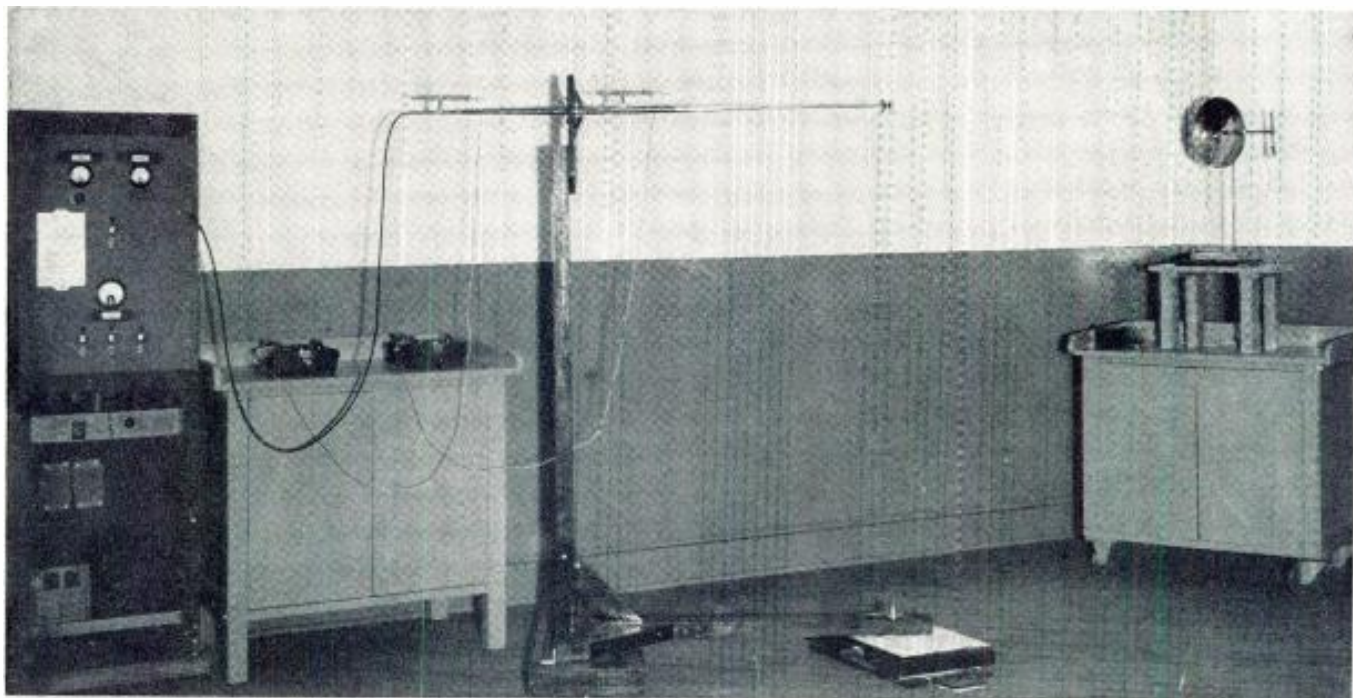

Figure 1  
Complete setup of equipment used for measuring vertical radiation pattern of microwave antennas.

IN THE DEVELOPMENT of high-gain antennas of the types employed in f-m broadcasting, it is important to measure the horizontal and the vertical radiation patterns. A multi-element antenna designed for this purpose is quite heavy and unwieldy, and is, therefore, inconvenient to rotate about its horizontal or its vertical axis.

A reasonable solution of this problem is to scale the antenna down to operate at microwave frequencies, and to measure the vertical and horizontal radiation patterns by placing the field-strength measuring set in a fixed position, while the transmitting antenna is rotated in turn about its vertical and horizontal axes.<sup>1</sup>

It is a comparatively simple matter to obtain the horizontal radiation pattern of a microwave antenna, since it may be conveniently rotated about its vertical axis. It is inherently more difficult to measure the vertical radiation pattern of an antenna.

The problem was solved with a comparatively simple apparatus\* which

\*Apparatus was built in connection with a research project in which it was desired to determine the vertical radiation patterns of biconical antennas and other antennas used in the 88 to 108-mc f-m band.

---

## Simple Setup Used to Measure Vertical Radiation Patterns of V-H-F Antennas, Antennas Being Scaled Down to Microwave Dimensions for Convenience in Pattern Measurements.

---

by **M. A. HONNELL** and **J. D. ALBRIGHT**

Professor of Electrical Engineering

Graduate Student

Georgia School of Technology

provided measurements of vertical radiation patterns of antennas operating at a wavelength of 10 centimeters.

### Description Of Equipment

The construction of the antenna-pattern measuring device is shown in Figure 1. It consists of a well-braced L-shaped wooden frame pivoted at one end, with the opposite end mounted on casters in order that the frame may be rotated freely about the pivot. A large

protractor mounted about the pivot indicates polar angles.

The microwave antennas are mounted directly over the pivot at the end of the transmission line which is fastened horizontally on a metal flange at the top of the wooden upright. The outer conductor of this line is standard  $\frac{3}{8}$ " copper tubing, while the inner conductor is  $\frac{1}{8}$ " rod. The line has a nominal characteristic impedance of 55 ohms, which is close to the value of

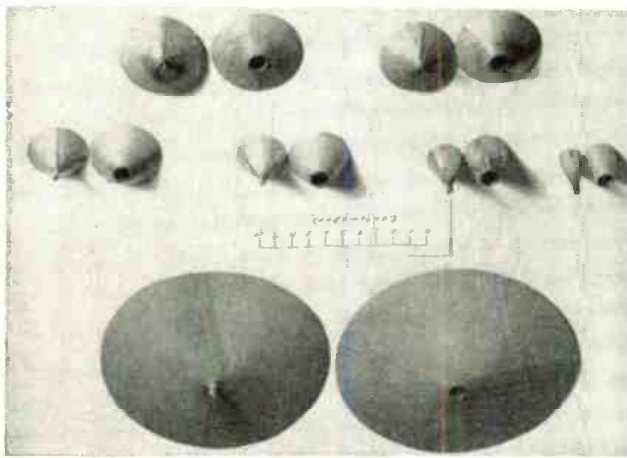

Figure 2  
Typical biconical antennas tested.

51.5 ohms recommended for i-m and television uses.

A slotted-line section is used to measure standing-wave ratios for the purpose of calculating the input impedance of the antennas. To facilitate probing, the slotted line is made from a section of 55-ohm,  $\frac{7}{8}$ " coaxial transmission line connected to the  $\frac{3}{8}$ " line by means of tapered line sections three wavelengths long, having tapered inner and outer conductors.

The input voltage to the line and

standing waves in the slotted section are measured with stub-tuned crystal detectors and associated microammeters. The line assembly is connected to a 10-centimeter klystron oscillator through a flexible coaxial cable. It is important that the klystron power supply be well regulated to keep

Figure 4  
Measured vertical radiation patterns of biconical antenna having a  $10^\circ$  flare angle. The broken-line pattern was obtained when a quarter-wave decoupling sleeve was added.

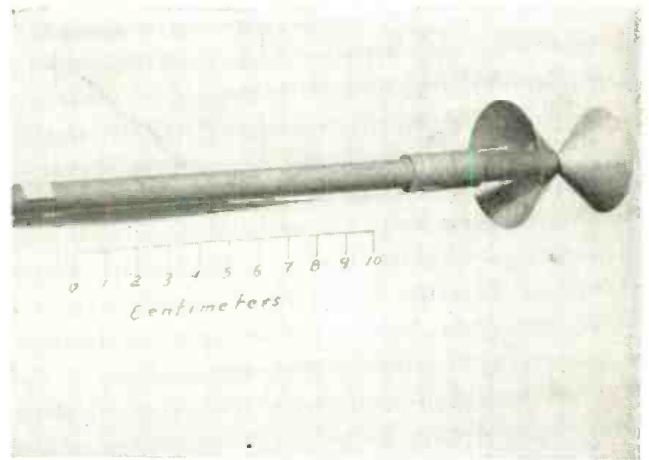
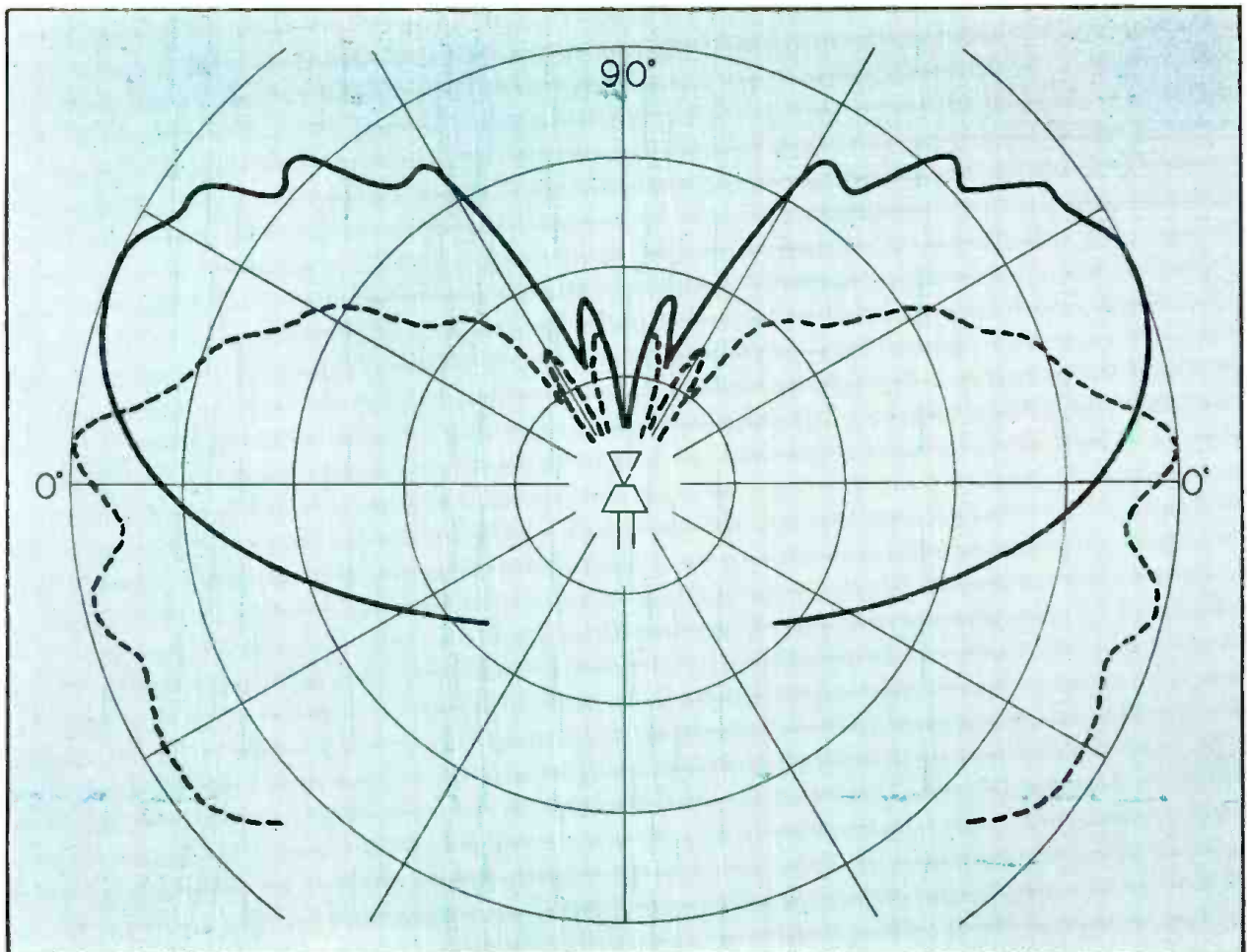

Figure 3  
Biconical antenna, having a  $30^\circ$  angle, with a decoupling sleeve in position.

the input to the antenna constant.

The radiated wave is received on a simple field-strength meter consisting of an antenna, a crystal detector, and a recording meter. The receiving antenna, Figure 1, consists of a half-wave dipole and parasitic reflector at the focus of a small parabola. The dimensions of the receiving antenna should be small if sharp angular definition is desired.

The crystal detectors used in conjunction with the slotted line and with

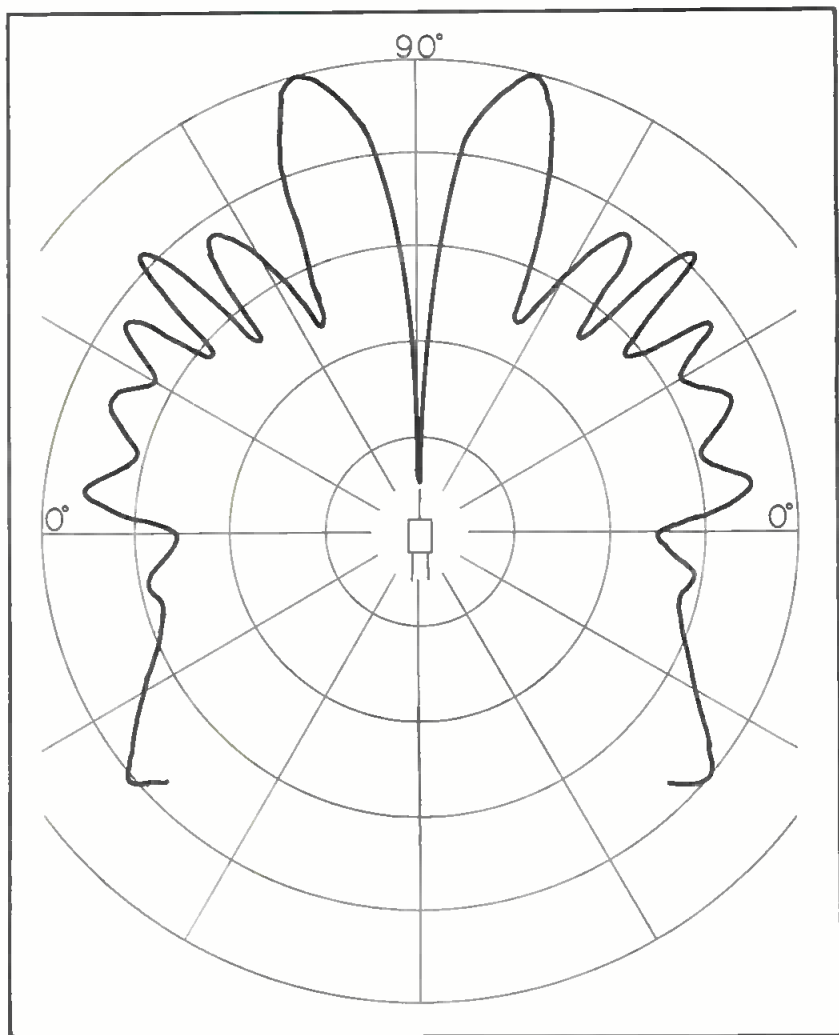

Figure 5  
The measured vertical radiation pattern of a coaxial antenna.

the receiving antenna must be calibrated since they have non-linear response characteristics.<sup>2</sup> Greater overall sensitivity may be obtained by modulating the klystron with a square wave. The output of the crystal detector is then amplified and recorded on a vacuum-tube voltmeter or copper-oxide rectifier meter.

Figure 2 illustrates some of the typical biconical antennas tested. A close-up of one of the antennas mounted in position is shown in Figure 3. A quarter-wave decoupling sleeve is seen on the line next to the antenna.

#### Measurement Technique

Antenna pattern measurements are preferably made in a large open area. However, satisfactory measurements may be made in a large room reasonably free from reflecting obstructions.

It is important to insure that the input power to the antenna system be kept constant. This is conveniently achieved by use of the monitoring

crystal detector at the input to the line, as shown in Figure 1.

The receiving antenna is placed at a point remote from the transmitting antenna, and the relative field strength is recorded as the transmitting antenna assembly is rotated about the pivot. Readings are customarily obtained for angular increments of 5°. The presence of minor lobes and of nulls is determined with greater accuracy by using a graphic recording meter in conjunction with the field-strength equipment.

A standard technique is used to measure the input impedance of the antennas.<sup>3</sup> The magnitude and nature of the antenna impedance is calculated from the measured standing-wave ratios and node positions in the slotted line. The slotted line section is not a necessary part of the system, if impedance values are not required.

In many cases it is more convenient to obtain the radiation pattern of an

<sup>5</sup>Data on measuring equipment, described in this paper, were taken in part from a master's thesis research project pursued by Mr. Albright under the direction of Professor Honnell.

antenna by using it as a receiving antenna.<sup>4</sup> In this case, the frame supporting the antenna may be mechanically connected to a polar-type graphic recording meter to plot directly the directional pattern of the antenna.

#### Typical Results

The vertical radiation pattern of a biconical antenna with a flare angle of 10° is shown in Figure 4. This pattern was obtained in a 20' by 30' room with a separation of approximately 20 wavelengths between the transmitting and receiving antennas. The effect of the decoupling sleeve on the radiation pattern is clearly shown in the figure.

Figure 5 shows the measured vertical radiation pattern of a coaxial antenna which was expected to have a pattern closely resembling the theoretical pattern of a vertical dipole. The advantage of being able to measure the vertical pattern of an antenna is immediately apparent. The distortion of this pattern is due in part to spurious currents flowing on the outer surface of the coaxial line.

In conclusion, it was found that a considerable amount of time is saved in the initial testing of antennas if they are scaled down to microwave dimensions. However, it is not always possible to reduce all of the significant dimensions in the proper ratio. Appropriate compensation for these discrepancies may be made in the final full-scale model of the antenna.

#### Acknowledgment<sup>5</sup>

The writers are grateful to the Georgia Tech Engineering Experiment Station for the assistance given them in the construction of the measuring equipment.

#### References

<sup>1</sup>Honnell, M. A., *Microwave Model Antennas*, p. 43, COMMUNICATIONS; June, 1945.

<sup>2</sup>King, R. W. P., *Electromagnetic Engineering*, Vol. 1, p. 316-320, McGraw-Hill Book Co., Inc.; 1945.

<sup>3</sup>Meagher, J. R., and Markley, H. J., *Practical Analysis of Ultra High Frequency*, p. 24, RCA Service Co., Inc.

<sup>4</sup>Hoadley, G. B., *An Analysis of R-F Transmission Lines*, p. 22, COMMUNICATIONS; February, 1943.

<sup>5</sup>King, R. W. P., Mimno, H. R., and Wing, A. H., *Transmission Lines, Antennas and Wave Guides*, p. 216-219, McGraw-Hill Book Co., Inc.; 1945



# Television stations get programs by telephone lines, too



Thousands of pairs of wire in telephone cables radiate from every central office. That is why cable pairs will be handy to link cameras and transmitters wherever a television program may originate.

Since cable pairs are designed first for voice transmission—top frequency, about 3200 cycles per second—the loss at picture frequencies up to 4,000,000 cycles is high, so an amplifier is inserted about every mile. Equalizing networks are also needed to bring the losses at all frequencies to the same value.

Recently, the Laboratories have developed a

“video pair” in which polyethylene string and tape are used instead of paper, and which has a shielding copper tape over all. It is being built into new telephone cables which go to points where television programs are certain to originate. Losses are so much less that amplifiers can be four miles apart.

Inside an all-weather sheath, “video” travels safely and reliably alongside your telephone call, a sound program, telegraph signals, pictures for tomorrow’s papers. This service of the telephone cable was ready when television needed it because of Bell Laboratories activity.



**BELL TELEPHONE LABORATORIES** EXPLORING AND INVENTING,  
DEIVING AND PERFECTING, FOR CONTINUED IMPROVEMENTS AND ECONOMIES IN TELEPHONE SERVICE

# TUBE *Engineering News*

## Design and Application Notes on the TV Image Dissector. Blowers Used for Cooling External Anode, Tube Header or Electrode Seal, or Glass Envelope of Radiation-Cooled Anode Type Tubes.

### The Image Dissector<sup>1</sup>

THE IMAGE DISSECTOR pickup tube, used in telecine projectors,<sup>2</sup> and also for direct pickup where the average subject brightness is not less than 150-250 candles per square foot when used with a  $f/2.5$  lens, has many interesting design and application features.

Internal parts of the tube are a photo-sensitive cathode, an anode for accelerating the electrons emitted therefrom, and a shielded target containing a small aperture and an electron-multiplier. Its external accessories are a focusing coil, a high-frequency horizontal scanning coil and a low-frequency vertical scanning coil.

The cathode is a spun silver cup with a flat bottom on whose inner surface a caesium-silver oxide film has been formed: it occupies one end of the glass cylinder. The other end is a plane glass surface. The anode is a conducting nickel coating on the inner surface of the cylinder. The target is placed close to the plane glass end. The entire cylinder fits into the focusing coil by which an axial magnetic field is established throughout the length of the cylinder. The coil and tube are placed within a supporting framework, consisting of the horizontal and vertical scanning coils.

The dissector is operated<sup>3</sup> by focusing an optical image from a lens through the plane glass end on to the photo-sensitive cathode at the other end.

Electrons are accelerated from the cathode toward the target by means of a positive potential of several hundred volts on the anode and, by means of the axial magnetic field from the focusing coil, are sharply focused as an electron image in the plane of the aperture in the target. The number of electrons per unit area in this electron image corresponds to the brightness of the corresponding areas in the optical image focused on the cathode.

### Sensitivity

The cathode of a dissector tube has a sensitivity of 30 to 45 microamperes per lumen. Its caesiated surface has a spectral response which peaks at about 7,500 angstroms. If a tungsten lamp at normal brilliancy is used as the source of light, the combination of the two spectral distribution curves results in *best focus* being obtained at about 8,000 angstroms. With 10 lumens in the high lights (200-foot candles when the optical area is  $2\frac{1}{4}'' \times 3''$ ), a dissector having a sensitivity of 35 microamperes per lumen provides a calcu-

<sup>1</sup>Farnsworth.

<sup>2</sup>In telecine operation it is customary to use a light source in the projector to provide about 200 foot candles on the cathode of the tube.

<sup>3</sup>Typical operating characteristics: Amount of light for good pictures, 20 lumens; standard defining aperture, .012" by .012"; dissector voltage, collector 0 v and cathode, 1500 v; dissector current, 0.2 ma; focusing coil current, 20 ma d-c; h-f deflecting-coil current, 250 ma; i-f deflecting-coil current, 16 ma. Multiplier voltage . . . 1st stage, 1100 v; 2nd stage, 1000 v; 3rd stage, 900 v; 4th stage, 800 v; 5th stage, 700 v; 6th stage, 600 v; 7th stage, 500 v; 8th stage, 400 v; 9th stage, 300 v; 10th stage, 200 v; and 11th stage, 100 v.

lated current of  $1.3 \times 10^{-9}$  amperes through the aperture.

If we assume a constant secondary emission ratio for each multiplier surface, we can find the output current with the equation,  $i = i_0 s^n$ , where  $i_0$  is the initial photocurrent,  $s$  is the secondary emission ratio, and  $n$  is the number of stages. With 100 volts per stage,  $s$  is found to be approximately 2.6. With 11 stages,  $1.3 \times 10^{-9}$  amperes is thus amplified to 50 microamperes. Across a 4,000-ohm resistor we have a .2-volt signal, when the resistance is calculated for a video cut-off frequency of 3.5 mc. In view of this relatively high voltage output it is often possible to use a single stage in the head amplifier of a television camera.

### Resolution

Assuming that the optical image on the dissector-tube is  $1\frac{1}{2}'' \times 1\frac{1}{8}''$ , and that the ratio of the optical image to the electron image area is 1:2, a 525-line theoretical resolution with a 4:3 aspect ratio can be obtained from a scanning aperture .007" square. This aperture size divides the image into approximately 350,000 picture elements. A larger electron image permits the use of a larger aperture to obtain the same resolution, since the resolution is a function of the ratio of the aperture size to the size of the electron image. An aperture .012" x .012" has been found to be effective in giving a good



**WILCOX...  
First Choice  
OF THE  
MAIN LINE  
AIRWAY**



## **UNITED AIR LINES Selects New WILCOX VHF Receiver For Ground Installations**

*New Fixed Frequency Receiver  
Offers New Performance Features  
in the 118-136 Mc. Band*

- Selectivity Permits 100 Kc. Adjacent Channel Operation
- No Interference from Spurious Frequency Responses
- Simplicity of Circuit Design Means Easy Maintenance
- New Noise Limiter Means Better Reception
- Single Unit Construction Saves Space



*Write Today For Complete  
Information on the  
WILCOX 305A RECEIVER*

THE NAME

**WILCOX** MEANS *Dependable Communication*

WILCOX ELECTRIC COMPANY • Kansas City 1, Missouri

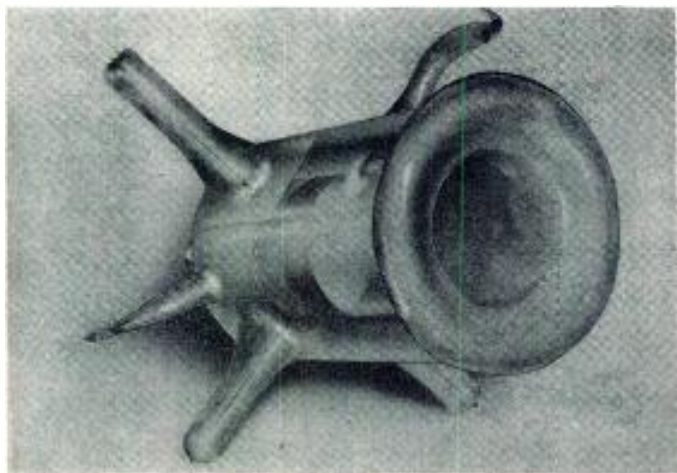

One of the first image dissector tubes made by Philo Farnsworth.

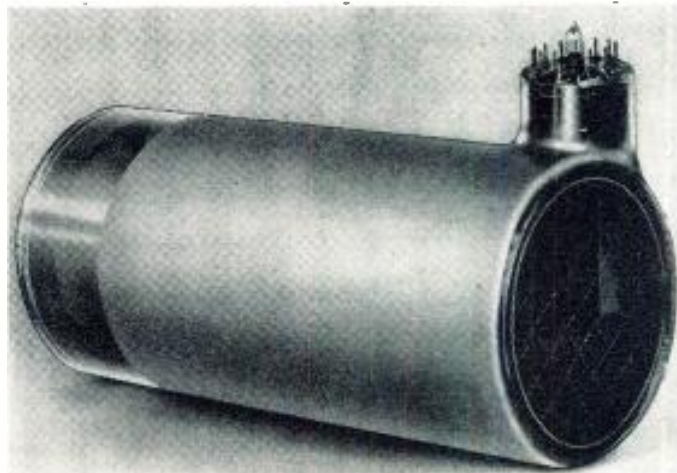

Current model of the Farnsworth image dissector.

signal-to-noise ratio for the 525-line resolution.

The tube's output is effectively the photoelectric current from the light-sensitive cathode. There are no secondary electrons near the cathode to rain back and reduce the contrast or otherwise introduce undesirable shading signals.

The photoelectric current is the only source of the output current, and therefore the d-c output is directly proportional to the picture background. This information may be utilized in several ways to provide the proper background level for transmitter modulation.<sup>4</sup>

Image dissectors are made in two standard sizes. One is a long tube with a cylinder length of 10½" and a diameter of 4½"; its target is placed off center. The other is a short tube with a length of 7¾" for the same diameter, and requires special focusing and scanning coils; the target is in the center, near the plane glass end.

#### Blower Requirements For Forced-Air-Cooled Tubes

THE SELECTION OF A FAN OR BLOWER for a particular tube or application requires that three important factors be known; airflow required, static pressure at blower outlet, and amount of permissible noise.

#### Airflow Required

The airflow required depends upon the amount of anode dissipation and upon the maximum ambient temperature expected in a given application. This value of required airflow, usually measured in cubic feet per minute (*cfm*), and the corresponding value of

anode temperature rise above the ambient value are given as part of the tube data. In no case should the sum of the ambient temperature and the anode temperature rise above ambient exceed the maximum rated value of anode temperature as given in the tube ratings. Because the *cfm* value is based on air of standard density (0.075 lbs/ft<sup>3</sup>), a correction must be made for applications at altitudes greater than 5,000' above sea level.

#### Static Pressure

The static pressure ( $P_s$ ) at the blower outlet depends upon the pressure-versus-airflow characteristics of the system into which the blower must deliver the required volume of air. The static pressure for any system varies approximately as the square of the *cfm*<sup>2</sup> and is determined by the following factors:

(1)—The static pressure rating of the tube cooler when the required airflow or *cfm* is passing through it. This rating is given in the tube data as a function of airflow or *cfm*. When the outlet of a blower discharges into free air, as is the case when a blower is directed at a tube header, bulb, or seal, the static pressure at the blower outlet is zero, provided no ducts, constrictions, or nozzles are used. This discharge rating in *cfm* of a blower at zero static pressure is sometimes called the *free delivery* rating of the blower.

(2)—The friction losses in connecting pipes and components such as elbows, interlock vanes, and air filters. Standard tables of duct-pressure loss

<sup>4</sup>This feature eliminates the need for a separate photocell, and associated direct coupled amplifier, to pick up background information.

may be used for estimating duct friction if the effective duct length is large.<sup>1, 2, 3, 4</sup>

(3)—The change in static pressure in a duct due to changes in cross-sectional area which increase or decrease the velocity of the air in the duct. Whenever there is any change in cross-sectional area between the blower outlet and the tube inlet, a correction for velocity changes must be added algebraically to the static pressure at the blower outlet. This correction, which is positive for a contraction in area and negative for an expansion in area, is given by the relation

$$P_s \text{ (inches of water)} = \frac{V_2^2 - V_1^2}{(4000)^2} \quad (1)$$

where,  $V_1$  is the velocity of the air in feet per minute before the change in area and  $V_2$  is the velocity of the air in feet per minute after the change. These velocities may be found from the expression

$$V \text{ (feet per minute)} = \frac{cfm}{A} \quad (2)$$

where,  $A$  is the cross-sectional area in square feet at the place of measurement. The factor 4000 of equation (1) is the velocity constant for air of standard density of 0.075 lb/ft<sup>3</sup>. Corrections should be made for different values of air density from the data supplied in table I.

A change in cross-sectional area also causes friction losses. Such losses are small and can be ignored when the change in cross-sectional area is gradual and occurs over a duct length of more than six duct diameters. When, however, the change is abrupt, that is, when it occurs over a duct length of less than one diameter, a correction for friction losses must be made in addition to the correction made for velocity changes in the duct. For duct

Altitude above Sea Level (ft)	Density of Air* (lbs/ft <sup>3</sup> )	Velocity Constant
0	0.0750	4000
1000	0.0722	4080
2000	0.0695	4165
3000	0.0668	4240
4000	0.0643	4320
5000	0.0619	4410
6000	0.0596	4500
7000	0.0573	4580
8000	0.0552	4670
9000	0.0532	4760
10000	0.0511	4850

\*Temperature is constant at approximately 70°F.

Table I. Density of air and velocity constants versus altitudes

changes occurring over intermediate lengths, a correction for friction losses should be estimated. Corrections for friction losses, whether due to either a contraction or expansion in duct area, are always positive and are added to the system static pressure.

### Permissible Noise

The third important factor which should be considered in the selection of a fan or blower is the amount of noise which can be tolerated. In general, a blower operating with high blade-tip velocity and developing a value of  $P_p$  in excess of two inches of water will usually produce a noticeable amount of noise in quiet surroundings.

A matter of lesser importance but which may require some design con-

Tube Type	Part Cooled	cfm	Cooling Recommended
6C24	Filament seals and grid connector	—	Defect portion of main air stream used to cool anode.
7C24	Header and filament seals	10	Defect portion of main air stream or use A, B, C, D, or E blowers.
9C21			
9C22			
9C25			
9C27			
9C21	Bulb	250	F.
9C27			
81D21	Bulb and electrode seal	40	A, B, C, or E.
833-A			
880			
889			
806	Bulb	—	Use ordinary small propeller fan or blower such as A, B, C, D, or E.
826			
829-B			
834			
8012-A			
8025-A			
4-125A			
4D21			

A—(ILG) . . . No. 6S, 70 cfm free delivery.  
 B—(Delco) . . . No. 5062369, 60 cfm free delivery.  
 C—(F. A. Smith) . . . No. 50747, 50 cfm free delivery.  
 D—(F. A. Smith) . . . No. 50745, 15 cfm free delivery.  
 E—(Amer. Blower) . . . No. 3011, 83 cfm free delivery.

Table II. Blowers for cooling headers, seals, and bulbs

sideration is the effect of the temperature of the air leaving the tube cooler on some of the circuit components such as filament bypass capacitors. If some components are exposed to temperature exceeding their normal ratings, it will be necessary to reduce the temperature of the outgoing air by selecting a blower which will provide a greater airflow. The rise in temperature ( $\Delta T$ ) of the outgoing air in the cooler may be determined from

$$\Delta T \text{ (degrees C)} = \frac{T_1 + 273}{169} \times \frac{P_p + P_r}{cfm} \quad (3)$$

where,  $T_1$  is the temperature of the incoming air in degrees centigrade;  $P_p$  is the plate dissipation in watts; and,  $P_r$  is the filament power in watts. For incoming air at room temperature ( $25^\circ \text{C}$ ), this relation may be simplified to

$$\Delta T = 1.75 \times \frac{P_p + P_r}{cfm} \quad (4)$$

The calculated value of  $\Delta T$  will usually be higher than the measured value because some of the heat produced by the plate and by the filament will be carried away by conduction in the filament leads and cooler support. A further reason is that the heated outgoing air, because of its relatively high velocity, mixes immediately with the surrounding air.

### Motor Overload

A further matter which is also usually of minor importance is the question of motor overload when the tube is removed from its socket. When this matter is important, a non-overloading type of blower such as one having backwardly inclined blades can be selected. Because higher blade-tip speeds are usually necessary with this type of blower, the noise output may be increased.

### References

1. Sturtevant Catalog 500, *What We Make*, p. 124.
2. American Blower Corp., Bulletin 2824, including *Fan Selection Data*.
3. ILG Catalog 24, including *Engineering Data*.
4. John J. Alden, *Design of Industrial Exhaust Systems*, The Industrial Press, New York; 1939.
5. W. H. McAdams, *Heat Transmission*, Second Edition, McGraw-Hill Publishing Company; 1942.
6. *Sound Measurements Test Code for Centrifugal and Axial Fans*, National Association of Fan Manufacturers Bulletin 104.
7. *Fan Engineering*, Edited by Richard D. Madison, Buffalo Forge Company, Buffalo, N. Y.; 1938.
8. *Standard Test Code for Centrifugal and Axial Fans*, National Association of Fan Manufacturers Bulletin 103.

[Blower requirement data based on copyrighted material supplied by RCA.]

Tube Type	Area (ft <sup>2</sup> )	Volume (cfm)	$P_p$ (inches of water)	Blower Recommended
6C24	0.022	135	0	Use blower such as G or H, if a gradual transition is made from 3" outlet diameter of blower to 2" nozzle diameter required by 6C24.
7C24	0.12	275	1.75	J, K, L, or M
9C22	0.74	1800	2.4	N, P, Q, or BB
9C25	0.55	1000	2.25	R, S, or CC
827-R	0.12	100	0.45	X or Y
889R-A	0.31	500	0.95	T or U
891-R	0.31	450	0.5	V or W
892-R				
5588	0.012	10	0.4*	A, B, or C
5592	0.55	1100	2.65	A-A or BB

These blower recommendations are based upon tube operation at maximum rated plate dissipation under class C telegraphy conditions at an ambient temperature of  $45^\circ \text{C}$  and at sea level. Unless otherwise specified, the static pressure at the tube inlet has been increased by 0.25" of water to allow for incidental pressure losses due to air filters, interlocks, etc. Direct-connected units are specified where possible.

\*Without allowance for incidental pressure losses.

F—(Amer. Blower) . . . B Type P, 268 cfm at  $2\frac{1}{2}$ " of water.

G—(Amer. Blower) . . . Type P Cat. A;  $\frac{1}{8}$ -hp, 3450-rpm motor, direct connected.

H—(ILG) . . . Type P 7 $\frac{1}{2}$ P;  $\frac{1}{8}$ -hp, 3400-rpm motor, direct connected.

J—(ILG) . . . Type B9;  $\frac{1}{8}$ -hp, 3450-rpm motor, direct connected.

K—(Amer. Blower) . . . Type P Cat. B;  $\frac{1}{3}$ -hp, 3450-rpm motor, direct connected.

L—(Buffalo) . . . Type E 3E;  $\frac{1}{3}$ -hp, 3450-rpm motor, direct connected.

M—(Clarage) . . . Type C1 6 (C wheel);  $\frac{1}{4}$ -hp, 1750-rpm motor, direct connected.

N—(Amer. Blower) . . . No. 105 utility set direct driven at 1725-rpm from suitable  $\frac{1}{2}$ -hp motor.

P—(Clarage) . . . Type HV  $\frac{3}{4}$  single width, single inlet belt driven at 1550 rpm by suitable  $\frac{1}{2}$ -hp motor.

Q—(ILG) . . . Type BW, No. 25 single width, single inlet belt driven at 1450-rpm by suitable  $\frac{1}{2}$ -hp motor.

R—(Clarage) . . . Type HV, No.  $\frac{3}{4}$  single width, single inlet; 1-hp, 1750-rpm motor, direct connected.

S—(Amer. Blower) . . . B18;  $\frac{1}{4}$ -hp, 1750-rpm motor, direct connected.

T—(Amer. Blower) . . . 1 $\frac{1}{2}$ -H utility set;  $\frac{1}{3}$ -hp, 1725-rpm motor, direct connected.

U—(Clarage) . . . DF  $\frac{1}{2}$ ;  $\frac{1}{4}$ -hp, 1750-rpm, direct connected.

V—(Buffalo) . . . Size D baby vent set,  $\frac{1}{6}$ -hp, 1750-rpm motor, direct connected.

W—(ILG) . . . B-12;  $\frac{1}{6}$ -hp, 1750-rpm motor, direct connected.

X—(ILG) . . . B-9;  $\frac{1}{20}$ -hp, 1750-rpm motor, direct connected.

Y—(Buffalo) . . . Size B baby vent set;  $\frac{1}{20}$ -hp, 1750-rpm motor, direct connected.

A-A—(ILG) . . . BC-25, single width type BC, belt driven at 2250-rpm by suitable 1-hp motor.

BB—Buffalo . . . No. 2 single width type LL, belt driven at 2400 rpm by suitable 1-hp motor.

ILG Electric Ventilating Co., 2850 N. Crawford Ave., Chicago, Ill.; Delco Appliance Div., General Motors Corp., Rochester, New York; F. A. Smith Mfg. Co., Inc., P. O. Box 509, Rochester 2, New York; American Blower Corp., P. O. Box 58, Roosevelt Park Annex, Detroit, Michigan; Buffalo Forge Company, Buffalo, New York; Clarage Fan Co., Kalamazoo, Michigan.

Table III. Blowers for cooling external-anode tube tubes having integral air coolers

# NOISE Measurements

by **ROBERT L. MORGAN**

Engineering Sales Manager  
Norman B. Neely Enterprises

THE PROBLEM OF NOISE and its measurement is one that is rapidly gaining the attention of engineers in many fields, as the public is becoming increasingly more noise conscious and has come to appreciate the value of *noiseless* equipment and working conditions. However, this increase in acoustical activity, often on the part of engineers not trained in this field, has frequently resulted in considerable confusion and wasted effort. This is due, to a large extent, to a lack of a clear understanding of some of the terms and concepts used in acoustics and a failure to appreciate the many variables that enter into an apparently simple measurement.

Dr. E. J. Abbott, of the University of Michigan, once said, "... after an engineer has been told that 50 db at 1,000 cycles is louder than 60 db at 100 cycles because the ear is more sensitive to the higher frequency, and then he is told that 50 db at 100 cycles is louder than 60 db at 1,000 cycles because the loudness of low-pitched sounds increases more rapidly than high-pitched ones, and finally that 50 db at 100 cycles is louder than 60 db at 100 cycles, he is convinced that acousticians don't know what they are talking about, and it does not help him much to be told that the first comparison was made in sound pressure levels, the second in sensation levels, and the third was caused by a difference in reference levels."

Dr. Abbott has not exaggerated the difficulty, for to the newcomer, the relations involving reference levels, ear-weighting characteristics and loudness are often as perplexing as depicted above. However, they need not be so, and it is hoped that this discussion will help to clarify some of the confusion.

Sound measurements, when made with a standard sound-level meter, are determinations of sound-intensity levels and are expressed in decibels. This unit is approximately the smallest change in intensity level that the average ear can detect. Most engineers are familiar with this term as used in transmission engineering. It is defined here by the relationship  $db =$

$$10 \log_{10} \left( \frac{E}{E_0} \right),$$

where  $E$  is the energy flux density of the sound wave in question and  $E_0$  is  $10^{-16}$  watts per sq. cm, the zero or reference level for

sound-intensity measurements. This reference level approximately represents the threshold of hearing of an acute ear at 1,000 cycles. The intensity level of a sound is then defined as the number of decibels above  $10^{-16}$  watts per sq. cm. Ten or more years ago one millibar (one-thousandth of a dyne per sq. cm.) of sound pressure was used as the standard reference level, which gave sound levels 13.8 db lower than those based on  $10^{-16}$  watts per sq. cm.

Having established the terms in which sound measurements are to be expressed, it would be well to examine the range of sound levels that may be

encountered. Figure 1 shows the range of intensity levels covered by some familiar sounds, with whispers and low conversation between 35 and 45 db, average home radio at about 70, and automobile horns, riveters and the like at 100 db or above.<sup>1</sup> As the intensity of a sound varies approximately inversely as the square of the listener's distance from the source, the sound levels listed here may vary over fairly wide limits, depending on their distance. It will be seen that audible sound may range from the threshold of audibility near zero db on up to about 120 db above this level, where the intensity becomes so great that sound begins to be felt as well as heard. This upper level is consequently called the threshold of feeling.

When making measurements in a *sound-proof* room, one should not be surprised to find the sound meter indicating levels that cannot be heard at all. This may be caused by two factors. First, it will be found that even in the most carefully constructed *sound-proof* rooms there may be appreciable sound energy present, generally of such a low frequency, that it is below audibility. This originates chiefly from traffic and other similar disturbances that vibrate the building and which, due to their low-frequency nature, are extremely difficult to insulate against. Although a room may have an insulation of 60 db or better at frequencies above 1,000 cycles, its insulation may often be of the order of 10 db for frequencies below 20 cycles where a great deal of the traffic rumble and vibration occurs. Secondly, when the acoustic energy actually is very low, the sound meter gain must be raised to high values to get a readable indication on the meter. Under these conditions the inherent electronic noise within the sound meter, consisting of thermal and vacuum-tube noise, may be amplified sufficiently to be readable. This electronic noise constitutes the lower limit near or below which actual sound level measurements cannot be made. A determination of the electronic noise level in the sound meter can readily be made by taking readings with a dummy microphone, consisting of a non-inductive resistor of the same value as the nominal microphone impedance.

Where it is necessary to measure

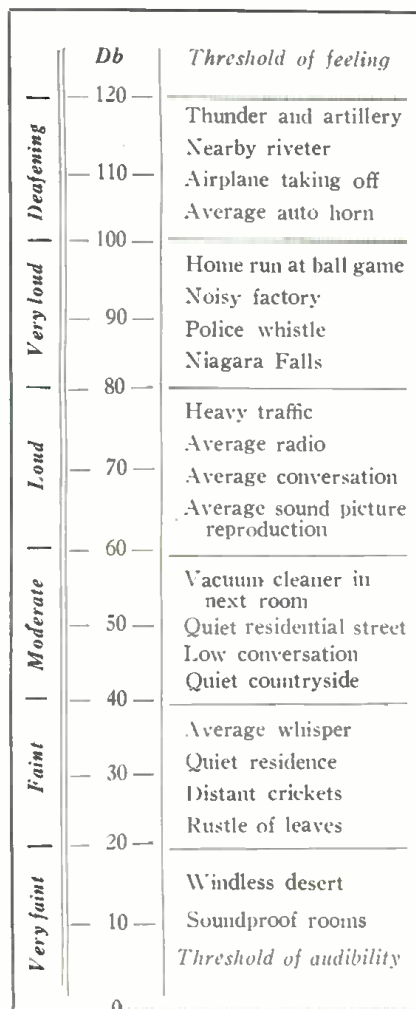

Figure 1  
Typical sound levels.

<sup>1</sup>These sound levels were measured using the appropriate ear-weighting characteristics, discussed in later portions of this paper.

## Relation of Reference Levels, Ear Weighting and Loudness and Loudness Levels. Ranges of Sound Levels Often Encountered in Measuring Work. Use of Sound Meters. Microphone Positioning. Relation of Direct and Reverberant Sounds. Measurements in Rooms, Studio and Plants.

low sound levels, within a few db of the electronic noise level, recourse may be made to the formula:  $C = 10 \log_{10}$

$\left(\frac{R}{C}\right)$  where  $C$  is the correction

in decibels to be subtracted from the total noise reading, and  $R$  is the power ratio corresponding to the difference in decibels between the total noise and the background noise alone. This formula is useful not only against an electronic noise background, but also in the more frequently encountered case where a background of acoustic noise is present.

The range of sound levels usually encountered in measurement runs from about 30 to 120 db or a spread of 90 db. This constitutes a power ratio of one to one billion, that the microphone and sound meter must accommodate. They must have sufficient sensitivity to give readable indications on sound levels around 30 db or below and yet not overload at power levels a billion times as great. In the case of the microphone, this is a stiff specification, as the microphone has no input gain control to protect it from the higher levels.

### Sound Meter

The sound meter itself is merely a high gain, quiet-operating amplifier provided with gain stabilizing features such as negative feedback. It is equipped with a gain control calibrated usually in 5 db steps and terminates in a rectifier working into a milliammeter calibrated in decibels. Generally a rectifying meter is employed with the rectifier contained in the meter case. Comprehensive standards<sup>2</sup> have been established, covering the frequency response of the amplifier and the dy-

<sup>2</sup>American Standard for Sound Level Meters, bulletin Z24.3, American Standards Association, New York, N. Y.; 1944.

Figure 2  
Loudness contours.

(Courtesy: ASA)

namic characteristics of the indicating meter so that these approximate the corresponding characteristics of the human ear.

Engineers frequently complain that sound meters often give indications considerably at variance with what their ears tell them. This is a valid objection, but usually arises from a lack of an understanding of the characteristics of the human ear and the relation between intensity and loudness which is complicated and far from linear. For example, two sounds having the same intensity, and hence reading the same on a flat<sup>3</sup> sound meter, may not necessarily sound equally loud to the ear. Again, at certain intensity levels, noise  $A$  may sound louder than  $B$ , but if both are lowered 20 db in intensity their relative loudness may reverse with  $B$  sounding louder than  $A$ . Similarly, if two sounds of the same intensity, but different frequency,

<sup>3</sup>Discussed under ear-weighting characteristics.

are shifted in frequency while keeping the intensity the same, their relative loudness may vary widely.

Figure 2 is fundamental to an understanding of this problem and will help to explain how these seemingly paradoxical effects can occur. This drawing gives, for the average ear, contours of equal loudness for pure tones throughout the audible range. The loudness level of a sound may be defined briefly as the intensity level of the equally-loud 1,000-cycle tone in the same position with respect to the listener. Thus, each contour is a locus of tones of equal loudness level and therefore shows the intensity level required at each frequency, in order that all frequencies will be heard at a particular loudness.

For example, let us consider the 10-db contour near the bottom. This is approximately the threshold of hearing for an average ear. At 1,000 cycles, an intensity level of 10 db would be required to cause the average ear to just perceive the tone. However, at a frequency of 30 cycles per second, an intensity level of about 68 db would be required to cause the tone to be perceived. In other words, near the threshold of audibility the sensitivity of the average ear falls off rapidly at low frequencies. However, the 100-db contour, which applies for very loud sounds, is practically flat (except above 1,000 cycles) so that an intensity level of 100 db will elicit about the same response from the ear at 30 cycles as at 1,000 cycles.

This explains why the bass response seems to drop out in a receiver as you

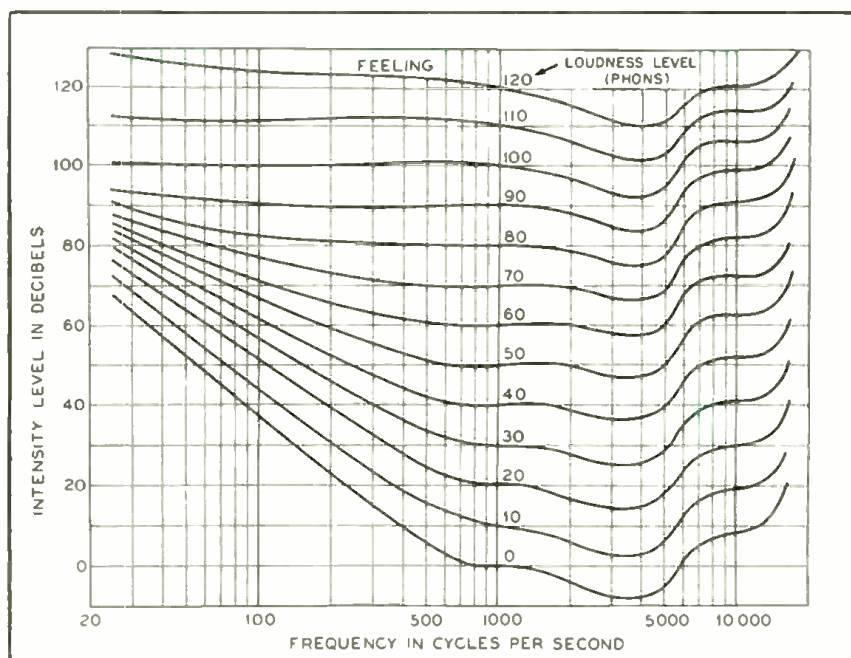



# How 19,000 companies up take-home pay

## *without upping payrolls*

Can you deduct \$18.75 from \$60.00 and get \$66.25? Yes. And the way you can do it is mighty important to your company—and to the nation!

You start with \$60, representing someone's weekly take-home pay. You deduct \$18.75 for the purchase of a U.S. Savings Bond. That leaves \$41.25. But \$41.25 isn't what the worker takes home. He takes home \$41.25 *plus* a \$25 Savings Bond. Total (assuming he holds the Bond till maturity): \$66.25.

#### WHAT 19,000 COMPANIES HAVE LEARNED

In the 19,000 companies that are operating the Payroll Savings Plan for the regular purchase of Savings Bonds, employees have been more contented in their jobs—absenteeism has decreased—even accidents have been fewer!

Those are the "company" benefits the Plan provides, in addition to extra security for individual employees.

But the Plan has other, far-reaching benefits of basic importance to both your business and the national economy...

#### SPREADING THE NATIONAL DEBT HELPS SECURE YOUR FUTURE

The future of your business is closely dependent upon the future economy of your country. To a major extent, that future depends upon management of the public debt. Distribution of the debt as widely as possible among the people of the nation will result in the greatest good for all.

How that works is clearly and briefly described in the free brochure shown at the right. Request your copy—*today*—from your State Director of the U. S. Treasury Department's Savings Bonds Division.

#### ACTION BY TOP MANAGEMENT NEEDED

The benefits of regular Bond-buying are as important today as ever—but war-time emotional appeals are gone. Sponsorship of the Payroll Savings Plan by a responsible executive in your company is necessary to keep its benefits *advertised to your employees.*

Banks don't sell Savings Bonds on the "installment plan"—which is the way most workers prefer to buy them. *Such workers want and need the Payroll Savings Plan.*

Those are the reasons why it's important to make sure that the Plan is adequately maintained in your company.

The State Director will gladly give you any assistance you wish.

#### "The National Debt and You,"

a 12-page pocket-size brochure, expresses the views of W. Randolph Burgess, Vice Chairman of the Board of the National City Bank of New York—and of Clarence Francis, Chairman of the Board, General Foods Corporation. Be sure to get your copy from the Treasury Department's State Director, Savings Bonds Division.



*The Treasury Department acknowledges with appreciation the publication of this message by*

## COMMUNICATIONS

*This is an official U. S. Treasury advertisement prepared under the auspices of the Treasury Department and the Advertising Council*





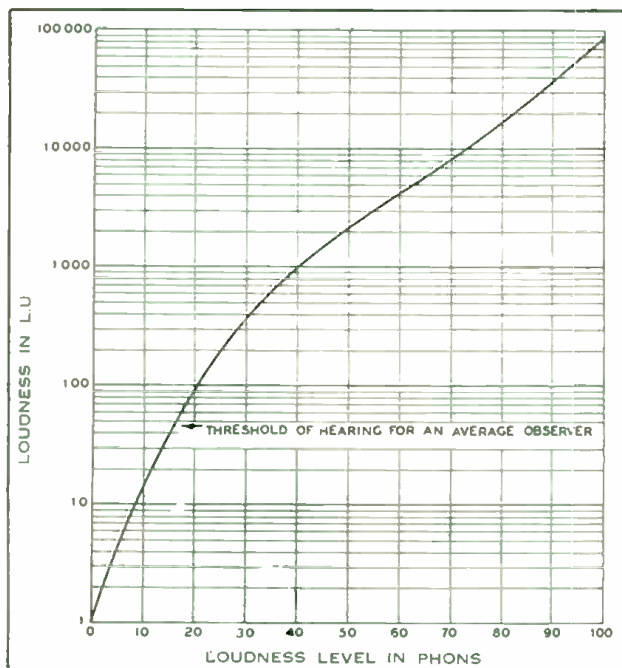

Figure 3  
Relation between loudness and loudness level.  
(Courtesy ASA)

turn the volume down low and why bass-compensated volume controls are needed. Another example of this effect can be noted when listening to a band marching down the street. As the band passes into the distance, the bass drum fades out first, followed in turn by the other low-pitched instruments until finally, to the ear, the band seems to be composed entirely of brasses and the higher pitched instruments.

Loudness level and intensity level are, by definition, equal at 1,000 cycles, but it will be noted from Figure 2 that they are also equal at a frequency between 5,000 and 6,000 cycles, depending on the loudness level. (The phon is the unit of loudness level. Thus 50 phons and a loudness level of 50 db express the same thing.)

Loudness level is not loudness as the layman understands the term. He is accustomed to speaking of one sound as twice or ten times as loud as another. But loudness level does not readily permit of such a comparison. For example, a loudness level of 60 phons does not sound twice as loud as a loudness level of 30 phons, but more nearly twelve times as loud.

To overcome this objection the relation between loudness and loudness level, shown in Figure 3, has been agreed upon. This drawing has an arbitrary logarithmic scale of loudness running from 1 to 100,000, corresponding to a linear scale of loudness levels from 0 to 100 db. By this relationship a loudness of 3,000 sounds three times as loud as one of 1,000. This curve makes it possible to relate loudness to loudness level and in turn, through Figure 2, to intensity level

and thus achieve a quantitative relationship between what the ear hears and what the sound meter reads. On the more linear part of this curve, from 40 db up, which is the range most commonly encountered, a 10-db change in loudness level corresponds to changing the loudness by a factor of approximately two.

While Figure 3 is valid for any sound, it must be remembered that the loudness contours given in Figure 2 apply to pure tones only. The loudness level of complex sounds can be calculated if the frequency and amplitude of the components are known.<sup>4</sup> Otherwise, the loudness of the complex sound can be compared aurally to the loudness of a pure tone whose intensity level can be measured and converted to loudness level by Figure 2.

From the loudness contours, it will be seen that for a sound meter to have a response similar to that of the human ear, it would be necessary to provide it with a large number of interchangeable frequency characteristics, one for each intensity level that might be encountered. Obviously this is not practicable, but sound meters approximate this by providing the amplifier with two frequency-discriminating circuits, one to approximate the inverse of the 40 db loudness contour and the other approximating the inverse of the 70 db contour. A flat-frequency characteristic approximates the 100 db loudness contour and may be used for high sound levels. Thus at these three intensity levels the sound meter will re-

<sup>4</sup>H. Fletcher and W. A. Munson, *Loudness, Its Definition, Measurement and Calculation*, Journal of the Acoustical Society of America; October, 1933.

spond approximately as the ear does. These characteristics, which are known as the ear-weighting characteristics of the sound meter are made available by operating a switch, which changes the size of an interstage coupling capacitor to droop the low frequency response.

When making noise measurements in which the annoyance factor of the sound is of interest and the sound meter should hear approximately as the ear does, it is necessary to use the ear-weighting characteristic which most nearly corresponds to the intensity level being measured. Absolute measurements without reference to the ear are made on flat.

### Microphone Positions

An engineer making noise measurements for the first time may be surprised to find level differences of 5 db or more between microphone positions a few inches apart and equi-distant from the source. These differences are attributable to the interference pattern between direct and reflected sound which is never completely absent, even when measurements are made in the open air. At any given microphone position, these reflections will increase or decrease the sound level, depending on the relative phase of the reflected wave and the direct wave. As a result, some reflections will be in phase and will re-enforce the direct wave, while others will be 180° out and will cancel and all phase relations in between are possible. To minimize the variations resulting from interference, most acoustical test rooms are made highly sound absorbent but this precaution is not entirely adequate with ordinary commercially available sound-absorbing materials. It is, therefore, advisable to make a number of measurements in different microphone positions which can then be averaged to obtain a representative noise reading.

It should also be borne in mind that most pieces of equipment must be considered as a whole when determining their radiated noise. It is difficult, for example, to measure only the commutator noise of a motor, because all parts of the machine are fastened together in such a manner that sound is fairly readily transmitted from one part to another and the highest intensities may be found, not necessarily at their primary source, but at the particular part which is able to vibrate most freely. It is, therefore, advisable to make measurements spaced around a circle with the machine in question at the center.

[To Be Continued]



## HIGH FIDELITY EV-635 MICROPHONE USES "XL" PLUG

Electro-Voice has equipped the new EV-635 High Fidelity Dynamic Microphone for studio and remote broadcasting, with the Cannon Type XL-3-11 Plug—a quality plug for a quality microphone.

Shown at left is the new XL-3-36 Wall Receptacle (pin insert) engaged with an XL-3-11 Plug. XL-3-36 is priced at \$5.43 List; and XL-3-35 (socket insert) \$4.93 List.



For a practical, low cost but high quality connector series having three 15-amp. contacts, choose the "XL". Four plug types and six receptacles with 3 adapter receptacles are available. Min. flashover voltage 1500 Volts.



Above are the two zinc plugs (Left) XL-2-12, List \$1.20 and (right) XL-2-11, List \$1.25.

No other small electric connector has all the features of the XL, including the safety latch lock.

XL Connectors are available from more than 250 radio supply houses throughout the U.S.A.

For complete information on the XL, write for Bulletins XL-347 and XL-PR1. Address Dept. B-121.

SINCE 1915

**CANNON**  
**ELECTRIC**

*Development Company*

3209 HUMBOLDT ST., LOS ANGELES 31, CALIF.  
IN CANADA & BRITISH EMPIRE:  
CANNON ELECTRIC CO., LTD., TORONTO 13, ONT.  
WORLD EXPORT (Excepting British Empire):  
FRAZER & HANSEN, 301 CLAY ST., SAN FRANCISCO

## Bypass Capacitors

(Continued from page 19)

of value  $C_x$ . Since  $C'$  and  $C_x$ , in series tune the coil,  $C$  is equal to the series combination of  $C$  and  $C_x$ , or

$$C = \frac{C' C_x}{C' + C_x} \quad \text{or} \quad C_x = \frac{C C'}{C' - C} \quad (5)$$

### Experimental Check

Using the foregoing method, nine types\*\*\*\* of bypass capacitors (shown in Fig. 2) were checked at 30 and 100 mc. A tabulation of the results of the tests appear in Figure 3.

Only a few of the nine types could be considered effective for bypassing at 100 mc. Several of each type (more than four) were checked against each other to insure a truer sampling.

### Operation of Q Meter

In the operation of the  $Q$ -meter, care must be used to eliminate errors from backlash. The change in capacity is quite small and is hard to measure at best, hence backlash will contribute an appreciable error.

As a final operational note, the  $Q$  of the circuit (coil) should be made high so the meter will read almost full-scale, thus allowing more accurate data.

\*\*\*\*The types used happened to be on hand and were used simply to demonstrate the method.

### 360-KW F-M TEST BROADCAST



Owen Fiet, checking instruments used in making impedance measurements on a pylon antenna before and after a recent f-m test broadcast involving 360 kw of radiated power.  
(Courtesy RCA)

# THANKS FOR YOUR RESPONSE

requesting more information on the wide-band superhet A-M tuner which was described in an article on Page 20 of the December 1947 issue of Communications. Detailed performance specifications, based on recent tests made in collaboration with a 50 KW Southern California broadcast station, of the new tuner are being mailed. Specifications will cover the balanced mixer with Germanium Diodes, Broad band I-F, Infinite-Impedance Second Detector, Tuning Meter, Cathode Follower and 10-kc Filter. Production of these tuners has been expanded and orders are being filled from stock. Please be patient and thanks again.

Address all future inquiries to

THE **KAPPLER** CO.

7302 MELROSE AVENUE  
LOS ANGELES 46, CALIFORNIA

# COME



MARCH 22-25, 1948

Grand Central Palace, New York City

HEAR—over 100 Technical papers, many on F.M. and television.

MEET—many old friends.

SEE—176 Engineering Exhibits.

4 Day Registration is \$3.00



THE INSTITUTE OF  
RADIO ENGINEERS, Inc.  
1 East 79th Street  
New York 21, N. Y.

## Facsimile Transmitter

(Continued from page 15)

ing by  $18^\circ$ , but only one of these positions is correct. The establishment of the correct angular relation is referred to as *phasing*.

A circuit is provided which acts on the scanner motor automatically until the correct relation is reached. A commutator with a pair of brushes is mounted on the drum shaft in the pulse generator and rotates at 360 rpm. It has a conducting segment which completes a circuit from positive plate supply through resistors for  $6^\circ$  of rotation.

The phasing commutator is a part of a driven sleeve which determines the angular position of the scanner drum when it is rotating. Its angular position is correct when the pulse-generator commutator-conducting interval occurs during the scanner-phasing-commutator non-conducting interval. If both commutators conduct simultaneously, a relay is operated by the plate supply from the pulse generator. A capacitor makes it possible for the relay to operate on the short pulse through the commutator. Operation of the relay opens the power supply to the scanner synchronous motor so that it momentarily drops below synchronous speed and the angular relation of the scanner drum to the pulse generator drum changes. This action is repeated until the correct angular position is reached.

### Phasing of Recorder

It is also necessary to have a definite angular relation between the drums on the recorders and the drums in both the pulse generator and scanners. Both recorders phase automatically when a suitable signal is being recorded. This consists of a signal for recording black (maximum signal) for all but  $15^\circ$  of the drum rotation, during which the signal is zero.

If marking current corresponding to black is supplied to the recorder while the commutator circuit is made, a relay will receive a pulse of current each revolution of the helix drum. A capacitor across the relay winding makes it possible for the relay to operate on these pulses, which would otherwise be of too short duration. The operation of the relay slows down the synchronous motor. Since the signal for phasing is black except for a  $15^\circ$  interval, the relay will continue to operate with each revolution until the interval when the commutator circuit is made falls within this  $15^\circ$  interval. The recorder will then be correctly phased.

# Shallcross ATTENUATORS

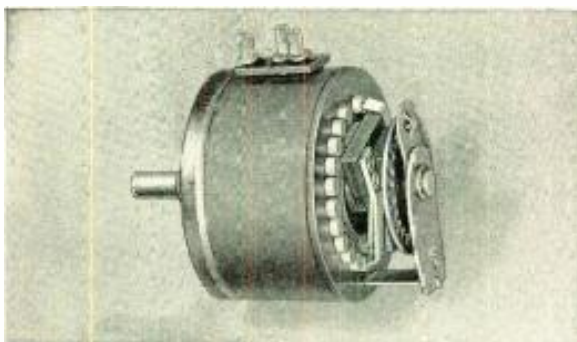

### BRIDGED 'T' ATTENUATOR Type 410-4B1

10 steps, 4 db/step.  
Linear attenuation  
with detent.  $2\frac{1}{8}$ " diameter,  
 $2\frac{1}{8}$ " depth.

### BRIDGED 'T' ATTENUATOR Type 420-2B2

20 steps, 2 db/step.  
Linear attenuation with  
off position and detent.  
 $2\frac{1}{8}$ " diameter,  $2\frac{1}{8}$ "  
depth.

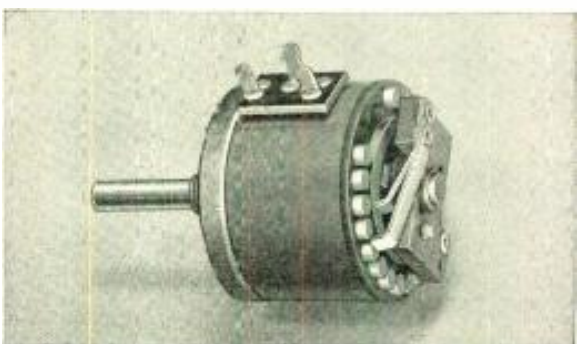
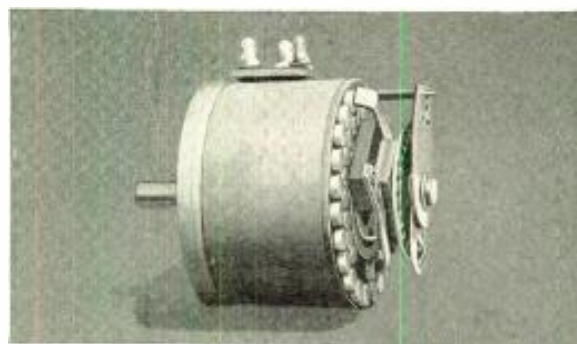

### POTENTIOMETER Type C720-2A3

20 steps, 2 db/step,  
tapered on last three  
steps to off, composition  
resistors.  $1\frac{3}{4}$ " diameter,  
 $1\frac{3}{4}$ " depth.

### These Shallcross Features Mean Better Performance— Better Value!

Off position attenuation well in excess of 100 db.

25% to 50% fewer soldered joints.

Noise level ratings that are factual. (130 db. or more below zero level.)

Non-inductive Shallcross precision resistors used throughout assure flat attenuation to and beyond 30 kc.

Types and sizes engineered for all needs. Attenuation accuracies of 1%. Resistor accuracies of 0.1%, on special order.

### SHALLCROSS ATTENUATORS

Shallcross variable attenuators have proved their remarkable quietness and serviceability in dozens of applications for leading users in all parts of the world. Such important details as the use of spring-temper silver alloy wiper arms, silver alloy collector rings and contacts, non-inductive precision resistors, and sturdy, substantial mounting plates have made possible the high standard of performance attributed to Shallcross.

Standard types include ladder and bridged T mixer controls, bridged T and straight T master gain controls and V.U. meter multipliers, wirewound and composition potentiometers for grid control. Cueing attenuators, and fixed pads, both composition and wirewound, in all circuit configurations are also available.

Write for Catalog and Attenuator Specification Sheet.

**SHALLCROSS MANUFACTURING COMPANY**  
Department C-28, Collingdale, Pa.

A WELL KNOWN NAME IN RADIO FOR OVER A QUARTER OF A CENTURY

**RCA** **HAR-CAM** **COMACO**

# Carter Motorola

**PREFERRED POWER**  
**of America's Foremost**  
**Mobile Transmitters**

**RELIABILITY** . . . Designed especially for mobile transmitter use. Specified and preferred by Police Networks for over 14 years!

**INSTANT POWER** . . . Only CARTER GENEMOTOR delivers full output in less than 3/10 second! The fastest starting Dynamotor made.

**SMALL SIZE** . . . Simplicity of design permits minimum mounting space, high efficiency.

**INSULATION** . . . First laminated slot insulation, double varnished. Triple insulated windings. Transformer grade laminations.

**BRUSHES** . . . Size and grade designed for long brush and commutator life. Beryllium springs.

**COMMUTATORS** . . . Hard drawn copper silver alloy bars.

**CARTER** . . . The oldest name in Rotary Power Supplies for mobile radio! Write for free Bulletin.



**Marconi**

**Carter Motor Co.**  
 Chicago, Illinois

**RAI JEFFERSON, INC.**  
 Radio Accessories, Inc.

**Doolittle**

**KAR ENGINEERING CO.**

**FEDERAL OVERSEAS TELEPHONE**

**GE**

2647 N. MAPLEWOOD AVENUE • CABLE: GENEMOTOR

## The Industry Offers

### G-R 20-AMPERE VARIAC AUTOTRANSFORMER

A 115-volt model Variac, type V-20M, capable of handling 20 amperes, has been announced by General Radio Company, 275 Massachusetts Avenue, Cambridge 39, Mass.

Type V-20M is rated at 3.45 kva; a 230-volt model, type V-20HM, at 2.3 kva.

Output voltage is continuously adjustable from zero to 17% above input line voltage. Terminal box is designed for use with BX or conduit.

Overall dimensions are 7 7/8" x 9 5/8" x 5 1/2".



### G. E. SELENIUM RECTIFIERS

Two models of 1" square selenium rectifiers, 6RS5GH1 and 6RS5GH2, have been made available by the tube division of G. E.

Each rectifier is said to be able to withstand inverse peak voltages obtained when rectifying (half-wave) 110-125 volts, rms. Ratings are based on ambient temperatures of 50° to 60° C.

The forward voltage drop through the rectifier is approximately 5 volts at rated current output.

### LENKURT ELECTRIC ELEVEN-CHANNEL CARRIER SYSTEM

A system, type 42, providing up to eleven duplex voice channels on a two-way radio circuit, has been developed by Lenkurt Electric Co., 1124 County Road, San Carlos, Calif.

System permits a 15-kc program channel with one to eight added carrier channels.



# PRECISION

## CRYSTALS



RH-9

**Reeves-Hoffman Crystal Units** are produced under rigidly controlled manufacturing conditions. Low humidity, close temperature control, and dust free air assure precision and dependable performance of each unit.



RH-7B

**Individual Testing** of each unit assures uniformity of production. All units of a type must produce the same test results.

**Pre-Aging of All Crystal Units** and etching to frequency assures not only extreme accuracy but prevents any future frequency drift due to aging.



RH-12

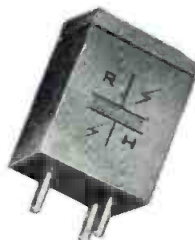

RH-53

**For Complete Information** write for catalog RHC-1.



## REEVES-HOFFMAN CORPORATION

SALES OFFICE: 215 EAST 91 STREET, NEW YORK 28, N. Y.  
 PLANT: 321 CHERRY STREET, CARLISLE, PA.

### ALLIED CONTROL ALL-PURPOSE RELAYS

Two all-purpose relays, types PO and POY, have been announced by Allied Control Co., Inc., 2 East End Ave., New York 21, N. Y.

Type PO is supplied in 2-, 3- and 4-pole normally closed, normally open or double-throw contacts. Has standard silver contacts with carrying capacity of 15 amperes at 24 volts d-c or 110 volts a-c non-inductive. Coil rating up to 220 volts, 25 and 60 cycles at 10.5 volt amperes; 120 volts d-c at 2.5 watts. Dimensions of 3-pole are 2 1/4" (height) x 1 7/8" (length) x 1 5/8" (width). The 4-pole is 2 3/4" x 1 7/8" x 2 3/8".

Type POY, intended for operation direct from plate of a tube or other limited power circuit, is a semi-sensitive, dual-coil relay for d-c only. Identical with type PO in contact arrangements, ratings, dimensions and mountings, except that it is not supplied with stop nuts. Coil rating up to 110 volts d-c at 1 watt.

### HEWLETT-PACKARD RESISTANCE-TUNED OSCILLATOR

A resistance-tuned oscillator, model 650A, which covers a frequency range of 10 cycles to 10 mc. in decade ranges, has been announced by the Hewlett Packard Company, 395 Page Mill Road, Palo Alto, California. Voltage range is .00003 to 3 volts. Output impedance is 600 ohms; a 6-ohm impedance is also available through an output voltage divider, supplied with the instrument.

Other features of the oscillator include a 94" scale length, a 6 to 1 micro-controlled vernier tuning drive and a vacuum-tube voltmeter to monitor output in volts or db at the 600-ohm level.



### BROWNING SWEEP CALIBRATOR

A sweep calibrator, model GL-22, which is a pulsed timing marker oscillator designed for use with standard scopes and synchroscopes for the accurate measurement of time intervals on either triggered or recurrent sweeps, has been announced by Browning Laboratories, Inc., Winchester, Mass.

Variable amplitude markers of either polarity are provided with sufficient amplitude for use as intensity markers or directly on the cathode ray tube plates as deflection markers. Markers available are 0.1, 0.5, 1.0, 10, 100 microseconds. A positive or negative variable width gate pulse output is provided for test purposes. The duration of this pulse corresponds to the duration of the marker group.

Operation of the calibrator may be by use of external synchronizing triggers or from its own trigger generator with output triggers of both polarities available at front panel connections.



### HARVEY SIGNAL GENERATOR

A v-h-f signal generator, 196TS, which is said to have a constant output and extremely low leakage, has been developed by Harvey Radio Laboratories, Inc., 439 Concord Avenue, Cambridge 38, Mass. Constant output is maintained by a feedback voltage control circuit.

Uses a piston-type attenuator; linear, directly calibrated in db. Range of attenuation, 0-114 db below .1 volt.

(Continued on page 36)

## Simple New *Solderless* Couplings

### Maintain Constant 51.5 Ohm Impedance



## ANDREW *Flanged* COAXIAL TRANSMISSION LINE FOR FM-TV

Offering the dual advantage of easy, solderless assembly and a constant impedance of 51.5 ohms, this new ANDREW FM-TV line is available in four diameters. Each line fully meets official RMA standards. It also is recommended for AM installations of 5 Kw or over.

Fabricated in twenty foot lengths with brass connector flanges silver brazed to the ends, sections are easily bolted together. A circular synthetic rubber "O" gasket effectively seals the line. Flux corrosion and pressure leaks are avoided. A bullet-shaped device positively connects inner conductors.

Close tolerances are maintained on characteristic impedance in both line and fittings, assuring an essentially "flat" transmission line system.

Mechanically and electrically better than previous types, this new line has steatite insulators of exceptionally low loss factor. Both inner and outer conductors of all four sizes are all copper having very high conductivity.

Flanged 45 and 90 degree elbow sections, and a complete line of accessories and fittings available.

Better be safe, than sorry. Avoid costly post-installation line changes. Get complete technical data, and engineering advice, from ANDREW now.

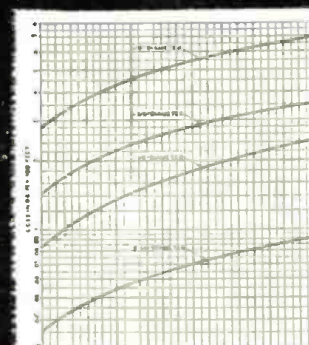

### ATTENUATION CURVE

shows total loss plus 10% derating factor to allow for resistance of joints and deterioration with time. Four diameters available: 6 1/8" - 3 1/8" - 1 1/2" and 7/8".

# Andrew

CORPORATION

363 EAST 75th STREET · CHICAGO 19

Pioneer Specialists in the Manufacture of a Complete Line of Antenna Equipment



## COSMALITE<sup>®</sup> FORMS FOR

# Television RECEIVERS

These spirally laminated paper base, Phenolic Tubes are delivered already punched and notched to meet the exact requirements of the customer. Ask also about . . .

#96 COSMALITE for coil forms in all standard broadcast receiving sets.  
SLF COSMALITE for Permeability Tuners.

Spirally wound kraft and fish paper Coil Forms and Condenser Tubes.  
*There is a definite saving to you in specifying and using Cosmalite.*

.. See Our Exhibit #220 at the ..  
I.R.E. Radio Engineering Show ..

Trade Mark Registered

## The CLEVELAND CONTAINER Co.

6201 BARBERTON AVE. CLEVELAND 2, OHIO

- All-Fibre Cans • Combination Metal and Paper Cans
- Spirally Wound Tubes and Cores for all Purposes
- Plastic and Combination Paper and Plastic Items

PRODUCTION PLANTS also at Plymouth, Wisc., Ogdensburg, N. Y., Chicago, Ill., Detroit, Mich., Jamesburg, N. J.  
PLASTICS DIVISIONS at Plymouth, Wisc., Ogdensburg, N. Y. • ABRASIVE DIVISION at Cleveland, Ohio  
SALES OFFICES - Room 223, 1186 Broadway, N. Y. C. also 647 Main St., Hartford, Conn.  
IN CANADA - The Cleveland Container Canada Ltd., Prescott, Ontario.



## The Industry Offers

(Continued from page 35)

### RMC HYPER-MAG SPEAKERS

Speakers featuring a *hyper-mag* magnet and a center dome with a parabolic projector which is said to provide broad high-frequency distribution have been announced by Radio-Music Corporation, Port Chester, New York.

The *hyper-mag* magnet design is said to concentrate the flux density in the working air gap with minimum leakage loss.

Three types are available: an 8" (12-15 watts) with a 100-10,000 cps range; 12" for 50 to 10,000 cps and 15 to 20 and 25-30 watts.

Bulletin HS-4 available upon request.



### UTC TRANSFORMERS

A line of audio components, input transformers, modulation, power, and filament transformers. CG series, has been announced by United Transformer Corporation, 150 Varick St., N. Y. 13, N. Y.

Audio components range from low level, hum-bucking, multiple-alloy shielded input transformers to 600-watt *varimatch* modulation transformers. Power and filament components range up to those required for a 3,000-volt 1-ampere plate supply.



### TRIPLETT MODULATION MONITOR

A modulation monitor, 3296, with tuning and a-f ranges of 1550 to 30,000 kc and 60 to 10,000 cps, has been announced by The Triplett Electrical Instrument Co., Bluffton, Ohio.

Four separate circuits for measuring a-m: Per cent modulation (average); peak flash per cent modulation; carrier shift; and audio output for headphone. The peak indicator may be preset for any per cent of modulation from 20-120. The per cent modulation meter provides a rapid up and slow down swing.

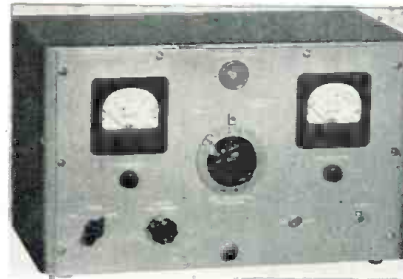

**For HEAVY DUTY WORK!** Severest Electrical Services!

**JONES PLUGS & SOCKETS**  
500 SERIES  
*Proven Quality*

P-506-CE Plug with Cap

S-506-DB Socket with deep Bracket

For 5,000 Volts, 25 Amperes per Contact Alterable by circuit Characteristics.

Socket contacts phosphor bronze, knife-switch type, cadmium plated. Plug contacts hard brass, cadmium plated. 2, 4, 6, 8, 10, and 12 contacts. Plugs and sockets polarized. Long leakage path from terminal, and terminal to ground. Caps and brackets, steel parkerized (*rust-proofed*). Plug and socket blocks interchangeable in caps and brackets. Terminal connections most accessible. Cap insulated with canvas bakelite.

Write for Jones BULLETIN 500 for full details on line.

**HOWARD B. JONES DIVISION**  
Cinch Mfg. Corp.  
2460 W. GEORGE ST. CHICAGO 18, ILL.

**FREE**

**CONCORD**

**NEW! COMPLETE!**  
*Concord*  
**Radio Catalog**  
160 Value-Packed Pages of  
the LATEST and BEST in  
RADIO • TELEVISION and  
ELECTRONIC EQUIPMENT  
at LOWEST PRICES  
Write for FREE copy. Address Dept. R-28

**CONCORD RADIO CORP.**  
CHICAGO 7 ATLANTA 3  
301 W. Jackson Blvd. 265 Peachtree St.  
Downtown Chicago Branch - 229 West Madison St.  
LAFAYETTE RADIO CORP.

**W. E. INTERMODULATION ANALYZER SYSTEM**

A signal-generator (RA-1258) and intermodulation analyzer (KA-1257), have been announced by the Electrical Research Products Division of the Western Electric Company. In operation, a signal of two frequencies, the low between 40 and 150 cycles and the high either 2000 cycles or between 7000 and 12,000 cycles, are added by the signal generator with a minimum of amplitude modulation of one frequency by the other. The high frequency is attenuated to a desired ratio, which may be 1:1, 1:2, 1:4, or 1:10, and the two frequencies combined in a hybrid coil. Output levels range between +23 and -44 dbm at 600 ohms output impedance. The summed voltage is passed through the device under test.

The output from the equipment being tested is fed to the analyzer where the percentage of intermodulation, or the percentage of amplitude modulation of the h-f signal by the l-f signal may be measured. A distortion phase meter is provided for determining, when measuring variable density recordings, whether compression is occurring on the positive or negative half of the low frequency signal.



**DU MONT SYNC SIGNAL GENERATOR**

A synchronizing signal generator, model TA-107 A/B, has been announced by the television equipment division of Allen B. Du Mont Labs., Inc., 42 Harding Ave., Clifton, N. J.

Equipment conforms to RMA and FCC specs for standard output signals, horizontal and vertical driving signals, composite video blanking signal, and composite sync signal. Linearity test signals at 900 cycles provide 15 horizontal bars, while 157.5 kc signals provide 10 vertical bars mixed with blanking, by means of a switch, for use in checking scanning linearity of picture monitors and television receivers. These horizontal and vertical bars appear on two 3" cathode-ray tubes used in simultaneous monitoring (without

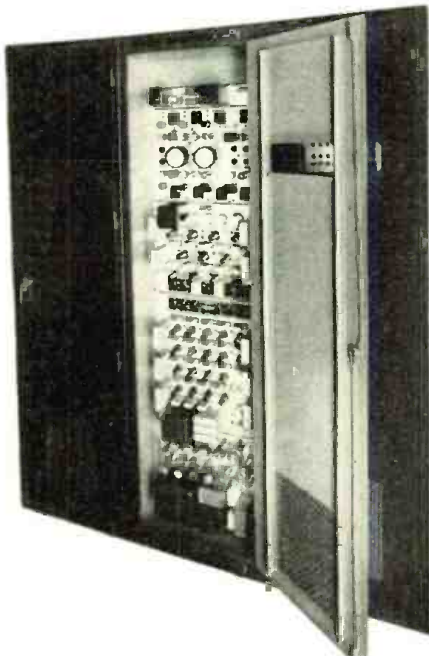

testing **STRETCH**ability here

...gives you better **WORK**ability

**in PANTHER and DRAGON Rubber Tapes**

Testing the tape's stretchability on a Scott tester, as shown here, is only one of a series of quality control tests made during various stages of production that make PANTHER and DRAGON Rubber Tapes "tops in tapes". You can count on these tapes to be strong enough to stretch without breaking . . . make better splices that will last longer.

Made by a company in the insulation business for nearly 70 years, PANTHER and DRAGON Friction and Rubber Tapes pass ASTM and federal specifications for electrical and physical properties with a wide margin of safety. They have proved their worth in successful splicing jobs of all kinds. Sold only through recognized independent wholesalers. Hazard Insulated Wire Works, Division of The Okonite Company, Wilkes-Barre, Pa.



**Panther and Dragon friction and rubber tapes**

6173

switching) of all frequencies in the sync generator.

Leading edges of equalizing pulses are also leading edges of horizontal and vertical sync pulses, thus insuring perfect interlacing. A crystal oscillator at 1.75 kc, or a highly stable self-excited oscillator, may be selected by a switch for use as master oscillator. Self-excited master oscillator is useful for synchronizing the generator, by means of lock-in circuit, to 60 cycle power line or to a remotely generated sync signal.

**SHALLCROSS BRIDGED T ATTENUATORS**

A series of bridged T attenuators of 2 1/4" in diameter, has been announced by the Shallcross Manufacturing Company, Collingdale, Pa.

The series 420-OBO 20-step, are said to have an attenuation characteristic essentially flat from 30 to 15,000 cycles; attenuation in off posi-

tion is said to be 100 db or better. Resistors are noninductively wound and sealed against moisture and shock.

The back-of-panel depth is 2" for all units, or 2 1/2" when equipped with detent mechanism.

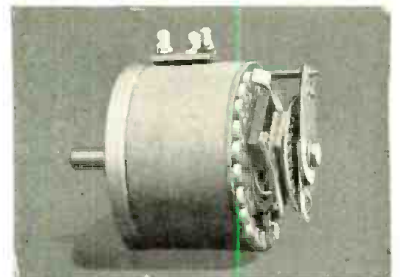

PREMAX

# NO QUESTION

## about Premax ANTENNAS

*They Get the Signal*

Premax Telescoping Tubular Antennas are widely used for reception and transmission by amateurs, and for commercial, mobile and emergency installations. They may be had in sectional types, in steel, aluminum or monel—with extended heights of 5 to 35 feet. Due to their carefully engineered construction, they get the signal.

ASK YOUR RADIG JOBBER

### Premax Products

Div. CHISHOLM-RYDER CO., INC.  
4809 Highland Ave. - Niagara Falls, N. Y.

*Crystals for the Critical*



### JK STABILIZED JKO-3

This is a crystal oven designed to accommodate the following JK crystals: H7, H15, H17 and others. Operating temperature is adjustable and temperature stability is plus or minus 1° C. Heater is 6.3 volt and consumption is approximately 1 amp. Others on special order.

Visit JAMES KNIGHTS EXHIBIT,  
BOOTH H, IRE SHOW,  
GRAND CENTRAL PALACE

The JAMES KNIGHTS CO.  
SANDWICH, ILLINOIS

# News Briefs

## INDUSTRY ACTIVITIES

The IRE-RMA Spring Meeting on transmitters will be held at the Syracuse Hotel, Syracuse, N. Y., on April 26, 27 and 28.

The Spring Meeting committee consists of Dr. W.R.G. Baker, vice president of G. E. and engineering director of RMA, V. M. Graham, Sylvania Electric, and associate director of engineering of RMA, E. A. LaPort, RCA International Division, and M. R. Briggs, Westinghouse Electric Manufacturing Company.

L. C. F. Horle, chief engineer of RMA and L. G. Cumming, technical secretary of IRE will arrange the technical committee sessions. J. J. Farrell, G. E., will handle arrangements for the technical program.

The Los Angeles section of the IRE will hold its Pacific Coast convention at the Los Angeles Biltmore on Sept. 30 and Oct. 1 and 2, simultaneously with the 4th annual Pacific Electronic Exhibition. C. Frederick Wolcott, technical director for Gilfillan Bros. Inc., will serve as IRE liaison man for the exhibition.

Officers of the IRE Los Angeles section are: Walter Kenworth, consulting engineer, chairman; Bernard Walley, RCA-Victor field engineer, vice chairman; Ray Montford, Los Angeles Times chief television engineer, secretary-treasurer; and Lloyd Sigmon, KMPC chief engineer, coast convention chairman.

A. T. & T. has filed rates with the FCC for 50 to 15,000 cycles intercity channels.

Monthly rate asked for is \$10 a mile. Rate for 5,000-cycle channel, type most commonly used by broadcasters at present, is \$6 a mile.

C. P. Clare & Co. has moved its N. Y. City office to suite 310, 420 Lexington Avenue.

American Relay & Controls, Inc., 2555 West Diversey Avenue, has been purchased by David T. Siegel, president of Ohmite, Inc. Plant will be at 4900 West Flournoy St., Chicago 44, Ill.

Selenium Corporation of America, an affiliate of Vickers, Inc., Detroit, Michigan, and a unit of The Sperry Corporation, has been voluntarily dissolved, and succeeded by the Vickers Electric Division, Vickers Inc., 2160 East Imperial Highway, El Segundo, California.

The Parts Section of G. E. has been transferred from the Specialty Division to the Receiver Division.

Russell S. Fenton, who was sales manager of the section while it was incorporated in the Specialty Division, will continue in that capacity. J. K. Eaton will remain as supervisor of commercial service.

## PERSONALS

Virgil M. Graham, director of technical relations for Sylvania Electric Products Inc., has been elected chairman of the Joint Electron Tube Engineering Council which is sponsored by the RMA and NEMA.



V. M. Graham

William Petzold and Frank Holdenecker are principals of a new organization, The Dilks Company, located at Seymour, Conn., manufacturing Dilks Vocal-Aire speaker units.

Anthony Marra and Arthur J. Sanial, have purchased the portable electric megaphone patents, rights to manufacture, and inventory, from the Guided Radio Corporation, N. Y., and have formed the Audio Equipment Company, Inc., at 80-20 45th Avenue, Elmhurst, N. Y., to produce these megaphones. Marra will serve as president and Sanial as chief engineer. Marra is owner of Audio Engineering Corp., Brooklyn, N. Y. Sanial was formerly chief engineer and vice president of Guided Radio.

## THE COLLINS FM/AM TUNER



You've heard a lot about it and it is truly the finest of its type on the market today. No other tuner has the wide range response on AM that this one has. Coupled with this super AM circuit is Armstrong FM with a full complement of tubes; three I.F. stages and two limiters. We have taken no short cuts to bring you the ultimate. You will not be completely satisfied until you have one.

### COLLINS AUDIO PRODUCTS CO., INC.

P. O. Box 368, Westfield, N. J.  
Plant on Route 29, Mountainside, N. J.

INSIDE INFO...

"ELEMENTS OF MAGNETIC  
TAPE RECORDING and  
999 APPLICATIONS"

by A. C. Shaney

ORDER NOW

AVAILABLE AT ONLY 25¢

AMPLIFIER CORP. of AMERICA

398-31 Broadway • New York 13, N. Y.

Be sure to visit  
COMMUNICATIONS

Booth 290  
At the I. R. E.  
Engineering Show

Grand Central Palace  
New York

March 22-25, 1948



**Ray Hutmacher** of Ray Hutmacher & Associates, Chicago, has become Utah Radio representative in Illinois, Wisconsin, and St. Louis County, Missouri.

**James F. Cosgrove** has joined the Federal Telephone and Radio Corporation, Clifton, N. J., to act as district representative for broadcast equipment in the New York-New England area.

**R. P. Lamons** formerly eastern district representative for Andrew, is now with FTR as district representative for broadcast equipment covering Illinois, Indiana, Michigan, Ohio, Kentucky, Minnesota, Wisconsin, Missouri and Kansas. Headquarters are at 343 N. Michigan Blvd., Chicago.

**Wm. E. Wilson**, who has been sales manager of the Acme Electric Corp. of Cuba for the past three years, has been elected vice president in charge of sales.

**E. E. Crump**, formerly of Bell Telephone Labs. and L. L. Libby, formerly with Federal Telecommunications Labs. are now president and chief engineer, respectively, of Omega Labs., Inc., Pine Brook, N. J.

Corporation is an outgrowth of Kay Electric Company, Pine Brook, N. J., who will relinquish its special development work to Omega and concentrate on the manufacturing of electronic measurement instruments.

**Donald E. Busse** has been appointed sales engineer of Wilcox Electric Company, Inc. Busse was formerly with Trans World Airlines as supervisor of ground radio engineering.



D. E. Busse

**William O. Spink** has been named field engineer for the radio division of Sylvania Electric Products Inc. Spink will cover Michigan, Ohio and Indiana territories.

**Robert A. Elliot** is now manager of RCA broadcast audio sales. Prior to this assignment, Elliot supervised export sales of broadcast audio equipment for the RCA International Division.

**Richard H. Rudolph** has been appointed sales manager of precision and laboratory test equipment and crystals for the Specialty Division of G. E.

#### LITERATURE

**Pickering & Company, Inc.**, 29 W. 57th Street, New York 19, have published a bulletin describing a diamond cartridge, model D-120M and equalizer amplifier, model 125H.

**United Electronics Company**, 42 Spring Street, Newark 2, N. J., have released a 12-page catalog, No. 1-GPW-7, describing graphite anode tubes and 30-kv vacuum capacitors.

**The Seletron Division, Radio Receptor Company, Inc.**, 251 W. 19th St., New York 11, N. Y., have published a five-page bulletin describing 19 selenium rectifiers most frequently required by manufacturers, public utilities, labs., maintenance and test departments, railroad hobbyists, plating hobbyists, and amateurs.

**The RCA Tube Department** has prepared a 14-page technical booklet, RSB 1000, describing the *Special Red* tube line. Booklet is available from the Commercial Engineering Section, RCA Tube Department, Harrison, N. J.

First of the *Special Reds*, which are identified by red bases for glass types and red envelopes and bases for metal types, are the 5691, a high- $\mu$  triode; 5692, a medium- $\mu$  twin triode; and the 5693, a sharp cutoff pentode.

Tubes feature girder construction which is said to hold internal elements rigidly in adjustment and ultra-precise fitting of parts.

**Hewlett-Packard Company**, 395 Page Mill Road, Palo Alto, California, have published a 4-page bulletin describing eleven instruments now being produced.



## A COMPACT POWER RELAY FOR A WIDE RANGE OF APPLICATIONS

This new addition to the Allied line of precision relays is available in 1, 2, 3, or 4-pole, double-throw, normally-open or normally-closed and in double-break contact arrangements.

These are some of the important reasons why this small relay is equipped to do a big job:

- **Contact Rating**—10 amperes, or 30 amperes for double-break contacts, at 24 volts D.C. and 110 volts A.C. non-inductive with standard silver contacts. This rating is attained by high contact pressures which usually are obtainable only in a much larger relay.
- **Coil Rating**—D.C.—up to 120 volts. A.C.—up to 220 volts with a maximum contact arrangement of double-pole, double-throw.
- **Mounting**—horizontal or vertical mounting frame for maximum adaptability.
- **Terminals**—easy-to-wire contacts and coil terminals are conveniently located.

#### HERMETICALLY SEALED TYPE PR RELAYS

**Type PRH**—Solder terminals. Up to four-pole, double-throw.

**Type PRHO**—Standard octal plug-in base. Up to three-pole, single-throw, normally-open or closed or any combination of six contact arms.



**ALLIED CONTROL COMPANY, Inc.**

2 EAST END AVENUE • NEW YORK 21, N. Y.

**NEW...IMPROVED**

**PRECISION ATTENUATORS**

**by TECH LABS**

TYPE  
850-A 850-B

The units illustrated represent a complete redesign of our older precision attenuators for laboratory standards. Flat for all frequencies in the audio range. Reasonably flat to 200 k.c. up to 70 db.

Bulletin sent on request.

**TECH**  
LABORATORIES, INC.

Manufacturers of Precision Electrical Resistance Instruments  
337 CENTRAL AVE. • JERSEY CITY 7, N. J.

*Designed for*



*Application*



90811

**90811 HIGH FREQUENCY  
RF AMPLIFIER**

The No. 90811 RF Amplifier is the same unit as used in the No. 90810 complete 2-6-10-20 meter Ham Band crystal controlled transmitter. Can be panel or base mounted. Uses 829B or 3E29 tube with normal 75 watt output. (Higher output may be obtained by the use of forced cooling.) Provisions are made for quick band shift by means of the new 48000 series high frequency plug-in coils. Extremely compact. Chassis 4" x 7 3/4" exclusive of flanges. Over-all height 6 3/4".

**JAMES MILLEN  
MFG. CO., INC.**

MAIN OFFICE AND FACTORY  
MALDEN  
MASSACHUSETTS



ADVERTISERS IN THIS ISSUE

COMMUNICATIONS INDEX

FEBRUARY, 1948

ALLIED CONTROL CO., INC.	39
Agency: Michel-Cather, Inc.	
AMERICAN TELEPHONE & TELEGRAPH CO.	23
Agency: N. W. Ayer & Son, Inc.	
AMPLIFIER CORP. OF AMERICA	38
Agency: H. J. Gold Co.	
ANDREW CORPORATION	35
Agency: Burton Browne, Advertising	
CANNON ELECTRIC DEVELOPMENT CO.	32
Agency: Dana Jones Co.	
CARTER MOTOR CORP.	34
Agency: Robert Peterson Adv. Agency	
THE CLEVELAND CONTAINER CO.	36
Agency: The Nesbitt Service Co.	
COLLINS AUDIO PRODUCTS CO., INC.	38
CONCORD RADIO CORP.	36
Agency: E. H. Brown Adv. Agency	
FAIRCHILD CAMERA & INSTRUMENT CORP.	1
Agency: G. M. Basford Co.	
FEDERAL TELEPHONE & RADIO CORP.	17
Agency: Rickard & Co.	
GENERAL RADIO CO.	Inside Back Cover
HAZARD INSULATED WIRE WORKS	37
Agency: Doyle, Kitchen & McCormick, Inc.	
THE INSTITUTE OF RADIO ENGINEERS	32
JENSEN MFG. CO.	4
Agency: Burton Browne, Advertising	
HOWARD B. JONES DIV. CINCH MFG. CORP.	36
Agency: Merrill Symonds, Advertising	
THE KAPPLER CO.	32
Agency: Thomas Moody & Associates	
KELLOGG SWITCHBOARD & SUPPLY CO.	3
Agency: Evans Associates, Inc.	
THE JAMES KNIGHTS CO.	38
Agency: Rudolph Bartz, Advertising	
JAMES MILLEN MFG. CO.	40
PHILCO CORPORATION	Back Cover
Agency: Julian G. Pollock Co.	
PREMAX PRODUCTS DIV. CHISHOLM-RYDER CO., INC.	38
Agency: Norton Adv. Service.	
REEVES-HOFFMAN CORP.	34
SHALLCROSS MFG. CO.	33
Agency: The Harry P. Bridge Co.	
SORENSEN & CO., INC.	Inside Front Cover
Agency: Henry A. Stephens, Inc.	
TARTAK SPEAKERS, INC.	40
Agency: Sylvester-Meeder Adv. Corp.	
TECH LABORATORIES, INC.	39
Agency: Lewis Adv. Agency	
U. S. TREASURY DEPT.	30
WILCOX ELECTRIC CO., INC.	25
Agency: Arthur G. Rippey & Co.	



**A FULL LINE**



**OF PM AND**



**ELECTRO-DYNAMIC**



**SPEAKERS**  
*for the trade, in*  
**3, 4, 5, 6, 8, 10 & 12 in. sizes**

Tartak speakers are available near you for immediate shipment and at competitive prices. You can install or sell Tartak with confidence—there is none better. Write for specifications and prices.

*Over 2 decades in Speakers*

**TARTAK SPEAKERS, Inc.**  
CONTRACTS DIVISION  
3120 E. PICO BLVD.  
LOS ANGELES 23, CALIF., U.S.A.

# for A-F DISTORTION and NOISE MEASUREMENTS

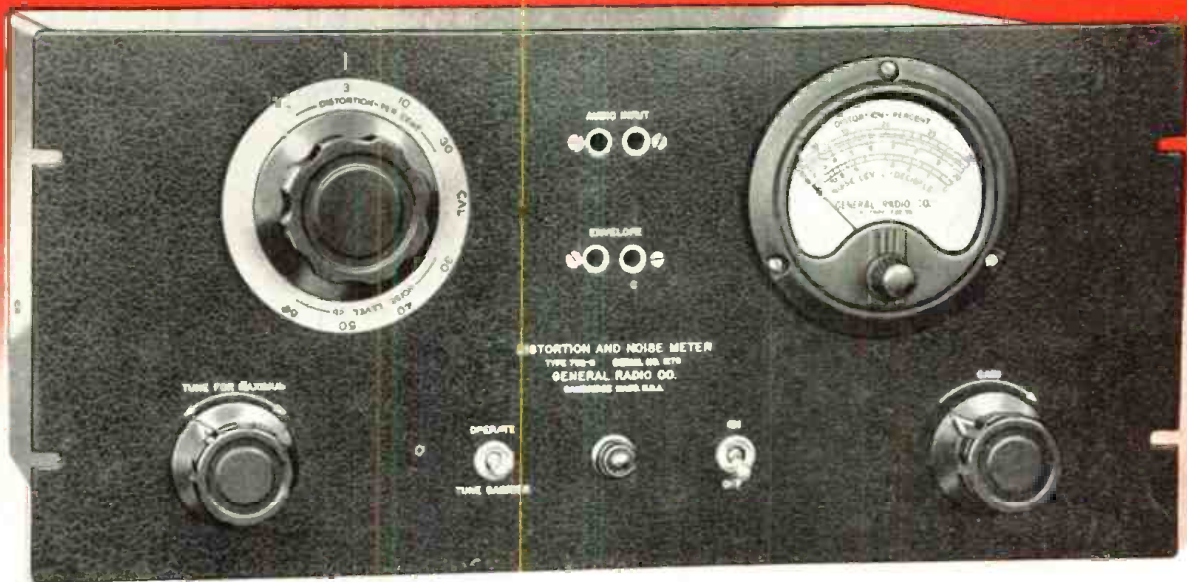

- ... in Sound on Film and Disc Recordings
- ... in Production Tests on Radio Transmitters & Receivers

FROM necessity, because of war production, the pre-war very popular Type 732-B Distortion & Noise Meter was dropped from the G-R line. It is now in production again to meet an insistent demand for a meter to supplement the new Type 1932-A which is designed primarily for broadcast and communication applications.

The Type 732-B is equipped with a 400-cycle high-pass L-C filter so that harmonic content measurements of a 400-cycle signal can be made rapidly. Because of the width of the pass band, unsteady signals, "wows" and other irregularities do not affect the accuracy of measurement.

The ease with which accurate measurements can be made over the distortion range of 0.25 to 30% and noise range of 30 to 70 db below 100% modulation, make it very valuable in these types of production testing:

#### ON RADIO TRANSMITTERS

- Signal-to-noise ratio
- Distortion vs.
  - power
  - r-f levels
  - frequency
  - percentage modulation

- A-F response
- Noise vs carrier level
- Hum modulation
- Hum level

#### ON RADIO RECEIVERS

- Distortion & noise vs a-f output
- Whistle output at 2nd and 3rd harmonic of i.f.
- Two-signal cross-talk

The broad pass band characteristic of this meter is particularly useful when making distortion measurements on sound on film or on disc recordings where the fundamental frequency is not constant.

The Type 732-P1 Range Extension Filter is available as an auxiliary unit so that measurements at additional frequencies of 50, 100, 1000, 5000 and 7500 cycles can be made.

TYPE 732-B DISTORTION and NOISE METER . . . . \$374.00  
(For either 0.5 to 8 Mc or 3 to 60 Mc carrier range, specify which)

TYPE 732-P1 RANGE EXTENSION FILTER . . . . . \$209.00

WE HAVE A FEW IN STOCK. ORDER NOW FOR PROMPT SHIPMENT



## GENERAL RADIO COMPANY

Cambridge 39,  
Massachusetts

90 West St., New York 6

920 S. Michigan Ave., Chicago 5

950 N. Highland Ave., Los Angeles 38

# New, Sensational FM Radiophone COMMUNICATIONS SYSTEMS

by **PHILCO**  
—the Leader

with  
"MICRO-SELECTIVITY"



## ONLY PHILCO HAS IT!

The amazing PHILCO FM "Channel Saver" Circuit operates within a band width of only 20 Kilocycles. Its "micro-selectivity"—better than 85 db. down at 40 Kc from center frequency—permits adjacent channel operation on the basis of present frequency allocations. This allows higher standards of efficiency in only half the channel width without loss in voice quality, protects you against equipment obsolescence. Only PHILCO Has It . . . Plus . . . many new developments in equipment design. Mail the coupon, today, for full details.

- Philco Radiophone Systems are Available for Operation on All Frequencies Assigned for Mobile Communications.
- Free Engineering Consultation Service.
- Nationwide Service Organization.

# PHILCO

**INDUSTRIAL DIVISION**

PHILADELPHIA • PENNSYLVANIA

Dept. J-9, Industrial Division  
Philco Corporation  
C and Tioga Streets  
Philadelphia 34, Penna.

Gentlemen:

Please send me information about the new  
PHILCO FM Radiophone Communication  
System.

NAME \_\_\_\_\_

ADDRESS \_\_\_\_\_

CITY \_\_\_\_\_