

COMMUNICATIONS

INCLUDING "RADIO ENGINEERING" AND "TELEVISION ENGINEERING"

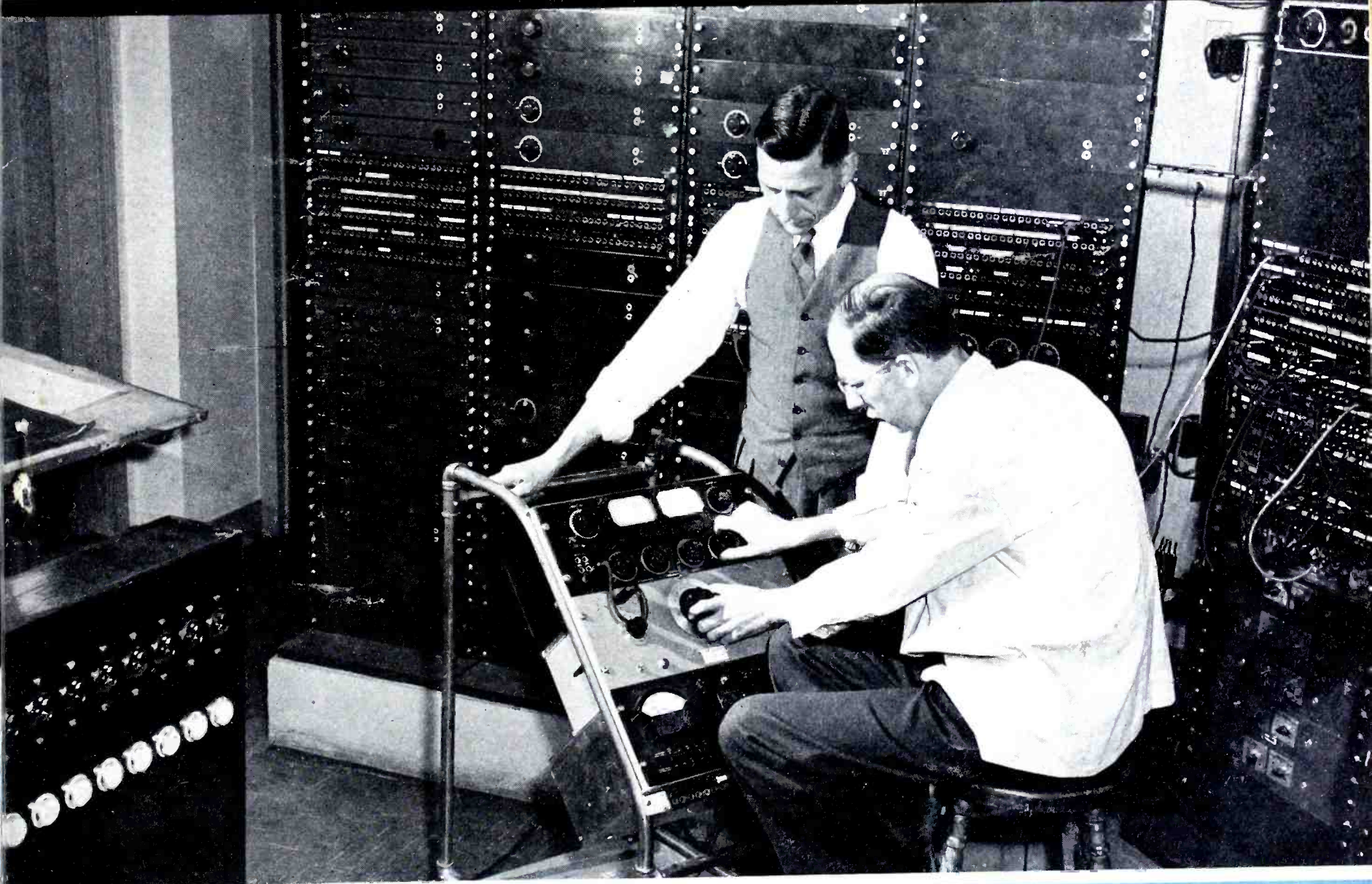

SEPTEMBER

- ★ WHAT IS WRONG WITH TV SOUND?
- ★ THE WNOW A-M/F-M INSTALLATION
- ★ DIRECTIONAL ANTENNA PATTERN NOMENCLATURE

1948

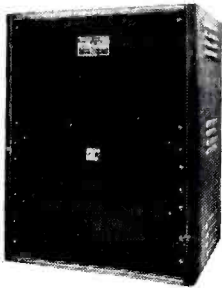

3-Phase Regulation

MODEL	LOAD RANGE VOLT-AMPERES	*REGULATION ACCURACY
3P15,000	1500-15,000	0.5%
3P30,000	3000-30,000	0.5%
3P45,000	4500-45,000	0.5%

• Harmonic Distortion on above models 3%.
Lower capacities also available.

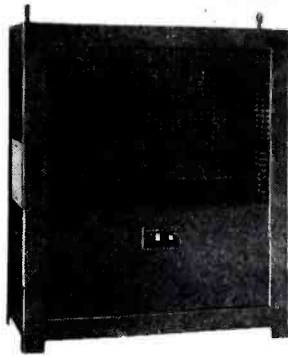

Extra Heavy Loads

MODEL	LOAD RANGE VOLT-AMPERES	*REGULATION ACCURACY
5,000*	500 - 5,000	0.5%
10,000*	1000-10,000	0.5%
15,000*	1500-15,000	0.5%

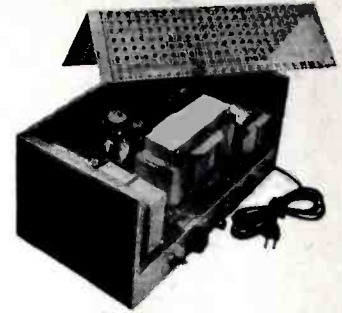

General Application

MODEL	LOAD RANGE VOLT-AMPERES	*REGULATION ACCURACY
150	25 - 150	0.5%
250	25 - 250	0.2%
500	50 - 500	0.5%
1000	100-1000	0.2%
2000	200-2000	0.2%



400-800 Cycle Line INVERTER AND GENERATOR REGULATORS FOR AIRCRAFT.

Single Phase and Three Phase

MODEL	LOAD RANGE VOLT-AMPERES	*REGULATION ACCURACY
D500	50 - 500	0.5%
D1200	120-1200	0.5%
3PD250	25 - 250	0.5%
3PD750	75 - 750	0.5%

Other capacities also available

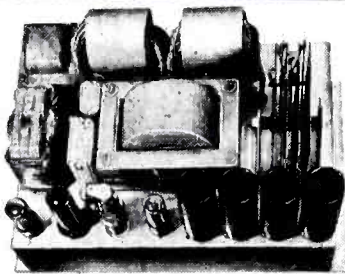

The NOBATRON Line

Output Voltage DC	Load Range Amps.
6 volts	15-40-100
12 "	15
28 "	10-30
48 "	15
125 "	5-10

• Regulation Accuracy 0.25% from 1/4
to full load.

SORENSEN

The First Line of standard electronic AC Voltage Regulators and Nobatrons

GENERAL SPECIFICATIONS:

- Harmonic distortion max. 5% basic, 2% "S" models
- Input voltage range 95-125: 220-240 volts (-2 models)
- Output adjustable bet. 110-120: 220-240 (-2 models)
- Recovery time: 6 cycles: + (9 cycles)
- Input frequency range: 50 to 65 cycles
- Power factor range: down to 0.7 P.F.
- Ambient temperature range: -50°C to +50°C

All AC Regulators & Nobatrons may be used with no load.

*Models available with increased regulation accuracy.

Special Models designed to meet your unusual applications.

Write for the new Sorensen catalog. It contains complete specifications on standard Voltage Regulators, Nobatrons, Incevolts, Transformers, DC Power Supplies, Saturable Core Reactors and Meter Calibrators.

SORENSEN & CO., INC.
STAMFORD CONNECTICUT

Represented in all principal cities.

Announcing A NEW LINE OF **SPRAGUE** ELECTROLYTIC CAPACITORS

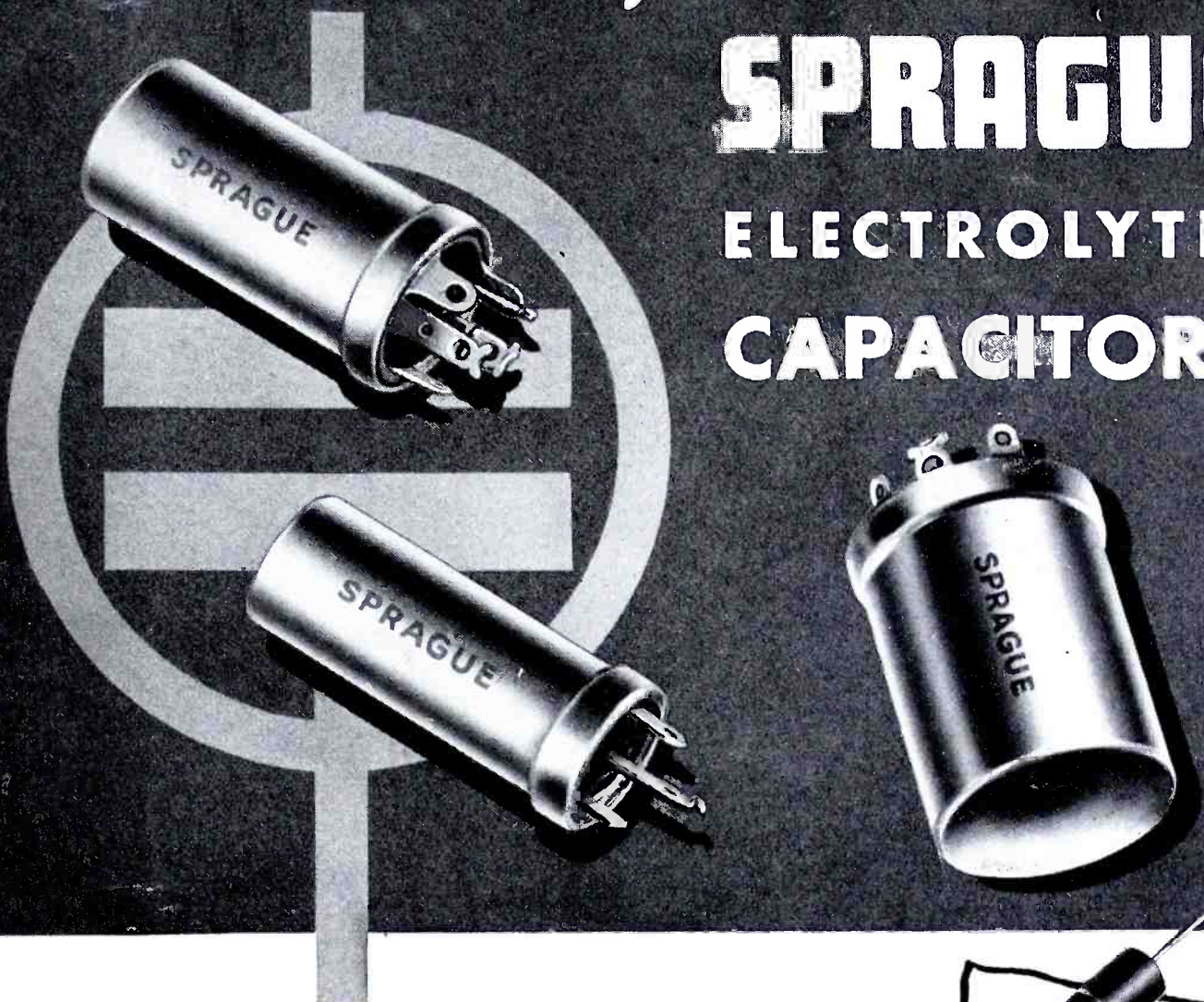

Designed for Television Use (for operation up to 450 volts at 85° C.)

With some 7 times as many components in a television receiver as in the average radio, the possibility of service calls is greatly increased. The new SPRAGUE ELECTROLYTIC line offers the first practical solution to this problem.

Designed for dependable operation up to 450 volts at 85° C. these new units are ideally suited for television's severest electrolytic assignments. Every care has been taken to make these new capacitors the finest electrolytics available today. Stable operation is assured even after extended shelf life, because of a new processing technique developed by Sprague research and development engineers, and involving new and substantially increased manufacturing facilities. More than ever before your judgment is confirmed when you *SPECIFY SPRAGUE ELECTROLYTICS FOR TELEVISION AND ALL OTHER EXACTING ELECTROLYTIC APPLICATIONS!* Sprague Electric Company invites your inquiry concerning these new units.

SPRAGUE ELECTRIC COMPANY • NORTH ADAMS, MASS.

**WORTHY
COMPANIONS
FOR THE NEW
ELECTROLYTICS!
SPRAGUE MOLDED
TUBULARS . . .**

Highly heat- and moisture-resistant
Non-inflammable • Moderately priced
Conservatively rated for -40°C to
+85°C operation
Small in size • Completely insulated
Mechanically rugged
Write for Engineering Bulletin No. 210A

SPRAGUE

Capacitors

* Koolohm Resistors

P I O N E E R S O F

ELECTRIC AND ELECTRONIC PROGRESS

•Trademarks reg. U. S. Pat. Office

COMMUNICATIONS

Including Television Engineering, Radio Engineering, Communication & Broadcast Engineering, The Broadcast Engineer, Registered U. S. Patent Office.

LEWIS WINNER

Editor

F. WALEN

Assistant Editor

Bryan S. Davis, President

Paul S. Weil, Vice Pres.-Gen. Mgr.

F. Walen, Secretary

A. Goebel, Circulation Manager

Cleveland Representative:

James C. Munn
2253 Delaware Dr., Cleveland 6, Ohio
Telephone: Erievue 1726

Pacific Coast Representative:

Brand & Brand
1052 W. Sixth St., Los Angeles 14, Calif.
Telephone: Michigan 1732

Suite 1204, Russ Building, San Francisco 4, Calif.
Telephone: SUTter 1-2251

Wellington, New Zealand: Te Aro Book Depot.
Melbourne, Australia: McGill's Agency.

Entered as second-class matter Oct. 1, 1937 at the Post Office at New York, N. Y., under the Act of March 3, 1879. Subscription price: \$2.00 per year in the United States of America and Canada; 25 cents per copy. \$3.00 per year in foreign countries; 35 cents per copy.

COMMUNICATIONS is indexed in the Industrial Arts Index.

COVER ILLUSTRATION

Lyman Wiggin, chief engineer of Reeves Sound Studios, supervising a distortion run in the sound system transmission room. Assisting is Homer Elder, Reeves Sound engineer.

TELEVISION ENGINEERING

What Is Wrong With TV Sound?.....Scott Helt 8
TV Audio Study Reveals Picture Control Receiving More Attention Than Sound, Resulting in Low-Quality Aural Output. Improvement Procedures Outlined Include Extreme Caution in Handling of Studio Equipment and Scenic Sets.

A-M/F-M BROADCASTING

The WNOW A-M/F-M
InstallationWillis N. Weaver and N. Carl Kitchen 10
Transmitter Housed in Cinder Block Building in Pennsylvania Wooded Area 830 Feet Above Sea Level. F-M has 4-Section Pylon Mounted Atop 154 Foot Tower. Mounted Atop 154 Foot Tower.

BROADCAST ANTENNA ENGINEERING

Directional Antenna Pattern Nomenclature.....Carl E. Smith 12
Symbols Adopted to Describe Directional Antenna Arrays. Formats Prepared for Horizontal Plane Pattern Sheets.

REMOTE CONTROL

Traveling Light on Remote Assignments.....George Drisko 15
Compact, Lightweight Unit, Provides Extremely Flexible Remote Facilities.

F-M COMMUNICATIONS

F-M Communications In Oil Well Drilling Operations..Ted W. Mayborn 18
Eleven Station, 2-Way Net, Operating in Northern Texas on 31.74 Mc, Provides Contact to Drilling Rigs, Pickup Trucks, Superintendent's Car, Etc.

TRANSMITTING TUBES

Tube Engineering News..... 22
Adjusting 1B3GT Filament Voltage by Observation of Filament Temperature. Application Data for New 812A Medium Mu Power Triode.

SOUND ENGINEERING

Lateral RecordingW. H. Robinson 34
Notes on Discs, Pickups, Scratch Filters, Preemphasis, etc.

MONTHLY FEATURES

News and Views.....Lewis Winner 7
Veteran Wireless Operators' Association News..... 23
The Industry Offers..... 24
News Briefs of the Month..... 28
Advertising Index 40

Entire contents Copyright 1948, Bryan Davis Publishing Co., Inc.



Published monthly by Bryan Davis Publishing Co., Inc.

52 Vanderbilt Avenue, New York 17, N. Y. Telephone MURray Hill 4-0170



In every type of home radio
SYLVANIA tubes speak for themselves

Admiral

ARVIN

Bendix
 THE REAL VOICE OF
Radio

CROSLEY

Emerson
Radio

ESPEY

FADA
Radio

Farnsworth

GLOBE

hallicrafters



Miniatures, standard types, and famous Lock-Ins are all included in the Sylvania line.

In the leading makes of home radios—from portable models to console combinations—you'll find Sylvania tubes helping to assure fine reception and lasting service. The quality of Sylvania tubes has made them famous throughout the world.

For information on Sylvania tubes, see Sylvania Distributors, or write Radio Tube Division, Emporium, Pa.

SYLVANIA

ELECTRIC

RADIO TUBES; CATHODE RAY TUBES; ELECTRONIC DEVICES; FLUORESCENT LAMPS, FIXTURES, WIRING DEVICES; ELECTRIC LIGHT BULBS; PHOTOFLASH BULBS

Motorola

Olympic
 Radio and Television

PHILCO

Regal

Silvertone

Spartan

STROMBERG-CARLSON

Temple

TRAV-LER

Westinghouse

ZENITH
 LONG DISTANCE RADIO

SECURITY QUIZ

for MANAGEMENT MEN

can you answer these important questions?

How many of your employees are buying U. S. Security Bonds regularly via the Payroll Savings Plan? (35% to 50% of employees buy Security Bonds on the Payroll Savings Plan in those companies in which top management backs the Plan.)

• How does their average holding compare with the national average? (The national average among P.S.P. participants is \$1200 per family.)

• Why is it vital—to you, your company, and your country—that you personally get behind the Payroll Savings Plan this month? You and your business have an important stake in wise management of the public debt. Bankers, economists, and industrialists agree that business and the public will derive maximum security from distribution of the debt as widely as possible.

Every Security Bond dollar that is built up in the Treasury is used to retire a dollar of the national debt that is potentially inflationary. Moreover, every Security Bond held by anyone means fewer dollars go to market to bid up prices on scarce goods.

• Can't your employees buy Bonds at banks? Banks don't provide Security Bonds on the "installment plan"—which is the way most workers pre-

fer to obtain them. Such workers want and need Payroll Savings.

• What direct benefits are there for your company? In 19,000 industrial concerns operating Payroll Savings, employees are more contented. Worker production has increased, absenteeism has decreased—even accidents have been fewer!

All these benefits accrue in addition to extra security for the individual who gets and holds Bonds. (Every \$3 invested pay \$4 at maturity.)

But even a plan with all these benefits requires the sponsorship of top management for real success.

• What do you have to do? The Treasury has prepared a kit of material especially for you to distribute among certain key men in your company. This will be your part in the all-out campaign—starting April 15

—for America's economic security.

Make sure you get your kit. Be sure to give it your personal attention. Keep the Payroll Savings Plan operating at its full potential in your company. It's a major factor in America's security—your best business security!

For any help you want, call on your Treasury Department's State Director, Savings Bonds Division.

The Treasury Department acknowledges with appreciation the publication of this message by

COMMUNICATIONS

This is an official U. S. Treasury Advertisement prepared under auspices of the Treasury Department and the Advertising Council



ALPETH

NEW WORD ON TELEPHONE CABLES

Lead makes an excellent sheath for telephone cables—sixty years and thousands of miles in service have well proven that. But lead is useful in other ways—storage batteries and paint, to name only two. So the telephone industry shares the limited available supply with other claimants.

Before the war when there was no lead shortage, Bell Laboratories engineers sought to develop better and cheaper cable sheaths. An ideal sheath is strong, flexible, moisture-proof, durable and must meet specific electrical requirements. No single material had all those virtues, so thoughts turned to a composite sheath, each element of which should make a specific contribution to the whole.

Various materials and combinations were studied. Desirable combinations that satisfactorily met the laboratory tests were made up in experimental lengths, and spent the war years hung on pole lines and buried in the ground. After the war, with an unparalleled demand for cable and with lead in short supply, selection was made of a strong composite sheath of ALuminum and PolyETHylene. Now Western Electric is meeting a part of the Bell System's needs with "ALPETH" sheathed cable.

Meeting emergencies—whether they be storm, flood or shortage of materials—is a Bell System job in which the Laboratories are proud to take part.

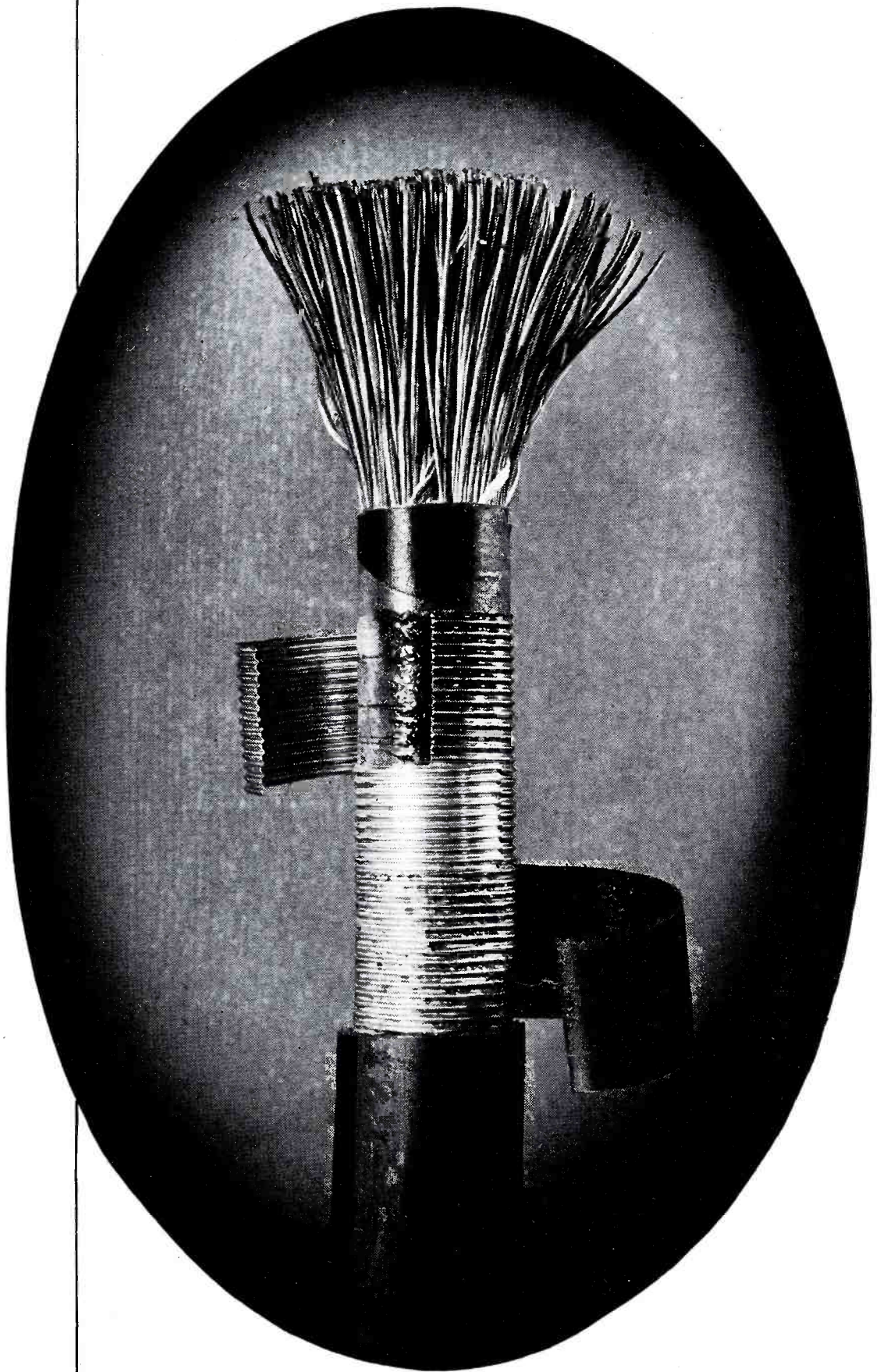

BELL TELEPHONE LABORATORIES



• EXPLORING AND INVENTING, DEVISING AND PERFECTING FOR
CONTINUED IMPROVEMENTS AND ECONOMIES IN TELEPHONE SERVICE.

**For top-flight quality and rock-bottom economy
in telecast programming . . . DU MONT Type 5130-B**

16mm SOUND

Telecasting Projector

◆ Superlative movie programming utilizing economical 16 mm sound films—that's the meaning of this latest Du Mont achievement.

Designed and built "from scratch" to meet the exacting needs of movie telecasting. Not to be confused with usual improvisations. Definitely, with this unique projector, movie telecasting comes of age.

Ready for the heavy-duty service normal to telecast operations. All parts readily inspected, checked, replaced, when needed. Self-contained. Fully enclosed. Streamlined. Smartly designed.

Better movie presentations over the air are bound to follow the installation of such equipment by telecasters seeking the largest audiences.

◆ *Details on request. Meanwhile, submit your telecasting problems and requirements.*

FEATURING . . .

Complete with sound preamplifier and necessary power supplies.

Sound system response of 50 to 5000 cycles—quality of reproduction limited solely by film sound track.

Ample reel reservoir capacity permitting use of 4000 ft. feature movies.

Synchronous locking type driving motor ensuring perfect tie-in with television sync generator.

Lamp assembly and pull-down mechanism available for instant replacement.

Adjustment for both positive and negative film.

Light output far exceeds previous equipment, permitting use of low sensitivity pickup tubes even with narrow vertical blanking interval.

For direct throw on television mosaic or with intermediate translucent screen and prism for utilization of Image Orthicon Camera for film pickup.

Built for continuous use on an average of 20 hours weekly. At least 3000 hours' life expectancy for major components.

In sum, the stability and performance which television film pickup has needed for many years.

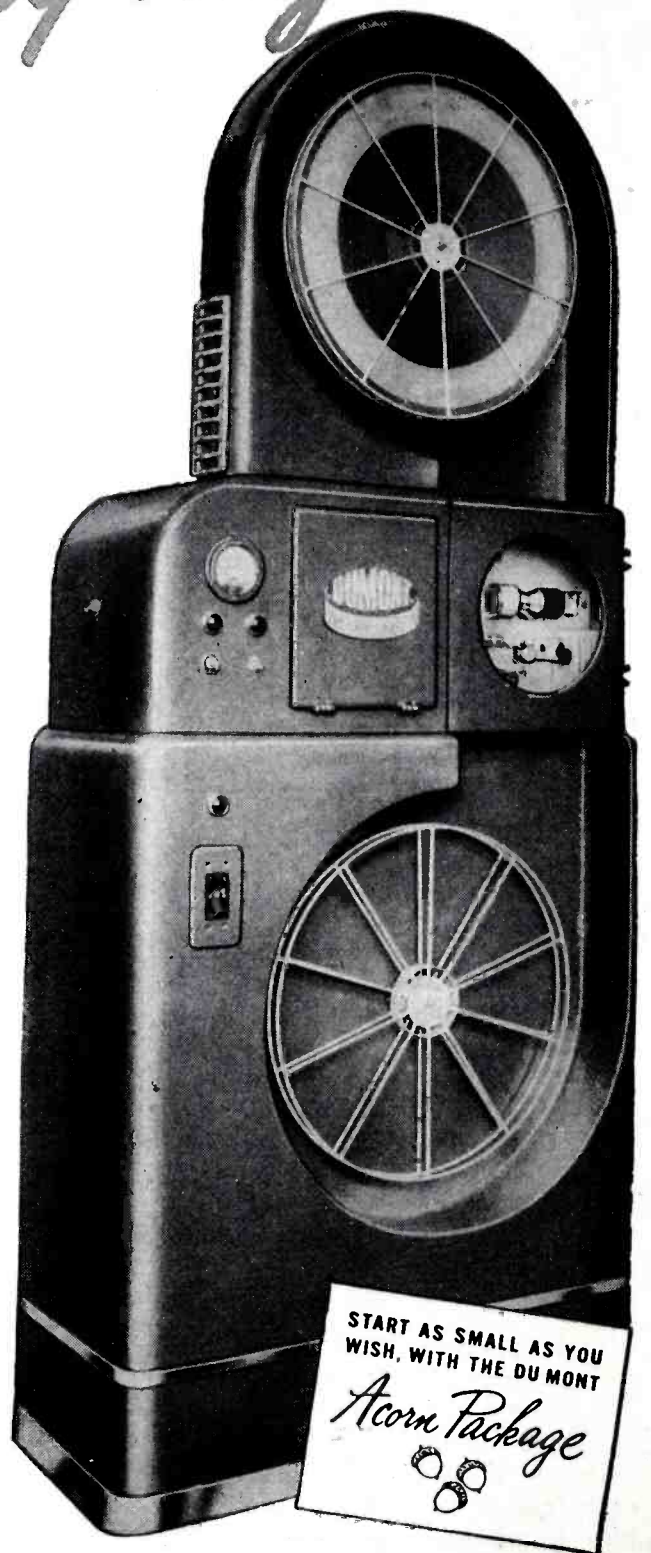

© ALLEN B. DU MONT LABORATORIES, INC.

DU MONT

First with the Finest in Television

ALLEN B. DU MONT LABORATORIES, INC. • TELEVISION EQUIPMENT DIVISION, 42 HARDING AVE., CLIFTON, N. J. • DU MONT NETWORK AND STATION WABD, 515 MADISON AVE., NEW YORK 22, N. Y. • DU MONT'S JOHN WANAMAKER TELEVISION STUDIOS, WANAMAKER PLACE, NEW YORK 3, N. Y. • STATION WTTG, WASHINGTON, D. C. • HOME OFFICES AND PLANTS, PASSAIC, N. J.

COMMUNICATIONS

LEWIS WINNER, Editor

SEPTEMBER, 1948

Magnetic Tape Recorders

RECORDING ON MAGNETIC TAPE, which has been beset by many problems, may soon look to a brighter way of life, having received the blessings of a series of speed standards proposed by the NAB Recording and Reproducing Standards Committee.

Speed control, one of the major deterrents to the widespread use of magnetic tape, will now have, according to the proposed standards, three classifications: a primary standard speed of 15 inches per second, secondary standard of 7.5 inches per second and a supplemental standard of 30 inches per second.

The 7.5-inch speed corresponds to the RMA recently proposed standard for home recordings. The 30-inch speed will correspond to the speed of broadcast station type equipment now in production and also to the European standard of 77 mm or 30.318 inches established by the German magnetophone.

The committee pointed out that the 15-inch speed would meet the NAB frequency-response characteristics minimum specifications from 50 to 15,000 cycles. At the present time, this fidelity will be difficult to obtain, but with advancing knowledge this speed should provide sufficient margin to justify its adoption. The 7.5-inch speed would meet the NAB All-Industry Engineering Planning Group's specifications for a 50 to 7,500-cycle response. The group reported that the 30-inch speed is expected to meet all wide-range standards.

Three other standards were also proposed by the committee. One involved the minimum playing time per reel which was cited as 33 minutes. Another standard concerned noise level which was set at least 40 db below peak signal level. And the third was zero db level which was set at 2% distortion.

Previously the committee had recommended that the width of the tape should be .250 plus 0 minus .006", and tape thickness was not to exceed .0022".

It is expected that the proposals will

be formally adopted in November by the NAB board.

Congratulations to the committee—Dr. S. J. Begun of Brush Development, chairman; Price Fish, CBS; O. Kornei, Brush Development; R. Marchant, Minnesota Mining and Manufacturing Company; Neal McNaughten, NAB; R. H. Ranger, Rangertone, Inc.; H. E. Roys, RCA; D.G.C. Hare, Derring Milliken Research Trust; M. J. Stolaroff Ampex Electric; R. F. Bigwood, ABC; C. G. Baker, Magnecord and W. E. Stewart, RCA Victor—for a job well done!

Fax Standards

STANDARDS FOR FAXCASTING were announced recently by FCC.

The standards prescribe that rectilinear scanning (scanning of an area in a predetermined sequence of narrow straight parallel strips) shall be used and the number of scanning lines per minute shall be 360. The standard index of cooperation shall be 984 (product of the number of lines per inch, available line length in inches and the reciprocal of the line-use ratio; $105 \times 8.2 \times \frac{1}{8} = 984$).

Continuing, the standards provide that the line-use ratio (ratio of the available line to the total length of scanning line) shall be $\frac{7}{8}$ or 315° of the full scanning cycle. The $\frac{1}{8}$ cycle or 45° not included in the available scanning line shall be divided into 3 equal parts, the first 15° being used for transmission at approximately white level, the second 15° for transmission at approximately black level, and the third 15° for transmission at approximately white level.

The standards also state that amplitude modulation of subcarrier modulation shall be used and the subcarrier modulation should normally vary approximately linearly with the optical density of the copy. Subcarrier noise level shall be maintained at least 30 db below maximum or black picture modulation level at the transmitter input.

Ionospheric Radio Propagation

ONE OF THE MOST COMPREHENSIVE

discussions of the all-important subject of *ionospheric radio propagation* appears in a recently published Bureau of Standards book. The treatment is in part a revision and expansion of the IRPL Radio Propagation Handbook that was prepared during the war at the request of the Armed Services.

In a detailed analysis of measurement techniques appears data on the measurement of virtual height, sky-wave field intensity and radio noise (atmospheric, cosmic, and solar, thermal, etc.)

In another chapter maximum usable frequencies are probed. Here appears a discussion of the technique of predicting maximum usable frequencies for transmission over any path, the use of world charts, distance factors and their application to nomograms, etc.

Other chapters in the volume cover characteristics of the *E* layer, *D* region and *F1* and *F2* layers; theory of radio wave propagation, fading, radiated power and absorption, and interpretation of absorption measurements.

This valuable book is obtainable from the Superintendent of Documents, U. S. Government Printing Office, Washington 25, D.C., for \$1.00.

Certainly a good buy.

The British Phasitron

THE PHASITRON, which has served to describe the well-known f-m modulator tube proposed by Adler of Zenith, has now been adopted by the British to identify an electronic capacity measuring device containing a phase modulated oscillator, peak limiter and a demodulator in a small single tube unit.

Reporting on the British *phasitron* before the British Kinematograph Society, J. A. Sargrove disclosed that this development introduces a new medium for the use of a frequency modulated carrier at high frequencies as a means of translating sound waves and feeding to extremely small, yet very efficient microphones.

A complete report on this interesting development will appear in an early issue of COMMUNICATIONS.—L. W.

What Is Wrong With TV Sound?

THE ENGINEERING PERSONNEL at most tv stations have made appreciable progress since the war in improving the general quality of the pictures being transmitted. Some of this improvement has been due to the acquisition of improved equipment not available during the war years. Partly, the improvement has been through greater *know how*, the product of wartime experience with *radar*, *loran*, and other military electronic equipment. Indicative of the trend towards improved picture transmitter operation is the set of curves shown in Figure 1, detailing the overall picture transmission characteristic of WTTG in Washington. It will be noted that transmission performance exceeds both the requirements of the *FCC Standards of Good Engineering Practice* and those standards promulgated by RMA.

So much attention has been directed, however, towards improvement of picture quality that little interest has been evidenced by the average telecaster towards making full use of the aural facilities at his disposal. This is particularly true of studio sound facilities, and one has only to compare the quality of the sound transmitted by the average tv station with that of a standard a-m station to immediately arrive at the same conclusion.

The FCC Standards For TV Sound

The FCC standards, citing the quality requirements expected of a licensed tv station, refer to the *entire* transmitting system . . . "from input terminals of microphone preamplifier, through audio facilities at the studio, through audio facilities at a transmitter, and through the transmitter, but excluding equalizers for the correction of deficiencies in microphone response."

The standards specifically state that the *entire* system must be capable of transmitting a band of frequencies from 50 to 15,000 cps.

Since an f-m transmitter is employed for aural transmission it is required that preemphasis be employed in accordance with the impedance-frequency characteristic of a series inductance-resistance network having a time constant of 75 microseconds. The deviation of the system response from the standard must lie between certain

Full Capabilities of Studio TV Audio Facilities Attained in Few Instances by Telecasters. Wide Band 50-15,000 CPS Aural System Standards Demand Extreme Caution in Handling and Maintaining of Microphones, Dollies and Other Equipment to Eliminate Studio Noise, a Serious Cause of Quality Deficiency. Studio Design, With Careful Consideration of Scenic Sets, Another Video Sound Problem Which Must Be Overcome to Assure Fidelity Outputs.

by **SCOTT HELT**

Chief Engineer
Du Mont Television Network

limits, as shown in Figure 2. The important point is that the *system* response must be uniform within these limits. This means that the entire transmitting system, *from the input of the microphone preamps to the transmitter output*, must be taken into account when measurements are made to determine if the *system* meets these specifications.

It is wise, therefore, for the conscientious chief engineer of a tv station to make sure that the amplitude versus frequency response characteristic of the aural transmitting system is substantially *flat* from microphone input at the studio speech console to transmitter input, and throughout the band or 50 to 15,000 cps. To insure proper and acceptable quality the system should be *flat* up to the input terminals of the transmitter. This is a fundamental and elementary consideration.

If this is accomplished, then insertion of the standard preemphasis network at the proper point in the system will insure the preemphasis characteristic required by FCC, and recommended by RMA and IRE.

Deviation of the system from the standard preemphasis curve must be

carefully controlled so that:

- (1) The upper of the limits (Figure 2) shall be uniform from 50 to 15,000 cps.
- (2) The lower limit shall be uniform from 100 to 7,500 cps, and 3 db below the upper limit.
- (3) From 100 to 50 cps the lower limit shall fall from the 3-db limit at a uniform rate of 1 db per octave (4 db at 50 cps).
- (4) From 7,500 to 15,000 cps the lower limit shall fall from the 3-db limit at a uniform rate of 2 db per octave (5 db at 15,000 cps).

If the foregoing overall frequency response characteristic and preemphasis characteristics are maintained for the *entire* transmitting system, receivers which employ a carefully engineered deemphasis network will yield tv sound of a vastly superior order than we are accustomed to generally.

Additional Audio Considerations

Harmonic distortion throughout the *entire transmitting system* must also be carefully kept below permissible limits; that is, if we are fundamentally interested in making full use of the transmitting system. The standards specify that the combined audio-frequency harmonics, as measured at

¹Du Mont Master Series transmitter.

the output of the system (and at modulation percentages of 25%, 50%, and 100%) must not exceed three rms values:

50 to 100 cps.....	3.5%
100 to 7,500 cps.....	2.5%
7,500 to 15,000 cps.....	3.0%

In making measurements to determine the overall distortion characteristic of the system, neither the (1) *studio audio facilities*, (2) *studio to transmitter circuit*, nor (3) *transmitter*, should contribute more than one-half of the total distortion determined to be present for the complete system. Thus, none of the three divisions of the system should contribute more than the following maximum harmonic distortion:

50 to 100 cps.....	1.750%
100 to 7,500 cps.....	1.250%
7,500 to 15,000 cps.....	1.5%

When measuring overall distortion contributed by speech consoles, bridging amplifiers, telephone circuits, or the transmitter (individually) — the foregoing values must never be exceeded. This is extremely important, since "no chain is stronger than its weakest link." The entire system noise level, of course, affects audio quality, and the f-m noise in the 50 to 15,000-cps band must be at least 55 db below the level representing 100% modulation (25 kc swing). The reference level is based on 1 db representing .001 watt or 1.73 volts in a 600-ohm line, or 0 db reference level being equivalent to the audio level through the transmitter, sinusoidal tone employed for modulation, and the carrier *swinging* ± 25 kc.

The a-m noise level is equally important. In the 50- to 15,000-cps band, it must be at least 50 db below the level representing 100% amplitude modulation.

The Studio and TV Sound

Now, in order to fully comply with the FCC requirements it is not permissible to employ low- or high-pass filters in the system to eliminate portions of the pass-band where *studio noise*, *rumble*, or other extraneous noises develop. Good engineering practice dictates that these sources of noise be eliminated. This might mean more precise instruction of studio personnel in the mechanical movement of microphones and cameras (as action takes place). Often a few hours spent with a *mike boom operator* will be quite profitable revealing the necessity

(Continued on page 37)

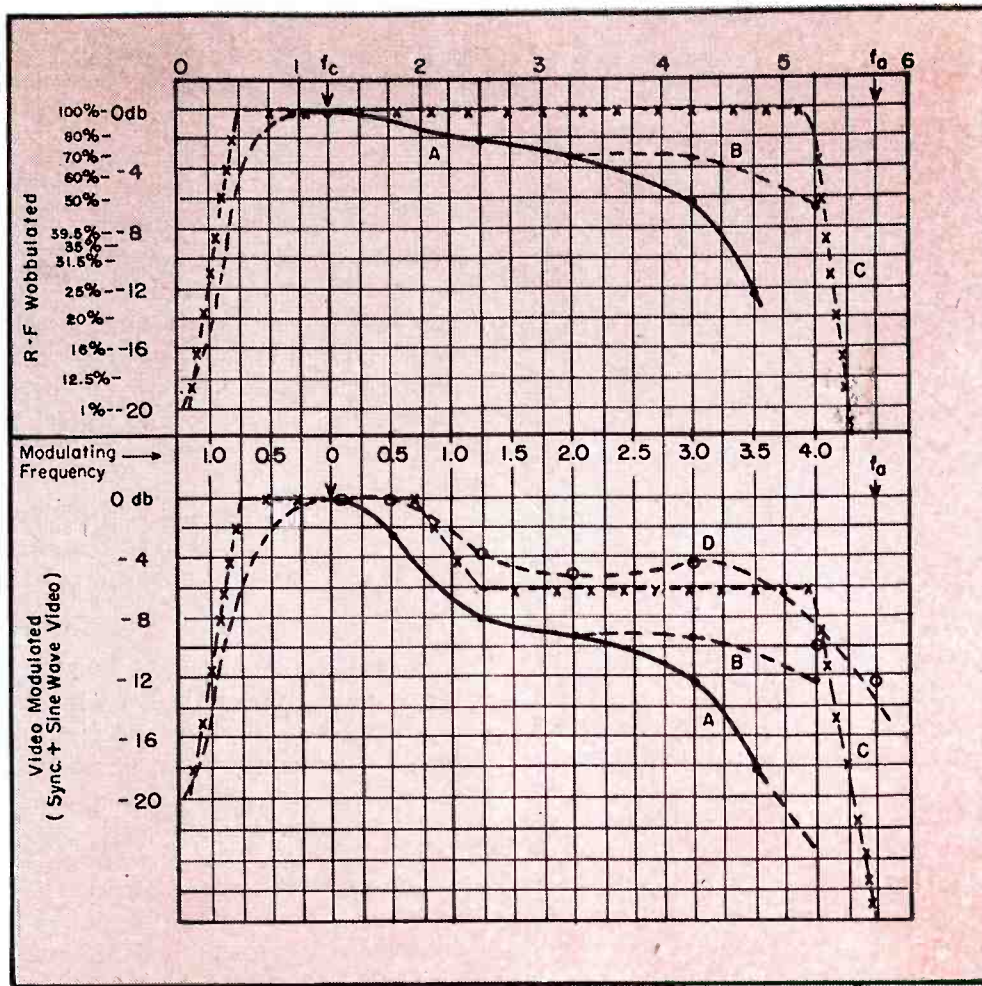
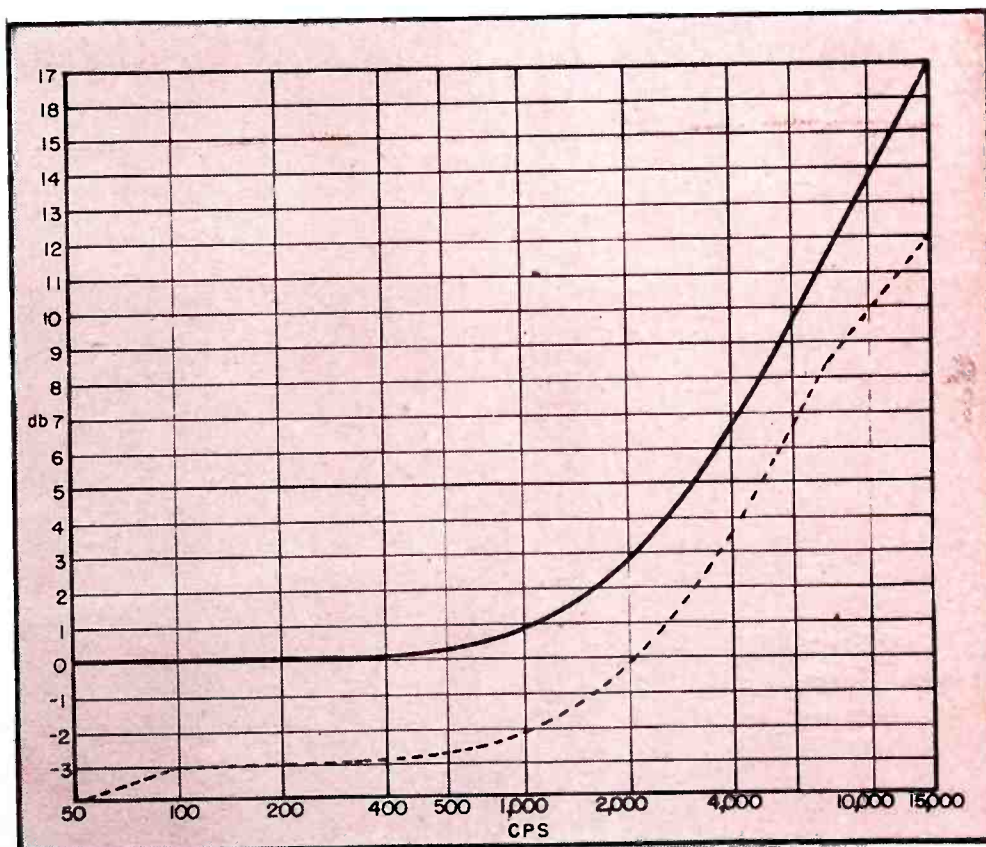

Figure 1

Amplitude versus frequency characteristics of WTTG. In the plot of the r-f wobulated wave, A curve corresponds to the FCC specification, and B curve represents the RMA specs. In both cases any curve is permitted between 0 and 1.25 mc. The C curve represents the ideal. In the plot below A again represents the FCC specs and B the RMA specs, while C is the ideal. The actual performance characteristic of WTTG is shown in curve D.

Figure 2

Standard preemphasis curve, with time constant of 75 microseconds (solid line); frequency response limits shown by use of solid and dashed lines.



The WNOW

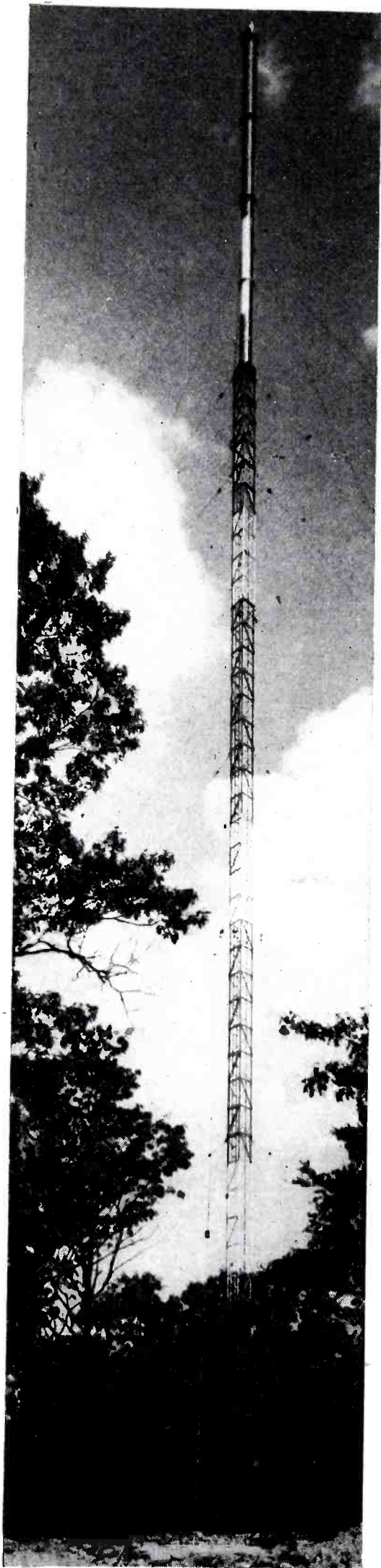

IN PLANNING THE INSTALLATION of our station, the selection of a site was a priority item. In the site search, two factors were of particular concern to us—telephone and power facilities. These are vital cost factors, particularly three-phase power which most f-m transmitters require.

We chose a site 830 feet above sea level. For an approach to the site, we had to clear away a mile and a half of woodland.

A building, 33' by 20', with a basement under the entire structure, was built to house the a-m and f-m equipment.¹ Incidentally the building was made large enough to accommodate a tv transmitter.

Construction was of cinder block with roof, floor and joists of precast concrete, thus making the building fireproof and reducing insurance rates, which is vital to a site located in woodland.

All cinder blocks above the finished grade were painted with two coats of white Portland cement paint. All cinder blocks below ground level were waterproofed with heated bituminous compound, thus assuring a dry watertight building. Interior walls were

(Left)
The a-m/f-m antenna system.

(Right)
Method used at WNOW for feeding f-m transmission lines, mounted on towers for a-m work, to prevent detuning at the a-m frequencies.

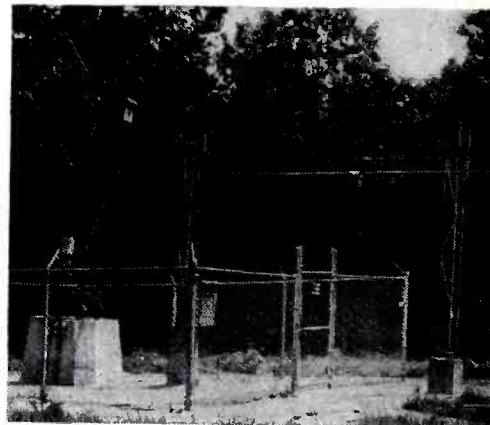

(Above)
View of a-m and f-m isolation unit and coax feed lines.

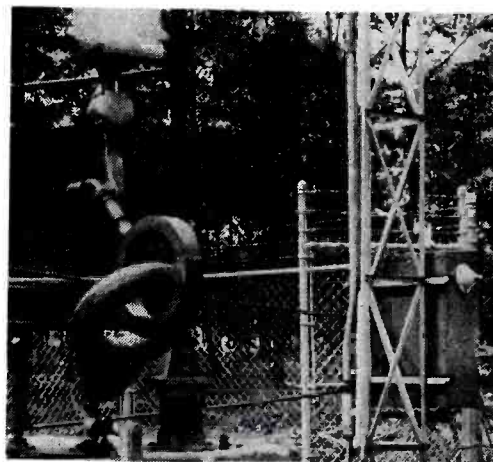

(Above)
Closeup of tower lighting arrangement and utility lighting outlets at WNOW.

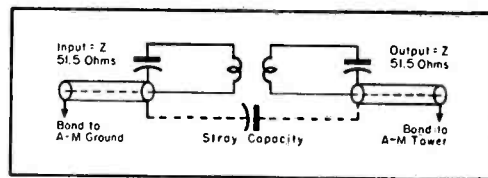

Willis N. Weaver discussing the WNOW tuning unit with N. Carl Kitchen (extreme left) and Lowell W. Williams, manager of WNOW.

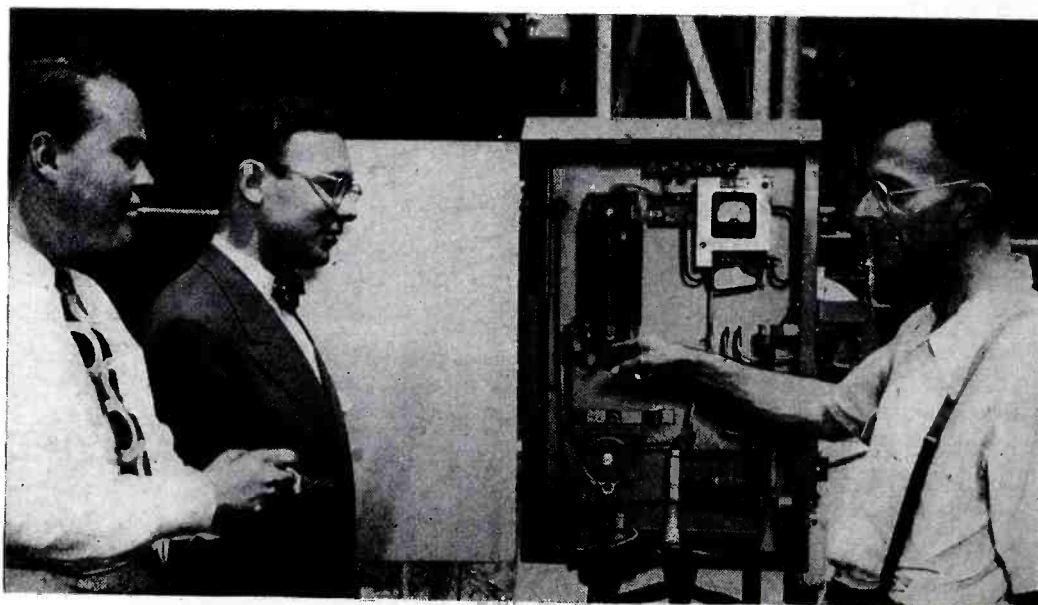

A-M / F-M Installation

finished with celotex board and the ceiling with acoustical tile. The cement floor was covered with cork which, in addition to absorbing vibrations set up by the transmitter, has a high coefficient of sound absorption.

Openings were provided in the concrete floor for wiring and ventilating the transmitter. Grills were installed above the transmitter in conjunction with an exhaust fan overhead. A housing was provided at the bottom of the transmitter containing two fans which pull air through spun glass filters, thereby assuring an abundance of circulating air.

Standards of good engineering practice were followed in the installation of the ground system, which consists of a copper ground mesh screen 48' by 48', silver soldered to 120 radials 210' in length. All radials were silver soldered to a driven ground at their ends.

For our f-m system we used a four-section pylon² with a total overall length of 54'. In hoisting the pylon a fifty-foot boom was attached, first to the 154' a-m tower and guyed. This was the main fulcrum for raising the pylon. A sling was thrown around the pylon ten feet from the center of gravity enabling the boom to hoist it above the lever of the a-m tower. After about two hours of hoisting the pylon 154', the four-bay unit was in place.

The distance between the transmitter building and the tower base is 190'. The transmitter line is supported by thirteen 10' towers which in turn support a six-wire a-m transmission line. A 1 $\frac{5}{8}$ " coaxial f-m transmission line

Cinder Block Building, Housing Transmitter, Located in Pennsylvania Woodland Area, 830 Feet Above Sea Level. Four Section F-M Pylon Erected Atop 154 Foot A-M Tower.

by **WILLIS N. WEAVER** and **N. CARL KITCHEN**

Chief Engineer

Continuity Director

WNOW, York, Penna.

and 1 $\frac{1}{2}$ " conduit carry tower lighting, remote monitoring meter and utility lighting circuits. Expansion joints are used on the 1 $\frac{1}{2}$ " conduit, which is broken at 60' intervals for the insertion of vapor-proof lights along the catwalk.

At present, we have two studios with facilities to run shows from the control room either by an announcer or engineer. There is also a remote control room which was included in the event that separate programs for f-m are required. The large studio is 35' by 50' and uses a polycylindrical acoustical treatment, while the smaller studio, 22' by 30', uses a diagonal treatment.

The audio rack consists of four jack strips and enough auxiliary equipment to run the control room without the consolette. All mixer inputs appear

on the audio rack to facilitate operation.

All offices are equipped with speakers and can be fed individual programs originating in the studios or on turntables. Normally they are fed from a separate amplifier bridged across the program bus.

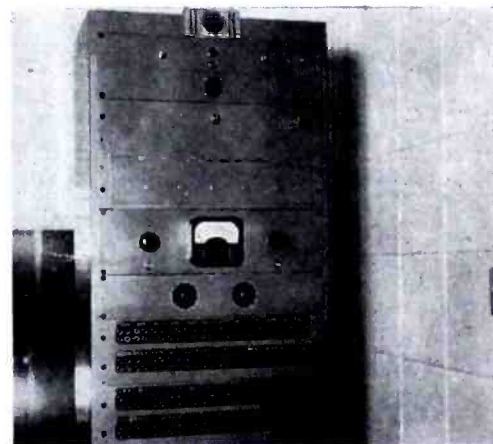

The patchboard panel in the control room.

Left: A view of the a-m transmitter. Note vent grills in ceiling. Right: View of studio A and control room.

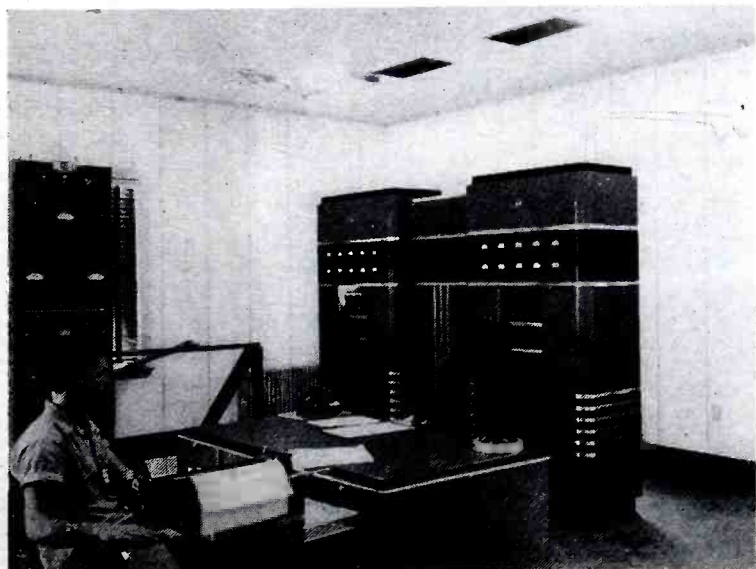

Directional Antenna Pattern Nomenclature

Symbols Adopted to Describe a Directional Antenna Array . . . Formats for Horizontal Plane Pattern Sheets Which Can Be Used for FCC Presentation.

THERE ARE MORE WAYS of describing a directional antenna than there are engineers. At least in the past, practically every new consulting radio engineer introduced his own pet scheme of presenting directional antenna patterns.

Early in 1947 FCC established a *Directional Antenna Pattern Nomenclature Committee*. After several meetings of this committee and considerable correspondence between committee members and other parties interested in the subject it was possible to reach a compromise agreement upon the nomenclature symbols to be used. It is doubtful if any consultant will agree completely with this nomenclature because even the author and committee members were not completely satisfied. It is believed, however, that the selection of symbols and method of presenting directional antenna data finally agreed upon and discussed in this paper is a step in the right direction.

The committee also studied formats which could be used for the horizontal plane pattern sheet, considering the wishes of FCC, as expressed by James Barr, Chief of Standard Broadcast Division. The pattern sheet containing, in so far as possible, the required data, is also analyzed and illustrated in this paper.

Nomenclature

The symbols needed to describe a directional antenna array must include antenna height, true orientation, tower spacing, electric current or electric field phasing, electric field intensity at

¹President, Cleveland Institute of Radio Electronics; Author of *Directional Antennas*, a book containing over 15,000 directional antenna patterns.

by **CARL E. SMITH¹**

Vice President, In Charge of Engineering,
United Broadcasting Company

unit distance and elevation angle. For convenience it is desirable to add a symbol to express the vertical radiation characteristic and the ratio of field intensities.

The symbols chosen by the committee are those most widely used by the profession, with a few exceptions. The exceptions were necessary in order to make the system consistent in itself and not cause undue conflict with other usages of the terms. The choice of terms and their use was also influenced to a great extent by the present practice of FCC. For example, the true azimuth angle is expressed by ϕ and is measured clockwise from true north. This practice differs from mathematics where angles are measured counterclockwise from the positive X-axis. It also differs from electrical engineering where the symbol ϕ is used to measure phase angle. In another case the angle θ is used to express elevation angle instead of zenith angle as is the usual case in mathematical treatments involving space geometry. On the other hand some consultants in the past have chosen to express the vertical angle or elevation angle by the symbol V .

Another difference of opinion revolved about the symbol to use for electrical height. The letter h or H is descriptive but the letter G was selected because of its rather general usage. Since the symbol ϕ was used for azimuth the symbol Ψ was selected to express phase angle.

Considerable discussion revolved around the selection of a term to ex-

press field intensity ratio. The term r for ratio had been used but caused confusion because of its common use to express resistance. The term M had been used to express current ratio, but since this is often different from the field ratio, it was decided to retain M to express current ratio. The term F was finally selected to express field ratio, hence it can no longer be used to express field intensity interchangeably with the term E . This should cause no undue hardship since subscripts can be employed to distinguish between the various field intensities.

There was very little discussion regarding the selection of S for spacing, although such terms as A and d have been used to express this parameter in the past.

Horizontal Pattern Sheet

To illustrate the use of the foregoing nomenclature a directional antenna array has been quite completely specified in Figure 2, employing polar coordinate paper¹ prepared in accordance with recommendations offered by the committee.

In preparing the pattern data, the following factors were considered:

Horizontal plane pattern plot with azimuth angles measured clockwise from true north.

Direction and distance to each protected station, with the azimuth sector indicated if an area is to be protected.

Pattern plotted to the largest scale possible on polar coordinate paper having 10 or 15 major radial divisions, using divisions and subdivisions having values of 1, 2, 5 or 10°.

Minimum values, where possible, plotted on a 10 x expanded scale.

MEOV (maximum expected operating value) plotted and designated on the ex-

¹Two types of polar coordinate paper have been prepared by the author, with 50 and 75 complete circles. Figure 1 illustrates a graph paper with 50 complete circles, 10 of which are printed with heavy lines to make plotting easy. Figure 2 (page 14) shows the 75-circle paper, 15 of which are printed with heavy lines. By using these two types of polar coordinate paper and reasonable scales the pattern can be drawn to at least 67% of full scale value. Usually the pattern will be much closer to full scale value. The graph paper of Figures 1 and 2 has a diameter of 10" and is printed on standard 11" x 17" sheets which can be reduced to 8½" x 11" for record purposes.

The polar coordinate paper is marked with zero degrees azimuth to the north and the true azimuth bearing in degrees is measured clockwise from true north.

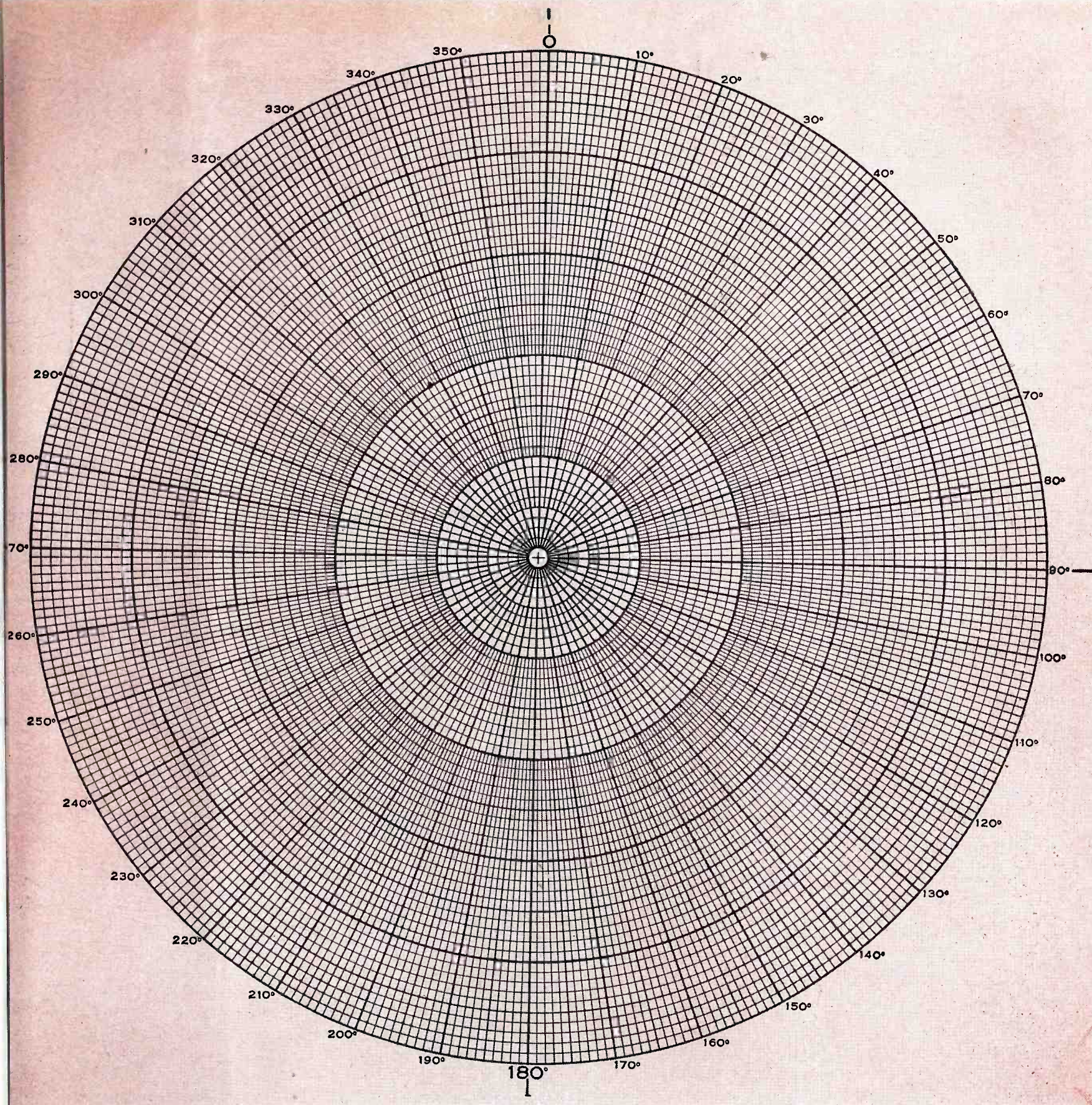

Figure 1
Ten major circle polar coordinate paper designed for the plotting of horizontal plane patterns.

panded scales and on the regular scales where the expanded scales do not apply.

Horizontal *rms* field intensity circle, E_0 , drawn on the pattern sheet.

Tower placement sketch showing the location and number of each tower with true north at the top of the diagram, along with dimensions useful in special design equations if such are used to make the pattern computations.

Use of symbol definitions, adopted by committee:

G , the electrical height, should be the value used in the vertical radiation characteristic function,

$$f(\theta) = \frac{\cos(G \sin \theta) - \cos G}{(1 - \cos G) \cos \theta}$$

If this is not the case, then the cor-

rect vertical radiation characteristic should be furnished.

ϕ true orientation of observation point measured in degrees.

ϕ with a subscript, as ϕ_2 for No. 2 tower, describes the true orientation of each tower in the system.

S with a subscript, as S_2 for No. 2 tower, describes the spacing of each tower from the space reference point measured in degrees.

Ψ with a subscript, as Ψ_2 for No. 2 tower, describes the phase of the electric field with respect to the voltage tower, describes the phase of the electric field with respect to the voltage tower, describes the phase of the electric field with respect to the voltage tower, describes the phase of the electric field with respect to the voltage tower.

E the total field intensity at the angle ϕ and θ .

E with a subscript, as E_2 for No. 2 tower, describes the magnitude of the horizontal field intensity of each tower in the system. It is convenient to express this value in millivolts per meter unattenuated field intensity at one mile.

F the ratio of the horizontal field intensities. Double subscripts can be used if the value is to be expressed outside the table, thus

$$F_{21} = \frac{E_2}{E_1}$$

M tower current ratios which may be
(Continued on page 36; Figure 2 on page 14)

Figure 2
Fifteen major circle polar coordinate paper which was used to produce the horizontal plane pattern illustrated.

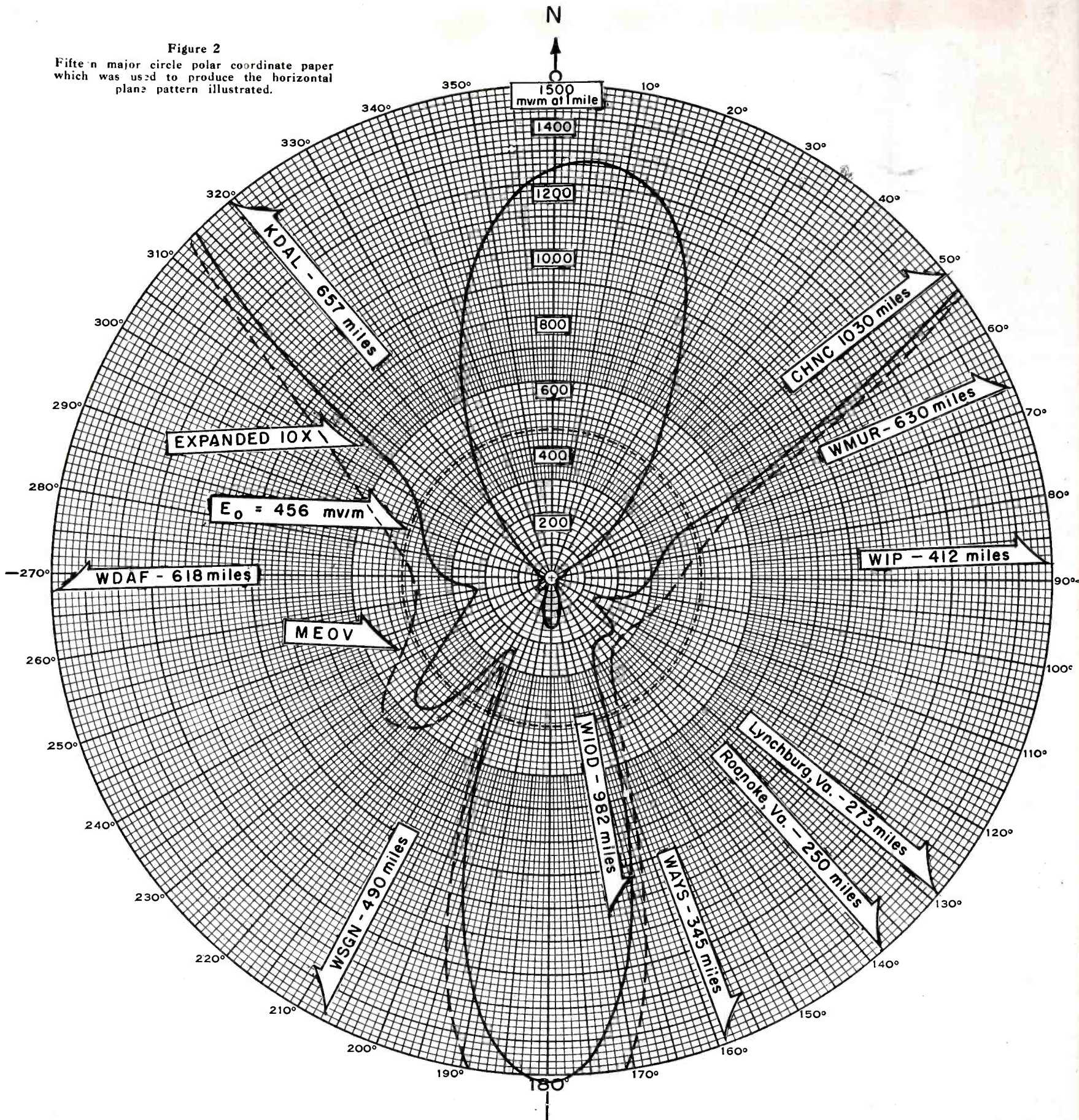

TOWER PLACEMENT SKETCH		PATTERN PARAMETERS							STATION DATA			
		TOWER No.	ELECTRICAL HEIGHT G'	TRUE TOWER ORIENTATION θ°	SPACING S'	PHASING ψ°	HORIZONTAL FIELD mv/m E	FIELD RATIO F	ELEV. ANGLE θ°	ELEVATION RMS FIELD mv/m E _g	CALL	WHKC
1	45	78.68	185.70	133.3	154.5	1.00	0	456	610	5	U	
2	45	108.97	195.53	226.7	163.8	1.06	10	415	610	5	U	
3	90	178.38	50.00	226.7	327.5	2.12	20	401	610	5	U	
4	90	257.99	178.08	226.7	163.8	1.06	30	343	610	5	U	
5	138	289.58	187.79	133.3	154.5	1.00	40	300	610	5	U	
6	52	358.38	50.00	133.3	309.0	2.00	50	260	610	5	U	
7							60	186				
8							70	100				
9							80	21				
10												
<input type="checkbox"/> DAYTIME OPERATION <input checked="" type="checkbox"/> NIGHTTIME OPERATION									E ₀ = 340 mv/m	POWER	470423	
									P _r = 5 kw	FREQUENCY	470919	
										TYPE OF OPERATION	DA-N	
										DAYTIME TOWERS	No. 5	
										NIGHTTIME TOWERS	1, 2, 3, 4, 5, 6	
										No. RADIALS PER TOWER	120	
										LENGTH OF RADIALS	90° 400 ft.	
										GROUND SCREEN DIMENSION		
										LAT.	39° 52' 26.2"	
										LONG.	82° 58' 36.1"	
										SUPERSEDES	470423	
										PATTERN No.	470919	

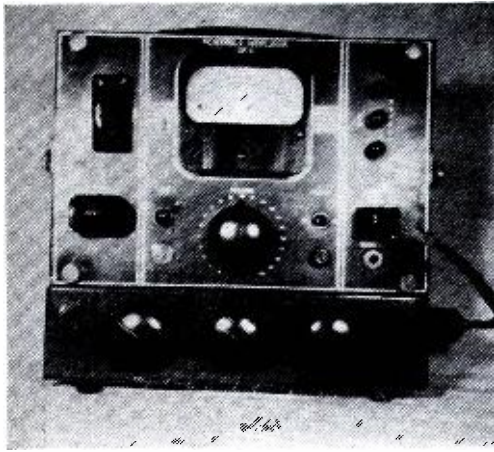

Front view of the unit showing battery cord connected and the three control knobs of the new addition.

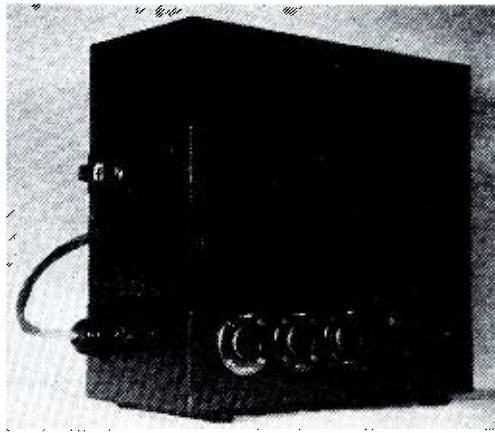

Rear view showing connectors and octal plug used in battery operation.

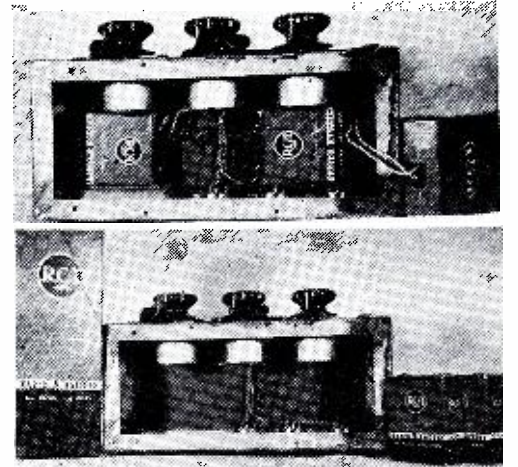

Bottom views of the unit illustrating the relative position of the step attenuator, connectors and the batteries.

Traveling Light On Remote Assignments

THE EQUIPMENT required to adequately cover the small remote pickup program is often quite a problem. It is necessary to be fortified with enough equipment to cover any emergency and still not be overburdened with too many extras.

The street quiz program, the hotel trios, the weekly church pickups, the six- or seven-piece orchestras, and the *on the spot* news stories, to mention only a few, each present a different problem in the selection of equipment. One, two, or more mikes may be needed; then, too, a-c power may not be available and engineering space is often at a premium.

With these problems in mind, WAGE engineers came up with a simple solution that minimizes the amount of equipment that has to be carried. It is entirely contained in a metal chassis 3" high by 5¾" deep by 12½" long which is attached directly to the bottom of a one-channel portable amplifier. Previously this piece of equipment was taken when-only one mike was to be used on a program. When more mike channels were needed an additional mixing unit was required. If d-c was necessary a forty-pound battery box had to be carried.

The new unit, which adds only three inches to the height of the original amplifier unit and six and one-half pounds to the weight, affords low level mixing of three mike channels and enough battery power to carry through a 15- or 30-minute show should the a-c power fail. The volume control on the portable amplifier

Compact, Lightweight Unit, Provides Extremely Flexible Remote Facilities, Affording Low-Level Mixing of Three-Mike Channels With Sufficient Battery Power, for a 30-Minute Show, if A-C Fails.

by **GEORGE DRISKO**

Engineering Staff
WAGE, Syracuse, N. Y.

becomes the master control, with three attenuators in the new unit used to balance the show.

The chassis, made of light steel, contains three step attenuators¹ and three mike receptacles² connected in parallel across the auxiliary mike input of the remote amplifier. Regular portable receiver batteries were selected

¹Daven. ²Cannon. ³Jones.

Circuit of the WAGE remote control unit.

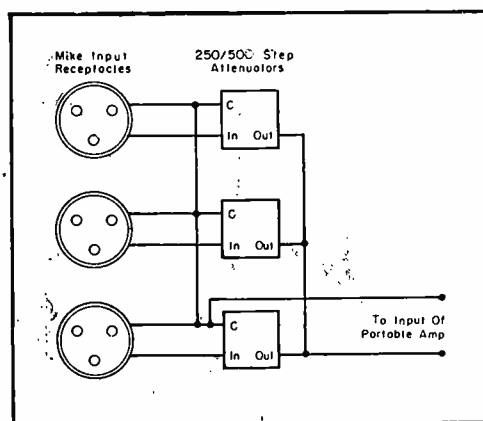

and then the unit was designed around them. One 6-volt battery serves for the filament supply and two 67½-volt batteries in series provide 135 volts for the B supply. These voltages are terminated on three prongs of an octal tube socket. A short connector cord was made up to bring these d-c voltages to a power plug³ on the amplifier.

The drawbacks of low-level mixing were considered before the unit was constructed, but it was decided to give the system a try. It was found that the advantages of the unit greatly outweighed all of the drawbacks usually expected of low-level mixing. By keeping the sliding contacts of the step attenuators clean and by making good grounding bonds on the mike inputs noise or interaction of mike circuits has been eliminated. The extra gain available in the remote amplifier easily makes up the loss in gain due to the lowering of the input circuit impedance. The insertion loss proved to be
(Continued on page 37)



(Courtesy of WGAR, Cleveland, Ohio)

Replace your old AM transmitter *with RCA's new 50 kw...*



The revolutionary, new power triode RCA-5671. This tube takes about one-third the filament power of conventional triodes used in the older transmitters. It reduces hum modulation below FCC requirements—*even without r-f feedback.*

The two 5671's in the r-f power amplifier and the two in the class B modulator of this 50-kw transmitter save up to \$1200 yearly in filament power alone.

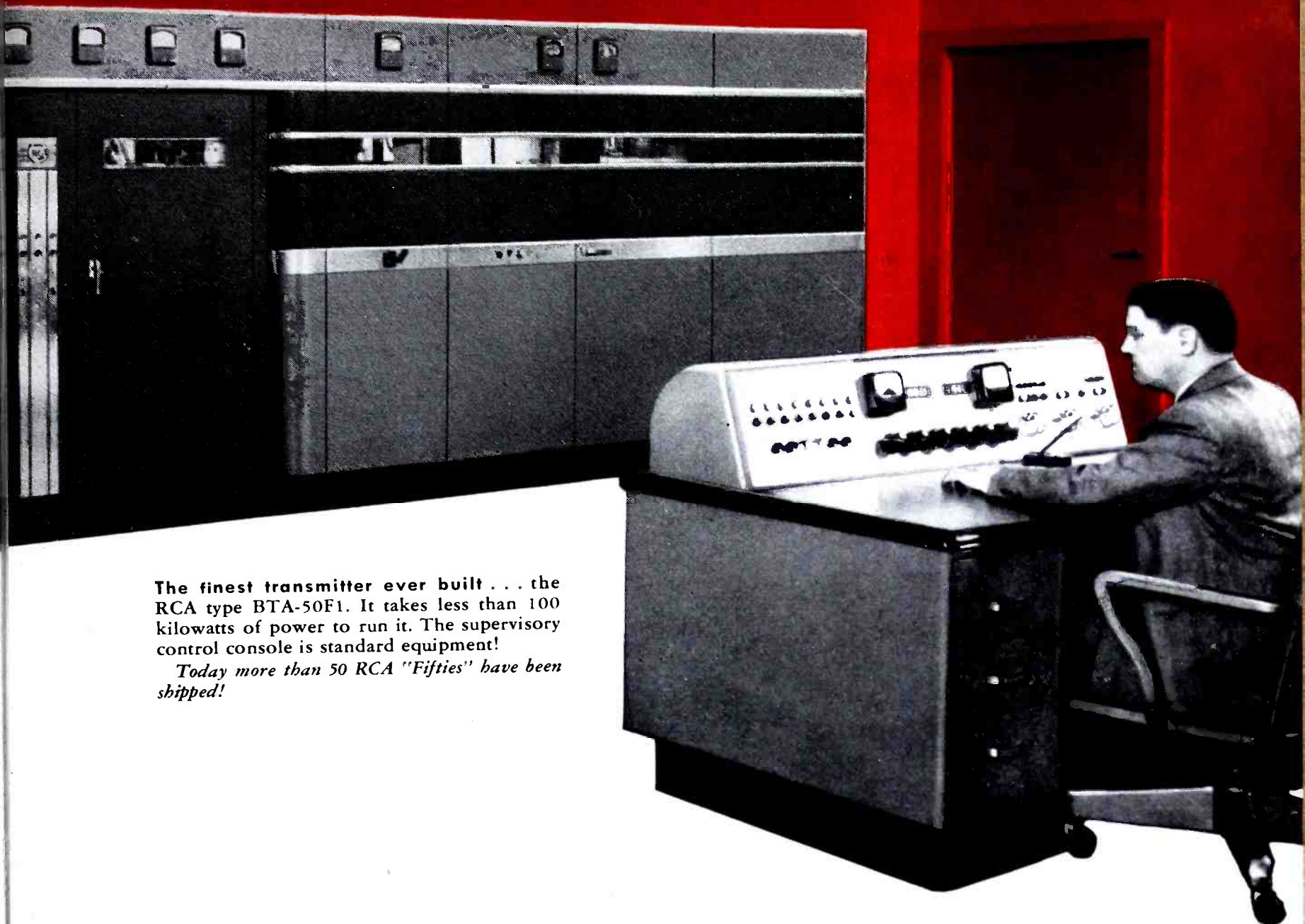

The finest transmitter ever built . . . the RCA type BTA-50F1. It takes less than 100 kilowatts of power to run it. The supervisory control console is standard equipment!

Today more than 50 RCA "Fifties" have been shipped!

and write off its cost in power savings alone!

It's a fact—as one high-power broadcaster recently discovered to his complete satisfaction. Now, he has replaced his old transmitter with an RCA "fifty"—and it's paying its way.

HERE'S WHY.

Using revolutionary new RCA-5671 power triodes that take about one-third the filament power of conventional types, this RCA "fifty" saves up to \$1.75 an hour in power savings over former transmitters—\$12,000 a year, based on daily operation at 19 hours a day!

Many other new design features, too, that add to this \$12,000 savings.

For example, only 29 tubes and 11 different tube types—less than half the number used in many present 50 kw's. True walk-in accessibility that assures faster maintenance—and lowers maintenance costs. Ultra-conservative operation of tubes and components—with less chance for outages.

Here is a 50-kw AM transmitter that does away entirely with oil circuit breakers—assures faster circuit protection. Because the BTA-50F1 operates from a 460-volt supply. Control and protection

circuits are the most complete of any transmitter designed to date. And its true unified front (an integral part separate from compartment enclosures) facilitates flush-mounting—gives your transmitter room a new, handsome appearance.

Write for the new 28-page brochure about the BTA-50F1. It gives you complete details—including circuits, specifications, floor plans, and full-page pictures showing the remarkable accessibility of this great transmitter.

Dept. 231, RCA Engineering Products, Camden, New Jersey.

The One Equipment Source for Everything in **BROADCASTING**—is RCA



**BROADCAST EQUIPMENT
RADIO CORPORATION of AMERICA
ENGINEERING PRODUCTS DEPARTMENT, CAMDEN, N.J.**

In Canada: RCA VICTOR Company Limited, Montreal

F-M Communications In

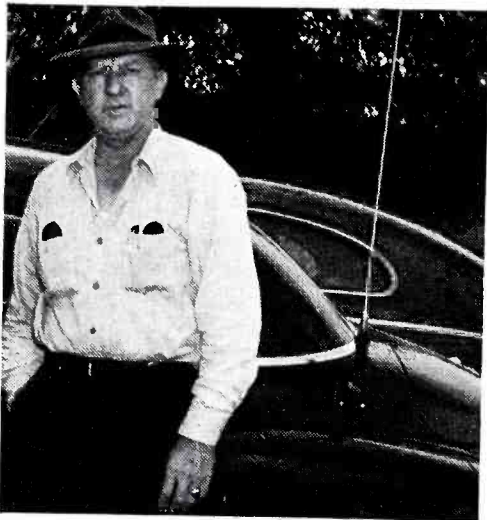

Field superintendent Walter Plemmons beside one of the three passenger cars in which two-way f-m units are installed.



Toolpusher Eddie Plemmons and the two-way unit at his bedside through which all emergency reports can be relayed.

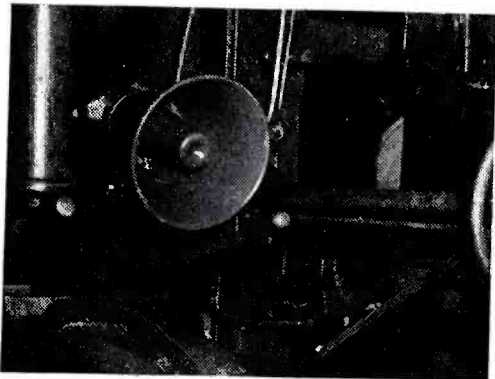

Weatherproof speaker mounted near driller's position. Speaker is connected to the receiver in tool house and is on 24 hours a day.

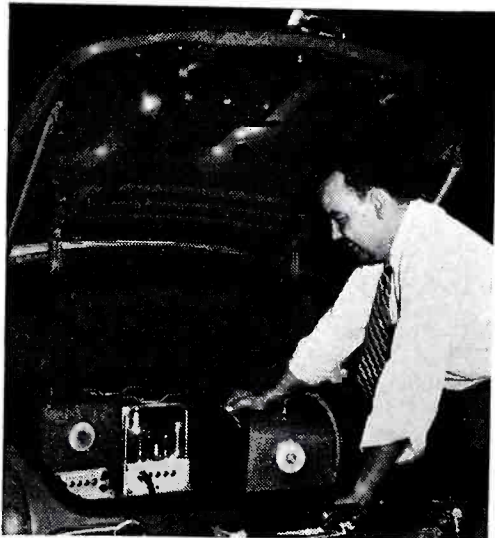

Eleven-Station Two-Way Net, Operating in Northern Texas on 37.14 Mc, Provides Contact to Drilling Rigs, Pickup Trucks, Superintendent's Car, Owner's Car and Toolpusher's Home. Equipment, Operating 24 Hours a Day, Has Proved Invaluable in Speeding Up Deliveries, Reducing Trips and Accelerating Important Operational Decisions.

by TED W. MAYBORN

RE MOTENESS OF OIL WELL drilling activity, coupled with the mobile nature of its modern equipment, precludes economical wire communication, and two-way f-m contact represents not a substitute but a sole means of satisfactory contact.

Growing Demand for Service

Radio communications now play a vital part in many oil operations, but in the oil well drilling branch the greatest demand is anticipated.

In oil well drilling, the demand for radio communications is keyed to major economies for the operator rather than better service as would be the case in taxi operation. These economies have, in every instance of installation to date, paid for the initial investment in less than six months, and in one case in six weeks. This is due in part to the costly nature of the drilling operations and the greater opportunity for major savings. Better service to the company-employer who is using an independent drilling contractor is a favorable factor, and is a

selling point for the contractor in securing contracts. Through radio communication to this employer from a remote drilling rig, the oil company executive is kept in touch with all important operations and is given opportunity to make decisions without delaying further activity at the rig. As important as this may seem, the real economies are obtained primarily in saving extra and unnecessary trips to the rig by the toolpusher (supt.) or delivery trucks. Breakdown of equipment or other delaying factors are remedied more promptly when f-m communications to the home office, or to the superintendent's home, at night, can describe the trouble and bring proper tools and expert machinists to the location in less time than it would take a man to drive into the nearest town in his car.

Dallas Setup

A typical example of radio's use in drilling operations is found in the F. B. Paine Drilling Company of Dallas, which operates five drilling rigs in the north Texas area. The modern rotary rig designed for drilling to 8,000 to 10,000 feet is an intricate assemblage of costly engines and hoisting equipment totaling more than \$100,000 per rig. Wells drilled by these rigs average \$50,000 to \$60,000 each and require approximately 30

(Left)

Lacy Goosetree of the Dallas G.E. office with f-m transmitter and receiver which are mounted in trunk compartment of passenger cars.

Oil Well Drilling Operations

days per well. Running five rigs, then, becomes a major investment in every phase of operation.

Drilling Rig Link

The Paine Drilling Company is an average sized company in oil well drilling. Some firms operate 25 to 40 such rigs, others only one or two. This firm, one of the first among drilling contractors to install f-m communications, operates a network of eleven f-m transmitters in North Texas on a frequency of 37.14 mc.

Each of its five drilling rigs is equipped with a radiotelephone transmitter and receiver, and the other six sets are installed in pickup trucks, superintendent's car, owner's car in Dallas, and in the toolpusher's home. All of the sets are identical and are operated by six-volt automobile storage batteries that are kept charged by usual auto generators. Installations at the rigs are charged by generators run from V-belts attached to the drilling engine fan pulleys.

Continuous Services

All sets are kept on continuously at the rig, since drilling is a continuous 24-hour job involving three crews. Log of conversations is not kept except in cases of equipment failures, interference or difficulties with radio transmission, and in these latter cases the log must be kept for a year.

The initial investment in radiotelephone equipment for the Paine Drilling Company was \$7,000. In the first few weeks the company estimated more than \$2,500 savings in operations due to speeded up delivery, unnecessary trip reductions and through issuance of prompt decisions that would have shut down operations had not two-way radio been available. This initial cost was wiped off the books within the first five months through these constant savings, according to the manager, C. J. Paine of Dallas.

Costs

In the meantime, cost per unit for the equipment averages \$5 per month

for mobile sets and \$15 for portable units. FCC's estimate on life of f-m equipment is from seven to nine years; oil well drillers slice this to a maximum five years due to roughness of the industry's usual operations on all equipment. Contractors, however, declare that for \$50 per month per rig the entire cost of maintenance and initial installation can be amortized within the five-year period.

Multiple Uses of Channels

Greatest difficulty is expected eventually from this industry because of the scarcity of h-f channels for their part of the petroleum industry's allocation of wavelengths. Stationary plants of the utility nature, including gas and oil marketing, have the lion's share. Already in the north Texas area, where installations soon followed the original one of the Paine Drilling Co., two and three firms have joined in *party line* stacking on the same assignment. Strangely enough this has worked out well in the several installations now taking place. In no case, however, have competitive companies joined in the stacking. One or two producers of oil, and a contractor, have made up one group. A supply house, a producer and a contractor have made up the other. Even so, the number of areas are filling up to a point where north Texas can take no more. West Texas is the next big area, with applications already well underway, and agreements for similar groupings on the same dial number are expected.

Advantages of Service

The field is only scratched, and what will become of the future applications in these filled areas is a headache that the drilling industry and the FCC must work out.

Other economic and administrative improvements due to f-m's advent into oil well drilling are interesting, too. A toolpusher who once drove two hundred miles a day looking after two or three drilling rigs, and finding in most cases that the trip was little more than a routine check which did not result in accomplishment, now finds that such

trips are necessary to make only when his assistant calls upon him. This leaves him greater time for other types of work connected with efficient drilling, and in the case of the Paine Drilling Company made it possible to purchase two more drilling rigs to be supervised by the same superintendent. This added employment for thirty more men, five in each shift three times a day on both rigs, and did not increase administrative costs.

The Squelch Circuit

Use of the squelch circuit on receivers installed in cars and in the homes enables these 24-hour supervisors to retire with full confidence that the speaker will awaken them if an emergency arises on any of the rigs. The speakers on each drilling rig are given enough volume to be heard clearly by every employee even above the roar of three big diesel engines.

Field Incidents

Typical of the importance of f-m in hazardous drilling operations are two recent incidents. Near Madisonville, Texas, during completion of a high pressure gas well, the pipe ruptured near the surface of the ground and soon the surrounding area was blanketed by poisonous hydrogen sulphide gas. Crews were unable to approach the well to close safety valves. An f-m call to the Houston home office brought, within the hour, a plane loaded with gas masks and special tools. The saving cannot be reckoned, since total loss would have involved human lives as well as valuable property. Another example, in the northern part of the state, credits f-m with the saving of one life. A man who had been working on a line heater during the February ice age heard his receiver warn him of a freeze in the gas line farther down the string. He left forthwith in his car and had driven but a quarter mile when the pipe burst and the line heater was demolished.

Unique Operation

In north Texas and the Panhandle, rigs were kept in operation during the

FCC Category	District	Major (Integrated) Oil Firms	Independents	Drilling Contractors	Pipe Line Companies	Geophysical Companies	Pipe Line Contractors
Provisional	9	7	4	1	1	4	—
	10	7	3	7	14	1	3
Utility	9	—	—	—	3	—	—
	10	4	1	—	11	—	—
Geophysical	9	3	2	—	—	16	—
	10	12	2	—	—	18	—
Experimental	9	1	2	—	—	—	—
	10	4	1	5	—	3	—
Special Emergency	9	—	—	—	—	—	—
	10	—	1	—	2	—	—

Oil industry operators of industrial f-m networks in southwest (excluding marine transport).

freezing weather that otherwise would have had to shut down.

Coverage

Distance assured by f-m installations in the drilling industry is a factor of greatest importance. Many contract drilling companies, and some producing oil companies with their own far flung drilling rigs, cover large areas of an oil producing sector. From fixed stations to mobile units the distances are increased by use of towers. A 200' 60-watt tower will reach a car fifty miles away. The antenna on a 130' drilling derrick will reach a car forty-five miles away. Tower to car, with 250 watts, can extend the distance to sixty-five miles. A 300' tower of 60 watts will accomplish the same result. But to reach 90 miles from tower to drilling derrick, without use of directional beaming, the tower must be 300' with 60 watts. With directional beaming a 200' tower of 60 watts will do the same work. Directional beaming in oil well drilling is not always practicable, because the portable installations on drilling rigs are moved to new locations at the start of each new well. It is used largely by the stationary utility type of petroleum company, or pipe line company.

West Texas Installations

West Texas, where radiotelephone installations already have become pop-

ular, the distances covered are greater and drilling costs are higher. Opportunity for savings are thus more pressing, and advantages of f-m become more obvious. The first installation there was confronted with poor reception in low areas, particularly around Odessa and Midland. To answer the issue raised by oil companies, a test was conducted.¹ While most oil field installations are of 50- and 60-watt power, the tests were run with only 30 watts to offset any advantages that test equipment might have over ordinary installations.

Field Tests

The initial tests were conducted from the 120' City water tower at downtown Midland with runs made north to Andrews and Seminole. Contact with the car was maintained to a point 12 miles north of Andrews, an airline distance of 46 miles from Midland. A temporary antenna was placed on the 130' derrick 12 miles south of Seminole and connected into the car. Contact was reestablished with Midland at an airline distance of 61 miles. Reception at the rig was good, but that at Midland was poor due to the high noise level prevailing at the downtown location. This confirmed previous experience where it has been found that best results can be obtained by locating a central station at a home or in suburban areas free from X-ray machines, diathermy and other interfer-

¹Test conducted by G. E. Dallas office engineers, and Jerry S. Stover of Communications Engineering Co. of Dallas.

ence downtown. This also aids the operator to use the f-m system in the day at his office and at home at night.

Use of Towers

Thus, in order to approximate the conditions of a suburban location, and to test the advantage of a higher antenna, tests were then conducted from a 300' tower of KCRS, just west of Midland. From this location solid communications were established south out of Midland to Iraan . . . but as the car dropped down into the hilly area, 55 airline miles from Midland, the contact became spotty and was satisfactory only when the car was on a hill. From a hill 83 miles south of Midland the contact was excellent, the greatest distance obtained in car to station tests and proof enough of the value of high towers and good locations. Dropping off of the hill, contact was lost and not reestablished until a temporary antenna was placed on an oil derrick 130' high, 90 miles from Midland. From both ends the communication was clear.

Day-Night Tests

These long haul tests included night and day runs, varying weather conditions and tests for absorption and noise, and in every instance demonstrated that day and night and every sort of weather failed to alter reception.

Future of Service

Thus f-m radiotelephone has entered a big business field where 60- to 80-mile range is demanded for west Texas operations, and where the only solution appears to be 200' and 250' towers. This, according to estimates of experts, raises the monthly amortization cost from the north Texas \$50 to a west Texas \$63 over a five-year period.

But when one considers how many operating hours (at \$800 a day normal . . . up to \$1,200) can be lost each month and how much driving is done just because there is no communication out to a \$100,000 drilling rig, it is easy to see why f-m pays for itself in short order.

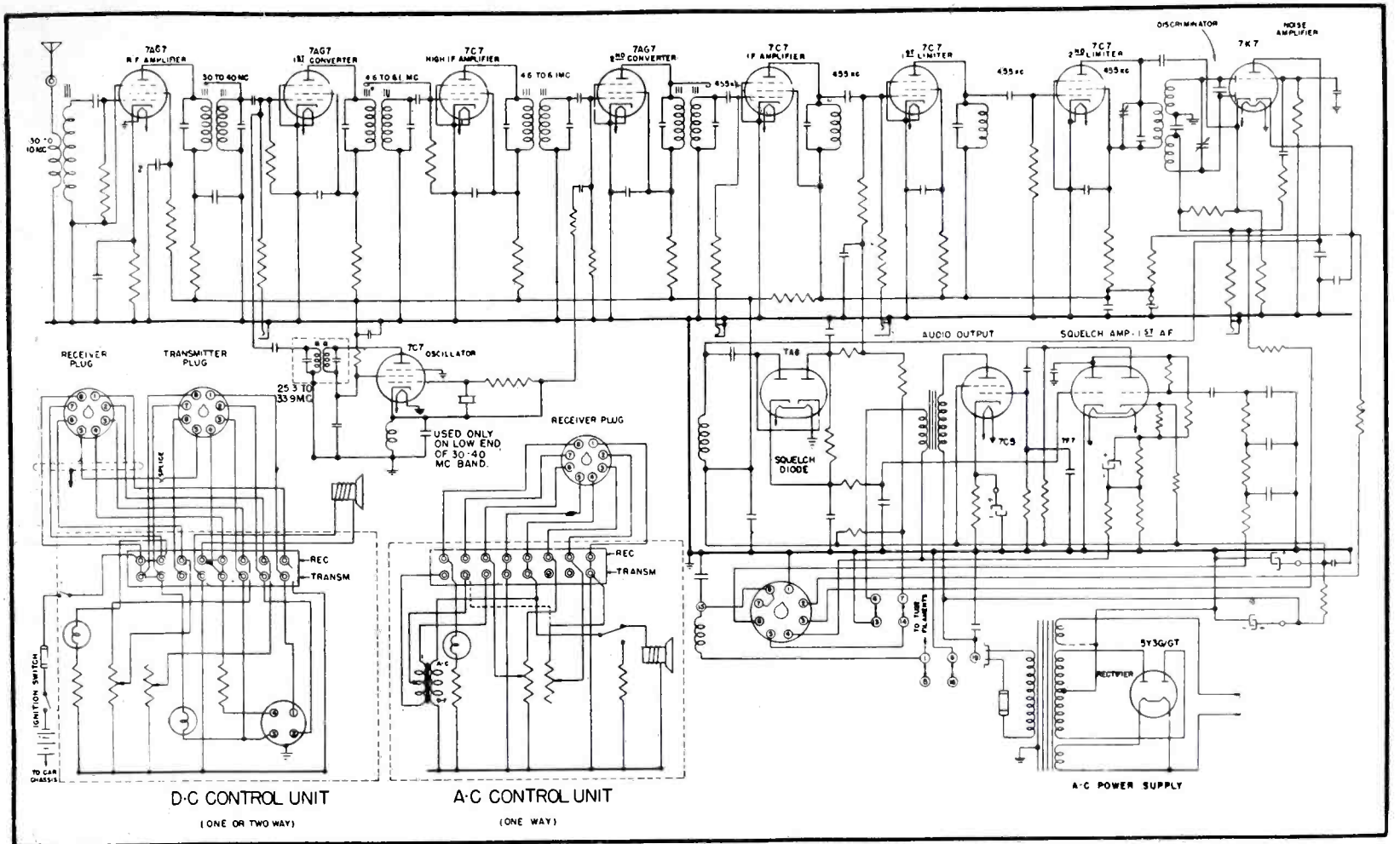

The f-m receiver used for 30 to 40 mc reception. (Courtesy G.E.)

F-m transmitter used in oil well drilling two-way system. (Courtesy G.E.)

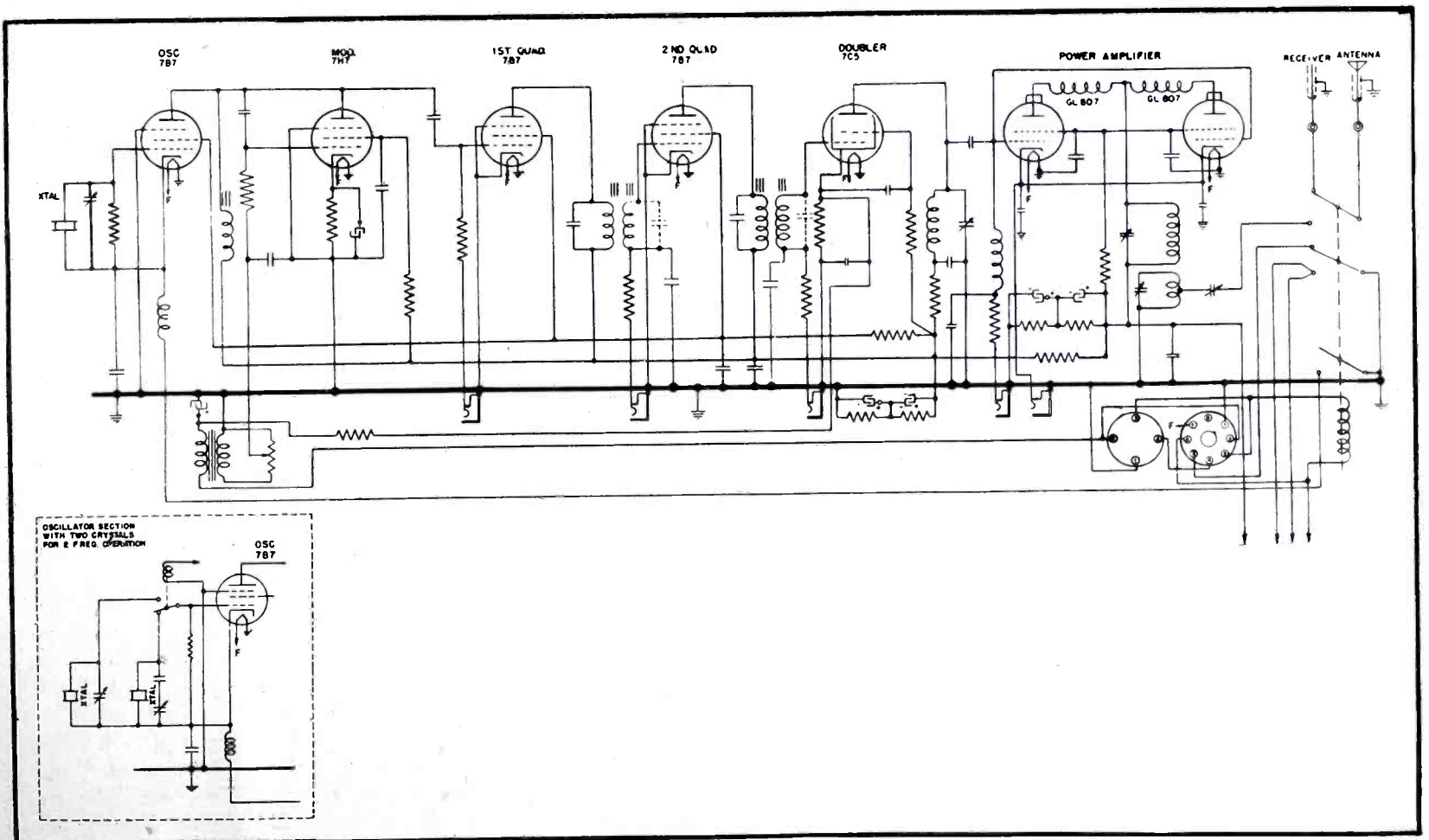

TUBE *Engineering News*

Adjusting 1B3GT Filament Voltage by Observation of Filament Temperature. Application Data for New 812A Medium Mu Power Triode.

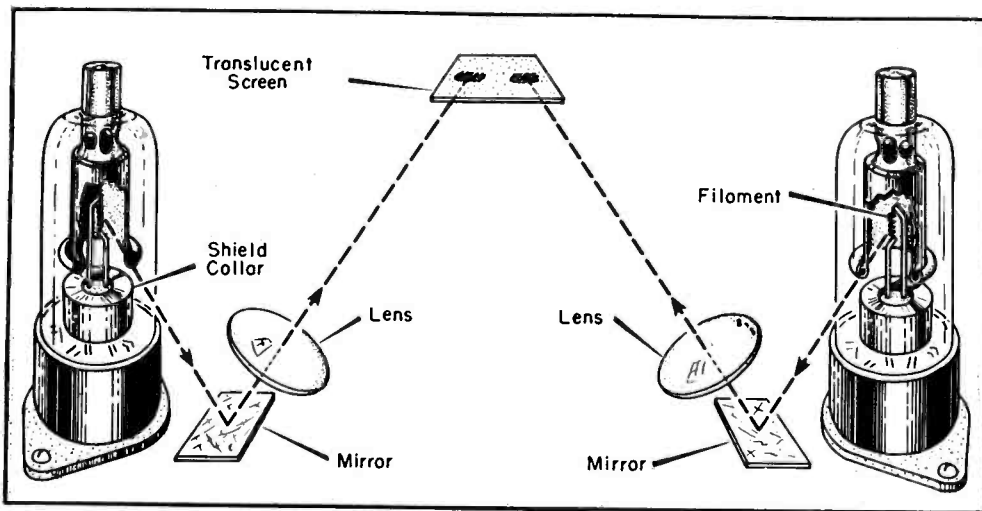

Figure 1
How direct observation method can be used for adjustment of filament voltage of the 1B3GT. The plate cylinders have been cut away to show the filaments.

A MEDIUM-MU POWER triode, 812A, superseding the 812, featuring a zirconium-coated plate having radiating fins to give greater dissipation capability and grid and plate leads designed to have low r-f loss, has been announced by the tube department of RCA. The tube has a maximum plate dissipation of 65 watts (*icas*) in unmodulated class C service. It is also

intended for use as a plate-modulated r-f power amplifier, and as a class B a-f power amplifier and modulator.

Having a high perveance, the 812A can be operated with low plate voltage and low driving power. For example, a pair under *icas* conditions in class C telegraph service can be operated with a plate input of 520 watts and with a driving power of 13 watts. Operation

Figure 2
Circuit of a c-w transmitter for the 812A, providing an approximate power output of 380 watts under *icas* conditions. Coils L₂, L₃, L₄ are tuned to the frequency. L₅ is a 500 ma r-f choke.

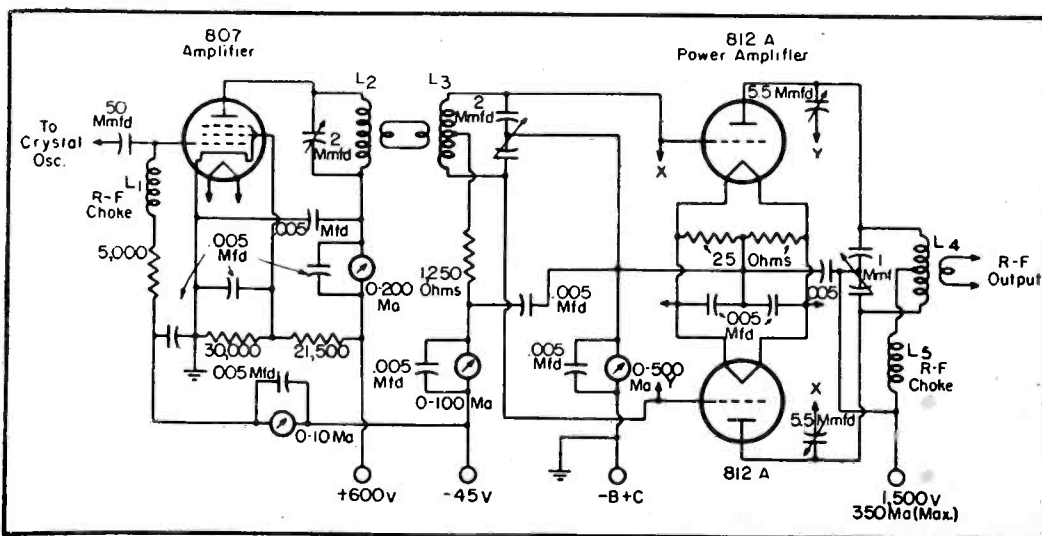

with maximum ratings is permissible up to 30 mc, and with reduced ratings up to 100 mc.

In class B modulator service, two 812As under *icas* conditions are capable of modulating 100 per cent an r-f amplifier having an input of 680 watts.

Application Data

In class B modulator or a-f service, the 812A should have an input transformer which will afford good frequency response when operated into an open circuit, such as that represented by the grid circuit of the class B stage when the signal input is small. The transformer should also be capable of handling the required input power for a strong signal. In addition, the output transformer design should be such that the resistance load presented by the modulated class C stage is reflected as the recommended plate-to-plate load in the class B stage. Grid bias should be obtained from a battery or other d-c source of good regulation.

In class C service, the driving power and grid current are subject to wide variations depending on the impedance of the plate circuit. High-impedance plate circuits require more grid current and driving power to obtain the desired output. Low-impedance circuits need less grid current and driving power, but plate-circuit efficiency is sacrificed. The driving stage should have a tank circuit of good regulation and should be capable of supplying considerably more than the required driving power.

In plate-modulated class C r-f service, the 812A should preferably be supplied with bias from a grid resistor; a combination of grid resistor and cathode resistor or grid resistor and fixed supply may also be used. The cathode resistor should be bypassed for both audio and radio frequencies. The combination method has the advantage not only of protecting the tube from damage through loss of excitation but also of minimizing distortion through bias-supply compensation.

The 812A can be biased by any convenient method, but the use of a grid resistor is preferred because the bias is automatically adjusted as the load on the circuit varies. In those applications where grid current and grid voltage may vary widely because of fluctuating loads, equipment must be so designed that the maximum grid-cur-

(Continued on page 38)



Personals

VETERAN VWOA MEMBER Stanley Wolff, who's in charge of the Associated Press listening post at Valhalla, N. Y., was in the news recently with his ham station, having established important two-way contact for UN officials in Palestine. . . . Life member Arthur Lynch, who is chairman of the VWOA Ways and Means Committee, attended the recent NAB Second District Meeting in Boston. Talked at length with Hermon Hosmer Scott, manufacturer of the disc noise suppressing equipment which he sells in Florida. The August-September high winds are now keeping AHL a pretty busy man at his home in Ft. Myers. Hope the winds pass by his home. . . . Ero Erickson, veteran VWOA member, resigned as secretary-treasurer of the Associated Police Communications Officers recently because of heavy assignments in his police work. Ero did a bang-up job. The members of APCO were deeply grateful to him. . . . Walt Jablon, who is vice president in charge of sales for Espey, will be a pretty busy man in September, having been chosen to direct the forthcoming sessions of the Town Meeting of Service Men at the Hotel Astor. Meeting, scheduled for September 27, 28 and 29, will be an afternoon and night project, and will be open to all Service Men and others interested in the technical aspects of a-m, f-m and tv. . . . We were shocked to hear of the death of Ludwig Arnson's son, Richard, who had been serving as advertising manager of the Communications Division of Radio Receptor. . . . Life member Pete Boucheron's address is at Farnsworth in Ft. Wayne. He is directing broadcast activities for Farnsworth. . . . Sam Freedman, who is now serving as a development engineer for De Mornay-Budd, recently returned from a hush-hush trip to Oak Ridge. Sam was able to disclose that wave guides will be playing quite a role in atomic energy control activities. . . . George Clark is vacationing in New Jersey and keeping trim by riding a bicycle to and from. . . . Don de Neuf, chief engineer of the Rural Radio Network in Ithaca, N. Y., has written an



Life member Arthur H. Lynch, now a resident of Ft. Myers, Florida, who visited the New England area during the summer months.

extremely interesting analysis of the network for the October issue of COMMUNICATIONS. Don discusses, for the first time, the complete structure of this most unusual six-station system providing a very graphic description of the facilities at the network.

The Fall Meeting

THE ANNUAL FALL MEETING of the VWOA will be held at the Fireplace Inn, New York City, Thursday, Oct. 21. Complete details of the meeting will be mailed out to all members within the next few weeks. . . . Hard working secretary, Bill Simon, took a long-needed vacation a few weeks ago. . . . Ye prexy also took a much-needed rest, spending, however, much of the time house hunting, an activity on which suggestions will be more than welcome. . . . The September issue of *Fortune* contains an extremely interesting article on VWOA life member Brig. Gen. David Sarnoff and RCA's activities in television. In the article DS says: "I don't look upon the future as merely television; our future is the electronics field, wherever it may bring us. The number of things a tube can do I do not know; or whether it is a tube that will do the next great

thing, that, even, I do not know." . . . Looking over the membership list of VWOA, we find a galaxy of interesting addresses. Hawaii appears to have the lead with G. P. Gray of RCA Communications at Kahuku, Oahu; Hermann Florez at Waianae; Lee R. Dawson and A. M. DaVico at Honolulu; Capt. C. H. Maddox at Pearl Harbor; W. W. Hofmann of RCA, also at Kahuku, Oahu, and Warner Hobdy also on Oahu. Preston L. Stocum of the CAA is up at Moses Point, Alaska. Mail reaches him via Fairbanks. M. E. Montgomery is down at Rio de Janeiro and C. W. Horn is in Mexico. E. H. Grimsley, president of Press Wireless of Cuba, is located in Havana, Cuba. C. M. Hodge of the Arabian American Oil Co. receives his mail at Bahrain Island in the Persian Gulf. W. A. Paul is in Tangier, Morocco. George E. Schellhas is located at Guayama, Porto Rico.

The VWOA Monument

THE MONUMENT DEDICATED TO THE MEMORY of wireless operators located in Battery Park overlooking New York Bay has been a point of constant interest to not only ops, but everyone in the communications world. Built originally by popular subscription, funds for maintenance have been of late years handled by a committee which in 1940 consisted of Jack Duffy; Fred Muller, Benjamin Beckerman, Sam Schneider and George Clark. Following the death of Mr. Duffy, V. P. Villandre was selected by the committee to fill the vacancy. Unfortunately at the present moment, the monument cannot be seen because of a high board fence which has been erected during the Battery-to-Brooklyn tunnel work. The city of New York has indicated that when the Battery grounds are repaired, the monument will be provided a prominent site, and the Park Commission has stated that it will assist in a memorial site design that will be worthy of the monument.

The Industry Offers



G.R. BEAT-FREQUENCY OSCILLATOR

A beat-frequency oscillator, type 1304-A, superseding the type 913-C, has been announced by the General Radio Company, 275 Massachusetts Ave., Cambridge 39, Mass.

Over-all frequency range is 20 cycles to 20 kc, with an accuracy of $\pm(1\% + .5 \text{ cycle})$ after the dial zero has been set in terms of the a-c line frequency. Illuminated, precision, gear-drive dial has a logarithmic scale. A frequency increment dial with a range of ± 50 cycles is provided.

Output impedance is 600 ohms, balanced or unbalanced. Normal maximum output is .3 watt with total distortion of less than .25% over most of the range. Distortion is slightly higher below 100 cycles and above 7,500. With distortion of 1% between 100 and 7,500 cycles, a maximum output of 1 watt can be obtained. A-c hum is said to be less than .1% of output voltage.

Open-circuit output voltages for the two output levels are 25 and 40, respectively. Output voltage said to vary less than $\pm .25$ db over the entire frequency range.

Frequency drift from a cold start is less than 7 cycles in the first hour, and is essentially completed after two hours.

B. & W. SINE WAVE CLIPPER

A sine wave clipper has been announced by Barker & Williamson, Upper Darby, Pa.

Designed to be driven by an audio oscillator, clipper provides a clipped sine wave.

B. & W. engineers state that they have photographed and classified the typical kinds of distortion viewed on the 'scope when testing equipment in conjunction with the clipper. Photos are reproduced in the instruction book accompanying each clipper.

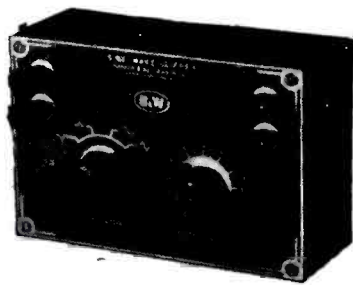

SIMPSON ELECTRIC ROTO-RANGER VOLT-OHM-MILLIAMMETER

An a-c/d-c volt-ohm-milliammeter, equipped with the *Roto-Ranger* principle, model 221, has been announced by Simpson Electric Co., Chicago, Ill. In operation, as the selector switch is moved to the range desired, the proper scale for that range is brought into place behind the meter window.

Roto-Ranger is said to be capable of measuring a-c diode balancing circuits, grid currents of oscillator tubes and power tubes, bias of power detectors, a-c diode currents, rectified r-f current, high- μ triode plate voltage, etc.

Ranges (20,000 ohms per volt d-c, 1,000 ohms per volt a-c): Volts, a-c, 2.5, 10, 50, 250, 1,000, 5,000; volts, d-c, 2.5, 10, 50, 300, 1,000, 5,000; ma, d-c, 10, 100, 500; microamperes, d-c, 100; amperes, d-c, 10; output, 2.5, 10, 50, 250, 1,000; ohms, 0-2,000 (12 ohms center), 0-200,000 (1,200 ohms center), 0-20 megohms (120,000 ohms center).

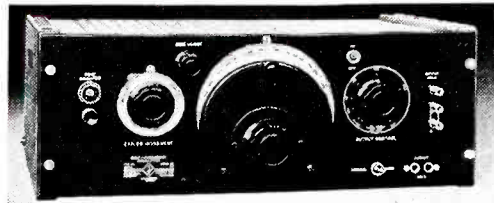

BROWNING AMPLIFIER

An amplifier, type TAA-16, useful in determination of standing wave voltage ratio when used in connection with square law detector probes and slotted waveguides, has been developed by Browning Laboratories, Inc., Winchester, Mass.

Two inputs, selectable by switch for rapid comparison, are available. Operating frequencies are from 500 to 5,000 cycles and operation can be wide band or highly selective as needed. Selective network is panel tuned through the range noted above. Output meter is calibrated directly in *standing wave voltage ratio*. External meter may be used if desired.

Full scale meter readings are obtained with 15 microvolts at the input under wide band operation, while 10 microvolts signal will produce this result under selective operation. Power supply is electronically regulated.

WEBSTER ELECTRIC PORTABLE TAPE RECORDER-REPRODUCER

A portable tape recorder-reproducer, the *Eko-tape*, has been announced by Webster Electric Company, Racine, Wisconsin.

Has an oversize motor with high inertia fly-wheel which is said to permit maximum instantaneous speed variation below one per cent. Features include recording volume indicator eye, fast rewind (10X) and fast forward speeds without rethreading the tape.

Motor drive and capstan operate continuously so that tape starts and stops instantaneously without coasting, permitting accurate cueing.

RAYTHEON SUBMINIATURE

A subminiature, type CK571AX, electrometer type, with a filament operated directly from a 1.25-volt battery cell and drawing 10 ma has been announced by the special tube section of Raytheon Manufacturing Company, Newton, Mass.

In addition to its applications in the 2-tube zeus circuit, for which type CK5697/CK570AX electrometer tube was originally designed, it may also be conveniently used in single tube circuits.

COMAR D-C RELAY

A sensitive d-c relay, type E, $2\frac{1}{2}'' \times 1\frac{1}{4}'' \times 1\frac{1}{2}''$, has been developed by the Comar Electric Company, 3148 N. Washtenaw Ave., Chicago 18, Illinois.

Contact capacity up to 5 amperes, at 25 volts non-inductive load. Power consumption 60 milliwatts. Supplied with fine silver contacts, or other material on specification.

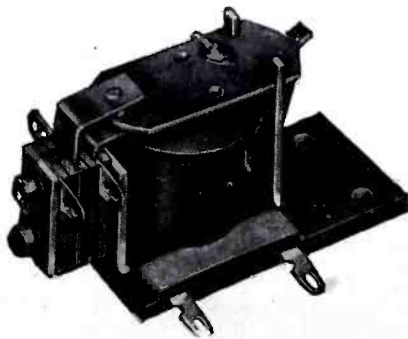

AMPEX TAPE RECORDER

A tape recorder, which offers a 35-minute transcribing capacity at 30 inches of tape per second, has been announced by Ampex Electric Corp., 105 Howard Avenue, San Carlos, Calif.

Frequency response is said to be within ± 1 db between 30 and 15,000 cps; distortion of the overall system, 4 per cent *intermodulation* at peak meter reading; 10 db above peak meter reading the total rms harmonic distortion does not exceed 5 per cent. Unweighted noise level is said to be 60 db below 5 per cent harmonic distortion for the system as a whole. Accuracy of playback timing is said to be $\pm .2$ per cent.

Other features include instantaneous monitoring through separate record and playback heads; marking device for spotting tape when editing; safety flange with rapid threading hub for tape storage and handling; relay and push-button controls allowing remote operation and fast forward and rewind speeds of over 300 in. per sec.

BELMONT TV TEST EQUIPMENT

A composite video generator, model 30G1, r-f alignment signal generator, model 6G111, and antenna alignment communicator, model 3AW8, have been produced by the Belmont Radio Corporation, 5921 West Dickens Avenue, Chicago 39, Illinois.

Video generator has independent simultaneous positive and negative outputs of 0.5. Also has an auxiliary output for synchronizing monoscope, camera, or other picture signal generators.

The alignment signal generator covers 4.5, 10.7, 22.25 and 25 mc ranges for sweep frequency. The r-f ranges covered are 4 to 5, 9.5 to 12.5, 20 to 30, 40 to 70, 70 to 120, 120 to 240 mc.

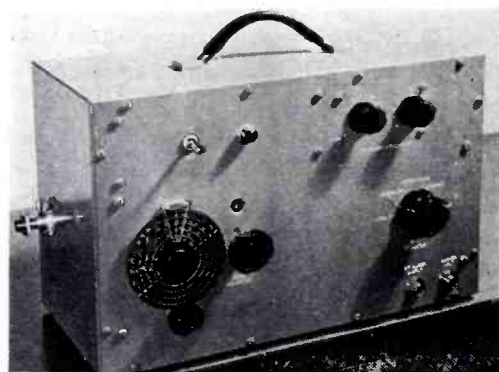

Belmont video generator.

MALLORY MIDGET VARIABLE RESISTOR

A $15/16''$ variable resistor, the *Midgetrol*, has been announced by P. R. Mallory & Co., Inc., of Indianapolis, Indiana.

One feature is a flat shaft which is easily adapted to fit any type of knob now in use. The flat shaft is also said to provide high uniformity in production and a degree of standardization.

Other design features include two-point shaft suspension, providing even contact pressure at all points of rotation; machine-coated carbon elements; hot-tinned terminals; Mallory switch; fully insulated current-carrying parts and special phenolic shaft for tv applications.

SPRAGUE TV ELECTROLYTIC CAPACITORS

A line of electrolytic capacitors designed specifically for tv requirements has been announced by Sprague Electric Company, North Adams, Mass. The new units are rated for operation at 85° C up to 450 volts.



* * *

WESTERN LITHO CODE MARKERS

E-Z code identification markers, with a *speed* tab have been announced by the Western Lithograph Company, 600 E. Second St., Los Angeles 54, California.

Tab consists of a 10" strip of cardboard that is perforated near one end. When it is broken at the perforation, the code marker is freed from the smaller segment of the card and applied to the pipe without moistening.

* * *

G. E. SQUARE WAVE GENERATOR

A square wave generator, type YGL-1, has been announced by the specialty division of G. E.

Features six overlapping frequency ranges, giving continuous coverage from 5 to 125,000 cycles. Delivers a rectangular wave output voltage with a 25% negative pulse, and a rise time for the leading edge of .3 microsecond.

* * *

EICOR DYNAMOTORS

A series of dynamotors, from 2 5/8" in diameter to 6 5/8" in diameter, providing from 10 to 500 watts output, is being produced by Eicor, Inc., 1501 West Congress Street, Chicago 7, Ill.

Models known as the 3300, 2700, 3400, 4100, 4500, 5100 and 6100 series, designed to operate from 12- or 24-volt source.

* * *

BETA ELECTRONICS REGULATED SUPPLY

A power supply, model 251, with its output voltage continuously variable from 0, or any greater value, to 500 volts, either positive or negative with respect to ground, has been announced by the Beta Electronic Company, 1762 Third Avenue, New York 29, New York.

Output voltage is stabilized by means of cascaded VR tubes. Variable output is obtained from the tap of a 25-watt G-R precision rheostat. For finer voltage control, a 3-, 10-, or 15-turn potentiometer can be provided.

Regulation said to be less than 1/2% due to line voltage variations at any line voltage setting. Not regulated against load fluctuations.

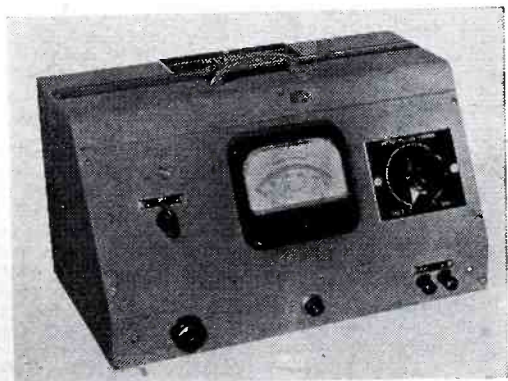

3 Outstanding COSMALITE* COIL FORMS

Each specially designed and produced by us to give exceptional performance, and at a saving in cost to this country's leading manufacturers of radio and television receivers.

Your specifications as to punching, threading, notching and grooving are followed with the most exacting care. Ask about our many stock punching dies available to you.

Are you familiar with our #96 COSMALITE for coil forms in all standard broadcast receiving sets; SLF COSMALITE for permeability tuners; COSMALITE deflection yoke shells, cores and rings?

Spirally wound kraft and fish paper Coil Forms and Condenser Tubes.

*Trade Mark Registered

The CLEVELAND CONTAINER Co.
 6201 BARBERTON AVE. CLEVELAND 2, OHIO

PRODUCTION PLANTS also at Plymouth, Wisc., Ogdensburg, N.Y., Chicago, Ill., Detroit, Mich., Jamesburg, N.J.
 PLASTICS DIVISION at Plymouth, Wisc. • ABRASIVE DIVISION at Cleveland, Ohio
 SALES OFFICES: Room 5632, Grand Central Term. Bldg., New York 17, N.Y., also 647 Main St., Hartford, Conn.
 CANADIAN PLANT: The Cleveland Container Canada, Ltd., Prescott, Ontario



Designed for

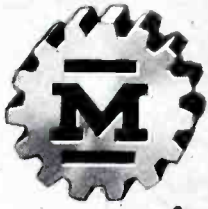

Application

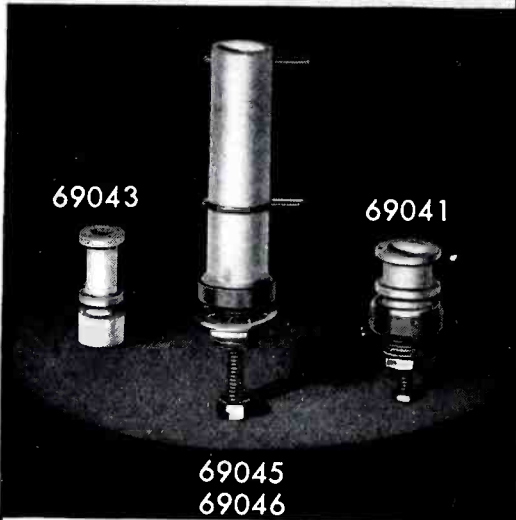

The No. 69040 Series
of
PERMEABILITY TUNED
CERAMIC FORMS

In addition to the popular shielded plug-in permeability tuned forms, 74000 series, the 69040 series of ceramic permeability tuned unshielded forms are available as standard stock items. Winding diameters and lengths of winding space are $1\frac{1}{2} \times \frac{1}{32}$; $\frac{1}{4} \times \frac{3}{16}$; and $\frac{1}{2} \times \frac{1}{16}$, for the 69041, 69043 and 69045 respectively. Nos. 69043 and 69046 have powdered iron slugs while Nos. 69041 and 69045 have copper slugs.

JAMES MILLEN
MFG. CO., INC.

MAIN OFFICE AND FACTORY
MALDEN
MASSACHUSETTS



The Industry Offers

(Continued from page 25)

RCA PORTABLE SOUND SYSTEM

A deluxe portable sound system, type SP-15A, which employs a 15-watt amplifier and said to provide acoustical output equivalent to that of a 30-watt portable sound system incorporating two average p-m speakers, has been announced by the RCA Engineering Products Department. Consists of an aerodynamic microphone, low-distortion, high-output amplifier, a heavy-duty alnico p-m loudspeaker, and a two-tone luggage-size carrying case.

SPRAGUE MOLDED
PROKAR CAPACITORS

The Sprague Prokar capacitors, which were designed specifically to satisfy stringent military requirements, are now in mass production and available in a wide range of capacities.

Capacitors are said to be the smallest molded tubulars ever produced. Impregnated with a new and exclusive high temperature plastic, which is said to permit a considerable size and performance advantage at high temperatures.

Rated for -50°C to $+125^{\circ}\text{C}$ operation. Full details appear in engineering bulletin 211; address Sprague Electric Co., North Adams, Mass.

G. E. AUTOMATIC VOLTAGE
STABILIZER UNITS

Redesigned automatic voltage stabilizers in the 100-, 250- and 500-v ratings have been announced by General Electric's Specialty Transformer and Ballast Divisions.

The 100-v unit is of totally enclosed design. The 250- and 500-v units are of exposed core construction.

Units are said to provide a steady output of 115 volts (± 1 per cent for fixed, unity power factor loads) with input voltages ranging from 95 to 130 volts.

Detailed information is contained in bulletin GEA 3634, available from G. E., Schenectady 5, N. Y.

TACO H-F TV ANTENNA ADAPTER

A h-f tv antenna adapter, type 445, comprising a half-wave folded dipole with reflector as well as a quarter-wave connecting link with the existing antenna, has been announced by Technical Appliance Corp., Sherburne, N. Y. The matching network is said to be so designed that instead of the usual loss that occurs when loading one antenna with another, a gain is actually the result over the low band.

Adapter is supplied with an aluminum tubular mast extension which mounts to the mast of the existing low-frequency antenna assembly, by means of a coupling clamp.

DECIMETER DIVERSE ADAPTOR

A diverse adaptor, type DM-430, for diversity reception application has been announced by Decimeter, Inc., 1428 Market Street, Denver 2, Colorado. Has one stage of broad-band amplification.

Adaptor is said to select the proper antenna on as little as .05 volts of a.c. It operates on 300 to 300 volts at 15 ma and filament supply of 6.13 v a-c at 1.5 amperes. All connections are made to barrier strip terminals mounted on the chassis top. Chassis size is $7'' \times 7'' \times 2''$. Bulletin 24G provides complete data.



FOR PUBLIC
ADDRESS, RADIO,
and kindred fields,
JONES 400
SERIES
PLUGS & SOCKETS

of proven quality!

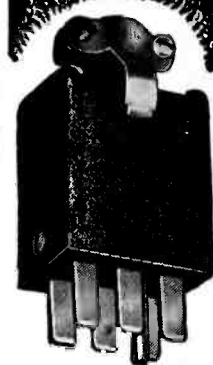

P-406-CCT

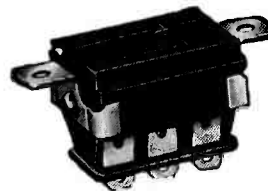

S-406-AB

Socket contacts phosphor bronze cadmium plated. Plug contacts hard brass cadmium plated. Insulation molded bakelite. Plugs and sockets polarized. 2, 4, 6, 8, 10, 12 contacts. Steel caps with baked black crackle enamel.

Catalog No. 16 gives full information on complete line of Jones Electrical Connecting Devices — Plugs, Sockets and Terminal Strips. Write

HOWARD B. JONES DIVISION
Cinch Mfg. Corp.
2460 W. GEORGE ST. CHICAGO 18, ILL.

TELEQUIP TV TEST UNITS

A combination sync generator, monoscope, picture generator, and distribution panel developed for production line testing of tv equipment and for transmission stations, has been announced by Telequip Radio Company, 1901 South Washtenaw Avenue, Chicago 8, Ill.

Two monographs describing the equipment in detail, explaining the theory of operation, and giving instructions for its use and maintenance are available.

C-D SHIELDED MULTIPLE CAPACITOR

A shielded multiple section capacitor, type MC-9A63, $4 \times .02$ mfd and 500 v d-c, has been announced by Cornell-Dubilier Electric Corporation, South Plainfield, New Jersey.

Size, $1\frac{1}{2}'' \times 1\frac{1}{8}'' \times 2\frac{3}{4}''$, plus a $\frac{1}{2}''$ terminal above the case. Designed to JAN-C-25 performance characteristic E. Has ceramic-kovar solder sealed terminals; bracket available for upright or inverted mounting position; metal hermetically-sealed, for operation from -55°C to $+100^{\circ}\text{C}$. Each capacitor section fully electrostatically shielded from others.

WALLACE & TIERNAN
D-C RECORDER

A portable d-c recorder for the measurement of micro currents and voltages has been produced by Wallace & Tiernan Products, Inc., Belleville 9, N. J.

Minimum full scale range of the instrument is 0 to 0.1 ma and the maximum is 0 to 12 amperes. Sensitivity is 1 part in 1,000.

Recorder is of the moving magnet, interchangeable coil type and is designed for continuous duty. Eight different coils are available and each is adjustable over a range of 11.5 to 1. The zero on the scale can be suppressed up to 80%. The chart is of the circular 24-hour type and is driven by a conventional synchronous motor consuming approximately 5 wats. Further data appears in bulletin No. TP-18-A.

DIAL LIGHT CO.

MULTIVUE CAP PILOT LIGHT

A pilot light with a *multivue cap*, which is said to be highly effective with neon lamps (NE-51 glow type) has been developed by the Dial Light Co. of America, Inc., 900 Broadway, New York 3, N. Y.

Light from the glowing electrodes is refracted in such a way that a multiple image is seen from any viewing angle.

Necessary resistor for the neon lamp is built into the assembly, and is proportioned to the voltage and service. Voltage may be 110 or 220 or higher, with small additional resistor.

Connections are made to binding screw terminals, or to soldering lugs which are optional.

MILLIVAC D-C MILLIVOLT METER

A vacuum tube millivolt meter for a-c, model MV-17A, which measures one millivolt full scale on its lowest range at 6 megohms input impedance, has been developed by Millivac Instruments, P. O. Box 3027, New Haven, Conn. Has 12 additional ranges up to 1,000 v full scale at 60 megohms input impedance. Contains a high-impedance shunting contact type magnetic modulator which converts d-c input voltages into a 120-cycle carrier wave which is amplified, rectified and metered.

Reads 150 μ ma full scale; up to 10^{13} to 10^{14} ohms with an external voltage source.

SPERRY CAVITY METERS

Four models of high-Q tunable cavities that are said to measure microwave frequencies to absolute accuracies between 1/10,000 and 1/20,000, have been announced by the Industrial Department, Sperry Gyroscope Company, Great Neck, New York.

Four models are 28A for 4500 to 5600 mc, 208 for 5350 to 8100 mc, 291A for 2570 to 3750 mc, and 901B for 8100 to 10,500 mc. Loaded Q's range from 5000 to 16,000. The tuning plungers use a double wavetrap.

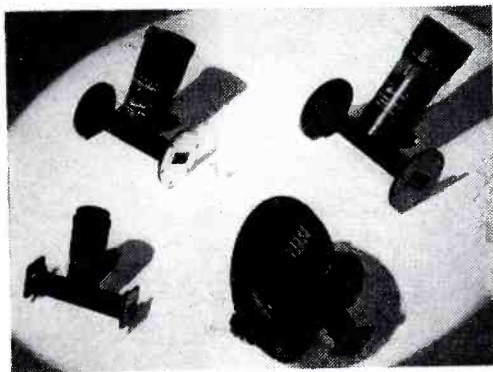

RAYTHEON CUE ATTENUATORS

Cue attenuators have been added to the Raytheon line of studio consoles.

Added to the fader controls for two turntables, the attenuators permit cueing of records without putting them on the air.

RCA MICROPHONE BOOM STAND

A one-hand telescoping microphone boom stand, type KS-4A, has been announced by the RCA Engineering Products Department.

Magic locks on both the main shaft of the stand and on the boom allow one-hand universal movement of the boom without operation of screws or other release mechanisms.

Consisting of two telescoping four-foot sections, the boom has a controllable arc of about 180° and is counter-balanced. The microphone cable is guided at six points. The stand is adjustable in height from six to nine feet, and the boom, when closed, has a radius of five feet.

SOLA LOW-HARMONIC DISTORTION CONSTANT VOLTAGE TRANSFORMERS

A line of constant voltage transformers, type CVH, designed to deliver a constant output voltage having low harmonic distortion, has been announced by the Sola Electric Company, 4633 West 16th Street, Chicago 50, Illinois. Equipped with an additional circuit component which is said to neutralize the harmonics, normally present in the output of constant voltage transformers. Available in 250, 500 and 1,000 va capacities.

PRECISION RESISTORS!



Shallcross makes them all!

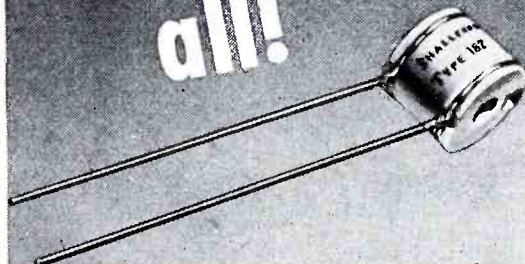

- ... Wire wound with any alloy to meet JAN-R-93 styles
- ... Hermetically sealed
- ... With low temperature coefficient
- ... With predetermined time constants
- ... For high resistance in small space
- ... With definite positive or negative temperature coefficient
- ... With special low-tolerance
- ... With highest stability of resistance values
- ... For high voltage applications
- ... Potted (for RC, bridge and fixed pad networks)
- ... Mounting styles for any need

Write for Shallcross Akra-Ohm Precision Resistor Catalog R-1. Let Shallcross precision resistor engineering specialists recommend suitable types for your application.

MOISTURE SEALED OUT . . . Accuracy and Dependability Sealed in!



Unique, simplified, yet rugged construction characterizes the well-known Shallcross Akra-Ohm hermetically sealed precision resistors. Resistance values up to 20 megohms.



SHALLCROSS MANUFACTURING COMPANY Dept. C-98, Collingdale, Penna.

Shallcross—the only complete precision resistor line!

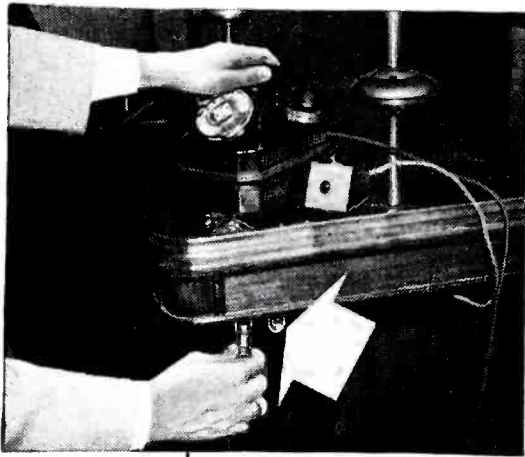

"X" MARKS THE SPOT

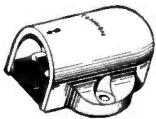

... where the X-3-42 Receptacle (shown just above) unobtrusively reposes underneath the table top so that the intercommunication phone may be moved around the executive conference table. The Type "X" Series is particularly adapted to plug-in intercom systems such as shown above, and is also widely used in sound service, instruments, radio and public



X-3-11 Plug
\$1.75 List

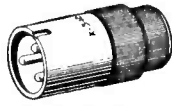

X-3-12 Plug
\$1.25 List

address systems. Two plug and 3 receptacle types are available with 3 different insert arrangements (interchangeable): one 15-amp.; three 15-amp.; and three 10-amp. and one 15-amp. contacts. Shells are diecast zinc



X-3-13 Receptacle
\$1.75 List



X-3-14 Receptacle
\$1.25 List

with bright nickel finish, and have accommodation for 3/16" to 9/32" cable. Friction engagement. Available direct from more than 225 distributors over the U.S.A. or from factory.

Listed and priced in the RJC-2 and C-47 Condensed Catalogs. Engineering drawings of the "X" in P&O Bulletin. Specify bulletin desired. Address Dept. 1-121.

CANNON
ELECTRIC

Development Company

3209 HUMBOLDT ST., LOS ANGELES 31, CALIF.

IN CANADA & BRITISH EMPIRE:
CANNON ELECTRIC CO., LTD., TORONTO 13, ONT.

WORLD EXPORT (Excepting British Empire):
FRAZAR & HANSEN, 301 CLAY ST., SAN FRANCISCO

News Briefs

INDUSTRY ACTIVITIES

Oral arguments involving the recently FCC proposed general and public mobile, land transportation, industrial, and public safety radio services, and frequency allocations between 25-30, 44-50, 72-76 and 450-460 mc have been scheduled, to commence on October 6.

Chiefly concerned in the hearings are land transportation services such as intercity buses and trucks, urban transit vehicles, taxicabs and railroads; domestic public mobile radio-telephone services offering common carrier telephone connection with land vehicles; industrial radio services for power, petroleum, forest products and other commercial or industrial operations; and public safety services covering police, fire, special emergency, forestry-conservation, and highway maintenance radio communication.

Antenna design, stratovision, station monitors, audio development, instruments and aeronautical communications will be featured topics during the IRE Pacific Coast Meeting, Sept. 30, Oct. 1 and 2.

On Thursday, Sept. 30, broadcasting and the allied arts will be the subjects of most papers. D. E. Foster, Hazeltine Research, Inc., of California, will cover *Antenna Input Systems for Television Receivers*, analyzing the problem of impedance matching, gain, and bandwidth in the 5 to 1 frequency range of the assigned channels.

Stratovision Development will be the subject of C. E. Nobles, of Westinghouse.

In a paper on an *A-M Broadcast Station Monitor*, H. R. Summerhayes, Jr., of General Electric, will describe a new instrument which features a local oscillator which is synchronized in constant phase relation with the carrier component for the modulated signal from the transmitter. The local oscillator signal, in turn, energizes a quartz crystal discriminator which indicates deviation from assigned transmitter frequency. The local oscillator signal is also added to the modulated wave from the transmitter to reduce the effective percentage of modulation, thereby eliminating negative peak clipping in the detector.

W. H. Doherty of Bell Telephone Labs will cover the *Operation of A-M Broadcast Transmitters Into Sharply Tuned Antenna Systems*.

J. K. Hilliard, Altec Lansing; R. R. Scoville, Western Electric; J. P. Maxfield, Acoustic Consultant; Walter Carruthers, Don Lee; Jack Mullens, W. A. Palmer Co.; James Bayless, R. C. A.; and E. H. Schreiber, Bell Telephone, will appear on an *Audio Symposium on High Quality Sound Reproduction*.

Discussion will cover the general philosophy of high quality, equipment requirements, technique of pickup and reproduction and proposal of new standards for both disc and magnetic recording.

On Friday, Oct. 1, devoted to measurements and propagation, *A New Method of Obtaining the Product of Two Voltages* will be described by D. B. Sinclair of General Radio.

R. H. Delano of the Hughes Aircraft Company will talk about a graphical method for determining the signal and noise output of an ideal linear or envelope detector; the method is applicable to any kind of amplitude modulated signal at any signal/noise ratio.

On Saturday, Oct. 2, systems and navigational aids will be featured topics.

The *Design of Antennas for Optimum Directivity* will be covered by T. T. Taylor of the Hughes Aircraft Company.

F. G. Suffield of Suffield-Vose and Associates will describe the *Design of a Commercial Airlines Radar*.

And W. G. Tuller of Melpar, Inc., will discuss *Bandwidth Reduction in Communication Systems*.

The Chicago Civic Theatre has been leased on a long term basis by the American Broadcasting Company and has been converted into a-m and tv studios.

Will serve as tv studio for WENR-TV. The seating capacity of the new studio is 878; 502 seats will be provided on the main floor, 190 in the dress circle and 186 in the balcony.

The stage measures 72' in width and 32' in depth. The height from the stage to the rigging loft is 70'. The proscenium measures 30' in height and 34' in width.

The WENR-TV transmitter is located on the 44th floor of the Civic Opera Building and the antenna, the total height of which is 613', is located atop the building's roof.

MEASUREMENTS

MEGACYCLE METER

MODEL
59



Radio's newest, multi-purpose instrument consisting of a grid-dip oscillator connected to its power supply by a flexible cord.

A most versatile instrument for the engineer, service-man or amateur. Write for descriptive circular.

SPECIFICATIONS:
Power Unit: 5 1/2" wide; 6 3/4" high; 7 1/2" deep.
Oscillator Unit: 3 3/4" diameter; 2" deep.

FREQUENCY:
2.2 mc. to 400 mc.; seven plug-in coils.

MODULATION:
CW or 120 cycles; or external.

POWER SUPPLY:
110-120 volts, 50-60 cycles; 20 watts.

MEASUREMENTS CORPORATION
BOONTON NEW JERSEY

A mobile tv truck has been announced by the Transmitter Division of G. E. The first unit of its type is now in use at Yankee Network's WNAC-TV in Boston, Mass.

The interior of the truck contains an operating table, to which are shock-mounted three control and monitor units, a mixer amplifier unit, and portable audio equipment. Housed beneath this table are three low-voltage power supplies, a distribution amplifier, and sync generator.

The City of Richmond, Virginia, now has a 250-watt h-f transmitter, two auxiliary 45-watt transmitters, and more than a hundred two-way mobile units, all RCA, mounted in police cars, fire-fighting equipment, city ambulances, and other city-owned vehicles.

The system, broadcasting over WPHF, operates at 155.01 mc for the station transmitter and mobile receivers, and 156.09 mc for the mobile transmitters.

The fleet of eight 5,000-ton steam cargo ships owned and operated by Flota Mercante Grancolombiana, representing the combined shipping interests of Colombia, Venezuela, and Ecuador, is being equipped with Westinghouse type MU 3.2-cm radar.

Equipment uses a seven-inch 'scope. Range from 80 yards to 40 miles.

General Instrument Corp. control has been acquired by a group headed by C. Russell Feldmann and Richard E. Laux, executive vice president of the company.

Mr. Feldmann has been elected chairman of the board, succeeding Samuel Cohen, while Mr. Laux becomes president and treasurer, succeeding Abraham Blumenkrantz from whom the controlling interest was purchased. Elected to the board of directors in addition to Mr. Feldmann were Harry E. Collin, Toledo investment banker and industrialist, and Kenneth C. Meinken, president of National Union Radio Corporation. Cohen and Blumenkrantz have resigned from the board as has Louis Scadron.

KLEE-TV, Houston, Tex., will soon install a G. E. low-channel transmitter and antenna. Studio and remote mobile equipment will also be by G. E.

The **Southwestern IRE** Conference sponsored by the IRE, Dallas-Fort Worth Section, will be held December 10 and 11, 1948, at the Baker Hotel, Dallas, Texas.

It is a regional convention covering the states of Texas, Louisiana, Arkansas, Oklahoma, and New Mexico.

Two fellowships have been established by Airborne Instruments Laboratory, Inc., 160 Old Country Road, Mineola, New York, to aid worthy young men to obtain advanced degrees in the field of communications and electronics. To be known as the *Airborne Instruments Laboratory Fellowships*, one is in the amount of \$1,000 plus tuition at Stanford University, Palo Alto, Calif.; the other, in the amount of \$1,200 for a single man or \$1,800 for a married man, plus tuition, is at MIT.

Recipients of these fellowships will be selected by the staffs of the electrical engineering departments of the two schools. They will be awarded on the basis of high scholarship, but also with some consideration of the applicant's personality and need for financial assistance.

The donor has not dictated any particular problems in the field of communications and electronics but, other things being equal, has expressed a preference that the awards be made to men who are interested in broadband high-frequency systems, including filters, transmission lines and vacuum-tube generators or amplifiers.

PERSONALS

Hobart C. McDaniel has been appointed manager of the technical press service in the public relations department of Westinghouse Electric Corporation, Pittsburgh, Pa. McDaniel succeeds Carl E. Nagel, who has resigned to join McGraw-Hill Book Company in New York as editor of mail sales books for the engineering and industrial fields.

Myron Stolaroff, electrical engineer, Ampex Electric Corporation, San Carlos, Calif., has been appointed to the NAB subcommittee on magnetic recording.

Norman H. Lawton, vice president in charge of sales for the A. W. Franklin Manufacturing Corp., and the Franklin Airloop Corp., has announced the appointment of six sales engineers for California, the midwest, Pennsylvania, metropolitan New York, New York State and New England:

Harry A. Lasure, with offices in Los Angeles, sales engineer for California and the western states; Henry D. Sarkis, with offices in Chicago, sales engineer for the mid-western states; Dixie M. Hilliard, with offices in Jenkintown, sales engineer for Pennsylvania; David Sonken, with offices in New York City, sales engineer for metropolitan New York; William Franklin, with offices in Syracuse, sales engineer for New York State; and Harry Gerber, with offices in Boston, sales engineer for New England.



N. H. Lawton

F. P. Barnes has been appointed assistant to the manager of sales for the G. E. transmitter division.

David J. Miller, Jr., has been appointed television operations supervisor of the American Broadcasting Company.

Miller will be in charge of all technical television operations in the New York area under George O. Milne, ABC's director of technical operations.

A Report



from COTO-COIL

COTO-COIL'S 30 years of experience . . . a modern plant . . . latest equipment and skilled operators make it possible to produce coil windings promptly and efficiently.

If your product calls for coil windings, we can serve you well.

Send Us Your
Specifications For

BOBBINS • PAPER INTERLEAVE
ACETATE INTERLEAVE • COTTON INTERWEAVE
TAPED FORM WOUND
UNIVERSAL SINGLE OR MULTI-PIE CROSS WOUND

We shall be
glad to quote.

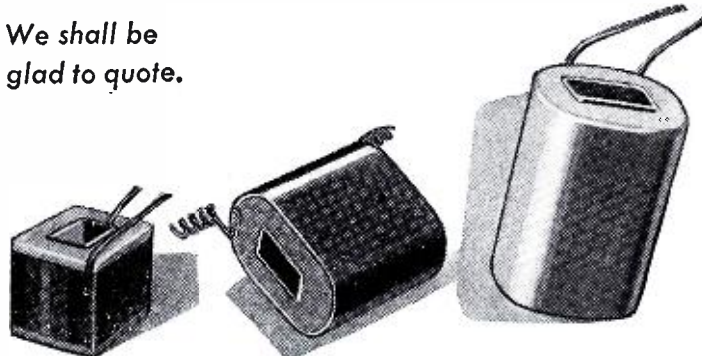

COTO-COIL CO., INC.
COIL SPECIALISTS SINCE 1917
65 Pavilion Ave., Providence 5, R. I.

Proved in Millions
of Applications!



RELAYS
RESISTORS
RHEOSTATS

Vast Variety of Stock Units

ANSWERS EVERYDAY NEEDS ECONOMICALLY

Relays are available from stock in general-purpose, industrial, and radio amateur types for continuous or intermittent duty.

Vitrohm wire-wound Fixed Resistors are available in 8 stock sizes from 5 to 200 watts. Adjustohms in 7 stock sizes from 10 to 200 watts. Plaque Resistors in 3 sizes from 20 to 125 watts. Discohms in 18 watts. Strip-ohm in 5 stock sizes from 30 watts to 75 watts. Ring-type close control Rheostats in 4 stock sizes from 25 to 150 watts. (Plate Type Rheostats recommended for larger sizes.) Wide variety of Resistance Values.

AUTHORIZED DISTRIBUTORS EVERYWHERE
WARD LEONARD ELECTRIC COMPANY

Radio & Electronic Distributor Division
53-M West Jackson Blvd., Chicago 4, U. S. A.

SEND FOR HELPFUL CATALOGS
Catalog D-30 gives complete data and listings on stock units available in Resistors, Rheostats and Radio Amateur Relays. *Catalog D-20* lists Industrial and General-Purpose Relays. Write for them today!

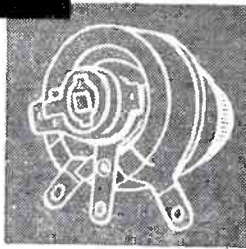
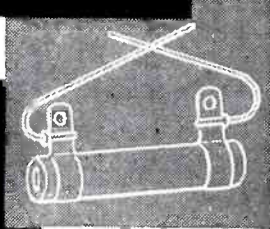
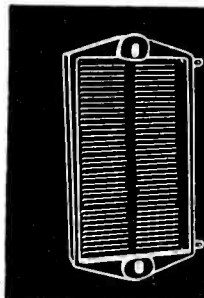
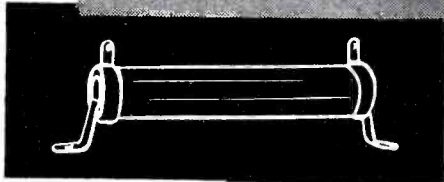
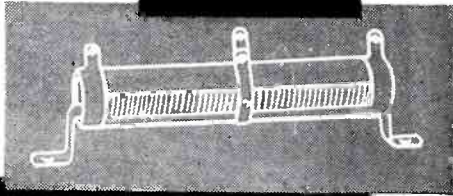
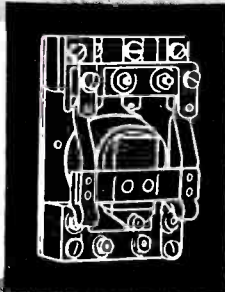

WARD LEONARD

Basic 3R's in Current Control

News Briefs

(Continued from page 29)

Herbert Bachman has been appointed manager of television research for the American Broadcasting Company.

Bachman has been with the ABC research department since February 1946.

Henry Grossman is now director of broadcast operations for the Columbia Broadcasting System, including tv, a-m and f-m.

Grossman, with CBS since 1930, has been director of technical and building operations since last January.

Sydney H. Eiges, vice president in charge of press for NBC, will serve as chairman of the radio division in the 1948 fund drive for the Travelers Aid Society of New York.

A. C. Monteith has been elected vice president in charge of engineering and research of Westinghouse. He succeeds Marvin W. Smith who has become executive vice president of Baldwin Locomotive Works.

John W. Walt has been appointed sales promotion manager of Webster-Chicago Corporation, Chicago, Ill. Walt was formerly sales supervisor for Webster-Chicago nylon needles.

Rear Admiral Ellery W. Stone (USNR) has been elected president and **General William H. Harrison** has become chairman of the board of both the Federal Telephone and Radio Corporation and its subsidiary, the International Standard Electric Corporation. Fred T. Caldwell, formerly president of FTR and ISE is now vice chairman of the boards of both corporations.

Justin J. Callahan has joined FTR, Clifton, N. J., as sales representative covering the New England territory for Federal's mobile radio division.

Jay C. Fonda has joined the Morris F. Taylor Company, Silver Spring, Maryland headquarters.

Mr. Fonda will serve as sales engineer calling on industrial plants in eastern Pennsylvania, Delaware and southern New Jersey.



Jay C. Fonda

R. W. Ferrell has been appointed assistant manager of the receiver division in General Electric's Electronics Department.

George W. Henyan, assistant to the vice president, has been named manager of the new G. E. Industrial and Transmitting Tube Division.

This new division will consolidate all sales, design engineering and manufacturing activities related to the former power electronics division.

K. C. DeWalt and **E. F. Peterson** have been appointed assistant managers of the tube division. DeWalt will be responsible for all design engineering and manufacturing activities related to cathode-ray tube product lines while Peterson will be responsible for all design engineering and manufacturing activities related to receiving tube product lines.

Simultaneously, **O. W. Pike**, engineer of the tube division, has been appointed manager of engineering of the tube divisions.



G. W. Henyan



K. C. DeWalt



E. F. Petersen



O. W. Pike

Royal V. Howard, director of the NAB engineering department, has been awarded a certificate of appreciation for his "outstanding contribution to the work of the Office of Scientific Research and Development during World War II."

The certificate, given by the War and Navy Departments jointly, was signed by Robert P. Patterson, Secretary of War at the time of the official award, and James Forrestal, then Navy Secretary.

The award was in recognition of his work as director of the operational analysts staff, headquarters, U. S. Army, European theatre, the group known as *combat scientists*.

Robert E. Kintner, executive vice president of the American Broadcasting Company, has been elected a member of the board of directors of the TBA.

F. J. Bingley, a director of TBA, who has been affiliated with the Philco Corporation for many years, has become chief television engineer for WOR-TV, New York, and WOIC in Washington.

Frank W. Walker, former chief engineer for Greyhound Bus Corp., has been appointed by Motorola, Inc., as radio communication engineer in the state of Michigan. Walker was formerly chief engineer for the Michigan State Police.



Frank W. Walker

Ray Davis Kell, director of television research at the RCA Laboratories in Princeton, N. J., will be the 1948 recipient of the Stuart Ballantine Medal of The Franklin Institute. Medal will be given "in consideration of his outstanding pioneer work in television; the adaptation of this means of communication to military needs, and for his inventive contributions and leadership in the development of color television."

The medal will be awarded to Kell by Richard T. Nalle, president of The Franklin Institute, at traditional Medal Day ceremonies in Philadelphia, October 20.



R. D. Kell

W. N. Goodwin, Jr., recently completed 50 years with the Weston Electrical Instrument Corporation, Newark, N. J.

Joining the organization in 1898, after graduation from the University of Pennsylvania, Goodwin was selected in 1906 by Dr. Edward Weston, the founder, as chief engineer and director of research, and was eventually elected vice president in charge of research and engineering.

During 1904-1908 Goodwin developed the basic mathematical equations for instrument design.

Among the many developments by Goodwin were the thermo-ammeter for the measurement of r-f current, in 1915, which was followed some years later by the rectifier type instrument. He developed the Weston exposure meter and the coordinating Weston film rating system in 1932.

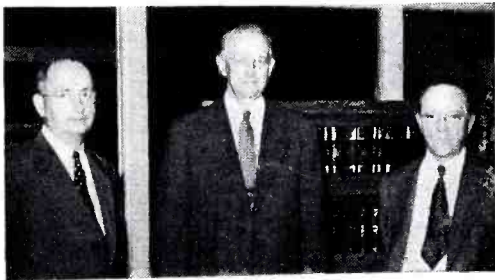

Left to right: Earl R. Mellen, president of the Weston Electrical Instrument Corporation; W. N. Goodwin, Jr., retired vice president of the company in charge of research and engineering, and Edward F. Weston, chairman of the board of directors, at ceremonies marking the fiftieth anniversary of Mr. Goodwin's association with Weston.

Charles A. Nuebling, formerly with the Servo Corporation of America, Lindenhurst, N. Y., as administrator of the electronics department, has become director of electronics of the W. L. Maxson Corp., New York.

Nuebling previously was on the McGraw-Hill staff as technical editor.

Want the
MOST EFFICIENT
TRANSMISSION LINE
for Your Station?
ANDREW

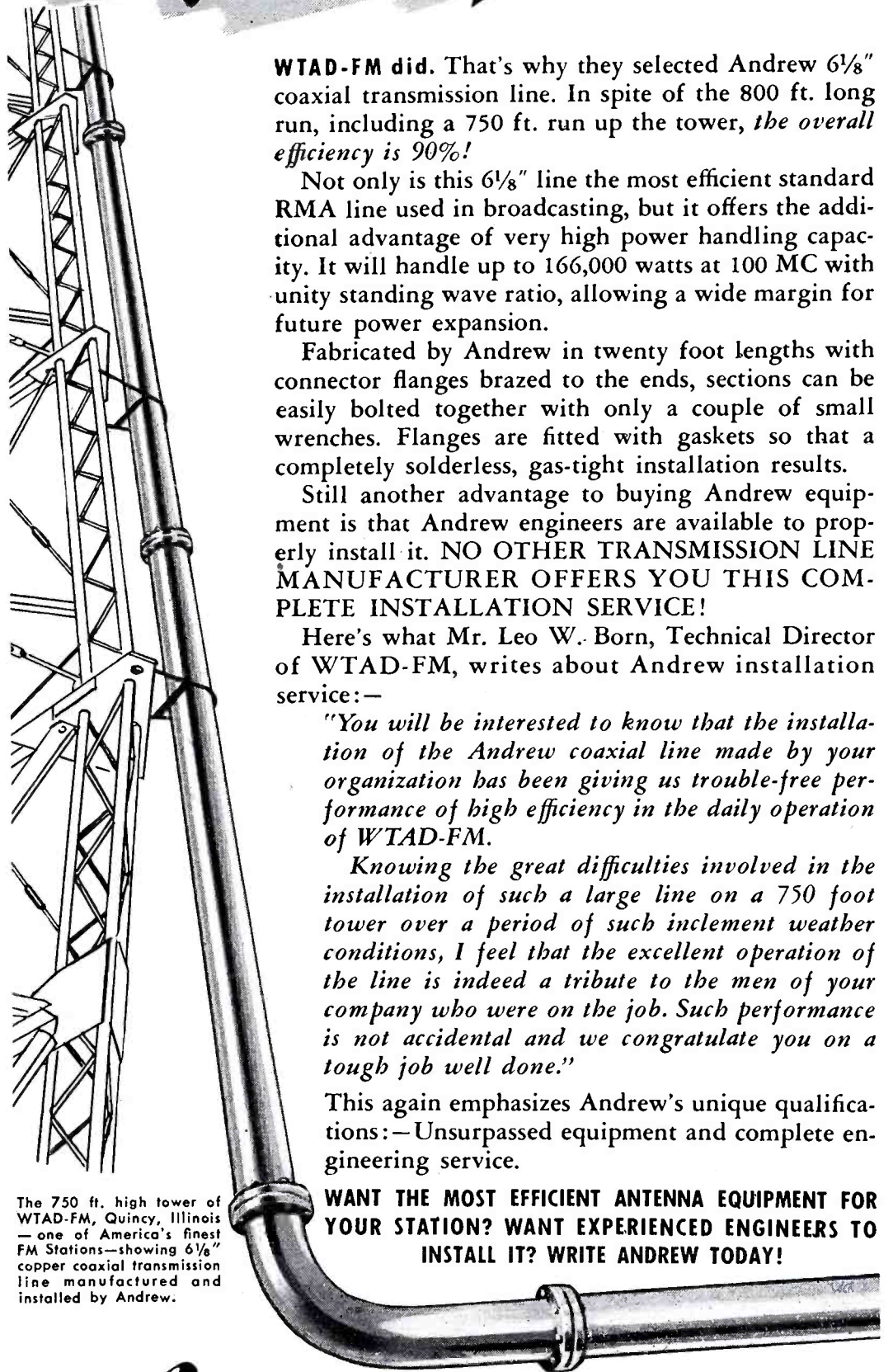

The 750 ft. high tower of WTAD-FM, Quincy, Illinois — one of America's finest FM Stations—showing 6 1/8" copper coaxial transmission line manufactured and installed by Andrew.

WTAD-FM did. That's why they selected Andrew 6 1/8" coaxial transmission line. In spite of the 800 ft. long run, including a 750 ft. run up the tower, the overall efficiency is 90%!

Not only is this 6 1/8" line the most efficient standard RMA line used in broadcasting, but it offers the additional advantage of very high power handling capacity. It will handle up to 166,000 watts at 100 MC with unity standing wave ratio, allowing a wide margin for future power expansion.

Fabricated by Andrew in twenty foot lengths with connector flanges brazed to the ends, sections can be easily bolted together with only a couple of small wrenches. Flanges are fitted with gaskets so that a completely solderless, gas-tight installation results.

Still another advantage to buying Andrew equipment is that Andrew engineers are available to properly install it. NO OTHER TRANSMISSION LINE MANUFACTURER OFFERS YOU THIS COMPLETE INSTALLATION SERVICE!

Here's what Mr. Leo W. Born, Technical Director of WTAD-FM, writes about Andrew installation service:—

"You will be interested to know that the installation of the Andrew coaxial line made by your organization has been giving us trouble-free performance of high efficiency in the daily operation of WTAD-FM.

Knowing the great difficulties involved in the installation of such a large line on a 750 foot tower over a period of such inclement weather conditions, I feel that the excellent operation of the line is indeed a tribute to the men of your company who were on the job. Such performance is not accidental and we congratulate you on a tough job well done."

This again emphasizes Andrew's unique qualifications:—Unsurpassed equipment and complete engineering service.

WANT THE MOST EFFICIENT ANTENNA EQUIPMENT FOR YOUR STATION? WANT EXPERIENCED ENGINEERS TO INSTALL IT? WRITE ANDREW TODAY!

Andrew TRANSMISSION LINES
CORPORATION ANTENNA EQUIPMENT

363 EAST 75TH STREET, CHICAGO 19 • EASTERN OFFICE: 421 SEVENTH AVENUE, NEW YORK CITY

News Briefs

(Continued from page 31)

Charles L. Townsend is now television operations supervisor of WNBQ, Chicago. Courtney Snell is field supervisor for that area.

Morrison L. Gable, Motorola communications engineer, has received a commendation for emergency flood control work in Parkersburg, West Virginia.

George M. Lebedeff, formerly chief engineer, Heintz & Kaufman Ltd., has joined Lenkurt Electric Co., San Carlos, Calif., as a carrier engineer.

LITERATURE

Reeves-Hoffman Corporation, 321 Cherry Street, Carlisle, Pa., have published a catalog (RHC-X) covering a line of quartz crystal units. Bulletin illustrates the variety of crystal holders available for special purpose calibration, mobile, aircraft, commercial, and general radio use. Featured is a small universal crystal holder with a frequency coverage from 50 kc to 100 mc.

Andrew Corp., 363 East 75th St., Chicago 19, have released a general price list, offering a tabulation of transmission line, antenna and related equipment manufactured and sold by Andrew Corp. It includes type numbers, descriptions and prices for over 600 items.

Electro-Voice, Inc., Buchanan, Michigan, have prepared a 4-page condensed bulletin (No. 103) on microphones, stands and accessories.

Bulletin includes data on cardioid dynamic and crystal microphones, broadcast and general purpose dynamic and crystal microphones, carbon, dynamic and crystal mobil-mikes, differential microphones, velocity microphones, contact mike, and low-cost multi-purpose microphones.

International Resistance Company, 401 N. Broad St., Philadelphia 8, Pa., have released a 4-page bulletin, F-1, with complete specifications and characteristics for type MP h-f resistors; ¼ to 90 watts, 8 terminal types.

Federal Telecommunication Laboratories, Inc., 500 Washington Ave., Nutley 10, N. J., have released five bulletins describing a 23-channel pulse-time multiplex radio link, f-m u-h-f radio link, tv broadcast transmitter monitor, f-m u-h-f broadband radio link, and all metal dummy antenna for f-m broadcast transmitters.

Radio and Electronic Distributor Division, Ward Leonard Electric Company, 53 W. Jackson Blvd., Chicago 4, Illinois, have prepared a reference-guide catalog, D-130, which describes and illustrates the W-L line of stock units in resistors, rheostats, and radio amateur relays.

The Instrument Division, Allen B. Du Mont Labs., Inc., 1000 Main Ave., Clifton, N. J., have released a 63-page book entitled "The Cathode-ray Tube and Typical Applications."

Book is intended especially for high schools, technical schools and colleges, particularly in conjunction with the Du Mont wall chart on the cathode-ray tube. A copy of both the wall chart and the book may be obtained by any instructor requesting same on school stationery. To others primer will be furnished at 50c per copy. Bulk quantities for school use will be furnished at \$2.50 per dozen copies.

The RCA Engineering Products Department have prepared an 84-page illustrated sound products catalog, 218-P.

Booklet is divided into sections dealing with such sound products as microphones, amplifiers, speakers, program control and distribution facilities, and specialty products. Each section in turn presents a list of products designed to meet needs ranging from those of portable systems to those of large sound installations.

Descriptions of each model include such information as special features, uses, and specifications, as well as photographs and diagrams. Many new items, such as the RCA wire recorder, model SP-15A portable sound system, the RCA intercom system, 250-watt amplifier, and the bantam velocity microphone (MI-12002), are described.

John F. Rider, Publisher, Inc., 404 Fourth Avenue, New York 16, N. Y.; will soon publish a 204-page loose-leaf Public Address Manual, containing the products of 147 p-a equipment manufacturers. Price will be \$18.

ZOPHAR WAXES COMPOUNDS and EMULSIONS



FOR
INSULATING and WATERPROOFING
of ELECTRICAL and
RADIO COMPONENTS

Also for
CONTAINERS and PAPER
IMPREGNATION

FUNGUS RESISTANT WAXES

ZOPHAR WAXES and COMPOUNDS

Meet all army and navy
specifications if required

Inquiries Invited

ZOPHAR MILLS, INC.
FOUNDED 1846

122-26th ST., BROOKLYN, N. Y.

American Phenolic Corp., 1830 South 54th Avenue, Chicago 50, Ill., have published a 74-page catalog (A-1) on AN connectors and fittings. Catalog contains data on an assortment of Army-Navy electrical connectors. Each page gives specifications as to number of contacts, current or wire size, voltage or contact spacing. Illustrations show the assortment of insert arrangements available, and the number and size contacts and mechanical spacing is tabulated.

AN fittings are presented with information required to make a selection and are indexed in numerical sequence for ready reference, dimensions and functional diagrams. Inserts are numerically listed by the Army-Navy numbers and cross-checked by page reference to available types of shells and constructions. Send requests on business letterhead.

Kenyon Transformer Co., Inc., 840 Barry St., New York 59, N. Y., have released a 12-page catalog describing audio transformers, filter reactors, swinging reactors, plate and filament reactors, power line auto transformers, filament transformers, humbucking transformers, isolation transformers, broadcast remote line-to-line, line-to-grid, interstage, and output transformers and chokes.

Also presented is a graph providing rapid readings of reactance, capacity, inductance, and resonant frequency.

Simpson Electric Company, 5200-18 West Kinzie St., Chicago 44, Ill., have prepared a 28-page operator's manual for the model 221 volt-ohm-milliammeter. Manual, which accompanies instrument, offers operational and maintenance data, circuit applications, resistor and capacitor color code charts, volt-db conversion chart and reactance data for a-f and r-f.

CORRECTION

The output voltage formula, appearing in the K. H. Fox article on *Dynamotor Design* on page 14, August, COMMUNICATIONS, should have read:

$$E_{\text{output}} = \left[(E_{\text{in}} - I_{\text{n}}R_{\text{in}}) \frac{T_{\text{out}}}{T_{\text{in}}} \right] - I_{\text{out}}R_{\text{out}}$$

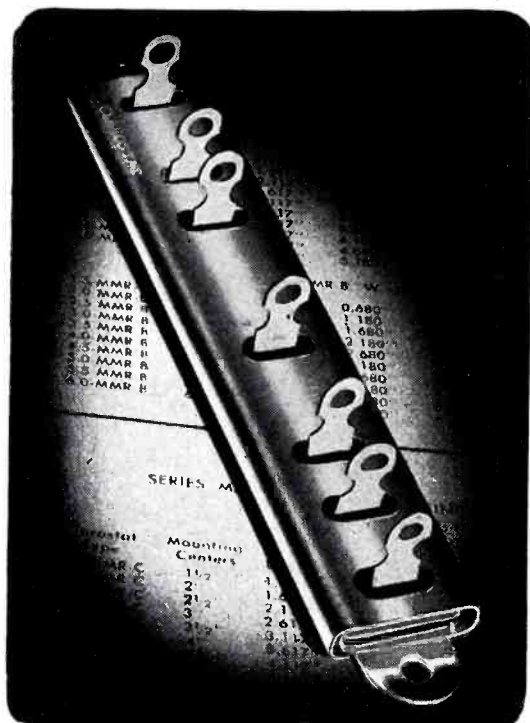

VOLTAGE DIVIDERS

★ Clarostat Series MMR bakelite-insulated metal-clad resistors run definitely COOLER than any other similar types. SIZE FOR SIZE. Or putting it another way, these strip resistors will DISSIPATE MORE POWER for the same temperature rise. SIZE FOR SIZE.

Hundreds of thousands in daily use! They tell their own story!

Resistance values from fraction of ohm to 15,000 ohms per winding inch. In standard, inverted and vertical mounting types. Any number of intermediate taps within reason. 5 watts per winding inch mounted on metal radiating surface; 2½ watts in free air.

Engineering Bulletin 109 on request. Let us quote.

CLAROSTAT



Controls and Resistors

CLAROSTAT MFG. CO., Inc. - 285-7 N. 6th St., Brooklyn, N. Y.

In Canada: CANADIAN MARCONI CO., Ltd. Montreal, P. Q., and branches

Taxicab Two-Way System



Antenna system of the Yellow Taxicab two-way radio setup located at Third and Lucas Streets, Los Angeles, Calif.



Mobile Communications control cabinet used in the Yellow Cab System.

Mobile Communications cab transmitter and antenna. (All photos courtesy Cannon Electric Development Co.)

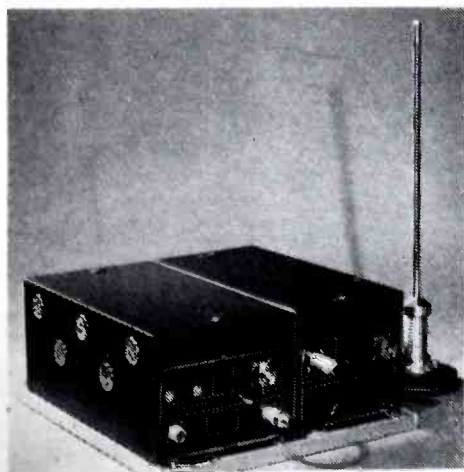

Flexibility makes

"the Service Man's Line"

Brach antennas . . . long known for dependability . . . maximum reception . . . trouble-free operation . . . durability and ease of installation . . . now feature an added extra . . . Flexibility. Unique construction features aid the service man in making a more rapid installation to which future additions or modifications can be easily made.

1. FLEXIBILITY A complete line designed with basic antenna parts which are convertible to more complex arrays as required by location and reception problems.

2. COMPLETE KITS Each antenna model is independently designed and furnished in a completely packaged kit containing all necessary hardware, download (when desired) and the Universal Base Mount . . . ready for installation.

3. PRE-ASSEMBLY Each antenna is factory pre-assembled as far as possible, ready to erect. Complete and simple installation instructions. Saves valuable man-hours on the roof.

4. MECHANICAL STRENGTH Weather - tested for durability, Brach Antennas feature a husky steel mast, rigid connections, sturdy base mount, neat appearance. All parts corrosion resistant.

5. SUPERIOR RECEPTION Designed with engineering "know-how". All Brach antennas are factory pre-tuned, matched for 300 ohm transmission line with large diameter aluminum elements for better signal pick-up. Directivity patterns and standing wave ratios available upon request.

New! Tops in TV! HI-LO ROTATABLE Antenna

Here it is! A rotatable antenna to provide peak performance with any station at any time. Brach introduces the new "Superview" Rotatable, covering both high (174 MC to 216 MC) and low (88 MC to 108 MC) TV bands. High band extension available for easy addition to standard dipole array for separate orientation. No more multiple images. No more "weak" stations. Brach's Superview HI-LO assures television reception that's tops. Make sure and investigate the new Superview line today.

Write for Free Brach catalog showing complete line of TV and FM antennas and accessories.

Send for Catalog No. C304

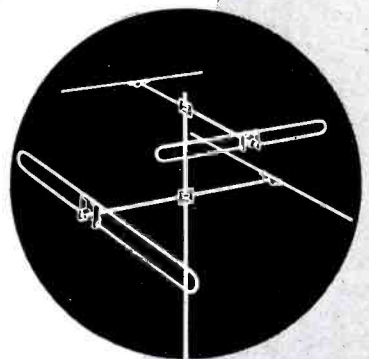

L. S. BRACH MFG. CORP.

200 CENTRAL AVENUE, NEWARK, N. J.

WORLD'S OLDEST AND LARGEST MANUFACTURERS OF RADIO ANTENNAS AND ACCESSORIES

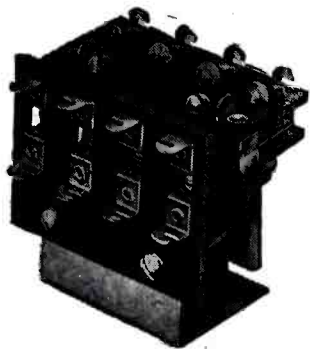

ALLIED PO AND POY MEDIUM POWER RELAYS PO RELAY

This relay is supplied in 2-, 3-, and 4-pole normally closed, normally open or double throw contacts. Its standard silver contacts have carrying capacity of 15 amperes at 24 volts D.C. or 110 volts A.C. non-inductive.

DIMENSIONS—2-Pole: same as 3-pole except for omission of center contact arm and assembly. 3-Pole: 2 1/4" h., 1 7/8" l., 1 5/8" w., 4-Pole: 2 1/4" h., 1 7/8" l., 2-3/16" w. **COIL RATING**—A.C.—10.5 volt-amperes nominal or 17.5 volt-amperes maximum at 25 to 60 cycles and up to 220 volts. D.C.—Up to 120 volts at 1 watt minimum or 8 watts maximum. **MOUNTING**—Standard #6-32 tapped holes. Also supplied with #6-32 stop nuts.

POY RELAY

A semi-sensitive, dual coil relay for operation in vacuum tube or other limited power circuits. Same contact ratings and arrangements as PO. **DIMENSIONS**—Same as PO. **COIL RATING**—Up to 110 volts D.C. at 600 milliwatts. Not supplied for A.C. **MOUNTING**—Standard #6-32 tapped holes. Not supplied with stop nuts.

For complete information on these and other Allied Relays, write us for the latest Allied catalog.

AL-122



ALLIED CONTROL COMPANY, Inc.

2 EAST END AVENUE • NEW YORK 21, N. Y.

Lateral Recording¹

BY W. H. ROBINSON

THERE ARE MANY grades of lacquer instantaneous discs. A good disc must have a good frequency characteristic and offer a minimum of much noise on playback. It must not harden appreciably with age and should be capable of being played back a reasonable number of times without a great increase in noise level or loss of high frequency modulation.

It is a simple matter to make a disc which will cut a quiet groove by simply making the material soft enough, but this type of disc will not retain the higher frequencies and will tend to distort the grooves as they dry out. This type of disc can be cut with even a dull stylus without greatly affecting the noise level. From the preceding then, it can be seen that the coating material must have a reasonable hardness or firmness to be able to properly hold the higher frequencies; however, as the hardness of the blanks is increased in many blanks, the noise level tends to rise. This can be overcome as is evidenced by the number of good discs available which offer good frequency response, low noise level, and have a reasonably long life.

Any good disc today will not dry out too much after cutting. This is a good feature to keep in mind because as the cut disc dries out and hardens, it is bound to distort the modulation in the cut grooves.

There is a very simple method which can be used to test the relative noise levels of discs under comparison. It consists simply of connecting the cutter head to the input of the recording system and inserting a *vi* meter across the output of the amplifier. With the amplifier gain open, the cutting head is lowered on the disc to be compared and a few blank grooves are cut. As these grooves are being cut, any imperfections in the material that will cause noise and act against the cutter stylus causing it to move, thus developing a voltage across the cutter head terminals. This in turn will be amplified and will show as a reading on the *vi* connected to the output of the amplifier. Naturally, the disc that causes the greatest reading on the *vi* is the one that will give the most difficulty from the standpoint of noise.

As far as the capability of the disc to retain the higher frequencies is con-

¹In the February and April, 1947, issues of COMMUNICATIONS appeared a two-part article on Lateral Recording by Mr. Robinson. In this installment additional data on the subject are offered.

STATION WHKC ...Selects TECH LABS

VERTICAL ATTENUATORS

for new CONSOLE INSTALLATION

The flick of a finger operates the patented "Gove" Vertical Attenuator. Representing the very latest in broadcast components, these units are suitable for every type of sound equipment from elaborate broadcast stations to the simplest P.A. system. Unit gives smooth easy operation and can be cleaned from front of panel by removing escutcheon. Completely shielded and dust proof.

Courtesy of WHKC, United Broadcasting Co.

Write for Descriptive Bulletin

TECH LABORATORIES, INC. Manufacturers of Precision Electrical Resistance Instruments
337 CENTRAL AVE. • JERSEY CITY 7, N. J.

No value equal to it...

Model 260 Volt-Ohm-Milliammeter

There's good reason why this is the world's most popular high sensitivity volt-ohm-milliammeter. In every part, from smallest component to overall design, no competing instrument can show superiority. It outsells because it

outranks every similar instrument. And in the Simpson patented Roll Top safety case, shown here, it brings you important and exclusive protection and convenience.

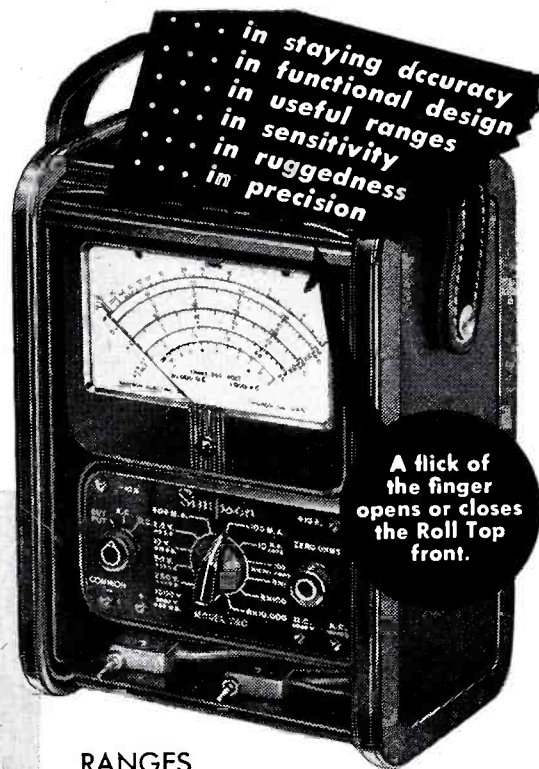

• in staying accuracy
• in functional design
• in useful ranges
• in sensitivity
• in ruggedness
• in precision

A flick of the finger opens or closes the Roll Top front.

Sub-Panel Assembly—Strong, Simple, Accessible

The ruggedness, the simplicity of design, and the consequent accessibility of components are shown here. Molded of sturdiest bakelite, the sub-panel provides separate pockets for resistors. This separation makes for orderly assembly, highest possible accessibility, and added insulation for preventing shorts. All connections are short and direct. Cable wiring is eliminated. Each battery has its own compartment, again increasing accessibility.

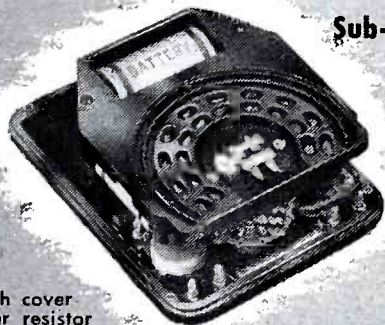

with cover over resistor pockets removed to show design



High voltage probe (25,000 volts) for TV, radar, x-ray and other high voltage tests, also available.

RANGES

20,000 Ohms per Volt D.C., 1,000 Ohms per Volt A.C.
Volts: A.C. and D.C.: 2.5, 10, 50, 250, 1000, 5,000
Output: 2.5, 10, 50, 250, 1000
Milliamperes, D.C.: 10, 100, 500
Microamperes, D.C.: 100
Amperes, D.C.: 10
Decibels (5 ranges): -10 to +52 D.B.
Ohms: 0-2000 (12 ohms center), 0-200,000 (1200 ohms center), 0-20 megohms (120,000 ohms center).
Model 260, Size: 5 1/4" x 7" x 3 1/8".....\$38.95
Model 260 in Roll Top Safety Case, as shown, Size: 5 3/8" x 7" x 4 3/4".....\$45.95
Both complete with test leads and 32-page Operator's Manual

Ask your jobber or write for complete descriptive literature.

Simpson
INSTRUMENTS THAT STAY ACCURATE

SIMPSON ELECTRIC COMPANY
5200-5218 W. Kinzie St., Chicago 44, Ill.
In Canada: Bach-Simpson, Ltd., London, Ont.

cerned, it is a simple matter to record a frequency of 500 cycles, and other frequency bands from 6000 to 10,000 cycles, on the discs and compare the results obtained.

Any disc that will allow a recording system to record a good frequency pattern on it and retain it, and which will not develop too much noise, while keeping the distortion low over a reasonable length of time, is a good disc to use on that system. If distortion measuring equipment is available, it is a simple matter to make a comparative test of distortion over a given length of time.

Pickups

The pickup should be extremely light. Some of the latest types have pressures considerably less than one ounce. The playback needle should be of such a size and shape as to be firmly gripped by the groove sidewalls, so as to force the playback needle to follow the groove excursions. To accomplish this with present day cutting standards, the radius of curvature of the playback point should be approximately .003". A smaller playback needle will be thrown from one wall to the other and will generate considerable distortion. It has been shown that the lateral playback needle must

be capable of moving in a vertical direction to minimize the effects of the squeeze of the groove at the higher frequencies.

Scratch Filters and Preemphasis

As we have seen, the cutter head, being a constant velocity device, cuts a modulated groove with its amplitude decreasing 6 db per octave above a definite turnover point. This leaves the recording with a very low amplitude of modulation at the higher frequencies which we are recording. Using a 500-cycle turnover which can be considered standard for the industry, the amplitude at 10,000 cycles will be well over 25 db below that at the turnover point. As we stated before, the amplitude of the modulation, even at frequencies in the middle range, will be attenuated to such an extent that a very small imperfection in the groove, such as a scratch, dirt, rough spot in the material, will cause enough reproduced voltage to partly mask the desired sounds. In many cases, the noise level on reproduction is enough to entirely ruin the disc for reproduction purposes unless the frequencies above about 4500 cycles are entirely wiped out by a so-called scratch filter.

When one stops to consider the labor spent to record all the frequencies up to 8000 to 10,000 cycles, it

doesn't seem a reasonable act to deliberately throw them away. In many cases, however, this is very necessary. To overcome this difficulty the NAB system of preemphasizing the higher frequencies were developed. It is a well known fact that most of the power in audio frequencies is contained in a narrow range of frequencies between 150 cycles to approximately 1000 cycles. It can be seen that it is possible to emphasize the frequencies above the turnover point so that the recording at the upper frequencies begins to approach a constant amplitude. In the system of recording, the amplifier system feeding the cutting head is equalized so that the stylus velocity, instead of remaining a constant, gradually increases, so that at 1500 cycles it is up 3 db from the 500-turnover point. From there on to the highest frequency, the rise approaches 6 db per octave; it is actually something less than this. It must be remembered that an increase in velocity of the stylus allows it to cut a more nearly constant amplitude as the frequency increases. This system gives a very much greater amplitude of modulation in the groove than was achieved by cutting the straight characteristics of the head.

[To Be Continued]



JOHNSON
a famous name in radio

**BROADCAST
EQUIPMENT**

Adjustable phase sampling loops

Isolation filters

Sampling lines

FM and AM concentric lines

Fixed capacitors

Variable capacitors

Phase sampling transformers

FM iso-couplers

Standing wave indicators

Tower lighting filters

Supports for open wire transmission lines

Pressurized capacitors

Neutralizing capacitors

Fixed inductors

Variable inductors

Write for specific information directly or through your consulting engineer.

E. F. JOHNSON CO.
WASECA, MINNESOTA

OVER 10,000*
Broadcast
Communications
Radio-Television
Engineers & Executives
Subscribe to
COMMUNICATIONS

Advertising pays dividends!
* ABC net paid.

Antenna Pattern

(Continued from page 13)

considerably different than the field ratios. This symbol is not needed in the systematization on this sheet.

θ elevation angle from the space reference point measured in degrees.

E_{θ} the magnitude of the *rms* field intensity circle at the elevation angle θ . Subscripts are used, such as E_0 at zero degrees elevation and E_{40} at 40 degrees elevation, to denote the elevation angle of the *rms* field intensity. It is convenient to express this value in millivolts per meter unattenuated field intensity at one mile.

E_s the field intensity of an equivalent standard hemispherical uniform radiator. For 1 kw of radiated power this standard hemispherical uniform radiator will give 152.1 mv/m unattenuated field intensity at one mile.

P_r the amount of radiated power from the proposed directional antenna.

Station Data Tabulation

Station data tabulation, with station call letters entered on the first line of station data; if the call letters have not been assigned, line remain blanks or the word *new* inserted. The proposed operating frequency in kc and the proposed operating power in kw inserted. Time of operation designated by one of the following:

- U* unlimited.
- D* daytime.
- N* night time.
- ST* shares time.
- L* limited time with dominant station.
- LS* local sunset.
- SH* specified hours.
- SA* special authorization

Type of operation specified by one of the following:

- DA-N* directional antenna night time.
- DA-D* directional antenna day time.
- DA-1* directional antenna with same power and same pattern day and night.
- DA-2* directional antenna with different power and/or different pattern day and night.

Ground system briefly described by the number of radials per tower, the length of these radials and the dimension of the ground screen if used.

Latitude and longitude given for the space reference point of the directional antenna system. Supersedes refers to the previous design pattern, if any. This number can be given as year in two digits, month in two digits, and day in two digits. Pattern number refers to the proposed pattern and is given as year in two digits, month in two digits and day in two digits.



**MOORE
SET SCREWS**

Spotlight Progressive Industry

GEORGE W. MOORE, Inc.
100 BEAVER ST. WALTHAM, MASS.

**CO-AX
CONNECTORS**



**AVAILABLE FOR
IMMEDIATE
DELIVERY**

We carry all popular standard and British type coaxial cable connectors in stock. These connectors are brand new and were produced for the Government by the leading manufacturers in this field. Our inventory contains sufficient quantities for the largest users at prices well below the market. Write or wire for special Coaxial Cable and Connector Listing 100A or send us your requirements.

**Manufacturers
and Distributors**

Wells maintains one of the world's largest inventories of highest quality radio-electronic components. Our new catalog, now ready, will be mailed upon request.

**WRITE
FOR
CATALOG!**

**WELLS
SALES, INC.**

320 N. LaSalle St., Dept. M
Chicago 10, Illinois

TV Sound

(Continued from page 9)

for operating his boom with the minimum of noise. The operator will learn how to direct his overhead microphone from one artist to another, as the production proceeds, without giving the listener the impression that *someone is building a house in the studio*. Proper handling of a studio boom microphone can only come through experience, together with interest on the part of the operator in doing an acceptable job. But, if microphone booms can be noiselessly handled in motion picture studios, they can most certainly be so handled in the tv studio.

The proper maintenance of studio camera dollies, frequent lubrication of moving mechanical parts, and a genuine interest on the part of the cameraman in keeping the extraneous noise developed by his camera to the minimum, can result in the same type of noiseless dolly operation we find in the professional motion picture studio.

Studio Acoustics

Studio acoustics present another problem in tv sound work. Since the flats, back-drops, and other material employed in building sets is, for the most part, hard-surfaced material, it is fairly *live*. Such non-porous material leads to over-accentuation of the higher frequencies within the pass-band. This seems to indicate the need for better acoustical treatment of the tv studio, and particularly the use of more porous, absorbent acoustical material in studio construction. Thus, if the studio is made more highly absorbent, then when the *live* flats are moved in, a more proper balance, acoustically, will be obtained. This is a difficult problem which requires thorough study on the part of competent acoustical engineers.

Sight and Sound Fidelity

In conclusion, let us bear in mind that in telecasting we are appealing to two senses, seeing and hearing. One is no more important than the other, and the owner of a tv receiver is equally interested in receiving high-quality sound as well as a high-definition picture. The two transmitting media, visual and aural, must advance *together* as techniques are improved. Of importance at the moment should be our efforts to make the fullest use of both the visual and aural facilities at our disposal.



KINGS

MINIATURE CONNECTORS

KINGS ELECTRONICS, the largest manufacturer of co-axial connectors, brings you a complete line of ultra small co-axial connectors for RG 58/U and RG 59/U (television) cables. Combining economy and operating efficiency, these precision-made connectors are up to KINGS high standards of manufacture.

Plugs and junctions are well matched in impedance and will handle 50 watts R.F. power. The plugs feature a simple assembly to the cable, which requires no soldering of braid wires or inner conductor.

A positive, low resistance contact between the plug and receptacle shells is achieved through the use of a ball and line type contact.

The following miniature connectors are available:

	RG 58/U	RG 59/U
CHASSIS FEED THRU . . .	KP 6000	KP 6500
PLUG BODY	KP 7000	KP 7500
FEED THRU	KP 8000	KP 8500
RECEPTACLE CHASSIS . .	KP 9000	KP 9500

Write for further details and prices.

KINGS
Electronics
372 CLASSON AVE. BROOKLYN 5, N. Y.

FM TELEVISION & HAM ANTENNAS • MICROPHONE PLUGS & JACKS
VARIABLE CONDENSERS • CO-AXIAL CONNECTORS • WAVE GUIDES
WAVE TRAPS • RADAR ASSEMBLIES • SPECIAL ELECTRONIC EQUIPMENT

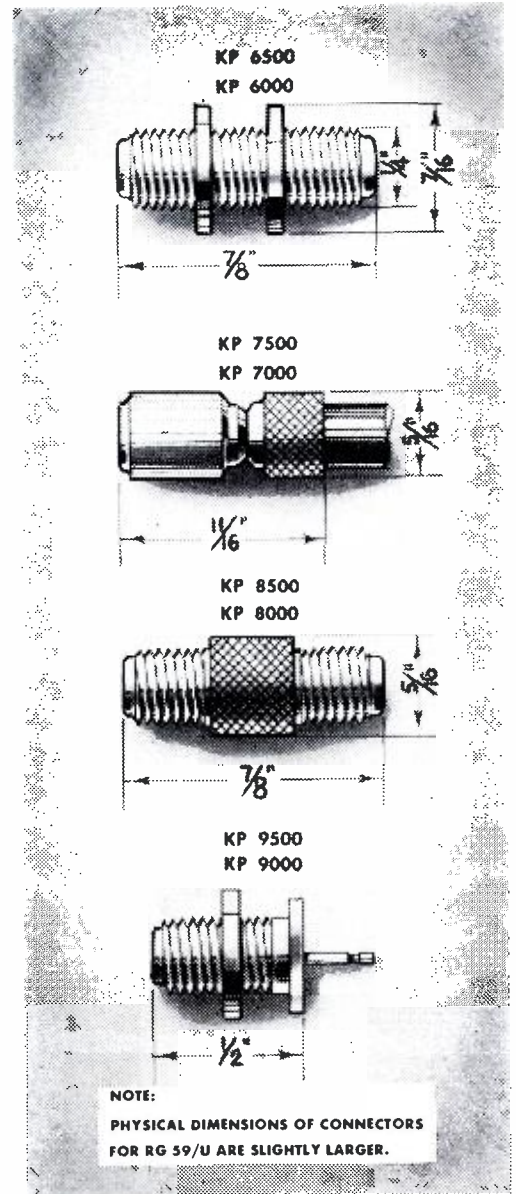

Remote Unit

(Continued from page 15)

approximately 6 db at 1,000 cycles on a tone test.

Unit's Advantages

The engineering staff of WAGE does not claim any originality with this addition, but we find it much easier to handle most of the remote pickups with one unit, instead of two and sometimes three units that were previously necessary.

MOTORCYCLE POLICE F-M



Recently developed police motorcycle car featuring a 7 to 10 watt f-m two-way system, operating in the 152 to 162-mc band. (Courtesy Harley-Davidson and Motorola)

KEEP POSTED ON ELECTRON TUBES

Use this convenient coupon for obtaining the RCA tube reference data you need.

RCA, Commercial Engineering, Section IW38, Harrison, N. J.
Send me the RCA publications checked below. I am enclosing \$..... to cover cost of the books for which there is a charge.

Name _____
Address _____
City _____ Zone _____ State _____

- Quick-Reference Chart, Miniature Tubes (Free). [A]
- HB-3 Tube Handbook (\$10.00)*. [B]
- RC-15 Receiving Tube Manual (35 cents). [C]
- Receiving Tubes for AM, FM, and Television Broadcast (10 cents). [D]
- Radiotron Designers Handbook (\$1.25). [E]
- Quick Selection Guide, Non-Receiving Types (Free). [F]
- Power and Gas Tubes for Radio and Industry (10 cents). [G]
- Phototubes, Cathode-Ray and Special Types (10 cents). [H]
- RCA Preferred Types List (Free). [I]
- Headliners for Hams (Free). [J]

*Price applies to U. S. and possessions only.



TUBE DEPARTMENT

RADIO CORPORATION of AMERICA
HARRISON, N. J.



Tube News

(Continued from page 22)

rent and grid-voltage ratings are never exceeded for any load. An approximate rule is to adjust the grid-current and grid-voltage values at full load to one-half of the corresponding maximum values. This operating condition permits grid-current and grid-voltage values to rise from zero load to twice their full-load values, and usually provides adequate leeway.

At frequencies as high as 30 mc, the 812A can be operated at maximum ratings in all classes of service. The tube may be operated at higher frequencies provided the maximum value of plate voltage and power input are reduced as the frequency is raised.

In table 1 appears a tabulation which shows the highest percentage of maximum plate voltage and power input that can be used up to 100 mc for various services.

Frequency (mc)	30	60	80	100
Max. Permissible Percentage of Max. Rated Plate Voltage and Plate Input:				
Class C telephony ..	100	89	70	55
Class C telegraphy ..	100	89	70	55
Self-rectifying oscillator	100	89	70	55

Table 1

Highest percentage of maximum plate voltage and power input that can be used for 812A up to 100 mc.

The push-pull or the parallel connection may be used, when more power output is required than can be obtained from a single 812A. For example, two tubes connected in push-pull or in parallel will give approximately twice the power output of one tube. The parallel connection requires no increase in exciting voltage; the push-

LONG DISTANCE RADIOTELEPHONE CALL SETUP



Major Emilio J. Baduel, Director of the Military Factory for Communications Equipment of the Argentine Army (at right of front seat in auto) placing a phone call from Philadelphia to an official in Buenos Aires via a Philco f-m transmitter. Driver of the car is Leslie J. Woods, general manager, Industrial Division, Philco.

REVOLUTIONARY SOLDERING IRON

TRANSVISION Soldetron

Tr. Mark Reg., Pat. Pend.

For Easier, Better Soldering—on Any Job!

- Weighs only 3 ozs., yet can do the job of a 200 watt iron.
- Heats up in 20 seconds from a cold start; saves time.
- Fingertip control; permits soldering without fatigue.



Ready for attachment and operation on 110 V A.C., 50-60 cycles, through transformer supplied with iron, or 6-8 volt A.C. or D.C. without transformer (from an automobile battery).

Overall size of iron 9 1/4" x 15/16"; shipping weight approx. 4 lbs.



- Ideal for fine precision work in "hard-to-reach" places.
- Readily interchangeable tip-heads; no cleaning or filing.
- Retains heat with switch off up to 1 minute; efficient.
- Bakelite handle, cork covering, for comfortable cool grip.

PRICE: including transformer and Tip-Head "A", \$13.95
5% higher west of Mississippi; fair traded

Ask your distributor, or for further information write to:

TRANSVISION, INC., Dept. C, NEW ROCHELLE, N. Y.

IN CALIF.: Transvision of Cal., 8572 Santa Monica Blvd., Hollywood 46

pull connection requires twice the r-f excitation voltage necessary to drive a single tube. With either connection, the driving power required is approximately twice that for single-tube operation while the grid bias is the same as that for a single tube. The push-pull arrangement has the advantage of simplifying the neutralization of h-f circuits and of minimizing the even-order harmonics in the output.

If parasitic oscillations occur in the parallel or the push-pull circuits, they can often be eliminated by connecting a non-inductive resistor of 10 to 100 ohms in series with each grid lead, as close to the socket terminal as possible.

1B3GT Filament Voltage Control

When the 1B3GT is used as a high-voltage rectifier with an r-f power supply or a pulse-operated power supply for a tv receiver, its filament is supplied from a h-f power source, which is at a high d-c potential with respect to ground. Consequently, adjustment of the filament operating conditions by direct measurement of the filament voltage or current is usually impractical. However, a simple method utilizing visual comparison of filament temperatures has been found very satisfactory for such adjustments.

The cutaway view of the tube (Figure 1) reveals that the filament is mounted well inside the plate cylinder. This mounting is an important feature of the tube because, if the emitting surface of the filament extended below the edge of the plate, electrons drawn from the filament could miss the plate, strike the glass with high velocity, and lead to gas liberation and early tube failure. The most common mounting position for the 1B3GT is vertical, base down, inside a shield enclosing the power supply. In such a position, it is generally not possible to observe the filament directly for a temperature determination. In a dark room, however, it is possible to see the light from the filament reflected from the shield collar. A feasible method for determining the filament temperature, therefore, involves observing the reflected light when the filament is heated with a measured d-c or low-frequency a-c voltage, connecting the h-f supply, and then adjusting the h-f power until the same light is obtained.

Methods Employing Direct Observation

With many power supplies, it is possible to place a small mirror near the base of the 1B3GT in such a position that the reflection of the filament can be observed directly. Because this

guaranteed footage here gives you full value in PANTHER and DRAGON TAPES

The footage meter illustrated tells the operator automatically the exact length of tape on the rolls. This is but one of many measures used in the production of PANTHER and DRAGON Friction and Rubber Tapes that assure you of full value every time. And these tapes rate high in all the qualities that make for lasting splices.

Made by a company in the insulation business for nearly 70 years, PANTHER and DRAGON Tapes pass ASTM and federal specifications for electrical and physical properties with a wide margin of safety. They have proved their worth in successful splicing jobs of all kinds. These tapes are sold only through recognized independent wholesalers.

The Okonite Company, Passaic, N. J.



Panther and Dragon friction and rubber tapes

method permits direct comparison of filament colors, more light can be tolerated in the room when comparisons are being made. A further improvement is to project the images of the two filaments, side by side, on a translucent screen; two mirrors, two simple lenses, and a piece of tracing paper, arranged as in Figure 1, are required. A very high accuracy of matching can be achieved with such an arrangement. It would also be possible to use an optical pyrometer with the aid of a mirror, but comparisons should still be made between color temperatures observed with d-c and high-frequency power to avoid any error which might

arise from discoloration of the mirror or the glass of the tube.

Tests made in the labs of the RCA Tube Department indicate a standard deviation of .024 volt for a series of comparison readings made with d-c on the filaments of both tubes of the pair under test. An accuracy of better than 5 per cent in the adjustment of filament voltage at standard line voltage is desired in order to minimize excessive deviation in one direction or the other with line voltage variation.

(Data based on copyrighted material prepared by RCA.)

Engineered to the Highest FM and AM Broadcast Standards



Model 650
(Output -46 db)

NEW!

High Fidelity Dynamic



BROADCAST
Microphones

FEATURES LIKE THESE
WIN TOP RATING

by Station and Network Engineers!

Flat out to 15 kc! Extremely high output! Impedance selector! Dual-type shock-mount! Remarkably rugged! Individually calibrated!

Developed in cooperation with station and network engineers, the new "650" and "645" meet exacting requirements of modern high fidelity FM and AM broadcast service. Proved in studio and remote use. Polar pattern is non-directional at low frequencies, becoming directional at high frequencies. Recessed switch gives instant selection of 50 or 250 ohms impedance. Exclusive Acoustalloy diaphragm withstands toughest use. Many other important features assure the ultimate in broadcast quality. Satin chromium finish. Fully guaranteed.

Model 650. Output level -46 db. List \$150.00

Model 645. Output level -50 db. List \$100.00

Broadcast Engineers: Put the "650" or "645" to the test in your station. Know the thrill of using the newest and finest. Write for full details.



Model 645
(Output -50 db)

NO FINER CHOICE THAN

Electro-Voice

ELECTRO-VOICE, INC., BUCHANAN, MICHIGAN
Export: 13 East 40th St., New York 16, U.S.A. Cables: Arlab

ADVERTISERS IN THIS ISSUE

COMMUNICATIONS INDEX

SEPTEMBER, 1948

ALLIED CONTROL CO., INC.	34
Agency: Michel-Cather, Inc.	
ANDREW CO.	31
Agency: Burton Browne, Advertising	
BELL TELEPHONE LABORATORIES.	5
Agency: N. W. Ayer & Son, Inc.	
L. S. BRACH MFG. CORP.	33
Agency: A. W. Lewin Co.	
CANNON ELECTRIC DEVELOPMENT CO.	28
Agency: Dana Jones Co.	
CLAROSTAT MFG. CO., INC.	32
Agency: Austin C. Lescarboura & Staff	
THE CLEVELAND CONTAINER CO.	25
Agency: The Nesbitt Service Co.	
COTO-COIL CO., INC.	29
Agency: Frank E. Dodge & Co., Inc.	
ALLEN B. DuMONT LABORATORIES, INC.	6
Agency: Austin C. Lescarboura & Staff	
ELECTRO-VOICE, INC.	40
Agency: Henry H. Teplitz, Advertising	
FEDERAL TELEPHONE & RADIO CORP. Back Cover	
Agency: J. M. Mathes, Inc.	
GENERAL RADIO CO.	Inside Back Cover
E. F. JOHNSON CO.	32
Agency: Rudolph Bartz, Advertising	
HOWARD B. JONES DIV. CINCH MFG. CORP. 26	
Agency: Symonds, MacKenzie & Co.	
KINGS ELECTRONICS CO.	37
Agency: Howard Adv. Associates, Inc.	
MEASUREMENTS CORPORATION	28
Agency: Frederick Smith	
JAMES MILLEN MFG. CO., INC.	26
GEORGE W. MOORE, INC.	36
Agency: Julian Brightman Co.	
THE OKONITE CO.	39
Agency: Doyle, Kitchen & MacCormick, Inc.	
RADIO CORPORATION OF AMERICA. . . 16, 17, 38	
Agency: J. Walter Thompson Co.	
SHALLCROSS MFG. CO.	27
Agency: The Harry P. Bridge Co.	
SIMPSON ELECTRIC CO.	35
Agency: Kreicker & Melon, Inc.	
SORENSEN & CO., INC.	Inside Front Cover
Agency: Lindsay Advertising	
SPRAGUE ELECTRIC CO.	1
Agency: The Harry P. Bridge Co.	
SYLVANIA ELECTRIC	3
Agency: Newell-Emmett Co.	
TECH LABORATORIES	34
Agency: Lewis Adv. Agency	
TRANSVISION INC.	38
Agency: H. J. Gold Co.	
U. S. TREASURY DEPT.	4
WARD LEONARD ELECTRIC CO.	30
Agency: Henry H. Teplitz, Advertising	
WELLS SALES, INC.	36
Agency: Turner Adv. Agency	
ZOPHAR MILLS, INC.	32
Agency: Gunn-Mears Adv. Agency	

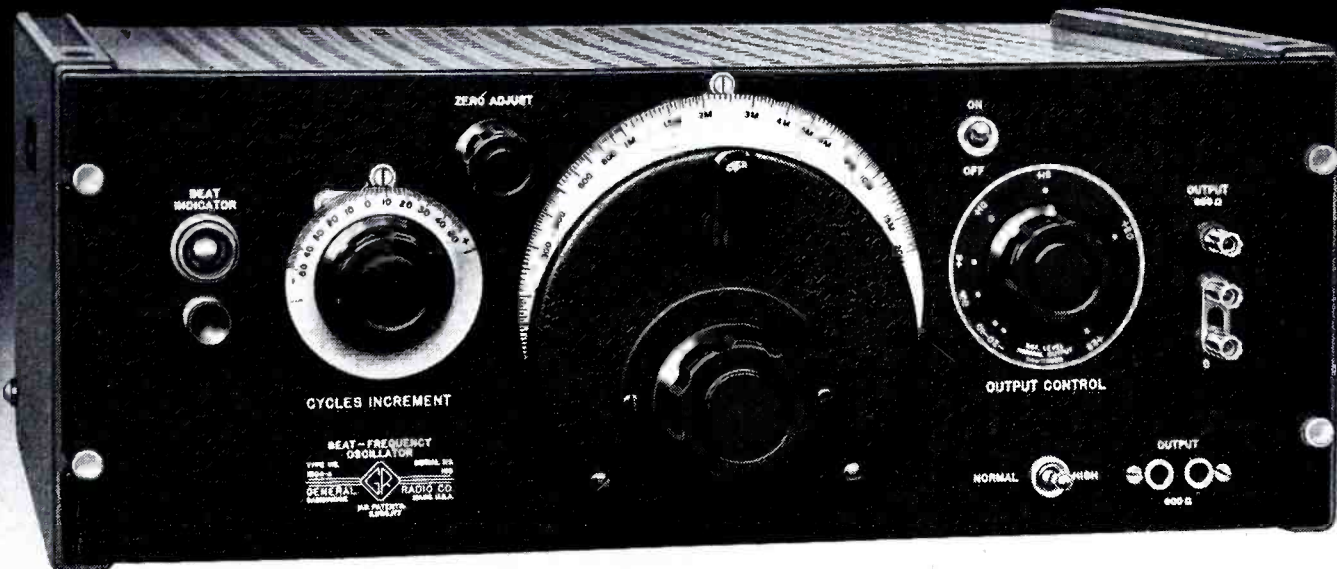

NEW OSCILLATOR with Greater Accuracy • Less Distortion • Better Zero Adjustment • New Operating Conveniences

CHECK THESE SPECIFICATIONS

- ✓ **FREQUENCY RANGE:** 20 to 20,000 cycles.
- ✓ **FREQUENCY CONTROL:** main dial true logarithmic scale 12 inches long. Frequency-increment dial calibrated from +50 to -50 cycles.
- ✓ **FREQUENCY CALIBRATION:** can be standardized within 1 cycle at any time by setting instrument to line frequency or zero beat.
- ✓ **ZERO BEAT INDICATOR:** neon lamp for zero beat at line frequency or zero scale.
- ✓ **FREQUENCY STABILITY:** drift from cold start less than 7 cycles in first hour and completed in 2 hours.
- ✓ **OUTPUT IMPEDANCE:** 600 ohms, either grounded or balanced-to-ground, and essentially constant at all output voltages.
- ✓ **OUTPUT VOLTAGE:** approximately 25 volts open circuit. For matched resistive load voltage varies less than ± 0.25 db between 20 and 20,000 cycles.
- ✓ **OUTPUT CONTROL:** calibrated from +25 db to -20 db referred to 1 milliwatt into 600 ohms.

THE Type 913-A Beat-Frequency Oscillator, introduced by General Radio in 1942 immediately set a standard of excellence because of its high frequency stability, low distortion and constant output. Since then two improved models have increased its utility and acceptance.

The new Type 1304-A Oscillator is so different from the original that it is essentially a new instrument with many refinements in the circuit, in the oscillator, addition of buffer amplifiers, improved mixer and new amplifier. It is the finest beat-frequency oscillator obtainable.

Included in the features of the new instrument are:

- **Cycles Increment Dial.**
- **Higher Accuracy of Calibration** — adjusted to $\pm(0.5 \text{ cycle} + 1\%)$. . . closer than zero beat can be established with the beat indicator.
- **More Accurate Zero Adjustment** — line voltage is fed into beat-indicator circuit, permitting oscillator output to beat with line frequency to calibrate instrument within 1 cycle.
- **Improvement in Distortion Below 100 Cycles** — through new circuits and buffer amplifiers.
- **New Gear-Drive Dial** — better bearings . . . smoother running gears . . . less backlash . . . illuminated dial.

Check the abridged specifications at left. You'll agree that you cannot buy a more adaptable instrument.

TYPE 1304-A BEAT-FREQUENCY OSCILLATOR
\$450.00



GENERAL RADIO COMPANY Cambridge 39, Massachusetts

90 West St., New York 6

920 S. Michigan Ave., Chicago 5

950 N. Highland Ave., Los Angeles 38

NEW POLICE "NERVE CENTER" STANDS GUARD OVER WASHINGTON

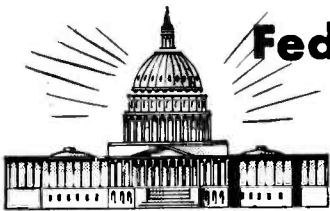

Federal Remote Control Streamlines Mobile Radio for Police in District of Columbia

Now police radio dispatching has a broader range...higher efficiency...greater accuracy...for the better protection of our national capital.

A new system using two Federal Remote Control Consoles eliminates telephone relay of messages from the Communications Center to the transmitter several miles away. Time is saved and possible errors are avoided by talking direct to 105 radio patrol cars from the Center.

Now the Center is also in immediate contact at all times with the metropolitan fire department and the police forces of the adjoining county and state.

Calls received over 10 telephone trunk lines are diagnosed on the spot and routed by radio or telephone. Even the few seconds required to fill out a complaint form can

be eliminated by simultaneous listening control. Notified by a flash, console operators actually can listen in on a call as it comes through the switchboard. A log record is kept of all calls received, and there is automatic teletype follow-up to precinct stations.

The Washington Police Department, after exhaustive study, specified Federal 106-A Remote Control as the best designed "nerve center" for this new network of protection. The Remote Control Console is only one unit of the complete line of Federal Mobile FM Radio Telephone Equipment — for police and fire departments, taxis, buses, service cars—"for anything that moves." For complete information, write to Department I-410.

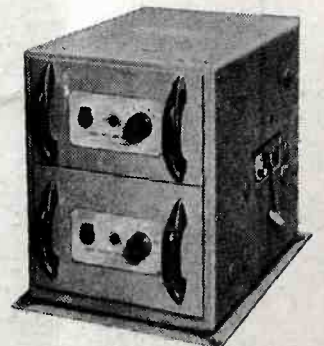

Federal Telephone and Radio Corporation

100 KINGSLAND ROAD, CLIFTON, NEW JERSEY

KEEPING FEDERAL YEARS AHEAD... is IT&T's world-wide research and engineering organization, of which the Federal Telecommunication Laboratories, Nutley, N. J., is a unit.

In Canada: Federal Electric Manufacturing Company, Ltd., Montreal, P. Q.
Export Distributors: - International Standard Electric Corp, 67 Broad St., N. Y.