

Radio Editors of magazines and newspapers will be given permission to reprint in whole or in part, with proper credit to the Aerovox Corporation, the contents of this issue of the Aerovox Research Worker, upon written request.

The AEROVOX Research Worker

The Aerovox Research Worker is edited and published by the Aerovox Corporation to bring to the Radio Experimenter and Engineer, authoritative, first hand information on capacitors and resistors for electrical and electronic application.

VOL. 22, NO. 8

AUGUST, 1952

Subscription By Application Only

The Dielectric Amplifier

By the Engineering Department, Aerovox Corporation

THE intensive use of complicated electronic devices having hundreds of circuits, such as computers, guided missiles, radar, electric musical instruments, and others, has added impetus to the search for substitutes for the conventional vacuum tube. Especially in applications where extreme reliability of operation, low heat dissipation, and freedom from microphonic effects are needed, the fragile vacuum tube leaves much to be desired. The electronics design engineer has long dreamed of a rugged, practically indestructible gadget of small dimensions capable of efficient and "fool-proof" operation to fill such critical sockets. Attempts to realize this long-sought ideal have resulted in the invention and development of the transistor, the magnetic amplifier, and the dielectric amplifier. All of these approaches hold great promise of alleviating the "tube problem" in certain fields and are of interest to workers in electronics. This issue is devoted to a practical discussion of the characteristics of the latter device.

The dielectric amplifier finds its major field of use as a d.c. or low-frequency a.c. amplifier in "work horse" circuits where special characteristics of vacuum tubes are not needed. Its

upper frequency limit appears to be in the vicinity of 10 megacycles at the present stage of development, although time may prove that appreciable extension is possible, as was the case with the vacuum tube. Having the same basic structure as a capacitor, it has none of the fragility of a tube and is much cheaper to con-

struct. Requiring no vacuum and having no filament or heater, it is much more reliable — an important consideration in today's electronic warfare where the failure of a single 6AK5 can cause a ten-thousand dollar bomber mission to "abort". And, because of the extreme simplicity of its construction, the dielectric amplifier should be

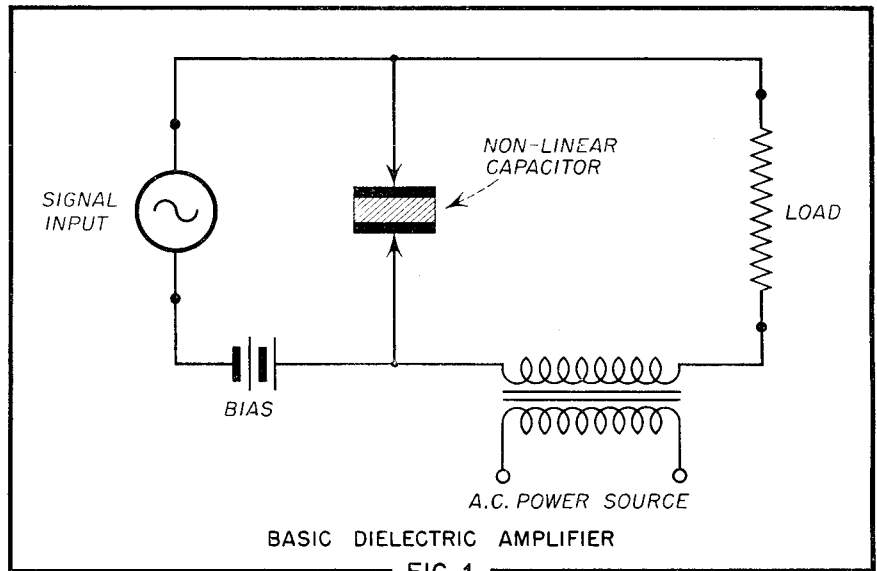

MAKE AEROVOX YOUR FIRST CHOICE

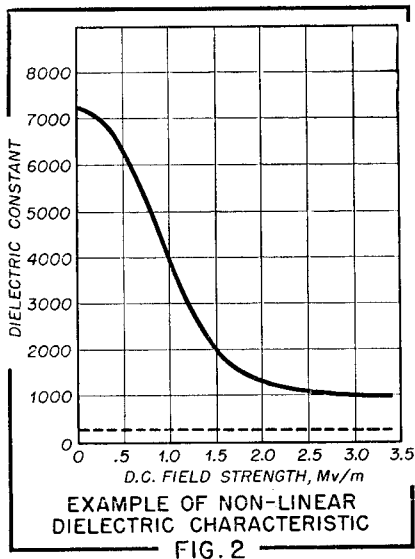

easy to mass-produce with uniform characteristics — a difficult accomplishment with vacuum tubes.

Principles of Operation

Figure 1 shows the basic circuit of the dielectric amplifier. It consists of a special capacitor connected in such a manner that the application of a small signal voltage to the "input", or "control", circuit causes a variation in the capacitance of the unit and hence a change in the alternating current flowing in the "output", or "load", circuit. The power variation in the output circuit may be many times greater than the power change in the input circuit which produced it. Hence the device is a practical amplifier.

The capacitor used in dielectric amplifiers must have what is known as a *non-linear* capacitance characteristic, i.e., the dielectric constant, and therefore the capacity, changes with the value of applied voltage. This non-linear property is exhibited by capacitors which are constructed with *polycrystalline* dielectric materials which show *ferro-electric* effects. Ceramics which have been used most extensively to date include barium titanate, strontium titanate, barium zirconate, lead zirconate, and various combinations of these. (It is interesting to note that barium and strontium *carbonates* are the materials most commonly used to coat the cathodes of vacuum tubes.) The study of dielectrics of this type is relatively new and it is probable that further research in ceramics will yield more useful varieties.

The dielectric "constant" versus applied electric field strength of a typical non-linear dielectric is plotted in Fig. 2. The characteristic for a

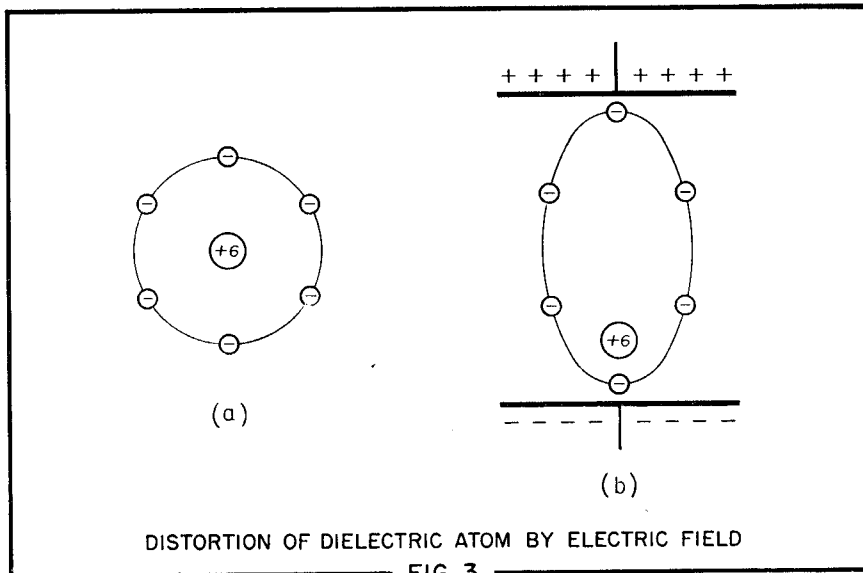

DISTORTION OF DIELECTRIC ATOM BY ELECTRIC FIELD

standard "linear" capacitor is shown in dotted lines for comparison. Changes in dielectric constant exceeding 10:1 have been observed in practice. Initial constants for typical non-linear dielectrics in common use range from 1000 to about 9000.

Dielectric Fundamentals

To gain a working knowledge of the operating principles underlying the dielectric amplifier, a review of the fundamental properties of dielectric materials is profitable. It will be recalled that a dielectric is an insulating body in which electronic conduction is essentially impossible because of the fact that all electrons are firmly bound to their atomic nuclei, so that very few free *valence* elect-

rons are available for current conduction. Thus, when the atoms of a dielectric material are "at rest", the structure of the individual atoms can be visualized as in Fig. 3a, which represents a positive nucleus surrounded by a symmetrical system of electrons held captive by the positive charge of the nucleus. However, if an electric field is impressed upon a hypothetical dielectric made up of such atoms, the system is distorted by the forces set up by the field, so that it is no longer symmetrical, as illustrated in Fig. 3b. In this condition, the atom is called an *induced dipole*, and the dielectric is said to be *polarized*. If the impressed electrostatic field is removed, the atoms revert to the symmetrical condition.

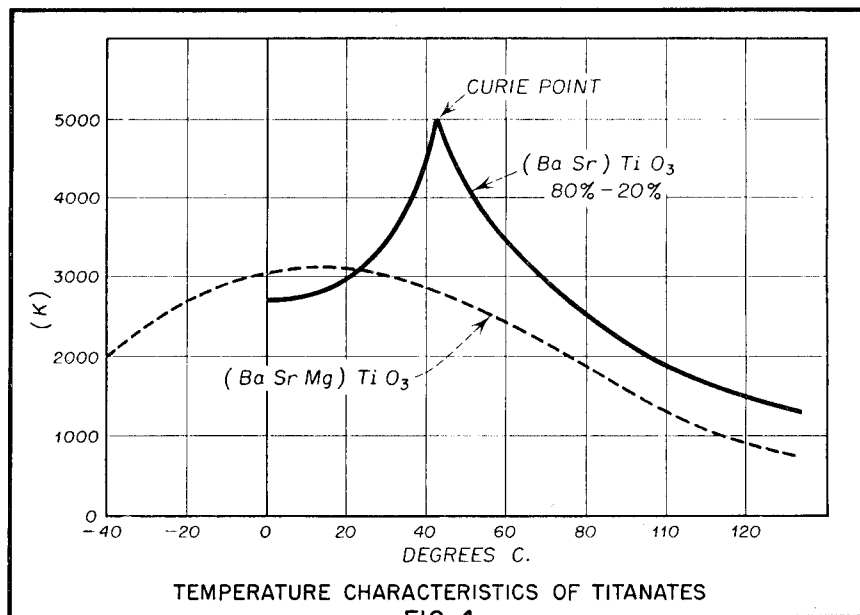

TEMPERATURE CHARACTERISTICS OF TITANATES

The result of the polarization of a dielectric material is that surface charges are set up on the surfaces of the dielectric adjacent to the charged electrodes which apply the polarizing field. These surface charges act to reduce the electric field within the dielectric, compared to what it would be if the dielectric were not present. In other words, the *permittivity* of the space between the electrodes is decreased. The reduction of the internal field depends upon the amount of distortion of the atomic structure; the degree to which the dielectric can be polarized. This is found to be essentially constant for any given type of conventional dielectric material and is for this reason termed the "dielectric constant". Materials with low constants undergo only slight deformation of the atoms, while those with high dielectric constant (K) experience greater distortion.

The non-linear dielectrics differ from the more common types principally in that the amount of distortion, or polarization, is not constant, but varies with the impressed electric field. Therefore, the dielectric constant is not "constant". With it, of course, the capacity and reactance of the condenser change also. The other unique characteristic of these special dielectric materials is their extremely high dielectric constants, as mentioned above. This means that great distortion of the molecular structure is taking place. (Metals are sometimes considered dielectrics of *infinite* dielectric constant since extreme distortion of the atoms — including the complete removal of valence electrons — takes place, and the internal fields fall to zero.)

One difficulty that is encountered with the presently available grades of non-linear dielectrics is the dependence of the dielectric properties upon temperature. This is illustrated in Fig. 4, which is the curve of dielectric constant versus temperature for a barium-strontium titanate body of 80%-20% consistency, respectively. The temperature at which the dielectric constant peaks is known as the "Curie point". Different ceramic mixtures have widely differing Curie points. Dielectric amplifiers are usually operated on the negative slope near the peak. Changes in the temperature of the material can cause gain instability unless special measures, such as temperature regulation or compensation are applied. Here, again, further research is expected to unearth improved materials having less temperature dependence. The dotted curve of Fig. 4 represents one example of this. By combining mag-

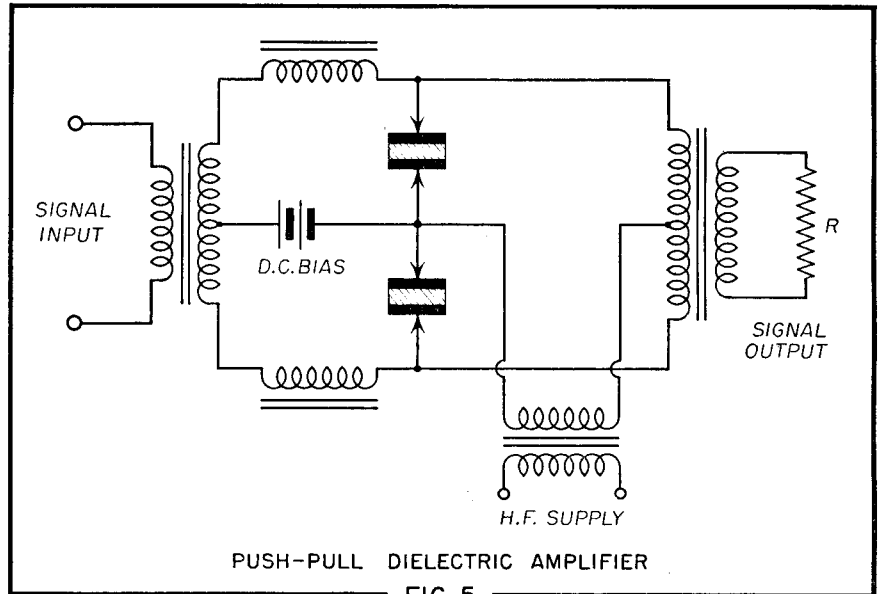

FIG. 5

nesium titanate with the usual barium-strontium titanate mixture, one firm has produced a ceramic having much more uniform dielectric properties at room temperature. It will be noted that the maximum dielectric constant is reduced, but occurs over a much greater range of temperature.

Practical Considerations

A practical circuit for a dielectric amplifier is given in Fig. 5. Here two non-linear capacitors are employed in a push-pull arrangement. Transformer input and output matching is used for impedance considerations and for added voltage gain. A high-frequency alternating current power supply must be used in the "plate" circuit of any dielectric amplifier, since a change in the reactance of the control capacitor can only have an effect on alternating

current. A self-rectifying radio-frequency power oscillator is commonly utilized for this power source.

The chokes shown in Fig. 5 are for the purpose of isolating the signal input circuit from the a.c. power in the output circuit. The d.c. bias serves to place the operating point on a suitable part of the characteristic curve of the particular dielectric used. A typical curve of input voltage versus output current for a barium titanate condenser is shown in Fig. 6. Note that this curve bears a resemblance to the E_g - I_p characteristic of a conventional vacuum tube amplifier (dotted line, Fig. 6) with the exception that it is symmetrical about the zero bias axis. This symmetry of the transfer characteristic is due to the fact that the reactance of the non-linear capacitor is increased by either a positive-going or negative-going signal at zero bias. In other words, an electric field of either polarity causes the dielectric constant to vary. The vacuum tube characteristic normally has only a positive slope. Another point of difference is that complete cut-off of output current does not occur in the dielectric amplifier as in vacuum tube devices. This follows since the dielectric constant never becomes zero, as is indicated by the plateau on the right-hand side of the curve of dielectric constant versus applied electric field shown in Fig. 2.

Dielectric amplifiers are usually biased for operation on the most linear portion of the positive slope as in conventional Class "A" operation, although other manners of operation are possible. If operated at zero bias, the dielectric amplifier acts as a frequency doubler.

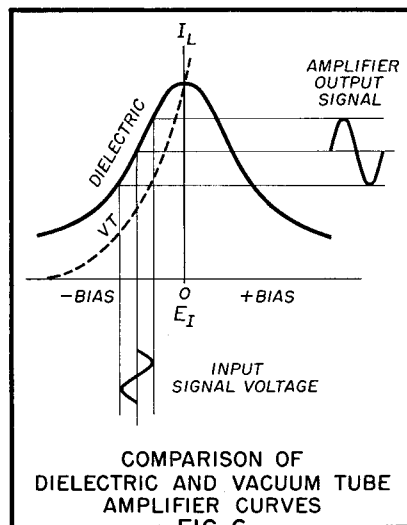
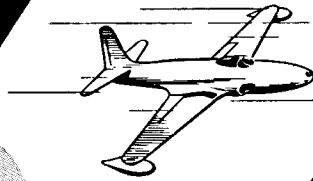
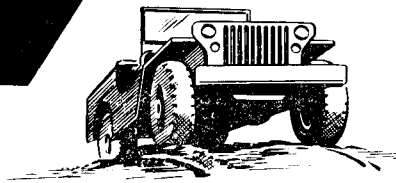

FIG. 6

Putting the **HUSH**
on radio background noises...



AEROVOX "INTER- FERENCE" FILTERS



• That "radio quiet," so vital to satisfactory communications, radar and allied radio-electronic functions on land and sea and in the air, is now simplified with AEROVOX INTERFERENCE FILTERS. These latest filter units provide maximum attenuation from 150 KC well up into the UHF range. And they are extra-rugged, extra-compact, extra-efficient, by any comparison with previous filters.

Primary applications are in r.f. noise suppression work in military or commercial aircraft and for vehicular low-voltage d.c. applications. Also, for special applications such as battery or low-voltage d.c. filters, for shield room applications, and for critical equipment.

Available in seven standard types meeting a wide variety of applications. For extraordinary requirements, special filters can be developed and built to your order.

- Write on your letterhead for latest literature. Consult AEROVOX on your noise-suppression problems, as well as capacitor requirements in general.

Remarkably small sizes and minimized weights.

Cases and terminals based on time-and-service-proven AEROVOX hermetically-sealed containers and terminals.

Cases of non-magnetic material suitably protected to withstand military service requirements for humidity, immersion, vibration, etc.

Advanced pi type construction for highest efficiency.

Capacitor sections utilize AEROLITE* metallized-paper dielectric, assuring maximum reliability and life including "fault isolation" characteristics for protection against extreme surge voltages above rated voltages.

Filter chokes of newest design, embodying high impedance to r.f. currents and low d.c. resistance, assuring low voltage drop and minimum heating.

*trade-mark

AEROVOX INTERFERENCE FILTERS			
Aerovox Type	Amps.	VDC	Size (l. x w. x h.)
IN 148	2.0	150	1 $\frac{3}{4}$ " x 1" x $\frac{7}{8}$ "
IN 150	3.0	150	1 $\frac{13}{16}$ " x 1" x 1"
IN 151	5.0	150	1 $\frac{13}{16}$ " x 1 $\frac{1}{4}$ " x 1"
IN 152	10.0	150	2 $\frac{1}{16}$ " x 1 $\frac{1}{4}$ " x 1"
IN 153	25.0	150	2" x 2" x 1 $\frac{3}{16}$ "
IN 156	40.0	150	5 $\frac{1}{16}$ " x 1 $\frac{13}{32}$ " x 1 $\frac{1}{16}$ "
IN 154	100.0	150	3 $\frac{1}{16}$ " x 2 $\frac{1}{8}$ " x 2 $\frac{7}{8}$ "



THE HOME OF CAPACITOR CRAFTSMANSHIP

AEROVOX CORPORATION, NEW BEDFORD, MASS., U. S. A.

Export: 41 East 42nd Street, New York 17, N. Y. • Cable: AEROCAP, N. Y. • In Canada: AEROVOX CANADA LTD., Hamilton, Ont.

SALES OFFICES IN ALL PRINCIPAL CITIES