

Radio Editors of magazines and newspapers will be given permission to reprint in whole or in part, with proper credit to the Aerovox Corporation, the contents of this issue of the Aerovox Research Worker, upon written request.

The AEROVOX Research Worker

The Aerovox Research Worker is edited and published by the Aerovox Corporation to bring to the Radio Experimenter and Engineer, authoritative, first hand information on capacitors and resistors for electrical and electronic application.

VOL. 22, NO. 9

SEPTEMBER, 1952

Subscription By
Application Only

Directional VHF Antennas

- Part 3 -

A High-Gain, All-Channel Television Antenna

By the Engineering Department, Aerovox Corporation

THE July and August, 1949 issues of the AEROVOX RESEARCH WORKER discussed the fundamental properties of directional antenna arrays used in the very-high-frequency region and also described various typical antenna designs which make practical use of those properties. The design of an all-channel VHF television antenna capable of excellent performance in "fringe" service areas is currently of particular interest and will be treated as a special case in this issue. Complete information on the constructional details of such an antenna are given.

The present VHF television frequency allocations, which provide for thirteen channels in two widely separated bands, makes the design of a single antenna for all channel operation a difficult engineering problem. The requirements of broad-band operation, together with high gain, are seemingly contradictory and are difficult to attain in practice. In addition, a satisfactory design must exhibit the following characteristics:

(1) A reasonably constant feeding impedance over both VHF bands.

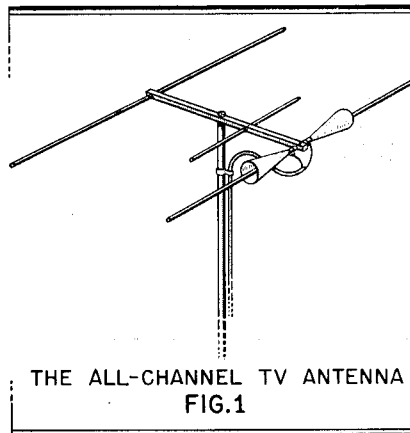

- (2) Sufficient mechanical strength to withstand heavy wind-loading, ice-loading, and, in some localities, bird-loading.
- (3) Sufficient front-to-back discrimination to reduce "ghost" picture reception.
- (4) A neat, unobtrusive rooftop appearance.
- (5) A low angle of reception.
- (6) Ease and economy of fabrication.

The complete fulfillment of these requirements is seldom if ever encountered in any single design and most commercial TV antennas presently available are compromises between the various factors enumerated above. The antenna to be described here is a particularly satisfactory solution to such compromise design problems. Its physical appearance is as shown in Fig. 1.

Design Considerations

In the design of a fringe area television antenna it can usually be assumed that all of the transmitting stations to be received are grouped in a distant metropolitan area so that a single broad-band array with fixed orientation may be used. In areas where weak signals are received at azimuthal angles greater than the width of the pattern of the antenna being used, mechanical rotation of the array is usually best. This solution has more "landlord appeal" than the use of separate arrays for each channel to be received.

The operation of a single dipole antenna over either the entire low band (54-88 Mc.) or the high band

MAKE AEROVOX YOUR FIRST CHOICE

(174-216 Mc.) is not too difficult if the dipole is made of larger diameter conductor or is of the folded-dipole type. Length-to-diameter ratios of 200:1 or less in a simple dipole result in Q values sufficiently low to permit efficient operation over such ranges. The usual practice is to cut the dipole to resonate near the low frequency end of the band to be covered. It is then inductive at the adjacent higher frequencies but functions efficiently since the reactance does not vary as rapidly on the inductive side of resonance as it does on the capacitive side. A more uniform response versus frequency characteristic is thus obtained over a limited range.

A simple dipole cannot be used effectively in fringe areas to receive all of the presently assigned VHF channels, however. This limitation arises since a 4:1 frequency ratio exists between the extremities of these two television bands. If a dipole is one-half wavelength long in the lower portion of the low band, it will be between three and four half-wavelengths long at the high channels. Such "harmonic" operation of an antenna results in "splitting" of the simple figure-eight dipole pattern into multiple lobes. The number of lobes will be equal to twice the number of half-wavelengths in the radiator. Fig. 2 illustrates the radiation pattern of a straight-conductor antenna which is three half-wavelengths long. The complex pattern is caused by the out-of-phase currents indicated by arrows in Fig. 2. Such a pattern is highly undesirable, especially at the high-band frequencies, since the response is considerably reduced in the direction perpendicular to the axis of the antenna and the large side lobes make the antenna susceptible to multi-path reception, i. e., "ghosts". The dipole thus has very poor high-band response in the direction which it favors when used for the low channels.

One remedy which has been widely used in commercial designs to prevent lobe-splitting on the high bands, involves bending the arms of the dipole forward to form an obtuse-angle "V". This modification of the dipole tends to superimpose the lobes of the otherwise-split pattern (Fig. 2) and thus maintain response in the desired direction.

Another method of maintaining a uniform dipole pattern has been suggested.* This arrangement incorporates phase-reversing sections in such a manner that the dipole func-

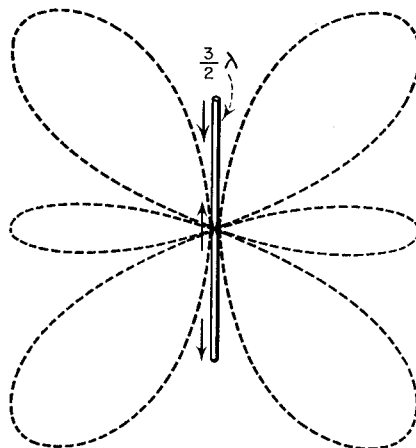

SHOWING "SPLIT"
RADIATION PATTERN OF ANTENNA
 $\frac{3}{2}$ WAVELENGTHS LONG
FIG. 2

tions as three collinear half waves in-phase on the high-band, while performing as a single half-wave element on the low channels. It will be recalled, from the discussion of collinear dipoles in the July 1949 issue that, if the alternate half-wave sections of a long wire antenna are folded into quarter wave phasing stubs to prevent radiation from them, the currents in the radiating sections are *in-phase* and their radiations add in the plane normal to the axis of the wire. The resulting collinear antenna, having three dipoles in-phase, has a gain of almost 3 db. (power gain of 2) compared with a single resonant dipole on the high bands.

In the present design, phase reversal is accomplished by two conical sleeves, mounted coaxially with the low-band dipole and with apieces connected to it at the feed-point. These sleeves are one-quarter wavelength long at the high-band mid-frequency. The outside surfaces act as part of the radiating system of the antenna while the inside surfaces function as folded coaxial phasing-sections. Fig. 3 shows the current and voltage stand-

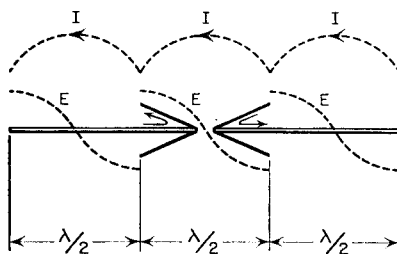

OPERATION OF DIPOLE
ON HIGH CHANNELS

ing-wave distributions on the combination dipole for both the low and high VHF channels. The conical phasing sections do not appreciably effect the performance of the dipole on the low band.

The dipole thus modified gives a uniform bi-directional pattern over both bands to be covered. To reduce "ghost" reception and co-channel interference from the rear, however, a unidirectional pattern is highly desirable. Such directional characteristics, as well as additional gain, may be achieved by the judicious use of parasitic reflectors. Most designs use wide spaced reflectors to avoid excessive reduction of the radiation resistance of the driven element and narrowing of the operating bandwidth. A reflector spacing of one-quarter wavelength at the low band is usually chosen. A reflector thus spaced also acts as a reflector on the high channels since its spacing is approximately three quarter-wavelength at these frequencies. Its effectiveness is considerably reduced, however, and at frequencies where the spacing approaches one full wavelength, the pattern becomes bidirectional. For this reason, separate reflectors are used in the present design for each band of television frequencies.

Construction

The physical dimensions of the antenna are shown in Fig. 4. The reflectors and low-band dipole are constructed of $\frac{1}{2}$ inch aluminum or duralumin (24ST) tubing. The center boom can be made of wood although $1\frac{1}{2}$ -inch square aluminum tubing (61S) is preferable. The cones are constructed of thin copper or aluminum sheet stock or may be made of copper screen. If the latter construction is used, a $\frac{1}{2}$ -inch wide strip of sheet copper should be formed into a 6-inch ring and soldered to the inside surface of the cone at the large end to add mechanical support. With some grades of screening, it may also be necessary to reinforce the cones by soldering several similar

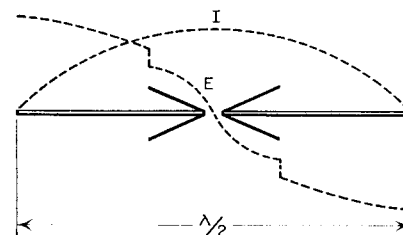

OPERATION OF DIPOLE
ON LOW BAND

FIG. 3

*W. Todd, Patent disclosure dated Dec. '48.



narrow copper stripes along the sides. The cones should make electrical contact with the low-band dipole only at the apexes, Fig. 5 gives the dimensions of the sheet-stock from which the cones are formed. If aluminum is used, rivets must be employed to join the seams. Copper, of course may be soldered. For a small fee the services of a tin shop may be engaged to form the cones.

Electrical contact is made between the small end of the cones and the low-band dipole by cutting "fingers" in the former which fit around the dipole and are tightened by a strip-metal clamp. Two 8-32 screws are used to tighten the clamps and also provide convenient terminals for the attachment of the 300 ohm transmission line.

The center spacer of the dipole assembly is made of 3/4-inch round bakelite rod about one foot long. This rod is turned down to the inside diameter of the dipole tubing for a distance of 4 1/2-inches from either end. The center portion of the bakelite rod fits through a 3/4-inch hole in the boom and is secured by a 10-32 screw. The ends of the low-band dipole tubing are slotted with a "hack-saw to a depth of 3/4-inch so that the clamps which tighten the fingers of the phase-reversing cones also secure the low band dipole to the bakelite center-insulator. Fig. 6 illustrates the details of this mounting.

The high and low band reflectors are secured to the boom in a manner similar to that employed for the driven element. The boom is drilled to receive the 1/2-inch tubing which is held in place by 10-32 screws through the tubing and one wall of the boom. (Assuming square aluminum tubing

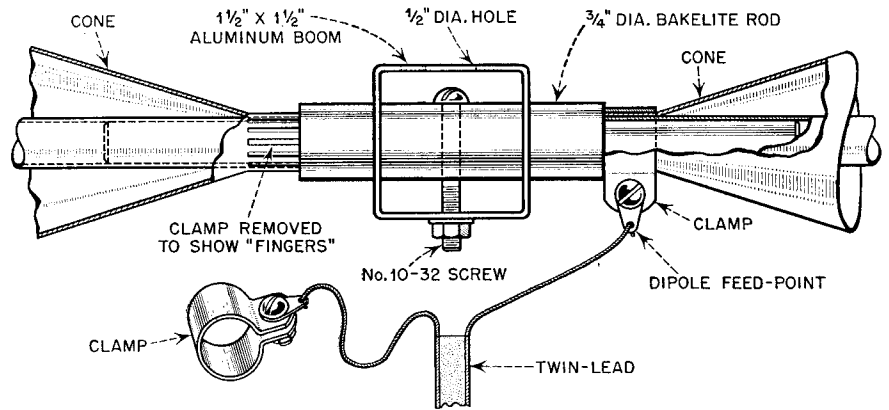

SHOWING DETAILS OF CENTER INSULATOR AND MOUNTING
FIG. 6

is used). The opposite wall of the boom is drilled with a 1/2-inch hole to facilitate introducing the screws.

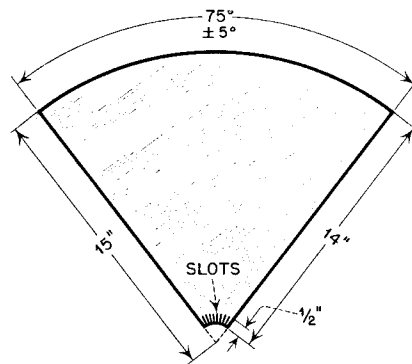

DIMENSIONS OF SHEET STOCK FOR PHASING CONES
FIG. 5

Performance

Although complete gain and pattern data are not as yet available on

this antenna design, field testing in weak-signal areas have proven it capable of consistent all-channel reception in localities as remote as 85 miles from the transmitters.

For improved gain, two such antennas may be "stacked" one above the other a distance of one-half wavelength at the low band (about 90 inches.). Feeding is accomplished by joining the two feed-points with a straight, un-transposed length of 300 ohm transmission line and connecting the 300 ohm receiver feed-line to the center of this length.

In connecting such broad-band systems to the television receiver, some compromises are usually necessary, and perfect impedance matching is not always possible. Impedance mismatches between the antenna and the transmission line are not nearly as serious as a miss-match between the feed-line and the receiver. In the latter case high standing-wave ratios are set up on the line, resulting in greater losses in the dielectric and by radiation. A miss-match between receiving antenna and line, on the other hand, effects only the efficiency of power transfer. Therefore, more care is usually taken to achieve a good match at the receiver end and accept any necessary compromise at the antenna end. In the case of radio transmission systems this situation is reversed.

In erecting the television antenna, height is of extreme importance. Also a location as remote as possible from busy highways should be sought, since automobile ignition noise is a prime source of TV interference. The antenna should be tried in several locations on the roof while the results are monitored on the TV set. If interfering "ghosts" are present, a location change of only a small fraction of a wavelength will frequently cause great improvement.

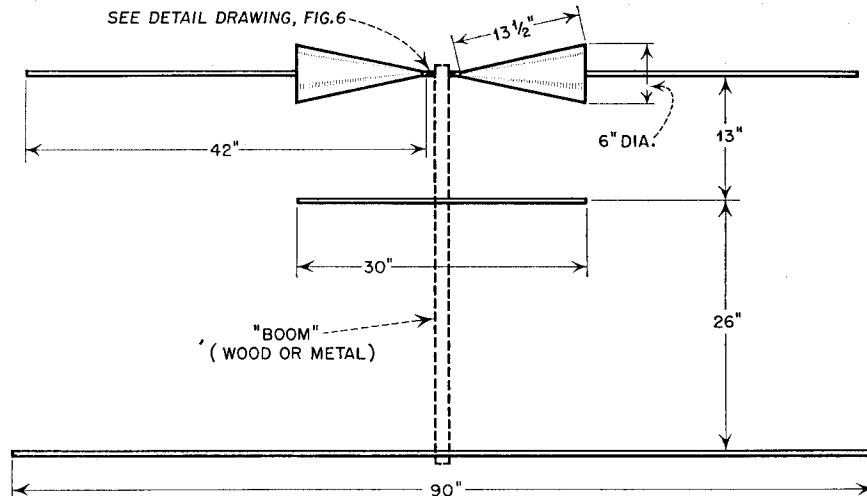

PHYSICAL DIMENSIONS
FIG. 4

marching along together...
AEROVOX resistors
capacitors



For your convenience and satisfaction, don't overlook the fact that Aerovox means RESISTORS quite as well as capacitors for your initial-equipment and service needs.

You can be sure of **top quality** in each resistor category, namely:

Insulated Carbons: 1/2 and 1 watt. Small. Noiseless. Vibration-proof. Crack-proof molded casing around molded carbon resistance element. 2" pigtail leads. Humidity-resistant. Standard tolerances, plus/minus 10%. RTMA color-coded plus stamped resistance value.

Carbofilm Precision Resistors: 1/2, 1 and 2 watt. Plus/minus 1%. Packed in sealed plastic tubes for your protection. Provide accuracy and stability of wire-wound resistors with space-saving and economy of carbon-deposit type. Also available in hermetically-sealed metal-cased units for extra-severe-service applications.

Wire-Wound Power Resistors: Wire winding protected by tough, crazeless vitreous-enamel coating. Fixed type: 10 and 20 watt. Adjustable or "Slideohm" type: 25 to 200 watt.

Ask your Aerovox distributor . . .

Order any of these essential Aerovox-resistors. Widest selection of standard resistance values listed in latest Aerovox catalog. Ask for your copy — or write us.



AEROVOX CORPORATION

NEW BEDFORD, MASS.

Hi-Q DIVISION
 OLEAN, N. Y.

WILKOR DIVISION
 CLEVELAND, OHIO

Export: 41 E. 42nd St., New York 17, N. Y. • Cable: AEROCAP, N. Y. • In Canada: AEROVOX CANADA LTD., Hamilton, Ont. JOBBER ADDRESS: 740 Belleville Ave., New Bedford, Mass.