

Radio Editors of magazines and newspapers will be given permission to reprint in whole or in part, with proper credit to the Aerovox Corporation, the contents of this issue of the Aerovox Research Worker, upon written request.

The AEROVOX Research Worker



The Aerovox Research Worker is edited and published by the Aerovox Corporation to bring to the Radio Experimenter and Engineer, authoritative, first hand information on capacitors and resistors for electrical and electronic application.

VOL. 27 NOS. 6 and 7

JUNE - JULY, 1957

Subscription By
Application Only

Small High-Voltage Supplies

By the Engineering Department, Aerovox Corporation

HIGH-voltage, low-current power supplies are required functional blocks in radiation detectors and counters, photoflash units, insulation testers, photomultiplier circuitry, cathode ray equipment, photoluminescent sources, and x-ray devices. And there are many other applications of these supplies.

Since most power supplies in the low-current category are small in size and light in weight, they are well suited to use in portable equipment, especially in battery-operated equipment. In recent years, there has been an increasing demand for small-sized, high-voltage, battery-operated supplies. The purpose of this

article is to describe the types of circuits which are being employed, giving practical examples and comparing their characteristics. It is expected that this survey will be a guide in the selection of the proper supply unit for a given application.

Many arrangements are not included in this resume', since they are highly experimental in nature or are of a makeshift character. Practical units which have proven themselves in the field generally falls under the headings: (a) batteries, (b) charged-capacitor type, (c) vibrator-transformer type, (d) vacuum-tube flyback type, and (e) transistor oscillator type.

Battery Supply

The simplest d-c voltage supply is a battery. Miniature dry batteries are available from stock in 90- and 300-volt sizes. These batteries may be series-connected for higher voltages than their rated values and are used frequently to build up a high-potential supply.

In some applications, especially those in which circuitry must be kept simple and at a minimum, only batteries can be used. The complication and added space requirements attendant to the use of tubes, transformers, filter chokes and capacitors, and voltage regulators thus are avoided.

AEROVOX - - The Finest In Electronic Components



Despite its simplicity, high-voltage battery operation is the most expensive way to obtain kilovolt potentials. A high-voltage supply using batteries only has the highest initial and replacement costs: about 26 cents per volt for the 300-volt units and approximately 31 cents per volt for the miniature 90-volt units. The milliampere-hours per dollar output rating likewise is poorer than that of other types of high-voltage supplies. There are several types of batteries available and the characteristics for these can be obtained from the manufacturer, but it is safe to state that these batteries are definitely low-current units the useful lifetime of which is abbreviated sharply by all operation at high levels, as well as by long, continuous operation at low current drain.

Because of the expense of miniature high-voltage batteries, a current-limiting resistor should be connected in series with them, whenever circuit peculiarities permit, to prevent their rapid destruction in case of a short circuit. The operator should take care to switch the batteries off at all times when they are not actually in use. A cool, dry environment is the most satisfactory condition under which such batteries should be operated. When not in use for long periods of time batteries should be stored at temperatures between 40°-60° c.

Charged-Capacitor Circuits

In circuits in which current drain is quite low (i. e., under 1 milliampere), and operating time can be reduced to a series of short intervals, charged capacitors may be operated in series to supply high d-c voltages. This permits a reduction of battery expense, since only one battery is needed to charge a number of capacitors in parallel which then may

be switched in series to deliver as many times the battery voltage.

The time interval during which the voltage obtained in this way may be held to a useful level depends upon the total capacitance of the series capacitor combination and upon the output current drain. At any current level, the higher the capacitance the longer the interval. In practical circuits in which this type of supply is used, a switch (usually a pushbutton) is provided for momentarily re-connecting the capacitors in parallel for charging.

Figure 1 shows a charged-capacitor type of supply operated from a miniature 300-volt battery (such as Burgess U200, Eveready 493, or RCA VS093) and delivering 900 volts dc. When the 6-pole, 2-position switch ($S_1, S_2, S_3, S_4, S_5, S_6$) is temporarily at its left-hand CHARGE position, capacitors $C_1, C_2,$ and C_3 are connected in parallel with the battery and become charged. When the switch then is thrown to its right-hand DISCHARGE position, the capacitors are connected in series, and 900 volts are available at the output terminals of the circuit. The total capacitance in the discharge condition is 0.333 ufd. It is convenient to have the

switch rest normally in the DISCHARGE position to provide a normal connection of the series combination to the output terminals. If the switch has a spring return, the capacitors are charged each time the switch is depressed or thrown, after which the switch returns automatically to the DISCHARGE position to deliver high-voltage output.

It might be expected that this scheme could be extended indefinitely, the voltage multiplication being proportional to the number of capacitors. It is limited, however, by the number of poles and contacts which may be included in a practical switch without the latter reaching ungainly size. Also, in order to obtain a sufficiently high total capacitance with a large number of capacitors in series, the required individual capacitance values would become so large as to raise both the size and cost of the supply out of reasonable bounds.

Figure 2 shows a simplified charged-capacitor circuit which delivers twice the battery voltage. In this arrangement; when the dpdt switch (S_1-S_2) temporarily is at its left-hand CHARGE position, capaci-

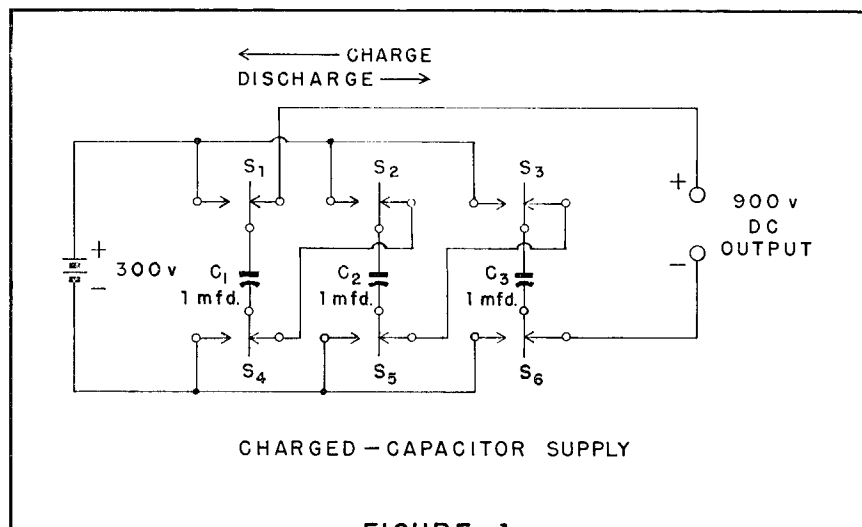

FIGURE 1

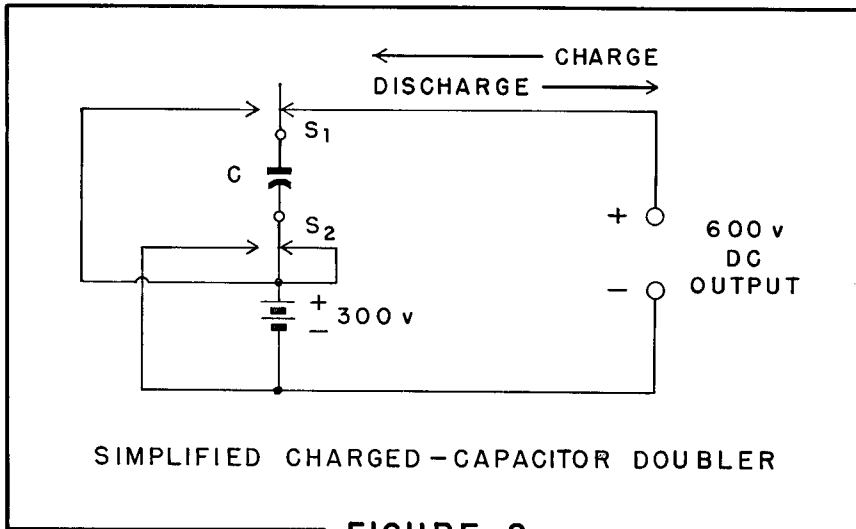

FIGURE 2

tor C is charged from the 300-volt battery. When the switch is reduced to its normal, right-hand DISCHARGE position, the charged capacitor is connected in series with the battery. The voltage at the output terminals then is the sum of the battery and capacitor voltages, or 600 volts.

Charged-capacitor supplies basically are low-current, short-interval units. At extremely low current drains, however, the time interval during which the voltage is maintained near its required level may be extended to a reasonable length by employing high capacitances. For example: Consider 1000 volts supplied by a total capacitance of 100 microfarads. At a current drain of 100 microamperes (load resistance of 10 megohms), the capacitor still will have 90% of its charge (output voltage will have fallen 10% from its original value) in 1½ minute of operation. The circuit then may be pulsed with another charge to bring the voltage back up to the original level. After 16 minutes of operation, because of the exponential decay of the charge, the output voltage of this capacitor will be approximately 370 volts.

Buzzer-Transformer Circuit

A miniature vibrator-transformer and rectifier combination, similar in principle to the conventional automobile radio power supply, provides the basis for a high-voltage d-c operated from a small, inexpensive battery — often a single 1½-volt flashlight cell.

Figure 3(A) shows the circuit of a vibrator (buzzer) type high-voltage supply of this kind. The vibrator transformer here is a Precise Model 10. This is a small unit (having about the same dimensions as a 6L6 metal tube) which plugs into an octal

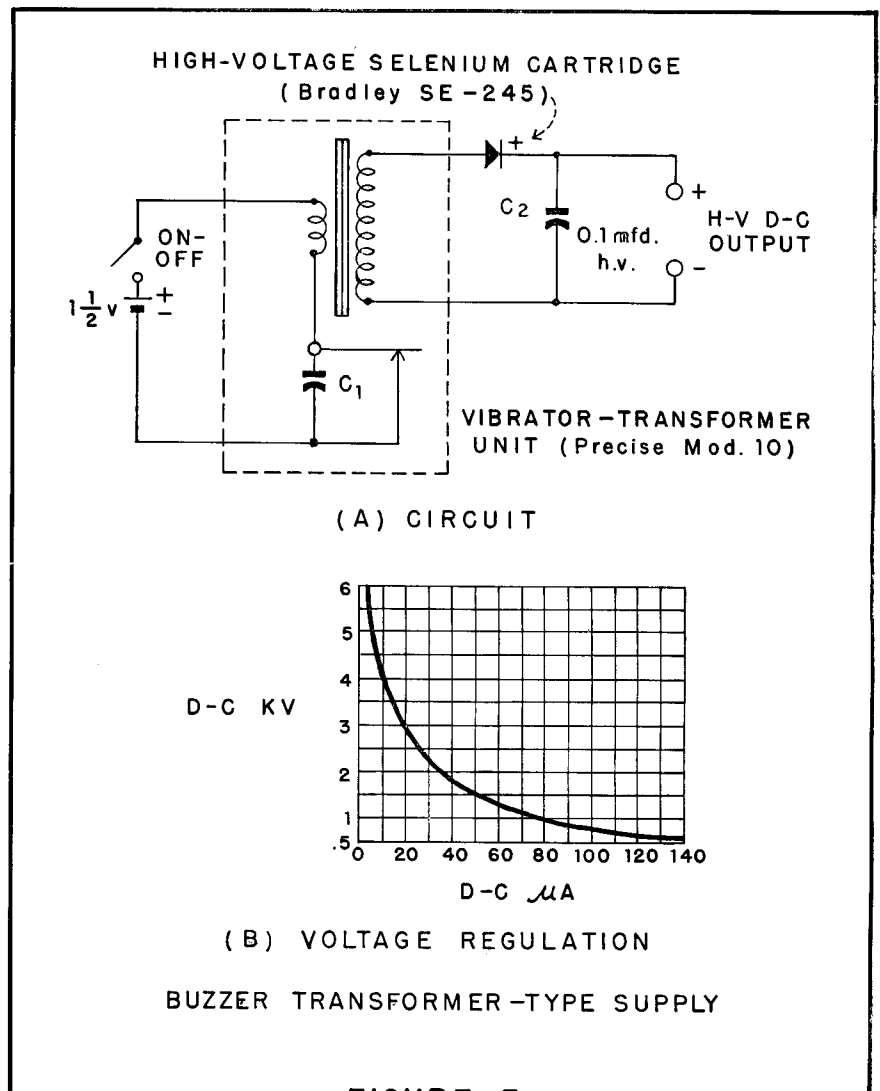

FIGURE 3

socket. The step-up transformer, vibrator, and spark suppression capacitor (C_1) are self-contained. A single 1½-volt, Size-D flashlight cell supplies the d-c driving voltage. Current drain is approximately 35 milliamperes.

The high-voltage ac, generated by the vibrator-transformer, is rectified by a single, high-voltage selenium cartridge-type rectifier and is filtered by the 0.1-ufd capacitor, C_2 .

The open-circuit output potential is 6000 volts dc. Figure 3(B) shows the voltage regulation of the circuit. From this plot, it may be seen that the output voltage falls to approximately 500 v at a current drain of 140 microamperes (load resistance of 3½ megohms). A potential of 1 kv is obtained at 70 ua drain. The output voltage may be regulated through the use of a filamentless, miniature regulator tube such as Type CK5517 for 2.3 kilovolts, 5841 for 900 v, or CK1036 for 700 volts.

At light current drains (under 150 ua), adequate filtering action will be provided by capacitor C_2 . In applications requiring increased smoothing of the output, a 100,000-ohm filter resistor and additional 0.01-ufd capacitor may be employed.

The vibrator-type d-c supply is compact and tubeless and is light in weight. The Size-D flashlight cell which drives it is small and inexpensive and will give 150 hours service when used continuously 2 hours per day, 90 hours on an 8 hours-per-day basis, and 60 hours on a 24 hours-per-day basis.

Flyback-Type Supply

Figure 4 shows the circuit of a high-voltage supply which utilizes the rapid decay of plate current (flyback) through a high inductance to gener-

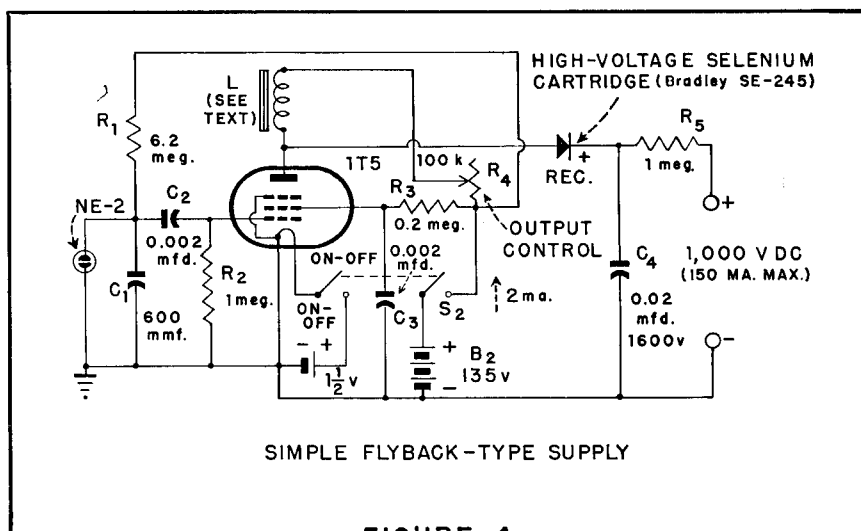

FIGURE 4

ate high-voltage pulses. The resulting pulse train is rectified and filtered for d-c output.

In this circuit, a relaxation oscillator (comprised by the NE-2 neon bulb, capacitor C_1 , and resistor R_1) is operated from the 135-volt battery, B_2 . The output of this oscillator is coupled, through capacitor C_2 , to the 1T5 tube. (A miniature Type 3S4 tube also may be used). Inductor L in the plate circuit of this tube is a miniature interstage transformer (U. T. C. Type 0-15) with its primary and secondary windings connected in series-aiding. Plate and screen potentials for the tube also are supplied by battery B_2 . Filament current is supplied by B_1 .

The quiescent plate current is quite small. However, the rising, positive-going portion of the sawtooth pulse from the relaxation oscillator increases this current to a maximum. With the rapid fall, or flyback of the sawtooth, the plate current collapses and a high voltage pulse (e) is generated across inductor L: $e = L(di/dt)$. The high-voltage selenium cartridge rectifier (REC) serves to pass the positive swing of the voltage pulse and to block the

negative swing. The connections of this rectifier may be reversed for negative d-c output, if desired.

Rheostat R_4 serves as an output-voltage control by permitting adjustment of the plate current. Screen current is limited by the 200,000-ohm resistor, R_3 . The circuit may be operated from a 1½-volt, Size-D flashlight cell at B_1 , and two midget 67½-volt batteries in series for 135 v at B_2 .

Resistor R_5 is included for output current limiting, to protect the rectifier in the event of an external short circuit and to safeguard the operator in case of contact. This resistor may be omitted if it causes too large a voltage drop for certain applications.

Transistorized Supply

In the compact power supply shown in Figure 5, the signal-output voltage of a transistorized oscillator operated from a small 6-volt battery is stepped up by transformer T. The secondary voltage of the transformer then is applied to a voltage quadrupler circuit (consisting of selenium cartridges rectifiers D_1, D_2, D_3, D_4 ; and capacitors C_2, C_3, C_4 , and C_5) which delivers a d-c output

equal to 5.6 times the applied a-c voltage.

The transistor oscillator is a Hartley-type circuit. The required, tapped coil is obtained by connecting to primary terminals 1, 2, and 3 of the miniature line-to-grid transformer (U. T. C. Type O-2). The entire secondary winding (taps 6 and 8) is used. Formerly, experimenters have been unsuccessful in boosting the voltage output of a low-voltage transistor oscillator because small transformers with sufficiently high turns ratios and primary inductance have not been commercially available. The use of the O-2 "Ouncer" transformer has been suggested by T. G. Knight (*Radio-Electronics Magazine*, September 1956, p. 106). The Editors have modified Knight's original oscillator and added a voltage quadrupler for higher d-c output.

The 25,000-ohm rheostat, R_2 , allows the base bias current to be set for easy starting of the oscillator and for full 1200 volts dc output. This control should be set so that the oscillator starts up readily when the ON-OFF switch, S, is closed. A d-c vacuum-tube voltmeter, set to its 0-1500-volt range and connected to the 1200-volt output terminals, should be used as an indicator during this adjustment.

The builder must be careful to follow the exact polarities indicated in Figure 5 for the transistor, battery B, and the rectifiers.

Capacitors C_2 , C_3 , C_4 , and C_5 are standard 500-volt mica components. Output capacitor C_6 , however, must be rated at 1600 volts dc, or better.

Current drain from the 6-volt battery is approximately 2½ milliamperes. This low requirement may be met even with four series-connected 1½-volt penlight cells.

Recent Developments

Stock-model, transistorized high-voltage power supplies presently are available commercially in ratings up to 20,000 volts dc output. Custom units may be obtained up to 100,000 volts dc. All of these units operate from one or two 1½-volt flashlight cells or from mercury cells. One such unit together with its cell is no larger than the Geiger tube it is designed to power.

One company has developed a miniature version of the Wimshurst static machine, familiar to all science students. This reduced-scale model is spun by means of gearing operated by means of a pushbutton, and delivers several kilovolts from a charged capacitor. While this unit is not available at this writing, it is expected to reach production in the near future.

Attention again has turned to the electret as a repository of high-potential charges. Electrostatically, this device is somewhat analogous and dual to the permanent magnet. It has been known for several decades but has found no noteworthy practical application up to this time. Essentially, it is a cake of carnauba

wax that has been cooled down from the molten state while in a high-voltage electrostatic field. Research and development work presently is being pursued to determine the potentialities of the electret as a high-voltage d-c supply.

Safety Precautions

Every high-voltage supply should be handled with caution. Miniature units are no exception. Although, in most instances, miniature supplies are incapable of delivering damaging currents, the voltages that they do put out can cause dangerous reflex actions which have been known to cripple the heart and cause death. High-voltage batteries are especially nasty.

Small, high-voltage supplies often are more deadly than full-size units, simply because of their deceptive size. Being small and quiet, they just do not look dangerous. However, the false sense of trust they inspire encourages only a stupid technician to grow careless with them.

Regard all high-voltage supplies as threats to personal safety and well-being. Know your circuit well and avoid all bodily contact with its high-voltage points.

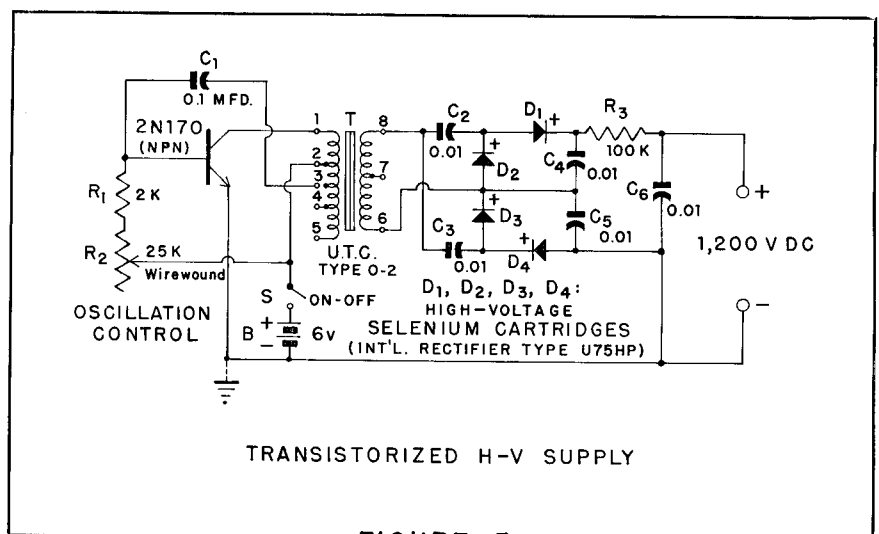

FIGURE 5

the first really new paper tubular capacitor... **AEROVOX "WHITECAP"** **"WAX-FREE"**

TYPE V84 TUBULAR CAPACITOR!

Aerovox announces the development of a WAX-FREE paper tubular capacitor with electrical characteristics surpassing all others . . . even the best molded units.

Aerovox "WHITECAP" capacitors offer a distinctive white case, completely free of wax. The absence of any wax facilitates handling and assembly procedures. No dripping and no gummed-up machines. Light in weight and clearly marked, these units will enhance the appearance of any assembly.

Aerovox "WHITECAP" capacitors are superior electrically over **ALL** other conventional paper tubulars including molded units. Outstanding humidity resistance . . . far greater than ever known before in units designed for radio-TV applications. Highest Insulation Resistance ever offered before in a paper tubular. Wide temperature range . . . low-power-factor. New standards of reliability backed by millions of hours of life and service tests.

Operating Temperatures — -40°C to 85°C at full voltage rating and to 100°C with voltage rating of 75%

Power-Factor — at room temperature will not exceed 1%

Humidity — will withstand 95% relative humidity at 40°C in accordance with RETMA Specification RS164 except that exposure will be increased to 500 hours instead of 100

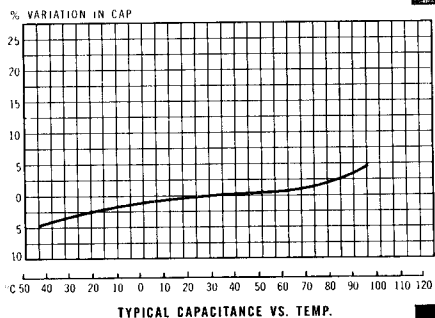
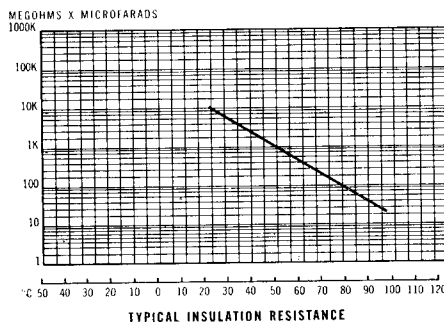

Immediate delivery on all production quantities. For full details contact your local Aerovox Sales Representative or write immediately to . . .

AEROVOX CORPORATION
NEW BEDFORD, MASSACHUSETTS

