

# THE ED

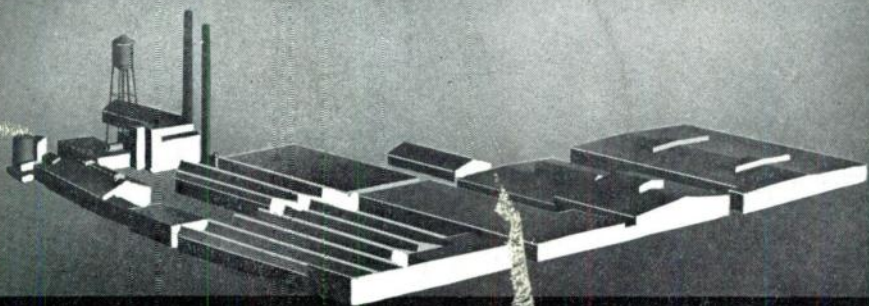

# CAPACITOR

Vol. 4

OCTOBER, 1940

No. 7

CORNELL-DUBILIER ELECTRIC CORP.  
HAMILTON BOULEVARD  
SOUTH PLAINFIELD, N. J.

Sec. 562, P. L.&R.  
U. S. POSTAGE  
PAID  
So. Plainfield, N. J.  
Permit No. 1

Mr. George M. Beale  
130 25th Ave.  
San Francisco, Calif.

# RADIO SERVICE HINTS

**Practical Suggestions on Solution of Radio Servicing Problems Encountered in Actual Experience by Servicemen Everywhere**

This section, conducted by our servicemen readers, will be a regular feature of the C-D Capacitor, and is intended to provide other servicemen with helpful notes on testing, locating troubles in specific models of sets, repairing them, or any other suggestions to simplify service work.

Cornell-Dubilier will pay \$2.00 for each hint published in this section. Notes must be limited to 75 words, or less. Any number of hints may be submitted at one time. Unpublished items will not be returned. Be sure to give your name and mailing address. Send hints to: Editor, C-D Capacitor, Cornell-Dubilier Electric Corp., So. Plainfield, N. J.

## Handy Solder Coils

Here is a handy way to prepare lengths of core solder for convenient use either on the bench or on an outside job.

Wind up the solder on a tapered object such as a plumb bob, or on a rod or thick pencil. Then bring one end through the inside of the coil after removing the form. In the case of the plumb bob, bring the end at the larger turns through the smaller turns or pointed end of the coil. The solder can then be pulled out as used through one end of the coil which serves as a handle. Several coils of solder prepared in this manner can be made up in advance ready for use when needed. — *Robert J. Oja, Calumet, Mich.*

## Testing Electrolytics

Here is a method of testing electrolytic capacitors that the writer suggests to determine opens and capacity.

After making sure the capacitor is not shorted, connect it in series with an A.C. milliammeter across 2.75 volts A.C., or 2.65 volts to be more exact. Capacity will be noted by meter reading of one mil. for each mfd. The a.c. voltage can be taken from a 3 volt filament transformer and the secondary shunted with a resistor to give proper voltage.—*Chas. Sandberg, Brooklyn, N. Y.*

## Leaky Capacitor Blocks

If abnormal voltages appear on cathodes of audio tubes, or hum prevails even though individual sections of a capacitor block check O.K., test for leakage between sections of the unit. Leakage between sections in many of the capacitor blocks used in the lower priced sets seems to be a common fault.

Neon leakage test between capacitor sections will reveal the definite source of trouble encountered. The remedy, obviously, is to replace faulty sections with individual units such as C-D "Beavers" or multiple section units of the same values and voltage ratings.—*L. W. Krizan, Chicago, Ill.*

## Locating Defective Capacitors

In the intermittent jobs which are usually so puzzling to servicemen, the writer has employed a very simple method to locate defective capacitors quite satisfactorily.

Remove all tubes from the set and apply a d.c. voltage to the plate and screen grid circuits. A voltage from 300 to 400 volts will be ample. A capacitor in the circuit which is causing the intermittent will readily be located by sizzling, and finally breaking down. Thus the stage causing the trouble can be located, and the defective capacitor replaced with a new unit.—*Samuel A. Gornick, Detroit, Mich.*



## Capacitor Substitution Box

One of the handiest pieces of test equipment about the writer's shop is a plain wooden box in which is mounted 18 tubular paper-wound and electrolytic type capacitors of various standard capacities commonly used in most radio receivers.

The outside foil lead of the paper tubulars, or ground (neg.) terminal of electrolytics are all connected to one common terminal, while the other terminal of each capacitor is connected to one point of a multitap switch, the rotary arm of which serves as the second or positive terminal. Values of capacitors used by the writer are as follows:

.0001 mfd.	.05 mfd.
.0002	.1
.00025	.25
.001	.5
.002	1.0
.004	2.0
.005	4.0
.006	8.0
.01	16.0

Test prods are connected to the switch arm and common terminals for convenient use and any of the above capacities can be selected by rotating the switch.—*Harold Miller, Boston, Mass.*

## 6A 8G Tube Trouble

An unusual source of trouble arising in sets that employ 6A8 tubes has been traced to tubes of this type becoming defective after being in operation for some time. Generally, the symptom of this trouble will make itself evident by discontinuing to function shortly after the set has been turned on, or reception fading out completely within a few minutes.

The simplest solution to this problem is to replace the 6A8 with a new tube which will give satisfactory performance in the circuit, regardless of the fact that the old tube checks O.K. on test in the tube checker.—*Laird A. Chambers, Collingdale, Pa.*

## Dress Output Wiring

Audio oscillation in many of the modern receivers is often caused by the disarrangement of output transformer wiring during servicing work. In order to stop oscillation be sure to dress output transformer leads so that they will be separated as far as possible from those of the volume control. Also keep output transformer leads away from the chassis and power transformer to avoid shorts which may occur by melting of the rubber wire insulation.—*E. D. Griggs, Atlanta, Ga.*

## Grunow Models 501-550

When very weak and distorted reception occurs in these models the trouble may be traced to a high resistance short between terminals of the 25Z5 wafer-type tube socket due to moisture collecting between the two insulating wafers of the socket.

This is a common source of trouble in most sets of any make employing wafer-type sockets and can readily be remedied by replacing the faulty socket with a moulded bakelite type tube socket.—*F. J. Prosser, Cleveland, Ohio.*

## Additional Note On Alignment Indicator

When using the Output Aligning Meter, described on page 3 August issue of the "C-D Capacitor," on A.C.-D.C. sets which are not provided with proper line-to-ground blocking capacitors, it is important that the meter chassis be grounded to the chassis of the set under test. In other words, the meter chassis and set chassis must be grounded to the same side of the line for safety and sufficient stability for accurate work.

For safety's sake, the meter itself may be provided with .05 mfd. ground blocking capacitors.



## A Free Market-Place for Buyers, Sellers, and Swappers.

These advertisements are listed FREE of charge to C-D readers so if there is anything you would like to buy or sell; if you wish to obtain a position or if you have a position to offer to C-D readers, just send in your ad.

These columns are open only to those who have a legitimate, WANTED, SELL or SWAP proposition to offer. The Cornell-Dubilier Electric Corp. reserves the right to edit advertisements submitted, and to refuse to run any which may be considered unsuitable. We shall endeavor to restrict the ads to legitimate offers but cannot assume any responsibility for the transactions involved.

Please limit your ad to a maximum of 40 words, including name and address. Advertisements will be run as promptly as space limitations permit.

**FOR SALE OR TRADE**—Complete RCA radio correspondence course consisting of about 80 lessons and a large collection of back number radio magazines and publications. All in good condition. Write for list. Interested in Rider's manuals, condenser tester, or a 1939-40 radio. What have you? Geo. Anderson, 2236 Indiana Ave., St. Louis, Mo.

**FOR TRADE**—Presto model G recorder, two speed, complete with mike and stand, etc. Almost brand new. Want 16 mm. sound picture projector, 1600 ft. capacity, 750 to 1000 watt bulb. Lee Radio Service, 717 Valley St., Orange, N. J.

**WANTED**—Rider service manuals 8, 9, or 10, used in fair condition. Please state prices. Robert Layton, 509 So. Chickasaw St., Pauls Valley, Okla.

**FOR SALE OR TRADE**—Jewell 76, 0-150 v.a.c. voltmeter; Jewell 88, 0-200 v.d.c. milliammeter; pair Brush crystal headphones in new condition; several 0-5 volt Jewell and Weston plug-in meters; Maytag twin, also Briggs Stratton single, motor scooter wheels and parts. Want tools, service equipment, or what have you. Lewis J. Putman, Hartley, Iowa.

**FOR SALE**—16 mm. Bell movie camera. Also 16 mm. projector. Both for \$22. All condition. Write John's Radio Shop, 604 Charles St., Providence, R. I.

**WILL TRADE**—Radio Physics Course by Ghirardi for Modern Radio Servicing by Ghirardi. Peter J. Jarvis, 4817 S. Elizabeth St., Chicago, Ill.

**FOR SALE**—Radio electric service business, fully equipped. Established 5 years and business now going well. Good chance for man with ideas. Very little competition, large territory. Reasonable offers considered. Write Sids Radio Electric Shop, 300 Anderson Ave., Fairview, N. J.

**FOR SALE OR TRADE**—Triplet 1212 tube tester, reg. price \$22, sell for \$8.00. Tests tubes up to 50 v. fil. One adapter covers all octals, not supplied. Steel case, first class condition. Want Rider's vols. 1, 2, 3, 4. Clark Radio Lab., 39 Lincoln Place, No. Plainfield, N. J.

**FOR SALE**—Triplet 1151-A signal generator. Sell or swap for phono equipment. John Moskal, 85 Gardner Ave., So. Attleboro, Mass.

**FOR SALE**—National SW-3, AC, 6 sets of coils and power supply. What am I offered? Will prepay express charges, C.O.D. only. Write J.F. Intiso, 1730 Fillmore St., Bronx, New York.

**FOR SALE**—Triplet signal generator No. 1231, new, \$20.00. Readrite set tester No. 710, \$10.00. De Forest radio course, complete \$20.00. Pekoscope hand operated motion picture projector, \$10.00. Astatic magnetic pickup No. 0-7, \$2.50. Marvin W. Carnett, Box 363, Cumberland, Ky.

**WANTED**—Weston model 669 vacuum tube voltmeter. Cash or swap for radio equipment. W. W. Baldwin, 1626 Texas Ave., St. Louis, Mo.

*(Continued on page 14)*

# ANALYZING RADIO NOISES

By the Engineering Department, Cornell-Dubilier Electric Corp.

## PART II

### Procedure to Provide Noise Free Reception

To provide noise free radio reception for your customers, it is first necessary to erect an antenna outside the field caused by direct or indirect radiation from the offending device. In practically every household there are appliances capable of causing interference. Apartment houses in particular, with elevator motors, and controls, which are located near the roof, radiate very strong disturbances. These disturbances may be picked up directly by both the aerial and the lead-in if they are close enough to it.

Before installing an antenna, it is good practice to examine the immediate vicinity for best possible location with respect to power lines, other conductors, and possible sources of noise. The use of a small portable battery set is an excellent way of determining the best direction for the antenna, as well as a satisfactory height above the ground. The interference level should be checked in at least six possible locations before the final location is decided upon.

The familiar noise reducing antenna systems such as the doubler, shielded lead-in, and the similar modifications of these types provide noise free reception with respect to the lead-in only, as the main part of the antenna is not protected against the absorption of high frequency disturbance energy. All types of antennae should be located at the greatest possible height above ground. After the antenna has been erected, it is essential that either a transposed or shielded lead-in provided with suitable coupling transformers be used so that the entire installation may be maintained in a noise-free condition.

Although these types of lead-ins are effective under usual conditions, it is occasionally necessary at some locations to use the lead-in described in Fig. 2 (see Sept. issue) where this connection can be made at a considerable distance from possible sources of severe radiated interference. This procedure is to connect the lead-in at the far end of the antenna then bury it under ground from this point to the place where it enters the house.

The actual noise level in the antenna system is dependent to a considerable degree on the type of ground connection used. Radiators and water pipes frequently have a long path of appreciable impedance to the point of contact with the earth. This connection is also subject to the same precautions which normally would be observed when erecting the antenna. However, there is little that can be done about providing a completely satisfactory grounding system and usually the best solution is to select the best point for this connection by a process of elimination. If the radiator, water pipe, gas pipe and power line receptacle plate, do not provide a satisfactory noise-free ground, for individual houses it is frequently possible to run a connection to the water pipe entrance to the building. In such cases it is recommended that the connection be made on the street side of the water meter.

### Measurement of Antenna Efficiency

Noise and broadcast signal measurements can be made to check the efficiency of the antenna system by connecting these two points to a portable battery receiver. The actual per-

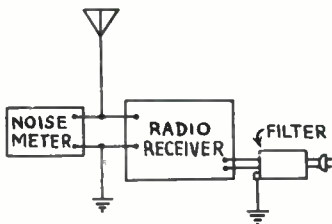

Fig. 3. Circuit for measuring the strength of signal and noise on antenna.

formance of this system may be checked comparatively with similar installations which have been similarly tested. Practically any small battery receiver of adequate sensitivity with the internal antenna disconnected and other small changes, such as adding an output meter is satisfactory for such a measurement. See Fig. 3.

Very interesting results have been obtained after checking the efficiency of house antennae installed in a number of apartment houses. It is surprising to state that in many cases the broadcast signal available was considerably inferior to that which could be obtained with a six foot length wire dropped out a convenient window. The radio noise measurements on many of these systems have indicated that they are actually the cause of the radio disturbance making available a signal to noise ratio which was entirely unsatisfactory. These installations were erected using the very latest type of noise reducing antenna equipment but through either some oversight on the part of the contractor who did the work or because of some defect which developed at a later date, were quite inadequate.

One of the most useful devices to correct radio noise conditions is the line filter, which is installed between the supply line and the power input to the receiver. This consists of one or more inductance coils on each side of the line with several capacitors shunted across the line. The effect of this is to present a high impedance to the high frequency components in the power line at one point, and at another point to short circuit the noise

voltages to ground, which otherwise would be introduced into the receiver. The connection to the line filter should be as short as possible to reduce any coupling of noise energy to the wiring of the radio receiver. Although line filters are usually provided with a long line cord for convenience, it is frequently more satisfactory to shorten this cord and that of the receiver to the minimum required for the installation.

## Measurement of Line Noise

To check the relative efficiency of the line filter remove the antenna and short circuit the antenna and ground terminals. Connect the chassis to a satisfactory ground through a small capacitor and place the radio in operation. By removing the line filter, an observation can be made as to the relative value. Frequently, the exposed wires of the receiver may be subject to direct radiation from a noise source. If any appreciable noise is present when making this test, it is recommended that the set be rotated through an arc of 180 degrees to find the point at which this effect is minimized.

It is important to note that the ground terminal on the filter should not be connected to the same ground as the connection to the radio receiver if best results are to be obtained. Since the filter passes appreciable noise energy back to the ground system,

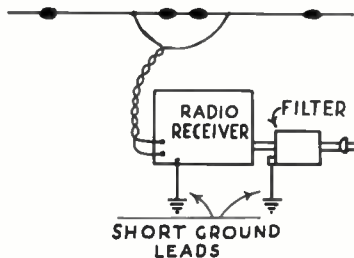

Fig. 4. Conventional doublet antenna connected to receiver with line filter. Use separate ground leads to eliminate common impedance in filter and receiver circuits.

a noise voltage is set up in this system. If this circuit were to be used to provide a ground for the receiver, this voltage would be introduced into the receiver with resultant interference. For this reason, it is essential to avoid using this common impedance ground and to connect each device separately to two different grounding circuits. See Fig. 4.

By providing efficient antenna and ground system, and filtered power line connection, a radio receiver thus installed should give noise-free radio reception unless the antenna is being induced with noise energy radiated from a point which cannot be identified. This is a condition which is frequently encountered. Together with the fact that the most carefully designed antenna system has certain imperfections, it is necessary to further analyze the various methods and conditions of control of man-made radio noise emanating from electric equipment.

## Location of Noise Source

The problem of locating the source of radio disturbance is frequently quite simple as the operator of the receiver may be the owner of the offending appliance. To locate the origin of other disturbances again, a portable battery set is extremely helpful. The built in antenna has a directional effect which usually is in the direction at

right angles to the control panel. By rotating the receiver through an arc of 180 degrees the noise level will reach a maximum and can be traced by maintaining the receiver in this position and by walking in the direction which gives the greatest increase of signal. For apartment houses, where this procedure would be extremely

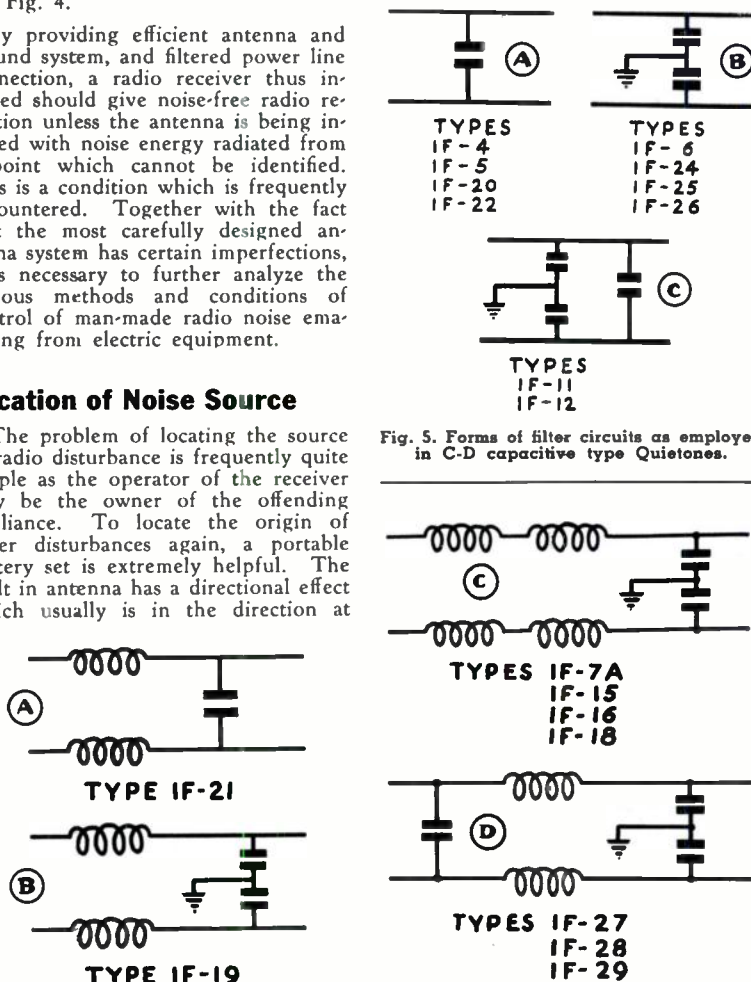

Fig. 5. Forms of filter circuits as employed in C-D capacitive type Quietones.

Fig. 6. Forms of filter circuits as employed in C-D capacitive-inductive type Quietones.

difficult to follow, tests can be made at the service entrances or at the point where the electric meters for each apartment are installed.

It is possible to place the battery receiver at each watt hour meter and to identify which circuit is causing the greater disturbance. A fuse may be loosened or if a switch is provided, it may be disconnected for a few minutes to check the preliminary observation to confirm the original suspicions. If the radio noise condition disappears when the circuit is opened it is then a simple matter to approach the owner of the particular apartment and request his co-operation in completing your survey.

It is not claimed that you will meet with a measure of success in convincing him that he should apply a filter to his disturbing appliance, but it is not unusual for him to welcome the suggestion as a relief from his own radio noise problem.

When it is realized that one appliance can cause a disturbance in a great number of radio receivers, it can be understood that it is much more economical to correct the condition caused by that particular appliance rather than to apply preventive or corrective methods at the receiving stations. Many electrical manufacturers realizing the extent of trouble caused by radio noise conditions have taken steps to apply some degree of improvement in the way of filtering their devices. Unfortunately, their type of business is highly competitive and they find that it is impossible to provide adequate correction, within the very limited cost they can extend in this direction.

As a net result there are literally hundreds of millions of electrical appliances and devices which are setting up disturbances some of which interfere with practically every radio receiver in the country. It is expected that for some years it will be necessary for servicemen to apply standard methods of correcting the individual trouble by installing suitable filtering devices on the wide variety of electrical appliances which are in use today.

## Correction of Radio Noise at its Source

When the source of radio disturbance is traced to an electrical device, there is little question of the advantages of applying corrective measures provided it is possible to do so, within practical and economical limitations. Since the problem deals with electrical oscillations a suitable arrangement of capacitors, inductors, and resistors either individually or in various combinations usually will produce the desired conditions.

### Capacitive Filters

For certain types of appliances such as electric shavers, and barber clippers where direct conduction of the noise energy is of serious consequence, a capacitor shunted across the power line connection will result in a marked decrease in the disturbance. Although the radiation from these devices is of high intensity, it has been found impractical to employ any other type of capacitor arrangement. See Fig. 5.

A very inexpensive and highly efficient filter is one where two capacitors are connected in series across the line with the common connection to the frame of the appliance. This is by far the most widely used arrangement for vacuum cleaners, food mixers, sewing machines and similar devices which employ small universal motors. For appliances with ungrounded housings or frames, the capacity values used should not exceed .1 mfd. because higher capacity would cause an appreciable leakage of current to flow from the common connection to the frame of the appliance creating a condition capable of producing an electric shock. Should these higher capacity values be used in such a filter circuit, the operator of the appliance would be in a position to receive a shock when touching the frame of the appliance. This limitation exists for other types of filters which have the frame lead connected to an ungrounded electrical device.



A third type of capacitor filter consists of an arrangement of the two types just mentioned where it is desirable to have a large capacity connected between the lines and also to provide a frame connection which will not produce a shock condition. The larger type of industrial electrical equipment, such as motors, generators, elevators, stokers, and floor sanders, requires this filtering arrangement.

### Capacitive-Inductive Filters

Where the radio disturbance is of high intensity both in direct radiation and conduction and persists when capacitor filters are employed, a capacitive inductive circuit must be used. This usually consists of one or more inductance coils connected in each leg of the power line with one of the capacitor filters just described connected on either one or both sides of the inductance coils. Where capacity is employed to short circuit the interference currents, inductance is used for the opposite purpose, to impede or prevent the flow in the direction of the receiving system. See Fig. 6.

Some combination of these electrical parts will, with very few exceptions, provide the desired effect.

### Capacitive-Resistive Filters

In the types of filter circuits we have under discussion resistors are employed to dissipate or in effect absorb the noise energy by converting it into heat. They are frequently used in low current devices in place of inductance because of their small size and low cost. Electric shavers and some types of vibrators use resistors

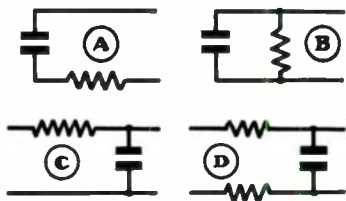

Fig. 7. Forms of circuits employed in capacitive-resistive filters.

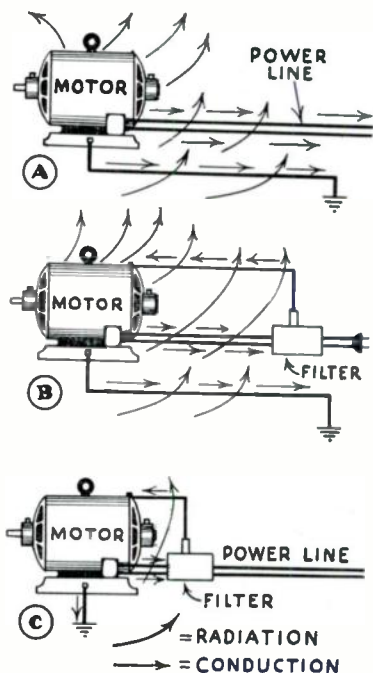

Fig. 8

A—Points of conduction and radiation of noise signals without filter.

B—Conduction and radiation of noise signals with filter installed with long connections.

C—Filter installed to give maximum performance at all frequencies with short connections to reduce radiation.

in this connection. Resistors are also used in conjunction with capacitors across thermostat contacts to limit the rate of capacitor discharge so as to prevent sticking or freezing of the contacts.

The values of capacity employed in filters for household appliances usually range between .01 and 1 mfd., while for larger industrial equipment higher values in the order of .1 to 4 mfd. are required. Inductances range from 200 to 2,000 micro-henries for all types of apparatus, with resistance usually being less than 1,000 ohms.

It is important to note that while a coil has inductance, it also is affected by its internal distributed capacity, likewise a capacitor has self-inductance unless special precautions are observed in its basic design.

These qualities are of little importance at audio frequencies but at high frequencies have a considerable bearing upon the operating conditions of these parts. Capacitors and inductances must be designed for high frequency operation when employed in radio noise filters. In other words a filter must be designed to have an efficient radio frequency performance. Simply connecting a number of capacitors and coils in a suitable circuit will not provide a satisfactory filter. Each element of the filter must be designed and arranged to perform a given function with due consideration taking into account allowing for losses and frequency characteristics.

For the above reasons, certain manufacturers have provided the trade with filters equipped with suitable adaptors for convenient connection to the many types of electrical appliances. While they may have found a greater market for their products by recommending certain values of capacity and inductance to be employed in different circuit arrangements, it was determined from previous experience that such practice was inadequate with respect to the ultimate results obtained by such methods.

## Installation of Filter

It is possible to connect a highly efficient filter to an appliance and get an unsatisfactory reduction of noise. Such a condition is usually due to the fact that the instructions provided with the filter were inadequate or else the serviceman making the installation was not entirely familiar with such work. Radio interference correction may be attained only by providing low loss connections between the filter and the disturbing appliance.

Every inch of wire between these two devices will lower the effectiveness of the installation. See Fig. 8. These

wires carry the noise current and will radiate this energy in approximately direct proportion to their length. It is important to state "emphatically" that every unnecessary inch of wire in the circuit between the filter and the noise producing appliance be eliminated. The remaining leads should be shielded wherever possible with flexible copper braid and this shielding should be connected to the frame of the appliance.

It is of the utmost importance to make a low resistance connection when attaching the frame lead to an electrical device. The point of contact should be thoroughly clean and the connection made securely so it will not break, or become loosened, after a period of time.

It has been observed that filters installed without following the precautions just mentioned, may give satisfactory operation at broadcast frequencies yet at higher frequencies offer little noise reduction. Under all circumstances, it is necessary to install the filter so that it will not interfere with operation of the appliance and for convenience a longer lead connection may have to be used. However, for ordinary cases, every effort should be made to have the filter operate under the best circumstances.

## Measurement of Noise at Source

A portable, battery operated, receiver may be used for checking the efficiency of a filter installation as shown in Figs. 9, 10, and 11. The relative noise in the power line may be measured to determine just what part of the disturbance is being caused by the appliance in question. When the filter is installed, the direct radiation from the appliance may be measured by operating the receiver within a few feet of the appliance housing. Quite satisfactory measurements of the power line conduction and power line radiation may be obtained by connecting the receiver to the power line by means of a simple capacitor-resistor network. By this means, it is entirely possible to

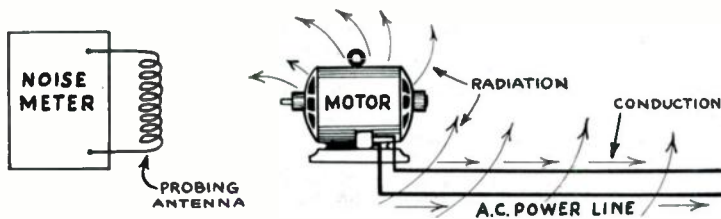

Fig. 9. Circuit to measure direct and line radiation.

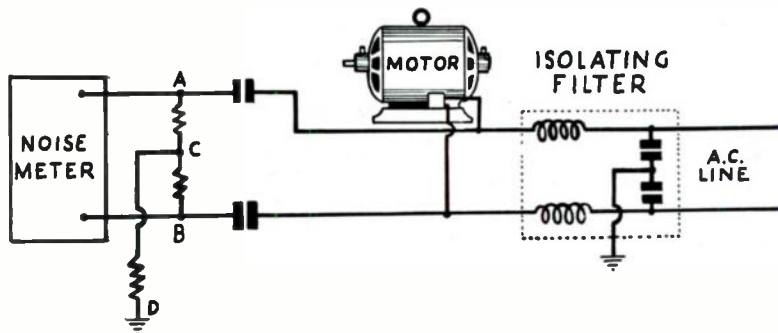

Fig. 10. Circuit to measure line to line and line to ground noise caused by motor.

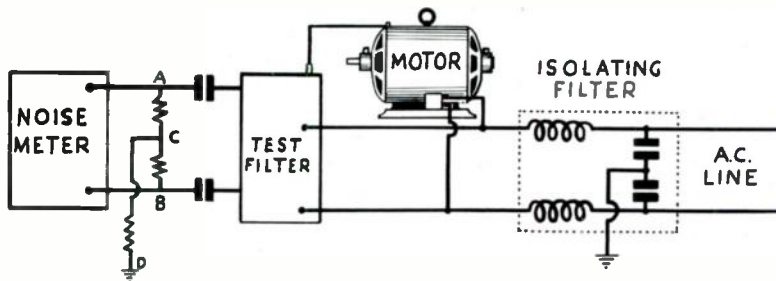

Fig. 11. Circuit to measure factors in Fig. 10 with test filter installed.

ascertain the complete effectiveness of the installation, to make any adjustments found necessary and to eliminate any doubt about the merits of the filter.

One of the most serious difficulties encountered when making a filter installation is that the line cord of the appliance by necessity must be maintained at a length of four to six feet. In such cases the radiation of noise

energy from the line cord may overshadow the effect of a filter. The long frame lead required, may be twisted around the line cord so as to be inconspicuous, yet after an appreciable amount of work and expense satisfactory noise conditions may not be obtained.

In such cases it is recommended that the line cord of the appliance be  
(Continued on page 15)

# NOTES ON P-M SPEAKERS\*

IN many cases where an enterprising Service Man is called upon to administer to an ailing receiver, he will give his customer just a little extra. This additional service, not only brings more profits immediately, but, causing a marked improvement in performance, will increase his prestige with his customer.

The advantages of p-m speakers for universal replacement in compacts are not generally realized. It seems the customer benefits as much as the service man when p-ms are substituted for electro-dynamics. See if you don't think so after taking the following analysis into consideration.

(1) With alnico and similar alloy magnets, more field energy (higher flux density in the voice-coil air gap) is provided than is ordinarily available in the average size electro-dynamic speaker. This will permit greater power output from the set as well as improving the sensitivity and low - frequency response of the speaker. In replacing magnetic speakers now being used in some cheap midgets, the improvement in sensitivity, quality, and power output will be very marked. In most cases, a p-m speaker will do a better job than the electro that it replaces.

(2) An obvious advantage is the elimination of open field problems especially in high-resistance speakers wound with very small wire. Sets used near the water, or in any damp climate are particularly prone to this trouble. Then there is no need for a hum-bucking, or neutralizing coil.

\* By M. Heller in "Service" magazine

Where a shunt field has been used, eliminating the field load lessens the current drain on the rectifier tube and also, in time, saves the customer something on the power bill. Eliminating the field load also raises the B voltages, allowing greater sensitivity and increased power output.

(3) A small stock will suffice for universal replacement purposes since there is no need of a variety of field resistances. P-ms require less space than electros, too. Hence, problems of installation in close spots should be minimized. Having no field coils, there is no heat developed—an important factor in midget receivers. P-ms are fully dust-proof, eliminating the possibility of rattles due to

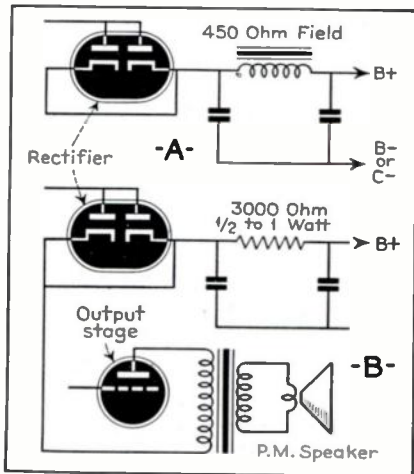

Fig. 1. A.C., D.C. receivers that employ a 450-ohm, or similar, electro-dynamic speaker require the addition of an r-c filter when a p-m is used as a substitute. It may also be necessary to increase the capacity of the filter condensers.

dust particles. Also, a p-m equipped set is more modern—according to present trends.

There are a few cases where exact duplicate speakers must be used. With a little thought, however, and minor changes in design, all types of electro-magnetic speakers can be replaced with p-ms. They may be fitted to most auto sets, saving from 1 to 1½ amps battery drain when replacing an electro-dynamic.

P-ms also make handy micro-phones suitable for limited p-a work, radio nurse or interoffice communication systems, etc. The smaller diameter speakers are preferable, giving good quality at a high output level.

Fig. 1 shows the changes necessary in replacing a series - field speaker with a p-m. A choke could be substituted for the field coil, no other changes being necessary. However, the arrangement shown at B will usually prove entirely satisfactory and is a lot more economical. A resistor of the order of 3,000 ohms is substituted for the field and the power tube plate voltage is now derived directly from the filter input. If the current through the filter resistor is 10 ma or less ( $I^2 R = 0.3$  watt) a ½-watt resistor is adequate. If greater than 10 ma, a 1 watt should be used.

Fig. 2 shows the changes required in replacing a shunt field speaker. At A, the field had its own separate B supply which is usually the case. The two rectifier cathodes are tied to-

gether thereby dividing the load and halving the internal resistance. The tube life will be increased after substitution and the B voltage raised a

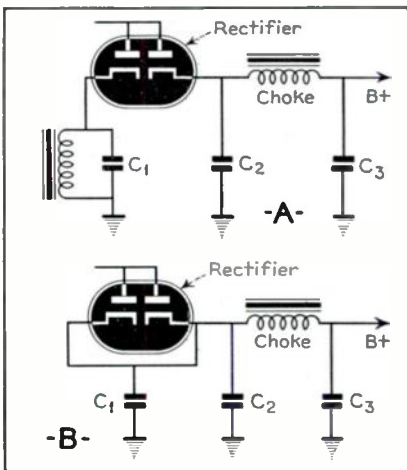

Fig. 2. In A.C., D.C. sets which employ a speaker field which is connected to one of the diodes of the rectifier with a separate filter condenser, no additional parts are required. The cathode formerly connected to the field, together with its condenser, can be tied to the plate supply circuits where it will serve to boost the voltage somewhat.

little. The shunt field filter condenser C<sub>1</sub> should be used to help along the B filter. If a choke had been used, it may as well be let alone, the power tube deriving voltage from the filter output. However, it may be permissible to substitute a resistor, as in Fig. 1, switching the power tube to the filter input.

A p-m speaker may be substituted directly for a magnetic, no changes being necessary.

# THE RADIO TRADING POST

(Continued from page 4)

**SALE OR TRADE**—Two brand new RCA 860 tubes, bought for S.W. diathermy but never used, \$10.00 each. Want crystal mike and electric drill. J. C. Coe, 3718 10th Rd. No., Arlington, Va.

**SALE OR TRADE**—Have 160 watt, 40 meter C.W. transmitter, crystal 2B6 Lestet T55 final 3 power supplies, 600-600 and 1200 d.c. All working order, also Skychief. Need Rider's manuals and test equipment. What have you? W. S. Crooks, R.F.D. No. 3, Kent, Ohio.

**WANTED**—Used Rider's service manuals. Give full particulars as to numbers, condition and lowest price. I have RCA service course to sell or swap. Geo. H. Cook, Jr., 8 Glynn Ave., Brunswick, Ga.

**SELL CHEAP OR SWAP**—Oscillator, xtal mike, large file of QST magazines, amateur equipment, xtals, tubes, x formers, meters, large dictionary, etc. Want auto radio or radio books. Jack Bannon, 121 Washington Ave., Oil City, Penn.

**SWAP**—Wireless phono oscillator, with 2 tubes, new. Mike, transformer and new combination A.F. amplifier and power supply, complete. Trade both for good "A-B" battery substitute with 2 v. "A," 135 v. "B," 22.5 v. and 4.5 v. "C." A Penquite, Jr., 513 So. 5th St., Marshalltown, Iowa.

**FOR SALE**—Rider Channalyt. Can't be told from new, only used a short while. Complete with all cords and instruction book. Used radio service books. Disposing as no longer active in radio service work. Write for list. W. A. Haensinger, 1102 Marion St., Winona, Minn.

**POSITION WANTED**—Young man, student of Nat. Radio Inst. Can speak, read and write English, Spanish and Portuguese. Has practical experience in water-proofing materials, and knowledge in air conditioning, refrigeration and electricity. Will go anywhere. Cornelius Britto, 11 Paul St., Boston, Mass.

**FOR SALE**—Supreme 333 set analyzer, \$5.00. Radio-technic Lab. tube tester, will test localts and 117 tubes, \$15.00. Write for more detailed information of either one of these instruments. H. A. Zettler, P. O. Box 72, Luxemburg, Wis.

**FOR SALE**—Supreme 89 De Luxe voltmeter-ohmmeter-capacity checker and tube checker combined panel mount. A1 condition, \$18.50. \$10.00 cash, balance on C.O.D. Ideal Radio Service, 1713 Larabee St., Chicago, Ill.

**FOR SALE**—Best offer takes \$17 "Blue Racer" Vibroplex key in good condition. Herman Yellin, 351 New Lots Ave., Brooklyn, N. Y.

**WANTED**—Entire set of Rider's Manuals. Please state prices and condition of books. Ellis Legg, Warland, Wyo.

**SWAP OR SELL**—Best offer takes Supreme 333 De Luxe analyzer, Confidence tube checker and Clough-Brengle O-C oscillator. Cost \$150.00 new. All in good condition. Herbert Varney 4627 Enright Ave., St. Louis, Mo.

**FOR TRADE**—Have complete carpentry and building course and complete real estate course. Also have 35 large volumes of "Cyclopedia of Law and Procedure" and facsimile records for use on 78 r.p.m. record players (wireless or wired) for testing or demonstrating facsimile receivers. Want test equipment, receivers, recording equipment, amplifier, etc. D. I. Foard, 1419 Reed St., Kalamazoo, Mich.

**FOR SALE**—Complete shop equipment. Clough-Brengle OMA frequency modulated signal generator, Model 105 oscillograph, Meissner Analyst, Jacksons 637 tube-set tester, ATR auto "A" batt. eliminator, Gernsback service manuals 1, 2, 3, 4 and 5, Rider's 7, 8, 9, 10, chassis rack, etc. Highest offer takes them. Fred. Wolfenbarger, 1945 So. Custer Rd., Monroe, Mich.

**SALE OR SWAP**—Two A-K 10 1/4" speakers, one 10" RCA with matching transformer, one Majestic 90 receiver with tubes, speaker less cabinet, A-K steel cabinet No. 44. Many other parts. Write for list. Want test equipment. Elton Bell, 1408 Walnut St., Duncan, Okla.

**FOR SALE**—National NC80X communication receiver, brand new, in original crate, speaker in carton never opened. Want \$33.00. Set in metal cabinet, 10 metal tubes, 4-band super, 550 k.c. to 32 m.c., slide rule dial. Works on 110 v. a. c. or d. c. with 8" speaker. Robt. Patterson, 1629 Park Ave., New York City.

**WANTED**—Electric food mixers, all kinds. Also photo enlarger, at least 2 1/4 x 3 1/4. State make, condition, serial nos. and prices. Have radio parts and magazines in exchange or will pay cash. Geo. Kinkade, 910 Adams St., Wilmington, Del.

(Continued on page 15)

## THE RADIO TRADING POST

(Continued from page 14)

**FOR SALE**—1939 N.R.I. course on Radio Servicing \$45.00. Supreme 551 analyzer \$12.00. Readrite 430 tube tester with Triplett meter \$12.00. All in A1 condition. Wm. Du Bois, 3457 N. Lee St., Phila., Pa.

**WANTED**—Electrical Experimenter before Jan. 1920, also Science & Invention after April, 1923. Copies of Nov. 1919, Mar. 1920 and Aug. 1921 Radio News, and back numbers of other radio magazines, except Radio-Craft and Service. John C. Barnhart, 243 Spruce St., Sunbury, Pa.

**WANTED**—Copy of schematic diagram of Hickock tube tester model 38. Will return original in same shape as received together with suitable remuneration mutually agreed upon. Wm. Ankeny, 3852 28th St., Detroit, Mich.

**WILL SWAP** — Amperite velocity mike model RBS for a good record changer in first class shape. Also have an Astatic crystal pickup that will trade for a 2" or 3" 0-150 a.c. voltmeter. Shines Radio Shack, 60 West 23 St., Chattanooga, Tenn.

**SELL OR SWAP**—Keystone movie projector model 575 standard size. Want small hand printing press or what have you? J. W. Stubblebine, 127 Hamilton St., Reading, Pa.

**FOR SALE OR TRADE**—Triplett model 1181 portable radio lab. set, includes 1125 V-O-M at 1000 ohms per volt; 1151 all-wave S.G., 1166 socket analyzer, \$27.00, in good condition. Will trade for complete set of watchmakers tools. Harold Gochenour, Route No. 1, Buckhannon, W. Va.

**FOR SALE OR TRADE**—Radio parts, test equipment, amplifier, air compressor; battery charger, flexible shaft outfit, etc. Want still and motion picture camera or projector, silent or sound. Also films, travelogues of foreign lands. Hansen Radio Service, Niles, Mich.

## ANALYZING RADIO NOISES

(Continued from page 11)

replaced with a shielded line cord which has a layer of insulation over the shield. The frame connection of the filter may be attached to this shield at one end of the cord and the other end of the shield can be attached to the frame of the appliance. Such

an installation will undoubtedly result in a marked decrease of the noise level.

The shielded line cords may be obtained from almost any electrical supply company. They are provided with conductors attached to each end of the shield, and may be installed with little difficulty.

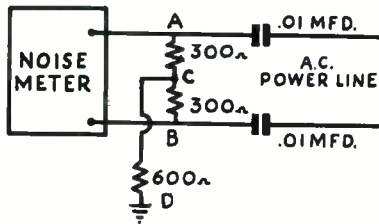

Fig. 12. Circuit to measure line noise.

Certain types of high speed drills, fans, and electrical governor controlled units which employ series motors are extremely difficult to service. The exceedingly rapid rate at which the sparks are created at the contact between the brushes and the commutator results in a severe radio disturbance. For equipment of this type it is essential to use extremely short connections to the filter circuit. In many cases, satisfactory results may be obtained only by using a three wire shielded line cord as previously described. X-ray and diathermy machines, electric ignition type oil burners and arc producing flour bleachers, require extensive shielding around the equipment in addition to the application of filters. Such apparatus, as shall be described later, emanate extremely strong radiation which is capable of affecting receiving systems for a considerable area.

We have been dealing with types of filters which may be connected externally to electrical devices. In very few cases is it at all possible to make internal installations because of the failure of the manufacturers of such equipment in providing adequate space for filters.

(To be continued)

# SERVICEMEN REPORT "EXACT REPLACEMENT"

# Headaches GONE!



Read how Cornell-Dubilier's amazingly versatile TYPE BR etched foil capacitors solve servicemen's "exact replacement" problem . . . cut inventory cost . . . increase profit and prestige!

Servicemen know that C-D "Blue Beaver" etched-foil electrolytics—like every capacitor-type bearing the C-D seal—has those

hidden extras that mean finer quality, better performance and longer lasting dependability. No wonder there are more C-Ds in use today than any other make!

## TYPE BR SAVES TIME, MONEY!

Alert servicemen have discovered an added advantage in the Type BR, however, to save them time, trouble and money. You can meet over 95% of all high-capacity filter and by-pass replacement requirements with just a few Type BR sizes in stock. Gone are the old "exact replacement" headaches. Use versatile capacitors . . . increase profits and prestige! Cornell-Dubilier "Blue Beaver" reduce servicing time and inventory expense, giving you extra working hours and a wider profit margin. For complete listing see your local jobber, or send for FREE Cornell-Dubilier Servicing Manual today!

\*Reg. U. S. Pat. Off.

*Next time insist on C-D's*  
**YOUR BIGGEST DOLLAR VALUE IN CAPACITORS!**