

The CORNELL-DUBILIER Capacitor



Vol. 9

JAN.-FEB., 1944

Nos. 1 & 2

CORNELL-DUBILIER ELECTRIC CORP.
HAMILTON BOULEVARD
SOUTH PLAINFIELD, N. J.

Sec. 562, P. L.&R.
U. S. POSTAGE
PAID
So. Plainfield, N. J.
Permit No. 1

FOR VICTORY



BUY
UNITED
STATES
WAR
BONDS
AND
STAMPS

Mr. George M. Beale
130 25th Ave.
San Francisco, Calif.

SQUARE-WAVE TESTING OF AMPLIFIERS*

In the testing of amplifiers, the usual method calls for injecting various frequencies into the amplifier and noting the response curve obtained. With increase of uniform frequency-response width due to higher fidelity requirements, the point-to-point method becomes lengthy and time consuming and does not allow rapid changes to be made in circuit design. What is needed is some method which will allow rapid adjustment of amplifier circuits and at the same time not lose any accuracy because of the speed requirement. Such a means has been found and is known as square-wave testing.

In order to appreciate this method, let us review some of the properties of square waves, one of which is pictured in Fig. 1. The equation of this wave

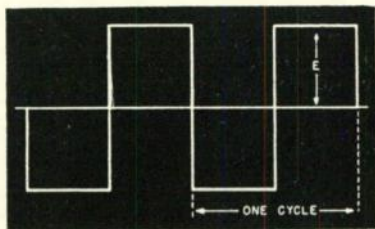

Fig. 1. Square wave.

shows that it is made up of an infinite number of sine waves superimposed on each other. The lowest frequency sine wave is, of course, the fundamental, and each of the other sine waves are odd harmonics of this fundamental. There are no even harmonics. Therefore, if we have a fundamental of 300 cycles, then the sequence will run 300; 900; 1500; 2100 cycles, etc. The lowest frequency wave is the strongest, the strength of each harmonic varying inversely to the frequency. Hence, to a good approximation we need only include about 30 harmonics with our fundamental to get a good square wave.

If any of the frequencies making up the square wave are not transmitted through a network in the same manner, relatively speaking, then the resultant square wave in the output will have its shape modified. It is through these changes in waveform that the basis for this method of testing amplifiers is formed. Although any type of distorted wave rich in harmonics can be used for the testing, the square wave has a convenient form, in which changes are quickly noted. Another important feature of amplifier testing is phase distortion, an ever present menace in television receivers. Here phase distortion means picture displacement with resultant marring of detail. This type of distortion cannot be found by the point-to-point method of testing.

The frequency of the square wave itself, called the repetition frequency, is the same as the fundamental. By varying the repetition or fundamental frequency of the square wave we can test an amplifier for low- or high-frequency response independently of each other. The repetition frequencies used for testing the networks in this article were 60 cycles for the low end and between 1000 and 2000 cycles for the high end. Due to the harmonics a band of frequencies was obtained that extended from 60 cycles to almost 100,000 cycles. While this is far greater than is needed for ordinary audio amplifiers, television requirements call for flat-top response from 30 cycles to 4,000,000 cycles.

All the apparatus necessary is a square-wave generator and an oscilloscope. After the square wave is passed through the amplifier under test, it is viewed on the screen of the oscilloscope and any distortion noted. Rapid and accurate adjustments can then be made on the equipment, meanwhile noting the effect on the output wave.

It might be pointed out by some readers that since a square wave con-

(Continued on page 12)

* By John Williams in "Radio News."



A Free Market-Place for Buyers, Sellers, and Swappers.

These advertisements are listed FREE of charge to C-D readers so if there is anything you would like to buy or sell; if you wish to obtain a position or if you have a position to offer to C-D readers, just send in your ad.

These columns are open only to those who have a legitimate, WANTED, SELL or SWAP proposition to offer. The Cornell-Dubilier Electric Corp. reserves the right to edit advertisements submitted, and to refuse to run any which may be considered unsuitable. We shall endeavor to restrict the ads to legitimate offers but cannot assume any responsibility for the transactions involved.

Please limit your ad to a maximum of 40 words, including name and address. Advertisements will be run as promptly as space limitations permit.

WANTED—Only one 35Y4 tube. Cash for same. E. L. Palmer, 305 Main Street, Manchester, Ga.

FOR SALE—New R-55 Multimeter. Never used. **WANTED**—One National School radio and television course and kit of parts. Cecil Morgan, 2209 Edison Ave., Jacksonville 4, Fla.

FOR SALE OR TRADE—Postal Packing Mamma has radios, tubes, parts, etc. Limited stocks but unlimited supply of items to keep you selling. 300% profit. Send \$3.50 for \$10 assortment, or 25c (coin) for sample. Will send the list of your needs with sample order. P. O. Box 275, Palmyra, Penna.

WANTED—A good signal generator. Have many meters which I would like to trade for same or will pay cash. Also want a multimeter. Sam Berenblum, Greenwich, Conn.

SELL OR TRADE—6, 8 and 11 in. dynamic speakers, Atw. K., etc. Speaker units, ear phones, electric vibrator. Want Rider Manuals 8 to 13, voltohmmeter. Theodore Lohr, 140-28—247th St., Rosedale, L. I.

FOR SALE OR TRADE—Webster P.A. amplifier, model A66 with tubes, 50 watt class A, using 2 866 rectifier, 2 845 in output; 2 Atlas weather-proof baffles, with 20 watt PM units, PM speakers, like new, 1 new Shure 55 Caniod high imp. microphone; also used crystal microphones, high imp. Bechdolts Radio Sales, 310 North St., Wapakoneta, Ohio.

WANT—Hand vacuum cleaner, 8mm projector, midget radio. Have many types of tubes, cabinets, filters, meters, also cash. G Samkasky, 527 Bedford Ave., Brooklyn, N. Y.

FOR SALE—4 Majestic 90s chassis and pwr. pk., 1 Zenith 420, 2 spkrs.; 3 brand new Kolster K5 amplifiers, 1 Temple chassis and pwr. pk., 1 G. E. K32 chassis and spkr., 1 Espey A eliminator, 1 Kodak battery charger, new; 1 table model 5 tube radio. Louis A. Goldstone, 1279 Sheridan Ave., Bronx, New York 56, N. Y.

WILL TRADE ONLY — German camera, make unknown, folding metal base, black leather covered, with 1" (10 cm. focal length) F 3.8 Laack-Reguldtt lens and Compur shutter, fastest 1/250. Have 10 120 films goes with it only, also have Eastman carry case for same. Have Eastman pocket type range finder, will trade this separately or with camera. Present value of above now about \$75. Do not need money, only need high grade equipment. Want VTVM, multimeters, VOM. Radio Shack of Brady Lake, W. S. Crooks, Box 94, Kent, Ohio.

WANTED — Superior Channel analyzer, also Superior signal generator, model 1230 or model 702 RCP signal generator. Harold Arnett, 820 S. Gordon St., Piqua, Ohio.

WANTED — Have \$25.00 plus express charges for Rider's Manuals 6 to 13 inclusive; also want C.D. or Solar condenser tester. Ray Daniels, Rt. 1, Box No. 144, Hopkins, Minnesota.

FOR SALE — Model 333 Simpson tube tester. Has 117 v. filament transf. and toggle switches in place of standard switches originally used. \$25.00. Consider T-125 as part payment. W. Cox, 1009 Broadway, New Orleans, La.

EXCHANGE — Two Meissner 9-1081 112mc Transceivers (7A4-6S7G-6G6G, crystal or carbon mike inputs, AC power supply, tubes and cabinets) for communication receiver; Howard 436-7, Sky Buddy, EC-1, or SW3 plus cash. N. Bell, Rockland Rd., Libertyville, Ill.

SWAP—RCA Rider's Chanalyst in excellent condition, complete for 2 1/4 x 3 1/4 or 3 1/4 x 4 1/4 Speed-Graphic camera. Will pay cash for difference. Describe fully condition, lens, and accessories. Modern Radio Service, 532 Brady Street, Davenport, Iowa.

WANTED FOR CASH—Any late model Jackson testing equipment such as Models 637, 634, 650A or 640, or 660 signal analyzer; also Rider's Manuals 1 to 13 in excellent or new condition. D. O. Braden, Box 150, Washington, Iowa.

WANTED — Battery operated ohm meter such as RCP, also any other test equipment. Describe and give the cash price. W. S. Crooks, Box 94, Kent, Ohio.

RADIO TELEPHONE OPERATOR with 1st class license in radio since 1930, 7 years ham, over 2 years' experience as B.C. operator and chief engineer in small stations, might listen to your proposition. Can become available if the job and price is right. Address letters to W. S. Crooks, Box 94, Kent, Ohio.

WANTED, CASH OR SWAP—8mm. movie projector. Have micrometer, vise, wire, and other radio parts. State make, condition, and price wanted in first letter. Arthur Beiser, 2910 Wallace Avenue, Bronx 67, New York.

WILL SWAP—1 pair homing pigeons for three 1A76T or 1H56T tubes. Have several pair to swap. Chas. L. Culley, Melville, Louisiana.

WANTED—A 0-100 microammeter, any make. Frank J. Polinski, Warren, N. Y.

SWAP—35 mm. movie projector, Janette rotary converter, several vols. QST, Pop. Science, Life, Radio Engineering; RCA Radio course, auto and other radios, photographic enlarger. WANT signal generator, scope, good VOM milliammeter, 35 mm still camera, 8 mm movie camera and projector, gas-electric generator, .22 repeater rifle, or what have you? Joseph Leeb, 1380 Merriam Ave., Bronx 52, New York.

WANTED — Broadcast band coils for H.R.O. K. L. Wagner, 500 Capital City Bank Bldg., Des Moines, Iowa.

FOR SALE OR TRADE — 1 comp. set of Graham rotary files, new, never used. Want a signal generator or a Precision 920 P. Will take \$75.00 cash, cost me over \$300. Also have new bicycle. Write for more details. Mr. Stolove, 715-19 Hopkinson Ave., Brooklyn, N. Y.

FOR SALE—RME 69 communication receiver, excellent condition. Six bands from 550 to 32,000 kc., phone and C.W. 8 in. P.M. speaker to match. \$189.50 complete. Shipped F.O.B. on receipt of price. L. J. Schnedorf, 610 Monroe Ave., River Forest, Illinois.

FOR SALE—Coaxial cable of soft copper tubing 3/8" O.D. with No. 12 A.W.G. inner conductor, 125 foot length, \$59.50. Relay rack, steel 76 ins. high, for 19 in. panels, \$29.50, shipped F.O.B. on receipt of price. L. J. Schnedorf, 610 Monroe Ave., River Forest, Illinois.

WANTED — Hallicrafter S19R, Triplett 1200F, Meissner 13-7614 tuning unit, Sprague standard telohmike. State price in first letter. Louis Bauerleind, Box 264, Hortonville, Wisconsin.

SELL OR TRADE—Jewell meters, pattern 25, 10-0-10 ma dc; 0-15 v. dc; two 0-30 v. dc. Pattern 164, two 0-5 a. r.f. Sell for cash or trade for oscilloscope, test equipment or what have you. Make offer. F. A. Fillmore, 500 E. Logan St., St. Louis 15, Mo.

SWAP—One 12 in. band saw new with two blades for part payment for good used outboard motor. C. W. Hull, Mineral Springs, Penna.

WANTED to hear from someone who will sell me 2 12A8GT and 2 12SQ 7GT good, new or used tubes. Will also buy a portable, recorder playback radio, combination new or used. S. T. Smith, 90 Summit St., Manchester, Conn.

WANTED—16 mm sound projector, complete, state make, model, description, and price. Must be in good condition. Will pay cash. Write Geo. J. Dohm, 500 W. Jackson St., York, Pa.

WANTED—VOM, condenser analyzer, ac voltmeter and wattmeter, phase angle meter, etc. Also want Rider's Manuals, complete set or what have you. Meinen Electric Co., Chippewa Falls, Wisconsin.

FOR SALE OR SWAP—INCA D88 choke 10 henry; INCA N30A Universal modulation transformer; Thordarson T57A41 pushpull input transformer; SW3 receiver without power supply. Will swap for Rider's vols. 11, 12, 13. E. J. Anderson, 1331 Schley, Butte, Mont.

WANTED—Latest N.R.I. radio course, in good condition, state price wanted. All offers answered. Phil Roane, 38 Harrison Street, Hartford, Conn.

WANTED—Drill press; bandsaw; Craftsman, Delta, etc. State model, condition and price. Also, crystal lapel mike and crystal ear piece. J. W. Bourke, 196 Clinton Ave., Brooklyn 5, N. Y.

WANTED—Rider's Manuals, 6 to 13; late model testing equipment, electric drill, late tubes. Will pay cash. All must be in perfect condition. Eugene Gilbert Radio, 1296 Sheridan Avenue, Bronx 56, New York.

FOR SALE—Tubes and neon sign. 6L6G, 6SF7, 6SK7, 6SH7, 7C7, 12B7, 12B8 qt, 384, 1T4, 5U4G, 26, 3Q5qt at 25% off list price, tubes new in sealed cartons, neon sign and transformer, "Radio Service" in 6" letters to hang in window. Radio Electronic Labs., Hudson, Wisconsin.

WANTED — Table model radios and phono-radio combinations. Will pay cash. Write me what you have to sell. Eugene Gilbert Radio, 1296 Sheridan Ave., Bronx, New York.

WANTED — Late edition Rider's Automatic Record Changers. State price. Have K & E log duplex slide rule with instructions, drafting set, Delaker and Hartig Calculus, 1935, French Eng. Drawing and Aeroplane Construction and Repair Book. Unexcelled Radio Co., 155 Blackford Ave., P. R., Staten Island 2, New York.

WANTED — One Remington automatic rifle, model 81A "Woodmaster 300 cal." A. E. Rowe, Arbutuck, California.

FOR SALE—Scott Phantom deluxe. Still serviced under original guarantee. Practically brand new. \$200.00. J. Schneider, 1175 Wheeler Ave., Bronx, New York.

WANTED — 1 Hickok Tracometer, new or used. Will pay good price if new or in good condition. State price and condition. All letters answered. Radio Service Co., 603 Granby St., High Point, N. C.

WANTED—Complete unit or parts for W.E. or E.R.P.I. amplifiers, type 41A, 42A, 43A or 46C for sound pictures. Also sound projector parts or units, and tubes WE 205D, 211E, 264A. F. B. Bloomer, 4434 7th Ave., Rock Island, Illinois.

WANTED—Up to 100 6X5GT tubes at list price, or will exchange for 12SQ7GTs on basis favorable to you. Humphreys Music Co., 130 Pine Ave., Long Beach 2, Calif.

WILL TRADE—Radio and Television Institute book course complete, for Superior tube checker, model 1240, or what have you, willing to trade after five days approval of books. George J. Smith, 132 S. 7th St., Steubenville, Ohio.

WILL TRADE 12SK7, 12SQ7, 35L6 or 50L6 for equal number of new 12SA7 tubes. Urgently needed for servicemen's radios. Also have for sale one Conley 5x7 sheet film or plate camera with plate holders, film holders, carrying case and focusing cloth \$10 FOB. Johnson Radio Service, 302 Oakwood St., Austin, Minn.

FOR SALE—1 110 v. dc to 110 v. ac 500 watt Westinghouse converter, new. 1 32 v. dc to 110 ac converter with filters. Used three months. Smith's, Inc., Leonardtown, Maryland.

WANTED—Garrard Changer RC30, RC31 or any other model in good or not working condition. Aladdin Camera & Radio Exchange, 4 East 32nd St., New York 16, N. Y.

WANTED—Foreign Radio tubes, buy, sell or exchange. Aladdin Camera Exchange, 4 East 32nd St., New York 16, New York.

FOR SALE — DC-AC converter formerly used on the "Normandle" in perfect operating condition, 105-125 volts, \$35. Aladdin Camera & Radio Exchange, 4 East 32nd Street, New York 16, N. Y.

SELL OR SWAP — 1 Superior genemotor with these features: RF oscillator 100 kc to 105 mc; AF oscillator 35 cycles to 10,000 cycles. Built in output meter, all AC operated. Can be used as saw tooth sweep in oscilloscope work, will test condenser leakage, instructions included. R. Dyer, 306 Kenwood Ave., Syracuse, N. Y.

WANTED—Late model tube tester or one that can be converted. J. M. Baldwin, Station KDYL, Salt Lake City, Utah.

WANTED—Outboard motor around 5 or 6 H.P. in good shape. John Francis Abt, 10 Richards Ave., Stamford, Conn.

TRADE—Confidence tube tester, type-writer, 25 vol. Mark Twain's works, 22 Stevens bolt action repeater, power transformer, many items. Want Rider's 10-13, Rider's Signal Tracing, etc. Duck decoys, guns in need of repair. W. J. Closson, 295 8th Street, Troy, N. Y.

WANTED—Recording turntable and cutting arm complete—or inexpensive recorder. Ward Lantis, 1217½ S. Washington, Marion, Indiana.

WANTED—Signal generator and a set analyzer or multimeter. Will pay fair price for equipment in A1 condition. All letters answered. Philip D. Howes, Patten, Maine.

WANTED—Amplifier for musical instrument use, reasonably priced. Write H. W. Brock, 621 S. Rock Island, El Reno, Okla.

(Continued on page 15)

WANTED: Signal Corps Equipment

You may have Radio-Amateur and Photographic equipment that is urgently needed by the Army Signal Corps. The Army will buy the following from private individuals.

Radio: Standard and commercial built short wave transmitters (such as Hallicrafters HT-1, etc.; Temco and Collins Model 32 and 30) and Standard and commercial built short wave receivers (such as Hallicrafter, National, RCA, RME, Hammarlund or Howard); AC and DC Voltmeters, Ammeters, Milliammeters, Radio Frequency Meters and Volt-ohm, milliammeters; Oscilloscopes, 2-3 inch; Audio sig. gen. 30-15,000 cycles; RF sig. gen. 15-215 megacycles; late model Tube Checkers, and other test equipment.

Photographic: 35 MM Motion Picture Cameras (such as Mitchell (all models), Bell & Howell - Standard Professional, Akeley-Professional (all models) and Eyemo (all models) Bell & Howell Mfg.), etc., and 16 MM Motion Picture Cameras (such as Cine-Kodak Special, Magazine Cine-Kodak, Filmo 70.D or Filmo Auto Master); Tripods; Lenses, all types for 35mm and 16mm equipment; Exposure Meters; and Cameras (such as Speed Graphic 4" x 5", and Speed Graphic 2 1/4" x 3 1/4" with or without flash synchronizers) and Leica Model III (F) or 11B (C), or equal; Range Finders; Pack Adaptors and Cut Film Holders.

If you have this type of equipment, you can assist the war effort materially by selling it to the Army. Write to:

**EMERGENCY RELIEF SECTION
PHILADELPHIA SIGNAL CORPS PROCUREMENT DISTRICT
5000 WISSAHICKON AVENUE, PHILADELPHIA, PA.**

briefly describing the equipment you have and stating the price at which you can offer each item, FOB Philadelphia. Do not ship any material without specific directions from that office.

Price consideration is based upon your net cost less reasonable depreciation for use, age, and condition of equipment. Inasmuch as all equipment is being purchased FOB Philadelphia, cost of packing and shipping can be shown separately so that an allowance for the costs can be made when material is accepted.

FEATURES OF INVERSE FEEDBACK AMPLIFIERS*

The application of inverse feedback to an amplifier, if present in sufficient quantity, contributes a material reduction of noise and distortion produced in the circuits. When no reactances are present in the feedback path a wide range of flat frequency response is obtained with virtually zero phase shift. The gain is made constant, and the impedance and output voltage regulation is greatly improved. Equalization is easily introduced by the addition of relatively simple networks to the feedback loop. This equalization can be set to apply at either end of the frequency range.

When inverse feedback is applied to an ordinary amplifier, several important features appear, all very desirable from the standpoint of fidelity of reproduction. For purposes of illustration, Fig. 1 is a typical three-stage amplifier circuit utilizing overall voltage feedback. That is, the feedback voltage is proportional to the output voltage of the amplifier.

Another type of inverse feedback is produced when the feedback voltage is proportional to the output current. Of these two fundamental types, voltage feedback is more desirable, since it effectively reduces the internal impedance of the amplifier. This effect is similar to lowering the plate resistance of the output tubes, namely stabilization of the output impedance of the amplifier when feeding a variable reactive load, such as a loudspeaker.

The chief disadvantage of current feedback lies in the fact that where a transformer is the coupling medium between the tube and the load, current feedback tends to make the primary magnetizing current sinusoidal. Amplitude distortion is thereby increased. The internal amplifier impedance is also increased, obviously an unwanted effect for a loudspeaker load.

An examination of the voltage feedback loop indicates that some portion of the amplifier output voltage is returned to the input and superimposed upon the signal input voltage. If the feedback voltage is in phase opposition to the signal voltage, it will re-

duce the effective input voltage, and consequently the output voltage of the amplifier also will be reduced. This gain reduction may be offset by an increase in the original input signal.

Excursions in output voltage with frequency will be corrected by feedback. If, at some audio frequency the output voltage is lower than at the reference frequency, the feedback voltage will be low. The effective input voltage will then increase with subsequent increased output for that frequency. Converse action takes place at frequencies where the output voltage is higher than at the reference frequency. The feedback voltage then will be high, reducing the effective input voltage so that the output voltage will drop.

Output Regulation

It can be seen that the output voltage regulation of a feedback amplifier is excellent, and distortion produced by a variable output load will be greatly reduced. For a frequency where the load impedance varies from the optimum value, the feedback voltage also will vary in such a manner that stabilization of the output occurs. In case of a loudspeaker load, cone resonance and "hangover" effects are minimized. The frequency response of the amplifier of Fig. 1 with and without feedback is shown in Fig. 2.

When a harmonic voltage is generated by the amplifier that was not present in the original signal, it will be fed back so as to oppose the original component. Thus distortion is re-

* By Philip C. Erborn in "Electronic Industries."

duced. Because noise, such as hum appearing in the output stage of an amplifier is greatly reduced by feed-

characteristics of the loop and consequently of the amplifier will be independent of frequency.

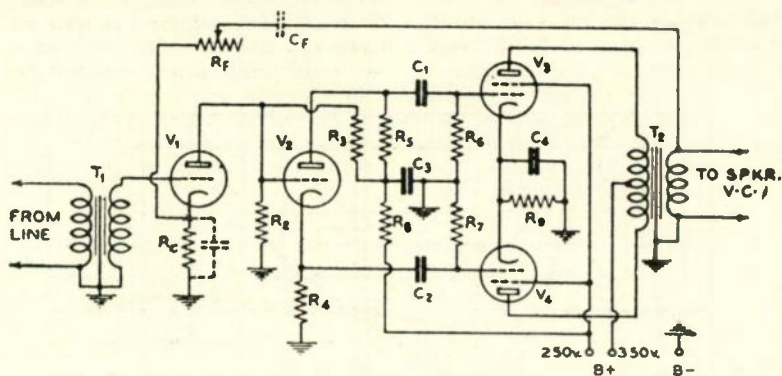

Fig. 1—Typical three-stage amplifier circuit utilizing overall voltage feedback

T₁—Multiple line to grid (20-500 Ω to 100M Ω)

T₂—Push-pull plates to line or voice coil (6000 Ω P-P to 500 or 8 Ω) 35 watts, class AB, 2 tubes

V₁—6CS, 6J5

V₂—6CS, 6J5, 76

V₃, V₄—8L6G

R_f—500M Ω variable pot

R_c—2000 Ω 1 watt

R₂—500M Ω 1 watt

R₁—1.0 megohm 1 watt

R₃, R₅—50M Ω 1 watt

R₄, R₇—100M Ω 1 watt

R₆—25M Ω 1 watt

R₈—250 Ω wire wound, 10 watts

C₁, C₂—See values in Fig. 3

C₃, C₄—0.25 Mfd. paper, 400 volts

C₅—8.0 Mfd. electrolytic, 450 volts

C₆—50.0 Mfd. electrolytic, 50 volts

Note—Power supply should be external to amplifier chassis

back, the power supply need not have other than ordinary filtering.

The quantity AB is termed the feedback factor and controls the feedback effect, where A is the gain of the amplifier over the feedback loop and B is the ratio of the feedback voltage to the total voltage. B is negative for inverse feedback. If this feedback factor is considerably larger than unity, the gain will approach $-1/B$. With AB large and only resistance present in the feedback loop, the amplification

An interesting feature of inverse feedback is its usefulness in equalizing an otherwise flat response band of frequencies. Normal equalization may be carried out without in any way contributing to the distortion in the amplifier. Indeed, the distortion actually is reduced, particularly in the regions of flat frequency response. This method is known as equalization through selective inverse feedback, and at any given frequency the gain of the amplifier and the amount of

feedback used are closely tied together.

Middle Range

For example, if the gain at 40 cycles and the gain at 8,000 cycles are to be raised 15 db compared to

It will be found that at the equalized frequencies, where the feedback is small, the feedback factor AB is small. Hence the gain of the amplifier no longer approaches $-1/B$. As a result the actual mathematics used in de-

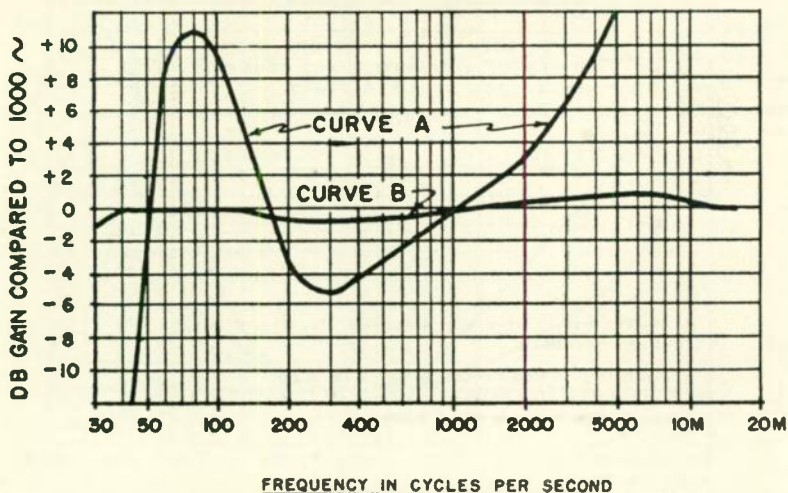

Fig. 2—Circuit of Fig. 1, curve A showing characteristics with no feedback, and curve B with 25 db feedback, with resistive line input and 8 ohm loudspeaker load

a 1,000 cycle reference level, then at least 15 db of feedback must be used. The increased gain at these frequencies is not accomplished by "boosting." Instead, feedback reduces the amplifier gain 15 db for the middle range frequencies, and the gain at 40 cycles and at 8,000 cycles approaches the level existing without feedback. To accomplish this, frequency discrimination networks are inserted in the feedback loop. These networks cause the gain characteristic of the feedback loop to vary with frequency inversely as the desired amplifier gain characteristic varies with frequency. Thus it is seen that the constants of the feedback loop must be altered to give it a response curve opposite to that wanted from the amplifier.

termining the constants of the equalizing networks becomes involved. The characteristics of the amplifier and feedback path with regard to frequency must be known. Because some of the networks are tied across the input cathode resistor (as shown by dotted lines in Fig. 1) current feedback present in this stage must also be considered in the calculations.

The usual "cut and try" methods, however, may be used for rough setting of the capacitor values necessary to produce equalized curves similar to those shown in Fig. 3. As a matter of note, current feedback of the type existing in the input stage normally contributes only a reduction in the gain of the stage and a reduction of distortion. The frequency response is unaffected since only the output cur-

rent is made constant, and the output voltage may still vary with frequency.

Peaks Minimized

Particularly with power pentodes and beam tetrodes in the power output stage, the effects of transient peaks

volume levels. This is caused by the natural characteristics of the ear, augmented by the reduced output of the loudspeaker at extreme frequencies. Definition will be restored if sufficient equalization is used to compensate for

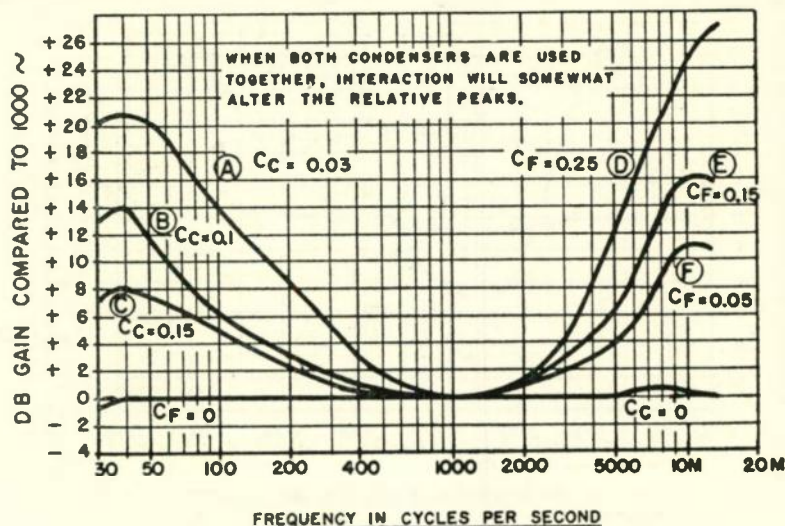

Fig. 3—Equalizing constants for circuit of Fig. 1, curves A and C with cathode condenser, and curves D and F with series loop condenser, 34 db feedback, resistive load

may be minimized only by applying feedback which tends to produce a flat frequency response. Distortion measurements made with the circuit of Fig. 1 run unreasonably high in the absence of feedback. Logically then, extensive equalizing should not be carried out altogether in the power amplifier. Distortion will not be reduced for high and low frequencies where its presence is most objectionable to the ear. Some equalizing can take place in the power amplifier, and the remainder can be delegated to a preceding preamplifier. Note also that any distortion and noise introduced by circuits external to those within the feedback loop will not be affected by this feedback.

An apparent loss of intelligibility may be noted when listening at low

the loudspeaker, although some additional compensation may be used when the signal source is not flat.

Imperfections Exaggerated

It is important to note that a high fidelity amplifying system will accurately reproduce any imperfections present in the signal source. When extensive equalizing is used for one reason or another, these imperfections will be tremendously exaggerated. Obviously, cheap microphones and phonograph pickups should not be used with such a system, particularly from the standpoint of amplitude distortion.

Although the basic circuit of Fig. 1 is not new, it has proved to be an excellent medium for experiments with large amounts of feedback. An unusual feature is presented by the sin-

gle-tube phase inverter which gets its bias from the "B" supply and is direct-coupled to the input tube. With 200 volts applied to the plate load resistor R_3 from the decoupling network, and R_3 set at 1.5 megohms, the plate,

Bias Adjustment

Bias adjustment for the phase inverter is automatic, and tolerance in the value of R_3 may be ordinary. The signal input to the phase inverter appears between grid and ground, an

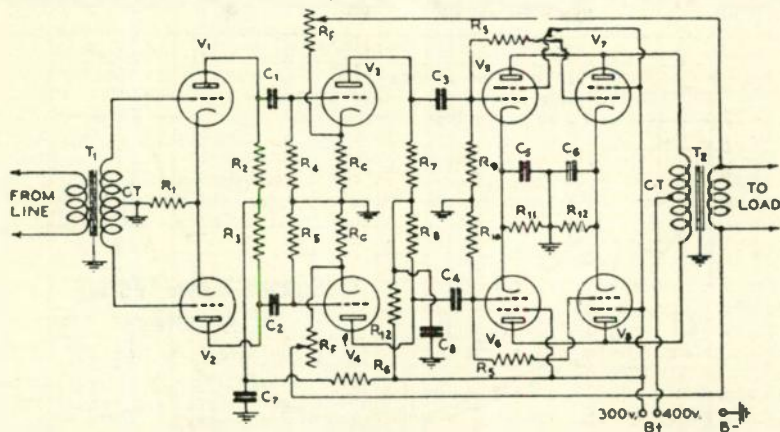

Fig. 4—Push-pull parallel amplifier to deliver 80 watts with 400 volts plate potential

T_1 —Multiple line to push-pull grids (30-500 Ω to 120 Ω total secondary)

T_2 —Push-pull plates to line (3200 Ω P-P to 500 Ω) 75 watts, class AB, 4 tubes

V_1, V_2 —6CS, 6J5

V_3, V_4 —6CS, 6J5, 76

V_5, V_6, V_7, V_8 —6L6G

R_3 —500M Ω variable pot

R_1, R_2 —100M Ω 1 watt

R_4, R_5 —250M Ω 1 watt

C_1, C_2 —0.1 Mfd. paper, 400 volts

C_3, C_4 —0.1 Mfd. paper, 400 volts

C_5, C_6 —50 Mfd. electrolytic, 50 volts

C_7, C_8 —8.0 Mfd. oil filled, 600 volts

R_9 —2000 Ω 1 watt

R_6 —50M Ω 1 watt

R_7, R_8 —50M Ω 1 watt

R_9, R_{10} —100M Ω 1 watt

R_{11}, R_{12} —200 Ω 10 watt, wire wound

R_8 —100 Ω 1 watt (See text)

R_{12} —25M Ω 1 watt

Note—Power supply should be external to amplifier chassis

grid, and cathode are all 50 volts above ground for a plate current of 1.0 ma. In operation this plate current increases slightly so that approximately 4.5 volts of bias is applied to the grid. The value of R_3 has been reduced to 1.0 megohm to compensate for plate current drawn by the input tube, and the 50 volts available at the grid of the phase inverter is directly applied to this plate.

excellent feature for hum elimination. Driving voltage for the output grids is adequate and is taken from the plate and cathode of the phase inverter (180 deg. phase difference). No bypass capacitor can be used across R_4 or serious unbalance would occur.

A very slight high frequency phase difference in the two signals at the output grids does exist, and is caused by some capacity between cathode and

heater. This may be minimized by using a separate heater transformer for the phase inverter, connecting the center tap to a circuit point about equal in potential to the cathode, rather than to ground. However, when the heater is operated from a transformer common to the other stages, this phase shift actually is of no consequence compared to that realized with an ordinary interstage transformer, or the more usual two-tube phase inverters.

The elimination of the coupling capacitor and any decoupling network between the first two stages, the absence of cathode by-pass capacitors in these stages, and excellent balance in phase inverter contributes materially to the low inherent phase shift of the amplifier. Because rather large current feedback is also present in the cathode circuit of the phase inverter, no gain is contributed by this stage. The actual stage gain is close to unity for each side.

Tube Capabilities

An example of receiving type tubes doing the work of more expensive class B tubes is shown in the circuit of Fig. 4. Four type 6L6G tubes connected in push-pull parallel deliver an output in excess of 60 watts at a plate potential of only 400 volts. Since these tubes are capable of high distortion, inverse feedback is applied in a balanced fashion to both sides of the amplifier comprising the voltage driver and power output stage.

Any distortion generated in the push-pull input stage is reduced by current feedback in the common cathode circuit and the balance is improved. The resistors R_a connected between each parallel pair of 6L6 grids are sometimes necessary to squelch parasitic oscillations at inaudible frequencies common to this connection. Transformer input is shown since perforce a balanced input is necessary. A two-stage preamplifier should easily drive the power amplifier from an ordinary source.

Ordinary power supplies may be used for either of these amplifiers, but a heater winding on the plate transformer should not be used for the am-

plifier heater circuits. The amplifier tubes should be allowed to reach proper operating temperature before the plate voltage is applied. A voltage surge caused by light loading of the power supply during this heating period may cause momentary oscillation to occur. If the amplitude of the oscillations reaches a high value, stem flashover in the 6L6's may result as well as puncture of the output transformer insulation. The presence of such oscillation may be noted on an ac voltmeter connected across the amplifier output. A slight reduction in the amount of feedback used will also clear up the condition if a check shows that it exists.

Square-Wave Testing of Amplifiers

(Continued from page 2)

sists of a set of discrete frequencies and not a continuous band, we are only testing the amplifier at various points

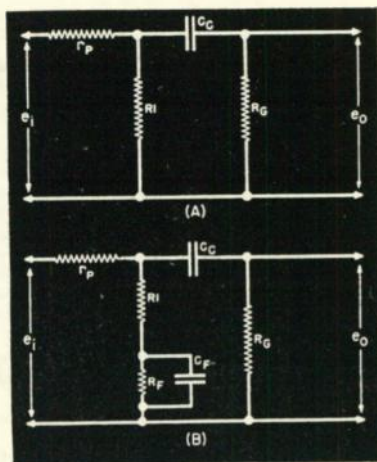

Fig. 2. Equivalent circuit of a resistance-coupled amplifier at the low frequencies. (A) Uncompensated. (B) Compensated.

on its response curve, not all along the curve. This might appear as a disadvantage but actually it is not, since response curves tend to vary smoothly and do not usually have sharp breaks.

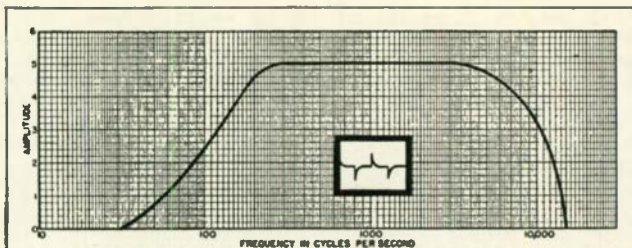

Fig. 3. Response curve and pattern indicating poor low-frequency characteristics.

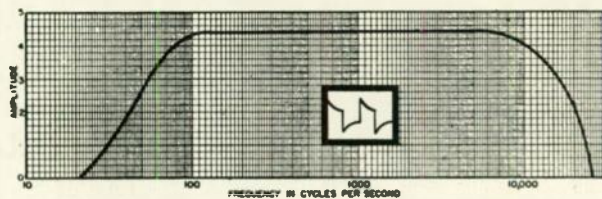

Fig. 4. Curve showing improvement after low-frequency correction has been made.

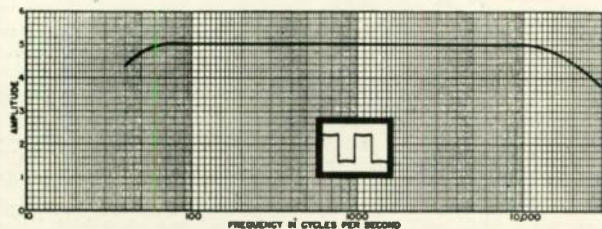

Fig. 5. Frequency-response curve obtained by using satisfactory compensation.

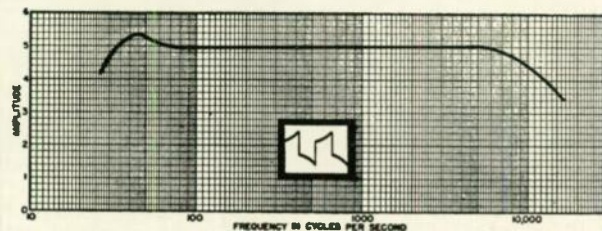

Fig. 6. Characteristic curve obtained by over-compensation of the low frequencies.

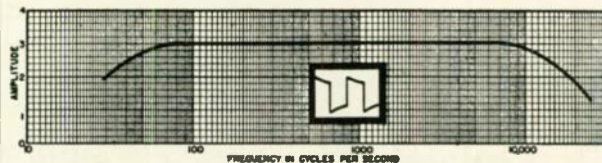

Fig. 7. Frequency-response curve showing the results of under-compensation.

Also, by varying the repetition frequency we can cover any lapses that occur and bring to light sharp breaks in the frequency-response curve.

Since experience in recognizing the various patterns of square waves obtained is necessary for interpretation of results and the rapid adjustment of the amplifiers, representative square wave patterns will be examined, and their shapes interpreted. In order to further facilitate the work, the low- and high-frequency responses will be separately analyzed.

Low Frequency

In Fig. 2A, we have the equivalent circuit for a resistance-coupled amplifier at the low frequencies. As is well known, low output is usually attributed to the relatively large voltage drop across the coupling condenser C_c . A typical response curve of an amplifier with such poor low frequency response is given in Fig. 3. If the square wave, depicted in Fig. 1, is now sent through this amplifier with a repetition frequency of 60 cycles, the oscilloscope picture will appear as in Fig. 3. This distorted square-wave pattern shows two things very clearly: phase and frequency distortion. Frequency distortion is indicated by the fact that the wave is not flat-topped and phase or delay distortion is brought out by the sloping of the square wave.

Making C_c larger or increasing R_0 will improve the low frequency output, because then more input voltage will appear across R_0 to be amplified by the succeeding stage. Fig. 4 is the response curve plotted for such an amplifier after the improvement mentioned above has been made and the oscilloscope picture shows the square wave after it passed through the amplifier. It will be observed that the distortion is now less.

The above process of making C_c or R_0 larger cannot be carried on indefinitely to improve the low end response for several reasons:

1. As C_c gets larger, its leakage current will increase, and soon a fairly large positive voltage will be placed on the grid of the next tube.

2. Increasing R_0 can prove injurious if there is even a slight amount of gas in the next tube.

3. And lastly, if too large values of either R_0 or C_c are used, relaxation oscillations may set in.

With these limitations in mind, designers turned to a compensating circuit such as shown in Fig. 2B. The added resistor R_F and condenser C_F , if chosen right, will give the response pictured in Fig. 5. Slight over-compensation will result in the pattern of Fig. 6 and slight undercompensation, in the pattern of Fig. 7. The condenser C_F shorts out the added resistor at the high frequencies so the upper portion of the response curve is not altered by the insertion of C_F and R_F . It can also be shown that this added network introduces a phase shift opposite to the shift of C_c and R_0 , thus further aiding the low-frequency output. The latter is very important in television work, where the phase characteristics of a network are sometimes much more important than the gain. Since this is not an article of amplifier design, methods of computing the values of C_F and R_F have been omitted. However, references 1-4 at the end of this article will serve as an excellent guide.

Pictured with the square-wave patterns of Figs. 5, 6 and 7 are found the frequency-response curves applicable to each. Study of the figures will demonstrate how sensitive the square-wave method is and some grasp of its possibilities obtained.

These pictures are only representative of what can be had. While there are many more in the low-frequency region, they usually fall close to one of the types shown.

(To be continued)

**KEEP ON BACKING
THE ATTACK.
BUY WAR BONDS**

THE RADIO TRADING POST

(Continued from page 5)

FOR SALE—1 Supreme signal generator, Model 561, like new. 1 Supreme Vedyolizer, Model 560 in perfect condition. Price \$225.00 for both, F.O.B., New York City. Tony's Radio Shop, 1729 Lexington Ave., New York City. Phone Lehigh 4-2858.

WANTED—One Readite Ranger Big Boy VOM, Model 860, 5000 per v., and N.R.I. all wave, all purpose tester, 4 in. meter. Alva L. Crouch, 633 W. Main St., Thornstown, Ind.

WILL TRADE or sell old copies QST, Radio, Radio Today, Radiocraft, Short Wave, Short Wave Craft, Radio and Television, Radio News, Radio Retailing, Service, etc. What have you, what do you want. Major Fred Kline, Kent, Ohio.

FOR SALE—The following 24 new Turner Vibrators in unbroken cartons. \$40.00 for all or 50% from list for individual vibrators. Non-synchronous, 3 T1A, 3 T4S, 3 T5, 3 T5S, 3 T6S, 1 T10S, 1 T14S, 1 T19S. Synchronous vibrators, 1 T50, 1 T59, 1 T60, 2 T61, 1 T67. Fox Sound Equipment Company, 435 South Fifth St, Richmond, Indiana.

WANTED—Small electric powered bench saw complete with dado saws and motor. I will swap Triplett battery operated signal generator, model 1231 less battery. This generator has never been used. Comes from 120 kc to 30 mc, also 400 c. audio signal. All letters answered. Marvin W. Armitt, Box 363, Cumberland, Ky.

TRADE OR SALE—Teleplex electric code machine with speed control, headphones and several rolls of practice code messages. Sell for 29.50 or exchange for new midget radios. Also Philco non-refrigerated window air conditioner, \$39.50. Sell or trade as above. Miller Electric Service, Ellettsville, N. Y.

FOR SALE—2 Thordarson No. 5738 interstage transformers, 2 1100-0-1100 1 amp. trans., 20 1 mid. 900 v. cond., 4 1 mid. 200 v., 4 2 mid. 2000 v. cond., 1 500 ma. swinging choke, 1 UTC VM, 4 Universal 300 watt Class B output transformer, 2 300 ma. 20 h. chokes, 1 .0025-12000 v. cond., 1 WE 307-A transformer, Johnson 70CD130 1/2 inch spacing variable cond. Other misc. parts. N. K. Stover, 1357 Hill St., York, Pa.

WANTED—Late model tube tester in A-1 condition and not shop worn. Prefer Hickok, model 530 or 510X. Cash to the right party. State model and price. Sam's Radio Shop, 57 Mechanic Street, Lawrence, Mass.

FOR SALE—Leeds and Northrup Wheatstone Bridge, Type S, \$50. Weston Model 440 Galv. 30-0-30 .5 microamps. per division, \$25.00. 1 Swire, 98 Bulwer Place, Brooklyn, N. Y.

WANTED—Supreme model 504A tube and set tester, also Cornell-Dubilier condenser tester or any good condenser tester. Will pay list price if in new condition. James H. Hosie, 1530 Archer Road, Parkchester, Bronx, New York.

SWAP—ICS Radio Principles \$200 course issued Dec., 1941, and cash for any good servicing equipment, such as Chamalyst, Audolyzer or set tester. Ty Lindgren, 274 Dolores St., San Francisco 3, Calif.

FOR SALE — Meissner or G.I. recorder and single record play back, one unit on metal panel for cabinet mounting, \$30.00, also have 5 Shure crystal speakers that can be used as mikes, 4 in., in good shape. Need 8 or 9 in. meter, prefer Hickok model 133 or 210S, also Hickok signal generator, model 177X, 188X or 177, 188. University Radio Service, 134 Merrimac St., Buffalo, N. Y.

WANTED—15 or 20 watt public address system with crystal or dynamic microphone and floor stand. Southern Radio Service, Thomasville, Georgia.

FOR SALE—Complete circuit diagrams any set 50c. Tubes, condensers, resistors, transformers, replacement parts for obsolete receivers, etc. Write us your needs. E. J. Thomas, 763 Ten Eyck Avenue, Lyndhurst, New Jersey.

FOR SALE—One Turner crystal 22X mike, highest offer takes it. One new Index for Rider's Manual, covers 1 to X vols., \$1.50. New Zenith cabinet for Model 5L228A, factory carton 3.00. H. Ursillo, 85 State Street, E. Providence, R. I.

WANTED—Phono motors with turntables and a good volt ohmmeter. Will pay cash or trade with tubes such as 12A6s replaces 50L6s, 7Q7, 25Z6s, 12J5s, 7B7s, etc. John K. Matsuhiro, 8-6-B Relocation Br., McGehee, Ark.

WANTED — For cash Gernsback Radio Manuals Vol. 7 and some others before 1941 in good condition only. Want vol. 7 especially. Give best price first letter. W. S. Crooks, Box 94, Kent, Ohio.

WANTED — A.C. operated VOM, small battery charger, Rider's Manuals, any number except No. 13, 0-250 v. a.c. meter. Have a 427A Jackson tube checker for sale. York Radio Service, Milan, Indiana.

Keep 'em Listening
with
CORNELL-DUBILIER
Capacitors

*"Now I use only
C-D Capacitors"*

—writes **EUGENE G. KLINEDINST**
126 N. Queen St., York, Pa.

"The first and second time a receiver was sent in to me for repair, I used capacitors of different makes. The first lasted two weeks; the second, three. Then I used a C-D Capacitor. I examined the receiver three days ago, after more than six months' use, and found that C-D Capacitors had stood the test. From now on I use only C-Ds." C-D Capacitors always stand the test. Cornell-Dubilier has put 33 years of experience behind building the most dependable capacitors sold.

SEND FOR CATALOG



MICA • PAPER • DYKANOL • WET AND DRY ELECTROLYTIC CAPACITORS

Cornell Dubilier

ELECTRIC CORPORATION

1049 HAMILTON BLVD. • SO. PLAINFIELD, N. J.

MORE IN USE TODAY THAN ANY OTHER MAKE