

The CORNELL-DUBILIER Capacitor

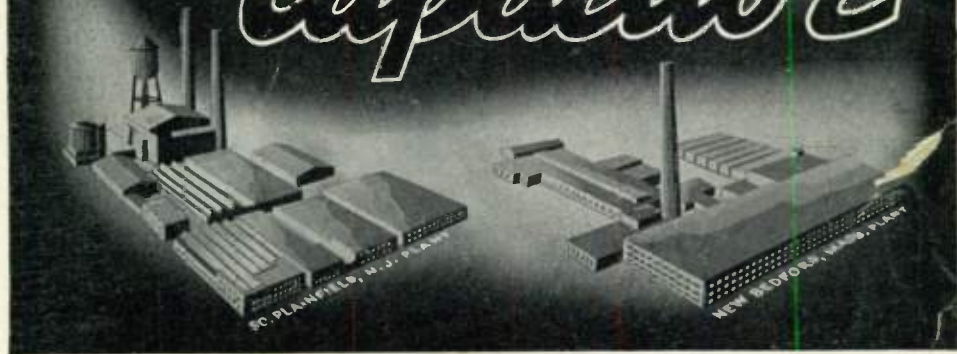

Vol. 11

APRIL, 1946

No. 4

CORNELL-DUBILIER ELECTRIC CORP.
HAMILTON BOULEVARD
SOUTH PLAINFIELD, N. J.

Sec. 562, P. L. & R.
U. S. POSTAGE
PAID
So. Plainfield, N. J.
Permit No. 1

Mr. George M. Beale
130 25th Ave.
San Francisco, Calif.

more helps from C-D

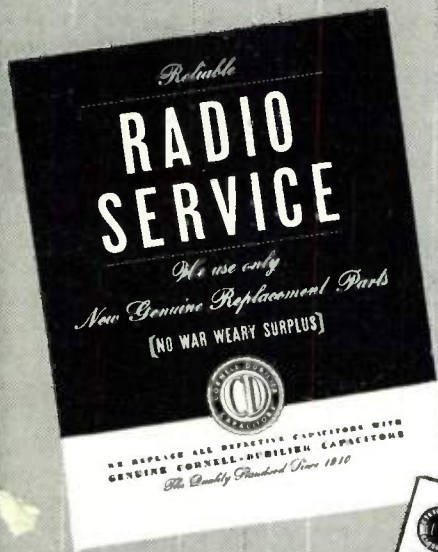

Here's a timely selling tool for you. It tells your customers that you sell the standard of quality in capacitors—C-D—that they won't get inferior, war-weary surplus parts in your store. Put this card in your window as a mark of reliable service and as a proof that you stand by standards. See your C-D distributor today. He will give you one or more of these handsome, colorful 11 x 14" displays, or write us direct — Cornell-Dubilier, New Bedford, Mass.

To help you quickly identify mica capacitors by the official RMA color code—C-D offers you a large wall chart to hang in your shop and small pocket-size cards for ready reference. You can see at a glance the characteristics, decimal multiplier, and tolerance as indicated by a distinct color for each number. These Color Code Cards and Charts are also available from your local C-D distributor.

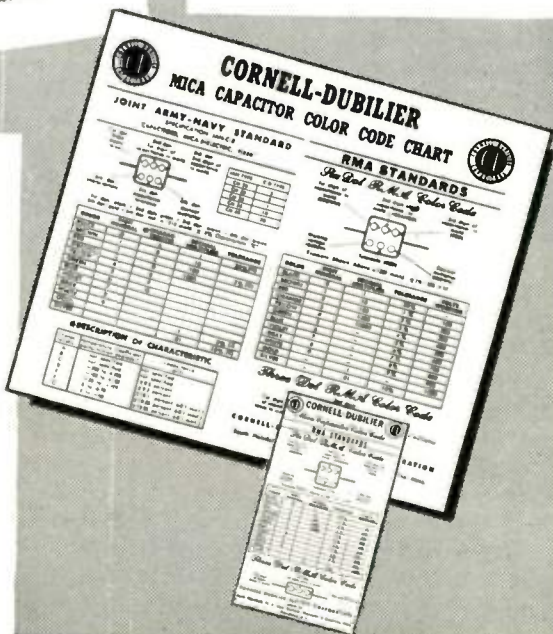

PRINTED
IN
U.S.A.

HUM ELIMINATION*

Hum, that bane of every engineer's existence, the spoiler of recorded and transcribed music, can be eliminated. It merely requires careful analysis and a large dose of common sense. There is a myriad of ways that this insidious nuisance can creep into an otherwise well-designed piece of equipment, either through faulty design or from aging or faulty components.

First, hum may be eliminated through proper design. One of the most violent sources of hum is lack of filtering. Proper filter components are arrived at by designing the power supply—for the unit under consideration—to have a certain percentage ripple when loaded with the load the unit will draw. This is not always enough. It is sometimes necessary to utilize a voltage-regulated power supply to reduce the ripple to the desired amount. This may take the form of the well-known RCA circuit which uses a sharp cut-off pentode to receive the variations in the D.C. output voltage and with a resistor in its plate circuit to influence the grids of several power

smaller loads, a gaseous regulator of the VR-150 type may be employed.

In the former case, the regulator may function well with a resistive load, but when coupled to the circuit it is intended to power, ripple develops. This may be caused by several things. First and foremost is the shielding of the grid circuit of the pentode which controls the regulator tubes. If 60 cycles is introduced at this point, the tube will amplify the 60 cycles and swing the D.C. voltage at this frequency. Secondly, this type of power supply cannot be overloaded. It must be designed to handle the maximum current to be delivered. The regulation and ripple increase very rapidly after its maximum output has been reached.

If a VR tube is used as a regulator, its current range cannot be exceeded. This tube must be supplied with a minimum of 5 milliamperes, else it will not remain in a conducting condition. It must be remembered that the line voltage may change, so a low line voltage condition should be used to figure the minimum current value and the highest line voltage for the maximum current value. This current should not exceed the current rating for the tube.

These tubes under certain conditions will oscillate. This condition may be cured in some cases by inserting a series resistance of about twenty ohms between the VR tube and ground. It is interesting to note that VR tubes have an effective resistance in the order of 40 ohms.

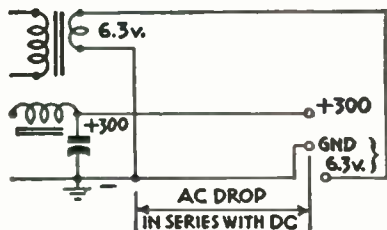

Fig. 1—Piping A.C. hum into a D.C. circuit.

tubes such as 6B4G or 2A3's, connected in series with the power supply. Their resistance is increased or decreased, and, thereby, the voltage held constant and the ripple wiped out. For

Magnetic Field Couplings

The power supply should be laid out with the fields generated by the power transformer and chokes proper-

* By J. C. Hoadley in "Radio-Craft."

ly oriented. The chokes and power transformers should be magnetically shielded and placed so their cores are at right angles to each other, as there is no point in building a good low-ripple power supply and then inducing a volt or so of 60 cycle from the power transformer into the chokes. This hum source will cause even more trouble if audio transformers are involved, as there is usually a considerable amount of amplification following these items and the induced hum is amplified accordingly.

Audio transformers should of course be kept away from power transformers and chokes and should be oriented properly as well. If these components are mounted on a common iron or steel chassis, their cores should be kept away from the chassis by mounting them on aluminum or brass bushings, as the magnetic chassis becomes a common lamination in the core of each transformer and comprises a convenient path for the transference of magnetic fields.

In general, the smaller an audio transformer is, the fewer external magnetic lines will cut it and, consequently, the less it will be bothered by external fields.

Remember that the field around a conductor is proportional to the current that conductor is carrying, so be very careful with leads such as supply lines for the power and filament transformers, and filament wiring which supplies a large number of tubes. Grounding one side of the heater winding on one place is helpful, but keep the filament wiring to itself. This, of course, applies also to high voltage wiring to the rectifier tubes. Don't forget to shield all mercury-vapor rectifiers.

"Ground" Circuit Couplings

Where the power supply and the unit to be powered are separated, do NOT run the negative B voltage and

the grounded side of the filament through a common wire, because (as a look at Fig. 1 will show you) you will effectively connect an A.C. voltage in series with the D.C. supply which you consider hum-free. Although this voltage is small, being due to the filament current, it may be amplified many times by several tubes and assume much greater proportions in the output of your device.

It is somewhat risky to ground the filaments of high-gain amplifiers in several places or depend on the chassis to carry one side of the filament current. This is quite all right from the current standpoint, but if a previous plate is by-passed at Point A in Fig. 2 and a subsequent grid is returned to point B, then a hum voltage may be

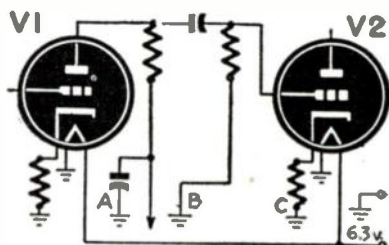

Fig. 2—Effect of voltage drops on a chassis.

placed in series with the grid of the second tube. Even though this voltage is in the order of .01 volts or smaller, if that tube is a pentode with an amplification of several hundred followed by several more amplifier stages, as in a microphone amplifier, then this hum voltage can be very appreciable.

In high-gain stages, incidentally, hum may be caused by emission from the heater to the cathode, or emission from the cathode to the heater. This condition may be reduced or eliminated, in the first instance by applying a positive voltage on the heater, sufficient to make it as positive as the

(Continued on page 12)



A Free Market-Place for Buyers, Sellers, and Swappers.

These advertisements are listed FREE of charge to C-D readers so if there is anything you would like to buy or sell, if you wish to obtain a position or if you have a position to offer to C-D readers, just send in your ad.

These columns are open only to those who have a legitimate, WANTED, SELL or SWAP proposition to offer. The Cornell-Dubilier Electric Corp. reserves the right to edit advertisements submitted, and to refuse to run any which may be considered unsuitable. We shall endeavor to restrict the ads to legitimate offers but cannot assume any responsibility for the transaction involved.

Please limit your ad to a maximum of 40 words, including name and address. Advertisements will be run as promptly as space limitations permit.

WANTED — Combination auto. changer phono-radio in good condition, table or console mod. Also motion camera, projector, optical equipment. Give details. S. Blatt, 42-65 80th St., Elmhurst, N. Y.

WANTED—Carborundum crystal detector cartridge, held in slit by thumb nuts in detector unit, consisting of crystal, rheostat and batt. clips, in moulded case. Used in 20 Ties. Cash awaits. Lloyd L. Melton, Norwalk State Hospital, Norwalk, Calif.

FOR SALE—Supreme 85 tube tester, tests to 30 v. including leakage test. Adapters for octal tubes. RMS Philco wiring diagrams, Vol. II, 1937-38 mods., and vol. showing 1941 models. Have misc. parts. Make offer. G. N. Hartwell, 68 Charlemont St., Newton Highlands 61, Mass.

FOR SALE—Abbott MRT-3 with tubes, Radiart 6 v. Vibrapack and a Universal carbon hand-mike, ready to operate on 2 meters. Perfect condition. Best price takes it. W. H. Schroeder, The Annesley, 512 First Ave., Asbury Park, N. J.

FOR SALE — Supreme tube tester 85, \$20; ABC Unameter tube tester \$30; J. L. D. Morrison sig. tracer with diag. and instr. for using, \$15; all in A1 condition. Leon P. Weaver, R. 4, Towanda, Pa.

FOR SALE—1938 Chev. Delco deluxe auto radio, \$30; 1939 Chev. de luxe auto radio, \$35, both new condition. Two 1/4 hp. ac motors \$12 each. Paul Capito, 637 W. 21 St., Erie, Pa.

FOR SALE—1400 new IRC and Bradley gold and silver band resistors. About 20 different values from 10 ohms to 1 1/2 megohms. 3c each or first M.O. for \$37 takes all. Clarke, Box 18, Inwood Station, New York 34, N. Y.

WANTED—Radio tubes, AK2, EF13, AF3, AZ1, ABL1, for Philips German radio. Will pay top prices for any or all tubes listed. Henry Clark, Siler City, N. C.

SELL OR TRADE — Powerpack for neon sign in car or truck. Input 6 v, 3 amps, output 7,500 v, 10 ma. Charles E. Keinath, 38 Prospect St., Newark, Ohio.

WANT TO BUY—Very early batt. radios, such as Atwater-Kent, Grebe, RCA, Ace, Fada, Zenith, etc. Table mods. only. Need not be in working order. State age, mod., condition, tubes, and price. Chas. E. Keinath, 38 Prospect St., Newark, Ohio.

FOR SALE—Radio parts, tubes, etc., at list prices. Let me know your needs. Small sets at times. AM answered. W. O'Brien, 266 W. 4th, Fulton, N. Y.

FOR SALE—Lot Rider books \$7 prepaid; The Oscillator at Work, The Cathode Ray Tube at Work, FM, AVC, and AFC. Two Dodge 12 v. gens. \$4 ea. collect. Want square copper wire, ga. No. 7 and 8. Harry Kay, Rt. 2, Imlay, Mich.

FOR SALE—All types of tubes in stock. Write for catalog. Also 20,000 acorn tubes at 75 cents each. Sable Radio, 7 Dyer Street, Dorchester, Mass.

FOR SALE—Meisner 14 tube communication set, partly wired, \$85; Webster deluxe changer and recorder, \$68; GE LB-530 portable \$30; Wollensak F 3.5 3" enlarging lens, mounting, dust cover, \$20; Plans for diathermy and wood-working machinery. All new. J. Bourke, 148 Winthrop St., Brooklyn, N. Y.

SALE OR TRADE—Birnback trans. lead-in insulators, 15" long. Birnback stand-off insulators 4½" high. PL-55 phono plugs. Solar trans. mica condensers, type XS, .0015 mf. at 3000 v, 2 amp at 300 kc; C-D "Tiger" paper condensers, .25 mf. 400 v.d.c. All new, guaranteed. Abel Gomes, 8 Duke St., Ludlow, Mass.

WANTED—35Z5s, 50L6s, 6A8s, and 12SA7s. All mail answered. John J. Sturek, 2621 "F" Street, Omaha 7, Nebraska.

FOR SALE OR TRADE—Odd numbers QST for 1930 to 1936. RCA and A-K manuals. Smajd's, 724 Meadow Ave., Joliet, Illinois.

FOR SALE—6 v. Philco dynamotor, 180 v., 50 ma, like new, \$3.50. Five 9003 new, \$1.50 each, WE 360A and 361A, \$1 ea. RCA 913-CRO at \$2.50. R. E. Franklin, 233 Martool Drive, Woodbridge, N. J.

FOR SALE—German meters, 1 5½" x 2¼", 110 v. 0-500 wattmeter; 10 2" 0-40, 40-100 milliammeters; 1 3" 0-0.6 ammeter; 10 2" 0-250 v., ac and dc voltmeters. Want German tube type DCH-11, DF-11, DL-11, DAF-11 and a UY-11. Will pay cash. Albert C. Hart, 4842 Linden Ave., Hammond, Indiana.

WANTED—Good ham receiver, will pay cash, will sell a mod. TAV-3 navy transmitter-receiver complete with generator for portable operations, \$75 cash takes all. Fred W. Rudolph, W8WSC, Stryker, Ohio.

FOR SALE—Power Lighting Plant in perfect condition. No. 107929 Crocker Wheeler, size 1690, type CCD, 150 kw at 200 rpm, 250 kw at 600 rpm, arm. No. 5416 with Ball Engine Co., containing 7" fly wheel. Balancer Crocker Wheeler 233285, Size 1 L type CCM, rpm 1600, 125 v, 35 amps. Contact Manufacturer's Scrap Iron & Metal Co., 402-404 New Britain Rd., Kensington, Conn.

WANTED—Meisner signal shifter, will pay cash or trade transmitting tubes, chokes, transformers. J. M. Bradley, W4ERJ, Watertown, Tenn.

FOR SALE—Triplett master tube tester, mod. 1210A. Odds and ends of radio repair equipment. Mrs. Edward Dugner, Box 1022, Short Hills, N. J. Tel. S. H. 7-2734.

FOR SALE—About 100 tubes including 1A7, 1N5, 1LA4, 1LNS, 6A7, 6F5, 6N7, 6SA7, 6SC7, 7L7, 12SA7, 12SQ7, 35L6, 35Z5, 50L6, 117L7, 2B7, 32, many others, 50% off list. Luckey's Radio, 117 Lafayette St., Bend, Ore.

FOR SALE—Supreme tube checker 85, Supreme set analyzer 333, Tobe cond. analyzer. All in excellent working order. Best offer takes all. John Asheld, 54-45 65th Place, Maspeth, N. Y.

FOR SALE—New radio tubes, including hard to get numbers. Discounts on large diversified orders. Will ship C.O.D. Also transis., spkrs., and vol. controls. Academy Radio, 1901 Mott Ave., Far Rockaway, N. Y.

FOR SALE—25 new tubes, one each, 6SD 7GT, 6G6G, 6AF6G, 85, 1D7G, 6SN7GT, 6W6GT, 6A6, 1B4, 950, two each 6N6G, 84, 78, Five 12SR7, four 26. First \$20.00 takes entire lot, guaranteed, postpaid. Frank's Radio Lab., New London, Iowa.

SALE OR TRADE—Briggs & Stratton WM engine with rope starter and large gas tank. Completely overhauled, first \$25 takes it or what have you? Frank's Radio Lab., New London, Iowa.

WANTED—VOM, condenser tester, also power tools, such as large jig saw, small hand saw, etc. State price, make and condition. H. G. Radcliffe, 1013 High St., Petersburg, Virginia.

FOR SALE—Latest complete NRI course in practical radio, radio servicing and merchandising, 65 lessons, including television servicing, also power pack and kits, tubes. Want good signal gen. or cash. A. Bullhorse, 605 East 168 St., Bronx 56, New York.

WANT—Universal coil winding machine of motor driven type with gear wheels. L. W. Thomsen, 46 Ledge Lane, Stamford, Conn.

FOR SALE—Unused Superior channel analyzer, WE 4A oil damped pickup and arm, Universal KK DB. mike and nickel ring desk stand, GE 10A, 110 v. ac rec. wattmeter, 2A ac and 150 v. ac oval table top meters, Bodine 10", Patent 12", RCA 12" disc phono motors. Best offer. Soundways, 560 Walnut, Fall River, Mass.

FOR SALE—Motors, 110v, ac-dc, ½ hp, \$15; 24v, ac-dc, 1/5 hp with gear reduction, \$10; 24v. ac-dc, 1/3 hp motor and air compressor, \$22.50. B. D. Albin, 1243 So. Sycamore St., Los Angeles 35, Calif.

FOR SALE—80 different types of tubes 40% off. Send for list. Henshaw Radio, 3313 Delavan, Kansas City 2, Kans.

(Continued on page 11)

ALIGNING SUPERHETS*

Output Meter and VTVM Connections. Using Signal Generator Correctly. Dummy Antenna Choice.

To function properly, a radio's tuned-circuits must be properly aligned. Improper alignment may produce gross defects like interstation interference, whistles, and oscillation. It may also cause more subtle symptoms, such as distortion due to side-band clipping. Many cases of decreased sensitivity and reduced volume may be traced to misalignment. Proper alignment, thus, is one of the most important conditions of satisfactory receiver performance.

Several methods of alignment are in current use. One is the "ear and screwdriver" technique, in general disrepute, but still used by a small mi-

nority of technicians. The second is the signal generator and output meter method, with which this article will concern itself. The third involves the use of a cathode ray oscilloscope, and is usually reserved for high-fidelity, FM, and television receivers.

Purpose of Alignment

The proper alignment of AM superhets aims at obtaining a correlation between dial setting and the frequency of the station being received of 2 or 3%. This should hold true of all the stations on the dial. In addition, proper alignment requires that sidebands be ample for good fidelity.

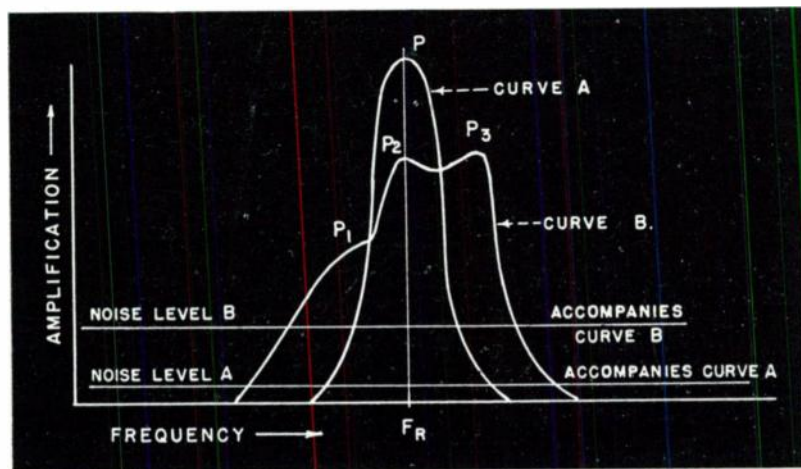

Misalignment may cause the correct tuning curve indicated by A, to be replaced by a curve like B. In this case, 3 peaks— P_1 , P_2 and P_3 —replace the single peak of curve A. Volume is also decreased, and the noise level (B) is raised, due to decreased AVC action.

* Courtesy of "Radio & Television Retailing."

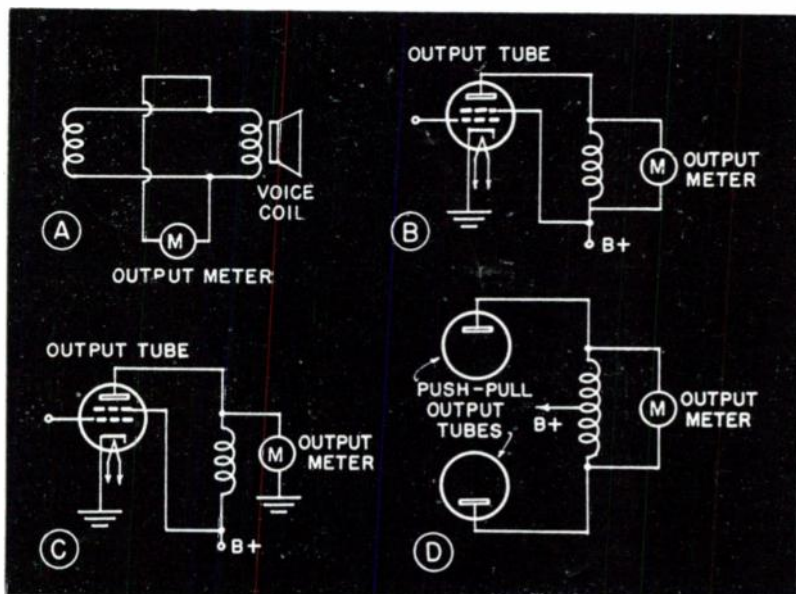

Methods of connecting an output meter in determining maximum signal generator output.

The most important item required is a good signal generator. The generator should have a range of 100 kc to 50 mc and an output of at least 1/10 v., and should be capable of producing a 400-cycle modulated signal.

Other tools needed include a fiber-handle or non-metallic screwdriver, aligning wrench, and output meter. The output meter is generally an ac high-resistance voltmeter, with an enclosed copper-oxide rectifier. It is used for determining maximum output of the test oscillator. Some radiomen judge this output aurally, but this practice is not as accurate as the meter method. If the set to be aligned has a resonance indicator such as the "magic eye," no other output measuring instrument will be necessary.

The output meter may be connected in several different ways. If it is a very

sensitive unit, it may be hooked across the voice coil. If its sensitivity is average, it may be connected across the primary of the output transformer, or from plate of output tube to chassis or B—. When the latter type of connection is made, a .1 mfd capacitor should be inserted between meter lead and plate, to protect the instrument from dc current.

When the output tubes are in push-pull, the output meter may be connected from plate to plate.

A vacuum tube voltmeter may be used instead of an ac output meter as an alignment indicator. The connections in this case are as follows: Hook the negative terminal of the vtvm through a 2 meg resistor to any grid return connection in the avc circuit—it doesn't matter which, since all points in this circuit are at the

same dc potential. Connect the positive terminal of the v-t voltmeter to a B— or ground point of the set.

The advantage of a vtvm over an ac output meter lies in the fact that it reads the avc voltage, instead of the ac signal output. Since the avc voltage tends to hold back increases in signal output, the measurement of this ac signal output is subject to error. Measurement of the avc voltage, on the other hand, is not impeded in this way.

Checking Generator Accuracy

Before using the signal generator, the technician should be certain that its dial calibration is accurate. The possibility that the test oscillator is not "on the beam" must never be overlooked. Otherwise, considerable time may be wasted in an attempt to make precision adjustments with an imprecise instrument.

To test the accuracy of a signal generator, a radio whose alignment is

above suspicion is necessary. Tune in on this set to a broadcast station in the high frequency section of the dial. Then connect the "high" generator lead to the antenna of the set, and the generator ground to set ground lead, through a .1 mfd capacitor. The generator's dial should be set at the same frequency as the broadcast station.

If the test oscillator is accurate, "zero beat" should be obtained at the generator dial setting—that is, a beat note should be audible before and after, but not at, this setting. If zero beat occurs at some other point, the signal generator must be adjusted.

Many signal generators have a compensating capacitor which is adjustable, and makes up for calibration drift. If the generator is not accurate, adjust this compensating capacitor until the dial reading of the unit at zero beat coincides with the known station frequency.

The test process described may be repeated at the low frequency end of the signal generator's dial, and the

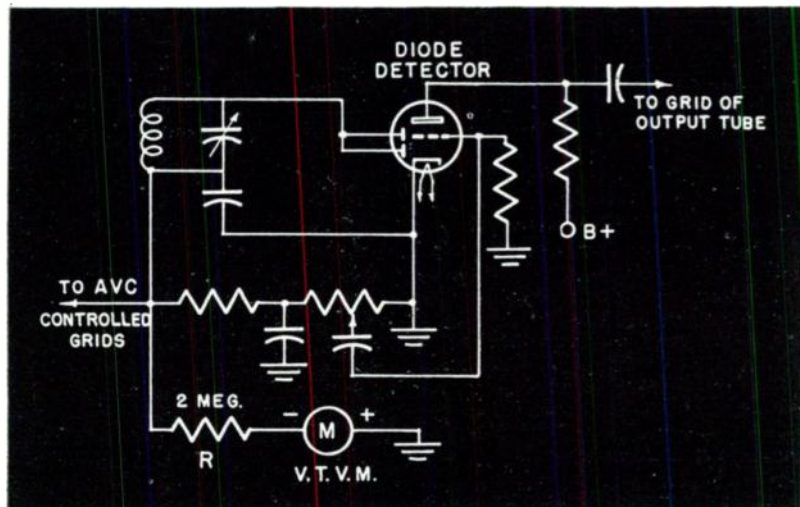

Connecting a vacuum-tube voltmeter for use as an alignment indicator.

compensating capacitor adjusted, when necessary, until zero beat is obtained at that point between receiver and generator.

External aerials must be disconnected from the set while it is being aligned. Allowance, however, has to be made for the effect the antenna will have on the receiver, when it is reconnected after alignment has been completed. A substitute for the aerial, known as a dummy antenna, is therefore connected in series with the signal generator and the receiver antenna terminal.

For maximum gain from the r-f amplifier, the dummy antenna capacitance should be the same as the capacitance of the receiver antenna. Auto radio antennas range in capacitance from 65 mmfd (.000065 mfd) to 250 mmfd (.00025 mfd). The set will not operate at maximum efficiency unless antenna and dummy antenna capacities are matched up.

If a whip or streamlined antenna is used on the set, the signal generator output should be connected through a .0001 mfd capacitor to the antenna terminal of the receiver. When a

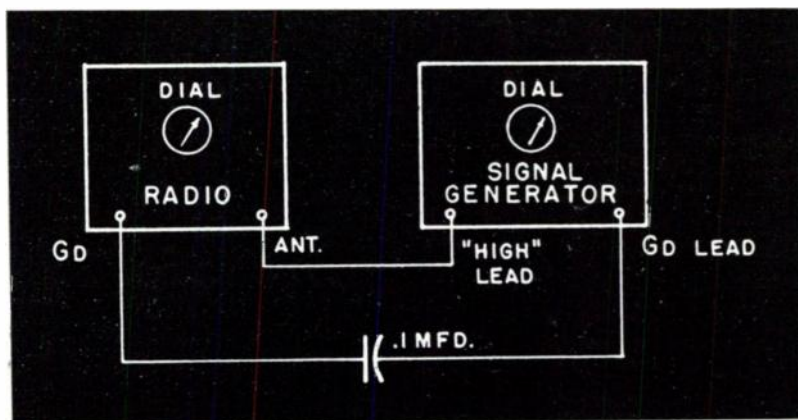

Connecting signal generator to radio for generator accuracy check.

For frequencies between 600 and 1700 kc, a capacitor of 200 micro-microfarads (.0002 mfd) may be considered equivalent to the average antenna. Above 1700 kc, a 400 ohm resistor will function as an adequate substitute. When intermediate frequencies—such as 175 kc, 465 kc, etc., are introduced into the set for alignment purposes, a .1 mfd capacitor will serve as a dummy antenna.

Dummy Antennas for Car Sets

Auto radio antennas deserve separate consideration. To obtain maxi-

large antenna, such as running board type, or built-in top antenna, is present, a .0002 mfd capacitor will be a good substitute.

A number of preliminary adjustments may be necessary before starting alignment. First, examine all control settings. The volume control of the receiver should be at maximum, or in the "fully on" position throughout the alignment procedure. If push-buttons are present, they should be in "off" position, with the "manual" button alone pushed in. The tone control should be on "speech" or "treble"

setting. If a phono-radio switch is present, it should, of course, be on "radio." The bandswitch should be set at "broadcast" when broadcast frequencies are to be aligned, and on "short-wave" for short-wave alignment.

Preliminary Checks

Several cautions may be given at this point: Don't use a metal workbench to align sets on. When working on a set with a built-in loop an-

tenna, make sure that no metal is near the loop. Allow receiver and signal generator to heat up for several minutes, before beginning alignment.

The receiver's dial calibration should be checked to see whether it tracks properly with the ganged tuning capacitor. If it doesn't, close the tuning capacitor and set the dial pointer on the first mark at the left edge, or low frequency end, of the broadcast scale.

THE RADIO TRADING POST

(Continued from page 6)

SALE OR SWAP—Carron signal tracer, GE remote tuning unit, numerous radio books. Make offer. Want 8mm movie equipment. L. J. Cherne, 5254 Fulton St., Chicago 44, Illinois.

FOR SALE — Rotary duplicator machine, excellent cond., prints post card to legal size forms, 500 sheets 8 1/2 x 14 paper included, \$20. Avis Baldwin, Box 373, Emporium, Pa.

FOR SALE—Most types new radio tubes, immediate shipment. What types do you need? Prices are retail list. Standing orders accepted. Edward Howell, Rt. 2, Dillon, S. C.

WANTED FOR CASH—Modern tube tester, good cond., sig. gen., cap. analyzer and Rider's Manuals 1 to 5 abridged or 1 to 13 inclusive. Price and details first letter. Nicholas E. Basil, 611 1st Avenue, Rock Falls, Ill.

FOR SALE—New Vibra-packs for operating 1.4 v batt. radios from 6 v or 2 v storage batt. \$6.50 each. Milam's Radio Service, 215 East Grant St., Decatur, Ala.

FOR SALE—One new deck type xmtr., 300w, band 28, 56, 112 mc. Will sell for price of parts. A. M. Volpe, 80 Batavia Place, Harrison, New York.

FOR SALE—6v 15 amp. power packs, \$24; 8" sq. 0-1 mil. meter \$16.50; Era vtvm \$40; port. elec. phono, amp. and spkr. \$30 with auto record changer \$45. All new. J. W. Bourke, 148 Winthrop St., Brooklyn 25, N. Y.

TUBES FOR SALE—15c each above wholesale price. 6 each, total 132. Write for List. E. Watson, Sr., 683 Washington Ave., Brooklyn 16, N. Y.

SALE OR TRADE — Superior osc., mod. 1120-S, 100 kc to 22, mc, ac. and dc. with instructions \$10. Talking-movie projector, with 6 sound and one silent films, hand oper., \$9. Firestone pocket radio, ac-dc, batt. complete \$20. Need 3 or 5 shot 12 or 16 gauge. John Meek, 5619 W. Chicago, Detroit 4, Mich.

FOR SALE — Two giant racon units (50w peak), 6v field with 36" long, 22 1/2" sq. bell metal trumpets to match, \$50; Malory 230 vibrator \$3; Stromberg Carlson 3-A magnetic pickup with built-in vol. control and matching input trans. \$3. Dr. Walter A. Schroeder, Broughton, Illinois.

TRADE—Complete HO railroad equipment, worth \$150 and U. S. Sig. Corps oscilloscope unit BC-412-B with tubes, for VTVM, Rider's Manuals, tubes, etc. George H. Bollman, 205 Perrine St., Dayton 10, Ohio.

FOR SALE—Relays, silver contacts, dpdt, 15 amps, 115v ac, \$1.25 ea. Air Trimmer capacitors, 4 to 14 mmf., \$1.50 doz. Rectifiers, 115v, 60 cy., \$3.50. Mack, P.O. 123, New Hyde Park, N. Y.

SALE OR SWAP—NRI Triplett made all-wave set tester, with tubes, perfect. Requires one 45v batt. Want good receiver. Will pay difference if necessary. P. J. Sidari, 210 Lincoln Place, Garfield, New Jersey.

FOR SALE—Gernsback manual 4, Supreme No. 1 and one No. 2, prepaid \$5.25; Radio physics course, prepaid \$4.85; 6 1C5, 6 6K6, 3 6H6GT, 6 6J5GT, 6 6C5, 6 6B8G, 6 6C8G, 3 6R7, and 4 6K8GT, new radio tubes, in cartons, \$35.00 prepaid. Johnson Radio Service, 302 Oakwood St., Austin, Minn.

(Continued on page 14)

HUM ELIMINATION

(Continued from page 4)

cathode. In the second instance, the application of a negative voltage on the heater sufficient to make the heater-cathode voltage difference small is the remedy.

It must be remembered that although a tube is supposedly cut off by the application of bias to the cathode, the cathode does not always cover the heater completely, and that emission can occur from the heater to the plate. If this emission takes place from one exposed heater wire, said emission will not be from an equipotential surface and will vary as the heater supply frequency.

It is best, in audio amplifier design, not to rely on multiple grounds to the chassis. It is better to carry the ground circuit from point to point with a heavy copper wire, and this ground, insulated from the chassis, should be grounded in one spot only. This spot will have to be found by trial and error. This is particularly effective in high-gain amplifiers. A spot will be found at which the hum will drop appreciably and even reduce to the vanishing point.

Resistance-Capacity Filters

It sometimes becomes impractical from an economic standpoint to use brute force methods, such as capacitive filters and regulators, to effectively filter the entire power supply, when the addition of an RC network, in one or more circuits, will accomplish the desired result. This may be either keeping the supply ripple from this stage, or isolating the plate excursions of this stage from the power supply. RC filter networks are usually figured on the basis of $T=RC$ (see Fig. 3) where T is the time in seconds, R is the resistance in ohms, and C is the capacity in farads.

It might be pointed out that a lot of time can be saved and time-constant problems can be worked in the head,

if you remember that microseconds equals ohms times microfarads or that microseconds equals megohms times micro-microfarads. One of these formulas puts the parameter you want in the terms that you want it and eliminates converting farads, for instance, to microfarads or micro-microfarads, or ohms to megohms. This will also eliminate the possibility of error in adding and subtracting negative and positive exponents.

This formula states the time, T , it takes the voltage across the condenser, C , to charge to 2/3 of its full value or to discharge to 1/3 of its original value. These fractions are approximate, as the exact amount that the value C charges to is equal to

$$1 - \frac{1}{e} \text{ and the value it discharges to is } \frac{1}{e}.$$

The condenser charges or discharges according to an exponential function so that it takes a much longer time to change even a much smaller additional amount in the direction we are considering. (See Fig. 4.) It is interesting to note that C may charge to 95% of its maximum in $3RC$ (seconds)

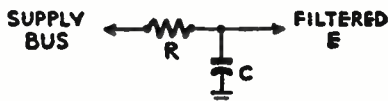

Fig. 3—Charging time is set by R and C .

or it will discharge to 5% of its total value in the same time, as the case may be. This figure is accurate to about three decimal places.

If we compute our RC value on the basis of $T=RC$ in an isolation filter, we will still have 1/3 of the original amount of ripple left, which in most cases is not reducing it to a sufficiently low value. We could compute

the necessary RC to reduce the ripple to any premeditated value but for a reasonably close estimate we may use

the formula $T = \frac{RC}{25D}$ where D is the

duty cycle expressed in a fraction of one. This will yield an RC filter which will reduce the ripple to approximately 1% of its unfiltered value. The duty cycle is the ratio of time of duration of a wave form to the period of successive wave forms. In the case of a sine wave these values are equal, so D will equal .5.

Remember when using RC filters that the choice of R is limited to the largest value that will give the re-

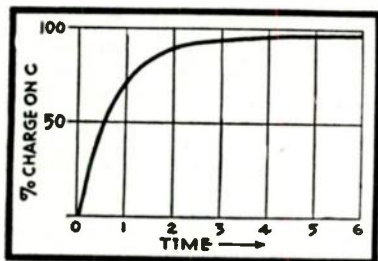

Fig. 4—Graph of condenser charging time.

quired filtering but which will not drop the average DC potential on the tube plate to a value lower than the value which was used in designing the components for that stage.

The importance of this factor "D" will be more evident when a non-sinusoidal circuit is to be decoupled. For instance, a multivibrator which produces a square wave ten microseconds wide and then rests for ten thousand microseconds will draw current for 10 $\mu\text{sec.}$, whereas one which produces a square wave three thousand $\mu\text{sec.}$ wide and rests for seven thousand $\mu\text{sec.}$ will draw current for 3,000 $\mu\text{sec.}$ and will, therefore, discharge our C to a much lower voltage,

indicating the necessity for a bigger C or a larger R.

In any event, when unequal wave forms are considered, it is more convenient to consider time constants rather than impedances and reactances.

Miscellaneous Methods

Decoupling is necessary where several stages are to be cascaded, as oscillation can result. It is conventional, therefore, to isolate several or all the stages, not only in the interest of hum reduction, but to eliminate the unwanted regeneration introduced by common coupling in the power supply.

Hum which cannot be eliminated in any other manner can be reduced by the application of degeneration which will reduce the hum, within the loop, proportional to the amount of feedback. In several cases, this feedback loop could be resonant at the hum frequency only, so that a maximum of degeneration is introduced at the hum frequency.

In cases where the low-frequency response is not important, it is feasible to reduce the coupling time constants by reducing the coupling condensers and grid resistors, reducing the gain at the hum frequencies. When all other means fail or when economy dictates, hum may be balanced out by applying to the circuit in question a hum voltage of proper amplitude and 180° out of phase. This voltage may be applied to any of the tube elements in a number of ways.

Remember that the field of a dynamic speaker, when used as choke in the power supply, has a very strong hum field surrounding it and an input transformer should not be located close thereto. A velocity microphone will pick up a strong hum voltage when located as far as 8 or 9 feet from such a speaker field. Microphone orientation will reduce this pickup to a minimum.

When connecting a self-powered tuner to an amplifier, remember to re-

verse the line connections if undue hum results. If both units have bypass condensers from one side of the line to ground, it is possible to plug the units into the supply mains in such a way as to place some, or all, of the 110 V A.C. 60 cycle power source in series with the common ground between the units.

Consider, when using a cathode follower, that the cathode is swinging with the signal, and, at some parts of the cycle, it may well be a hundred volts above the filament, which may give rise to cathode-filament emission, or capacitive hum coupling.

Electrolytic condensers are a potential hum source. Their capacity reduces with age and their impedance increases, which can also give rise to oscillation. They should not be depended upon for R.F. bypassing and, in such instances, should be paralleled with a good paper or mica condenser.

Don't forget to bypass to ground all the cathodes in which degeneration is not desired. The value of the condenser should be large so that its impedance at 60 cycles will be much lower than that of the cathode resistor, so that any hum developed between the heater and the cathode will be bypassed to ground. It is important that this condenser be grounded to the same place as the grid and cathode resistors, so that an AC circulating current in the chassis is not connected in series with the cathode bypass condenser. (See Fig. 2.) Electrolytics used for bypassing sometimes give rise to tunable hums in radio tuners. Tunable hums have also been known to be caused by unwanted 60 cycles introduced into the oscillator of a super-heterodyne receiver, due either to faulty bypassing or a faulty tube.

Hum can be caused by induction from a phonograph motor to a magnetic pickup. This can be reduced by magnetically shielding the pickup and using an iron turntable. Of course, the leads from the pickup should be

run through shielded wire and, in low-level pickups or microphones, the shield braid should not be relied upon for the ground return. Rather, use double wire shielded cable, connecting shield braid to the amplifier chassis and the ground wire to the amplifier ground. In this instance, do NOT connect the braid to the ground at the microphone or pickup but only to its frame. In connection with phonographs, it may be noted that what appears to be a hum only when records are played, may be turntable rumble. This may be reduced by replacing the rubber drive wheel on the rim drive models or by reducing the low frequency response of the amplifier.

Last, but not least, mechanical vibration can be responsible for hum. In such cases mechanical isolation is indicated. Mounting on rubber or removal of the source is the answer.

There are very few cases where the annoying hums cannot be eliminated or reduced to the point where they are no longer objectionable and the full capabilities of the unit under consideration can be realized.

THE TRADING POST

(Continued from page 11)

FOR SALE—New Majestic 8B tube, 3 band civilian version of famous G.I. 426, ac-dc and batt. oper. receiver. Extremely sensitive tuned rf stage plus 2 if stages conforming to army specifications. G. W. Splittgerber, 409 Congdon Ave., Elgin, Illinois.

FOR SALE—Hallcrafters Sky Chief, complete and in good condition, first \$25 in cash takes it. Wills Radio Service, 213 So. Michael St., St. Mary's Penna.

SELL OR SWAP — Radio Circuit Manual 1942 Radercraft Publications, Inc., publisher for Vol. 5 Rider's. Also need vol. 1 and 10. Cash for any vol. mentioned above. Turner's, 125-127 So. Weadock St., Saginaw, Michigan.

FOR SALE—Two WE turntables, can be used for recording or playback, 120v, 60 cyc. ac. Come and get it. Park Plaza Radio, 1801 University Ave., Bronx 53, N. Y. Tel. Lu 7-1230.

FOR SALE—Airline radio mod. 62-280, 62-282 5 tube including cathode ray tuning eye, 6v, \$25; two aircraft radio 5 tube sets, 1940 mods. \$22.50 each. Will play, first offer takes them. Snyder's Radio Service, Sunbury, Penna.

SELL OR SWAP—Eimac type 24G transmitting tubes, sell for \$4, or swap for equivalent in radio or photo equipment. Good for UHF, rated power output 130 w. class C. F. F. McClatchie, 1531 Benedict Canyon Dr., Beverly Hills, Calif.

FOR SALE—Radio Engineering, 1932, '34, '35, some '36, some '33, Nov., Dec. '27, Communications, 1940, Feb. to Dec. 1939, Jan. to April, Nov., Dec. 1941. H. A. Bremer, 43 Washington Ave., Lake Hiawatha, N. J.

SALE OR TRADE—New transmitting tubes, many types. Philco console radio, ham and aircraft crystals, Vibroplex; for communications recv., ham xmt, kw parts, xmt cabinet or what have you. Geo. Pasquale, 601 Bashford Lane, Alexandria, Va.

FOR SALE—Solar mod. CE Capacitor Exam-eter with operating manual. Only had instrument two weeks. Same condition as when it left factory. Will explain reason for sale to interested parties. \$44.90 C.O.D. Harry Banister, La Fontaine, Indiana.

TRADE—Browning preselector and tube for high voltage power supply equipment. Also have 211-D which I would trade for final tank condenser, 2000 v., 50 or 100 mid. total capacity. Richard F. Burns, W9NVC, 3698261, Branch 6, 725 Band, Greensboro, N. Carolina.

WANTED—German-made Phillips tubes types UBL21, UY1N and UCH21, also wiring diagram of mod. ZGW643 Blaupunkt set. Will pay cash or swap hard to get tubes. Wayne Storch, W9FOC, Beecher, Ill.

FOR SALE—RCP mod. 663A, VTVM, new; 2 amp. GE Tungar batt. charger, like new; 2 amp. Westinghouse batt. charg., new bulb; .22 cal. Remington repeating, mod. 12A rifle, excellent; 6v-180v generator. Wanted Vol. II Rider's, any condition. Clifford D. Lessig, 24 Eighth St., Frenchtown, N. J.

WANTED—Single unit dash auto radio new or used for 1941 Pontiac. Also 3" or 5" oscilloscope. Paul Capito, 637 W. 21 St., Erie, Pa.

FOR SALE—Power packs, RCA Electrifier, replaces batt. 748, new, factory sealed cartons, complete, \$5 each. Harbor Radio Co., 309 E. Wishkah St., Aberdeen, Wash.

FOR SALE OR TRADE—Complete course in hypnotism and ventriloquism. J. W. Phillips, Oneida, Tenn.

FOR SALE—WE 118-A 50 w. amplifier; 4 6L6s, 2 6J7s, 5Z3. High impedance or 600 ohm line bridging input, gain 63 db, range 35-15000 cps. Instruction book, circuits, engr. rack panel Output to line and voice coil, 1 1000 ohms. George E. Beggs, Jr., Warrington, Penna.

WANTED—0-1 dc ma, 2" or 3" Triplett, Jewel or Weston meter desired. Will answer all letters. Chas. J. Kukura, P. O. Box 91, Genoa, Illinois.

WANTED—Coils for HRO, complete set or individuals from 550 kc up. D. C. Harrington, 242 Ruth, St. Paul 6, Minn.

TRADE—New 50L6, 35L6, 35Z5, 12SQ7, 12SK7, 12SA7, 20 of each. What have you to trade for these. Svants Radio, 2224 W. Belden Ave., Chicago 47, Ill.

SELL OR SWAP—Superior 1230 signal generator in good condition. Want a Carron CCH signal tracer. David Friedman, 1741 W. 7th St., Brooklyn 23, N. Y.

FOR SALE—Meters, all types. GE 3" 0-1 ma with vom scale, \$6.50; GE 3" 500 ua with extra scale, \$7.75; Weston 0-1 ma basic and vom scale, \$6.75; RCP 461 meter box and panel com. with res. and controls, no 50ua meter, \$8.00; many others, A. O. Gioia, 41-18 29th St., L. I. City 1, N. Y.

FOR SALE—General Industries mod. GIRC 130 combination record changer and recorder. Best cash offer. E. R. Bushman, Grand Marais, Minn.

SWAP—Strad model cello, two bows, value \$200, for surveyor's transit, level, or typewriter. Give or take cash difference. Fred Edmonds, 426 6th St. N., St. Petersburg, Fla.

FOR SALE—Majestic 50, table mod. with tubes; Majestic 310 B, table mod., 2 spkrs.; Macy's table mod. with tubes. Swap 2 Raytheon rectifying tubes BH, 125 mills, for 2 2Z5s or 2 25Z6 tubes. Louis A. Goldstone, 1279 Sheridan Ave., Bronx 56, New York.

WANTED—Drafting work design or development in electronics, electro-mechanical or mechanical fields. J. W. Bourke, 148 Winthrop St., Brooklynn 25, N. Y.

TRADE—Swiss music box for teleplex, ac operated Instructograph or G-L model S sender. Also have tubes, speakers, meters, some cash. G. Samkofsky, 527 Bedford Ave., Brooklyn, N. Y.

busy beavers . . .



C-D's "Blue Beavers" are small, powerful, adaptable, tough. These little electrolytics fit into a multitude of applications and make every service call a profitable one. Available in a complete range of capacities and voltage ratings.

Radio service men write us of their appreciation of C-D's unflinching reliability — the result of 36 years devoted to building better capacitors. You'll want all the facts about this complete dependable capacitor line for servicing. Write for Catalog No. 195 today.

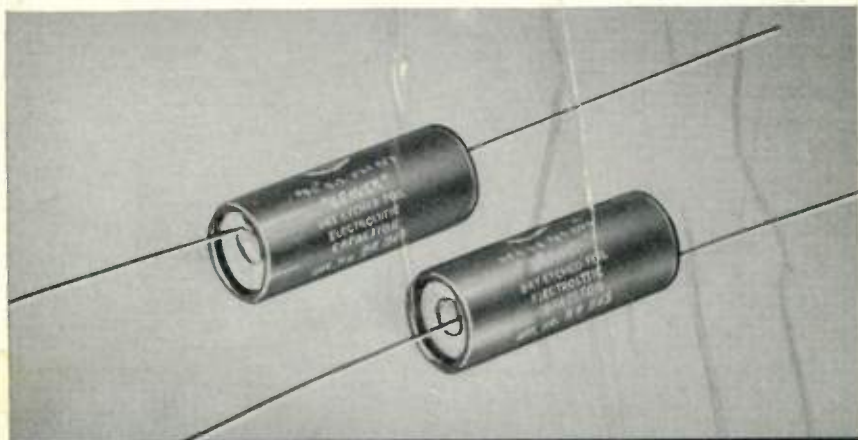

CORNELL DUBILIER ELECTRIC CORPORATION

World's Largest Manufacturer of Capacitors

MICA • DYKANOL • PAPER • ELECTROLYTICS

1049 Hamilton Blvd.

So. Plainfield, N. J.

