



Vol. 11

MAY, 1946

No. 5

CORNELL-DUBILIER ELECTRIC CORP.
HAMILTON BOULEVARD
SOUTH PLAINFIELD, N. J.

Sec. 562, P. L. & R.
U. S. POSTAGE
PAID
So. Plainfield, N. J.
Permit No. 1

Mr. George M. Beale
130 25th Ave.
San Francisco, Calif.

ALIGNING SUPERHETS*

PART II

A Complete Alignment Procedure Designed to Cover Most All-Wave Superhet Receivers

In the April issue the alignment preliminaries were explained. This month we shall continue with the details of alignment procedures. Before doing so, however, several cautions on the use of the signal generator may be added to those mentioned in the preceding article.

First, always keep the generator output as low as possible, to prevent action of the avc circuit.

Second, connect the test oscillator only across two points having the same dc potential, otherwise the attenuator may be burnt out. A capacitor of .1 mfd or less should be used in series with one of the leads, when the generator is connected between two circuits having different dc potentials.

Alignment of an ac-dc set requires special precautions. Since an ac-dc chassis is hooked to one side of the line, the signal generator's attenuator may be burnt out during alignment, if the ground lead of the generator is accidentally, or intentionally, attached to an external ground. To eliminate this possibility, two capacitors may be used, one in series with each generator lead.

The capacitor in series with the "hot" lead may also serve as a dummy antenna, and should have the value required by the dummy antenna, as listed in the accompanying chart. When no dummy antenna is required, a .1 mfd capacitor may be used. A .1 mfd capacitor may also be used in series with the ground lead of the generator.

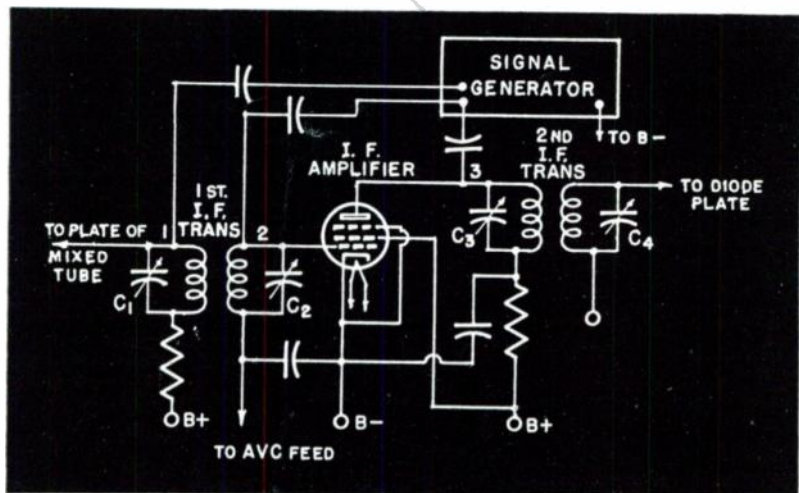

When dummy capacitors are used, the signal generator may be connected without danger of shorts to points such as (1) mixer plate, (2) i-f grid, (3) i-f plate.

* Courtesy of "Radio & Television Retailing."

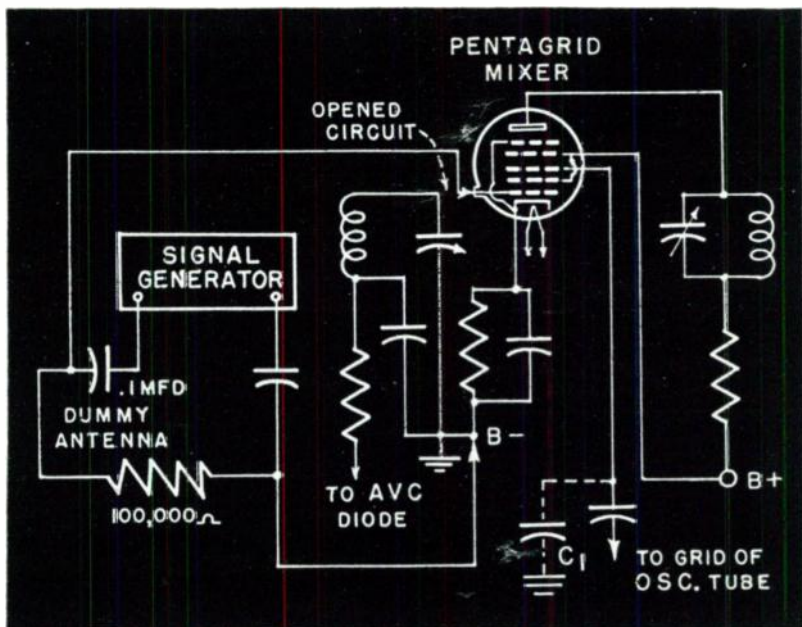

When the mixer tube has a grid cap, it is removed in order to open the r-f signal circuit. The 100,000 ohm resistor used in the dummy antenna provides a d-c grid return.

To provide a closed circuit for the grid return, a 100,000 ohm resistor should be connected across the generator leads, at the receiver side of the dummy capacitors.

If the set manufacturer's instructions regarding alignment are available, they should be faithfully carried out. The information presented here is intended only for cases where such instructions are absent.

When aligning radio stages, a certain sequence must be observed. This sequence may be listed in order as: 2nd i-f (2 i-f transformers are assumed), 1st i-t, oscillator, and r-f stages. If short-wave bands are to be aligned, the short-wave oscillator and r-f trimmers should be adjusted before the broadcast oscillator and r-f units.

It is generally necessary to stop the set oscillator from functioning during i-f amplifier alignment, to prevent the

appearance of troublesome beat notes. To do this, connect a .5 mfd capacitor between oscillator grid and ground, or between the stator section of the oscillator tuning capacitor and ground.

Couple to Mixer Grid

The next step in aligning a peaked i-f amplifier stage is to connect the "high" side of the test oscillator to the control grid of the first detector or mixer tube. The connection may be made to a tuning capacitor stator lug, if the control grid is attached to the lug.

The removal of any connection from the previous r-f coil to this control grid is recommended, since the r-f coil circuit is resonated to a considerably higher frequency than the incoming i-f signal, and may effectively short-circuit the signal generator output. Radio signals received through the r-f stages might also beat with the test oscillator,

and produce spurious beat notes, if the r-f circuit leading to the 1st detector grid is not disconnected.

In receivers on which this grid terminates in a top-cap, and self-biasing by means of a cathode resistor is present, the top-cap clip may be removed, and the signal generator output connected between grid cap and chassis.

In cases where control grid bias comes from a voltage divider, the signal generator output may be inserted between the grid cap and the grid clip. The grounded shield lead of the generator should go to the grid clip lead. In

Then the output meter may be connected to the receiver, in one of the ways described in last month's article.

After turning the radio on and allowing it to warm up for several minutes, and setting all the controls properly, the attenuator control of the signal generator should be adjusted, so that the output meter gives a readable indication. As low an output as possible should be used.

Correct Trimming Sequence

Adjust the i-f trimmers, starting with the last, for maximum output, as registered on the output meter. When con-

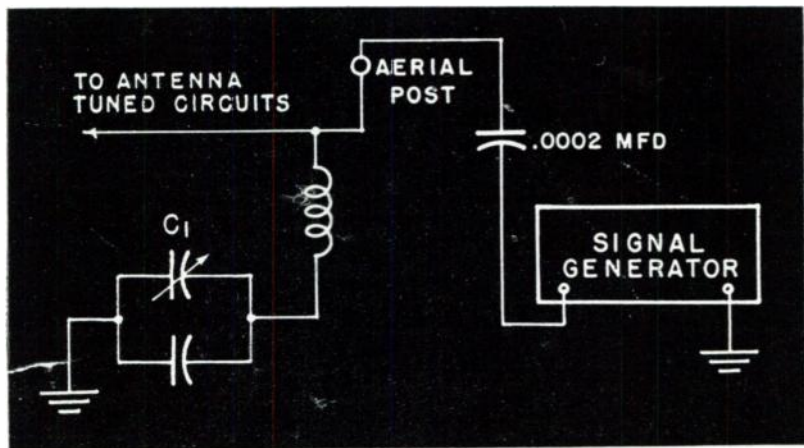

I-f wave trap is set last, to give minimum response to a 455 kc signal.

the other instances, the generator ground lead is hooked to set ground. Signal generator leads must be kept as far as possible from the grid leads of other tubes.

Final Preliminaries

A .1 mfd capacitor will serve as a dummy antenna when the i-f stages are being aligned. The gang tuning capacitor should be set at a quiet position on the dial, possibly at 600 kc, or 1600 kc.

After allowing the signal generator to warm up and reach a steady state, it is adjusted to deliver the correct i-f for the receiver being aligned. An audio-modulated i-f signal should be used.

siderable misalignment is present and difficulty is experienced in bringing a signal through the 2nd i-f, one stage at a time should be aligned, instead of both at once.

The signal generator may, in these cases, be connected to the first i-f grid, while the second i-f is being lined up. The first i-f may be aligned with the "high" generator lead hooked to the first detector grid.

If an i-f amplifier doesn't peak, look for an open coil, or shorted turns in the coil winding, or a shorted capacitor in the coil circuit. Infrequently, inability to peak is caused by an in-

(Continued on page 13)



A Free Market-Place for Buyers, Sellers, and Swappers.

These advertisements are listed FREE of charge to C-D readers so if there is anything you would like to buy or sell, if you wish to obtain a position or if you have a position to offer to C-D readers, just send in your ad.

These columns are open only to those who have a legitimate, WANTED, SELL or SWAP proposition to offer. The Cornell-Dubilier Electric Corp. reserves the right to edit advertisements submitted, and to refuse to run any which may be considered unsuitable. We shall endeavor to restrict the ads to legitimate offers but cannot assume any responsibility for the transaction involved.

Please limit your ad to a maximum of 40 words, including name and address. Advertisements will be run as promptly as space limitations permit.

FOR SALE—Midwest receiver, 5 bands, model 16-35, \$22.50. Two theater speakers 500 ohms, dynamic. What am I offered? I have the power supply also with these two speakers to supply the field voltage. Could use radio parts, tubes, testing equipment, etc. Henry Bollmann, Springfield and Plainfield Aves., Berkeley Heights, N. J.

WANTED—Latest model tube checker or combination set any make. Must have roller chart. Also good signal generator. Please give price and details in first letter. Magic Radio Service, 303 West Flagler St., Miami, Florida.

FOR SALE—Macy, Majestic, Philco and Kolster radios. Write for list. Louis Goldstone, 1279 Sheridan Ave., Bronx 56, New York.

WANTED—Riders 6, 8, 10, 11, 12 single or as a lot. Need badly. Royce Saxton's Radio Shop, Route 1, Pontiac, Ill.

FOR SALE—Late model Metropolitan condenser and resistor analyzer with signal tracer combined. New. Make an offer. Roy E. Carr, Harper, Kan.

FOR SALE—Weston model 414 7" meter \$3; Supreme tube checker fan type meter approximately 10 M.A. \$1.50; Thordarson home built 1" oscilloscope (needs repairs) \$10. Anthony Pusateri, 1101 Fleming St., Coraopolis, Pa.

FOR SALE—Triplett model 1210A tube tester. Good condition. \$15. Herbert Levinson, 2422 Natrona St., Phila. 32, Pa.

FOR SALE—Type A brush crystal headphones, Brush PL-20 crystal pick up. Weston precision resistors. Also I.R.C. 2 speed English phono motor. J. R. Holloway, Box 133, Haddonfield, N. J.

WANTED—Good 16mm projector, such as 500 watt Keystone or Eastman Kodascope, model EE, series 11. Will trade for above the following: 35 watt amp. with tubes, new. One 12" speaker PM. 20 watt, one crystal mike and cable, one 16mm motor drive projector. One 35mm strip film projector, SVE model E.A. One 16mm hand crank projector, 300 6.3 volt radio tubes. John Arnold, Box 84, Bluffs, Ill.

WANTED—16mm motor driven projector, aluminum bass violin, accordion, solo vox. Have large amplifiers, radio tubes, parts, small motors and radios. Also cash. List by request. Saws, fans, all electric. John Arnold, Box 84, Bluffs, Ill.

WANTED—28 gauge shotgun shells. Z. T. Bogar, Route 1, Box 286, Laurel, Md.

WANTED—Wide angle and telephoto lenses for Leica camera. Give all lens information and price. Also flash-gun. Leonard C. Pochop, 4117 37th St., N.W., Washington 8, D. C.

FOR SALE OR TRADE—1 pair of headphones with PL54 plug and without headstraps. Two new 38 tubes in cartons. One carton opened. One second-hand 10 or 12 inch PM speaker, without transformer, in good condition. John Poirier, Harlowton, Mont.

CONTACT—Write me for tubes, parts, etc. I have been able so far to supply most any tube at reasonable prices. All letters and cards answered. Refunds where necessary. O'Brien, 266 W. 4th, Fulton, New York.

WANTED—Hammarlund Super pro., Scott or similar short-wave receiver. Condition or age not important. Have testing equipment, National FB-7 receiver and other items or cash. Glenn Watt, Chanute, Kans.

FOR SALE OR TRADE—G. E. rechargeable portable LB530. In working condition but wet cell only fair. Also small photo print dryer (electric) and light steel long fishing rod. Desire large PM speaker, multimeters, test equipment, communications receiver, etc. R. Jos. Flowers, 33 N. 18th St., Harrisburg, Pa.

WILL TRADE—New tubes for Webster or other record changer with motor. Edward Howell, Route 2, Dillon, S. C.

FOR SALE—Professional model semi-automatic telegraph key, with carrying case and spring connector and cord. \$10 plus express. Norman P. Eisnor, 129 Summer St., Somerville, Mass.

WANTED—Rider manuals, any volume. State condition and price. Frank Teicher, 717 E. 175 St., New York 57, N. Y.

WANTED—Rider manuals N9. State price and condition. Will sell Gumbach radio manuals, new and used. Frank Cresswell, 48 College Ave., Tarrytown, N. Y.

FOR SALE—Amertran transformer No. 26579, output 6200 volts, 2KVA with choke, Kenyon No. S-9882 to match. Best offer. O. M. Green, 507 Madison St., N. W., Washington 11, D. C.

FOR SALE—Have Superior 1030S comb. Clough-Bringle Signal generator and scope. Motorola car set. National FB-7 communication receiver. Prism binoculars. Apex electric sweeper. Want Hammarlund Super Pro or similar. Glenn Watt, Chanute, Kans.

FOR SALE—Oscilloscopes: vert. amp. flat 20 to 3.5 mc; hor. amp. 10-100kc; Linear sweep 15-30,000; built in vert. and horiz. television sweeps. 5" size \$150; 7" size \$190. Also kits. Modern Design, 143 Winthrop St., Brooklyn 25, N. Y.

WANTED—Latest Meissner deluxe signal shifter. Send description and price wanted. C. Chiarenza, 2 Ritz St., Rochester 5, N. Y.

FOR SALE—1 pair 35mm movie projectors, complete with good sound and speaker. Ready to go. Price, \$350. Harland Stewart, Spooner, Wis.

TRADE OR SELL—New R.C.A. 814 beam power tube. Want 12" or 15" concert type speaker, dynamic mike or .22 target revolver. Want S-20R Hallicrafter receiver in good condition. T. W. Hopkinson, 600 Bashford Lane, Alexandria, Virginia.

FOR SALE OR TRADE—Meissner 7 tube A. C. Utility Super Broadcast receiver, No. 10-1103, with front panel and tubes; also 6 watt amplifier with 10" Jensen speaker. Speaker can be used for receiver. Best cash offer, or will trade all for Precision E-200 Signal generator. J. Lipiner, 1032 Rutland Road, Brooklyn 12, N. Y.

FOR SALE—Complete radio shop in live city in Illinois. Stock consists of 400 tubes, equipment neon sign and large amount of parts. For full information write Wm. Baldwin, Momence, Ill.

REPAIRS—On European radios. Rewired for American tubes. Want "Telefunken" and "Phillips" radios for salvage. Some German precision test equipment for sale or trade for Signal generator, late tube tester or photo equipment. Robert Jones, 6425 Marchand, Pittsburgh 6, Pa.

FOR SALE—Radio tubes, most all types at 25 off list, Hickok Traceometer, Philco Signal generator. Leo Bowman, Ronan, Montana.

FOR SALE—32 volt D.C. to 110 A.C. A.T.R. inverter with new vibrator, \$10. Also 800 watt 32 volt Dineto generator, 32 volt motors. V. L. Tillman, Bishop Hill, Illinois.

WANTED—World War II veteran wants to buy candy making equipment. 3 ft. or 4 ft. Fondant creamer, copper kettles, candy cutters or what have you for making candy. Write to C. A. Ward, 1517 Library St., San Fernando, Cal.

FOR SALE—1933 QST, 1 and 8 missing, \$1.60; 1934 and 1935 QST, complete with index, \$2 each year; 1936 to 1939 QST, complete, \$2 each year. William McLaughlin 9345 Vanderveer St., Queens Village, N. Y.

FOR SALE—New record player in table cabinet, 15-12A6 tubes and resistors. Philco console radio, like new, airline console 10 tube radio, service supplies. Lukelectric Supply, Baltic, Ohio.

WANTED—Gardiner-Levering model S code sender, also Teleplex or A.C. Instructograph. Will trade 1½ and 90V battery eliminator, also meters, tubes filters. Also have a Swiss music box. Will also buy for cash. Gerald Samkolsky, 527 Bedford Ave., Brooklyn, N. Y.

(Continued on page 16)

SERVICE KIT*

The purpose of this article will be to discuss some of the considerations involved in trouble shooting a receiver in the customer's home and making an estimate of the cost of repairs.

A prime objective for the outside serviceman should be the development of a systematic and methodical test procedure. Short cuts and "kinks" have a definite place, but inasmuch as they are not applicable in every instance, reliance must be placed on a series of routine checks. These checks involve the application of the fundamental principles that are old stuff to experienced men, but the newcomer will find them of great value.

A reasonable degree of familiarity with circuit arrangements is presumed. By this is meant that the technician must be able to make and interpret simple measurements without recourse to circuit diagrams. If this ability is lacking, it will be found more profitable to remove the receiver to the shop before an estimate is given. If experience is limited on any particular set and you are unable to trace the trouble within the first few minutes of your call, don't make matters worse by bluffing your way through. The average customer, with no knowledge of radio, can tell almost instantly when you are experiencing difficulty, and once this happens, the set-owner's confidence in your ability takes a nosedive.

Until such time as you have developed a sense of poise and self-confidence, your best bet is to try to persuade the customer into allowing you to remove the set to your shop. This should present little difficulty if you explain to him that the defect is of such nature that the full facilities of your shop are required in order to trace the trouble and determine an equitable service charge. Make it

clear that you do not wish to take advantage of his unfamiliarity with technical details to make a guess as to the source of trouble. If you explain that a guess is invariably accompanied by unreasonably high charges, much of his resistance will be overcome. (Of course, a guess sometimes will result in a substantial loss to you, but the customer doesn't have to know that!)

For the clincher, make it a practice to carry along on all service calls a table-model set that can be left on loan while his set is being repaired.

While on the subject of sets on loan, be smart enough to leave a radio that is presentable and attractive. Many men "miss the boat" by leaving an old piece of junk that tells the customer, better than words, that he is not to be trusted with anything worthwhile. Loan a set that will stimulate the housewife's desire for an extra receiver for the bedroom or kitchen. Aside from the extra dollars that can be made in this fashion (and they can amount to a sizeable portion of your income) you are building one of your most profitable assets: Good Will.

Removing the set to the shop for an estimate is recommended to even the experienced man in those instances when the trouble is obscure. There are numerous times when an hour's work is required, with all the facilities of the shop, to trace the defect. In the customer's home, this hour could grow into a two or three hour affair, with no guarantee of ultimate success.

Once the set is in the shop and the estimate has been made, contact the customer by phone if possible and give the results of your findings. Be specific about the repairs you propose to make. Stress the results of your work, e.g., "The radio will receive

* By E. T. Bicak in "Radio Maintenance."

station WBUNK with greater clarity, there will be no more hum, etc., etc."

If it is necessary to contact the owner by mail, be sure to enclose a stamped self-addressed envelope.

Returning to the problem of service technique, let us first consider the matter of the "question and answer period" during the time that you are getting out your tools and otherwise preparing for the job. Induce the customer to talk about his radio. Not so much for the sake of obtaining clues toward the source of trouble, but more for the purpose of determining the specific complaint. There are any number of defects which you, as a technical man, will consider of prime importance but which to the customer are insignificant and unimportant. On the other hand, some minor defect, which you are apt to overlook, may form the major, and in some cases, the sole complaint.

For example, you may discover that an ailing receiver is out of alignment—there may be evidences of poor selectivity, side band cutting, etc. The customer, however, may have called you in only because the cabinet rattles on loud notes, or because the tuning dial sometimes slips. The evidences of misalignment may have developed so gradually that the customer has grown accustomed to them, but that rattle is something else again! Your realignment job, however workmanlike, will go for naught if you are called back after the job is ostensibly finished to correct a fault you knew nothing about.

Now the question arises—shall the set be checked in or out of the cabinet?

The writer's practice has been to leave the set in the cabinet while testing, wherever space limitations do not make it impossible. From the top-side of the chassis, a few simple checks can be made. About 90% of the time, the trouble will be revealed by these checks.

To begin with, a great number of service calls are taken care of with tube replacements. Certainly there

can be no justification for pulling out the chassis to change a tube or two.

Secondly, it must be borne in mind that no service man is going to bat 1000 on outside service calls. At the best, about five calls out of one hundred will result in "no-sale." If to the cost of gas and traveling time, you must add the time and trouble needed to remove a chassis and then replace it when the customer can't be sold, you are apt to be operating at a loss. Figuring labor at a minimum of \$4.00 an hour, it costs from \$1.00 to \$2.00, or even more to remove the set, test it, and then re-install it in the cabinet. The minimum service charge of \$1.00 or \$1.50 will just about pay for gas and traveling time. Of course, if you figure your labor at 75¢ or \$1.00 an hour, then this is a minor consideration.

So much for the preliminaries.

Now for a look at some of the tests that are possible from the top of the chassis.

1. Set does not light when switch is turned on:

The most obvious check is not on the receiver, but on the power outlet. Connecting a voltmeter across the contacts of the plug will quickly eliminate the outlet as a source of trouble. If the receptacle is defective or a house fuse is blown, it is just as well to find out about it at the outset instead of tracing non-existent

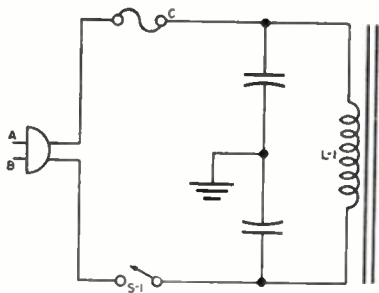

Fig. 1. Typical line power circuit for A-C receiver.

trouble in the receiver. Some men prefer to check receptacles with a trouble lamp rather than with a meter. This has the advantage that the customer can see for himself that his receiver is defective and that it is not a "loose plug" that is causing the trouble.

If the receptacle checks okay, proceed with the following:

Fig. 1 shows a fairly representative arrangement of the primary circuit in receivers.

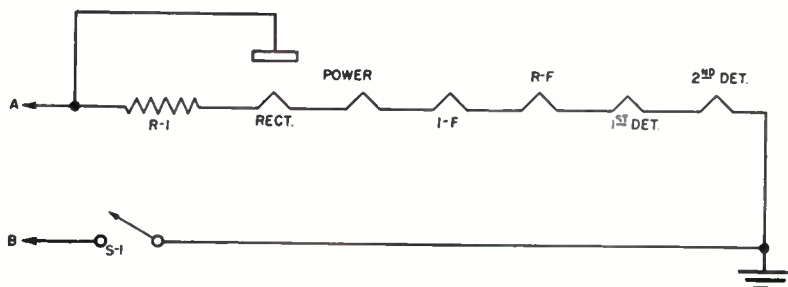

Fig. 2. Line power circuit for six-tube AC-DC set.

Measuring resistance between "A" and "B" with the switch on should give 4-10 ohms.

Fuses, practically always, are located where they may be conveniently reached. Testing from "A" to "C" will check the fuse.

An open in the transformer primary, L-1, will be revealed by infinite resistance between "A" and "B."

Where the receiver uses a universal power supply, the set is generally as shown in Fig. 2.

Since the rectifier filaments are almost invariably at the highest potential with respect to ground, the dropping resistor, R-1, may be checked by measuring from "A" to the filaments of the rectifier.

If R-1 is okay remove all tubes and check for filament continuity.

R-1 may sometimes be in the form of the speaker field resistance (D-C sets only. ED.), or may not be used at all in cases where the combined

filament drops equal the line voltage. Regardless of the arrangement, the rectifier filaments will be nearest point "A."

2. Tubes light up but the set remains inoperative:

Allow the set to warm up. Removing or loosening the detector or driver tube will be accompanied by a sharp click if the audio section is in order and the power supply has suffered no major breakdown. Work-

ing back toward the input, the defective stage can be isolated when passing from a "click" to a "no-click" stage.

Should no click be forthcoming when any tube is pulled out, then look for trouble in the speaker or power supply.

This circuit disturbance test can be of great aid if the user is reasonably familiar with common circuit arrangements.

In transformerless power supplies where series-connected filaments are the rule, removing tubes, cannot reveal much, since all tube circuits are interrupted when any tube is removed.

Although we are dealing primarily with console type sets in this discussion a word of caution may be necessary. This test is definitely "out" in the cases where low voltage, low current tubes (such as are used in portable sets) are encountered.

Now for some of the checks that

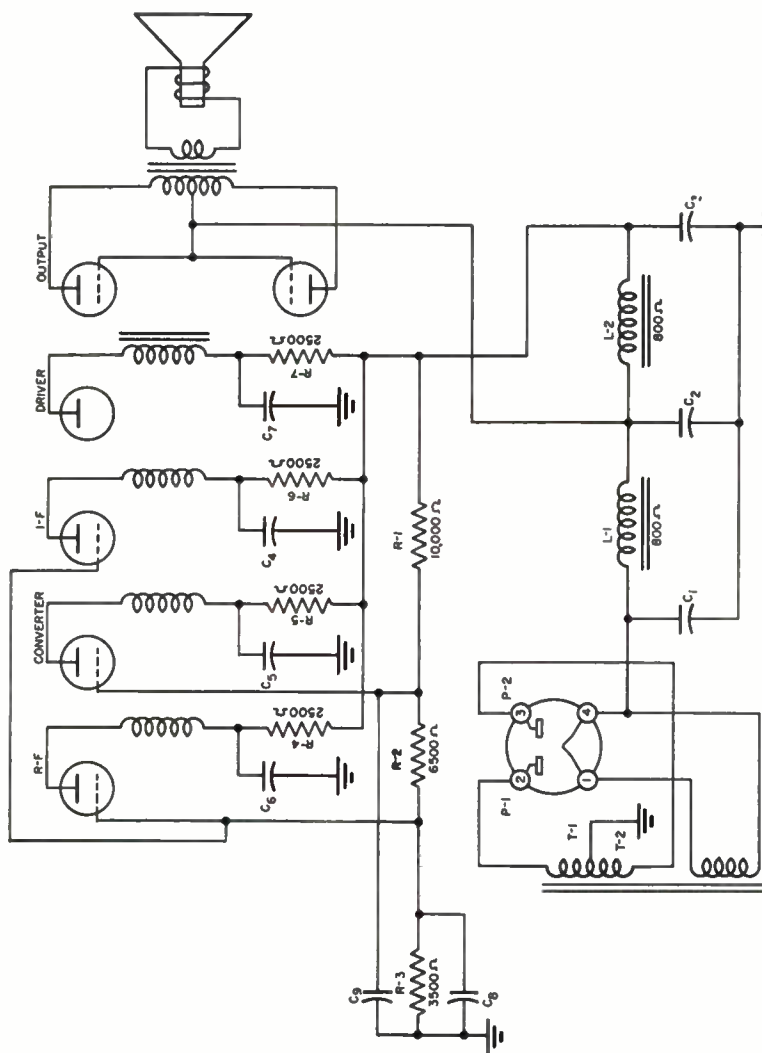

Fig. 3. D-C power distribution throughout 7-tube super-heterodyne.

may be made from the topside of the chassis.

Fig. 3 is a representative circuit of the voltage distribution system in recent sets. With minor variations this system will be found in any of the common receivers.

If power supply trouble is suspected, the procedure would be as follows:

Remove and test the rectifier tube. Then with the rectifier tube out, measure resistance across P-1 and P-2 at the socket. Open secondary

(T-1 or T-2) will be located immediately.

Testing from the rectifier filament to ground should give about 21,000 ohms. Readings other than this would be interpreted as follows:

- (a) Zero resistance. Shorted C-1.
- (b) 800 ohms. Shorted C-2. Confirm by checking for zero resistance from screen of output tubes to ground.
- (c) 1600 ohms. Shorted C-3. Confirm by repeating check of (b). C-3, if shorted, will show 800 ohms from screen to ground.
- (d) 11,600 ohms. Shorted C-9. Screen of converter tube is zero ohms to ground.
- (e) 18,100 ohms. Shorted C-8. Screen of R-F tube to ground gives zero ohms.

Shorted filter condensers that place an effective load on the rectifier of 3000 ohms or less will wreck any of the common 125 ma rectifiers if the set has been operated for any length of time. Test the rectifier tube, and if it is found defective make the above checks before replacing with new tube.

(f) Infinity. Open in any of the following: L-1, L-2, R-1, R-2, or R-3.

In the event of an open in I-1, L-2, R-1, or R-2, bear in mind that the original cause of trouble may have been a short in C-2, C-3, etc. For example, an open at L-1 may have been caused by shorted C-2 or C-3.

3. Defective stage isolated, power supply normal:

Check from the filament of the rectifier to the plate of defective stage as follows:

- (a) Plate of output tube—open transformer primary revealed.
- (b) Plate of driver—open transformer primary or decoupling resistor.
- (c) Plates of R-F, converter, and I-F tubes—open transformer primaries or decoupling resistors.

One significant point emerges from the foregoing: Resistance checks must be made with care. The man who uses an ohmmeter set to highest

range at all times and is content to observe only circuit continuity will find these tests of little value.

4. No response from circuit disturbance test, power supply okay.

Check the speaker voice coil and the secondary of the output transformer. Here the low resistance voice coil shunts the transformer secondary, making it necessary to disconnect the voice coil if it is suspected. Since the connections are generally made on an exposed terminal board or strip, this poses no great problem.

Familiarity with the basing arrangements of the common types of tubes is, of course, very necessary. Figs. 4 to 6 are illustrative of the most frequently encountered types. Fig. 4 shows the arrangement of the most used types of octal based tubes such as 6K7, 6J7, 6V6, 6K6, 6L6, etc.

Single ended types vary considerably.

The majority of lock-in tubes will follow the arrangement shown in Fig. 5.

With the old type 6-prong tubes, the arrangement most often found is that of Fig. 6.

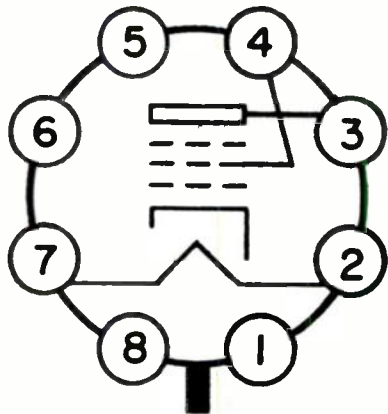

Fig. 4. Top-of-socket location of elements in most-used power pentodes and beam tetrodes, as well as older types such as 6K7, 6J7, etc.

Service Charges

Now for a few words about the subject of proper service charges. This is largely a matter of personal choice of the individual service man. Some men value their services highly,

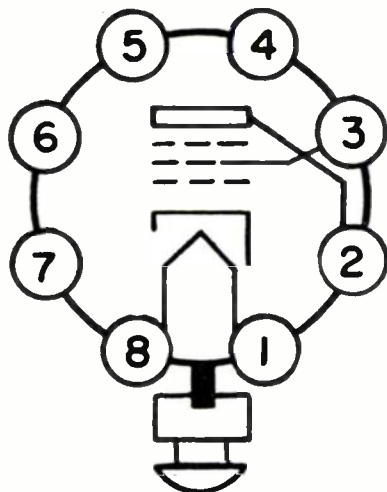

Fig. 5. Top-of-socket connections for the commonly used lock-in types.

others are content with only a very nominal fee. No hard and fast rule can be laid down; however, I have found that no charge, however high, is exorbitant if the set is repaired and stays repaired. I have seen good servicemen charge \$6.00 to repair a \$9.95 AC-DC set and have the customer well pleased. On the other hand, I have known men to charge \$1.50 to repair a \$275.00 console and have the customer highly displeased because the set developed trouble shortly after the repair job.

In determining the charge, set certain definite standards for yourself. Charge a fair price and leave room for a decent profit. Above all, don't try to cut corners on a repair. If the customer will not pay your price it is poor policy to attempt to sell a repair job by "doping" parts or ignoring components that you suspect will

give trouble in the near future. If the customer wants a bargain price job, let someone else do it and get the headaches. Don't make the mistake of reasoning that a job refused represents a loss.

When called upon to service a set over a year old, the possibility of selling an overhaul arises. Since an overhaul works to the advantage of both the serviceman and the customer, every attempt should be made to sell it.

Although there are many ideas about what constitutes an overhaul, the following items, in my opinion, represent the minimum requirements:

1. New set of tubes.
2. Replacement of filter condensers.
3. Replacement of volume and tone controls.
4. Cleaning or replacement of wave band switches.
5. Cleaning and re-centering of speaker.
6. If the voice coil shows evidences of rubbing against the pole piece, replace the cone, or at least dope the coil.

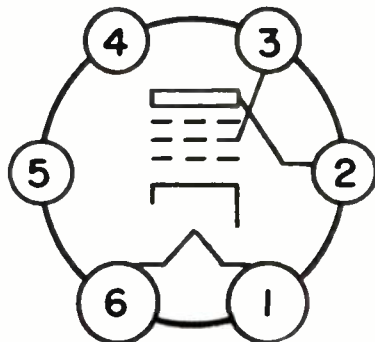

Fig. 6. Typical connection for 6-prong tubes, such as 6D6, 58, 2A5, 41, 42 from top of socket.

7. Clean tuning condensers and tighten grounding clips.
8. Replacement of cracked or overly brittle mica in trimmer condensers.
9. Re-alignment.

10. Replacement of parts that do not pass visual inspection, regardless of their electrical condition, as for example, paper condensers that have begun to leak wax. Sure they may last for years this way—and then again, they may not. Why take chances when the cost of replacement is so small?

11. After all these steps have been taken, allow a set to play for at least two hours. During this time, subject it to thorough vibration check by tap-

ping chassis and components with rubber mallet or other suitable instrument.

12. Finally, a complete and thorough check of the customer's antenna system when the set is returned is a worthwhile feature of your 12-point plan.

Admittedly this is an expensive procedure, but the customer is getting his money's worth and you may rest assured that the possibilities of complaint are minor.

ALIGNING SUPERHETS

(Continued from page 4)

correctly rewound coil. Replacement is the best remedy in such a case.

After first adjusting the secondary, then the primary, of the last i-f stage, repeat the procedure for greater accuracy, then go on to the preceding i-f. The attenuator control should be lowered, when necessary, to keep the output meter reading within scale range.

After the i-f stages have been aligned, the oscillator and r-f circuits may be adjusted. The short across the set oscillator should be removed, and the test oscillator coupled to the receiver.

A 200 mmfd (.0002) capacitor may be used as dummy antenna, and inserted in series with the "high" lead of the test oscillator. This lead is then attached to the receiver antenna post.

How to Couple to Loop

When sets having loop antennas are being aligned, another method of coupling the test oscillator output to the receiver is recommended. A loop may be made up from a few turns of wire, and connected to the signal generator output terminals. The generator is placed near the receiver's loop, which then picks up the generator's output.

Since trimmers have greatest effect when the circuit capacitance is low, the oscillator and r-f trimmers should be adjusted at the high frequency (low capacitance) end of the tuning range. A point near, rather than at, the end of the tuning range should be chosen,

to avoid mistracking over adjacent parts of the band; 1400 kc is the recommended choice for the broadcast range.

The receiver and signal generator should be set for this frequency, and the oscillator high frequency padding capacitor adjusted for maximum output. This capacitor may generally be identified by its shunt connection with the oscillator coil.

The antenna and r-f circuits may next be aligned, at the same 1400 kc setting. Following this adjustment, the low frequency oscillator padder should be aligned. This padder is the capacitor in series with the oscillator coil. Signal generator and receiver may be set at 600 kc for this adjustment. The rotor of the gang tuning capacitor should be rocked back and forth, and the trimmer adjusted, until the peak of greatest intensity is obtained.

Choose the Correct Trimmers

Trimmers for the antenna and oscillator coils are often located on the gang tuning capacitor. Usually the front section holds the oscillator trimmer, while the rear section contains the antenna trimmer. In some cases, the trimmers for oscillator and antenna coils are located on the coils themselves.

Where to Find Coils

Antenna coils may be placed above chassis, but oscillator coils are almost invariably located underneath the chassis. This information is given to aid

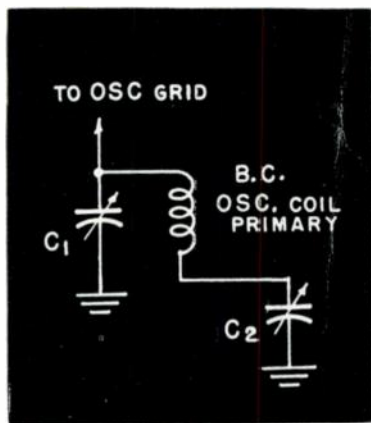

C1 is oscillator trimmer; C2 is paddler.

in the identification of oscillator and antenna coils.

When it is desired to align short-wave bands, procedures similar to those outlined for broadcast band r-f and oscillator alignment should be followed. Frequencies to be used depend on the bands present. Some common ones used for alignment are 9.6 mc, 11.8 mc, 15.2 mc, and 18.0 mc. Manufacturers' instructions should be followed whenever they are available.

How to Check Image Response

Care should be taken during the oscillator adjustment, to see that it is aligned to the correct signal frequency, rather than to the "image." For example, assume that our signal generator and receiver are aligned at 20 mc, and that the set's i-f is 455 kc. The image frequency is 910 kc (twice the i-f) higher or lower than the dial setting.

If the set is designed to have the oscillator "track" 455 kc higher than the signal, the image will be 20.910 mc. If the oscillator is supposed to be on the low side, the image should be at 19.090 mc. The presence of the image can be used to check whether the oscillator has been aligned to track on the proper side of the signal.

To find it, leave the set dial untouched and tune the signal generator through the expected image frequency. The response to the image frequency should be much weaker than at the correct signal frequency—so much so that it may be necessary to increase the generator output in order to hear it. If this image cannot be tuned in, the oscillator trimmer has been incorrectly adjusted and should be re-aligned.

Test for Wrong Peak

If, on the other hand, the image is stronger than the signal, the r-f and antenna trimmers have probably been incorrectly adjusted. If it is not known on which side of the signal frequency the oscillator is supposed to track, it should be aligned before the r-f and antenna trimmers are touched.

With the signal generator on the correct alignment frequency (20 mc in the above example) and the output turned down low, the strongest, if not the only, generator signal tuned in by the oscillator trimmer will be the proper frequency.

Some superhet receivers use a wave trap, for the purpose of eliminating interference emanating from code stations. These stations operate on a frequency of approximately 455 kc. The wave trap is made up of a coil, a fixed capacitor, and a trimmer capacitor, as shown in accompanying diagram. It should be adjusted after all other alignment operations have been completed.

Wave Trap Is Set Last

To adjust, feed a 455 kc signal from the generator through a 200 mmfd capacitor into the antenna terminal of the receiver, and align trimmer for minimum signal output, as registered by output meter. The gang tuning capacitor should be fully open, and volume control fully on, during this operation.

Proper alignment of modern superhets is not difficult, and is highly essential to flawless set performance. The competent technician will not neglect this important phase of radio maintenance.

THE RADIO TRADING POST

(Continued from page 6)

WANTED—500, 750 or 1000 watt Class B transformer secondary to Class C RF load; also a plate transformer 3500 volts DC at 500MA. W3BBV 1357 Hill St., York, Pa.

FOR SALE OR SWAP—Delco 32 volt good used plants, batteries, motors, radios, appliances, new and used repair parts, what do you need? For late model test equipment, what have you? Knortz Electric Co., Honeoye Falls, N. Y.

WANTED—U.S. or foreign stamp collection, recent Scott catalog, and opera glasses. Will trade transmitting and receiving parts, tubes, meters, etc. Send for list. B. Bernbaum, 5746 Nortn Park Ave., Philadelphia 41, Pa.

WANTED—Gear drive unit dial, National NPW-O with drive shaft perpendicular to panel. State condition and price wanted. Charles Kukura, Genoa, Ill.

FOR SALE — Warner electroplating outfit for brush plating, gold, silver and nickel. Like new. Complete outfit with instructions. Original cost, \$64.50. Make offer. Stokes Radio, 6020 Locust St., Philadelphia 39, Pa.

BUILD your own test equipment. Combination VTVM and VOMA. Wide range 5" cath. ray scope with provision for television reception. FM and AM oscillators. Write for details. Modern Design, 148 Winthrop St., Brooklyn, N. Y.

WANTED — Coils for HRO pre-war model. Write George Williams, 5720 Broadway, Columbus, Ga.

FOR SALE—3 Racon 3¼ ft. trumpets, two 25 watt 6 volt field units, 1 Hickok S.G. 4600 set tester five meters rebuilt by Hickok. Also fifty used tubes, set tested. All goods trade or sell radio equipment, etc. Helfrich Radio Service, 228 7th St., North Canton, Ohio.

WANTED—Electronic magazine, May 1944. Will pay full price for same. Also want Atlas small lathe, size 12" with 6" swing or other metal lathe. John Kozma, 3104 Wilkinson Ave., New York 61, New York.

FOR SALE—American model EL. D.B. mike, shielded cable, desk stand, complete, like new, \$7. General radio, 350 mixed variable condensers, \$1 each. Want Johnson HI-Q variable inductor, 250W, for 10 meters. Also Coto BTVL variable inductor for 10 meters. Will buy SX25 in perfect condition. Jack Abramowitz, 118 Clara St., Brooklyn 18, N. Y.

WANTED—Rider's vol. 4 and 5. AC ammeter, 0-10 or 0-5 amps. 2 or 3 recorders. Heavy duty PM speakers. Will sell or swap Jackson tube tester, model 627, modernized at factory. Radio Electronics Co., 143 North St., Waukesha, Wis.

FOR SALE OR SWAP—Set of six books, Theory and Applications of Electronic Tubes, Reich; Fundamentals of Vacuum Tubes, Eastman; Communication Engineering, Everitt; Prin. of Radio Engineering, Glasgow; Eng. Electronics, Fink; Measurements in Radio Engineering, Terman. These books like new. H. Glen Alden, 216 Weller Ave., Zanesville, Ohio.

FOR SALE—1000 labels printed in blue on white gummed paper to your copy. 4 lines of copy printed for you and delivered postpaid \$1. Use these to mark merchandise as business cards that really stick. National Radio, 2456 Shirley Ave., Baltimore 15, Md.

WANTED—Late model signal generator in good condition, also tape puller, instructor or other code training equipment. George Drab, RFD 1, Fort Plain, New York.

WANTED—Publications back issues, excellent condition. State titles, dates, condition and best cash offer including transportation. Raymond H. Kasl, 465 Douglass St., San Francisco 21, Calif.

FOR SALE—Dynamic hand microphone, \$7. Hi impedance. New and guaranteed.. A. E. Olson, 3831 N. Fremont, Chicago, 13, Illinois.

FOR SALE OR SWAP—Radio course; multi-meter; small radio; signal tracer and amplifier; photo-electric set; adding machine; camera; electric clock, toaster and grill. Want automatic record player. O. H. Klinsfelter, 42 Stephen St., Glen Ridge, N. J.

FOR SALE—One Kato Rotary Converter type 669, 115 volt D.C. to 115 volt A.C., single phase, 60 cycle, 1800 RPM, \$163. FOB Washington, D. C. Capitol Radio Wholesalers, 2120 14th St., N. W., Washington, D. C.

SWAP—DeForest radio course; L.E.S. radio engineering course; drafting-tool designing course, including instruments and equipment; N.E.A. photography course, 10 volumes; N.E.A. aviation course, 9 volumes; Crosley Facsimile Receiver; sun glasses, 2 prs. worth \$24. Want Communication equipment and servicing equipment. P. Brassard, 16 Cumberland, Brunswick, Maine.

look for the C and the D

CAPACITOR

DEPENDABILITY

The C and the D also spell Customer good will and Dollars in repeat business. Kenneth Savage of Dorchester, Mass. echoes the sentiments of many when he writes: "I have used many of your condensers and found them to be the best obtainable."

Maybe it's because we have made capacitors longer than anyone else, and made *more* of them—or that our experience over 36

years has enabled us to build-in that extra something that guarantees lasting satisfaction. This Type BRD is a small electrolytic you'll find handy—fits anywhere, packs a big wallop. Get acquainted with our complete line for servicing—*WRITE FOR CATALOG 195*. CORNELL DUBILIER ELECTRIC CORPORATION, 1049 Hamilton Blvd., So. Plainfield, N. J.



CORNELL DUBILIER ELECTRIC CORPORATION

World's Largest Manufacturer of Capacitors

MICA • DYKANOL • PAPER • ELECTROLYTICS

1049 Hamilton Blvd.

So. Plainfield, N. J.



Printed in U.S.A.