

Vol. 11

OCTOBER, 1946

No. 10

CORNELL-DUBILIER ELECTRIC CORP.
Hamilton Boulevard, South Plainfield, N. J.

POSTMASTER: If undeliverable for any
reason, notify stating reason, on Form 3547
postage for which is guaranteed.

Sec. 562, P. L. & R.
U. S. POSTAGE
PAID
So. Plainfield, N. J.
Permit No. 1

Mr. George M. Beale
130 25th Ave.
San Francisco, Calif.

PHASE INVERSION CIRCUITS*

In the operation of "push-pull" amplifiers it is standard practice to supply the two amplifier grids with approximately identical signal voltages that are presumed to be 180 degrees out of phase. Originally this was done by means of special audio transformers which were generally designed to work out of a single tube plate circuit into the two grids. In this arrangement a centertap is necessary on the secondary winding in order to feed bias voltage to the grids. The use of such transformers for present day needs meets with a number of difficulties. First, a GOOD audio transformer is a large, heavy, and expensive affair at best and the difficulties in design of an accurately center-tapped secondary are great. Second, at best it is limited to the "high fidelity" audio range and thus its usefulness is limited. Third, it is often the source of hum pickup. In the course of time a number of vacuum tube phase inversion (or "paraphase") circuits have been developed which provide grid driving voltage for push-pull stages without the use of transformers and their attendant limitations. Five such circuits will be considered.

What is probably the original vacuum tube paraphrase circuit is shown in Fig. 1. It will be seen that in this circuit the output of T1 appears across the series combination of R1 and R2 and also that R1 and R2 in series serve as grid resistor for T3. Ignoring for the moment the effects of coupling and stray capacities, the voltage across R1-R2 is 180 degrees out of phase with the input to T1. A portion of the output of T1 is fed to the input of T2, the amplitude of this input being determined by the input to T1 and by the ratio $R1/(R1+R2)$. If this ratio is made exactly equal to the reciprocal of the gain of T2, the signal voltage applied to the grid of

T2 will be equal to—and 180 degrees out of phase with—the signal applied to the input terminals. The result will be perfectly balanced signal voltages at the grids of T3 and T4. The combination of T1 and T2 provides an overall voltage gain equal to twice the voltage gain of T1 alone. This circuit has given quite reasonable satisfaction and is still quite popular.

There are a number of disadvantages which the circuit of Fig. 1 shares to a greater or less extent with other phase inversion circuits. Appreciable unbalance will result if the gain in either T1 or T2 changes for any reason. This could be caused by a change in characteristics of either T1 or T2, by a change in the load resistor of either tube, by a change in the value of either R1 or R2 and also, to a lesser extent, by a change in R3.

The circuit of Fig. 1 is also subject to considerable phase distortion. A signal applied to the grid of T1 is subject to a normal amount of phase distortion at high and low frequencies before it reaches the grid of T3. However a portion of the signal voltage applied to T3 is fed through T2 to the grid of T4 and in this process the equivalent of an extra stage of phase distortion is introduced. Thus at both ends of the useful frequency range the signal voltages applied to T3 and T4 are not exactly 180 degrees out of phase. A direct result of this additional phase distortion is some additional attenuation at the high and low frequency ends of the range.

In like manner the signal voltage arriving at T4 will have been subjected to two stages of frequency distortion at the high and low frequencies. The net result is a rather complex combination of phase and frequency distortion. As an example, consider the condition when the gain reduction in either T1 or T2 at some extreme fre-

* By J. H. Platz in the "Broadcast Engineers' Journal."

quency is 3DB with the accompanying additional phase shift of 45 degrees each in T1 and T2. The grid to grid voltage across T3-T4 will have shifted

pair. In both cases as long as unbalance is not too severe it is the magnitude of voltage difference rather than the matter of exact balance that deter-

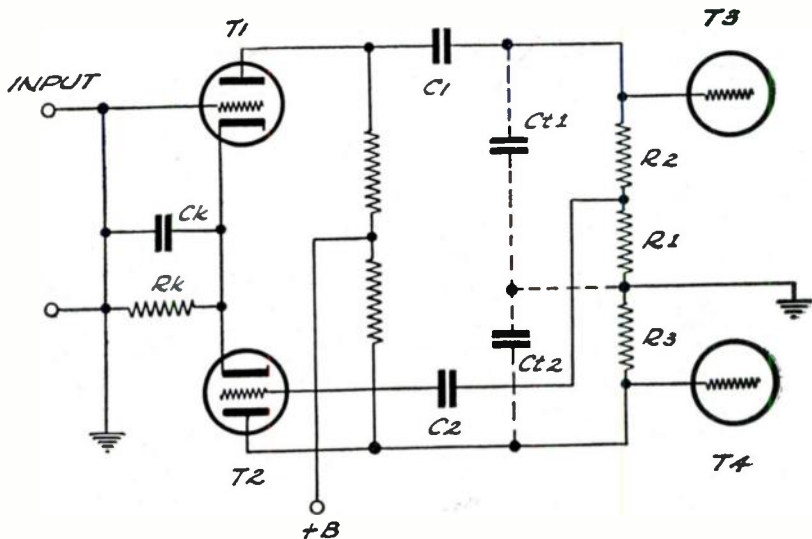

Fig. 1. Basic phase inversion circuit, where R_1 plus R_2 equals R_3 , and $(R_1 + R_2) / R_1 = \text{Gain of T}_2$. C_{t1} and C_{t2} are stray Capacities to ground.

approximately 65 degrees with respect to mid-frequency operation while the total amplitude reduction will be about 5DB. The net effect of this distortion can be lessened by designing the circuits of T1 and T2 for operation over a frequency range extending well beyond the range which will actually be used.

In most cases phase distortion is more troublesome than moderate unbalance. Generally the actual amplitude of plate-to-plate output voltage from a push-pull amplifier is more important than whether or not one tube is supplying perhaps 10% or even 20% more than the other tube. Push-pull audio output transformers take output from both tubes and deliver it to a single load. Push-pull deflection amplifiers used in oscillographs merely provide a voltage difference between opposite plates of a

mines the output. On the other hand push-pull amplifiers in oscillograph use are subject to severe limitations in phase shift since improper phase shift will modify wave forms under observation and defeat the original purpose of the instrument. About the only objection to a moderate amount of unbalance in the output of two tubes in push-pull operation is the fact that such operation does not make maximum use of the output capabilities of the two tubes involved.

Certain phase inversion circuits have been designed with the purpose of holding down phase shift by one means or another. Figure 2 is an example. It will be seen that phase inversion is accomplished by dividing the load resistor into two equal resistors, R_{11} in the plate circuit and R_{12} in the cathode circuit. Signal voltage at the plate of T1 will be 180 degrees out

of phase with the input signal while (remembering the cathode follower) voltage at the upper end of R_{12} will be in phase with the input signal. If

phase and frequency distortion at high frequencies and to make matters worse, this distortion will not be identical in the two outputs because of the above-

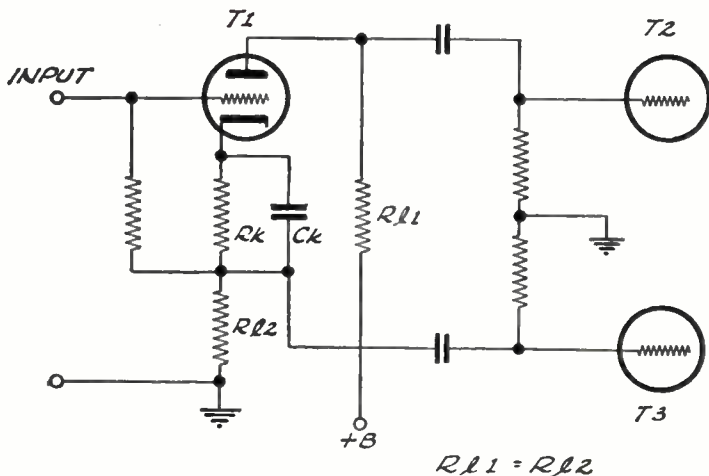

Fig. 2. Single-tube cathode-coupled phase inversion circuit.

R_{11} and R_{12} are equal the voltages across them will be equal since the same current flows through both of them. Phase shift to the grids of T_2 and T_3 will be about the same as for a single-stage amplifier.

In the circuit of Fig. 2, T_1 has 50% inverse feedback which results in low gain through the tube. The signal voltage applied to each push-pull grid is slightly less than the signal applied to the grid of T_1 . With the high percentage of feedback, distortion in T_1 is negligible. Since phase inversion is accomplished in the one tube, a change in tube characteristics will not unbalance the output but of course, a change in value of R_{11} or R_{12} will directly affect balance.

The principal difficulty with this arrangement is a difference in incidental capacities which exist across the two load resistors. Since the load resistances are generally quite high, 50,000 ohms or more, appreciable capacity across them will result in

mentioned difference in capacities involved. A decrease in the value of R_{11} and R_{12} will increase the practical upper frequency limit just as was the case in video amplifiers and the gain is already so low that the slight resultant reduction would not be noticeable. All in all, the circuit of Fig. 2 is an improvement over that of Fig. 1, combining good balance with reduced phase distortion.

Another variety of cathode coupled paraphase circuit is shown in Fig. 3. In this case a minimum of phase distortion is accomplished but at some sacrifice of balance. Phase inversion is accomplished in T_1 and T_2 in conjunction with R_k , the unbypassed cathode resistor. Signal input is applied to the grid of T_1 and the grid of T_2 is grounded. Here again a variety of cathode loading is used. When a signal is applied to T_1 the cathode potential of T_1 rises and falls in phase with the input signal and a portion of the input signal appears

across R_k . However, since R_k is connected between grid and cathode of T_2 , the signal voltage existing across R_k becomes the grid input to T_2 . Furthermore the cathode end of R_k being in phase with the signal voltage applied to T_1 , the opposite or grounded end of R_k is out of phase with the grid of T_2 180 degrees out of phase with the grid of T_1 . However the action is not quite so simple as it first seems. If T_1 and T_2 are truly push-pull with grid inputs of exactly equal amplitude there will be equal and opposite changes of current in R_k , resulting in a constant current in—and constant voltage across—the cathode resistor R_k . A constant voltage across R_k means no signal input to T_2 . Obviously the final result is that plate current changes in T_2 are always less than the corresponding changes in T_1 and there will be a certain definite amount of unbalance in the output of the two tubes. However since R_k is always quite low—in

the neighborhood of a few hundred ohms—the effect of parallel capacities will be quite negligible. Probably the best testimonial for the circuit of Fig. 3 is its use by Du Mont in horizontal and vertical deflection amplifiers which are designed to handle input signals having component frequencies up to one megacycle.

A fourth form of phase inverter, known as the "Floating Paraphase" is shown in Fig. 4. This arrangement employs the differential between the outputs of two tubes as the input to the phase inverter section. T_1 is an amplifier to increase the amplitude of the applied signal. The output of T_1 appears across the series combination of R_1 and R_3 . For this discussion R_1 , R_2 , and R_3 will be considered as equals although in actual practice R_3 is sometimes as low as 20% of R_1 . In any event however, R_1 and R_2 must be equal to each other.

In operation a portion of the output of T_1 appears across R_3 and is applied to the grid of T_2 . The output of T_2

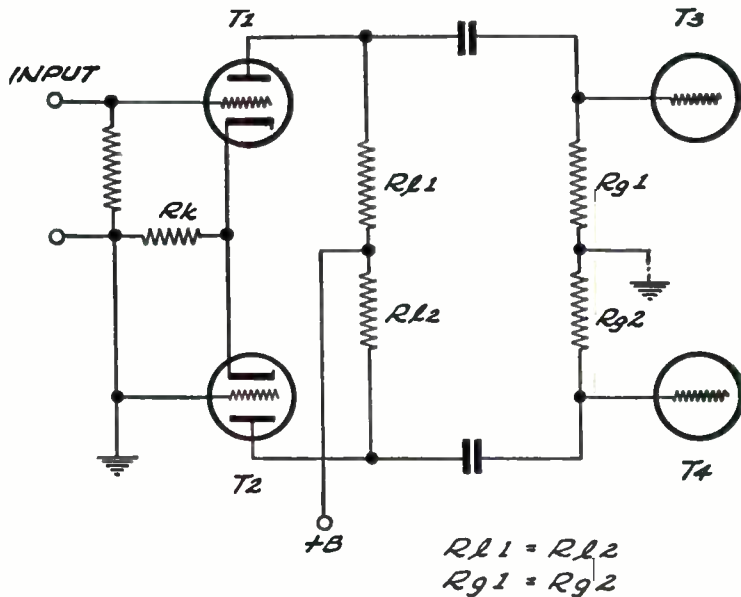

Fig. 3. Two-tube cathode-coupled phase inverter.

is applied across the series combination of R2 and R3. Thus a part of the outputs of both T1 and T2 appears across R3. However the outputs of

It might be well to examine the operation of the circuit of Fig. 4 from a somewhat different attack. Assume that a steady sine wave is being

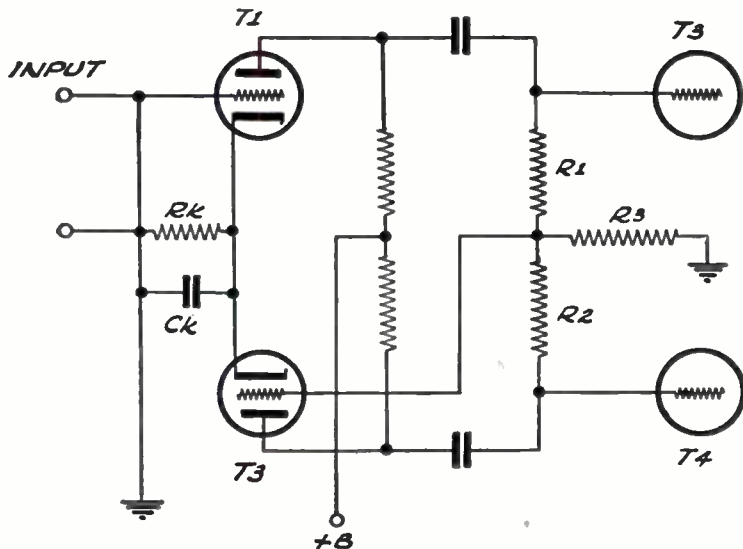

Fig. 4. Floating paraphase. $R_1=R_2$. R_3 is smaller than R_1 .

T1 and T2 are out of phase so that the net voltage appearing at point "x" will be the difference between the two individual output voltages which are developed across R3. If these two output voltages are exactly equal there will be no voltage at "x" and no voltage to be applied to the grid of T2. Therefore in operation the output voltage from T2 approaches but never quite equals the output voltage from T1. The unbalance is so small that it can be disregarded in ordinary practice and the inputs to T3 and T4 are considered to be equal and 180 degrees out of phase. This circuit is widely used because of its self balancing properties. Since the voltage at point "x" required to drive T2 will decrease as the gain of T2 is increased, normal practice is to use pentodes at T1 and T2 instead of the triodes shown in the figure.

applied to the grid of T1. Imagine action in the circuit to be stopped at the instant when the grid of T1 reaches its greatest positive swing. We shall look at the instantaneous voltages existing elsewhere in the circuit at the same moment. Since the grid of T1 is being driven positive, the plate voltage will be driven in a negative direction and point "x" will be negative with respect to ground. This negative voltage will be applied to the grid of T2 and the plate of T2 will go positive. Since a portion of the output of T2 appears at "x," the tendency will be for it to be driven positive by T2. But at the same instant it is being driven negative by the output of T1. If the outputs of T1 and T2 are exactly equal, the net result at point "x" will be zero and there will be zero grid driving voltage for T2.

(Continued on page 15)

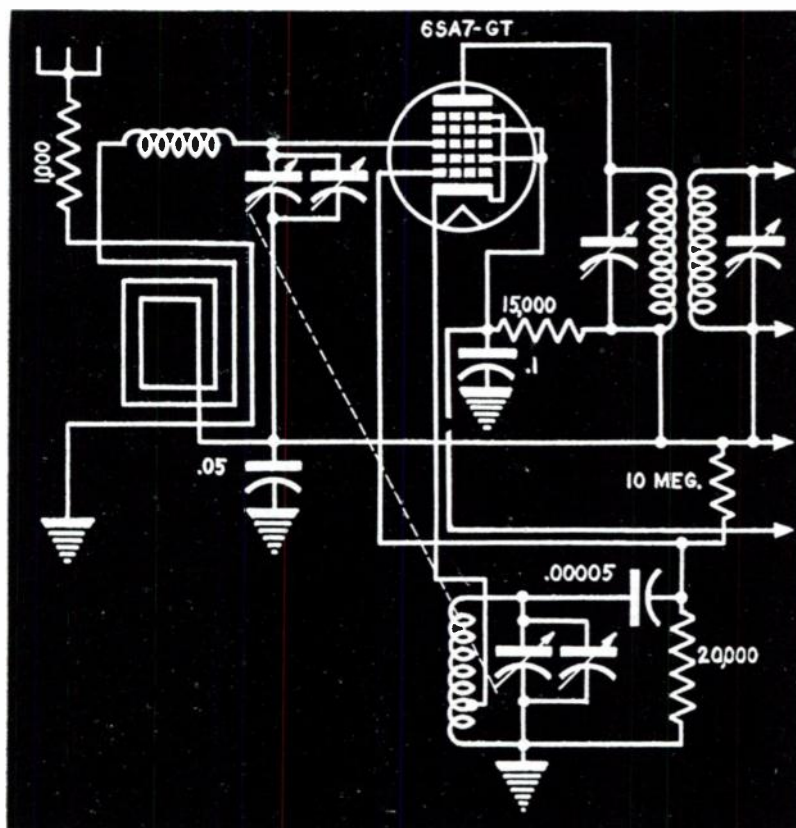

Fig. 2.

Four types of loop-antenna systems used in table receivers are shown in Figs. 1 to 4. Fig. 1 is the input circuit of Allied D-174. In Fig. 2 (Air King 4136), a resistor is used in series with the antenna to reduce the sensitivity at the high end of the tuning range. Loading coils are used in series with the loops of Figs. 2 and 3 (General Television 530) to reduce the distributed capacity, thereby extending the tuning range. Fig. 4 shows the input of Motorola 61L11/61L12.

effects. Since the voltage pickup is proportional to the loop area, the winding is made as large as the receiver dimensions permit. The Q of most

loops is low because they must be placed only an inch or two from the chassis to save space.

For additional pickup, most loops are provided with some sort of antenna primary coil to induce voltage from an external antenna to supplement that picked up directly by the loop. Used in this manner, the loop becomes the secondary of an antenna transformer. In Fig. 1 the antenna primary consists of a single turn around the outside of the loop adjacent to the low potential side, the avc end, so as to minimize capacity coupling. This method of

coupling favors the high-frequency end of the band, but the response may be flattened by simply inserting a series resistor of about 1,000 ohms, as in Fig. 2 (Air King 4136). Great care must be taken not to obtain too close coupling, for then we have hum modulation and the adjacent channel selectivity becomes poor.

The range of tuning of simple loops, as in Fig. 1, is usually 1,700 to 540 kc although new sets will probably cover 1,720 to 535 kc. A given variable condenser will tune over a wider band if a loading coil is connected in

series with the loop on the high side, as in the model shown in Fig. 2. The presence of the loading coil lowers the impedance of the loop which results in a net lowering of the distributed capacitance, permitting the wider range. The loop being large, and being placed close to the chassis, has a large distributed capacity while the small, high-Q loading coil has a comparatively low distributed capacitance. Note the 1,000-ohm antenna series resistor, previously referred to, which reduces the high-frequency pickup and, therefore improves the selectivity.

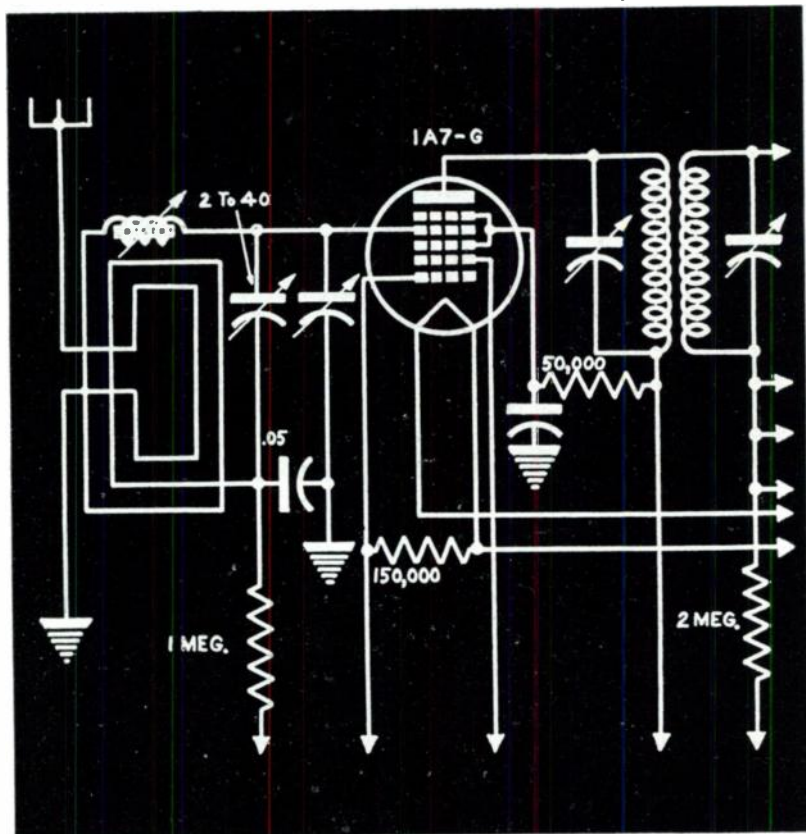

Fig. 3.

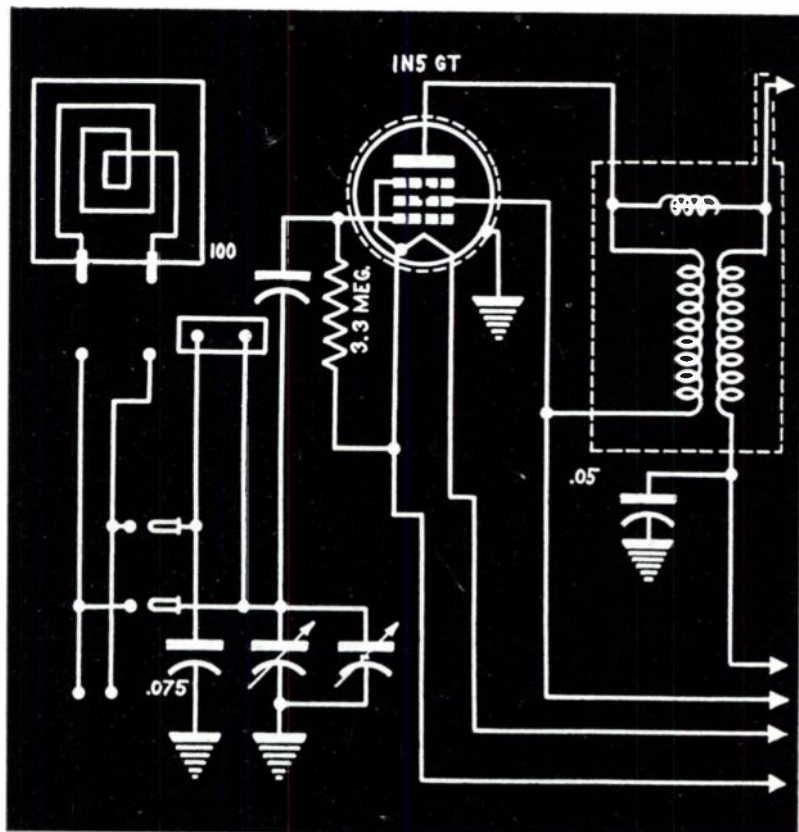

Fig. 4.

Adjustable Loop Loading Coil

The General Television & Radio Company model 530, shown in Fig. 3, has an adjustable loop loading coil, permeability tuned, which has the characteristics of Fig. 2 plus a high Q. The adjustment is used to trim the set on the low frequency end. Antenna coupling is obtained through a single turn as before.

Plug-in Loop

In the portable Motorola model 61L11, Fig. 4, the loop is a plug-in type which is placed in the cover.

When the cover is open the loop is placed away from the chassis, making the absorption negligible and the Q much higher than in fixed loops. This cover may be plugged in at the front or rear by means of a special receptacle and provision is also made for an external loop similar to the ones used by Zenith (Wavemagnets) or G.E. (Beam-a-Scopes). These types of flexible, remote loops have proved quite effective in difficult locations such as in a car, train, or plane where, in order to get any signals at all, the antenna

(Continued on page 15)



A Free Market-Place for Buyers, Sellers, and Swappers.

These advertisements are listed FREE of charge to C-D readers so if there is anything you would like to buy or sell, if you wish to obtain a position or if you have a position to offer to C-D readers, just send in your ad.

These columns are open only to those who have a legitimate, WANTED, SELL or SWAP proposition to offer. The Cornell-Dubilier Electric Corp. reserves the right to edit advertisements submitted, and to refuse to run any which may be considered unsuitable. We shall endeavor to restrict the ads to legitimate offers but cannot assume any responsibility for the transaction involved.

Please limit your ad to a maximum of 40 words, including name and address. Advertisements will be run as promptly as space limitations permit.

FOR SALE—Tubes. All numbers. Good discounts. Write for list. Bill's Radio Repair Shop, 2038-40 Washington St., Boston, Mass.

FOR SALE OR SWAP—Complete back issues of radio and sporting magazines, electric shaver, radio transmitters and receivers, transformers, meters, condensers, resistors, oscilloscope, .22 rifle with sling and scope, old coins, and other items. Stamp for list. Raymond H. Ives, 822 Windsor Ave., Norfolk 4, Va.

FOR SALE OR TRADE—Clough Brenle oscillator, model OMA, for trade for grandfather clock or sell for cash. M. W. Buening, Red Lodge, Montana.

SWAP—Practically new GE Selsyns, 57½ volt ac, 400 cycle, will operate on 60 cycle; 3 pair for Hallicrafters S-38 communications receiver. Have five 28 volt dc Delco, 145 rpm tiny motors to trade also. John V. Craig, La Fayette, Ga.

EXCHANGE—A Rider's XIII Manual for a Rider's IV Manual (even trade). Frank J. Sosolik, College Station, Texas.

WANTED—Television receiver. State make, model, condition and price. Also want Rider's manuals 9, 10, 12 and 13. George Kinkade, 8 W. Salisbury Dr., Wilmington 261, Del.

SWAP—6X30 binoculars (new), small lathe, hunting knives, stop watch, lensatic compass. Want signal generator, 2" or 3" oscilloscope, modern tube tester, and other test equipment. Robert W. Luke, 347 W. Master St., Philadelphia 22, Pa.

FOR SALE—Brand new astatic pickups with L26, L40 or L70 cartridge, \$2.95 each, 3 for \$8.50. F. Lewis, 548 Brompton, Chicago, Ill.

FOR SALE—150 new and used radio receiving tubes, uncartoned. All meter-tested for mutual conductance before shipment, 50% off list. Also power transformers, mostly 2½ volt filament types. Output transformers and speakers. Write for full list and prices. A v.t.v.m RCA type, slide back. Shop discontinued. Martin D. Johnson, Alliance Public High School, Alliance, Neb.

FOR SALE—2-tube phono oscillators with tubes, 40% off list, \$5.95. Any quantity. Need tube tester, service oscillator, tubes. Have radio, illumination, photographic and aviation courses, telephone handset, Crosely Facsimile Printer, etc., for swap. P. Brassard, Box 353, Brunswick, Me.

FOR SALE—OR TRADE—One new Weston meg-ohm meter, panel type, 4" square meter, 50 micro-amp movement, 200 meg., hi-range. Want to hear from some one having Hickok traceometer for sale. Paul Tyrlick, Embden, N. Dak.

SWAP—A set of I.C.S. electrical engineering books in A-1 condition valued at \$35, for tube tester, capable of testing up to and including 117 volt tubes. Harry I. Shroyer, 815 S. 15th St., St. Joseph 36, Mo.

FOR SALE—Wireless phonograph oscillators, complete with volume control and tubes, \$12 each. Big Bend Radio, 732 E. Big Bend, Webster Groves 19, Mo.

FOR SALE—Supreme model 550 deluxe set analyzer and condenser tester, like new condition, used very little. Giving up hobby, no reasonable offer refused. Thomas Daddario, 135-45 117 St., Ozone Park 16, N. Y.

FOR SALE—Relays. 24 volt dc. DPDT general purpose, \$2. SPST heavy duty contacts carry 75 amps, \$3. Two DPDT's with 5 terminal strip, complete assembly, \$4.50. 12 volt dc DPST norm. open, \$2. All new but not originally boxed. Paul Weisenbach, 13604 Lambert, Cleveland 20, Ohio.

FOR SALE OR TRADE—40 6SN7GT, five 12K8, new, not in cartons. Need 1½ volt tubes. Tiner Radio Shop, 110 Main St., Fort Payne, Ala.

FOR SALE—Surplus Army radio receiver, BC342N, in excellent condition, manufactured by Farnsworth Radio Corp. Receiver privately owned. Notify by mail if interested. Everett Teixeira, 2 Parnell St., E. Cambridge 41, Mass.

FOR SALE OR TRADE—110 volt 60 cycle ac generator, 250 watt. Will sell or trade for test equipment. Want good VT voltmeter or good volt-ohm-milimeter. Locke's Radio and Sound Service, Box 38, Vienna, Ill.

FOR SALE—One Dooling midjet race car, powered by an Atwood Champion motor, clocked at 85 mph, extra tail assembly, rear axle, radiator shell, coil, batteries, spark plugs, price \$45. William T. Kline, 115 N. Franklin St., Lancaster, Pa.

SWAP—30 watt amplifier for signal generator or war surplus radio equipment, or what have you. J. Bazewick, 3000 N. Christiana, Chicago 18, Ill.

FOR SALE—Motor generator, voltmeter, and four meter test panels. For complete description and prices, write to H. S. Sawyer, 5140 W. Lisbon Ave., Milwaukee 10, Wis.

ATTENTION—DeForest student wishes to write letters to girl student, one who is interested in radio and television and also has equipment. Penpal talk about things in general. Joseph Zukauskas, 2044 N. 3rd St., Philadelphia 22, Pa.

FOR SALE—Volume II, 1932 Rider's Perpetual Trouble Shooters manual and 2nd edition Radio Field Service Data (no binder). Best offer takes both. C.O.D. T. A. Znotin, 24 Dunster Rd., Everett 49, Mass.

FOR SALE—Aircraft batteries, 12 volt, \$10; 24 volt, \$15. 11, 17 and 35 ampere hour capacity. Will answer all correspondence promptly. Batteries in good condition. R. N. Fesneault, 229 N. E. 70th St., Miami 38, Fla.

WANTED—Hallicrafter receiver, model S29 or S39 in good condition. P. Jansen, 325 E. 163 St., New York 56, N. Y.

FOR SALE—9 tube Grunow short wave broadcast receiver, less case. Includes 80 meters. Complete with tubes, dial, and 12" speaker. Two bands. Only \$12 complete. Shipping charges extra. R. L. Bruce, 1171 Union St., Manchester, N. H.

SWAP—35mm Univex Mercury. 3.5 lens, exposure meter, National CW3, dial, tubes, 5880 Velvet AB supply, bicycle brakes. Need outboard motor, 8mm projector, Rider's X to date, gasoline camp stove. W. J. Closson, 295 8th St., Troy, New York.

WANTED—Stancor Master Pack, Stancor Master Deluxe, or ATR model A battery eliminator, or heavy duty eliminator for auto radios. Will pay cash. Sound Radio and Electronics, 210 Kings Highway, Brooklyn 23, N. Y.

FOR SALE OR TRADE—One ICS 1943 edition Radio Serviceman's Course in good condition. Best offer takes it. Bert Salladay, 412 W. Blaine, Brazil, Ind.

WANTED—10" or 12" PM speakers of 10 to 15 watts each. Must be in good condition. Can use 3 or 4 of each. Will trade the following for speakers or pay cash if priced right: 16mm movie projector, lapel crystal mike, 35mm still strip film projector, small amplifiers, tubes, etc. Want 7" or 8" power floor sander. John Arnold, Box 84, Bluffs, Ill.

POSITION WANTED—As serviceman or helper in shop or store in San Francisco. I am nearly 17, and taking a course at Samuel Gompers Trades School. Carl Huth, Jr., 1290 Thomas Ave., San Francisco 24, Calif.

FOR SALE—Tubes, parts, supplies at lowest special pre-war net quotations. For price list and information, write to J. C. Thimijan, 715 N. 7th St., Lake City, Minn.

WANTED—Short-wave or all-wave set, age and condition not important. Weston 772 or similar. Late tube tester. Send list. Glenn Watt, Chanute, Kan.

FOR SALE OR EXCHANGE—For tubes. Power transformers, 50L6 and 6F6 output trans., volume controls, 10 watt resistors, kits of one, one-half, and one-third dial cable, phono needles, pickup arms, Xtals, knobs, cabinets, etc. Send for list. Elena Electric Co., 500 Oak St., Old Forge, Pa.

SELL OR TRADE—Transmitting and receiving parts, tubes, meters, National NC-81X oscilloscope for U. S. or foreign stamp collection, and opera or field glasses. Send for list. B. Bernbaum, 5746 N. Park Ave., Philadelphia 41, Pa.

WANTED—Dealer will buy electric motors 1/4 hp and up, new or used. Also will buy burned out motors if frames are O.K. Write, giving nameplate data, condition and price wanted. Richardson, 530 W. 136th St., New York 31, N. Y.

WANTED—Communications receiver, 10 to 80 meter bands, tube tester, and signal generator. Must be reasonable. Barnett Grier, 74 Grant Ct., Long Branch, N. J.

FOR SALE—Back issues of Radio Craft 1936 to 1946; Radio News, 1922 to 1930; Service, 1936 to 1946. Sold per year or per copy or what have you. Also power packs sold or traded. Lawrence Roeshot, 77 Church St., Wilkes-Barre, Pa.

FOR SALE — Various radio magazines, early and late issues. QST, Radio News, Radio Craft, etc., 10 and 15 cents each. Let me know which issues you want or send for list. G. Samkofsky, 527 Bedford Ave., Brooklyn, N. Y.

TRADE—Will give \$250 in new transmitting parts, power transformers, filter chokes, condensers, tubes and meters for a good SX-28A receiver. Radio Communication Service, 4475 Myrtle St., San Diego 5, Calif.

FOR SALE—Bliley SMC 100 calibrator crystals, new, \$5.50; Hickok model AC-51 tube checker, modernized, \$75; GE pyranol condensers, 2 mfd, 5000 volt dc, \$15 each; 250 assorted IRC resistors, \$15. Satullo, 7635 E. Jefferson, Detroit 14, Michigan.

WANTED—Philco dynamic tester, model 030. Will pay cash. State price and condition of tester. Burger Appliance Store, Westphalia, Kansas.

FOR SALE OR SWAP—For what have you. Pair AmpereX, HF100; RCA 809; 210; 281; type C Balwin phones; Astatic type AB8 phono pick-up; Green Flyer phono motor; many other items. Send for list and prices. C. F. Lohner, 157 Logan St., Bedford, Ohio.

FOR SALE—Radio tubes, parts, and text books; also used records, all kinds, in good condition. Free list on request. Alvin J. Fischer, 1000 Faile St., Bronx 59, New York.

WANTED—Superior set tester, model 1280, must be in good condition and reasonably priced. Send complete information. R. W. Smith, 408 Wilson Ave., Brooklyn 21, New York.

FOR SALE—Various radio items at bottom prices. Send stamp for complete list. G. Samkofsky, 527 Bedford Ave., Brooklyn, N. Y.

FOR SALE—Radio tubes. Will ship COD. Write for complete list and prices. Worden Radio Shop, 121 Maple St., Friend, Nebraska.

FOR SALE—Grocery, confectionery, used magazines, used books, radio shop, equipment. 1600 playable tubes, Weston tube tester, multimeter, oscillators, signal tracer, Riders' manuals 1-6, Supreme diagrams 1-6. Low rent. \$2,800. Mendel, 2022 Lowrie St., Pittsburgh 12, Pa.

FOR SALE OR TRADE—Have 200 double pole, double throw toggle switches, plus 400 feet 2 wire, shielded, rubber-covered microphone cable, and 60 feet 8 wire shielded, rubber-covered wire for what have you? M. Rolland, 5219 9th Ave., Brooklyn 20, N. Y.

FOR SALE—RCA 155 oscilloscope tube, \$75; also have transmitter complete or parts, miscellaneous meters, etc. Write your requirements. J. D. Miller, 212 Douglas N E, Washington 2, D. C.

FOR SALE OR TRADE—Two each: 849, 204A, RK48, 829, 829B, 807, 814, 866A, 1852, 955, 954, 956 and others. New motor, generates 28 volts dc to 1000 at 300 ma., \$35. New RCP signal generator, No. 705. Want jewelers lathes, miller, shaper, etc. Mulno Engineering, 94 Butman Rd., Lowell, Mass.

FOR SALE—Triplett ac-dc volt ohm millimeter, model 1200E, A1 condition, can not be told from new. Audels Electric Library, 12 volumes. L. N. LaBossiere, 11 Gareau Ave., Ware, Mass.

FOR SALE—R. H. Macy, Majestic, Sparton, Philco, Fada, Kolster, Colonial and Brunswick radios. Louis A. Goldstone, 1279 Sheridan Ave., Bronx 56, N. Y.

WANTED—Photographic printing box suitable for handling negatives up to 4"x6". Also want electronic timer with a range of about 1/2 second to 5 minutes or more. State brand, model number, condition, and price job Long Island City. Dexter Kurs, 4525 45th St., Long Island City 4, N. Y.

WANTED—DCH-11, DF-11, DAF-11, DL-11, UY-11 German radio tubes. Also a 12A8-GT. I have German electrical meters. Al. Hart, 4848 Linden Ave., Hammond, Ind.

SWAP—High power transmitting equipment for late model communication receiver—SX-28A or equivalent. Have RME-510X high frequency converter, 3" oscilloscope, UTC and Thordarson high fidelity audio transformers. Radio Communication Service, 4475 Myrtle St., San Diego 5, Calif.

FOR SALE OR SWAP—Craftsman back geared screw cutting lathe, 6" swing, 18" centers, 3 jaw chuck, steady rest, 1/4 hp 110-220 volt 60 cycle motor. All in A1 shape. What have you in communication radio, Hi-fi amplifiers or 8mm motion picture equipment? Donald R. Barber, 607 W. High St., Piqua, Ohio.

- FOR SALE**—All types tubes at list. No exceptions or quantity limitations. Also other parts and supplies reasonable. Have a large assortment of tubes and supplies as lot for \$500 cash. Need Rider's manuals and ham stuff. What do you need and what do you have? Eddie Howell, Route 2, Dillon, S. C.
- FOR SALE**—All types of standard repair parts at wholesale prices. Send for list. Also want a salesman to sell my parts in his home town to dealers on a commission basis. Write for details. Martin Boxer, c/o Pioneer Radio Co., 397 Stone Ave., Brooklyn, N. Y.
- WANTED** — Used radio and television books, manuals and correspondence courses of every description. Write, giving title, publisher and latest copyright date. I will reply immediately, stating cash purchase price and include shipping labels. R. Landry, 6027 Eddy St., Chicago 34, Ill.
- WANTED**—Grinding machine for making duplicate keys for locks. Also want key blanks. Greiner Radio Service, 114 N. Elmwood Ave., Buffalo 1, N. Y.
- FOR SALE OR TRADE**—1 Jewell 0-6 volts, dc; 1 Jewell 0-25 mils, dc; 1 Weston 0-10 mils, 1 Jewell 0-200 mils, and 1 Jewell 0-25 mils, all 3 1/2" meters in perfect condition. Make offer. Wills Expert Radio, 215 S. Michael St., St. Mary's, Pa.
- WANTED**—Hickok tube tester with filament voltages up to 117 volts. Also Hickok signal generator. Give model, condition, age, and price. M. Gottlieb, 1745 Fulton Ave., New York 57, N. Y.
- TRADE**—Typewriter, Remington No. 10 in excellent condition. Will trade for good portable typewriter and carrying case. H. Galanty, 287 Conklin Ave., Hillside, New Jersey.
- FOR SALE** — Simpson model 305 tube tester, \$39.50. Monitor Crystaliner signal generator, \$57.50. TS-1 signal tracer, \$10.69. IRC volume control cabinet, \$14.67. Eveready 2 volt SA-2600 "air cell" batteries, \$5.95. All items are brand new. All prices less postage. Draughn Radio Service, Hindman, Ky.
- FOR SALE OR TRADE**—New Silver Vomax model 900. Want late model Meissner analyst. Ledbetter's Radio Sales and Service, Elizabethtown, Ill.
- WANTED** — Like new copy of "Radio Theory and Operating" by Mary Texana Loomis. State condition and price. W. Frankart, 37 Dean NW, Grand Rapids 5, Mich.
- WANTED**—Modulation reactor approximately 50 HY inductance at 350 ma. State price, make and specifications. Joseph Mackora, 328 Saybrooke St., Hartford, Connecticut.
- FOR SALE**—New instruments. Industrial instruments, model RN-1 Wheatstone Bridge, \$90. Model DR-52 resistance decade, \$100. Model 652 Jackson audio oscillator, \$90. Model 546 Supreme oscilloscope, \$70. Variable voltage adjuster, ac, with voltmeter, \$25. Have other parts. Send for list. L. Dye, 150 Sunset Ave., Dayton, Ohio.
- FOR SALE**—Two 6J5 2-meter trans-receivers with built in speakers, one will fit in glove compartment of car. \$18 and \$20. All inquiries answered. Alfred Freitag, 1437 Patapsco St., Baltimore 30, Maryland.
- FOR SALE** — New precision 912 tube checker, \$45. Simpson model 325 tube checker, \$30. Clough Bregle model DC oscillator, \$25. Superior X-rayometer, all brass bug, \$8. Want Riders' numbers 12 and 14. Roosevelt Appliance, Roosevelt, New York.
- FOR SALE**—8" electro-dynamic speaker, 2500 field coil, output transformer attached. Utah type, never mounted. Few hours experimental use. Best offer takes it. Shipping weight 4 pounds. Lloyd L. Melton, Norwalk State Hospital, Norwalk, Calif.
- WANTED**—Shoulder strap loop aerial for Emerson personal radio, model DU379. Tan color. Must be in good condition. Any reasonable price. Grant R. Berkebile, Box 1180 Bedford St., Johnstown, Pennsylvania.
- FOR SALE**—Two 12" turntable record players with crystal pick-ups in good condition and in cabinet. One motor 33 or 78 rpm both variable. Other motor 78 rpm. \$35 takes it or send for photo. Specialty Builders, 1018 S. La Brea Ave., Los Angeles 35, Calif.
- WANTED**—QST, 1938, October and December; 1939, January, February, March. Electronics, 1938, January, April, June, August, November; 1939, April. James Darby, 1686 Clay Avenue, New York 57, New York.
- FOR SALE** — Supreme signal generator, model 580, deluxe, ac operated. AF, RF and FM signals. Size 7" x 11" x 1 1/2", \$30. Ernest Kumfert, 21 Walker St., New London, Conn.
- FOR SALE**—Fada ac-dc battery, 5 tube portable superhet. Perfect condition, excellent tone. Complete with tubes and batteries, \$23, cash, no trades. Herman Fischer, 625 Carlton Ave., Brooklyn 17, New York.
- FOR SALE**—One RCA remote program amplifier, type 62A complete with power supply and connecting cable. This outfit is complete with all tubes and ready for immediate use. Price \$100. Harry M. Boone, 10 E. North Ave., Baltimore 2, Md.

TRADE ONLY—Miller P.S. 12-500 meters with 3 tubes; Bud phono oscill. with tube; 10" T T and motor; Weiller speed iron; all in new condition. Want wind charger, rod, reel or guns. No juice here is reason for trade. J. C. Richard, Bennetts Point, via Green Pond, S. C.

WANTED—A radio man to start a radio business in Sunbury, Pa., on a fifty-fifty base. A very good location for radio repair service, pop. 28,000, very respectful town. I have most of equipment to open a shop. Refer to Snyder's Radio Service, in care of Parsett N. Snyder, Prop., Pitman, Pa.

TRADE—Weston 3" 0-1.5 scale dc ammeter, new, for dc voltmeter of similar size or larger with 0-300 scale or better. Cannon Radio, 6821 First Ave. N., Birmingham, Ala.

PHASE INVERSION CIRCUITS

(Continued from page 6)

Therefore point "x" must never be zero (except at the instant of zero input to the grid of T1) and for this to be true it is necessary for the output of T2 to always be slightly less than the output of T1.

The circuit of Figure 4 will show a relatively small but nevertheless definite amount of phase distortion. For audio purposes it is quite satisfactory but it can not be used in high frequency pedestal or sawtooth applications. Its operation can be materially improved by removing the bypass condenser Ck. This change will cause Rk to develop some phase inversion voltage just as does Rk of Fig. 3. As in the circuit of Fig. 3 the voltage across Rk (of Fig. 4) will be insufficient for perfect balance of output but on the other hand there will be essentially no undesirable phase distortion in the voltage developed across Rk because Rk will be only a few hundred ohms. However the voltage developed across Rk is augmented by the unbalance voltage developed at point "x." The improvement obtained by removing Ck comes from the fact that most of the grid input to T2 is developed across Rk and only a relatively small voltage need be developed across R3. Since any voltage appearing across R3 is the result of unbalance in the output of T1 and T2 it follows that a very small

unbalance will result in adequate voltage across R3 which is added to the voltage across Rk. Since the major portion of the grid drive for T2 comes from Rk, phase distortion will be considerably less than with Ck in the circuit and this arrangement has been found useful in certain wartime indicating devices.

The phase inverters discussed herein are examples of types of circuits and numerous modifications are possible. For example, the circuits of both amplifier and phase inverter tubes may be modified to include compensation for wide band operation. Again, while the phase inversion circuits as described are of too high output impedance to drive a Class B amplifier, the push-pull tubes might be operated as cathode followers and successfully used to drive a Class B stage.

RECEIVER INPUT CIRCUITS

(Continued from page 10)

must be placed close to a window. Incidentally, the loops are tuned directly by a gang condenser, but capacity coupled to the r-f amplifier grid through a 1,000-mmfd capacitor. A 3.3-megohm grid leak completes the grid circuit to the negative filament leg.

(To be continued)

When You Move or Change Your Address

Be sure to notify the Mailing Dept. of "The C-D Capacitor," Cornell-Dubilier Electric Corp., South Plainfield, New Jersey, giving the old as well as the new address, and do this at least four weeks in advance. The Post Office Department does not forward magazines unless you pay additional postage, and we cannot duplicate copies mailed to the old address. We ask your co-operation.

Now They Call Me Doc

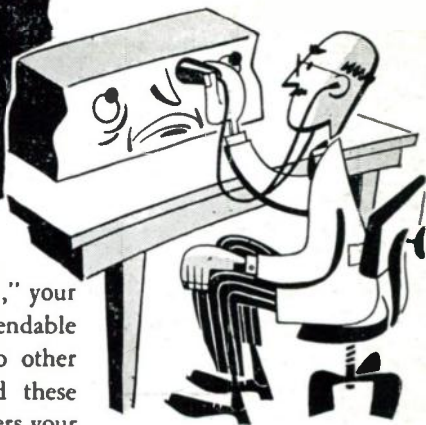

Whenever an ailing set needs a "physical," your local prospect will go hunting for a dependable serviceman. That's why, in addition to other valuable sales aids, C-D has prepared these prestige-building decals to direct customers your way. Mount a decal on your door or window where everyone can see that you are the reliable radio servicing specialist of your community. It's free!

RELIABLE RADIO SERVICING

WE USE ONLY GENUINE

CORNELL DUBILIER CAPACITORS

QUALITY LINE SINCE 1910

WORLD'S LARGEST MANUFACTURER OF CAPACITORS

GET THESE C-D SALES AIDS!



- Newspaper Mats
- Match Books
- Counter Cards
- Stationery
- Decals
- Shipping Labels
- Postcards
- "C-D Capacitor"
- Catalogs

let yourself grow! See your local C-D jobber today and order these powerful sales builders. Most of them are FREE. If you're not on the regular monthly mailing list for your free "C-D Capacitor," write direct to: Cornell-Dubilier Electric Corp., South Plainfield, N. J. Other plants at New Bedford, Worcester, and Brookline, Mass.; and Providence, R. I.



MICA • DYKANOL • PAPER • ELECTROLYTIC

CORNELL-DUBILIER

WORLD'S LARGEST MANUFACTURER OF

CAPACITORS

Printed in U.S.A.