

Mullard Outlook

A U S T R A L I A N E D I T I O N

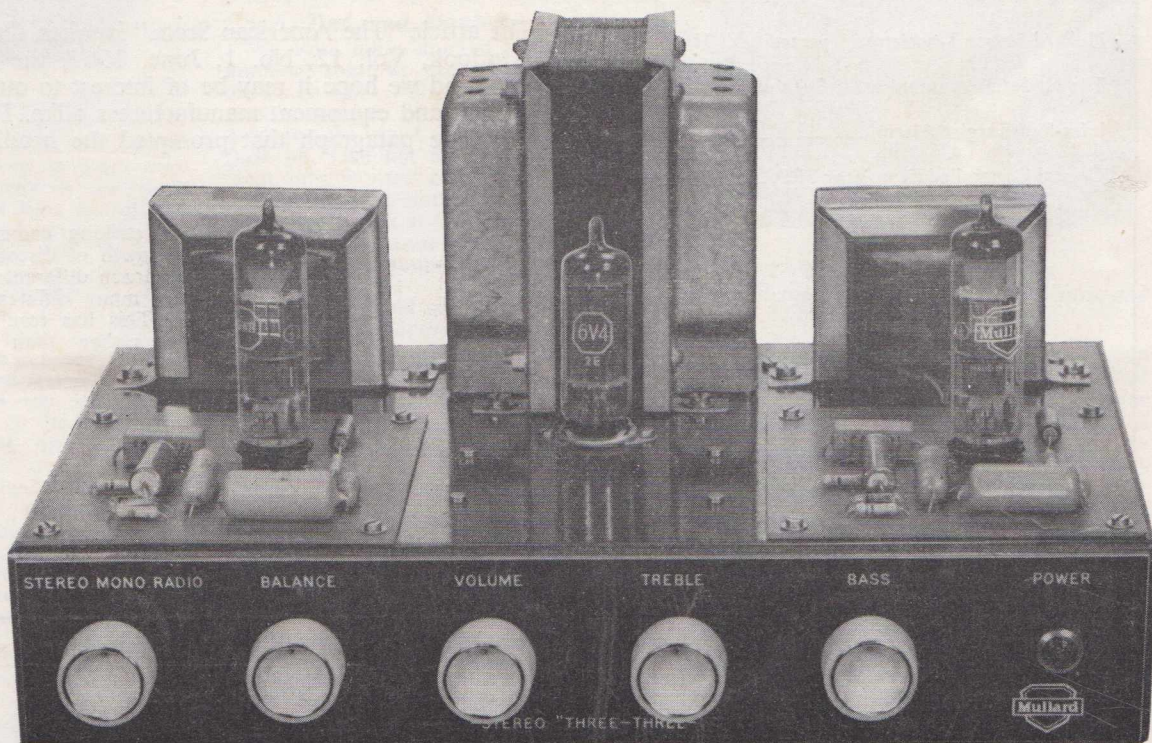

VOL. 5, No. 3,
MAY-JUNE, 1962



MULLARD-AUSTRALIA PTY. LTD.



VOL. 5 — No. 3

MAY-JUNE, 1962

Editorial Office:

35-43 Clarence Street, Sydney.
Telephone: 29 2006

Editor:

JOERN BORK

All rights reserved by Mullard-Australia Pty. Ltd., Sydney. Information given in this publication does not imply a licence under any patent. Original articles or illustrations reproduced in whole or in part must be accompanied by full acknowledgement: Mullard Outlook, Australian Edition.

TABLE OF CONTENTS

	Page
Editorial	26
Viewpoint with Mullard	27
Mullard Stereo "Three-Three"	28
Mullard Power Transistors Uprated	31
The Modern Communication Receiver.....	32
Infra-Red Burglar Alarm	35
Crystal Controlled Transistor BFO	36

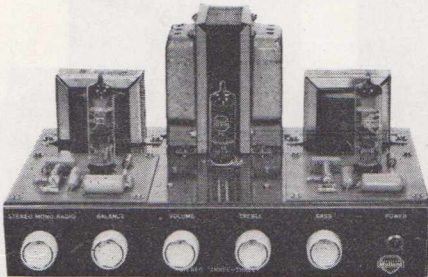

The new Mullard Stereophonic "Three-Three" Audio Amplifier has been designed by Mullard engineers to provide dual-channel stereophonic amplification of a reasonably good quality at low cost. The Amplifier is described in detail on page 28.

MULLARD-AUSTRALIA PTY. LTD.

35-43 CLARENCE STREET, SYDNEY
Phone: 29 2006

123-129 VICTORIA PDE., COLLINGWOOD, N.5
VICTORIA

Phone: 41 6644

Associated with
MULLARD LTD., LONDON

— high pressure buying rather than high pressure selling!

The reference is to discounting by retailers in the United States and provides a theme worth pondering, both by the high-pressure entrepreneur and the old trouper who sets out to please in another way.

It is an extract from the impressions gained by the winners of a recent Mullard U.K. business promotion contest, Messrs. Jones and Stone, during a short visit to the United States and is reprinted in full in this issue.

Outlook readers who are not aware of the wide acceptance in the United States of Mullard valves may find this also of interest, for an unrivalled reputation has been built up, with a keynote on quality. Closer to home and apart from valves, the theme has been vividly illustrated here in Australia, where it is now accepted that Mullard Radiant Screen Long Life Picture Tubes have indeed a long life—in fact an extremely long one.

The article "The American Scene" is taken directly from the Mullard U.K. Outlook, Vol. 12, No. 1, June, 1962, the Journal of our Parent Company and we hope it may be of interest to our many retailer readers in Australia and equipment manufacturers alike. For good measure then, we repeat the paragraph that prompted the heading of this editorial:—

"One of the most striking commercial developments is the growth of discounting. You can walk into a dozen different establishments and find as many different discounts being offered. This has resulted in high-pressure buying rather than high-pressure selling."

M.A.B.

MULLARD DISTRIBUTORS:—

New South Wales

Martin de Launay Pty. Ltd.
Cnr. Druitt & Clarence Sts.,
Sydney. Phone: 29 5834

Cnr. King & Darby Streets,
Newcastle. Phone: 2 4741

144 Keira St., Wollongong.
Phone: B 6020

Victoria

Howard Electrical & Radio
Company.

Vere Street, Richmond,
Phone: JB 4716

South Australia

Agents:

Woollard & Crabbe Limited
180 Wright Street West,
Adelaide. Phone: LA 4713

Western Australia

Harris, Scarfe & Sandovers
Limited.

495 Newcastle Street, Perth.
Phones: 28 1171, 28 0131

Queensland

C. A. Pearce & Co.
Pty. Limited.
33 Bowen Street, Brisbane.
Phone: 2 5860, 2 8510

Tasmania

Medhursts Wholesale Ltd.
163 Collins Street, Hobart.
Phone: 2 2911

136 Wellington Street,
Launceston. Phone: 2 2091
106 Wilson Street, Burnie
Phone: 1919

and all leading wholesalers throughout the Commonwealth

VIEWPOINT WITH MULLARD

The American Scene

The winners of Mullard U.K. Business Promotion Contest No. 4—Bryan Jones and Colin Stone of Kingsteignton, Devon—recently returned from their fact-finding study of the U.S. radio and TV industry. Shortly after touching down on home soil they recorded the following impressions.

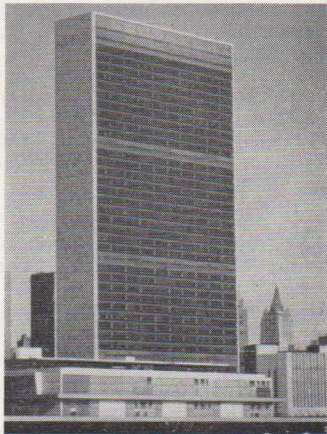

United Nations Headquarters—
New York City

It was a memorable trip in every way. Even though we were only in the States for a short week, it was long enough for us to get a pretty sound grasp of their working methods—thanks to the fine arrangements laid on by Mullard with their friends, International Electronics Corporation of New York.

These can only be brief impressions. There just isn't space to set down a full account of all we saw and learned. But we hope what we have to say will be of interest to our colleagues in the trade here.

Firstly we found little resembling the pattern we know so well over here. The small dealer business doesn't exist. The manufacturer sells goods to distributors—rather like our wholesalers—department stores and appointed service dealers. The distributor, as well as selling direct to the public at advertised discounts, also supplies non-appointed service dealers.

One of the most striking commercial developments is the growth of discounting. You can walk into a dozen different establishments and find as many different discounts being offered. This has resulted in high-pressure buying rather than high-pressure selling!

Re-sale price maintenance is almost non-existent, save on a few selected lines. This means that larger distributors can offer very substantial discounts because of their regular turnover and the fact that they assume no after-sales service responsibilities.

The manufacturer guarantees his goods for a specified period. Some of the bigger concerns handle repairs through a nationwide network of service companies. Once the guarantee has expired the customer may be offered a service contract covering valves, tubes, components and labour for between £15-£20 a year. On the other hand he can take his set to a local service dealer or

one of the independent service men who appear to flourish in large numbers.

Tune-up Week

The latter have no ties and most are self-employed. Many are highly-skilled, but amateurs abound.

It appears that anybody can take a three-month correspondence course in radio servicing and then set up in business, charging anything up to five dollars a call for his services.

This has given the industry a bad name. And to undo some of the harm the trade is boosting the taking of proper courses, full-time, at technical colleges. Successful graduates get a diploma issued by the Federal Communications Commission.

Service men are encouraged by the local TV stations to get more business. One of the methods is called Tune-Up Week. Viewers in the area are sent a test card and invited to check it against a similar one screened at intervals during the campaign week. If all does not appear to be well, viewers are encouraged to call in their service man.

We can't say we were particularly impressed by this form of business-building

Good, Bad and Doubtful

We were quite shocked by another promotional stunt we ran across. They call it the *Drug Store Valve Tester*. The public—usually people with no inkling of the hazards—are urged to take off the back of their set, take out all the valves and test them unsupervised on a dubious contraption in the drug store on the corner.

We had a look at this machine. It seemed to be nothing more than a tester giving continuity or mutual conductance indications.

A dial registered one of three positions—*Good, Bad, Doubtful*. The *Good* section occupied only a small area of the dial. We also noted that few people bothered to check valves they had bought in replacement.

On the Wane

Competition in the American valve market is keen. The influence of discounting is as apparent as in the set sphere. One can buy unbranded valves—probably ex-Government types—at hefty discounts.

But Mullard valves clearly sold on quality. This is not to be wondered at, because quality is the current theme of American radio industry advertising.

Manufacturers are going all out to eliminate annoying faults in set design. More and more trouble is being taken over layout. The printed circuit seems to be on the wane and many makers are stressing the 'handcrafted' aspect of their receivers. Even those who still cling to printed wiring make great play of the fact that special vents are fitted for air cooling. Apparently they have shared the troubles we have known with overheating.

Tuner Troubles

Receiver design, technically, resembles the British pattern. Tuners, though, are a bit smaller and seem to give a certain amount of difficulty. We came across one firm specialising in tuner repairs and giving a 24-hour service. (*Australian Edition Outlook readers are already well-catered for with a fine tuner replacement service.—Ed.*)

MULLARD-AUSTRALIA PERSONALITIES



Mr. J. E. Pearce

recently appointed Manager for Victoria and Tasmania

An Associate Member of the Institution of Radio Engineers, Aust., he studied Applied Physics at the Royal Melbourne Institute of Technology before journeying to England, where he gained experience with a number of the large electronic companies, spending much time on television transmitting equipment. During this period he had the opportunity of furthering his studies at the Northampton Polytechnic.

Returning to Australia in 1957, he continued in the television transmission equipment field before accepting an appointment with us as Technical Commercial Manager at our Victorian Branch. John's sporting interests are mainly squash, golf, tennis and an occasional visit to the snowfields.

Mr. Graham Gale now heads the Technical Commercial Section in Victoria and becomes assistant to Mr. Pearce.

We were surprised to find that the large mains transformer is still in use, as is the large valve rectifier. These vanished from the British TV set long ago.

We found colour TV most impressive. The number of controls have been reduced, operation is far simpler and reliability has improved. As a result sales are moving upwards, albeit slowly.

Random Recollections

The widespread interest in Hi-Fi equipment, usually selling at strict list prices . . .

(Continued on page 36)



MULLARD STEREO "THREE-THREE"

Only one 6GW8/ECL86 is used in each channel of the three-watt stereophonic amplifier described in this article. Whilst the design is, therefore, very economical, reasonably good quality of reproduction is achieved.

Bass-boost and treble-cut tone controls are provided. The sensitivity of the amplifier is sufficient for use with crystal pick-up heads, but a pre-amplifier will be necessary with magnetic pick-up heads.

CIRCUIT DESCRIPTION

The circuit diagram for one channel of the three-watt amplifier is shown in Fig. 1. The complete amplifier uses two 6GW8 triode-pentodes and a 6CA4/EZ81 rectifier.

Input Selector Switch

The input stages of both channels are connected to the 3-way input selector switch SA, which provides facilities for stereophonic reproduction from a crystal or ceramic pick-up head, and dual-channel monophonic reproduction from a monophonic pick-up head or wide band tuner.

Driver Stage

The triode section of one 6GW8 is used in the first stage of the two-stage amplifier. The voltage gain of the stage is approximately 50 times.

Output Stage

The pentode section of the 6GW8 is used in a class A output stage. The operating conditions are:

$$\begin{aligned} V_a = V_{g2} &= 250V \\ I_{a(o)} &= 36mA \\ R_a &= 7k\Omega \end{aligned}$$

A cathode resistance of $170\Omega^*$ provides the required bias of just over 7V. The HT line voltage should be chosen so that,

*For speech or music signals, the standard value of 180Ω can be used.

allowing for the voltage dropped across the primary winding of the output transformer, the anode-to-cathode voltage is 250V. With the transformer used in the prototype amplifier, a line voltage of 270V is required.

The transformer used in the prototype amplifier has the following specifications:

$$\begin{aligned} \text{Primary inductance} & 10H \\ \text{Primary resistance} & 350\Omega \end{aligned}$$

The frequency response characteristic shown in Fig. 2 will be achieved if the output transformer is free of resonances up to some 50 kc/s. If this is not so, it may be necessary to cut the treble response to ensure HF stability.

Negative Feedback

The amount of negative feedback taken from the secondary winding of the output transformer to the cathode of the driver stage is 18dB. The prototype amplifier is stable with a considerably greater amount of feedback, but 18dB is about the maximum which can be applied if the sensitivity is to be sufficient for use with crystal pick-up heads.

Tone-control Circuits

The parallel combination of a $0.22\mu F$ capacitor and a $10k\Omega$ variable resistor in the feedback path provides continuously variable bass boost. A passive RC network in the input circuit gives continuously variable treble cut.

Balance Control

The balance control consists of a dual-ganged potentiometer, one track obeying a logarithmic law and the other an anti-logarithmic law.

Power Supply

The total HT current consumption of both channels of the amplifier is about 75mA, and a 6CA4 is a suitable rectifier for these requirements.

PERFORMANCE

Sensitivity

The sensitivity of the amplifier for an output power of 3W is $60mV$ without feedback and $500mV$ with feedback.

Frequency Response

The frequency response of the amplifier (for an output of 50mW) is flat to within 3dB from 20 c/s to 20 kc/s. At an output level of 3W, when the amplifier is fed from a low impedance source, the 3dB points occur at 100 c/s and 20 kc/s respectively.

Because of the high value of the input capacitance of the triode, the HF response is somewhat dependent on the setting of the volume control (Miller feedback). The maximum loss of response at 10 kc/s is 5dB, and this is not large enough to be objectionable.

Harmonic Distortion

Total harmonic distortion is plotted against output power in Fig. 3. The distortion at an output power of 3W is of the order of 4%. The output power available with 10% harmonic distortion is 3.2W.

Output Impedance

The output impedance of the amplifier measured at the 15Ω terminals is 1.5Ω , which gives a damping factor of 10.

Tone-control Characteristics

The response characteristics of the tone-control circuits are shown in Fig. 2. The maximum bass boost available at 70 c/s is 11dB relative to the response at 1 kc/s, and the maximum treble cut at 10 kc/s is 16dB.

Hum and Noise

The level of hum and noise in the prototype amplifier, measured with an open-circuited input and the tone controls set

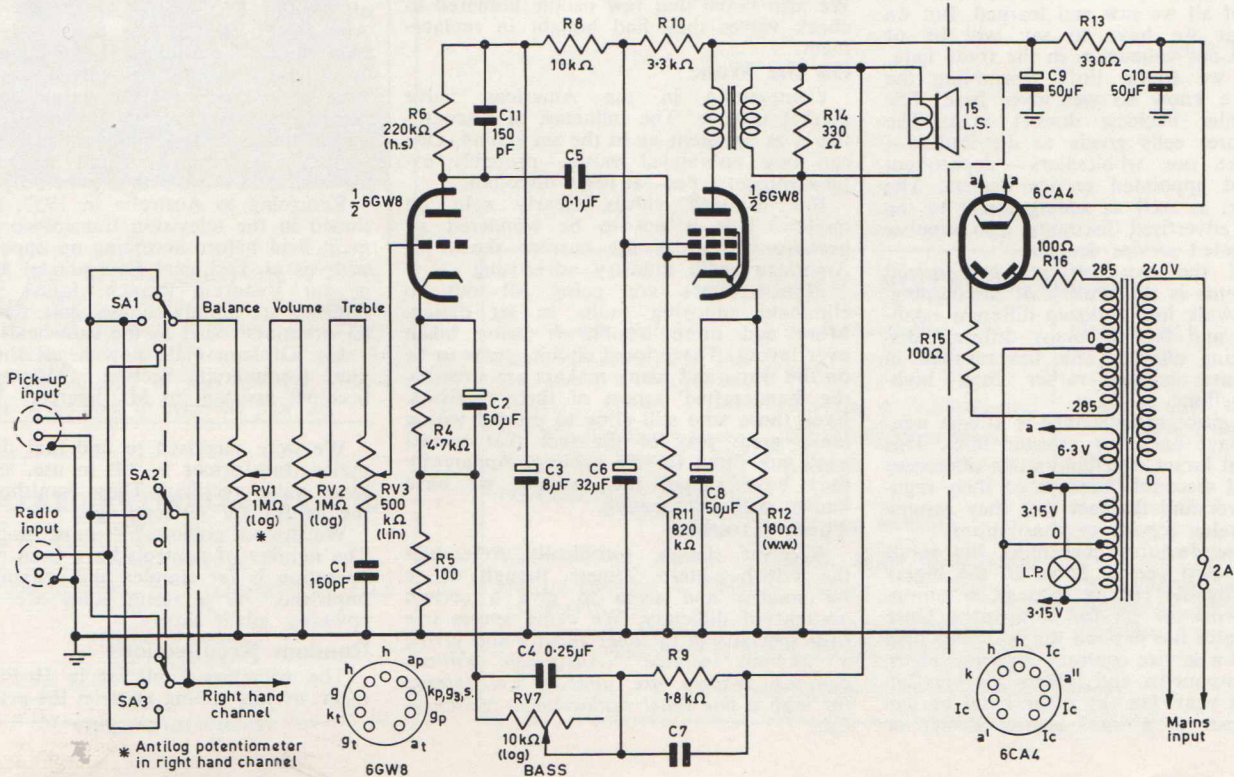

(Fig. 1)

for a flat response, is approximately 65dB below 3W.

ASSEMBLY OF 3W AMPLIFIER

Since the wiring of the 3W amplifier is critical, the use of printed-circuit boards is advocated, and a printed-circuit version only is discussed.

Because of the high voltage gain of the 6GW8, great care has been taken in the layout of the amplifier. In particular, every precaution is taken to minimise stray capacitive coupling between the grid circuit of the triode section and the anode circuit of the pentode section of the 6GW8. The valve-holders for the 6GW8 should be nylon or polypropalene loaded and preferably skirted.

CONSTRUCTION OF 3W AMPLIFIER CHASSIS

The chassis for the 3W amplifier is made from 16 s.w.g. metal sheet. The dimensions (in inches) of the pieces are:

- (a) Main chassis $16\frac{1}{2} \times 12\frac{1}{2}$
- (b) Cover plate $12\frac{3}{4} \times 7\frac{3}{4}$
- (c) Screen $12\frac{3}{4} \times 2\frac{3}{16}$

Each piece should be marked as shown in Fig. 4, and the holes should be cut as indicated.

Resistors and capacitors in the left-hand channel are numbered 1, 2, 3, etc.; corresponding components in the right-hand channel are numbered 101, 102, 103, etc.

Resistors

Circuit Ref.	Value	Tolerance ($\pm\%$)	Rating (W)
RV1	1 M Ω	logarithmic potentiometer	
RV100	1 M Ω	antilogarithmic potentiometer	
RV2 and RV102	2 \times 1 M Ω	logarithmic potentiometer	
RV3 and RV103	2 \times 500 k Ω	linear potentiometer	
R4 R104	4.7 k Ω	5	$\frac{1}{2}$
R5 R105	100 Ω	5	$\frac{1}{2}$
*R6 R106	220 k Ω	5	$\frac{1}{2}$
RV7 and RV107	2 \times 10 k Ω	logarithmic potentiometer	
R8 R108	10 k Ω	10	$\frac{1}{2}$
R9 R109	1.8 k Ω	5	$\frac{1}{2}$
R10 R110	3.3 k Ω	10	$\frac{1}{2}$
R11 R111	820 k Ω	10	$\frac{1}{2}$
**R12 R112	180 Ω	5	3
R13	330 Ω	10	3
R14 R114	330 Ω	10	$\frac{1}{2}$
R15	100 Ω	10	1
R16	100 Ω	10	1

- * High stability.
- ** Wire wound.

Capacitors

Circuit Ref.	Value	Description	Rating (V)
C1 C101	150 pF	Polystyrene	125
C2 C102	50 μ F	Electrolytic	6
C3 C103	8 μ F	Electrolytic	350
C4 C104	0.22 μ F	Polyester	125
C5 C105	0.1 μ F	Polyester	400
C6 C106	32 μ F	Electrolytic	350
C7 C107	1000 pF	Polyester	400
	2200 pF	(for A & R)	400
		Polyester (for Ferguson and Special Transformers)	
C8 C108	50 μ F	Electrolytic	25
C9	50 μ F	Electrolytic	350
C10	50 μ F	Electrolytic	350
C11 C111	150 pF	Polystyrene	600

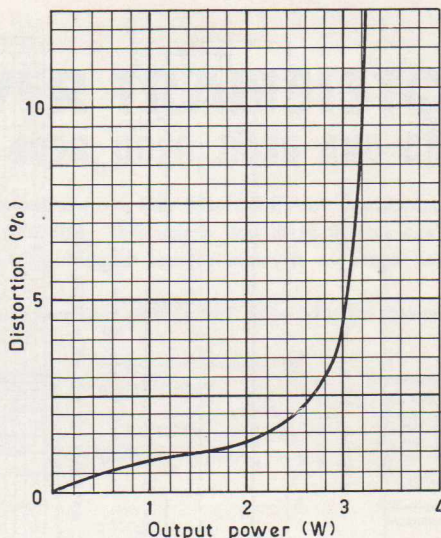

(Fig. 3)

DC Conditions in Each Channel of 3W Amplifier

Point of Measurement	Voltage (V)	Range of DC Avometer (V)
C9 (common to both channels)	270 320	1000
6GW8 Pentode anode	257	1000
Pentode screen grid	250	1000
Pentode cathode	6.8	100
Triode anode	160	1000
Triode cathode	1.75	100

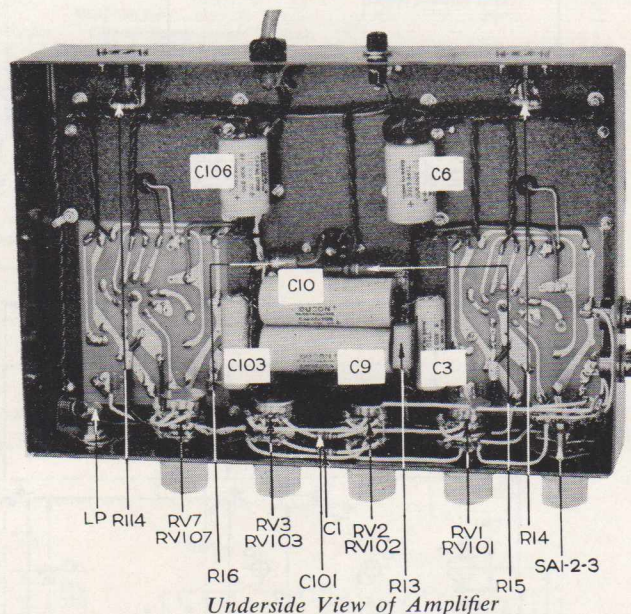

Underside View of Amplifier

Mains Transformer

Primary: 230V, 240V, 50 c/s
 Secondaries: 285V—0—285V, 80mA
 6.3V tapped 5V—2A 6.3V—2A—CT, 6.3V—2A
 Ferguson Type No. PF170 A & R Type No. PT1885

Output Transformers

Primary impedance 7k Ω
 Special Transformers Type No. ST340
 Ferguson Type No. OPM1A
 A & R Type No. 2624

Valves

Mullard 6GW8 (two) 6CA4

Valveholders

B9A (noval) with screening skirt (printed circuit type) (polypropalene type or mica-filled type)
 B9A (noval) (for 6CA4) (polypropalene type or mica-filled type)

Printed Circuit Board

R. C. S. Radio Pty. Ltd. 651 Forest Road, Bexley, Part No.599

Miscellaneous

Fuseholder, Belling Lee miniature Fuse 2A
 Lampholder and Bezel
 Indicator lamp, 6.3V, 0.15A
 Input socket, 2-pin (two) (Acme)
 Output socket, 4-pin Tagstrip—13 lugs (2)
 Tagstrip—8 lugs (2) Tagstrip—3 lugs (2)
 Selector switch, 3-pole, 3-way, miniature rotary.
 Pointer knob (5)
 Miscellaneous hardware, screws, grommets, etc., as required.

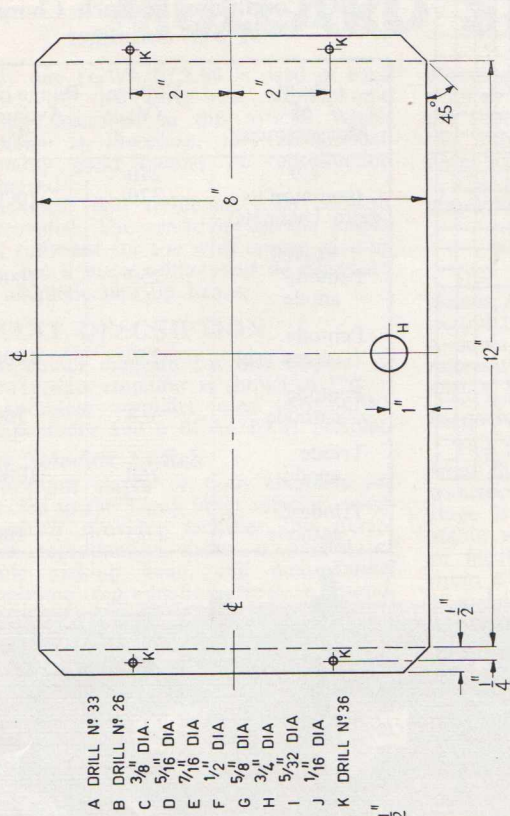

- A DRILL N° 33
- B DRILL N° 26
- C $\frac{3}{8}$ " DIA.
- D $\frac{5}{16}$ " DIA
- E $\frac{7}{16}$ " DIA
- F $\frac{1}{2}$ " DIA
- G $\frac{5}{8}$ " DIA
- H $\frac{3}{4}$ " DIA
- I $\frac{5}{8}$ " DIA
- J $\frac{3}{2}$ " DIA
- K DRILL N° 36

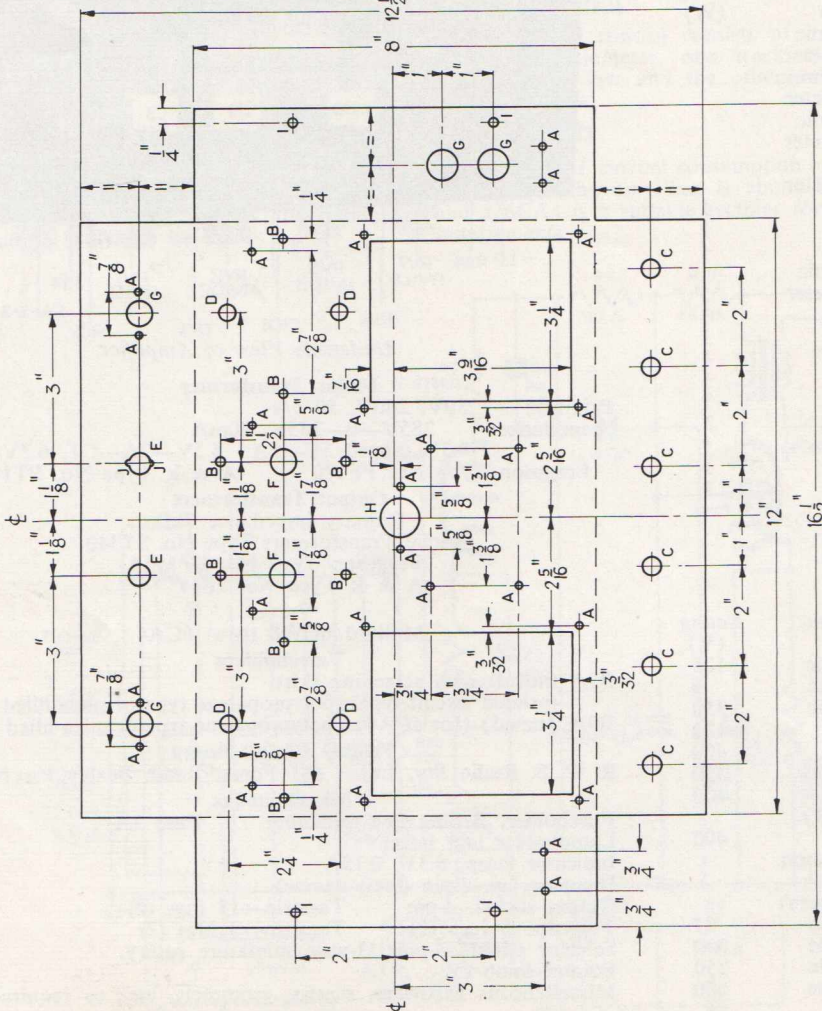
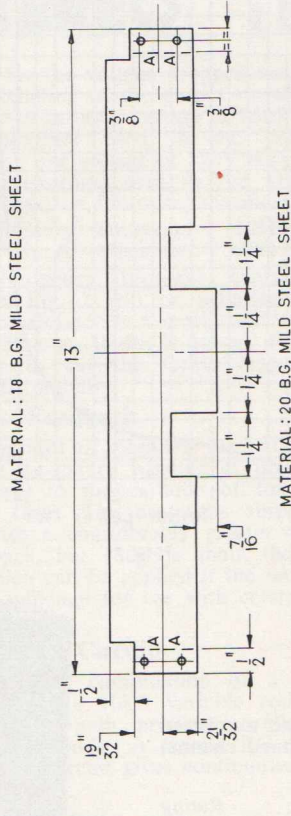

(Fig. 4)

Chassis Outlines and Dimensions Mullard Stereo "Three-Three" and Frequency Response Curves

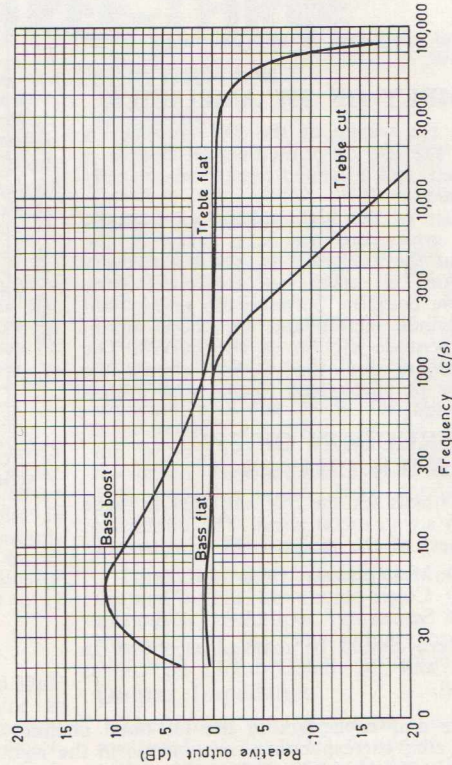

(Fig. 2)

MULLARD POWER TRANSISTORS UPDATED

TYPES OC28, OC29, OC35 AND OC36

The maximum DC and average collector current of these four Mullard Power Transistors is now 8A instead of 6A and the maximum allowable peak current has been raised from 6A to 10A. This means that these devices can now be used in high current applications, for example, in high current servo systems where it has hitherto been necessary to use larger and more expensive power transistors, often in the 12A range.

Consequently, it becomes possible to have more amps per shilling with these Mullard Power Transistors, since they are available at the same price as that before their updating.

QUICK REFERENCE DATA

Power junction transistors of the p-n-p alloy type intended for use in medium and high voltage and high current switching applications. Matched pairs of each type are available under the prefix '2-OC' e.g. 2-OC28.

	OC28	OC29	OC35	OC36	
V_{CB} max. ($I_E = 0A$)	-80	-60	-60	-80	V
V_{CE} max. ($I_E = 0.5A$)	-60	-48	-48	-60	V
V_{CE} max. ($I_E = 6.0A$)	-60	-32	-32	-32	V
h_{FE} ($I_C = 1.0A$)	20-55	45-130	25-75	30-110	

Unless otherwise shown, data is applicable to all types

ABSOLUTE MAXIMUM RATINGS

The equipment designer must ensure that no transistor exceeds these ratings. In arriving at the actual operating conditions, variations in supply voltages, component tolerances and ambient temperatures must also be taken into account.

	OC28	OC29	OC35	OC36	
Collector voltage					
V_{CB} max. ($I_E = 0A$)	-80	-60	-60	-80	V
V_{CE} max. ($I_E = 0.5A$)	-60	-48	-48	-60	V
V_{CE} max. ($I_E = 6.0A$)	-60	-32	-32	-32	V
Collector current					
I_{CM} max.				10	A
$\dagger I_{C(AV)}$ max.				8.0	A
Emitter current					
I_{EM} max.				12	A
$\dagger I_{E(AV)}$ max.				9.0	A
Reverse emitter-base voltage					
V_{EB} max. ($I_C = 0A$)				-40	V
Base current					
I_{BM} max.				2.0	A
$\dagger I_{B(AV)}$ max.				1.0	A
Total Dissipation at $T_{case} \leq 45^\circ C$					30 W

$$T_{case} > 45^\circ C \quad P_{tot} \max. = \frac{T_j \max - T_{case}}{\theta_j - case}$$

\dagger Averaged over any 20ms period.

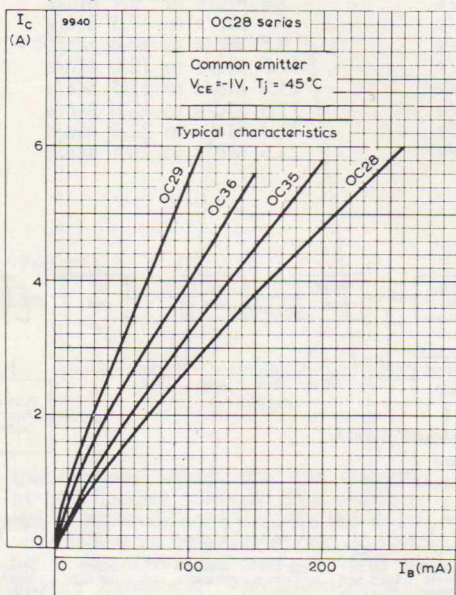

TRANSFER AND INPUT CHARACTERISTICS. COMMON EMITTER

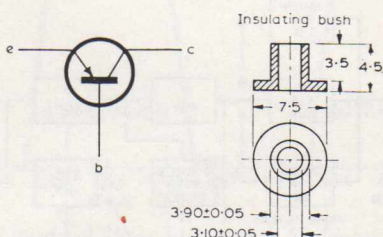
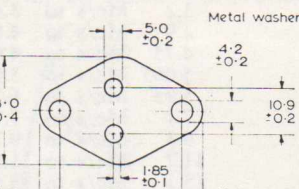
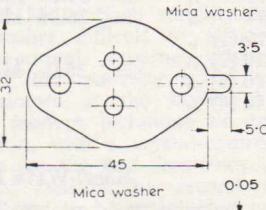
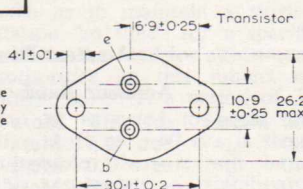
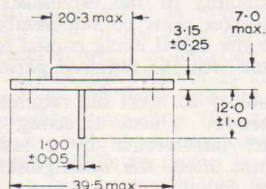

All dimensions in mm

OUTLINES AND DIMENSIONS
TRANSISTOR TYPES
OC28, OC29, OC35 and OC36

Temperature ratings

T_{sig} max.	75	$^\circ C$
T_{sig} min.	-55	$^\circ C$
T_j max. (Continuous operation)	90	$^\circ C$
$\dagger T_j$ max. (Intermittent operation total duration 200 hours)	100	$^\circ C$
θ_j case max.	1.5	$^\circ C/W$
$\theta_{case-heat sink}$ max. (when mounted with metal washer 0.127mm thick and with mica washer)	0.5	$^\circ C/W$

\dagger Likelihood of full performance of a circuit at this temperature is also dependent on the type of application.

CHARACTERISTICS at $T_{case} = 25^\circ C$

Common base	I_{CBO}	Typical production spread
		Min. Typ. Max.
Collector leakage current ($V_{CB} = -500mV, I_E = 0mA$)		— — 100 μA
($V_{CB} = -14V, I_E = 0mA, T_{case} = 100^\circ C$)		— — 20 mA
($V_{CB} = -60V, I_E = 0mA, T_{case} = 100^\circ C$)	OC29, OC35	— 8.5 30 mA
($V_{CB} = -80V, I_E = 0mA, T_{case} = 100^\circ C$)	OC28, OC36	— 12 30 mA
Emitter cut-off voltage ($V_{CB} = -48V, I_E = 0mA, T_{case} = 100^\circ C$)	V_{EB}	— — -500 mV
Common emitter		
Collector knee voltage at $I_C = 6A$ (see Fig. 1)	$V_{C(knee)}$	— -0.5 -1.0 V

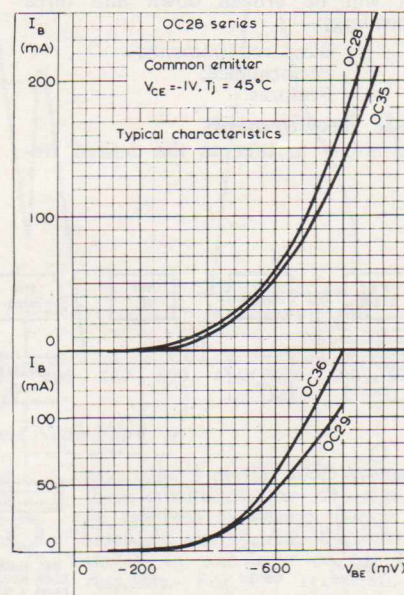
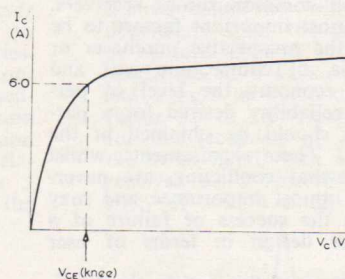

TRANSFER AND INPUT CHARACTERISTICS. COMMON EMITTER

THE MODERN COMMUNICATION RECEIVER

A SUGGESTED USER SPECIFICATION

The need by the newly independent countries of the world for space in the radio frequency spectrum for communications, together with the increasing demands of existing services, has led to greater congestion in the high frequency communications bands. In the absence of revolutionary techniques which will allow of extremely narrow voice communication channels, the present answer to this spectrum space problem lies in carrying out improvements in the design of new communications equipment.

With this in mind we shall attempt to arrive at a specification for a receiver, which we feel is truly representative of modern thought in the communication field. Such a specification would, of course, need to be somewhat comprehensive in order to facilitate the translation of the written specification into the production of an actual receiver and we do not intend to progress to this stage at the present time.

Diversity reception will not be considered, as this article is not intended to refer to remote receiving facilities but only to cases where a single receiver is in use under the direct control of an operator.

The detailed specifications of a communications receiver must, of necessity, depend upon the service required and therefore the material to follow must be considered applicable to all communications receivers.

One of the most important factors to be considered by the prospective purchaser or manufacturer is, of course, the cost and for maximum economy the level of performance and reliability desired for a particular service, should be obtained at the minimum cost. These requirements, whilst obviously somewhat conflicting, are nevertheless of the utmost importance and may well determine the success or failure of a specific receiver design in terms of user acceptance.

For the purpose of this article the specification will be broken down into three main headings:—

- (1) Basic requirements;
- (2) Performance;
- (3) Features.

1. Basic Requirements

(a) The ability to tune to the desired frequency,

amplify the wanted signal to a level at which detection can be accomplished thus enabling the information to be extracted.

- (b) Ease of tuning must be provided for by means of a slow tuning rate and adequate bandsread together with a high degree of mechanical stability and reset accuracy.
- (c) The stability of the oscillators used in the receiver must be sufficiently high to enable the signal being copied to be held "in tune" for the required period.
- (d) The ability to meet the requirements of (a) above, whilst rejecting adjacent channel interference to a level which does not affect the intelligibility of the wanted signal.

2. Performance

(a) **Tuning Range**

For a general coverage receiver, say 2 Mc/s to 30 Mc/s, to meet the band-spread conditions laid down under the heading of basic requirements, some 28 bands, of 1 Mc/s each, may be necessary. However, where a receiver is required to cover a smaller section of the 2 Mc/s to 30 Mc/s portion of the radio frequency spectrum, the mechanical bandsread, for a given gear reduction, may be doubled by tuning a range of 500 kc/s on each band.

Examples of this technique are shown in two receivers designed to tune amateur MF and HF bands, or short-wave broadcasting bands.

(Continued overleaf)

TABLE 1.
Amateur Band Receiver Tuning Ranges.

Amateur Band	Receiver Tuning Range
160 Metres	1.8 Mc/s to 1.86 Mc/s
80 "	3.5 Mc/s to 3.7 Mc/s
40 "	7.0 Mc/s to 7.15 Mc/s
20 "	14.0 Mc/s to 14.35 Mc/s
15 "	21.0 Mc/s to 21.45 Mc/s
11 "	26.96 Mc/s to 27.23 Mc/s
10 (1) "	28.0 Mc/s to 29.7 Mc/s
10 (2) "	
10 (3) "	
10 (4) "	
10 (5) "	
	1.5 Mc/s to 2.0 Mc/s
	3.5 Mc/s to 4.0 Mc/s
	7.0 Mc/s to 7.5 Mc/s
	14.0 Mc/s to 14.5 Mc/s
	21.0 Mc/s to 21.5 Mc/s
	26.9 Mc/s to 27.4 Mc/s
	28.0 Mc/s to 28.5 Mc/s
	28.5 Mc/s to 29.0 Mc/s
	29.0 Mc/s to 29.5 Mc/s
	29.5 Mc/s to 30.0 Mc/s

TABLE 2.
Short-Wave Broadcast Receiver Tuning Ranges.

Short-Wave Broadcasting Band	Receiver Tuning Range
2.3 Mc/s to 2.495 Mc/s	2.0 Mc/s to 2.5 Mc/s
3.2 Mc/s to 3.4 Mc/s	3.0 Mc/s to 3.5 Mc/s
3.9 Mc/s to 4.0 Mc/s	3.5 Mc/s to 4.0 Mc/s
4.75 Mc/s to 4.995 Mc/s	
5.005 Mc/s to 5.06 Mc/s	4.6 Mc/s to 5.1 Mc/s
5.95 Mc/s to 6.2 Mc/s	5.9 Mc/s to 6.4 Mc/s
7.1 Mc/s to 7.3 Mc/s	7.0 Mc/s to 7.5 Mc/s
9.5 Mc/s to 9.775 Mc/s	9.5 Mc/s to 10.0 Mc/s
11.7 Mc/s to 11.975 Mc/s	11.5 Mc/s to 12.0 Mc/s
15.1 Mc/s to 15.45 Mc/s	15.0 Mc/s to 15.5 Mc/s
17.7 Mc/s to 17.9 Mc/s	17.5 Mc/s to 18.0 Mc/s
21.45 Mc/s to 21.75 Mc/s	21.4 Mc/s to 21.9 Mc/s
25.6 Mc/s to 26.1 Mc/s	25.6 Mc/s to 26.1 Mc/s

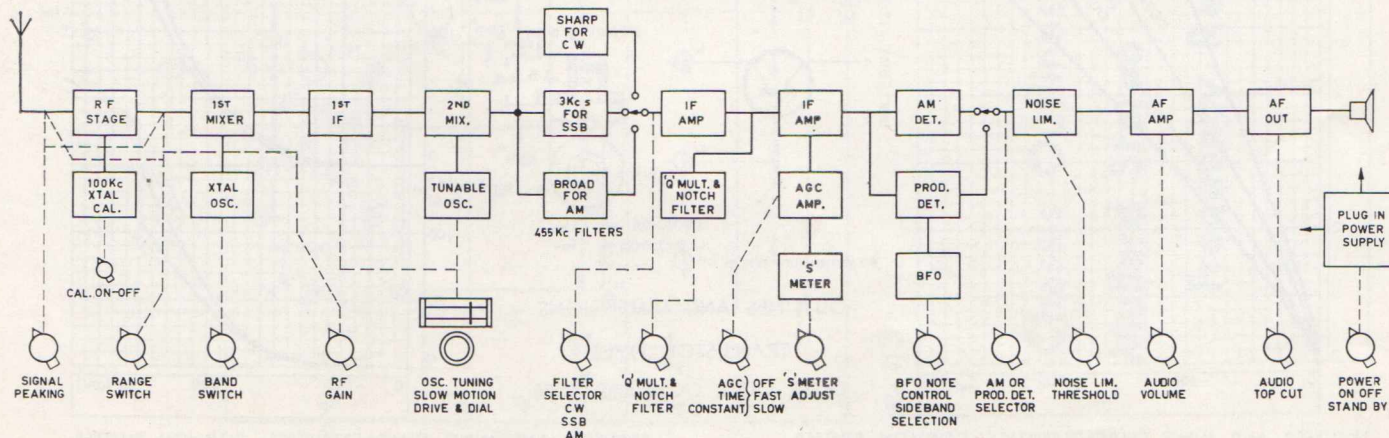

Typical High Quality (2 Mc/s to 30 Mc/s) Communications Receiver

This approach is quite practical and a communications receiver could be designed to have twelve ranges each 500 kc/s wide available, thus ensuring that any one service in the fixed/mobile bands could be adequately catered for, together with a selection of short wave broadcasting and other services. For instance, the small ships' radio communication service in the 2 Mc/s to 10 Mc/s section of the frequency spectrum could be covered by eight 500 kc/s bands, leaving four for other services.

(b) **Sensitivity**

For satisfactory communications, the received signal level must be of sufficient amplitude to over-ride the noise level at the output of the receiver. There must, therefore, exist a minimum usable field intensity which is dependent on the receiving antenna, the receiver bandwidth and noise figure, atmospheric noise, site noise in terms of man-made electrical interference and the quality of service required. Provided that the noise figure and cross-modulation characteristics of a receiver are such that the level of atmospheric noise over the desired frequency range under the quietest atmospheric conditions is the limiting factor, then under conditions, of greater atmospheric and/or man-made noise, reception cannot be improved by using a receiver of superior noise figure. Were it possible to produce an ideal receiver (noise free), then the only noise would be that due to thermal noise in the antenna system and a maximum signal-to-noise ratio would be achieved for the current atmospheric conditions. Where the receiver input circuit matches the antenna, a theoretical noise figure of 3dB is possible, however in practice, due to the limitations set by atmospheric etc., noise figures of up to 7dB may be acceptable. Examination of communication receiver

mission being received. In order to consistently obtain the sensitivity figures quoted above, an RF stage is essential, especially where a wide range of frequencies is to be covered. The RF stage should be designed to provide, in conjunction with the mixer, the desired noise figure and RF sensitivity. It should have very low cross-modulation characteristics over a wide range of input signal levels and provide the desired degree of image rejection.

(c) **Stability**

Stability is of three types—initial, short term and long term—and each will be considered separately.

(1) Initial stability is mainly governed by the drift in the local oscillator(s) of the receiver when switched on from cold. The service the receiver is called upon to provide will determine the minimum permissible time for the receiver to reach a stable operating condition and the author believes that a period of five minutes can be considered adequate.

(2) The short-term stability should be such as to maintain a single sideband station "in tune" for a specified period without the need for adjustment. Various authorities on this subject are apt to differ, however, a period of 30 minutes can be expected to prove satisfactory. If a drift of ± 90 c/s is the maximum allowable, then it will be seen that this represents a stability factor of 1 ppm/min at 3 Mc/s but 0.1 ppm/min at 30 Mc/s. Such stability figures may be rather difficult to achieve with a conventional superheterodyne receiver where the tendency is for stability to deteriorate at the higher frequencies. The modern technique of double conversion, with a crystal-controlled oscillator for the first frequency conversion stage, enables the second conversion oscillator to be maintained at the relatively low frequency of, say 2 to 3 Mc/s for all bands, thus providing the

tioned in the previous sections, together with the addition of component ageing and calibration accuracy. A figure of 0.05% would be considered typical for a period of several months. The provision of a 100 kc/s crystal calibrator in a receiver will do much to nullify the effects of both short-term and long-term frequency errors and, indeed, this facility would be expected in a modern high quality receiver.

(d) **Selectivity IF Amplification and Spurious Responses**

Since it is impractical to provide all of the selectivity ahead of the first amplifier, careful selection of the frequencies used in the crystal oscillator, first IF, variable frequency oscillator and second IF, is necessary to avoid spurious responses.

The generally accepted standard of 455 kc/s may be used for the second IF, thus making provision for the use of a mechanical filter, one of the relatively modern methods of obtaining selectivity in the IF channel.

Spurious responses, that is, interfering signals from harmonics of oscillators in the receiver, should ideally be more than 60dB down on the desired signal level at the detector; however, whether this can always be achieved in practice is rather doubtful, therefore some authorities quote a figure equivalent to 0.25 μ V across the antenna terminals as being the maximum level to be tolerated. The desired selectivity will, of course, be dependent upon the nature of signals to be received and a receiver having a bandwidth of 6 kc/s at the 6dB points and 9 kc/s at the 60dB points, (shape factor 1.5 to 1.0) would be satisfactory for the reception of AM signals. On the other hand, such a signal could be received on a receiver having a selectivity of 3 kc/s at the 6dB points and,

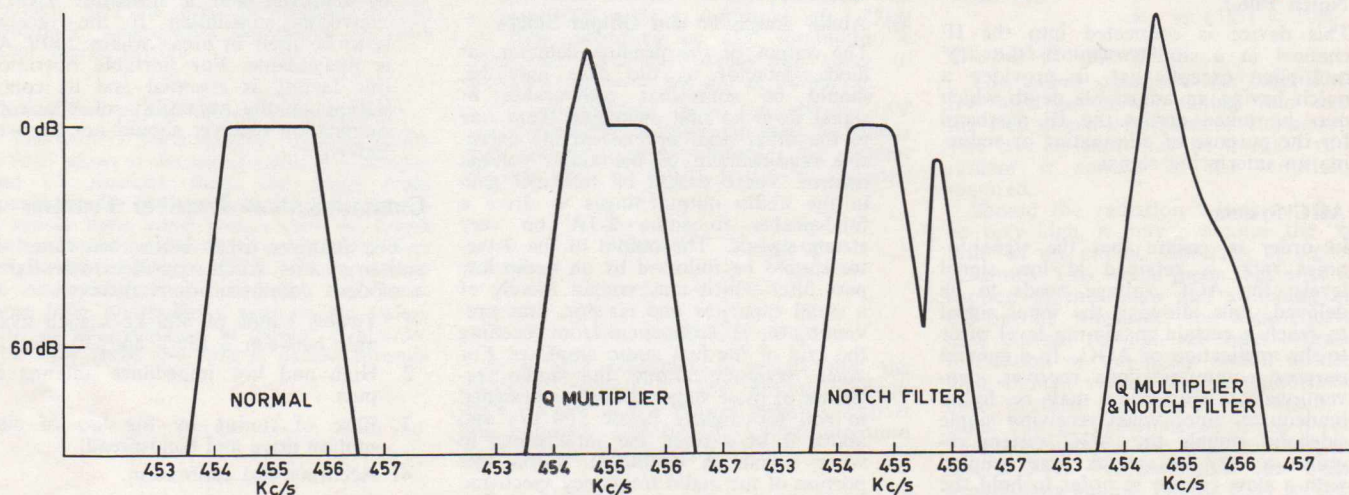

Modification to IF Passband Shape by Use of Q Multiplier and Notch Filter

specifications reveals that the majority of high quality receivers offer sensitivities of better than 1 μ V across the aerial terminals at an input impedance of 50 Ω , for a signal-to-noise ratio of 10dB at 3 kc/s bandwidth. The effective sensitivity of a receiver may be increased by reducing the bandwidth to such limits as may be imposed by the type of trans-

desired increase in stability factor at the higher frequencies. Apart from mechanical considerations the tunable oscillator circuit constants must be tolerant of the variable factors of ambient temperature and line voltage which calls for some sophistication in circuit design.

(3) Under long-term stability the factors to be considered are those already men-

say, 6 kc/s at the 60dB points. Under these conditions, the AM signal would be received as though it was a single sideband signal with the carrier positioned to one side of the band-pass response. For CW reception, a bandwidth of 1 kc/s at 6dB and 2 kc/s at 60dB may be considered typical. It would, therefore, seem logical that a

general purpose receiver would require three different selectivities available to the operator from the receiver front panel. Another form of spurious response that should be considered under this heading is that due to cross-modulation. For instance, when a receiver is tuned to a weak signal and a high amplitude signal is present outside the passband of the intermediate frequency filter, it is possible for the RF amplifier and/or mixer to be driven into a non-linear operating condition which may result in weak signals being modulated by the unwanted signal. The effect of cross-modulation may be minimised by the use of an RF amplifier valve having a long grid base and the ability to retain its linearity under the influence of strong signals. The filter should be placed ahead of the IF amplifier stage, where the signal level is too low to cause overloading and consequent loss of filter characteristics. Sufficient gain is required in the IF stages to increase the signal level to a figure sufficiently high for detection. The valves used in the IF amplifiers should be of the variable μ type, suitable for the application of AGC.

(f) "Q" Multiplier

Further modification of the IF passband may be achieved by the use of a "Q" multiplier and/or "Notch Filter". The "Q" multiplier consists of a regenerative circuit connected in parallel with the IF transformer, following the filter amplifier. It is capable of superimposing a highly selective peak on the IF passband and may be found useful in peaking a CW signal for improved reception. The ability to tune the peak across the passband, together with an amplitude adjustment, should be available to the operator.

(g) Notch Filter

This device is connected into the IF channel in a similar way to the "Q" multiplier except that it provides a notch having an adjustable depth which may be tuned across the IF passband for the purpose of eliminating or reducing an interfering signal.

(h) AGC System

In order to ensure that the signal-to-noise ratio is retained at low signal levels, the AGC voltage needs to be delayed, thus allowing the input signal to reach a certain maximum level prior to the application of AGC. In a general purpose communications receiver, conventional AGC systems may be found inadequate, since when receiving single sideband signals the AGC system requires a very fast attack time coupled with a slow release in order to hold the receiver gain at a certain level during pauses between words whilst receiving a single sideband signal, since there is no carrier to provide an average DC level. Some AGC systems are designed to operate from the audio stage of the receiver and whilst in general these appear to be fairly satisfactory, the audio gain control cannot be inserted between the detector and first audio stage or it will affect the AGC level. Therefore the writer believes that the AGC should be ob-

tained from the modulation envelope per medium of a separate AGC amplifier and rectifier.

(i) Signal Detection

For reception of single sideband signals, the product detector is generally considered to be superior to the diode detector since it minimises inter-modulation distortion products present in the audio output signal and, furthermore, does not require a large local carrier voltage. The product detector would, therefore, be used when receiving single sideband, double sideband and CW signals but for AM it may be preferable to use the standard diode detector, especially where some drift may occur in the frequency of the received signal. It should be remembered that although we are trying to set a receiver specification in terms of an ideal performance, this does not necessarily mean that the stability or quality of the signals to be received will always be compatible with the quality of the receiver and it is most annoying when receiving an AM signal which is drifting to have to be continually resetting the beat frequency oscillator, as would be the case should the product detector be used for reception of all signals. Furthermore, unless the AM signal is being received as a SSB signal with one sideband removed by the IF filter, considerable phase distortion can result when using the product detector. The beat frequency oscillator may be either crystal-controlled or continuously variable, either method being quite satisfactory, provided that in the case of the variable frequency oscillator, adequate stability exists. Sideband selection should be available from the front panel which may require special consideration being given to the design of BFO and tunable 2nd oscillator circuits to avoid the need for retuning when switching sidebands.

(j) Audio Amplifier and Output Stages

The output of the product detector, or diode detector as the case may be, should be somewhat comparable in signal level so that switching from one to the other does not necessitate extensive readjustment of the audio volume control. There should be sufficient gain in the audio output stages to drive a loudspeaker to some 2-3W on very strong signals. The output of the detector should be followed by an audio low pass filter which may consist merely of a small capacitor and resistor, thus preventing the IF component from reaching the grid of the first audio amplifier. For voice communications the audio response of these stages should be designed to roll off slightly below 300 c/s and above 3 kc/s since the intelligence in voice signals is contained within this portion of the audio frequency spectrum. The inclusion of a noise limiter is essential and this should be effective on all types of signals, CW, SSB, AM and so on. For some applications a squelch (device to attenuate output of receiver when no signal being received), may also be found desirable, however it is felt that for a receiver such as this, which is intended to be supervised by an operator, the squelch may not be important. The provision of suitably attenuated outputs for both low and high

impedance headphones, together with a loudspeaker is essential, as is some form of receiver muting at periods when an associated transmitter may be switched on.

(k) Signal Strength Meter

Whilst this item may be considered an accessory, provision should be made for inclusion of the device on the front panel, so that it may be an integral part of the receiver itself. The author believes that the vacuum tube voltmeter "S" meter circuit, whilst being somewhat more expensive than other methods, has much to offer in that it provides adequate ease of adjustment and calibration. The subject of "S" meter calibration is quite controversial, although it would appear that nowadays it is generally accepted that an S9 signal represents a signal 54dB above the receiver noise level. It will readily be seen that an "S" meter reading means nothing unless the receiver sensitivity is quoted at the same time. Each "S" point represents 6dB in this case, and of course, signals above S9 may be quoted in decibels. Thus, a signal level of 30dB over S9 means in effect that the signal is 84dB above the receiver noise level. This, of course, implies that the receiver signal-to-noise ratio and sensitivity should be the same at all points throughout the frequency range of the receiver. This is most unlikely and some means of calibrating the "S" meter will have to be provided if accuracy in reporting received signal levels is desired. The "S" meter, therefore, becomes an accessory, for signal strength comparisons and perhaps an aid to receiver tuning.

(l) Power Supply

The use of silicon rectifiers will contribute to a reduction in the size of the power supply, which we believe should be built as a plug-in unit. The unit may be removed and a transistor DC-DC converter substituted if the receiver is to be used in areas where 240V AC is unavailable. For portable operation, this facility is essential and its contribution to the versatility of the communication receiver should not be overlooked.

Communication Receiver Features

The features listed below are those the author of this article considers essential in a modern communications receiver.

1. Twelve bands of 500 kc/s each available between 2 Mc/s and 30 Mc/s.
2. High and low impedance antenna inputs.
3. Ease of tuning by the use of slow motion drive and bandspread.
4. Accurate dial calibration.
5. 100 kc/s crystal calibration and calibration control.
6. RF stage and separate gain control.
7. Double conversion with relatively high frequency tunable first IF.
8. Crystal-controlled first conversion oscillator.
9. Various degrees of selectivity available from front panel.

(Continued on page 36)

INFRA-RED BURGLAR ALARM

USING OCP71 PHOTOTRISTOR

The burglar alarm circuit described is operated by an intruder breaking an invisible beam in the near infra-red region. The receiver comprises an optical lens and two DC-coupled transistors operating a relay. The infra-red radiation may be obtained from an under-run car headlamp bulb in conjunction with an infra-red filter*. The system operates satisfactorily over a temperature range from 0-40°C.

When the infra-red source is off, Tr2 bottoms because of base current through the resistor R_c . The emitter of Tr1 is held a few volts negative to earth by the potential divider action of the relay and the emitter resistor R_e , and the base-emitter diode of the phototransistor Tr1 will be cut off by this voltage. The radiation focused on the phototransistor will not normally produce a large enough voltage at the base to overcome this value, but the depression of the spring-loaded RESET switch momentarily interrupts the relay current, and the voltage across the emitter resistor falls to zero. If the radiation is now focused on the OCP71 it is sufficient to bottom it, thus absorbing the current which had been flowing in the base of the BCZ11. This is a stable state because the bottoming voltage of the OCP71 is lower than the minimum BCZ11 base-emitter voltage necessary for conduction.

Immediately the beam is interrupted, however, the photo-current collapses and the OCP71 can no longer remain bottomed. The increased base-emitter voltage of the BCZ11 causes this transistor to switch on and thus to operate the relay. The OCP71 cannot switch on again, because of the large reverse bias developed by the relay current at its emitter, as previously described.

The switching time of the transistors is likely to be of the order of a few microseconds, therefore any interruption of the beam for a period longer than this will cause operation of the relay. The relay contacts may be used to operate a bell, automatic announcing equipment or any other alarm system.

Typical Source and Optical Arrangements

The OCP71 has a spectral response which is 80% down at the wavelengths 0.5 microns and 1.7 microns. Since the range from approximately 0.4 microns to 0.8 microns is visible light, some source must be found with an output which has no shorter wavelength than 1 micron. Such an output may be obtained from an ordinary car headlamp bulb, which has a peak output (when run at full voltage) at about 1 micron. The light from the bulb is passed through

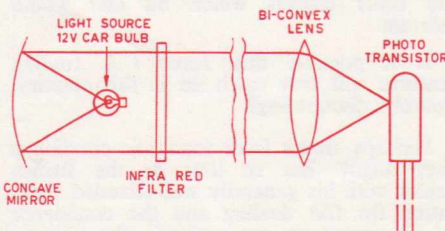

an infra-red filter* which transmits wavelengths longer than 1 micron and suppresses shorter wavelengths. In the experimental layout, a concave mirror was placed behind the lamp.

At the receiver a simple bi-convex lens focuses the available radiation on to the OCP71.

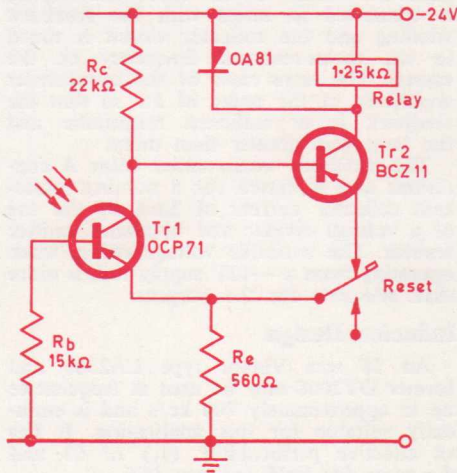

Fig. 1. Burglar alarm circuit.

Circuit Design

It was considered that the temperature range of 0° to 40°C was sufficient and a tolerance in supply voltage from 23V to 25V was taken into account.

The relay chosen for the prototype was a type 3000 with a resistance of 1.25kΩ ± 10% operating at 15V minimum. A diode is connected across the relay to limit the collector voltage at switch-off.

To ensure that there are always 15V across the relay at minimum relay resistance and minimum supply voltage, the emitter resistor may be found from the equation

$$\frac{15V}{1125\Omega} = \frac{8V}{R_c(\max)}$$

where

$$R_c(\max) = 600\Omega$$

and

$$R_e = 560\Omega \pm 5\%$$

It is also necessary to ensure that the collector resistor R_c will provide enough base current to the second stage to support the collector current I_{c2} . Using minimum voltage and maximum current

$$I_{c2} = \frac{23}{1125 + 532} = 13.9mA$$

The maximum value of R_c may be calculated, using the same value of R_e . Thus

$$23 = \frac{I_{c2}R_c(\max)}{a'_{min}} + V_{be}(\max) + I_{c2}R_e$$

$$= \frac{13.9mA \cdot R_c(\max)}{25 + (13.9mA \times 532\Omega)} + 0.82V$$

where

$$R_c(\max) = 26.6k\Omega$$

and

$$R_c = 22k\Omega \pm 10\%$$

These values give a minimum current in the first stage of

$$\frac{23}{24.2 + 0.532} = 0.93mA$$

In order that the first stage will not be bottomed by I_{c0} flowing when the beam is interrupted, the base resistor must not cause the base voltage to exceed that of the emitter plus V_{be} .

Now

$$V_{be}(\min) = 0.93mA \times 532\Omega = 0.5V$$

and V_{be} at maximum temperature is approximately 50mV minimum. Therefore

$$V_b < 0.55V.$$

Since, if the first stage comes out of bottoming, a cumulative switching action will occur, up to the minimum base current may be allowed to flow and the circuit will still function satisfactorily. This value may be subtracted from the I_{c0} maximum value, therefore

$$I_{c0}(\max) - \frac{I_{c0}(\min)}{a'_{max}} R_b(\max) \approx 0.55V$$

That is,

$$R_b(\max) = \frac{0.55V}{33.4\mu A} = 16.5k\Omega$$

Therefore

$$R_b = 15k\Omega \pm 10\%$$

Practical Configuration

The circuit described has been designed for high sensitivity, taking into account the full spread of transistor characteristics. The base resistor may be a 15kΩ variable resistor if control of the sensitivity is required.

Should the radiation falling on the cell be very high, it may overcome the "backlash" of the circuit, especially at high temperatures. This would mean that after interruption of the beam and switching on of the second transistor, the high equivalent base current through the base resistor on restoration of the beam would produce a high enough voltage at the phototransistor base to turn the OCP71 on again. This effect can be overcome by using a further 'make' contact on the relay to short-circuit the BCZ11. Provided that the beam is broken long enough for the relay to operate, the circuit will lock in the 'operated' position.

Should the incident radiation be just sufficient at normal temperature, it may be insufficient to hold the OCP71 bottomed when I_{c0} falls at low temperature. The minimum radiation required at room temperature should, therefore, be increased by 20 or 25% to ensure operation at low temperatures.

(Continued on page 36)

THE MODERN COMMUNICATION RECEIVER

(Continued from page 34)

10. Choice of AM or product detector.
11. Sideband selection without adjusting main tuning.
12. Amplified AGC and choice of AGC time constants from front panel.
13. "Q" multiplier and/or Notch Filter.
14. Separate BFO switch.
15. Noise limiter, effective on CW, AM, SSB, etc.
16. "S" meter.
17. Audio volume and top cut control.
18. Power "on-off-standby" switch on front panel.
19. Provision for loudspeaker and headphones.
20. Plug-in 240V AC or 12V DC Power Supply.
21. Protection for RF input circuit during transmission.

Conclusion

No doubt there are available many communication receivers capable of satisfying this example of a user specification which has been prepared in an effort to clarify much of the confusion which may arise when comparing receiver specifications. By comparing the specification of a particular receiver under review, with a user specification, selection may be made easier and the decision to purchase a particular receiver type or model is more likely to be the correct one. It, therefore, behoves the prospective purchaser to write a user specification applicable to the individual situation prior to investigation of receiver suppliers' specifications and equipment.

B. P. A. BERESFORD

INFRA-RED BURGLAR ALARM

(Continued from Page 35)

Performance

Simple tests have been made on a prototype alarm circuit, using an under-run 12V 36W car bulb (with an infra-red filter*) as the source. Details of these tests are given below.

1. With a throw of three feet the lamp required about 4.5V for correct operation.
2. With a throw of about 25 feet the lamp required 11V for correct operation.

For test purposes the phototransistor Tr1 was selected for high limit I_c , and the silicon transistor Tr2 was selected for low limit α .

Operation throughout the required temperature range was satisfactory; and, in practice, operation from below 0°C to greater than 50°C was found to be possible.

*A suitable filter is the Kodak Wratten type 88A.

This article is based on a report prepared by J. A. Everist of the Mullard Semiconductor Measurement and Application Laboratory.

CRYSTAL CONTROLLED TRANSISTOR BFO

We were recently requested to provide a circuit for a low frequency crystal controlled oscillator for use as a BFO at 455 kc/s in a small communications receiver. The design was based on an article featuring a 500 kc/s transmitter which was described in Mullard Outlook, Volume 3, Number 1. The results obtained were more than satisfactory and the details are presented herein for those readers who may have similar requirements.

The circuit uses a tuned collector, feedback being obtained by transformer coupling from the parallel-tuned circuit in the collector circuit to the base. The crystal is connected in series with the feedback winding and the collector circuit is tuned to the series-resonant frequency of the crystal. The turns ratio of the transformer should be of the order of 3:1 so that the feedback is of sufficient magnitude and the loop gain greater than unity.

The oscillator works under Class A conditions and is biased for a nominal quiescent collector current of 2mA by the use of a voltage divider and by-passed emitter resistor. The available voltage swing, when operating from a -12V supply rail, is more than adequate for the purpose.

Inductor Design

An 18 mm Vinkor type LA2509 and former DT2008 may be used at frequencies up to approximately 700 kc/s and is eminently suitable for this application. It has an effective permeability (μ_e) of 63 and the turns for $1mH$ (α) are 83.6.

Assuming a feedback winding of 6 turns, the collector winding becomes $6 \times 3 = 18$ turns. Since 18 turns on an LA2509 represents an inductance of 46.4 μH , which requires a capacitor of 2630pF to resonate at 455 kc/s, a more practical approach may be to use a tuning capacitor of, say, 680pF ($\pm 5\%$) which requires an inductance of 180 μH to resonate at this frequency and results in a greater degree of inductance adjustment by the tuning slug to allow for compensation of transistor output and circuit capacitance.

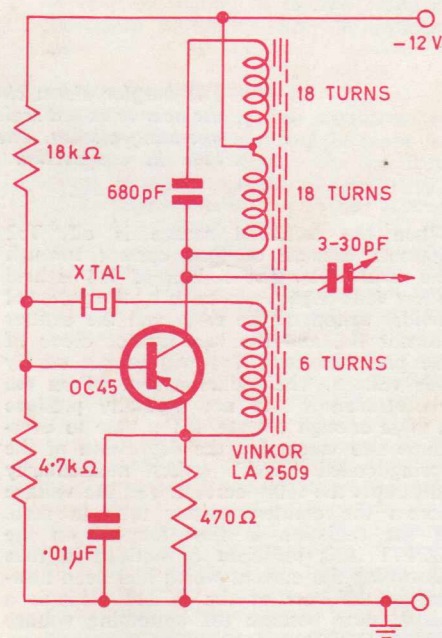

Turns required for an inductance of 180 μH on LA2509:—

$$N = 83.6 \sqrt{L(mH)} = 83.6 \times \sqrt{0.18} = 36 \text{ approx.}$$

This gives an inductor of 36 turns tapped at 18, plus 6 turns feedback.

Reference to winding data for LA2509 shows that 78 turns of 28 s.w.g. en. cu. may be accommodated on a single-section DT2008 former, thus leaving adequate space to insulate the collector and base windings from each other.

Should the circuit fail to oscillate, reverse the connections to the feedback winding and readjust the Vinkor slug. The injection level may be adjusted by the air trimmer coupling capacitor.

VIEWPOINT WITH MULLARD

(Continued from page 27)

The free gifts offered by manufacturers, ranging from garden seats to golf balls . . .

The 'early American' designs of TV cabinets . . .

The absence of direct-current electricity supplies . . .

The poor sale of transistor portables and the reluctance of service men to handle them . . .

The wonderful range of instruments of all types and the equally impressive choice of workshop furniture and gadgets . . .

The good quality technical magazines with their coloured circuit diagrams complete with oscillograms . . .

The technical slant of consumer advertising. Phrases like *Golden Throat Sound*, *Fin-Cooled Mains Transformer*, and *20,000 Volts of Picture Power* are slogans that stick in the mind . . .

The absence of rental or second-hand sets . . .

The freedom of sellers to strike their own bargains and arrange their own 'buying-on-time' (HP) contracts with buyers . . .

Different Set-up

It would not be easy to answer the question: Can America teach us anything about the radio business? They operate according to a vastly different set-up, in different circumstances and—though it's hard to appreciate at the present time—against enormously fiercer competition. There are features of their *modus operandi* which would be very acceptable here. There are other aspects which no one would tolerate.

Is it possible that some U.S. trading features will ever catch on in this country, notably discounting?

Perhaps, under freer economic conditions they might. But so long as the British dealer with his generally well-founded reputation for fair dealing and the confidence of his customers can maintain the kind of service—in its broadest sense—that the public have come to expect, we can live with any changes that might come about. Certainly the imagination that is so much a part of the American pattern could be found a useful job to do here.