

PHILCO

TECHREP DIVISION BULLETIN



MARCH
1952

**Bonus Payment
for
BULLETIN Articles**

Effective with this issue, each contributor of a BULLETIN article will be paid a bonus of \$25.00 for each article accepted for publication. The minimum length of article for which this payment will be made has been placed at 500 words. (Items shorter than 500 words are ordinarily considered as fillers.)

It is emphasized that these bonuses are not intended as payment for articles, since the credit and recognition received by the author of a BULLETIN article are considered to be adequate compensation for the time and effort involved. However, since BULLETIN contributions are completely voluntary, and since they do require initiative, Philco wishes to thus express its appreciation to those who *do* contribute to the continued success of the magazine. This policy applies, of course, to non-Philco contributors as well as to our own personnel.

PHILCO TECHREP DIVISION BULLETIN

Published Monthly by
The TechRep Division of Philco Corporation
Philadelphia, Pennsylvania

Volume II

MARCH, 1952

Number 3

CONTENTS

Editorial	2
<i>By John E. Remich</i>	
Philco Training Materials.....	3
<i>By Joseph R. Lewis</i>	
Trigger Device for Line Checking SCR-695	11
A Dynamotor Test Stand.....	12
<i>By G. R. Petsche</i>	
Increasing Field Excitation of D-C Generators... ..	14
A Quick Method for Determining the Phasing of Power Transformers.....	15
<i>By David Scheff</i>	
In Coming Issues.....	16
Book Reviews.....	17
Aid to Circuit Tracing.....	18
LORAC—What It Is and How It Works.....	19
<i>By Edward J. Crossland</i>	
What's Your Answer?.....	26
Solution to Last Month's "What's Your Answer?"	26
Popular Misconceptions.....	27
A Practical Use for January's "What's Your Answer?" Circuit.....	Inside Back Cover

Editor
John E. Remich

Managing Editor
Robert L. Gish

Technical Editors
Frederick S. Mohr
Francis R. Sherman
Gail W. Woodward

**EDITORIAL OFFICE:
PHILCO CORPORATION
TECHREP DIVISION
22nd and LEHIGH AVENUE
PHILADELPHIA 32, PA.**

If any information contained herein conflicts with a technical order, manual, or other official publication of the U.S. Armed Forces, the information in the official publication should be used.

Editorial

New Training-Article Series

by John E. Remich
Manager, Technical Department

In this issue of the Bulletin we are publishing the first of a series of articles covering the Philco Standardized Training Program. The articles will be of particular interest to our readers as almost all have training problems. The program represents "team effort," since it incorporates the combined ideas of Philco men in the field as well as Headquarters personnel. Many of our readers will recognize their contribution to the overall program.

After a study of existing training courses on basic electronics, it became apparent that there was a need for the development of more effective electronic training material. The use of obsolete electronic equipment as a training aid resulted in a poor tie-in between lecture and laboratory. This article stresses the use of newly developed electronic training material.

The effectiveness of this approach to basic electronic training has been amply proven by the success of hundreds of graduates over a period of several years.



PHILCO TRAINING MATERIALS

By Joseph R. Lewis
Director of Training, TechRep Division

A general discussion of the Philco training-materials program, with data on applications, construction, special features, and development trends.

(Editor's Note: As the Philco training program expands, and as more new training equipment reaches the field, we are receiving an ever increasing number of requests for data on new developments. Since the program involves such a large volume of material, we find it impractical to attempt a "one-shot" coverage of the subject. Therefore, this represents the first in a series of articles embracing the entire field of electronics training.)

WE OF PHILCO became involved in electronics training through the world-wide activities of our field engineers, who are assigned to Army, Navy, Air Force, and industrial establishments. One of the primary duties of the field engineer is to provide formal and on-the-job training for military or civilian personnel. During the past ten years, we have been actively seeking better ways to provide the most effective training in the field of electronics. The training materials described in this article represent the culmination of those years of experimenting, testing, revising, and improving.

DEMONSTRATION UNITS

Our approach to the training problem has been to break down complex electronic equipment into a number of basic circuits. We have built each of these circuits in the form of demonstration units, such as are shown in figure 1. Each circuit is completely operational, either as an individual unit or when combined with other circuits with which it is normally associated. This feature is of basic importance in our training approach.

In order to simplify training problems, we have found it extremely de-

sirable to be able to teach only one circuit at a time. There are two reasons for this approach.

First, the student is never confused by being asked, in an early stage of his training, to understand a complex group of circuits, or to mentally eliminate from consideration all of a complex equipment except one small portion on which he is expected to concentrate.

Second, the student's interest is captured and held by allowing him to apply each bit of knowledge, as he acquires it, to a common practical use.

To illustrate, let us follow through on just how we use the group of units shown in figure 1. We start out with the simple power-supply circuit shown in figure 2. None of the other units is mounted on the rack. The instructor then proceeds with his explanation of the power-supply circuit. During his lecture, he demonstrates all of the operational features of the circuit. This is easy for him to do because all of the important circuit components are instantly removable and replaceable. As a part of his lecture, he can demonstrate the effect of larger or smaller values of capacitance or resistance, and even the effect of defective components, upon the operation of the circuit. In short, he can show any features of the circuit about which he is telling the student. Besides letting the student actually see what happens, the saving in time and effort for the instructor is appreciable. He doesn't have to draw a diagram because the diagram is there in plain sight, imprinted into the demonstra-

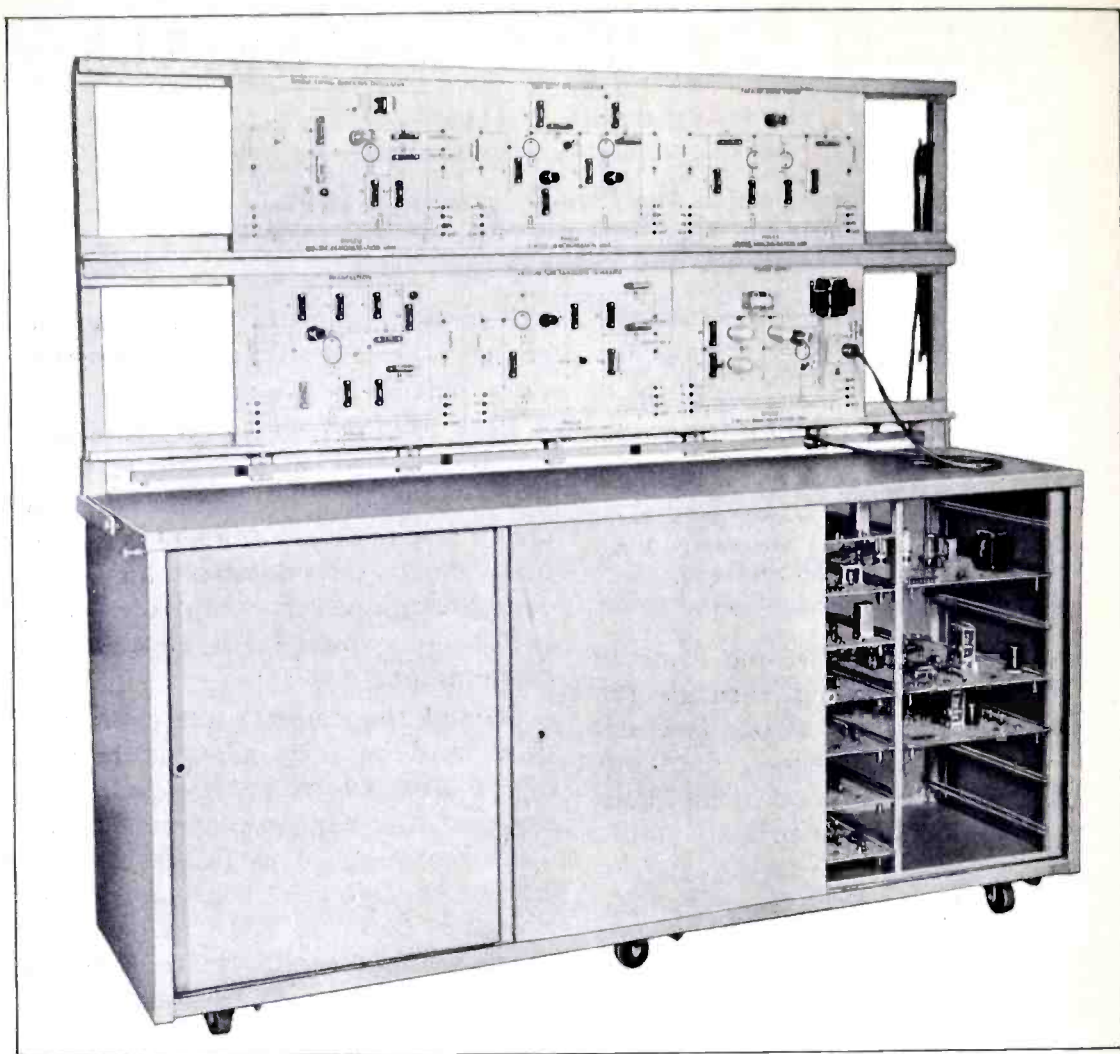

Figure 1. Demonstration Console, Showing Six Circuits in Position on the Rack

tion unit itself. If he wants to add voltages, waveforms, component values, or any other pertinent information about the circuit, he can do so by writing on the special baked-enamel surface, with ordinary grease pencil. These markings can be easily wiped off when the lecture is over.

As can be seen, the physical components of the circuit are all located adjacent to the symbols on the circuit diagram. This association of components with symbols is a bonus feature which assists the student's learning processes. Furthermore, there are no hidden elements on the back of the board to confuse the student, and the rugged construction of the units in-

dures against waste of class time due to trouble in the demonstration equipment.

When the instructor has finished his explanation of this first circuit, the power supply, the student has acquired a unit of knowledge, and a *practical use* of this unit is pointed out to him to arouse his interest. For example, the power supply just explained can be compared to a battery charger, or to a d-c supply for electroplating. The student is now ready to add another unit of knowledge. In order to further secure his interest and enthusiasm, the progression of circuits is deliberately selected so that with each additional unit of

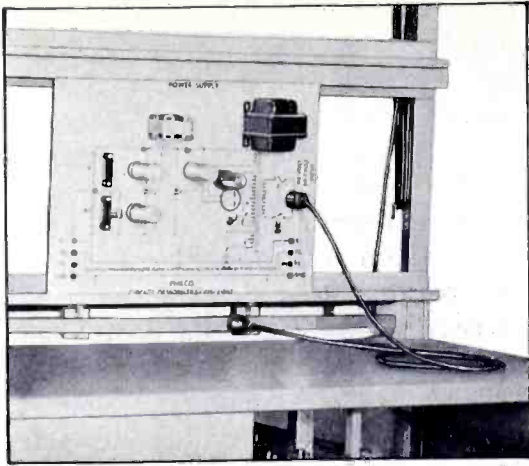

Figure 2. Power-Supply Demonstration Unit

knowledge the student acquires an understanding of a practical electronic device. Accordingly, we add an audio-voltage amplifier, combine it with the power supply, and we have in effect a small amplifier such as a hearing aid or a simple intercommunications amplifier. The student himself will usually recognize the limitations of this equipment, and lead himself into the study of the next logical step, the power amplifier. With the addition of this circuit, and after only a few days of schooling, he can picture himself as a "sound-systems" man with an understanding of public-address systems. This step-by-step approach always adds something useful to the man's knowledge. One of the greatest advantages of this approach to electronics training is the fact that the student never feels that he is being "snowed under" with a group of unassociated circuits which he must remember merely for the sake of remembering. In accordance with this step-by-step procedure, we add a detector to the a-f amplifier to make a very simple radio, add a tuned-amplifier stage to improve the radio, and eventually develop a complete superheterodyne receiver (figure 3), complex only in that it looks complex, since the student knows first hand that

it is merely a combination of very simple circuits, each of which he thoroughly understands.

As the student continues to learn individual circuits, we lose no opportunities to bring home to him the fact that many basic circuits are known by different names when they are doing different jobs. For example, when a student is studying the superheterodyne receiver, he learns how an oscillator works. (At that time it is part of the converter.) When he begins his study of transmitters, he runs into this same circuit under its more common name, "oscillator." However, it is still essentially the same circuit, and this point is brought forcefully to his attention. After he has brought three simple circuits together to make a simple c-w transmitter, he learns how easily his "PA system" (which he has most recently used as the audio section of his superheterodyne radio) can be adapted for use with his transmitter by two simple changes. First, we add a modulation transformer, and, second, we change the name. Here is one group of basic circuits doing three different jobs under three different aliases. It is no wonder then that our student soon adopts the very impor-

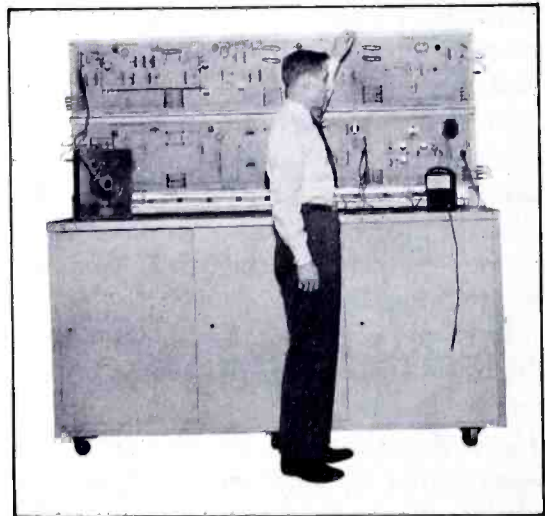

Figure 3. Complete Demonstration Superheterodyne Receiver, with Instructor Performing Alignment

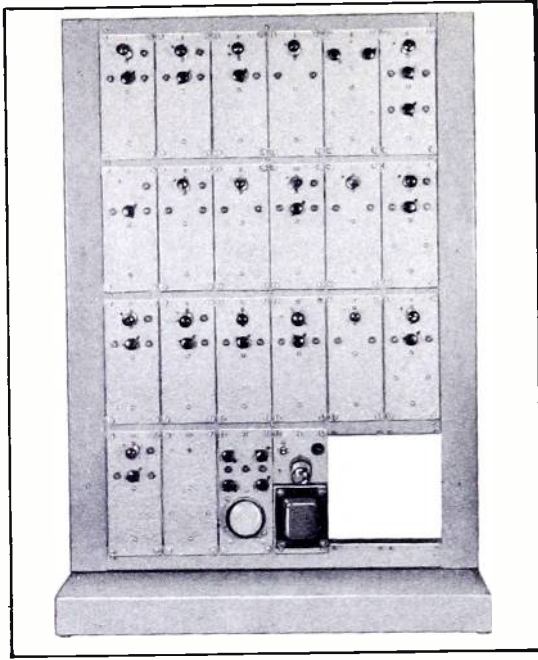

Figure 4. Laboratory Rack, Showing 22 Circuits in Position

tant attitude that no matter how big and complex the equipment may be, or what kind of a fancy name by which he may call it, it is merely a collection of basically simple circuits, any one of which he can master as an individual circuit, and, hence, any combination of which he can master as an equipment.

LABORATORY UNITS

As anyone knows who has ever tried to teach, it is not enough to merely *tell* a student certain information, or even to *tell* him *and show* him. If you really want the material to stick with the student, he must be given an opportunity to learn by doing. *Tell, show, and do* are the three important principles. Accordingly, then, we of Philco have devised sets of laboratory training materials (figure 4) paralleling the demonstration units, to enable the student to do, in the lab, all of the things which were shown to him and explained to him in the lecture room. These individual chassis incorporate all of the important features of the demonstra-

tion units. Figure 5 shows the power-supply chassis which is similar in use and circuitry to the demonstration unit shown in figure 2. Each chassis is an individual operational circuit; each chassis will operate properly when combined with those other circuits with which it is normally associated in operational equipment; and each chassis has its important components easily removable so that the student can study the equipment under all conditions of normal and abnormal operation. He can observe the effects of incorrect component values by merely substituting components.

All parts of the circuit are easily available for examination and connection to test equipment, and when the student has completed his study of the circuit under normal and experimental operating conditions, the instructor can insert a defective component (from a complete supply of troubleshooting components), and present the student with a troubleshooting problem which closely duplicates real "trouble on the gear." No longer is it necessary for the

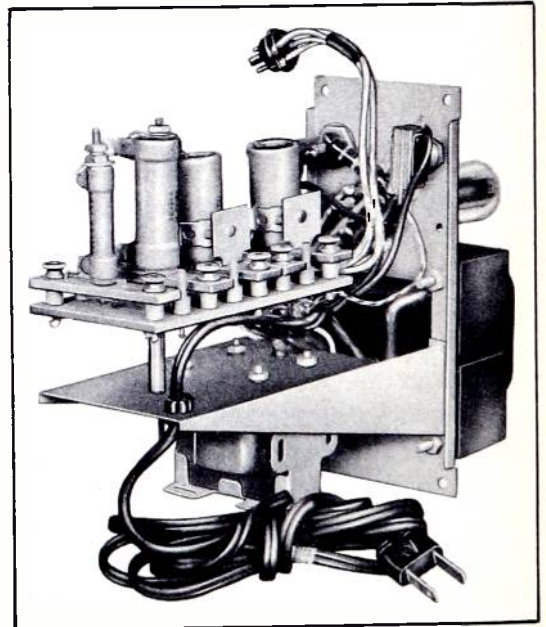

Figure 5. Rear View of Laboratory Power Supply, Showing Accessibility of Components

instructor to attempt to simulate trouble by surreptitiously clipping off wires, inserting bits of cellophane tape, cutting pins from tubes, or using any of the other well-worn dodges. Instead, the instructor can ask the student to turn his back for ten seconds, remove a good component, and replace it with a defective component. The student will be required to locate the trouble, using a logical, established, troubleshooting procedure. There will be no physical indication to give him a clue. For example, one of the components seen in figure 6 is defective — only the instructor *knows* which component is defective.

The reader has probably noted that on the demonstration units the removable components are plugged in, using banana jacks and banana plugs. The removable components of the students' chassis are attached by a knurled nut and screw arrangement. The reason for this is obvious to anyone who has taught beginners in any art. The laboratory chassis must stand the abuse which is normal to that level of training. To the beginner there is some fascination in exposed wire leads, etc., which seemingly must be twisted, bent, probed, and pulled until something gives. Accordingly, these lab chassis are made so that while the student will have complete liberty to adjust the circuit parameters, the components themselves are so ruggedly constructed, and the units so assembled, that maintenance problems are minimized. The demonstration units are designed for use by an experienced instructor who will give the equipment reasonable care, or at least will not deliberately abuse it. For this reason, we accept slightly less-rugged construction in order to obtain flexibility in interchangeability of parts.

SPECIAL FEATURES

There are a number of features of these training materials which are not immediately apparent, but which warrant mention. For example, an adaptor panel, shown in figure 7, permits the instructor to use circuits from the set of laboratory chassis in connection with the demonstration units. As you can see, the demonstration units themselves offer space for eight circuits on the rack. To enable the instructor to demonstrate more complex circuits, the adaptor panel is used, with the appropriate laboratory chassis taking the place of a circuit or group of circuits which have previously been ex-

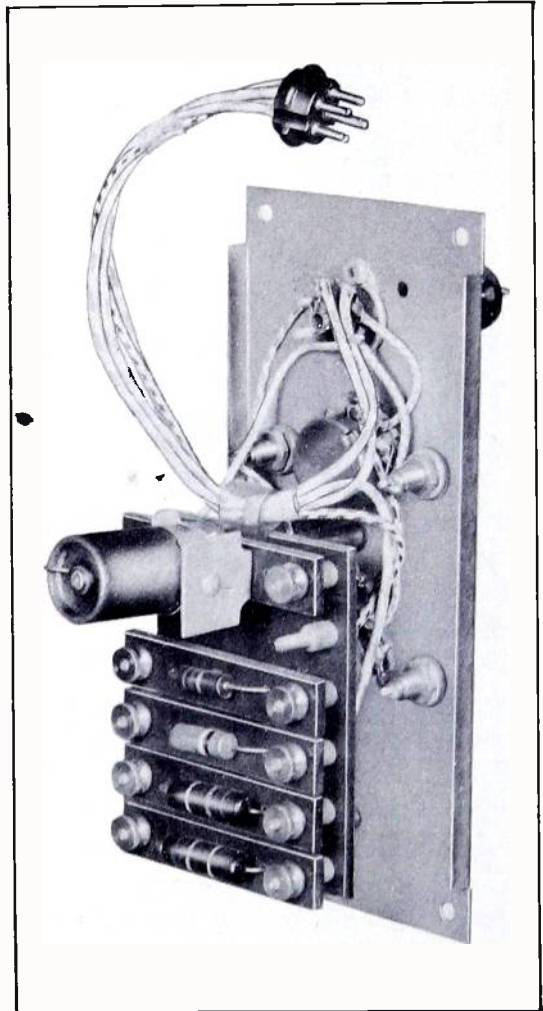

Figure 6. Rear View of Laboratory Chassis, Showing Use of a Defective Component (Lower Capacitor)

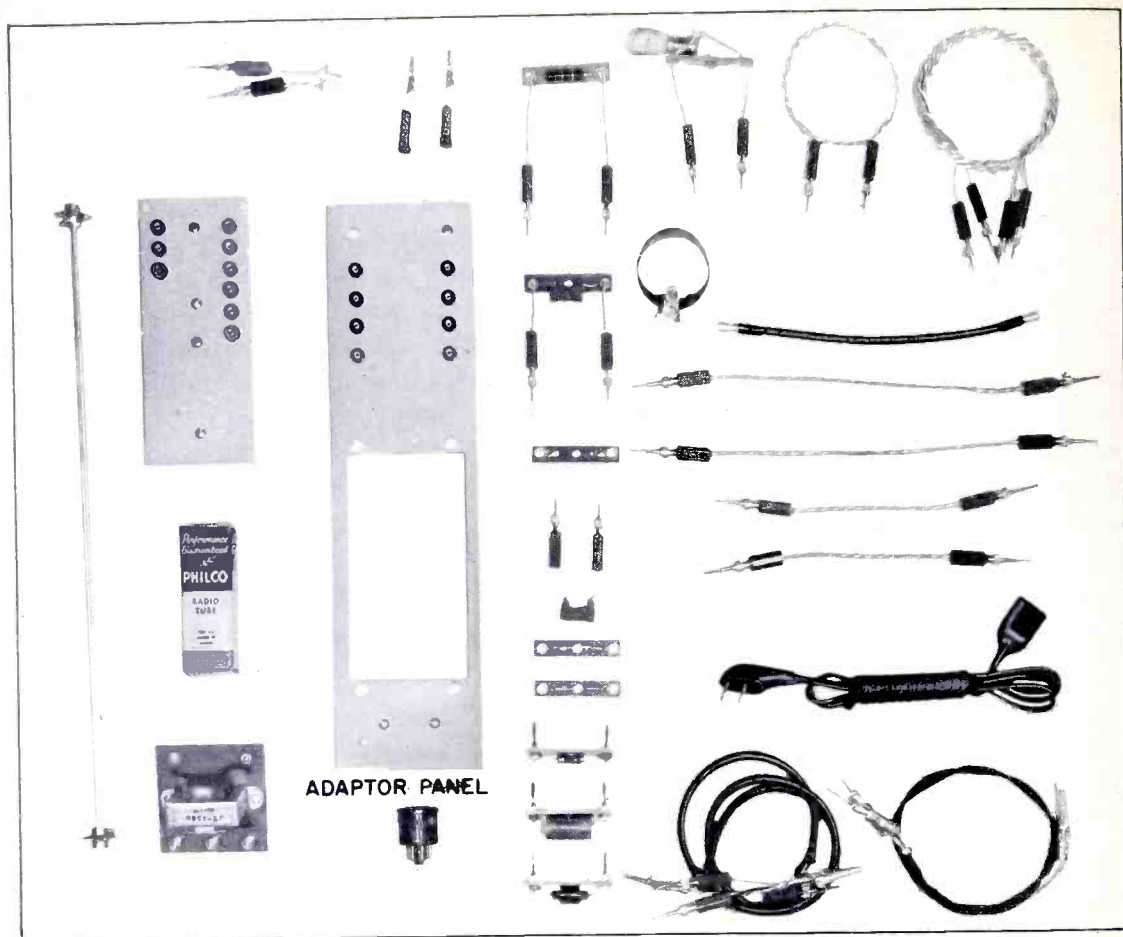

Figure 7. Demonstration-Unit Accessory Kit, Showing Adaptor Panel

plained. Thus, plenty of space is available to spread out the circuits which will receive full discussion, while the more common circuits, such as perhaps the power supply and voltage amplifier, could be set up on adaptor panels. This adds considerably to the scope and versatility of the demonstration units.

The console itself, which is completely self-contained (see figure 8), is designed for maximum mobility, and has a number of interesting features such as the built-in speaker. With the demonstration units stored in their respective slots, the doors can be closed and locked, insuring that the next time the instructor needs the units they will be there and in condition to be used. Furthermore, the rack itself is hinged in such a way that it can be folded over the front of

the console, thus providing a rugged framework, and protecting the doors if the console is moved from point to point. The heavy-duty casters make it easy to move the complete unit from room to room, or even to load it into a truck or aboard a plane, in case the training has to be carried on at more than one point. Note that the plug-in strip provides electrical outlets for all the test equipment which would normally be used for demonstration, and that an extension cord is attached to the rear unit. These features have proved very useful in that the unit can be set up, the demonstration prepared in a hallway or an unused anteroom, and rolled into the classroom ready to go. This, of course, means that no classroom time is wasted in set-up and tear-down of demonstrations.



Figure 8. End View of Demonstration Console

The laboratory rack also has a number of interesting features. For example, you will note, in figure 9, that each row of chassis can be fed from a separate line of power-feed plugs. Each line, in turn, can be connected to one or more of the other lines. This means that the student can operate his chain of circuits from one, two, or even three separate power supplies if the complexity of the circuits and their interaction require it. This, in itself, simulates actual equipment construction in that it is common practice to separate interacting circuits by feeding them from separate power supplies, or to provide separate power supplies for groups of circuits which are commonly located in different "black boxes."

A careful observer, comparing the list of circuits included in the demonstration units with those in the laboratory chassis, would note that there are two or three points where the circuits are not identical. This too is by deliberate design to add to

the over-all versatility of the training materials. Note that there is a phantatron demonstration unit (lower left-hand unit in figure 1) but not a laboratory chassis for this circuit. It was felt that the phantatron is sufficiently common to warrant a careful explanation and demonstration, but that it was not important enough to be included as a laboratory chassis, or to be made a separate laboratory experiment. On the other hand, more types of multivibrators are included in the laboratory chassis than in the demonstration units. This was done in order that the student would be enabled to build up more representative chains of circuits, thus simulating more-complex radar equipment. This is true because many radar chains will contain two, three, or more multivibrators of various types to produce a particular waveform output.

ADVANCED TRAINING

While the usefulness of these materials has been discussed with rela-

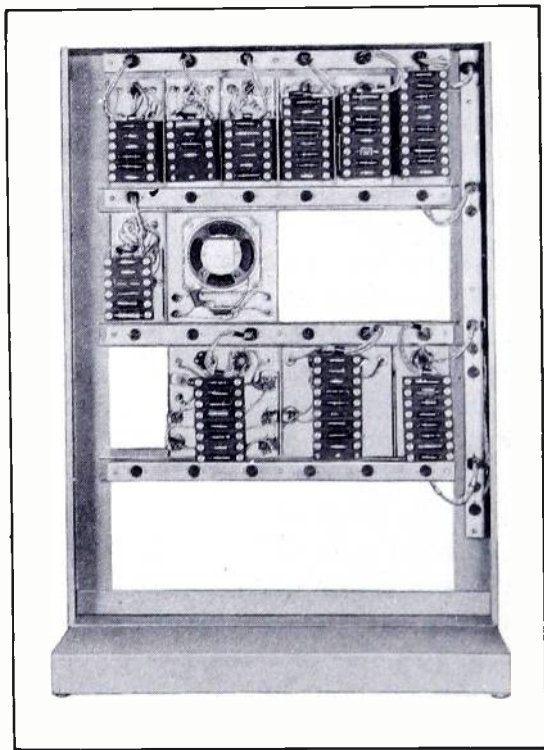

Figure 9. Rear View of Laboratory Rack, Showing Power-Distribution System



Joseph R. Lewis was born in Elvenfeld, Pa. on November 11, 1913. He received the degree of B.S. in E.E. from the University of Pittsburgh, in 1936. His pre-War experience included six years as power-distribution engineer with the West Penn Power Company.

His military experience includes four years in the U. S. Navy, during which he received electronics training at Harvard, Massachusetts Institute of Technology, and the Naval Air Technical Training Center at Corpus Christi, Texas. He served as Senior Electronics Officer of Argus Unit 14, in the South Pacific, and later as Electronics Training and Maintenance Officer of OTU #1, Kingsville, Texas. He achieved the rank of LCDR during the period. He is presently a member of the U. S. Naval Reserve, assigned to VAU-4-3 (Electronics), Naval Air Station, Willow Grove, Pa.

He joined Philco in January, 1946, as a technical writer in the Technical Publications Department, and a short time later became supervisor of the Special Projects writing group. He transferred to the Technical Department of the TechRep Division in 1947, as an instructor, and quickly rose to Chief Instructor, Headquarters Airmen's School. In November, 1951, he became Director of Training, TechRep Division. In addition to his duties in connection with training, he has, for some time, assisted John E. Remich, Manager of the Technical Department, on special projects.

tion to training on fundamentals, it should be pointed out at this time that we have experienced a great deal of success in using them in more advanced training. We have found, for example, that they are extremely useful in simulating whole sections of typical radars. This is true because all of the circuits are basic, and all of the components are easily replaceable. Note that no values are shown on any of the diagrams or mounting strips. Therefore, an instructor wishing to explain, let us say, the sweep-generating chain from an AN/APS-31, would refer to the HMI for that equipment, and arrange the demonstration materials to produce waveforms and voltages similar to those found in the analogous circuits of the AN/APS-31. He can do this by arranging his circuit values to agree with the circuits from the equipment. A little "cut and

try" may be helpful in obtaining circuit operation sufficiently accurate to suit his purposes.

This feature, which we refer to as simulation of equipment, has been found very useful in decreasing the number of operational equipments required for a particular training need. This does not mean that no operational equipments would be required for training, but only that the number can be materially decreased. It is always desirable that the student complete his training with a brief period of familiarization on the equipment itself. However, if a student can simulate important sections out of an operational equipment, the operational equipment is needed for that much less of the training, and this can be translated into fewer equipments per group of trainees. If one then com-

pare. the cost of the operational equipments which would otherwise have been required, with the cost of the training materials which can be used as a substitute, the potential saving of dollars is significant. Of far greater importance, however, is the relative availability, in an emergency, of equipment which would otherwise have to be utilized for training.

CONCLUSION

The training materials described here should not be considered to be a completed project; indeed, we are even now preparing for production of certain additional circuits which will

enable us to expand the coverage of these materials. Certain groups of circuits can be added to this basic group to cover special equipments. Training material covering the subject of super-sonics, for example, is at present being worked out for the Navy, to aid in their sonar training program. Microwave circuits are also being included, to provide coverage of this new field. The circuits available at this time, however, constitute the basic group, and enable a comprehensive course to be conducted covering the whole field of basic electronics, radio receivers, radio transmitters, and basic radar systems.

TRIGGER DEVICE FOR LINE CHECKING SCR-695

Anyone familiar with the SCR-695 realizes that the usual line check (test oscillator, receiver, and earphones) can be improved upon. At this base we have constructed a test unit which has become very popular with the line crew, and which requires only one man to operate it.

With slight modification (see figure), the local oscillator from an AN/APN-2 receiver can be used to trigger the SCR-695. A 0-to-1 milliammeter,

connected through a diode, serves as an indicator of the output and coding of the unit under test. The test set, including the batteries, can be enclosed in a 5" x 5" x 10" case. It was originally intended that the SCR-695 antenna would be placed through the pickup loops when testing the output, but tests proved that placing the test set about two feet from the antenna was a better procedure.

C. D. Craighead

Philco Field Engineer

Erding Air Depot

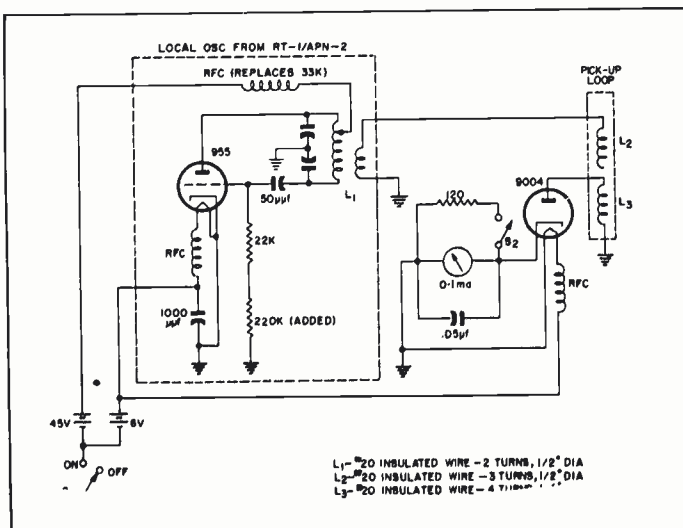

A DYNAMOTOR TEST STAND

By G. R. Petsche

Philco Field Engineer

An easily built piece of test equipment that aids in the preventive maintenance of dynamotors.

PROPER MAINTENANCE of aircraft radio equipment requires that the associated dynamotors be given periodic inspections. These inspections are usually made every 100 hours, and generally include checks on the ripple voltage, the output voltage, and the cleanliness of the dynamotor, as well as on the condition of the brushes, commutator, and bearings.

The dynamotor test stand (figure 1) described here greatly simplifies these inspections, since connecting cables and other associated equipments are removed from the work area. Plug-in mounts allow for rapid connection of all power input and output leads, while the meter on the panel is easily set for checking either the input voltage or the output voltage.

Originally designed for testing the dynamotors found on SA-16 aircraft, the plug-in mounts provided are for the SCR-274N dynamotor, and the AN/ARC-3 transmitter and receiver dynamotors.

Also, there is a special curved mount provided to hold other dynamotors that have odd bases or odd terminal connections. (A jack and a special test lead are provided for connecting these units with the test circuit.)

DESCRIPTION

The test stand is a compact unit occupying a work-bench space of only 13 by 14 inches. The rear panel is 9½ inches high, and is sloped slightly

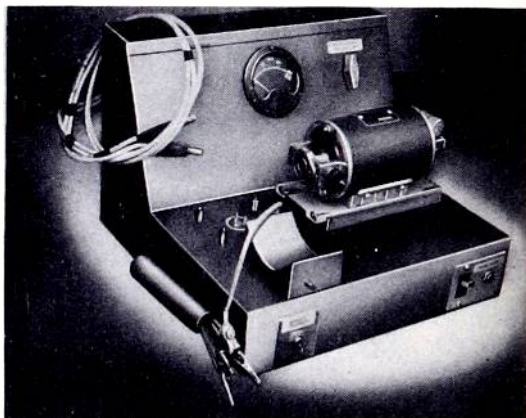

Figure 1. Dynamotor Test Stand

to make it easier to read the meter. Mounted on the left front of the base is the curved universal mount, while the external dynamotor jack, J₁, is mounted directly below, on the front panel. In the model shown in figure 1, a test-lead holder, consisting of a short piece of tubing, has been fastened to the side of the test stand for the special lead used with the curved mount.

The smaller of the two plug-in mounts is located directly behind the curved mount on the base. The combination mount for the AN/ARC-3 transmitter and receiver dynamotors and the SCR-274N modulator dynamotor is located on the right side, toward the back of the base panel. The actual location of the mounts is left to the builder, but a neater stand will result if the plug-in mounts are arranged as nearly in line with each other as possible. Switch S₁ and jack J₄ are mounted on the right side of the front panel. Jack J₄ is a JK-34A

headset jack, while jack J_1 is a JK-43 microphone jack.

The wiring is not complicated, and is as shown in the schematic diagram (figure 3). It is quite possible that additional meter ranges may be desired for testing various dynamotors. These may be readily provided by substituting a multiposition switch for S_2 , and adding additional multiplying resistors. The stand is connected to the 28-volt, d-c power supply in the shop by means of leads coming out of the back of the stand. These leads can be seen in figure 1, coiled on the corner of the back panel.

OPERATION

With the unit to be tested secured

in its mount, the end covers are removed, exposing the bearings, the brushes, and the commutator. These should be checked for unusual wear or for need of lubrication. Power switch S_1 is then turned on, and the meter-selector switch turned to the 30-volt position to check the input voltage. Any change from the rated input should be noted as a possible cause of a different output voltage from that marked on the nameplate. The switch is then turned to the 600-volt position, and the output voltage noted. Ripple voltage is checked by means of a headset plugged into jack J_4 .

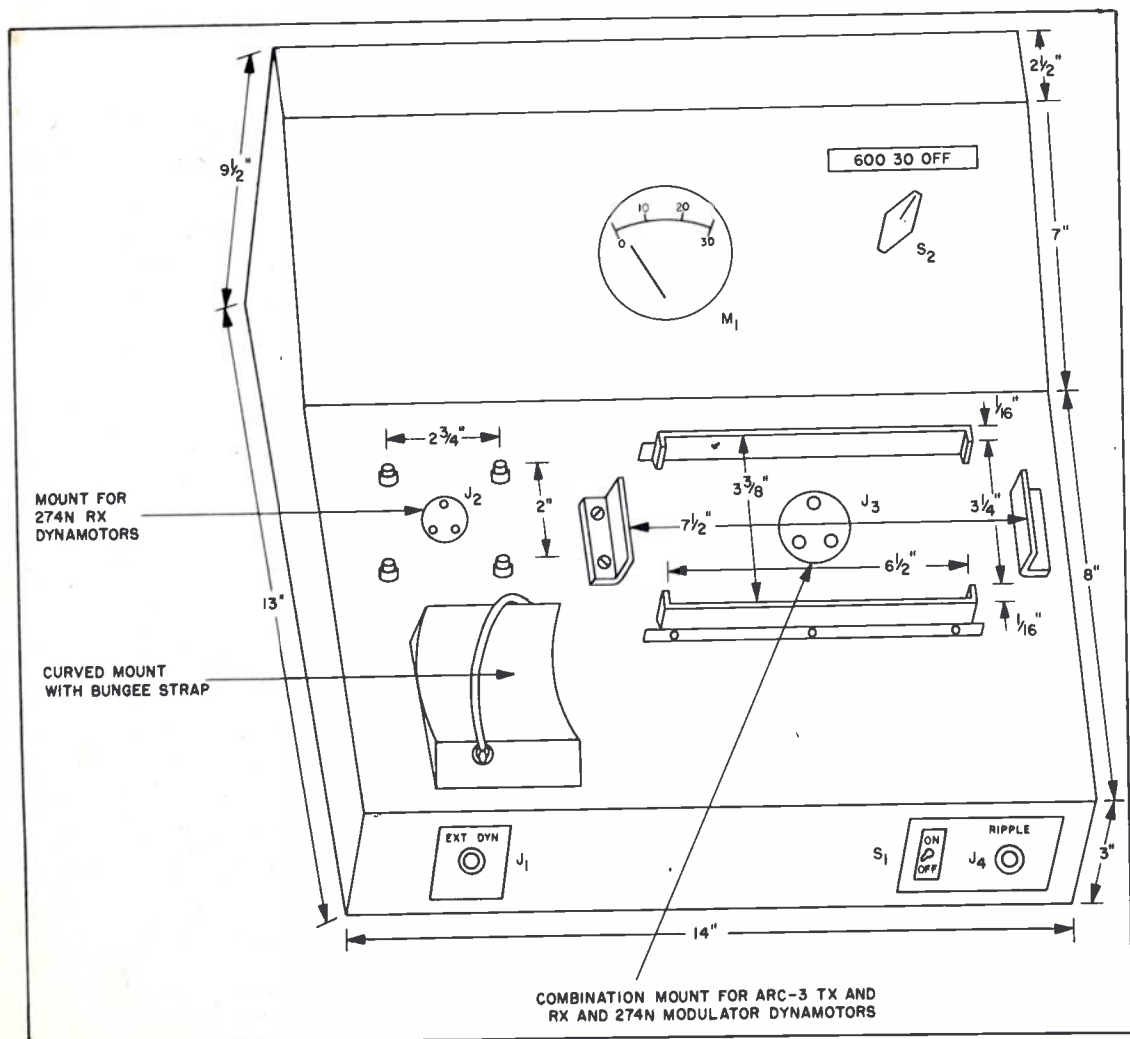

Figure 2. Construction Details of Test Stand

Correct ripple voltage is determined by listening to several dynamotors known to be in good condition. Although the dynamotors are not tested under load, faults should show up as either low output voltage, or as excessive ripple voltage. It will be noted that after using the test stand for a while, the time required for inspection of dynamotors will lessen.

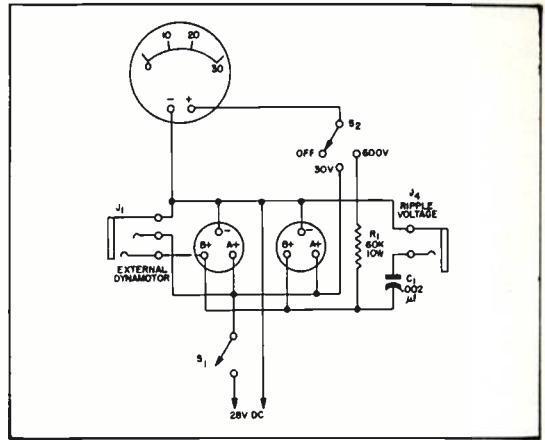
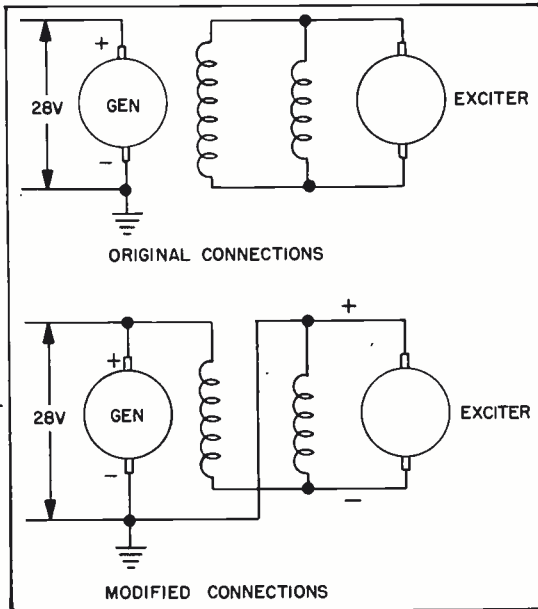

Figure 3. Schematic Diagram of Dynamotor Test Stand

INCREASING FIELD EXCITATION OF D-C GENERATORS



D-C Generator, Showing Original Connections and Modified Connections for Increased Field Excitation

Trouble was encountered in the operation of two motor generators used to supply the d-c power for the local shop. These generators were designed to operate from a 3-phase, 220/440-

volt, 60-cycle power source, while the only available power was from 380-volt, 50-cycle German power lines. As a result, the maximum no-load d-c output of the generators was only 31 volts, which was not sufficient for regulation at 28 volts, even under fairly light loads.

Investigation revealed that the field voltage for the 28-volt d-c generator should have been 125 volts, but was only 100 volts. This voltage is furnished by a small exciter, mounted on the front end of the main generator housing, and driven by the same armature shaft as the main generator.

The low-field-voltage difficulty was overcome by connecting the 100-volt exciter output in series with the 28-volt output of the main generator, and using the total voltage for field excitation of the main generator. (See the accompanying figure.)

C. D. Craighead
Philco Field Engineer
Erding Air Depot

A Quick Method for Determining the Phasing of Power Transformers

By David Scheff
Philco Field Engineer

A simple field expedient to facilitate correct connection of multiwinding transformers when the phasing of the windings is not marked.

A PERPLEXING PROBLEM presented itself at one of the radar locations in the European Command when a fire-control radar was delivered without a power unit. Inspection disclosed that this radar set required a 3-phase, 115-volt, 10-kw. source of power, but the only power plant available was a PE-215-C, which supplied 3-phase power at 220 volts. Universal windings were not incorporated in the power transformer of this radar unit, so it was not possible to operate it directly from the PE-215-C.

After a prolonged search, three power transformers of British origin, rated at 220/115 volts, 3.5 kva, were procured. The problem presented was to properly phase the respective primary and secondary windings to provide the necessary 115-volt, 3-phase power. The improvised field expedient employed was as follows:

Two pieces of hookup wire were soldered to a BA-30 flashlight cell, and the cell was then connected across the primary winding of one transformer, as shown in figure 1. This established the applied polarity to the primary winding. Note that either winding can be used as a reference. A multimeter, connected to the secondary winding and set on a low d-c voltage range, was used as the polarity indicator.

Bridging, or flashing, the dry cell across primary winding AB estab-

lished both primary and secondary polarity with respect to the meter deflection, since the meter leads were polarized.

After the polarity of the windings was ascertained for each of the three transformers, and the windings were appropriately marked, the transformers were connected as shown in figure 2. This provided a delta-to-delta hookup, with proper phasing of the windings. A wye connection could also have been used, in which case all the negative terminals would be

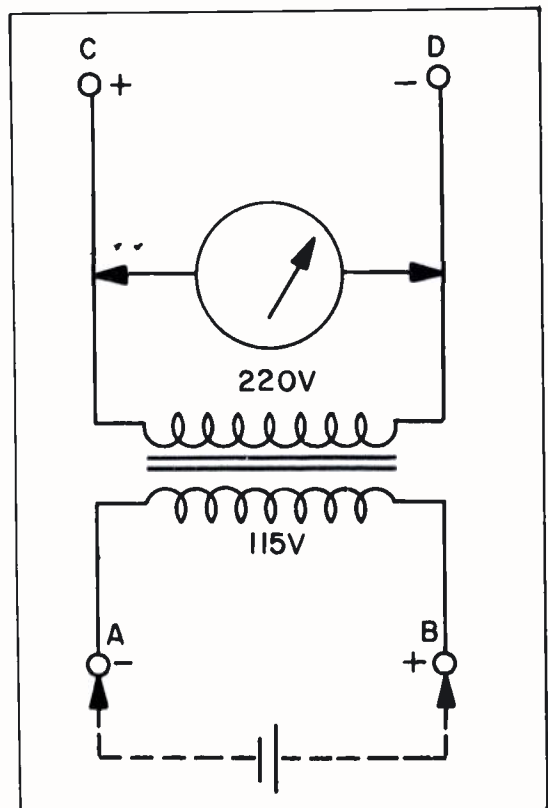

Figure 1. Circuit for Determining Polarity of Transformer Windings

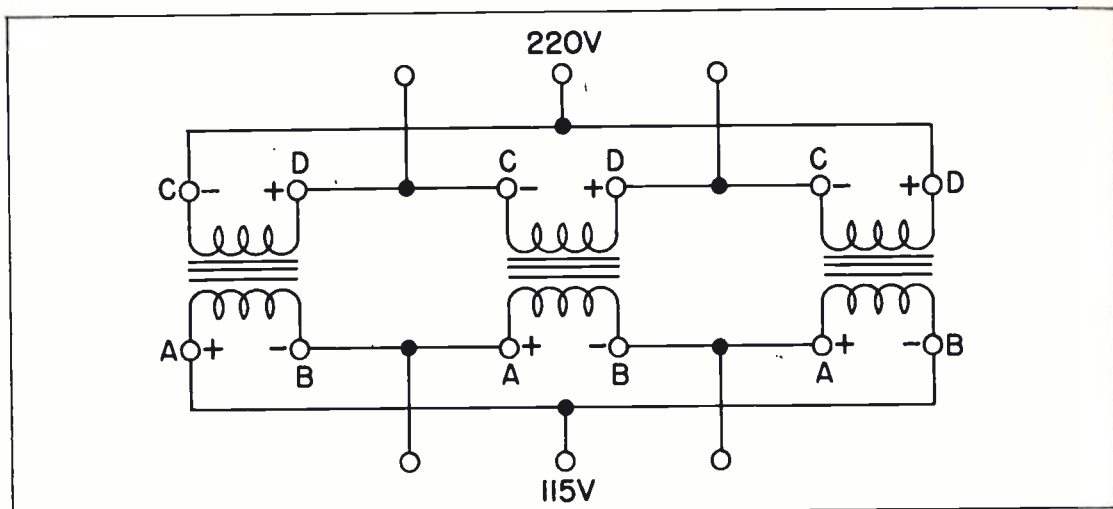

Figure 2. Delta-to-Delta Transformer Connection for 3-Phase Operation

connected together, and a common ground wire would be required.

To insure correct phasing of the windings, thus eliminating guesswork and the chance of "phase bucking" of the windings, the applied voltage was taken from the PE-215-C at reduced output, and the multimeter (set on an a-c range) was applied across the

phase windings to determine the correct wiring. Reduced voltage output can be obtained by either cutting in field-excitation resistance, or by reducing the engine speed of the power unit. Equal voltmeter readings across all phases indicate that the wiring is correct, and this condition should be ascertained before application of full operating voltage.

In Coming Issues

The eagerly awaited second installment of "Introduction to Transistor Electronics," by John Buchanan, is scheduled for next month's issue. Our mail has been unusually heavy in recent weeks as a result of the response to the first installment (January, 1952), and we are certain that BULLETIN readers will find the second equally fascinating. (Any reader who missed the January issue may obtain a copy by writing the editorial office.)

Also to appear in the April issue is another article in our television series—this one titled "Low-Noise Considerations in TV Tuners," by Thomas J. Ryan, a member of the Headquarters Training Materials Development staff, and a frequent contributor to the BULLETIN. This article deals with the low-noise r-f amplifier circuits which led to the cascode type amplifier, and to the even more efficient circuitry now used in Philco's newest television tuners. Considerable data is included on sources of noise, methods of noise reduction, and on the characteristics of various input coupling techniques. Don't miss this very significant article.

Book Reviews

SATURATING CORE DEVICES. By Leonard R. Crow. Edwards Brothers, Inc., Ann Arbor, Michigan; 1949. Cloth, 6 x 9 inches, 373 pp., illus., \$4.75.

This review is a bit late, since the book was published nearly three years ago; however, we feel that our readers should be told of any publication which sets forth basic principles of saturating-core devices in such an enlightening manner.

Mr. Crow, who was the Director of Research and Development, Universal Scientific Company, Inc., at the time the book was published, was obviously aware of the need for a non-mathematical treatment. He has made every attempt to simplify the subject, and we feel that he was successful.

The book opens with a thorough discussion of saturable-core reactors, and then covers, in detail, a series of applications of practical devices. Next, it very clearly presents a series of advanced concepts dealing with resonance. Later chapters deal with wave shaping, wave forms, voltage regulation, frequency multiplying, flux gates, earth-inductor compasses, servo-mechanisms, and magnetic amplifiers. The last chapter deals with the saturable-core reactor and its relationship to electronics.

The ever-increasing use of saturating-core devices makes it desirable, if not imperative, that the field engineer become acquainted with the basic principles involved. This book meets that need, and, at the same time, fills a long-standing gap in available literature.

One further note to the student and the engineer—the last five pages of the book are devoted to a fairly good bibliography and a list of U. S. patents related to saturable-core devices.

RADIO AND TELEVISION MATHEMATICS. By Bernard Fischer, Ph.D. The Macmillan Company, New York; 1949. Cloth 5½ x 8¼ inches, 484 pp., illus., \$6.00.

Dr. Fischer, who is the Vice President in charge of the Training Division at the American Television Laboratories, received his degree from the University of Vienna, and has been extensively engaged in teaching activities. He taught physics and mathematics in the city school system of Vienna, and, prior to his present position, taught war-training courses at the University of California.

Section One of this book consists of a series of typical problems found in the field of electronics. Each problem is fully explained, and the solution is given in step-by-step form in such a manner that even the beginning student can follow the development. Each solution is augmented by a practical discussion of its meaning.

Section Two consists of a series of *Problems for Further Practice*. The correct answers for this section appear in the Appendix.

Section Three lists *Some Important Tools of Radio Mathematics*, such as powers of ten, the slide rule, the J-operator, and vectors.

Section Four is a well-conceived compilation of *Formulas and Tables*. This section will be very valuable to the field engineer as reference handbook.

We recommend this book to all our readers.

HOW TO PASS RADIO LICENSE EXAMINATIONS (Third Edition). By Charles E. Drew. John Wiley & Sons, Inc., New York; 1952. Paper, 6 x 9½ inches, 367 pp., illus., \$4.50.

The purpose of this book is clearly indicated by the title. The third edition incorporates the recently-revised list of FCC study-guide questions, and sufficient data is presented on each question to enable an individual to supply an intelligent answer to FCC examination questions, and thereby to obtain a license. Elements 1 through 6 are covered with detailed answers, and four appendices contain related data.

After a careful scan of this book, we have only one criticism—no index is included, and, as a result, specific facts are somewhat difficult to locate. Aside from this fault (which really isn't a fault unless you want to use the book as a reference source), we recommend this book to all who are interested in obtaining a government radio license.

PRINCIPLES OF RADIO (Sixth Edition).

By Keith Henny and Glen A. Richardson. John Wiley & Sons, Inc., New York; 1952. Cloth, 6 x 8¾ inches, 655 pp., illus., \$5.50.

Principles of Radio is by no means new to the field engineer, even though it has been seven years since the last edition. Most reference shelves contain one and possibly more of

the earlier editions. The authors have made sure that the field of radio is covered in its broadest sense in this book, and have apparently attempted to make the presentation reminiscent of text-book form.

This sixth edition is a completely revised and rewritten version of earlier editions, and represents an improved approach to the subject. A number of laboratory-tested experiments, which will prove most enlightening to the student of radio, are included in the presentation, and sufficient detail is given to enable anyone to follow the outlined procedures. Detailed examples of calculations are given where there is a possibility of confusion.

After the sections on basic radio and electronic theory are discussions of the basic aspects of UHF, microwaves, test equipment, nonsinusoidal-wave techniques, television, and radar. These subjects round out a well-balanced book, and help make the edition a valuable one for the field engineer.

SERVOMECHANISMS AND REGULATING SYSTEM DESIGN. *By Harold Chestnut and Robert W. Mayer. John Wiley & Sons, Inc., New York; 1951. Cloth, 6¼ x 9¼ inches, 505 pp., illus., \$7.75.*
The authors of this book, which is one of

a series covering advanced engineering at the General Electric Company, have an impressive background. Mr. Chestnut received his M.S. degree from M.I.T. in 1940. During 1940 and 1941, he was on the General Electric Test Course; following this, he entered the Advanced Development Division of the Aeronautic and Ordnance Systems Divisions where he continued his work up to the present time.

Mr. Mayer received his M.S. degree from M.I.T. in 1942, and since that time has been in the Aeronautics and Ordnance Systems Divisions of the General Electric Company. At present, he is a project engineer on a guided-missile program.

The presentation of the material is detailed, well-organized, and slanted toward the development engineer. The subjects covered include a discussion of the control problem, manipulation of complex numbers, Laplace transforms, and a detailed treatment of servo-mechanism design factors. Since the technical level is well above that of field maintenance, and since the systems dealt with relate to theoretical rather than actual systems, the field engineer will find little use for the book; however, the mathematics presented will certainly be of interest to the advanced student engineer.

AID TO CIRCUIT TRACING

Have you ever tried to trace a B+ circuit through a complicated schematic diagram, and found that you came to a junction and did not know which way to go? Much time can be saved in familiarization with a complicated circuit if arrowheads are inserted showing the way back to the power supply. This principle can be improved on vastly, but even with the little bit of help, it is amazing how much time is saved.

Hal Gullstad
Philco Field Engineer

LORAC—

What It Is and How It Works

By Edward J. Crossland, Research Engineer
Seismograph Service Corporation

A discussion of the basic principles of an entirely new, long-range position location system, with data on equipment requirements, system accuracy, and operational test results.

DURING RECENT YEARS the oil industry has displayed great interest in the Continental Shelf Area of the Gulf of Mexico, under which large quantities of oil are believed to exist. The subsequent increase in geophysical activity in this area has resulted in some unusual and interesting problems. One of these problems is the determination of the geographic positions of the points at which geophysical observations are made. To solve this problem, Seismograph Service Corporation has developed a radiolocation system designed to make possible an accurate determination of position at long range; hence the name LORAC—L**O**ng Range **A**ccuracy.

Marine geophysical surveys conducted shortly after the conclusion of World War II employed optical methods, radar, and Shoran for position-fixing purposes. As the scope of the work was extended beyond the sight of land, and as much of the work was conducted during periods of poor visibility, the optical methods were the first to be replaced. Shoran and radar suffer a severe handicap due to their line-of-sight limitations. The LORAC system was designed to extend the range of operation beyond the line of sight without sacrificing accuracy of position determination.

LORAC is a phase-comparison system of radiolocation which has some rather unique features:

Frequencies—The frequencies used

are governed by the range and accuracy requirements, with, in general, the accuracy increasing and the range decreasing with an increase in frequency. No harmonic relationship of frequencies is required; two narrow unrelated frequency channels are sufficient for complete system operation. Medium frequencies are normally used, resulting in adequate range and a high degree of accuracy.

Synchronization—Through transmission of a modulated "reference" signal, no synchronization, or phase-locking, of transmitters is required, and the resultant instrumentation is simplified.

Users—The entire area of operation is covered by the radio-wave pattern generated by the transmitting stations, and since only receivers are used by the position-fixing equipment in this area, the system is fundamentally a multiuser system.

Range—Ground-wave propagation is normally employed, and, with the use of medium frequencies which follow the curvature of the earth's surface, operation is obtained beyond the line of sight.

Equipment—Instrumentation is not complex. The equipment consists essentially of continuous-wave amplitude-modulated transmitters and receivers, the latter being connected to phase-indicating equipment.

Operation—Operation requires only the reading of two dials. Fixing a position requires only the use of these two readings as map coordinates.

BASIC PRINCIPLE

The basic principle employed in the LORAC system is that of measuring the phase difference of the radio waves received from two continuous-wave transmitters. This measurement is not made directly because phase measurement is rather difficult at the radio frequencies employed. In practice the transmitters are operated on two frequencies which differ by an audio frequency. A reference signal is established by detecting the heterodyne beat between the two transmitted signals. This detection takes place at a fixed point, and therefore has a constant phase angle. The reference signal is transferred to the mobile receiver by modulating a third, separate transmitter. The heterodyne signal received directly at the mobile receiver will have a phase angle which is dependent upon the position of the receiver. The direct-heterodyne and the reference-heterodyne signals at the mobile receiver are compared, and the angle between them is measured. This measured angle is indicative of the position of the receiver with respect to the fixed transmitters.

Figure 1 illustrates the method used in the LORAC system. Transmitters T_1 and T_2 radiate continuous waves, and transmitter T_3 is an amplitude-

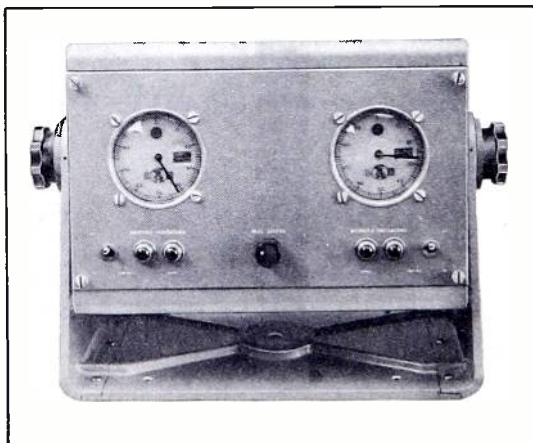

Dual Integrating Phase-Difference Indicator Used for Position Location

modulated transmitter. Transmitters T_1 and T_2 operate, respectively, on frequencies F_1 and F_2 , which differ by an audio frequency. Receiver R detects the heterodyne audio beat signal which exists between frequencies F_1 and F_2 . This audio beat note is used to modulate transmitter T_3 . Since receiver R is fixed in position, the phase angle of the audio beat note will remain constant. Its actual value will depend upon the time origin selected. Point P, the mobile unit, has two receivers, one tuned to the frequencies of T_1 and T_2 , and one tuned to the frequency of T_3 . The first receiver detects the heterodyne, or audio, beat signal which exists between transmitters T_1 and T_2 . This audio beat note can have any phase angle because the position of P is not fixed. It is called the *position* signal. The second receiver detects the audio beat signal from R, which has a constant phase angle. Since it does not change regardless of the position of P, it is called the *reference* signal. The *reference* and *position* signals are then compared, and the phase angle between them measured. This angle is indicative of the position of the mobile unit P with respect to the fixed transmitter stations.

It will be found that, if a course is maintained that yields a constant phase-meter reading, the path followed by P will be that of a hyperbola with the transmitting stations T_1 and T_2 as foci.

When point P is moved so there is a change in its relative position from the two shore stations, the phase value of the beat-frequency signal received directly at P will change, but the phase value of the beat-frequency signal received at R and relayed by station 3 will not change. Consequently, the phase meter will indicate the

change in phase relationship between the two beat notes. If point P continues to move relative to the two transmitters, the relative phase of the two beat-frequency signals will change until a complete 360-degree phase rotation has taken place. At that time an integrating-counter mechanism in the phase meter adds or subtracts a digit to indicate that point P has a new 360-degree phase position, or "lane." The phase meter continues to indicate the position within the new lane. If point P is moved so there is no change in the reading of the phase meter, the course followed must be along one of the hyperbolas of the coordinate system.

The method of transferring a reference signal to the mobile receiver-indicator eliminates the need for any phase synchronization between the shore transmitters; if slight electrical changes take place at either shore station, the variation will appear in both the reference and position signals, and will have no effects on the readings of the phase meters.

From the standpoint of determining absolute position, a single phase-angle measurement is not sufficient because the same phase indication would be obtained at any point along a given hyperbolic line. Accordingly, the entire set of shore equipment is duplicated with a second pair of fixed shore stations placed so that its hyperbolas will intersect those of the first pair to form a grid of hyperbolic equiphase lines (see figure 2) which blanket the area in which position information is desired. Then, by obtaining a phase-relationship indication at point P from this second set of transmitters, a position determination may be made since the point P must then be at the intersection of the two hyperbolas defined by the readings of the two phase

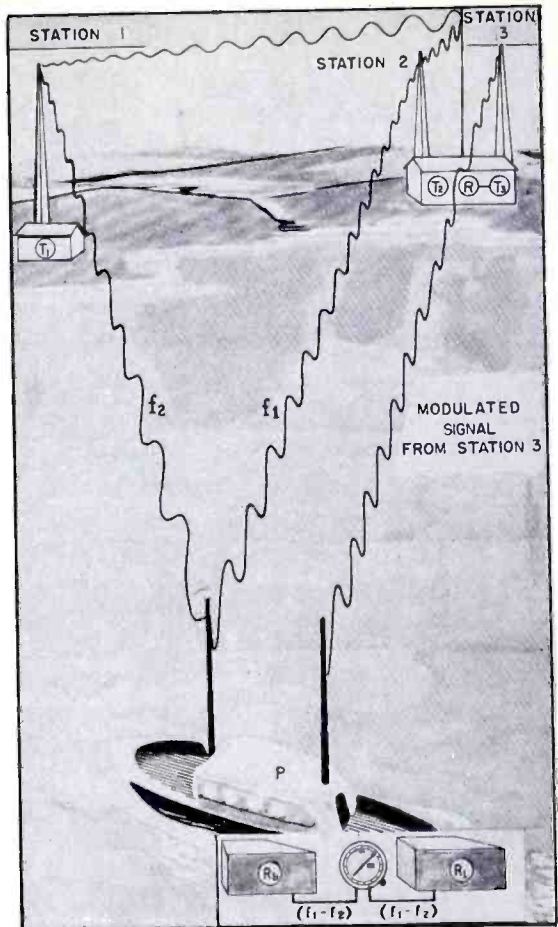

Figure 1. Basic LORAC System

meters. Thus, the basic system requires six transmitters, six receivers, and four frequency channels to locate one point or ship. There is no limit, however, to the number of ships that can successfully and simultaneously utilize the emissions from the same shore installations.

LORAC TYPE "A" SYSTEM

The LORAC type "A" system presents a distinct improvement over the basic system, and realizes desirable savings in equipment and frequency channels. In the type "A" system, with a time-sharing arrangement, the independent reference transmitters are eliminated, and the beat notes they normally transmit carried as modulation signals on the carriers of two of the primary transmitters themselves. Consequently, fewer receivers are re-

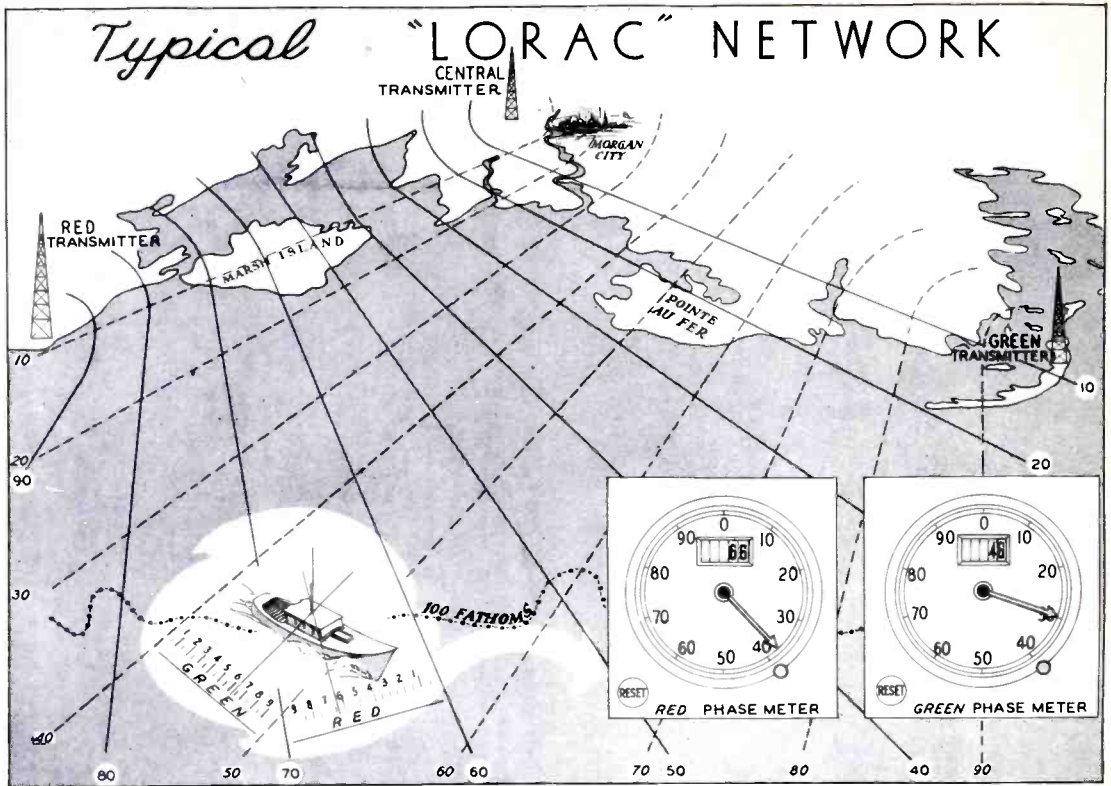

Figure 2. LORAC System, Showing Grid Lines

quired on the ship, and extra reference-transmitter frequency channels are not required. The type "A" system reduces the frequency channels required to two. The system thus functions on two frequency channels, and requires only three transmitters and two receivers to establish a hyperbolic grid. A pair of receivers and a pair of phase meters are required for each mobile unit.

Figures 3, 4, and 5 illustrate the operation of the LORAC type "A" system. The transmitter at the central shore station is alternately switched between frequencies A and B by a suitable switching device. The solid arrow lines of figure 3 depict the significant emissions during the first half of the switching cycle, when the central transmitter is radiating frequency A. The dashed lines of figure 4 show the significant emissions during the second half of the switching cycle,

when frequency B is being radiated. The equipment shown on each half cycle is that functioning during that particular half cycle. Transmitter T_2 serves as the heterodyning complement of the center transmitter during the first half cycle, and as a reference transmitter to convey the reference beat-frequency signal of the other pair to the ship during the second half cycle. Transmitter T_1 performs for the other half cycle of the system, but in the reverse cyclic order. As a result of the switching operation, each phase meter operates for one half of the complete cycle.

Figure 5 illustrates the complete cycle of operation. It is, in effect, a superposition of the two half cycles shown in figures 3 and 4.

In common with many other continuous-wave comparison systems, the type "A" system is a differential dis-

number must not be lost.

ACCURACY

The accuracy provided by any radiolocation system is a function of several variables and cannot be expressed by one simple and constant value. In continuous-wave phase measuring systems, the integral number of one-half wavelengths are counted and then a phase measurement made of the remaining fractional one-half wavelength. The potential accuracy of radiolocation systems based on the phase measurement of continuous waves is thus very high.

The accuracy of all phase-comparison systems is a function of the frequency employed. For frequencies on the order of 2000 kilocycles, the wavelength is approximately 500 feet. On the baseline between transmitters, a lane (one-half wavelength) is approx-

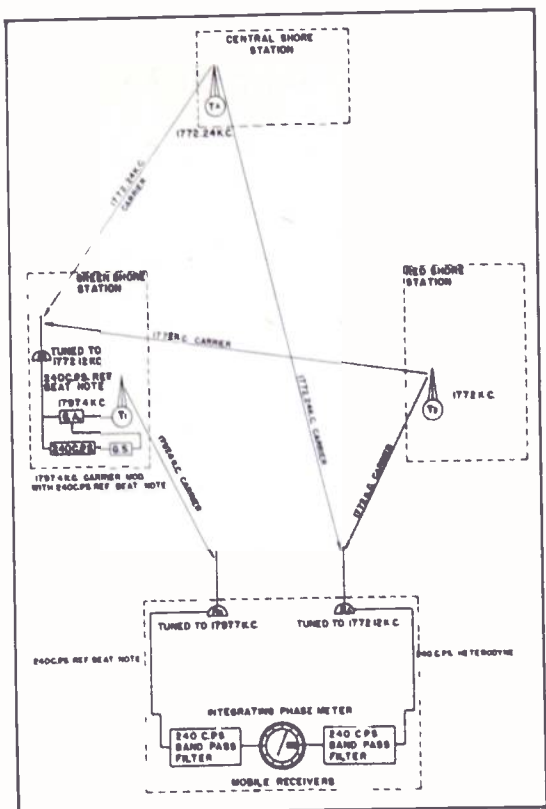

Figure 3. LORAC Type "A" System, Showing Signals Radiated During First Half of Switching Cycle (Solid Lines)

tance-measuring system, absolute distances to the transmitter not being given directly. Before undertaking to navigate with this system, each phase meter must be set to indicate the proper phase relationship at some known location. This is accomplished by electrically driving the pointer through the desired number of revolutions until the number on the counter corresponds to the desired lane number. The phase meter must be set manually to the correct phase position within the lane to agree with a computed reading for that particular position. An alarm circuit causes a red lamp on the indicator panel to light if the signal should fail. In case of a service interruption, it is only necessary that the ship does not move more than plus or minus one-half a lane; the phase position within a lane will automatically be taken up on resumption of service, but the lane

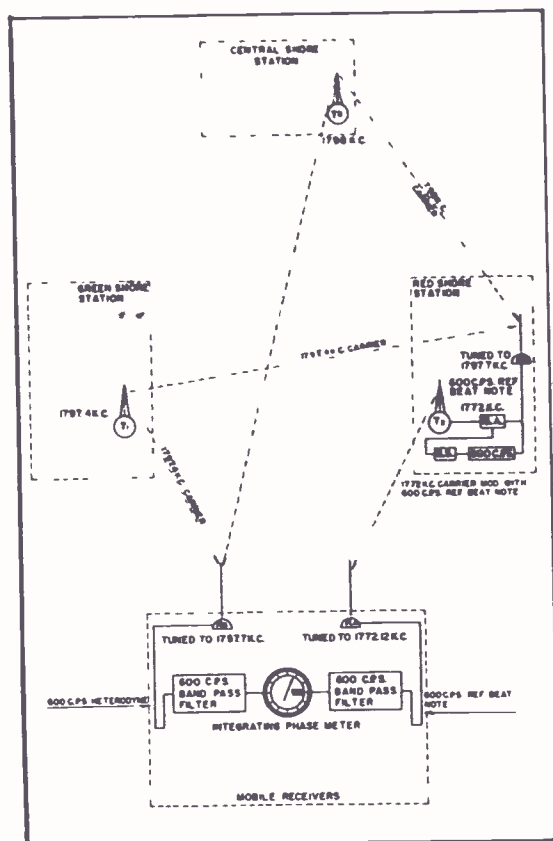
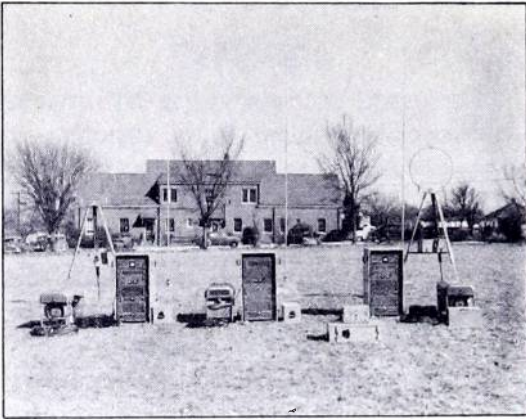

Figure 4. LORAC Type "A" System, Showing Signals Radiated During Second Half of Switching Cycle (Dashed Lines)



Complete Equipment Layout for Three-Station System

imately 250 feet. Since this constitutes a phase shift of 360 degrees, and since an instrument accuracy of ± 3.6 degrees is not difficult to obtain, an instrumental accuracy (excluding propagation effects) of $1/100$ th of 250 feet, or ± 2.5 feet, is reasonable to expect with the LORAC system on the baseline. Away from the baseline, the lanes widen, and the accuracy of position determination is reduced.

Propagation effects may introduce errors of location, particularly over ground of variable electrical conductivity. The magnitude of these errors has not been completely investigated, but tests indicate that, over land, a phase shift of more than one-tenth of a lane would be unusual. Larger errors are to be expected over rough terrain where the degree of error appears to be in proportion to the relative difference in elevation, with some shadow effect behind hills. A short distance above the earth, this effect should be greatly reduced since the radiation would then be governed by its free-space characteristics. Near telephone lines, power lines, or other objects which may act as parasitic antennas, large phase discrepancies may result. However, in general, this effect should be local to these objects, and in practical operation should not be serious. Over water, conditions are of course

much more uniform, and much greater accuracy is obtained. Over either land or water, the "repeatability" is related to signal strength, a limitation due more to instrumental considerations than to propagation effects.

Sky wave propagation will introduce error at a distance and at a time of day when the sky wave becomes of appreciable magnitude compared to the ground wave. This, in turn, will depend upon the frequency band selected and the conductivity of the earth over which transmission is made.

AMBIGUITY

The method of transferring a reference beat note to the mobile unit obviates the need for phase synchronization of the transmitters, and is entirely satisfactory, but another problem arises in the operation of a continuous-wave system in that ambiguity exists in the phase measurements

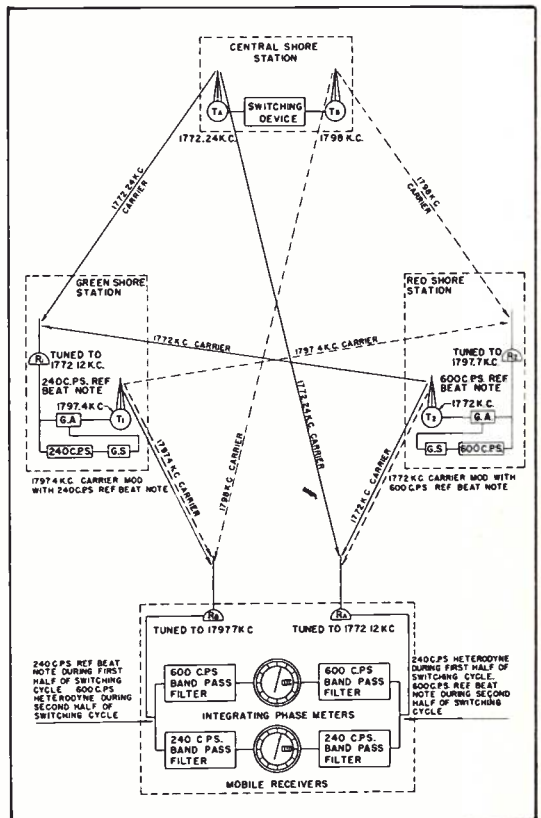

Figure 5. LORAC Type "A" System, Showing Complete Cycle of Operation

which provide the desired position information. The two phase measurements identify the position of the receiving station relative to two intersecting pairs of hyperbolic isophase lines, but they do not indicate the pairs of lines to which the readings are related. This means that the geographic location of the receiving station must be known at the start of movement of the receiving station, and, furthermore, that the successive half-wavelength intervals be counted as the receiving station is moved relative to the grid-like pattern of hyperbolic lines. It is obvious that this will require that each ship desiring to use the information available enter the radiation pattern at some known point appropriately marked, or that it carry additional equipment to determine its position; or, alternatively, that some lane-identification means be provided.

RESULTS

The LORAC system has undergone extensive tests in the Bahamas Islands and off the Louisiana coast. These tests were conducted over a six-month period during which all possible conditions of operation were tested. The tests in the Bahamas Islands were conducted in conjunction with the Hydrographic Office of the U. S. Navy. Those off the Louisiana coast were conducted for the benefit of several major oil companies, which subsequently became very interested in the geophysical application of the LORAC system. The tests in the Bahamas Islands resulted in several contracts with the Bureau of Ships of the U. S. Navy. Equipment being manufactured under these contracts will be delivered shortly, and will find many applications in Naval operations. At present, there are in operation two LORAC systems providing position information to SSC's clients.



Edward J. Crossland was born in Tulsa, Oklahoma, on January 17, 1927. His pre-War training and experience in electronics was acquired with the Tulsa Public Service Company. In 1946, he entered the U. S. Army Signal Corps, and received extensive training in radar, communications, and electronic control systems, after which he was assigned to the Air Force, in Europe. He spent five months at Munich, and the following 14 months at Erding Air Base, Germany, where he eventually became Section Chief of Radar Maintenance.

Following his Army discharge, in 1949, he entered the University of Tulsa, where he majored in engineering physics. He joined the Philco TechRep Division in January, 1951, and served as an instructor in heavy ground radar, both at Headquarters and at Warner-Robbins A.F.B., Macon, Georgia.

In September, 1951, he left Philco to return to Tulsa, and since that time has been associated with the Seismograph Service Corporation, as research engineer.

What's Your Answer?

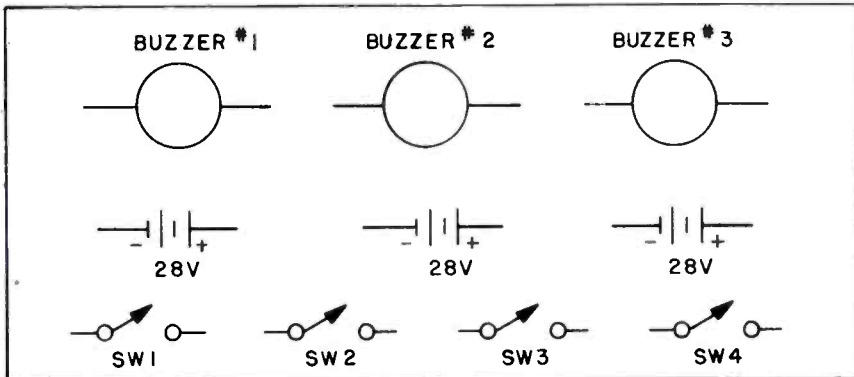

This month's problem was submitted by Warren Kitter, of the Technical Publications Department. We have found that it requires a bit of careful thought to get the right answer.

Assume that only hookup wire is used in addition to the parts shown in the figure; that the buzzers are each 28-volt, d-c units; and that all four switches are of the single-pole, normally open, momentary type.

The object of the circuit is as follows:

SW₁ should ring the #1 buzzer.

SW₂ should ring the #2 buzzer.

SW₃ should ring the #3 buzzer.

SW₄ should ring all three buzzers.

(Solution next month)

Solution to

Last Month's "What's Your Answer?"

To determine which bar is magnetized, place the bars as shown in the drawing. If attraction is exhibited, bar #2 is magnetized; if no attraction is found, bar #1 is magnetized.

The theory of this solution involves the configuration of the field about a magnetized bar. Since the bar is considered to be of uniform cross section and material, one end will represent a north pole of equal magnitude to the south pole at the other end. In the exact center, therefore, no pole exists.

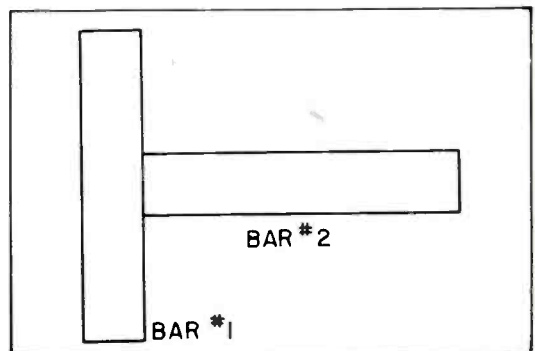

To further verify the solution, reverse the position of the two bars, and the manifested condition of attraction or non-attraction will also reverse.

POPULAR MISCONCEPTIONS

Do you know of a circuit explanation or item of theory which is commonly used in the classroom but which doesn't "hold water" under close scrutiny? Have you ever felt exasperated when, in answer to a question, someone tossed you a "snow job" which sounded good on the surface, but which fell completely apart when you examined it?

Help us spike these misconceptions by writing up those you have encountered in electronics, and sending them to the BULLETIN.

The subject of the following item is one which, in our opinion, certainly falls into the category of popular misconceptions:

CONSIDER the function of the plate capacitor (C_1) shown in the figure. The circuit is that of a Pierce crystal oscillator, which is in wide use. C_1 is usually referred to as a d-c blocking capacitor, and it is often stated that the capacitor blocks d.c. from the crystal to protect it from the stresses produced by a high voltage applied across it.

Circuit examination will show that in terms of d.c., the crystal and C_1 are in series between B+ and ground. Also in terms of d.c., the crystal presents capacity to the circuit consisting of the holder capacity (a few micro-microfarads at most). For the purpose of explanation, assume C_1 to be about $1000\mu\text{f.}$ and a crystal-holder capacity of about $10\mu\text{f.}$ According to fundamentals, the voltage distribution in a series capacitor circuit is inversely proportional to the individual capacitance values. Therefore, in this case, C_1 would assume a charge of 1/100 of the charge assumed by the crystal holder. If B+ is 100 volts, it can be seen that the crystal holder will charge to about 99 volts. In considering leakage, it is very likely that C_1 will show the lowest leakage resistance since quartz is an excellent insulator. (This is even more obvious in air-gap holders.)

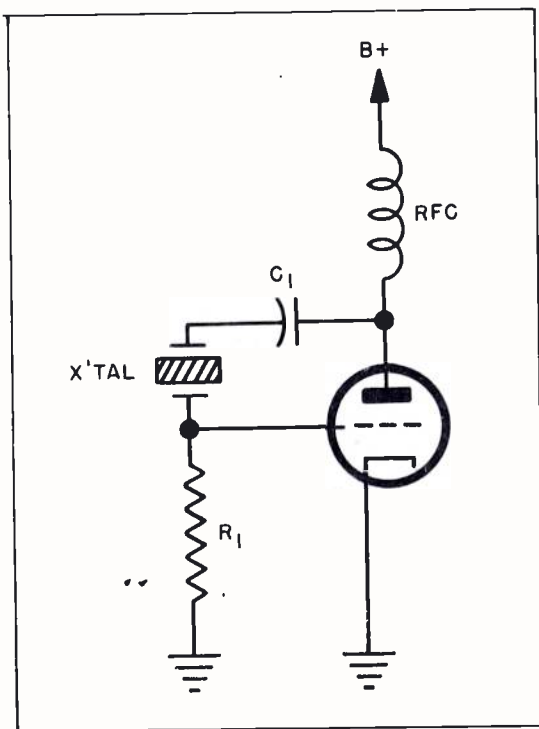

Of course if a meter were connected across the crystal to measure the voltage, the charge would quickly leak through the meter circuit, and no voltage would be measured. This action leads to the reason for the capacitor. In the process of removing and inserting crystals, the operator may come into contact with the circuit; contact between the crystal terminal and ground might place the operator between B+ and ground if it were not

for C_1 . Also, a shorted crystal holder would ground B+ if C_1 were not present.

To emphasize the above, it is pointed out that in a great many cir-

cuits where the crystal is left undisturbed for long periods, C_1 is omitted (the crystal is connected directly between grid and plate) with no apparent change in circuit function.



**NEW
TRAINING MANUAL
FOR PHILCO TIME DIVISION
MULTIPLEX EQUIPMENT CMT-4**

As this issue goes to press, the printing has just been completed on the eagerly awaited Philco training manual for the CMT-4. The writing and preparation of this publication have been a major project, and it is with considerable pride that we announce its completion. The initial distribution of the new manual will be made in the weekly mailing of 18 April, and some field engineers may already have received their copies by the time this announcement is read.

The manual has been prepared in accordance with our standard training-manual format, and is over 200 pages in length, with eight wall charts. When used in conjunction with the recently released Philco Training Manual for the CLR-6 (Philco Microwave Radio Relay Equipment), the new manual will provide a complete training package for the new multichannel microwave communications systems now rapidly blanketing the United States and many overseas areas.

A Practical Use for January's "What's Your Answer?" Circuit

Last month we listed two possible solutions to the "What's Your Answer?" problem presented in the January issue. Although we printed what we thought were the two most-probable solutions, we did not anticipate the number of amateur photographers among our readers who have come up with a very practical third solution. The following letter from Philco Field Engineer B. G. Sullivan is typical of many letters we have received on this problem.

26 February 1951

Mr Robert L Gish
Managing Editor
PHILCO TECHREP DIVISION BULLETIN
22nd Street & Lehigh Ave
PHILADELPHIA, PENNA

Dear Mr Gish:

The "What's Your Answer?" problem in the January issue brings back fond memories.

In fact, I considered that it was my idea originally (although probably 17,000 others probably thought of it before I did). Some twenty years ago, I thought it might be a good idea in photoflood photography if the photoflood lamps (whose life is notoriously short) could be used in series for posing and focussing, then turned up to full brilliance and put it into use. At that time, I figured out the circuit and for those Philco men who are interested in this type of work, it is still good since it not only saves the lamps - but is also much easier on the eyes of a live subject.

I incorporated the circuit and switch in a box equipped with outlets so that the floods could be plugged in. If I recall, the circuit goes something like this:

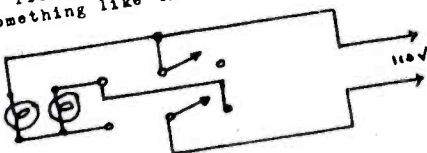

Very truly yours,

Baldwin G Sullivan
Baldwin G Sullivan
Editor, TechRep TOPICS (on TDY)

P S The Bulletin is a topnotch publication and is appreciatively received by all members of the Armed Forces with whom I work.

