

PHILCO

TECHREP DIVISION BULLETIN



MAY
1952

PHILCO TECHREP DIVISION BULLETIN

Published Monthly by
The TechRep Division of Philco Corporation
Philadelphia, Pennsylvania

Volume II

MAY, 1952

Number 5

CONTENTS

Editorial	2
<i>By John E. Remich</i>	
Screen Room Construction	3
<i>By Frederick S. Mohr</i>	
In Coming Issues	10
Operational Analysis of a Phase-Modulator Circuit	11
<i>By John W. Adams</i>	
Low-Noise Considerations in TV Tuners	17
<i>By Thomas J. Ryan</i>	
An Application of Simple Mathematics to a Field Problem	46
Calibration Adjustments of DBE Loran Equipment	47
A Crystal-Diode Tester	47
What's Your Answer?	48
Solution to Last Month's "What's Your Answer?"	48

Editor
John E. Remich

Managing Editor
Robert L. Gish

Technical Editors
Frederick S. Mohr
Francis R. Sherman
Gail W. Woodward

**EDITORIAL OFFICE:
PHILCO CORPORATION
TECHREP DIVISION
22nd and LEHIGH AVENUE
PHILADELPHIA 32, PA.**

If any information contained herein conflicts with a technical order, manual, or other official publication of the U.S. Armed Forces, the information in the official publication should be used.

Editorial

SPECIALIZATION VERSUS DIVERSIFICATION

By John E. Remich, *Manager, Technical Department*

The newly graduated electronics engineer today is faced with a problem of considerable magnitude—the decision of whether to concentrate on a particular phase of electronics activity, and thus to become a “specialist,” or to set as his goal a career as a “systems engineer,” with a broad general knowledge of an entire field. Both types of careers offer distinct advantages, and both classes of engineers are in great demand.

Hardly a reader of this page has not at some time felt a pang of regret when he compared the vast quantity of data now known, with that which can be assimilated, integrated, and put to use by one man in one lifetime, under our present educational system. In every research laboratory, can be found the man who not only has limited his attention to one type of equipment, but to a particular function in that equipment, and even to the development of a single circuit component. Such projects often require years of study and experiment, all within very narrow limits, yet unless many thousands of such specialized projects had been carried through, the modern miracles of transcontinental television, microwave communication, high-definition radar, electronic “brains,” etc., would not have been possible.

On the other hand, however, there is an equivalent need for the “systems” engineer, whose job it is to evaluate the electronic requirements of a particular situation, to devise a plan for meeting these requirements, to prepare specifications for the engineering and production specialists who will design and build the equipment, and finally to supervise the installation, adjustment, testing, and general maintenance of the completed system.

The diversification of field activities allows the Philco Field Engineer to examine and evaluate almost the entire field of electronics. Thus, he can find that phase of engineering best suited to his particular talents and desires.

SCREEN-ROOM CONSTRUCTION

By Frederick S. Mohr
Headquarters Technical Staff

A discussion of the theory and important construction details involved in building a shielded room.

The principles of shielding are not new to the electronics industry, as practically every piece of electronic equipment employs some form of shielding. At times, though, it is necessary to place a shield around the operating area of the equipment, either for the purpose of performing tests on the equipment, or to confine the r-f field radiated by the equipment (figure 1). This article deals with shielded rooms built for testing communication equipment, particularly the radio compass.

Since the purpose of such a shielded room is to provide a space free from external electromagnetic fields, the theory underlying the methods of doing this might well be briefly considered. The shield eliminates the electromagnetic field by reflection and by attenuation. Electromagnetic waves tend to be reflected when they strike a medium that has an impedance different from the impedance of the medium through which the waves have been traveling. Some waves are thus reflected when they strike the metal shield, while others tend to penetrate the metal, and, in doing so, are attenuated. Since the waves which seek to penetrate the shield constitute the larger percentage, the effectiveness of a shielded room primarily depends upon how much attenuation the shielding provides.

Ideally, the greatest attenuation would be provided by plates of copper, but, for reasons of economy, rooms are not so constructed. Instead,

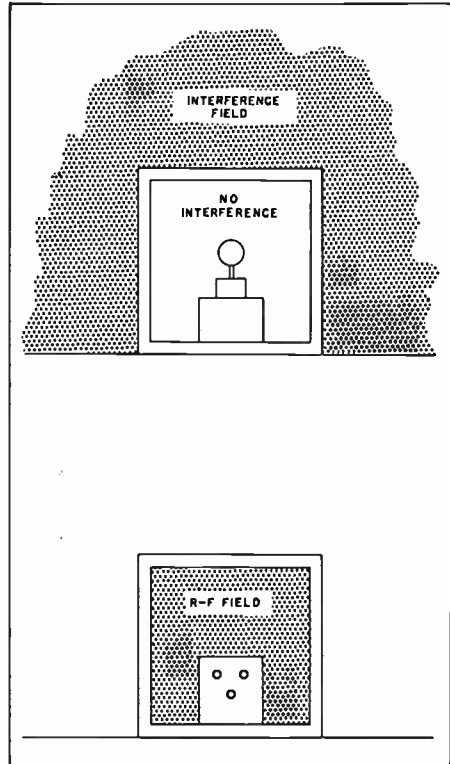

Figure 1. Shielded Room Provides an Interference-Free Area for Performing Tests, or Confines an R-F Field

copper foil or copper screen, such as is used for door or window screens, is used to provide the shielding; this is a compromise between optimum attenuation and economical construction. The use of screen greatly simplifies the problems of ventilating and lighting the room, keeping the costs of these items down. Whereas the use of only one shield might provide an attenuation of 50 db, due to the thickness of the wire, a second

shield placed approximately 4 inches from the first will double the attenuation. Therefore, rooms are usually constructed with an inner and an outer shield. In cases of excessive interference, modifications are made to the basic room to meet the special conditions.

Maximum attenuation results if the two shields are not connected at any point. Since it is generally necessary to provide a duct through which power lines can be run into the room, the next best condition is obtained if connection between the shields is limited to this one point. Connecting the two shields at more than one point would lower the total attenuation provided by the shields because reflection from the inner shield would be reduced (any currents flowing on the inner surface of the outer shield would also flow on the outer surface of the inner shield). However, attenuation of the electromagnetic waves, caused by flow through the metal, would still be present, and since the thickness of metal is greater when two shields are used, the total attenuation of a two-shielded room

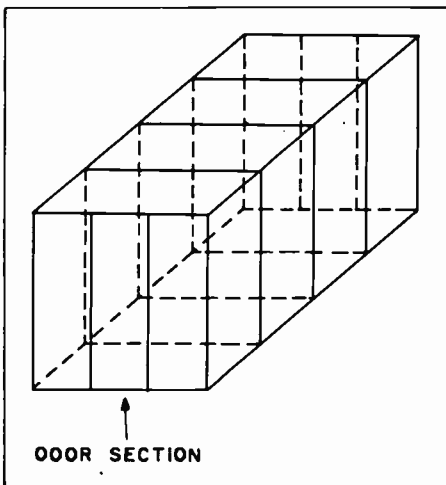

Figure 2. Diagram Showing How Cells Make Up a Shielded Room

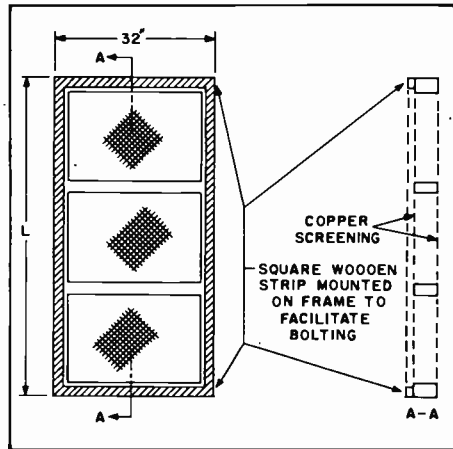

Figure 3. Construction of a Typical Cell

is therefore greater than that of a room employing only one shield. This principle is used in screen rooms employing cell-type construction. Cell-type screen rooms are so named because they are made up of a number of sections, or cells, bolted together to form a room (figure 2). Each cell is usually 4 inches thick, 32 inches wide, and of a length equal to the height or width of the completed room (figure 3). The inner and outer screens of each cell are lapped around the sides so that when two cells are bolted together, four screens are in contact. Care must be taken to see that the bolts draw the two sections together tightly enough so that no gap is left between the screens of each section. The advantage of this type of room is that it may be easily assembled or disassembled, and it can therefore be moved from one location to another without any difficulty.

DESIGN FACTORS

In the construction of any shielded room, certain basic factors must regularly be considered. These factors include shielding material, access, lighting, ventilation, and power-supply filtering.

The use of foil or of solid metal plate for shielding complicates the lighting and ventilation factors; for this reason, copper screen is the most commonly used material. When selecting the screen to be used, a mesh should be selected which is small compared to the thickness of the metal surrounding the hole. An electromagnetic field sets up currents which flow in parallel lines on the surface of the metal. If the mesh is large, the holes will interrupt the current flow, and cause it to flow around the surface of the break to the other face of the screen, where a new field will be set up by re-radiation. This, of course, reduces the effectiveness of the room. A screen between a 16-mesh and a 22-mesh will give good results; a 22-mesh screen is preferred.

Another factor to be considered is that of providing adequate access to

the room. If the room is to serve the purpose for which it was constructed, it must be possible to move tools, equipment, and test instruments in and out of the room easily. This requires a door of adequate size, but a door means a discontinuity in the shield, and a consequent reduction in the attenuation of the interfering field. This difficulty, however, may be overcome by providing contacts around the edges of the door so that when it is closed, the inner and outer screens of the door make contact with the respective shields of the room. Strips of phosphor bronze or of copper weatherstripping are ideal for this purpose.

Adequate filtering of the power lines entering the room is very necessary. These lines will have a voltage induced in them by the fields outside the shield, and, if adequate filtering is not provided, similar fields will be

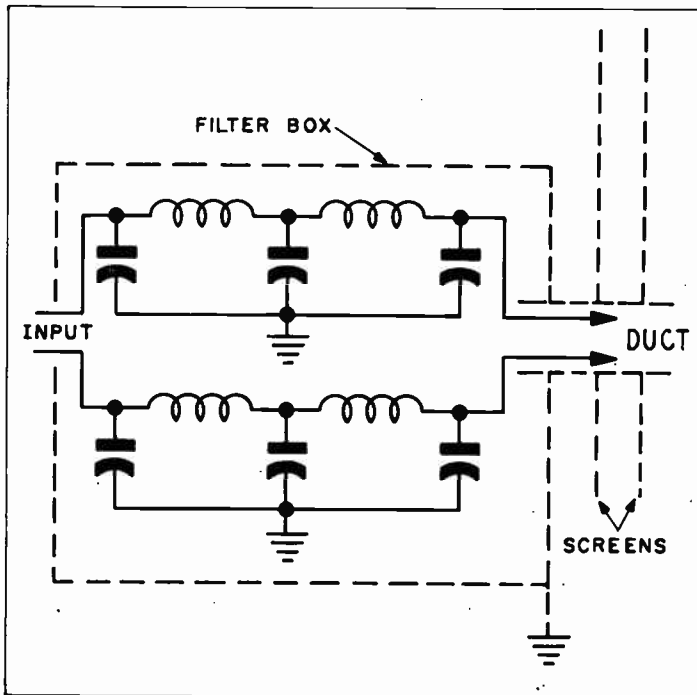

Figure 4. Typical Power-Line Filter

established inside the room by re-radiation. Each power line will require a pi-type filter inserted into the line immediately before it enters the room (figure 4). These filters should be capable of handling the power requirements of the equipment in the room, and should be designed to attenuate the interference. Equally important is the proper shielding of the filter, and of the lines as they enter the room. This shielding of the lines must make direct connection with each screen through which it passes, if the effectiveness of the shielding is to be maintained (figure 5).

CONSTRUCTION

Before starting the actual construction of the room, there are several things to be decided, such as how much space is available for the room, whether the test area is to be used solely for testing one type of equipment or for many types, and whether the screen room is to be a permanent or a temporary fixture.

Upon these decisions will depend the type of room that is built. If the installation is to be permanent, and there is adequate space available, the conventional double-shield type of room is best. However, if it is desirable to move the room occasionally, even though adequate space exists, then the cell-type room is best.

One point which often bothers the technician who has never built a screen room is the choice of the size of the room. Size of the screen room is not critical. This point is well illustrated by the many different sizes which have been built in the past. One radio-compass manufacturer specifies a room 12 feet 8 inches long, 9 feet wide, and 12 feet high. A company that sells screen rooms provides them in three different heights, two widths, and in a variety of

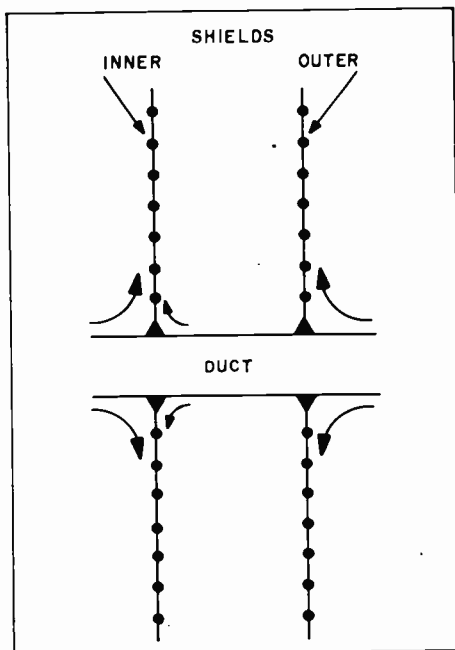

Figure 5. Paths Taken by Interference When Duct for Power Line is Soldered to Both Shields

lengths. The "poor man's screen room" (figure 6), which is a fairly new type designed for situations where space cannot be made available for the usual screen room, is only 4 feet long, 2 feet wide, and 2 feet 6 inches high. All of these rooms provide good attenuation of unwanted interference. The main point is to provide sufficient room for all equipment required, plus sufficient working space, without having excess space.

In designing the screen room, the space available will dictate the maximum possible dimensions. This is particularly true of the height, as many shops may not have a 12 foot ceiling. Also to be considered is the layout of all of the equipment involved in the tests. If the length and width chosen are multiples of the screen width, extra work can be avoided in cutting the screening material. A suggested screen room for

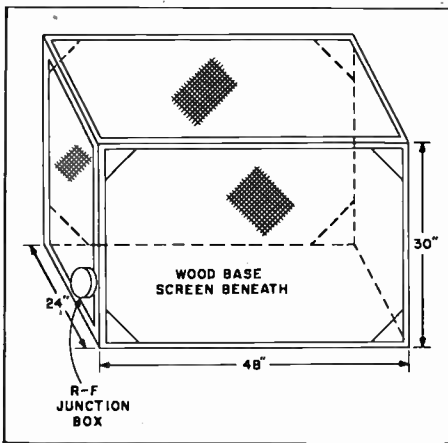

Figure 6. Poor Man's Screen Room

testing radio compasses is one which is 12 feet long, 9 feet wide, and, if possible, 12 feet high.

The framework of the room should be constructed of well-seasoned, 2- by 4-inch white-pine lumber. This lumber will provide a sturdy frame for the room, and maintain a 4-inch space between the two screens, which is desirable (figure 7). In building a double-shielded room, normal room-construction practices are followed in setting up the framework. When nails or screws are used in construction, care should be taken to see that there is no possibility of shorts between inner and outer screens, and that any nails or screws which pierce either screen are soldered to the screen. A unique method was used in the construction of a screen room at one base—wooden pegs were used instead of nails to fasten the framework together. This completely eliminated any chance of a short between the two screens.

Once the framework is built, the screen is cut to fit the various sides of the room. Panels for the walls are cut to fit vertically from the ceiling to the floor. For the ceiling or floor, the panels are cut to fit across the

width of the room. The individual panels are then laid out on the shop floor to form a large panel for each wall, floor, and ceiling. This makes soldering much easier, and a better job results. Each section of screen should overlap the next section by $\frac{1}{4}$ of an inch. If it is necessary to use soldering flux, a noncorrosive flux should be used, and all excess flux should be carefully cleaned off to prevent any possible corrosion.

Angles made from strips of sheet tin greatly facilitate making joints between each wall, floor, and ceiling. Cut the tin into strips $2\frac{1}{2}$ inches wide, the width of each panel, and bend them into right angles $1\frac{1}{2}$ inches on each leg. The angles are then carefully soldered to the top and bottom ends of each wall panel (figure 8). When this has been done, each wall panel is rolled up, carried into the room, and the metal angle on the outside of the roll is tacked to the top edge of the framework. The roll is then unrolled, and the bottom edge is also tacked down. It may be advisable to tack the screen at several other points on the framework. Every tack head must be soldered to the screen; otherwise radiation will leak

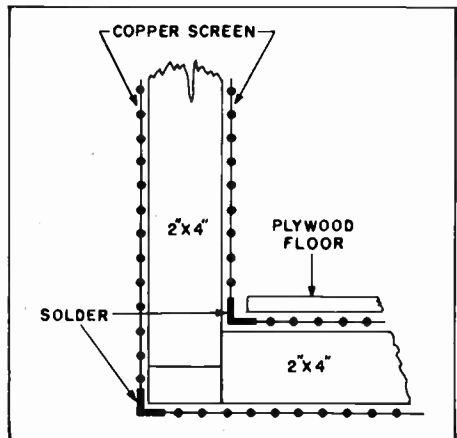

Figure 7. Construction Details at Joint of Floor and Wall

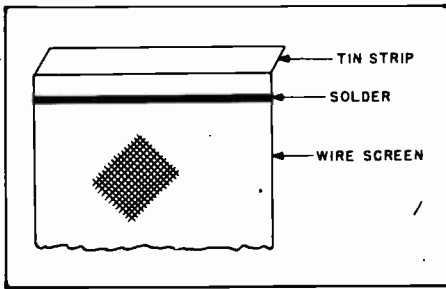

Figure 8. Tin Strip Fastened to End of Screen Panel

through at these points. The angles are then soldered to the ceiling and floor panels, and additional angles are used to connect each wall to the adjacent walls. Of course it is possible to erect the screen without using the angles, but they have been found to simplify the job greatly, and to insure a room with no holes through which the interference field may leak.

The door should be located in the center of one end wall. It is important that, when the door is closed, good contact is made between the screens on both faces of the door and the respective screens of the room. Any discontinuity of the shields will allow interference to leak through, and will lower the total attenuation factor of the room. As mentioned before, copper weatherstripping can be used for the purpose of connecting the shields on the door to the room shields.

FILTERING THE POWER SUPPLY

One of the most difficult parts in the construction of a good screen room is the bringing of the necessary power into the enclosed area (figure 9). It will be necessary to bring 110-volt 60-cycle power, 110-volt 400-cycle power, and 28-volt d-c power into the room. Each of these power lines should have a suitable low-pass filter inserted into each side of the line. Commercial filters can be purchased

for this purpose, or filters can be made from parts on hand. If the filters are constructed in the shop, be sure that the chokes are made of wire large enough to carry the power used in the room.

These filters should be mounted next to the point of entry of the power lines into the room. A suitable metal box with a tight-fitting hinged cover should be provided for shielding these filters. The size of the box will depend upon the size of the filters used; ample room should be provided for making the electrical connections without undue crowding. It should also be kept in mind when designing the box that the duct carrying the wires into the screen room should also enter the box.

The duct may be any suitable metal pipe, conduit, or waveguide. When the length of the duct is at least three times its diameter, the duct will attenuate all frequencies below its cutoff frequency. The formula for determining the cutoff frequency is

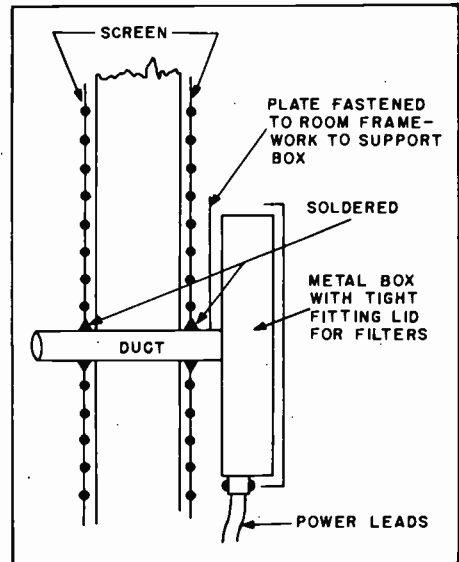

Figure 9. Details of Power Entrance to Screen Room

$f = \frac{6820}{d}$, where f is the frequency in mc., and d is the diameter expressed in inches. Ducts which have cutoff frequencies higher than the interference frequencies are also useful for the entrance of various services, such as compressed air, water, or gas, that might be needed in the room. These ducts are also a means of providing ventilation in rooms having solid walls.

GROUNDING

If the room has been well constructed, the addition of an external ground will not affect the attenuation of the room. This is because the shielding provided by the room occurs as a result of reflection and attenuation of the waves by the metal of the shields. Additional attenuation of the interference field by grounding the

shield is difficult to provide over a wide range of frequencies. Such attenuation is only provided when a low-impedance path is provided to ground. (When the distance between a point and ground is an odd multiple of a quarter wavelength, a high-impedance path is shown, and no additional attenuation results.) However, the "poor man's room" requires an external ground for best results. The point at which to attach this ground is found experimentally by sliding the ground connection over the bottom of the cage until a point of minimum noise is found. Usually this point will be located at the center of the bottom panel.

Even though an external ground is not essential for attenuation purposes, it should be used to prevent the screen's rising from above a-c ground owing to the power-line



Frederick S. Mohr was born November 22, 1921, at Ardmore, Pennsylvania, and received his early education in the Pennsylvania-New Jersey area. After graduation from Lawrenceville School, N. J. in June, 1941, he was employed for two years as an Electrical Draftsman by the

Cramp Shipbuilding Company, of Philadelphia.

He entered the U. S. Marine Corps in 1943, and attended Service electronics schools at Chicago, Illinois, Logan, Utah, and NATTC, Corpus Christi, Texas.

He joined the Philco TechRep Division as a Field Engineer, in September, 1946, and completed a tour of duty which included service at Clark Field, P. I., Tokyo, Japan, and Guam.

He left Philco in July, 1947, to complete his education, and attended Lehigh University, at Bethlehem, Pennsylvania until June, 1951, when he received the degree of Bachelor of Science in Business Administration. Immediately after graduation he returned to Philco, and since that time has been a member of the BULLETIN staff, in a technical-editing capacity.

filters. A No. 6 (AWG), or larger, wire should be fastened to the screen, preferably near the power-line filters, and to either a cold-water pipe or to a pipe driven into the ground adjacent to the room.

SUMMARY

The most important points to remember to insure the maximum

shielding when building a screen room are to practice good workmanship, to make sure there are no breaks or gaps in the shields, and to filter and shield the power lines completely at the point of entry into the room. If these precautions are followed, an attenuation of at least 100 db can be reasonably expected from a double-shield room.

BIBLIOGRAPHY

1. Morgan, Gustavus A., Jr., *Notes on Design, Construction, and Evaluation of Shielded Rooms*, Naval Research Laboratory, NRL Report 3578, 1949.
2. Zepher, E. E., *The Technique of Radio Design*, John Wiley & Sons, Inc., 1943.
3. Pine, C. C., "Construction of Shielded Room in VHF Field," *Electronics*, Vol. 21, No. 4, April, 1948.
4. Swan, A. G., "Radiation from R-F Heating Generators," *Electronics*, Vol. 19, No. 5, May, 1946.
5. ———, "ARRL Screen Room," *Digest of U. S. Naval Electronics*, January, 1948.
6. ———, "AN/ARN-6 Maintenance," *Digest of U. S. Naval Electronics*, Vol. 9, No. 11, June, 1950.

In Coming Issues

Those BULLETIN readers who have been following John Buchanan's series of articles on transistors will be pleased to learn that the next installment is rapidly nearing completion, and will appear shortly.

For the TV enthusiasts, we are currently working on two articles. Mark Flomenhoft, of the Technical Publications Department, has written a fine article on "Sync Separation and the Gated-Beam Tube," and John Carnuccio, of the Headquarters Technical Staff, recently completed a most useful summary of construction data titled "Physical Constants for TV Antennas."

Another forthcoming article, "Effects of Electric Shock on the Human Body," by Dr. George J. Nichols, M.D., presents a realistic approach to a widely misunderstood subject.

Finally, don't miss next month's "What's Your Answer?" We think it's one of the best we've ever published.

OPERATIONAL ANALYSIS OF A PHASE-MODULATOR CIRCUIT

A detailed discussion of the basic differences between phase modulation and frequency modulation

By John W. Adams
Technical Publications Dept.

Editor's Note: The aura of confusion that surrounds the terms "phase modulation" and "frequency modulation" led the author to a thorough consideration of the matter and to the following attempt at clarification.

Both phase modulation and frequency modulation are means for achieving the same end result—a frequency-modulated wave. Theoretically, the only difference between the frequency-modulated waves produced by each of these means lies in the phase relationship between the modulating signal and the deviation. However, there is another very practical difference—with phase modulation, the

frequency stability of the carrier can be much greater than is possible with frequency modulation. When frequency modulation is used, the modulation must be applied directly to the oscillator circuit, and such an arrangement is obviously not conducive to a high degree of carrier-frequency stability. When phase modulation is used, the oscillator may be crystal-controlled and the modulation may be applied to a later stage.

The crystal-oscillator output is usually fed through a buffer amplifier and then applied to the grid of the phase-modulator tube, which, for this

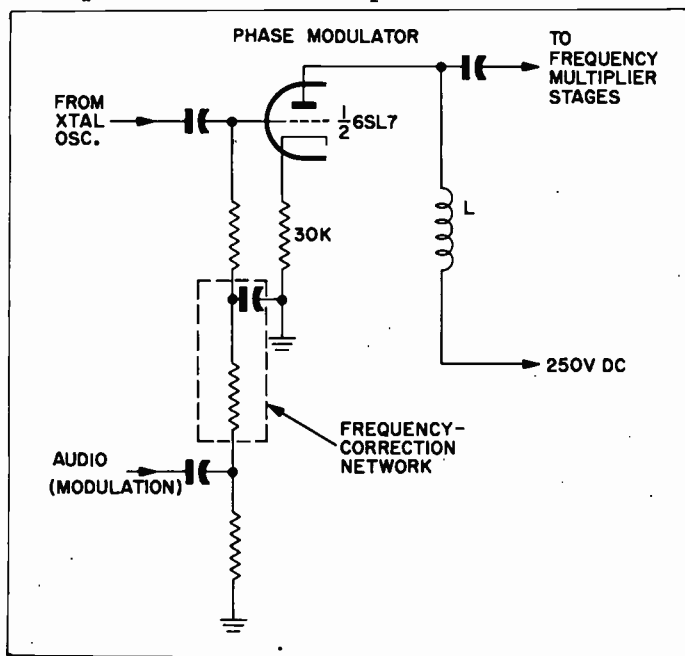

Figure 1. Schematic Diagram of Phase Modulator

explanation, is assumed to be half of a 6SL7GT, as shown in figure 1. The input to the phase-modulator tube, which we will call "the r-f signal," affects the plate circuit through the action of two different properties of the tube: the first is the grid-to-plate interelectrode capacitance (we will call the plate-circuit signal resulting from this action "the C_{gp} component"); the second is the transconductance (we will call the plate-circuit signal resulting from this action "the G_m component"). The C_{gp} component is nearly in phase with the r-f signal on the grid; however, the G_m component behaves in a different manner.

The equivalent circuit of the phase modulator is shown in figure 2. The plate inductor (L) is tuned by the stray circuit capacitance (which consists of the capacitance of the input circuit of the first multiplier, the phase-modulator plate-to-ground capacitance, and the wiring capacitance) to a frequency slightly below the lowest r-f signal frequency. For this reason, the plate load circuit will always appear capacitive, as shown by the dotted-line equivalent. The tube's plate resistance appears in series with the load as far as the amplified signal is concerned, and since the 6SL7 tube in the circuit shown will have a large value of r_p , as compared with the capacitive reactance of the load circuit, a large phase shift will occur (about 80 degrees at 1000 kc.). Thus, it can be seen that the normal 180-degree phase difference between the grid and plate signals of a vacuum tube is reduced by nearly 100 degrees.

Normally, the G_m component would far exceed the C_{gp} component; however, it is necessary to the proper functioning of this circuit that the two plate-signal components be nearly equal in amplitude. To accomplish this, the cathode resistor of the tube is made large enough (in this case

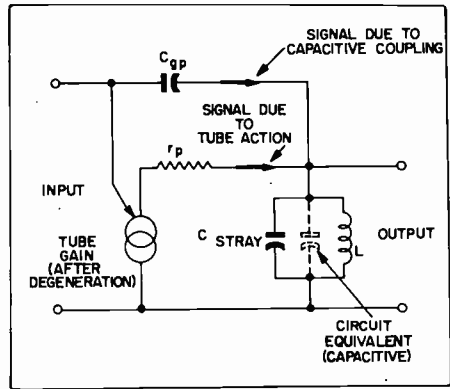

Figure 2. Equivalent Circuit of Phase Modulator

30,000 ohms) to cause a considerable amount of degeneration in the circuit.

The vector diagram in part A of figure 3 shows that the two signal components are 100° apart; this represents an average condition. The output signal appearing across the plate load circuit will be the vector sum of the two components, and, since the amplitudes of the component signals are equal, the output signal (represented in the vector diagram by the symbol S_r) will be midway in phase between the two. Because of the nearly quadrature phase relationship, this vector will rotate, in the direction shown by the arrow, through one complete revolution for each complete cycle of r-f signal applied to the grid of the tube. Under the condition of no modulation, it is obvious that the output signal (S_r) will have the same frequency as the r-f signal, i.e., the output frequency of the phase-modulator stage will be the crystal frequency.

When a modulating signal is applied to the grid of the modulator tube, the output frequency of the stage will no longer be constant; it will deviate above and below the crystal frequency at a rate dependent upon the frequency of the modulating

signal. In phase modulation, unlike frequency modulation, maximum deviation occurs when the rate of change in the amplitude of the modulating signal is maximum; that is, when the modulating signal is crossing the zero axis. To illustrate this point, let us see (vectorially) what happens to the output frequency of the phase modulator throughout one complete cycle of modulating signal.

Assuming, for purposes of explanation, that the starting point is that instant when the modulating signal is crossing the zero axis and increasing in a positive direction (see conditions at left in figure 4), the following facts should be obvious:

As the modulating signal increases in amplitude in a positive direction, the amplitude of the component G_m will increase; the amplitude of the C_{gp} component, on the other hand, will remain constant and will not be affected by the changes in grid-voltage level caused by the modulating signal. Since the G_m component is greater in amplitude, it is evident that the vector sum of the G_m and C_{gp} components will no longer be centered between the two but will be moved toward the G_m component. This is shown in part B of figure 3. Since it has been established that the vector S_r will rotate through one complete cycle for each cycle of the r-f signal, it can be seen that the resultant will no longer rotate at a constant frequency. When the modulating signal reaches its positive peak, the G_m component is maximum, and at that instant the resultant is closest to the G_m component. However, at this instant the resultant is again rotating at the crystal frequency. When the amplitude of the modulating signal goes from the positive peak to the negative peak, the resultant moves from the position shown in part B of

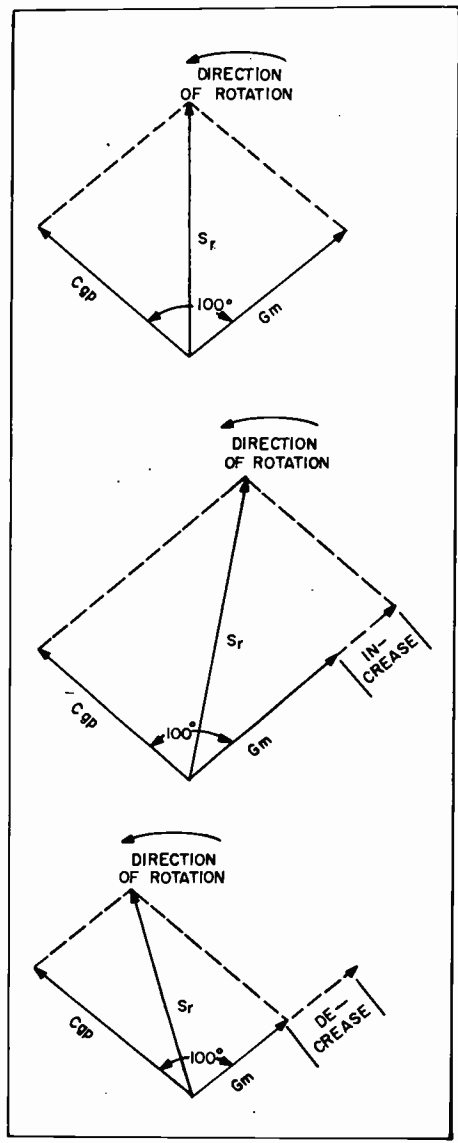

Figure 3. Vector Diagram Showing Effect of Modulation

figure 3 to the position shown in part C of figure 3, at which instant it is again at its extreme limit and therefore rotating at the crystal frequency.

What, then, has happened to the frequency of the resultant vector between the extremes shown in parts B and C? Starting at the extreme

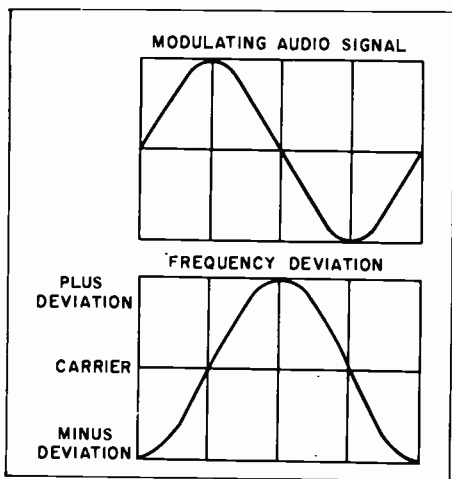

Figure 4. Phase Relationship Between Modulating Signal and Carrier Deviation

shown in part B, the resultant moves, in the direction of vector rotation, at ever-increasing speed until it reaches maximum speed at the point where the modulating signal is crossing the zero axis (the point of maximum rate of change of the modulating signal). If, at this point, the rate of rotation of the resultant is just 2° per r-f cycle greater than its "no-modulation" rate, the frequency deviation (for a crystal frequency of 1000 kc.) will be:

$$\frac{2 \text{ (degrees)} \times 1,000,000 \text{ (cycles)}}{360 \text{ (degrees)}} \\ = 5555 \text{ cycles}$$

Since the resultant vector is shifted in the same direction as it is rotating, the frequency shift is added to the crystal frequency to produce deviation on the high side of the crystal frequency. From the midway point to the extreme shown in part C, the rate of rotation of the resultant vector decreases until, at C, it is again rotating at the crystal frequency. To complete the cycle of the modulating signal, the rate of rotation of the resultant vector continues to decrease until it is again midway between the vectors representing the C_{gp} and G_m signal com-

ponents. This occurs as the modulating signal is again crossing the zero axis and increasing in the positive direction. At this point, the rate of rotation of the resultant is minimum (2° per r-f cycle slower than with no modulation), and the output frequency at this instant is the crystal frequency minus the deviation, or 1000 kc.—5555 cycles. From this point, the rate of rotation of the resultant once more increases until, as the modulating signal again reaches its positive peak, the resultant is again rotating at the crystal frequency (shown in part B). The relationship of the modulating signal to the deviation is shown in figure 3.

The deviation described here (2° shift for one r-f cycle) is an exaggerated value—for explanation purposes only. If phase shifting of this magnitude were attempted, much distortion would result. A close examination of the vectors shown in parts B and C of figure 3 will reveal that the extreme angular shift shown in part C exceeds that shown in part B, even though the increase and decrease of the G_m vector are of equal magnitude. To avoid this distortion (which is an inherent characteristic of phase modulation), the amplitude of the modulating signal is kept small, so that the maximum phase shift per r-f cycle is less than 0.1° . This produces much less deviation than that described in the example given above. In order to increase the deviation to that required at the transmitter output (usually ± 75 kc.), frequency-multiplier stages are always used in a phase-modulated transmitter.

Consideration of the action of the phase modulator will reveal another basic difference between frequency modulation and phase modulation. When frequency modulation is used, the deviation is determined only by the amplitude of the modulating



John Adams was born in Philadelphia, Pennsylvania, on March 9, 1924. After graduating from Frankford High School, he entered the U. S. Civil Service, and was assigned to the Philadelphia Signal Depot. In April, 1943, John entered the U. S. Army, and shortly afterward was assigned to a heavy air bombardment group in

England, where he performed electronic equipment maintenance. After reaching the rank of Staff Sergeant, he received his discharge in October, 1945.

In June, 1946, he joined the Tech-Rep Division, as a Philco Field Engineer, and was sent to the Philippines, where he served as an instructor and maintenance engineer. Here considerable experience was gained in communications and navigation equipment.

Since July, 1948, he has been working in the Technical Publications Department, where he has distinguished himself in a number of ways. He has acted as group leader for such projects as the Philco Training Manuals on the AN/TRC-1, 3, & 4, the CLR-6, and the CMT-4, and has assisted in the production of many noteworthy Philco service manuals.

signal. However, with phase modulation, the deviation is proportional to the frequency as well as the amplitude of the modulating signal.

The effect of changes in the frequency of the modulating signal can be seen in figure 5. Two sine-wave modulating signals of equal amplitude are shown, one of which is twice the frequency of the other. Consider the effect of the two sine waves in connection with the vector analysis used in figure 3. The solid lines in figure 5 represent the low-frequency sine waves, and, between points B and C, the rotating vector has been caused to move (in this case) in the direction of normal vector rotation. Thus, as the sine wave progresses from B to C, the output frequency is caused to vary from its center value to some higher frequency and then

back to the center value since the deviation is determined by how rapidly the amplitude of the modulating signal (and, therefore, the rate of vector rotation) changes. If the high-frequency modulating signal (dotted lines of figure 5) is considered, the corresponding points in the modulation cycle are points F and G. It is apparent that the rotating vector must now move through the same angular distance in half of the time. This means that the rate of change in rotational velocity is doubled, thereby doubling the deviation. Each time the modulating frequency is doubled (with constant amplitude), the deviation is doubled—a rise of 6 db per octave. This increase in deviation produced by a phase modulator as the frequency of the modulating signal increases is called pre-empha-

sis*, and it is a condition which is not desired.

To make the deviation produced by a phase modulator independent of changes in the modulating frequency, a frequency-correcting network is employed (usually at the input to the phase modulator). This network is called a de-emphasis circuit, or pre-distorter, and its action is to decrease the amplitude of the modulating signal in proportion to frequency. (It is actually a low-pass filter.) This effectively causes the G_m component to exhibit smaller changes in amplitude for higher modulating frequencies than would otherwise be the case, and thus restricts the extremes of movement of the resultant vector; that is, it causes the resultant vector to move through the same portions of a degree per r-f cycle for all modulating frequencies of the same amplitude.

Another way to consider the action of the de-emphasis circuit is to note (figure 5) that phase modulation effectively differentiates the modulating signal. The de-emphasis circuit provides sufficient integrator (low-pass-filter) action to exactly offset the effect of phase modulation. The overall result is a true frequency-modulated wave.

*It has become standard practice in both TV sound and standard broadcasting to allow a controlled degree of pre-emphasis (increased deviation at higher audio frequencies). The agreed value of the effective differentiator action (high-pass filter) is equivalent to that which would be produced by an RC network with a 75-microsecond time constant. This means that the higher

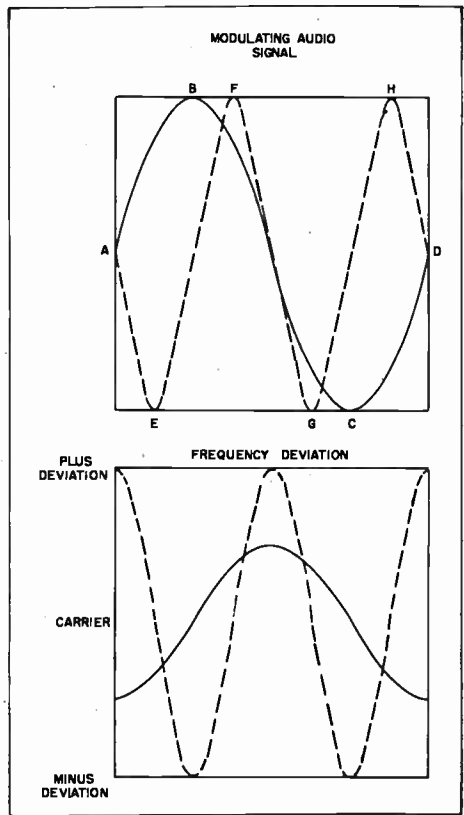

Figure 5. Comparison of Two Modulating Signals to Carrier Deviation, Showing the Effect of Increasing the Modulating Frequency

audio frequencies are actually emphasized in terms of modulation. This can be done without overmodulating because it has been found that audio-signal components at the higher frequencies ordinarily are of relatively low amplitudes. Of course, it is necessary to compensate for this effect at the receiver by inserting a 75-microsecond de-emphasis network into the audio system. The advantage in allowing pre-emphasis lies in the fact that most noise signals represent the higher audio frequencies, and increasing the modulation at these frequencies will tend to mask the noise.

ERRATUM

April issue, page 31; the last item in the parts list should read, "1 ea. Tube, miniature type OA2."

LOW-NOISE CONSIDERATIONS IN TV TUNERS

by Thomas J. Ryan, Member, I.R.E.
Headquarters Technical Staff

A treatment of the design considerations of r-f amplifiers used in TV tuners. Special emphasis is placed upon the cascode circuit and its newest refinements, as well as on sources of noise, methods of noise reduction, and input coupling techniques.

A great amount of emphasis, both in advertising claims and in design engineering, has been placed upon the r-f tuner, or "front end," used in television receivers. Though the specific requirements which all of these circuits must perform are fixed, it is in these circuits that the greatest range of design variations can be seen. It is found that these variations in circuit design have culminated in a nearly perfect r-f amplifier circuit, the basic form of which is known as the *cascode*, or *Wallman*, amplifier, and an improved version of which is incorporated into Philco's "Colorado" tuner.

REQUIREMENTS OF TV R-F AMPLIFIERS

Since the r-f amplifier, being the major source of receiver noise, limits the minimum perceptible, or usable, signal, let us consider the requirements that must, in some measure, be met in the design of such a stage.

Since the major purpose of this article is to discuss low-noise considerations in TV tuners, it is emphasized that the term *receiver noise*, as used in this article, refers to that noise which is generated within the receiver itself, as distinct from external noise injected into the receiver from the antenna; i.e., atmospheric, TVI, man-made noise, etc. For a better understanding of just how receiver noise

fits into the overall picture, the following TV r-f amplifier requirements are discussed briefly:

The first, but not the most important requirement is adequate sensitivity. Second, proper impedance matching to the antenna does much to increase the efficiency of the input stage, which, of course, improves the performance of the whole receiver. Third, sufficient selectivity to provide good image rejection along with adequate bandwidth (5 mc. or 6 mc. between 3-db points), could definitely be considered a requirement. Fourth, since an r-f amplifier is capable of suppressing local-oscillator radiation into the antenna, and therefore, subsequent external radiation, this feature could be considered as an additional requirement (oscillator radiation from receivers without an r-f amplifier is definitely a TVI problem in congested areas). The fifth, and probably the most important requirement, is that the r-f stage, being the first in the amplifier chain, must contribute as little receiver noise as possible to the following stages, where great amounts of amplification take place. This low-noise feature will be investigated in greater detail later in this article, and it will appear as the prime implement for determining maximum sensitivity.

Along with the above electronic requirements, this list should include the following other important con-

LOW-BAND FREQUENCIES			
CHANNEL	BANDWIDTH (MC.)	VIDEO CARRIER FREQUENCY (MC.)	AUDIO CARRIER FREQUENCY (MC.)
2	54— 60	55.25	59.75
3	60— 66	61.25	65.75
4	66— 72	67.25	71.75
5	76— 82	77.25	81.75
6	82— 88	83.25	87.75
HIGH-BAND FREQUENCIES			
7	174—180	175.25	179.75
8	180—186	181.25	185.75
9	186—192	187.25	191.75
10	192—198	193.25	197.75
11	198—204	199.25	203.75
12	204—210	205.25	209.75
13	210—216	211.25	215.75

Table I. Frequency Allocations For Television Channels 2 to 13

siderations:

The entire TV operating frequency range must be covered. At present, the VHF range includes twelve 6-mc. channels, spaced in the 54 mc. to 88 mc. and the 174 mc. to 216 mc. ranges, with a gap from 72 mc. to 76 mc. The actual channel assignments are shown in Table I. In a TV tuner there are three basic methods of selecting channels. The first entails a partial or complete circuit-substitution method, as exemplified by the turret tuner. It is an expensive and mechanically complicated method because of the coexistence in the tuner of the many circuit components. The second method requires considerably fewer components, in that circuit values of L or C are added incrementally to reduce the operating frequency (select channels); this type is exemplified by the wafer-switch tuner. The third type is the continuous

tuner, which, by changing L or C in a manner quite like that used in broadcast receivers, tunes a continuous band.

The assorted problems involved with channel selection in the continuous and wafer-switch type tuners are aggravated by the large frequency gap between the high and low bands; however, a number of ingenious methods have been devised to lessen the aggravation. Various combinations of the three basic channel-selection methods also exist, such as the use of a wafer switch to provide circuit substitution.

Two supplementary requirements of a TV tuner are circuit stability and reproducibility. It isn't enough that a circuit will work well when built in a laboratory, under the control of an engineer; it must also be readily mass-produced, easy to align, and

foolproof enough to be operated in the home.

A final requirement, which has been anticipated for several years and is now a reality, is the adaptability of the circuit to the new UHF TV channels recently approved by the FCC. It appears that only the turret type tuner can escape the addition of a converter mounted external to the tuner in operating in the UHF range from 400 mc. to 890 mc. (For the turret-type tuner, the UHF circuits can be supplied on turret-insert strips.) Almost all TV tuners will be able to receive UHF TV signals with the aid of an external converter. Figure 1 graphically shows the wide range covered by the VHF and UHF bands.

R-F AMPLIFIER REQUIREMENTS AS MET IN VARIOUS CIRCUITS

The basic cascode low-noise r-f amplifier is related to other amplifiers in many ways, so for background material let us first examine a few other circuits. An r-f amplifier may be thought of as consisting of three main portions: the input section, the amplification section (or tube), and the output section. In this discussion the last two portions will be considered together. Six examples of r-f amplifier input circuits are shown in figure 2.

The balanced, 300-ohm twinlead so very extensively used in modern TV requires a balanced input. In the transformer-coupled input circuit illustrated in figure 2A, the balance is provided by R_1 and R_2 connected across the transformer primary. In this circuit, we see the conventional grid-driven, grounded-cathode pentode input circuit. Signal-to-noise ratio is improved as much as 2 db by using a transformer to match the high grid-to-ground impedance of this amplifier to the transmission line.

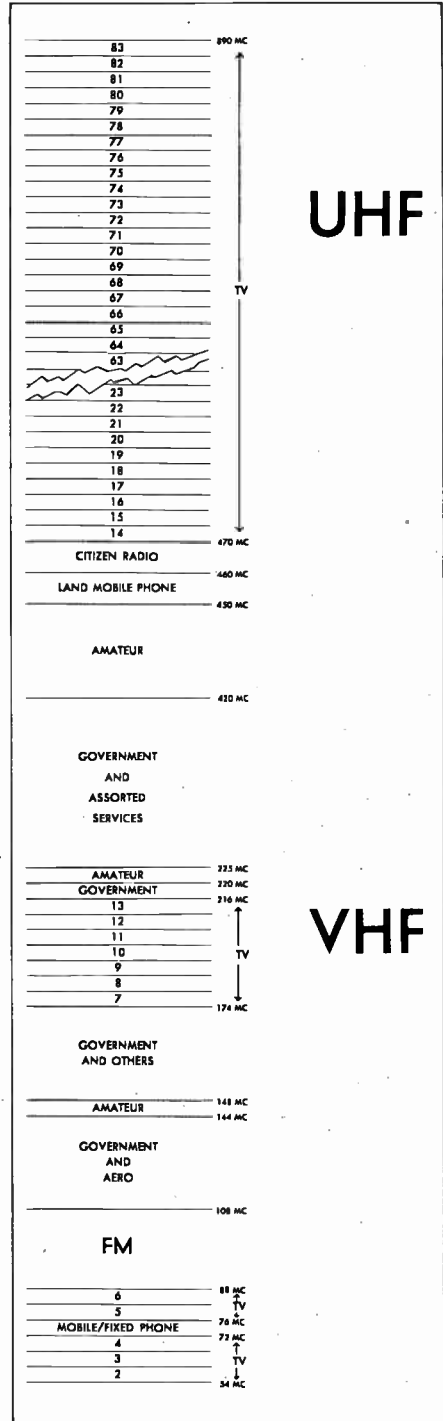

Figure 1. TV-Channel Frequency Allocations

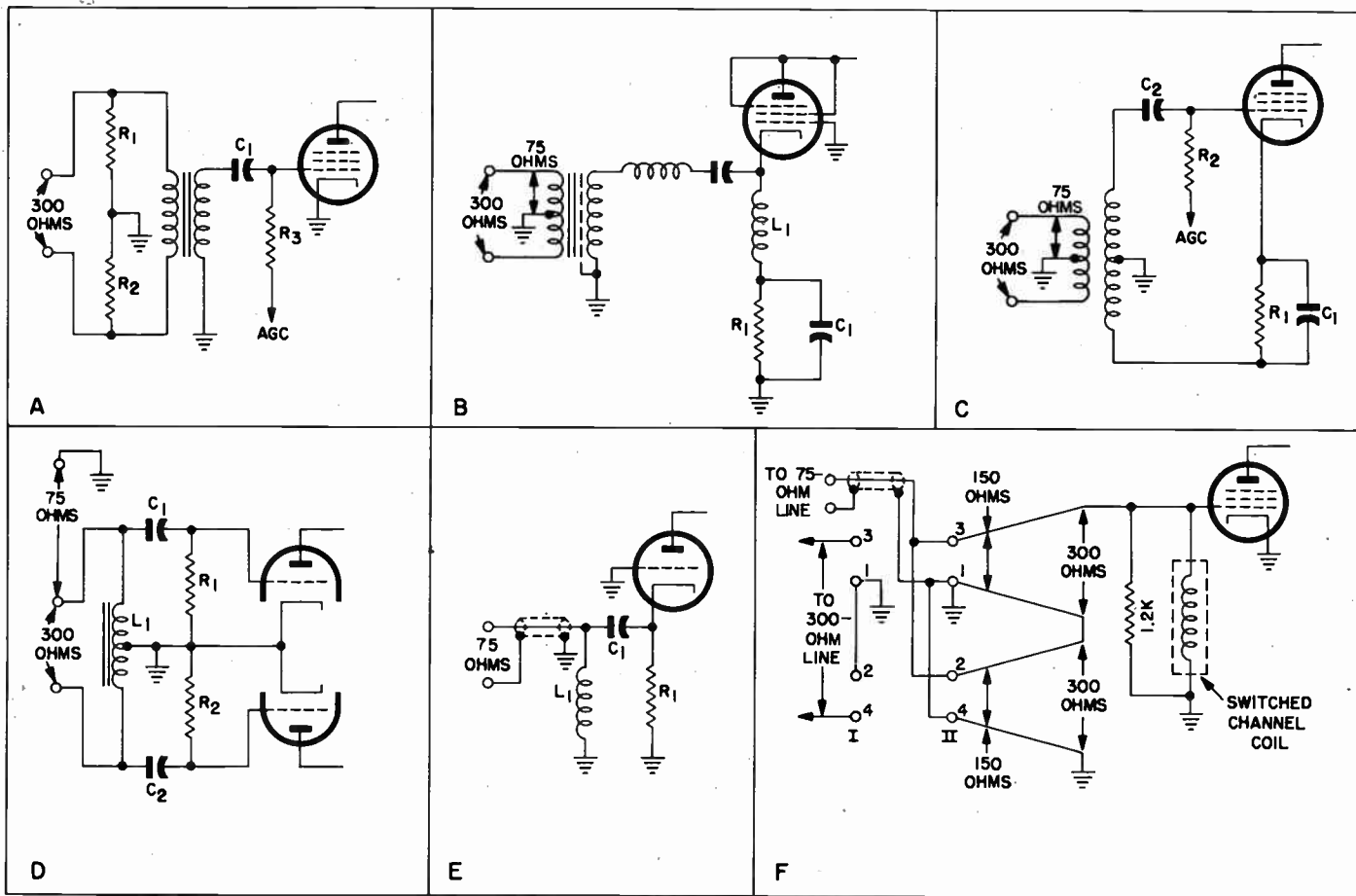

Figure 2. R-F Amplifier Input Circuits

A. Grid-Drive
 B. Cathode-Drive

C. Combination Grid-and-Cathode Drive
 D. Balanced Push-Pull Input

E. 75-Ohm Unbalanced Input
 F. Tapered-Line Input Section

In figure 2B, transformer coupling is also employed, but the design of the transformer includes a center-tapped primary which matches the 300-ohm impedance of the line. A Faraday shield isolates the secondary from electrostatically coupled noise from the primary. Cathode drive is used since the stage operates with a grounded grid. The plate current through R_1 develops bias for the stage, and since R_1 is bypassed by C_1 , the input signal appears across L_1 . Tuning of L_1 by any convenient method is, of course, highly desirable. (Note the absence of AGC voltage in this input-coupling method.)

A combination of the circuits shown in figures 2A and 2B is shown in figure 2C. This circuit allows use of both AGC and a balanced input, in that the signal is coupled to both the grid and the cathode. As in figure 2B, plate current through R_1 (bypassed by C_1) provides the bias. In effect, this input circuit is a transformer whose primary and secondary are center-tapped. The transmission line is terminated by a combination of the cathode input resistance and the tube's input resistance reflected through the transformer. For additional gain, the lower end of R_2 may be grounded instead of being connected to an AGC-voltage source.

It is an easy step from the center-tapped input transformer, driving the grid and cathode of a pentode, to the same type of input circuit driving two triode grids as a push-pull amplifier. In figure 2D, the transformer gives way to a balanced, center-tapped, powdered-iron-core choke, L_1 , and the signal developed across it is capacitively coupled to the grids across R_1 and R_2 (150 ohms each) which reflect the correct matching impedance across L_1 for input termination. For a 75-ohm coaxial input, the coax shield could be connected

to ground and the inner conductor to one input terminal, allowing the mutual inductance of L_1 to develop the signal for the other grid. We find in figure 2E an input circuit designed expressly for 75-ohm coax, but with this circuit external provisions would have to be made to use any other input impedance. The 75-ohm unbalanced coax impresses the signal across choke L_1 , and capacitive coupling is used to drive the cathode of this grounded-grid amplifier. It can be seen that varying the value of R_1 will change the input impedance of the circuit, and thus afford a means of matching impedances.

TAPERED-LINE INPUT SECTION

It is best, of course, if provisions are made to allow the use of either a 75-ohm or a 300-ohm input. This feature is found in the novel input circuit shown in figure 2F, which incorporates the tapered-line input section. Proper connections to the terminals will allow either 300-ohm or 75-ohm transmission lines to be properly matched. The two methods of connection are shown in (I) and (II) of this figure. The action of the tapered-line input section can be seen by noting figure 3 in which the two portions of the tapered-line section are expressed as equivalent resistances. The two main sections of the tapered-line input are open-wire transmission lines wound upon coil forms. Since the impedance of any air dielectric transmission line depends only upon the diameter and spacing of the conductors, we find that the shortness of this line, wound as it is upon these forms, does not enter into the impedance calculations, and the line may be considered to be electrically a long line.

The transmission line (acting as a long, open-wire line) has the two conductors closely spaced at the top

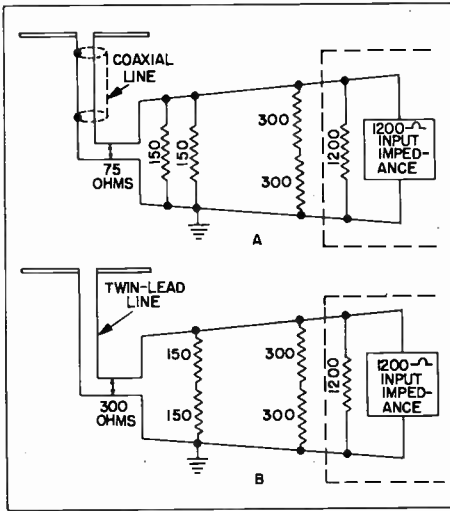

Figure 3. Simplified Diagram of Tapered-Line Input Section

of the form, and more widely spaced at the bottom, thus providing a transmission line whose impedance varies gradually along its length. The variation in spacing on each of the two forms can be seen in the photograph in figure 4.

The input end (closely spaced) of each tapered line has a characteristic impedance of 150 ohms, and the output end (widely spaced) has an impedance of 300 ohms. Since two identical lines are used, a 75-ohm input impedance can be obtained by paralleling the two lines, or a 300-ohm input impedance by connecting them in series. At all times the output ends are series connected, providing a 600-ohm output impedance. It is most desirable that the impedance be high at this point so as to afford a match to the grid input resistance of the amplifier.

INPUT RESISTANCE VERSUS FREQUENCY

The input resistance of an amplifier tube is known to change with frequency. In design engineering, the

reciprocal of input resistance (input conductance) of a vacuum tube is more conveniently used, and it varies approximately as the square of the frequency. Obviously, over a frequency range as great as the TV band, the input-conductance variation of an r-f amplifier tube is large. The relationship of input resistance versus frequency of a 6AG5 is shown graphically in figure 5. This change of input resistance with frequency is of great importance in the explanation of noise of an amplifier, and the graph will thus have a second and greater importance later. Note that at the low-band TV frequencies, a relatively high input resistance is presented by the tube, whereas at the high-band frequencies, this impedance drops to a very low value. The 1200-ohm resistor used as a termination to the tapered-line section (figure 2F) is equivalent to the input impedance of the tube at about 180 megacycles. The use of a resistor of 1200 ohms is a compromise value at best, but it provides the best overall performance. This 1200-ohm input impedance represents the input capacitive reactance of the tube, combined with the reactance of the grid coil which is inserted into the circuit. Two advantages are thus obtained: a voltage step-up, and a minimum standing-wave ratio presented to the antenna over the greatest part of the operating range. The voltage step-up in this circuit is proportional to the

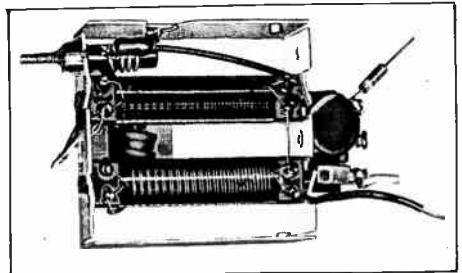

Figure 4. Tapered-Line Input Section

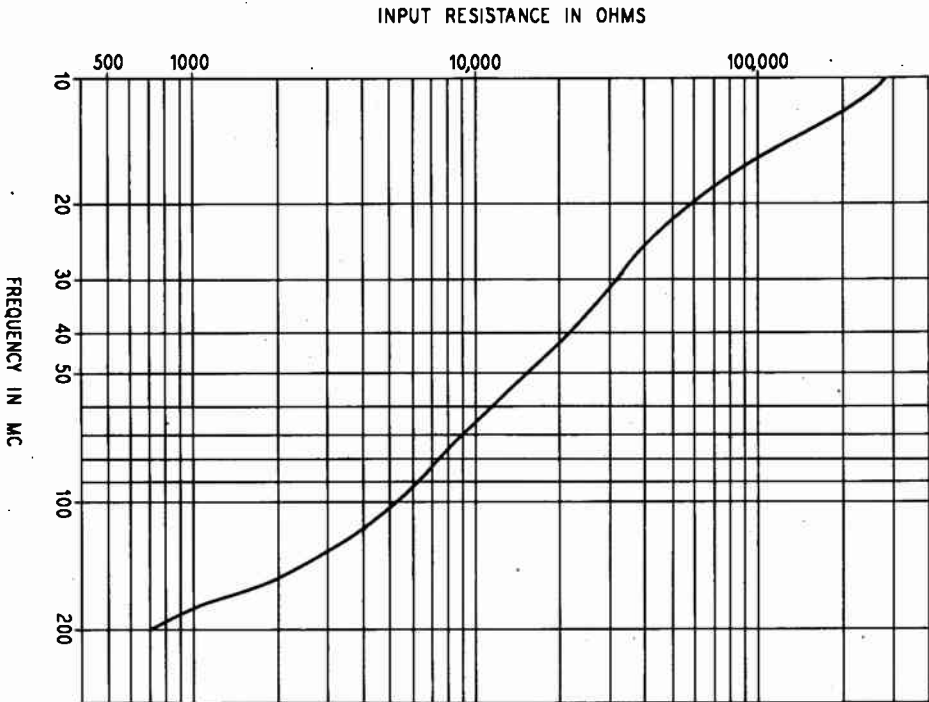

Figure 5. Input Resistance of a 6AG5 at Various Frequencies

square root of the impedance ratio. Thus, with an input impedance of 300 ohms and an output impedance of 600 ohms, a step-up of approximately 40% (in voltage) is realized. There is a limit to the amount of step-up which can be thus produced; this limit is set by the amount of input shunt capacitance present. For example, with a 10 μmf . input capacitance, the maximum permissible value of terminating resistance for a bandwidth of 6 mc. would be 1500 ohms.

TYPICAL CIRCUITS

Since the input section is a real part of the r-f amplifier, it will also be a factor in receiver-noise determination. By the use of a transformer or a bandpass filter, it is possible to step-up the signal voltage to the grid in an effort to overcome the receiver noise voltage. It has been mentioned

that there is a limit to how much improvement in noise factor can be achieved by the use of single- or double-tuned networks in the input. The double-tuned network is, in certain cases, most desirable from a noise standpoint, but not the most convenient to adjust in a production-type circuit. It exists in three common forms: the basic mutually coupled transformer, the pi (π) section, and the T section. Later in this article, an example of noise reduction by the use of an input transformer will be given. However, a little more introductory material is in order, so let us examine the r-f amplifier circuits shown in figure 6. It should be emphasized that these schematics represent only a fraction of the possible combinations of circuit components that may be encountered, and that many more combinations do exist.

In figure 6A, a push-pull r-f am-

plifier is illustrated, showing use of balanced input and output circuits. With triode operation at TV frequencies, neutralization is required. If the tube used in this circuit is a 6J6, which has a $1.6\text{-}\mu\text{f}$. interelectrode capacitance between grid and plate, the use of about the same value of neutralizing capacitance would require that C_1 and C_2 be about $1.6\text{-}\mu\text{f}$. each. Resistor R_3 across the center-tapped tank coil swamps the circuit to insure wide bandpass. Continuous tuning is obtained with C_3 and C_4 . The use of a grounded rotor in this circuit is highly advantageous, since no r-f current flows through the sliding contacts. R_4 is used as an isolating resistor so that any unbalance in the electrical configuration of the plate-coil circuit is provided with isolation from ground (through the power supply).

Triodes can be used without neutralization as VHF amplifiers in special circuits. One common circuit, called a grounded-grid r-f amplifier (figure 6B) has the advantage of reduced oscillator radiation (as compared with the grounded-cathode triode). The grounded grid acts as a shield between the input circuit and the output circuit, and, in conjunction with the cathode degeneration, eliminates the neutralization problem. In this common-impedance type of coupling circuit, C_6 is part of the mixer circuit as well as part of the r-f amplifier tuning circuit. By using C_6 in this position, the signal voltage developed across it from the r-f amplifier will also drive the mixer grid, and in this way C_6 will govern the bandpass of the mixer coupling circuit.

Grounded-grid amplifier service is not limited to triodes. To illustrate, in figure 6C a grounded-grid circuit is shown in which a pentode is triode-connected. The advantage of using

the triode-connected pentode in grounded-grid service is an improvement in noise figure on the order of 10 db as compared with the same tube in conventional pentode operation. In fact, this circuit was used successfully in a TV tuner because the pentode chosen had a lower noise factor when connected as a triode than did a triode used in grounded-grid service. In figure 6C, we see a different approach to the design of input and output circuits. A switch in the cathode lead connects L_2 and L_3 in parallel for high-band operation, in order to lower the total inductance. For low-band operation, the switch is opened, so that the entire inductance of L_2 is used. This method effects better matching in each range than if one swamped coil were used, and is cheaper than using a different coil for each of the twelve channels.

The advantages of triode operation, such as lower noise and simple circuits, are overlooked when high gain is desired, and the pentode tube, connected in the conventional manner, is used to develop the high gain. The pentode r-f amplifier shown in figure 6D uses the combination grid-and-cathode-drive type of input circuit, and a shunt-fed output circuit. The shunt feed is advantageous in a tuning circuit where sliding contacts are used to change the inductance, because it eliminates plate-current flow from this element. Because of the IR drop across plate-load resistor R_3 , the plate may be at a lower voltage than the screen unless a screen-dropping resistor is used. In the circuit of figure 6D, R_4 is the screen-dropping resistor, bypassed by C_4 . Where an inductive load is used in the plate circuit, such a small voltage drop exists across it that the screen may be directly connected to the B+ end of the plate tank, placing the screen and plate at about the same potential. An

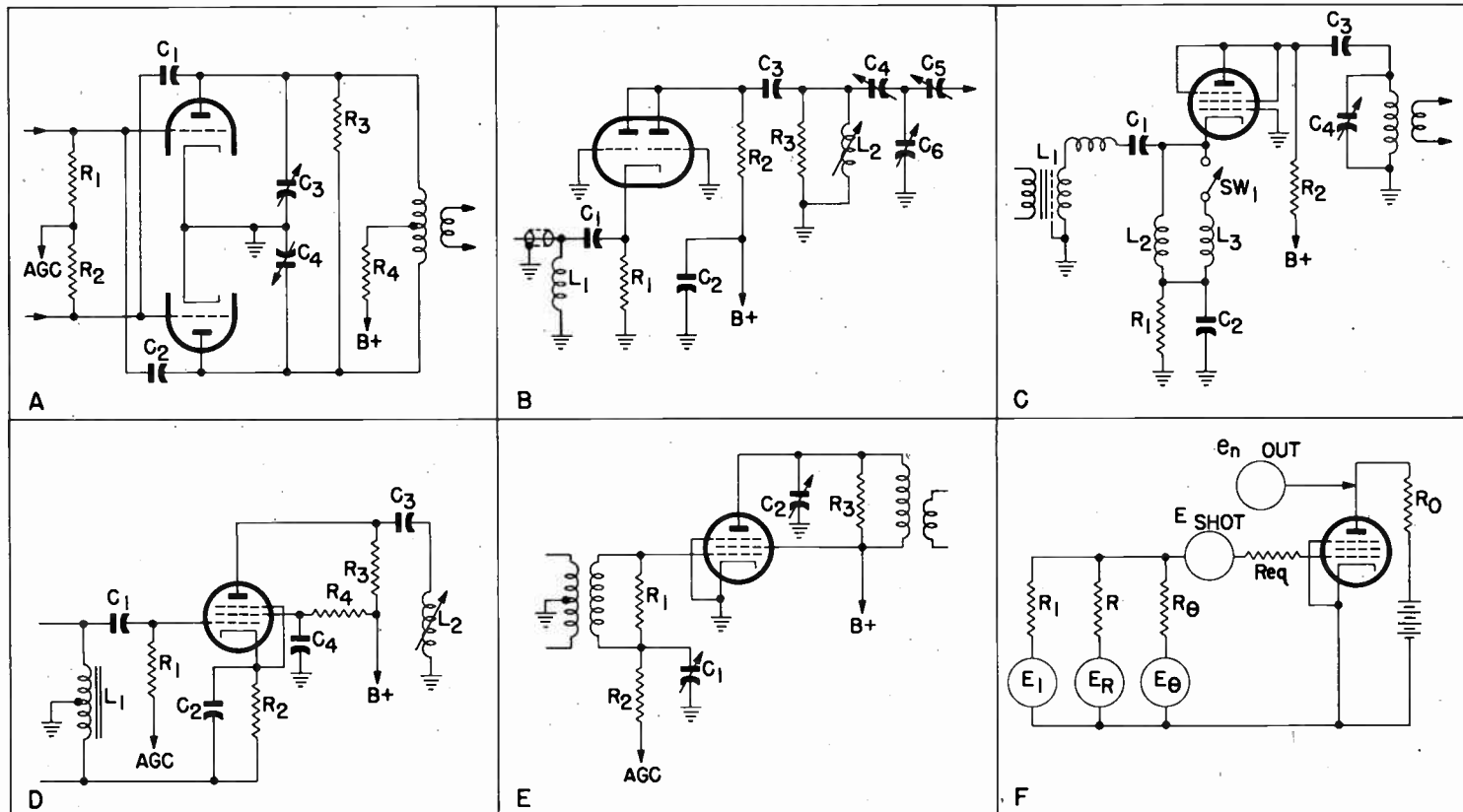

Figure 6. R-F Amplifier Circuits

- | | | |
|-------------------------|--------------------------------|--|
| A. Push-Pull Triode | C. Grounded-Grid Pentode | E. Grounded-Cathode Pentode |
| B. Grounded-Grid Triode | D. Grid-Cathode Driven Pentode | F. Noise Sources of a Grounded-Cathode Pentode |

inductive load is used in another very conventional type of pentode circuit illustrated in figure 6E. Grid drive is used in this pentode r-f amplifier in which the grid and plate circuits are not only shunted with resistors for wide bandpass, but the tuned circuits are stagger-tuned as well. Even with the resultant low-Q circuits, some care must be taken to prevent this circuit from operating as a tuned-plate tuned-grid oscillator.

NOISE CONSIDERATIONS

The expression "noise factor" has been mentioned a number of times in this article, so let us set down in exact terms just what it is. Its close relationship to "signal-to-noise ratio" (S/N) is pointed out by the expression for noise factor (NF) as a ratio:

$$NF = \frac{S/N_i}{S/N_a} = \frac{N_a}{N_i} \quad (1)$$

where

S = signal voltage

N_a = actual-amplifier noise voltage

N_i = ideal-amplifier noise voltage

This can best be expressed as the ratio of the amount of noise voltage that an actual amplifier would contribute to the following stage as compared to the amount of noise voltage an ideal amplifier would contribute. Expressed in decibels the equation becomes:

$$NF = 20 \log_{10} \frac{N_a}{N_i} \quad (2)$$

An ideal amplifier, in this case, is one which would amplify only the thermal noise voltage of the antenna itself. This antenna noise voltage would, in most cases, be the noise generated by the thermal agitation of an ideal 300-ohm resistor. The thermal agitation of an ohmic source will produce a value of noise voltage which is directly proportional to the square root of the resistance. The random nature of

noise will also require knowledge of the frequency band over which the noise is measured. Two other factors to be considered are the complex value of Boltzmann's constant and the temperature of the resistor. Noise voltage can be found by use of the expression:

$$e_n = \sqrt{4KT \Delta FR} \quad (3)$$

where:

e_n = noise voltage

K = Boltzmann's constant (1.37 x 10⁻²³ joules per degree Kelvin)

T = temperature in degrees Kelvin

ΔF = bandwidth in cycles per second

R = resistance in ohms

Since many are not accustomed to manipulating Kelvin-scale temperatures or values expressed in joules, a method of finding e_n in terms of R and ΔF should prove welcome at this time. After performing the necessary mathematical operations, the equation for e_n at room temperature becomes:

$$e_n = 1.28 \sqrt{R \Delta F} (10^{-10}) \quad (4)$$

We will find that equation 4 will be a most helpful tool in receiver-noise determination.

The first use to which equation 4 might be put is that of finding the value of noise voltage of a 300-ohm, TV-antenna input. It will be the same noise voltage as that of a 300-ohm resistor, so in all of our calculations we can use an equivalent resistor whenever we desire to know the noise voltage of some impedance. As ΔF we will use the standard 6-mc. TV bandwidth.

Substituting in equation 4 we have:

$$e_n = 1.28 \sqrt{3 \times 10^2 \times 6 \times 10^6} (10^{-10})$$

$$e_n = 5.39 \text{ microvolts} \quad (5)$$

It may come as a surprise to those readers in communications who are accustomed to using signals on the order of a microvolt or less, to find

that the thermal noise of the antenna input is over 5 microvolts. When it is considered that this one source of noise may account for only 1/6th or less of the total receiver noise, one can see the importance of good design with emphasis on low-noise operation if it is desired to operate the receiver on any signal of less than a few hundred (or more) microvolts. It would be wonderful indeed if, even with this large noise voltage we have to start with (5.39 microvolts), we could hope to apply it to an amplifier input, along with whatever signal voltage we had developed in the antenna, and have both amplified, with the resultant amplified output possessing the same signal-to-noise ratio as the input. Such a circuit could well be called an "ideal amplifier," but such a circuit does not exist. To find the total noise input, the 5.39-microvolt antenna noise must be added to the various other noise voltages contributed by the amplifier itself. For purposes of calculation, these voltages can also be reduced to equivalent resistive thermal noise voltages as with the 300-ohm impedance of the antenna.

To enumerate all the noise sources and find the total noise of an r-f amplifier, we might use as an example the equivalent circuit of a grounded-cathode amplifier having an untuned (or broadly tuned) input circuit shunted with an input terminating resistor, and show each of the noise sources as resistive elements across which thermal noise voltage is developed. Figure 6F is such an equivalent noise circuit. Because of the signal amplification that takes place, the noise generated by the output impedance and the noises generated by the following tubes can be neglected, because the noise developed beyond the input stage has very little effect on the over-all noise factor of the re-

ceiver; in fact, the following tube seldom increases the noise factor by even .5 db.

The single source of noise voltage already mentioned is, of course, included in this circuit as R_1 , the generator (or antenna) impedance. By using equation 4, the thermal-agitation voltage produced by R_1 can be found; this voltage is indicated as E_1 . A voltage-divider network is produced by the line terminating resistor R and the transit-time resistance R_θ . The "equivalent noise resistance" (R_{eq}) of the tube ("shot noise") is in series, and therefore plays no part in the divider. The portion of E_1 reaching the grid can be called e_{g1} , and the voltage-divider action expressed as:

$$e_{g1} = E_1 \left[\frac{1}{\frac{R_1 (R + R_\theta)}{R R_\theta} + 1} \right] \quad (6)$$

The second noise voltage appearing at the grid is the thermal-agitation voltage developed by the resistor R used as the line termination; this noise can be calculated as E_R by the use of equation 4. We can find the amount of E_R that will be applied to the grid and call it e_{gR} , because E_R is applied to a similar voltage-dividing network. Substituting values, we can apply the form of equation 6 to produce:

$$e_{gR} = E_R \left[\frac{1}{\frac{R (R_1 + R_\theta)}{R_1 R_\theta} + 1} \right] \quad (7)$$

The third noise voltage applied to the grid is that due to the transit-time input resistance (R_θ) of the tube. As are the other noise voltages already discussed, it is related to the band of frequencies to be amplified, but its value is determined more by the frequency of operation than by the bandwidth.

The loading effect of the tube's lead inductance and the effect of transit time tend to make the input conductance higher at high frequencies than at low frequencies. For an improvement of noise figure, the choice of tube used in the amplifier requires close grid-cathode spacing to reduce transit time and to reduce the length of tube-element leads as much as possible.

The input conductance varies almost as the square of the frequency so the transit-time resistance can be assumed to vary inversely as the square of the frequency. While it is almost infinite at low frequencies, transit-time resistance drops to only a few hundred ohms in the VHF range, and can become the largest source of noise at frequencies over 100 mc. The graph of figure 5 illustrates this relation between frequency and input resistance for a typical tube.

It has been found that a fairly accurate value of noise voltage can be calculated for the transit-time input resistance (R_{θ}) by considering the thermal-agitation as existing at a level of five times room temperature. The expression for the noise voltage of R_{θ} (equation 4) thus becomes:

$$\begin{aligned} E_{\theta} &= 1.28 \sqrt{5R_{\theta} \Delta F} (10^{-10}) \\ &= 2.87 \sqrt{R_{\theta} \Delta F} (10^{-10}) \end{aligned} \quad (8)$$

Since the noise voltage E_{θ} appears across the third portion of the voltage divider network, we can find that portion which is applied to the grid and call it $e_{g\theta}$ which, as before, is found by

$$e_{g\theta} = E_{\theta} \left[\frac{1}{\frac{R_{\theta} (R + R_1)}{RR_1} + 1} \right] \quad (9)$$

The final noise voltage applied to

the grid is the sum of the shot noises generated within the tube. Some of this noise is generated as a result of the random emission of electrons from the cathode and their random arrival at the plate, but the largest factor in shot noise is the thermionically produced noise voltages generated within the tube elements themselves as a result of their temperature. (Some readers may be acquainted with the use of thermionic tubes as noise generators.) Apparently these noise sources are unaffected by frequency of operation, and therefore their effect remains constant throughout the range of the television bands.

For ease of calculation, we might lump all the tube's noises together and express the total in terms of a value of resistance (R_{eq}) that would produce the same amount of thermal-agitation noise voltage as is being produced by shot effect. This would enable us to handle shot noise as a common-resistance noise source. If the shot-noise voltage of a large assortment of tubes were measured and then reduced to the noise developed by an equivalent resistance R_{eq} , then from the data so obtained the value of R_{eq} would be found to relate to certain tube characteristics, as shown below in the case of a triode:

$$R_{eq} = \frac{2.5}{g_m} \quad (10)$$

where

g_m = mutual conductance of the tube in mhos

2.5 = an empirical constant

Equation 10 indicates only the noise developed by the random emission and collection of electrons by the cathode and plate in a triode, but if an additional element were added such as a screen grid, an additional noise source must be taken into account. The partition effect in a screen-grid tube (where a random division

of cathode current is passed off as part screen current and part plate current) requires the inclusion of these two factors in determining the value of R_{eq} . Modifying equation 10 for screen-grid tubes:

$$R_{eq} = \frac{I_p}{I_p + I_{sc}} \left(\frac{2.5}{g_m} + \frac{20 (I_{sc})}{g_m^2} \right) \quad (11)$$

where

I_p = plate current in amperes
 I_{sc} = screen current in amperes

By comparing equations 10 and 11 it can be seen that a pentode is a source of greater shot noise than is a triode.

Since R_{eq} is not a real resistor but simply a value that represents a noise source within the tube, it is placed in series with the external noise sources, and need not be considered in the voltage-divider action. The value of R_{eq} can be used in equation 4 to find the value of shot-noise voltage E_{shot} which is applied directly to the grid as e_{gs} , so it can be expressed as:

$$E_{shot} = e_{gs} \quad (12)$$

The total noise voltage e_{gt} appearing at the grid is quite easy to determine, because the random nature of the noise will produce an rms sum of the four individual sources. Thus:

$$e_{gt} = \sqrt{e_{g1}^2 + e_{gR}^2 + e_{g\theta}^2 + e_{gs}^2} \quad (13)$$

The total noise voltage e_{gt} at the grid will be amplified by the tube in the same manner as would a signal. The pentode will have a gain which will exist in this relation:

$$\text{Gain} = g_m R_o \quad (14)$$

where:

g_m = tube's mutual conductance in mhos

R_o = output load resistance
 (where $R_o \ll r_p$) and r_p is the tube's plate resistance

in ohms.)

The pentode gain factor so derived indicates only tube gain, not the overall gain available from the circuit, but this gain factor can be applied to the noise voltage e_{gt} at the grid to find the output noise voltage at the plate. Thus:

$$e_{n \text{ out}} = g_m R_o e_{gt} \quad (15)$$

where

$e_{n \text{ out}}$ = output noise voltage

If it is recalled that the noise factor is simply the ratio of the noise of an actual amplifier to that of an ideal amplifier (equation 1), it will be noted that the value of $e_{n \text{ out}}$ is the noise voltage of an actual amplifier. The output noise voltage of the ideal amplifier is e_{g1} times the gain, because in an ideal amplifier all other noise voltage would be zero, leaving only e_{g1} to be amplified. Expressed as an equation:

$$NF = \frac{N_a}{N_i} = \frac{e_{n \text{ out}}}{e_{g1} g_m R_o} \quad (16)$$

The difference between the two values of noise is obvious, in that N_a contains the values of amplified noise of e_{gR} , $e_{g\theta}$, and e_{gs} , as well as that of e_{g1} , whereas N_i contains only the amplified value of e_{g1} .

If we select a tube such as the 6AG5 to use as an example, various tube and circuit constants then avail themselves for use in obtaining an actual numerical value for noise factor in the circuit of figure 6F. One of the values required has already been given (300 ohms, for R_1). Since R is the resistor shunted by R_θ as a termination for the 300-ohm transmission line, the proper value for R can be found by:

$$R = \frac{R_\theta R_1}{R_\theta - R_1} \quad (17)$$

The selection of the 6AG5 will set the values for R_o , g_m , and R_{eq} , and, in a sense, the value for R_o as well. The graph of figure 5 enables us to find a value of R_o for any given frequency (F) for this tube, but if the graph were not available, knowledge of the input conductance would be required. If such data were at hand, the input conductance would be converted to R_o by taking the reciprocal of R_o and remembering that it varies approximately as the square of the frequency. Since R_o varies with the operating frequency, then so will the proper value of R because of the relation shown as equation 17. At very low frequencies, R_o would be near-infinite, but at 70 mc. (near the center of the low-band VHF TV channels), its value drops to about 9000 ohms, and at 195 mc. (near the center of the high-band TV channels), R_o is somewhat less than 800 ohms—a great change indeed. If we were to substitute these values of R_o in equation 17, assuming $R_1 = 300$ ohms, the values of R would be found to be:

at low frequencies	300 ohms
at 70 mc.	310 ohms
at 195 mc.	480 ohms

It can be seen from the above values, that if only one compromise value of resistor R were chosen, it would be a value that would favor a desired portion of the frequency range over the other; however in our example we will use the above values. With an assumed value of $10 \mu\mu\text{f.}$ as the complete output circuit capacitance, R_o may be determined for a bandwidth of 6 mc. If a fair approximation of R_o is desired, the following expression may be used:

$$R_o = \frac{0.046}{f_1 C} \quad (18)$$

where

C = total shunt capacitance

f_1 = across R, in farads
 = one half the bandwidth
 desired in the plate circuit,
 in cycles per second
 0.046 = a constant for this
 approximation

If the aforementioned values were substituted in equation 18, R_o would equal approximately 1530 ohms. In an actual circuit, the output load shown as R_o may be higher than the value of 1530 ohms, but it should be understood that R_o would be shunted by the R_o of the following tube to the extent that the actual value of effective load would remain at 1530 ohms. A list of the 6AG5 tube characteristics provides the values of mutual conductance ($5000 \mu\text{mhos}$), plate current (0.007 amp.), and screen current (0.002 amp.) required for determining the value of the last unknown, the equivalent noise resistance of the tube, R_{eq} . Substituting this data in equation 11 and solving for R_{eq} :

$$R_{eq} = \frac{0.007}{0.007 + 0.002} \times \left[\frac{2.5}{5 \times 10^{-3}} + \frac{20 \times 0.002}{5^2 \times 10^{-6}} \right] = 0.778 (500 + 1600) = 1634 \text{ ohms} \quad (19)$$

A recapitulation of the data now at hand that will provide a value of noise factor at the low- and high-band center frequencies is tabulated in Table 2. The choice of a 6AG5 tube as the example is a rather fair start so far as noise factor is concerned, because even if an improved type of pentode such as the 6CB6 were used in the example in place of the 6AG5, the NF would be 13.3 db at 70 mc., and 13.7 db at 195 mc. Though only a 0.5 db improvement would be realized, such a reduction is always sought after, especially since neither set of noise factors is particularly good.

FUNCTION	SOURCE	AT 70 MC.	AT 195 MC.
e_{g1}	Equations 4 and 6	2.7 μ volts	2.7 μ volts
e_{gR}	Equations 4 and 7	2.7 μ volts	2.1 μ volts
e_{gO}	Equations 8 and 9	1.1 μ volts	3.7 μ volts
e_{gS}	Equations 4 and 12	12.62 μ volts	12.62 μ volts
e_{gt}	Equation 13	13.2 μ volts	13.6 μ volts
$e_{n \text{ out}}$	Equation 15	101.0 μ volts	104.0 μ volts
N.F.	Equations 2 and 16	13.8 db	14.0 db

Table II. Noise Characteristics of 6AG5 in Circuit Without Input Voltage Step-Up

Even with the large variation in transit-time input resistance (R_{θ}) between high and low band and its effect on the value of circuit resistance, (R), less than one-half db difference in the noise factor can be thus attributed, because of the dominance of shot noise (E_{shot}) with the aforementioned tubes in this circuit.

The fair showing of the 6AG5 would appear a lot better if it were considered alongside a tube like the 6AU6 where the value for E_{shot} is about 16 microvolts as compared to 12.6 microvolts for the 6AG5.

NOISE-FACTOR IMPROVEMENT

With any given tube, an improved noise factor can be realized over that of an untuned input circuit by inserting a band-pass filter for each television channel and obtaining a signal-voltage step-up through transformer action in an effort to overcome the shot noise of the tube. Since this circuit is located within a television tuner, it will result in an excessive amount of input capacitance due to the switch and stray capacitance which will total about 10 $\mu\text{mf.}$ in a practical tuner. If this high value of input capacitance is used along with a value of 6 mc. for the bandwidth in determining a value

of effective secondary shunt resistance (R_s) by means of equation 18, the result will be:

$$R_s = \frac{0.046}{3 \times 10^6 \times 10^{-11}} = 1,530 \text{ ohms} \quad (20)$$

In view of the fact that this 1,530-ohm value of R_s represents the upper limit (as long as R_{θ} is greater than 1530 ohms), then no further noise-factor improvement can be obtained by this means. It is interesting to note that this value of R_s does not correspond to perfect impedance match; however, the mismatch is tolerated in order to obtain the best noise factor. In fact, a perfect impedance match may increase the noise figure in some circuits by more than 3 db.

If the operating frequency is raised to a point where R_{θ} falls below 1530 ohms, then the value of R_s must be reduced by a like amount, or the noise factor will be increased. With the 6AG5 as the example, this means that operation above about 160 mc. will result in a value of R_{θ} below 1530 ohms, with a consequent reduction of R_s (from the graph in figure 5). The primary circuit resistance (as seen from the secondary) will be R_1 , and therefore the same value as R_s ;

FUNCTION	SOURCE	AT 70 MC.	AT 195 MC.
e_{g1}	Equations 4 and 6	6.13 μ volts	4.43 μ volts
e_{gR}	Equations 4 and 7	5.59 μ volts	0.0 μ volts
$e_{g\theta}$	Equations 8 and 9	5.66 μ volts	9.9 μ volts
e_{gs}	Equations 4 and 12	12.62 μ volts	12.62 μ volts
e_{gt}	Equation 13	16.1 μ volts	16.6 μ volts
$e_{n \text{ out}}$	Equation 15	123.17 μ volts	126.99 μ volts
N.F.	Equations 2 and 16	8.4 db	11.5 db

Table III. Noise Characteristics of 6AG5 in Circuit With Step-Up Input Transformer

consequently both R_1 and R_s will be varied lower in value when the circuit is operated at frequencies above 160 mc. because of their dependence on R_θ .

As before, resistor R shunted across R_θ brings the combination down to the value of R_s in the same manner as in equation 17. Thus:

$$R = \frac{R_s R_\theta}{R_\theta - R_s} \quad (21)$$

Numerical values for R_s in the circuit of figure 6F (modified to include step-up transformer input, and incorporating a 6AG5 tube) are as follows:

At low frequencies, where R_θ is infinite: $R_s = 1530$ ohms.

At 70 mc., where R_θ is 9000 ohms: $R_s = 1530$ ohms.

At 195 mc., where R_θ is 800 ohms: $R_s = 800$ ohms.

There is now enough data to compute the noise voltages and noise factor of the 6AG5 pentode in the grounded-cathode r-f amplifier with a step-up input transformer. The essential data is presented in Table III, in the same form as in Table II.

There are two paramount conclusions to be drawn from an examination and comparison of the values

recorded in Tables II and III.

First, for a given tube and an input circuit that includes a properly designed step-up transformer, the noise factor can be reduced by an amount in excess of 3 db. However, the improvement is limited to the extent that as the input resistance of the circuit (R_θ) is reduced by an increase of the operating frequency range, the step-up and resultant noise-factor improvement is reduced to a minimum value. It was pointed out that the largest noise voltage was that due to the tube's shot effect which remained constant with each input circuit, so the improvement can be laid to the increase in the value of e_{g1} produced by the step-up transformer.

The second (and equally important) conclusion is that though the employment of a tube with a lower value of shot noise, such as the 6CB6 whose R_{eq} is 210 ohms lower, with a resultant lower e_{gs} , may provide a better noise factor in some instances (no step-up input circuit), but in others a poorer noise figure due to the generally lower value of input resistance R_θ at all frequencies which puts a lower maximum and minimum limit on the allowable step-up ratio.

There is an ingenious method of reducing the input conductance of a

tube, with the resultant increase of R_0 and noise-factor improvement, but it is conspicuous by its absence in the r-f amplifier of television tuners. The inclusion of an inductive element in the screen-grid lead reflects to the control grid (by virtue of Miller effect) an amount of negative resistance which tends to increase the input resistance R_0 .

THE TRIODE R-F AMPLIFIER

A number of attempts have been made to utilize triodes as the r-f amplifier in television tuners in order to take advantage of their relatively noise-free operation. Such circuits as the grounded-grid triode and the push-pull triode amplifiers are notable examples. However, they have the disadvantages of providing less gain, severe oscillator radiation (through their high grid-to-plate capacitance) and their requirement of neutralization. The overall noise factor of the triode grounded-grid amplifier is very

much dependent on conditions in the following stages. It can be expressed by the relationship:

$$NF_t = NF_1 + \frac{NF_2 - 1}{G_1} \quad (22)$$

where

NF_t = noise factor of entire amplifier

NF_1 = noise factor of first stage

NF_2 = noise factor of second stage

G_1 = power gain of first stage

The noise factor of the second stage depends, to a great extent, upon the impedance of the source driving the first stage. When minimizing the noise factor of the two stages as a unit, the source impedance may well be a different value than that which would provide the best first-stage noise factor. The noise factors for push-pull amplifiers used without input transformers are the same as for their single-ended equivalents, except that the tube noise contribution is double that of the single-ended circuits—in

TUBE	CIRCUIT	NOISE FACTOR (DB)	
		AT 70 MC.	AT 195 MC.
6AB4	Triode, grounded grid, with broadly tuned matching transformer	5.0	6.0
6AB4	Triode, grounded grid, matching transformer, with 12AT7 converter	6.6	8.2
6CB6	Pentode, grid-and-cathode fed, with broadly tuned matching transformer	7.0	11.6
6AG5	Pentode, grounded cathode, with step-up input transformer	8.4	11.5
6CB6	Pentode, grounded cathode, with step-up input transformer	8.5	12.1
6CB6	Pentode, grounded cathode, with no step-up at input	13.3	13.7
6AG5	Pentode, grounded cathode, with no step-up at input	13.8	14.0

Table IV. Comparison of Noise Factors of Various Typical Circuits

the push-pull case, R_{eq} would be replaced by $2R_{eq}$. However, if a step-up input transformer is employed, so that a voltage equal to or greater than the input voltage is applied to the grid, then an improvement in noise factor will be obtained. Noise factors for these and other circuits can be obtained by developing equivalent noise circuits and proceeding along courses of calculation similar to that accomplished with the 6AG5 pentode circuit. The results of such labors are tabulated for comparison in Table IV.

THE CASCODE R-F AMPLIFIER

An almost incredible combination of the favorable characteristics of triodes was developed by Henry Wallman, in the form of a very-low-noise-factor circuit called the "Cascode" amplifier. It uses a grounded-cathode triode amplifier driving a grounded-grid triode amplifier. The usual instability of triodes is avoided through the action of the low input impedance of the grounded-grid amplifier acting as the plate load for the first stage. In fact, the first-stage plate load is of such a low value that the voltage amplification of the stage is unity, or

in many cases, less than unity. However, the complete two-tube circuit will provide the gain of a pentode, along with the stability and non-critical operation of the pentode. The most important feature of the cascode, from the standpoint of this article, is that along with the "pentode gain" it has the low noise factor of a triode. The use of a triode as the second tube keeps the noise factor, NF_2 , to as low a value as possible (see equation 22), and the first tube provides the necessary power gain (G_1) to make the total noise factor (NF_1) almost entirely related to the noise factor of the first triode (NF_1).

It seems that for a given type of triode, the same factor will result, regardless of which of the three types of input circuits the tube is associated with. The three input circuits (the grounded cathode, the grounded grid, or grounded plate) can be cascaded in nine possible ways when two triodes are used. Wallman, A. B. Macnee, and C. P. Gadsden made theoretical and experimental investigation of these nine possibilities, and found the best combination with regard to noise factor, stability, and

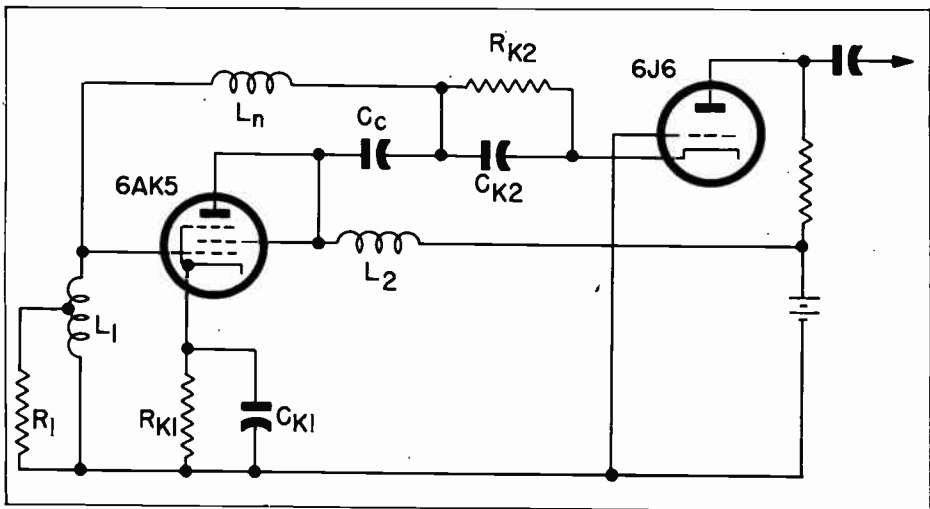

Figure 7. Basic Wallman Cascode Amplifier

gain. The result of this work appears as the practical circuit illustrated in figure 7.

Because of some desirable electrical characteristics which will be explained in detail shortly, a 6AK5 was triode-connected and used as the grounded-cathode input stage in this circuit. One might think that the existence of the grounded suppressor between the screen and plate would effect the operation of the stage because of the increased plate-to-cathode capacitance. Such a connection would result in a C_{p-k} of about $3 \mu\text{mf.}$, but this capacitance is tuned out by external elements. To make the matter conclusive, equal performance was actually obtained with a 6AS6 whose screen and suppressor were both tied to the plate.

Due to the aforementioned high plate-to-cathode capacitance, it is not practical to use a pentode which has the suppressor internally connected to the cathode in grounded-grid service. Therefore, a triode of the 6J6 type is often used. A much better triode such as the type 6J4 could be used, but this stage of the cascode contributes so little noise that its use would be sheer extravagance. The 6J6 in this service provides a G_m of $5000 \mu\text{mhos}$, and, when properly grounded, has a cathode-to-plate capacitance of only $0.25 \mu\text{mf.}$

Conventional cathode bias is produced for each stage by resistors R_{k1} and R_{k2} , bypassed by capacitors C_{k1} and C_{k2} . The input transformer L_1 is resonated at the operating frequency by the input circuit capacitance.

The source resistance, R_1 (like R_1 mentioned previously), is stepped up by L_1 to an optimum value of R_s which, for minimum noise factor in this circuit configuration, is 2500 ohms at 30 mc., and 400 ohms at 150 mc. These figures indicate the step-up

limitation to be expected in this circuit by a reduction of R_s .

The tuned circuit of L_2 , resonated by about $10 \mu\text{mf.}$ of interstage capacitance, is heavily loaded by the grounded-grid stage, which makes for very-wide-band operation.

Plate current for the 6J6 flows through L_1 , L_n , R_{k2} , the tube, and thence through its output load to B+.

The neutralizing coil (L_n) is not a critical component, and is not required for stability. Used only to lower the noise factor, its removal would increase the noise factor more at high operating frequencies than at low frequencies. L_n is tuned to the operating frequency by the $1.2\text{-}\mu\text{mf.}$ grid-to-plate capacitance of the 6AK5, and should, if used, have a Q of about 200 for best noise factor.

In a 30-mc. cascode amplifier with 6-mc. bandwidth (as constructed by Lawson and Nelson) over 100 different 6AK5 tubes were checked for system noise factor with results running from 1.1 db to 1.9 db, with a mean noise factor of 1.35 db. Circuit values of interest included a Q of over 200 for L_1 , 70 ohms for R_{k1} , and 70 volts on the plate of the 6AK5. This circuit would make a wonderful i-f amplifier input section.

SOURCES OF NOISE IN THE CASCODE CIRCUIT

In figure 8, the circuit of figure 7 is converted to an equivalent-noise-source schematic for determination of cascode noise factor, in the same manner as was done with the pentode. To provide a different set of values, we might use a single duo-triode of the 12AT7 type which, though not designed for use in cascode service, will serve as an example in this theoretical cascode amplifier in which each section is a high- μ triode. This tube has exceptionally good characteristics

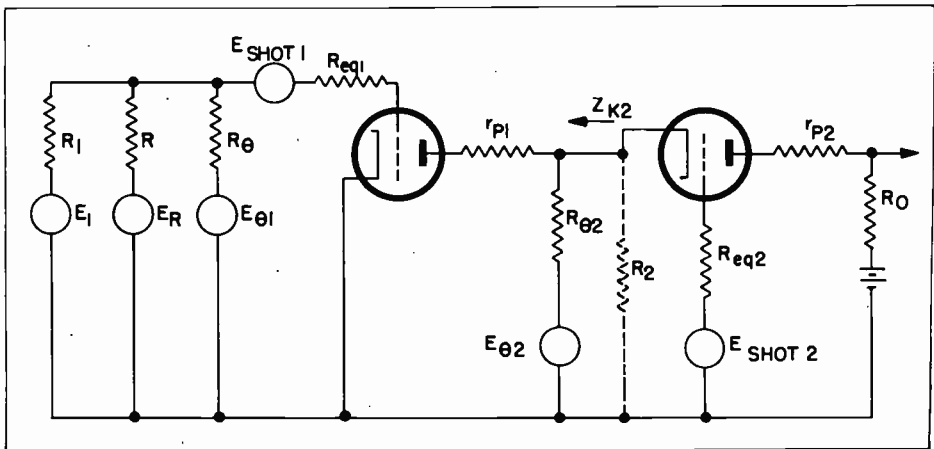

Figure 8. Noises Sources in a Modified Cascode Amplifier

for cascode service except that no means is internally provided to shield the two sections. For ease of calculation, the neutralizing coil (L_n) has been omitted, and the d-c paths of plate current have been put in series to simplify biasing. For the 12AT7 tube, values of $R_{\theta 1}$ and $R_{\theta 2}$ are approximately 12,800 ohms at 70 mc., and 1600 ohms at 195 mc.

It can be seen that the value of noise voltage e_{n1} can be found in the same manner as was done for $e_{n \text{ out}}$ in the pentode grounded-cathode amplifier. The input impedance (R_1) of the primary, or source impedance, will equal R_s and be the largest value possible in view of circuit capacitance and bandwidth, quite the same value as indicated in equation 20. R_1 produces a noise voltage at the grid, e_{g1} , which, due to divider action, will be obtained as in equation 4, and divided as in equation 6. Because a step-up input transformer is used, the value of resistor R will be related to R_s and $R_{\theta 1}$ as it was in equation 21. Therefore, the noise voltage E_R associated with resistor R is found by equation 4, and suffers voltage-divider action determined by use of equation 7, with the resultant voltage appearing at the grid as e_{gR} .

Using the approximate values of the 12AT7 tube for $R_{\theta 1}$ and $R_{\theta 2}$, the noise voltage developed by R_{θ} in each case can be found by use of equation 8. The value of E_{θ} so produced is manipulated as in equation 9 to find $e_{g\theta 1}$. The next noise voltage at the grid of the first triode is the shot noise produced by the triode's value of R_{eq1} which was found by equation 10 to be less than that of a pentode. This value of R_{eq} produces a noise voltage E_{shot1} which equals e_{gS1} ; this voltage is found by using equations 4 and 12.

The total noise voltage at the grid of the first triode, e_{g1} , is found in the manner of equation 13, with which an r-m-s value is obtained.

The noise voltage at the grid of the first triode, e_{g1} , may be used with the equations for grounded-grid amplifier operation in determining the total amplifier noise voltage e_{nt} . A number of rather intangible values exist in this grounded-grid circuit, which should be described. First, the external resistance appearing between cathode and ground of the second triode must be considered. Designated as Z_{k2} in figure 8, it exists as:

$$Z_{k2} = \frac{R_{\theta 2} r_{p1}}{R_{\theta 2} + r_{p1}} \quad (23)$$

where:

$R_{\theta 2}$ = second triode's transit-time input resistance

r_{p1} = first triode's plate resistance (10,900 ohms for 12AT7)

Second, the value of apparent plate resistance (r'_{p2}) for the second triode, which may approach the value of required damping, is found by the equation:

$$r'_{p2} = r_{p2} + Z_{k2} (\mu_2 + 1) \quad (24)$$

where:

μ_2 = second triode's amplification factor (60 for 12AT7)

Third, because the output circuit is damped by r'_{p2} in parallel with R_0 , we have an effective damping resistance (R_d) which is determined from the bandwidth desired and the circuit shunt capacitance in the manner that R_0 was found in equation 18. Therefore, the value of R_d , which, as before, amounts to 1530 ohms, will be used to find a value of R_0 as:

$$R_0 = \frac{R_d r'_{p2}}{r'_{p2} - R_d} \quad (25)$$

Fourth, the value of R_2 is the usual low input resistance of a grounded-grid amplifier (not an actual resistor); the value of this resistance can be found by:

$$R_2 = \frac{r_{p2} + R_0}{\mu_2 + 1} \quad (26)$$

To obtain the value of output noise voltage (e_{n1}) of the first triode, we need only substitute in the pentode-tube gain factor of equation 15, the value of output impedance of the first triode, which consists of Z_{k2} and R_2 in parallel, making equation 15 appear as:

$$e_{n1} = (e_{gt1}) g_m \left[\frac{Z_{k2} R_2}{Z_{k2} + R_2} \right] \quad (27)$$

where:

$g_m = 5500 \mu\text{mhos}$ for the 12AT7.

The noise voltage associated with the first stage (e_{n1}) is applied directly to the cathode of the second stage for amplification as e_{kn1} . Another voltage appearing at the cathode of the second triode is the value of the effective portion of $E_{\theta 2}$. As in equation 8, the value of $E_{\theta 2}$ caused by $R_{\theta 2}$ can be found. Due to voltage-divider action, the part of $E_{\theta 2}$ which appears between ground and cathode, ($e_{k\theta 2}$) becomes:

$$e_{k\theta 2} = E_{\theta 2} \left[\frac{1}{\frac{R_{\theta 2} (R_2 + r_{p1})}{R_2 r_{p1}} + 1} \right] \quad (28)$$

We now have the two main noise voltages at the input to the second stage, and to determine the noise voltage they cause at the plate, we need only find their combined r-m-s value and the amplification they undergo. As in equation 13, which gave the total grid noise voltage of the pentode, the second triode's input noise ($e_{k2 \text{ in}}$) can be found by:

$$e_{k2 \text{ in}} = \sqrt{e_{kn1}^2 + e_{k\theta 2}^2} \quad (29)$$

Thus the noise input to the second triode will be amplified by the tube gain as:

$$\text{gain factor} = \frac{R_0 (\mu_2 + 1)}{r_{p2} + R_0} \quad (30)$$

This gain factor can be applied to the input noise voltage to give a value of noise voltage (e_{pk2}) at the plate, where:

$$e_{pk2} = e_{k2 \text{ in}} \left[\frac{R_0 (\mu_2 + 1)}{r_{p2} + R_0} \right] \quad (31)$$

The reader will note that the value of e_{pk2} does not include any component of shot noise introduced by the second triode. This shot noise must be considered, but by a slightly different method. The shot noise for the grounded-grid stage ($E_{\text{shot}2}$) is obtained by using the tube's value of R_{eg2} in equation 4. The $E_{\text{shot}2}$ noise

is greatly degenerated by the unby-passed external cathode resistance Z_{k2} (by cathode-follower action), so that the grid-to-cathode voltage will be reduced. The net grid-to-cathode voltage is then amplified by a gain factor, which, unlike that of equation 30, must consider the value of Z_{k2} as part of the resistive load. Expressing the noise voltage at the plate due to E_{shot2} (e_{ps2}) as an equation:

$$e_{ps2} = E_{shot2} \left[\frac{\mu_2 R_o}{r_{p2} + R_o + Z_{k2} (\mu_2 + 1)} \right] \quad (32)$$

The r-m-s value of the two noise voltages appearing at the plate, (e_{ps2} and e_{pk2}) will be the total noise voltage, e_{nt} , for the entire amplifier:

$$e_{nt} = \sqrt{e_{pk2}^2 + e_{ps2}^2} \quad (33)$$

The value e_{g1} , when multiplied by the gain factor of each section, provides the value of output noise voltage produced by R_1 . The amplified value of e_{g1} will therefore be the

noise of an "ideal" amplifier, N_i , expressed as an equation:

$$N_i = (e_{g1}) g_m \times \left[\frac{Z_{k2} R_2}{Z_{k2} + R_2} \right] \left[\frac{R_o (\mu_2 + 1)}{r_{p2} + R_o} \right] \quad (34)$$

The value of e_{nt} is, in fact, the noise voltage of an "actual" amplifier (N_a), so the noise factor of a cascode amplifier becomes:

$$NF = \frac{N_a}{N_i} =$$

$$\frac{e_{nt}}{(e_{g1}) g_m \left[\frac{Z_{k2} R_2}{Z_{k2} + R_2} \right] \left[\frac{R_o (\mu_2 + 1)}{r_{p2} + R_o} \right]} \quad (35)$$

The values that make up e_{nt} , as shown in equations 31, 32, and 33, are determined in part by the gain of the grounded-grid amplifier; therefore the gain factor of the grounded-grid amplifier effectively appears in

FUNCTION	EQUATIONS USED TO OBTAIN VALUES	VALUE	
		AT 70 MC.	AT 195 MC.
e_{g1}	20, 4, 21, 6	6.12 μ volts	6.12 μ volts
e_{gr}	21, 4, 7	5.72 μ volts	1.28 μ volts
$e_{g\theta 1}$	8, 9	4.67 μ volts	13.44 μ volts
e_{gs1}	10, 4, 12	6.66 μ volts	6.66 μ volts
e_{gt1}	13	11.7 μ volts	16.2 μ volts
e_{n1}	23, 26, and 27, 13	12.65 μ volts	15.85 μ volts
e_{kn1}	same as e_{n1}	12.65 μ volts	15.85 μ volts
$e_{k\theta 2}$	4, 28	1.2 μ volts	3.1 μ volts
$e_{kz \text{ in}}$	27, 28, and 29	12.8 μ volts	16.15 μ volts
e_{pk2}	31	96.0 μ volts	123.0 μ volts
e_{ps2}	32	1.66 μ volts	6.35 μ volts
e_{nt}, N_a	33	96.0 μ volts	123.1 μ volts
N_i	34	49.6 μ volts	46.0 μ volts
NF	35	6.0 db	8.5 db

Table V. Characteristics of 12AT7 in Circuit of Figure 8

both the numerator and denominator of equation 35, leaving the overall noise factor determined mainly by the first stage. (Compare this with equation 22.)

Using the characteristics of the 12AT7 tube, Table V lists the real values of noise voltage and noise factor of a cascode amplifier provided with a step-up input circuit.

It can be seen from the values listed in Table V that the shot noise of the second triode (e_{ps2}) does not effect the noise factor. Also, unlike the pentode in which shot noise was the determining factor, the triode's noise factor is most affected by the transit-time input resistance, R_{θ} . The fact that in this circuit $R_{\theta 1}$ is always greater than the value of R_s , at frequencies below 200 mc., indicates that the value of R_s is established by the circuit capacitance and bandwidth, rather than by $R_{\theta 1}$. (At 200 mc., $R_{\theta 1}$ drops below 1530 ohms.) If the step-up advantage obtained by having R_s greater than 300 ohms (R_1) were not used in the cascode input circuit, we could expect that the noise factor would be quite poor. This is proved to be true by recalculation of the voltages of Table V for a circuit involving no step-up in the input. The result is a noise-factor increase of about 5 db.

TUBES IMPROVE THE NOISE FACTOR

The values of noise factor in Table V are by no means the ultimate obtainable, for as we examine the results obtained with Wallman's basic circuit we see that the tubes used in the circuit held the key to further improvement. The 6AK5 and 6J6 could have been used in a TV tuner, but economic objections arose which called for a re-examination of values. The obvious answers were to include the desirable characteristics of a 6AK5

into the design of triode elements, include two of these improved triodes within one envelope, shield the triodes one from the other, and so produce a low-noise duo-triode expressly built for cascode service. Such a tube is the 6BQ7.

Factors that made the 6AK5 a low-noise tube are included in the 6BQ7, and are mainly concerned with the grid and cathode.

First, the closer the grid-to-cathode spacing, the higher the maximum frequency at which the voltage amplification drops to unity. The improvement in the tube as the grid-to-cathode spacing is reduced is very large, but reducing the spacing below about .003 inch produces great mechanical difficulties. In the 6BQ7, for example, the grid-to-cathode clearance is even less than the above value, and becomes .0028 inch after processing. To make best use of this close grid-to-cathode spacing, the pitch of the control-grid wire is made quite small (only .005 inch) with a wire size of .001 inch. The grid wire consists of a tungsten wire which has been gold-plated to reduce grid primary emission, which would result in a reduction of input conductance. The grid wires are made as small as possible so as to block off no more of the region of electron flow than is necessary.

Second, an obvious feature was to reduce lead inductance by making the leads as short as possible to reduce the loading caused by input conductance, which is, in part, determined by lead inductance. For example, the cathode-lead inductance of a 6AK5 has been reduced to an estimated .02 microhenries, and the transit time has been so reduced that the upper end of the tube's useful frequency range is limited, for the most part, by lead inductance.

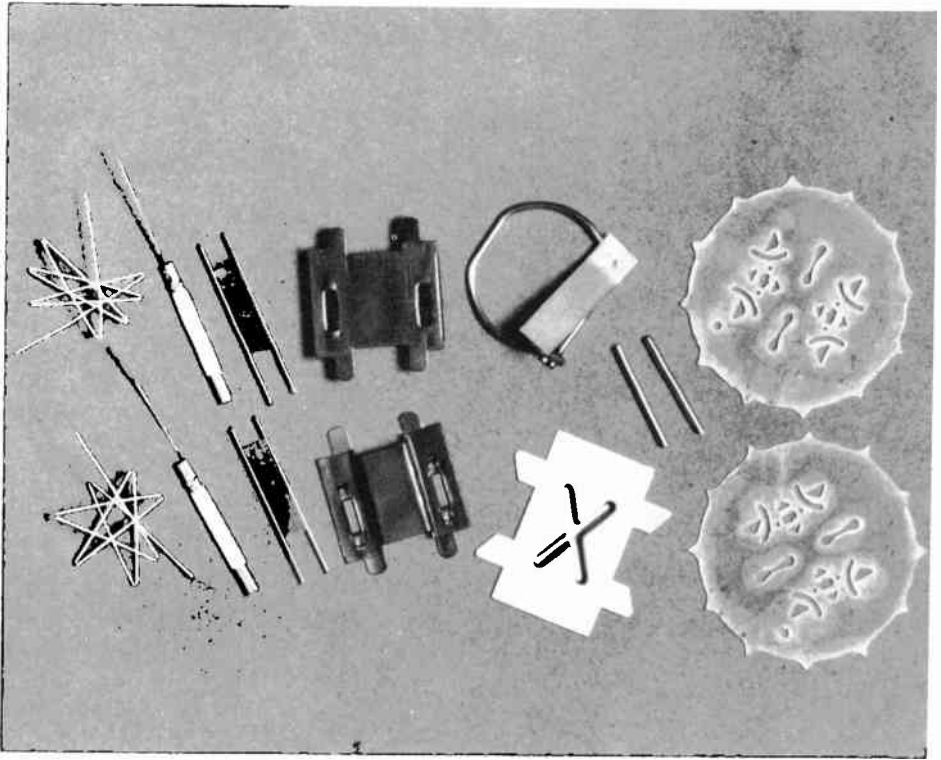

Figure 9. Internal Components of a 6BQ7 Tube, Showing Filaments, Cathodes, Grids, Plates, Shield, Mica Spacers, Getter Assembly, and Getter-Assembly Mounting Rods

tube can be seen in figure 9. The gold-plated grid is illustrated, with its almost indiscernible wire. The heater elements shown are of the conventional folded type with eight legs of coated tungsten wire having a diameter of .0014 inch, and an unfolded length of 3.3 inches. It should be pointed out that the filament wire is insulated with a coating of fired aluminum oxide which is about .0025 inch thick, and that this filament is inserted into the cathode structure by hand.

The cathode can be seen to have an oval cross section, shaped to conform to the inside of the control grid, with a maximum dimension of .048 inch, and a minimum dimension of .025 inch. The cathode sleeve is .47 inch long, and coated with barium,

calcium, and strontium oxides over .28 inch of its length. Before processing, this cathode emitting surface is about .002 inch in thickness, and in processing is reduced to .001 inch.

The unassembled rectangular plate can also be seen in figure 9, and consists of a pair of carbonized .005-inch nickel blanks.

Other parts also illustrated are the shield used between the two triode sections, the magnesium-oxide-coated mica spacers, and the getter assembly.

The assembled 6BQ7 tube is shown in figure 10, both as it exists before inclusion in an envelope, and as it appears after complete processing. The layout of the elements and the location of the internal shield can be seen at the left in figure 10. The electrical characteristics of the 6BQ7 are

listed in table VI. The production of this tube made possible the commercial use of a cascode type of amplifier in a television tuner.

PHILCO COLORADO TUNER

The Philco Colorado Tuner uses a modified cascode circuit, with the 6BQ7 tube as the r-f amplifier. A schematic of the r-f section of the original Colorado tuner is illustrated in figure 11. A number of interesting innovations in the circuit make it advisable to devote some attention to it in this article. In the upper-left corner, is shown the original version of the tapered-line input section illustrated in figure 2F. As used in the Colorado tuner, the tapered-line input section, tuned by distributed capacitance, is connected in such a way as to provide inductive coupling for the signal. This affords a reduction of interference from signals below the television-channel frequencies, at a slight loss in sensitivity. As a safety feature in receiver chassis employing

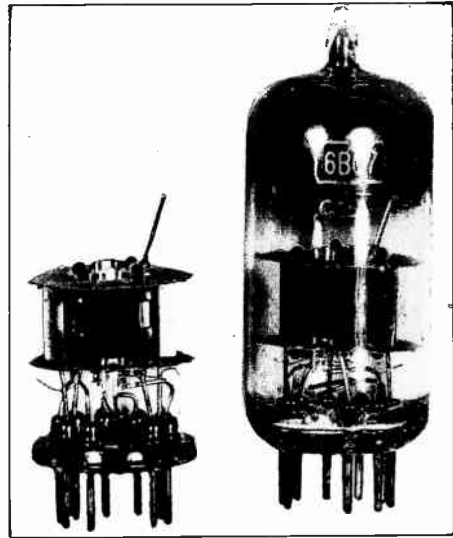

Figure 10. Left—An Assembled 6BQ7 Tube (less getter assembly), Prior to Insertion into Envelope
Right—The Completed 6BQ7

a transformerless power supply, the 75-ohm connection is not provided because of possible a-c potentials on the chassis (ground). This is true of all the latest models. An FM trap is

Table VI. Electrical Characteristics of 6BQ7

Heater Voltage (a-c or d-c)	6.3 volts	
Plate Voltage (max.)	250 volts	
Plate Dissipation (max.)	2 watts	
Cathode Current (max.)	20 ma.	
Direct Interelectrodé Capacitances in $\mu\mu\text{f.}$ (shielded):		
	<u>Section 1</u>	<u>Section 2</u>
Grid-to-Plate	1.15	1.15
Input	2.25	
Input (grounded-grid)		4.75
Output	1.30	
Output (grounded-grid)		2.40
Circuit Conditions as Class-A Amplifier		
Plate Voltage	150 volts	
Cathode Bias Resistor	220 ohms	
Plate Current	9 ma.	
Amplification Factor	35	
Mutual Conductance	6000 μmhos	
Plate Resistance	5800 ohms	

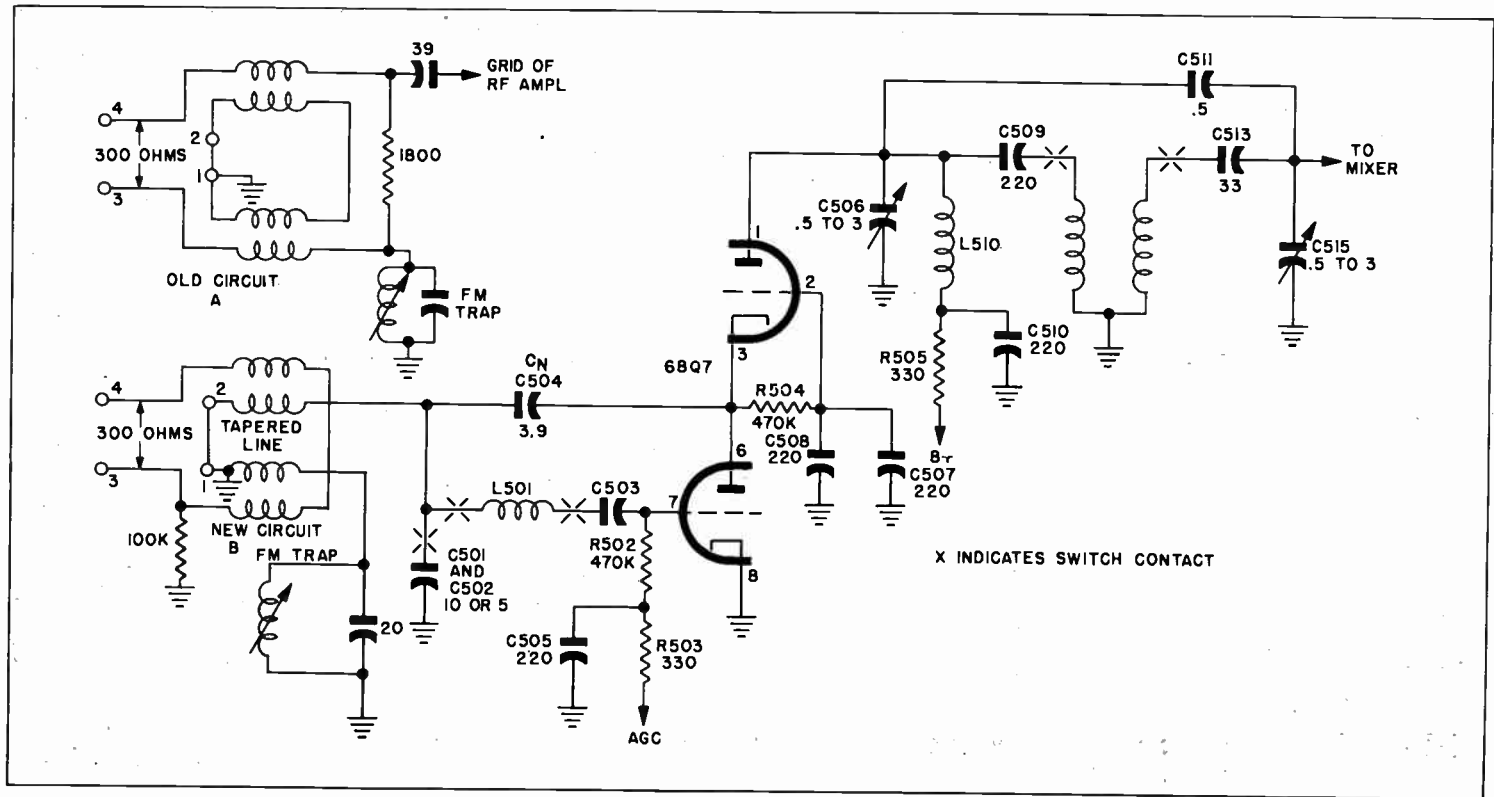

Figure 11. Simplified Schematic of R-F Section of the Basic Colorado Tuner

included to reject interference from the FM band, and can be seen in the upper-right portion of figure 4.

As indicated in figure 11, a number of circuit components are varied incrementally by means of a wafer-type channel-selection switch.

To prevent a reduction of input impedance, with the resultant increase of noise factor, neutralization is provided by means of C_n . The switched, series-tuned input circuit is made up of C501, C502, C503, L501, and the input capacitance of the first triode section. C501 and C502 are switched out of the circuit on the high channels. The signal voltage developed at the plate of the first triode section is applied directly to the cathode of the second section, which presents the usual low input impedance of a grounded-grid stage to the output of the first section.

Since the plate capacitances of various tubes may differ, C506 is provided to allow compensation. It should be noted that the only bias placed on the grid of the second triode section is the "contact potential," developed across the large value of grid resistor R504. Due to this method of biasing used in this version of the Colorado tuner, the a-g-c voltage placed on the grid of the first triode section did not produce great changes of circuit gain, and in some cases it was impossible to reduce the gain sufficiently to prevent overloading. Therefore, a circuit change was instituted to improve operation; simplified schematics of the old and new circuits are shown at A and B, respectively, of figure 12. In the new circuit, the grid of the second triode is connected to the center of a high-resistance voltage divider which is connected between B+ and ground. With this circuit the grid bias of the second triode section remains nearly

constant so far as d.c. is concerned. When a negative a-g-c voltage is applied to the first triode grid, the cathode of the second triode becomes more positive, thus reducing the gain of the second stage as well as the first. The result is a larger variation in gain for a given change in a-g-c voltage.

IMPROVED COLORADO TUNER

Improvements resulting from field

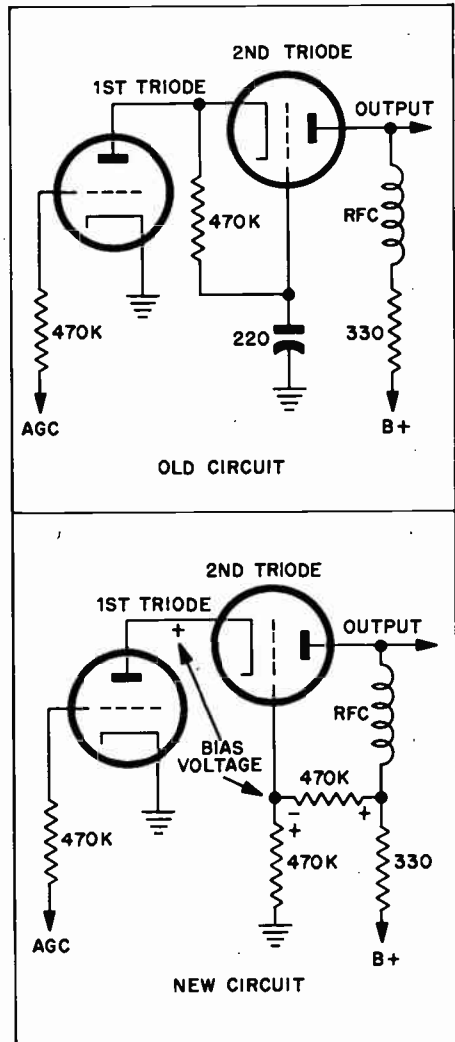

Figure 12. Circuit Modification for Improved AGC Performance

CHANNEL	NF IN DB
2	6.0
3	6.0
4	6.1
5	6.2
6	6.2
7	9.6
8	9.2
9	8.5
10	8.5
11	8.5
12	8.7
13	10.0

Table VII. Average Noise Factors on All Channels, for 12 Super Colorado Tuners Chosen at Random from the Philco Production Line

experience with many thousands of tuners, plus other recent "advancements in the art" have been incorporated into Philco's latest tuner known as the Super Colorado tuner. The modified cascode r-f amplifier, is shown with all its associated components except the incrementally tuned coils, in simplified schematic form in figure 13.

The tapered-line assembly is connected, as in previous versions of the tuner, to provide a step-up ratio of about 1.4 to 1 over the entire TV range. The FM trap, which is factory set at 100 mc. but can be adjusted to trap any interference signal in the FM band, is also included.

Comparing the input circuit of figure 13 with that of figure 11, it can be seen that a hookup has been used which eliminates C501 and C502, along with their switching elements. Also, the tuned grid coil is returned to ground in a parallel-tuned circuit that eliminates another switching component and further reduces switch-contact problems.

The a-g-c voltage is applied to the circuit through a decoupling filter which consists of capacitor C505 and resistor R503.

A unique and important addition has been made to the path between the first triode plate and the second triode cathode, in the form of a 150-ohm transmission line (L538). The action of L538 is to tune out the stray capacitances in the circuit in a way quite like that of series-peaking coils in video amplifiers. It has the effect of further reducing the noise factor of the amplifier, and provides a slight boost in gain at the high-band frequencies.

The grid of the second triode section uses a biasing circuit consisting of a divider from B+. The r-f grounding of the grid is made complete by means of three capacitors (C504, C507, and C508) which bypass the resistive elements of the divider and the lead inductances, as well as the grid itself.

The stray capacitance in the plate circuit, combined with the shunt-fed, series-tuned, incrementally-switched, plate-tank coil provide the plate load of the second triode. R-f choke L510 completes the d-c path. C506 is provided, as in the earlier model, to compensate for tube output-capacitance variations.

The B+ voltage required for the r-f amplifier is obtained through two decoupling filters consisting of R505 and C510, and R515 and C532.

When only a schematic or basic design information available, it is necessary to determine noise factor mathematically. However, when a complete operating circuit is available, electrical tests may be conducted to determine actual values of noise factor. Twelve Super Colorado tuners were taken at random from the pro-

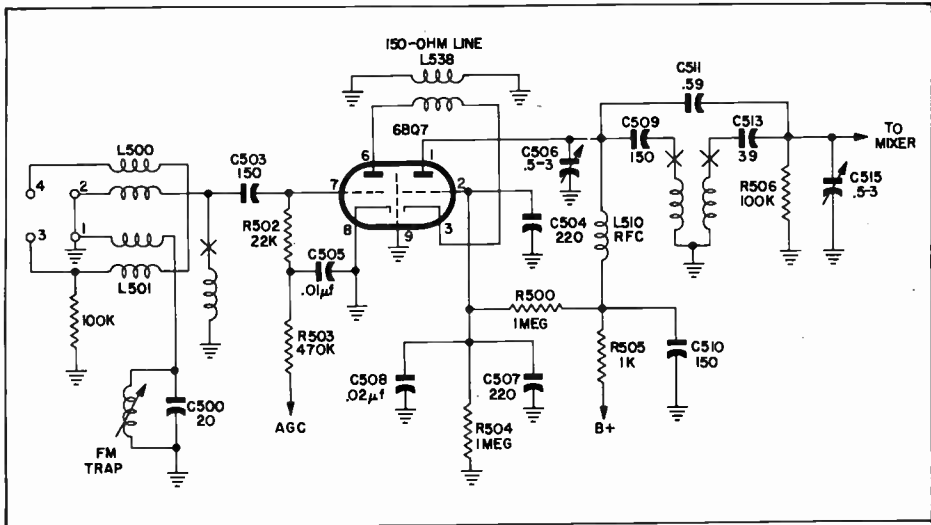

Figure 13. Simplified Schematic of R-F Section of the Super Colorado Tuner

duction line and tested for noise factor of the complete tuner on each of the twelve channels. The results were recorded, and the mean values of noise factor for each channel are presented in Table VII.

CONCLUSION

By prudent selection of tubes, circuit components, and electrical-circuit

configuration, the goal of ideal low-noise operation can be closely approached. The benefits of so doing may not be apparent in areas of high-signal reception, but when real "fringe area" reception is desired (when the signal-to-noise ratio is of prime importance), the reduction of noise factor is quite rewarding.

BIBLIOGRAPHY

1. *A Low-Noise Amplifier*, H. Wallman, A. B. Macnee, and C. P. Gadsden; Proc. of I.R.E., vol. 36, June, 1948, pp. 700-708.
2. *Some Notes on Noise Figures*, H. Goldberg; Proc. I.R.E., vol. 36, Oct., 1948, pp. 1205-1214.
3. *Design of Low-Noise Input Circuits*, M. T. Lebenbaum; Proc. I.R.E., vol. 38, Jan. 1950, pp. 75-80.
4. *Radar Systems and Components*, Bell Laboratories Staff, D. Van Nostrand Co., New York, N. Y., 1949.
5. *Television Tuning Units*, W. W. Hensler, Photofact Index Number 24, H. W. Sams and Co.
6. *Television Tuner Servicing Handbook*, PR 1945, Philco Corporation.
7. *Service Information for Philco Chassis Types 41, 44, D-1, D-4*, PR 1941, Philco Corporation.

An Application of Simple Mathematics to a Field Problem

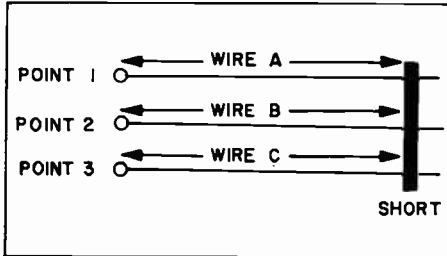

Shorted Three-Wire Circuit

Field maintenance personnel are sometimes confronted with the problem of shorted three-wire lines. The basic problem is the location of the short circuit. This article will show a simple mathematical development of a formula for the solution of such a problem.

Figure 1 shows the circuit under consideration. It is apparent that if the resistance of wire A is known, the distance from point 1 to the short can be calculated by consulting the wire table giving the number of feet per ohm. The only measurements that can be conveniently made are three resistance values—point 1 to point 2, point 2 to point 3, and point 1 to point 3. To simplify, we will assume the following:

- Resistance between points 1 and 2 = X
- Resistance between points 2 and 3 = Y
- Resistance between points 1 and 3 = Z

It can be seen that:

- X = wire-A ohms + wire-B ohms (1)
- Y = wire-B ohms + wire-C ohms (2)
- Z = wire-A ohms + wire-C ohms (3)

By subtracting equation (2) from

equation (3), we obtain

$Z - Y = \text{wire-A ohms} - \text{wire-B ohms}$ (4)
By adding equation (1) to equation (4), we obtain

$$X + Z - Y = 2 \text{ (wire-A ohms), or}$$

$$\text{Wire-A ohms} = \frac{X + Z - Y}{2}$$

(Basic Formula)

Thus we have the resistance of wire A in terms of three simple resistance measurements.

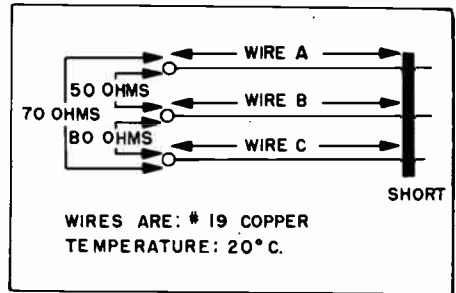

Wire-to-Wire Resistance Measured on Shorted Three-Wire Circuit

To give a practical example, assume the conditions shown in figure 2. It can be seen that X = 50 ohms, Y = 80 ohms, and Z = 70 ohms. By substituting into the formula.

$$\text{Wire-A ohms} = \frac{50 + 70 - 80}{2} = 20$$

The wire table indicates 124.2 feet per ohm for the conditions given. Therefore, 20 ohms represents (20 x 124.2) feet, or 2484 feet. Thus, wire A must be 2484 feet long.

John Adams
Tech Publ. Dept.

Calibration Adjustments of DBE Loran Equipment

During calibration of a DBE Loran receiver recently, considerable difficulty was experienced in making the phase-shifting-transformer and the phase-shifting-capacitor adjustments. Conditions of reasonable circuit stability could not be attained.

Investigation of the frequencies obtained at various divider circuits (by measuring the period of one cycle with a TS-239) revealed a discrepancy in the B divider. It was found that if the B divider was adjusted to conform to the "Typical Divider B Test Pattern" shown in the Instruction Book (Figure 5-6) a fre-

quency other than 20 kc. would be obtained. The correct adjustment of the B divider provides four (4) distinct short pulses with none of the four short pulses partially obscured by the long pulses.

When the B divider was adjusted in this manner, no further difficulty was experienced in completing the calibration adjustments. Comparison checks were made on two other similar equipments, and the same condition was found to exist.

J. P. Tyler
Philco Field Engineer

A Crystal-Diode Tester

The testing of crystal diodes requires the checking of the forward resistance and the back resistance. When a large number of crystal diodes are to be tested, as in a complex computer circuit, considerable time will be saved by using the special set of test prods illustrated. A double-pole, double-throw pushbutton switch is mounted in one of the test prods, near the tip. When the button is pressed, the switch reverses the lead connections to the meter. Releasing the button restores the original hookup.

Warren Kitter
Technical Publications Dept.

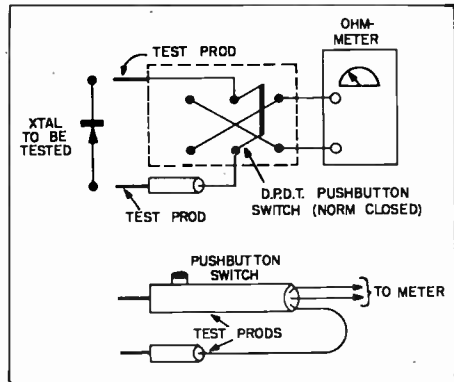

WHAT'S YOUR ANSWER?

The problem this month is to find the maximum and minimum resonant frequencies corresponding to the extreme values of the variable inductor. (Yes, there is an easy way.)

(Solution next month)

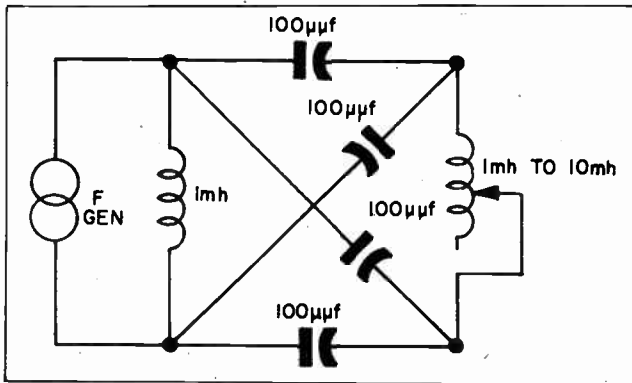

Solution to . . .

Last Month's "What's Your Answer?"

The circuit values shown in last month's problem will provide unity power factor at all frequencies—therefore, the circuit is antiresonant at all frequencies. This will be found in a mathematical analysis as an indeterminate value of F_{gen} . This condition will occur for any case where the two resistor values are equal to each other and are also equal to the square root of L/C .

