

# PHILCO

## TECHREP DIVISION BULLETIN

Volume 4

July and August, 1954

No. 2

### *In This Issue...*

Editorial.....	<i>John E. Remich</i>	1
A Simple Aid To Antenna Instruction.....	<i>Murray E. Baird</i>	2
1954 Conference on Cryogenic Engineering.....		6
The Surface-Barrier Transistor, Part II.....		7
Crystal Substitution For Radio Receiver R-19/TRC-1.....	<i>Herbert L. Mallincoat</i>	13
Servicing Synchros and Servomechanisms.....	<i>J. J. Mills</i>	15
What's Your Answer?.....		22
Shoran Equipment.....	<i>Michael W. Onushco</i>	23
Solution to May-June "What's Your Answer".....		29

**PHILCO**  
**TECHREP DIVISION**  
**BULLETIN**

*Published bimonthly by*

**The TechRep Division of Philco Corporation**  
**Philadelphia, Pennsylvania**

---

---

*Editor* . . . . . John E. Remich

*Managing Editor* . . . . . Gail W. Woodward

*Technical Editors* . . . . . Francis R. Sherman  
John W. Adams  
Baldwin G. Sullivan

---

---

*Editorial Office:*

**Technical Information Section**  
**Philco TechRep Division**  
**22nd St. and Lehigh Avenue**  
**Philadelphia 32, Penna.**

If any information contained herein conflicts with a technical order, manual, or other official publication of the U.S. Armed Forces, the information in the official publication should be used. Views expressed in this publication are the opinions of the authors and do not necessarily represent those of Philco Corporation. All technical information and circuits are presented without responsibility as to patent infringement.

# *Editorial . . .*

## **THE GROWTH OF FIELD ENGINEERING**

by John E. Remich

*Manager, Technical Department*

The profession of field engineering is relatively new although to us who are concerned with it each day, it may seem to have been with us forever. As short a time ago as the beginning of the Second World War, the nearest approach to the electronics field engineer of today was the hobbiest, radio ham, and radio servicemen all of whom were regarded perhaps as "tinkerers."

Looking back now, we can see that the many men who answered the call for electronics field engineers had embarked on careers which have led them to greater responsibilities, greater knowledge of electronics, and the reward of real achievement in an ever-growing field. The serviceman, ham, tinkerer, or whatever he was called, became a key figure in electronics and the nucleus of the field engineering profession.

Today the field engineer, who started out with little more than a practical knowledge of electronics maintenance on receiving and transmitting equipment, is the engineer whose knowledge enables him to design and engineer complete communications and radar system networks. Although there were no doubt some dark moments, the field engineer studied hard, worked hard, and not only kept the new electronic marvels performing according to specifications but also gained a very broad picture of the application of electronics.

It is to the great credit of these pioneers of the field engineering profession that they were able to help in the development and utilization of electronics systems which contribute so much to industry and to the power of our Armed Forces on land, sea, and in the air. These men who have led the way have shown that electronics field engineering offers opportunities for personal growth far beyond that found in many other fields of endeavor. We do not feel that it would be too immodest to suggest that the growth of electronics in quantity and capability has received real and substantial assistance from the electronics field engineers throughout the years. You men who are now in positions of rendering technical assistance on large, complex electronics systems know how rewarding the sense of accomplishment is. Those of you who more recently joined the profession of field engineering can look forward to achieving still greater heights in the years to come.

# A SIMPLE AID TO ANTENNA INSTRUCTION

by Murray E. Baird

Philco Field Engineer

**An easily constructed device that permits an instructor to demonstrate the characteristics of almost any antenna array in miniature.**

*(Editor's Note: The device discussed in this article is one of a series developed by the author when the need for accelerated training arose. While the primary purpose is antenna instruction, many interesting possibilities arise. For example, the same equipment could be used for transmission line demonstration, scale-model antenna testing, and simulation of large antenna systems would be possible.*

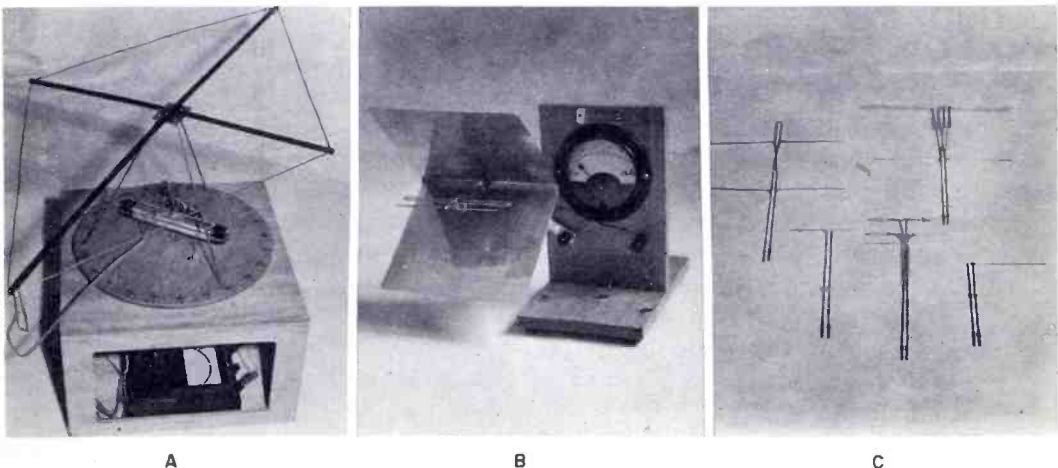
*One important factor that any user must consider for devices of this type is the possible violation of FCC regulations on unauthorized radiation. It is the responsibility of the user to make certain that no violation occurs.)*

**T**HE ANTENNA DEMONSTRATOR, shown in figure 1, consists basically of a low-power transmitter mounted in a container with calibrated turntable (left), a sensitive field-strength meter (center), and an assortment of commonly encountered antennas (right). An operating wavelength of 30 cm. (1000 mc.) was chosen as a compromise between a de-

sire to miniaturize equipment and feasibility of construction with commonly available materials.

## TRANSMITTER

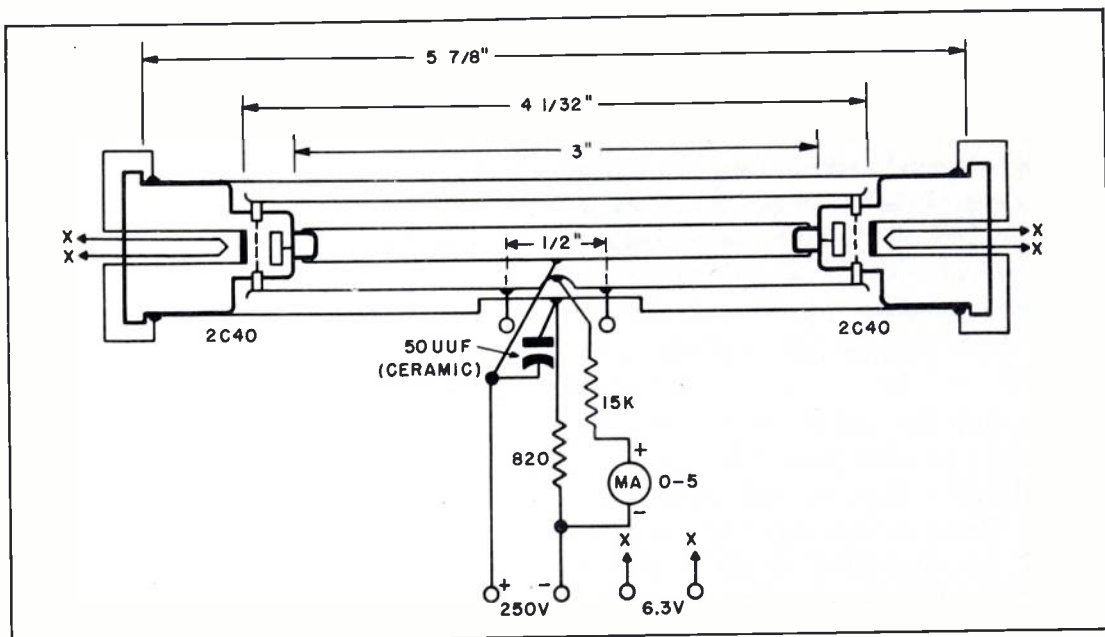
The transmitter, shown in schematic form in figure 2, consists of two 2C40 lighthouse triodes connected in a push-pull coaxial-line oscillator circuit. All



**Figure 1. The Complete Antenna Demonstrator**

- A. Transmitting Assembly, Showing Terminated Rhombic in Position**
- B. Field-Strength Meter, Showing Construction Details and Simplified Mounting Method**
- C. Several Different Antennas Designed for the Antenna Demonstrator.**





**Figure 2. Diagram of Transmitter, Showing Critical Dimensions**

line elements are made of thin-walled seamless brass tubing in commonly available sizes. The plate line is  $9/32''$  o.d. tubing; the grid line is  $7/8''$  o.d. tubing, and the outside shield is  $1\frac{1}{4}''$  o.d. tubing. Length dimensions are shown in figure 2.

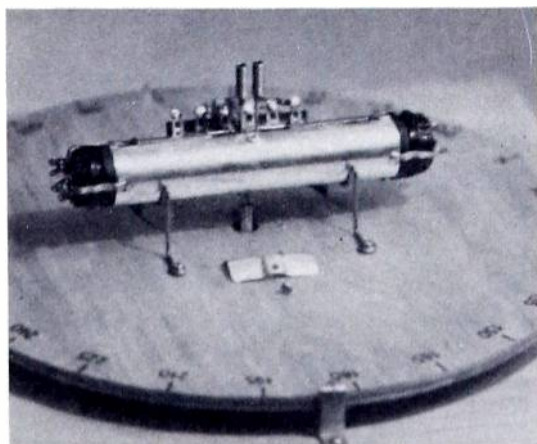
The plate line is sawed lengthwise for approximately  $\frac{1}{2}''$  at each end, and the ends are formed to make secure electrical contact with the plate terminals of the 2C40 tubes. The grid line has  $\frac{1}{2}''$  lengthwise cuts spaced at 45-degree intervals about the circumference, and is flared slightly at each end. A  $\frac{1}{4}''$  hole is drilled through the wall of the grid line, at the exact center, to allow the B+ lead to pass through. The outside shield has one lengthwise cut, the full length of the tube, and, to facilitate assembly, a  $9/16'' \times 1-9/16''$  aperture is made at the center, as shown in figure 3. Three small nuts are soldered to the outside surface of the shield to allow mounting of the terminal strip and the aperture cover, as shown in figure 3. It is advisable to have all lines silver-plated in the interest of increased efficiency and good contact with the tube terminals.

It is suggested that the Bakelite bases

of the 2C40 tubes be ground to the same diameter as the cathode ring, to simplify the assembly of the unit.

The transmitter components should be assembled as follows:

An insulated lead is made mechanically fast, and soldered to the center of the plate line. This lead can be ordinary hook-up wire. A 15K,  $\frac{1}{2}$ -watt resistor is soldered to the center of the grid line on the perimeter of the  $\frac{1}{4}''$  hole. The plate line is then slipped inside the grid line, and the B+ lead is guided through the  $\frac{1}{4}''$  hole. The lighthouse tubes are then



**Figure 3. Close-up View of Transmitter, Showing Construction Details**

inserted in each end of the line, making certain that the grid line is evenly centered. The outer shield is then slipped over the assembly, and centered.

Standard octal sockets, with mounting flanges removed, are plugged into each tube, and pins 3, 5, and 8 are connected to the shield with 3/16" wire braid. A 6-lug terminal strip is mounted, and connections are made as indicated in figure 2.

Mounting brackets for the transmitter are fashioned from heavy copper wire, and are spot-soldered to the shield. Two banana jacks, with excess hardware removed, are connected to the grid line about 1/4" each side of center with short lengths of #12 wire.

A plate, as shown in figure 3, should

be made to cover as much as possible of the aperture in the outside shield. This cover plate reduces a reactive component which appears in the grid circuit as a result of the gap in the shield, and increases the power output.

### FIELD STRENGTH METER

Various types of antennas were tried for use with the field strength meter, and a corner-reflector type was chosen for its high gain, simplicity of construction, and excellent directivity, which reduces response to random reflected signals.

The reflector is formed from light-gauge sheet aluminum with dimensions as shown in figure 4. The folded dipole supported by a quarter-wave stub, is made from ordinary heavy copper wire. A close-spaced director was found to

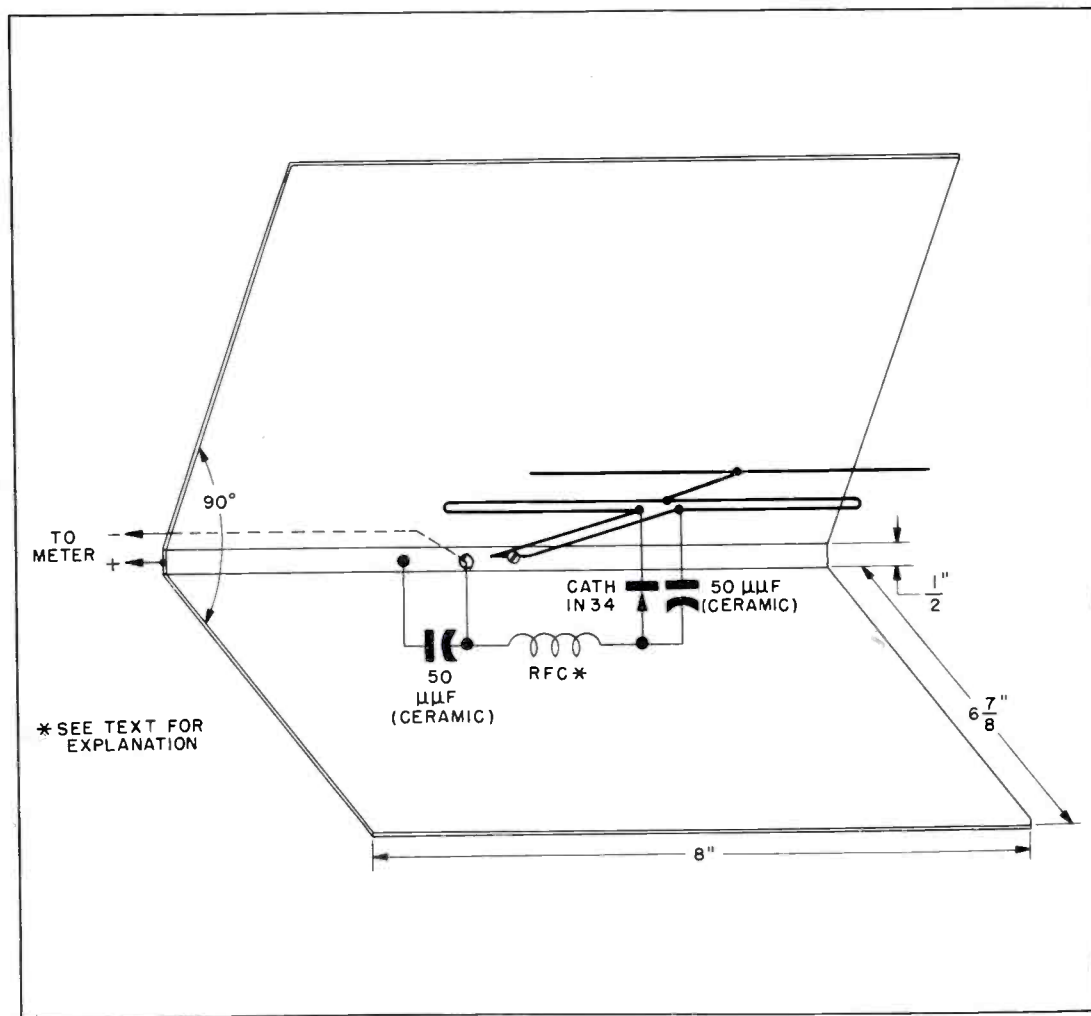


Figure 4. Detailed Construction Drawing of Field-Strength Meter Antenna

substantially increase gain, and was therefore included. A type 1N34 crystal serves to rectify the incoming signal. The r-f component is removed by a choke consisting of 11 turns of hook-up wire spaced 2" with a diameter of 5/16". This choke should be tuned for maximum meter indication by varying its spacing slightly.

Any sensitive meter will serve as an indicator, excellent results being obtained from a conventional multimeter. Part B of figure 1 shows a suggested mounting of the antenna assembly on a common laboratory-type microammeter.

### CONTAINER AND TURNTABLE

A box large enough to accommodate a small power supply, a grid meter, and storage space for the antennas may be fabricated from common plywood, as shown in figure 5. A turntable mounted on a hollow bearing should be attached to the top of the cabinet, and azimuth markings inscribed every 15 degrees. A pointer may be fashioned from sheet metal. It is suggested that a stop arrangement be made to limit rotation of the turntable to a single revolution.

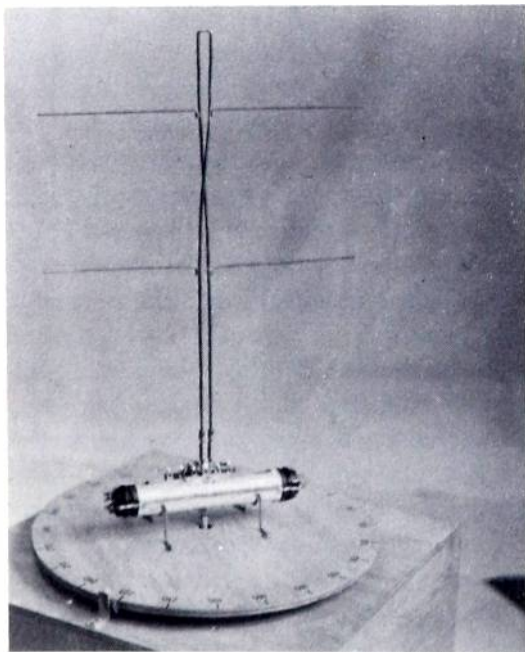


Figure 5. Antenna Demonstrator with Lazy-H Antenna in Operation

## ANTENNAS

A number of antennas have been constructed to demonstrate center and end-fed dipoles; parasitic, end-fire, and broadside arrays; and long-wire systems. All antennas are made from #10 gauge copper wire, and are fed with resonant transmission lines with the exception of the Rhombic, shown in part A of figure 1, which uses 150-ohm Twin-lead matched with a shorted quarter-wave stub. This antenna is terminated with an 820-ohm, 1/2-watt carbon resistor. All transmission lines are provided with banana plugs. It was found that plexiglass provides adequate insulation if it is located only at current loops. The use of quarter-wave "metallic insulators" is recommended whenever feasible, except in the simpler types of antennas where their use might confuse a beginning student.

Lengths and spacings of antennas depend on the exact frequency of the transmitter, but follow established formulae as given in the Philco Training Manual on Antennas (Volume I). Lengths of all transmission lines are calculated to present a low impedance at the point of connection to the transmitter. When determining line dimensions, the length of connecting lead from the grid line to the banana jacks must be considered, since this forms a part of the transmission line.

### OPERATION

Power requirements are 6.3 volts at 1.5 amp., and 250 volts at approximately 20 ma. Higher plate voltages are not recommended, as the dissipation of heat is limited because of the type of construction involved. Grid current will normally be about 2 ma. with the transmitter properly loaded. Loading can be varied by moving the spacing of the taps on the grid line, but 1/2" spacing should suffice for all antennas. Frequency drift will be considerable during initial warm-up of the transmitter, but stable opera-

tion is reached after about 15 minutes of operation.

The exact transmitter wavelength can be easily measured by holding a metal sheet in front of the antenna. Grid current will dip at  $\frac{1}{2}$ -wavelength intervals as the spacing between the sheet and the antenna is varied.

### CONCLUSION

This training aid has been found useful at all levels of student proficiency. Field patterns of almost any antenna can be easily measured and plotted. In the case of advanced students, the transmitter frequency can be given and the student required to design and construct various types of antennas which can be readily tested for gain and radiation pat-

tern. Various types of radiation phenomena can be displayed. A metal sheet a few square feet in area will produce radar-like reflections at distances as great as 10 wavelengths from the signal source. The flutter encountered in FM and TV reception due to passing aircraft, as well as multipath fading, can be easily demonstrated. These types of visual demonstrations are useful in maintaining a high level of student interest.

*(The author wishes to acknowledge the help of Major Eric J. Braun, MAAG-Denmark and Herr J. Tiedeman Kruse, instructor at the Danish Army Telegraph School, both of whom offered many constructive suggestions during the accomplishment of this project.)*

## 1954 CONFERENCE ON CRYOGENIC ENGINEERING

The 1954 Conference on Cryogenic Engineering will be held September 8, 9, and 10 under the sponsorship of the National Bureau of Standards at the NBS-AEC Cryogenic Engineering Laboratory, in Boulder, Colorado (See the May-June, 1954, BULLETIN). The first meeting of its kind in this important new field, the Conference will treat engineering problems in the temperature range below  $150^{\circ}\text{K}$  ( $-123^{\circ}\text{C}$ ). Plans call for the presentation of technical papers which will deal chiefly with problems encountered in the production, storage, transportation, and use of low-temperature liquefied gases—hydrogen, nitrogen, and oxygen. Information regarding registration and reservations may be obtained from M. M. Reynolds, of the NBS Boulder Laboratories, who is Chairman of the Conference.

In addition to the technical sessions, the Conference on Cryogenic Engineering will take part in the official dedication of the National Bureau of Standards Boulder Laboratories on September 11, 1954. A symposium on Propagation,

Standards, and Problems of the Ionosphere has also been arranged by the Bureau's radio propagation laboratories in connection with the dedication.

Low-temperature liquefied gases are finding increased application in industry and national defense, making necessary larger, more convenient, and less hazardous equipment for producing and handling them. As a result, many new and highly complex engineering problems have arisen in the low-temperature field, where much remains to be learned about the mechanical and thermal behavior of engineering materials, and the nature of the processes. There are such marked differences between the behavior of matter at ordinary and very-low temperatures that the low-temperature properties cannot generally be obtained by extrapolation. Although low-temperature processes have been very useful in the past, further studies of the processes promise to be very fruitful. The NBS-AEC Cryogenic Engineering Laboratory has been engaged in this type of research and development since its inception in 1951.



# THE SURFACE-BARRIER TRANSISTOR

## PART II (CONCLUSION)

This article concludes the series that began in the May-June, 1954, BULLETIN. The first article covered theory and construction of the Surface-Barrier Transistor, while this article deals with specific Surface-Barrier Transistor circuits and performance.

THE SURFACE-BARRIER TRANSISTOR has great appeal to circuit applications engineers, because it enables them to obtain the low-power advantages of junction triode transistors in many new applications. The high cutoff frequency of these devices means that usable gain can be obtained in the very-high-frequency range. Furthermore, because of their high cutoff frequency and low capacitance, these devices make good video amplifiers.

In order to appreciate the possibility of performance at low power levels, refer to the set of typical collector characteristics shown in figure 1. These curves show collector current as a function of collector voltage, for various fixed values of base current, with a grounded-emitter connection. The right-hand set

of the two sets of characteristics shows that the output impedance and the current gain remain high even at collector potentials of a few tenths of a volt and collector currents of much less than 1 milliampere. As is well known, the grounded-emitter connection accentuates any imperfections in the characteristics as compared with common-base characteristics—in other words, grounded-base collector characteristics would appear even more ideal. By way of contrast, note the collector characteristics of a typical point-contact transistor in a grounded-base connection in figure 2. These characteristics were taken with the same voltage and current scales as were those in the right-hand set of curves in figure 1. It is easy to see that these characteristics are not very useful

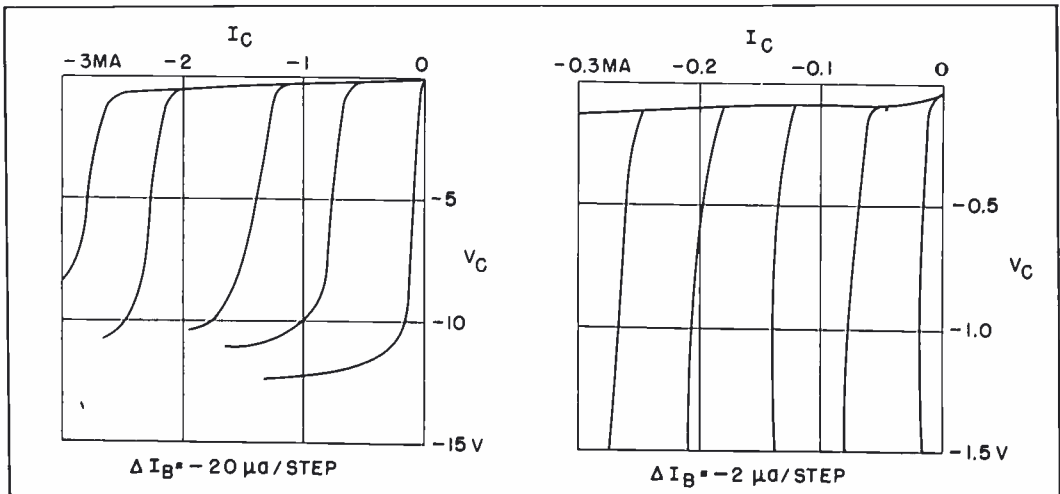
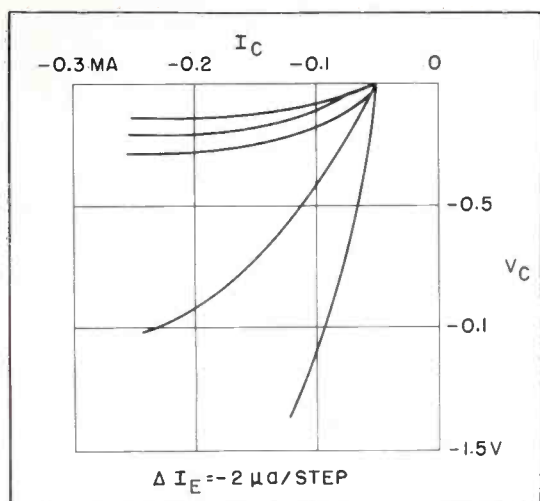


Figure 1. Collector Characteristics of Grounded-Emitter Surface-Barrier Transistor



**Figure 2. Collector Characteristics of Grounded-Base Point-Contact Transistor**

in the range below one volt and one milliamper.

Junction tetrode type transistors have been operated at relatively high frequencies; however, the power level must be increased considerably for this type of operation. Optimum performance for such a tetrode is typically quoted for a total dissipation in the transistor of approximately 50 milliwatts from the collector and auxiliary-base supply circuits.

We will now discuss some typical tuned and low-pass circuits in which Surface-Barrier Transistors have been used. In this discussion we will consider some of the figures of merit, which indicate that the Surface-Barrier Transistor is a well-optimized device for these applications.

By way of reference consider a v-h-f radio receiver, in which Surface-Barrier Transistors can perform most of the functions necessary for reception. Such a receiver might contain Surface-Barrier Transistors in a tuned r-f stage, the oscillator, the mixer, the i-f amplifier, and possibly the detector.

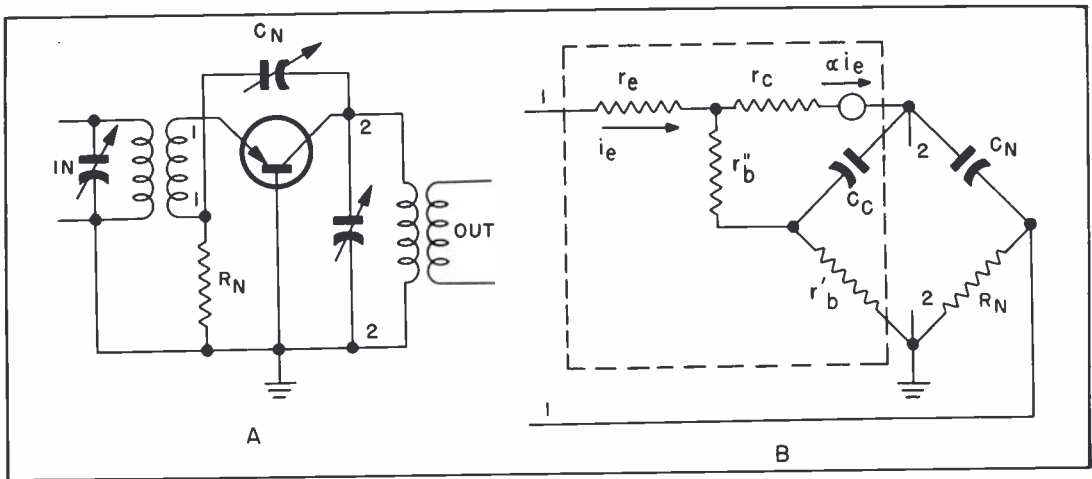
### TUNED AMPLIFIERS

Perhaps the most important new problem that results from the applica-

tion of transistors to tuned amplifiers can be attributed to feedback. The inherent feedback within transistors frequently causes oscillation of tuned stages, even with current gains of less than unity. If oscillations are not encountered, difficulty in tuning a cascaded amplifier may be experienced because of feedback. In order to avoid these problems, neutralization can be employed with great success, but fortunately, it is not necessary with Surface-Barrier Transistors at the lower frequencies used for i-f amplification. Since unneutralized Surface-Barrier Transistor amplifiers are conventional, only the neutralized version will be covered here.

A technique of neutralization which has been found very convenient is shown in the circuit of a grounded-base stage in part A of figure 3. The additional components in the amplifier,  $R_N$  and  $C_N$ , form the neutralizing circuit. How neutralization is provided becomes obvious when we refer to the equivalent circuit of the transistor, shown in part B of figure 3. Note that the external component form a bridge circuit with the internal high-frequency base resistance ( $r_b'$ ) and the collector capacitance ( $C_c$ ) of the transistor. When this bridge is balanced, any voltage appearing across the load (terminals 2-2) produces no corresponding input voltage across terminals 1-1. In order to get maximum power gain with this neutralized grounded-base circuit, the ratio of the impedances of  $R_N$  and  $C_N$  to the impedances of the internal transistor parameters,  $r_b'$  and  $C_c$ , should be approximately unity.

Many amplifiers using this neutralizing circuit have been constructed. A 50-mc. r-f stage is an example. Using the values for a transistor actually employed in this circuit, a neutralized gain of 9 db was computed, and a net insertion gain of 6 db was measured, counting coil losses of 3 db. At 30 mc., gains of 20 db,



**Figure 3. Neutralized Tuned Transistor Amplifier**

- A. Simplified Schematic
- B. Equivalent Circuit

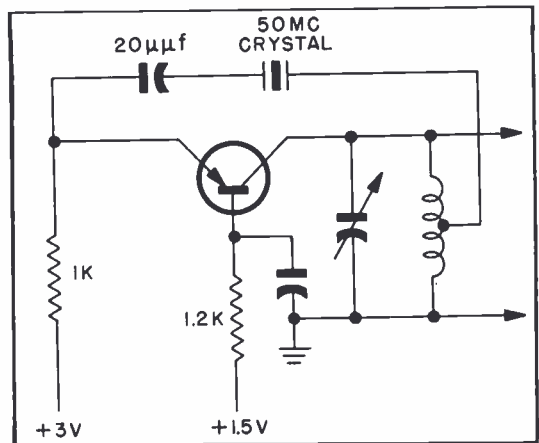
which is approximately the value that would be predicted, have been obtained consistently. At 5 mc., maximum gains of 25 db are achieved without neutralization.

### OSCILLATORS

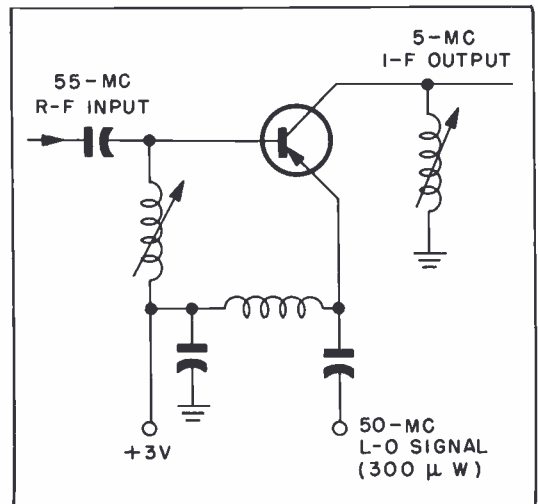
Both L-C and crystal-controlled oscillators have been made using Surface-Barrier Transistors. The schematic of a 50-mc. crystal-controlled oscillator is shown in figure 4. When a transistor with a 50-mc. alpha cutoff frequency was used, a power output of 400 microwatts into a dummy load was obtained with a total input of 1.5 mw. from the 3-volt supply. Thus, even at this frequency, the upper limit, this circuit was about 25 percent efficient. If the crystal is short-circuited in this circuit, a standard L-C oscillator, which gives even better efficiency, is obtained.

### MIXER

A typical mixer circuit is shown in figure 5. The r-f signal is fed into the base, while the local-oscillator signal is applied to the emitter. The input circuit, between the base and the emitter, has no quiescent bias, and therefore serves as a diode detector. The i-f current generated in this diode is amplified by the transistor action of the mixer, and the desired



**Figure 4. Crystal-Controlled Oscillator Using a Surface-Barrier Transistor**



**Figure 5. V-H-F Mixer Using a Surface-Barrier Transistor**

i-f signal is produced in the tuned load. A local-oscillator signal of 300 microwatts is sufficient to provide a gain of 9 db between an r-f input at 50 mc. and an i-f output at 5 mc.

## VIDEO AMPLIFIER

A typical video amplifier circuit will be considered now in order to show why the characteristics of Surface-Barrier Transistors make them very suitable for this application.

One of the most interesting video-amplifier configurations is that in which a number of similar stages are cascaded directly together. This condition is of particular interest because it is not possible to employ transformer impedance matching in a video amplifier. Furthermore, it has been found that the most efficient use of transistors for this function is obtained by using a grounded-emitter connection for all the transistors. When this configuration is employed, the input impedance of any stage is equal to the load impedance of that stage, since the load impedance is the input impedance of the next stage.

On the basis of the assumption of equal input and load impedances, the voltage gain of a low-pass amplifier is equal to the magnitude of the current gain. The bandwidth of such a stage will be determined by either the alpha cutoff frequency or the collector capacitance. When the alpha cutoff is the limitation, and if it is assumed that the frequency dependence of alpha is like that of a single-section low-pass filter, the gain-bandwidth product of a single stage is very nearly equal to the alpha cutoff frequency of the transistor used in the stage. When collector capacitance limits the bandwidth, the gain-bandwidth product is the reciprocal of the product of base resistance and collector capacitance, as in the case of the tuned amplifier. The only difference is that, in this case, it may be necessary to

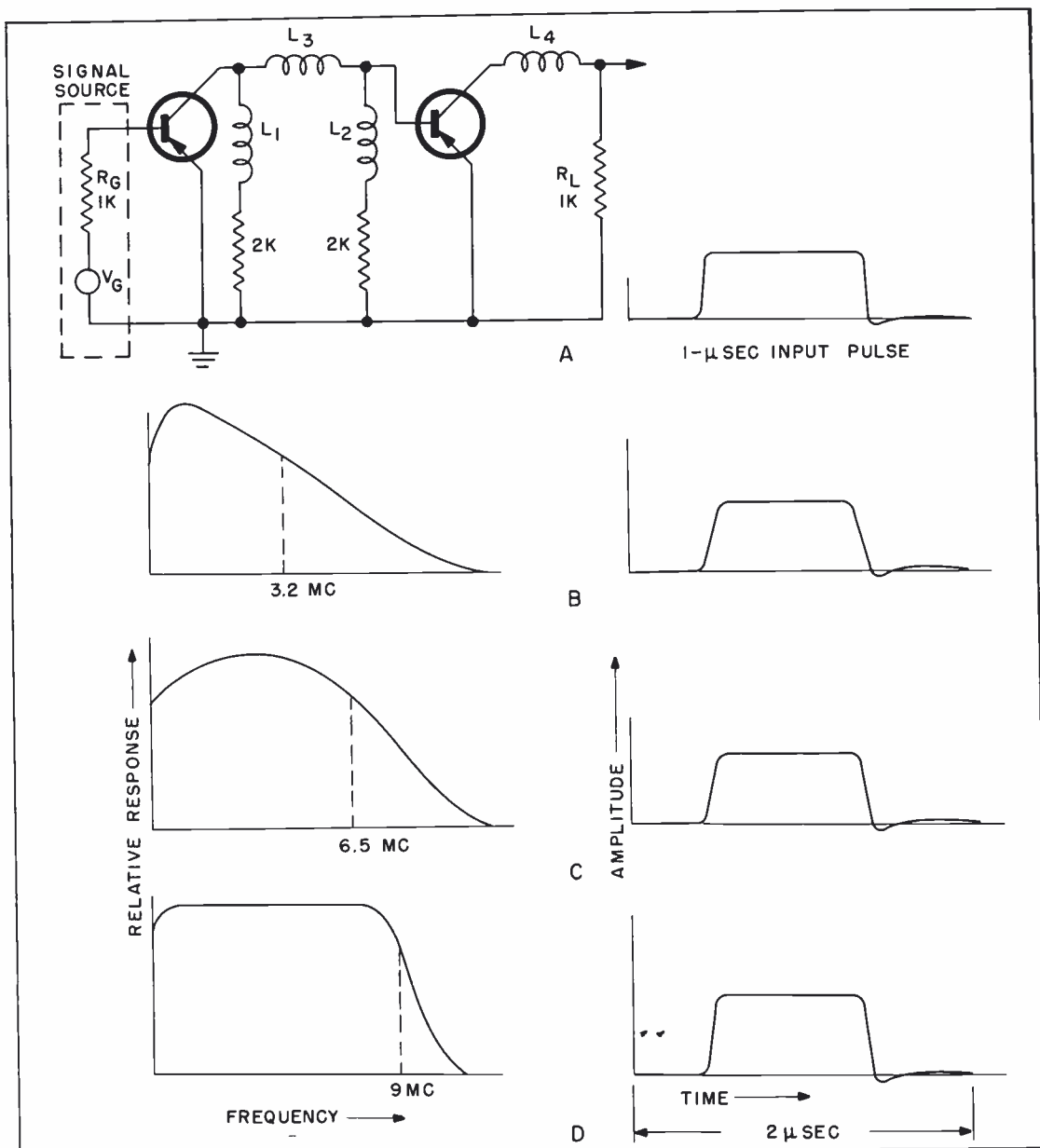
consider the low-frequency base resistance. For almost all Surface-Barrier Transistors, the gain-bandwidth product due to collector capacitance is appreciably higher than that due to alpha cutoff, and consequently is of little importance.

A two-stage video amplifier using similar transistors having alpha cutoff frequencies of approximately 50 mc., gave the performance shown in figure 6. With all four coils in the circuit shorted, the bandwidth and transient response were as shown in part B of figure 6—a bandwidth of 3.2 mc. was obtained. The gain between the 1000-ohm source and the load impedance was 28 db. This gave a gain-bandwidth product of 16 mc. per stage. This figure is lower than the predicted value of 50 mc. for two reasons: First, the supply resistors dissipate some of the power gain of the first stage. When shunt chokes were employed in series with these supply resistors, to raise their impedance at the higher frequencies, the bandwidth was increased to 6.5 mc., as shown in part C of figure 6, giving a gain-bandwidth product of 33 mc. for each stage. Second, the circuit and collector capacitances cause some bandwidth limiting. Adding series peaking coils,  $L_3$  and  $L_4$ , in order to resonate the collector capacitances, increased the bandwidth to 9 mc., as shown in part D of figure 6, and made the gain-bandwidth product equal to the theoretically predicted value. Parts C and D of figure 6 also show the resultant improvement in transient response. Thus it is evident that, although the collector capacitance is not sufficiently great to predominate in limiting the bandwidth, it can have an appreciable effect.

## TRIGGER CIRCUITS

Various trigger circuits have been made using Surface-Barrier Transistors with good success. Since a trigger circuit is somewhat like an overdriven low-pass amplifier, the same parameters that



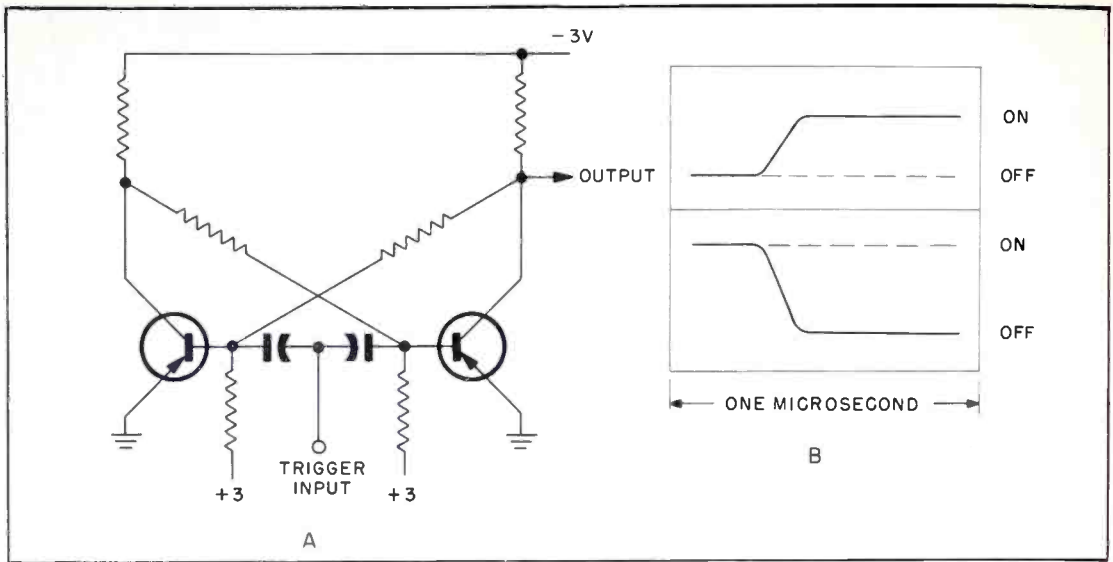


**Figure 6. Two-Stage Video Amplifier Using Surface-Barrier Transistors**

- A. Simplified Schematic and Input Pulse**
- B. Frequency and Transient Response with All Four Peaking Coils Shorted ( $L_1 = L_2 = L_3 = L_4 = 0$ )**
- C. Frequency and Transient Response with  $L_1$  and  $L_2$  in the Circuit ( $L_3 = L_4 = 0$ )**
- D. Frequency and Transient Response with All Four Peaking Coils in Use**

result in a good video amplifier also lead one to suspect that a fast trigger circuit can be made. A typical bistable flip-flop is shown in part A of figure 7. The basic circuit, as shown, is essentially that of a collector-coupled flip-flop employing grounded-emitter-connected transistors. The rise and fall waveforms

of this circuit, shown in part B of figure 7, indicate a switching time of less than 0.1 microsecond. As in the case of the previous circuits, this flip-flop requires a maximum collector potential of 3 volts, and could be operated, with a somewhat increased switching time, at even lower voltages.



**Figure 7. Bistable Flip-Flop Using Surface-Barrier Transistors**  
**A. Schematic Diagram**  
**B. Output Waveforms Showing Switching Action**

### CONCLUSIONS

The circuits that have been considered have shown that it is possible to use Surface-Barrier Transistors to provide wide-band amplification, or high-frequency signal generation and amplification, with a very low total power consumption. With these transistors it is possible to design stable i-f circuitry, in

many cases taking advantage of the simplicity of unneutralized triode amplification. Thus they have extended the very low power advantages and the circuit simplicity of junction triode transistors into the v-h-f range, thereby opening up a completely new class of circuit applications requiring very low power dissipation.



# CRYSTAL SUBSTITUTION FOR RADIO RECEIVER R-19/TRC-1

by Herbert L. Mallicoat

*Philco Field Engineer*

**A method of reducing AN/TRC-1 or -3 communication outage time by having a pretuned back-up Radio Receiver R-19/TRC-1.**

**M**ANY COMMUNICATIONS ENGINEERS are faced with a problem of back-up for their carrier-loaded AN/TRC-1 or 3 equipment because they either have no back-up equipment, or have back-up equipment but only one receiver crystal. Thus it is impossible to have a pretuned back-up receiver since the only receiver crystal is in the operating circuit. Consequently, when a receiver circuit failure occurs, it is necessary to remove the crystal from the defective receiver to tune the back-up receiver. In many instances semi-skilled personnel are required to tune the receiver, and circuit outage time soars while they perform this job. The ideal situation is to provide a method whereby the semi-skilled personnel could tune the back-up receiver before a failure occurs. Then, in case of a break-down, all that is required to restore service is to change the antenna and control cable from the defective receiver to the back-up receiver. This can be accomplished in most cases with the equipment on hand.

Most stations are authorized a crystal bank that is kept in Chest CY-44. This bank contains two transmitting crystals for each channel between 70 mc. and 99.9 mc., and one receiver crystal for each of the above channels. In the past many stations have attempted to solve the receiver back-up problem by using the next channel crystal, either above or below the operating frequency, to tune the back-up receiver. This, however, is a poor solution to the problem.

In the crystal bank there are 25 combinations of crystals, and although the channel numbers (stamped on top of the crystal holder) differ, some have the same fundamental frequency. For example, if a station receiving at a frequency of 70 mc. has an outage due to crystal failure, an exact replacement crystal is the crystal for the 85-mc. channel, since the fundamental frequency of both the 70-mc. channel and 85-mc. channel crystals is 7500 kc. The crystals which may be used as direct replacements are listed in the following chart.

In many cases where a direct crystal replacement cannot be made, a close substitution can be effected. For example, if a station receiving at 70.1 mc. had a crystal failure, it would be possible to substitute the crystal for the 85.1-mc. channel. Although this is not an exact substitution, it is one that will work satisfactorily in an emergency, and is certainly a better solution to the problem than tuning the back-up receiver to an adjacent channel. The fundamental frequency of the receiver crystal for 70.1 mc. is 7510 kc., and the fundamental for channel 85.1 mc. is 7508.3 kc. This is a difference of 1.7 kc.; however, the difference in adjacent channel crystals is either 10 kc. or 8.3 kc., depending on the operating frequency. The proper receiver tuning procedure is to use the 70.1-mc. transmitting crystal in the TS-32, and proceed as if the proper crystal were in the receiver. When the back-up receiver is placed in use, only the an-

tenna and first r-f controls need be adjusted to the incoming signal.

The reason that two crystals stamped with different channel numbers may have the same or nearly the same operating frequency is that the double-conversion system is used in the R-19/TRC-1 receiver. The range of the receiver is from 70 mc. to 99.9 mc. The range of the crystal oscillator is from 7300 kc. to 8750 kc. These figures, however, do not tell the complete story. It would appear that the 7300-kc. crystal is the crystal for the 70-mc channel, and the 8750-kc. crystal is the crystal for the 99.9-mc. channel. But this is not the case, because from 70 to 82.5 mc. the crystal oscillator range is from 7500 to 8750 kc., and the heterodyning frequency is the 5th harmonic of the crystal frequency. From 82.6 to 99.9 mc. the crystal oscillator range is from 7300 to 8741.7 kc., and the heterodyning frequency is the 6th harmonic of the crystal.

Between 82.5 and 84.9 mc. there are no possible substitutions. This is of little concern, as these are mid-band frequencies and can be avoided, if necessary, since duplex circuits either transmit high or low, and will receive at the opposite end band. Mid-band frequencies are seldom used in carrier-loaded duplex systems.

The above example of a close substitution is but one of many. Consult TM-11-2601, dated December, 1951, Table V, pages 71 through 73. Perhaps you have a crystal for that back-up circuit and never realized it.

### CRYSTAL SUBSTITUTION CHART

CRYSTAL FREQUENCY (KC.)	LOW-BAND CHANNEL (MC.)	HIGH-BAND CHANNEL (MC.)
7500	70.0	85.0
7550	70.5	85.6
7600	71.0	86.2
7650	71.5	86.8
7700	72.0	87.4
7750	72.5	88.0
7800	73.0	88.6
7850	73.5	89.2
7900	74.0	89.8
7950	74.5	90.4
8000	75.0	91.0
8050	75.5	91.6
8100	76.0	92.2
8150	76.5	92.8
8200	77.0	93.4
8250	77.5	94.0
8300	78.0	94.6
8350	78.5	95.2
8400	79.0	95.8
8450	79.5	96.4
8500	80.0	97.0
8550	80.5	97.6
8600	81.0	98.2
8650	81.5	98.8
8700	82.0	99.4





# SERVICING SYNCHROS AND SERVOMECHANISMS

## PART 2 OF A SERIES

by J. J. Mills

Philco Field Engineer

**A further discussion of the operation and characteristics of synchro systems. Part 2 deals with synchros as components of the larger positioning servomechanisms. The article covers other servo components, servo response, and system accuracy, and includes an organized outline for trouble-shooting a positioning servo system.**

**I**N THE FIRST INSTALLMENT of this series (May-June, 1954, BULLETIN), the author discussed the construction and operational principles of the synchro transmitter, follower, and differential. An analysis of the resultant fields set up in the synchro stator windings for various displacement angles was given, along with the determination of values of induced voltages for each displacement angle. The article covered electrical zeroing, torque characteristics, and standard practices relating to synchro systems. A step-by-step trouble-shooting procedure for a typical synchro data transmission system concluded the first installment. Part 2 starts with a study of the remaining synchro unit, the control transformer, and follows with a logical exposition of the positioning servo from that point.

### POSITIONING SERVOMECHANISMS

In the previous installment, it was shown how a simple synchro system is used in remote-indicator applications. For such applications, relatively low torque is sufficient to position the load, which usually consists of a light-weight dial or pointer. However, it is often necessary to position other loads which, because of high inertia and friction

characteristics, require higher torque than a synchro follower can supply. Positioning servomechanisms, with their inherent amplification, are used to fulfill this need.

The essential components of a positioning servomechanism are the data transmission system, the servo controller, and the servomotor.

The data transmission system must (1) transmit a signal proportional to the servo input, (2) compare the input signal with a signal proportional to the servo output, and (3) transmit a signal to the servo controller which represents the *difference* between the servo input signal and the servo output signal.

The servo controller must amplify the error signal to a level adequate to control the servomotor and, in some systems, must also (1) change the error signal into suitable form for controlling the servomotor, and (2) provide special characteristics required for good stability and response of the mechanism.

The servomotor must supply the torque, power, and dynamic characteristics to satisfactorily position the servo load. The ideal servomotor should require small power from the servo ampli-

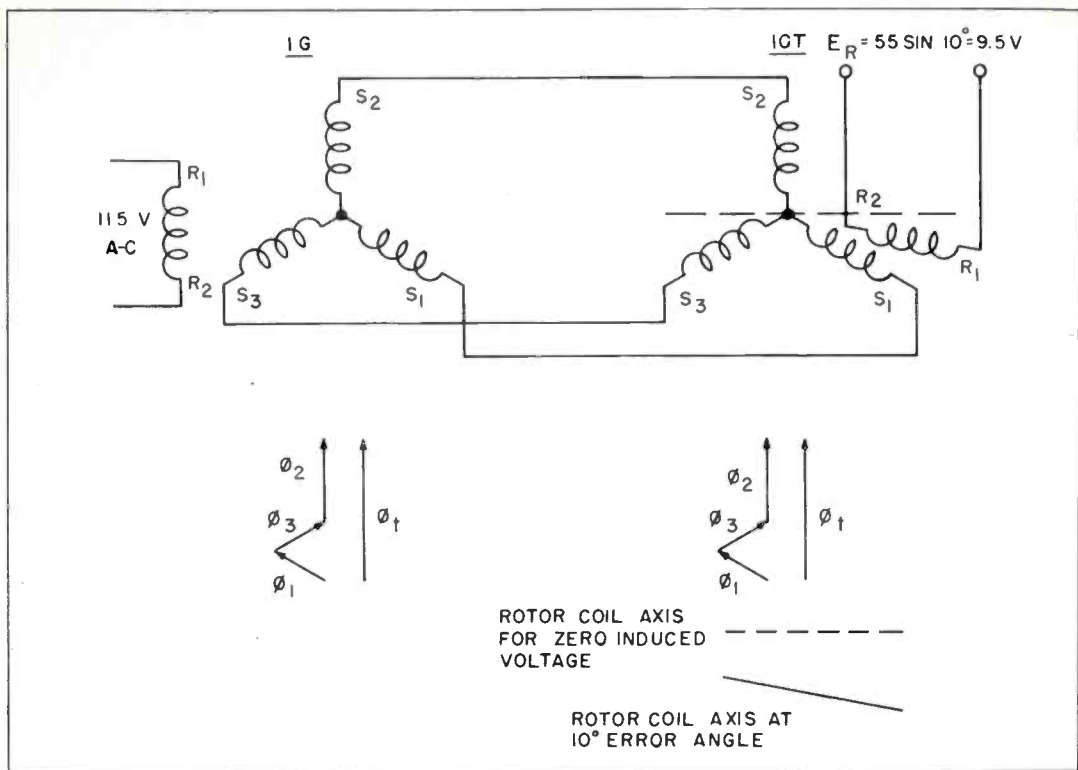


Figure 1. Synchro Control Transformer (CT) Connected to a Transmitter, Showing a 10-Degree Error Condition

fier, should be small in size and weight, should be capable of rapid acceleration, and should have an adequate speed range.

### THE CONTROL TRANSFORMER AS AN ERROR DETECTOR

Although the outer physical appearance of the control transformer is similar to that of a synchro transmitter or follower, it is, in use and electrical characteristics, quite dissimilar to those machines. It is designed with high-impedance stator coils, which draw relatively little current from the synchro transmitter feeding it. Its rotor is not excited; therefore, any rotor voltage present is *induced* by the magnetic field created by stator-coil currents. The induced rotor voltage is always fed to a high-impedance load; the resulting rotor current is so negligible that it causes no tendency for the rotor to align itself parallel to the magnetic field which is created by the stator-coil currents.

The principal physical difference between the control transformer and the synchro transmitter or follower is found in the construction of the rotor core. In contrast to the salient-pole type of rotor, which in the synchro follower aids the pull-in torque, the control transformer has a cylindrical rotor. The reluctance of the flux path through the cylindrical rotor is the same for any rotor position, so there is no torque exerted by the flux seeking the easiest path. Consequently, there is no tendency of the CT rotor to pull itself into an aligned position.

When the stator terminals of a control transformer are connected to the stator terminals of an excited synchro transmitter, as shown in figure 1, a magnetic field will be set up within the CT barrel. Unless the rotor coil is perpendicular to this magnetic field, a voltage will be induced in it. The Navy synchro control transformer is so designed that if its rotor is *parallel* to the magnetic field, there will be 55 volts induced in the

rotor coil. Hence the induced rotor voltage for any rotor position will be

$$E_R = 55 \sin \theta$$

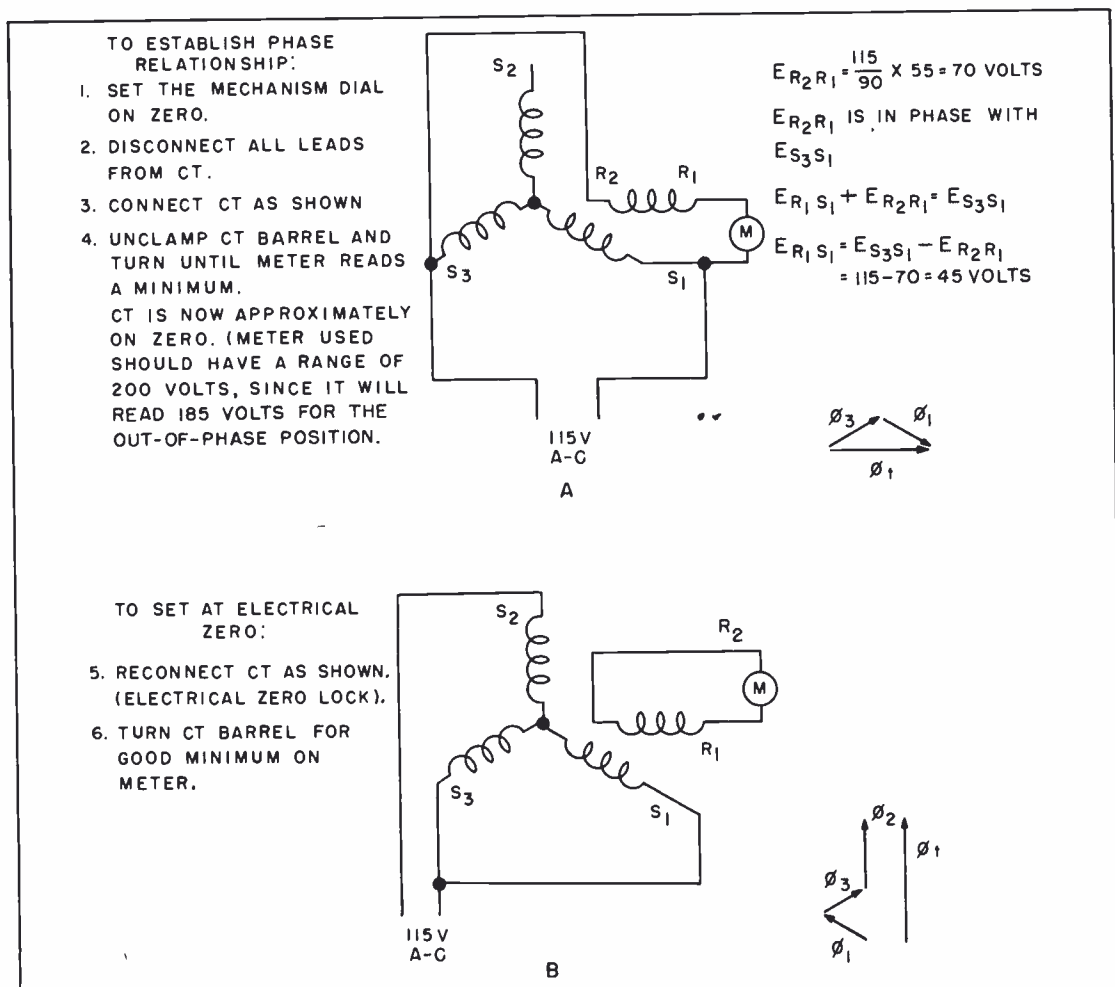
where  $\theta$  is the *error angle*, or the angular difference between a line perpendicular to the rotor axis and the direction of the total magnetic field within the CT barrel.

Since the CT is used in positioning servomechanisms as a null instrument, the point of main interest is that rotor position in which there is minimum induced rotor voltage. Since with an electrical-zero order applied the direction of the magnetic field is *parallel* to the  $S_2$  coil, the rotor coil axis for the electrical-zero reference is taken *perpendicular* to the  $S_2$  coil axis. Figure 2

shows the procedure for zeroing a CT by the jumper method.

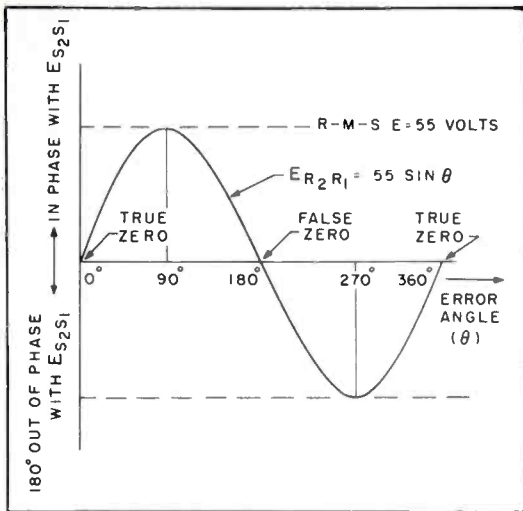
**CAUTION:** Since synchros are designed for a maximum of 90 volts across any two stator coils, 115 volts should be applied for short intervals only. If a longer time is required, a 78-volt transformer or an equivalent voltage-dropping device should be used.

If the synchro transmitter is set to its electrical-zero position, and the CT rotor is turned through one complete revolution from its electrical-zero position, the induced voltage in the CT rotor will vary as shown in figure 3. Note that there are two zero-voltage positions of



**Figure 2. Jumper Method of Zeroing a Synchro Control Transformer**  
**A. Phase-Determining Connections**  
**B. Zeroing Connections**

## SYNCHRO CAPACITORS AS USED WITH CONTROL TRANSFORMERS



**Figure 3. Graph Showing Voltage Induced into a Synchro Control Transformer Rotor as a Function of Error Angle**

the CT rotor, and that the position found at 180° is an unstable one. When the rotor is properly connected into a positioning servomechanism, the mechanism quickly positions itself to the correct null of the control transformer.

Control transformers, like differential generators, are not characterized by zero stator current for any rotor position. Unbalanced stator currents flow, causing unbalanced internal impedance drops, with a resultant inaccuracy in servomechanism positioning. In order to reduce the reactive current, synchro capacitors, connected in delta, are connected to the stator leads of control transformers. The capacitors should always be mounted as close as possible to the CT, so as to keep the IR drop in the cable to a minimum.

Some characteristics of Navy synchro control transformers, and the synchro capacitors used with them, are given in TABLE 1.

**TABLE 1. CONTROL TRANSFORMER CHARACTERISTICS**

SYNCHRO DESIGNATION	MARK	USE WITH CAPACITOR		EXCITING CURRENT (AMPS)		D-C RESISTANCE	
		TYPE	CAP. PER SECT.	WITH CAP.	LESS CAP.	BETWEEN S LEADS	BETWEEN R LEADS
1CT	5	1C MK12	0.6	.02	.045	700 to 850 ohms	200 to 500 ohms
5CT	3	1C MK12	0.6	.015	.045	175 to 275 ohms	75 to 160 ohms

## TWO-PHASE INDUCTION MOTOR

A servomotor frequently used in instrument servomechanisms (those requiring less than 1/10 horsepower) is the two-phase induction motor.

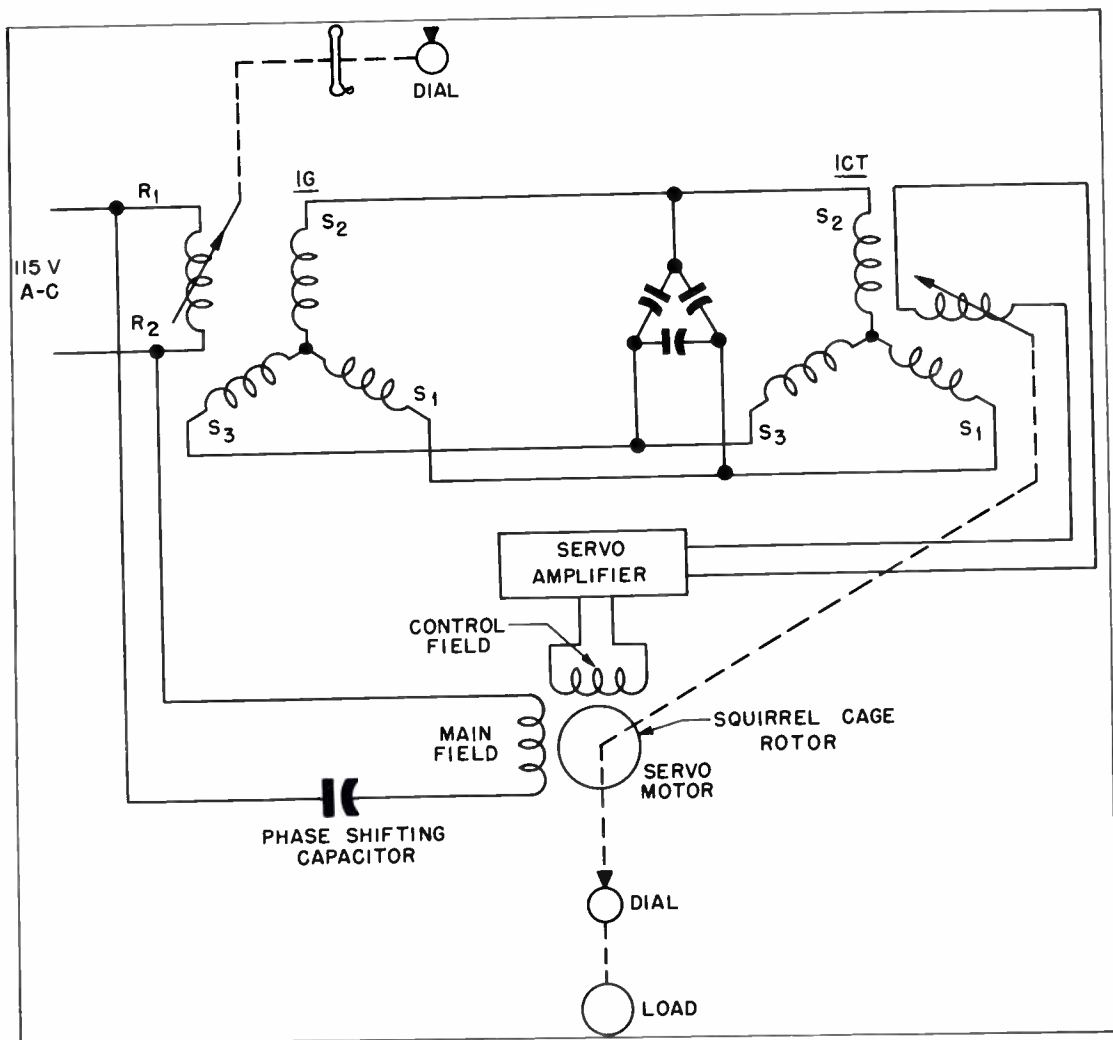
The stator and rotor of this motor are constructed with sheet-steel laminations. The stator consists of two coils, physically displaced from each other 90°. A squirrel-cage rotor is generally used, although some motors use a short-circuited wound rotor.

Maximum torque is developed by this motor when the stator-coil currents are

equal and 90° out of phase. These currents produce a rotating field of constant speed and amplitude, the speed of the field being determined by the stator-current frequency.

Rotation of this field past the rotor conductors induces voltages in them, causing currents to flow in the short-circuited rotor winding. Consequently, the rotor becomes a magnet which tends to align itself with the stator field, thus producing a torque which causes the rotor to follow in the direction of the stator's rotating magnetic field.





**Figure 4. Typical Positioning Servomechanism, Showing the Use Synchro Capacitors on the Synchro Control Transformer**

The speed of the induction motor is always less than the synchronous speed, since there must be relative motion between the rotor and the rotating magnetic field in order to induce voltage in the rotor. The torque of the motor varies with rotor speed, since the frequency, amplitude, and phase angle of the induced rotor voltage varies with the "slip" of the rotor behind synchronous speed. Two-phase induction motors used as prime movers have relatively low-resistance rotors. It is necessary, however, to use high-resistance rotors in servomotors, in order to effect a smooth control over the torque-speed characteristics. In a servomotor, maximum torque should occur at zero speed, to prevent

momentary acceleration from producing excessive torque and a tendency to oscillate.

### THE SYNCHRO POSITIONING SERVOMECHANISM

Figure 4 shows a typical positioning servomechanism in block diagram form. The 1G synchro transmitter is excited by 115 volts, a.c., and its stator voltages are fed to the stator terminals of the ICT. The resulting stator currents create a magnetic field within the CT, the direction of which is parallel to that of the 1G rotor. If the CT rotor is not perpendicular to this magnetic field, a rotor voltage is induced. This voltage is

reinforced by the servo amplifier, the output of which is fed to the *control field* of the servomotor. The *reference field* of the motor, frequently called the fixed field or the main field, is constantly excited by the same source that excites the 1G. However, the phase of the reference-field current is shifted by the series capacitor shown, so that the reference-field current leads the control-field current by approximately  $90^\circ$ .<sup>\*</sup> With voltages on both fields, then, the motor turns, and, since it is geared to the CT rotor as well as to the load, the CT rotor is turned until it is perpendicular to the magnetic field within the CT, at which time there will be zero induced rotor voltage, and therefore zero voltage on the motor control field. The system will remain at rest until the synchro transmitter rotor is turned, changing the direction of the magnetic field in the CT, and again inducing a voltage in the CT rotor.

### OPERATING CHARACTERISTICS OF SERVOMECHANISMS

Gain, stability, and response are all interrelated characteristics of any servomechanism. They are functions of the servo controller, the servomotor, and the mechanical load. The load characteristics (inertia, friction, etc.) are usually fixed quantities around which the system is designed.

The gain, stability, and response of the system are controlled in design by the proper choice of a servomotor and proper design of the servo controller. It is beyond the scope of this article to go into servomechanism design, but it is believed worthwhile to discuss briefly some of the factors affecting system characteristics. It should be noted that, although the proper choice of a servomotor is important, once that choice is

made its characteristics are fixed. Servo controller characteristics, however, are more easily modified; the designer, therefore, controls most of the system characteristics by servo controller design.

The over-all system gain has quite an important effect on the response characteristics, and is one of the more easily adjustable quantities in electronic servo controllers. Increasing the system gain reduces the velocity lag errors, and those static errors resulting from restricting torques on the mechanism. Increasing the system gain also increases the system's natural frequency, and, therefore, its speed of response. Continued increase in gain, however, eventually produces instability, and the mechanism will hunt about its equilibrium position. The gain, then, should be as high as is commensurate with system damping.

There are several methods of designing stability into servo systems, each possessing inherent advantages and disadvantages. Each method, of course, is more readily adapted to some systems than to others. The more frequently used damping methods, some of which will be discussed in connection with specific servomechanisms, are:

1. Tachometer feedback from a d-c generator geared to the mechanism.
2. Eddy-current damping obtained by the use of an induction-cup servomotor.
3. Negative feedback.
4. D-c and a-c lead networks, which produce a leading phase shift of the error signal to compensate for the phase lag in other parts of the system.
5. Velocity feedback from an induction generator (a-c) geared to the mechanism.

<sup>\*</sup> In many systems, the required phase shift is accomplished by a phase-shift network in the servo controller.

## SERVICING THE ONE-SPEED SERVOMECHANISM

Troubles encountered in one-speed CT positioned mechanisms can be classified as follows:

1. Mechanism does not move when data transmitter is turned.
2. Mechanism follows data transmitter sluggishly; no stiffness in response.
3. Mechanism follows data transmitter, but with inaccuracies; stiffness good.
4. Mechanism motorizes.
5. Mechanism hunts.

Before analyzing trouble in a servo system, the mechanism should first be turned by hand with the power off to determine whether any mechanical binding exists. If the servomotor shaft is readily accessible, it should be checked to make sure that it spins freely, especially in the case of an instrument servomechanism. If the motor shaft is not accessible, some other component of the mechanism should be checked for restricting torque, such as the dial or a gear in the mechanism, keeping in mind that the restricting torque varies inversely with the gear ratio between the component turned and the motor shaft.

1. If the mechanism is free to turn, but doesn't move when the data transmitter is turned, perhaps the best place to start is at the servomotor fields. Offset the data transmitter from the remote mechanism, and check the voltage at the reference and control fields of the motor. If no voltage is present at the reference field, check the system excitation circuits. If no control field voltage is present check the stator voltages at the synchro control transformer; if these voltages are present, check the induced CT rotor voltage. If this voltage is present, the trouble has been isolated in the servo amplifier. If a multi-stage servo amplifier is used, the CT rotor voltage "signal" can be traced through

the amplifier in order to quickly determine where it is lost.

If voltage is present at both fields, and the resistance of both field windings is correct, assuming that no mechanical bind is present, the voltages at the control and reference fields should be checked for phase difference.

2. As stated previously, the response of a servomechanism is proportional to the system gain. If the mechanism follows sluggishly, the servo controller gain should be investigated. It is possible that the damping present is limiting the effective system gain.

3. If the mechanism follows with inaccuracies, the type of inaccuracy should first be determined. If erratic, the possibility of followers being tied to the same bus should be investigated. This is considered bad practice, for two reasons:

- a. A binding synchro follower will reflect its own induced stator voltages throughout the synchro system, and cause the entire system to be erratic.
- b. It can be shown that coercion exists in parallel synchro systems; i.e., unless the synchro transmitter is very large compared to the load, its stator voltages will be incorrect for its given angle of rotation, and a control transformer tied to the line will position its mechanism to this incorrect stator-voltage position.

Another cause of erratic following is brush or slip-ring trouble.

If a constant error exists, the system simply needs to be zeroed.

If a smooth error exists, the possibility of unbalanced stator resistances should be investigated. This unbalance could be caused either by open or shorted leads, or by defects in the stator

coils of any of the synchros tied to the bus.

4. Under certain conditions, if the control-field voltage to a two-phase induction motor is not present, the motor, once started, will continue to rotate because of its fixed-field excitation. This is known as "motorizing," or "single-phasing." The single-phase torque of the motor must, of course, be sufficient to overcome the resisting torque of the load, in order to sustain continuous rotation.

To eliminate the possibility of motorizing, it is necessary to cut off the fixed-field excitation to servomotors when the system is secured. In many present-day computers it is necessary in making static tests to set certain mechanisms (which are ordinarily positioned by synchro positioning systems) by hand to given dial readings. In order to avoid motorizing, a switch is provided for each positioning system, which, when pulled, both short-circuits the control-field winding and opens the supply line to the fixed-field winding. The mechanism and its dial, then, will remain on

the position at which it was set, with no possibility of motorizing.

5. A hunting servomechanism can present a difficult problem, since a dynamic measurement taken anywhere around the closed loop will show nothing but a manifestation of the hunting. The basic cause of hunting, as previously stated, is insufficient damping for the amount of system gain.

Hunting can be caused by mechanical as well as electrical defects. Backlash in gear trains often produces instability of either very high or very low frequency. Experience has shown that the backlash must be less than one-half the acceptable positioning error.

When trouble-shooting servo oscillations in systems using a d-c or an a-c generator for velocity feedback, the amplitude and polarity or phase of the feedback voltage can be checked while slewing the mechanism. In systems using static forms of feedback, a check of all components in the anti-hunt network usually produces the best results.

*(To be continued)*



### ***What's Your Answer?***

This month's problem was submitted by Gabe Rumble, Philco Field Engineer who will be remembered for a tricky power transformer problem (January, 1953, BULLETIN).

The problem concerns an r-f amplifier of the class-B linear type, such as is used in a low-level modulated broadcast transmitter. The average power furnished by the power supply to the amplifier is the same, whether the r-f input is modulated or unmodulated. However, the r-f output power delivered by the stage rises with the application of modulation. (In fact, for 100% sine-wave modulation, 50% more power than for the unmodulated condition is delivered to the load.)

For example, assume an unmodulated carrier level of 100 watts. For 100% sine-wave modulation, the power output is 150 watts, but the plate current (and voltage) supplied to the amplifier do not change from the unmodulated values.

The problem is to explain where the extra power comes from during modulation?

*(Solution next issue)*

# SHORAN EQUIPMENT

by Michael W. Onushco

*Philco Field Engineer*

**An insight into how a navigational type of equipment can be used for precision blind bombing and for mapping operations.**

**SHORAN** (SHOrt Range Air Navigation) is a precision distance-measuring device which employs the radar pulse timing principle for making measurements between an aircraft and two outlying responder (beacon) ground stations.

Shoran was originally designed in 1940 for short-range navigation and precision bombing (known as H-system). The Air Force put it into practical use during the latter part of World War II; it was used to bomb targets which were generally not suited for visual bombing because of cloud coverage, screening smoke, or a lack of identifying features. Results obtained with Shoran were, in most cases, remarkable. Although the equipment was operated by personnel possessing little or no operating experience, the results compared very favorably with results obtained by visual means on other targets.

In postwar days, Shoran equipment proved applicable to other uses as well as those mentioned above. It is and has been used extensively for trilateration survey distance measurements and controlled photography. Civilian concerns have used Shoran in conjunction with a magnetometer in locating and fixing the position of oil deposits.

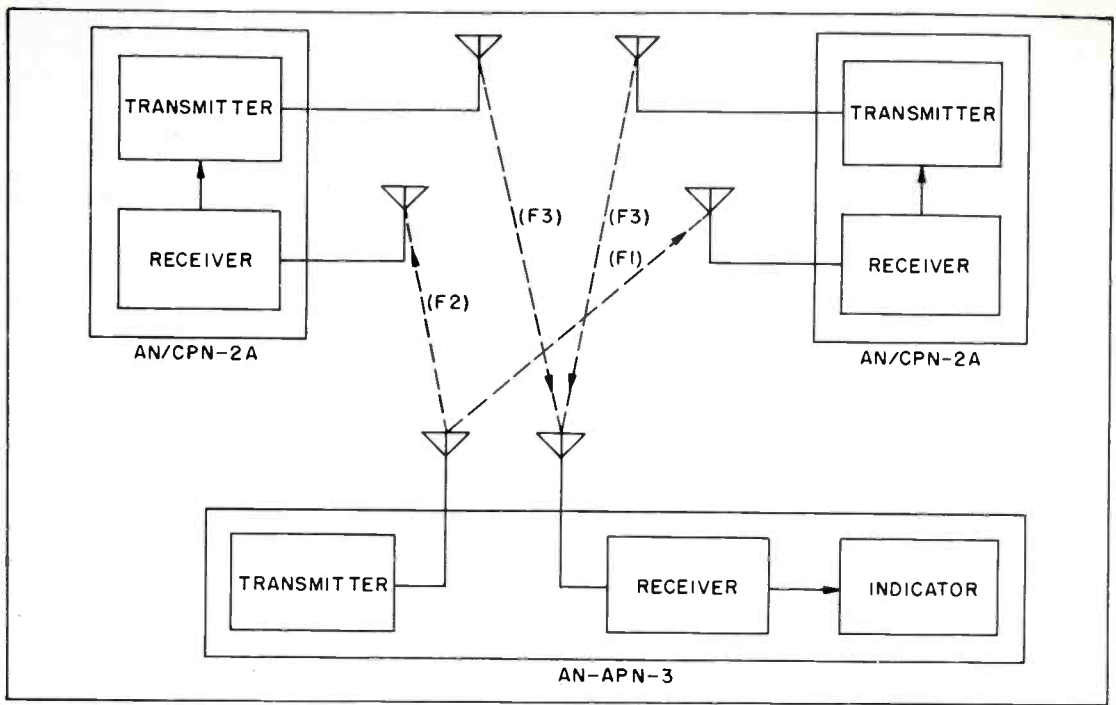
In the Korean campaign, Shoran again proved its usefulness for bombing and navigation, and for bombing it was used more frequently than any other method.

## PRINCIPLES OF OPERATION

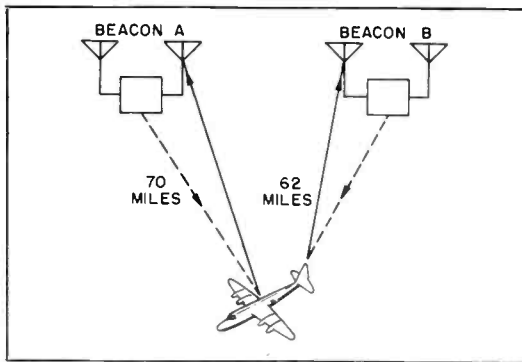
The Shoran system consists of the AN/APN-3 interrogator-responder airborne equipment, which operates in conjunction with two AN/CPN-2A ground beacon equipments, as illustrated in figure 1. The beacons, which consist basically of a receiver and a transmitter, are fixed station installations located miles apart and operating independently of each other. The AN/APN-3 equipment consists basically of a transmitter-receiver unit and a timer-indicator unit. The transmitter alternately produces two different operating frequencies, and can operate on any two frequencies in the 220- to 260-mc. band. The two operating frequencies are separated by about 20 mc., with one used to trigger one ground beacon and the other to trigger the second beacon. Although the two beacons are interrogated by signals on different frequencies, they both respond on the same frequency. The AN/APN-3 receiver operates in the 220- to 330-mc. band, and applies its output to the indicator. Similar unidirectional antennas are used for both receiving and transmitting; one is mounted on the top and the other on the bottom of the aircraft.

The airborne transmitter transmits pulses of r-f energy at a rate of 931 times per second; this rate is obtained by stepping down the output of a 93.1-kc. timing oscillator. A rate of 931 times per second will allow the signal to complete a 100-mile loop (out and back) before the next pulse is transmitted. A

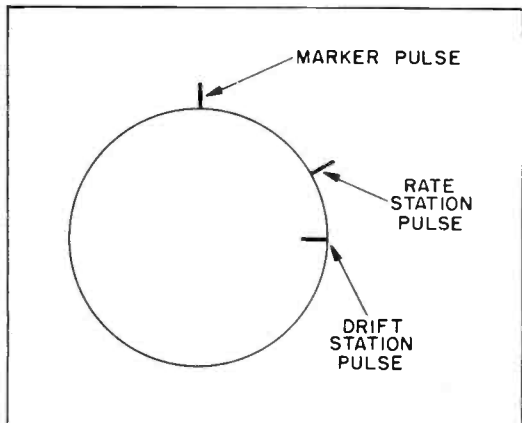




**Figure 1. Basic Elements of the Shoran System**



**Figure 2. Example of Distance Measurements, Using Shoran Equipment**

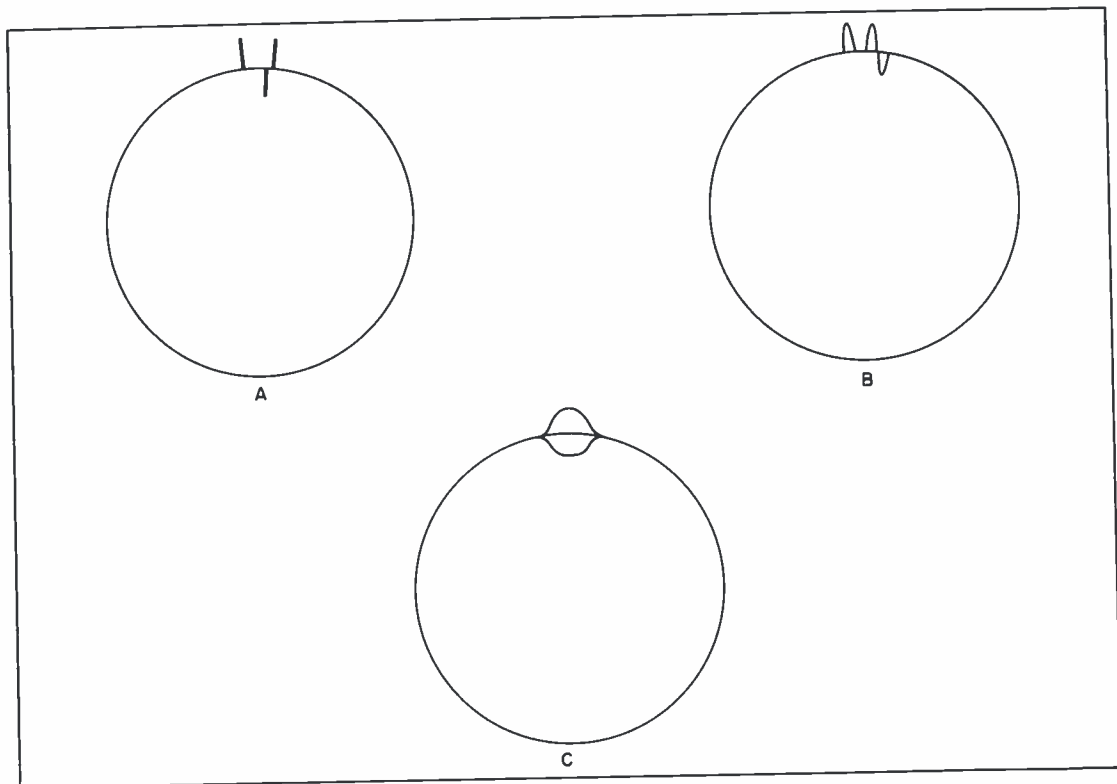


**Figure 3. Identification of Pulses**

commutator-type switching arrangement is used to enable the transmitter to send a series of pulses first at one frequency and then at the other. The switching rate is 10 c.p.s. Upon reception of an interrogation pulse the beacon equipment is triggered into operation. Then, through due processes of electronics, it replies with a  $0.55\text{-}\mu\text{sec.}$  pulse for each pulse received.

By interrogating first one beacon and then the other, as described above, the airborne equipment obtains data regarding its position relative to each beacon. The equipment measures the elapsed time between transmission and reception, and converts this time into loop miles, as illustrated in figure 2.

The indicator unit utilizes a circular-type J-scan sweep scope to display the pulses. The return from one of the beacons points outward from the sweep, and is called the rate station pulse; the other return points inward, and is called the drift station pulse (see figure 3). In addition, a fixed marker pulse generated within the equipment is displayed at the



**Figure 4. Method of Adjusting Pulses for Coincidence**

top of the sweep. Actually two circular sweeps are employed; they are in coincidence with each other so that they appear as one. The marker pulse is associated with one of the the sweeps, and the two return signals with the other.

### **METHOD OF OPERATION**

In actual practice, when an aircraft is moving away from the beacons, the rate and drift pulses observed on the AN/APN-3 scope move in a clockwise direction on the sweep and vice versa. The pulses can also be advanced or retarded with respect to the fixed marker by adjustments on the timer-indicator unit. One dial and a vernier counter, calibrated in miles, tenths of a mile, and hundredths of a mile, are used in connection with each received pulse. The method of determining absolute position relative to the two beacons is to adjust the pulse positions, using the dials and vernier counters, until the received pair coincide with the marker. The distances between the aircraft and the beacons are

then read from the mileage indications on the dials and vernier counters. Three sweep scales of 100, 10, and 1 mile are used to obtain accuracy in the coincidence alignment of the pulses.

The method of adjusting for coincidence is as follows: Assume that the position of the pulses to begin with is as shown in figure 3 (which is a representation of the 100-mile scale). The first step is to adjust the rate station mileage dial and the drift station mileage dial until both pulses are to the right but within approximately  $15^\circ$  of the marker pulse, as shown in part A of figure 4. The equipment is then switched to the 10-mile scale and the procedure repeated, with the result shown in part B of figure 4. The same procedure is again repeated on the 1-mile scale except that the bases of the leading edges of the pulses are made to coincide, as shown in part C of figure 4. The mileage to each beacon is now available to the hundredth of a mile, and can be approximated to the nearest thousandth of a mile. (The

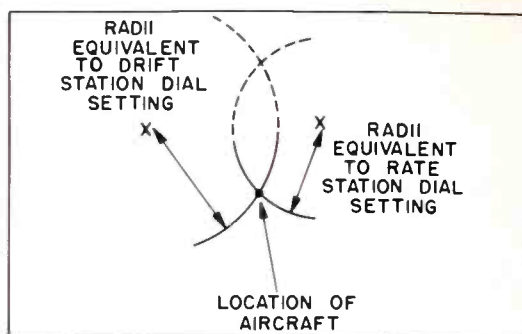
estimated probable error claimed when the equipment is properly used is within  $\pm 50$  feet.)

Since the locations of the beacon stations are marked on a map, the operator can determine the aircraft location by drawing arcs on the map, the arcs having radii equivalent to the readings obtained on the dials and vernier counters as shown by the solid lines in figure 5. Figure 5 also illustrates that by extending the arcs (dotted lines), another possible location for the aircraft will be obtained. In actual practice, this ambiguity is resolved by the navigator's use of other information at his disposal. By obtaining a series of readings and making a series of equivalent plots on the map, the operator can use the Shoran system for navigation.

The range of the equipment according to dial readings is 100 miles; however, line-of-sight transmission to and from an aircraft at an altitude of 40,000 feet is approximately 280 miles. Actually, the equipment can be used at distances of over 100 and even 200 miles from the ground stations. A dial indication of 50 miles, for example could also be 150 or 250 miles, and the navigator need only resolve the distance to the nearest 100 miles to determine actual distance.

### TYPES OF OPERATION

The Shoran equipment, with its ability to measure distances accurately, is used in conjunction with a Computer Comparator and Pilot Direction Indicator to drop bombs with very precise results. It is also used in conjunction with the AN/APA-54 Recorder unit to obtain survey measurements and reconnaissance data; also, with the addition of a Straight Line Indicator unit and associated Pilot Direction Indicator to the surveying system, it makes controlled photography possible.



*Figure 5. Method of Locating Position of Aircraft, Showing Associated Ambiguity*

### Bombing Technique

A Shoran organization must perform a series of functions before a bombing mission can become a reality. First, the exact geodetic positions of the ground stations and the target must be known. This information can be obtained by using existing geodetic data or large-scale maps. The positions may also be obtained by Shoran reconnaissance if existing information is not available. Second, personnel utilizing the geodetic positions must complete three phases of computation. Phase I is the computation of true geodetic distance between the ground stations and the target. Phase II is the conversion of the geodetic distances to Shoran ray path distances; this is the actual Shoran distance between the ground-station antenna and a point at bombing altitude directly over the target. Phase III is the application of the bomb variables to solve the no-wind bombing problem. The result of all computations is a Shoran data sheet which lists all the preset information for the Computer.

For a bombing mission the rate and drift dial settings at the exact bomb-release point are known, and are preset before the mission is begun. The aircraft is flown in a prescribed path until the drift station pulse is in coincidence with the marker pulse. This is one of the coordinates of the bomb-release point, as shown in figure 6. The aircraft

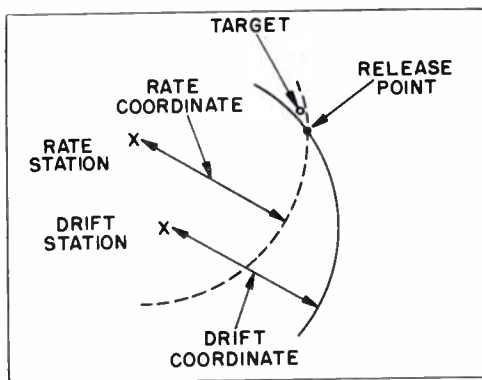
is then flown toward the release point, keeping the drift station and marker pulses aligned. The flight pattern is therefore the arc of a circle whose radius is the same as the distance between the drift station and the bomb-release point.

The instantaneous distance between the aircraft and the rate station is also constantly measured. The bomb release occurs when the solution of the "miles to release" problem, by the Computer, reaches zero. At this time, the distance measured has increased or decreased to equal the Shoran distance between the second ground station and the true release point, as shown by the intersection of the solid and dotted arcs in figure 6.

The ground station around which the aircraft flies is designated as the drift station. Either ground station may be used as the drift station and a change-over switch is incorporated in the AN/APN-3 so that the pulses from either station may point inward on the trace, and vice versa.

There are four possible approaches to a target. These approaches are clockwise and counterclockwise around each of the two stations, as shown in figure 7.

As mentioned previously, one ground station receives a higher-frequency signal from the airborne equipment than the other. As an additional aid in establishing course headings, the position of the two ground stations relative to each other should be known. The two beacon stations are so positioned that the general target area is on a broad front parallel to a line drawn between the stations. The target area will nearly always be in one direction from a line drawn between the stations. The following rule is used to establish which is the high-frequency station and which is low. Stand on an imaginary line between the two ground stations, and face the target area. The one to the right is the high-frequency station, and the one to the



**Figure 6. Method of Bombing with Shoran Equipment**

left is the low-frequency station, as shown in figure 7.

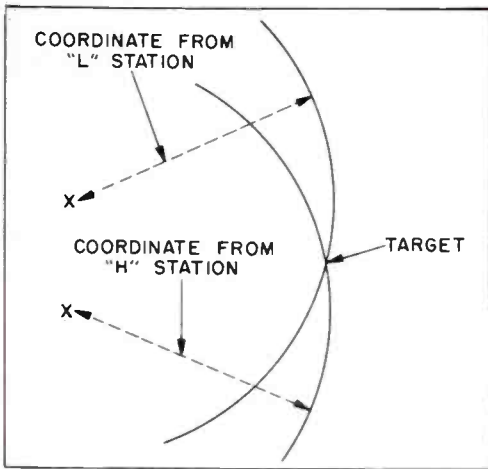
### Ground Mapping

Controlled photography is accomplished by utilizing a Straight Line Indicator unit. This unit acts as a simulator for the ground stations and the aircraft. The "bug" on the simulator travels along a track as long as the aircraft is flown on a predetermined line of flight. The aerial photo is taken during the procedure.

### LIMITATIONS AND ADVANTAGES

Shoran has a number of limitations. Those listed most frequently are as follows:

1. Shoran indicates radar line-of-sight range from the ground stations. This is because it operates in the v-h-f and u-h-f range (225 and 330 megacycles).
2. The exact geodetic location of the target for bombing must be known. This is because the distance between each of the ground stations and the target must be precomputed.
3. The exact geodetic locations of the ground stations must be known in order to accurately fix the position of the aircraft.



**Figure 7. Possible Target Approach Routes and Station Identification**

4. Not more than approximately 20 aircraft can utilize a pair of ground stations at any one time, because the beacons can be triggered only a limited number of times per second without overload.

5. The angle formed by lines drawn from the target through the ground stations should be within  $30^\circ$  and  $150^\circ$ , to obtain the accurate ground-speed indications required during a bombing run and for navigation.

The advantages of the system are numerous. The following is a list of the more outstanding ones:

1. It can be used in all types of weather because visibility is not necessary.

2. Normally, combat operational loss rate is considerably decreased because

night strikes against enemy targets can be flown.

3. Target identification is not required during the mission; therefore, target study during combat crew briefing is eliminated.

4. The operator need not make any bombing computations during the mission; the entire no-wind problem is pre-set into the Computer.

5. Equipment leveling is unnecessary because vertical sighting angles are not used.

6. Calibration can be accomplished in a matter of seconds; only one adjustment is necessary.

7. Maintenance problems are few because the equipment is not very complex.

8. A high degree of accuracy can be obtained, even from high altitudes.

## CONCLUSION

During the years that Shoran has been in use, it has provided invaluable aid in navigation, bombing, and ground mapping; however, as in all electronic equipments, improvements can be made. As a result, the AN/APN-3 has undergone extensive redesign, and a new Shoran set, the AN/APN-84, is being procured. The AN/APN-84 is expected to improve the precision and ease of distance measurements, particularly in geodetic surveying and in controlled photography.



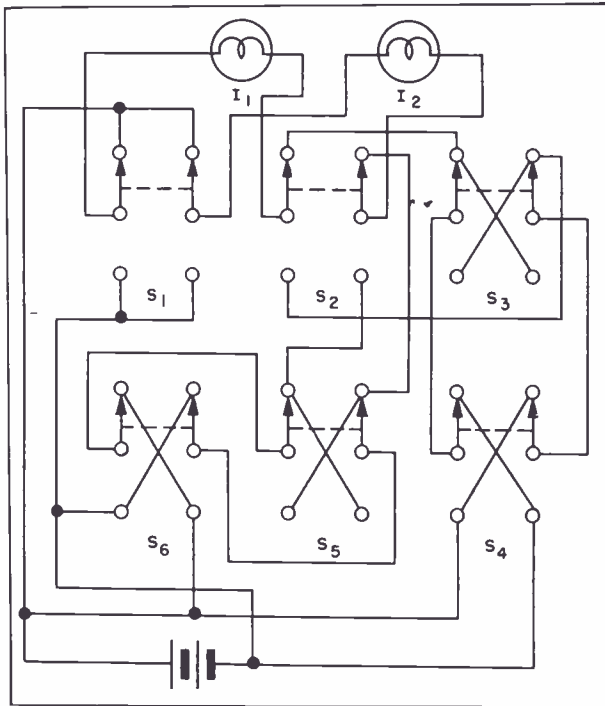
Solution to . . .

May-June

**"WHAT'S  
YOUR  
ANSWER?"**

The following schematic diagram represents the solution that Mr. Day offers for his problem.

The Technical Information Section arrived at a slight variation in wiring that will accomplish the desired result, so we can safely say that more than one solution is possible. However, the principle behind the two solutions is the same, and our experts doubt that there can be more than two.



**CONSULTING, PROJECT, AND FIELD ENGINEERING**

- ELECTRONICS • COMMUNICATIONS**
- POWER PLANT • REFRIGERATION**
- SPECIAL SYSTEMS**

**"3-D" TRAINING**

- COURSE MATERIAL**
- TRAINING DEVICES**
- INSTRUCTORS**



**WRITING, PROCESSING, AND PUBLISHING  
OF TECHNICAL LITERATURE**

- TECHNICAL MANUALS • INSTRUCTION BOOKS**
- CATALOGING • TECHNICAL REPORTS**
- DESCRIPTIONS OF MANUFACTURE**