

PHILCO
TECHREP DIVISION
BULLETIN

Published bimonthly by

The TechRep Division of Philco Corporation
Philadelphia, Pennsylvania

Editor John E. Remich

Managing Editor John W. Adams

Technical Editors Francis R. Sherman
Baldwin G. Sullivan
John A. Meehan, Jr.

Editorial Office:

Technical Information Section
Philco TechRep Division
22nd St. and Lehigh Avenue
Philadelphia 32, Penna.

If any information contained herein conflicts with a technical order, manual, or other official publication of the U.S. Armed Forces, the information in the official publication should be used. Views expressed in this publication are the opinions of the authors and do not necessarily represent those of Philco Corporation. All technical information and circuits are presented without responsibility as to patent infringement.

Editorial . . .

EQUIPMENT FAILURE REPORTS

by John E. Remich

Manager, Technical Department

Equipment Failure Reports are a major element in a comprehensive field support program of electronics equipment, since they present factual information on the performance of equipment under actual operating conditions. To the field engineer, field reports represent an opportunity to make a direct and important contribution to improved equipment reliability and performance.

It is a well-known fact that all the operating conditions to which military equipment will be subjected in the field cannot be satisfactorily duplicated in the laboratory. The effects of altitude, humidity, vibration, and temperature, to say nothing of the rugged conditions to which military equipment is subjected in ordinary use, are all factors which affect the design. The engineering departments of equipment manufacturers lean heavily upon field reports for guidance in modifying their original design. The Tech Rep field engineer perhaps does not always know the far-reaching effect of his report, but his report, combined with those of other field personnel, quickly establishes chronic faults requiring action. Prompt, accurate reports will enable the engineering staff of the equipment manufacturer to make the required modifications while the equipment is still in production.

The Equipment Failure Report supplies much more information than the mere fact that a component part has failed. The compiling of parts failures also establishes the quantities and components required as spare parts. An adequate supply of spare parts means less outage time, as well as lower costs for equipment support.

The Tech Rep field engineer may feel that when a defective or inoperative piece of equipment has been repaired he has discharged his responsibility. While the importance of this function to the using activity cannot be minimized, the reporting of the defect will be even more important and of greater benefit at all levels of engineering and maintenance.

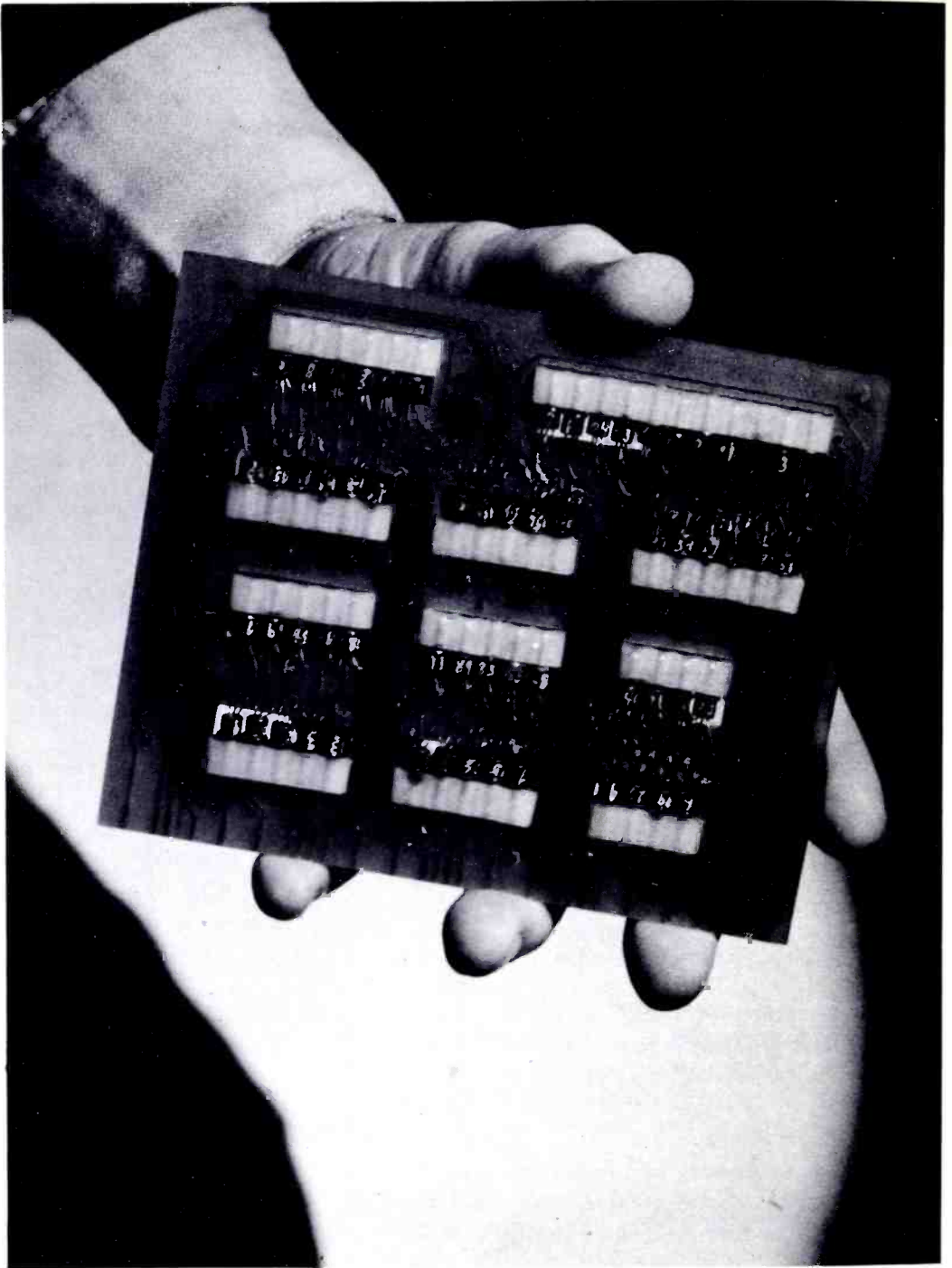

Printed Circuit Module for TRANSAC Computer

SWITCHING CIRCUITS FOR THE TRANSAC DIGITAL COMPUTER

A brief discussion covering some of the Surface-Barrier transistor switching circuits used in the design of the new Philco TRANSAC Digital Computer.

(Editor's Note: On March 24, 1955, the Philco TRANSAC computer was introduced at the I.R.E. Convention in New York City. At this meeting, a paper was presented entitled, "Surface-Barrier Transistor Switching Circuits," by Ralph H. Beter, William E. Bradley, and Ralph B. Brown, Senior Engineers of the Philco Government and Industrial Division, in collaboration with Morris Rubinoff, Moore School, University of Pennsylvania. This article is based upon the material presented in the I.R.E. paper.

The article does not attempt to explain the fundamental concepts in the theory and operation of digital computers. For a basic understanding of digital computer theory, the reader is referred to a series of five articles entitled, "Electronic Computers". These articles appeared in the BULLETIN issues for Nov. 1952, Dec. 1952, Jan. 1953, April 1953, and Nov.-Dec. 1953.)

AT THE PRESENT TIME, considerable activity in electronic development is being directed toward the computer. This fact was illustrated graphically by the many computer exhibits on display during the recent I.R.E. Convention in New York. Most of the large "electronic brains" have been widely publicized; therefore, it is no secret that they are expensive, large in size, contain thousands of vacuum tubes, and consume large amounts of power.

Since its introduction in 1948, the transistor has proven to be admirably suited for use in digital computer circuits—but not for the sole reason that it may be used as a substitute for the vacuum tube. Actually, alloy junction transistors and especially Surface-Barrier transistors (which have a higher speed of response than the alloy junction type) are suitable for switching circuits because of peculiar characteristics which enable them to act as true relays, rather than mere replacements for vacuum

tubes. These characteristics make it possible for the Surface-Barrier transistors to be used in the newly developed direct-coupled switching circuits. Through the use of the new circuits, the number of components required is drastically reduced—in fact, the arithmetic section of the TRANSAC computer consists only of transistors and resistors. As a consequence, the extremely small size of the transistors and circuit components, as well as the elimination of most components used in conventional circuits, makes it possible for the over-all TRANSAC computer package to be made a fraction of the size and weight of an equivalent conventional computer. (Editor's Note: It must be pointed out that the TRANSAC represents an entirely new concept in computer design because of the compatibility of the Surface-Barrier transistors with the newly designed switching circuits. Therefore, the TRANSAC is not to be regarded as an ordinary transistorized computer. For

reason, the term "conventional computer" is used here to denote conventional transistorized computers, as well as the vacuum-tube type.)

In addition to the advantages of compactness, light weight, and minimum number of circuit components, transistor circuit power requirements are incredibly small. As an example, a typical Eccles-Jordan flip-flop circuit, using vacuum tubes, requires 13.4 watts for its operation, whereas an equivalent circuit, the Philco transistor flip-flop, requires but 0.018 watt. When Surface-Barrier transistors are used in the new circuit combinations to make up a twenty bit TRANSAC computer, the components used to control and perform the complete arithmetic operation number approximately 1700 transistors, 500 resistors, and 20 capacitors, the latter being used in the control circuits only. Such a TRANSAC unit is contained in a volume of less than 300 cubic inches, and requires less than 8 watts at -3 volts.

COLLECTOR-BASE CHARACTERISTICS

The characteristics which make the Surface-Barrier transistor particularly adaptable to the new switching circuits are found when the transistors are connected in a common-emitter configuration. Figure 1 illustrates a typical transfer characteristic of a Surface-Barrier transistor when it is connected in a common-emitter circuit. The curves represent sweeps of collector current for different values of constant base current, curve A being collector current for $50 \mu\text{a.}$ base current, curve B for $100 \mu\text{a.}$, curve C for $150 \mu\text{a.}$, and so on to curve G which represents collector current for $350 \mu\text{a.}$ of base current.

Typical collector characteristics, using the same transistor in the same circuit, are shown in figure 2. Since the collector voltage scale is expanded to coincide with the base voltage values of figure 1,

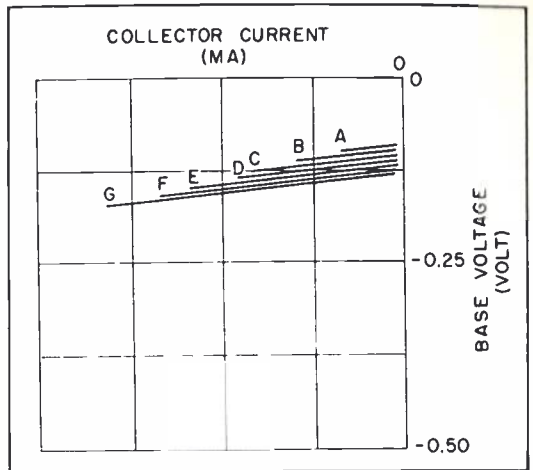

Figure 1. Typical Transfer Characteristic for a Surface-Barrier Transistor Connected in a Common-Emitter Circuit

the two sets of characteristics may be superimposed in figure 2, as shown. The collector curves are given for constant base currents starting at $50 \mu\text{a.}$ and increasing in $50\text{-}\mu\text{a.}$ steps. Inspection of the figure 2 curves shows that the transfer characteristic terminations are directly above the corresponding curves of constant base current in the collector voltage-collector current characteristic. Consequently, the range of base voltages necessary for satisfactory operation of the transistor amplifier circuit lies in the linear region of the collector characteristic. This means that the collector of one amplifier stage may be connected

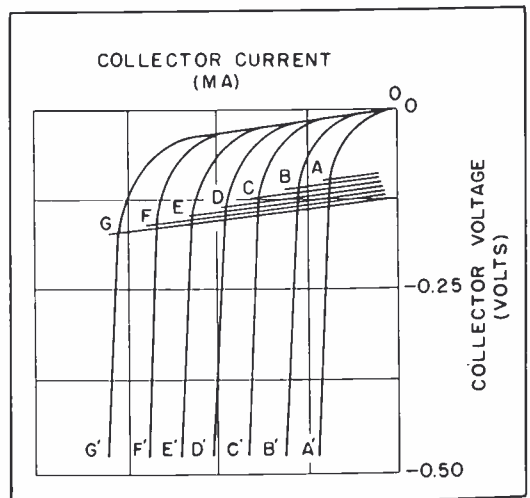

Figure 2. Typical Collector Characteristics Superimposed on the Curves of Figure 1, Given for the Same Transistor in the Same Circuit

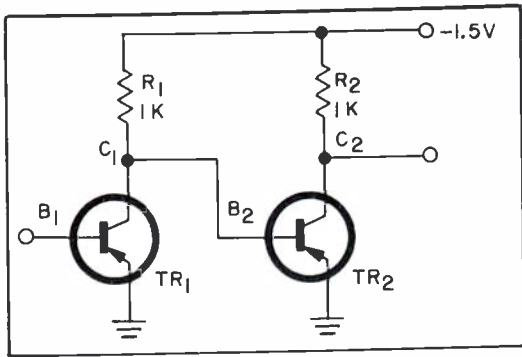

Figure 3. Two-Stage Direct-Coupled Amplifier

directly to the base of a following stage, resulting in the true direct-coupled amplifier shown schematically in figure 3. (It will be shown later that current gain is a requirement for direct-coupled circuits; hence, the common-emitter configuration must be used.)

TRANSISTOR SWITCHING CIRCUIT OPERATION

Before going into the switching circuit operation, it is advisable to define the terms "rise" and "fall" of voltage, as used in this article. Referring to negative power supplies, the expression, "the voltage rises to a value of -10 volts" is a common one. It means that some negative voltage, let's say -50 volts, has risen 40 volts closer to ground potential. Voltage-wise, however, it is clear that the voltage has actually *dropped* 40 volts if the polarity sign is neglected.

In this article, ground potential is considered as zero volts, and any value higher than zero, whether positive or negative in sign, represents a rise in voltage. Conversely, a drop in voltage is considered as an excursion toward ground from either a positive or negative direction. This definition seems less confusing, and also has a distinct advantage in that the terminology used herein is equally correct for n-p-n as well as p-n-p transistors in the "rise" and "fall" expressions; obviously, the terminology would have to be reversed if the other definition was used.

Saturation Flip-Flop

Referring to the direct-coupled amplifier in figure 3, let it be assumed that a current drive is applied to base B_1 of sufficient value to drive TR_1 into saturation. With TR_1 in the saturated state, it will be found that the collector voltage of TR_1 (and hence the base voltage of TR_2) is low enough so that TR_2 is effectively cut off. If no drive is applied to base B_1 , TR_1 is cut off but R_1 allows sufficient current flow to B_2 to drive TR_2 into saturation. At this point, the voltage at C_2 will have dropped to a value near ground potential, thereby assuming the same value as C_1 in the previous state. In the circuit of figure 3, typical values may be -0.35 volt for C_1 and -0.03 volt for C_2 , in which event TR_1 is considered "off" and TR_2 "on."

Suppose now that the output (C_2) of TR_2 is connected to the input (B_1) of TR_1 . The result is a bistable saturation flip-flop circuit, as shown in figure 4. If it is assumed that TR_2 is "on" and TR_1 is "off" in figure 4, the state can be changed by dropping the base voltage at B_2 toward ground (less negative). This is accomplished by applying the appropriate drive to the base of TR_1 . The state may be changed back to the original condition by applying drive to B_2 .

When Surface-Barrier transistors are used in the saturation flip-flop circuits, the state-to-state transitions can be

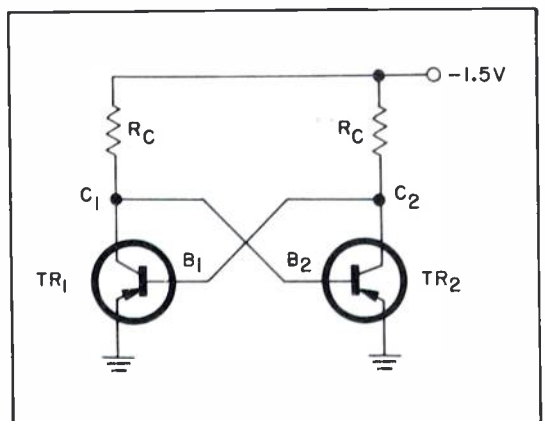

Figure 4. Saturation Flip-Flop Circuit

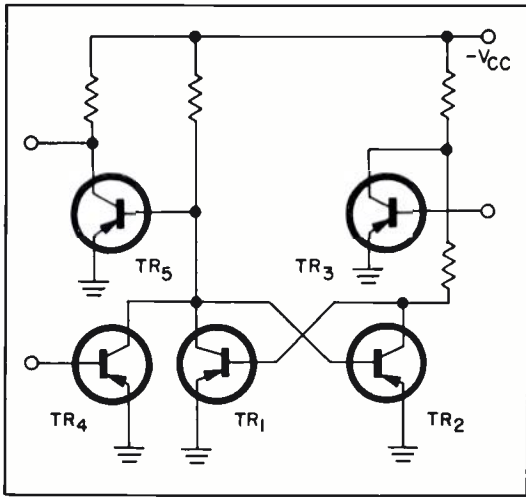

Figure 5. Flip-Flop Triggering and Sensing

effected in one-tenth microsecond or less. This two-state stable condition of the transistor fulfills the "off" and "on" requirements commonly found in digital computer circuit design. Figure 5 shows a typical saturation flip-flop circuit with three transistors added to show input triggering and sensing actions.

One-Shot Multivibrator

In order to obtain a monostable or one-shot circuit, the flip-flop circuit of figure 4 is altered to include an R-C combination. In the one-shot circuit, shown in part A of figure 6, the base of TR₂ is returned to the supply voltage through the added resistor, R₀. A third transistor, TR₃, has been added to show how the trigger is applied. It should be noted that the output of TR₂ is still directly coupled to the input of TR₁, as it was in the flip-flop circuit. For proper operation of the circuit, TR₂ must be in the saturated condition during the steady state; therefore, the value of R₀ is chosen to fulfill this condition.

Operation of the one-shot circuit in part A of figure 6 is as follows:

If it is assumed that no trigger is applied to TR₃, then TR₂ is in saturation, and its collector voltage is about -0.03 volt, or sufficiently close to ground po-

tential to ensure that TR₁ is cut off. As a consequence, for this condition, the collector voltage of TR₁ is essentially the same as the supply voltage, or -1.5 volts. This steady state exists from t_0 to t_1 on the time base of the waveforms in part B of figure 6. At time t_1 , a negative pulse is applied to B₃, causing TR₃ to conduct, thus bringing the collector voltages of TR₃ and TR₁ (since they are tied together) down near ground potential. The positive-going pulse at C₁ is applied through capacitor C₀ to B₂, driving TR₂ to cutoff. For the duration of the TR₂ cutoff time, the voltage at C₂ is sufficiently negative to hold TR₁ in saturation until capacitor C₀ has discharged enough to allow TR₂ to conduct again, as indicated at t_2 on the time base. Just as in the case of vacuum-tube multivibrators, the cutoff time of TR₂ is a function of the R-C time constant of the circuit, being independent of input pulse duration. The positive pulse at C₁-C₃, however, may be a function of the input pulse if the latter has a duration longer

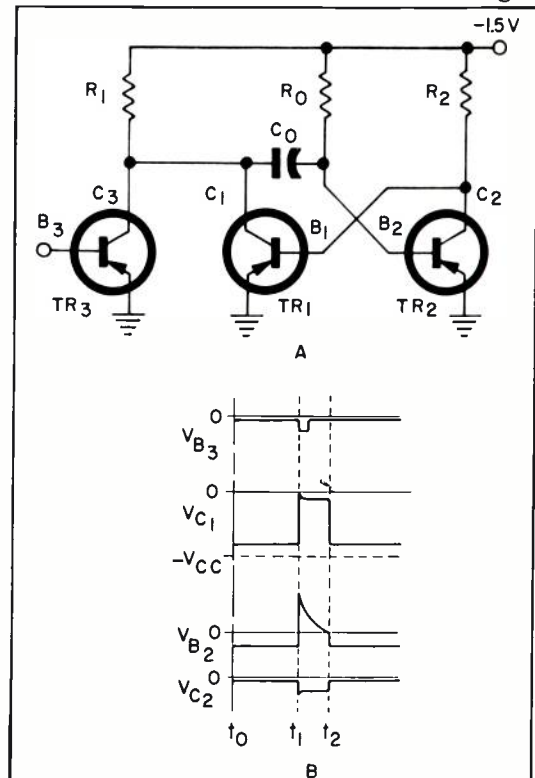

Figure 6. One-Shot Multivibrator Circuit with Waveforms

than that of the R-C time constant.

The multivibrator circuit of figure 6 can be made free running (astable operation) if R_0 is of such a value that the base drive to TR_2 is insufficient to produce collector saturation. For free-running operation, the transistors are biased so that their operating points lie in the high-gain regions; thus, any slight circuit disturbance will cause a condition of oscillation.

AND Gating Circuit

Figure 7 (part A) shows three Surface-Barrier transistors in a cascode con-

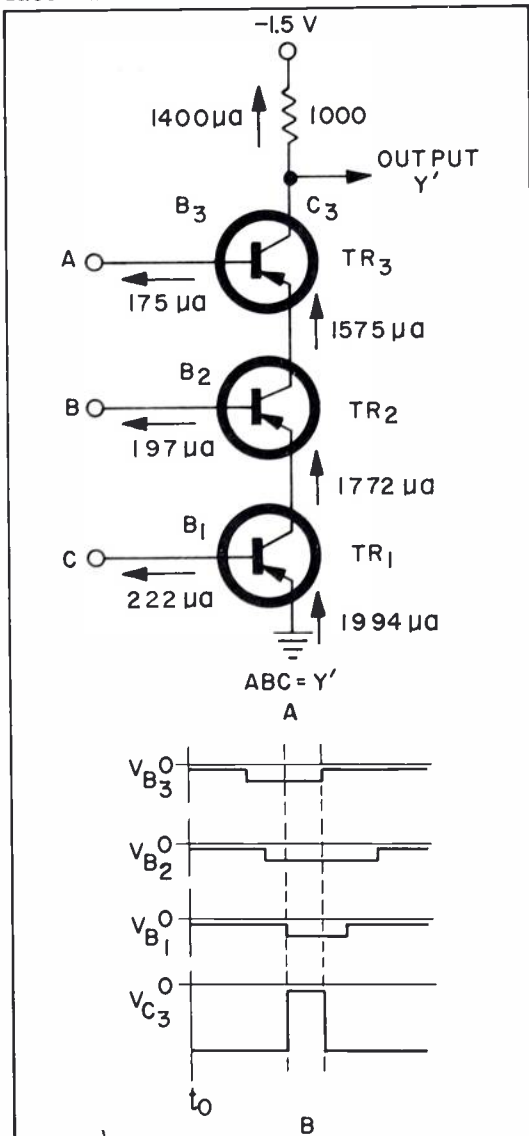

Figure 7. Three-Input AND Gate Circuit with Waveforms

nection known as an AND or coincidence circuit. This circuit exploits the ability of the Surface-Barrier transistor to function with a collector voltage much lower than the base voltage when used in a common-emitter configuration. As shown in the schematic diagram, the current through the common load resistor is controlled by the three base input circuits. It can be seen that, if the voltage on one or more of the transistor bases is reduced to a value near ground potential, the particular transistor is cut off and the series path through the transistors is effectively open. Thus, with no AND gate current through the load resistor, the output voltage tends toward -1.5 volts, but may be held to some lower value by succeeding circuits. In order to have current flow through the load resistor, all three bases must be driven sufficiently negative to ensure a low-impedance path through the transistors.* In this condition, the output voltage will drop to approximately -0.1 volt with respect to ground.

When used in conjunction with the saturation flip-flop circuit, the AND gate of figure 7 must have sufficient current flowing through the load resistor to bring the collector of TR_3 to the assumed -0.1 -volt (cutoff) value mentioned above. This is approximately the minimum value necessary to set a flip-flop circuit when the AND gate load resistor is also one of the load resistors for the flip-flop. Therefore, since -1.4 volts must be dropped across the load resistor (to trigger the flip-flop), the current through the resistor must be at least $1400 \mu\text{a}$. when all the AND gate bases are energized. Assuming that an effective current gain of 8 is obtained for each transistor from base to collector, the following values may be taken as typical for the circuit of figure 7:

* Boolean notation is used in the expressions accompanying figures 7, 8, and 9.

TR ₃ collector current	1400 μ a.
base current	175 μ a.
emitter current	1575 μ a.
TR ₂ collector current	1575 μ a.
base current	197 μ a.
emitter current	1772 μ a.
TR ₁ collector current	1772 μ a.
base current	222 μ a.
emitter current	1994 μ a.

It will be noted that the collector current of TR₁ is a higher value than that for TR₂, which in turn, has a higher collector current than TR₃. This means that the base of TR₁ requires the greatest drive in order to perform the gating function. Examination of the circuit reveals that there is a slight decrease in effective base-to-emitter voltage in going from TR₁ to TR₂ to TR₃; part of the base-to-ground voltage of TR₂, for example, is lost in the drop across the collector and emitter of TR₁. Consequently, if the three bases are energized from sources having equal voltage levels, the base of TR₁ will receive the greatest drive automatically because its emitter is directly at ground potential. Typical waveforms for the AND circuit are given in part B of figure 7, showing the three negative input pulses and the positive output pulse. It has been found that as many as five transistors can be cascaded in the circuit shown. A greater number may be cascaded if special biasing is provided; however, there has been no need for more than five transistors in cascade for any of the switching circuits used in TRANSAC computers.

OR Buffer

It has been shown that the AND gate has an output only when the proper drive signals are applied simultaneously to *all* input terminals (A and B and C in the example of figure 7). If the transistors are now connected in parallel, and have a common load resistor, the result is an OR buffer, as illustrated in figure 8. In this circuit, each transistor

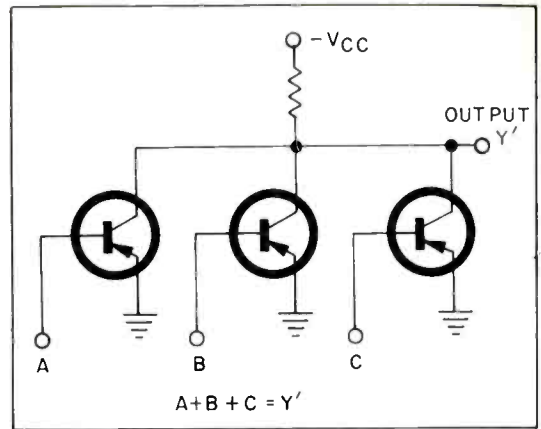

Figure 8. Three-Input OR Buffer Circuit

must draw enough current through the load resistor to drop the output voltage close to ground potential. Thus, with the OR circuit, an input pulse at A or B or C, or at any combination of the three, will produce a positive output pulse.

Combination of AND and OR Circuits

Figure 9 is a schematic diagram of a simple logic circuit employing six transistors and a common load resistor in a combination AND-OR circuit. Examination of the circuit shows that several different combinations of input signals exist for which an output will be produced, as indicated by the Boolean expression given for the circuit configuration.

Gating-Chain Design Considerations

Design considerations sometimes require that a number of gate inputs be driven from a single source, which might be a flip-flop circuit or another gate. For a practical demonstration of design procedure, the typical circuit shown in figure 10 will be used as an example. Here, five transistors are to be driven from the single gate circuit of TR₁. Assume now that there exists a maximum variation of 2 to 1 in the d-c input impedances of the five driven transistors, as indicated by the base current vs. base voltage curves of figure 11.

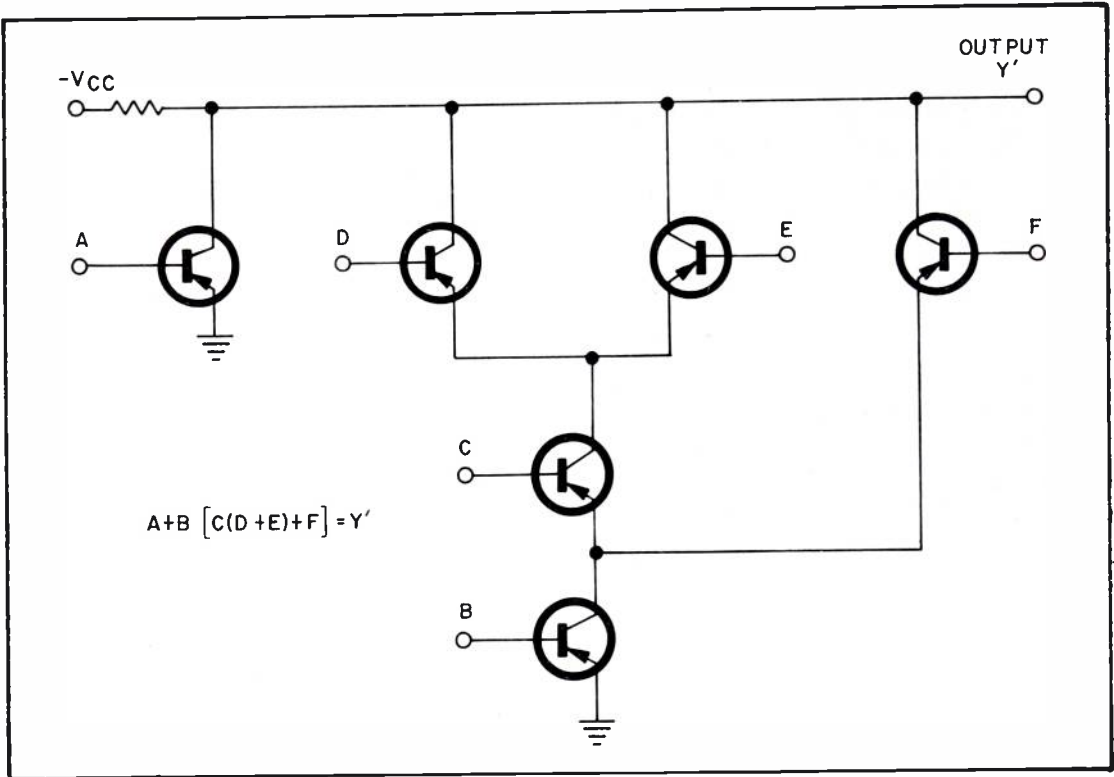

Figure 9. Combination of AND and OR Circuits

With a 750-ohm load resistor, suppose that the "poorest" transistor in the chain requires at least one-fourth as much base current as its collector saturation current in order to drop the collector voltage to -0.05 volt. Then, considering a current gain of 4 for the "poorest" transistor:

$$\begin{aligned} \frac{\alpha}{1-\alpha} &= 4 \\ \alpha &= 4(1-\alpha) \\ 5\alpha &= 4 \\ \alpha &= 0.800 \end{aligned}$$

This condition would indicate an alpha of 0.800, which is much lower than the values now available. The example, then,

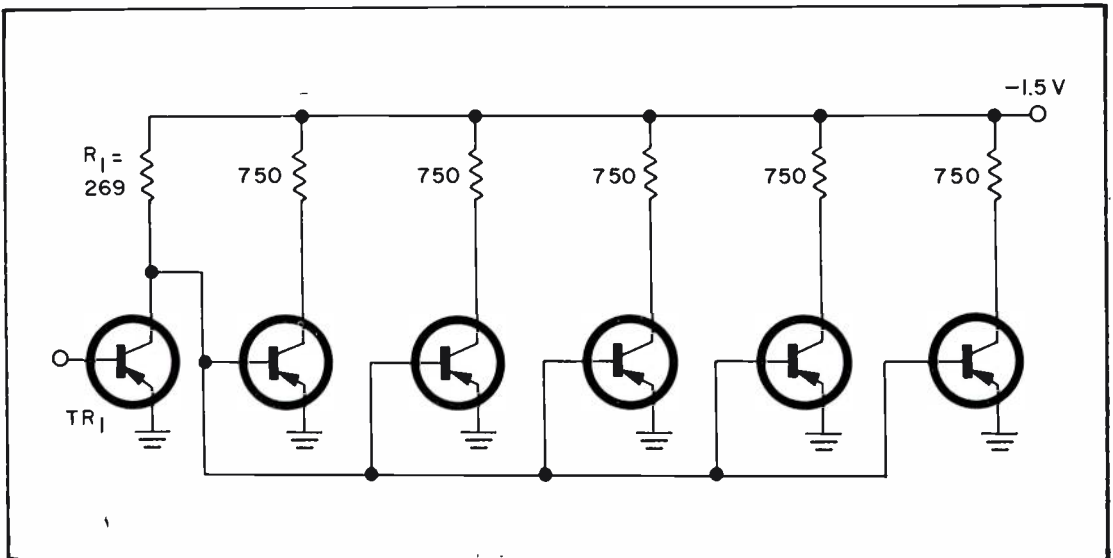

Figure 10. Gating-Chain Driving Requirements

is deliberately chosen to demonstrate marginal design.

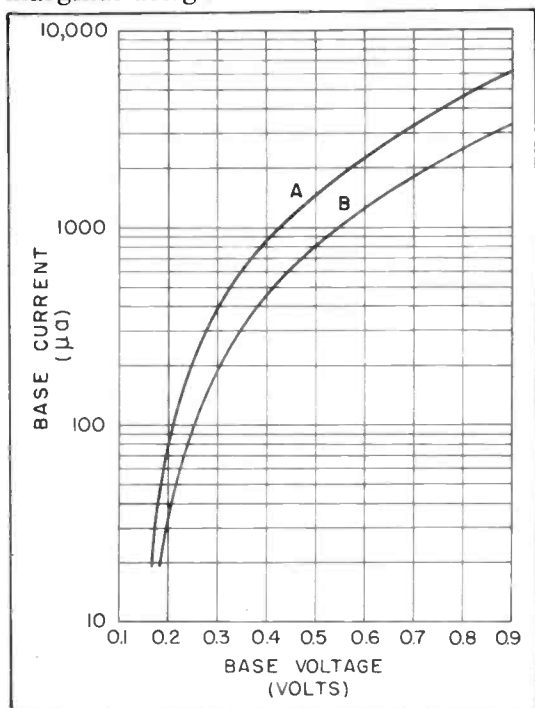

Figure 11. Transistor Base Characteristics

The next step is to determine the maximum value for resistor R_1 which will ensure ample drive for the five parallel bases. If it is assumed that the collector voltage for each transistor has been determined as -0.05 volt at saturation, then 1.45 volts must be dropped across each load resistor. Therefore, the collector current for each transistor will be:

$$\frac{1.45}{750} = 1930 \mu\text{a.}$$

The base current for the "poorest" transistor was stipulated as one fourth of this collector current, or $483 \mu\text{a.}$ Now, should the base current vs. base voltage curves for any of the five transistors fall within the limits of curves A and B of figure 11, the driving voltage applied to the five parallel bases must have a mini-

imum value of -0.4 volt, as indicated. In an extreme case, let it be assumed that four of the transistors have characteristics corresponding to curve A, and the remaining one corresponding to curve B. At -0.4 volt, the curves give a value of $900 \mu\text{a.}$ of base current for each of the four "curve A" transistors. The base current for the "poorest" transistor has already been established at $483 \mu\text{a.}$ Consequently, a total base current of 4.083 ma. at -0.4 volt is required to drive the five parallel transistors. Therefore, since 1.1 volts is to be dropped across R_1 :

$$R_1 = \frac{1.1}{0.004083} = 269 \text{ ohms}$$

SUMMARY

The circuits described in this article are sensitive to signal thresholds rather than to rate-of-change signals; thus they are especially suitable for use in asynchronous digital computers and switching circuits. An advantageous feature of the new switching circuits is that the design of the data handling circuits may avoid the use of the R-C networks conventionally used in the synchronous type of computer. It can be seen, then, that the circuits are less dependent upon the component reliability factor since component tolerances are strict in circuits where time and rate-of-change are involved. However, when used in switching circuits, Surface-Barrier transistors have exhibited rise times on the order of $0.08 \mu\text{sec.}$, and fall times of about $0.10 \mu\text{sec.}$ Therefore, since the Surface-Barrier transistors do have this speed of response, and since very short rise and fall times are necessary in synchronous computers, the new switching circuits may be used in synchronous computers, as well.



PRINTED CIRCUITS

by Carl Tillman

Technical Publications Department

A discussion of some of the basic techniques involved in the manufacturing, trouble-shooting, and repairing of printed circuits.

IN RECENT YEARS, printed-circuit electronic equipment has been so well developed that most manufacturers are now using printed circuits for both civilian and military equipment. Printed circuits offer many advantages over standard circuits from production and quality control points of view. Among these advantages are the saving of labor in assembly, the adaptability of printed-circuit production on automatic or semi-automatic assembly lines, and the elimination of variations in distributed capacitances and stray coupling. These advantages tend to reduce cost while improving the quality of the products.

MANUFACTURING

Printed circuits fall into two classes: printed components and printed wiring. Printed components are elements of resistance, capacitance, and inductance printed on plastic or ceramic base materials. Two or more elements are usually printed as one unit. Special inks are used to form the elements and leads, a resistive ink for resistors and a good conductive ink for the capacitors, coils, low inductance, and leads. A baking process dries and hardens the ink. After the printed components are completed, they are usually coated with an opaque insulating material which serves to protect the parts from both moisture and physical damage. As a finished product, the printed component is in the form of a flat molded unit. Its size and the number of leads which come out of the unit vary depending upon the number of elements which the unit contains. Printed components are wired into the equipment in the same manner as ordinary

components; however, fewer solder and lead connections are required because several components have been already combined and connected within the unit in the printing process. Printed components are available as stock items for such applications as audio amplifier plate-to-grid coupling networks, diode detector filter networks, a-v-c filter networks, high-frequency receiving antenna coupling networks, and many others in an ever increasing list.

Printed-wiring circuits are produced by a photo-etching or offset-printing process. A copper-clad plastic sheet is the basis for a printed-wiring circuit. In the photo-etching process, the copper surface is first coated with a light-sensitive enamel. A mask, which contains the circuit wiring design that will ultimately appear on the sheet, is placed over the surface, and the whole is then exposed to light. Following this, the mask is removed and the sheet goes through a photographic developing and printing process in which the enamel remains, as a protective covering, on parts of the sheet. The sheet is then put through an etching process, which removes the exposed copper portions of the sheet.

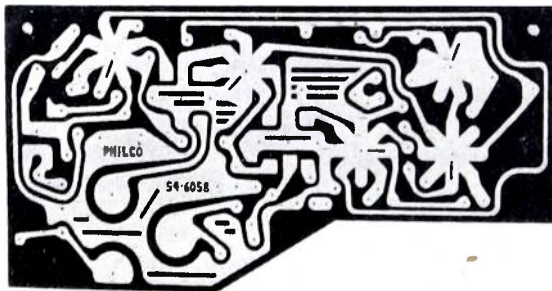

Figure 1. Printed-Wiring-Circuit Sheet after Photo-Etching or Offset-Printing Process has been Completed

Finally, the enamel is removed, and the finished printed-wiring circuit appears as illustrated in figure 1. In the offset-printing process, the circuit wiring design is printed with an asphalt ink directly on the copper surface of the plastic sheet. This ink is resistant to the etching process and only the exposed copper surface is removed. The ink is then removed, and the result is the same as that obtained by the photo-etching process.

Holes are punched in these sheets to hold tube sockets, i-f transformers, and other components, as shown in figure 2.

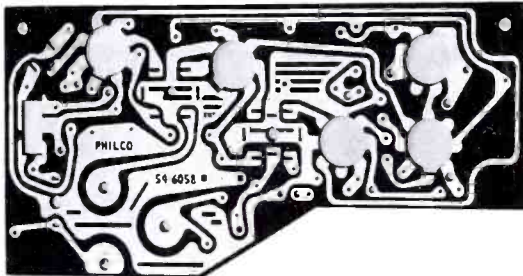

Figure 2. Printed-Wiring Sheet with Holes Punched To Receive Components

The holes are punched adjacent to, or through the center of, the copper connecting ribbons so that the components may be assembled to the plastic sheet by merely pushing the component leads through the holes and soldering them to the copper ribbon, as illustrated in figure 3. The heavier components and tube sockets are usually constructed with metal clips which attach them to the plastic sheet so that they do not depend upon the solder joints to hold them in place. The solder joints in this case furnish good electrical connections only.

TROUBLE SHOOTING

Although normal trouble-shooting techniques may be used on printed-circuit equipment, a few new rules and procedures must be observed. When one part of a printed-component network is found to be defective, the entire network should be replaced. For example, if the printed network is a plate-to-grid cou-

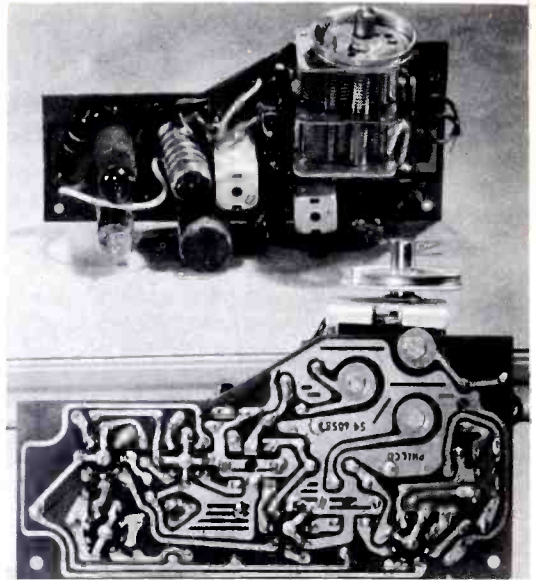

Figure 3. Top and Bottom Views (through Mirror), Showing Components Mounted on Printed-Wiring Sheet

pling circuit, as shown in figure 4, and the coupling capacitor is shorted, the entire network must be replaced. If the coupling capacitor is open, the entire network should be replaced, although an emergency repair could be effected by connecting a capacitor of the proper value from plate to grid. It is poor practice, however, to attempt a permanent repair by replacing only the capacitor, as a future breakdown may occur at this point. If the defective printed network is connected in a circuit where distributed wiring capacitances are more critical than in the above example, the entire network should always be replaced.

In some printed-component networks all the individual components are not terminated in the connecting leads. An example of such a network is the integrating circuit shown in figure 5. If C1 or C2 were shorted, ohmmeter readings between terminals A and C or terminals B and C would not show a short circuit. The reading obtained would be the value of the resistors in series with the shorted capacitor. If one or more of the capacitors were to become leaky, it would be difficult to determine which was defec-

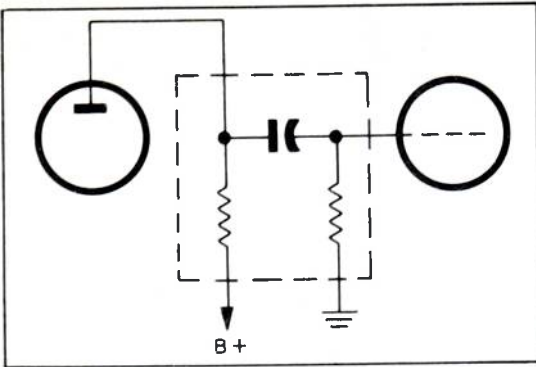

Figure 4. Printed Circuit of Plate-to-Grid Coupling Network

tive, because ohmmeter readings would not indicate the defective component directly. However, it is possible to determine at once whether a given network is faulty and needs replacing—which is the important information needed for efficient servicing. In this respect, printed-circuit equipment should be easier to trouble-shoot than other types.

REPAIRING

In the repair of printed-wiring circuits normal procedures are also employed. However, care should be taken to avoid mechanical damage to the thin conductors on the plastic boards. Careless handling may damage these conductors. In soldering connections to the conductors, the heat should be applied to each joint for as short a time as possible to avoid damage to the plastic base material.

The replacement of a component having flexible leads, in printed-wiring equipment, presents no special problem. It is only necessary to use normal care in soldering, to prevent the occurrence of short circuits between adjacent conductors. By using a minimum amount of solder and a small soldering tip, this trouble is easily avoided.

The replacement of a component having rigid leads or terminals (tube sockets, i-f transformers, etc.) may involve some difficulty in removing the old component unless the proper procedure is employed. Where the removal of a component re-

quires the unsoldering of several terminals at the same time, hold or position the equipment so that the terminals to be unsoldered are positioned as shown in part A of figure 6, and proceed as follows:

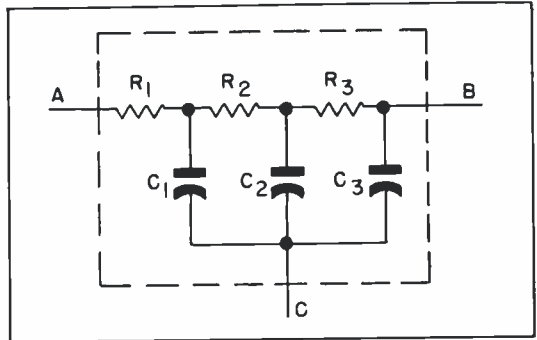

Figure 5. Printed Circuit of an Integrating Network

Place the tip of a hot soldering copper under each of the terminals in turn, as shown in part B of figure 6, and drain off all of the solder. This solder will flow down to the soldering tip and can be removed from the tip by wiping it on a cloth. Remove all the solder that can possibly be removed from each of the terminals. A small amount of solder will

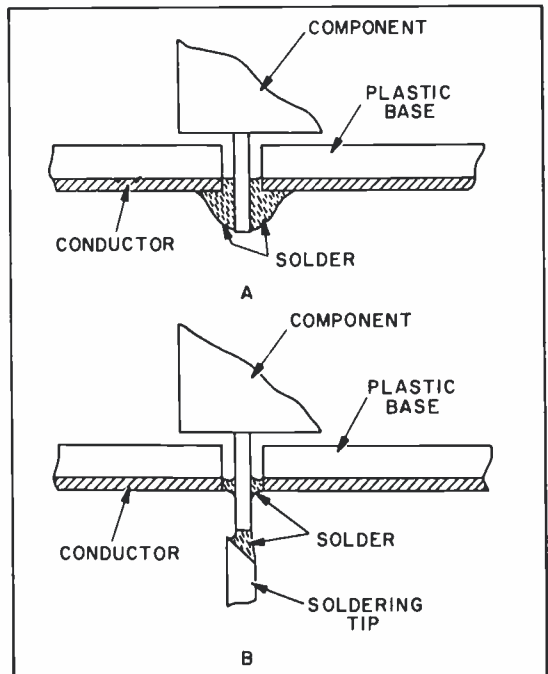

Figure 6. Method of Removing a Component without Damaging the Printed-Wiring Circuit

still remain between the terminals and the connecting conductor on the printed wiring board. This remaining solder can be removed by scraping it away with the point of a knife or other sharp instrument. When the connections to all the terminals have been loosened, the part may be lifted from the printed wiring board and a new one installed in its place. If the component is mounted with a spring clip in addition to the solder terminals, loosen or remove the clip before attempting to remove the component. The part to be removed should never be pried or forced loose. Any attempt to force a part loose may result in a broken printed-wiring board. If the terminals are too tight to pass through their mounting holes, all excess solder was not removed.

When repairs to printed-wiring equipment are completed, a thorough inspection of the equipment should be made to ensure that no solder drippings or wire clippings remain. Solder drippings or wire clippings are more apt to cause short circuits in printed-wiring equipment than in conventional equipment. If the wiring board was removed from its mountings, care must be taken in reinstalling it to avoid damage to the board. Do not attempt to force it in place, twist it, or tighten the mounting screws excessively. If reasonable care is used in handling the printed-wiring board, it will give excellent service and long life, and will present few service problems not found in conventionally wired equipment.

“What’s Your Answer?”

Philco Field Engineer Regis E. Gates thinks that this month’s problem, which he submitted, will appear contradictory but he has proved it is not.

A certain resistor will receive the maximum possible power from the circuit shown whether it is connected from A to B or from B to C. What is the ohmic value of the resistor?

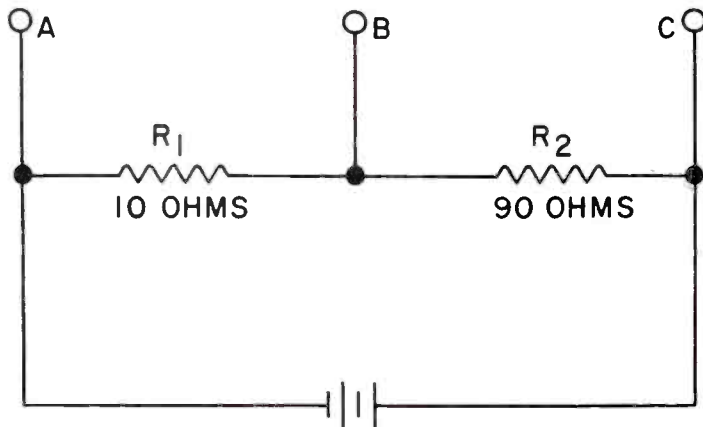

(Solution next issue . . .)

SIGNAL CORPS SUPPLY AND MAINTENANCE

(Editor's Note: The following article is based on a supply and maintenance pamphlet originated by the Signal Corps. Only those parts of this pamphlet which are considered to be of general interest have been used.)

THE SIGNAL SUPPLY SYSTEM

THE SIGNAL CORPS procures, stores, and issues some 150,000 different items of communication supplies and equipment to the Army, Navy, Air Force, Marines, and other agencies. In order to ensure a steady and dependable flow of new equipment and replacements to every American outpost all over the world, it is imperative for the Signal Corps to maintain an extensive and competent organization that uses definite methods and well-tried procedures to accomplish its work.

Signal Corps Structure

The Procurement and Distribution Division, Office of the Chief Signal Officer (OCSigO), in Washington, is responsible for the over-all operation of the signal supply system in the Zone of the Interior (ZI). Theater signal officers have similar organizations to exercise control over the signal supply system of their respective theaters. The Procurement and Distribution Division is primarily concerned with planning and policymaking. It supervises the operations of its several field agencies and its many supply establishments throughout the United States.

The Signal Corps Supply Agency, in Philadelphia, is one of the field agencies of the Procurement and Distribution Division. Its job is to perform four of the most important functions of signal supply—stock control, supply control, procurement, and inspection. As the central stock control point in the signal supply system, it makes allocations of stock to the depots, which are the main distribution points in the supply system.

The Signal Corps depot system in the ZI consists of several branch depots and several signal sections of general depots. A branch depot handles the supplies of one technical service, while general depots handle the supplies of more than one technical service. A depot normally is responsible for receiving, storing, and issuing supplies and equipment for a specific geographical area.

Station supply serves posts, camps, and stations. In the ZI, most posts, camps, and stations have one or more station accountable officers. It is their responsibility to draw equipment and supplies from the depots, and to issue these to organizations and activities, which in turn reissue them to the using units or subordinate activities.

Oversea supply furnishes equipment and supplies to an oversea command from a ZI port of embarkation. In oversea areas, material may go through a number of depots, supply points, and dumps before it reaches the using unit. The route followed will depend upon the size of the theater, the type of action involved, and the command structure of the theater. Supplies generally go to a base depot from the port of debarkation. From there they may go directly to army depots, or may progress in an extensive communications zone from a base depot, to an intermediate depot, to an advance depot, and to an army depot.

Unit and Organization Supply

Unit and Organization Supply is the requisition, storage, and issue of supplies and equipment. Each company commander is responsible for the following:

1. Requisitioning all authorized supplies and equipment.
2. Accountability of property; records should reflect the supply status of what is on hand, on requisition, or due-in.
3. Safeguarding of equipment against fire, theft, and the weather.
4. Adequate and effective preventive maintenance to ensure that the equipment of the unit is in a serviceable condition.

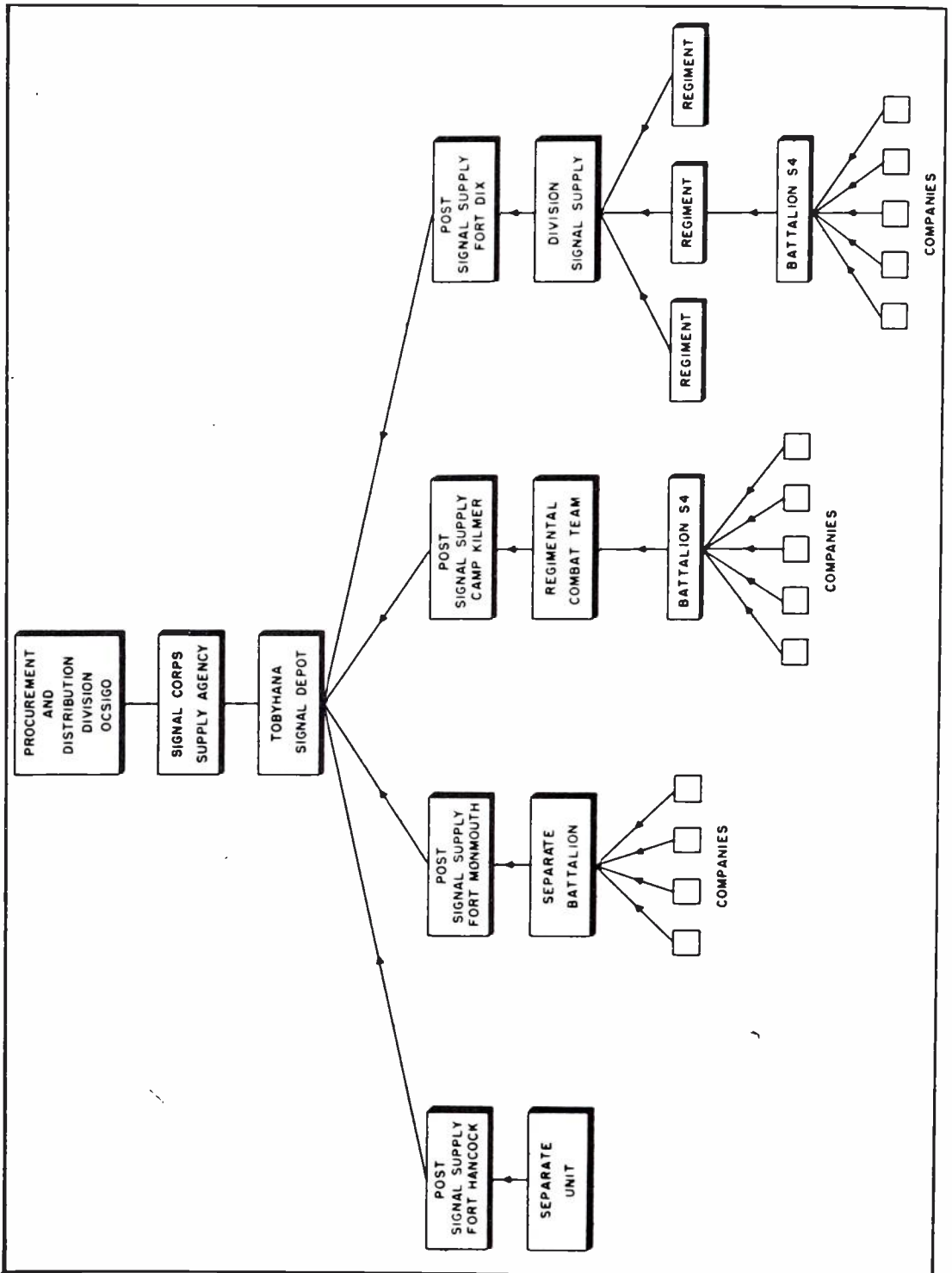

Figure 1. Flow of Requisitions for Signal Supplies within the Continental United States

5. Continual supervision to see that all excesses of supplies and equipment above authorized allowances are turned in.

Requisitioning Procedures

A requisition is a request to a supply agency for authorized supplies. A unit or organization requisitioning supplies from a higher echelon or station supply officer submits the requisition on the appropriate form. Stations submit requisitions for supplies to a depot. In emergencies, a requisition may be submitted by radio, teletypewriter, telephone, or other means and followed up by written confirmation.

Organizations consolidate their several requisitions and forward them to the next higher organization having supply responsibility. Normally they reach the signal supply officer of a post, camp, or station.

Station supply maintains a limited stock to fill requisitions of a recurring nature. If the items are not available, the signal supply officer requisitions them from the depot servicing the area. Depots normally maintain sufficient stocks to supply items requested by station signal supply officers.

Within a combat zone, organizations submit their requisitions for supplies to the organizations having supply responsibility, or directly to an Army signal supply point, a depot, or an Army signal supply officer. The Army supply point maintains a level of fast moving items. Items not available at the Army depot are requisitioned from the communications zone (ComZ) depot. In order to maintain established levels, the ComZ depot submits requisitions to the theater signal supply officer for local procurement or requisition on the ZI.

Stock Control

Stock control is that part of the Army property control system pertaining to

the supervision of equipment and supplies.

In practice, stock control is based on three common-sense principles. These principles are: (1) **KNOW WHAT YOU NEED**—Computation of requirements; (2) **KNOW WHAT YOU HAVE** — Stock accounting, and (3) **GET, OR GET RID OF, THE DIFFERENCE** — Requisition and turn-in of supplies.

Each depot has stock control responsibility for all supplies within the depot and has a designated mission area for supply support. This entails maintaining adequate levels to ensure that the needs of the mission areas are satisfied. These stock levels are the medium used to assure an even flow of supplies to the using units. It is a responsibility of the depot to ensure that supplies in excess of these levels are not accumulated.

Supply Control

Supply control is the balancing of requirements against resources.

Adequate equipment must be available to supply the entire Army and at the same time prevent the accumulation of excess stocks. This requires a great deal of planning, which in turn requires data that can be obtained only from supply control studies. Supply studies are founded upon the Army troop basis, tables of organization and equipment, equipment status reports, depot stock status reports, and forecasts of all requirements of oversea commands.

Equipment is obtained through procurement, set assembly, and repair of unserviceable items in the system.

The three main supply control points in the Signal Corps are the Requirements Branch, Procurement and Distribution Division, OCSigO; the Signal Corps Plant Engineering Agency; and the Signal Corps Supply Agency. A supply control point is normally responsible

for the over-all requirements, budgeting, funding, procurement initiation, repair requirements, set assembly requirements, disposal initiation, and distribution planning for the item controlled.

The Signal Corps Supply Agency maintains supply control over all Signal Corps items except those assigned to other supply control points, and procures all Signal Corps equipment and

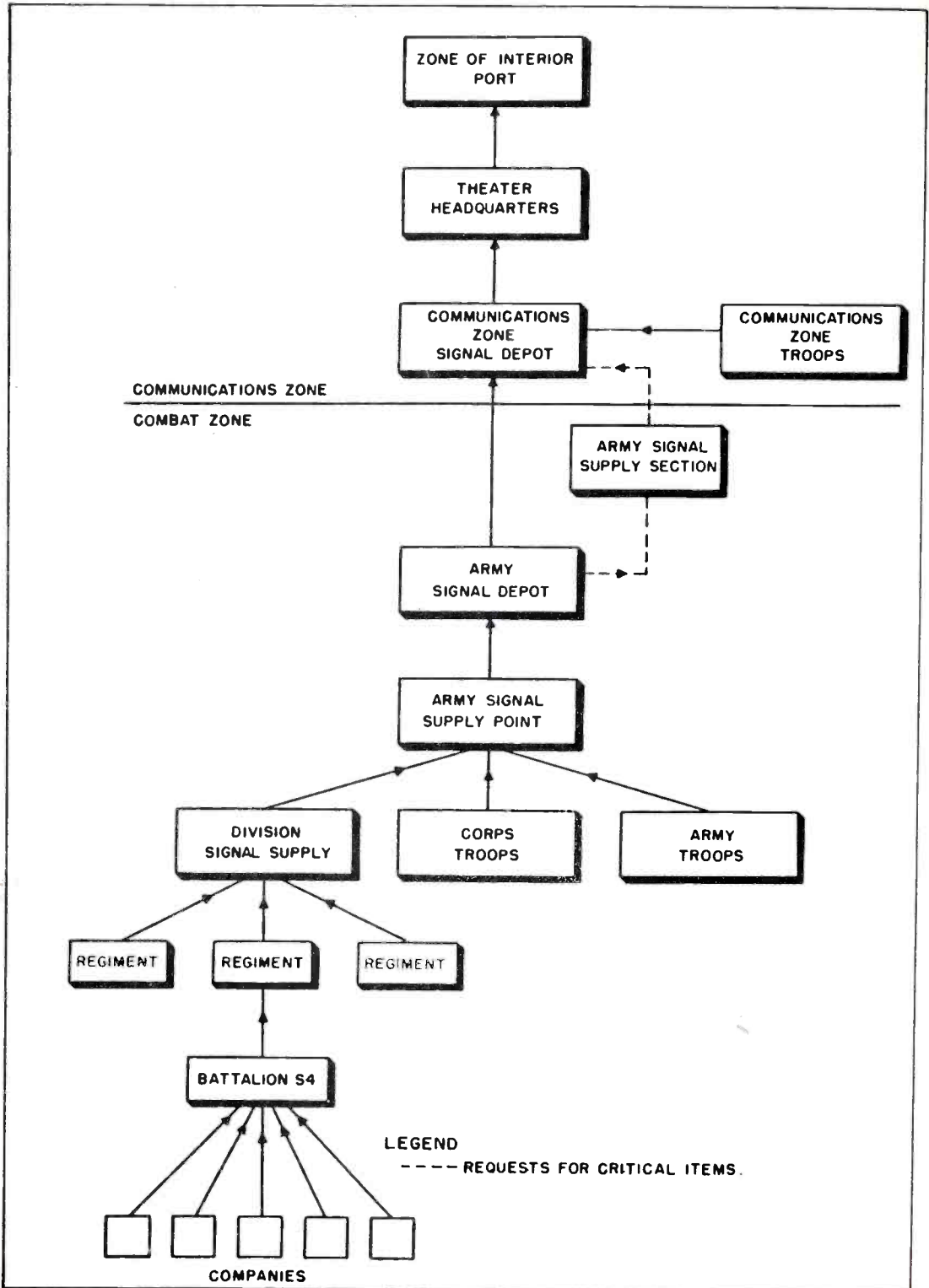

Figure 2. Flow of Requisitions for Signal Supplies within an Oversea Theater

supplies. As part of its procurement mission, the Signal Corps Supply Agency is responsible for developing, packing, packaging and marking specifications, and for inspecting and accepting all equipment and supplies procured by the Signal Corps. Because of its control over the supply system, the agency serves as the central point for availability information, and monitors requisition processing.

Under Industrial Mobilization, the Signal Corps Supply Agency is responsible for plans to ensure maximum use of the nation's industrial facilities. Its mission also includes the maintenance of fiscal records of allotments, commitments, obligations and expenditures, payments to contractors, and the performance of necessary audits. In addition, the Agency is charged with the responsibility for stock numbering and cataloging for the Signal Corps.

ECHELONS OF MAINTENANCE

Maintenance is the care taken and the work performed to keep equipment at peak operating efficiency.

By joint agreement, the Army, Navy, and Air Force have grouped all maintenance operations under three broad categories: organizational, field, and depot. The Army has subdivided these categories into five echelons (see figure 3). Repairs should be performed at the lowest echelon of maintenance which has the necessary spare parts, tools, test equipment, personnel, and time to do the job. No echelon will do the work of a higher echelon at the expense of neglecting its assigned functions. Ordinarily, material needing repair that is beyond the capability of one echelon is evacuated to the next higher echelon.

Organizational maintenance is performed by unit personnel on their own equipment; it is limited only by time, competence of personnel, and availability of tools, test equipment, and spare parts.

Field maintenance is performed by trained Signal Corps repairmen in mobile or fixed shops. Repaired equipment is returned to the user.

Depot maintenance is performed by a signal base maintenance company, or depot maintenance divisions located at a base depot. This work includes major repairs and the rebuilding of equipment, after which it is returned to stock.

There are five steps or echelons of maintenance. These are not necessarily related to echelons or levels of command. They are guides to the amount and extent of work to be done by personnel in accordance with military occupational specialties and the unit's mission.

First echelon maintenance is performed by the user of the equipment. It includes preventive maintenance, which consists of the inspection and care of signal equipment in accordance with appropriate procedures and maintenance check lists.

Second echelon maintenance is performed by school-trained mechanics organic to the major headquarters of the using organization. It consists of preventive maintenance and the inspection, adjustment, lubrication, replacement of worn parts, and other repairs of equipment in accordance with appropriate maintenance check lists.

Third echelon maintenance is performed by school-trained Signal Corps repairmen organic to units charged with furnishing major repair and maintenance support. It consists of the inspection, adjustment, major repair, and preventive maintenance of equipment in accordance with appropriate maintenance check lists.

Fourth echelon maintenance is performed by school-trained Signal Corps repairmen in semi-fixed or fixed shops. It consists of inspection and repairs beyond the capability of lower echelon maintenance facilities.

Fifth echelon maintenance is performed by trained Signal Corps repairmen in a base depot. It consists of the major overhauling and complete rebuilding of signal equipment for return to stock.

The Signal Corps has responsibility for complete control over Signal Corps depot maintenance which involves command authority vested in the Chief Signal Officer, and for technical supervision of all communications maintenance operations at all levels which involve the technical training, supervision, advice, and assistance furnished by Signal Corps personnel.

The Signal Corps meets its technical responsibility in three ways: (1) by providing teams of technicians that visit

Army installations to advise and assist in maintenance matters; (2) by establishing technical schools for training enlisted personnel in the techniques of maintenance (enabling them to perform duties as repairmen and maintenance supervisors in Army organizations), and (3) by formulating technical information and doctrine which the Army publishes as technical literature. Signal Corps supply manuals also are published to provide essential information for the requisitioning of maintenance parts.

Maintenance reports are submitted in accordance with special regulations. Two examples of these reports are equipment maintenance check lists, and unsatisfactory equipment reports (UER's). Unsatisfactory equipment reports will be

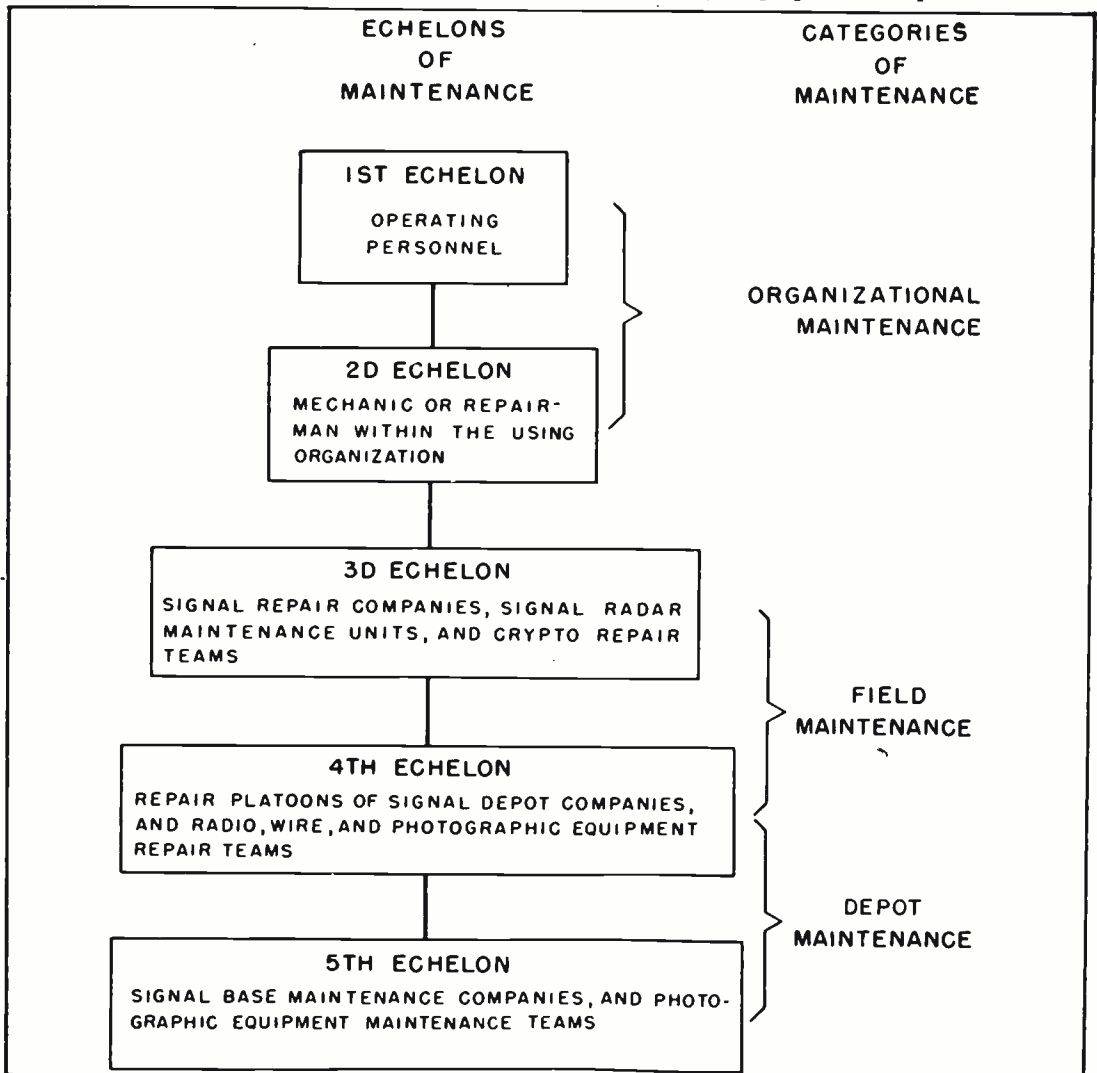

Figure 3. Categories and Echelons of Signal Maintenance

submitted when failures or malfunctions occur or are recognized in which unsatisfactory design of material is indicated, rather than avoidable accidental damage; when continued use of unsatisfactory material is deemed to be hazardous; when technical inaccuracies are noted in instructions pertaining to operation and maintenance of equipment; and when defects traceable to functional or physical shortcomings of spare parts used in repairing equipment are discovered. Unsatisfactory equipment reports are forwarded to the Chief Signal Officer, who then directs that laboratory personnel investigate each case and determine what corrective action is required. When appropriate, modification work orders are issued to correct such failures.

SIGNAL CORPS SUPPLY MANUALS

Signal Corps supply manuals provide an authoritative, usable record of item names, stock numbers, standard descriptions, prescribed allowances, and related information. The planning and distribution of these publications are keyed to the needs of the supply echelon involved.

Signal Corps supply manuals include the following:

SIG 1, INTRODUCTION OF SIGNAL CORPS SUPPLY MANUALS, which is a general introduction to the organization, content, purpose, and use of each section of the other signal supply manuals.

SIG 3, LIST OF CURRENT ISSUE ITEMS, which lists signal equipment appearing on tables of allowance, tables of organization and equipment, and certain items not on tables which are important to using organizations. Items are arranged alphabetically by item nomenclature, followed by stock number and descriptive data.

SIG 5, STOCK LIST OF ALL ITEMS, which provides official descriptive information on items of signal supply when the Signal Corps stock number is known. In the new columnar-group

manuals, descriptions may be found when either the Signal Corps stock number or the Federal Stock Number is known.

SIG 5-2, CROSS INDEX BY GOVERNMENT AND MANUFACTURERS' NUMBERS TO SIGNAL CORPS STOCK NUMBERS, which is an alphabetical-numerical cross index between government or manufacturers' and Signal Corps stock numbers. It assists in the location of a Signal Corps stock number when only the manufacturers' part number or a government number such as type, model, drawing or specification is known.

SIG 5-5, PRICING GUIDE FOR SIGNAL CORPS EQUIPMENT, which lists Signal Corps equipment in stock-numbered sequence showing the unit cost of each. It also designates stock fund and non-stock fund items.

SIG 6, SETS OF EQUIPMENT, which is a series of pamphlets that list tool sets, tool equipments, test equipment sets, maintenance kits, and other similar sets of equipments. Each pamphlet pertains to one kit or set.

SIG 7 & 8, ORGANIZATIONAL MAINTENANCE ALLOWANCES AND FIELD AND DEPOT MAINTENANCE STOCKAGE GUIDE, which is a series of pamphlets each of which lists the organization, field, and depot maintenance parts for a principal component common to several major items.

SIG 9, LIST OF ALL SERVICE PARTS FOR OVERHAUL AND ISSUE OF SIGNAL CORPS EQUIPMENT, which lists the components required to make an equipment complete. It also shows running spares, that is, spare parts such as tubes and fuses, which are shipped concurrently with the equipment.

(Note: SIG 2 and SIG 4 numbers are not assigned to publications.)

PRACTICAL SCOPE PHOTOGRAPHY

by Bud M. Compton

Philco Field Engineer

A discussion covering some of the factors involved in the photography of various patterns displayed on the cathode-ray tube.

THERE ARE MANY TIMES, especially while conducting training activities, when the field engineer's presentation would be enhanced by the use of actual photographs of various cathode-ray-tube displays. Equipment for making such photographs may be found in some of the larger laboratories. In the field, however, specialized equipment and experienced scope photographers are rarely available. The practical information contained in this article has been selected in the hope that satisfactory results may be obtained by any field engineer who has an average working knowledge of photography.

Any project involving scope photography includes the following basic considerations:

1. Security of classified information.
2. Equipment required.
3. Photo materials required.
4. Exposure control.
5. Processing of photo material.

SECURITY OF CLASSIFIED INFORMATION

The matter of security must be considered before the technical problems are tackled. The first step is to make sure that the project has been given the

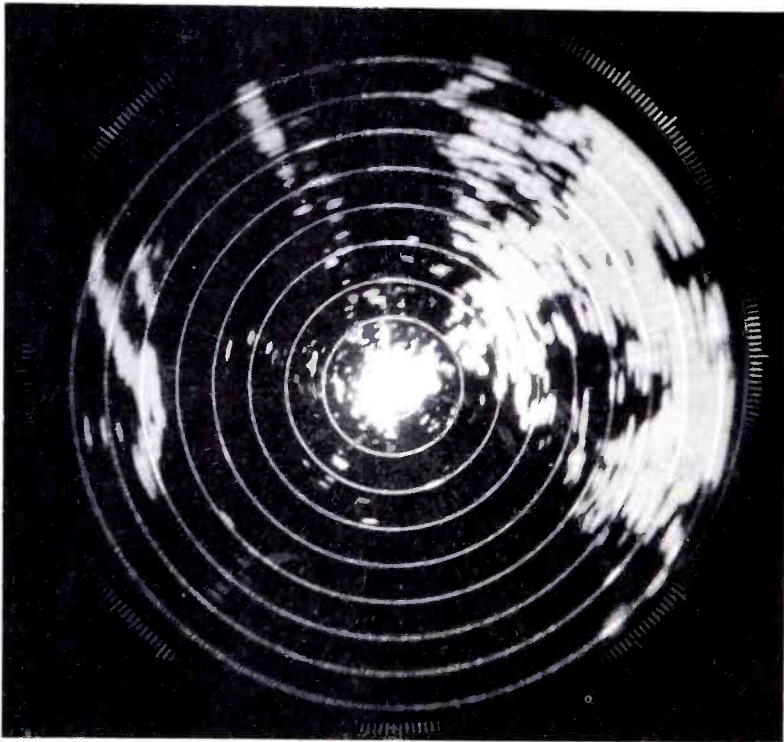

Figure 1. PPI Presentation from 7-Inch Scope, Using Plus-X Film, 6 R.P.M. Antenna Rotation, Normal Gain and Video. Exposure was one complete sweep at effective $f:7.33$. The camera was a 4x5 Speed Graphic

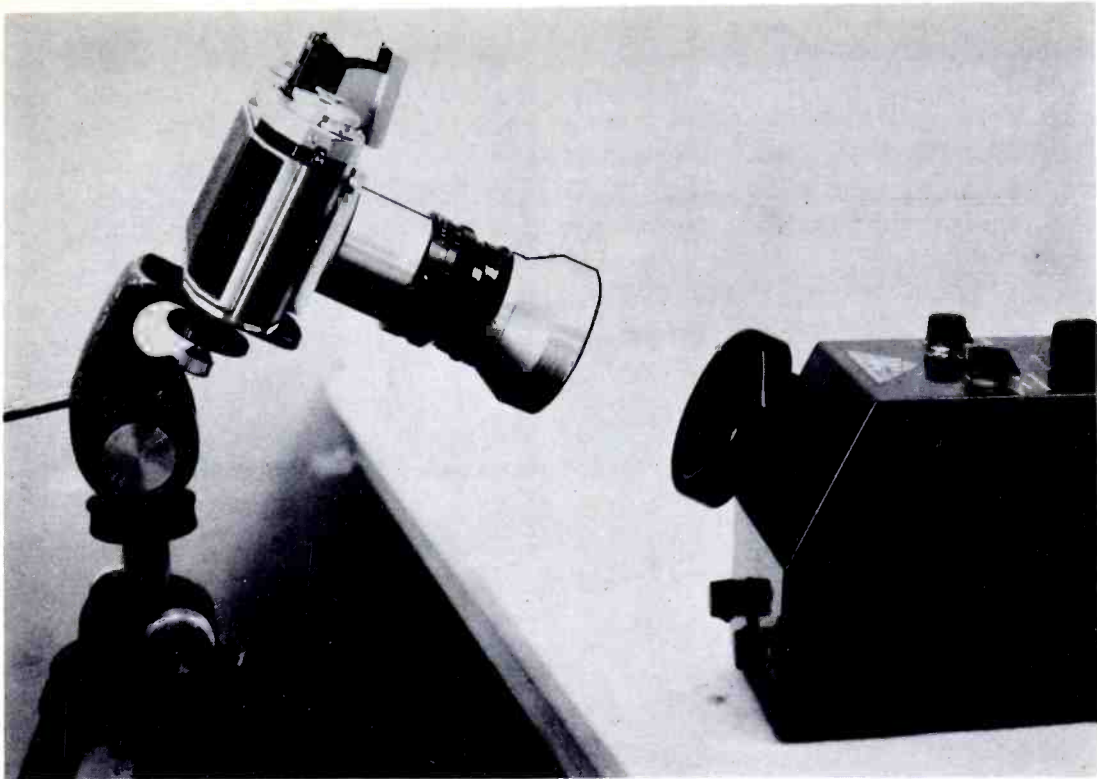

Figure 2. *Typical Setup Using 35 MM. Camera with Single-Lens Reflex Viewing and Extension Tube. The camera is equipped with an $f:2$ lens and is mounted on an elevator tripod. The oscilloscope has a 2-inch tube.*

“green light” by the proper military superior. Once permission has been granted, the photographs can be made and processed according to plan. Processing of the photographic material will depend upon the security measures involved. For instance, if security control must be exercised in a particular case, processing by the base photo laboratory is usually indicated. The photos are then reviewed, and either cleared for use or confiscated if it is decided that security is violated.

EQUIPMENT REQUIRED

The camera used for scope photography must have provisions for “time” or “bulb” shutter control in order to photograph PPI and related presentations such as the one shown in figure 1. It must be capable of focusing to a very short distance so that the scope image covers the negative—in other words, to make use of as much negative area as possible. Cameras with double-extension

bellows qualify, but other cameras of the type shown in figure 2 may need extension tubes. It is further desired that the camera have a ground-glass back or a single-lens reflex viewing arrangement so as to ensure sharp focusing of the image. Finally, a fast lens is important where short exposures are needed, since it is the combination of lens speed and film speed which determines the minimum exposure time possible.

To support the camera, an elevator tripod is favored; other means may be employed with less convenience. In any event, rigidity of support is essential when time exposures are made. Moreover, the camera must be carefully positioned so that the film surface is parallel to the scope face (figure 2).

Many photographers have been known to use flash lamps when first experimenting with scope photography (particularly when attempting to shoot TV screens). Obviously such a procedure wipes out the image completely. In scope

photography, an exactly opposite technique is required in that all extraneous light must be shielded from the scope. Darkening the room usually suffices, but there are times when a dark cloth hood or other light shield must be used.

PHOTO MATERIALS REQUIRED

It is important to select a film emulsion which has a good sensitivity to the fluorescence of the scope being photographed. The fluorescence characteristics of some of the more common coatings are as follows:

1. P1—Green. General oscilloscope, medium persistence.
2. P4—White. Television, medium persistence.
3. P7—Blue. Radar and sonar, long persistence.
4. P14—Purple-white. Radar and sonar, long persistence.

In general, orthochromatic and panchromatic emulsions are satisfactory; infra-red film is not recommended. Ortho emulsions such as Super Ortho-Press and Ortho-X are recommended where extreme film speed is not demanded. For faster film speeds, Tri-X, Royal Pan, or other high-speed pan emulsions may be used. Plus-X and Super-XX are panchromatic films which may be used in roll-film cameras for general scope photography; they have the advantage of being available wherever film is sold.

From the standpoints of speed and facility, very good results for general scope photography can be realized through the use of Polaroid Land film. Fortunately, special adapters are available which allow the use of this material with standard press-type cameras, so that the ground-glass-focusing specification may be met. As most photographers know, the complete processing, including the delivery of a finished contact print, is accomplished in one minute. Figure 3 is an example of the use of the standard Polaroid Land material.

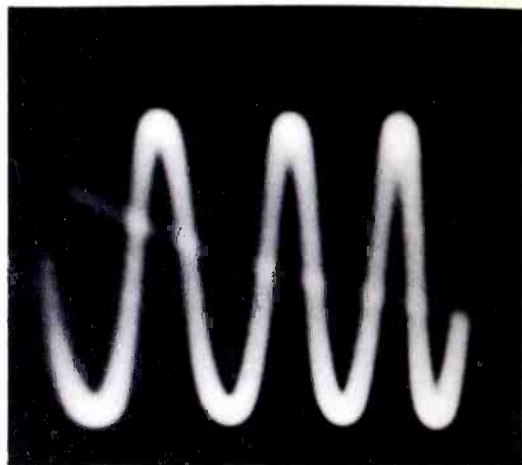

Figure 3. 400 C.P.S. Sinusoidal Wave Taken from a 2-Inch Scope with Polaroid Land Film. Exposure was 3 seconds at effective $f:12.1$

Recently, the author has experimented with the new Polaroid Type 44 film. This new film, still considered experimental, is panchromatic and has an ASA rating of 400, which makes it two stops faster than the standard Polaroid film. Another new film, Polaroid Professional Pan (ASA 200), will be introduced in the near future, and for the first time, enlargements may be made directly from its acetate negative. This amazing new development opens up an entirely new field in Polaroid photography.*

Use of the new Type 44 film permitted the photographing of a TV screen at an exposure of only 1/50 second. The resulting picture showed a complete TV frame, plus a small overlap of the second (following) frame. As each frame on the TV picture is scanned in 1/60 second, and with two frames necessary for interlace, the shutter speed was clearly documented.

EXPOSURE CONTROL

Photographic exposure is a term expressing the product of light intensity and time. Thus, adjustment of lens aper-

*A complete description of the new Polaroid film and new photographic techniques using this material is given in MODERN PHOTOGRAPHY, May 1955.

ture and of shutter speed are the two variables provided. Ofttimes, the nature of the scope photography limits the choice of shutter speeds, in which event the lens opening remains as the principal variable in controlling exposure. For instance, when making PPI photographs, the minimum exposure time is the time taken by one revolution of the antenna. Also, variation of shutter speed is restricted when transients are to be photographed. Another case of shutter speed limitation is found in shooting TV pictures; to show a complete picture with all scanning lines, the exposure time can be no shorter than 1/30 second, as shown in figure 4.

Lens opening graduations are given in "f" numbers—the smaller the "f" number, the wider the opening. The "f" number of a lens is found by dividing

the focal length of the lens by its effective diameter. (The focal length is the distance between the optical center of the lens and the film plane when the camera is focused on an object at infinity.) Thus, a lens which has an 8-inch focal length, and is 2 inches in diameter, is rated at f:4. TABLE I indicates relative amounts of light admitted, according to "f" numbers.

TABLE I

F NUMBER	1.4	2	2.8	4	5.6	8	11	16
RELATIVE SPEED	128	64	32	16	8	4	2	1

As noted above, the "f" number marked on the barrel of a lens is a true value only when the camera is focused at infinity, since at this focus, the image on the film is one focal length away from the lens. When the camera is focused to shorter distances, the illumination is re-

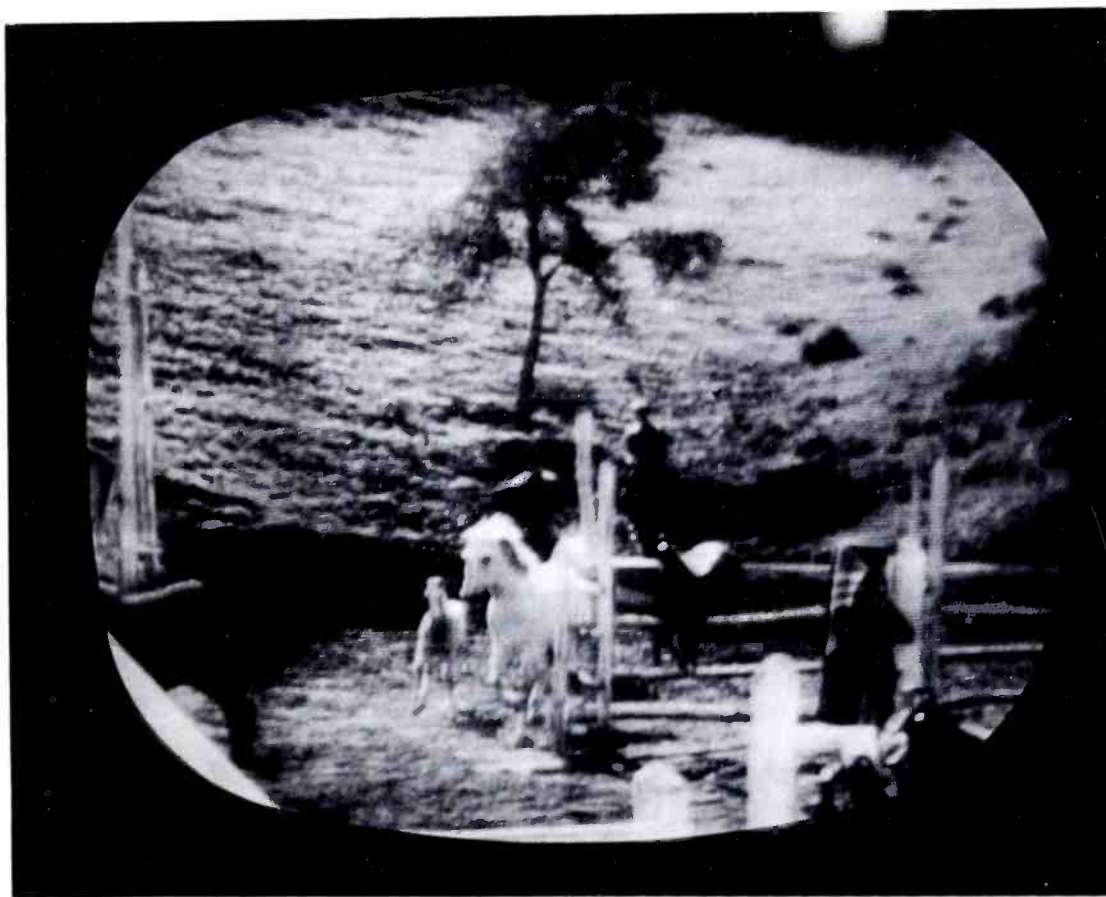

Figure 4. Photo of TV Picture Tube Made with Twin-Lens Reflex Camera. Exposure was 1/25 second at f:5.6 on Tri-X film, with camera lens 3½ feet from the screen for an effective f:6.2. The film was developed for 16 minutes in Microdol

duced because the distance from the lens to the film plane becomes greater. In ordinary photography, this is not too important since the change in distance is comparatively small and the necessary compensation is found in the latitude of most negative emulsions. However, at very short distances from the subject, where extension bellows and tubes must be used, the increased distance between the lens and the film becomes a real factor, and the "f" number assumes a larger value. The new "f" number can be computed by any one of three formulas:

$$\text{effective } f = f + f \frac{s'}{s} \quad (1)$$

$$\text{effective } f = f(1 + m) \quad (2)$$

$$\text{effective } f = \frac{s' \times f}{L} \quad (3)$$

where s' = distance from film to optical center of lens

s = distance from optical center of lens to scope (object)

f = indicated or marked "f" number (as read on camera)

m = magnification

L = focal length of lens (as marked on lens)

Examples of typical corrections can be taken from the illustrations. In figure 3, $s' = 5.5$ in., $s = 3.5$ in., and the marked "f" number was 4.7 (wide open for the particular camera). It can be seen from the s' and s figures that the scope pattern has been magnified, i.e., the photographic image is larger than the original pattern by a factor of 1.57. Using formula (1) and rounding off:

$$\text{effective } f = 4.7 + 4.7 \frac{5.5}{3.5} = 12.1 \quad (1)$$

or

$$\text{effective } f = 4.7(1 + 1.57) = 12.1 \quad (2)$$

Note that the actual amount of light admitted at $f:12.1$ is only 15% as much

as it would have been for $f:4.7$. Another example is provided by figure 1 to represent a typical correction for PPI photographs:

$$\text{effective } f = 4.7 + 4.7 \frac{8.5}{15} = 7.33 \quad (1)$$

The exposure data included in the photograph captions exemplify ordinary values, but a few additional points may be mentioned. For repetitive waveforms or patterns, exposures can be as long as found necessary. Normally, this would be one sweep at $f:8$, using Plus-X film for slow antenna rotations or, in the case of "A" scope photographs, 1/10 second. For PPI photographs with faster antenna rotation, a faster film or larger lens opening may be used, or the exposure may be set for more than one sweep. When undecided about exposure time, several photographs should be made, using different "f" numbers and/or number of sweeps where applicable. Furthermore, it is advisable to form the habit of shooting extra negatives at slightly different values in order to have a selection of negatives from which to make the final prints.

PROCESSING OF PHOTO MATERIAL

Where security measures are not involved, the processing of the negative material may be done by a commercial finishing firm or by the field engineer himself. If the processing is done by the field engineer, the author assumes that the engineer has a knowledge of such work; therefore, no instructional data are included here. For Polaroid photography, the processing is automatic. When ortho emulsions are developed, they may be inspected during the process by using a dark red safelight. In the development of panchromatic film, the process must be carried out by the time and temperature method, since it is done in complete darkness. A somewhat extended development will generally increase the film speed and contrast. Excessive overdevelopment, on the other hand, results in

chemical "fogging" which decreases contrast. Usually the development time may be extended by as much as 50% in cases where normal development doesn't quite bring out the proper negative density.

When good negatives are obtained, they may be printed on normal contrast paper (No. 2). Extra contrast is often desired for "A" scope pictures, or for prints made from thin negatives; use contrast grade No. 3 or higher to obtain the necessary photographic "snap."

RECEIVING-ANTENNA PATCH PANEL

The following suggestion is submitted as a method for easing one of the many field maintenance headaches.

THE USE OF A HAPHAZARD METHOD of connecting antenna transmission lead-in lines to receivers has quite often produced unsatisfactory results.

In many receiver installations all the transmission lines from the receiving antennas are brought into the building en masse through an aperture in the wall. The lines then branch out and run on overhead racks to the various receivers. To identify a particular antenna and its operating frequency, a tag is

placed on each transmission lead-in at the time of installation. In time, because of repeated changing of the leads in the course of maintenance, the tags quite often become illegible or are destroyed. Since a receiver may be easily connected to the wrong antenna using this type of system, mismatches and even outages may occur.

To prevent the occurrence of these conditions and to provide a convenient method of changing antennas when re-

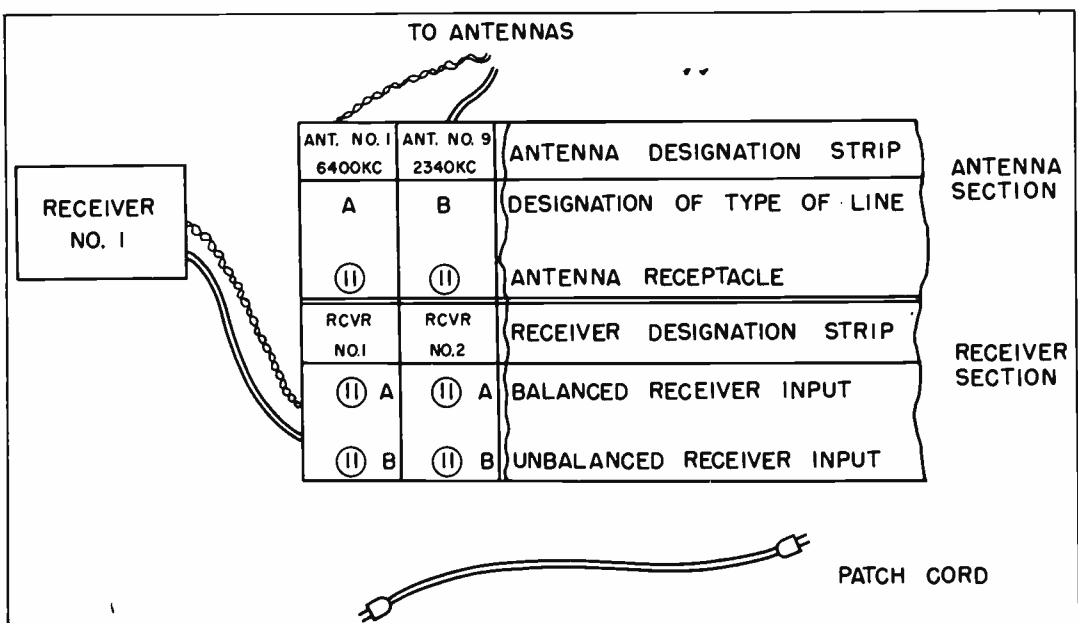

Figure 1. Suggested Patch Panel Arrangement

quired, the use of a receiving-antenna patch panel of the type shown in figure 1 is recommended. The panel consists of an antenna section and a receiver section. Since most receivers have both balanced and unbalanced inputs, it is recommended that each input be connected to an individual receptacle on the receiver section of the panel.

As illustrated in figure 1, the antenna section should contain a designation strip which lists the operating frequency and identification number of each antenna. Beneath this strip is mounted a row of female receptacles (as many as required) to which the transmission lines from the various antennas are connected. In order to indicate whether a given receptacle is connected to a balanced or unbalanced transmission line, a letter is assigned to each receptacle. In the figure the letter A is used to indicate a balanced line, and the letter B to indicate an unbalanced line.

The receiver section contains two rows of female receptacles and a desig-

nation strip. Most receivers have provision for using either a balanced or unbalanced line, and these are connected to two receptacles, as shown in figure 1. The receptacles are marked with A and B to identify each type input, and above the pair on the designation strip is marked the receiver identification.

To illustrate the use of the panel, suppose that receiver No. 1 operates at a frequency of 2340 kc., which is the frequency to which antenna No. 9 is cut. Since antenna No. 9 has an unbalanced lead-in line, the patch cord, which has two male receptacles, as illustrated in figure 1, would be connected from the receptacle under antenna No. 9 to the B receptacle under receiver No. 1.

Thus, a receiving-antenna patch panel similar to the one shown in figure 1 provides a permanent, easy-to-use method of choosing the correct antenna for any receiver. By using this panel, both operators and mechanics can make the correct antenna-to-receiver connections without the chance of a mismatch.

Perry S. Gaye

Philco Field Engineer

PHILCO TRANSISTORIZED AUTO RADIO

"Surface-Barrier" transistors developed by Philco will be used in the first transistorized radio to be built into any line of new cars. The use of transistors makes it possible to build a more compact receiver, small enough to be installed practically anywhere in the car. This radio will be special equipment in Chrysler and Imperial lines this fall.

A reduction in physical size is achieved since use of this new type transistor eliminates all electron tubes, the vibrator, the power transformer, and the rectifier. In addition, the battery drain is less than one-tenth that of standard auto radios.

Production of the auto radio in which eleven tiny transistors are used will commence as soon as tooling has been completed at the Philco Plant in Sandusky, Ohio.

Solution to . . . March-April

“What’s Your Answer?”

The value of R_1 is 28 ohms. To verify this, proceed as follows:

Let E equal the battery voltage and I_1 equal the current through the circuit when R_2 is 8 ohms.

$$\text{Then, } E = I_1 (R_1 + 8) \quad (1)$$

Let I_2 equal the current drawn from E when R_2 is 98 ohms.

$$\text{Then, } E = I_2 (R_1 + 98) \quad (2)$$

Setting (1) and (2) equal, and solving for R_1 gives:

$$I_1 (R_1 + 8) = I_2 (R_1 + 98)$$

$$I_1 R_1 + 8I_1 = I_2 R_1 + 98I_2$$

$$I_1 R_1 - I_2 R_1 = 98I_2 - 8I_1$$

$$R_1 (I_1 - I_2) = 98I_2 - 8I_1$$

$$R_1 = \frac{98I_2 - 8I_1}{I_1 - I_2} \quad (3)$$

$$\text{The power dissipated by } R_2 \text{ when it equals 8 ohms is } 8I_1^2. \quad (4)$$

$$\text{The power dissipated by } R_2 \text{ when it equals 98 ohms is } 98I_2^2. \quad (5)$$

The problem specified that (4) and (5) are equal.

$$\text{Therefore, } 8I_1^2 = 98I_2^2 \quad (6)$$

Solving (6) for I_1 :

$$I_1^2 = \frac{98I_2^2}{8}$$

$$\sqrt{12.25I_2^2} = 3.5I_2 \quad (7)$$

By substituting the value of I_1 from (7) into (3), R_1 can be found as follows:

$$R_1 = \frac{98I_2 - 8(3.5I_2)}{3.5I_2 - I_2}$$

$$R_1 = \frac{98I_2 - 28I_2}{2.5I_2}$$

$$R_1 = \frac{70I_2}{2.5I_2} = 28 \text{ ohms}$$



CONSULTING, PROJECT, AND FIELD ENGINEERING

- ELECTRONICS • COMMUNICATIONS**
- POWER PLANT • REFRIGERATION**
- SPECIAL SYSTEMS**

"3-D" TRAINING

- COURSE MATERIAL**
- TRAINING DEVICES**
- INSTRUCTORS**



**WRITING, PROCESSING, AND PUBLISHING
OF TECHNICAL LITERATURE**

- TECHNICAL MANUALS • INSTRUCTION BOOKS**
- CATALOGING • TECHNICAL REPORTS**
- DESCRIPTIONS OF MANUFACTURE**