

PHILCO

TECHREP DIVISION BULLETIN

Volume 6

November-December, 1956

No. 6

In This Issue...

Editorial	<i>John E. Remick</i>	1
Letters to the Editor		2
A New Beam-Indexing Color Television Display System		3
Using a Type F-3 Motor-Generator on 50 Cycles	<i>T/Sgt. Val Fish, Jr.</i>	14
Delta-to-Wye and Wye-to-Delta Transformation		18
Passive Reflectors as Navigational Aid	<i>William Baughman</i>	21
New Antenna Manual		24
Servicing Transistor Circuits	<i>Carl Tillman</i>	25
"What's Your Answer?"		33
New Philco Transistors		34
Solution to September-October "What's Your Answer?"		34
Tech Info Mail Bag		35
Index for Volume 6, Philco TechRep Division BULLETIN		36

PHILCO

TECHREP DIVISION

BULLETIN

Published bimonthly by

The TechRep Division of Philco Corporation

Philadelphia, Pennsylvania

Editor John E. Remich

Managing Editor John W. Adams

Technical Editors Francis R. Sherman
Robert D. Hunter
Harvey W. Mertz

Editorial Office:

**Technical Information Section
Philco TechRep Division
22nd St. and Lehigh Avenue
Philadelphia 32, Penna.**

If any information contained herein conflicts with a technical order, manual, or other official publication of the U.S. Armed Forces, the information in the official publication should be used. Views expressed in this publication are the opinions of the authors and do not necessarily represent those of Philco Corporation. All technical information and circuits are presented without responsibility as to patent infringement.

Editorial . . .

by John E. Remich

Manager, Technical Department

THE "GROWING PAINS" OF ELECTRONICS

Since the early days of radio, the development of electronics has been accompanied by technological "growing pains." One of these has been the training problem. Because of continual advances in electronics, as well as the relatively abstract nature of electronic equipment operation, it has always been necessary, in communications and allied fields, to provide training for operating and maintenance personnel.

Although the training problem has been basically the same over the years, there have been several distinct changes in it. The most obvious of these is the increasing complexity of the equipment itself, as reflected by the greatly increased number of components making up a single equipment. This change alone has greatly increased the complexity of the maintenance problem associated with such equipments. The second, and somewhat more subtle, change that has taken place over the years is the diversification in the techniques and theory upon which the actual equipment is based. This effect was probably most pronounced early in World War II with the introduction of radar equipment for widespread use. The training problem created by this situation is well remembered by many of the "old timers" in the field.

Today, as in the past, the training problem is acute. The difficulty of the problem has been substantially increased by both of the factors described above, and no relief is yet in sight. Equipment design today is in many cases based on electronic concepts which were not even in existence ten years ago.

Thorough and effective training programs are obviously necessary to cope with the problem that exists, if we are to eliminate our present technical manpower shortage. One of the most important factors involved in producing such a training program is an alert, enthusiastic, and technically well-trained instructor in electronics, as represented by the Philco TechRep Field Engineer. His role in overcoming one of the "growing pains" of electronics offers the tremendous challenge of effectively and efficiently training others and the satisfaction of doing an important job well.

LETTERS TO THE EDITOR

"In conjunction with a television retransmission project, can you supply me with either the formulas required for computing the dimensions of a discone antenna for operation between 750 mc. and 900 mc., or the actual dimensions of such an antenna. The cutoff frequency should be 750 mc."

George P. Weimer
Philco TechRep Field Engineer

(Information on this discone antenna may be found in the references listed below.)

"Designing Discone Antennas," by J. J. Nail
Electronics, August 1953

The Radio Manual, 4th Edition
Sterling and Monroe

"Discone Skywire," by J. M. Boner
CQ, July, 1949

There are apparently no set formulas for computing discone antenna dimensions. The main requirement is that the slant height be slightly greater than a quarter wavelength at the lowest operating frequency. In this case, the slant height should be slightly greater than 10 cm. The flare angle may vary between 60 and 90 degrees. Ed.)

"We have been asked to install HF radio communications between our location in South Carolina and Christchurch, New Zealand. Types of communications will be voice, CW, single sideband, and teletype. Frequencies will be about 14, 20, and 28 mc. I would like to know the great circle bearing from South Carolina to New Zealand, the best suitable antenna for limited space (other than the three-element beam already installed), the best method of matching to the transmission line, and the usefulness of the assigned frequencies."

Paul F. Alexander
Philco TechRep Field Engineer

(The true bearing is approximately 250 degrees. This is only a rough estimate based on approximate latitude and longitude of the two locations. The bearing may be computed accurately by use of spherical trigonometry formulas. The *Philco Construction Handbook on Communications Antennas* (Antenna Series, Volume 2) lists several different types of antennas. A rhombic or sloping V would give best results, but a corner reflector might be used if you're limited for space. The *Philco Training Manual on Antennas* (Antenna Series, Volume 1) gives a detailed analysis of a number of different methods of impedance matching. Propagation forecasts for three months in advance are contained in a pamphlet entitled "Monthly Basic Radio Propagation Predictions," obtainable from Central Radio Propagation Laboratories, Bureau of Standards, Washington, D. C., or from TM 11-499 and TB 11-499, Ed.)

"I would appreciate any available information on the development and application of π networks (both for interstage and antenna coupling) and the development of the signal radiated from the VHF Omnidirectional Range."

Stephen E. Shoemaker
Philco TechRep Field Engineer

(Information on π networks may be found in most reference texts; three of these texts are listed below.)

Radiotron Designers Handbook, 4th Edition
Reference Data for Radio Engineers, 3rd Edition
Radio Amateur's Handbook.

The *Philco Training Manual on Antennas* contains information on the application of the π network as an antenna coupler. With regard to the radiated VOR signal, a complete discussion of this system and development of the signals may be found in the *Philco Training Manual on Electronic Navigation Systems*. Ed.)

"I would like to know the cost of Philco's SB-100 transistor, and whether this transistor would be suitable for use as a superregenerative detector at 27 mc. I would also like to know whether there is a transistor available which will replace the 3A4 vacuum tube."

Lyle A. Gallegos
Philco TechRep Field Engineer

(Philco's Surface-Barrier Transistor, the SB-100, will operate satisfactorily as a superregenerative detector at the required frequency, and the unit cost of this transistor is approximately \$6.00. However, the Philco 2N128 transistor would probably be better for the purpose, since it has a higher alpha cutoff (45 mc.). The unit cost of the 2N128 is approximately \$7.50.)

At the present time there is no transistor which would replace the 3A4. The circuit might be redesigned to accomplish the same function using a combination of transistors and suitable circuitry. Ed.)

"With reference to Mr. W. Warriner McQueen's letter to the Editor in the September-October, 1956 issue of the Philco TechRep Division BULLETIN, I have, in association with Mr. Frank A. Eble, recently completed a detailed study of the structural characteristics of large (30- and 60-foot diameter) paraboloidal antennas for AACS.

"Much of the information pertaining to the adequacy of the structural analyses is of a professional nature. However, our preliminary study of large commercially available paraboloidal reflectors is open for review to properly qualified engineers concerned with this subject. The study contains a review of the design analyses, a study of modes in structural failures, and the economics of cost involved in procurement and erection."

John J. Carroll, P.E.
Chief Structural Engineer, AACS

A NEW BEAM-INDEXING COLOR TELEVISION DISPLAY SYSTEM

by E. M. Creamer of the Television Div., Philco Corp.; R. G. Clapp, S. W. Moulton, and M. E. Partin of the Research Div., Philco Corp.; J. S. Bryan, formerly of the Research Div. Philco Corp.

This article describes a single-gun cathode-ray display system (the Philco Apple* System) for color television receivers based on the phenomenon of secondary emission. An index signal, derived from a secondary emissive structure built into the screen of the tube, continuously indicates the position of the scanning spot relative to the color phosphor structure. This positional information is combined with the color television signal, and the combined signal modulates the scanning spot in amplitude and phase in such a manner that the spot sequentially illuminates the primary colors in the appropriate amounts and proportions to reproduce the televised scene. This article describes the general features of the system and the philosophy behind its development, and the derivation of the index signal and its utilization in the color-processing and grid-drive circuits.

(Editor's Note: This article and those relating to this subject which are to follow in subsequent issues of the BULLETIN, were originally published in the September 1956 issue of the "Proceedings of the IRE," which is published by the Institute of Radio Engineers, Inc., and appears here with the Institute's permission.)

INTRODUCTION

FROM ITS INCEPTION many years ago, the aim of the Philco color television development program has been to produce a color television display in which the picture tube and its external beam-controlling parts are as simple as possible. Most other color display systems are based either on the principle that each of several color phosphors is excited by its own electron beam while being protected from the other beams by mechanical or electromechanical means, or on the principle that a single electron beam is directed to several color phosphors by electromechanical means. These types of display require special mechanical structures within the tube and present problems in registration or focus, or both.

The beam-indexing system is based on the principle that a single electron beam

can be used to excite the several color phosphors without auxiliary color deflection or beam shadowing. Instead of being forced to land on a particular phosphor, the beam is passed over all color phosphors in rapid succession and modulated in accordance with its position to produce the required color. Operation based on this principle requires an indexing system to provide information concerning the whereabouts of the writing beam, and a modulating system to provide the required beam modulation. The beam-indexing display system avoids the mechanical and registrational problems of other color tubes, the implications of which are discussed at the conclusion of this article.

Among the important advantages of the beam-indexing tube is its similarity

*The term *Apple* is simply a code name for this type of color system.

to a black-and-white tube; in fact, in the absence of a chrominance signal, it cannot help making a good black and white picture. No part of the writing beam in the Apple tube is intercepted or deflected in such a way as to waste any high-voltage power, and there is no problem of matching the characteristics of three guns to obtain good color fidelity. As a result of these characteristics, a receiver using a beam-indexing tube can give performance superior to that of a three-gun-tube receiver. Moreover, in the opinion of the authors, the present system is potentially more economical than any other color receiver because it is simple in those portions where much of the cost of all television receivers is concentrated, and, in addition, has more possibilities of future improvement.

The two fundamental processes involved in Apple system operation are *sequential writing* and *electrical indexing*. The expression *sequential writing* means that the beam passes successively over triplets of fine, vertical stripes of red, green, and blue phosphors, as shown in figure 1. A particular color is produced by modulating the beam during its passage over each triplet, according to the proportions of primaries in the desired color. The expression *electrical index* refers to a signal, derived from the luminescent screen of the Apple tube itself, that continuously gives information on the location of the beam. The

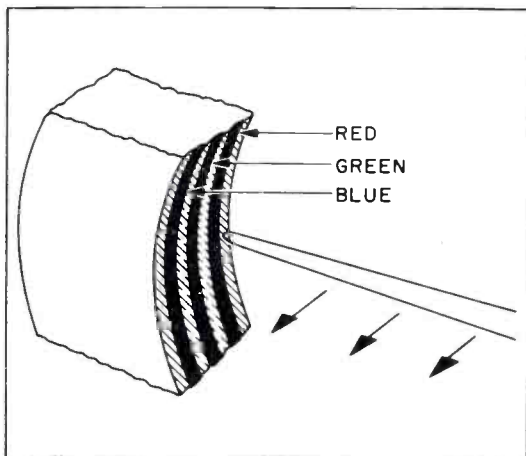

Figure 1. Apple Tube Stripe Structure

beam current responds to two types of instructions: the color video signal from the transmitter and the index signal. The only circuitry unique to the Apple system is that required to perform these functions.

The signal required to produce the color picture on the beam-indexing tube resembles very closely that required by the FCC standard color television system. That is, the Apple system produces a high-quality black-and-white picture from the luminance signal and, by adding a high-frequency chrominance component to the luminance signal, produces colors. As will be shown, the similarity of these signals to the transmitted signals enables the beam-indexing tube to utilize the broadcast signal efficiently, with a minimum of color-processing circuitry.

An important requirement of the system is small spot size. Obviously, for the production of saturated primary colors, the spot size at peak beam current must be small enough to minimize the beam current that hits adjacent phosphor stripes. The means of obtaining small spot size will be described in another article in a subsequent issue of the BULLETIN.

Several different forms of Apple display systems have been investigated, and each has been found to have certain advantages and disadvantages. Rather than to describe all of these different forms, it seems preferable to discuss in detail only one specific form of the system. It should be recognized, however, that there are many other ways by which color pictures can be made following the broad Apple concept.

DERIVATION OF THE INDEX SIGNAL

The index signal is obtained from the tube by means of the structure shown in the insert in figure 2, where a line, called the *index stripe*, of a material having high secondary emission compared to the aluminized coating, is placed behind every red line. The sec-

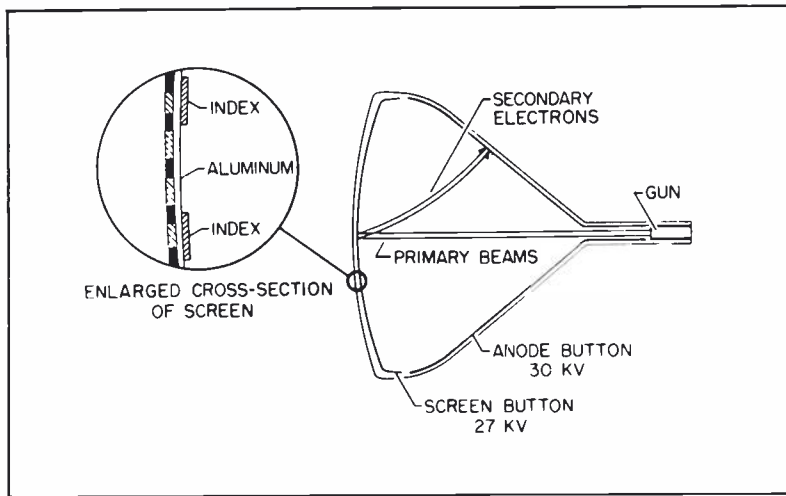

Figure 2. Cross Section of Apple Tube

ondary emission current produced as the beam crosses these index stripes is collected and amplified, resulting finally in a signal at the same frequency as that at which the beam must be varied to produce colors. This beam, which actually produces the picture, is called the *writing beam* to distinguish it from the *pilot beam* which derives the index information as described later in this article.

The waveform produced by the index structure is similar to that shown in figure 3, which is an idealized curve of secondary emission ratio vs beam position. The waveform obtained by scanning such a structure with a beam of constant amplitude is represented by a Fourier series in cosines. The only term of interest is $A_1 \cos \theta$, the fundamental component. If the phase of this single component in the index current is preserved, sufficient information for proper

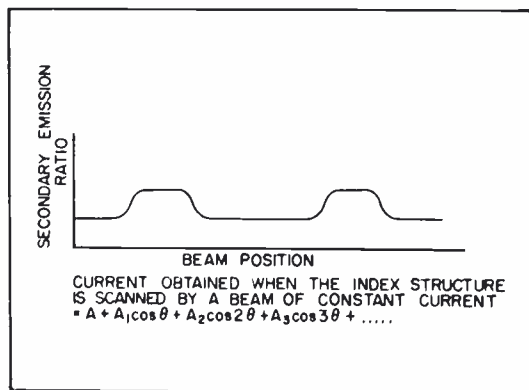

Figure 3. Apple Index Waveform

operation will be available. Amplitude variations of the coefficient A_1 are removed by means of limiters.

However, the writing beam is not of constant amplitude. The variations that produce color also produce an a-c component of the secondary emission current at the same frequency as the desired index signal, and at any phase with respect to it. Since this a-c component produces a perturbation of the desired index phase, the secondary emission current may not be used directly as the index signal.

The problem is overcome by the use of frequency separation. A second beam of low current, called the pilot beam, is introduced. Its beam current contains a constant amplitude component of frequency, F , called the *pilot carrier-frequency*; F is chosen to be above the video- and color-frequency range. An idealized diagram of the single gun which produces the two beams is shown in figure 4. Two sidebands are produced as the beams sweep over the index stripes, formed by the component F beating against the desired $A_1 \cos \theta$ component of the index function. Either sideband contains the desired phase information.

The pilot beam is aligned so that it always strikes the same color line as the picture writing beam. If the pilot carrier were made a part of the writing beam,

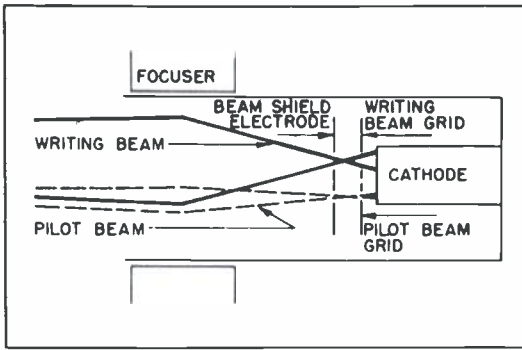

Figure 4. Idealized Cross Section of Apple Tube Gun

gun nonlinearity might cause intermodulation between the pilot carrier and writing frequency signal. The sidebands produced by this intermodulation would have the same frequencies as the desired sidebands and might contaminate the index signal. An easy solution to the problem is the use of two beams. The pilot beam illuminates the luminescent screen at a low, constant level which affects the contrast ratio only slightly. This background illumination is generally about 1/2 foot-lambert. A highlight brightness of 40 foot-lamberts allows a contrast ratio of 80 to 1.

THE APPLE CONTROL CIRCUITS

The index signal from the Apple tube must be amplified, combined with instructions from the transmitter, and restored to the writing frequency (frequency at which the beams cross the triplets), and then applied to the writing-beam grid of the tube to produce a color picture. Throughout these operations the phase of the index signal must be preserved.

A simple mixer is shown in the upper part of figure 5, in which the output voltage is the product of two input signals. Considering only the output terms as the sum or difference of the input frequencies, the output phase is the linear sum or difference of the two input phases, depending on which output sideband is considered. Thus, in the phase domain, a heterodyning process is an addition or subtraction of phases. This

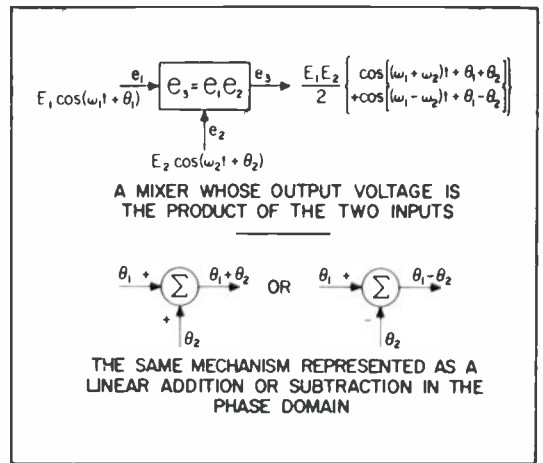

Figure 5. An Analysis of Operation of Simple Mixer in Phase Domain

is shown diagrammatically in the lower part of figure 5. The Apple index mechanism is just such a mixer, whose output is the product of the pilot beam current and the index function; and it is necessary to retain only one of the sidebands produced at the screen to obtain the essential phase information. A second heterodyning with the pilot carrier frequency is necessary to restore the sideband frequency to the original index frequency, which is needed for writing colors. The block diagram of figure 6 shows the Apple indexing system. First, a pilot oscillator at 41.7 mc. drives the pilot beam grid. The useful sideband output at 48.1 mc. is amplified in the sideband amplifier and then applied to a mixer. Here it is heterodyned with the pilot oscillator output, producing the 6-4-mc. signal for the writing grid.

If the horizontal scanning velocity is constant, the index signal reaches the writing grid without any change of phase, and produces variations of the writing beam current so that it illuminates successive lines of the same color; this action results in a solid field of uniform color. If, however, the horizontal scan increases or decreases in speed, the a-c component of the beam current is retarded or advanced in phase and so produces a slightly different color. This phase change with changing sweep speed

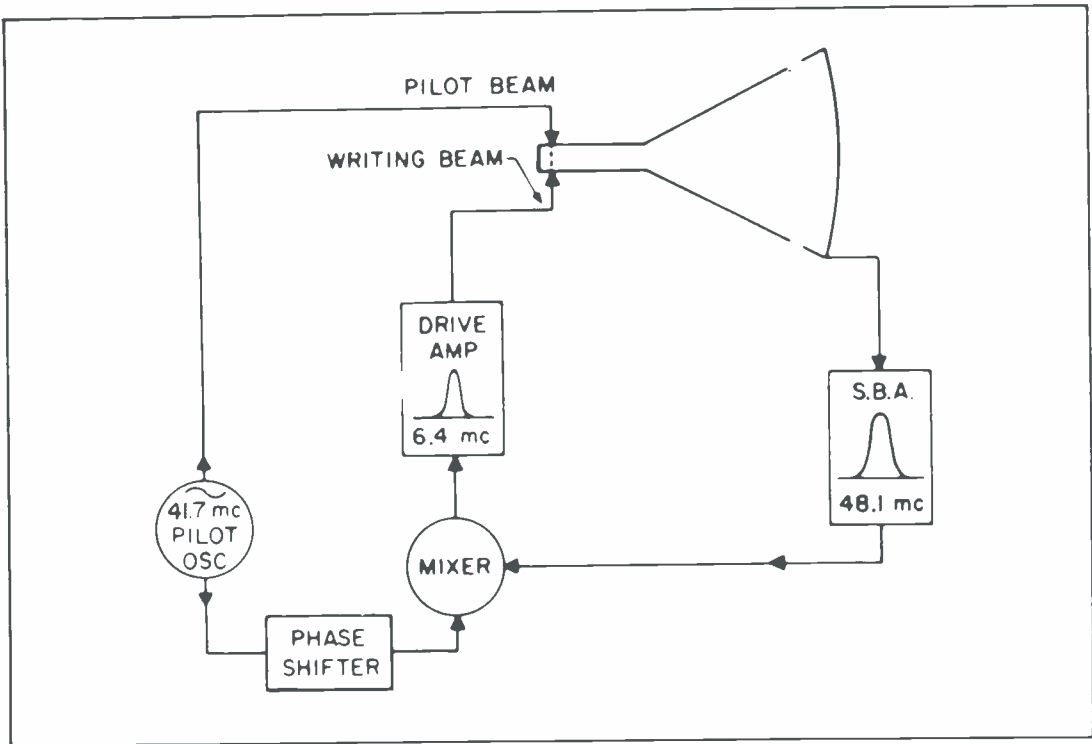

Figure 6. Simple Block Diagram for Generating Flat Fields

or index frequency is proportional to the slope of the phase-frequency characteristic (the envelope time delay) of the index sideband amplifier. Sweep nonlinearities produce color errors which are the product of the amplifier time delay and the incremental index frequency change.

In order to change deliberately the color of a flat field, it is necessary to change only the phase of the pilot carrier entering the mixer; this could be accomplished by the phase shifter shown in figure 6.

The optimum envelope time delay of the sideband amplifier is affected by the possible contamination of the index signal by the writing beam. Figure 7 shows the spectrum of the complete signal at the input to the sideband amplifier. The energy concentrations at one-half the writing frequency above and below the useful sideband frequency are caused by harmonics of the writing frequency in the writing beam and video modulation of these harmonics.

For system stability the sideband-

amplifier response must be well down at these points of energy concentration, for they represent interference to the index function and can cause various forms of color interference. A design compromise must therefore be made in the selection of a sideband-amplifier response curve to have sufficient skirt selectivity to reject unwanted writing beam interference, and yet have a short enough time delay to permit a realistic amount of horizontal sweep nonlinearity without too much color nonuniformity.

Typical design permits about a 1-microsecond delay from the Apple tube screen to the writing grid. This delay produces about 10 degrees of color error for a sweep nonlinearity of $\frac{1}{2}$ percent. Such linearity requirements, though severe, have been found to be practically realizable. Suitable circuits will be described in another article in a subsequent issue of the BULLETIN.

PICTURE WRITING TECHNIQUES

In order to make the system illustrated in figure 6 show complete color pictures instead of solid fields of color, it is only

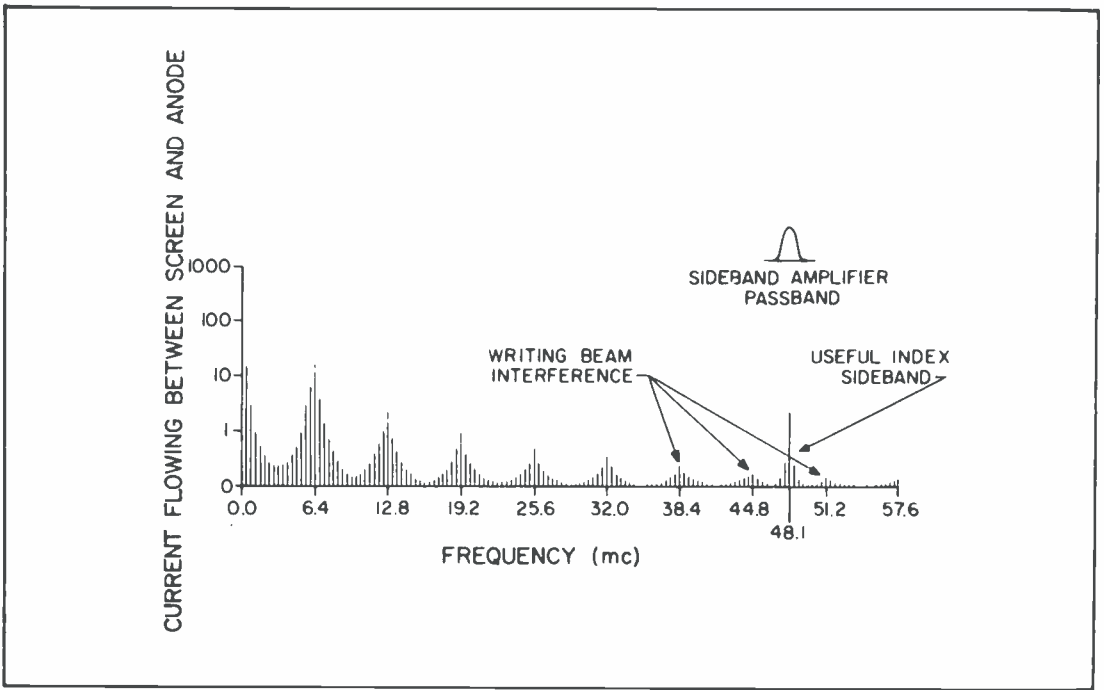

Figure 7. Spectrum of Complete Signal at Input to Sideband Amplifier

necessary to vary dynamically the phase and amplitude of the pilot-carrier signal entering the mixer. The voltage on the writing grid is simultaneously varied at the video frequency to control the luminance. The total current illuminating the three phosphors depends on the video-frequency portion of the signal applied to the writing grid, and the way

in which this current is divided among the three phosphors is determined by the amplitude and phase of the writing component of the grid signal.

Consider the tube to have infinitesimal spot size and line width so that it is a sampler of very narrow aperture. Let the lines be equally spaced, as shown at the top of figure 8. If the video-frequency

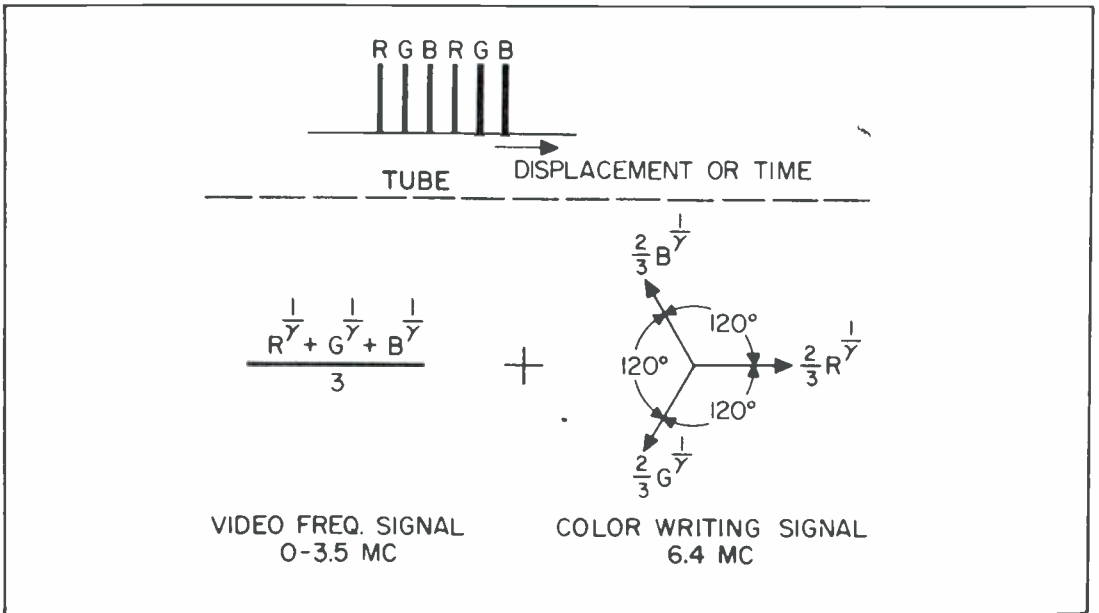

Figure 8. Development of Required Signal for Color Writing

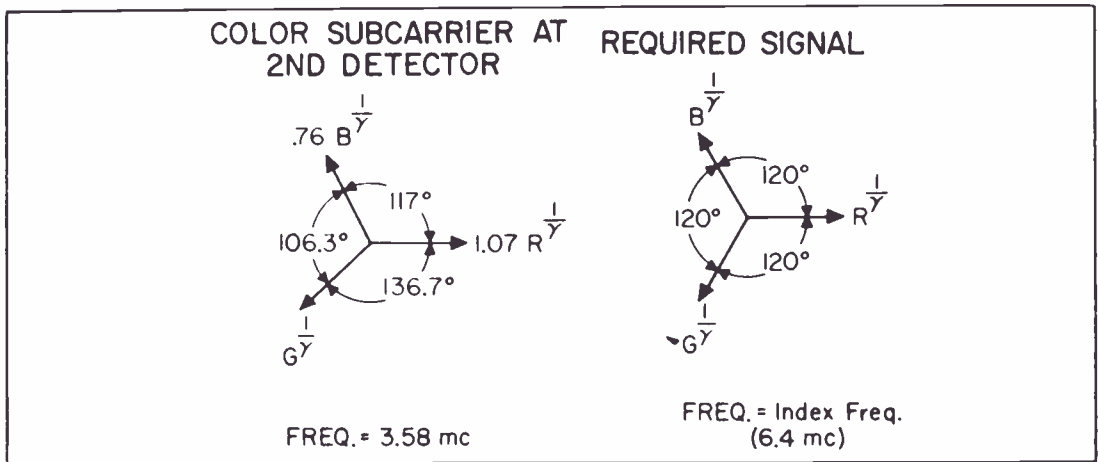

Figure 9. Comparison of Color Subcarrier at Second Detector and Required Signal

and the color-writing frequency portions of the signal are as shown in the figure, accurate color fidelity exists. The video-frequency portion of the signal is the linear sum of gamma-corrected red, green, and blue, and the color-writing signal is the sum of three equally spaced vectors. This signal is similar to the combined color video available at the second detector.

The color subcarrier may be represented in terms of I and Q, or more conveniently for analysis of the present system, as shown on the left side of figure 9. The required drive signal is shown again on the right. Two differences exist between the color subcarrier and the drive signal. First, the received color subcarrier is not equiangular; and second, the signal required to drive the tube must be locked to the stripe structure at 6.4 mc. rather than at the 3.58 mc. frequency of the transmitted chrominance subcarrier. The color subcarrier could be simply corrected to the equiangular form by an elliptic conversion or it could be compensated for by unequal stripe placement on the tube; however, since the visible difference in the picture is less than 10 color degrees, correction of the subcarrier is usually neglected.

The conversion from 3.58 mc. to 6.4 mc. is achieved through heterodyning, as shown in figure 10. The pilot-carrier signal required by the pilot-beam grid

is generated by beating the 3.58-mc. color reference signal against an oscillator signal 3.58 mc. below the desired pilot-carrier frequency. The required pilot carrier entering the mixer is generated by beating the same oscillator signal against the 3.58-mc. signal with color modulation. The mixer output is a signal at writing frequency locked to the color line structure but having the same amplitude and phase variations as did the original 3.58-mc. color signal.

For the required video frequency, the Y signal available at the second detector can be used as shown in figure 10. If slightly better colorimetric accuracy is desired, a monochrome correction signal of the type indicated algebraically in figure 11 can be added to the Y signal, converting it to "M".* Monochrome correction is derived by synchronously detecting the 3.58-mc. color signal with the 3.58-mc. reference signal as shown in figure 12. These are all the steps that are needed if the spot size and line width are reasonably near the infinitesimal ideal. The effect of greater spot sizes and line widths is a slight desaturation of the colors. Correction of this condition is accomplished by increasing the chroma gain about 33 percent and adding a second low-frequency signal called *saturation correction*. This correction results in almost perfect color fidelity.

*M is called the Monochrome signal and is commonly defined as $\frac{1}{3} R + \frac{1}{3} G + \frac{1}{3} B$.

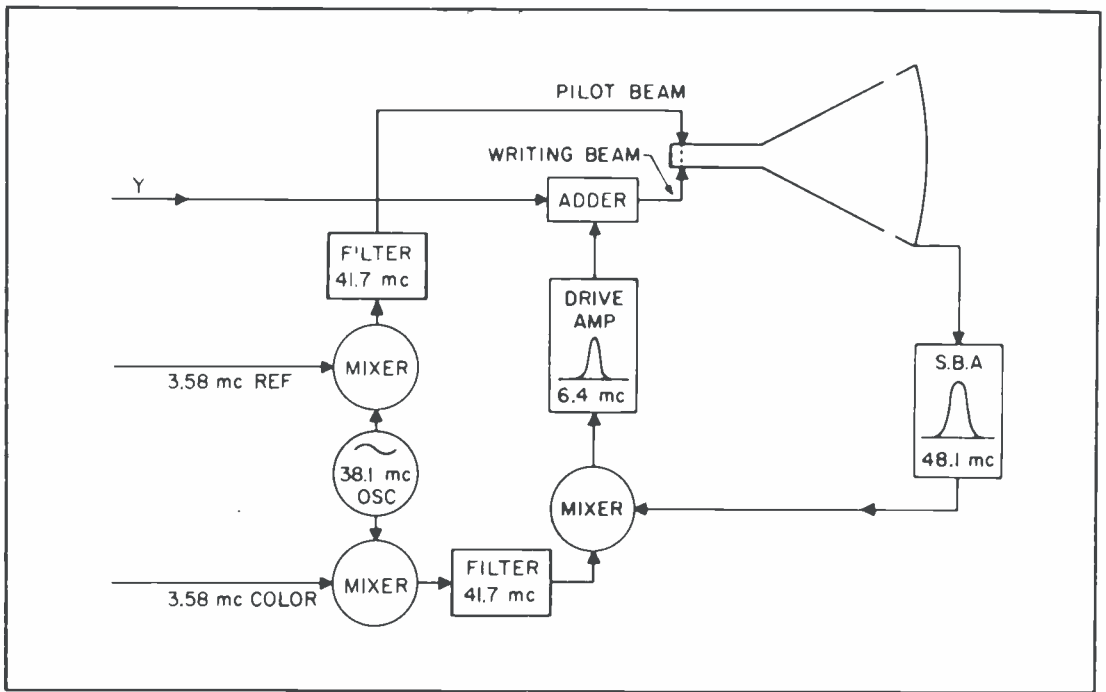

Figure 10. Block Diagram Showing Method of Heterodyning to Convert from 3.58 Mc. to 6.4 Mc.

The saturation correction signal biases the tube negatively an amount proportional to the amplitude of the color sub-carrier and has the effect of reducing the conduction angle, particularly on primaries. The saturation correction signal is derived from the same detector as the monochrome correction, but does not represent a sacrifice in brightness since the chroma gain has been increased. Differences caused by monochrome and saturation corrections are small and recent practice has been to ignore them.

The block diagram shown in figure 10 represents the entire picture and index signal handling sections of the display. The only other parts which must be added, as shown in figure 13, are the sweep circuits, the high-voltage supply with outputs at 27 kv. and 30 kv., the magnetic focuser with vertical dynamic focus, and the width servo. Not shown are the reference generator, the audio, the i.f., and the tuner.

COMPARISON OF THE INHERENT COMPLEXITIES OF VARIOUS TYPES OF COLOR TELEVISION DISPLAY

There are several considerations in color television receiver design which

have a bearing on the degree of complexity that is inherent in the display device. These considerations are: physical devices, circuitry, and adjustment procedures.

The physical devices include the cathode-ray tube itself, the yoke, the focuser, any special auxiliary devices such as convergence coils, purity coils, and magnets, and any special magnetic or electric shielding which may be required. The penalty which one must pay for complexity in this area is primarily that of using more material in the receiver.

Circuit complexities which are inher-

$$\begin{aligned}
 & \underbrace{30R^{\frac{1}{\sqrt{2}}} + .59G^{\frac{1}{\sqrt{2}}} + 11B^{\frac{1}{\sqrt{2}}}}_{\text{"Y" SIGNAL AVAILABLE AT 2ND DETECTOR}} + \underbrace{.03R^{\frac{1}{\sqrt{2}}} - 26G^{\frac{1}{\sqrt{2}}} + 22B^{\frac{1}{\sqrt{2}}}}_{\text{"MONOCHROME CORRECTION"}} \\
 & = \frac{R^{\frac{1}{\sqrt{2}}} + G^{\frac{1}{\sqrt{2}}} + B^{\frac{1}{\sqrt{2}}}}{3} \\
 & = \text{DESIRED SIGNAL}
 \end{aligned}$$

Figure 11. Addition of Y Signal at Second Detector and Monochrome Correction Signal to Produce Desired Signal

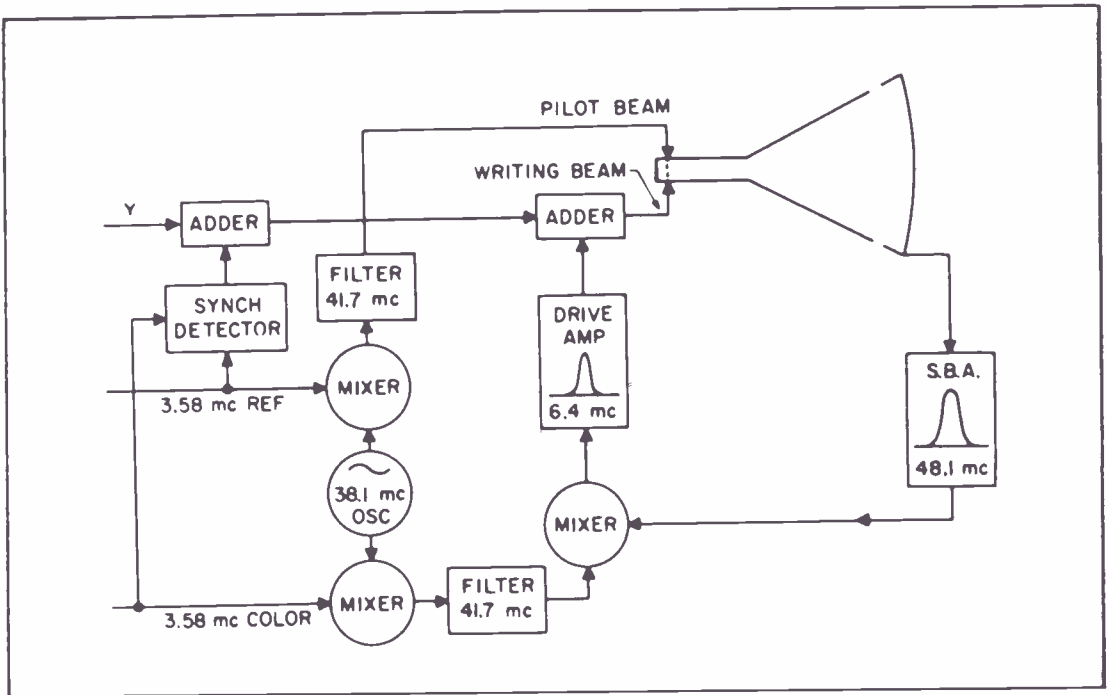

Figure 12. Block Diagram Showing Production of Monochrome Correction by Synchronous Detection of 3.58-mc. Color Signal with 3.58-mc. Reference Signal

ently associated with various display devices include the following: separate video channels for the three primary colors, abnormally wide bandwidths in any channel, regulated voltages, making two regulated voltages track each other, sweep circuits with remarkably good linearity, and the amplification of index

signals. Complexity in this area leads to the use of more material, but it should be pointed out that apparent circuit complexity is liable to misinterpretation. The mere number of vacuum tubes in a receiver is often a very poor guide to evaluation of its true complexity. It is well known that in many cases the over-

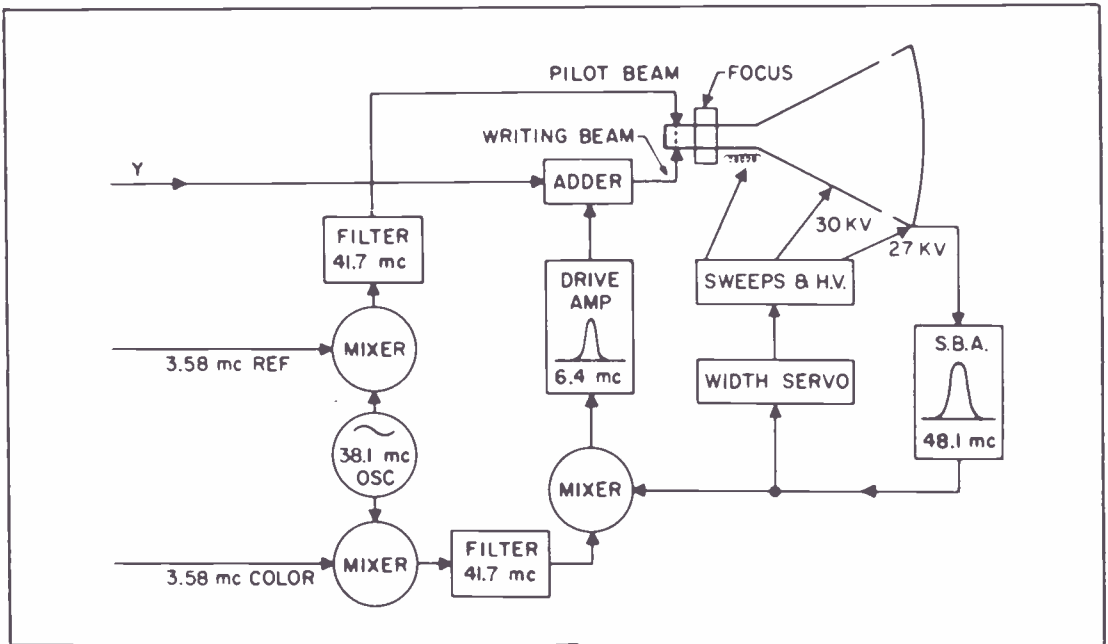

Figure 13. Block Diagram of Receiver with Sweep Circuits and High-Voltage Supply Added

all complexity of a receiver can actually be reduced by adding tubes, provided the addition of tubes and circuits permits the removal of complicated tubes or circuits and simplification of adjustment of the receiver.

The third consideration, adjustment procedures, is the most difficult to evaluate quantitatively. The presence of the following factors is suggested as a true measure of complexity: large number of adjustments, either in the factory or those required of field service personnel, inter-related adjustments, adjustments whose effect is difficult to evaluate, adjustments requiring the use of unusual test equipment, and adjustments which must be frequently repeated because of instability in the receiver or because of abnormal sensitivity to external effects. The penalties for complexity of adjustment procedures are the use of more material, increased factory labor, more field service and, very often, inferior performance in the field.

There are three principal types of display to be considered: the three-gun type represented by the shadow-mask and post acceleration tubes, the Lawrence tube and the index type represented by the present form of the Apple tube.

The complexities of three-gun tubes which are of most concern are those inherently associated with the use of three guns. The convergence of the three beams must be maintained throughout the scanning of the entire raster. This is difficult because the three beams have different centers of deflection and because of the effect of external magnetic fields, such as that of the earth. Maintenance of color purity throughout the raster requires accurate control of the direction of arrival of the three beams, in the presence of the effects of external fields. Both convergence and purity vary from tube to tube. These effects have led to the use of relatively elaborate devices external to the tube to deflect the three beams, in addition to the normal sweeps. These complexities add to the material cost of the receivers, and may add as

many as 25 adjustments in a typical shadow-mask receiver. These adjustments require judgment since they must be made by inspection of the effects of the adjustments on the picture; also, they are interrelated and they must be repeated whenever the physical position of the receiver is changed.

The use of three guns also imposes the requirement that the characteristics of the three guns be matched or compensated so as to produce good white balance at all brightnesses. Cathode-ray-tube guns cannot easily be built with inherently matched characteristics, so circuit adjustments must be used. This adds four more critical adjustments which must be made while watching the tube face and which require judgment.

In connection with circuit complexity there is the requirement for color demodulators and separate channels for the three primary colors. The shadow-mask type of three-gun tube has the further inherent disadvantage of inefficient use of high-voltage power, resulting in extra expense and complexity in the regulated high-voltage supply.

The various types of three-gun tube are relatively complex in themselves, both because of the three guns and because of the other internal structures (shadow masks or grilles) required to direct the beams to the proper colored phosphors. None of these complexities exists in the single-gun index type display.

The Lawrence tube has none of the complexities just discussed as applying to the three-gun displays, except the complexity of the tube itself and one aspect of the color purity problem. It has, however, two types of problem which are unique, and are inherent in its method of operation. One is the need for a high-power, synchronized switching signal. The provision of this signal causes extra circuit complexity and expense, and requires elaborate shielding to reduce radiation. The other is the need for special signal processing to ob-

tain good colorimetry from a tube which deflects the beam sinusoidally over the color stripes. These complexities are largely in the field of circuitry. The Lawrence-tube adjustment procedures seem to be reasonably simple.

Index type displays, such as the present Apple system, have their own unique and inherent problems. One of the most important of these is the generation and amplification of the index signal. The means of generating the signal is built into the tube at the expense of very little complexity. The amplification and handling of the index signal requires a moderate amount of conventional circuitry and about 30 adjustments. These adjustments represent a source of complexity only in their number. They are not interrelated; their effect is easy to evaluate since they are simple maximizing or minimizing operations that are made while reading meters; they require no unusual test equipment; and once set up, they are stable for long periods of time.

The present Apple system requires accurate control of horizontal linearity and width. This represents a complexity only in circuitry. There are no elaborate devices nor adjustment procedures involved.

Another requirement of index-type displays is small spot size. This requirement is met partly by care in tube design, which does not in itself result in tube expense nor complexity, partly by some extra complexity in the yoke and focuser, and partly by the use of a high, regulated anode voltage. The latter two

requirements make the high-voltage supply almost as elaborate as that for shadow-mask tubes. The yoke and focuser alignment procedures required for good spot size are much simpler than those required in shadow-mask displays for convergence and purity, and are comparable to those used in good black and white practice.

The only other unique and inherent requirement of the present type of Apple display is that of beam tracking. It is met partly by characteristics built into the tube at no extra expense and partly by observing the same precautions in yoke and focuser alignment as are required for small spot size.

In weighing these considerations, one reaches the conclusion that any color set is substantially more complex than a black-and-white set. By comparing the various types and severities of the complications of the different displays, one further finds reason to believe that the beam-indexing system is considerably less complex than other systems of comparable performance.

ACKNOWLEDGMENT

Obviously, this development was not the work of a small number of individuals. A great many engineers have made significant contributions. In particular, the authors wish to acknowledge the contributions of William E. Bradley, David Brunner, Monte I. Burgett, Charles Comeau, Richard K. Gardner, Richard Gudis, Lincoln Hershinger, Carl Mutschler, Charles Simmons, and David E. Sunstein.



USING A TYPE F-3 MOTOR GENERATOR ON 50 CYCLES

by T/Sgt. Val Fish, Jr.

The problem of adapting 60-cycle equipment for operation from a 50-cycle power source is quite common and difficult to overcome. This article illustrates a method of overcoming the problem with a particular motor-generator.

MANY SHOP SUPERVISORS have been faced with the problem of using a type F-3 motor-generator to provide 115 volts, 400 cycles for aircraft-equipment testing in an area where 50-cycle base power is the only power available. This problem can be solved by a simple modification requiring approximately 30 man-hours and the manufacturing of a few parts.

The type F-3 motor-generator consists of a 6200-volt-ampere, 220-volt, 3-phase, 60-cycle induction motor driving a generator rotating at a speed of 3600 r.p.m. When used with the correct 60-cycle frequency, its output is 115 volts, 400 cycles. Operation on 50 cycles causes the unit to run at a slower speed, thus producing a lower frequency. This lower frequency is usually below the frequency limits specified in technical orders for most aircraft electronic equipment designed for 400-cycle operation. Operation at the lower frequency will cause transformers to overheat and will also cause increased power-supply ripple voltage. For most equipments, these effects render operation unsatisfactory.

It is possible to increase the output frequency of the F-3 motor-generator in either of two ways. The generator may be rebuilt with a different number of poles, or the speed may be increased. It was decided that the latter was more practicable. This shop has had experience with two different models of F-3 motor-generators, and it is probable that more than this number are in use throughout the Air Force. Of the two used at this

shop, one is manufactured by the Master Electric Co., and the other by the Continental Electric Co., Inc. The Continental generator supports the motor and generator armature windings on the same shaft. In order to increase the generator speed, the shaft must be driven by an external power source. Examination revealed that the shaft could be drilled and tapped for a "screw-in" shaft extension at the motor end, and that the bearing hole in the end bell could be enlarged to permit installation of the shaft with a pulley mounted to it. With the proper pulley ratio, this pulley could then be driven at the correct speed by an external electric motor or another type F-3 motor-generator.

A shaft extension was built and construction was started on the pulleys for the system, which was to be put in operation upon the arrival of another type F-3 motor-generator for driving power. Arrival of the type F-3 motor-generator, however, necessitated a change of plans. The second generator was a Master Electric Co. model. This model employs separate motor and generator units, coupled directly through a finger coupler. The motor and generator are bolted on a cast frame mounting. Located between the motor and generator, and bolted to the coupling device, is a blower assembly for cooling the generator. It was decided that this motor-generator unit could be modified for use on 50-cycle power without the necessity of external equipment. By separating the motor from the generator and con-

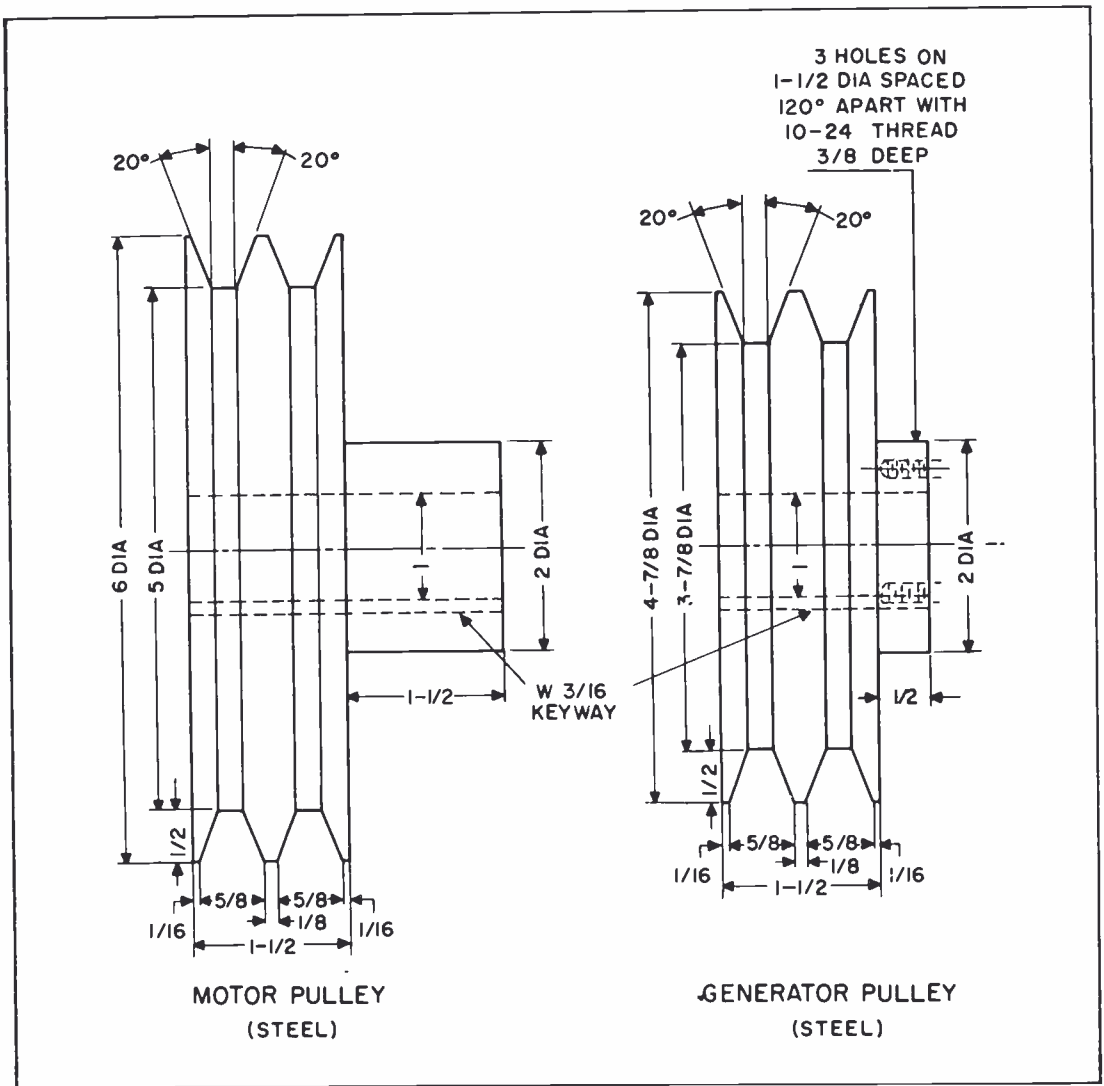

Figure 1. Pulleys Used for Generator Speed Change

necting them together through pulleys of proper ratio, the generator speed may be increased to produce 400-cycle output.

Pulleys were designed from references given in the 14th Edition of the *Machinery's Handbook* to couple 10 horsepower at 3600 r.p.m. using two "V" belts. These pulleys were made of standard rod stock material and are shown in figure 1. Mountings were built from 2-inch angle iron, as shown in figure 2. A fan to replace the blower was made of ST aluminum, cut as shown in figure 3.

The modification is accomplished by the following procedure:

1. Remove motor from mounting.
2. Remove blower assembly and couplings from shafts.

3. Install pulleys and fan blade.
4. Install motor mounting brackets and braces.
5. Install extension cable from motor to control box.
6. Install "V" belts.

The modified motor-generator is shown in figure 4.

The generator output frequency with no load is 415 cycles. When fully loaded at 55 amperes, the generator output frequency is 400 cycles. The generator is cool to the touch with a continuous output of 30 amperes. Although continuous full output has not been tested, short operating periods at an output of 55 amperes indicate satisfactory performance.

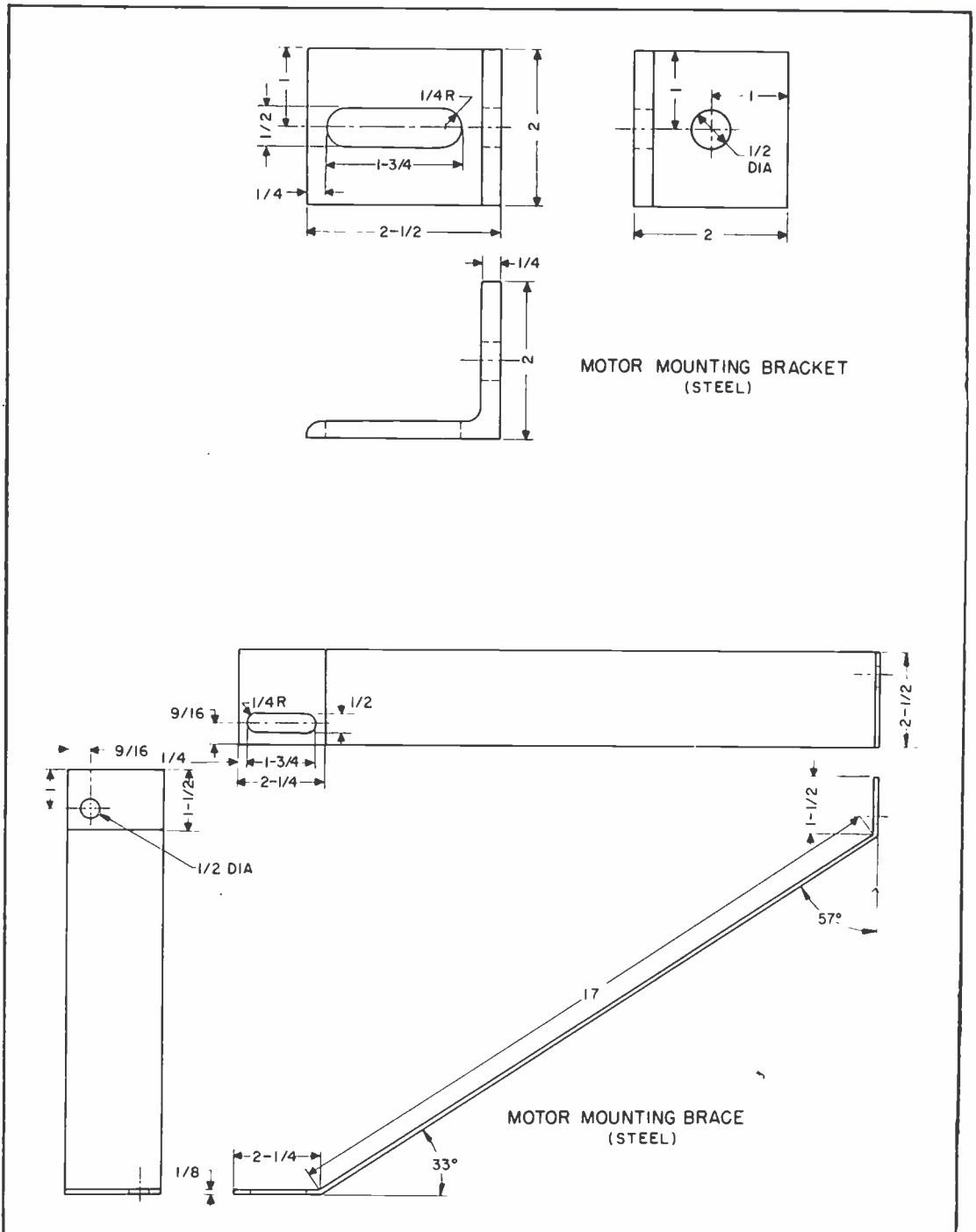

Figure 2. Bracket and Brace Required for Remounting the Motor

The unit described operates in an enclosed box to reduce noise. Although the noise is not excessive, the box makes nearby operation more pleasant. For convenient remote control, the control box is located outside the enclosure. A fan blows air through a filtered inlet, from where it circulates through the en-

closure for cooling. The unit has been meeting the power requirements of the Field Maintenance Electronics Shop for 3 months and has proved entirely satisfactory.

Since the motor-generator parts do not have to be changed, the unit may be converted back to the original design at any time.

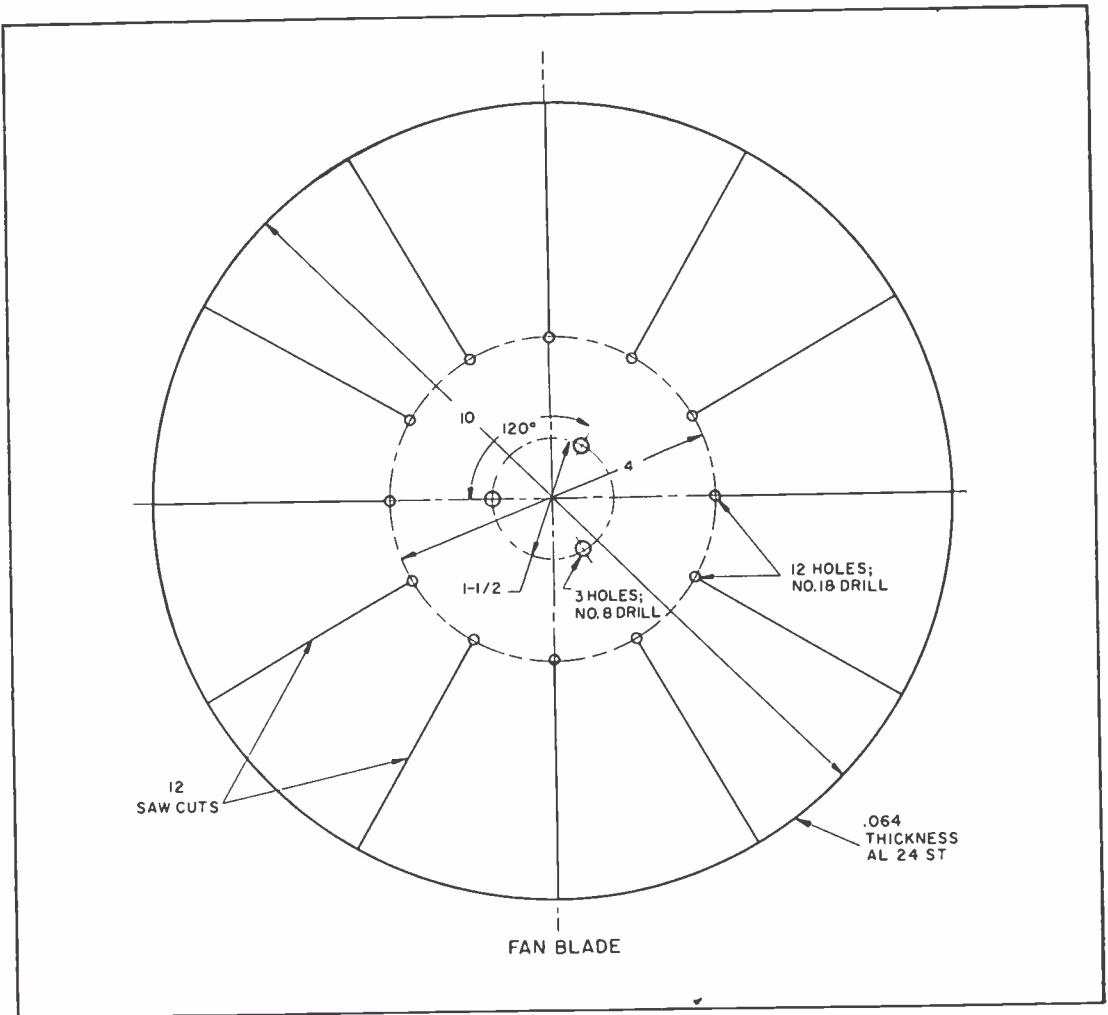

Figure 3. Fan Blade Required for Cooling When Motor Is Remounted

MATERIALS REQUIRED TO MODIFY MASTER MODEL TYPE F-3 MOTOR-GENERATOR

Manufactured Parts

- 1—generator pulley; made from 5" dia. x 2" steel rod
- 1—motor pulley; made from 6" dia. x 3" steel rod
- 2—motor mounting braces; made from 2.5" x 21" x 0.125" flat steel
- 2—motor mounting brackets; made from 2.5" x 2.5" x 0.26" steel angle
- 1—fan blade; made from 10" dia. x 0.064" aluminum (24 ST)

AF Supply Parts

- 4—2" x 1/2" x 20 bolts
- 2—1 1/2" x 1/2" x 20 bolts
- 14—1/2" flat washers
- 8—1/2" lock washers

- 15 feet No. 10 wire
- 2—52" Thermoid 5L520 "V" belts
- 48 inches 2" vinyl tubing

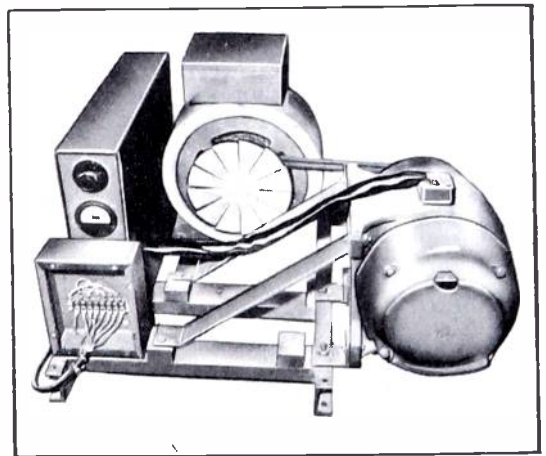

Figure 4. Completed Modification of F-3 Motor-Generator Unit

DELTA-TO-WYE AND WYE-TO-DELTA TRANSFORMATION

THE DELTA-TO-WYE TRANSFORMATION and its inverse, the wye-to-delta transformation, form a very useful tool of electronics which is often neglected. Their use can simplify the solution of certain problems to a great extent when the use of Kirchhoff's laws proves to be cumbersome and unwieldy.

The delta-to-wye and wye-to-delta transformations merely give values for components of equivalent networks, and are derived from a consideration of equivalent impedances between terminals and solution of three simultaneous equations. Figure 1 shows equivalent delta- and wye-connected networks.

For the delta-to-wye conversion, the equivalent impedances are given by:

$$R_a = \frac{R_1 R_2}{R_1 + R_2 + R_3}$$

$$R_b = \frac{R_1 R_3}{R_1 + R_2 + R_3}$$

$$R_c = \frac{R_2 R_3}{R_1 + R_2 + R_3}$$

while for its inverse, the wye-to-delta conversion, the equivalent impedances are given by:

$$R_1 = \frac{R_a R_b + R_b R_c + R_c R_a}{R_c}$$

$$R_2 = \frac{R_a R_b + R_b R_c + R_c R_a}{R_b}$$

$$R_3 = \frac{R_a R_b + R_b R_c + R_c R_a}{R_a}$$

It will be noticed that the symbol R has been used for each of the components, indicating that the impedances are actually resistors. This is, of course, not always the case in practical circuits. Whenever reactive components appear in combination with, or in place of, pure resistance the R should be replaced by Z, where $Z = R + j(X_L - X_C)$.

Let us see how these transformations can be used in resolving a complex situation. The famous problem of the total resistance of the resistor cube circuit (used as a "What's Your Answer?" problem in the October 1951 issue of

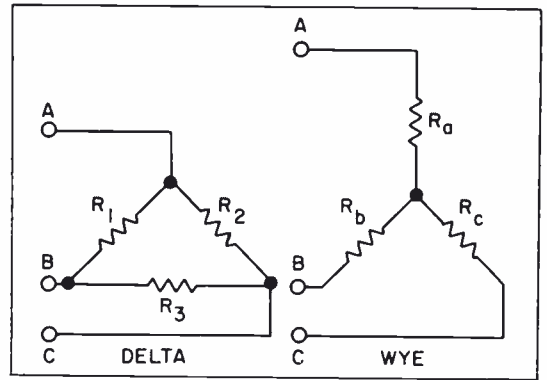

Figure 1. Equivalent Delta- and Wye-Connected Networks

the BULLETIN) shown in figure 2 is an example. If these resistors are all made equal, there is a simple method of solution; but with any other conditions a different method must be used. If Kirchhoff's laws are applied, the equations (12 of them) become unwieldy unless you are familiar with the branch of higher mathematics known as matrix algebra. Even with this method, a slip in arithmetic is very easy. However, as can be seen by working the problem, a few simple transformations can greatly simplify the circuit. In all, a total of seven transformations are made, of

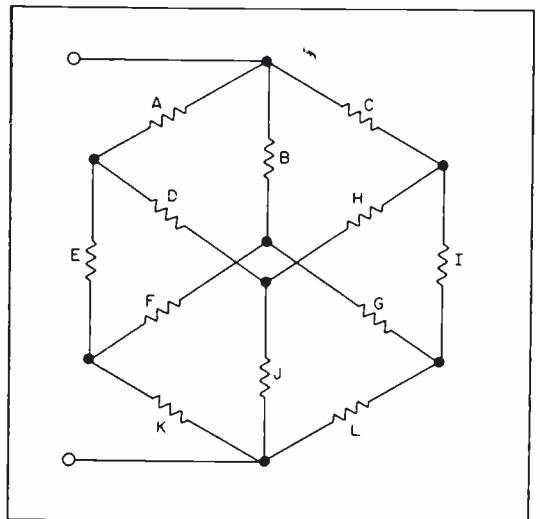

Figure 2. Resistor Cube Circuit

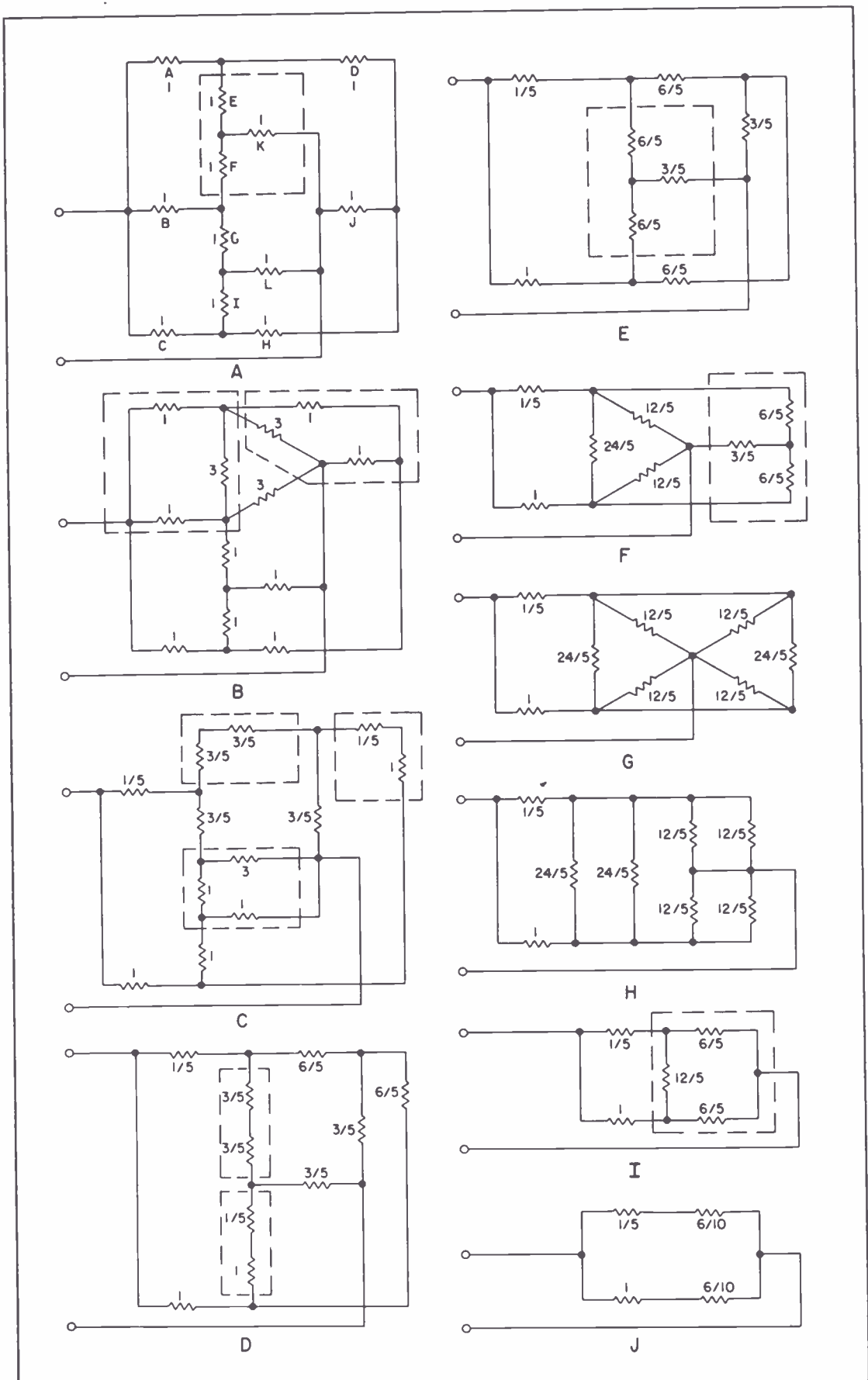

Figure 3. Step-By-Step Solution of the Resistor Cube Circuit

which three are wye-to-delta transformations and four are delta-to-wye transformations.

For simplicity in illustrating how to use the transformations on the circuit in figure 2, assume that every resistance value is 1 ohm. The first step in the solution is shown in part A of figure 3. Here the circuit is redrawn, and the wye circuit consisting of resistors E, F, and K is selected for the first wye-to-delta transformation. In part B of figure 3 this transformation has been accomplished, and the delta circuit and the new resistance values have been substituted; also, two delta-to-wye circuits are shown enclosed by dashed lines. The transformation of these produces the circuit shown in part C. Here the two indicated $3/5$ -ohm resistors are combined into one $6/5$ -ohm resistor (in part D), and the $1/5$ - and 1-ohm resistors are also combined. The indicated delta circuit of part C is transformed into a wye, as shown in part D. In each of the two-resistor combinations indicated in part D, the resistors are combined to provide the circuit shown in part E. The circuit transformations indicated in parts E and

F are performed to produce the circuit in part G. This in turn is redrawn to form the circuit shown in part H, which, when simplified, becomes the circuit shown in part I. After the delta-to-wye transformation indicated in part I is performed, the circuit resolves to that shown in part J. This circuit, when simplified, resolves down to one resistor having a value of $5/6$ of an ohm for the example chosen.

It may be argued that, because of the symmetry of this network, a much simpler solution is immediately available. This is undoubtedly true in the particular case given, but imagine what would happen if, instead of the unusual symmetry, the values of resistance were all different, or impedances were used in place of resistors. The situation would be quite different, and application of Kirchhoff's laws, while giving a correct solution, would be extremely cumbersome.

In conclusion, the transformations do not provide a "cure-all" method for all problems, but in the solution of many complex problems they do make possible an extremely useful short cut.

Harvey W. Mertz

**The TechRep Division of the Philco Corporation
wishes you and yours a very**

Merry Christmas

and a

Happy New Year

PASSIVE REFLECTORS AS NAVIGATIONAL AID

by William Baughman
Philco TechRep Field Engineer

This article describes the construction of a modified type of radar corner reflector and its use in radar navigation where other aids are not available or where existing aids are obscured by clutter at short ranges.

GENERAL

RADAR TECHNICIANS and operators are all familiar with the basic electronic principles of the detection of targets by radar and the characteristic returns, or echos, received from different types of targets such as mountains, cities, coastlines, ships, and so on. The pattern and intensity of an echo primarily depend on the size, shape, and material of the reflecting surface. Another fact, and one which is not well known, is that a relatively small device may be constructed to give a deceptively large return for its size. These devices are known as radar reflectors, and since, unlike the familiar radar beacons, the reflectors contribute no power or signal of their own, they should more properly be called passive radar reflectors.

The theory of operation of the passive reflector is derived from the principle of constructive interference. This type of interference occurs when all of the transmitted energy striking the reflector is reflected back towards the radar antenna at the same time and, more important, in the same phase. The received signal strength, therefore, is the sum of all of the reflections, in distinct contrast to the reflections from a random surface. This fact does not by any means imply that the returning echo signal strength may be greater than the transmitted signal strength. This is manifestly impossible under the physical conditions of operation, since the air itself produces scattering and attenuation. However, the return from a properly designed re-

flector is strikingly intense as compared to the returns from normal targets of like size.

To obtain the greatest effect, a passive reflector must be carefully constructed of metal or metal-covered surfaces, and these surfaces must be free from corrugations, pits, dents, or other irregularities. Any metal is suitable, but since paints and other finishes tend to absorb energy at radar frequencies, it is desirable to use a noncorroding metal such as aluminum or copper. Aircraft aluminum, for example, is an excellent material.

USE IN NAVIGATION

One of the first navigational aids in which the corner reflector was a component of the equipment was GCA, the blind landing system by which the position of an aircraft is exactly calculated during the landing procedure by a ground station and compared with a series of known reference points. The operators at the ground station are then able to talk the aircraft down by giving instructions to the pilot over normal communications channels. The reference points upon which the system depends are provided by passive reflectors located at known positions with respect to the radar antenna.

This use of the passive reflector, while it is certainly important and valuable, is not by any means the only navigational use. Since the return from a properly designed and oriented reflector will appear on the indicator of an airborne

radar, the reflector can be used for precision navigation if the reflector ground position is accurately known. A single reflector, or a number of reflectors grouped in a distinctive pattern, may be used for marking a reporting point along a flight path, a special terrain feature such as a peak, small island, or a rock on a seaplane landing strip, a drop zone for supplies at isolated locations, or a site of rescue operations. In connection with this last use, it should be mentioned that a folding reflector has proved valuable enough to be included in the kit of lifeboats and rafts either on shipboard or transoceanic aircraft. Reflectors are also included in life rafts on all naval aircraft.

In larger numbers, reflectors may be used either singly or in groups to outline a runway or seaplane landing strip, for a locating device to permit an aircraft to be lined up properly for the final approach leg of a landing, or for checking both compass and radar for accuracy. The use of reflectors to outline a runway and provide a means for aligning an aircraft properly on the final approach of a landing is of particular interest, since it would, in case of necessity, provide a highly simplified and reasonably accurate blind landing system. It would only be necessary to calculate in advance the proper altitude of the aircraft as it passed over each reflector. Since it is somewhat difficult to tell exactly when the reflector is directly below an aircraft, this would probably be modified to the altitude as each reflector in turn passes a given range. This system would not, of course, be as accurate as GCA, but could with practice provide reasonable accuracy at locations where GCA or another blind landing system is not available.

PHYSICAL APPEARANCE

There are three general forms of passive reflectors in common use at the present time. The earliest type, and still in use with GCA units, is the triangular corner reflector. It consists of three

metallic triangles which are mutually perpendicular, and is most suitable for X and S band frequencies where the application demands a minimum of weight and expense together with fairly omnidirectional characteristics.

The second type, known as the circular corner reflector, consists of three mutually perpendicular quadrants of a circle. It is more highly directional than the triangular type, but affords approximately four times as much gain. The greater difficulty in holding it rigid is also a disadvantage, since any slight deformation results in a large loss of effectiveness.

The third type, which was used in the experimental work, is the square corner reflector. It gives the highest gain, but is also the most highly directional. The pattern is approximately 40 degrees wide at the half-power points, while the gain is approximately nine times that of the triangular type. It is, of course, the most difficult of the three types to hold rigid, and the directivity necessitates the use of several reflectors in a cluster to achieve omnidirectional characteristics. In some applications, however, these disadvantages are more than offset by the advantage of increased range of reception. A reflector of this type should be clearly visible at ranges up to 50 miles from high altitudes.

SQUARE CORNER REFLECTOR CONSTRUCTION

The size of a reflector is extremely important, since it can be shown that the gain is a fourth power function of the length of an edge. Gain is here expressed in terms of the equivalent number of square feet of a flat target. It might be assumed from this that the larger the reflector, the greater the return. However, practical considerations provide limitations. For example, it is difficult to maintain rigidity and symmetry of a reflector if the edge length is greater than 2 or 3 feet, and the increase in brightness of the PPI scope return does not increase perceptibly

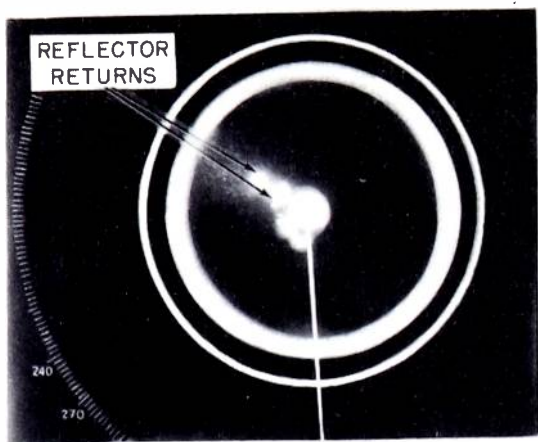

Figure 1. Radar Scope Photo Illustrating Effect of Two Passive Reflectors

after a near saturation value of signal strength is reached. Instead, the return tends to "bloom," as shown in figure 1. Note how prominent the reflector returns are in figure 1.

It is absolutely essential that the accuracy of construction be extremely high. The reflector surfaces must be perpendicular within a maximum tolerance of 1 degree. The edge lengths must be equal to within one tenth of an inch or

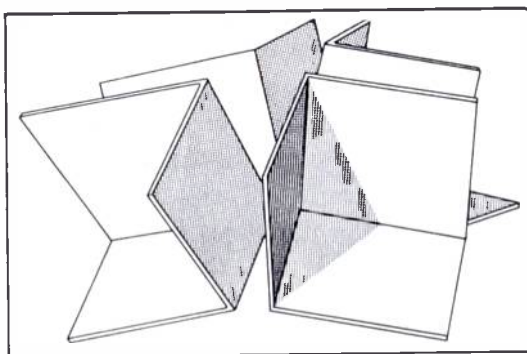

Figure 2. Top and Side Views of a Cluster of Four Square Corner Reflectors

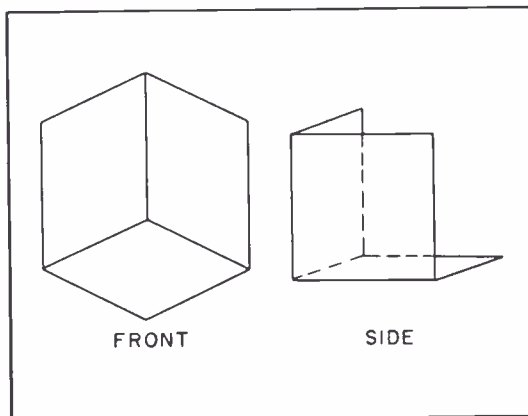

Figure 3. Front and Side Views of a Single Corner Reflector

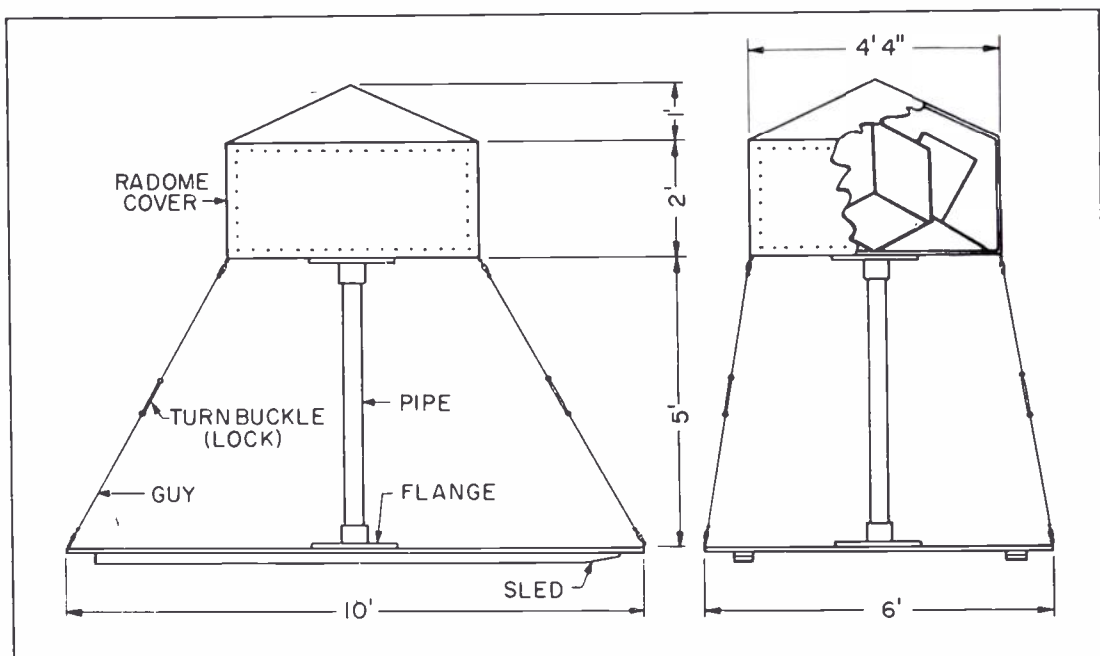

Figure 4. Construction of Mounting for Cluster of Four Reflectors

less. Any slight deformation caused by a force fit can result very quickly in loss of up to 90 percent of the return.

The optimum angle of presentation to the aircraft (the deviation from horizontal) has been found to be about 3 degrees. However, this value is not critical. A cluster of four reflectors is shown in figure 2, illustrating the angle of presentation. Its height above ground is not important, except that if possible, it should be higher than nearby objects which provide clutter.

This reflector gives a good return from any direction, with maximum return in four 40-degree sectors. Two such reflector groups installed at adjacent locations with a 45-degree difference in orientation will provide improved omnidirectional characteristics. Figure 3 shows the construction of a single reflector. It is constructed of No.

8 gauge aircraft aluminum, and is assembled by placing Duralumin angle strips behind the edges and riveting with flush rivets. To provide the greatest amount of independence from weather conditions, it is desirable to construct a "radome" shield. While a covering of aircraft radome material would be most desirable, double-weight canvas has proven satisfactory. Figure 4 shows a possible mounting arrangement and cover; other mounting arrangements and covers may be used, depending on local conditions.

Several of the corner reflectors described have been used under arctic conditions for a considerable time, and have proven extremely valuable in that area as permanent reference points which can be relied upon to produce good results both for navigation and landing.



NEW ANTENNA MANUAL

The PHILCO TRAINING MANUAL ON ANTENNAS (Antenna Series, Volume I), which formerly was designated as AN-150B, has been replaced by a revised and greatly enlarged new edition, designated as AN-374. The new manual incorporates all of the information that was contained in the AN-150B and, in addition, includes a great deal of new material resulting from advances made in recent years. There is a complete new section on scatter propagation, and the section entitled "Types of Antennas" has been enlarged to include many more types, such as discones, helix corner reflectors, VOR antennas, and microwave electronic lenses. Also, sections have been added to cover radio astronomy and conical scanning. Altogether, a total of approximately 40 pages and 35 new drawings have been added to bring the manual up to date. The new manual may be ordered under the designation AN-374 by writing to:

PHILCO TECHNICAL PUBLICATIONS DEPARTMENT
18th and Courtland Streets
Philadelphia 40, Pa.

SERVICING TRANSISTOR CIRCUITS

by Carl Tillman

Technical Publications Department

(Editor's Note: This article was written by the author in conjunction with the Electronics Education Unit of the Philco Service Division and originally appeared in the September, 1956 issue of the Philco Service Supervisor.)

INTRODUCTION

RECENT DEVELOPMENTS in transistor circuitry have raised many questions concerning proper servicing procedures. Although most of the trouble-shooting and repair procedures that have been used with other types of electronic equipment may be applied, some special precautions should be taken when servicing transistor circuits. This article will describe some of these new techniques, using the Philco Model T-7 Transistor Portable Radio as an example of a typical transistor set.

TEST EQUIPMENT AND TOOLS

Most good-quality test equipment which has been used for vacuum tube circuit trouble-shooting may also be used for transistor circuits. Before employing any equipment it should first be determined that the equipment meets the requirements given in the paragraphs below.

Signal generators, both r-f and audio, may be used if the power supply in these equipments is isolated from the power line through a transformer. Line-connected (transformerless) power supply type signal generators cannot be used unless an external isolation transformer is used. If a line-connected signal generator is connected to transistor equipment, the transistors may be damaged by line current passing through the equipment under test. On signal generators which have transformers in their power supplies, damage can still be done to the transistor by the a-c voltages impressed on the signal generator chassis by the line filter capacitors (see figure 1). These capacitors form a voltage divider as shown by the voltages in the diagram. If the transistor set were grounded to earth and the signal generator were connected to the transistor

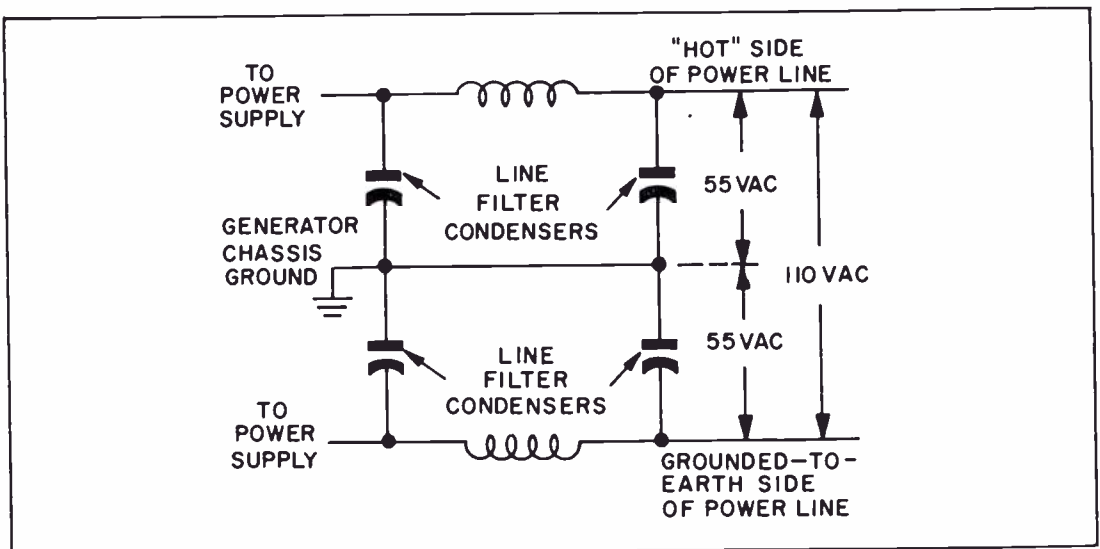

Figure 1. Line Filter Capacitors in Test Equipment as Possible Source of Transistor Damage

circuit, the 55 volts, a.c. would be impressed across the transistors, and thus damage the transistors. To avoid such damage, a common ground wire should be connected from the transistor set chassis to the chassis of the signal generator before any other connections are made.

Signal tracers may be used with transistor circuits if the precautions concerning the power supplies in signal generators are observed. Many signal tracers use transformerless power supplies, and should, therefore, be isolated by an isolation transformer if they are to be used for signal tracing in transistor circuits.

Multimeters should have a sensitivity of 5000-ohms-per-volt or better on all voltage ranges, when used for voltage measurements in transistor circuits. Meters with a lower sensitivity will draw too much current from the circuits under test, when used on their low-voltage ranges. The sensitivity of some multimeters differs on d-c and a-c ranges (for example 20,000 ohms-per-volt on d.c., and 10,000 ohms-per-volt on a.c.). It is important that no meter range lower than 5000-ohms-per-volt be used. A 20,000 ohms-per-volt meter or a vacuum-tube voltmeter is 11 megohms or higher on all voltage ranges; therefore, they draw very little current from the circuit under test. If a vacuum-tube voltmeter is used, all the precautions concerning power supplies, as given for signal generators, must be observed.

Ohmmeter circuits which pass a current of more than 1 milliampere through the circuit under test cannot be used safely in testing transistor circuits. Many vacuum-tube voltmeters with ohmmeter circuits exceed this safe value of 1 milliampere by an excessive amount. High-sensitivity multimeters are often shunted down on ohmmeter ranges, so that they too pass a current of more than 1 milliampere through the circuit under test. Before any ohmmeter is used on a transistor circuit, the current it passes through the circuit under test should be

checked on all ranges. Do not use any range which passes more than 1 milliampere. To check the current, adjust the ohmmeter for resistance measurements, then connect a milliammeter in series with the test leads, as if measuring its resistance, and observe the indication on the milliammeter (see figure 2). The milliammeter used should have a low resistance.

Battery eliminators should never be used with transistor circuits. Because of the low current drain of transistor circuits, the voltage regulation of battery eliminators is poor. Effective testing of the circuits cannot be accomplished with poor voltage regulation; therefore, the proper batteries as specified for the set, should always be used for the d-c supply. Use fresh batteries and always observe polarity when connecting batteries. Polarity reversal may cause damage to the transistors.

Soldering guns or irons of the heavy duty type should never be used when performing soldering operations on transistor circuits. The high heat level in the tips of these irons may be high enough to damage transistors. Only a

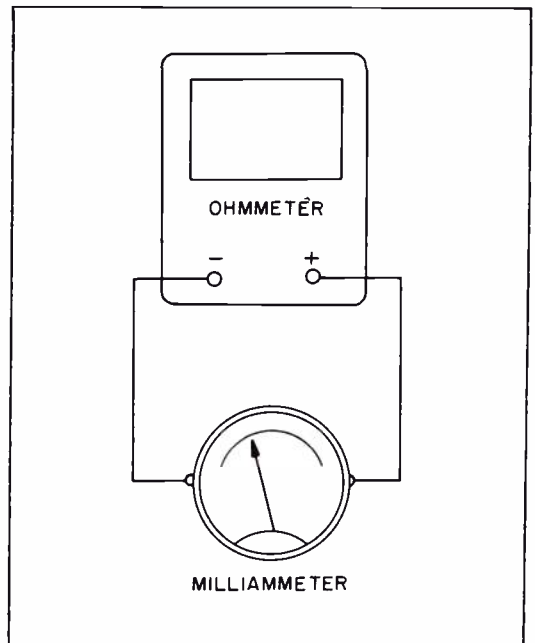

Figure 2. Method of Checking Ohmmeter To Be Sure That Current Passed Will Not Exceed 1 Milliampere

light-duty, 20- to 25-watt soldering iron should be used, and a careful check made to make certain that there is no leakage current in the iron. To check the soldering iron for leakage, connect one lead of an a-c voltmeter to ground (water pipe or power line ground) and the other lead of the voltmeter to the tip of the soldering iron. Plug the iron into the a-c line and wait for the iron to heat up. Reverse the a-c plug when the iron is heated. If any indication is obtained on the voltmeter, the soldering iron has leakage. If there is any doubt about leakage in the soldering iron, operate it through an isolation transformer. If an isolation transformer is not available, bring the iron to soldering temperature, remove the plug from the a-c outlet, and perform the soldering operation. When the iron cools, reheat it by replacing the plug, but do not perform any soldering while the iron is connected to the line. If a small-tipped iron of low wattage is not available, a piece of No. 10 copper wire wrapped around the tip of a large iron and allowed to extend beyond the tip may be used for soldering operations. This is illustrated in figure 3.

The use of an isolation transformer is a good precaution to follow with all test equipment that is operated from the a-c power line unless it has been definitely determined that the equipment contains a transformer in its power supply. With all test equipment, whether transformer-operated or not, a common ground lead should always be connected from the chassis of the set under test to the test equipment. A ground lead connected from the tip of the soldering iron to the chassis during soldering operations will prevent damage to transistors due to leakage current in the soldering iron.

TROUBLE-SHOOTING (GENERAL)

The first step in trouble-shooting transistor circuits is a visual inspection of the entire receiver. Loose connections, broken leads, corroded battery terminals, and any other visible damage should first

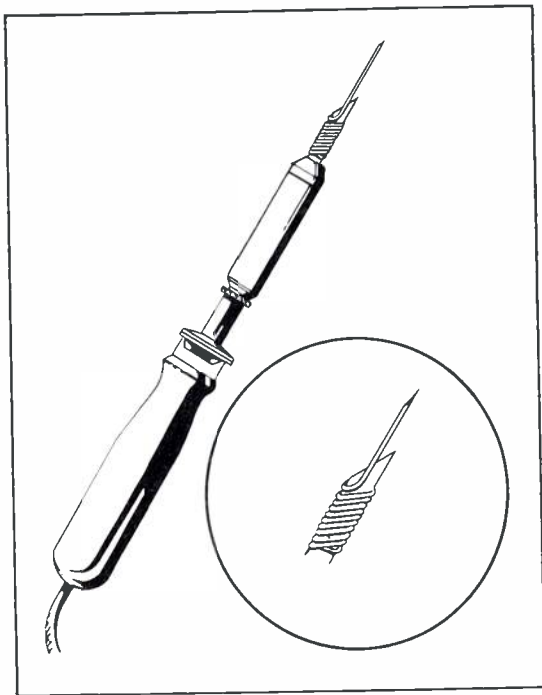

Figure 3. A Method of Using a High-Wattage Soldering Iron for Transistor Maintenance

be repaired before proceeding to the next steps of the trouble-shooting procedure. A careful visual inspection of the equipment will save many hours of trouble-shooting.

After any visible defects have been corrected, the batteries should be tested or replaced with batteries known to be good. Although transistor sets will often operate with batteries that are so run-down that they would not operate a vacuum-tube set, it is of course good practice to start with good batteries and thereby eliminate any possible trouble from this source.

When the visible defects have been corrected and good batteries installed, conventional isolation of the faulty stage can be accomplished by either the signal-substitution method or the signal-tracing method. When connecting any test equipment to the transistor set, always connect a common ground lead between the test equipment and the chassis ground before making any other connections. If the signal-tracing method is used, conventional stage-by-stage tracing of the signal from antenna to speaker should be followed. If signal substitution

is to be used, conventional substitution methods should be used starting with signal injection at the output stage and working towards the antenna.

After the faulty stage has been isolated, voltage and resistance measurements are made within the stage to locate the defective component. When making measurements, always observe the precautions for multimeters and ohmmeters as given in the paragraphs on test equipment. Failure to observe these precautions will result in damage to the transistors. If the transistors are not soldered into the circuit, they may be removed from their sockets while making ohmmeter tests. Never remove or replace a transistor while the batteries are connected to the set; before removing or replacing a transistor, either turn off the set by means of the "on-off" switch, or remove the batteries. Failure to observe this precaution may cause damage to the transistors due to surge currents. Once the defective component has been located, its replacement follows conventional procedures.

If the transistor itself is suspected, it may be removed from the receiver for testing. In sets employing sockets for the transistors, it is merely necessary to remove the transistor from the socket. If the transistor is soldered into the set, it is necessary to remove the transistor by unsoldering it. In this case extreme care must be used to prevent damage to the transistor from the heat of the soldering iron. Figure 4 shows a method of unsoldering a transistor that will prevent heat from being conducted to the transistor. The relatively large jaws of the pliers carry away the heat while the solder on the transistor lead is being melted by the iron. The soldering iron should be held on the solder joint just long enough to melt the solder, and it is especially important that no part of the transistor, other than the solder joint, be touched with the soldering iron.

After removal of the transistor from

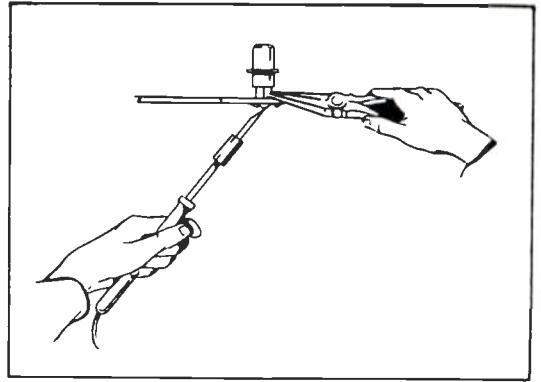

Figure 4. Method of Unsoldering Transistor from Circuit

the set, it may be tested in any transistor tester. The tester should be used as directed in the instructions supplied with it. If a tester is not available, the transistor may be tested for leakage and shorts with an ohmmeter. It is important that the ohmmeter pass not more than 1 ma. through the circuit under test as explained previously. Connect the ohmmeter leads to the transistor as shown in figure 5. With the positive ohmmeter lead connected to the base of a PNP transistor, a high-resistance reading (50,000 ohms or higher) should be obtained between base and emitter, and between base and collector. With the negative ohmmeter lead connected to the base of a PNP transistor, the resistance between base and collector and between base and emitter should be 500 ohms or less. If the same ohmmeter tests are made on an NPN transistor, the high-resistance readings will be obtained with the negative ohmmeter lead connected to the base, and the low readings with the positive ohmmeter lead connected to the base. If the correct resistance readings are not obtained from the ohmmeter test, the transistor should be replaced.

Before replacing a transistor in any circuit, it should first be determined that no short circuit or other defect which affects the voltages at the transistor terminals is present. A short circuit which affects the bias voltage on the transistor can cause the destruction of the transistor

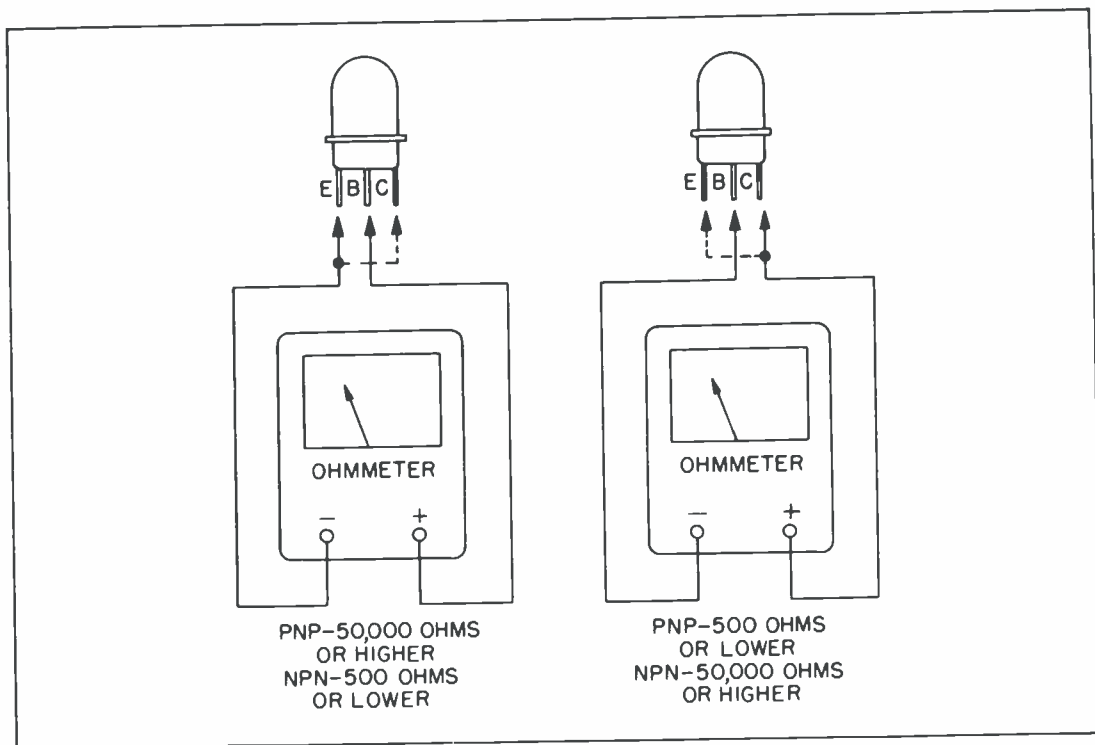

Figure 5. Transistor Testing Procedure

in a few seconds. The transistor should not be replaced in the circuit until all troubles in the circuit have been corrected. Always make certain that the set has been turned off or the batteries disconnected before a transistor is reinserted into its socket or soldered back into the set.

Because transistors are very sensitive to improper bias voltages, the practice of trouble-shooting by shorting various points to ground and listening for a click must be avoided. This method will result in damaged transistors and will give no useful results. Short circuits of any kind are likely to damage transistors.

When working on compact portables or in closely spaced areas of any set, the conventional test prods are often the cause of accidental shorts between adjacent terminals. In vacuum-tube circuits the momentary short caused by test prods rarely causes damage, but in transistor circuits this momentary short may ruin a transistor. Extreme care must be used to avoid these shorts. A piece of solid hookup wire, with the insulation pushed back so as to leave a bare piece

of wire between $\frac{1}{8}$ " and $\frac{1}{4}$ " long exposed at the end, used in place of a test prod, will help to prevent accidental shorts. If preferred, conventional test prods may be covered with insulation for all but a short piece of the tip.

TROUBLE-SHOOTING THE PHILCO TRANSISTOR PORTABLE MODEL T-7

A schematic diagram of a typical transistor radio, Philco Model T-7, is shown in figure 6. The following trouble-shooting procedure is based upon this receiver. Reference should be made to figure 6 for the location of all test points and components, and to figure 7 for the location of components on the printed wiring panel. The wiring panel need not be removed from the chassis for trouble-shooting or replacement of most components; in fact, most tests can be made with the chassis and wiring panel left in normal position in the plastic case. For the replacement of components the standard procedures employed for other types of receivers using printed wiring circuits may be employed. The practice of clipping leads close to the component and using the leads as connection points

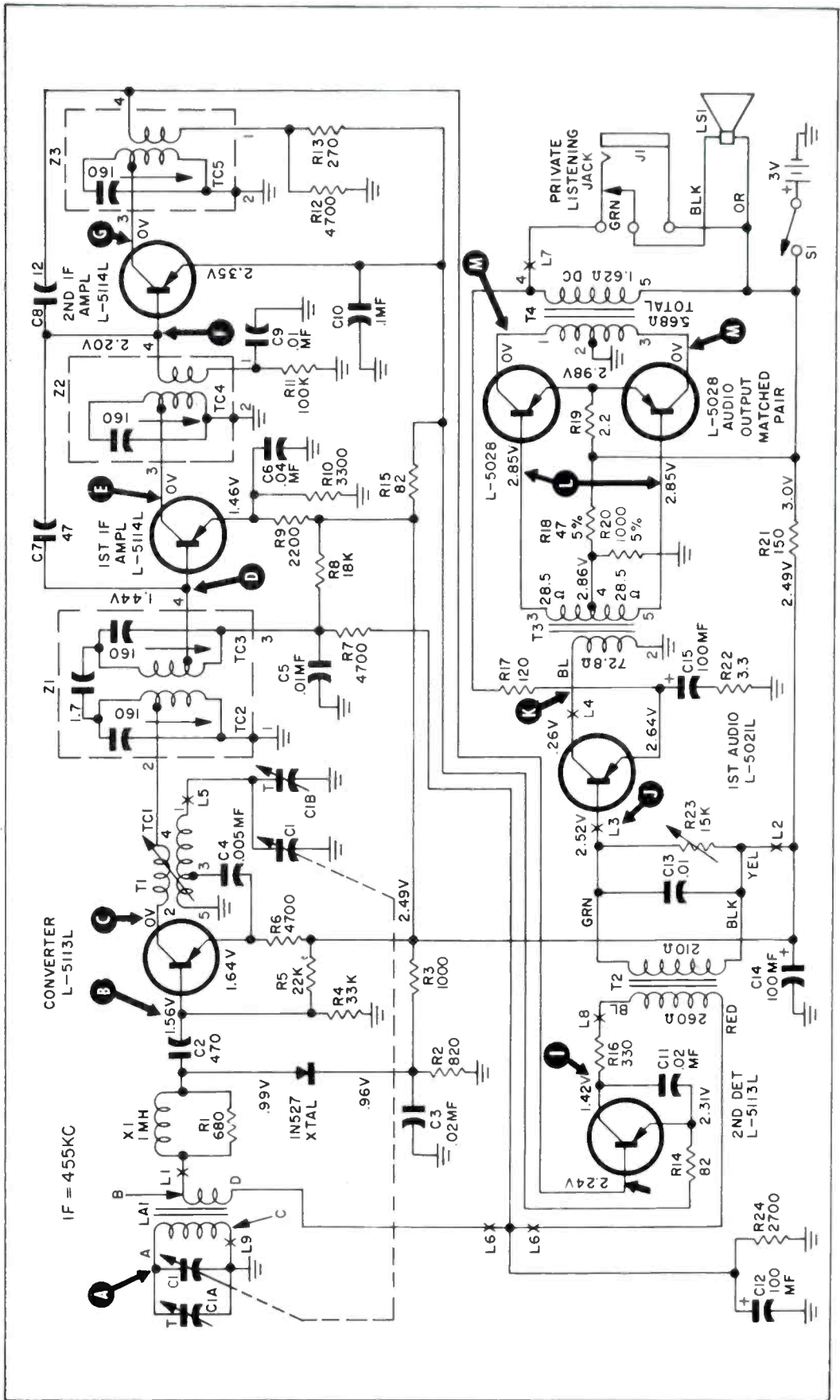

Figure 6. Schematic Diagram of Philco Model T-7 Transistor Portable Radio

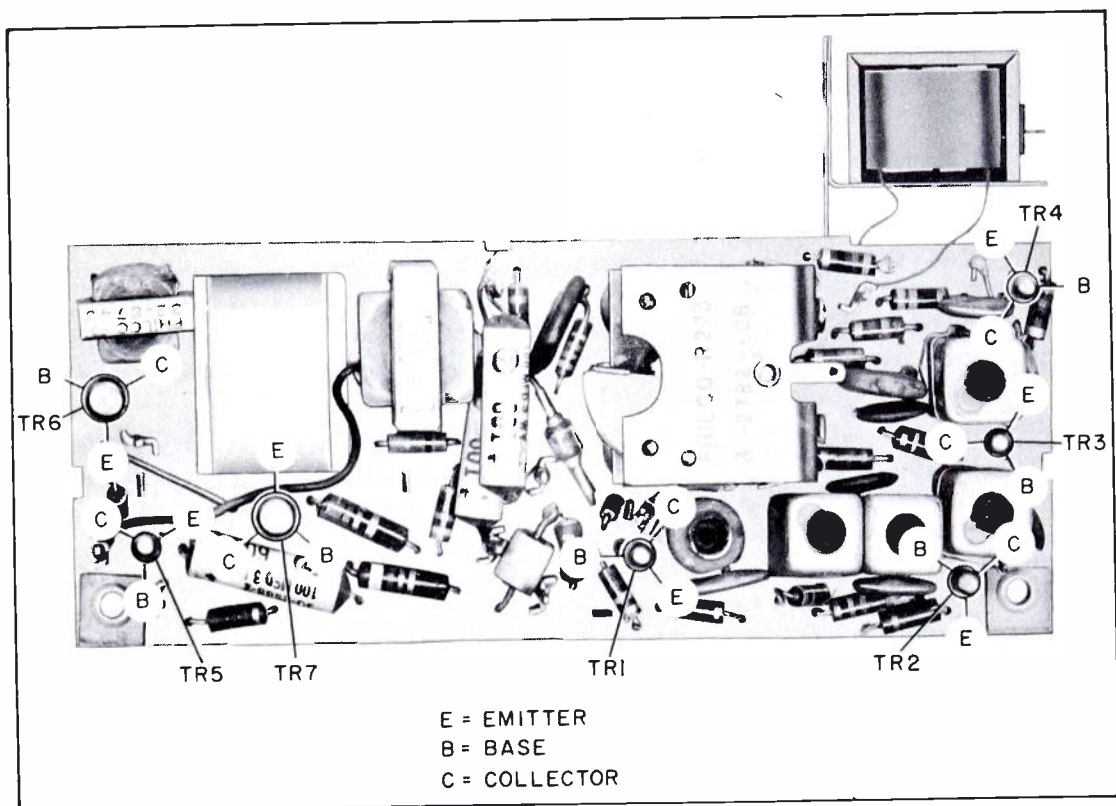

Figure 7. Printed Wiring Panel of Model T-7

is recommended for all new components with pigtail leads except the transistors. It is not advisable to clip the leads on a transistor to be replaced, and then solder the new transistor to these leads, because the metal shell of the transistor may short out one or more of the leads and thus damage the transistor. If it becomes necessary to remove a transistor, the wiring panel must be removed from the case and chassis, and the transistor unsoldered from the panel. As previously stated, figure 4 shows a method of protecting the transistor from the heat of the soldering iron.

If the signal-substitution method is to be used, connect the output of an audio oscillator from test points H, I, J, K, L, and M to ground. Apply the signal first to point M, then L, K, J, etc., working toward H. Each time the signal is moved toward the i-f section and a transistor is passed, an increase in output should be observed. For example, at either end of point M the signal passes through the output transformer to the speaker; while

at either end of point L the signal passes through TR6 and TR7 with amplification, and then through the output transformer to the speaker. The output level will of course increase as the signal is moved from M to L. A further increase in output should be observed when moving from K to J, and from I to H.

If the output should disappear or become weaker than normal as the test signal is moved forward, the defective component is located between the last point where the output was normal and the point where the output disappeared or became weaker than normal. For example, with signal applied to J the output is normal, but with signal applied to I no output is obtained; therefore, the 330-ohm resistor, the coupling transformer, the 2700-ohm resistor, or the 100- μ f. capacitor is probably faulty. Ohmmeter measurements will determine which, if any, of these components should be replaced.

If the output is normal when the audio signal is applied to test point H, the

audio section of the receiver is functioning properly. The next step is to apply a modulated 455-kc. signal to test points B, C, D, E, F, G, and H. The signal is injected at each test point, starting at H and working toward B. Again the output should increase each time the signal is moved forward past a transistor. When the output is abnormal with a signal injected at a given test point, similar reasoning to that used for the audio section may be used to locate the faulty component.

If the output is normal with an i-f signal applied to point B, the next step is the injection of an r-f signal at point B, then point A. Tune the signal generator to a frequency in the broadcast band, and tune the receiver to the same frequency. If an output is not obtained, move the dial of the signal generator above and below the frequency indicated on the receiver dial until an output is obtained. If no output is obtained with the r-f signal at point B, after the signal generator frequency has been varied to make certain the signal generator and receiver are tuned to the same frequency, but an output is obtained with an i-f signal at point B, the defective component is in the oscillator section of the converter. If an output is obtained with an r-f signal injected at point B, the signal is next injected at point A.

If the output is lost when moving the signal from collector to base of one of the transistors, the trouble may be a defective transistor or in the circuits which feed the voltage to the transistor. By making a few voltage measurements at the transistor terminals, an open circuit can be detected. It is important to note that due to the low voltages used, even minor changes in voltage can be

an indication of trouble. If the circuit is found to be normal, the transistor should be removed and tested.

It can be seen from the above description of signal substitution that the procedure used is almost identical to that used with vacuum-tube circuits, a method with which the experienced radio serviceman is well acquainted. If desired, signal tracing may be employed instead. However, in the case of signal tracing the procedure is started at test point A, and checks are made progressively, moving along through the various test points in alphabetical order toward M. When the faulty stage is located, voltage and resistance measurements will quickly find the faulty component.

CONCLUSIONS

Servicing transistor circuits presents no completely new problems to the serviceman, but does require a modification of presently used and familiar techniques. It must be remembered that transistors are sensitive to voltages above their maximum ratings, and that these maximum voltages are very low compared to those which apply to vacuum tubes. A good transistor is easily ruined by even momentarily exceeding its maximum voltage rating.

Transistors are also sensitive to improper bias, so that a short circuit may cause breakdown of a transistor, even though the short is present for only a moment. Therefore, any accidental or deliberate short-circuiting of transistor circuits must be avoided, in order to prevent unnecessary damage to transistors. If these precautions are observed, the servicing of transistor receivers will be substantially similar to the servicing of vacuum-tube receivers.

“What’s Your Answer?”

This issue’s problem, which was submitted by Philco TechRep Field Engineer Milt Badt, is an unusual variation of the common lamp-and-switch-type problem. The components required for the problem are shown in the accompanying diagram, and consist of the following:

1. A battery
2. Five single-pole, single-throw switches of the momentary-on type
3. Five lamps (having a resistance of 1000 ohms each when hot)
4. Six resistors of 1000 ohms each

Using only the components shown, draw the connections which will give the following results:

1. Pushing switch S_1 lights lamp I_1 only.
2. Pushing switch S_2 lights lamps I_1 and I_3 only.
3. Pushing switch S_3 lights lamps I_1 , I_2 , and I_3 only.
4. Pushing switch S_4 lights lamps S_1 and S_4 only.
5. Pushing switch S_5 lights all five lamps.
6. The current through each lamp that lights does not depend on the switch that is pushed, but is the same for any of the preceding five conditions.

Many circuits that meet the first five conditions can be easily devised, but the sixth condition imposes a severe restriction that eliminates most of the simple solutions. There is, however, at least one possible solution.

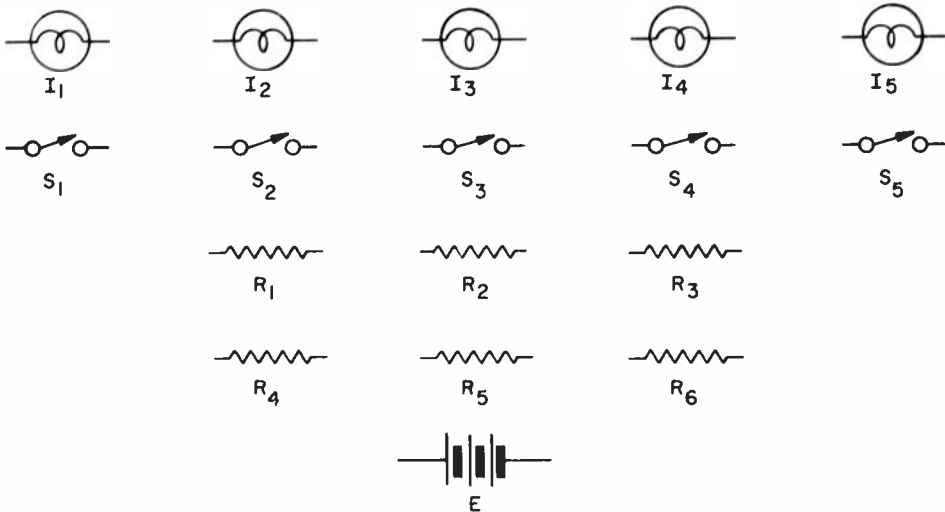

NEW PHILCO TRANSISTORS

In cooperation with the Navy, Army Signal Corps, and Air Force, the Philco Research Laboratories have developed two new types of transistors, a Micro-Alloy Transistor (MAT) and a Surface-Barrier Diffused Transistor (SBDT). These were developed as a result of new techniques which represent a major advance in semiconductor technology.

The MAT and SBDT will be produced by the Lansdale Tube Co., a division of Philco, for use in electronic "brains," guided missiles, communications, radar, and other military equipment. Both are fabricated from germanium utilizing Philco's unique Surface-Barrier techniques, now highly mechanized to permit mass production of transistors requiring high precision control of critical dimensions.

The MAT was primarily designed for high-speed electronic computers, and a new Philco "microalloying process" is used in its fabrication. This new method permits precision control of fabrication, with the result that the MAT is reported to be at least 10 times faster than the fastest vacuum tube in electronic computers.

The SBDT, on the other hand, will operate in the u-h-f range of 500 mc., and will probably find widest use in the 20- to 200-mc. range. The surface diffusion and microalloying techniques used in its fabrication result in the achievement of an alpha cutoff frequency above 600 mc.

These two new transistors, the MAT and SBDT, thus join the group of Philco transistors that run the gamut from milliwatt hearing aid amplifiers to 10-watt power units, and from audio frequencies to u-h-f, including the 40- to 80-mc. Surface-Barrier Transistors now used in computers.

Solution to September-October "What's Your Answer?"

In the problem given in the September-October issue, E_{out} will be a highly attenuated replica of the input voltage, E_{in} . It can be seen that the combination of the 1-megohm resistor and the 10- μmf . capacitor constitutes an integrating circuit with a time constant that is quite long (10 seconds) compared to the 100-microsecond period. The output voltage of this integrator is applied to a differentiator, consisting of the 10- μmf . capacitor and the 1K resistor, which has a time constant (0.01 microsecond) that is quite short compared to the 100-microsecond period. Since differentiation is the inverse process of integration, the output voltage is substantially unchanged except that it is highly attenuated.

As shown in the waveform diagram below, the output of the integrator is nearly a perfect "ramp" voltage, and the derivative of this voltage is nearly a perfect "step" voltage.

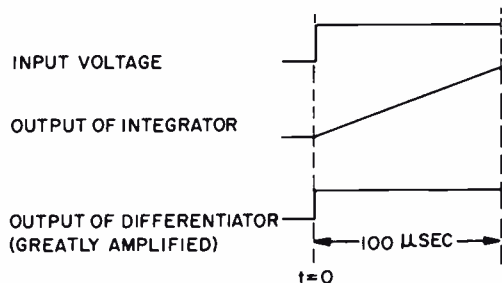

The following problem, which concerns the rather common question of how to operate 60-cycle equipment from a 50-cycle source, was submitted by Philco TechRep Field Engineer Charles A. Swab.

"I have a Hammond Electric Organ which has been designed to operate from a 60-cycle, a-c source. Unfortunately, the only power available here is 50 cycles, a.c. The voltage is correct, namely, 115 volts, and most of the circuits in the organ operate satisfactorily from the 50-cycle source. There is one item, however, which causes considerable difference in the organ sound with 50-cycle operation. This item is a synchronous motor of approximately 1/40 horsepower which is used to control the tone of the organ. The motor was designed to operate from a 60-cycle source and any internal alterations are highly impractical. What would be the least costly method, either mechanical or electronic, of solving this problem?"

Here are several possible solutions given by Mr. Swab, together with the disadvantages of each.

A motor-alternator, either belt-coupled or direct-coupled, could be used to provide the required 60-cycle power. The motor would run on the 50-cycle input, and the alternator would produce a 60-cycle output. The disadvantages of this method are both cost and size.

A combination of thyatron, transformer, and capacitor could provide a 60-cycle output, but a specially wound transformer and high-accuracy components would be required.

A circuit consisting of a frequency multiplier, step counter, blocking oscillator, and power amplifier could be designed to provide the proper output. However, this circuit would be quite complex and costly.

An oscillator, either R-C or other type, operating at 60 cycles could be used to feed a buffer amplifier, which would provide the input to a push-pull power amplifier utilizing transformer coupling at the output. This method would require the use of a rectifier power supply; therefore, the over-all circuitry would be complex and quite costly.

Do you have a better solution?

Index for Volume 6, Philco TechRep Division BULLETIN

	Month	Page
1N263, Philco X-Band Mixer Crystal Diode Type	May-June	17
15-J-1-C (AN/UPS-T4), Electrical Operation of the	July-Aug.	3
15-J-4-p (AN/UPS-T4), Mechanical Troubles in the Standard Target Course Generator	Jan.-Feb.	15
A		
A-F-C Systems, Radar Receiver (Part 4)	Jan.-Feb.	11
Amplifiers, Principles of Magnetic	Sept.-Oct.	3
AN/ARC-27 Signal Tracer	Sept.-Oct.	15
AN/FPS-3 and AN/FPS-8 Radars, Synchronized Operation of	July-Aug.	30
AN/GTA Cross Modulation Problem and Solution	July-Aug.	10
Antennas, New Philco Training Manual on	Nov.-Dec.	24
AN/UPS-T4, Electrical Operation of the 15-J-1-c	July-Aug.	3
AN/UPS-T4, Mechanical Troubles in the Standard Target Course Generator 15-J-4-p	Jan.-Feb.	15
Audipage System, Philco	Sept.-Oct.	12
B		
Beam-Indexing Color Television Display System, A New Bulletin Feature, New	Nov.-Dec. May-June	3 10
C		
Cable Testing, A Tester for Simplifying Computers, D-C Analog	July-Aug.	23
Part 1	Jan.-Feb.	24
Part 2	Mar.-Apr.	9
Part 3	May-June	12
Part 4	July-Aug.	13
Computers, Digital, High-Density Tape Recording for Crystal Diode Type 1N263, Philco X-Band Mixer	Sept.-Oct. May-June	21 17
D		
Delta-to-Wye and Wye-to-Delta Transformation	Nov.-Dec.	18
Digital Computers, High-Density Tape Recording for	Sept.-Oct.	21
E		
Editorials		
Automation	Jan.-Feb.	1
Equipment Reliability	Mar.-Apr.	1
New Bulletin Feature	May-June	1
A New Challenge—Transistorized Equipment Maintenance	July-Aug.	1
The Past, Present, and Future	Sept.-Oct.	1
The "Growing Pains" of Electronics	Nov.-Dec.	1
F		
F-3 Motor-Generator, Using a Type, on 50 Cycles	Nov.-Dec.	14
Forward Scatter of Radio Waves		
Part 1	Mar.-Apr.	13
Part 2	May-June	2
L		
Letters to the Editor Column	July-Aug. Sept.-Oct. Nov.-Dec.	2 2
M		
Magnetic Amplifiers, Principles of	Sept.-Oct.	3
Motor-Generator, F-3, Using on 50 Cycles	Nov.-Dec.	14
MTI Vectors	Mar.-Apr.	21
N		
Navigation Aids, Passive Reflectors as NBS	Nov.-Dec.	21
Forward Scatter of Radio Waves		
Part 1	Mar.-Apr.	13
Part 2	May-June	2
High-Density Tape Recording for Digital Computers	Sept.-Oct.	21
P		
Passive Reflectors as Navigation Aids	Nov.-Dec.	21
Philco Audipage System	Sept.-Oct.	12
Philco Color Television Textbook	July-Aug.	10
Philco Medium Power Transistors	May-June	22

Index (Cont.)

	Month	Page
Philco Silicon Transistor, New	Jan.-Feb.	19
Philco Subminiature Transistor	May-June	11
Philco Training Materials, Collegiate Use of	Mar.-Apr.	2
Philco Training Manual, New (Antennas)	Nov.-Dec.	24
Philco Training Manual, New (Tubes and Semiconductors)	May-June	36
Philco U-H-F and High-Speed Transistors	Nov.-Dec.	34
Philco X-Band Mixer Crystal Diode Type 1N263	May-June	17
PRF, Pulse-Shape, and Pulse-Width Checker Setup	July-Aug.	29
R		
Radar Coverage, Some Aspects of	Sept.-Oct.	18
Radar Receiver, A-F-C Systems (Part 4)	Jan.-Feb.	11
Radars, Synchronized Operation of AN/FPS-3 and AN/FPS-8	July-Aug.	30
Range Tracking, Principles of Automatic	May-June	23
S		
Scatter of Radio Waves, Forward		
Part 1	Mar.-Apr.	13
Part 2	May-June	2
Screen Room Maintenance	Mar.-Apr.	28
Semiconductors, Handbook of Tubes and	July-Aug.	32
Shielded Enclosures	Jan.-Feb.	2
Signal Tracer, AN/ARC-27	Sept.-Oct.	15
Standard Target Course Generator 15-J-4-p, Mechanical Troubles in	Jan.-Feb.	15
Statduct Aligner	Jan.-Feb.	20
T		
Tech Info Mail Bag		
AN/GTA-6A Cross Modulation Problem and Solution	July-Aug.	10
Dummy Load (Diesel) Problem and Solution	May-June	10
Dummy Load (May-June), Another Solution	July-Aug.	10
Facsimile Problem and Solution	Sept.-Oct.	27
Hammond Electric Organ Problem and Solution	Nov.-Dec.	35
Measurement and Calculation of the Phase Shift Characteristics of a Transformer	Sept.-Oct.	27
Technical Sketch		
James Clerk Maxwell	July-Aug.	33
Oliver Heaviside	Sept.-Oct.	29
Television Display, Beam Indexing Color	Nov.-Dec.	3
Television Textbook, Philco Color	July-Aug.	10
Training Materials, Collegiate Use of the Philco	Mar.-Apr.	2
Transistor Circuits, Servicing	Nov.-Dec.	25
Transistor, New Philco Silicon	Jan.-Feb.	19
Transistor, Philco Subminiature	May-June	11
Transistor Servicing Precautions	May-June	33
Transistors, Philco Medium Power	May-June	22
Transistors, Philco U-H-F and High-Speed	Nov.-Dec.	34
Tubes and Semiconductors, Handbook of	May-June	32
V		
Vectors, MTI	Mar.-Apr.	21
W		
What's Your Answer?		
Inductance Problem	July-Aug.	22
Solution	Sept.-Oct.	17
Modulation Problem	Mar.-Apr.	8
Solution	May-June	9
Positive Grid Voltage Problem	May-June	16
Solution	July-Aug.	9
Step-Function Problem	Sept.-Oct.	20
Solution	Nov.-Dec.	34
Switch Problem	Nov.-Dec.	33
Three-Resistor Problem on Impedance	Jan.-Feb.	18
Solution	Mar.-Apr.	27
Wye-to-Delta Transformation, Delta-to-Wye and	Nov.-Dec.	18
X		
X-Band Mixer Crystal Diode Type 1N263, Philco	May-June	17

**CONSULTING, PROJECT, AND FIELD ENGINEERING
CONTRACT AUGMENTATION**

**ELECTRONICS • COMMUNICATIONS
POWER PLANT • REFRIGERATION
ELECTROMECHANICAL AND SPECIAL SYSTEMS**

STANDARDIZED TRAINING

**COURSES • TRAINING DEVICES
INSTRUCTORS
for
EDUCATIONAL INSTITUTIONS
ARMED FORCES • INDUSTRY**



**COMPLETE PUBLICATIONS FACILITY FOR PREPARATION
OF TECHNICAL MANUALS *such as—***

**MAINTENANCE HANDBOOKS • OPERATIONAL HANDBOOKS
ILLUSTRATED PARTS BREAKDOWNS • CATALOGS
ENGINEERING REPORTS • SPECIAL PROJECTS**