

WESTINGHOUSE

# Engineer

6-2-1946  
10-1-1946



JULY 1946

World Radio History

# Gas-Pressure Spectrum

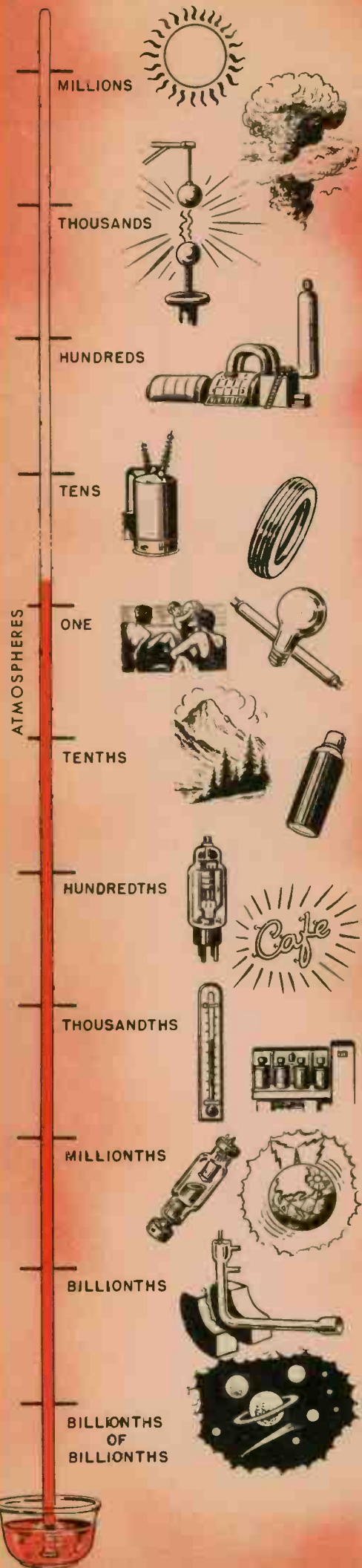

Man has pushed back his geographical frontiers until now but little of the globe is beyond his use, and with all the talk about radar and rockets, he threatens to expand his domain to the moon and planets. A kindred expansion has been going on less spectacularly in another of man's "worlds," that of gas pressures. Both lower and upper limits of pressures of gases are being extended with benefits in many fields, particularly electronics, nuclear physics, and power generation.

Engineers have at their command a range of gas pressures from about one thousandth of one billionth of an atmosphere up to roughly 200 atmospheres. Engineers are rightfully proud of their ability to produce and maintain large volumes on an industrial scale at pressures as low as one ten billionth of an atmosphere (about  $10^{-7}$  mm of Hg; 760 mm of Hg = one atmosphere). This is surprisingly close—probably about one order of magnitude—to the best that can be done under laboratory conditions. Steam plants represent about the top in commercial high pressures. These are usually 1200 pounds per square inch or less, but run as high as 2500 pounds in a few isolated cases.

A vacuum of  $10^{-8}$  mm of Hg would seem to be a pretty complete removal of all the gas molecules. Actually the molecule population is still an astronomical figure. A space of one cubic inch at  $10^{-8}$  mm contains about 4 500 000 000 molecules—more molecules than there are people on the earth. But in another very real sense the space is virtually empty because the molecules are so small. This is indicated by the average distance a molecule has to travel before it strikes another molecule and is called the mean free path. At  $10^{-8}$  mm, although the number of molecules is large, a single molecule has to travel on the average of 4.5 miles before it bumps into a neighbor. At the other end of man's gas-pressure spectrum—say 200 atmospheres—the molecule density is great, about  $8 \times 10^{22}$  per cubic inch and the mean free path is only about 1500 millionths of an inch.

Man's best vacuum and highest pressure are still far from equaling what nature can do. Physicists estimate that in interstellar space there is not more than one molecule per cubic inch. This corresponds to a pressure of about  $2.5 \times 10^{-21}$  atmospheres and a mean free path of 20 billion miles. The ionosphere, 30 to 50 miles above the earth is only a mild vacuum. It is of the order of one ten thousandth of an atmosphere ( $10^{-4}$ ).

On the other hand, the stars are thought to be gases at extremely high temperatures. A representative estimate of the sun's interior

pressure is a hundred billion atmospheres at a temperature of 40 000 000 degrees F.

Man has experimented with vacuum ever since Otto Von Guericke, Burgomaster of Magdeburg, carefully fitted together two large hemispheres and proved to an astonished audience that horses could not separate them when the fitted halves were evacuated. The reason—atmospheric air pressure—was then unknown. Not much was done about vacuums, except to say they were abhorred by nature.

Low pressures remained in the laboratory until the invention of the diffusion pump about 1915. The diffusion pump (described in this issue) marked the beginning of large-scale, hard vacuums, quickly made and easily kept, without highly skilled technicians.

Without commercial-scale low pressures, made possible by the diffusion pump, electronics would not have been born, for most electronic devices require long mean free paths for electron movement.

The early incandescent lamps were probably the first important commercial product using extreme vacuums. These early lamps were evacuated to one hundredth of a mm of Hg. (Present-day lamps are filled with inert gas close to atmospheric pressure.) Many other common industrial processes depend on large volumes maintained at low pressure such as distillation in the chemical industry, where volatilization at the high temperatures that go with ordinary pressures would ruin the product. Needless to say, present nuclear physics rests squarely on the diffusion pump and its high vacuums.

Gases at a wide variety of pressures are employed in many ordinary devices. Electronic tubes such as those used for x-ray machines, radio transmitters, and mass spectrographs use about the "hardest" vacuums:  $10^{-6}$  to  $10^{-8}$  mm Hg. Radio receiver tubes use slightly higher pressures. The gases in mercury-arc rectifiers and thyratrons are in the general neighborhood of  $10^{-2}$  mm while gas-filled tubes such as glow lamps and neon tubing lie in the zone from 0.1 to 20 mm. The vacuum in the humble mercury thermometer is pretty good—of the order of  $10^{-3}$  mm.

Many everyday devices, such as tires, employ pressures of a few atmospheres. The vapors in high-pressure mercury lamps vary from 1 to 100 atmospheres. In experimental arcs pressures of 1000 atmospheres have been obtained. Without doubt the highest pressure achieved by man was with the atomic bomb. Pressures estimated at a thousand billion atmospheres are created in times of the order of one half of a millionth of a second.



On the Side

*The Cover*—Fog and darkness are transparent to the eyes of radar, which make them invaluable to the ship pilot. The first commercial type of application of this miracle of science—marine navigational radar—is symbolized on this issue's cover.

• • •

*High-Speed Generating Units* — Another large step in the rising cascade of 3600-rpm generating unit ratings is marked by a 100 000-kw machine to be built for the Sewaren station of the Public Service Electric & Gas Company of New Jersey.

It is a tandem condensing unit noteworthy not alone by its being one fifth larger in power output than previous high-speed units but also because of the very significant increase in total temperature and steam pressure. The top temperature will be 1050 degrees F, nearly 100 degrees higher than has been the common upper limit for several years. The steam pressure—1500 pounds per square inch—while far below that used in a couple of isolated cases, is an appreciable increase over the 1250 pounds commonly used.

• • •

*Stratovision Verified*—Flight tests made during the past six months prove the Stratovision system of broadcasting television signals to be superior to the calculations. A B-25 bomber, modified by the Glenn L. Martin Company, has been used for flight testing, flying between Baltimore, Maryland, and New Haven, Connecticut. Measurements of signal strengths have been made under different conditions, the tests being checked by engineers of the Federal Communications Commission. Usable signals have been received over a distance of 240 airline-miles from 25 000 feet, using only 250 watts.

In This Issue

RADAR MARINE NAVIGATION..... 98

HIGH VACUUMS AND HOW THEY ARE OBTAINED..... 103  
*A. P. Colaiaco and D. L. Hopper*

DETECTING VACUUM LEAKS ELECTRONICALLY..... 108  
*H. A. Thomas, T. W. Williams and J. A. Hipple*

THE MINING AND PROCESSING OF PHOSPHATE..... 111

GEAR GRINDING, A NEW METHOD..... 117  
*T. J. Putz and H. W. Semar*

THE STRUCTURE OF THE NUCLEUS..... 118  
*Dr. W. E. Shoupp*

NUCLEAR ENERGY POTENTIALITIES..... 125  
*C. F. Wagner and J. A. Hutcheson*

STORY OF RESEARCH..... 128

Editor

CHARLES A. SCARLOTT

Editorial Advisors

R. C. BERGVAL

TOMLINSON FORT

G. EDWARD PENDRAY

The *Westinghouse ENGINEER* is issued six times a year by the Westinghouse Electric Corporation. Dates of publication are January, March, May, July, September, and November. The annual subscription price in the United States and its possessions is \$2.00; in Canada, \$2.50; and in other countries, \$2.25. Price of a single copy is 35c. Address all communications to the *Westinghouse ENGINEER*, 306 Fourth Ave., P.O. Box 1017, Pittsburgh (30), Pennsylvania

THE WESTINGHOUSE ENGINEER IS PRINTED IN THE UNITED STATES BY THE LAKESIDE PRESS, CHICAGO, ILLINOIS

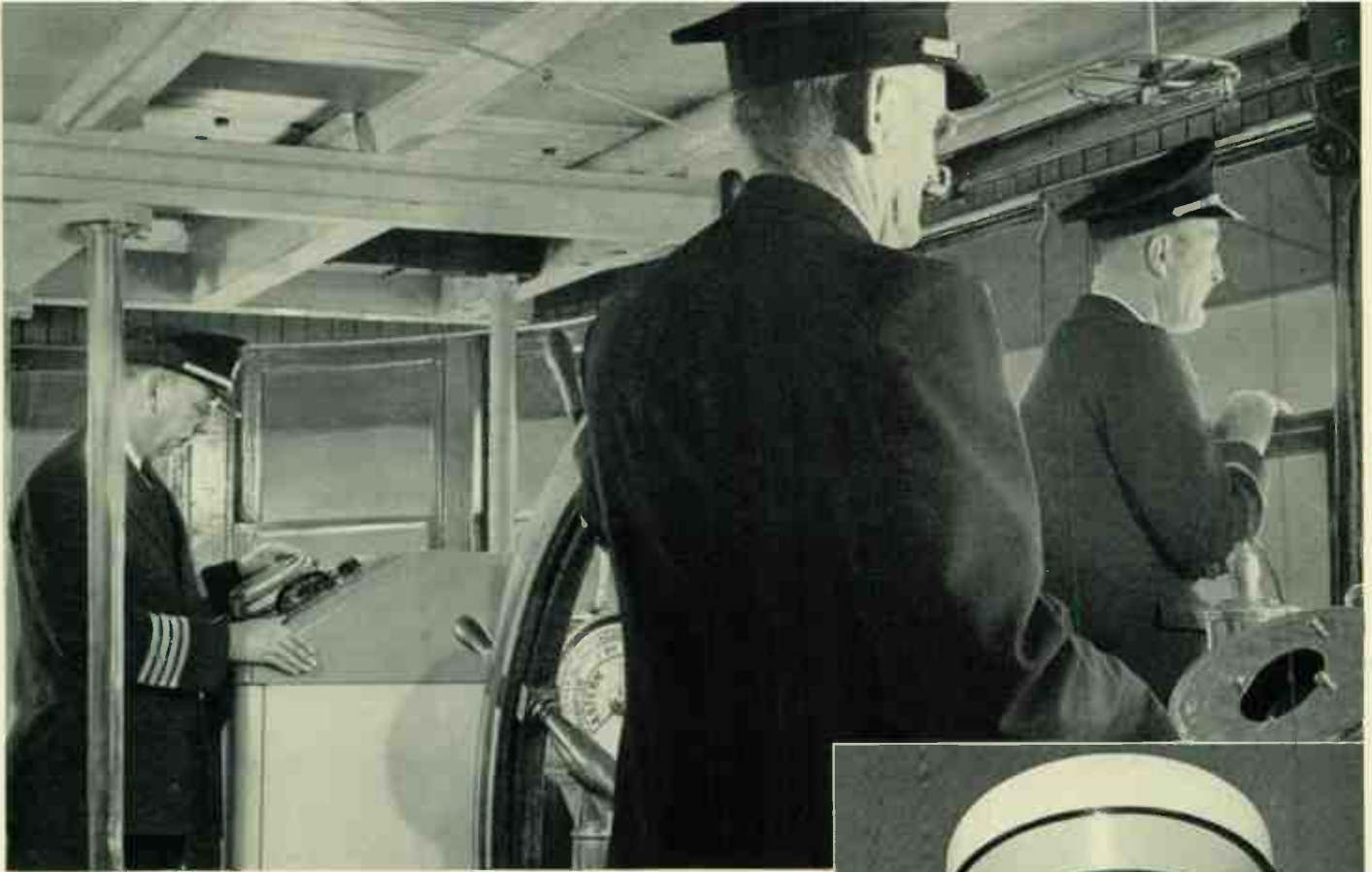

## Radar Marine Navigation

Radar—one of the great scientific achievements of the war—has now assumed a historic role in peace. For the first time, ships at sea have a navigational and anti-collision device, impervious to weather, storms, or darkness and fog. Based on the fabulous military radar systems, marine radar is already proving its peacetime worth in coastwise navigation and promises to become a standard instrument of navigation supplementing the compass and sextant.

RADAR assumes its initial peacetime role as Westinghouse marine radar, the first commercial application of radar. Already in use by the Old Bay Line of Baltimore, Maryland, marine radar incorporates all of the essential features of a typical military surface-search system with the added advantages of small size, simplicity of control, and reliability of operation without the constant attendance of technical personnel.

Designed specifically for navigation and anti-collision purposes, marine radar detects the presence of other vessels, of buoys, lighthouses, and shorelines by presenting a continuous picture of the territory surrounding the vessel on a cathode-ray tube type of indicator. In this fashion, marine radar permits safe navigation in spite of fogs, darkness, or storms.

The system has been planned particularly for the navigator. A skilled operator is not needed, for circuits and controls have been simplified. In military radar, for example, gun-fire control requires exceedingly accurate range, and special circuits and indicators (the so-called A-type) are necessary in addition to the PPI (Plan Position Indicator—a cathode-ray indicator that presents a map-like view of the surrounding territory). For marine radar, however, the PPI alone is entirely adequate, both for range and bearing.

Prepared by Hugh Odishaw of the Editorial Staff of the *Westinghouse ENGINEER* with the cooperation of G. H. Phelps (Manager, Commercial Engineering) and Coleman London (Section Engineer, Commercial Radar Section) of the Westinghouse Industrial Electronics Division.

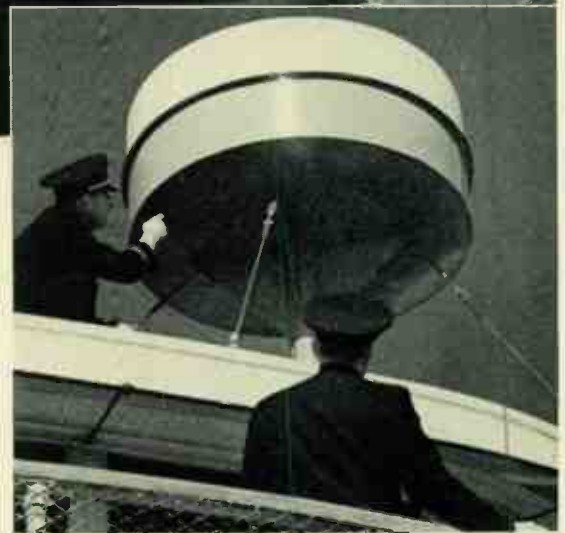

Marine radar console aboard the Old Bay Line's *City of Richmond* (upper). The radome (lower), housing the antenna, is mounted just above the bridge.

Again, exigencies of war demand controls for focusing, sensitivity, and anti-jamming—as well as controls for stopping antenna rotation or limiting it to a given angle—necessary in military applications but superfluous in marine navigation.

Eliminating circuits and controls of these types permits such simplification that a navigator can operate marine radar as easily as an ordinary radio with less than an hour of practice, and he can read the PPI oscilloscope indicator as easily as his navigational charts after a few hours.

### Radar Navigation

For navigational purposes, the range and bearing of objects are needed, whether the object is a coastline, island, lighthouse, or another ship. These two coordinates are obtained by transmitting high-frequency energy in short bursts or pulses and waiting for the reflections to return during the relatively long period when the transmitter is quiescent. Range determination is possible because electromagnetic waves travel at a constant



speed—that of light: 186 000 miles per second or approximately 1000 feet per microsecond. Thus, range depends upon the time it takes a signal to travel from the system to an object and back again, and measurement of this elapsed time is one of the primary functions of a radar system.

For range measurement, the radial sweep of the electron beam in the special cathode-ray tube constituting the PPI is coordinated with the transmission of pulses. Thus the electron beam starts moving from the center of the screen to the rim every time a pulse leaves the antenna, traveling to the rim in the subsequent period of transmitter quiescence during which reflected signals can return. The reflected signal is fed to the PPI in such a manner that the normally faint stream of electrons is intensified, and the scope brightens at a point on the screen corresponding to the range of the reflecting object. The scope face is calibrated in miles, and at convenient intervals markers, turned on at the operator's option, inscribe the range electronically by bright lines.

Accurate bearing information is possible because the energy travels in straight lines. Bearing is obtained by using a synchro-tie system that rotates the electron beam in synchronism with the radiator. Thus the electron beam not only sweeps radially from the center of the scope to the rim, for range purposes, but rotates synchronously so that reflections appear properly in bearing.

At those points where the electron beam is intensified, the PPI screen brightens; in other portions it remains dark, for ordinarily the intensity of the beam is maintained at a level insufficient for fluorescence of the screen coating. This coating has long persistence so that signals brightening the face remain as bright and intelligible spots or areas in spite of the rotation of the antenna beam.

The amount of energy returning to the system, determining the amount of brightness on the scope face, depends on the reflectivity of surrounding objects. Water reflects very little in any uniform fashion, ground reflects a fair amount, while

built-up areas (like cities, ships, lighthouses, and buoys) reflect a great deal. Thus the picture of the PPI presents not only the correct range and bearing aspects of surrounding objects but also some indication of their nature. Moreover, because the process is continuous, changes in the position of such objects are faithfully recorded. Thus, the motion of another ship or an iceberg, for example, can be followed precisely, while a comparison of the PPI map with navigational charts permits accurate navigation.

### Major and Auxiliary Components

The marine system consists essentially of two units: the antenna pedestal and the indicator console. The upper section of the antenna pedestal contains the cut paraboloidal antenna, the driving a-c motor, the associated drive-gears, and the synchro-tie system which links the antenna rotation with the rotation of the electron beam in the cathode-ray indicator. The upper half of the radome is fabricated from synthetics that provide an effective shield from the elements without attenuating the high-frequency energy transmitted and received by the rotating antenna.

The lower section of the antenna pedestal encloses the high-voltage power supply, the modulator, and the so-called r-f (radio-frequency) head that includes the magnetron oscillator, the crystal detector, local oscillator, and associated high-frequency circuits. These components are included in the antenna pedestal because serious power attenuation occurs at microwave frequencies if an appreciable distance separates the transmitter and antenna. To secure a short path between the magnetron and the antenna, even though the relatively efficient wave guides are used as energy conductors, the r-f components are mounted as close to the antenna as possible.

The only remaining major component is the indicator console, mounted in the wheelhouse at a position convenient for the navigator. Within the console are the low-voltage power supply, the intermediate- and video frequency amplifiers, the

The radar scope (lower right) presents a map-like picture of the ship's surroundings, with the ship itself at the center. Here an eight-mile radial range was in use as the ship steamed out of Baltimore. Comparison of scope details and the map (lower left), marked with a circle covering the region shown on the scope, reveals the fidelity of the radar picture. The signals in the water area are from other vessels, both at anchor (the upper group) and in motion, and buoys. Continuous patterns of this type permit navigation and prevent collision regardless of weather or visibility. Depending upon the navigator's interest, ranges of 2, 8, and 32 miles can be presented on the PPI scope.

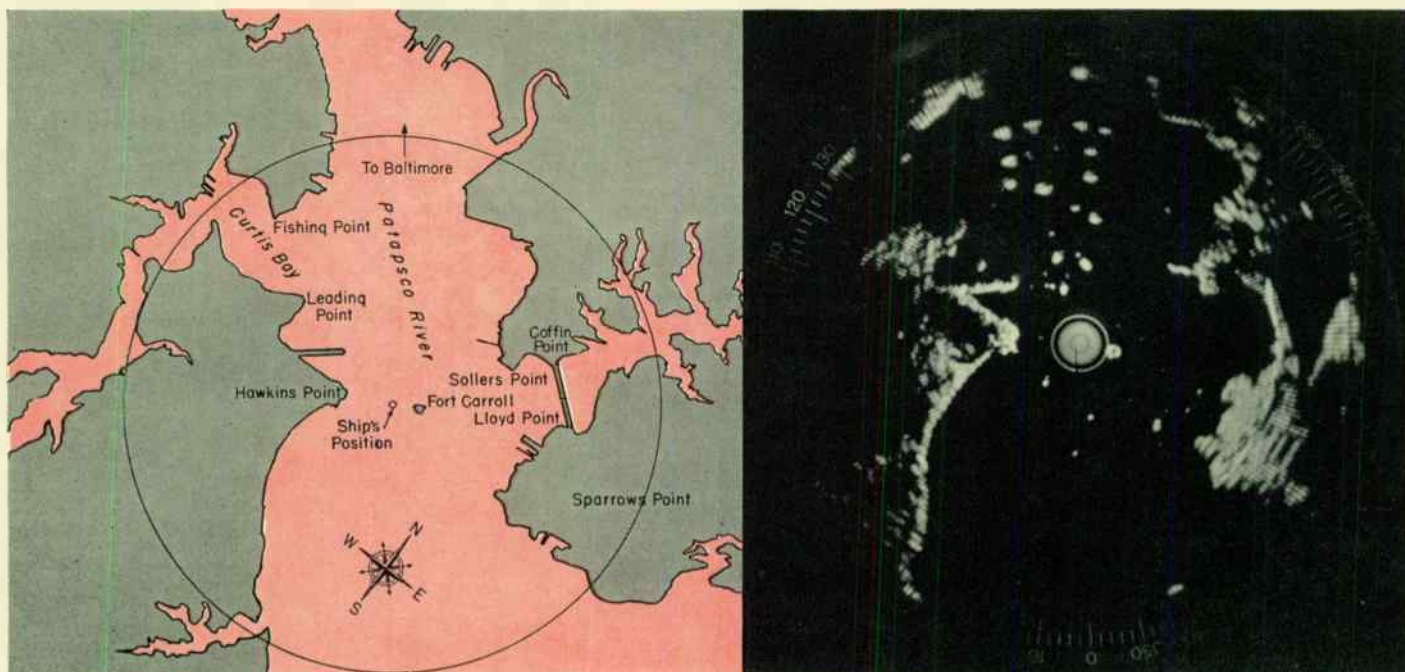

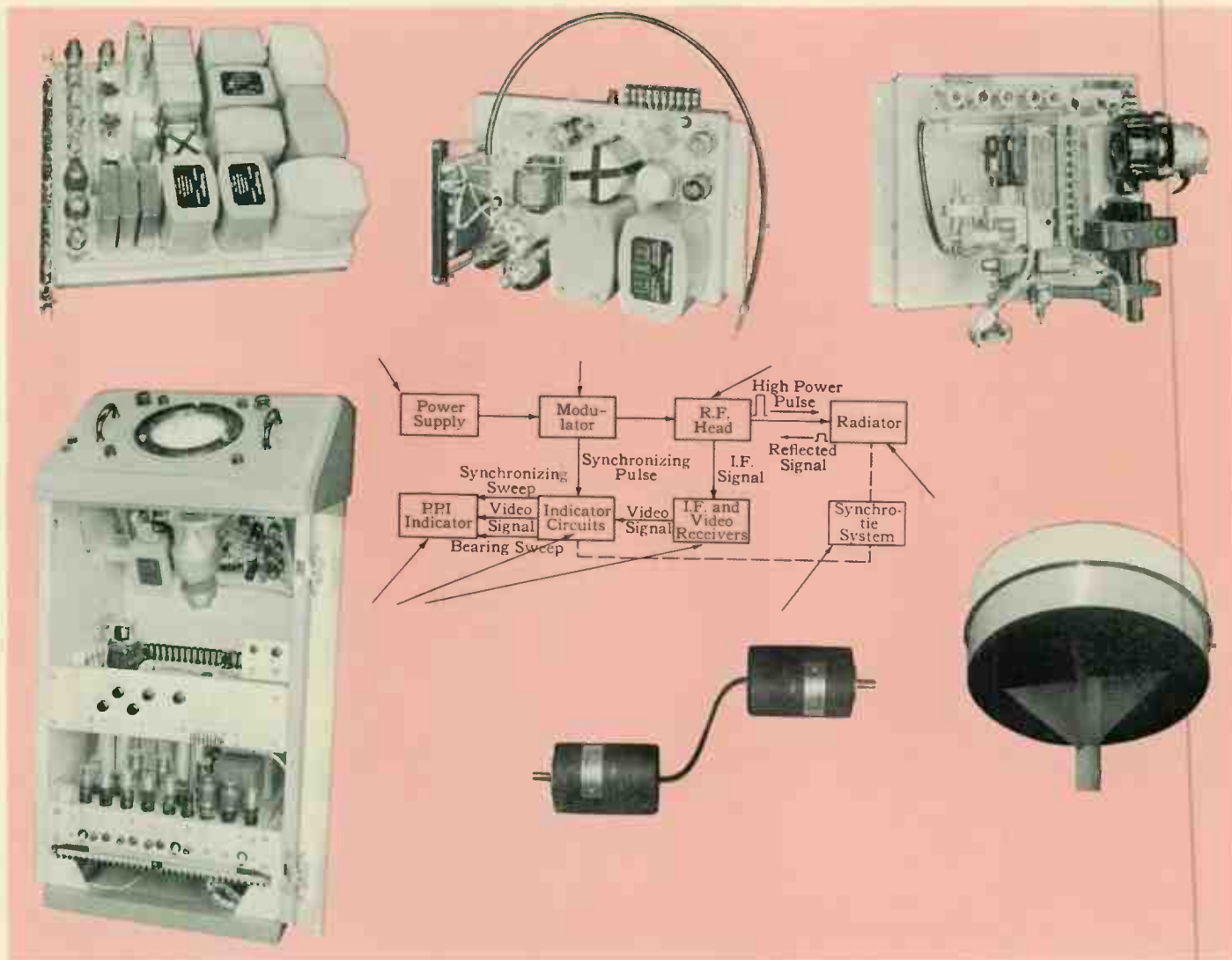

Fig. 1—The essential components of marine radar are shown in the block diagram. High-voltage power is fashioned by the modulator into sharp 0.4 microsecond pulses that trigger the oscillator in the r-f head. The oscillator output, high-power, high-frequency energy (about 10 000 megacycles) is radiated into space by the rotating radiator. Reflections from objects return to the antenna during the interval of transmitter quiescence following transmission. These echo-signals are detected and amplified in the r-f receiver, whose output is a signal at 60 megacycles. Further

amplification takes place in the receiver console where another stage of detection lowers the signal frequency to the video level. This signal is used by the indicator to intensify the electron beam of the PPI scope, brightening the screen at every point where reflections are present. For range purposes, the radial sweep of the electron beam is triggered by a pulse from the modulator. Coincidentally, a synchro-tie system rotates this sweep by linking the motion of the scope magnetic-deflection coils with the rotation of the antenna, reproducing the bearing of reflecting objects.

PPI indicator and its circuits, and all operating controls.

Auxiliary equipment consists of a motor-generator set, remote PPI indicators, and azimuth stabilization for true bearing presentation. The motor-generator set, standard in design, is necessary only if the vessel's primary power supply does not provide the 115-volt, single-phase, 60-cycle energy required by the system.

Remote PPI indicators may be desirable at various locations on large vessels. The circuits of the indicator console are designed so that as many as four of these light and small remote indicators may be operated simultaneously with the main indicator.

Ordinarily, the bearing presented on the PPI scope is relative bearing with respect to the heading of the ship. Sometimes true bearing—bearing with respect to North—is desired. This is possible if the vessel is equipped with a standard gyro-compass. At the same time, an electronic cursor—a sharp line across the scope—presents the heading of the ship.

### Block-Diagram Analysis

The essential components of marine radar, common to all search systems, are the transmitter, the radiator, the receiver, and the indicator unit. The function of the transmitter is to create a short and powerful pulse of microwave energy. The radiator, consisting of a "horn"-type wave-guide feed and a paraboloidal reflector, receives this pulse through a wave-guide system, directs it into a narrow beam, and radiates it through space. Objects in the path of the energy reflect portions of it, and some returns to the radiator, which serves both as a receiving and a sending device. The intercepted reflections are detected by the superheterodyne method, amplified, and fed to the indicator.

The sequence of events and the principal components of marine radar are presented in considerable detail in Fig. 1. High- and low-voltage power packs are required for creating the potentials necessary to drive the magnetron oscillator and the various electronic tubes of the system. High-voltage power



is required by the modulator, the heart of the system. The modulator has two functions. First, it must form a suitable, powerful pulse to drive the magnetron; second, it provides the synchronizing pulse that triggers the indicator circuits so that the PPI electron beam starts its sweep from the center of the scope to the rim every time a pulse leaves the magnetron.

The pulse from the modulator triggers the magnetron in the r-f head, and a high-power, high-frequency signal is sent to the antenna, which radiates it through space in a narrow beam. Reflected signals return to the antenna and are detected by the receiver in the r-f head. Some amplification occurs here, and an intermediate-frequency signal, considerably strengthened by this amplification, is fed to the i-f receiver in the indicator console.

The i-f receiver further amplifies this signal, which is again detected—this time to a video frequency suitable for visual representation on the indicator. After video amplification, the signal is used by the indicator circuits to intensify the electron beam in the PPI so that the scope face brightens, indicating the presence of an object. Throughout this process, the synchro-tie system causes the PPI beam to rotate in step with the revolving radiator.

To secure the proper sharp, short transmitted signal from the magnetron, an accurately formed, high-power signal must be impressed between the cathode and anode of the magnetron. Such a signal is provided by the modulator (Fig. 2). The high-voltage power supply, of the voltage doubler type, delivers 3000 volts to the modulator. A charging inductor, in conjunction with a resonant-pulse network consisting of capacitors and inductors, increases this voltage to 5100 volts. Such a voltage would oscillate in amplitude, becoming gradually damped, so that a hold-off diode is inserted between the charging inductor and the pulse network, preventing a reversal in current direction and thus maintaining the voltage at 5100 volts.

In a pulsed radar system, short, carefully timed signals are desired. Such signals are attained by using a sine-wave oscillator, a blocking oscillator, and a thyatron tube. These three elements constitute the timing device. The sine-wave oscillator produces accurately timed signals. The blocking oscillator eliminates the negative portion and converts the positive portion into a sharp pulse that rises sharply and decays exponentially. This pulse is applied to the grid of the thyatron whose anode and cathode are linked to the pulse network of the modulator and the pulse transformer in the r-f head. The thyatron fires every time the blocking oscillator delivers its positive pulse, discharging the pulse network through the primary of the pulse transformer. The impedance of the transformer is identical with that of the network so that the 5100 volts are divided equally between the two, and a negative

pulse of 2550 volts is applied to the transformer winding.

The design of the modulator and, in particular, the time constants used, provide a high-voltage pulse of 0.4-microsecond duration, repeated at the rate of 2000 times per second. This signal is stepped up to approximately — 12 500 volts by the pulse transformer and is then applied to the cathode of the magnetron (Fig. 3), driving it negative with respect to the anode and causing the tube to oscillate. The magnetron is of the 3-cm type, so that the transmitted signal has a frequency of about 10 000 megacycles, and has a peak power output of more than 15 kw.

The magnetron pulse is conducted by wave guides to the radiator. A horn-type wave guide feeds the energy to the truncated paraboloid that radiates the pulse in a vertical fan pattern, two degrees wide horizontally and approximately fifteen degrees vertically. Continuous rotation of the radiator, at 12 rpm, is effected by a small 115-volt a-c drive motor.

Because the power of the outbound signal is great and because the receiver must be sensitive to detect the generally minute reflected signals, some method equivalent to disconnecting and thus protecting the receiver during transmission must be used. At the same time, reflected energy must not be lost by traveling to the now-idle magnetron. For these purposes, t-r (transmit-receive) and anti-t-r tubes are employed. The t-r tube is a hydrogen- and vapor-filled tube housing two spark-gap electrodes in a resonant cavity placed at a T-junction connecting the magnetron, receiver, and antenna. When the powerful outbound pulse travels toward the antenna, the t-r tube fires, effectively short-circuiting the receiver. Sufficient ions are maintained in the cavity at all times by a keep-alive electrode, so that quick firing is assured. Water vapor is included in the cavity for rapid recovery of the tube and its return to the unfired state because reflected signals from short-range targets arrive almost instantly—for example, reflections from an object 500 feet away arrive in about 0.5 microsecond.

Partial loss of the reflected signal to the magnetron is avoided by the anti-t-r tube, essentially another t-r tube appended to the wave guide on the magnetron side. During transmission, this tube also fires, preventing waste of the transmitted pulse; during reception, it blocks the reflected signal by presenting, along with the associated wave guide, a large impedance to the signal.

The reflected signal is detected by a synthetic-type crystal, for at ultra-high frequencies the transit time of electrons in the conventional tubes constitutes an appreciable portion of the energy cycle, and special crystal detectors must be used. To obtain a signal at a frequency convenient for amplification, the superheterodyne principle is used, and the reflected signal is mixed in the detector with a signal from the local os-

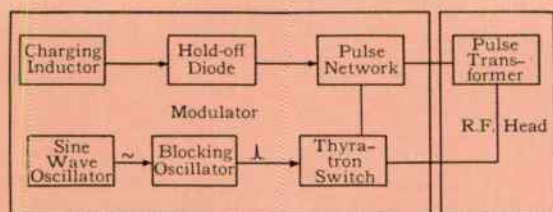
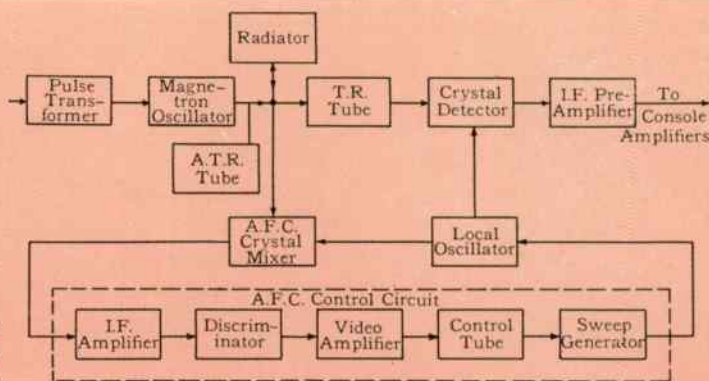
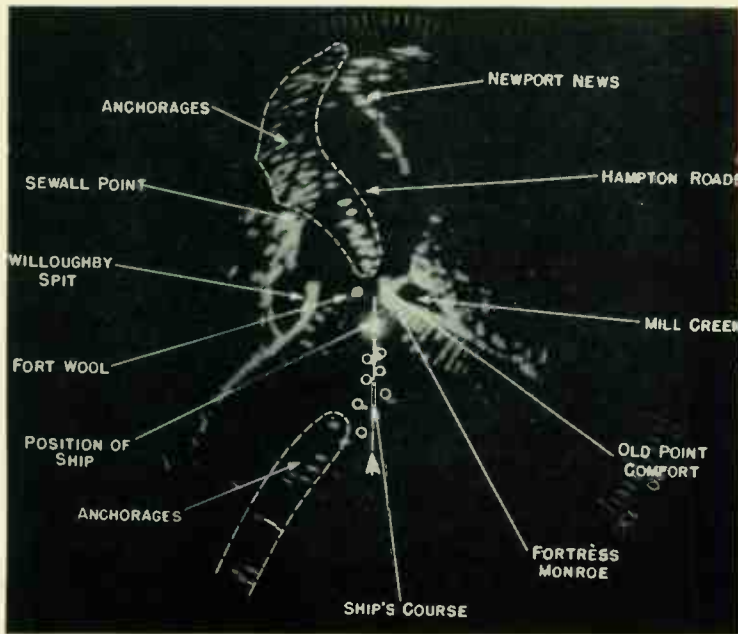

Fig. 2 (above). The principal components of the modulator. This is the heart of the system and provides the trigger pulse for the magnetron and for the indicator circuits.

Fig. 3 (right) shows the components of the r-f head (and the radiator), which includes the microwave parts of the unit, the automatic frequency control, and the preamplifier.





Typical radar scope views aboard the *City of Richmond*. At left, the vessel is approaching Hampton Roads en route to Norfolk. The scope picture represents an area 16 miles in diameter. Below, the vessel is leaving Baltimore harbor, between guarding channel buoys, and entering Chesapeake Bay. The light circles represent ranges of one-half mile.

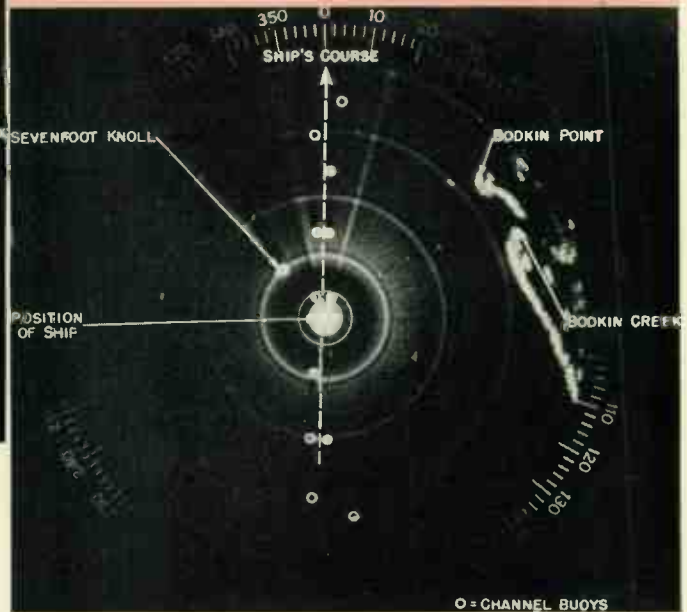

cillator (a klystron), emerging at the intermediate frequency of 60 megacycles.

The intermediate- and video-frequency receivers are tuned to accept certain bandwidths. It is therefore necessary that the signal from the mixer remain within these bands. Because the magnetron frequency varies (principally as a result of variations in the impedance of the output wave-guide, antenna, and atmosphere), an automatic frequency control (Fig. 3) is utilized to maintain the klystron at such a frequency that the i-f signal remain at 60 megacycles. A dynamic method of control, relying on a crystal mixer, amplifier, discriminator, control tube, and sweep generator, performs this function by altering the reflector voltage of the klystron, for klystron frequency is voltage-sensitive.

The control crystal is coupled to the output waveguide in a directional fashion so that only a small portion of the transmitted signal is intercepted while essentially none of the reflected signal is absorbed. This signal is mixed with a portion of the klystron output. The i-f signal is amplified and applied to the discriminator (a capacitor-inductor circuit) which is highly sensitive to frequency. The resulting signal is amplified and fed to the control tube which actuates the sweep generator that continuously varies the klystron voltage over a predetermined range. The net effect is to produce a voltage that keeps the klystron frequency within the desired range so that the reflected signal output of the receiver proper falls within the desired bandwidth.

In spite of i-f detection, the reflected signal is still at a high frequency and low in power. To keep the signal-to-noise ratio as high as possible, two stages of preamplification occur in the r-f head. The signal is then transmitted to the console where further i-f amplification—five stages—occurs followed by a second detection to the video level and a stage of video amplification. The signal is then applied to the indicator circuits, which use it to intensity-modulate the electron beam in the PPI-type indicator tube.

The maximum range of the system is 32 miles. This range depends on the amount of power transmitted and upon the height of the antenna above the surface of the earth. In general, shipborne radar systems are limited in range by antenna elevation. The minimum range, on the other hand, is determined by the pulse width. For reflections at short range, the pulse must be short enough so that the signal returns after the

pulse has ended, otherwise the reflection cannot be distinguished from the transmitted pulse. With a pulse length of 0.4 microsecond and by use of special anti-clutter circuits in the receiver that eliminate sea-clutter (random returns from the immediate sea-surface surrounding the ship), the system permits the detection of objects as close as 100 yards.

#### Navigational Significance

Small in size, light in weight, and simple and reliable in operation—marine radar is designed for anti-collision and navigational purposes. Its marine use runs the gamut from large, ocean-going passenger vessels to tugs and ferries plying in harbors. It has been built with these specific purposes in mind. Thus, neither an experienced radar nor a radio operator is needed; present personnel aboard ship or tug can operate and use the system; and the reliability of the system is such that maintenance can be done during periods when the vessel is normally in port.

The anti-collision value of marine radar is apparent. The importance of such a navigational aid lies, however, not merely in any accruing element of safety but in the availability, for the first time, of a device that permits operation of many vessels hitherto harbor-bound in inclement weather. The tie-up of ore-vessels in the Great Lakes, for example, is a costly handicap, and a one-day delay in entering port of a weather-bound fruit ship may mean the ruin of an entire cargo. Marine radar dispenses with these eventualities, and in many cases a single day's operation of an otherwise idle vessel justifies the addition of this system. It is, however, unlikely that ordinary pleasure craft will be sporting radar in the near future. For most of these boats, size and weight are still excessive and sufficient power is unavailable. Moreover, radar components are still complex, requiring costly materials and time for production. But for commercial vessels—whether ocean liners, coast-line traders, lake freighters, or tugs and ferries—marine radar provides an economically valuable navigational device, to say nothing of the attendant safety.



# High Vacuums and How They Are Obtained

Pressures of thousands of pounds per square inch in steam turbines or compressed-air containers are regularly obtained with comparative ease. But when it comes to removing every bit of gas from a chamber, although the pressure is only fifteen pounds per square inch, quite another problem ensues. Until recently really high vacuums have been attained with difficulty. Now pumps are available with sufficient capacity and speed for industrial service, yet they can draw vacuums of laboratory quality.

A. P. COLAIACO and D. L. HOPPER  
*Rectifier Engineers*  
*Westinghouse Electric Corporation*

DEVELOPMENTS in vacuum equipment and technique have made possible large all-metal vacuum systems operating at pressures as low as one millionth of a millimeter of mercury (one thousandth micron), a feat previously possible only on a laboratory scale. High-vacuum systems were extensively employed on the atomic-bomb project. In both the electromagnetic and gaseous-diffusion methods of isotope separation, vacuum systems of unprecedented size and capacity were needed, which required, among other things, the development of the world's largest diffusion pumps.

Accelerated drying under high vacuum has resulted in dehydrated foods in which the nutritive value and taste approach the quality of fresh foods. The common method of dehydrating food is by applying heat to hasten evaporation of moisture, resulting in destruction of food value and taste. With high-vacuum dehydration, less heat is necessary, as the lowering of pressure increases the rate of evaporation.

The seven circular units shown in the foreground mounted on the jig are electric heaters used in the diffusion pump to evaporate the oil and, by the resulting downward jet motion of the oil particles, drive off gas molecules by diffusion from the chamber evacuated.



Vacuums are also important in the metallurgical industry. Thermal reduction under high vacuum is applicable to many of the lower melting point metals, such as the reduction of magnesium from dolomite under high vacuum.\* Another possibility is the casting of metals in a vacuum to eliminate blow holes and reduce oxidation.

## Rotary Vacuum Pump

As shown by the sketch of a rotary vacuum pump in table I, air originally occupying the volume  $V_2$  is compressed by the rotor and vane and forced through a check valve into the atmosphere. Meanwhile, gas is drawn from the vacuum chamber into  $V_1$  until the rotor seals off the suction port and the process is repeated.

Back leakage around the vanes and rotor limits the ultimate pressure (lowest attainable pressure) of this type of pump to about five microns. In evacuating a vessel, the efficiency and therefore the speed of this pump drop off rapidly as the vessel pressure decreases until at the pump's ultimate pressure the pump efficiency is zero. Therefore, processes using rotary vacuum pumps are limited in practice to a pressure region considerably higher than the ultimate pressure of the pump.

\*See "Magnesium Sources and Manufacture," in *Westinghouse ENGINEER*, March 1944, p. 46.

TABLE I

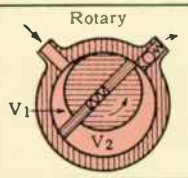
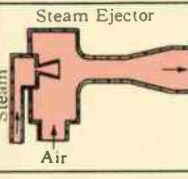
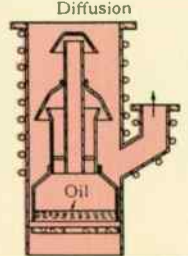
Type and Construction	Ultimate Vacuum		Maximum Exhaust Pressure		Speed Range (Intake Pressure)	
	Mm Hg	Microns	Mm Hg	Microns	Liters Per Second	Cubic Feet Per Minute
 Rotary	5 X 10 <sup>-3</sup>	5	760		1/2 to 356	1 to 750
 Steam Ejector	0.1	100	760		One Pound per Hour and Up	
 Diffusion	Booster		0.3 to 2.0	300 to 2000	50 to 300	105 to 630
	Primary		0.02 to 0.15	20 to 150	30 to 16 000	63 to 34 000

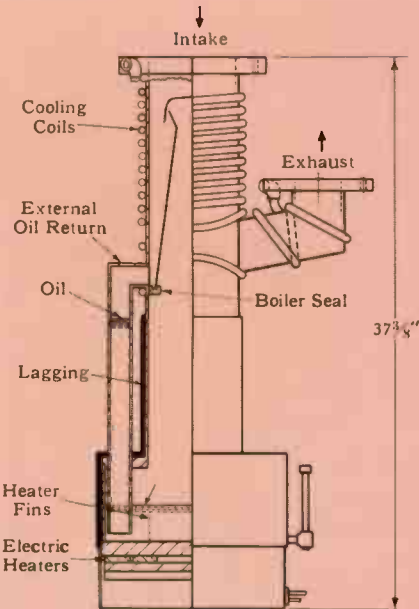

Fig. 1—A half-sectional view of a six-inch single-stage booster diffusion pump.

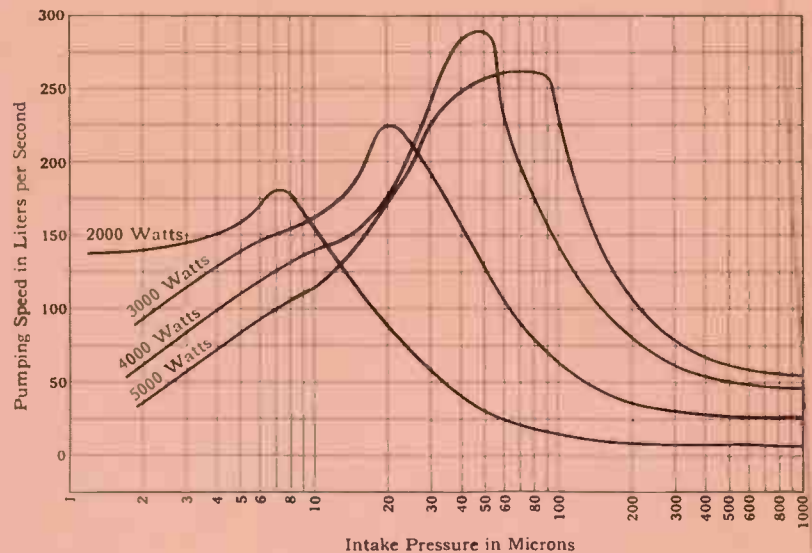

Fig. 2—Pumping-speed characteristics of a six-inch oil diffusion pump.

### Vacuum Diffusion Pumps

Where a higher vacuum than the mechanical pump limit is required, a diffusion pump must be used ahead of the rotary pump. The principle of diffusion as applied to vacuum pumps is not new, but the earlier pumps were constructed of glass and therefore were limited in size and capacity. The all-metal diffusion pump has removed these limitations. A typical two-jet oil diffusion pump is illustrated in table I (but the same general form holds for the diffusion pump using mercury instead of oil). Oil is rapidly evaporated in an electrically heated boiler in the base of the pump. This oil vapor is forced up central chimneys to the various jets. Leaving the top jet, the oil-vapor molecules travel downward and collide with the gas molecules that have diffused into this region.

In these high vacuums, the gas molecules are relatively few and far between, traveling great distances before colliding with each other. The diffusion pump has no means for reaching out and trapping these wandering molecules. It must wait until their devious paths bring them into contact with the vapor stream issuing from the jets of the pump. Once the gas molecules have diffused into the oil-vapor stream, they are given a downward motion and are slightly crowded together. The pressure to which this jet can compress the gas may still be too low for efficient operation of a forepump and additional jets may be required to compress the gas further. The oil vapor impinges on the water-cooled wall condenser, and returns to the boiler for re-evaporation while the gas is pumped off by the forepump. Because, at these extremely high vacuums, we must wait for the occasional gas molecule to wander at random into the pump before it can be removed, attainment of the last fraction of a micron of vacuum becomes increasingly difficult.

The entire action of the diffusion pump is through the motion of heated oil molecules. Hence it has no moving parts to wear or be maintained. The process is continuous in a closed cycle as soon as the oil is heated. It can be started and stopped by an inexperienced operator and once it is in action, no further attention is needed.

The incorporation of both high pumping speeds and high maximum exhaust pressures in the same pump is impractical. Diffusion pumps designed for high pumping speeds and high ultimate vacuum inherently have low maximum exhaust pressures. Likewise diffusion pumps designed for high maximum exhaust pressures have low speeds and low ultimate vacuums.

Inasmuch as nearly every vacuum application requires different pumping characteristics, diffusion pumps are most feasibly grouped into two types: the booster diffusion pump and the primary diffusion pump. Their principle of operation is the same and their construction is similar. Their physical differences result from the difference in volumes and pressures with which they must contend. Booster pumps have been built in various sizes up to ones requiring a four-kw heater. The largest size primary pump has a six-kw heater, although for convenience diffusion pumps of whatever type are identified by the diameter of the upper jet flange in inches. However, any diffusion pump is specifically rated in terms of volume pumping capacity which is measured in liters of gas handled per second at intake pressure.

### Booster Diffusion Pumps

The booster diffusion pump has been developed to operate against exhaust pressures as high as 2 mm for pumps using oil as a pumping medium and 25 mm for pumps using mercury. The maximum exhaust pressure, i.e., the highest pressure against which the diffusion pump can operate, is important because it determines the capacity of the supporting rotary pump. As the intake pressure of the rotary pump is increased, its efficiency and speed also are increased. Therefore, the maximum exhaust pressure of the diffusion pump should be as high as possible. A six-inch booster diffusion pump developed for use on the atomic-bomb project is shown in Fig. 1 and its speed and exhaust-pressure characteristics are shown by the curves of Figs. 2 and 3.

A booster pump requires a boiler pressure considerably greater than the exhaust pressure being pumped against. This high boiler pressure demands that the entrance to the oil re-



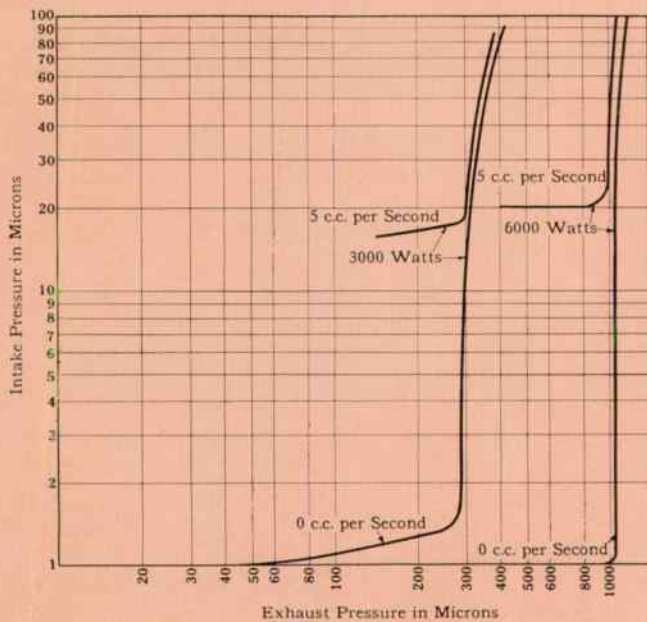

Fig. 3—Exhaust pressures obtainable with a six-inch oil diffusion pump.

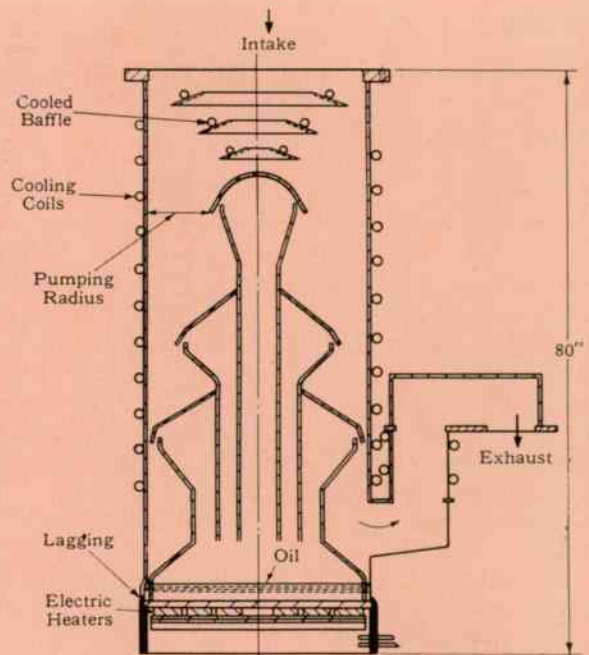

Fig. 4—Sectional view of a three-stage primary oil diffusion pump.

turn tube be located higher above the oil level than the difference in pressure between the boiler and the exhaust, else the boiler pressure would force oil into the exhaust port of the pump and stop its action. This in turn determines the location of the seal between the jet chimney and the boiler. Sealing the chimney to the boiler assures that the only oil vapor leaving the boiler is through the jet. The oil condensed on the walls of the pump collects at this seal and is returned to the boiler by the external oil return. Water cooling of the seal prevents re-evaporation of this oil before it returns to the boiler. Because the oil return is external, the surface of the fluid in the return is kept below the boiling point by air cooling, thus preventing rapid evaporation in the return system. Evaporation in the oil return results in a stream of oil vapor in a direction opposite to that of the main jet, a phenomenon known as backstreaming.

Single-jet booster pumps operate against higher maximum exhaust pressures than pumps with a multiplicity of jets. In a single-jet design, all oil vapor is released in a small region, thus creating a solid umbrella of vapor extremely resistant to backstreaming air molecules. The more solid this stream, the higher the pressure against which it can pump. As the amount of vapor evaporated is proportional to the area of evaporating surface and applied heat, this booster pump is designed with an expanded boiler providing a large evaporating surface and a large heater contact surface. To facilitate heat transfer, fins are welded to the boiler plates. Arrangement of heaters and fins is shown in Fig. 1.

Power is supplied to the boiler by electrical heaters clamped to the bottom of the boiler plate, and hence can be easily replaced when necessary. The boiler is well insulated to minimize heat loss to the atmosphere. A thermo-switch located on the pumps disconnects the heaters in case of water failure. The most recent form of six-inch booster pump is a compact unit weighing approximately 150 pounds that could be placed with room to spare in a small trunk, and it can be incorporated easily in any vacuum system. By comparison previous booster pumps were large and awkward.

### Primary Diffusion Pumps

The primary oil diffusion pump, Fig. 4, operates with higher pumping speeds than the booster pumps and obtains the higher ultimate vacuum. Unlike the booster pump, the primary pump must handle large volumes of relatively rare gases. The distance from pump wall to the outer diameter of the top jet, referred to as the "pumping radius," must be much greater to handle this increased volume. In consequence, the oil stream is spread out over a wide area. Because of this large pumping radius, the compression ratio across the top jet is small. Therefore, other jets with gradually decreasing pumping radii must be applied in series with the top jet to compress the gas sufficiently for efficient handling by a booster pump or a rotary pump. These large pumping radii afford low impedance to backstreaming gas molecules, permitting the primary pump to work only against low maximum exhaust pressure of 20 to 150 microns. This maximum exhaust pressure can be increased by increasing the power input. However, as the power input to the boiler is increased, an optimum pumping speed is obtained beyond which further power input results in decreased pumping speed with only a slight increase in the maximum exhaust pressure, Fig. 5. Therefore, to operate the primary pump at its optimum pumping speed, maximum exhaust pressure must be sacrificed.

Another phase of the atomic-bomb project required a mobile diffusion pump. A two-inch all-metal, high-speed, air-cooled pump was developed for this purpose. The cooling coils are replaced by copper fins brazed to the outside of the pump barrel and enclosed by a metal jacket. Cooling air is supplied by a small blower, resulting in a small, compact unit requiring only electrical connections.

### Pumping Mediums

The two main pumping mediums used in diffusion pumps are mercury and certain oils possessing low-vapor pressure. Early diffusion pumps used only mercury, which could be used only in applications where mercury was not objectionable. The poisonous effect of mercury prohibits certain uses.

TABLE II—MEAN FREE PATH OF AIR AT VARIOUS PRESSURES

Pressure, mm	Mean free path, cm
760	0.0000855
1.5	0.00434
$10^{-1}$	0.065
$10^{-2}$	6.50
$10^{-4}$	6500.0

Mercury pumps are ideally adaptable to such applications as mercury-arc rectifiers. Here the migration of mercury from the pump to the rectifier tank or from the tank to the pump does not interfere with the operation of either. If oil were used, migration in either direction would interfere with the operation of either the rectifier or the pump. One important advantage of mercury pumps is that maximum exhaust pressures up to 25 mm can be obtained.

Oil diffusion pumps can be employed in nearly any application as their oils are inactive and non-poisonous. These oils in general have lower vapor pressures than mercury and therefore, without cold traps, oil diffusion pumps can attain higher ultimate vacuum than mercury pumps. The highest ultimate vacuums are obtainable with the lowest vapor pressure oils. Representative oils are Litton Molecular Lubricants (Litton Engineering Laboratories), Amoil and Octoil (Distillation Products, Incorporated) and Aroclor 1254 (Monsanto Chemical Company). These oils have a tendency to 'crack' and form sludge at elevated temperatures and upon exposure to oxygen while still hot. Some metals when hot act as catalysts to the 'cracking' of the oil. Other metals, particularly copper, are corroded by the hot oils. Hence, use of these metals should be minimized. The recent availability of heat-resistant silicone pumping oils (Dow Corning Corporation) offers promise of operating boilers at higher temperatures and pressures. Because silicone oils are stable at the temperatures involved, the pumps can be opened while they are still hot.

### Baffling

When migration of pumping fluid from either the intake or the exhaust of a pump is undesirable, some form of baffling is

necessary. In the design of baffles an important factor is the molecular mean free path, or the mean distance a molecule travels between collisions, in the region of baffling. In the high-vacuum regions where the mean free path is extremely long (see table II), effective baffling must be practically opaque. Where higher pressures are encountered as at the exhaust of a booster pump, the mean free path is short, resulting in a mass flow of gas rather than diffusion. Opaque baffling alone is not adequate and must be augmented by contact with large cooled surfaces. Baffles are commonly cooled by water, refrigeration, or liquid nitrogen.

Where a large quantity of gas flow is encountered as in booster pumps, large quantities of oil are swept out the exhaust. This would soon result in a complete depletion of boiler oil in the pump, stopping its pumping action, and destruction of the heater. A baffle must, therefore, be inserted at this point to collect and return this oil to the boiler.

The insertion of baffles in a vacuum system offers an impedance to air flow and results in an increased time of evacuation and a decrease in the system pumping speed. In a system in which gases are continually evolved, this loss in pumping speed caused by baffling is apparent as an increased pressure in the vacuum vessel.

### Typical Vacuum System

The schematic diagram of a complete portable vacuum pumping unit including the primary oil diffusion pumps, booster oil diffusion pumps, a rotary vacuum pump, vacuum valves, refrigerated baffles, and pressure measuring devices is given in Fig. 6.

In some applications the system must intermittently be opened to atmosphere and then evacuated. As diffusion pumps should not be opened to high pressures while hot, either cooling down and reheating periods are necessary, or some means provided to isolate these pumps from high pressures. A bypass connection and necessary valves around the diffusion pumps permit the rotary vacuum pump to exhaust the system to a pressure safe for the operation of diffusion pumps. Thus the diffusion pumps can be kept hot continuously, shortening the pumping cycle. This unit requires only water and power connections, and is portable, enabling it to be rolled to

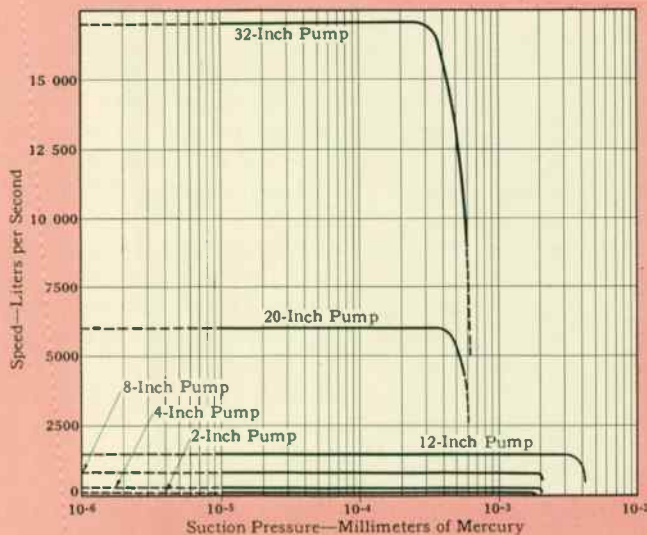
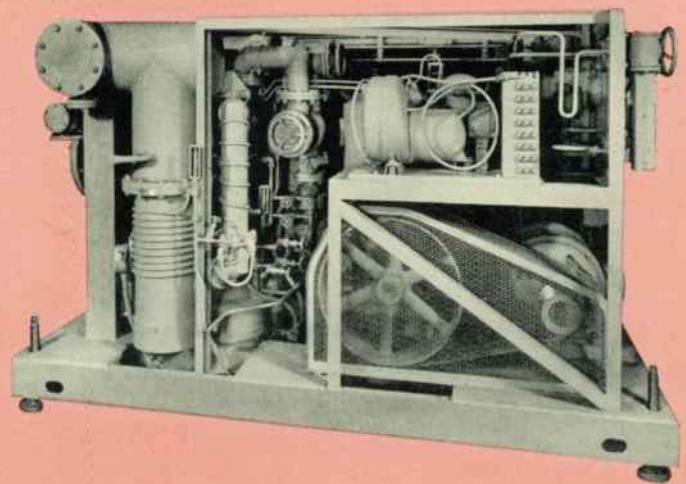

Fig. 5—Pumping performance of primary diffusion pump.



A complete pumping system may require several diffusion pumps, a rotary pump, and miscellaneous pipes and valves as seen in the above assembly mounted on a truck for mobility about a plant.



Fig. 6—Typical arrangement of a vacuum system consisting of a rotary vacuum pump and two sets of primary and two booster diffusion pumps paralleled.

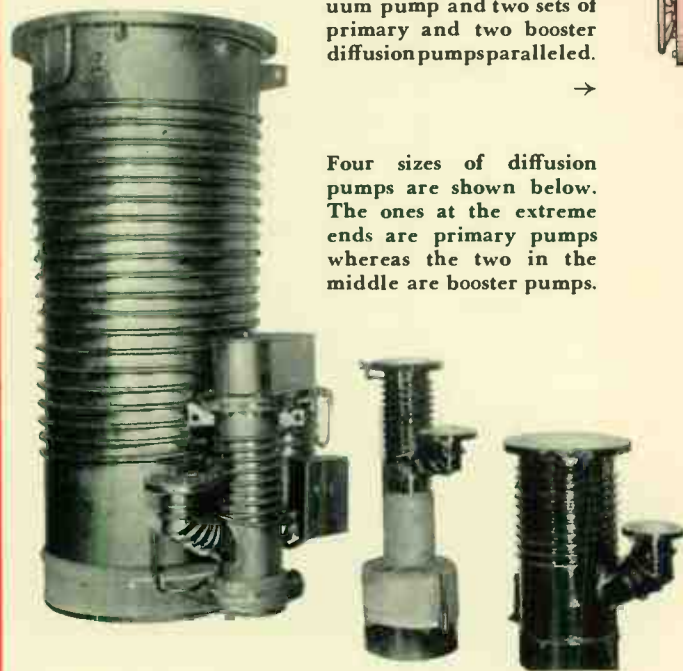

Four sizes of diffusion pumps are shown below. The ones at the extreme ends are primary pumps whereas the two in the middle are booster pumps.

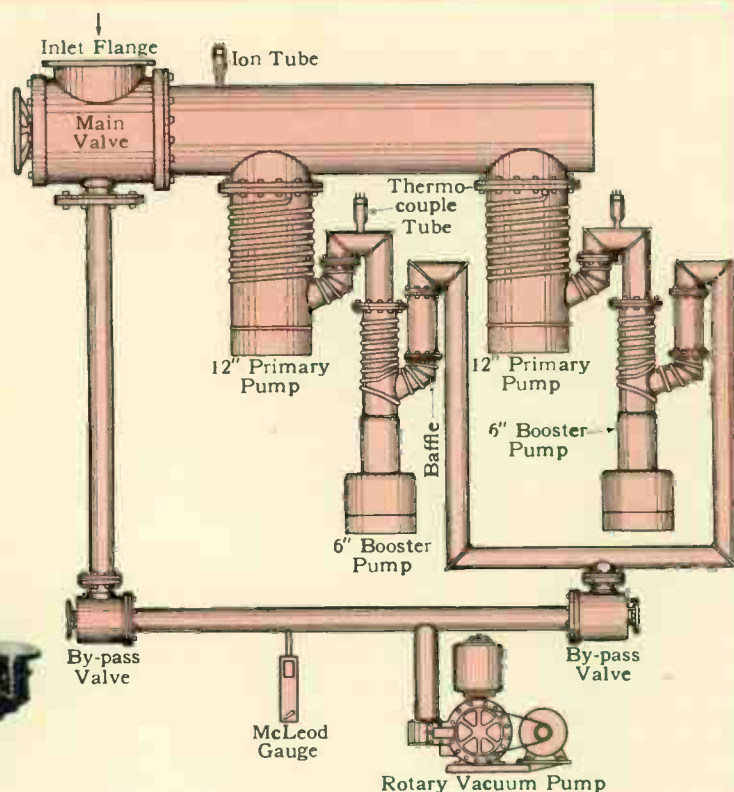

any part of the factory where a vacuum is needed.

Of the various available pressure-measuring devices, the ones most commonly used in commercial systems are the McLeod gauge, thermocouple gauge, and ionization gauge. The ionization gauge, having a range from  $10^{-7}$  to  $10^{-2}$  mm, is used to measure the highest vacuums. This gauge contains an electronic tube whose envelope is connected to the vacuum system. Ionization taking place in this tube is proportional to pressure, and therefore the positive ion current can be calibrated against the pressure. The thermocouple vacuum gauge measures vacuums from  $10^{-4}$  to 1 mm. As the thermal conductivity of a gas is proportional to pressure, the temperature of a filament heated by a constant current is proportional to the pressure. This temperature, which is measured by a thermocouple whose hot junction is attached to the filament, can be calibrated against pressure. The McLeod gauge measures pressures from  $10^{-4}$  to 5 mm and is manually operated. In this gauge a large known volume of gas is compressed to a smaller known volume. The pressure required to compress this gas is a measure of the unknown pressure, the calibration being calculated from the dimensions of the gauge.

In the pressure region where the mean free path of the gas molecules is comparable to the vessel dimensions, very careful gas flow considerations are necessary. In this region the impedance to flow in a pipe is inversely proportional to the third power of the diameter ( $d^3$ ). For the necessary mass flow the volumetric flow must be extremely large and the impedance as small as possible. Therefore, short, large diameter pipes and a minimum of bends and valves should be used.

### Leak Hunting

With the advent of large all-metal systems came the immense problem of finding the leaks due to porous material, poor welding, bad gasket joints, etc. This problem was quite different from the one encountered in glass systems where the

leaks were readily found with a Tesla induction coil. Until recently, the methods most commonly employed were:

1. Water submersion test. Gas pressure is applied to the inside of the vessel and the vessel submerged under water. Bubbles will be observed rising from the leaks. This method is adaptable only to small vessels or systems.

2. Halide-torch method. Freon gas under pressure is introduced into the vessel being tested. The gas escaping from leaks is sucked into a special acetylene torch (halide torch) causing the flame to change color.

3. Soap-bubble method. In this test also, gas pressure is applied to the inside of the vessel. A solution of soap and water is brushed over the suspected joints. Gas escaping through leaks forms soap bubbles.

All of these methods detect leaks of approximately the same order of magnitude, though none will detect extremely small leaks. The magnitude of leakage of any section of a vacuum system can be determined by evacuating this section and noting its rate of pressure rise when completely isolated. Hence, testing time is shortened as the above methods need be applied only to the sections with excessive leakage.

The necessity for detecting extremely small leaks became acute with the development of large, metal, permanently sealed-off ignitrons. The solution to this problem was the development of the electronic leak detector, an instrument capable of detecting leaks 1/500th of the magnitude of any previously detectable by any other method. This instrument is described in detail in a companion article in this issue.

No limit has yet been reached as to size and capacity of vacuum pumps and systems. The development of new pumping mediums may make possible vacuum pumps with greater pumping speeds and higher maximum exhaust pressures. These factors, along with the new advances in vacuum equipment design and leak-hunting techniques, promise an ever-increasing use of this tool in industry.

---

# Detecting Vacuum Leaks Electronically

---

Hand in hand with every great new machine or process must go some method of measurement adapted to it. Industrial use of large volumes of gases at extremely high vacuums has demanded a method of leak detection many times more sensitive than those previously available. Electronics has again provided the answer.

H. A. THOMAS      T. W. WILLIAMS      J. A. HIPPLE  
*Westinghouse Research Laboratories,  
Westinghouse Electric Corporation*

VACUUMS have long been an important industrial tool, but the recent great increase in their use and the introduction of several new applications have demanded new methods of leak detection and measurement. The atomic-bomb project required vacuums of extreme hardness and on a scale never before imagined. Fortunately the ability to create extreme vacuums on an extensive commercial basis<sup>1</sup> has been matched by a new means of leak hunting. It is based on the use of the mass spectrometer,<sup>2</sup> a device, incidentally, that distinguished itself otherwise on the Manhattan project as being the basis of one of the three successful types of isotope separation.

The electronic leak detector, as shown in Figs. 1 and 2, consists of a small cabinet on wheels for mobility about the plant. The general scheme of its operation is to explore the piping or reservoir of the vacuum system with a tiny jet of helium. Some of the gas from the evacuated system is drawn off and passed through a mass-spectrometer tube as indicated in Fig. 3. This tube is designed specifically for the detection of helium so that as the helium probe is played slowly over all suspected areas any leak is quickly registered on the output meter of the mass-spectrometer tube. Because the mass-spectrometer tube

separates and measures the helium present in the system under test in spite of the presence of other gases, it makes an extremely sensitive detector. The instrument can detect as little as one part of helium in 400 000 parts of air at an operating pressure of 0.3 micron of mercury.

The time required for the gas flow to reach an equilibrium depends upon the size of the system and upon the pumping speed. It may require several seconds in the case of large systems but is usually much less than this. Not only can the leaks be detected very rapidly, but they also can be located accurately; if a fine jet of helium is used, it is ordinarily possible to locate the leak within a quarter of an inch.

## The Mass-Spectrometer Tube

The principles of operation of the mass-spectrometer tube are given in Fig. 4. Electrons emitted from a hot filament are accelerated by a potential difference of 100 volts between the filament and plate 1. Approximately 80 percent of the electrons in the electron beam pass through the slit in plate 1 because they are focused by a magnetic field. The ions produced by the electron beam are drawn out through the other slit in

Fig. 1—An operator plays a tiny stream of helium over the evacuated chamber. Small samples of the gas in the vacuum system are drawn off into the mass-spectrometer tube of the leak detector. The tube is set to be sensitive to helium atoms and quickly registers their presence in the system on the recording instrument.

Fig. 2—A view of the leak detector from the rear, with covers removed, shows at the top the mass-spectrometer tube, magnet, and amplifier unit. Power supplies are in the two shelves immediately below. In the section at the left are the rotary and diffusion pumps for maintaining vacuum in the mass-spectrometer tube.

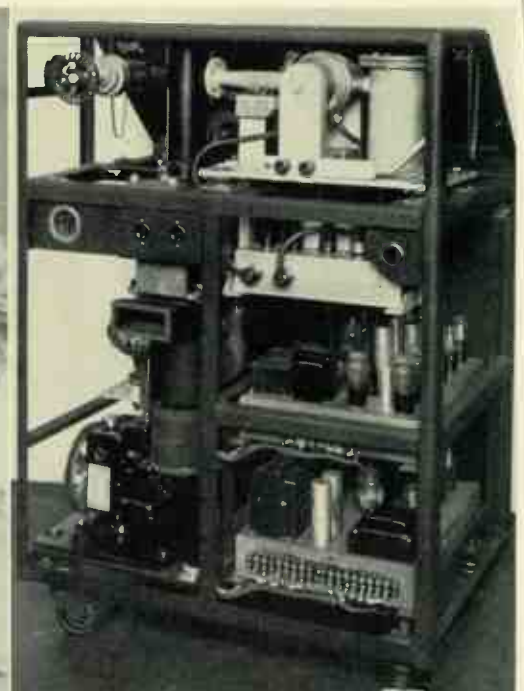



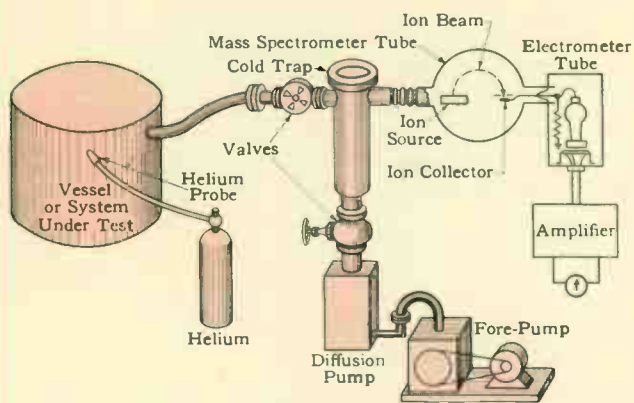

Fig. 3—The manner of leak hunting is indicated by this schematic arrangement of the leak-detector components.

plate 1 by the few volts potential difference between plates 1 and 2. The ions are then accelerated through the slit in plate 3 by a potential difference of 350 volts. Because the ions are traveling at right angles to the magnetic field, they move in circular paths whose radii, for constant field strength and ionizing potential, are dependent solely on the masses of the ions and their charge, which will be some multiple of the electron charge. Thus a singly charged helium ion will move in an arc of certain radius, and any other singly charged ion (except hydrogen) will move in an arc of larger radius because it is heavier. In the tube shown in Fig. 5 the radius of the helium-ion path is 3.5 centimeters, which requires a field strength of approximately 1540 oersteds when helium ions are accelerated through a potential difference of 350 volts.

After traversing a 180-degree circular path, the ions of a given mass are focussed and pass through the slit in plate 4 to the collector plate. From the collector plate the ion current flows to ground through a high resistance. An electrometer tube and amplifier across this high resistance provide a current proportional to the ion current. This final current produces an indication on the output meter.

The tube and magnet assembly is constructed so that the Alnico magnet can be rotated to one side and a cover-plate removed from the tube, allowing access to the tube interior. The filament, which is a plug-in type, and the ion source are both readily removable for cleaning or replacement. This type of construction is particularly important where the instrument is to be operated by relatively unskilled operators in industrial plants.

An emission regulator using the feedback principle holds the total emission from the filament constant, and a regulated power pack supplies the various electrode voltages.

Also mounted in the tube and utilizing the same magnetic field is a Phillips' ion gauge<sup>3&4</sup> for monitoring tube pressure.

#### Ion Current Amplifier

The ion-current amplifier is of the balanced d-c type employing 100-percent negative feedback. The electrometer tube has an input resistance of  $2 \times 10^{11}$  ohms and is followed by two high-gain stages and a cathode-follower output. Because all of the output voltage is fed back to the input, the voltage gain is unity. The current gain, therefore, is the ratio of the input impedance to the output impedance, and is approximately two hundred million. The negative feedback contributes appreciably to stability and also reduces the time constant of

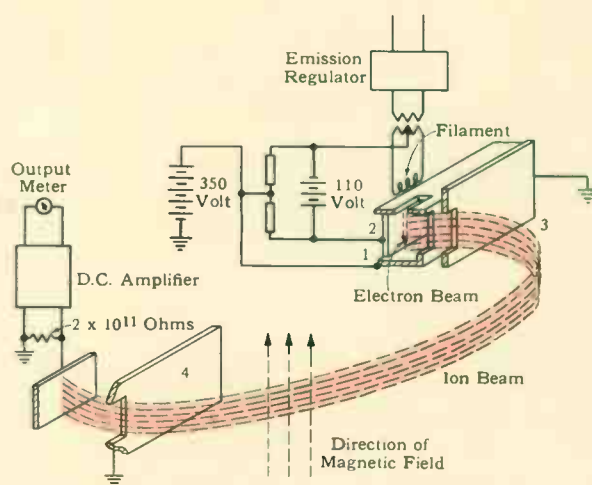
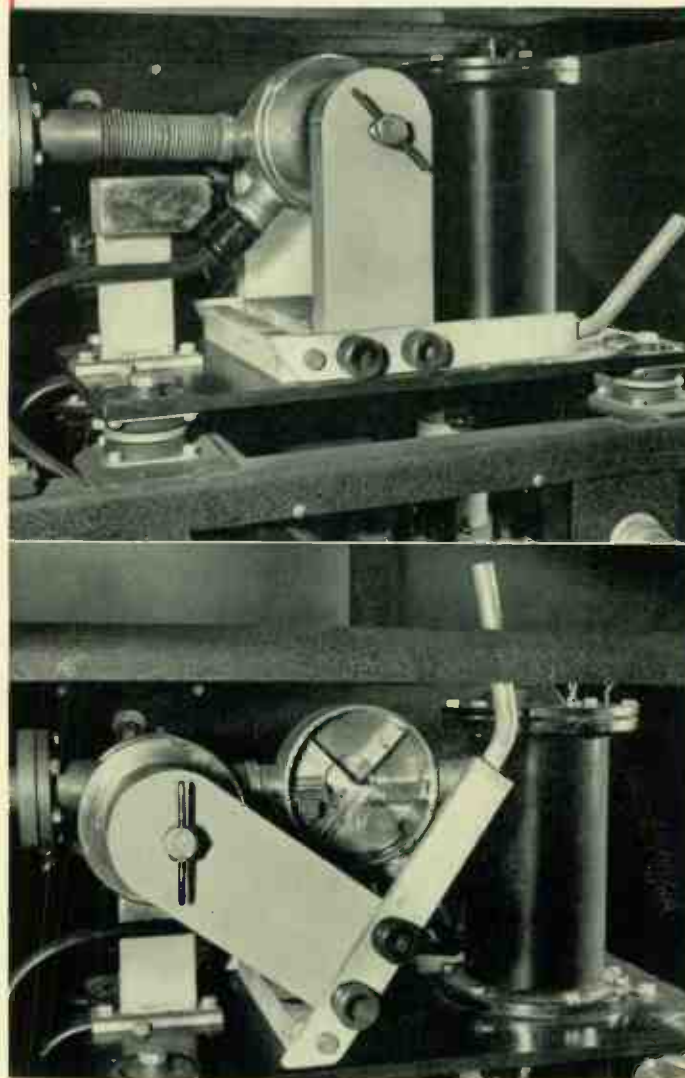

Fig. 4—The principles of operation of the mass spectrometer are shown by this combination electric and physical circuit.

Fig. 5—The top view shows the mass-spectrometer tube in normal operation. The gas sample enters at the left to the tube in the center. In front and behind the tube are the magnets. The amplifier is in the right vertical cylinder. The view at the bottom shows the magnets swung aside and the cover plate to the tube removed exposing filament and slits.



the input circuit<sup>5</sup> so that the response is essentially that of the output meter.

The stability is further enhanced by using a well-regulated power pack to supply the filament current of the amplifier tubes as well as the various electrode voltages. The stability is good enough so that ion currents producing deflections of the meter as small as five percent of full scale on the most sensitive range are easily detected. This corresponds to an actual ion current of approximately  $10^{-14}$  amperes, i.e., one hundredth of a millionth of a millionth of an ampere.

When searching for leaks, the magnitude of ion currents ensuing cannot be predicted. The meter is accordingly protected by a relay circuit that automatically prevents it from going off scale on any range, and energizes a warning light so that the operator can change the meter range switch.

The output meter with the necessary operating controls is mounted in a small portable box connected to the console by a long cord. It is also possible to use an audible signal instead of a visual one. This box can be placed anywhere convenient to the operator using the helium probe without moving the console. This makes the entire leak-hunting procedure essentially a one-man operation.

As shown in Fig. 3, the leak detector has its own vacuum system so that it may be operated independently of the system under test. The two-inch diffusion pump used is air-cooled, thus requiring no water connections. Throttling valves are used so that pressure in the test vessel may be higher than the operating pressure of the tube. Also included in the vacuum system but not shown in Fig. 3 is a by-pass valve for admitting air to the tube when a filament is to be replaced without the delay of cooling the diffusion pump.

The speed of the pumping system is sufficient to handle test vessels with low outgassing rates, but large vessels require an auxiliary pump. It is possible to find relatively small leaks even with an auxiliary pump.

It is necessary to operate the mass-spectrometer tube within a certain pressure range. The tube is equipped with a Phillips' ion gauge which has a linear response in this range. At the same time, it serves as the basis for a filament protective device by automatically opening the filament circuit when the pressure rises above a safe operating value. The ion gauge consists of a cylindrical metal can containing a metal ring that is 1000

volts positive with respect to the can. A magnetic field in the direction shown in Fig. 6 is also necessary.

The few free electrons produced by cosmic ray and other stray radiations oscillate in the direction of the magnetic field because the field does not allow them to fall onto the anode (ring) until they have been deviated to it by a number of collisions with gas molecules. These electrons produce further ionization until a sustained glow discharge takes place, the current of which varies with pressure. By the proper choice of dimensions, series resistance, and voltage, the current can be made approximately a linear function of the pressure over a given operating range. The Phillips' ion-gauge current is quite linear over the range of pressures at which the mass-spectrometer tube is normally operated. This is shown in Fig. 7. The Phillips' ion-gauge current actuates a relay that cuts off all of the mass-spectrometer electrode voltages if the pressure rises too high for safe operation of the tube.

Since electrometer tube amplifiers of the type used here are usually affected adversely by shock and vibration, the tube and magnet assembly and the amplifier are mounted on a single steel plate supported from the frame by rubber shock-proof mountings. Furthermore, the electrometer tube and input resistor are mounted in a heavy shield-can, which is an integral part of the mass-spectrometer tube. Evacuation of this can by means of the forepump insures maintenance of the high input resistance.

To remove moisture and pumping-oil vapor from the gas sample the detector employs a cold trap. It is of the type that holds its own cooling liquid and liquid nitrogen may be used with it.

The leak detector is self-contained except for a source of 110-volts, 60-cycle power. The unit draws less than one kilowatt of power. No water connections are necessary.

Several of these instruments have been in continuous operation in war industries for some months. One instrument operated continuously for more than 900 hours. In that period the filament life averaged over 150 hours although unskilled operators were using it.

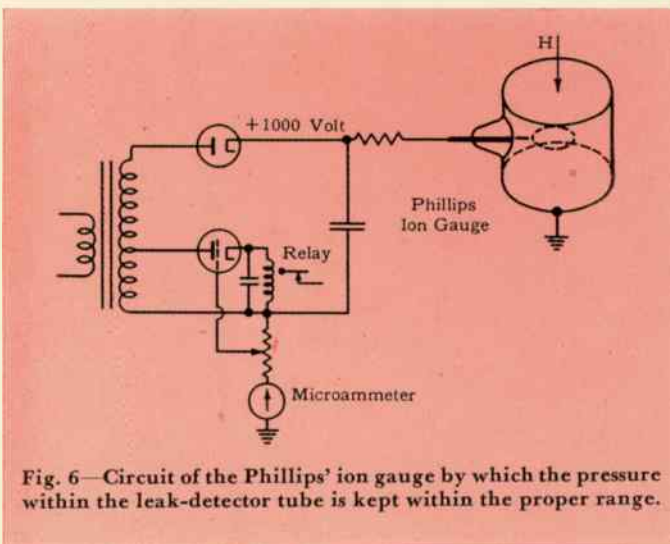

Fig. 6—Circuit of the Phillips' ion gauge by which the pressure within the leak-detector tube is kept within the proper range.

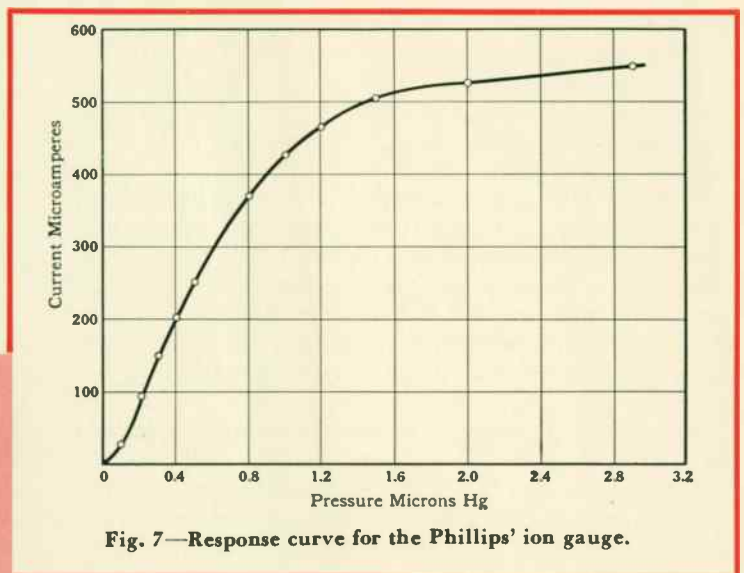

Fig. 7—Response curve for the Phillips' ion gauge.

#### REFERENCES

- 1—"High-Vacuum Techniques" on p. 103 of this issue.
- 2—"The Mass Spectrometer for Gas Analysis," *Westinghouse ENGINEER*, J. A. Hipple, November, 1943, p. 127-30.
- 3—"The Glow Discharge at Low Pressure Between Coaxial Cylinders in an Axial Magnetic Field," *Physica*, Vol. III, F. M. Penning, p. 873 (1936).
- 4—"A New Manometer for Low Pressure, Particularly Between  $10^{-3}$  and  $10^{-4}$  mm," *Physica*, Vol. IV, No. 2, F. M. Penning, p. 71 (1937).
- 5—"Electronics of the Mass Spectrometer," J. A. Hipple, D. J. Grove, and W. M. Hickam, *Electrical Engineering*, p. 141, April, 1945.





Phosphate ore is mined with draglines like this latest walking type with a 215-foot boom and a bucket capacity of about 25 tons.

---

## The Mining and Processing of Phosphate

---

In the catalogue of mineral resources, phosphate rightfully ranks high. Life as we know it would be impossible without phosphorus, for the structure, growth, and well-being of all living things—plant, animal, and man—depend on phosphorus, and it has no substitute. The chief role of phosphates thus inevitably is agricultural—in replenishing the soil. At the same time, the unusual chemical activity of phosphorus makes it a powerful catalyst in chemistry and industry, in addition to its value as a basic material, alone or in compounds. It is thus fortunate that the phosphate resources of the United States are practically inexhaustible.

ONE of the most important of the non-metallic mineral resources of the United States is phosphorus. Like organic nitrate, well known as fertilizer and ordnance raw material, mineral phosphate occupies a twofold strategic role in the national economy. Not only is it a chemically significant industrial material, but it is an essential, growth-producing element in agriculture; and commercially it ranks high in importance among the non-ferrous minerals.

Abundant in nature, phosphorus is so active, however, that it is never found in a free state, occurring in natural deposits of rocks and minerals as a phosphate—an oxidized form. The mining and recovery of this ore is the first necessary step in the production of usable phosphates, and a large domestic industry, characterized by modern progressive engineering and technological methods, has grown up within the last fifty years, producing approximately five million tons of phosphate annually—half the world's production.

Nearly nine tenths of the phosphates go into fertilizers to replenish fields that have given up their store of phosphorus

to crops. The remainder is used by the chemical industry in many ways. During the war, half of this latter portion went into the production of smoke bombs, grenades, and tracer shells. The smoke-screen role of phosphorus depends on its unusually high obscuring power. Phosphorus smoke does not block light, but effectively distorts visibility. At Anzio, for example, no ships were lost to air attacks after phosphorus smoke screens were laid, and the fleet at Okinawa hid successfully from the Kamikaze planes beneath such screens. Moreover, its value as an incendiary and the severe contact burns which it can inflict make it a dreaded weapon.

In addition to ordnance use, phosphates also go into the manufacture of phosphoric acid and phosphorus compounds. Some phosphoric compounds act as catalysts in many chemical reactions. Various other compounds are used in the manufacture of penicillin, sulfa drugs, and atabrine. The fireproofing of woods and textiles is achieved through ammonium phosphates while phosphoric acid is used for metal rustproofing. Metallic phosphates are important in ceramics and pharmaceuticals, as detergents, and as water softeners.

Phosphorus compounds are also important in the food industry. Monocalcium phosphate, for example, is one of the

Prepared by Hugh Odishaw of the Westinghouse ENGINEER staff from published material and information provided by executives and technical experts of the International Minerals & Chemical Corporation.

Phosphate ore, scooped out of the mining pit by draglines, is unloaded along the strip where water under pressure is used to create a slurry of sand, phosphate, clay, and water (center). The slurry flows into a well and is then pumped through 14-inch pipes to the washer plant (right) where successive screenings and washings isolate phosphate particles larger than the sand. Further recovery requires the more elaborate techniques of flotation.

most important industrial compounds, and finds extensive application in the food industry as a leavening agent in baking powders and flours and as a conditioner for salt, sugar, and soda to prevent caking. It has a place in the manufacture of beverages, sugars, yeast, ice-cream, processed cheese, and jellies, and is sometimes added to foods as a mineral supplement.

By far the most important role of phosphates in the national economy lies in their contribution to soil fertility, for phosphorus is an indispensable element associated with the beginnings of all forms of life. Not much is known about how or why this is so. But it is known that the nucleus of every living cell, whether plant or animal, is rich in phosphorus. Phosphorus is needed in cell division and in the formation of fat and albumen. It hastens the maturation of crops, encourages root development, and increases disease resistance. In men and animals phosphorus compounds are responsible for bone and tooth structure and have no substitute.

The eventual source of all phosphorus for living things is the soil. Where phosphorus is lacking in the soil, crops do not grow and develop fully, even though their superficial appearance may not reveal it, and eventually men and animals suffer from the deficiency. The significance of phosphates in agriculture, and more broadly in the national economy, can only be understood in terms of the role of the ten or eleven minerals—phosphorus, potassium, sulphur, calcium, magnesium, iron, manganese, copper, zinc, boron, and molybdenum—that provide structure and growth in all growing things and which permit plants to utilize the organic elements—carbon, hydrogen, oxygen, and nitrogen—in the formation of energy-giving compounds. The organic elements are not, strictly speaking, a fundamental contribution of the soil. These elements come from the atmosphere in one fashion or another, and the contribution of the soil—its fertility—consists of the above minerals.

Thus, both from an agricultural point of view and from a biological one the soil must be replenished where harvested crops in the past have already exhausted or where erosion and leaching have dissipated the natural stores. Prior to man's civilizing activities, soil deficiencies were by and large

unknown. Food from the soil was absorbed by plants. The plants then decayed, returning the minerals and nitrogen necessary for succeeding generations. Or else the plants were consumed by animals, but these in turn died on the soil, returning their borrowings. Contemporary society, however, had disrupted this natural cycle. Crops are harvested and animals are slaughtered for human consumption in one form or another. The net effect is to make unavailable astronomic quantities of mineral and organic compounds: these must be made up if decreasing productivity and decreasing nutritional values are to be avoided.

Fortunately, plant requirements for the critical minerals are exceedingly small, and the supply in the soil is adequate despite depletions—with the exception of phosphorus, potassium, and nitrogen. These three elements make up current fertilizers. Their importance is gradually being realized (see table I), although only a beginning has actually been made in this direction, for the concept of plenty has largely prevailed as a national philosophy.

#### Phosphate Deposits

Phosphate rock exists in many forms, ranging from soft sand and gravel types to massive, hard-rock types and varying in color from white to black. The chief chemical constituents of the ore are calcium, phosphorus, and fluorine in a com-

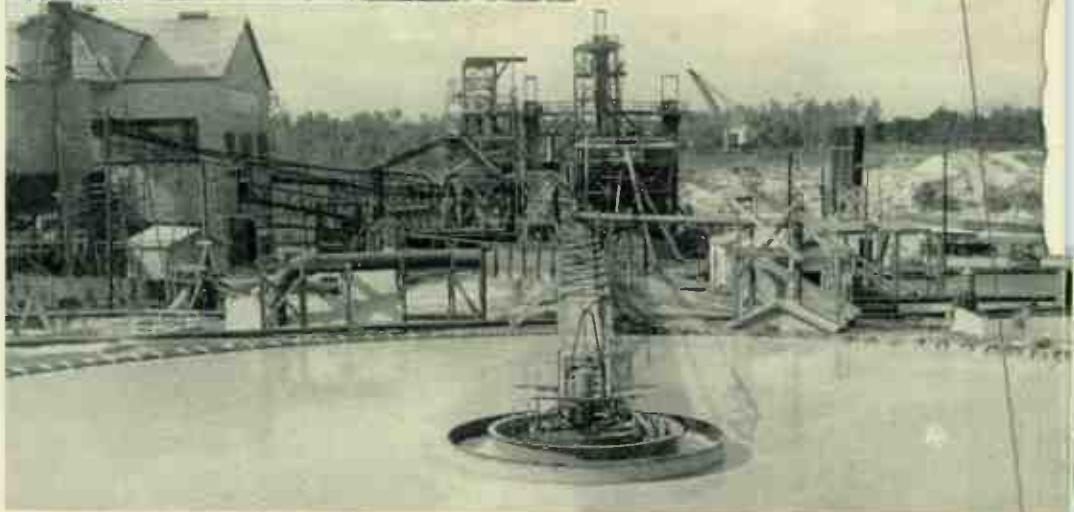
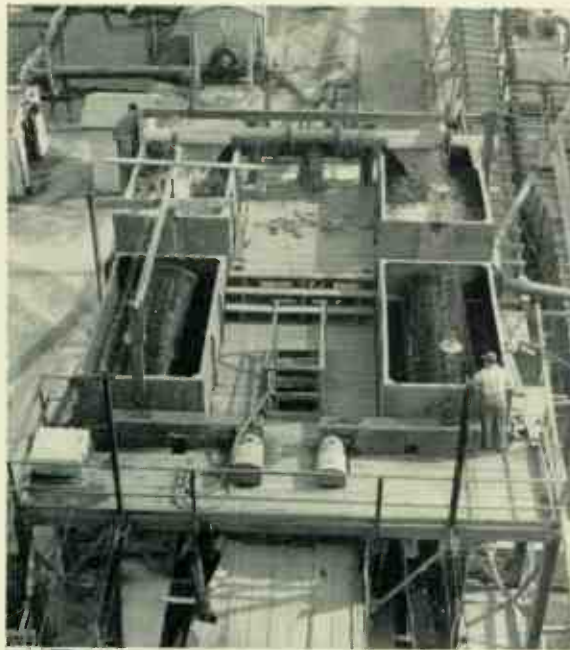





For fine phosphate recovery, clay, slime, and unclean water are removed by hydroseparators (extreme lower left). Sizers divide the mixture into 1 mm to 35 mesh, in which gravity separation of sand and phosphate is possible using reagents and special vibrating tables (lower right), and 35 to 150 mesh. The latter must be treated with reagents that effect separation by attracting air bubbles and float first the phosphate (left) and then the sand.

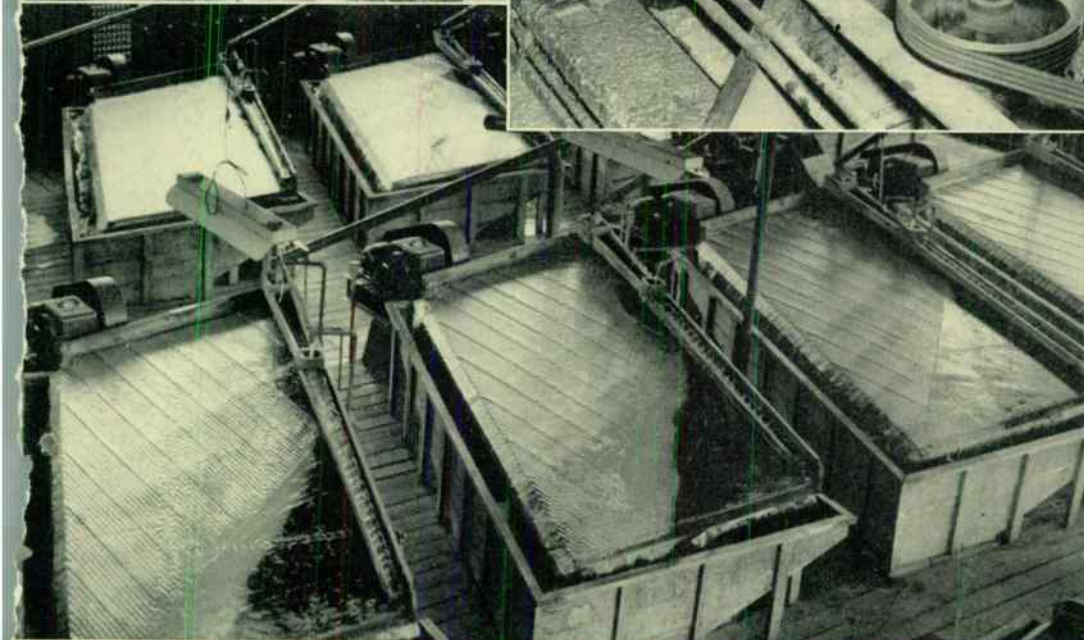

serves alone will last 2000 years. If other reserves are considered— possible reserves and inferior grades, the deposits withdrawn in 2 000 000 acres of the Western Field and 66 000 acres in the Florida field not examined in the estimate, and deposits in the Western Field ignored because they are not in the main field—it is evident that our phosphate resources are practically unlimited. This is fortunate, for the availability of such extensive deposits is doubly significant in this period when certain other resources, like petroleum and some metals, are approaching depletion. Not only must soil fertility be maintained for the sake of food, clothing, and shelter in the traditional sense, but for the sake of crops that can be synthesized into fuel alcohols and plastics as substitutes for vanishing raw materials like petroleum and certain metals.

plex compound known as fluor apatite— $3\text{Ca}_3(\text{PO}_4)_2 \cdot \text{CaF}_2 \cdot \text{CaCO}_3$ —but often referred to as tricalcium phosphate or bone phosphate of lime (B. P. L.). The quality of the ore and of the recovered product is determined by the percent of B. P. L. present. Commercially acceptable phosphate rock ranges from 66 to 77 percent B. P. L., the remainder consisting of various impurities, including calcite, magnesite, quartz, clay, pyrite, and organic matter.

The principal source of phosphates in the United States consists of phosphate rock deposits scattered in a dozen states. The nature of these deposits and the methods of operation vary, depending chiefly on whether the ore is hard or soft and on whether the deposits are near the surface or deep within the earth. The most important field lies in Florida where both hard rock and soft pebble deposits are found while Tennessee ranks second in commercial importance. Phosphate rock is also available in Georgia, Alabama, North Carolina, South Carolina, Kentucky, Arkansas, and in the so-called Western Field—Utah, Idaho, Wyoming, and Montana where the ore is mined in tunnels like coal.

Conservative estimates indicate that there are more than ten billion long tons of phosphate ore in these fields (table II), exclusive of possible reserves and of certain phosphatic limestone deposits in Florida and Tennessee. At present rates of usage—about five million tons annually—the estimated re-

### Prospecting and Mining

The mining and recovery of phosphate rock in Florida involves five rather well defined steps. First, a region which is to be mined soon is carefully prospected, in spite of the fact that initial and cursory prospecting has indicated the presence of phosphate rock. A detailed analysis of the deposits prior to mining establishes more definitely the value of the deposits, the extent to which the overburden of earth must be cut and removed, and the depth to which mining can proceed. The next step consists of mining, using draglines both for overburden removal and for digging out the phosphate-bearing ore. The third phase consists of washing the ore, screening out the bulk of the phosphate rock. Still more rock—the finer and smaller portion—is recovered in the flotation recovery plant. Finally, drying and pulverizing prepare the rock for shipment as commercial phosphate.

The operations and procedures of the International Minerals and Chemical Corporation can be taken as typical. International, the largest single producer of phosphate rock in the United States, is active in Florida, Tennessee, and the Western Field. The Florida mines of International are located at Peace Valley, not far from Lakeland and Tampa, the largest phosphate mines in America. Here the deposits of soft, pebble rock are embedded in a matrix of earth 5 to 20 feet thick and 10 to 30 feet below the surface.



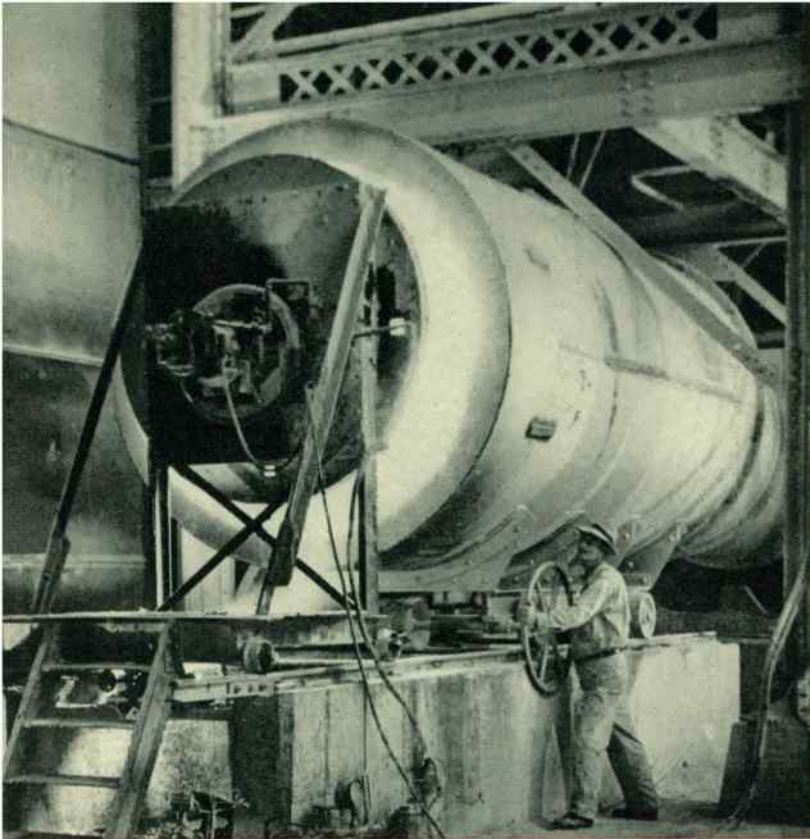

Phosphate ore recovered in the washing and flotation plants is dried in giant, oil-fired rotary kilns like the one above. The ore is then pulverized into a powder, ready for storage, bagging or shipment.

Once mining has been decided upon, a long rectangular strip, at least a quarter of a mile long and about 200 feet or more in width, is cut by two electrically driven draglines. Working closely together, one dragline removes the overburden, piling it along the mined strip. The second dragline follows, scooping out the ore and also widening the cut. This cooperative action reduces the time lost in dragline movement and provides cuts of maximum width for dragline reach. For overburden removal, International uses a dragline having a 150-foot boom and a 9-cubic yard bucket and, for ore digging, one with a 125-foot boom and a 5-cubic yard bucket.

The most recent dragline added by International is a Westinghouse-equipped Bucyrus-Erie walking dragline. Called "Bigger Digger," this 2 571 000-pound dragline has a 215-foot boom and a 21.4-cubic yard bucket. Two huge "shoes," each 9 by 54 feet, permit Bigger Digger to walk at a speed of 0.11 mile per hour. The length of the boom, capacity of the bucket, and the ability to move freely (in contrast to the ordinary dragline which must move on mat-placed tracks) permit this single dragline to conduct stripping and matrix mining simultaneously. Thirty-eight motors—the largest rated at 1250 hp, the smallest  $\frac{1}{2}$  hp—are required as drives and in various auxiliary capacities.

The dragline scoops the ore—over twenty tons at a time by Bigger Digger—and unloads it at the side of the strip. Here the phosphate-rich earth is sluiced into a sump by two hydraulic guns playing water at from 65 to 100 psi, depending on the adhesiveness of the matrix. From the sump, the slurry is pumped to the washer plant. The pump, along with its motor and controls, is mounted in a portable pitcar for convenience in moving with the mining of successive sectors.

#### Washing and Flotation

The slurry of water, phosphate pebbles, sand, and clay is pumped to the washer plant in the mine field through 14-inch pipes. The matrix thus mixed in with the pumping water

consists of approximately 50–60 percent phosphate rock, 10–25 percent sand, and 15–40 percent clay, depending upon the nature of the field or even a particular portion of a field. The washer plant, consisting of a series of screens and washing machines, can separate all the phosphate rock larger in size than the accompanying sand. At times this amounts to only 10 percent or less of the phosphate present in the ore.

The slurry, divided into two channels for rapid segregation, passes over successively finer meshed screens. Sprayers wash off the clay. A hammer mill breaks up unduly large aggregates and these are reintroduced into the system. The successive screen overflows in the washer plant consist of the larger sized phosphate pebbles, essentially free of sand, gravel, clay, and slime. These particles are stored in bins, ready for shipment to the drying and grinding plant.

The successive underflows, on the other hand, consist of small particles, mostly phosphate rock and sand, plus minute particles of clay and some slime. This slurry is pumped to the flotation plant. The problem here is to separate the sand and phosphate. In the past, this was thought impractical because no simple, mechanical method of separation is possible. Yet this mixture is rich in phosphate rock, accounting for 90 percent of the ore phosphate, and one of the engineering innovations in the phosphate industry has been the flotation method of separating these minute but extensive particles of phosphate.

A series of three hydroseparators removes most of the water and the most finely divided, irredeemable matter (smaller than 150 mesh), which are pumped to artificial lakes for clarification before the water is allowed to return to the area's water system. Agitating machines separate the desired underflow of the hydroseparators into two classes: 1 mm to 35 mesh and 35 to 150 mesh. The phosphate in the former mixture is separated from the sand by using special reagents and vibrating tables that are inclined and grooved in a fashion permitting segregation.

The 35 to 150 mesh particles, however, are recoverable only by "pure" flotation. This process involves the treatment of the mixture with a reagent (caustic soda, fatty acid, and fuel oil) that clings to the phosphate particles and attracts air bubbles, thus floating the phosphate. Because a small amount of sand is still present, another and final flotation step is necessary. Here the reagent (amine) clings to the sand and floats it through the attraction of air bubbles. The underflow consists of extremely pure phosphate concentrate, ready for shipment to the dryers and pulverizers.

#### Drying and Pulverizing

The recovered phosphate rock is separated in accordance with the percent of phosphate present and is shipped in standard-gauge railroad cars to the drying and pulverizing plant of the International Corporation at Mulberry, not far from the Peace Valley fields. The cars are run onto an elevated track and the different grades are dumped into pre-selected sectors. Underground conveyors pick up the desired grade of mineral, or a combination of grades, and raise the ore to elevated dryer feed bins. From here, the phosphate is dropped into the oil-fired rotary dryers and then to automatic weighing scales. Pulverization before shipment depends on consumer requirements.

#### Engineering Advances

In contrast to the old steam-driven phosphate plants, modern establishments are entirely electrical. At Peace Valley power is drawn from the local utility 66-kv lines.

WESTINGHOUSE ENGINEER



Transformer stations near the operation step this down to 11 000 for transmission to International's substations from where 2300-volt lines are tapped for the draglines and 220 or 440 volts for auxiliary motors, both at the mines and at the reclamation, drying, pulverizing, and shipment plants.

The method of mining itself has been improved. A few years ago, hydraulic mining was common even in the soft pebble fields. Draglines were used only for overburden removal, and the hydraulic guns and pumping station were placed in the pit, washing out the matrix by water under pressures of from 200 to 225 psi. This method required pit crews of from ten to twelve men. The present method—dry mining in which the draglines not only remove the overburden but mine the ore—permits much lower pressures (about 100 psi) and reduces the pump personnel to four men. The development of huge draglines of the Bigger Digger type, capable of moving freely without tracks and having large bucket capacities, is still another engineering achievement, for such draglines can serve both as overburden removers and matrix miners, in the place of two conventional machines.

In addition to draglines, auxiliary excavators are used for the construction of drainage ditches and dams and for miscellaneous excavating purposes. This activity is necessary from a water conservation point of view. Large quantities of water are needed in phosphate mining and reclamation: 25 000 to 35 000 gallons per minute at the recovery plants

and 3500 gpm at the mines. Water is drawn both from streams and from specially built wells, and Peace Valley is fortunate in having a large annual rainfall—62.23 inches in 1945. The waste waters, however, are heavily laden with sediment and must be clarified before entering the water system of the state. For this reason, artificial lakes are constructed with dams and sluices, and settled waters are gradually permitted to flow into adjacent streams.

By far the greatest innovation in phosphate recovery has been the development and introduction of flotation methods, increasing the percentage of recovered phosphate from an average of about 35 percent to almost 90 percent, depending on the particular plant, for washer units can reclaim only the phosphate rock larger in size than the sand particles.

### Phosphorus and Superphosphate

Although a small quantity of the mineral phosphate rock finds use in direct application to the soil, most phosphate, for agricultural as well as industrial uses, is chemically processed.

Elementary phosphorus, produced either for the element itself or for formation of phosphoric compounds, is commonly prepared in electric furnaces. Sand and powdered coke are added to the phosphate rock, and the mixture is heated at a high temperature. Phosphorus gas is set free, condensing in cold-water traps. The solidified phosphorus is white (except for the surface, which is usually yellow), extremely poisonous,

Two sets of synchronous motor-generators (below) provide the power used by Bigger Digger, the 2-million pound dragline on page 111. Some of the boom and bucket control-cables and drive-drums are shown at the right. Bigger Digger does the work of two ordinary draglines, partly because it is mobile and has a large bucket capacity and partly because Rototrol controls (lower right) permit great ease and speed of operation.

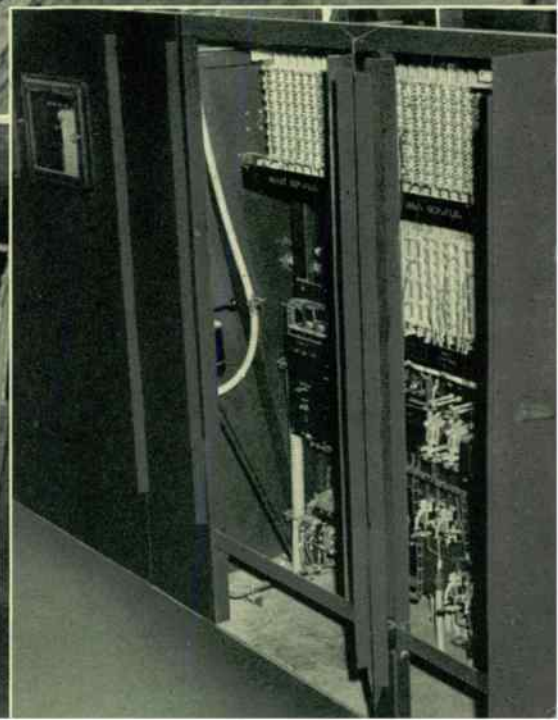
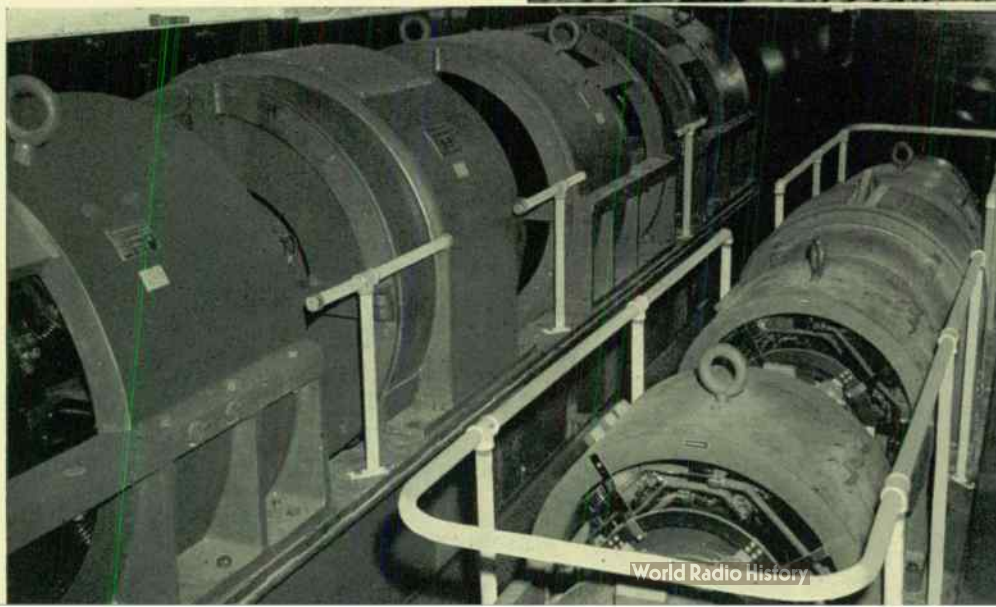
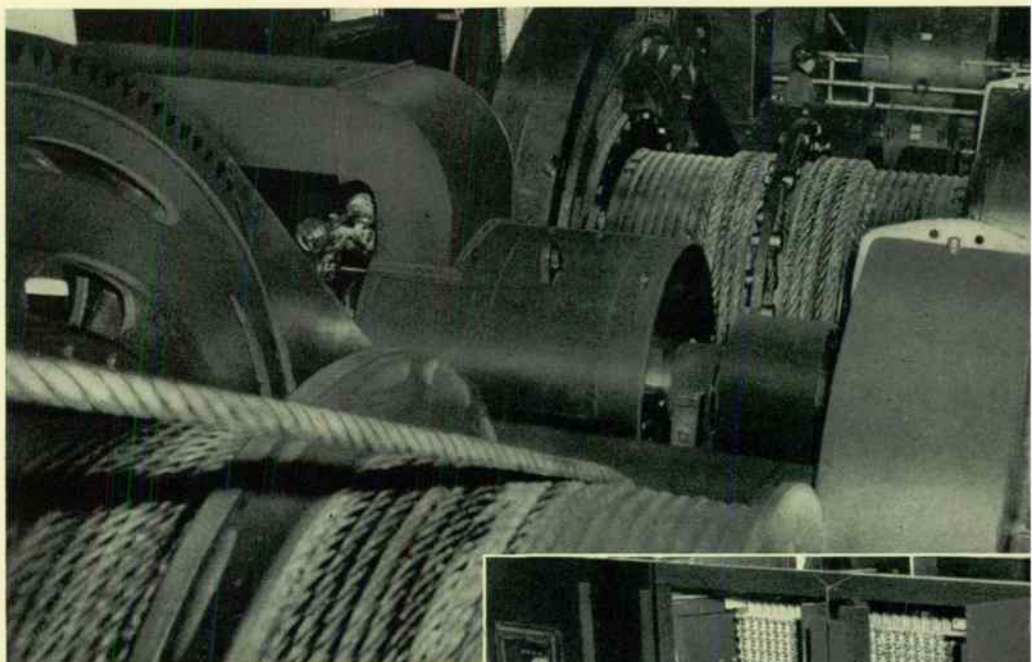



TABLE I. GROWTH OF FERTILIZER CONSUMPTION IN THE UNITED STATES

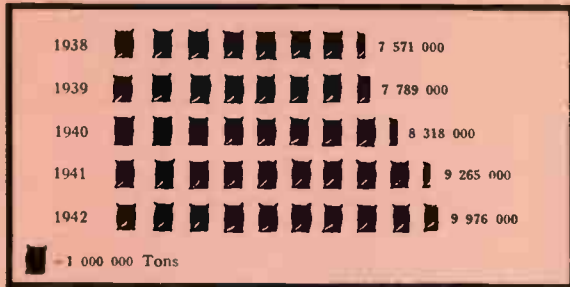

TABLE III—PRODUCTION AND USE OF PHOSPHATE ROCK IN THE UNITED STATES, 1930-1941\*  
(Annual Averages at Three-Year Intervals in Thousands of Long Tons)

Years	Super-phosphate (Fertilizer)	Phosphorus Compounds (Chemical and Industrial)	Direct Application to Soil	Fertilizer Filler	Stock and Poultry Feed	Miscellaneous	Total
1930-32	1525	246	23	29	2	5	1830
1933-35	1573	274	20	27	1	3	1898
1936-38	2078	429	71	30	4	9	2621
1939-41	2528	552	115	32	2	8	3237

\*After United States Bureau of Mines

and highly inflammable in oxygen. Heating with a trace of iodine produces a stable and non-poisonous form that ignites only when heated appreciably. This is the form used, along with phosphorus trisulfide, for the strike-anywhere matches. Safety matches rely on sulfur or antimony trisulfide for the burning match tip, and red phosphorus is used to coat the striking surface of the container. The burning of this phosphorus ignites the less easily fired match tip.

The principal value of phosphate rock lies not in the production of elementary phosphorus or phosphorus compounds for industrial uses, important though these are, but in fertilizer application (see table III). Here, too, chemical processing is necessary if the phosphates are to be made readily available for plant use. Pulverized phosphate rock may be used directly as a soil enricher, but the presence of fluoride in phosphate rock makes it practically insoluble in water, and soil acids must be relied upon for conversion into solution.

A soluble compound, monocalcium phosphate, turns out to be satisfactory for plant utilization. It is commonly prepared by treating phosphate rock with sulfuric acid. The fluoride present in the mineral is released during the reaction,

and a mixture of monocalcium phosphate and calcium sulfate is produced, called "superphosphate" in the fertilizer industry.

The role of superphosphate, in brief, is the replenishment of soil phosphorus—a vital role if soil starvation and failure are to be avoided. The fact that once fertile zones, like the Sahara Desert and certain regions in Asia and South America, teeming with agriculture and trade, supporting ancient civilizations, are now barren stems directly from soil failure.

In the United States, three billion tons of solid material are washed out of the soil annually, containing over 92 million tons of the principal elements of plant food—phosphorus, potassium, nitrogen, calcium, and magnesium. Of this over 43 million tons consist of phosphorus, potassium, and nitrogen.

The problem of soil preservation is clearly complex, but the broad outlines are self-evident. If progressive destruction of the soil is to be avoided, soil conservation measures (involving water control, reforestation, the use of binding grasses, and careful tilling to avoid soil drainage) are called for. And if soil fertility is to be maintained in spite of the removal of crops from the soil, the essential elements—phosphorus, potassium, and nitrogen—must be artificially added.

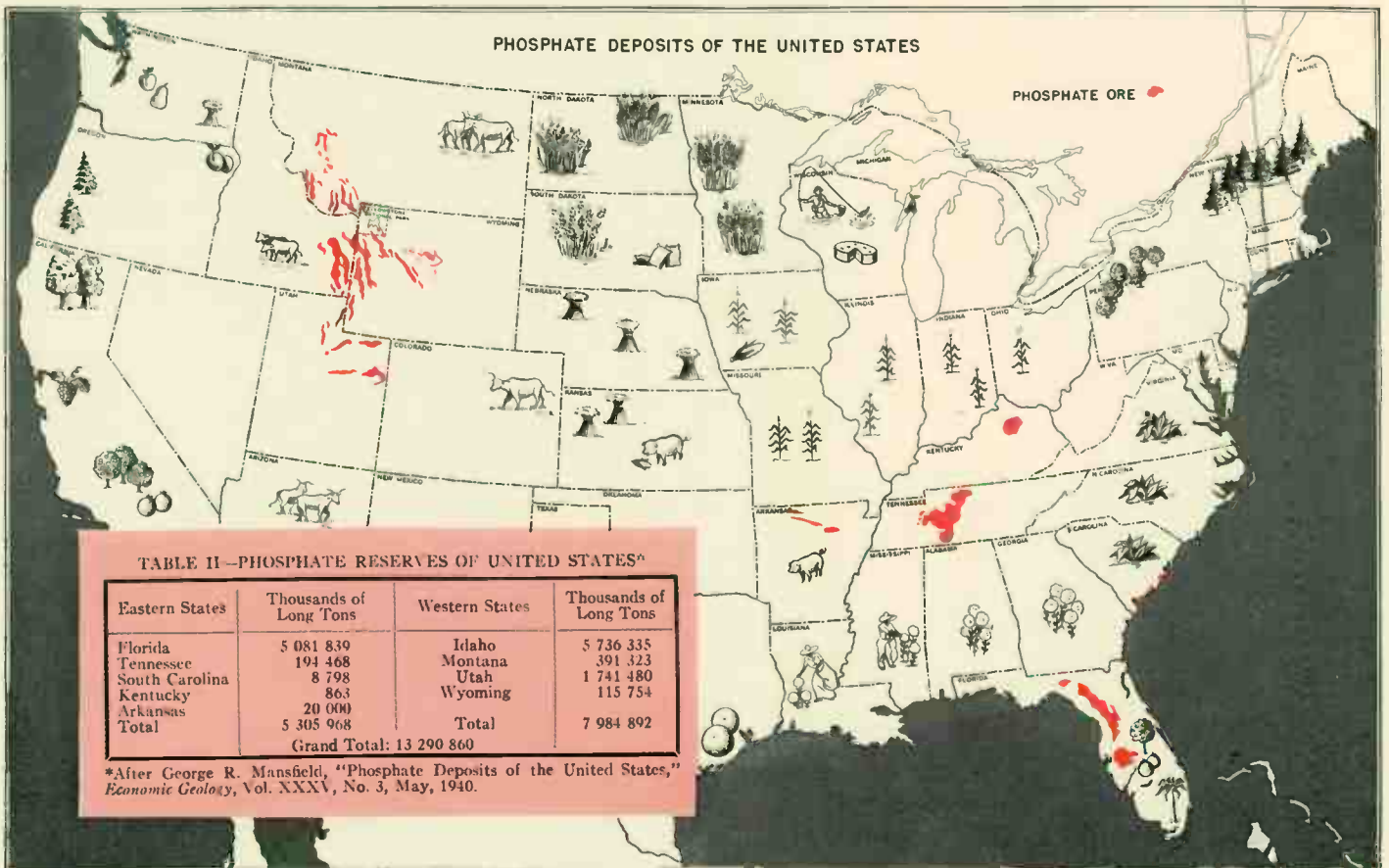
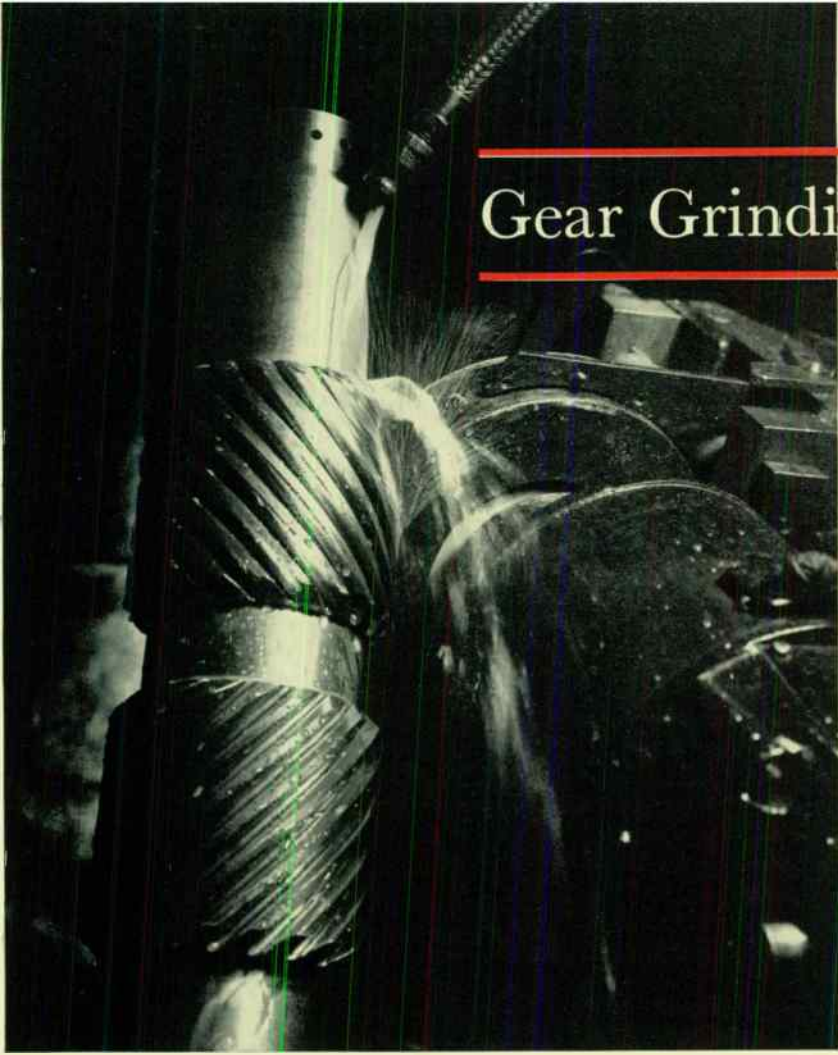

TABLE II—PHOSPHATE RESERVES OF UNITED STATES\*

Eastern States		Western States	
	Thousands of Long Tons		Thousands of Long Tons
Florida	5 081 839	Idaho	5 736 335
Tennessee	194 468	Montana	391 323
South Carolina	8 798	Utah	1 741 480
Kentucky	863	Wyoming	115 754
Arkansas	20 000		
Total	5 305 968	Total	7 984 892
Grand Total: 13 290 860			

\*After George R. Mansfield, "Phosphate Deposits of the United States," *Economic Geology*, Vol. XXXV, No. 3, May, 1940.





# Gear Grinding, A New Method

T. J. PUTZ

*Gas and Turbine Locomotive Engineer*

H. W. SEMAR

*Gear Machinery and Assembly Engineer  
Westinghouse Electric Corporation*

The answer to transportation industry's demand for more compact gears is use of great hardness, in which teeth are formed by a new technique by which the grinding is done continuously.

One reason the geared-turbine locomotive is possible is the compact, heavily loaded gear. Here the high-speed pinion is formed by a new grinding process.

THE trend of requirements for gearing by industry generally and the transportation industry in particular is for greater torque transmission, frequently at a wider speed change, and without any increase in dimensions and weight. Inasmuch as size and weight are proportional to the load-carrying capacity of the gear, the limits of gear of given hardness are set by such difficulties as pitting and galling of the tooth surface. For conventional gearing, these load-carrying limits have been established and further gains can be made only by using harder gear materials built to the highest degree of accuracy and surface finish. About the hardest steel in which gear teeth can be cut by the conventional hobbing methods is 350 Brinell. Further reductions in gear size and weight require the development of tooth surfaces in hardened steel, finished to the highest degree of profile accuracy and surface smoothness.

Grinding is a long-established method of finishing the working surface of gear teeth in steel above the hobbing range. There are many established grinding methods for finishing gear teeth. In the transportation field, namely, the automotive, aircraft, railway industries, full advantage has been taken of these grinding processes in building compact gear transmissions. However, these established grinding methods do not produce a gear of sufficient accuracy for turbine transmissions where quiet operation is essential at speeds up to 20 000 feet per minute and powers of as much as 53 000 horsepower.

To obtain gears of the sizes and accuracies needed for turbine transmissions, a new method of grinding gear teeth suitable for large double-helical gearing has been developed. By other grinding methods one tooth is ground at a time

while the stock is held stationary. Then the stock is indexed and the next tooth cut. In this new method, however, the heavy gear blank is rotated slowly and continuously during grinding and is not subjected to the starts, stops, and reversals that limit other processes to gears of lower powers or speeds.

The grinding surface is the flat side of a wheel that is analogous to the plane surface of a rack tooth in its generating action. The wheel is automatically dressed and compensated for wear at regular intervals by advancing the wheel and traversing it with a diamond during the return of the cutting stroke. The grinding plane is thus maintained by the diamond, independent of wheel wear.

The generating action is accomplished by a cyclic motion of the grinder head. In the generating phase of this motion the grinding wheel moves slowly in a straight line and at uniform speed. The wheel then withdraws, returns, and re-enters the adjacent tooth to start the next cycle.

Because the cyclic motion of the grinder head is analogous to the rotation of the hob, the other motions, feed and indexing, are similar to the corresponding motions in hobbing. Therefore, the high orders of accuracy that permit hobbled gears to operate quietly at high speeds can be obtained with the ground gears. The method is without limit to gear size.

The advantage in reduced weight and space requirements for naval propulsion, realized by using hardened and ground gears, has long been recognized. However, the need for large numbers of proven and standardized designs during the war postponed this development. A light-weight 6000-hp gear for ship propulsion is being designed on this basis.

In the development of the geared-turbine locomotive now operating on the Pennsylvania Railroad the severe space limitations suggested the use of hardened (500 to 550 Brinell) and ground teeth. This gearing has recently been inspected after 47 700 miles of main-line operation and has been found to be in excellent condition. The ground gear was 7.3 inches in diameter. A hobbled gear would have been about 9 inches in diameter and 2 inches longer.

Gear-grinding technique applied to harder steels is changing our notions of gear loading. Already experimental gears have been operated for several thousand hours at loadings five times normal. The prospect is for smaller, lighter gears.



---

# The Structure of the Nucleus

---

DR. W. E. SHOUPP, *Manager, Electronics Department, Westinghouse Research Laboratories*

UNTIL the discovery of natural radioactivity, the important part of the atom was its outer structure—in particular, the behavior of the electrons in the outer shells, for the rearrangement of these electrons accounts for chemical reactions. The tacit assumption of the nucleus as a simple, positive charge was thus adequate in the explanation of such reactions because the nucleus played no role in them. The advent of nuclear physics, however, suggested the existence of reactions involving only the inner portion of the atom.

The investigation of these reactions led to the realization that tremendous quantities of energy are released in transmutations of nuclei and that these reactions are amenable to study, control, and utilization by man.

In chemical reactions like the burning of coal for heat or its synthesis into alcohol or dyes, only outer electrons are affected; the nuclei remain intact; and the elements retain their identity before, during, and after the reactions. In nuclear reactions, on the contrary, fundamental changes in the nuclei occur and the elements involved are transmuted into other elements, suggesting at once that the essence of matter is not atomic (in the sense that atoms are indivisible and fundamental particles of matter) but nuclear.

The atom is thus no longer the "building block" of the universe. And the so-called elements are no longer "elemental." The suspicion that more "elemental" units characterize the old elements has been completely demonstrated by nuclear physics. The structure of nuclei, and hence of matter, hinges on the existence of these new units or particles, on their nature, and on the diverse relationships existing among them.

## Nuclear Building Blocks

All nuclei are believed to be composed of protons and neutrons, the most significant particles of nuclear physics. The nucleus of every element is made up of tightly held clusters of neutrons and protons, beginning with hydrogen which has a single proton and ending (among natural elements) with uranium which has 92 protons and from 142 to 146 neutrons. The sum of protons and neutrons comprising a particular nucleus is the mass number or atomic weight of that nucleus. Because the atom as a whole (including the exterior electrons) is electrically neutral, the number of protons in the atomic nucleus is equal to the number of electrons that revolve about the nucleus. While the number of protons determines a particular element, the number of neutrons establishes the particular isotope of that element. The number of neutrons and protons in various nuclei is shown graphically in Fig. 1. For the lighter elements the number of protons is roughly equal to the number of neutrons; for heavier elements the number of neutrons is greater.

The first nuclear building block, the proton, is character-

ized by a positive charge equal in magnitude but opposite in sign to the electron. It has a relative mass of 1.00758 (using one sixteenth of the mass of the oxygen atom  $^{16}\text{O}$  as a standard), which is roughly 1838 times that of the electron. Because the nucleus of the hydrogen atom consists of a single proton, the proton is often referred to as the hydrogen nucleus. Protons accelerated to high velocities in one of the several types of atom smashers may be used to cause atomic disintegrations in other nuclei; beryllium, for example, may be changed into boron by proton bombardment.

The second nuclear building block, the neutron, discovered by Chadwick in 1932, has a relative mass of 1.00894, nearly the same as that of the proton. In fact, as pointed out later, the neutron can sometimes be considered as a proton combined with an electron. The salient characteristic of the neutron is that it possesses no electrical charge. Charged bodies like electrons or protons ionize substances through which they pass. This means, in effect, that they lose some of their energies, slow down, and usually cannot travel far before collision or capture. The neutron, however, does not cause ionization in the ordinary sense and so loses very little energy in passing through most materials—even several feet of steel. The uncharged neutron, therefore, does not exert electrical forces on other particles. A very strong attractive force, as yet not completely understood, is exerted between the neutron and proton when they are brought very close together—as in the nuclei of atoms.

Neutrons very rarely collide with protons in such a manner that they approach sufficiently close to cause any attraction. In fact, neutrons usually bounce off other nuclei just as a billiard ball bounces when it strikes another ball—i.e., elastic collision. A neutron wanders through other materials unchecked unless it collides with an atomic nucleus. In such an encounter, provided the atomic nucleus is heavy, the neutron loses very little of its energy in the collision, merely suffering a change in direction like a ball striking a massive object. How-

ever, when a neutron collides with a proton, a particle of similar mass, roughly half of the original neutron energy, is lost by transfer to the proton as in the case of two colliding billiard balls. Therefore, relatively few collisions with protons are required to slow neutrons to velocities such that they may be absorbed by nuclear processes. While a reasonable thickness of lead or steel suffices to stop other particles, neutron shielding requires light substances rich in hydrogen, and hence in protons, such as water or paraffin.

The non-ionizing character of the neutron makes it difficult to detect and control. Detection is generally accomplished by observing nuclear reactions because such reactions usually produce an ionizing particle that may be examined

The exploitation of nuclear energy in the atomic bomb attests to the magnitude of the energies involved in nuclear physics. The basic significance of nuclear knowledge, however, lies in the attendant new concepts of the nature of matter. From a scientific point of view, the constituents, the forces, and the structure of the nucleus transcend utilitarian considerations, and their analysis suggests an unprecedented insight into the structure of the universe.



Fig. 1—Chart of isotopes. Open circles represent stable isotopes less than 5 percent in abundance; half-filled circles, 5 to 20 percent abundance; filled circles, greater than 20 percent abundance; squares, radioactive.

experimentally by observing the ionized trail it leaves in, say, supersaturated gas. The only means of controlling neutrons is to put other nuclei in their paths so that the neutrons may be absorbed, deflected, or slowed down by collisions.

Neutrons are obtained as a disintegration product of nuclear reactions and can in turn be used to cause other nuclear transformations. One of the chief sources of neutrons is in the disintegration of beryllium metal when it is bombarded in a cyclotron by nuclei of deuterium (a heavy hydrogen isotope). The disintegration of uranium by neutrons leads to the release of the nuclear energy exploited in the atomic bomb with such remarkable energy effects.

In addition to protons and neutrons, there are a number of other particles (summarized in table I) involved in the existence and behavior of atomic nuclei. One of the structurally most important of these is the so-called alpha-particle, first observed as an emission from natural radioactive materials. Because alpha-particles consist of two protons and two neutrons, they are identical with the nucleus of the helium atom and are represented by the symbol  ${}^2\text{He}^4$ , where the 2 indicates the total number of nuclear protons and the 4 the total number of nuclear protons and neutrons. If a nucleus emits an alpha-particle, it thus loses two of its units of positive charge and four units of mass. When uranium, for example, emits an alpha-particle, it is transmuted into an isotope of thorium (UX1), its mass changing from 238 to 234 and charge decreasing from 92 to 90.

### Nuclear Structure

The electrical charge is the most important characteristic of the nucleus. Since the atom as a whole is electrically neutral, the number of outer orbital electrons is equal to the units of positive charge  $Z^1$  of the nucleus. The letter  $Z$  is known as the atomic number. Elements possessing values of  $Z=1$  (hydrogen) to  $Z=92$  (uranium) have been found in nature except for  $Z=61, 85,$  and  $87$ . Recently four new elements have been created artificially, corresponding to  $Z=93$  (neptunium),  $Z=94$  (plutonium),  $Z=95$  (americium), and  $Z=96$  (curium).

Some naturally occurring elements are composed of mixtures of several different atoms having the same nuclear charge  $Z$  but differing in their

nuclear weights. The various weights of atoms of a particular element are called isotopes. Thus the element iron ( $Z=26$ ) is composed of three isotopes having atomic weights of approximately 54, 56, and 57, where the atomic weight  $M$  is based on the scale that the oxygen atom ( ${}^{16}\text{O}$ ) has an atomic weight of exactly 16. The number of isotopes of the elements varies from one for many elements to as high as ten for tin. The whole number nearest to the atomic weight of a particular atom is called the "mass number" and is designated by  $A$ . Thus the isotopes of iron have the three mass numbers indicated above ( $A=54, A=55, A=57$ ) and atomic number of  $Z=26$ .<sup>2</sup>

The atomic number subscript  $Z$  in nuclear notation therefore indicates how many protons there are in the particular nucleus—e.g., helium  ${}^2\text{He}^4$  has two protons while  ${}^{15}\text{P}^{31}$  has fifteen. The mass number  $A$  is equal to the sum of the number of protons  $Z$  and number of neutrons  $N$  in the nucleus:

$$A = Z + N$$

The number of neutrons in the nucleus is then the difference between the superscript and the subscript in nuclear notation; for example, there are  $N=31-15=16$  neutrons in the phosphorus nucleus  ${}^{15}\text{P}^{31}$ .

However, the mass of a nucleus is less than the sum of the neutron (1.00894) and proton (1.00758) masses of which the nucleus is composed. This can be interpreted by Einstein's law<sup>2</sup> of the equivalence of mass and energy ( $E=mc^2$ ) and indicates that the "binding energy" that holds the nuclear particles together decreases the total energy of the nucleus. For example, the binding energy of the phosphorus nucleus

<sup>1</sup>The symbol  $Z$  is customarily used to denote nuclear charge;  $P$  is also used but there is danger of confusing it with the identical chemical symbol for phosphorus.  
<sup>2</sup>Frederick Seitz, Jr., "The Relation Between Mass and Energy," *Westinghouse ENGINEER*, March, 1946, p. 35.

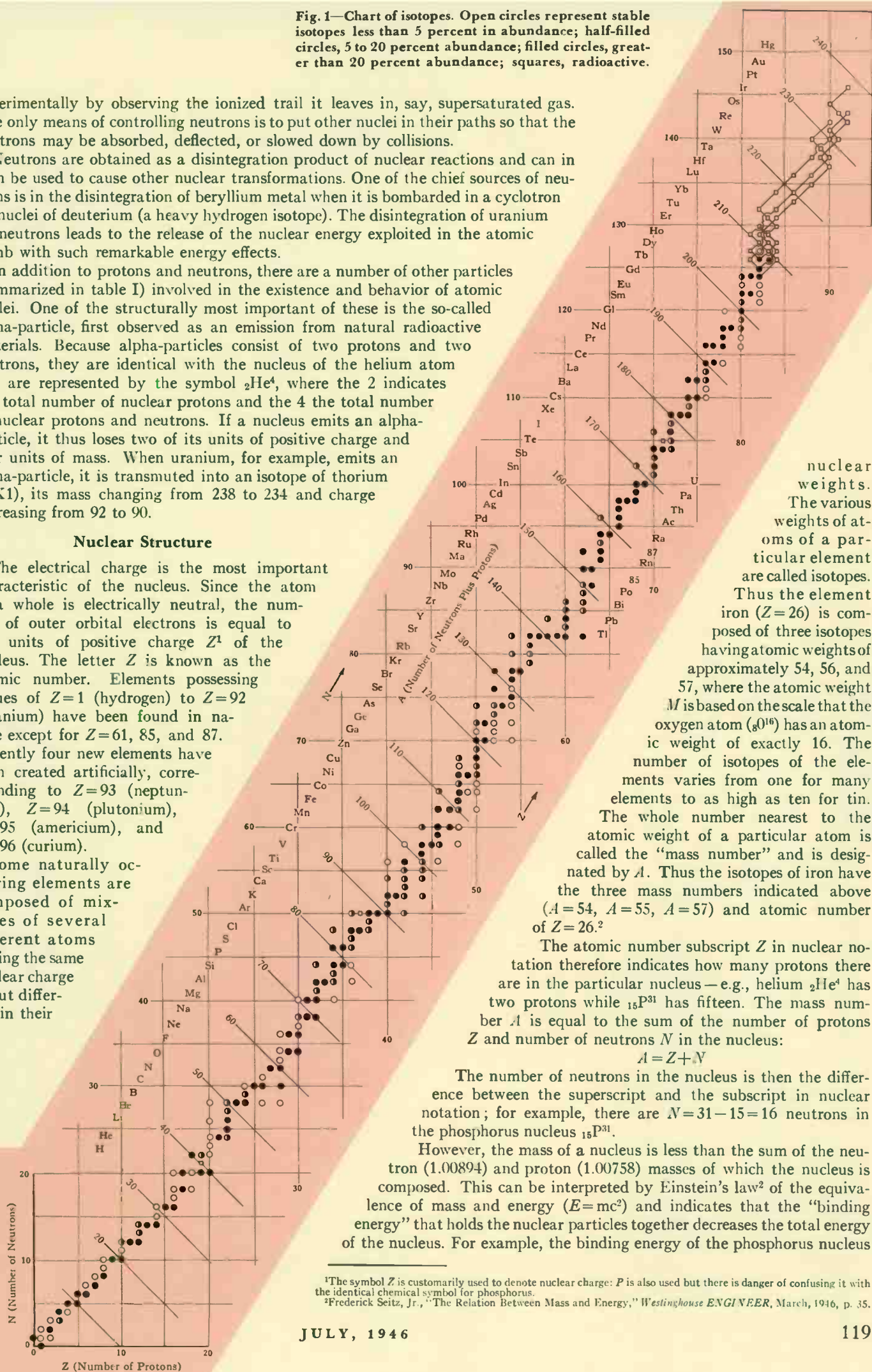



The fundamental particles of nuclear physics are the proton and the neutron, the components of all nuclei. The *proton*, discovered by Rutherford in 1919, has a single positive charge, equal in magnitude to that of an electron, and an atomic mass of 1.00758 units (with respect to 16 for oxygen  ${}_8\text{O}^{16}$  or about 1838 times the mass of an electron. The hydrogen atom (left) has a nucleus containing a single proton, and for this reason the proton is sometimes referred to as the hydrogen nucleus. The charged nature of the proton permits its study by observation of ionization trails.

The chargeless *neutron* was discovered in 1930, but its properties were unrecognized until 1932. Neither exerting nor encountering electrical forces, it does not produce ionization and has great penetrating powers, giving up energy only on collision. By observing protons ejected from nuclei by neutron bombardment, Chadwick established its uncharged nature and mass—1.008939, about that of a proton. Proton-neutron combinations characterize all nuclei, ranging from one proton for hydrogen to 92 protons and 142 to 146 neutrons for uranium. Oxygen  ${}_8\text{O}^{16}$  (left) has eight of each.

Particles consisting of protons and neutrons are themselves nuclear particles. Two of the most important of these are the *deuteron* and the *alpha-particle*. The deuteron consists of a proton and a neutron, closely held. Its mass is 2.01418 and it has a unit positive charge. The hydrogen isotope  ${}_1\text{H}^2$  (left) consists of such a particle, and the deuteron is often called the heavy hydrogen nucleus. The significance of the deuteron in nuclear physics stems from its important role in nuclear transmutations. Deuterons, accelerated in cyclotrons, are used to create many artificially radioactive nuclei.

The *alpha particle* consists of two protons and two neutrons, characteristic of the nucleus of the helium  ${}_2\text{He}^4$  atom (left). Like deuterons, alpha particles can be accelerated in cyclotrons. Moreover, they are structurally significant: the forces binding the four components exhibit a saturation property that favors the intimate association of just four such units. Thus, protons and neutrons in heavier nuclei tend to form alpha-particle groups or sub-shells. It was the emission of alpha particles by natural radioactive substances that opened up the subject of nuclear transformations late in the nineteenth century.

In addition to protons and neutrons, there are several other fundamental particles in contrast to the composite nature of deuterons and alpha particles. The *beta particle*, long known in nuclear disintegrations, is one of these. It is a high-speed electron with the identical charge and mass of an ordinary electron. The effect of beta emission is to increase the number of protons in a nucleus; under some circumstances a neutron becomes a proton by expulsion of a beta particle. The charged nature of beta particles causes ionization, and they are deflected in magnetic fields (suggested at left).

${}_{15}\text{P}^{31}$ , composed of 15 protons and 16 neutrons, can be computed in the following fashion

$$\begin{aligned} \text{Mass Protons} &= 15 \times 1.0076 = 15.114 \\ \text{Mass Neutrons} &= 16 \times 1.0089 = 16.142 \\ \text{Total} &= 31.256 \end{aligned}$$

$$\text{Actual Mass of } {}_{15}\text{P}^{31} \text{ Nucleus} = 30.976$$

$$\text{Binding Energy} = 0.280 \text{ mass units}$$

For  ${}_{15}\text{P}^{31}$  the total binding energy is thus 0.280 mass units, or the binding energy per particle  $B$  is about 0.009 mass units. The mass unit is that energy equivalent to one sixteenth that of the oxygen nucleus  ${}_8\text{O}^{16}$  determined according to Einstein's law  $E=mc^2$ . One mass unit turns out to be equivalent to 0.00149 ergs or 931 mev.<sup>2</sup>

### Nuclear Forces

The binding energy per nuclear particle ( $B$ ) is a measure of how tightly the particles of a particular nucleus are held together. An examination of the isotope chart (Fig. 1) shows that the number of protons ( $Z$ ) in the nucleus is about equal to the number of neutrons ( $N$ ), at least for lighter nuclei. This fact and the existence of binding energy shed light on the nature of the forces involved in the nucleus (for further details, see "Nature of Nuclear Forces" on page 122).

The concept of the nucleus as a tight cluster of uncharged and positively charged masses suggests that the nucleus cannot be a static, impotent entity. On the contrary, violent forces contend within it. The electrical repulsive force between protons, called the coulomb force, varies inversely as the square of the distance of their separation. In view of the small diameter of the nucleus itself, of the order of  $10^{-12}$  cm, the coulomb forces are substantial, and protons within the nucleus tend to fly apart. There must then exist other forces, attractive in nature, tending to hold nuclear particles together if atoms are to exist at all. The net excess of the attractive forces over the repulsive forces between nuclear particles is represented by the binding energy.

These nuclear characteristics permit the following deductions:

1—The mere existence of nuclei reveals that the specifically nuclear forces are much greater than the coulomb forces if the nuclei contain protons.

2—The proton-neutron force is probably the strongest force in nuclei. If this were not true, most stable nuclei would consist either entirely of protons or neutrons.

3—The fact that the number of protons is equal to the number of neutrons ( $Z=N$ , approximately) signifies that the proton-proton (p-p) force and the neutron-neutron (n-n) force are about equal. If this were not true, then isotopes of maximum stability ( ${}_6\text{C}^{12}$ ,  ${}_2\text{He}^4$ ,  ${}_7\text{N}^{14}$ , etc.) would not occur for equal numbers of protons and neutrons, but would tend to occur for larger  $Z$  or larger  $N$ .

In Fig. 2 the binding energy per particle is plotted as a function of the mass number for most known nuclei. Elements around  $A=65$  (copper, nickel, and zinc) are more stable than either lighter or heavier elements. The approximate equality of  $Z$  and  $N$  for lighter elements ( $A < 40$ ) bears out the deduction regarding the strength of the basic nuclear force—otherwise a prevalence of protons or of neutrons would be natural (Fig. 3). As the nuclei increase in size, however, it appears that the increased coulomb forces (because of the larger number of protons) eliminate some of the protons, and the heavier stable nuclei tend to have fewer protons than neutrons (Fig. 3).

The oscillations in the  $B$ -vs- $A$  curve of Fig. 2 for  $A$  less



than 30 have considerable structural significance. They are a consequence of the formation of alpha-particle groups (called sub-shells) in the nuclei—in a sense, these nuclear sub-shells can be viewed as analogues of the electron shells of the outer atom. Maximum nuclear stability points are obtained when the nuclei are composed of completed alpha-particle groups (2 protons+2 neutrons)—that is, when  $Z = A/2 = N$  (e.g.,  ${}^4_2\text{He}$ ,  ${}^{12}_6\text{C}$ ,  ${}^{16}_8\text{O}$ ,  ${}^{20}_{12}\text{Mg}$ ). Again, the electron-shell analogy, with definite orbits and energy levels for the outer electrons, is helpful.

For heavy nuclei ( $Z > 90$ ) the coulomb repulsion between the protons in the nuclei becomes increasingly important since the charge of the nuclei increases much more rapidly than the volume for increasing  $A$ . This increasing importance of coulomb repulsion for heavy nuclei therefore tends to decrease the binding energy per particle ( $B$ ). This continues until nuclei are no longer stable. The unstable point occurs for values for  $Z$  above 92 and for  $A$  about 235. This instability condition, due to the competition between the coulomb electrical repulsion and the attractive nuclear forces, accounts also for the radioactive instability of the heavier elements (radium, uranium, etc.) and for the non-existence in nature of elements beyond uranium.

It is this decrease in binding energy for large values of  $A$  (Fig. 2) that makes it possible to extract energy from the nucleus. Consider the disintegration of a heavy nucleus—e.g., uranium  ${}^{235}_{92}\text{U}$  to which a neutron has been added giving  $A = 236$ —into two equal nuclei having masses of  $A = 118$ . The nuclei having mass  $A = 118$  are more stable; so the sum of their masses is less than that of the heavy nucleus. We see that the binding energy per particle, ( $B$ ) in Fig. 2, drops from 0.0093 mass units for  $A = 118$  to 0.0085 mass units for  $A = 236$ . The total energy gained in such a process is then the number of particles concerned multiplied by the change in binding energy per particle in the process:

$$236 (0.0093 - 0.0085) 931 = 175 \text{ mev}$$

where the factor of 931 is introduced solely to obtain energy in mev.<sup>2</sup>

This simple calculation shows that 175 mev are available in such a process. The nuclear fission reaction used in the atomic bomb is a process of this type. The nuclear transformation liberates the energy incident to the decrease in binding energy per particle ( $B$ ) for large atomic numbers ( $A$ ). Greater energy could be obtained if heavy nuclei disintegrate into somewhat lighter nuclei than those used above or by combining very light nuclei into heavier ones.

### Particles and Dynamics

Although the nucleus of the atom has been described as consisting of protons and neutrons, exerting and undergoing certain forces, still other particles are involved in nuclear transformations (see table I). The discovery of these particles, as indeed of the proton and neutron, and their importance arises from the dynamic nature of nuclei. One of these particles has already been mentioned—the alpha-particle—in connection with the phenomena of radioactive emission. Emission itself is a clear indication of the dynamic condition of the nucleus. The forces in nuclei are not always balanced, and any instability in these forces and the relations among particles in the nucleus leads to emission of one kind or another as the nucleus seeks a state of maximum stability. This holds true in naturally radioactive substances, while artificially radioactive materials are formed by creating unstable nuclei by bombarding the nucleus so that particles are either deleted or added.

Like the beta particle—or an electron—in every respect except charge and life-span, the *positron* is a positively charged electron that seldom exists longer than a fraction of a second. Its discovery in 1932 by Anderson resulted from cloud-chamber observations in which ionization trails were observed similar to those of beta particles but deflected by the magnetic field in the opposite direction (right). Positrons are common in the field of artificial radioactivity. Their existence, however, is transitory, for they unite readily with negative electrons in the creation of gamma radiation.

In 1936 the last of the mass-bearing particles, *mesons*, were discovered by Anderson during cosmic-ray studies. Cosmic rays are high-energy radiations from interstellar space, and they were observed to eject mesons from the walls of cloud chambers. Mesons are both positive and negative, with charges equal in magnitude to that of an electron, although neutral mesons may have been detected. In this respect they thus resemble beta particles and positrons. However, their masses are between 20 and 200 times as great. Mesons have been produced artificially recently by 100-mev x-rays.

Along with alpha and beta particles, *gamma rays* were observed originally as emanations from natural radioactive elements. They are electromagnetic radiations of the hard x-ray type, but they should be viewed as quanta of energy in nuclear physics rather than as waves. Gamma rays are often correlated with the presence of certain energy levels in nuclei. They can expel pairs of beta particles and positrons (right). Gamma rays can also energize electrons with which they have collided, projecting them in the original direction of the quantum, or eject electrons from atoms by the photoelectric effect.

The transformation of a neutron into a proton and a beta particle has led to the postulation of the existence of the *neutrino*, a chargeless particle possessing energy and angular momentum with a mass less than one-tenth that of an electron. The evidence of the existence of the neutrino, almost entirely theoretical, stems from the principle of conservation of energy or momentum. In nuclear disintegrations, beta particles are emitted, but all the disintegration energy does not go to the beta particle, suggesting the existence of another energy-sharing particle.

In a similar fashion, the existence of the *anti-neutrino* appears probable. In the transformation of a proton into a neutron (right), a positron is emitted, but the disintegration energies are again large compared with those of the positron. It is believed that a neutrino-like particle shares in this energy, and this hypothetical particle is called the anti-neutrino. These small, neutron-like particles have never been detected experimentally, but in explaining certain nuclear transmutations, they are valuable as theoretical entities. Subsequent investigations, however, may alter our concepts of them.



## Nature of Nuclear Forces

Examination of the components of nuclei has indicated that the nuclear forces must be greater than the coulomb forces, that the proton-neutron (p-n) force is probably the greatest force in the nucleus, and that the proton-proton (p-p) and neutron-neutron (n-n) forces are about equal.

If each of these primary nuclear particles interacted with every other particle, the total nuclear binding energy would vary as  $A/2(A-1)$ , or approximately as  $A^2$ . Experimental values of the binding energy, however, indicate that the binding energy varies only as the first power of the number of particles in the nucleus ( $A$ ). Or, the binding energy per particle is, to a first order approximation, constant for heavier nuclei.

This phenomenon—constant binding energy per particle—suggests the existence of a nuclear force that has the property of saturation. Here the force field observed in the case of a liquid hydrogen droplet offers an analogous situation. A strong “homo-polar binding” exists in this case—i.e., two hydrogen atoms attract each other very strongly, forming a hydrogen molecule; but if a third atom is brought up, it is only weakly attached to the other two. The binding energy in the case of liquid hydrogen is consequently proportional to the number of pairs of hydrogen atoms, and in this case shows the phenomenon of saturation. In a corresponding manner, two protons and two neutrons unite in the formation of an alpha particle with comparable saturation effects.

Furthermore, pursuing the hydrogen analogy for illustrative purposes, there exists between hydrogen molecules a gravitational-like force of attraction—the Van der Waals force—that varies as  $1/r^7$  for a molecular separation  $r$  greater than a certain critical minimum value. This additional attractive force between the saturated particles will, in the case of nuclei, correspond to an attraction between the fundamental group of particles that exhibit the characteristics of saturation (as do the hydrogen atoms). In other words, a Van der Waals type of attractive force exists among alpha-particle groups.

A strong repulsive force also exists between hydrogen molecules in liquid hydrogen droplets for separations less than a critical minimum distance. This force prevents interpenetration between the saturated groups (i.e., the hydrogen molecules). In a similar fashion, a repulsive force exists among alpha-particle groups at extremely short distances, preventing the penetration of one group or its components into another. Re-examination of the binding energy curve below reveals that, beyond the alpha particle shell groups, the binding energy per particle in-

creases gradually from 7.0 to 8.5 mev per particle in the range from  $A = 16$  to about  $A = 60$ . This excess of 1.5 mev is partly due to the Van der Waals attraction. Interpenetration of alpha particles is evidently prevented by the very short range repulsive force, noted in the case of hydrogen liquid droplets.

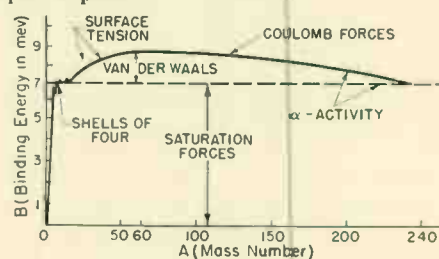

Still another force should be considered in postulating a nuclear model. Surface tension, again referring to the hydrogen droplet as an analogue, should be effective. The particles on the surface of the liquid droplet have fewer surrounding neighbors with which to react than those near the center. For a spherical droplet the surface area varies as the  $2/3$  power of the volume. Now the volume of nuclei is observed to be proportional to the number of particles. It is reasonable to expect, therefore, that as the mass number  $A$  increases, the area (and hence surface tension energy) varies as  $A^{2/3}$ . In other words,

$$T \sim A^{2/3}$$

where  $T$  is the force of surface tension. Under these conditions, the effect of surface tension in lowering the binding energy will gradually decrease as  $A$  increases and will lower the binding energy by decreasing amounts as  $A$  becomes larger. Therefore, the effect of surface tension should be added to the Van der Waals force in raising the binding energy per particle from 7.0 to 8.5 mev in the first half of the binding energy curve.

For large values of mass number  $A$ , the coulomb force gradually overcomes the surface tension and Van der Waals effects. The coulomb repulsion potential for two protons spaced about a nuclear radius apart is

$$E = e^2/r = 0.3 \text{ mev at } r = 5 \times 10^{-13} \text{ cm.}$$

For  $Z$  protons distributed uniformly throughout the volume of the nucleus, the total electrostatic energy is

In all, ten particles are associated with nuclear physics. These may be divided into “material” and “non-material” particles although such a designation should not be accepted too literally. The classification merely means that, at present, there are some particles with which mass is associated and others with apparently no mass.

The two fundamental particles are, of course, the proton and the neutron and these have mass. Two other material particles are the alpha particle and the deuteron, consisting of protons and neutrons. The alpha particle, as we have seen, consists of two protons and two neutrons and exhibits saturation property significant in the structure of the nucleus.

Because the nucleus of the helium atom consists of such a group of protons and neutrons, the alpha particle is often referred to as the helium nucleus  ${}^4_2\text{He}$ .

The deuteron is a particle consisting of one proton and one neutron. It is the nucleus of the heavy hydrogen isotope called deuterium,  ${}^2_1\text{H}$ . Like the alpha particle, the deuteron is not a fundamental particle, but it plays an important role in certain nuclear disintegration processes. For example, when deuterons, highly accelerated in a cyclotron, are allowed to strike lithium nuclei, a nuclear reaction results in which two alpha particles are formed, and many artificially radioactive nuclei are created by deuteron bombardment—e.g. radio-

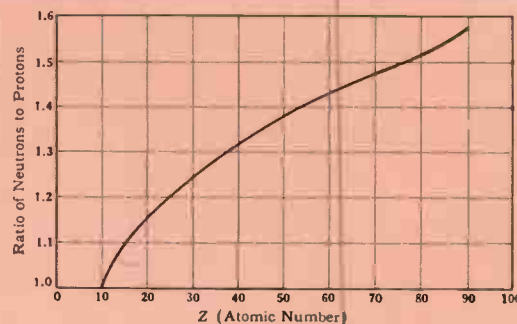
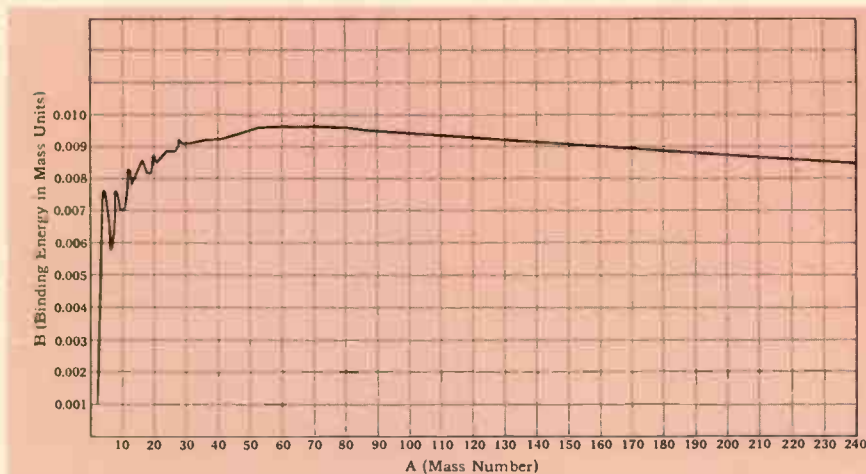

Fig. 2 (left) shows variation in binding energy with mass number. Fig. 3 (above) plots the neutron-proton ratio against the number of protons in nuclei for some of the nuclei of Fig. 2.



$$W = 0.6 (Z^2 - Z) (e^2/r).$$

Neglecting  $Z$  with respect to  $Z^2$ , this becomes

$$W = 0.6 Z^2 (e^2/r).$$

Experimentally, the volume of nuclei is roughly proportional to the number of particles comprising the nucleus, or  $V \sim A^{1/3}$ . The total electrostatic energy then becomes, remembering that  $Z \cong A/2$ ,

$$W = 0.15 e^2 A^{5/3}.$$

The effect of the  $A^{5/3}$  coulomb term is twofold:

1—The binding energy per particle falls as the coulomb repulsion overcomes the other forces. Consequently, the binding-energy curve decreases for large values of mass number.

2—For heavier nuclei, the rule that  $Z = N$  is not quite valid. For large values of mass number  $A$ , greater stability is obtained with the addition of neutrons to nuclei rather than protons. Thus more neutrons than protons should enter into the composition of nuclei of heavy elements, where  $A$  is large. This is true experimentally. Uranium ( ${}_{92}\text{U}^{238}$ ), for example, has 92 protons and 146 neutrons, giving the relation that  $1.6Z = N$ .

The consequences of (1) are that the binding energy per particle drops to about 7 mev for heavier nuclei and we should expect alpha-emission. This is, of course, observed for the heavier nuclei, known to be radioactive. The binding energy per particle, however, is not evenly distributed among the particles of a nucleus. This effect has been experimentally observed in the case of  ${}_{63}\text{Sm}^{143}$ , which is radioactive by alpha-emission even though the binding energy per particle is greater than 7 mev. The non-uniform energy distribution is not surprising, for such shielding phenomena are not unusual in physics.

The overall binding energy curve then appears as above. The first part of the curve rises to 7 mev and then levels off, exhibiting at the plateau the characteristics of the alpha-particle shell groups. The binding energy now increases somewhat, presumably as a result of decreasing surface tension with increasing  $A$  and the effect of the Van der Waals force, until it reaches a maximum at about  $A = 60$ . The binding energy per particle then decreases from about 8.5 mev to 7 mev. This decrease is due to the coulomb force overcoming the effects of the surface tension and Van der Waals forces. Alpha activity is then to be expected at values of  $A$  where the coulomb forces again reduce the binding energy to roughly 7 mev per particle.

◆ In summary, four influences affect binding energy:

1—Saturation effects and shell of four (alpha-particle groups); proportional to  $A/4$ .



2—Surface tension forces; proportional to  $A^{2/3}$ .

3—Van der Waals forces; proportional to the number of alpha-particle groups; proportional to  $A/4$ .

4—The coulomb forces; proportional to  $A^{5/3}$ .

It should be noted also that the excess of neutrons varies as  $A^{5/3}$ . This indicates that the extra neutrons in heavy nuclei are indeed responsible for the existence of stable heavy nuclei, for the (n-n) forces overcome the inverse-square coulomb forces. Furthermore, the (n-n) force is not zero because isotopes exist in which one of the protons is replaced by a neutron. These isotopes are called isobars, and two examples of such stable isobars are the  ${}_{48}\text{Cd}^{113}$  and  ${}_{49}\text{In}^{113}$ , isotopes of cadmium and indium.

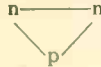
If the (n-n) force were not about the same as the (p-n) force in such an isobaric pair, there would be an energy difference in the nucleus, and some sort of transition between these nuclei would occur. Remembering that the (p-p) force is equal to the (n-n) force, except for the coulomb repulsion, there should not be too much difference in the magnitude between either the (p-p) or the (n-n) force and the (p-n) force of attraction. The equivalence of the (p-p) and (n-n) force, neglecting coulomb forces, can be exhibited by comparing the binding energies in  ${}^1_1\text{H}^3$  and  ${}^2_2\text{He}^3$ :

Isotope	Representation	Forces	Mass	Binding Energy
${}^1_1\text{H}^3$		2(p-n) + 1(n-n)	3.01705	8.32
${}^2_2\text{He}^3$		2(p-n) + 1(n-n)	3.01699	7.62

The difference between the two binding energies is 0.70 mev, but the coulomb energy in  ${}^2_2\text{He}^3$ , resulting from the presence of two protons, is  $(0.6Ze^2)/r$ , equal to 0.72 mev and accounting for the difference in binding energies. Thus, the (p-p) and (n-n) forces are essentially equal. Comparison of data on the angular distribution of protons scattered by protons, along with the binding energy of  ${}^1_1\text{H}^2$  and  ${}^2_2\text{He}^4$  show that the (p-p) force is about 98 percent as strong as the (p-n) force. Roughly, then, the magnitude of these forces may be summarized as follows: (1) the (p-p) and the (n-n) forces are nearly equal and (2) the (p-p) and (n-n) forces are each equal to or less than the (p-n) forces.

active sodium which may be used for medical applications in place of the more expensive radium.

Another of the material particles is the beta particle. These particles are electrons traveling at very high speeds. That such particles are created and emitted in nuclear reactions is well known, and the effect of beta emission is to increase the number of protons in the nucleus: under some circumstances, an energized neutron apparently becomes a proton by expelling a beta particle. A startling illustration of alpha and beta activity is present in the disintegration of uranium  ${}_{92}\text{U}^{238}$ , through a long series of transformations, into the stable form of radium  ${}_{82}\text{Ra}^{206}$ . Fifteen stages of successive

emission of alpha and beta particles are required in this process as the nuclei move from a structurally unstable condition to a stable one (Fig. 4). Here, then, is a natural prototype of nuclear disintegration coincident with the release of energy.

Still another of the material particles is the positron. In a sense, the positron is the converse of the beta particle, for it is an electron with a positive charge instead of the traditional negative charge. Many artificially radioactive substances emit positrons. In fact, in the field of induced radioactivity, the positron is more common than the negative electron. The positron, however, has only a transitory existence, for it unites readily with any adjacent (negative) electron to form

TABLE 1—PROPERTIES OF THE "PARTICLES" OF NUCLEAR PHYSICS

	Proton	Neutron	Alpha-Particle ( $\alpha$ )	Deuteron	Beta-Particle ( $\beta$ )	Positron	Meson	Gamma Rays ( $\gamma$ )	Neutrino	Anti-Neutrino
Nuclear symbol	${}^1_1\text{H}^1$	${}^0_0\text{n}^1$	${}^4_2\text{He}^4$	${}^2_1\text{D}^2$ ( ${}^1_1\text{H}^1 + {}^1_0\text{n}^1$ )	${}^0_{-1}\text{e}^{-1}$	${}^0_{+1}\text{e}^{+1}$			${}^0_0\nu^0$	${}^0_{+1}\bar{\nu}^0$
Charge in esu	$+4.80 \times 10^{-10}$	0	$+9.60 \times 10^{-10}$	$+4.80 \times 10^{-10}$	$-4.80 \times 10^{-10}$	$+4.80 \times 10^{-10}$	$\pm 4.8 \times 10^{-10}$ (or neutral)	0	0	0
Mass in units of electronic mass (9.02 $\times 10^{-28}$ grams)	1838	1838	7352	3676	1	1	20 to 200	0	<0.1	<0.1
Mass relative to ${}^1_1\text{H}^1 = 16$	1.00758	1.008939	4.00276	2.01418	0.00055	0.00055	0.01 to 0.1	0	<0.00005	<0.00005
Mass Energy ( $mc^2$ ) in mev	938	939	3720	1876	0.511	0.511	5 to 50	0	<0.05	<0.05
Mechanical Moment in units of $\frac{h}{2\pi}$ (h = Planck's constant)	1/2	1/2	0	1	1/2	1/2	unknown	0	unknown	unknown

Fig. 4—Successive emanations of alpha and beta particles transform uranium  ${}_{92}\text{U}^{238}$  into the stable form of radium  ${}_{82}\text{Ra}^{206}$  through fifteen stages.

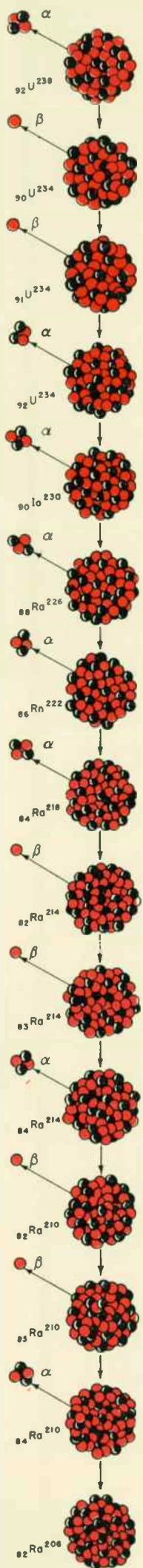

one gamma ray of 1.02 mev or two gamma rays of 0.51 mev energy.<sup>2</sup> This positron annihilation process is observed experimentally and is a prime example of the conversion of mass into energy according to the Einstein relation.<sup>2</sup>

Mesons, the last of the "material" particles, were discovered in 1936 during cosmic-ray investigations. Cosmic rays, high-energy radiations from interstellar space, about which comparatively little is known, were observed to eject certain particles from the glass walls of Wilson cloud chambers. Because their mass is intermediate between that of electrons and protons, these particles were called mesons or mesotrons. Mesons have been produced artificially recently by impinging 100-million volt x-rays on the walls of a cloud chamber.

Like many other nuclear phenomenon, mesons are studied in Wilson cloud chambers, which consist of a cavity containing water vapor and maintained within a magnetic field. The paths of mesons ejected by cosmic-ray bombardment are bent by the magnetic field, while ionization of the vapor by the charged particles permits photography of their trajectories. From measurements of the radius of curvature of these paths and of the strength of the magnetic field, it is readily possible to determine the meson momenta.

Their mass can be found when the ionization density along the paths is known. Such experiments indicate that mesons have a mass 20 to 200 times that of an electron, that there are both positive and negative mesons, and that the magnitude of the charge is identical with that of an electron. Moreover, mesons are radioactive and decay into a neutral particle and an electron or positron in about a millionth of a second. Thus mesons have a transitory existence just as do positrons.

It was such experiments, incidentally, that led to the discovery of positrons, for some particle paths were bent in the opposite direction to that taken by ordinary electrons. Because all other factors were identical, the only explanation of this phenomenon was the assumption of positive electrons.

In addition to these seven material particles—proton, neutron, alpha particle, deuteron, beta particle, positron, and meson—there are three non-material particles associated with the nucleus or nuclear activity: gamma radiation, the neutrino, and the anti-neutrino.

The discovery of gamma rays in 1896 by Becquerel coincided with the discovery of radioactivity. The examination of certain uranium salts revealed the presence of certain penetrating radiations that were, in fact, a result of the nuclear disintegration of radium in the sample. Not only radium, but thorium, polonium, and actinium emit these so-called gamma rays. Gamma radiation is electromagnetic, identical to light and radio waves except in wavelength, for gamma rays are characterized by their very short wavelength. This means

that they have great penetrating power and high energy. Now that it is possible to generate x-rays both longer and shorter than gamma rays, the gamma-ray spectrum can be considered a portion of the x-ray spectrum. The nuclear significance of gamma rays lies in their revelation of nuclear energy states, analogous to those of the electron shells in the outer atom.

The remaining non-material particles are the neutrino and the anti-neutrino. Not only are they non-material: they may well be non-existent, for they are, at present, hypothetical entities postulated to account for certain nuclear disintegrations. When positrons or electrons are emitted by radioactive substances, it is considered that an unstable nucleus passes into a nucleus of greater stability. Electrons or positrons do not exist in the interior of nuclei; however, since they are observed to be present in nuclear disintegrations, it is necessary to assume that they are "created" in the moment of emission.

In such a transformation, noting that there are energy levels in the nucleus, particles ought to be emitted with a discrete energy similar to that occurring in gamma-ray emission. The energy distribution of the emitted electrons or positrons is not discrete; in fact, a continuous distribution of energies up to a certain maximum value is observed experimentally.

This disturbing condition is explained by assuming that a small neutral particle (the neutrino) is emitted along with the electron or positron during each radioactive disintegration. The neutrino possesses energy and angular momentum but has a mass less than 1/10 that of the electron. It has not been observed experimentally, but its existence has been rather well established. The mechanism of beta-particle emission may then be considered to be the result of a neutron breaking up into a proton, neutrino, and an electron—the latter being emitted as a beta-particle (see sketches on p. 121).

The converse reaction to account for positron emission (p. 121) also occurs. In this case, instead of the neutrino, a similar particle called the anti-neutrino, as well as a positron and a neutron, is emitted according to this assumption. The theory postulating the existence of the neutrino and the anti-neutrino is the only one that accounts for all of the present experimental observations. As such, it is valuable, but most scientists believe that fuller knowledge of radioactive transformation will require a modification of the theory.

The existence of ten particles—real or theoretical ones—indicates the complexity of the nuclear problem, even aside from the several forces that prevail in the nucleus. The analysis of relations among protons and neutrons alone is difficult, for in all but the lightest elements the number is so large that rigid mathematical solutions are almost impossible. Hence, statistical quantum-mechanical methods are employed, yielding a picture of the nucleus as a sort of liquid droplet. Energy states and shell structure follow in a manner reminiscent in some ways of the outer atomic structure and in others of a hydrogen liquid droplet. Such forces as the coulomb, saturation, surface tension, and Van der Waals are involved.

Incomplete though our knowledge is, it has proved adequate in predicting much of the behavior of nuclei in nuclear reactions. For this reason, if for no other, present concepts of the nucleus are valuable. They have permitted the creation of artificial isotopes. They have enabled us to cause nuclear disintegrations in the laboratory. They have led to the production of the atomic bomb, and the peaceful utilization of nuclear energy depends primarily on economic and political factors—not physical or technical ones.

It is these confirmations that promise a fuller knowledge of nuclear phenomenon and, concomitantly, of the nature of matter. In the long run, this is the goal of nuclear physics.



---

# Nuclear-Energy Potentialities

---

Is nuclear-energy so expensive that we should forget it, or will it be so cheap that meter reading can be abandoned? Available facts—admittedly not complete—indicate, as one might guess, that neither is the case. Also, cost is not the whole story.

C. F. WAGNER,                      J. A. HUTCHESON  
Manager                              Associate Director  
Central Station Section      Research Laboratories  
Westinghouse Electric Corporation

FEW power engineers have failed to ask themselves: Is nuclear energy commercially feasible? If so, how will it affect the present forms of fuel-fired power plants? Too many facts are still missing to allow complete answers to these questions. However, it is a help to one's thinking to assemble the knowns, and these can be supplemented by estimates of cost that can readily be made by any power engineer armed with a slide rule and a few assumptions. The gist of the conclusions arrived at by such an interim study is that nuclear-energy is quite likely to become commercial, that the cost will not be excessive but neither is it likely to revolutionize power costs, and very importantly that numerous large technical difficulties must be resolved—probably by years of development—before a commercial nuclear-energy power plant can be established.

At the moment private experimentation with fissionable materials is not generally allowed. That the government will continue to exercise strict control over ownership and experimentation with fissionable material goes without saying. What sort of controls—whether civilian or military—over production and use of nuclear-energy materials will be established by congress is still undecided. Probably fissionable materials will be made available under strict supervision for commercial experiment and possibly for commercial use. At present, however, civilian experimentation with uranium is strictly limited.

It is relatively easy for anyone familiar with the electric-power industry to make an estimate of cost of electricity produced from uranium disintegration. It involves, of course, numerous assumptions that may or may not prove to be justified but which seem to have considerable foundation. On this basis nuclear-produced power seems to be not so cheap as to revolutionize the power picture, but neither is it so high as to preclude its consideration as a competitor to fuel.

To establish some general boundaries of costs, let us estimate the comparative economics of two 100 000-kw power plants, one using coal or oil and the other nuclear-energy obtained from a pile including pure but natural uranium. Present indications are that the first useful plants will be large, possibly of the order of 100 000 to 200 000 kilowatts. Because of the shielding required to protect personnel from the incidental radiations, it doesn't now appear feasible to consider smaller plants.

Our hypothetical power plant will use as its fuel purified natural uranium. In this unenriched state, uranium contains 0.7 percent by weight of the active U235 isotope. The total available energy of the "pile" is then 81 500 kwhr per pound of the uranium metal. There will be the usual radiation and exhaust losses so that an overall thermal efficiency of 25 percent can be assumed in converting the available

*Editor's Note:* Much of this article is speculation based, of course, on facts gleaned from what has been permitted to appear in the technical press, particularly with regard to the nature, form and cost of the power plant. Since the preparation of this article, however, announcement has been made that the Federal Government has undertaken an experiment on a full-sized power plant at Oak Ridge, Tennessee. In this project Westinghouse engineers are participating. Many of these unsettled and dubious questions will be given definite answers.

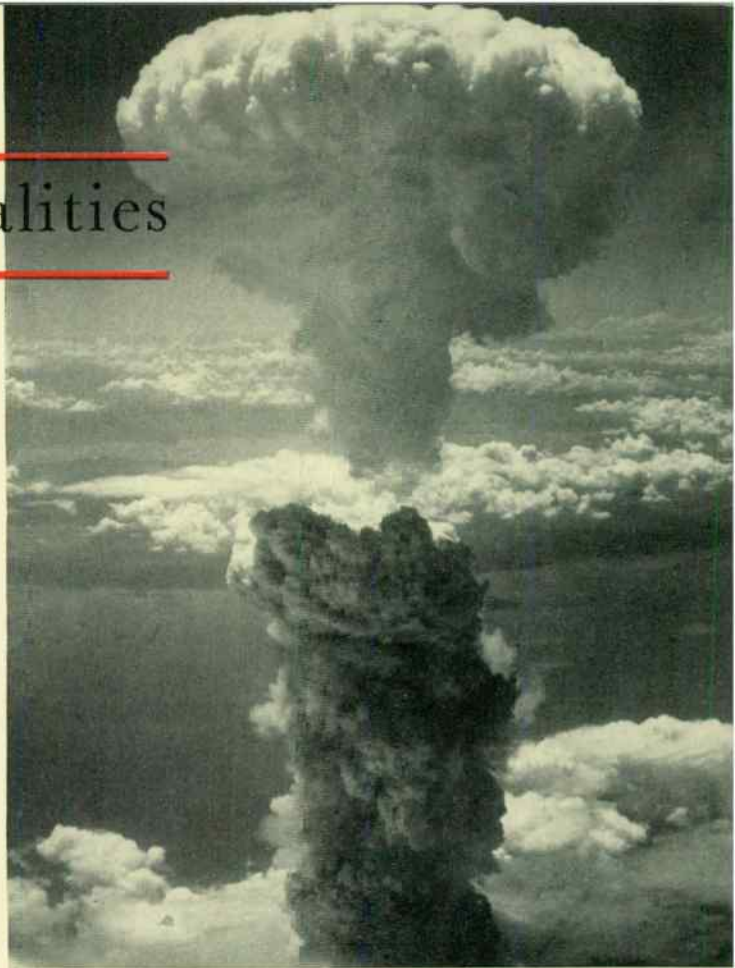

thermal energy into electrical energy. Thus 20 400 kwhrs of electrical energy are obtained from each pound of pure, natural uranium. This ignores the heat obtained in the operation of a uranium pile as the result of formation and eventual fission of plutonium from U238. Little data on this is available, but in a commercial plant credit would of course be taken for this heat.

The cost of pure but unenriched uranium has been quoted in the literature as being about \$20 a pound. With mass-production methods the actual cost may be considerably less than this figure. However, the first cost of uranium may not be its effective cost. When a U235 atom is disintegrated by bombardment of a neutron, other products are formed, in addition to the release of energy. These are elements of roughly half the atomic weight of uranium. Barium, with atomic weight of 137, and krypton, atomic weight of 83, are representative fission products. These products tend to poison the pile, i.e., to neutralize the process just as ash accumulating around a lump of burning coke retards combustion. The full energy of the U235 cannot be obtained from the pile without the removal, from time to time, of this nuclear-reaction "ash" so that the process can continue. This periodic refining or repurifying of the uranium is a chemical process. It entails additional expense, but how much is as yet unknown. In view of the foregoing considerations, the cost of uranium in this study has been varied over a range of from 0 to 50 dollars per pound, each pound of which makes 81 500 kwhrs of energy available by fission.

The exact manner in which the energy in a uranium pile will be used in the generation of electrical energy is still subject to further investigation. However, we shall assume a conventional steam or gas

turbine and that steam, or some other gas, will be passed through the pile. In other words the pile would replace the boiler, stoker, draft machinery, fuel-storage and fuel-handling facilities, and present ash-removal equipment. Some of the energy-conserving devices like feed-water heaters, reheaters, etc., used in fuel-fired power plants to squeeze the last Btu out of the fuel might prove uneconomical with the uranium-pile plant. Also, the economic justification of a steam condenser would require study.

### Investment

Inspection of investments reported on several conventional steam-generating stations within range of 100 000 kilowatts indicates that a total investment of \$90 per kilowatt of installed capacity represents a typical investment in a modern coal-burning steam station. A further apportionment of cost is made by estimating that boilers, turbines, and steam auxiliaries cost \$30 per kilowatt of installed capacity. This portion of the total cost is segregated because apparently only the "mechanical equipment" in a generating station will be radically changed from present design to accommodate atomic fuel; electrical equipment, exterior building, and service equipment are not expected to undergo such sweeping changes that their costs will be materially altered. To reduce fixed costs to a basis comparable with fuel costs, it is assumed that yearly depreciation, maintenance, taxes, interest and labor charges will amount, in total, to 15 percent of the entire plant investment. In evaluating the fuel costs of a coal-burning plant, the heat content of coal is assumed to be 12 000 Btu per pound, and the efficiency of conversion of fuel to electrical output is assumed to be 25 percent.

It is anticipated that an atomic fuel generating plant will cost more than a conventional coal-burning plant. It further appears that the major increase in cost will develop in the mechanical equipment section, composed of boiler, prime

mover and associated auxiliaries. Cost increase factors of both two and four are considered in this analysis. These factors are applied to the cost of mechanical equipment in a conventional steam plant, resulting in costs of \$60 per kilowatt and \$120 per kilowatt, respectively, for the heat utilization equipment peculiar to an atomic-powered generating station. Translated into terms of total investment, these estimates permit \$6 000 000 and \$12 000 000 to be spent for the specialized equipment necessary in an atomic power plant. If to these totals are added those costs believed to be substantially constant (\$6 000 000), figures of \$12 000 000 and \$18 000 000 result as total station investment. To reduce the total investment estimate to a basis comparable with fuel costs, yearly costs aside from fuel were estimated to be 15 percent of total investment; this results in yearly charges of \$1 800 000 and \$2 700 000. If the 100 000-kilowatt station under consideration operates at 100-percent load factor, these yearly costs reduce to 2.06 mils per kilowatt-hour and 3.08 mils per kilowatt-hour. If the station operates at only 50-percent load factor, fixed charges will be 4.12 mils per kilowatt-hour and 6.16 mils per kilowatt-hour.

If the eventual design of atomic power plants should permit their being located near the electrical center of the load which they serve, a substantial decrease in cost of power transmission would result. While it seems unlikely that all power transmission costs could be eliminated in any practical case, such a condition is considered in this analysis in order to establish the range through which costs might be affected by reduction of investment in transmission lines. It is assumed that transmission cost in a typical power system is \$80 per kilowatt of installed capacity. This cost can be distributed at the rate of 2.74 mils per kilowatt-hour, if yearly charges are again evaluated at 15 percent and system load factor is assumed to be 50 percent.

The figures resulting from the calculations based on these

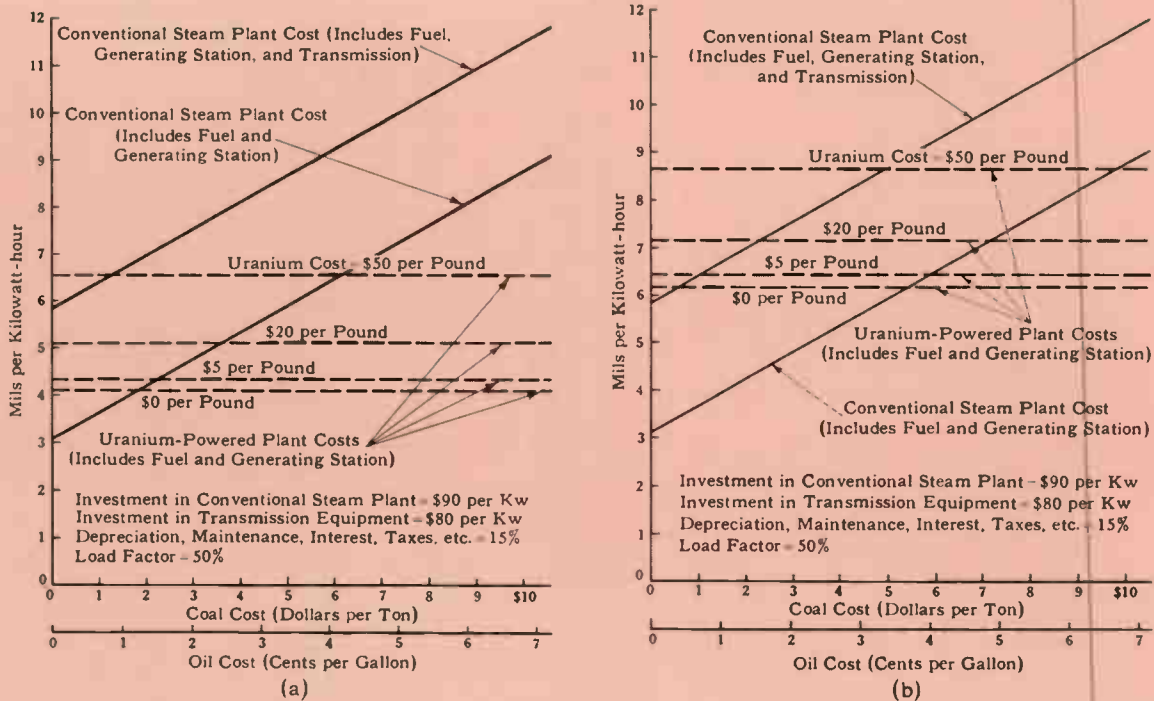

Fig. 1—Relative cost of power developed by uranium versus coal or oil. Fig. 1(a) is based on an estimated investment of \$120 per kw in the uranium-powered plant; Fig. 1(b) is based on an investment of \$180 per kw.



several assumptions are given in Fig. 1 for a load factor of 50 percent. They show that with uranium at \$20 per pound and with uranium-plant investment of \$120 per kw, the energy cost is 5.1 mils per kwhr, Fig 1(a). This corresponds to the energy cost of a station using coal costing \$3.60 per ton or oil at 2.4 cents per gallon. The corresponding energy cost for \$5 uranium is 4.4 mils per kwhr and for \$50 uranium, 6.6 mils. Fig. 1(b), similarly considers the case where the uranium plant investment is taken at four times that of the comparable elements of the conventional plant, i.e., \$180 per kw.

The salient figures based on these assumptions are summarized in table I. It must be emphasized that these comparisons hold only for the given assumptions, which for clarity are repeated in Fig. 1(a) and (b). For other assumptions similar comparisons can be made. The results of this comparison assist in judging the economics of atomic power.

### Engineering Considerations

Other factors than straight economics will probably dictate when and where uranium-pile power plants will materialize. Whereas the uranium pile simplifies the power plant in some regards, it brings with it a host of engineering problems of first order of magnitude.

Most of these problems center around the radioactivity of the products of the nuclear disintegration. These end products and everything exposed to them, such as the water or other heat-exchange medium, become powerfully radioactive. The radiations produced as the atoms return to a stable state are extremely hazardous to life. Consequently the pile itself and all parts of the system in contact with the heat-carrying medium, and this may include the turbine, must be carefully shielded to protect the personnel. This requires considerable masses of materials surrounding the equipment.

Much of the nuclear-energy apparatus will have to be operated remotely. As has been mentioned earlier, the uranium-bearing material must be removed from time to time in order that it may be repurified. This requirement imposes many problems. Means must be provided to handle these intensely radioactive elements without endangering the well-being of the personnel. This implies remote handling and disposition of these elements. Similarly if any of the control devices should fail, they cannot be repaired because they too would be radioactive. Therefore it is likely that means will be provided which will permit remote handling and replacement of the control devices.

In short, while the brilliant, breath-taking achievement of tapping the storehouse of nuclear-energy has been achieved, there remains a multitude of engineering problems that must be solved before the new ability can be put to workaday use.

### Size of Pile

For the energy-releasing reaction to be continuous or self-sustaining in a pile including natural uranium, the size of the pile must be above a certain critical large size. This size has not been definitely stated but is of the order of several tons or a block several feet on a side. If the pile were small—i.e., a lump in which the ratio of surface to volume is larger—the loss of the reaction-causing neutrons from the surface would be so great as not to allow the reaction to be self-sustaining. Moreover “ash” accumulation means that the pile size must be considerably above a critical size otherwise these accumulating impurities would soon absorb so many neutrons as to stop the reaction. Therefore, a pile capable of reasonably constant energy release requires a large mass of fissionable material and also movable neutron absorbers, such as cad-

TABLE I— COMPARATIVE ENERGY COSTS 100 000-KW POWER STATIONS USING PURE, UNENRICHED URANIUM AND COAL (50% LOAD FACTOR)

Uranium Cost Dollars per pound	Investment in Uranium-Powered Plant—Dollars per Kw			
	\$120		\$180	
	Mils per Kwhr	Equivalent Coal \$ per ton	Mils per Kwhr	Equivalent Coal \$ per ton
0	4.1	1.8	6.2	5.4
5	4.4	2.3	6.4	5.8
20	5.1	3.6	7.1	7.2
50	6.6	6.2	8.6	9.8

mium, as control devices. Then ash accumulation can be compensated by gradual withdrawal of the absorbers. This can be continued, holding the energy release substantially constant, until the control devices have been withdrawn, after which the reaction speed would decline and eventually cease altogether. For practical power purposes such operation would be unsatisfactory. It is this fact which requires the ability to reprocess and repurify the atomic fuel without necessitating shutdown of the pile. Enrichment of the U235 isotope of the uranium would make possible correspondingly smaller energy-releasing piles. Increase in the proportion of U235 could be continued until, as in the atomic bomb, the critical size for self-sustaining reaction becomes relatively small. Although possible, this procedure rapidly increases the expense of any commercial form of energy generator. In the atomic-bomb project three methods of isotope separation, i.e., U235 enrichment, were applied successfully. All were costly, although uranium isotope separation can unquestionably become more economical. There is always, of course, the possibility that some new and cheaper method of isotope separation may be developed. However, as matters stand now U235 enrichment is costly—so much so as to make its use as a power-plant fuel unlikely.

The high cost of a pile of small size is, incidentally, one of two reasons why small power plants for ordinary purposes like vehicles are out of the question. The other is that the weight of the shielding required to protect passengers and operators from the intense radiations raises the bulk to unreasonable proportions for automobile, aircraft, and probably locomotive use. For submarines or battleships, on the other hand, where a saving in fuel storage, weight, and volume has great value and where necessity of refueling is a disadvantage, such a power plant may prove justified. Generally, a “teacup” nuclear power plant is, at present, pure fantasy.

It is a human characteristic to interpret the new in terms of the old, and thereby so often misjudge the new. That may be what is happening with atomic power, just as the first automobile was conceived as a buggy driven by an engine. Perhaps atom-fuel power will be of greatest use at places on the earth where there is now fuel famine.

Other quite different methods of tapping the atom storehouse may be found. This may be either by fission of heavy atoms into elements near the middle of the atomic scale, or by synthesis of lightweight elements into heavier ones. Heat from the sun is thought to be energy released from the combination of hydrogen atoms with helium atoms by successive nuclear reactions. Certainly we cannot ignore atomic energy. It is of major importance to us as engineers, and even more important to us as citizens of the world.

# STORY OF RESEARCH

## Photomultiplier X-ray Detector

**Y**ou can't teach an old dog new tricks" may be a valid generalization in the canine kingdom, but in electronics scientists think nothing of twisting old adages by the tail. This time the standard photomultiplier tube, used conventionally in the past as a light-sensitive device, has succumbed to their blandishments, coming out with a new and unsuspected property: the ability to measure x-radiations with remarkable accuracy and speed over a wide range of intensities.

In the past, the difficulty of measuring the quantity or intensity of x-radiations has persistently plagued the user of x-rays. Standard x-ray detectors like photographic film, ionization chambers, or Geiger counters are either impractical in many x-ray applications, or fail to provide continuous information, or are limited in their response to broad ranges of intensities. The photomultiplier has none of these shortcomings.

Introduced a few years ago, the only wide x-ray use of the photomultiplier tube has been in automatic exposure timing for mass medical radiography. Here the relative speed of the timer was the primary consideration. The tube was used in the customary way to measure light intensity (like light from a fluorescent screen). That such a tube could measure amounts of radiation precisely was unsuspected.

Recent studies by Drs. John W. Colt-

man and Fitz-Hugh Marshall of the Westinghouse Research Laboratories have indicated that the tube is a suitable tool for quantitative measurement of x-rays, both in production and research. The discovery of the unsuspected sensitivity to x-rays of the conventional photomultiplier tube used with a fluorescent screen opens up the whole field of x-ray applications. For the first time, electronic controls and measuring or detecting devices can be utilized extensively with x-ray equipment.

The simplicity of the detector is one of its outstanding attributes. All that is needed is a standard photomultiplier tube wrapped about with a sheet of fluorescent screen and then a sheet of black paper to cut out room light. The tube requires a low-current, thousand-volt d-c power supply and a measuring device such as a microammeter, a galvanometer, or an oscilloscope.

Minute, as well as gross, quantities of radiation can be detected. An ordinary photocell has only a feeble response, but the photomultiplier contains not only the photocathode but nine stages of secondary emission amplification. When an electron is emitted by the cathode, it is swept by a 100-volt field to the first dynode where it ejects four or five secondary emission electrons. These are similarly amplified at the second dynode until the amplification, after nine stages, totals between 100 000 and 2 000 000. Such amplification could be obtained externally at the expense of speed of response, but elaborate circuit

balancing, insulation, desiccation, electromagnetic shielding, and thermal padding would be necessary.

In contrast to photographic film methods, the photomultiplier has the advantage of simplicity, speed, and continuity. Moreover, it is more sensitive to small changes and provides direct reading. Ionization chambers, while sensitive, are definitely research instruments that require careful handling and critical balancing techniques. Here the ruggedness and operational ease of the photomultiplier constitutes its superiority. The tube, with its response to a very wide range of intensities, is also superior to the Geiger counter which is limited to low intensities. The ultimate limit of sensitivity of the photomultiplier under many operating conditions is set by the statistical noise of the x-ray quanta themselves—the maximum attainable sensitivity of any detector.

The one defect of the photomultiplier tube is its susceptibility to fatigue, but there are several practical methods of nullifying this disadvantage. The tube can be aged to a fatigue plateau and then operated continuously at this level. It can be operated at a low level where fatigue is negligible. Or a reference point may be returned to at regular intervals, providing the correction factor on the assumption that fatigue is a linear function. Still another possibility is the use of a standard source of intensity for monitoring the sensitivity of the detector.

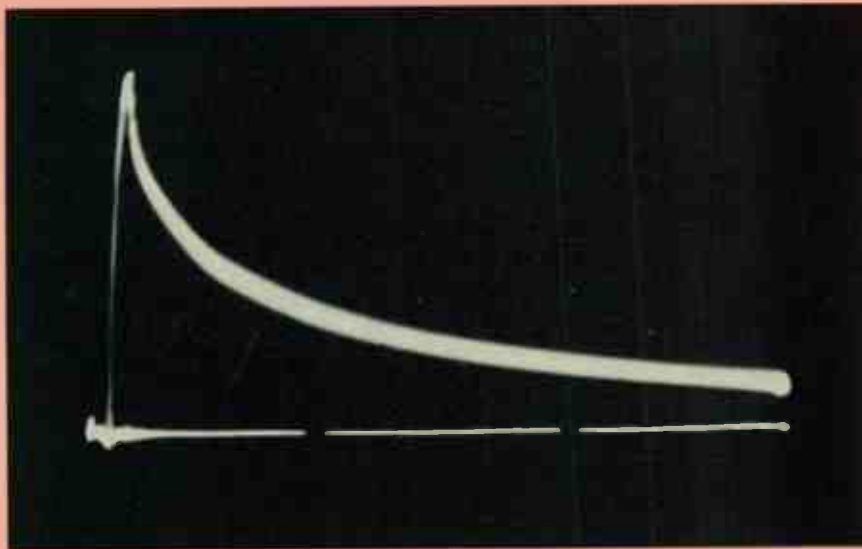

Speed of response is one of the characteristics of the photomultiplier detector. Here x-rays were turned on for one microsecond. The oscillogram shows almost instantaneous response of the tube—within a microsecond. Recovery occurred in only ten microseconds as shown by the 10-microsecond markers on the lower time trace.

The nine stages of amplification in the photomultiplier tube account for its wide range of sensitivity. A single electron leaving the cathode may knock out, for example, four electrons from the first dynode. Each of these, in turn, elicits four electrons from the second dynode, and the cumulative process produces over 250 000 electrons at the anode. Conventional photoelectric tubes could be used in x-ray detection, but the noise level of external amplification would override weak signals. The internal amplification of the photomultiplier, however, permits detection of a single x-ray quantum.

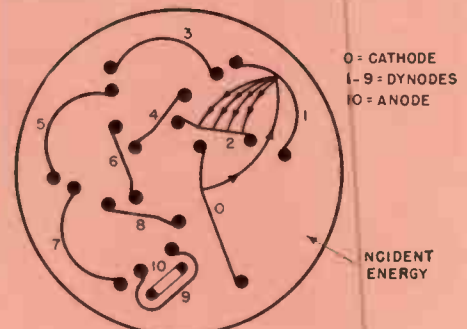

0 = CATHODE  
1-9 = DYNODES  
10 = ANODE

INCIDENT ENERGY



# PERSONALITY PROFILES

*J. A. Hipple* is a native Pennsylvanian. He divided his undergraduate training between Penn State (two years) and Franklin and Marshall, graduating from the latter in 1933. To his B.S. degree he promptly added an M.S. and Ph.D. in physics at Princeton, topped off by a year of research at Princeton on the mass spectrometer under such men of renown in that field as Bleakney and Smythe (recently of atomic-bomb report fame). Hipple became the first Westinghouse Research fellow in 1938, continuing his research on the mass spectrometer, which culminated in the mass-spectrometer analyzer.

In 1944, *H. A. Thomas*, associate professor of Electrical Engineering at Texas A & M, was granted a leave of absence to come to Westinghouse to gather background in mass spectroscopy in anticipation of a research program at Texas A & M on that subject. Arriving at Westinghouse just at the time the need for the super-sensitive vacuum leak detector on the atomic-bomb project was most pressing, he assisted in bringing it to fruition, aiding the war program and at the same time gathering valuable experience with the mass spectrometer, heart of the electronic leak detector. Thomas has since returned to Texas.

*T. W. Williams* is another atom-bomb alumnus. He served a turn of several months applying his skills in high-vacuum techniques. He has acquired his valuable experience in that field as a member of the electrophysics division of the Westinghouse Research Laboratories working on mass-spectrometer analyzer and leak-detector problems.

Williams obtained his formal engineering education at Hampden Sydney College, from which he graduated in 1938, and at the University of Virginia, which conferred on him a Ph.D. in physics in 1943. His thesis work, appropriately enough, was done in isotope separation. Williams joined Westinghouse in 1943, becoming attached to the Mechanics Section of the Research Laboratory and working initially on problems of vibration of high-speed machines.

The method of grinding gear teeth described in this issue, and thought by many to be the most important recent innovation in cutting teeth of large power gears, was conceived and developed by *Harold W. Semar*. In 15 years since graduating from Lehigh University in mechanical engineering, Semar has become one of the country's outstanding experts in gear construction, albeit one of the quietest, most self-effacing ones. For several years after

completing the test course at Westinghouse Semar applied himself as a design engineer in the Steam Division, specializing on gears, then became Manufacturing Engineer, and last year was appointed Assistant Superintendent of the Gear Manufacturing and Erecting Dept.

*H. Putz*, also a mechanical engineer, has had a briefer but more varied career. A product of the University of Illinois, class of 1938, Putz also came to Westinghouse to the Steam Division. Three years were applied in development engineering, primarily on impulse blade problems employing the optical system of blade vibration analysis. This was followed by a year on control for central-station turbines, nearly two years on marine turbine engineering, during which time he had charge of shop tests on certain aircraft-carrier drives and of tank-drive controls. Early in 1944 he was given charge of the section handling gas and turbine locomotives.

*W. E. Shoupp* has been delving into the nucleus of the atom for well on 15 years—a period belying his youth. His interest began in 1930 while he was an undergraduate at Miami University, Oxford, Ohio. After receiving his A.B. degree in 1931, he spent six years at the University of Illinois, studying and teach-

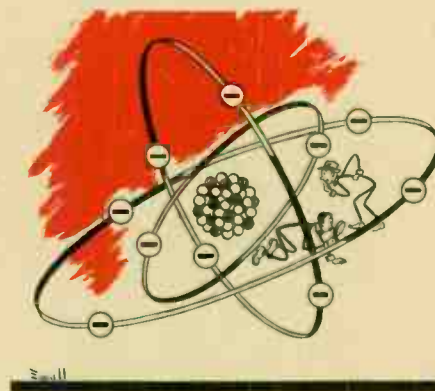

ing physics, obtaining his Doctor of Philosophy degree in 1937. This period marked the flowering of nuclear research in this country, and Shoupp was active in the projects inaugurated at Illinois.

His career at the Westinghouse Research Laboratories dates back to 1938 when he arrived in the fall as a Westinghouse Research Fellow. Two years before, construction had started on the Westinghouse 4 000 000-volt Van de Graaf generator, and Shoupp was placed in charge of the project under the aegis of Dr. E. U. Condon. Shoupp's outstanding contribution to the field of nuclear physics was the

co-discovery of photofission—the splitting of uranium atoms by high-speed gamma rays.

Appointed manager of the Electronics Department of the Laboratories in 1943, he has divided his efforts during the war between the atomic bomb project and radar. What with shuttling between coasts and directing the two programs at the Laboratories, he has had little time for tennis, golf, and bridge.

Although their early backgrounds are quite different, the records of *D. L. Hopper* and *A. P. Colaiaco* bear several similarities. Further their recent histories are strikingly characteristic of that of the typical young engineer. Both were graduated early in the war—1942—and were thrust almost at once into war work of high priority, each performing with the quality of veterans. Both are extremely industrious and are diligently engaged in post-graduate studies.

Colaiaco, a native of Italy, became a Pennsylvanian at the age of six and sought his engineering education at Penn State. There he received his B.S. in electrical engineering, although he feels he should also have had a degree in dishwashing, furnace tending, and baby sitting.

Hopper is from Kentucky. Although he too studied electrical engineering (at the University of Kentucky), he distinguished himself as an athlete, being a football quarterback, a sprinter, and on the basketball team. Neither Hopper nor Colaiaco found that extracurricular activities interfered too much with studies—both were elected members of Tau Beta Pi.

These young engineers took the Westinghouse student training course in 1942—abbreviated by the war and the urgent demand for engineers—and soon found themselves in the mercury-arc rectifier section, where high vacuums are the order of the day. Hopper spent a year on developing manufacturing processes for ignitrons, then so greatly needed for light-metal production, while Colaiaco went to work on devices to handle high vacuums. Soon Project X—now recognized as the atomic project—appeared with great secrecy and mystery. For it, high vacuums on a scale never before imagined were necessary, and both Hopper and Colaiaco found themselves working almost literally night and day on various aspects of diffusion-pump production. Busy though they were in this war work, neither allowed his plans for further engineering training to be scuttled. Hopper now has his master's degree, and Colaiaco is well on the way for his. And they are both still less than 30.



# ATOM SORTER

The mass spectrometer can segregate atoms and molecules of gases according to their weights. Such ability is made the basis of the vacuum leak detector described herein. This is a rare photograph of a mass spectrometer in action, sorting molecules of three masses.