

WESTINGHOUSE

Engineer

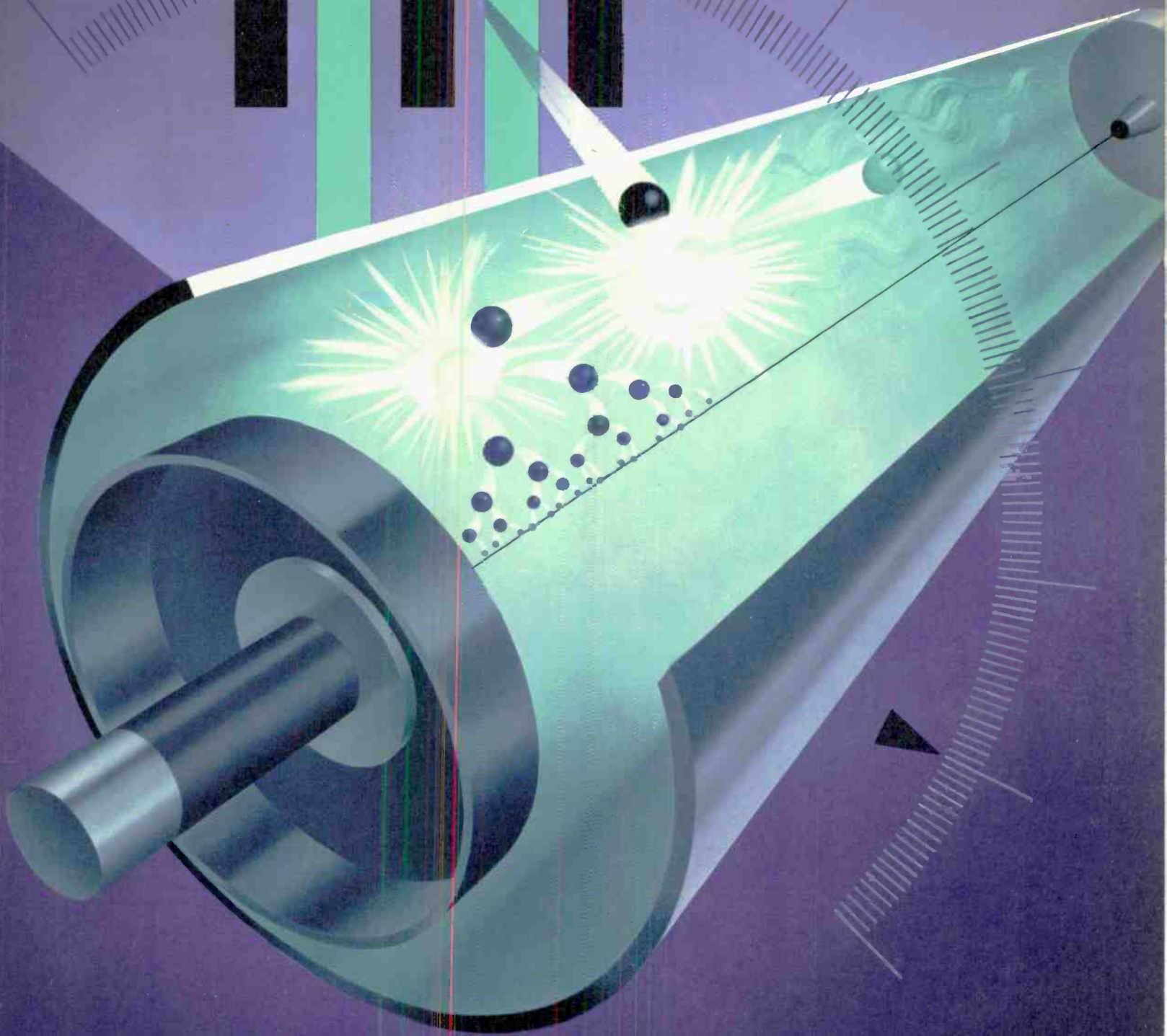

MAY 1957

● That science and engineering are constantly finding new fields to explore, and thereby constantly branching out in many new areas like the roots of a tree is today an obvious fact. This has a tendency to isolate technical groups from one another and make the task of keeping posted on technical developments more difficult for all scientists and engineers. But it is an extremely necessary effort. Useful information turned up by a scientist in one field often has application in a totally unrelated field.

While more dramatic examples of this fact could undoubtedly be found, two articles in this issue serve the purpose. These concern the Hall effect, (p. 71) and electroluminescence, (p. 93). The Hall effect, though interesting scientifically, apparently had no practical significance when it was first noted by Professor Hall in 1879. Until fairly recently, it remained merely a scientific phenomenon. The same can be said for electroluminescence, which was first discovered by Professor Georges Destriau in 1936; until the last few years, when dramatic progress has been made toward making this a practical light source, electroluminescence was largely a scientific curiosity, with no apparent application.

Twenty years ago there was little common ground for the Hall effect and electroluminescence. The Hall effect concerns magnetic fields; electroluminescence concerns electric fields. The Hall effect, initially, dealt with metals and the flow of current through them; electroluminescence concerned the seemingly unrelated field of phosphors, and light production. Neither phenomenon attracted much attention from the standpoint of practical application.

Then came tremendous interest in a different field—semiconductors—the half-insulator, half-conductor materials, such as silicon, germanium, and various compounds. The possibilities for practical application of semiconductor devices spurred a great deal of work, in both science and engineering, and has led to an increasing knowledge of their behavior. It led not only to a greater attempt to develop theory concerning their behavior, but also to an intense effort to develop better semiconductor materials. This, in turn, led to many new techniques of preparing semiconductor materials, since almost fantastic purities must first be achieved and then infinitesimal amounts of impurities added to achieve the desired results.

From a casual glance, this seems a far cry from either the Hall effect or electroluminescence as they were first discovered. But, as can be seen in the articles, there is a common denominator. Information and development work in the field of semiconductors has led to a greater understanding of both the Hall effect and electroluminescence. Also, the materials and the processing techniques have been of tremendous help in both areas. In fact, the Hall effect now appears to have promise for practical application because it is found also in semiconductor materials, which are used in place of the metal conductor with which Professor Hall demonstrated the effect. This is but one small example of the fact that although technical fields are becoming more numerous and divergent, they frequently have relationships, regardless of how remote the subjects may seem from one another.

As science and engineering become more and more complex and, in some cases, more specialized, the problem of communication between technical groups becomes more difficult. But at the same time the necessity for good communication becomes greater, almost in a straight-line relationship. No matter how unrelated the fields may seem, nearly always some information is of common interest and mutual benefit. R.W.D.

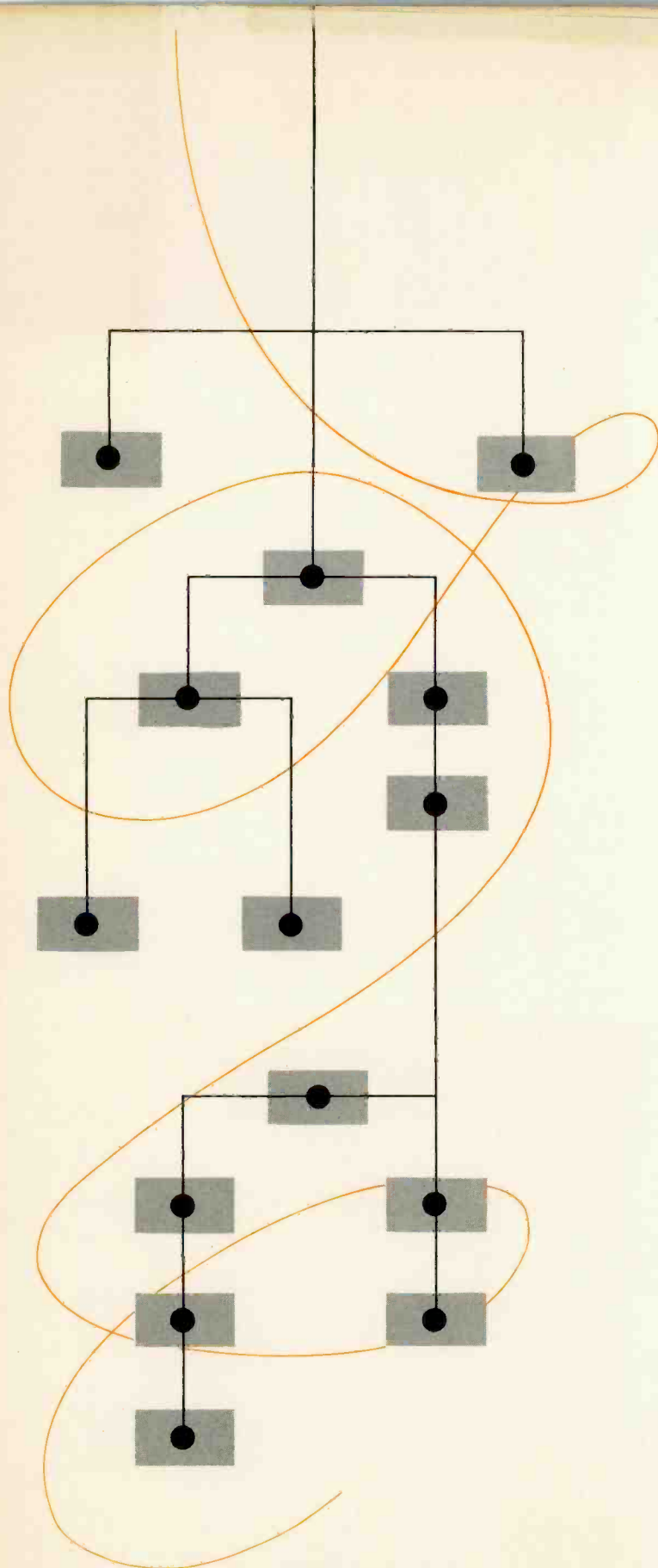

The Common Threads in Engineering

WESTINGHOUSE

Engineer

VOLUME SEVENTEEN • NUMBER THREE • MAY, 1957

In This Issue

As industry expands, it increases the demand for electrical engineers and opens many new fields of opportunity.

With increased knowledge of semiconductor materials, a laboratory phenomenon has practical applications.

Improved performance, higher power densities, and better service and life for special-purpose electronic tubes.

One of the "fathers" of Westinghouse control centers, he's a very busy man.

Forge for turbine blades—High-speed circuit breaker—Potentiometer tester—Shippingport generator—Gas-filled circuit breaker.

Improved d-c power supply made possible by high-power silicon rectifiers.

A new tandem cross-compound, quadruple-exhaust steam-turbine design.

Improved arrester characteristics provide more protection for equipment, and more freedom of system design.

This fourth basic type of light source may revolutionize lighting techniques if it can achieve its full potential.

- 66 Trends in Industry and Their Effect on Electrical Engineering
W. R. Harris
- 71 The Hall Effect and Its Uses
T. R. Lawson, Jr.
- 74 An "Age of Refinement" For Special Purpose Tubes
Harry F. Dart
- 79 An Engineering Personality—E. G. Wise
- 80 What's New
- 82 New D-C Power Supply For Aircraft
R. E. King and V. Janonis
- 86 The "Cross-Quad" 3600—3600
Norris D. Gove
- 88 Protective Characteristics of the Autovalve Arrester
A. M. Opsahl and N. K. Osmundsen
- 93 Electroluminescence—A Laboratory Curiosity Approaches Practicality
H. F. Ivey

The following terms, which appear in this issue, are trademarks of the Westinghouse Electric Corporation and its subsidiaries:

Kovar, Autovalve, Mobilarc

THE COVER

Special-purpose electronic tubes fill a variety of assignments—neutron detection for control of nuclear reactors is a relatively recent application. A neutron counter tube is symbolically portrayed by cover artist Dick Marsh.



Editor . . . RICHARD W. DODGE

Managing Editor MATT MATTHEWS Design and Production JAMES G. WESCOTT

Editorial Advisors J. A. HUTCHESON, J. H. JEWELL, DALE McFEATHERS

Published bimonthly (January, March, May, July, September, and November) by the Westinghouse Electric Corporation, Pittsburgh, Pa.

Subscriptions: Annual subscription price in the United States and possessions is \$2.50; in Canada, \$3.00; other countries, \$3.00. Single copy, 50¢. Address all communications to *Westinghouse ENGINEER*, P. O. Box 2278, 3 Gateway Center, Pittsburgh 30, Pa.

Indexing and Microfilm: *Westinghouse ENGINEER* contents are regularly indexed in *Industrial Arts Index*. Reproductions of the magazine by years are available on positive microfilm from *University Microfilms*, 313 N. First Street, Ann Arbor, Michigan.

THE WESTINGHOUSE ENGINEER IS PRINTED IN THE UNITED STATES BY THE LAKESIDE PRESS, CHICAGO, ILLINOIS

trends in industry —AND THEIR EFFECT

ON ELECTRICAL ENGINEERING. *Demands for faster, higher quality, and more automatic production have many effects—both direct and indirect—on the future of electrical engineering.*

W. R. HARRIS

Manager, Industry Engineering
Westinghouse Electric Corporation
East Pittsburgh, Pennsylvania

Fig. 1

Horsepower per worker in this country has been increasing at a sharp rate, especially in the last few decades. Most of this is electrical.

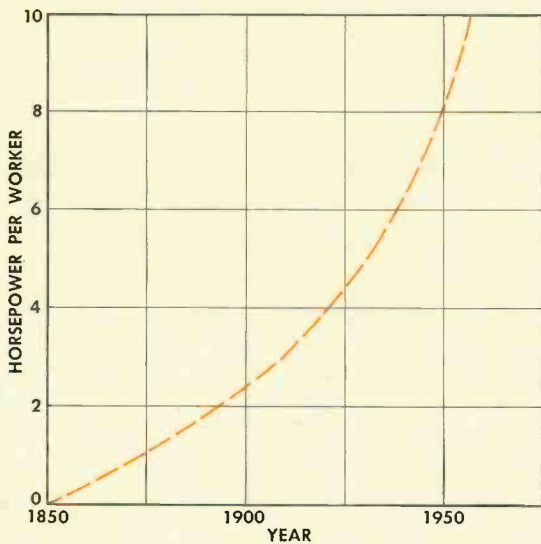

■ The accelerated pace of industry has wrought considerable change in the status and qualifications of the engineer. There is great demand for his services, pressure to increase his technical know-how, and a growing awareness of his importance in business and community affairs. Various forces and circumstances have brought about the changes.

The character of industry has changed tremendously in the last ten years. Each new plant, new process, or new machine tool is a little more automatic than the last. The trend is a slow, creeping evolution, and not a revolution. In the future, industry will continue to use more horsepower, work at faster speeds, use more continuous processes, and modernize its plant equipment.

The electrical engineer, in particular, is affected by these trends. Electricity is the only kind of power that can be easily produced in a central location, transmitted over long distances, and most important, easily split up into small fractions. Consider the growth of horsepower per worker plotted in Fig. 1. In 1850 very little horsepower was used, and it was largely mechanical. About 1910, $2\frac{1}{2}$ horsepower per worker was used, and about 60 percent was mechanically produced by waterwheels and steam engines. At present however, about 95 percent of the total is electric power. This reversal is the result of the inherent advantages of electricity. However, many other trends contribute to the changing pattern of electrical engineering.

Fig. 2
growth of basic industries 1945-1955

Size of each industry in 1945 is arbitrarily assumed to be 1.00. Chart represents growth only, not relative size of these industries.



The Increasing Requirements of Industry

Size—The growth of basic industry in the last ten years has been tremendous. The size ratios of a few industries are shown in Fig. 2. Economists predict that these industries will continue to expand, most of them at about the same rate.

Growth in itself brings difficult problems. For example, consider the electric-utility industry, which has doubled in size each ten years since 1919. The utilities are operating with lower margins of reserve generating capacity than ever before. This necessitates more power pools with other utilities for reserve and peaking capacity, and has opened up many new problems pertaining to system interconnection and system stability. The huge size of many new generating stations makes it necessary to locate them adjacent to water and fuel supplies. Frequently, this means extra-high transmission voltages to economically transport power to the load areas. Phenomena that are relatively unimportant at lower voltage levels assume major proportions at high voltages, and a whole new field of study and investigation is required to determine design and operating practices.

Probably the most significant trend is toward automatic control, which to date has been applied principally to isolated tie lines, and generating and loading stations. Many companies are now considering load and frequency control, coupled with an economic dispatch computer, to automatically allocate generation on the system. Furthermore, increase in size has accelerated interest in supercritical pressures for better plant efficiency, such as a 325 000-kw, 5000-pound cross-compound turbine generator now under construction. The electrical protective devices and interlocking of the various components is becoming a major project and requires close coordination with the turbine designers. For instance, on such large units the interceptor valve control alone has required as many as eight limit switches and a synchro unit to indicate position. Engineering manhours expended in the design of such plants is tremendous as compared to conventional facilities.

Increased Speed of Production—From machine tools to giant steel rolling mills, no matter what industry, speeds are invariably higher. Horsepower has climbed directly with speed. But more important, the difficulty of control has increased about as the square of the speed. Three time constants are involved. The first is a longer mechanical time constant because of increased stored energy in the moving parts. The next is the longer electrical time constant inherent in the larger machines. The third is the human time constant which varies from person to person depending on age, dexterity, mental alertness, attitude, etc.

The first two time constants can be reduced by forcing systems, but it is difficult to do much about the third. Human reactions are just not fast enough, accurate enough, or reliable enough to meet the requirements of high-speed mills, and this has led to increasing use of regulating systems. As an example, consider a mile-a-minute winder in the paper industry (Fig. 3). The purpose of the winder is to take paper from the forming machine, slit it to the proper width, and rewind it into rolls for shipment. Low-speed winders of several years ago used a simple adjustable-voltage drive manually controlled by a pushbutton and a rheostat. A mechanical brake provided a degree of tension between the unwind and the wind stand.

A modern winder for kraft paper is operated at around 6000 fpm, and requires a much more complex drive system. At this speed and power a simple mechanical brake on the unwind stand is undesirable because of heat dissipation problems and maintenance. So an electrical braking generator is pressed into service. The control system utilizes a regulator for unwind tension and winding speed, plus acceleration and deceleration current-limit and inertia compensation devices. No matter how fast the operator attempts to increase speed, the tension between the units is maintained and the electrical currents are within the commutating abilities of the drive motors. The complexity of this system is almost entirely the result of increased operating speed.

Continuous Processing—Along with increase in speed, continuous mills and processing lines are in more widespread use. Here several separate machines are integrated into a complex system that requires the ultimate in coordination. The impact of this trend on the steel industry is dramatically illustrated by plotting the man-hours per ton of finished steel from data published by the American Iron & Steel Institute. This curve (Fig. 4) shows a rapid decrease from 1938 to 1941, which followed major installations of continuous hot and cold strip mills. Such mills would have been impossible without the development of successful drive systems.

A graphic example of such a system is in tinning. In the old "hot dip" method of making tin plate, small individual sheets were dipped in a bath of molten tin. In contrast, the high-speed electronic lines are a marvelous complex of integrated machinery. In high-speed electrolytic tinning line, the strip passes through a cleaning solution, an acid tank to prepare the surface of the strip for the tin coating, a plating section to electrolytically deposit tin on both sides of the strip, a tin reflow section, cooling and drying equipment, and a rewind section. This line is truly continuous. Looping pits furnish strip while the entry and delivery ends are stopped for welding, shearing, and threading operations. Such lines produce tin plate at speeds up to 2500 fpm. The drive system

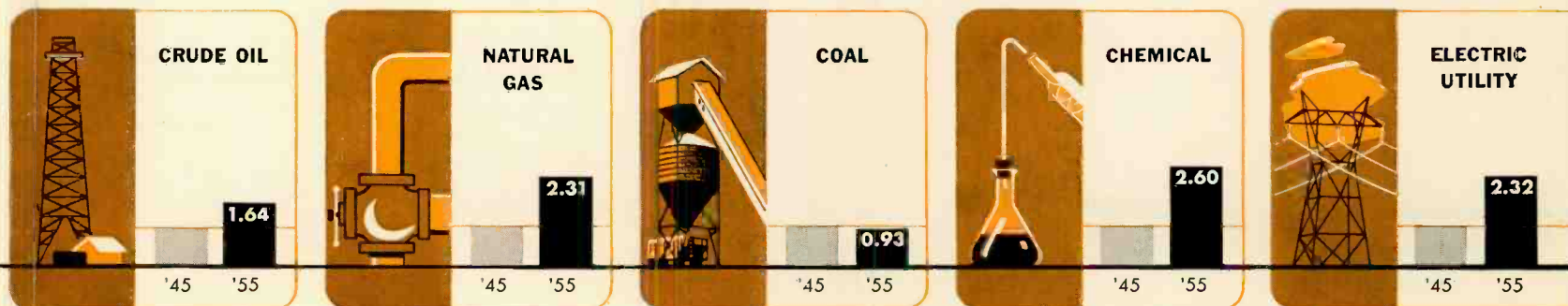
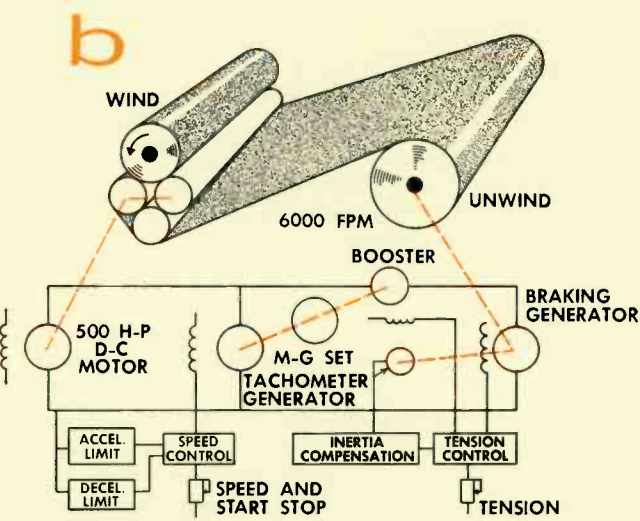
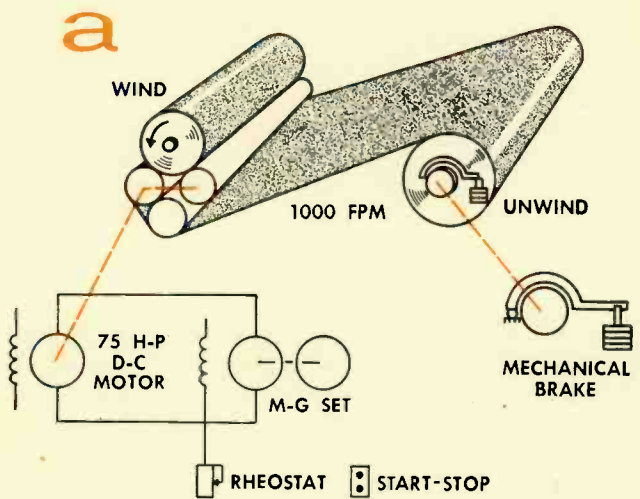

Fig. 3

a. Low-speed paper winders used a simple adjustable-voltage drive, with a mechanical brake to hold tension. b. Modern high-speed winders, in contrast, require a different drive system. This more complex drive is almost entirely the result of increases in operating speed.



consists of as many as 134 d-c motors ranging in size from 2 to 200 horsepower. The electrolytic cleaning section utilizes 12 500 amperes at 18–25 volts d-c, plating requires 180 000 amperes at 18–25 volts d-c, and the reflow section uses 2400 kilowatts of radio-frequency oscillators, which is equivalent to 48 high-power radio stations. A number of regulators are used to control speed, tension, loop depth, plating current, and reflow power. A master control system ties all the operations together so that the tin is properly deposited and reflowed under any normal operating procedure.

A somewhat different type of continuous production is used in the automotive and appliance manufacturing industries. Here the problem is making or assembling a large number of duplicate parts. The operation is made continuous by putting the production machine tools in line and arranging automatic material handling to transport material from one machine to the other. Such a line, for machining the cylinder blocks of V-8 automobile engines, appears in the photo below. The block progresses from station to station, where drilling, tapping, and milling operations are performed. The electrical equipment consists of squirrel-cage motors, a-c relays, line starters, pushbuttons, limit switches, and solenoid-operated valves. The control is the comparatively simple interlocking and sequencing type, but, due to the extremely large number of operations to be performed, the control panels are almost as long as the machine. For example, the assembly conveyor system at one such engine plant utilizes over 2500 limit switches and 2000 relays. Although each control function is simple, it must be unusually reliable to prevent shutdown of high-cost, high-production facilities.

Higher Production From Existing Facilities—Rising labor, material, and capital costs are forcing industry to get more production from existing units even where high speeds and continuous processes are not used. Here more production results through faster acting or more accurate control of the drive or the process. For example, on modern blooming mills the speed of the main rolls has not been increased, but the number of regulating systems has jumped from 3 to about 20 to decrease the reversal time of the mill, control the various auxiliary operations, and to protect the drive equipment and the mill from undue stress. The motor room of a recent drive, shown at the top of the page, illustrates the tremendous amount of auxiliary electrical equipment required.

Stringent Performance Specifications—The foregoing trends have resulted in more stringent performance specifications. The demand for better and more consistent performance has necessitated tremendous improvement in the accuracy, tran-

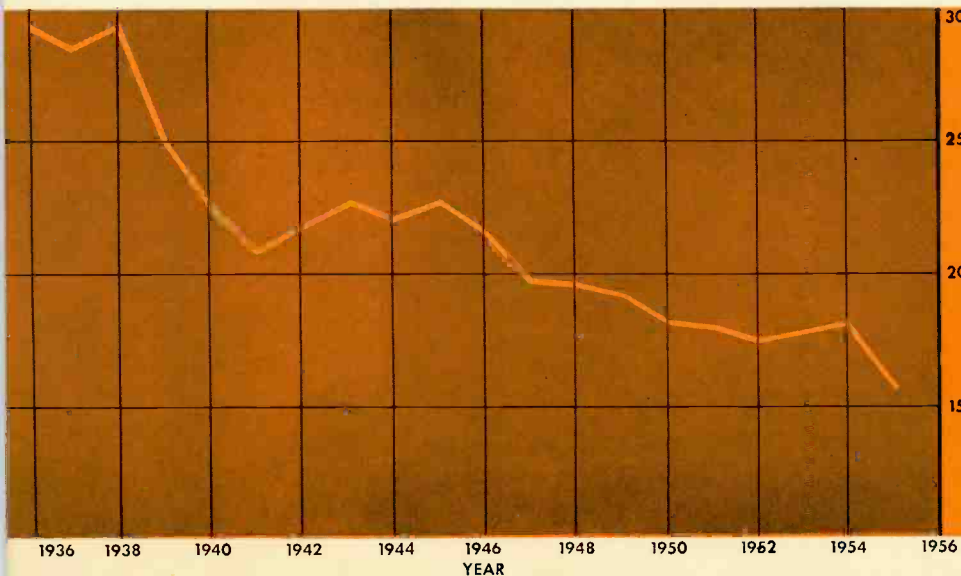
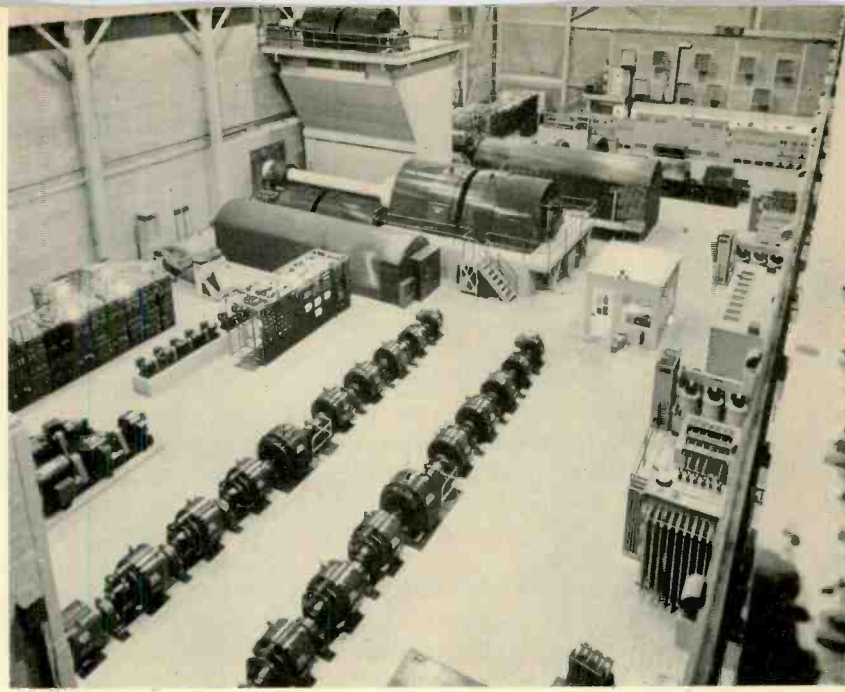

Fig. 4

man-hours per ton of finished steel

A complex line for automatically machining cylinder blocks for V-8 automobile engines.

Motor room of a 16 000-hp drive for a slabbing mill illustrates the large number of auxiliary machines and regulating systems required for close control of the drive to obtain high production.



sient response, and reliability of regulated systems. A tandem cold reduction mill requires an extremely fast and well damped regulating system to control the mill properly during acceleration, deceleration, or energy stopping. This is necessary to prevent tearing the metal between the stands because of too much or too little tension.

For example, in one system a response time of less than 0.1 second is achieved even though the sluggish field of the main generator has an electrical time constant of about four seconds. To force this response, the regulating system raises the exciter voltage to 4.8 times normal in about 1/30 second. In less time than it takes to snap your finger, the generator field voltage rises to many times rated value to force a correction, then returns to normal in time to stop overshooting.

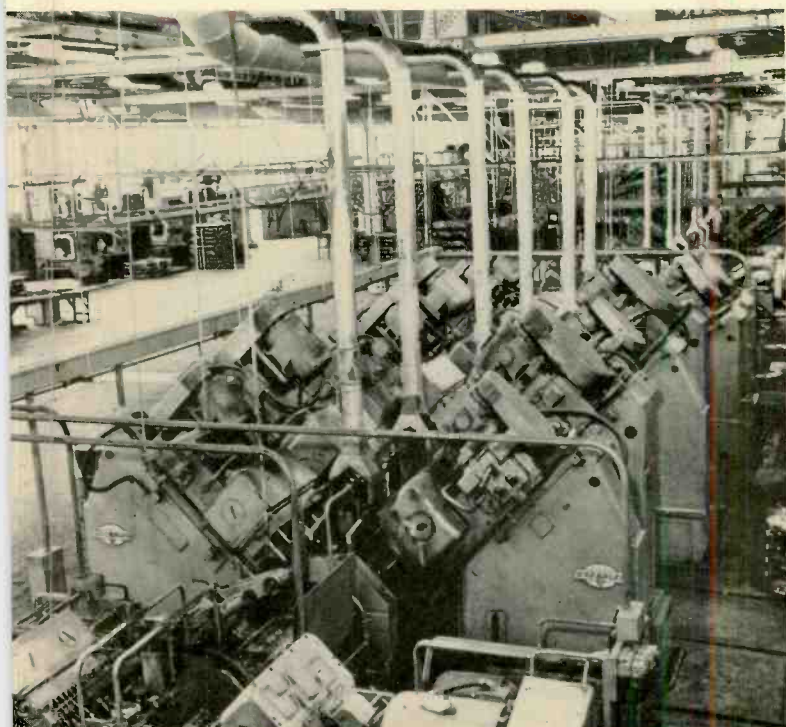
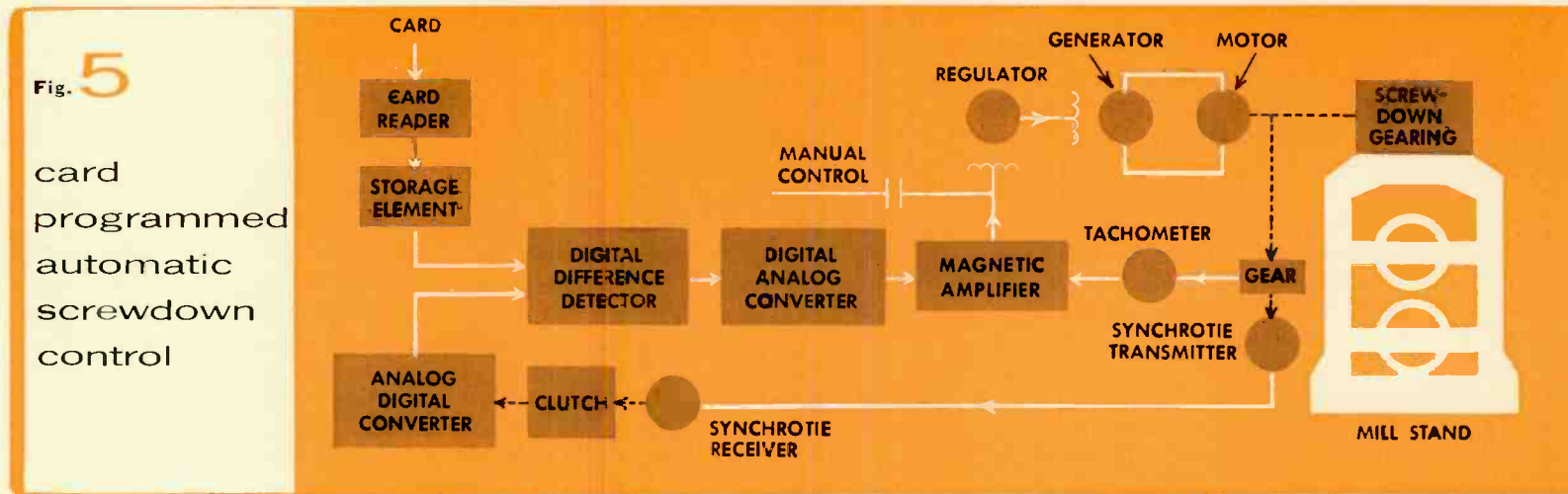

New Products and New Processes—The number of new products and new processes developed is increasing rapidly. Chemical and plastics companies are selling millions of pounds of materials today that were unheard of a few years ago. Each new material necessitates studies to specify control and drive systems to meet processing and quality requirements. Quite frequently standard equipment must be modified to meet the peculiar problems that arise.

Sometimes the search for something new results in a completely new industry. For instance, beneficiation of low-grade iron ore from the Mesabi Range is becoming necessary because of depletion of high-grade ore beds. This is a new process, just beginning to get into gear, and it is expected to eventually increase the kilowatt-hours per ton of ore from 5 to 70. It will be a major problem to provide this energy because of the remote location of most ore beds.

Several fairly large beneficiation plants are now in operation, and our nation has a brand new industry that will require high capital investment by private firms, extensive use of special massive machinery, a large amount of electric drive and control equipment, and large electric power consumption.

Automatic Control—The development of better control systems, and the rapid advances in the design of computing or information-handling equipment in the last few years, has resulted in an increasing awareness of the advantages of auto-

matic control. In particular, the use of computers has given rise to an entirely new concept of automatic control of industrial processes. The necessary information to control an entire production sequence is stored on punched cards or on magnetic tape; special reading equipment "interprets" these cards and sends control signals to the equipment. Westinghouse is building several card-programmed screwdown controls for the steel industry (Fig. 5), an analog-type economic dispatch computer for the utility industry, and an automatically-programmed digester control for the paper industry, to mention a few. Extremely high interest also exists in automatic control of machine tools, automatically-programmed testing and inspection, and automatic gauge control in rolling mill processes.

National Defense—Defense effort is taking a large share of engineering manpower. The development and testing of guided missiles, high-speed aircraft, automatic fire control systems, and atomic weapons, requires huge numbers of engineers. Here again new fields of opportunity are open to the electrical engineer, and the demand for his services is correspondingly greater.

Military development helped put computers to work both as design aids and as control elements for aiming and firing our guns, whether mounted on the ground, on a tank, or on a plane. The problem was to act quickly during the very limited time when the enemy was observable and in range. This forced the organization of computations in advance of the heat of action, and the relegation of computations to machines capable of sensing and acting much quicker and more accurately than a human. Work of this sort is responsible for much of the interest in pushbutton-operated factories, and in the growing use of computers for industrial process control.

While a number of the concepts used in military equipment are suitable for industrial applications, redesign is usually necessary because of major differences in philosophy of operation and maintenance. Equipment in industrial plants must operate on a continuous basis, must be easy to maintain without replacing the entire element, and must have a life many times that of military equipment. Generally the basic problems of error detection, speed of response, and stability are similar in nature but differ in degree.

Effects on Engineering

Any one of these trends would have a sizable effect on electrical engineering; together their effect is tremendous.

First, they have resulted in a huge demand for engineering talent. This fact is highly appreciated by anyone who has attempted to hire engineers during the last few years. They will continue to be a major factor in the shortage of engineers that will exist for at least the next decade, and will tend to increase the demand and make the shortage greater. Most certainly, no engineer will lack for opportunity in future years.

Second, a higher level of technical competence is necessary. The complexity of industrial and military equipment has increased vastly, and the trend is likely to accelerate. The engineer trained in mathematics and system analysis is more and more in demand. Engineering by "rule of thumb" is out of style and cannot compete.

Third, the engineer who has the ability to earn and retain technical leadership in his field will be even more of a key figure in his company. In the dynamic industrial atmosphere of today, the importance of top design talent cannot be over-emphasized. In recognition of this, many companies provide

opportunities for advancement in pure engineering parallel to advancement in management.

Fourth, another type of engineer, the "application" man, who can design machines and components into systems, is becoming of greater importance. For example, about two-thirds of Westinghouse sales to the steel industry are for complex systems and drives. The application engineer fits together the motors, generators, controls, switchgear, regulating devices, ventilating systems, etc., to provide a satisfactory drive system. This demands top knowledge of the characteristics of electrical apparatus, but even more important, a thorough grounding in the process requirements of the industry and the production machinery it uses. Application requirements must be interpreted to the component designer so that he can develop apparatus that will behave harmoniously with other equipment. In other words, these trends are increasing the engineering content of our apparatus, and are making it more essential that system requirements be considered by component designers.

Fifth, engineering alone is not enough. The electrical engineer should be aware of the short- and long-term trends in his primary and related fields in order to develop apparatus to keep abreast of requirements, and to keep his company in good competitive position. Participation in association activities, such as the AIEE, is helpful in this regard. Furthermore, the engineer who broadens his grasp of corporate affairs and human relations can better understand company policies and build more harmonious relations with other departments. The effect on his reputation is obvious.

Sixth, these trends are important to the engineers who operate and maintain our industrial plants. As equipment and systems become more complex, the operating man needs to know more about regulating systems, rotating machines, and controls, so that he can keep his plant running at top efficiency, intelligently participate in decisions on the purchase of new equipment, and make certain that such equipment will meet operating and environmental conditions.

Last, there is a real challenge to the engineer as to whether he permits engineering to become a commodity or a profession. The engineer's training inherently makes him management's right-hand man. A sound product is the foundation on which a successful company is built. Since a sound product is based on sound engineering, success begins in the engineering department.

The engineer is also the right-hand man of management in dealings with customers and suppliers. Management depends on him to act for them in most matters pertaining to system or component design, application, operation, raw material characteristics, tolerances, fabrication, or construction, and to prepare background material for policy decisions. The engineer that shoulders full responsibility in these matters is definitely a part of the management team of his company. Any contribution that he makes toward increasing his company's success makes him a more valuable man and enhances his position in corporate affairs.

The forces and circumstances that are compelling industry to look ahead toward automation are also very materially increasing the demand for engineers and opening new fields of opportunity. The foundation of automation is engineering.

Along with increased demand and opportunity come additional responsibilities. The challenges of technical competence, professional development, and technical leadership are clear cut. If the engineer aggressively meets these responsibilities, he can look forward to increased status in both business and community. ■

the Hall Effect

AND ITS USES. *This little-used phenomenon holds much promise for the future. Better knowledge of semiconductor materials makes this possible.*

T. R. LAWSON, JR.

Materials Engineering Department
Westinghouse Electric Corporation
East Pittsburgh, Pennsylvania

■ If a conductor carries a current at right angles to a magnetic field, a charge difference is generated on the surface of the conductor in a direction which is mutually perpendicular to both the field and the current. This is the so-called Hall effect, discovered first in 1879. Until recently this was largely a laboratory phenomenon; now, with the increased knowledge of semiconductor materials, practical, and valuable applications loom on the horizon.

The intermetallic semiconductors indium-antimony and indium-arsenic have properties that make a practical application of the Hall effect possible; in fact, technically usable circuit elements from these materials, called Hall generators, have been developed (Fig. 1). With most metals, the voltage produced by such a device is in the vicinity of one microvolt. Some of the semiconducting compounds, however, have outputs of one or more volts, with sufficient power to operate a sensitive relay. Such a device has many possible applications.

The Hall generator is essentially a device that provides a voltage output proportional to the product of two quantities—(a) the current being fed to it, and (b) the magnetic field perpendicular to it. This permits many novel applications in measuring circuits and equipment design.

A carefully designed and built Hall generator can have an output exactly proportional to the product of the magnetic field strength and the current. This product formation suggests uses as an analog computer element. A Hall generator can be used, for example, to multiply directly two electrical quantities. One of these electrical quantities is expressed as a current and the other electrical quantity is expressed as a magnetic field. The maximum frequency at which the above considerations are true can be from 10^{12} to 10^{14} cycles.

Similarly, an electrical quantity can be squared by such an analog element. The quantity to be squared is simply expressed both as a field and as a current. Under these conditions application of the electrical quantity to the input of the device will yield a Hall voltage proportional to the square of the input parameter.

If the magnetic field penetrates the Hall generator at some angle other than 90 degrees, the output of the Hall generator is proportional to the magnetic field times the cosine of the angle between the normal to the Hall generator plane and the magnetic flux lines (Fig. 2). This method gives a very precise and simple method for obtaining an electrical analog of the cosine or sine of a mechanical rotary displacement. This analog automatically goes through zero and produces polarity reversals in different quadrants.

This type of Hall generator can also be used as a position indicator (Fig. 3). A magnetic field is set up and a constant control current is sent through the generator. The output of the generator will be some function of the distance of the generator from the magnetic pole. In this way the generator can act as an indicator of position. Obviously, since the output of the Hall generator is exactly proportional to the magnetic field, this device can be used as a simple and portable method for probing magnetic fields. In this application the Hall generator would be made extremely small in size to obtain a high degree of accuracy in plotting the magnetic field. These devices are also used to measure a uniform magnetic field and to observe its fluctuations with time.

If a Hall generator is placed in the air gap of a split C yoke (Fig. 4), it is possible, by placing the yoke around the bus bar, to measure high bus-bar currents without breaking the current path and without many of the inherent difficulties with the present measuring apparatus. High current measuring devices have been developed along these lines which allow ex-

Fig. 1

The control current, i_s , at right angles to the magnetic field, B , produces a voltage, V_H , in a polycrystalline Hall generator.

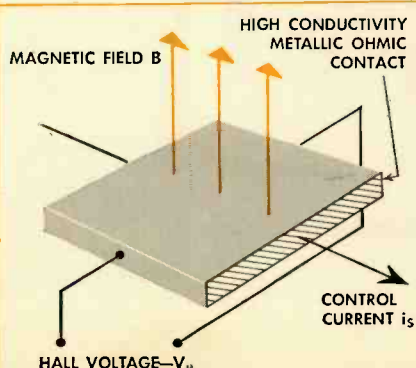

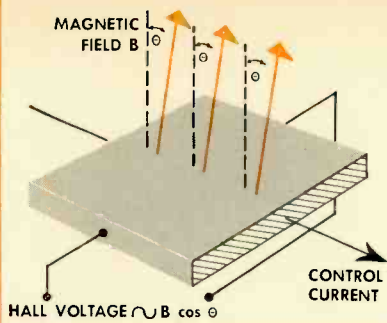

Fig. 2

If a magnetic field penetrates the Hall generator at some angle other than 90 degrees, output of the device is a function of the displacement angle and the magnetic field.

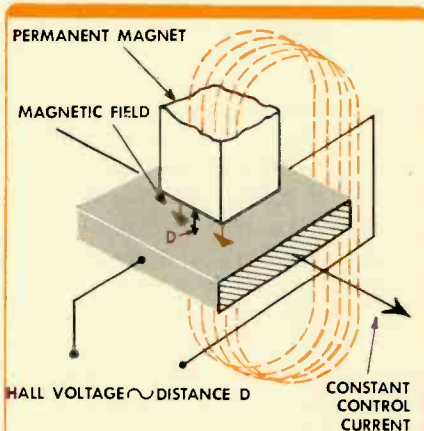

Fig. 3

If constant control current is sent through the Hall generator, output is a function of the distance of the permanent-magnet pole from the generator. This set-up can thus be used as a distance indicator.

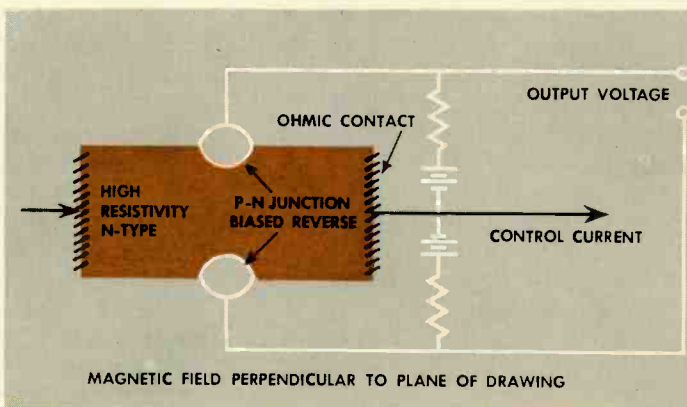
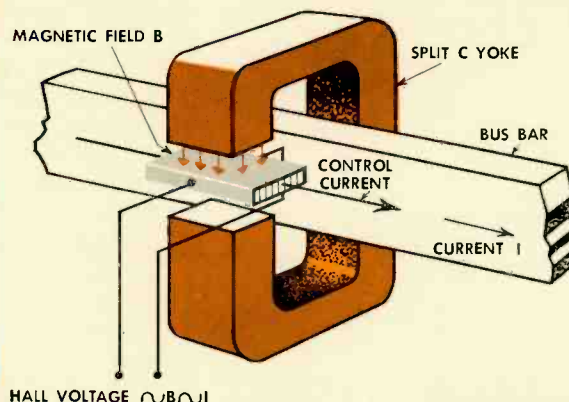

Fig. 5

A junction Hall generator, made from a single crystalline material of fairly high resistivity, with high output impedance.

Fig. 4

By use of a split C yoke, a Hall generator can also be used to measure bus bar current as shown here.



tremely high precision for this type of measurement and at the same time offer the convenience of not having to break the high current circuit.

Because of their extremely fast response time Hall generators can be used to measure the power content of transients. In plots of fuse blowout or lightning arrester breakdown the current and voltage surges do not coincide. To calculate the maximum power developed in the device during a fault, the appropriate voltage and current curves are multiplied, point by point. The fault voltage or a proportional fraction thereof is impressed on a Hall generator and the fault current generates a magnetic field. The Hall voltage then generates a trace on an oscillograph that is the product of these two and thus is proportional to the power content of the fault pulse. This method, of course, is considerably faster and nearly as accurate as point-by-point plotting methods. By similar circuitry, an economical wattmeter having no moving parts can be devised. This wattmeter would automatically give a true indication of wattage regardless of the power factor of the load.

Hall generators have been used to measure the internal torque of d-c motors. This is done in one of several ways. One of the most common is to place the Hall generator in the air gap on the surface of one of the pole shoes. A current proportional to the armature current is fed through the Hall generator. Since the internal torque of a d-c machine is proportional to the product of the armature current and the flux density in the air gap, the output of the Hall generator is also proportional to the internal torque of this machine. By placing the Hall generator on the armature rather than on the pole shoe, the actual variations in magnetic flux can be determined as a function of rotation of the armature. These

facts make possible design improvements of an electric motor.

Hall generators as described above suffer one important limitation. Their output impedance is very low—of the order of .01 to 20 ohms. Many measuring circuits will not match the peak power output of the device. Although it is not possible to obtain much power from the Hall generator in a high impedance device, the output voltage can be easily measured by high impedance voltmeters.

The above limitation applies primarily to the polycrystalline, low impedance Hall generator. On the other hand, another type can be used for some special applications. This is frequently called the "junction Hall generator." This device is made from single crystalline material usually of fairly high resistivity, and having a high output impedance.

The theory for the junction Hall generator is not as well developed as for the polycrystalline Hall generator. However, qualitatively it can be understood by examination of Fig. 5. The current carriers are deflected to one side of the

conductor is assumed. If a voltage is applied to the electrodes, without a magnetic field, the electrons flow in a direction parallel to the longitudinal direction of the conductor. When the magnetic field is first switched on, the electrons are deflected (by the Lorenz-force), perpendicular to the magnetic and electrical fields. Because of this, one longitudinal side of the conductor builds up a negative and the other a positive charge. This leads to an electrical field, the Hall field. This greatly simplified manner of looking at the problem does not yet result in a resistivity change in the magnetic field. In reality, however, a positive resistivity change always exists in a magnetic field. It results from the fact that electrons do not have a uniform velocity. The nonuniform velocity now makes it impossible for a single Hall field to compensate the magnetic force for every electron. Deflections of the electron trajectories occur to the right as to the left with respect to the longitudinal direction of the rod. This is the reason that electron movement in a magnetic field always leads to an increase of the electrical resistivity as compared to the case without a magnetic field.

This resistivity change is proportional to the square of the carrier mobility in the material under question. Since the intermetallic (groups III-V) semiconductors have very high electron mobilities it is now possible to make practical use of this increase in resistivity. Thus, a simple resistance device made of the proper materials and in the proper shape might show a value of resistance without a magnetic field of 0.1 ohm. When placed in a field of 10 000 gauss, however, this resistance may change by much as a factor of 25 to 50. This effect yields another method of measuring magnetic effects. Also, the magneto-resistance change of a semiconductor with extremely high mobility can be used as a method for fulfilling some of the applications discussed for polycrystalline Hall generators. Naturally the circuitry may be just a little more complicated in this case, and magneto resistance suffers one major fault in that the resistance never falls to zero, whereas the output of the Hall generator does. In applications where zero is one of the values that is sought, the magneto-resistance devices may not be applicable. Also, such devices cannot be used for any process involving the multiplication of the control current and the magnetic field. These devices do, however, offer a simple method for measuring magnetic field strength and for indicating position, as has been outlined previously for the polycrystalline Hall generator.

The shape most often used for these experiments is shown in Fig. 6. This is called a Corbino disk, after the man who first did so much work with this shape of conductor. The Corbino disk suffers another disadvantage in that the power available from such a device is limited. The resistance change is an inverse function of the radius of the inner electrode. On the other hand, the power available is a direct function of this radius. It can be seen then that for large resistance changes the power available from a Corbino disk will be limited. Conversely, if one wishes to draw a fair amount of power from a Corbino disk, the usable range of resistance change will be decreased. These devices, being made of the same materials as a polycrystalline Hall generator, also suffer from being very low impedance devices.

The development and purification of the new intermetallic semiconductors has enabled the practical use of galvanoelectric effects that have been known for many years. In addition to showing promise as analog computer elements, some of these devices could revolutionize the methods now being used for measurement of some electrical quantities. ■

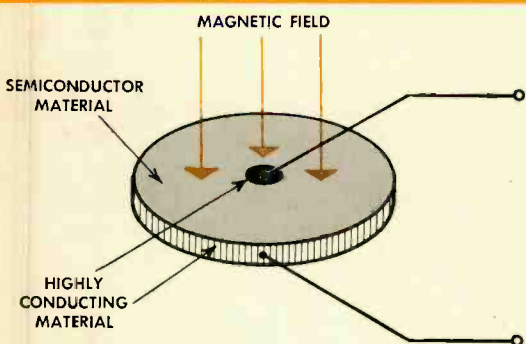

Fig. 6
This is a Corbino disk. These are low impedance devices and the power available from them is limited.

generator due to the magnetic field. This in turn affects the leakage characteristics of both the junctions applied to opposite faces. In this way, the current through the load resistors changes by an appreciable factor. Due to the high value of load resistor and the high voltage applied to these devices, the output impedance of the junction Hall generator may be of the order of 500 000 ohms.

Theoretically, the junction Hall generator would seem to have as many, if not more, applications than the polycrystalline type. Unfortunately, the theory of operation underlying the junction Hall generator has not been developed very well. These devices are usually quite non-linear as well; but for certain applications where a high output impedance is necessary, special calibration techniques could be used that would enable use of the device.

The junction Hall generators generate rather low power and, having a semiconductor junction, exhibit low frequency cut off. It may be possible to make such devices having a frequency in the low megacycle range.

Magneto-Resistance

Experience has proved that electronic conductors, metals as well as semiconductors, increase their electrical resistivity when brought into a magnetic field. This effect is called the resistivity change in the magnetic field.

For the purpose of measuring the transverse resistivity change in the usual physical sense, a long conductor having electrodes at both ends, is put into a magnetic field perpendicular to the drawing plane. At first a pure electronic con-

AN "Age of Refinement" FOR

SPECIAL PURPOSE TUBES, *abetted by military and industrial requirements, has resulted in increased power densities, improved performance characteristics, and a higher degree of service reliability for electronic tubes*

HARRY F. DART

Electronic Tube Division
Westinghouse Electric Corporation
Elmira, New York

■ The special-purpose tube family, the big fellows used in high-powered industrial and special-purpose applications, is ever increasing in size to meet incessant demands for more power, higher frequencies, and greater reliability. Many of the new designs have been prompted by military requirements; others have been developed to aid the industrial, medical, communication, and atomic-power equipment designer.

The name "age of refinement" can be applied to the many improvements built into earlier lines of tubes to produce better service and life. New glasses make for better seals, and new getters keep the high degree of vacuum more lasting. Some of the modifications have resulted in more stable operation of the tube or in greater power output for a given size. Although some changes have been so small and inconspicuous that revision of test or acceptance specifications have been unnecessary, they have produced tangible results in service reliability.

A major trend has been more power from smaller tube generators, that is, greater power densities. Much progress has been achieved in designing industrial and special-purpose tubes that are more rugged, to better withstand the rigors of factory environments. Naturally, where expensive production lines are involved, the tubes must also be constructed to possess a high degree of reliability.

A minor trend is the assembly of more than one tube unit in an envelope, although this is not nearly as prevalent in the large sizes as in the receiving-tube field where multi-unit tubes are quite common. The television-camera tube (image orthicon) can be considered a multiple-unit device with four separate and distinct cooperating functions combined into a single tube assembly.

Envelopes—Until recently more or less traditional glass bulbs were the envelopes for nearly all types of tubes. New glasses and improved ceramics have made possible tube designs that will stand high-frequency operation for television broadcasting, high voltage for rectifier service, high temperatures for more efficient operation, and operation in a strong radio-frequency field. The "custard cup" type of base structure provides a contour to which metal thimbles are easily attached, and forms part of the vacuum envelope. Kovar alloy, with an expansion characteristic that matches 7052 glass, makes possible rugged metal-to-glass seals in very large sizes.

In the multiform process, powdered glass is mixed with a binder and dry pressed into a toroid shape. The ring is next

heated in an oven, which sinters the glass particles into one solid piece. The glass ring can be subsequently sealed on both its inside and outside edges to metal cylinders, which form part of the electrical lead-in system. Furnace sealing of the glass ring and tube parts has been made possible, and results in a tube with concentric input and output electrode leads that are most suitable for high-frequency operation. A new ten-kilowatt tube (WL-6567) for frequencies up to 30 mc, for application in induction or dielectric heater service, uses this concentric lead-in system.

Leads—To operate effectively, electric power must get into and out of a tube with a minimum of losses. Filament power and the various d-c, a-c, and r-f potentials are applied to the input electrodes, and the output energy taken from the anode. The high-voltage insulation and current-carrying capability

Automatic Exhaust—Industrial tubes (WL-579B kenotrons) being evacuated on an automatic exhaust machine. Each tube is placed on a port and air exhausted from the bulb as it goes through successive stages of induction heating and other operations.



of the leads, and their high-frequency inductance and mechanical strength are important design considerations. Of course, the anode of the external anode tube forms its own "lead" since external circuit connections are made directly.

Tungsten wire is often used as a lead-in conductor for power tubes since it can be sealed readily to glass, particularly in the smaller sizes. Although the expansion of tungsten does not exactly match glass, the proper annealing schedule or controlled cooling of the glass results in satisfactory seals. Dumet, a nickel-iron wire with a sheath of copper, seals readily to many types of glass and is widely used, particularly for receiving tubes.

"Flying leads," long flexible copper ribbons permanently attached to the pins in the base of the tube, make possible positive and more efficient connections with external circuit elements. Electrical resistance is kept low and the chance of overheating is minimized. Also, more flexibility is provided for circuit connections.

The concentric input and output leads discussed above are essential in ultra-high-frequency service. They permit direct coupling between the internal electrodes and the external circuit, which can be designed to prevent loss of radio-frequency energy at this point. Concentric leads are used for the filament circuit in some power tubes; power input and output circuits also employ this general principle in some uhf generators, such as magnetrons.

Insulation—In most power tubes the various electrodes are rigidly supported with respect to each other with spacers, in addition to the lead wires embedded in the envelope. A newly designed spider insulator supports long filament wires at critical points, and can operate at the high temperature (approximately 2000 degrees C) inside this filament cage.

Sometimes the need for still higher operating bulb temperatures and higher frequencies requires ceramic parts to support and insulate the electrodes, and simultaneously form part of the vacuum envelope. High purity alumina is useful because of its high operating temperature, low loss factor, high strength,

and relative freedom from gas. Usually it is coated with a surface layer of metal at the electrode seals. The coated alumina can be brazed to metal parts and forms a vacuum-tight joint of high strength.

Fabrication of alumina is comparatively simple and the material can be made either non-porous or porous, the latter being preferable when efficient out-gassing is a consideration, such as for internal insulation. Non-porous ceramics are used for vacuum-type envelopes. The parts can be made in sizes from a fraction of an inch to ten inches. Alumina windows have been made as thin as 0.010 inch, although flat pieces are usually somewhat thicker.

Cathodes—Power-tube cathodes have continued the trend toward more extensive use of thoriated tungsten for filament material. Until recently, the use of thoriated-tungsten cathodes in tubes with anode voltages above about 5000 volts was considered unsatisfactory. If the ratio of peak available electron emission to the total electron emission demanded by the circuit is kept above a ratio of about three to one, and if a high degree of vacuum is maintained, thoriated-tungsten filaments prove satisfactory under relatively severe and continuous operating conditions. Electron emission is a key factor in tube operation and must be maintained at a high level.

Gas molecules exist in the best vacuums and, if too numerous, cause irreparable damage of the cathode by positive-ion bombardment. A cermet cathode can stand higher temperatures caused by back bombardment, and has been used where particularly severe operating conditions prevail, such as in a high-powered magnetron. An oxide-coated cathode in a tube of such large size would cause trouble because of barium evaporation.

Grids—Grid surfaces must be preventives of primary and sometimes secondary emission. Occasionally a material with little if any secondary emission is desired, while at other times a large number of secondary electrons are needed. Usually, secondary emission should be maintained at a constant level throughout tube life rather than be non-existent.

Power-tube grids must be capable of dissipating a fair amount of power, have low thermionic emission, and maintain good mechanical strength at high temperatures. Some thorium may evaporate from thoriated-tungsten filaments, and a por-

Single Exhaust—Specialized industrial tubes manufactured in smaller numbers are evacuated in special ovens. Here, operator is using a pyrometer to check the temperature of a tube (WL-5936 triode), which is being evacuated by a vacuum pump.



Flying Leads on this tube (WL-6623 on the left) provide for electrical circuit connections with a minimum of resistance losses.

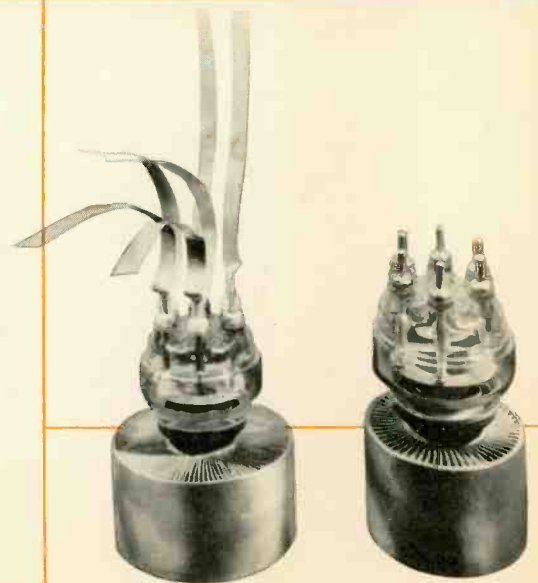

tion of this can deposit on the grid, producing cumulatively higher primary electron emission. To keep grid emission from becoming too high, an emission-inhibiting grid material such as a platinum-clad wire of molybdenum or tungsten is used. The oxide-coated cathode of a typical receiving tube tends to deposit a layer of barium on the grid; here, gold plating prevents the unwanted primary emission.

In multigrid tubes, wire turns should present an unobstructed electrostatic lens system to electron flow. This prevents many electrons from striking the grid structure as they move from cathode to anode. Screen-grid wires should be placed in the electron-beam shadows of the control-grid wires. Also, close spacing and accurate grid alignment keeps important electrical operating characteristics from changing during tube service.

Anodes—Despite all efforts to achieve the highest possible tube efficiency, considerable power in the form of heat must be dissipated by the anode. In the air-cooled tubes, the internal anode radiates most of its heat directly through the envelope walls. The solid-anode x-ray rectifier tube operates particularly well under the relatively high peak power loads that are often encountered in service.

Some electronic-tube anodes are of the external type, forming part of the envelope and resulting in a relatively compact tube. A metal-to-glass seal is required, but with techniques using a feather edge of thin copper or one of heavy Kovar metal, these seals are relatively easy to produce. The anode portion of the tube is mounted in a water jacket and water cooling is quite effective.

Forced-air cooling can be accomplished by blowing air at high velocity over radiator fins attached to the external anode.

Multiform Glass Seals—Three multiform glass seals are used in the lead construction for this new type tube (WL-6406). This concentric lead construction is effective in preventing loss of radio-frequency energy in ultra-high-frequency applications.



Spider Insulator—This newly-designed spider insulator holds filament strands from moving radially in the WL-5936 triode.

This cooling method has proved satisfactory where cooling water is undesirable. To eliminate noise of blowing air at high velocity, the radiator of the new WL-6623 tube has been designed to operate most efficiently at relatively low air flow. A further advantage is the lower cost of a low-pressure air blower, compared to a high-pressure blower.

Some design improvements are not easily noticed. For example, studies of the air flow over radiator fins reveal that most efficient cooling is obtained with a reasonable amount of air turbulence. The smooth slip stream so necessary for jet planes is definitely not wanted. Agitation of the air is accomplished by roughing the radiator fin surfaces with corrugations and using the proper air-flow rate.

A new rectifier tube (WL-6103) has been built with an external anode that includes a radiator portion for either air- or oil-cooled operation. The WL-6102 rectifier has been designed particularly for oil-immersed installation, and can be mounted inside the a-c power transformer tank. Such installation provides two advantages: (1) voltage and current ratings are comparatively high, and (2) any tendency to arc-over is minimized since the oil serves as both coolant and insulator.

Gas Filling—Thyratrons, ignitrons, and certain microwave devices are filled to a specific pressure (usually considerably less than atmospheric) with a gas, vapor, or a mixture of these. Air is first pumped out and a measured amount of the desired gas introduced to give the vapor pressure required for special operating conditions. In the thyatron the hot cathode provides electrons as in a conventional vacuum tube. In passing from

the cathode to the anode, these electrons collide with gas molecules and produce additional electrons and free ions, which reduce voltage drop through the tube to an extremely low value. This accounts for the high efficiencies obtained with gas-filled tubes.

The thyatron grid prevents current from passing between the cathode and anode until a desired time, after which the amount of current flow depends solely upon the electrical values of the external circuit. The grid cannot regain control until the current flow is stopped when anode potential goes negative. Thus the grid in a gas-filled tube controls the power handled in the tube by determining the portion of the a-c cycle that current can flow; it cannot determine the magnitude of the current through direct and continuous control of the amount of electron flow, as is done in a vacuum tube.

Mercury vapor has been the traditional filling for thyatrons and works efficiently. Objections to its use are its sensitivity to extremes in both high and low ambient temperatures. When too cold, the tube is slow in starting up, and can produce a damaging "surge"; if too hot, a destructive arc-back can result. The control grid has been redesigned and shield grids added to restrict the spread of ionization during operation so that the deionization occurs more rapidly than in the earlier tubes, resulting in better control.

Inert gases, such as argon, neon, and xenon remain in the gas phase throughout the normal operating-temperature range. In recent years, xenon gas has become readily available commercially and has been adopted almost exclusively in thyatrons for industrial purposes where the ambient-temperature effects must be eliminated. Advantageous operating characteristics are sometimes obtained by using a combination filling of an inert gas and mercury.

When extremely rapid ionization and deionization properties are desired, such as for modulating radar equipment, thyatrons are being filled with hydrogen gas. The maintenance of a suitable concentration of active hydrogen in the larger tube sizes is achieved with a storage unit that stores hydrogen. The pressure of the hydrogen gas phase is a function of the temperature of the storage unit until the stored gas is all liberated and used up. Since hydrogen is also an inert gas, the hydrogen thyatron is not influenced by ambient-temperature conditions over its usual operating range.

Ultrasonic Cleaning—Improvement of techniques for electronic tube manufacture show up most spectacularly in the widespread and active interest in ultrasonic cleaning. This combination of mechanical vibration and chemical agents produces a superb degree of cleaning or degreasing with the simultaneous advantage of a high production rate.

Ultrasonic vibrations are above the range of audible sound, and range from 20 000 to 400 000 cycles per second. The sonic waves can be produced by piezo-electric crystals or by magnetostriction action on a metal body. Both devices are transducers that convert electrical energy into mechanical energy at an ultrasonic rate. One method has the container and its contents, the liquid and the material being cleaned, vibrated as a unit; another uses specially shaped transducers immersed in the liquid to focus the energy on the parts being cleaned.

This new cleaning system has achieved outstanding results in removing residues remaining from the compounds used on metal surfaces during buffing, polishing, and drawing. Ultrasonics speeds up the cleaning action, and makes removal of surface scale more thorough by shaking loose any inert soil particles as the oil and grease in the lubricant is dissolved from around the particles. This enables the solvent to penetrate faster and to a greater depth, especially around crevices

and joints. Ultrasonic cleaning equipment has been developed to the point where it can be placed on production lines.

Ultrasonics has been found useful also in assisting chemical action in plating operations. The mechanical vibrations knock loose any small bubbles formed during plating and thus shorten plating time by providing a more intimate contact of the solution with the metal. Also, since there is continuous vibration at the interface between the solution and the metal, lower concentrations of chemicals can provide equally fast plating action.

Mechanical Cleaning—Oxides or other metallic compounds, commonly referred to as rust or scale, are sometimes removed by mechanical means, such as abrasive blasting. Considerable advances have been made in barrel tumbling by improved tumbling equipment and special compounds for the actual cleansing process.

Non-Destructive Inspection—In this age of refinement, important advances have been made with chemical, ultrasonic, high-frequency, magnetic, fluorescent penetration, and x-ray methods to check the quality of materials and parts. The polariscope for examination of many forms of glass and glass-to-metal seals is another non-destructive testing technique.

Refinement of an old method can be used for inspection of steel parts. The material to be inspected is first dipped in an acid bath to produce an insoluble coating of material that leaves a matte background surface. The parts are next placed in a penetrant, such as an acid mixture, after which they are removed, washed, and dried. The penetrant "bleeds-out" of any cracks or fissures and leaves a permanent indication of flaws, easily observed under natural light.

In ultrasonic testing, high-frequency sound waves are sent into a material and their travel pattern noted. A fissure will reflect these mechanical vibrations, and by careful measure-

Ultrasonic Cleaning—Many electronic tube parts are cleaned ultrasonically. Ultrasonic cleaning speeds up the removal of impurities and foreign material, and achieves a more thorough job.

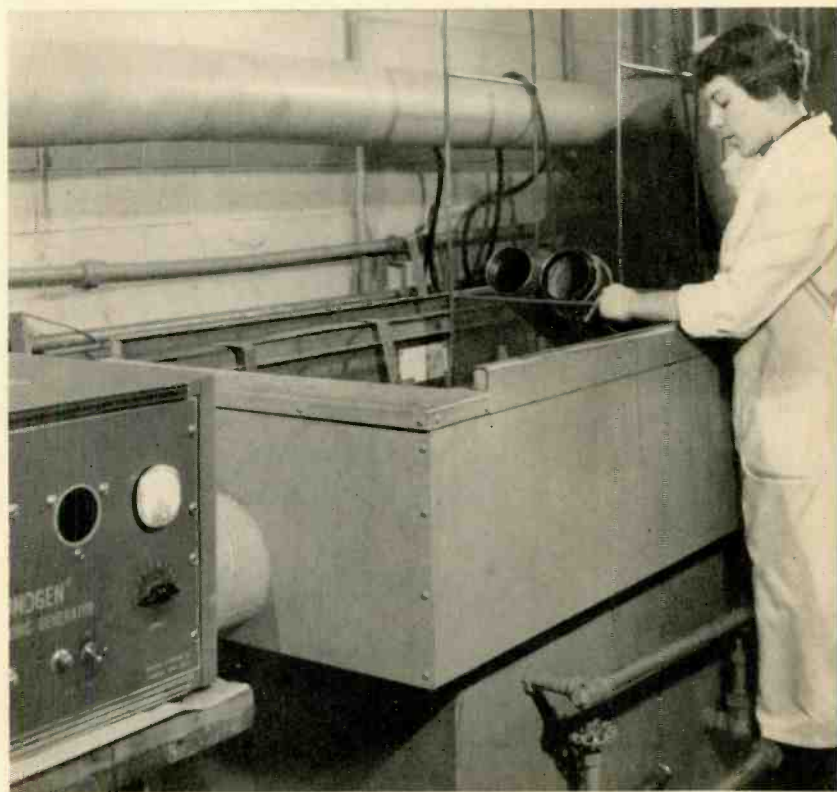



Cermet Cathode—An indirectly-heated cermet cathode being installed in a magnetron (WL-6249). The cathode proper is the smaller cylindrical section about $\frac{3}{8}$ inch long, which is located about $\frac{1}{2}$ inch from the free end of the cathode-mount assembly.

ment, location of a flaw can be accurately determined. X-ray pictures will reveal hidden cracks or voids, and are also used to check internal spacing, such as the distance between the grid and anode structures in large water-cooled power tubes.

Ignitrons—The popularity of the ignitron is attested by its extensive use in the automobile industry as a precision switch for welding automobile bodies and frames together. The ignitron requires a small amount of water flow for cooling purposes to maintain rated temperature. Usually the operator will not turn off the water flow when the welder equipment is not in operation, and thus much water is wasted. An important ignitron improvement is a thermal control device that performs this function. A small plate mounted on the side of the tube detects any internal temperature change through a raised section in the inner cylinder of the body of the tube. By mounting a thermostat on this plate, internal tube temperature is measured. The flow of cooling water can be controlled so that an ample amount is available when the tube is working, and is turned off when the welder stands idle or there is no load on the ignitron. The tube is interchangeable with the previous version, so that a new tube can be easily installed and the thermal control features added.

Magnetrons—Briefly, the magnetron is a tube that utilizes a strong magnetic field to produce ultra-high frequency oscillations, generally for radar transmission purposes. To produce oscillations of one specific frequency, the several internal anode segments must have nearly identical dimensions. However, in many cases, a change in basic frequency is desirable. The x-band magnetron (WL-6249) can be tuned by pushing a set of pins into, or removing them from the anode cavities. This magnetron, mechanically tunable over a frequency range of 8500 to 9600 mc, is a vastly improved model over World War II designs that were not tunable.

With the advent of high-speed jet planes, greater and greater distances must be searched to intercept approaching aircraft. A new magnetron (type WL-6285) has a peak power rating of 10 megawatts and enables radar to "see" a plane at a distance of 400 miles. This tube has obtained the highest power-duty product for any magnetron using pulse widths up to 10 microseconds and 0.0018 duty. Naturally, development of "Big Maggie" required many technical design improvements, such as raising the initial "sparking barrier" that results in break-down of the vacuum insulation between the high-potential electrodes within the tube. The operating characteristics of this tube help reveal its true king size. The cermet cathode power is 4 kilowatts for starting, and reduces during oscillation to between 1 and 3 kilowatts, depending upon average anode input power. Rated plate voltage is up to 70 kilovolts, and the peak anode current is 350 amperes. The magnetron delivers its power into a 6½-inch diameter waveguide with no pressurizing or gas insulation required. The anode and end covers are water cooled, and forced-air cooling is required for the output glass window. The efficiency varies from 46 to 50 percent depending upon the operating point.

Counter Tubes—In the atomic-energy field, neutron-detection tubes have been developed to monitor and control atomic reactors while in use. A complete line of electronic tubes can cover a neutron flux range of at least 12 decades. They have been designed with sturdy integral structures to withstand any normal operating conditions of temperature and vibrations to which equipment using these tubes may be subjected.

These tubes aid in controlling reactor operation, particularly during start up. Some of the counter tubes are used for monitoring the reactor. Other counter tubes are used for health monitoring for the safety of the operating personnel. ■

Neutron Detectors—Three of the Westinghouse line of neutron counter tubes used in the atomic energy field. These tubes help control reactor operation, and perform other neutron detection and measurement functions.

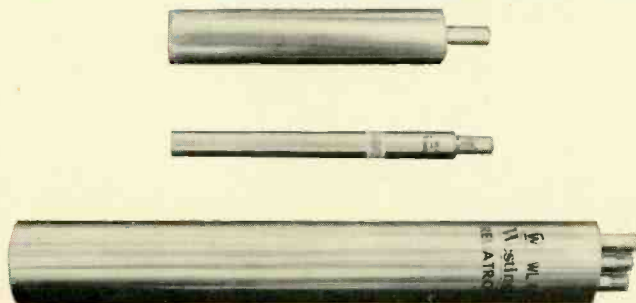



AN ENGINEERING PERSONALITY

E. G. Wise

■ If asked to describe *E. G. Wise* in “so-many-words-or-less,” a fitting resume would be “busy . . . busy . . . busy . . . busy . . .” And this description wouldn’t be far off. Ernie has been going at a busy clip since he joined Westinghouse in 1921, while still attending Armour Institute (now Illinois Institute of Technology).

One of the “fathers” of Westinghouse motor control centers, Wise is best known for his activity in this field. It started when he joined the Company, in the engineering department of the Chicago Manufacturing and Repair plant. This was before the day of centralized motor controls, but he worked at estimating, designing, and pricing panelboards and switchboards. His enthusiasm for the product soon got him into the sales department also. So by 1930 Ernie had two desks, one in engineering and the other in sales. Wise worked on small breakers and panelboards, and in 1936 took a job as specialist handling small breakers and panelboards in the St. Louis office. His territory was the whole southwestern portion of the United States, and Ernie really covered it. Often, he would stay on the road from one to four weeks at a stretch.

When the war clouds gathered in Europe, Wise decided that a refresher course in mathematics was in order, and took a two-year course at Washington University in St. Louis. As war plants, air bases, powder factories, and arsenals started going up, Ernie was right in the thick of it, helping with plant distribution and control. His chief concern soon became following and handling war plant installations. He liked this job, and the work with architects and other engineers. In fact, with the pinch in personnel, he soon found himself doing free-lance consulting for elec-

trical contractors in his spare time. He obtained a Missouri Professional Engineer’s license, which he still holds. He later added another from Illinois.

In 1943, he was asked to come to the Construction and Communications section in headquarters industry sales in East Pittsburgh. He was given the job of working with building contractors all over the United States. This was really a beat, but didn’t daunt Ernie a bit; he just did a little more traveling.

After a year’s service in this section, the Switchgear Division offered him a control job. Ernie was well suited for this activity, for while in St. Louis, he had helped promote the service centers built at that time. In 1945 when a control specialist was needed in the northwestern district, Ernie volunteered—and returned to the Chicago office. Here, Wise spent several months making surveys to determine likes and dislikes in motor control. Working with consulting engineers and architects, he found the trend was toward centralized motor control. He knew what industry wanted, and worked closely with the group of engineers assigned to establish the design features of the control center put on the market in 1950 (Ernie is holding a model of the device).

Ernie’s original placement in the Chicago office was on a trial basis, to see if a control specialist would be of benefit in providing technical assistance for control installations. Wise proved this to be the case, and official recognition of this need was made in 1952, when Wise was made district industrial control engineer for the northwestern region. In his present position, Wise provides effective technical assistance on control problems, as well as a communication of ideas between district consulting and application engineers and the control departments at the Buffalo division. His overall knowledge of the motor control field is well recognized. And his willingness to provide help is widely appreciated. Often, to assist a potential user of a control center and to expedite his planning, Wise has taken the problem home with him and drawn up a complete floor layout—or contrived some modification of a switch or breaker in his own workshop. He is constantly on the lookout for control center improvements. He recently developed a color-coded flow-line diagram of the system being controlled; the diagram is built of plastic strips that change color with lighting from behind the board as the controls are manipulated. Although Wise has spent most of his time in application rather than design, he has some half-dozen patents to his credit.

But his last move to Chicago and the sudden decrease in travel left Ernie with time on his hands. And Ernie likes to keep busy. So he bought four acres of land near Bass Lake, Indiana, about 72 miles from Chicago. First, he scientifically analyzed the soil and prepared it for future planting with fir and other trees.

Then, since he didn’t need the whole four acres for the house he was planning, he decided to convert one end of the property to commercial use. After a thorough study of cement mixing, casting, and curing, he selected concrete blocks for a product. A floor slab was poured, the cement-block machinery installed, and he promptly went to work casting block to complete the building. With an operating partner running the plant and Ernie providing technical assistance and help on weekends, his factory was soon producing over 1000 blocks per day. As the business grew, Ernie was soon faced with the alternative of going into his own business full time and leaving Westinghouse, or selling the business; Ernie sold the machinery and now rents the building.

Out of the cement block business, and once more with time on his hands, Ernie decided to build a house. During the last 4½ years, Wise has built by himself in his spare time, an 8-room house with a 2-car garage. He did everything—carpentry, plumbing, wiring, even planted a garden and an orchard. Mr. Wise is indeed “busy . . . busy . . . busy . . .” ■

Giant Hammer Forges World's Largest Blades

One of the largest turbine blades of its type in the world is being forged under this 23 000-pound forging hammer at the Westinghouse metals development plant. Heated to 2000 degrees Fahrenheit, the white-hot stainless steel blade is shaped by hammer blows equal to 475 000 foot-pounds, an impact roughly equivalent to that from a 320-pound weight falling from the observation platform of the Empire State Building to the street below.

Measuring 44 inches in length, the blade pictured is one

of 200 being forged for the world's most advanced turbine-generator, now under construction at the Steam Division for the Philadelphia Electric Company. The unit, rated at 325 000 kilowatts, will have the highest operating temperatures and pressure, as well as the highest efficiency, of any existing or proposed steam turbine.

In the low-pressure machine of this cross-compound unit, these 44-inch turbine blades will revolve at 1800 rpm—with a tip speed of 944 miles per hour.

what's

High-Speed 5-Kv Circuit Breaker

A new five-kv magnetic circuit breaker with a two-cycle interrupting time (type 50-DHHS) has been developed for 4.16-kv distribution systems. The new 600-ampere breaker has an interrupting capacity of 30 000 amperes (40 000 momentary), and can be applied where conventional 150-mva circuit breakers are now used. The fast interrupting time is expected to reduce wire damage caused by faults on overhead distribution lines, thereby permitting improved

continuity of service and reduced line maintenance.

All moving parts are made of light-weight, high-strength materials to permit high-speed operation without excessive closing currents. Also, roller bearings are used to reduce friction to a minimum.

These mechanical refinements combined with a novel high-speed trip device, permit a contact parting time of only $\frac{3}{4}$ cycle after energizing the trip coil.

new!

Pot Tester

This machine has been designed for testing gang-operated precision computing potentiometers. These potentiometers are devices in which shaft rotation moves a contact along the resistance element generating a desired functional relationship between the output voltage and shaft position. Very few pots are built to the same exact specifications, but each must be extremely accurate; furthermore in a gang-operated pot, each individual potentiometer, or cup, must be accurately aligned with the rest. To perform

these checks, the pot-testing machine is controlled by decks of punched cards. These cards set up the individual test, indicate the accuracy limit desired, and control the machine to make the test. The potentiometers are tested for resistance, linearity of conformity, dielectric strength, and electrical noise. The machine works at the rate of one test operation per second. Formerly, pot tests for a six-cup gang took about four hours; with this device, only 10 minutes are needed and much greater accuracy is achieved.

Generator for Shippingport Atomic Power Plant

Bound for Shippingport, Pa., site of the nation's first full-scale atomic power plant devoted exclusively to serving civilian needs, this 100 000-kilowatt generator is prepared for shipment at the East Pittsburgh plant. Shown being lowered onto a flatcar by two traveling cranes, the 403 500-pound giant measures nearly 29 feet in overall length. When installed at the Shippingport site, the unit will operate in the open without the protection of walls or roofs—the first

such installation of its type in this part of the country. Duquesne Light Company of Pittsburgh is building the electric generating part of the Shippingport plant and will operate the overall plant. Westinghouse, in addition to having built the generator shown, is also designing and developing the plant's nuclear reactor under contract to the Atomic Energy Commission. The Shippingport plant is expected to be in operation in 1957.

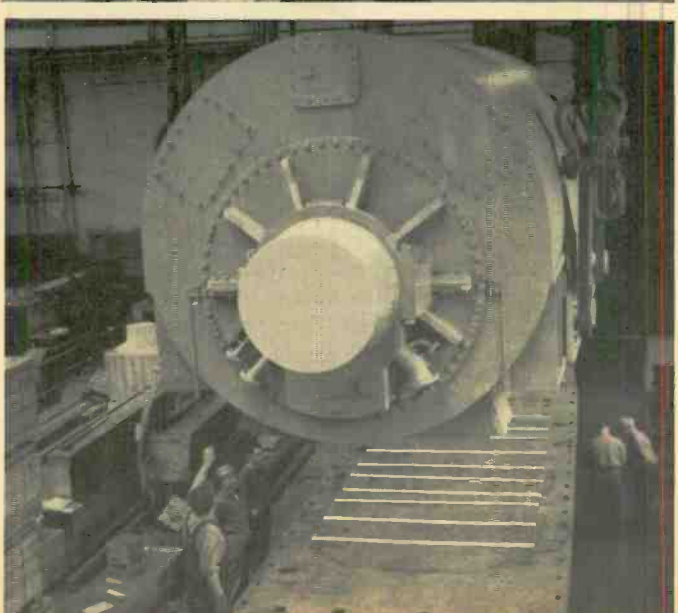
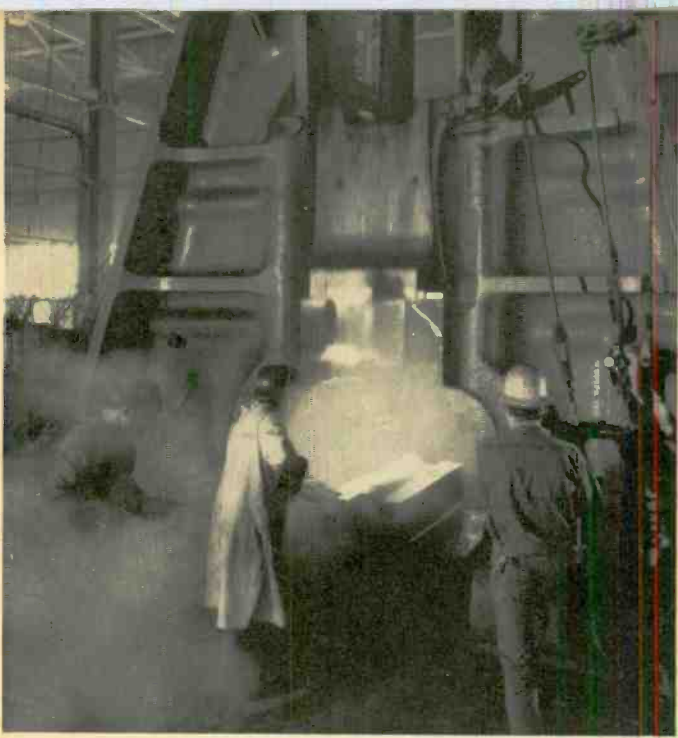

Gas-Filled Power Circuit Breakers

These are three of the first experimental gas-filled (SF_6) power circuit breakers ever built. Developed by Westinghouse, the 115-kv, 1000-mva breakers are installed on the Gulf Power Company system's Pace substation, Pensacola, Fla., to obtain performance data.

The breakers have a continuous current rating of 400 amperes rms. will interrupt in 5 cycles and reclose in less than 15 cycles. The SF_6 breaker is restrike free, which makes it particularly well adapted for switching capacitors, either single bank or bank against bank.

The gas has excellent insulation properties and is used at relatively low pressure (45 psig). A porcelain housing is used for the enclosure. The upper half of the porcelain-clad pole unit contains the interrupting device, and the lower half provides insulation to ground.

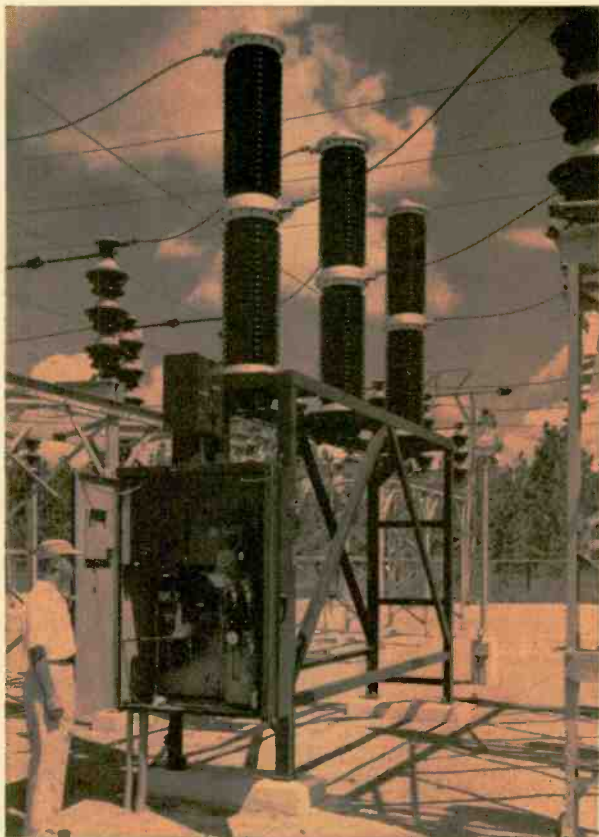

Three curved, double-armed, U-shaped moving contact castings are mounted on a rotating shaft and mate with six stationary contacts to provide a total of six breaks per phase. The breaks are formed within an insulating tube in which the stationary contacts are located and through which the arms of the moving contact pass. The short stroke and small amount of closing energy required of this breaker allows eleven closing operations without going below minimum closing pressure with the standard pneumatic operating mechanism.

Each pole unit is approximately nine feet high by one foot wide and weighs approximately 1000 pounds.

NEW D-C power supply

FOR AIRCRAFT combines silicon diode rectifiers with a magnetic amplifier regulator to provide high-powered rectification from a static device.

R. E. KING

Aviation Engineering Department
Westinghouse Electric Corporation
Lima, Ohio

V. JANONIS

Director Systems Department
Westinghouse Electric Corporation
Pittsburgh, Pennsylvania

High performance demanded by new military aircraft under severe operating conditions has pushed the rectifying element requirements beyond the inherent capabilities of selenium, even though recent developments of selenium rectifiers capable of operating at ambient temperature of 150 degrees C have been highly successful. The rectifier is not the only component that has been pushed beyond existing limits. Practically all of the components involved, such as magnetic amplifiers, transformers, wire and insulation have had to be redesigned or have required the development and substitution of new materials.

By far the majority of aircraft transformer-rectifier applications to date have been of the non-regulated type, but in conjunction with environmental advances operating characteristics also demanded improvement.

use of present developments in high-gain, self-saturating magnetic amplifiers possible.

From the preliminary survey of the field, the need for a regulated 200-ampere transformer-rectifier unit was apparent. A silicon rectifier capable of carrying 20 amperes average d-c current at 120 degrees C ambient temperature was deemed most practical in view of the low leakage desired for the self-saturating magnetic amplifiers, and the present state of silicon rectifier development.

Several power-supply requirements also influenced the rectifier design. Overload currents of 150 percent for five minutes and 250 percent for one minute, with short-circuit capabilities sufficient to clear faults and permit fuse coordination, eliminated the usual meaning of normal rated current as far as the rectifier was concerned. For a transformer-rectifier

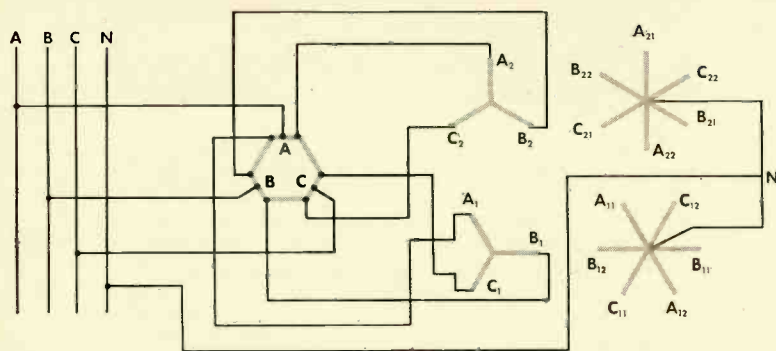
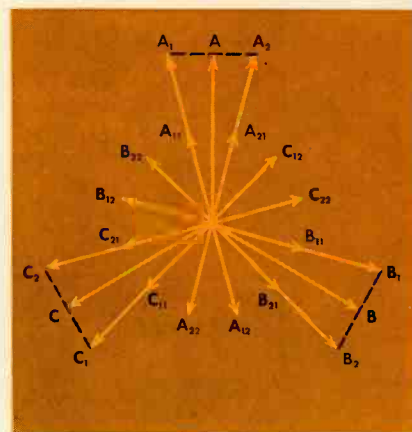

Fig. 1

This circuit vector diagram represents the phase shifter and transformer configurations used in obtaining 12-phase rectification with single-phase transformers.



Silicon Rectifiers

The development of the high-power silicon rectifier is a major advancement toward better performance at elevated temperatures and extreme environmental conditions. Temperature ceilings are raised; drastic reductions in size and weight are realized; susceptibility to environmental conditions is practically eliminated; efficiency is improved; and the much lower back-leakage current of the silicon rectifier makes the

unit, like switchgear, current-carrying capacity determines the design of the unit. High ambient temperatures and pressure altitudes of 60 000 feet also influenced rectifier design.

Overvoltages and overloads can be applied to the selenium rectifiers and, if not excessive, have no effect other than to decrease the life or rapidly age the rectifier. The current-carrying capacity of silicon, just as for selenium, is determined by the temperature of the rectifying junction. However, the high efficiency, the much higher current density in the junction, and the capability of working at higher junction temperatures make it possible for the silicon rectifier to handle

This article was adopted from a technical paper originally written by R. E. King and R. G. Engman.

the same amount of power as a selenium cell with amazing reductions in volume and weight. Operation of the silicon device at elevated temperatures near the critical junction value does not impair the silicon device in any way, and the same operating characteristics remain when normal conditions prevail. This is not so with selenium. Consequently, the silicon rectifier has been applied closer to its maximum capacity at nominal load conditions. Naturally, heavy overloads cause the rectifier to fail and since the failure is very sudden and complete, the property of having no overload capacity has unjustly been attributed to silicon rectifiers when, if anything, it has better properties when properly evaluated and applied.

Environmental conditions should also be considered in determining the adequacy of the silicon rectifier for a particular application. Based on forced-air cooling conditions, the temperature rise of a surface at 60 000 feet pressure-altitude is approximately eight times the temperature rise at sea level. However, test results indicate a factor of approximately six is more accurate for the given conditions since radiation and conduction cooling naturally aid in reducing the temperature.

Transformer Configuration

Several factors governed the choice of transformer configuration. Most important at the time was the availability and current-carrying capacity of silicon rectifiers with sufficiently low leakage currents for magnetic-amplifier applications. Consequently, an average d-c phase current of 20 amperes under normal operating conditions was the major factor in the selection of the transformer configuration used. A second factor was the desire to reduce the d-c output ripple to one volt peak with a minimum amount of filtering. A 12-phase circuit with its inherent no-load ripple of one percent was indicated. A second consideration was the reduction of reflected harmonics in the a-c supply. Distortion in the a-c supply is also reduced in 12-phase rectification.

The transformer configuration used has special features that make it desirable for the application, but exhibits some characteristics that complicate the design. To simplify the analysis of operation, the circuit can be treated as two six-phase circuits operating in parallel. The vector diagram of the transformer circuits is shown in Fig. 1. To obtain 12-phase operation, two sets of three single-phase transformers with center-tapped secondaries are connected in a wye-star configuration. The 3-phase inputs to the two sets are shifted 30 degrees out of phase with a phase shifter. The phase-shifter vector diagram is also shown; parallel sides represent windings on a common leg of a three-legged core. The output from the phase shifter gives two sets of 3-phase voltages displaced 30 degrees

from each other. The diametrical connection of the transformer secondaries results in a 6-phase full-wave output so that when the two sets are paralleled at the d-c bus, a 12-phase system is realized. The vector diagram of the voltages in the 12-phase transformer configuration is shown in Fig. 2 and labeled with reference to the transformer windings indicated by the vectors in Fig. 1. By using six single-phase transformers instead of two three-legged transformers, inter-phase transformers are not required to obtain the characteristic of multiple-phase systems, where several anodes would conduct simultaneously.

Magnetic-Amplifier Regulator

The output stage consists of a reactor in series with each of the twelve power rectifiers. The twelve reactors plus the rectifiers form a 12-phase self-saturating amplifier when the control windings for the reactors are connected in series. Toroidal cores for the output stage were chosen with two views in mind—to keep reactor weight to a minimum, and to obtain a high-performance amplifier.

Designing the amplifiers in the unit to meet the electrical characteristics was part of the over-all problem. Because of the ambient temperature of 120 degrees C, several physical problems connected with magnetic-amplifier design had to be solved. A high-temperature core box had to be developed to withstand temperatures of 200 degrees C, as well as a new method for damping the cores to prevent strain due to vibration. A potting compound capable of withstanding thermal shocks from -55 to +200 degrees C was another challenging design problem, which had to be solved to make the amplifier a physical reality. These temperature-design problems were solved by use of such materials as Silastic, ceramics, Teflon, and high-temperature phenolics.

For purposes of understanding, the output stage may be thought of as twelve half-wave amplifiers operating in parallel. As has been discussed, the mode of operation for the transformers is such that four rectifiers conduct at any instant of time. With four reactors conducting, the maximum gating period for each half-wave amplifier is 120 electrical degrees with a reset period of 240 electrical degrees.

The first stage is a conventional full-wave self-saturating bridge-type amplifier (Fig. 3). All compensation necessary for system stability is provided by this stage. The design of the first stage is such that a large number of control turns can be used on the reference winding, thus reducing the amount of reference current required.

The first stage is resistively coupled to the second stage, which is biased to cut off with bias current taken from the d-c bus. A reference current is fed into a first-stage control winding, which drives the first stage beyond positive saturation. The d-c output voltage is fed back through a sensing resistor to a control winding in opposition to the reference winding, the difference in reference and sensing ampere turns at no-load sets the bus voltage to be regulated. Any change in bus voltage provides a differential ampere-turn signal to the first stage, which drives the second stage. A decrease in bus voltage due to load drives the first stage toward full output and thus the second stage also toward full output. The second stage could be operated without bias by reversing all control circuits, but this introduces a problem of recovery for the regulator after a fault. The mode of operation used was chosen to avoid the danger of having the first-stage magnetic amplifier driven beyond cut-off up the back side of its characteristic curve for a large drop in output voltage.

Phase Balance

Obtaining a 12-phase system from a 3-phase supply entails complex combinations of transformer windings. The constructional difficulties of the single-phase transformer used in this unit are by far the simplest of the 12-phase systems, but as with any system, phase balance is necessary for stable operation and minimum ripple. The addition of a series regulator in each phase of the system greatly magnifies the unbalance problems.

Fig. 2

Vector diagram of voltages in 12-phase transformer-rectifier circuit, which is shown in Fig. 1.

A very simple effective means is employed to obtain the feed-back necessary to reshape the twelve half-wave amplifiers. The load winding of each reactor is shunted with a resistor according to its characteristic. The result is varying amounts of negative feed-back around each half-wave amplifier resulting in identical dynamic characteristics. The very linear transfer curve shown in Fig. 5 is the other two transfer curves after the appropriate shunts have been applied. The gain reduction is approximately two-to-one for balance. The method is extremely effective and involves nothing but twelve adjustable resistors.

Paralleling

To operate regulated d-c voltage sources into a common load, some type of differential forcing is required to cause the sources to share load. The method employed in this design to provide load sharing allows a number of units to work into a

common bus with a maximum current unbalance between units equal to five percent of the full-load current rating of a single unit, for a one-volt difference in voltage setting between parallel units.

Each power supply is provided with a transducer, which has a d-c output current proportional to the load current being supplied by the unit. The output of each transducer is run through a winding on its respective first stage and out to a common paralleling bus. A difference in current output from various units operating in parallel causes a net circulating current in the paralleling loop, which adjusts the output of the individual units. Gain adjustment in the loop is provided by a potentiometer load on each transducer. This method of power supply paralleling provides a system based directly on the d-c load current; as such it is not affected by harmonics or phase unbalance, which might cause difficulty in a system employing a current transformer in the a-c side of the power supply regulator.

This aircraft d-c power supply (Type ATR-200A) delivers 200 amperes at 28 volts, with voltage regulation of ± 3.7 percent.

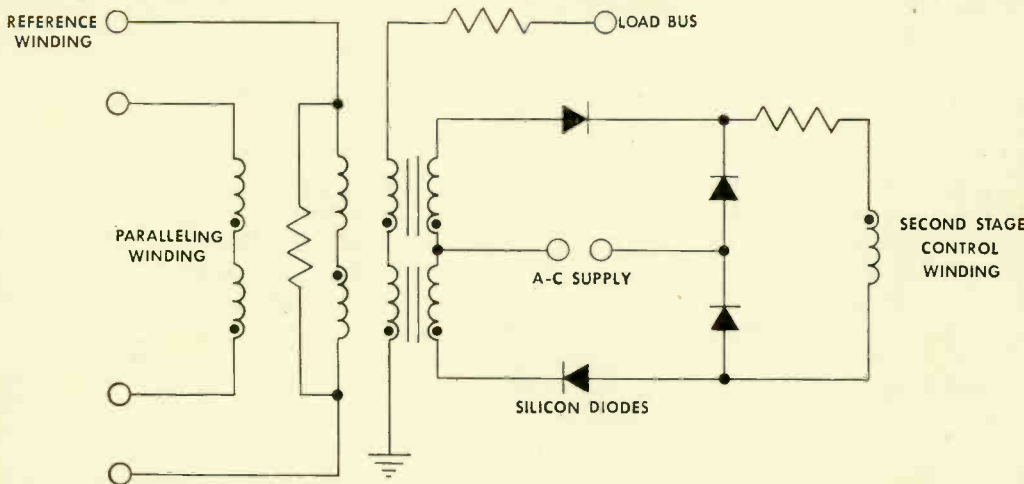
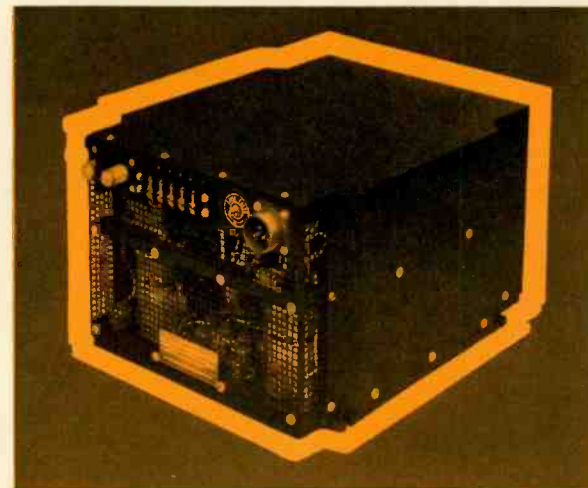

Fig. 3

Diagram of the first-stage magnetic amplifier. This stage compares the d-c output voltage to a reference signal and amplifies the difference to control the second-stage unit.

Fig. 4

Schematic diagram of the second-stage amplifier, which takes 400-cycle, three-phase a-c power from the phase-shifting transformer and converts it to regulated d-c power.

Conclusions

Test results on prototype transformer-rectifier units built to the design described have proved highly successful. Voltage regulation at room ambient conditions is one percent or better with the supply voltage and frequency varied plus-or-minus five percent. At 250 percent overload, the two-percent regulation obtained is still within the plus-or-minus one volt desired. The recovery time is extremely fast. Load switching transients are within the one volt regulation limit in 0.08 seconds. Recovery time after 650 percent short-circuit current is 0.045 seconds or even faster than the full-load to no-load recovery time. One volt peak is the practical limit for ripple voltage in the d-c output. Reduced ripple voltages can be obtained by matching components for critical applications.

Complete qualification tests are expected to further indicate the ability of this unit to meet the required high-performance design objectives. ■

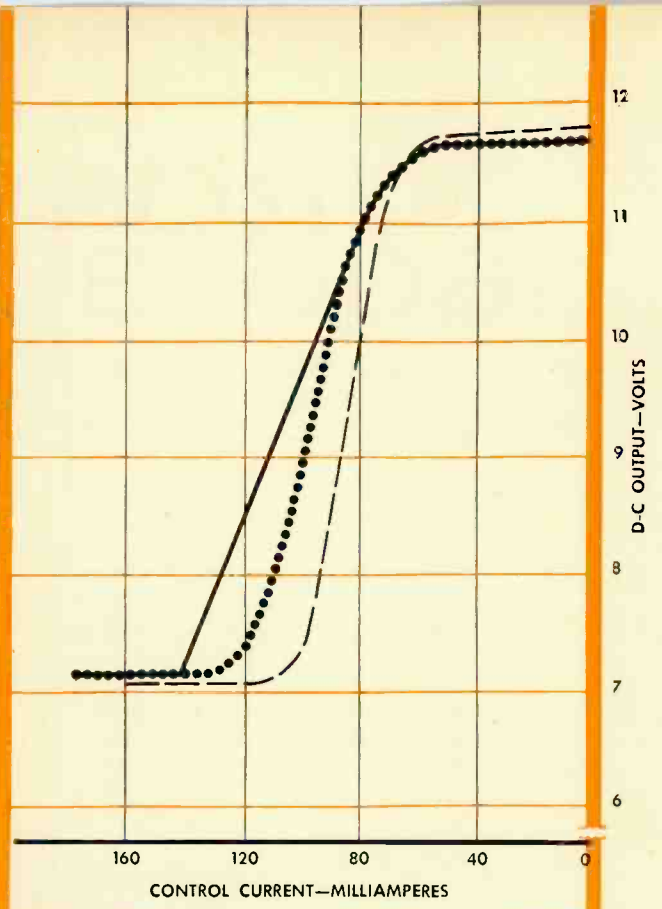
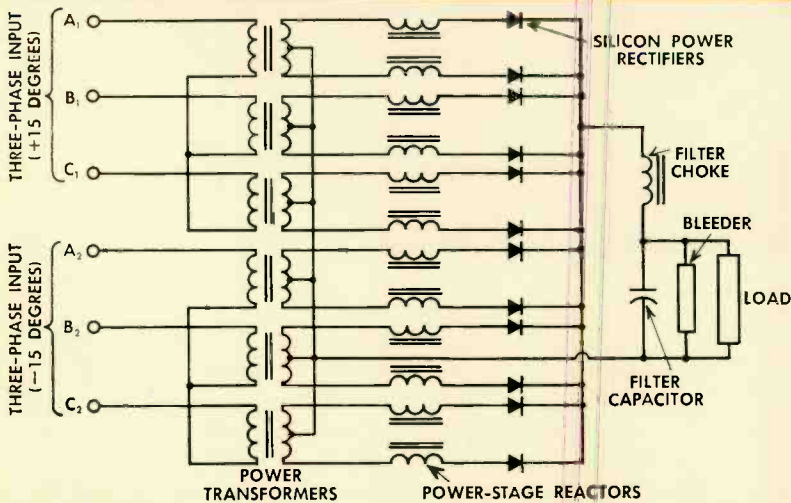

Fig. 5
Second-stage half-wave transfer curves for two reactors are shown by the broken lines. The linear solid-line curve represents these same reactors with appropriate shunting resistors.



These are examples of the essential electrical components that go into the d-c power supply. All components are designed for 120 degree C ambient temperature or better.



THE "CROSS-QUAD"TM 3600-3600

... is engineer's shorthand for a
new tandem cross-compound, quadruple-exhaust turbine design,
with both shafts operating at 3600 rpm.

NORRIS D. GOVE

Steam Division
Westinghouse Electric Corporation
South Philadelphia, Pennsylvania

Model of the new cross-compound quadruple-exhaust turbine, which will drive two 145-mw generators.

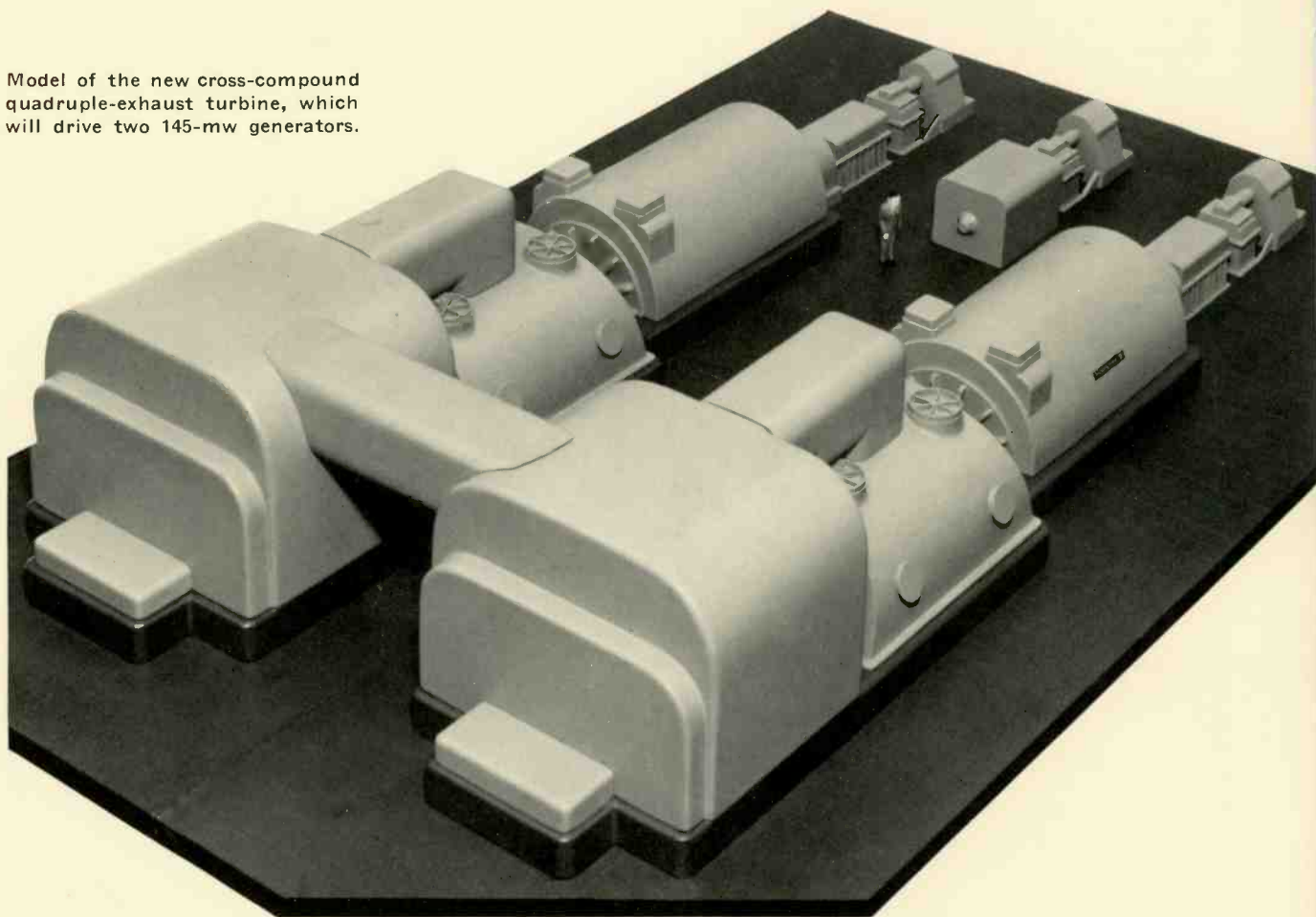

■ Demand for improvements in construction, higher steam conditions, and larger ratings result in new steam-turbine designs and furnish a constant spur to inventiveness. A steam turbine design has been developed for Public Service Electric and Gas Company of New Jersey to permit the use of a cross-compound 3600-rpm unit for ratings up to 300 000 kw, with steam inlet pressures from 2000 to 3000 psig, and steam inlet temperatures of 1000, 1050 or 1100 degrees F. The tandem cross-compound, quadruple-exhaust turbine has been dubbed colloquially the "cross-quad" by its designers. The 1800-rpm shaft usually associated with cross-compound machines has been replaced by a 3600-rpm shaft, so that both shafts of the cross-compound unit operate at 3600 rpm. The principles of the new arrangement are applicable to units up to 500 mw, al-

though a sextuple-flow exhaust would be required at this rating.

A major advantage of the 3600/3600 arrangement is the near-duplication of the two parallel turbine-generator units. The only difference is that one has a high-pressure turbine element, and the other an intermediate-pressure element. Everything else, the low-pressure elements, the generators, and the associated switchgear components are the same for both parallel units, so that the utility can carry common parts for both units. This results in a savings in maintenance costs.

The cross-quad is shown diagrammatically in Fig. 1. The high-pressure turbine receives high-pressure steam from the boiler and discharges it to the reheater. The intermediate-pressure turbine receives reheated steam at the center and discharges half of it from each end to one of the double-flow, low-

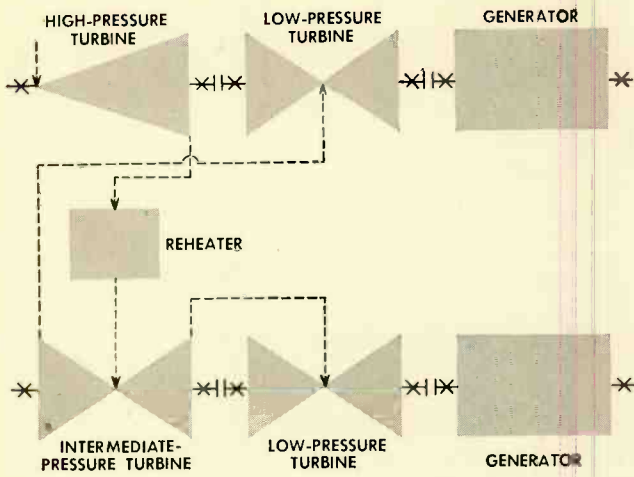

Fig. 1 Steam flow is shown in this diagrammatic arrangement for the cross-compound, quadruple-exhaust turbine.

pressure turbines. The steam flows through each of the two double-flow low-pressure turbines to a common condenser. Thus, the increasingly large volumes of steam are handled in one passage through the high-pressure turbine, two parallel paths through the intermediate pressure, and four through the low-pressure turbines.

The turbines will operate under high, but not novel, steam conditions of 2350 psig, 1100 degrees F with reheat to 1050 degrees F. For steam inlet temperatures of 1100 degrees F, austenitic steel is used in the inlet pipe, nozzle chambers, and nozzle blocks. For lower inlet steam temperatures up to and including 1050 degrees F, ferritic steels are used throughout. The high-pressure element embodies the complete mass-flow cooling principle, which results in relatively low cylinder wall temperatures with thinner walls and smaller diameter bolting.

Although 3600/3600 cross-compound arrangement is unusual, the components have been proven in previous designs. For example, the double-exhaust elements are conventional in every respect and embody the principle utilized in the low-pressure element in a tandem-compound double-exhaust unit.

By the proper choice of reheat pressure and entrance pressure to the low-pressure elements, the load can be balanced between the two shafts at a selective point, and this balance will be retained over a wide portion of the operating range. The two 3600-rpm shafts drive identical generators, which divide the load evenly at the rated 290-mw output. This equal division varies only a little at lower loads. For example, at 115 mw load, the division is 53-47 percent, the greatest departure from equality. The load division between the two power shafts at rating and at loads above and below this rating is shown graphically in Fig. 2.

The new machine will be installed in the Bergen Station of the Public Service Electric and Gas Company of New Jersey. The selection of this machine by their engineers was the result of a study of this and other arrangements.

Turbine units of nearly as large capacity are built as tandem-compound units with three sets of exhaust blades operating at 3600 rpm. This construction could not be considered for Bergen because of the high vacuum associated with cold condensing water, and the resulting large exhaust volumes of steam. Another possibility was the conventional cross-compound construction consisting of a 3600-rpm high-pressure and low-pressure element, with an 1800-rpm double-flow low-pressure turbine. However, the 3600/3600 machine is less costly, and will require 20 feet less in power plant width, less crane capacity, and less expensive foundations because of the lighter weight of the components.

The cross-quad construction with two 3600-rpm generators also promoted another Public Service project. Two boiler feed pumps will be driven from the shafts of the two generators. The arrangement can be seen in the photograph of the model. Next to the generator is the housing for a gear-tooth type coupling to drive the pump and to provide for differential axial expansion. Next in line is a hydraulic coupling with provisions for varying the pump speed in response to boiler demands. The pump can be brought to a dead stop with the generator operating at full speed. Between the hydraulic coupling and the pump is a speed-up gear which raises the speed of the pump to 8400 rpm. The two pumps will meet all requirements of the boiler at any load. They are backed up by a separate motor-drive pump of the same capacity. This direct-driven pump equipment uses space that must be segregated for generator-rotor removal, and eliminates two 4500-rpm motors and their controls that would otherwise be required. ■

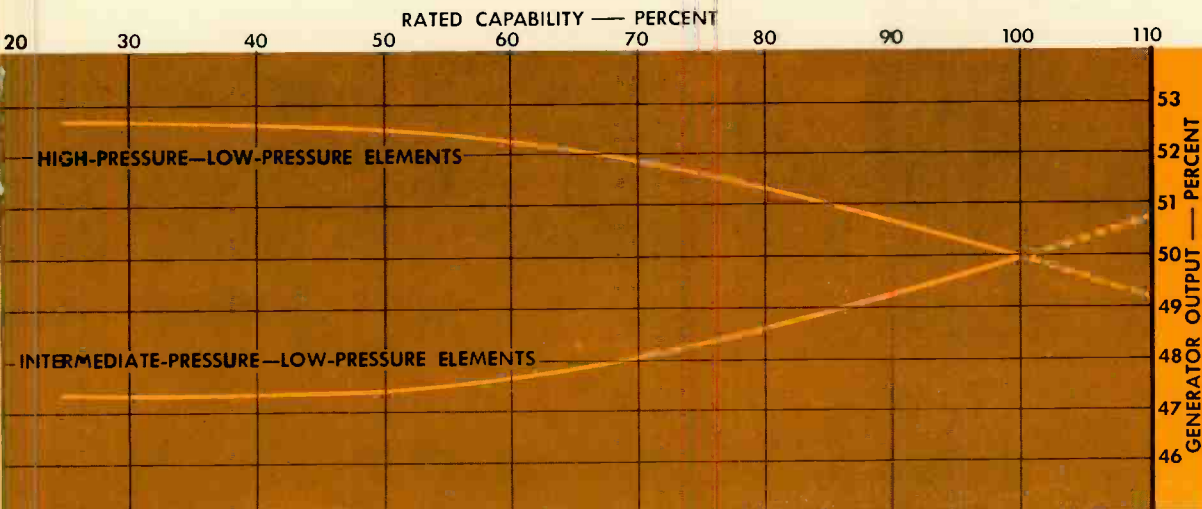

Fig. 2 Division of load shown between the two 3600-rpm generators of the cross-compound, quadruple-flow machine.

PROTECTIVE CHARACTERISTICS OF THE

Autovalve Arrester...

...keep discharge voltages across the arrester below the breakdown strength of apparatus insulation.

A. M. OPSAHL

N. K. OSMUNDSEN

Switchgear Distribution Apparatus Engineering
Westinghouse Electric Corporation
East Pittsburgh, Pennsylvania

■ The improved discharge-voltage characteristics of station- and line-type valve arresters have increased the margin of protection over that provided when the basic insulation levels were adopted by the electrical industry in 1941. The discharge-voltage characteristics of the Autovalve lightning arrester are relatively insensitive to surge-current magnitude, and to changes in rates of current rise. As a result, lower levels of apparatus insulation can be protected. Although insulation stresses other than lightning surges must be evaluated, the improved valve arrester often makes possible a reduced basic impulse insulation level (BIL) for system equipment, or more freedom of system design, such as greater allowable distances between arrester and transformer location.

Valve-Arrester Operation

When a lightning surge strikes a line, a high voltage is produced across any impedance in its path to ground. If the voltage resulting from a line stroke exceeds the insulation strength of a piece of connected equipment, such as a transformer, the insulation breaks down and system fault current follows this same path until some back-up device removes the fault from the line. Lightning protection consists of providing a lower impedance path to ground (the lightning arrester) so that the lightning surge is limited to a voltage below the insulation strength of the connected equipment.

The Autovalve arrester consists of two main elements: the Mobilarc gap, and the Autovalve lightning-arrester block. During most of its life, the lightning arrester is an insulator. The gap prevents system current from flowing through the device. If a lightning surge exceeds the spark-over voltage of the gap, the gap flashes over and the surge is discharged through the non-linear conducting valve element. After the surge has passed, the Autovalve element limits follow current to a relatively small percentage of the total fault current available so that it can be interrupted by the arrester gap at the first current zero. The arrester operation takes place within one-half cycle of 60-cycle operation, for by that time the voltage has gone through zero and the arrester has ceased operating. The protective sequence is over before any fuses blow or breakers operate in normal arrester protective performance. The arrester remains an insulator until another lightning disturbance, and is expected to perform this protective action many times without failure.

All Autovalve arresters, as shown by the cutaway view of a station-type unit above, are composed of these two essential

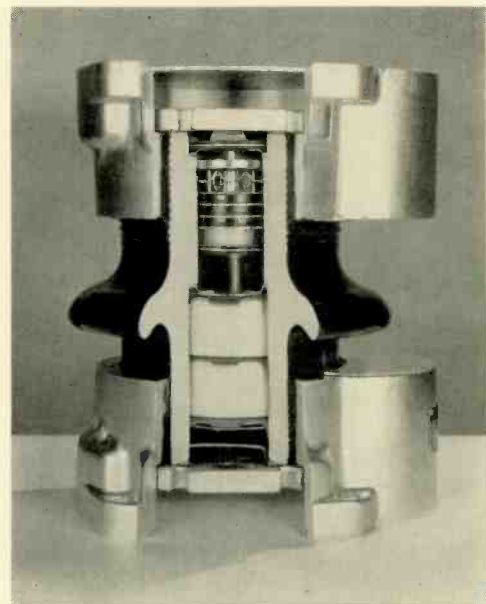

Cutaway of a 6-kv station-type Autovalve lightning arrester.

elements—the Mobilarc gap and the Autovalve block. For higher voltage ratings, additional numbers of blocks and gaps are combined in one porcelain housing or in a series of housings to obtain the proper voltage rating. The gaps are contained in an individual housing, which is dried out and sealed.

The gaps and blocks are assembled in a porcelain housing, the entire unit is sealed, and the assembly is tested for gap spark-over. The lightning-arrester unit has terminal connections on each end and is ready for installation. One of the larger types of Autovalve lightning arresters is the 258-kv suspended zig-zag assembly. This particular unit is made up of seven individual 37-kv station-type arrester units. The assembly is hung from the sub-station framework and protects large power transformers. The overall length of the assembly is 32 feet and it weighs 3600 pounds. In contrast, the smallest rating for protection of distribution equipment is the 3-kv distribution-type Autovalve lightning arrester, which is 8 inches long and weighs 11 pounds.

Arrester Rating

The voltage rating given an arrester is the power voltage at which follow current can be interrupted after being initiated

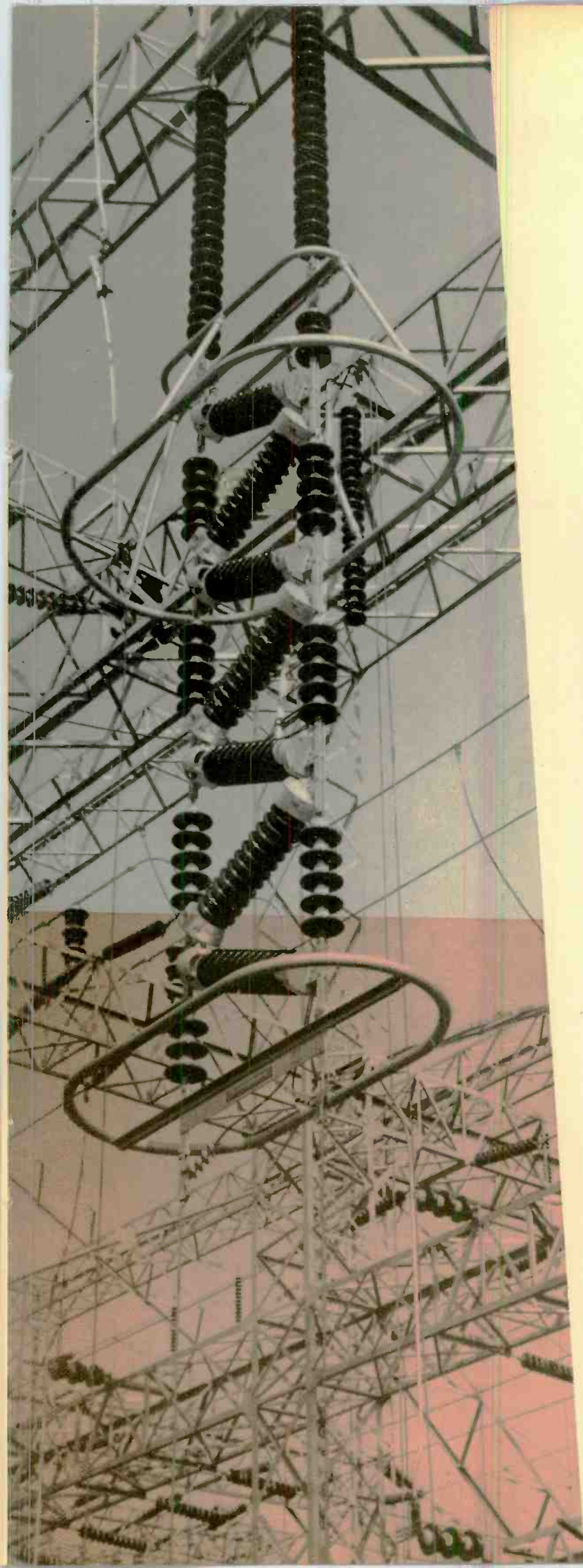

Suspended 258-kv zigzag lightning arrester.

Distribution arrester of 3-kv rating.

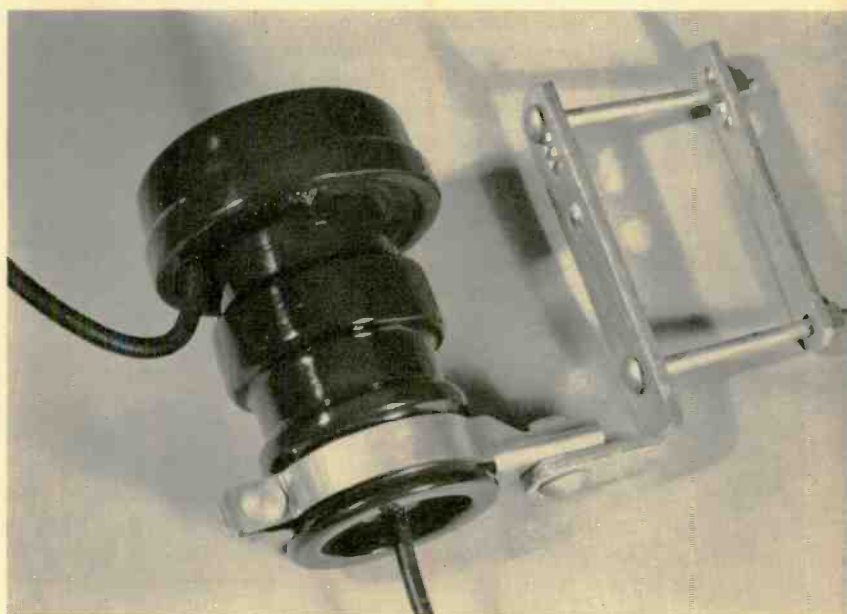

by a surge discharge. At power voltages above this arrester rating, follow current interruption is doubtful. The safe arrester rating is usually determined by the highest power voltage that can appear from line-to-ground during unbalance faults and loss of system grounds.

The valve arrester, as a good surge-protective device, is of necessity very sensitive to power overvoltage. After spark-over of the arrester gap, follow current through the non-linear valve element increases rapidly with an increase in power voltage. The margin between gap sparkover and power voltage after current zero is also decreased.

High-voltage systems can be divided into two categories for arrester application: (1) *Impedance-grounded* systems allow line-to-ground voltage at the arrester during faults to rise as high as normal line-to-line voltage. (2) *Effectively-grounded* systems have enough grounded neutral capacity so that line-to-ground voltage at the arrester location cannot exceed 80 percent of maximum line-to-line voltage during faults. If the system is better than effectively grounded, arresters rated about 75 percent of maximum line-to-line voltage can be used.

The trend in higher circuit voltages is toward better than effective neutral grounding. Use of the lowest safe arrester rating is desirable, since this limits surge voltage to the great-

est degree. However, each circuit should be carefully examined before applying reduced arrester ratings to be sure that the arrester will not be subjected to voltages greater than its rated voltage.

Simulation of Lightning Discharges

The build-up of a charge and the spark discharge must be simulated in the laboratory to test and evaluate lightning protective devices. This is accomplished with a surge generator, which consists essentially of capacitors, spark gaps, and resistors so connected that the capacitors are charged in parallel from a relatively low-voltage source, and then discharged in a series arrangement through the device being tested. The currents and resulting voltages are recorded with a cathode-ray oscillograph. The time of the surge can be recorded in terms of microseconds.

A lightning surge is generally described in terms of *crest magnitude* and *wave shape*. The wave crest is the maximum or highest value reached; wave shape is expressed as a combination of the time from zero to crest value, and the time from zero to one-half crest on the wave tail (Fig. 1). Both values of time are expressed in microseconds. The *rate of rise* of current is determined by the slope of a line drawn through points of 10 and 90 percent of crest current.

Discharge-Voltage Characteristics

An examination of the discharge-voltage characteristics of the Autovalve arrester for variations in magnitude and rate of rise of current surges indicates the effectiveness of the device. The non-linear property of the Autovalve lightning arrester makes it a particularly useful device for protecting electrical equipment.

The discharge voltage across the arrester for a variation in surge-current magnitude from 1500 to 100 000 amperes is shown in Fig. 2. For this increase in current from 1500 to 100 000 amperes (66 times) and the accompanying increase in rate of current rise, the discharge voltage crest rises in magnitude only 1.7 times. The curves illustrate the characteristic arrester discharge-voltage shape—a rapid rise on the front, a flat-top section, and then a gradual decline.

Rate of current rise is the biggest factor in determining discharge voltage. The discharge voltages for 5000-ampere surge currents of 3×20 , 6×20 , and 10×20 microsecond shapes are shown in Fig. 3. The corresponding nominal rate of

wave shape (10x20 microseconds)

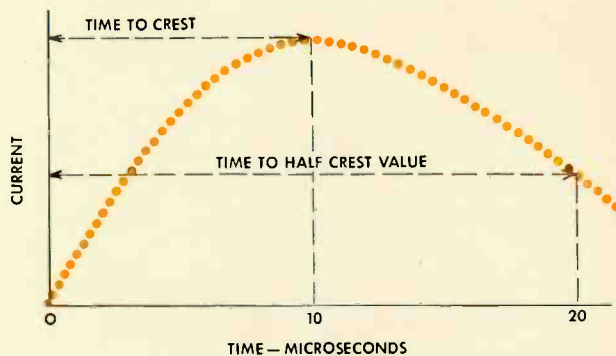

rate of rise

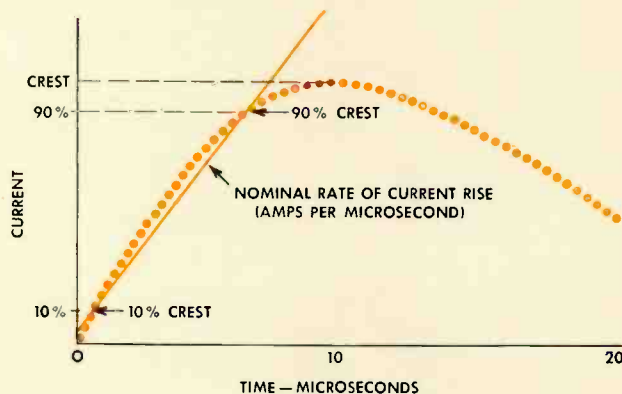
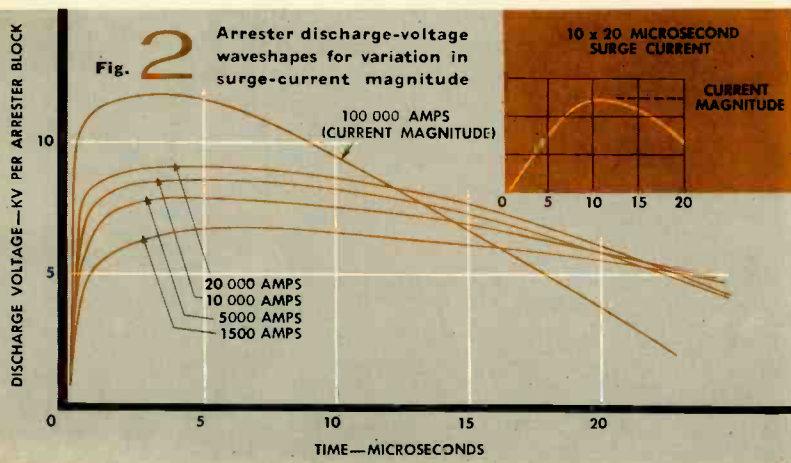

Fig. 1 Lightning surge definitions.



rise for these three wave shapes are: 3000 amperes per microsecond for the 3×20 microsecond surge, 1200 amperes per microsecond for the 6×20 surge, and 600 amperes per microsecond for the 10×20 surge. The curves show that after falling to half of crest current on the tail, at 20 microseconds, the voltages corresponding to these three surge currents reach about the same value. For the *sleepy* rates of current rise, the discharge voltage also *rises* to a higher, sharper or shorter peak but then falls off more rapidly. Hence, as lightning surge-current magnitude and rate of current rise increase, the crest of the discharge voltage across the arrester increases. However, the relationship is not linear, so that only a relatively small variation in discharge voltage results from wide variations in current rate of rise and magnitude. The variation of discharge voltage for variations in current magnitude and time to crest are summarized in Fig. 4.

Insulation Coordination

Insulation coordination is the process of correlating electrical apparatus withstand strength as measured by the standard impulse insulation tests, with anticipated overvoltages and with voltages as limited by surge-protective devices. The standard arrester test employs the 10×20 microsecond current wave shape previously described. The impulse insulation test for electrical apparatus, such as transformers, is a voltage of a 1.5×40 microsecond wave shape with a crest value chosen to correspond with the rated voltage of the equipment. This crest value is the basic impulse insulation level (BIL). The standard basic insulation level values for the various distribution and power classes of equipment are summarized in Table I.

Equipment of reduced insulation level can be used on systems that are effectively grounded and permit the application of reduced-rating arresters. This lowers insulation withstand strength, and for proper protection of transformer insulation the arrester must limit voltage to a value below this insulation level. The effectiveness of a 145-kv arrester for variations in lightning-surge current and magnitude is shown in Fig. 5. This arrester protects a 138-kv class transformer with a BIL of 650-kv crest. These present characteristics are about 25 percent below those available in 1941. On the basis of impulse protection alone, there is a margin for a stepdown in insulation level of apparatus without reducing the rating of the arrester.

Impulse withstand strength for electrical apparatus, such as transformers, is higher for short periods of time. Two additional insulation tests are chopped-wave and front-of-wave tests. The chopped wave is an impulse-voltage wave with a crest magnitude about 15 percent above the BIL; it starts as a 1.5×40 microsecond wave and is chopped or interrupted at about 3 microseconds. The impulse voltage in the front-of-wave test usually starts as a 1.5×40 microsecond wave having the proper rate of voltage rise and is chopped on the rising portion of the wave by a gap. These insulation tests are illustrated in Fig. 5.

The full-wave, chopped-wave, and front-of-wave insulation tests illustrate that for short intervals insulation will withstand higher voltages than for longer periods. With a steep rate of current rise (3000 amperes per microsecond in Fig. 3) the arrester discharge voltage rises to a higher initial crest, but transformer insulation will withstand a higher crest-

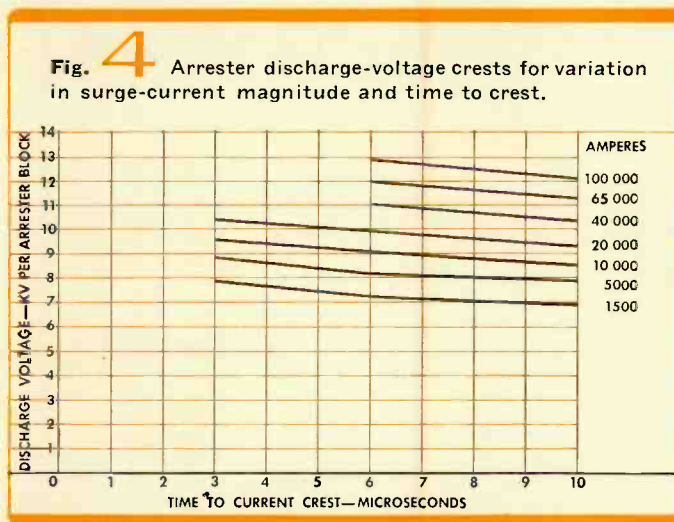
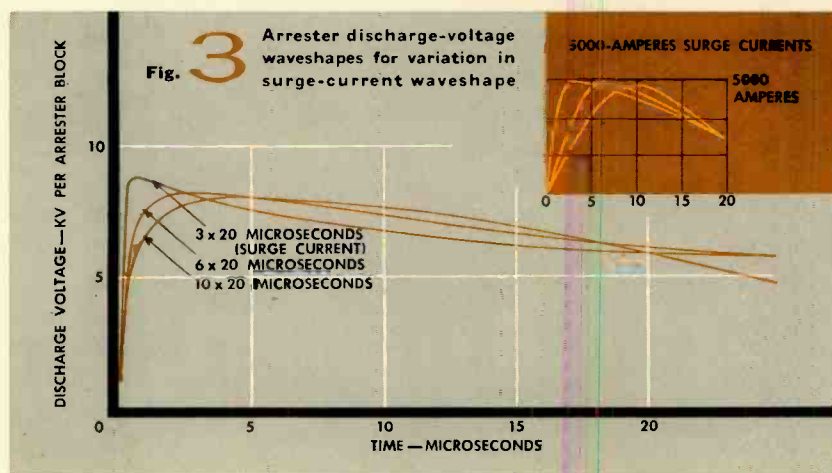

voltage full wave of this wave shape. However, for both steep rate of current rise and high-magnitude surge current (100 000 amperes crest, 12 000 amperes per microsecond in Fig. 2) the discharge-voltage crests are well below the full-wave (BIL) values of the transformers (Fig. 5).

As previously shown, arrester discharge-voltage crest and wave shape vary a relatively small amount with changes of surge-current magnitude and rate of rise. The 10×20 microsecond current wave shape has become standard for determining arrester discharge voltage as a basis for insulation coordination. Before assuming a surge-current magnitude for a given case, consideration must be given to the amount of direct-stroke shielding for the circuit in question, since this affects the current that the arrester must discharge. For example, on a high-voltage line with good station shielding, and overhead ground wires about a mile out from the station, 5000-ampere surge current can be considered adequate; but on highly insulated, unshielded wood pole lines, arrester characteristics at about 20 000-ampere currents should be con-

table I

BASIC IMPULSE INSULATION LEVELS FOR POWER CLASS EQUIPMENT

Reference Class KV	Standard Basic Impulse Level—KV	Reduced Insulation Levels In Use—KV
1.2	45	
2.5	60	
5.0	75	
8.7	95	
15	110	
23	150	
34.5	200	
46	250	
69	350	
92	450	
115	550	450
138	650	550-450
161	750	650
196	900	
230	1050	900-825

sidered. The maximum performance characteristics for station (SV) and line-type (LVS) Autovalve arresters are summarized for these two values of surge current in Table II.

Summary

The crest discharge-voltage characteristics for the 3000 ampere per microsecond discharge is well below the full BIL

crest voltage (Fig. 5), and also below the BIL of 550 kv insulation one class lower. In comparing the discharge-voltage curves for the standard 10×20 discharge current with the discharge voltage for the same current amplitude with the steeper rate of rise of current, 3000 amperes per microsecond, it is not obvious which discharge voltage is most severe when compared with the 1.5×40 microsecond voltage wave that establishes the BIL. ■

table II

MAXIMUM PERFORMANCE CHARACTERISTICS OF STATION (SV) AND LINE-TYPE (LVS) ARRESTERS

Arrester Rating KV	Maximum Discharge Voltage for Currents 10 x 20 Wave Shape, 5000 and 20 000 Crest				BILs of Application with which the Arresters are Used
	5000, 10x20		20 000, 10x20		
	SV	LVS	SV	LVS	
3	8.5	12	10	14	45, 60, 75,
6	17	23	20	27	60, 75, 95,
9	24	29	28	36	60, 75, 95, 110
12	32	36	38	44	75, 95, 110
15	40	46	47	56	75, 95, 110
20	55	63	65	77	150
25	65	76	76	93	150
30	80	90	94	111	200
37	96	116	113	143	200
40	104	125	123	154	250
50	130	152	153	187	250
60	160	180	189	222	350
73	195	230	230	282	350
90	240	270	283	332	450
97	258	296	304	364	450 — 550
109	282		333		450, 550
121	320		378		550, 650
133	350		410		650
145	375		440		650, 750
169	450		530		750
182	470		552		825, 900
195	500		588		900
242	640		755		1050
258	685		805		1175
264	700		825		1175
276	730		860		

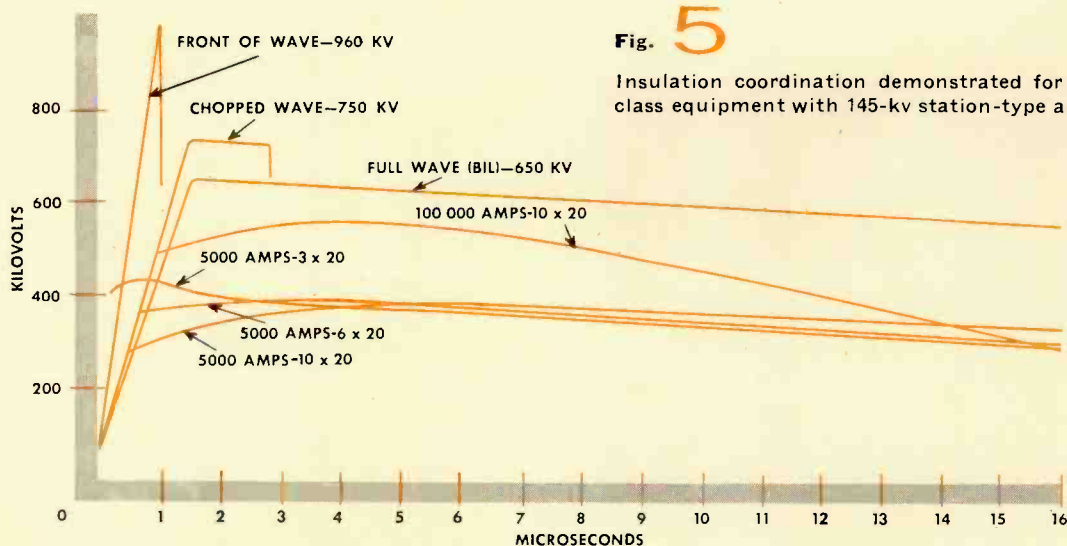

Fig. 5

Insulation coordination demonstrated for 138-kv class equipment with 145-kv station-type arrester.

electroluminescence...

A LABORATORY CURIOSITY

APPROACHES PRACTICALITY *as a result of tremendous improvement made in this light source in the last few years.*

HENRY F. IVEY

Section Manager, Phosphors
Research Department
Lamp Division
Westinghouse Electric Corp.
Bloomfield, New Jersey

■ Since electric lighting first became practical, only three basically different light sources have achieved widespread use—incandescent, fluorescent, and gas-discharge lamps. Now a fourth basic type is nearing practicality, and if it achieves its full potential it may well revolutionize lighting. This newcomer is electroluminescence, which is the generation of light in a solid material by the application of voltage to the material.

Electroluminescence differs substantially from its three predecessors; in fact, these differences are partly responsible for its promise. In an incandescent lamp, light is generated by heating a tungsten filament in a glass bulb filled with inert gas, or evacuated. Light is a direct result of the high temperature. Gas-discharge lamps, on the other hand, rely on the fact that an electrical discharge in a gas or vapor produces some visible light; from this phenomenon have resulted carbon-arc lamps, neon tubes, and mercury-vapor lamps, among others. Fluorescent lamps are gas-discharge lamps, with one important difference: only part of their light comes directly from the gas discharge. The majority comes from the invisible ultraviolet light, which is transformed into visible light by a coating of phosphor on the inside surface of the tube.

Electroluminescence, on the other hand, does not depend on heating nor upon a gas discharge for its light output. No

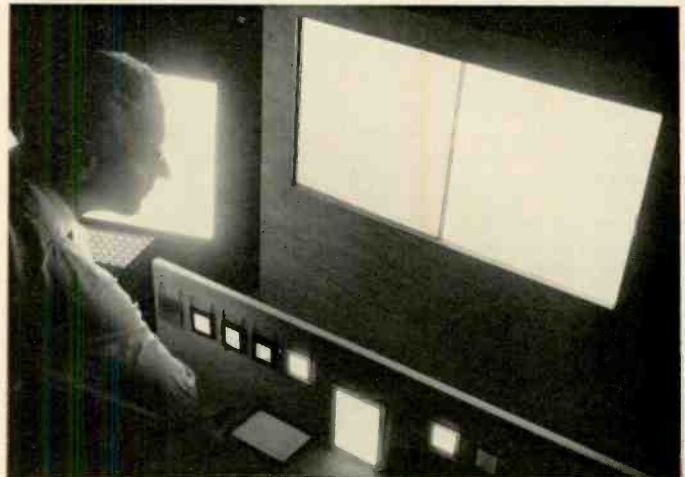

bulb is needed; light can be produced by a flat plate no thicker than ordinary window glass. This fact alone is sufficient to suggest a promising future for electroluminescence. But in addition, electroluminescent sources can be constructed such that color can be varied by the twist of a knob; also, there seems to be no reason why an electroluminescent source cannot be made in a variety of geometric shapes and sizes.

As yet, electroluminescence has not achieved practicality except for a few special applications. However, tremendous strides have been made in the past few years and many of the obstacles that previously blocked the use of this phenomenon have been removed. If the present rate of development can be continued, the day of practical application to general lighting is not far off.

table I

TYPE OF LUMINESCENCE	EXCITING SOURCES
Photoluminescence	Visible light or ultraviolet
Roentgenoluminescence	X-rays
Cathodoluminescence	Cathode rays
Ionoluminescence	Ion beams
Radioluminescence	Alpha or gamma rays
Triboluminescence	Mechanical action
Chemluminescence	Chemical action
Electroluminescence	Electric field

What Is Electroluminescence?

Luminescence, of which electroluminescence is one form, is a distinctly different phenomenon from incandescence. Any solid material, heated sufficiently, gives off some incandescent light. Luminescence is the process in which a material gives off more light or radiation than is produced by incandescence at the same temperature. Luminescence can be produced in liquids, solids, or gases. It can be excited or produced by a number of different forms of energy. Several different forms are listed in Table 1.

In *electroluminescence*, light is produced by phosphors excited by an alternating electric field produced by an applied voltage. The scientific theory that explains electroluminescence (see simplified discussion, p. 94) is similar to semiconductor physics. Semiconductor devices, such as transistors, are "cousins" of electroluminescent cells, although their end results and uses differ considerably.

The phenomenon of electroluminescence was first discovered by Professor Georges Destriau of France in 1936. In the

SIMPLIFIED THEORY OF ELECTROLUMINESCENCE

Energy-level diagrams are commonly used to explain the actions of semiconductor materials, and are equally useful in explaining electroluminescence. They represent the energy states of electrons in crystals. These diagrams consist of three different regions: (1) a valence band filled with electrons of varying energy, (2) a forbidden band, which cannot be occupied by electrons, and (3) a band accessible to electrons, but normally not occupied by them, called the conduction band. Once in this band electrons can move freely.

These bands are characteristic of defect-free, chemically pure material. However such an ideal material cannot be luminescent. To produce luminescence, a defect or impurity, called a "luminescence center" must be introduced in the material. The impurity, or activator, most often used for electroluminescence is copper. This luminescence center on the energy-level diagram is located in the forbidden band, near the filled band.

Generally speaking, electroluminescence is produced in a similar manner to photoluminescence. In the latter process the incident ultraviolet radiation is absorbed by an electron in the activator center. This raises the energy of the electron to a value corresponding to the conduction band. The electron is then free to move within this band. In some cases, the electron may immediately fall back to the center from which it came. In this event it will give up part of the energy it acquired as radiation. The remainder of the energy appears as heat. Because of this loss in energy the wavelength of the emitted energy is longer than that of the absorbed radiation; thus the radiation can be visible light.

Some electrons do not fall immediately back to the center from which they came. These electrons travel in the conduction band until they lose some energy and combine with empty luminescent centers—not necessarily the ones they came from—and light is emitted.

Electroluminescence differs from photoluminescence primarily on two counts. In photoluminescence, the incident ultraviolet radiation provides the necessary energy to raise electrons into the conduction band; in electroluminescence, the electric field provides this energy. However, generally speaking, the electric field is not as "efficient" a producer of high-energy electrons as is ultraviolet radiation. Therefore, in electroluminescence, each electron freed must in turn produce other electrons, so that a plentiful supply is available in the conduction band. Electrons raised to this conduction band are accelerated by the electric field. Some collide with luminescent centers, freeing other electrons, which in turn are accelerated and collide with other luminescent centers, and so on. Emission occurs when the direction of the field reverses so that the electrons that originally occupied luminescence centers may return to the now empty centers and recombine with them to produce light.

"Destriau effect," particles of a suitable powdered substance were suspended or embedded in an electrical insulator, and an intense alternating electric field applied to the combination. Under such excitation, the particles became luminescent. The light produced was extremely weak—so much so that it could be seen only in a darkened room—and little interest was aroused until after World War II. As a matter of fact, some doubt was expressed, as late as 1950, as to the existence of electroluminescence; some felt that the feeble light might be produced by separate small arcs within the insulating material, or by other effects.

Shortly after Destriau published an extensive account of his results in 1947, Westinghouse scientists began research on the subject. Progress at first was distressingly slow, but in the past few years tremendous progress has been made (Fig. 1), to the point where electroluminescence is standing at the brink of practical application. The dramatic progress achieved was demonstrated last year at the dedication of the new Westinghouse Research Laboratories, where an entire room was lighted with electroluminescent panels, and demonstrations were made of the feasibility of color variation by a twist of a knob.

The Electroluminescent "Lamp"

Perhaps the simplest form of electroluminescent lamp is that shown in Fig. 2. Here two wires, or electrodes, are wound on a core; the space between the wires is then filled with a plastic containing the phosphors. A different arrangement, and one that could be flat, appears in Fig. 3. Here the electrodes are applied on a flat base in an interlocking fashion, and the phosphor-containing plastic coated over the entire surface. Either of these simple designs, connected to an alternating-current source of proper voltage and frequency could produce visible light. The field set up between the two electrodes excites the phosphor and light is emitted.

One obvious drawback to both of these simple cells, however, is the fact that the light is not uniform over the surface of the lamp, because the field itself is not uniform over the entire area. One solution to this is to make the electrodes of large, flat area, and place the phosphor mixture between. This requires that at least one of the electrodes be transparent, but this problem is easily solved. Coatings of tin oxide or other material on glass produce a transparent, electrically conducting electrode.

A variety of cells can be made in this "sandwich" fashion. One version uses one metal electrode and one of glass with a conducting coating; the phosphor is suspended in an insulating liquid held between the two electrodes. In still another type, illustrated in Fig. 4, the phosphor is suspended in a plastic solution and sprayed or painted on glass. The glass is then heated to set the plastic, after which silver paint or vacuum-deposited aluminum is coated over the plastic to serve as the second electrode. This provides a reflective surface for light emitted in this direction. Still another type of cell uses a low melting point glass or enamel as the material in which the phosphor is held (Fig. 5). Over a sheet of metal, a coating of white reflecting enamel is applied; over this goes a transparent conducting coating, then the phosphor-containing layer, another transparent conducting material as the second electrode, and then a transparent protective layer.

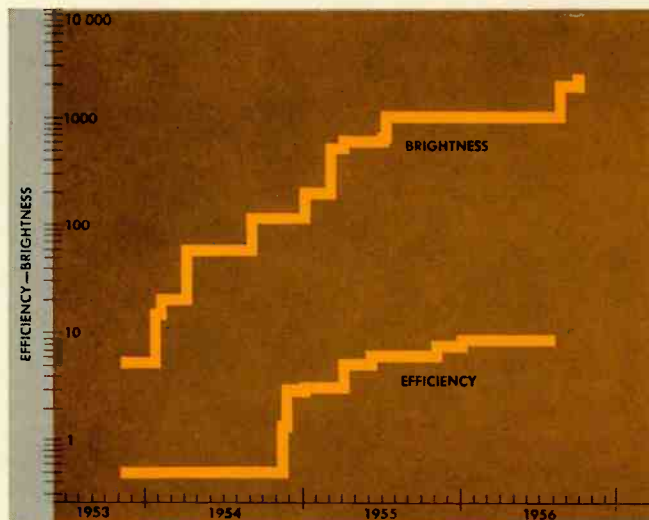

Fig. 1
Increase in brightness and efficiency of electroluminescence, 1953-1956. Brightness at 600 volts rms and 20 000 cycles; efficiency at optimum conditions of about 300 volts rms and 500 cycles per second.

Any electroluminescent cell, which consists of two electrodes with an intermediate insulating material, is a capacitor with high losses. The dielectric loss of the capacitor is that part of the energy converted to light. Some energy, of course, is converted to heat. To make a cell that will operate at relatively low voltages and yet provide the high field strength required, an extremely thin layer of phosphor insulator is necessary—from one- to three-thousandths inch thick. Applied field strengths produced are about 100 000 volts per inch.

Variables and Their Effect on Color and Brightness

Zinc-sulphide phosphors were used by Destriau in his original experiments and, despite extensive investigation since that time, are still the best performers. Phosphors of this type are numerous, but only a small fraction exhibit electroluminescence. The major research and development effort in electroluminescence has been in attempting to find out more about the actions of phosphors, and to find better varieties.

By proper choice of phosphors, a wide variety of colors can be produced in electroluminescent cells, including blue, green, yellow, or red. By blending these materials properly, white light can be produced.

When the frequency of the applied voltage is varied, some phosphors emit a different color. As frequency is increased, the color shift is always toward the shorter wavelengths, i.e., toward the blue end of the spectrum. Actually the light produced by each of these phosphors consists of one or more bands in specific wavelength regions. Thus one phosphor, for example, may emit both green and blue light. The effect of frequency change is to alter the relative amount of light emitted in each color band. Thus an increase in frequency might change the phosphor's output from a predominantly green to a predominantly blue. Thus one method of varying the colors produced by electroluminescent cells is apparent.

Brightness of the electroluminescent cell is also affected by frequency, and in addition by voltage. Raising either one increases the brightness. The fact that some phosphors are available that change in brightness with frequency suggests another method of varying the color of an electroluminescent cell. For example, consider a cell made of two different phosphor materials, one relatively unaffected by frequency changes and one whose output increases rapidly with frequency. At

low frequencies, the color output is dominated by the first phosphor, but as frequency is increased the color of the second phosphor predominates.

Cells can also be made in multi-layer construction. Each cell is connected through series inductors to a common variable-frequency power supply. Since the cells are capacitors, a set of tuned circuits is thus formed; by proper choice of the inductors, only one cell at a time is excited as the applied frequency is varied.

In addition to brightness and color, efficiency of electroluminescent cells is also important. As mentioned, brightness increases with either frequency or voltage; efficiency, however, does not. Optimum efficiencies so far have usually resulted at intermediate frequencies (between 500 and 1000 cycles) and voltages. At present, the highest brightness achieved at 60 cycles is 20 foot-lamberts. At higher frequencies much greater brightnesses have been achieved; brightnesses of 2500 foot-lamberts have been attained with a green-phosphor cell operated at 20 000 cycles. In comparison, the output of a 40-watt fluorescent lamp is about 2800 lumens corresponding to a brightness of about 1800 foot-lamberts. At present, efficiency at this high brightness is low—about one lumen per watt. Maximum efficiency thus far attained is about 10 lumens per watt, with a resultant brightness of 65 foot-lamberts. In comparison, the efficiency of a 100-watt incandescent lamp is 16 lumens per watt, and of the 40-watt fluorescent lamp about 65 lumens per watt.

Some Possible Uses . . .

At present, electroluminescence is not yet ready for widespread general lighting purposes. Research and development work are proceeding to find the best phosphors, and the most practical cell construction, and optimum operating conditions, among other things. No insurmountable problems are apparent, although considerable engineering remains to be done.

The fact that high brightness is attained at higher than line frequency appears to be no particular problem. Electroluminescent cells can be powered from line circuits through small frequency-converter circuits utilizing power transistors, which are available. Or, in large buildings rotating frequency converters could supply the power.

The principal advantage of electroluminescence over incandescent and fluorescent lamps is that it provides the first large

Fig. 2

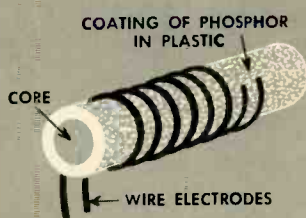

A simple electroluminescent lamp has electrodes wound on core, phosphor between wires.

Fig. 3

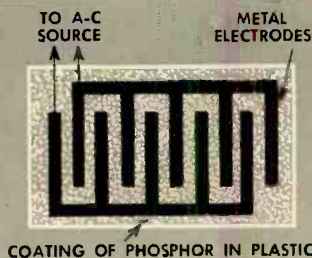

Another simple electroluminescent lamp, of different construction. This could be flat.

Fig. 4

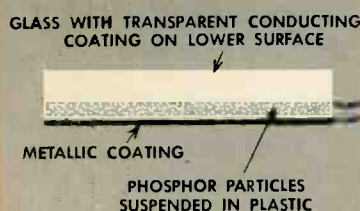

Phosphor can also be suspended in plastic, as shown here. Metallic coating can be added.

Fig. 5

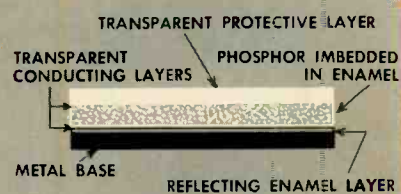

Still another cell has phosphor embedded in enamel, and enamel used as reflecting surface.

EFFICIENCY OF LIGHT SOURCES

All electric lamps have a maximum theoretical efficiency, toward which engineers can strive but probably not achieve. If all the electrical input to a theoretical light source could be converted to a yellow-green light having maximum effect on the human retina, an efficiency of about 680 lumens per watt could be expected. However, if white light (i.e., approximately sunlight) is to be generated the maximum is reduced to about 252 lumens per watt.

An incandescent lamp is limited by the melting point of its tungsten filament; at the melting point its efficiency would be about 53 lumens per watt of applied power, which is its theoretical maximum.

A fluorescent lamp, on the other hand, is limited because only about 50 percent of input energy can be converted to ultraviolet. Also the conversion of ultraviolet to visible light has an approximate efficiency of 50 percent. The fluorescent lamp can perhaps be raised from about 70 to 100 lumens per watt in the foreseeable future, but gains beyond that will be increasingly difficult.

Electroluminescence has fewer theoretical limitations. Although maximum efficiency thus far attained is about 10 lumens per watt, there are no fundamental reasons why well over 100 lumens per watt cannot be reached.

In both fluorescent and incandescent lamps most of the input energy is lost as radiated, conducted, or convected heat. In a 100-watt incandescent lamp, about 90 percent of the input energy is lost as heat; even in the 40-watt fluorescent lamp, generally considered a "cool" lamp, nearly 80 percent of the input is lost as heat. At the present stage of development, under the best conditions, about 98 percent of the input power to electroluminescent cells appears as heat.

area source of light. Electroluminescence is also the first light source that automatically produces an even, glare-free light. Other potential advantages of electroluminescence include the fact that it can be made in virtually any size or shape. Also its thinness would be an important economic factor in sky-scraper construction.

Because its efficiency is still below that of conventional sources, electroluminescent cells will probably be first used for special lighting applications. In addition to general lighting, it is also ideally suited for such things as photographic darkroom lighting, aircraft and auto panel lighting, signs, and many other uses.

Although lighting uses appear to be closer to reality, electroluminescence has many other fascinating potentialities. For example, if the necessary signal distribution circuits can be developed to the practical state, electroluminescence offers a

possible means to "picture frame" television; an electroluminescent cell might replace the conventional cathode-ray tube in such a set.

Many possible applications of electroluminescence result if it is combined with a light- or radiation-sensitive device such as a photoconductor. These electrophosphor-photoconductor combinations are of interest for signal storage and other functions in modern electronic computers. Consider the device shown in Fig. 6, in which a photoconductor and an electrophosphor are connected in series across a voltage source, and where for the moment the opaque layer between them in the figure is omitted. The voltage appearing across the electrophosphor, and its light output, is determined by the impedance of the photoconductor, which in turn depends on the light incident on it, which, in this case, may include that emitted by the electrophosphor. Once such device has been switched on, either optically (perhaps by another electroluminescent cell) or by means of a voltage pulse, it will continue to emit, being "locked in" by its emission; this then is a storage device. Other electroluminescent cell photoconductor combinations can serve as logic "and," "or," "not," and "nor" function elements for computers. Perhaps the greatest present disadvantage to such electrophosphor-photoconductor devices is their speed of response, which is limited by the characteristics of currently available photoconductors. Further research and development in this direction seems likely to alleviate some of these difficulties.

Electroluminescence also makes possible a wide variety of image conversion devices. Consider again the device of Fig. 6 and assume that an image is focused on the photoconductor. The type of radiation forming this image is immaterial as long as the photoconductor will respond to it—x-rays, cathode-rays, ultraviolet or visible light can be used. The principle of operation is identical to that of the devices discussed above, the essential difference being that the voltage across the electrophosphor layer is controlled from point to point in accordance with the intensity of the incident radiation, and the incident image is thus reproduced in the electroluminescent output. To preserve the image quality, the layers must be thin enough or the impedance characteristics in the lateral direction so controlled that the variation in voltage over the area is not dissipated laterally. If the photoconductor is responsive to the electroluminescent emission, then an opaque layer must also be inserted between the photoconductor and the phosphor to avoid optical feedback and resultant "lock-in" and loss of faithfulness of image reproduction. Such solid-state image devices are of interest in the conversion of invisible radiation, such as ultraviolet or x-rays, into visible images. The application to x-ray fluoroscopy is obvious; since the x-ray beam serves only as a control element while the power for the visible emission is supplied by the alternating voltage source, the brightness obtained may be many times that emitted if the x-rays were allowed to excite luminescence directly as in the case of a normal fluoroscopic screen. In the same manner, the output image controlled by a visible image may be many times brighter than the original so that a true "image amplifier" can be constructed.

The possibilities for electroluminescence as a lighting source alone are tremendous. Only a few of the promising applications have been mentioned here. As progress continues however, many other possibilities also loom for such devices. The future of electroluminescence may well extend into many areas not even foreseen today, if the remaining obstacles can be overcome. Based on the present rate of progress with this development, eventual success seems a matter of time.

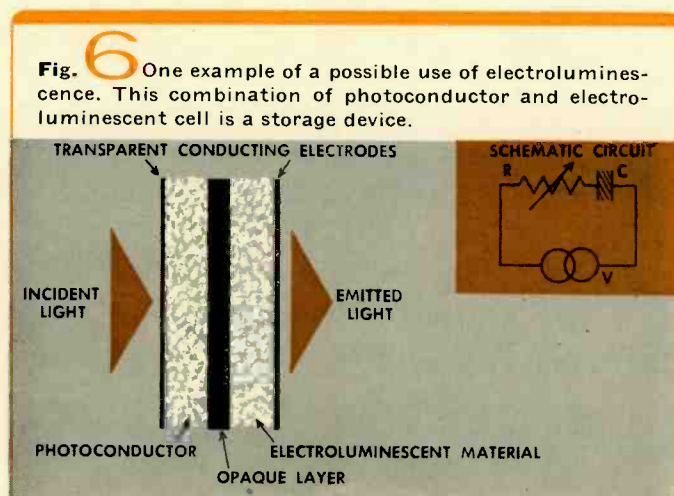

personality profiles

Harry F. Dart • T. R. Lawson, Jr. • W. R. Harris
Norris D. Gove • R. E. King • V. Janonis
A. M. Opsahl and N. K. Osmundsen • Henry F. Ivey

• **Harry F. Dart** has been working with electronic tubes since his graduation from Purdue with a BSEE in 1917. (In 1923, he obtained a professional degree in EE.) Fresh out of college, he helped give radio tubes their baptism of fire in World War I as a Signal Corps officer. Then after a three-year stint at teaching, which included Rice Institute and Harvard University, Dart joined the Westinghouse Lamp Company in 1922. At that time, three receiving tube types were in production, including the WD11 (one of the first dry battery radio receiving tubes). Continuously associated with tubes since these pioneering days, Dart has held many design and supervisory assignments in the engineering department, with a break of several years in commercial engineering. When the Electronic Tube Division was established in Elmira, N.Y. in 1952, Harry moved with the division and is now Patent Engineer. Hence, he is well qualified to describe recent advances in industrial tubes, which he does in this issue.

Dart is a senior member of the IRE and has served on many committees and held various section offices. He was elected a Regional Director in 1951 and 1952. He is also an active member of the AIEE. He holds Professional Engineer licenses in New Jersey and New York.

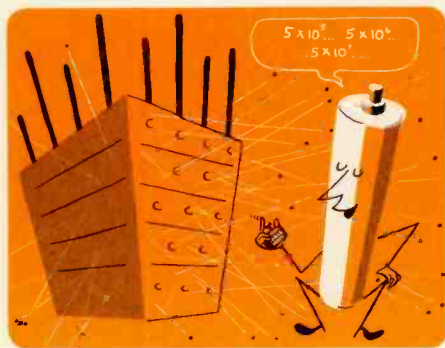

• We welcome back this month two authors who have appeared in previous issues. This is the second article for **T. R. Lawson, Jr.** of the Materials Engineering Department, who in 1954 wrote on the basic theory of semiconductors. For **W. R. Harris**, this is the fourth appearance, the first of which dates back to 1946. Harris is in an excellent position to keep up with industrial trends, since he is manager of the Industry Engineering Department, which deals with all types of industries.

• **Norris D. Gove** brought a nice new diploma from New Hampshire State College to South Philadelphia in 1920. Following the then customary training period in the shop assembly sections, he graduated into steam service work and spent the next few years in Philadelphia, New York, San Francisco, and Seattle. For the last 30 years he has been a turbine design engineer at South Philadelphia, working at first on

the industrial sizes and later on the largest central station units. Some of these for short periods were the largest of their kind, until he helped displace them with newer and still larger machines. He is presently Supervisory Engineer of the large turbine apparatus section.

Although Gove loves his work, he admits that he never thinks of turbines when he is looking along the sights of a pistol. He refuses to be called a champion pistol shooter, but he captains a successful team and is continually training new recruits.

• As it often happens, **R. E. King's** choice of an electrical engineering career was partly based on his military service. An Air Force cryptographer in the China-Burma-India theater, King's exposure to communications and electronics interested him in things electrical. Upon release from the service in 1946, he obtained a BA in physics from Wooster College, Wooster, Ohio (his home town) in 1950 and a BSEE from Massachusetts Institute of Technology in 1952. He promptly came on the Westinghouse Graduate Student Program, and never left his first engineering assignment in what is now the Aircraft Equipment Department at Lima, Ohio. He was in the aviation control section working with automatic paralleling systems and control panels until 1955, when he became a charter member of the transformer-rectifier section (now electrical conversion section). Here he helped design the new silicon TR unit, of which he writes in this issue.

Vytautas Janonis, who joins King in co-authoring the article on the new TR unit, helped design the magnetic amplifiers for the unit. "Vito" was born in Lithuania and came to this country in 1949. Upon graduation from Northeastern University, Massachusetts, with a BSEE in 1955, he joined the Westinghouse Director Systems Department. His main line of interest materialized in magnetic amplifiers. One of his first projects was the design of a TR magnetic amplifier unit for the Lima Aircraft Equipment Department. He is presently in the magnetic amplifier engineering section in customer order development.

• Except for a two-year stretch during World War II, **A. M. Opsahl** has been working with lightning since joining Westinghouse in 1925. Opsahl graduated from Luther College, Iowa in 1924, and after a year of teaching at Luther, came with the Company engineering laboratories in East Pittsburgh. Here, he was introduced to his future career through experimental work with artificial and natural lightning. In 1929, he began designing and applying lightning arresters. He took a brief holiday from lightning when he worked on the design and production of equipment for processing uranium during the war, but soon returned to lightning arresters.

A Fellow of AIEE, Opsahl—logically enough

—is active in the lightning field. He is vice-chairman of the Protective Devices Committee, and has participated in standardizing meetings with this committee since 1927. His love, or possibly respect, for lightning even laps over into his hobbies. An avid camera fan, he spends considerable time photographing—you guessed it—lightning.

N. K. Osmundsen, who co-authors the article on Autovalve lightning arresters with Opsahl, started with Westinghouse on the Graduate Student Course in 1946. A graduate of Carnegie Institute of Technology, with a BSME, Osmundsen's first job was in the plating and plastic section of the Feeder and Service division. Here he worked at time study, material handling, and layout and cost analysis of plastic operations. In 1950, he switched to manufacturing engineering in that division, to work in the plastic development laboratory on molding, finishing, and cost reduction.

Two years later, when the lightning-arrester section needed a designer to help with the non-linear valve element, Osmundsen entered the lightning arrester field.

Osmundsen obtained his MS in General Engineering from the University of Pittsburgh in 1949, and is presently enrolled in the Business and Management Program at Pitt.

• **Henry F. Ivey** has been concerned with phosphors of one kind or another for much of the time since he left college. After he obtained his AB degree from the University of Georgia in 1940—major in physics, minor in math—he went on to obtain his master's degree at the same school. He then went to Massachusetts Institute of Technology, as a teaching fellow in physics. From 1942 to 1945 he was a member of



the Radiation Laboratory at MIT, and during that time earned his PhD from that school. Here he first delved into the subject of phosphors, working on cathode-ray tube screens for radar. After leaving MIT he worked for a radio-television company for one year, again on phosphor problems. In 1945 he joined the Westinghouse Lamp Division's Research Department and from that time until 1952 was engaged in research on thermionic emission and electron space-charge problems. In 1953 he was placed in charge of the phosphor physics group, which was chiefly concerned with electroluminescence. In 1956 he was given responsibility for the entire Phosphor Section which is interested in photoluminescence and cathodoluminescence as well.

Ivey is a member of the American Physical Society, the Electrochemical Society, and the IRE. He was invited to present the keynote speech at the Luminescence Symposium held by the Electrochemical Society this month.



new jet engine alloy

A new high-strength, high-temperature alloy for use in jet engines is now being made on a pilot plant scale at the metals manufacturing plant at Blairsville, Pa. Developed by scientists at the materials engineering department, the new metal, called W545, promises to permit higher operating temperatures for jet engines with a corresponding increase in the speed of supersonic jet aircraft.