

WESTINGHOUSE

# Engineer



MAY 1950

# Time—A Product Raw Material

American-engineered products are good products. Seldom does a new device or machine get as far as commercial use and then fall completely flat. Even first editions of new apparatus are expected to have few basic troubles and the minimum of “bugs.” The percentages of success read more like baseball fielding averages than batting averages.



The story on the engineering development laboratory that features this issue suggests the reason for the general excellence of new equipment when it reaches the general market—the long road over which a device must travel before it becomes a production-line item. The pathway, often wholly or in part beginning with research, through materials testing, component testing, prototypes, performance and life testing, field trials, pilot-plant production, and experimental use, is a rigorous one.

This makes it clear, too, why new machines, like Rome, are not built in a day. The development period, which may be as short as a year but usually is several years, is an essential part of the engineer’s orderly program.



Several examples of this can be observed in the variety of topics in this issue. In 1943, an enterprising young electrochemical engineer—George Jernstedt—was in charge of electroplating activities at the Westinghouse Meter Division. An impatient youth, he was irked by the time consumed for the plating of magnets and other objects. He explored various ways of speeding up the process—and he arrived at the periodic reverse current plating method. The principle was announced about four years ago, but only now can it be said (see p. 139) to be in full scale use—such was the time necessary to develop it for commercial service.



Infrequently—but it does happen—development spans decades. The rectifier locomotive, announced on the adjoining page, had its origin at Westinghouse some 40 years ago, but for success had to wait for

ignitron-rectifier developments of the past decade.



Consumers profit from the development period in two ways. In the first place the large, experienced manufacturer gives appliances that are to be made by the thousands exceptionally thorough field trials before stepping up manufacturing lines to full production. Usually this means that, after exhaustive laboratory testing is completed, pilot-line models of a new product are placed in representative homes for actual in-use service. This is a final insurance that tens of thousands of buyers will not be “stuck” with a basically faulty product. Also, this period permits the development of tools and creation of manufacturing setups that permit the item to be made at the lowest possible cost. Competition sees to this, but it does mean production-line appliances of lower cost to the consumer—a condition for which American industry is famous. The new dishwasher discussed on page 154 for several years underwent laboratory development.



Development can be hurried but it is wasteful and costly. Premier example of this is atomic energy. Although it remained an idea since 1906, when Einstein made his mass-energy announcement, development really began in 1939. Under the enormous pressure of war, it was brought to “commercial” form in 1945—but at a cost of two billion dollars, admittedly far more than would have been necessary if more orderly, step-by-step engineering development could have been pursued.



Time is an essential ingredient of all products. It is of different length in different cases. It cannot be too short. Also it cannot be too long, as development time is expensive and human interest cannot be too long maintained. Those experienced in guiding development work come to have a feeling—a sort of sixth sense—about development time. But in any case, time is a vital component of the handiwork of scientists and engineers.

VOLUME TEN

MAY, 1950

NUMBER THREE

On the Side

*The Cover:* An illustration that depicts the complete variety of laboratory apparatus and functions would look like a dime-store window. But artist Richard Marsh has captured the wide scope of the engineering laboratory, using as his central theme the dramatic six-foot spheres of a 3.6-million-volt lightning generator.

• • •

The success of the experimental rectifier multiple-unit car (mentioned in the November, 1949 issue) has been such that two road locomotives based on the ignitron principle are to be built.

Designed for freight service, these will be 122-foot, two-unit locomotives rated at 6000 hp continuously. Each will be powered by 12 d-c motors, which will be supplied through 24 ignitron tubes from the 11 000-volt, 25-cycle trolley. These freight locomotives will weigh 330 tons each, and will be capable of a maximum speed of 63 mph.

For the same number of axles, the rectifier locomotive will provide 47 percent more tractive effort than a locomotive with a-c series motors of about the same horsepower.

Other advantages for the rectifier locomotive are the use of d-c motors and improved power factor and efficiency. Compared to conventional diesel-electric freight locomotives, approximately 67 percent greater horsepower per axle will be provided.

The development of these locomotives is a joint program on the part of the Pennsylvania Railroad and Westinghouse.

The contents of the *Westinghouse ENGINEER* are analyzed and indexed in the INDUSTRIAL ARTS INDEX.

In This Issue

THE ROLE OF THE ENGINEERING LABORATORIES.....130

NUCLEAR REACTIONS OF LIGHT ELEMENTS.....138

BRIGHTER FINISHES VIA PR PLATING.....139  
*George W. Jernstedt*

THE *Essays*—DREDGE EXTRAORDINARY.....144

AN AMPLIFIER FOR MAGNETIC OSCILLOGRAPHS.....146  
*C. J. Tirk*

LIGHTNING ARRESTER—ELECTRICAL PROTECTOR.....148  
*Edward Beck*

WHAT'S NEW!.....153  
Rototrol for dredge—Transformer book—Precipitron in textile mill—  
Slipsyn motor starter—New Life-Linestarter—Stoplight for school buses—  
Automatic defrosting refrigerator—Toss-away bags—New electric range—  
Rigid-mount washer—Automatic dishwasher—Network calculator.

GRAPHICAL STATISTICS—AN ENGINEERING APPROACH.....157  
*L. R. Hill and P. L. Schmidt*

Editor

CHARLES A. SCARLOTT

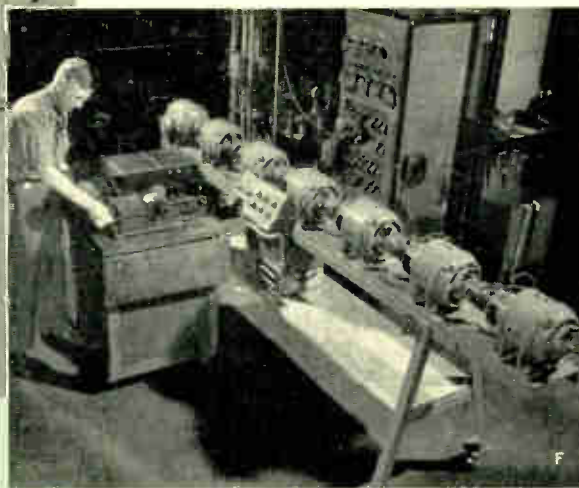
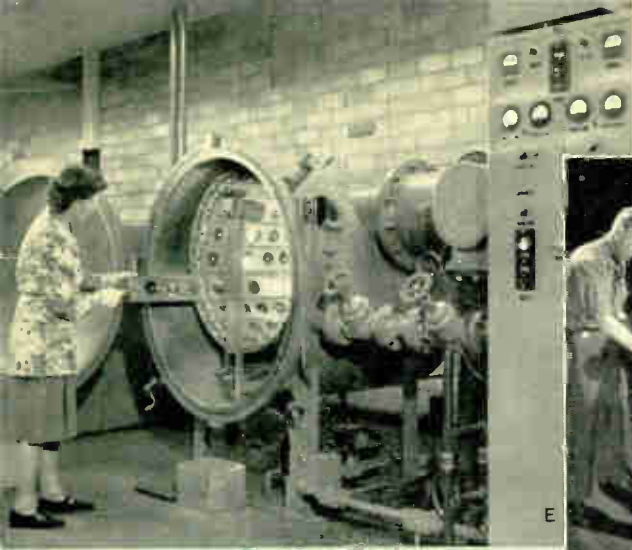
Editorial Advisers

R. C. BERGVALL  
T. FORT

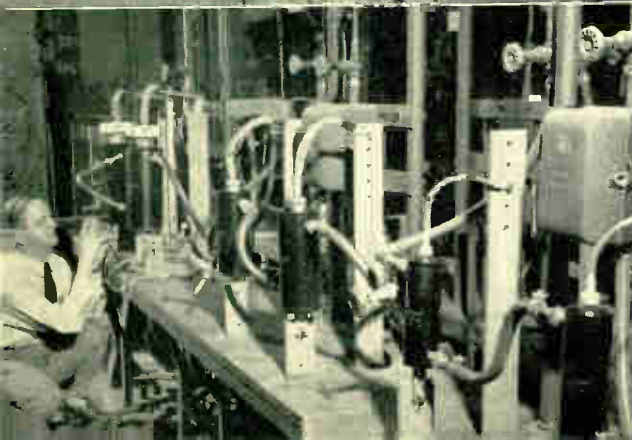
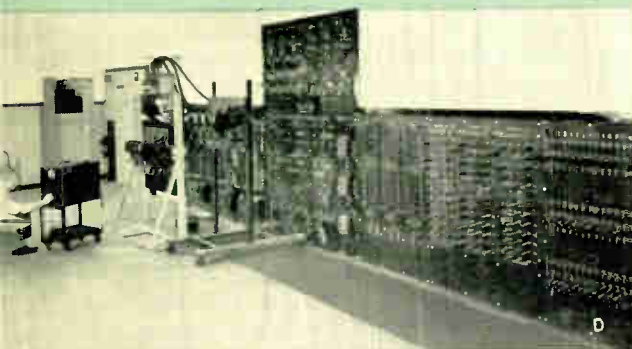
The *Westinghouse ENGINEER* is issued six times a year by the Westinghouse Electric Corporation. Dates of publication are January, March, May, July, September, and November. The annual subscription price in the United States and its possessions is \$2.00; in Canada, \$2.50; and in other countries, \$2.25. Price of a single copy is 35c. Address all communications to the *Westinghouse ENGINEER*, 306 Fourth Ave., P.O. Box 1017, Pittsburgh (30), Pennsylvania.

THE WESTINGHOUSE ENGINEER IS PRINTED IN THE UNITED STATES BY THE LAKESIDE PRESS, CHICAGO, ILLINOIS

University of Southern California Library



**C**—Tests of lubricants in sealed bearings at different temperatures and loads have been going on here for years. **D**—Development of new a-c contactors requires an imposing array of power and load facilities. **E**—Where better disc rectifiers are born. **F**—Rotating regulators are tailored to provide a precise set of characteristics. Here the performance of a six-element Rototrol gets an oscillographic check. **G**—One Industrial Electronics laboratory deals with improved power-line communications equipments.

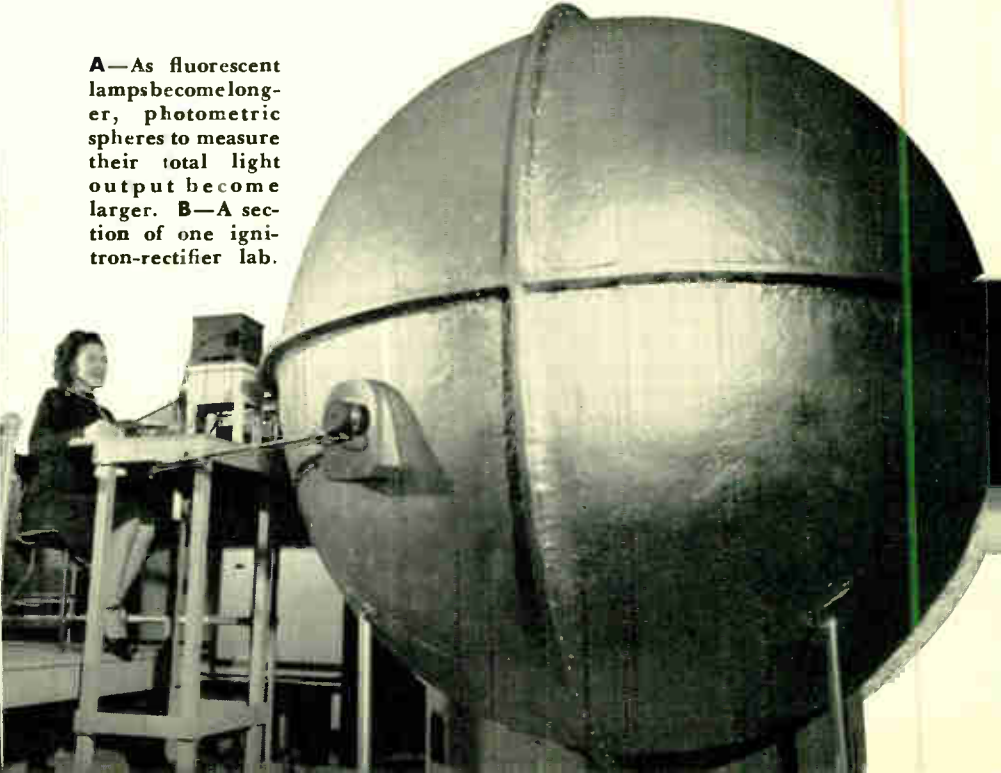


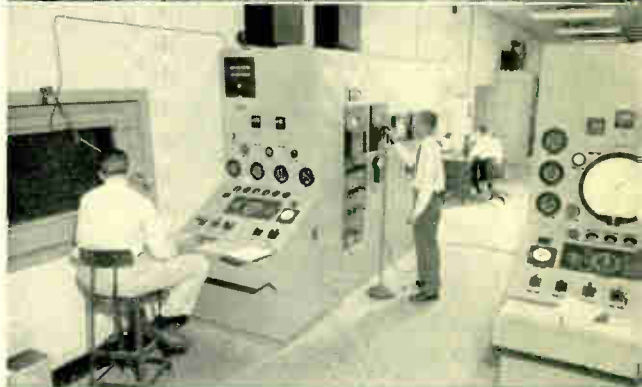
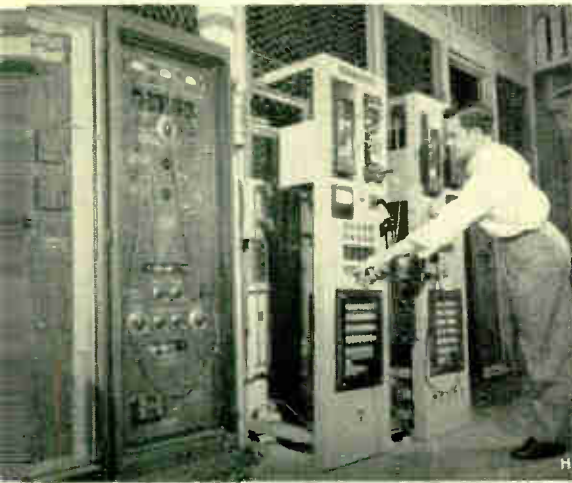
## THE ROLE OF THE

THE PATH that a new device must traverse from concept to use is a long one, with many hurdles. Along this route it has a steady, little-noticed companion—the engineering laboratory. In fact, the product development laboratory is one of the most vital, but least recognized, ingredients in engineering progress.

One reason for the comparative obscurity, perhaps, is that the work of the research departments, which are separate and distinct from the engineering laboratory, is generally more conspicuous and often more spectacular. The work done in the engineering laboratory is seldom glamorous. Also, there is another factor. Engineering development becomes so intimately associated with a new or improved device—through various stages of its design, prototype models, final production, shipment, application, and even finally for analysis of any service difficulties—that it serves a variety of functions and assumes many different physical forms. The laboratory often even loses its physical identity and merges with raw-material inspection, production-line quality control, inspection or performance testing. Or, the development lab may leave the manufacturing center altogether. It may take up a position on

**A**—As fluorescent lamps become longer, photometric spheres to measure their total light output become larger. **B**—A section of one ignition-rectifier lab.





# ENGINEERING

# LABORATORIES

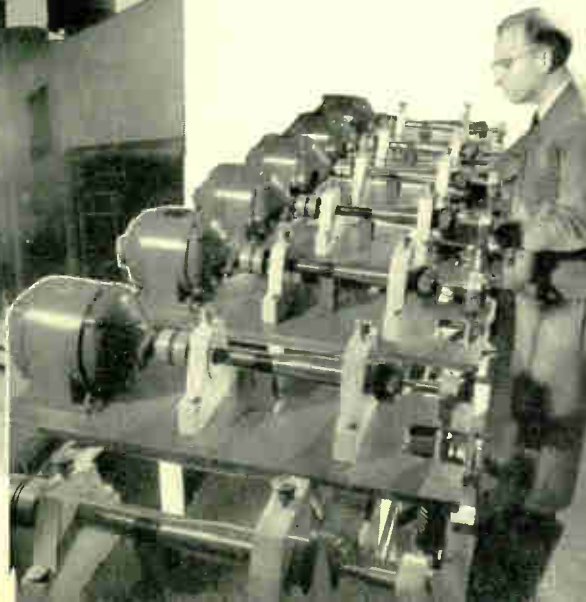
a mountain top for jet-engine icing studies, or an actual but experimental transmission line for study of corona, or at a nearby lake for underwater ordnance development.

What is an engineering-development laboratory? In a company that manufactures many thousands of kinds of products—from grain-of-wheat lamps to hugesteam turbines—no succinct definition can be given. Not even a rigorous count can be made, but by any definition the engineering laboratories for the some two dozen Westinghouse plants where products are engineered approach 200.

In a typical product plant—if there were such a thing—the complement of engineering development laboratories adds up about like this. Among the several laboratories will be one devoted to chemical and one to physical analysis (at least one of each, perhaps more).



**N**—Fatigue machines provide essential data for turbine designers. **O**—Giant arcs provide the best laboratory shows.



**H**—Relay engineers try new carrier apparatus on two 30-mile artificial lines. **I**—An electric typewriter automatically records a temperature reading on a refrigerator every 2.5 seconds. **J**—An operator puts a new jet engine through its paces. **K**—As a hassock-type fan is slowly turned its output in all directions is integrated. **L**—Control room of a jet laboratory operated for the U. S. Navy. **M**—Aircraft generators are given through performance and life trials.



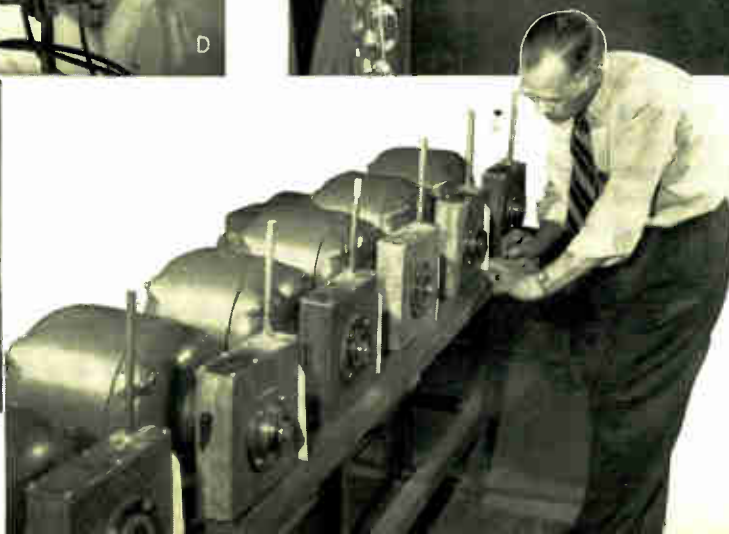
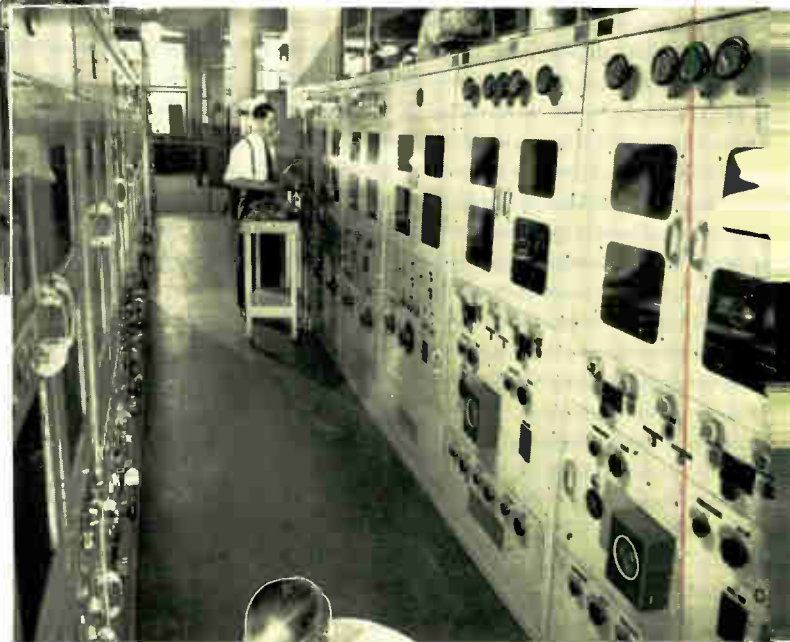
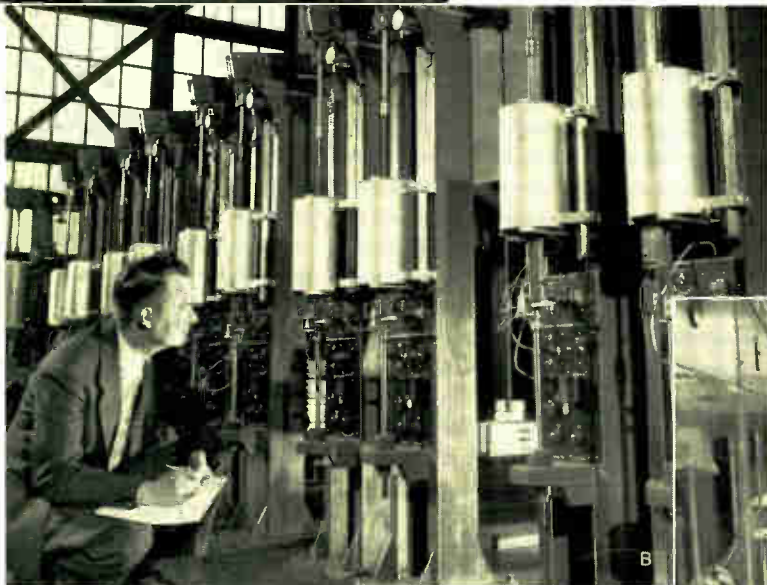


In addition to these two basic laboratories the "average" manufacturing center contains several specialized product development labs, usually one for each distinct kind of product manufactured. Also available are one or more model shops where prototypes are built, possibly one or more pilot plants depending on the nature of the products and the quantities in which they are to be produced. All these, be it understood, are in addition to research facilities.

Then, like as not, there are certain satellite laboratories, with various degrees of detachment from the strictly engineering lab setup. These may be metallographic, x-ray, noise, materials-testing, performance-testing facilities, sometimes used jointly with purchasing or production departments. The findings of shop quality-control laboratories are carried back to designers and have a bearing on product development. Sometimes, even, because of the nature and expense of manufacturing setups, prototypes are developed on normal-production facilities. Turbines for example.

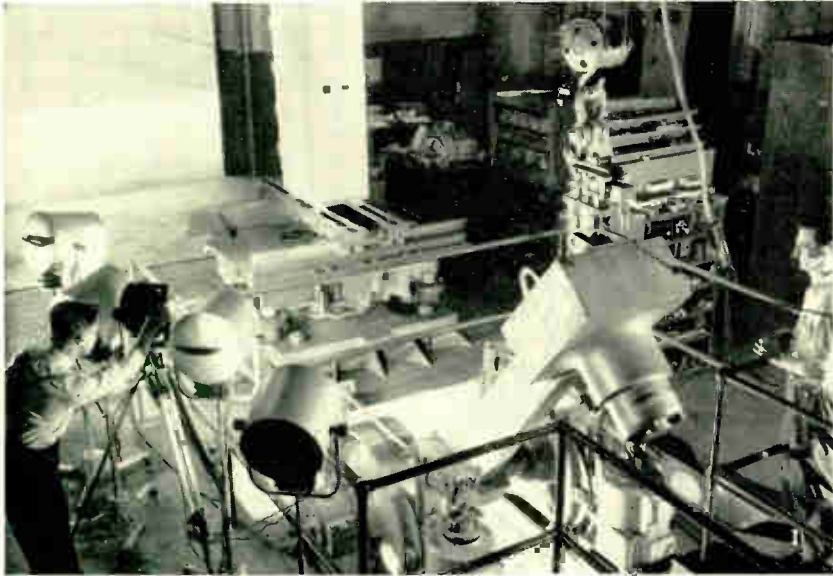
## -TO SIMULATE NATURE

Nature imposes many severe ordeals on man's devices. These two pages show but a few of many laboratory duplications of the facets of nature. **A and B**—Temperatures, in two extremes, are illustrated: the effect of cold on a switch and of heat (creep) on turbine materials. **C**—Time is an important quality and here vacuum tubes are receiving life tests. **D**—"Sunshine" from arc lamps with intervals of "rain" are being imposed on panels of different finishes for transformer cases.



**E**—High winds are provided in several locations. This one is an atmospheric tunnel for turbine-blade studies. **F**—Dusts of different kinds are contained in the housings around pre-lubricated, sealed motor bearings.

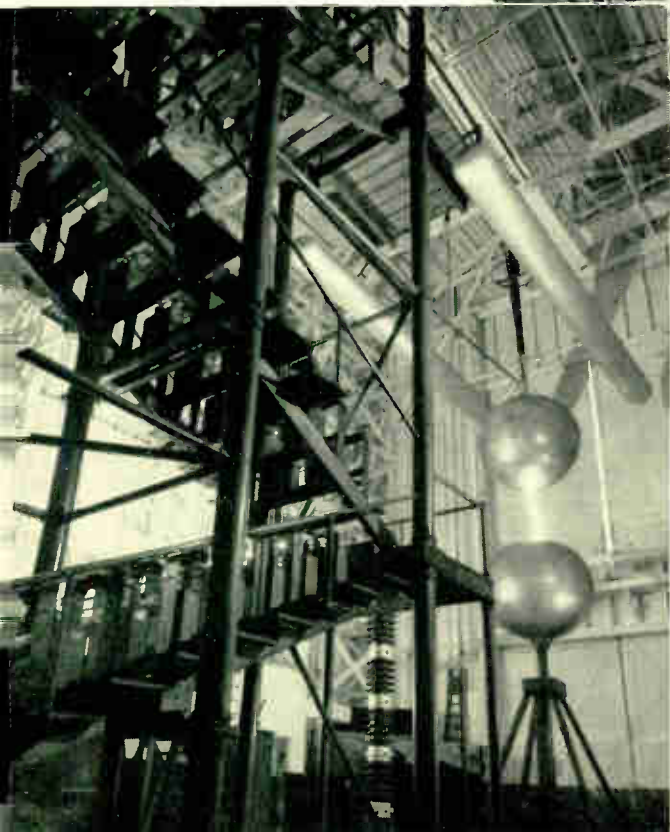
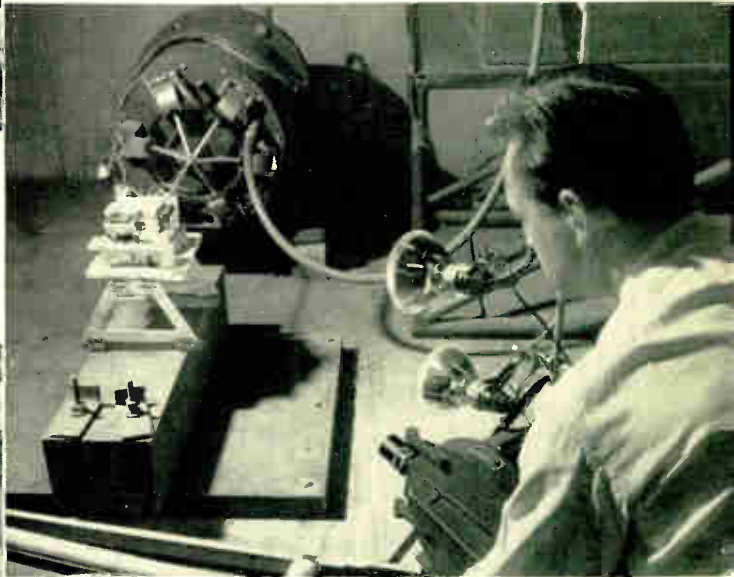
**G**—Rain is easy to duplicate, as is here being done on a new street-light fixture. **H**—Sea air, fine for humans, plays havoc with machines. Salt-atmosphere cabinets are standard equipment at most plants, as at the one making aircraft electrical apparatus.



**K**—Acid and alkali conditions are duplicated at the transformer plant with a device that dips panels with different finishes into and out of test baths at intervals. The effect of years of exposure to the weather can be ascertained in short order.



**I**—Earthquakes, as it were, are reproduced on shock stands. What happens to switchgear when struck with an 18 000-pound-foot blow is being recorded by high-speed cameras. **J**—Vibration, at controlled frequencies and amplitudes, is being applied to an aircraft generator control assembly.



**L**—Lightning strokes of different kinds and sizes must be had at will. This is the 3.6 million-volt generator used for transformer development. **M**—Fungus is a problem in humid regions. The young lady is growing fungi for tests of finishes.





## —TO SIMULATE HUMAN USE

**A**—Engineers learn how many “bangings” a Laundromat door will take. **B**—The “drawing power” of a tank-type cleaner is tested. **C**—Strength of washed fabric is measured.

**G**—In eight miniature washing machines different detergents are studied under all conditions.



**H**—Electric-range elements must be able to take the ordeal of cold, corrosive liquids. Here, measured quantities of cold salt water are poured on hot cooking elements. **I**—In the quiet room, a refrigerator proves that it will not create noise.

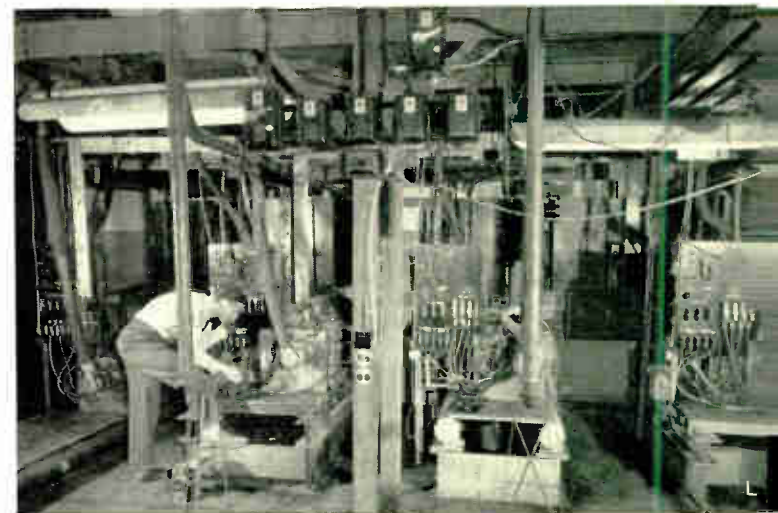


Engineers associated with specific apparatus have, within a few yards from their desks, all the laboratory facilities normally required for those particular products. In addition, they have access to extensive facilities maintained at a central location for unusual requirements or for development work basic to all products. Such facilities are too costly for a single plant but can be provided by a large engineering organization. Thus at East Pittsburgh are maintained 36 separate and distinct headquarters' laboratories divided between general and material development.

Enumeration of the principal ones serves to illustrate the broad scope of the centralized-laboratory activity. Among the general facilities are two rectifier laboratories (one for pumped, one for sealed units), two shock stands (for different sizes of apparatus), separate labs for development of railway apparatus, capacitors, and electroplating techniques. Three separate and dissimilar facilities are devoted to circuit-interruption: the famous and world's largest a-c contactor laboratory, one for smaller a-c contactor investigation, and one for improvement of d-c switching. Several lightning or surge generators are available, one for three-million volts. Others include those for stability studies, an oscillographic center, and one for radio-influence work.

Many engineering laboratories carry on the development of new materials, some of which had their beginnings in research. These include laboratories for development or pilot-plant production of powdered metals, precision castings, heat

(Cont'd. on p. 136)





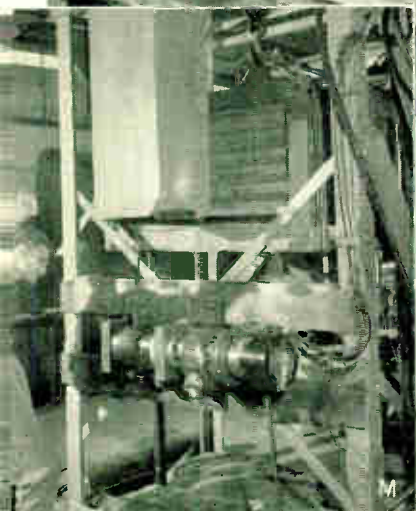
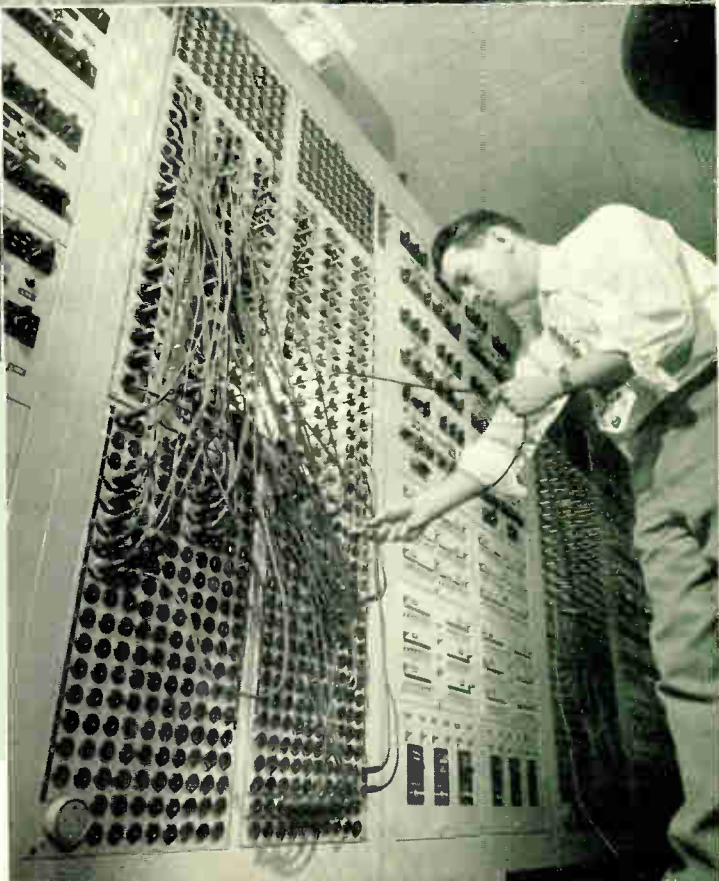
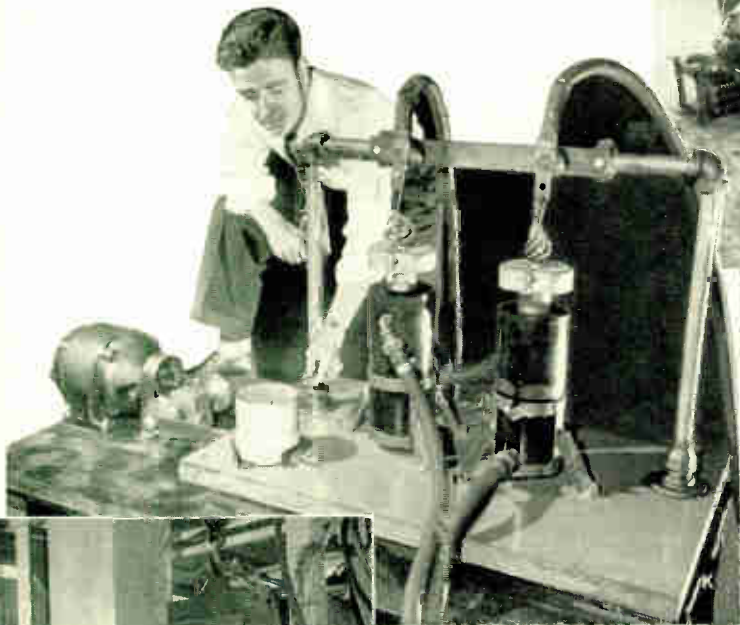
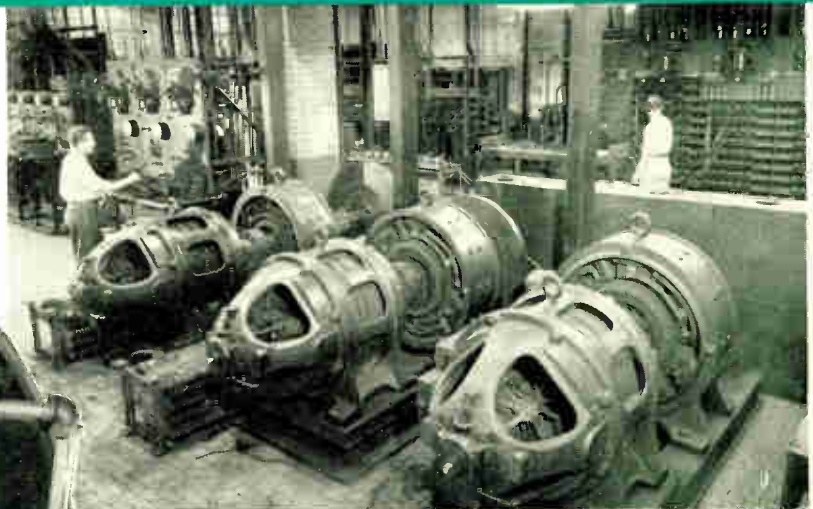


**D**—Tattle-tale grey concerns laundry-equipment designers. A reflectometer checks fabric whiteness.

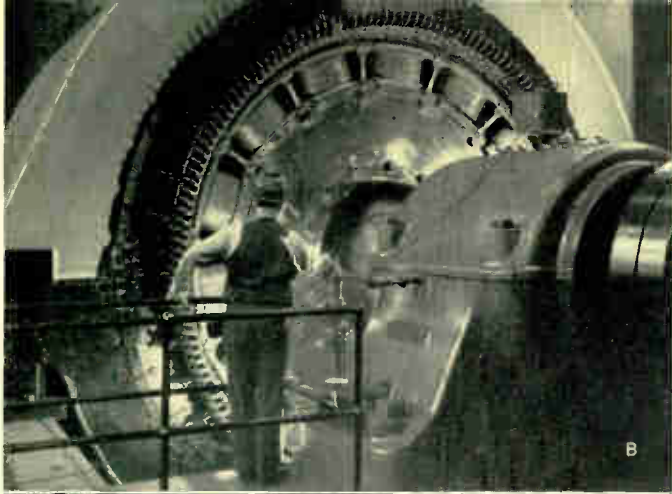
**E**—To test washing techniques, fabric must be made dirty. Here is the machine that soils cloth. **F**—Asbestos shavings and heavy oil simulate stiff cake batter.

## -TO SIMULATE APPLICATIONS

**J**—The flywheel motor-generator sets and panels in the rear with capacitors provide an artificial transmission line for stability studies. **K**—This device is a locomotive, or so it appears to the mercury-arc rectifiers given a shake test to determine their action in rail service.



**L**—A four-engine airplane is duplicated on the ground to give thorough trials to new electrical-power systems. **M**—Airplane loading is simulated for this cargo hoist, such as used on the Berlin air lift. **N**—On the analog computer almost any mechanical, electrical, thermal, or hydraulic situation can be duplicated and fully analyzed.



B



C

A catalog of specialized apparatus in the nearly 200 Westinghouse laboratories would include almost every known test device and many truly unique. This page shows but a few diverse ones. **A**—A sound-proof room in which transformers are tested for noise. **B**—One of the high-current generators at headquarters, and **C**—Special equipment for testing properties of transformer steel.



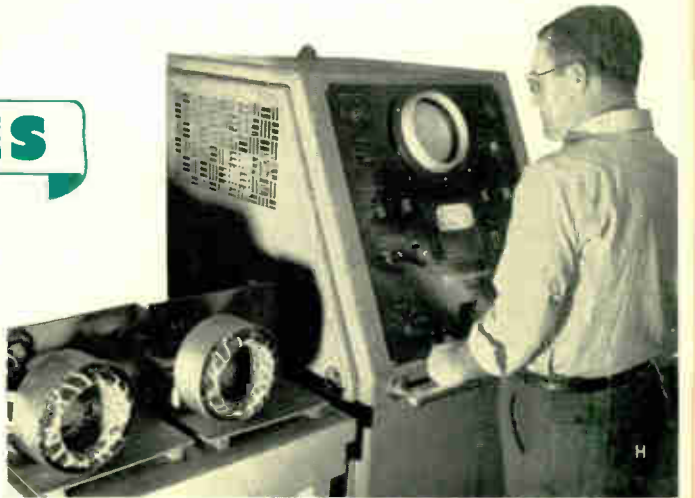
A

treatments, lubrication, paints, synthetic resins, and wire insulations, backed up by chemical and physical laboratories. The variety of type and function of the engineering laboratory is told here with photographs that illustrate but a few of the many different laboratories. They are grouped, for interest sake, into arbitrary and somewhat overlapping categories. They suggest that standing behind the production lines of a large engineering company are laboratory facilities surprising in number and remarkable in variety.

**-TO PROVIDE SPECIAL TEST FACILITIES**



D



H

**E**—Beside the engineer is a frequency standard accurate to 0.01 part per million. **F**—Many rooms isolate noise, high frequency, x-rays, or nuclear radiation. This is a radio-noise room.



E

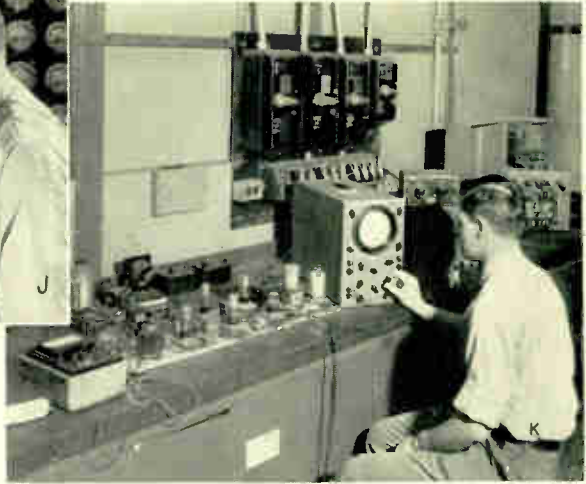
**D**—Metallographic camera for analysis of turbine alloys.



G

**G**—"Torture" chamber where electronics are tried at high altitudes and a range of temperatures and humidities. **H**—Small-motor circuits are investigated by a surge comparator.





I—A synthetic-resin pilot plant. J—Detailed analyses of production models of meters aid the development engineer.

## -TO ACCOMPANY PRODUCT

## FROM CONCEPT TO SERVICE



K—Some products, like electronic control, can be developed as readily on the breadboard as on the drafting board. L—Manufacturing engineers also have laboratories for creating better ways of making things—such as better cutting methods. M—In the appliance shipability laboratory the product and its container as a unit are given preshipment trials.

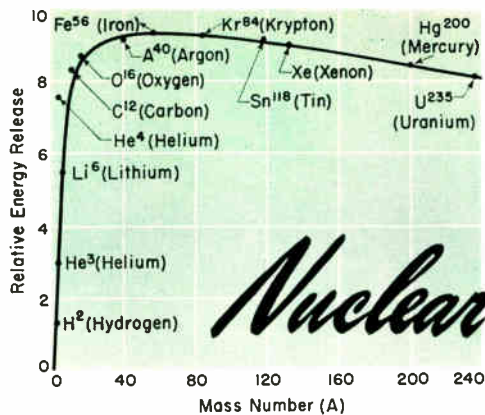


Product-development laboratories differ widely in physical form because they have such diverse functions. Some are shown here. Others include model shops, materials labs, and many entirely outside the factories, for example, an airplane, or a skyscraper elevator shaft.



N—Cooperating with the armed forces, Mt. Washington becomes a jet-engine icing lab. O—A city street is a lab for lighting studies. P—Uses of standard products, such as r-f heating, need laboratory study.



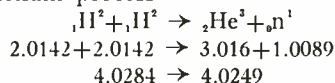


That energy is released on the synthesis or fusion of light elements, as well as by fission of heavy ones, has long been known. This was mentioned in the Smythe Report in 1945 and in several articles of the nuclear-principles series in the *Westinghouse ENGINEER* for Nov., 1945; March, July, and Nov., 1946; May, 1947; March, 1948. This addition to the series is by Richard W. Dodge, Assistant Editor.

# Nuclear Reactions of Light Elements

THE TREMENDOUS and awe-inspiring success of the first atomic bomb in 1945 highlighted a theory of large-scale energy production that had long been deemed possible—the “chain reaction” fission of heavy elements, such as uranium. But in the excitement and widespread discussion that followed this spectacular demonstration, another theoretically promising reaction for releasing nuclear energy—the “fusion,” or combining of lighter elements to form a heavier element—was temporarily obscured.

Actually, weight for weight, the fusion process can release more energy than the fission of uranium. For example, when two deuterium nuclei (heavy hydrogen—one proton, one neutron) are combined to form helium—as has often been accomplished by the bombardment of heavy water with deuterons—a definite mass is “lost,” being converted to energy according to Einstein’s theory that  $E=mc^2$  (where  $E$  is the energy in ergs,  $m$  the mass in grams, and  $c$  the speed of light in cm per second). This mass difference is illustrated by the deuterium-to-helium process:



The net mass defect, or loss, in this case 0.0035 mass units, is equal to energy of about 3.26 million electron volts, or  $5.23 \times 10^{-6}$  ergs. When a uranium nucleus is broken into two approximately equal fragments, about 200 million electron volts are released; but although the energy release per individual reaction is greater than for deuterium fusion, for equal weights of material it is about half as great, since uranium has a mass over 100 times that of deuterium.

Why, then, did not scientists concentrate their efforts on the fusion process, instead of on fission? The answer is largely wrapped up in the fact that the bombardment process, using such tools as the cyclotron, accomplishes only random fission or fusion of elements, insufficient in number to release large amounts of energy. But in the case of uranium, scientists discovered that when its nucleus split, a high-energy free neutron was produced, which in turn caused other nuclei to divide, releasing more neutrons—so that a chain reaction was instituted.

Fundamentally the problem of fusing particles by thermonuclear reaction is much the same as accomplishing the same thing in an atom smasher. Particles must reach sufficient velocity to overcome the natural repellent force of their similar charges. In the thermal process, heat accomplishes the same objective as a particle accelerator, i.e., it increases particle velocity. As the temperature increases, the movement of particles becomes much more rapid, and eventually, at the right temperature, they reach sufficient velocity to overcome the natural electric repellent force between them, and collide. This does not happen all at once, i.e., all the particles do not suddenly begin to react with others at a certain definite temperature. In any group of particles some are abnormally fast, and these combine sooner than others. As a result there is a gradual increase in the number of individual reactions, which

rises very rapidly as extremely high temperatures in the millions are reached. For example, at 800 000 degrees K in the deuterium-to-helium reaction, a gram of highly compressed material releases about 400 watts of energy (100 calories per second); at a little over a million degrees the energy liberation approaches 4000 kw; at higher temperatures the energy release is so sudden that it becomes an explosion.

The creation of such temperatures, even momentarily, seemed an insurmountable obstacle ten years ago. The perfection of the atom bomb, however, suggested a solution. At the peak of its reaction, sufficient temperature is reached momentarily to “trigger” a fusion reaction. Possibly in this brief span sufficient hydrogen or other nuclei would combine to produce a second and even greater energy release, thus maintaining the high temperature necessary to sustain the fusion reaction momentarily.

The amount of energy realized from the combination of nuclei depends directly on what elements are “packed,” or combined and what element is the result, as well as on the temperature. Theoretically the largest energy release would accompany the packing of hydrogen into iron (see curve). At present, however, no means of accomplishing this is evident, and likely the first attempts will be made to pack hydrogen, or one of its isotopes (deuterium, tritium), into helium or lithium, which would yield almost as much energy.

Almost any reaction is possible in theory, although some seem highly unlikely from a practical standpoint. All elements in the periodic table are in a metastable state, with those in the upper half, i.e., of greater weight, more susceptible to fission, those in the lower half more easily persuaded to combine. Those near the extremes of the table, the lightest and the heaviest, are most susceptible to transmutation, while those approximately in the center of the table are the most stable. Thus uranium is one of the most suitable fission materials, while hydrogen or one of its isotopes is best adapted to fusion.

At present, no practical means of utilizing the energy of fusion for peaceful use is apparent, partially because of the absence of a suitable container for the reaction. The melting points of all known materials are insignificant figures beside the temperatures needed to sustain a “nuclear burning” fusion reaction. Even tungsten melts at 3370 degrees C, and boils at about 5900 degrees. That the reaction itself is possible, however, is indicated by the sun, in which hydrogen is transformed to helium in a series of nuclear processes. The temperature at the center of the sun, however, is estimated at 20 million degrees C—well beyond the limits of the imagination, as well as those of practicality!

Thus although a “one-shot” reaction in the form of a sudden and almost instantaneous energy release seems possible, a sustained fusion process is impractical, at least based on present knowledge. However, the realization that only a decade or so ago large-scale energy production from fission seemed equally impractical is encouraging. Given time, science may also succeed in untying this even more knotty problem.

# Brighter Finishes via *PR Plating*

Bright plating has been the problem child of electroplaters. Its processes were either so complex or so perverse that many a manufacturer preferred to settle for less bright plating and then buff the surfaces. Periodic-reverse-current plating, plus a new addition agent, is now helping to solve this problem in many applications.

GEORGE W. JERNSTEDT, *Manager, Electroplating Projects, Westinghouse Electric Corporation, East Pittsburgh, Pennsylvania*

**B**RIGHT electroplating has always been a headache to manufacturers despite the brilliance and pleasing appearance it gives their products. More often than not a bright-plating process that works well in the laboratory is less successful in the production line. Quality is not uniform, and the more rapidly the process is operated, the greater the need for buffing and polishing. If the processes are slowed down, a production bottleneck is formed, and even then buffing is often required. Periodic-reverse-current (PR) electroplating\* plus a new inorganic addition agent called Wes-X\*\* seems well on its way to solving these and many other problems associated with bright copper plating.

In electroplating, addition agents act somewhat like vitamins in the human body. In general, their composition is roughly similar, in that vitamins and addition agents are both composed of carbon, hydrogen, nitrogen, and sulphur atoms. Organic addition agents are typified by compounds such as saccharin and nickel naphthalene trisulphonate. These compounds in plating solutions, like vitamins in the human body, have startling effects in minute concentrations, and, therefore, are generally known as addition agents since they consist of such a small portion of the plating bath. Their concentration is generally from 0.01 to 0.5 ounce per gallon.

A serious disadvantage of organic addition agents is that they are susceptible to decomposition by electrolytic oxidation or reduction, and the decomposition products quite frequently are detrimental to the plating bath. When these decomposition products build up in a solution, the bath must be treated with activated carbon, which selectively removes both

the decomposition product and a portion of the original organic addition agent. However, in many cases the decomposition products are not removed by activated carbon, and control of the plating process becomes difficult.

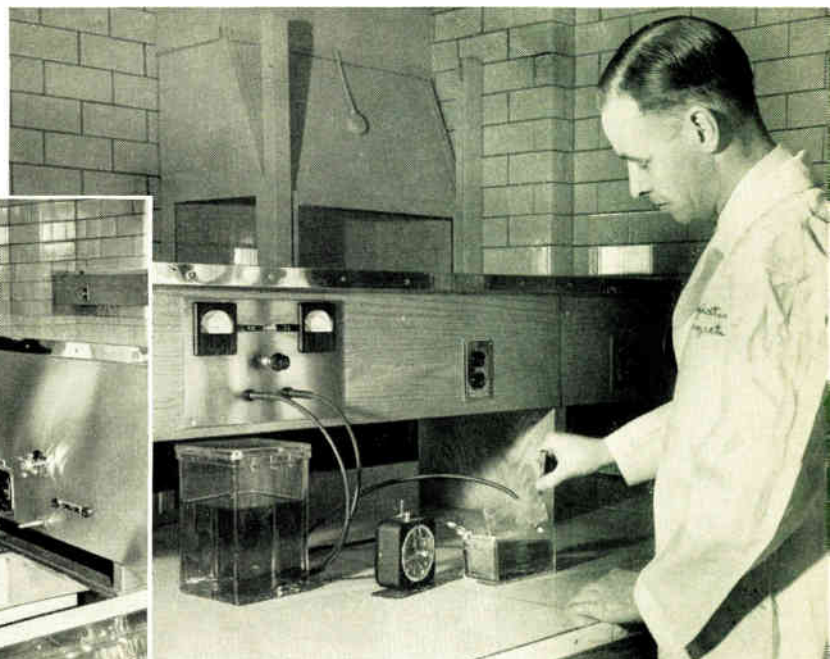
Recently a new type of addition agent—a metallic inorganic compound—has been developed for the production of bright copper plate. The material is not susceptible to detrimental decomposition products and is not affected by activated carbon. As a result, the solutions can be continually treated with activated carbon to remove extraneous organic material, thereby maintaining a high-quality solution even under heavy production schedules. This agent, plus the PR-plating process, makes possible full bright copper plate and in many cases totally eliminates buffing. In the automotive field, buffing costs for high luster finishes average as high as 70 percent of the total finishing cost. Thus this new plating process is of vital importance.

The various aspects of the new process have been carefully explored in the laboratory, and a great many tests made over a wide range of variables—temperature, solution composition, agitation, anode corrosion, and the many other items involved in the electroplating process. Initial investigations were in a Hull cell (Fig. 1), which enables a single plating test to give results over a range of current densities from 10 to 300 amperes per square foot; then tests were moved to four-gallon tanks (Fig. 2) to get a better picture of the plating of irregu-

\*See "PR Plating—A New Tool for Electroplaters," *Westinghouse ENGINEER*, May, 1947, pp. 89-92.

\*\*Wes-X (Trademark) metallic, inorganic, cyanide copper electroplating addition agent.

Fig. 1 (far right) shows the Hull cell, in which initial investigations on the PR process were made. Fig. 2 contains the four-gallon tanks used in the second stage of development.



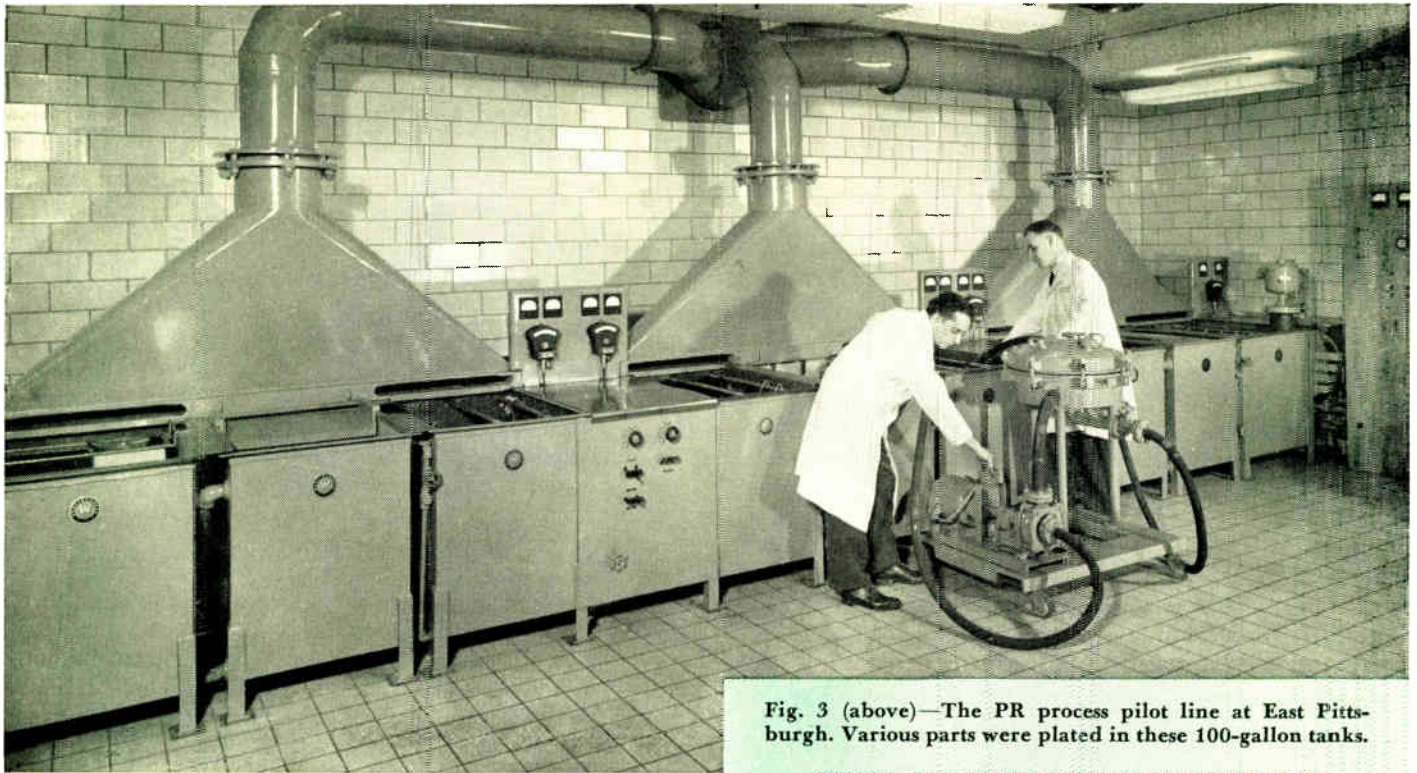


Fig. 3 (above)—The PR process pilot line at East Pittsburgh. Various parts were plated in these 100-gallon tanks.

larly shaped objects. Finally a pilot line (Fig. 3) was set up. This consisted of 100-gallon tanks where standard parts from appliance divisions and automotive plants were plated to determine whether specifications could be met. After pilot-line operation, the process was applied to several large production lines with outstanding results; it is now ready for widespread commercial application. In less than nine months, over 50 000 pounds of the material (Wes-X) have been manufactured and it is now a standard item of production. \*

#### PR-Current Process

The PR-plating process consists essentially of periodically reversing the d-c plating current for a definite time interval. By repeating this operation, the plate becomes smoother, and metal of higher quality is deposited. Normally, with conventional direct current, electrodeposits become progressively more nodular, i.e., the crystalline structure becomes larger. By reversing the current, the crystal growth is interrupted, and when current is reapplied in the plating direction new crystals commence to form, the result being the all-over fine grain structure characteristic of "as plated" bright deposits.

Due to a phenomenon known as polarization, when metal is removed the net result of reversing the current is a more level and uniform deposit over the whole plated part. With normally applied direct current, the edges and outer extremities on any particular part generally build up from 50 to 100 percent greater coating thickness than the more recessed or inner portions. In PR plating, when the current is reversed more metal is stripped off the outer edges and protruding areas. As a result, a piece such as a bumper may have a uniform deposit over its entire surface, with a maximum difference from the edges to the center of 10 to 20 percent. This uniformity of deposited coating results in an appreciable saving of metal and an improved finish. Obviously the thinnest portion of any surface determines its corrosion resistance, and the minimum thickness is no less with PR plating than with other methods.

In the past the most widely employed bright-plating meth-

TABLE I—RECOMMENDED SOLUTION COMPOSITIONS

Process Variables	Optimum	Limits
Copper as metal	8.0 oz/gal	7.5 - 9.0 oz/gal
Free potassium cyanide	1.0 oz/gal	0.8 - 2.0 oz/gal
Potassium hydroxide	5.0 oz/gal	4.0 - 6.0 oz/gal
Wes-X	0.8 oz/gal	0.5 - 1.0 oz/gal
Temperature	180 degrees F	170-190 degrees F
In the event that the solution is to be a sodium bath instead of potassium, the only changes are in the metal concentration and hydroxide concentration.		
Copper as metal	11.5 oz/gal	11.0 - 12.0 oz/gal
Free sodium cyanide	1.0 oz/gal	0.8 - 2.0 oz/gal
Sodium hydroxide	4.0 oz/gal	4.0 - 6.0 oz/gal
Wes-X	0.8 oz/gal	0.5 - 1.0 oz/gal
Temperature	180 degrees F	170-190 degrees F
Another satisfactory solution is a Rochelle-type bath of the following composition:		
Copper as metal	6.0 oz/gal	4.0 - 8.0 oz/gal
Free sodium	1.0 oz/gal	0.8 - 2.0 oz/gal
Sodium hydroxide	2.0 oz/gal	1.0 - 3.0 oz/gal
Rochelle salt	5.0 oz/gal	4.0 - 6.0 oz/gal
Wes-X	0.8 oz/gal	0.5 - 1.0 oz/gal
Temperature	180 degrees F	140-180 degrees F <sup>2</sup>

od utilized commercially has been that of adding complex organic compounds, as previously mentioned, to produce a refined grain structure. A major disadvantage of this procedure is brittle deposits. In the PR process, with inorganic constituents, considerable grain refining is obtained, and the resulting deposit is ductile and has unusual physical properties.

Other methods of current manipulation have been offered over the past forty years; however, none of these have found commercial application. Two methods that received the most attention were the application of a superimposed alternating current and the application of a pulsed direct current. Both of these methods were patented as far back as 1906. However, no commercial application of any consequence has persisted.

The PR-current process applies to other metals as well as copper. Brass deposits can be secured with 100-percent plating efficiency in comparison with the 50 to 70 percent normally obtained; pilot lines are now being constructed for plating wire and sheet. Silver and zinc are also being commercially plated with PR. A new process for nickel plating will soon be introduced. Chromium is the only metal that has not responded to the PR process, probably because in this method

the part being plated becomes the anode for a portion of the cycle; chromium anodes cannot be employed because of their excessive solution rate compared to their low deposition rate.

Probably the main limitation of the PR process is the increased current required because of the stripping portion of the cycle. Additional equipment is also necessary, but this has not been a deterrent.

### Elimination of Organic Addition Agents

In the early application of the PR-plating process, it became evident that if widespread commercial use of the process was to be made, better addition agents than the then-common organic compounds must be found. The difficulties encountered with the organic addition agent included: (a) a solution control problem—the analysis of the organic constituent was indefinite; (b) at high current densities rough deposits occurred; and (c) deposits were nonuniform due to decomposition products and nonuniform addition agents.

One possibility of improving the process appeared to be the elimination of the organic addition agents; however, the PR process by itself did not offer sufficient grain refining to give the high luster required for bright finishing. When the metallic inorganic addition agent was developed, increased grain refining was secured. The reason for this has not been definitely established; however, there are indications that the metallic portion of the inorganic compound precipitates at the interface between the part being plated and the solution adjacent to it. This forms a screen that prevents the formation of large crystals, and is conducive to more small crystals.

Since the plating solution is free from organic addition agents, it can be maintained free from extraneous organic constituents, which enter by such means as drag-in from the cleaning solution, dropping into the solution from the mechanical equipment, or as contamination in the plating salts employed. Cyanide copper baths containing the new inorganic addition agent can be treated continuously with activated carbon to remove this type of impurity. The results are a more uniform, high-quality deposit than has previously been secured. In general, this inorganic addition agent can be employed in all of the commercial cyanide copper-plating processes. The compositions of the three most widely employed solutions for copper plating are shown in table I.

### Conversion of Existing Baths

One feature of the new process for copper plating is that any cyanide solution presently operated with organic addition agents can be converted without any major shutdown of the plating line. In the past, when the organic constituent was changed, a great deal of difficulty was encountered. The procedure employed to convert to the Wes-X solution is merely to treat with activated carbon and correct the solution to one of the formulas in table I. If the solution is to be employed continually, most of the benefits can be secured on a graduated basis if the bath is continuously filtered through activated carbon. One 28 000-gallon tank has been converted in this manner. However, if convenient, a better method is to remove the solution from the plating tank and treat it all at once with activated carbon. The benefits are then derived almost immediately. Some organic compound will remain in the bath for as long as a month because all organic constituents are not removed by activated carbon. These remaining constituents will be plated out in the deposits in the first few weeks of operation. During this transition period, if the Wes-X addition agent has been added the solution operates on a continually improving basis with resultant saving.

Most organic addition agents cost from six to twelve cents per pound of copper deposited. If the cost of purification with carbon and the loss due to poor quality are included, the expense is actually much greater. The cost of Wes-X averages from two to four cents per pound of copper deposited. Also, this addition agent does not decompose under electroplating conditions and is readily controlled by analytical procedure.

### Acid Copper Replacement

There has been a strong tendency in the past few years to replace cyanide copper-plating solutions with acid copper-plating solutions. The deposits from the latter process in general are not as high quality as those secured from the commercially employed cyanide process; however, the acid-plating bath costs approximately one third as much. In addition, there is little problem in the disposal of plating-room wastes with the acid process. In spite of these advantages, with the advent of the PR and Wes-X copper-plating process, this tendency has been reversed.

Since it is now possible to plate with speeds two or three times greater than with the acid-plating process, and to secure greatly improved deposits, the factors of solution cost and disposal of wastes are tolerated with a new overall cost reduction in plating. Several acid copper solutions have already been converted to the Wes-X cyanide copper-plating process. In these acid-plating tanks, the original solutions were less expensive; however, four organic addition agents were necessary. This resulted in a cost of 12 cents per pound of copper plate shipped. Also, the rejects due to nonuniformity more than made up for the cost difference between the two plating solutions. When 30 percent more production was secured through these same tanks, little difficulty was encountered in justifying the use of the Westinghouse process.

### Physical Properties

The physical properties of an electrodeposit are equally, or possibly more important than the physical properties of structural metal parts. Electrodeposited parts may be formed or drawn after plating, and yet they must retain high quality. In addition the actual service of some parts, such as automobile bumpers, puts heavy requirements on tensile strength and hardness of the surface.

The tensile strength of cyanide copper-plated deposits in the past was about 30 000 to 40 000 psi. Some acid-copper deposits have been made with a tensile strength as great as 80 000 psi, and with hardnesses of 130 to 160 Vickers. How-

Fig. 4—A general view of part of the electroplating laboratory.





Fig. 5—A PR-plated door for an automatic washing machine.

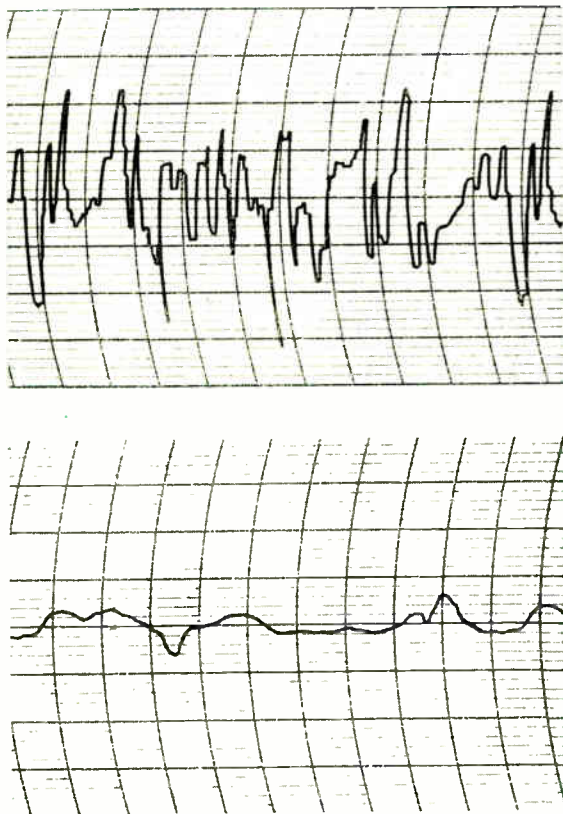


Fig. 6—Surface profiles of the washing-machine door before (above) and after (below) PR plating.

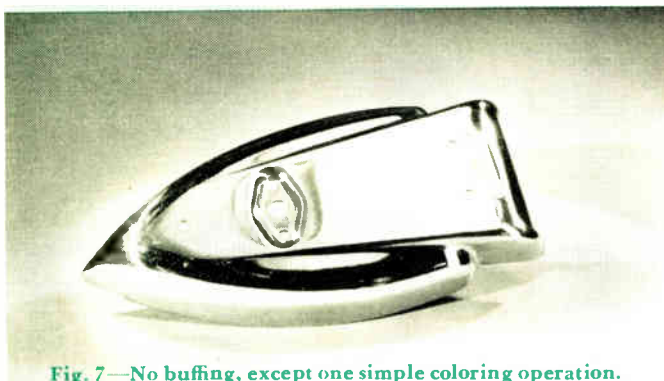


Fig. 7—No buffing, except one simple coloring operation, was done on this PR-plated cover for an electric iron.

ever, this condition was secured only through the use of large quantities of organic constituents such as glue and molasses. In any event, when this high tensile strength was obtained, the elongation was generally below one percent, and the deposits were very brittle.

In an initial exploration of the physical properties of the PR cyanide copper-plated deposits, the tensile strength varied between 100 000 and 110 000 psi, with an elongation of 9 percent. The deposits were ductile and varied in hardness from 200 to 220 Vickers. No evidence has been uncovered in any literature or at the National Bureau of Standards of any previous copper deposits with such unusual physical properties.

### Applications

Physical properties such as these have aroused the interest of the printing industry, the phonograph recording industry, and the wire industry. Initial applications have been made in all these fields, plus several others.

### Decorative

There are two possible approaches to the decorative plating of steel parts, such as home appliances and automobile trim. The first is to utilize the maximum rate of deposition with little regard for color, in the event buffing is to be done. A typical PR cycle for this type of processing would be 15 seconds plating and 3 seconds deplating.

The other system, which will be employed more generally with the more widespread use of PR plating plus Wes-X, is to use as high a grade of steel as possible, do some polishing in the flat if production is high enough, stamp and form parts, deburr them, then deposit the required amount of copper by the PR process, and plate bright nickel and chromium. This produces a finished part without any intermediate polishing or buffing whatsoever.

An example of this type of finishing is shown in the automatic washing-machine door in Fig. 5. The steel employed was not particularly smooth before finishing, as shown in Fig. 6. However, after copper plating, the part was sufficiently bright that no buffing was necessary. The PR cycle for this work is about 20 seconds plating and 15 seconds deplating.

Sadiron covers are also finished by the same process (Fig. 7). A considerable saving per cover was realized in this application. All buffing except one simple coloring operation was eliminated. An auto parts manufacturer in the Detroit area was able to free 30 men in the buffing department for other work upon the introduction of PR and the new cyanide copper-plating solution.

### Printing

In the printing industry a number of applications are now being tested. Printing plates have been made with a 0.006-inch layer of PR copper on the surface. Indications are that these plates etch better and last longer in production. Several rotogravure rolls (Fig. 9) coated with 0.006 inch of PR copper required less machining and setup time. Although these operations are still experimental, the results are promising.

### Record Stampers

In the manufacture of phonograph records the die consists of a copper electroform. This electroform is generally prepared from an acid copper-plating solution. The physical properties of the resultant copper are very limited, and in general, about 1000 impressions can be made per stamper. However, with the cyanide solution and the PR and Wes-X process, stampers have been made with a life many times greater.



In addition, after as few as 200 stampings, the acid copper stamper shows metal flow, and distortion is evident in the music. With the PR stamper, no evidence of distortion could be detected in the same period of usage. An experimental unit is now producing stampers in this fashion to determine the value of the improvement to the record industry.

### Heavy Deposits

In the past, copper coatings of more than 0.003 to 0.004 inch thick from a cyanide bath have not been possible without encountering nodules and other imperfections in the deposit. The new PR-plating process enables smooth and hard deposits of almost any thickness. In fact, a surface can be produced that is considerably smoother than the base member (Fig. 6) when heavy deposits are used. This type of deposit can be secured not only on flat or symmetrical objects, but on irregularly shaped pieces, providing some solution agitation is used.

In the wire-plating field, deposits of 0.006 inch have been obtained having a higher conductivity than that theoretically possible for copper. This is probably due to the increased density of metal, as well as the uniform fine-grain crystalline pattern of these deposits. This increased conductivity is probably obtained only in the direction parallel to the base member, while in the perpendicular direction the conductivity is less. Measurements are to be made to verify this.

A pilot plant is now in operation producing continuously copper-coated steel wire having a 0.006-inch copper layer on the surface. When plated directly, many benefits are obtained that otherwise would be impossible. High tensile-strength steel wire for the core can be employed, which is not possible in the cladding technique used commercially today. In the cladding process, poor concentricity results in high rejects; however, with electroplating, far superior uniformity results.

### Field Reversal

When PR plating was first applied in industry, large contactors on the tank side of the generator seemed necessary. The reason was the slow reversal of the generator output current when the field current was reversed. In Fig. 8 is shown what happens to the current with field reversal, as compared with contactor reversal, for a cycle of five seconds plating and one second deplating. At least one large commercial installation has operated for a long period of time under these conditions of field reversal. However, the cycles employed today are considerably longer—approximately 20 to 30 seconds.

The effect of longer cycles on field reversal is shown in Fig. 10. Still further increases in the reverse period minimize the losses due to the slowness of the generator field in reversing.

When rectifiers are employed as a current source, fairly large contactors are still required. The problem is not as difficult as the generator contactors because the rectifier can be turned off for each cycle, so that the low-voltage contactors are not required actually to make and break the circuit. A complete range of contactors from 300 to 3000 amperes has been designed for this application. These contactors are very simple in design and have a long life. All that is required with this contactor is a timer to complete a PR-current installation. Three different timers are now available—an electronic device, an electric-clock mechanism with cams, and a pneumatic delay timer.

The process of PR plating with a new addition agent, Wes-X, solves many previous electroplating problems, producing a plate that is not only of high luster, but also of more uniform density. Costs incidental to plating, such as buffing and polishing, can often be completely eliminated.

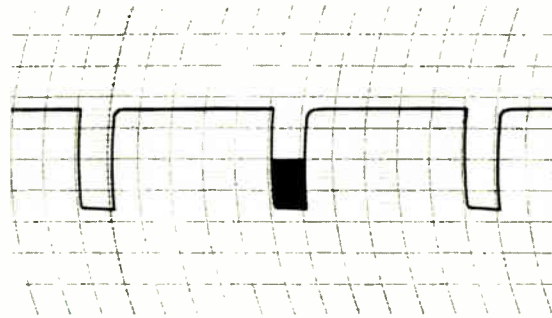
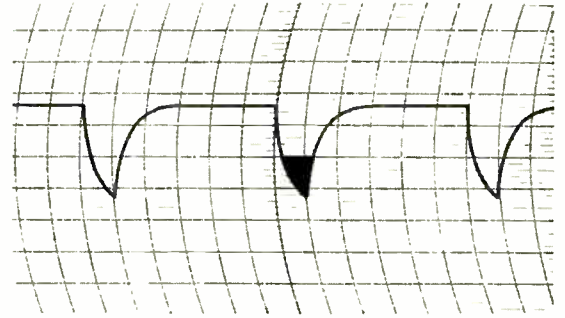


Fig. 8—The current wave with field reversal (above) and with contactor reversal (below). Cycle in each case was five seconds plating, one second deplating.



Fig. 9—A rotogravure roll plated by the PR process.

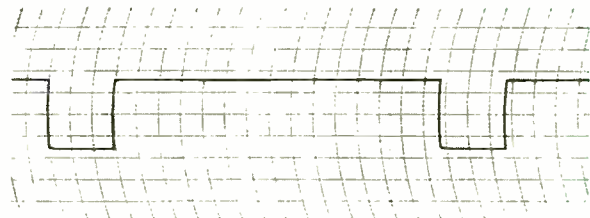
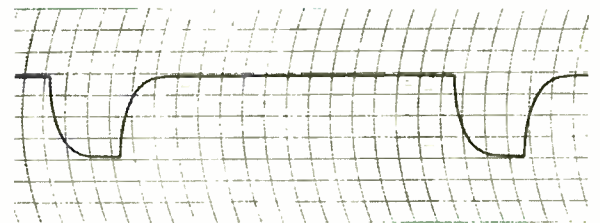


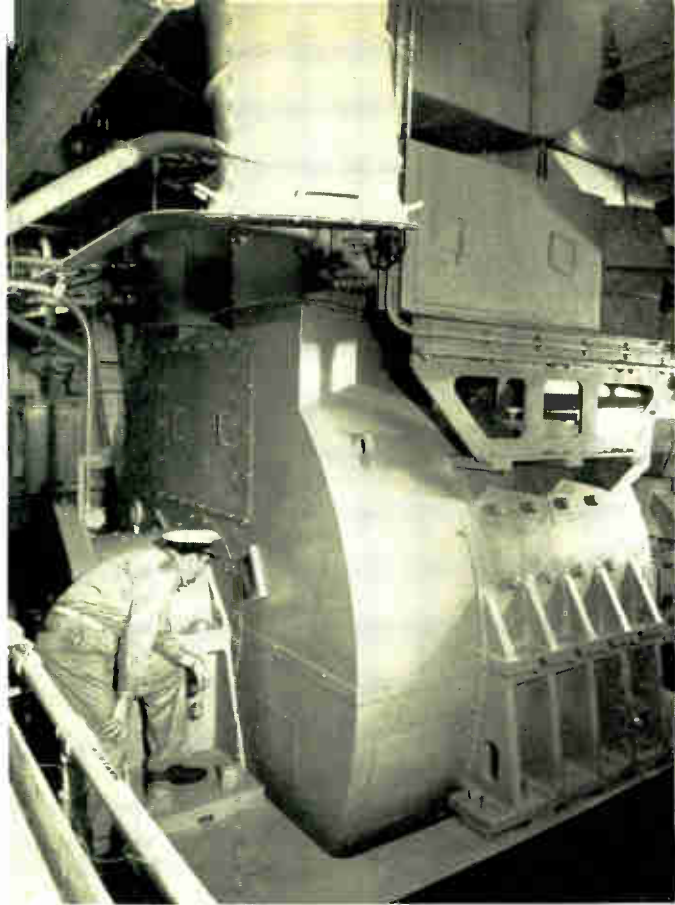
Fig. 10—Field reversal (above) and contactor reversal (below) current waves with a fifteen-second plating, three-second deplating PR cycle.

# The "Essayons"— Dredge Extraord

KEEPING the nation's harbor channels open is a never-ending task. The actions of tidal currents, which constantly rearrange the bottom, and the influx of material from streams and rivers, which would soon silt up the channels. The endless job of maintaining these passages falls to the people of the Army Corps of Engineers, who make up in pure persistence and efficiency what it lacks in manpower.

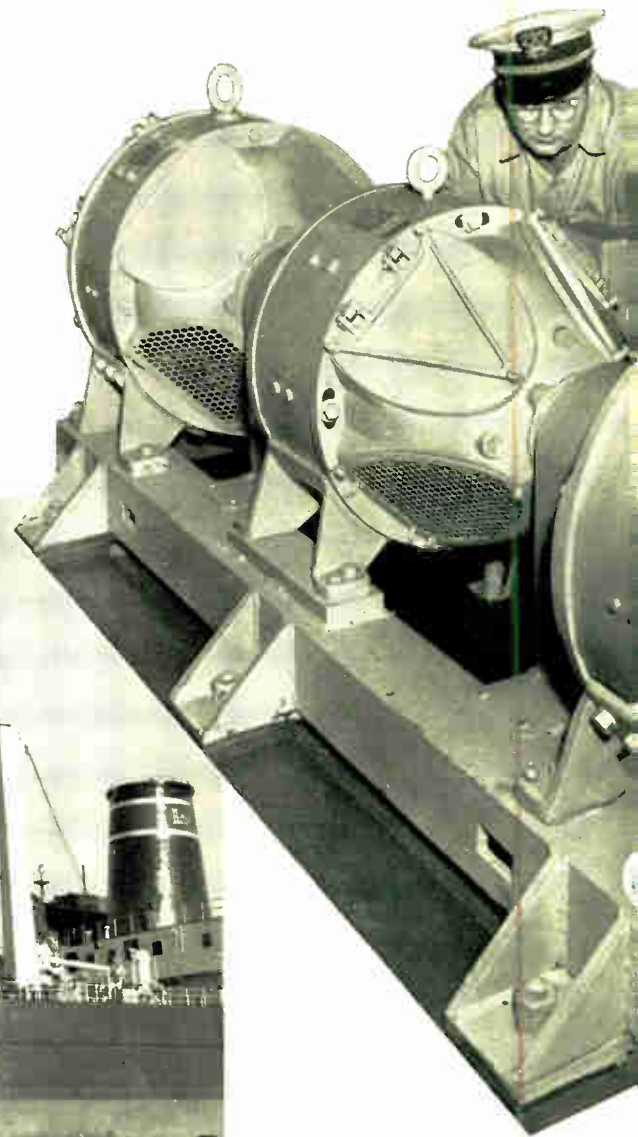
Newest in the fleet of dredges operated by the Army Corps of Engineers are the 10 700-ton *Essayons*, whose capacity of 8000 cubic yards makes them the largest seagoing hopper dredge.

An outstanding feature of this new dredge is the unique application of Rotrotrol controls to synchronize the hoisting of the 82-ton, three-section drag chain. This application is described on page 153.

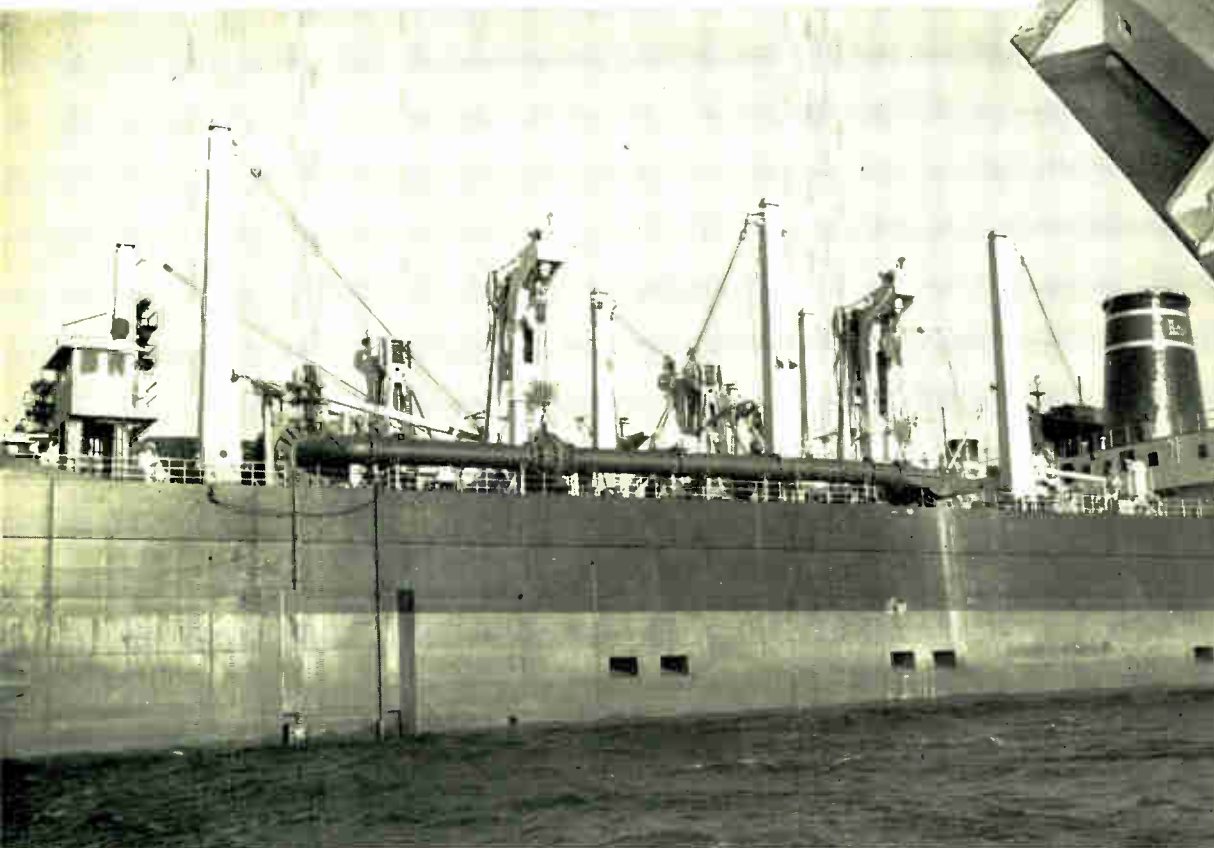


Each of the dredge's two 4000-hp propulsion motors is solidly connected electrically to its respective generator.

This Rotrotrol control automatically maintains constant horsepower at any speed setting and prevents motor overload.



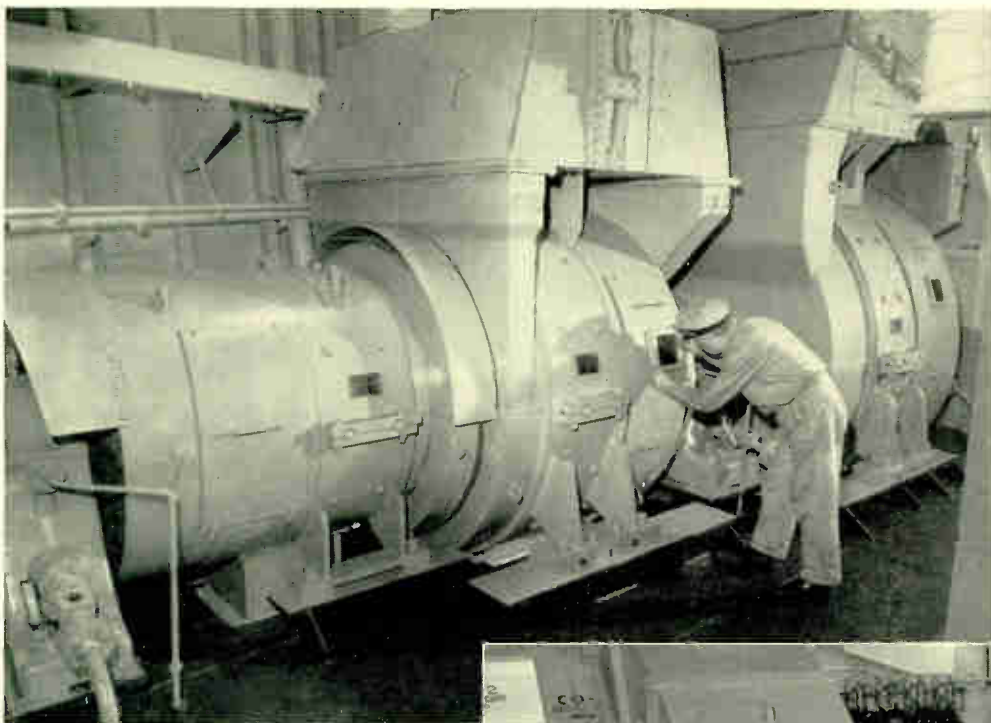
In this view from the water, the dragpipe can be seen along the ship's side.



ury

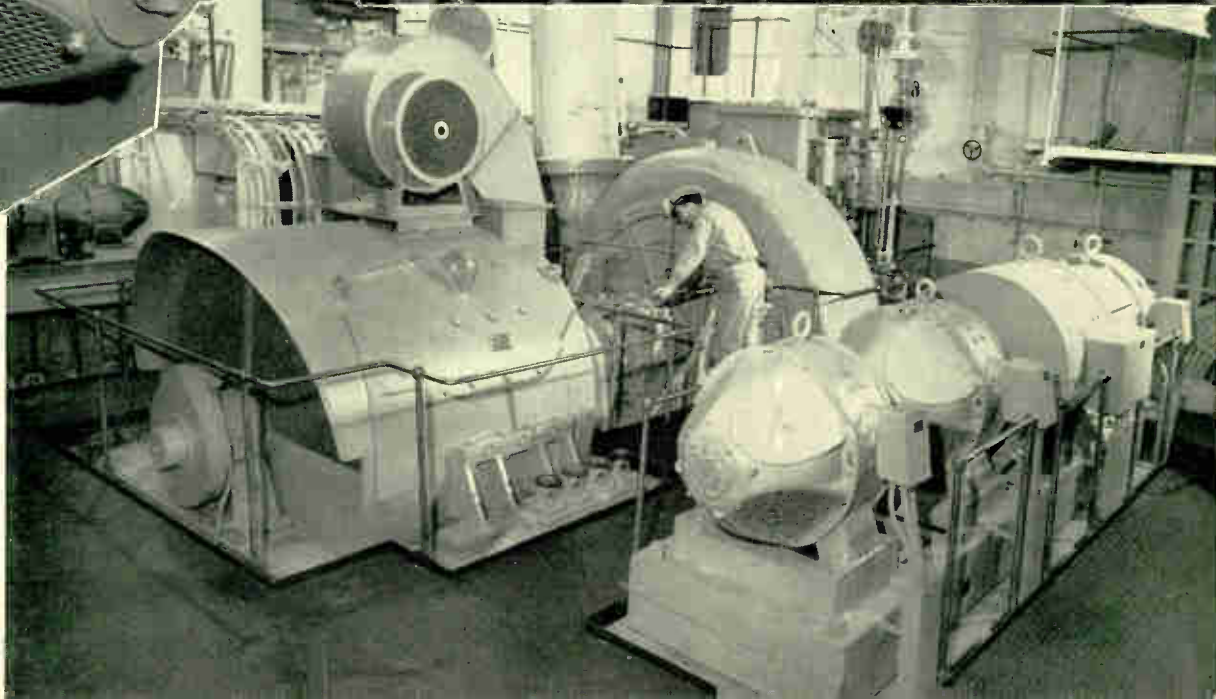
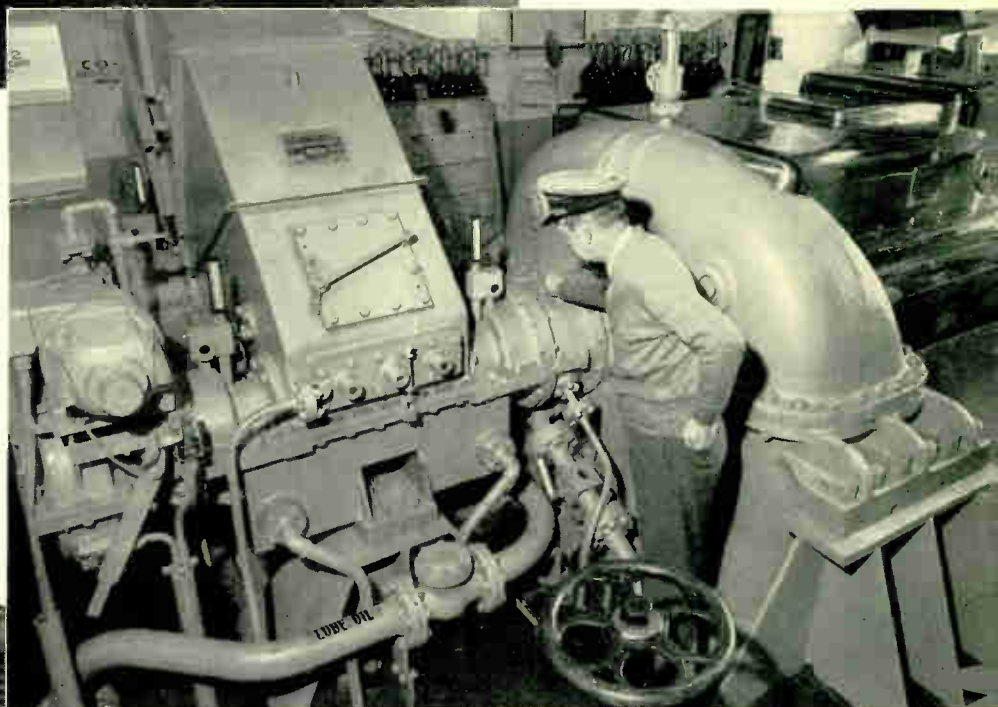
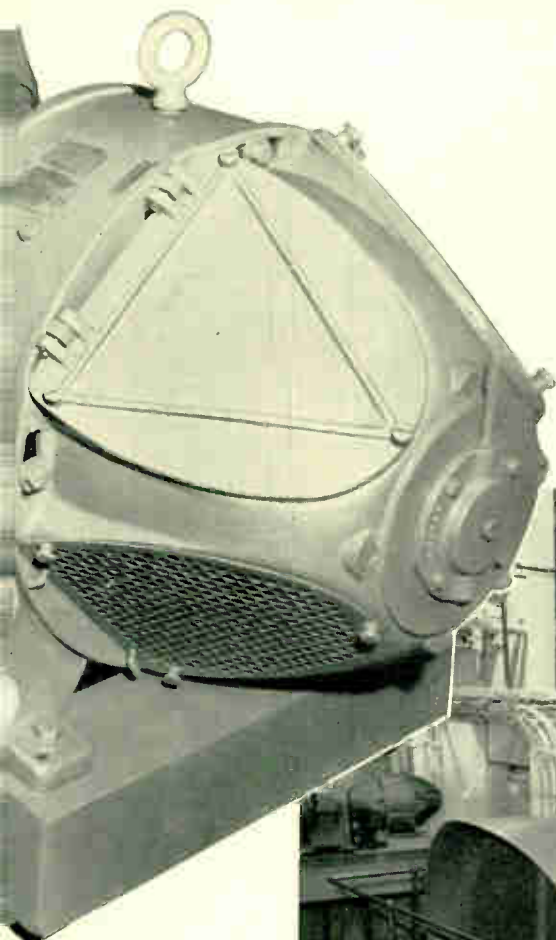
against  
ed, and  
se chan-  
dredge,  
lamour.  
rs is the  
world's

f Roto-  
-this ap-



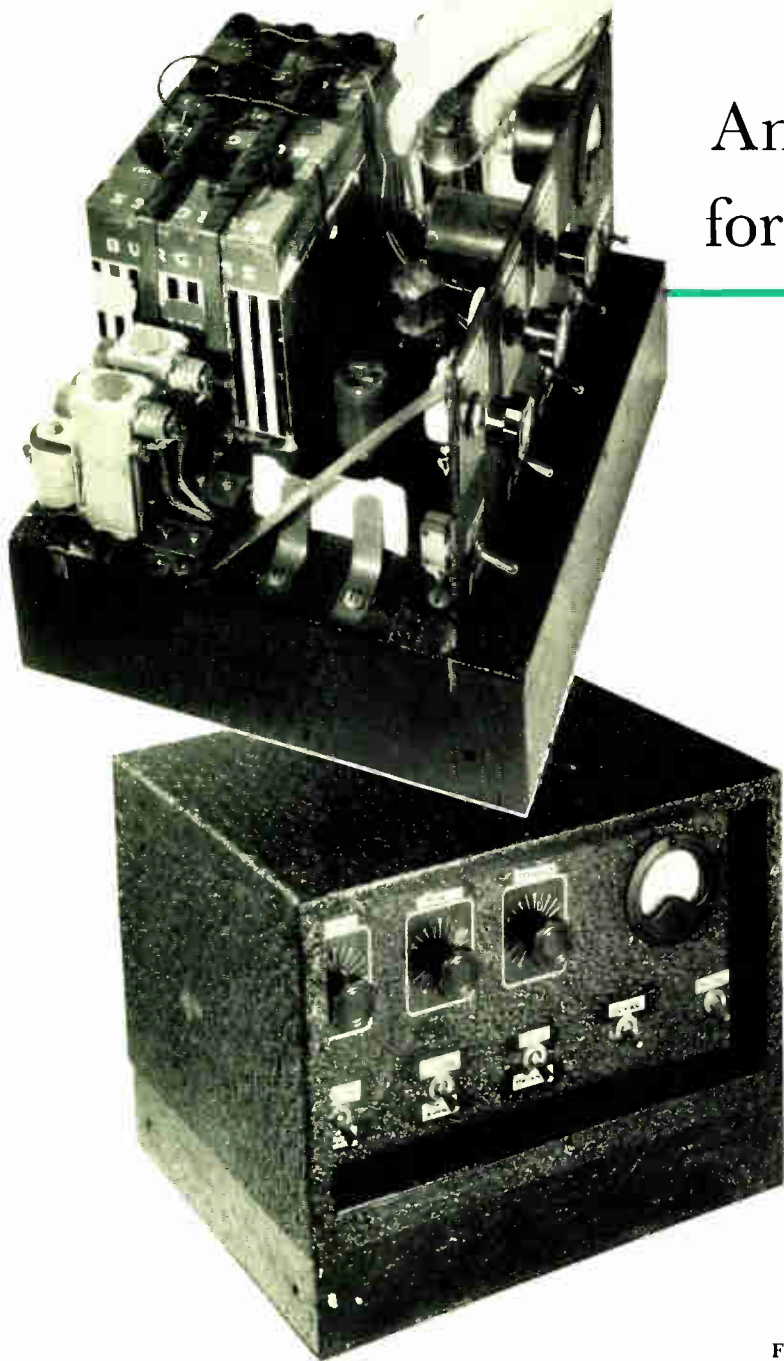
Each turbine drives propulsion, pump, auxiliary generators, tandem connected.

Two of these 3800-kw turbines furnish all propulsion, pumping, and auxiliary power for this seagoing dredge.



dge pump motors are  
d at 1850 hp each. At  
it, a draghoist m-g set.

# An *Amplifier* for Magnetic Oscillographs



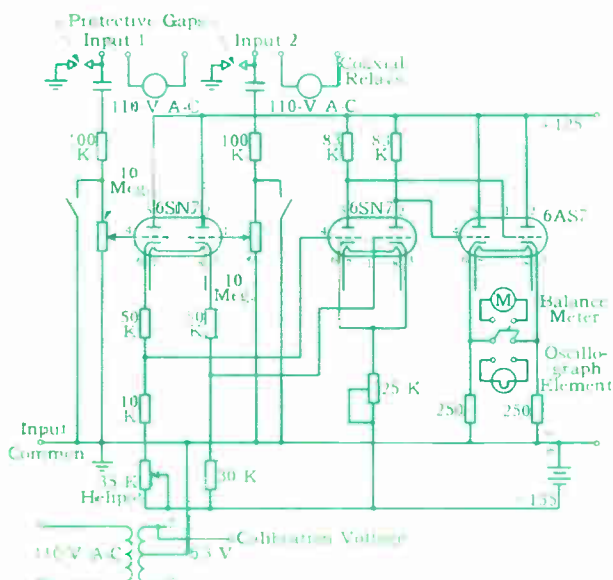
**B**UT FOR ONE major limitation—low input impedance—the magnetic oscillograph would have a much wider field of application. It could, for example, be used to record voltages appearing at potential taps of condenser bushings, a use for which it is ideally suited, but for its one drawback. The advent of a new amplifier, which offers the necessary high-impedance input, will undoubtedly extend the utility of the already useful magnetic oscillograph.

By the use of this amplifier the field of the magnetic oscillograph is extended to include many measurement problems confronting utility and industrial engineers. In addition to the application mentioned above, utility engineers could use the oscillograph for such things as recording voltages at the potential taps of carrier-current coupling devices; engineers in industry can find a multitude of new uses, such as in recording the operation of electronic devices.

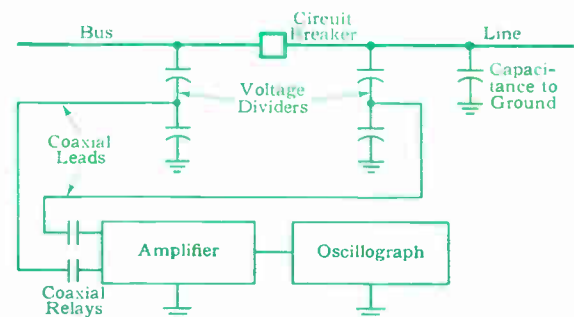
The magnetic oscillograph is primarily a recording device. It can make multiple, simultaneous records, and is well adapted to measurements of transient phenomena. The frequency response of the magnetic oscillograph extends from direct current to several thousand cycles per second alternating current, which range is adequate for many important measurements.

Without modifying any of these desirable characteristics, the new amplifier, which has an input impedance of 10 megohms, removes the impedance limitation. This condition permits the use of the oscillograph with various forms of capacitance voltage dividers, as well as making possible a performance record of electronic control systems and servomechanisms, with no more burden on the circuits than would be imposed by a vacuum-tube voltmeter.

The new amplifier has three stages (see Fig. 1). The input

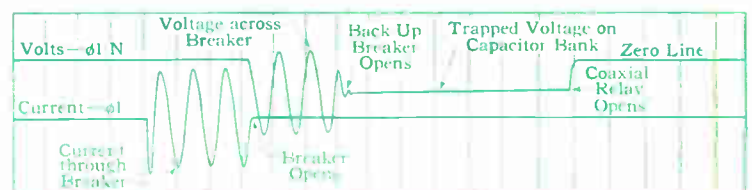


**Fig. 1—The new amplifier has three stages. Input and output stages are cathode coupled.**



**Fig. 2—A circuit for measuring the voltage across a circuit breaker, using the new amplifier.**

**Fig. 3—An oscillogram of a simulated line-dropping test, in which a capacitor bank was the "stand-in" for the open line. A circuit similar to Fig. 2 was used, with two capacitance dividers and an amplifier.**



**Sometimes the addition of a relatively simple component to an already useful device opens up whole new areas of application. Such is the case with a new amplifier for the magnetic oscillograph, which increases many-fold the utility of this convenient and valuable recording instrument.**

C. J. TIRK, *Engineering Laboratories, Westinghouse Electric Corporation, East Pittsburgh, Pennsylvania*

and output stages are cathode coupled to give high input and low output impedances, and the second stage is plate coupled to provide voltage gain. Twin triodes are used throughout. The double input is so arranged that the difference of two voltages that are above ground potential can be measured, with the amplifier chassis and power supply grounded.

A separate amplifier is required for each oscillograph element. Within the frequency range of the oscillograph, the amplifier distortion, including phase shift, is negligible. The overall sensitivity of the amplifier-oscillograph combination depends in part, of course, on the oscillograph sensitivity. With a high-frequency-response element, the sensitivity is about three volts per inch; with a high-sensitivity element, it is about 0.06 volt per inch.

Because most tests in which the amplifier is used are staged, or are of such a nature that the device is self-calibrating, no special precautions were taken in the circuit to minimize drift. A regulated heater voltage can be used if desired. A lead from the heater transformer provides a convenient source of calibrating voltage. The input leads are shielded cable and are connected to the amplifier through coaxial-type relays, which maintain the integrity of the shielding, and make possible the convenient connection or disconnection of the input. Small gaps provide protection against accidental overvoltages. The plate circuit requires 0.5 ampere at 125 volts direct current. A small motor-generator set is the most convenient source of plate voltage, since it is independent of line-voltage fluctuations and can carry a number of amplifiers without overload. The drain on the 135-volt batteries is so light that their life is long. The amplifier is small, 10 by 10 by 12 inches, and is designed to withstand shipping (see pictures at left).

Preparatory to operation, the amplifier is balanced and the gain adjusted for a satisfactory oscillograph deflection. With the balance meter (see Fig. 1) in the circuit, the variable resistor in the cathode circuit of the first stage is adjusted to give a zero reading. Then, with the oscillograph in the circuit, the input-voltage dividers are adjusted to give the required deflection. No other adjustments of the amplifier are necessary; it is ready for operation.

This amplifier, with its double-input feature, is particularly useful in line-dropping tests, in which the voltage across the terminals of a circuit breaker is to be measured. For example, in the circuit of Fig. 2, the voltage across the breaker on opening is required. The double input permits the voltage across the two capacitance dividers to be measured with the amplifier, power supply, and oscillograph grounded. If a single-input amplifier were used, all apparatus would have to be insulated from ground, which is inconvenient and can lead to measurement errors.

The relays on the amplifier chassis are a convenience in tests of this type. By opening the circuit to one divider the gain can be adjusted for proper deflection. Furthermore, the relays make possible rapid disconnection of the amplifier if draining of the voltage divider must be avoided.

The measuring circuits ahead of the amplifier must be ar-

ranged so that the signal appearing at the amplifier input is faithful to the original voltage. These circuits will depend on the particular measurement required, and are a separate problem in themselves.\*

An amplifier of this design has been used for over a year in the Westinghouse High-Power Laboratory. An oscillogram of a simulated line-dropping test, in which a capacitor bank simulates an open line, is shown in Fig. 3. This shows the unsymmetrical voltage across the breaker and the trapped voltage on the capacitors. A circuit similar to that of Fig. 2 was used, with two capacitance dividers and an amplifier.

Earlier models of this amplifier have been used successfully in a number of field tests. These tests showed the desirability of certain features that add to the convenience of operation, particularly the coaxial relays and the motor-generator set for the plate supply.

Although the amplifier is not on the market, it consists of standard components available from radio parts suppliers, and can be assembled by any competent meter shop. The cost is so small that practically any job that can use such a device warrants its construction.

\*"A Simple and Inexpensive Method for Accurately Measuring Steady-State and Transient Voltages," by H. L. Levinton, Proc. AIEE, 1947, Vol. 66.

## Zinc Dust Collection

At the Jones & Laughlin Steel Corporation's Aliquippa Works, an effective system has been devised for the collection of zinc dust, and for the removal of the dangerous "free" hydrogen produced from cleaning dip-galvanized pipe. This installation, in use for over a year, has proved also that it will pay for itself in zinc saved in a short time. Below, high-pressure steam is being blown through a pipe to remove excess zinc from the inner surface. Note the absence of the usual cloud of zinc dust and moisture around the "blowbox." The main component of the exhaust system is a special heavy-duty fan in a sheet-metal structure to draw the dust through a cyclone collector, which separates out the zinc dust and allows it to fall into a barrel through a rotary valve feeder. The air and gases are forced out the stack. To reduce blade erosion and uneven loading, the fan is on the "clean" side of the collector.



# Lightning Arrester—Electrical Protector

Protection of apparatus against lightning-induced voltages is not an intensely complex business. But it is well to know that the differences between distribution, line, and station-type arresters are not described by their names. Also the principles of operation of valve and expulsion arresters, and the basis for current and voltage ratings should be known.

EDWARD BECK, *Manager, Lightning Arrester Design Section, Westinghouse Electric Corporation, East Pittsburgh, Pennsylvania*

LIGHTNING arresters are an essential factor in assuring the maintenance of an uninterrupted supply of power to users. The largest single cause of system outage on unprotected electric power or distribution systems is lightning. No insulation yet devised can withstand these high lightning potentials, which far exceed the system voltage. On unprotected systems lightning potentials can result in flashovers and short circuits, which cause circuit breaker or fuse operation to interrupt power flow. Also, lightning may cause permanent damage to apparatus, necessitating repairs or replacements. In addition to the considerable inconvenience to all users, even a short interruption of power to a continuous process, such as paper or textile making, can entail considerable damage.

When lightning strikes a conductor it suddenly dumps energy into the circuit. This is the cause of the potentials dangerous to insulation.<sup>1</sup> The principal function of a protective

device is to limit the potentials, thus preventing flashovers or punctures, which can be followed, with disastrous consequences, by the system 60-cycle power current. This is called power-follow current.

A lightning rod, connected to the system conductors and ground, would limit the voltages but would not be satisfactory because it would act as a permanent short circuit on the system. Ordinary simple spark gaps, such as a gap between two rods or spheres, can be set to flash over at a predetermined voltage, and could be used to limit the voltage on the conductor.<sup>2</sup> But if installed for that purpose, the heavy power-frequency current that would follow a sparkover could not be interrupted without somehow de-energizing the system. The lightning arrester combines the functions of lightning rod, spark gap, and current interrupter. It grounds the system momentarily during the surge, then interrupts the arrester power-follow current. "Lightning arrester" is a misnomer for this device; it is a lightning diverter and a power-follow arrester.

A lightning arrester can be likened to a circuit breaker connected in parallel with the insulation it is to protect—a breaker that is normally open, but which closes almost instantaneously when a high voltage appears, then reopens after it has disappeared. Mechanical movements are too sluggish for the closing mechanism because lightning voltages can rise at the rate of hundreds of thousands of volts per microsecond. The switching mechanism of a lightning arrester is a spark-gap structure. It provides insulation at normal system voltages. When the lightning voltages occur, the gap sparks at a predetermined value and establishes a path for the lightning current and for power current. The power-follow current must be extinguished quickly, and a vital element of lightning arresters is a contrivance in series with the spark gap that either interrupts the follow current or aids the series gap to interrupt it. At present there are two practical ways of doing this, resulting in two arrester types, expulsion and valve.

## Operating Principles of Arresters

The expulsion arrester, Fig. 1, consists of an external gap in series with a second

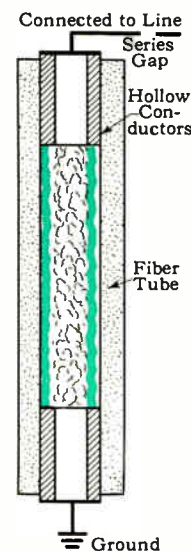
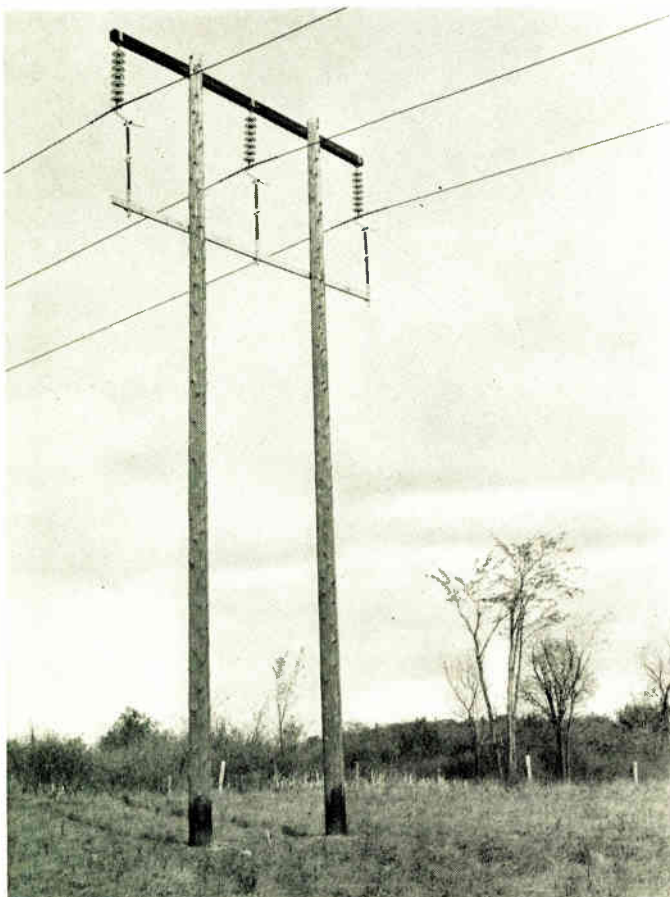


Fig. 1—A simplified sketch of the elements of the expulsion-type arrester. Color shows the gas-producing arc formed when a lightning strike occurs. The expulsion arresters, in the picture, protect transmission-line insulation.

gap inside a fiber tube. When a high voltage appears, both the external gap and the gap in the tube spark, thus establishing a current path. Because the impedance of this path is extremely low, it acts as a momentary short circuit on the system. The arc causes gas to be expelled from the walls of the fiber tube. The gas is an un-ionized mixture of water vapor absorbed in the fiber and hydrocarbon gases resulting from the volatilization of minute portions of the fiber. This mixes with the ionized air in the arc path and promotes de-ionization. When the power-follow current wave passes through instantaneous zero, the arc path de-ionizes rapidly. Hence, when the system voltage across the device rises to its normal value, the gap space has recovered its insulation strength and power-follow current is not reestablished. The power-follow current in an expulsion arrester can be of considerable magnitude, but its duration is not more than one or two half cycles, and is generally less than one-half cycle. Thus, no disturbance is noticeable on the connected system.

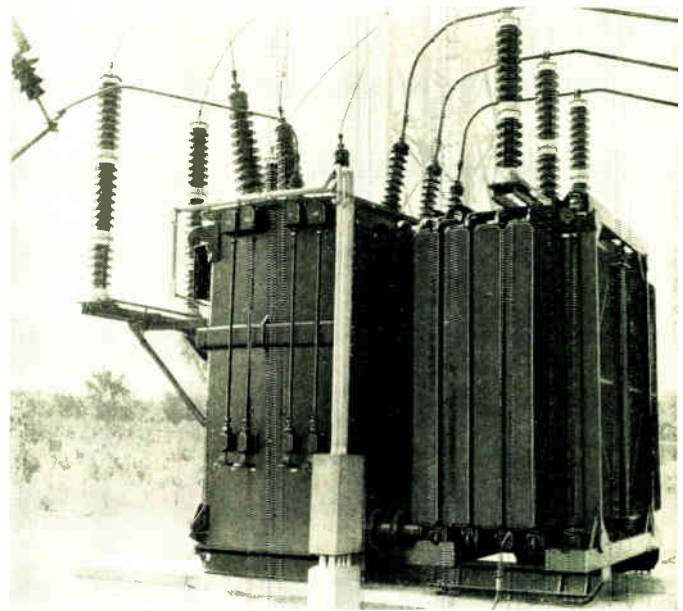
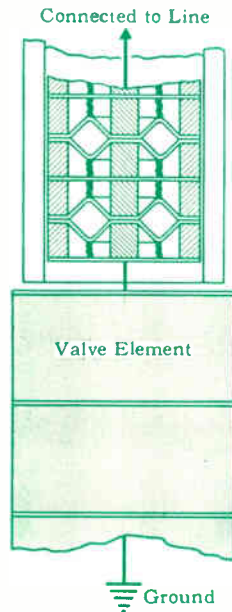
As the gases liberated by arc formation must be vented, one or both electrodes are hollow and open at one or both ends to allow the gas to be expelled. Hence, this arrester is called the expulsion type.

Although the interrupting chamber incorporates a spark gap, it is not connected directly to the system because constant voltage on the fiber eventually causes tracking and carbonization. The external series gap prevents this. Surge discharges or a few half cycles of power current do not produce carbonization but leave the fiber walls remarkably clean. The expulsion arrester operates repeatedly without attention.

The valve arrester performs the same function as the expulsion, but its operating elements, Fig. 2, are different. The series gap normally provides insulation and sparks to close the circuit when the need arises. But this gap must also reopen the circuit by interrupting the power-follow current when the surge has passed. These gaps consist of a series of short spaces between flat or slightly curved electrodes. This type of gap has excellent impulse-breakdown characteristics, but cannot interrupt high 60-cycle power-follow currents. Therefore, the power-follow current must be limited to a magnitude that the series gap can interrupt. This current limitation is provided by series resistance.

Resistance of the constant or linear type, of a magnitude that limits the normal system current to the required moderate value, is not suitable. The voltage drop across such a resistor of a given value would be so high, when carrying the high lightning current, that the arrester would provide no protection. The resistance used in valve arresters must have different characteristics. The voltage across it does not vary directly with the current but as a fractional power of the current. When only the normal system voltage is applied, the

Fig. 2—The sketch gives the basic elements of a valve-type lightning arrester. The spark-gap units are shown relatively larger than actual. Valve-type lightning arresters, right, are mounted on the bracket to the left of the transformer itself and on the radiators.



current is small because the apparent resistance is high. During the discharge of a high surge current, however, the apparent resistance is low and the voltage remains relatively low. The variable-resistance device passes lightning currents without permitting high voltage, yet limits the power-follow current to a value the gap can interrupt.

Valve elements usually consist of many small crystals of silicon carbide, although in some cases other materials are used. The unusual characteristics of these elements reside in phenomena—about which little is known—that take place at the contacts between the constituent particles.

#### Expulsion Arresters for Transmission Lines

The simplest lightning arrester in practical use on power systems is the type of expulsion arrester used to protect transmission-line insulation against flashover where overhead ground wires are not used; or where they are not effective or economical. The transmission-line-type expulsion arrester is similar to the drawing of Fig. 1. It is mounted so as to shunt the insulators it is to protect. The series gap is made by leaving a space between the end of the fiber tube and the line conductor. The top of the tube may have an arc-shaped horn (Fig. 1) that maintains a reasonably constant length of gap when the conductor swings with the wind.

The flashover value of the insulation in shunt with the arrester must be higher than the sparkover value of the arrester. In the transmission-line type, the 60-cycle voltage against which the arrester will interrupt power-follow current is determined principally by the length of the gap in the arc chamber. This in turn largely fixes the impulse sparkover, the effect of the external series gap being small.

The power-follow current of these arresters is determined almost entirely by the system constants; the arrester itself influences it very little. The current is usually about what would flow if the arrester were short circuited by a metallic conductor; it is the fault current of the system for a fault at the arrester location.

Fault currents vary over wide ranges, depending on the system voltage, kva, and impedances. As it is generally not practical to make a simple expulsion arrester to handle any fault current that may be encountered, these arresters have maximum and minimum 60-cycle current limits. If applied where

the fault current exceeds the maximum limit, the tube may burst from the high gas pressure. If the follow current is less than the minimum limit, not enough gas is formed to extinguish the power-follow arc. The nameplates of these arresters, therefore, state the voltage rating and minimum and maximum current ratings. For any one voltage rating, there may be several, usually three, different arresters, each with its own current rating. Both the 60-cycle voltage and current ratings define the power-follow interrupting limits of the device and provide information useful in applying them.

The transmission-line arrester must be simple, having a low cost to compete with the overhead ground wire. The choice between ground wire and transmission-line arresters is determined by simple economic facts. However, the arrester has one advantage over the ground wire; its effectiveness at the point where it is located is not handicapped by high ground resistance. Arrester and insulation are directly in parallel, so that at any arrester location, the ground is external to the protective circuit. On the other hand, a ground wire is a simple mechanical device and where the cost of an effective ground-wire system is commensurate, it is usually to be preferred.

#### Arresters for Apparatus Protection

Lightning arresters for the protection of apparatus are of two classes: one for distribution equipment and the other for power apparatus. The expulsion arresters for transmission-line protection are not suitable for apparatus protection because the potentials required for them to function sometimes exceed the "insulation withstand strengths" of equipment.

In this discussion, distribution equipment is considered that connected to circuits of from 2400 to not more than 15 000 volts. This is a loose definition because there are circuits of these voltages that are power circuits, but arresters used with apparatus at these voltages are generally termed distribution arresters. They are small, relatively inexpensive devices,

as they are used in large quantities on distribution systems.

Both expulsion and valve types are used in distribution service. Distribution arresters of the expulsion type are of more elaborate constructions than those used for transmission-line protection because of more rigid requirements. Their impulse-sparkover voltages must be sufficiently low to provide ample margin below the insulation levels of distribution apparatus. Furthermore, their 60-cycle current-clearing range should be as wide as possible. Because the fault currents, on distribution systems considered as a whole, vary over wide ranges, users do not want to be bothered either with numerous ratings of distribution arresters or the designated zones of applications for these ratings. Also, it is not economical to devote engineering time to the application of arresters of different current ratings to these systems. Distribution arresters in general use have impulse characteristics that provide ample protection and, in most cases, are built to be applicable practically anywhere on any system.<sup>3</sup>

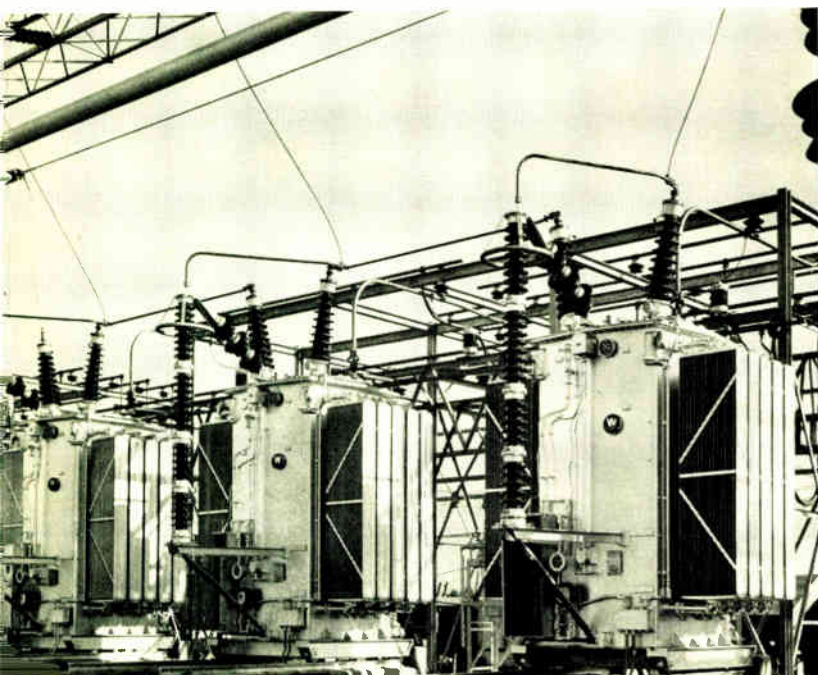
The question frequently arises as to which type is preferred. Certain electrical and mechanical features of the two differ. Manufacturers who make both types would probably prefer to make only one. However, both types satisfactorily perform their required functions, hence there are demands for both. If there were conclusive evidence of the superiority of one over the other, then only one would be in demand and manufactured. Manufacturers who build both do so because they find that superiority of one type cannot be demonstrated clearly and that operating engineers insist both be available. The selection of a certain type is probably influenced largely by weighing those points in which the expulsion and valve arresters for distribution circuits differ. This is the way many things, such as automobiles and radio sets, are purchased. Even in things engineering, human judgments differ.

However, discretion should be used in the selection of the type of distribution arresters for some locations on high-capacity distribution systems where short-circuit currents can be of high magnitudes. For example, in a substation, if the short-circuit current at the proposed arrester location is about 6 to 10 thousand amperes symmetrical rms, the erosion in an expulsion arrester would be appreciable. The valve arrester is probably preferable here because it is indifferent to system short-circuit capacity. Usually, however, the fault currents one or two miles from the substation are limited appreciably by line reactance and this consideration disappears.

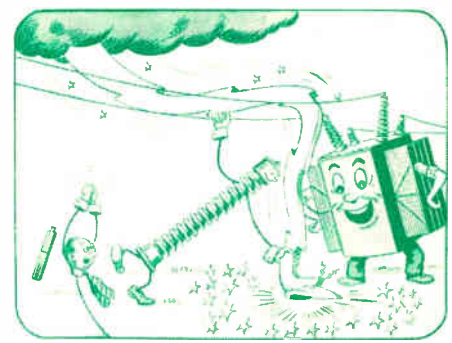
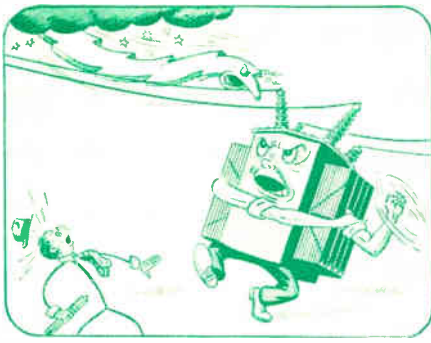
Lightning arresters applied to terminals of rotating machinery, such as motors and generators, must definitely be of the valve type and designed particularly for this service.<sup>4</sup>

For apparatus protection on voltages higher than 15 000, the field is restricted to valve-type arresters. Expulsion arresters are not recommended because their impulse-sparkover voltages are higher than those of valve arresters of the same rating. In the range of distribution voltages this is not of any consequence because the margin is large between the spark potential of the expulsion arrester and the impulse voltages that the apparatus will withstand. But in the higher voltage applications, the ratio between the basic-impulse-insulation withstand strength of apparatus—commonly called basic-impulse-insulation level or BIL—and the operating voltage is less than in distribution apparatus. This necessitates greater relative limitation of surge voltages and valve arresters to accomplish that limitation. Valve arresters are in use on systems operating at voltages ranging from the low signal and control voltages to those of 287 kv for transmitting power. They will be used on systems of even higher voltage as arresters are in service on an experimental line carrying 500 000 volts.

**Fig. 3—Installation of a large valve-type lightning arrester beside each transformer. The rings at the top of these long arresters provide a more uniform electrostatic field surrounding the arrester, giving uniform voltage distribution over the spark gaps.**







### Station Arresters

The term "station arrester" denotes a type of arrester and a class of arrester performance. Originally designed for optimum performance when used with large station-type equipment, it has become associated with a particular performance rather than the particular application its name implies. Station-type arresters are the most effective and most rugged.

The series-gap structure consists of a multiplicity of short gaps that make a compact, totally enclosed arrangement possible. Use of short gaps provides good impulse sparkover characteristics; many such gaps assure good power-follow extinguishing ability; and enclosure eliminates effects of weather. Each individual gap is shunted by high resistance to ensure good 60-cycle voltage distribution, and each gap is equipped with a small pre-ionizing device consisting of a material of high dielectric constant that ensures low and consistent impulse sparkover.

Station-type arresters are built in units, each unit being a complete arrester. Low-voltage arresters may consist of only one unit; high-voltage arresters have several units bolted together in series, as in the arresters shown in Fig. 3.

### Line Arresters

The appellation "line type" is somewhat misleading. These arresters are not used to protect lines, but when first developed they were intended for protection of small transformer banks "out on the line." The line type has, like station type, become, by long usage, the accepted identification for a classification of performance.

The line-type valve arrester is a smaller, lower priced edition of the station arrester. It has series-gap structures almost identical with those of the station arrester. The valve elements are smaller in cross section and volume, making the whole arrester smaller in diameter and lighter in weight. Also the surge voltages are higher and surge-current-withstand ability is less than in station arresters. Line-type arresters are built in units like station arresters. Line-type arresters rated 20 to 37 kv consist of one unit, and 40- to 73-kv arresters of two units bolted together.

Where the highest degree of protection is desired, station arresters are preferred; line-type arresters are used for the protection of smaller equipment where the cost of the station arrester is not warranted. Line-type arresters are used on systems from 23 to 69 kv. Below 23 kv, distribution-type arresters are applicable, and above 69 kv the station-type are preferred.

Arresters can be reclassified into two groups, those used for the protection of apparatus and those used for the protection of transmission-line insulation. In the case of the transmission-line arresters, cost is of prime importance; more so than low impulse characteristics because transmission-line insulation is, in general, relatively high. At least it is higher

than the insulation in the connected equipment. Therefore, transmission-line arresters are of the simple expulsion type. Although arresters intended for apparatus protection could be used, their use would be uneconomical.

In the case of the arresters for apparatus protection, the impulse characteristics and arrester life are of first importance and cost is secondary. These arresters for apparatus protection are divided into several groups, according to the type of apparatus protected.

For the protection of distribution apparatus both the valve and expulsion distribution arresters are used. Station-type arresters, also, are frequently used for the protection of large apparatus operating at distribution voltages. For the large power equipment, and where the highest degree of protection is desired, station-type valve arresters are used. These are available for circuits at voltages from 2400 to 500 000.

For the smaller power equipment, such as relatively small transformer banks where the user does not consider the cost of station-type arresters warranted, valve arresters of the line type are used.

### Lightning-Arrester Ratings

The rating of a device is a designation of its operating limits. It usually gives, in addition, some information on how the device can be expected to perform when used within its rating. The rating implies that, if the device is used beyond its rating, it will not perform as expected and will likely be damaged. Lightning arresters are voltage-sensitive devices. All a-c arresters have a voltage rating expressed in terms of 60-cycle voltage. This rating is maximum, and designates the highest 60-cycle voltage against which the arrester can interrupt power-follow current and revert to its insulating condition following a surge discharge. Neither the 60-cycle sparkover of the arrester nor its impulse characteristics designate the system voltage against which an arrester can clear power-follow current. This clearing characteristic is defined completely and only by the voltage rating that appears on the nameplates of all arresters. In selecting an arrester for a given application, therefore, attention must be given to its voltage rating for the sake of safety to the arrester.

It is important to bear in mind what the rating of a lightning arrester means. If the 60-cycle system voltage existing across an arrester at the time it is discharged by a surge exceeds the arrester rating, there is a high degree of risk that the arrester will not perform its function. First, the power-follow current is increased beyond normal; second, the gaps must extinguish a higher voltage than normal. Thus there are two strikes against the arrester with the probability that power-follow current will not be interrupted, the arrester will be overstressed and damaged, and an outage will occur.

As arresters are usually applied from line to ground, it follows that the arrester is interested more in the 60-cycle

voltage from line to ground than between phases. The so-called standard voltage ratings do not necessarily correspond numerically to any preferred system voltages. However they are such that the ratings included in the standard line are applicable to the systems now in general use. To illustrate the relation of systems and arrester ratings—on a 138-kv three-phase system with the neutral not effectively grounded, an arrester rated 145 kv is generally used. If the system neutral is effectively grounded to prevent an unbalance of voltages to ground during accidental faults to ground on one phase, an arrester rated 121 kv is usually applied. This same 121-kv arrester would also be used on a 115-kv system not effectively grounded, but a 97-kv arrester is generally used on a 115-kv effectively grounded system. It is sometimes desirable to make a study of system characteristics to determine the voltages that can occur from phase to neutral during abnormal conditions. This is done because the lower arrester ratings permit lower impulse voltages and lower costs.

Expulsion arresters, which might require limitations on the power-follow current, are rated in 60-cycle amperes as well as volts. The current rating is often called fault-current rating because it is given in terms of symmetrical 60-cycle short-circuit current that would occur at the arrester location if the arrester were short circuited by a solid conductor. Although the actual power-follow current can differ from this value, this rating method simplifies application because it relates the arrester to system characteristics. Valve arresters, in which the arresters limit the power-follow current, are rated only in volts. In applying this type it is not necessary to know the system short-circuit characteristics.

The nameplates of lightning arresters state the manufacturers' identifying catalog number, voltage rating, and, in the case of expulsion arresters, the minimum and maximum current ratings. The impulse characteristics are not stated on nameplates but are given in manufacturers' catalogs tied to the arrester type, rating, and catalog number. The higher the voltage rating of an arrester, the higher its impulse characteristics. In most types there is a fixed ratio between the arrester voltage rating and the impulse characteristics.

#### Arrester Application

In applying arresters, two conditions should be met. The impulse characteristics of the selected arrester should protect the equipment over a wide range of lightning severity. And the rating of the chosen arrester should be high enough to avoid risk of damage to the arrester from normal or expected abnormal system voltages. It appears as if the arrester is being squeezed between ceiling and floor, and sometimes it is. However, with arresters and apparatus built to present standards, arresters with proper ratings for the voltage of the system to which they are applied do give adequate protection to the insulation of the apparatus on the system. Actually the basic-impulse-insulation levels of modern apparatus have been set largely on the basis of the protective levels available in modern station-type lightning arresters.

Arresters should be connected in shunt with the insulation they are to protect. They should be close to the apparatus and leads should be short. Leads have inductance and the rapidly changing currents of lightning discharges produce undesired voltage drops as a result of this inductance, adding to the voltage across the arrester. Furthermore, traveling-wave effects in conductors result in higher voltages existing at points remote from the arrester than those appearing at the arrester terminals. The impulse characteristics of arresters are measured at their terminals, extraneous effects of lead

lengths or resistances increase these voltages at the locations of the protected apparatus.

The proper coordination between systems and arrester voltage ratings depends on the system voltage from line to ground. Certain general rules of thumb have been developed,<sup>5</sup> and methods are available for determining, with a high degree of accuracy, the magnitude of the 60-cycle voltage that can exist across arresters under any system conditions, provided those conditions are known.

The usual procedure in choosing an arrester is to determine what rating is needed to ensure, as far as possible, immunity from damage to the arrester and then to see whether the insulation protected has a higher withstand strength than the arrester impulse level. (Withstand strengths of apparatus are stated in numerous industry standards. Impulse characteristics of arresters are given in manufacturers' catalogs and in committee reports of the AIEE.)<sup>6</sup> Usually it will work out so. However, there may be cases, such as on very old apparatus having impulse levels that are considerably lower than modern equipment, where coordination is not achieved in the usual manner. In such cases it may be advisable to select an arrester with a lower rating that provides protection for the equipment but involves a known and recognized risk of damage to the arrester. The best thing to do to ensure the highest degree of freedom from service outage and equipment damage is to re-insulate such old apparatus or replace it with apparatus built to modern standards. If this is uneconomical, then it is the author's philosophy that it is better to sacrifice a lightning arrester than to damage a large piece of equipment such as a transformer or important switchgear.

#### Conclusions

Lightning arresters are designed to be economical and practical for the conditions they are intended to meet. They are meant to operate for a short period of time only; all but a small portion of an arrester's life being spent in serene idleness. An arrester is not a voltage regulator and, if forced to pass current for an extended time, it is being asked to do something for which it is not intended. It can handle extremely high currents for a short time. When used within their proper field and within their ratings, arresters are highly reliable devices. This is borne out not only by laboratory tests and field experience, but by the high degree of dependence placed on arresters by the operators of transmission and distribution systems. In fact, the modern lightning arrester may exert a significant effect on the insulation levels of high-voltage equipment. Possibly savings in insulation, and therefore in equipment costs, will be realized as a result of the protective levels established by modern arresters and by their reliability. Already this is contemplated in projected systems of very high voltage.<sup>7</sup>

#### REFERENCES

1. "Lightning Strokes Prefer Tall Structures," by E. Beck, *Westinghouse ENGINEER*, July, 1949, p. 124.
2. "Comparison of Lightning Protection Methods," by E. Beck and G. D. McCann, *Westinghouse ENGINEER*, November, 1942, p. 133.
3. "Lightning Arresters for Distribution Apparatus," by E. Beck and A. D. Forbes, *Trans. AIEE*, Vol. 64, 1945, p. 719.
4. "Lightning Protection for Rotating Machines," by G. D. McCann, E. Beck, and L. A. Finzi, *Trans. AIEE*, Vol. 63, 1944, p. 319.
5. *EEI-NEMA Report on Preferred Voltage Ratings for AC Systems and Equipment*, EEI Publication No. R-6, NEMA Publication No. 117, May, 1949.
6. "Performance Characteristics of Lightning Protective Devices," AIEE Paper No. 49-286.
7. "Transmission of Electric Power at Extra High Voltages," by P. Sporn and A. C. Monteith, *Trans. AIEE*, Vol. 66, 1947, p. 1571.

# What's NEW!

## Coordinated Hoisting for 90-Foot Drag Pipe

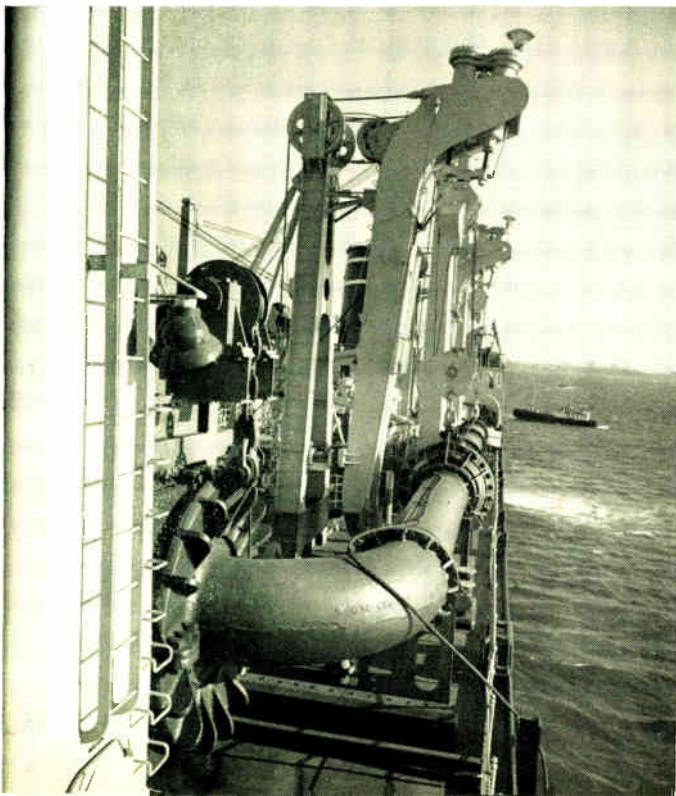
**H**OISTING, ordinarily not much of a problem, gets more difficult when the object weighs 82 tons, is 90 feet long, 36 inches in diameters and jointed, so as to require three separate winches hoisting at different speeds, yet properly synchronized. Such is the case with the drag pipes for the Corps of Engineers new dredge, *Essayons*, which has a hopper capacity of 8000 cubic yards, or approximately 12 000 tons of dredged material. This dredge and its drag pipe are, incidentally, the largest in existence.

The external suction pipe—called the drag pipe—has a drag head at its after end that is moved along the channel bottom, a ball joint at a point about two-thirds of the length of the pipe from the after end, and a sliding trunnion joint on the forward end. Through this joint the dredged material enters the dredge pump and is subsequently discharged into the various hoppers. The drag head and ball joint are raised and lowered in an arc about the trunnion pivot and also move simultaneously with the sliding trunnion. Each of these three points—drag head, ball joint and trunnion—is positioned by an individual winch, because each must be adjustable to ensure proper contact of the drag head with the channel bottom, to permit inspection of the drag head, to limit the angle of bend at the ball joint, and to allow stowage of the drag pipe on deck.

In actual dredging operations, the pipe is immersed or withdrawn from the water as first one location is dredged and then another. The drag head is also raised or lowered to suit the topography of the channel bottom. Normally, this is accomplished by using only the winches at the ball joint and drag head. But when the entire pipe is raised to the deck level (and when it is again lowered) all three winches must be used. This imposes quite a problem, because all three must be coordinated so that each runs at the proper, and necessarily different, speed.

The pipe is lowered from deck level in a horizontal position until the sliding trunnion registers with the suction opening in the hull, at which time the trunnion winch stops automatically.

**The drag pipe of the *Essayons* in its deck position. Further pictures of this dredge appear on pages 144 and 145.**



The other two winches continue to lower, but the drag end goes faster so as to maintain a straight pipe or predetermined angle at the ball joint. Raising the drag pipe to deck level is accomplished in the reverse order. During the complete operation, the angular position of the pipe is shown on an indicator. If the angular limit is exceeded, the winch system is automatically shut down. For adjustment purposes, each winch can be operated individually.

Synchronization of the three winches is accomplished by a system of Rototrol regulators and rheostats. The rheostats, which are connected in a bridge circuit, are geared to the winches and rotate with them. If the winches move in synchronism, there is no current in the Rototrol control fields. If the winches do not move in synchronism, the bridge circuit is unbalanced, creating a current in the Rototrol fields. The Rototrol then adjusts the speed of one of the winch motors (by adjusting the field of its individual generator) until synchronism is attained.

This complication of operations, together with the bulk and weight of equipment handled, makes this one of the most unusual sets of conditions to which Rototrol has ever been applied.

## “Transformer Principles and Practice”

**T**HE LONG-familiar book on transformers by J. B. Gibbs has reappeared, revised to include the technology that has been added since the volume first was issued 14 years ago. Most information relating to transformers is ageless—transformer connections, polarity, parallel operation, and phase transformation—and here the new edition, like the first, is strong. However, much has happened of importance in mechanical construction of transformers, cooling, and oil preservation. The book contains a valuable chapter on transformer obsolescence, i.e., factors that effect the economy of transformer operation. The book comprises 24 chapters, well illustrated, covering 236 pages. It is written with the minimum of mathematics, primarily for those who apply, operate, and maintain transformers.

This is the third book of the Westinghouse-McGraw-Hill Engineering Books for Industry series. The two previous books dealt with aircraft gas turbines and power capacitors.

The book is published by the McGraw-Hill Book Company, New York. List price, \$3.50.

## Now White Stays White

**W**HEN TEXTILE manufacturers set out to make white yarn, they can almost count on the fact that much of the finished yarn will wind up as some other color. Not that they want it that way—but air-borne dirt soils the yarn so that it must be reprocessed and dyed. This is obviously exasperating, but, more important, it is expensive. Many manufacturers have largely overcome this difficulty by installing electronic air cleaners. One southern mill reports an increase of 14 percent in top-quality production after the installation of Precipitrons.

The dirt problem arises in several operations. In the first place, many textile operations involve high-velocity movement of yarn, such as warping, twisting, throwing, and spinning. High static charges are sometimes built up on the yarn during these processes with the result that it readily attracts atmospheric dirt particles. These particles, often carbon, cause permanent discoloration. Another source of trouble is yarn or filament breakage, which causes loose ends to whip around at high speed. These also attract dirt particles. In another operation, yarn is dried by passing heated air through a “package,” which is a spool of nearly finished yarn. This yarn acts much like a mechanical filter, retaining any dirt particles in the air.

The use of Precipitron air cleaners in ventilating and air-condi-

tioning systems has proved valuable in each of these operations. Not only has the rate of spoilage been reduced, but the plants can now operate in any kind of weather; previously many plants found it necessary to shut down certain operations on foggy and smoky days, or accept a high spoilage of yarn.

The latest manufacturer to utilize the Precipitron to advantage is a mill in North Carolina, which recently installed two 20000-cfm units in a yarn-drying process. Their results show a much higher percentage of clean yarn.

## For Accurate Motor Starting—The Slipsyn

**S**TARTING a synchronous motor used to be a job that required infinite patience, fast action, and a sixth sense on the part of the operator. But with modern controls—exemplified by the new Slipsyn automatic starter—the job is done surely, safely, quickly, and with highly accurate timing.

Heart of the Slipsyn starter is the new ASR synchronizing relay, a simple and sturdy device that applies the field not only at the proper speed, but also at the most favorable rotor position. This relay can be adjusted to operate over a range of frequency of the induced field current of 1 to 3.5 cycles—corresponding to 98-

to 94-percent motor speed (based on a 60-cycle motor). The relay is normally set to operate at the lowest frequency (highest motor speed) that the motor can attain under the most severe starting condition, so that maximum usable pull-in torque is available.

The Slipsyn starter also incorporates a pull-out relay to protect the motor in case it fails to synchronize, or if the motor pulls out of step after once being in synchronization. This relay can be adjusted either to open the line contactor, or to remove excitation by opening the field contactor and initiating a re-synchronizing action. The fast action of this relay is of especial importance, since the motor is more quickly resynchronized under load if the excitation is quickly removed so that the drop in speed is small.

Stator and rotor windings are each protected by individual relays to protect the stator against sustained overloads and rotor damper windings against failure of the motor to start.

The whole starter assembly is enclosed in a metal cabinet, and is completely factory wired and tested; all on-the-job wiring except external connections is thereby eliminated.

The Slipsyn motor control is available in a variety of standard interrupting capacities (ten times full-load amperes) as well as several high interrupting capacities up to 250 000 kva at 4800 volts, 3 phase, 60 cycles.

---

## For the Home

**Automatic Defrosting of Refrigerators**—Appliance engineering has eliminated an age-old nuisance to the housewife—defrosting the refrigerator. The purpose of this operation is, of course, to melt the ice that accumulates and restricts the flow of heat from the food to the coils. The old method is to shut the refrigerator off overnight or to use pans of hot water to melt the ice and frost from the evaporator. This can also be done automatically, but the objection in both cases is that everything else in the evaporator, including frozen food, is also defrosted.

A new automatic defroster does the job in a matter of minutes, during which the ice on the evaporator is melted but the food remains frozen. It consists of a heating element that quickly warms the refrigerant flowing through the coils. The warm refrigerant melts the ice and the water is conveyed to a large pan in the motor compartment of the refrigerator. Here it is evaporated into the warm air passing through the compartment. The heater is shut off when the temperature of the refrigerant, as it leaves the freezing coils, exceeds 32 degrees F, the melting point of ice. A counter operates the defrosting contactor to turn on the heater once every 60 openings of the refrigerator door, the average per day as established by tests.

**Toss-Away Bags**—The dirty chore of emptying a vacuum cleaner need be dirty no more. The dust, instead of being deposited in the conventional cloth bag, now accumulates in a Toss-Away bag, which is discarded after use. The bag, made of a specially developed paper with high filtering quality, slips over the metal nozzle at the base of the vacuum cleaner. Toss-Away bags are available for two models of Westinghouse cleaners.

**The "Rancho" Electric Range**—For small kitchens where storage space is at a premium, a new electric range—called the Rancho—provides space for a stool, wastebasket, or other kitchen item. Resembling a knee-hole desk, this electric range has four Corox surface units, two eight-inch and two six-inch, and features automatic oven-heat control. It can also be equipped with a platform lamp and oven timer, as accessories.

**Rigid-Mount Laundromat Washer**—The housewife is just as insistent as the plant manager that the equipment she purchases render trouble-free and economical service. Hence, the engineering of appliances must be just as skillful and ingenious as the engineering of industrial machines—even more so, for many thousands of a single appliance model are usually manufactured.

Consider, for example, the Laundromat automatic washing machine. One feature of the original model is its flexible mount-

ing, whose design involved considerable engineering talent. During the drying operation, the clothes basket, its driving equipment, and its nine-pound load rotate at a speed of 470 rpm, creating unbalanced forces. The magnitudes of these forces are reduced by eight coil springs that support the rotating equipment in the flexible mounting.

A new low-cost model of the Laundromat washer is rigidly mounted and of simpler construction because flexible equipment is not used. During washing, the operation and speed of rotation of the rigid machine is identical to that of the flexible machine. But during drying, the basket of the rigid machine rotates at a lower speed (360 rpm) than that of the flexible, the purpose being to reduce transmitted vibration. The supports of the new Laundromat are stressed in tension or compression only, and not in bending, to reduce any metal fatigue and eliminate the possibility of breakage.

Laundromats, like all appliances, are continually subjected to the close scrutiny of engineers bent on making improvements. A recent change in the Laundromat concerns the enclosed transmission, which provides the two speeds for washing and drying. To prevent leakage of oil from the gearbox, an oil-tight bellows is used around the solenoid-operated, speed-changing rod entering the transmission. This bellows was at first made of metal, but because it was only about four thousandths of an inch thick, it was somewhat susceptible to damage. A more durable bellows of synthetic rubber is now used.

Micarta gears have been employed for several years in many ways; for example, as timing gears in automobile engines. They reduce noise and friction and last longer than metal gears, and being more resilient, they help absorb shock. Such gears have recently been applied to the Laundromat washer. They are used as the planetary gears, between the pinion and ring gear, of the transmission.

**Automatic Dishwasher**—A new automatic dishwasher, the result of six years of engineering development and consumer testing, features a front-opening, top-loading design. Its washing cycles consist of a purge rinse, averaging 37½ seconds, a five-minute washing action, two separate one-minute rinses, and a concluding 22-minute drying cycle.

The new dishwasher is available in three models—a 48-inch electric sink, a 24-inch cabinet model that can be placed anywhere in the kitchen, and an under-counter model that can be built into new buildings or existing work surfaces.

Installation is simplified by the fact that existing drain plumbing can be used. Used water is pumped up to the drain.



Automatic Defrosting Refrigerator



Rigid-Mount Laundromat

Toss-Away Bags



Automatic Dishwasher

The "Rancho" Electric Range

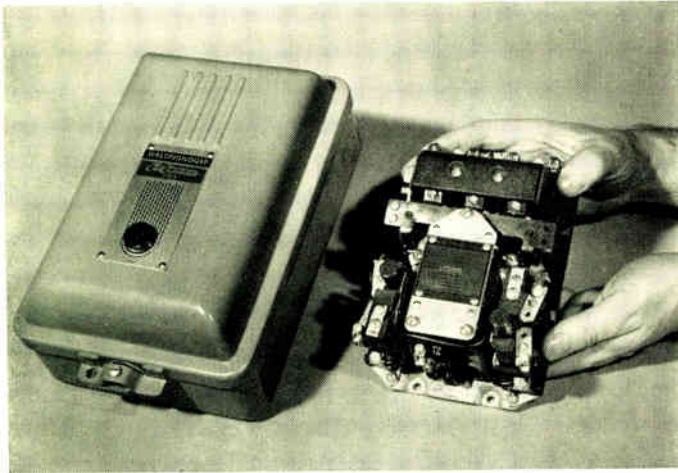


# What's NEW!

## The Life-Linestarter

**F**ORTUNATELY for progress, engineers are rarely completely happy with their brainchildren, no matter how marvelous they may be. Take linestarters for induction motors, for example. For years these devices have been considered reliable, and satisfactory for their purpose; now however, as a result of almost constant effort to improve them, engineers have come up with valuable new features, which are incorporated in the new Life-Linestarters.

Simplification and flexibility are the keynotes of this new design. For example, there is but one moving element in the whole



Shown here is the first of the new Life-Linestarters, the type N.

starter; this opens and closes the contacts. This moving member fulcrums on a hardened knife-edge, relieving most of the wear commonly associated with moving or sliding parts.

These starters are built in a wide range of sizes, up to 100 hp, 600 volts a-c (NEMA sizes 0 through 4), yet their basic design and appearance are the same. A De-ion arc quencher extinguishes, in a half cycle or less, the arc created when contacts separate, thus minimizing contact damage. Overload protection is by a bimetallic, snap-action, disc-type overload relay. By simple adjust-

ment this can be set for automatic, hand, or no-stop operation. In the automatic position the relay opens and resets itself. In the hand position, opening is automatic; resetting must be done by the operator. The no-stop position is similar to hand, except that the reset button cannot be used to stop the motor.

The basic starter mechanism can be used in a number of different ways. Open starters, without the usual enclosure, are particularly suited to built-in or panel applications. Careful arrangement of components in the starter enables removal of all parts from the front, eliminating the need for extra space adjacent to the starter for servicing. Special requirements are satisfied by several explosionproof designs, a dust-tight, sheet-steel enclosure, and a water-and-dust-tight construction.

When circuit protection and disconnecting means can be combined with the starter unit, a space-saving Life-Linestarter, incorporating an AB breaker and handle mechanism, can be used.

## New Stoplight for School Buses

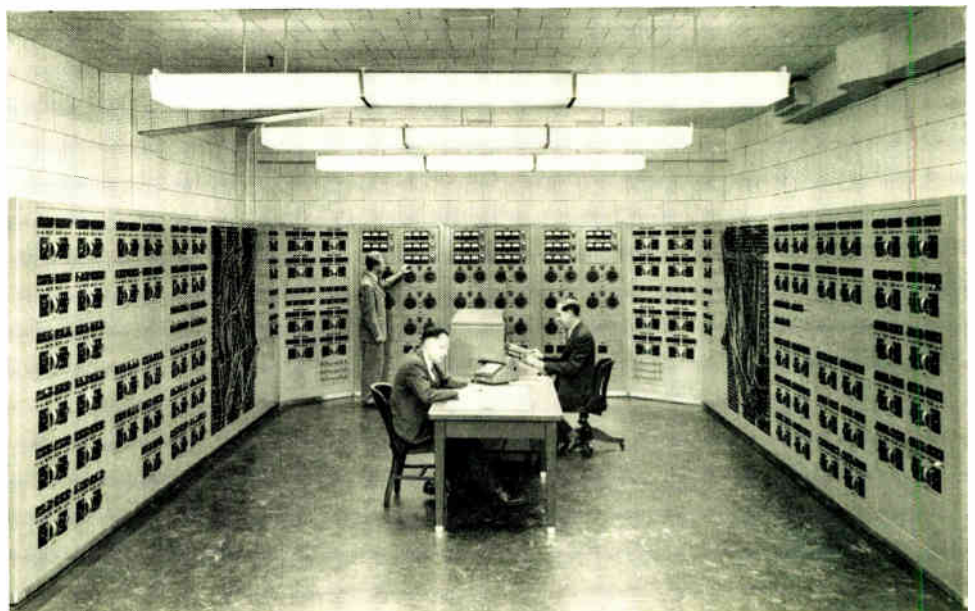
**M**OST motorists like to apply a healthy margin of safety when approaching a school bus from either direction. But such buses are often difficult to distinguish from other vehicles, so some definite and unmistakable indication is necessary. A new school-bus stoplight provides this identification.

Essentially, the stoplight is of the same design as the sealed-beam headlight, except for a treated, hard red glass lens. The glass used, a special type resistant to high temperature, is available only in a natural clear color. Formerly a red lacquer was sprayed on the outside of the lens to give it the distinctive red color. This was unprotected from the elements and from abrasive sand and dust particles, and eventually dulled considerably, cutting down the light from the lamp, and decreasing its visibility. On the new lamp a red stain is baked on the inside of the glass lens, eliminating the effects of weather on its color, with the net result that the lamp stays bright longer.

Laws concerning school buses are not universal as yet, but in 32 states motorists must stop when approaching a school bus halted on the opposite side of the highway. In addition most motorists automatically apply the brakes when overtaking a halted school bus—when they see it. This light will give drivers a greater warning, and thus increase highway safety.

## Network Calculator

Typical of the latest in network calculators for utilities is this installation at Consolidated Gas, Electric Light and Power Company of Baltimore. The calculator is being used to solve transmission and distribution problems characteristic of big-city systems. Across the nation, in San Francisco, is another unit, that of Pacific Gas and Electric Company. This calculator is being used for solving problems concerning long transmission lines. Because the equivalent of a long line may be represented by the well-known  $\pi$  circuit (series resistance and reactance, with parallel capacitance on each side), the components are already connected in  $\pi$ , thereby facilitating the setting up of a problem. These equipments are the 12th and 13th Westinghouse network calculators in the United States. For most problems, two men with such a calculator can accomplish in one week the equivalent of twelve men working approximately three months.



# Graphical Statistics—

## An Engineering Approach

**Facts and figures are so much Greek without some means of interpreting them. So it is with statistics, which have little or no meaning as figures, but whose interpretation can reveal much interesting and valuable information. The simple graphical method of statistical analysis provides such interpretation without complex calculation.**

L. R. HILL and P. L. SCHMIDT  
*Materials Engineering Department  
Westinghouse Electric Corporation  
East Pittsburgh, Pennsylvania*

WITH PROPER interpretation of their meaning, statistics are an invaluable aid in many kinds of engineering. A previous article\* introduced the basic concepts of a graphical method of analysis, demonstrating the use of probability paper as a means of studying engineering data. Nearly all the information necessary can be obtained from a probability curve drawn on this paper, namely, the average value ( $\bar{X}$ ), standard deviation ( $\sigma$ ), and how closely the data approaches a normal distribution curve.

However, statistical analysis with probability paper has far more utility than merely finding these results. It is possible, for example, to determine the interval within which the true average and standard deviation lie with a predetermined probability. Also it can be shown whether two distributions are actually different, or whether there is a high probability that they are from the same total distribution. The graphical method of solving these otherwise complicated analytical problems is easily understood, time saving, less laborious, and yields results that are as reliable as analytical methods.

### Confidence Limits for $\bar{X}$ and $\sigma$ .

Everyone who has used the graphical method of plotting distributions has become aware of the fact that the straight line drawn on probability paper is not necessarily the true distribution from which the finite sample was obtained. If a second set of observations is taken, and plotted on probability paper, a slightly different distribution is usually obtained. Thus it is obvious that a finite number of observations does not infer the true distribution with absolute certainty, because a finite set of values does not establish unconditionally either the true average or standard deviation of a distribution. However, in the case of the average and standard deviation, a group of data of finite size does allow the calculation, by statistical methods, of the intervals within which the true average and true standard deviation lie with a predetermined probability. In like manner, a finite sample gives an area, or envelope, on probability paper, within which the true distribution lies with a given probability. The significance of this envelope and the method of calculating its position are described in the following paragraphs.

Statistical theory tells us that if a number of samples of size  $n$  are drawn from a normal distribution of individual values having an average  $\bar{X}$  and a standard deviation  $\sigma$ , the average values of the individual samples of size  $n$  then form a new distribution whose most probable average is again  $\bar{X}$  and whose most probable standard deviation is given by the expression  $\sigma_X = \sigma/\sqrt{n}$ . It is this new distribution of the average values of samples of size  $n$  that is necessary in determining the sampling error in a mean value.

For example, suppose we have an infinitely large number of steel balls, whose diameters have been measured and stamped on them. Also assume that the distribution of the ball diameters is normal and that the average diameter ( $\bar{X}$ ) is 0.5 inch and that the standard deviation ( $\sigma$ ) is 0.004 inch. Now, if we pick from the infinitely large number of steel balls a number of groups of balls with 16 in each group and average these 16 values, the most probable grand average of the individual averages of the groups of 16 is again 0.5 inch and the most probable standard deviation of the individual averages of the groups of 16 is  $\sigma/\sqrt{n} = 0.004/\sqrt{16} = 0.001$ .

Before going further, it is of interest to note that a fundamental property of all normal distributions concerns the way in which the values group around the mean value. If one moves a distance on each side of the mean equal to the standard deviation, an interval is obtained within which about 68 percent of all the values of the distribution lie. A distance equal to plus and minus  $2\sigma$  includes about 95 percent of all values, while plus and minus  $3\sigma$  includes 99.73 percent of all distribution values.

This theory enables us to say that if we select one sample of 16 balls, then the average of the group of 16 lies in the interval  $\bar{X} \pm 3\sigma_X$  or  $0.5 \pm (3)(0.001) = 0.5 \pm 0.003$  about 997 times out of a thousand.

Looking at this from another standpoint, suppose we do not know the  $\bar{X}$  and  $\sigma$  of the infinitely large distribution, and that we obtain a sample of size  $n$  from the infinite distribution. If we then calculate the  $\bar{X}$  and  $\sigma$  of the sample of size  $n$ , we can say that the true average of the infinitely large distribution from which it was drawn lies within  $\pm 3\sigma_X$  of the average of the sample of size  $n$  with a probability of 0.997, where  $\sigma_X$  is estimated from the  $\sigma$  of the sample of size  $n$ , namely  $\sigma_X = \sigma/\sqrt{n-1}$ .\*\*

Going back to the example of the steel balls, suppose the true average and standard deviation are not known. If we then select a sample of 17 balls we might find that the  $\bar{X}$  and  $\sigma$  of the sample were 0.502 and 0.005 respectively. From this data we can estimate that  $\sigma_X = 0.005/\sqrt{17-1} = 0.005/4 = 0.0012$  and that the true average lies in the interval  $0.502 \pm (3)(0.0012) = 0.502 \pm 0.0036$  with a probability of 0.997.

The factor (three in the above case) by which  $\sigma_X$  is multiplied, determines the probability with which the true average lies within the calculated interval. Depending on how certain one wishes to be concerning the interval within which the

\*"Graphical Statistics—An Engineering Approach (Part I)" by L. R. Hill and P. L. Schmidt, *Westinghouse ENGINEER*, March, 1950, p. 120.

\*\*This formula as well as others in this discussion is derived from statistical theory. Since the method of analysis described here is for the practical use of engineers, no attempt is made to show derivations.

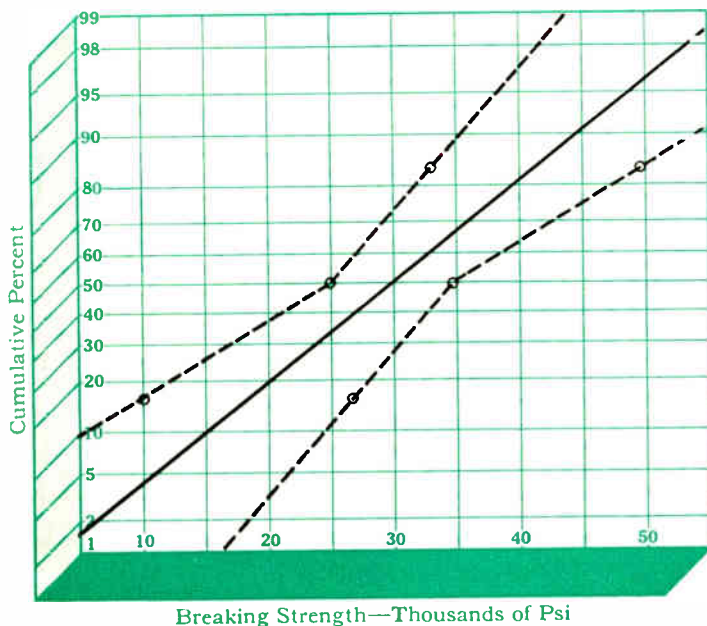


Fig. 1—Points on the 50-percent line are 4.8 units on either side of the curve; on the 16- and 84-percent lines, 8.2 units away.

true distribution lies, other factors can be chosen. If a probability of 0.99 is satisfactory, then the factor becomes 2.58 or approximately 2.6. If 0.95 is satisfactory, the factor becomes 1.96 or approximately 2.0 and if 0.9 is satisfactory, approximately 1.6 is used. The much misused term “probable error” of the average employs a factor of 0.6745, which means that the probability is only 0.5, i.e., there is a 50-50 chance that the true average is within the interval. Usually certainties of this order are not high enough for engineering work, where it is essential that predictions be correct much more often than half the time. In general, when a sample of size  $n$  is obtained, the true average of the distribution lies within the interval  $\bar{X}$  (of the sample)  $\pm k\sigma/\sqrt{n-1}$  with a probability that depends on the value of  $k$ . In like manner it can be shown that the true standard deviation lies in the interval,  $\sigma$  (of the sample)  $\pm k\sigma/\sqrt{2(n-1)}$ , with a certain probability depending on the value of  $k$ . The certainty level associated with various values of  $k$  is given in table I.

Referring again to the example of the steel balls, we selected a sample of 17 balls from an infinitely large distribution for which  $\bar{X}$  and  $\sigma$  were unknown, and found that the true average of the distribution was somewhere in the interval  $0.502 \pm 0.0036$  with a probability of 0.997. We can now also calculate the range within which the true  $\sigma$  of the infinitely large distribution of ball sizes lies. The true standard deviation lies in the interval  $\sigma$  (of the sample)  $\pm 3\sigma/\sqrt{2(n-1)}$  or  $0.005 \pm 3(0.005/\sqrt{32}=0.005) \pm 0.00265$  with a probability of 0.997. The probability level can be changed as desired by using a different value of  $k$  from table I instead of using  $k=3$  as was done in this example.

#### Method of Drawing Confidence Envelopes on Probability Paper

Suppose we have obtained a distribution of strength values as shown in Fig. 1 from a sample of 25 specimens. Consider first that only the average,  $\bar{X}$ , of this distribution deviates from the true average. From the preceding, the error in the

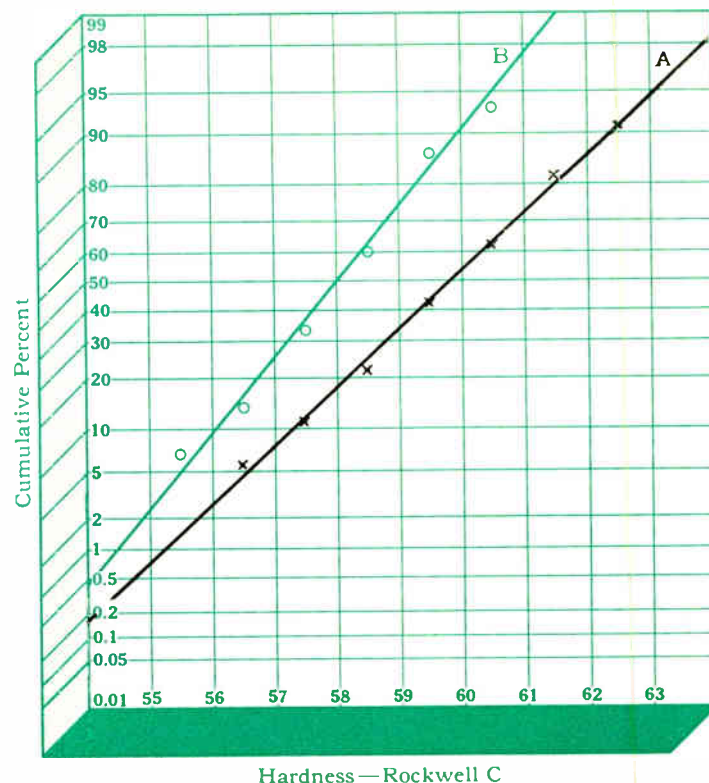


Fig. 2—The distributions above were obtained from the two sets of hardness data shown in table II. Using the methods outlined. . .

average at the 0.95 probability level is  $1.96\sigma/\sqrt{25-1} = 1.96 \times 12/4.9 = 4.8$ . Thus, if this were the only sampling error, the true distribution would lie somewhere within an envelope enclosed by two lines parallel to the original curve, one 4.8 units to the right and the other 4.8 units to the left.

Actually, however, there is also an error in determining  $\sigma$  from the finite sample, so that in addition to the error in the average, there is also an error in the standard deviation. This means that the two parallel lines forming the envelope can now change slope by rotation through a definite angle about the point where the parallel lines intersect the 50-percent line. Thus the region within which the true distribution probably lies is an hour-glass shaped envelope.

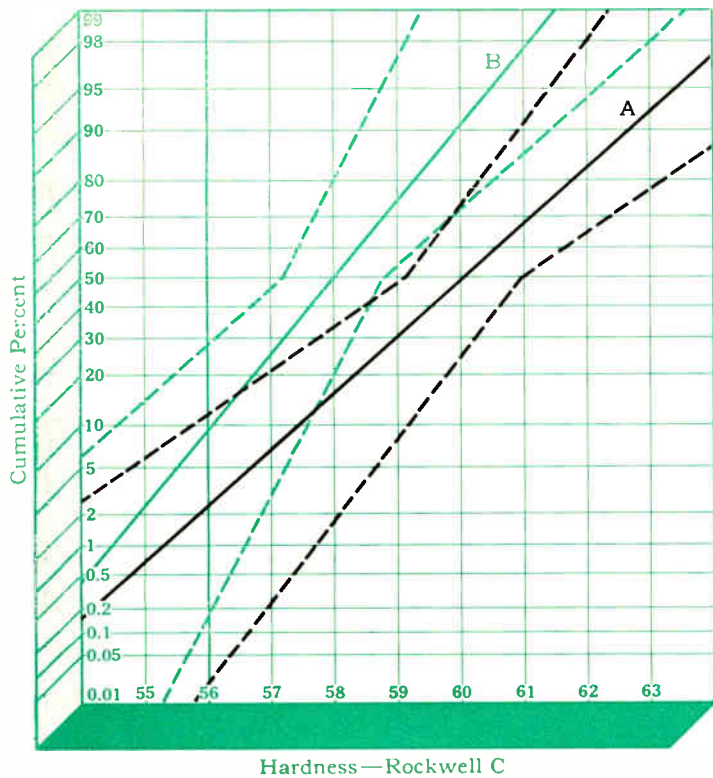
The envelope can be drawn as follows: First, select the probability level considered satisfactory. This determines the constant  $k$ , which is found from table I, used in determining the error in the mean and standard deviation. Suppose in this case the 0.95 probability level is used, making  $k=1.96$ . As already shown, the error in  $\bar{X}$  at this level is 4.8, so a point is placed on the 50-percent line 4.8 units to the right and 4.8 units to the left of the average value. The error in  $\sigma$  at the 0.95 probability level is  $1.96 \times 12/\sqrt{50-2} = 3.4$ .

If two points are placed on the 84-percent line 8.2 units ( $4.8+3.4$ ) to the right and 8.2 units to the left of the original curve and the procedure repeated on the 16 percent line, the confidence envelope can be constructed by drawing lines through these points as shown in Fig. 1. This is the area within which the true distribution lies with a probability of 0.95.

#### Significant Difference between Two Distributions

Another useful application of this statistical method is in comparing two sets of data to decide whether they were picked from the same or from different distributions. This is a rather general problem, in that many situations occur where a design or a process is changed and then the problem arises as to whether a real improvement has been made, and whether





... the confidence envelopes can be drawn (Fig. 3). From these curves the differences between processes A and B can be ascertained.

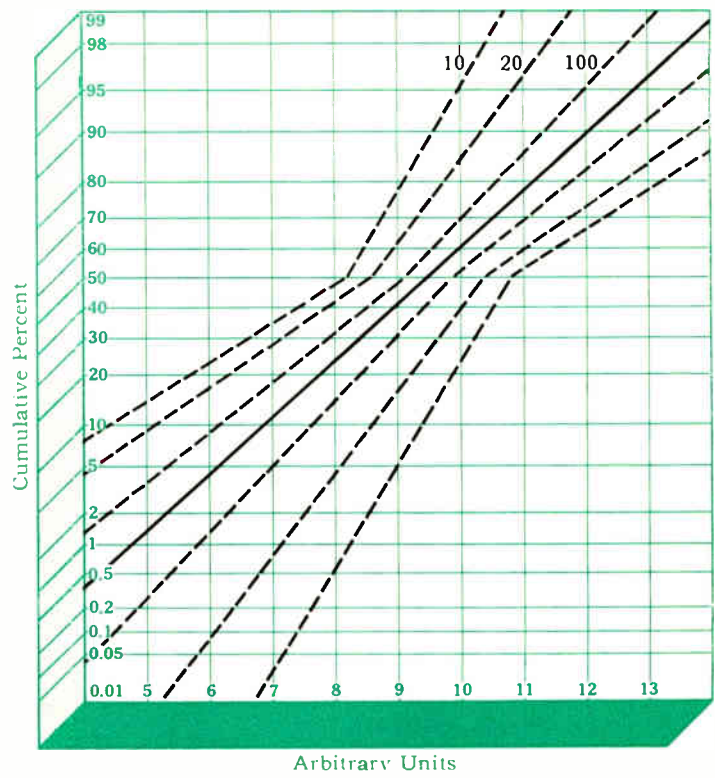


Fig. 4—These confidence envelopes show that the decrease in uncertainty as the number of observations is increased is not linear.

the change in results matches the economic factors involved. This concept cannot be overemphasized, since it is possible that an unrepresentative sample indicates an improvement where none really exists.

As an example, consider two sets of hardness data shown in table II, produced by a change in heat-treating process. Here the object was to increase the actual hardness as well as the piece-to-piece uniformity of the product.

These two distributions are plotted together on probability paper in Fig. 2. The average value of distribution A is 60 with a  $\sigma$  of 2, and for distribution B, the average is 58 with a  $\sigma$  of 1.5. From the considerations involved we would like to decide on odds of 19:1 that process A is really better than process B. Referring to table I, this gives a  $k$  value of 1.96 for use in calculating the error in  $\bar{X}$  and  $\sigma$ . This calculation is as follows:

$$\begin{aligned} \text{Uncertainty in } \bar{X}_A &= 1.96 \times 2 / \sqrt{20-1} = \pm 0.90 \\ \text{Uncertainty in } \sigma_A &= 1.96 \times 2 / \sqrt{40-2} = \pm 0.63 \\ \text{Uncertainty in } \bar{X}_B &= 1.96 \times 1.5 / \sqrt{15-1} = \pm 0.79 \\ \text{Uncertainty in } \sigma_B &= 1.96 \times 1.5 / \sqrt{30-2} = \pm 0.56 \end{aligned}$$

Using this data and the procedure previously outlined the envelope around each distribution line can be plotted as in Fig. 3. This plot shows that process A can be relied upon to produce higher average hardness more than 95 times out of

100. The variation in hardness produced by process A is definitely no less than that produced by process B. Now suppose that the application specification for this material requires a minimum hardness of 56 Rockwell C (indicated on the graph of Fig. 3 above). The variation factor thus is extremely important because 95 times out of 100 process A might produce as little as 0.02 percent or as much as 12 percent defective material. With the same degree of certainty, process B might produce as little as 2 percent or as much as 28 percent defective material. Neither process could be relied upon to give less than 5 percent.

The question of assuming that a distribution is really normal is often raised and the accuracy of these methods might be questioned because they are based on the assumption of normality. In those cases where the test or measured values lie largely within the certainty envelope for a distribution, it is obviously impossible to decide whether or not the distribution is really normal, so for engineering purposes the assumption of normality is usually justified.\*

\*For those who wish to be more rigorous, an analytical test can be used to determine significant differences. This test, known as Fisher's "t" test, involves calculation of the ratio of the difference between two averages and the most probable standard deviation of that difference. The resultant ratio, known as "t" must then be compared with tabular values, which delineate between significant and nonsignificant values of "t" for stated degrees of certainty. If one finds that the graphical method shows a significant difference between two sets of data, the "t" test will also indicate a significant difference at the same level of certainty since the graphical method of analysis is slightly more pessimistic than the "t" test.

TABLE I

Value of $k$	Certainty Level
0.6745	0.5
1.0	0.683
1.15	0.75
1.64	0.90
1.96	0.95
2.58	0.99
3.0	0.9973
4.0	0.99994

TABLE II

Sample A		Sample B	
Hardness (Rockwell C)	No. of Values	Hardness (Rockwell C)	No. of Values
56	1	55	1
57	1	56	1
58	2	57	3
59	4	58	4
60	4	59	4
61	4	60	1
62	2	61	1
63	2		

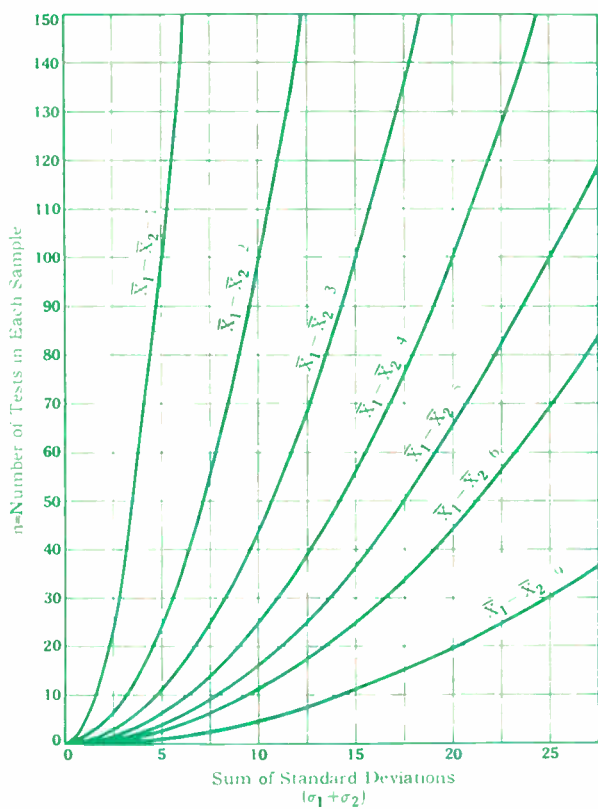


Fig. 5—These curves show the number of tests needed to establish significant differences between two sets of data.

The uncertainty associated with the real position of a distribution curve can be reduced to any desired value at the expense of additional observation. This increase in precision is not linear, but varies as the square root of the number of observations and so is susceptible to the idea of diminishing returns. The decrease in uncertainty as the number of observations is increased is shown in Fig. 4. If the cost per observation is fixed, it is obvious that certainty can be a very expensive commodity.

Two common questions that arise in the application of statistical methods are: first, what level of certainty should one choose, and second, how many tests should one actually make. Certainty level is actually a matter of personal opinion and experience. A level of 0.95 seems to be about the correct value for preliminary engineering investigations. In those cases where considerable capital expenditures are involved in latter stages of development and planning work, a level of about 0.99 is usually recommended.

Having decided on a level of certainty, the number of tests to be run must be planned. Without having prior information concerning the probable value of standard deviation and mean of the data, it is impossible to specify the number of samples needed; therefore one must obtain a value for  $\sigma$ . One method is to obtain a preliminary sample of six and estimate  $\bar{X}$  and  $\sigma$  from this sample. Then it is possible to calculate the number of samples necessary to show that two sets of data are, or are not, significantly different at any confidence level. In Fig. 5, the number of tests needed to establish significant differences between two sets of data is given, based on a separation of the 0.95 confidence envelope. This information is a convenient guide but is only approximate, since it is assumed that the same number of tests is made on both groups of samples and since both  $\sigma$  and  $\bar{X}$  are only estimates.

As a typical example, suppose that a preliminary sample of

six tests shows that a sample *A* has an  $X_1=35$  and  $\sigma_1=3$ , while sample *B* has a  $\bar{X}_2$  of 37 and a  $\sigma_2=2$ . The difference in the mean is 2, while the sum of the standard deviation is 5. Reference to Fig. 5 indicates that *n* should be about 25, or that we need 19 more tests. This is also useful for cases where the difference in the mean is greater than 9 since both parameters can be multiplied by 10 without changing the value of *n*, the number of tests.

A working knowledge of these simple graphical methods enables engineers with little or no statistical background to unscramble many complex and baffling problems. In some cases "engineering intuition" had been applied with negative results and it was not until statistical methods were used that a rational solution resulted. A previous article<sup>1</sup> showed the successful application of these techniques to the quality control of high-voltage insulation. Another example is the problem of determining how the size of an insulated structure affects the chance of failure. This problem was solved using some of these simple techniques.<sup>2</sup> For many years, engineers were somewhat confused concerning the manner in which the variation of surface resistance in individual magnetic laminations affected the loss in electrical machines. This situation was finally cleared up by the application of the statistical methods<sup>3</sup> described here.

Application of distribution curves to studies of the quality of raw material used in manufacturing has often resulted in better products. Materials subject to these studies have included such things as electrical steel, banding wire, spring steel, cotton yarns, capacitor paper, insulating varnish, lubricating greases, precision castings, and many others.

Although variation cannot be entirely eliminated, by the use of simple graphical methods, its effect on our products can be predicted, and, finally, adequately controlled. This use of simple statistical methods is increasing, and can be applied by many design and manufacturing engineers to their own particular problems.

REFERENCES

1. "Statistics—The Insulation Engineer's Crystal Ball," by William Schneider and G. L. Moses, *Westinghouse ENGINEER*, September, 1948, p. 150.
2. "Insulation Breakdown as a Function of Area," by L. R. Hill and P. L. Schmidt, *AIEE Proceedings*, Vol. 67, 1948.
3. "Interlaminar Eddy Current Loss in Laminated Cores," by A. C. Beiler and P. L. Schmidt, *AIEE Proceedings*, Vol. 66, 1947.

Bound Volume Service

If you wish to maintain a permanent file of the Westinghouse ENGINEER for reference, you may send your copies to the address below for inclusion in an attractive, rust-colored Buckram binding. Two years' issues are included in a single book, with an index; missing copies will be supplied, if available, at the following prices, postpaid.

	Cost of Binding	Cost of Each Missing Issue
Vol. 1 and 2		
Issues of 1941 and 1942	\$3.50	\$0.50
Vol. 3 and 4		
Issues of 1943 and 1944	3.50	0.50
Vol. 5 and 6		
Issues of 1945 and 1946	3.50	0.35
Vol. 7 and 8		
Issues of 1947 and 1948	3.50	0.35
Bindings for 1949 and 1950		
issues are not yet available.		

Send your copies, carefully wrapped, and marked with your name and address to:  
 Westinghouse ENGINEER  
 306 Fourth Avenue, Pittsburgh 22, Pa.

# Personality Profiles

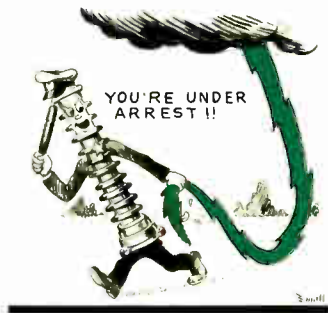


George W. Jernstedt tackled a tough problem when he decided to wage war on corrosion, tarnish, and rust—but thus far he has had outstanding results. His developments started with beryllia plating, in which beryllium oxide is deposited on silver or copper to ward off tarnish. They continued with a pre-dip process for phosphating that enhances the normally good qualities of Bonderizing; and with bright alloy plating, which results in superior finishes from copper, zinc, and tin alloys.

Jernstedt's career with Westinghouse began in 1937, shortly after he graduated from Newark College of Engineering with

a B.S. degree in chemical engineering. Immediately thereafter he resumed his studies, doing post-graduate work in physio-chemistry and electro-chemistry at Polytechnic Institute of Brooklyn. In 1939 he was awarded the Westinghouse Lamme Scholarship, with which he obtained his Master's degree after a year at Michigan State. In March, 1946 Jernstedt was appointed manager of electro-plating projects, the position he now holds.

Two years ago, Jernstedt described on these pages a new process—PR plating; now he is back with a story of an improved PR process, and its applications.



Last summer we spoke of Edward Beck as the "one-time" leader in the author derby. With this issue, Beck ranks as the all-time sweepstakes winner, having appeared between our covers eight times. Seven of these articles pertain, and most logically so, to lightning and lightning protection, the field of Beck's work since joining Westinghouse in 1923.

Reading all of the articles that have been authored or co-authored by Beck in the last eight years could be likened to taking a short course in lightning and lightning arresters. Beginning with two

elementary pieces, "Lightning Strokes Prefer Tall Structures" (July, 1949) and the article in this issue, the course includes "Comparison of Lightning Protection Devices" (November, 1942), "Selection of Lightning Arrester Voltage Ratings" (February, 1942). Also "Lightning Protection for Railway Signal Circuits" (November, 1943) and "Lightning Protection for Rotating Machines" (March, 1944 and May, 1949). Beck co-authored an article on the electronic oscillograph (November, 1944), but aside from this one instance he has not strayed from the field of his choice.

The team, consisting of C. J. Tirk and his favorite oscillograph, has made measurements in some highly unusual and interesting places. They have conducted tests in airplanes at 10 000 feet, at sea level on ships on both oceans—and even 500 feet underground. And among other things Tirk has made tests at 300 mph on planes, at 125 mph on locomotives, and at 1/10 mph on an electric shovel. Tirk estimates that in the course of making various tests, he has covered over 300 000 miles in the United States and Canada.

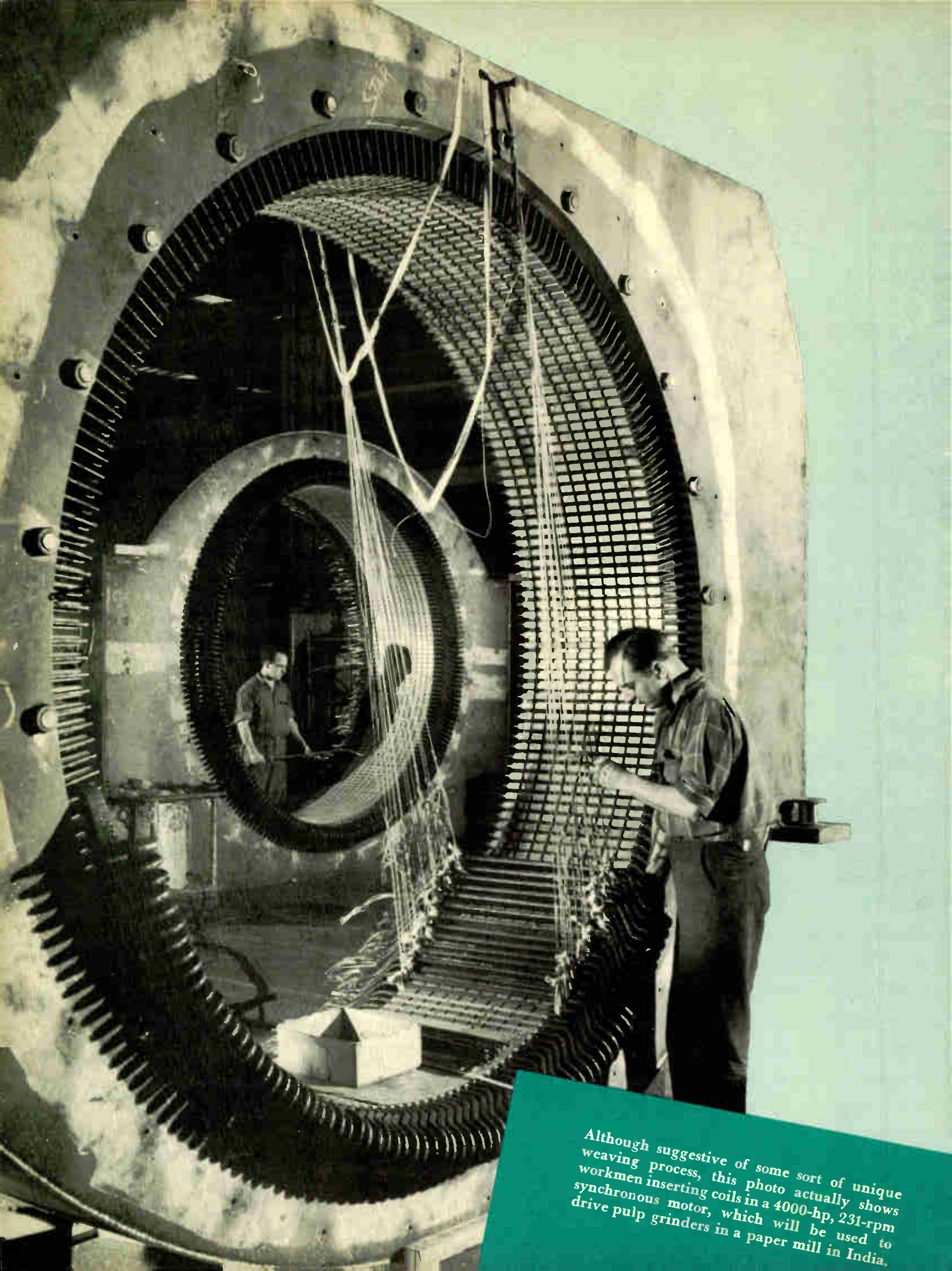
Tirk's career with Westinghouse has been almost as varied as the kinds of tests he has made with the oscillograph. He came to Westinghouse in 1920, spending the first few years in the Micarta Department and the Small Motor Department, and concurrently attending Westinghouse Technical Night School. Deciding that he would like to broaden his knowledge of the Company's various activities, Tirk spent some time in a great many, including such widely varied departments as Accounting

and Shipping, and Switchboard Wiring. After his graduation from night school, Tirk went to work in the Engineering Laboratories. Since then he has worked in nearly every laboratory in this group.

In his work in the Oscillograph Laboratory, Tirk has taken mechanical and electrical test oscillograms on a wide variety of devices, including circuit breakers, gears, ignitrons, motors, transformers, steel mills, oil wells, and turbines. In between these assignments Tirk spends his time at the laboratories developing new apparatus for making oscillograms.

Although all these activities would seem to leave him few leisure hours, Tirk has found time to build and operate an amateur radio station (W3KTP), and talk to many foreign countries. Considering his numerous travels and activities with the oscillograph, we strongly suspect that maybe Tirk's nocturnal talks via radio are merely an attempt to find more troubles in some far distant place that he and his oscillograph could solve.





Although suggestive of some sort of unique weaving process, this photo actually shows workmen inserting coils in a 4000-hp, 231-rpm synchronous motor, which will be used to drive pulp grinders in a paper mill in India.