

hambrew

FOR AMATEUR RADIO DESIGNERS AND BUILDERS

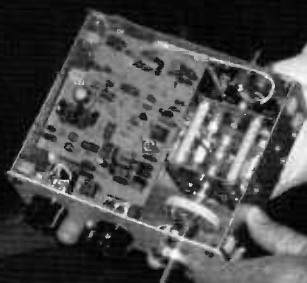

GLEN REID, K5HGB
Sub Exp: 7-94
1305 CARLOTTA LANE
AUSTIN, TX, 78733

**Inside The Shack
Of W5NOE**

SUMMER 1994

- PORTABLE QRP CW TRANSCEIVER -
DEC. '90 & JAN. '91 QST BY GARY BREED K9AY

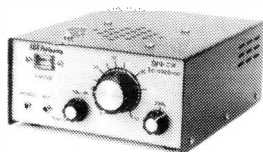

Features: SINGLE-SIGNAL receiver, VFO tuning, AGC for listening comfort, 5 Watts output, Semi-QSK TR switching and CW sidetone. Add a battery, key and antenna and you're on the air. FULL 100% KIT including a custom pre-painted, punched and lettered metal enclosure. 20, 30, 40 Meter available.

Complete Kit Only \$159.95

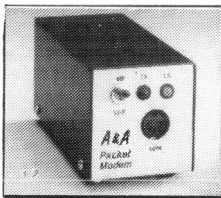

**BayCom
Compatible**
Low Cost Packet
for PC / Clones

Features: Software-based PACKET that makes your computer emulate a TNC. Modem connects from serial port to RIG. Watchdog timer & reed relay PTT standard. Operates from 12VDC @ 100ma, wall power supply included. Uses crystal controlled 7910 chip, VHF and HF. Lock & TX LED indicators. Free copy of Version 1.40 English software included.

Kit.....\$59.95 Enclosure.....\$10
Assembled & Tested in Box.....\$89.95

WEATHER FAX

Satellite & HF FAX for IBM / Clones



Shown with optional 20 LED Tuning Aid

Features: Processes WEFAX, VIS & IR NOAA, ME-TEOR, APT, 240LPM, 120LPM & HF WEFAX. Connects to Computer Line Printer Port. The software was created by Dr. Ralph E. Taggart, WB8DAT. For details see Chapter 5, Fifth Edition of the *Weather Satellite Handbook*.

Complete Kit Only\$159.95
Assembled & Tested\$189.95
Optional 20 LED Tuning Aidadd \$ 40.00



**- Smart
Battery
Charger**



JUN 87 QST

BY WARREN DION N1BBH

FOR GEL-CELLS or LEAD ACID BATTERIES.

Features: Precision temperature tracking voltage reference & three mode charging sequence. Standard kit is for 12V @ 1/2 or 1 Amp, user selectable. Can be connected to the battery indefinitely, will not overcharge. Weighs 2 pounds and measures 4"W x 5 1/2"D x 2 1/2"H. Finished enclosure included in kit.

Complete Kit Only\$59.95
Assembled & Tested\$79.95



450 MHz SPECTRUM ANALYZER

Adapted from Nov. 85 QST article
by Al Helfrick K2BLA

Complete Kit Only . . . \$459.95
Assembled & Tested . . \$799.95

FEATURES: Three digit LED center frequency digital readout. 12 position calibrated scan width 1KHz to 50MHz, switchable bandwidth; wide = 300KHz, narrow = 10KHz. Use your low frequency scope for the display portion. Switchable 10KHz video filter. Variable IF attenuator, LOG output calibrated in 10 db steps.

CA Residents add 7.75% sales tax. S&H: \$5.00 (insured). Foreign orders add 20%. For more info or price list send legal size SASE (52¢) to:



A&A Engineering



2521 W. La Palma #K • Anaheim, CA 92801
(714) 952-2114 • FAX: (714) 952-3280

• Contents •

Letters	4
Kit Review: K6LMN Kits Single Conversion Superhet	7
A Crystal Controlled Signal Generator: Carl Merrill, N1QLC	9
New Products: Ramsey RF Sniff-it Probe	16
Neophyte Roundup	17
A Unique Wide Range 80 Meter VXO QRP Transmitter: Roy Gregson, W6EMT	21
The Pipsqueak X-1 40 Meter Transmitter: <i>Hambrew</i>	27
The NG7D 20 Meter One-Der: John Christopher, NG7D	28
20/20 Hindsight	31
Kit Selection and Construction Practices: Bruce O. Williams, WA6IVC	35
He Still Rolls His Own: Fred Bonavita, W5QJM (Cover Story)	38
Wires and Pliers: Don McCoy, WAØHKC	45
Thoughts on Theory: James G. Lee, W6VAT	43
Classified Ads	46

Photographic Credits:

*Front Cover, pp 38, 39, 41: Don Randall, WB5ROU; pp 9, 10, 12, 15: Carl Merrill, N1QLC
p. 28: John Christopher, NG7D; p. 34: Dave Clingerman, W6OAL*

hambrew

COPYRIGHT 1994, Smoking Pencil & Co.
All Rights Reserved

FOR AMATEUR RADIO DESIGNERS AND BUILDERS

SUMMER, 1994 • VOL. 2, NO.3

Publisher.....George De Grazio, WFØK

Contest Editor.....Bruce Muscolino, WA6TOY/3

Writers, Editors and Contributors:

*Fred Bonavita, W5QJM; Bruce O. Williams, WA6IVC; Don Randall, WB5ROU;
Dave Clingerman, W6OAL; Roy Gregson, W6EMT; Dick Pattinson, VE7GC; Carl Merrill,
N1QLC; James G. Lee, W6VAT; John Christopher, NG7D; Don McCoy, WAØHKC*

Ads & Subscriptions: 1-800-5-HAM RIG • Editorial Office: (303) 989-5642

Hambrew is published quarterly by Smoking Pencil & Co., Publishers, Offices at 13562 West
Dakota Ave., Lakewood, Colorado 80228. Application to Mail at Second-Class Postage Rates
is Pending at Denver, Colorado. POSTMASTER: Send address changes to
Hambrew, P.O. Box 260083, Lakewood, CO 80226-0083.

Hambrew is sold by subscription only.

\$20 per year (domestic), \$35 (foreign), \$25 (Canada and Mexico)

We welcome submission of articles, photos and manuscripts (S.A.S.E. for return)

• LETTERS •

From The Publisher

Summer is here. The golf courses, streams, lakes, baseball parks and picnic grounds beckon would-be hambrewers around the world to desert their work benches in lieu of the great outdoors. I cannot help but agree that the lure is mighty irresistible. I've weakened to the extent of making junkets here and there to satisfy the urge to fish, travel and whack weeds at the local golf course, but I've noticed lately that building and operating still seem more satisfying and do remain to take priority over the paucity of quality evening programming to be found on the commercial video bands around here, in spite of the sixty-whatever channels available on cable. I hope you are keeping your hobby going, if even at half-throttle.

If not, we'll try to stimulate your imagination with this issue, which contains some notable new ideas brought to fruition: a new contest schedule is herein revealed, of which we hope you will avail yourself with participatory zeal. We are pleased and proud to introduce *Hambrew* Contest Editor **Bruce Muscolino, WA6TOY/3**, who proposes some very interesting and fun ideas which we think you will enjoy, plus our contests are deliberately formulated to award extra points to operators who build their own equipment. The Pipsqueak transmitter has put some spin on a new award which is offered in a spirit of lighthearted operating adventure, since we want to stimulate your operating appetite as well. We are delighted to have Bruce on board.

W5QJM, Fred Bonavita, introduces us to a truly great homebrewer, **Dave Anthony**,

W5NOE, who graces our cover this issue. Thanks, Fred, for a really fine profile! **Carl Merrill, N1QLC**, provides a neat crystal controlled signal generator as a test equipment project. It has been said that to design a tool is the highest achievement level of design, whether electronic or mechanical/physical. If this is true, then Carl favors us herein. **Dick Pattinson, VE7GC**, exhibits the innards of a preamp/AGC/S-meter circuit for the Neophyte which we like very much.

Roy Gregson (W6EMT) is a truly creative designer and homebrewer who has adapted a VXO circuit which exhibits a broad range of frequency tuning-width into his 80 meter transmitter shown in this issue. The cunning schematic reclines upon the centerfold.

NG7D, John Christopher also contributes to the Rig-O-Rama effort with the One-Der, and it's a wonder! John performed surgery on the Oner transmitter originally from the UK., and shows us how. **Bruce Williams, WA6IVC**, has another great installment in the QRP Design and Construction Series. Warm up those irons for the Autumn Issue, as Bruce will start us building circuits. It will be a real opportunity to learn on the inside track with a kit designer.

Theory is part of homebrewing, and we embark on a theoretical investigative series by **Jim Lee, W6VAT**. He will show us in a circuit-specific manner how the cow eats the cabbage.

So Summer doesn't have to mean cobwebs on the solder roll *or* the main tuning knob! Enjoy, and we hope to hear you on the air in the contests soon! -George

RIG-O-RAMA

WINNER TO BE ANNOUNCED AUTUMN, '94

...I have really enjoyed the two issues I have received so far...the best magazine I have seen in my nearly 30 years of playing with radios! By the way, I am currently building a SSB Transceiver for 40 meters. I will send you a picture when its done. Thanks for putting out a great magazine.

Jim Gates, WAØNOV
Boone, IA

I am sending you a marked up copy of the spring issue of Hambrew. I of course know that you are free to dismiss my comments by "you cant (sic) please everybody", "just a bitter old b....d", or other maybe true responses.

I do however feel that many years of experience and training qualifies (sic) me to "air" my views for your consideration.

Realizing that anyone can complain I also offer the following subject matters for your consideration, with the thought in mind only breif (sic) coverage can be provided in your format. 1. How to install PL259 connectors or RG/8 ect (sic) coax.

-Not another solder through the holes statement. Everyone knows this will not work worth a d.n. Folding the shield back over the insulation and screwing on the PL259 is the real accepted method. Soldering is easier if you choose this ridiculous method by installing shrink tubing under the shield to protect center of coax. 2. How to calibrate your pwr meter- not a dumb article to compare it to a known good one. 3. A remote RF field sensor. A sensor to be placed in remote ant field and field strength transmitted (not on wire) to indicator in shack so matching-adjustment for min SWR in shack does not necessarily correspond to max radiated pwr. A remote monitor will also show ant changes that no shack meter will do. 4. Packet to VHF-HF switch. A switch to select connection of either VHF or HF rig mikes and audio to TNC both with and without spkr monitoring. NO RFI PLEASE! The MFJ switch will work for only one rig and not very well at that! 5. How to install a tower-tilt or walk-up. An article on what it takes to really install- raise & lower a tower. The term "walk up" is a great sounding adv. but is total BS. 6. A freq compensated signal pickup-or

two for monitoring transmitter-linear output to feed line. 7. A total station disconnect panel-including gnd. A simple disconnect panel using plugs, no d.n switches, for protection of all station equipment. Must leave all shack equipment free of any connections, ant-rotors gnds. pwr lin-phone line ect. (sic)

Thanks for your attention. 73s

C.W. Bovender KD4KOX

Greensboro, NC

Dear C.W.,

Though I cannot apologise for the articles related to QRP gear which you have so thoughtfully marked for my attention in the Spring Issue, I will point out that we have never announced ourselves to be a strictly QRP-oriented periodical. As it seems that many many of the builders in the ham community do build gear which relate to QRP operation, and since I am a QRP builder/op myself, I suppose that I am and do seem grateful for each and every QRP-related project that comes across my desk. However we do wish to pursue and publish articles having to do with the topics which you have set forth! And I can see some interesting projects in your list, C.W.. I really do regret that we cannot simply get to work on filling out your requests, for the simple reason that we cannot mail-order topics without the interest and participation of qualified ham-builders who have taken the time to pursue each specific topic area.

Yet I will publish your letter and this response in the hope that one or more of our readers will take an interest and come up with some information, though I suspect that you may know the answers to some of the problems already. How about an article from you on one or more of them?

Dear George:

I think that you have a very fine publication underway and I certainly hope that the market supports it. I'm enclosing my subscription herewith.

Good luck with your mag. Very fine publication.

73,

Ade Weiss, WØRSP

Vermillion, SD

The operator of the above-named Amateur Radio Station
has achieved the distinctive status of

Certified QRM Fighter

For having achieved two-way communication with
"The Pipsqueak" QRP Transmitter, Power Out: _____ Mw
operated by WJGR/QRP

Awarded this day of _____ Certificate Number _____
Date of Contact _____ Time of Contact _____ Frequency _____
By _____

Work The Pipsqueak For This Award...

This certificate will be awarded for two-way CW contact with The Pipsqueak, which will be on 40 meters at 7.040 MHz +/- 4 KHz every Sunday evening, operator willing, at 0400Z. The certificate costs nothing and will be mailed postpaid.

It will be awarded based on contact and entry in the WFØK logbook. Allow two weeks for delivery.

Working the pipsqueak with a homebrewed receiver will count as a Class A certificate; any factory-constructed receiver used will count as a Class B certificate. Class of operation not indicated in the exchange will be awarded a Class B certificate.

The Pipsqueak will be on the air beginning August 7th, 1994, and will return each Sunday at 0400Z until further notice. Certificate numbers will be awarded in sequence with contacts beginning August 7, 1994. Contacts and numbers will be published in future issues of *Hambrew*.

BACK ISSUES OF HAMBREW:

To keep your **Hambrew** collection complete, we still have a number of back issues available. Our Inaugural Issue was Autumn, '93. We're told it's already a collector's item. Back issues are \$6/each, mailed in an envelope via first class mail. Supplies are limited.

KIT REVIEW

K6LMN Kits Single Conversion Superhet

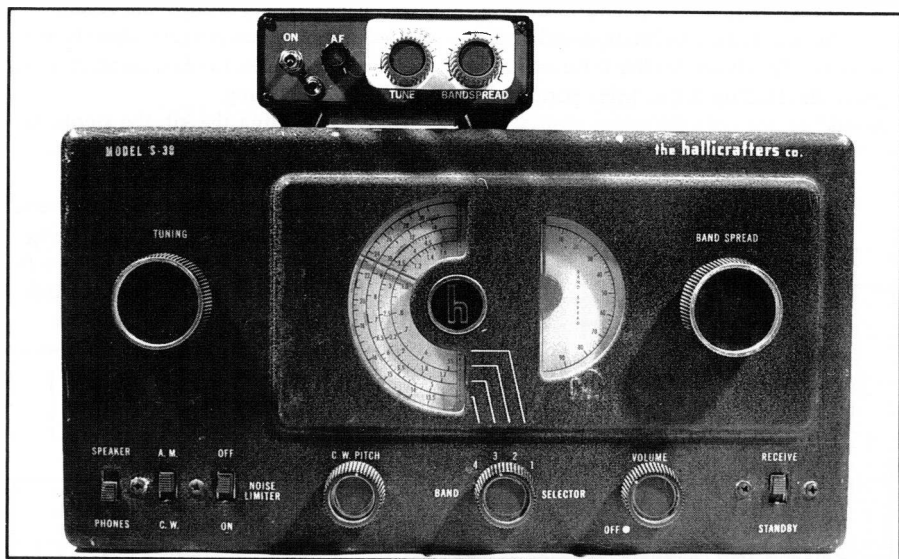

The K6LMN Superhet is dwarfed by a classic Hallicrafters Receiver

Based on a tip from John Christopher, NG7D, in California, we contacted a ham in Los Angeles by the name of Roger Wagner, K6LMN, who sells a single-conversion superhet receiver kit. This particular kit is designed for tailoring to SSB, CW and AM modes on the buyer's choice of 80/75, 40, 30 or 20 meters.

Upon hearing that the VFO is a varactor-diode tuned type, the first thought was that this could be another "drifter" destined to wander up or down the band aimlessly, making communications-level operation a joke at the operator's expense. To belay the suspense, if any, it turned out that after a short warm up (5 minutes, plus or minus) the receiver is stable to a very tolerable extent. K6LMN offers alternatives of construction if the 100-200 Hz nega-

tive-going drift is unacceptable to the constructor.

Figure 1 shows the block diagram of the design. From it may be seen that there are three chips on the board: two NE602ANs, and a LM386. Two crystal filters are also supplied.

The unusual and fun thing about this K6LMN kit, and we suspect that it could be true of the other kits which Roger is developing, is that it is an *experimenter's* kit. By this we mean Roger has presented alternatives for a builder who wants to customize or play with the possibilities of configuration of sections (within reason). A quote from the instructions will perhaps illustrate this angle:

"With a 9.000 MHz i.f. filter the oscillator must be offset 9.000 MHz lower or higher than

(Continued from page 7)

the desired 20M signal, i.e., 5.000 MHz or 23.000 MHz for 14.000 MHz antenna input frequency. In the interest of good oscillator stability the lower frequency 5.000 MHz is desirable. Thus to tune the entire 14.0 to 14.35 MHz band the VFO must tune from 5.000 to 5.350 MHz respectively. An external digital frequency counter connected to the VFO can provide continuous frequency readout of the received signal. Connect counter to U-7 via a small capacitor like 10-47pF (to avoid loading the VFO). Simply add 9 MHz to the reading or ignore the leading 5.xxx MHz portion displayed."

come into contact with his kits.

The kit includes components with two variable pots for panel mounting, the PCB and instructions. The instructions are not the step-by-step type. Building the kit involves looking repeatedly at the parts-placement diagram and the parts list. As the board is not screened to locate the position of the components, care must be exercised to position the parts-leads in the correct holes, but there are etching pattern clues on the drawing to aid in this regard. We did add a band spread pot (500 ohm) to avoid installing a reduction drive on the main tuning control for fine tuning.

Upon completing the kit, the smoke test

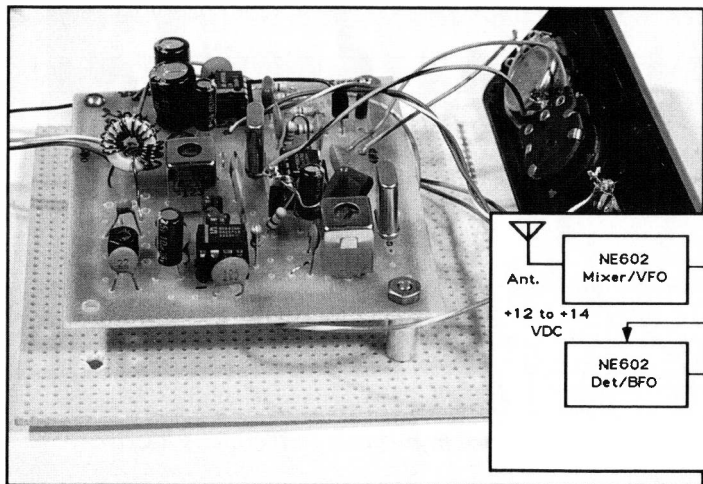

Left: Bandspread aids fine tuning. Below (Figure 1): Receiver block diagram

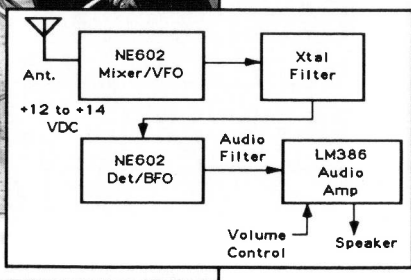

Roger goes on to point out possible alternate i.f. frequencies which could be used, and he locates the points of modification in the resonant circuitry to accomplish this. There are other examples of the options available to the builder which make this much more than a cookbook, color the numbers or follow the bouncing ball type of kit.

What results is that the builder finds himself thinking of other approaches with a modicum of guidance from the designer. This gives insight to the builder and helps to understand what is happening and why, to begin to think creatively about the project, and to share in the design to some degree...unique! It becomes obvious that Roger enjoys his designing and enjoys sharing that knowledge with those who

produced reception of a RZ1 station in St. Petersburg, Russia, a QSO between a JA in Mexico City and a Bolivian station, and a QRP 1-lander calling CQ. Later we heard a KH6/QRP (all CW)....this receiver is sensitive. Audio gain is sufficient for a speaker at low-level audibility, though an additional 386 chip would give it more AF oomph. The QSK is a twin-diode/coil configuration, perhaps a very slight bit lossy, but not enough to prevent reception of the stations heard in the above examples.

Ready for the best part? The retail price of the kit is \$20 plus \$3 shipping and handling.

K6LMN Kits, 1045 S. Manning Ave., Los Angeles, CA 90024. Send S.A.S.E. for catalog.

A Crystal Controlled Signal Generator

Carl Merrill, N1QLC

22 Buxton Avenue, #2, Somerset, MA 02726-4454

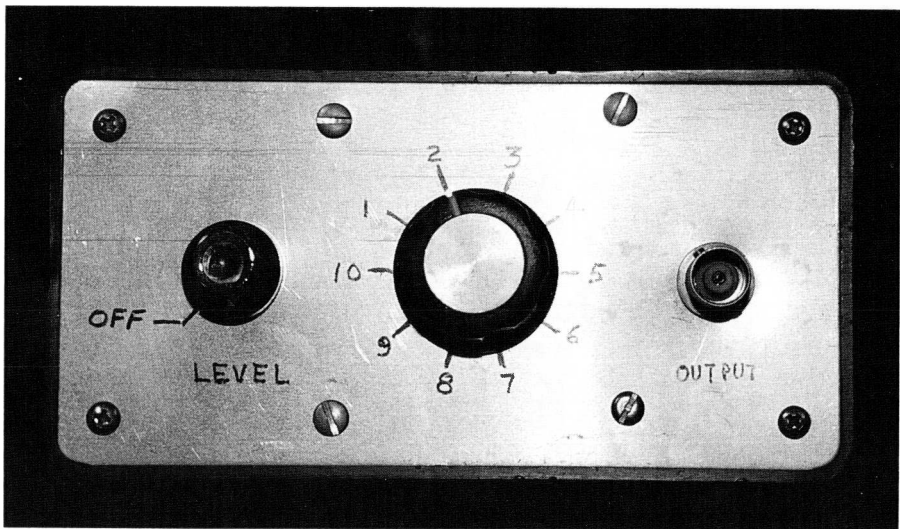

Photo 1: Front panel of the N1QLC Signal Generator

Ever had the need for a quick method of generating some of the I.F. Frequencies like 7.7975, 7.800, 7.8025, 10.6925, 10.6950, 10.6975, 10.700, 10.000, etc.? With this handy little gadget you can generate crystal controlled signals in the 1 to 20 MHz range.

It consists of a Colpitts crystal oscillator (Q1), and a buffer amplifier (Q2). Q1 and the selected crystal and its trimmer capacitor determines the frequency of oscillation. The trimmer capacitor allows the crystal to be trimmed "Right On" frequency. The frequency is amplified via Q2, a Dual Gate FET. Gain of the stage is controlled via a DC control voltage on G2 of the FET. Output is coupled to a BNC jack on the front panel. It is very stable, with low long-term drift. Uses HC-18/U or HC-25/U crystals.

PC Board: All holes are on .100" centers,

simplifying construction. Use the drilling template to drill the holes in the board, or use a .100" grid board for a drilling jig. If using a grid board as a jig, clamp the two boards together with small "C" clamps. The crystal locations are drilled for both .200 and .300 inch spacing, depending on which type of crystal socket you may decide to use, if any. The use of female socket pins from a "Winchester" type connector will make socket pins for the crystal, mounting it into board with a # 55 or \$ 56 drill.

Construction: Use the drilled pc board to locate the switch and spacer mounting holes. Layout the front panel, drill mounting holes. Mount components to front panel. Complete pc board, putting about 1" wires into solder lands at top of each crystal, for connection to switch. Mount to front panel with 1/2" spac-

ers. Connect the switch to the board by the aforementioned wires. Wire up the control, and the BNC output jack. Connect the black wire from the battery clip to the GND buss. Connect the power switch, S2 to the battery + and in series to +9 buss. Connect the output BNC jack to the output pad at C17. Run a black wire from GND buss to ground on front panel.

Label the front panel using press on labeling, etc. The 10 position switch can use a "Croname" type label, or use your imagination. We used a separate typed sheet stuck to the top of the enclosure to indicate the frequencies according to switch position.

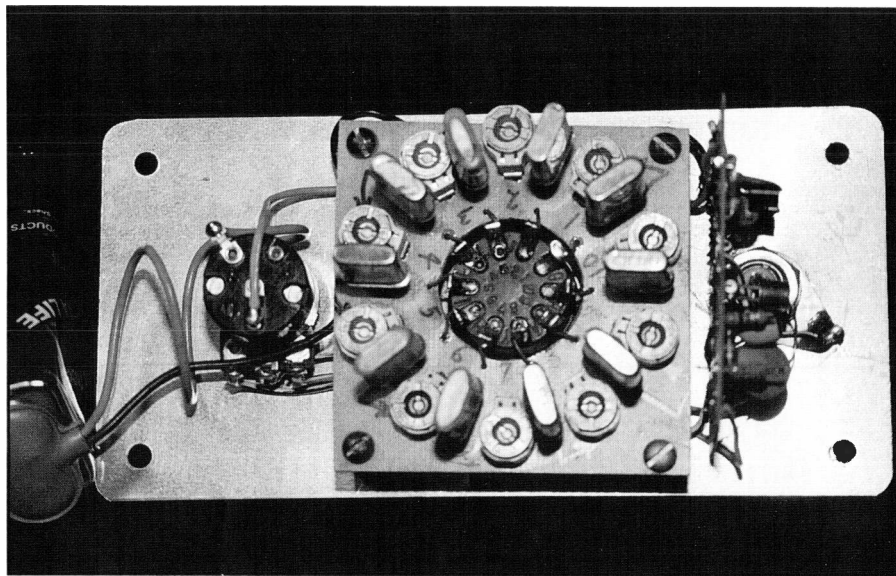

Photo 2: Rear of panel, showing crystal board, switch wiring and crystal and trimmer orientation

Checkout: Check all wiring for shorts, install the crystals of your choice. Connect the output to a Frequency Counter and adjust the trimmers for each individual crystal for the proper frequency outputs. Note* there are additional holes near each trimmer in case they would be needed. Prototype used 7.8 MHz, 10.695 MHz, 9.025 MHz, and 10.0000 MHz families.

Usage: Use the 10.000 MHz to check out frequency counters, SW Receivers, etc. The 10.6925, 10.6950, 10.6975 MHz crystals are especially useful. By injecting them into the IF strip of some of the 10M transceivers, you can quickly check the receiver and the offset oscillators for "Zero-Beat", and see that the receiver IF strip is working.

You will find this to be a real troubleshooting aid. •••

(Continued on page 12)

Alignment of Subcarrier Oscillators with "ZERO BEAT" Method

Carl Merrill, N1QLC

Most of the time, the subcarrier oscillators in HF Transceivers are hard to get adjusted correctly because the Counter Cable capacitance loads the circuit down and shifts the frequency of the crystal oscillator.

In the RCI 2950 for example, alignment instructions specify to connect the counter into a test point, and turn the "Carrier Balance" control to one end. We haven't been able to get a correct reading from this procedure, because the signal level is too low to activate our counters. Coupling the counter further back towards the oscillator causes the oscillator to shift frequency because of cable capacitance.

A faster way: Connect the output of a signal generator or fixed crystal oscillator to a counter and also to the IF strip after the IF Filter. The coupling to the IF Transistor can be accomplished by using an alligator clip and clipping it to the body of the transistor. Use enough level to hear the "Hetrodyne" in the speaker. By adjusting the proper coil for the function, you will hear a "ZERO-BEAT" as the coil is tuned properly. Do this for each of the SSB functions. On AM, the test point will allow you to read the correct frequency most of the time.

Sound complicated? Not really, for every time your function is on SSB and a carrier is present, you can adjust the "Clarifier", "Fine Tune", or "RIT" control to change the Hetrodyne beat.

The above method has been used successfully in many brands of HF Transceivers with good results. Try both methods, and you'll find that counter loading of the oscillator will shift the frequencies.

N1QLC Crystal Controlled Signal Generator Parts List

BA1	Battery, 9 volt, Eveready 216 or equal.
C1-10	9 - 50 pf trimmer Caps. Digi-Key SG1007 or equal.
C11	100 pf NPO ceramic Cap.
C12,14,17	1000 pf ceramic capacitors
C13,15,16	.1 mfd./ 50 volt capacitor
L1	1 mh rf choke (Digi-Key # M8049-ND)
R1	220k 1/4 watt
R2,7	1k 1/4 watt
R3	220k 1/4 watt
R4	10k 1/4 watt
R5	50k Potentiometer (Level Control)
R6	100k 1/4 watt
R8	270 ohm 1/4 watt
S1	1 pole 10 pos. switch (Digi-Key # EG 1951ND)
S2	SPST min. toggle switch

X1-10 HC-18/U (or HC-25/U) crystals, 1 to 20 mhz., 32 pf.

Crystek, JAN, or equal

Enclosure: Radio Shack # 270-627 or equal

PC Board: Fabricate to suit.

Jack: BNC panel mounting jack, UG-625B/U or equal.

Knobs: as needed

Digi-Key Corporation

P.O. Box 677

Thief River Falls, MN 56701-0677

Tel. 1-800-344-4539

Mouser Electronics

2401 Hwy 287 N.

Mansfield, TX 76063-4827

Tel. 1-800-346-6873

Radio Shack various locations.

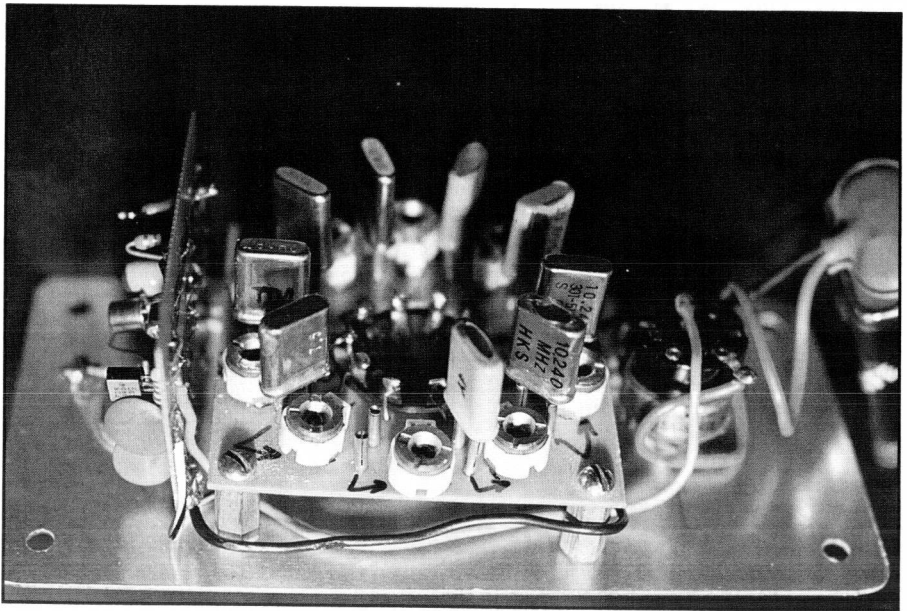
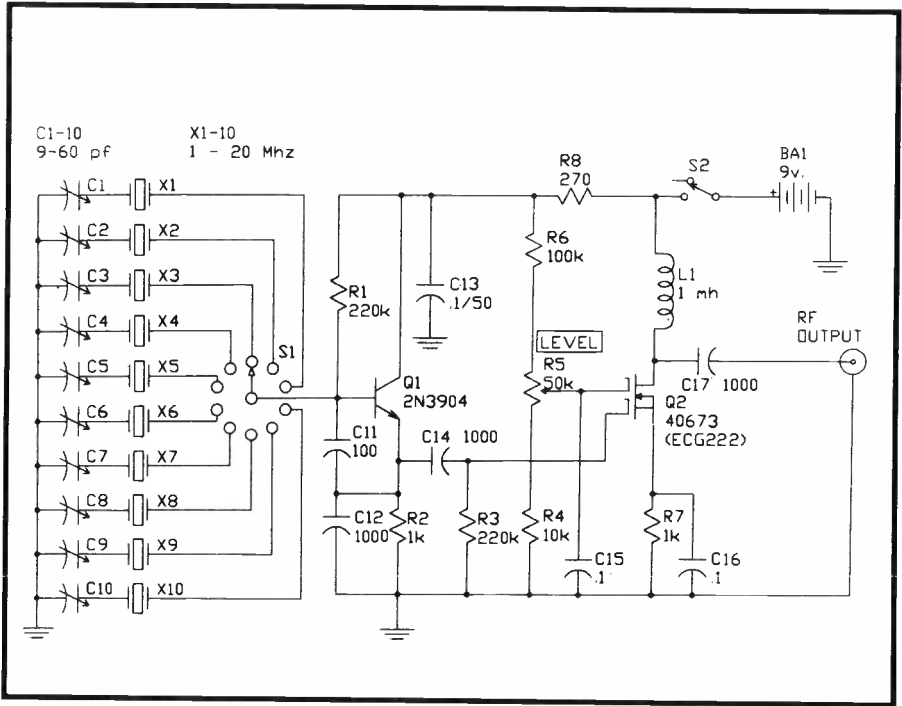

Photo 3: Close-up of crystal mountings

(See additional notes, photo, page 15)

QUALITY KITS FROM 624

5 Watt QRP Transceiver Kit

Superhet Single Signal Receive Crystal Ladder Filter
 Smooth AGC Built in Audio Filter
 Semi Break-In Keying Sidetone Oscillator
 12 Volt DC Operation Full 5 Watt Output



• Available on 15, 17, 20, 30, 40, 80 or 160 Meters
 Complete kit with Pre-Punched, Painted and Silkscreened Ten Tec enclosure, 40 page Instruction Manual and all parts including wire and hardware **\$153.00**

Also available as a Semi-kit, with all PC Board parts and controls. You supply your own custom enclosure.

\$115.00

add \$5.50 S & H

Curtis 8044ABM Keyer Kit

Based on the new Curtis 8044ABM Chip, this keyer is a great addition to any rig. The PC board is 2" x 2" and will fit nicely into most QRP rigs. Power can be supplied by a standard 9 volt battery or from your rig's power supply. The kit includes all parts, PC board and the 8044ABM chip with data sheet.

8044ABM Keyer Kit \$31.00

8044ABM Chip and Data Sheet \$17.50

W7EL QRP Wattmeter

This kit is based on the excellent design described in February 1990 QST. It uses a unique microstrip line on the PC board and is accurate to 450 Mhz. It measures both power and SWR in 3 ranges: 10, 1 and .1 watt. Our kit includes the PC board and parts, all switches and controls and the battery connector. We also have available an LMB minibox and a nice meter as options. The kit uses a 9 Volt battery for power.

Wattmeter Kit \$36.00

With Minibox \$45.00

With Minibox and meter \$53.00

Mini Circuits Labs Mixers

SBL-1 \$6.00
 SBL-3 \$6.50
 TUF-1 \$6.50

Toroid Cores

T37-2	.30	T50-2	.40
T37-6	.38	T50-6	.45
T68-2	.50	T68-6	.55
T68-7	.60		
FT37-43	.30		
FT37-77	.45		
FT50-43	.40		
Small Type 43 Bead	.10		
Large Type 43 Bead	.15		
Large Type 73 Bead	.18		

All of our cores are made by Micrometals and Fairite, the same suppliers that Amidon uses.

Specials

NE602AN 10 for \$14.50 Postpaid

10 FT37-43 cores \$2.25

10 T50-2 cores \$2.25

10 T37-2 cores \$2.25

IC's

NE602AN 1.65
 LM386N 1.00
 LF353N 1.00
 LM358N .75
 LM324N 1.00
 NE555N .75

MC3362P 3.50
 LM6321N 5.00

Experimenter's Kit

This kit includes a FAR Circuits Prototype PC Board from the QRP Notebook and the following parts:

5 T50-2 cores
 5 FT37-43 cores
 1 T68-7 core
 1 T68-6 core
 6' #24 Magnet Wire
 6' #26 Magnet Wire
 2 MPF 102 FET
 2 2N2222A Metal
 5 2N3904
 1 2N3866 and heat sink
 10 .1 μ F Monolithic Capacitors
 10 .01 μ F Ceramic Capacitors
 5 10 μ F Electrolytic Capacitors

Experimenter's Kit \$13.00

• 624 Kits •

171 Springlake Drive
 Spartanburg, S.C. 29302

803-573-6677

Send 2 First Class Stamps for Catalog • VISA and MasterCard Welcome



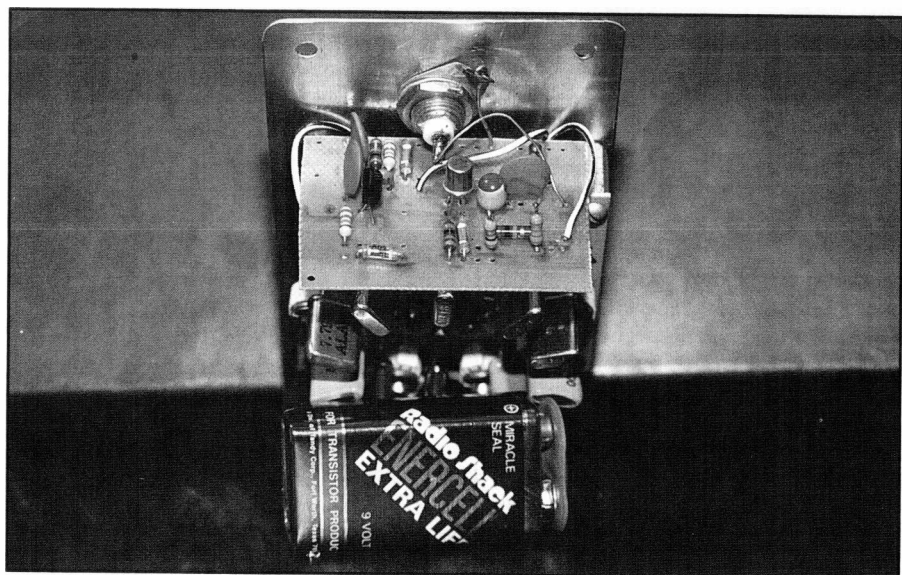

*Photo 4: Top view of oscillator-amplifier section.
Parts-placement diagrams, etching pattern on pages 33 and 34.*

Miscellaneous Notes On The Project

This was the first unit, and has been in service for 3 years. You'll note that it has two boards, one for the crystals and trimmers, and one for the transistors. This was to fit into this smaller cabinet. The crystal mountings are rotated around the contacts of the switch. The trimmer capacitors each have three legs, and need to have slots instead of single drilled holes. Second unit was labeled better, but the same internally. The revised board print you have does away with any special layout, since everything is on 0.100" centers.

The switch was manufactured by Grayhill for a military transmitter, body measures 3/4", overall diameter is 13/16", depth behind panel is 21/32" to end of solder lugs. I tried to select a suitable, economical, easy to find reliable substitute.

Note the crystal sockets. They were made from female contacts from "Winchester" connectors. I had just taken some female pins from a TRW type DB-25F connector, and they fit the crystal pins. They can be cut off at the flatted shoulder, then soldered into the board. The trimmer capacitors were selected to mount in holes that are 0.200" apart, simplifying the mounting procedure. -N1QLC

...

• New Products •

New Sniff-it RF Detector Probe from Ramsey Electronics

A brand new product from Ramsey Electronics is now available, and it has proven itself to be a very valuable tool for the builder who does not have a high-frequency oscilloscope or VTVM for measuring and sensing RMS voltage and RF in circuitry at low levels. The "Sniff-it" RF Detector Probe is billed as being "super sensitive" by the manufacturer, and it performs true to billing.

The probe works in concert with any multimeter (not included) and the frequency range is listed as being from 100 KHz to 1000 MHz. Its output (through leads terminated in banana plugs, positive and negative) is connected to a voltmeter (or oscilloscope, if available) and a ground clip lead at the probe is connected to the ground of the circuit under test. Schottky diodes (NEC type 1SS99) provide detection with a logarithmic output.

Many applications are suggested to even the casual builder. On the bench, we wished to know if there was RF present at the output of the oscillator section of a simple transmitter, and if so, where was it disappearing prior to the antenna? The "grabber" tip was attached at the collector of the oscillator transistor, and .642V was detected. Likewise, RF was presenting itself to the base of the PA transistor. However, at the antenna side of the harmonic filter the RF was only .24V. Aha! By experimenting with two variable capacitors in parallel with the existing two capacitors in the pi-configured filter, it was possible to raise the RF level at the antenna to 1.650V.

The above shows just one of many applica-

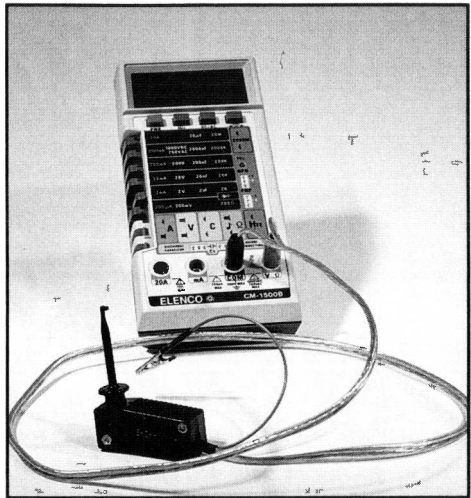

Although the probe ground lead (alligator clip) is short, it can be easily extended.

tions of this handy probe. Anywhere there is RF, even at microwatt levels, the probe will verify its presence. Nice information for the building of transmitters, multiplier chains, receivers, and other radio equipment.

Sniff-it RF Detector Probe Model RF-1:
Price \$22.95 (5-12-94)

Specifications:

Frequency Range	100 KHz - 1 GHz
Maximum RF Input	100 mW, 2.23V into 50 ohms
Maximum DC Input	50VDC max.

Ramsey Electronics, 793 Canning Parkway,
Victor, NY 14564
(716) 924-4560

Have a new product?
Put it in *Hambrew!*

Neophyte Roundup

Another Report In An Ongoing
Compilation Of Neophyte Information



Adding Bandsread Tuning To The Neophyte

If there is any operational feature of the Neophyte which might be termed a liability to ease of operation, it could be the wide tuning range of the main tuning capacitor. The original capacitor selected by the designer was a 365pF broadcast-type variable, which can cover a great general coverage range on 40 meters from 7.000 to 7.450+ MHz, but makes fine tuning difficult without a reduction drive or focusing the tuning spread to a more narrow margin by reducing the main tuning capacitance.

One solution to the problem is to install a bandsread capacitor, albeit the drawback is the growing lack of availability of variable capacitors of any value, much less one somewhere within a 0 to 25-75pF range (less capacitance equals a finer tuning range).

The bandsread installation could not be simpler. Wire it in parallel with the main tuning capacitor and a very workable fine-tuning capability is added to the functionality of the receiver. Fixed capacitance may be added (in parallel) or subtracted (add in series with the bandsread variable) to adjust the fine tuning as desired. For varactor-diode tuned versions, wire a 250 or 500Ω variable in series with the main tuning pot. After all, the bandsread idea worked as a tuning principle for several decades (Hallicrafters, Hammarlund, et al.), and it still works today! •••

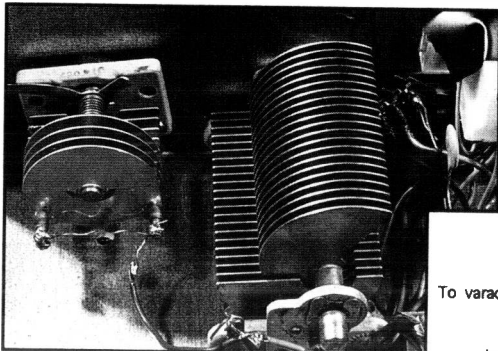
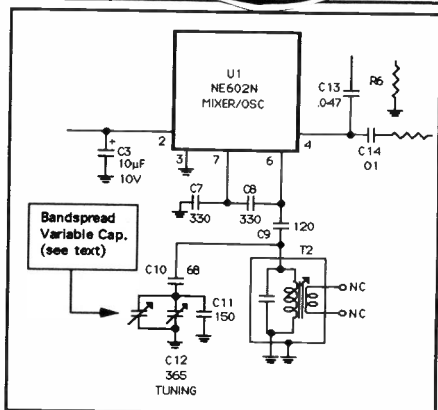

Left: Parallel variable capacitors
in the 80 Meter Neophyte

Right: Varactor-diode Tuning
bandsread scheme

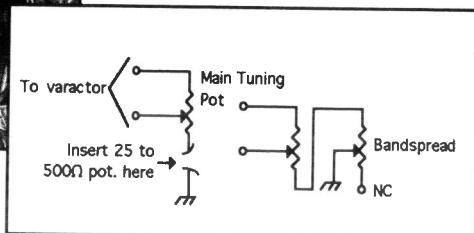

Pre-Amp and AGC for the Neophyte

Dick Pattinson, VE7GC
295 Price Road
Salt Spring Island, B.C.
Canada V8K 2E9

Dick has sent the following circuit and information, adding that he does not take credit for the design; the circuit has been around for some time.

- R1 - 1 Megohm
- R2 - 4.7k
- R3 - 4.7k
- R4 - 100

- C1 - 100pF for 7 MHz,
400pF for 3.7 MHz
- C2 - 47pF
- C3 - 0.1μF
- C4 - 0.1μF
- C5 - 0.1μF

- Q1 - MPF 102
- Q2 - 2N2222 or 2N3904
- T1 - Tak Lee 10.7 MHz
(green core) or equiv.

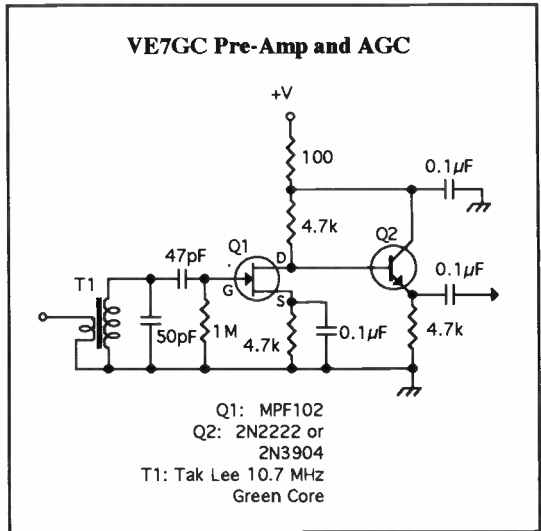

Components are mounted on the copper side of single-sided board. Connections are made on the plain side through holes cleared of copper (see above) with drill bit.

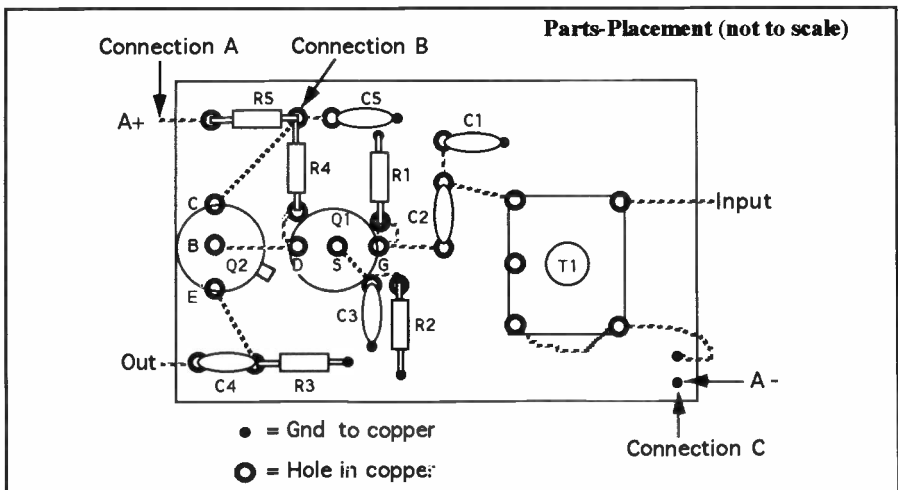

Preamp Connection Points on the Neophyte

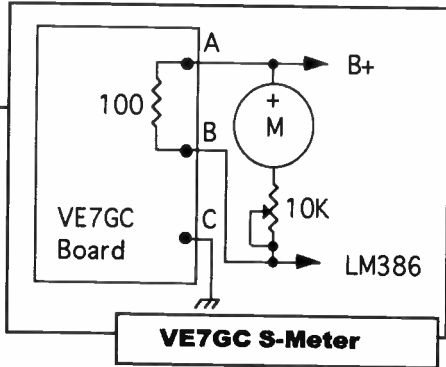
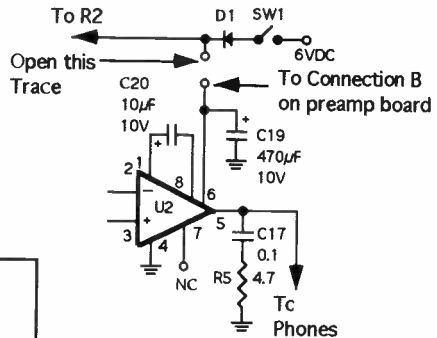
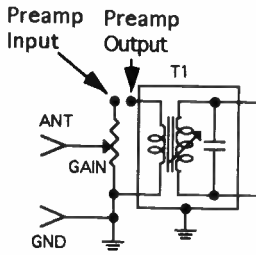

For location of connection points A, B and C, refer to the part-placement diagram on page 18.

VE7AKA S-Meter Mod For The VE7GC Preamp And ALC Board

Modification:

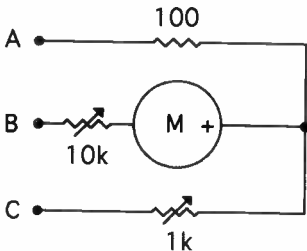

Desired Bridge Circuit

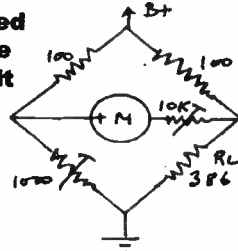

These components, together with the meter sensitivity control, may be mounted on a small panel bolted on the S meter terminals.

The load resistance R_L represented by the LM386 and the preamp board in the sketch of the desired bridge circuit may vary in individual cases according to the type of LM386 (1-4) and the B-plus voltage applied. To find the approximate resistance in the quiescent state:

1. Measure voltage, junction of 386 & preamp (no signal);
2. Measure combined current of 386 & preamp (no signal);
3. Calculate resistance to ground by Ohm's law:

$$R = E/I \text{ (in my case } 4.4\text{V and } 6.7\text{mA)} = 657 \text{ ohms}$$

A 1k trimpot set to the above value gave a zero reading at switch on with no antenna connected. The sensitivity pot can be adjusted to suit your generosity.

Announcing The MXM Simple Transceiver

- Double-Conversion Superhet
- Electronic Instantaneous QSK
- Transmit Monitoring
- Superb Sensitivity
- Two to Three Watt Output
- Single-band Design
- Dual IF Filters
- Variable Bandwidth
- Variable Pitch
- 100-1500-Hz Selectivity
- Case & Tuning Capacitor Included
- 20-, 30-, 40-, or 80-meters

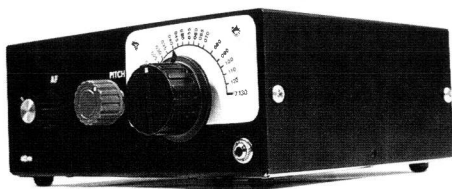

MXM Industries announces their new concept in QRP high-frequency equipment for the home builder, the Simple Transceiver! This revolutionary new design permits the experienced homebrew constructor to have the finest QRP station in existence today. Based on the MXM line of Simple receivers and transmitters, the selectivity and sensitivity of this design are unmatched by any other equipment at any price! The complete station is on a board that is only 3-1/2 inches by 4-1/2 inches in size—just right for that portable or backpack rig you've always wanted! The tuning capacitor, bandwidth capacitor and cabinet are included in the kit. The cabinet is 0.040-inch aluminum, 6-1/2 inches wide by 5-1/2 inches deep by 2-1/2 inches tall. All you need is a volume control, coax connector, and jacks for power, keying, and audio output, and you're on the air!

The Simple Transceiver is covered by the MXM warranty — If you can't make it work, send it back and WE WILL!

INTRODUCTORY PRICE **\$129.95** \$5 Shipping & Handling

©1994 MXM Industries

MXM INDUSTRIES

Rt 1, Box 156C • Smithville, TX 78957 • 512-237-3906

•TIME TO RENEW HAMBREW?•

Check your mailing label for the expiration date of your subscription, and don't miss a single issue! *Hambrew* - The Builder's Choice!

\$20 per year mailed Second Class

Hambrew • POB 260083 • Lakewood, CO 80226-0083

VISA or MasterCard: Call 1-800-5-HAM RIG

Name _____ Call _____

Address _____

City _____ State _____ Zip _____

VISA MC#

Exp: _____

Foreign Rates: \$35/year; Canada, Mexico \$25/year

A Unique Wide Range 80 Meter VXO QRP Transmitter

Roy Gregson, W6EMT
13848 SE 10th., Bellevue, WA 98005



From research by Ha-Jo Brandt DJ1ZB, on a wide range VXO oscillator (*QRP Quarterly* July 93), I became interested in trying his circuit for a VXO QRP transmitter. I had already put together a 30 meter version that works great, and wanted to try other bands. Since the higher frequencies are dying out, I thought this would be a good time to get on 80 meters with a QRP rig.

Ha-Jo had found that a single inductor with a total of 480 uH as in this rig would not work. But smaller value inductors in series did work. I tried several different arrangements of the inductors and variable capacitors, (cut and try) and ended up with six inductors that gave an unusual amount of frequency shift. In this rig it's possible to pull a 3.579 crystal from 3575 down to 3550. Actually it will go down to near 3510, but the frequency stability suffers some at the lower end. The inductors (chokes) I used are of the 1/4 watt resistor size.

The buffer and driver are standard circuits.

I chose a 10.7 MHz 10mm IF can for driver tuning (no toroid to wind). A 470 pf capacitor across the primary allows the circuit to tune to resonance, and provides adequate drive for the PA stage.

I used an RCA 4013 for the PA and it provided 5 watts output. A small push-on heat sink does an adequate job of cooling, only getting a little warm during a normal QSO. I tried a "recycled" PA transistor from a CB radio, a C756, which easily exceeded 5 watts output. So if you have a spare PA transistor in your junk box you'd like to try, you may be surprised, (or disappointed) how it performs. I tried a 2N5109, 2N3053, 2N3553 and a 2N2219, all of which worked for up to 2+ watts out. I tried several T0220 PA-type transistors that all put the watt meter over 5 watts.

The circuit composed of C12, L9, and D2-D5 is for receiver antenna switching. It provides a low impedance path on transmit to protect the receiver, and a series resonant

circuit on receive. There are probably some losses through this circuit, but in practical use, my ear couldn't tell the difference. There's some sharpening of the received signal with the transmit filters- a definite advantage.

Keying is from my favorite keying circuit, and gives a clean sounding signal on the receiving end, I'm told. The components chosen shape the keying envelope like the "ideal" handbook picture. Keyed ground and +12V is provided for external sidetone, relay muting, etc.

When the spot switch is closed, 12V is applied to the oscillator. Diode D1 isolates the 12V from the rest of the transmitter. This allows setting the transmitter on the desired frequency, or finding what frequency the transmitter is on without "swishing" your full 5 watts across the band. Your fellow hams will appreciate it very much. And the reduced level of the oscillator signal to the receiver won't blow you out of the shack. Your ears will appreciate that !.

I used "Ugly" construction on my original with scrap PCB material. In trying to keep things simple, there are only two toroids to wind. All other inductors are standard "off the shelf" items. Nothing seemed especially critical at 80 meters, except the inductance values

for the VX0 portion. I used a poly variable capacitor with good results, but your junk box may produce something different. Although I show a 200 pf capacitor, I found smaller values allowed the tuning range to be tailored for individual choice. The series inductor values in the VX0 may be varied somewhat to accommodate the tuning range, but only change the smaller inductor nearest the crystal. A change of only a few microhenrys can make a big change in the tuning range.

I found that building in stages and testing as I go saves lots of frustration later. Familiarize yourself to the in and out connections on the board, and using scrap component leads, solder short wires to these points for test connections. Since you will need the keyer in most all testing, build it first.

Refer to fig 1. The keyer circuitry consists of R10, R11, R12, R13, C16, C17, C18, C19 and Q5. To test, connect your key and apply +12V to the +12v and ground inputs on bottom left of the board. Connect a voltmeter to the upper end of R13 and measure +12V when keyed.

Refer to figure 2. Build the oscillator using C1, L1-L6, X1, R1, R2, D1, C2, C3, C4, C5, C6, and Q1. Connect a frequency counter to TP1, or listen for the signal in your station receiver. Apply 12V as before, key and measure the

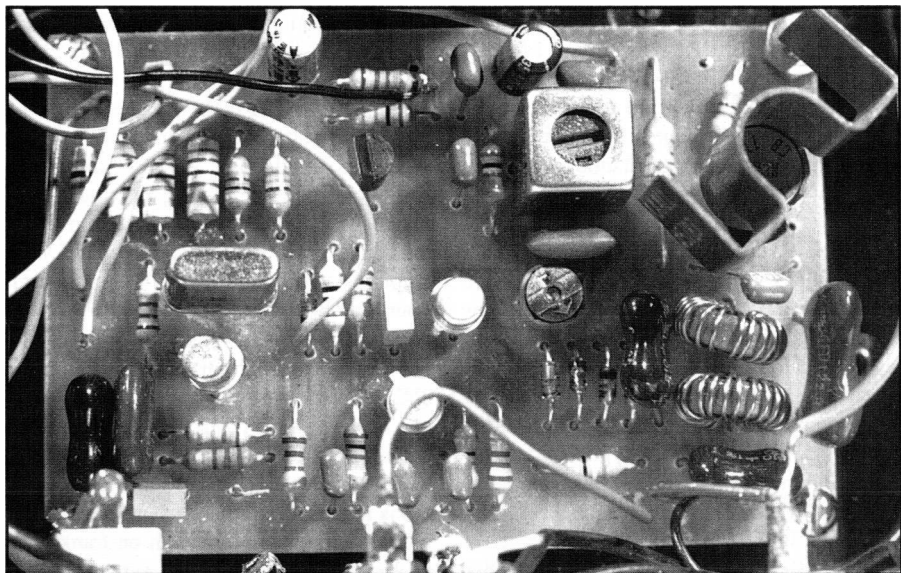

frequency, 3575 KHz or below. Adjusting C1 will move the frequency. This is the time to check the tuning range, and adjust if necessary. This is also the time to check the SPOT switch. Tune your station receiver to the oscillator frequency while keying the transmitter. Close the spot switch and you will hear the signal in the receiver, although at a little lower level. You may need to connect a wire to TP1 to get enough signal.

OK, so far so good. Refer to figure 3. Now build the buffer and driver stage with, R3, R4, R5, C5, C6, Q2, Q3, T1, R6, R7, R8, R9, C7, C8, and C9. Connect an RF voltmeter to TP2 at the base of Q4. Temporarily solder a scrap component for connection. Apply 12V as before, key the transmitter and peak T1 for maximum reading on the RF voltmeter, or listen to the signal in the station receiver and peak for maximum S-meter reading.

Almost finished !.....Refer to figure 4. Build the PA section with Q4, (slip on the heat sink first) RCF1, C10, C11, C12, C13, C14, C15, L7, L8, L9, and D2 thru D5. Take time to admire your handiwork. Check your wiring. Connect a dummy load and wattmeter to the antenna connection. Cross your fingers and key the transmitter. Check the wattmeter: the reading should be around 5 watts (with no smoke). Key again and repeak T1 for maximum reading. I find that I almost always have to play with the turns of the output filter toroids by squeezing together or spreading apart to get maximum output. Try to not key the transmitter for long periods while adjusting the toroids. Check Q4 occasionally with a finger to monitor its temperature. If it burns your finger, it's too hot and should cool down a bit before proceeding. Actually I found that I could keep it keyed for a couple of minutes without it getting too hot.

Connect a wire or coax from the REC connection and to your station receiver. Connect the transmitter to your favorite 80 meter antenna. Tune in a station and adjust C12 for a peak reading or loudest signal.

You may complete the rig by installing it in a box or cabinet, your choice. I'm going to install mine in my old Drake 2A receiver. Plenty of room...rob 12V ac from the tube

filament supply for a 12VDC source. Connect a muting circuit and.....

Well, that's it for the transmitter -all finished- ready for that first contact!

Operation is like the (good) old days before transceivers. You'll need to interface the transmitter with your receiver. I found that the popular W7EL muting circuit when used in conjunction with the receiver antenna circuit as used here allows you to hear between characters. QSK, right! Makes operating fun. No switches to throw, no annoying clattering relays to listen to, just start sending, and if some QRM appears on your frequency, you'll hear it! I don't know about you, but when I turn it over to the other station and find a strong signal on frequency, I wonder how long it's been there and how long was I transmitting and not being heard. My old ICOM 720A doesn't have this nice feature. Almost forgot....along with QSK, you now have RIT, (very wide range) isn't that great! You'll hear the transmitter in the receiver for a sidetone, or you could use the keyed +12V for a sidetone circuit of your choice.

I hope you enjoy this rig as I have.....
73's/72's W6EMT

Parts-placement diagrams and etching pattern for the W6EMT 80 Meter VXO Transmitter are on page 26.

The

HAMBREW FALL FESTIVAL

Will Be On The Air!

**See Page 42 And
Back Cover
Of This Issue
For Contest Details!**

W6EMT 80 Meter VXO Transmitter

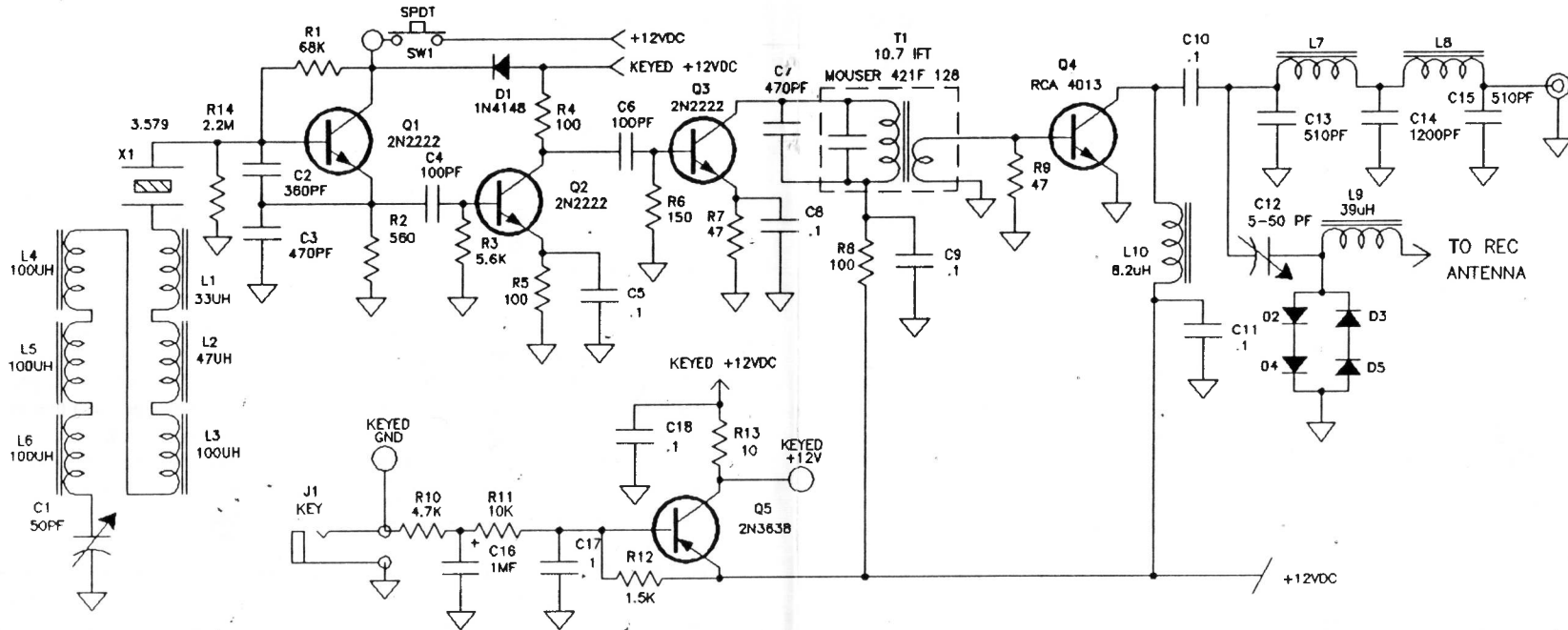

80 METER VXO PARTS

R13	-----	10 OHM
R7,Rg	-----	47 "
R4,R5,R8	-----	100 "
R2	-----	560 "
R6	-----	150 "
R12	-----	1.5K "
R10	-----	4.7K "
R3	-----	5.6K "
R11	-----	10K "
R1	-----	68K "
R14	-----	2.2M "

C4,C6	-----	100 PF
C2	-----	360 PF
C3,C7	-----	470 PF
C5,C8,C9,C10,C11,C17,C18	-----	.1 MF
C10	-----	.1 MF
CERAMIC 100V		
C16	-----	1 MF 25V
C19	-----	10 MF 25V
C13,C15	-----	510 PF
C14	-----	1200 PF
C12	-----	5-50 PF

TRIMMER		
C1	-----	50 PF
VARIABLE		
CX	-----	10 PF
RFC1	-----	8.2 uH
L9	-----	39 uH
MOLDED CHOKE		
L1	-----	33 uH "
L2	-----	47 uH "
L3,L4,L5,L6	-----	100 uH "
L7,L8	-----	20T #28 T37-2
15" wire		
T1	-----	10.7 MOUSER

GREEN CORE 421F 128		
DI-D5	-----	1N4148
X1	-----	3.579 KHZ
CRYSTAL		
Q1,Q2,Q3	-----	2N2222 NPN
(2N3904, ETC)		
Q4	-----	4013
Q5	-----	2N3638 PNP
(2N4125,2N3906, ETC)		
MISC. KEYJACK, ANTENNA CONNec-		
TOR, SPOT SWITCH,		
SPST NORMALLY-OPEN PUSH-		
BUTTON TYPE		

W6EMT 80 Meter

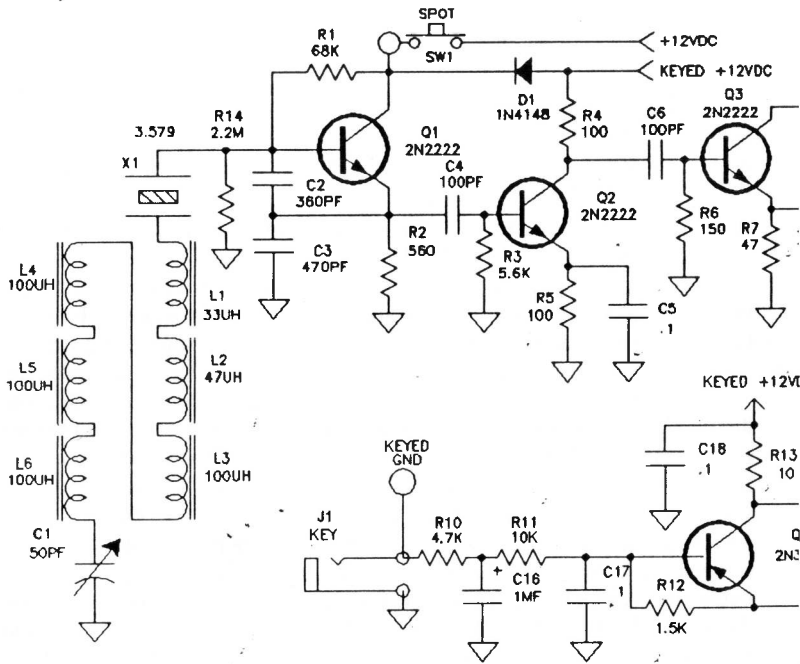

80 METER VFO PARTS

R13	-----	10 OHM
R7,Rg	-----	47 "
R4,R5,R8	-----	100 "
R2	-----	560 "
R6	-----	150 "
R12	-----	1.5K "
R10	-----	4.7K "
R3	-----	5.6K "
R11	-----	10K "
R1	-----	68K "
R14	-----	2.2M "

C4,C6	-----	100 PF
C2	-----	360 PF
C3,C7	-----	470 PF
C5,C8,C9,C10,C11,C17,C18	-----	.1 MF
		MYLAR
C10	-----	.1 MF
		CERAMIC 100V
C16	-----	1 MF 25V
C19	-----	10 MF 25V
C13,C15	-----	510 PF
C14	-----	1200 PF
C12	-----	5-50 PF

XO Transmitter

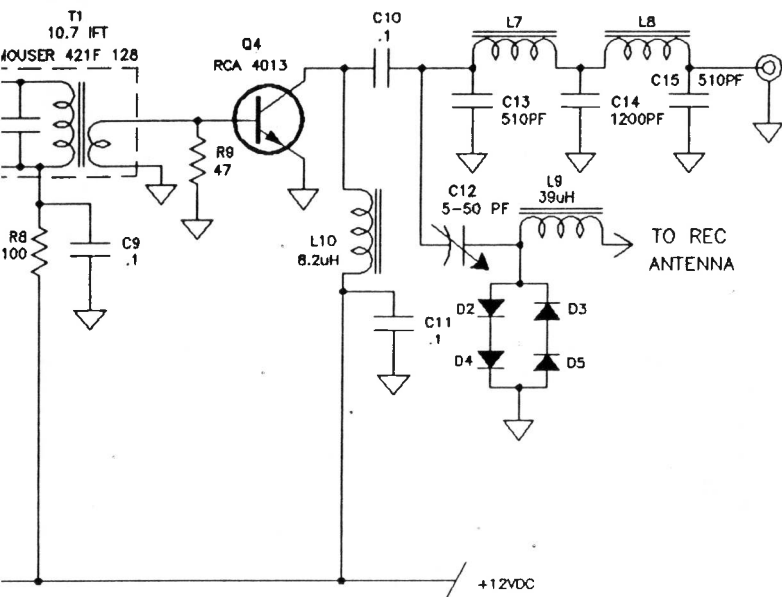

TRIMMER

C1 ----- 50 PF

VARIABLE

CX ----- 10 PF

RFC1 ----- 8.2 uH

L9 ----- 39 uH

MOLDED CHOKE

L1 ----- 33 uH "

L2 ----- 47 uH "

L3,L4,L5,L6 ----- 100 uH "

L7,L8 ----- 20T #28 T37-2

15" wire

T1 ----- 10.7 MOUSER

GREEN CORE 421F 128

DI-D5 ----- IN4148

X1 ----- 3.579 KHZ

CRYSTAL

Q1,Q2,Q3 ----- 2N2222 NPN
(2N3904, ETC)

Q4 ----- 4013

Q5 ----- 2N3638 PNP
(2N4125,2N3906, ETC)

MISC. KEYJACK, ANTENNA CONNec-
TOR, SPOT SWITCH,
SPST NORMALLY-OPEN PUSH-
BUTTON TYPE

THE PIPSQUEAK X-1

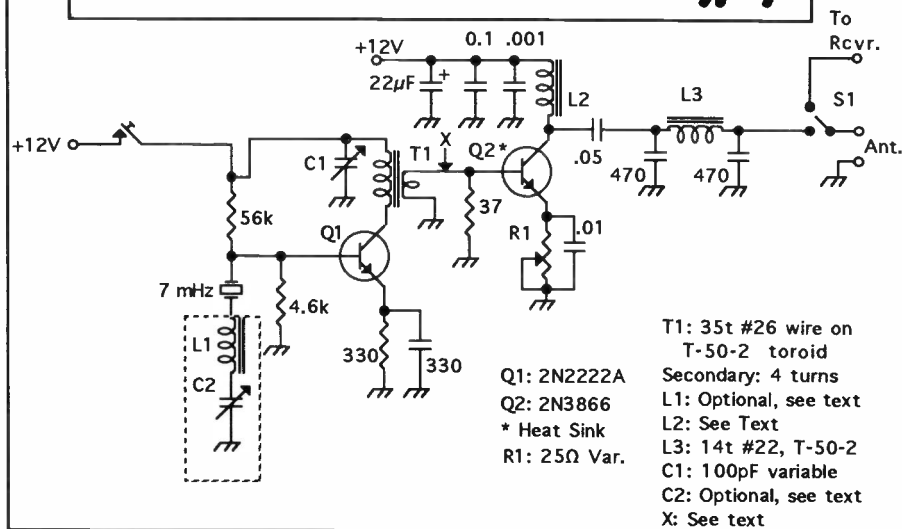

The first incarnation of the original Pipsqueak (Hambrew, Winter '94 Issue) is shown above. By changing several elements and adding a PA section based on the Universal Transmitter (*Solid State Design For The Radio Amateur*: Doug DeMaw, W1FB and Wes Hayward, W7ZOI, ARRL Pub.), this transmitter now puts out approximately 750 mw of power on the 40 meter band. The value of L2 is 22 microhenries, and the resistor R1 allows for variable power down to near 100 milliwatts. Point "X" on the schematic designates the location to place a DPDT switch to isolate the oscillator for spotting purposes. The other half of the switch may be the S1 "Armstrong" T/R switch designated in the schematic. Thus, this switch routes the antenna to the receiver and also provides an oscillator-only frequency apprehension.

More experimentation will be carried out on this circuit, as more power should be attainable using the 2N3866 PA. A PNP keying transistor will be added for switching 12VDC to the oscillator in the X-2 version to follow.

L1 and C2 as shown are optional V XO components. The prototype X-1 utilized switchable 3.3, 8, 10 and 15 pF capacitors to

change the crystal frequency, installed between the crystal and ground (see external switch in photo, this page). This version was built "ugly style" on a copper board. It is chirp-free, and no key click upon keydown was discerned or reported in QSOs with KM6YA, Dave, in Eureka, CA, KL7S, John, in Seattle, or WB8AJR, Bill, in Akron, OH. The signal can be adjusted for quality and power by tuning capacitor C1.

If your iron is cold, we invite you to plug it in and build alongside. Together we can increase the power and serviceability of the next version!

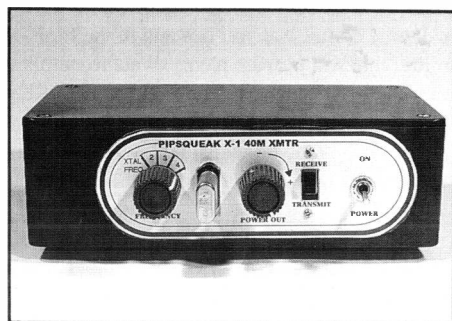

The project box allows room for additions.



NG7D 20 Meter One-Der

John Christopher, NG7D
622 West Alpine, Santa Ana, CA 92707

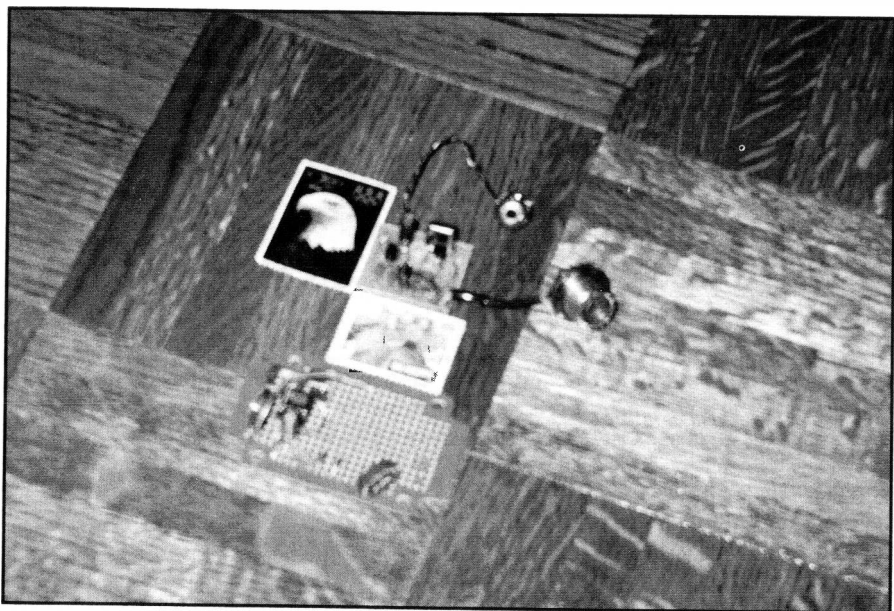

The 20 meter One-Der: smaller than a commemorative postage stamp!

Here's a little beauty that some of you beginners as well as seasoned builders might want to try out. I have added a simple sidetone circuit that you can add to the transmitter that will provide plenty of audio output to monitor your sending during transmit. RF output can be expected to be somewhere between 1/2 watt to just over 1 watt during transmit using the VNI0KM MOSFET transistor.

The original transmitter design was called a "ONER" and came out of Great Britain some years ago. Originally it had no sidetone circuit and the crystal oscillator was in an ON state all the time. This was great for frequency mark-

ing but lousy for a ORP transmitter, especially if you were using a separate receiver and this crystal-controlled transmitter. Who wants to copy CW with a carrier on the receive frequency!

I discovered what was wrong, corrected the circuit design, added some good design techniques and came out with a good QRP design. Believe it or not, the answer to the Oner's design flaw came from the TWO FER III Salvation. The original designer had placed the 3.3k resistor at the wrong point in this circuit (I assume) at the Emitter of Q1 switching transistor 2N3906 to the Crystal Oscillator Q2 2N4401 transistor collector. The transmit-

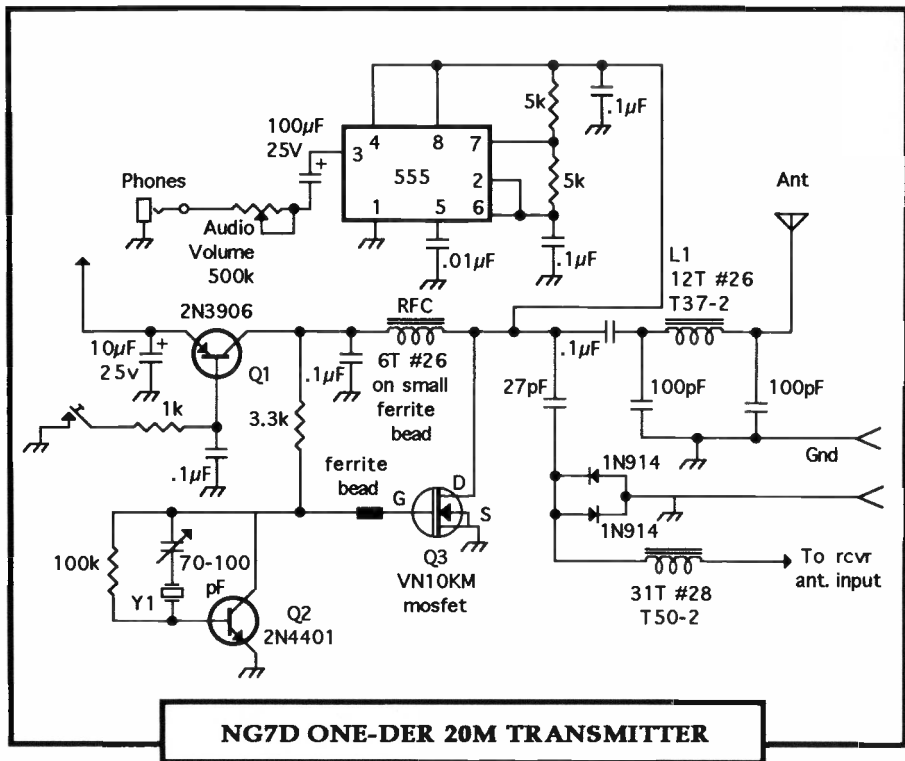

ter will still function, but it will also continue to produce a steady carrier on the receiver as well. If you want to be able to generate the tone, just add a momentary spot switch between the Q1 emitter and the Q2 collector. The transmitter activates only upon key down, and the crystal oscillator remains quiet during non-transmit periods just like the TWO FER III. Better yet, this same point is used to power the sidetone oscillator as well, so you could say this is the control point for the whole circuit.

What I found fantastic about the "One Der" as I now call it, is that it requires no driver stage, no toroidal transformer core or winding. Very few parts, less than 200ma current draw at 13.8 volts DC, will transmit over a frequency range of 4 to 5 KHz with the on-board mini VXO pot and a HC/3 type crystal. The transmitter will operate on voltages ranging from 9 volts to 13.8 volts DC. No heat sink is required if a VN10KM MOSFET is used. The

heat sink is built into the device already. The actual transmitter can be built into an area smaller than a U. S. Commemorative Postage Stamp! I don't think a Ham transmitter can get any smaller than this one. Of course adding additional parts and a sidetone will increase the size of the unit by an inch or so. Yet, its pretty amazing how small you can go- a true wonder of electronics!

Using different MOSFET-type transistors could gain additional watts with this design. I think it might be possible to produce a unit that will give you a full 5 watts output or more, but the small size is then compromised by the use of larger devices and heat sinks. If this design looks familiar to you, it should. Its basically a mini-version of the TWO FER III Salvation transmitter. However the ONE-DER uses a lot less components and is a true QRP/QRPp transmitter, depending on band of operation and voltage going in to it. Its much easier to build, and a great first time project for the

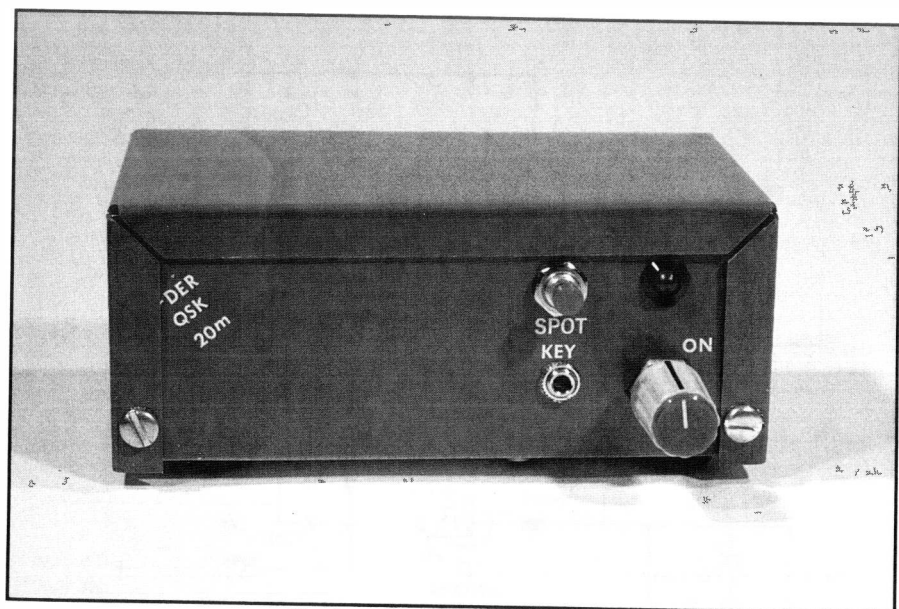

Hambrew-built 20 Meter One-Der

beginning builder. It can be made to operate on bands from 160 to 17 meters by designing proper low pass filter stages for each band and changing the fundamental crystal, but I suspect it can be made to operate on *any* HF band. More than likely, you will need to have the 20 meter HC33 fundamental crystal made commercially for this circuit. It's not exactly a surplus item in the ham radio market today. FT-243-style crystals may work, but remember that they will not shift frequency as has been noted with the other style, if they shift at all.

The operation of this transmitter is very simple. 12 volts DC is applied to Transistor Q1 2N3906. When Q1 is keyed to ground, the Q1 collector opens, sending 12 volts DC to the crystal oscillator transistor Q2 (2N4401) which appears to be incorporated into a Pierce design. The oscillator signal is then fed to the RF amplifier at Q3 (MOSFET VN10KM), where the signal is amplified and sent to the lowpass filter stage and out to the antenna. The sidetone oscillator U1, a 555 timer IC chip, is also powered up on key down.

Audio output is controlled by the 500k variable resistor. The ferrite bead on the gate

of Q3 is used to prevent feedback oscillation within the RF amplifier stage. A small ferrite bead is used to make up an RF choke for the unit, consisting of 6 turns of #26 enameled wire wound through the bead, not over it. This circuit is very easily constructed on perfboard. It is important to keep the point to point connections as short as possible to keep capacitance to a minimum at solder points. Try these design modifications on the schematic shown, and you too can build and own one of these little marvels with a mere one or two hour investment of your time. Just remember to use a fundamental crystal and a 50 ohm load with a low VSWR and this transmitter will last for a long time, providing you with a nice clean note on the air. Good luck and happy building, fellow QRPers. •••

Please see the 20/20 Hindsight Section of this issue for information regarding the availability of a PCB for John's project The TwoFer III Salvation Transmitter featured in Hambrew Spring, '94.

20/20 Hindsight



Looking Back Into Past Issues • Updates & Elaborations

The 8 Minute I.D. Timer schematic in the Winter, '94 issue contained an incorrect polarity for LED2. Please see the correct polarity in Figure 1 (right).

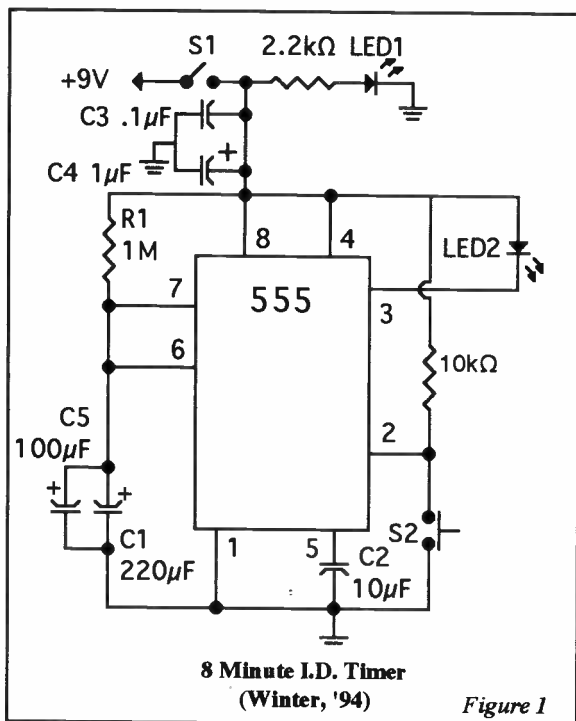

Figure 1

An alternative way to regulate the timing cycle in this project would be to use a variable resistor at R1. Concerning the high/low pinout status, **Dave Haworth, NØKYP** writes:
"During the timing cycle the following (timer 555) pins were

1	2	3	4	5	6	7	8
L	H	H	H	H	X	X	H

During the blinking cycle the pins were

1	2	3	4	5	6	7	8
L	H	L	H	H	L	L	H

To make LED2 blink the leads have to be reversed: Cathode lead to pin 3 and anode lead to pin 4 (+)."

VSWR Characteristics of the DiConical Antenna

Hambrew, Winter, '94

20/20
cont.



Photo 1 shows the VSWR characteristics of the Di Conical Antenna. The presentation is a frequency sweep from 100 MHz on the left to 200 MHz on the right. The center of the sweep is 150 MHz. There are ten divisions across the scope face representing 10 MHz per division; therefore, it can be seen that the VSWR is all but flat from 130 - 170 MHz and the 2:1 VSWR points are 122 - 177 MHz (for whatever that is worth). However, 2:1 VSWR does represent 10 dB return loss. I guess I'm fairly impressed with the performance of the Di-Conical.

Dave - W6OAL

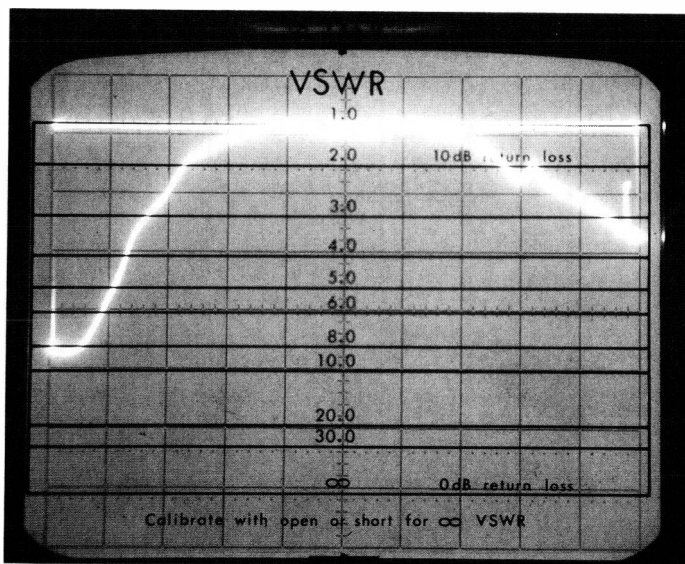

Photo 1:
VSWR Curve of
the W6OAL
DiConical Antenna

K6EIL Improved Neophyte Receiver

Hambrew, Winter, '94

Correction: L1 secondary winding is 2 turns rather than 1 turn as published (see parts list, Winter, '94: pg. 27).

NG7D Two Fer III Salvation Transmitter

Hambrew Spring, '94

NG7D tells us that a circuit board for the Two Fer III Salvation Transmitter will be available through FAR Circuits, 18N640 Field Ct., Dundee, IL 60118 later this summer or fall. Price per board will be \$4.25 (+ \$1.50 S&H per up to four boards ordered).

N1QLC Crystal Signal Generator

(cont. from pg. 15)

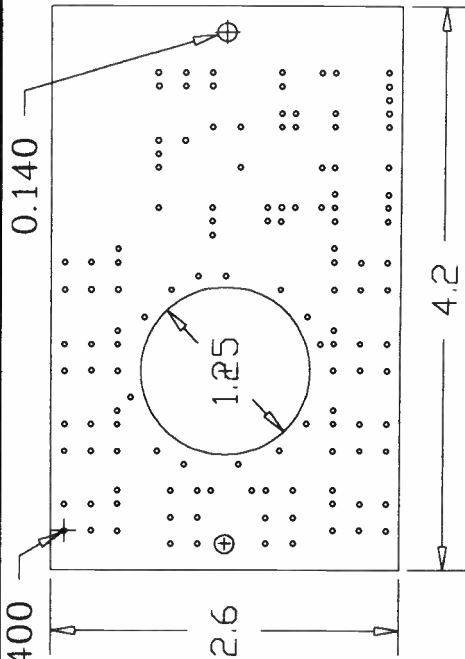

Drilling template,
all holes on .100 centers

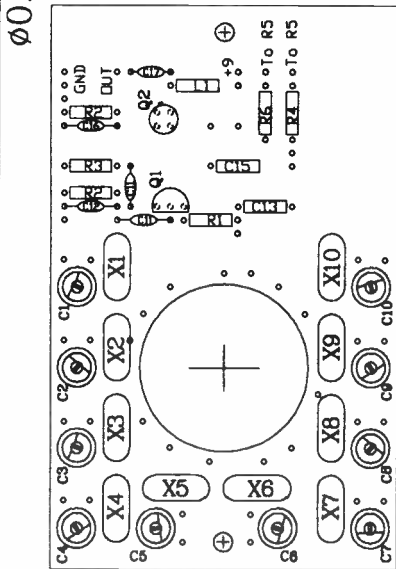

Top View

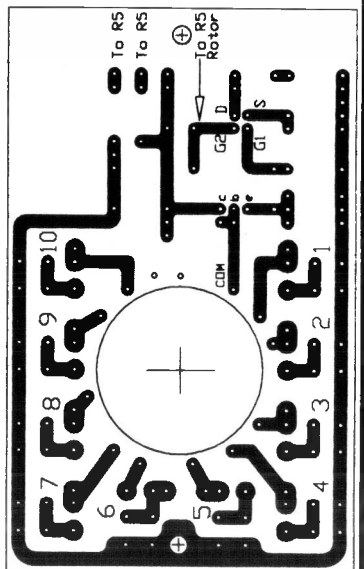

Article concludes on pg. 34

NIQLC Crystal Signal Generator

(cont. from pg. 33)

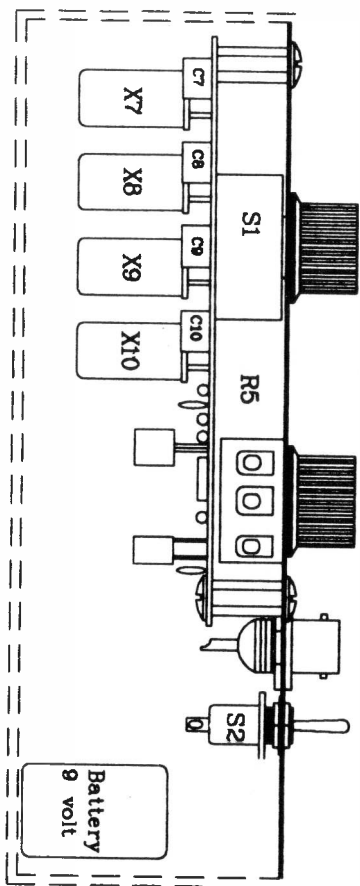
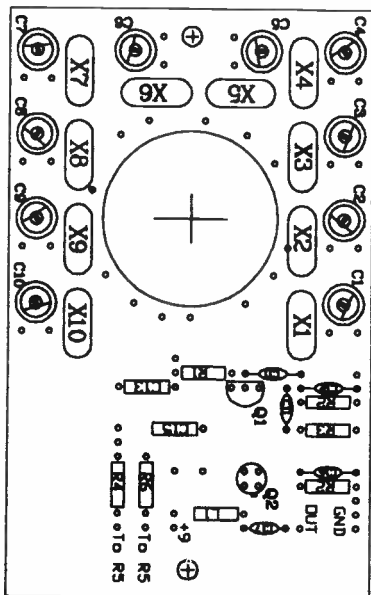

Side View-- cabinet in dashed lines.

Kit Selection and Construction Practices

Bruce O. Williams, WA6IVC

MXM Industries, Smithville, TX 78957

Forty years ago, or more, it was common for everyone in Amateur Radio to build much if not all of their station equipment. One reason was the relative high cost of commercial equipment, and another was that the desired equipment was not even available commercially. We all built the small, simple peripheral equipment such as SWR meters, antenna tuners, and such that were required for efficient operating. Heath was the forerunner in this field, but there were several other suppliers that had good, easy-to-build kits. There were few kits available for the major operating devices—receivers and transmitters, and there were NO transceivers available! Transceivers did not appear in the Amateur Radio field until the early 1960s, and they were not offered in kit form for many years after. Luckily, this has all changed for the better and today we have a wide choice of equipment kits to choose from.

Today, several manufacturers provide receiver, transmitter and transceiver kits at fairly reasonable prices, and some also provide kits for the necessary peripherals. It is only necessary to look in the advertisement pages of any of the Amateur Radio publications to find several choices of ready-to-assemble kits. If you are getting ready to build your first project, look carefully at your options.

1. You can buy a "beginner's" kit, usually consisting of a circuit board with all, or part of the necessary components. You generally must select and buy your own cabinet, tuning capacitor, jacks, plugs and any thing else you might need. This is undoubtedly the least expensive way in terms of initial cost, but be aware that your own contribution may be much higher in cost and technical requirements than

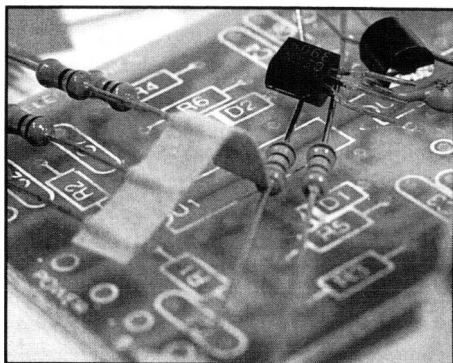

with other kits. Consider the overall cost, and your own capabilities carefully. Realize that you may have problems getting the components you need to complete the job. Also, each supplier has minimum order requirements, and the cost of shipping for several vendors may eat up any hoped-for savings.

2. A complete kit with cabinet, circuit boards, all components and hardware, and good instructions is the easiest way to go. You don't have to worry about separate purchases of parts, with their attendant minimum buys and shipping costs. Of course, you do have to know what you're buying. Don't depend on the seductive wording in the advertisement—ask around among your friends who might have some knowledge about the kit you're considering, or read the reviews in the ham magazines. Write to the supplier and ask to buy a set of instructions separately to see if all parts are supplied and that you can work to the instructions as given. Be prepared to pay a couple of bucks for the instructions, but reviewing them beforehand may save you lots of time and trouble in the long run. Ask about technical assistance and warranties! I estimate

that at least 30 per cent of all kits are never finished—either the builder loses his interest, or the technical problems are too much for the beginning builder. Buy from an equipment designer that makes the kits himself! It's easy to get one of an item to work, and many kits are assembled by someone other than the designer who bases his decision on one or two prototypes that seem to work fine. If you buy your kit from a supplier who doesn't know the technical aspects of the design, you might not be able to get any help if you need it.

3. Do it the "hard way" by building your own circuit board and buying the components on your own. I wouldn't recommend this approach to anyone but the experienced builder. First of all, you have to select a good design, or do the designing yourself. Reading the construction articles published in the magazines is a good start—before you invest any time or money, be sure that the design will do what you want it to. Find out if all the required parts are available on the market at reasonable prices. I once designed and published a piece of equipment using a part I had in my junkbox, but that I KNEW was available at the local electronics store—I had their latest catalog! Unfortunately, by the time the article was published, the supplier had exhausted his stock and there was no other source available. I not only had a lot of EGG on face, but had to answer a lot of irate letters and phone calls to boot! NEVER AGAIN! If the writer of the article does not kit the item, beware. There may be a problem getting the necessary parts. Also, if you don't have a lot of the parts on hand, be prepared to pay for S & H, as well as minimum order charges.

There are some suppliers that provide etched and drilled circuit boards for most of the projects that appear in *QST*, *73 Amateur Radio*, and the now-discontinued *Ham Radio*. Generally, they provide only boards, and do not sell parts or provide copies of the article. Write to FAR Circuits for a catalog of PC boards available. Another source is A & A Engineering (see notes). Buying a drilled and etched board is a much better option if the proper board is available than trying to do it

yourself.

CABINETS AND GROUNDING

In starting the construction, begin by marking the cabinet for standoffs to mount the circuit board(s). Firmly press the board against the cabinet bottom and mark the location of each hole. Center punch each location and drill each hole as closely as possible to the punched marks. If you wait to do this until your board is populated, you will probably end up with oval-shaped holes, and in the wrong places.

Use a metal cabinet! Although plastic cabinets are pretty and cheaper than metal, they provide no shielding and are prone to warping and may sustain damage from heat. If your cabinet is metal, you can depend on the common ground connection through the standoffs rather than provide a wire ground to each plug and jack, etc., that might result in ground loops in your circuit.

COMPONENT INSTALLATION

Do not install all of the parts at one time and then try to solder through the forest of component leads! Only install a few parts at a time, solder them, clip leads, check for solder bridges, and then repeat the process. I generally install the parts with the lowest profiles first—resistors, ICs, small capacitors. It's easier to install them than try to put them in through the higher parts such as electrolytics and transformers. Mount all parts as close to the board as possible. Component leads are solid wire and will crystallize and break off if they are moved about. If your board is closely populated, take a little time to plan your installation so that you don't have to put some parts in with tweezers and a magnifier! One of my early mentors carefully measured 1/8th inch spacing off the board for parts in case one burned up and he had to read the marking on the board. Most of the parts broke off the board during testing and installation in the cabinet.

WIRING AND GROUNDING

Do not use solid wire for interconnections from the board to the panels. Use insulated, stranded, tinned wire of about No. 26 ga. size. The holes for component leads on most printed circuit boards are made with No.64 or 65 drill bits, and can't accommodate larger wire sizes. Sometimes this size wire is hard to find, but your local telephone company uses lots of it. Try to get next to a telephone installer or repairman and talk him out of a few feet of it. The telephone wire comes in cables that are made up of several (maybe 26) color coded twisted pairs in a plastic sheath. A few feet of this cable will last you for years.

An exception: Use solid tinned wire for the connection to the tuning capacitor. Stranded wire is flexible (that's why we use it), but it can vibrate or bend during movement of the rig and the slight change in the capacitance between the wire and the cabinet will affect stability of your rig. Use No.20 or 22 wire for this, as short as possible.

Spend a buck or two at a local machinist's supply house for a couple of No. 64 drill bits. If you use them in a pin vise, obtainable at hobby stores, you can clean out the mounting holes easily. They are also invaluable if you make your own boards.

Depend on the ground plane in the circuit board and metal standoffs for a common ground with the metal cabinet. I haven't discovered how to design around hand capacitance using a VFO, and I don't know that anyone else has. The metal cabinet helps, though.

MISTAKES AND CORRECTIONS

They put erasers on the end of pencils for a reason. Likewise, every builder must, at some time, remove components from a board and change them. There's a couple of ways to do this. Some builders use a solder removal tool (solder sucker), and have very good luck with them. I have always used solder wicking, and recommend this approach. There are several brands of wicking material. They all consist of copper braid that is impregnated with a solder-

ing flux. Some of it is pre-tinned—stay away from it! When you apply the wicking material to the solder joint and heat it, the wick sucks up all the solder in the joint. I use an expensive type, available in 100-ft rolls at about \$30.00. With the heavy use in my shack, this lasts for about a year. There are several brands available in 5-ft rolls for a buck or so. Beware: some brands sold by the local outlet don't contain a good flux, or there isn't enough of it— it doesn't work very well!

CONCLUSION

Building your own electronic equipment is not easy. It requires a lot of research into techniques and methods, and a not inconsequential investment in learning, tools and parts. But talk about rewarding! There is nothing to equal the satisfaction you have when the equipment you have built really works and does what you want it to!

Next time we'll look at the necessary tools (gottahaves), and some optional nice things (wannahaves). We'll also start burning some solder and searing some fingers on a few simple designs that I've found to be useful.

NOTES

Here are a few suppliers that I have found to be excellent:

Circuit Boards _____

FAR Circuits

18N640 Field Court

Dundee, IL 60118

Catalog free

Circuit boards and kits _____

A & A Engineering

2521 W. La Palma, #K

Anaheim, CA 92801

714-952-2114

Oak Hills Research

20879 Madison St.

Big Rapids, MI 49307

Catalog \$1

Parts and kits _____

Dan's Small Parts and Kits

1935 So 3rd West #1

Missoula, MT 59801

Catalog Two stamps

He Still Rolls His Own

Fred Bonavita, W5QJM

PO Box 2764
San Antonio, TX 78299

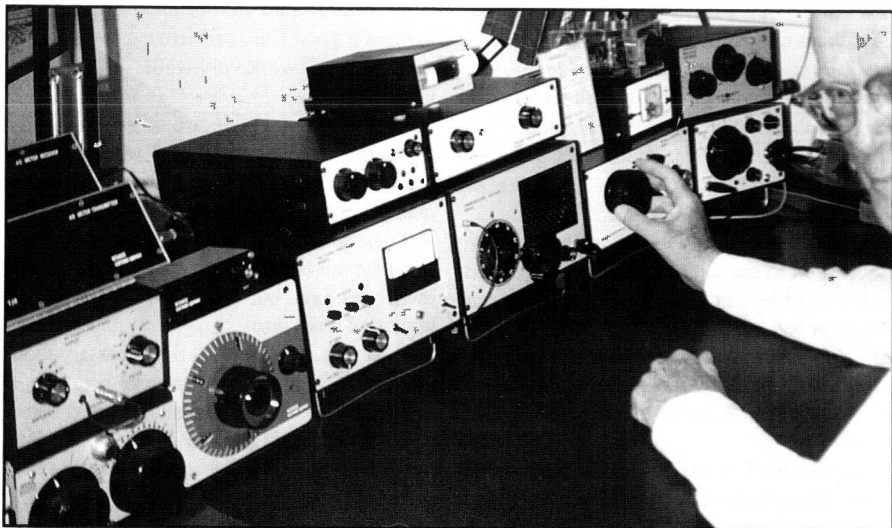

An impressive array of home-brewed gear sits before Dave Anthony, WSNOE. His work shows a careful attention to appearance as well as to design in the circuits inside the cabinets.

David Anthony, WSNOE, held up the latest example of his work for closer inspection, doing little to conceal his enthusiasm.

"Take a look at that. That's a NorCal 40," Dave said, referring to the 40-meter transceiver that became virtually an overnight sensation with the QRP community when the kit was marketed by the Northern California QRP Club.

As he has countless times over the half-century-plus he has been an Amateur Radio operator, Dave had found a design that intrigued him. So he built one from scratch and on his own, modifying the circuit slightly as he went.

Within a few weeks after getting a copy of the NorCal 40 schematic, he had laid out and made his own printed-circuit boards, raided his well-stocked parts bin and produced a

firstclass rig from scratch. The result was a transceiver in keeping with the detail and workmanship that have marked his work for years.

His craftsmanship is clear in the array of receivers, transmitters, transceivers, power supplies, antenna tuners, and keyer that are his all-home-brewed station.

The ham world got a peek at Dave Anthony's work in the "Up Front" section of OST for January 1993 when a color photo appeared showing his formidable station (maximum power output is 20 watts) at his home in Columbus, Texas, population about 3,500 and roughly half way between San Antonio and Houston.

I recalled that photo late in 1993 when I called CQ on the 80-meter QRP frequency one evening and was answered by WSNOE. It turned out Dave was breaking in a new trans-

mitter he'd just built. It was putting out around 750 mW with good, crisp keying and a steady signal. He later showed it to me, and it literally is a handfull.

After about a half-hour chat on the air, I arranged to visit Dave to see his work first hand and meet the man. It turned out to be something of a guilt trip, however, and I came away feeling very guilty about not building more.

Dave is enthusiastic about home-built equipment as the way to go, even for those starting out in Amateur Radio and uncertain about tackling the job and about the future availability of components.

"For a guy to start building now, the sky is the limit," he says. "He can build and build and build for so many years before he comes to the point where I think I am now and that I've built everything."

Dave's first project was a two-tube regenerative receiver, which he built from an article in the then-popular *Shortwave Craft* in the late 1930s. His family lived in a suburb of Boston then, and it was there that he passed his examination for his first ham ticket (a Class B license, as it was called then) in 1942. He got his operator's license, but World War II kept him from getting his station license until he got out of the Navy in 1946: WIOPN.

Receivers have remained Dave Anthony's favorite piece of amateur gear. In 1939, he built his first superhet with a regenerative IF. He was reading OST regularly and getting ideas for his own designs — something he does today, too, but from other sources as well.

"Every month there was a fist full of really wonderful technical articles," Dave recalls about *QST*. "I don't think I really ever built anything I ever copied, but as I got to know more and more about circuits, I did my own imaginative things."

After college and a job with Raytheon, where he did some early experiments with subminia-

ture tubes in receivers, Dave and his wife, Betty, moved to Dallas, and he took a job with Texas Instruments. Eight years later, they moved to Columbus.

"I didn't do much operating," Dave says of this period. "I did some now and then, and when I did, it was CW. I was never interested in phone."

One reason Dave is able to turn out the equipment he does is his enviable parts inventory, which consumes part of one wall of his garage. He frequently shopped the surplus electronics market, including a store Collins

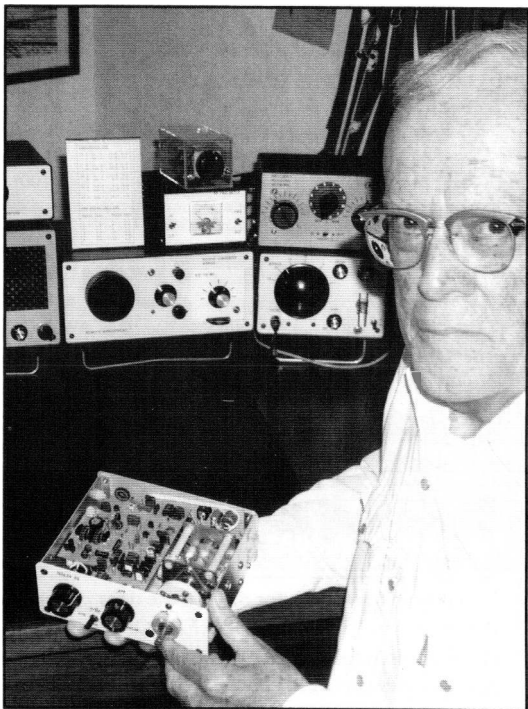

A close-up shot of the W5NOE version of the NorCal 40 shows the home-brewed p-c board and the air-variable capacitor that replaced the voltage variable capacitor for main tuning.

Radio Co. once operated in the Dallas area. It was there he snapped up components, metal cabinets, some of the famous mechanical filters which made Collins equipment the envy of many, and so on. He still feeds from that reservoir of components.

So what would Dave Anthony recommend

OAK HILLS RESEARCH QRP Headquarters

QRP WATTMETER KIT

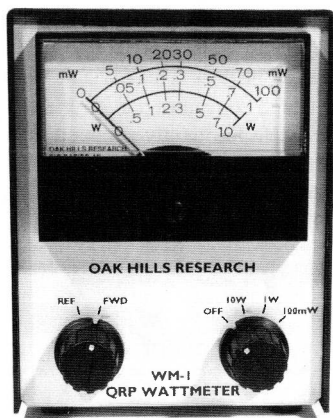

- A wattmeter designed specifically for the QRP operator and builder (1.8 to 54 MHz.)
- Measures forward & reflected power at QRP levels
- Select from three full scale power levels: 10W, 1W or 100mW
- Measure power down to 5mW
- Large easy to read 3" meter
- Low current drain meter circuit uses 9V battery (battery not included)
- Great for portable use • Easy to build and align
- Align with a digital voltmeter
- Source of RF not required
- Measures (HWD): 4 1/2" x 3 1/2" x 5"
- 100% complete kit (less battery) including cabinet, all components and instructions



\$89.95 Plus \$4.50
S & H



CAT #WM-1

OAK HILLS RESEARCH

9AM to 6PM
Mon - Fri
EST

20879 Madison Street
Big Rapids, MI 49307

Michigan residents
add 6%
state sales tax

Orders 616-796-1460

Tech Info (616) 796-0920

Fax: (616) 796-6633

You can't get much for \$2.00 these days. But \$2.00 will buy you *WIREBOOK II* (1993 edition), published by The Wireman, Inc., 261 Pittman Road, Landrum, SC 29356, phone (800) 727-WIRE. This 55 page book is written by Press Jones, N8UG, who calls himself "The Wireman," and as you might expect, is in the business of selling wire, coax, connectors and other antenna components. (Press sells the low loss 4XL and newer X-4XL coax cables that you may have seen described recently in *QST*.) Much of the book contains detailed information and technical data about the products offered for sale. However, Press also dis-

cusses, in practical terms, a number of subjects such as antenna baluns, burying coax cable, lightning protection and RF grounding your station. Illustrations are included. These parts of the book are better written and more useful than any such discussions that I've read elsewhere. In short, *WIREBOOK II* is of special interest to QRPers looking for high quality antenna system components, in particular coax cable. All amateurs, even oldtimers, will learn something new about antennas and antenna installation in the practical application discussions. •Wes Baden, K6EIL, reprinted from *The Microvolt* (Utah Amateur Radio Club)

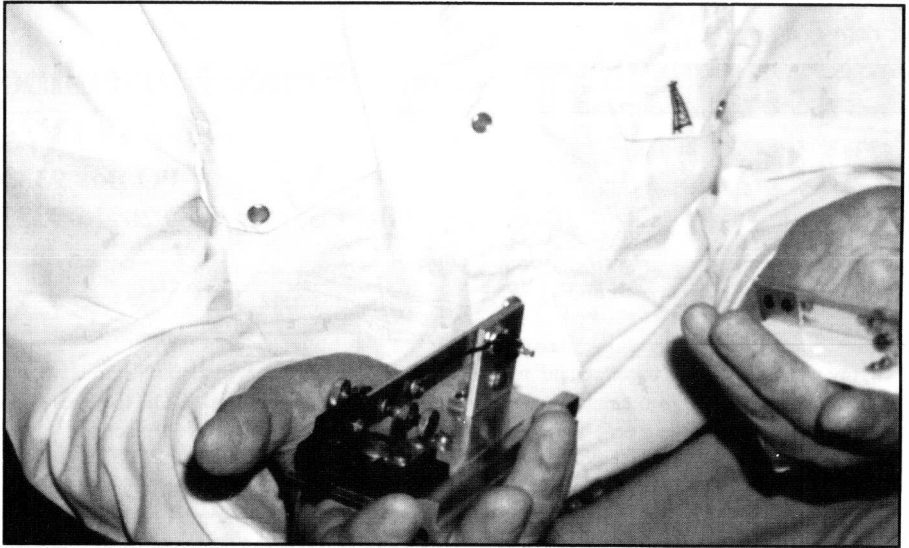

It's not all receivers and transmitters. Here Dave holds two single-paddle keyers he made from strips of p-c board stock and contacts from surplus relays.

would-be builders do, especially in the face of the shrinking supplies of RF related components?

"I wouldn't recommend they start off completely cold," he replies. "My feelings are that a guy's first project should be a kit."

He says builders should shy away from the two extremes of kits — those that baby the builder by dictating how many inches of what color wire should be connected between which two points ("To heck with that. That's insulting," he says) or those that throw a handful of parts and say, "Good luck."

He also advocates cannibalism: Worn out high fidelity amplifiers, television sets, tube-type test gear and the like are gold mines of components, wiring and hardware waiting to be salvaged instead of being junked.

"Builders also should scout organizations that have lots of home brewers, although how to go about that I don't know.

Dave also urges builders to keep accurate records (schematics, parts lists, references, etc.) of what they build so they can repair or revise their work as needed. And, he says, he does not like so-called "ugly construction" and prefers neatly laid out printed circuit boards to make

troubleshooting easier.

"One of the beauties of home brewing is that you know what's in the box, and if you want to do something with it, you've got the circuit diagrams," he says.

But doesn't home brewing require a large and complicated array of test equipment? he was asked.

"All I have is an old standby — the most useful thing of all — a Millen grid dip meter from 40 years ago. It still runs. The capacitors have never failed," he replies.

"Then I've got a Heathkit vacuum tube voltmeter. That's a good one and very useful. And I've got a little Radio Shack volt-ohm meter. And that's about all."

As for the future, Dave says: "The technology that we have known — the analog circuits — has stopped growing. Everything is headed toward digital and so rapidly now. They don't even make MOSFETs any more.

"I'm searching for what I ought to build next. Antennas don't intrigue me, so I guess I'll take a sabbatical here for the next few months and look at the NorCal 40 and the originality in it," he says. •••

From The

CONTEST GURU

Bruce Muscolino

WA6TOY/3

PO Box 9333

Silver Spring, MD 20916-9333



Hi, my name's **Bruce Muscolino** and my call is **WA6TOY/3**. The /3 means I got out of California before the "big un". Three weeks before to be exact, and no, I don't feel bad about it. In case you haven't read your last issue of *Hambrew*, I'm the guy who answered editor/publisher **George De Grazio's** ad for a contest guru. I have a beard and longish hair, so I'm certifiable as a guru.

Yes, I'm a contester. One of those wierdos who mess up your favorite bands on the only Saturdays and Sundays they're open when you're not working. But, in self defense, I was always under orders. **NOT!**

I've always had unique views on contesting. On the one hand, a contest is one of the best ways to determine how well your station works. Within 24 hours you'll know where you're heard and where you're not. On the other hand, with the glove, contest is two words: **CON** and **TEST**. We all know what a **TEST** is, it's

HARD WORK! We also all know what a **CON** is, so contesting is a **CON** to get us to do some **HARD WORK!** Not Exactly!

Our contest goal at *Hambrew* is provide you an opportunity to have some fun with that new piece of equipment you just finished. Remember what I said about a quick performance test for your station. We're going to do this with a series of contests. In this issue George announces his weekly QRM operation. That should be fun. I'm pumping to have it expanded to include all the writers/editors, too. That takes care of your Sunday evenings.

This side of the page is going to start off with a contest in October. I'm going to call it **HAMBREW's FALL FESTIVAL**. After that, look for another contest during the Christmas/New Year's holiday. Then next year we'll have a whole new series of contests for your operating pleasure.

**Details on The Hambrew Fall Festival
are on the back cover of this issue**

MOVING?

*Notify the Postal Service
of your new address - don't
miss a single issue of **Hambrew!***

DESIGN BASICS SERIES

Thoughts On Theory

James G. Lee, W6VAT

What's a column on "theory" doing in a magazine devoted to "do it yourself" homebrewers? It's here to help you understand a bit more why circuits work the way they do, some of their design concepts, and as an aid to troubleshooting those circuits that don't work. I've never drawn a circuit on paper that didn't work - it's when I build them that problems sometimes occur. In fact I have probably learned as much about electronics from testing and troubleshooting circuits as I have from all the textbooks I've ever read.

I'm still an inveterate homebrewer even though I was originally licensed some 50 years ago. It wasn't that commercial rigs weren't available then, it was because as a young teenager I was normally afflicted with impecuniosity (I was penniless) most of the time. So in order to get a rig on the air, I had to scrounge parts, spend some of my meager newspaper route money for certain critical parts, and hope that everything I built worked. But I discovered that of the many things one can do in this great hobby of ours, homebrewing is fun.

In this column I'll try not to use any more mathematics than necessary. There are only about four or five laws of physics which cover much of electronics - Ohm's Law being one example. Another example is the formula for resonant frequency, i.e., $\omega = 1/LC$, where $\omega = 2\pi f$. Both of these laws are expressed by simple algebraic equations, but many people are uncomfortable around mathematics. Still, a little "arithmetic" won't hurt you, and once you go through a bit of it successfully, you'll feel better about it.

A SIMPLE EXAMPLE

So let's begin with something you are all familiar with - a circuit schematic. When you look at a schematic diagram, you are actually looking at two schematics - an AC (or signal) schematic and a DC schematic - at the same time. FIGURE 1 shows a diagram of a typical low frequency transistor amplifier. It has biasing resistors (R1, R2) which essentially set the "no-signal" operating point of the ampli-

Figure 1:
Typical
Common-Emitter
Amplifier

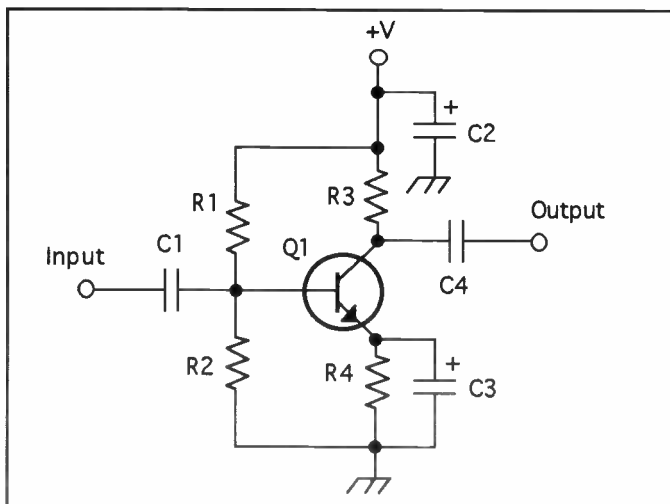

fier. It has a load resistor (R_3) across which the output signal is developed.

It also has input and output coupling capacitors (C_1 , C_4) which couple the signal (or AC wave form) to and from the amplifier. Capacitors C_2 and C_3 provide bypassing of signal voltages so that stable operation of the amplifier is maintained. No, I didn't forget R_4 - it is part of the total DC load resistance and I'll be discussing all of these in more detail in a later article.

The schematic of FIGURE 2a is what the signal sees as it travels from input to output. All of the capacitors appear as short circuits (or very low resistances) to the signal. The DC schematic

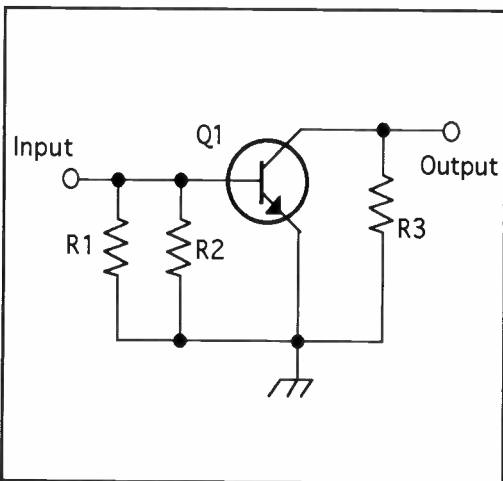

of FIGURE 2b sees the capacitors essentially as open circuits once they have become fully charged. Both circuits see all of the resistances, but in different ways.

A signal sees the bias resistors as being in parallel, and it does not see the emitter resistor at all. The load resistor R_3 also appears to be grounded to the signal. The bypass capacitors on the DC leads appear as shorts to the signal, but open circuits to the DC voltages. Thus the emitter bypass capacitor shorts the emitter resistor to ground at the signal frequency.

In the schematic of FIGURE 2b, the capacitors appear as open circuits to the applied DC voltages. So the bias resistors

appear in series, and act as a voltage-divider network to set the proper bias on Q_1 . The collector resistor is above ground to the DC voltage. The emitter resistor - along with the collector load resistor - determine the current drawn by the transistor. The emitter resistor also acts as a stabilizing factor, and I'll talk more about this in a later article.

Capacitors C_1 , C_3 , and C_4 perform another important function where the signal is concerned. They affect the overall frequency response of the circuit. The coupling capacitors C_1 and C_4 affect the high frequency response, while the bypass capacitor C_3 affects the low frequency response of the circuit.

The type of coupling shown in the amplifier is called RC coupling. The signal output from Q_1 is coupled to the next stage by the combination of R_3 and C_4 , and that's where it gets its name. If more gain is needed, it is possible to cascade two or more of the amplifiers shown in FIGURE 1, but

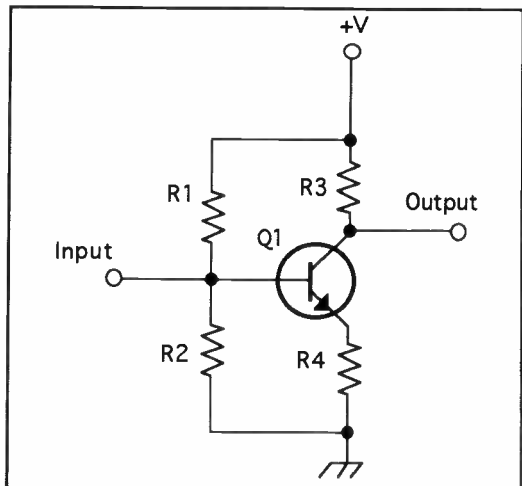

this can introduce a problem. For maximum power transfer you need to have the input and output "impedances" matched. (Think of "impedance" as AC resistance).

But as we've seen in FIGURE 2a, the input to Q1 seen by the signal is composed of the two bias resistors in parallel and they are also in parallel with the input impedance of Q1. The input impedance of a common-emitter stage is normally a medium impedance in the range of 1-k Ω to 5-k Ω . So if the parallel combination at the input to the next stage is not close to the value of the load resistor R3, maximum power transfer will not occur. Fortunately, there are a couple ways to achieve it.

The first is to use transformers for interstage coupling. This - as you would suspect - is called transformer coupling, and can provide a wide range of impedance matching. But transformers are often more costly than simple resistors and capacitors. In addition they can take up more space than simple components, so it is often easier and cheaper to add one more RC-coupled amplifier to your circuit than transformers.

RESISTOR R4

Although I've only just mentioned this resistor, it can play a couple of roles in this type of amplifier. It is part of the output load, and also can be proportioned to adjust the input impedance of Q1 closer to the desired value for better impedance matching. Right now I don't want to get into too much detail since I'll be talking more about all of the resistors later.

So the next time you look at a schematic diagram, remember that you are looking at two schematics at the same time. Pick a simple schematic out of *Hambrew* and first draw the signal schematic, and then draw the DC schematic. You'll feel more at home with schematics and circuits when you do a couple of them this way. ***

WIRES AND PLIERS

Don McCoy, WAØHKC

Here is a handy little circuit to install on a vehicle without an audio reminder to tell you your lights are on after you shut off the ignition.

I use it in my '73 Datsun 240-Z and in my '88 Mazda pickup.

The diode is biased in both directions when the ignition switch is on and the lights are on. No current flows, and the buzzer is silent.

When the ignition is shut off with the lights on, the +12VDC from the lights forward-bias the diode and operate the buzzer. The +12VDC finds ground back through the ignition switch accessory terminal.

The diode is a 1N2071 or any silicone diode that can handle the buzzer current. The buzzer can be a Sonalert or any 12VDC buzzer. You can add a resistor in series to limit current. I never have done this, but some folks have tried it.

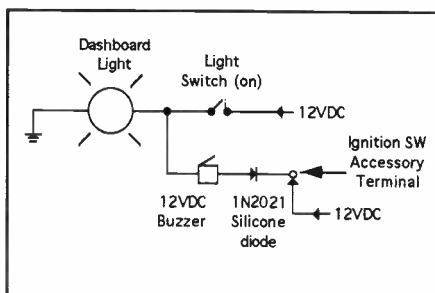

I attached the light end to the dashboard light wiring. It is easiest to access. The ignition switch end can go to the accessory terminal. You may not be able to get to the accessory terminal on some (new) cars, so it would be necessary to test for an accessory that goes off with the ignition and splice into its wire. Happy Wiring!

CLASSIFIED ADS

A Reader Service of **Hambrew** - No charge to subscribers to place one ham-related ad per issue, limit 15 words, 25 cents per word thereafter.

Commercial or non-commercial subscribers, no minimum. All ads must be related to amateur radio.

Hambrew does not vouch for nor guarantee the reliability nor legitimacy of any item or company represented herein. Deadlines: Sept.1 (Autumn), Dec.1 (Winter), March 1 (Spring)

June 1 (Summer). We reserve the right to deny publication of any ad. Copy To:

PO Box 260083, Lakewood, CO 80226-0083. Sorry, no phone orders on classified ads.

Prepay only.

Wheel Antennas For UHF! 70 cm, 900 Mhz, 23 cm, 13 cm.: \$39.95 each, any band! Easily stackable. Mag Wheels: Magnetically mounted versions of any of the above antennas only \$59.95! Olde Antenna Lab, 4725 W. Quincy, Denver, CO 80236 (303) 798-5926

J.W. Miller slug tuned ceramic inductors, used in the old QST homebrew projects. Very limited supply! SASE for list. Jeffrey Viola, 784 Eltone Rd., Jackson, NJ 08527

CHASSIS AND CABINET KITS: #10 SASE 5120-H HARMONY GROVE RD., DOVER, PA 17315. 717-292-4901 EVENINGS

I NEED 2SK19Y FET'S. These are for a R/S Communications receiver 460 Model. Any help will be appreciated. Need a copy of a schematic for a RCA Victor Model 97KG Superheterodyne. I will pay for any of the above items. Please send to Gordon Alexander, 1649 Newark, Aurora, Colorado 80010.

2N4416A FETs for sale. Prime/JAN devices in ESD pack 10/\$6.00 PPD to KC5RT, 701 Oakridge, Liberty, MO 64068

For Sale: Collins RE Mechanical filters

F-455-FA27-6810 2.7Kc at 455KHz PC Mount (not plug in). \$27.50 ea., Postpaid. Henry Mohr, 1005 W. Wyoming St., Allentown, PA 18103

The History of QRP in the U.S. 1924-60 by Ade Weiss K8EFG/WØRSP. 208 pages, 56 photos/16 illustrations-WIFB: "I recommend this book for your Amateur Radio library, even if you never become a member of the fast-growing QRP fraternity..." WB8UUJ: "something to warm the cold winter nights with good memories..." \$12/1st Class (\$10 Sen. Cts.) Ade Weiss,

526 N. Dakota St., Vermillion, SD 57069

Free 112 page catalog of electronic components, kits, test equipment, tools, books, much more. Ocean State Electronics, PO Box 1458 Westerly, RI 02891 - 401-596-3080

Builders! Hard-to-find ceramic rotary switches. Ideal for bandswitching, antenna tuners, etc. Four wafers with single pole, five positions on each. Limited supply. \$5 post-paid. Limit one per person. Unfilled orders returned. Fred Bonavita, W5QJM, Box 2764, San Antonio, TX 78299-2764

ELECTRONICS GRAB BAG! 500 PIECES OF NEW COMPONENTS: INDUCTORS, CAPACITORS, DIODES, RESISTORS. \$5 POSTPAID. ALLTRONICS, 2300 ZANKER RD., SAN JOSE, CA 95131

Simple QRP Kits: Communications-Quality Receivers, Transmitters, Guaranteed to work! SASE for catalog: MXM Industries, Rt 1, Box 156C, Smithville, TX 78957 (512) 237-3906

NEW NN1G MARK 11 CW SUPERHET TRANSCEIVER KIT. AVAIL. FOR 80 METERS, 40 METERS, 30 METERS AND 20 METERS PRICE \$59.95 PLUS \$3.75 SHIPPING CK/MO. TO DAN'S SMALL PARTS AND KITS, 1935 SO 3RD WEST #1, MISSOULA, MT. 59801. 1994 CATALOG: TWO STAMPS

**HAMBREW CLASSIFIEDS
ARE A GOOD DEAL...
THEY'RE FREE!**

OCEAN STATE ELECTRONICS

GRP CW TRANSCEIVER KIT

- Covers 14.0 MHz to 14.1 MHz on 20M or cover 7.0MHz to 7.150 MHz on 40M
- Available on 20M or 40M band
- Superior superhet
- Single signal receiver
- CW crystal ladder filter
- VFO tuning with vernier dial
- RIT w/center detent control
- Very effective AGC
- Selectable audio filter
- Sidestone Oscillator
- 2-3 watts of RF output
- Semi break-in
- 12VDC operation
- Custom pre-painted, punched & silkscreened cabinet
- 100% complete kit with instruction. Nothing else to buy!
- Measures (HWD) 2 1/4" x 6 1/4" x 6"
- Weight 24 oz.



GRP-20 20M VERSION\$149.95

GRP-40 40M VERSION\$149.95

DIGITAL CAPACITANCE/INDUCTANCE METER

DIGITAL LCR METER measures inductance, capacitance and resistance. At Last! An LCR meter that everyone can afford. Now you can measure coils, transformers, chokes from 1µH to 200H. Capacitors from .1pfd to 200 mfd and resistors from .1 ohms to 20 meg ohms. All in one handheld instrument.



MODEL LCR-1801 ..\$119.95

DELUX CODE KEY



Adjustable, heavy duty brass base with ball bearing pivots. Designed for hard usage. 3/16" plated contacts. \$11.75

MAKE CIRCUIT BOARDS THE NEW, EASY WAY WITH TEC-200 FILM

JUST 3 EASY STEPS:

- Copy circuit pattern on TEC-200 film using any plain paper copier
- Iron film on to copper clad board
- Peel off film and etch



Convenient 8 1/2 x 11 size With Complete Instructions

5 SHEETS\$6.25
10 SHEETS\$10.75
20 SHEETS\$16.25



MAGNET WIRE

Enamel coated solid copper. For winding coils, transformers and toroids. Prices for 1/4 lb. spools.

#14 3.85	#24 3.85	#34 4.80
#16 3.85	#26 3.95	#36 4.90
#18 3.85	#28 3.95	#38 5.25
#20 3.85	#30 4.00	#40 5.65
#22 3.85	#32 4.40	

TOROIDS

IRON	FERRITE
T-25-2 40	FT37-43 60
T-25-6 40	FT37-61 60
T-37-6 45	FT37-77 60
T-37-12 45	FT50-43 75
T-50-2 55	FT50-61 75
T-50-3 55	FT50-77 75
T50-6 55	FT82-43 1.00
T68-0 75	FT82-67 1.00
T68-2 75	FT82-68 1.00
T68-6 75	FT114-61 2.15
T80-2 85	FT140-43 4.10
T200-2 4.00	FT240-61 8.00

WE STOCK A COMPLETE LINE OF TOROIDS AND BEADS.

Q-DOPE

Solution of pure polystyrene in solvents. Dries fast and leaves a clear, protective coating on toroids, coils and transformers, with no or minimal effect on inductive values. May also be used as a cement for molded or fabricated items made of polystyrene.

(Bottle with Brush 2 fl. oz. 59 ml)\$3.75



SIGNETICS NE602AN

Balanced Mixer/OSC. Popular IC among experimenters for DC and super-het receivers.

\$2.49 BUY 3 OR MORE ...\$2.25

MINI-CIRCUITS SBL-1 DIODE RING MIXER

Double balance Mixer
LO/RF - 1-500MHz
RF DC - 500 MHz

\$6.75



VERNIER DIALS

1-1/2" Diameter 0-10 Marking\$8.25
1-1/2" Diameter 0-100 Marking\$9.25
2" Diameter 0-100 Marking\$10.25

MINIATURE TOGGLE SWITCHES

3A 125V Solder Terminals

SPDT ON-ON\$1.25
DPDT ON-ON\$1.50

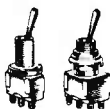

COPPER CLAD PC BOARDS

One oz. copper, phenolic base.

7" x 5" SINGLE SIDED\$1.50
3 1/4" x 6 1/2" DOUBLE SIDED\$1.25

TO PLACE AN ORDER
Call 1-800-866-6626

Ocean State Electronics,
6 Industrial Dr., P.O. Box 1458
Westerly, R.I. 02891

Mail in orders please include \$4.50 shipping
ALASKA & HAWAII \$9.00
Minimum order \$10.00
(before shipping)

R. I. Residents add 7% Sales Tax

Local calls 596-3080



TRANSISTORS

PN2222A	.10
2N2222A	.32
2N3055	.69
2N3553	2.75
2N3866	1.05
2N3904	.10
2N3906	.10
2N4401	.13
2N4416	1.25
2N5179	.75
MPF102	.49
MRF475	6.75
MRF476	3.95
MRF477	12.50
40673	3.90
3N204	3.90

LINEAR IC'S

NE555	.35
NE564	1.75
MC1350P	1.09
MC1496N	.99
LM317T	.79
7805	.49
7812	.49
7905	.75
7912	.75

MONOLITHIC CERAMIC DISCS

ONLY 1.1" L.S.

.01µF	.20
.047µF	.25
.10µF	.28
.22µF	.40
.47µF	.50

DIODES

1N914	.04
1N4148	.04
1N34A	.20
1N4001	.10
1N4004	.11
1N4007	.14

CALL OR WRITE FOR OUR FREE 112 PAGE CATALOG 1-401-596-3080



THE HAMBREW FALL FESTIVAL



CONTEST PERIOD: This is our first contest, and since our contests are intended to be FUN events, I'm going to let it run for 24 hours, but you can only operate 12 hours of during the contest period. This should limit its impact on the rest of your life.

The contest period will begin at 2000 hours UTC on Saturday October 8 and end at 2000 hours UTC on Sunday October 9.

CLASSES: CW ONLY. Single operator, single- or multi-band. Multi-band entries may use different equipment for each band, but only one band may be used at a time. Your log must show the times you began and ended operation on each band, and once you've made a contact on any band you must remain on that band for a minimum of 10 minutes.

FREQUENCIES: QRP operating frequencies +/- 5 kHz on the 80, 40, 20, 15, and 10 meter amateur bands only.

EXCHANGE: Call "CQ HB Contest"; Exchange RST, State/Province/Country, Output Power, and Homebrew (H), Kit (K), or Commercial (C). A typical exchange might be 599MD3K.

POINTS: Homebrew Stations: Count 3 points for each US and Canadian contact and 5 points for each DX contact. Kit-built Stations: Count 2 points for each US and Canadian contact and 4 points for each DX contact. Commercial Stations: Count 1 point for each US and Canadian contact and 3 points for each DX contact. All Stations: Score 5 points for each HAMBREW editor/author

worked. A list of HAMBREW editors/authors appears in each issue.

MULTIPLIERS: States and Canadian Provinces count one multiplier point each PER BAND. DX countries count 3 points each PER BAND.

SCORING: Final score is total of QSO points multiplied by total of multiplier points. Multi-band stations total single band scores for a grand total.

AWARDS: Certificates will be awarded to the high scoring single-band and multi-band station by equipment category in each US state, Canadian Province, and country. Second and third place certificates may be awarded depending upon number of entries. HAMBREW reserves the right to make other awards at its discretion. HAMBREW also reserves the right to ask for photographs of the winning operators AND their stations for use in the magazine.

LOGGING: Valid logs must include Date and Time of each contest QSO, Frequency, Call, Exchange, and start and stop times of operation for each band. Check logs are welcome and will be credited.

Address entries to:

**Bruce Muscolino,
HAMBREW Contest Manager,
P.O. Box 9333
Silver Spring, MD 20916-9333.**

Logs must be mailed within 30 days from the end of the contest.