

The DCP-2 Dual Controller / Phaser

Mark Connelly - WA1ION - 08 MAY 1996

The DCP-2 Dual Controller / Phaser is an updated version of the previous DCP-1. It retains the original ability to tune up to two varactor-tuned remote antennas (active or passive). It can still be used for (remote) L/C-type phasing in the fashion of the DCP-1. Phasing capabilities have been enhanced by the addition of a built-in delay-line circuit. This allows phasing without the detuning of the inputs sometimes needed to implement nulling via L/C methods. Keeping the inputs correctly peaked can give better signal-to-noise margins on weaker stations audible after having nulled a dominant. The delay-line and remote L/C methods can be combined for even greater nulling flexibility. The DCP-2 can now additionally be used as a full-featured delay-line phaser for two broadband (untuned) sources such as active whips, longwires, etc.: it can now do anything the DL-2 phaser does (besides being a dual controller as well).

Besides the addition of the delay-line circuitry, some changes have been made at the inputs to permit control of Byan-type remote antenna terminators using Vactrols (EG&G Vactec VTL3A17 / Allied 980-0206, or equivalent). These remotely-adjustable resistors can be used for Beverage, Ewe, and rhombic termination; remote amplifier gain control; and other useful tasks. Two Beverages, with remotely-adjusted terminations, running through the DCP-2's delay-line phasing circuit and then followed by a low-noise high-Q regenerative preselector en route to the receiver would make a superb set-up for serious DXing.

DCP-2 controls and jacks are compatible with WA1ION DX Labs remotely-tuned antenna systems such as the RL-1, RTL-2, RTL-1A, and RTL-1 Remotely-Tuned Loops and the RW-1 and RTU-1 / MFJ 1024 Remotely-Tuned Active Whips. Two cables connect the DCP-2 to each active antenna (4 DCP-2 - to- antenna cables total). One of these two cables per antenna is the coaxial line which transfers DC power (+12 V nominal) to the antenna and RF output from it. The other cable transfers varactor and bandswitch-relay control voltage to the antenna. For short cable runs (up to 20 ft. / 6 m), a stereo jumper cable (two shielded cables formed into a single assembly), modified for the correct connectors, will work well for each remotely-tuned active antenna, even if the impedance of it may not be exactly 50 ohms. On longer runs, the RF/DC power section should be implemented with good 50 ohm coaxial cable for best results.

When remotely-terminated wire antennas are used, they are connected to various banana jack inputs (as noted in the procedures), rather than to the BNC and stereo jacks used for remotely-tuned antennas.

***** DCP-2 Inputs / Outputs *****

- J1: transfers DC power to, and RF from, active Antenna #1
- J2: transfers DC power to, and RF from, active Antenna #2
- J3: transfers varactor and relay control to active Antenna #1
- J4: transfers varactor and relay control to active Antenna #2
- J5: used for 'A' lead of rhombic #1 or Beverage #1
- J6: used for 'A' lead of rhombic #2 or Beverage #2
- J7: used for 'B' lead of Beverage #1; or used for longwire #1
- J8: used for 'B' lead of Beverage #2; or used for longwire #2
- J9: used for 'B' lead of rhombic #1; or used for float GND #1
- J10: used for 'B' lead of rhombic #2; or used for float GND #2
- J11: transfers RF from the DCP-2 to the receiver
- J12: input for DC 'car power' source (+11.5 to +15.5 volts typical)

***** DCP-2 Controls *****

- R1: adjusts the Antenna #1 varactor or terminator control voltage
- R2: adjusts the Antenna #2 varactor or terminator control voltage
- R3: adjusts the undelayed channel signal amplitude
- R4: adjusts the delayed channel 0/180-degree signal amplitude
- R5: adjusts the delayed channel 90/270-degree signal amplitude

- S1: selects floating or common GND when wire antennas are used at any of the line #1 wire input jacks (J5/J7/J9)
- S2: selects floating or common GND when wire antennas are used at any of the line #2 wire input jacks (J6/J8/J10)
- S3: enables / disables DC voltage used to control and power remote Antenna #1
- S4: enables / disables DC voltage used to control and power remote Antenna #2
- S5: selects which input (1 or 2) goes to the Undelayed channel; it sends the other input to the Delayed channel
- S6: selects Undelayed output, Delayed output, or one of the two Null modes (a or b) that combine the two antenna channel outputs
- S7: controls the relays in Antenna #1 and Antenna #2 that select low-band or high-band frequency range
- S8: selects the delay-line's delay time range: different settings may give best results as frequencies and antenna impedances vary
- S9: turns the DCP-2's broadband output amplifier on (for extra gain when needed) or off

Using the DCP-2 (Refer to Figures 5 and 6.)

1.0 ***** Remotely-Tuned Antennas *****

1.1 Preliminary Set-up

Connect Antenna #1 to J1 (RF/DC) and to J3 (control).
Connect Antenna #2 to J2 (RF/DC) and to J4 (control).
Connect the receiver to J11. Connect DC power (+12V) to J12.
Jacks not mentioned are not used at this time.

Set R3 and R4 about a eighth of a turn from fully counterclockwise (anti-clockwise): e.g. at 8:30 hour-hand pointer position if 7 o'clock is fully CCW. Set R5 to mechanical center (knob pointer at 12 o'clock). R1 and R2 will be adjusted in subsequent procedures.

Set S3 and S4 to On (up).
Set S5 to [U=1,D=2] (up).
Set S6 to Undelayed.
Set S7 to HB (high-band).
Set S8 to 150 ns.
Set S9 to Output Amplifier off.

Positions of these switches may be changed during the procedures to follow. Positions of switches not mentioned may be ignored at this time.

1.2 Tune Antenna #1

Adjust R1 for a peak signal on the desired frequency. If a well-defined peak does not occur, or if it is at the CCW or CW end of R1's adjustment range, change the setting of S7 (the band-select switch) and then re-adjust R1 to get the desired peak.

1.3 Tune Antenna #2

Set S5 to [U=2,D=1] (down). [Note: Antenna #2 must be tuning-range compatible with Antenna #1 as there is only one band-select switch (S7).] Adjust R2 for a peak signal on the desired frequency.

1.4 Select "Weaker" Input as Undelayed Channel

Flip S5 between up and down positions. Leave it on the position that yields the lower level of signal from the dominant station or noise source to be nulled. If there is no observable strength difference, set S5 to a default position of [U=1,D=2] (up).

1.5 Balance Line Levels

Set S6 to Undelayed and to Delayed. Compare the strength of the station to be nulled at each of these settings.

If the Undelayed S6 position has a stronger signal than the Delayed position, adjust R3 until these levels are equal.

If the Delayed S6 position has a stronger signal than the Undelayed position, adjust R4 until these levels are equal.

1.6 Determine S6 position to use

Try both positions (Null-a, Null-b) of S6. If one position yields a noticeably weaker signal from the station to be nulled, leave S6 on that setting, otherwise "default it" to Null-a.

1.7 Nulling

Adjust R5 (90/270 pot) for a null of the dominant station. If an obvious null does not occur, return R5 to mechanical center (12:00) and use R4 (0/180 pot) to look for a null. Once an approximate null has been created, make small interactive adjustments of R4 and R5 to "finish off" the pest station.

Sometimes moving a bit past the best dip on a given pot (e. g. R4) might result in a superior overall null when the slight adjustment of the other delay pot (e. g. R5) is made. Interactive R4 / R5 adjustments should be VERY SMALL as the final null is being approached. It may then help to add some very minor R3 adjustments into the mix as well.

If a reasonable null does not set up, return R4 to 8:30 and R5 to 12:00; then set S8 to one of the other delay range positions and repeat steps 1.5 through 1.7. In most cases, setting S8 to either 150 ns or 300 ns will work.

1.8 Final nulling

By this time, a null should be well-established. At the end, blend in some minor touch-ups to R1 and R2 (slight control-voltage shifts) along with the small R3-R4-R5 final adjustments.

When one or more remotely-tuned loops are the antennas being controlled, slight physical re-positionings of these can also help.

1.9 Amplification

If the desired DX station (left after nulling) is too weak, switch in the DCP-2's amplifier by setting S9 to Output Amplifier On (up). If the broadband amplifier overloads and causes spurious responses, the recommendation is to set S9 back to Off and use a tuned external amplifier (such as the MWT-3) between the DCP-2 output and receiver input.

1.10 Application notes: remotely-tuned active antennas

If the null is too "narrow-banded" (not nulling both sidebands of an AM signal as well as the carrier), set the Q-spoiling switches on the two active antennae to "Low Q" instead of "Normal Q".

To gain experience in using the DCP-2 to phase two remotely-tuned antennas, practice on daytime MW broadcast signals, especially those having a subdominant that, before null attempts, is perceivable behind the dominant station. "Graveyard" channels (1230, 1240, 1340, 1400, 1450, 1490 kHz in North America) are usually prime candidates. Phasing skip signals at night is considerably more difficult, especially above 1 MHz on short-skip where multiple skip modes and rapid changes in arrival angle occur.

2.0 ***** Remotely-Terminated Wire Antennas *****

2.1 Preliminary Set-up

If the two wires of Antenna #1 are a Beverage:

Connect the Vactrol positive lead (wire '1A') to J5.

Connect the Vactrol negative lead (wire '1B') to J7.

Set S1 to FLT only if a ground wire or low-noise counterpoise is tied to J9; otherwise, S1 must be set to COM. (The COM S1 position can be used whether or not J9 has a wire connected to it.)

If the two wires of Antenna #1 are a rhombic:

Connect the Vactrol positive lead (wire '1A') to J5.

Connect the Vactrol negative lead (wire '1B') to J9.

Set S1 to FLT. If the desired pattern and/or noise suppression turns out to be better with S1 on COM, leave it there instead.

If the two wires of Antenna #2 are a Beverage:

Connect the Vactrol positive lead (wire '2A') to J6.

Connect the Vactrol negative lead (wire '2B') to J8.

Set S2 to FLT only if a ground wire or low-noise counterpoise is tied to J10; otherwise, S2 must be set to COM. (The COM S2 position can be used whether or not J10 has a wire connected to it.)

If the two wires of Antenna #2 are a rhombic:

Connect the Vactrol positive lead (wire '2A') to J6.

Connect the Vactrol negative lead (wire '2B') to J10.

Set S2 to FLT. If the desired pattern and/or noise suppression turns out to be better with S2 on COM, leave it there instead.

2.1a Additional Preliminary Set-up

Connect the receiver to J11. Connect DC power (+12V) to J12. Jacks not mentioned up to this point are not used at this time.

Set R3 and R4 about a eighth of a turn from fully counterclockwise: e.g. at 8:30 hour-hand pointer position if 7 o'clock is fully CCW. Set R5 to mechanical center (knob pointer at 12 o'clock). R1 and R2 will be adjusted in subsequent procedures.

Set S3 and S4 to On (up).

Set S5 to [U=1,D=2] (up).

Set S6 to Undelayed.

Set S7 to HB (high-band).

Set S8 to 150 ns.

Set S9 to Output Amplifier off.

Positions of these switches may be changed during the procedures to follow. Positions of switches not mentioned may be ignored at this time.

2.2 Adjust Antenna #1 Remote Termination

Adjust R1 for the best possible rejection of interfering signals and noise from undesired directions. Depending on the frequency range, antenna length, and quality of termination, this pattern alteration may be subtle or it may be quite obvious. Most of the effective range will be in the first two turns of (10-turn pot) R1 from the fully CCW position.

2.3 Adjust Antenna #2 Remote Termination

Set S5 to [U=2,D=1] (down). Adjust R2 for the best possible rejection of interfering signals and noise from undesired directions. Most of the effective range will be in the first two turns of (10-turn pot) R2 from the fully CCW position.

2.4 Select "Weaker" Input as Undelayed Channel: See Step 1.4

2.5 Balance Line Levels: See Step 1.5

2.6 Determine S6 position to use: See Step 1.6

2.7 Nulling: See Step 1.7

2.8 Final nulling: See Step 1.8

2.9 Amplification: See Step 1.9

3.0 ***** Passive Wire Antennas (control voltages not needed) *****

3.1 Preliminary Set-up

Connect Wire #1 to J7 and Wire #2 to J8.

Set S1 to FLT only if a ground wire or low-noise counterpoise is tied to J9; otherwise, S1 must be set to COM. (The COM S1 position can be used whether or not J9 has a wire connected to it.)

Set S2 to FLT only if a ground wire or low-noise counterpoise is tied to J10; otherwise, S2 must be set to COM. (The COM S2 position can be used whether or not J10 has a wire connected to it.)

Connect the receiver to J11. Connect DC power (+12V) to J12 if use of the DCP-2's output amplifier is anticipated. Jacks not mentioned are not used at this time.

Set R3 and R4 about a eighth of a turn from fully counterclockwise: e.g. at 8:30 hour-hand pointer position if 7 o'clock is fully CCW. Set R5 to mechanical center (knob pointer at 12 o'clock). R1 and R2 will be adjusted in subsequent procedures.

A14/-5-3

- Set S3 and S4 to Off (down).
- Set S5 to [U=1,D=2] (up).
- Set S6 to Undelayed.
- Set S7 to HB (high-band).
- Set S8 to 150 ns.
- Set S9 to Output Amplifier off.

Positions of these switches may be changed during the procedures to follow. Positions of switches not mentioned may be ignored at this time.

- 3.2 Select "Weaker" Input as Undelayed Channel: See Step 1.4
- 3.3 Balance Line Levels: See Step 1.5
- 3.4 Determine S6 position to use: See Step 1.6
- 3.5 Nulling: See Step 1.7
- 3.6 Amplification: See Step 1.9

*** Comments on Phasing with the DCP-2 ***

Phasing methods are not "cast in concrete"; numerous working strategies exist. Sometimes there is collateral nulling of DX along with "pests". The likelihood of this occurring is much less if an active loop is phased against an active whip than if two whips or two loops are phased. Useful nulls - those that remove pests without killing DX as well - have been obtained using two loops when the loops have been spaced at least 3.3 ft./ 1 m apart and oriented at right angles to each other.

***** CONSTRUCTION DATA *****

Building the DCP-2 Dual Controller / Phaser

The documentation (schematics, assembly drawings, parts lists, hole lists, etc.) serves as the starting point. The following procedure should serve as an outline for the builder.

This is NOT a beginner's project. Some experience in electronic "homebrewing" is advisable.

1. Gather all necessary parts (see Tables 2, 3, 4). Prepare work area with appropriate tools.
2. Drill out chassis box, in accordance with Table 1.
3. Assemble the BBA-C1 Broadband Amplifier Card to be used for A1. Refer to the Super-MWDX-5 article and to Table 3.
4. Assemble the DLC-B delay-line card in accordance with Figure 4 and Table 4.
5. Mount the following components in the chassis box per pictorials (Figures 5, 6, 7), hole list (Table 1), and parts list (Table 2):
 LEFT SIDE: J1 through J10, S1, S2, G1
 TOP SIDE: R1 through R5, M1, S3 through S9, G2, G3, G4
 RIGHT SIDE: A1, G5, J11, J12

Note that each grounding hardware assembly (G1 through G5) consists of a 4-40 X 0.375" screw, a #4 solder lug, and a 4-40 hex nut. The lug and the nut are on the inside of the chassis box; the head of the attached screw is outside the box.

6. Install remaining electrical components and wiring inside the chassis box in accordance with the parts list (Table 2), the assembly pictorial (Figure 7), and the schematics (Figures 1 through 3).
7. Install knobs on R1 through R5, S6, and S8 per Figure 7 and Table 2.

Table 1: DCP-2 hole-drilling list

X = Horizontal distance, in inches, from the vertical centerline (VCL) on the side observed. Negative values of X are left of VCL, positive values of X are right of VCL.

Y = Vertical distance, in inches, from the bottom horizontal edge of the side observed.

D = Hole diameter in inches.

Hole loci are first marked on the box with a scriber and are then drilled with a .125" bit. Subsequently, as required, the holes are enlarged to the proper size by using progressively larger bits up to that corresponding to the final desired diameter.

Chassis Box = Mouser # 537-TF-782: 7" X 5" X 3"

LEFT SIDE

Hole #	Comp. Desig.	Description	X	Y	D
1	J3	Ant.1 control-stereo jack	-1.875	1.5	0.375
2	J1	Ant.1 RF / DC - BNC jack	-1.875	0.5	0.375
3	S1	Line 1 GND mode - shaft	-1.125	1.625	0.25
4	S1	Line 1 GND mode - tab	-1.125	1.375	0.125
5	J9	RH1B/FloatGND1-blk banana jk	-0.5	2	0.3125
6	J7	BEV1B - yellow banana jack	-0.5	1.25	0.3125
7	J5	RH1A/BEV1A - red banana jack	-0.5	0.5	0.3125
8	G1	grounding H/W - internal lug	0	2.5	0.125
9	J10	RH2B/FloatGND2-blk banana jk	0.5	2	0.3125
10	J8	BEV2B - yellow banana jack	0.5	1.25	0.3125
11	J6	RH2A/BEV2A - red banana jack	0.5	0.5	0.3125
12	S2	Line 2 GND mode - shaft	1.125	1.625	0.25
13	S2	Line 2 GND mode - tab	1.125	1.375	0.125
14	J4	Ant.2 control-stereo jack	1.875	1.5	0.375
15	J2	Ant.2 RF / DC - BNC jack	1.875	0.5	0.375

TOP SIDE

Hole #	Comp. Desig.	Description	X	Y	D
1	S3	Line 1 DC power swt. - shaft	-2.5	3.875	0.25
2	S3	Line 1 DC power swt. - tab	-2.5	3.625	0.125
3	S5	Swap switch - shaft	-2.5	2.5	0.25
4	S5	Swap switch - tab	-2.5	2.25	0.125
5	S4	Line 2 DC power swt. - shaft	-2.5	1.125	0.25
6	S4	Line 2 DC power swt. - tab	-2.5	0.875	0.125
7	G2	grounding H/W - internal lug	-1.5	2.5	0.125
8	R1	Line 1 tune pot - shaft	-1.25	3.875	0.375
9	R2	Line 2 tune pot - shaft	-1.25	1.125	0.375
10	S6	Output Select switch - shaft	-0.375	2.5	0.375
11	S6	Output Select switch - tab	0.125	2.5	0.144
12	G3	grounding H/W - internal lug	-0.125	4.125	0.125
13	G4	grounding H/W - internal lug	-0.125	1.375	0.125
14	S7	Band Relay switch - shaft	-0.125	0.5	0.25
15	S7	Band Relay switch - tab	-0.125	0.25	0.125
16	R3	undelayed level pot - shaft	1	4	0.3125
17	R3	undelayed level pot - tab	1.3125	4	0.144
18	R4	0/180 deg. delay pot - shaft	1	2.5	0.3125
19	R4	0/180 deg. delay pot - tab	1.3125	2.5	0.144
20	R5	90/270 deg. delay pot - shaft	1	1	0.3125
21	R5	90/270 deg. delay pot - tab	1.3125	1	0.144
22	S9	Amplifier switch - shaft	2.25	4	0.25
23	S9	Amplifier switch - tab	2.25	3.75	0.125
24	S8	Delay Range switch - shaft	2.5	2.5	0.375
25	S8	Delay Range switch - tab	3	2.5	0.144
26	M1	DLC-B delay card mtg. H/W	2.125	1	0.125

RIGHT SIDE

Hole #	Comp. Desig.	Description	X	Y	D
1	J12	B+ input - phono jack	0	1.625	0.25
2	G5	grounding H/W - internal lug	0	1.125	0.125
3	J11	RF out - BNC jack	0	0.5	0.375
4	A1	Broadband Amp. Card - H/W 3	1	1.625	0.125
5	A1	Broadband Amp. Card - H/W 1	1	0.625	0.125
6	A1	Broadband Amp. Card - H/W 4	2	1.625	0.125
7	A1	Broadband Amp. Card - H/W 2	2	0.625	0.125

Table 2: DCP-2 "upper level" parts list

NOTE: Amplifier components are itemized in Table 3. Delay-line card components are itemized in Table 4. *: Note follows parts list.

A 141-5-4

Vendor codes for this and subsequent parts lists:

- AST = Astrum Electronics / 3 Commerce Drive / Atkinson, NH 03811 / Tel. 1-603-898-3399
- CS = Circuit Specialists / P. O. Box 3047 / Scottsdale, AZ 85271-3047 / Tel. 1-800-528-1417, 602-464-2485
- DC = DC Electronics / P. O. Box 3203 / Scottsdale, AZ 85257-3293 / Tel. 1-800-467-7736, 602-945-7736
- MCL = Mini-Circuits Lab. / P. O. Box 350166 / Brooklyn, NY 11235-0003 / Tel. 1-800-654-7949, 417-335-5935
- MOU = Mouser Electronics / 958 North Main Street / Mansfield, TX 76063-4827 / Tel. 1-800-346-6873, 817-483-5712 (export)
- RS = Radio Shack / Many locations worldwide

Item	Designator	Description/Value	Vendor	Vendor Stock #	QTY
1	A 1	BBA-C1 amp. card	>>>	see text & Table 3	1
2	C 1-16,18	capacitor, 0.1 uF	MOU	539-CK05104K	17
3	C 17	capacitor, 0.47 uF	MOU	581-UDW474M1	1
4	G 1-5	solder lug, #4	MOU	534-7311	5
5	G 1-5	screw, 4-40 X.375"	MOU	572-01881	5
6	G 1-5	hex nut, 4-40	MOU	572-00484	5
7	J 1,2,11	BNC jack	RS	278-105	3
8	J 3,4	stereo headphone jk	DC	16PJ080	2
9	J 5,6	red banana jack	CS	229B-RED	2
10	J 7,8	yellow banana jack	CS	229B-YELLOW	2
11	J 9,10	black banana jack	CS	229B-BLACK	2
12	J 12	RCA phono jack	RS	274-346	1
13	M 1	DLC-B delay card	>>>	see Fig.4, Table 4	1
14	R 1,2	pot,2K, 10-turn lin	DC	53611202	2
15	R 3,4,5	pot,500 ohm, linear	MOU	31CR205	3
16	R 6,7	resistor, 680 ohm	CS	RA680	2
17	R 8,9,10	resistor, 4.7 ohm	CS	RA4.7	3
18	RFC 1-12	RF choke, 1.8 mH	MOU	434-05-182J	12

19	S 1,2,7	switch, SPDT, on-on	RS	275-635	3
20	S 3,4,5	switch, DPDT, on-on	RS	275-636	3
21	S 6	switch/3pole/4pos.r	MOU	10YX034	1
22	S 8	switch/2pole/6pos.r	MOU	10YX026	1
23	S 9	switch,3PDT,on-on	MOU	10TC280	1
24	T 1,2	RF transformer,4:1	MCL	T4-6T-X65	2
25	T 3,4	RF transformer,1:2	MCL	T2-1T-X65	2
26	VR 1,2	voltage reg., 10 V	DC	78L10	2
27		chassis box, 7X5X3"	MOU	537-TF-782	1
28	*	knob, 0.94" black	MOU	45KN013	7
29	*	screw, 4-40 X .25"	MOU	572-01880	5
30	*	split lockwasher,#4	MOU	572-00649	5

Misc. items: hook-up wire, buss wire, solder, labels "AS REQUIRED"

- * Item 28: one each for R1, R2, R3, R4, R5, S6, S8
- * Item 29: four each for A1 mount; one for M1 mount
- * Item 30: four each for A1 mount; one for M1 mount

Table 3: (A1) BBA-C1 Broadband Amplifier card parts list

For schematic and assembly, refer to "Super-MWDX-5" article.

Item	Designator	Description/Value	Vendor	Vendor Stock #	QTY
1	BD	perfboard: 1.4"X1.4"	RS	276-1396 (cut)	1
2	C 1,2,5,6	capacitor, 0.1 uF	MOU	539-CK05104K	4
3	C 3	capacitor, 10uF tant	MOU	581-10K35	1
4	C 4	capacitor, 0.001 uF	MOU	539-CK05102K	1
5	H 1,2,3,4	screw, 4-40 X .25"	MOU	572-01880	4
6	H 1,2,3,4	spacer, 4-40 X .5"	MOU	534-1450C	4
7	H 1,2,3	split lockwasher,#4	MOU	572-00649	3
8	H 4	solder lug, #4	MOU	534-7311	1
9	P 1-8	flea-clip,.042"hole	MOU	574-T42-1/C	8
10	Q 1	transistor, 2N3866	MOU	511-2N3866	1
11	R 1,5,8	resistor, 4.7 ohm	CS	RA4.7	3
12	R 2	resistor, 33 ohm	CS	RA33	1
13	R 3,6	resistor, 680 ohm	CS	RA680	2
14	R 4	resistor, 2.7K	CS	RA2.7K	1
15	R 7	resistor, 1 ohm	CS	RA1.0	1
16	RFC 1	RF choke, 2.2 mH	MOU	434-05-222J	1
17	U 1	voltage reg., 12-V	CS	7812	1

Misc. items: buss wire, solder "AS REQUIRED"

Table 4: (M1) DLC-B Delay Line Card subassembly parts list

Vendor codes per Table 2.

Schematic = part of Figure 3; Assembly = Figure 4

Item	Designator	Description/Value	Vendor	Vendor Stock #	QTY
1	BD	perfboard:0.7"X1.1"	RS	276-1396 (cut)	1
2	H 1	screw, 4-40 X .25"	MOU	572-01880	1
3	H 1	split lockwasher,#4	MOU	572-00649	1
4	H 1	solder lug, #4	MOU	534-7311	1
5	H 1	spacer, 4-40 X.375"	MOU	534-1450B	1
6	P 1-8	flea clip,.042"hole	MOU	574-T42-1/100	8
7	(for Z1)	14-pin DIP socket	RS	276-1999	1
8	Z 1	500 ns delay-line	AST	(Rhombus) TZB98-10	1

Misc. items: buss wire, solder "AS REQUIRED"

Table 5: control orientation conventions

Orientations are as viewed from outside the chassis box assembly.

Knob pointers should be aligned to the clock hour-hand positions indicated.

Side	Control	Orientation Conventions
left	S1	noise reducing (float) GND = up; common GND= down
left	S2	noise reducing (float) GND = up; common GND= down
top	R1	CCW = max. Line 1 control voltage CW = min. Line 1 control voltage
top	R2	CCW = max. Line 2 control voltage CW = min. Line 2 control voltage
top	R3	CCW & CW = max. level Undelayed Channel = 7:00 center = min. level Undelayed Channel = 12:00
top	R4	CCW = maximum delay level (0 degrees) = 7:00 center = min. delay level (0/180 degrees) = 12:00 CW = maximum delay level (180 degrees) = 5:00
top	R5	CCW = maximum delay level (90 degrees) = 7:00 center = min. delay level (90/270 degrees) = 12:00 CW = maximum delay level (270 degrees) = 5:00
top	S3	Line 1 power on = up; Line 1 power off = down
top	S4	Line 2 power on = up; Line 2 power off = down
top	S5	Undelayed Channel: Line 1 / Delayed: Line 2 = up Undelayed Channel: Line 2 / Delayed: Line 1 = down
top	S6	Undelayed = 10:30; Delayed = 11:30; Null-a = 12:30; Null-b = 1:30
top	S7	HB (high-band, ext. relay de-energized) = up LB (low-band, ext. relay energized) = down
top	S8	delay line disconnect = 9:30; 500 ns = 10:30; 400 ns = 11:30; 300 ns = 12:30; 150 ns = 1:30; 50 ns = 2:30
top	S9	Output Amplifier On = Up; Amplifier Off = down

DCP-2 DUAL CONTROLLER / PHASER

FIGURE 1: LINE 1 INPUT / CONTROL SECTION

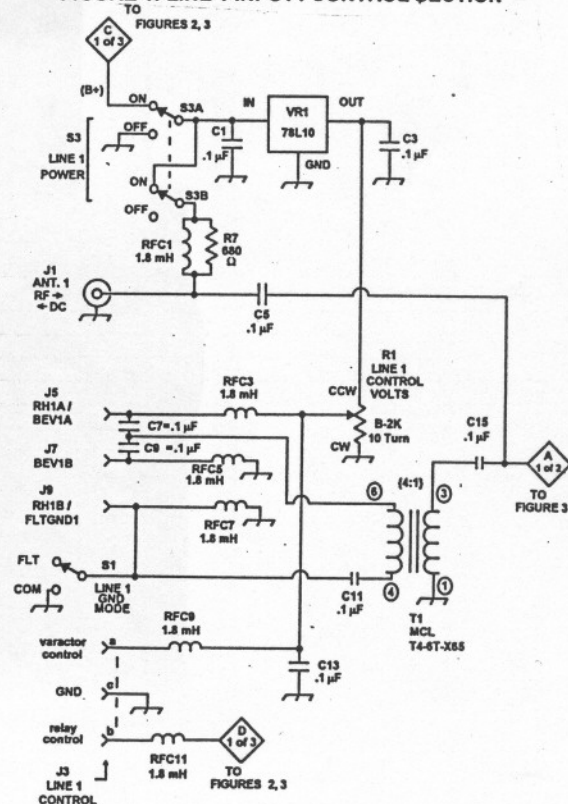

A141-5-5

DCP-2 DUAL CONTROLLER / PHASER
FIGURE 2: LINE 2 INPUT / CONTROL SECTION

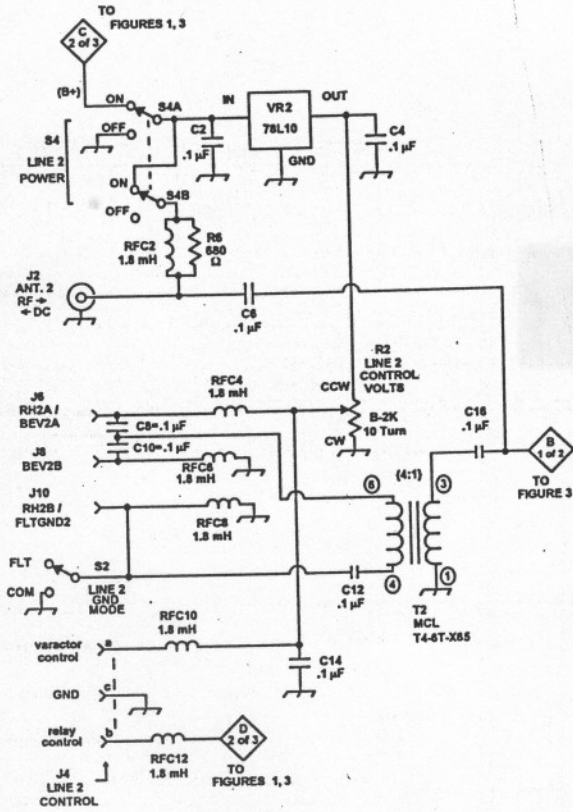

DCP-2 DUAL CONTROLLER / PHASER
FIGURE 3: OUTPUT SECTION

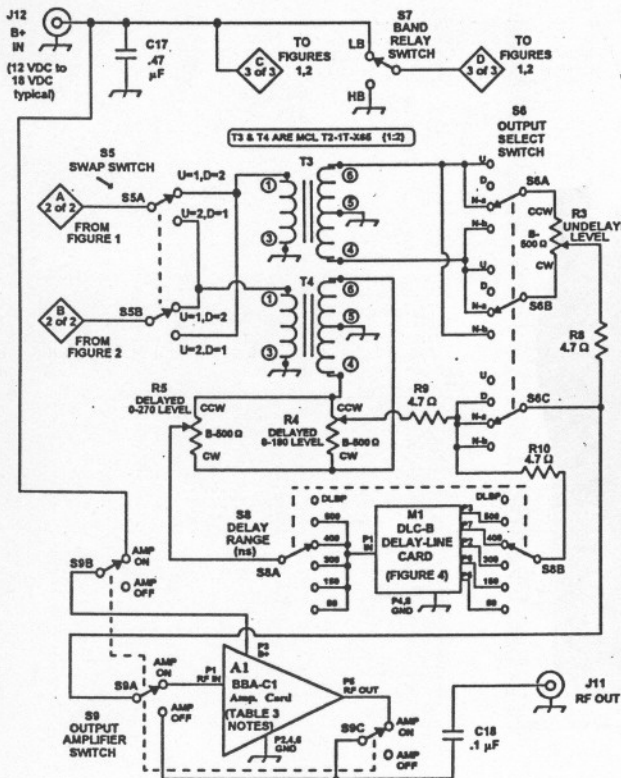

DCP-2 DUAL CONTROLLER / PHASER

FIGURE 5: TOP SIDE PICTORIAL

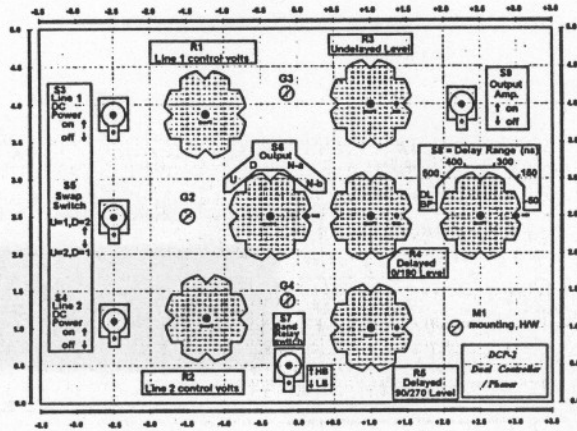
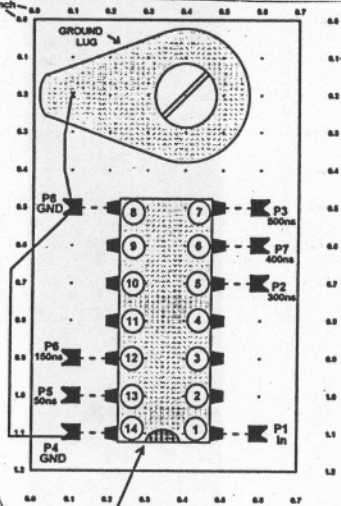

FIGURE 4: DLC-B DELAY-LINE CARD

(M1 OF DCP-2 DUAL CONTROLLER / PHASER)



For complete parts list, see Table 4.
For connections, see Figure 3.
P4 to P8 wire is insulated.

DCP-2 DUAL CONTROLLER / PHASER
FIGURE 6: LEFT SIDE, RIGHT SIDE PICTORIALS

