



DX Monitor

Devoted Exclusively to
Broadcast Band DXing

August 7, 1982

Volume 19, Number 33

Issue Number 620

All sorts of things have been happening in radioland lately. There's a new station in Utah on 1210, the first regular AM stereo broadcasts have begun, and KIKX-580 ran afoul of the FCC and left the air. Check inside for details on these and other happenings.....

New Members	2	DXWWII	19
Volume 20 Publishing Schedule	2	Nicaragua: Latest Information ..	22
Broadcasting Information	3	New Frequencies: Costa Rica	23
California Angels Spanish Network ..	4	Rudiments of Spanish	24
XERF may begin Country Music Pgm ..	4	Eastern DX Roundup	25
Eastern DX Forum	5	Central DX Roundup	25
Western DX Forum	7	Western DX Roundup	26
Thoughts on the Future of DXing ..	10	AM Stereo Premieres	31
FCC Moves Slowly for Utah AM	11	Staff Members Join KIKX s/off ..	31
The IRCA Technical Column	12	DX Worldwide East	32
DXing Dick Tracy Style	17	DX Worldwide West	34
The Iowa Radio Network	18	Old Magazines for Sale	39
How to Get Around Cuban QRM	18	WNYC Power Boost Turned Down ...	39

John Clemmer reports by phone that preconvention activities are moving along smoothly. Last minute reservations can still be made by calling him at (309)796-0684. In the meantime, it's time to start thinking about a site for next year's convention. Hosting a convention can be a lot of fun, not only do you get to meet a lot of DXers, but you save a bundle of money by not having to pay for plane fare or gasoline to get there. This year's convention will be east of the Mississippi (just barely....), so, based on club tradition, next year's convention should be somewhere west of the river (wanna try for Davenport, John?). All sorts of hotbeds of IRCAdom come to mind immediately...San Francisco, Los Angeles, Victoria, Vancouver, San Diego, Aberdeen, Seaside, Rawlins, even Seattle. (Sorry, gang, Amarillo's been ruled ineligible, hi). So if you're interested in hosting the 1983 convention, write Don Kaskey for a convention bid form.

If you can't make the IRCA convention August 13-15, there are a couple of others you might consider. The Miami Valley DX Club will host an all-wave convention on August 21-22, 1982 at DJ Country/Buck Lake Ranch near Angola, Indiana. For more details, write to Miami Valley DX Club, c/o David Hammer, 4666 Larkhall Lane, Columbus, OH 43229. Be sure to enclose an SASE. The National Radio Club will hold its annual convention in Louisville, KY over Labor Day weekend. For details, send an SASE to Dick Truax, Box 32125, Louisville, KY 40232.

Don't forget the contests! You can have your artistic talents immortalized forever on the front of the upcoming Almanac. Design a cover for the Almanac, and if your entry is judged the best, it'll be used on the cover and you'll win a free copy of the book. Your entry must be in black ink on white paper and it must be taller than it is wide. Deadline for entries is October 1. Send entries and questions to Bill Hardy, 2301 Pacific Avenue, Aberdeen, WA 98520. And while we're talking contests, don't forget the IRCA Domestic DX Contests....see page 2 of the July 10 issue for details.

The Courtesy Programs Committee is in need of volunteers to write stations and arrange for DX Programs. If you're interested, contact Phil Bytheway, 9722 Mary Avenue NW, Seattle, WA 98117.

That does it for another front page. Now turn to page 2 and start reading the remaining 39 pages. Next issue comes out August 28, with an August 23 deadline. See you then! 73, bp.

★ ★ *New Members* ★ ★

IRCA—Our 17th Year

Editor: Rich Segalas • P.O. Box 26254 • San Francisco, CA 94126

New Members, Membership Renewal, Address Changes—Send to the Above Address

Jeff Brydle, 11141 Gerald Ave., Granada Hills, CA 91344
 Wayne J. Benkinney, 2367 N. Genesee Rd., Burton, MI 48509
 Mark J. Zavatsky, 196 Figlar Ave., Fairfield, CT 06430 (rejoin)
 Don Hutchins, 3114 Bavarian Lane, Rockford, IL 61109
 T.F. Kline, 2032 Kimberly Dr., Eugene, Ore. 97405
 Marc A. Bergman, 1120 Hull Pl., No. 4, Oxnard, CA 93030 (rejoin)
 Chester A. Beck, 9045 Margaret St., Downey, CA 90241

ADDRESS CHANGES

Craig Cook, 1813 E. Newton Ave., Sherwood, WI 53211
 Thomas H. White, 1140 W. Grace St. #6, Richmond, VA 23220
 David Oliphant, 798-16th St. N.E., Medicine Hat, AB, CANADA T1A 5X3
 Glen Kippel, 612 West Ave., Merced, CA 95340
 Rich Teebe, 2388 American Ave., Hayward, CA 94545
 Ken L.A. Burgess, 459-4th Ave. NW, Swift Current, SK, CANADA S9H 0V4

RENEWALS AS OF 29 JULY 1982

Richard Eckman, Michael A. Bittner, Karl Jeter, David Oliphant, David J. Williams, Glenn Hauser, Br. Dennis Bednarz, George Carter, Craig Cook, James Vernen

DON'T FORGET THAT ALL RENEWALS AND ADDRESS CHANGES SHOULD COME TO ME AT THE ABOVE ADDRESS AT LEAST ONE WEEK BEFORE YOUR MEMBERSHIP EXPIRES OR YOUR NEW ADDRESS TAKES EFFECT.

If your label says "LAST ISSUE" on the bottom line your dues should arrive in San Francisco by 20 August 1982 in order to receive DX MONITOR uninterrupted. If not received by then your label will be pulled from the next mailing to Seattle.

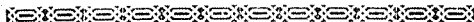

VOLUME 20 Publishing Schedule

<u>Issue</u>	<u>Masthead Date</u>	<u>Deadline</u>	<u>Issue</u>	<u>Masthead Date</u>	<u>Deadline</u>
1	September 18	Sept 10	18	Jan 22	Jan 14
2	October 2	Sept 24	19	Jan 29	Jan 21
3	October 9	Oct 1	20	Feb 5	Jan 28
4	October 16	Oct 8	21	Feb 12	Feb 4
5	October 23	Oct 15	22	Feb 19	Feb 11
6	October 30	Oct 22	23	Feb 26	Feb 18
7	Nov 6	Oct 29	24	Mar 5	Feb 25
8	Nov 13	Nov 5	25	Mar 12	Mar 4
9	Nov 20	Nov 12	26	Mar 19	Mar 11
10	Nov 27	Nov 19	27	Mar 26	Mar 18
11	Dec 4	Nov 26	28	April 2	Mar 25
12	Dec 11	Dec 3	29	April 16	April 8
13	Dec 18	Dec 10	30	May 7	April 29
14	Dec 25	Dec 17	31	May 28	May 20
15	Jan 1	Dec 24	32	June 25	June 17
16	Jan 8	Dec 31	33	July 23	July 15
17	Jan 15	Jan 7	34	Aug 20	Aug 12

Note the change in deadlines, effective with Volume 20, Number 1. The switch from Monday to Friday deadlines was made because several schedule conflicts made it difficult to work around Monday deadlines during the past season. The above deadlines are for material sent to Box 21074. Last minute information, such as DX Test notifications, etc., can be phoned in as late as Sunday night and still find their way into print.

---- Bruce Portzer, Editor-in-Chief

BROADCASTING INFORMATION

Greg Monti
1110 Fidler Lane, #1424 ✓
Silver Spring MD 20910

call	kHz	day/night	
WRUS	610	500/	Russelville KY wants 5000/
KCNL	620	5000/5000	Homer AK granted KGTL
KGDN	630	5000/1000	Edmonds WA granted 5000/2500
KSXX	630	1000/500	Sandy UT granted KZJO
WOGO	680	2500/	Cornell WI wants Hallie WI and 2500/500
appl	760	50000/1000	San Antonio TX wants KSJL
appl	770	1000/	Celine TN
KULF	790	5000/5000	Houston TX wants KKBQ
appl	830	1000/	Del Rio TX application returned
appl	880	500/	Glencoe MN application returned
WRKL	910	1000/	New City NY granted 1000/1000
KELP	920	1000/500	El Paso TX wants KYSR
WAFL	930	500/	Milford DE wants WYUS
KNST	940	1000/250	Tucson AZ granted 5000/1000
appl	940	10000/	Pembroke NC
KLER	950	1000/500	Orofino ID granted 1300 kHz & 1000/1000
WREI	960	500/500	Quebradillas PR granted WJYT
appl	960	1000/	La Follette TN wants WWGR
WWSW	970	5000/5000	Pittsburgh PA granted WTKN
KAYT	970	1000/	Rupert ID wants 2500/
WBSS	980	2500/500	Pompano Beach FL granted 2500/1000, wants 5000/1000
KXLA	990	250/	Rayville LA wants 1000/250
WABT	1000	5000/	Montgomery AL granted WZTN
new	1030	5000/250	Florence AZ granted construction permit
new	1040	250/	Moca PR granted WCXQ
WQIO	1060	5000/	Canton OH granted WRCW
appl	1100	1000/	Thompson Station TN
new	1110	2500/	Marana AZ granted KLLC
appl	1140	1000/	Pine Hills FL
KWBZ	1150	5000/1000	Englewood CO granted KRZN
WLKE	1170	1000/	Waupin WI wants WGZS
appl	1230	1000/250	Valdez AK wants KVAK
new	1240	1000/250	Cross City FL granted WDKA
KWMS	1280	5000/500	Salt Lake City UT wants KDXL
KKIO	1290	500/	Santa Barbara CA granted KXXXN
WMAK	1300	5000/5000	Nashville TN granted WLUY
KWBQ	1340	1000/250	Hot Springs AR granted KZNG
WCWR	1350	1000/1000	Cocoa FL granted WEZY
KNTB	1350	1000/	Bakersfield CA wants KLYD
KIVM	1350	5000/5000	Lihue HI granted KIPO, wants 570 kHz
appl	1380	5000/5000	Pearl City HI wants KLNI
WMZK	1400	1000/250	Detroit MI granted WQBH
new	1400	1000/250	Elmwood Township MI granted WLJN
KPAM	1410	5000/	Portland OR wants KCNR
KDBQ	1420	1000/	Aberdeen SD granted KGIM
appl	1420	5000/5000	Michigan City IN competes with WIMS renewal
WBRB	1430	500/500	Mount Clemens MI wants WWHK
WENZ	1450	1000/250	Highland Springs MI wants WNWZ
WFAB	1460	500/500	Juncos PR wants 770 kHz & 5000/5000
KWRD	1470	500/	Henderson TX wants 2500/
WLOX	1490	1000/250	Biloxi MS granted WBND
appl	1490	1000/250	Samson AL wants WRDJ
KXRK	1500	50000/50000	San Jose CA wants KHTT
appl	1510	5000/	Monroeville AL
WGNB	1520	1000/	Indian Rocks Beach FL granted Seminole FL and 10000/1000
appl	1530	500/	Babson Park FL
WCBK	1540	500/	Martinsville IN wants WMCB
appl	1550	500/	Solvang CA wants KVKG
WLEJ	1560	250/	Ellijay GA wants 1000/
KGCG	1590	500/	Kenryetta OK granted KHEN
WGOE	1590	5000/	Richmond VA granted WFTH
appl	1600	5000/5000	Honolulu HI wants KHNL

The FCC has proposed allowing multiple-city, legal station identification announcements for any broadcast station so long as its signal strength is sufficient over the new city and as long as the station informs the FCC in advance, stating the new city and date on which multiple-city identification will begin; construction permits will no longer be required.

The FCC is now accepting applications for new daytimers which will be within the protected nighttime contour of existing class I-A (clear channel) stations but outside the I-A's protected daytime contour. The Commission is also accepting applications for existing daytimers in the above situation who want power increases. In practice, this will not increase interference since the new stations will be daytimers, except, of course, at sunrise and sunset.

The FCC has scheduled for 7/21/82, oral arguments in the case of WNYC-830 New York NY's application to increase hours of operation and WCCO-830 Minneapolis MN's objections thereto. WNYC currently operates after sunset until 2200 EST.

-- from the Jun 28, July 5, 12, 19 issues of Broadcasting - - - - -

RADIO Stationstuff: WQBH-1400 Detroit MI (x-WMZK)
 PROGRAMMING is moving from ethnic to black-oriented personality
 NOTES radio. The ethnic programming may move to another metro
 Detroit AM...KJET-1590 Seattle WA (x-KZOK) is now
 "modern rock" (somewhere near new wave), automated...KLAY-1480 Lakewood
 WA is now live with adult contemporary...WTRU-1600 Muskegon MI is off
 the air at last notice and should return with a new format, which is
 apparently top-secret...WBRB-1430 Mount Clemens MI is switching to big
 band/nostalgia concurrent with its calls change to WWHK.

Networks: CBS News correspondent Charles Collingwood, who has been with the network 41 years, retired on 6/30; he'll be doing occasional assignments for the net now...New to AEC/Talkradio: WERE-1300 OH, WGBM-680 MD...New to MBS Larry King net: WHAS-840 KY, KPRZ-1150 CA... New to NBC: KING-1090 WA (was RKO)...and on NBC/Talknet: WAMR-1320 FL, WAVG-970 KY...New to SMN/StarDust nostalgic satellite net is KIXI-910 WA. A partial StarDust lineup (in ELT): 1300 Joe Lycinda, 1700 Mark Edwards, 2100 Ralph Sherman, 0100 Don Lucky, 0600 Ed Joyce (Lame excuse time: the clock times are out of order due to me translating them from PLT at the same time as typing them. Your editor will now be punished for that by having to take a business trip to Alaska and experiencing much jet lag.)

Syndication: American Top 40 Is now on XETRA-690 BCN...The Royalty of Rock: A Celebration of the Rock Empire, one of those all-weekend specials, will be out from TM Productions this fall.

Sources: Phil Boersma, Spring Lake MI; Robert Unmacht, Seattle WA; Ken MacHarg, Jeffersonville IN; Detroit Free Press; CBS Press Release; various Broadcastings.

Below: via Rich Toebe
 Right: via Steve Mittman
 from LA Times

For the first time, California Angels baseball will be broadcast in Spanish, with a four-station Spanish radio network to provide play-by-play for all Angels home games.

They are KROQ (1500) in Los Angeles, KNSE (1510) in Ontario, KRCQ (1400) in Indio and XEGM (950) in Los Angeles/Tijuana/San Diego. These stations average approximately 3.5 million Hispanic listeners in Los Angeles, Orange, San Bernardino, Riverside and San Diego counties.

Ulpiano Coa Villa, Antonio Gonzales and Jose David Freire will call the play-by-play.

Border station may blast country music once again

DEL RIO, Texas (AP) — The super-powerful "borderblaster" radio station where Wolfman Jack and "Good Neighbor" Paul Kallinger once sandwiched hill-billy and blues records between long-winded mail-order commercials and whining preachers, may be getting back into the music business.

Arturo Gonzalez, an attorney from Del Rio, says he has been negotiating for XERP — which claims to be the most powerful commercial radio station in the world — to broadcast an early morning country music show with commercials directed at the trucking set.

A show of that type after several years of exclusive religious programming could strike fear in the hearts of executives of U.S. "clear channel" stations transmitting their trucker shows at a mere 50,000 watts of power.

XERP, its transmitter located in Mexico about nine miles south of the Rio Grande — and out of reach of U.S. Federal Communications Commission power limitations — operates at 250,000 watts that can send its signal halfway round the world.

And now Wolfman Jack, a DJ known round the world himself, says from Hollywood that he is "99 percent" ready to film a movie here about the radio station and his exploits as a disc jockey from 1962-64.

ZIGGY



EASTERN DX FORUM

RICHARD EVANS
P.O. Box 1294
NORTH WALES, PA 19454

Deadlines: 8/10; ? (11 days before masthead date)

C. M. Stanbury II, RR #1, Ridgeway, Ontario LOS 1N0

Okay, still trying to keep BCB DXing interest alive, some history. I see where Don Jensen (in NASWA's July FRENDX) has decided to revive that "rather silly controversy" about the location of R. Swan (aka Americas). While it is true the station's main XMTR site was always on Swan Island, alternate sites were planned and available during the Bay of Pigs. This is established by statements in E. Howard Hunt's "Give Us This Day" (pages 164 & 165 of the original hardcover edition - Hunt was connected with R. Swan during the Bay of Pigs), a New York Times story, and somewhat more oblique references to alternate sites in Dave Phillips' "The Night Watch". Phillips headed R. Swan. During the 1962 Cuban missile crisis R. Americas IDs, for security reasons, originated from XMTR sites other than the one on Swan Island. I base this on statements in my files from one of the consulting engineers involved in setting up the expanded VOA network during this period - specifically the USN controlled Dry Tortugas relay on 1040 kHz (the same freq R. Marti would like to use). Unfortunately, VOA sites are no longer IDed on the air so freq/site interchanges would now be much more difficult to track down. Best.

Bill Townshend, 4500 Connecticut Ave. Northwest, Apt. 901, Washington, DC 202-966-8046. In my last Forum, I said I couldn't get WLS //20008 or WLW in midday at summer solstice. Famous last words, hi. I finally did it, hearing WLS-890 Chicago, Ill at high noon in late June with the sun at 73 degrees above the horizon (17 degrees from zenith) at midpoint of the 620-mile (1000 km) overland route between Chicago and Washington. At that high angle, even on a gray overcast day a person with light sensitive skin can get a severe sunburn or even skin cancer by prolonged exposure. At that time WLS was airing an ice cream store spot (yours truly is the "ice cream kid") and a V-8 Juice spot. In fact, I wasn't even doing any serious DXing but I was listening to my beloved oldies on the Pat O'Leary Show on WLMD-900 with my trusty TRF. Then on second thought, I decided to see if anything was happening on adjoining 890. Darn if I didn't hear anything so I stayed on channel for six minutes after the oldies on 900 ended, getting enough copy for a reception report. I hope the OSL comes in time before I leave for the Quad Cities convention. This is one of the ultimate BCB DXing challenges. After I was satisfied with 890, I "turned to" (navy lingo for going back to work (not WORK-107.1 Barre, Vt.)) for the rest of the afternoon. I logged four newies on FM two weeks ago, but AM is zilch so far this month. My FM total is 79. I'm doing more "bikini-chasing" and swimming as I spend more time at the pools and less time at the dials, now that summer has dumped down on us. Now for SP. CUN 28. 73's.

Gerry Thomas, P. O. Box 2036, Pensacola, Florida 32503

No, I haven't passed away; I've just gone through the most horrendous nine months of my life. Since last fall, adjusting to the death of my last surviving relative, a divorce, and the exhaustion of holding down three jobs left very little time for, or interest in, DX. Since July 1, though, things have smoothed out appreciably and I've found myself tickling the knobs more often and getting back to Comquest Research. To all of those who requested info on Comquest, I appreciate your patience and understanding; hopefully, by the fall things will be back on track. The same to IRCANs who have contributed to Midday DX Records. Regarding DX, Charlie Barfield recently got a new Sony portable---the ICF-6500W which is a combination AM, FM, SW rx with LCD read-out. It's a pretty respectable little radio off-the-shelf but a bit too wide on the selectivity dimension for serious foreign DX. We put in a switchable muRata CFS455J ceramic IF filter (3 kHz at -6dB, 9 kHz at -70dB) which does wonders and makes it a super portable for BCB (and SW)DX. A report is nearly finished and should appear shortly. Finally, I'll be spending a week in Jamaica in August where I hope to get in some good Latin DX as well as catch up on nine months of ~~DX~~ and ~~DXN~~. 'Til next time---73's. (Sorry to hear of your problems, Gerry---rce)

Tom Jasinski, 503 Jensen, Shorewood, Illinois 60436

Greetings. So far this has been an interesting summer. Last month I had two weeks of jury duty and served on two different court cases. One was criminal and the other civil. Both involved stabbings with knives. Presently I am involved in a 6 month training program at my job (Commonwealth Edison Generating station near Morris, Ill). This program covers all facets of water purification. This generating station produces approximately 1 million gallons per day of ultra pure water for 5 large boiler/turbine units. This nite, 7-22, is the second to last of two weeks of nite in the chemical laboratory doing nite water chemistry. On a recent trip to Brookfield Zoo near Chicago I heard the "TIS" on 1610 kHz, KMB 3957. On the car radio it had an effective range of less than 5 miles. The broadcast is approx. 1 min. recording consisting of call sign and brief parking and local traffic info for the zoo. Noticed Don Erickson's "Century Print Shop" mentioned in August, 82, Popular Mechanics magazine. Good work Don. I will be making a precision rectifier circuit for an AM Detector and will let you know how it works. "73"

Karl Zuk, 224-04 Stronghurst Avenue, Queens Village, New York 11427

I recently covered the fourth Space Shuttle for ABC Radio in Houston, Texas, and I had a little time to DX, but not much! I was working 18 hour days for over two weeks, because I was the only engineer ABC Radio sent to this event. It was very hot and humid, but the people I worked with were great, and the Mexican food was even better! The burritos were so huge, some of them has Texas license plates! The major surprise was how well WWL from New Orleans covered this area. Using a lousy car radio with a windshield antenna, I could pick them up anywhere I went. I still haven't mastered the Spanish alphabet enough to easily recognize call letters, but I did notice endless amounts of Mexican stations on the dial; even though I had trouble discerning which was which. I did most of my DXing with a RCA 6 transistor radio my girlfriend gave me because she doesn't listen to MW anymore. (Sound familiar?) I heard stations from all over Texas and Louisiana, and a few from other surrounding states, but I did not catch any from the Caribbean, which was a disappointment. Everyone listened to NASA's Xmr on 171.15 MHz, to listen to the astronauts. All for now.

George Hakiel, 739 Van Buren Avenue, West Islip, New York 11795

Welcome from a first time writer. I wish to intro myself. I am 65 years old and retired. I have been DXing since last August (1981). My main interests are in foreign DXing. My first set was a FRG 7700, which I recently replaced with a Drake R7A. I also use a GE Superadio, 250' LW antenna, SM-2, Sanserino Loop, QF-1A sound filter. Total foreign countries received 48 - Total foreign stations (no Canadians included) 197 - mostly LAs and SAs - 25 TAs. Hope to increase these totals with my new R7A. I do not verify tho I may change my mind and verify better catches. Perhaps my latest catch is my best, LRA1 (870 kHz) Buenos Aires - 5200 miles distant. Had this on two nights with excellent clarity. If anyone could fill me in on phased longwire antennas I would appreciate it. Where can I purchase phasing units? Hope to contribute more to thses columns in the future. 73's. (phone 516-587-5812) (Welcome to the column, George--rce)

Bruce Portzer - 6546 19th Avenue Northeast - Seattle, WA 98115

Thanks Rick, for leaving some room. I was in Amarillo again in late July; the only bit of excitement, DXwise, was that KIXZ-940 was having xr problems beginning 7/22, with loud heavily distorted audio on about 980/900 and much weaker than normal audio on 940. It was still that way when I left on the night of 7/23, but for their sake I hope it's since been corrected. I've tried SRS DXing recently and, on occasion, have noticed a nice sunrise enhancement of down under signals at the high end of the dial around sunrise. 2NA was actually readable with KGA-1510 on, 2 kHz away, one AM, and 4QD-1548 poked through the spatter from KJZZ-1540 (5 miles away) at times. One major change in local radio: KAYO-1150 changed from country mx to 1940s/50s mx, and on 8/2 changed calls to KSPL. Meanwhile, if anyone hears "Radio London" IDs on 1590 it's KJET. They frequently run SIDs from the 1960's British pirate as part of their hourly ID! 73.

KBMY

1240 ON YOUR DIAL . ABC NETWORK STATION
P. O. BOX 20316 . BILLINGS, MONTANA 59102

CHQT
RADIO 1110
10154 . 103 ST. EDMONTON, ALTA
TSJ OXB

RSEM, INC.

The Basin Station - Drawer S
MOSES LAKE, WASHINGTON
98837



Western DX Forum

★ ★ ★ ★

IRCA—Serving the Broadcast Band DX'er Since 1964

Editor: Ric Heald, P.O. Box 4861, Santa Rosa, CA 95402-4861, (707) 538-5187

GLEN KIPPEL, 612 WEST AVENUE, MERCED, CA 95340

Hello again. About the time you read this my address will be as above and thankfully away from the high-powered line noise that I've experienced at my previous location. Before the walls went on the new house, I took the liberty of mounting a pair of large-aperture loops directly to the studs, so the antennas will really be out-of-sight. I hope the DX will be better from the new location.

KRVN 880 seems to be off only on Sunday mornings, vastly decreasing opportunities to hear Peru. Verie finally in from R. Union, by the way. . . a card signed by Roberto Adrianzen Huaman. KWSO 1180 now on nights.

MW DX has been so nonexistent that I gave into the temptation to find out what those signals were next to WWV on 5 MHz and logged South Africa, Siberia, Sarawak and Solomon Islands (among others). . . and I hope you all forgive me for a temporary defection from BCB.

The NAB is still interested in any information regarding the Cuban interference problem - - it seems like an area where DX'ers can be of real service to the country and/or broadcast industry. Information on the new stations, frequency changes and especially any increases in signal strengths can be sent to: Science and Technology Dept., National Association of Broadcasters, 1771 N St., NW, Washington, DC 20036, Attention Mike Rau.

Local KLBS 1330 Los Banos now under new ownership and thinking about 5 kw days and night operation. That's it for now, so I'll turn the page over to--

BILL HARDY, 2301 PACIFIC AVE., ADBERDEEN, WA 98520

The weekend of 10 & 11 July Nancy and I camped on the coast at Kalaloch, WA, just one year after Glenn Hauser stayed at Kalaloch Lodge. Glenn, I don't know what the National Park Service would think of Beverage antennas, but you are right, radio propagation there is quite unique.

With my GE 7-2963A portable, I did a few daytime bandscans 11 & 12 July at Kaloch Campground and at an overflow campground 3 miles south. Signal strength ranges from 1-poor to 5-excellent. Nobody got a 5, but CBU-690, KNPT-1310, and KTIL-1590 shared honors for best daytime signal. The full dial:

540 LPRT 1 1/2 (relaying CBU), 550 religion tentatively KARI 3, 570 KVI 1 1/2, 600 CJOR 3, 620 weak unID, 630 KSHR 2½ with a SAH, 690 CBU 4-, 710 KIRO 2+, 730 CKLG 2, 900 CJVI 3, 930 KSWB 3, 1000 KOMO 1½, 1090 KING 2-, 1130 CKWX 2½, 1220 CKDA 2½, 1230 three stations SAH'ing with pop-top 40 atop from KHSN, suspect KVAS/KTDO for the others, strength 2; 1310 KNPT 4-, 1320 KKRO 2-, 1340 SAH weak, possibly KBBR/KAPA, 1370 weak unID possibly KAST, 1400 KCBH 2, 1410 CFUN 1, 1420 KYNG 1+ (ID'd after much listening, no longer top 40, now BFL format & few ID's, Ae nx delayed to hour), 1450 Ai nx weak possibly KBKW, 1470 very weak unID possibly KDUN, 1490 KVAC 3-, 1590 KTIL 4-. (Interesting info on KYNG 1420, Bill, we can't hear 'em down here daytime even though we are closer. KSHR 630 Coquille, close to Coos Bay but farther inland, puts in a fine midday signal here, however-RET)

KBCH-1400 is definitely weaker than past years when they were on 1380. Other interesting items included the total lack of anything between 730 and 900, the profusion of signals from metro Coos Bay on 630-1230-1420 at a distance of some 300 miles, the fact that KNPT 1310 at 200+ miles was outperforming KVAC-1490 at 30 miles, and the readability of the LPRT (Ucluelet) on 540. 73 and good DX.

THOMAS L. NYQUIST, PSC BOX 109 APO SEATTLE, WA 98764 (Alaska)

Hello everyone. I've been a member of IRCA for only a few, short months. I'm 24, single and in the Air Force, stationed at a remote radar site 168 miles west of Anchorage. I've been DX'ing for about three years with my interest centering upon BCB but I enjoy FM and of course, SW. I use a Superadio with a 200-foot longwire, and sometimes supplement frequency checks with

W M B D
RADIO • TELEVISION
"First in the Heart of Illinois"

212 S.W. JEFFERSON AVENUE • PEDRIA, ILLINOIS • 61602

WIN-W WONDERFUL 1520
RADIO CANTON
4111 MARTINDALE RD. N. E. • CANTON, OHIO 44705

RF-2600. Also, my Yamaha T-7 seems to do an unusually good job on AM for an AM/FM tuner. Odd, because tuners with exceptional FM sections usually have lousy AM sides.

I'm located atop a 3,100-foot mountain in south-central Alaska, called Sparrevohn AFS for a Colonel Frank Sparrevohn who, defying death, heli-coptered out here to the tundra and discovered this here mountain (thanks Frank). Anyway, reception goes from terrible (like when everyone decides to dry their hair with megawatt hairdryers, or the time the bulldozer was clearing snow and cleared my longwire in the process), to good (when I was able to get something every 10 kHz and I ID'ed KDWN 720 and KSL was good).

Now, I've got a 200-foot longwire and when I'm not busy axing heater motors, dimmer switches and malfunctioning HF radios, I get pretty fair DX, KGO is pretty easy, KFBK, KEX come in OK.

Most nights, the west coast (now that night is only four hours long) is usually pretty much open up here, as signals usually are traveling over water. Winter, of course, is best. From 1500-to-1000 ALT you've got darkness.

As far as daytimers, KFQD Anchorage seems to get over the monstrous Alaska Range best. Others are lost in the site-generated QRM, but do come in variably. I think my main obstacle is not distance but the horrendous interference generated on the site.

By August though, I'll be back at Great Falls, Montana. DX is great down there. I hope I'll be able to continue reporting to WDXF from there. Well, until next time, 73 and best of luck from the tundra. (Welcome to IRCA and WDXF. Good to have a report from Alaska - where I lived for four years - and hopefully soon from Montana-Rth/RET.)

ALBERT S. LOBEL, POST OFFICE BOX 26762, SAN DIEGO, CA 92126

Someone is either trying to tell this DX'er something or is really watching out for him. Remember the PSA Flight 182 crash in San Diego back in 1978? Well, this DX'er almost got hit by some debris from the PSA plane. You must have heard by now about the PanAm Flight 759 crash in New Orleans. Well, this DX'er was on that very same plane only thirteen days before--YES--that very same plane! My curiosity got the better of me and I called PanAm to confirm that it was the same plane. The answer was--you guessed it--YES! A lucky twist of fate. (you gotta watch 13, though, broke my leg on Friday the 13th once--ouch ouch, hi, RET). And you, Ric, got worried when I went into the Bermuda Triangle on that cruise ship! HI! (Some people are permanently in the Triangle, hi, Rth). My luck with planes is fantastic. Little known to most DX'ers is an almost unexpected trip to Cuba thirteen years ago. When my wife and I got married on 22 June 69 we spent our honeymoon in Las Vegas and then in San Francisco. We were flying standby on Western Airlines and had to switch to United for the return flight to San Diego. We were going to make one plane and instead took one that went out ten minutes later. The one we were thinking of making was hijacked to Havana.

Not much is new DX wise. (For real excitement, try for the DU beacon on 1615, Albert, hi RET). In fact the receiver has not been turned on since returning from the Caribbean Cruise (except the G. E. Superadio and only to locals). Will probably switch to FM and/or TV DX'ing for the summer. So until the fall you probably won't hear much about me. (A few DU's are sneaking in, Albert, in case you want to get up at 4 AM, hi RET).

Ric; what do you think of the San Diego Padres being in second place and having the second best record in baseball at the All-Star break? (What is baseball? Is there a team in the Bay Area? Hi-Rth.) 73 de ASL.

RANDY TOMER, 1969 27th ST., ARCATA, CA 95521

It's been nice having Rth in town - having someone else around who actually DX'es is a big incentive to DX. (Especially when the new kid in town up-stages Tomer, hi-Rth.) Is KUJ 1420 off the air nights now? KUJ and KSTN used to have 1420 pretty much tied up, but recently I got a good, clear signal from KITI for the first time heard after years of trying (thanks to Rth's phone tip). There's been no sign of KUJ so maybe with some good Hawaiian cx I'll finally get a long-sought ID from KCCN Honolulu. I've heard Hawaiian music on 1420 before (KCCN's format) but never an ID at this QTH. (Oh, that pest, hi-Rth.)

Noted KYAC 650 Anchorage with Larry King 0000-0100 PLT 11 July, in with a good, steady signal. The DU beacon "OR" finally made it to this QTH, heard early 16 July over mucho crudo. Exciting programming. (Almost as good as Eureka area radio, hi -RtH.)

The plug-in ferrite loop (unamplified) I made for my GE Superadio works like a champ. The first night I tried it gave me good, readable copy from Kiribati 846 and New Zealand 1035, in spite of mediocre DX conditions. Not only does it boost signal strength, but it adds a bit of selectivity and it rotates. Now if GE would finally get off their pot and send me the Superadio schematic that I ordered long ago, I can get my PCIM frequency display hooked up to it and I'll have a real DX receiver. A little increase in selectivity couldn't hurt the Superadio, but little has been mentioned by other IRCA Superadio owners. If anyone with any hot ideas on this please write a forum or a letter. I've been taping with the idea of using regeneration in the Superadio like MC did with his TRF.

A few notes re the June DXM. SPM, Art Peterson of the Bay Area has also complained of the mystery beeper on 1610-15 and feels it's of local origin.

KNUI 900 is indeed a strong Hawaiian; heard often here with a loop antenna. KMVI 550 has gotta be the strongest, often toppling the WC 550's. KORL/KIKI are over-rated due to lack of co-channel interference on the WC. They and KPOI seem to be the best bets for reception back east, however. If KZOO had any competition on 1210 here on the WC, it would never be heard.

Some interesting LA catches by bp and NHP last May. In the works at my Fieldbrook DX'pedition site is a 500 or 1,000-foot mini-Beverage aimed towards Central America. I'll also have use of a new building with electricity and the property owner will string out the antenna, which is a good deal for me because it's through some pretty thick brush.

Conditions must be picking up. The other night was getting some good copy of what must have been the Wallis Islands on 1188, but no ID - KEX off. Sure as heck wasn't pest JOCP. (Braggert, hi-RtH.)

If RtH stays in the area I don't know what I'm gonna do. I mean, two forums in a row after I said I had hung up the earphones for the season. (He's actually hoping I'll go elsewhere and eliminate the competition, hi RtH.) Summer DX not that bad after all. 73 de RET.

RIC HEALD, P.O. BOX 4861, SANTA ROSA, CA 95402 (Still in Eureka/Arcata)

Howdy. Yup, still up here in the North Coast country; job ends 15 August and God only knows where I'll be after that, but will continue the Santa Rosa address, so until further notice, keep sending your forums to the P.O. Box.

I'd like to thank Randy Tomer for his assistance with this month's column. He got such a kick out of it, he promptly handed it back to me, hi. Seriously though, it's great having another serious DX'er in the area. I understand there are a couple other IRCAnS in the area and we still have a Beverage party in the planning stages. Hurry up guys, I leave in two weeks, hi.

Randy also took a look at my car radio and what, if any, could be done re the ignition noise. The answer: Nothing. The generator is about eight inches from the bottom of the windshield antenna. Oh well. Of course Randy once again tried to interest me in a diesel engine, hi.

Sure is nice getting away from Bay Area radio. KATA 1340 is the only AN'er and they're off MM. Have discovered a horrendous half harmonic of KATA on 670. Can be heard up to ten miles from transmitter site, and at my QTH, one-half mile from KATA, it registers 30db over S/9.

DX? Ah yes. It does exist and is living in Humboldt County, hi. Have heard tons of hets, several TP's and DU's and Hawaii sounds like they're just down the road. Notably, KNUI 900 is a real blockbuster. And Domestic? Unfortunately, the Bay Area is very strong at night. Have noticed the Northwest tends to dominate, whereas from Santa Rosa it was SoCal. Did take excellent copy on USSR 1476 at 0500 PLT 27 July. Rolling in with 30db over S/9 peaks. Haven't heard them since Venetie, Alaska in 1969 when they were on 1470, I think, hi.

OK, all you propagation buffs, put your thinking caps on. KPOD 1240 Crescent City rolls in here daytime, of course. When they drop their power, they're heard well on my car radio in Eureka and about halfway to Arcata they fade and by the time I'm home, they're gone. Now, Arcata is seven miles north (toward Crescent City) of Eureka. The only thing I can figure is that Eureka is about two miles closer to the ocean than my QTH, and would that explain why KPOD dies? I mean, would two miles make that much difference? By the way, KPOD has got Eureka area radio beat by a country mile.

Guess I've rambled long enough. See y'all next month. 73 de RtH. .

THOUGHTS ON THE FUTURE OF DXING

Karl Zuk, 224-04 Stronghurst Ave., Queens Village, NY 11427
Medium Wave seems to be going through radical changes lately. I think we are all fearing the planned obsolescence of the band we concentrate on. The band is sounding more and more like the endless drone of heterodynes any owner of a CB radio knows. The deregulation of radio and the end of the clear channels will speed this trend dramatically. I feel that I am kissing good friends like KSL, WBAP and WDAI goodbye for the last time, as the Cuban superpowers and new Canadians, Mexicans and low powered locals take control of these frequencies. BCB is becoming what FM was 20 years ago: an unpopular medium that is trying hard to survive. The broadcasting of music is certainly becoming just a memory. AM Stereo should prove interesting now that the industry seems to finally be settling on a standard system (Kahn). The broadcast industry is now suggesting new and novel ways to keep BCB alive, should stereo fail. One idea is the concept of many synchronous low powered stations on one frequency instead of one clear channel. This may prove to be the answer should the Cuban media war heat up. Another is the use of subaudible frequency transmission to control things or transmit data or other information. The FCC recently released a Report and Order on such an idea permitting AM radio stations to use subaudible tones for utility load management. What this means is that a utility company can lease the range below 30hz on an AM radio station to send signals that will control air conditioners, hot water heaters, or whatever, at remote locations. These machines will be connected to special AM receivers that will decode these subaudible tones and use them as signals to start or finish certain tasks. Three 10 millisecond 25hz tones could mean "Air Conditioning ON", etc. The advantages in using MW AM broadcast over the now common FM SCA system are obvious, at least to the designers of this system. AM broadcast can cover larger areas with no elaborate antenna systems, and show much more stability than SCA subcarriers on FM that can be interfered with easily by multipath created by locale or passing objects, like planes or cars. This system was suggested by the McGraw Edison Company of Pittsburgh, PA. and has been dubbed "The Altran System."

The idea of synchronous transmitters on the same frequency is also being refined by high technology. A firm called Kinemetrics has designed a receiver that will make synchronous transmission by several transmitters much easier and trouble free. The biggest single problem of synchronous transmission has always been keeping all the transmitters on the same exact frequency so that they will not create low frequency heterodyne beats and growls with eachother. The Kinemetrics device creates

a common frequency standard from WWVB on 60 kHz. If you connect and calibrate one of these units to each of your transmitters' crystal controlled master oscillators, they will all be using the same frequency standard (WWVB), and will all be accurately on frequency with one another. This is very important to the new AM stereo systems, since the phase and subcarrier information are dependent on these subaudible audio frequencies for accurate reproduction. If the Cuban or other high powered MW operators make long haul transmission impossible for current stations using a single 50 kW transmitter in The States or Canada, a string of lower powered stations on the same frequency may be the only way to battle the foreign superpowers.

It just won't be the same, though. There just isn't a romantic feeling about listening to a repeater of a distant station as compared to hearing the real thing. Just think what a challenge it will be to verify all the repeaters of one station, and trying to tell the difference between them! Maybe subaudible encoded ID signals will be what we will search for in the future, instead of a human voice announcing a clever station slogan. My thanks to Radio World magazine for the information used in this column. Time marches on! And at our expense! 73 de KJZ

Below: Broadcasting 7-17-82, used by permission via Steve Mittman and Greg Monti

The FCC clock ticks slowly for Utah AM

Request to switch frequency and raise power has been in the works since 1973

Nobody expects the FCC to grant an application to upgrade an AM station overnight. That's a process that can take time. In fact, with complications, as Julie P. Miner, owner of KDXU(AM) St. George Utah, could testify, the process can go on for nearly 10 years—and even then there may be no final resolution in sight.

Miner's tale began in 1973, when she, also the owner of KZEZ(FM) St. George, decided to try to upgrade her AM. She proposed moving KDXU, which operates on 1450 khz with 1 kw day and 250 w night, to 890 khz. She also proposed to increase power to 10 kw day and night. Before her application had completed its run through the FCC, however, Albert Crain submitted his own application for an AM station on 890 khz that would operate with 50 kw night and 10 kw day. At the time of the application, Crain lived in Collierville, Tenn., and operated WMSO(AM) there and KBNJ(AM) Crane, Tex.

Crain's application was preferred by both the administrative law judge who presided at the comparative hearing and the Review Board. The full commission declined to review the decision.

Both the ALJ and the Review Board gave Miner a preference for integration of

ownership and management. But both also said the FCC's policy goal of promoting diversification of media interests overrode Miner's preferences: they said Crain would bring a new voice to the community and provide what the Review Board said was "the only competition to a two-station local monopoly."

In 1980, however, the U.S. Court of Appeals in Washington reversed the FCC decision, contending that the commission had erred in making findings on fact instead of making findings on assumption (BROADCASTING, Dec. 8, 1980). The court said the FCC had simply assumed that if Crain's application were granted, Miner would continue to operate her AM on 1450 khz, but that if her application were granted, it was unlikely that a newcomer, such as Crain, in the face of competition from a high-power station, would start a new service on the vacated 1450 khz.

The court added that although diversification might be of primary importance in comparative hearings, diversification does not automatically disadvantage existing licensees who have a record of service in favor of untried newcomers." According to the court, it was "patently unfair" to resolve a comparative hearing on the issue of desired competition without investigating "the factual realities of whether increased competition will actually result."

In the wake of the reversal, the FCC asked for comments from both Crain and Miner on how the FCC should proceed. Although the FCC suggested further hearings, both parties rejected that, contending that the issues already had been adequately addressed.

The next move is still up to the commission, which, according to an FCC source, must decide whether to offer new justification for awarding the frequency to Crain, or to grant KDXU's application.

The chances of the commission making that move soon seem slight, however. The case already has been awaiting action in the FCC General Counsel's Office for more than a year. John Riffer, associate general counsel for that office's adjudication division, said the case's "complexity" and office backlogs were "unfortunately" to blame for the inaction. Also "unfortunately," Riffer said he couldn't predict when the case would finally make it onto the commission's agenda.

L. John Miner, KDXU general manager (Julie Miner's husband), meanwhile, told BROADCASTING that KDXU still wants the new frequency and the power boost. Since the station originally made its application, the St. George market had become more competitive, "so the commission can't use diversity as an argument as far as I'm concerned," Miner said.

Miner noted that while KDXU and KZEZ (formerly KDXU-FM) were once the only stations in town, they now have company. KCLG(AM), which went on the air last month, is licensed to Washington, Utah, just outside St. George, and has been authorized to operate on 1210 khz at 10 kw day and 250 w night, Miner said.

According to Miner, KSUB-AM-FM and KBRE-AM-FM, both licensed to Cedar City, Utah, now have translators in St. George, (Dixie College, based in St. George, operates noncommercial KRDC-FM.)

As a result, KDXU needs the improved facilities "now more than ever to compete with the new stations," Miner said. □



the irca technical column

Editor: Nick Hall-Patch
1538 Amphion St.
Victoria, B.C. V8R 4Z6
Canada

A High Performance Preselector for MW

by Don Moman

(In recent years, relatively inexpensive shortwave receivers have come on the market with some good features--digital readout, reasonable selectivity, ease of use etc. Although such receivers as the FRG-7700 and the R-1000 tune medium wave, they are not ideal MW DX machines in any but the most rural areas when using a random wire antenna, due to problems with front end overloading. A few random wire tuners are on the market, but only the McKay Dymek DP-40 uses two tuned circuits of preselection, and two seem necessary when strong stations are nearby. Don Moman of Shortwave Horizons has devised a random wire tuner for MW which will help out a good many receivers with MW overload problems. The following article is from the CIDX Messenger. --ed.)

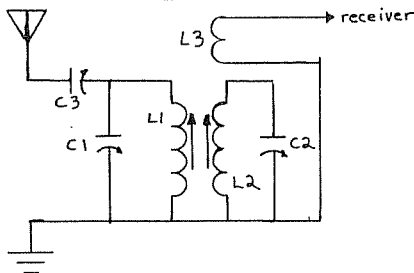

Components:

C1, C2, C3 are 365 pF variable capacitors
L1 and L2 are variable loopstick antenna coils. J.W. Miller #2007 or #6300 should do the job
L3 is wound on L2 and consists of 12 turns of #22 gauge insulated wire.

Construction:

The unit should be built in a suitably sized metal cabinet for shielding purposes. Parts layout is up to the builder but should follow the basic plan at the left.

L1 and L2 are simply mounted end-to-end. A $\frac{1}{4}$ inch round piece of wood can be inserted in each coil to keep them in alignment. This is important as the coupling between L1 and L2 provides the means of signal transfer.

The cases of C1 and C2 should be connected to ground as in the schematic. C3 must not touch the case. It may be mounted using rubber Silastic RTV type adhesive--sold in many hardware stores as

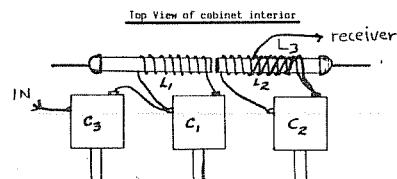

Silicone Rubber product. It provides a strong but flexible bond that is electrically non-conductive. You may want to use a plastic extension shaft on C3 and mount it back farther in the cabinet to prevent undesired pickup from your hand.

Operation and Initial Set-up

L1 and L2 have adjustable cores so coverage of the MW band is made easy. Just set C2 at maximum capacity (plates meshed) and adjust L2 so you get a signal peak at 540 kHz. L1 can be set so the core is in the same position as L2. In use, the setting of C2 will be quite predictable, i.e. the dial can be roughly calibrated. C1 and C3 interact greatly and will vary somewhat depending on what antenna you are using. Adjusting them simultaneously you will find there are many positions of signal peaking but the maximum peak will only occur at one setting. This is harder to explain than it is to actually perform!

Performance

The RF selectivity provided by this device will greatly increase the MW capability of modern broadband sets like the Yaesu FRG-7700 and others, in areas of high signal density. In fact the 7700 and tuner will outperform, by a large margin, a "lone" Drake R-7. I have noted, on hundreds of comparisons, that a weak signal on the R-7 (covered by intermod products) is free from such products on the 7700 using the tuner. This is not to infer that the 7700 is the ultimate MW set, just that a simple set of tuned circuits can allow it to outperform a set costing twice as much. When the tuner is used with the R-7 the resulting system is capable of operating under extremely high signal levels. Now if we could just get rid of those w-i-d-e local AM'ers--or at least convince them to reduce

modulation levels to less than 100%--we might even be able to do some DX'ing from our urban locations.

Further Performance Notes (NHP)

Tune-up procedure:

- 1) Tune radio to desired channel with tuner bypassed and tune C3 to minimum capacity (plates unmeshed)
- 2) Switch in tuner. If no signal noted, increase C3's capacity until some signal is heard. Tune C2 to peak; tune C1 to peak. Reduce C3's capacity if attenuation (for better signal handling in radio) is required; retune C1 for peak.

My homebrew toy radio has reasonable signal handling ability in the city using a loop, but a 50' random wire makes it useless without some sort of tuner. Don's tuner really makes a worthwhile addition to the radio in this case. Before sunset at this location, CKDA-1220 can make mincemeat of KFBK-1530 (2x1220 - 2x455 = 1530) using a random wire straight to the receiver. With the tuner, there's just the slightest birdie on KFBK. My own homebrew preselector (described in DX Monitor Jan 27, 1979) can eliminate the last remnants of the birdie, but in general, there's little to choose between the two circuits.

Another good example was Belize-834 which was inaudible one evening when using the random wire directly--all that could be heard was intermodulation distortion (IMD) from locals. With the tuner, the IMD was gone and Belize was heard at fair strength using the same wire. Even using a 1000' Beverage out in the sticks with this tuner made my radio handle signals a lot better.

Are there any drawbacks to the preselector? Other than adding a few more knobs to turn, there is some loss of signal on some parts of the band when using the tuner. In general, this shouldn't be a problem as most modern radios have plenty of sensitivity to spare on MW. If the loss worries you, try adding a "loading coil"--another loopstick will do--between the antenna and the input of the preselector. C3 will then peak a signal as do C1 and C2, though it will still interact with C1. Different adjustments of this loopstick slug may be needed when using different antennas, but in general there will now be no loss of signal through the tuner. Also, the loading coil/C3 combination will provide another stage of tuning between the antenna and receiver which will reduce overload problems further.

If constructing such a preselector looks too challenging to you, write SW Horizons, 6815 12th Ave., Edmonton, Alberta T6K 3J6 for a price on making one up for you.

* * * * *

The "Select-a-Tenna" booster antenna reviewed in these pages by Randy Tomer on Jan 2, 1982 is available from Intensitronics Corp., P.O. Box 562, Hales Corners, WI 53130. The model 541 is \$24.95 postpaid, while the model 541M (with external antenna terminals) is \$29.95. Write to Intensitronics for a brochure on the Select-a-Tenna if interested.

* * * * *

Time Documentation of DX

by Charles R. Smiley Jr.

Early morning DX is great, especially towards the sunrise period. The problem is that most of us would rather sleep than DX. If we could shift the best DX period at will to the time available, we could harvest more new stations. Western DXers benefit greatly by sunrise conditions, and sunrise time is our only real means of hearing eastern daytimers when their sign-on period edges into darkness.

To accommodate my desire for sleep and still DX the early morning period, I employed my reel-to-reel recorder and several special innovations. The recorder I used is an Ampex AX-300 stereo model, aging, but in good repair, and one that is blessed with many useful features. Stereo decks are a natural for using the second, and otherwise unused, audio channel to record WWV in parallel with the DX channel. A second receiver is need to accomplish this. My first scheme used a Radio Shack "Time Kube", a small solid state crystal controlled receiver tuned to either 5, 10, or 15 MHz. Its part number is 12-159 and its price is currently US\$34.95 (see review in the Technical Column of March 13, 1982). I pulled the printed circuit board out, with the front bezel, speaker and push button assembly left intact. A square hole was cut in a 5¼" high rack panel plate for it.

Other assemblies were also installed on the panel, such as a 9 volt regulated power supply and digital clock module with large size LED numerals. The LED clock module is a National Semiconductor MA1026 model that is sold

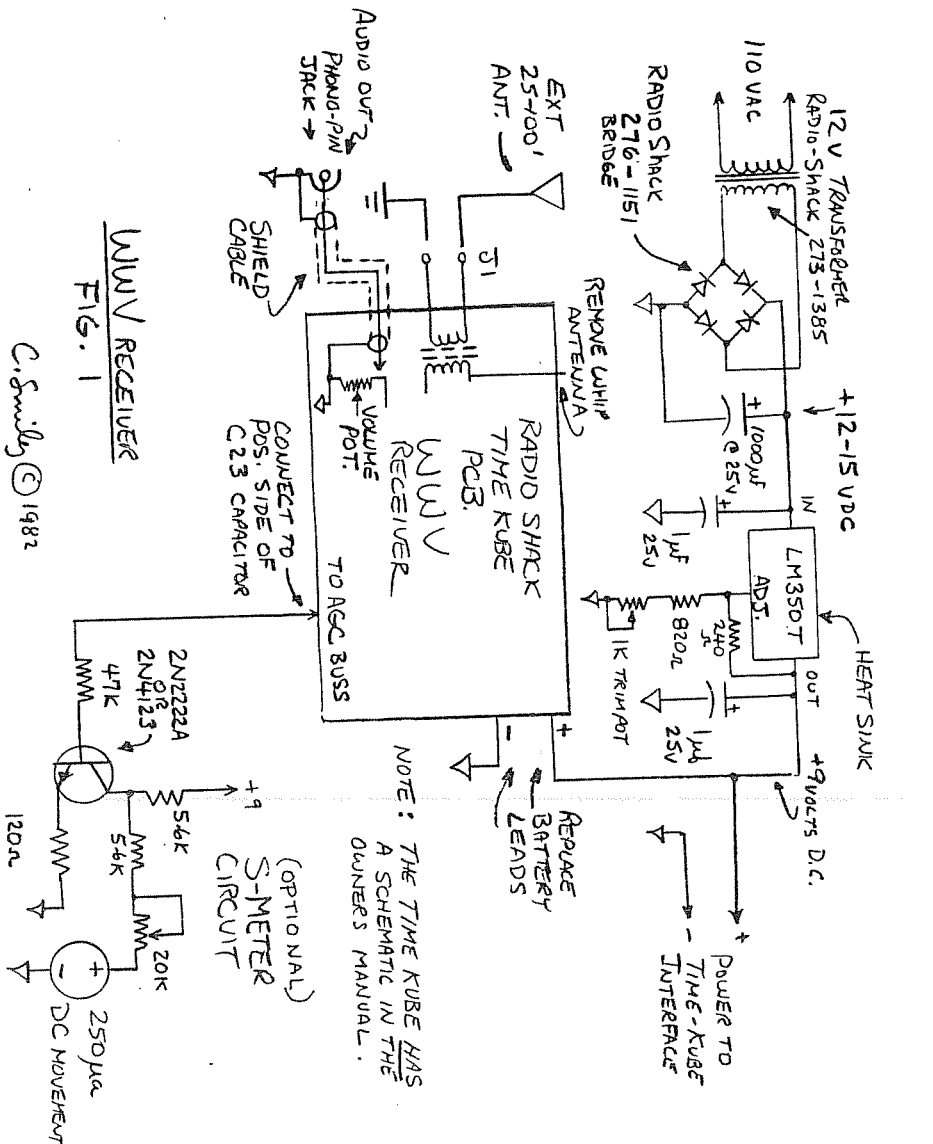

WWV RECEIVER
FIG. 1

C. Smully © 1982

by Radio Shack and other hobby outlets, for between 15 and 25 dollars. The latest Radio Shack catalog does not list this assembly, but this may be an oversight; they also offer a matching small transformer for the clock, part number 276-1734, and a well detailed application guide, part number 277-1006. Jameco Electronics, 1355 Shoreway Blvd., Belmont, CA 94002 carries the MA1026 and transformer also. A rectangular hole needed to be cut to mount the clock as well. The clock has provision for driving a relay which may be used to turn on a remote controllable tape recorder at a specific "alarm" preset time, but this is rather complex to put into practice.

The WWV Receiver Interface Scheme

The Time Kube's value for under 35 dollars is great. Three small buttons select the WWV frequency and one larger one is used to turn the receiver off. It comes with a whip antenna, but I preferred to use an outside antenna

as it has external antenna terminals. I have a McKay Dymek DA-100 all band vertical amplified antenna, on a 20 foot high mast, that feeds the Time Kube and at times my main receiver. Connecting an audio RCA phono-pin style jack across the top (signal end) of the Time Kube's volume control with the shield referred to the common ground will produce a line-level audio signal for the tape input. See figure 1 on the previous page for the complete modified Time Kube. The 9 volt supply is needed because this module is left on for hours at a time.

The WWV interface has its shortcomings however. If you select one of WWV's three frequencies on the Time Kube, there is no guarantee that this frequency will remain the right choice for 3, much less 6 hours. Frequently during the night, 5 MHz loses all its audio here, making 2.5 MHz the desired WWV frequency. Unfortunately, the Time Kube doesn't have this channel at its disposal.

The Vox Clock Interface Scheme

The Vox Clock is a synthesized "talking clock" available from Radio Shack (#63-902) which eliminates the potential problems using the Time Kube. I mounted it on my panel with the other units, but it requires additional circuitry to interface it to the second audio tape channel. The push button on its front panel must be pushed to cause it to "speak". The Vox Clock does have an "announce" on/off mode switch that causes the unit to announce the time each hour without the push button contact closure, but this is not frequent enough for our needs. The schematic provided here (Fig. 2) shows how a NE-555 Timer IC and a Hewlett Packard 6N138 Opto-Isolator IC are used to connect the push button connections together at a regular rate (approximately once every 3 seconds). Since neither push button connection is referenced to either supply lead, it was necessary to have a common connection that floated as well, hence the opto-isolator. The LM7805 regulator IC supplies 5 volts to the two IC's, and through the 1N4001 diode, about 4.5 volts to the Vox Clock module (replacing the 3 AA cells required). A 600 ohm 1:1 ratio audio transformer was purchased from Radio Shack but there doesn't seem to be a listing for it in their catalog. This transformer converts the floating speaker leads such that the secondary refers to ground to produce a normal audio line level output. If the transformer is equipped with a center-tap lead, it should be ignored. (See figures 2 and 3 below for details)

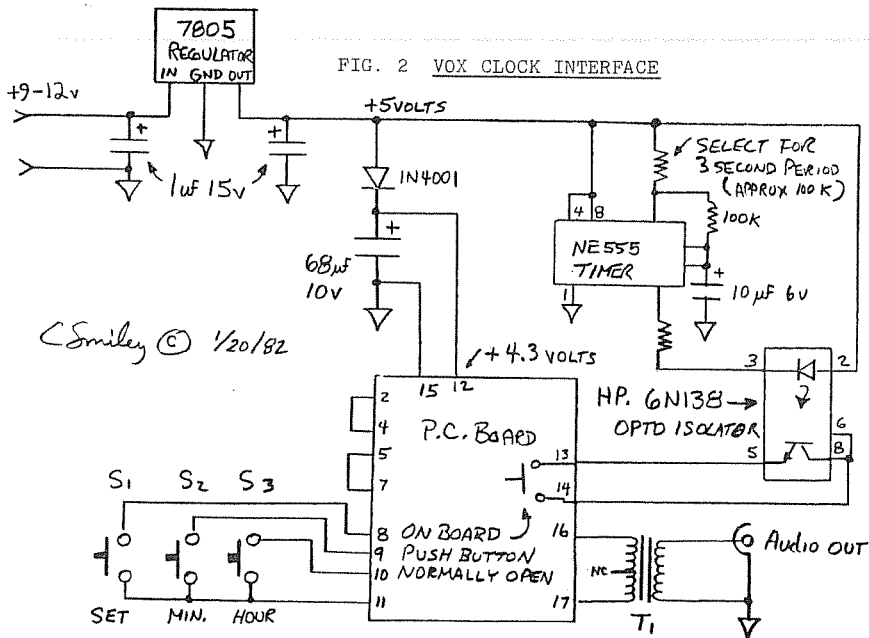

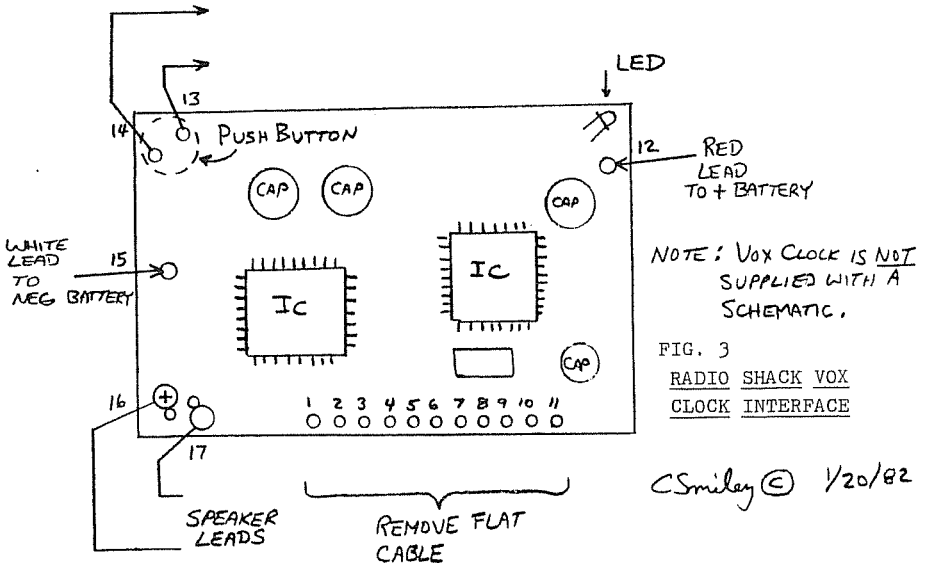

Before building this circuit, the flat flex-cable attached to the Vox Clock circuit board should be removed with care using de-soldering braid (Radio Shack #64-2090) and an iron of 30 watts or less. Three momentary push buttons with normally open contacts, such as Radio Shack #275-1571 are used for panel mounted set controls.

One problem with the Vox Clock is that it produces radio frequency noise that can be picked up by a loop antenna within 4 or 5 feet. Installing the Vox Clock module in a die-cast metal box (about 3-5 dollars) and using bypassed feed-thrus for power and the audio output leads will cure the problem. The switches should be mounted such that only the toggle levers or push buttons are outside the box. If the module is rack panel mounted, the user only needs to place a metal cover box over the area that mounts the module (see Fig. 4 below). A SPST toggle switch in series with the LED inside of the Opto-Isolator can be included to disable the noise if the user suspects the clock. For extremely weak DX, it might be best to leave the switch off and use the WWV method alone.

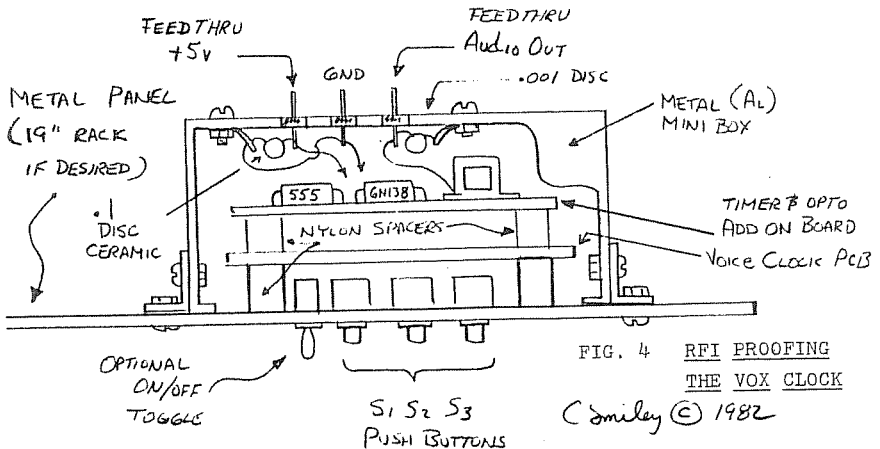

Operational Considerations

The usual reel-to-reel recorder with $7\frac{1}{2}$ inch reels running at $3\frac{3}{4}$ IPS can record for over 3 hours, if a 3600 foot reel of tape is used. 3M Scotch Dynarange tape, part number 214-7R-3600, is used here and the usual price per reel is \$15 or more. I have used the same reel for over a year now, running almost 6 hours every night average and the tape is still in excellent condition. This is very thin tape however, and the tape drive must be in good repair and basically a gentle tape handler. Some reel-to-reels will run at $1\frac{7}{8}$ IPS, such as the old Ampex AX-300. This provides over 6 hours of record time in one direction. Some reel-to-reel recorders can "auto reverse" in the record mode and if recording at $3\frac{3}{4}$ IPS can also run for over 6 hours non-stop. The larger machines with the $10\frac{1}{2}$ " NAB style reels can achieve long record times at $3\frac{3}{4}$ IPS when loaded with the thin tape.

Now, if we have 3 to 6 hours of record time, we need a way of finding specific times on tape. Sign-on times are usually in 15 minute increments and nearly always right on the dot. This makes a one minute period each 15 minutes a likely place to check for call signs and sign-on routines. This way we can compress a full morning's DX into a much shorter period of time. The WWV scheme co-recorded on the tape will locate these points with obvious accuracy. I remember reading an article by a West German who drew up tape counter vs. elapsed time charts, since the tape counter is not a linear counter. This method, while less expensive, is cumbersome to me. It's a good idea, however, to make up such a chart to find areas on tape as a first order approximation.

Although I have both the Time Kube and Vox Clock mounted on my panel, you may consider using just one or the other. The WWV receiver costs less than the Vox Clock and can also bring the user conditions of propagation. This is far less than buying a second general coverage receiver and its accuracy is unquestionable. My Vox Clock is as accurate as any clock in the house and doesn't require any antenna, thus it is never victimized by poor reception conditions.

Either method will document your DX while you're sleeping, or while you're actually listening. This way you can write very accurate reception reports by reviewing your DX catch over and over if necessary. My tape edit scheme runs the reel-to-reel outputs to a cassette recorder (Technics M21), also robbed from my stereo system. The M21 has the "cue and review" feature which makes repeating short phrases, such as ID's, very easy. If you decide to buy a cassette deck, this is one feature worth considering. With a flip of the finger you can "loop" on a faint ID until you either figure it out or give up on it. A switch to effectively connect both ear-phone channels to the DX track of the tape in one position, and split the earphones between the DX channel and the time track will be needed. Some reel-to-reel decks have this feature (Mono R, Mono L, Stereo RL) in addition to a headphone output for stereo headphones.

The DXer will find that planning a sleep period tape session adds to the strategy. A frequency is picked based on a hunch, tip, or a known DX test. The DXer points the antenna in a logical direction and starts the tape. The next day the tape is scanned and harvested for new ID's. Other uses involve blind recording of a frequency when a pesty NSP leaves the air on the rare Monday morning. I give this situation top priority and yet, can still start the work-week properly rested.

Lately, eighty percent of my DX is performed in this fashion. It forces me to plan things a little better but increases my yield. One more benefit, when I'm DXing from tape and the phone or doorbell rings, I press the pause button and miss nothing.

DXING
DICK TRACY
STYLE

(From
Electronic
Engineering
Times,
ca. 7-82)

CHICAGO — If several of the new products displayed at the Consumer Electronics Show (CES) here are any portent of the future, wrist "watches" will soon do a lot more than just tell time. They'll also be entertainment centers that provide news, music or late-night talk shows, television soap operas, sports or specials or the action of electronic games. And if the wearer is in a foreign country where radio or television aren't much fun because the language is a mystery or

wrist-worn games are boring there'll be "watchnes" to help with the translation needed to order a good meal.

Apparently spurred by the reception given Sanyo's prototype AM radio/wrist watch earlier this year at the winter CES, several manufacturers are striving to move electronic gadgetry out of the pocket or off the table and onto the wrist. Sanyo itself used last week's CES to show the first commercial version of its AM radio/wrist watch.

The watch radio has volume and station-selection controls

and features the usual LCD display to show the date and time. A pair of headphones plug into the watch, and a pair of user-replaceable lithium cells, one for the timekeeper and one for the radio, provide the power. Playing time is 50 to 60 hours.

An AM-radio watch is apparently only the first in a line of products from Sanyo. The company also displayed, but without much fanfare, the prototype of an AM/FM version that may be on the market before the end of this year

IOWA RADIO NETWORK

Enclosed is a listing of the stations apparently on the Iowa Radio Network. You may already have this information, but in any event this is as it seems to be as of this date. All the stations are in Iowa and the networks address and phone are as follows: 319 - East 5(th), Des Moines; Iowa and (515) 244-2115.

Call	Freq.	City
KJAN	1220 d	Atlantic
KRCS	1340	Clinton
KSIB	1520 &	Crysten
KDSM	1530 d	Denison
KCEC	1390	Des Moines - same address as I.R.N.
WDBQ	1490	Dubuque
KILR	1070 d	Estherville
KVFD	1400	Fort Dodge
KOKY	1310	Keokuk
KLHM	1410 d	LeMars
KFJB	1230	Marshalltown
KSMN	1010 d	Mason City
KCEC	740 d	Oskaloosa
KAIL	990 d	Storm Lake

As is probably obvious, the "d" after the frequency indicates a daytime station.

KXIC 800 d Iowa City has been on the network but is not on it at this time. I called and checked that this morning. (Tnx to Dr. Tom Gruis)

How to get around, or overcome, Cuban interference hassle

Diplomacy is the favored solution, but military attack isn't beyond imagining, say commenters to FCC

A long-term solution to Cuban interference with U.S. AM stations must be arrived at diplomatically, and the U.S. must use every possible means to get the Cubans to the negotiating table, according to most of the commenters filed at the FCC. Nonetheless, the commenters said, the FCC shouldn't abandon efforts to seek short-term solutions.

The comments came in response to a notice of inquiry on implementation of the final acts of the Region II Administrative Radio Conference for AM Broadcasting, from which Cuba withdrew (BROADCASTING, Dec. 21, 1981). Although the notice addressed other issues as well, most of the commenters focused on the Cuban situation.

The National Association of Broadcasters reiterated that the FCC should continue offering affected U.S. licensees special temporary authority for power increases to contend with the interference, but stressed that the only long-term solution would be through "meaningful diplomatic discussions with Cuba."

The Association for Broadcast Engineering Standards Inc. said that "every possible diplomatic effort should be considered in an effort to resolve the devastating interference problems" that

are anticipated. "If bilateral negotiation are not possible, we would urge that consideration be given to multilateral discussions which would include representatives of the various countries affected by Cuban interference," ABES said.

Cox Broadcasting Corp. said the commission should continue to authorize power increases to whatever level is necessary to recoup lost service, as long as other domestic and foreign stations are protected. According to Cox, the FCC should also undertake studies of possible technical solutions and actively support bills like H.R. 5427, which would authorize Radio Marti and give the Board for International Broadcasting authority to compensate broadcast licensees for expenses and costs related to foreign interference. "Such compensation should be retroactive and cover not only out-of-pocket expenses for capital changes such as construction, but all costs related to the interference problem, such as legal and engineering fees, advertising costs and lowered rates," Cox said.

The Florida Association of Broadcasters and the South Florida Radio Broadcasters Association agreed that any long-term solution would have to come on the diplomatic front, but that no solution should come at the expense of having to "substantially modify" or eliminate any existing U.S. stations.

For the short term, the groups said, the FCC should continue its policy of granting STA's and conditional licenses. But it also should remember that its first priority is to protect U.S. stations, refusing to provide protection for any Cuban radio stations "until the overall problem is resolved," the groups said.

Ronald Schatz, who identified himself as a "technical consultant," agreed that diplomacy must produce the ultimate solution. But if the Cubans can't be persuaded to sit down at the negotiating table through "reasonable" or legal means, Schatz said electronic countermeasures—such as the use of jamming devices mounted on ships or located in the Florida Keys—"will be able to pressure the Cubans into seeking relief from their own interference."

As a last resort, Schatz said, the U.S. should even consider military action. "Air strikes against the Cuban facilities responsible for interference to our stations would definitely stop the interference... but the potential consequences must be weighed against the value of the original cause," Schatz said.

"We must face the fact that we are presently engaged in a radio war with Cuba," Schatz said. "If we choose to back down in fear rather than take the initiative and convince Cuba that its present policies are not in its own best interests, we had best prepare to accept the rapid deterioration of our AM broadcast services as normal and inevitable," Schatz said. □

Broadcasting Magazine
July 12, 1982
via Greg Monti
used by permission

KCUB
1290 · TUCSON

80 South Stone Avenue Tucson, Arizona 85701



CAROLINA RADIO
OF DURHAM, INC.

P.O. BOX 1331 DURHAM, N.C. 27702

DX WW II

EDITED BY
PETER V. TAYLOR
2614 JACKSON STREET
SAN FRANCISCO, CA. 94115

T R A N S - P A C I F I C

AUSTRALIA - 3CS-1134 Colac (audible in Melbourne) is now "country/country crossover" (ADXN).

CHINA - Guangxi PBS P1 792/1070/1440, 2110-0500, 0850-1605; P2 846/1161/1224, 2125-2400, 0255-0620, 0950-1505. Liaoning PBS-1089 Shenyang 2050-0100 (to 0200 Sun.); 0250-0610 Tue.; 0250-0640 (not Tue./Sun.); 0300-0640 Sun.; 0855-1550 (Sun. from 0825). Jiangsu PBS Nanjing-702, started broadcasts to Taiwan 7/1/82 "in order to strive for the early realization of the great cause of the peaceful reunification of the motherland." Times: 1600-1640, 2045-2110 (BBC). (This is not new. Taiwan service pgmg. on powerful PRC MW outlets goes back many years, and is listed in early '70 WRTBs. In addition, I heard it in 1979 when I was over there. What's different is that these are locally oriented Jiangsu pgms. rather than canned Radio Peking/Beijing shows--PT). Xinjiang PBS began programs in Kirghiz on 6/28; frequency unspecified. This is the 5th minority language to be used (BBC). Fujian PBS has changed the name of its "Broadcasts to Jimmen and Mazu (Quemoy & Matsu)" to "Broadcasts to Taiwan." As of 7/1 the programs are on 505 558 612 824 840 882 1050 1370 1400 1420 1491 in Amoy 0130-0200 & 1500-1530, and Standard Chinese 0400-0430, 1400-1430, 2100-2130, and on 1467kHz in Std. Chinese 1500-1530. FJPBS provincial service schedules: P1 is on 505 558 612 824 840 882 1050 1370 1400 1420 1452 1491 from 2050-0600, 0600-0850 (Sun./Tue./Thu./Sat.) and 0850-1600. P2 is on 1467kHz 2120-2400, 0250-1600. (These hours include the Taiwan oriented programming noted above. And yes, the 505kHz freq. appears to be correct; CAT or FERC, can you confirm? Not too good for SOS situations--PT).

INDIA - Some eastern zone AIR stations are off the air, presumably due to electricity shortages -- 1062-Passighat, 1332-Tezu, 1341-Kohima, 1449-Sambalpur, 1521-Tawang. UNID AIR outlets are being heard on 657 (not Calcutta), 855, 945, 1080. (NZDXT). (GP lists Ahmedabad & Vijayawada, both 300kw on 657; Alleppey, Aurangabad, & Sambalpur all 855, 300kw; Dharmasala and Pondicherry, both 300kw, and Najibabad 200/100 kw on 945; and Madurai (300kw) and Najibabad (100kw) on 1080 - PT).

JAPAN - JONF-1098 Miyazaki is now on 936; FEN-1566 Sesebo now 1575 (FERC)

KOREA, N. (PDR) - Pyongyang 1368 external service closes 1650 (FERC)

PAKISTAN - External service: Hazargi to Afghanistan on 756kHz 1300-1430; and Dari for Afghanistan 1600-1800 (BBC)

MALAYSIA - UNID heard on 621kHz, //576 (NZDXT) (Segamat 100kw and Sibul 10kw are listed. Segamat began 11/1/81 -- PT).

NEW ZEALAND - Between 6/7/81 and 2/10/83, 1ZE-1215 Kaikohe will have local pgms. roughly 13 days a month between 2100-0300; 1ZK-1026 Kaitiaki will do the same roughly 8 or 9 days a month, same dates & times. Both usually relay 1ZN-1026 Whangarei. A one week warrant has been issued for a Polynesian station to operate from Papatotetoe (Auckland area) in October. It will be commercial, and it is hoped that it will grow into a regular access station. RNZ has approached 1XP R. Pacific, which has experienced financial difficulties and gone through a staff shakeup recently, in hopes that a cooperative arrangement may come about making 1XP the Polynesian station mentioned above. (Bryan Clark, Dave Ricquish, NZDXT).

PHILIPPINES - DWLW-675 Laong, Banahaw BC is on (FERC)

SOLOMON ISLANDS - The new relay station at Lata, Teriotu province (formerly Graciosa Bay, Eastern Is. province) on 963kHz should be on in early 1983 (M. Hadlow, SX)

SRI LANKA - SLBC has opened the new Mahayagane station, the 22nd put up with the assistance of the FRG since 1967; three more will open by the end of the year (Ratnapura, Ambawala, Kantalai) (BBC; no freqs. specified)

TAIWAN - Police Bc. Network, Hualien, heard on 990 (SDXL via ARC). "Voice of Free China" (VOFC) broadcasts to mainland China are in Amoy on 1200kHz 1045-1600. "Standard Chinese Network #1" is 24 hours: 2045-0100, 0345-0700, 1600-1900 on 1200 1100 900 750 600; 0700-1600 on 1100 900 750 600; 0100-0345 on 1200 900 600; and 1900-2045 on 900kHz. (Net. #2 is SW). "Standard Chinese News & Music" is on 1000kHz 0955-2200. (BBC).

VIETNAM - New UNID outlet observed on 610/680/870 (T. Oka, FERC & SX)

T R A N S - A T L A N T I C

BOPHUTHATSWANA/SOUTH AFRICA - Channel 702 (sometimes known as "Radio Bop") carries Casey Kasem's "American Top 40" Sundays at 1500. Station is MOR but becomes more rock oriented at night (Les Wright)

BULGARIA - External services on 1224kHz: GREEK 0400-0430 ex-Sun; 0900-0955 Sun.; 1400-1500; 1930-2000; 2030-2100. SERBO/CROAT 0500-0600 & 0730-0855 Sun.; 1530-1600; 2130-2200. TURKISH 0600-0730 Sun.; 1830-1900. ITALIAN 2200-2230. ALBANIAN 1500-1530, 1600-1630, 1800-1825, 2000-2025 (BBC)

CYPRUS - Radio Bayrak 1098 is now reported on with 10kw (EBU via ARC)

EGYPT, ARAB REPUBLIC OF - DST finally began 7/25 and will run through 9/30 (BBC)

ENGLAND - IBA Bury St. Edmunds-1251 is on with 1kw and IBA Marcher Sound-1260 is testing (EBU via ARC)

GERMANY, EAST/GDR - External service of RBI on 1359kHz: FF 1730-1815, 2200-2245; EE 1815-1900, 2115-2200; ITAL. 1900-1945, 2030-2115; DANISH 1945-2030 (BBC); pgms. 1 hour later after 9/26/82)

GERMANY, WEST/BRD - The new NDR 828kHz 100kw XR in Hannover was due to go on 8/1/82 (BT in ARC)

IRAN - Recently heard: Abadan-1160 and 1224; Moghan-1197 20kw; UNID-1240; Bushehr-1300 with AA 0300 Mon. & Tue.; Ardabil-1555 10kw; Bandar 'Abbas-1566 100kw, domestic svc. in Persian, 0200-1530 (EBU, BBC, ARC). UNID Iranian observed on 776.5//15084 (SX)

IRAQ - Recently heard: UNID-765, strong; Misan-846 (EBU via ARC). Radio Baghdad has replaced its "Voice of Egypt of Arabism" with a new but slightly shorter service, "Corner of the Arab World" on 1035kHz 2000-2140. The "Voice of Palestine" and "Voice of Arab Syria" are heard on 1116 and 1035kHz from 1600-1700 & 1800-2000 respectively (BBC)

IRELAND - R. Nova-846 will increase to 50kw (ARC)

ISRAEL/LEBANON - The Israel Defence Forces have set up a new 1134kHz XR north of Sidon (25 mi. SSW of Beirut; N. Western sector) which is //756, 1287, 1305 (S. Western sector), 1368, and 1584 (Eastern sector) (BBC).

LEBANON - The PLO's "Voice of Palestine/V. of the Pal. Rev." is now on 1140//1150 but the 1162 & 1270kHz outlets do not appear to be on the air. Radio Lebanon domestic service is now only on 836kHz in AA 0355-2210. Other Lebanon frequencies observed the first week in July: 585 (R. of Free & Unified Lebanon); 872 (Voice of Lebanon); 930 (Voice of Arab Lebanon); 945//1593 (Voice of Hope); 1140//1150 (VOP/VPR); 1185 (Voice of the Arab Revolution); 1476 (Radio Free Lebanon)(BBC). (Does anyone out there have an address yet for Radio Free Lebanon-1476, ex-1500? - PT)

LIBYA - 1061 & 1579 reported out of service; El Beida-1124 has made the move to 1125 (SDXL via ARC)

MALTA - R. Malta 1-999 reported on (EBU via ARC). A new station "for the Mediterranean countries" is being considered; it would broadcast in AA, EE, FF, & Greek. Cyclops-1557 DW FS programming: AA 0415-0550, 1100-1150, 1900-2035; GG 1400-1800; and Maghribi 2045-2120 (BBC)

MOROCCO - New outlet reported on 1325 (EBU via ARC) (Safi from 1323?-PT) The 600kw outlet previously referred to, with the 180 degree DA, was on 1053kHz; this is Tanger/Tadhart, replacing Tetuan on this freq.-PT.

NIGERIA - Federal Radio Corp. of Nigeria (FRCN) operates Radio Nigeria-1 on 1088kHz 0430-2305/09 and R.N.-2 on 1458 kHz 0453-2300, both in Lagos and in EE. Ikeja (Lagos State service) is on 918kHz 0430-2305 in Egun, EE, Yoruba. Enugu-827 is on 0430-2306 in EE & Igbo. Ibadan-657 is on 0430-2305 in EE & Yoruba. R.N.-2 Ibadan on 567 is on 567kHz 0430-2308 in EE, Edo, Igala, Urhobo, Yoruba. Radio O-Y-O Ibadan, 575kHz is on 0355-2400 in EE & 6 dialects. (Methinks there is a fluff, with Ibadan on 567 & 575; WRTH lists 567 in Akure-PT). R.N.-Kaduna 593/1107 is on 0430-2302 in EE/Hausa. Radio Abuja-909 is on 0450-2235 in EE & 7 dialects. (BBC)

NORWAY - Kvitsoy-1314 began 6/15. Relays P2, and when it is off, P1. During night hours, FS will be broadcast (Geir Stokkeland, ARC. No details on the FS - PT)

POLAND - Latest Radio Polonia FS programming includes the nightly "Concert" on 738/1206/1260/1503kHz 2303-2400. SPANISH is on 1503 0400-0500. The remaining are 1/2 hour and are on 1503: GERMAN 0500, 1200, 1400, 1600, 1700, 1800, 1900. ESPERANTO 0530, 2130. SWEDISH 1130, 1500, 1730. DANISH 1430, 1530. ENGLISH 1830, 2230. FINNISH 2000. FRENCH 2200 (BBC)

PORTUGAL - RdP Porto-1368 10kw is on 1377 as of 5/15 (EBU via ARC)

ROMANIA - R. Bucharest external service on LugoJ-756 (1/2 hour pgms.): SERBO/CROAT 1700, 1830. TURKISH 1730. GREEK 1800, 1930. ITALIAN 1900, 2000. GERMAN is on 2030-2130, and Romanian/EE/FF/GG tourist program is on 2230-2300(BBC).

SAUDI ARABIA - Foreign service on 1098/1224/1485: FF 0500-0700, 1500-1700; EE 1100-1300, 1700-2100 (BBC)

SPAIN - EAK21 RP de Badajoz-1224 heard on 1209 since 4/19 (EBU via ARC)

SWEDEN - Horby-1179 foreign language pgms. 5/2 - 9/5/82 (all 1/2 hour). ENGLISH 1830 2100 2300. FRENCH 1800 2030. GERMAN 1630. SPANISH 2230. PORTUGUESE 1730. RUSSIAN 1700 1930 2200 (Radio Sweden.)

TRANSKEI/SOUTH AFRICA - Capital Radio-603 began broadcasting 12/26/79 but its improperly grounded antennas were struck by lightning during the next two days, causing it to operate at reduced power. In addition, the XR location was wrong for its proposed coverage. After 12 months, coverage of southern Africa was poor and erratic. After some re-thinking, it was decided that Durban and Cape Town should be the main target areas. A 500kw XR was built at Umzimkulu on the northern border of Natal (200 miles from Durban.) This began operation in mid-1981, but was closed this year due to high electrical costs. A 50kw XR is now used daytime. At 1700, they switch to the Herschel XR in southern Transkei. Both XRs are fed by microwave from the studio site, Port St. Johns, but the studios & offices are moving to Johannesburg. One reason for this is the turnover of announcers (Port St. Johns is somewhat desolate.) They also plan to improve the station's signal in a southerly direction. (Les Wright, Queensburgh, Natal). However, BBC reports that during a phone-in show on the station 7/13, it was said that the studios would move to Umtata...A Swedish source has heard Capital Radio on 855 and wonders if this is ex-603 (Skala/SDXX) (Probably a British stn.-PT)

TUNISIA - Djedeida is back on 629 from 630 (EBU via ARC)

YUGOSLAVIA - Stations will be reducing their daytime powers by 1/3 to 1/2 in the near future to conserve energy; night powers will be unaffected. In the same article, they will be improving audibility of radio broadcasts in border areas by extension of the repeater network. Radio Ljubljana 648/918 carries tourist program 0835 Mon.-Sat. in EE/GG/Ital. with weather, border crossing information, and news (BBC).

INTERNATIONAL WATERS - My Swedish still isn't too good, but I can make out two things in ARC's comments on Radio Caroline: (1) "problem" (which means they're not on yet) and (2) "Major Market Radio" which will probably rep them in the U. S. (ARC, brilliantly translated by PT). "Voice of Peace"-1539 has been heard since 5/4 "from somewhere in the Meditteranean..." (BBC)

P A N A M E R I C A N

ARGENTINA - LRA22-830 R. Nac., San Salvador now on 790. LRA15-1190, R. Nac., San Miguel now 50kw 0900-0300. LT2-1230 R. Gen. San Martin is 25kw 0900-0400 (SCDX/WRTH via ARC)

BAHAMAS - DST began 4/25 (BBC). ZNS3-810 Freeport now 10kw DA (NRC)

BOLIVIA - CP63 R. San Gabriel is 20kw 0830-0200. CP185-780 now on 860, 5kw. CP145-980 5kw 1000-0300, R. Paititi; CP69-1250 5kw is ex-CP40; on 1000-0400 (Sun. 1200-0300). CP29-1110 R. Fides is back on, but on 1300. CP173-1320 is ex-CP137. CP156-1560 is R. Minería, ex. R. 18 de Mayo (WRTH/RFA via ARC)

BRAZIL - ZYH...-700 Rdif. e Cultura, Feira de Sanatna, BA new, 10/.25kw. ZYH...-930 R. Ajuricaba, Manaus, AM new, 10/5kw. ZYL316-1590 now on 1070; ZYK330-1510 now on 1140; ZYK345-1590 now on 1260. Delete ZYI...-850 Soc. R. Marabá and ZYI...-1070, Rdef. Princesa do Sul (CRM via ARC)

CHILE - ...is on UTC-4 until 2nd Sat. in October (BBC)

COLOMBIA - HJDP-1005 R. Caracol, Neiva, ex-R. Neiva. HJJH-1600 R. Ciudad Milagro now on 1460. HJLS-1520 R. Popayan now 7kw (DSWCI via ARC)

CUBA - Radio Havana's "La Voz de Cuba" is in SS on from 0400-0925 on 1160 (to 0900), 720, 690, 950, 630. No EE MW programs are listed in their latest schedule (BBC)

DOMINICAN REPUBLIC - HION-1040 10kw R. Central is on 24h; Aptdo. 715-2 Santo Domingo (WRTH via ARC)

ECUADOR - HCBA6-845 R. Ambato 3kw 0900-0500. HCOT1-965 R. Zaracay 25kw 1000-0500. HCEP5-1045 Escuelas Radiofonicas Populares 10kw 1000-0300 (nom. freq. is now 1570). HCRT5-1120 LV de Tomebamba is now 1070, 3.5 kw. HCPV6-1125 R. Centro ism 5kw 0900-0600. HCDY4-1440 R. Iris on 1000-0400; nom. freq. is 1465. HCCS5-1445 R. Calidad, ex-R. Rubi now 24h, 5kw (WRTH via ARC)

EL SALVADOR - YSS-655 is R. El Salvador (ex-R. Nacional). YSMM-1380 R. Tiempo is now on 1200, 1100-0400 (NASWA via ARC)

GUATEMALA - The govt. has cancelled the licenses of R. Poderosa (TGC-1120), R. Sultana de Oriente (TGXC-1550) and R. Mil Noventa (TGZ-1090). Others are under investigation (BBC).

HONDURAS - HR...-1510 R. Cinema, Tegucigalpa is new (ARC)

MEXICO - XERPM-660 is now "La Nueva" (ex-R. Uno, LV de la Ciudad). XEMP-710 R. Juventud, ex-R. Dos; XEZA-740 Los Mochis has moved from 1600; Zeta Super Sonido. XEW-900 new address: Ayuntamiento 52, Mexico 1 (Jorge H. Yanez, Ops. Dir.) Guadalupe's XEUNO-1120 R. Exitos and XECCC-1440 R. Canon are new (ARC).

NICARAGUA - UNID-790, mentioning Nicaragua, R. Carvenge? Observed during beverage expedition in Australia (SX). (Not on recent Nicaragua list - PT)

PANAMA - Circuito RPC changes. HOH2-560 CoTo, 1kw; HOH4-570 David, 10kw, ex-580; HOH3-590, Chitre', 10kw; HOHM-610, Panama', 10kw; all 1000-0500. (WRTH via ARC)

PARAGUAY - ZP35-1427 R. LV de Misiones is now on 1410 (CRM via ARC)

PERU - OAX6D-1120 R. Nac. del Peru is now on 830. OBX4G-730 R. Programas del Peru now on 1500 (RFA via ARC, who wonders what became of OBX41).

PUERTO RICO - WKVM-810 is back on the air and is operated by the Catholic church (Dave Gleason, NRC)

TURKS & CAICOS - Full page ad in Religious Broadcasting Magazine lists 1020, 1570, 100.1 as "Caicos Beacon" frequencies (NASWA via ARC)

URUGUAY - CW1-550 R. Colonia has lost its license. CW31-1120 R. Salto 10kw 1000-0300. CV146-1460 R. Bat. y Ordenez is now on 1320 according to official sources which ARC believes are incorrect...

VENEZUELA - YVKL-590 R. Continente and YVTB-800 R. Exitos are both now 100kw. YV.-1450 10kw new, R. Fe' y Alegria Anzoategui, Campo de Mata (same owners as YVZA-1390 but different pgms.) (WRTH via ARC)

That's most of it for this month. Congratulations to Bryan & Sandy Clark of NZ on the addition to their family, Daniel Bryan Clark. The Clarks hosted Kristine and me while we were in Wellington on our honeymoon a few years back; they're now in Auckland. And welcome back everyone from Squint City. We have been experimenting with different type style & size, but after reduction, the last DXWNII was a bit tiny for these orbs. I did get some new info in from Ollie Alm of ARC relating to European MW beacons which will be put on hold. Who'll be the first to log Radio Nova-846? Has anyone heard the megawatt Venezuelan on 1240 yet? Keep tuned! And furthermore, if not in this issue, then coming up are new Costa Rican and Nicaraguan lists, plus a look at radio in New Zealand.

Our sources this month: BBC - BBC Monitoring Service (copyrighted). ARC - Arctic Radio Club. FERC - Far East Radio Club. SX- Southern Cross DX Club. ADXN - Australian DX News. NZDXT - NZ DX Times. Les Wright of Queensburgh, Natal.

=====

NICARAGUA: LATEST INFORMATION

Observations in ARC "Ekko" by George Wood, SCDX, and Lauri Levanto, SDXL, while visiting in Nicaragua:

- 540 R. Corporacion, Managua
- 555 R. 19 de Julio, Chinandega; ex-R. Tic Tac; own pgms, R. Sandino
- 590 R. Quinientos Noventa, Managua
- 620 LV de Nicaragua, Managua
- 640 R. ABC - closed; no station on this channel
- 650 R. Sport, Granada
- 660 Mi Preferida, Managua - closed by government
- 680 R. Deporte - replaces Union Radio
- 700 El Fabuloso Siete, Managua
- 720* R. Catolica de Nicaragua - closed by govt.
- 725 R. Titania, Chinandega - not heard
- 750 R. Sandino, Managua
- 780 R. Cosmos, Managua - not heard; off air
- 800 R. Amor Managua - closed by govt.
- 810 R. Frente Sur, Rivas, replaces R. Rumbos Revolucionaria
- 820 R. Ondas de Luz, Managua
- 830 R. Pinares, Ocotal - off the air
- 940 R. Noticias, Managua
- 850 R. Continental, Managua
- 880 R. Exito, Managua
- 900 R. Tiempo, Managua
- 920 R. Mundial, managua
- 960 R. Managua, closed? Not heard
- 980 R. Hits, Managua - apparently off
- 1000 R. Mil, Managua
- 1020 R. Reloj - now on 1100 (1020 vacant)
- 1060 R. Futura, Managua - not heard/off air
- 1070 R. Granada, Granada - not heard; off air
- 1100 R. Reloj, Managua - ex 1020; replaces R. Lider
- 1115 R. Centro, Leon, not heard; off air
- 1140 R. Continental, Matagalpa not heard
- 1155 R. Cosiguina, Managua - not heard/off air
- 1260 R. Gueguence, Managua
- 1270 R. Atenas, Leon
- 1300 Canal 130 AM, Managua
- 1320 R. Maravilla, Managua not heard/off air
- 1340 Ondas Sonoras, Managua - not heard
- 1390 R. Ver, Puerto Cabezas - replaces R. Mar
- 1410 R. Venceremos, Leon
- 1440 R. Sol, Ocotal, off air
- 1470 R. Cosiguina, Chinandega, not heard
- 1500 R. Minuto, Managua
- 1510 R. Progreso, Leon - not heard/off air
- 1560 R. Minerva, Managua - not heard/off air

* Since their visit, R. Catolica has resumed broadcasting

NEW FREQUENCIES: COSTA RICA

New Freq.	CALLS	Old Freq.	Other info
530	TICAL	525	R. Rumbo, Cartago
550	(C.P.)	--	R. Santa Clara, 50kw (Rel.)
570	TISBJ	550	R. Libertad, San Jose'
590	TIRN	575	R. Nacional, San Jose'
610	TIRSU	600	R. Sistema Universal, San Jose'
640	TIQQ	625	R. Cu-Cu, San Jose'
670	TIBAS	650	R. Monumental, San Jose'
700	TIJC	675	R. Sonora, San Jose
730	TIHB	700	R. Reloj, San Jose'
760	TILX	725	R. Columbia, San Jose'
780	TIRA	750	R. America Latina, San Jose'
800	TIW	775	R. Uno, San Jose
820	TIGC	800	R. Centro, San Jose'
850	TIOS	825	R. Titania, San Jose'
870	TIUCR	850	R. Univ. de C.R., San Jose'
	TIUCR	850	R. Univ. de C.R., Liberia(1)
890	TIBAS	875	R. Monumental, Liberia (2)
910	TIQM	900	R. Monumental, San Jose'
930	TIJJ	925	R. Juvenil, San Jose'
960	TIECO	950	R. Eco, San Jose'
980	TIABC	975	R. ABC, San Jose'
1000	TIMIL	same	R. Mil, San Jose'
1020	TIBAS	1050	R. Monumental, Puntarenas (2)
1040	TIAC	1025	R. Fides, San Jose'
1060	TILX	1100	R. Columbia, San Isidro (3)
1080	TIFC	1075	R. Faro del Caribe, San Jose'
1100	(C.P.)	--	R. Santa Cruz, 20kw (rel.)
1120	TISTHB	same	R. Sonido 11-20, San Jose'
(However, they have permission to go on 1125...)			
1140	TIBAS	same	R. Monumental, San Isidro (2)
1160	TILX	same	R. Columbia, Puntarenas (3)
1180	TIQ	same	R. Casino, Limon
1200	D E L E T E		
1220	TIPJ	same	R. Nueva Victoria, Heredia
1240	TIR	same	R. Casino, Limon (4)
1260	TIHN	same	R. Emaus, San Vito de Coto Brus
1280	TIHT	same	R. Alajuela, Alajuela
1300	TILC	same	R. La Fuente Musical, Cartago
1320	TILX	same	R. Columbia, Limon (3)
1340	TIHR	same	R. Sideral, San Ramon
1360	TIBAS	same	R. Monumental, Limon (2)
1380	TILX	same	R. Columbia, Nicoya (3)
1400	TIQJ	same	R. Sinai, San Isidro
1420	TIBAS	same	R. Monumental, Nicoya (2)
1440	TIDVC	same	R. San Carlos, San Carlos (2)
1460	TILX	same	R. Columbia, San Carlos
1480	TIAW	same	R. Nueva Puntarenas, Puntarenas
1500	TIASF	same	R. Cima, San Carlos
1520	TILX	same	R. Columbia, Turrialba (3)
1540	TIACA	same	R. Lira, San Jose'
1560	TIFQ	same	R. Nicoya, Nicoya
1580	TIMS	same	R. Guanacaste, Liberia
1600	TILVT	1025	LV de Talamanca, Amubre
	TIJV	same	R. Quepos, Quepos
	TILGJ	same	R. 16, Grecia
	TIMQ	same	R. Pococi', Guapiles
	TIRCT	same	R. Cult. de Turrialba, Turr.
	TI...	--	3 additional stations

- (1) Relay R. Universidad de Costa Rica-870 (synchronized)
- (2) Relay R. Monumental San Jose', 670kHz
- (3) Relay R. Columbia San Jose, 760 kHz
- (4) Relay 1180kHz

These changes took place 4/30/82, 1900 UTC.
 Information courtesy of Giovanni Mora Cespedes, ARC.

XEFU

630 Kcs
 5000 Watts
 VOZ AMIGA
 de la CUENCA
 del
 PAPALOAPAN

Apartado 18
 Telefono 33
 Cosamalopan. Ver
 JAROCHA
 DIOSINCRACIA!

"YOUR STATION"

Colonial Broadcasting Co. Inc.

AM-FM FARMVILLE, VIRGINIA 23901

SOME RUDIMENTS OF SPANISH PRONUNCIATION. Spanish is spoken in:

Argentina	Dominican Republic	Nicaragua
Bolivia	Ecuador	Panama
Chile	El Salvador	Paraguay
Colombia	Guatemala	Peru
Costa Rica	Honduras	Uruguay
Cuba	Mexico	Venezuela

A word has as many syllables as it has single vowels (Há-ba-na) or vowels and diphthongs (Bue-nos Ai-res). A diphthong is a combination of two vowels.

<u>Vowel or diphthong</u>	<u>Sound in Spanish</u>
a	ah
e	a in <u>gate</u>
i	ee in <u>seen</u>
o	o in <u>bone</u>
u	oo in <u>tool</u>
u after g is silent before e and i, unless it has a diaeresis - <u>ü</u> . Then it sounds like <u>w</u> - glira (gweerah)	
ai	i in <u>site</u>
au	ow in <u>scow</u>
ei	ay in <u>stay</u>
eu	eh-oo, run together
ia	ya in <u>yacht</u>
io	yo in <u>yodel</u>
ie	yea
iu	you
oi	oy in <u>boy</u>
ou	oh-oo, run together
ua	wah
ue	way
ui	wee
uo	woe
y is sometimes a vowel, equal to Spanish <u>i</u> .	

Consonants. A number of consonants differ slightly from English consonants in pronunciation; this difference must be learned by ear. In addition:

- c is like k before a, o, and u.
- ç is like ç before e and i.
- ch is one letter, pronounced like ch in church.
- g is like g in gate before a, o, and u.
- g is like German ch before e and i.
- (Those unfamiliar with the German sound may simplify this sound to h, as in he.)
- h by itself is always silent.
- j is always like German ch, or Spanish g before e and i.
- ll is one letter, usually pronounced like y in yet.
- n is like ny in canyon.
- q is always followed by u. The two letters together are pronounced like k.
- rr is one letter, strongly trilled.
- y as a consonant is like y in yet.
- s and z are always like ss, in Spanish America.

Stress. When there is a written accent, the stress falls on the syllable indicated. Alcántara.

When a word ends in a vowel, in n, or in s, the stress falls on the next to the last syllable. Clara; regiones.

When a word ends in a consonant not n or s, the stress falls on the last syllable. Meridional.

Note: Ae, ao, ea, ee, eo, oa and oe (combinations of a, o, and e) do not form diphthongs, but two syllables; e. g. á-re-a, Bil-ba-o, Bal-bo-a.

PORTUGUESE PRONUNCIATION

Portuguese is the language of Brazil, long a colony of Portugal.

Portuguese pronunciation is difficult to represent phonetically, except by standard phonetic symbols, unfamiliar to many people. It has a number of nasal sounds; j has the sound of z in azure; lh is equivalent to the Spanish ll, and nh to the Spanish ñ.

EASTERN DX ROUNDUP

Bob Lazar

1711 Wainwright Dr.

Reston, VA 22090

Next deadline: Tuesday August 17

All times Eastern

- 730(WPKX)VA Alexandria, 6/25 1330 noted off air. (WPT-MD)
WPIT PA Pittsburgh, 6/25 1330 tail end of religious pgm, ID by man.
Fair. (WPT-MD)
740 WRNR WV Martinsburg, 6/25 1332 promo for 25th Anniversary of the History of R&R. ID by man. Fair. (WPT-MD)
760 WJR MI Detroit, 7/3 1152 wx discussion by m. Fair. (WPT-DC)
1100 WWWE OH Cleveland, 7/3 1158 local nx, then CBS nx by f. Fair. (WPT-DC)
1340 WHPA PA Williamsport, 6/28 0011 s/off by f after nx & wx. Fair atop channel. (WPT-DC)

Hearing a little more than static

WPT - Bill Townshend, 4500 Connecticut Ave. NW, #901, Washington, DC 20008
(Realistic TRF, Sony ICF-S5W)
(WPT-MD) indicates DX done at work in Marlow Heights, Maryland

CENTRAL DX ROUNDUP

Robert Kramer

6416 N. Richmond

Chicago, IL 60645

SPECIAL, UNIDED, CHANGES, et. al.

- 1580 KXRX IA DAVENPORT, ex-KWNT, noted w/new calls on 7/23, still MOYL. JC-IL
1590 WAIK IL GALESBURG, stn has been noted off the air totally w/no sign of life while driving by Galesburg on 7/9 & 7/23. JC-IL

All da Rest

- 560 KLVI TX BEAUMONT, 7/1 1800 strong W/C&W format. KZ-TX
570 WFAA TX DALLAS, 2300 6/28 Sunday Nx Wrap-Up. KZ-TX
590 KLEB TX AUSTIN, 7/1 1900 W/CBS Nx, Fair. KZ-TX
610 KILT TX HOUSTON, 7/1 1815 C&W format, strong. KZ-TX
650 KIKK TX PASADENA, 7/1 C&W format w/kick 65 & FM 96 IDs, strong. KZ-TX
680 KXYX TX SAN ANTONIO, 6/28 2300 W/RKO Nx & 740 format. Ment. of Central TX. KZ-TX
740 KTRH TX HOUSTON, 7/1 2100 W/CBS nx on hour, MBS nx on half hour, strong W/talk format. KZ-TX
790 KULF TX HOUSTON, 7/1 2040 w/adult-contemp. format, strong. KZ-TX
850 KEYH TX HOUSTON, 7/1 2050 W/SS pgms., mx. KZ-TX
920 KYST TX TEXAS CITY, 7/1 1915 W/rock format, ID AM 92, strong. KZ-TX
950 KPBE TX HOUSTON, 7/2 1900 W/NBC nx. KZ-TX
990 KALO TX BEAUMONT, 7/1 1905 W/R&B format, fair. KZ-TX
1010 KLAT TX HOUSTON, 7/1 1907 W/SS format strong. KZ-TX
1030 KCTA TX CORPUS-CHRISTI, tent. is this stn SS ? KZ-TX
1070 KENR TX HOUSTON, 7/1 2012 W/sports talk about Astros, etc. Strong. KZ-TX
1090 KACO TX BELLEVILLE, 7/1 2022 ID KACO Bellville, fair. KZ-TX
1110 KTEK TX ALVIN, 1205 7/2 C&W mx, very strong. KZ-TX
1230 KNUZ TX HOUSTON, 1213 7/2 ABC stn W/C&W format. KZ-TX
1250 KTXC TX PORT ARTHUR, 1225 7/2 ID as TX-1250, C&W format. (Karl, note new calls, ed)
1320 KXYZ TX HOUSTON, 1245 7/2 W/SS format. Strong. KZ-TX
1360 KBUK TX BAYTOWN, 6/25 1415 strong. KZ-TX
1400 KILE TX GALVESTON, 6/24 1500 W/T-40 format. KZ-TX
1430 KCOH TX HOUSTON, 6/24 1505 W/Soul format. Good. KZ-TX
1450 KAYC TX BEAUMONT, 6/24 1550 ID: "The Golden Triangle's inf. service KAYC" weak//
1480 KLVL TX PASADENA, 6/24 1540 W/SS format, strong. KZ-TX
1610 TX GALVESTON, 6/28 0400 very strong LORAN drones & chirps. KZ-TX
TX HOUSTON, IAH Houston International Airport. Open carrier W/possible weak Morse ID 6/22 1700. KZ-TX
TX HOUSTON, Hobby Airport. 'IS also W/open carrier. Both airports had signs alerting motorists, but just carriers. 6/27 0000. KZ-TX

These Guys are actually DXing

- JC.... John Clemmer 4524 7th St. #2303 E. Moline, IL 61244
KZ.... Karl J. Zuk Johnson Space Center Clear Lake City, TX
RCA RCA 1049 6 transistor radio, no penguins) (How about any other form of wild animal ?ed.)

WESTERN DX ROUNDUP

Nancy Hardy
2301 Pacific Avenue
Aberdeen, WA 98520

All times are
Eastern Local

Phone for hot WDXR tips: (206) 532-6827 till 10:30pm(PLT)--no collect calls
DEADLINES: Thurs. 8/19, Tuesdays 9/7, 9/21, 9/28, 10/5, 10/12, 10/19, 10/26

REPORTERS FOR THIS ISSUE:

- (BB) Bill Block-9307 S.E. Clay St.-Portland, OR 97226
(GC) George Carter-1405 Stonegate Dr.-Sheridan, WY 82801
RF-2600 & 2' coil select-a-tenna
(BH) Bill Hardy-2301 Pacific Ave.-Aberdeen, WA 98520
FRG-7, SM-1
(NH) Nancy Hardy-2301 Pacific Ave.-Aberdeen, WA 98520
FRG-7, SM-1
(WJH) Bill Harms-University Station P.O. Box 7428-Provo, UT 84602
Hallicrafters S-85, 150' & 300' longwires, 3' wedge
(SMM) Steve Mittman-2248 W. 37th St.-San Pedro, CA 90732
Realistic TRF, 3' wedge
(SMM-CA2) DX'ing at Edwards A.F.B., CA; near Lancaster & Mojave
Realistic TRF, 3' wedge
(bp) Bruce Portzer-DX'ing at Jordan River, BC
FRG-7, 2000' Beverage (E-W)
(MaS) Mark Strickert-706-25th Ave.-San Francisco, CA 94121
Panasonic RF-2200, "TRF"
(MaS-CA2) While waiting for a bus in Albany, CA w/RF-2200
(MaS-CA3) DX'ing in Berkeley, CA w/RF-2200
(MaS-CA4) DXpedition at Point Reyes, CA DX-200, 800' wire
(RW) Robert Wien-1309 Dentwood Dr.-San Jose, CA 95118
GE long-range portable, SM-2

***** OF SPECIAL INTEREST:

- 630 KZJO UT, Sandy (ex-KSXX) has dropped the satellite format ("The Star Station"), calls itself "63-Joe". 60's to present pop mx format. Call change since about June 20. (WJH-UT)
- 690 XETRA BCN, Tijuana has picked up AT-40 (ex-KGB-1360). Carries it Sundays 9am-1pm PLT. (SMM-CA)
- 710 KFIA CA, Carmichael 7/2 2031 very good w/promo for power increase... now 10kw days, w/main lobe of direct. pattern practically right down my throat here, hi. (MaS-CA)
- KMPC CA, Los Angeles in May dropped its talk format & returned to its old MOR format. (SMM-CA)
- 990 KTLT UT, Tooele (ex-KDYL) call change since about June 20. Same format. Pop mx/ C&W block program w/farm programming. Local high school sports also. This was the oldest call letters in Utah. (WJH-UT)
- 1210 KCLG UT, Washington new stn has been on the air since the 1st part of June. Hrd here first around 6/15 or 6/20. Poor daytime signal, but good at SRS & SSS. Country format. No slogan hrd. They are currently 10kw day/250w night. The nighttime authorization not used yet as no 250w xmtr installed. (WJH-UT)
+7/12 0834-0935+ brand new stn suddenly appearing out of nowhere w/s/on at 0834. Ment. of xmtr locale as 500 East block of I-15, studios at 127 East Center in Washington, UT. Ment. of 10000 watts days & 250 watts nights. Into C&W. Signal extremely strong & steady for a good hour and 35 min. past San Jose SR! Signal finally lost about 0950! Listed as ND in NRC Log. When did they go on the air? (RW-CA)
+Wed. 7/14 0950 extremely weak w/C&W mx nearly 1½ hours after SR o/KCLG. Caught ment. of I-15, which runs right near this town. 2254 very good w/KGYN (as well as Long Beach St. LP) looped out w/C&W mx, then "It's 8:54 right now on KCLG & that means it's about time for me to be a-steppin' out of here". S/off at 2257 gave pwr as 10,000day/250night--but, of course, night rig isn't on yet or they wouldn't be signing off. Thanks to Bill Harms for this tip! (SMM-CA)
- 1480 KGMQ CO, Pueblo new call & pop/C&W format. ex-KPUB. Hrd while driving through Pueblo on 6/27. (GC-WY)
- KUUX NM, Hobbs 6/6 2329 ID as K-W-X into C&W. New 24 hr. format. ex-KWEW. (GC-WY)
- 1590 KJBK ID, Twin Falls 6/4 0704 from rock into ID. New. (GC-WY)

521 "INE" MT, Missoula 6/27 0357 good w/"I-N-E" in Morse code. (MaS-CA4)

550 KOY AZ, Phoenix 6/27 0418 fair/good w/adult contemporary mx. (MaS-CA4)

570 KLAC CA, Los Angeles 7/5 0343 poor way u/KVI & KSFO-560 slop w/C&W mx. (MaS-CA3)

590 KUGN OR, Eugene-Springfield 7/5 0347 fair-poor but alone w/MOR mx, ment. KUGN (as opposed to, say, WEEI, hi). (MaS-CA3)

630 KOH NV, Reno 7/3 1150 fair-poor u/KIDD w/local sports, CBS promo, "KOH newstime 1151", CBS feature...only 2nd out-of-state daytime catch here (the ground is a bit wavy here, hi.) (MaS-CA)

680 KNBR CA, San Francisco Su 7/4 poor midday w/usual rock mx; ID 1524. Scant XETRA-690 slop. Normally drowned out midday back home by excessive XETRA slop. (SMM-CA2)

(KNBR) 7/2 0445 noted totally off. (RW-CA)

720 *KDWN* NV, Las Vegas MM 5/31 0418 noted w/OC. Anyone know this stn's sked? (SMM-CA)

780 *KROW* NV, Reno 6/28 0428 good w/OC. (RW-CA)

790 KGHL MT, Billings 7/3 0324 good in KABC null w/C&W mx, promo for "Billboard" (local events calendar). (MaS-CA)

800 KHIS CA, Bakersfield Su 7/4 1502 good w/AP Network News. At 1534 "KHIS-AM presents the best of country gospel daily--right here on Country Gospel Time". Never hrd back home. (SMM-CA2)

CKOK BC, Penticton 7/3 0327 fair-good o/KGO-810 splatter w/"Okanagan (?) Radio", 2 plays of same shopping centre ad, top 40 mx. (MaS-CA)

810 KGO CA, San Francisco Tu 6/29 2300 new legal ID noted as "KGO--AM and FM--San Francisco. Eight o'clock." into A1 mx. Apparently just // for nx, as afterwards jingle went "Welcome to the nighttime on KGO--Newstalk Radio 81". (Or do they need a new jingle now for both AM & FM?! Bay area DX'ers, who's the new FM (freq?)?! (SMM-CA)(Ex-KSFX-103.7, was KGO-FM years ago.-NH)

830 KIKI HI, Honolulu 6/27 0333 poor u/WCCO, 0700 good w/no WCCO w/top 40 mx & dippy female anncr (Tho she was nice enough to give 2 ID's in 4 minutes!). (MaS-CA4)

WCCO MN, Minneapolis-St. Paul 6/27 0331 fair-poor o/KIKI w/phone-in show. (MaS-CA4)

850 KHLO HI, Hilo 6/27 0353 fair mix w/KOA. Adult contemporary mx, jingle, female anncr. On top by 0403, out (assumed off?) by 0510. (MaS-CA4)

900 KNUI HI, Kahului 6/27 0753-0810 good-xlnt (little, if any, KNEW-910 slop) w/adult contemporary mx, nx (lead stories--downtown car chase at midnight, foam floating in the harbor). Garbled jingle ID at 0801, ads, Maui Humane Society PSA, "K-900." (RW) (MaS-CA4)

910 CKDQ AB, Drumheller 7/13 0510 good w/"91 Q" ID o/XEAO in KNEW null.

930 KEWQ CA, Paradise 7/3 1159 fair w/"The Christian Stn-KEWQ Paradise", ad for flea collar (is that what those minister's collars are? Hi.) (MaS-CA)

940 KNST AZ, Tucson 6/28 0336 poor o/u XEQ in CJIB null w/phone-in talk show, ID. Call change ex-KMGX. (RW-CA)

(KFRE) CA, Fresno 6/28 0431-0830+ and 7/5 0404-0800+ totally off these periods. (RW-CA)

990 KIXZ TX, Amarillo 7/5 0510 good w/TC, ID; o/mess. (RW-CA)

KTKT AZ, Tucson 7/7 0508 xlnt but slightly fadey w/ID. They must've done something to their xmtr or upped their pwr, as they have suddenly begun to boom in here regularly nightly after KKIS s/off. A listenable signal! (RW-CA)

1000 KOMO WA, Seattle 7/5 0350 noted on all night w/what sounded like RS, live DJ, local spots, etc. Hope this was just 4th of July weekend special or something. (RW-CA)

1030 (KTWO) WY, Casper Wed 7/7 0551 suddenly off air at 0500. Off rest of morning, but was on RS MM, so is this new night for weekly SP? WBEZ/XEQR in as usual when they're off. (RW-CA)

1040 KPOI HI, Honolulu 6/27 0205 poor u/WHO w/adult contemporary mx, "1040 K-Poi". (MaS-CA4)

1070 KNX CA, Los Angeles 7/12 0420 noted on w/RS during normal 2nd MM SP. Is this SP gone now, too? (RW-CA)

1080 KSCO CA, Santa Cruz 7/5 1955 good w/Superman movie mx, local PSA. Can barely get at my QTH--maybe I should try bus stop benches in Albany more often, hi. (MaS-CA2)

1090 KING WA, Seattle 7/3 noted rejoining NBC net (which they had 1959-1975), dropping RKO-2 net & also dropping RKO's "America Over-night" talkshow. Also dropped RKO's "Solid Gold Saturday Night," rats. (BH-WA)

- 1100 KREX CO, Grand Junction 7/5 0207 s/off u/KFAX w/SSB (male group) before s/off annct. (bp-BC)
- 1110 *KHAC* AZ, Window Rock 7/12 0516-? ET'ing good portion of morning way o/KFAB w/many gospel songs, ID at 0526 "This is KHAC, Window Rock, AZ". Freq. changed--logged on 1300. Hrd 1300 f/c in 1978. (RW-CA)
- *KRLA* CA, Pasadena 7/19 0327 extremely strong w/TT. (RW-CA)
- 1120 KMOX MO, St. Louis 7/3 0300 fair-poor way u/KPNW w/talk, ID, CBS nx. (MaS-CA)
- 1130 KSDO CA, San Diego 7/7 0435 fair o/u KRDU in CKWX null w/KSDO sports promo, ID as "News 1130". Only 2nd time ever hrd on night pattern. KFWB-980 w/great signal tonight, so good cx to So. CA.
- 1140 KMJJ NV, North Las Vegas Su 7/4 1119 very loud midday w/r/r mx, (RW) then "Magic 11--KMJJ--plays the best oldies." Too much KPRZ-1150 back home to get this midday. (SMM-CA2)
+7/7 0452 almost even w/KRAK w/"Magic 11" ID, much stronger than usual. (RW-CA)
- 1150 KPRZ CA, Los Angeles mentioned being a new affiliate of the Larry King show, on 7/1. (RW-CA) (Guess KMPC-710 would drop Larry-NH)
- KAYO WA, Seattle format change first noted 7/5 while driving near Tacoma. No longer C&W. Has a format of old MOR mx, some big bands & some Beatles ballads but heavily into 1950's & 1960's MOR, so it's not quite MYL but similar. Dropped NBC net (which returned to KING-1090) & uses APR nx plus local. Gives KAYO ID only on hour, "the new 11-50 A-M" other times. Asks for requests for "Seattle's special survey." Call change to KSPL is pending-- hmmm! (BH-WA)
+6/27 0350 poor but on top in KPRZ null w/wx. Not hrd in a long time thanks to you-know-who! (RW-CA)
- 1170 (KLOK) CA, San Jose 6/27 0315-0645+ totally off on a Su. KVOO/KCBQ/KPUG mixing. (RW-CA)
- 1180 KWSO CA, Wasco ex-1050 Th 7/8 2315 very good (in fact, a real pest) w/relig. programming. IDs as "KWSO" & "The new AM 1180". KOFI can sometimes poorly be hrd under. Currently has 0200 s/off. Will count as new stn. Hrd Su 7/18 1550 midday in extremely tight KEZY-1190 null (while DJ was talking) w/snatch of relig. rhetoric. Midday # 124. (SMM-CA)
+7/20 0020-0026½ "Insights For Living" relig. pgm, 0026½ "ad" for relig. publications, 0028-0029 end of "Insights" pgm. 0029 "The new AM-1180" & legal ID, into Biola Univ. relig. pgm. Quite strong & clear--no sign of KOFI. (NH-WA)
+7/20 0059 poor to nil, two KWSO mentions between relig. shows. KOFI nulled, some KEX-1190 splatter. KWSO much weaker & KOFI much stronger than Nancy's logging ½ hour earlier. Never logged on 1050. (BH-WA)
- 1190 KEZY CA, Anaheim 7/3 0254 fair-poor u/KEX w/AOR mx. (MaS-CA)
+Su 7/4 1125 surprisingly strong w/a block of AC/DC, then: "You're listening to another KEZY California Superstars Superstars weekend," and into a block of Rush moments later. (SMM-CA2)
- 1210 "KDNF"
Pirate CA, Sherman Oaks (or Ventura Co.?) Sa 5/15 0350-MM 5/17 0300 Pirate noted here w/rock mx. 0400 went into 2-hour talk show recorded by them in 1963 about sex, drugs, & rock 'n roll, and society's image of them. Tuned in again next day during RS of rock mx & hrd IDs as "The Big 1210--KDNF." Also gave phone no. so at 1710 I called & spoke w/"head DJ," Steve Ricketts, who couldn't believe I was picking them up "Way out" in San Pedro!" He ment that they were using "only" 250 watts & have been on & off the air since the late 50's. They s/off MM 5/17 0300 & "official-sounding" annct ment. that they are a "Non-profit and legal broadcast stn. authorized by the F.C.C." & gave Sherman Oaks address. Final words were "KDNF--Ventura Co.--the big 1210," which is also the way KAZ hrd them ID a few months ago. Hrd 7/11 back on the air 0254 again w/oldies mx. IDs as "The Music Machine--KDNF." DJ ment. a couple of times that they'd be on till 3am (0600 ELT). (SMM-CA)
- 1220 KASY WA, Auburn 7/10 2357-2359 good after KCCS s/off w/Gary Crawford DJ, local spot, into s/off. Not hrd in a while. No sign of CKDA. (RW-CA)
- CKDA BC, Victoria Su 7/4 0440 good w/Rolling Stones song (recorded live in Hampton, VA 12/19/81 for Pay-TV telecast), then PDT TC & clear "CKDA" ID. Never hrd this one back home! (SMM-CA2)

1230 KPRL CA, Paso Robles 7/3 0244 fair-poor w/"Grab Bag" contest, then lost in the usual GY hash. (MaS-CA)

KRDG CA, Redding 7/3 0247 fair in jumble w/top 40 mx, fireworks promo, Redding wx. (MaS-CA)

KWG CA, Stockton has changed formats to oldies from C&W. ID'ing as "The all-new G-1-23." (RW-CA)

KYJC OR, Medford 7/3 0241 poor in jumble. Faded up for a local spot. "KYJC" jingle, John Denver mx, then out (Far out! Hi.) (MaS-CA)

1240 KPOD CA, Crescent City 7/3 0229 hrd clear "KPOD" thru jumble, but nothing else attributable to that str.(MaS-CA)

?KLOA? Ridgecrest 7/19 0859 tent. w/ID in KNRY null just before that irritating "het" came on which ruined signal. Possible ment. of "Hang in there for a minute, I'll be right back...", then ID on hour tent. as "KLOA, Ridgecrest" into big band mx. Lost immediately. Won't count yet. (RW-CA)

KROY CA, Sacramento 7/3 0230 poor in the babbling w/top 40 mx, "Kroy." (MaS-CA)

1260 KVSV NM, Santa Fe 7/3 0528 fair o/u CFRN-KGIL in KYA null w/promo for Loretta Lynn concert, ID. (RW-CA)

1270 KROI NV, Sparks 7/3 0221 good w/oldies mx, "K-Roy" slogan. Nearly even in format & strength w/local KYA-1260. (MaS-CA)

1280 KFRN CA, Long Beach 7/3 0216 fair-poor u/KJOY w/choir mx (from "Family Radio"). (MaS-CA)

KWMS UT, Salt Lake City now all news. CNN-2 & local nx blocks. Uses "Newsradio 1280 KWMS" slogan. (WJH-UT)

1290 *KHSL* CA, Chico 6/28 0341 xlnt w/TT. (RW-CA)

1300 KYNO CA, Fresno 7/3 0212 poor-fair u/KMPS/KDIA-1310 sloppola w/ adult contemporary mx, local spots. (MaS-CA)

1320 KGNR CA, Sacramento 7/30 0205 fair o/KDIA-1310 sloop w/end of Ai net nx, into "CNN-2" news. (MaS-CA)

1330 KENU WA, Enumclaw noted on car rx in Enumclaw 7/4. To clarify report in 4/17 WDXR, KENU has Ac net. Mx seems to be "all over the road," hi - some current pop, some C&W, some MYL! Still not logged at home. (BH-WA)

1360 KFIV CA, Modesto 6/21 2325 xlnt w/wx. Not hrd often here. In KEEN-1370 null. (RW-CA)

KMO WA, Tacoma 6/25 0435 good through tremendous KEEN-1370 sloop w/"1360, KMO" ID. (RW-CA)

1370 (KEEN) CA, San Jose 7/9 0520 totally off. KSOP/KWRM mixing. (RW-CA)

1380 KKZZ CA, Lancaster Su 7/4 provided comprehensive Space Shuttle coverage, utilizing their own facilities & NBC nx. Following Shuttle coverage, entered "The Best of Contemporary Christian Music." At 1500 entered format which can only be described as a "grab bag." One moment they'd play a golden oldie, then a C&W tune, then hard/AOR rock, then jazz, then a 1930's tune, etc!! (SMM-CA2)

KTOM CA, Salinas 7/3 0147 fair o/KGMS w/Pepsi giveaway contest, "Wildwood Weed" (song by Jim Stafford, not a giveaway, hi). (MaS-CA)

1390 KCEY CA, Turlock 7/3 0142 very good o/KGER/KRE-1400 sloop. Male annr: "Surgeon General states that listening to KCEY causes sterility in mice", into Anne Murray song. (MaS-CA)

1400 *KVOY* AZ, Yuma 6/28 0358 definitely logged w/ID "This is KVOY, Yuma, on the air for testing", Willie Nelson mx. Way o/KRE/unID TT'er, KSLY, & KFPN. (RW-CA)

KSLY CA, San Luis Obispo MM 5/24 0308 DJ ment that all phone calls to the str are recorded for possible playback o/the air!(SMM-CA)

1410 KMYC CA, Marysville 7/3 0138 weak & fadey u/GPUN/KCAL/KRE-1400 Sloop w/"We're ... favorite mx, KMYC", into Moody Blues. (MaS-CA)

1420 CJVR SK, Melfort 7/5 0531 dominant w/promo for farm pgm, no sign of Kuj/KITL. Now NSP? (bp-BG)

1450 KYET ID, Payette 7/29 0738-0806 way o/KONE/KVEN, KEST w/OC 0738-0755 due to tech. problems, leaving 1450 wide open. KYET even audible in KEST null when they came back on. Yawning annr w/C&W mx, jingle ID at 0748 "KYET", local nx & sports on top of hour, including wx. ID "currently, 550 here at KYET." Lost by 0806 u/KONE. 1450 #20. (RW-CA)

1470 KUTY CA, Palmdale Su 7/4 noted w/new format of C&W mx. KUTY is, of course, also fulltime now, and they--along w/KDOL--provide the only round-the-clock service to the Antelope Valley.(SMM-CA2)

KXOA CA, Sacramento 6/28 0334 xlnt w/TT. (RW-CA)

1480 KPHX AZ, Phoenix 6/7 0200 EE ID. Very strong. (GC-WY)
 KYOS CA, Merced 7/3 0016 good way o/KWUN/KAAR w/Merced high school annot, "KYOS" jingle, top 40-ish mx. (MaS-CA)
 KGCX MT, Sidney 6/9 noted fairly new 24-hour format w/Larry King. Regular. (GC-WY)

1490 KBLF CA, Red Bluff 7/3 0010 fair u/KTOB w/A's baseball. (MaS-CA)
 KRIB IA, Mason City 6/5 2330 ID into pop mx. Extreme fading. (GC-WY)
 (KLYC) MT, Laurel 6/15 2158 annrc broke silence at this time to announce the stn had been off due to direct lightening hit. (GC-WY)

KOVC ND, Valley City 6/6 0735 hrd only ID. Alone w/CKSW. (GC-WY)
 KORN SD, Mitchell 6/7 0205-0210 TT. Good signal. (GC-WY)

1530 (KFBK) CA, Sacramento 7/12 0421 totally off. (RW-CA)
 1540 (KZLA) CA, Los Angeles 7/19 0325 totally off, back on at 0410. (RW-CA)
 KTIA TX, Ft. Worth 7/19 0346 good thru KZLA OC w/SS ID. (RW-CA)

1550 KRGO UT, West Valley City finally got around to officially logging this pest's new city of license MM 5/31 0401 "Your Rocky Mountain Country Station--KRGO, West Valley City". (SMM-CA)
 KRGO 6/28 0412 apparently ETing on day power/pattern. Off & on w/C&W mx. Extremely strong, stronger than KEEN-1370, hi. (RW)
 (KVAN) WA, Vancouver seemed to be off MM 7/5. Only a weak jumble noted. (bp-BC)

1570 CKTA AB, Taber 7/5 0416 fair-good I presume it is they who relay CHEC-1090 Lethbridge, AB? Hrd "Picnic Contest" for "1090 Check"--ironically CHEC is inaudible here thanks to XEPRS. (MaS-CA3)

1580 KLOQ CA, Merced 7/5 0905 blasting in w/pop mx & ID. (bp-BC)
 1590 KCIN CA, Victorville Su 7/4 1545 strong w/C&W mx. Long jingle ID at 1546. Thought this was KBBQ, until I hrd the ID. C&W also noted u/KCIN, which I assume is probably the Bar-B-Q. (SMM-CA2)

1610 TIS OR, The Dalles 7/17 hrd while driving on I-84 w/info on motels, The Dalles Dam & other info on The Dalles. Was hrd for some 4 miles w/good signals. (BB-OR)

June f/c's NOT hrd:
 1st MM KQIK-1230 OR (RW-CA)
 KMGL-1240 ID (RW-CA)
 ID'ing an UNID:
 1490 KDB CA, Santa Barbara Wed 6/30 0200+ mystery solved! Hrd ID, into CNN nx; so this apparently the CNN & CNN-2 nx format affiliate 1st hrd on 4/25 out in Twentynine Palms & by RW on 5/17 (see 5/22 & 6/12 WDXR's)--Slogans are "Santa Barbara's only all nx station" & "KDB Newsradio 1490." The reason it took me so long to solve this mystery is because KDB is a semi-local & is right u/my nose, hi. (Thank goodness this 3-letter call didn't decide to change calls also!) (SMM-CA)

UNID's:
 540 7/5 0340 weak but steady w/very low-key preacher. (MaS-CA3)
 550 7/5 0344 fair u/KSFO-560 slop w/"America Overnight" network pgm. (MaS-CA3)
 940 7/5 0615 suddenly appeared out of nowhere as if some pattern change or something, in CJIB null. Simply ID'ing as "...here at 94 country," lost immediately. According to slogan list, WEL0-TN has this slogan, but seriously doubt them. Does KIXZ or KDEO use this slogan? (RW-CA)
 940 7/12 0404 w/NBC nx. No one listed. Briefly on top then gone. KFRE off on apparently new regular MM SP 0400-0800. (RW-CA)
 980 Su 7/4 0430 strong TT's u/KFWB. Kept going on & off, but no IDs hrd. (SMM-CA2)
 1160 6/27 0305 u/KSL w/EZL. No ID's. (RW-CA)
 1250 7/8 0420 unID TT'er o/u KTMS/KKFX. ETing w/C&W mx later on. Looped east. Possibly KNEU? (RW-CA)
 1340 7/19 0541 suddenly appearing on top w/ad mentioning "...around Guymon Oklahoma, in this area..." Lost very quickly. Way too early for a power change. No 1340 stns in Guymon area, perhaps some KMAK truck stop ad? (RW-CA)
 1390 7/9 2354 carrying Seattle Mariners baseball in mess. Has to be either KBBO or KSLM, and I suspect KSLM more than KBBO, since KBBO is relig, I think, but no one listed on 1390 on Mariners sked. Who is this? (RW-CA) (It is KSLM per new list. Yakima outlet still KIT-1280.--NH)
 1400 7/9 0115 u/KRE carrying Oakland A's baseball. KUKI or KQMS? (RW-CA) (KQMS only 1400 listed.--NH)

- 1420 Someone putting what sounds like a strange "het" on KSTN nightly, just like KNRY (ex-KESE) does on 1240 throughout the Bay area during the daytime. Is XEXX leaving their OC on all night & is off freq., or what? This also occurs before XEXX s/off. (RW-CA)
- 1440 7/3 0111 poor u/KVON w/Dodgers baseball. (MaS-CA)
- 1450 6/26 0616 w/big band-style mx way u/KEST. Looping SE. KVEN also in there. KNOT or KPSI? (RW-CA)
- 1480 6/7 0110 TT w/ID KEPS?? w/location of "....ton." (GC-WY)
- 1490 6/21 2340 noted carrying Calif. Angels baseball. No one listed. Who? (RW-CA) (KDB?--NH)
- 1490 7/5 0428 C&W quite strong o/mess. By 0500 o/u mess, & pretty much gone u/the mess by 0515 or 0530. In KRRX-1500 null. A possible ment of "good morning, Okanagan...", but no unusual cx to BC. Lost to KBAS & unID R&B (KBZY?), CK00-1 would then be the one, but listed as being off this hour. (RW-CA) (Prob. CK00-1. CKOK-800 & its twins are now NSP.--NH)
- 1560 7/12 0700 SSB very weak u/KPMC OC before being obliterated by KPMC s/on. Lots of possibilities. (RW-CA)

Wow! A very good turnout for a summer issue! Some reporters are having trouble converting times for tips to WDXR. One person last issue converted incorrectly, & another this issue. Times in WDXR are EASTERN local time, so you must ADD three hours to our Pacific time (my reporters in the Mountain time zone are doing just fine--so I'm only talking to the Pacific time members for the moment!). Using the 24-hour clock has bothered some. One person this week had a tip listed as "1216am". That one should have read "0016"...and in this case, don't forget to add a day! It may be 9pm or 10pm here--but it's already the next day in the Eastern time zone! For those of you unfamiliar w/the 24 hour clock here are some examples, 9am=0900, noon=1200, 2pm=1400, 5pm=1700, 8pm=2000, 11pm=2300 & midnight is 0000. The early morning times are real easy--just put a zero before the hour; 1am=0100, 3am=0300, 6am=0600. Now, if anyone makes a mistake w/a time conversion, you will get a stiff penguin flipper. You've been warned! ♡

AM stereo premieres after ruling

WASHINGTON (AP) — A handful of AM stations across the country are broadcasting in stereo, just days after the government cleared the way for them to start competing head-on with FM stations for the music-listening audience.

"I think it's here to stay," said Phil Lerza, the chief engineer for San Francisco's KFRC-AM, which turned on its stereo system Saturday morning.

"We've spent all weekend going crazy (promoting) it," added Kim Curry, the

program director at KTSA-AM in San Antonio, Texas. "It's a godsend for us, because now we're finally going back into competition with FM stations."

KTSA, according to an informal survey by The Associated Press, became the first AM station in the country to offer full-time stereo broadcasts last Friday afternoon.

It took station executives only 30 minutes to turn on their stereo equipment after learning of a decision by the Federal Communications Commission.

KFRC and Los Angeles' KHJ-AM followed suit on Saturday morning, with KMBZ-AM in Kansas City, Mo., joining them Monday.

Executives at all four stations are convinced AM stereo offers them a fighting chance to reclaim a music-loving audience from FM stations.

The FCC's decision also marks the start of what is shaping up as a major battle between the proponents of five different AM stereo systems.

On Friday, the FCC granted the first so-called type acceptance authorization for AM stereo equipment. Type acceptance is the process by which the FCC tests the technical characteristics of new electronic equipment to ensure it will not cause interference.

By type accepting the stereo equipment of Kahn Communications Inc., the FCC said, in effect, that any station that had purchased Kahn's equipment was free to begin using it.

The problem, however, is that the FCC refused four months ago to select Kahn's system as the industry standard. The commission closed a 5-year-old proceeding by deciding the marketplace should choose the system it liked best.

In other words, broadcasters were told they had to choose among five, incompatible stereo transmission systems.

Langsdale (PA) Register 7/27/82 via Richard Evans. Related material from Rich Toebe and Peggy Thompson.

STAFF MEMBERS JOIN KIKX LAST ROUND-UP

TUCSON (AP)—Country music radio station KIKX, which was stripped of its broadcast license after a kidnaping hoax, left the air for good Sunday morning to the strains of "The Last Cowboy Song."

Disc jockey Steve Ellberg cued up the farewell tribute and bade goodby to listeners, who did not know that the station had picked a sign-off time. Only the staff, 13 full-time and two part-time employees, had been told of the decision and they kept it secret.

The decision to fold the 500-watt AM station followed a 2-1 ruling May 26 by the U.S. Court of Appeals in Washington that upheld a Federal Communications Commission decision to strip the station of its operating license.

The FCC acted after a fake news story Jan. 19, 1974. Disc jockey Timothy Ingstad told listeners that another of the station's disc jockeys had been kidnaped. Both men were fired but the FCC decided not to renew the station's license.

"It's a shame these people have to suffer because of the indiscretions of previous employees," said Jim Scopac, the general manager.

"We were a big family and we just wanted to be together," Diane Hart, 18, a part-time disc jockey, said as most of the staff gathered at the station for the sign-off. "We wanted to do this professionally."

Scopac said the station's owner, John Walton Stations of Pebble Beach, Calif., decided not to appeal the court ruling, which came at a time when the station's ratings were low.

via Steve Mittman & Robert Wien

* Actually, 5000d/500n.

DX WORLDWIDE EAST

Neil Kazaross, Editor
 518 E. Grand Avenue
 El Segundo, CA 90245
 (213)322 3119

We have a nice column this week, thanx to a couple of active summer contributors. But, first of all, we must give thanx to my fiancée, Laura, who has lent me her typewriter and thus spared all of you a visit to the optomitrlist. I couldn't believe how badly the last few columns looked, even though I put in a new ribbon.

TRANS ATLANTIC DX ROUNDUP

- 164 FRANCE Allouis O200 July 5 FF talk & American mx. Fr-gd. (Hakiel-NY)
 Welcome to DXWV-E!!!! George has a nice DX location on Long Island only two miles from the Atlantic. Droool!! I wish I was back in Narragansett, RI, etc. -homesick ed.
- 1584 SPAIN Graveyarders O440 July 9 SS talk jumbled, poor only TA hrd tonite. (Hakiel-NY)

Now that we've covered both ends of the TA spectrum it's time for.....

PAN AMERICAN DX ROUNDUP

- 540 VENEZUELA Villa del Rosario YVOV July 20 0757-0802 xlnt-all alone. some slow vocal mx, then OM w/"R.Perija" ID's frequent TC's, freq & Ven. mentions. (Sullivan-NC) Also hrd 0310 July 9 w/SS vocal mx fair-gd. (Hakiel-NY)
- 550 VENEZUELA Caracas YVKE 0330 July 9 SS made vocal mx, R.Mundial ID
- 580 PUERTO RICO San Juan WKAQ 0530 July 5, singing ID"WKAQ,R.Reloj" good sig. (Hakiel-NY, last two)
- 640 COLOMBIA Santa Marta HJBJ July 20 0804 fr. rising o/Cuban? OM w/"RCN" & Col. ment. (Sullivan-NC)
- 650 VENEZUELA Maracay YVLH 0200 July 4 LA mx, talk, ID R.Vision. fair.
- 725 SURINAM PARAMARIBO PXX26 0405 July 9 EE songs "Dear John" then "Speedy Gonzalez" DD talk, very good signal. (Haki el-NY, last two)
- 740 VENEZUELA Maracaibo YVNC July 17 0635 pr. u/KRMG. Vocal mx, R. Maracaibo ID's (Sullivan-NC)
- 750 VENEZUELA Caracas YVKS 0210 July 4 ID R.Caracas, v.gd. no WSB. & 0150 July 11 SS RR mx, ID, very big signal! Where is WSB? (Hakiel) You should ask Chuck Hutton that question!!-hi. Seriously, at your QTH, I'll bet you find YVKS is most often above WSB-ed.
- 770 PANAMA Chitre HOL47 0825 July 12 lively LA mx, ment. of Panama. ID as R.Nacional de Panama. WABC off. fair sig. (Hakiel-NY)
- 800 NETHERLANDS ANTILLES Bonaire TWR 0410 July 9 EE Rlg.preacher, regularly hrd with xlnt. signal. (Hakiel-NY)
- 825 ST.KITTS Basseterre R.Paradise 0415 July 9- EE rlg. pgm. hrd night-ly w/ v.gd. volume. (Hakiel-NY)
- 830 VENEZUELA San Antonio de los Altos YVLT July 21 0452 fr. w/some WKIX slop o/WCCO. OM w/ R.Sensacion ID's, some mx, then s/off w/NA(I think, because I've never hrd it before.) (Mucho violins near the end-ed) (Sullivan-NC) 0420 July 9 SS vocals w/guitar mx R.Sensacion ID V.Gd. (Hakiel-NY)
- 830 COLOMBIA Medellin HJDM July 16 0833 fr w/mx OM w/R.Vision ID's & Caracol ment. (Sullivan-NC)
- 834 BELIZE R.Belize 0430 July 9 EE C&W mx, "Green Grass of Home" (my grass hasn't been green since May-ed) Good volume (Hakiel-NY)
- 860 BRAZIL Rio de Janeiro ZYJ459 0835 July 12 Pop jive mx, PP talk, R.Mundial ID, An xlnt. signal! Very strong (Hakiel-NY)
- *****870***** ARGENTINA Buenos Aires LRA-1 (condensation of 3 reports & 2 phone calls -ed) 0430-0500 July 5 hrd tango-type mx, & at 0450 had a positive ID "LRA-1, R.Nacional, Buenos Aires. fr-gd signals w/WWL looped out. 0409 July 11 hrd briefly-old time US jazz, good sig. while it lasted, faded out. Third time heard, can't understand why this stn. hasn't been rptd. before. 0423-0515 July 12. Heard again w/Xlnt. signals w/some fading periods. Nice sounding tango-type mx. 6 pips at 0500. This stn. is becoming a regular-unbelievable! (Hakiel-NY) This was last heard(by me) on Sept. 1 1979, prior to that this stn. was reported a couple of times per year. They have 6 pips on the hour w/the final one prolonged. They also have timepips on the ½ hr., too, although I'm not sure how many. LRA is also on SW 6060 & is easy (here, anyway) after RHC 6060 s/off. I've tried several times to hear this in WWL null but no luck so far -ed.

- 980 DOMINICAN REPUBLIC Santo Domingo HIFA July 17 0100 gd. o/other SS stn. Trumpets at the top of the hour, then SS OM ID as "Esta es abceh-ee-ehfeh-ah (HIFA), LV de Fuerzas Armadas, Republica Dominicana." Then HIFA in code and festive instr mx. (Sullivan-NC) Code ID's on the hour should cut thru all sorts of QRN-ed.
- 1000 CUBA San Cristobal CMAO July 19 0958 V.gd o/YVOA which was fading out. OM & YL w/R.Guama ID's // 1020(much stronger) (Sullivan-NC) AU mornings at SRS are an xlnt. time to DX the weaker Cubans after the normally dominant more eastern QRM has faded -ed.
- 1000 VENEZUELA San Cristobal YVOA July 19 0945 fair w/2 other LA's. SS vocal mx, then OM w/loud "R.Tachira" (Sullivan-NC) Nice catch, John, usually HJAQ & YVNM are dominant -ed
- 1020 VENEZUELA La Asuncion YVRS July 12 0510 gd-v.gd w/KDKA off. OM ID "Mundial Margarita, Venezuela" (Sullivan-NC)
- 1040 COLOMBIA Bogota HJCJ July 17 0602-0605 gd. o/WHO. Many "Super!" & Bogota ments. (Sullivan-NC)
- 1040 DOMINICAN REPUBLIC Santo Domingo HION July 15 0040-0045 Xlnt. OM DJ playing SS & US pop tunes, spots for local businesses, "R. Central" ID's (Sullivan-NC)
- 1070 COLOMBIA Barranquilla HJAG 0623 July 12 female SS singing "Emisora Atlantico" ID good signal. (Hakiel-NY)
- 1130 COLOMBIA Barranquilla HJAC July 21 0452 fair rising out of LA crowd. OM w/TC & "Emisora Rio-Mar" ID. Into SS pop tunes.(Sullivan)
- 1130 COLOMBIA Bogota HJCO July 20 0220 pr o/HIRL. OM w/"Emisora Eldorado" ID & what sd/lk "Grupo ? Colombiano." Static from T-storm made readability tough, but they must have been mentioning their affiliation w/Cadena Grupo Radial Colombiano. (Sullivan-NC)
- 1165 ANTIGUA St. John's Caribbean Radio Lighthouse 0131 July 10. Stn. ID & TC, fol. by symphonic mx. Good. (Hakiel-NY)
- 1190 COLOMBIA Bogota HJCV July 22 0556 pr u/WOWO OM W/'R. Cordillera" ID, then mx. (Sullivan-NC)
- 1430 CUBA Ciego de Avila CMIL July 19 xlnt o/everything. YL w/"Escucha! Aqui tuben(?) tu por R.Surcos Cadena Provincial de Ciego Avila." Into slow SS YL vocal (Sullivan-NC)
- 1550 COLOMBIA Barranquilla HJCB July 16 0600-0612 pr. u/WYNX most of time OM w/RCN ID & Barranquilla ment. Also got half an ID w/"Portena!" hrd. Mx rest of the time. (Sullivan-NC)
- 1530 CUBA Moron CMIM Moron 0125 July 12 "Born Free" song by male in SS Then into other LA numbers-fair signal. (Hakiel-NY) If the vocalist was Cuban he was "Born Free" but he's sure not anymore!!-ed
- 1550 t COLOMBIA Barranquilla 0035 July 12 hrd briefly at SSS. SS talk. NO ID hrd. (Hakiel-NY) At sunset HITS or perhaps WKFE are also possible. 0035 is past WRHC or WYOU (Fla. SS daytimers) s/off times. HJCB is the dominant LA here later at night and plays much Colombian accordion mx if I remember correctly-ed.
- 1580 MEXICO Hermosillo XEDM June 21 0555-0602 fr-gd o/u WSRF. 2 OM's w/ SS talk, one who said, "La Grande de Sonora" also "Deh-ehmeh" (D-M) (Sullivan-NC)
- 1610 ANGUILLA Caribbean Beacon 0135 July 10 EE preacher. Good signal. (Hakiel-NY)

It's good to see that some people are DXing LA's this summer. My experiences (several years) show that summer can be an xlnt. time to DX LA's, especially on relatively quiet nights. Domestic generally do not come in as well as in the winter, while LA's, especially YV's, HJ's & Carib. come in just as well. DSA'a are also occasionally good in the summer. However, T-storm QRN is the big, noisy problem. By the way, my reception of LRA-1 870 in 1979 was during a T-storm w/visible lightning so by no means do T-storms prevent DX, they just make it more difficult and unpleasant to many.

Sunset LA DX in the summer & early fall can be superb because, do to global sunset patterns, the midwestern clears are not in'til later but the LA's are in full darkness and easily receivable at SSS.

CONTRIBUTORS TO THIS TINY BIT OF DX HISTORY ARE:

George Hakiel, 739 Van Buren Ave. W. Islip, NY 11795- Drake R7A, Superadio, 250' LW, SM2, Sanserino Loop
John Sullivan, 5007 Tall Pines Ct. Raleigh, NC 27609- RF-2200 w/120'LW

73's and get set for a great DX season

- KAZ -

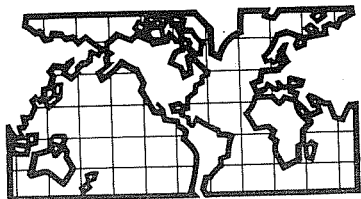

DX WORLDWIDE - WEST

Pat Martin - Editor

P.O. Box 843, Seaside, Oregon 97138

(503) 861-3185 deadline Tuesday

PAN-AMERICAN DX ROUNDUP

- 540 MEXICO, S.L.P.-XENA good s6 to s7 at 1105 GMT on 7/17. (JJR-Wa)
660 CUBA, Santa Clara?*Radio Progreso w/usual pgm,wiped out by KERPM and stronger than // 790,880,900, list time hrd R. Progreso on this freq.,must be powerful to wipe out KERPM! Seemed to be slightly off freq,could hear het at 0500 7/22. (CG-Texas)
780 HONDURAS, San Pedro Sula? on 7/6/82 at 0300,hrd OM w/talk in SS, followed by jingle "Emisora Unidas EN Honduras",got jingle on tape, later hrd ballads and other SS Pop tunes,good for a while,no WBBM(CG)
860 MEXICO, Tijuana-XEMO-Radio 86, with frequent ID,preceded by chimes, hrd on car radio in Hayward,Ca. at 0720-7/19.(BPS-Ca)
950 MEXICO, Tijuana-XEGM hrd on radio radio between Livermore and Castro Valley Highway 580 from 0540-0600 7/16. (BPS-Ca)
1050 MEXICO, Mexicali-XED-Frequent ID "La Grand D" by OM,0830 Rooster crow on 7/19. (BPS-Ca)
1090 MEXICO, Rosarito-XEPRS-hrd 7/19 from 0944-1006,with oldies rr mx.(BPS)
1470 MEXICO, Tijuana-XEBBC-in SS 0644-0715,ID's,Trad Mex. mx.(BPS-Ca)
970(opps)MEXICO, Matamoros-XEO w/ID into clas. mx,vy slushy arrangements,usually KEYJ is the dom. station.(CG-Texas) (Time? Date?-PM)
1613 GUATEMALA,Rabinal-"RAB" beacon,weak,w/beeper 0850-7/20.(JJR-Wa)

TRANS-PACIFIC DX ROUNDUP

- 531 AUSTRALIA, Kempsey-2MC-presumed here at 1058,list Aust. to produce audio 6/27,didn't last long (DM-Ab)
*Also noted 7/19 mixing w/4XA at 0915 with C&W mx,4XA w/rr.(PM-Or)
UNID, weak DU station here AM of 6/27 and 7/4-Prob.2MC and 4XA from 0900 on (SPM-PR)
AUSTRALIA, Kempsey-2MC 7/5 1200 Mid Coast Radio and 2MC ID's after 6 slow dips,"CQ" preceded nx,also hrd preceding nx on 2RE-1557,are these same nx net now? (NHP-BC) (Could be, as alot of Australian stations use news nets, like Maquarrie.PM)
540 AUSTRALIA, Longreach-4QL fair w/ABC nx at 1000, o/unids on 7/19.(PM-Or)
549 AUSTRALIA, Orange-2CR,fair w/EZL mx at 1015 on 7/19,terrible KMVI slop-550. (PM-Or)
550 HAWAII, Wailuku-KMVI-so strong the AM on 7/19, that they slopped from 530 to 570,awful, I am wondering id their tower is in my backyard,hi.(PM)
558 FIJI/UNID, Radio Fiji here fighting it out w/unid Clas. station,presume it was 4ZG-NZ,but other possibles too at 0830-7/19.(PM-Or)
567 NEW ZEALAND, Wellington-2YA 7/5-1139 YL talking // 756 Nil to fair, both channels (NHP-BC)
*Also good w/Pop mx // 756 1139-7/5 (BP-BC)
*Also noted with National pgm // 756 1036 on 7/19 (PM-Or)
576 AUSTRALIA, Sydney-2FC at 1212,poor w/nx by OM //657 (NHP-BC)
*Also noted 1141-7/5 fair to good w/pgm of short statements in SS by OM or YL,alternating w/man in EE,seemed be on Nicaragua,NX //657 et al 1200-1215,then broke away for own discussion pgm. (BP-BC)
*Also noted w/Clas. mx on 7/19 at 1034,in passing. (PM-Or)
594 AUSTRALIA, Horsham-3WV-fair here w/ABC nx at 1101-7/19(PM-Or)
612 AUSTRALIA, Brisbane-4QR-fair with MOR mx and TC at 1023 on 7/18.(PM-Or)
UNID, het here on KFRC-610,6/27-7/14. (SPM-PR)
621 t AUSTRALIA, Melbourne-3AR, trying to break through 620 mess or Hawaii/KGW w/Clas. mx at 1045 on 7/19. (PM-Or)
639 FIJI, Radio Fiji here, hetting KFI badly at 1130 on 7/18 and 7/19.(PM-Or)
648 t AMERICAN SAMOA, Pago Pago-WUVU-surely the one w/mostly currant Top 40 mx 1146-1200 7/5,faded across the hour,but back by 1204-1207, nx by YL in American EE and ad for shop at airport,Same YL back at 1210 w/talk in South Seas vernacular,signal strong to nil,much 2NU QRM, and awful KORL slop.No ID,hrd but ths the only thing that fits.(BP-BC)
*Also noted with YL ancr w/nx at 0900 On 7/19, KFI/KORL slop,ment. of Samoa and WUVU and the Pacific, Reported. PM-Or)
AUSTRALIA, Tamworth-2NU good to nil w/nx 1207-7/5 // 657. (BP-BC)

- 650 HAWAII, Honolulu-KORL-on July 8, fair to good at 1150. (JJR-Wa)
 *Also noted w/usual EZL mx "Mx of Your Life" at 1122, fair het from 648, good sig, but didn't last long, never hrd again all week. Usually no problem to hear reg. on beverage, noted 6/27 (DM-Ab)
 *Also w/exc. signal, pegging meter both mornings 6/27 and 7/4, w/MOYL K-65 ID's, Hawaii spots. Also noted in San Rafael w/SH sig at 1255 7/19 w/MOYL. (SPM-PR)
- 657 AUSTRALIA, Byrock-2BY-7/5 1212 fair to good w/nx //675, etc. (NHP-BC)
 *Also noted powerhouse signal 1213 7/5 w/nx and wx, single tone and TC 1215 then pgm of light classics. (BP-BC)
 *Also noted fighting it out w/NZ w/light mx and soft ancrs-1146-7/19(PM)
UNID at 1224-6/27 OM accented talk not sure if 2YC, because no 882, just 4BH. (SPM-PR)(Poss. 2BY, PM)
- 666 NEW CALEDONIA, Noumea-FR3 w/OM ancr in FF, soft Jazz-0756-7/19. (PM-Or)
 675 NEW ZEALAND, Christchurch-3YA good w/National Pgm of MOR mx, 1120-7/18
 684 FIJI, Radio Fiji here fighting it out w/KNBR slop and Aussie, w/ (PM)
 OM and Island mx at 0839-7/19. (PM-Or)
- 702 AUSTRALIA, Sydney-2BL-fair w/Classical mx // 738-1131 7/4, 2NR much better (SPM-PR)
 *Also noted w/good signals, ABC pips on hour at 1000 on 7/18. (PM-Or)
- 711 AUSTRALIA, two stations mixing here all AM of 7/19. Suspect 7NT and 4QW, tho there is supposed to be a new one in NSW-2CU-10 KW. (PM-Or)
 720 HAWAII, KUAI v'y good all AM, way o/KDWN w/rr mx and ancr with spots noted 0847-7/18. (PM-Or)
- 729 AUSTRALIA, Adelaide-5CL w/Operatic mx // 837, 846, nice loud signal creaming CKLG at 1227 6/27 (SPM-PR)
 *Also noted v'y strong o/CKLG het w/Opera at 1134 7/19. (PM-Or)
- 738 AUSTRALIA, Grafton-2NR loud signal w/class. mx // 702 1129 7/4, louder than CKLG-730, KCBS off SM SP. (SPM-PR)
- 747 AUSTRALIA, Toowoomba-4QS w/clas. mx poor // 738 at 1012-6/27 (SPM-PR)
 *Also noted 7/5-1220, good Orch. mx // 657 (NHP-BC)
 *Also heard clas. mx // 657 1220 7/5, good. (BP-BC)
- 756 NEW ZEALAND, Auckland-1YA-good w/nx 1005 7/5 (BP-BC)
 *Also noted w/National pgm at 1115-7/18 (PM-Or)
- 765 AUSTRALIA, Bega-2BE good signal w/ID and ment. of Australia by accented ancr 1250-6/27, Quite a surprise 3.5 KW listed. (SPM-PR)(Believe they are now 5 KW DA, a good catch. PM)
NEW ZEALAND, Hastings-2ZK-good w/clas. mx and unid rr underneath at 1045-7/19. Suspect 2BE underneath. (PM-Or)
- 774 AUSTRALIA, Melbourne-3LO MOR EZL mx o/unid DU 1247(4T0?)-1247-6/27 (SPM) Prob. 4T0, PM)
JAPAN, Akita-JOUB fair at 1242 7/4 w/JJ ancr talk, took 1/2 hour to move beverage from 250 to 310 degrees, to hear this. (SPM-PR)
- 792 AUSTRALIA, Brisbane-4QG, good w/clas. mx, at 0950-7/18. (PM-Or)
UNID, hetting 790 0917 6/27 4QG? (SPM-PR)
- 801 UNID, weak station here at 1103 w/nx ABC?, lots of splash-7/19 (PM-Or)
 819 UNID, female singer at 1125-7/17. (JJR-Wa) (Prob. 1Y2, PM)
 828 AUSTRALIA, Sale-3GI-fair w/male talk 0951-7/5 (BP-BC)
NEW ZEALAND, Palmerston North-2XS-fairly good o/Aussie w/rr mx a couple spots from 1206-7/18, noted also 7/19. (PM-Or)
UNID, het against KIRI most of morn. 6/27, 7/4 -3GI? (SPM-PR)
- 830 HAWAII, Honolulu-KIRI-1130 ID and jingle, soft rr songs het from 828 again like KORL, only hrd 6/27. (DM-Ab)
 *Also noted w/usual rr, loud, list w/WCCO, then alone-1100-6/27, 7/4 (SPM)
- 837 AUSTRALIA, Rockhampton-4RK w/clas. mx // 846 1140, 6/27 (SPM-PR)
 *Also noted w/sym. mx 0952, male talk 7/5 (BP-BC)
- 846 AUSTRALIA, Canberra-2CY w/clas. mx at 1015 on 7/18, fair. (PM-Or)
 *Also noted w/fair sig. 1147-6/27 w/clas. mx // 837, better (SPM-PR)
KIRIBATI, Tarawa-beautiful signal at 0947 7/4, C&W mx ancr in Gilbertese, best ever, KHLO splatter noted. (SPM-PR)
 *Also noted good w/Island mx, female vocal 0921 7/5 (BP-BC)
- 850 HAWAII, Hilo-KHLO creaming KOA both nights till 1000 s/off w/rr mx and R-85 ID's by YL, ads for shopping center, 0945-6/27 (SPM-PR)
- 855 AUSTRALIA, Maryborough/Eidsvoid-4QB/4QO here w/ABC nx at 1100-7/19(PM)
 864 AUSTRALIA, Hobart-7HO, good o/NZ w/ "8-6-4, 7-H-O ID, into rr mx at 1156 on 7/19, haven't hrd in a while, surprised. (PM-Or)
PAUPA/NEW GUINEA, NBC hrd in EE/Native language, mixing u/ 7HO briefly at 1158-7/19, then gone. (PM-Or)
- 870 HAWAII, Honolulu-KAIM fair to good w/rel. talk, het from 873, at 1150 7/5. (SPM-PR)
- 873 AUSTRALIA, Sydney-2GB-1136 6/27, talk show, open line, faded at 1140(DM-Ab)
 *Also noted 1158-7/5, good "Join us for the 10 O'clock nx on 2GB (NHP-BC)
 *Also hrd w/teletalk 1225-7/5 (BP-BC)

- 873 AUSTRALIA, Sydney-2GB-good w/telephone talk at 0856-7/17.(PM-Or)
- 882 AUSTRALIA, Brisbane-4BH-7/5 1206,Fair Macquarie nx //1026(NHP-BC)
 *Also noted with LYC, LYC-Class. mx, 4BH o/u LYC 0930-6/27,7/4 (SPM)
 NEW ZEALAND, Auckland-LYC-presumed the one w/lite clas. mx, strong
 at times,but KRVN-880 was a problem, 1142-6/28 (DM-Ab)
- 891 AUSTRALIA, Adelaide-SAN-w/MOR/EZL mx o/unid at 1148-6/27 (SPM-PR)
 NEW ZEALAND,Wellington-2KW-Radio Windy mixing w/SAN and FIJI at
 0846 on 7/19, rr mx noted. (PM-Or)
- 900 HAWAII, Kahaui-KNUU,huge signal,like a local both AM's 6/27,7/4,
 best around 1200-1300, at 1155 6/27,noted KNUU's Night Flight pgm
 local nx and SID on hour at 1200 (The SID ID sounds 30 years old,
 doesn't it Pat?) (Yep,PM),into Ads,ment. sev. Maui names, love
 those names! (SPM-PR)
 *Also noted fair u/CJVI w/rr mx and local PSA 0631-7/5 (BP-BC)
 UNID, DU (Suspect 1ZB,Auckland) (1ZB is on 1080, poss. 4YC-Dunedin,
 has been hrd by Hank Wilkinson,Santa Rosa-1980-PM), end of rr song,
 6 pips u/KNUU at 1200 7/4. vy interesting. (SPM-PR) (One other
 thing, 4YC would be Classical, poss. an Australian. PM)
- 918 NEW ZEALAND, Greymouth-3YZ, 7/5 1227,fair w/pop mx //819 (NHP-BC)
 *Also 3YZ hrd fair w/Pop mx //819 1227 7/5,o/weak unid (BP-BC)
- 927 NEW ZEALAND, Palmerston North-2ZA,fair o/4CD w/Tonight Show, Pop
 mx at 1020 on 7/19. (PM-Or)
 AUSTRALIA, Gladstone-4CD-under 2ZA w/C&W mx, a couple ads for
 bus. in Gladstone at 1022-7/19. (PM-Or)
- 936 AUSTRALIA, Townsville-4AY-Fair w/Pop mx, and 940 slop at 1026-
 7/19, "4AY" jingle, back into Pop mx. (PM-Or)
- 945 NEW ZEALAND, Gisborne-2ZG, hrd // 927, 1008,etc w/Pop mx at 1018,
 on 7/19, weak. (PM-Or)
- 954 AUSTRALIA, Sydney-2UE, hrd w/ancr giving call, sounded like tele-
 talk, unneeded so moved on, at 1027-7/18, also hrd on 19th. (PM-Or)
- 963 NEW ZEALAND, Christchurch-3YC-hrd w/Clas. mx // 882 at 0734-7/19(PM)
- 990 HAWAII, Honolulu-KHWH-hrd w/temp. and News R. 990 unid clas. station
 u/o 1025 7/4. KKIS off. (SPM-PR)
- 1008 NEW ZEALAND/AUSTRALIA, presumed 410 mixing w/12D at 1116 on 7/19,
 both w/rr mx, fast paced ann, under 12D. (PM-Or)
- 1017 AUSTRALIA, Sydney-2KY-7/5 1207 fair w/racing results, bound to be
 this one, good at times (NHP-BC)
 *Also fair to poor w/quick 2KY ID by OM ancr at 1012 7/4,was pleased
 to get this one, only s/3 on meter,Tonga off (SPM-PR)
 TONGA, Nuku Alofa-A3Z-w/Beautiful Island mx,OM in Tonganese,0907
 6/27, KTNO-1020 slop as usual (SPM-PR)
 *Also noted, good w/usual island vocals 0852-7/5 (BP-BC)
- 1026 AUSTRALIA, MacKay-4NK 1112 to past 1125 w/EZL rr "Laughter in the
 Rain",etc., fair 7/1,another DU station mixing,never surfaced.(DM-Ab)
 (Either 3DB or the two NZers.PM)
 *Also noted 7/5 1206,4MK fair w/Macquarie nx "This is 4BH",ID which
 prompted me to check 882,which was also in. (NHP-BC)
 *Also noted 4MK,ad for Waterbed store, 1107-7/5,rr mx,Good/Fair (BP-BC)
 UNID, on 7/8/82-1150 UTC, fair sig. w/DU ancr,commercial. (JJR-Wa)
 UNID, here w/C&W folk song,fair 1014 7/4,not sure if 4NK or 1ZK/N
 hrd. Pops (SPM-PR) (Could be either. PM)
- 1035 NEW ZEALAND, Wellington-2ZB,mx "Tonight" telephone pgm "Fools Rush
 In" song, promo skiing near Queenstown,etc, 1127-6/28,29,30,7/1 (DM)
 *Also noted 2ZB w/exc. signals, on 6/27,7/4, noted w/UNID station
 underneath, SIBC? (SPM-PR) (Prob. SIBC. PM)
 *Also noted 2ZB good w/teletalk and concert promo 1129 7/5,weak
 anther in background, prob. SIBC (BP-BC)
 SOLOMON ISLANDS, Honaira-Talk in vernacular, into EE 1110 7/5,then
 C&W song good,but later QRMd by NZ(BP-BC)
 *Also noted 7/5 1107 w/C&W mx,man slipping from EE to Island lingo
 and back again (NHP-BC)
- *Also noted at 0650 on 7/19, w/OM in EE, old pops and C&W mx. (PM-Or)
- 1040 HAWAII, Honolulu-KPOI, usual good/exc. sig. MOR mx,wx,6/27,7/4 (SPM)
- 1044 NEW ZEALAND, Dunedin-4ZB noted fair/poor // 1035,better at 1020 on
 7/4,noted fair other times, hear UNID under 4ZB, who?(SPM-PR) (Poss.
 an Aussie.PM)
 *Also noted at 1150 on 7/8,fair (JJR-Wa)
 * Also hrd faintly w "I've Never Been to Me" song,6/30 (DM-Ab)
- 1053 NEW ZEALAND,New Plymouth-2ZP, good w/slight 1050 slop // 1035 w/
 Tonight Show at 0916-7/19. (PM-Or)

- 1062 UNID, DU here at 0948-7/19, w/OM speaking, suspect 4TI or 2AP. (PM-Or)
- 1071 UNID, DU here at 0951-7/19, w/Pop mx briefly, suspect 3CV. (PM-Or)
- 1080 HAWAII, Honolulu-KIOE-caught mighty 10-80 ID and Number for Oahu and other islands at 1033-7/4, way on top of KWJJ w/talk show, enjoyed this one! Noted even after moved bev. to 310 degrees. (SPM-PR)
- 1098 MARSHALL ISLANDS, Marjoe-hrd w/Pop mx (American w/KFAX slop at 0957 on 7/19, fair o/UNID. (PM-Or)
- 1107 AUSTRALIA, Sydney-2UW good w/rr "Better music 2UW" ID, string of ads, 1248-7/5. (BP-BC)
- 1116 *Also noted at 1154 on 7/18, w "Better Music" ID, into Pops. (PM-Or)
AUSTRALIA, Brisbane-4BC on 7/5-1304, fair w/forecast for Brisbane metro area by OM. (NHP-BC)
- *Noted w/ jingle and rr mx at 1023-7/18. (PM-Or)
UNID, tele-talk noted in passing 1232 7/5- Prob. 4BC. (BP-BC)
UNID, DU here w/MOR mx fair at 1231-6/27, 4BC? (SPM-PR) (Poss. Brisbane or NZ. PM)
- 1125 t VANUATU, suspect this here at 0955 on 7/16, w/Native Children singing, and OM in language, vy weak, 1120/1130 slop. (PM-Or)
- 1130 HAWAII, Kailua-KLEI, w/MOR mx and s/off anmt. w/details "Windward K-LET" slogan during s/off 1000-7/4, list time heard at Pt. Reyes. (SPM)
- 1134 UNID's, here, one EZL mx, other pops at 0856-7/18, suspect NZ/Aust. (PM)
- 1143 NEW ZEALAND, Hamilton-1YW hrd w/MOR and brief ann, sounded like National Pgm, as usual at 0858-7/17. (PM-Or)
- 1152 NEW ZEALAND/AUSTRALIA, 3ZC/2WG, mixing here at 0903 on 7/17, 3ZC w/Tonight Show // 1008 and 2WG w/pop mx, ads, good. (PM-Or)
- 1161 NEW ZEALAND, Wellington-2ZM, fair w/"ZM" ID at 1100-7/19 (PM-Or)
I believe this one is supposed to move to FM (PM)
UNID, carrier hetting KSL at 1231-6/27 (SPM-PR)
- 1179 AUSTRALIA, Melbourne-3KZ fair/good signal noted w/several spots, Inc. Restaurant, 1232-6/27, 1180 het. (SPM-PR)
- *Also noted w/rr mx, ads at 1151 on 7/17 "3KZ" jingle (PM-Or)
- 1188 t AUSTRALIA, Inverell, 2NZ, EF talk, pop mx 1244 7/5, almost equal w/KEK at times!!! No ID, but this is only thing most likely hrd. (BP-BC)
*Also noted 7/5-1034, fair w/pop mx and ment. of Macquarrie mx (NHP-BC)
*Also noted 7/16 at 1000, after Wallis Is s/off, all alone w/pop mx (PM)
WALLIS ISLANDS, Uvea-FR3, heard once again, but best this time, w/ Native songs to 0957, then YL ancr, giving s/off info, ment. Wallis, France Regions 3, etc, s/off with FF National Anthem at 0959, carrier off at 1000. Taped and reported again. (PM-Or)
- 1197 NEW ZEALAND, Wanganui-2ZW, hrd well w/Tonight show // 1008 at 1008 7/19, Unid underneath, poss. 4GG or 5KA. (PM-Or)
AUSTRALIA, Adelaide-5KA-7/5, 1238 fair to nil w/MOR mx, time check and SKA ID, a real catch as stronger S Australians on 891 and 639 were not hrd, tho been logged before. (NHP-BC) (Good catch, PM)
*Also noted 5KA w/rr mx, 11 past 10 TC at 1241 7/5. (BP-BC) (Good catch)
AUSTRALIA, Grafton-2GF, 1136 w/car dealer ad, OM ancr, poor 7/1 (DM-Ab)
*Also noted 2GF 7/5-1234, fair w/12 oh 6, 2GF ID, rr mx (NHP-BC)
*Also noted w/ 12 oh 6" ID, o/4XO w/pops at 1145-7/18 (PM-Or)
*Also hrd with great signal w/C&W mx, ID 1200-1210, 7/4 (SPM-PR)
- 1206 t NEW ZEALAND, Dunedin-4XO Radio Otago, the pop rr station u/2GF, fair occ. 2GF fades 1205-7/4 (SPM-PR)
- 1215 NEW ZEALAND, Kaikohe-1ZF, good and // 1026 w/Pop mx at 1133-7/18 (PM)
- 1224 UNID, Telephone talk station at 1147 on 7/17, o/u unid MOR station, Talk station prob. 2WS, followed by AFRS-Marshall Is. (PM-Or)
- 1233 AUSTRALIA, Newcastle-2NC 7/5-1237, poor w/Jazz //702 (NHP-BC)
- 1251 WESTERN SAMOA, hrd // 1404 at 0930-7/19 w/Native Lingo. (PM-Or)
UNID het here all night 7/4, 6/27 (SPM-PR)
- 1314 AUSTRALIA, Wollongong-2Wlr mx 1251-7/5 "Position 13, 2WL" ID, into mx fair w/domestic splat (BP-BC)
- 1332 UNID, het on 1330 1020-6/27 (SPM-PR)
NEW ZEALAND, Auckland-1XI, Radio I ID at 1209-7/19, KUPL slop. (PM-Or)
AUSTRALIA, Bunderburg-4BU rr/pop mx 7/5 1253 almost equal KUPL at one point, fair in splat 1259 w/ s/off ann, announce 5:30 s/on, then anthem and off (BP-BC) (They are directional this way, per verie. PM)
- 1350 HAWAII, Lihue-KIVM, noted on top of other 1350's w/rr mx, noted s/off at 1100-7/4. Does this station sound muffled to you? (SPM-PR)
(Listened to them last October 31st, and were distorted then, PM)
- 1386 AUSTRALIA, Sydney-2EA -hrd w/East Eur. language pgm at 1031-7/18, o/unids. (PM-Or)

- 1386 UNID, YL in DU EE weak 1011 7/5, then light inst. mx Who?(BP-BC)
(Sounds vry much like 5AA, especially since you hrd 5KA, and 5AA
is EZL w/night time YL ancr. PH)
- 1404 WESTFRN SAMOA, Apia-2AP vry good w/OM in Samoan and Native mx, at
0949-7/19, checked // 1251 and looked for 1062. (PM-Or)
- 1413 AUSTRALIA, Newcastle-2RO, hrd w/rr mx and "2KO" ID, into Rod
Stewart song at 1140 on 7/18. (PM-Or)
- 1431 UNID, Sounded like bits of ABC news at 1100-7/18, in slop, 2WN? (PM)
- 1458 UNID, carrier hetting 1460-1021, 6/27 (SPM-FR)
- 1467 FIJI, Radio Fiji here w/Island mx at 0745-7/19. (PM-Or)
- 1475 UNID, het on 1476 good signal female ancr w/Pop mx of some sort,
Western Style, prob. Sabah. (JJR-Wa)
- 1476 UNID'S, several stations mixing, prob. DU's, mess 1020-6/27 (SPM-FR)
NEW ZEALAND, Auckland-1XA-presumed w/Bob Dylan song 1036, hetting other
AM's-6/29 (DM-Ab)
- 1485 UNID'S, two or three vry weak DU's here most of the AM on 6/18 and 19,
several poss. (PM-Or)
- 1503 UNID, Loud het on KJRX-1500, poor audio 1244-6/27, NZ? (SPM-FR)
(NZ or 3AK, which is EZL. PM)
- 1512 AUSTRALIA, Newcastle-2NA-w/Clas. mx //729, etc. 1245-6/27 (SPM-FR)
*Also noted at 0835, nil to fair w/YL and OM talking //9680 (NHP-BC)
*Also noted OM and YL talking // 9680-0845-7/5 (BP-BC)
- 1539 UNID, weak het on KJZZ no hope of audio 1302-7/5 (BP-BC) (NZ? PM)
- 1548 AUSTRALIA, Emerald-4QD-Nice signal better than 1550-1240-6/27 (SPM)
*Also noted good w/Sports //4920 0840-7/5, 1st time hrd since moved
from 1550, KVAN/KKHT off, leaving 1550 quiet. (BP-BC)
- 1557 t AUSTRALIA, Taree-2RE strong/nil rr mx 0825-7/5, rx 0830, begin w/
morse code "C-Q", more rr, finally hrd 2RE SID during C&W pgm-1047 (BP-BC)
- 1557 NEW ZEALAND/AUSTRALIA-2ZH/2RE both here 2ZH w/Tonite Show, 2RE w/
MOR all AM of 7/19. (PM-Or)
- 1566 AUSTRALIA, Wangaratta-3NE- fair 6/27, 7/4 past 1200 w/C&W mx (SPM-FR)
*Also noted well w/C&W music at 1217 on 7/19. (PM-Or)
- 1575 AUSTRALIA, Wollongong-200, 2-Double O, hrd well w/rr mx all AM 7/18,
19th. (PM-Or)
- 1615 *Also hrd 2 Double O noted a play, by OM & YL ancrs-1239-6/27 (SPM)
NEW ZEALAND, Ohura-"OR" beacon fair ID over and over, 0825-7/5 (NHP-BC)
*Also noted 1122, fair, 7/5 (BP-BC)
*Also noted fair to good CW ID 1238-6/27 (SPM-FR)
*Also hrd with OR in CW ID, 1054-6/29, 1012-7/1 (DM-Ab)
- UNID, "N-Z" Distinct NZ noted way under OR, same time marker as OR-
1238-6/27. Nice lullaby to mark .ZZZZZZZZ.hi. (SPM-FR)
- 1620 UNID, station playing EZL mx 1046 7/1, Other AM's often had a het
here, but this time for audio, no anmts, signal too steady for DU (DM-Ab)
- 1685 UNID, "M-H" in code blasting in 1137 7/5 (BP-BC)

Well there it is for another column. I think I got everything. Sorry if I missed anyone's catches. I have papers all over the table, as I had my paste-up all ready done when I received a couple more reports. Now to the list of helpers this time.....

- CG-Texas Charles George-6407 Howard-Dallas, Texas 75227
- SPM-FR Steve McGreevy-45 Elda Drive-San Rafael, Ca. 94903
DXing at Point Reyes, Ca w/DX 200(modified)-1000' bev. 250 degrees
- DM-Ab Don Noman-6815-12 Ave.-Edmonton, Alberta, Canada T6K 3J6
DXing Cardinal Divide, 80 km s of Hilton, Ab of 6/27
DXing Blackstone River, 16 miles NW of Nordegg, Ab.-6/28
with Drake R-7, FRG-7700m, SWH Preselector, 850' beverage, 150' LW
- NHP-BC Nick Hall-Patch-DXing at Jordan River, B.C., 300 meter Bev, 470 ohm
resistor at 240 m in wire, at 270 degree bev, homebrew rx, preselector
- BP-BC Bruce Portzer-DXing at Jordan River, B.C, w/FRG-7 w/mech. filter
2,000 ft. E-W Bev.
- JJR-Wa John Reh-510 Mt. Defiance-Issaquah, Wa. 98027
R-1000, MFJ Ant. tuner, 250' wire ant.
- BPS-CA Bryan P. Sharpe-3737 East Castro Valley Blvd.-Castro Valley, CA. 94546
DX-302, w/without 1020 MFJ tuner, 2 1/2-7 feet of wire
- PM-Or Yer Editor-
E.H. Scott (RBO-2) with 600 ft. LW, running NE, Ground system
SP-600 JX (Hammarlund) with same wire and Ground, ant. tuner (homebrew)

Jim G. H. Robinson
109 Spadina Road
Toronto, Ontario,
Canada M5R 2T1

I'm wondering whether your organization or any of its members would be interested in some radio and electronics magazines collected by my father, going back as far as 1932.

I suspect the articles and advertisements of 30, 40 and 50 years ago might be of historic or nostalgic value to someone in the field.

I have the following magazines:

QST - Various issues of 1932, 1934, 1935, 1937, 1938, 1939, 1942, 1943, 1945 and 1947;
Radio News - Various issues of 1938, 1943, 1944, 1945, 1946, 1947 and 1948;
Radio and Television News (formerly Radio News) - Various issues of 1948, 1949, 1950 and 1951;
Radio and TV News (formerly Radio and Television News) - Various issues of 1957 and 1959;
Electronics World (formerly Radio and TV News) - November, 1960 issue;
Radio Craft - Various issues of 1943, 1944, 1946, 1947 and 1948;
Radio-Electronics (formerly Radio Craft) - Various issues of 1948, 1949, 1950, 1951, 1955, 1959 and 1960;
Audio Engineering - Most issues of 1947 and 1948;
Electronics - Various issues of 1948, 1949, 1950 and 1951;
Tele-Tech - (formerly Electronic Industries) - July, 1950 issue, part 1 only;
Electronic Engineering - January, 1944 issue;
Electrical Engineering - January, 1940 issue;
Electronics and Communication - 1947 Annual;
Communications - February, 1949 issue;
Science Digest - July, 1950 issue

I have no idea what these magazines may be worth and therefore no preconceived selling prices. I'll simply let them go for the best offer, however high or low it is. I hope you'll pass the information along as I'm sure there's a collector out there somewhere and it would be a shame to throw the magazines away if someone would like them.

WNYC Rebuffed on Request To Increase Broadcast Power

Special to The New York Times

NY Times, 7/22/82, via Karl Zuk

WASHINGTON, July 21 — The Federal Communications Commission, in a case that has been pending since 1942, tentatively decided today to deny an application by WNYC-AM to move its transmitter to Staten Island and increase its broadcasting power to 50,000 watts.

If the commission makes the decision final, as most observers expect, it will be a considerable setback for the 52-year-old municipal station, which wanted the change so it could reach the entire metropolitan New York area.

At the same time, the ruling would be a victory for WCCO-AM in Minneapolis, which has been fighting WNYC since the 40's, alleging that the New York station already interfered with its nighttime clear-channel signal and would create major problems if the power were to be increased.

In its announcement today, the

F.C.C. said it had "instructed the staff to prepare for its further consideration a draft decision denying the application of the City of New York Municipal Broadcasting System to increase power of WNYC to 50 kw. to operate from 6 A.M. to 10 P.M. each day and to change its transmitter location."

Although technically the commission thus reserved the right to reverse itself before formally adopting the final order, veteran observers of the agency's actions said a change appeared unlikely.

Mutual Interference Problems

Both WCCO and WNYC occupy 830 on the AM dial, and for the last four decades have had mutual interference problems because of the extensive propagation characteristics of signals at night.

At its inception, WNYC was authorized

to operate with 1 kilowatt, or 1,000 watts, of power from sunrise to sunset, but in 1942 the station asked for the right to operate over longer hours and was granted authorization during World War II to stay on the air daily from 6 A.M. to 10 P.M.

Ever since, there has been a jockeying between WNYC and WCCO. WCCO also asked to change the site of its transmitting equipment, a move that has been opposed by some airlines, which say the action would create a hazard to air navigation. The F.C.C. today tentatively decided to deny WCCO's move, too.

The F.C.C. said that the instructions to its staff to draw up formal papers denying the applications were "subject to commission review and revision at a subsequent time when the F.C.C. will adopt its final decision in the case."

Yours truly

Jim Robinson

THE INTERNATIONAL RADIO CLUB OF AMERICA

A non-profit organization devoted to the hobby of listening to distant stations on the AM broadcast band (510 to 1630 kHz). IRCA is a member of ANARC, the Association of North American Radio Clubs.

OFFICERS: President--Don Kaskey, 465 Burnett, Apt. 1, San Francisco, CA 94131. Secretary--Rich Segelas, Board of Directors--Phil Bythway, Nick Hall-Patch, Ernie Cooper, Jef Jaisun, Bruce Portzer, Niel Wolfish.

MEMBERSHIP DUES: \$16.50 First Class to the U.S.A., Canada, and Mexico. \$20.00 Air Mail to the rest of the world via Canada. Air mail direct from the U.S. \$25.00 to Central America, Caribbean, Colombia, and Venezuela \$30.00 to the rest of the world. Sample copies cost 50¢ each or three International Reply Coupons. Make checks and money orders payable to I.R.C.A. Persons living outside the U.S. should send checks or money orders payable in U.S. funds. DUES AND ADDRESS CHANGES should be sent to Rich Segelas, P.O. Box 26254, San Francisco, CA 94126.

DX MONITOR, the official bulletin of the IRCA, is published 3 1/2 times a year: weekly from October to March, twice in September and April, and monthly from May to August.

PUBLISHING STAFF: Bruce Portzer (editor-in-chief), phone(206)-522-2521, Evelyn Portzer, Nick Hall-Patch, Jef Jaisun, and Phil Bythway.

THE IRCA GOODIE FACTORY. The IRCA Almanac, Foreign Logs, reprints, and other materials are available for nominal charges. For a complete list, write to P.O. Box 17088, Seattle, WA 98107.

Unless otherwise noted, permission is granted to publish, broadcast, or otherwise reproduce non-copyrighted material appearing in DX Monitor, provided credit is given to IRCA and the original contributor.

Opinions expressed in DX Monitor are those of the contributors and do not necessarily reflect those of the IRCA, its publishing staff, editors, or officers.

DX Monitor is printed by Save-on Printing, Seattle, WA.

IRCA

P.O. BOX 21074

SEATTLE, WA 98111

U.S.A.

First Class

FIRST CLASS MAIL
U.S. POSTAGE
PAID
Seattle, WA
Permit No. 601

D. A. NYHOLM

2071 CEDAR STREET
SAN CARLOS CA

94070

19