



Foreign ✓

DX Monitor

Devoted Exclusively to
Broadcast Band DXing

March 30, 1965

Vol. XXII, No. XXVII

Issue Number ??

28

In This Issue

Arts & Entertainment Section	2	Eastern DX Roundup	14
Eastern DX Forum	3	Western DX Roundup	15
Summary of Unreported Stations ...	4	The Royal Reporter	19
Western DX Forum	5	Discovery Explains AM Overkill ..	19
The Semitruth About Semiconductors	8	Miscellaneous Weirdness	19
The Mitchell Lee Loop Amplifier ..	9	DX Worldwide East	20
Central DX Roundup	10	The Akutagawa Radio Cassette	21
Antarctic DX Roundup	11	Slogan List Announcement	21
Details of Proposed IRCA Buyout		DX Worldwide West	22
of CBS Broadcasting	12	Kanuck Kaperns	23

Flash Tips

We have several interesting flash tips to open this week's DX Monitor, including the following:

KCTA-1030 - Corpus Christi, TX, will TEST April 15 0500-0600 EST using 50kw nondirectional power, tones, music, and IDs. Their phone (no collect calls) is 512-643-3541. Reports can be sent to Tim Walker, Director of Engineering, Box 898, Corpus Christi, TX 78403. Arranged by George Santulli.

From Rod O'Conner comes word that KGHX-1300 in Fairbanks, AK is now off the air. They left the air in early March, pending sale to new owners. Rod also says KCSY-1140 in Soldotna, AK is now testing, prior to beginning regular broadcasting. From the Modesto Bee, via Mike Hardester, comes the news of KTRB-860 receiving the okay to raise power to 50 kw. They hope to be using this power by late summer, once a fifth tower is erected at their xr site.

NEW COLUMNS

Odds and Ends

The IRCA publishing committee is pleased to announce that several new columns will soon appear in the pages of DX Monitor. While final details have yet to be worked out, we are planning to break the DX Roundup columns down into regions and subregions. This way you won't have to wade through loggings from people hundreds of miles away when looking for DX tips. So far, we plan to add the following columns: Northeast Northeast DX Roundup (covering most of New England), North Central North East DX Roundup (covering most of New York), South Central North East DX Roundup (covering Pennsylvania and New Jersey), South Bronx DX Roundup (covering Brooklyn and Manhattan), and Southeast Northeast DX Roundup (covering West Virginia and Ohio). Meanwhile, DXers in Texas will report to the Eastern Southwest DX Roundup, while those in Arizona will report to the west Central Southwest DX Roundup. DXers in New Mexico will report to the East Central Southwest DX Roundup. DX ers in Los Angeles will report to the Central Western Southwest DX Roundup, those in San Diego will report to the Southwestern Southwest DX Roundup, and those in Central California will report to the Northwest Western Southwest DX Roundup. The divisions for the rest of the U.S. and Canada are still being worked out. We are also trying to work out a system for DX Worldwide based on location of the station and the DXer. For example, reception of Far East stations in WA, OR, & BC would go to DX Northwest East Asia, while reception of Arab stations in New England would be reported in DX Northeast Mid-east. However, this plan needs more work, since some areas are rarely heard in some parts of the U.S. and Canada. This would result in some equally rare columns, such as DX Great Lakes Western Australia.

NRC REPORTS IRCA DEMISE

The National Radio Club, in their latest issue of DX News, has announced, for the third year in a row, that the IRCA has folded. Don't worry, we're still around. It's only their annual April Fool's Gag. According to NRC publisher Mike Knitter, "I don't think we told it quite right the first two times because people didn't think it was very funny. But this year I think we have a better punch line. If not, we'll try again next year". Good luck, Mike.

I WAS A TEENAGE DX ADDICT

**THE SHOCKING STORY
NOW TOLD FOR
THE FIRST TIME!!**

**STATIC!! QRM!!
TRANSATLANTICS!!
HETRODYNES!! FADING!!
CUBAN RELOJ STATIONS EVERYWHERE!!**

**THE WHOLE GRUESOME
STORY OF A CHILDHOOD
WASTED ON THE
MEDIUMWAVES!!**

"This movie is sick"—National Inquirer

"Barfo"—New York Times "So-so"—NRC DX News

"Scared me to death!"—Truman Capote "DX Bondage"—Penthouse

"Excellent! Well-directed, intriguing, & informative"—IRCA DX Monitor

*"The Radio Bosphuawandaland sequence
is worth the price of admission alone"—Karl Zuk*

"I liked the Trans-Monongahela receptions"—Jim Hall

DON'T MISS IT!!

**DIRECTED BY GARDNER SMITH
PRODUCED BY PORTZER BROTHERS-BEVERIDGE STUDIOS
IN PAN-AMERICANVISION AND AM STEREO**

**NOW PLAYING AT ALL K-B WOBEGONE THEATRES
—IN THE DALES—
CHIPPENDALE—AIREDALE—MONDALE—CLYDESDALE
AND ALL THE OTHER DALES**

EASTERN DX FORUM

RICHARD EVANS
P.O. Box 1294
NORTH WALES, PA 19454

Deadlines: 3/30 4/13 5/4 6/1 6/29 7/27
This is the last of the weekly columns!

Rob Gerardi, 1421 North Franklin, #7 Benton, Illinois 62812
This time of year marks the anniversary of three important events in my life: My birthday, starting in the hobby, and of course IRCA's anniversary. I list them in that manner, because if not for the first two, I wouldn't be able to say (for the third) HAPPY ANNIVERSARY to all from the northern fringe of the Southern Illinois Ozarks. I'd like to thank all the editors, contributors, and members who have made this a great club for the past 21 years and especially for the last 10 (since I've been a member). As for the re-intro, I'm now 33, presently single, and employed by the County Sheriff's (police) Department. Started DX'ing in 1967 with an RCA tube/clock radio (made in 1948). Since then I've DX'ed from Southeast Asia, West Germany, Alaska, and Canada as well as several US states. In that time, I've been fortunate enough to log all fifty states, 10 provinces, and 35 countries. I also DX the Ham bands, a little FM, and some SWBC, but MW BCB is my favorite. If it wasn't for IRCA, I sure wouldn't be able to keep up with the ever changing domestic DX scene. So, I'm glad and proud to be a member. Got my first QSL of the year, WZAL. What a QSL tool! A nice certificate, CM, program guide, and form letter from Mr. DeVan. (Let's see if we can get this guy in our club!) Kermit Geary, thanks for your efforts in arranging this test! I wasn't too sure I logged them, when WZAL was using only 4 watts...I heard a sweep tone but only VERY faint audio. I sent a tape of that and the 2.5 kw (several ID's heard then), and they must have been able to ID what audio I had recorded because they verified my reception of that part of the test. 73.

Ernest Cooper, 5 Anthony Street, Provincetown, Massachusetts 02657
617-467-9337. A few veries have been trickling in, like W⁷AL-1540 (a beautiful certificate of verification), a hand-written v/l from WGHW-1110 (ex-WNAR), w/CM, WOZW-710, W⁷YT-1270, a very attractive v/q, and some nice ones from the band where 70% of the population listens. Some comments on questions, etc. in recent Monitors. Gardner Smith, I think it had to be someone other than CBJ-1580 with Vivaldi at 0200; this was a weekday when they begin their AN TT at 0105 or thereabouts. Rich Segalas: it's good to see the lists of new members and addresses in DX Monitor - the "other club" doesn't mention new members any more. Bill Harms: WSSV is on 1240 and in Petersburg, Va., not 1340 and Richmond. Tim Noonan: Your 840 station is WBHY-840, Mobile, Ala. Jim Hall: Jamaican stations are all FE, no SS. To Pat Martin: How much money is "500K"? ((Five Hundred thousand dollars, isn't it? I usually see "K" as a symbol for thousand, although in transportation "M" represents thousand--rce) To Ernest Cooper (who?): WNVN-1380 Naugatuck, Conn. has gone dark; looks as though they were the slightly off-frequency 1380-er. Gardner Smith: I think your cl mx on 710 was YVKA, R. Capital, Caracas, and not a Canadian. Robert Ross: I believe WAKY-790 is still T-40 RR, not c/w. Locally, WVLC-1170 is again gone; they're now WKPE, and all they are is a relay of their AdCon FM of the same call, a real waste of one of the two AM channels on Cape Code. Boston's WHUF-1150 has been off AN for the last several days; they were off all day today 3/5, leaving a solid signal from CHSJ all day, with a little of (assumed WQMR) in back - coulda been WCNX, though, wich took over at 1730, till their 1800 s/off, then CHSJ again till a nearby TV killed everything. The DX Tests from WQJQ-1590 and WZAL-1540 made it here, the latter only the TT periods, u/WPTR. A special test by WVFR-850 also made it here on FM 2/18, they've since changed calls to WREF (radio Eight-Fifty). Nearby WKZU-1350-NH is now WMRS, oldies, ex-c/w. Oh yes, Stan Morss, NRC, tells me the new calls for WHUE-1150 will be WMEX. Older DXers will remember WMEX, Boston, on 1510, now WMRE. Twilight DX of late has netted me things like WSEN-1050 NY u/WHN, WPGR-1540-PA u/WPTR; WSKE-PA and WJTB-OH, both 1040. Heard, but not enough yet for a report, have been WRIT-CT and WVSG-NY, both 1170, on 15 minutes after the s/off of local WKPE (1745-1800 in March). Forward - March!

S. D. Warren, Rt. 2, Box 285, Nettleton, Mississippi 38858
Happy 21st anniversary, IRCA. For a re-intro, I'm 37, single, and work at Southern Belle Foods, Inc. in Tupelo, Miss. I have been a member of

IRCA since December, 1983, but an active DXer since the late 50's on BC and TV and the 60's with FM and SW. Although I have always TV-FM DX during the summer and have done my share of country chasing on SW, BC DXing was my main interest for about 20 years. Mississippi was once a good place to hear stations from most of NA, CA, and northern SA and occasionally as far away as New Zealand and DU. DXing on MM with many frequencies open to most areas of the US and Canada allowed me to hear 45 states and 9 provinces by 1973. Although there were some NSP stations these were located throughout the US and Canada and some other countries such as Colombia. Even many NSPers would sometimes leave the air on MM leaving the channel open to DX. Today the dial is so cluttered by stations from a few hundred miles away that MM DXing is practically a waste of time. MM sleeping is now more worthwhile. Powerful Cubans and Mexicans QRM many channels so even if a "clear channel" station is off for its annual SP, there is no worthwhile "DX" audible. The clear channel breakdown is mainly responsible for my 40 new stations (not including call changes) in 1984. I heard Senegal on 765 and Grenada on 535 which brings my total of foreign countries to 32. In early '85, I have heard two stations from Minnesota, WKKQ-650 and WQPM-1300 ET as well as stations in the southeast for a total of 7. My main equipment for BC and SW DXing is an NRD-515 rx with a Radio West loop and a Gilfer Eavesdropper antenna. A 100' TV-FM tower is a big help for tuning tropics and skip in the summer and fall. I also own a Satellite receiver, a Sony ICF-6700W, two cassette decks and a video recorder, which I sometimes tape TV-DX on. While BC DXing has really deteriorated since I started DXing, I enjoy being in the IRCA very much and feel that it is more vital today than ever to be a member of a fine club such as this because we need all the help we can get to hear anything new. 73 and good DX.

Jim Hall, 290 Byron Road, Pittsburgh, Pennsylvania 15237

Nothing makes me angrier than having to fix downed antennas. This time, about 900 feet down the line, high winds and falling trees ripped up a few hundred feet on my bev. Had no choice to fix it in driving rain as conditions were pretty good and I had some time to DX. It's not very fun sloshing around a steep slope on a moonless night in the mud looking for snapped wires. All was not lost as some good LA stuff was heard that night. Larry Black, thanks for the confirmation on CKAP-580. Guess I'll send for a verie. With the addition of Pay TV to my home came intense QRN when the downstairs TV set's on. I know why though and it's my fault. Don't tell anyone, but I ran a cable to my room for remote viewing and the QRN came with it, no charge. I've already worked around it though. Robert Kramer, hope you received my package.

SUMMARY OF UNREPORTED STATIONS

Through Volume 22 #23 dated February 23, 1985

compiled by Don Kaskey, 465 Burnett St. #1, San Francisco CA 94131

The following chart lists the total number of stations in the USA and CANADA and the volume they were last reported as being heard in DX MONITOR.

<u>COUNTRY</u>	<u>V22</u>	<u>V21</u>	<u>V20</u>	<u>V19</u>	<u>V18</u>	<u>V17</u>	<u>V16</u>	<u>V15</u>	<u>V14</u>	<u>V13</u>	<u>V12</u>	<u>Prior</u>	<u>Total</u>
CANADA	195	69	25	26	20	12	13	5	6	0	2	46	== 419
U.S.A.	1732	876	583	374	328	160	184	77	53	29	48	299	==4743
TOTAL	1927	945	608	400	348	172	197	82	59	29	50	345	==5162

New stations reported as having taken the air during the period between V22 #21 through #23:

590--WAFB-FL	1280--WAQB-IN
910--WKBEQ-KY	1330--WMJT-TN
1000--WXWY-AL	1520--WLGC-KY
1030--WMIN-MN (x-1010)	

Previously unreported stations noted by IRCA reporters in DX MONITOR since the last update (V22 #23).....Covers V22 #21 through #23:

KY--10--WKEQ--910 (Jeter-GA)
MN---4--WMIN-1030 (Sherman-MN)
OK---7--KKGC-1320 (Wilkins-GO)
WV---7--WHAW--980 (Ritchey-PA); WVVW-1570 (Hall-PA)

OFF THE AIR STATIONS: 4 more stations have been reported as being off the air: 600-CFCT-NWT, 910-KOYN-MT, 790-KXTC-GA, 1510-KKZU-WA...Makes 42 now.



Western DX Forum

★ ★ ★ ★

IRCA—Serving the Broadcast Band DX'er Since 1964

Editor: Ric Heald, 1632 J St., #3, Eureka, CA 95501

1985 DEADLINES: 02 & 16 APRIL, 07 MAY, 04 JUNE, 02 JULY

(Anniversary Issue - Part II. The Postal Service took their own sweet time with the following forums - in one case, eight days!-RtH)

JIM HILLIKER, 1502 E. HEDGEWOOD, ANAHEIM, CA 92805 (714) 991-3839

Hello everyone and Happy Anniversary IRCA! The 20th was a great one, so I hope the 21st will be just as good. I've been here for the last three, have been a member since September 1982. For the traditional re-intro: I'm 29 (will turn 30 July 23). (Oh God, another Cancer, hi. I'm 6 days ahead of you, Jim-RtH.) I'm from Wisconsin, but have lived in southern California since I was two. I graduated from Cal State Fullerton in 1979 with a BA in Telecommunications, concentrating on radio-TV broadcasting. I worked at KNOB-FM Long Beach and have been at KYMS-FM 106.3 since July 1979. Currently, I'm the afternoon newscaster and new director and have a DJ shift Saturday morning. We're the #1 station in Orange County (September 20 to December 20, 1984) out of nine stations in the market. We were mentioned in the March 11 issue of Time magazine in an article on contemporary Christian music, which is our format.

Back to me now, hi. I'm basically a domestic DX'er, but do some foreign DX when the mood strikes me and conditions are right. I was into SW for most of the '70s. I'm also a member of NRC. My current totals are 525 heard, 586 if you count call changes. I have 168 paper veries with over 300 on tape. I've logged 34 states (31 veried), five provinces (all veried), and seven countries (none veried). I also enjoy collecting promo items like coverage maps, stickers, t-shirts, pens, etc. I'm also very much interested in the study of the history of BCB stations and DX'ing.

My other interests are music (favorite format is oldies), movies, TV trivia and Trivial Pursuit, baseball and California history and geography. I've been single, but as I announced recently, I'll be married this summer to Laura Pederson. She met a few DX'ers at the '83 IRCA convention, so she knows what she's getting into, hi.

I've found some time to DX. Oh yes, I use the modified Kenwood R-1000 with the Radio West ferrite loop. I've added seven new stations, three with KLAC off MM 04 February. They were in WDXR. (Cont. next issue. And Jim, 23 July makes you a Leo, not Cancer. . .RtH is spacing out, hi-RtH.)

PAUL SWEARINGEN, 7310 ENSIGN AVE., SUN VALLEY, CA 91352 (818) 765-7651

Greetings to all IRCA members. I felt that having been an IRCA member for a number of years it might (at last) be appropriate to join in with the rest of the gang in the anniversary issue, having contributed only one other itme to DXM in the past. I'm 39, single (divorced) and currently employed as an electronics salesman at Montgomery Ward in Panorama City. I'm also free-lancing in media-related products, both writing and recording. I've been a BCB DX'er since about 1955, starting on a five-tuber and graduating just a few years ago to a Hammarlund HQ-180. My portables include a Sharp FV-610, Radio Shack 12-655 and 656, Sony ICF-S5W, GE Superadio and assorted other shelf-fillers. I pull in the DX with a Martens loop (which I also import and sell) and the infamous Twentynine Palms Beverage antennas. I've been editing Musings of the Members for NRC's DX News for a couple of years and Club Corner for Monitoring Times. I collect books (especially science fiction), records, cameras, maps and much etc. which gets thrown out periodically. In my spare time I eat and sleep, hi.

I use a Commodore 64 and am interested in trading programs; I'd also like to trade for airchecks from days gone by, especially from WLS Chicago and WHB Kansas City; what have you? My main DX interest is foreign DX and taking tapes of all ID's; I've never sent for a verie.

Just a comment for those who listened to the Ray Briem show. . .I've been amused by some of the comments from various DX'ers who have felt that the show should have included more commentary about. . .(fill in with SW, BCB, FM, or whatever you're interested in) instead of. . .(fill in with what you are NOT interested in). (One club even billed the show as THEIR club on network radio, as if it was produced by them.) Speaking as one who was in the studio when it was on the air - we were lucky that Greg Hardison and Ray

agreed to take one night to talk about DX'ing at all. The vast majority of the audience probably have never heard of the term "DX'ing" at all, and you have to remember that a five-hour program has to be couched in terms that any listener can understand. Let's not spoil it by over-analyzing the content of the show; let's just ready to listen and call in when it hits the airwaves next year (if it does). 73. (Thanks for the forum, Paul, but PLEASE, my poor bloodshot eyes, double space next time-RtH.)

DALE PARK, 2253 KANEALII AVE., HONOLULU, HI 96813-1345 (808) 523-1284

For some reason only one of my forums I sent last year was printed by Ric, so I guess I should send one now to let everyone know I can still write paragraphs, hi. (I sent them with the 1984 anniversary forum, remember Ric?) (I have trouble remembering yesterday, let alone last year, hi. But if I goof on that forum you can kick me in the okoli, hi-RtH.)

I can't DX much because I'm studying for my master's at the University of Hawaii here. (Also known as Vacation U, hi-RtH.) I graduated with a BS in math but I couldn't continue with my mediocre GPA. I'm thinking of switching to communications. (On the other hand, Richard Wood tells the story of a man who received a PhD in communications and became a professor in Massachusetts but was let go after only three years, and without tenure; he now lives below the poverty line somewhere in the USA. A scary story if you ask me.) (Below poverty line? Must work in radio, hi-RtH.) I spend a little time on MW DX since there's so much QRM here including more NSP stations. If I do DX, it's usually on location in places like Kailua Beach Park.

I more or less co-ordinate meetings for an informally-organized DX club here. The meetings are usually held the third Saturday of the month in the afternoon. If you're planning to come here and would like to meet the local DX'ers, give me a call nights. So far the most successful meeting was in February when NINE folks showed up to hear guest speaker, Dr. Richard E. Wood.

Before I go, I would like to congratulate IRCA for finally reaching the age of majority. Also, I'd like to thank the DX'ers I met last summer on the Mainland, Jim Hilliker (how's your golf game? hi), "Classic" Terry Klasek, Eric Buenemann and Roger Giannini. DX'ing is such a lonely hobby there should be more contact between radio enthusiasts. That's my thought for 1985. Ch'il-ship-sam and pal-ship-pal.

STEVE MITTMAN, 2248 W. 37th ST., SAN PEDRO, CA 90732 (213) 833-1010

Hi all. Didn't want to break tradition by missing the annual re-intro, so I figured I'd stick in my two cents worth. . .er, twenty-two cents worth, hi. Was born 09 March 1957 in Poughkeepsie, New York - a fitting place considering that's where they make all the comic books! When I was eight, we moved to SoCal - which I think is probably the greatest place in the entire world! (Ah ha! So you've never seen the REAL California, hi-RtH.) It's great being able to wear short sleeves year-round and not have to bundle up everytime you have to run outside for a minute. And if I want to go skiing, the snow is just two hours away. (Two hours? The UPI story on 18 March said it was right in your back yard. There were kids on surfboards sledding down the slopes of Verdugo Hills Golf Course, hi-RtH.) I do enjoy visiting the snow, but at the end of the day, it sure is great to be able to leave it behind. And plus, I live right on the coast, and it's great being able to go body surfing and skin diving the year-round. So you can take to freezing San Franciscos, and rainy Seattles and windy Chicagos and snowed-in New Yorks and dust-filled Oklahomas and hurricaned Miamis, blizzardy Fargos. . .and take my SoCal. . . even with all its faults.

I graduated from U.C. Irvine in 1979 with a BA in psychology and my current occupation is the Benefits Administrator for a major retail record, tape and video chain (stores in six western states). I handle the insurance and benefits (i.e., group medical, dental, worker's comp., disability, L.T.D., etc.) for approximately 2,000 employees. Besides DX'ing and skiing, other hobbies/interests include science fiction (I'm the V.P. of a social sic-fi club), space exploration and dolphin intelligence and communication. I'm also addicted to playing video/computer games and going to rock concerts. A new hobby I have is paying with my VCR.

I enjoy taping station ID's, network and cable logos, promos, jingles, and other bizzare things. (My favorite logo of all time is the old NBC peacock.) Back in the '60s, I used to make audio recordings of TV theme songs (I just recently learned that a young lady in my sic-fi club used to do the same thing. Now with my VCR I've been going back and re-taping all those great classics, such as F-Troop, The Invaders, Daktari, Green Acres, Hawaii 5-0, I spy, etc. (Classics? My you are young, VERY young, hi-RtH.)) (The reason for this bizzare behavior is because I was born where they make all the comic books!) 73 and remember, DX'ers do it in the dark, Trekkies do it at warp speed, psych majors do it with insight and KLZZ does it with Class.

CHARLES A. TAYLOR, NAVY CALIBRATION LABORATORY (NAVICALAB), NAS WHIDBEY ISLAND, OAK HARBOR, WA 98278

Greetings from the Pacific Northwest. I haven't written to WDXr since arriving on-island August 1984. Because it's re-intro time, I suppose I oughta. First of all, Happy Birthday to IRCA and congrats to all those who make it up and make it possible. As for me, I'm 38, an exiled Hosier (kicked me out of Indiana, what with all that static and noise coming out of my funny-looking radios), married to one Leonor Lasao, exiled Filipina (kicked her out of the Philippines for marrying a Hoosier, etc). We have four good little (??) young'uns, ages 11-15. Have been a BCB DX'er since 1960 and have DX'ed from Indianapolis, Philippines, Bermuda, Okinawa (Plus short-term from Great Lakes, Illinois; San Diego; Pontiac, Michigan; Evansville, Indiana; and Vietnam. Am also a tech-grade ham, call WD9INP (Indy's Notorious Pest). Main interest in BCB DX is foreign, although I'm mainly DX'ing Washington, British Columbia and Oregon (by choice and circumstance) from here. I'm a Navy vet ('66-'72), now an employee (metrology specialist GS-9) of Navy Calibration Laboratory Whidbey Island. Expect to be here no longer than 18 months more, then back overseas.

Other interests (more or less in order): Church-work, running (about 15 miles a day), foreign languages, electronics. Other BCB DX interests are county DX from Indiana and here (Washington). I tape nearly all DX and dub ID's onto permanent tapes. Mostly, I have one cut per station ID'ed. (Sometimes I have more than one cut per station, for a variety of reasons, but only count each station once.) Have a tape library on cassettes of my DX from Bermuda, Philippines, Okinawa and here.

Equipment: Receivers are 1) R-390A/URR (motorola manufacture), 2) Sony ICF 2001, 3) Drake SPR-4, 4) Panasonic Rv-2900/DR-9 (for sale, I don't need it.) Antennas: SM-2 and 95-foot longwire. Recorders are two Sony TCS-310 stereo Walkman (Best I've bought for the money). Right now I'm in the process of building a 30-inch ferrite antenna. Results so far are very good.

I've DX'ed on a mad menagerie of sets, from regenerative sets with O1A's to Ford and Delco car radios, to the Radio Shack TRF, National NC-200, RCA AR-88, HRO-500, R-390, R-390A, Heath GR-78; to Admiral, Arvin, Zenith, RCA four, five and six-tube AC/DC sets to a Hallicrafters S-40B. With all of this I've logged 1,453 stations from my QTH in Indianapolis, with 156 veries from 20 countries, 45 states and six provinces. Best veried from Indianapolis are: KFQD 730 Alaska, WJTO 730 Maine, KMGM 730 New Mexico, WHEB 750 New Hampshire, WCMC 1230 New Jersey (250 watts) and WDEL 1150 Delaware.

Have logged/taped 350 from Bermuda; 337 from Sorsogon, Philippines; 301 from Okinawa, and 141 from Oak Harbor, Washington, so far.

Aside from the preceding, some of my most memorable DX experiences are hearing the Brazilian GY'er on 1560 back in the mid-'60s, hearing AHD 780 Ramey AFB Puerto Rico (with 50 watts) signing on at 0400 EST on MM's during WBBM's SP; hearing Idaho state Conelrad testing on 640, also in the mid-'60s; and back when the GY's went silent on MM's. Thems were the days!

Also, I'm a retired bootlegger/pirate (last operation was in 1970 from Indianapolis).

In otherness, I'm also a member of NRC and of the Far East Radio Club (Japan). Also, a tech-grade ham. 73 de Charlie.

RIC HEALD, 1632 J ST., #3, EUREKA, CA 95501

You guys did it again. Typewriter's broke once again after the anniversary issue. The lever that advances to the next line is broke!

I just sent a verie from KRED to Bill Harms for a two-year-old report that went unanswered. I'd like to hear from those in broadcasting as to your station's policy about keeping logs and how long. Of course you all know we no longer have to keep logs (tech logs, yes), but of course we still do so we can properly bill our clients. At KRED, we don't write the time a spot ran, we just check it off, so in a report to us with exact time is worthless. The log, of course, is on 8x11 sheets by the hour and during slack time is broken only by a spot we have to run near :30, and is broken down into quarter hours during morning and afternoon drive when spot load is heaviest. I confirmed Bill's report as he had the spots correct, but I had no way of back-checking the logs. How do the rest of you guys in the "biz" do it? Of course if you were to report our FM, exact time is fine as the machine imprints exact time to the second when a spot is run; that's great for automation, but not live. Of course, add logs no longer necessary to no requirements for new, sports, public affairs, public service announcements, etc., etc., that Uncle Ronnie has put his signature to.

Have been twisting the dials after work and did note some hets toward Asia morning after morning with little audio except on the usual powerhouses. Did note KFI 640 with OC and TT on 20 March at 0215 PST with a good copy on Cuba under the OC. Wha's my JJ (at least it sounded like JJ) on 596? Finally bagged KHLO 850 (first time from Eureka), got my boss excited when I played him the tape. He worked at competitor KIPA and knows the KHLO owner.

Has KFAX 1100 new owners. They used to be a station that (to paraphrase

Willie Nelson), if you've got the money, honey, we've got the time. Not only have they gone legit religious, they even had a SSID at top of the hour and announcer asking for letters regarding the "new" sound on K-rAX. A bit of trivia, K-FAX was the FIRST station in the US with all news format (hence the calls), but was before its time and later went to block programming.

And Charlie, you jarred my memory regarding '60s DX conditions. Best GY catch from the Bay Area was WVON 1450 Cicero, Illinois. . .alone on 1450! Best regional was WRAN 1510 Dover, New Jersey. And it was common (almost boring, hi) to hear 1kw and 5kw regional stations s/on on MM from the East Coast. I can remember working three frequencies, 1460, 1470, 1480 at the top of the hour starting at 0200 PST and by time zones listen to the nation s/on, much in the same way you guys back east would work SSS and catch the daytimers signing off all the way to the West Coast. I believe 1580 was one prime frequency along with 1550.

Please note the deadlines as we go off season. Midwest, where are you? Best of DX to all. . .it's getting into prime DU/TP season. 73 de Rth. .

The Semitruth about Semiconductors

M. A. VINOR

Department of Semistry
Institute for Advanced Anti-Semics

At present the research in the field of semiconductors is so heavily bombarded by mathematical artillery and so full of red herrings of new concepts such as traps, defects, holes, vacancies and the like, that one can hardly see the semiconductor for the holes. Therefore, we think that it is high time to revive the fundamental concepts and primary axioms and thus relieve the weary inquisitive reader of going through heaps of senseless papers which would be completely useless five years from now, anyway.

The First Dogma of the Semiconductor Creed is:

**FOR ANYTHING WHATSOEVER ALWAYS
PUT THE BLAME ON THE ELECTRON** (its negative charge, its negative attitude to life, etc.)

Metals are exceptional in that they conduct electricity well. This is because they contain electrons on the loose and any bad influence, such as an electric field, pushes them to damnation.

Now, if you hang a piece of semiconductor (i.e. not exactly a non-metal) on a long piece of red tape in the middle of a conference hall, and if the people present argue hotly enough about it, then the sign of the current carriers in the semiconductor may be determined. This is known as the Hall Effect.

By applying the Hall Effect to many things it was found that some semiconductors had electrons as carriers, while others had positive carriers, which, evidently, could not be electrons since electrons are by definition always negative (see Dogma above).

The poor semiconductors were, therefore, divided into two classes:

- 1) Semiconductors of the n type (n = normal) in which the electrons misbehave as usual.
- 2) Semiconductors of p type (p = pervers) in which the electrons misbehave even more.

Now, solid state physicists could not assume the positive carriers to be some sort of positive electrons (positrons) because they have already been discovered by nuclear physicists and no original idea would be in-

volved. Therefore, after many sleepless nights of beer (alco-hole) sipping, a new and very, very original idea was found. The Positive Carriers are HOLES!

If an electron jumps out of its place and goes, probably full of doubtful intentions, to Conduction Alley—then everybody is so glad that its vacancy is named Positive Hole. If another electron fills the vacancy—then it is considered good form to say (especially if ladies are present): "The Hole went away." And so, if you pump a German full of Holes, you don't get a sieve but a piece of p type Germanium.

A piece of solid is also full of other queer irrelevancies such as phonons, excitons, traps, etc. Electrons are always in the habit of getting pushed about by photons and phonons and falling into traps. This causes some confusion since nice people do not say that an electron came out of a trap, but say instead: "A Hole fell into a trap." This should not cause any misunderstanding if the true facts are borne in mind and point only to personal shyness.

We should also mention the Taboo of Semiconductors. By the ingenious definition above, Holes have negative masses. This is to mean that if you inject enough Holes into a semiconductor it should fly like a balloon. One usually finds that in conversation physicists evade or side-track the questions about this property. There are two reasons for it.

(a) They are embarrassed because this idea is not so very original; it was used long ago by the chemists who adhered to the Phlogiston theory (but do physicists know chemistry?).

(b) The whole subject is highly classified as this principle of annulling gravitational force is being secretly developed for guided missiles against guided missiles.

We hope that by laying bare before the reader the essential facts concerning semiconductors, we have shown that one can talk in a very learned fashion about them and never be exposed; one has only to observe two simple rules (one Dogma and one Taboo) and keep the face straight.

Good luck!

EQUIPMENT REVIEW

DX Lab. Test of the Mitchell Lee Loop Amplifier
 (with comparison to a high-Z FET-input front-end)
 =====

Mark Connelly -- WALION DX Labs -- 25 FEB 1985

The May 1984 issue of "Lowdown" contained an article by Mitchell Lee on a low-impedance-input 3-transistor amplifier designed to be used for series-tuned loops. The main advantage of this design was stated to be good dynamic range (freedom from overloading / spurious-signal generation). A slightly-modified version of this design was built here at Billerica. It's been dubbed FE-C (Front-End card, version C). FE-A is the FET-input amp. (used in the RT-1 Remote Tuner project) against which FE-C was compared; FE-B is the regenerative front-end used in the APT-3 regen. tuner. Figure 1 (schematic) and Figure 2 (component roadmap) illustrate the FE-C version of Mitchell Lee's loop amplifier.

Figure 1: FE-C schematic

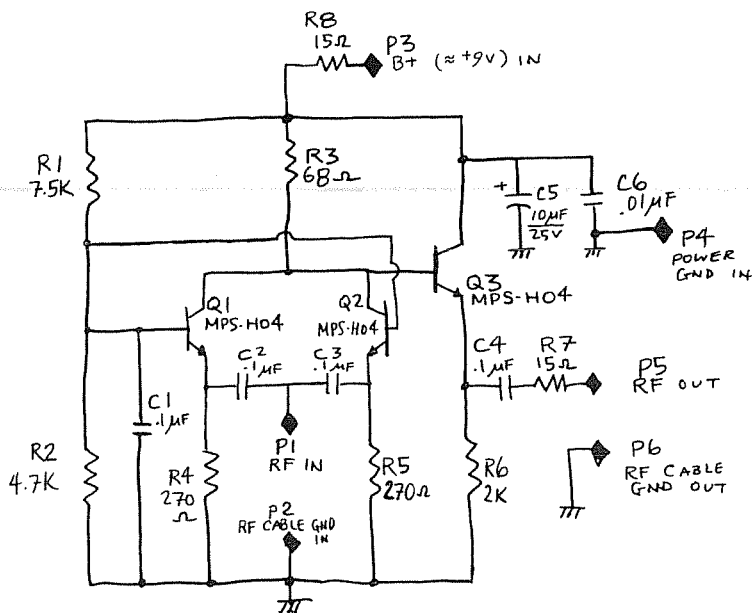

The purpose of the testing was to judge the low-Z input FE-C's performance against that of the FE-A (which uses the traditional high-Z-FET-input / parallel L-C tank approach). Factors considered included gain, noise, and spurious signal occurrences in the presence of potent local stations WRKO - 680, WHDH - 850, WBZ - 1030, and WMRE - 1510. In addition to loop operation, the use of each front-end in random-wire-tuning applications was evaluated. The schematic of the FE-A card is included in Figure 3 for reference.

Figure 2: FE-C component roadmap

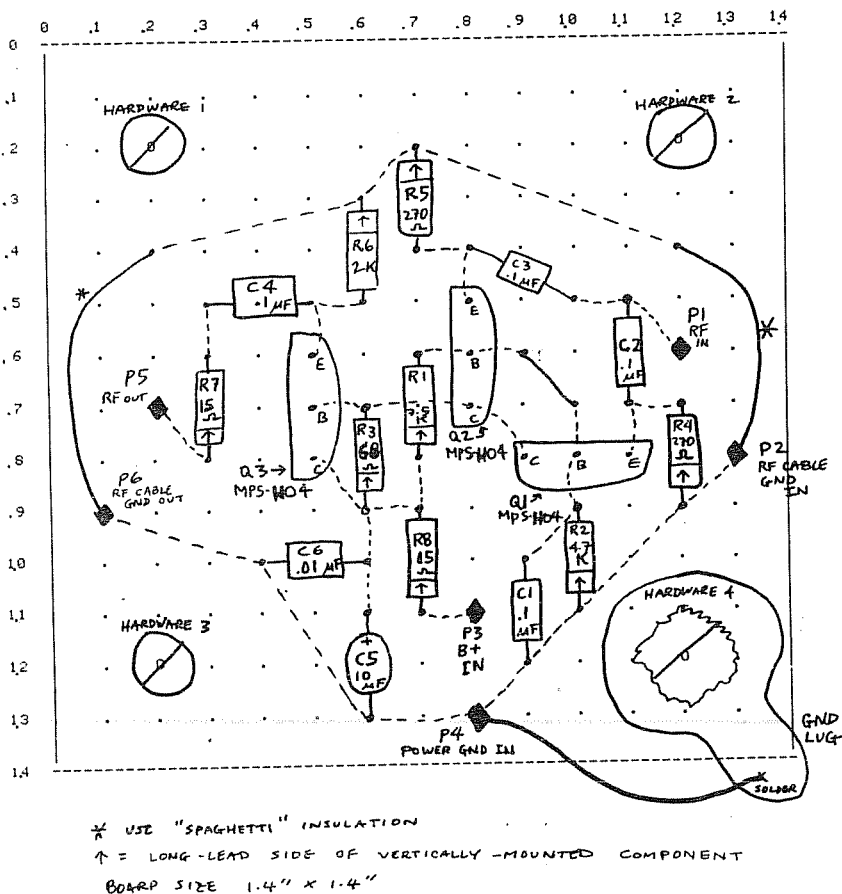

The input tuning configurations tested are shown in Figures 4a through 4g. The tuning capacitor's rotor, indicated by the curved line, is grounded (whenever possible) or is tied to a low-Z point so that hand-capacitance-detuning is eliminated, even in high-Q tuning usages. Each figure has accompanying text describing its purpose. In each figure, two points are identified by a number within a diamond: we'll call them Node 1 and Node 2.

The RF input pin (P1) of the FE-C card was tied to Node 2 of each figure for its test. Node 1 did not connect directly to the card; rather, as each figure shows, it was connected via the main tank coil to Node 1.

For FE-A card tests, FE-A card input pin P1 was tied to Node 1 of each figure; Node 2 was connected to ground.

If these tuning configurations were to be used as passive tuners, Node 2 would be tied to the receiver (or broadband-amp.) input and also to the "top" of an added tap (inductive-divider) coil of inductance approximately 15 % of that of the main tank coil. The "bottom" of the added coil would be grounded. (Passive tuner tests were not done in this evaluation project.)

Figure 3: FE-A schematic

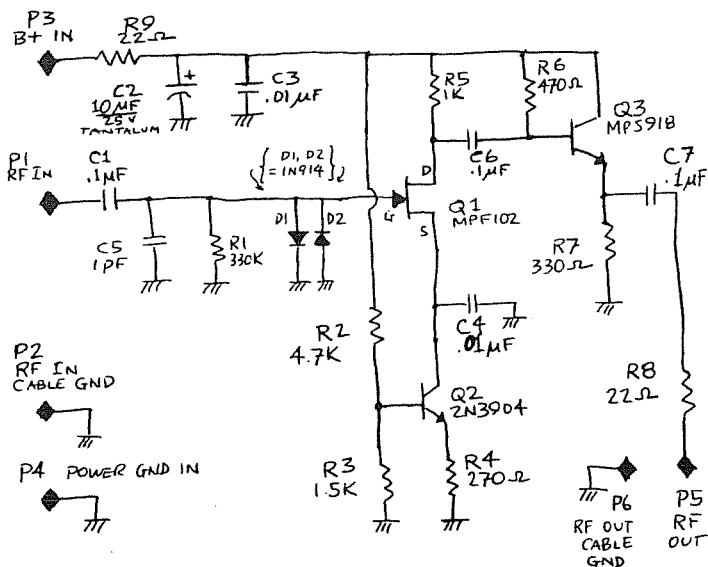

Figure 4a

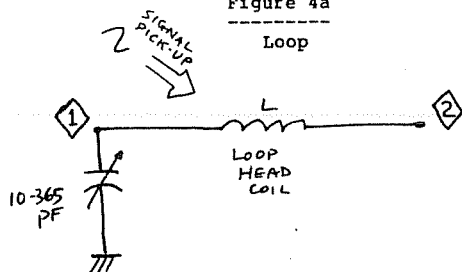
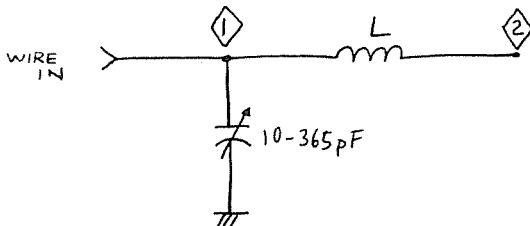

Figure 4b

Wire Tuner for antennae having effective capacitance less than 50 pF or effective inductance greater than 4*L (where L is the value of the main tank coil). /* TYPICAL "SHORTWIRE" TUNER */



Figures 4c and 4d

Wire Tuners for antennae having effective capacitance between 50 pF and 500 pF. /* TYPICAL "MEDIUM-LENGTH WIRE" TUNERS */

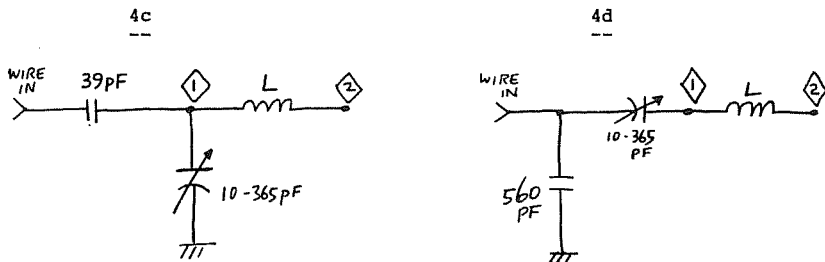
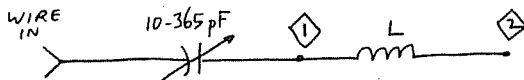

Figure 4e

Wire Tuner for antennae having effective capacitance greater than 500 pF or effective inductance less than $L/4$ (where L is the value of the main tank coil).



Figures 4f and 4g

Wire Tuners for antennae having effective inductance between $L/4$ and $L*4$ (where L is the value of the main tank coil).

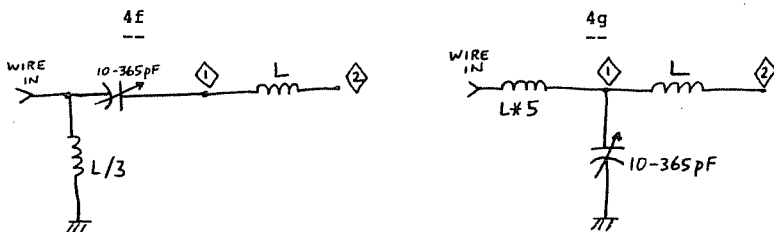

Note: In figures 4a through 4g, Q-spoiling for phasing applications may be effected by switching in a 15K fixed resistor (or 25K pot) from Node 1 to ground. This is independent of the type of amplifier used.

Test Results

GAIN

The FE-A card gave consistently greater output level (approx. 10 to 15 dB in most cases). The output level of the FE-C still was substantially better than the level obtained by connecting the test longwire directly to the 50-ohm-terminated receiver input. The higher

gain afforded by the FE-A was sometimes unusable at this suburban QTH, however, because of spurious responses (see next item).

DYNAMIC RANGE

The FE-C amplifier clearly outshone the FE-A in this realm. It could handle a good deal more signal before producing spurious (off-channel) responses than the FE-A could.

NOISE

The FE-C was somewhat quieter than the FE-A; however, in light of the FE-C's lower gain, actual signal-to-noise on both front-end cards was about the same.

MISCELLANEOUS CONSIDERATIONS

The FE-C performed in a more stable manner with high-Q L-C tanks than the FE-A did: high-Z-input FET amplifiers are more likely to go into oscillation. Use of a pot of about 250 K or 500 K would cure the FET's tendency to oscillate (CCW of pot to Node 1, arm of pot to P1 input of FE-A, CW of pot to ground).

It seems that the FE-C is less likely to be "blown" during nearby thunderstorms.

FE-A has a slightly lower current draw (hence, longer battery life) than FE-C. FE-C operation at 8 to 9 volts DC did not appreciably differ from operation at the 12 volt DC level originally specified in Mitchell Lee's article.

Conclusions

In situations demanding high gain (e. g. physically small loop, short wire, or remote location far from cities), the FE-A would be the front-end card of preference. At urban locations and/or when a loop of efficient (high-pickup / high-Q) design is available, use the FE-C: chances are that the diminished gain will be more than offset by a welcome freedom from spurious signals. Extra gain, if required, can be supplied by a "crunchproof" broadband amplifier using a Motorola MHW- or MWA-series or TRW CA-series amplifier of the sort used in CATV line-amp. applications. These amplifiers require a "beefy" power supply (e. g. 24 V, > 60 mA); portable operation is unlikely. An amplifier suitable for use after either the FE-A or FE-C Front-End card is shown in Figure 5.

Figure 5

BBA-C High-Signal-Level Broadband Amplifier

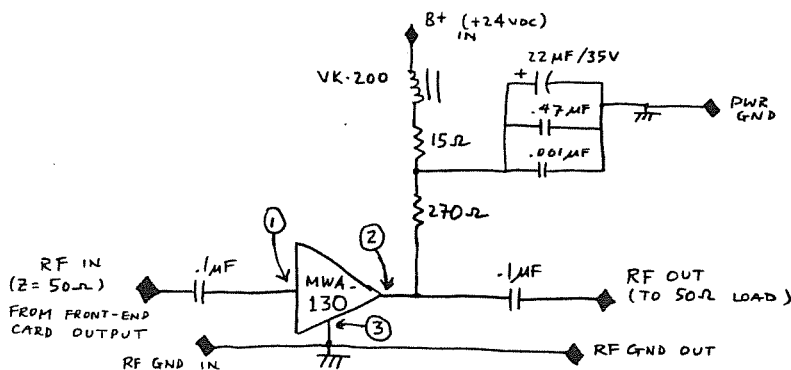

This column is getting short... 

Eastern DX Roundup

We need your support!!!...so...
Send in your tips or attack cats hit!

Karl J. Zuk, 154 Old Post Road North, Croton-on-Hudson, New York 10520

REPORTERS IN THIS WEEK'S ISSUE:

- (RB-A-NY) Richard E. Berg-Andersson, 47-11 48th Avenue, #1, Woodside, NY 11377
GE Superadio, Sony ICF-6500W, built-in antennae.
- (MB-ON) Mike Brooker, 245 Old Forest Hill Road, Toronto, ON M6C 2H5
Panasonic RF-2200
- (JHD-PA) John H. Demmitt, K0848, Box A, Bellefonte, PA 16823
Sony ICF-S5W
- (DP-HI) Dale Park, 2253 Kanealii Avenue, Honolulu, HI 96813
(with more info for East Coasters - special guest appearance)
- (NjW-ON) Niel J. Wolfish, 3900 Yonge Street, #706, Toronto, ON M4N 3N6
GE Superadio, (PRG-7 sold...R-71 on the way!)

- *****
- 550 WGR NY, Buffalo. 3-8 2301 Fair after nulling out Cuban with trivia show, asked question and played tape pertaining to question, then took call (after giving ID) from Niagra Falls. (RB-A-NY)
 - 580 WCHS WV, Charleston. 3-8 2351 Fair with pop music. ID followed by Julian Lennon tune, faded out only to fade in again moments later. Some interference from a Cuban. (RB-A-NY)
 - 730 CHYR-7 ON, Leamington. 3-7 0150 Fair with rock music, heard in CKAC's, Montreal, PQ, null. ID "three songs in a row on CHYR." Another DJ, who, thankfully, dragged out the call slowly. Faded back into the din at 0152 under CKAC, which I couldn't null completely. (RB-A-NY)
 - 920 WHJJ RI, Providence. 3-7 0200 Poor and weak signal with news. IDed with slogan "The Talk Of Rhode Island." (RB-A-NY)
 - 1060 CJRP QC, Quebec. 3-5 0640 In French with ID, ad for Subway Shop Restaurant, and someone named John gave a traffic report. Good. (JHD-PA)
 - 1130 WASP PA, Brownsville. 2-12 1747-1755 with spot for The Clothing Works in Uniontown mall, ID as "Your Country Companion, WASP" into C&W songs. At 1755, there was a full sign-off announcement mentioning 5kW power and location of transmitters 1.65 miles northwest of Brownsville, off PA route 88, off with musical rendition of The Lord's Prayer, fair to good over WCXI, Detroit, MI, and WNEW, New York, NY. (MB-ON)
 - 1250 WGHB NC, Farmville. 3-8 2104 Fair in WTAE's, Pittsburgh, PA, null with ads and country music. ID was a country music jingle including call at the end. (RB-A-NY)
 - 1300 WXPX PA, West Hazelton. 2-23 1747 with spot for local restaurant, ID as "13 XPX, 61 degrees on the outside," then lost to WERE, Cleveland, OH and semi-local WXRL, Lancaster, NY. (MB-ON) (Ex-WWKC-kz)
 - 1310 WXMC NJ, Parsippany-Troy Hills. 2-23 1751 with local weather for Morris County, promo message for an SAT preparation workshop offered by Morris Center YMCA in Cedar Knolls, ID as "60 degrees at WXMC." Fair to good for a minute or so, then lost under CKOY, Ottawa, ON. Heard before as WQTK or WBIO during an ET. That was back in 1977 or so. Did they lose their license, go bankrupt and stay off the air for several years? (MB-ON) (Yes, this station has never been too stable. They went off the air for quite some time. The local joke is that the people in Parsippany don't even hear them! Very poor sig-kz)
 - 1350 WOYK PA, York. 2-23 1704-1711 with local weather, promo for "Saturday Night Dance Party" program "right here on WOYK," ID as "Stardust 1350, WOYK" into WOYL-type music, 1710 was spot for Purex, WGN Superchannel, another "Stardust Station, WOYK" ID and more MOYL music. Fair to good in CKAR, Oshawa, ON, ans WSLR, Akron, OH null. (MB-ON)
 - 1420 WCED PA, DuBois. 3-3 1759-1812 with end of local news, message from the American Chiropractic Association, legal ID at 1800 into "The World Tonight" from CBS news, spots for Toshiba copiers, AT&T and The United Way heard during breaks in CBS news. Fair to good overcoming WHK, Cleveland, OH and slop from CJCL, 1430, Toronto, ON, until lost to WHK at 1815 (presumed pattern change time)(MB-ON)
 - 1550 WOKJ MS, Jackson. 2-25 0130 with all-night Gospel music program called "The King's Highway" with OM in southern accent playing Gospel music, a run-down of church events in churches in MS, AL, and LA. In good to very good. Are they "No Silent Period" now? Probably a Gospel music program for truckers, although the main highways in Ontario are called "The King's Highways." (MB-ON)
 - 1622 KPF-941 NY, Yonkers. 3-4 2115 with male announcer playing records like "Da DooRon Ron" at 2136. Announcer said it was one of his favorite oldies and played it again. (JHD-PA)

Quick news via Dale Park: These stations add Larry King: WPAM 1450, Pottsville, PA, WGH, 1310, Newport News, VA, WBAL, 1090, Baltimore, MD, WNEB, 1230, Worcesete MA, WVMT, 620, Burlington, VT. Jim Hall, your UNID on 580 (2-16 DXM) could be either CKAP or CKPR, per Niel Wolfish. R.Sweden at 1400 now on 15345 kHz. Bye-k
GMR

WESTERN DX ROUNDUP

Nancy Hardy
2301 Pacific Avenue
Aberdeen, WA 98520

All times are
Eastern Local

Phone for hot WDXR tips: (206)532-6827 till 10pm(PLT)-----

DEADLINES: Tuesdays April 16, May 7, June 4, July 2-----

REPORTERS FOR THIS ISSUE:

- (NH) Nancy Hardy-2301 Pacific Ave.-Aberdeen, WA 98520
FRG-7, wedge, SM-1
- (JH) Jim Hilliker-1502 E. Hedgewood Ave.-Anaheim, CA 92805
Kenwood R-1000, Radio West loop
- (GL) Gary Larson-2806 Lincoln-Burbank, CA 91504
DX'ing at work in Sylmar, CA using car radio
- (ASL) Albert Lobel-P.O. Box 26762-San Diego, CA 92126
GE Superadio, GE long-range portable, SM-2
- (PM) Patrick Martin-P.O. Box 843-Seaside, OR 97138
SP-600 JX, two E. Beverages 1500' long, one term. 200' NE
longwire, grounds
- (AWP) Art Peterson-851 31st Street-Richmond, CA 94804
FRG-7, Radio West loop, longwire
- (RW) Robert Wien-1309 Dentwood Dr.-San Jose, CA 95118
GE Superadio, GE long-range portable, SM-2
- (JW) John Wilkins-4385 Hoyt St. #205-Wheat Ridge, CO 80033
R-1000, 4' box loop

***** OF SPECIAL INTEREST:

- 740 WBAM AL, Montgomery per call to WBAM, will switch calls to WLWI "in the next few weeks," and will change format from C&W. Is already sold to new owners. (RW-CA)
- 1380 KGMS CA, Sacramento per call to KGMS, will change calls to KSMJ on 3/15. Unsure if they'll change format. (RW-CA)
- 1400 KFTN UT, Provo per call to KFTN, calls are now KXYO, format still C&W. No longer 24 hours, sked now is 0900-0300. (RW-CA)
- 1450 KAYO WA, Aberdeen is now 24 hours. They are off Monday mornings 0300 until 0800. (NH-WA)
- *****
- 540 KVIP CA, Redding 3/16 2111-2114 generally fair w/vocal rendition of SSB, into full-data s/off, ID, power 1kw, etc. gave address, mentioned being non-profit, said to tune to FM freq. 98.1, or to "one of the translator frequencies near you." "From the staff and management of KVIP, have a pleasant good evening." Into song, then off. Also tent. 3/12 0940 w/soft relig. instrumental mx. Probably them. (JH-CA)
- KNOE LA, Monroe-W. Monroe 3/10 heard well w/C&W mx & ID after AP News at 0306. Then back into C&W mx. This is now stronger most nights than WWL, w/all the QRM on 870. WWL is reg. but not as good as KNOE w/1kw! (PM-OR)
- 544 "KDX" CA, Stanton that's the legal ID this pirate now gives. Good strong signal, so he can't be too far from me. End of song "That's Barry Manilow on KDX Radio," into recorded PSA for Nat'l Hunting and Fishing Day Sept. 22nd! Recorded ID by deep-voiced anncr "Playing your favorite hit music, KDX radio." Into long ad-lib s/off by DJ. "This is KDX radio, at 5-4-4 kHz, and a transmitter output of approx. 250 watts. KDX now concludes its testing on this frequency." DJ ment. he hasn't been on in awhile, new format will be "Hot Hits," was a mix of everything. Also ment. that he's aquired an RCA 250w xmtr (I can tell his audio is much better than when he was on 540). Heard testing 3/9 0040 w/OC, IDs "1,2,3,4, okay, this is KDX testing..." Talk about his audio processing, some mx, more OC, etc. 3/16 0230 testing again, many professional sounding recorded IDs, live IDs by anncr in middle of songs, mostly rock, dead air, then "KDX at the left of your radio, AM 54, testing" or "KDX, testing on 5-4-4 kilohertz." Back into various records. Audio was being adjusted quite a bit, distorted at times, other times more bass than treble, etc. Strong here, 10 over S-9. (JH-CA)
- 570 KIPO HI, Lihue hrd quite well w/rr mx & "KIPO-57" IDs, w/no sign of KVI, a little KLAC in the background. This one is sure a lot better since the move to 570 from 1350. They weren't hrd often on 1350. They are only 1kw on 570. (PM-OR)

580 CKUA AB, Edmonton 3/19 0156 nat. and Alberta nx, sports, wx. ID at 0200 into 2 minute s/off listing all FM relays. Fair to good w/KCMX nulled. New. (NH-WA)

590 KSSK HI, Honolulu 3/9 0225 way o/all others w/K-59 IDs. Annct for concert in Honolulu, another reg. but better than usual. (PM-OR)

600 KSXO CA, Redding 3/8 hrd w/non-stop rr mx & ID at 0000:JOEST "Playing all the Hits all the Time, we're KSXO Redding." Haven't hrd this in years. KSXO is the rarest Redding station. KLZZ QRM. (PM-OR)

670 *KBOI* ID, Boise MM 3/4 0433 ET'ing w/OC, TT's, seemed to lower power or change patterns a couple of times. (JH-CA)
 (KBOI)+3/11 0226 totally off. (RW-CA)
 +3/11 0314 totally off. (GL-CA)

680 KWKA NM, Clovis 3/11 0439 wx forecast. Fair, mixing w/KNBR. (ØW-CO)

700 WLW OH, Cincinnati 3/4 0150 very weak voice u/KFAM Salt Lake City, UT. (ASL-CA)
 KFAM UT, N. Salt Lake City 3/11 0315 in good. Some XETRA-690 slop. Easy listening mx. (GL-CA)

710 (KMPC) CA, Los Angeles MM 3/4 0445 off air for usual MM SP, but all I get is spur from KLAC-570, even when KMPC had OC at 0455! Back to RS at 0500. Oh, well. (JH-CA)
 +3/11 0316 totally off. Usually returns at 0500. (GL-CA)

740 *KBRT* CA, Avalon MM 3/11 0350 noted testing, covering up KCBS. Playing music, some IDs. (JH-CA)
 KCBS CA, San Francisco 3/11 0318 fading, some talk program. Possibly KBRT OC on. Also hrd talking under, maybe KTRH. (GL-CA)

770 (KOB) NM, Albuquerque 3/7 0430 totally off. Has also been off every day this week after midnight. (RW-CA)
 +MM 3/11 0355 noted off again, they've sure been silent the past few MM's. (JH-CA)

780 KROW NV, Reno 3/11 0319 in fair w/Solid Gold Country. Some KABC-790 QRM. (GL-CA)

800 CKOK BC, Penticton 3/4 0205 under on/off carrier of XEMMM which was back on by 0208 w/full carrier & screeching Mexican annrc followed by ranchera music. (ASL-CA)

830 WCCO MN, Minneapolis-St. Paul 3/4 0220 w/talk about local events in lots of QRM. (ASL-CA)

840 KSDP AK, Sandpoint 3/9 hrd fair again w/Fleetwood Mac song at 0350, then wx anncts & into "Alaska's Flag" (state song) and off by 0401. (PM-OR)
 KSWB OR, Seaside 3/12 0130 noted fairly strong in WHAS null, first time since 10/27, been trying a lot too! Rock mx, many local ads, promo for local sports broadcast (high school?) ment. state tournament "You can be there with 840, KSWB." Many ments of "Highway 101 north of Seaside." Woman on most ads, ment. the "Seaside Gulls." Also good 3/14 w/s/off 0258-0300, ment. of "new AM 840, KSWB, with 1000 watts day, 500 watts night..."(JH)

860 *KTRB* CA, Modesto 3/11 0334 w/TT. (RW-CA)

870 KUUY WY, Orchard Valley-Cheyenne 3/17 0520 strong w/C&W mx o/KIEV in partial null of KIEV. Into wx & ID "low of 20-25, on Sunday, breezy and warm with a high near 55. That's the weather outlook from Cheyenne's favorite, 870, K-U-U-Y." Into C&W. Good. New. WY #5. (JH-CA)

880 KRVN NE, Lexington 3/4 0230 "Wild Midwest Weather Report" (quote of DJ). (ASL-CA)

890 WLS IL, Chicago 3/4 0245 w/talk show on local voting. (ASL-CA)

960 KOOL AZ, Phoenix 3/11 0321 fading w/KABL. MOR mx. (GL-CA)

1000 KRHS AZ, Bullhead City 3/4 0845 good w/s/on & ID, into C&W mx. Also heard 3/4 2032 at SSS w/female DJ, ID, and now using the slogan "100 degree country, KRHS." Get it, 1000? hi. (JH-CA)

KKIM NM, Albuquerque 3/12 0844 fair o/KKMX, in KOMO null. Instrumental mx, relig talk, ID "The Joy of 100, KKIM." Haven't heard this in a year or so. (JH-CA)

1030 KHWH CA, Folsom monitored 3/4 0618-0640. C&W program, at least some satellite/network feed (x minutes after the hour TCs). All IDs were by a female group, either K-H-W-Y or an almost whispered K-Highway. Good signal but not really solid as you would expect only 70 miles away. (AWP-CA)

KBSM MO, Blue Springs 3/11 0250 good sig, dominant w/KTWO off. Rock oldies, 0300 ID "...from Boss Radio, the new K-Best 10-30, KBSM, Blue Springs-Kansas City." Then more oldies. Was looking for KHWH. (ØW-CO)

- 050 KBUF KS, Garden City 2/26 1800 ABC nx, "High Plains Forecast," then local nx, ads. Fair at best w/slop from KLMO-1060. (ØW-CO)
 KORE OR, Springfield-Eugene 3/4 2116 poor w/s/off mixing w/XED. (JH)
 ?KORE?+3/12 1030 prob. one w/end of "Through the Bible" program, YL w/prayer, ID as "???" of the Great Northwest," into another relig program, completely gone u/KOBY by 1100, 1:34 min. after San Jose ISR. Thought it might be KSPO, called station, but they carry "Haven of Rest" during these hours. (RW-CA) (How about KBLE?-NH)
- 090 XEPRS BCN, Rosarito 3/11 0325 SS strong. Found out station is now owned by Mexican government, meaning no more EE. Will call the Glendale, CA number to verify. (GL-CA)
- 110 *KRLA* CA, Pasadena 3/11 0325 ET'ing, fading w/various tones up and down. (GL-CA)
 +MM 3/11 0330 noted testing, OC & TTs at this time, and probably all morning, noted still ET'ing 0430. (JH-CA)
 (KRLA)+3/3 0415 a rare Sun. morn. SP, also off MM 3/4 0315, noted testing later 0409, off by 0645. (JH-CA)
- KBND OR, Bend 3/3 0430 and MM 3/4 0330 on w/Talknet, fighting slop from KPNW-1120, KFAX-1100 & XEPRS-1090. Good poor ID 3/3, but good clear ID 3/4 0330 "Talknet, America's fastest-growing talk show, hear...(gave name of host) weeknights, beginning at 7, on KBND, Bend." Called station, they hope to go 24 hours later this year. New, Oregon #26. (JH-CA)
- 140 KRAK CA, Sacramento 3/11 0327 C&W, fading some. KMJJ also heard some. (GL-CA)
- 180 KDAN AZ, Williams 2/10 2120 C&W mx; occas. ads for Williams businesses. New, AZ #38. QRM from several. (ØW-CO)
- KERI CA, Wasco-Bakersfield 2/10 2030 relig. vocals. Fair to good, but freq. messy w/VOA, KOFT, and KDAN all in there. (ØW-CO)
- VOA FL, Marathon 2/10 2100 nx and commentary in SS; o/u QRM. (ØW-CO)
- 190 KEZY CA, Anaheim per call to station 3/5, the CP for 10,000 watts day has been on about a month, directional towards NW. Somewhat stronger here, much more splatter noticed. Also, when they start construction on new 2,500w nite site, day site will go there also, NE of Brea near LA-Orange County line off Hwy 57, will be 4-tower pattern. Steve Mittman noticed them to be in stereo in his car. CE says only the pilot was on, but no stereo programming. KEZY will use Harris system for now. (JH-CA)
- 220 WSLM IN, Salem 2/18 0559 s/on. "Studios atop Radio Ridge." Poor w/QRM. (ØW-CO)
- 230 KLAJ NV, Las Vegas MM 3/4 0901 must've been off all night, full-data s/on in KGFJ null, poor. (JH-CA)
- 240 KXLE WA, Ellensburg 3/10 w/"KXLE" ID at 0250, after annc. (PM-OR)
- 250 KWSU WA, Pullman 3/5 0045 dominating the freq. tonite, well above KTWMS w/classical mx, ID at 0059. Not heard in awhile. (JH-CA)
- 270 KCOK CA, Tulare-Visalia 3/4 2027 noted w/ID and oldies. Weren't they news/talk previously? Good signal. (JH-CA)
- 280 KTOL WA, Lacey this station is now u/KYKN daily, where KMAS used to be on top. Is KTOL lower power? Noted C&W mx at 2010 on 3/15. (PM-OR) (KMAS was 2500 watts, I believe KTOL is 1000.--NH)
- 320 KBUG UT, Salt Lake City 3/11 0330 rr mx w/Four Tops then time check into REO Speedwagon song. Fading bad. (GL-CA)
- 330 KGAK NM, Gallup 3/4 0129 ID "We're the News Center, K-G-A-K, Gallup, New Mexico." Then Mutual nx, followed by Larry King. (ØW-CO)
- CKKR SK, Rosetown 3/16 0015 hrd fair o/u KUPL & KPH, w/MYL, IDs as "AM 13-30." (PM-OR)
- 340 KIKO AZ, Miami 3/4 0758 fair w/SSB s/on, good ID "KIKO, Miami, AZ and KIKO-FM Globe, AZ," then totally disappeared. Don Kaskey says they hadn't been reported in 4 years, and I hear 'em twice in 1½ months! On their verie, it says "KIKO-AM Globe-Miami." (JH)
 KWXY CA, Cathedral City 3/10 1941 on top briefly w/BTFL mx, into two ads, ment. of Palm Desert & Hwy 111, then lost in the mess.(JH)
 KSFE CA, Needles more on my logging 2/4 0300 s/off, they are now using SMN's Stardust format, // KDON-1460 & KWRM-1370. I kept tuning back from 1370 to 1340, heard same mx, tent. w/spot ment. Hwy 95, about to ID 0300, into s/off. Per call to station, went SMN two months ago. Sked is 0800-0300 every day. Sometimes has good sig. o/u KRAM at SSS now, always seems to fade at ID time. (JH-CA)
 +3/10 2033 out of SMN "Stardust Format," into spot for "Regency Casino" ment. Hwy 40. Poor. Better 3/11 0230-0234, fair to poor w/Big Band mx // KWRM-1370 & KDON-1460. Into Red Cross PSA, lost briefly to KATY, then back in. ID by SMN's anncr "This is Don

- 1340 KSFPE Parker, and KSFPE..." Faded. Into s/off 0234. Called cont'd station to confirm, they are lkw fulltime, "the 250 watts mentioned in s/off needs to be corrected" according to person I talked with. Also, they're thinking about whether to stay w/ Stardust or change format again. Anyway, w/lkw, they're getting out more often now. (JH-CA)
- 1350 KCKC CA, San Bernardino 3/11 0211 wx forecast, then quick ID & into more mx. Heard briefly in QRM. New, CA #37. (ØW-CO)
- 1380 KLPZ AZ, Parker 3/4 0850 good, before the KGER-1390 slop took over at 0855. ID "The station giving you more in '85, KLPZ." Into "Today in Farming" from the SW Agri-Radio Net. (JH-CA)
- 1400 KART ID, Jerome 3/4 0810 fair, on top w/local rx, ment. Boise many times. "That's a look at Magic Valley and state news for the moment. Larry --- for Cart news. Update on sports, next." Into sports. Best ever heard here, fourth time logged. (JH-CA)
- KTRC NM, Santa Fe 2/11 2343 ID "You're listening to unforgettable K-T-R-C," followed by "This Old House" & other MYL/EZL stuff. This station is not all SS, as NRC Log indicates. (ØW-CO)
- KEYE TX, Perryton 2/11 2242 sked for high school BKB games (Rangers and Rangerettes) to be broadcast live on "14 AM and FM 96." Then into mx. Quickly gone to QRM. New, TX #70. (ØW-CO)
- 1450 KLEB OR, La Grande 3/10 0301 heard w/s/off intro for AM only. Presume FM was already off or on later. (PM-OR) (Bill says FM is separate.--NH)
- 1470 KUTY CA, Palmdale 3/11 0217 blasting in w/MCN, absolutely no fading, slopping 1460-1480! Did they forget to switch to night power? (RW-CA) (Loud here too that morning.--NH)
- ?KUTY? 3/11 0345 no OC from the Mexican this morning. C&W mx, fair to good, most likely KUTY in KWIZ semi-null, 1480 slop. (JH-CA)
- 1480 (KWIZ) CA, Santa Ana 3/15 0405-0420 was off, then had OC, still OC 0430. Fairly rare SP for a Friday morn. (JH-CA)
- KLEO KS, Wichita 3/15 0406 a real surprise, some fading, but fairly good on the peaks. Out of mx, local ad, ID "1480, KLEO, good morning..." wx, "low of 35, it's now 41" at KLEO." Into Talknet jingle "...enjoy Talknet on KLEO." Into Talknet show, giving phone numbers, etc. New, Kansas #8, #527 overall. (JH-CA)
- KUUX NM, Hobbs 3/15 0415 nulling KLEO, fair to good, C&W mx, "K-double U-X" ID, seemed to be live, MST TC's. Not MCN overnite anymore? (JH-CA)
- CKER AB, Edmonton 3/16 0020 fair o/u KGCC w/program in Chinese. (PM)
- 1490 KBLF CA, Red Bluff 3/12 0306 usually all I get is KWIZ-1480 slop, but this signal was good enough to "punch" its way through. Nice full-data s/off "KBLF is owned & operated by Wireless...with studios and offices at 2090 Walnut Creek, Red Bluff, CA." Ment 1490 kHz, "with an effective radiated power of 1000 watts. (Isn't it illegal for AM's to say "ERP," thought only FM's use ERP. AM's are supposed to say "output power" aren't they? That's what my CE told me!) Into vocal SSB, sounded like Statler Bros. I only need KSYC & KTOB for all CA 1490's. New, CA #196. (JH)
- 1520 KOMA OK, Oklahoma City 3/11 0332 C&W "Koma Country," giving phone number. Lots of skywave fading. (GL-CA)
- 1550 ?KQXI? CO, Arvada 3/4 0817-0829 tent. w/relig. program on top of KRGO, fair. Started to give a Denver address, mixing w/KRGO, then wiped out by KUAT s/on 0830. This is a most-wanted, hope to get it soon! (JH-CA)
- 1560 KLLV CO, Breen 3/4 & 3/5 0837 quite strong in KPMC null, w/good legal ID! Relig. mx, the ID by woman "This is the sound of love, KLLV, Breen." Into relig. taped show. On 3/5 ID was "KLLV, Breen reminds you that love was born in Christ the King." (JH-CA)
- WQXR NY, New York 3/17 0558-0600 came up o/unID TT's. Classical mx, poor, fighting KDAY-1580 slop. Mx good at 0559 (poss. FM getting ready to hook up w/the AM?). At 0600 mx ended, low audio, man "Good morning..." faded out, poss. s/on, then faded up to hear "...and WQXR-AM at 1560..." gone again, later heard weak class. mx, tried to pull more audio till 0610, but no luck. Still, it's NY #4. (JH-CA)
- KKAA SD, Aberdeen 3/17 2158 C&W mx, 2200 ID into Satellite News. Haven't heard this one in 5+ years due to ever present KGHO OC (which is now on 1490). (NH-WA)
- 1600 KWOW CA, Pomona 3/11 0335 fading bad w/another station, w/talk show. (GL-CA)

March f/c's tentatively heard:
 2nd Su 0200-0202 KWIV-1470 WY (RW-CA)
 2nd MM 0215-0220 KVOW-1450 WY (RW-CA)

UNIDs:

- 560 MM 3/4 0425-0430 someone w/TT's, looping east in KSFO's null, w/ KLAC-570 slop. (JH-CA)
- 1010 3/4 0323 SS poor w/fading. (GL-CA) (Probably the Mexican.--NH)
- 1240 3/11 0329 two stations. One w/a talk program & the other w/PSA. Both fading. (GL-CA)
- 1330 3/10 2110-2114 something in KFAC null (KFAC was in SS & their modulation was lower than usual). Heard song "The Shadow of Your Smile," then into the Portuguses nat'l anthem (just like on R. Portugal on SW), faded, then heard a weak SSB that got stronger till the end. Maybe KLBS? Do they broadcast in many languages? (JH-CA)
- 1400 3/11 0210-0213 UNID TT beginning promptly at 0210 while sitting on freq. trying for KXYC's s/off which I didn't hear, TT promptly ended at 0213. New f/c? (RW-CA)
- 1400 3/17 2118 annc't. of no "Concert Hall" this evening because of Portland Trailblazers basketball game. Is this KJDY, or is someone else on 1400 carrying the Trailblazers? KJDY is a much-wanted! (NH-WA)

By the way, KORY-1270 is now KPLY. While typing the column I put 1270 on and heard their new calls! This is the last weekly DXM, so remember to check my deadlines. ♡

Music has strange powers to inflame the human breast, but not, it seems, the breast of an Emperor penguin. A report in last week's *Outlook* on the World Service was devoted to the all-Scottish expedition to Antarctica of 1902-4. One of their scientific experiments involved tethering an Emperor penguin to a piton hammered into the polar ice, and observing its reactions to a performance at close range by Mr Caird, the expedition's piper. All kinds of music were tried, from reels to pibrochs, with no success. 'The phlegmatic bird', in the words of the official report, 'responded only with an attitude of sleepy indifference.' It is one of the things I like about the radio that one can switch it on at random, like a sortilege, and acquire such brief but wonderfully emblematic glimpses into the nature of human endeavour.

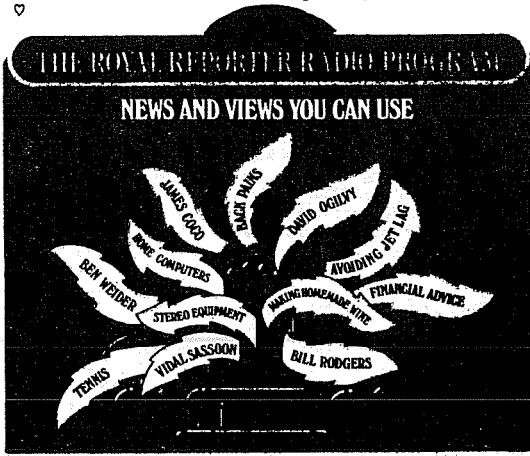

Above: The Spectator
 11-10-84 via Nick
 Hall -Patch

Right via Nick Hall-Patch

Below University of San
 Diego Vista 3-14-85, via
 Father Jack Pejza

HEARD IN YOUR AREA ON:

Abbotsford CFVR 10:05 am Mon.-Fri.	Castlegar CKQR 8:25 am Mon.-Fri. 6:30 pm Mon.-Fri.	Chilliwack CHWK (Fraser Valley) 2:20 pm Mon.-Fri.	Duncan CKAY 3:30 pm Mon.-Fri. 9:30 pm Mon.-Fri.	Grand Forks CKGF 7:20 am Mon.-Fri. 11:30 am Mon.-Fri. 4:15 pm Sunday	Kelowna CKOV 12:27 pm Mon.-Fri.	Penticton CKOR-FM 7:56 am Mon.-Fri. 5:20 pm Mon.-Fri. 1:05 pm Saturday	Terrace CJFW-FM 10:15 am Mon.-Fri. 12:15 pm Sunday
							Vancouver CJOR 5:51 am Mon.-Fri. 8:23 am Mon.-Fri.
							Victoria CFMS-FM 4:30 am Mon.-Fri. 11:30 am Mon.-Fri.
							Victoria CJVI 2:17 pm Mon.-Fri.

Discovery Explains AM "Overkill"

By Joanne Andreoli
 Staff Writer

When I was young, I used to think that there were little men inside my radio that would play music and sing and sometimes even talk to me. But then I grew up—well, got older, anyway—and discovered records. Now I knew that there were not little men inside the radio making music. However, I made another startling discovery; even though there are no miniature men playing music or singing inside the radio, there are still little men running around in there.

I've learned that their names are simply "A" and "M." Do you know what they

do? They kill songs through a torture method technically called "repeatitis." In layman's terms, that is overplay.

I'll bet you didn't know that there is a Federal law that says "radio stations cannot play the same song more than twice a day." It's true. What these demons (A&M) do is run interference and play a tape that they have of all the songs they like. Many times, they become all the songs you hate. It really doesn't matter which station you listen to, they are there, playing the songs they want you to hear over and over.

I'm really quite surprised that it took so long for someone to finally figure it out. It

seems so obvious. Did you really think any D.J. in his right mind would play "Girls Just Wanna Have Fun," or "Purple Rain more than once an hour?"

You know what is really frightening? They have also got a hold on MTV. It's true! Now you can see Madonna rolling around like a virgin at least twice an hour, more like the V.J. is J.J. Jackson.

The next thing you know, they will try to take over television. Can you imagine having to watch repeats of shows until you can quote Jack, Janet, and Chrissy? Or wading through reruns of "I Love Lucy." I thought you couldn't.

DX WORLDWIDE EAST

From Paul W. Ormandy of the New Zealand DX Times comes another confirmation on Niel Wolfish's unID Colombian on 1580 in issue #703. La Voz de las Estrellas is the slogan of a radio network, and HJQZ has apparently joined the 'cadena'. Does the '85 handbook have this listed anyone? Also these notes from Paul: Fritz Mellberg, your 1280 unID in issue #702 is none other than 4VAM in Port-au-Prince, Haiti. I checked and it's in the '84 handbook as such. An interesting note about this station - they announce 1290 and have that frequency on its letterhead and stickers, but still verify their correct channel. The often reported Latin unID on 1425, Radio Guapiles TI?? was heard at Paul's QTH with an 0402 sign off in Sept. of '84. Paul needs help on an unID - a Radio Reloj on 710, heard in June of '84 with UTC-4 time checks and news in Spanish. I have no information on this station - I was unaware of a Reloj on 710 unless it's a slogan change. Does anyone else know? Thanks Paul, for this information. Regarding Gardner Smith's unID/Korean a couple issues back - Gardner, read the write-up by Kaz on M.J. Stutterheim's 1566 unID in the 12/3/83 DXM, it may assist on identification. New reporter this week - Richard E. Berg-Andersson. Welcome and report often as possible. TA conditions are steadily dropping off as Spring appears, but there are still some nights worth staying up til 0600 for. All times are expressed in GMT/UTC.

I R A N S - A T L A N T I C D X

- 756 unID - 0103 3/18: Good carrier with snippets of audio through heavy splash. Sd/1k man in unID lang. Dropped out by 0105. (Hall-PA)
- 891 t ALGERIA, Alger 0349 3/17: Someone hetting 890 profusely, Algeria likely. Noted many other nights w/good TACX. (Hall-PA)
- 1458 ALBANIA, Lushnje? 0418 3/16: Good carrier and audio - woman in unID lang. Lushnje only reasonable TA. (Hall-PA)
- 1503 unID - Someone here w/"Careless Whisper" 0454 3/15. Quickly faded. Often noted during this time pd. but never good enough for an ID. (Hall-PA)
- 1521 SAUDI ARABIA, Duba 0310 3/11: Squawking WKBW ; so strong, I didn't hear the het & thought WKBW was into a format change w/AA chanting, hi. (Actually, stranger things have happened). Duba is fairly regular here at local sunset, but the Spanish GY is usually here this late. (Smith-DC)
- 1584 SPAIN, graveyarders - Just about every night this month Spain has been audible, here and other high-band freqs. (Hall-PA)
- 1593 WEST GERMANY, Langenberg - This station has attained "pest" dimensions this year. In 0245-0315 like a forest fire, perfect copy w/Eurorock (in EE but unidentifiable) and interminable GG talk by woman. Later, 0435, more Eurorock but with man DJ. 0457 choral hymn that sounds like a NA and then ID: "Hier is der West Deutscher Randfunk und der (?Suddeutscher?) Randfunk. No IS. (Smith-DC)
- 1611 t VATICAN, Vatican City 0519 3/16: Poor but bits and peices of audio showed. This is often noted on a very good night. (Hall-PA)

P A N - A M E R I C A N D X

- 535 GRENADA - 0035 3/13: Poor, not usually noted this early. Best on Beverage. (Hall)
- 555 unID - Either St. Kitts or Nicaragua here 0247 3/15 w/US & SS mx mix. (Hall-PA)
- 550 CUBA, Pinar del Rio CMAA 0358 3/9: Good o/moderate QRM w/American pop mx, female voice ID 0400 "Radio Rebelde, la Habana" followed by Latin mx. ID included some chintzy march-like mx before and after ann. (Berg-Andersson-NY)
- 580 CUBA, Baracoa CMMF 0455 3/9: Fair thru QRM w/mx "While My Guitar Gently Weeps", same female voice ID as CMAA 0500 "Radio Rebelde, la Habana", followed by nx in SS. //550. (Berg-Andersson-NY)
- PUERTO RICO, San Juan WKAQ 0501 3/9: Poor u/CMMF and fair after nulling Cuban. SS nx, ID 0508, musical jx ending w/words "Radio Reloj" followed by ads in SS. Doesn't have same sound as R. Reloj, Cuba, which I've heard before. Also no pips (actually clicks. Pips are tones.ed.) or "RRR" code. Per WRTH only Reloj in LA on 580 is PR (if so, 1st PR hrd at this QTH), which is why I'm being cautious. (Berg-Andersson-NY) (It's them.ed.)
- 590 CUBA, La Julia CMCA 0511 3/9: SS nx. ID 0013 (you mean 0513, Richard?) male voice, "Radio Rebelde, la Habana" followed by BFL mx, then Latin mx. BFL mx sd/1k it was part of ID ann (usually is if it's short and sounds studio-faded.ed.) At least it's better than that march-like mx on the hour. //550/580. (Berg-A.-NY)
- 600 CUBA, Urbano Noris CMKA 0527 3/9: Latin ballad mx w/female vocalist. R. Rebelde, //590. Fair u/fluttering WICC. (Berg-Andersson-NY)
- 690 CUBA, Santa Clara CMEC 0531 3/9: Latin ballad mx w/male vocalist. Radio Rebelde again //590/600. Good sig, clear audio, best of them all. (Berg-Andersson-NY)
- 790 ? CUBA? Radio Reloj? 0544 3/9: Heard clock ticks, beep on the minute, and "RRR" CW, as descr in WRTH. Weak sig, fair copy. If there was SS nx behind it, it was down in the mud and I couldn't dig it out. Also, new WRTH doesn't have a listing on this freq. (Berg-Andersson-NY) (This is likely one of Cuba's anti-Marti stns. Can anyone get more on this?ed.)

- 820 CUBA, La Habana CMBU 0345 3/12: "Radio Moscow" ID in SS w/pop Russian tunes. Dom channel. (Smith-DC)
- 830 DOMINICAN REPUBLIC, Santo Domingo HIJB 0355 3/12: XInt sig w/smooth romantic ballads. ID w/callsign. WCCO way down, no sign of Belize. (Smith-DC)
- 1180 CUBA, La Habana CMOO Radio George Washington 0001 4/1: The "South Florida" service of the Voice of Cuba. Brand new, they've finally got this thing on the air. The Cuban Senate was really angry at the delay. S/on using IS "I'm A Material Girl" by Madonna, repeated over and over for half hour. Very nice. (April Fool) (Smith-DC) (C'mon.ed.)
- 1540 BAHAMAS, Nassau 0215 3/12: ID as "R. Bahamas". On top o/WPTR w/wailing and screeching - apparently soul mx (reggae'd.) Later w/mellow early 1950's doo-wop vocals. (Smith-DC)
- 1550 COLOMBIA, Barranquilla HJCB 0300 3/7: "En Barranquilla, R. Exito - La Radio de Colombia". XInt over CBE. (Smith-DC)
- 1555 CAYMAN ISLANDS - Radio Cayman w/BFL/EZL mx 0402 3/18. Best on Beverage - not often hrd anymore, QXR slop was minimal tonite. Also mx by w, ID by m. (Hall-PA)
- 1580 ANTIGUA VOA 0320 3/9: Rolling in o/CBJ w/old 1950's jazz mx. Think the deejay is Willis Conover, star of the "Morning Show" on VOA for so many years. Several low-grade hets. Spain-1584 appeared suddenly at 0330. (Smith-DC)

CREDITS:

- (Berg-Andersson-NY) Richard E. Berg-Andersson, 47-11 48th Ave. #1, Woodside, NY 11377
(GE Superradio, Panasonic RF-2200, batt pwred, using built-in AT. Sharp portable cassette deck.)
- (Smith-DC) Gardner Smith, 1000 Perry St. Washington DC, 20017
(Toshiba F-11)
- (Hall-PA) Jim Hall, 240 Byron Road, Pittsburgh, PA 15237
(R7A, loops, lw's, Beverage)

The Akutagawa Radio-Cassette

At first glance, this appears to be a nice little set, and I do mean little--- $3\frac{1}{2}$ " wide x 2" high x $\frac{1}{2}$ " thick. The cassette player portion is really tiny, smaller even than a "miniset" player, so obviously this is a type of cassette tape that hasn't made it to the North American market yet. In most respects except its size it seems to be similar to other stereo radio-cassette jobs on the market; two speakers, level meters, pushbutton tape controls, tuning and volume knobs etc. It does not have a digital display, and its slide rule dial shows something a little strange. The FM dial covers only 76-90 MHz, the Japanese band, so the importer really goofed on this one. Oddly, the AM band is marked 530 to only 1400 kHz.

Well, let's see if it'll tune any higher. Hmm, the tuning knob won't move. Hmm, none of the pushbuttons work. Try switching it on...take a firm grip of the volume knob and twist...no results...but the knob does seem to be getting softer under pressure. After licking my fingers, I conclude that the spiffy chocolate coloring is more than skin deep. Suddenly, my wife and daughters appear and show a keen interest. I am handed a knife and instructed to make a fair division. Just as well that my DX receiver doesn't have a sugar content....

SLOGAN LIST PROJECT FOR NEW IRCA ALMANAC

As you all know, the fourth edition of the IRCA Almanac is scheduled to be released this summer. As editor of the Slogans List, I want to make it as complete and accurate as possible. Take some time, please, and jot down all of the slogans used by your locals. If you have some extra time, go after your semi-locals as well. I need your information to confirm whether a slogan already listed is still being used (remember, it's been a few years since the last edition of the Almanac was published), if any new ones can be added, or if listed slogans are obsolete and should be discarded. Many entries in my master list are years old, some date back to 1980; this information needs to be updated. Presently, the List is especially weak on stations on the Graveyard frequencies, and many daytimers are also not well represented. Your local "pests" are someone else's DX, so please help! It really does not take that long to do a survey of your locals, and if everybody in the club helps out, (even you, hi!) the Slogans List will truly be a valuable DXer's aid!

Please send your tips to: Rich Toebe
2388 American Avenue
Hayward, CA 94545

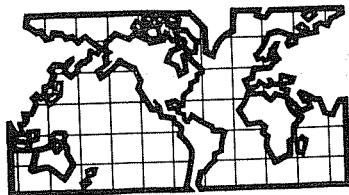

DX WORLDWIDE - WEST

Pat Martin - Editor

P.O. Box 843, Seaside, Oregon 97138

PHONE: (503) 861-3185

TRANS-ATLANTIC DX ROUNDUP

- 747 NAMIBIA, Gobabis-Radio Herero 3/11 at 0420 again. African choir 0421 into light Western mx. SW 3270 which was observed in // at my first reception was apparently not on the air, other Namibia SWs then were not //. Quite good signal but still not enough details for a report (REW) 1198 IRAQ, Don't count jammers as loggings, and 100% ID is hardly possible, but the bubbling sound of an Iraqi jammer is unmistakable, and was atop the unid JO. here 3/13 at 1655. (REW-Hi) 1224 IRAN/IRAQ, abadan 3/13 VOIRI had AA talk on "Qur'an al Karim" with typical Iraqi bubbling jammer at 1659. (REW-Hi) 1314 NORWAY, Kvitsøy-3/13 at 0456 10-note guitar and similar stringed IS to 0500 s/on NN ID, into nx, quite good and heard on two different beverages, but not on the 3rd. This Home service IS is not the same as the Foreign Service IS, also hrd on 1314. (REW-Hi) 1332 IRAQ, Another jammer here 3/13 at 1655, JOSF under (REW-Hi) 1458 ALBANIA, Lushnje 3/11 0435 Greek nx //SW6200 Good. Have hrd this one about 8 times now. (REW-Hi) 1566 IRAN, Bandar Abbas 3/13 at 1705 AR Rel. talk no jamming hrd this day but often hrd. (REW-Hi) SWITZERLAND, Sarnen 3/12 0543 brass band at 0545 GG talk, about the 4th time hrd here. (REW-Hi) 1593 WEST GERMANY, Langenberg-WDR 3/11 0438 light mx, GG anmts. Fair (REW-Hi)

PAN-AMERICAN DX ROUNDUP

- 535 GRENADA, St. Georges-Radio Grenada at 1000 1/14 apparent s/on. Audio v/ muddy sig. weak. New Country. (AWP-Ca) 700 JAMAICA, Montego Bay JBC 3/13 0657 reggae, 0700 Jamaican-accented DJ into soul and rock, promo'd his show as running 11:30 PM to 6AM daily M-F. ID "On the new one" (Radio One of JBC) Checked other JBC channels but no sign. A little WLW and Latin, perhaps Colombia, at times, but mostly good. Country #68 and unexpected. (REW-Hi) 770 URUGUAY, Montevideo Radio Oriental CX12 3/11 booming signal on a vintage South American night which for once did not favor Brazil. Phone interview w/the commentator of the game in which Uruguay beat Ecuador. Frashback recordings on goal during it. Time checks and SS rr. In clear occasional traces of KOB 0423-0450. (REW-Hi) 854 PERU, Lima Radio Nacional OAX4A 3/11 at 1005 news by two alternating males. Heterodyne against unid on 855. (REW-Hi) 930 PERU, Lima-Radio Moderna OAX4E 3/7 0420-0440 "todos los exitos.... a través de Radio Moderna" Peruvian pops o/u KHJ (REW-Hi) 1180 CHILE, Santiago-CB118 Radio Portales 3/11 1000 s/on nx appeal for volunteers to help earthquake recovery, tcs, lottery results. This should be the best bet for Chile in most parts of U.S. Also heard 0400. (REW-Hi) 1200+++ BOLIVIA, Santa Cruz-Radio Oriental CP31 3/11 0920-0952 (WOAI carrier on) SS DJ show w/tcs in AST, Andean folk mx, one singer promo'd her coming performance, speaking in Aymara w/many SS words, gift shop ads, many IDs, flute and accordean folk mx, Indian accented SS. Good signal at best, only QRM a Latin farther North, perhaps in Colombia. Country #67, my best ever Latin catch, and most colorful programming. Now I just need the three former Guianas. (REW-Hi) 1260 BRAZIL, Sao Paulo, Radio Mulher ZYK688 3/13 at 0513-0600 DX show, phone interviews, ads for a slimming aid, sambas and tropical mx, voice and sung IDs as "Radio Mulher. Brazil #12 and Brazil may talk over Colombia as number 1 South American country here. Good a little KGIL. (REW-Hi) 1300 PERU, Lima-Radio Atalaya OAX4M 3/7 0400-0430 phone interview w/Argentinian comedian, quoted Lima newspaper, nx promo, romantic and rr mx, some in EE (REW-Hi) 1335 ECUADOR, Machala-Radio Nacional El Oro 3/13 at 0800 nx, 0805 sports into Ecuadorian mx, many IDs as "Radio El Oro" Machala #3 here (REW-Hi) 1340 MEXICO, Los Mochis, Sin. Radio Variedades XECW 3/8 0330 atop briefly w/clear ID "XECW Radio Variedades Los Mochis" into romantic mx, but not enough for a report. Beware, there are other Radio Variedades here (REW-Hi)

- 1400 MEXICO, Culiacan Sin. Radio Felicidad XEEX 3/8 0300 Nortena mx, many IDs for Radio Felicidad and XEEX, tcs for MST, alone and clear, KRE nulled by using most Southerly Beverage. (REW-Hi)
- 1410 MEXICO, Los Mochis, Sin. XECF 3/13 at 0559 s/off after full s/off text, specifying 1,000 watts. #2 Los Mochis here, clear little KERN. (REW-Hi)
- 1560 UNID, 3/11 1010-1020 serious talk/discussion pgm in Indian language, strongly suspect Peru. (REW-Hi)

TRANS-PACIFIC DX ROUNDUP

- 585 U.S.S.R., Svobobnyy, hrd fair w/Radio Moscow IS at 1259 on 3/19. Best hrd in a while. (PM-Or)
- 720 U.S.S.R., Yuzhno-Sakhalinsk-Moscow JJ Service vy good o/u KDWN and 1340 on 3/19. (PM-Or)
- 801 U.S.S.R., Unknown Far East location 3/11 at 0850 Ulan Ude the farthest east listed, seems a little too far West for the time. Political speech in RR. Ulan Ude is listed as carrying Foreign Service. (REW-Hi)
- 1116 U.S.S.R., Unknown FE 3/9 0915 clas. violin duet. Bearing suggests The Vladivostok area rather than father North or West. (REW-Hi)
- 1134 INDIA, Calcutta 3/13 at 1700 Indian vocals w/ squeezebox type accompaniment. Vy good on Buenos Aries beverage whose back bean hits Calcutta, and only South Asian at this time. (REW-Hi)

VERIFICATIONS:

- 837 PHILIPPINES, General Santos City-DXRE, rec. a nice letter back after 1½ years. By the letter apparently my report was correct, as they read my report over the air, the Manager was quite excited and they mentioned that "they would never be heard this far". This is Philippine #7 QSL'd. 1KW. (PM-Or)

THANKS TO THESE REPORTERS:

- AWP-Ca Art W. Peterson-851 31st Street-Richmond, California 94804
 REW-Hi Richard E. Wood PHD-Post Office Box 5074-Hilo, Hawaii 96720
 R-1000, 3 Beverages
 PM-Or Yer Editor
 SP-600JX, 2 East Beverages 1500' long, Term. 200' LW, Grounds.

KANUCK KATZES! Hudes of da Knorth. April 1, 1905

- 540 NB CLIP Joint, Manitoba...usual Barbershop music.
 555 PQ CINQ Five, Quebec...Cinq is five in French, ya hosers.
 610 AB CBER Drumhecker, Albirda...with Good Buddy Mike Raphone.
 620 NS CBED Seabed, NB...Cleaver Slogan, CBC. "Seated Radio".
 640 NF CBAD Needs Glasses, Newfoundland.
 650 SA CAPE Moose Meat, Sask... "The Crazy Sound From Tinny Town"
 690 BC C... Calls unclear... "Sea Hunt Radio 69" Lloyd Bridges, DJ.
 770 NB CAB Fare. Testing with Tijuana Band music.
 810 PQ CAPE Ex-presso...now country music...pour me another cup of
 900 BC CALM Cool--Collected "Twin Cities Radio"
 1010 BC COOL Aid, BC...a twin of 900-CALM
 1060 AB CALL Letter...soon on the air.
 1120 ON CASH Johnny...Yahoo! Another Metro Hogtown country sound.
 1200 ON CQQQ Ham--Ilton testing with Morse code.
 1210 NF CASE Beer, Newfoundland...a new twin for G-jug.
 1280 MB CORN Cob, Manitoba "Corny Music"
 1310 UN CLAP Your Hands, Ontario. Is this still on?
 1330 UN CATV testing with leaks, distortion, & the usual...
 1340 MB CUSA Winnigoose. CP for 1,000,000 watts U1
 This one will broadcast entirely in "Americaneese"
 to those wishing the truth about America. The RCMP
 are screening announcers now.

A new...what else...twin network in BC! All news: CABC, CCBS, CHBC, CBBC, CVOA, CNHK, & CMBB will twin oother, CPBI.

Next time...there won't be a next time! You guys steal all my stuff, print it in your crummy log and leave my name out. Ya hosers!

THE INTERNATIONAL RADIO CLUB OF AMERICA

THE IRCA IS A NON-PROFIT ORGANIZATION DEVOTED TO THE HOBBY OF LISTENING TO DISTANT STATIONS ON THE AM BROADCAST BAND (535 TO 1625 KHZ). DX MONITOR, THE OFFICIAL PUBLICATION OF THE IRCA, IS PRINTED 34 TIMES PER YEAR: WEEKLY FROM OCTOBER TO MARCH, TWICE A MONTH IN SEPTEMBER AND APRIL, AND MONTHLY FROM MAY TO AUGUST. DX MONITOR CONTAINS MEMBERS LOGGINGS, INFORMATION AND ARTICLES ON RADIO STATIONS, RECEIVER REVIEWS, TECHNICAL ARTICLES AND CONSTRUCTION PROJECTS, TIPS ON DX'ING, NEWS OF MEMBERS' DX'ING ACTIVITIES, AND OTHER MATERIAL TO HELP MEMBERS ENJOY THEIR HOBBY. IRCA ALSO PUBLISHES VARIOUS BOOKS ON MEDIUM WAVE DX'ING AND HOLDS AN ANNUAL CONVENTION AND OTHER ACTIVITIES.

CLUB ADDRESSES AND OFFICERS

PRESIDENT: PHIL BYTHEWAY, 9705 HARY AVENUE N.W., SEATTLE, WA 98117. PHONE: 206-784-5145.
SECRETARY-TREASURER: RICH SEGALAS, P. O. Box 26254, SAN FRANCISCO, CA 94126.
EDITOR-IN-CHIEF: BRUCE PORTZER, 6546 19TH AVENUE N.E., SEATTLE, WA 98115. PHONE: 206-522-2921.
BOARD OF DIRECTORS: ERNEST COOPER, NANCY HARDY, RIC HEALD, NEIL KAZAROSS, BRUCE PORTZER, PETER TAYLOR, AND NIEL WOLFFISH.

MEMBERSHIP DUES

U.S.: \$20.00 PER YEAR: CANADA AND MEXICO (ONE ISSUE MAILED EACH WEEK): \$26; (TWO ISSUES EVERY TWO WEEKS): \$20; OVERSEAS: SURFACE MAIL, \$21; AIR MAIL TO CENTRAL AMERICA, COLOMBIA, VENEZUELA, AND THE CARIBBEAN, \$27; AIR MAIL TO LATIN AMERICA, WESTERN EUROPE, NORTH AFRICA, AND THE MIDDLE EAST, \$30; REST OF THE WORLD AIR MAIL, \$34. SPECIAL TRIAL MEMBERSHIP \$17.50 TO U.S., CANADA, AND MEXICO ONLY, INCLUDES 10 ISSUES OF DX MONITOR AND A NEW MEMBER PACKET. MAKE CHECKS AND MONEY ORDERS PAYABLE TO IRCA AND SEND DUES TO: IRCA, P. O. Box 26254, SAN FRANCISCO, CA 94126. PERSONS LIVING OUTSIDE THE U.S. SHOULD MAKE DUES PAYMENTS BY INTERNATIONAL MONEY ORDER IN U.S. FUNDS. SAMPLE COPIES OF DX MONITOR COST 50¢ EACH OR THREE INTERNATIONAL REPLY COUPONS.

OPINIONS EXPRESSED IN DX MONITOR ARE THOSE OF THE ORIGINAL CONTRIBUTOR AND NOT NECESSARILY THOSE OF THE IRCA. ITS OFFICERS, EDITORS, OR PUBLISHING COMMITTEE. UNLESS OTHERWISE NOTED, PERMISSION IS GIVEN TO RE-PUBLISH NON-COPYRIGHTED MATERIAL PROVIDED CREDIT IS GIVEN TO IRCA AND THE ORIGINAL CONTRIBUTOR.

FIRST CLASS MAIL
U.S. POSTAGE
PAID
Seattle, WA
Permit No. 601

first class

19

D. A. NYHOLM
2071 CEDAR STREET
SAN CARLOS CA
94070

Postmaster: if undeliverable, return to
P.O. Box 21074, Seattle, WA 98111, U.S.A.