



# DX Monitor

Devoted Exclusively to  
Broadcast Band DXing

January 11, 1986

Volume 23, Number 16

Issue 739

## In This Issue

Broadcasting Information .....	2	Eastern DX Roundup .....	14
Eastern DX Forum .....	6	Western DX Roundup .....	16
Western DX Forum .....	7	DX Worldwide West .....	18
The IRCA Technical Column .....	11	Format Experimentation on AM ..	19

## DX Test

Tuesday January 14, 1986

WFIX-1000 in Jenkins, KY will test 0130 to 0230 EST with tones, music and lots of IDs. Reception reports should go to Mr. John Mussell, Chief Engineer, P.O. Box 312, Jenkins, KY 41537. Arranged by John Malicky, NRC. Info via Mike Knitter.

## Odds and Ends

Get-together: There will be another get-together in Seattle on February 1, 1986 from 2 p.m. onward. As usual, it will be held at the home of Bruce and Evelyn Portzer, 6546 19th Avenue Northeast, Seattle, 98115. Bring potluck munchies, pop, or beer, receivers, veries, or whatever else you may want to produce for show and tell. Around dinner time, we'll pass around the hat for pizza or whatever else sounds good. For more information call 206-522-2521.

IRCA Almanacs: Orders for the IRCA Almanac, fourth edition, should now be sent to the IRCA good factory in Tempe, AZ (see back page). Prices, etc are the same as in earlier bulletins.

IRCs: We're almost out of International Reply Coupons. If you were thinking about ordering some but haven't, then wait. We'll let you know when the supply is again replenished.

British Pirates: We reported several weeks ago that the British Offshore Pirate, Radio Laser, was off the air. The full story is that on November 6, the ship raised anchor and was escorted into Harwich by a government surveillance ship. The station had had generator problems for several weeks and during a Force 9 storm on the evening of Nov 5, they suffered a complete power failure and requested assistance from the British government vessel. There had been rumors of unrest on board for some time, including reports of unpaid wages and horrendous living conditions. Food and equipment for the ship were smuggled in under cover of darkness, but the station was "out of everything, even toilet paper". There were also reports of unpaid adverts and other deals that fell through. In the aftermath, Radio Caroline, the only other offshore station, took over Laser's old frequency of 558 kHz. (Info condensed from recent Review of International Broadcasting.)

New DX Worldwide II Editor: Pending board approval, the new DX WWII editor will be Paul Swearingen, PO Box 4812, Panorama City, CA 91412. Paul is well known in DX circles, as editor of other columns for NRC and Monitoring Times. We'll be looking forward to his columns in the not too distant future.

Glad to see the reports picking up after the usual Christmas season slack. Hope Santa was good to all of you and that you'll all have good DXing in 1986. In the meantime, enjoy this week's DX Monitor.

## BROADCASTING INFORMATION

Greg Monti, 1301 S. Cleveland St. #356, Arlington, VA 22204  
prepared 21 Dec 85

call	kHz	day/night	at city
WSON	600	500/	OH Salem wants 1000/
KSTR	620	5000/	CO Grand Junction application for 5000/1000 returned
new	640	50000/1000	GA Atlanta granted construction permit
new	640	1000/1000	FL Wildwood wants WPMA
appl	670	500/	TN Farregut
appl	680	5000/	MT East Helena
appl	700	1000/	AR Marvell application returned
appl	700	5000/	FL Union Park application returned
appl	700	220/	VA McLean (reapplies with lower power)
appl	720	10000/1000	FL Dover (reapplies)
KQLX	720	500/	ND Lisbon granted 890 kHz (Dabelatein NRC) This freq change occurred before station ever went on air and was never reported by FCC notices
KTOX	730	500/	ID Boise application for 1000/ dismissed
KSSS	740	1000/250	CO Colorado Springs wants 3000/1500
appl	740	5000/800	WA Auburn (reapplies with lower power)
WRGE	750	2500/	PA Olyphant wants 400/
new	760	10000/1000	FL Brandon granted construction permit (was 770 once)
WSST	820	50000/1000	FL Largo granted WRFA
WRFD	880	5000/	OH Columbus granted 50000/
WPRX	880	1000/500	PR Sabana Grande granted WBOZ
appl	890	25000/1000	CA Rosamond (reapplies)
appl	890	25000/1000	MA Dedham (reapplies?)
appl	890	5000/	MN Blackduck
appl	890	1500/	MO Gladstone
appl	890	1000/	MO Smithville
appl	890	10000/1000	NM Bernalillo (reapplies)
appl	890	10000/	PA Nicholson (reapplies)
appl	890	10000/	VA Falmouth (reapplies?)
appl	890	25000/	VA Surry (reapplies?)
KYSR	920	1000/500	TX El Paso granted KDXX
WBYG	930	500/500	IL Sandwich granted 710/2200 (not 710/2600)
KDOT	960	5000/1000	UT Provo granted KLZX
KMIN	980	1000/	NM Grants granted 1400 kHz and 1000/1000
WCEL	990	10000/	NC Southern Pines granted WEEB (again)
KMLO	1000	2500/250	CA Vista wants KKOS
new	1020	500/	AL Heflin granted WBSH
appl	1020	2500/	MI Mount Pleasant application dismissed
new	1020	1000/1000	PR Adjuntas granted construction permit
appl	1020	2500/	SC Blythewood application returned
appl	1020	1000/	TN Alcoa application dismissed
new	1030	5000/	MI Sterling Heights granted WWRM
WGTX	1040	1000/	AL Fort Deposit granted WLUL
appl	1040	25000/1000	NY Delmar
appl	1040	10000/250	NY Owego
appl	1050	2500/	CA Frazier Park (competes with existing application)
appl	1050	5000/	NV Winchester
WOKL	1050	5000/	WI Altoona call change to WISM set aside, then granted WISM again
WWTG	1070	250/	MI Stanwood wants 10000/1000
WJKK	1070	10000/	WV Beckley granted WCIR (again)
appl	1060	1000/	CA Templeton
appl	1090	1000/	MN Fergus Falls
appl	1120	500/	AL Oxford application returned
new	1120	1000/1000	MA Concord granted WWCC ("Walden Communications")
new	1120	1000/	TX Manor granted KTCO
WDGY	1130	50000/25000	MN Minneapolis wants 50000/30500
WONQ	1140	2500/	FL Pine Hills granted Orlando FL, wants 5000/
appl	1160	10000/400	GA Sandy Springs application returned
KERI	1180	10000/1000	CA Wasco wants 50000/1000
WKKE	1180	10000/5000	MS Pearl granted 50000/5000 (not 50000/50000)
WGCR	1180	1000/	NC Brevard granted 720 kHz and 1000/ (Starr NRC) This freq change was made before station ever went on air and was never reported by FCC notices
KMCW	1190	500/	AR Kensett wants KMOA
WXTO	1190	10000/5000	PR San Juan granted WBMJ (again)

WKOX 1200 50000/50000 MA Framingham has apparently decided not to use the whole 50000/50000 recently granted them and will be 10000/1000 once construction is complete(Conti NRC)

KLAZ 1250 1000/500 AR Little Rock granted 2500/5000  
 KWFI 1260 1000/ ID Weiser wants KUZN ("cousin"?)  
 KIPR 1260 500/ TX Huntington wants KBBQ (Texas "barbecue"?)  
 WSHF 1290 1000/ AL Sheffield granted WHCM  
 appl 1290 1000/ MS Meridian  
 KKQA 1300 5000/5000 UT Nephi application to extend time to construct new station denied. Delete. (Starr NRC)

KKCC 1320 1000/ OK Clinton granted KXOL  
 WLGW 1320 1000/ VA Lynchburg granted WHRQ  
 KLBS 1330 500/ CA Los Banos wants 500/5000  
 KSKI 1330 5000/1000 ID Hailey granted KNRC  
 KLVR 1340 1000/1000 UT Heber City wants 1210 kHz and 5000/1000  
 WINY 1350 1000/ CT Putnam wants 5000/  
 WEBB 1360 5000/ MD Baltimore granted 1000/1500 (earlier report says 5000/1700)

WBLC 1360 1000/ TN Lenoir City wants 670 kHz  
 KMMM 1370 1000/ TX Austin granted Rollingwood TX and 5000/500 and granted KOKE (again)

WZEL 1380 500/ GA Young Harris granted 770 kHz and 750/  
 WKY 1380 2500/ KY Winchester granted WHRS  
 KCHS 1400 250/250 NM Truth or Consequences wants 1000/1000  
 WANK 1410 1000/ MA Brockton granted WATD  
 WGGW 1410 5000/ VA Chester granted 820 kHz and 10000/1000  
 WINI 1420 500/500 IL Murphysboro granted 420/420 (still has appl for 1000/500)

WMYL 1420 1000/ NY Herkimer granted WLIR contingent on WMYL's owner, Phoenix Media, being granted interim operating authority for WLIR-FM 92.7 Garden City NY. The FM's license has been under challenge for about 15 years. The use of the WLIR calls on the out-of-town AM station gives Phoenix an advantage over all the other competing applicants; it has the well-recognized call sign which any future owners of the FM will want to have. If someone else ultimately wins the FM license, he'll have to give up the WLIR calls to the then-no-longer-co-owned AM in Herkimer, unless he makes a deal, possibly including ownership interest, with Phoenix. This arm-twisting strategy which assures Phoenix that it will be a party in the winning applicant, could not have been done a year ago when AM's and FM's in different cities couldn't have the same calls.

KNTA 1430 1000/1000 CA Santa Clara granted 1000/2500  
 WBUG 1430 1000/ SC Ridgeland wants 880/  
 appl 1440 1000/ AR Pea Ridge application dismissed  
 new 1440 1000/ AR Lowell granted construction permit (funny, I seem to remember seeing this application dismissed!)

new 1450 250/250 CO Buena Vista granted construction permit  
 appl 1450 500/250 CO Buena Vista application dismissed in above grant  
 WMYB 1450 1000/1000 SC Myrtle Beach granted WCSE  
 new 1450 1000/1000 UT Saint George granted KATJ (replaces KDXU which moved to 890 kHz)

KOLI 1470 500/ CA Coalinga granted KKF0  
 WKCK 1470 1000/1000 PR Orocovis granted 1000/2500  
 WPWC 1480 500/500 VA Quantico wants 1000/500  
 appl 1490 819/819 SD Custer (competes with existing application)  
 WYKR 1490 1000/1000 VT Wells River granted 1100 kHz and 5000/ (daytimer)  
 WNNR 1500 1000/ LA New Orleans correction to last month: this station does not exist (Starr NRC)

WGMF 1500 1000/ NY Watkins Glen wants 1490 kHz and 1000/1000  
 KCIG 1500 500/ WA Tumwater wants KCIF  
 WLGC 1520 5000/ KY Greenup application for 9000/ returned  
 KSMH 1530 500/ MN Shakopee wants 8670/  
 WWMK 1540 250/ MI Harrison construction permit extended for new stn  
 WRHC 1550 10000/500 FL Coral Gables appl for 1560 kHz and 50000/5000 returned; still has appl for 10000/4400 on 1550

KAJN 1560 1000/ LA Crowley never changed calls to KPWS, still KAJN  
 KPTJ 1560 500/ WA Sumner granted KARP  
 WVVW 1570 1000/ WV Saint Marys appl for 630 kHz and 500/ returned

WEBG 1580 1000/ PA Ebensburg application for 650 kHz dismissed  
 KTLU 1580 500/ TX Rusk wants 1000/  
 WQIQ 1590 1000/1000 PA Chester granted WCZN

The period which a permittee now has to construct a radio station has been increased from 12 months to 18 months. The FCC, in making this rule change, also put the broadcasting industry on notice that strict guidelines would be applied to anyone who asks for an extension of time to construct, i.e., that abuses of the relaxed rule would not be allowed. (BC)

Canadian death row update: Two CBC-owned AM stations not mentioned in any earlier lists have been given short-term renewals: CFGB 1340 Happy Valley NF and CBDP 1490 Webush NF. Providing that adequate FM service of the CBC mono network is available in those areas in a year or two, the Canadian Radio-Television and Telecommunications Commission will order these two stations off the air along with those already mentioned. Also, the CBC has surrendered the license for CBNC 1190 Stepphenville NF. It went off the air 7/1/85; service now provided by CBNC-FM. (MSJ)

Except as noted from the 25 Nov and 2, 9, 16 Dec issues of Broadcasting and from the 25 Nov and 2, 9, 16 Dec issues of The M Street Journal.

-----  
**RADIO PROGRAMMING NOTES:**

call kHz st city  
 WIND 560 IL Chicago now Spanish as of 1300 CT on 12/12, was news-talk  
 WOCR 560 TN Brentwood new station is contemporary hits "Car 56"  
 WRTH 590 IL Wood River adds NBC network (Kemp NRC)  
 KXOK 630 MO Saint Louis drops NBC network (Kemp NRC)  
 WNZK 690 MI Westland new station is ethnic format, "Station of the nations" (Rose NRC)  
 WAQI 710 FL Miami dropped Mutual Larry King show upon going Spanish(Kemp)  
 WOCR 720 NC Brevard new station is country  
 WQSF 740 VA Williamsburg now easy listening FM simulcast, was adult standards as WMBG  
 WKYJ 770 KY Nicholasville new station will be religious  
 WABC 770 NY New York dropped some of the ABC Talkradio programming it was carrying: Michael Jackson, Toni Grant & David Viscott(KempNRC)  
 WBBM 780 IL Chicago adds radio classics weeknights at 2000 CT begin 12/16  
 KGO 810 CA San Francisco has announced the return of Owen Spann, the talk host who left for ABC Talkradio, New York, last year. Spann's new KGO show is fed live from New York at 1100 PT which is just after his network show which still runs at 0900 PT (BC)  
 WBHY 840 AL Mobile now silent, was rock oldies  
 WEAT 850 FL West Palm Beach now easy listening, was adult contemp as WCGY  
 WCKS 860 FL Cocoa now contemporary hits "CK 86," was black as WJZX  
 KONO 860 TX San Antonio now rock oldies, "Your one and oldies station," also adds NBC news at :54 past hour (Hale NRC)  
 KQLX 890 ND Lisbon new station is country "Q country" (Debelstein NRC)  
 WRXJ 930 FL Jacksonville now rock oldies, was black as WJAX  
 WBYG 930 IL Sandwich new station is adult contemporary  
 WBBF 950 NY Rochester now rock oldies, was news-talk (BC)  
 WDCE 970 NM Espanola now country, was Spanish  
 WMMA 990 FL Orlando now adult contemporary "Magic 99," was country as WHOO  
 WIXI 1000 FL Jupiter now contemporary hits, was black  
 WJOR 1040 TN Saint Joseph new station is country and gospel  
 KLSC 1090 CO Aurora now soft adult contemporary, was ad con as KLSZ  
 KKLC 1110 LA Pineville now silent, was country as KPAL  
 WDFB 1170 KY Junction City new station is religious/gospel  
 WWLD 1190 FL Pine Castle now a mix of adult standards & visitor information (for Orlando), was straight adult standards as WREM  
 KLDI 1210 WY Laramie new station is adult contemporary, "The 10000 watt stereo diamond in the gem city" (Moser NRC)  
 WBOP 1230 FL Pensacola now black, was country as WNVV  
 KLIC 1230 LA Monroe now rock oldies, was country  
 WNDE 1260 IN Indianapolis is bringing back more news and features under Taft ownership and is playing later oldies ('60s thru '80s instead of '50s thru '60s) (Kemp NRC)  
 WAOB 1280 IN Winamac new station is on air, format unknown  
 KESP 1290 CA Santa Barbara now Spanish, was silent  
 WCCC 1290 CT Hartford now country, was contemporary hits  
 WFBR 1300 MD Baltimore adds CBS network (Kemp NRC)  
 KHBS 1310 LA West Monroe now adult standards, was jazz as KUZN  
 WEBY 1330 FL Milton now adult contemporary, was silent as WAVX

WBEM 1350 PA Windber now news-talk, was country as WQBR  
 WKAT 1360 FL Miami Beach adds Mutual's Larry King Show (Kemp NRC)  
 WFIW 1390 IL Fairfield now country, was adult standards  
 KSUN 1400 AZ Phoenix back on air, format unknown, was silent (Carpenter NRC)  
 KDBS 1410 LA Alexandria now religious/gospel, was adult standards (NOYL)  
 WATD 1410 MA Brockton now silent, was adult contemporary as WAMK  
 KESY 1420 NE Omaha now easy listening, simulcasting FM, was adult standards  
 as KROM  
 WLAU 1430 MS Laurel now silent, was religious  
 WRPZ 1440 KY Paris now black "Z-1440," was adult contemporary as WILP  
 WJBX 1450 CT Bridgeport now adult contemporary, was silent as WNAW  
 WLPW 1450 VA Suffolk now contemporary hits, was adult standards  
 WGUD 1460 MS Moss Point now soft adult contemporary, was black and country  
 as WJKK  
 KGHO 1490 WA Hoquiam now SMN Stardust adult standards, was Transtar Format  
 41 (adult standards-adult contemporary mix) (Hardy NRC)  
 WLGY 1500 OH Xenia now rock oldies, was country as WBZI  
 KNTS 1510 AZ Mesa now news-talk-sports, was urban contemporary as KDJQ  
 (Carpenter NRC)  
 WOIX 1510 NC Blowing Rock soon to be soft rock, was contemp hits (Mitkus NRC)  
 WADM 1540 IL Decatur now silent, was adult contemporary  
 WPKY 1580 KY Princeton now contemporary hits, was country  
 WSLI 1580 MS Centreville now silent, was black  
 WPSL 1590 FL Port Saint Lucie new station is rock oldies (Hughes NRC)  
 WCZN 1590 PA Chester now country "country cousin," was rock oldies (?)  
 as WQIQ (Apel PA & Schmidt NRC)  
 KCRG 1600 IA Cedar Rapids now adult contemporary, was adult standards

**Networks:** Dr. Sonya Friedman from WXYT 1270 Detroit will fill the Monday-Tuesday 1700-1900 ET slot on ABC Talkradio recently vacated by Dr. Toni Grant. (BC)

The Mutual Radio Network was officially bought by Westwood One on 12/2 for about \$39 million. The seller was Amway, the home products concern. Mutual is now a sub-network of Westwood One. Mutual will keep its name and will continue to concentrate on news, talk and music shows geared for older adults while Westwood One continues to concentrate on rock and country music, Spanish programming and specials for younger audiences. Mutual's "Larry King Show," currently fed 0006-0500 ET Tue-Sat will be extended to feed 2306-0500 ET beginning 2/3. The 0306-0500 portion will be a repeat of the 2306-0100 portion each day and live interviews with newsmakers and reporters will often be heard in the first hour, giving it more of a current-events sound. (BC and Monti)

**Other news:** With General Electric swallowing up RCA, including RCA's subsidiary NBC, in a \$6.3 billion deal, expect some or all of NBC's radio stations to be up for sale to comply with the FCC's one-station-to-a-market rule. (Existing AM-FM-TV combinations are grandfathered until ownership changes.) Assuming the sale goes through and unless GE applies for (and gets) a waiver of the rules, WNBC 660 New York, WMAQ 670 Chicago and KNBR 680 San Francisco may all be sold by the end of 1986. (BC)

The offshore pirate Laser 558 went off the air for ship repairs and was confiscated when it sailed into British waters. Radio Caroline, Laser's offshore competitor, is duplicating its programming on 558 kHz to fill the gap. (MSJ)

Statistical Research's RADAR 32 report on national radio listening reports that AM listenership is at a new low. Of all radio listening done on the average day in the US, only 28.2% is to AM stations. However, radio continues to reach 95% of all persons in the US over the age of 12, a cumulative audience of 185 million people. (BC and MSJ)

(Programming items are from The M Street Journal except BC = Broadcasting, NRC = National Radio Club PX News or named reporters)

**RECENTLY ANNOUNCED (and still pending) STATION SALES:**

KENI 550 AK, WGAI 560 NC, WRUS 610 KY, KHOW 630 CO, KDWB 630 MN, WKKK 650 MN, KKUA 690 HI, WOZW 710 ME, WWJ 760 MI, WYAI 780 MS, WBHY 840 AL, KFRE 940 CA, WRGL 940 OR, KTON 940 TX, WOOB 1030 AL, WAMT 1060 FL, KATQ 1070 MT, WRLX 1230 AL, KEZD 1230 NV, WJPD 1240 MI, WHPA 1240 MS, WWON 1240 RI, KSOK 1280 AR, KZBQ 1290 ID, WIBR 1300 LA, KEIN 1310 MT, WJQZ 1310 PA, WRAM 1330 IL, WQKJ 1350 SC, KOFE 1400 ID, KEYL 1400 NM, WHCC 1400 NC, KLLB 1410 CA, KMLB 1440 LA, WMER 1440 ME, WBLA 1440 NC, WWMW 1450 GA, WQLS 1460 OH, WVTV 1470 FL, KDUN 1470 OR, WDUR 1490 NC, KOAW 1490 NM, WBXM 1540 MO, WBRV 1540 TN, KVAN 1550 WA, WXTR 1560 MD, WBKC 1560 OH, WLFR 1570 NY, WKBH 1570 WI.

# EASTERN DX FORUM

RICHARD EVANS  
English Village Apts; Bldg 23 Apt. B-6  
NORTH WALES, PA 19454

Deadlines: Saturdays  
Deadline for Anniversary Issue: 3/8  
This column typed: 12/28/85.

John H. Demmitt, Box A K0848, Bellefonte, Pennsylvania 16823

Due to a slight mix up in my membership renewal, I have not been contributing on a regular basis as I have in the past. After seeing the wrong address listed in Karl's column for myself and in a later column, my loggings but no name or address, I decided to take the hint and start contributing on a regular basis before I am entirely forgotten, hi. On Dec. 15th, I was surprised to find spurs from WRSC-1390 State College, Penn. on the frequencies of 1360 and 1420 kHz. Frequencies inbetween, including neighboring 1380 and 1400 kHz were not affected and the normal stations could be heard there without QRM. I sent the station notification of the malfunctioning transmitter at the end of the day when it appeared they were not aware of the problem. (Second report) WRSC-1390 continues to dump their modulation on 1360 & 1420 kHz in spite of being aware of the problem. This has been going on for over a week so perhaps they will be receiving a visit from the FCC. Propagation from the south is unusually good for this time of the year and one can often hear stations from Central and South American during the dark hours so this is your chance to catch some unheard stations. Best to all during the new year. 73.

Richard C. Evans, English Village 23-B-6, North Wales, Pennsylvania 19454

A couple of quick notes. A few DXEs ago, Bill Hardy mentioned that the western boundary of CDXR is no longer the Rocky Mountains. I thought it had been changed but I don't have even an outdated copy of the Editorial Policy here. However, technically he's right about the 85th meridian, and I'm wrong about the eastern boundary of CDXR following a line running north/south thru the Indiana/Ohio state line. However, a check of the map at work shows that the 85th line falls only about 12 miles west of the Ohio state line. The Ind/Ohio line makes a good reference point that most can easily use. And that should be the major deciding point: What is the easiest thing for the members of the club. I feel the current way of doing things is the easiest. The time question got started this time around by the suggestion that each member use his own local time when reporting to the columns. Now that we realize that no one column involves only one time zone, shouldn't we put the question to rest, and go back to passing on DX information and encouraging others to DX the AM band. Interesting Christmas card in today from a cousin who now lives in Hawaii (no return address on the envelope). He's studying electrical engineering at the University of Hawaii, and said it probably came as a result of a week I spent with him and his parents when they lived in Maine, and I introduced him to ECB DXing. When did it happen? February, 1966. We never know how we will touch other lives. PTL.

## Amateur Broadcasting Station 10-BQ

BRANTFORD, ONTARIO

CHIEF OPERATOR  
HAROLD BROWN



TELEPHONE  
CITY  
CANADA

ASSISTANT OPERATORS  
ALBERT ELLIS  
WILHELM BROWN  
EDGAR BROWN

250 METRES — 1200 KILOCYCLES

Regular D-X Programs  
First Saturday Morning  
in the Month  
2-3.30 a.m. E. S. T.

Nov. 5-1932	Special 2-3.30 a.m. E. S. T. Atlantic Radio Club
Dec. 3-1932	
Dec. 11-1932	
Jan. 7-1933	
Jan. 7-1933-Special ?	
Feb. 4-1933	
Feb. 7-1933-Special ?	
March 4-1933	
March 7-1933-Special ?	

Our Power at time of (Special  
D-X Programme

Power Output (Tube Rating 7 1/2 Watts)  
Using 2 Tubes as Oscillators - 15 Watts  
and Home-Made Double Button Microphone.  
Antenna Current 15 Amps.  
Input Volts 500. Milliamps 75 on Oscillators.  
Input Volts 500. Milliamps 30 on Modulators.

WE APPRECIATE YOUR REPORT.  
This will verify your reception.

*Harold Brown*  
Manager.



# WESTERN DX FORUM



EDITOR: RIC HEALD  
8539 BELLAMY WAY  
SACRAMENTO, CA 95828 USA

1986 DEADLINES - WEEKLY ON TUESDAY

TEVE MITTMAN, 2248 W. 37th ST., SAN PEDRO, CA 90732-4506 (213) 833-1010

Enjoyed the Ray Briem DX Special again this year. And again, as with last year, KABC 790 only carried two-thirds of the show. The rest was taken up by pots. And also again, as with last year, KTMS 1250 carried the entire program. However, KTMS was being severely QRM'ed by XEDL Hermosillo and another unID exican this year. Program was primarily about SWL, though they did touch on AM X a bit. It happens that I disagree with Briem's opinion regarding the breakdown of the Clears (and Regionals). He feels that it's good as it permits ore stations to come on and that smaller communities will thus be served. One ew people in the small communities might benefit, thousands more people who sed to listen to the "clear" station, now actually lose a station. How ironic rat as that point was being made, I was struggling to hear it through the 1250 ess. . .when KTMS used to be a semi-local here - and other callers were mplaining that KABC had lost its Central California/Bay Area reach due to KXTC lovis-Fresno now fulltime.

A good friend of mine just started college up in Thousand Oaks. (OK Ric, ou're always claiming to be such an expert on California. What college would rat be? (How are things at Cal Luthren these days? Next, hi-RtH.) I visited him ecently and the first thing I noticed was that you can see Comedy Radio KMDY's owers from his dorm. Funny - when I estatically pointed that out to him, I oticed that he didn't seem to be (shall we say) "overcome with emotion," hi. ren I further informed him that a station in Denver operates on their frequency d if we were back home we'd be hearing the Denver station instead, that piece f news didn't particularly excite him either, hi. Odd. But here's the clincher: ater on I told him that I wanted to excuse myself as I wanted to DX from my car or a couple of hours. (Surely a perfectly normal request!) He just had this lank look on his face, hi. Oh well - we DX'ers know what is truly important in ife, hi. Anyway, the results are in WDXR. Although Thousand Oaks isn't too far om L.A., it's just far enough away for the L.A. stations to be weak, and (in y opinion, if not perhaps legally), for Thousand Oaks to warrant itself as a istinct market. (Legality has nothing to do with markets, at least FCC-wise; ey could care less-RtH.)

I would like to input on the time zone usage discussion. Some would like to ee all columns use Eastern time, some would like for all to use UTC/GMT, and till others think that each column should use local time. I think that this mportant point should be kept in mind: Whatever system is used, supposedly that ystem should be the simplest system for the greatest number of people. herefore, what is the simplest system? My hunch is that it is simpler for most eople to convert to Eastern time than UTC. However, I also think that it's mpler for most people to use their own time zone, rather than to convert to other one. To resolve the issue, a ballot should be sent out for everyone to te. Additionally, whatever the outcome may be, I think that after the club has ted and used the system for a year, ANOTHER ballot should then be sent out skin people if they think it's working, or should they try another/the old athod. Often times it seems to be human nature to leave things as they are. (as ill Harms put it: "If it ain't broke, why fix it?") However, people - and clubs - must grow and evolve. To do so effectively, people need to know that they need ot fear that if they try something new and it doesn't work, they're stuck. As ng as people know that if a new way doesn't work, and they can always return o the old way or a different way, they will usually be willing to try something ew.

Ric, a morning drive DJ on 69 Extra Gold (XETRA) has the name of - Ric Thomas! on't tell me that you're commuting daily between Sacramento and San Diego like hat DJ who's flying between Houston and Chicago daily, hi. (Ya caught me, eave. Now I know where to send my "Catch Our Smile" bill to, hi-RtH.) 73 de 4M.

GARY LARSON, 2806 LINCOLN, BURBANK, CA 91504 (818) 843-3344

Left home the morning of 21 December driving to Palm Springs in search of new DJ 1140 transmitting site. It's just off I-10 north of the freeway between lm Drive and Date Palm Drive. Believe access is off Date Palm on a dirt road. here are five towers in all. After seeing them, I passed by KKAM's four towers 6699B Vista Chino. Apparently no road to them so access must be via a 4WD. I opped by KKAM and found rear door unlocked so went in and met the DJ, Gary ne and spoke with the CE who was preparing the FM van for a remote later on in

Palm Desert. We talked of radio and I showed him a copy of DXM; says he's seen the IRCA logo before. KKAM is C&W and their FM is rock. Left KKAM to find KPSI's tower. It's off El Cielo Road near highway 111. Someone at another station mentioned they may have to find a new site due to construction in the area.

After KPSI I went over to KWXY - front door unlocked, so went in. Talked to announcer who says I could come by during business hours for a tour. Stopped by KHNWZ 1270 and spoke to sports program host who gave me stickers. Was thinking of going by KRCCQ but since it's SS, doubted if I could go in. (Why?-Rth.)

Stopped at KGUD transmitter but no one there - I tried an old address, 101 E. Nicolette, but found Banning H.S. instead. (Did you at least DX a pom-pom? Hi-Rth.) Called an old number and was referred to an Arizona number. Called another and was transferred to KOLA-FM Riverside where I found out KGUD is operated from KOLA on weekends. KGUD transmitter is at 527 N. Omar. Stopped in at KCAL Redlands. Was told long ago they had three towers on Greenspot Road, but after driving the length of road, came back to the building at 29800 Greenspot and door was unlocked. Talked to the FM research director who says there's three towers off Boulder Avenue, East Highlands, so found them on Boulder north of Baseline. I got no bleedover on nearby frequencies, so believe this is a nighttime transmitter. Daytime transmitter (one tower) is located at approximately 27101 Lugonia Avenue near Alabama in Redlands.

Found my way to the freeway to head for KAVR. While on Barstow Freeway near Devore heard the KAVR s/off so knew I missed chance to see "AM 96 all oldies."

Jim Hilliker told me during recent call, KKAR 540 was building towers in desert. Decided to search for them. While in Victorville, tried locating KVVQ AM/FM. Two addresses in local phone directory - one on Civic Drive. No answer at that number so tried finding address. They're in a new building at 11920 Hesperia Road, Hesperia. Stopped, but unable to get a response. One thing I know, 910 is NOT on the air yet.

I went to KAVR @ Apple Valley Inn, but DJ told me by phone it was his first night there and was going by the books regarding station rules, so I headed east on highway 18. Had looked for and found KKAR 540 at 14901 Barstow Road, Lucerne Valley. Decided to find transmitter and sleep in car. About 15 miles from Apple Valley came to Barstow Road and could see two towers lit up north of the area. Ended up six miles north of highway 18. Wow! Both were spread out on open land and tall. Checked AM - lots of SS in well. Nothing to speak of that was new. 540 vacant, of course. In the morning discovered not two but six towers (only two were lit up); they're impressive. Listed power is for 1,500 watts and wonder if I'll be able to hear them when they go on. Transmitter building very small. Site is near or maybe part of Lucerne Dry Lake. Had thought towers would be close or in Hesperia.

On return trip stopped by KFXM 590 and talked briefly via phone to the DJ.

On way to L.A. cut across Ontario to Chino, past KTSJ transmitter at 3990 Riverside, and up past KWOW site to I-10 where I returned to Burbank.

JH says KWRM has to move transmitter because of I-15 freeway next to the site. Found the five towers south of Riverside Freeway east of new Devore Freeway on Parkridge Avenue.

Chatted briefly with Rth Christmas Eve and had a nice conversation. Learned the Valley and Bay Area have been socked in with fog. (And still is a week later, hi-Rth.) Here it's been almost summer-like.

RW, nothing here on 1500 yet.

73 to all.

#### RICHARD E. WOOD, P.O. BOX 5074, HILO, HI 96720 (808) 966-7091

Finally, and so late in the season, this year's first opening to Europe, as distinct from already-logged North Africa. It was 19 December, just a modest opening with two definite, DW Malta 1557 and WDXR Langenberg 1593; unIDs were Brazilians, the East Coast, many Asians and a rare log of WXLG Kwajalein 1224, relaying AFRS Los Angeles - the West Pacific is generally difficult here in east Hawaii.

My thanks to all who asked me questions or otherwise participated in the successful ABC TalkNet Ray Briem show. Compared with December 1984 it was an effortless night, as the audio piped via KABC landline was superb; thus I didn't have to tune to KGU (or in the first two hours, before KGU joined the net, direct to KABC) and then race back to the phone whenever a call seemed to be directed to me, and coming to a close, to beat the seven-second delay. Just as well, because, as Bruce Fortzer noted in 14 December DXM, conditions the night of the Ray Briem show were northerly - while he was getting northerly CFCW 790 and only a trace of his usual KGH, I was getting KGH rather than my usual KABC; also the Cuban, but at least not much KKON on the mainland Beverage.

December looks like the best DX month since record-breaking June; fall here, with no Europeans, no WDXR, no CBJ, no WRVA, nothing much of interest, was a washout, but with Europe and a slew of Brazilians now back, I can't complain about December. Latest verie is XENQ, La voz de Hildago, Culiacan, Sinaloa 1580, where the station accountant, saying it was unlikely any other staffer would answer me, took the responsibility of answering me. Interestingly, he said the only other non-Mexican report XENQ had had was from Japan, in the same time slot. Though I have seen, alas, many questionable reports from Japan at US



stations, this seems like a possible reception; I know XERF and other high-end Mexicans are heard in Japan.

Thanks to Roy Millar for his appreciation of my "Lapland" book review; also to Randy Seaver for pointing out that KSDG 1040 San Diego, which seemed to be listed in the Finnish booklet as already received, but rarely, in that country, is not on the air yet. I found a few other listings like this - CP's, silent stations, etc., which I might have queried in a longer review. No specifics of reception - date, time, name of listener or DX'pedition, etc., were given, and there may well be errors. But in its broad outline, the booklet seems accurate, and is in accord with many Finnish DX'ers. Don't hold your breath, but I really do plan to spend some future winter in Finland, probably teaching English at a college in Lapland, and originate some of that DX myself. I wonder how my bones will react after Hawaii - especially the warm, dry winter we're having. Aloha

GUY KUDLEMYER, 1320 CITY VIEW 31, EUGENE, OR 97402

OK gang, wake up and pay attention! It's question and answer time. OK, let me see a show of hands. 1) How many of you DX'ers mentally convert all of your words to Swahili or Tahitian before you speak? Uh huh. OK, question 2) How many of you DX'ers convert all of your money to yen or pesos or dinero before you spend your paycheck? OK, just as I thought. (Of course technically, dinero means money, hi-Rth.) Final question, and raise those hands high: How many of you convert all of your DX catches to GMT or NIDL? (Northern Indian Ocean Local Time) before you enter them in your logbook? Wow-it's worse than I thought. . . I bet you guys are the same guys who try to write a check in the 8 Items or Less, No Checks Please, Express line at the supermarket. The same guys who say, "Do you have a pen I could borrow,?" and "What's the date today?" while I'm standing in line behind you with two quarts of ice cream dribbling down my elbows.

In short, you're the guys who try to make everything more difficult than it really needs to be. Call me dense, call me thick-skulled, call me obstinate, but to me, converting all your catches to ELT or GMT or some other equally ridiculous and irrelevant time zone makes about as much sense to me as giving valium to a Postal worker.

For the record, I, like Ric, log everyting in the 24-hour time, Pacific zone. After all, that's where I live, on the West Coast, and I don't give a rat's tail-end what time it is in New York or Greenwich or Katmandu when I make a logging.

I see this time zone thing as such a non-issue that I just want to crack some heads when I see how much ink it's getting in DXM when there are so many more important things to be using our page space on. Things like, how to quell the increasing apathy towards reporting and participating in club elections that is spreading through the club like so much cancer. If any of you guys or gals are having a particularly rough time converting between time zones, drop me a line and I'll send you a conversion chart free of charge.. Maybe that'll take some of the trauma out of it for you. If we can just silence the time zone illiterates for a few minutes, maybe we can actually put some time and effort into attacking some of the REAL issues that our club needs to address.

There are 24 time zones in the world; enough of a selection for just about everyone. Let's pick one and agree on it and use it and get on with something else instead of quibbling over whose time zone to use like a bunch of school boys fighting over whose ball to use to play softball with. I don't know, maybe I'm missing it. Maybe there's some sort of perverse, convoluted logic in reporting everything in some irrelevant, exotic time zone for a place half-way around the world and I'm just not seeing it.

Maybe it impresses your girlfriend, your letter carrier or your dog. I see it as...as big of a waste of time and page space and ink as some of the Look How Smart I AM technical articles that are proliferating throughout the Mediumwave bulletins these days. At least the Look How Smart I Am types are sharing with us the fruit of their "being on the cutting edge of MWDX" labors and we should thank them for that.

The time zone hagglers are just wasting my time, and yours too. Let's all pull our heads out, resolve this thing and get on with DX'ing and reporting and quit arguing amongst ourselves about what time zone to use. It really isn't worth the time it took to type this forum.

OK, lecture's over. You all can go back to counting your dinero and practicing your Swahili. I'll sit down and shut up before somebody tries to silence me. .

RIC HEALD, 8539 BELLAMY WAY, SACRAMENTO, CA 95828 Tele-Forum: (916) 386-8677 to 2200 PLT & ppd

Looks like even mailing the column a day early to accomodate the Christmas rush didn't help matters with the 28 December DXM. Yes, with the exception of right along the coast, most of the west has been socked in with fog which doesn't help transportation matters any. The Sacramento/San Joaquin Valleys are accustomed to winter fog, but we've been setting records all over the place, not to mention te coldest December in 32 years for Sacramento.

Steve, I don't want to sound too jaded, but do you really think a ballot regarding time zone usage will produce results? I mean look at the dismal turnout for club elections. I'm wondering if this apathy might correlate with

the national public apathy in the '84 election when only 51% of the voters voted? Hey folks, this is YOUR club and it was founded on the sole purpose of the club members being able to have a say on what goes on in their own organization. Write or call your various BoD members and let them know your views and where you stand.

Richard Wood, in 21 December DXM noted your logging of KINS 980 Eureka. I'm a little puzzled, however. Eureka Adult School and the town of Arcata, correct, but KINS is an MoR station, granted however, many country artists have crossed over to the pop side - your reference to a C&W song. In the 3-plus years I lived there I made frequent references to Humboldt County. No Gresham County in California. Not one Gresham even in the phone directory, hi. Otherwise, good catch - hope they verify. KINS is not noted for quick verifications.

Sacramento Bee reported KAH1 950 Auburn now fulltime with 1.5 kw at night. Sure 'nough they're there and louder at night than with their 5 kw day signal. Can be nulled quite well to bring in a very strong XEGM. Swell. Never did see this in Broadcasting Info, unless I missed it which with all the changes in the last couple years is quite possible.

Finally fished out KQTL 1210 on 30 December at SRS. Also caught an unID with time check (MST) with a sports report, gave calls which sounded like KPOD (impossible, of course), maybe KR5V (?), but will keep after that one.

NRC Logbook lists KRAK 1140 as a U3 operation. Don't believe so anymore, possibly due to fulltime at KCMJ, although I would think KCMJ would have to concede to KRAK and fully protect them, but, twice now I've heard a two-second off air at 4:45 PM PST last week of December, which is power down time, indicating that KRAK now has maybe a different night pattern. CE at KRAK is impossible to reach, or has been to my previous calls.

For those writing me commenting on the "new look" of WDXF, please be patient. I think the kinks have been worked out. The 21 December issue looked OK, but as you can see I've played around with the printer so that the full page is now used and will keep ribbon up to snuff so you can read the bloomin' thing, hi. Ya guys have just plain been used to one typewriter for the last seven years is all. Previous typewriter was same print size as this dot-matrix printer. If maybe in another month popular consensus favors it, I'll go back to the old style. Quite frankly, the Atari is faster, everything is kept on file, and your column is being maintained in a much improved manner.

Have done a little dial spinning, nothing really serious, but have been following SSS and SRS, logging KMTI 1590 Manti, Utah by total surprise, well after their sunrise and atop the channel (with KLIV nulled, of course). But, who is the SS with ranchera music on 1590? Did KOGD go SS or is that McFarland? Another mystery: Who's REL on 1550? Sounded like a live program (not church service) on 21 December at 0747 PLT. And I must have missed the boat on this one, living formerly so close to Medford and all, but noted KBOY 730 at sunset s/off; when did they go back to KBOY and to rock? Talk about bare bones s/off, just the legal stuff, folks, with mention of 24-hour FM, then cut carrier shortly after start of next song, two minutes early I might add.

Is it KN6S or KWSD with 49'ers play-by-play, or both? Heard a wrap-up on 22 December, break into local spots (couldn't pull 'em good enough to figure out locations on spots and KGW was doing a number to the frequency). Had it been KWSD they committed a no-no, as program continued past 1645 PLT December s/off. If KN6S, a little strange they would be carrying 49'ers so deep into Rams & Raiders turf.

Speaking of sports, NorCal stations have been carrying Raiders football, locally it's KN6R 1320. Also, KFBK 1530 carries (for what it's worth, hi), Sacramento Kings basketball (KQVR TV with telecast).

Browsed through latest (which isn't all that recent an edition) Vane Jones, and noted a ton of mistakes. Was really disappointed with the FM section - no listings for power, antenna height, etc. Now I realize it's extremely easy to become confused and make mistakes with the mania to fill the Clears, but I mean obvious mistakes. And speaking of the mania with new stations, has anyone noticed the large scale trend for stations to return to their original call letters? I guess it stems from the "new" station not making it and returning to calls more familiar to the audience (read ratings).

That about wraps it up from the capital city. On a weather note it was pointed out (on local news media), that Anchorage, Alaska was four degrees warmer than Sacramento the other day. We're into our third week of tule fog. I warmer the rain of Humboldt for this?-hi. See y'all in 7 and best of DX in '86 de Rth. .



Active Short-wire Phasing System Using Modified Hagan Amp  
by Mark Connelly

A modified version of Jim Hagan's 2-FET loop amplifier has been found to be useful in phasing very short antennas (e.g. car whips or the whip sections of a "TV Rabbit Ears" type antenna)

The amplifier card including phase-reversing transformer can be assembled on a 1.9" x 1.4" vectorboard for a very compact installation. The design eliminates the need for a balun transformer; resistive summing of the "Line 1" and "Line 2" outputs is done instead (with about a 6 dB reduction in achievable output level into 50 ohms.) If the loss is a problem, use of a BBA-1 broadband amplifier module (March 2, 1984 DX Monitor) may be used between the phaser's output and the receiver's input.

Figure 1 shows the schematic of the modified Hagan amplifier card.

Figure 2 shows the overall short-wire phaser schematic.

Figure 3 shows module hook-up to receiver and aerials.

Customary phasing procedures (peak each line at maximum tank Q, equalise levels, decide null mode to use, tweak controls for null) are employed.

FIGURE 1 - MODIFIED HAGAN LOOP AMP CARD

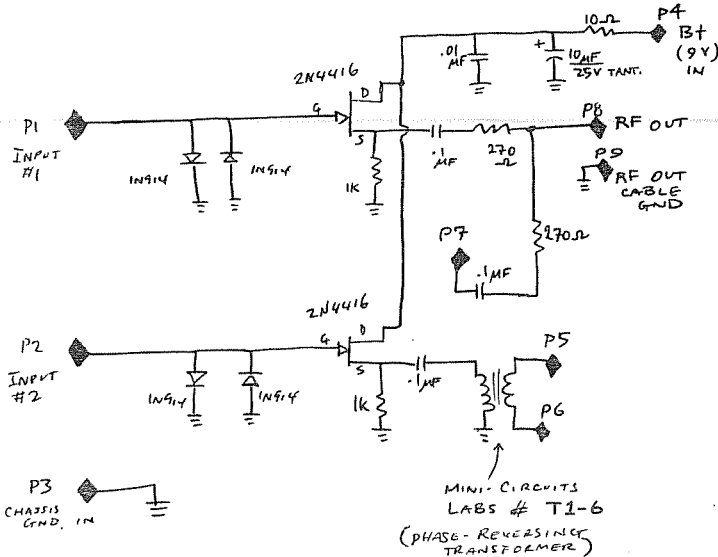

Cases of 2N4416's are connected to chassis GND.

FIGURE 2 OVERALL SCHEMATIC OF SHORTWIRE PHASOR

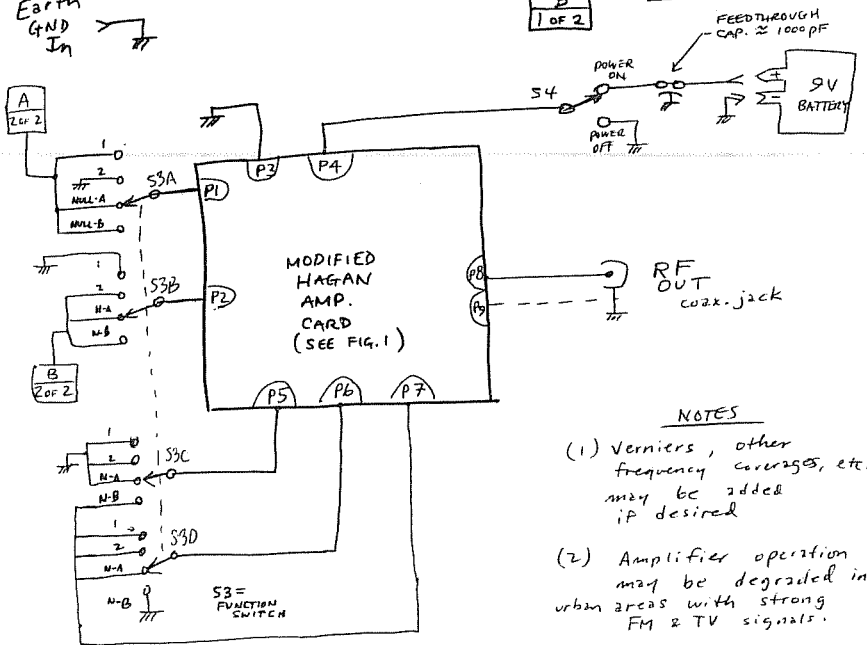
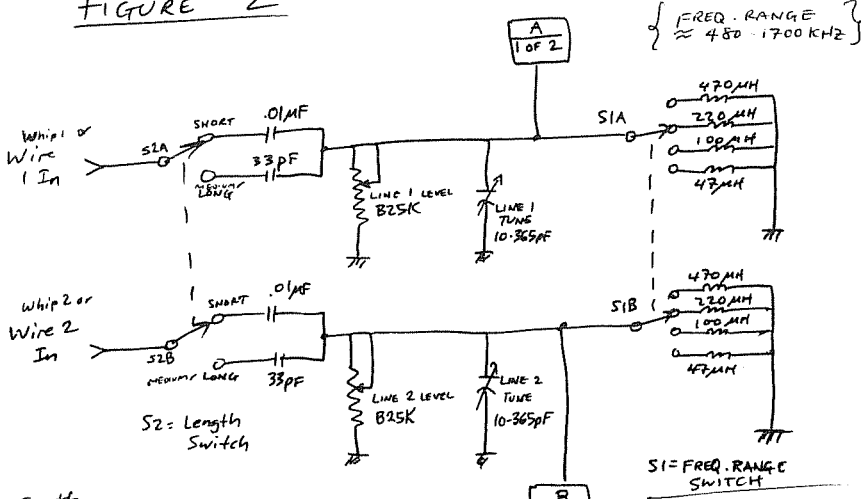

NOTES

- (1) Verniers, other frequency coverses, etc. may be added if desired
- (2) Amplifier operation may be degraded in urban areas with strong FM & TV signals.

# FIGURE 3

## MODULE INTERCONNECTIONS

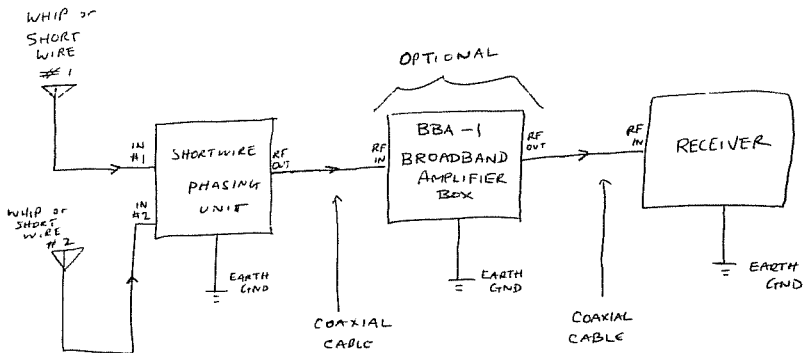

EARTH GROUNDS NOTED ABOVE MAY BE OMITTED IF RECEIVER CHASSIS IS GROUNDED TO MAINS GROUND (CENTRE PIN OF 3-PRONG PLUG) AND IF TOTAL LENGTH OF COAXIAL INTERCONNECTING CABLES IS LESS THAN 6-M/20-FT

\* \* \* \*

Derek Claridge, 815 9th St., Nelson, B.C. V1L 3C1 has acquired a number of circuit boards which contain four small relays and associated diodes and resistors. They are new material and each relay is single pole, normally open, operates at 12v, 3 mA and releases at 8v, 1.8 mA, with a coil resistance of 4300 ohms. They are available for \$1 for a card of four; write Derek if you're interested. Derek also notes that Morning Distributors is sold out of the 365 pF capacitors mentioned awhile back in these pages.

\* \* \* \*

Karl Zuk has received a couple of circulars from Kahn Communications concerning a modification to the SONY car radio, model XR-A33. Does anyone have any details about this one? Obviously, it's a radio capable of decoding Kahn AM stereo, but beyond that?? The circular that Karl received concerns killing the mute circuit of this radio

\* \* \* \*

Best wishes for 1986 to all, especially to Mark Connelly, Laurens Engel, Jim Herkimer, Jim Hill, Dennis Kibbe, Don Moman, Ben Peters and Karl Zuk, who helped make the tech column possible in 1985. Also, thanks to those who have been sending their completed technical articles directly to Seattle; I've greatly enjoyed them.



**EASTERN DX ROUNDUP** Karl J. Zuk, 154 Old Post Road North, Croton, New York 10520  
 \*\*\*\*\*

**REPORTERS IN THIS WEEK'S ISSUE:**

- (MB-ON) Mike Brooker, 245 Old Forest Hill Road, Toronto, ON M6C 2H5  
Panasonic RF-2200
- (JHD-PA) John H. Demmitt, K0848, Box A, Bellefonte, PA 16823  
Sony ICF-S5W
- (MP-MA) Mark L. Perlmutter, 10 Karen Circle, Unit 18, Billerica, MA 01821  
Icom R71A and Palomar loop. (Welcome aboard, Mark!)
- \*\*\*\*\*
- 580 WCHS WV, Charleston. 12-15 2228 Good with ad for downtown Charleston restaurant  
ID promo by Dick Clark, record. Cuba interfering. (JHD-PA)
- 590 WEEI MA, Boston. 12-15 2050 Fair with call-in program on WEEI programming. (JHD)
- 590 CKEY ON, Toronto. 12-15 0705 Good with ID, weather, record "Walk On By." Promo  
for next news at 0800. (JHD-PA)
- 620 WTMJ WI, Milwaukee. 12-9 0700 Fair with news, ad for First Bank of Milwaukee,  
with interference from CHJB, R.Rebelde, Cuba. (JHD-PA)
- 640 KFI CA, Los Angeles. 12-14 0710 Fair with "KFI Cash Jackpot", time check, ID,  
"KFI-640", pop records. Interference from WHLO, Akron, OH. (JHD-PA)
- 680 KKYX TX, San Antonio. 12-9 0722 Poor with ID "KYX Traffic Control" In slop. (JHD)
- 680 WPTF NC, Raleigh. 12-15 2140 Fair with Bing Crosby special, ID, "Road To  
Morocco" song. (JHD-PA)
- 720 WGN IL, Chicago. 12-9 0857 Good with ads for Trees, Cream of Wheat. ID, male  
and female DJ, ID, weather. (JHD-PA)
- 730 WMTC KY, Vanleave. 11-28 1728-1730 Local weather, short bit of gospel music,  
then sign off announcement mentioning "The radio voice of the Kentucky  
Mountain Holiness Association," no SSB, over CKAC, Montreal, PQ and slop  
from CBL, Toronto, ON, on 740 kHz. (MB-ON)
- 740 CBL ON, Toronto. 12-9 1100 Fair with ID as "CBC", hourly news, weather, talk  
about Manitoba by two men. (JHD-PA)
- 750 WPDx WV, Clarksburg. 11-15 1623-1625 Heard over CBL, Toronto, ON, on 740 kHz,  
with C&W music, Hills Discount Store spot, promo for a health program  
presented in cooperation with the WV School of Nursing, Country Club  
Chrysler-Plymouth-Dodge spot, Wv weather, then more C&W music. (MB-ON)
- 760 WJR MI, Detroit. 12-9 0855 Good with song "September Morn", ID, bank ad,  
traffic report. (JHD-PA)
- 770 WJMW AL, Athens. 11-15 1741-1753 in fair to poor in WABC, NY, NY, null, C&W  
music, spot of answering service in Athens, promo for "Screen Test" movie  
trivia program, ID by woman DJ as "77 WJMW" into more C&W music. (MB-ON)
- 780 WABS VA, Arlington. 12-9 0851 Poor with man preaching in a distant voice.  
WBWM, Chicago, IL interfering badly. (JHD-PA)
- 790 WNPS RI, Providence. 12-11 2152 with sports talk program with male announcer,  
Good signal, ex-WEAN. (MP-MA)
- 820 CHAM ON, Hamilton. 12-12 0742 Good with ID "C-Ham", Ad for jeweler in Hamilton,  
"Lone Ranger weather forecast", time check. (JHD-PA)
- 820 WAIT IL, Chicago. 12-5 2032 with local weather and MOR music, very good signal.  
(MP-MA)+12-15 1950 with ID, talk on Theresa Brewer, played her records.  
Fair. (JHD-PA)
- 830 WLND OH, Cortland 12-12 0752 Fair with Gatlin Brothers record, ID, ad for Dec.  
14th Christmas party and promo for John Williams Show. ID. (JHD-PA)
- 830 CFJR ON, Brockville. 12-15 2120 Fair with hockey game in progress. ID and  
mention of station contest winner. (JHD-PA)
- 840 CHUR ON, North Bay. 12-10 1740-1758 Noted in WHAS, Louisville, KY null, with  
apparent CHR or AdCon format, ID "840 AM Stereo CHUR," jingle "Music  
Radio CHUR," fairly good signal overcoming WHAS until they suddenly  
disappeared at 1758, possibly a pattern change at that time. (MB-ON)
- 860 CJBC ON, Toronto. 12-12 0800 Fair with ID, news, in with WAMO, Pittsburgh, PA.  
(JHD-PA)
- 870 WKAR MI, East Lansing. 12-9 0827 Good with ID, promo for talk show on electrical  
wiring, weather, toy safety PSA, news dealer ad, "Today In History", ID.  
(JHD-PA)
- 910 CKLY ON, Lindsay. (no date, time) with weather forecast, male announcer, good  
signal, then into oldies program. (MP-MA)
- 920 WHJJ RI, Providence. 12-5 1846 with sports talk program and excellent signal.  
(MP-MA)
- 930 WEEN NY, Buffalo. 12-15 1830 ID, Bank ad, ad for "42nd Street" play, hotel ad,  
ID and sports with Buffalo Sabres news. Good. (JHD-PA) +12-5 1832 with  
weather by man, ad for Red Door Ski Shop. Excellent. (MP-MA)
- 960 WELI CT, New Haven. 12-9 1851 Talk program with male announcer, excellent  
signal. (MP-MA)
- 990 WNYR NY, Rochester. 12-5 2152 Good with ID "WNYR Sound Of The Season" into  
C&W music. (MP-MA)
- 1040 WHO IA, DesMoines. 12-11 0750 Ad, weather, fair signals. (JHD-PA)
- 1070 CBA NB, Moncton. 12-15 2157 Good with book being read then filler music.  
ID "This is CBC Radio New Brunswick," then CBC news. (JHD-PA)
- 1070 CHOK ON, Sarnia. 12-11 0718 Good with talk about snowblowers, "The Royal  
Reporter", weather, McDonalds ad, Salvation Army PSA. (JHD-PA)

14  
much more to come!



Always on  
Target!!!  
Eastern DX  
Roundup.....

- 1070 WINA VA, Charlottesville. 12-11 0723 Fair with ID "on WINA" by man, "Grandma Got Run Over By A Reindeer" song, weather. (JHD-PA)
- 1150 WDEL DE, Wilmington. 12-15 2204 Poor with news, ID "WDEL", in mix of many stations. (JHD-PA)
- 1160 WCCS PA, Homer City. 12-9 1020 Fair with ad for 700 Shops For Levi Products Store in Homer City. Station does not ID often. (JHD-PA)
- 1170 WWVA WV, Wheeling. 12-12 0815 Good with C&W music, ID with new jingle of group singing holiday greetings from downtown Wheeling. Promo for "Jamboree USA" (JHD-PA)
- 1190 WANN MD, Annapolis. 12-12 0820 Good with announcer reading addresses, all in Annapolis area, "This is WANN" ID. Interference from WKDJ, Hugesville, PA. (JHD-PA)
- 1190 WKDJ PA, Hugesville. 11-9 1006 Fair with ads for a beauty shop and car dealer, ID "All New 11-90." Records. Interference from WOWO, Ft. Wayne, IN. (JHD-PA)
- 1200 WAGE VA, Leesburg. 12-12 0822 Good with Christams song, ID, contest via phone with woman who won "5 Draw Trivia", comedy program after ID. (JHD-PA)
- 1240 CJCS ON, Stratford. 12-2 1505-1517 with promo for Dale Carnegie course sponsored by CJCS, for more information "listen daily to CJCS or call 271-2450," song by Brian Adams, followed by long run-down of local events postponed or cancelled because of bad weather. Fair groundwave signal for only 500 watts, over CHWO, 1250 kHz, Oakville, ON slop, usually over powered by a number of US graveyarders. (MB-ON)
- 1260 WWDC DC, Washington. 12-11 0652 Fair with promo for "Big Band Sounds." ID "WWDC" by man. (JHD-PA)
- 1280 WTTX VA, Appomattox. 11-16 1710 Heard popping up briefly over WPXY, Rochester, NY with break in Virginia Tech football game, local weather including ID ".at WTTX", then back to game. (MB-ON)
- 1280 WKST PA, New Castle. 11-20 0826-0830 In over CJMS, Montreal, PQ and WPXY, Rochester, NY, with Pittsburgh Steelers report, spot for Paul's Appliances on Wilmington Road in New Castle, station promo, McDonalds spot into Paul Harvey News. (MB-ON)
- 1280 WHVR PA, Hanover. 11-23 1603-1607 Heard in WPXY, Pocheater, NY-CJMS, Montreal, PQ null with wrap-up of District 3-A High School football game, Campbell vs. Hanover. Hanover won, hence ID as "WHVR, home of District 3, Class A champions." spot for Schultz AMC/Chevy/Jeep/ Renault, post-game show interviewing winning Hanover coach. (MB-ON)
- 1300 WAVZ CT, New Haven. 12-5 2110 Good signal with Dean Witter ad, oldies music. (MB)
- 1310 WICH CT, Norwich. 12-5 2112 Very good signal with weather and Coke ad. (MP-MA)
- 1350 WNIS VA, Portsmouth. 11-23 1704 with NBC news, local news at 1705, poor in CKAR, Oshawa, ON, null and gone by 1706. (MB-ON)
- 1360 WIXZ PA, McKeesport. 12-9 0944 Fair with ID, Louise Mandrell record. Interference form WMNS, Olean, NY. (JHD-PA)
- 1360 WMNS NY, Olean. 12-9 0949 Poor with "Viewpoint" woman announcer took calls on women in the priesthood, state colleges, etc. (JHD-PA)
- 1380 WSYB VT, Rutland. 12-4 2218 with good signals, EZ listening music, contest on the radio for money. (MP-MA)
- 1470 CHOW ON, Welland. 12-9 0920 Fair with Nashville Brass song, ID, ad for Towers apartments, Job line promo. ID "1470 CHOW", DJ took calls, ID "C-How". (JHD-PA)
- 1480 WISL PA, Shamokin. 12-9 0920 Poor with PSA for Shamokin Police seeking funds for drive. (JHD-PA)
- 1480 WCNS PA, Latrobe. 12-9 0915 Fair with ID, "Love Me Tender" by Elvis. (JHD-PA)
- 1560 WRIN IN, Rensselaer. 11-16 1829-1854 very good in WQXR, NY, NY null, playing gospel music, spots for Armand Tire Center and Stanley Garden Center, run down of tomorrow's church services (Sunday) in Rensselaer area, CST time checks. 1854 Man host-DJ mentioned that someone in Maryland just picked up WRIN and called station. Not usually heard and this is way past sunset. Perhaps they forgot to switch their night pattern. (MB-ON)
- 1580 WUIV NC, Icard Township. 11-30 1706-1713 with gospel music, talk by announcer Eric Calhoun, mentioning some of the programs to be heard on. "All New Beautiful Gospel WUIV" tomorrow, 1713 sign off announcement "In concluding this day of broadcast, Beautiful Gospel thanks you for listening..." followed by SSB, then announcement continued after SSB, "This is WUIV, Icard, NC, concluding this day fo broadcast service." Fair to good, strongest signal on frequency, over WJIK, Camp LeJeune, NC, with similar religious format. (MB-ON)
- 1580 WEBG PA, Ebensburg. 11-20 0158-0200 Engineering test with pop music, ID at 0159 "This is WEBG Ebensburg, PA on the air for test purposes. Testing is now complete...WEBG, Ebensburg." brief open carrier then off. In good to very good over CBJ, Chicoutimi, PQ's ever present carrier and tones. Heard before during SSS, several call changes ago as WEND. (MB-ON)
- 1590 WJSO TN, Jonesboro. 11-30 1717-1732 with spots for Johnson City Mall, Valley Federal Savings and loan, Ford and M&S Auto Parts. Football call-in show with phone numbers: 963-2121 Johnson City, 543-7325 Elizabethton, 1-800-222-9570 toll free. Talk about U of T and Vanderbilt, football score rundown, Good-Very Good signal, overpowering WAKR, Akron, OH. (MB-ON)

EASTERN DX ROUNDUP concludes!.....

1590 WTVB MI, Coldwater. 11\*16 1607-1609 with wrap-up of Michigan Wolverines football, spots for Coldwater Cablevision, Jim's Shoes and Boots, and Coast to Coast Hardware. ID as "Wolverine Football is a presentation of 16 T'V and Michigan Sports Service," Fair to good in WAKR, Akron, OH null. (MB-ON)

Welcome to Mark Perlmutter who is becoming active in IRCA for the first time since the 70s. Write often, Mark, and enjoy that fine receiver!

# WESTERN DX ROUNDUP

Nancy Hardy  
2301 Pacific Avenue  
Aberdeen, WA 98520

All times are  
Eastern Local

Phone for hot WDXR tips: (206)532-6827 till 10pm(PLT)

DEADLINES: Tuesdays

REPORTERS FOR THIS ISSUE:

- (GL) Gary Larson-2806 Lincoln-Burbank, CA 91504  
GE Superadio
- (5P) Dale Park-DX'ing at Sandy Beach, Honolulu  
Becker car radio
- (AWP) Art Peterson-851 31st Street-Richmond, CA 94804  
FRG-7 & 600' longwire at Gualala, CA
- (RW) Robert Wien-1309 Dentwood Dr.-San Jose, CA 95118  
GE Superadio, GE long-range portable, SM-2
- (JW) Jack Woods-P. O. Box 1003-Waldport, OR 97394  
Barlow Wadley XCR-30, Martens loop

OF SPECIAL INTEREST:

- 1340 KNRC ID, Hailey ex-KSKI, 0830-0500 sked, CP for 1330 put on shelf  
For moment. (RW-CA)

- 530 KNEU564 CA, Truckee 12/18 2040-2100 in like gangbusters! Not long after LSS, sig. came up swiftly peaking 20/S-9 at best. Gave address & I-80 highway conditions (Address: CALTRANS, Box 8, Nevada City, CA 95959. Letters welcome.) Location is Truckee Maint. Yard at lat. 39°19'52"N, long. 120°11'00"W at 5900' elevation, 10 watts directional N-S-E. Verie ment. 10 watt non-dir. TIS on 530 at Camino, CA, lat. 38°44'55"N, long. 120°36'47"W. (AWP-CA)  
+12/23 0354 good w/YL doing Hiway 80 road cx, ment. to write to CALTRANS, Nevada City, CA 95959 to comment on the broadcast.(RW)
- 560 KSFO CA, San Francisco 12/23 0558 theme from "Exodus" by Ferrante and Teicher; ID "5-60 KSFO" & AP nx. Poor, unID co-channel moving in & out like the tide, het QRM, lightning QRN. (5P-HI)
- 580 (KMJ) CA, Fresno 12/23 0324 totally off, back on RS at 0352. Was off all last MM, so perhaps now at least a weekly MM partial SP?(RW)
- 670 KPUA HI, Hilo 12/23 0557 Flack & Hathaway's "The Closer I Get To You," then long period of dead air. Thought this was KBOI until ID ended suspense, "67 KPUA," followed by ad for Hilo shopping Center, aargh! KPUA must be the first Neighbor Island station that has NSP, right REW? I guess KBOI was underneath. Fair. (5P)
- (KWNK) CA, Simi Valley 12/23 0305 off on reg. SP. (GL-CA)
- 700 KFAM UT, North Salt Lake City 12/20 1436 poor w/Xmas mx, local spot. (RW-CA)
- 710 KMPC CA, Los Angeles 12/23 0303 s/off ment. routine maint. (GL-CA)
- 720 KDWN NV, Las Vegas 12/20 1434 good w/talk show. (RW-CA)
- 740 KCBS CA, San Francisco 12/25 1033 u/KBRT w/unknown talk program. (GL)
- KTRH TX, Houston 12/23 0555 farm program w/ag. prices, etc; wx w/Joe Sobol. Fair w/KRMG-740 in back playing pop mx, KGU-760 sloop, het QRM. (5P-HI)
- 760 KGU HI, Honolulu 12/22 0556 fair w/talk show on medical problems of the eye, ID as KGU AM, "Information Radio," HI nx & wx, into national nx. (JW-OR)
- 790 KAEC CA, Los Angeles 12/23 0552 usual Tom Hall talk show, but w/unID strn in back (KGHL?) playing Hank Williams Junior mx. Fair w/TP het QRM. (5P-HI)
- 810 KGO CA, San Francisco 12/25 1035 in clear w/Christmas mx, wx, more mx. (GL-CA)
- 830 KNCO CA, Grass Valley no trace of this at 1038 12/25. (GL-CA)



- 850 KOA CO, Denver 12/20 1438 long deep fades but fair on peaks w/state  
 nx, farthest mid-day logging for me to date. (RW-CA)  
 KHLO HI, Hilo 12/21 0907-0930 good w/MOR, slogan "Home Town 85," Big  
 Island wx, ID. Over KOA. (JW-OR)
- 860 KTRB CA, Modesto 12/23 0307 in fair o/XEMO. (GL-CA)  
 870 (KAIM) HI, Honolulu 12/23 0550 noted off on a rare SP, bless their  
 hearts! Is this regular? (5P-HI)
- 890 (WLS) IL, Chicago 12/23 0232 totally off, TT'ing later on. Only very  
 weak SS in. (RW-CA)  
 KDXU UT, St. George-NV, Las Vegas 12/20 1432 fair w/ID. First daytime  
 logging of this one. (RW-CA)  
 (KDXU)+12/23 0255 noted off. (GL-CA)
- 870 WWL LA, New Orleans 12/23 0550 regional wx & traffic advisory. A  
 trucker via phone w/promo for DJ "Big Redd" on "The Road Gang"  
 show; into C&W oldie "What's He Doin' In My World." New from  
 HI, LA #2! KAIM off, fair w/TP het QRM. (5P-HI)
- 900 KNUI HI, Kanului 12/22 0655 fair w/fades, w/oldies EZL, ID. CJVI  
 partially nulled; their signal apparently weaker than usual.  
 New, HI #8. (JW-OR)
- 940 (KFRE) CA, Fresno 12/23 0328 totally off. (RW-CA)  
 960 KABL CA, Oakland-San Francisco 12/23 0602 national, Calif., and Bay  
 Area nx read by Harry Webster. PSA for a senior citizen center's  
 New Year's Eve afternoon party. ID as "KABL 96 AM & 98 FM,"  
 into EZL Christmas mx. Fair signal, unID stn w/CBS nx rippling  
 in back, het QRM. (5P-HI)
- 1060 \*KPAY\* CA, Chico 12/23 0532 noted w/TT. (RW-CA)  
 1200 WOAI TX, San Antonio 12/23 0547 Mutual's "America In The Morning" w/  
 sports promo, back to Jim Bohannon looking back at 1985. Fair  
 w/unID underneath, lightning QRN. (5P-HI)
- 1260 KGIL CA, San Fernando 12/25 1039 mx instead of talk. (GL-CA)  
 1290 KMJK OR, Lake Oswego-Portland 12/23 0544 Eddie Murphy's "Party All  
 the Time," man w/ID "Hit Radio Majic 1-0-7 FM" & Vancouver and  
 Portland phone numbers; into Elton John song. New, OR #6. Poor,  
 QRM from unID stn underneath and TP het. (5P-HI)
- 1310 KDIA CA, Oakland 12/23 0311 in poor to fair w/Stevie Wonder song. (GL)  
 +12/23 0538 "Got To Get You Into My Life," ID and promo about  
 "The Phrase That Pays, The Boss of the Bay Is Back" for Jan. 1986  
 (if you mail it in to KDIA at 100 Swan St., you might have one  
 of your bills paid by KDIA), into more soul mx. First time  
 actually logged w/new "old" format. Fair w/electrical QRM. (5P)
- 1320 KGNR CA, Sacramento 12/23 1045 in good w/Christmas mx & 1045 promo  
 by staff member wishing all a happy holiday w/legal ID. Never  
 heard here at this time! Fog in Bay Area probably helped. (GL)  
 1350 KSRO CA, Santa Rosa 12/25 1054 in fair to good w/Christmas mx &  
 greetings from people who call 270-KSRO. Also ment. of Mr.  
 Energizer at front lobby for free batteries to those that need  
 them. Nice to hear KSRO. (GL-CA)
- 1390 KCEY CA, Turlock 12/23 0608 man w/San Joaquin Valley wx, oldie  
 Christmas mx. Poor w/probable KGER in back, KLNI-1380 slop. (5P)  
 1400 KRE CA, Berkeley 12/23 0609 noted in passing w/gospel-style mx. Poor,  
 het QRM. (5P-HI)
- 1440 KVON CA, Napa 12/25 1100 w/ABC nx then local nx about crash at Sun  
 Valley Mall in Concord Calif. (GL-CA)  
 KMED OR, Medford 12/25 1058 nx features, local spots (ski place),  
 wx for ski areas. 270 in area, into Christmas mx, o/u KVON. (GL)
- 1460 KLCZ CA, Salinas 12/23 0321 very strong w/oldies-T40. Almost no  
 KTYM. (GL-CA)
- 1470 KUTY CA, Palmdale 12/25 1106 spot for Arrow Appl. Lancaster, then  
 into Christmas song. Clear, almost no Tijuana. (GL-CA)  
 1480 KWIZ CA, Santa Ana 12/23 0610 Chicago's "Hard Habit To Break," ID as  
 "No ? Radio," TC of 3:09 and promo for DJ "Candid Richard"  
 coming on at 6 o'clock on "Kwiz and Kwiz FM," song by Air  
 Supply. Poor to fair, QRM het on about 1476. (5P-HI)
- 1500 KHTT CA, San Jose 12/25 1111 in clear w/some Christmas mx, "1500  
 KHTT" then more mx, fading in & out. (GL-CA)
- 1580 \*KDAY\* CA, Santa Monica 12/23 0430 noted turning OC off/on, KNIX in as  
 usual along w/my very weak unID talk show way underneath them  
 on peaks, still haven't ID'd it! Possibly KZIA. (RW-CA)
- 1600 KUBA CA, Yuba City 12/25 1119 local spots then promo ment. KUBA and  
 Z-104 FM Christmas wishes; fading u/KWOW. (GL-CA)

UNIDs:

- 1370 12/25 1055 two stations fighting for freq. Some SS but also inst.  
 Christmas mx. Maybe KWRM playing mx? Some fading of both. (GL-CA)  
 1390 12/25 1050 faint mx & talk u/KGEN. (GL-CA)  
 1400 12/23 0313 poor w/big band mx. (GL-CA)

If you live in WDXR-land, remember to send in your loggings. ♡

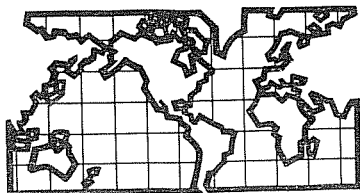

DX WORLDWIDE - WEST

Pat Martin - Editor

P.O. Box 843, Seaside, Oregon 97138

PHONE: (503) 861-3185

We have abit of DU News this time around from the NZDXL. News from Arthur Cushen: The latest commercial station for New Zealand--Radio Horowhenua-- has been granted a warrant from the Broadcasting Tribunal to serve the Kapiti Coast North of Wellington and should be operating in 1986 on 1377 KHZ. The Tribunal was faced with five applications for the warrant, two on MW and 3 on FM. Radio Horowhenua's application for an AM Warrant was to operate from studios in Levin and Paraparaumu through a transmitter sited at Otaki. The station proposes to broadcast a programme with local content from the two studeos on weekdays between 6AM and 7PM. From 7PM to Midnight (New Zealand Time) it would broadcast 2ZM's programme, from Midnight to 5AM Radio Horowhenua would broadcast the Radio New Zealand Community Network, All-Nighter, and 5AM-6AM the ZM Breakfast Show (All these relay programmes originate from Wellington. On Sundays the station will have its own programmes from 8AM to 5PM and the balance of the day would be: ZM Programming 5PM to Midnight and midnight to 5AM the Connet Programme. The station aims at an audience in the 15-44 age group. In Australia Station News: An application has been sought by the Queensland Girl Guides Association for their International Camp-Noora Ku-Meena to be held near Brisbane at Greenbank. Official on air period will be 3 January to 11 January 1986 with Test possible in the fortnight prior. Operating hours are 2000 to 1200 UTC. Power of 50 watts and the frequency sought is 1610, 1611, or 1539. Call sign 4HKKN. To help DXers the station will stay on the air from 1230 UTC to 1530 UTC on 4 January, 1986. Address: Girl Guides Association of Queensland-9-11 Butterfield Street-Herston, Q. 4006. Another licence being sought after: Scout Association of Australia for the XIV Australian Jamboree to be held in Appin, SW of Sydney. Official on-air period from Dec 20-Jan 9th. 50 watts on 1611 KHZ, 1539 KHZ still being considered. Call sign is 2SJ-Address:70 Dowling Street-Arncliffe, NSW 2205 or C/Eric Van De Weyer VK2KUR 21 Dawes Street, Little Bay, NSW 2036. Other news: 2CS Coffs Harbour, NSW is on 639 KHZ with 5KW-24 hours. Address: Box 1234-Coffs Harbour, NSW. 5CC, Eyre, South Australia is on 765 KHZ. Plus there were seveaal short term low power stations on during the Christmas Season that are mostly off. Now on with reports:

DX REPORT FROM HAWAII

- 880 BRAZIL, Belo Horizonte, Radio Inconfidencia ZYL250 11/25 at 0430 "Two lovely black eyes" (!) Interval signal, full ID, list of all frequencies including FM, Most other regulat Brazilians in then (REW)
- 950 MEXICO, Nuevo Rosita, Coah-XEYJ 12/9 at 0955 PSA for Movimento Jovenes de Nuevo Larado, spots for N.L., Coahuila and Tamaulipas states. Dominant. (REW-Hi)
- 1224 MARSHALL ISLANDS, Kwajalein, AFRTS-WXLG 12/19 1635 on automated relay from AFRTS-Los Angeles, as per sked. PSAs, 5-Minute Wx Block. Quite good, not often hrd this year. (REW) (When WXLG was on 1220, I hrd then 4 MMs in a row back in the late 60s. 1220 KHZ was clear in those days. Sent a nice vl also-PM)
- 1323 P.R. CHINA, Radio Beijing Ex. Service 12/12 1635 Urdu Talk on Soviet Troops in Afghanistan Good. (REW)
- 1512 SAUDI ARABIA, Jeddah-12/12 1630 AR ID for Makkah (Mecca) Qur'an recitation. New and better than usually dominant 1440 this AM. (REW)
- 1557 MALTA, DW Relay, Cyclops-12/19 0445 AR Political commentary, alternate m/f voice. Finally an opening to Europe, lare this season.Fair (REW)
- 1570 MEXICO, Cd. Acuna,Coah. XERF 12/12 0855 s/off wording in SS. still used term "1570 kilociclos. Note that XERF carries Bishop S.McDowell Shelton of Philadelphia preaching in FF, so FF hrd on 1570 in not necessarily a FF Canadian. (REW)
- 1593 WEST GERMANY, Langenberg-WDR 12/19 0459 GC talk, 0500 time signal, ID Nx, fair. (REW)

RAH-AMERICAN DX ROUNDUP

- 890 UNID, 12/23 at 0903 SS fading up w/ID "Radio Nacioal" WLS off, prob. WJCE, which is common here, but I don't have then listed under this call. (RW-Ca) (I believe that was WJCE you hrd, as I remember hearing then a few months back with "Radio Nacioal" IDs.PM)
- 1000 UNID, 12/23 at 1258 hrd with Mexican NA, apparent s/on wiped out by KKKX s/on Heavy KIQI/KKIS s/on in KOMOS null, faded out. Back up again at 1358 with 4 note IS "-...:" XEFVs s/on listed as 1200, XEYO AN. Most likely XEMIL, though it's off by 6 minues of local time listed in 12/7 DXWW-West. (RW-Ca) (Being an XE it doesn't mean they couldn't be on later.PM)

## VERIFICATIONS:

- 710 MEXICO, Culiacan, Sin. XEBL-Radio Bonita, fine partial-data letter from C.P. Pablo Perez Ramirez-Sub Director General. Says it had never had a report from such a distance and understands the water path involved. (REW)
- 1200 BRAZIL, Sao Paulo ZYK520, Radio Cultura A surprise second letter after the first verification 6 months ago. This time from Jose Carlos da Silva, whose home address is Rua Professor Antonio de Queiros Filho 81, Sao Caetano do Sul CEP 09500, Sao Paulo. He is a DXer and would be glad to hear (in PP---SS would probably do) from DXers everywhere. He is an engineer at RCGP and typed a specific verie on an internal engineering trouble shooting form for transmitter STL outages. Says power was 20KW at the time I hrd them when they were on the air for 20 minutes later than the usual 0500 UTC s/off.(REW)
- 1580 MEXICO, Radio Tulancingo,Hgo. XENQ Pleasant but no-data letter typed all in capitals by Alfonso Medina Galindo, Contador, who said he took the responsibility for answering since other staffers were unlikely to. Said XENQ had only one other foreign report, from Japan for the same time slot as my reception. (REW)

## THANKS TO THESE REPORTERS:

- RW-CA ROBERT WIEN-1309 Dentwood Drive-San Jose, California 95118  
GE Superadio, Loop
- REW-HI RICHARD E. WOOD-Post Office Box 5074-Hilo, Hawaii 96720  
R-1000, 4 Beverages, Amp.

Broadcasting, 11/11/85

via Robert Wien

### Format experimentation on the AM band

With a steady decline in listeners over the past 10 years, the AM dial is seen by many today as primarily featuring news and information. While that approach has been successful for many stations, there is little doubt among industry executives that many other AM outlets will have to carve out a new programming niche to survive. As BROADCASTING has reported throughout the year, AM broadcasters have begun to experiment with format concepts.

In Los Angeles, RKO's KJLH(AM) switched from an all-music, adult contemporary format in 1984 to one centering on local traffic reports, which has been appropriately dubbed "Car Radio." "We work under the assumption that all radio listeners in Los Angeles are in their cars because there is no real mass transportation system," said Waller Sabo, New York-based consultant to RKO's owned radio stations. "The first thing we did was go to the American Automobile Association and the Department of Transportation to gather information about drivers in Los Angeles and built a format from that data," he said.

According to Sabo, the format is targeted to the average age of the licensed driver in Los Angeles, 31, and the average one-way commuting time in that city, an hour and 40 minutes. Traffic reports, said Sabo, are aired every 10 minutes. Along with the traffic reports, eight adult contemporary songs are played every hour. Local newscasts are only aired at the top of each hour during drive time. This is one of the few formats requiring the programming and sales departments to work closely together, said Sabo.

"In order for an AM radio station to be financially viable, it must have a logical and immediate sales hook and it must be entertaining enough to eventually get good ratings," he said. Sabo noted that many of the station's accounts are automotive-related businesses.

Last April, Sabo also helped to establish the "Game Zone" format over RKO-owned adult contemporary KFRC(AM) San Francisco. The station programs a block of game shows from 9 a.m. to 3 p.m. each weekday as well as a two-hour dating call-in show each night, *Affair of the Air*. These formats are viewed not as programming entities but as "marketing concepts," according to Sabo.

"One of the greatest myths of our time was that listeners began to tune to FM radio because it was in stereo," said Sabo. "The real reason they switched was because FM programming was different and better. It all comes down to programming. The reason why stations like WCCO(AM) Minneapolis-St. Paul and WGN(AM) Chicago remained so strong is because they offer something of value to the listener. The challenge facing AM radio today is getting listeners to sample the band," he said.

Another new experimental AM format in San Francisco was launched by Bonneville International last summer. "Trendformation" made its debut on July 15 over Bonneville's KXLR(AM) which was formerly airing Bonneville's easy listening format under the call letters of KOIT.

Trendformation was conceived by Jack Adamson, former president of the California division of Bonneville and currently a senior vice president of the company, and developed by Norm Woodruff, a radio programming consultant now with the station full time. The station features information on news events and emerging trends along with a combination of "light jazz" and "new age" music. There are no conventional newscasts, but rather, as Woodruff calls them, "facts of the hour." These are

described as uncolorful, concise reports with clear text. The trend information basically comes from six-minute hourly interviews with experts in a variety of fields.

Adamson said trendformation was inspired by the notion that today's baby boomers are getting into the corporate mainstream "and are looking for information that will affect their lives and careers." He added that KXLR is the pilot for a light, lean budgeted information station that could be sold in combination with an FM music station (Bonneville airs a soft contemporary format on its KJLH(AM) there).

Airing another format first is WWTW(AM) Minneapolis-St. Paul, which last September abandoned its urban contemporary sound that had a last-place 12-plus rating of 0.3 in the spring Arbitron report, and adopted "Weatheradio."

The staple of the format is local weather reports that air every five minutes, according to wwr General Manager Sam Sherwood. But the station takes its reporting a step further with regional, national and international weather forecasts. Additionally, wwr airs extensive traffic reports and updated airline departure and arrival information.

"I heard so many horror stories about AM radio that I decided the direction to go is not redesigning the wheel, but redesigning the product," said Sherwood, who created the format.

Sherwood acknowledged that the station has experienced "a lot of reluctance" from ad agencies. "They are not sure how to use us," he said. "We don't have any target audience demographics because weather is sensitive to everyone in this city. We are a concept sell." Sherwood said that the station has had "mild success" in persuading local retailers to buy time.

There are still many AM music stations across the country, such as WABC New York, that are establishing themselves as full-service outlets with strong personality lineups.

In addition to adult contemporary, other proved AM music formats include country and big band/nostalgia. Al Ham's "Music of Your Life" format was one of the first programming alternatives offered to AM stations in the late 1970s when FM listening overtook AM. Today, "MOL" is aired by more than 150 stations, the majority of which are AMs.

On the syndication side, the Radio Group, a subsidiary of the LaMarca Group, a New York-based media and marketing service company, will soon offer AM stations a 24-hour, tape-distributed format entitled "Comedy Radio." The format, conceived by company president Jim LaMarca, will cover the "entire spectrum" of comedy including contemporary satire, stand-up bits and classic comedy routines.

Celebrating one year on the air on Dec. 1 is Marina del Rey, Calif.-based Children's Radio Network, headed by Bill Oswalt. The network, which is targeted for the preteen-age audience as well as 18-49-year-old mothers, currently has an affiliation base of four AM stations: KSUN Phoenix; WKRG Grand Rapids, Mich.; WFMJ Indianapolis; and wxoz (formerly WEX) Jacksonville, Fla. (the last owned by the Children's Radio Network). Oswalt describes his programming as both entertaining and educational with "an eclectic blend of music." It is distributed on tape to stations. The format is an alternative to more traditional programming, especially for AM stations, said Oswalt. "But it was not designed to save AM radio."

Many radio executives also noted that AM stereo, especially with what they saw as a lack of interest among both receiver manufacturers and listeners, will not be AM radio's salvation.

THE INTERNATIONAL RADIO CLUB OF AMERICA (IRCA)

The IRCA is a non-profit organization devoted to the hobby of hearing distant stations on the AM Broadcast Band (310 - 1630 kHz). "DX Monitor", the official publication of the IRCA, is published 34 times a year: weekly from October to March, twice in September and April, and monthly from May to August. "DX Monitor" contains members' loggings, articles on radio stations, receiver reviews, technical articles, DX tips, and other material of interest to radio hobbyists. IRCA is a member of ANARC, the Association of North American Radio Clubs.

CLUB ADDRESSES AND OFFICERS

1090

President: Dr. Richard E. Wood, Ph.D., P.O. Box 5074, Hilo, HI 96720.  
Secretary-Treasurer: John Clemmer, P.O. Box 482, E. Moline, IL 61244.  
Board of Directors: Ernest R. Cooper, Nancy Hardy, Bill Harms, Patrick Martin, Bruce Portzer, Neil Wolfish, Karl Zuk.  
Editor-in-Chief: Bruce Portzer, 6546 19th Ave/ N.E., Seattle, WA 98115, (206) 522-2521.

MEMBERSHIP DUES

U.S. - \$20.00 per year. Canada/Mexico - \$26 (one issue mailed every week) or \$20 (two issues every two weeks). Overseas Surface - \$21. Overseas Airmail - \$30 (Central America, Caribbean, Colombia, and Venezuela), \$33 (Europe, North Africa, Middle East), \$37 (rest of the world). Trial Membership - \$7.50 (10 issues of "DX Monitor" and a New Member Packet, U.S./Canada/Mexico only). Make checks and money orders payable to IRCA and send all dues to: IRCA, P.O. Box 482, E. Moline, IL 61244. Persons living outside the U.S., please use International Money Order in U.S. funds. Sample copies of "DX Monitor" are 50 cents or three International Reply Coupons each and are available from: IRCA, P.O. Box 21074, Seattle, WA 98111.

THE IRCA GOODIE FACTORY

Reprints of more than 400 articles from past issues of "DX Monitor" are available from the IRCA Goodie Factory. Also available is IRCA stationery and the very popular IRCA publications: "The IRCA Almanac", "A DXer's Technical Guide", and the "IRCA Foreign Logs". For a complete list of available publications and their costs, send a self-addressed, stamped envelope to: IRCA Goodie Factory, 1017 West Manhattan Drive, Tempe, AZ 85282.

Unless otherwise noted, permission is granted to publish, broadcast, or otherwise reproduce non-copyrighted material appearing in "DX Monitor" provided credit is given to IRCA and the original contributor. Opinions expressed in "DX Monitor" are those of the original contributors and do not necessarily reflect those of the IRCA, its publishing staff, editors or officers.

P.O. Box 21074, Seattle, WA 98111, U.S.A.

first class

D. A. NYHOLM  
2071 CEDAR STREET  
SAN CARLOS CA  
94070

RENEW

19

FIRST CLASS MAIL  
U.S. POSTAGE  
PAID  
Seattle, WA  
Permit No. 601