

April 29, 1989 - Volume 26, Number 29 - Edition 853 - ISSN 0899-9732 ✓

News From HQ

Wanted: Goodie Factory Manager.
 Floyd Perry has found it necessary to resign due to a big increase in his job commitments. We need a replacement as soon as possible. You'll be filling reprint and publication orders, which generally requires a couple hours a week and access to low cost photocopying services. Contact our president, Karl Zuk, right away if you are interested in taking over. In the meantime, please be patient if it takes a while to process your reprint order.

Election Results: Karl Zuk was re-elected president, and Don Erickson was elected Secretary-Treasurer. Most of the current Board of Directors were re-elected, except... there was a tie vote for seventh place. According to our Bylaws, a runoff is needed. We'll have more information soon. Ernest Cooper won the TVA award, and Sacramento won the vote for the convention site. Complete election results are on page 11. Congratulations to the winners.

The IRCA Almanac: The Almanac is progressing well. We now have well over half the material here at HQ ready for processing. Expect a prepublication price announcement in the next DX Monitor.

Convention News

It's official, the 1989 IRCA Convention will be held in Sacramento, CA on July 4 weekend. It will be a lot of fun, so plan to be there. Don't forget to donate something to the auction. The money we raise will go direct to the club treasury and stave off future dues increases. So pack up those old radios, books, T-Shirts, posters, and other radio items and ship them to Ric. Or bring them with you. See page 7 and Ric Heald's forum report for more info.

In This Issue

Eastern DX Roundup	7
Central DX Roundup	10
Western DX Roundup	12
Eastern DX Forum	16
Western DX Forum	18
Broadcasting Information	3
Hearing it Through the Grapevine	5
IRCA Convention News	6
Election Results	11
Albuquerque Daytime Bandscan	17
Micro-MWDX-4A Loop-vs-Wire Phaser ..	20

We don't have any DXWW columns again this time. I assume it's because of the poor conditions for foreign DX. All the more reason to report the foreign DX you do hear.

This issue includes what will hopefully be a regular feature in DX Monitor. See page 4. The new column is designed to fill some of the gaps we have in DX Roundup and other columns. Hopefully it will be of interest to the experienced DXer as well as the newcomer. Please give Shawn you support and contributions, and let him or I know what you think of the column.

New Members

Our ranks continue to grow, as we welcome the following new members:

- Andrew Claret, JAFFO, New York
- Stephen Ponder, Shreveport, LA (rejoin)
- David Braun, Anchorage, AK
- Bob Post, Boise, ID

Volume 26 Sched

The next DX Monitor will come out on May 13. HQ deadline will be May 6. DXMs after that will come out on May 27, June 17, July 15, and August 12. See the columns for editors' deadlines.

broadcasting information

Editor: Geov Parrish, 1201 S. Court House Rd. #240, Arlington VA 22204
 Deadlines: 4/29, 6/3, 7/1, etc. * * * compiled 4/05/89

A relatively short column this time, after the forest-eater of March...

NEW STATIONS

<u>call</u>	<u>KHz</u>	<u>power/antenna</u>	<u>state/city</u>
new 630	10000/10000	DA-1	HI ORANGE COVE application granted
WBMX 640	1000/250	ND	MI ZEELAND requests extension of time; application dismissed to move to Merrillville IN, 250/250 w ND, new xmtr location
KMCE 650	25000/5000	DA-2	CA RANCHO CORDOVA requests extension of time
WORL 650	10000/	DA-D	FL CHRISTMAS applies for 5000 w days
WWFE 670	50000/2500	DA-2	FL MIAMI granted ext. of time, now testing
WAQX 670	2500/	DA-2	NY SYRACUSE dismissed app. to move xmtr locatn
new 680	800/400	DA-N	LA TIOGA new app. (replaces expired KVGO CP)
KRMW 700	50000/1000	DA-2	CO SILT granted extension of time
WRBR 720	5000/	ND-D	MS RICHLAND granted extension of time
KSP0 740	500/	ND-D	WA DISMAN dismissed app. to move xmtr locatn
WNYS 750	5000/1000	DA-2	NY CANTON amends app. to 730 w nights
new 780	500/370	DA-2	FL MULBERRY new application
WGBV 830	50000/1000	DA-2	GA LITHIA SPRINGS applies to move to Smyrna GA; 50000/500 w DA-2, 10000 w critical hours
KUIP 840	10000/1000	DA-N	NV GARDNERVILLE denied extension of time
WKTR 840	8200/	DA-D	VA EARLYSVILLE requests extension of time
KUTE 880	500/250	ND	CA DESERT HOT SPRINGS req. extension of time; applies for 3000/900 w DA-1
KPT0 890	50000/1000	DA-2	CA SLOUGHHOUSE target date now 6/12/89
KNSA 930	2500/2500	ND	AK UNALAKLEET req. replacement for expired CP
KBTB 1000	1000/	DA-D	TX MARION requests extension of time
new 1100	25000/1000	DA-2	AZ SUN CITY application dismissed
WWWF 1160	5000/250	ND	FL WOODVILLE granted extension of time
WOOD 1190	1000/1000	DA-N	FL ROYAL PALM BEACH granted extension of time
KOQI 1200	25000/1000	DA-N	CA SOQUEL granted extension of time
new 1270	1000/	ND-D	NY LANSING application dismissed
new 1310	1000/1000	DA-2	NC CHARLOTTE app. vs. WGSP dismissed
new 1450	??/?	?	PQ GASPE applies to increase night power
new 1490	??/?	?	ON GRAVENHURST applies to increase nite power
new 1500	5000/	ND-D	GA CLARKESVILLE new app. (competes with WLTA)
new 1600	5000/5000	DA-1	WA DUNGENESS application granted

CHANGES IN EXISTING FACILITIES

<u>call</u>	<u>KHz</u>	<u>power/antenna</u>	<u>state/city</u>
WGTO 540	50000/5000	DA-1	FL CYPRESS GARDENS granted move to Pine Hills FL (near Orlando), 50000/50000 w DA-2
KDFT 540	1000/250	DA-D	TX FERRIS applies for 220 w nights
WVLK 590	5000/1000	DA-2	KY LEXINGTON granted 1600 w nights
KJLM 760	5000/1000	DA-N	CO THORNTON granted 50000 w days, DA-2
CBST 800			BC LANGLEY applies for 25000/25000 w DA-2
WRFF 850	1000/	ND-D	CT RIDGEFIELD applies for 5000 w ND-D
CHVO 850			NF SPANIARDS BAY reapplies to move to 560 KHz; 5000/5000 w DA-2
WSEA 900	1000/	ND-D	DE GEORGETOWN applies for 1000 w nights
WEKO 930	2500/2500	ND	PR CABO ROJO applies for 4000 w nights
KXEN 1010	50000/	DA-D	MO FESTUS granted 500 w nights
WUFL 1030	5000/	DA-D	MI STERLING HEIGHTS reapplies to modify DA
WAMN 1040	1500/	ND-D	WV GREEN VALLEY applies to move to 1050 KHz; 1430 w ND-D day only
WSML 1190	1000/	DA-D	NC GRAHAM granted extension of time for move to 1200 KHz, 10000/1000 w DA-N
WMNE 1360	1000/	ND-D	WI MENOMONIE applies to modify CP to move to 880 KHz (instead of 870); 10000/210 w DA-2
WZAL 1410	1000/	ND-D	GA McDONOUGH move here from 1540 KHz was due 4/1/89; applies for 2500 w ND-D
WKAM 1460	1000/500	DA-N	IN GOSHEN granted 2500 w days
CKO 1470			PQ POINTE CLAIRE applies to move to 650 KHz;

10000/2500 w DA-2

KCVR 1570 5000/340 DA-D CA LODI granted 5000/500 w DA-2
WPEP 1570 500/ DA-D MA TAUNTON dismissed app. for 2000 w days
KNIM 1580 250/ ND-D MO MARYSVILLE applies for 1000 w days
WONX 1590 1000/2500 DA-N IL EVANSTON applies for 3500 w days, add DA
KSSA 1600 5000/1000 DA-1 TX DALLAS amend night DA for synch. xmtr

CALL LETTER CHANGES

(\$ means change accompanies a station sale; * check for format info)

WGOR 650 FL Christmas is now WORL KZOI 1360 CO Johnstown is now KHNC
WAWB 810 GA Habira WXLR WQMI 1380 NH Portsmouth \$ WCQL
KADO 940 TX Texarkana * KTNW KBLX 1400 CA Berkeley * KBFN
WRPT 1050 NH Peterborough WMDK KWEZ 1440 LA Monroe * KJLO
KPHD 1140 TX Conroe \$ KSSQ KDON 1460 CA Salinas * KZXR
WPTY 1150 SC Rock Hill WXLF WNNV 1460 IN North Vernon WKRP
WBYG 1160 VA Fieldale WCBX KOAW 1490 NM Ruidoso Downs * KRUI
WHTO 1190 PA Hughesville \$ WHUM KHTT 1500 CA San Jose KSJX
WMXA 1200 IL Chicago WOPA WSSH 1510 MA Boston * WKKU
WPLZ 1240 VA Petersburg WGCV WKNT 1520 OH Kent WJMP
WHDZ 1260 PA Erie WRIB KSVZ 1540 TX Fort Worth KSGB
WTNT 1270 FL Tallahassee * WYYN WTHB 1550 GA Augusta * WNTA
WYGO 1330 KY Corbin \$ WKDP KKJO 1550 MO St. Joseph * KSFT
KVKM 1330 TX Monahans \$ KLBO KXOJ 1550 OK Sapulpa KBLK
KFIV 1360 CA Modesto * KASH WCQC 1580 PR Morovis WMTI

CALL LETTER CHANGES THAT NEVER HAPPENED: WANM-1070 Tallahassee FL was supposed to have moved to 1270 KHz, with 1070 becoming WSUY, about two years ago. The sale and move never happened; WANM remains on 1070 KHz.

FORMAT CHANGES

WVOC 560 SC COLUMBIA was adult contemporary, talk, now all talk
KXOK 630 MO ST. LOUIS was news-talk, to become all news
WQXI 790 GA ATLANTA AC-CHR // FM, drops evening jazz
KIKN 840 TX PHARR was country, now country // FM
WPTX 920 MD LEXINGTON PARK was CHR/dance // FM, now adult contemporary
WGFP 940 MA WEBSTER was adult standards, now adult contemporary
KTNW 940 TX TEXARKANA was KADO, black, now rock oldies
KAHI 950 CA AUBURN was adult standards, now SMN adult contemporary
WLHX 980 GA ROSSVILLE was WGVF, gospel, now AC-oldies // FM
KKRE 1040 CO MONUMENT was religious, now business news
KUKQ 1060 AZ TEMPE was country, now "modern rock"
KTOZ 1060 MO SPRINGFIELD was adult contemporary, now adult standards
CKKW 1090 ON KITCHENER was rock oldies, now CHR
KVRE 1150 CA SANTA ROSA was KPLS, now "adult alternative contemporary"
(staff from old KVRE-FM-101.7) (Taylor-CA)
KAMJ 1230 AZ PHOENIX was Transtar 41 soft AC // FM, now all sports (!)
KLAV 1230 NV LAS VEGAS was oldies, now country, sports
WCBY 1240 MI CHEBOYGAN was country, now adult standards
WYYN 1270 FL TALLAHASSEE was WTNT, country // FM, now motivational talk
WNPT 1280 AL TUSCALOOSA was CHR, now news, sports, rock oldies
WGLI 1290 NY BABYLON was satellite oldies, to be silent upon sale
KPMO 1300 CA MENDOCINO was country, now news-talk
KRLW 1320 AR WALNUT RIDGE was country, now country // FM
WKDP 1330 KY CORBIN was WYGO, CHR // FM, now country // FM
KATA 1340 CA ARCATA was adult contemporary, now Transtar oldies Channel,
Larry King evenings (Tomer-CA)
KTCR 1340 WA KENNEWICK was KOTY, country, now news, talk, sports
KASH 1360 CA MODESTO was KFIV, CHR, now bus. news days, CHR // FM nights
KUVR 1380 NE HOLDREDGE was variety, now adult contemporary // FM
WTVR 1380 VA RICHMOND was country, now adult standards
KBFN 1400 CA BERKELEY was KBLX, soft AC // FM, now Money Radio network
business news (local only for traffic!) (Taylor-CA)
KIXT 1420 AR HOT SPRINGS was country, now easy listening
KJLO 1440 LA MONROE was KWEZ, black oldies, now country // FM
KZZR 1460 CA SALINAS was KDON, CHR // FM, now SMN "Z-Rock" (Taylor-CA)
KRUI 1490 NM RUIDOSO was KOAW, ad. con., now soft adult contemporary
KBIX 1490 OK MUSKOGEE was adult contemporary, now country
WKKU 1510 MA BOSTON was WSSH, soft AC // FM, now country
WNTA 1550 GA AUGUSTA was WTHB, black gospel, now news-talk
KKJO 1550 MO ST. JOSEPH was KKJO, adult contemporary, now country

WGLI-1290 Babylon NY has been purchased (pending FCC approval, haha) by the owners of WADO-1280 New York, who plan to take it off the air so they can expand WADO's coverage. This will apparently be the first test case of the FCC's new laissez-faire approach to interference - allowing one station or applicant to buy out another as a solution to competing applications, co-channel or adjacent channel QRM, and all other matter of irritating matters the FCC is legally obliged to regulate.

* * * * D I A L C A R D * * * *

After the multi-multi large sections of Dial Card and Trivia ? in the anniversary issue, we'll take a break this month. Remember, your city or region could appear here!

PROPOSED STATION SALES (* means check the format listings for more info)

WAAX-570-AL, KJMM-580-AZ (now silent), WELO-580-MS, WTPR-710-TN, KOSY-790-AR, KQAD-800-MN, KCHG-810-TX, KIKN-840-TX*, WHDH-850-MA, KGRL-940-OR, WDIG-950-OH, KHVN-970-TX, KLPL-1050-LA, KMIS-1050-MO, WSMT-1050-TN, KPHD-1140-TX, KUQT-1170-MO, WHUM-1190-PA, KCPC-1200-CA (unbuilt CP), KGIR-1220-MO, KYOR-1240-AZ, WJPD-1240-MI, WCGC-1270-NC, WANS-1280-SC, WFBR-1300-MD, WDLW-1330-MA, WHYS-1350-FL, KSPG-1360-KS, WBYE-1370-AL, KCLN-1390-IA, KPAG-1400-CO, KUNO-1400-TX, WRJN-1400-WI, KEZW-1430-CO, WFOB-1430-OH, WMMM-1430-VA, WJBX-1450-CT, WWBB-1450-WV, KKVU-1470-UT, KMEZ-1480-TX, WJFL-1490-MS, WWIL-1490-NC, WTNI-1490-SC, WJJM-1490-TN, KACJ-1510-AR, WRQK-1520-OH, KFRS-1560-WA (now silent again), WKBH-1570-WI, KTSS-1580-IA (now silent), WEBG-1580-PA (now silent again too), WPSK-1580-VA, WKWF-1600-FL

STATION SALES THAT FAILED: KHUG-1300-OR (now silent), WPLB-1380-MI

MISCELLANEOUS NOTES: A refreshing antidote to the seemingly endless proliferation of radio networks: the Pennsylvania State Network, with 68 affiliates in PA, DE & NJ, has gone dark.

HEARING IT THRU THE

GRAPEVINE

SHAWN AXELROD
30 BECONTREE BAY 204-253-8644
WINNIPEG MB
R2N 2K9 CANADA BEFORE 2300 ELT

Welcome to all of you to this new section of DXM. This is not an official column for the publication. It is a trial column. If you find things in this column that you like or don't like feel free to inform me.

I would like to thank Bruce Portzer and Karl Zuk for giving me the chance to do this section. I hope to live up to their & more importantly your expectations. Also I would like to thank Hana Leah, my daughter, for doing the top of the page. Art is not one of my fortes.

To start I would like to tell you a bit about myself. I was born raised & have lived all of my 36 years in Winnipeg. I graduated from the U of Winnipeg with a B.A. in History and Political Science. I am employed at Manitoba Hydro where I am Supervisor of the Mailing Section. In October of 1973 I married Helen Karen Alderson and we have two children: a son Arlin David aged 11 and a daughter Hana Leah aged 9. I began DX'ing at High School in 1971. BCE DX'ing in a serious way began about 4-5 years ago when fellow IRCA member N J Wolfish got me away from the Ham Bands. This is not the first section in a publication that I have edited as I did the Ham Band Column for CIDX for 4½ years.

As for this trial column I have some thoughts on what it could contain. I would like to see loggings and information that could fit into several areas:

A- The State/Povince/Country of the Month.

B- The Frequency of the Month.

In these two sections members could send in the stations they hear on a regular basis. It could include such info as best times to hear them, formats, and slogans. This would give everybody a chance to see what is really going on in a state or on a certain frequency.

C- Best Bets for Hearing Each State/Province from a Particular Location. This area could include the harder to get states and provinces from your location. For example it would be of no practical use for me to tell you what Manitoba Sask., Minnesota, & North Dakota stations are my Best Bets as there are dozens to choose from. However Oregon, Mississippi Florida and Nova Scotia pose new challenges to be met. The states and provinces as well as frequencies would vary depending on your location and the degree of difficulty of hearing them.

D- Silent Periods

Members would be invited to send in lists of when their local or semi-local stations have SP's. No use in looking for a station if it is off or if it is blocking a frequency you want to DX other stations on.

E-Help with Most Wanted's.

This is one area where all of us can help each other. It could be used as a type of Bulletin Board Service. Members would send in a list of states/provinces/stations they really need. Along with your requests you could leave your telephone number and time when you want and more importantly do not want calls with "hot tips" from other members. You could also say whether collect calls are all right or not. Having two children as I do calls after 2300 ELT are not good for me at all as you will be waking up the children as well as my wife. This is a hobby not grounds for divorce. HI!!!

F- Bandscans

In this section I would take bandscans of your area. Although this has been done elsewhere in DXM, I would like to suggest that when a bandscan is done you not only list frequencies and callsigns but also formats and slogans. This would provide more information to the other members to help them catch your local pest that is their rare DX.

These are only preliminary ideas. Not all of them may survive the test of time. This is your column and as readers it will be you who decide what will and will not stay. I intend to publish the column MONTHLY, and would like to set a deadline of the 15th of each month. I hope that this will appear in the April 29 issue, so try to have material to me by May 15th if possible.

This should insure a new column for the June 17th issue. I don't expect any best bets as that could take you a while to compile. However I would like to see a Bandscan or two, your Most Wanted and Silent Periods. As for a frequency of the month let's start at the high end of the dial. 1600 will be the first Frequency of the Month. Always wanted to start at the end of something HI!! As for a Province/State of the month let us go with Kansas which is in the middle.

To kick off the whole thing here is a band scan from the 'Peg.

580	CKY	Winnipeg	Greatest hits of the 60's,70's,80's	KY-58
630	CKRC	Winnipeg	Country & Western	
680	CJOB	Winnipeg	Variety MX TX Sports NX	OB-68
920	CFRY	Portage la P	Country & Western	
950	CFAM	Altona	Classical EZL Local	R. Southern Man.
990	CBW	Winnipeg	C B C Station	
1050	CKSB	Winnipeg	C B C French (Radio Canada)	
1250	CHSM	Stienbach	// to 950	
1290	CIFX	Winnipeg	Greatest Hits of the 60's,70's,80's	1290 Fox
1570	CKMW	Morden	Country & Western	

Well that is about it from me. I hope you like the ideas put forth and if you have any comments please feel free to send them along. As I said this is a trial column so it may or may not last that is up to you and the B.O.D.'s approval. Also don't feel that you cannot contribute because you only have a little bit to send in. My grand-mother had an old saying "A little and a little makes a full pot." See you soon.

Shawn

HEAD FOR SACRAMENTO

Join us in the heart of the Central Valley, California's Capitol, for IRCA's Silver Anniversary Convention. We're certainly hoping you're planning your vacation around the convention as there's so much to see and do in the area. From boating, rafting and fishing on the Sacramento, American Rivers and the Delta, to the beautiful Sierras, Lake Tahoe, the Casinos and the Coast all within a two-hour drive. Take time to visit Old Sacramento, a 12-square block area on the river restored to the 1850's. Adjacent is the world's largest interruptive railroad museum. Sacramento was the western terminus of the Pony Express and later the Transcontinental Railroad. Enjoy a free guided tour of the restored capital building and the Victorian Governor's mansion. There's a lot to see and do and we have lots of activities planned.

On tap, station tour Friday afternoon, a MM DX'pedition, softball game and picnic on Sunday afternoon, as well as the banquet, auction, speakers and other activities - our club prez has already volunteered to be thrown into the pool!

Set aside 30 June, 1 & 2 July and make your way to Sacramento for IRCA's 25th Convention.

From I-5, US 99, eastbound I-80 & US 50, exit Sunrise Blvd. S. from US 50 to Folsom Blvd. (first light), left on Folsom to Best Western Heritage Inn, 11269 Point East Dr., left off Folsom and you're there! From westbound I-80, exit Sunrise Blvd. S., south approx. 5 miles, cross over US 50 and follow above.

Registration is \$22 and includes breakfast each day. Room rates are \$48 single, \$52 double and \$7 additional for a third person. If you want a wet bar and jacuzzi in your room, add \$6 to above rate plus 6 1/2% tax. Banquet is \$10.95 plus tax plus 15% gratuity. The hotel has a beautiful restaurant and bar, pool, spa and sauna. If you wish to share, we'll make every effort to locate a roommate, however, if we cannot, applicable rate must be paid.

BEST WESTERN
HERITAGE INN

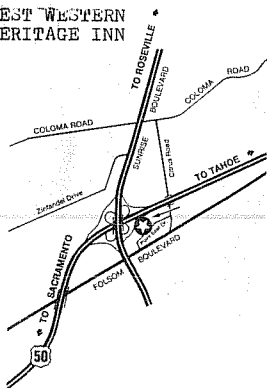

Yes, count me in. I'll be in Sacramento!

Name _____

Address _____

Phone _____

I'll be arriving (day) _____ (time) _____ (car) _____ (flight) _____
(train) _____ (other) _____

I'd like a Single _____, Double _____, Triple _____. Share with _____

I'd like a room for Fri., 30 June _____, Sat., 01 July _____, Sun., 02 July _____

My registration fee is enclosed (\$22) _____. Deadline: 15 June 1989

Departing Sacramento on _____, via _____

Mail your registration along with any items for the auction (we prefer you bring them) to Ric Heald, 8539 Bellamy Way, Sacramento, CA 95828. If you have any questions, please contact me. Hope to see you for IRCA's 25th Anniversary Convention, 30 June through 02 July 1989! Oh yes, please specify Smoking or Non-Smoking room, and whether you wish Standard or Deluxe.

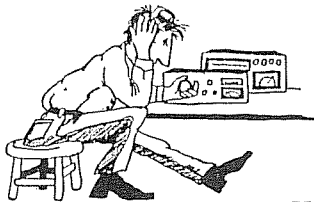

Eastern DX Roundup

Editor: Ray Bauernhuber
141-12 243 Street, Rosedale, N.Y. 11422

May 1, 1989

DEADLINE: for the May 13th Edition

=====
(JDS1-AL) J.D. Stephens
122 Brawley Drive
Owens Cross Roads, AL - 35763
Panasonic RF-2600 w/30' longwire
(JDS2-AL) Sears AM/FM car rig w/car whip
(RJB-NY) Your Editor w/SONY-2010 + Shotgun Loop
(GH-PA) Gary Heisey
Box 310F RD 1
Osterburg, PA - 16667
Philco Radio; GE Superadio
(NJW-MI) Neil J. Wolfish
178 Florence Avenue
Willowdale, Ontario M2N 1G4
DX'ing in Brighton, MI on M.A.R.E.
(Michigan Area Radio Enthusiasts)
Sony 2010 + beverage
(MB-ON) Mike Brooker
99 Wychcrest Avenue
Toronto, ON M6G 3X8
RF-2200 and ICF-7600D
(RSR-ON) Robert S. Ross VE3JFC
Box 4373, Stn. C
London, Ontario N5W 5J2
Kenwood TS4305/longwire
Sony 2010/loop
(WPT-DC) William P. Townshend
4500 Connecticut Ave NW 1901
Washington, D.C. 20008
Sony 2010
(AS-AL) Al Stewart
2007 Buena Vista Drive
Birmingham, AL - 35216
Several receivers
=====

540 WSTH GA, COLUMBUS 2/12/89 1229 ID, c/w, "SOS Auto Dealers Sale" promo. (AS-AL)
640 KFI CA, LOS ANGELES 4/1/89 0551 FAIR ID by/m, talk show with talk about other L.A. radio stations [somebody was poking fun at another station]: "Give us 22 minutes and we'll give you Guns 'n' Roses." (NJW-MI)
740 WRNR WV, MARTINSBURG 3/22/89 1920 noted on late for first time with OLD-T-40 songs, ID as 74-RNR under CBL. (GH-PA)
860 WDMG GA, DOUGLAS 2/15/89 2300 ID, SSB and s/off. (AS-AL)
860 WHRT AL, HARTSELLE 3/23/89 0325 VERY WEAK w/static, SS, weak CJBC. Eddie Rabbit song, c/w, "WHRT, HARTSELLE" by/m, clear on top at times. Helped by a 100' longwire. (GH-PA)
890 WFKJ PA, CASHTOWN 3/1/89 1800 pr in WLS null w/USA Network nx, spot for World Vision mentioning 1-800-4HUNGER toll-free number, noted "AM 89 WFKJ" ID at 1804 but then lost under strong WLS. (MB-ON)
900 WEAS GA, SAVANNAH 3/9/89 2250 Surfaced out of jumble w/"Radio with a vision - WEAS", then gone. (JDS2-AL)
920 KARN ARK, LITTLE ROCK 2/10/89 1923 ID, talk, ad for Airport. (AS-AL)
970 WFLA FL, TAMPA 3/25/89 1824 GOOD w/no sign of WAVG w/promo for the Bob Lassiter show "on Newsradio 970 WFLA", spots for Standard Register and State Farm, into talk show. (JDS2-AL)
990 WYAT LA, NEW ORLEANS 4/2/89 0417-0502 POOR w/a Latin; various oldies by John Lennon, Rolling Stones, Animals; f/ann, ID @0500. (NJW-MI)

990 WIVK TN, KNOXVILLE 2/10/89 1942 ID, c/w, "Snapper" and "Nissan" ads; had been on 850 khz. (AS-AL)

1010 WQYK FL, SEFFNER 3/25/89 0530 FAIR getting weaker with several IDs by/m, going into 3 c/w songs in a row. No WINS or CFRB; AU CX are starting. (GH-PA)

1060 WHFB MI, BENTON HARBOR-ST.JOSEPH 4/1/89 0602 FAIR w/Mexican (R. Educacion); local nx read by Rene, 0607 NBC TV spot. (NJW-MI)

1080 WDJX KY, LOUISVILLE 4/1/89 0526 POOR w/WTIC; CHR by R.E.M. and Little Debbie Gibson, lady w/"99.7 WDJX" IDs. (NJW-MI)

1160 WAMB TN, DONELSON 2/12/89 1300 ID, baseball, Mutual nx, POOR. (AS-AL)

1160 WJJD IL, CHICAGO 2/11/89 2314 ID, EZL, clear after Radio Sohetos/off. (AS-AL)

1170 WHZI AL, HANCEVILLE 2/12/89 1243 ID and slogan as "Your favorite Gospel mx w/less talk." (AS-AL)

1190 WVSL MS, BAY SAINT LOUIS 3/10/89 1855 FAIR oldies song by Beatles; "Sound and spirit of Mississippi gulf coast, 1190, WVSL"; last heard as WXGR. (GH-PA)

1230 WNUZ AL, TALLADEGA 2/12/89 1302 ID, EZL, POOR. (AS-AL)

1240 KASO LA, MINDEN 3/2/89 1300 ID, "Focus on Family" program [caught on the car radio on I-20]. (AS-AL)

1250 WRKQ TN, MADISONVILLE 3/15/89 0052 Frequency check w/uninterrupted c/w, then @0057 "This is WRKQ in Madisonville, Tennessee on the air for equipment check", then gone. (JDS1-AL)

1300 WKXI MS, JACKSON 2/11/89 2346 ID, soul mx, spot for Tigers baseball. (AS-AL)

1300 WNGM TN, NASHVILLE 2/11/89 ID, Religious program, "Day Spring" program, request for mail. (AS-AL)

1300 WIMG NJ, EWING 3/29/89 2100 FAIR-GOOD ID by/m w/ment of Delaware Valley; o/u WFBR. (WPT-DC)

1320 WKAN IL, KANKAKEE 3/14/89 1858 FAIR ID by/m with slogan = "Sounds of the 40s, 50s and 60s." (WPT-DC)

1330 WEYZ PA, ERIE 3/7/89 1725 GOOD-VERY GOOD dominating frequency w/"30 at 5" newscast, sports rpt, "Skywatch" wx at 1730, IDs as "Radio 1330 WEYZ" into MYL mx at 1735. A new station, moving from 1450 and replacing WRIE which is now defunct. In between the demise of WRIE and WEYZ's move from 1450, WSPQ Springville, NY was noted here. I count frequency swaps such as this one as new stations (I heard WEYZ on 1450 in 1987). But if WRIE had simply changed calls I wouldn't count it as a new station. (MB-ON)

1330 WVHI IN, EVANSVILLE 3/11/89 1900 POOR u/WSSY w/religious mx, ID as "WVHI...Evansville's only full-time Christian music station", then disappeared under WSSY & WEYZ. (MB-ON)

1370 WBYE AL, CALERA 2/12/89 1750 ID, FAIR until power was reduced. (AS-AL)

1370 WKIK MD, LEONARDTOWN 3/14/89 2105 FAIR c/w, ID, Network News by f/ann. (WPT-DC)

1380 WYSH TN, CLINTON 3/18/89 1920 GOOD o/WAOK w/many "Top 40 Country WYSH" slogans, promos for the WYSH Birthday Club, phone #457-1380; c/w. (JDS1-AL)

1380 WYNK LA, BATON ROUGE 3/21/89 1851 FAIR w/"Your wx station WYNK", Bob Bishop w/traffic, local spots, "AM 1380 WYNK" slogan. (JDS2-AL)

1440 WGIG GA, BRUNSWICK 3/10/89 0100 FAIR c/w, "WGIG, Brunswick, Saint Simons Islands" ToH then ABC nx. (GH-PA)

1460 WMBA PA, AMBRIDGE 3/9/89 1950 POOR fading in mess; 266-7544 to request oldies songs; ID then WCMB took over. (GH-PA)

1460 WBCU SC, UNION 3/18/89 1910 GOOD w/racing show promo, promo for "The Good Afternoon Show", "...on AM 1460, WBCU", into NCAA bkb tournament game. (JDS1-AL)

1500 WLTA GA, CLARKSVILLE 3/22/89 0630 FAIR-FADEY w/church mx, "WLTA AM 1500" slogan, mention of "...all you need to do is drop a card or letter to WLTA, Box 468...", wx, into gospel mx. (JDS1-AL)

1550 WCSJ IL, MORRIS 4/2/89 0400-0500 POOR-FAIR with Jim Bohannon, 0459 spot for Tree Surgeon in Seneca; ID = "You're listening to 15-50 WCSJ in Morris", Mutual news. (NJW-MI)

1560 WPAD KY, PADUCAH 2/26/89 1808 ID, "Country Weekend" program, clicked...then gone. (AS-AL)

1570 WCRL AL, ONEONTA 2/12/89 1008 ID, MYL featuring sounds from 1942. (AS-AL)
 1580 WOXR AL, OXFORD 2/12/89 1029 ID, BBD mx. (AS-AL)
 1590 WDBL TN, SPRINGFIELD 2/10/89 2015 ID = "This is WDBL, Springfield". (AS-AL)
 1600 WEUP AL, HUNTSVILLE 2/12/89 1100 ID, soul/blues, ad for "Huntville's Blue Beard Shop." (AS-AL)

=====

TENTATIVE...PIRATES...UNIDENTIFIES...TIS

=====

530 unID TIS 4/12/89 2115 POOR-FAIR repeated taped messages as: "Welcome to Kennedy Airport. This is a test of the Port Authority's Commuter Traffic Advisory & Airport Information Radio. Within the next few weeks we plan to begin broadcasting current airport information on this frequency, 530, on your AM dial. Broadcasts will include parking lot and terminal conditions as well as up-to-date traffic reports of both airport and surrounding roadways. The construction phase of our re-development program has already begun and we hope to provide you with up-to-date traffic information so that your trip through Kennedy will be easier. Please watch for the road way information signs which will let you know when our new radio service begins. Enjoy your trip and keep listening. (RB-NY)

530 unID MD., HAGERSSTOWN 3/18/89 1340 WEAK calls sounded like WXM -42 and NOAA Station operates 162.475 mhz continuous weather tape loop, operated by National Weather Service forecast office. Why am I getting this on 530 kc? [Could this be a TIS broadcast?-rb]. (GH-PA)

0660 KTNN AZ, WINDOW ROCK 3/25/89 0355-0500 TENTATIVE VERY WEAK (t) under WFAN; Cuba null. Heard c/w clear at times but only one (1) VERY POOR ID at 0400 which sounded like KTNN. I used a loop antenna as the longwire only gave me Cuba. Who else has c/w at this time? (GH-PA)

0850 WUTK TN, KNOXVILLE 3/11/89 0755 WEAK in mess w/slogan "All nx all the time, WUTK, Knoxville"; calls not clear; talk about how you could get wild horses; into nx by/f. (GH-PA) (t)

1620 WJDI NY, COBLESKILL 3/13/89 2300-2323 PIRATE sign on @2300; (P) ESB, oldies, rock mx, m/DJ, funny ads; IDs as "WJDI, AM, 1620 Stereo" + address as Box 142 Cobleskill, NY 12415. (RSR-ON)

=====

QUIPS & QUOTES

=====

FROM: MIKE BROOKER, ONTARIO: All of my loggings this time were noted before the A-Index hit triple figures!

FROM: RAY BAUERNHUBER, NY: Thanks to all the contributors for this column - cx aren't that great and the loggings are fewer. I really am upset that Karl lost his position with Popular Communications...maybe we should consider starting our own magazine? Comments are welcome re. this matter. We're into the season of DX Monitors every 2 weeks so the next deadline for this column is MAY 1ST at my QTH. Until then, good DX to all and 73 de Mr. B.

Shirley Jones sues radio station

FORT LAUDERDALE, Fla. (AP) — Entertainer Shirley Jones is suing an Orlando radio station for invasion of privacy because of an unexpected, on-the-air wakeup call.

Jones was in Orlando for an October concert when WHTQ-AM telephoned her at her hotel between 6 and 7 a.m., the lawsuit said.

The station and its owner, TK Communications of Fort Lauderdale,

have a celebrity wakeup feature in which well-known people are roused "from a deep sleep, without their knowledge, to see what embarrassing or confusing things might be said," said the lawsuit.

Jones's lawsuit also claims that WHTQ should have arranged for a commercial fee to be paid to her.

WHTQ and TK Communications refused comment.



[Baltimore, MD]



WESTERN DX ROUNDUP

2301 PACIFIC AVE., ABERDEEN WA 98520

Deadlines for receiving WDXR tips: Mondays 5/1, 5/15, 6/5, 7/3, & 7/31

REPORTERS FOR THIS ISSUE:

- (TRH) Tim Hall-350 G St. #F-1-Chula Vista, CA 92010
DX 150B, ICF-2010, Radio West loop
- (JH) Jim Hilliker-P.O. Box 1499-Carmel Valley, CA 93924
GE Superadio and old Sony TRF
- (SSH) Steve Howe-250 Waverley St., Apt. 5-Menlo Park, CA 94025
Realistic DX-150, Radio West loop
- (SMM) Steve Mittman-2248 West 37th Street-San Pedro, CA 90732
Realistic #12-655; Kenwood KRC-939 AM stereo car receiver
- (FPJ) Floyd Perry, Jr.-6408 Morgan Pl. #218-Stockton, CA 95209
GE Superadio
- (MS) Mike Sanburn-P.O. Box 1256-Bellflower, CA 90706
GE Superadio & Sony SRF M40W (Walkman)
- (RW) Robert Wien-1309 Dentwood Dr.-San Jose, CA 95118
GE Superadio, GE long-range portable, SM-2

OF SPECIAL INTEREST:

- 950 XEKAM BCN, Tijuana 3/24 2145 following a one week "SP" (see below),
Returned to the air with these new calls ("Equis-eh-kah-ah-
emme")! A week later, 4/7, another surprise, they changed from
Spanish to English! Carries FBN (Financial Business Network) 24
hours. At 100, sloppily cuts to UPI Radio News. Legal IDs (in
Spanish) are very sloppily dropped in over programming anytime
from :58-:06. IDs in English are simply "AM 950." 4/8 0545 FBN
carried interview with FBN's founder, Glen Taylor, who said
that FBN--which is brand new, and the radio counterpart of his
TV's FNN, the Financial News Network (which began in 1981)--
will only be carried on AM stations; no FM. He also ment. that
they got signed to a "high-powered" station in Nevada "which
covers 8 western states." (SMM-CA)
- 1220 KRGO CA, Fowler 4/3 0907 call change, ex-KLIP good in KDFC null
with local spots, Jim Bohannon with Mutual sports. ID "...on
1220, KRGO." (RW-CA)
- *****
- 540 KVIP CA, Redding 3/29 1753-1802 good signal but oddly muffled
audio over KSFO-560 with relig. talk & music, news, legal ID,
and plea from their operations manager for donations to keep
station going. (SSH-CA)
- 580 KMJ CA, Fresno 3/29 1958-2037 excellent with weather, legal ID,
NBC News, local & regional news with lots of "News 58" special
reports, traffic, and spots. (SSH-CA)
- 620 KIPA HI, Hilo 3/15 0500 poor under KTAR with NBC News, sounded like
Talknet after. Not heard in a while. (TRH-CA)
- 630 KYDC CA, Monterey 4/1 1557-1700 good over partially nulled KOH &
KFRC-610. EZL music, legal IDs, "Ecstasy" slogans, many local
spots, and weather. (SSH-CA)
- KIDO ID, Boise 4/3 0822 strong over mess with "KIDO Weatherwire."
(RW-CA)
- KOH NV, Reno 4/1 1815-1907 good but fluttery over partially nulled
KXDC. Syndicated "Garden Line" program, IDs, promos, several
local spots, legal ID, and CBS News. (SSH-CA)
- 650 CISL BC, Richmond 4/2 0614-0631 fair o/u unID Spanish station
(XETNT?) with quick ID & oldies rock music. (SSH-CA)

- 660 KTNB AZ, Window Rock 3/15 0510 has added Interstate Radio Network, so resumes 24h operation & becomes a pest again. This station has been the focus of controversy as it is playing a key role in the current power struggle for control of the Navajo Tribe. (TRH-CA)
- 700 *KKJZ* CA, Soledad Fr 3/31 1730-1930 new local not on yet, but first time heard ET'ing. Continuous loop tape with two IDs. One was legal ID. The other ID said "This is K-K-J-Z, Soledad, CA, running equipment tests on 700 kHz, with day power of 330 watts and night power of 500 watts." In between IDs, the same short classical music piece played and then TT's. Carrier off at 1930. Strong signal for the power, only slightly weaker than 5kw KKMC-880. No phone number listed yet. (JH-CA)
- 750 KAMA TX, El Paso 4/3 0510 new Spanish pest. IDs as "K-A-M-A, radio Kama." American oldies music mixed with Mexican tunes. Ment. Rosarito, Mexico. Over KOAL. (MS-CA)
- 840 (KVEG) NV, North Las Vegas Sa 4/8 0358 noted with OC. (TRH-CA)
- 880 KKMC CA, Gonzales 3/31 1911-1926 fair but buzzy with relig. music, ID, spot, and promo. (SSH-CA)
- 930 KRTH CA, Los Angeles 3/31 2131-2143 fair but fluttery with KFRE-940 partially nulled. Oldies Motown & rock music, quick IDs, talk, and ABC sports. (SSH-CA)
- KSEI ID, Pocatello 3/25 0524 poor under KRTH with Dara Welles Talknet, network & local ads, and several IDs. This was my UNID a few issues back, not KAGI as I had hoped. (TRH-CA)
- 950 KAHI CA, Auburn 3/16 0610 fair with oldies in local XEGM/XEK's week-long SP! Still using "9-50 K-High" slogan. (TRH-CA)
- KYGO CO, Denver 3/24 2226 poor-fair mixing with several XB's in flaky local XEGM/XEK's absence. (TRH-CA)
- XEGM BCN, Tijuana 4/10 0200 noted carrying Financial Business Network, Spanish ID on hour, then UPI News. (RW-CA)
- (XEGM)+ Fr 3/24 noted off the air, per phone tip from Tim Hall. Remained off for a week! Fr 3/31 1215 was on again, but with very low power (est. approx. 250 watts). Off again at recheck at 1630. Finally back on again with full power at sunset that day. See "Of Special Interest" for details. (SMM-CA)
- 960 KZXY CA, Apple Valley Fr 3/24-Fr 3/31 good midday with local 950 off. Sometimes up strong enough for stereo reception on car rx. Format is light MOR with "Cozy 960 AM" IDs. Taped legal IDs as "From Palm Springs to Parker (AZ--SMM); from Needles to the California coast; this is KZXY, Apple Valley--your 'Cozy' radio station." Ex-KAVR. (SMM-CA)
- KNEZ CA, Lompoc Fr 3/24-Fr 3/31 fair midday with Spanish under KZXY. Station gets completely lost to KZXY just a few miles inland. (Incidentally, this city is pronounced "Lompoke.") (SMM-CA)
- KLAD OR, Klamath Falls 4/1 2240 xint in KABL null with ID "here on Oregon's Country Giant, KLAD." (RW-CA)
- 970 KNUU NV, Paradise-Las Vegas 3/24 2233 fair with local news & weather, back to Tom Snyder show. Rare here, usually I get a KAFY/KVIM/XEJ mix. (TRH-CA)
- 1000 KVSD CA, Vista 3/16 0408 noted back to NSP schedule with "The American Radio Network" all-night talk show. Haven't heard this on any other station. (TRH-CA)
- 1020 (KCKN) NM, Roswell 4/2 0428 totally off until about 0500, leaving KTNQ by itself this time. (TRH-CA)
- 1040 WHO IA, Des Moines Sa 3/11 0512 interesting promo heard: "From coast to coast, border to border--and then some--this is WHO, Des Moines." (SMM-CA)
- CKXY BC, Vancouver 4/3 0645 first time logged with IDs as "Kicks" and "Vancouver's music power." Contest promos and CHR tunes. Very powerful signal, but still nulls nicely for WHO. (MS-CA)
- 1060 KUKQ AZ, Tempe 3/24 0213 and other nights, noted //FM KUPD with oldies instead of usual C&W. Don't know yet if this is just a late-night simulcast or a full format change. (TRH-CA)
- +MM 4/3 0344 heard with AOR and new slogan "Alternative music is 10-60 KQ." Program director must belong to the format-of-the-month club, hi. (TRH-CA)
- *KPAY* CA, Chico 4/3 0414 noted with TT. (RW-CA)
- 1070 (KWSA) OR, West Klamath per call on 4/7, still awaiting FCC approval to come on air (mentioned "These things take time, I guess."). They're not kidding! (RW-CA)

- 1090 7KTNS? CA, Oakhurst 4/3 0944 again tent. with ID "We're playing yesterday's favorites, and today's hits..." into "How Can I Fall?" by Breathe. Not KNCR as I had them nulls out! (RW-CA)
- 1140 (KRAK) CA, Sacramento 3/15 0515 totally off, leaving KGEM & a very weak KCMJ. Haven't caught this one off in years. (TRH-CA)
- KGEM ID, Boise 3/15 0516-0603 poor in KSDO-1130 slop but steady with satellite nostalgia, lots of pre-recorded IDs, and slogans like "K-Gem," "AM Stereo 11-40," and "The Gem of Idaho." Not heard since the late 70's, when KRAK had a regular MM SP. Wasn't in my totals, so call it ID #15. (TRH)
- (KRSR) NV, North Las Vegas 3/15 0515 also off--I applaud their timing, hi. (TRH-CA)
- 1150 KIIS CA, Los Angeles Sa 4/1 dropped rap music format, and is now 100% simulcasting CHR 102.7 KIIS-FM (again!). Taped legal IDs every other hour as :52 approx. as: "Rockin' Southern California from the top of Mt. Wilson, to the open Pacific--and beyond! KIIS-FM and AM, Los Angeles." (Jingle.) "Kiss-FM, Los Angeles!" (Alternate hours, legal ID is simply a quick, "KIIS-FM and AM, Los Angeles.") Frequent slogan used is "Kiss-FM--More music, better variety, less talk." (SMM-CA)
- 1160 KSL UT, Salt Lake City has new interesting legal IDs every hour: "KSL, Salt Lake City, United States of America." (SMM-CA)
- 1190 KORG CA, Anaheim 3/16 0459 noted with ID, CNN News on the hour, and later with Business Radio Network feed. Slogans "K-Orange" and "Southern California's newest talk radio station." Ex-KPZE. (TRH-CA)
- 1220 KBET CA, Canyon Country per call on 4/7, still having technical problems, should be on air in about 3 weeks (approx. end of April). (RW-CA)
- 1260 KTEE ID, Idaho Falls 4/10 0730 strong at s/on in KOIT null. This s/on is well before 6am, MDT, & Idaho LSR in April is approx. 0845. How can they s/on before 6am without a nighttime authority? PSA power only good from 6am till LSR! (RW-CA) (Bill says nighttime authority is valid from sunset to sunrise, usually less power than after 6am.--NH)
- 1280 (KFRN) CA, Long Beach Th 3/16 open carrier tonight, leaving 2 very weak stations (probably KHEP /KREL) underneath. (TRH-CA)
- KREL NV, Henderson 4/10 0100 poor in mess with Spanish & English ID. (RW-CA)
- 1300 KAZN CA, Pasadena 4/9 0237 finally logged this call change with man praising Filipinos in English, sang "Happy Birthday," ID as "Radio Filipino, KAZN." Faded under KROP/KMPS. New. (RW-CA)
- 1360 KZIQ CA, Ridgecrest 4/3 0400 while trying for call change of KASH-1360 Modesto ex-KPIV, this faded up strong in KEEN-1370 null with ID "Serving eastern Kern County 24 hours a day, 1360, KZIQ, Ridgecrest." When did they go 24 hours? New nighttime PSSA? (RW-CA)
- KKMO WA, Tacoma 4/10 0125 o/u KRKK while trying for KASH call change (ex-KFIV) with relig. program asking to phone in pledges in So. King County. (RW-CA)
- KRKK WY, Rock Springs 4/3 0402 faded up right after KZIQ fade-out over KLEFF/KPOP with blip "KRKK, Rock Springs" ID, then gone. (RW-CA)
- 1460 KZXR CA, Salinas 3/24 1350-1405 call change, ex-KDON, and format change, ex-CHR with KDON-FM, now hard rock/heavy metal! First day of new format & calls. Seems like a satellite net, ment. "America's Pure Rock Network." At 1401, into local promo & ID "The search is on for the new 14-60, K-Z-X-R." Into short talk by KDON-AM GM about how the calls KDON were on 1460 since 1949, ment. brief history of being a Top-40 leader, and other formats. Then, he was abruptly interrupted by a male who said "Get the hell out of here!" Into loud promo with hard rock music under: "Get ready for 14-60, KZXR, 'rock of the '90's', at 1460 on your AM dial. It's new, it's hot..." then into spot, then legal ID "KZXR, Salinas, Santa Cruz, Monterey." Back to music. (JH-CA)
- +4/3 has switched from CHR //FM to believe it or not, heavy metal music. I believe they are SMN's Z-Rock. IDs include "1460 KZXR, Salinas, Santa Cruz, Monterey. Welcome to the jungle." "Don't tell anyone about us, keep us your little secret, KZXR" and "Watch out 107.1 FM for AM 1460, KZXR." Apparently 107.1 is some sort of competition for them. 1460 Salinas has had so many format changes, I really can't keep up with it, hi. (FPJ-CA)

- 1460 KZXR cont'd +4/3 0413 usual fair but phase-distorted signal NSP now, call change ex-KDON. Heavy metal format not // KDON-102.5 FM. ID "Here's what they're saying about 1460, KZXR...(people on phone praising KZXR)..." "If you don't like to rock, turn it to FM. This is the music your parents hate, 1460, KZXR, the rock of the 90's, KZXR, Salinas-Santa Cruz-Monterey." (RW)
- 1490 KBAS AZ, Bullhead City 4/3 0334 very good with ID "Colorado River Country is, 1490, KBAS," "K-Bass" weather. (RW-CA)
- KRKC CA, King City 4/4 0200 caught very loud ID "KRKC Springfield-King City-Soledad" and s/off. Ment. address, 1134 Broadway, King City. (MS-CA)
- 1500 KSJX CA, San Jose 3/18 0224 good with Business Radio Network news feed. ID & slogan "Business radio 15 hundred" into talkshow hosted by Don McDonald. Ex-KHTT. (TRH-CA)
- (KSJX)+4/2 0540(EST), 4/3 0310(EDF) totally off both these times. (RW)
- ?KUMU? HI, Honolulu 4/3 0505 tent. over KSTP/XERH with soft EZL music looping E-W. (RW-CA)
- 1510 KCAF CA, San Rafael 3/28 2037-2115 s/off excellent with KSJX-1500 partially nulled. C&W music, spots, traffic, weather, legal ID, UPI News, and long s/off ID followed by hoedown music. (SSH-CA)
- 1530 *KFBK* CA, Sacramento 4/3 0608 noted with TT. (RW-CA)
- (KFBK)+MM 3/13 0306 s/off for SP, said they'd be back around 0630 or 0700. (TRH-CA)
- 1550 KZQQ UT, West Valley City 4/3 0417 definitely has "rap" format in early morning, classical format around sunrise, weird combo. ID by woman at 0417 "More jammin' on K-Z-Double Q, 1550 AM," into song "Jam, Mutha, Jam." (RW-CA)
- 1560 KCEB CA, Norwalk 4/3 2100 low power AM station from Cerritos College heard here at home, about 2 or 3 miles from the school. ID as "KCEB, the Beat." Music by TNT, The Sex Pistols, and the Beatles. Many PSA's & spots for activity days. Station uses about 1 watt (previous freq. 830 & 550). Promptly buried by KPMC at sunset. (MS-CA)
- 1570 KCVR CA, Lodi 4/5 0230 heard o/u XERF with IDs as "K-W-I-N, "K-Win-FM, Hot FM." Music by the Travelling Willburys, and promo for Carribean cruise contest. (MS-CA) (Yes Mike, they are still KCVR. However they only ID as such during the time they don't simulcast their FM, KWIN!--NH)
- 1580 ?KNUS? NM, Albuquerque 4/10 0834 poss. the one with news talk type format way under KNIX-KDAY. Gone in about 2 minutes. Albuquerque sunrise in April is 0830, so would've just signed on. A most-wanted here still... (RW-CA)

Help with an unID:

- 910 KMJC CA, El Cajon this is Steve Mittman's unID. They've had a Sat. night "trivia game" for several years now. This is one of those "anything for a buck" stations, so you never know what you'll hear on it. (TRH-CA)

UNIDs:

- 1070 4/2 0443 unID station with MOR music under KNX. Maybe CFA? (TRH-CA)
- 1190 3/16 0456-0600 poor with Larry King to 0500 followed by Bruce Williams Talknet. NBC News on the hour. WOWO-IN is the only 1190 station currently listed as airing both King & Talknet, but I know KLIF has aired them both at several times in the past. (TRH-CA)
- 1230 MM 3/13 0220 MYL/NOS music. Not KLAV, which has switched to C&W. Who? (TRH-CA)
- 1300 Sun. 3/31 0600 heard "CBS News" sounder down in the mud. Lost to KROP's UPI News. Who is CBS on 1300? (SMM-CA)
- 1400 3/12 0407 unID with United Stations Radio Network news. I show no nearby affiliates. Anybody know who this is? (TRH-CA)
- 1400 4/2 0558 Money Radio network feed. Probably KBFN-CA, per tip from Robert Wien. (TRH-CA)
- 1480 3/16 0435 Ray Briem Show // KAEC-790. Maybe KYOS runs ABC talk after Larry King? (TRH-CA)
- 1570 4/2 0605 Satellite Radio Network news & weather. Probably CHUB, which is rare here. (TRH-CA)

We'll be back with another WDXR in two weeks! ♡

EASTERN DX FORUM

Richard C. Evans
Apt. 10
5104 N. Lovers Lane
Milwaukee, Wisconsin
53225

414-466-8754

DEADLINES: 4/29 5/13 6/3 7/1 7/29

Charley Keleher, 18747 Deerpath Road, Wildwood, Illinois 60030

While tuning across the dial on my car radio, on March 30, at about 1900 EST, I happened to hear mention of DXing. This was on what has come to be known as the "dahlmyer" show on WLUP-1000. One of the announcers was reading a reception report from one Anders B., of Stockholm, in an attempted Swedish accent. The other was making remarks, some of them rather bitter, in criticism of Anders and DXers in general. At one time, he referred to our type as an "international conspiracy of wimps". I really think that Anders in particular is deserving of an apology, but let me explain the situation here. For a long time, WLS-890 was famous throughout the U.S. as "the" Chicago station, due to its superior getting-out signal and appeal to a youthful audience. In Chicagoland, however, WLS was just known as "the kids' station" as few adults ever listened to it. The dahlmyers got their start on WLS, back around 1982, but showed up on WLUP shortly after that station took over the old WCFL transmitter. WLUP is now the new "kids' station". WLS is quite different now. Perhaps they decided that, based on the success of such stations as WGN-720, the only real audience for AM radio was persons over 21 years old (maybe over 41 years old?). The only significant feature of the dahlmyer show, in my opinion, is that the announcers like to see how close they can come to violating the FCC rules regarding obscenity without actually getting cited for it. But then, does the FCC even issue such citations any more? Does the FCC do anything any more? Anyway, it's mostly kids who enjoy this sort of nonsense. Being a DXer on the AM band involves a person in an area of nonconformity. You're not necessarily listening to a station to be entertained by the program content, and you're not paying for it by patronizing the local businesses who pay for the spots, which is what the station owners would like nice, predictable listeners to do. But I'm surprised that the dahlmyers, who probably take pride in their own nonconformity, should be so hostile toward those who practice a different sort. Maybe I shouldn't be surprised. I remember reading, in a college humor magazine, a definition of the seven-letter "A" word: "anyone who is not a member of your fraternity, or who does not particularly go along with your way of thinking." Next subject: I read in the Anniv. issue that someone got a form-letter reply from CVM-940 saying they weren't issuing veries any more. Are all CBC stations doing this? In days past, CBC stations were real good verifiers, though some may have been automatic ones. Also, back in the real old days when most radio transmission was in code, as I understood it, 73 (singular) meant Best Wishes (plural); perhaps someone more knowledgeable can comment on this. 73 to all.

Karl J. Zuk, 154 Old Post Road North, Croton-on-Hudson, New York 10520

Congratulations to Bruce Fortzer for an amazing anniversary issue, and to all the thousands of members who contributed to it. It turned out to be a wonderful keepsake of our club. I think the best thing about our club is that egos are held to a minimum, and fun is always at a maximum. We're serious about enjoying our hobby instead of reducing it to a science, or a military exercise. It's so nice to be a part of. Well, I may have been dropped by Pop Comm, but I am now writing the column that Paul Swearingen used to write for in Monitoring Times. The competition picked me up fast, and that was really flattering. What is sort of strange is the format of the column itself. It is the only column in the entire magazine that does not really cover DXing. MT is a very shortwave oriented publication, but I will try to show them that although marketing studies supposedly show that AM/FM/TV DXing is not terribly popular, the people who enjoy it are a very active and interesting crowd. Both publications are not very keen on clubs in general. I wonder how that all came to be. This is another thing I will try to correct. Maybe I am just naive. Or maybe I don't know all the other clubs very well. If I made the deadline, and if MT publishes my work, I should be in both Pop Comm and MT in June, for one month only. For all who are interested, my beacon station is on 530 kHz screaming its flea-power signal as far as it can. I am using a motor driven identifier from the MV Sarah of RNI fame. It is an AM carrier with a Morse code identifier. I will be glad to QSL anyone who might hear it. I have heard it as

far as 20 miles away using a car radio as a receiver. It might be worth a shot. I find that a square wave tone gives me much more modulation power than a nice musical tone. If you are using the power I am, you need to modulate at 300 percent! I find that my antenna needs tweaking whenever the ground soil changes in moisture content. Rainy days load up much differently than dry ones. I should have my new, improved vertical up soon, with a better ground system. Wasn't the aurora of March 14-16 amazing? The band got very quiet here, with all sorts of semi-local stations showing up very strongly. For example, WBNR on 1260 kHz with their satellited oldies format was bombing in from Beacon, New York. I never heard this one well, and I heard it all the way down to Manhattan, way over 50 miles away. Strong regulars like WKBW, CKLW, WCKY, and all the others were gone, gone, gone! I was also treated to seeing an incredibly strong reception of Nebraska Public TV with a little black and white set and a monowhip antenna of about 2 feet long, on channel 3 at one in the morning. If this is a sign of what the summer will bring, we are in for some amazing fun! Anyway, please feel free to write or phone. I'd be glad to hear from you! 73s KZ.

Rick Evans, Apt. 19, 5104 North Lovers Lane, Milwaukee, Wisconsin 53225
 Charlie, do you remember back in the late 50's or early 60's when both WLS-890 and WCFL-1000 both played rock for the kids, WLS ran their news at :55 while WCFL ran the news at :00, WAAF-950 (now WJPC-950) used to run back-to-back rock from :55 to :05 to catch the kids switching their dials back and forth between WLS and WCFL. The list of Chicago call letters in the 4/1 issue was interesting, but a shock to find Milwaukee's WTMJ and Kankakee's WKAN listed. I found the anniversary issue fascinating to read. Bruce Fortzer is to be commended for putting it altogether. I was surprised to find that I could identify Percy Kesteven in his picture instantly, even tho I last saw him in August, 1971. A lot of other familiar names and faces in there also. I spent most of this afternoon and evening at a local get-together at Tim Noonan's place in northwest Milwaukee. I had a very enjoyable time, and felt it was worth giving up 8 hours of work for! We talked about all three bands, AM, FM, and TV. Some FM and TV skip was in. Two weeks ago, right after I finished off the last EDXF, sealed it up in an envelope and put it out ready to mail, I went to bed, turned on the clock radio, and discovered that local WOKY-920 was going off for a couple of hours for technical adjustments. I got up a few minutes later, turned on the HQ, and bagged KDHL-920 Faribault, Minn. and also an apparent WBAA-920 sign/off. Gotta run as it's late. See you in two weeks. 73.

ALBUQUERQUE BANDSCAN (DAYTIME)

From: Doug Pifer--Air Training Command, Kirtland AFB, NM.,
 3/21- 4/1/89 using a G.E. portable.

All stations are from Albuquerque except where noted.

- 610 KZSS ID-"Z-94 is 94 Rock KZRR and 610 KZSS."
- 730 KDAZ "K-DAZE-73", Contemp. Christian, CBN network.
- 770 KOB "The news authority KKOB", hmmm. ABC.
- 810 KMIK Santa Fe, "K-MIKE, AM-81" CBS, MOR mx.
- 860 KARS Belen, "KARS radio, ABC, CW mx //97.7
- 920 KQEO "9-20 KQEO, greatest hits of the 50-60-70's"
- 1000 KKIM "AM-1000, your constant Christian companion"
- 1150 KDEF "Playing all your favorites from the last five decades, AM-1150 KDEF", Sat. News Network.
- 1190 KXKS Full ID's in both EE and SS. Type SS mx, ???
- 1240? KALY "Radio KALY, caliente" in EE/SS. Many ID's, never heard a freq. Every song seemed to have both languages!
- 1310 KZRQ Corrales. Nothin' but Z-ROCK, except top of hr.
- 1350 KABQ Many ID's, "La Musica Fabulosa-KABQ" EE/SS
- 1450 KRZY "14-50 Crazy", CW mx, Natl WX SVC.
- 1520 KAMX "Solid rock, FM-108, KPMG, Albuquerque's classic rock. Full ID on hr.
- 1580? KNUS "K-NEWS radio" CBS nx, call in program. Freq?

A DXer's TECHNICAL GUIDE

Now in its 2nd edition, this 120-page book answers questions on how receivers work, how to make them work better, what audio filters and loop antennas will do for you, how to build a beverage and phasing unit, and much more. Only \$5.50 for members, \$6.50 for nonmembers (\$2.00 extra for overseas airmail). Write IRCA, P.O. Box 21074, Seattle, WA 98111.

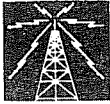

Western DX Forum

★ ★ ★ ★

IRCA - The #1 Choice of the Broadcast Band DX'er

Editor: Ric Heald • 8539 Bellamy Way • Sacramento, CA 95828 USA • (916) 386-8677

DEADLINES - 15 MAY, 05 JUN, 03 JUL
CONVENTION REGISTRATION DEADLINE - 15 JUN

TIM HALL, 350 G ST., #F-1, CHULA VISTA, CA 92010-4559 (619) 426-3584 NSP

Howdy. Lots of interesting things happening in SoCal radio this month. First of all, we have a major call and format change down here - or do we? About a week after being silent, XEGM 950 Tijuana returned, identifying as XEK-AM (Steve Mittman caught this first and called me - thanks Steve). A couple days later they were in EE with a 24-hour staellite feed from the Financial Broadcasting Network (FBN). This format is about personal finances and so is closer to Money Radio than to BRN. They splice in UPI news and features whenever they feel like it, often cutting off the FBN feed in mid-sentence. Then they cut off the UPI feed in mid-sentence to give their own pre-recorded ID in SS! (I thought the Mexican government had cracked down on border stations broadcasting in EE! Are they cutting off the UPI and FBN mentions? Illegal feed - as in not paying for it maybe?-RtH.)

Both Steve and I have noticed faint SS talk underneath the FBN feed. Seems to be there just about all the time. As if things weren't strange enough, last night (Saturday morning 08 April) they fell off the air for a few hours and returned in SS, badly distorted, with their old noise spurs back on 890 and 1010! They were running the syndicated all night show from Laboratorios Camacho that they used to run. This morning they were back to the FBN feed, still distorted, and gave the top-of-the-hour ID at 1100 PLI as XEGM. Finally heard a local (Los Angeles) ad this morning, also badly distorted. (My guess, they bought new equipment, i.e. transmitter, dish, etc., and something went wrong, went back to old equipment to stay on air and at least got the dish working again-Rt.)

More strangeness - for those of you who like slogans, try KFI, especially right before the top-of-the-hour. They seem to have embarked on a quest to find the world's strangest slogans. Examples: "KFI Talkradio - low sodium, high in protein." "When it comes to talk radio, we have twice the traffic." "KFI Talkradio - some assembly required." "Your parents have a talkradio station, now you do too." The war with KABC is going strong. KFI has used it to get lots of free publicity at KABC's expense. They started by calling KABC "the nursing home of talkradio" and followed by copying KABC's "talkradio" slogan and using it as often as they could fit it in to the conversation. KABC has countered with some sort of a "stop it or else" letter, raising speculation that a lawsuit is imminent. Of course, the media got hold of this and KFI once again got free publicity. Will that mean ratings? Probably not, hi. (I'd sure hate to be in management at KFI, hi-RtH.)

Final note: Local KVSD 1000 Vista is now 24 hours and NSP again with "The American Radio Network" talk show. Haven't heard this show on any other station. I'd call the station to ask about it, but as a rule they won't talk with listeners on the phone.

Well, that's it for now. Exams in two-to-three weeks, will resume DX'ing in May. Until then, 73 de TRH.

STEVE HOWE, 250 WAVERLY ST., #5, MENLO PARK, CA 94025

Wasn't the 25th Anniversary issue fabulous? What a trip down memory lane! It's encouraging how many of the names so familiar to me 20 years ago still pop up in the DX Monitor today. I'd almost forgotten about the Paul Lotsoff episode, hi. (And I can tell you a whole lot more, too-hi-RtH.) It's so good to be back that I wish I had never left.

Ric, I too remember with pleasure my catching WKTE 1090 King, NC on a DX Test on 08 March 1971 from Long Island. Of course I was 2,000 miles closer to the station than you were and their power was up to 1 kw by that time, but I still enjoyed that test. (I missed that one and I was living in Flatbush, Brooklyn at the time!-RtH.) Did you know that Chuck Webster is still their PD? Speaking of DX Tests, does the IRCA have an active Courtesy Programs Committee? It seemed to me that NRC was the only club setting up any tests this past winter, concentrating on Alabama stations. I realize many fewer stations have silent periods these days, and that those stations that do have them seem to change the hours around much more frequently, but I bet IRCA could come up with some good tests.

A word of caution. I was in a local ham radio store last weekend and spotted a new edition of White's Radio Log. WRL used to appear in Communications World until that magazine ceased publication after 1981. WRL now has been revived in the form of a paperback book about the size of TB Guide. Unfortunately, the new edition in badly out-of-date with many incorrect calls, frequencies and powers. One example: KDXU 890 St. George, UT (10 kw) is still listed on 1450 with 1000/250 watts even though they began broadcasting on 890 with their increased power on 18 November 1985! Rather a disappointment to say the least. 73 de SSH.

RIC HEALD, 8539 BELLAMY WAY, SACRAMENTO, CA 95828 (916) EV6-8677 1000-1300
PLF & ppp

Greetings from Convention headquarters! Got the news via landline from Segalas' wife Saturday (15th) who was here in town. I'd like to thank all who voted for IRCA to have it's own convention this year. Because it went to a vote and because the convention date is early so as not to interfere with those wanting to attend the NRC convention, we lost a couple months of registration time. For all of you who've been expressing interest in Sacramento, I need for you to get your registration form (which should be in this issue) and fee in ASAP! Muy importante. This issue will reach you the first week of May, so time is of the essence. Registration fee is \$22 and includes breakfast Saturday, Sunday and Monday mornings.

From whatever route you're traveling (except westbound I-80) just follow the signs to US 50 Placerville/S. Lake Tahoe and exit Sunrise in Rancho Cordova about 15 minutes from downtown Sacramento. The W-X Freeway is the interconnector. Because freeways were built at different times, the off and on ramps can be a bit awkward, but just follow the signs. I spent the first 18 months in Sac. trying to figure out what "W-X" stood for and finally the light went on. . . it's between W and X Streets. . . daaaa, hi.

Lots of good stuff on tap. Bring your radio gear, your veries and anything else you'd like to show off. Remember the auction and load up your car with goodies for same. If you're flying in, airport security has gotten a little nervous about radio gear - don't pack it, carry it on board. Of course a R-390 might be a little awkward, hi. Profits from the auction go to the club.

Oh yes, if you're traveling from the east, wetbound I-80, exit at Sunrise south and continue four or five miles on that surface street, crossing over US 50, left at Folsom, left at East Dr. to Best Western Heritage Inn.

If you're arriving by train - Sacramento is served by the Zephyr or Coast Daylight - please let me know. Zephyr has decent arrival/departure time, Coast Daylight arrives from SoCal at 2300 and from the Northwest at 0600!

Metro Airport doesn't have public transportation. Some hotels do, but they charge 75 plus bucks a night, which I didn't think the membership would go for, hi. All major car rental companies are at the airport. Additional service is provided out of San Francisco, Oakland and San Jose Airports, but count on renting a car or hooking up with a Bay Area member and it'll be a two-to-three hour drive up the river, depending on airport. United, American, Delta, US Air, Southwest Air, America West serve Sacramento.

Make your checks for registration (do not send cash) out to IRCA Convention. DO NOT make them out to me, hi. The hotel accepts all major credit cards. Please don't try to charge your registration fee, hi.

DX. Hmmm. Been busy around here. Have noticed a station fairly strong under KGO. My speculation is Santa Fe with new night power. 20 years ago I would've speculated KCMO or WGY. . . oh well.

I'm well over limit. Get your registration in quickly and I'm looking forward to seeing all your smiling faces the weekend of June 30th in Sacramento. Best of DX and 73 de Rth. .

IRCA Foreign DX Reference, Volumes 23-25

You're tuning around and hear a carrier from foreign origin on a frequency (say TA on 891). You want to quickly know which countries have been heard on the frequency and what type of programming was heard. Or, you're DXing and have heard several stations from one foreign area (say Japan) and want to quickly know what other stations have been heard from that area. These are the situations the IRCA Foreign DX Reference was created for. No longer will you need to thumb through tens of back issues of "DX Monitor" to find the information you need. With the IRCA Foreign DX Reference you can quickly determine which foreign stations might on a particular frequency or where to look for more stations from a particular area.

In honor of IRCA's 25th anniversary (and because it sounded like a good idea), this year's Reference was compiled from the last *three* years of "DX Monitor"!

The IRCA Foreign DX Reference is a cross reference listing of all the stations reported to DXWW-W and DXWW-E during volumes 23-25 of "DX Monitor" (9/85-8/88). Three sections are available: Trans-Atlantic, Pan American, and Trans-Pacific. Each section contains a frequency listing (countries reported for each frequency) and a country listing (frequencies reported for each country) including the "DX Monitor" issue in which they were reported (volume and number). The Reference is an indispensable guide to what was reported the last three years, and where to find specific information about the receptions.

Each listing is 6 or 7 pages long. You can order any one of the three (TA, PA or TP) for \$2.00 each, or all three for \$5.00. Order your copy now before the 1988-89 season gets underway. Make checks out to IRCA and send them to: 9705 Mary N.W., Seattle, WA 98117. (bill by/bwavy)

Micro-MWDX-4A Loop-vs.-Wire Phaser
Mark Connelly - WAIION - 15 MAR 1989

Phasing a loop against a longwire or a vertical to establish a cardioid pattern continues to be a popular concept in the DX press. Over the years, numerous schemes have evolved: Dallas Lankford, Paul Swain, Ron Schatz, and others have done articles on this specific issue. My previous phasing unit articles accentuated two-wire phasing, but loop-vs.-wire and loop-vs.-loop possibilities have been addressed.

The units used to establish the null between the loop (oriented for maximum pickup of the station to be nulled) and the sense antenna (most often a vertical or other nearly-omnidirectional aerial) take several forms. Units that merely resistively-sum the wire's contribution with that of the loop, with no tuning of the wire at all, are difficult to use; nulls are pretty much hit-or-miss. Of greater value are designs that use a tuned circuit to couple in the RF contribution from the wire. Dallas Lankford's LIL-1 ("DX News", 27 FEB 1989) operates on such a principle. A possible drawback in that design is that no Q-spoiling is being employed either on the loop's L-C tank or on the tank circuit used for the wire (sense) aerial. Not spoiling the Q results in a very narrow-band null: as both Dallas and I have noted, you can null the carrier deeply without nulling the sidebands anywhere near as much. This is even worse if the two tank Q's aren't fairly closely matched. Real QRM-killing, therefore, is limited with such a scheme. Null "touchiness" with arrival-angle / hop-mode variation on skywave signals is also made worse by employing high-Q tanks. My experimentation indicates that a resistor of between 10K and 50K should be put across each L-C tank (loop and wire-tuner). This will widen the bandwidth and improve the steadiness of the null. Better than a fixed resistor is a "Q-skewing" pot of 50K (linear, non-reactive) - normally set to mid-range (25K) - across each tank. When "closing in" on a null, tweaking one Q-skewing pot and/or the other can "finish off" the pest station. When the Q's / frequency-response curves of the two tanks are fairly close, null bandwidth improves. The pots help to match tank Q's as well as providing controlled Q-reduction. The trade-offs with Q-spoiling are (1) the amount of phase shift for a given amount of tank capacitor detuning is lessened and (2) system sensitivity is lower. The way around problem (1) is to put a switchable (0/180 degree) phase-reversal transformer in one of the two signal lines (e. g. the loop line) enroute to the summation point that feeds the receiver. This allows a capacitor-detuning phase shift of +/- 90 degrees to do the work that previously required a +/- 180 degree detuning-created shift. Problem (2), sensitivity reduction, is easily solved by amplification. Gain is cheap below 30 MHz. Amplifier noise is seldom as limiting a factor as the amplifier's strong-signal handling ability. Amplification may be broadband, using a circuit similar to that in my "EBA" unit (NRC/IRCA reprint) or like that in Gerry Thomas's "Phase One". In strong signal areas, tuned amplification is preferable. When using Q-spoiled tanks, received bandwidth is relatively wide; therefore, a broadband amplifier after the phasing unit could get "creamed" by off-frequency locals: mix spurs / "intermod" could result. Even in the "boondocks", a broadband amplifier may get bothered by strong shortwave broadcast and utility signals coupled in from the longwire: mix spurs of RTTY, FAX, and other unwanted garbage could show up. Tuned (especially high-Q / regenerative) amplification after the phasing unit's summation point is definitely the way to go when DX signal levels after pest-nulling are low. Ken Cornell has published a schematic for such a tuned amp. in "Monitoring Times" and NRC/IRCA have reprints of my "MWT-1" unit. "MWT-2", under development, combines the best features of MWT-1 and Ken Cornell's tuner-amp. Commercially-made active tuner-preamps. by MFJ, Grove, Arcomm, et al could be used as well. If a really good receiver (e. g. R-71A, R390A, HQ180A) is used, amplification is seldom necessary. With a Sony ICF-2010, on the other hand, you'll need it.

Another criticism that I have of some of the other loop-vs.-wire designs (and other tuner and phaser designs, in general) is an apparent fixation with clumsy homemade coils. Commercially-

available inductors from Mouser, Digi-Key, and others do the job fine. Capacitive-coupling of the longwire to the tank gets rid of the need to use link-coupling. Once that requirement goes away, there's little need for homebrew coils. When small moulded inductors (resembling resistors) are used, bandswitching becomes easier. Rules-of-thumb ("heuristics" for you AI types) employed are that (1) The ratio of maximum tuning capacitance to input coupling capacitance should be about 6 to 1: 56 or 62 pF to couple to a tank that has a 10 to 365 pF variable cap. is about right for "average" wire aerials and (2) The ratio between the inductor that goes from the tank "high-Z" point (tuning capacitor stator) to the "tap" point (for low-Z output) should be about 5 times greater in value than the inductor which goes from the "tap" point to ground: e. g. 220 uH (high-Z to tap) and 47 (or 39) uH (tap to ground). In a phasing system, the Q of the coils used is of little importance: the Q-spoiling pot (set to 25K until null-finalization) is the main determining factor in tank Q.

ON 27 JAN 1986, I published an article entitled "The Micro-MWDX-4 Phasing Unit: A Small, Cheap, and Simple Approach". The article appeared shortly thereafter in "DX News" & "DX Monitor". The unit was presented as both a wire-vs.-wire and a loop-vs.-wire phaser. Its nulling performance as a two-wire phaser was not as good as phasing units employing a separate tank circuit for each wire. As a loop-vs.-wire unit, however, it worked quite well. A problem noted was signal loss because of the 100-ohm resistors in each signal line and because of the relatively-low coupling capacitor (39 pF) chosen to couple the longwire to the tank. The fixed 27K Q-spoiling resistor was adjudged to be less worthwhile than a 50K Q-skew pot across the wire-aerial tuning tank. If the pot could be squeezed into the box somehow, it would be. With all of these ideas in mind, I set about to create the Micro-MWDX-4A, a replacement for its predecessor. Furthermore, this newer unit was designed to be a loop-vs.-wire phasing unit only. Good two-wire phasing requires two L-C tanks, or (perhaps) delay-line techniques à la Gerry Thomas. (The jury's still out on that design.)

Micro-MWDX-4A: Relevant design features

- * A "1-2-Null" function switch (S2) is used. This is standard on my newer phasing units. This feature is important because it allows isolation of each line, enabling independent peaking and level-setting prior to nulling.
- * As on the earlier unit, a three-position bandswitch (S1) allows the wire-tuning tank to cover 500 to 1800 kHz without a great deal of influence by the length of wire connected.
- * The coupling capacitor (C2), 62 pF, is a good compromise value between maximum achievable signal level and maximum tuning bandwidth. A higher value might couple in a bit more signal but the tuning and phase-shifting range would decrease. A lower value would give more phase-shifting and band-coverage capability, but with poorer signal-coupling efficiency.
- * Two 500-ohm level pots (R1, R2) are used. With each pot set for maximum signal, the 500 ohm resistance of each pot to ground causes minimal signal loss when the phaser's output is "playing" into 50 ohms. These pots are available commercially for less than \$2 each.
- * The phase-reversal transformer (T1: Mini-Circuits part number T1-6) as previously mentioned, permits nulls with less capacitor-detuning required. Because this is now a loop-vs.-wire unit, S3 is now used with T1, rather than to swap the two inputs.
- * The 50K Q-skewing pot (R3) has been found to be very useful in nulling out the last few dB of a "pest" station or electrical noise.
- * A Mouser 45KN100 vernier knob is used on C1. It costs about \$8, a good deal less than some of the other vernier drives people have been using lately.

Micro-MWDX-4A: Loop-vs.-Wire Phasing Procedure

Figure 1, which follows in this article, is the schematic of the Micro-MWDX-4A. Please refer to it during this discussion of phasing procedure.

The desired effect of loop-vs.-wire phasing is to receive stations in the opposite direction of the station to be nulled out: this is something a loop, on its own, generally cannot do. The loop should be physically positioned for maximum signal from the direction of the desired station, regardless of the direction of the station to be nulled. When the desired station is in the opposite direction of the "pest", the loop will also be positioned for maximum "pest" station pickup.

The loop to be used may be either passive or active as long as the signal fed by it to the phasing unit is of a low impedance suitable to feed to a receiver's input. This low impedance signal, in the passive loop case, would come from a coupling link relatively loosely-coupled to the loop's high-Z LC tank. For active loops, the loop amplifier's output is, of course, used. For best phasing results the loop should be "Q-spoiled" somewhat by clipping in a fixed resistor of about 15K, or (preferably) a non-inductive, linear-taper 50K pot normally set to center (25K). This resistance is to be connected in parallel with the loop's parallel inductance / tuning capacitance. Of course, the connection should be easily removable for use of the loop in high-Q, non-phasing applications.

In the following procedure, the use of a 50K pot shunting the loop's LC tank will be assumed. This pot will be referred to as "Loop-R". The loop's tuning capacitor will be referred to as "Loop-C".

1.0 Phasing Steps

- 1.1 Connect longwire to J1. Connect loop output coaxial cable to J2. Connect earth ground, if available, to J3. Connect phaser's output (J4), via coaxial cable, to the input of the receiver to be used, or to an RF amplifier between phaser and receiver.
- 1.2 Set level pots R1 and R2 to fully counterclockwise (CCW) (maximum resistance arm to ground). Set longwire-Q pot R3 and Loop-R to mechanical center (approx. 25K each).
- 1.3 Set frequency-range switch S1 to the correct range for the frequency of operation (see Table 1). Set function switch S2 to 1 (wire). Null-mode switch S3 may be put in either position: it doesn't matter yet.
- 1.4 Tune Line 1 (signal from longwire) by peaking desired-frequency signal strength with C1. At this time, leave C1 at its peaked-signal position.
- 1.5 Set S2 to 2 (loop). Use Loop-C to peak the desired-frequency coming from the loop.
- 1.6 Switch S2 back and forth between 1 and 2. If "1" is stronger than "2", adjust R1 until the levels are equal. If "2" is stronger than "1", adjust R2 until the levels are equal. Once this has been done, set S2 to Null.
- 1.7 Switch S3 back and forth between Null-a and Null-b positions. Leave S3 on the position yielding the weaker level (more cancellation) of the dominant station (or electrical noise) to be nulled. Subdominant signals, if present, should become more apparent if the proper S3 null position has been chosen.
- 1.8 Try to enhance the null by adjusting the pot set in step 1.6. If the best null is with that pot fully CCW, leave it there. Try to enhance the null by adjusting the opposite line's pot (R2 if you previously adjusted R1 or vice versa). If the best null is with that pot fully CCW, leave it there.
- 1.9 Adjust C1 to get a null of the dominant station. If a null doesn't occur, set S2 to 1, re-peak C1, then set S2 to Null and adjust Loop-C for a null.

- 1.10 Make successive adjustments of the capacitor which provided null improvement in step 1.9 and the pot that provided null improvement in step 1.8. After several of these successive adjustments, a fairly good null should be obtained. To finalize the null, try slight adjustments of R3 and Loop-R blended into the previous cycle of two-control tweaking. Slight physical re-positioning of the loop may also help.

This guide to loop-vs.-wire phasing is a starting point. Often it takes experience to get the correct "feel" for a given nulling situation: experience that will allow the minimum number of control manipulations and the quickest route to the desired null.

Building the Micro-MWDX-4A

Construction details given here are the schematic (Figure 1), the parts list, the hole-drilling list, and pictorials to assist in mounting the vernier knob for C1 and a perboard on which T1 is mounted. Given these pieces of information, most people with even modest homebrewing experience should have no trouble. Wire runs should be as short as practicable.

FIGURE 1 : SCHEMATIC

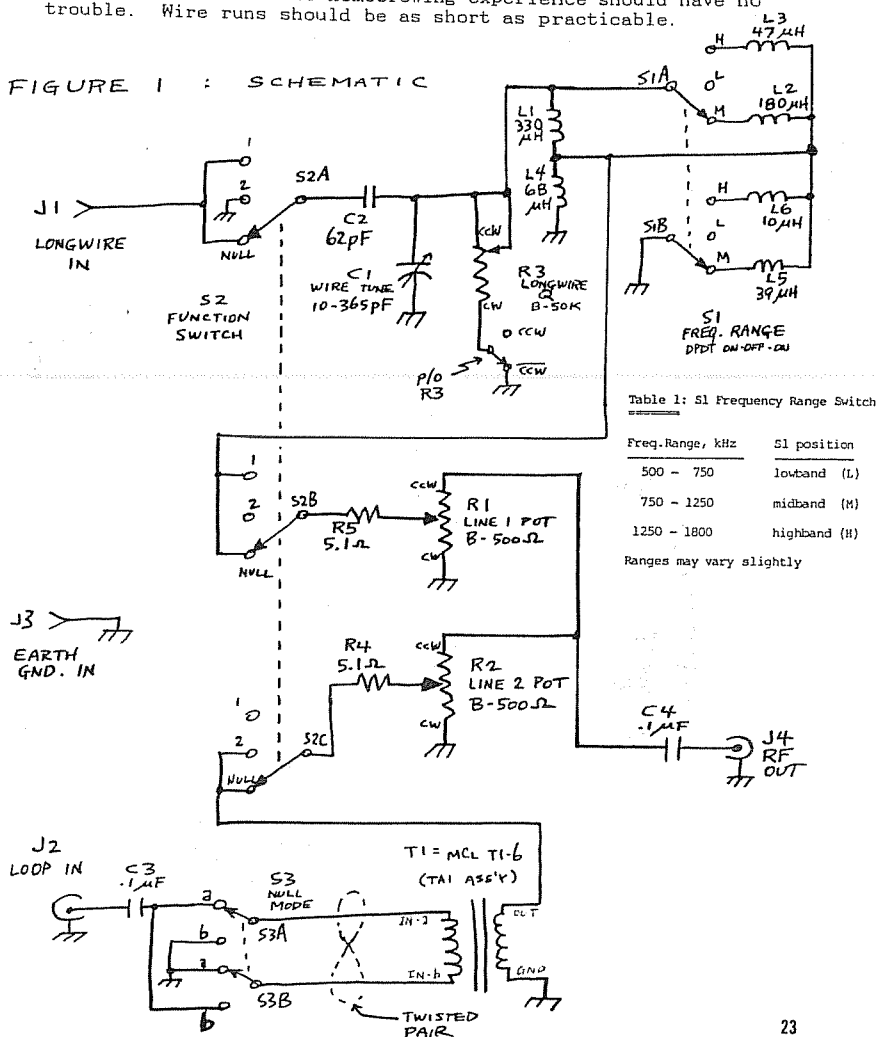

Table 1: S1 Frequency Range Switch

Freq. Range, kHz	S1 position
500 - 750	lowband (L)
750 - 1250	midband (M)
1250 - 1800	highband (H)

Ranges may vary slightly

THE INTERNATIONAL RADIO CLUB OF AMERICA (IRCA)

International Radio Club of America
P.O. Box 21074
Seattle WA 98111

The IRCA is a non-profit organization devoted to the hobby of hearing distant stations on the AM Broadcast Band (510 - 1630 kHz). "DX Monitor", the official publication of the IRCA, is published 34 times a year, weekly from October to March, twice in September and April, and monthly from May to August. "DX Monitor" contains members' loggings, articles on radio stations, receiver reviews, technical articles, DX tips, and other material of interest to Broadcast Band DX hobbyists. IRCA is a member of ANARC, the Association of North American Radio Clubs.



CLUB ADDRESSES AND OFFICERS

President: Karl Zuk, 154 Old Post Road North, Croton, NY 10520-1932.
Secretary-Treasurer: John Clemmer, P.O. Box 482, E. Moline, IL 61244.
Board of Directors: Ernest R. Cooper, Richard Evans, Ric Heald, John C. Johnson, Patrick Martin, Bruce Portzer, Rich Toebe.
Editor-in-Chief: Bruce Portzer, 6546 19th Ave. N.E., Seattle, WA 98115.

MEMBERSHIP DUES

U.S. - \$20.00 per year. Canada/Mexico - \$30 (one issue mailed every week) or \$22 (two issues every two weeks). Overseas Surface - \$21. Overseas Airmail - \$30 (Central America, Caribbean, Colombia and Venezuela), \$33 (Europe, North Africa, Middle East), \$37 (rest of the world). Trial Membership - \$7.50 (10 issues of "DX Monitor" and a New Member Packet; U.S./Canada/Mexico only). Make checks and money orders payable to IRCA and send all dues to: IRCA, P.O. Box 482, E. Moline, IL 61244. Persons living outside the U.S., please use International Money Order in U.S. funds. Sample copies of "DX Monitor" are 50 cents or three International Reply Coupons each and are available from: IRCA, P.O. Box 21074, Seattle, WA 98111.

THE IRCA GOODIE FACTORY

Reprints of more than 400 articles from past issues of "DX Monitor" are available from the IRCA Goodie Factory. Also available is IRCA stationery and the very popular IRCA publications: "IRCA Almanac", "A DXers Technical Guide", "IRCA Foreign DX Reference" and the "IRCA Foreign Log". For a complete list of available publications and their costs, send a self-addressed, stamped envelope to: IRCA Goodie Factory, P.O. Box 21074, Seattle, WA 98111.

Unless otherwise noted, permission is granted to publish, broadcast, or otherwise reproduce non-copyrighted material appearing in "DX Monitor" provided credit is given to the IRCA and the original contributor. Opinions expressed in "DX Monitor" are those of the original contributors and do not necessarily reflect those of the IRCA; its publishing staff, editors or officers.

FIRST CLASS

FIRST CLASS MAIL
US POSTAGE
PAID
Seattle WA
Permit No. 601

D. A. NYHOLM 19
2071 CEDAR STREET
SAN CARLOS CA 94070
*
PRINTED MATTER