

DX MONITOR

THE OFFICIAL
PUBLICATION
OF THE



INTERNATIONAL
RADIO CLUB
OF AMERICA

DEVOTED EXCLUSIVELY TO BROADCAST BAND DXING

APRIL 13, 1991 - VOLUME 28 - NUMBER 29 - EDITION 921 - ISSN 0899-9732

BROADCASTING INFORMATION.....	2	EASTERN DX FORUM.....	9
DX WORLDWIDE WEST.....	3	GEOMAGNETIC INDICES.....	
DX WORLDWIDE EAST.....		VERIFICATION SIGNERS.....	
DX WORLDWIDE II.....		HEARING IT THRU THE GRAPEVINE.....	11
WESTERN DX ROUNDUP.....	3	TECHNICAL TOPICS.....	12
CENTRAL DX ROUNDUP.....	5	PRESIDENT'S REPORT.....	
EASTERN DX ROUNDUP.....	7	KANADIAN KORNER.....	
WESTERN DX FORUM.....		IRCA OFFICERS & DUES INFO..	BACK PAGE

IRCA ADDRESS CHANGES, RENEWALS TO PUBLISHER: RALPH SANSENERINO 11300 MAGNOLIA #43 RIVERSIDE CA 92505

IRCA REPRINTS TO REPRINT SERVICE: STEVE RATZLAFF 295 PETTIS AVENUE MOUNTAIN VIEW CA 94041

IRCA ALMANAC 5, TECHNICAL GUIDES, FOREIGN LOG & FOREIGN DX REFERENCE: PHIL BYTHEWAY 9705 MARY AVENUE NW SEATTLE WA 98117

DX TESTS courtesy National Radio Club - Colorado CPC Machine - Thank You

APRIL 15th, 1991 WJTZ-640, 640 RADIO WAY SUITE 286-B, BLOUNTVILLE, TN 37617 time 0430-0500 EST. Test will be tones, code ID's, this will be the last portion of WJTZ's POP test. Thanks Mitch Sandidge CK.

APRIL 22nd, 1991 WYRU-1160, BOX 711, RED SPRINGS, NC 28377 time 0540-0545 EST. Test is code ID's just before s/on at 0545. Thanks Richard Atwell.

CONVENTION: Anyone wishing to host the 1991 IRCA convention contact: Karl Zuk for a bid form at 154 Old Post Road North, Croton, NY 10520.

BALLOTS: The ballots are due back in Albert S Lobels hands by May 1st. I hope everyone votes. May 1st is closing in, so mail them to Albert soon.

WANTED: From J.D. Stephens 122 Brawley, Owens Cross Roads, AL 35763. JD wants the owners manual for the Sony ICF-2001 and is looking for a GE Superadio digital model. Hope someone can help JD.

FROM THE PUBLISHERS DESK: Not much going on here, had a bad cold for 6 days and it is still hanging around. It was a struggle to get this issue out. WEEKLIES: I know one person who is glad the weeklies have gone there way. Now I can get caught up on all the stuff I put on the shelf, I mean shelves. I have 4 HQ 180As to get ready to sell, 6 DX440s to modify and sell, 7 loop antennas to build and then I got to find time to go fish a bass tournament. Got to keep charging it keeps you young...Onward...73..



VERIFICATION OF RECEPTION

BROADCASTING INFORMATION

Editor: Geov Parrish, P.O. Box 15164, Seattle, WA 98115-0164

* compiled 3/31/91 *

This is my last column as editor of BI. Hopefully my health will stabilize and I'll be able to pick up some of the work again in the future, but for the time being it seems wise not to be obligating myself. Thanks for everyone's support over the years - it's been more appreciated than you know!

GOING OFF THE AIR

KNSP 1430 1000/ ND-D MN STAPLES was country, now silent

GOING ON THE AIR

WOEQ 1190 1000/420 DA-N FL ROYAL PALM BEACH new, Spanish

NEW STATIONS

WCRN 830 3000/1000 ND MA CHERRY VALLEY granted extension of time
WCBX 1160 500/250 DA-2 VA FIELDALE wants CP to reinstate exp. permit

CHANGES IN EXISTING FACILITIES

KGDP 660 10000/10000 DA-2 CA ORCUTT amends app. to 50000/10000 w, DA-2
WILC 900 2400/500 DA-2 MD LAUREL granted 1900/500 w, DA-2
KASM 1150 2500/ ND-D MN ALBANY applies for 2100/ w, ND-D
WGAB 1180 1000/ ND-D IN NEWBURGH applies for 675/ w, ND-D
WLCK 1250 1000/86 ND KY SCOTTSVILLE granted 860/86 w ND
WINU 1510 1000/ DA-D IL HIGHLAND granted ext. of time for 880 move

CALL LETTER CHANGES

(\$ means change accompanies a station sale)

KIXC 1150 TX Quannah is now KVDL WOJY 1470 PA Farrell is now \$ WRQQ
KDON 1460 CA Salinas KRQC KVOG 1510 AR Greenwood \$ KPBI
KSIR 1470 CO Estes Park \$ KRKI WSMD 1560 MD La Plata \$ WMOM

FORMAT CHANGES

KVIS 910 OK MIAMI was KGLC, country, now southern gospel & religion
KORG 1190 CA ANAHEIM was standards, talk, now brokered ethnic/variety
WZBO 1260 NC EDENTON was religion, now satellite talk
WGH 1310 VA NEWPORT NEWS was news, now satellite traditional country
WIZO 1380 TN FRANKLIN rock oldies, will be adult standards // WHNK-1430
WPAY 1400 OH PORTSMOUTH was sat. adult standards, now sat. rock oldies
KCOL 1410 CO FORT COLLINS was AC, talk, now all news
WHIS 1440 WV BLUEFIELD was rock oldies, now satellite business news
WNTJ 1490 PA JOHNSTOWN was WKQS, adult contemp. // FM, now all news

PROPOSED STATION SALES (* means check the format listings for more info)
WBNI-910-VA (now silent), KICA-980-NM (now silent), WPLX-1170-TN, KESP-1290-CA (now silent), WMML-1410-AL (now silent; given the new owner's history, it will probably come back as religion), WPNC-1470-NC, WSMD-1560-MD (now silent, sold to a local FM so look for a quick return to air)

MISCELLANEOUS NOTES: KJME-1390-CO was fined \$5,000 by the FCC for consistently operating over power - as much as 450%, according to FCC Denver field office measurements. It's KJME's second fine in a year for the same violation...network death: "NTR" talk network, based at Pat Robertson's WNTR-1050-MD, has virtually folded; only one program remains. Cash problems compounded by a recent fire doomed the network. No telling what the current programming is at the three network-owned stations: WNTR, WCNT-1480-NC, and an FM in Oklahoma City.

2

Peace, love & sabotage, *Geov*

* * * * *



PAT MARTIN P.O. BOX 843 SEASIDE, OR 97138

DX Worldwide - West

Time: UTC phone (503) 861-3185

DEADLINES: 4/16, 5/7, 6/4, 7/9

We have a report this week from John Bryant. He did a little DXing out at Grayland, Washington again. So on with his report:

DXPEDITION TO GRAYLAND, WASHINGTON 3/16/91

Dxing with Guy Atkins and John Bryant with 2 NRD 525s w/1000' Beverage at 25 degrees, 1200' at Zero degrees. Both on beach.

Much poorer DX than earlier times. Aussies 3L0-774 KHZ-Melbourne and 2BL 702 KHZ-Sydney noted in // with ABC1 programming at 1130 UTC for about 30 minutes of moderate level. By 1200 JOUB-774 KHZ-Akita, Japan was dom. on 774 KHZ. Also at 11200 UTC unid Aussie on 855 KHZ with poor level. JOBB-828 KHZ-Osaka, Japan was noted on 828 KHZ with EE language lessons at 1328 at moderate level. At 1400 the dawn enhancement has JOUB-774 KHZ good, JOBK-666 KHZ-Osaka was poor. Also threshold KK language on 657 KHZ at 1420 (DPR of Korea?) Only other activity was 891 Radio Fiji 2 in Hindi good at 1045 and 1620 KHZ presumed 1PPP Canberra at good levels around 1100. Not even any other hets noted. Very sub-par for a coastal beverage at near Equinox. That's what keeps it interesting.



WESTERN DX ROUNDUP

Nancy Hardy
2301 Pacific Ave.
Aberdeen, WA 98520

WDXR deadlines are Monday April 15

REPORTERS FOR THIS ISSUE:

- (TRH) Tim Hall-350 G St. #F-1-Chula Vista, CA 91910
Sony ICF-2010, Radio West loop
- (BH) Bill Hardy-2301 Pacific Ave.-Aberdeen, WA 98520
FRG-7, Radio West loop
- (NH) Nancy Hardy-2301 Pacific Ave.-Aberdeen, WA 98520
FRG-7, Radio West loop
- (GL) Gary Larson-2806 Lincoln-Burbank, CA 91504
- (MS) Mike Sanburn-P.O. Box 1256-Bellflower, CA 90706
GE Superadio, Sony SRFM40W
- (RW) Robert Wien-1309 Dentwood Dr.-San Jose, CA 95118
GE Superadio, GE long-range portable, SM-2

***** OF SPECIAL INTEREST

- 1040 CIMA BC, Vancouver per call to "Magic 104" AM, their call letters are now CIMA, ex-CKXY. But, they "rarely" ID on the air. (RW-CA)
- 1360 KFIV CA, Modesto 3/25 0945 good briefly thru KEEN-1370 splash with "1360 KFIV Metro Traffic," then CNN news. Ex-KASH. (RW)
- 1580 (KDAY) CA, Santa Monica 3/28 went dark at 1600. The previous hour was on with oldies such as "Could It Be I'm Falling in Love" anncets they would be "going dark" & calls from listeners. According to station employee, they will return in about 2 weeks with new format. (GL-CA)

KELA CA, Santa Monica 3/30 1524 NEW, ex-KDAY, testing with open carrier and voice IDs "KELA Santa Monica," about every 10 minutes. (MS-CA)

720 *KDWN* NV, Las Vegas 3/25 0452 with OC, TT later on. (RW-CA)

1020 *KTNQ* CA, Los Angeles 3/11 0515 with OC over KCKN. (MS-CA)

1050 KORE OR, Springfield 3/11 0512 at loud level tonight with Christian music. (MS-CA)

1230 KDAC CA, Ft. Bragg 3/28 2159 inst. music to 2200 "You're listening to the Family Radio Channel, AM 1-2-3, in Fort Bragg, California" into AP news. Excellent over all. (NH&BH-WA)

1270 KTFI ID, Twin Falls 3/21 0300 not heard in quite a while! Came up over mess with legal ID right at the top-of-the-hour. (MS)

1310 KLIX ID, Twin Falls 3/11 0443 good under KXAM with ID "... here on Clicks" followed by C&W song "Friends in Low Places." (MS-CA)

1320 KCTC CA, Sacramento 3/25 0606 noted using "Sunny 1320" IDs now. (RW-CA)

1330 ?KUPL? OR, Portland 3/22 0205 C&W station noted playing "Why Not Me" in tight KWKW null. Was trying for KGAK F/C. (Have heard as KPOK). (MS-CA)

1340 KKAM CA, Fresno 3/25 0325 momentarily dominant with ID followed by tune "Cherie Amour." (MS-CA)

1360 KRKK WY, Rock Springs 3/11 0358 above the rest momentarily with slogan "Good time rock 'n roll" followed by spot and Neil Diamond tune. ID 0403 "1360 AM KRKK." (MS-CA)

1450*?KVOW?* WY, Riverton 3/11 0210-0220 noted steady 1 kHz tone here again. Presumed KVOW F/C. Reception in Jan. was considerably stronger. (MS-CA)

1490 KYCA AZ, Prescott 3/28 2130 on top tonight with Phoenix Suns EKB vs Milwaukee Bucks. Spot for Honda dealer in Prescott at 2136. (MS-CA)

1570 CFEZ AB, Taber 3/30 0150-0350 incredibly huge signal in XERF absence. Several IDs as "Easy 1570" with mentions of music in stereo, and "Southern Alberta's first & only easy listening station." New for me. (MS-CA)

1570 KPRO CA, Riverside 3/30 1700 very weak signal logged during silence of KDAY/KELA-1580. Heard preaching, inspirational music, spot, then ID at top-of-the-hour. Never heard as KACE, KHNY or KMAY. (MS-CA)

1590 KCIN CA, Victorville 3/30 1420 logged easily without the usual QRM from KDAY-1580 and KMNY-1600. Heard CNN sports & headline news. ID and spots for True Value/Dennys/Goodyear at 1428-1430. (MS-CA)

1600 KXEW AZ, Tucson 3/24 0500 dominant in KMNY SP. English ID on hour, read by woman, followed by "Noticias." KRXY (Y-108) also noted in mess. (MS-CA)

1610 KOP055 NM, Sandia Crest 3/31 0335-0707 collection of tape loops with short musical theme between messages. Ment. of "Radio Sandia," authorized by "National Forestry Station(?) in Albuquerque, NM." Several tape loops -- female with list of interpretative programs offered in the park, man with weather. Occasionally used other tape loops with dramatizations from local area. Frequent use of Radio Sandia slogan. In null of Balboa Park; Phoenix Airport and unID also there. Call sounded like "KOP055." New. (TRH)

Thanks to the reporters this week! We'll be back next week, but then will skip a week. Keep the reports coming. ♥

IRCA Foreign Logs

Before the creation of the IRCA Foreign DX Reference, the IRCA published nine editions of the IRCA Foreign log. Each edition contained the actual tips that were reported to the DXWW sections during an entire year (2 years in Volume 9), recompiled and retyped in a book format. In addition, special features include: articles on foreign DXing (Vols. 6-9), utility lists (Vols. 7-8), shortwave parallels (Vols. 8-9) and BCB propagation (Vols. 6-8). IRCA archives still has Volumes 3, 4 and 6-9 of the IRCA Foreign Log available to all for \$2.50 each. Make checks out to Phil Bytheway and send them to: 9705 Mary N.W., Seattle, WA 98117



Central DX Roundup

Editor: **John C. Johnson**
979 Neptune Boulevard
Billings, Montana 59105-2129

FOR THE RECORD

Report in Eastern time. Deadlines: 5/4, 6/1, 7/6, 8/3, 8/31, 9/14.
CDXR accepts reports via computer through Prodigy, my address: MPNN49A.

RIDING GAIN

[DX-MB] = DX'pedition at Arnes, Manitoba 3/16, 17, 18

*Icom IC-R70.

*3 bev's between 700-1500 feet.

*Shawn Axelrod and Wayne McRae of Winnipeg, MB.

[SA-MB] = Shawn Axelrod, 30 Becontree Bay, Winnipeg, MB R2N 2X9
Icom IC-R70, 100' longwire, 3' loop.

[TML-IN] = Tom Laskowski, 1334 East Miner Street, South Bend, IN 46617
Icom IC-R71A, loop.

[JcJ-MT] = Your editor using an Icom IC-R71A with Radio West Loop.

DX TEST

640 KTIB LA Thibodaux, 3/11 poor. 0220 w/music (C&W or Cajun/Creole?)
ID as "The music of your day and the music of your life."
We're AM 64 KTIB." [TML-IN]

DOWN THE DIAL

610 CKYL AB Peace River, 3/27 good in KFRC null. 0800 ID "CKYL 610
Peace River, 530 High Level" into Broadcast News. Not
needed, very rare here. [JcJ-MT]

660 KEYZ ND Williston, EX-1360. 3/13 fair. 1926 w/C&W music, "KEYZ"
ID. New for me, ND#38. [SA-MB]

950 KOEL IA Oelwien, 3/16 fair o/u/CFAM. 1840 w/Iowa sports roundup.
New, IA#55. [MB-DX]

1010 KRNI IA Mason City, EX-KLSS. 3/17 poor. 1910 with man and woman
doing local spots. IA#57. [MB-DX]

1030 WJKZ TN White Bluff, 3/18 fair o/u/WBZ, KFAY. 0540 with "We may
(nose?) but we never close. AM 10-30 K-Z Country." C&W.
0600 ID "WJKZ." TN#11, my old unID. [MB-DX]

1110 WUNN MI Mason, 3/16 fair. 1810 with Gospel program (letters from
across US, mentioned WUFL as an affiliate.) IDING as
"Family Life Radio" and "AM 11-10 WUNN." New for us.
MI#68. [MB-DX]

1160 WAMB TN Donelson, 3/18 good, no KSL! 0750 w/BBD/NOS music. "WAMB"
ID. TN#12. [MB-DX]

1180 WGAB IN Newberg, 3/9 fair. 0759 w/"Radio 11-80 WGAB Newburg" into
USA Radio Network News. New for me, IN#20. [SA-MB]

1190 KORG CA Anaheim, 3/25 briefly good o/KRDS then lost. 0245 with
Easy Listening music, ID between songs "11-90 K-orange,
your station for original hits." Very much needed, but
not enough for a report. [JcJ-MT]

KVSV KS Beloit, 3/27 brief u/KEX, KRDS. 0700 end of SSB, sign
on. Mentioned "KVSV AM and KVSV FM." Lost quickly. Not
needed, but rare here. [JcJ-MT]

1240 KICD IA Spence, 3/17 fair. 0530 with "KICD AM and FM" ID. New
sign on time (was 0630) or now 24 hours. IA#56. [MB-DX]

KIUL KS Garden City, 3/18 good. 0623 w/Kansas AG Network, "KIUL
more of your music, more of your memories." Either on 24
hours now, or just a new sign on time. KS#29. [MB-DX]
(JcJ: I have a verie from KIUL for when they had a
transmitter problem and were strong on 2480! John.)

KNSS KS Wichita, 3/17 good. 0659 w/"KNSS Wichita's News-Talk 12-
40." Into CBS News. Note new format. KS#28. [MB-DX]

WSDR IL Sterling, 3/18 good. 0608 w/local news, spot for Ford, ID
"AM 12-40 WSDR." IL#57. [MB-DX]

1250 WGL IN Fort Wayne, 3/18 good. 0520 w/CNN News, sports, "WGL" ID.
No longer 0525 sign on. IN#22. [MB-DX]

1270 WCMR IN Elkhart, 3/17 fair. 1937 w/"WCMR" ID at end of UNLV vs
Georgetown basketball game. IN#21. [MB-DX]

1280 WGLR WI Lancaster, 3/16 fair. 1907 w/C&W music, "WAXL" ID. Talk
about WI. ||FM WAXL. New, WI#77. [MB-DX]

CDXR Continued....

- 1300 WQPM MN Princeton, 3/10 fair. 1913 with local spots, sports talk. MN#106. [MB-DX]
- 1310 KFLA KS Scott City, 3/18 fair in a mess. 0808 w/"KFLA" ID. New for us, KS#30. [MB-DX]
- 1340 KHUB NE Freemont, 3/9 fair. 0848 w/"Cat's In The Cradle" song, ID "KHUB" and a EST TC. New for me, NE#35. [SA-MB]
- WWPA PA Williams Port, 3/17 fair. 0640 with "Twin W" ID, oldies format. PA#11. [MB-DX]
- 1470 WCFJ IL Chicago Heights, 3/16 fair. 1943 with Gospel music, ID as "WCFJ." IL#69. [MB-DX]

TIS AND BEACONS

- 516 YWA ON Petawawa, 3/16 fair. 2043. [MB-DX]
- 521 ORC IA Orange City, 3/16 fair. 2048. [MB-DX]
- 524 VOC IA Iowa City, 3/16 fair. 1924. [MB-DX]
- 1610 IL Illinois State Highway TIS. 3/18 fair. 0434. [MB-DX]

UNIDS

- 1240 unID 3/18 fair. One of the Chicago's on 1240, 0528 w/SS talk, and lively music. Which one of the Chicago stations is on at this time? [MB-DX]
- 1500 unID 3/18 fair. 0730 w/"CJ The DJ" doing a phone-in program. Mentions of Atlanta. Noted "southern accents" by two DJs and callers. Not KSTP. [MB-DX]

IDING THE UNIDS

Tim Hall of Chula Vista, CA and Tim Noonan of Madison, WI both offer [SA-MB] the same advice on his 3/23 unID:
 1030 unID with "The all new AM 10-30 K-Z Country" is most likely WJKZ White Bluff, TN. Tim Hall says "...apparently gets out well."
 Tim Noonan has heard the "KZ Country" on a SID, also "10-30 JKZ" ID back in 1989. Thanks Tim and Tim, note 1030 above!

CORRECTION

Listing in 3/23 issue for WULF-1030, state is MI not IL.

25 YEARS AGO

April 16, 1966 issue of DX Monitor...Bill Nittler said he had all states except VT verified.....George Junak told of his visit to KRLA, included talking with Casey Kasem...Larry Godwin submitted an article on "How Do You Rate Your Best Catch?"



OPEN MIKE

 Keep conscience clear, then never fear. [TML-IN] said he tried, but didn't hear the KTTG-1540 test. This is the last of the weekly issues, please note the deadlines above. Prodigy: MPNN49A. 73, John.

NEWSRADIO 91

KBLG

***** IRCA AM-FM ALMANAC, 5th Edition 1991 *****

The fifth edition of the IRCA AM-FM Almanac is now available! This 240 page book is a must have cross reference for the serious AM DXer. Within it you will find the current frequency check list, affiliates for news and talk show networks, syndicated music and religious programs, AM-FM simulcasts, station slogans, broadcasting in Canada, AM stereo, sports networks, utility stations and many articles on AM broadcasting. In addition, Volume V contains a section focusing on AM band foreign DXing (including a compressed IRCA Foreign DX Reference). Each list is in frequency order and many include the FM frequencies as well as the AM (great for FM DXers).

The IRCA AM-FM Almanac is available in large comb bound or loose leaf (please state preference when ordering). Post-publication prices are:

IRCA member: US - \$13.00 Canada - \$14.00 Overseas Sea Mail - \$14.00 Overseas Air-Mail - \$17.00
 non-members: US - \$15.00 Canada - \$16.00 Overseas Sea Mail - \$16.00 Overseas Air-Mail - \$19.00

The IRCA AM-FM Almanac is available from: Phil Bytheway, 9705 Mary NW, Seattle, WA 98117.

A DXers TECHNICAL GUIDE

Now in its 2nd edition, this 120 page book answers questions on how receivers work, how to make them work better, what audio filters and loop antennas will do for you, how to build a beverage and phasing unit, and much more. Only \$5.50 for IRCA members, \$6.50 for non-members (add \$2.50 for overseas airmail). Write: Phil Bytheway, 9705 Mary N.W., Seattle, WA 98117.



Eastern DX Roundup

Ray Bauernhuber
141-12 243rd Street
Rosedale, NY 11422

- (TF-CT) Tony Fitzherbert 356 Jackman Ave., Fairfield, CT - 06432; GE Superadio, ICF55W & ICF-6500W
- (JDS-AL) J.D. Stephens 122 Brawley Drive, Owens Cross Roads, AL - 35763; Panasonic RF-2600; RF-B300; SONY ICF-2001 + several wires
- (RCR-PA) Robert Ritchie 210 S. Walnut St., Martinsburg, PA -16662; Superadio II + 400' longwire.
- 640 KFI CA, LOS ANGELES 3/11 0258 FAIR mixing w/KTIB test. Mention of news "Updated on the hour, every hour", schedule of talk programming which included "Best of King." Several "Newsradio 640 KFI" IDs. First time positively ID'd! CA #4. (JDS-AL)
- 730 WJMT WI, MERRILL 3/11 0200 WEAK u/XEW; faded up briefly and heard the "WJMT" calls, then back down in the mud. (JDS-AL)
- 740 KCBS CA, SAN FRANCISCO 3/11 0258 WEAK u/CBX w/Newstalk; heard "On 74" mentioned; ID as "News 74, KCBS", CBS nx. New...CA #5. (JDS-AL)
- 740 CBX AB, EDMONTON 3/11 0350 FAIR w/"RSVP" classical mx program. ID and CBC nx at ToH. KRMG, KTRH and CBL all off at the same time. This won't happen again for 100 years! (JDS-AL)
- 830 WWMO NC, EDEN 3/16 1754 GOOD w/gospel mx; at 1800 ID'd as "WKXT and WWMO, Eden/Danville", into Piedmont Nx and gone by 1810. (TF-CT)
- 900 WURD PA, PHILADELPHIA 3/24 1826 WEAK w/gospel mx, "WURD" ID at 1830. (TF-CT)
- 900 WGOK AL, MOBILE 3/27 1954 FAIR UC mx, ID as "WGOK" by/m and back to mx. (RCR-PA)
- 940 WINZ FL, MIAMI 3/26 2050 GOOD w/CNN Headline nx, ID by/f as "940 Wins", State nx/wx and CNN Headline Sports. (RCR-PA)
- 1030 KCTA TX, CORPUS CHRISTI 3/27 1945 FAIR w/religious mx, S/off by/m, mention of 50kw, no SSB. (RCR-PA)
- 1060 WPMX MS, TUPELO 3/24 0100 POOR S/off by/m, mention of 1000 and 31 watts; ID as "WPMX Tupelo"; no SSB. (RCR-PA)
- 1180 WJJP RI, HOPE VALLEY 3/29 1724 c/w, ads for mail order houses and gone by 1730. (TF-CT)
- 1190 WBSL MS, BAY ST. LOUIS 3/27 1910 FAIR c/w, ID by/m as "The all new 1190 WBSL", wx, another ID as "1190 WBSL" and back to c/w. (RCR-PA)
- 1250 WGHB NC, FARMVILLE 3/16 1850 LOCAL-LIKE signal w/gospel mx, USA News at 1900; "Eastern NC's Home of Southern Gospel, WGHB - Farmville" ID at 1700. (TF-CT)
- 1250 WANL GA, ALBANY 3/25 0020 STRONG w/"Evensong" program, ID as "You are tuned to AM 1250 WANL, Albany, Georgia, Albany's New Life station." UPI radio nx; religious format. (JDS-AL)
- 1320 WQIK FL, JACKSONVILLE 3/24 0230 FAIR c/w, ID by/m as "99 WQIK" and back to c/w. (RCR-PA)
- 1530 WRTP NC, CHAPEL HILL 3/17 1820 w/gospel mx, very detailed sign-off at 1830 w/prayer for the station; local WJZJ off tonight at 1800. (TF-CT)
- 1570 WFEL MD, TOWSON 3/17 1748 w/Bible Study Hour w/Dr. James (?); USA News at 1800 followed by Christian rock at 1803 and then lost to WBUX. (TF-CT)

- 1570 WPGM PA, DANVILLE 3/17 1804 w/wx for Danville and EZL mx. (TF-CT)
- 1570 WRHZ NY, RIVERHEAD 3/30 1840-1910 c/w, automated IDs for "AM-1570, WRHZ"; mentioned 24 hour operation for c/w all the time; no sign tonight of WBUX or anyone else. (TF-CT)
- 1580 WWOE NC, CAMP LEJEUNE 3/18 1813 Christian rock mx, s/off at 1815 mentioning that they hope that something that they did had been a blessing for the listeners. Post Office returned reception report for the second time this year, can't they find a 10,000 watt station!?!??

=====

DX TESTS, FREQUENCY CHECKS, TIS

=====

- 640 KTIB LA, THIBODAUX 3/11 0209-0400 STRONG DX TEST w/Cajun mx, c/w by "Alabama" & George Jones, "Blue Bayou" by Linda Rondstadt; frequent IDs including "You're listening to the news of your day & the music of your life; we're AM 64 KTIB, Thibodaux/Houma." No code ID noted. (JDS-AL)
- 1510 WNLC CT, WATERFORD 3/18 0416 & 0421 DX TEST WEAK code IDs u/WLAC. Not sure but thought I heard "CT" transmitted, so possibly gave the location also. (JDS-AL)

=====

HELP W/UNIDENTIFIED'S

=====

From: Tim Hall: "Just a quick note regarding unID's: Mike Hardester's "XL-102" in the 3/16 MONITOR is WRNL, Virginia. To answer J.D. Stephens question in the 3/9 MONITOR, KKDA-TX (730) raised night power from 10 watts to 500 watts last year. Neil Kazaross and I caught them when they were still 10 watts! 73 and good DX - Tim."

=====

COMMENTS

=====

Thanks to all of this issue's reporters. Can anyone shed some light on Tony Fitzherbert's problem with WWOE? Thanks goes to Tim Hall with some unID help. Until next issue, CONTINUED GOOD DX MY FRIENDS and 73 de Mr. B

IRCA Mexican List, 2nd edition

The IRCA Mexican List, 2nd edition, is now available from the IRCA Reprint Service! This comprehensive guide lists calls, frequencies, locations, powers, schedules, networks, slogans and formats of AM stations throughout Mexico. It contains a wealth of never-before-published information received direct from Mexico City, and has been updated by listener tips though September 15, 1990. AM radio in Mexico has undergone an extensive shuffle in the past year. If you DX Mexico (or want to), you need this publication.

The IRCA Mexican List is available in four convenient formats:

- | | | | |
|--|-----------|---------------|----------------|
| Volume I - Sorted by Frequency, State, City (24 pages) | US \$3.75 | Canada \$4.75 | Foreign \$6.00 |
| Volume II - Sorted by State, City, Frequency (21 pages) | US \$3.25 | Canada \$4.25 | Foreign \$5.25 |
| Volume III - Sorted by State, Frequency, City (22 pages) | US \$3.50 | Canada \$4.50 | Foreign \$5.50 |
| Volume IV - Call Index (Call/State/City/Freq only) (6 pages) | US \$1.00 | Canada \$1.25 | Foreign \$1.50 |

8 Send your order to: IRCA Reprint Service, c/o Steve Ratzlaff, 295 Pettis Ave., Mountain View, CA 94041
Please be sure to specify the volume(s) desired.

EASTERN DX FORUM

RICHARD C. EVANS
PO BOX 21883
MILWAUKEE WI 53221

Reports from members living east of the Mississippi River
Deadlines: 5/4 6/1 7/6 8/10

J.D. Stephens, 122 Brawley Drive, Owens Cross Roads, Alabama 35763

In reference to Bill Hardy's Forum in edition 910, I am volunteering to reactivate IRCA's CPC to arrange DX tests. I have often wondered why the club didn't do this and feel that IRCA can receive additional respect and prestige within the hobby and foster goodwill with the broadcasting industry with such a program. I have recently had bestowed upon me a Tandy 1200 HD (IBM PC clone) computer and an Epsom printer. I also have computer programming experience, so writing a program to generate letters to send to stations would be quite simple to do. But first, I need input from the membership. Has anyone seen the letter that NRC has been using? Is there any literature available through the reprint service that tells how to go about it? Perhaps other members have arranged tests in the past and can relay their experiences? Members, please let me have your input. I will be looking forward to receiving your input at the above address. (Bill Hardy, I have written to you personally concerning this, but no reply. Did my letter not reach you?) So, how about it club members? Let me hear from you. 73's...J.D. (J.D., I think your best bet is to wait and see who won the election—either John or Phil—and then write that person direct. I'm sure they will be happy to hear from you--rce)

Tom Jasinski, 419 North Raven, Shorewood, Illinois 60435

Greetings and a belated happy anniversary IRCA. We had a spectacular aurora on Sunday, March 24th. A late afternoon band scan revealed conditions similar to Make Hardester's on March 3rd. Had WRFA, Largo, Fla on 820 at 1845. When they faded at 1855, the AM band had only locals. For a while nothing in over 100 miles away. At 2245 had WMOB, Mobile, Ala. in on top with Gospel. Anticipating an aurora, I checked the sky several times. At 2245 (2145 local time) my wife and I were rewarded with an aurora display that covered 1/4 of the sky. From due north to due east to nearly overhead the sky was full of beautiful colors. This was visible even with a half moon just over the west of the zenith. Back at the dials WMOB was still in. There was a lack of Latins. Caught WMOB s/off at 2400. Recent verie in from KOJM-610 for their 1st Thursday PC on March 7th. They also sent a copy of the frequency check results from the monitoring company (Frequency Measuring Service in Commerce City, CO). It listed their frequency as 609.998 kHz or 2Hz low. The KOJM PC is my best catch for a regular PC. The distance is about 1100 miles. Veries are coming in slow. Need to follow up on almost half of them. Nothing back from the KLEY-1130 DX Test on Nov. 4th of last year, even after a followup. Is this one going to be like the WKEN DX Test. Nothing back from WKEN after 2 followups!! 73's and happy Easter.

Steven D. Miller, 368 Quincy St, Apt. 1, Boston, Massachusetts 02125

(cont. from two weeks ago) ...As you've maybe read in this week's EDXR, I've been very busy at the dials, hi Ray! If anyone knows about the latest Almanac, please let me know. Fee free to write me at my Boston address if you like to correspond. After my 2nd year in the Navy, I'm gonna be interested in buying several of the classic DX receivers, e.g., a Drake SPR4 and Pennants I love pennants, and selected back issues of DX Monitor-DX News; several other hobby related publications, bulletins including shortwave. Also I'm gonna pursue some of the club's famed DX Achievement Awards to display in my DX shack. Anybody know Pete Nolan? of the Golden West DXers Assoc. from Vanouwer, B.C. Several years back, Pete visited my

QTH, very interesting guy, hey Pete thanks for the visit even though it was brief. Maybe I'll return the surprise. The following is a listing of my favorite stations heard since '78. (Those beginning with 822 keeping the list of 25 stns can write to Steve direct--rce) News, notes, tidbits: local 1150 WMEX BRN affiliate as of 3/1 is now simul-casting FM sister WMJX's music programming. Ex-WKOS is now WCNN or WVNN-930 Rochester, NH. My most prized verie is not from a BCB stn. It's a 9 1/2 x 14 diploma QSL from the Voice of Vietnam Shortwave; it's a beaut! I got it framed. I'll let you all see it when I send hq a photo for publication of my DX shack. If I'm stationed overseas I'll report my DX heard wherever I'm stationed. This season, I believe is one of the best I remember for MW DXing. So, I hope all of my tips in EDXR encourages everyone to contribute, contribute, contribute! My last anniversary issue of DXM was dated 3/25/89. That issue was 67 pages big! Not bad, I hope this yrs and 27th anniversary issue is at least 80 to 90 pages big! And come the club's 30th Anniversary issue let's go for 100 pages! Imagine 10 pages each for each section of the bulletin. Since I won't be back until the fall, I'll close by saying: I wish everyone in the club a healthy safe prosperous 91 and please support the clubs efforts, editors alike, etc. Say, Mike Hardester, if you've had this tell me a little about the Navy. I DX MW, FM, Shortwave, eventually utes and long wave. 73. (portions cut because they were long lists of stations or outdated comments--rce)

Rick Evans, P. O. Box 21883, Milwaukee, Wisconsin 53221

Not much to add here. I didn't see the Auroral display Tom mentioned but I did hear them comment about it on the news that night, and planned to comment on it in last week's EDXF but I forgot. I had wondered how it would affect BCB DX but was in no position to check it out as I was working the next morning. What little I've heard of WJUB-1420 since I typed last week's column has done nothing to impress me any more on their programming. In some ways I can't wait to get moved down to the south side. On the car radio at S. 27th and Edgerton, I have heard someone under WKSH-1370 while up here there's no way it can be done. I've also heard someone on 1380 but no ID yet. I assume it is WBEL-1380 in S. Beloit, Ill., since that's what I hear up here, but... The election looks interesting. A hard choice in some cases. One thing which would have been nice would have been a statement of when the ballots have to be back in San Diego. However, it was nice to see campaign statements in other than alphabetical order. 73.

Patrick Martin



STUDIOS AND OFFICES
McMAHONS ROAD
NORTH NOWRA

P.O. Box 540
Nowra, 2540

Tel.: (044) 2 0055
Telex: 24563

We thank you for your report covering reception of our

Coastal Transmitter 999 kHz dated 2-11-81

Highlands Translator 1215 kHz dated

This corresponds with our Station log for that day.

P. Martin

STATION ENGINEER

Hearing It Through The Grape Vine

SHAWN AXELROD, 30 Becontree Bay, Winnipeg, MB R2N 2X9 Canada (204) 253-8644 before 2300 E.L.T.

CONTRIBUTORS:

TOM LASKOWSKI 1334 E. Miner St. South Bend IN 46617
 MIKE SANBURN P.O. BOX 1256 Bellflower Ca. 90706
 KARL ZUK 154 Old Post Road North Croton-on-Hudson NY 10520
 YE OLDE EDITOR

FREQUENCY OF THE MONTH 730 KHZ

MIKE SANBURN REPORTS:

XEX Mexico DF	Nights	CKLG Vancouver BC	Winter nights
KBOY Medford OR	Heard 1975	KSVN Ogden UT	Medium Rare
KUCL Boise ID	Occasional nights		

TOM LASKOWSKI REPORTS:

XEX Mexico DF	Was regular	CKAC Montreal	Rare
CJNR Blind River ON	Rare	CHYR Leamington ON	Rare
WPIT Pittsburgh PA	SSS in 1986	WJYM Bowling Green OH	SSS in 1987
WDKT Madison AL	SSS in 1987	KWRE Warrenton MO	Rare at SS
KSUD W. Memphis AR	Once in 1989	WLIL Lenoir City TN	Once in 1990
WOHS Shelby NC	Mixes with WLIL	WJMT Merrill WI	1990 Dx'pedition
KBDA Gr. Prairie TX	SRS on occasion	WFMW Madisonville KY	SSS in 1990
WCPT Alexandria VA	SSS in 1990	WMTC Van Cleve KY	SSS in 1990
WFMC Goldsboro NC	SSS in 1990	CKDM Dauphin MB	Dec 1990

YE OLDE EDITOR:

CKDM Dauphin MB	Dominates day & night	CKAC Montreal QU	SR
XEX Mexico DF	On good skip nights	CJNR Blind River ON	SRS
CHYR Leamington ON	SRS	CKLG Vancouver BC	SRS
KWOA Worthington MN	SRS	KWRE Warrenton MO	SRS
WJVC Lansing MI	SRS once	TGN Guatemala City	Auroral CX once
WJMT Merrill WI	SRS once		

STATE OF THE MONTH CONNECTICUT

MIKE SANBURN:

NOTHING YET BUT.....

TOM LASKOWSKI:

960 WELL New Haven Once in 84
 1080 WTIC Hartford SSS
 1410 WPOP Hartford SSS in 1988

YE OLDE EDITOR

1080 WTIC Hartford Winter nights

BANDSCANS BEST BETS HELP/MOST WANTEDS SILENT PERIODS

NONE THIS TIME AROUND

CLASSIFIEDS

KARL ZUK has for sale;

M Street Journal 1989 Edition Price \$5.00 post paid to the USA

Seems he has 17 copies left listing US and Canadian stations addresses, owners powers and ratings for each market.

WRTH Handbooks 1981,82,83,84,85,86, 88 Make an offer

Most copies present to 1987 of SHORTWAVE MAGAZINE from Britian. Willing to send some or all to anyone for cost of postage.

All procedes to IRCA!!!!!!

NEXT MONTH:

FREQUENCY OF THE MONTH WILL BE 1250 KHZ
 STATE OF THE MONTH WILL BE MISSISSIPPI

Hopefully there will be a better turn out next time. The DEADLINE will be one month after this is published.

ON A CLEAR DAY YOU CAN HEAR FOREVER.

Shawn

of a tuned passive loop) but is of insufficient level to overcome receiver noise. Untuned shortwire antennae may be broadband-amplified if there are no extremely strong signals present that could cause mixing spurs to be produced.

Table 11: holes added to implement options

Refer to Table 3 for definitions of X, Y, D hole drilling parameters.

Holes added for Option 1

T O P S I D E

Hole #	Comp. Desig.	Description	X	Y	D
18	J7	External Coil In-stereo jack	-0.125	3.25	0.375

++++
Holes added for Option 2

T O P S I D E

Hole #	Comp. Desig.	Description	X	Y	D
19	R3	Regen. Vernier pot - shaft	1.5	0.625	0.3125
20	R3	Regen. Vernier pot - tab	2.0	0.625	0.144

++++
Holes added for Option 3

R I G H T S I D E

Hole #	Comp. Desig.	Description	X	Y	D
10	A1	Broadband Amp. Card - H/W 3	-1.625	1.375	0.125
11	A1	Broadband Amp. Card - H/W 1	-1.625	0.375	0.125
12	A1	Broadband Amp. Card - H/W 4	-0.625	1.375	0.125
13	A1	Broadband Amp. Card - H/W 2	-0.625	0.375	0.125

++++
Holes added for Option 4

L E F T S I D E

Hole #	Comp. Desig.	Description	X	Y	D
7	TA1	Imped. Transformer - H/W 1	0.7	1.875	0.125
8	TA1	Imped. Transformer - H/W 2	1.5	1.875	0.125

++++

Supplementary Articles and Publications

Additional information on construction practices and DX-related circuit design may be obtained from the following:

(* = NRC / IRCA reprints)

- * MWDX-4 and Mini-MWDX-4 series Phasing Units - Mark Connelly - 11 OCT 1985 (Shows BBA-B amp. card which may be used in place of Option 3 BBA-C)
- * The Mini-MWDX-3: A Simple, Effective Phasing Unit - Mark Connelly - 5 DEC 1984 (construction practices)
- * RT-1: Remotely - Controlled Antenna Tuner - Mark Connelly - 24 OCT / 26 DEC / 27 DEC, 1984. (construction practices)

publications

NRC: Antenna Manuals, Receiver Manuals, Beverage Manual, Loop Manual

IRCA: Technical Guide

Ken Cornell: Low & Medium Frequency Scrapbook

ARRL: Radio Amateur's Handbook, Low Band DXing (ON4UN)

Fine Tuning / John Bryant: Proceedings 1988, Proceedings 1989

AWARD WINNING **IMPACT** * PHOTOGRAPHY

5 Nov 1990

Dear Patrick,

Pleased to hear that we, out here in the Marshall Islands, have a sometime listener in Seaside, Oregon. From your discription of what you received it could have been none other than our 1000 Watt ERP transmitters. Please consider your QSL card valid. Good to hear from you. Best wishes from Kwajalein!

Sincerely

Kerry
Kerry Matheson
Program Director
Central Pacific
Network

© 606-H WOODLIGHT ON WAJALEIN BEACH THE NORTHSHORE OF OAHU HAWAII
KAUNA POINT IN THE BACKGROUND
PHOTOGRAPHER - JOHN WAGNER



Patrick Martin
P.O. Box 843
Seaside, Oregon
97138

IMPACT * "LIFE LIKE PHOTO ART"
PUBLISHED BY: IMPACT
© IMPACT 1977

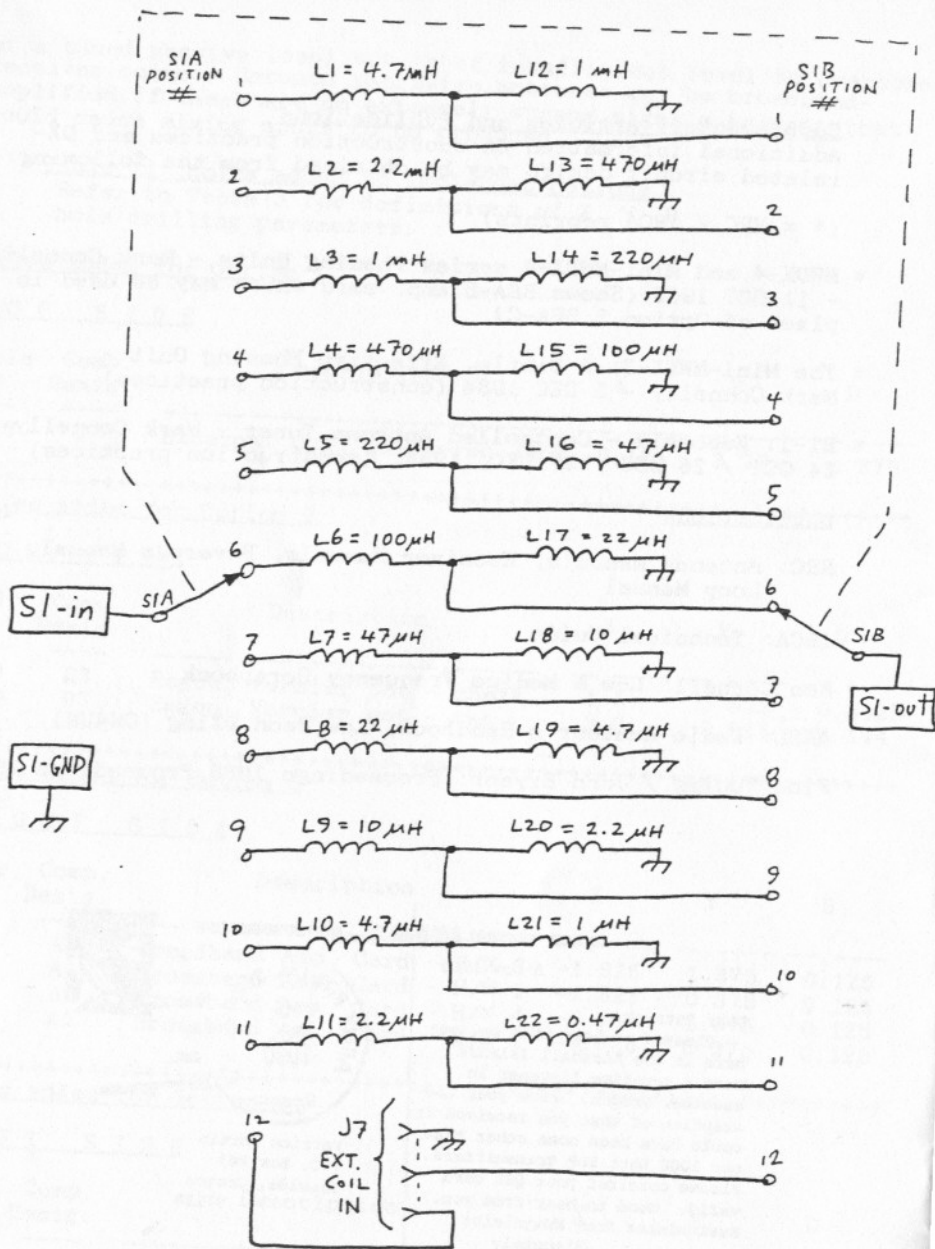

FOR CONNECTIONS, SEE FIGURE 8.
 SWITCH IS MOUSER 10WR212, OR EQUIVALENT.
 FOR FREQUENCY RANGES, SEE TABLE 9.

MWT-2
OPTION 3

FIGURE 5

BBA-C BROADBAND AMPLIFIER CARD : SCHEMATIC
FOR CONNECTIONS, SEE FIGURE 8.

(COMPONENT DESIGNATIONS ARE INDEPENDENT OF MWT-2 MAIN ASSEMBLY COMPONENT)

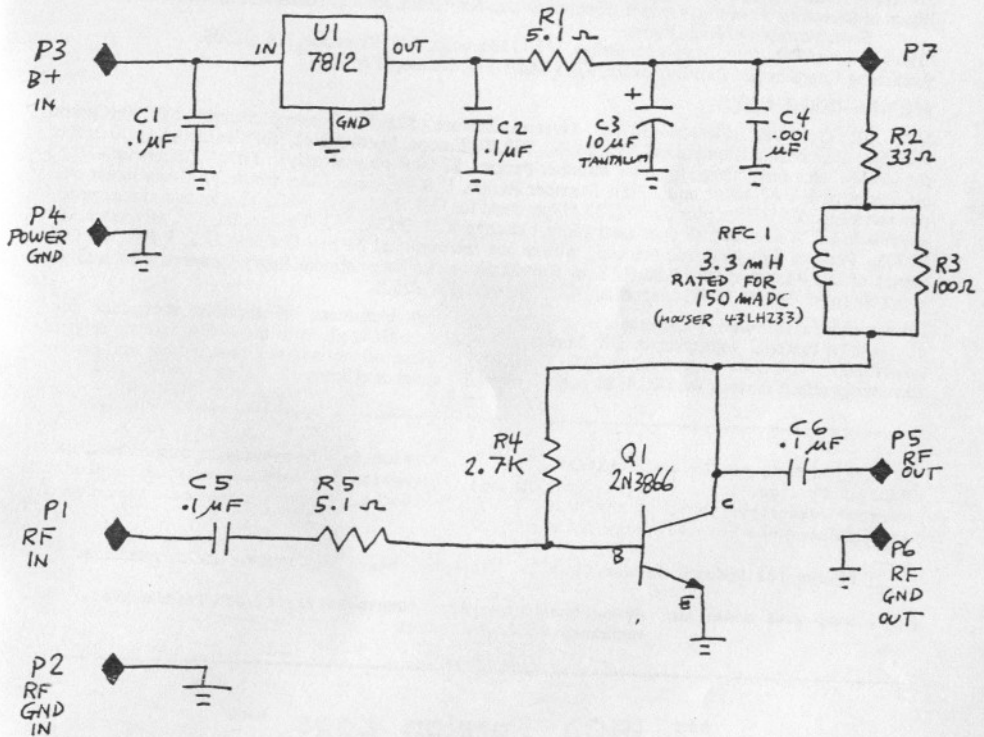

NOTES

\perp = CIRCUIT BOARD GROUND

FOR ASSEMBLY DRAWING, SEE FIGURE 6.

FOR PARTS LIST, SEE TABLE 10.

THIS IS "A1" OF MWT-2 (OPTION 3).

THE INTERNATIONAL RADIO CLUB OF AMERICA (IRCA)

The IRCA is a non-profit organization devoted to the hobby of hearing distant stations on the AM Broadcast Band (510 - 1630 khz). **DX Monitor**, the official publication of the IRCA, is published 34 times a year, weekly from October to March, twice in September and April, and monthly from May to August. **DX Monitor** contains members' loggings, articles on radio stations, receiver reviews, technical articles, DX tips, and other material of interest to Broadcast Band DX hobbyists. IRCA is a member of ANARC, the Association of North American Radio Clubs.

CLUB ADDRESSES AND OFFICERS

President: Karl Zuk, 154 Old Post Road North, Croton, NY 10520-1932 (proposals).

Secretary-Treasurer: Bruce Portzer, 6546 19th NE, Seattle, WA 98115.

Board of Directors: Ernest R. Cooper, Richard Evans, Ric Heald, John C. Johnson, Patrick Martin, Bruce Portzer and Rich Toebe.

Editor-in-Chief/Publisher: Ralph Sanserino, 11300 Magnolia, #43, Riverside, CA 92505.

Publishing Coordinator: Phil Bytheway, 9705 Mary NW, Seattle, WA 98117.

MEMBERSHIP DUES

U.S. - \$25.00 per year. Canada - \$27.00. Overseas Surface - \$28.50. Overseas Airmail - \$35.00 (Central America, Caribbean, Colombia and Venezuela), \$38.00 (Europe, North Africa, Middle East), \$41.00 (rest of the world). One time charge for New Member Packet - \$2.00 (first year only). Trial Membership - \$9.50 (10 issues of **DX Monitor** and a New Member Packet, U.S. / Canada / Mexico only). Installment rate: two payments of 1/2 dues plus \$1.00 (\$13.50/payment for U.S. members). Make checks and money orders payable to IRCA and send all dues (and address changes) to: IRCA, 11300 Magnolia, #43, Riverside, CA 92505. Persons living outside the U.S., please use International Money Order in U.S. funds. Sample copies of **DX Monitor** are \$1.00 (U.S. or Canadian) or two International Reply Coupons each and are available from: IRCA, 11300 Magnolia, #43, Riverside, CA 92505.

Unless otherwise noted, permission is granted to publish, broadcast, or otherwise reproduce non-copyrighted material appearing in **DX Monitor** provided credit is given to the IRCA and the original contributor. Opinions expressed in **DX Monitor** are those of the original contributors and do not necessarily reflect those of the IRCA, its publishing staff, editors or officers.

UPDATER #1 to the IRCA MEXICAN LIST, 2nd EDITION is now available from the IRCA Reprint Service. This updater contains new information for over 140 stations, plus tips on identifying some of the Mexican radio networks. Much of the monitoring for this updater was actually done in Mexico!

Prices for Updater #1 are \$1.00 to the U.S., \$1.25 to Canada, \$1.75 overseas.

Send your order to: IRCA Reprint Service, Steve Ratzlaff, 295 Pettis Ave., Mountain View, CA 94041

*** IRCA Foreign Logs ***

Before the creation of the IRCA Foreign DX Reference, the IRCA published nine editions of the IRCA Foreign log. Each edition contained the actual tips that were reported to the DXWW sections during an entire year (2 years in Volume 9), recompiled and retyped in a book format. In addition, special features include: articles on foreign DXing (Vols. 6-9), utility lists (Vols. 7-8), shortwave parallels (Vols. 8-9) and BCB propagation (Vols. 6-8). IRCA archives still has Volumes 3, 4 and 6-9 of the IRCA Foreign Log available to all for \$2.50 each. Make checks out to Phil Bytheway and send them to: 9705 Mary N.W., Seattle, WA 98117

*** A DXers TECHNICAL GUIDE ***

Now in its 2nd edition, this 120 page book answers questions on how receivers work, how to make them work better, what audio filters and loop antennas will do for you, how to build a beverage and phasing unit, and much more. Only \$5.50 for IRCA members, \$6.50 for non-members (add \$2.50 for overseas airmail). Write: Phil Bytheway, 9705 Mary N.W., Seattle, WA 98117.