

# DX MONITOR

THE OFFICIAL PUBLICATION OF THE **IRCA** INTERNATIONAL RADIO CLUB OF AMERICA

DEVOTED EXCLUSIVELY TO BROADCAST BAND DXING

DECEMBER 19, 1992 - VOLUME 30 - NUMBER 14 - EDITION 972 - ISSN 0899-9732

**PUBLISHING:** I have decided to stay on as Publisher of the DX Monitor for awhile. Some changes may need to be made down the road, but we can handle it and the NRC merger can be put to rest. So you remaining renegades can relax and we can get on with club business and DXing the thing we do best.

**NEW ADDRESS FOR IRCA:** IRCA PO Box 70223 Riverside CA 92503-0223. Please send all mail to the new address. I am moving and the old address is out as of right now. My new location is quiet and I hope to hear some DX. Pub.

**IN THIS ISSUE:** Front cover has a very rare and nice verie from India sent by Patrick Martin. Excellent catch Patrick. **PAGE 1:** IRCA DX Test Schedule. **PAGE 2:** DX Worldwide West. **PAGE 3:** Western DX Roundup. **PAGE 5:** Central DX Roundup. **PAGE 9:** Eastern DX Roundup. **PAGE 11:** Western DX Forum. **PAGE 12:** DX Techniques. **PAGE 14:** Technical Column. **PAGE 16:** Ribbon Cable Loop (1 more page remaining on this article). In the DX Techniques column we have part 3 of the computer article. Hope we have something for everyone.....

**TED VASILOPOULOS AWARD:** IRCA's highest honor, the TVA, is awarded each year to the IRCA member contributing the most to the DX hobby and IRCA during the preceding year. We will vote on the TVA during the March 1993 election of IRCA officers. Publisher Ralph Sanserino, 1992 TVA winner, is chairman of the nominating committee. Because of Ralph's busy schedule, he has asked that nominations be sent to 1991 winner Bill Hardy. You may nominate any IRCA member in good standing, except those who have won the award in the past five years: Ralph Sanserino, Bill Hardy, Ernest R. Cooper, Richard Evans, and Karl Zuk. If you know of any member who is deserving of the TVA, please send their name and a brief reason why they deserve the award. Please send it by January 31 so there will be time to get the names onto the March ballot. Write to Bill Hardy, 2301 Pacific Ave., Aberdeen, WA 98520-4527. Thank you.

No. 3/1/92-E, III / 4366

DIRECTORATE GENERAL  
ALL INDIA RADIO  
AKASHVANI BHAWAN,  
PARLIAMENT STREET,  
NEW DELHI-110001 INDIA



Dated the..... 01.12.92

Dear Sir/Madam,

We gratefully acknowledge your Reception Report and confirm your listening to our transmission on 894..... kHz on..... 04.10.92 at 350-1410C

The transmission originated from our Station at..... S. H. Long (MM)

Your faithfully,

Asst Director Frequency Measurements for Director General

Maitreya, Thiruvananthapuram

AKASHWANI

भारत सरकार द्वारा  
INDIA GOVT. SERVICE



वर्षाद्वारा प्रेषित  
Archaeological Survey of India

To,  
Patrick Martin,  
Post Office Box 843,  
Seaside, Oregon-97138-0843  
U.S.A.

LEN 7  
75 Palace  
Thomson

# IRCA DX TEST BULLETIN

MONDAY, DECEMBER 21, 1992 - KGWA-960, P.O. BOX 960, ENID, OK 73702 WILL CONDUCT A DX TEST FROM 1:01 - 1:30 AM EST. THE TEST WILL INCLUDE MORSE CODE, TONES, VOICE ID'S & MARCH MUSIC. RECEPTION REPORTS MAY BE SENT TO: MR. SCOTT CLARK (WA7UIB) - CHIEF ENGINEER. (ARRANGED BY J.D. STEPHENS FOR IRCA CPC)

MONDAY, DECEMBER 21, 1992 - KNED-1150, BOX 1068, MCALESTER, OK 74502 WILL CONDUCT A DX TEST FROM 2:00 - 2:30 AM EST. THE TEST WILL INCLUDE MORSE CODE, TONES, VOICE ID'S, AND MUSIC. RECEPTION REPORTS MAY BE SENT TO: MR. LEE ANDERSON (WB5RYX) - PROGRAM DIRECTOR. (ARRANGED BY J.D. STEPHENS FOR IRCA CPC)

WEDNESDAY, DECEMBER 23, 1992 - WSMI-1540, P.O. BOX 10, LITCHFIELD, IL 62056 WILL CONDUCT A DX TEST BETWEEN 1:00 & 1:10 AM EST. THE TEST WILL INCLUDE MORSE CODE, TONES, AND VOICE ID'S AND WILL BE PART OF THE STATION'S MONTHLY FREQUENCY CHECK. RECEPTION REPORTS MAY BE SENT TO: MR. BRIAN TALLEY (N90WV) - CHIEF ENGINEER. MR. TALLEY REQUESTS AN SASE BE INCLUDED WITH ALL REPORTS. (ARRANGED BY J.D. STEPHENS FOR IRCA CPC)

MONDAY, DECEMBER 28, 1992 - WKGF-1480, P.O. BOX 794, ARCADIA, FL 33821 WILL CONDUCT A DX TEST FROM 2:00 - 2:30 AM EST. THE TEST WILL INCLUDE MORSE CODE, VOICE ID'S, AND CONTEMPORARY CHRISTIAN MUSIC. RECEPTION REPORTS MAY BE SENT TO: MR. QUICK CODDINGTON (K8TRR) - CHIEF ENGINEER. (ARRANGED BY J.D. STEPHENS FOR IRCA CPC)

MONDAY, JANUARY 4, 1993 - KNAK-540, P.O. BOX 636, DELTA, UT 84624 WILL CONDUCT A RESCHEDULED DX TEST BETWEEN 2:00 & 2:30 AM EST. THE TEST WILL INCLUDE MORSE CODE, TONES, AND VOICE ID'S. RECEPTION REPORTS MAY BE SENT TO: MR. DOUGLAS BARTON - OWNER. (ARRANGED BY J.D. STEPHENS FOR IRCA CPC)

MONDAY, JANUARY 4, 1993 - WNTK-1020, P.O. BOX 2295, NEW LONDON, NH 03257 WILL CONDUCT A DX TEST FROM 3:00 - 3:30 AM EST. THE TEST WILL INCLUDE MORSE CODE, TONES, AND VOICE ID'S. POWER WILL BE 10 KW USING AN OMNIDIRECTIONAL ANTENNA PATTERN. RECEPTION REPORTS MAY BE SENT TO: MR. ROBERT L. VINIKOOR - PRESIDENT. (ARRANGED BY J.D. STEPHENS FOR IRCA CPC)

MONDAY, JANUARY 4, 1993 - KEAN-1280, P.O. BOX 3098, ABILENE, TX 79604 WILL CONDUCT A DX TEST FROM 3:30 - 4:00 AM EST. THE TEST WILL INCLUDE MORSE CODE, TONES, VOICE ID'S, AND COUNTRY MUSIC. RECEPTION REPORTS MAY BE SENT TO: MR. JAMES CAMERON - CHIEF ENGINEER. (ARRANGED BY J.D. STEPHENS FOR IRCA CPC)

MONDAY, JANUARY 11, 1993 - KDES-920, P.O. BOX 2745, PALM SPRINGS, CA 92263-2745 WILL CONDUCT A DX TEST FROM 4:00 - 4:30 AM EST. THE TEST WILL INCLUDE MORSE CODE ID'S AND MUSIC. RECEPTION REPORTS MAY BE SENT TO: MR. JOE TOURTELOT (KB6FX) - VICE PRESIDENT & GENERAL MANAGER. (ARRANGED BY J.D. STEPHENS FOR IRCA CPC)

MONDAY, JANUARY 11, 1993 - KCKY-1150, P.O. BOX 6, COOLIDGE, AZ 85228 WILL CONDUCT A DX TEST FROM 4:30 - 5:00 AM EST. THE TEST WILL INCLUDE MORSE CODE ID'S. RECEPTION REPORTS MAY BE SENT TO: MR. BILL OOSTENBURG - CHIEF ENGINEER/PROGRAM DIRECTOR. (ARRANGED BY J.D. STEPHENS FOR IRCA CPC)

MONDAY, JANUARY 18, 1993 - WOC-1420, 3535 EAST KIMBERLY ROAD, DAVENPORT, IA 52807 WILL CONDUCT A DX TEST FROM 2:15 - 2:30 AM EST. THE TEST WILL INCLUDE MORSE CODE, TONES, VOICE ID'S, AND BIG BAND MUSIC. RECEPTION REPORTS MAY BE SENT TO: MR. JON BOOK (KB0EDE) - DIRECTOR OF ENGINEERING. (ARRANGED BY J.D. STEPHENS FOR IRCA CPC)

MONDAY, JANUARY 18, 1993 - KXTQ-950, 904 EAST BROADWAY, LUBBOCK, TX 79403 WILL CONDUCT A DX TEST FROM 2:30 - 3:00 AM EST. THE TEST WILL INCLUDE MORSE CODE ID'S, AND BILINGUAL (SPANISH & ENGLISH) PROGRAM MATERIAL. RECEPTION REPORTS MAY BE SENT TO: TANYA ROBERTS - GENERAL MANAGER. (ARRANGED BY J.D. STEPHENS FOR IRCA CPC)

**WCXI**  
**AM 1130**



PAT MARTIN P.O. BOX 843 SEASIDE. OR 97138

# DX Worldwide - West

Time: UTC phone (503) 861-3185

DEADLINE: MONDAYS

## PAN-AMERICAN DX ROUNDUP

- 1650 UNID, very weak woman spoke 0404 11/23. Could be Latin America or image. Anyone else hear? (LG-MT)  
1685 COLOMBIA, Mercaderes again hrd w/Morse Code ID "EMER" weakly 0400 11/23. (LG-MT)

## TRANS-PACIFIC DX ROUNDUP

- 531 JAPAN, Morioka-JOQG good with JJ talk at 1510 12/7 (PM-OR)  
540 JAPAN, Synchros here //531-NHK1 JJ talk 1511 12/7 (PM-OR)  
603 UNID, strange Asian language here at 1730 12/7, too weak to copy (PM-OR)  
711 UNID, may have been Korean, but hard to tell 1645 12/7 (PM-OR)  
729 JAPAN, Nagoya-JOCK good //531 KHZ 1515 12/7 (PM-OR)  
738 t TAIWAN, Cantonese talk in jumble at 1525 12/7 (PM-OR)  
747 UNID, weak Asian talk at 1535 12/7 (PM-OR)  
783 RUSSIA, man in Russian and semi-classical mx 1521 12/7 (PM-OR)  
801 UNID, hymn heard in KGO splat, Guam? 1529 12/7 (PM-OR)  
846 JAPAN, Synchros here //531 1517 12/7 (PM-OR)  
864 JAPAN, two or three stations mixing here in JJ 1540 12/7 (PM-OR)  
954 JAPAN, Tokyo-JOKR-fair w/JJ Pops at 1527 12/6 (PM-OR)  
1107 JAPAN, UNID JJ here 1522 12/6 (PM-OR)  
1134 JAPAN, Tokyo-JOQR-fair w/man in JJ 1519 12/6 (PM-OR)  
1161 UNID, CC talk at 1540 12/6 (PM-OR)  
1242 JAPAN, TOKYO-JOLF-fair w/man in JJ 1542 12/5 (PM-OR)  
1287 JAPAN, Sapporo-JOHR-fair JJ talk 1512 12/6 (PM-OR)  
1314 JAPAN, Osaka-JOUF-fair YL in JJ 1514 12/6 (PM-OR)  
1619 UNID, Asian moderating strong, noted for first time 11/26 1415-1445, my LSR. At 1430 choral mx (similar to Opera), ended, followed by brief strains of nationalistic inst. mx. Man spoke in Unid language (not JJ) between 1431-1445. I see NHP reported possible KK on 1616 11/21 issue. Is this one drifting upward? (LG-MT) (Larry: Noted here on 1617 KHZ a couple weeks ago, but the format you list sounds like the same station. PM)

## VERIFICATIONS

- 765 AUSTRALIA, Port Lincoln-5CC-friendly letter from Jack Martin-CE confirming my report, along with a nice QSL card, sticker, and Tourist info in 5 weeks for taped report. 5KW directional P.O. Box 483-Port Lincoln, S.A. 5606 Australia. (PM-OR)

## THANKS TO THESE REPORTERS

- LG-MT LARRY GODWIN-2390 Clydes Dale Lane-Missoula, MT 59801  
Hammarlund HQ-150, Sanserino air-core box loop  
PM-OR YOUR EDITOR  
Drake R8, Hammarlund SP-600, Term. 1600' NNW Bev, Term. 200ft.  
SW/NE Wire, Ground system

**IRCA Stationery**

2

Red and black masthead with the IRCA logo and name. Great for using when writing for verifications. 100 sheets, \$5.00. Order yours today from: IRCA Bookstore, 9705 Mary Ave NW, Seattle WA 98117



# WESTERN DX ROUNDUP

Nancy Hardy  
2301 Pacific Ave.  
Aberdeen, WA 98520

DEADLINE FOR WDXR TIPS IS MONDAY. PLEASE USE EASTERN TIME.

REPORTERS FOR THIS ISSUE:

- (DG) Dennis Gibson-442 Ellwood Beach Dr. #3-Goleta, CA 93117  
GE Superadio II & III, Sony ICF-2010, Select-a-tenna
- (LG) Larry Godwin-2390 Clydes Dale Lane-Missoula, MT 59801  
Hammarlund HQ-150, Sanserino air-core box loop
- (JH) Jim Hilliker-1705 Withers Ave. #14-Monterey, CA 93940  
GE Superadio
- (GJ) Gary Jackson-7735 Center Parkway-Sacramento, CA  
FRG-8800, Dymek DA5 antenna  
(GJ-CA1) DX'ing in Hanford, CA
- (PM) Patrick Martin-P.O. Box 843-Seaside, OR 97138  
Drake R8, SP-600-JX17, term. 200' SW/NE wire, 1600' NNW  
terminated Beverage, 1500' E Beverage
- (MS) Mike Sanburn-P.O. Box 1256-Bellflower, CA 90707  
GE Superadio II
- (RW) Robert Wine-1309 Dentwood Dr.-San Jose, CA 95118  
GE Superadio, GE long-range portable, SM-2

\*\*\*\*\*  
OF SPECIAL INTEREST

- 990 KQSB CA, Santa Barbara 11/30 0900 on with new call (was KKJZ) and new format (news/talk). Slogan is "Talkradio 990." 4th call used this year (others were KTUN, KSSM, and KKJZ). Hope this format outlasts the last one (2½ months). (DG)  
+11/30 0944-0950 good in KKIS null over XECL, with sports, local spot & ID. Call change ex-KKJZ. (RW-CA)
- 1430 KFIG CA, Fresno 11/30 0500 this station changed calls after all, ex-KWDO, in tight KNTA null with ID after "Heartbreak Hotel," "You're hearing the greatest hits of all time, on (jingle) KFIG, Fresno." (RW-CA)
- 1510 KTID CA, San Rafael 11/30 1001 good over KSJX-1500 null with talk on Elvis stamp, traffic report, ID on hour "KTID AM & FM, San Rafael." Call change, ex-KAPX. (RW-CA)
- \*\*\*\*\*
- 540 CBK SK, Watrous 11/23 0200 unusually loud through KJQI with ID "Join us here on CBC Radio 540 for Saskatchewan." Good conditions to the north country. (MS-CA)
- 590 (KSRO) CA, San Bernardino 11/27 0300 off! (MS-CA)  
KID ID, Idaho Falls 11/27 0425 thought I was listening to KUGN u/o/KSUB. Heard spots, phone numbers, Talknet, and finally an ID at 0507. Wanted for many moons. ID #12. (MS-CA)  
KSUB UT, Cedar City 11/27 0430+ mostly dominant in KRSO absence. ID "Southern Utah's listening legacy, 590 KSUB." Slogan on the hour was "Color Country." (MS-CA)
- ?KAQQ? WA, Spokane 11/27 0410 tentative ID, spots for Gold Bond, and book. Nostalgia music including songs "Hold Me, Thrill Me" and "Yesterday When I Was Young." Ex-KHQ for me. (MS)
- 840 KSWB OR, Seaside has been testing on and off with C&W and Christmas music. Says they should be back on in early Dec. (PM-OR)
- 990 KKJZ CA, Santa Barbara 11/15 2000 logged their call change by accident. Spot for hair salon, ID, phone number, then signal gone. Ex-KKSM, KTUN, KBBQ, etc. Dennis Gibson said they are planning to change call letters again to KQSB. (MS-CA) (See "Of Special Interest!"--NH)
- 1040 KURS CA, San Diego 11/28 1955 new Spanish pest! Songs, phone requests, ID "KURS San Diego (English), esta es KURS San

Diego-Tijuana-Los Angeles." Slogan is "Radio San Diego."  
Possible power drop/pattern change at 2015. Address is  
296 H. Chula Vista, California. (MS-CA)

+11/30 0930 good in CKST null, heavy KOFY-1050 splash with  
numerous "Radio San Diego" slogans. Are the calls on this  
KIRS or KURS? I believe the latter. New, regardless. (RW)  
(Calls are KURS.--NH)

+11/30 1500 new station noted on with Spanish format.  
Slogan is "Ka diez cuarenta (K 1040) Radio San Diego."  
Daytime signal is good considering only 900 watts non-  
directional and diplexing off a much shorter tower (KSON-  
1240). Night signal not very strong--my wife is happy  
because it doesn't mess with her favorite station (CKST)  
very much. (DG-CA)

1340 KIHRR OR, Hood River 12/3 1859-1904 only 2nd time logged. This  
time all alone on the frequency. Good legal ID with promo  
for morning show. Into news for 1 minute with Becky Bailey  
(Mutual?). 1902 after network spot "I'm Art Baily with AM  
13-40 news." Several local news items mentioning Hood River  
and vicinity. Lost at 1904 as other stations faded in.  
(JH-CA)

CINL BC, Ashcroft 11/30 1215 very good on top with "NL" news,  
Kamloops spots. Called station and they ID'd what I had  
heard. New. (PM-OR)

CIVH BC, Vanderhoof 11/30 1216 fair u/o CINL with CJCI-620  
programming. Called station and they ID'd what I heard.  
Also new. (PM-OR)

1370 KPCC CA, Quincy 11/18 0200 ID "Keeping you informed, KPCC  
Quincy," CBS news. (MS-CA)

1400 KUKI CA, Ukiah 11/28 2243 C&W song "I'd Love You All Over Again"  
followed by ID "AM 1400 KUKI." Becoming a regular here!  
(MS-CA)

1430 KYKN OR, Salem 12/3 1906 good with ID "Now back to Bruce  
Williams on newsradio 14-30, KYKN, Salem." New. (JH-CA)

1440 KODL OR, The Dalles 12/3 1840-1855 dominant several times with  
C&W music, ID's at 1840, 1849 and 1853. Usually "KODL,  
Oregon Trail Country," 1840 had local sponsored weather.  
New. (JH-CA)

1480 KSBQ CA, Santa Maria per Auto Answers host on KNRY, Auto Answers  
is on KSBQ Saturdays 0900-1300. (JH-CA)

KHQN UT, Spanish Fork 11/30 0901 way over mess with New-Age  
style music, then Hari Krishna programming. Faded rapidly.  
Looking for KRXR (might have been in there!). (RW-CA)

1490 KBKR OR, Baker 11/29 0900 on top with moderate signal. (LG-MT)

1580 KWYD CO, Colorado Springs popped up with an ID at 1000 11/20.  
Latest NRC Log lists as a CP; has it been on long? (LG-MT)  
(Yes, I heard them over 20 years ago from NY as KPIK!--NH)

1620 (TIS) CA, Pebble Beach I haven't heard since mid-October although  
I've tried 6-8 mornings. Is it still getting out? (LG-MT)

KVGB KS, Great Bend a nightly visitor with highly distorted  
signal around 2230 through mid-November, but not heard at  
the end of the month. Maybe transmitter problem has been  
fixed. (LG-MT)

#### LOCAL NEWS

1080 KSCO CA, Santa Cruz now carries Dr. Joy Browne 2200-0100 M-F, in  
Tom Snyder's old time slot. Last live Snyder show on ABC  
was 11/25. Also, KSCO now using 1,000 watts non-  
directional at night to cover Santa Cruz better than their  
5kw night DA, which went west. Can be heard at night in  
San Jose now, too. (JH-CA)

1240 KNRY CA, Monterey carries L.A. Lakers NBA games again this  
season (and KLAU-1540 carries the Warriors). Also, M-F  
2030-2100, KNRY carries Jim Healy sports from KMPC-710!  
(JH-CA)

#### DX TESTS

540 (KNAK) UT, Delta 11/23 0200-0230 DX test tried, not heard. Have  
logged previously as KDLT. (MS-CA)



570 KCNO CA, Alturas DX test in strong 11/30 0330-0405 with Morse code, march music, country music, many mentions of KCNO Alturas, Susanville, Alturas-Lakeview! Singer Nevada Slim, also mentioned at 0354 "Go to church in Alturas, a town that never met a stranger!" (GJ-CA)  
 +11/30 0330-0410+ very good on DX test over KISN/KVI, with lots of code ID's, march music, "Nevada Slim" program, lots of slogan ID's, info on Alturas. Very well-done and professional test, ran past sked end time. (RW-CA)

UNIDS

950 My unID in 11/28/92 WDXR likely XEPB Hermosillo. ID'd MM 11/30 using same slogan after s/on of "Radio Azul" (Radio Blue) 0801. (RW-CA)  
 1650 Woman spoke very faintly at 2304 11/23. Anything listed? (LG-MT)

We hope everyone has a happy holiday season!



# Central DX Roundup



John C. Johnson  
 979 Neptune Boulevard  
 Billings, Montana 59105-2129

**★ PRODIGY**  
 MPNN49A

## FOR THE RECORD

REPORT ALL TIMES AS EASTERN. DEADLINES: MAIL: SATURDAYS. PRODIGY: SUNDAYS.  
 FAX REPORTS ACCEPTED. 406-259-9210. CONTACT EDITOR FOR TIME PERIOD TO SEND.

## RIDING GAIN

- [SA-MB] = Shawn Axelrod, 30 Becontree Bay, Winnipeg, Manitoba R2N 2X9  
 Icom IC-R70 with PLAM board and 4kHz filter, 4-foot box loop, 100' wire.
- [VAL-DX] = DX'pedition at Valhalla Beach, MB 11/21 & 22.  
 Two Icom IC-R70 with PLAM board and 4kHz filter, NE, S, and W beverages.  
 Attending: Shawn Axelrod and Wayne McRae of Winnipeg, MB  
 Note, Shawn returned home Sunday AM, Wayne remained thru MM.
- [TMJ-IL] = Tom Jasinski, 419 North Raven, Shorewood, Illinois 60435-9640  
 FRG-7, Quantum loop, 2½ foot loop.
- [PAL-MN] = Paul A. LaFreniere, P.O. Box 606, Grand Marais, MN 55604  
 Zenith Transoceanic, Dymek DA-S loop.
- [WMC-MB] = Wayne McRae, 103 Donegal Bay, Winnipeg, Manitoba R2K 2B5  
 Icom IC-R70 with PLAM board and 4kHz filter, 3 foot loop.
- [TN-WI] = Tim Noonan, 4609 Crescent Road, Apt. 5, Madison, WI 53711-4672  
 Drake SW-4A, Sangen ATS-803A, "Radio West" loop.
- [JcJ-MT] = Your editor using an Icom IC-R71A with a "Radio West" loop.

## DOWN THE DIAL

- 530 ..... ND, Fargo. 11/22 very poor. **WNWN-881** T.A.S. station as logged previously in ND.  
 Information about Fargo and area. [VAL-DX]
- 570 **CKGL** ON, Kitchener. 11/21 fair. 2354 with C&W. 0000 news. New. [VAL-DX]  
**KISN** UT, Salt Lake City. 11/21 very poor in heavy CKY slop. "KISN" ID. New. [VAL-DX]
- 590 **KGLE** MT, Glendive. 11/22 fair. 0900 with "KGLE Glendive" ID into religious program.  
 New. [VAL-DX]
- 640 **WBOW** IN, Terre Haute. EX-1230. 11/22. 1200 noted with fair to poor daytime signal about  
 equal to WOI. [TMJ-IL]

- 690 **WPDQ** FL, Jacksonville. TENTATIVE. 11/22 very good signal. 2135-2155 then very poor. Can't be sure of WPDQ ID. "The Sunday Night Scoreboard on the American Radio Network" and "American Forum Radio Network." Lost to KOAQ at 2155. [VAL-DX]
- 720 **KDWN** NV, Las Vegas. 11/22 good. 0350-0405 with sports talk. [TMJ-IL]  
(WGN) IL, Chicago. 11/22. 0330 noted of the air. (Previously noted off 10/18.) [TMJ-IL]
- 730 **KURL** MT, Billings. 11/22 good w/CJDM. 1000 with weather, "KURL" ID and slogan "Christian Radio." New. [VAL-DX]
- 740 **KSSS?** CO, Colorado Springs. 11/23 fair. 0845 with weather for "The Springs" and ID (poor) that sounded like KUUU not KSSS or slogan "K-Triple-S." Has this changed? [VAL-DX]
- 770 **KUOM** MN, Minneapolis. 11/21 fair. 1724 with ID and classical music. Until now I had only heard their former share-timer WCAL. [TN-WI]
- 790 **KFGO** ND, Fargo. 11/21 fair. 1720 with Fargo area weather and PSA with ID. [TN-WI]
- 810 **WJJQ** WI, Tomahawk. 11/22 poor w/CKJS. 1028 with "Double J" ID and mentions of WI. Weather report. New. [VAL-DX]
- 860 **KKOW** KS, Pittsburg. 11/21 fair to good. 1806 with ID "The area's number one sports station. 86 AM KKOW." [TN-WI]
- 890 (WLS) IL, Chicago. 11/22. 0330 noted off the air. Channel dead. [TMJ-IL]
- 900 **WFIA** KY, Louisville. 11/7 good. 0730 with "AM 900 WFIA Louisville" after church announcements into religious talk show. [WMC-MB]
- 950 **CKBB** ON, Barrie. 11/21 good o/u/WWJ. 2339 with oldies, local spots. Numerous "CKBB" IDs. New. [VAL-DX]
- WJPC** IL, Chicago. 11/23 fair mixing with WWJ. 0135 with "Rap Radio WJPC" IDs. Nearby, but KOEL dominates here days. [TN-IL]
- 1010 **KBIS** AR, Little Rock. 11/17 very good, dominating frequency. No CFRB (at last). 0700 with "AM 10-10 KBIS" ID. [SA-MB]
- KKGZ** CO, Brush. 11/21 good. 1722 with Colorado State football. \1440 KRDZ and both IDing as "KSIR." [VAL-DX]
- WINS** NY, New York. 11/23 good o/CFRB. 0221 with "10-10 Wins" IDs. Heard this one in the car before, now finally logged from home. [TN-WI]
- 1140 **CFXX?** AB, Calgary. Might not be CFXX anymore! 11/22 excellent. 1800 with "The sounds of Calgary and AM Stereo XL 11-40." Very light rock format, more like adult standards. Broadcast News on hour. Formerly CKXL, but CKXL is now used by FM 91.1 in Winnipeg. Does anyone have information on this call change? [VAL-DX]
- 1150 **WHBY** WI, Kimberly. 11/22 fair o/u/WAVY. 0915 with local spot for a meat market. Green Bay football talk. New. [VAL-DX]
- 1220 **WKRS** IL, Waukegan. 11/28 good. 0855 with sports talk about local high schools. "WKRS Sports" slogan. [PAL-MN]
- 1230 **WJBC** IL, Bloomington. 11/22 poor. 1850 with lots of talk about Bloomington, including spots. No WJBC ID given. Rock oldies format. [VAL-DX]
- 1240 **WMFG** MN, Hibbing. 11/28 fair o/unIDs. 1341 with oldies and spots for local firms, PSA for Christmas Seals. [PAL-MN]
- 1250 **KCUE** MN, Red Wing. 11/21 good. 1743 with ID and "K-cue" slogan back into American Country Countdown. [TN-WI]
- 1310 **KLIX** ID, Twin Falls. 11/23 brief, fair. 0830 with lots of "Click AM 13-10" slogans, no mention of KLIX. [VAL-DX]
- KNOX** ND, Grand Forks. 11/28 fair. 1324 with spots for a Toyota Dealer and a furniture store. Oldies music. [PAL-MN]
- 1350 **CKDO** ON, Oshawa. 11/18 good. 2319 with local spots and lots of "CKDO" IDs. No indication of them being \FM. New one for me, #1500 from southern MB. [SA-MB]
- 1360 **WIXZ** PA, McKeesport. 11/28 good. 1655 with "Live coverage of championship football on WIXZ." Mentioned "Channel 11 News" and East Allegheny. 1700 signal promptly disappeared. [PAL-MN]
- 1380 **KQKD** SD, Redfield. 11/22 very good. 1315 with weather for Redfield and SD. "KQ Country" slogan. [VAL-DX]
- 1390 **KENN** NM, Farmington. 11/11 fair. 1830 with "KENN AM 13-90 Farmington" ID into C&W music. [WMC-MB]

- WTJS** TN, Jackson. 11/17 fair in WRTH null. 1940 with ID. New for me. Thanks to Wayne McRae for the tip! [SA-MB]
- 1400 **KGVL** TX, Greenville. 11/11 fair. 1805 out of ABC news with "You're source for news, information, and sports in ... county and north-east Texas is AM 1400 KGVL." Spot for TX crime and justice program. Into talk program. [WMc-MB]
- KVOE** KS, Emporia. 11/13 poor in GY mess. 2255 with spots for Emporia business. Mentioned phone numbers, all started with 342-. No ID heard. [WMc-MB]
- WGIL** IL, Salisbury. 11/22 fair. 1845 with "Salisbury Radio 14" and "WGIL" IDs. Rock music format. [VAL-DX]
- 1410 **KRWB** MN, Roseau. 11/28 good. 1255 with news from Minnesota News Network. 1300 ID into ABC News. [PAL-MN]
- 1420 **WJUB** WI, Plymouth. 11/11 fair. 0710 with UST Today Radio Sports. Full ID into farm report. [WMc-MB]
- 1420 **WTCR** WV, Kenova. 11/21 good. 1659 with legal ID and mention of simulcast with 103.3 FM. [TN-WI]
- 1440 **KKXL** ND, Grand Forks. 11/15 excellent. 1518 with modern variety C&W music. "Double K Country" IDs. [SA-MB]  
 +11/28 fair. 1250 with C&W and spot for a travel agency and Ben Franklin. Noted western MN and ND stations in fair to good all day 11/28. [PAL-MN]
- KMAJ** KS, Topeka. 11/29 briefly weak in CJOI null. 0305 with promo for ESPN "...on AM 14-40 KMAJ..." Need for follow up report, but not enough this time. [JcJ-MT]
- KRDZ** CO, Wray. 11/14 very good. 1850 with "Hits of 60s, 70s and 80s on the new 10-10 and FM 107 KSIR." Noted 11010. Is this still KRDZ? [WMc-MB]
- WMAX** MI, Bay City. 11/18. 2223 with "14-40 WMAX" ID and CNN Sports. New. [SA-MB]
- 1450 **KBMW** MN, Breckenridge. 11/28 poor. 1246 with promo for Paul Harvey "...on KBMW." Program followed was a radio-auction type show. [PAL-MN]
- WELY** MN, Ely. 11/28 fair in GY mess, mixing with KBMW. 1244 with polka music and a promo for Minnesota Timberwolves on WELY. [PAL-MN]
- 1460 **KKAQ** MN, Thief River Falls. 11/28 good. 1242 with spot for T.R.F. Utilities and other local spots. [PAL-MN]
- KKCS** CO, Colorado Springs. 11/14 brief. 0940 with C&W, spot for Colorado Springs night club "...where Saturday night is party night." No ID heard. [WMc-MB]
- WTMB** WI, Tomah. 11/11 poor with KKAQ and KLTC nulled. 0725 with adult standards format. [WMc-MB]
- 1470 **KWOG** WY, Douglas. 11/22 poor o/w/CJVB. 0845 with "KWOG" ID and slogan "Word Of God." Christian music. New. [VAL-DX]
- WHRD** WV, Huntington. 11/27 good in WMBD null. 0705 signal popped out of nowhere (power change or pattern change at sunrise?). Spot for several ski areas in WV. Not needed, first heard as WWHY. [TMJ-IL]
- WTKO** NY, Ithaca. 11/27 poor w/WMBD. No sign of regular CHOW this morning. 0359 with ID into news. [TMJ-IL]
- 1480 **KZSN** KS, Wichita. 11/14 poor. 0920 with spots and weather for Wichita. "FM 102" slogan. C&W music. No KZSN ID. [WMc-MB]
- 1490 **KKAN** KS, Phillipsburg. 11/14 poor. 0915 with "KQMA" ID, talk about Kansas into a song by the Cars. [WMc-MB]
- KOKC** OK, Guthrie. 11/16 good. 1930 with "14-90 KOKC" after rock oldies tune. [WMc-MB]
- KOVC** ND, Valley City. 11/28 fair. 1238 with C&W music and local spots. Noticed ND stations in fair to good at midday today. [PAL-MN]
- 1510 **WAUK** WI, Waukesha. 11/22 poor. 0910 with polka music. "WAUK" ID and "Energy 15-10" slogan. [VAL-DX]
- 1520 **KMAV** ND, Mayville. 11/28 good. 1225 with C&W, local news and weather. [PAL-MN]
- KSIB** IA, Creston. 11/21 good u/KOMA. 1755 w/C&W, "Creston Radio" slogan. [VAL-DX]
- WOOD** IN, Shelbyville. 11/22 good. 0630 with a promo for a contest to win a turkey "...on W-3-Oh." New. [VAL-DX]
- 7 **WWKB** NY, Buffalo. 11/21 fair u/KOMA. 1745 with "Miami Hurricanes Football Network" IDs and finally "WWKB" and "KB" IDs (had us fooled for awhile.) [VAL-DX]



- 1540 **WAKY KY**, Greenburg. 11/23 poor w/KXEL. 0930 with logs of talk about Greenburg. Woman host. No WAKY ID heard. [VAL-DX]  
 1600 **WSFN MI**, Muskegon. 11/17 fair. 1933 with "Sports Radio." New for me. [SA-MB]  
 1610 ..... **MT**, Deer Lodge. 11/22 poor. **KOP-796**. Info on Deer Lodge Valley Historical Sites. New. [VAL-DX]  
 ..... **WI**, Kenosha. 11/22 good. 1017 with "Welcome to Wisconsin. You're listening to Wisconsin travelers radio broadcast from Kenosha by the Wisconsin Department of Tourism." All kinds of event info throughout the state. This was in almost continuously from 1622 on. A big pest. [VAL-DX]

### TESTS

- 540(KNAK) **UT**, Delta. 11/23 DX Test tried for, but not heard here. [TN-WI] & [TMJ-IL]  
 570 **KCNO CA**, Alturas. 11/30 DX Test very weak w/WNAX, WWNC, and severe WIND-560 slop. 0333 and 0338 with code. 0338 code was stronger and briefly in the clear. Could make out only a few code characters. A taped report was sent. [TMJ-IL]  
 +11/30 DX Test tried for, but not heard here. [PAL-MN]  
 910(KCJB) **ND**, Minot. 11/23 tried for scheduled frequency check at 0105, not heard. [TN-WI]  
 1150 **WIMA OH**, Lima. 11/28 poor to good, mixing w/KWKY and others. 0030-0101 with IDs mentioning IRCA, station address, and verification cards. Code IDs, band music. Thanks J.D.! Report and thank you sent. [TN-WI]  
 1260(KROX) **MN**, Crookston. 11/23 tried for scheduled freq. check at 0110, not heard [TN-WI]  
 1530 **WVFC PA**, McConnellsburg. 11/23. 0030-0040 regular frequency check. TT and several voice IDs during test. Note this is the 4th MM. (Robert Wein may want to make a note for the next F/C list.) [TMJ-IL]  
 1540 **WSMI IL**, Litchfield. 11/25 weak. 0101-0115 with TT during DX Test. [TMJ-IL]

### unIDs

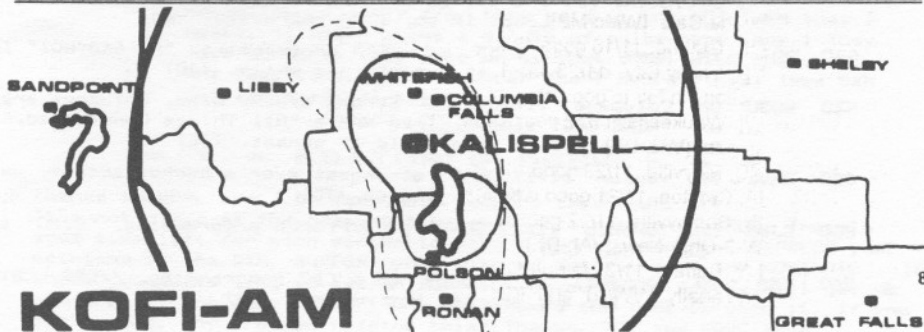
- 1460 unID 11/14 brief, but excellent signal. 0930 with Big Band format. Woman gave birthday announcements. Became very poor quickly. Might be KKOY. KS stations everywhere for a 30 minute period. [WMc-MB]  
 1500 unID 11/16 poor. No KSTP. 1715 w/"The greatest hits of all time" NOS format. [WMc-MB]  
 1570 unID 11/22 fair (best on south wire). 0930 with "All new, all sports radio 15-70 AM covering sports of the (?) Coolie (?) region, the midwest, and the world." [VAL-DX]

### 25 YEARS AGO

December 23, 1967 issue of IRCA's DX Monitor....Rick Evans of Gary, IN received 21 veries in a 2 week period in November...Bruce Portzner of Seattle, WA said his totals were now 420/77...Ernest J. Wesolowski of Omaha, NE mentioned so far this year he had sent out 109 reports. He asked how many remembered when stamps cost 4 cents.

### OPEN MIKE

The human race has one really effective weapon, and that is laughter. Shawn and Wayne's latest outing to Valhalla Beach required walking through knee deep snow to run wires. This in 28 degree temps. Trust me, these guys are dedicated to DX! Billings '93. KEEP IRCA AND DX MONITOR ALIVE!!! 73, John.



# EDXR

EASTERN DX ROUNDUP  
Leonard Hyde  
1805 Whipple Dr #26  
Blacksburg VA  
24060-2436

## SAVE IRCA - SAVE IRCA - SAVE IRCA - SAVE IRCA

This week, a report from J.D. on some stations from the "Great White North," and Karl Jeter checks in with a GREAT DX test logging and other stuff, too. Take off, eh! - to EDXR!

### \* \* \* THE REPORTERS \* \* \*

- (JD) J.D. Stephens-3715 Conger Road-Huntsville AL 35805  
Panasonic RF-2600, Sony ICF-2001, several longwires
- (KVJ) Karl V. Jeter-2115 Scarbrough Road-Stone Mountain GA 30088
- (ed) The editor at home with 1956 Oldsmobile car radio,  
2' box loop, Autek QF-1

### \* OF SPECIAL INTEREST \*

- 1560 WQEW NY, New York 11/29 0230 ex-WQXR using new calls, still classical format. This "transmogrification" of WQXR/WNEW calls, and change to AS format an obvious attempt to pick up WNEW's "jilted" audience when the former goes BUS NX. Very smart. (ed)

### \* \* \* THE REPORT \* \* \*

- 530 TIS GA, Stone Mtn. Park TIS stn w/cont 15 min loop mentioning to stay tuned for future info on park services & events. "This transmitter test courtesy of nearby DeKalb College." Ends w/plug for college. Park about 7 miles away. (KVJ)
- CIAO ON, Brampton 11/27 0525-0540 foreign language program, (SS?), spot for "Frankie's Deli" in EE. (KVJ)
- 550 WAYR FL, Orange Park 11/17 1700 "Broadcasting the way of salvation, WAY-RADIO." Into Chuck Swindoll pgm. (KVJ)
- 580 WELO MS, Tupelo 11/23 1859 "Your great memory stn in Tupelo, AM-580." NOS type mx. (KVJ)
- 590 WCAB NC, Rutherfordton 11/23 1758 Charlotte Hornets rpt, promo ment "#1 for sports in Rutherford Co." (KVJ)
- WGNE FL, Panama City 11/23 2205-2215 EZL mx, "Soft & easy AM-STERED 590" promos. Local WKHX nulled. (KVJ)
- WMBS PA, Uniontown 11/28 0616 local ads, ment of Xmas charity, jingle ID, all in WHKX null. (You forgot to mention what equipment you are using, Karl: are you nulling your local w/the Quantum Loop? If so, I AM impressed! -ed)
- 640 WOI IA, Ames 11/12 1755 gd w/NPR programming. "AM 640-WOI" ID Into nx. Not heard at sunset in a while. (JD)
- 820 WOSU OH, Columbus 11/12 1800 Strong o/WBAP w/nx, Columbus area wx. "NEWS-820" slogan. Into NPR's "All Things Considered." Another not heard in a while at sunset. (JD)
- 850 CKVL PQ, Verdun 11/17 0045 strongest ever w/hockey scores, wx, all in French. "CKVL" jingle. (JD)
- 860 CJBC ON, Toronto 11/17 0040 gd w/French programming, "CJBC" & "CBC" IDs. (JD)
- 9 940 CBM PQ, Montreal 11/17 0059 gd w/CBC programming, //CBE, CBY. CBC nx, ID, wx, sports. Not needed. (JD)

990 \*CBY\* NF, Corner Brook 11/17 0058 fr w/CBC programming //CBE. CBC nx, Newfoundland wx, ID. Not needed. This has been some night for Canadians! (JD) (Where was I on this night when badly needed NF was heard in the Southland? At WORK! -ed)

1130 WKED KY, Frankfort 11/23 1655 promo for "11th annual Xmas contest" and "1130-WKED." (KVJ)

1210 WDAO OH, Dayton 11/17 0655 fair w/black GDS mx. (KVJ)

1290 CJBK ON, London 11/17 0034 popped up briefly w/a slogan that said, "THIS IS YOUR MAJOR LEAGUE STATION-1290 CJBK." Into "Layla" by Derek & the Dominoes. Also heard a "1290-CJBK" ID before fading. New. (JD)

1320 WQIX FL, Jacksonville 11/17 0038 briefly strong w/spot for WNFT-TV, alarm company. "WQIX AM & FM." (JD)

1340 KZNG AR, Hot Springs 11/17 0112 roaring in w/f/ancr. Spot for Hot Springs Mall. "RIGHT HERE ON ARKANSAS' POWER STATIONS: US 97 & KZNG AM 1340." Into C&W mx, gone by 0116. (JD)

1490 WDMI KY, Owensboro 11/18 0006 in briefly w/f/voice: "You're listening to 1490-WDMI." (KVJ)

1530 WRTP NC, Chapel Hill 11/21 0813 rlg, scripture reading and Bible contest w/f/ancr. WCKY nulled. (KVJ)

1550 CBE ON, Windsor 11/17 0056 strong w/chamber mx. Tx by m/ancr about upcoming concert at the Chrysler Auditorium. Several "THIS IS CBC RADIO 1550, WINDSOR" IDs. CBC nx, wx, s/off by f/ancr. "O Canada," off at 0110. New. (JD)

WMDH IN, New Castle 11/19 0000 surfaced w/promo for gardening show, "RIGHT HERE ON WMDH, NEW CASTLE." (JD) (Bob Wien verified 250 watts night power. -ed)

\* \* \* \* DX TESTS \* \* \* \*

All IRCA DX Tests are arranged by J.D. Stephens. Thanks to him, Lynn Hollerman, Jim Pogue, and all who contribute to the IRCA CPC effort.

540 (KNAK) UT, Delta 11/23 this was a no show due to technical difficulties. Has been rescheduled for January. Watch DXM for details. (JD) (Good! I missed it. -ed)

570 \*KCND\* CA, Alturas 11/30 definite blks of code IDs, 1 min in duration each, at 0330 and 0339 thru KLIF QRM. 1st new CA stn since 1975! (KVJ) (Xlnt!!! -ed)

(KCND) CA, Alturas 11/29 0330-0400 nope. QRM from WKBN, unID C&W station (WWNC?) Regular in CA, needed here. (ed)

\* \* \* \* f/c's \* \* \* \*

960 unID 11/9 0204 per letter to KNEB-NE, answering my tentative reception of their f/c, they said it WAS NOT THEM that I heard. (I heard about a minute of pulse-type tone.) They (did confirm) they were on at that time, with the usual 1 kHz test tone. Now, I wonder who I heard? (KVJ) (See DXM 969 for original logging. -ed)

\* \* \* \* EDITOR'S DESK \* \* \* \*

Thanks to KARL and J.D. for their support this week. It's not clear at the present time what will become of IRCA. There's some time left for each member to make a difference. How? EXPRESS your opinions in the DXM, SUPPORT your club by contributing and NOMINATE 10 those you would like to see in the club government. Apathy will get us nowhere. If you care about IRCA, then now's the time to show it. If you don't care, why are you reading this? Thanks, 73, and SAVE IRCA. HE CAN'T RUN IF YOU DON'T NOMINATE HIM: SEND IN YOUR NOMINATIONS NOW!



# Western DX Forum ★ ★ ★ ★ ★

Reid Wheeler 5910 Boulevard Loop SE Olympia, WA 98501

Deadline: Saturday 2 weeks before publication

John C. Johnson, 979 Neptune Blvd, Billings, MT 59105-2129  
(406) 259-9210

[11/29] Only one verie this week, that from KDUN-1030. Leonard Hyde's recent comments about IRCA were right on! Hopefully one of our many members is interested in print or knows someone who is in the printing industry. We must not let the IRCA fold. You think you've seen a large number of call changes lately? A recent article in BROADCASTING said the FCC has processed 6,201 call changes since 1984. That works out to about 700 per month! If you were wondering, if more than one station applies for the same call, the station with the oldest continuous license gets the call. FCC's Clay Pendarvis says, "*The process is now real easy and real fast ... If the call sign is available, we'll sign it.*" I don't know about you, but if I didn't have by own computer based station guide it would be difficult to keep up with what's out there to DX. Billings '93. KEEP IRCA AND DX MONITOR ALIVE! 73, John.

Robert Wein, 1309 Dentwood Dr., San Jose, CA 95118

[12/1] Haven't sent in a forum for a long time, so feel one is due. First off, IRCA has been around for well over a quarter of a century, and never before have we been faced with the prospect of ceasing to exist as a DX club. Part of the problem seems to be the fact that only a minority of the membership contributes to the club, the majority being apparently apathetic with a "I belong to the club, I didn't know I had to contribute" attitude. Involvement of the membership of IRCA in club activities, contributions to the bulletins, etc., has, at least to me, declined steadily over the years. That's one reason the club is facing this dilemma we are now in. It's difficult for one member or just a small group of members to do the majority of the work in the club. If a club's membership doesn't seem to care about what's happening within it, why bother having a club to begin with? That's the question we all have to answer for ourselves. Well, off my soapbox. DX has been terrific of late at least here, set a record MM 11/30 for me with 5 newies, 3 call changes, and 2 solid newies, the sold newies being: XEPB-950 and KUSR-1040, call changes including KFIG-1430 ex-KWDO, KQSB-990 ex-KKJZ and KTID-1510 ex-KAPX. Cx are improving. 73's.



# DX TECHNIQUES

Leonard Hyde  
1805 Whipple Dr #26  
Blacksburg VA  
24060-2436

## USING THE COMPUTER IN DXING - PART 3

**LARRY GODWIN:** REPORTS TO DX MONITOR: I use my word processor for this. I name my files by the column to which I am reporting, and the date. For example, my second report to DXR this month would be "DXR-92K.2" The "K" (11th letter of the alphabet) refers to the 11th month. This system properly alphabetizes the files in order on my hard disk.

**LOG OF STATIONS HEARD:** I have a crude but workable way of keeping my "heard" logbook. I keep two log files: one for domestic, one for foreign stations. After I type a report to DXR, I copy it to my domestic log file "DXR.CON," and similarly, I copy each DXWW report to my "DXWW.CON" file. After each report, I intersperse the new additions with the stations already in the file by frequency. That way, I have a continuous listing of all stations I heard and reported to DX Monitor.

**LOG OF BEST CATCHES:** I do keep a database for this purpose. I've defined 10 fields: Station, Frequency, City, Power, Distance, Latitude, Longitude, Bearing, Date first heard, and Alternate city (for locations not defined in my world atlas.) I have sort indices by power and distance.

**DISTANCES:** I use two programs to calculate distances, and both work almost identically. "PC Globe" is my favorite: I input my home base coordinates and those of my catch, and it calculates distance in miles, as well as bearings. It is commercially available from most software houses for about \$40. "Bearings" is a little more time consuming to operate, and will only produce distances in kilometers. I ordered mine from Zephyr Services (412-422-6600) for \$25.95 a year ago.

**SUNRISE AND SUNSET TIMES:** I use "Suntimes" to calculate precise data for any day of the year, for any location on Earth. It will also produce a chart for an entire month. This program is also available from Zephyr Services: mine cost \$30.95 a year ago.

**THE EDITOR:** Larry mentioned that he believes it would be possible to keep the log on a database, and print a copy of tagged files only for reports to the DXM columns. That is exactly what I do. My computer is ancient, and so is my software, so I don't know how valuable what I do will be to the membership. I use the Condor 20 database to enter all stations logged at each sitting. I still use a composition book to actually log the stations in longhand. The database sorts the loggings, weeds out stations already in the file, and posts them to the database. I then periodically run reports in three formats: by frequency, state, and call in alphabetical order. I generally enter loggings every few weeks. Since I am too frugal to run a new report every time I update the database (all three reports take about 50 sheets of paper-horrors!) I have auxiliary databases set up which contain only the new loggings since the last report was printed. These databases are automatically posted at each entry session, and then update sheets are printed with only the new stations heard since last report printout. I have dBASE, and it can be used in the same manner, but since I started out with Condor, I will stick with it: I'm not about to re-enter 1000 stations all over again! By the way, all the automatic posting and update sheet printing is done under the CP/M batch process utility "SUBMIT," which I have written in such a manner that it FORCES me to back up every entry session on TWO floppy disks, which are then stored in two different places! If you've ever lost all your files before, you'll take steps to make sure it never happens again!

At report time, the stations are automatically numbered by date, so that AL #1 is always the first station I ever heard from that state, and so on. Therefore, I don't even have to worry about numbers when entering stations. I also have foreign and domestic loggings in separate databases. It's easy to find the original logging of any station in the handwritten notebooks using the date. If there is a flaw, it's that I 12 have no record of loggings of the same station on different dates. It's not a perfect system, but it works for me.

I also use my word processor for reporting to the DXM columns. I have



report forms for each column (Forum, DXWW-E, etc.) which makes it much easier to report regularly. If there is one best use of the computer for DXing, this is it. Those of you who dread writing out reports in longhand would be surprised how easy it is to report when you have a pre-generated form, which only needs to be brought up, info filled in, printed out and mailed. If more people did this, we'd have a lot more people who report regularly to the DXM columns.

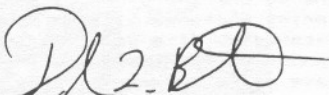
The report forms already contain the editor's address, salutation, etc. At printout time, even the envelope is addressed. It took awhile to develop all this! I'm only sorry that I am not IBM-compatible. I'd be only too happy to send anyone a disk who wanted it.

Fascinating subject! Thanks to Mark and Larry for their support. Last time, I mentioned a new format for DX Techniques. The POSED TOPIC idea is being dropped: it only narrowed the scope of tips received. Henceforth, you may report at ANY time on ANY topic that is proper DX Techniques subject matter. I already have a number of tips for the next issue. Thanks to all, and send in those tips, ideas, and questions! 73.

# KMTI 630AM

P.O. Box K • 1600 West River Lane Rd. • Manti, UT 84642 • 835-7301

DEAR Mike Sanburn THIS IS TO CONFIRM YOUR  
RECEPTION OF KMTI AM 650 ON 3/9/92 - 12:39/AM MST  
KMTI-AM IS LOCATED AT THE CENTER OF UTAH AT MANTI, UTAH, APPROXIMATELY 120 MILES SOUTH OF SALT LAKE CITY. MANTI IS THE COUNTY SEAT FOR SANPETE COUNTY, AND MANTI HAS A POPULATION OF 2,600 PEOPLE. KMTI-AM FIRST SIGNED ON THE AIR ON JUNE 7TH, 1976 ON 1340 KHZ, NON-DIRECTIONAL WITH 1,000 WATTS DAYTIME AND 250 WATTS NIGHTTIME. ON MAY 23, 1981, KMTI CHANGED FREQUENCIES FROM 1340 KHZ TO 1590 KHZ, WITH A DAYTIME POWER OF 5,000 WATTS NON-DIRECTIONAL AND 1,000 WATTS NIGHTTIME POWER, WITH A DIRECTIONAL ARRAY. ON OCTOBER 16, 1990, KMTI AM ONCE AGAIN CHANGED FREQUENCIES FROM 1590 KHZ TO 650 KHZ, INCREASED OUR POWER TO 10,000 WATTS DAYTIME DIRECTIONAL, WITH MAJOR LOBES GOING NORTH, SOUTH, AND WEST. AND KMTI'S NIGHTTIME POWER IS CURRENTLY 900 WATTS, ALSO USING A DIRECTIONAL PATTERN, WITH MAJOR LOBES GOING IN THE NORTHERN AND SOUTHERN DIRECTIONS. KMTI SENDS LIMITED SIGNAL TO THE SOUTHEAST AND NORTHEAST DURING THE DAY TO PROTECT KTNM, 660 KHZ, WINDOW ROCK, ARIZONA, AND KUUY 650 KHZ, ORCHARD VALLEY, WYOMING. AND DUE TO THE FACT THAT WSM, 650 KHZ, NASHVILLE, TENNESSEE, ALSO IS ASSIGNED TO 650 KHZ, KMTI RESTRICTS SIGNAL TO THE EAST, DURING NIGHTTIME OPERATION. KMTI'S TRANSMITTER LOCATION IS ABOUT 2 MILES NORTH OF MANTI, UTAH. KMTI OPERATES WITH TWO, 340 FOOT TOWERS, SPACED 700 FEET APART. A 10,000 WATT, "NAUTEL" SOLID STATE TRANSMITTER, IS USED BY KMTI AS ITS MAIN TRANSMITTER. KMTI'S TRANSMITTER FACILITY IS EQUIPPED WITH AN EMERGENCY 40 KW DIESEL GENERATOR, A BACKUP STUDIO, AND A 1KW "GATES" AUXILIARY TRANSMITTER. KMTI'S STUDIOS ARE LOCATED ONE MILE WEST OF MANTI, AND KMTI-AM IS OPERATED FROM OUR STUDIOS BY REMOTE CONTROL. THANK YOU FOR YOUR RECEPTION REPORT OF KMTI-AM, MANTI, UTAH. IF YOU ARE EVER IN CENTRAL UTAH, PLEASE STOP BY AND SEE US.





## The ICOM R-9000

by Don Moman

The R-9000 is ICOM's top of the line full coverage receiver incorporating a spectrum display unit, similar to their IC-781 amateur transceiver. The U.S. list price is \$5495; the Canadian list is C\$6601 plus GST.

### Basic features:

100 kHz to 1999.98 MHz continuous coverage in AM, SSB, CW, FM, FM Wide, FSK and TV (displayed on built-in CRT). Has 1000 memory channels. The CRT display features a spectrum display and indicates memory channels, scan conditions, dual time zones, tuning steps etc. Tuning rates are 10 Hz to 100 kHz. It has dual clocks and sleep timers, 5 independent timers, automatic tape recorder control, IF shift and notch filter, Automatic Frequency Control (AFC) and seven Scan modes.

Obviously, this is one rather complete unit, capable of detecting almost any form of radio emissions that one is likely to encounter. It is essentially the R-71 and the R-7000 radios in one cabinet and considering how good those sets are, it would seem logical to give the combination very high marks indeed. But without any dual receive capability, the R-9000 cannot perform the basic operating function that most hobbyists demand: that of scanning the VHF/UHF bands while tuning around on the HF bands. However, with such a large price tag, one could argue that the receiver is targeted at a more professional monitoring market where other things are more important.

Filter selection is nothing special. In AM you have 15 kHz, 6 kHz and 2.4 kHz, while in SSB/CW you have 2.6 kHz, 2.4 kHz and 500 Hz. FM lets you select between 30, 15 or 6 kHz with a fixed 150 kHz filter for FM broadcast/TV. Selectivity occurs mainly at 455 kHz. The 2.4 kHz FL-44A and 500 Hz FL-52A are high quality filters, but inexpensive ceramic filters are used for AM; a quality 4 kHz filter would be useful here. The 2.6 filter is pretty muddy in AM but moving the IF shift all the way to one side improves the audio bandwidth. There is no synchronous AM detector, but the accurate and stable 10 Hz resolution allows ECSS tuning. The master oscillator is adjustable (recessed screwdriver slot) via the front panel, so you have a form of RIT to tune between the 10 Hz steps. The IF Shift and Notch Filter function in both AM and SSB. AGC is switchable between fast, slow and off. On AM, both AGC speeds are way too slow for quick bandscanning, while on SSB the speed seems fine.

Sensitivity is excellent from SW thru UHF (my signal generator runs out at 500 Mhz so above that.....). At 5 Mhz an AM signal of less than .1uv was detectable, and at 150 Mhz an FM signal of less than .15 uv was just discernable. MW performance is tailored for urban areas; a fixed 6 db pad is built into the 500 to 1600 kHz bandpass filter section and the preamplifier is bypassed. At 1000 kHz, one could just detect a .5 uv signal, which is less than adequate in a quiet location at sunrise enhancement.

I doubt that many R-9000's will be used on Beverage expeditions, but the R-9000 will function on 12 volts DC. It draws approximately 2.5 amps so an automotive or (preferably) deep cycle marine battery is needed.

Two HF antenna inputs are provided and are front panel switchable. In addition, a switched 12 volt line (100 ma output) is available to power a remote antenna relay and/or preamplifier. Separate N type connectors are provided for 30 to 1000 MHz and 1000 to 2000 MHz.

As a scanner on the VHF/UHF bands the R-9000 performs very well. It has the delay before resume circuit that was so badly missed on the R-7000, and the delay time as well as the scan speed is adjustable. Scan speed is rated at about 13 ch/sec. Tuning steps are from 10 Hz to 100 kHz but the default step is 20 kHz, which can let you tune right by some channels.

A wide array of scan modes is available for any of the 1000 memory channels plus 10 program ranges and 10 memory select tags. A voice scan function senses audio variations and rejects channels with carriers and/or tones. Having the roll function and the ability to see 10 memory channels at once on the CRT is very nice. All memory channels can be tagged with an 8 digit alphanumeric identifier, handy to keep track of what frequency is for what purpose.

Automatic Frequency Control is selectable (FM and FM wide modes only), and when turned on will actually change the frequency display until you are tuned to the center of the station. AFC is often needed on unstable receivers to keep them tuned; in this case you'll have to look for a drifting signal to actually make use of it!

Wideband FM is not particularly good in strong signal areas, but the R-7000 suffers similarly. TV reception is quite good although the amber display CRT leaves a lot to be desired. Hooking the video to a color monitor results in a very good picture. Selectivity and adjacent channel rejection is quite good, somewhat better than my R-7000 with the TV option. Like the R-7000, TV audio can be heard well before any recognizable picture appears.

Separate wide range bass and treble controls allow excellent high fidelity audio, somewhat limited by the smallish top mounted speaker. However, audio in all modes even with the built in speaker has to be rated as very good.

#### SPECTRUM DISPLAY

This displays 25, 50 or 100 kHz on either side of the channel to which one is tuned. Band activity can be seen at a glance and off channel signals stand out clearly. The +/- 25 kHz position makes each vertical marker equal 5 kHz, handy for sizing up the SWBC activity, while on medium wave the +/- 50 kHz position matches the channel spacing nicely. The frequency calibration of the display does not require any adjustment and is very accurate. For VHF and UHF scanning a much wider span would have been beneficial, even +/- 100 kHz is a mere drop in the Megahertz bucket at those frequencies.

The ability to view the spectrum is a feature generally not appreciated by those who haven't had the chance to experience it. For the DX'er in the middle of a hot band opening, the ability to be many places at once is essential in catching a sign-on or a quick fade up.

On the negative side, the spectrum display lags behind the tuning dial enough to make tuning awkward if you are attempting to "move" a signal pip to the center of the display. Once you stop tuning, the display catches up quickly. I quickly became very comfortable with the display and I certainly missed the ability to see what the spectrum was doing when I returned to my own receiver. It's hard to say in qualitative terms how much use the display is, as it doesn't make the signals clearer or stronger in any way, but it certainly is nice to have.

#### CONCLUSION

Overall, the R-9000 rates as a very professional high quality receiver, with no real glaring performance shortcomings. Some features could have been implemented in a more user friendly fashion, but it's mainly a matter of getting used to the many features available on this set. Yet there is nothing in the signal path that sets it apart from any other good SW receiver, most of which sell for one quarter to one third the price of the R-9000. In common with high quality audio equipment, the law of diminishing returns means that you pay dearly for those extra features and/or that extra performance. In the case of the R-9000 you are mainly paying to have everything in one box, with lots of features...including the one that I got attached to, the spectrum display.

To operate on a lower frequency range, the use of more conductors and/or a longer piece of ribbon cable is suggested. Initially, I had used 24 of the original 25 conductors and I tuned in on robust signals from longwave aerobeacons and Trans-Atlantic broadcasters around 250 kHz. Fewer conductors and/or shorter lengths of ribbon cable will raise the operating band: this leads to thoughts of tropical-band and 160/80/75 meter ham use.

Figure 5 illustrates the schematic of an active loop for use with ribbon cable loop heads. The base unit will also work with ferrite heads such as Quantum and Palomar. Base circuitry should be assembled in a metal box. For BUF-A documentation, see my article "BUF-A Buffer Amplifier Card: A Valuable Building Block for DX Projects" (15 JUN 1992). For BBA-C1 documentation, see "RTL-1A: Improved Version of RTL-1 Remotely-Tuned Loop" (15 APR 1992). For ease of tuning, it is recommended that R2 of Figure 5 be a 10-turn type. A single-turn pot could be used, but tuning would be touchier.

As active air-core loops are more susceptible than ferrite loops to shortwave mixing spurs, series inductors (RFC1 & RFC2 = 33 uH, in this case) should be used. If spurs persist, increase these to 100 uH each.

Because a varactor is used for tuning, the problems of variable capacitor availability, complicated mounting schemes, and hand capacitance are eliminated. In the worst strong-signal environments, the varactor might create spurs; if that's the case, replace it by a variable capacitor with a range of approximately 30 to 530 pF (placed across the loop head coil) and delete the varactor-tuning-related components - Figure 5: C1, C5, C6, D1, D2, R2, R7, R8, RFC3, and RFC4.

### Passive Loops

-----

Tapping down allows for passive loop operation. This is typically done by bringing out 2 tap leads; these should be 1 turn away from the center tap (ground) in each direction. See Figure 6. Passive loops are, of course, much less sensitive than active loops but they have the advantage of no distortion products from overload; this is especially the case with air loops with no ferrite core material to saturate. A passive loop is the only workable medium wave antenna at some urban locations. A larger loop (e. g. 3.3 ft. / 1 m. on each side of the square) will probably be necessary. Add or remove conductors from the ends, as required, to establish the correct tuning range.

FIGURE 2 : STEREO PHONE PLUG CONNECTIONS  
(PLUG SHOWN WITH SHELL REMOVED)

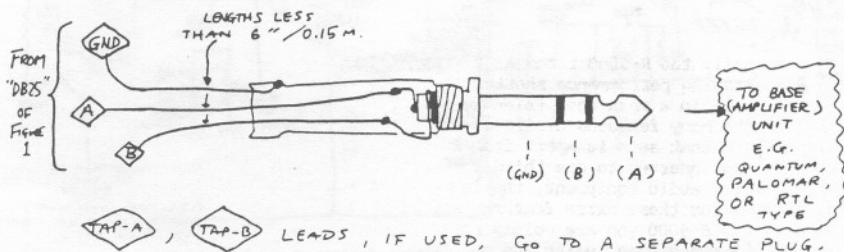
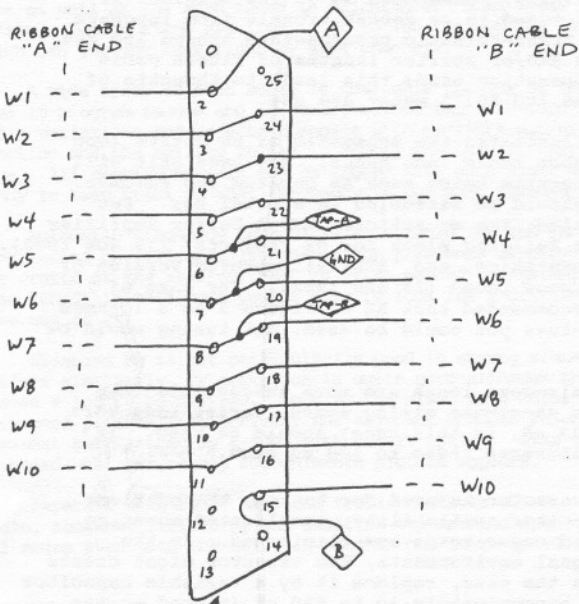


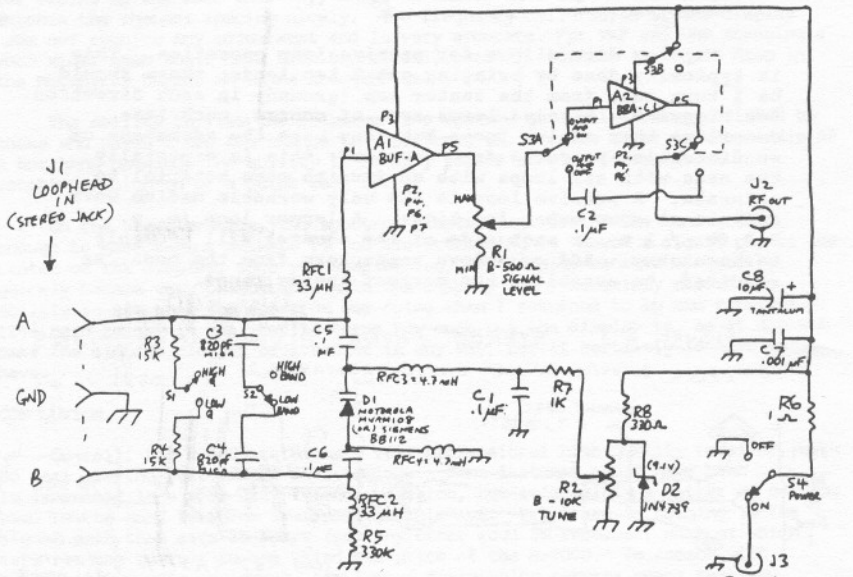
FIGURE 1: JUNCTION AT ENDS OF RIBBON CABLE



THE RIBBON CABLE CONDUCTORS (WIRES) ARE IDENTIFIED AS W1 THROUGH W10.

"DB25" CONNECTOR (RADIO SHACK P/N 276-1548)

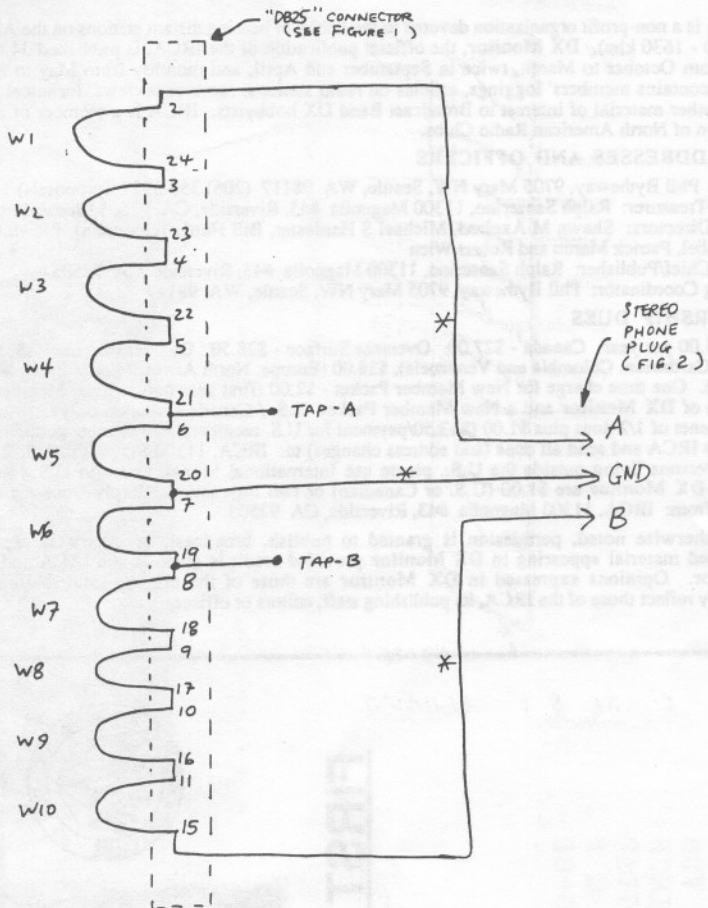
FIGURE 5: SCHEMATIC OF A BASE (AMPLIFIER) UNIT



A1 (BUF-A BUFFER AMP.) AND A2 (BBA-C1 BROADBAND AMP.) ARE DESCRIBED IN OTHER ARTICLES, AS NOTED IN THE TEXT OF THIS ARTICLE

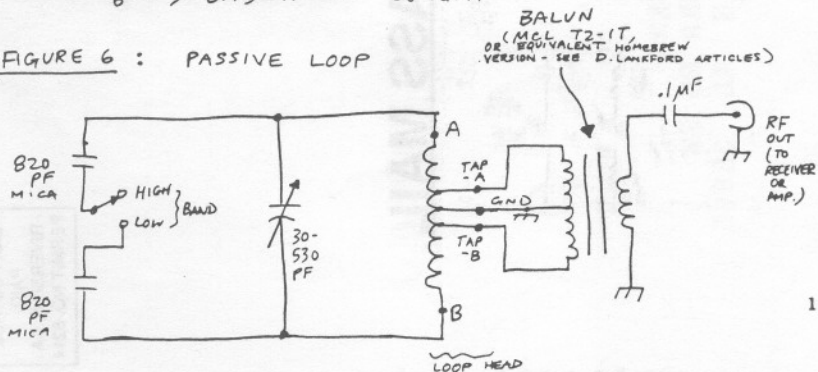


FIGURE 3: HEAD SCHEMATIC



\* = LEADS INDICATED SHOULD BE LESS THAN 6" / 0.15 M. IN LENGTH

FIGURE 6: PASSIVE LOOP



## THE INTERNATIONAL RADIO CLUB OF AMERICA (IRCA)

The IRCA is a non-profit organization devoted to the hobby of hearing distant stations on the AM Broadcast Band (510 - 1630 khz). DX Monitor, the official publication of the IRCA, is published 34 times a year, weekly from October to March, twice in September and April, and monthly from May to August. DX Monitor contains members' loggings, articles on radio stations, receiver reviews, technical articles, DX tips, and other material of interest to Broadcast Band DX hobbyists. IRCA is a member of ANARC, the Association of North American Radio Clubs.

### CLUB ADDRESSES AND OFFICERS

President: Phil Bytheway, 9705 Mary NW, Seattle, WA 98117 (206) 356-3927 (proposals)  
Secretary-Treasurer: Ralph Sanserino, 11300 Magnolia #43, Riverside, CA 92505 (dues/address changes)  
Board of Directors: Shawn M Axelrod, Michael S Hardester, Bill Hardy (chairman), Ric Heald, Albert S Lobel, Patrick Martin and Robert Wien  
Editor-in-Chief/Publisher: Ralph Sanserino, 11300 Magnolia #43, Riverside, CA 92505  
Publishing Coordinator: Phil Bytheway, 9705 Mary NW, Seattle, WA 98117

### MEMBERSHIP DUES

U.S. - \$25.00 per year. Canada - \$27.00. Overseas Surface - \$28.50. Overseas Airmail - \$35.00 (Central America, Caribbean, Colombia and Venezuela), \$38.00 (Europe, North Africa, Middle East), \$41.00 (rest of the world). One time charge for New Member Packet - \$2.00 (first year only). Trial Membership - \$9.50 (10 issues of DX Monitor and a New Member Packet, U.S. / Canada / Mexico only). Installment rate: two payments of 1/2 dues plus \$1.00 (\$13.50/payment for U.S. members). Make checks and money orders payable to IRCA and send all dues (and address changes) to: IRCA, 11300 Magnolia, #43, Riverside, CA 92505. Persons living outside the U.S., please use International Money Order in U.S. funds. Sample copies of DX Monitor are \$1.00 (U.S. or Canadian) or two International Reply Coupons each and are available from: IRCA, 11300 Magnolia #43, Riverside, CA 92505.

Unless otherwise noted, permission is granted to publish, broadcast, or otherwise reproduce non-copyrighted material appearing in DX Monitor provided credit is given to the IRCA and the original contributor. Opinions expressed in DX Monitor are those of the original contributors and do not necessarily reflect those of the IRCA, its publishing staff, editors or officers.

**IRCA**

INTERNATIONAL RADIO  
CLUB OF AMERICA  
11300 MAGNOLIA #43  
RIVERSIDE, CA 92505



**FIRST CLASS MAIL**

30-09  
J D STEPHENS  
3715 CONGER RD SW  
HUNTSVILLE AL 35805  
USA

FIRST CLASS  
U.S. POSTAGE  
PAID  
RIVERSIDE, CA  
PERMIT NO. 5214