

May 29, 2004 - Volume 41, Number 27 - Edition 1319 - ISSN 899-9733

EiC Notes

One new member this time - **Charles N. Kaeff** - Covington, KY (HDXM). Don't forget to vote.

"Via e-mail from IRCA member Pat Martin, fellow IRCA member **Chuck Boehnke** of Keaau, HI passed away on May 6, 2004 due to cancer. Chuck was 75. Chuck had just renewed his SDXM membership, and at the request of his widow, Ginny, the remainder of his dues will be donated to Hospice of Hilo. Some other IRCA members have expressed an interest in adding to the donation; to that end, I am accepting donations and will consolidate them into a single check from IRCA to Hospice of Hilo in Chuck's memory. Please send your donations (\$10 or less suggested) to lynnhollerman@geocities.com via PayPal - please note, this address does NOT accept credit card payments. You can also send your donations to IRCA's PO box (PO Box 60241, Lafayette, LA 70506) - just put "memory" on the envelope - but please, I don't want to draw this out - please e-mail or postal mail them to me by June 1, 2004.

Thank you for your time!" - **Lynn Hollerman**

IRCA Convention. Dates: July 23-25, **Hotel:** Rodeway INN, 1115 North Curtis Rd, Boise ID 83706 (1-208-376-2700 or 1-800-272-5993). **Rates:** \$59.95 plus 12% tax or \$67.14. **Starts:** Friday 9 AM, **ends:** Sunday afternoon after Bar-b-que. **Tentative tours:** KIDO/KFXD and KBOI. **Convention fee:** \$25.00, can also be paid via Paypal at: N7SOK@aol.com. **Auction items:** send to Frank Aden, 4096 Marcia Pl., Boise ID 83704. **E-mail inquires:** send to: IRCA2004@aol.com... make your plans NOW - pb.

WTFDA 2004 - Omaha, NE. The WTFDA annual convention takes a stop in Omaha, NE July 30 - Aug 1, 2004, hosted by **Matt Sittel** and **Michael Hawk**. This year's \$28 convention fee brings you a tour of skip-magnet KMTV, technical talks, the annual banquet, and on-site antenna and radio demos. The convention site is centrally located at the Park Plaza Regency Lodge. More information is available at <http://www.amfmdx.net/WTFDA2004/>, or write **Matt Sittel** at mcsittel@cox.net or 15013 Eureux St, Bellevue, NE 68123.

DX Test *Lynn Hollerman*

Daily 0255-0305 1220 WRIB Providence RI (Healy)

Daily, from 2:55am-3:05am EST - WRIB-1220 - Providence, RI - This test is scheduled to run indefinitely.

Reception reports (with return postage) may be sent to:

Craig Healy, NG1U

WRIB
200 Water St.
East Providence, RI 02914

OR

WWW: <http://www.wrrib.com>

(Arranged by **Craig Healy, NG1U** and AM-DX.COM.)

In This Issue:	
EiC Notes...	1
DX Tests...	1
Broadcasting Information...	2
Western DX Roundup...	4
Central DX Roundup...	10
Eastern DX Roundup...	11
DX WorldWide - West...	12
DX WorldWide - East...	13
Western DX Forum...	19
Eastern DX Forum...	20
IRCA Technical Column...	21
2003-2004 Contests...	27
Sports on Radio...	28
Geomagnetic Indices...	31

BROADCASTING INFORMATION

Robert Wien - 801 E. Alosta Ave. G-100 - Azusa, CA 91702-2744

Email: wienbob@aol.com

phone: 626-812-4389

Ham calls: KG6RJW

CALL CHANGES

FREQ	OLD CALL	CITY	NEW CALL
620	WZNN	Lexington, AL	WJHX
690	KZNR	Blackfoot, ID	KSLJ
850	WPTB	Statesboro, GA	WMCD
1060	WPHC	Waverly, TN	WMQV (note: station silent-ye ed.)
1260	KZNI	Idaho Falls, ID	KSSL
1280	KVWG	Pearsall, TX	KSAH
1320	WKJM	Mayfield, KY	WNGO
1330	WMNN	Minneapolis, MN	WLOL
1370	KENT	Pearl City, HI	KITT
1370	WKJF	Cadillac, MI	WLJW
1400	KITT	Parowan, UT	KENT
1560	KEGG	Daingerfield, TX	KNGR
1590	WJQY	Springfield, TN	WDBL
1600	KWOM	Watertown, MN	KZGX (note: station silent-ye ed.)

FORMAT CHANGES

FREQ	CALL	CITY	OLD INFO	NEW INFO
580	CKY	Winnipeg, MB	AC	silent
700	WCAT	Orange, MA	ethnic	nx/talk
770	KKOB	Albuquerque, NM	nx/talk	CHR (anyone confirm!?-ye ed)
890	WEEZ	Laurel, MS	black gospel	blues
900	WIAM	Williamston, NC	rel. teaching	s. gospel (Salem gospel)
930	WPAT	Paterson, NY	ethnic	Spanish
950	KYNG	Denison, TX	ethnic	SS religion
960	KGKL	San Angelo, TX	classic country	talk
980	WDVH	Gainesville, FL	WW1 AS	WW1 country
980	WTOT	Marianna, FL	silent	AS (ABC Stardust)
1000	WNSI	Robertsdale, AL	Americana	talk
1040	WZNA	Moca, PR	SS nx/talk	SS contemp. Xtian
1050	WCMS	Norfolk, VA	classic country	sports, Fox Sports Radio
1060	KIJN	Farwell, TX	rel. teaching	SS religion
1070	KRAM	Klamath Falls, OR	silent	AS (anyone confirm!?-ye ed)
1080	KRLD	Dallas, TX	nx	nx/talk
1150	KCCT	Corpus Christi, TX	Americana	oldies
1190	WAMT	Pinecastle, FL	business nx	talk
1220	KCCS	Salem, OR	cont. Xtian	talk
1230	KZZR	Burns, OR	Jones classic C&W	Jones classic hits
1230	WCWA	Toledo, OH	talk	sports, Fox Sports Radio
1240	KSQR	Sacramento, CA	silent	talk
1240	WEBJ	Brewton, AL	oldies	talk
1250	KZDC	San Antonio, TX	SS talk	reg. Mexican
1250	WWFT	Nicholasville, KY	rel. teaching	talk
1270	KAJO	Grants Pass, OR	AS, ABC Stardust	drops ABC Stardust
1280	KSAH	Pearsall, TX	classic country	cont. Xtian
1280	WGLR	Lancaster, WI	country	sports, ESPN radio
1280	WGTX	De Funiak Springs, FL	oldies	talk
1310	KZIP	Amarillo, TX	SS oldies	SS talk
1350	WGDN	Gladwin, MI	talk	R. Disney
1400	WFLI	Ft. Lauderdale, FL	business nx	sports (SNR)
1410	WIQR	Prattville, AL	silent	sports
1410	WQBQ	Leesburg, FL	travel info	silent
1450	WHSC	Harstville, SC	CHR	sports, ESPN radio
1460	KCNR	Shasta, CA	AS	silent (this has been silent for a LONG time-ye ed.)
1470	KLCL	Lake Charles, LA	talk	classic country



1480	WJBM	Jerseyville, IL	oldies	talk
1520	WQMA	Marks, MS	CHR, then silent	oldies
1580	KAMI	Cozad, NE	silent	rel. teaching
1590	WGGO	Olean, NY	AS	soft AC, ABC Memories
1590	WPVL	Platteville, WI	oldies	sports, ESPN radio
1600	KEED	Eugene, OR	rel. teaching	talk
1600	KWOM	Watertown, MN	oldies	silent
1620	KBLL	Blackfoot, ID	SS	sports, ESPN radio

CONSTRUCTION AND FACILITY PERMIT STATUS

700	KMJY	Airway Heights, WA	change from 10000/1000 DA-N to 10000/600 DA-N
720	KFIR	Sweet Home, OR	change from 1000/184 to 184/1000
730	KULE	Ephrata, WA	dec from 1000/100 to 1000/29
810	WJJQ	Tomahawk, WI	add 13-N
890	KTXV	Frankiston, TX	dec. from 2000/8 DA-2 to 250/2 DA-D (new CP)
890	WBAJ	Blythewood, SC	inc. from 8500-D to 50000-D
930	WHLM	Bloomsburg, PA	dec from 1000/23 to 1000/18
980	KSVC	Richfield, UT	change from 5000/1000 to 11000/1000
990	KATD	Pittsburg, CA	change from 5000/5000 DA-2 to 10000/500 DA-2
1010	KIQI	San Francisco, CA	change from 10000/5000 DA-2 to 35000/500 DA-2
1090	WBZB	Selma, NC	change from 800-ND-D to 9000-ND-D
1130	WSDX	Brazil, IN	add 20-N, ND
1150	WHBY	Kimberly, WI	change from 5000/5000 to 20000/25000
1180	WVFC	McConnellsburg, PA	change from 1000-D to 300-D
1220	WZOT	Rockmart, GA	change from 500/103 to 256/103.4
1230	KYVA	Gallup, NM	dec. from 1000/1000 to 920/920
1330	KSNA	Shasta Lake, CA	1000/1000 DA-2 (new CP)
1390	WKAP	Lynchburg, VA	change from 3500-D to 4700/34
1410	KDBS	Alexandria, LA	dec from 1000/50 to 1000/30
1410	KRIL	Odessa, TX	change from 1000/1000 to 900/235
1470	WBFC	Stanton, KY	dec. from 1000/82 to 850/82
1500	KSTP	St. Paul, MN	change from 50000-DA-N to 50000-ND-N
1600	WIBF	Dover, DE	change from 5000/1000 DA-2 to 4000/110 DA2

ADDITIONAL NOTES: (CONTRIBUTOR IN PARANTHESES)

PUBLIC LISTINGS:

WDEN 1500 Macon GA flips from country // **WDEN-FM** 99.1 to ESPN sports.

WATV 900 Birmingham AL flips from R&B oldies/black gospel "900 Gold" to black gospel "The Light."

KPTL 1300 Carson City NV flips from oldies to talk.

KRLD 1080 Dallas TX backs away from all-news, adding more talk to its format.

WMNN 1330 Minneapolis MN comes full-circle, changing calls back to **WLOL**, the callsign it used until 1980.

KRAM 1070 West Klamath OR returns to the air with standards.

KSMM 1530 Shakopee/Minneapolis-St. Paul MN will flip from Starboard/EWTN Catholic religion to talk (including Air America's Al Franken), with the format moving over from **WMNN** 1330 Minneapolis MN, which in turn flips to Starboard/EWTN Catholic religion.

WITH 1230 Baltimore MD has flipped to Salem's conservative talk from a simulcast of religious **WAVA** 105.1 Arlington VA/Washington DC.

KZNR 690 Blackfoot ID changes calls to **KSLJ** and **KZNI** 1260 Idaho Falls ID changes calls to **KSSL**; is a brand extension from co-owned **KSL** 1160 Salt Lake City UT in the works?

WGLR 1280 Lancaster WI and **WPVL** 1590 Platteville WI (on the fringes of the Dubuque market) drop their FM simulcasts and go ESPN sports.

KCEO 1000 Vista/San Diego CA drops its "Premium 1000" modern rock format that ran at night and on weekends, replacing it with oldies as "The Owl." KCEO keeps business news during the day.

KUDO 1080 Anchorage AK flips from business news to talk, including Air America's Al Franken and Bruce Williams.

KDFO 800 Bakersfield CA flips from Fox sports to regional Mexican oldies "La Preciosa".

KCCT 1150 Corpus Christi TX flips from Americana "Texas Radio" to oldies "Jalapeno Oldies 1150."

KKEE 1230 Astoria OR flips from oldies to ESPN sports.

WDGR 1210 Dahlonega GA returns to the air with leased-time ethnic Korean as "US Korea Radio 1210."

WFLL 1400 Fort Lauderdale FL flips from business talk to Sporting News sports as "1400 the Fan."

KJON 850 Carrollton/Dallas TX has completed testing and signed on with Spanish-language music.

WKPA 1170 Lynchburg VA has completed its move to 1390, going from 3500 watts DA-D to 4700/30 watts ND.

KCNZ 1250 Cedar Falls IA and **KDNZ** 1650 Cedar Falls IA swap calls, sending KDNZ to 1250 and KCNZ to 1650.

KELY 1230 Ely NV flips from oldies to classic hits.

CONTRIBUTOR LISTINGS:

840 KSWB Seaside is now more "Oldies" than Nos. They are playing Chuck Berry, America, etc. I guess to pick up a bit where 1230 dropped off, but KKEE was 50s oldies for the most part. (PM-OR)

Pat also confirms earlier info on KKEE-1230 OR, Pat mentions they changed formats 5/3/04. (PM-OR)

Tim Noonan confirms earlier call letter changes in the column. (TN-WI)

Art Blair sends along an article on Air America Radio, basically saying the network is in trouble currently. (AB-CA)

Contributors:

PM-OR - **Pat Martin**, Seaside, OR

AB-CA - **Art Blair**, Folsom, CA

TN-WI - **Tim Noonan**, Madison, WI

Moving out of my current apartment on June 27th, after that date, please send contributions to the following address: 7190 Abigail Place, Fontana, CA. 92336-5752. I don't know my new phone number yet, will let you know when that gets set up. Please use current address until June 27th, I will have mail forwarded to the new address after that effective date. 73's.

WESTERN DX ROUNDUP

Nancy Johnson – 265 Waterton Wy – Billings, MT 59102-7755

E-mail: NancyJohnson@prodigy.net

WDXR DEADLINES: June 4, June 25, July 9, July 23. Please use Eastern Time.

REPORTERS FOR THIS ISSUE:

- (RA) **René E. Auvray**-Henderson, NV
General Electric P2900A
- (RA-CA) DX'ing in Los Angeles, CA using 2002 Saturn car radio
- (RA-CA2) DX'ing in Barstow, CA with 2004 Ford Taurus car radio
- (LG) **Larry Godwin**-2390 Clydes Dale Lane-Missoula, MT 59804 lbg@mtwi.net
Hammarlund HQ-150, Sanserino air-core box loop
- (NHP) **Nick Hall-Patch**-1538 Amphion St.-Victoria, BC V8R 4Z6 nhp@ieee.org
Drake R8, ALA100 16" square single turn loop, laptop recorder using ReCall Pro
- (GH) **Glen Hansen**-1925 Tualatin St.-St. Helens, OR 97051
skinner@columbia-center.org
Hammarlund HQ-150, National NC-109 & 57B, Drake R8B, various longwires, amplified Sanserino, RS and Select-A-Tenna loops
- (CM) **Curtis McMenamin**-153 Calle Tepic-Vacaville, CA 95687-6530
Sony ICF-2010, Q Stick loop
- (DN) **Doug Nyholm**-2336 Autumn Ridge Dr.-Sandy, UT 84092
dougnholm@msn.com
Radio Shack DX-398, Yaesu FRG-7, loop

(DN/MR-UT) **Doug Nyholm & Mike Riordan** DX'ing in Sandy, UT
Radio Shack DX-398, Yaesu FRG-7000, Grundig YB400Pi, Radio West loop,
Select-A-Tenna, 1000' E-W Beverage

(DN-UT1) DX'ing on car radio in Provo, UT

(5P) **Dale Park**-Honolulu, HI **DXFool@aol.com**
Sangean ATS-818CS, Terk AM1000 loop

(5P-CA) DX'ing in southern CA with Ford car radio

(5P-CA1) DX'ing in the Bay Area with Suzuki car radio

(5P-CA2) DX'ing in Fairfield with Suzuki car radio

(KR) **Kevin Redding**-Mesa, AZ **amfmdx@fastq.com**
Sony ICF-2010 with no external antenna, Kenwood R-1000 & 60' wire

(MS) **Mike Sanburn**-P.O. Box 1256-Bellflower, CA 90707-1256
mikesanburn@hotmail.com
GE Superadio II, car radio

(RW) **Robert Wien**-801 East Alosta Avenue Apt. G-1000-Azusa, CA 91702-2748
rjwmail@webtv.net
GE Superadio, Select-A-Tenna

530 WAMP-??? CA, Los Altos 4/23 1617 three different messages, all related to disaster preparedness. Operated by the City of Los Altos. Bill Harms TIS list says callsign is WNUT422. Heard in Sunnyvale, no WNSA851 Sunnyvale TIS heard. Fair, over WNPZ947 Mineta-San Jose Int'l Airport TIS and another TIS. (5P-CA1)

WNHV296 CA, Los Angeles 4/28 1750 airport information station sounding like a commercial station, complete with background music & announcements by professional announcer. Heard in Westchester. Did note signs along I-405 freeway near airport urging drivers to tune to 1700 for traffic info, but nothing heard. (5P-CA)

540 XESUR BCN, Tijuana 5/21 0633 very weak with oldies under CBK. (DN-UT)

550 KUZZ CA, Bakersfield 5/7 0350 in fair with KUZZ ID. (CM-CA)
KOAC OR, Corvallis 5/7 0400 in poor with "KOAC Corvallis." (CM-CA)

570 KVI WA, Seattle 5/7 0405 in poor with KVI ID. (CM-CA)

600 CJWW SK, Saskatoon the surprise of the night! Heard briefly 5/2 0044-0047 with C&W music, then quick ID for CJWW Saskatoon. Took call or request from caller in Saskatoon then back into C&W music. KOGO soon killed this one but it was nice to hear if only briefly. (DN/MR-UT)

620 KPOJ OR, Portland 5/7 0410 poor, "This is talkradio KPOJ Portland." (CM-CA)

630 KHOW CO, Denver 5/10 0000 hour of Coast to Coast with Art Bell, segment closing with Jethro Tull's "Living in the Past," call ID followed by an Indian show to be held (American Indians). QRM possibly KFXD, and others. (RA-NV)

KFXD ID, Boise 5/9 0059 call ID, stations competing, KFI-640 carryover. (RA-NV)

670 WSCR IL, Chicago 5/8 2330 noted with sports talk early. Decent signal on top of KBOI. (DN-UT1)

680 KNBR CA, San Francisco 5/17 0657 network ads, ID "KNBR San Francisco-Oakland" and "This is KNBR 6-80 San Francisco" into AP network news. Had been noted the day before at 0800 with local non-sports current affairs magazine. Poor, KORL-650 running open carrier. (5P-HI)

KWKA NM, Clovis 5/19 0000 very weak but fighting KNBR with oldies music and ID on the hour "KWKA, Your Good Time Oldies Station," then into Simon & Garfunkel song. First new station I've heard on 680 in 15 years! (DN/MR-UT)

690 KRCO OR, Prineville 4/29 0757 atop CBU with ID "AM 690, KRCO Country." (LG-MT)

720 ?KDWN? NV, Las Vegas 5/15 0711 man said "Cut 33" followed by three pips and news actuality, poor under KUAL which was playing "I Need Love" from Seal, then a C&W song; interesting contrast between news and music. (5P-HI)

760 ?KGU? HI, Honolulu 5/20 0155-0200 suspected to be the one with organ music and religious programming under KFMB and I believe KKZN on the Beverage. (DN/MR-UT)

770 KTTH WA, Seattle 5/8 2310 Lars Larsen show with guest Luis Palav. Fair signal with KKOB? Underneath. Not heard since October. Drake & RS loop. (GH-OR)

790 KGMI WA, Bellingham 4/27 0100 news & talk show in the mix mostly on top. Not heard since February. Poor signal with NC-109 & Select-A-Tenna loop. (GH-OR)

800 CKOR BC, Penticton 5/9 0100 AdCon/EZL format and ID. Good signal. Very seldom does this one get over semi-local KPDQ. Rare! NC-109 on E-W wire. (GH-OR)

810 KBHB SD, Sturgis 5/19 noted on late, well after sunset at 2045-2105 with almost continuous music and no ID's. Weather just before the hour and then KBHB quick ID and back into music. Completely looped surprisingly weak KGO. (DN/MR-UT)

820 WBAP TX, Fort Worth 5/7 0455 in poor with WBAP ID. I don't hear them all the time from Vacaville due to the Mexican on the frequency. (CM-CA)

830 WCCO MN, Minneapolis 5/20 Mike caught this one first but it is the first time I have heard them in Utah. 5/20 0121 with sports talk, mixing with CKKY. (DN/MR-UT)

840 KSWB OR, Seaside 5/6 0105 man said "Memories on the Oregon Coast 840 K-S-W-B," NOS format. Fair to poor. This one seldom gets over the Coast Range. Drake with N-S wire. (GH-OR)

870 KFLD WA, Pasco 4/27 0045 heard ID and talk program in severe 860 KPAM splatter. Weak but stable with Drake on E-W wire. (GH-OR)

900 CKBI SK, Prince Albert 4/27 0030 man said "You're listening to Country 900 CKBI," then wild sounding instrumental on the fiddle. Drake on N-S wire. (GH-OR)

920 KVIN CA, Ceres 5/7 0500 in fair with oldies music & KVIN ID. (CM-CA)
KPSI CA, Palm Springs 5/1 0615 with an interesting program called Cowboy Corner with stories about the old west and western themes. (KR-AZ)

KXLY WA, Spokane 4/27 0000 talk show with faint ID in the jumble. Weak with NC-57B & Sanserino loop. (GH-OR)

930 CJCA AB, Edmonton 5/6 0030 suddenly up out of the mix with ID and inspirational music. KSEI underneath, fair to poor with Drake on e-W wire. (GH-OR)

990 KATD CA, Pittsburg 5/13 had poor signal and played New Age music with call ID at 0800. In again at 0759 on 5/20 with rap/rock music and ID that sounded like KITS San Francisco and KATD Pittsburg-Sacramento. CBW had faded and I had XECL nulled. (LG-MT)

1030 (TIS) CA, 4/26 Emeryville 1845 TIS in Emeryville and Vallejo (WTEI434) not noted while driving through the area. (5P-CA1)

1050 KCAA CA, San Bernardino 4/30 1810 tape-delayed Air America Network program "The O'Franken Factor." Heard poor in Pasadena. Also heard with fair signal 5/2 1458 in Irvine with announcer apologizing for power failure interrupting religious program, said they were broadcasting from Carousel Mall in San Bernardino. Used slogans "The Talk Radio Express" & "Where We Leave No Listener Behind." Used NBC sounder before local newscast. This used to be KBBV Big Bear Lake. (5P-CA)

1150 KSEN MT, Shelby 5/16 s/on (no SSB) strong at 0758. Sunday s/on is later than usual. (LG-MT)

1160 KSL UT, Salt Lake City 4/26 2221 local ads, back to "Sports Final" snow on "Newsradio 11-60 KSL." Fair. (5P-CA2)
+5/8 0106 out of extreme KXTA-1150 carryover, mentioning ad for Riverton Music Stores (4 locations), call ID "KSL Newsradio 1160," into a talk show. KXTA QRM returning. Very rare. (RA-CA)

1170 KFAQ OK, Tulsa 5/8 2345 another station heard clearly in Provo (20 mi south) with talk. I guess that 20 miles further away from KSL definitely makes a difference. (DN-UT1)
+5/21 best signal ever as KSL was doing a very quiet talk show and splash was minimal. Political talk program heard at 0648. Interference from KCBQ and unID station with religious programming. (DN-UT)

- 1190 KVCU CO, Boulder 4/25 fair at 0800 and very strong 4/27 at 0900 with same ID by woman. There was xylophone music, and then she said "Radio 1190, K-V-C-U, Boulder." (LG-MT)
- KEX OR, Portland 5/8 0044 Mother's Day ad, back to talk show. Extremely weak fighting through local KXXM and other stations competing. (RA-CA)
- XEMO BCN, Tijuana 5/15 0706 completely alone in tight KBEE null. (DN-UT)
- 1220 KGYN OK, Guymon 5/9 2330 ending of a C&W song, ID, actor Leslie Neilson announced a talk show was coming on. Came out with stations competing. (RA-CA2)
- CJRB MB, Boisevain while continuing to unsuccessfully chase the WRIB test, have often recorded classical music on this channel, but never any ID. Finally heard "Classics till dawn...this is CJRB..." by man, fair strength, dominant but not as dominant as the 1230/1210 splash, at 0300 on 4/26. (NHP-BC)
- 1240 KQEN OR, Roseburg 5/1 0130 sportstalk in the mix with unID playing oldies. Assumed Canadian, gave temperatures in Celsius. Heard once before back in January. (GH-OR)
- 1250 KZER CA, Santa Barbara 4/23 0000 good on top with ID "KZER, Santa Barbara," ID as "Radio Lazer." (RW-CA)
- KWSU WA, Pullman 5/19 heard weak but steady 2330 with jazz and discussion about Mardi Gras, mixing with KNEU. (DN/MR-UT)
- 1270 KDJI AZ, Holbrook 5/19 2348 quick ID and then back to ESPN programming with sports talk, quickly faded. (DN/MR-UT)
- CHAT AB, Medicine Hat 5/20 0107 powerhouse armchair signal with C&W and lots of ID's. Best that I have ever heard them. (DN/MR-UT)
- 1280 KUYL CA, Stockton 4/26 2353 Stockton Ports baseball vs. Modesto A's "On the Lighthouse, AM 12-80 KUYL," abruptly off at 2401, back on 2413. (5P-CA2)
- 1300 KLER ID, Orofino 5/19 2355 noted with Mariners baseball, good signal. (DN/MR-UT)
- KAPL OR, Phoenix 4/24 hard to read but on top at 0800 with ID "KAPL... Fellowship" followed by harp music. (LG-MT)
- KKOL WA, Seattle 4/22 2330 Mike Gallagher talk show above KAPL at times, weak but there. Drake on E-W wire. (GH-OR)
- 1310 KNOX ND, Grand Forks station #300 heard from Utah after 2 months of trying. Heard 4/22 0050-0100 with sports talk and an ad or PSA for hunting licenses in North Dakota. Mixing with unID Spanish station, very weak signal. (DN-UT)
- 1320 KXRO WA, Aberdeen 4/29 2305 news with faint ID in the pileup. KGDC in there too (I think). Weak with NC-57B and Sanserino loop. (GH-OR)
- 1340 KTMM CO, Grand Junction 5/5 000 with top of hour ID and Sporting News Radio. Shortly after that an exciting Enzyte ad. (KR-AZ)
- 1350 KRLC ID, Lewiston 5/20 noted very weak at 0034 with Mariners baseball. (DN/MR-UT)
- 1370 KPCC CA, Quincy 4/25 0457 overtaking the frequency in KWRM null with ID "1370 KPCC," NOS. (MS-CA)
- KXTL MT, Butte 4/25 0440 faded up coming out of "Sunshine Superman" by Donovan, ID, Four Tops, Temptations, Beatles, "Good times Great Oldies 1370 KXTL." (MS-CA)
- 1380 KLPZ AZ, Parker 4/25 0330 huge, back announcing song "Three Wooden Crosses" by Randy Travis. (MS-CA)
- 1390 KLOC CA, Turlock 4/23 0245 the Spanish station with Latin music mixing with another all talk Spanish station presumably KLTX. (DN-UT)
- +4/28 1257 man speaking Spanish (psychologist or therapist?) with teletalk with woman caller abruptly interrupted by woman "Trece noventa ah-emme," pause, ID "Kah-el-oh-say trece noventa ah-emme" into romantica ballad. No English ID. Poor, QRM form KVTO-1400. (5P-CA2)
- 1400 KJOK AZ, Yuma 4/25 0500 good with top of hour legal ID "KJOK Yuma," former KEZC & KVOY. (MS-CA)
- KKJL CA, San Luis Obispo 4/25 0347 ID "Here on the oldies station 1400 K-Jewel" into song "Five O'clock World." Ex-NOS format. Legal ID at the top of the hour. (MS-CA)
- 1410 KMYC CA, Marysville 4/27 1251 noted in passing with Rush Limbaugh, ID "Talkradio 14-10, KMYC Marysville-?-Yuaba City," ABC-I news. Poor, over then under unID with standards music, KSTN-1420 QRM. (5P-CA2)
- 1420 XEXX BCN, Tijuana 5/20 0125 moderate signal with Spanish programming. (DN/MR-UT)
- 1430 KBRC WA, Mt. Vernon 5/20 0040 buried several other stations under nulled KLO, also with Mariners baseball. (DN/MR-UT)
- 1440 KDIF CA, Roverside 5/20 0126 Spanish music, quite strong. (DN/MR-UT)
- 1460 KUTI WA, Yakima 4/28 2330 C&W with many "Country Cutie" ID's. 75% over KCKX with fair to poor signal. Drake on E-W wire. (GH-OR)
- 1470 KUTY CA, Palmdale 1470 is worse than a graveyard here at my location. Finally sat on the frequency for awhile and ID'd KUTY with Spanish talk 4/22 at 0015. Also mixing with another Spanish station, probably XERCN. KUTY all talk, XERCN musical program. (DN-UT)
- KIID CA, Sacramento 4/23 0010 briefly heard with Radio Disney. Never heard in Utah before, very weak. (DN-UT)
- 1480 KRXR ID, Gooding 4/23 0030 good signal in Spanish. (DN-UT)
- 1490 KWAC CA, Bakersfield 4/24 2140 becoming dominant in sunlight hours with spot for store in Bakersfield (Spanish) then Ranchera music. (MS-CA)
- KSYC CA, Yreka 4/29 2335 heard ID in a man's voice way out in the jumble. Sounded like some sort of talk show. Drake on N-S wire. (GH-OR)
- 1500 KSTP MN, St. Paul 5/3 0005 news into Coast to Coast with Art Bell. Fair to poor in KGA splatter. Heard back in December. Drake with N-S wire. (GH-OR)
- +5/7 0530 in poor with "Coast to Coast AM on KSTP." (CM-CA)
- 1510 (KLLB) UT, West Jordan 5/19-20 open carrier left on all night clanking everything on the frequency. (DN/MR-UT)
- KGA WA, Spokane 4/27 0037 program announced on "The Big Talker, 15-10 KGA," back to Talk Radio network's Jerry Doyle Show. Good to poor. (5P-CA2)
- +5/10 0220 "Spokane's Big Talker, 1510 KGA" slogan heard. Back to the Michael Savage show. Fair with QRM. (RA-NV)
- 1550 KXEX CA, Fresno noted in passing 5/19 2107 with typical Spanish music, news here and on top of the frequency. (DN/MR-UT)
- KKJY NM, Albuquerque 5/16 0708-0712 & 0728-0735 good in KYCY/XEBG null over unID Spanish station (KWRN?) and weak unID English (KMRI?) with promo to hear something from 4-6 "... on 1550 KJY," then song "You Gotta Have Heart." Tuned out, came back at 0728, booming in totally dominant with Frank Sinatra song, ID "Thanks for listening to the memories, here on 15-50 KJY." At 0730 faded out, back up strong with song "Roses Are Red" by Bobby Vinton at 0735. New, my #1 most wanted NM station finally heard! Ecstatic to hear this! (RW-CA)
- 1570 KCVR CA, Lodi 5/13 very strong, surely on day power, at 0754 with musical program in Spanish and slogan "La Consentida." (LG-MT)
- 1580 KBLA CA, Santa Monica 4/28 1756 man with Spanish Christian program, ID in English "You're listening to KBLA Santa Monica 15-80 and KALI San Gabriel 900 AM," big band music into Spanish program via telephone. Definitely // KALI-900. Not all Spanish though, noted 5/2 (Sunday) morning with English music show "Gospel Express." Heard in Westchester. (5P-CA)
- ?KGAL? OR, Lebanon 4/27 0015 Jim Bohannon Show // 1440 KVON-CA and 1520 KVTA-CA. KGAL website lists this show on at this time. Poor, over/under KMIK, no KBLA noted. (5P-CA2)
- 1600 KUBA CA, Yuba City 5/20 0132 strong under completely nulled KSGO with "AM 1600 KUBA" ID's. (DN/MR-UT)
- KEED OR, Eugene 5/19 2230 heard with religion weakly under KUBA. (DN/MR-UT)
- KVRI WA, Blaine 5/8 0000 chanting and gibberish with ID by male in English. Weak and drifty but alone. NC-57B with Sanserino loop. (GH-OR)
- 1620 ?KOZN? NE, Bellevue 4/27 0032 "Game Night on ESPN Radio" fair over/under KSMH. (5P-CA2)
- KYIZ WA, Renton 5/7 0550 in poor, have not heard for a while, "KYIZ" ID. (CM-CA)

- 1640 KDIA CA, Vallejo noted on car radio in Provo 5/8 2310 (20 miles south of Sandy) way on top with religion and virtually no sign of KBJA. (DN-UT1)
- 1660 KTIQ CA, Merced 4/26 1559 Spanish talk, network ID "Radio Visa," English ID "KTIQ Merced 16-60 AM," Spanish ID "... dieciseis sesenta ah-emme," Noticias de CNN with ID "Say-ehneh-ehneh en espanol radio. Ex-all sports. Fair. (5P-CA1)
- KXOL UT, Brigham City 4/25 0115 fair to poor in and out of the static and mixing with unID. Listening to this one on a recently restored (by me) Newcomb AM-500 formerly owned by Aloha School District. Just like the radios that were in the classrooms with I was in grade school in the late 60's-mid 70's. What memories! (GH-OR)
+4/27 0049 end of song "Ruby Tuesday," liner "Real oldies 16-60 KXOL" into Beatles song, fair over KTIQ. (5P-CA2)
- 1690 WQO808 CA, Culver City 4/25 1744 Culver City TIS tape loop with civic info. Gave incorrect time checks. (MS-CA)
- 1700 WPMD956 CA, Norwalk 5/1 1340 PSA's for city of Norwalk, into pop music played by man and woman. Operating as a college radio station by Cerritos Junior College. Heard in Downey. (5P-CA)
- KVNS TX, Brownsville 4/25 0130 loud with ID "... on newstalk 1700 KVNS, The Valley's Talk." Several PSA's (Veterans Administration, Rutherford Institute, etc) back into the Art Bell Show. Ex-KQXX for me. (MS-CA)

HELP WITH AN UNID

- 1310 Rene Auvray reported an unID station on 1310 with Radio Disney. Most probably, and I am 99% sure without actually hearing it, that it was KMKY-1310 from Oakland, CA. They make it here to Utah, carry Radio Disney, and most assuredly would make it to Nevada or So. Cal. (DN-UT)

UNIDS

- 650 5/10 0223 heard Fleetwood Mac song among a cluster of stations competing, very weak. Who is carrying what may be an oldies station on this channel? (RA-NV)
- 700 5/21 moderate Spanish station under KALL. Any ideas? (DN-UT)
- 780 5/7 0450 in under KKOH with Spanish music. What station is this? (CM-CA)
- 910 5/8 0051 heard ad for Capitol Honda, lots of QRM. Any clues if it is a San Francisco or Sacramento station? (RA-CA)
- 990 4/26 0000-0130 Public-type programming with CBC news. A Canadian I think, but which one? Good to fair signal way over everything. (GH-OR)
- 1010 5/10 0250-0300 jazz music with a lady DJ, spoke with a Canadian accent and mentioned several French musicians. Does any DX'er know where in Canada this station is from? (RW-NV)
- 1030 5/8 0056 Spanish station with what sounded like Merengue music with a disc jockey. No KTWO heard or KTNQ carryover. Who? (RA-CA)
- 1080 Heard Spanish talk under KSCO 4/23 0101, Spanish not previously heard on this frequency before. Any ideas? (DN-UT)
- 1250 5/20 0056-0105 classical violin music which at first sounded to me like CBC but nothing matches. Muddy audio at times. (DN/MR-UT)
- 1280 4/27 0001 jumble of stations noted after KUYL abruptly went off. One station with ABC news, then station ID'ing as "Sportsradio 12-80," then one with Dr. Laura (which dominated), another Bruce Williams, plus a Mexican-formatted station. KUYL returned at 0013. Internet research shows KIT probably the one with Dr. Laura, KXTK-CA or KZNV-UT the sports station, and KBNO-CO or KDOX-NV the regional Mexican. (5P-CA2)
- 1420 4/27 0102 ESPN Sportscenter // 1620. KPOC Pocahtontas, AR listed (dream on!). Poor, KSTN and mess over/under. (5P-CA2)
- 1430 5/8 0102 English station with a baseball game (not N.L.B.) trying to overtake KMRD at times. Do not think it was KLO. Any ideas? (RA-CA)
- 1450 5/11 0130 heard "Memories 1450" ID in a 3-way jumble with Coast to Coast AM talker and Spanish speaker. On top maybe only 20%, playing 70's type oldies with male announcer. (GH-OR)

- 1550 Radio Disney programming noted 4/21 0051. Nothing matches unless Disney has a new affiliate which I heard is unlikely since Disney purchases all its stations and is out of money to expand. Any ideas? (DN-UT)
- 1600 4/27 0043 plug for "Voice of the Martyrs" Christian magazine, faded under KGST/KUBA, back up with SelectQuote ad, Nevada State Corporate Network, ad, back to American Family Focus Line. KEED? Poor. (5P-CA2)
- 1630 4/27 0046 song "Word Up" by Cameo, man talking in Spanish over jazz music, remix of Outkast's "Hey Ya." XENT? KDIA-1640 QRM. (5P-CA2)
- 1650 4/28 0100-0200 religious talk program with female host in and out of the mix and static. Really weak & distorted. No listing for a REL on this frequency. (GH-OR)
- 1700 4/27 0052 weak sports talk under TIS noise. KTBK? Very poor. (5P-CA2)

Thanks to our reporters this week. Nancy 5/21 2100

CENTRAL DX ROUNDUP

John C. Johnson – 265 Waterton Wy – Billings, MT 59102-7755
E-mail: John_Johnson@prodigy.net CDXR reports ONLY: cdxr@prodigy.net

RIDING GAIN

- [NJ-MT] **Nancy Johnson**, Billings, MT NancyJohnson@Prodigy.net
Drake R8B, Kiwa loop.
- [SP-WI] **Sheryl Paskiewicz**, Manitowoc, WI spasz@dataplusnet.com
Icom R-8500 with AOR LA-350 loop, Sony 2010 with Select-a-Tenna
- [JJR-WI] **John J. Rieger**, South Milwaukee, WI JohnJRieger@webtv.net
<http://DX-midAMerica.com> <http://DXMW.com>
Icom IC-R75, Kiwa loop, MFJ959B, GE Superadio III, Terk AM 1000 loop.

DOWN THE DIAL

- 580 KANA MT, Anaconda. 5-1 good. 09:00 ID out of oldie into ABC News. [NJ-MT]
- 590 CKRS PQ, Jonquiere. 5-4. 22:29 with FF news, calls, talk, interview, spots. New for me. [SP-WI]
- 600 CKAT ON, North Bay. 5-1 way under WMT. 23:49 with calls, country. [JJR-WI]
- 680 CFTR ON, Toronto. 5-1 poor with others. 23:42 with "6-80 News" slogan, weather. Not common here. [JJR-WI]
- 690 WJOX AL, Birmingham. 4-27 good. 23:09 with Braves vs. Giants, ID. [SP-WI]
- 730 WLIL TN, Lenoir City. 4-26 poor. 22:31 with "baseball on 7-30 WLIL Lenoir City..." and baseball PBP. Some spots. Faded into the mud. New. [SP-WI]
- 800 KQCV OK, Oklahoma City. 4-30. 00:03 with easy listening piano music, devotion, calls and city mentioned by woman announcer. [SP-WI]
- 860 KKOW KS, Pittsburg. 5-15. 23:33 Fox Sports, calls, promo, spots. New. [SP-WI]
- 960 CFFX ON, Kingston. 5-9 poor. No WSBT. 05:36 with slogan "Kingston's Oldies 9-60." [JJR-WI]
- 970 WMAY IL, Springfield. 5-1 poor in fade up while chasing others. 23:37 with calls, NOS format. [JJR-WI]
- 1050 KLOH MN, Pipestone. 5-9 poor. WLIP off. 06:46 with calls, country. [JJR-WI]
- 1070 CBA NB, Moncton. 4-26 poor in fade up over WINA, WIBC. Long fades. 03:57 with "You're listening to CBC Radio" out of an educational program. [JJR-WI]
- CHOK ON, Samia. 4-26 poor with others. 03:39 with jingle into oldies. [JJR-WI]
- WINA VA, Charlottesville. 4-21 poor with two or three others. 03:49 ID. [JJR-WI]
- 1080 KYMN MN, Northfield. 5-9 fair, way on top. 06:00 with legal ID, "Unforgettable Favorites" slogan, CNN News. Rare here. [JJR-WI]
- 1150 WGGH IL, Marion. 5-18. 22:00 with "WGGH Marion" legal ID, possible country gospel music format. Lost signal. New for me. [SP-WI]
- 1180 WXLA MI, Diamondale. 5-2. 06:36 with gospel music, "WQHH" IDs, promo, dual WXLA – WQHH ID, weather "in the capital city." [SP-WI]
- 1390 WRIG WI, Schofield. 4-20 poor in WGCI null. 21:12 with calls, "Big Rig" slogan. NOS format. [JJR-WI]

1420 KTOE MN, Mankato. 4-27 fair. 22:18 with spots for Mankato, talk, possible calls heard at 22:30. New for me. [SP-WI]
 1480 WSDS MI, Salem Township. 5-10. 22:53 with country format, CBB News, "WSDS Salem" ID. New for me. [SP-WI]
 1570 WFUR MI, Grand Rapids. 5-10. 22:31 with weather, calls, Christian Contemporary music format. "Your Family Station." New for me. [SP-WI]
 1580 WLIJ TN, Shelbyville. 5-3. 23:09 with country music, weather for Shelbyville, spots. New for me. [SP-WI]
 WWSJ MI, St. Johns. 5-3. 22:53 with gospel format, calls. [SP-WI]

25 YEARS AGO

May 5, 1979 issue of IRCA's "DX Monitor" ... New Members included **Chris Knight** of Pueblo, CO ... **Steve Mittman** of San Pedro, CA told about XETRA 690 going AM Stereo ... **Dave Korinek** of Seattle, WA wrote his forum report while listening to KFQD 750 ... **Robert Wien** of San Jose, CA logged WBAM 740 for state number 42 ... **Rick Heald** of San Francisco, CA told about the April 27th earthquake.

May 19, 1979 issue of IRCA's "DX Monitor" ... **Bill Wurtzel** of New York, NY told about pirate station WFAT being busted by the FCC on April 14th ... **David Rogers** of Buffalo, OK said he was 30 and a charter member of the IRCA ... **Larry Godwin** of Corvallis, OR said he was moving to Durango, CO and offered to give away a lot of his radio related items ... **Bruce Portzer** of Seattle, WA told about KING 1090 doing AM stereo tests.

OPEN MIKE

This column was typed 5-8-04. Long time members may know 5-8-72 when my first day on the job at KOOK-TV! Today marks my 32nd anniversary at channel 2. 73, John Don't forget this year's IRCA Convention in Boise, Idaho in July. Frank Aden has put together a good one. Let Frank know if you are coming! This column was typed 5-22-04. 73, John

EASTERN DX ROUNDUP

Lee J. Freshwater – 414 SE 3rd St. – Ocala, FL 34471

E-mail: lfreshwater@cox.net

Deadlines are: 5/29, 6/12, 6/26, 7/10, 7/24, 8/7

STARS OF THE WEEK

(HN-GA) **Herb Newberry** 107 Trojan Road, Milledgeville, GA 31061
 Kenwood R-5000, Quan Loop, 700' L.W.
 (IEN-GA) **Ira Elbert New** Watkinsville, Ga
 1996 Isuzu Prem. Audio 8200
 (RW-KY) **R.C. Watts** 4109 Graf Dr., Louisville., KY 40220
 CC Radio, RS Loop

LOGGINGS

730 SC WSCC Charleston 4/13 1145-1205 Fair signal "Newsradio WSC" Paul Harvey; into Rush. A surprise for daytime; new. (HN-GA)
 780 NC WWOL Forest City 5/01 1830 S/off "780 WWOL." (IEN-GA)
 810 AL WCKS Jacksonville 4/13 1400 Bluegrass mx; legal ID. (HN-GA)
 850 OH WKNR Cleveland 5/01 All star game "Sports Talk 850WKNR. (IEN-GA)
 TN WKVL Knoxville 4/18 0730 Network ID at BOH "This is the Horn Radio Net"; then a list of stns Wx into local ads; EX; new. (HN-GA)
 990 TN WNOX Knoxville 5/20 2010 Bill O'Reilly on WW1. Lots of local spots and promos. "News Talk 99 WNOX. Faded away at 2025. May have been pattern change. (RCW-KY)
 1000 SC WWOFF Wachalla 4/18 1945 Lots of ID during JRN Oldies. "The Big One" (I show them as "silent" until 3/04 then ABC-Oldies- ed). (HN-GA)
 1170 SC WLGO Lexington 4/24 1803 Legal ID "We let God Happen" VG with Gospel mx. New.
 1200 NC WXIT Blowing Rock 5/0118 S/off "News-Talk 1200 WXIT. (IEN-GA)

1200 NC WSML Graham 4/24 1900 Minor league BB on "Newstalk 600 WSJS" // of WSJS. Fair; new. (HN-GA)
 1310 IN WTLC Indianapolis 5/19 1925 BLK GSPL mx'; Pastor Jackson with call ins. "AM 1310 The Light" (RCW-KY)
 1410 KY WHLN Harlan 4/18 2023 Singing WX jingle; Back to Oldies; "The Big One.." In and out; Poor; new. (HN-GA)
 1430 IN WXNT Indianapolis 5/20 2300 "...here on WXNT" Local spots; "AM 1430 WXNT" Indy Indians Baseball. Poor with fade (RCW-KY)
 1490 KY WFKY Frankfort 5/19 1445 Dr Joy Brown, CNN Radio NX; ID as Frankfort's Talk Station, 1490 WFKY & 940 WCND" (RCW-KY)

Enjoyed the HamVention in Dayton this year. But now its back the "grind". Thanks to R.C. we have a column this week. Local news is that WCFI 1290 has added "Real Country" to their news format. Doesn't make sense to me that you would take a 5K AM and try to compete with 2 Class C FM's with the same format....5/23 FRESH 05/23 0900

DX WORLDWIDE – WEST / TROPICAL BAND DX

Patrick Martin – P.O. Box 843 – Seaside OR 97138

E-mail: mwdxer@webtv.net

all times UTC

Greetings everyone;

I hope you are all having a good Summer. Not much DX over here, but we do have reports from **Chris Knight**, **Dale Park**, and **Kevin Redding** this time around.

As many of you know, long time MW DXer, a great IRCAer, and a very good friend, **Chuck Boehnke** of Hawaii passed away recently. I would like to dedicate this issue of DX Worldwide-West to him, especially with so many Mexican tips. Chuck loved to DX the Latin stations.

PAN-AMERICAN DX ROUNDUP

740 **MEXICO**, Los Mochis, Sin. XE?W (Unid) 5/19 0400-0442 UTC. SS, fair peaks over KVOR with "Radio Variedades" slogans and jingles, 6 noted whistle corresponding to the syllables of "Radio Variedades" used frequently, laser sound effects. At 0438, man gave power, callsign (last letter W), another man clearly said "Radio Variedades desde Los Mochis". XEHS was here but moved to 540 khz. Not sure who this guy is. Nothing found on the internet. (CK-CO)
 830 **MEXICO**, Linares, NL XELN 5/20 0317-0345. SS occasional fair to good peaks over XE jumble, musica romantica and La Super Llegadora" slogans, announced a //FM as XHMR (didn't copy frequency) (CK-CO)
 970 **MEXICO**, Caborca, Son. XEEZ 5/18 0510-0516. SS fair to good signal with "La Super Z" slogans, lite XE vocals, guitars also "La Super Z Carborca" heard. (CK-CO)
 1000 **MEXICO**, Cd. Juarez, Chih. XEFV 5/18 0520. SS "La Rancherita" slogan, promo for Banda music and group "Ritmo Norteno" PSA from La Secreteria Educacion Publica promo for Meganotchias 1000 news program. (CK-CO)
 1030 **MEXICO**, Los Mochis, Sin. XEMPM 5/15 0543-0546. SS fair signal with event promo and Radio Fama slogan under another SS station using "La mas Perrona slogans. (CK-CO)
 1080 **MEXICO**, San Luis Rio Colorado, Son XEDY 5/1 0400 with full ID and station particulars the Mexicans give. A reverse Murphy while listening to the Texas Rangers shellac the Boston Red Sox in a sweep of a double header on KRLD. Happened during the stop set between innings. Didn't miss any of the game. Sometimes life is good. (KR-AZ)
 1260 **MEXICO**, Ojinaga, Chih. XEOG 5/19 0339. SS very good signal with "Radio Ranchito me gusta mas" jingle into ranchera music. (CK-CO)
 1300 **MEXICO**, Cd. Juarez XEP 5/15 0527-0531. SS, Excellent signal and lite XE vocals and ballads, full ID by woman "XEP Radio Centro, 1300 kilohertz AM..." Gave studio address, mentioned 38,000 watts de potencia" also slogan "La Estacion de todo las Epocas" into recuerdo music (CK-CO)

- 1319.89 **MEXICO**, Piedras Negras, Coah XECPN 5/19 0226-0231. SS fair signal with SS vocals "La Mexicana" slogans and mention of "Radioama" network, mixing with another SS station IDing as "Radio Luz" (1320 khz) (CK-CO)
- 1340 **MEXICO**, Los Mochis, Sin. XECW 5/16 1300 with XE political talk popping up out of the mess and fading back down into the GY mess about 13 minutes later, but long enough to figure out who it was. #790 nueva! Escuha primera vez! (KR-AZ)
- 1420 **MEXICO**, Cd. Juarez, Chih. XEF 5/15 0359-0402. SS poor overall signal, but fair peak with full ID including callsign, studio address "14-20 AM" and "Linea Deportiva" slogans. (CK-CO)
- 1470 **MEXICO**, Tijuana, BCN XERCN 5/15 0522. SS ID "Estas escuchando XERCN, Radio Hispana, 14-70...." Into ads, Another SS station underneath, passibly KUTY. (CK-CO)
- 1550 **MEXICO**, Monterrey, NL XENU 5/15 0509-0511. SS fair peak with ranchera mx "La Ranchera" slogans over KKJY, local KADZ silent. (CK-CO)
- 1560 **MEXICO**, Cd. Juarez XEJPV 5/15 0517-0520. SS very good signal as "Radio Vida" slogan and into Christian vocal. (CK-CO)

TRANS-PACIFIC DX ROUNDUP

- 702t **AUSTRALIA**, Sydney, NSW, 2BL 5/15 1107 UTC Faint woman with teletalk, getting stronger, accent seemed Aussie. Poor, QRM KORL-690 and splatter from unk het. (5P-HI)

THANKS TO THESE REPORTERS

- CK-CO - **CHRIS KNIGHT**, 1018 Pacific Court, Fort Lupton, CO 80621-2515
 swrad@juno.com
 DXing with Drake R8, SSW Flag antenna (36' X 17') terminated
- 5P-HI - **DALE PARK**, PO Box 10640, Honolulu HI 96816 DXFool@aol.com
 DXing with Sangean ATS-818CS. Terk AM1000 loop
- KR-AZ - **KEVIN REDDING**, Mesa AZ amfmdx@fastq.com
 DXing with DX440 and CCR Radio barefoot.

DX WORLDWIDE - EAST

Brandon Jordan – 4920 Park Ave. – Memphis, TN 38117

E-mail: bjordan@bcdx.org all times UTC

Nice showing this issue, the highlight of which is **Mark Connelly's** logs of Radio Sawa in Djibouti! A hearty welcome to **Brent Taylor** who sent in a batch of very nice logs. In addition, in this issue we have an intriguing report from **Ray Moore** in Florida detailing his latest Trans-Pacific DX efforts. Thanks guys!

*** TRANS-PACIFIC DX ***

- 1098 **MARSHALL IS** V7AD, Majuro MAY 20 1032-1040, woman in English apparently reading news, mostly in noise with occasional peaks. Easily identified as it nulls at about 290 degrees, much further north than the down under stations. Not needed. [Moore-FL]
- 1314 **UNID TP** Strong carrier bearing 277 degrees MAY 23 1017-1035 with typical DX type fading. Must be new station as I check this frequency daily and haven't heard a trace of a carrier for some time. Bearing places it in Marshall Is or Kiribati most likely, or could be further west in Northern Australia, Papua New Guinea, or Solomon Is. Any help on this one? [Moore-FL]
- 1475 **SABAH** Kota Kinabalu (presumed) APR 17 1048-1054 strongest TP carrier ever heard here in Florida. At 1049 threshold level audio with snatches of music and woman's voice, then for about 30 seconds at 1050 a soft woman's voice rose out of the noise. It was not strong enough to determine the language. From there until 1054 occasional traces of music and woman's voice down in the noise. Local sunrise this date 1102. Modulation seems to be very low on this station. It is going to be difficult to pin this one down with no parallels and weak modulation. I believe this station comes in via a very rare gray line propagation. It has a bearing of 330 degrees from Florida and would normally be heard only November to February as the Japanese stations

are. However I have logged strong carriers or audio from this station on thirty-one mornings since 1998, thirteen times in August and September, fifteen in March and April, two in October and one in November. Checking www.spacew.com/www/realtime I find a perfect gray line from Florida to Sabah during August, September, March and April. The signal peaks between nine and seventeen minutes before Ft Myers sunrise. I have read that gray line reception rarely or never occurs on the broadcast band but I can't find any other explanation for this anomalous reception pattern. Incidentally, this gray line runs from Florida through Georgia and up through Chicago/Milwaukee area. [Moore-FL]

- 1503 **NEW ZEALAND** Radio Sport MAY 3 1034-1054, excellent signal but not 100% readable due to frequent bursts of static from nearby thunder storms. Discussion about recent and upcoming matches in England and Australia. Not sure which sport, possibly Rugby. Mention of Black Cats versus England. Mention of the Advertiser newspaper and commercial for cleaner floors. Threshold level audio also noted MAY 11, 13, 16, 17, 18. [Moore-FL]
- 1512 **AUSTRALIA** Assumed 2RN Newcastle, previously heard here. Weak man and woman down in noise MAY 16 1028-1042. [Moore-FL]
- 1611 **UNID** TP's, MAY 1038-1044, voices in jumble of stations, sounds like graveyard channel. [Moore-FL]
- 1629 **AUSTRALIA** Aussie X banders do not maintain frequency very well. Cacophony of heterodynes here from numerous stations. Same situation on 1638. [Moore-FL]

*** TRANS-ATLANTIC DX ***

- 153 **GERMANY** DeutschlandRadio, Donebach, APR 22 0120 - // 756 with classical piano music; fair over others. [Connelly*rw-MA]
- 162 **FRANCE** France-Inter, Allouis, APR 22 0119 - man in FR; good. [Connelly*rw-MA]
- 171 **MOROCCO** R. Mediterranee Internationale, Nador, APR 22 0119 - Arabic vocal. strings, drums; local-like. [Connelly*rw-MA]
- 177 **GERMANY** DeutschlandRadio Berlin, Oranienburg, APR 22 0118 - blues vocal; to good peak. [Connelly*rw-MA]
- 189 **ICELAND** Rikisutvarpid, Gufuskalar, APR 22 0118 - man & woman in Icelandic; fair. [Connelly*rw-MA]
- 198 **UNITED KINGDOM** BBC R.4, Droitwich et al., APR 22 0117 - segment of Smash Mouth song "All Star", then sports-related talk including mentions of marathon runners; good. [Connelly*rw-MA]
- 234 **LUXEMBOURG** R. Luxembourg, Junglinster, APR 22 0121 - good with U2 song "I Still Haven't Found What I'm Looking For". [Connelly*rw-MA]
- 252 **IRELAND** RTE R.1, Clarkestown, APR 22 0116 - // 567 with historical discussion; huge / local-like. [Connelly*rw-MA]
- 549 **ALGERIA** Chaîne 1, Ain Beida, APR 14 2338 - Fair/poor, with Arabic music and then female announcer who spoke for about two minutes and then back into an instrumental piece at 2340. [Taylor-NB]
- 567 **IRELAND** RTE R.1, Tullamore, APR 22 0116 - // 252 with historical discussion; good. [Connelly*rw-MA]
- 585 **SPAIN** RNE R.1, Madrid, APR 22 0115 - // 855 with upbeat talk & joking with several announcers; good. [Connelly*rw-MA]
- 612 **MOROCCO** RTM A, Sebaa-Aioun, APR 21 2348 - Arabic flute & string music; well over Ireland. [Connelly*rw-MA]
- 621 **CANARY ISLANDS // SPAIN** RNE R.1 synchros, Santa Cruz de Tenerife et al., APR 21 2330 - Spanish talk, laughing; excellent. [Connelly*rw-MA]
- 639 **SPAIN** RNE R.1, La Coruna, APR 22 0114 - // 855 with fast Spanish talk; through CBN slop. [Connelly*rw-MA]
- 657 **SPAIN** RNE R.5, Madrid, APR 22 0111 - // 855 with Spanish talk, joking; good. [Connelly*rw-MA]
- 675 **NETHERLANDS** R. 10, Lopik, APR 22 0113 - '80s-era pop-rock vocal; fair with WRKO phased. [Connelly*rw-MA]
- 684 **SPAIN** RNE R.1, Sevilla, APR 21 2332 - // 621 with Spanish interview; good. [Connelly*rw-MA]

693 **UNITED KINGDOM** BBC R. 5, Droitwich et al., APR 21 2333 - talk mentioning the European Union constitution; fair. [Connelly*rw-MA]

702 **MOROCCO** (t) RTM, Sebaa-Aioun, APR 21 2334 - carrier with weak audio that sounded like an Arabic vocal. [Connelly*rw-MA]

711 **FRANCE** Rennes, APR 21 2317 - initially the channel was a complete jumble (France/Libya/W.Sahara), but France finally struggled atop the pile with '50s R&B song "Work With Me Annie", // 945. [Connelly*rw-MA]

711.04 **WESTERN SAHARA** RTM, Laayoune, APR 21 2334 - female Arabic vocal; slightly over mess. [Connelly*rw-MA]

738 **SPAIN** RNE R.1, Barcelona, APR 21 2335 - Spanish talk; in CHCM slop. [Connelly*rw-MA]

747 **NETHERLANDS** Flevoland, APR 21 2336 - Dutch teletalk, mentioned Kuwait, Arabs; fair to good. [Connelly*rw-MA]

756 **GERMANY** DeutschlandRadio, Braunschweig & Ravensburg, APR 21 2338 - man in German, then sad-sounding folk male vocal. [Connelly*rw-MA]

765 **SWITZERLAND** RSR, Sottens, APR 15 2348 (p) - Good, with Cat Stevens' "Wild World" into two light French songs with no announcing. Lowest decent TA on the band this evening. [Taylor-NB]
+ APR 21 2340 - old style romantic French male vocal; very good. [Connelly*rw-MA]

774 **SPAIN** RNE R.1 synchros, APR 21 2341 - // 684 with group discussion, some audio echo noted; good over others. [Connelly*rw-MA]

783 **MAURITANIA** R. Mauritanie, Nouakchott, APR 21 2314 - // 4845 with stern Arabic talk by man (a sermon?); good. [Connelly*rw-MA]

792 **FRANCE** France Info, Limoges, APR 14 2341 - Fair/poor, with pop music. // to 945, but much weaker and more QRM as it is closer to the NA channel on 790. Still, came up to a nice peak at 2343. [Taylor-NB]
+ APR 21 2313 - // 945 with '40s big-band jazz, female vocal; good. [Connelly*rw-MA]
+ APR 21 2342 - // 1206 with jazz; excellent. [Connelly*rw-MA]

801 **SPAIN** RNE R.1 synchros, APR 21 2342 - fast Spanish talk in tough VOWR/CJAD/CHRC slop with WNNW phased. Possible Arabic music (Jordan?) mixed in at times. [Connelly*rw-MA]

837 **FRANCE** France Info, Nancy, APR 14 2345 - Poor, with same programming as // stations on 792 and 945. Weakest of all of the France Info stations audible this evening so far, and some other audio underneath, man talking, sounding like Spanish, with fiddle/violin stingers between phrases. [Taylor-NB]

837 **CANARY ISLANDS // SPAIN** COPE synchros, APR 21 2345 - news about Espana; over dogpile with France/Azores/others. [Connelly*rw-MA]

855 **SPAIN** RNE R.1 synchros, APR 14 2348 - Fair/good, with two men talking fast in Spanish and taking callers over the phone. Short jingle at 2349. [Taylor-NB]
+ APR 21 2306 - female folk vocal, then Spanish talk by man; actually overpowering WEEI when phaser was set for 850 null. [Connelly*rw-MA]

864 **EGYPT** (p), Santah, APR 14 2351 - Strong with male tenor Call to Prayer during fade down of France Bleu ("Wicked Game" by Chris Isaac). Interference free except for France. Hardly any domestic splatter. Nothing else in my book denoting Arab world on this Freq, so an presuming Egypt. If so, I think it's my first. BIG fade back up at 2356. [Taylor-NB]

864 **FRANCE** France Info, Paris, APR 14 - 2332 - Fair, with female vocal slow pop song in French. Segue into another slow pop song, male vocal, at 2035. Other talking underneath, almost wailing-sounding at times. [Taylor-NB]
+ APR 21 2346 - French female pop vocal, then French talk; good. [Connelly*rw-MA]

873 **SPAIN** SER synchros, APR 15 0009 - Fair/good See 1026 logging below, checked to confirm // broadcast, otherwise logging details the same. [Taylor-NB]
+ APR 21 2306 - SER news; poor to fair. [Connelly*rw-MA]

882 **UNITED KINGDOM** BBC R. Wales, Washford, APR 21 2354 - English talk, then "Desperado" by the Eagles; over Canaries/Spain. [Connelly*rw-MA]
+ APR 22 0105 - mentions of foreign university students having a hard time getting back into the US after visiting their families in China; over 2 other stations (Spanish, Arabic). [Connelly*rw-MA]

890.98 **ALGERIA** Chaîne 1, Algiers, APR 21 2356 - two men in Arabic, then music; at low audio level on big carrier. [Connelly*rw-MA]

909 **UNITED KINGDOM** BBC R.5 synchros, APR 15 0002 - Loud with "BBC Radio 1" news and into sports at 2103, with soccer scores. Clobbering 910 domestics on the pennant. Out of sports at 0004, music bed and strong Scots-accented guy with teaser talk on what's going in the newspapers "this morning." "First we begin with the news of another death in Iraq..." [Taylor-NB]
+ APR 21 2358 - talk about Australian cricketers, the proliferation of mobile phones making callboxes increasingly less available, BBC Five Live ID, "it's 1 o'clock" talk about possible reasons for the "big kill" 65 million years ago that made dinosaurs extinct, mention of TV announcer who made a racist comment; good signal. [Connelly*rw-MA]

936 **SPAIN** RNE R.5 synchros, APR 22 0104 - // 855 with Spanish news; poor to fair. [Connelly*rw-MA]

945 **FRANCE** France Info, Toulouse, APR 14 2330 - Good, with jazz music selection into male announcer in French at bottom of the hour. [Taylor-NB]
+ APR 21 2312 - French talk, swing jazz; LOUD. [Connelly*rw-MA]

954 **SPAIN** Onda Cero, Madrid, APR 22 0002 - Spanish news; over unID (Qatar or Turkey?) and tough CHNS slop. [Connelly*rw-MA]

981 **ALGERIA** RTVA Chaîne 2, Algiers, APR 21 2310 - news by man in Arabic; light audio level on massive carrier that was demolishing WCAP. [Connelly*rw-MA]

999 **SPAIN** COPE, Madrid, APR 21 2309 - fast Spanish talk; over Arabic music station (Morocco ?). [Connelly*rw-MA]
+ APR 22 0006 - Cadena COPE ID; huge. [Connelly*rw-MA]

1008 **CANARY ISLANDS** Onda Cero, Las Palmas, APR 21 2305 - non-SER Spanish talk; LOUD, way over SER station. [Connelly*rw-MA]

1008 **SPAIN** SER synchros, APR 21 2305 - // 873 with Spanish newstalk; under Canary Islands station. [Connelly*rw-MA]

1017 **SPAIN** RNE R.5 synchros, APR 22 0102 - // 855 with Spanish news interview; over Germany & Turkey. [Connelly*rw-MA]

1026 **SPAIN** SER synchros, APR 15 0007 - Classical music with female talking underneath. Two females faded up - one in studio and one on the phone. Lots of WBZ slop to contend with, but definitely // 873 which was weaker but more in the clear. Back to orchestral piece and female narration over top at 0011, and then took another female caller at 0012. [Taylor-NB]

1035 **PORTUGAL** R. Nacional, Lisboa, APR 22 0101 - Portuguese vocal; in WBZ slop. [Connelly*rw-MA]

1044 **MOROCCO** Sebaa-Aioun, APR 21 2304 - rustic banjo music and vocal that sounded like a fusion of North African, Japanese, and Appalachian music styles; HUGE S9+20 signal. [Connelly*rw-MA]

1044 **SPAIN** SER synchros, APR 15 0016 - Excellent, with woman host taking callers, male caller this time, followed by another, and // to 1026 and 873 loggings above at around the same time. [Taylor-NB]
+ APR 22 0009 - Spanish teletalk; excellent, mixed with blank carrier that may have been post-sign-off Morocco. [Connelly*rw-MA]

1053 **UNITED KINGDOM** TalkSport synchros, APR 22 0012 - phone-in poll on subject "Does being tall make you superior?", talk about extraordinary operations being performed in Beijing to make people taller, telephone number given as "704 20 20 20"; over others. [Connelly*rw-MA]
+ APR 22 0100 - advert for "adult telephone talk", then mention of claim line for injury insurance settlements (0800 783 8000), wine advert by Jamaican-accented man, ID "TalkSport 1053 and 1089", news; HUGE signal. [Connelly*rw-MA]

1062 **ITALY** RAI R. Uno synchros, APR 22 0013 - believed this with Italian-sounding talk, piano music. [Connelly*rw-MA]

1071 **SPAIN** Euskadi Irratia, Bilbao, APR 22 0057 - Spanish talk, guitar music; fair, in CBA slop. [Connelly*rw-MA]

1080 **SPAIN** SER synchros, APR 22 0057 - // 1044 with Spanish talk, musical interlude; under WTIC. [Connelly*rw-MA]

1089 **UNITED KINGDOM** TalkSport synchros, APR 15 0018 - Fair to very good, with two male hosts talking sports in English, and taking callers. Mention of "wee bit" by one of the hosts so not sure if I was hearing Scottish TX or not. Into commercial for a Roy Orbison compilation album at 0021. Gave order phone number, and then back to show with music intro at 0022. Arabic wailing and music underneath. Presume Chaine 1 Algeria 5 KW as the Saudi would be a real toughie at only 10 KW. [Taylor-NB]
 + APR 22 0017 - announcer said "Summer's coming. How would you like to win a crate of bitter? That's right, 24 cans of beer."; loud. [Connelly*rw-MA]

1098 **SPAIN** RNE R.5 synchros, APR 22 0019 - echoey SP teletalk. [Connelly*rw-MA]

1107 **SPAIN** RNE R.5 synchros, APR 22 0019 - // 1098 w/ teletalk; fr. [Connelly*rw-MA]

1116 **SPAIN** SER synchros, APR 15 0024 - Fair, and weak but clear with // to 873, 1026 and 1044 above. Female host with short music beds taking callers in Spanish. [Taylor-NB]
 + APR 22 0020 - // 1044 with talk; fair. [Connelly*rw-MA]

1125 **CROATIA** Hrvatski R., Deanovec, APR 22 0021 - // 1134 with Slavic talk by woman; over 2 others (presumed Spain/Madeira). [Connelly*rw-MA]

1134 **CROATIA** Hrvatski R., Zadar, APR 15 0026 - Fair, with male and female hosts alternating reading news items in what I presume was Croatian. [Taylor-NB]
 + APR 22 0022 - woman mentioned what sounded like "kniga na holokausto" (book about the Holocaust?) in panel discussion program; loud, way over Spain. [Connelly*rw-MA]

1143 **SPAIN** COPE synchros, APR 22 0022 - // 1296 with woman in Spanish. [Connelly*rw-MA]

1152 **SPAIN** RNE R.5 synchros, APR 22 0056 - // 855 with Spanish talk; over unID music. [Connelly*rw-MA]

1179 **CANARY ISLANDS // SPAIN** SER synchros, APR 15 0028 - Fair, and // to all the other SER catches tonight. Notable here were time pips underneath at 0030. Not sure which of the stations on 1179 may feature time pips at the half hour, but any help would be appreciated. [Taylor-NB]
 + APR 21 2220 - Spanish teletalk with woman; fair, fading up. [Connelly*rw-MA]

1206 **FRANCE** France Info, Bordeaux, APR 15 0032 - Good, with man reading news in French. Story about the war in Iraq. [Taylor-NB]
 + APR 21 2300 - musical fanfare, then into French news. [Connelly*rw-MA]

1215 **UNITED KINGDOM** Virgin R. synchros, APR 15 0033 - Good, but thin audio and Lynrd Skynrd's "Sweet Home Alabama" and straight segue into Coldplay hit "Clocks" from about a year ago. Nice and solid at fade up 0038. [Taylor-NB]
 + APR 21 2257 - "Kiss From a Rose" by Seal, then presenter gave web site, telephone, and postal address for Virgin Radio; good. [Connelly*rw-MA]

1224 **SPAIN** COPE synchros, APR 15 0040 (p) - Poor, with man and woman alternating on a talk show in what sounds like Spanish. Taking occasional callers, but not // to anything else heard from Spain so far this evening. [Taylor-NB]
 + APR 21 2222 - // 1296 with fast Spanish talk, teletalk; fair. [Connelly*rw-MA]

1242 **FRANCE** Marseille, APR 21 2256 - several French announcers; through WBUR splash. [Connelly*rw-MA]

1251 **LIBYA** Libyan Jamahiriya, Tripoli, APR 22 0055 - Arabic public address; fair to good. [Connelly*rw-MA]

1287 **SPAIN** SER synchros, APR 22 0054 - woman with Spanish teletalk; fair. [Connelly*rw-MA]

1296 **SPAIN** COPE, Valencia, APR 21 2222 - // 1224 with teletalk; through WJDA slop. [Connelly*rw-MA]

1296 **UNITED KINGDOM** R. XL, Langley Mill, APR 22 0054 - Indian music male vocal; good, over Spain. [Connelly*rw-MA]

1314 **NORWAY** NRK, Kvitsoy, APR 22 0025 - UK '90s era rock, man & woman in Norwegian; good to excellent. [Connelly*rw-MA]

1332 **ITALY** RAI R. Uno synchros, APR 15 0044 (t) - Poor/fair, with male announcer into big band music at 0046. Book shows several possibilities, but can't quite pull enough spoken audio to ID a language. Murphy's fade-up during music and fade-down during

talk law in effect here. I'm guessing Italian by the sound of the second ballad played at 0050. [Taylor-NB]
 + APR 22 0026 - Italian male opera vocal; excellent. [Connelly*rw-MA]

1341 **CANARY ISLANDS // SPAIN** SER synchros, APR 21 2255 - man in Spanish talk; over others. [Connelly*rw-MA]

1341 **NORTHERN IRELAND** BBC R. Ulster, Lisnagarvey, APR 22 0027 - talk about workers, contracts; to good peak. [Connelly*rw-MA]

1359 **SPAIN** Arganda, APR 21 2254 - Spanish interview; loud, clobbering WLYN. [Connelly*rw-MA]

1377 **FRANCE** Lille, APR 22 0029 - // 1206 with female blues vocal; good, over slight WMYF slop. [Connelly*rw-MA]

1395 **NETHERLANDS** Trintelhaven, APR 21 2252 - "Everlasting Love" by Robert Knight, then "I Want to Know What Love Is" by Foreigner; battling slop from WPLM-1390 & WIDE-1400. [Connelly*rw-MA]
 + APR 22 0030 - "Happy Together" by the Turtles. [Connelly*rw-MA]

1404 **FRANCE** synchros, APR 22 0030 - // 1206 with blues song, then man in French; to good peak. [Connelly*rw-MA]

1413 **SPAIN** RNE R.5 synchros, APR 21 2224 - Spanish talk; in jumble. [Connelly*rw-MA]

1422 **ALGERIA** Algiers, APR 21 2225 - Arabic music; good, well over Germany. [Connelly*rw-MA]

1422 **GERMANY** DeutschlandRadio, Heusweiler, APR 22 0050 - // 756 with classical piano music; good. [Connelly*rw-MA]

1431 **DJIBOUTI** R. Sawa, Arta, APR 21 2225 - pop Arabic vocal; fat het against WXKS.
 + APR 21 2245 - "Have You Ever Loved a Woman" by Bryan Adams, then into female disco vocal; briefly in the clear. [Connelly*rw-MA]
 + APR 22 0034-0044 - Arabic talk, web URL "www.radiosawa.com", "Get Busy" by Sean Paul, Arabic female vocal, talk with Sawa mention & electronic sound, then into "I'm Gonna Getcha Good" by Shania Twain; to good peaks. [Connelly*rw-MA]

1467 **FRANCE** TWR, Roumoules, APR 21 2203 - male Arabic vocal and guitar accompaniment in a Christian folk style; good signal more than 90 minutes before sunset. [Connelly*rw-MA]

1485 **SPAIN** SER synchros, APR 22 0047 - // 1044 with woman in Spanish; good. [Connelly*rw-MA]

1503 **SPAIN** RNE R.5 synchros, APR 21 2230 - Spanish news; over 2 others (likely Azores/Iran). [Connelly*rw-MA]

1521 **SAUDI ARABIA** BSKSA, Duba, APR 15 0053 - Loud as expected tonight with woman host and man on phone talking in Arabic. WWKB still strong, but broadcasting a baseball game tonight so splatter is at a minimum. [Taylor-NB]
 + APR 21 2205 - fading up to good strength with Arabic news, then man talking over string music. [Connelly*rw-MA]
 + APR 21 2230 - now at local-like strength! [Connelly*rw-MA]

1548 **GREAT BRITAIN** (p), Capital Gold, Saffron Green, APR 15 0105 - Nice & strong at fade-up w/ song "Addicted" by Enrique Iglesias, but then faded down & got clobbered by Radio Sawa at 0109. (See below). Faded back up somewhat during "Homeward Bound" by Simon and Garfunkel at 0124 but not to previous levels. Guy talking in English accent and interviewing an American-accented caller at 0126. [Taylor-NB]

1548 **KUWAIT** R. Sawa, Kabd - Kuwait City, APR 15 0109 - Strong, with Arabic pop-type song into Arabic talk at 0116. Two male anncrs alternating. Talk continued for extended period with no music until 0125. Full "Radio SAWA" ID with hit music clips at exactly 0133, then back into Arabic pop. [Taylor-NB]
 + APR 22 0048 - pop Arabic music; over UK talk stations. [Connelly*rw-MA]

1550 **ALGERIA** RASD Clandestine, Tindouf, APR 21 2235 - // 7460 with woman in Arabic; under WNTN, over WDZK. [Connelly*rw-MA]

1557 **FRANCE** France Info, Nice, APR 15 0058 - Huge with full-bodied audio and virtually no interference from a weakened WQEW leading up to the top of the hour, but then New York came back up to give it a pretty good fight from 0100 to about 0105. Still, no problem to copy France at will. [Taylor-NB]
 + APR 21 2206 - two men talking in French; to good peak, better than WQEW-1560. [Connelly*rw-MA]

- 1575 **SPAIN** SER synchros, APR 21 2237 - excited Spanish talk, SER mention; over 2 others. [Connelly*rw-MA]
 1584 **CEUTA** RadiOle, APR 21 2207 - Spanish female vocal in a style similar to mellow US soul; over others. 1 kHz tone-tester in the background. [Connelly*rw-MA]
 1593 **unID** APR 22 0049 - Egypt or Kuwait here with Arabic music; over mess. [Connelly*rw-MA]
 1602 **SPAIN** R. Vitoria, Vitoria, APR 21 2209 - Spanish rock; over SER synchros & tough WUNR slop. [Connelly*rw-MA]

*** **CONTRIBUTORS** ***

Mark Connolly - MarkWA1ION@aol.com

[Connelly*rw-MA] = Rowley, MA (GC= 70.829 W / 42.745 N) (Stackyard Road / Parker River - Nelson Island wildlife refuge: salt-marsh) Antenna system: Beverage-on-Ground (BOG) 152 m / 500 ft. (beamed east), homebrew active whip. Receiver: Drake R8A, Superphaser-2 phasing unit.

Brent Taylor - btaylor@nbnet.nb.ca

[Taylor-NB] = Doaktown, NB, Canada (FN66). Receiver: Icom R75 (Kiwa mods). Antenna: Pennant antenna oriented NE.

Ray Moore - rsmcomm@usa.net

[Moore-FL] = Ft. Myers, FL. Antenna system: 23" spiral loop, MAR-6 preamp. Receivers: Drake R8, MAR-6 preamp

Ray speaks: "After a very poor DX season it looks like the late spring/early summer down under DX season, which peaks in June, may be very good. From my most wanted list, Tonga has been putting in a good carrier on occasion, and I hope to get a decent tape on it this season. Sabah 1475 is now gone but will reappear in August. Thailand 1575 is long gone but should surface again starting in November. It peaks in December and January and is fairly easy to identify during its VOA Burmese program 1130-1200 when it is parallel with Sri Lanka 9890."

That's all for this issue. Good DX in this new year to all! 73, Brandon.

WESTERN DX FORUM

Reid Wheeler – 5910 Boulevard Lp SE – Olympia, WA 98501-8408

E-mail: WMA001@comcast.net Phone 360-786-6756 Fax 360-753-3824

All submittals to WDXF must be received on the Saturday before the next issue masthead. E-mail submittals are OK up to Sunday morning. I will be working an out-of-town job from now until the end of August that will prevent me from assembling and forwarding WDXF on Mondays. I expect to return to the regular schedule in September.

Doug Pifer, 3410 Marion St. SE, Albany, OR 97322 oregon4wd@comcast.net

Hi All. It feels good to be back helping out a little bit with the club. Phil's a good guy, knows the club business well and I think we make a pretty good team with him doing the tough job as editor and me doing the printing and mailing. While, I'm thinking about it, here's a reminder that all bulletin input goes to Phil as I have no ability to add anything, once I've received the master copy from him. The hard copy bulletin, HDXM, is all-digital from the beginning till it gets printed and I think it turns out a pretty sharp product. Along the same subject, sort of, I'd like to thank those who nominated me for the TVA and RHA awards, I'm not worthy, I'm not worthy, hi. Maybe a few years down the road would be more appropriate because I feel the long standing contributors really deserve the credit and are the real backbone of the club. My hat's off to all of them! My hat's off also to Phil and Karl, for their understanding and support while I was out of the picture for a few months.

As far as current happenings around here, my DXing has been sporadic at best, but I did manage to log three Japanese stations for the first time at this QTH a couple of months ago. I was quite thrilled. I've finally decided to learn Morse code and upgrade my ham ticket to the General Class. I can thank Karl for his very high motivational attitude and support for this. I wanted to learn this probably 25 years ago and just didn't know where to start. Two learning tools and I'm sure many more, are available now days to make learning code very easy. So

easy in fact, it almost seems wrong, hi. One is the pocket size MFJ Morse Tutor and also the web site: CWcom, which allows you to practice sending and receiving code on the net, with others worldwide. It's a lot of fun.

The IRCA convention is coming up soon. Make plans to attend! Boise, which is the Capitol of Idaho, is in a beautiful location (Treasure Valley) and I'd recommend staying a day or two extra to see the sights. See you there. 73 de Doug

Doug Nyholm - 2336 Autumn Ridge Dr. - Sandy, UT 84092 dougnyholm@msn.com

I have begun the daunting task of scanning all of my 1575+ verifications, coverage maps and stickers received over the past few decades. I will either burn out my scanner or have a stroke myself but it seems like an interesting project. I was wondering if anyone else out there has done the same for their verie collection and if so would be interested in sharing them via CD? I have seen from time to time really old QSL's from the 30's era and now with fewer and fewer stations even willing to verify anything, and fewer and fewer DX'ers sending reception reports, old QSL's can be very interesting. With the price of overseas mail and IRC's the cost of a foreign verie is now about \$2.50! Please contact me by email if you have scanned veries or would like a copy of mine on CD after I finish (and I guarantee that wont be next week!). Also, does anyone out there collect the EKKO verification stamps given out on QSL's years ago by many stations. I have seen very few of these and only have received one in my DX'ing lifetime, from KFI-640 way back in 1969. It would be interesting, but maybe not possible, to put together a list of stations that used verification stamps, let alone a collection of them. Other than that DX has been generally good here in Utah with my being able to log 300+ stations in less than 2 months. Over 100 reports sent with only about 35 veries back. I have some friends in Boise so am going to convince the wife that a weekend trip up there in July is necessary. Have a good summer. Doug

EASTERN DX FORUM

Richard C. Evans – 7416 Hearthstone Wy – Indianapolis IN 46227-7923

E-mail: REvans5435@aol.com DEADLINES: Sundays

Eric Bueneman (N0UIH), 631 Coachway Lane, Hazelwood, MO 63042-1347

May 17, 2004 was a somber day in St. Louis radio. Chuck Norman, owner of WGNU 920 Granite City, IL, passed away that morning in his penthouse across from the station's studios in the Senate apartment building (the old Senate Hotel) in St. Louis' Central West End. Norman, who was in his mid-80s, owned WGNU since its inception in 1961. He started his radio career shortly after the end of World War II as an advertising salesman for WTMV 1490 (now WESL) in East St. Louis; he would eventually move over to WIL 1430 (now WRTH) in St. Louis, where he hosted a late-night talk show called "Norman's Nite Cap". In 1961, WGNU signed on the air as a 500-watt daytimer with a mix of free-form talk and middle-of-the-road music (or MOR). Four years later, WGNU added an FM outlet at 106.5; one of the first FM Stereo stations in the St. Louis market. The FM side spent the first several years of its existence broadcasting country music. When the AM side went full-time in 1978 by adding 500-watt night service, Norman put WGNU-FM up for sale. While the FM has passed through several owners over the last quarter century, Norman held on to the AM station, which became the voice of St. Louis public opinion. He took a special interest in the day-to-day operations of the station until just a few weeks before he passed. Not only was Norman involved with the station, he was also very involved in the St. Louis community, volunteering with numerous charities. He also became famous for his billboards, always starting out with "Chuck Norman says". His last billboard campaign, started after the terrorist attacks on New York and Washington, DC on September 11, 2001, had them saying "God Bless America". He was also known for his Christmas parties, which raised money for over 50 charities dealing with children with disabilities. I had the honor and privilege of working for him during late 1996 and early 1997 as an engineer and news reader. WGNU was one of the last radio stations in the St. Louis area owned by a single individual; the last FM station owned by a single individual, WFUN-FM 95.5 (the station I worked for after my brief stint at WGNU), was sold in 1999. The station will pass to the employees. On May 20, 2004, WGNU broke from their regular free-form talk format to broadcast the old MOR format from 0700 to 0100 ELT.

Several radio and TV stations in St. Louis also paid tribute; I dedicated the Thursday morning show on WSIE 88.7 (where I was filling in that morning) to the memory of Chuck Norman. I can tell you several stories of my brief time at WGNU, but they would make this Forum too long. St. Louis has lost an icon of local radio. God bless Chuck Norman. 73.

Richard Evans, 7416 Hearthstone Way, Indianapolis, Indiana 46227-7923

Plenty of rain over the past week, so DXing hasn't been the best. Oh well. I've still had the chance to pick off some nearby stations I didn't know about plus some old stations I had forgotten about and hadn't logged here. Examples are WBAL-1090, KRLD-1080, KAAY-1090. Actually, I hadn't forgotten about KAAY -- I just hadn't been able to hear it, thanks to the Fort Wayne station and slop from WTAM-1100 and local WIBC-1080. It's bad, when a Cleveland station slops over when heard in Indianapolis, hi. Did pick off state 30 with KKOW-860 in Pittsburg, Kansas. My heard total here is now 262. With 1 verie. Dropped my list of frequencies with only one station heard on it down to 39 now. Some of them are Indy NSP stations or the frequency adjacent to the Indy frequencies it's a matter of constantly checking those spots. Last week, I heard a station under local WNTS-1590. I was able to loop WNTS out almost completely and found WAIK in Galesburg, Ill. There. The tower for WNTS is roughly five miles of me. With most of Indiana on Eastern Standard time, it's interesting to listen to some of the Indiana stations located along the Ohio border. They tend to either give both times, or just say Ohio time. Having dispatched trucks into the steel mills in northwest Indiana (many years ago), I consider myself bi-lingual as far as time goes anyway. That's it for this week. I see Lee has a EDXR deadline of 5/29 so I will try to get some stuff over to him before then. 73.

IRCA TECHNICAL COLUMN

Nick Hall-Patch – 1538 Amphion St – Victoria, BC, Canada V8R 4Z6
E-mail: nhp@ieee.org

Passive Broadband Phasing including Mini-DXP-5 phasing unit design

by **Mark Connelly**, WA1ION – 14 APR 2004

Phasing units that have been used widely in the medium-wave (AM broadcast band) DXing and 160-meter amateur radio communities have largely been either of a broadband design using active circuitry (e.g. ANC-4, MFJ-1026, Quantum Phaser, DXP-3) or of a tuned design using passive or active circuits (MWDX-5, Superphasers, etc.). What has not been generally available is a phaser encompassing broadband shifting and passive circuitry. Broadband and tuned approaches both have advantages and disadvantages. The same can be said of passive versus active circuits.

Broadband phasing allows the operator to move about the band without needing to make continual adjustments of the phasing unit controls. This also helps when checking for the same broadcast on parallel frequencies. With some antenna combinations, a null set up on one frequency in a given direction may be fairly effective plus or minus 100 kHz (or more) from that operating frequency.

Tuned phasing can sometimes provide better sensitivity and, more importantly for urban users, reduction in the strengths of off-frequency stations that could otherwise cause mixing spurs / images.

Passive circuits are recommended in areas where overloading is likely to be a problem. Passive and tuned would be the way to go in the most hostile urban receiving situations. The MWDX-5 [reference 1] offers this capability. In addition it has an amplifier that can be switched in for more sensitivity at sites with a less aggressive blend of incoming signals. Up to now, most passive phasing designs have been of the R-L-C tuned style.

Active circuits offer higher sensitivity, gain, and - if properly designed - improved noise figure. Since all variations of the phasing process involve some signal loss, having amplifier gain - preferably ahead of the shifting components - will preserve the ability to hear threshold-level signals presented from the antenna system components. Low-noise FET's used with L-C tuning in a preselector configuration on each of the two antenna inputs give the best possible signal-to-noise ratio: in some cases superior to that of the receiver itself. The

penalty is the lack of frequency agility inherent to tuned-circuit approaches. Broadband active phasing - to now the only common implementation of the broadband approach - has many advantages. Amplifier gain can largely mitigate the deleterious effects of phase-shifter insertion loss. The result is a noise figure nearly as good as what could be had with a direct antenna to receiver connection. The broadband phasing advantages of frequency agility and potentially wideband nulls towards a noise or "pest station" direction can be obtained. In recent years, some very popular phasing units using broadband active operation (notably the Quantum Phaser and the MFJ-1026) have become available. Many of these are in use throughout the world and results are usually positive. Hams and broadcast DXers can now create directive patterns and null out interference in ways that were not always achievable with loops or other previous methods.

The big "caveat" with all of the active broadband designs is the likelihood of spurious signals (intermodulation distortion products) caused by the overloading of amplifier circuitry. This has been the single biggest complaint raised by users of these units. Some have, of necessity, been driven back to the tuned R-L-C approach as the only feasible method in their high-RF areas.

Passive Broadband Phasing: another solution

If the advantages of broadband phasing can be presented in a circuit that is passive (and therefore overload-proof), users in strong signal areas can have the benefits of frequency agility / wideband nulls without the "headache" of spurious responses popping up all over the place. This concept is introduced in the Mini-DXP-5 Phasing Unit, described in this article.

Mini-DXP-5 Phasing Unit (variants: DXP-5, DXP-5A, DXP-5B, Super-DXP-5)

The Mini-DXP-5 is similar to the previous DXP-3 design [reference 2] except that a 9:1 stepdown transformer replaces the buffer amplifier used to convert the high impedance at the summing junction (arm of R3 phase shift potentiometer) to a low impedance suitable for a 50-ohm receiver input. To provide a lower probability of spurious responses, homebrew transformers using binocular cores are used in place of the small Mini-Circuits types used in the DXP-3 and some of the other similar designs. Figure 3 shows the binocular core and Figure 4 shows the method of winding transformers on one of these cores. The 2-turn primary and 2-turn secondary shown in Figure 4 are merely for illustration. Different numbers of windings are used on the Mini-DXP-5's actual transformers (T1, T2, and T3) as noted on the second schematic page (Figure 2). Figure 1 is the first of the two Mini-DXP-5 schematic drawings. This is such a simple circuit that parts lists and hole-drilling tables are not included. Those provided with DXP-3 should give a reasonable starting point for the experienced homebrewer.

As noted in other articles, the object of a phasing unit is to combine the contributions of two antennas at a 180 degree phase relation in order to null out a dominant signal (or noise) and let otherwise-inaudible weaker co-channel and adjacent channel signals come through from directions away from the general compass bearing of the null.

Mini-DXP-5, as shown, is optimized for medium wave (300 to 3000 kHz) operation. Reducing the values of C6 and C7 from 820 pF to something like 330 pF will give better nulling adjustment at frequencies above 3 MHz. Increasing the values of these capacitors to something on the order of 2200 pF each and increasing transformer turns some (while keeping roughly the same ratios) will improve usability down in the longwave range (i.e. 125 to 500 kHz). Phase shifting is wideband in nature: tuning is not required. With broadband phasing, a null set up in a given direction is often effective plus or minus 100 kHz or more from the set-up frequency.

The two antennas used should be somewhat different in directional pick-up characteristics (e.g. loop versus whip) if physically close to each other. Similar antenna types may be used if they are separated by at least 30 m / 100 ft. along the axis pointing towards signals to be nulled.

WBZB
1090 AM

**Mini-DXP-5
DXpedition Phasing Unit
Figure 1 : Input Section**

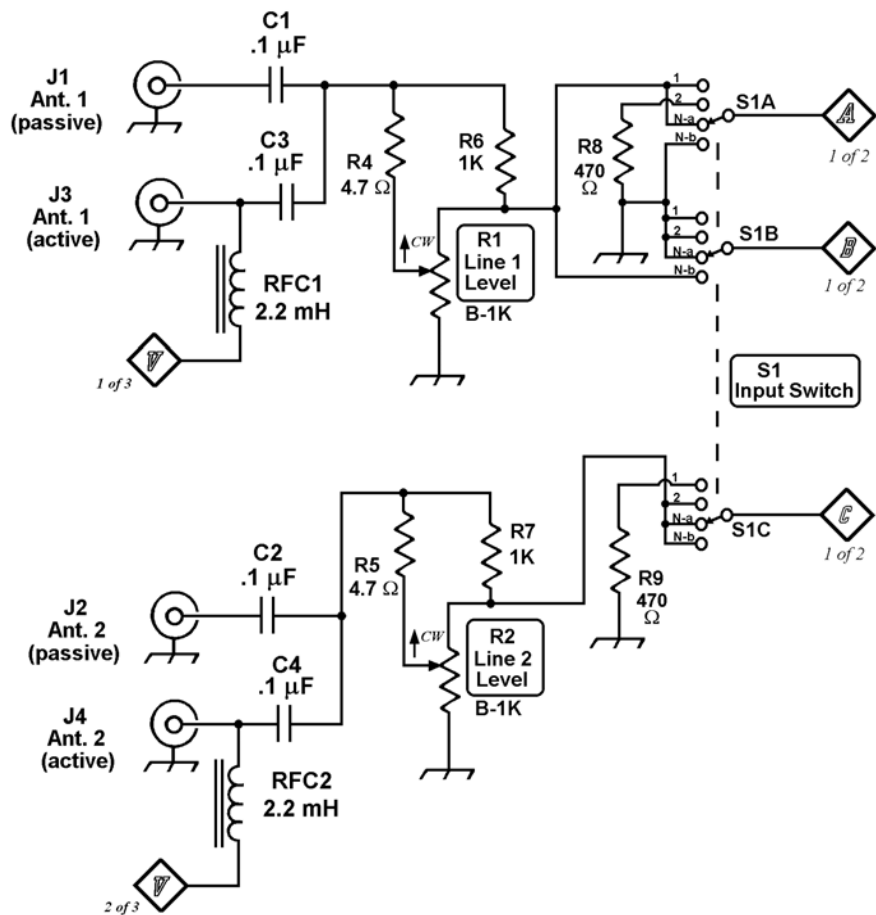

Figure 1: input section Mini-DXP-5 schematic

The Mini-DXP-5 allows independent observation of each input line as well as providing two combined signal (null) positions. This enables the user to balance amplitudes accurately, at least if the receiver has an S-meter, before adjusting the phase for a null. For good null depth, each of the two input lines must have a similar strength of the signal to be nulled.

There is an input (J6) for DC power on the Mini-DXP-5 even though the unit is passive. This is provided so that power may be provided to external active antennas (such as the MFJ-1024 whip) or to line amplifiers following low-gain antennas such as Pennants. If you never expect to use active antennas, you can simplify the design by deleting C3, C4, C5, J3, J4, J6, RFC1, and RFC2: all of these components are used to support the operation of active antennas or external line-amps.

**Mini-DXP-5
DXpedition Phasing Unit
Figure 2: Output Section**

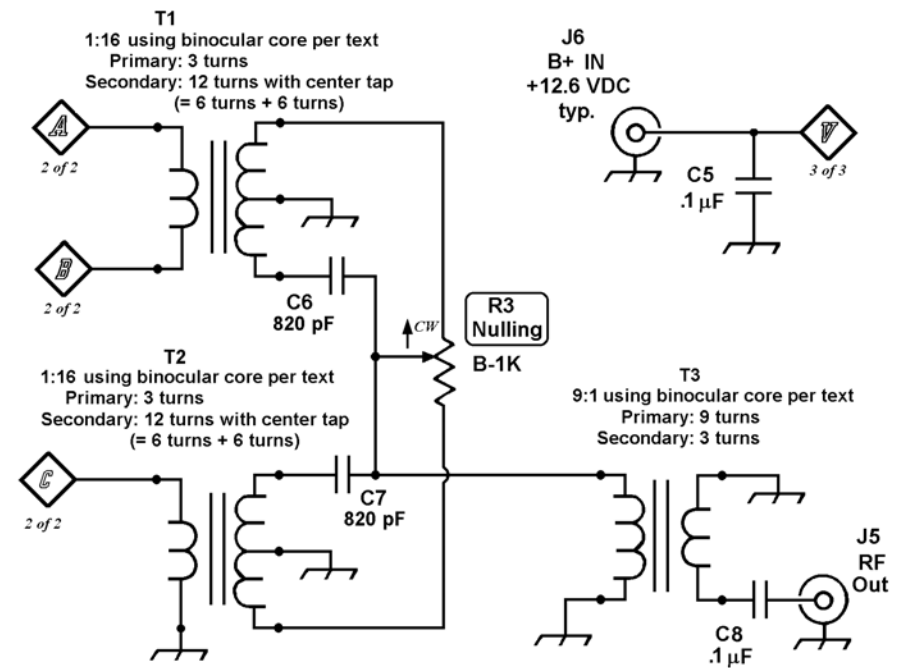
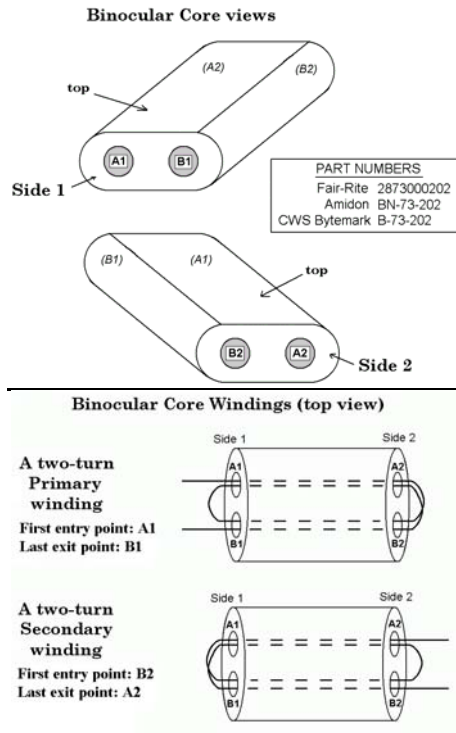

Figure 2: output section Mini-DXP-5 schematic

In high-signal urban areas, one could benefit from passive L-C preselection on each of the two input lines ahead of the unit. This can be accomplished with an **MWTU-1** outboard accessory on each input (see **Accessories**, an appendix to this article). In most cases, this isn't necessary.

Another accessory that may be usable is an external antenna amplifier, at least when you're using the Mini-DXP-5 in rural areas or with low-signal antennas such as Flags, Pennants, or BOG's (Beverage-on-ground). The **XA-1 Transfer Amplifier**, shown in the **Accessories** section, can fulfill this need. Its transfer feature couples the antenna through passively if DC power is not provided via choke-coupling to the coaxial center conductor. If power is provided, the amplifier, with about 20 dB of gain, kicks in. XA-1 has different input transformers to accommodate a variety of antennas including those in the terminated-loop family (Pennant, Flag, Kaz, Ewe, K9AY, etc.), broadband closed loops, noise-reduced slopers, verticals, Beverages, random wires, etc.





above - Figure 3: binocular core views and Figure 4: winding method

Operating the Mini-DXP-5

Practicing on stable daytime medium wave groundwave signals is the best way to become familiar with the unit's operation. When starting out, choose a frequency having some evidence of a second station under the dominant one.

Initial set-up:

- Connect a passive (unpowered) antenna to J1, or connect an active antenna (such as an MFJ-1024 whip) to J3.
- Connect the second antenna to J2 (if passive) or J4 (if active).
- Connect a DC power source of +12 volts (min.) to +18 volts (max.) to J6 if you had connected anything to J3 or J4.
- Connect the receiver, via coaxial cable, to J5.
- Set R1 and R2 fully clockwise.

Amplitude Balancing:

- Set R3 to center.
- With S1 on 1, observe the level of the dominant signal (or noise) to be nulled. Also do this with S1 on 2.
- If the signal level had been greater in the S1 = 1 position, adjust R1 so that the signal level measured with S1 on 1 is equal to that obtained with S1 on 2.
- Conversely, if the signal level had been greater in the S1 = 2 position, adjust R2 so that the signal level measured with S1 on 2 is equal to that obtained with S1 on 1.

Nulling:

- Set S1 to Null-a and adjust R3 for the best reduction of the dominant signal to be removed. Also do this R3 adjustment with S1 set to Null-b. Leave S1 on the null position which gave the deeper, better-defined null.
- Finish up the null by small interactive adjustments of R3, R1, and R2.

- Occasionally it may help to set R1 and R2 "fully clockwise minus 1 hour" (e.g. pointers at "4 o'clock" if fully clockwise is "5 o'clock") and then go back to the "Amplitude Balancing" section and proceed forward from there.

Variants: DXP-5, DXP-5A, DXP-5B, Super-DXP-5

DXP-5 is a more complex version that contains two switchable input amplifiers similar to what would be used in the external XA-1 accessory. **DXP-5A** contains a switchable output amplifier which can be selected instead of T3 after the summing junction. This is of a high-to-low impedance / gain type such as BBVA-A or BUF-B. **DXP-5B** contains a pair of switchable input amps and the single switchable output amplifier (i.e. features of both the DXP-5 and DXP-5A). **Super-DXP-5** contains all the above and also provides switchable L-C tank circuits on each input, similar to what using the MWU-1 external accessory would achieve.

References Cited:

Links to Internet based references may change over time. If a specified link does not work, articles may still be accessible by contacting me directly so I can mail a disk of the article or suggest an updated Web link. Web search engines may also help to find versions archived by various clubs. Also, in some cases, articles may be available in "hard copy" from IRCA reprint service as well as from the National Radio Club.

- [1] MWDX-5: web = "<http://hometown.aol.com/MarkWA1ION/mwdx5.pdf>"
- [2] DXP-3: web = "<http://www.qsl.net/wa1ion/dxp3.pdf>"

Many other articles may be found via links from "<http://www.qsl.net/wa1ion/index.html>"

APPENDIX: ACCESSORIES

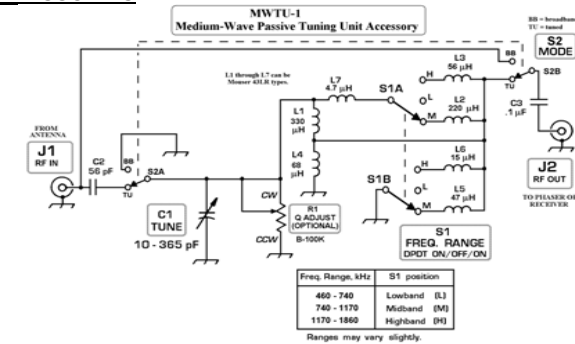

Figure 5: MWU-1 passive medium-wave tuner accessory

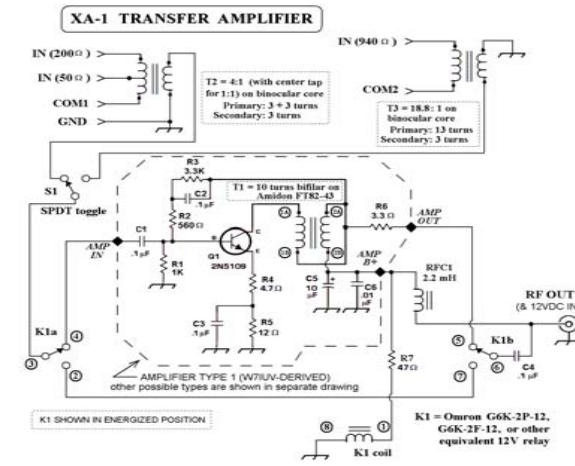

Figure 6: XA-1 transfer amplifier accessory

OTHER AMPLIFIERS THAT CAN BE USED IN THE XA-1

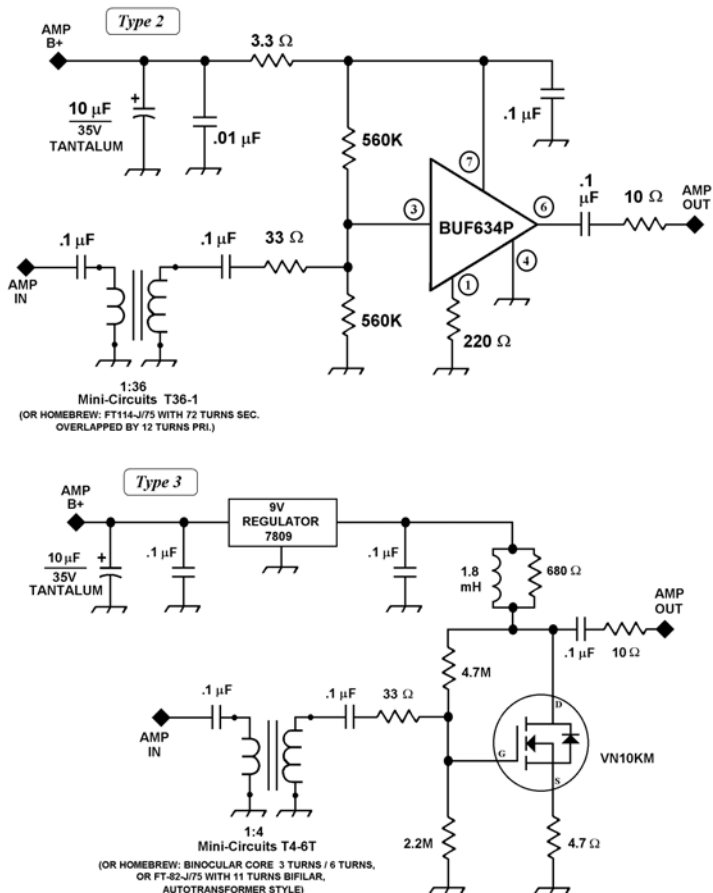

Figure 7: other amplifiers that can be used in the XA-1 box

2003-2004 DX CONTESTS

Manager: Nancy Johnson – 265 Waterton Wy – Billings, MT 59102-7755

E-mail: NancyJohnson@prodigy.net

Standings as of May 15, 2004

Regular Points + Mystery Points = Total Points

	R	M	T			
1. Bill Nittler	366	225	591	5. Chris Knight	72	50 122
2. Nigel Pimblett	306	125	431	6. Darrell Neft	73	25 98
3. Tim Noonan	129	75	204	7. Dale Park	29	50 79
4. Nancy Johnson*	69	100	169	8. Art Blair	29	0 29
				9. John C. Johnson	6	0 6

* Contest manager is not eligible to win.

You can join this year's contest at any time. Contest rules can be found online, or in DXM dated Aug. 23, 2003. You never know when you send me a contest entry what your total points will be, as you may have heard some mystery stations. The contest will end on May 31, 2004.

SPORTS ON RADIO

With: O. Howit Hertz

E-mail: artngwen@calweb.com

ANAHEIM ANGELS

Announcers: Rory Markas and Terry Smith. Ivan Lara & Jose Mota (Spanish).

- 600 KSJB Jamestown, ND
- 710 KSPN Los Angeles, CA (Flagship)
- 800 XESPN Tijuana, BCN
- 960 KIXW Apple Valley, CA
- 1020 KTNQ Los Angeles, CA (Spanish)

- 1240 KLOA Ridgecrest, CA
- 1350 KBID Bakersfield, CA
- 1450 KGAM Palm Springs, CA
- 1520 KVTA Port Hueneme, CA

BALTIMORE ORIOLES

- 540 WDMV Pocomoke City, MD
- 910 WRNL Richmond, VA
- 910 WSBA York, PA
- 930 WFMD Frederick, MD
- 960 WHYL Carlisle, PA
- 960 WTGM Salisbury, MD
- 1090 WBAL Baltimore, MD (Flagship)
- 1200 WAGE Leesburg, VA
- 1280 WHVR Hanover, PA
- 1340 WEPM Martinsburg, WV

- 1400 WINC Winchester, VA
- 1430 WNAV Annapolis, MD
- 1450 WTBO Cumberland, MD
- 1470 WTRR Westminster, MD
- 1490 WARK Hagerstown, MD

- 96.9 WBEY Crisfield, MD
- 105.3 WFRB Frostburg, MD
- 106.5 WKHW Pocomoke City, MD

PITTSBURGH PIRATES

- 590 WMBS Uniontown, PA
- 630 WJAW St. Marys, WV
- 800 WCHA Chambersburg, PA
- 1020 KDKA Pittsburgh, PA (Flagship)
- 1160 WCCS Homer City, PA
- 1200 WCED Du Bois, PA
- 1200 WKST New Castle, PA
- 1230 WBVP Beaver Falls, PA
- 1230 WTIV Titusville, PA
- 1270 WCBC Cumberland, MD
- 1300 WJYP St. Albans, WV
- 1310 WNAE Warren, PA
- 1340 WMON Montgomery, WV
- 1340 WOYL Oil City, PA
- 1340 WTRN Tyrone, PA
- 1340 WXXK Clarksburg, WV
- 1370 WWCB Corry, PA
- 1410 WSCW South Charleston, WV
- 1430 WEIR Weirton, WV

- 1430 WVAM Altoona, PA
- 1440 WAJR Morgantown, WV
- 1450 WFRA Franklin, PA
- 1450 WJPA Washington, PA
- 1450 WMAJ State College, PA
- 1460 WMBA Ambridge, PA
- 1480 WCNS Latrobe, PA
- 1490 WESB Bradford, PA
- 1490 WNGW Meadville, PA
- 1490 WSPQ Johnstown, PA (?)
- 1490 WTCS Fairmont, WV
- 1490 WWPR Bradenton, FL
- 1530 WEYZ North East, PA
- 1570 WANR Warren, OH

- 95.7 WVKF Wheeling, WV (?)
- 97.5 WDDH Saint Marys, PA
- 104.1 WPXZ Punxsutawney, PA
- 107.1 WEXC Greenville, PA

Minor League Baseball

ATLANTIC LEAGUE BASEBALL

- Atlantic City Surf - 1490 WUSS Pleasantville, NJ
- Bridgeport Bluefish - (?)
- Camden River Sharks - No Radio
- Lancaster Barn Stormers - No Radio
- Long Island Ducks - 540 WLIE Islip, NY
- Nashua Pride - 106.3 WHOB Nashua, NH
- Newark Bears - No Radio
- Pennsylvania Road Warriors - No Radio
- Somerset Patriots - 1040 WCHR Flemington, NJ
- 1450 WCTC New Brunswick, NJ

CAROLINA LEAGUE BASEBALL

- Frederick Keyes - No Radio

Kinston Indians -
 Play-by-Play: Ron Sinclair
 960 WRNS Kinston, NC (Flagship) 97.9 WNBB Bayboro, NC
 1250 WGHB Farmville, NC

Lynchburg Hillcats - 1050 WBRG Lynchburg, VA
 105.5 WKDE Alta Vista, VA

Myrtle Beach Pelicans - 1050 WIQE Conway, SC
 93.7 WXJY Georgetown, SC
 93.9 WJXY Conway, SC

Potomac Cannons - No Radio

Salem Avalanche - 810 WPIN Dublin, VA
 1240 WGMN Roanoke, VA (Flagship)
 1320 WVGM Lynchburg, VA
 1430 WKEX Blacksburg, VA

Wilmington Blue Rocks - 1290 WWTX Wilmington, DE
 1410 WDON Dover, DE

Winston-Salem Warthogs - 600 WSJS Winston-Salem, NC
 1200 WSML Graham, NC

CENTRAL LEAGUE BASEBALL

Amarillo Dillas – 1440 KPUR Amarillo, TX
 Coastal Bend Aviators – 1150 KCCT Corpus Christi, TX
 1230 KSIX Corpus Christi, TX
 Edinburg Roadrunners – 1240 KSOX Raymondville, TX
 Fort Worth Cats – 92.1 KTFW Glen Rose, TX
 Jackson Senators – 1240 WPBQ Flowood, MS
 Pensacola Pelicans – 94.1 WMEZ Pensacola, FL
 102.7 WXBM Milton, FL
 San Angelo Colts – 1260 KKSA San Angelo, TX
 Shreveport Sports – 1340 KRMD Shreveport, LA

FLORIDA STATE LEAGUE BASEBALL

Brevard County Manatees - 920 WMEL Melbourne, FL
 Clearwater Threshers - No Radio
 Daytona Cubs - 1380 WELE Ormond Beach, FL
 Dunedin Blue Jays - No Radio
 Fort Myers Miracle - 770 WWCN North Fort Myers, FL (40 home games)
 Jupiter Hammerheads - 760 WEFL Tequesta, FL
 88.1 WAYF West Palm Beach, FL

Lakeland Tigers - 1230 WONN Lakeland, FL
 97.5 WPCV Winter Haven, FL

Palm Beach Cardinals - 760 WEFL Tequesta, FL
 St. Lucie Mets - No Radio

Sarasota Red Sox - 88.1 WJIS Bradenton, FL
 96.5 WYNF Gray, GA
 107.9 WSRZ Coral Cove, FL

Tampa Yankees - No Radio
 Vero Beach Dodgers - 1370 WAXE Vero Beach, FL
 1490 WTTB Vero Beach, FL

FRONTIER LEAGUE BASEBALL

Chillicothe Paints – 100.9 WXIZ Waverly, OH
 Evansville Otters – 91.5 WUEV Evansville, IN
 Florence Freedom – Internet only. (?)

Gateway Grizzlies – 1400 KJFF Festus, MO
 104.7 WNSV Nashville, IL
 106.1 WSMI Litchfield, IL (Flagship)

Kalamazoo Kings – 1660 WQSN Kalamazoo, MI
 Mid-Missouri Mavericks – 1580 KTGR Columbia, MO
 900 KFAL Fulton, MO
 950 KWOS Jefferson City, MO (Selected Games)

Richmond Roosters - 1490 WKBV Richmond, IN (Flagship)
 1580 WCNB Connersville, IN
 98.3 WZZY Winchester, IN

River City Rascals – 104.5 KSLQ Washington, MO
 Rockford RiverHawks – 102.3 WRHL Rochelle, IL
 Springfield/Ozark Ducks – 98.7 KWTO Springfield, MO
 Washington Wild Things – 970 WBGW Pittsburgh, PA (Thursday & Friday night games)
 95.3 WJPA Washington, PA

Windy City Thunderbolts – (?)

MIDWEST LEAGUE BASEBALL

Battle Creek Yankees - No Radio
 Beloit Snappers - 1380 WTJK Beloit, IL
 Burlington Bees - 1360 KBKB Fort Madison, IA
 1490 KBUR Burlington, IA

Cedar Rapids Kernels - 1600 KCRG Cedar Rapids, IA
 Clinton Lumberkings - 1390 KCLN Clinton, IA
 94.7 KZEG Clinton, IA

Dayton Dragons - 1410 WING Dayton, OH
 Fort Wayne Wizards - 1380 WKJG Fort Wayne, IN
 Kane County Cougars - 1280 WBIG Aurora, IL (Nights)
 1530 WJGG Aurora, IL (Days)

Lansing Lugnuts - 730 WVFN East Lansing, MI
 Peoria Chiefs - 1350 WOAM Peoria, IL
 South Bend Silver Hawks - 1580 WDND South Bend, IN
 Swing of the Quad Cities - 104.9 KBOB De Witt, IA
 West Michigan Whitecaps - 1340 WBBL Grand Rapids, MI (Flagship)
 1380 WSCG Greenville, MI
 1450 WHTC Holland, MI
 97.3 WDEE Reed City, MI

Wisconsin Timber Rattlers - 104.3 WECB Seymour, WI

NEW YORK-PENN LEAGUE BASEBALL

Aberdeen IronBirds - 970 WAMD Aberdeen, MD
 Auburn DoubleDays - 89.1 WDWN Auburn, NY
 Batavia Muckdogs - 1490 WBTA Batavia, NY
 Brooklyn Cyclones - 620 WSNR Jersey City, NJ
 Hudson Valley Renegades - 1260 WBNR Beacon, NY
 Jamestown Jammers - 1340 WKSJ Jamestown, NY
 Lowell Spinners - 980 WCAP Lowell, MA
 Mahoning Valley Scrappers - 1390 WNIO Youngstown, OH
 New Jersey Cardinals - 1360 WNNJ Newton, NJ
 Oneonta Tigers - No Radio
 Staten Island Yankees - 88.9 WSIA Staten Island, NY
 Tri-City Valley Cats - 1160 WABY Mechanicsville, NY (Negotiating)
 Vermont Expos - 1390 WVAA Burlington, VT
 Williamsport Crosscutters - 91.7 WRLC Williamsport, PA (Away games only)

NORTHEAST LEAGUE

Aces – No radio
 Bangor Lumberjacks – 88.5 WHCF Bangor, ME
 Brockton Rox – 1460 WBET Brockton, MA
 Elmira Pioneers – No radio
 Les Capitaes de Quebec – 800 CHRC Quebec City, QC
 New Haven County Cutters – 1150 WMRD Middletown, CT
 New Jersey Jackals – 88.7 WPSC Wayne, NJ
 North Shore Spirit – 1230 WESX Salem, MA

PIONEER BASEBALL LEAGUE

Billings Mustangs - 970 KBUL Billings, MT
 Casper Rockies - 1230 KVOC Casper, WY
 Great Falls White Sox - 560 KMON Great Falls, MT
 Helena Brewers - 1340 KCAP Helena, MT

Idaho Falls Chukars - 980 KUPI Ammon, ID
 Missoula Osprey - 1340 KYLT Missoula, MT
 Ogden Raptors - 800 KSOS Brigham City, UT
 Provo Angels - 960 KOVO Provo, UT

SOUTH ATLANTIC LEAGUE BASEBALL

Asheville Tourists - No Radio
 Augusta GreenJackets - 1630 WRDW Augusta, GA
 Capital City Bombers - No Radio
 Charleston Alley Cats - 1240 WBES Dunbar, WV
 Columbus Catfish - 540 WDAK Columbus, GA
 Delmarva Shorebirds - 101.1 WQMR Snow Hill, MD
 107.1 WTDK Federalsburg, MD
 Greensboro Bats - 950 WPET Greensboro, NC
 Hagerstown Suns - 1410 WHAG Halfway, MD
 Hickory Crawdads - 92.1 WMNC Morganton, NC
 Kannapolis Intimidators - 1460 WRKB Kannapolis, NC
 Lake County Captains - 1330 WELW Willoughby, OH
 Lakewood BlueClaws - 1160 WOBM Lakewood Township, NJ
 Lexington Legends - 1300 WLXG Lexington, KY
 Rome Braves - 1410 WLAQ Rome, GA
 1430 WGAA Cedartown, GA
 95.7 WATG Trion, GA
 Savannah Sand Gnats - No Radio

GEOMAGNETIC INDICES

Compiled by: Phil Bytheway

E-mail: phil_tekno@yahoo.com

Geomagnetic Summary April 8 2004 through May 25 2004

Tabulated from email status daily.

Date	Flux	A	K	Space Wx Today	Space Wx Forecast	Au
4/ 8	98	13	3	no storms	no storms	9
9	94	17	2	no storms	no storms	9
10	90	18	3	minor	minor	7
11	88	12	3	no storms	minor	6
12	90	9	2	minor	minor	7
13	91	14	3	minor	no storms	8
14	93	8	2	no storms	no storms	4
15	95	5	1	no storms	no storms	5
16	97	4	2	minor	no storms	7
17	x	x	x	x	x	x
18	98	8	2	no storms	no storms	8
19	109	12	2	no storms	no storms	9
20	113	8	3	no storms	no storms	5
21	111	7	1	no storms	no storms	3
22	113	9	3	no storms	no storms	8
23	117	8	3	minor	no storms	4
24	115	16	2	minor	no storms	5
25	112	11	3	minor	no storms	3
26	107	14	3	minor	no storms	5
27	100	7	2	no storms	no storms	6
28	95	5	2	no storms	no storms	5
29	90	10	3	no storms	no storms	6
4/30	89	4	0	no storms	no storms	4
5/ 1	x	x	x	x	x	x
2	94	x	1	no storms	no storms	5
3	98	7	2	no storms	no storms	5
4	91	8	2	no storms	no storms	5
5	87	10	2	no storms	no storms	7
6	89	18	4	no storms	no storms	7
7	86	12	2	no storms	no storms	8

8	85	18	2	no storms	no storms	7
9	87	9	x	no storms	no storms	8
10	93	8	1	no storms	no storms	4
11	x	x	x	x	x	x
12	90	10	3	no storms	no storms	6
13	99	14	3	no storms	no storms	9
14	101	17	3	minor	no storms	7
15	110	8	2	no storms	no storms	4
16	115	10	2	no storms	no storms	5
17	118	6	2	no storms	no storms	7
18	111	6	3	no storms	no storms	4
19	108	9	3	no storms	no storms	4
20	109	13	3	no storms	no storms	6
21	105	16	3	minor	no storms	6
22	107	12	2	no storms	no storms	4
23	102	10	1	minor	minor	4
24	104	15	3	no storms	minor	10
5/25	105	15	3	no storms	minor	3

The IRCA is a non-profit organization devoted to the hobby of hearing distant stations on the Broadcast Band (510-1720 kHz). **DX Monitor**, the official publication of the IRCA, is published in "soft" form 35 times a year (weekly from November through March, twice monthly from April to November) and in printed form 30 times a year (weekly November through March, monthly April to November). **DX Monitor** contains members' loggings, articles on radio stations, receiver reviews, technical articles, DX tips, and other material of interest to Broadcast Band DX hobbyists. IRCA is a member of ANARC, the Association of North American Radio Clubs.



CLUB OFFICERS AND CONTACT INFORMATION

President: Nick Hall-Patch – 1538 Amphion St., Victoria, BC V8R4Z6 CANADA
 e-mail: nhp@ieee.org (proposals/gripes)

Secretary-Treasurer: Lynn Hollerman, P.O. Box 60241, Lafayette LA 70596
 e-mail: lynn@eatel.net or ircamember@ircaonline.org (dues, address changes, Topica sign-ups)

Board of Directors: Karl Zuk (chairman) karlzik@hotmail.com
 Phil Bytheway phil_tekno@yahoo.com, Patrick Martin mwdxer@webtv.net
 Mike Sanburn mikesanburn@hotmail.com, Pete Taylor ptdx@comcast.net,
 John C. Johnson John_Johnson@prodigy.net and Tim Noonan DXing2@aol.com
Editor-in-Chief: Phil Bytheway, 9705 Mary Ave NW, Seattle WA 98117-2334
 e-mail: phil_dxm@yahoo.com (all material for publication goes here)

MEMBERSHIP DUES (DXM=printed DX Monitor, SDXM=soft e-mailed version)

Destination	SDXM	DXM	DXM+SDXM
USA	\$10	\$30	\$35
Canada & Mexico (group 2)	\$10	\$36	\$41
Western Europe (group 3)	\$10	\$50	\$55
Australia/NZ/Japan (group 4)	\$10	\$51	\$56
Rest of world (group 5)	\$10	\$48	\$53

TRIAL MEMBERSHIP (10 issues) TO USA-CANADA-MEXICO only: \$10 DXM, \$12 DXM / SDXM Installment Rate: 2 payments a year of one-half dues plus \$1.

Make checks and Money Orders in US funds payable to IRCA.

All dues and address changes go to: **IRCA, PO Box 60241, Lafayette LA 70596**

Pay electronically with PayPal—add \$1 to all prices above. Go to www.paypal.com, then send your dues to ircamember@ircaonline.org --contact Lynn Hollerman for more information.

Sample copies of DX Monitor are available. Along with your request, please include first class postage of: **37c** for USA addresses. **60c** for Canada and Mexico or **2-International Reply Coupons** each, for other countries. Send to: **IRCA**— 3410 Marion St. SE, Albany, OR 97322-3871.

For information on **subscribing to the IRCA E-group** at Hard-Core-DX, a group e-mail service, contact the moderator, Lynn Hollerman at lynn@eatel.net or ircamember@ircaonline.org.

Unless otherwise noted, permission is granted to publish, broadcast, or otherwise reproduce non-copyrighted material appearing in **DX Monitor** provided credit is given to the IRCA and the original contributor. Opinions in **DX Monitor** are those of the original contributors and do not necessarily reflect those of the IRCA, its publishing staff, editors or officers.

©2004 International Radio Club of America

THE INTERNATIONAL RADIO CLUB OF AMERICA
 P.O. Box 60241, Lafayette LA 70596
<http://www.ircaonline.org>