

MEDIUM WAVE NEWS

MEDIUM WAVE CIRCLE

March 2006 Volume 51 No. 10

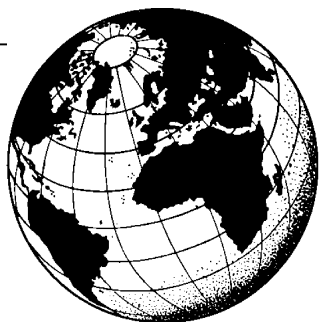

♣ *WWL & Katrina*

♣ *DRM & RTL*

♣ *Broadband phasing*

♣ *Future of DX tests*

♣ *2005: an excellent vintage*

♣ *Profile: Spectrum Radio*

Hon. President*	Bernard Brown, 130 Ashland Road West, Sutton-in-Ashfield, Notts. NG17 2HS	
Treasurer/ Secretary*	Clive Rooms, 59 Moat Lane, Luton LU3 1UU ☎ 01582-598989 (after 1800 hours)	(all general club enquiries) treasurer@mwcircle.org
MWN General Editor*	Steve Whitt, Landsvale, High Catton, Yorkshire YO41 1EH ☎ 01759-373704	editor@mwcircle.org (editorial & stop press news)
Membership Sec.	Paul Crankshaw, 3 North Neuk, Troon, Ayrshire KA10 6TT ☎ 01292-316008	membership@mwcircle.org (all changes of name or address)
MWN Despatch	Peter Wells, 9 Hadlow Way, Lancing, Sussex BN15 9DE ☎ 01903 851517	despatch@mwcircle.org (printing/ despatch enquiries)
External Representative	George Brown, 6 Glassel Park Road, Longniddry, East Lothian, EH32 0NT ☎ 01875-852317	(inter club liaison, advertising, publicity)
Reprints Manager	Clive Rooms	reprints@mwcircle.org (all orders for club publications & reprints)
MWN Contributing Editors (* = MWC Officer; all addresses are UK unless indicated)		
DX Loggings	Martin Hall, Glackin, 199 Clashmore, Lochinver, Lairg, Sutherland IV27 4JQ ☎ 01571-855360	dxlogs@mwcircle.org
Mailbag	Herman Boel, Roklijf 10, B-9300 Aalst, Vlaanderen (Belgium) ☎ +32-53-711 244	mailbag@mwcircle.org
Features	VACANCY	features@mwcircle.org
Home Front	John Williams, 100 Gravel Lane, Hemel Hempstead, Herts HP1 1SB ☎ 01442-408567	homefront@mwcircle.org
Eurolog	John Williams, 100 Gravel Lane, Hemel Hempstead, Herts HP1 1SB	
World News	Jeff Weston, 16, Whitmore Ct, Little London, Silverstone, Northants, NN12 8UP ☎ 01327 858472	world-news@mwcircle.org
Beacons/Utility Desk	VACANCY ☎ 01XXX	utility@mwcircle.org
Central American Desk	Tore Larsson, Frejagatan 14A, SE-521 43 Falköping, Sweden ☎ +-46-515-13702 fax: 00-46-515-723519	ca-news@mwcircle.org
S. American Desk	Tore B Vik, Post Box 88, NO-1851 Mysen, Norway ☎ +-47-69891192	sa-news@mwcircle.org
N. American Desk	Barry Davies, 20 Ryehill Park, Smithfield, Carlisle CA6 6BH	na-news@mwcircle.org
Verifications	Clive Rooms, 59 Moat Lane, Luton LU3 1UU	verifications@mwcircle.org
KEEP IN TOUCH	Internet: MWC Web site e-mail news service:	http://www.mwcircle.org FREE service for members; e-mail webmaster to join
Webmaster	Rémy Friess	webmaster@mwcircle.org

STOP PRESS:

This month we welcome the following new and re-joining members to the Circle: Howard Smith, Stonehaven; Torolf Johnsson, Stockholm, Sweden; Robert Luehrmann, Lengerich, Germany; Andrew Brade, Holme-on-Spalding Moor, Yorks. Welcome to the Circle!

USA: Off channel station: 1249.5 = WKBR-NH, off channel for at least a week now. Oldies format. (*Mark Connelly, WAIION*)

Stop Press Deadlines:	26 th March for April 2006	30 th April for May/June 2006
Cover illustration: Luxembourg celebrates the centenary of radio communications in 1996		
Medium Wave News is published 10 times a year by the Medium Wave Circle		© 2006

EDITORIAL

with Steve Whitt

✉ Landsvale, High Catton, Yorkshire YO41 1EH
e-mail: editor@mwcircle.org ☎ 01759-373704

Reminder: Membership Renewal Time

If your membership subscription to the Circle is due to run out at the end of March 2005 you should have received a renewal form included with the last issue of MWN. If you are in any doubt about when your membership runs out, please check the date on your address label on the envelope.

Please note that if you do not renew promptly the next issue will be the last copy of MWN that will arrive through your letter-box.

MEMBERSHIP FEES FROZEN FOR 13th YEAR RUNNING!!

	1 year to Mar 2006	2 year to Mar 2007	3 year to Mar 2008
UK	£12	£22	£33
Europe (Inc Eire)	£16/30Eu	£30/50Eu	£45/75Eu
Rest of World Airmail	£21 / \$35US	£39 / \$65US	£59 / \$95US
Surface	£16 / \$27US	£30 / \$50US	£45 / \$75US

DX warning: TOUCH LAMP NOISE

Patrick Martin writes, “ I was given a Christmas present of a touch lamp. Yes, even a DXer gets something other than what they want. However, this was an interesting gift, as I would never buy one myself, but it gave me a chance to check one out in the house. I first thought with it off, it would not present any problems, as I never heard any noise from it, so I thought. At full brightness, the noise was low, but in the middle positions, it is very noisy. It is a bed stand lamp. So I thought, I would just use it to get into bed and turn it off to listen to the radio. I listen to KKOH or KGO generally at night. Well, all has been fine the last 2 months, until today I noticed on the R8, the complete other side of the house, this terrible carrier from 1565 to 1585. Completely wiping out KCVR-1570 and KGAL-1580. This carrier was S-7 or 8. It seems I have heard a bit of noise there anyway, but I had not noticed much, until today.

I went to the bedroom to check out the touch lamp, thinking it might be it. I touched the lamp and the pitch of the carrier changed. I reached behind the bed and unplugged the lamp, and immediately the carrier was gone. In fact the overall noise level in the house dropped. There seemed to be some sort of low level hash behind some weak stations during the day I could not put my finger on. Well, the touch lamp is in the closet on the shelf and the regular old bed lamp with the regular bulb is back. I have it a chance. It is a nice lamp too. It is shame they put out so much garbage.” Caveat emptor!

Members Advert – For Sale

Mizuho UZ-77 Indoor Active Medium Wave Loop Antenna, as new. £65. Mike Tragenza 01392 811370 after 7 pm. Or write: Ranchi, Longdown, Exeter, Devon EX6 7SR.

NPL Standard Time

NPL Time & Frequency services: The MSF 60 kHz signal broadcast from the BT Rugby Radio Station is occasionally taken off air to allow maintenance work to be carried out in safety. The dates and times (UK local) scheduled for 2006-7 are:

Mon 15 May 2006 0800 BST until Fri 19 May 1600

Tue 5 Sep 2006 1000-1400 BST

Tue 2 Jan 2007 1000-1400 UT

During the main maintenance period in May, the service will be restored overnight when feasible. Duration of each outage will be kept to a minimum and the signal may be back on air prior to the times given. Additional info on Tele: 020 8943 6880; fax 020 8943 6458; e-mail: timc @ npl.co.uk Website: <http://www.npl.co.uk/time>.

MW Offset List

: <http://www.myradiobase.de/mediumwave/mwoffset.txt>

containing 1338 offsets! (but still 15874 active records in database without exact frequency....) This list is a collection of exact operating frequencies of Medium Wave stations. Even small deviations from the nominal frequencies ("offsets") help Medium Wave DXers to identify stations. When monitoring the nominal frequencies with software, DXers can see carriers which are so weak that they never would produce audio. Exact frequencies and fade-in/fade-out patterns can however help to identify the source of the signal. Initially compiled from own monitoring, data is now being added from various sources. The list is ordered by nominal frequency and then by exact (measured) frequency. If it has been determined that a station transmits exactly on frequency, it will also be included - not only when it is some Hz off.

WRTH 1947 to 1958 Reprint

Twelve editions with fully text search function on a CD! This is a joint venture between the WRTH Co. and ADDX on the occasion of the 60th edition of the WRTH! The rare old copies of the first editions of the WRTH occasionally can be found at eBay auction. Thus the 1949 edition was sold last summer for 750 U.S. Dollars! The first twelve editions have now been scanned and are sold on a CD which I have had a look at. It is very easy to work with and highly recommendable to all people interested in broadcast radio history. More at <http://www.addx.de/Service/CDreprint.php>. Until Jan 31, 2006, it is sold for 40 Euro including postage. After that date the CD will cost 50 Euro. Send your order and payment directly to ADDX, Scharsbergweg 14, D-41189 Moenchengladbach, Germany. Bank transfer to ADDX-Konto Nr. 8686800 at Deutschen Bank, Duesseldorf, BLZ 30070024 (IBAN: DE 7030 0700 1000 0868 6800, BIC: DEUT DE DB DUE). (Schmitz and Petersen)

Rogues gallery

Last month's rogues gallery line up were (from left to right): Steve Whitt, William Davies, Barry Davies and John Faulkner. Meanwhile the man in front with the hot soldering iron is Mark Hattam. Did you recognise them?

Have you got any similarly incriminating evidence of other DXers that we could inflict upon readers?



Thank you

Thank you to everyone who has already renewed their membership.

73s

Steve

P.S. PLEASE REMEMBER THE RENEWAL DEADLINE IF YOURS IS DUE NOW

IONOSPHERIC REPORT

from U.S. Dept. of Commerce, NOAA, Space Environment Center

Daily Geomagnetic Data

Date	Middle Latitude -- Fredericksburg --								High Latitude ---- College ----								Estimated ---- Planetary ----										
	A	K-indices							A	K-indices							Ap	K-indices									
2006 01 27	7	3	1	2	2	2	2	2	13	3	2	2	4	3	3	2	2	8	3	1	2	2	2	2	2	2	
2006 01 28	4	2	1	2	1	1	0	2	1	7	1	1	2	3	3	0	1	1	6	2	1	2	2	1	1	2	2
2006 01 29	1	0	1	0	0	0	0	0	0	2	1	1	1	1	0	0	0	1	3	1	1	1	0	1	1	0	0
2006 01 30	0	0	0	0	0	0	0	0	0	0	0	0	0	0	0	0	0	0	1	1	0	0	0	0	1	0	0
2006 01 31	1	0	0	0	0	1	1	1	0	1	0	0	0	0	1	1	0	0	2	0	0	0	0	1	1	0	1
2006 02 01	3	0	1	2	1	1	1	0	1	3	0	1	2	2	2	0	0	1	4	0	0	2	1	2	1	0	2
2006 02 02	1	1	0	0	1	0	0	1	1	3	0	0	0	3	2	0	1	0	3	1	0	0	1	1	0	1	2
2006 02 03	3	0	0	1	2	0	1	2	1	4	0	0	0	3	2	0	2	1	4	0	0	0	1	0	1	2	1
2006 02 04	3	1	3	1	1	1	0	0	0	6	1	1	2	3	3	1	0	0	4	1	2	2	1	1	0	0	1
2006 02 05	3	1	0	2	0	0	0	2	1	1	0	0	1	0	0	0	1	0	3	1	0	2	0	0	0	1	1
2006 02 06	11	1	3	2	2	3	2	3	3	32	0	2	4	5	7	3	2	3	12	1	4	2	2	3	2	3	3
2006 02 07	4	2	1	1	0	0	2	1	2	3	2	1	2	0	1	1	0	0	4	1	1	1	0	1	1	1	2
2006 02 08	2	2	1	2	0	0	0	0	0	2	0	0	2	2	1	0	0	0	3	2	0	2	1	1	0	0	0
2006 02 09	2	0	0	0	0	1	3	1	0	1	0	0	0	1	1	0	1	0	2	0	0	0	0	1	0	1	1
2006 02 10	2	1	0	0	0	0	0	1	2	1	0	0	0	1	0	0	0	1	2	1	0	0	0	0	0	1	2
2006 02 11	4	2	1	2	0	2	2	1	0	6	1	0	2	1	4	2	1	0	6	2	1	2	0	2	3	1	1
2006 02 12	2	1	1	1	0	1	1	0	0	2	0	2	0	0	2	1	0	0	3	2	2	1	0	1	0	0	0
2006 02 13	2	0	0	0	0	1	2	1	0	1	0	0	0	0	1	1	0	0	2	0	0	0	0	1	1	0	1
2006 02 14	1	0	0	0	0	1	0	0	1	0	0	0	0	0	0	0	0	1	1	0	0	0	0	0	0	0	1
2006 02 15	7	0	1	1	3	2	1	3	3	11	1	0	1	5	3	2	2	2	12	0	1	1	3	2	2	4	4
2006 02 16	7	2	2	2	2	2	2	2	1	17	3	2	5	5	3	0	1	1	8	3	2	3	3	1	0	1	2
2006 02 17	2	0	2	1	1	1	1	0	0	5	0	2	2	1	3	2	0	0	4	1	3	2	0	1	0	0	1
2006 02 18	2	0	0	0	1	2	0	1	1	2	0	1	0	1	2	0	0	0	2	0	0	0	0	1	0	0	1
2006 02 19	5	2	2	2	1	1	1	1	1	6	1	1	3	2	2	1	1	1	6	2	2	2	0	0	1	2	2
2006 02 20	9	1	2	2	3	3	3	2	2	44	2	2	3	6	6	7	3	3	20	2	2	3	4	4	6	2	2
2006 02 21	15	3	3	4	3	3	3	2	2	36	2	2	4	7	5	4	4	2	17	3	4	3	4	3	3	3	2
2006 02 22	11	4	3	3	2	2	2	1	1	25	3	2	3	6	5	4	2	0	12	4	3	3	3	3	2	1	2
2006 02 23	4	1	2	2	1	1	1	1	0	5	1	0	3	3	1	0	0	0	3	1	2	2	1	0	0	0	0
2006 02 24	4	2	1	0	2	2	1	2	0	13	1	0	1	5	5	1	0	0	6	2	2	0	3	3	0	0	0
2006 02 25	-1	-1	-1	-1	-1	-1	-1	-1	-1	-1	-1	-1	-1	-1	-1	-1	-1	-1	-1	1	0	0	-1	-1	-1	-1	-1

2005: an Excellent Vintage

Last year was clearly exceptional for MW DX, but just how good? One measure is the number of different North American stations heard by DXers in the UK & Ireland operating at home. If one excludes DX-peditions and Martin Hall at Clashmore (almost a permanent DX-pedition!) then one gets some interesting figures.

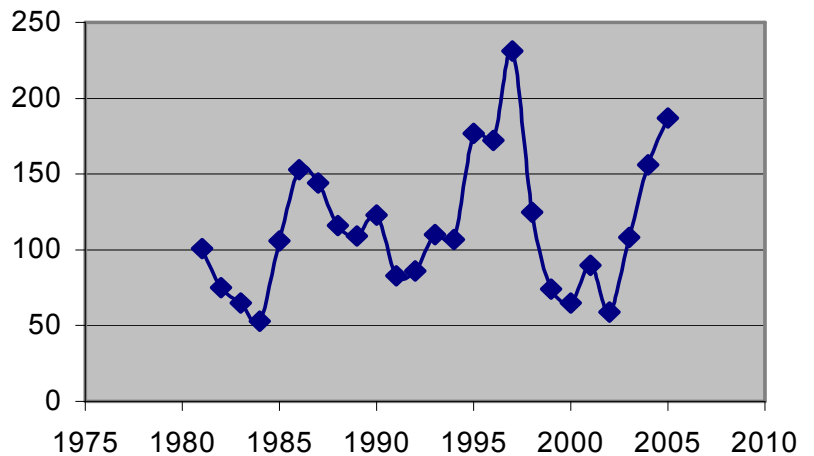

I have plotted these figures for every year since 1981, in the graph. They

clearly reveal the cyclical impact of the 11 year solar cycle. As you'll see from the graph the best DX years were 1986, 1997 and 2000? It is clear that 2005 seems unlikely to have been the peak. 2006 is the year of the forthcoming solar minimum and I would forecast that 2006 will be better than 2005 and I strongly feel that 2007 could be as good or better than 2006!

In summary, 2005 was the second best year for transatlantic MW DX in the UK in at least 24 years.

DIGITAL RADIO MONDIALE

with John Williams

RADIO LUXEMBOURG is back, although you would be forgiven for missing it. The once legendary radio station, which broadcast under the slogan “Two-O-Eight — your station of the stars”, was a dominant force in pop music in the 1950s and 1960s, an era when commercial radio did not exist in mainland Britain. Shut in 1992, when competition was too great, it has been quietly relaunched by RTL, its owner, this year.

Times and technology have changed, though. Radio Luxembourg is available only on Digital Radio Mondiale (DRM), an emerging European standard that is so new that almost nobody can listen to it. That will change from next year — and DRM will compete with, or perhaps compliment, Digital Audio Broadcasting (DAB), the prevailing UK digital standard.

RTL’s interest in DRM is borne partly from the technological backdrop in Europe. “DAB didn’t happen in countries like Germany or France; there was not the coming together of the public broadcasters and the commercial sector to make it happen,” DRM, though, is also interesting because of its coverage range. Its quality is slightly lower than DAB, but it can travel over vast distances, bouncing off the ionosphere. A signal can travel by several hops around the world, while one transmission site can cover a whole country — although it often has to be sited miles away because the signal does not travel directly to receivers.

With such capabilities, DRM quickly caught the eye of international broadcasters, such as the BBC World Service, which today is beaming unheard DRM signals into Europe. It is the only way that any international broadcaster can hope to get a good signal around the globe. John Sykes, a project director for the World Service, says: “Around 90 million of our listeners tune in via poor-quality short wave or medium wave. “You can imagine the logistical difficulties of setting up lots of local FMs around the world, and even satellite radio in the US uses ground relays that cost hundreds of millions in extra investment.”

RTL, though, thinks that it can use DRM to create national digital stations across Europe. It is already the dominant commercial operator in France on FM, but is interested in creating a national digital station there and in the otherwise localised German market. Radio Luxembourg, minus Jimmy Savile, perhaps, is its vehicle to break into the UK, a brand that it could cross-promote with Five, RTL’s TV channel. Getting together a few presenters for a relaunched station is certainly cheaper than buying GCap Media as a way to break into the UK.

DRM-capable radios will be available in January or February, as RTL-sponsored technical work becomes available. The new standard will be integrated into a complex box that includes DAB and receivers for every other frequency. “Our strategy is that consumers will be able to search simply by station name. The first product will be a high-level radio, under the Roberts brand, priced at about €220 (£150).”

In Britain, the conventional wisdom is that the two technologies are broadly complimentary, allowing, perhaps, broadcasters to fill in gaps in rural Scotland, or other remote areas not viable to reach with DAB. Phil Riley, the chief executive of Chrysalis Radio, says: “In Luxembourg, Germany and France, long-wave and medium-wave radio have been prevalent for a long time. The UK is a very different market and DRM will be a useful adjunct to DAB, rather than a replacement for it.” The worry is for the long-term future of DAB. Some other countries, such as Australia, are adopting the technology, but the concern is that manufacturers will not think it worthwhile to support a technology that has taken off only in a market of 60 million people. Could the UK, by taking the plunge, and being first, be going down a blind alley? (www.thetimes 23/12/05)

THE FUTURE OF DX TESTS?

with Les Rayburn, N1LF

NRC/IRCA Broadcast Test Coordinator

In the USA there has been a history of radio stations conducting special test broadcasts for the benefit of DXers. Sometimes a day time only station would test at night or a station might test its daytime antenna pattern at 2am. This would always require active participation by the station engineer which was not always practical or forthcoming. Now read on...

The "inventory insert" concept was the brain child of former NRC test coordinator, Fred Vobbe. Faced with more and more resistance to running traditional DX tests as part of scheduled maintenance periods, Fred searched for a way to encourage more stations to run tones, Morse Code and other unique identifiers that aid DX'ers.

Fred's original idea was to create sixty second long recordings that would include the stations voice ID, Morse Code identifications, and the NRC sweep tones. No change in the stations power level or antenna pattern would be required. Instead, the engineer would simply insert the "test commercial" into their overnight inventory of available local spots. The test could run several times each night for a number of days.

While these types of tests will lack the advantage of day power and patterns (at night), they possibly gain the advantage of providing a better chance for good propagation and/or low noise. We've all seen past tests that were ruined by aurora conditions, thunderstorms, or poor conditions.

Our first operational test of this new concept came last week (December 27th), when Chief Engineer Fred Giardina agreed to run the test on both WAPI 1070kHz and WJOX 690kHz both in Birmingham, Alabama for three nights.

In terms of what we hope for, this test was not ideal. Local inventory was limited to the spots airing only twice per night on each station...and the test period was limited to three nights. It's worth noting that the test occurred during the Xmas- New Year period, which is one of only two periods of each year when Arbitron ratings are not kept for radio stations in the US.

Despite the restrictions, the test was very successful. In summary the test was received in 15 states, and Canada. Best DX was nearly 2000 miles away in California, and in that case, both stations were received during the test period. [Martin Hall tried in Scotland but without any luck!]

Test Format

The test consisted of computer-generated voice ID using text to speech software. A female voice was chosen, with a slight British accent. The Voice ID consisted of the following phrases:

"This is WJOX conducting transmitter testing. Whiskey Juliet Oscar X-Ray Testing".

This was followed by Morse Code ID's transmitted at ten words per minute, using a 1,000 Hz tone. The station identification was repeated three times.

Following these identifiers, we inserted about twenty seconds of the NRC "Sweep Tones". These tones are commonly used to test various parts of the audio chain in a transmitter system, and have proven to be the most effective audio source when heard at a distance. Outperforming Morse Code, marching band music, and other program material that has been tried in the past. In many cases, these were the only identifiable part of the transmissions. While DX'ers can debate if successful reception of just the sweep tones would qualify for reception of a station, I believe that if the tones

can be correlated with exact time of transmission that would provide enough data to verify a successful logging.

What are the odds that any other station on that frequency would be running such a unique tone, at that given moment? I'd suggest so small as ruling out all other stations, and verifying the logging. That is for each station and/or individual DX'er to determine. In any event, the tones are very effective.

This pattern continues for the duration of the sixty second tests, and can be changed for each test to avoid people being able to "guess" what was transmitted. After creating the file, we further enhance the material for distant reception by boosting the 2-3 kHz range using Sony's Sound Forge 7.0 software. Compression is also applied to the file to insure maximum drive levels to the transmitter without clipping. We then send the file to the station as either an MP3 file or a .WAV file on a compact disc.

History

In recent weeks, it's come to my attention that the concept is not totally new. In the past, radio stations have added a single Morse Code ID to their normal top of the hour station identification. Sometimes this was by way of a "signature" for the station, and other times it was at the suggestion of DX'ers.

Even today, some stations transmit unique sound effects, tones, or other signature sounds at the top of the hour, which can aid identification. Fred Vobbe's concept really just expands on this idea.

Why change at all?

The relationship between distant listeners and broadcasters is changing rapidly, and nowhere that is more obvious than with tests. By law full power tests or nighttime operation on daytime antenna patterns can only be performed as part of a scheduled maintenance operation.

Station owners are more and more concerned about legal liability if such a test causes interference to other stations, and loss of revenue even at night if the station is not running its normal programming. In addition, many program providers such as Radio Disney have strict contractual agreements that preclude the station from running tests.

Add to that the need for an engineer to be on site or in the studio in the middle of the night, and a general lack of interest in our hobby among broadcasters, and you can see that the landscape is changing.

We've taken pro-active steps to help combat some of these issues. We regularly attend Society of Broadcast Engineering meetings in this region, and contribute posts to e-mail lists devoted to the broadcasting industry to help educate stations about our hobby. We've started relying more on telephone calls and personal contact with our members and less on random mass mailings to stations to request tests.

We post our cell phone number widely in engineering circles, asking them to contact us at anytime twenty four hours a day if they intend to be off the air for maintenance. And our formal requests are now accompanied with a CD of Morse Code ID's for the station, programming material, etc. to make it easier for stations to say "yes" to our requests.

We've also offered to handle reception reports, QSL's, etc for stations that agree to run tests. All these steps reflect a better understanding of the pressures that stations operate under now, and are designed to minimize our impact on their resources.

The Future of DX Tests?

Does this mean that we can't look forward to any future full power, daytime pattern tests? Quite the contrary, such tests are always our goal. The hobby remains fortunate to have a number of engineers and other station staff who are themselves active DX'ers, and enjoy putting on such tests when their stations have maintenance to be performed. And members continue to surprise me with their success in reaching out personally to their local stations to do such tests.

But I suspect that the "inventory insert" concept will be a popular choice for many broadcasters, and we can look forward to more of them. One test alone does not prove the concept, but if the WAPI-WJOX test is any indicator, these tests may rival their full power counterparts in terms of success.

These test results suggest that the greatest benefit will be for listeners within a 700-800 mile radius, where the change in programming may compensate for the low power or directional pattern. Results at greater distances are likely not to be as good as the full power/pattern tests, even if the DX'er concentrates on the test for an extended time.

But the nearly 2,000 mile reception of WAPI and WJOX indicates that long distance receptions will not be impossible, and are still aided greatly by the change in programming.

New techniques will need to be embraced by DX'ers to take full advantage of the test. Overnight, unattended recording using software like Total Recorder will be the best arrow in your quiver. Second to that will be the use of Phasers and loops to null other stations on the frequency, and possibly post recording audio processing to help reduce noise and pull out the desired signal.

The broadcasting industry is changing, and if we wish to be successful, we'll all have to embrace new technology and techniques to do so.

What can I do to help?

Individual DX'ers can do much to help the hobby in regards to DX Tests. We now encourage members to use their contacts at work, church, and civic organizations to get to know station managers, engineers, etc. If you ask around, you'll be surprised how quickly you can meet most of the people involved with radio in your area.

Find out if the Society of Broadcast Engineers (SBE) has a local chapter, if so, see if you can attend their meeting and give a short talk about our hobby. By contacting the NRC or IRCA, you can usually obtain plenty of back issues of our printed publications to hand out, and if you play some recordings of your best catches, you can give an entertaining talk for a half hour or so.

To find out if there is a chapter in your area, visit the SBE web site at:

http://www.sbe.org/chapter_find.php

Usually these clubs struggle to find speakers for their meetings at least once or twice a year, and will welcome something that will be a change of pace from their usual material.

One little tip that has worked for me, if you're invited to speak at the meeting, ask to see which local AM stations have engineers that are members. Send me an e-mail in advance, and I'll supply you with CD's full of station ID's, inventory inserts, sweep tones, etc. for you to give them directly. You're not likely to be turned down flat if you request a test in this fashion!

Stop playing cop

Another way that DX'ers can help is by being very careful about all contact you have with the broadcasting industry. The majority of stations are now owned by groups, and any tales of a bad experience with a radio hobbyist quickly spreads throughout the industry.

Some of us seem to delight in reporting stations to the FCC if we suspect them of "cheating" on their daytime power at night. I've heard all kinds of justification for these actions, but frankly, none of them benefit the hobby enough to offset the potential damage.

Even the term should be banned from our language...usually a station that is running at daytime power at night is the result of an automation problem, human error, or other technical issues. We should presume that the situation is unintentional and innocent.

If such operation continues for extended time, other stations on the frequency will notice and either contact the offending station directly or file a complaint with the FCC. Such complaints are given much more weight than those of "hobbyists" and by allowing the industry to police itself we avoid any ill feelings towards DX'ers.

Recently, I had a DX'er who frequently takes it upon himself to "play cop" attempt to justify his actions by saying that he never identified himself as a member of the National Radio Club or the International Radio Club of America. Instead, he complained to the station's owner stating that he was a "radio hobbyist"...for me; this is a distinction without a difference. The damage to the hobby is done.

In the mind of that owner, radio hobbyist now equals pain in the rear end. How much luck do you think we'll have with that station if we approach them about a test or ask for a QSL?

Radio is a business. The people involved in it are motivated by a desire for profit...listeners outside their local market are not measured for ratings purposes, and as such they are not very interested in your concerns. Fewer chief engineers these days are amateur radio operators or even shortwave listeners, so our hobby can seem strange and foreign to them. A QSL card may be the most important thing in the world to you, but to the station it may just mean "more work, with no benefit".

Be polite always, and if you don't achieve the desired result, be that a reception verification or acknowledgement of a transmitter problem, then give up. Get out of your shack, take a walk around the block and cool off. Becoming rude, or worse reporting that station to the FCC can only do harm to all of us.

Frankly, I resent even having to write these words, but my brief tenure as BTC as taught me that our numbers contain more of these types of "sea lawyers" than you might suspect.

Final Thoughts

Fred Vobbe is to be congratulated for a novel approach to getting more stations to conduct tests that benefit all of us. I'm happy to report that Fred was one of the DX'ers fortunate enough to log a new one during the recent WAPI-WJOX test...it's only fitting that he directly profited from his own imagination.

Thanks also to the dedicated members who have volunteered to help us set up tests in their area. Most of the tests in the past two seasons are the results of their efforts more than my own.

HOW WWL MET KATRINA

with Jim Pogue

Fello DXers, I hope you will indulge me a little. I am giving a speech next week to members of the local chapter of the Public Relations Society of America (PRSA) about my experiences in Baton Rouge as the U.S. Army Corps of Engineers Public Affairs Officer for the Louisiana Recovery Field Office. I devote a couple of pages of my remarks to the work done by WWL and the United Radio Broadcasters of New Orleans, and how we worked together to help the people affected by the hurricanes. Some of you may find this extract boring and TMI, but I hope some of you find it interesting and not too far off topic. Thanks. Jim Pogue, Memphis, TN

When Katrina hit New Orleans, some of its most severely affected victims were radio and TV stations. Most were simply knocked off the air with severe damage to their studios, transmitters or both. One notable exception was the 50,000-watt, clear channel blowtorch AM station in the area, WWL.

Most of New Orleans lost power when substations flooded →

WWL was able to get back on the air quickly, and with a coverage area that blankets most of the United States east of the Rocky Mountains at night and reaches almost to Memphis during the day, they were an absolute lifeline for people affected by the hurricane.

They also put together a coalition of other radio stations in the area as they came on the air to form what they called the United Radio Broadcasters of New Orleans. This ad hoc network eventually included nine AM stations, nine FM stations and a short wave station in South Carolina that was heard in every part of the globe including Europe, Australia, New Zealand and Japan.



The program hosts spent much of their time accepting calls in the typical radio talk show format from listeners who were looking for lost relatives, seeking assistance, or just wanted to complain. I was able to get the secret ``hot line`` numbers however, that got me to the head of the line when I called in.

I made it a practice to call in almost every morning for about the first month I was there to talk up some of the good work we were doing. I frequently explained the basic process storm victims needed to go through to get a blue roof, who qualified, who didn't and why they didn't, the locations of new walk-in centers for the blue roof program when they opened, information on debris pickup and how people could sort their debris to speed the cleanup, safety hazards --- and the list goes on and on. I never had a shortage of topics to discuss, and the program hosts always seemed glad to hear from me.

Another way in which having an ongoing relationship with the radio station proved valuable was in rumor control --- a real problem in the aftermath of the storm. Several times I received phone calls from our field personnel saying, ``870 AM is telling people that the Corps is not going to put any

more blue roofs on after Friday, `` or something similar. I could pick up the phone, dial the hot line and usually be on the air broadcasting the correct information in five minutes or less. This was a very powerful tool in the public information arena.

An example of how effective this medium was in reaching the public involved a problem we were having early in the blue roof mission. The Corps was working with FEMA to set up a call center where the public could get information on where to apply for a temporary roof. We --- the Corps --- felt like we were ready to go and that the public could benefit from the service. FEMA was hesitant, however, and instead of being willing to accept a 90 percent solution, wanted everything up and running perfectly when we pulled the trigger. The effect, however, was that the public was not getting the latest and most accurate information they needed. I had the information --- a list of 30 or so locations and hours of operation --- in paper form. The public needed the information.

During one of my call-ins to WWL at about 9 in the morning, I was apparently pretty worn out because anything resembling common sense simply vanished from my brain. I said on the air, ``if anyone needs information on where to apply for a blue roof, they can call me at --- and I gave out my cellphone number.``

Holy cow! My phone nearly jumped off my belt. As a matter of fact, I still occasionally get calls from people looking for information about how to get assistance. My co-workers thought I was crazy to have given out the number --- and at some point --- so did I. But in retrospect, it was the right thing to do. I was able to connect the public with the assistance they needed until the call center was up and running. It made my life even more chaotic for a few days, but I really have no regrets.

One last anecdote regarding the call-ins to WWL. One morning I was waiting my turn to talk, and was listening to the caller just ahead of me speak to the program host. Suddenly, he launched into a tirade about how he knew with certainty that the Corps of Engineers had blown the levees in New Orleans to save the rich people at the expense of the poor people. He said he'd heard this on CNN and even had the name of the Corps public affairs officer in Vicksburg, by then my recently retired boss, and that he was the source of the report.

The radio talk show host then said, ``Well, we have Jim Pogue on the line from the Corps of Engineers, and I'm sure he'll be happy to respond to that. Jim ?``

My friends, I hope you are never in that pair of shoes. With thousands of listeners throughout the region listening to their radios, I was being asked a question that was completely outside my lane since another group of Corps Public Affairs personnel were handling the levee questions, and the listener had made a strong argument that seemed to indicate he knew what he was talking about.

I took a quick, deep breath. I was as honest as I could be, and said I didn't know enough about the caller's statement to give a detailed answer. But that I could say with complete certainty that the Corps did NOT blow the levee and would never do anything like that which would intentionally endanger the lives of anyone. As for the report the listener said he heard from my former boss, I said I wasn't aware of the interview, but that at the early stages of the disaster we were very much in a situation like a war, and that the analogy of the fog of battle applied there just as well. I said that early reports were often sketchy, incomplete and inaccurate, and that I was sure whatever he had heard fell into that category.

To my surprise, the program host paused briefly, thanked me for being forthright and honest about the situation, and moved on to the topic I had called to discuss. I wonder if listeners heard my audible sigh of relief at that point?

BROADBAND MW PHASING

with Andrew Ikin - Wellbrook Communications

For some time I have been contemplating the possibility of designing a simple to use phasing unit with high gain active antennas.

However, until recently this was not possible due to lack of real estate and other commitments. Earlier this year I erected a log cabin and wooden posts for various antenna spacing of 30m to 60m in the paddock adjacent to my house. 10 posts were erected 2 at each Cardinal Point and 2 in the centre.

Each element is an Active Vertical Antenna (AVA) using a 5m-aluminium pole plus a 4-foot ground stake connected to 18dB amplifier with a high z input isolation transformer. This new amplifier is also used in the Wellbrook K9AY and the ALA100 large aperture broadband loop. These amplifiers have a MW intermod of; IP2 +80/90dBm, IP3 +44dBm.

To supplement the fixed antennas, I also used two Datong Active Dipole antennas with the dipole whips replaced with a rigid aluminium pole each 1.5m. These dipoles were each fitted to a tripod.

This article will only consider the phasing of 2 antenna elements. The reason for this is quite simple; there is no point trying to build a broadband multi-element phasing system unless one has considered the potential problems of 2-element phasing!

Several designs of phasing units including some of my own were considered for this project. None were considered suitable; due to either having a multitude of amplitude or phase controls, poor intermod or a phasing technique in degrees. Also some have limited bandwidth making them difficult to use for other than single frequency nulling. Another hindrance to broadband phasing is the none constant feeder impedance afforded by some phasers. Therefore, what is required is a phasing system that provides a consistently good F/B over the whole MW band with just a minor tweaking of the controls without any noticeable intermodulation.

Firstly, I believe there are basic requirements to be met for a Broadband phasing system:

- 1) Wide Bandwidth
- 2) Correct feeder termination
- 3) Reversible
- 4) High F/B
- 5) Easy to use i.e. minimum of controls, with negligible interaction
- 6) Constant gain antennas
- 7) Minimum real estate
- 8) Low intermod
- 9) Good signal to noise ratio

So let's consider the above requirements in detail;

Wide Bandwidth

To achieve a wide bandwidth F/B, the antennas are combined in anti-phase plus a nominal time delay line equal to the spacing of the elements (Delay line Anti-phasing). For example, with a spacing of 30m the delay is 100ns. This technique can be used for antenna spacing of a maximum

of 3/81 to approx. 1/161, thus giving a 6:1 frequency ratio. For the MW and Top-band listener, only a 4:1 bandwidth required.

It is important to note, that the time delay must be constant over the required frequency ratio.

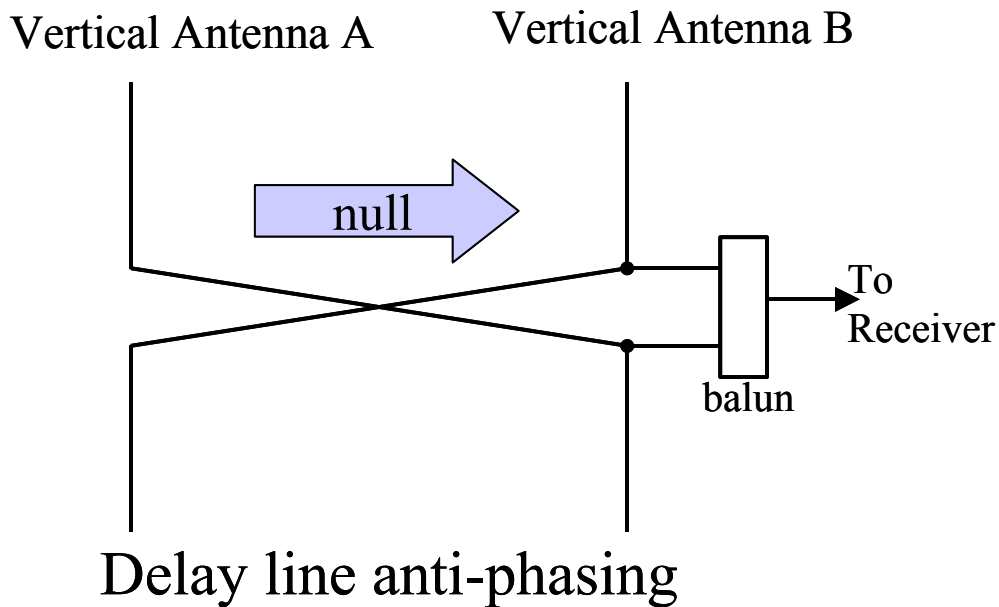
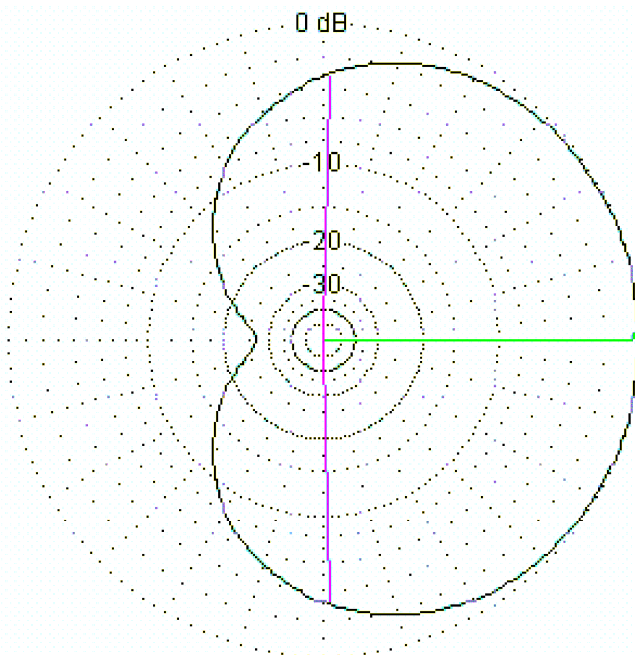

Figure 1 Illustrates this phasing technique. Consider two broadband antennas with equal gain connected via an open wire line with a 180° twist. The open wire line has a time delay equal to the wave propagation delay. Hence signals arriving from the back of the array at antenna A will induce a current to the open wire line, this current will be inverted when it arrives at Antenna B. At the same time the signal will cause Antenna B to induce a current into open wire line. Thus the two currents will cancel out due to the 180° twist. Signals arriving from the opposite side of the array will not cancel out because the signal arriving at Antenna A travels distance B-A in free space before inducing a current in antenna A which then travels back to B via the open wire line.

In practice the simple system in Figure 1 is impossible to optimise because the null is only total if the time taken for signals to travel from A to B are the same in free space as on the transmission line. Unfortunately the velocity of signals on transmission lines is always slower than in free space.



So in a practical phasing scheme, active antennas are used with equal length feeders and a delay line with a nominal equal time delay replaces the open wire line.

← *a desirable cardioid antenna pattern*

I have used this phasing technique (based on an idea in Les Moxon's Book "HF Antennas for all Locations") in the eighties with active antennas to reduce Soviet Jamming. This used a 30ns delay consisting of 3 Newport 10ns delay lines with a 1 pole 24way gold plated rotary switch, power combiner and a amplitude

balance potentiometer. However, the performance was limited due to not terminating the feeders correctly and skywave signal fluctuations.

I believe the origins of this phasing technique date back much earlier; e.g. the ZL special. The earliest reference I can find; is in "Wireless Direction Finding" by R Keen 1938. Keen refers to "Non central summation" of 2 vertical aerials in 180° phase opposition to provide a cardioid reception pattern. Keen also discusses the use artificial transmission lines with equal attenuation and equal speed to achieve a wideband width to achieve the equivalent phasing of "Non central summation".

Correct feeder termination

To ensure a high F/B ratio, the phasing unit must terminate both antenna feeders correctly; namely 50 Ohms. If they are not, there will be unwanted phase/amplitude changes over the required bandwidth. The antennas must also be isolated from each other. This reduces one antenna feeding current back to the other, thus causing a mis-match resulting in phase/amplitude variations. Any Phase control or Amplitude control must not affect the feeder termination. Furthermore, both antenna feeders must be of equal length. One cause of mis-termination, are the attenuator potentiometers at the antenna input of some phasers!

It is interesting note; that some receiving antenna array designs in Amateur Radio literature don't provide for any antenna isolation! This puts other constraints on the antenna design; namely that the antenna has to provide reverse termination for the feeder!

One serious cause of feeder mis-termination can be the receiver. For example with a passive delay line phaser; where the delay line is terminated by the receiver; if the receiver has a reactive input then the delay can be unpredictable resulting in a total failure of the array to provide any F/B. To resolve this problem the receiver output of the phaser should be buffered with a low noise 50 Ohm (resistive) input amplifier with high IP2/IP3 and very high input to output isolation.

Reversible

This is useful facility for the user to be able to adjust the amplitude balance for optimum F/B and listening to stations in the opposite direction.

High F/B

This is maintained by having correct feeder termination together with user control of primarily amplitude and to a much lesser extent phase.

Easy to use

Having a wide bandwidth and a bare minimum of controls, Direction; Phase and Balance, will greatly simplify its use. A primary requirement is negligible interaction between the Phase and Amplitude Balance control.

Constant gain antennas

Both antennas must be of the same type and have an identical frequency/gain characteristic. Otherwise, the F/B will not be the same over the MW band or when the array is reversed. To meet the requirement of constant antenna gain, active antennas that use the feeder cable as the RF return are not recommended.

The active antenna RF return path must be isolated from the feeder to reduce susceptibility to mains borne noise. Also the F/B may be compromised i.e. their gain can vary with feeder length and antenna height. Therefore most commercial whip active antennas may not be suitable.

Active Dipole, Active Vertical, Broadband loops can be used.

Minimum real estate

This is the most difficult requirement to meet! The experiments indicated; that a minimum of 30m-40m-antenna spacing was required for the lower end of MW.

Low intermod

With any broadband phasing system, the active antennas and any amplifier in the phasing unit must not produce ghost signals that may impair reception. These ghost signals are caused by non-linear amplifier performance; notably third order intermodulation (IP3) and more importantly second order intermodulation (IP2). An in depth discussion of intermodulation is not within the scope of this article; however, it is fair to say that any high gain active antenna and phasing unit amplifier should have an IP2 of +70/80dBm and an IP3 of +40/43dBm.

With one exception the Datong AD370, the phasing system described, has active antennas and amplifiers that meet the above requirement,

Good signal to noise ratio

This requirement can be easily met using the Active Vertical Antenna; the 5m high antenna element with the ground rod has a much greater efficiency than a typical active whip or dipole. The low noise 18dB amplifier provides a MW Antenna conversion Factor K of 0dB i.e. 1V/m = 1V at 50 Ohms. In other words, there is a direct 1:1 correlation of field strength in V/m to antenna output voltage. The antenna gain is approx. 8-10dB higher gain than some typical European commercial active antennas when mounted at ground level, hence, the stringent intermodulation requirement.

A Broadband Phasing Demonstrator was built to encompass the aforementioned requirements.

Phasing Unit Technical Description

In this phasing unit both antennas have their 12volt power fed via the feeder cable. The antenna outputs are connected to a 3PDT "Direction" switch (1 pole is used for a K9AY direction relay) via coupling capacitors. One antenna drives an LC delay line. The Delay line is built round 1 pole 12-way switch and terminated with a 56-Ohm resistor. Each delay element is 11ns (0.56μH and 220pF). The switch pole connects to a 500 Ohm potentiometer, the wiper connection inputs to a low noise buffer/broadband amplifier via a 200/50 Ohm matching transformer. The amplifier is a balanced phase inverting type, as used in the Wellbrook K9AY. The 56-Ohm delay line termination plus the slight loading of the Amplitude Balance pot/amplifier provides the correct 50-Ohm feeder termination. The amplifier output and the other antenna are connected to a 2-port combiner. The combiner output makes the connection to the receiver. The combiner improves the 50-Ohm match on the antenna feeder by providing antenna isolation. This reduces one antenna feeding current back to the other, which could cause a mis-match resulting in phase/amplitude variations; an essential feature.

The delay line is variable, in 11ns steps from approx. 20ns to 140ns including a 20ns Amplifier delay. The Amplitude Balance is approx. +7dB/-0dB.

Note; additional LC sections can be used in front of the variable delay line for 50m antenna spacing. Alternatively, one could use; say 5ns delay sections to fine tune the phasing with the additional delay line made from RG58c. 1m of RG58c = approx. 5ns.

Each delay line section is calculated from the formulae;

Delay in ns = $\sqrt{L \times C}$; where L is μH and C is pF.

Impedance = $\sqrt{L \times 1,000,000 / C}$, where L is μH and C is pF.

For example; 0.5μH with 200pF gives a 10ns at 50 Ohms.

Inductors are low cost commercial 10% types; Capacitors can be either low K ceramic or polyester 5%.

Figure 2 Shows the Broadband Phasing Demonstrator schematic.

Using this phasing system

Tests were carried out using either 2 of the 10 Active Vertical Antennas (AVA) or 2 Datong Active Dipoles. The feeders were each 100m of RG58c, with the surplus cable wound on drums and placed near to the Phasing Unit.

Note; AVAs and Active Dipoles were not used together.

Using two antennas spaced at 30m ($1/18\lambda$ at 540kHz), the results so far indicate; that to achieve a good F/B over a near 4:1 freq. 500kHz-2MHz; one only needs to amplitude balance the antennas and a small variation in phase shift to achieve a 30-40dB F/B.

A 42m-antenna spacing gave the best results. Over the MW, the broadband F/B with ground and steady skywave is 15-20dB over a most of the back of the array. However, approx. +/-30 degrees off the back of the array, one can tweak the F/B to 30/45dB with the Amplitude Balance pot. Where skywave conditions are less stable, a minor adjustment to the delay line is required to optimise the F/B.

For example; using NW-SE 42m spaced Active Vertical Antennas; once the array had been adjusted for 40dB F/B on Luxembourg 1440kHz, a 30/45 F/B ratio was achievable on most high power French (N-E), Belgium, Dutch and Ireland stations across the whole MW band.

Compared to a K9AY antenna, the Active Vertical array provided a 10-15dB improvement in F/B. Also the F/B was improved to higher angle signals just off the back of the array.

This phasing unit works well; with only max. 0.6dB amplitude variation over the delay range and there is negligible phase variation when adjusting the Amplitude Balance potentiometer.

The overall gain of the phasing unit is unity. However, there is some loss at the lower end and some gain at the higher end of the band when phasing the Active Vertical and Dipole antennas.

It should be noted, that improved performance may be possible with isolation amplifier at the phaser output to mitigate the reactive input of my JRC NRD 525 receiver!!!!

Observations

The maximum antenna spacing is approx. $3/8\lambda$, the minimum spacing was found to be $1/14\lambda$ using a fixed delay over a 5.3:1 freq. ratio.

A min. spacing of $1/18\lambda$ could be used for a 6.75:1 freq. ratio, provided that the delay line was switched to optimise the F/B. Thus, such close spacing is not recommended for a wideband system unless a variable delay line is used. However, a smaller bandwidth is useable with close spacing with high gain active elements.

To achieve a good F/B, balancing the antenna amplitude is more critical than correct phasing. This I believe is an essential feature.

The phasing system must provide a proper 50-Ohm termination for both feeders; this also means that the Rx must have 50-Ohm (resistive) input unless the phaser output is buffered.

Where the phasing system terminates the feeder impedance correctly and a combiner is used to isolate the antennas; the output impedance of the active antenna does not need to be 50 Ohms; it is only necessary to drive the 50-Ohm feeder.

The AVA or the Active Dipole defines the system S/N, so any small loss between the delay-line and the buffer/amplifier is not an issue.

Optimum Gain and F/B were achieved using either the Active Vertical Antenna or Active Dipoles, although the Active Vertical Antenna provided more gain and an improved s/n.

I also tried two special Broadband loops (4 foot diameter ALA1530s) erected NW-SE and spaced 42m. These proved to be a disappointment; to achieve a reasonable F/B, the delay line had to be adjusted to 65ns; much less than the antenna propagation delay spacing. This resulted in a considerable signal loss especially at the lower end of the MW band; also the skywave F/B was lower than with the Active Vertical Antenna and the Active Dipole.

Two special K9AYs (single loop) with an integral low noise 18dB amplifier were erected NW-SE and spaced 42m; I was unable to get this antenna configuration working as a fully reversible array! I suspect that the problem lay with not having the antennas matched. Further work on the phased K9AY may be continued in the coming year.

Other applications

Also one could improve the Beverage F/B i.e. erect two identical antennas spaced approx. 5m, but one antenna staggered approx. 40m or 50m back from the other. This has yet to be tested.

Conclusion

The phasing system as described achieves a consistent F/B over the whole MW band when only used with Active Vertical Antennas and Active Dipole antennas. This system is much simpler to use compared to most current phasing techniques. The use of the Amplitude Balance control, together with a small delay line adjustment allows the user to steer deep nulls over most of the back of the array.

Finally

The aforementioned phasing unit was built to demonstrate the possibilities of broadband phasing for MW only; therefore, it will not be manufactured in the form as described.

An Active Vertical Antenna array is being considered for production, this will use a switched delay line, with the some of the phasing functionality built into the Active Vertical Antenna amplifier module. This new simplified phaser will have the Amplitude Balance remotely controlled using a newly designed variable gain Active Vertical Antenna Head Amplifier Modules.

This unique Balance Control System will ensure maximum F/B because there will be no mis-termination caused amplitude potentiometer(s) in the phaser signal path.

The Active Vertical amplifier module is currently available separately or with Antenna interface. This Active Vertical amplifier can also be used as a "Head Amp" for the Flag and Kaz terminated loop antenna.

Copyright 2005/6 Wellbrook Communications

BROADBAND PHASING DEMONSTRATOR

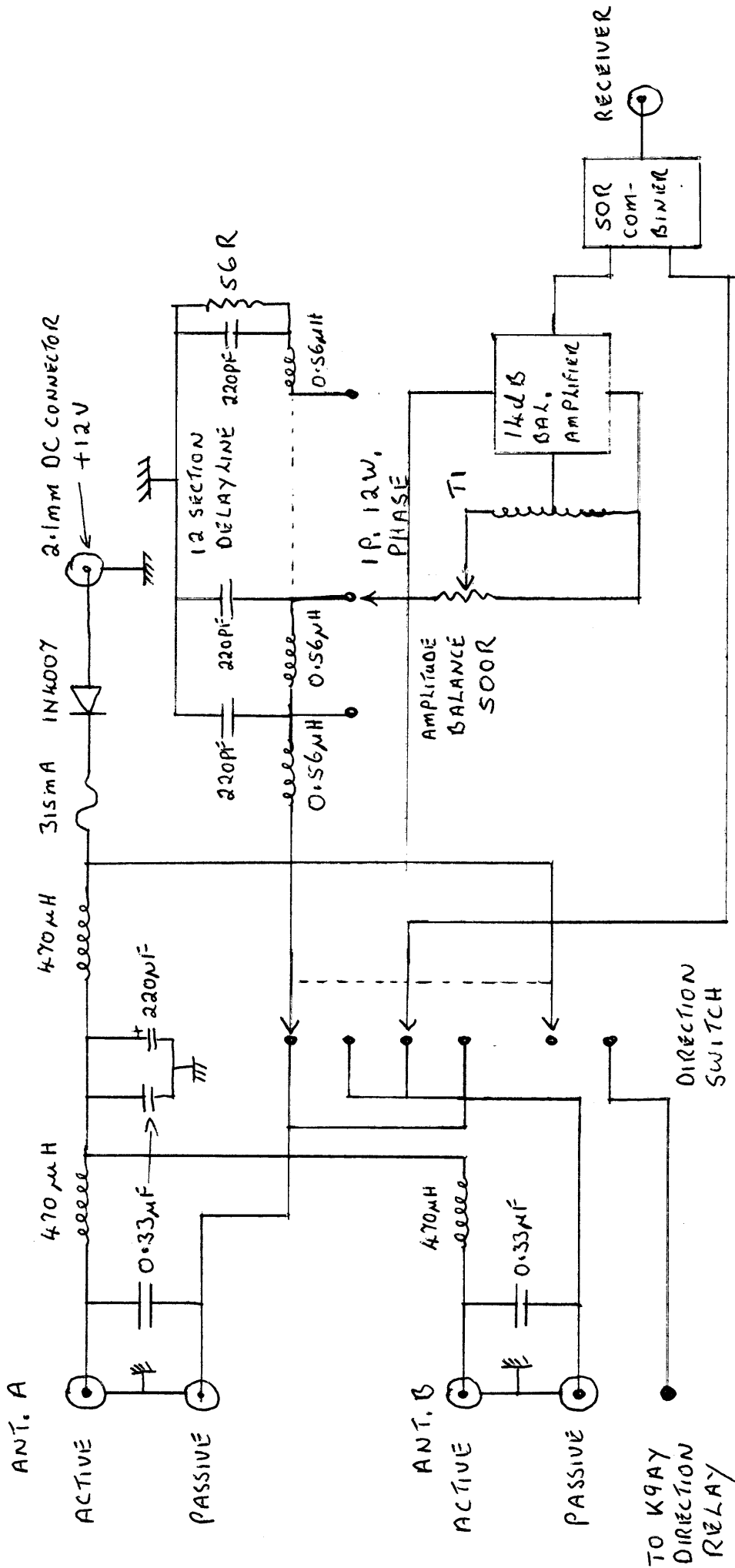

FIGURE 2

SPECTRUM RADIO 558 kHz

with John Williams

Spectrum Radio broadcasts from the heart of London to the Nation's capital and the South East of England on 558 kHz to a potential audience of over 13 million people.



Spectrum Radio is unique in the UK being the Country's only ethnic commercial radio station, and currently serves in excess of 20 different communities, a list of which is detailed below. The station states that it provides "music, news and information for ethnic communities." Spectrum claims that 1 in 3 of London's residents were born outside the UK i.e. 3.5 million people. 300 languages are now spoken.

Spectrum's coverage area officially covers beyond Luton to the North of London, Southend to the East, Crawley to the South and Reading to the West.

Spectrum Radio also broadcasts on DAB throughout London and on the Sky satellite platform. This service contains a mix of the existing programmes and programmes tailor made for communities not currently served on the 558kHz AM frequency. It also runs to separate internet audio streams.

Spectrum Radio specialises in broadcasting to what are considered niche communities. All the programmes broadcast contain news, information and music aimed to each individual community as well as providing a "gathering place" for community news.



The station commenced broadcasting on 25 June, 1990 and their current broadcasting licence expires on 31 December, 2009.

A typical days' broadcasting is as follows
(Monday to Friday): →

Sabras Radio recently commenced using the airwaves of Spectrum Radio to broadcast programmes from their Leicester base. Asian's in the London area are well served with Sunrise Radio 1458 kHz, Club Asia 963 and 972 kHz, and the Community stations Sound Radio 1503 kHz and Desi Radio 1602 kHz..

The station is not listed by RAJAR and no listening figures are available. However it claims a reach of 60000 people or a weekly reach of 517000 people, which in the context of Greater London and most of South East England is not a big audience.

The station address is: Spectrum Radio

International Radio Centre 4 Ingate Place London SW8 3NS; telephone:+44(0) 20 7627 4433 fax :+44(0) 20 7627 3409 and Email enquiries@spectrumradio.net.

00:00 HUNGARIAN PROGRAMME
00:30 BELGIAN PROGRAMME
01:00 POLISH PROGRAMME
01:30 SWEDISH PROGRAMME
02:00 AMERICAN PROGRAMME
03:00 CANADIAN PROGRAMME
04:00 AMRIT VELA SIKH RELIGIOUS PROGRAMME
06:00 RADIO ROMANIA
07:00 SABRAS RADIO
13:00 FIRST RUSSIAN RADIO
14:00 VOICE OF RUSSIA (RUSSIAN)
15:00 CRI BEIJING (ENGLISH)
18:00 CHINESE SPECTRUM
19:00 TAMIL PROGRAMME
21:00 ARABIC PROGRAMME
23:00 CRI BEIJING (CHINESE)

NORTH AMERICAN NEWS

✉ 20 Ryehill Park, Kirklington, Carlisle CA6 6BH

with Barry Davies

e-mail: na-news@mwcircle.org

Welcome to another round up of what's been happening on the North America AM dial. My grateful thanks to the organisations which provide the news. Thanks this month to: - Radio and Records.com, North American Radio Logbook, NERW, IRCA, DX-Mid-America and Ohio Media Watch.

The Sports Station
WQSN
AM 1660

1230 • WESX



- 890 WAMG Dedham MA. "ESPN Boston" has applied to lift night power from 3.4kW to 6kW.
- 1090 WILD Boston MA. The station drops black gospel **weekdays** to pick up black talk.
- 1120 WKQW Oil City PA. Format flips from news talk to country oldies. The station slogan now runs, "11-20 AM Wildcatter Country."
- 1160 WCRT Donelson TN. New calls ex WAMB. Format is religious teaching ex big band.
- 1160 WBOB Florence KY. This former news talk station is now playing oldies after the station's sale reported in the September NAN. The new owners have requested the call letters **WDIO** for the station. (BTW Their March power down is 23:45utc!)
- 1230 WESX Salem MA. This nostalgia station has been sold. Format to be religious. (NERW)
- 1300 WJDA Quincy MA. This nostalgia station has been sold. Format to be religious. (NERW)
- 1330 WJNX Fort Pierce FL. Drops SS talk for Mexican music and song.
- 1380 WBTK Richmond VA. This religious talker has been sold. No news of any format flips.
- 1420 WDJA Delray Beach FL. This business talk station and // 1000 WJBW have been sold. No news of any planned format changes.
- 1430 WNSW Newark NJ. Station now SS religion. (ex Korean) ID is Radio Cantico Nuevo. (ed)
- 1520 WWKB Buffalo NY. This radio legend drops oldies and goes all talk. (Scott Fybush) The new station slogan is, "AM 15-20 Buffalo's left channel."
- 1580 WSRF Fort Lauderdale FL. Back on air after hurricane Wilma damage. Their Caribbean format is // 1700 WJCC. (W. Curt Deegan)
- 1590 WONX Evanston IL. Format flips from all Spanish to ethnic languages.
- 1620 KBLI Blackfoot ID. This ESPN station is currently silent following its sale to Riverbend Communications and expired licence! **Unlikely** to come back on. (Scott Fybush)
- 1650 KHRO El Paso TX. This new talk station has joined the Air America network.
- 1660 WQSN Kalamazoo MI. This sports station has been sold. No news of any planned format changes. The sale is subject to FCC approval which is expected by May 2006.
- 1660 WWRU Jersey City NJ. This Korean language station has got the OK to go 10kW full time.
- 1690 WWAA Avondale Estates GA. This Air America talk affiliate has been sold. No news of any planned format changes.

ABC Property Sold By Disney As reported here in December's NAN and Russ Edmunds (IRCA) now confirms, we have a done deal with Citadel. The sale of ABC stations and networks went through with a price tag of \$2.7bn. The deal **excludes** the Radio Disney and ESPN networks. Changing hands are stations such as 760 WJR Detroit MI, 770 WABC NYC NY, 820 WBAP Fort Worth TX and 890 WLS Chicago IL. As I said back in December, 2006 could be very interesting!

Until next time, 73's

Barry

CENTRAL AMERICAN NEWS

✉ Frejagatan 14A, SE-521 43 Falköping, Sweden
e-mail: ca-news@mwcircle.org ☎ +46-515-13702

with Tore Larsson

Cuba

In case you haven't noticed, the 2006 patriotic slogan is "Año de la Revolución Energética" Glenn Hauser, DXLD

- 740 CM.. R. Ecos de Sagua, Sagua de Tanamo, Holguín Box Foxworth, Caribbean cruise loggings
730 CM.. R. Caribe, Nueva Gerona, Isla de la Juventud, new station, sharing the same tower as of R. Progreso
1220 CM.. R. Caribe, Isla de la Juventud, a new 5 kW transmitter is now on the air

Ask for confirmation to Radio Caribe, Isla de la Juventud, Cuba for the 1220 frequency, and to Radio Progreso, P.O. Box 3042, Havana 10300 to the attention of Chief Engineer José A. Fuentes.

Arnie Coro, RHC DXers Unlimited 28.1.2006 via ODXA via DXLD

Jamaica

550/580/700/720/770 RJR is using the slogan "Refreshing Jamaica Radio".

Raul Saavedra, Puerto Viejo, Costa Rica, 6.1.2006 via dxldyg via DXLD

México

- 620 XESS Ensenada. ESPN sports talk ex banda format "La Tremenda" Tim Hall, Chula Vista, CA, ABDX 21.1.2006 via DXLD
690 XETRA Tijuana. Grupo PRISA has acquired the right to programming XETRA which had been under control since 1980 by Clear Channel Communications through its affiliate Citicasters. Madridkid 27.1.2006 via DXLD
690 XETRA Tijuana – format change – the station is now running Spanish from the "W Radio" network. Tim Hall, Chula Vista, CA, 6.2.2006 via ABDX via DXLD
820 XEABCA R. Frontera, Mexicali ex XEMVS. Adress: Avenida Francisco y Madero numero 1535, Colonia Nueva, Mexicali. John Wilkins via NRC V73/16
1030 XESDD Ensenada "La Tremenda, ex sport talk Tim Hall, Chula Vista, CA, ABDX 21.1.2006 via DXLD

Puerto Rico

- 710 WKJB "R. Isla", Mayagüez Box Foxworth, Caribbean cruise loggings

SOUTH AMERICAN NEWS

✉ Kirkåsveien 15, NO-1850 Mysen, Norway

with Tore B. Vik

e-mail: sa-news@mwcircle.org ☎ +47-69891192

Argentina

- 950 LR3 From January 1, 2006 "La 950" is the new name on Radio Belgrano. Radio Belgrano is one of the oldest radio stations in Latin America – LR3 started the 1st of April 1935. station
970 R. Genesis is on the air again Cornachioni in ConDig
1140 R. Guaraní AM, Gran Buenos Aires - new station "no oficial". Cornachioni in ConDig
1280 R. Mística (ex 1320) - ✉ Calle Congresales 570, 1° Piso Localidad de Libertad, Partido de Merlo, Gran Buenos Aires Cornachioni in ConDig
1380 R. Buenas Nuevas – new station. ✉ Librería Cristiana Buenas Nuevas, La Calle Moreno 350, Merlo, Buenos Aires Cornachioni in ConDig

Argentina (cont)

- 1430 R. Sonidos del Cielo – new station. ✉ Calle Comandante Granville 220, (B1755DGF) Rafael Castillo, Buenos Aires - ☎ 11 4669 6240 Cornachioni in ConDig
1450 R. Ilusiones Berazategui (ex 930) Slaen in ConDig
1590 R. Cristiania Adanai, Banfield Oeste is on the air again Cornachioni in ConDig

1690 La Morena de Itati (ex 1530) Mika Mäkeläinen in Dxing.info

Inactive "no oficial" stations in the BA-area – reported in ConDig by Marcelo Cornachioni:

<u>930</u>	R. Alfa (Villa Ballester)	<u>1300</u>	R. Cadena Central (Bernal)
<u>1010</u>	R. Oasis (Victoria)	<u>1530</u>	R. Contemporánea (Lomas de Zamora)
<u>1010</u>	R. Antártida (San Justo)	<u>1650</u>	RDB – La R. de la Bendición (Quilmes Oeste)
<u>1050</u>	R. Conurbana (Gregorio de Laferrere)	<u>1670</u>	R. Central (Capital Federal)
<u>1120</u>	R. Catedral del Encuentro (Guernica)		

Brazil

<u>910</u>	R. Paranaíba (GO20) - ☒ Rua Minas Gerais 135, 75503-190 Itumbiara, GO	Rudolf Grimm
<u>1060</u>	R. Imaculada Conceição (ex R. Tupinambás), Dorados (MS39)	Cláudio Moraes
<u>1060</u>	R. Difusora (ex. R. Gazeta, ex R. Dif Gomes) (SC103)	Cláudio Moraes
<u>1330</u>	ZYK736 R. Iguatemi (ex R. Tupi) (SP187)	Björn Olsson, UKVK
<u>1350</u>	R. Clube, Itajaí SC (SC53) – E-mail: clubeam@atrix.com.br	Pedroso in ConDig
<u>1380</u>	R. Ireguencía, Garopaba (SC105) – is on the air	Cláudio Moraes
<u>1390</u>	ZYK594 R. Alfa (ex R. Anchieta) (SP90)	Björn Olsson, UKVK
<u>1450</u>	R. São Bento (SC62) - ☒ Rua Ervino Rank 37, Bairro Serra Alta, 89290-000 São Bento do Sul, SC	Rudolf Grimm
<u>1540</u>	ZYJ206 R. Litorânea (PR168) - ☒ Rua Guilherme Pequeno 413, Centro, 83280-000 Guaratuba, ☎ 41 3472 3019. E-mail: amlitorane@onda.com.br	ConDig

Colombia

<u>610</u>	HJKL Bolero 6-10, Santafé de Bogotá (ex La Cariñosa)	Rafael Rodríguez
<u>910</u>	HJS52 Colombia Estéreo, Florencia (ex Colombia Mía)	Rafael Rodríguez
<u>1340</u>	HJFB La Cariñosa, Santafé de Bogotá (ex Fiesta 13-40, ex R. Uno)	Rafael Rodríguez
<u>1560</u>	HJHE Voces Rovirenses, ☒ Calle 11 N° 6A-11, Edif. San Gabriel, 2° piso, Málaga.	Björn Olsson, UKVK

Paraguay

<u>1450</u>	ZP29 R. Vallemi, Vallemi – new station	Adán Mur
-------------	--	----------

Perú

<u>1110</u>	R. Sonora (LI24) heard as R. Antarquí	Hector Alvaro Gutierrez in ConDig
<u>1530</u>	R. Somos (ex R. Milenea?) (LI49) – reported by	Hector Alvaro Gutierrez in ConDig

Uruguay

<u>1600</u>	CV160 R. Mil, Pando (ex. Emisora Continental)	Håkan Sundman in UKVK
-------------	---	-----------------------

Venezuela

<u>590</u>	YVKL R. Continente, Caracas ID “Emisora Matriz de CRC”	Jay Novello visiting Bonaire via DXLD
<u>680</u>	YVQR R. Fé y Alegría, Cumaná, (ex R. Continente Cumaná)	Roland Åkesson, ARC
<u>810</u>	YVLP R. 810, Valencia, slogan: “La Suprema”	José Elías Díaz Gómez to WRTH
<u>810</u>	YV.. R. Piritu, Puerto Piritu, delete	José Elías Díaz Gómez to WRTH
<u>840</u>	YVMY 8-40 AM, Barquisimeto, (ex R. Juventud)	Rafael Rodríguez
<u>870</u>	YVRU CNB 870, location given as Barcelona	Jay Novello as above
<u>1050</u>	YVKZ R. Educativa, Caracas, (ex Radio Nacional de Venezuela, “Canal Musical”). Slogan is “Con todo lo que sucede en el Despacho Educativo”.	José Elías Díaz Gómez and Dino Bloise to WRTH
<u>1220</u>	YVVM R. Venezuela, Valencia ID “Valencia 1220”	Jay Novello as above
<u>1360</u>	YVTZ R. YVTZ, Charallave, (ex La Radio). ID “YVTZ AM Center”	Jay Novello as above
<u>1380</u>	YVNG Ondas del Mar, Puerto Cabello slogan “El dial popular”	José Elías Díaz Gómez to WRTH
<u>1450</u>	YVKJ R. María, Caracas (ex Sonera 1450 AM). ☒ 3era Norte Av. Guaicaipuro, Quinta Mirna, Caracas. Slogan is “Una Voz Católica en tu Casa”. E-mail: radiomariavenezuela@hotmail.com	José Elías Díaz Gómez and Dino Bloise to WRTH

WORLD NEWS

[Europe, Asia, Africa] 16, Whitmore Ct, Little London, Silverstone, Northants, NN12 8UP
With Jeff Weston e-mail:world-news@mwcircle.org ☎ 01327 858472

Afghanistan

Both the 400 kW MW transmitters --- R. Afghanistan on 1107 and IBB on 1296 --- are strong enough to put a daytime groundwave signal into Islamabad. RA now also remains on 1107 during the evening, rather than switching to 1278 at 1400 as was once the case. 9325, 9345 and 9365 were checked regularly for the reported US psyops transmissions, but none were heard. (*Chris Greenway, Pakistan, Feb BDXC-UK Communication via DX Listening Digest 6-028 (11/2-2006)*).

Albania

Current schedule of 2 medium wave transmitters located in Fllake near Durrës, Albania [UT]

freq	start	end	station	language	azimuth	
1215	0600	0630	VOA	ALBANIAN	N-D	FLLAKE - A
1215	0643	0700	DW	ALBANIAN	N-D	
1215	0700	0900	CRI	ENGLISH	N-D	
1395	0901	1000	TIR	ALBANIAN	033	
1215	1600	1700	CRI	ALBANIAN	N-D	
1215	1700	1800	CRI	ESPERANTO	N-D	
1215	1800	1900	CRI	ROMANIAN	N-D	
1395	1910	2200	TWR	Various	330	
1215	2201	2300	CRI	SERBIAN	N-D	
1458	0530	0600	VOA	CROATIAN	338	FLLAKE - B
1458	0630	0645	VOA	SERBIAN	338	
1458	0730	0900	TIR	ALBANIAN	338	
1458	1500	1630	TIR	ALBANIAN	N-D	
1458	1630	1645	TIR	TURKISH	N-D	Mon-Sat
1458	1645	1700	TIR	GREEK	N-D	Mon-Sat
1458	1700	1800	CRI	BULGARIAN	N-D	
1458	1800	1900	CRI	ITALIAN	N-D	
1458	1901	1929	TIR	GERMAN	338	Mon-Sat
1458	1930	2000	VOA	ALBANIAN	030	
1458	2001	2059	CRI	HUNGARIAN	N-D	
1458	2100	2115	DW	SERBIAN	338	
1458	2115	2130	TIR	SERBIAN	004	Mon-Sat
1458	2130	2230	CRI	POLISH	004	
1458	2230	2330	CRI	CZECH	338	

VOA -Voice of America DW -Deutsche Welle CRI -China Radio International
TIR -Radio Tirana (external service) TWR -Trans World Radio
(*Best regards & many 73s! Dragan Lekic, Subotica, Serbia, Feb 2, DX LISTENING DIGEST*).

Armenia

As from February 11, TWR via Gavar Yerevan extended daily 1825-1925 UT service in various NE/ME languages. Now on Sat only also additional 1925-2025 UT in Tatar, Farsi, Farsi/En, Farsi, Kurdish-Sorani. Other TWR services on 864, 5855 kHz 1710-1810, -1840 Suns. 1910-1940 UT.

864 kHz 1810-1925. 1350 kHz 1930-2100, -2030Thur. 0400-0430 UT. All checked and noted. [and also via 1467 Bishkek-KGZ 1500-1800 UT, but not heard in Bulgaria]. (*Rumen Pankov-BUL, wwdxc BC-DX Feb 14, Wolfgang Büschel via DXLD yg (18/2-2006)*).

Australia

The Australian Communications and Media Authority has decided to make channel capacity available for a new community radio service in Arnhem Land, Northern Territory. ACMA has made AM frequencies available for a community radio service at Nhulunbuy (1503 kHz), Yathalamarra (1593 kHz), Elcho Island (1566 kHz), Gapuwiyak (1476 kHz) and Darwin (1530 kHz). Nhulunbuy, Yathalamarra, Elcho Island and Gapuwiyak are located some 600 km east of Darwin. The decision follows a proposal from the Aboriginal Resource and Development Services Inc (ARDS), an aspirant community radio group wishing to establish a community broadcasting service in the Yolngu Matha language based in Nhulunbuy with translator services across north-east Arnhem Land and Darwin. ARDS has been operating services on a temporary community broadcasting licence at Nhulunbuy and Darwin since May 2004.

On 1 November 2005, ACMA released for comment a proposal that MF-AM band channel capacity be made available for a permanent community radio service in Arnhem Land. Six submissions which were all supportive of the proposal were received. ACMA will call for applications for the community radio licence later in 2006. A copy of the licence area plan is available on the ACMA website http://www.acma.gov.au/ACMAINTER.65650:STANDARD:1582295335:pc=PC_91708 or by calling Freecall 1800 810 241. Media Contact: Donald Robertson, ACMA Media Manager on (02) 9334 7890. (*ACMA Media Release 31 January 2006, via David Onley, HCDX Digest Vol 38, Issue 2*).

Azerbaijan

Voice of Azerbaijan observed on 1295 kHz on 2 February, in Arabic at 1700, English at 1800. Both continue to identify as "Voice of Azerbaijan" in those languages, rather than the recently reported Radio Azerbaijan International". A clip of these IDs can be found on the Interval Signals Online website at <http://www.intervalsignalsonline.com> (*Regards, Dave Kernick, UK, Feb 3, DX LISTENING DIGEST*).

Belgium

Tonight Belgium is still transmitting on 927 & 1512 at 0015utc. Usually these channels are clear well before midnight utc. Has BRT/RTBF changed schedules? Have these gone 24hrs? [Herman, have you any news?] (*Steve Whitt, 25 Jan 06*).

I'll probably have an answer for you tomorrow. My first guess was that the channels were being kept on air because of Belgian tennis players being active in the Australian Open, but I don't think there were any games at that time of day. (*Herman Boel, 27 Jan 06*).

Yes, I noted it too. This might have to do with the Australian Open tennis tournament and will soon be over. Can't find anything about a prolonged schedule on the VRT website. This morning I noticed better conditions on the lower MW band. 610 and 790 were going strong. Unfortunately I had to leave for work. (*73, Guido Schotmans, 27 Jan 06*).

I have new on this (and you're not going to like it): During the winter months the medium wave transmitters of both the VRT and RTBF are on the air all night long. There are two reasons for this: 1. the management cannot accept that during the night far away stations can be received with loud signal here. Rumour has it that those foreign stations have elevated their power output and no one can verify it. Only the electricity bill rises of course...2. When 540 and 621 kHz are switched off,

the temperature in the transmitter room at Waver drops substantially. So they prefer to keep the transmitters on so that things don't freeze (a part of the transmitters is water-cooled). So, basically the management does not tolerate any form of competition...Sad but true. (*Herman, www.emwg.info 27 Jan 06*).

Yesterday evening (sat) and today (sun), 621, 927 and 1512 kHz are back to their normal signing off times. (*Guido Schotmans, 31 Jan 06*).

Further to my earlier message, I have some further news. It seems that the VRT has conducted nightly DRM tests in the recent past. Unfortunately, they messed up such that they blew their main transmitter and had to use their spare transmitter for some time. They told the press there had been a lightning strike. As they are now back with their main transmitter, this may be the reason why the current transmissions seem to come with higher power. I have also heard that VRT has (had?) an option for a DRM transmitter at Telefunken. This is all highly internal information of course, which is very hard to come by... even in a 'western' country as our own. (*Herman Boel, 01 Feb 06*).

In view of the recent discussion on VRT/RVI txions on medium waves, I thought it appropriate to send you the following information received on Jan 27: "Very nice you could hear our local sports channel on 927 kHz, and thanks for the detailed report. The tx is located in Wolvertem and runs at the moment only 100 kW into a vertical antenna. If I can ask you a favour, we are particularly interested in the reception possibilities of our long range Medium Wave tx located at the same site on 1512 kHz running 300 kW before 8:00 AM and after 18:00 PM. Daylight operation is only 20 kW. Another AM tx of 540 kHz is located in Waver [sic] and operates 06:00-25:00 [sic]. If possible I would appreciate comparative reports from these three stations during a period of time. You would do us a great favour sending us reports on reception of these in Sweden. Pedro WYNS" The times given are no doubt UT. Personally I am surprised how difficult it is to hear the Waver tx on 540 kHz, where Budapest is really dominating, whereas the 1512 kHz tx is a real powerhouse, very seldom affected by bad conditions. For those who, like myself, are interested in doing some monitoring work for Pedro, his E-mail address is: (Pedro.WYNS @ VRT.BE, (*Ullmar Qvick-SWE, dxld Feb 12*)).

Croatia

I copied the letter of Ullmar Qvick (dxld) to the Technical Department of HRT Radio Zagreb at Deanovec, Technical Director Nikola Percin_HRT, Telecom Ministry Croatia, TX provider OIV at Zagreb, Croatia (*wb, Jan 21*). So, in connection[?] to these complaints, Croatia stopped DRM transmissions on 594 kHz to limited daytime operation since Jan 25, reported (*Patrick Robic AUT, A DX Jan 27, via DXLD*).

Estonia

Tartu Pereraadio which is running the Russian language channel "Tartuskoye Semeykoye Radio" on 1035 from Tartu is planning to replace the present 50kW Harris transmitter with a 200kW Telefunken (Transradio) TRAM 200 unit. A date for the power increase is not yet set. The transmitter will be DRM capable, and Pereraadio is considering DRM transmissions at certain times to start with. (*Bernd Trutenau-LTU, mwdx, 22 Feb 06*).

Faroe Islands

The medium wave transmitter at Akraberg on 531 kHz has got a new transmitter tube and is now heard much better with their 100 kW signal (except during their news broadcast at 18.30-19.00 UT when the power is up at 200 kW). An Italian lady living in the Faroes, Anna Lachino, has a show in English every Tuesday night at 20-21 UT called Soul Nation. If you live too far away from the Faroe Islands try a DX Tuner receiver or their live stream at: <http://www.portal.fo/?uf=play> - click

out left on ÚF LIVE (Media Pl.). (73, Erik Koie, Copenhagen (DXLD), via Mike Terry, BDXC-UK, 19 Feb 06).

France

The CSA (the French radio authority) has given the go-ahead to Paris Live Radio, an English-language station aimed at foreign visitors and English-speaking residents in the French capital, for a three months test period on 963 kHz. No date was mentioned but March 24 is generally believed to be the target date. (73s, Rémy Friess, 31 Jan 2006).

Germany

Westdeutscher Rundfunk ordered two 100 kW mediumwave transmitters (plus two 50 kW auxiliary transmitters) from the former Telefunken, now Transradio company. At present testing of these transmitters is under way at the Berlin workshop of Transradio while the staff of the Langenberg station provisionally moves the existing transmitter (Siemens 200 kW, installed around 1980) out of its place to make room for the new equipment. One of the new 100 kW transmitters is meant for 720, the other one for 1593. The former 1593 antenna equipment still exists at Langenberg in operational condition, so a reactivation of this frequency appears to be no big challenge. So far it is unknown who will or could use 1593 at Langenberg again. The transmitters are DRM-ready, but Westdeutscher Rundfunk staff does not dare to foretell if they will be ever used in this mode (short tests disregarded here of course). An addition re. Telefunken: The renaming into Transradio came into force as of January, and it is clear now that they were indeed forced somehow to give up the Telefunken brand (Kai Ludwig, Germany, Feb 3, DXLD).

Kai Ludwig writes: German public broadcaster WDR plans to start DRM tests on 1593 kHz in the summer. They will be run with 20 kW and are scheduled for a period of 18 months. The objective is to gather experience with the system in order to find out if it has a future. DRM receivers are expected (by WDR it seems, but the actual source of this statement remains unclear) to be available in summer of this year. Two new Transradio (ex Telefunken) mediumwave transmitters of 100 kW each are to be installed at WDR's Langenberg station where 1593 can be used again after IBB's Holzkirchen transmitter went to Kuwait. In the nineties WDR let IBB have 1593 after shutting down the 2x600 kW transmitters at Langenberg by the end of 1993 (due to PCB and asbestos in them) and got in exchange fulltime authorization for the ex-Holzkirchen channel 720 (previously available at Langenberg during daytime only). (Andy Sennitt, Media Network <http://medianetwork.blogspot.com/>, via Mike Terry, mwdx, 19 Feb 06).

This year Evangeliums-Rundfunk is in its tenth year of broadcasting over the Mainflingen station on 1539 kHz. In 2005 a new antenna was built to reduce local interference to electric appliances and to enhance reception Europe-wide. Unfortunately for the Christian broadcaster, their programmes are still broadcast via the old antenna. Because the WRTH 2006 does not mention it, it might be of interest for QSL-hunters, that there are foreign language programmes on the mediumwave station Mainflingen 1539 kHz. Currently, there is the following line up (UTC):

0400 Mo Arabic, Tu Farsi, We Russian, Th Turkish, Fr Su Croatian, Sa English
0415 Mo Arabic, Tu Farsi, We Russian, Th Turkish, Fr Spanish, Sa English, Su French (Radio Evangile)
0430 daily French (Radio Evangile)
0445 Mo Greek, Tu Arabic, We Russian, Th Turkish, Fr Croatian, Sa Kurdish-Sorani, Su English.

All programmes are religious in format. From 0500 to 2300 h the frequency is used for German.(Dr. Hansjoerg Biener, Germany, wwdxc BC- DX 30 Jan via DX Listening Digest 6-024 (5/2-2006)).

Antenne Saar (Saarbrücken, Germany) can still be heard on 1665 kHz. I found this in late December while in North-Germany and just checked again (0800 UTC), and it is still there. It is a spur and nobody really cares anymore. I wonder do they ever make measurements at their Tx site? (*Jurgen Bartels, via mwDX, 14 Feb 06*).

Greece

The two US international broadcasting relay stations in Greece, at Rhodes and Kavala, are to be closed. This news has been conveyed to staff by George Moore, Director of IBB's Office of Engineering and Technical Services. The high cost of operating shortwave and mediumwave relays, combined with the shift of audiences to other media such as FM, the Internet and television, are cited as the reasons for the decision. The news comes as no surprise, as a number of the languages broadcast from the Greek facilities are being eliminated in the proposed schedule effective in October 2006.

The first broadcasts were transmitted from Kavala on April 17, 1972. VOA broadcasts from the Rhodes Relay Station were first heard on May 19, 1964. (*VOA/IBB via Media Network weblog*)

Kashmir

Azad Kashmir Radio heard at various times on three frequencies --- 792, 936 and 4790. All three at times have separate programming. 4790 was heard as early as 0300 and closes after relaying 1700 Radio Pakistan news (but not on continuously between those times). 936 closes after relaying 1800 Radio Pakistan news. Listed 7265 not heard. V. of Jammu and Kashmir Freedom, 5102 heard closing as scheduled at 1430. Very strong signal, suggesting from Islamabad site, as indicated in WRTH 2006 page 527. Usual poor Pakistani modulation. (*Chris Greenway, Jan, Islamabad, Pakistan, Feb BDXC-UK Communication via DX Listening Digest 6-028 (11/2-2006)*).

Latvia

The Director of Pan-European radio station Radio Tatra International (RTI) has rubbished a story from an online source in Germany which says that "Due to a lack of funds at Radio Tatra International, the RTI relays via Kuldiga, Latvia on 1350 kHz (provided by Krebs TV) will end on 1 February." Eric Chilvers says that the author of the item (which was uncredited and unattributed) has not spoken to him or the Chairman of RTI, and points out that RTI is a 52% shareholder in KrebsTV. In fact, RTI has just signed a new 12 month contract for the use of 1350 kHz, which Chilvers describes as a "marketing tool." Furthermore, funding is not a problem at RTI, and the station has just invested in a new studio complex in Slovakia. <http://www.rti.fm/> (Mike Terry, mwDX, 29 Jan 06).

Lithuania

The relay service of Radio Baltic Waves International via Bubiai 1386 (7kW) will carry Radio Mi Amigo Sat & Sun 2200-2400 UTC on the coming 5 weekends (*February: 4&5, 11&12, 18&19, 25&26; March: 4&5*). (*Bernd Trutenau-LTU, via mwDX, 02 Feb 06*).

Netherlands

Radio 747AM to revert to old name of Radio 5 The public radio network currently known as 747AM will revert to its old name, Radio 5, and undergo a major change in profile. That's the most significant change in the radio strategy document published today by the Board of Management of Dutch public broadcasting. The changes to 747AM will account for around half of the 13 million euro per year savings that must be made across the public radio networks. The Board of Management describes the 'new style Radio 5' as a "colourful network in which outlooks on life, education and accessible music will be heard. It's hoped this will reach a bigger audience - the

current 747AM rarely gets above 1 percent audience share - and make it more attractive to those aged 55 and over with a lower level of formal education.

From the start of discussions over the new radio strategy, it was always clear that most of the savings would have to be made by 747AM, as spreading savings equally across all five networks would damage all of them. Two options were initially considered: setting up a "carousel of repeats" or make major savings on the existing 747AM programming. The management decided that neither of these options would deliver more listeners, so chose this third one. As far as the other networks are concerned, news and talk network Radio 1 will see hardly any changes. Radio 2 will undergo minor tweaks, and 3FM will continue its present schedule. Radio 4 will be re-profiled, and as well as a broad range of classical music it will also include jazz, world music, and programmes on art, culture and science. The Board of Management is now asking the various public broadcasting organisations for their reactions to the radio strategy by 15 March. (*R Netherlands Media Network Weblog, 09 Feb 06*).

New Zealand

TRN [The Radio Network] is testing a new frequency, 1278kHz for a possible new service to the southern Taranaki region in the western North Island. The transmitter is located at Rotokare, near the small town of Eltham. Maximum permitted power is 6.3kW. The tests have been reported as a series of tone tests. TRN already operates NewstalkZB from Napier on 1278kHz in the Hawkes Bay region on the eastern North Island coast. The licence is valid until November 1 2006. (*David Ricquish' Radio Heritage Foundation www.radioheritage.net, via hcdx, c 16 Feb 06*).

Poland

Two stations broadcasting in Belarusian from Poland to Belarus are due to be aired partly also on MW: 1. Radio Racja (Belarusian: Radyjo Racyja) with studio in Bialystok, Poland will broadcast daily 1700-1900 UTC via Koszecin 1080 kHz 350kW from today 22 February. 2. European Radio for Belarus (Belarusian: Eúrapejskaje Radyjo dlja Belarusi) with studio in Warsaw, which already is available via webcasting at <http://www.belradio.fm>, will be carried daily by Radio Baltic Waves in Vilnius on 612 kHz 100kW at 0600-0700, starting 26 February. (*Bernd Trutenau-LTU, mwdx, 22 Feb 06*).

Radio Racja, based in the eastern Polish city of Bialystok, has resumed transmissions in Belarusian targeted at audiences across the border. Radio Racja was initially launched in 1999 and suspended its operations in 2002 due to lack of funding. The station is broadcasting on mediumwave 1080 kHz from a transmitter near Katowice in the south of Poland, and on 105.5 MHz FM along the border with Belarus. Radio Racja is also broadcasting on 103.8 FM from Lithuania. For the time being it is airing a single-hour programme daily in the Belarusian language with repeats. The station is funded from the Polish government budget, but hopes to acquire other sponsors soon. (*Source: Radio Polonia via Media Network, via BDXC-UK, 22 Feb 06 [Moderator: No time was given for the broadcast - can anyone confirm when it is on the air?]*).

Russia

St. Petersburg: 828 (Radio Liberty) and 1440 (RFI) went dark on January 1st due to expired licences. Radio Liberty referred listeners to FM 71.24 and seems to have done with it. RFI is now at times relayed on 1188, previously used by Deutsche Welle exclusively. Wonder who took the initiative for this arrangement; RFI, DW or perhaps RTRS (the tx operator)? Anyway neither involved station gave the circumstances special publicity, at least I did not note any nx releases etc. This is quite different to the big fuss about 693 in Moscow (nobody seems to care for BBC and RFI in Moscow anymore since the DW txions on 693 are restored, by the way). (*Kai Ludwig, dxld Feb 12*).

Sankt-Peterburg since January, 1, 2006 relaying "Radio Freedom" on 828 kHz are stopped and the International French radio on 1440 kHz. RFI now divides Frequency 1188 kHz with "the German wave". Transfers on freq 1188 kHz (Saint Petersburg, 10 kW) go under the following schedule (UTC).

0300-0430 DW Russian	0430-0500 RFI Russian	0500-0600 DW Russian
0600-0700 DW German	0700-0800 DW Russian	0800-1000 DW German
1000-1200 RFI French	1200-1430 DW German	1430-1500 RFI Russian
1500-1900 DW Russian	1900-2000 RFI Russian	2000-2100 DW Russian
2100-2300 DW German		

Relay via 684 kHz (via Radio NERRS, Sankt-Peterburg, 10 kW)

0430-0457 Radio Slovakia International

0500-0527 Radio Prague

0530-0557 Radio Polonia

0600-0900 Radiogazeta Slovo

1200-1300 TWR

1300-1357 China Radio International

1400-1500 TWR

1500-1800 Pravoslavnoe Radio Sankt-Peterburg

1800-2000 Radio Radonezh

2000-2030 Radio Canada International

2030-2200 Radiogazeta Slovo

2200-2300 Radio Svobodnyy Golos

(Alexander Berezkin-RUS, RUSdx Feb 13)

Mediumwave BBC broadcasts resume in Moscow BBC World Service is back on mediumwave in Moscow. Following a brief interruption, BBC Russian has resumed broadcasting on the 1260 kHz frequency. The BBC came off air in Moscow when the technical licence of its former distributor, Octode, expired in late December 2005. The Head of BBC Russian, Sara Beck, said: "I am delighted by this news, as will be our medium wave audience in Moscow. They've got into the habit of listening to BBC Russian on mediumwave, and they have been letting us know just how much they were missing us. We are extremely pleased that it's business as usual, bringing international news to our listeners in Moscow." BBC Russian continues broadcasting on 1260 kHz in St Petersburg and on 666 kHz in Ekaterinburg. BBC Russian is also available in Moscow on FM via partner station, Radio Arsenal 87.5 FM. The audio of all BBC Russian programmes is available via its website bbcussian.com. *(Media network weblog 22 Feb)*.

South Africa

Talk Radio 702's Medium Wave transmitter at Garankuwa has been severely damaged by fire. It is currently not able to transmit our signal. An alternative signal is now available at 540 kHz. To continue listening to 702 you need to retune to 540 kilohertz on Medium Wave, or AM – the first medium wave signal on the left hand side of the dial. Talk Radio 702 is also still available on line via our audio streaming, DStv audio channel 56, and via 702 Live on 083 9000 702 (cell phone rates). (John Plimmer, via Steve Whitt, 05 Feb 06)....._Yes it's the old R. Bop 540 kHz TX at Ga-Rankuwa (just North of Pretoria). It is 50 kW and omni-directional. *(John Plimmer, Montagu, Western Cape Province, South Africa, 07 Feb 06)*.

THE HOME FRONT

[British & Irish News]
with John Williams

✉ 100 Gravel Lane, Hemel Hempstead, Herts HP1 1SB, UK
e-mail: homefront@mwcircle.org ☎ 01442 408567

Ofcom News

Ofcom proposes sponsor-branded radio channels

7 February, 2006

Advertisers should have the chance to sponsor and even name a radio station, (or television channel) according to Ofcom, the communications regulator.

The plan is the latest proposed relaxation of the strict broadcast advertising rules. However, Ofcom is still not willing to allow existing mainstream TV channels to adopt a sponsor's brand as part of their names. Instead, companies could launch new, branded radio stations as long as they owned them. The proposal could pave the way for the creation of "Coca-Cola radio", as a subsidiary of the drinks company. But under the proposals it would not be possible to sponsor ITV1, Channel 4, Five, or any other TV channel that carries news. That restriction would not apply to radio stations. The proposals are open to consultation until April 20.



A spokesman for Ofcom described the plans as a "liberalisation" but the regulator wants viewers to be clear "who is responsible for the editorial content of the service" - which is why the regulator is so keen to prevent advertisers from getting naming rights to any radio they did not own. Radio advertising

accounts for £500 million a year.

Ofcom awards 21 community radio licences

20 February, 2006

Of the 21 further community licences authorised by Ofcom only one is in respect of an AM station. KOOL AM (Harlow, Essex), Contact: Dave Ebdon, Burnt Mill School, First Avenue, Harlow, Essex CM20 2NR Tel: 07732 783013 email steve.saunders@paradisefm.co.uk This station is already broadcasting as an LPAM station on 1134 kHz. Website www.koolam.co.uk (although on 22 February site was not operating)

Community radio is a new sector of radio being introduced in the UK. It will become the third tier of radio which will complement the mix of services already provided by the BBC and commercial radio sectors. The characteristics of community radio are distinct from commercial radio in that the services will cover a small geographical area and be provided on a not-for-profit basis focusing on the delivery of specific social benefits to enrich a particular geographical community or a community of interest.

UK Radio News.

Latest Rajar listening figures

2 February, 2006

Chrysalis, the media group, fended off GCap, its resurgent rival, in London's fiercely competitive commercial radio market in the fourth quarter of 2005. But the BBC stretched its lead across the country as a whole, according to industry figures published today.

Figures from Rajar, the industry body, also showed that the BBC built its largest-ever lead over its commercial rivals, stretching its audience-share lead to more than 12 percentage points. BBC Radio had a 55 per cent share of the UK radio market in the final quarter of 2005, compared to 42.8 per cent for commercial stations. The corporation now pulls in nearly 33 million listeners per week.



Much of the focus within the industry will fall on the hotly contested London market, which is the biggest money-spinner for the commercial broadcasters. GCap, Britain's largest commercial radio group, saw Capital's share of the key London audience rise to 5.9 per cent from 5.1 per cent in the

previous quarter. The company's flagship Capital Radio station lost its pole position in London in the previous quarter.

Today's figures included three weeks of Capital's change of policy to reduce the number of advertisement breaks, and came before a re-branding of the station in early January. Heart FM 106.2 retained the top commercial spot in London, despite its audience share slipping to 6 per cent from 6.4 per cent in the previous quarter. Both stations' flagship breakfast shows increased their audiences.

Speech stations record highest number of listening hours 2 February, 2006

The UK's only national commercial speech station, talkSport, has recorded the highest number of total listening hours in the station's 10-year history as well as significant year-on-year increases in share and reach, according to figures released today by the Radio Joint Audience Research Committee (Rajar). The station has recorded over 19m total listening hours a week for all four quarters of last year for the first time since the station was launched as Talk Radio in 1995. Total listening hours equals the overall number of hours of adult listening to a station in the UK in an average week.



Speaking at a Rajar press conference, the chief executive of commercial radio's trade body, the Commercial Radio Companies Association, Paul Brown, said: "I am an avid listener of talkSport and over the last six months its output has improved dramatically. It is far more lively to listen to and this is reflected in the Rajar figures." The station also recorded an increased share in listening from 1.6 per cent to 1.8 per cent despite commercial radio losing 1.4 per cent in market share to the BBC over the last year.

Brown also mentioned the success of the LBC speech stations which have recorded a significant increase in reach both in London and across the UK. The total number of people listening to LBC in London and across the UK has risen by 9.9 per cent to 722,000 over the year. BBC Radio 4's share is up to 11.8 per cent, the station's highest figure since the first quarter of 2003 - during the Iraq war - and up from 11.5 per cent last quarter and last year. The station is still the most listened-to station in London. The Today programme attracts 1.75m listeners - equivalent to breakfast listening on Capital, Kiss, Magic and Heart added together.

Controller of BBC Radio 4 Mark Damazer told Press Gazette: "It's heartening that Radio 4's share has risen - particularly because it has not occurred as a result of any extraordinary news event. A number of Radio 4 programmes - in many different parts of the schedule - have been listened to more than before. "It's terrific that we do so well in London but I hope we can begin to match that performance across the U.K. Radio 4 is for everyone interested in intelligent speech - no matter where they live, no matter how old they are."

Commercial Radio News.

Chrysalis radio revenues slide

9 February, 2006

Heart and Galaxy owner Chrysalis has suffered a 2% decline in radio revenues over the first five months of its financial year, the company said today. However, the group - also home to LBC - said the downturn between September and January was only "modest" and had still "comfortably outperformed" the rest of the market.



The decline would have been steeper than 2% in the past three months, as the group earlier reported a 4% increase for September and October. It still represents an improvement on the 9% decrease recorded for the last financial year, which ended in August 2005.

The group is sticking with its twin focus on radio and music despite grumbling from some shareholders that it would do better to demerge the operations. Chrysalis has so far missed out on the consolidation in the radio sector that last year saw the creation of GCap Media, Emap's purchase of Scottish Radio Holdings and Ulster TV's deal to buy the Wireless Group.

UK media regulator announces decision on Classic Gold **9 February, 2006**

At its meeting on 9 February 2006, UK media regulator Ofcom's Radio Licensing Committee considered a request submitted by UBC Media Group plc, owners of the Classic Gold stations, to change the Formats of its services in two ways:

1. To be allowed to consolidate its portfolio of local services into a smaller number of regional 'clusters'. This reorganisation would affect 13 out of 18 Classic Gold stations;
2. To change the Formats of all 18 Classic Gold stations to allow them to schedule the four hours of locally made programming currently required by the Format at any time during weekday daytime (i.e. between 0600 – 1900hrs) rather than weekday peaktime (i.e. either breakfast or drivetime)

Ofcom took the view that these changes could substantially alter the character of the service and therefore, under the requirements of section 106ZA of the 1990 Broadcasting Act, a public consultation was held lasting 42 days.



A total of six responses were submitted from the industry and individuals; one respondent was in favour of the proposals. One response was confidential. After full and careful consideration the Committee decided as follows:

Proposal 1 :The proposal to regionalise output for 13 Classic Gold stations should not be agreed.

Proposal 2 : The proposal to amend the 18 Classic Gold station Formats to allow the four hours of locally made programming to be scheduled anywhere within daytime should be agreed.

Commercial radio bodies to merge **20 February, 2006**

Commercial radio's two main industry bodies will today announce a merger, forming a new organisation in a bid to promote the sector more effectively. The Radio Advertising Bureau and Commercial Radio Companies Organisation will join forces under a new umbrella organisation, which will see the CRCA cease to exist in its current form.

The as-yet-unnamed new body will bring all commercial radio company interests under one roof for the first time and will include a commissioning centre charged with making programmes for broadcast across the entire commercial radio network.

The RAB will remain intact as part of the new body and will continue to promote commercial radio advertising to advertisers and media agencies. The logic behind the move is to enable the commercial radio industry to act more quickly and effectively. In the last quarter of 2005 BBC radio opened up its biggest-ever lead over its commercial radio rivals with the gap in audience share of more than 12 percentage points.(www.mediaguardian.co.uk)

RSL & LPAM News

Football Club	Station	March fixtures	April fixtures
Crystal Palace	Palace Radio 1278 kHz	4 Leeds 18 Ipswich	1 Watford 15 Crewe 22 Southampton
Blackburn	Radio Rovers 1404 kHz	11 Aston Villa 18 Middlesborough	1 Wigan 15 Liverpool

			22 Chelsea
Manchester Utd	Manchester Utd Radio 1413 kHz	11 Newcastle 25 Birmingham	8 Arsenal 15 Sunderland 22 Middlesbrough
Barnsley	Oakwell 1575 kHz	4 Swansea 25 Bournemouth	8 Chesterfield 17 Southend 29 Bradford

Edinburgh's Garrison Radio to switch from mediumwave to FM 22 February, 2006

One of the smallest mediumwave broadcasters in the UK is to switch to FM after being awarded a community radio licence by the UK media regulator Ofcom. Garrison Radio, Scotland's first Army station, currently broadcasts to Dreghorn Barracks in Edinburgh on 1350 kHz, but has problems



reaching all the families of the soldiers serving there as it uses just one watt of power. The new FM licence (50 watts) will mean that Garrison Radio can reach the Army barracks at both Dreghorn and Redford. As a bonus, the station will also reach non-military listeners in the area.

(http://medianetwork.blogspot.com/2006_02_19_medianetwork_archive.html)

Hemel Hospital Radio 1350 kHz has not been on air for over a month. Furthermore their relay on **1287 kHz St Albans Hospital Radio** has not been active for the past 3 months despite the assertions of the Management that they would be "on air soon." Their web site www.hemelradio.com has been deleted – as at 23 February, 2006).

Irish News

UCB ceases transmissions on 549 kHz 1 February, 2006

Irish Christian Broadcasters (ICB) announces on its website that it has turned off the 549 AM Transmitter in Monaghan that was heard across Ireland and much of the UK. The transmitter has been re-broadcasting UCB Europe for the past 5 and 1/2 years. ICB says plans are well advanced towards obtaining a national licence. This week, it had a visit from officials of the Commission for Communications Regulation (ComReg) who instructed ICB to cease the mediumwave transmissions. (Media Network) The statement is at: <http://www.gracefellowship.ie/silent.htm> and includes thanks to: The Russian Federation and their Regulators – who allowed us to use their Frequencies of 549 AM and 846 AM - during the past 10 years for Christian Broadcasting to Britain and Ireland, and who have not objected to the transfer of these frequencies to Ireland, on ICB's initiative in 2002, for the purpose of Christian Broadcasting in Ireland UCB for providing us with a EU Regulated and Licensed Christian Service, which we could 're-transmit' in Ireland, while the prohibition on Christian Advertising exists and there continues to be an absence of licensed Christian Services available in Ireland.

Of course Russian regulators cannot assign frequencies to other countries and UCB always claimed that they did not authorise these relays. (via Mike Barraclough)

The **deadline** for the next issue is **21 March, 2006**.

73's John



DX LOGGINGS

✉ Glackin, 199 Clashmore, Lochinver, Lairg, Sutherland IV27 4JQ, Scotland
with Martin Hall e-mail: dxlogs@mwcircle.org ☎ 01571-855360

kHz	Callsign	Station, location; details heard etc	SIO	UTC	Date	Who
530		RVCI, Turks & Caicos (presumed); SS religious talk	F	0617	3/2	BGM
530		RVCI, Turks & Caicos; SS singing with full ID insert at toth http://tinyurl.com/9ynp5	G	0800	5/2	PC
540	CBT	Grand Falls NL; CBC news // 1070 kHz	W	0003	2/2	PC
550	CHLN	Trois-Rivières QC; FF tlk, ID "CHLN 5-50 ... Québec"	W/F	0900	8/2	mah
550	CHLN	Trois Rivières QC (presumed); FF talk from OM and YL	W	0751	10/2	PC
550	CHLN	Trois Rivières QC; phone-in; evening service // 730 CKAC	W	0123	14/2	JF
550	YVKE	Mundial, Caracas; serious SS tlk, ID "Mundial YVKE ..."	Fpks	0729	7/2	mah
550	YVKE	Mundial, Caracas; SS tlk, several "Mundial YVKE" IDs	F/G	0710	21/2	mah
560	WGAN	Portland ME; ads, "News Radio 5-60 WG", ID cut by intro to CBS News	Fpks	0900	30/1	mah
560	WGAN	Portland ME; "News Radio 5-60", C2C phone-in	23542	0330	31/1	DX183
560	CHVO	Spaniard's Bay NL; "VOCM – Newfoundland and Labrador's news authority"	W/F	2320	31/1	PC
560	CHVO	Spaniard's Bay NL; anns, "CHVO Country" IDs	P/Fpks	0944	6/2	mah
560	CHVO	Spaniard's Bay NL; VOCI ID // 620, 710, 740 kHz	W	2322	16/2	BGM
570	KVI	Seattle WA (tentative); 0810 ads, C2C, on the 340 degree bev; faded at 0830 break, gone by 0900	Wpks	0810	12/2	mah
580	CFRA	Ottawa ON; news, weather, CFRA ID	F	0008	10/2	PC
580	CFRA	Ottawa ON; with newstalk	W/F	0445	14/2	Rha
580		RJR Baileys Vale, Jamaica (pres); EE phone-in tlk-male/female only on 280°	0610	W	16/2	Rha
580	WKAQ	San Juan PR; SS tlk, "Radio Reloj"	33543	0555	2/2	DX183
585		AIR Nagpur; EE nx // various SW ch, 095 degrees	W/Fpks	1530	3/2	ss
585		IRIB Tehran, Iran; Farsi Quran px, 110 degrees	W/Fpks	1533	3/2	ss
585		PBC Islamabad; Urdu tlk, ID at 1529, 095 degrees DX183	F	1519	3/2	ss
		First				
590	WEZE	Boston MA; talk, www.familyradio.com , "Family Radio 5-90" and Christian songs	33433	0855	6/2	DX183
590	WEZE	Boston MA (presumed); rlg's tlk, briefly dominant over VOCI, Fpk but faded by the toth; (also presumed Wpks 0910 30/1)		0858	6/2	mah
590	CJCW	Sussex NB; VOCI in long fade to about 1040 left three stations cross-fading on the channel - presumed WEZE with religion, presumed CJCL with sports, and this one; at 0835 wx, clear "In Sussex it's minus 5" and weaker "Favourites 5-90", then light songs; UK FIRST	Fpks	1035	2/2	mah
590	VOCI	St John's NL; country music // 710 kHz	F	0741	25/1	JW
590	VOCI	St John's NL; advertisement, ID	G	0005	26/1	dxv
590	VOCI	St John's NL; "You're listening to 5-90 VOCI St John's. VOCI Depend on it"	F/G	0630	28/1	BGM
590	VOCI	St John's NL; trailer for VOCI programs	F	2351	1/2	PC
590	VOCI	St John's NL; C&W song // internet stream.	vW	1950	5/2	JF
590	VOCI	St John's NL; // 620 except for separate ads; programmes back in // after adbreak	G	0019	13/2	SW

kHz	Callsign	Station, location; details heard etc	SIO	UTC	Date	Who
590	VOCM	St John's NL; old country music progr	F	0442	14/2	Rha
590	CMHI	R Musical, Santa Clara; opera, SS anns, two clear IDs at 1003 as "CMBF Radio Musical Nacional"; with rather unstable modulation, typical of Cuban stations; on its own on the channel; last reported from Sheigra in 1996 with Radio Reloj programming; (also presumed Gpks 0832 1/2)	Fpks	0945	6/2	mah
594		BSKSA Juba, Saudi Arabia; //1521 kHz	W/Fpks	2120	31/1	ss
600	WBWL	Jacksonville FL; R Disney, "AM 600 WBWL"	23542	0750	17/1	DX183
600	WCAO	Baltimore MD ; black gospel, "WCAO Heaven 600"	32542	0440	5/2	DX183
600	CBNA	St Anthony NL; discussion about past PMs // 1070 kHz	F	2203	29/1	PC
600	CBNA	St Anthony NL; CBC news // 1070 kHz	F	2345	2/2	BGM
600	CBNA	St Anthony NL. CBC Radio ID in programme // 640	G	2310	11/2	JF
600	CBNA	St Anthony NL; few talk on CBC radio one	W/Fpks	0718	13/2	Rha
600	CMKV	Radio Rebelde, Urbano Noris; SS mx and talk // 5025 kHz	W	0619	3/2	BGM
600	CMKV	Radio Rebelde, Urbano Noris; YL talk, mention of Cuba // 5025	F	0802	5/2	PC
600	CMKV	R.Rebelde, Urbano Noris; SS, "Radio Rebelde" ID & Cuban cantados/mx	W/F	0600	16/2	Rha
610	WIOD	Miami FL; "WIOD", C2C	44544	0615	25/1	DX183
610	WIOD	Miami FL; weather report, "News Radio WIOD 6-10", mixing with R Rebelde	F	0006	26/1	dxv
610	WIOD	Miami FL; "News Radio 6-10 WIOD"	G	0733	6/2	ss
610	WTVN	Columbus OH; "6-10 WTVN" insert before going back to C2C	W/F	0810	14/2	mah
610	CHNC	New Carlisle QC (presumed); record "Heart of Gold" then into another soft rock record	F	0811	25/1	JW
610	CHNC	New Carlisle QC; EE & FF pops	G	0728	31/1	BD
610	CHNC	New Carlisle QC (pres); FF music and talk – no ID at toth	F/G	0000	1/2	PC
610	CHNC	New Carlisle QC; pop song then ID and chat	F	2305	1/2	JF
610	CHNC	New Carlisle QC; FF pop, "Vouz ecoutez CHNC et CHGM"	F	0358	4/2	BGM
610	CHNC	New Carlisle QC; music then apparent English ID at 0016 clearly mentioned New Carlisle and Gaspé	F	0015	13/2	SW
610	CHNC	New Carlisle QC; light pop music & French tlk	F	0555	14/2	Rha
610	CMAN	Radio Rebelde, Bahía Honda; melancholy songs // 5025 kHz	W/F	0737	30/1	BD
620	WZON	Bangor ME; promo "Westwood One" and "Sports Radio 6-20 WZON"; under CKCM; (also Wpks 0904 30/1)	W	0025	13/2	mah
620	CKCM	Grand Falls NL; VOCM ID, news	F	2033	21/1	dxv
620	CKCM	Grand Falls NL; VOCM ID	W	2143	26/1	BGM
620	CKCM	Grand Falls NL; country music // 710 kHz	W	2153	29/1	PC
620	CKCM	Grand Falls NF; country music YL DJ with phone numbers for St John's Metro area and toll free number 1-888-593-VOCM"	F	2322	5/2	JW
620	CKCM	Grand Falls NL; // 590 except for separate ads; programmes back in // after adbreak	G	0019	13/2	SW
620	CKCM	Grand Falls NF; VOCM IDs and anns for vocm.com	W	0149	14/2	RB
620	CKCM	Grand Falls NL; VOCM country-pops and "VOCM" ID	W/F	0700	16/2	Rha
620	CKCM	Grand Falls NL; commercials for Grand Falls businesses then VOCM country mx	G	0215	19/2	BD
620	CMGN	Radio Rebelde, Colón (presumed); // 5025 kHz	F	2325	23/1	dxv
630	CFCY	Charlottetown PE; "6-30 CFCY", country, over Euros	F	0719	30/1	mah
640	CBN	St John's NL; CBC program, // 1400,1070 kHz	F	2045	21/1	dxv
640	CBN	St John's NL; CBC News // 1070 kHz	F	0002	1/2	PC

kHz	Callsign	Station, location; details heard etc	SIO	UTC	Date	Who
640	CBN	St John's NL; CBC programme // 600 kHz; current affairs	G	2315	11/2	JF
640	CBN	St. John's NL; CBC feature interview // 1070 kHz	W	0220	19/2	BD
640	CM--	R Rebelde, 3 sites listed; música cubana // 5025 kHz	33543	0640	28/1	DX183
650		KNR Qeqertarsuaq (presumed); YL in Greenlandic	F	1801	21/1	dxv
650		KNR Qeqertarsuaq, Greenland; YL talking in Greenlandic	F	0727	2/2	JF
650		KNR Qeqertarsuaq (presumed); Greenlandic(?) talk	F	2340	2/2	BGM
650		KNR Qeqertarsuaq, Greenland; Inuit talk	W/F	0810	14/2	Rha
650	WSM	Nashville TN; "6-50 WSM, America's Country"	33533	0325	3/2	DX183
650	WSM	Nashville TN; after a fair peak the signal dropped down for the ID; classic country music	F	0508	10/2	JF
650	WSM	Nashville TN; country mx with "6-50 WSM" ID	F	0707	20/2	AB
650	CKGA	Gander NL; country music, VOXM ID, mixing with KNR	F/G	1956	24/1	dxv
650	CKGA	Gander NL; VOXM IDs	W	2123	31/1	PC
650	CKGA	Gander NL; country song // 620, 710, 590, 740 kHz	W	0030	1/2	SW
650	CKGA	Gander NL; VOXM I; (I was hoping for WSM!)	W	0800	2/2	JF
650	CKGA	Gander NL; Business news // 620 kHz	W	2342	2/2	BGM
650	CKGA	Gander NL; VOXM country MX // 620 kHz	W/F	0223	19/2	BD
650	HJKH	RCN Antena 2, SF de Bogotá; música romantica, "Antena Dos Colombia" (also 23442 0835 6/2)	33543	0350	31/1	DX183
650	HJKH	RCN Antena 2 Bogota; nx magazine with "RCN in the chat	G	0245	19/2	BD
660	WFAN	New York NY; ad for "Black & Decker products", ID; "Sports Radio 6-60 WFAN"	G	2330	25/1	dxv
660	WFAN	New York NY; plenty of sports talk	W	0743	29/1	JW
660	WFAN	New York NY; The Fan – WFAN, New York"	G	0005	1/2	PC
660	WFAN	New York NY; sports info & talk	W/F	0710	13/2	Rha
660	WFAN	New York NY; sports talk	G	0304	19/2	BD
670	CMBA	R. Rebelde, Arroyo Arenas; political speech, // 5025 kHz	F/G	2323	25/1	dxv
670	CMBA	Radio Rebelde, Arroyo Arenas; "Radio Rebelde" // 1180, 5025	W	0658	27/1	BGM
670	CMBA	Radio Rebelde, Arroyo Arenas; SS music // 5025 kHz	F/W	0812	28/1	PC
680	KBRW	Barrow AK (tentative); news, pop music, 3 short peaks from 1911 until 1944,also heard on 23/01 at the same time	Wpks	1911	22/1	dxv
680	KBRW	Barrow AK; - almost sure -, coverage of local meeting on drug problems, speech in Inuit with translation into English, prayer, several good peaks, heard until 1930	Gpks	1813	25/1	dxv
680	KBRW	Barrow AK; NPR; at 1459 "A very good morning early risers it's cold out there ... 43 degrees below at 2 AM ... now it's warmed up 37 degrees below zero in Barrow"; full ID at 1500 "... you're listening to KBRW-AM Barrow Alaska 6-80 AM ...", followed by NPR News; still there, W/F at 1647	F/G	1432	31/1	mah
680	KBRW	Barrow AK; rock mx noted F/G at 1221; ID at 1259 "You're listening to KBRW AM Barrow, Alaska, and KCDS FM Deadhorse"; no other Alaskans noted at 1221	Gpks	1259	3/2	mah
680	WRKO	Boston MA; promos for Coast-to-Coast-AM, ABC-news, ID "WRKO"	F/G	0755	26/1	dxv
680	WRKO	Boston MA; ID heard in mix	W	2352	1/2	PC
680	WRKO	Boston MA; phone-in talk	W/F	0445	4/2	Rha
680	WRKO	Boston MA; news reports from YL; mixing with CFTR	W	0600	18/2	JW

kHz	Callsign	Station, location; details heard etc	SIO	UTC	Date	Who
680	WPTF	Raleigh NC; talk, nice peak for ID "When it matters to you, this is the station you trust, News Talk 6-80 WPTF"; still daytime omnidirectional pattern on antenna - night-time has a deep null in the direction of the UK; xf CFTR; UK FIRST	P/Fpks	2257	5/2	mah
680	CFTR	Toronto ON; "All News Radio 6-80 News"	F	0623	3/2	BGM
680	CFTR	Toronto ON; "6-80 News time 2.50"; xf two others	Fpks	0750	9/2	mah
680	CFTR	Toronto ON; "Toronto's news, traffic and weather station"	F	0910	10/2	PC
680	CFTR	Toronto ON; ads after "6-80 Toronto" ID	F	0634	16/2	JF
680	CFTR	Toronto ON; OM with news reports, over/under WRKO	W	0600	18/2	JW
680	TGVP	R Norte, Cobán; rolling news, anns, National Anthem and off at 0400	33543	0355	31/1	DX183
690	CINF	Montréal QC; FF news	W/F	0007	2/1	PC
690	CINF	Montréal QC (presumed); in French, pushing past BBC 5Live	G	0900	14/2	JF
700	WLW	Cincinnati OH; news and weather, "700 WLW"	33543	0700	23/1	DX183
700	WLW	Cincinnati OH (presumed); ads including one for "O-O"?	vW	0733	25/1	JW
700	WLW	Cincinnati OH; weak "7-hundred WLW" ID	W	0006	2/2	PC
700	WLW	Cincinnati OH; "News Radio 700 WLW", nx, reports, wx	32542	0600	3/2	DX183
700	WLW	Cincinnati OH; "700 WLW ID" caught a few times	F	0002	10/2	JF
700	WLW	Cincinnati OH; "Radio 700 WLW" ID & wx	W/F	0306	19/2	BD
700	LV3	R Córdoba; LA mx, "cadenatres punto com"	Fpks	0720	21/2	mah
702		VOIRI Kiashar, Iran; Azeri FS // 6200 kHz	F/Gpks	1546	3/2	ss
710	WOR	New York NY; "That's WOR News"	44544	0705	23/1	DX183
710	WOR	New York NY; right-wing presenter "I'd rather be a poodle than a Democrat" // webcast	F/G	0008	1/2	PC
710	WOR	New York NY; "... on 7-10 WOR"	W	2324	2/2	BGM
710	WOR	New York NY; ID & paid for New Vitality infomercial show & WOR disclaimer	F	2329	4/2	SW
710	WOR	New York NY; promo for "Joey Reynolds, keeping you up all night on 7-10 WOR" promo at the half hour	G	2330	4/2	JF
710	WOR	New York NY; Joey Reynolds talk show	W/F	0800	14/2	Rha
710	CKVO	Clarenville NL; pop music, promo for VOXM and KFC	F/G	1940	24/1	dxv
710	CKVO	Clarenville NL; "VOXM" ID, country music // 590 kHz	W	0216	29/1	BGM
710	CKVO	Clarenville NL; VOXM ID	F	0857	29/1	PC
710	CKVO	Clarenville NL; VOXM programme	F	0650	30/1	JF
710	CKVO	Clarenville NL; election phone in // 560, 620, 650 kHz	F	0030	1/2	SW
710	CM--	Radio Rebelde, 4 possible sites; SS talk // 680, 1180, 5025 kHz	W	0659	27/1	BGM
710	CM--	Radio Rebelde, 4 sites listed; SS talk and music // 5025 kHz	F	0810	28/1	PC
720		VOIRI Tayebad, Iran; Tajik // 5945 kHz	W/Fpks	1620	1/2	ss
720	CHTN	Charlottetown PE; oldies, "CHTN Island forecast", wx	Fpk	0740	30/1	mah
730	CKAC	Montréal QC (presumed); FF talk	F/G	0642	3/2	BGM
730	CKAC	Montréal PQ (pres); French talk regular many mornings	F	0922	10/2	SW
730	CKAC	Montréal QC; phone-in; evening service // 550 CHLN	F	0123	14/2	JF
730	CKAC	Montréal QC; FF YL "CKAC - 6 heures 30"	F	2330	14/2	PC
730	CMBB	R Progreso, Nueva Gerona; mx, SS ID "Radio Progreso, Cadena Nacional, la Onda de l'Alegria", anns, noticias	W/Fpks	0900	25/1	mah
730	XEX	México DF; light songs and tlk, "XEX, Estudio W, en México, Distrito Federal"; only audible with phaser	33533	0725	19/1	DX183
730	HJCU	R Lider, SF de Bogotá; SS anns, "... Colombia, en Radio Lider ..." and "Radio Lider, lider en información" etc	F	0919	28/1	mah

kHz	Callsign	Station, location; details heard etc	SIO	UTC	Date	Who
740	CBX	Edmonton AB; CBC anns, News	W/Fpks	1000	31/1	mah
740	CHCM	Marystown NL; local + VOXM-CFBC IDs	F/G	1930	24/1	dxv
740	CHCM	Marystown NL; "VOXM – Newfoundland and Labrador's news authority"	W	2210	25/1	PC
740	CHCM	Marystown NL; VOXM programming and nx, VOXM ID	W	2103	26/1	BGM
740	CHCM	Marystown NL; VOXM programming, also mentioning CFBC	F	0043	28/1	JF
740	CHCM	Marystown NL; // 620 kHz	F	0030	1/2	SW
740	CHCM	Marystown NL; C&W music/songs	W/Fpks	0608	14/2	Rha
740	CHWO	Toronto ON (presumed); nostalgic music, "AM 7-40"	F/G	0740	22/1	dxv
740	CHWO	Toronto ON; Back-to-back oldies, "AM 7-40"	W	0320	4/2	BGM
740	CHWO	Toronto ON; "All-night jukebox"; "From Toronto, AM 7-40"	F	0801	6/2	PC
740	CMJL	R Progreso, Camagüey; political reports, ID: "Radio Progreso en toda la República Cubana"	F/G	0155	25/1	dxv
740	XECAQ	Radio Fórmula, Cancún; "Radio Fórmula" ID; SS talk – still with poor audio	F	0752	7/2	PC
740	XECAQ	Radio Fórmula, Cancún; News & info, promotions & YL with "Radio Fórmula" ID	F	0458	11/2	BD
740	ZHY446	R Sociedade da Bahia; ID "Rádio Sociedade da Bahia" // webcast	W/F	2358	6/2	PC
740	ZYH446	R Sociedade da Bahia, Salvador; PP tlk		0116	10/2	boc4
750	WSB	Atlanta GA; "Newstalk 7-50 WSB Atlanta" ID; several ID's noted, equal levels CBGY!	F	0719	2/2	JF
750	WSB	Atlanta GA; "Newstalk 7-50 WSB"	W/F	0750	2/2	PC
750	CBGY	Bonavista Bay NL; 24/1, 2010, news, report about the results of the Canadian elections, CBC-ID	G	2010	24/1	dxv
750	CBGY	Bonavista Bay NL; Canadian politics; stronger than 1070,1400	F/G	2118	29/1	PC
750	CBGY	Bonavista Bay NL; CBC Overnight programme // 1140 kHz	F	0649	31/1	BGM
760	WJR	Detroit MI; WJR weather following ABC News	W/F	0805	2/2	PC
760	WJR	Detroit MI; "Trucking Radio Network", "Newstalk 7-60 WJR"	F	0700	3/2	BGM
760	UNID	Brazilian station	W/F	0000	7/2	PC
770	WABC	New York NY; nostalgic music, many IDs	G	2325	21/1	dxv
770	WABC	New York NY; "Now, live from the underground command post deep in the bowels of WAB.....somewhere under Madison Square Garden we once again make contact with our leader – Mars the ??....." ! http://tinyurl.com/82j2w	F/G	0005	2/2	PC
770	WABC	New York NY; "77 WABC" ID caught in speech, xf CKVO	W	0033	5/2	JF
770	WABC	New York NY; Ultimate oldies show, " www.musicradio77.com WABC" and sung jingle	F	0009	19/2	BGM
770	KTTH	Seattle WA; noted with Seattle ads at 0754; ID at 0800 "... 7-70 KTTH"; 0803 promo "Rush Limbaugh weekday mornings at 9 on Talk 7-70 KTTH"; nice ID at 0807 "When you're listening to Michael Medved, you're listening to The Truth 7-70 KTTH The Truth KTTH Seattle"; UK FIRST	Fpks	0800	12/2	mah
770	CHQR	Calgary AB; "This is the BN Report", ads, poor ID at 0906 "All night talk, all night long ... AM 7-70 CHQR", C2C	Fpks	0903	31/1	mah
770	CHQR	Calgary AB; old time radio play noted at 0730 on the 340 degree beverage; ID at the toth "AM 7-70 CHQR Calgary"	Fpks	0800	12/2	mah
770	HJJX	RCN, SF de Bogotá; phone-in, "RCN, La Radio de Colombia"	33543	0720	3/2	DX183
774		AIR Shimla, India; nx // Shimla SW; different px MW/SW from 1545	W	1532	4/2	ss

kHz	Callsign	Station, location; details heard etc	SIO	UTC	Date	Who
780	CFDR	Dartmouth NS; country mx, "Classic Country 780 KIXX"	G	0017	23/1	dxv
780	CFDR	Dartmouth NS; continuous country music	F	0744	25/1	JW
780	CFDR	Dartmouth NS (pres); with religion	Exc	0031	1/2	SW
780	CFDR	Dartmouth NS; "7-80 Kixx" – Country music	F/G	0751	1/2	PC
780	CFDR	Dartmouth NS (presumed); phone in talk on diets	F	2304	2/2	JW
780	CFDR	Dartmouth NS; "CFDR Classic Country"	F	0555	3/2	JWe
780	CFDR	Dartmouth NS; "7-80 Kixx", country music	W	0627	3/2	BGM
780	CFDR	Dartmouth NS; still country music/songs "KIXX" ID	W/F	0438	6/2	Rha
780	CFDR	Dartmouth NS; country mx & "CFDR 7-80 AM with classic country" ID	F/G	0558	11/2	BD
780	CFDR	Dartmouth NS; still country classic on KIXX ID; jingle "Kixx" at 0615	W/Fpks	0610	13/2	Rha
780	WBBM	Chicago IL; "Traffic and weather together on the 8's every 10 minutes on News Radio 7-80 WBBM"; (also W/F 0730 30/1)	F/G	0739	14/2	mah
780	WBBM	Chicago IL; IDs "News Radio 7-80 WBBM and wbbm780.com"	Fpks	0722	15/2	mah
783		Voice of Vietnam, Can Tho; Vietnamese talk and typ folk; DX183 First	F/Gpks	1520	6/2	ss
790	KCAM	Glenallen AK; religious preacher - female; later at 0803 "K-C-A-M", announcements & sports-news	W/F	0733	14/2	Rha
790	WAXY	South Miami FL; "Sports talk 7-90, The Ticket – Sports Flash"	F	2343	4/2	PC
790	WAXY	South Miami FL; Fox sports talk & "sports talk 7-90 the ticket WAXY"	W/F	0500	7/2	BD
790	WAXY	South Miami FL; Westwood One programme "on 7-90 WAXY South Miami" ID at toh	F	0700	13/2	JF
790	WSKO	Providence RI (tent); 2 talk stations here – one with long formatP stuff about Olympics was ESPN; at 0903 heard CNN radio news but I don't think CNN & ESPN are the same station	P	0907	10/2	SW
790	CFNW	Port au Choix NL (presumed), country music, St John's mentioned	F	2025	24/1	dxv
790	CFNW	Port au Choix NL; CFCB promo	Fpks	2306	19/2	mah
790	CMAQ	Radio Reloj, Pinar del Rio; SS talk with "RR" cw ID every minute	W	0723	31/1	BGM
790	CMAQ	Radio Reloj, Pinar del Rio; OM with SS rolling nx over ticking clock & Morse "RR" ID	W	0503	7/2	BD
790	CMAQ	R Reloj, Pinar del Rio; Morse and time pip at toh	W	0700	13/2	JF
800	VOWR	St John's NL; full ID at top of hour following folk music show, then drug advice	G	0800	24/1	JF
800	VOWR	St John's NL; continuous folk music	F	0748	25/1	JW
800	VOWR	St John's NL, 26/1, 0935, "easy listening music", ID: "VOWR from St John's"	F/G	0965	26/1	dxv
800	VOWR	St John's NL; "You are listening to Newfoundland's Folk Sound on VOWR – Newfoundland's pioneer broadcasting station - 8 hundred on the dial"	F/G	0807	28/1	PC
800	VOWR	St John's NL; classical music // webcast www.vowr.org	W	2140	2/2	BGM
800	CHRC	Québec QC (presumed); plenty of FF talk	F	0750	25/1	JW
800	CHRC	Québec QC (presumed); in French possibly // 690 kHz?	F	0901	14/2	JF
800	CHRC	Québec QC, FF, French tlk – Coast to Coast & commercials	W/F	0808	16/2	Rha

kHz	Callsign	Station, location; details heard etc	SIO	UTC	Date	Who
810	WGY	Schenectady NY ; C2C, anns for "Hometown Hero", mentioning " ... 8-10 WGY" and "... available right now at wgy.com or at any Post Office 8-10 WGY"; personal first - last reported in the UK in 1986	Fpks	0730	14/2	mah
810	CJVA	Caraquet NB; FF country, ID "CJVA huit cent dix"; xf WGY under/equal R Scotland	Fpks	0724	14/2	mah
820	WWLZ	Horseheads NY ; heard the call in the mix (no recording ☺)	W	0035	4/2	PC
820	WBAP	Fort Worth TX; "WBAP newstime 11.04"	W	0504	4/2	PC
820	CHAM	Hamilton ON; "There's only one radio station that plays all-time country favourites – Hamilton's 8-20 Cham – The Legend"	F	0433	4/2	PC
820	CM--	Radio Reloj, 2 possible sites; "RR" cw ID noted under TBN	vW	0250	2/1	BGM
820	CM--	Radio Reloj, 2 possible sites; "RR" Morse signals on the minute; SS talk.	W	0337	4/2	PC
820	CM--	R Reloj, 2 possible sites; time pips, "RR" morse ID, etc.	W	0130	11/2	JF
820		TBN Charlestown, Nevis; rlg's broadcast, address given as "TBN Santa Ana California"	W	0157	2/1	BGM
820		TBN Charlestown, Nevis (presumed); religious broadcasting	F/G	0030	30/1	PC
820		TBN Charlestown, Nevis; talk on Moses	W	0751	2/2	JW
820		TBN Charlestown, Nevis; gospel mx, CD advert & OM with "Trinity Broadcasting Network" ID	F	0555	10/2	BD
820		Trinity Broadcasting Company, Charlestown, Nevis; usual religion	W	0200	11/2	JF
820		TBN Charlestown, Nevis; YL singing long version of SSB, then anns, ID at the toth "	F/G	2254	20/2	mah
828		Syrian R, Deir-al-Zawr; // al-Hassake 918 good, Tartus 783 fair	Gpks	1547	28/1	ss
830	WACC	Hialeah FL ; light SS songs, SS anns, ID at the toth "... Radio Paz WACC 8-30 AM Hialeah - Miami - Fort Lauderdale"; not sure if it was this or another that then had CBS News before WCRN came up again; UK FIRST	Fpks	0759	3/2	mah
830	WCRN	Worcester MA; ads, "WCRN storm center" and "8-30 Rock' n'Roll Radio"	F/Gpks	0020	30/1	ss
830	WCRN	Worcester MA; "The True Oldies Channel – WCRN" (unatt recording)	F	0350	2/2	PC
830	WCRN	Worcester MA; "WRCN the heart and soul of rock and roll - the all new true oldies channel"; (also W/F 1040 25/1)	W/F	0738	2/2	mah
830	WCRN	Worcester MA; still playing oldies & "This is the true oldies show" slogan	W	2202	5/2	BD
830	WCCO	Minneapolis MN; jingle and phone-no ...8779 WCCO, tlk	F	0708	2/2	ss
830	WTRU	Kernersville NC ; religious px first noted at 0723, cross-fading with WCRN and others; faded at toth, finally caught an ID at 0805 "AM 8-30 WTRU Kernersville Winston-Salem Greensboro High Point", then "Truths That Transform"; still there at 0856 and 1022; UK FIRST	Fpks	0805	10/2	mah
830	WEEU	Reading PA ; announcement about Superbowl then "right here W/F on the Voice of Berks County, 8-30 AM, WEEU" (tnx mah); UK FIRST	W/F	0100	2/2	PC

kHz	Call sign	Station, location; details heard etc	SIO	UTC	Date	Who
830	WEEU	Reading PA ; C2C noted cross-fading WCRN, only occasionally on top, best on the 290 degree beverage; hrd from 0744 to 0856; closest I got to an ID was at 0832 in a poor ad/promo for "... news and information you want ... morning ... readingeagle.com ... supplement to the Reading Eagle newspaper ... real time breaking news, background stories ... America ..."; tnx to SW for picking out more detail on this one	Fpks	0832	2/2	mah
830	YVLT	R Sensación, Caracas; Venezuelan NA, SS s/on anns "... capital W/P de la república boliviano de Venezuela, transmite Radio Sensación señal YVLT 830 kHz onda ..."; brief peak		0902	2/2	mah
830	YVLT	R Sensación, Caracas; "En Radio Sensación con las nueve y siete minutos"; xf WCRN	Fpks	0106	3/2	mah
840	WKJG	Fort Wayne IN ; ESPN Radio, "The Game 13-80 AM"	24442	0840	2/2	DX183
840	WHAS	Louisville KY; rolling news, "This is News radio WHAS"	33543	0800	20/1	DX183
840	WHAS	Louisville KY; "...for flash informations, it's 84 WHAS"	W/F	0456	30/1	RB
840	WHAS	Louisville KY; "The news you need, updated at the top and bottom of every hour around the clock, newsradio 84 WHAS"	F	0734	3/2	JF
840	WHAS	Louisville KY; Coast to Coast AM with Art Bell at 0500 ID "84 WHAS"	W/F	0450	4/2	Rha
840	WHAS	Louisville KY; WHAS wx & back to Matt Drudge talk show	F/G	0406	6/2	BD
840	WHAS	Louisville KY; Sung ID: "84 -WHAS"	W	0804	6/2	PC
840	WHAS	Louisville KY; "Eighty four WHAS" CBS News	W	0015	20/2	BGM
846		Umm al Quwaim, UAE; Malay service	P/F	1920	5/2	boc4
846.05		Voice of Kenya, Niyamnia; in Swahili, ID "KBC", good Afro-pop mx; hrd 2101-2110 s/off, 0145 s/on to 0359	F/G	2101	9/2	boc4
850	KICY	Nome AK; "This is KICY 8-50", newstime; snow chaos in NY, weather & sports	W/F	0900	14/2	Rha
850	WFTL	West Palm Beach FL; tlk and WFTL in the mix with WEEI	F/Gpks	0307	30/1	ss
850	WFTL	West Palm Beach FL; "Newstalk 8-5-0 WFTL"; also 7/2 0205	F	0508	30/1	RB
850	WFTL	West Palm Beach FL; "Newstalk Eight Five 0 WFTL" ID. Peaked over WEEI briefly	F	0359	3/2	JF
850	WEEI	Boston MA; plenty of sports talk – station mixing with another talker, // 1280 kHz	G	0814	25/1	JW
850	WEEI	Boston MA; "Sports Radio 8-50 WEEI Boston", Sports Flash	G	0030	1/2	SW
850	WEEI	Boston MA; "Sportsradio WEEI, 20/20 sports flash" Bruins game, leading 2-1	F	0130	3/2	JF
850	WEEI	Boston MA; "Sports Radio 8-50 WEEI" mixing with a second station	F	0747	3/2	PC
850	WEEI	Boston MA; sports talk of US bowl , soccer & Red Sox advertising	W/F	0733	13/2	Rha
860	CJBC	Toronto ON; FF announcement amid music "Radio Canada" ID	W	0856	10/2	PC
860	CJBC	Toronto ON (presumed); AA mx - thought it might be something exotic at first, but western mx next and then anns in FF; best on 290 degree bev	F/G	0737	15/2	mah
860	CJBC	Toronto ON; YL & OM with FF studio discussion	F	0320	19/2	BD
864		TWR Gavar; Armenia; IS	G	1707	3/2	ss
870	WWL	New Orleans LA; ads "WWL New Orleans"	W	0734	25/1	JWe
870	WWL	New Orleans LA; C2C talk show // 1700 kHz	W/F	0807	30/1	BD
870	WWL	New Orleans LA; Talk show, "From the heart of the Crescent City..."	W/F	0652	31/1	BGM

kHz	Call sign	Station, location; details heard etc	SIO	UTC	Date	Who
870	WWL	New Orleans LA; "The Big 8-70, WWL"	F	2354	31/1	PC
870	WWL	New Orleans LA; "From the heart of the Cajun ... ?? this is WWL" ID - dropped low at time of ID.	F	0730	3/2	JF
870	WWL	New Orleans LA; full ID; mentioned wwl.com and Entercom Communications	G	0930	10/2	SW
870	WWL	New Orleans LA; "The Big 8-70 WWL"; xf another unidentified station	Fpks	0806	15/2	mah
870	WWL	New Orleans LA; ID "the big 8-70", CBS-news & weather for LA	W/F	0705	16/2	Rha
880	WCBS	New York NY; "WCBS news time 6.25"	F	2325	25/1	PC
880	WCBS	New York NY; "WCBS Newstime"	F	0720	30/1	SW
880	WCBS	New York NY; YL news talk then ID "WCBS"	W	0749	31/1	JW
880	WCBS	New York NY; talk & business	W/F	0627	14/2	Rha
890	WLS	Chicago IL; "WLS News"	F	0805	14/2	PC
890	WAMG	Dedham MA; "ESPN Boston"	F	0918	10/2	PC
890	WAMG	Dedham MA; ID as "ESPN Boston"	W	0620	16/2	JF
890	CM--	Radio Progreso, 2 sites listed; SS drama // webcast	F	0016	30/1	PC
890	CMDZ	Radio Progreso, Chambas (per Distance); rancho/campesino songs & "Radio Progreso" ID in chat	W/F	0602	7/2	BD
890	YVVO	R Oriente, El Tigre; 27/1, 0020, LA pop, ID	P/F	0020	27/1	dxv
891		IRIB Yasui, Iran (presumed); Farsi, traditional Iranian music	F	1526	24/1	dxv
900	XEW	W Radio, México DF; SS anns, IDs "W Radio - tu escucha", and "Cadena W Radio", promos	Gpks	0750	31/1	mah
910	WABI	Bangor ME (presumed); light pops, Stevie Wonder with "I just call to say I love you"	W/Fpks	0615	14/2	Rha
910	CMFA	R Cadena Agramonte, Camagüey ; hrd from 0907 with Cuban music and SS anns, poor to begin with, fair around 0916, poor ID at 0931 "... Radio Cadena Agramonte ... Cuba"	F	0931	9/2	mah
910	LR5	La Red, Buenos Aires; "... transmite La Red Informativa ...", news and reports	22542	0625	27/1	DX183
920	UNID	Vernal UT (tentative); a very weak ID, sounding tentatively like KVEL; now not sure it was KVEL, listened again and it could have been something like KGCX, but I know that this makes no sense for the frequency; another mystery station	W	0800	20/2	AB
920	WOKY	Milwaukee WI; NOS, ID promo mentioning "WOKY"	W	1012	15/2	mah
920	CFRY	Portage La Prairie MB; BN, "CFRY forecast"	W/F	0803	14/2	mah
920	CJCH	Halifax NS; Talk Star Radio Network then ID, including sung "CJCH" at toth	F	0800	24/1	PC
920	CJCH	Halifax NS; sports results, "6:04 on CJCH"	F/G	0958	25/1	dxv
920	CJCH	Halifax NS; EZL music, "AM 9-20 CJCH"	W	0125	29/1	BGM
920	CJCH	Halifax NS; ID; ID +"Yesterday's Favorites"	F	0934	20/2	SW
920	CKNX	Wingham ON; C&W show, "you're listening to AM 9-20 CKNX" then ads	G	0756	24/1	JF
920	CKNX	Wingham ON; C&W music/songs noted	W/F	??	14/2	Rha
920	CKNX	Wingham ON; country mx; YL "Hey stick around, more great music is just ahead on AM 9-20 CKNX"; personal first	F	0820	15/2	PC
930	WBEN	Buffalo NY' "WBEN Newstime 4.04"	F	0904	10/2	PC
930	WBEN	Buffalo NY; "News Radio 9-30 WBEN" ID & WBEN News	F	0400	15/2	BD
930	CJYQ	St John's NL; pop music, advertisement, ID: "Radio Newfoundland"	G	2355	26/1	dxv

kHz	Callsign	Station, location; details heard etc	SIO	UTC	Date	Who
930	CJYQ	St John's NL; "You're listening to Radio Newfoundland"	F	2201	29/1	PC
930	CJYQ	St John's NL; folk music popping up early!	W	1947	5/2	JF
930	CJYQ	St John's NL; folk mx, ID "This is Radio Newfoundland CJYQ 9-30 AM Saint John's"	W/F	0930	6/2	mah
930	CJYQ	St John's NL; folk MX & "Radio Newfoundland" IDs	G	0355	7/2	BD
930	CJYQ	St John's NL; "This is Radio Newfoundland CJYQ 9-30 AM St W John's"		2331	7/2	BGM
930	CJYQ	St John's NL; weather, folk, "Radio Newfoundland"	F	2330	11/2	JWe
930	CJYQ	St John's NL; "Our music, our heritage" frequently heard with folk or Celtic music, but also carries Back to The Bible	G	2352	19/2	SW
930	CX30	R Monte Carlo, Montevideo; Gardel Tangos songs. "Desde Montevideo capital de la república del Uruguay transmite CX30 Radio Monte Carlo"	Gpks	0110	10/2	boc4
940	WINZ	Miami FL; phone-in, "Supertalk 9-40 WINZ"	32542	0715	3/2	DX183
940	CINW	Montreal QC; weather report, "The new 9-40 Montreal"	F/G	0044	23/1	dxv
940	CINW	Montreal QC; evening rolling news format	W	2217	25/1	BD
940	CINW	Montreal QC; "The new 9-40 Montreal", phone-in show	W	0224	29/1	BGM
940	CINW	Montreal QC; "6.41 on Montreal's new 9-40"	F	2341	31/1	PC
940	CINW	Montreal QC; weather forecast and ID "CINW Montreal"	F	2301	5/2	JW
950	CKNB	Campbellton NB; weather report, "95 CKNB"	G	0020	23/1	dxv
950	CKNB	Campbellton NB; promo for Talkback program on "Max 9-50"	W/F	0740	10/2	PC
950	CKNB	Campbellton NB; Campbellton weather; valentine day ads	F	2332	12/2	SW
950	CKNB	Campbellton NB; pop mx, "95 CKNB"	W	2234	17/2	BGM
950	CKNB	Campbellton NB; wx, ""95 CKNB" ID & pops	F	0128	19/2	BD
950	CM--	Radio Reloj, 2 possible sites; SS talk with "RR" cw ID every minute	W/F	0633	3/2	BGM
950	CM--	Radio Reloj, Havana; YL with rolling nx over ticking clock etc.	W/F	0402	8/2	BD
950	CM--	Radio Reloj, 2 sites listed; SS talk with 'RR' Morse ID	W	0738	10/2	PC
950	LR3	R Libertad, Buenos Aires; "esta es Libertad" "las 11 e 30 minutos" WRTH 2006 list R Belgrano (old name)	P/F	0045	10/2	boc4
950	LR3	R Belgrano, Buenos Aires (presumed); SS news, reports, IDing as "Las Nove Cincuenta" - new name or slogan for Belgrano?	Gpks	0732	21/2	mah
954		Qatar BC, Al Arish; Qu'ran	P/F	0235	4/2	boc4
960	WEAV	Plattsburgh NY; end of Fox News Radio, "The Zone" ID & talk show	W	0505	15/2	BD
960	WEAV	Plattsburg NY; "The Zone" IDs, promos	Fpks	0905	19/2	mah
960	CHNS	Halifax NS; "Oldies 96 - CHNS"	W/F	2340	31/1	PC
970	WFLA	Tampa FL; "News Radio 9-70 WFLA"	Fpks	0958	3/2	mah
970	WZAN	Portland, ME; WZAN ID	W	0029	30/1	PC
970	WZAN	Portland ME; OM & YL with studio chat show	W/F	0810	30/1	BD
970	WZAN	Portland ME; ID, easy now Germany nulled with EWE antenna; mixing another English station	F	0618	16/2	JF
970	WZAN	Portland ME (pres); Fox - call 877-99-ON-FOX	Fpk	0732	20/2	SW
970	YV--	Mundial Oriente, Barcelona; LA mx, 2200 music which sounded like an anthem, several ID: "Mundial 9-70"	F/G	2159	23/1	dxv
980	WOFX	Troy NY; Fox sports Radio with national sports talk	W/F	0710	14/2	Rha
980	WAAV	Leland NC; ads, "... WAAV Leland - Wilmington, news, talk and sport 9-80 The Wave"; CNN News	Fpks	1030	3/2	mah
980	CKRU	Peterborough ON; oldies from Tony Christie & Sam Cook , at 07.20 the song "Will be mind" in choir remix	W/Fpks	0720	14/2	Rha

kHz	Callsign	Station, location; details heard etc	SIO	UTC	Date	Who
981		CNR 1, several sites listed, China (presumed); advertisement	F	1405	22/1	dxv
990	WDYZ	Orlando FL; "Radio Disney", local ads, // 1560 kHz; "WDYZ Orlando Florida" (only with phaser)	22542	0530	5/2	DX183
990	CBY	Corner Brook NL; "Coming up now on CBC Radio 1	F	2329	2/2	PC
990	CKGM	Montreal QC; "Montreal's sports authority, The Team 9-90, we ain't fooling around"; over Euros and CBY	Fpks	0920	10/2	mah
1000	WMVP	Chicago IL; PSA, "This message brought to you by the Illinois Department of Transportation", promo/ID " weekdays at 9 on ESPN 1000 ...WMVP Chicago" and Sports Centre	Fpks	1000	10/2	mah
1000	WMVP	Chicago IL; sports talk & results on ESPN Radio	W	??	14/2	Rha
1000	WMVP	Chicago IL; "ESPN 1000, Chicago's leader in sports"	F/G	0802	14/2	PC
1000	KOMO	Seattle WA; Komo ads	32542	0440	3/2	DX183
1000	KOMO	Seattle WA; KOMO anns & phone-in talks	W/F	0820	14/2	Rha
1000	KOMO	Seattle WA; "Komo 4 News, first for news", usual TCs, reports; (W/P 0840 25/1, F/G 0809 31/1, Fpks 0750 12/2, G 0740 14/2)	F/G	0710	15/2	mah
1000	XEOY	R Mil, México DF; música romantica, "Desde Radio Mil"	23542	0630	21/1	DX183
1000	XEOY	R Mil, México DF; light SS songs (SS covers of US songs, frequent IDs as "Mil AM", occasional TCs, e.g. "3, 31" (i.e. UTC -6h); still there at 1109	Gpks	0931	10/2	mah
1000	HJAQ	RCN Cartagena; rolling news, "La Radio de Colombia"	23542	0640	21/1	DX183
1010	WINS	New York NY; "you give us 22 minutes, we'll give you the world ... this is Ten Ten Wins" News!	G	0020	24/1	JF
1010	WINS	New York NY; "Wins news time 3.22"	F	0822	29/1	PC
1010	WINS	New York NY; ID "Wins Newstime 7-0-8"	F	0007	1/2	SW
1010	WINS	New York NY; weather rpt on 10-10 WINS	F	??	14/2	Rha
1010	CFRB	Toronto ON; CFRB talk show	F	0840	26/1	BD
1010	CFRB	Toronto ON; "Newstalk Ten Ten CFRB" ID's	F	0015	28/1	JF
1010	CFRB	Toronto ON; consistently dominant over WINS most nights; "Newstalk 10-10 CFRB" & phone-in number	G	2355	1/2	SW
1010	CFRB	Toronto ON; OM "Good morning its 3o'clock , News talk 10-10 Toronto weather"	F	0800	2/2	JW
1010	CFRB	Toronto ON; "From Toronto, Newstalk on 10-10"	G	0706	3/2	BGM
1010	CFRB	Toronto ON; "News Talk 10-10 CFRB"	W	0650	4/2	JWe
1010	CFRB	Toronto ON; "News talk 10-10 CFRB" Big signal - http://tinyurl.com/7b66y	Exc	1000	10/2	PC
1010	CFRB	Toronto ON; Newstalk on 10-10 & Canadian px	W/Fpks	0727	13/2	Rha
1020	KDKA	Pittsburgh PA; ID "Newstalk 10-20 KDKA – up to the minute accu weather forecast"	F	0728	25/1	JW
1020	KDKA	Pittsburgh PA; "KDKA Weather Center"	W	2333	2/2	PC
1020	KDKA	Pittsburg PA; "Newstalk 10-20 KDKA" adverts; weather	F	0908	13/2	SW
1030	WBZ	Boston MA; "WBZee traffic on the three"	F/G	2053	21/1	dxv
1030	WBZ	Boston MA; "WBZ Newsradio 10-30, hi Danny, you're on on WBZ .." phone-in	F	0737	24/1	JF
1030	WBZ	Boston MA; "News Radio" heard then ads	W	0822	25/1	JW
1030	WBZ	Boston MA; "WBZ News Radio 10-30", and "WBZ News time 5.09"	F/G	2209	29/1	mah
1030	LS10	R del Plata, Buenos Aires; "las noticias Del Plata" YL speaker; best signal from Argentina. good peaks but long fading	P/Gpks	0028	10/2	boc4
1040	WLVJ	Boynton Beach FL; Christian tlk, "AM 10-40 WLVJ ..."	23542	0850	17/1	DX183

kHz	Callsign	Station, location; details heard etc	SIO	UTC	Date	Who
1040	WLVJ	Boynton Beach FL; ads, promo "... broadcast Monday through Friday 8.30 to 3 pm on AM 10-40 WLVJ - all on-air callers receive a free silver coin"; (also Fpks 0802 30/1)	W/F	0834	31/1	mah
1040	WHO	Des Moines IA; "10-40 WHO radio"	33543	0800	25/1	DX183
1040	WCHR	Flemington NJ; Christian talk and light songs, "WCHR, Your Station for Inspiration", ads	22542	0640	30/1	DX183
1040	CKST	Vancouver BC; "This is The Team 10-40 Vancouver - turn it up", Fox Sports Radio	W/F	0829	31/1	mah
1040	ZYK537	R Capital, São Paulo; sports news, ID	P/Gpks	0037	10/2	boc4
1050	WEPN	New York NY; sport news, several IDs	G	2322	21/1	dxv
1050	WEPN	New York NY; ESPN Radio - the sports talk of New York"	F	0016	29/1	PC
1050	WEPN	New York NY (presumed); Superbowl preview, "ESPN.COM"	F	2249	2/2	BGM
1050	CHUM	Toronto ON; // webcast oldies, "Dancing in the Street" etc	F	2349	18/2	PC
1060	WLNO	New Orleans LA (presumed); occasional snatches of rlg's tlk hrd from 2335, but didn't hear any more after 2345	Wpks	2335	10/2	mah
1060	WBIX	Natick MA; "AM 10-60 WBIX"	W/F	0800	31/1	mah
1060	WBIX	Natick MA; "this is WBIX"	W/F	0006	4/2	PC
1060	WBIX	Natick MA; partial ID "WBIX" and 0330 and into tlk	F	0629	4/2	ss
1060	WBIX	Boston MA; "WBIX - The Business Station"; xf classical music from presumed XEEP	Fpks	0930	11/2	mah
1060	XEEP	R Educación, México DF; SS music // 6185 kHz	F	0938	4/2	PC
1060	UNID	Mystery station briefly appeared in mix of 2 or more. Heard with ESPN sports	P	2343	29/1	SW
1060	UNID	ads, quiz - know what really matters, PSAs, mentioning something sounding like "KEWY" at 2352; possibly WLNO	Fpks	2349	10/2	mah
1070	CBA	Moncton NB; rock music, // 1400 kHz	F	2015	21/1	dxv
1070	CBA	Moncton NB; CBC news magazine	F	2250	25/1	BD
1070	CBA	Moncton NB; CBC radio	F	0020	29/1	PC
1070	CBA	Moncton NB; What's on for Moncton area, "This is CBC news"	F	2130	2/2	BGM
1070	CBA	Moncton NB; CBC Radio 1 talk show	P/F	0042	10/2	boc4
1070	CBA	Moncton NB; CBC Radio One ID; talk & reports	F	0800	16/2	Rha
1070	CBA	Moncton NB; talk on Women's hockey at the Olympics "CBC radio will carry the game live at 2.30 Eastern"	G	2314	19/2	JW
1070	CHOK	Sarnia ON; mx, ID "... on 10-70 CHOK"; under CBA	Fpks	0952	15/2	mah
1070	LR1	R El Mundo, Buenos Aires; boring OM & YL talks	P/F	0041	10/2	boc4
1071		IRIB, unknown location, Iran; Qu'ran - listed as Qom in WRTH - mah	P/F	0255	5/2	boc4
1080		PBC Lahore, Pakistan (presumed); quali music	F	1548	24/1	dxv
1080		GTRK Mordovija, Saransk; RR loc px, ID by YL and songs	F	1520	30/1	ss
1080		VOIRI Mahsahr, Iran; AA FS // 1161, 1224, 6065 110 degrees	G	1628	30/1	ss
1080	WTIC	Hartford CT; Europeans? What Europeans? The Ewe antenna has removed them! Coast 2 Coast show	F	0646	30/1	JF
1080	WTIC	Hartford CT; ads "WTIC Newstalk", nx	F	0356	31/1	ss
1080	WTIC	Hartford CT; news, "WTIC News time 5.10"	Gpks	1010	31/1	mah
1080	WTIC	Hartford CT; ad for live UCONN sports on wtic.com	F	0021	1/2	PC
1080	WTIC	Hartford CT; Hartford weather "WTIC 10-80 News"	Exc	0900	10/2	SW
1080	WTIC	Hartford CT; C2C talk show-format and ID "Thanks for listening to C2C AM on WTIC"; newstalk	F	0850	14/2	Rha
1080	WVCG	Coral Gables FL; SS rel songs "WVCG 1080" in SS	G	0922	29/1	ss

kHz	Callsign	Station, location; details heard etc	SIO	UTC	Date	Who
1080	UNID	carrier; 130 degrees, IRN pres, nothing at toh, switched off at 1605h	G/Exc	1645	30/1	ss
1089		BSKSA Qurayyat, Saudi Arabia; // 1467 kHz	F/G	2330	7/2	boc4
1090	WBAL	Baltimore MD; "WBAL News time 5.08"	F/G	1008	31/1	mah
1100	WHLI	Hempstead NY ; NOS, poor ID "This is 1100 WHLI"; in and out of the S9 splatter; didn't get any better IDs, and not heard after 2230, so it must have signed off on schedule; personal first, not reported in the UK since 1987	P/Fpks	2211	10/2	mah
1100	WHLI	Hempstead NY; NOS, ID "The ... flashes, the standards of yesterday here at 1100 WHLI"	Wpks	2224	17/2	mah
1110	WBT	Charlotte NC; ID "News talk 11-10 WBT" weather details then ID repeated	F	0801	25/1	JW
1110	WBT	Charlotte NC ; talk show. WBT IDs	W	2238	30/1	PC
1110	WBT	Charlotte NC; "11-10 WBT" ID at top of hour; very difficult channel due to local BBC R Derby to the SW	F	0100	5/2	JF
1100	WTAM	Cleveland OH; "Newsradio Eleven Hundred WTAM", talking about Cleveland	F	2330	1/2	JF
1100	WTAM	Cleveland OH; WTAM ID in very weak talk	Vw	0804	3/2	JW
1100	WTAM	Cleveland OH; "Cleveland Radio, WTAM, 11-hundred"	F	0932	4/2	PC
1100	WTAM	Cleveland OH; C2C talk show	F	0745	6/2	BD
1100	WTAM	Cleveland OH; "Coast to Coast AM on News Radio WTAM 1100"	Fpks	0807	9/2	mah
1100	WTAM	Cleveland OH; ID in programme promo about conservative radio	F	0857	10/2	SW
1110	LS1	R de la Ciudad, Buenos Aires; "Esta es LS1 Radio de la Ciudad", tlk	23542	0605	27/1	DX183
1116	UNID	jammer against whom? 095 degrees aerial	F	1511	28/1	ss
1120	KMOX	St Louis MO; "It's 2.06, I'm, KMOX News"	W/F	0806	4/2	PC
1120	CMCH	Radio Cadena Habana, Artemisa; us pop music, ID "Radio Cadena Habana"	F/G	0832	25/1	dxv
1120	CMCH	R Cadena Habana, Artemisa; Cuban songs, SS anns, ID " Radio Cadena Habana ..."	W/F	0916	25/1	mah
1130	KFAN	Minneapolis MN; sports/talk & info	W/F	0718	14/2	Rha
1130	KFAN	Minneapolis MN; ID "AM 11-30 KFAN Minneapolis St Paul", ESPN Radio Sports Centre; (+ F/G 0840 30/1, Fpks 0838 10/2)	F	1000	15/2	mah
1130	WBBR	New York NY; "Bloomberg weather and traffic ... the weather forecast on Bloomberg 11-30"	G	0905	22/1	dxv
1130	WBBR	New York NY; "Bloomberg business time on Wall St is 5.15"	F	2215	25/1	PC
1130	WBBR	New York NY; rolling business news	W/F	2254	25/1	BD
1130	WBBR	New York NY; World business news, "Bloomberg 11-3-0 Around the clock"	W	0715	31/1	BGM
1130	WBBR	New York NY; finance talk	W	0755	31/1	JW
1130	WBBR	New York NY; sports on WBBR 11-30; (also W 0628 6/2)	F	0624	14/2	Rha
1130	WBBR	New York NY; amazing signal! Political news and blood tests! "on Bloomberg Eleven Three O"	vG	0114	16/2	JF
1130	WBBR	New York NY; ID Bloomberg TV stock market report; briefly with music underneath – possible country tune	F	0845	20/2	SW
1130	CKWX	Vancouver BC; "Vancouver's news station, News 11-30"	Fpks	0812	31/1	mah
1134		CNR1, Golmud, China; traditional Chinese music, // 4800 kHz	F	1711	23/1	dxv
1140	CHRB	High River AB; religious speech prog	W	0915	14/2	Rha

kHz	Callsign	Station, location; details heard etc	SIO	UTC	Date	Who
1140	CBI	Sydney NS; classical music, // 1070 kHz	F/G	0848	22/1	dxv
1140	CBI	Sydney NS; CBC News	W	2223	25/1	PC
1140	CBI	Sydney NS; CBC overnight feature	W	0844	26/1	BD
1140	CBI	Sydney NS; "This is the world business (?) news on CBC Radio 1 and Radio 2"	F	2307	28/1	BGM
1140	CBI	Sydney NS; CBC overnight with CBC reports	W/Fpks	0632	6/2	Rha
1140	CBI	Sydney NS; local programming and local weather; but only ID as "CBC"	W	0914	10/2	SW
1140	CBI	Sydney NS; CBC news in // 1070 kHz	W/F	0101	13/2	RB
1150	WHBY	Kimberly WI ; C2C talk on "11-50 WHBY"	W/F	0635	6/2	Rha
1150	CHGM	Gaspé QC; pop song, CHNC ID // 610 CHNC	W	2305	1/2	JF
1152		IRIB Tabriz, Iran; Farsi, Gong, ID, 110 degrees	F	0230	30/1	ss
1152		RAK Media, Ras-al-Khaimah, UAE; AA "Ida' at Imirat...min Ras-al- Kaimah at s/on and 0232, 30 Min Quran chants, 130 degrees	F/Gpks	0200	30/1	ss
1160	WOBM	Lakewood Township NJ ; CNN News, "WOBM", NOS	23542	0900	25/1	DX183
1160	WABY	Mechanicville NY; NOS, "... this is WABY 11-60 AM and WUAM 900 The Moon"	Fpks	0832	11/2	mah
1161		VOIRI Qasr-e-Shirin, Iran, AA FS //1080, 1224, s/on	W	1624	30/1	ss
1170		VoA Poro, Philipines; Chinese // 11930 kHz	F	1440	6/2	ss
1170	WWVA	Wheeling WV, ID noted in the mix	W	0900	22/1	dxv
1170	WWVA	Wheeling WV; "This is the big one, the big one, news radio 11-70 WWVA, Wheeling"	F/G	0759	31/1	PC
1180	WHAM	Rochester NY; ID "Radio 11-80 WHAM" then into C2C	F	0807	25/1	JW
1180	WHAM	Rochester NY; "...Rochester's news leader, News Radio 11-80 WHAM"	F	1004	30/1	PC
1180	WHAM	Rochester NY; programme promo "on wham" & back to C2C talk show	W/F	0734	31/1	BD
1180	WHAM	Rochester NY; "Newsradio 11-80 WHAM" ID	F	2300	2/2	JF
1180	WHAM	Rochester NY; "Wham weather authority forecast" Also good at 0933 10/2 with Rush Limbaugh on Wham promo	F	0104	4/2	SW
1180	WHAM	Rochester NY; Sports phone-in, "50,000 watts 11-80 WHAM"	F	0039	10/2	BGM
1180	CM--	R Rebelde, 2 sites listed; political speech, // 5025 kHz	G	0033	23/1	dxv
1180	CMBA	Radio Rebelde, Villa María; SS music // 5025 kHz	W	0828	28/1	PC
1180	CMBA	Radio Rebelde, Villa María; SS football commentary, "Radio Rebelde" // 5025 kHz	W/F	0229	29/1	BGM
1180	CMBA	Radio Rebelde, Villa María; YL interview show // 5025 kHz	F	0733	31/1	BD
1180	CMBA	R Rebelde, 2 sites listed; // 5025 kHz	F	0740	20/2	SW
1188		EBU Ras Gharib, Egypt; AA // 819 (exc)	F/Gpks	2130	31/1	ss
1188		IRIB R Payam, Tehran, Iran; Farsi own px, ID			28/1	ss
1188		IRIB Teheran, Iran;	P/F	2320	9/2	boc4
1190	WOWO	Fort Wayne IN; "Wowo News"	33543	0400	3/2	DX183
1190	WOWO	Fort Wayne IN; just caught "WOWO" (not WoWo) ID	W	0032	4/2	PC
1190	WLIB	New York NY; promos, talk, "11-90 WLIB"	G	2240	21/1	dxv
1190	WLIB	New York NY; E tlk on baby boom, "11-90 WLIB"	F/Gpks	0212	30/1	ss
1190	WLIB	New York NY; "11-90 WLIB"	F	0712	31/1	BGM
1190	WLIB	New York NY; WLIB ID – "New York's Progressive Talk"	F	2252	31/1	PC
1190	WLIB	New York NY (pres); programme in // with WVAA 1690 kHz	Fpk	2323	4/2	SW
1190	LR9	R América, Buenos Aires; nx and wx	P/F	0050	10/2	boc4

kHz	Callsign	Station, location; details heard etc	SIO	UTC	Date	Who
1200	WKOX	Framingham MA; ads just before the hour, faded on the hour, so only caught a partial ID "... AM 1200 and 14-30", weather etc; 2203 "bostonsprogressivetalk.com"; 2206 "Boston's progressive talk is on AM 1200 and 14-30"; (Fpks 2200 17/2, W 0803 20/2)	P/Fpks	2200	11/2	mah
1200	WTLA	Syracuse NY (tentative); NOS, "... Music of Your Life, juke box ..."; only station carrying MOYL listed for the channel; there for a short while, xf CFGO and others	W/Fpks	0912	19/2	mah
1200	WOAI	San Antonio TX (presumed); C2C // 1700 kHz	W	0737	29/1	JW
1200	WOAI	San Antonio TX; "Newsradio 1200"	W	0520	30/1	RB
1200	WOAI	San Antonio TX; "News Radio 12 hundred WOAI, San Antonio"	W/F	0800	3/03	PC
1200	CFGO	Ottawa ON; ad for Petrol Canada, "The Team 1200"	G	0902	22/1	dxv
1200	CFGO	Ottawa ON; Fox Sports Radio. "CFGO Ottawa, The Team Twelve Hundred"	G	0100	30/1	JF
1200	CFGO	Ottawa ON; presumed with the "Third Shift on Fox" call 877-99-ON-FOX	G	0807	30/1	SW
1200	CFGO	Ottawa ON; Fox Sports Radio "12-hundred, The Team"	W	1001	30/1	PC
1200	CFGO	Ottawa ON; "Fox Sports Radio"	F	0656	3/2	BGM
1200	CFGO	Ottawa ON; sports talk and "Sports radio" ID	F	2255	10/2	JW
1200	CFGO	Ottawa ON; live broadcast of the NFL Pro-Bowl at 0235 in // with their webstream (approx 15sec delay)	W/F	0235	13/2	RB
1200	YVOZ	R Tiempo, Caracas; "Radio Tiempo", LA pop	33533	0705	28/1	DX183
1206		Kol Israel, Akko; Arabic , news and reports, ID	F/G	1540	22/1	dxv
1206		IBA Haifa, Israel; Reshet D in A // 5915 (under SVK)	G	1658	30/1	ss
1210	VOAR	Mount Pearl NL; Kids program - // webcast	F	2227	31/1	PC
1220	WHKW	Cleveland OH ; ID WHKW & WHKT; ad spot, weather & traffic at 0815; religious talks	W/F	0800	13/2	Rha
1220	ZYJ458	R Globo, Rio de Janeiro; sport	Gpks	0138	9/2	boc4
1220	ZYJ458	Rádio Globo, Rio de Janeiro; PP football commentary (lists suggest this is the only Brazilian station on 1220	W	2349	16/2	PC
1224		Galeil Zahal, Beersheba, Israel; Hebrew, sport news // 1287, 1368 kHz	F/G	1530	22/1	dxv
1230	WSBB	New Smyrna Beach FL; NOS, "WSBB"; (also 24542 0810 4/2)	24442	0745	26/1	DX183
1230	WWSD	Quincy FL; black gospel, "... on WWSD 12-30"	23542	0820	4/2	DX183
1230	WESX	Salem MA (tentative); very weak tentative toth ID, very weak in the noise "... -30 WESX"	vvW	1100	3/2	mah
1230	WMOU	Berlin NH; NOS, "WMOU"	33543	0835	23/1	DX183
1230	WCMC	Wildwood NJ (tentative); old standards; very weak anns in the noise, tentative ID "All the information you need, we're WCMC"	vvW	1054	3/2	mah
1230	HJKL	R Calidad, Cali; LA songs, "La Cariñosa", light instrumenta mx	23532	0755	28/1	DX183
1230	UNID	"Good morning, this is ... Radio 12-30 AM WCEC Warwick (??)"; that's what it sounded like, but probably only WCMC again; then wx; struggling in the noise	vvW	1102	3/2	mah
1233		RMC Cape Greco, Cyprus; A 2 x clear ID, extremely strong for 5 minutes, 1730 FF px and gone at 1740 and never again; DX183 First	F/Exc pk	1723	30/1	ss

kHz	Call sign	Station, location; details heard etc	SIO	UTC	Date	Who
1240	WMMB	Melbourne FL; webpage www.coastam.com given, traffic news and wx for Melbourne, " from the newstalk 12-40 WMMB traffic center"	Fpk	0757	25/1	dxv
1240	CKIM	Baie Verte NL; "VOCM radio network"	W	2358	5/2	PC
1242		Voice of Vietnam, Thoi Long (pres); YL in Vietnamese	F	1610	24/1	dxv
1242		Voice of Vietnam, Thoi Long; VN Vietnamese news & info talk; ID as Voice of Vietnam	W	1420	28/1	Rha
1242		Voice of Vietnam, Omon; FS in Thai, ID	G	1535	6/2	ss
1250	WEAE	Pittsburgh PA; insurance ad, then promo for the superbowl with the Pittsburgh Pirates and Detroit on ESPN radio		0737	3/2	JF
1250	WEAE	Pittsburgh PA; promo for show "only on Pittsburgh's ESPN radio"	F	0903	4/2	PC
1250	CJYE	Oakville ON; Godsongs, all of which sound like Westlife!	F	0812	24/1	JF
1250	CJYE	Oakville ON (pres); Christian pop, no ID – even after ads	F/G	0830	4/2	PC
1260		AIR Ambikapur, India (pres); modern Indian music, // 1206 kHz	F/G	0230	25/1	dxv
1260	WMKI	Boston MA; "Radio Disney", pop music	F/G	0227	25/1	dxv
1260	WMKI	Boston MA; Radio Disney // 1560 kHz	F	0802	29/1	PC
1260	WMKI	Boston MA; "R Disney", "WMKI AM12-60" at toh	F	0156	30/1	ss
1260	WMKI	Boston MA; Radio Disney // others	W	0724	30/1	JF
1269		IRIB Khalkhal, Iran; Farsi tlk //1503 Bushehr (good)	F	1502	28/1	ss
1270	WKBF	Rock Island IL ; phone-in, "12-70 AM WKBF"	23542	0410	3/2	DX183
1270	CJCB	Sydney NS; Irish folk music // webcast	F	0011	30/1	PC
1270	CJCB	Sydney NS; promo for "Talkback ... on Max 9-50", then "CJCB Satellite weather"	Fpk	1017	4/2	mah
1278		IRIB Kermanshah, Iran; in Farsi	F/G	0330	5/2	boc4
1280	VS2	Hamilton; Bible Broadcasting Network, talk and light songs	23542	0640	29/1	DX183
1280	WFAU	Gardiner ME; "Sports Radio 12-80 and 14-50"	F	0026	20/1	PC
1280	WFAU	Gardiner ME; "Fox Sports Radio"	F/G	2327	22/1	dxv
1280	WFAU	Gardiner ME; sports talk –Fox Sports freephone number // 850	W	0815	25/1	JW
1280	WFAU	Gardiner ME; Fox, "Sports R 14-50", 1280 not announced	F	0850	4/2	ss
1280	WFAU	Gardiner ME; Fox sports talk	W/F	2230	5/2	BD
1280	WFAU	Gardiner ME; lots of local adverts then very fast full legal ID mentioning WIGY Madison 97-5 and WFAU Gardiner	Exc	0055	18/2	SW
1280	CFMB	Montréal QC; II service pop mx show	W/F	2150	25/1	BD
1280	CFMB	Montréal QC (pres); Italian talk by OM	F	2147	31/1	PC
1280	WCMN	Arecibo PR; SS nx, "NotiUno" ID	23542	0810	28/1	DX183
1290	WJNO	West Palm Beach FL; "WJNO West Palm Beach" heard after other unid W call (WKBK?) at toh	W	0600	31/1	JF
1290	WJNO	West Palm Beach FL; phone-in, ads, "WJNO 12-90 AM"	33533	0330	4/2	DX183
1290	WJNO	West Palm Beach FL; Fox, nx, "brought to you from WJNO"	F	0357	4/2	ss
1290	KKAR	Omaha NE ; news and phone-in "This is CNN Radio"; "K-car Talk Radio 12-90"	23432	0700	6/2	DX183
1290	WKBK	Keene NH; CBS News, "12-90 WKBK", and " www.wbkb.com "	Fpks	0905	4/2	mah
1290	WKBK	Keene NH; "12-90 WKBK, Keene" ID at toth	W	0500	15/2	PC
1290	WNBF	Binghamton NY ; "Back to the new Talk Radio - Binghamton's news and weather station, News Radio 12-90 WNBF"	Fpk	0930	4/2	mah

kHz	Callsign	Station, location; details heard etc	SIO	UTC	Date	Who
1290	WRNI	Providence RI; poor ID "... wrni.org, a service of Boston News and WRNI ... NPR News"	Fpks	2301	2/2	mah
1290	WRNI	Providence RI; "here on stn...", BBC WS nx but lost	Wpk	0859	5/2	ss
1290	WDZY	Colonial Heights VA ; Radio Disney promos, ID "AM 12-90 WDZY Colonial Heights - Richmond"; occasionally on top; UK FIRST ; (also presumed Fpks 2232 2/2, P/Fpks 2244 4/2)	Fpks	2158	5/2	mah
1290	WDZY	Colonial Heights VA; Radio Disney ID and Natasha Bedingfield song; weak under talk station	W	0640	16/2	JF
1290	CFRW	Winnipeg MB; oldies, "Oldies 12-90 a Chum station"	33543	0845	23/1	DX183
1290	CJBK	London ON; Broadcast News, "News Talk 12-90 CJBK", C2C	Fpks	1004	4/2	mah
1290	YVLF	R Puerto Cabello, Puerto Cabello; romantic songs, ID, "... desde Puerto Cabello, primer lugar de sintonía"	F	0025	25/1	dxv
1290	YVLF	R Puerto Cabello, Puerto Cabello; dominating 1290 at this time with ID and lively Latin music	F	2336	30/1	JF
1290	YVLF	Radio Puerto Cabello, Puerto Cabello; Puerto Cabello sports	W/F	2228	10/2	BD
1290	UNID	Talk then ads including one with 406-1520	vW	0736	25/1	JW
1300	WOOD	Grand Rapids MI; "Twenty minutes after 5 o'clock on Grand Rapids Morning News on a rainy Monday morning"	F	1020	30/1	PC
1300	WOOD	Grand Rapids MI; phone-in "... Radio Wood 1300"	33543	0420	3/2	DX183
1300	WOOD	Grand Rapids MI; I think this one had C2C, ID "News Radio 1300 WOOD"; xf ESPN and old time radio play	Fpks	0758	4/2	mah
1300	WERE	Cleveland OH (pres); Point of View and USA Radio Network news. No ID at toth but matches schedule	F	0905	10/2	PC
1300	UNID	"ESPN Radio 1300"	W/F	0003	13/2	mah
1310	WLOB	Portland ME; ads, poor "... weeknights ?-9 on News Talk WLOB" promo/ID	P/Fpk	2235	10/2	mah
1310	WLOB	Portland ME; ads, promo "... on WLOB's Morning News"	Fpks	0923	12/2	mah
1320	WDER	Derry NH ; promo: "Truth For Life with Alistair Begg at 7.30 here on Life Changing Radio", their website confirms this, then the "WDER Weather Centre .." UK FIRST	W	0234	11/2	JF
1320.01	CKEC	New Glasgow NS; oldies of the 30s and 40s, weather rpt, ID "CKEC Radio New Glasgow"	G	2339	22/1	dxv
1320	CKEC	New Glasgow NS; "CKEC Radio Newswatch Show"	F	0004	29/1	PC
1320	CKEC	New Glasgow NS; pops, "This is CKEC New Glasgow"	33543	0600	5/2	DX183
1320.02	CKEC	New Glasgow NS; country mx show	W/F	2250	5/2	BD
1320	CKEC	New Glasgow NS; Broadcast news, weather ID "CKEC Radio New Glasgow"	G	2304	11/2	SW
1320	CKEC	New Glasgow NS; end of Broadcast News then CKEC weather	W	0004	12/2	JF
1320	CKEC	New Glasgow NS; nostalgia records	F	2322	12/2	JW
1320	CJMR	Mississauga ON (presumed); Indian music heard in CKEC fade	W	0005	12/2	JF
1320	CJMR	Mississauga ON; "You're listening to 13-20 CJMR - The Voice of the City"	G	0000	15/2	PC
1330	WRCA	Waltham MA; "A member of the Beasley Broadcast Group - this is 13-30 WRCA Waltham Boston"; programme of big band / nostalgia	W	0600	25/1	JF
1330	WRCA	Waltham MA; weak EE ID after toth "this is 13-30 WRCA"	W	0201	13/2	PC
1332		Teheran City Radio; ID, trad "sitar" music + recitations	F/G	0044	23/1	dxv
1340	CBGA7	St-Anne-des-Monts QC; tuned in to catch partial FF ID "CBGA Wpk Gaspésie et les Îles"	Wpk	1007	4/2	mah

kHz	Callsign	Station, location; details heard etc	SIO	UTC	Date	Who
1360	WDRC	Hartford CT; "AM 13-60 WDRC" heard whilst listening to WKAT	W	0800	25/1	PC
1360	WDRC	Hartford CT; "AM 13-60 WDRC" ID at toh in WKAT fade	W	0200	31/1	JF
1360	WKAT	North Miami FL; Mike Gallagher Show "WKAT, North Miami" ID at toth.	F	0756	25/1	PC
1360	WKAT	North Miami FL; "Newstalk WKAT", tlk px	F	0632	29/1	ss
1360	WKAT	North Miami FL; ads then "WKAT South Florida weather" ... only 77 degrees! "Newstalk 13-60 WKAT"	F	0040	31/1	JF
1368		IRIB Sari, Iran; IS //1430 Isfahan	F	1529	6/2	ss
1370	WDEA	Ellsworth ME; CBS news, ID	F	2304	24/1	dxv
1370	WDEA	Ellsworth ME; CBS News then "AM 13-70 WDEA"	F	2305	31/1	PC
1370	CFOK	Westlock AB; country, "OK radio"	24532	0905	23/1	DX183
1370	HJKX	R. Mundial, Bogotá; "Cadena Radial Autentica" ID	W	0200	13/2	RB
1377		R Free Africa, Mwanza, Tanzania; afro pop mix, ID Swahili/English	P/F	0215	9/2	boc4
1377		VoR Gavar, Armenia; R "Rkampagnia Golos Rossii – R Kanal Sodruzhesto", new on that channel	F/Gpks	1644	2/2	ss
1377		CNR Henan, China; CC; popular oldies, tlk // 4460 kHz	W	1450	5/2	Rha
1380	WWMI	Saint Petersburg FL (presumed); at 0955 "AM 13-80 your music, your way", Radio Disney promos; brief peak over the others; still waiting to get a full ID on this one!	Wpks	0957	25/1	mah
1380	WMYF	Portsmouth NH; "The Music Of Your Life on AM 13-80 WMYF"; nostalgia format; generally dominating the frequency	W	0150	2/2	JF
1380	WMYF	Portsmouth NH; NOS, periodic IDs; at 0921 "... and more AM 13-80 WMYF"; (also W/F 2316 3/2, F 0950 4/2)	Fpks	0921	5/2	mah
1380	WSYB	Rutland VT; I believe this one had C2C; ID at 1000 "... on News Talk and Sport WSYB AM 13-80 Rutland WWWT AM 13-20 Randolph"; then Fox News Radio; occasional peaks	Fpks	1000	5/2	mah
1380	CKLC	Kingston ON; oldies "13-80 CKLC" ID; fair peak but generally poor	F	0000	2/2	JF
1380	CKLC	Kingston ON: "CKLC, Kingston's radio station for all time favourites"	W/F	0736	4/2	PC
1380	CKLC	Kingston ON; songs from musicals, periodic IDs; at 0935 "It's Kingston's newest radio station, All Time Favourites 13-80 CKLC"	Fpks	0935	5/2	mah
1380	CKLC	Kingston ON; NOS mx & OM with "13-80 CKLC Kingston"	W	0750	6/2	BD
1380	YVNG	Ondas del Mar, Puerto Cabello; LA mx," transmite Ondas del Mar"	F/G	0851	27/1	dxv
1380	YVNG	Ondas del Mar, Puerto Cabello; SS anns/ads, ID/TC	F	0847	28/1	mah
1380	UNID	"... with the morning crew on newstalk 13-80 ..." sadly just too weak in the background to hear the call :0(vW	0000	2/2	JF
1380	UNID	C2C noted in the mix to after 0730, but never caught an ID - who might this be?	Fpks	0615	18/2	mah
1386.07		KBC Maralal, Kenya; "This is KBC" in English all night stable signals	F/vG	0210	9/2	boc4
1390	WEGP	Presque Isle ME; talk show, ID & USA network nx	W	0658	27/1	BD
1390	WEGP	Presque Isle ME; "...on WEGP 13-90 and WREM"	F	0833	29/1	PC
1390	WEGP	Presque Isle ME; ID "WEGP Presque Isle" then into USA Radio Network News	W	2259	1/2	JW
1390	WEGP	Presque Isle ME; local ads, WEGP/WREM ID	W	1100	4/2	mah

kHz	Callsign	Station, location; details heard etc	SIO	UTC	Date	Who
1390	WEGP	Presque Isle ME; a nightly regular with talk ; local ads before top of hour	G	0000	8/2	SW
1390	WEGP	Presque Isle ME; "WEGP 13-90 and WREM 7-10 The Talk of the Country"	W	0003	9/2	BGM
1390	WPLM	Plymouth MA; soft pops & "WPLM for the best songs on the radio" ID	W	0358	27/1	BD
1390	WPLM	Plymouth MA; EZL, "Easy 99 point 1"	33533	0620	1/2	DX183
1390	WPLM	Plymouth MA; relay of FM service "Easy 99" with Dick Robinson; crooning!	W	2347	4/2	JF
1390	WPLM	Plymouth MA (pres); with ads for Framingham Credit Union giving address in Concord (i.e. the home of WBNW, sister station to WPLM); live basketball	F	0013	7/2	SW
1390	WPLM	Plymouth MA; "Money Matters Radio Network" ID	W	0030	7/2	RB
1390	WPLM	Plymouth MA; EZL tunes "Easy 99.1, a breath of fresh air"	Fpk	0753	10/2	SW
1390	WFBL	Syracuse NY; "Talk Radio 13-90 WFBL, Syracuse	W	2353	2/2	PC
1390	WFBL	Syracuse NY; legal ID; x-fading WEGP	Fpk	0500	3/2	SW
1390	WFBL	Syracuse NY; promo "... on Talk Radio 13-90 WFBL"	W/F	1012	4/2	mah
1390	WFBL	Syracuse NY; ID in pile-up	W	2346	4/2	JF
1390	WFBL	Syracuse NY; ID/promo noted in the mix "... on Talk Radio 13-90 WFBL"	Fpk	1012	11/2	mah
1390	WRIG	Schofield WI; NOS, "AM 13-90 WRIG"; xf ESPN Radio	Wpks	1040	11/2	mah
1390	YVZA	R Fé y Alegría, Caracas; 27/1, 0845, LA music, ID: "en Fé y Alegría son las 4 y 45 minutos", sometimes mixing with R Lumen	Gpks	0845	27/1	dxv
1390	YVZO	R Lumen, Maracaibo; Christian songs, ID	F/G	2245	26/1	dxv
1395		AIR Bikaner, India; instrumental music, // 1467, 3315 kHz	F	1724	23/1	dxv
1395		AIR Bikaner, India; nx //various SW freqs	F	1543	3/2	ss
1400	WOND	Pleasantville NJ; "You're listening to WOND Coast to Coast AM", ads, phone-in	24442	0830	4/2	DX183
1400	WOND	Pleasantville NJ; E ads, "Newstalk 1400 WOND", C2C	F	0558	5/2	ss
1400	WOND	Pleasantville NJ; ID at top of hour "Newstalk Fourteen Hundred WOND Pleasantville, Atlantic City, radio you can depend on", then WOND sung jingle! Generally dominant over CBG	W	0100	18/2	JF
1400	CBG	Gander NL; "" You are listening to....on CBC R 1 and CBC R 2"	F/G	2104	21/1	dxv
1400	CBG	Gander NL; CBC overnight feature	W	0738	26/1	BD
1400	CBG	Gander NL; BBC World Service	F	0758	29/1	PC
1400	CBG	Gander NL; Mention of local events, "CBC Radio 1"	F	2049	2/2	BGM
1400	CBG	Gander NL; YL talking about her family // net stream	vW	1945	5/2	JF
1400	CBG	Gander NL; CBC World this Weekend	G	2300	11/2	SW
1410	WPOP	Hartford CT; "ESPN Radio 14-10 Connecticut's .. sports station"	F	0820	29/1	PC
1410	WPOP	Hartford CT; "ESPN 14-10" ID. WPOP call heard in severe splash at 07:00	F	0539	5/2	JF
1410	WPOP	Hartford CT; sports information 1one1	W	0744	16/2	Rha
1410	CFUN	Vancouver BC; "This is C-fun", C2C talk; (+ 23532 0815 25/1)	24532	0920	23/1	DX183
1410	HJFS	RCN Antena 2, Honda; música romantica, "Antena Dos"	33533	0740	1/2	DX183

kHz	Call sign	Station, location; details heard etc	SIO	UTC	Date	Who
1413		Bangladesh Betar, Comilla; Bengali OM/YL tlk, instr mx, clear ID as "Bangladesh Betar" by YL at 1459, nx pres, don't mix with BBC OMA Hindi until 1445, then EE and Urdu at 1500 listed 10 kW, DX183 First	W/Fpks	1437	3/2	ss
1413	JOIF	KBC Fukuoka ; lively talk in JJ, several KBC IDs, promos	F/G	1502	22/1	dxv
1413	JOIF	KBC Fukuoka ; Jap tlk though no ID, lost after 7 minutes	Fpk	1427	3/2	ss
1413		BBC Oman; Farsi	P/F	1629	6/2	boc4
1413	UNID	Chinese talk, no ID	vW	1357	28/1	Rha
1420	WBEC	Pittsfield MA; "... that really talks AM 14-20 WBEC" and Sporting News Flash	Fpks	0840	15/2	mah
1420	WHK	Cleveland OH; "Newstalk 14-20 WHK"	W/F	1020	10/2	PC
1420	WHK	Cleveland OH; "The station where your opinion counts - News Talk 14-20 WHK", more IDs	Wpks	1000	11/2	mah
1420	CKDY	Digby NS; country mx & "AVR" ID	W	0745	26/1	BD
1420	CKDY	Digby NS; country, ID "Thanks for making us your choice ... AVR"	W/F	0948	31/1	mah
1420	CKDY	Digby NS; full station ID	W	0802	13/2	mah
1420	CKPT	Peterborough ON ; "14-20 Memories" (according to KOJE and the NRC AM Radio Log, this is the slogan for the station), NOS, xf others; last reported in the UK pre-1965	Fpks	0941	11/2	mah
1420	YVNZ	R Marabina, Maracaibo (presumed); several refs to Maracaibo, anns. "Radio Cadena Venezuelana", "14-20"	F/G	0005	27/1	dxv
1420	YVNZ	Radio Marabina, Maracaibo; MOR SS songs & "Marabina" ID	W	0748	31/1	BD
1430		IRIB Isfahan, Iran; Farsi, gong, nx //1503, off channel	G	1430	30/1	ss
1430		IRIB Isfahan, Iran; (not 1431 kHz) xd Sawa Djibouti	P/F	0315	9/2	boc4
1430	KEZW	Aurora CO; NOS (50's), "14-30 Radio, Your Memory Station"	32542	0750	3/2	DX183
1430	WOIR	Homestead FL (presumed) good signal at end of programme called Cruzada con Luis Palau, no IDs heard before or after this 15 minute show; just music. "very probably WOIR Amanecer 14-30" says Henrik Klemetz; Personal First	Gpk	0715	11/2	SW
1430	WXNT	Indianapolis IN (tent); mixing with Indian language from CHKT; Valentine advert then ".Doyle Show" and "On 14-30" heard; websearch brings up The Jerry Doyle Show, and www.jerrydoyle.com lists WXNT as only station on 1430; personal first	P	0730	30/1	SW
1430	WNSW	Newark NJ; SS tlk, "AM 14-30 WNSW"	33533	0850	18/1	DX183
1430	WNSW	Newark NJ; SS religious programme from Radio Cantico Nuevo (which station confirms in my phone call)	F	0750	26/1	BD
1430	WNSW	Newark NJ; NOS, poor/difficult accented ID "AM 14-30 WNSW Newark New York City ... Broadcasting" (the final "W" of the call sounded like "dobleu oo")	Fpks	0359	4/2	mah
1430	WNSW	Newark NJ; oldies tune then into legal ID; then rapidly back to WENE; brief good peak just at the right moment! RARE	Fpk	0200	11/2	SW
1430	WENE	Endicott NY (presumed); sports talk	W	0739	26/1	JW
1430	WENE	Endicott NY; Fox sports talk	F	0757	26/1	BD
1430	WENE	Endicott NY; "WENE Endicott" legal ID (unatt recording)	W/F	0100	29/1	PC
1430	WENE	Endicott NY; "Sportsradio 14-30 The Team" in middle of ad break	F	0527	30/1	JF
1430	WENE	Endicott NY; legal IDs and slogans "A service of Clear Channel Radio" hourly; "Sports Radio 14-30 The Team"	F	0200	31/1	SW

kHz	Callsign	Station, location; details heard etc	SIO	UTC	Date	Who
1430	WENE	Endicott NY; ads, "Binghampton's all sports station, Sports Radio 14-30 The Team", Fox Sports	F	2342	3/2	mah
1430	WENE	Endicott NY; "Sports Radio 14-30 The Team"	F	2258	4/2	BGM
1430	WENE	Endicott NY; "Right here on <u>Binghampton's</u> All Sports station, sports radio 14-30 The Team"; regular signal	G	0729	12/2	SW
1430	WOWW	Germantown TN ; "Radio Disney", // 1560 kHz (this is the only Radio Disney station listed for the channel - mah)	23542	0730	5/2	DX183
1430	CHKT	Toronto ON; Tamil language programme at this time	W	0829	24/1	JF
1430	CHKT	Toronto ON; Indian film mx & Tamil announcements	W/F	0755	28/1	BD
1430	CHKT	Toronto ON; Chinese broadcast	W	0015	2/2	PC
1430	CHKT	Toronto ON; legal ID in English "AM 14-30 CHKT Fairchild Media (?) Toronto"; heard at other times in Chinese or Indian languages	Fpk	0100	2/2	SW
1430	CHKT	Toronto ON; CC tk, poor ID "... AM 14-30 CHKT Fairchild Radio Toronto. Now the Hindi programme on AM 14-30 CHKT Fairchild Radio"	Fpks	0100	4/2	mah
1430	CHKT	Toronto ON; non-stop S-AS mx, simply CHKT at 0701+0759	F/Gpks	0700	4/2	ss
1430	CHKT	Toronto ON; CC tk, EE ID at toth "AM 14-30 CHKT Fairchild Radio Toronto" followed by Indonesian px	W/F	2333	4/2	BGM
1440	WJAE	Westbrook ME; "Sporting News Radio". Sung ID "WJAB"	W/F	0743	1/2	PC
1440	WJAE	Westbrook ME; ad break mixing Luxy, mentioning tools and spare parts, WJAB ID v clearly heard with laser style zap jingle	F	0357	10/2	JF
1449		VOIRI Bandar-e-Torkoman, Iran; R FS, Quran, ID	G	1432	28/1	ss
1449		IRIB Bandart, Iran; Farsi songs & local music - female singer	F	0623	6/2	Rha
1450	VSBI	Hamilton; oldies, "14-50 AM VSBI"	33533	0855	18/1	DX183
1450	WCUM	Bridgeport CT; SS, tropical songs, "Radio Cumbre"	23442	0920	4/2	DX183
1450	WKXW	Atlantic City NJ; "ESPN Radio WKXW Atlantic City" ID	F	0300	24/1	JF
1450	WKXW	Atlantic City NJ; Baseball discussion "Sports talk on ESPN 14-50"	W/F	2249	30/1	PC
1450	WKXW	Atlantic City NJ; ESPN sports radio	W	0800	5/2	BD
1450	WKIP	Poughkeepsie NY ; NOS, CNN News, "Music of Your Life WKIP 14-50 AM"	24442	0845	4/2	DX183
1460	WZNZ	Jacksonville FL ; ESPN radio ID's; mixing gospel & Disney	W	0702	19/2	JF
1460	WDDY	Albany NY; Radio Disney // others	W	0724	30/1	JF
1460	WDDY	Albany NY; Radio Disney // 1560 kHz	W	0851	30/1	PC
1460	WDDY	Albany NY; Radio Disney pops heard	W/F	0925	14/2	Rha
1460	WDDY	Albany NY; occasional "Radio Disney 14-60" ID drop-ins	W	0200	19/2	JF
1460	WWWG	Rochester NY (presumed); with gospel and hymn singing; possible ID at 0734	W	0702	19/2	JF
1460	CJOY	Guelph ON; "Good morning it's 5.30 ... This is CJOY, your information leader", on top of the mix, briefly	Fpk	1030	10/2	mah
1467		AIR Jeypore, India; instrumental music, // 3315 kHz	F/G	1555	23/1	dxv
1467.2		IRIB Marival, Iran; Farsi // 1430 Isfahan	F	1603	3/2	ss
1467	HLKN	KBS Mokpo; OM in Korean, "KBS" ID at 1400	F/G	1353	22/1	dxv
1467		Radio Thailand, Pathum Thani; reports in Thai, most times dominating over AIR and BSKSA, kind of jingle, close down anns 1700 c/d with N/A	F/G	1645	24/1	dxv
1467		TWR Bishkek, Kyrgyzstan; Ukrainian(!), ID, addr in KAZ, 1443 TWR IS	F	1420	28/1	ss

kHz	Callsign	Station, location; details heard etc	SIO	UTC	Date	Who
1470	WWNN	Pompano Beach FL; phone-in, "AM 14-70 WWNN Pompano Beach"	33533	0720	29/1	DX183
1470	WWWN	Pompano Beach FL; peaked with clear advert for Al Henrickson Toyota, largest dealer in Broward County; first time this winter for me	Fpk	0657	16/2	SW
1470	WLAM	Lewiston ME (presumed); promos for ESPN programs like Mike & Mike in the Morning, "14-70 ESPN Radio"	G	2336	24/1	dxv
1470	WLAM	Lewiston ME; ESPN sports & "WLAM Lewiston Auburn" ID	F	0558	27/1	BD
1470	WLAM	Lewiston ME; ads for businesses in Auburn.	G	2218	31/1	PC
1470	WLAM	Lewiston ME; ESPN sport radio, "WLAM Lewiston Auburn It's LA's Sports Station"	W	0059	3/2	BGM
1470	WLAM	Lewiston ME; legal ID: "WLAM Lewiston-Auburn. It's LA's sports station 14-70 ESPN" heard most nights	F	0100	13/2	SW
1470	WNYY	Ithaca NY; Home for progressive talk 14-70 WNYY Ithaca" legal ID then CNN news	F	0000	2/2	SW
1470	XEAI	R Fórmula, Mexico City; ID in the mix	Fpk	0200	30/1	SW
1470	XEAI	Radio Fórmula, Mexico City; "Radio Fórmula" ID & programme promo from "Grupo Fórmula presenta..."	W	0400	31/1	BD
1470	XEAI	R Fórmula, México DF;	F/G	0613	5/2	boc4
1470	OAU4B	CPN Lima; news	P/F	0605	5/2	boc4
1470	OAU4B	CPN Radio Lima; nx, info & "CPN Radio" IDs in chat	W	0559	16/2	BD
1470	YVJW	R Latina, Valencia; relaying RCR 750	W/F	0115	7/2	RB
1470	YVSY	Radio Vibracion Carúpano; LA songs, "en Vibración cuatro cuarenta minutos"	G	0840	24/1	dxv
1470	YVSY	Radio Vibración Caúpano; lively Latin pops, "en Vibración" IDs & TCs	F	0705	28/1	BD
1470	YVSY	R Vibración, Carúpano; salsa etc, "... en Vibración ... minutos"	44544	0740	29/1	DX183
1470	YVSY	R Vibración, Carúpano; music programme with ID & TC	Fpk	0004	2/2	SW
1470	YVSY	R Vibración, Carúpano' mx and rare IDs	P/F	0230	10/2	boc4
1476		IRIB Sanandaj, Iran; in Farsi	F	0320	8/2	boc4
1476		R Thailand, Lamphun, songs and reports in Thai	G	1347	22/1	dxv
1476		R Thailand, Lamphun (presumed) very unusual language with chanting style singing – perhaps Mong hill tribe language discussed before in MWN. Excellent signal at 2340 which is dawn in Thailand then faded out around midnight utc	exc	2337	20/2	SW
1480	WSAR	Fall River MA; sports news, "AM14-80 WSAR"	G	0827	22/1	dxv
1480	WSAR	Fall River MA; ads, "... depend on South-eastern Massachusetts official weather station, 14-80 WSAR"; xd NOS	Fpks	0947	4/2	mah
1480	WSAR	Fall River MA; ad break with Fall River addresses, WSAR ID	F	0121	5/2	JF
1480	WGVU	Kentwood MI; ID before 0700 BBC World Service nx "...a public service of Grand Valley State University	W/F	0700	11/2	PC
1480	WHBC	Canton OH; Sung WHBC ID at toth after Radio America prog	W	0600	11/2	PC
1480	WLMV	Madison WI; just caught ID at 0830 "La Movida 14-80 AM, WLMV Madison, Wisconsin" also 0801 22/1 (missing from last month's log) http://tinyurl.com/8yth8	G	0830	21/1	PC
1480	WLMV	Madison WI; "La Movida" heard in pile-up with "La Movida" ID as per Paul Crankshaw's recording; also with "WLMV Catorce Ochenta" ID at 0521	W	0404	6/2	JF

kHz	Callsign	Station, location; details heard etc	SIO	UTC	Date	Who
1480	WMDD	Radio Tropical, Fajardo PR; religious program, ID:"WMDD con su programación de paz y justicia. Continuamos con el programa 'caballeros en amor' "	F	0130	24/1	dxv
1480	UNID	Loop ID "CBS Radio Network Channel 42"	W	0403	6/2	JF
1494		Xinjiang PBX, Korla, China; Chin // 5060 kHz	F/Gpks	1426	6/2	ss
1500	WTOP	Washington DC; ID traffic reports the ID "WTOP Radio"	F	0736	26/1	JW
1500	WTOP	Washington DC;"WTOP Weather and Travel"	F	0758	26/1	PC
1500	WTOP	Washington DC; WTOP traffic report	F	0809	26/1	BD
1500	WTOP	Washington DC; "WTOP newstime 7.40"	F	0040	1/2	SW
1500	WTOP	Washington DC; Still with WTOP calls at this time despite call change.	F	2250	1/2	JF
1500	WTWP	Washington DC; Travel news, "WTOP Weather Center... WTOP Radio"	F	0530	5/2	BGM
1500	WTOP	Washington DC; news, "WTOP 15 News radio"	F/G	0635	6/2	boc4
1500	WTOP	Washington DC; receiver was on auto-scan, and going through this channel I heard a reasonably clear ID "... classical station this is WGMS" - presumably a promo by WTOP for the FM station of the group	F	0811	6/2	mah
1500	WLQV	Detroit MI (tent); ID (tent) MO talking about the Bible briefly over WTOP; no ID at toh, just a musical fanfare	Fpk	0800	1/2	SW
1500	KSTP	St Paul MN; "AM Fifteen Hundred KSTP" ID at midnight!	W	2331	5/2	JF
1503	UNID	Tadjik stn; Tajik tlk, into Quran Mgrib evening prayer at 1425 (sunset), ID stating "Dushanbe" 1543 + 1553 but not copied completely. Porzer says for the 7 kW xmtr listed Mayak px, WRTH says VoR in R, blocked from EGY Al-Arish 1455, 130/110 degrees, 4635 HS and 7245 FS from TJI not in //	F/Gpks	1418	4/2	ss
1510	WWZN	Boston MA; Tony Bruno show, "it's Tony Bruno here and don't G miss my show ... on 15-10 The Zone, sporting news Radio"	G	0930	25/1	dxv
1510	WWZN	Boston MA; Harvard basketball commentary	F/G	0023	29/1	PC
1510	WWZN	Boston MA; college basketball then legal ID	G	2355	30/1	SW
1510	WWZN	Boston MA; "15-10 The Zone", "Sporting News radio Network"	F	0028	3/2	BGM
1510	WWZN	Boston MA; NFL talk	F	2317	10/2	JW
1510	WLAC	Nashville TN; mixing WWZN "Newsradio 15-10"	Fpk	2321	2/2	SW
1510	WLAC	Nashville TN; preaching	W/Fpks	0445	6/2	Rha
1510	WLAC	Nashville TN; "15-10 WLAC" under WWZN	W	2321	7/2	PC
1510	WLAC	Nashville TN; "Newsradio15-10 WLAC". At least four or five ID's within a minute! No trace of WWZN!	W	2320	8/2	JF
1510	UNID	C2C, under/equal WWZN - WLAC?	Fpks	0854	15/2	mah
1520	WIZZ	Greenfield MA ; news, local ads, "Wizz Radio" and "From WIZZ here's the weather forecast for Franklin county from the National Weather Service", wx, "Have a pleasant evening, thank you for listening to AM 15-20 for all theWizz Radio WIZZ", jingle, songs; another nice jingle at 2210; under/equal WWKB; UK FIRST	Fpks	2202	5/2	mah
1520	WIZZ	Greenfield MA; "From WIZZ, here's the weather forecast ...", and a minute later "Have a great weekend, and thank you for listening to AM 15-20 WIZZ" and a "15-20 WIZZ" jingle	P/Fpks	2203	10/2	mah
1520	WWKB	Buffalo NY; studi talk, "This is Buffalo's 50,000 watts 15-20 KB radio"	44544	0840	20/1	DX183

kHz	Callsign	Station, location; details heard etc	SIO	UTC	Date	Who
1520	WWKB	Buffalo NY; promo "call 866500-MEGA for affordable health insurance, home office Oklahoma City, Oklahoma, not available in all states", "This is Buffalo 50,000 watts KB-Radio"	vG	0828	23/1	dxv
1520	WWKB	Buffalo NY; "This is Buffalo, 50,000 watts, KB Radio 15-20"	F/G	0751	26/1	PC
1520	WWKB	Buffalo NY; network talk show	W/F	0812	26/1	BD
1520	WWKB	Buffalo NY; "Buffalo 50,000 watts KB Radio 15-20"	F	0647	27/1	BGM
1520	WWKB	Buffalo NY; "Greatest hits from the 50s & 60s KB Radio 15-20"	G	0110	4/2	SW
1520	WWKB	Buffalo NY; oldies programme and promo "The Beatles show 10 o'clock Sunday night"	F	2325	5/2	JW
1520	WWKB	Buffalo NY; "This is Buffalo's Best Talk – WWKB Buffalo" ID after a string of ads from 2300; New talk format with subtle call change	W	2333	8/2	JF
1520	WWKB	Buffalo NY; promo " ... on Buffalo's last chance AM 15-20"	Fpks	2156	10/2	mah
1520	WWKB	Buffalo NY; talk prog, ads then ID "You are tuned to our new voice, our new choice we are Buffalo's ... 15-20" then back into talk prog	F	2318	10/2	JW
1520	WWKB	Buffalo NY; YL "Good afternoon Buffalo" call "803 1520" To first caller "You 're on AM 1520"	Ex	2320	12/2	JW
1520	WWKB	Buffalo NY; some oldies on "KB 15-20"	W/F	0738	13/2	Rha
1520	WWKB	Buffalo NY; "A new voice, a new choice this Buffalo's Left Channel AM 15-20" [no more oldies music]	G	0043	18/2	SW
1520	WVOZ	Radio Voz, San Juan PR; 22/1, 2300, sports information, " ... una partida colosal a través de Radio Voz"	F/G	2300	22/1	dxv
1530		VOA São Tomé; VOA Africa in English	F/G	0310	7/2	boc4
1530	WCKY	Cincinnati OH; religious talk // webcast	F	0946	10/2	PC
1539		R Farda, Abu Dhabi UAE;	F/G	1615	6/2	boc4
1540	KXEL	Waterloo IA; talk px, poor ID "Iowa's news and talk station News Talk 15-40 KXEL Waterloo, Cedar Falls"	W	1100	5/2	mah
1540	KXEL	Waterloo IA; wx, "News Talk 15-40 KXEL"; xd pres CHIN	F	1006	15/2	mah
1540	KXEL	Waterloo IA; ID "Newstalk ... KXEL" in fade of CHIN	W	0300	19/2	JW
1540	WDCD	Albany NY; sung "Life Changing Radio"	F	0300	25/1	JW
1540	WDCD	Albany NY; Religious ads WDCD ID	W	0806	29/1	PC
1540	WDCD	Albany NY; "Life 15-40 WDCD" promo for Focus on the Family.	G	2337	1/2	SW
1540	WDCD	Albany NY; "The Life 15-40 live programme crew online today at 1540wdcd.com" ID; Christian format	G	0226	11/2	JF
1540	WNWR	Philadelphia PA (presumed); SSB noted at 2229, but check of recording didn't reveal any meaningful anns beforehand	F	2229	2/2	mah
1540	CHIN	Toronto ON (presumed); Italian programming	W	0846	30/1	PC
1540	CHIN	Toronto ON; ads then Chinese program	F	2302	1/2	JW
1540	CHIN	Toronto ON; CC talk // webcast www.chinradio.com	W	2221	2/2	BGM
1540	CHIN	Toronto ON; II phone in show	W/F	0825	3/2	BD
1540	CHIN	Toronto ON; nearly every morning; Radio Due in Italian	F	0930	15/2	SW
1550	CBE	Windsor ON; "CBC Radio One!, nx	24542	0800	24/1	DX183
1550		RASD, Tindouf, Algeria; excellent signal but signed off early at 2400 and did not go into Spanish programming	Exc	2350	25/2	SW
1557		R Asia, Ras-al-Khaimah, UAE; VV like Urdu "R Asia 1-5-5-7 AM"	F/Gpks	1608	28/1	ss

kHz	Callsign	Station, location; details heard etc	SIO	UTC	Date	Who
1557		WYFR, Kouhu, Taiwan; px in EE, ID	F/G	1457	22/1	dxv
1557		WYFR Tansui, Taiwan; local choir song & religious px	W/F	1403	28/1	Rha
1557		WYFR Kouhu Taiwan; EE ID, into rel px but not // SW or 1503 Moscow	G	1400	5/2	ss
1560	WQEW	New York NY; Radio Disney pops	W	0749	26/1	JW
1560	WQEW	New York NY; "Radio Disney plays your music"	F	0801	26/1	PC
1560	WQEW	New York NY; Radio Disney pop show	F/G	0819	26/1	BD
1560	WQEW	New York NY; pop mx, ads, "Radio Disney"	G	0729	3/2	BGM
1560	WQEW	New York NY; R Disney, jingle, pop mx	P/F	0652	6/2	boc4
1560	WQEW	New York NY; Disney slogan & promo	P	0033	12/2	SW
1566		AIR Nagpur, India; news in EE	G	1548	23/1	dxv
1566	UNID	in AA plus jammer, strongest on 150 degrees antenna; Gpks	W	1930	30/1	ss
1570	CFAV	Laval QC; oldies, "Boomer AM 15-70"	G	0852	25/1	dxv
1570	CFAV	Laval QC (presumed); FF EZL mx & talk, mention of Quebec	F	0642	27/1	BGM
1570	CFAV	Laval QC (presumed); record in EE "Magic Moments"	W	0903	31/1	JW
1570	CFAV	Laval PQ (presumed); oldies tunes; French OM	P	0752	1/2	SW
1570	CFAV	Laval QC; FF listener phone in show	W	2246	10/2	BD
1570	CFAV	Laval QC; FF "Boomer AM 15-70"	F	0921	19/2	PC
1570	XERF	Cd. Añuna; SS "Ecos de la tierra por La Poderosa 15-70"	F/Gpks		30/1	ss
1575		VOA Ayutthaya, Thailand; program in Asiatic lang., VOA ID	F	1328	22/1	dxv
1590	WRXB	St Pete Beach FL ; "The best R&B and gospel 24 hours a day, this is 15-90 WRXB", "The new 15-90 WRXB" & "This is the station with the best R&B and gospel - <i>R&B and gospel</i> [echo], the new 15-90 WRXB"	F	0717	16/2	JF
1590	WRXB	St Petersburg FL ; "The new 15-90 WRXB" several IDs between gospel tracks; weak but consistent for nearly 30 minutes; personal first	W	0700	18/2	SW
1590	WAKR	Akron OH; "This has been the 15-90 WAKR 50 seconds"	W/F	0005	30/1	PC
1590	WAKR	Akron OH; ABC NX, "15-90 WAKR Akron" ID & soft pop oldies	W/F	0605	3/2	BD
1590	WARV	Warwick RI; "15-90 AM this is WARV, Warwick, Providence" (unatt recording)	W	0300	31/1	PC
1590	WARV	Warwick RI; "15-90 AM WARV Good Morning"	W/F	1105	2/2	mah
1590	WARV	Warwick RI; religious px, "WARV" ID followed by wx forecast	W	0333	12/2	BGM
1590	WARV	Warwick RI; Back to the Bible. "Life Changing Radio"	W	0229	16/2	JF
1590	WARV	Warwick RI; legal ID	P	0300	19/2	SW
1590	XEVOZ	Radio Reloj, Mexico City; OM/YL with nx & information	W	0808	27/1	BD
1590	XEVOZ	R Reloj, Mexico City; many ID's, generally dominant in pile-up	W	0718	15/2	JF
1590	UNID	English OM with "W???" stormwatch"; second letter likely an "F" or "S" but could not get a positive ID	W	0355	19/2	SW
1590	UNID	With ESPN radio	P	0719	19/2	SW
1593		CNR1, unknown location; OM in CC, // 4800 kHz	F	2003	22/1	dxv
1593		VOA Kuwait; Special English	F/G	0038	7/2	boc4
1600	WMNE	Riviera Beach FL; Radio Disney // others	W	0726	30/1	JF
1600	WAAM	Ann Arbor MI; ID at top of the hour "Talkradio 16 Hundred WAAM"	W	0800	15/2	JF
1600	WWRL	New York NY; "There's more uncompromising talk coming up F on WWRL 16 hundred" (unatt recording)	F	0059	3/2	PC

kHz	Callsign	Station, location; details heard etc	SIO	UTC	Date	Who
1610	CJWI	Montréal QC; FF news mentioning Québec and Montréal	F	2335	9/2	PC
1620	WDHP	Frederiksted, USVI; Caribbean mx, YL with full ID & USA network NX	W/F	0355	26/1	BD
1620	WDHP	Frederiksted, USVI (presumed); Talk Star Radio	F/G	0731	4/2	PC
1620	WDHP	Frederiksted, USVI; studio talk, "Talk Star Radio Network", "You're listening to WDHP American Virgin Islands"	35543	0640	7/2	DX183
1620	WDHP	Frederiksted, USVI; "Talk Star" and telephone number 877 528 Exc 8255 then full ID by YL "You are listening to WDHP...."		0600	15/2	JW
1620	UNID	ESPN Radio, 2 stn listed	W	0606	30/1	RB
1620	UNID	'This is Buffalo County, BJP ??? (frequency) and KTSEK 1620'. Talk programme possibly news items followed. Now I know this all seems rather odd. So far as I can tell there is no W- or KBJP. Sadly the ??? frequency is indecipherable. The 1620 call sign was definitely K something SEK, could be KCSEK or even K3SEK, none of which make sense. KSEK isn't 1620. There's a Buffalo County in Nevada, Wisconsin and also of course NY.; recording accidentally destroyed on minidisk!		0642	18/2	AB
1630	WRDW	Augusta GA; SNR sports talk, "WRDW Augusta" ID & ABC News	W	0555	31/1	BD
1630	WRDW	Augusta GA; news, talks	P/F	0535	5/2	boc4
1630	KRND	Cheyenne WY (presumed); with Spanish programming over a presumed KCJJ with current pops; no evidence of WRDW	W	0730	15/2	JF
1630	UNID	Talk mixing with another talker	W/F	0722	18/2	JW
1635.01	LGV	Hammerfest Coast Radio Station, Norway; extremely rare	W	2310	29/1	SW
1640	WTNI	Biloxi MS (tent); with studio switching problem; transmitting repeating message "CBS Radio Network Channel 42"	G	0739	30/1	SW
1640	WTNI	Biloxi MS; C2C talk show // 1700 kHz	W/F	0740	31/1	BD
1640	WTNI	Biloxi MS; "16-40 WTNI Biloxi" legal ID	F	0000	2/2	PC
1640	WTNI	Biloxi MS; "More sports ... on WTNI"	W	2342	2/2	JF
1640	WTNI	Biloxi MS; ID		0656	18/2	AB
1640	WKSH	Sussex WI; Radio Disney // 1650 kHz	W	0329	6/2	JF
1640	WKSH	Sussex WI; Radio Disney pops // 1680 kHz	vW	0755	6/2	BD
1640	WKSH	Sussex WI; "This is Radio Disney" // 1650 kHz	F	0658	16/2	JW
1640	HI--	R Juventus Don Bosco, Santo Domingo; Christian songs, ID "Radio Juventus Don Bosco en la frecuencia de 1640 kHz, una voz para publicación del amor"	F	0045	26/1	dxv
1640	HI--	R Juventus Don Bosco, Santo Domingo; light mx, SS ID "Radio Juventus Don Bosco, en la frecuencia ... 1,640 kHz"	F/G	0825	28/1	mah
1650	KWHN	Fort Smith AR, tlk, ads "...from KWHN" and into nx	W/Fpks	0551	30/1	ss
1650	KWHN	Fort Smith AR; "it's 43° in downtown Fort Smith at KWHN and now the..."	W/F	0635	30/1	RB
1650	KWHN	Fort Smith AR; C2C talk show & "KWHN Fort Smith USA" ID	F	0757	30/1	BD
1650	KWHN	Fort Smith AR; ID over Disney	W	0357	6/2	JF
1650	WHKT	Portsmouth VA; Radio Disney pops	W	0723	26/1	JW
1650	WHKT	Portsmouth VA; Radio Disney pop mx	F/G	0823	26/1	BD
1650	WHKT	Portsmouth VA; Radio Disney // 1560 kHz	W/F	0008	30/1	PC
1650	WHKT	Portsmouth VA; R Disney "Who Let The Dogs Out" song	F	0007	3/2	JF
1650	WHKT	Portsmouth VA (pres); R Disney // 1560 kHz	F	0040	3/2	SW

kHz	Callsign	Station, location; details heard etc	SIO	UTC	Date	Who
1650	WHKT	Portsmouth VA; Radio Disney, YL schizoid IDs Jingles	P/F	0640	5/2	boc4
1660	WCNZ	Marco Island FL; religious studio discussion (must be 10kW)	F	0750	30/1	BD
1660	WCNZ	Marco Island FL; "Relevant Radio for SW Florida" giving details of both WMYR 1610 and 1660	F	2349	6/2	SW
1660	WCNZ	Marco Island FL; "Relevant Radio" ID, xd WWRU	P/F	0511	7/2	boc4
1660	WWRU	Jersey City NJ (presumed); Korean talk	W	0709	26/1	JW
1660	WWRU	Jersey City NJ; KK language program. At 2200 Radio Korea	G	2155	5/2	PC
1660	WWRU	Jersey City NJ; legal ID "WWRU Jersey City New York 1660 AM WWRU" then programming in Korean?	F	0300	14/2	JF
1660	WGIT	Canóvanas PR; race reports, "La Gigante"	G	2121	23/1	dxv
1660	WGIT	Canóvanas PR; Spanish rap music; "La Gigante" no English legal ID at top of hour; also huge signal at 2359 9/2	G	2300	29/1	SW
1660	WGIT	Canovans PR; plenty of SS rap music and EE music, SS announcements	Exc	2306	8/2	JW
1660	WGIT	Canóvanas PR; "La Gigantic" ID insert between reggaeton songs	F	2314	9/2	JF
1660	WGIT	Canóvanas PR; SS "...desde La Gigante, AM 1660"	F	0001	20/2	PC
1660	WGIT	Canovanas PR; lively Latin rhythms & SS announcements	F	0115	20/2	BD
1670	KHPY	Moreno Valley CA; SS romantic songs "Esta es KHPY 16-70"	W	0730	30/1	ss
1670	WLAA	Winter Garden FL (pres); SS popular music	F/G	0740	19/2	PC
1670	WMWR	Dry Branch GA; discos romanticos	W	0826	26/1	BD
1670	WMWR	Dry Branch GA; Mexican pops	F	0741	13/2	JW
1670	WMWR	Dry Branch GA; lots of "Viva", toth EE ID "WMWR"	S	0700	19/2	AB
1680	WLAA	Winter Garden FL; Mexican rhythms and ballads	W/F	0410	30/1	BD
1680	WLAA	Winter Garden FL; SS tlks	P/F	0515	5/2	boc4
1680	WLAA	Winter Garden FL; SS cultura discurso	W/Fpks	0455	6/2	Rha
1680	WLAA	Winter Garden FL; Mexican music	W	0656	15/2	JW
1680	WLAA	Winter Garden FL; no formal ID, but lots of "Que Buena" slogans		0716	18/2	AB
1680	KRJO	Monroe LA; hot gospel show	F/G	0802	30/1	BD
1680	WDSS	Ada MI; Radio Disney pops // 1650 kHz	W	0745	5/2	JF
1680	WDSS	Ada MI; pop mx // 1560 Radio Disney	W	2201	5/2	PC
1680	WDSS	Ada MI; Radio Disney spots & pops	W/F	0748	6/2	BD
1680	WDSS	Ada MI; Radio Disney programme // 1650 kHz	W	0738	13/2	JW
1680	UNID	non-stop LA music, ex WTTM testing ?	G	2127	21/1	dxv
1690	WWAA	Avondale Estates GA; political discussion	F	0747	30/1	BD
1690	WWAA	Avondale Estates GA; Randi Rhodes Show on Air America	F	2257	30/1	PC
1690	WWAA	Avondale Estates GA; "16-90 Your home for progressive talk"	F	2315	4/2	SW
1690	WWAA	Avondale Estates GA; "Air Atlanta 16-90 weather forecast", xd WPTX	P/F	0502	5/2	boc4
1690	WPTX	Lexington Park MD; "News talk 16-90 AM WPTX Lexington Park" ID & CNN rolling nx	W/F	0830	26/1	BD
1690	WPTX	Lexington Park MD; news, ID	W/F	0728	3/2	JWe
1690	WPTX	Lexington Park MD; "You are listening to Newstalk 16-90 AM, WPTX, Lexington Park	F	2300	7/2	PC
1690	UNID	Plenty of talk and ads –no ID though – suspect WWAA	W/F	0722	18/2	JW
1700	WEUP	Huntsville AL; Gospel singing and then weak WEUV ID	W	2301	30/1	PC
1700	WJCC	Miami Springs FL; FF talk	W	0720	26/1	JW

kHz	Callsign	Station, location; details heard etc	SIO	UTC	Date	Who
1700	WJCC	Miami Springs FL; pleasant French Caribbean mx followed by full legal ID at 0802	F	0757	1/2	PC
1700	KVNS	Brownsville TX; C2C talk show, KVNS ID & Fox News Radio News	W/F	0757	27/1	BD
1700	KVNS	Brownsville TX; "News talk 17-hundred KVNS"	F	2357	29/1	PC
1700	KVNS	Brownsville TX; legal ID	F	0059	4/2	SW
1700	KVNS	Brownsville TX; Coast to Coast, "KVNS Brownsville Newstalk 17-00"	W	0300	5/2	BGM
1700	KVNS	Brownsville TX; news, Public Service Network; xd WJCC and WEUP	P/f	0450	7/2	boc4
1700	KVNS	Brownsville TX; ID "Hear about it, talk about it, News talk 1700 KVNS" then repeated "News talk radio"	F	0757	9/2	JW
1713	LGV	Vardo, Coast Radio Station, Norway; extremely rare with 10-15% copy // 1731 Svalbard	W	2310	29/1	SW
1731	LGS	Svalbard Coast Radio Station, Norway; maritime info in English & Norwegian; 80% copy	F	2310	29/1	SW

Many thanks to the following reporters:

- AB Andrew Brade, East Yorkshire. AOR7030+, Racal RA1772, Sony Minidisc recorder, longwires 90m NW, 150m SW.
- BD Barry Davies, Carlisle, Cumbria. AOR AR 7030 , 130m longwire.
- BGM Brian Martlew, Warrington. AR7030, Wellbrook ALA100 + mini Pennant.
- boc4 Dario Monferini & Giampiero Bernardini, Bocca Di Magra (La Spezia), Italy. AOR 7030, Drake SPR-4, RF Space SDR-14, Ciao Radio H101, Degen 1103, Sangean ATS 909, Grundig Satellite 500, Wellbrook LFL 1010.
- DX183 Wilhelm Herbst, Fjerritslev, Denmark. Loggings made in conjunction with guests Kai-Uwe Scherliess (26/12-2/1), Ronald Hagensen (31/12-8/1), Christoph Meyer (3/1-15/1) and Manfred Manke (8/1-12/1); 21 beverages.
- dxv Michael Schnitzer, Rudolf Schneeberger and Thomas Berner, Sondre Vorupor, near Hanstholm, northern Denmark. 2 x ICOM R75, NRD535G, beverage antennas 270° 300m, 320° 430m, 80° 200m, an EWE and a longwire antenna.
- JF John Faulkner, Sutton-in-Ashfield, Notts. AOR AR7030, Wellbrook ALA1530 loop, EWE antenna, homebrew antenna phaser, Dream DSP-IF filter.
- JW John Williams, Hemel Hempstead. AOR 7030 and 40m long wire.
- JWe Jack Weber, Hertfordshire, WINRADIO G313i, Wellbrook ALA1530.
- mah Martin Hall, Clashmore, Sutherland. NRD-545, RPA-1 preamp, beverages: 513m at 240°, unterminated; 506m at 290°, terminated; 588m at 315°, terminated; 550m at 340°, terminated.; TotalRecorder, Technics RS-BX404 cassette deck.
- PC Paul Crankshaw, Troon, Scotland. AOR AR7030, 3.5x10m EWE, RecALL-PRO.
- RB Renato Bruni, Parma, JRC525, K9AY.
- Rha Ronald Hagensen , Ottersberg , Germany . AOR 7030plus , longwires 22m at 315° and 28m at 290° , beverage 243m at 345° , Mizuho antenna coupler AT-2000.
- ss Stefan Schliephacke, AR7030 (Collins), DX183 Antenna Farm
- SW Steve Whitt, High Catton near York. AOR7030+ and HF225 Europa with dual loop K9AY. Also some time with a 370m NW Beverage from 15/10.

Propagation conditions were good to North America in the last few days of January, and for the first half of February, though rather subdued compared with earlier in the season. Since the middle of February we've had a feel of spring on the bands, with South American stations becoming predominant.

Steve writes: "Though conditions were not spectacular it was nice to catch several "Personal Firsts" even if they were mostly tough to reel in". **Steve** forwarded an e-mail message from **Dario Monferini** with logs that he and **Giampiero Bernardini** made from 5-10 February at Bocca Di Magra. Since the format was not compatible with that for DX Loggings, I've had to re-type the logs and so have excluded logs from North Africa and Turkey; some of the details aren't particularly clear, so apologies if I've introduced any errors whilst re-typing the logs in the MWN format - mah.

John F tells us: "Still enjoying my new EWE antenna and Dream software. It is making a BIG difference to my DXing. The Europeans have, in many cases, just gone! Dream lets me record the entire session too, albeit with rather large file sizes in wav format. 12 hours equates to around 8GB. A quick rendering to mp3 with Audio Catalyst reduces the file down to around 250MB. Conditions not too bad either with several more personal firsts! :0)".

Brian says: "I've made a few changes to the station since last month. First the overnight recording system is now in full swing courtesy of RecAll Pro. This is a very useful piece of software and has already helped to increase the number of "catches" especially as I don't seem to get a great deal of time to actually sit in front of the receiver at the moment. The second change is the addition of a half sized Pennant antenna which I've set up in the loft to evaluate the design - seems to be working very well so far. Signal levels are way down and use of a preamp is essential but it has a very good cardioid pattern and doesn't need a ground connection".

Thomas writes about the German DXpedition to northern Denmark from 21-27 January: "Once again we spent a nice DX-week at Vorupør in Denmark. We had very good openings towards the north American east coast. Our two highlights: On 680 KBRW Barrow became audible one day. It was the first time that we succeeded to receive a station from Alaska. We also were happy to listen to the Japanese station KBC Fukuoka on 1413".

A warm welcome to **Andrew**, who sends in a first contribution, and says a little about himself: "I'm a keen DXer (have been for more than 25 years). A few years ago I turned my attention to transatlantic reception on the MW bands. I'd like to be able to e-mail you the audio (of some of the stations I've heard), but I'm in the process of sorting my computer out. I've just built it, and it can talk to the mini-disc recorder, and can download from it. I can't convert OpenMG files that Sony creates from the MD to MP3 format, but Windows Media Player does seem able to play the Sony format, even though it protests at doing so".

Paul C writes Not a very exciting month. Mind you I had thought for several nights recently that conditions were poor - when I decided, at the weekend, to check the antenna I found water had got into the coax! Things are better now"! In a similar vein, **Jack** says: "Almost nothing to report this month, I'm afraid. Mostly poor conditions and lack of time have been to blame".

Stefan: I'm back from DX183 and was there from 28/1 until 6/2. Two days prior my arrival there seemed to be a huge sun burst. I did my 110 RRs a 70 pc MW and LF, but condx been what I'd call instable. Instable in the way the changed rapidly regarding reception target and also came in and went away very quickly. Nevertheless I had some good catches from Asia (mainly) while TA did not show up with West Coast and Alaska and Southern America was not there as well".

Wilhelm writes: "WLIB broadcast every Saturday between 12 AM and 05 AM local New York time a French programme for the Haitian community which is called "Moment Creole". It is hosted by Stanley Barbot. The web address of WLIB: www.wlib.com. I thank Ydun Ritz, Vojens, Denmark for their great help to clear this fact". Once again I have only been able to include a selection of the 6 pages of logs that Wilhelm sent me from DX183, and a contribution received after the deadline will be held over until next month - mah

The **deadline** for the April DX Loggings is **Monday 20th March**. I look forward to receiving your logs by then, preferably electronically/via e-mail using the Word pro-forma, which I can supply on request. Please remember that I don't automatically include loggings sent to the MWC e-List, so please copy me separately if you would like them included in DX Loggings.

73's Martin

VERIFICATIONS SECTION

✉ 59 Moat Lane, Luton, Bedfordshire LU3 1UU, UK

with Clive Rooms

e-mail: verifications@mwcircle.org ☎ 01582 598989

Station	kHz	A	B	C	who	Station	kHz	A	B	C	who
CFRA Ottawa ON	580	lt	ret	24	GS	R Vision Cristiana	530	lt			HR
CHTN Charlottown PEI	720	e		28	HR						
CHCM Marystown NF	740	e		35	HR	<u>UAE</u>					
VOWR St John's NF	800	cert	\$1	14	GS	R Farda	<u>2</u> 1575	ppc			JR
CKDQ Drumheller AB	910	e		14	HR						
CKNX Wingham ON	920	lt	ms	26	BD	<u>UK</u>					
CHUM Toronto ON	1050	lt		7	HR	Queens R Belfast	1134	e		5	MaH
CBA Moncton NB	1070	lt		28	HR						
CBA Moncton NB	1070	lt	\$1	39	GS	<u>USA</u>					
CHMB Vancouver BC	1320	e		14	HR	WLW Cincinnati	700	e		21	HR
						WGN Chicago IL	720	cd		14	HR
<u>Czech Rep</u>						WCCO Minneapolis MN	830	cd		28	HR
CRo1	270	cd	no	14	JR	WWL New Orleans LA	870	cd		28	HR
						KPTK Seattle WA	1090	e		21	HR
<u>Dominican Rep</u>						WBAL Baltimore MD	1090	e		10	HR
R Juventus Don Bosco <u>1</u>	1640	lt		26	GS	KFAB Omaha NE	1110	e		21	HR
						WHBY Kimberly WI	1150	lt		14	HR
<u>Taiwan</u>						WYLL Chicago IL	1160	lt		28	HR
Voice of Han	846	cd		49	MvA	WNAM Neenah WI	1280	lt		28	HR
						KSTP St Paul MN	1500	e		21	HR
<u>Turks & Caicos</u>						KKAY White Castle LA <u>3</u>	1590	lt	ms	86	BD

A= what was received; B= what return postage was sent; C = days to get a reply

Notes:

- 1 Needed a follow-up reception report.
- 2 Behruz Kikzat, Radio Farda, Suite 400, 1201 Connecticut Ave. NW, Washington, DC 20036.
- 3 Barry reports that this one was inadvertently running day time power of 1000w when Barry heard it! The station also sent a couple of Cajun music CD's, stickers and a coffee mug!

Verification Signers

CKNX-Bill Townsend, Engineering

CBA-Bonnie Porter-Belliveau, Audience Relations

KKAY-Harry Hoyler, Station Manager

CFRA-Harrie Jones, Station Engineer

VOWR-John C Tessier, Station Manager

Queens R-Paul Kelly, Systems Admin.

Contributors

Thanks to the following: BD-Barry Davies, MvA-Max van Arnhem, GS-Guido Schotmans, HN-Hannu Romppainen, MaH-Martin Hall, JR-Jim Renfrew in NY, USA.