

**WPOE**  
**AM 1520**

Kermit Geary  
RD #4 Box 321  
Walnutport, Pa. 18088

Dear Kermit -

This is to confirm  
your SWR report of  
WPOE March 7 6:01-6:05 AM  
1981 - We are a directional  
(due East) 10 KW (Class II D)  
AM Broadcast Station, and  
So your hearing us under WKBW  
is quite a feat, since you would  
be in one of our deepest nulls -

Sincerely Yours

Jim Heringway, Chief Engineer

**POET'S SEAT BROADCASTING, INCORPORATED**  
154 FEDERAL STREET/ GREENFIELD, MASSACHUSETTS 01301/ (413) 774-2717

Transmitter at SAUGUS, MASS.  
1000 Watts • 830 KC

# STATION WHDH

MATHESON RADIO CO., Inc.

Office and Studios: HOTEL TOURAINE, BOSTON, MASS.

Corner Boylston and Tremont Sts.

Phone: Hancock 0900

January 18, 1938

Kermit Geary  
R. F. D. # 2  
Walnutport  
Pennsylvania

Dear Sir:

In answer to your letter of Jan. 9th we are glad to verify your reception of Station W H D H on the 8th of January, 1938, between approximately 5:15 and 5:30 p.m. E. S. T.

Hoping you continue to receive our programs, we are

Sincerely yours,

Station W H D H

*A. J. Matheson*

J.

Commercial Department



443 CONCORD AVE - CAMBRIDGE MA 02138

Hello Kermit —

Thanks for your wonderful reception report. Enclosed are some goodies for you. The booklet is from 1993, and is rather out-of-date; but I'm sure you'll enjoy it.

Best Wishes —  
Bob

P.S.  
WANNA TRY FOR WJTD'S 28-WATT SIGNAL AFTER SUNSET? I GET IT 120 MILES AWAY EASY!!

**Easy As The Breeze.... in Boston**

BOB BITTNER BROADCASTING, INC - 617-868-7400

717 MAIN STREET  
FITCHBURG, MASS.  
PHONE 1600



MEMBER:  
YANKEE NETWORK  
COLONIAL NETWORK  
NATIONAL ASSOCIATION  
OF BROADCASTERS

AFFILIATE: MUTUAL  
BROADCASTING SYSTEM

November 28, 1941

Mr. Kermit Geary  
R.F.D. #2  
Walnutport, Pennsylvania

Dear Mr. Geary:

Thank you very much for your communication concerning our  
DX Program of Monday, November 24, 1941.

Your report of the Program is correct, and your interest  
is sincerely appreciated.

Very truly yours

WEIM -- Fitchburg, Massachusetts.

By:

*Larry Roberts*

1090 ON YOUR DIAL

RADIO STATION **WBMS**

BROADCASTING THE WORLD'S MOST BEAUTIFUL MUSIC

OFFICE: 16 COURT STREET  
BOSTON 8, MASSACHUSETTS  
TELEPHONE LAFAYETTE 1666

1000 WATTS OF POWER 7 A.M. 'TIL SUNSET

February 13, 1947.

Mr. Kermit Geary,  
R. F. D. 2,  
Walnutport, Pennsylvania.

Dear Sir:

Thank you for your letter regarding reception of our program from WBMS. We wish to confirm your log of our programs on February 2, 1947 from 4:42 to 5:15 P. M., E. S. T. We feel that you might like to see one of our program schedules, so we are enclosing one.

Very truly yours,



Merle Towle  
Chief Engineer

MT:dw  
Enc.

**W N A W**

20 STATE STREET  
NORTH ADAMS, MASS.  
TELEPHONE 860

Sept. 26, 1949

Kermit Geary  
R.F.D.#2  
Walnutport  
Penn.

Dear Mr. Geary:

I was very happy to receive your very nice letter, and also pleased to find out that we get out so well.

Your log of program material is correct for Sept. 20, 1949

If you are ever up in this section of the country drop in and look over our installation.

Thank you again for your letter ,

Best of Luck and DX'S.

Yours very Truly

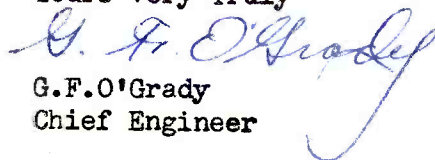

G.F.O'Grady  
Chief Engineer

# THE YANKEE NETWORK

DIVISION OF GENERAL TELERADIO, INC.

21 BROOKLINE AVENUE  
BOSTON 15, MASSACHUSETTS

January 25, 1955

Mr. Kermit Geary  
R.F.D. #2  
Walnutport  
Penna.

Dear Mr. Geary:

In reference to your letter of January 20, 1955,  
this is to verify your reception of WNAC from  
2:59 to 3:32 AM, Eastern Standard Time on the  
morning of January 20, 1955.

Thank you for your interest.

Very truly yours,

*I. B. Robinson*

I. B. Robinson  
Technical Director

IBR:md



WRKO AM • FM

21 BROOKLINE AVENUE • BOSTON, MASSACHUSETTS 02215 • 617-266-0800

January 6, 1968

Kermit Geary  
R.D. 2, Box 298  
Walnutport, Pa. 18088

Dear Mr. Geary:

This is to verify your reception of radio Station  
WRKO-AM, Boston, Massachusetts.

We are always more than happy to receive these re-  
ception reports.

Thank you for your time and interest in our station.

Keep listening.

Sincerely,

A handwritten signature in cursive script that reads "G.J. Capalbo".

G.J. CAPALBO  
ENGINEER IN CHARGE OF RADIO  
WRKO-AM-FM

GJC:pgf



Studio and Offices  
ACADEMY BUILDING

# WSAR

Telephones 7-9477 - 7-9478  
FALL RIVER, MASS.

ESTABLISHED 1921

1480 KILOCYCLES 1000 WATTS

Affiliated With  
MUTUAL-YANKEE  
NETWORKS

May, 5, 1948

Mr. Kermit Geary  
R.F.D No. 2  
Walnutport, Pennsylvania.

Dear Mr. Geary;

The management and staff of Station WSAR takes pleasure in informing you that you have won first prize of fifteen dollars in the DX program contest aired over this station on April 19th. We felt that your technical data and program suggestions were excellent and we appreciate the interest you have shown in the broadcast.

You may be interested to know that the other winners, of ten and five dollars respectively were as follows:

Lloyd J. French  
162 Englewood Ave.  
Elmwood 10, Conn.

and Bill Stone  
436 Sherbourne St  
Toronto 5, Ont. Canada

We hope that we may be able to serve you in the future and that you will show continued interest in station WSAR.

Sincerely yours

*Melvin Lahr*

Melvin Lahr  
Station Manager

BROADCASTING STATION

WCOP

Commonwealth 1717

MASSACHUSETTS BROADCASTING CORP.  
STUDIOS and OFFICES... COPLEY PLAZA HOTEL  
BOSTON, MASSACHUSETTS

Member National Association of Broadcasters

500 Watts Power

1120 Kilocycles - - 267.7 Meters

December 18th

I 9 3 5

Mr. Kermit Geary  
R. F. D. #2  
Walnutport, Pa.

Dear Sir:

This letter will serve as verification of the program which you heard broadcast from this station on November 30, 1935. Your comments are greatly appreciated.

Very truly yours,  
Massachusetts Broadcasting Corp.

*W. N. Hall*  
W. N. Hall  
Station Engineer



400 COMMONWEALTH AVENUE

BOSTON 15, MASSACHUSETTS

COPLEY 7-3005

EXECUTIVE OFFICES

PETER P. THEB  
WILDMANAGER

March 14, 1958

Kermit Geary  
R.D. 2, Box 298  
Walnutport, Pa.

Dear Kermit:

This will confirm your reception of WILD March 2,  
1958.

We appreciate your complete report on receiving  
conditions particularly considering the distance from  
Boston and the proximity of WBAL.

Sincerely,

A handwritten signature in cursive script that reads "Donald L. Snider".

Donald L. Snider Ch. Engr.

# WUNR

275 TREMONT STREET  
BOSTON, MASSACHUSETTS 02116

5000 WATTS - 1600 AM

TEL. (617) 357-8677

January 24, 1978

Kermit Geary  
R. D. 2 Box 298  
Walnutport, Pa. 18088

Dear Mr. Geary:

This is to confirm your reception of our AM station WUNR.

We are pleased that you enjoyed hearing our broadcast.  
Your letter and report on our programming is much appreciated.

Thank you for your interest in WUNR Radio.

Cordially,

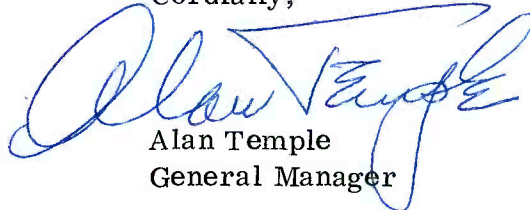

Alan Temple  
General Manager

AT/lm

# THE YANKEE NETWORK

TELEPHONE 6-1411

STATION WAAB  
STATE MUTUAL BUILDING  
WORCESTER, MASS.

February 16, 1944

Mr. Kermit Geary  
R.F.D. #2  
Walnut port  
Pennsylvania

Dear Mr. Geary:

Thank you for your letter of February 5.

The programs you mentioned were all  
heard over WAAB February 4.

Yours very truly,

*Dorothy B. Robinson* *m.s.*

(Mrs.) Dorothy B. Robinson  
Station Supervisor

DBR/ms

# W D E W

WESTFIELD, MASS.

October 8, 1957

Mr. Kermit Geary  
R.D. 2, Box 298  
Walnutport, Pa.

Dear Mr. Geary:

Thank you very much for your comprehensive letter reporting the reception of WDEW during our equipment test October 1, 1957. Confirmation is hereby acknowledged. Your report coincides with our log.

The worthwhile information contained in your letter is certainly appreciated and it is good to know that we will be so well received in Walnutport, Pennsylvania.

Sincerely,



Albert L. Capstaff

alc/eps



WTTT / THE VOICE OF COMMUNITY SERVICE / AMHERST MASSACHUSETTS

*November 12, 1963*

*Mr. Kermit Geary  
R.D. 2, Box 298  
Walnutport, Penna.*

*Dear Mr. Geary:*

*This letter will serve as confirmation that your logging of the WTTT signal on October 22, 23, and 25 is in substantial agreement with the official station logs of those dates.*

*Thank you for your best wishes.*

*Very truly yours,*

*Aug. L. Cavallaro*

*Augustine L. Cavallaro  
General Manager*

W H I L  
1540 KILOCYCLES  
CONANT BROADCASTING COMPANY, INC.

99 REVERE BEACH PARKWAY  
AT THE MALDEN RIVER BRIDGE  
MEDFORD 55, MASSACHUSETTS  
MYSTIC 8-2250

January 29, 1952

Kermit Geary  
R.F.D. #2  
Walnutport  
Pennsylvania

Dear Sir,-

This is to verify your report on our  
equipment test on January 5 at 3:16 A.M.  
According to our logs your report is on the beam.  
Thank you very much for time and report.

If ever your in this vicinity we would  
be very happy to see you.

Once again thank you and "Good Luck".

Very truly yours,

*Sal Fulcherio*



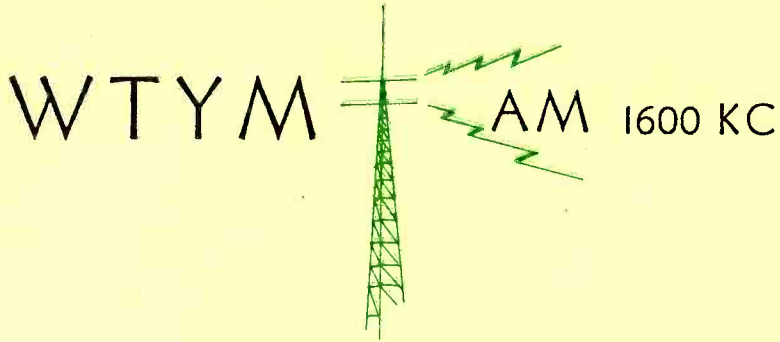

EXECUTIVE BROADCASTING CORPORATION

P. O. BOX 857

E. LONGMEADOW, MASS.

REPUBLIC 7-4707

January 6, 1962.

Mr. Kermit Geary  
Walnutport Pa.

Dear Sir:-

This will acknowledge your letter to our station dated December 24, 1961.

Thank you very much for your letter containing so much interesting information regarding the signal of WTYM as received at your home (QTH).

This letter was of such interest that I forwarded your communication to our New York office for their reading.

Kindly accept this letter as confirmation of your reception of WTYM on the 24th, December 1961.

Very truly yours,

Earle G Hewinson

Chief Engr. WTYM.

A handwritten signature in cursive script, appearing to read 'Earle G. Hewinson', is written below the typed name.

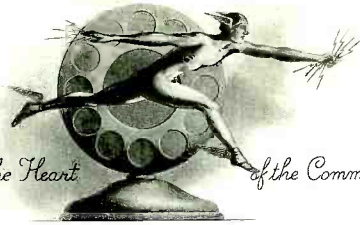

*The Voice from the Heart of the Commonwealth*

**WTAG**

RADIO STATION

OWNED AND OPERATED BY THE  
WORCESTER TELEGRAM AND GAZETTE

WORCESTER, MASS.

OFFICE OF THE  
MANAGING DIRECTOR



March 13, 1935.

Kermit Geary,  
R.F.D. #2,  
Walnutport, Pa.

Dear Sir:

Thank you for your letter of recent date notifying us that you heard WTAG on Sunday morning March 10th at 1:00 AM, Eastern Standard Time, at which time we were broadcasting the "Let's Dance" program.

WTAG broadcasts regularly on a frequency of 580 kilocycles daily, from 8:00 AM to 12:00 midnight; Saturdays 8:00 AM to 1:30 AM and Sundays 10:00 AM to 12:00 midnight.

This letter will serve as a verification of your reception.

Very truly yours,

*John J. Storey*  
John J. Storey  
Managing Director.

JJS/MMc



October 10, 1991

Kermit Geary  
1266 Riverport Drive  
Walnutport, PA 18088

Dear Kermit:

Thank you for your letter of October 1. Yes, Kermit, we did broadcast the programs and elements mentioned in your reception report.

Enclosed is our most recent program guide to confirm what you heard on the air.

It is always a pleasure receiving and reading letters from listeners. I would encourage you Kermit, to become a regular listener to our station. You will find the programs and music we broadcast inspiring, educational and life-changing if you will just spend time daily listening to WVNE.

Thanks again, Kermit, for your letter. Feel free to contact me at WVNE anytime in the future. Also, feel free to come by for a tour during office hours Monday through Friday. If you called ahead we would appreciate it.

Sincerely,

A handwritten signature in cursive script that reads "Steve Tuzeneu".

Steve Tuzeneu ('TOO-'zeh-new)  
Operations Manager

Enclosure



Dear Overseas Listener:

Thank you for your correspondence regarding hearing our radio station. After reviewing your reception report, I would like to confirm that you did hear our radio station. We are pleased to hear from listeners overseas. Attached please find a program guide and some information about WNRB 1510 AM.

Have a happy and safe holiday season!

Sincerely,

A handwritten signature in black ink that reads "R. Miller".

Rose Miller

500 West Cummings Park • Suite 2500 • Woburn, MA 01801

Phone: (617) 932-9672 (WNRB) • Fax: (617) 932-7359

*"A Communicom Station"*



February 18, 1994

Mr. Kermit Geary  
1266 Riverview Drive  
Walnutport, PA 18088

Dear Mr. Geary,

Thank you for your recent letter. I appreciate your reception report and comments about WNNW's signal and quality. Dx listeners like yourself are very important to the radio community, and you should be complemented on your efforts.

Thank you for taking the time to listen .

Keep an Ear to the Air,

A handwritten signature in blue ink, appearing to read 'Patrick J. Costa', with a long horizontal flourish extending to the right.

Patrick J. Costa  
WNNW Radio  
Costa Communications

PC/sag

**SPORTS  
RADIO WVEI**  
**1440 AM WORCESTER**

November 29, 1993

Kermit Geary  
1266 Riverview Drive  
Walnutport, PA 18088

Dear Kermit,

I am happy to confirm your reception report of WVEI on September 21, 1991. We were issued new call letters for WVEI effective September 3, 1991 when we began simulcasting WEEI 590 kHz from Boston. Prior to that the call sign was WFTQ.

WVEI is 5,000 watts Day and Night with a non-directional pattern day and a directional pattern at night. We moved our studios to Westborough from Worcester in March of 1992. Thank you for your detailed reception report.

Eric Fitch



Chief Engineer  
WVEI



THURSDAY, JULY 11, 1996

MR. KERMIT GEARY  
1266 RIVERSIDE DRIVE  
WALNUTPORT, PA 18088

TO WHOM IT MAY CONCERN-

IN MEETING WITH KERMIT GEARY ON THIS DATE, AND LISTENING TO HIS CASSETTE TAPE RECORDING OF HIS, I HAVE DETERMINED THAT WHAT HE HEARD IN WALNUTPORT, PA AND WHAT I HAVE HEARD FROM HIS TAPE RECORDING, WAS IN FACT WHMP 1400 AM AT 1kw on MONDAY EVENING, DECEMBER 11, 1995.

MAY THIS BE OFFICIAL CONFIRMATION OF MR. GEARY RECEIVING WHMP AM 1400!

THANK YOU,

A handwritten signature in blue ink, which appears to read "J. Campbell", is written over the "THANK YOU," text.

Jim Campbell  
WHMP-AM Assistant  
Program Director & Public  
Service Coordinator/Director

Post Office Box 268  
15 Hampton Avenue  
Northampton MA 01061  
(413) 586-7400  
(413) 585-0927 (FAX)

Michael J. Klein, NV1L  
POB 2181  
Lynn, MA. 01903  
USA

April 26 1990

Kermit Geary  
1266 Riverview Dr.  
Walnutport, PA. 18088

Dear Mr. Geary,

I am very pleased to verify your reception report of Medium Wave Broadcast Station WILD, heard on 1090 kHz., 22 January, 1990, at 02:00 to 02:30 EST (07:00 to 07:30 UTC). Thank you for your response to our test.

The test was not without a visit from Murphy! You may have noticed a "squealing" of sorts during breaks in the audio during the first portion of the test. This was the result of RF feedback into the mixer used for the test! It was several minutes before the problem was solved. Also, circumstances being as they were, we transmitted a 400 Hz. tone instead of a 1 kHz. tone as usual.

This DX test would not have been possible without the efforts of Chief Engineer, Grady Moates. Grady and I conducted the test at the transmitter site, as opposed to the studio, so the transmitter could be excited directly, and the waveform monitored for optimum modulation. Grady has been very supportive of many aspects of Amateur Radio and DXing in general, and his contributions to our hobby are greatly appreciated.

Some DXers have asked about me, and my role with WILD. I hold the Amateur Extra Class Licence and my personal callsign is NV1L. I have worked for Grady as a contract engineer for about nine years, during which time we built the new studio complex for WILD. My Amateur Radio hobby is CW DXing, and my home station includes a Yaesu FT 757GX transceiver and a 3 element triband (18 foot boom) Yagi antenna for 10, 15, and 20 meters operation which is mounted on a guyed roof tower and rotator at 65 feet above street level.

The above address is my personal QSL Box number, so if you would like further information please drop me a line. Since this test was conducted independently by myself and Grady, all requests for memorabilia have been forwarded to the station management. Thanks for your patience while waiting for verification.

Wishing you the best of reception

& 73,

(Got your correction for WADN)







Easy favorites of yesterday and today.

500 West Cummings Park  
Suite 2500  
Woburn, Massachusetts 01801  
617 938 0660



-- CONFIRMATION OF RECEPTION --

NAME: KERMIT GEARY  
ADDRESS: 1266 RIVERVIEW DRIVE  
WALNUTPORT, PA 18088

DATE OF RECEPTION: 9/6/89 | 9/9/89  
TIME OF RECEPTION: 5:35-6:03 | 19:55-20:45

CONFIRMATION CERTIFIED BY:

JOHN D. KENNEDY  
WKKU-AM CHIEF ENGINEER

--- THANKS FOR TUNING US IN !!! ---



**MEMO TO:** Kermit Geary

**DATE:** 1/9/89

**FROM:** Peter Q. George, Station Engineer

**RE/SUBJ:** DX Report

Hi Kermit,

It was really nice to hear from such a seasoned DX'er, such as yourself. The signal you heard was indeed WBET/1460. I myself have heard WCMB while at my home QTH while using a Field Strength Meter and nulling out WBET.

It was really a great piece of nostalgia hearing from someone who heard and actually remembered our interim 990 kHz operation back when WBET was using the silent facilities of the late WBKA until our own 1460 kHz operation was being completed. The 990 kHz operation was intended to just get us on the air until we could go fulltime on 1460 kHz. You may be interested to know that the Fuller family still owns and operates WBET and sister station WCAV-FM Stereo 97.7. Myron Fuller, son of the late Charles A. Fuller is the President of The Enterprise Publishing Company, parent company to WBET/WCAV-FM.

Could you possibly make me a photocopy of your 1946 verification of WBET. I'm sure it would be of personal <sup>value</sup> to both myself and the Fuller Family. I realize this is a rather big request, but it would be most appreciated.

Thank you again, Kermit, for a great report. I hope you continue DX'ing for another 55 years. Thanks for a trip down "Memory Lane". If you are ever in the Brockton area please stop by and let's gab about old time DX'ing.

By the way, I've been DX'ing for <sup>over</sup> 20 of my 29 years.

Best wishes,

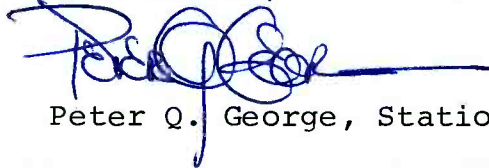

Peter Q. George, Station Engineer

**WBET**  
60 Main Street  
P.O. Box 787  
Brockton, MA 02403



AM 1460 • 60 MAIN STREET • P.O. BOX 787 • BROCKTON, MA. 02403 • (617) 587-2400

DATE: January 9, 1989

WBET (AM), 1460 kHz in Brockton, Massachusetts is pleased to confirm your reception of our signal on 1/2/89 at 0100-30 E.S.T./ ~~XXXXX~~.. WBET operates 24 hours a day, 7 days a week on 1460 kilohertz with 5,000 watts non-directional during the day and 1,000 watts directional at night, with the maximum lobe of the pattern aimed to the southeast of the City of Brockton.

Our transmission system, located in nearby West Bridgewater, consists of a Harris SX-5A connected to an antenna phasor unit (active only at night) and two self-supported towers of nearly 300' in height. Our FM Stereo sister station, WCAV-FM (97.7 MHz) has a 3-bay array mounted atop our eastern tower, with an E.R.P. of 3,000 watts.

I hope that this information is of interest to you. As a fellow DX'er, I wish you continued success in your future DX efforts. Best wishes and 73's.

Sincerely,

Peter Q. George (K1NHJ)  
Station Engineer, WBET/WCAV-FM

**WBET**  
60 Main Street  
P.O. Box 787  
Brockton, MA 02403



# WCRN 830 AM

Carter Broadcasting

March 7, 1995

Dear Kermit:

I just wanted to thank you for your interest in WCRN and verify that you did hear "The all new stereo AM 830 WCRN". We signed on the airwaves on December 5th and have been running twenty-four hours since. We are 7,000 Watts during the daytime hours and 5,000 after sundown. This is the first time I have started a station from scratch and I have to admit that it is not an easy task.

If you have any other questions about WCRN or radio stations in the Massachusetts area, feel free to contact me at (508) 792-5803. Thank you for taking interest in WCRN and good luck in the future.

Sincerely,

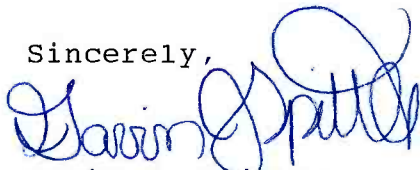

Gavin J. Spittle  
Program Director WCRN-AM 830

# WBIV RADIO

---

1105 COMMONWEALTH AVE., SUITE 204  
BOSTON, MA 02215  
PH. (617) 562-0620

Robert L. Tarpin  
Station Manager

May 4, 1993

Kermit Geary  
1266 Riverview Drive  
Walnutport, PA.  
18088

Dear Kermit,

The intent of this letter is to verify your reception of WBIV. According to our program logs, you have indeed received transmission of WBIV on Monday, March 29 of 1993 from 12:56am to 1:04am, EST. You have also received our signal on Tuesday, March 30 of 1993 from 1:18am to 3:12am.

WBIV is located at 1060 on the AM dial, and transmits at 25,000 watts day time, and 1,000 watts night time.

I hope the above was adequate for verification, and I wish you much luck with your hobby!

Very truly yours,



Robert L. Tarpin

**WBIV**

BOSTON'S INSPIRATIONAL VOICE

Kermit,

Sept 12, 1988

Good to see you in  
Boston. I hope you enjoy  
your stay, and stay in  
touch

Don Joscoe

P.S. This will confirm your  
reception of W.B.I.V. in  
Walnutport

BOSTON COUNTRY



RADIO 1330 AM

1/28/81

Dear Mr. Geary

I am verifying your reception of WDLW  
on 3/2/80 - your log matches ours

Sincerely,

Duncan Stewart  
Music Director





**Douglas Broadcasting**  
197 8th St. Suite 500  
Boston, MA 02129

July 11, 1996

Mr. Kermit Geary  
1266 Riverview Dr.  
Walnutport, PA 18088

Dear Mr. Geary:

I enjoyed your visit to WBPS' studios yesterday. I apologize that I was unable to spend more time with you. I have listened to the tape you left for me, and I wanted to send this letter to further confirm that you did, in fact, hear ~~WBMA~~ on November 14, 1994.

Once again, thank you for stopping by, and thank you for your interest in WBPS.

Sincerely,

A handwritten signature in black ink that reads "Patrick Tangney". The signature is written in a cursive style with a large, prominent initial "P".

Patrick Tangney  
Chief Board Operator



November 6, 1995

Mr. Kermit Geary  
1266 Riverview Drive  
Walnutport, PA 18088

Dear Kermit:

We received your letter today regarding your having been listening to WBPS on October 28, 1995 beginning at 5:42 PM. Based on your description of the programming you heard, you did in fact receive WBPS which broadcasts at 890 on the AM dial.

At the time you logged our radio station we were broadcasting at 25,000 watts of power.

We wish you well with your listening, and thanks for your letter,

Best regards,

  
Jeff Dorf  
General Manager

JD/hs



# WACM - ETHNIC COMMERCIAL RADIO

JACK & CARMEN SILVA  
34 SYLVAN STREET  
WEST SPRINGFIELD, MA 01089  
781-5200/1 - 781-WACM

Kenneth Geary  
Walnutport, PA

Dear Sir,

This confirms your reception of  
WACM "Radio Amor" on March 20, 1988  
at 7:01 P.M.

Sincerely,  
Jack Silva Presd.

1340 Kc.

# WGAW

1340 Kc.

4 PLEASANT STREET  
GARDNER, MASSACHUSETTS

*Mr. Hermit Geary  
Helmetsport Pa.  
Dear Mr. Geary,*

*January 21, 1954*

We have checked the information given us in your recent letter and are very happy to verify your reception of our special test program broadcast from 4:15 AM to 4:48 AM, Monday, January 18, 1954.

WGAW is one of the KBR Stations of New England and operates with a power of 250 watts on a carrier frequency of 1340 Kcs. We are affiliated with the American Broadcasting Company and carry all the important ABC programs, together with local sports and events, plus disc jockey presentations. Regular operating time is from 6:30 AM to 11:30 PM.

The transmitter is a General Electric BT-20-A Broadcast Transmitter with two 125 watt tubes in the final using high level modulation. Antenna is a 150 foot tower, uniform cross section, series excited. Ground system consists of 120 radials 150 feet long of buried copper wire.

Operation of the transmitter is entirely by remote control from our studios located in the heart of the business district of Gardner, Massachusetts. Remote control equipment was manufactured by the Rust Industrial Company of Manchester, N.H., and enables us to turn the transmitter on and off, read all necessary meters, turn controls up or down to adjust voltages, antenna loading, switch circuits for network programs, etc. A telephone type dial, one switch and one meter comprise the controls at the studios. In case of failure of the control circuit the transmitter is shut off within three seconds.

Your report of the reception of WGAW is greatly appreciated, and the response to the program has been far beyond our expectations. To date we have received letters from listeners as far south as West Virginia, west to Nebraska, and north to Northern Quebec.

Very sincerely yours and 73s

*Gordon V. N. Wiley*

GORDON V. N. WILEY, Engineer  
(Also operator of WLAUN since 1927)

him

*P.S. You apparently have a fine receiving location and equipment, your report was the most complete one we have received from your area.*

*True  
Gordon*

860 on every  
radio dial

THE POWERFUL RADIO VOICE OF ALL THE BERKSHIRES

WSBS

Offices and Studios  
Route 7, Great Barrington, Mass.

Studios in Lee, Mass.,  
and Canaan, Conn.

December 17, 1957

Mr. Kermit Geary  
R.D. 2, Box 298  
Walnutport, Pennsylvania

Dear Mr. Geary:

This will serve as verification of your reception of WSBS on December 6, 1957, from 5:58 to 6:30 AM. We have checked our program log for that day and find the information which you furnished was correct.

I am sorry to have taken so long in answering you, but the Christmas season starts about November 1st as far as radio is concerned, and we're not quite sure what mail gets answered, or when.

Best wishes for the holidays, and many thanks for your kind words.

Sincerely,

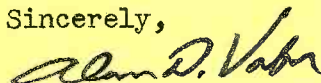

Alan D. Vaber  
Program Director

34 Mechanic Street • Worcester, Massachusetts 01608 • (617) 755-1444

WFTQ



14 FEB 1978

KERMIT GEARY  
R.D. 2, BOX 298  
WALNUTPORT, PA. 18088

DEAR KERMIT:

THIS IS TO CONFIRM YOUR RECEPTION OF WFTQ ON 2 JAN 1978  
FROM 1:40 TO 2:07 AM EST. YOUR LOG AGREES WITH OURS.  
THANKS FOR THE REPORT.

SINCERELY;

A handwritten signature in blue ink that reads "Stanley K. Jarvis". The signature is written in a cursive, flowing style.

STANLEY K. JARVIS  
CHIEF ENGINEER

SKJ



SERVING THE SOUTH SHORE  
1000 WATTS AT  
QUINCY, MASSACHUSETTS

JOSEPH H. TOBIN, PRES.  
JAMES D. ASHER, TREAS.

September 11, 1947

Telephone **1300** ON YOUR  
MAYFLOWER - 9 DIAL

Mr. Kermit Geary  
R.F.D. #2  
Walnutport, Pennsylvania

Dear Mr. Geary:

It was nice to have your letter of September 7th, and to learn that our signal reached you in such excellent quality. We here at WJDA are happy to have you among our valued charter listeners.

We will be standing by for your regular reports as we are now on the air daytime only.

Very sincerely yours,

James D. Asher/ij

RADIO 1170

**WJCC**

102 Pond Street, Norfolk, Massachusetts 02056 • (617) 384-2124

December 22, 1983

Mr. Kermit Geary  
1266 Riverview Drive  
Walnutpott, PA 18088

Dear Mr. Geary:

It gives me great pleasure to confirm your reception of WJCC December 2, 1983 from 7am until 7:11AM. We are currently operating with 1000 watts on 1170 KHZ, with a two tower directional antenna. Our major lobes are north and south, with nulls toward the east and west to protect WTTT Vernon, Ct. and WLIC, Orleans, Ma. Your reception is especially remarkable due to the close proximity to WWVA at your location.

Sincerely,

  
Steven J. Callahan  
Chief Engineer

*When you're in the Taunton area, listen to RADIO 1570 WPEP*



# THE NEIGHBORHOOD STATION

GET THE **WTAO** HABIT

740 KILOCYCLES

250 WATTS

Telephone ELiot 4-6745

---

447 CONCORD AVENUE

CAMBRIDGE 38, MASS.

---

29 November 1948

Mr. Kermit Geary  
R.D. #2  
Walnutport, Pennsylvania

Dear Mr. Geary:

Your nice letter of November 24th has just come in, and I am indeed pleased to be able to verify your reception of our AM Broadcasting Station operating on 740 kilocycles. We here at WTAO certainly appreciate the kind of report you have sent us, as it aids our engineering perspective on the coverage pattern of our station.

This is the most distant report we have received on our daytime programming and is probably due to wintertime sky wave propagation conditions.

I again want to thank you for your detailed report, as it is a very considerable help in understanding the propagation conditions we are getting on 740kc and also the interference conditions which we are meeting.

Very truly yours,

MIDDLESEX BROADCASTING CORPORATION

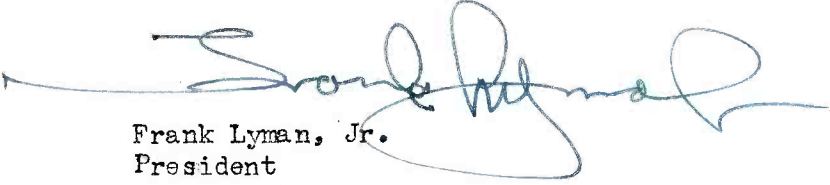
  
Frank Lyman, Jr.  
President

FLJR:dw

---

SERVING MIDDLESEX COUNTY WITH BOSTON AS A BONUS

---

1470 ON YOUR DIAL . . . 1000 WATTS

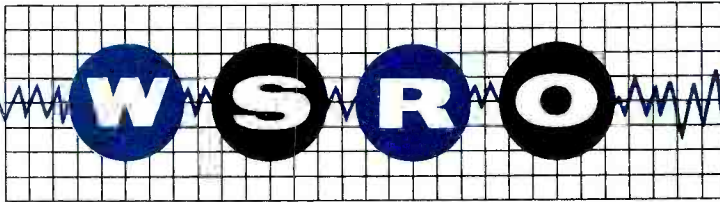

OWNED AND OPERATED BY COUNTY BROADCASTING CORPORATION

*Marlboro, Massachusetts*

OFFICES AND STUDIOS AT CURTIS AVE.

January 25, 1960

Mr. Kermit Geary

R.D. 2 Box 298

Walnutport, Pa.

Dear Mr. Geary:

Your very fine report of our January 18th. test transmission, is verified by our operating log. The items listed as broadcast between 4:30 AM and 5:00 AM E.S.T. are all correct. Out of about 20 reports recieved to date; the farthest was from Len Kruse, 816 Euclid Street, Dubuque, Iowa; 2 were from the Chicago area, one from Proctorville, Ohio; several from Pennsylvania. We might have recieved some from west of Iowa except XESM in Mexizo, with 5000 Watts was operating on 1470 K.C.

Sincerely,

*Kenneth H. Rockwell*  
Chief Engineer



SERVING THE NORTH SHORE

SALEM, MASSACHUSETTS

WILLIAM C. ASHER, PRES.  
JAMES D. ASHER, TREAS.

**1230** ON YOUR  
DIAL  
Telephone SALEM 5670 - NEptune 2-1301

October 27, 1954

Mr. Kermit Geary  
R. F. D. 2  
Walnutport, Pennsylvania

Dear Mr. Geary:

This is to confirm your letter of October twenty-fourth regarding reception of WESX on the morning of Sunday, October twenty-fourth.

Your listening report as detailed in your letter compares with our log so this will serve as verification of your report.

Many thanks for your letter and your interest in WESX.

Cordially yours,

WESX

William Asher  
Manager

WA:dp

**970** ON YOUR  
DIAL

. . . *The Hometown Station* - SERVING 450,000 ALERT NEW ENGLANDERS

**WESO** *inc.*

291 MAIN STREET, SOUTHBRIDGE, MASS.  
Telephone Southbridge 4-4381

270 MAIN STREET, WEBSTER, MASS.  
Telephone Webster 2699

Oct. 11, 1955

Mr. Kermit Geary  
R.D. 2, Box 298,  
Walnutport, Pa.

Dear Mr. Geary:

Many thanks for your letter of Oct. 8 reporting of your reception of our station on Saturday of the same date. Your logging of the stated portion of our program is correct. This is to verify it in writing for your own information.

Our chief engineer, Ralph Windquist, is now unable to answer you on the technical aspects of your letter as he is quite busy at the moment. However we'll pass him the letter in the event he has a chance to do so later.

Again many thanks for your interest.

Yours Truly



Robert S. Binet  
Program Director.

1110 AM  
1000 WATTS

# WGRG

PITTSFIELD, MASSACHUSETTS.  
PHONE 413-499-1531

March 13th

Dear Mr. Geary:

Thanks for your letter notifying us that you received WGRG on Friday, March 9th. This will confirm that what you heard was indeed what we were broadcasting at that time. We hope you enjoyed it.

Enclosed is our coverage map, which as you can see, doesn't quite include Walnutport, Pa.

Cordially,

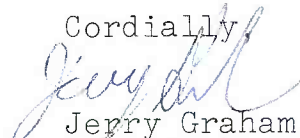

Jerry Graham  
President

"TOPS"  
ON YOUR RADIO DIAL  
AT 1580 KILOCYCLES

RADIO  
STATION

W F G M



1000 WATTS  
SUNRISE to SUNSET  
TELEPHONE 6377

*Studios in the Whitney and Basset Building*

455 MAIN STREET  
FITCHBURG, MASSACHUSETTS

March 10, 1950

Kermit Geary,  
R.F.D. #2  
Walnutport,  
Pennsylvania,

Dear Mr. Geary,

This will serve as conformation of your report of the  
operation of W F G M. Thank you for the report.

Sincerely yours,

*Donald L. Coleman Jr.*  
Donald L. Coleman Jr.,  
Chief Engineer.

OWNED AND OPERATED BY

*The Wachusett Broadcasting Corporation*

# WHOB

Member of the Associated Press

Colonial Hotel, Gardner, Massachusetts

1490 Kilocycles

Full Time

Telephone 1490

*Serving Northern Worcester County*

January 19, 1949

Kermit Geary

RED # 2

Walnutport, Penna.

Dear Sir:

This will confirm your reception of  
WHOB on Jan. 14, 1949 from 3:01 AM  
to 3:47 AM EST.

Thank you for your report.

Yours truly,

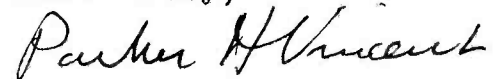

Parker H. Vincent,  
Chief Engineer

PV:jb



Matthew J. Valleau  
WMEX AM  
330 Stuart Street  
Boston, MA 02117

Kermit Geary,  
1266 Riverview Drive  
Walnut Port, PA 18088

September 26, 1985

Dear Sir,

This is the confirmation of your report dated April 9, 1985.

Thank you very much for your observations.

The studios of WMEX AM are located at 330 Stuart street, Boston, MA, and the transmitter is located in Lexington, MA.

Wmex operates at 5000 watts day and night with a directional antenna array. Enclosed you will find a copy of our coverage map and a WMEX bumper sticker.

Thank you again for your report.

Sincerely,

A handwritten signature in blue ink that reads "Matthew J. Valleau".

Matthew J. Valleau  
Engineer, WMEX AM



**WHEE** .. 1090 on the dial

35 COURT STREET  
BOSTON 8, MASS.  
LA 3-6100-1-2

January 24, 1952

Mr. Kermit Geary  
RFD #2  
Walnutport, Pa.

Dear Mr. Geary:

Let me thank you very much for your fine detailed letter concerning a listening check on WHEE as of Sunday, January 20, 1952 in the period of 8:00 to 8:26 AM EST.

This is our formal confirmation that the information for identification purposes is entirely correct, and that there is no doubt that you were listening to WHEE (formerly known as WBMS).

This station operates on an assigned frequency of 1090 kc with the power of 1,000 watts; and uses a late model Western Electric transmitter feeding into a 250' uniform cross section antenna located on the banks of the Malden River in Medford (which is about 4 miles due north of Boston).

Again, thank you for your checking of our signal.

Very sincerely yours,



Lambert B Beeuwkes  
General Manager

LBB/rw



**J-Light Radio Corp.**  
100 Mt. Wayte Ave. Framingham MA 01702  
Tel: 508-820-2425 Fax: 508-820-2429  
Website: [www.jlight.com](http://www.jlight.com) e-mail: [info@jlight.com](mailto:info@jlight.com)

Kermit Geary  
1266 Riverview Drive  
Walnutport, PA 18088

March 7, 2001

Dear Mr. Geary,

This letter is to confirm your reception of our programming, broadcast on 650 AM on November 16, 2000 at 4:15 and 4:45 PM EST and November 18, 2000 at 3:57 PM and 4:27 PM to 4:32 PM.. I apologize for the length of time it took me to write this letter, but we have undergone some major changes at our station, and things have been just about crazy!

It is always a pleasure to hear from DX' Listeners like yourself, and I sincerely hope that you are able to pick up our signal again sometime soon. We are very happy to be on the air at 650 AM, (250 w. non-directional), as we spread the gospel of Jesus Christ.

Thank you again for your letter, please feel free to contact us anytime at this address or online at [www.jlight.com](http://www.jlight.com). Have a wonderful day!

Sincerely Yours,

A handwritten signature in black ink, which appears to read "Lynn S. McHugh". The signature is written in a cursive style with some loops and flourishes.

Lynn S. McHugh  
Log Manager  
JLight Radio 650, WJLT

P.O. Box 329  
Middleboro, Mass. 02346

December 13, 1999

Mr. Kermit Geary  
1266 Riverview Drive  
Walnutport, PA 18088

Dear Mr. Geary:

It's with pleasure that I can confirm your reception of WVBF on December 4, 1999. I was especially impressed with your thorough DX report. All too often I get DX reports which are vague and lack detail. Yours' is certainly not that!

WVBF first signed on about 5 years ago and operates with 1000 watts nondirectionally into a 97 foot tower in North Middleboro. We have been airing the Massachusetts Reading Network for approximately 2 years with great listenership in both Massachusetts but also Rhode Island. To our knowledge, we are only the second station in the country to air a Reading Service full-time.

Once again, thanks for your report and I hope you'll try to listen to WVBF again in the future.

Sincerely,



Steven J. Callahan  
Owner

**the wburgroup**

Your NPR® news source 890 Commonwealth Avenue  
Boston University  
Boston, Massachusetts  
02215

617 353.4394  
617 353.0907 fax  
<http://www.wbur.org>  
Office of the  
General Manager

March 9, 2000

Mr. Kermit Geary  
1266 Riverview Avenue  
Walnutport, PA 18088

Dear Mr. Geary:

Thanks for your letter of March 3 and the cassette you provided. You did indeed hear WPNI on March 2.

WPNI has a rather unusual relationship with us and with WFCR, the public radio station in Amherst. It is a commercial licensee operating as a non-commercial station under special permission from NPR and PRI, the two major suppliers of public radio programming. As you noted (and your recording demonstrated), they carry our programs "The Connection" and "Here and Now" each weekday, and they credit us and WFCR with assistance in making this arrangement possible.

Your reception of the station is remarkable given its very low power at night. It has 5,000 watts daytime, but almost nothing after dark. You perceptively noted that it may have switched to daytime power at 5:58. Before the atmosphere heated up enough to lose the signal, WPNI may have gotten enough of a bounce to get to you.

Good listening!

Cordially yours,



Steve Elman  
Assistant General Manager

H:\MANAGERS\ADMIN\GEAR0309

**90.9 wbur**  
Boston's NPR® news station

**1240 wbur**  
NPR® news for the Cape and the Islands

**1290 wrni**  
Rhode Island's NPR® news station

# WHOOPBE

WUPE RADIO/73 Fourth Street/Pittsfield, Massachusetts 01201/Tel. (413) 499-1531

October 12, 1978

Dear Mr. Geary,

Thanks so very much for such a detailed reception report of WUPE. Your letter was passed on to the morning D.J. you heard at that time. He also found it most interesting.

WUPE does not have a printed QSL card to send you, however I believe this letter will suffice to confirm your report of reception of WUPE (a.m. 1110 khz. 1 kw. omnidirectional antenna) from 7:00 a.m. to 7:15 a.m. October 7, 1978.

Again, thanks for the report and good DXing.

73,

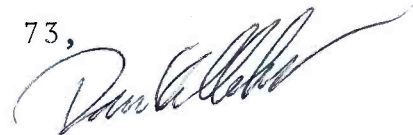

Dan Kelleher- Chief Engineer

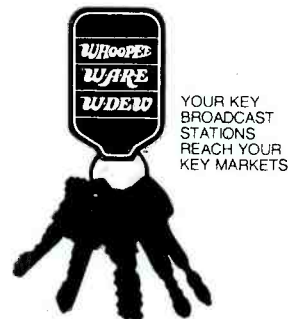

# WXKS

FOR "THE MUSIC OF  LIFE"

**1430 AM**

To: Kermit Geary  
R.D. 4 Box 321  
Walnutport, Pennsylvania  
18088

December 8, 1980

I am pleased to confirm your reception report of WXKS  
on: November 22/23 1980 at: (22) 4:22 - 4:30 Pm Est  
to: (23) 4:20 4:30 Pm Est

Heftel Broadcasting Corporation operates WXKS and WXKS-FM  
from studios and AM transmitter site at 99 Revere Beach Parkway  
Medford, Massachusetts. FM transmitters are located on Prudential  
Tower in downtown Boston.

Frequency: 1430 Khz

Transmitters: Harris MW-5A (main)  
RCA BTA-1M (auxiliary)

Antenna: 196' uniform cross-section, guyed, series excited  
vertical radiator located in Medford, 3 miles  
north of downtown Boston.

Power output: (X) 5000 watts full licensed power  
( ) 1000 watts  
( ) 500 watts pre-sunrise power

Thanks for taking the time out to write as we always enjoy  
hearing from Dx'ers



Christopher J Hall  
Technical Director

---

WVLC  
1170 AM

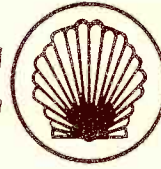

WLOM  
FM 104.7

December 16, 1979

Mr. Kermit Geary  
R.D. 4 Box 321  
Walnutport  
Pa 18088

Dear Mr. Geary:

Thank you for your reception report, and from the data it appears that you did indeed receive WVLC during our proof of performance tests.

Our antenna is two tower directional, with the towers fed so as to give a cardioid pattern with a null at 308 degrees true. One tower is 216 tall, the other is 345, supporting an FM antenna, 5 bays, as well. Power is 1000 watts.

Enclosed is a bumper sticker.

Sincerely,

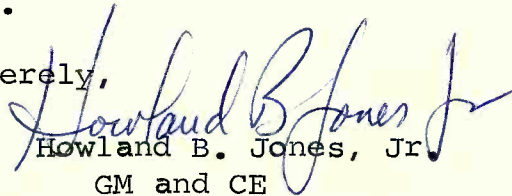
  
Howland B. Jones, Jr.  
GM and CE

# WVDA

Boston, Massachusetts

VICTOR DIEHM ASSOCIATES, Inc.  
5,000 Watts ABC 1260 Kilocycles

Hotel Bradford  
Hancock 6-1122

December 28, 1953

Mr. Kermit Geary  
R.F.D. # 2  
Walnutport, Pennsylvania

Dear Mr. Geary:

I am very glad to be able to verify your reception of this station at 0615 on 16 December 1953. Thank you for your report. We have much trouble with WNDR's signal even near here. I suppose they have the same with us.

I guess you are able to receive our other stations that are out in your area. They are listed on the bottom of this sheet.

Sincerely yours,

*Kenn Smith*  
Kenneth F. Smith  
Chief Engineer



# WKBG INC.

BOSTON, MASSACHUSETTS

WXHR AM/FM  
439 Concord Avenue  
Cambridge, Mass. 02138

March 20, 1967

Mr. Kermit Geary  
R.D. 2, Box 298  
Walnutport, Penn.  
18088

Dear Kermit:

This will confirm your reception of WXHR, Cambridge, Massachusetts on Monday, March 13, 1967, reflection programming during our test program as outlined in your report.

Wayne Plunkett of the NRC was able to coerce CBL into going off the air. Our primary east coast interference was from the Cuban, plus some from WKIS, an open carrier from KRMG, and of course KCBS until around 3 a.m. EST. A tape received from Bob Foxworth in North Carolina indicated a high noise level.

John Callarman, our Operations Manager, will send you a more personal reply as time permits (we keep him pretty busy!) I did want to get the verie on the way and to thank you for tuning us in and for your report.

Cordially,

*Great report!*  
*PT*

*Peter V. Taylor*

Peter V. Taylor  
Station Manager  
WXHR AM/FM

PVT:mp1

**KAISER**  
BROADCASTING

**The Boston Globe**



Dear *Kermit*:

Thank you for your report of having received WITS. WITS is licensed for 50KW daytime and 5KW night-time operation using two tower directional patterns. The day transmitter is an RCA Ampliphase BTA-50H1S, and the night transmitter is a Harris MW-5. Our studio location is noted at the bottom of this letter, and our transmitter site is located in North Quincy, Massachusetts.

We appreciate your time taken in reporting reception of our transmissions and inclose our QSL card.

Thank you for listening.

Best Regards,

A handwritten signature in black ink, appearing to read "R. Jolls", is written over the typed name.

Richard W. Jolls

Chief Engineer

# WIXY 16-AM

5,000 WATTS OVER SPRINGFIELD  
45 FISHER AVENUE  
EAST LONGMEADOW, MASS. 01028

CONFIRMATION OF RECEPTION

DATE request received: 4/20/78  
DATE OF RECEPTION: 4/10/78  
TIME OF RECEPTION: 2:05 AM  
FREQUENCY CHECK? YES  
NORMAL PROGRAMMING? NO

To:  
Kermit Geary  
R.O. 4, Box 321  
Walnutport, Pa. 18088

Sometime in the summer of 1978, WIXY, East Longmeadow, will begin fulltime operation. Currently WIXY operates with a Presunrise Authority from 6am, seven days weekly, and signs off at local sunset.

It will be WIXY's policy to be a continuous radio station. There will be no dark nights. We realize this will cause some dispair in DX circle, but we feel the service to our listening public, especially late workers who enjoy the country music we broadcast, must be constant and ever-present.

The date of the beginning of fulltime operation is not yet set; but if you wish to send us a STAMPED, SELF ADDRESSED ENVELOPE, we will be glad to send you press releases when the date is announced. You may wish to listen in to our first night of operation, both for the question of whether your DX-ing at 1600 will be affected, and just for the fun of hearing a new fulltimer. DO NOT SEND JUST A STAMP. Please include a self-addressed envelope. Send care of OPERATIONS MANAGER.

Thank you

THE VOICE OF THE BERKSHIRES



Pittsfield, Massachusetts

*Columbia Broadcasting System*

Mr. Kermit Geary

RFD #2,

Walnutport, Pa.

Dear Mr. Geary:

Your report of reception of transmission coincides with our log of the mentioned date.

We thank you for your report and trust that your interest in our transmissions continues.

Yours for more 'DX' ,

A handwritten signature in blue ink that reads "Norman H. Kellogg".

Chief Engineer

Handwritten initials "NH." in blue ink.

Under same management

*Waterbury's Dominant*  
Waterbury

The logo for WATR, featuring the call letters 'WATR' in a bold, sans-serif font. The letter 'A' is stylized with a horizontal line through its center.

*Broadcasting Station*  
Connecticut

**BROADCASTING SERVICE ORGANIZATION**  
INCORPORATED

**FORREST N. MADDIX**  
PRESIDENT AND MANAGER  
**LEONARD SPANGENBERG**  
TREASURER

**STATION W B S O**  
920 KC - DAYTIME ONLY

**BABSON PARK, MASS.**  
Feb. 28, 1934.

Mr. Kermit Geary  
R.F.D. #2  
Walnutport, Penna.

Dear Mr. Geary:

We wish to thank you for reporting reception of the test program from this station on February 18th, from 2:00 to 4:00 a.m.

We have checked your report with our station log, and are very glad to verify your reception.

Very truly yours,

*Merrill M. Hammond, Jr.*  
Merrill M. Hammond, Jr.  
Program Director.

# WHA1

. . . *Where the Mohawk Trail Begins*

Owned and Operated by  
JOHN W. HAIGIS

GREENFIELD, MASSACHUSETTS  
Telephone 4301

December 17, 1938

Mr. Kermit Geary  
R. F. D. #2  
Walnutport, Pennsylvania

Dear Mr. Geary:

This will verify your report of reception of Station WHAI during our Frequency Monitoring Test Period for the month of December.

Your comments were most helpful, and we will appreciate any future reports which you may care to make.

Very truly yours,

*James L. Spates*  
James L. Spates  
Station Manager

jls/c

RADIO STATION

W L L H

MERRIMAC BROADCASTING CO., Inc.

LOWELL AND LAWRENCE, MASSACHUSETTS

A. S. MOFFAT, President • TELEPHONES: LOWELL 2121 • LAWRENCE 2-2148

January 2th, 1940

Mr. Kermit Geary  
RFD 2  
Walnutport, Pennsylvania

Dear Mr. Geary:

Thank you for your recent communication regarding your reception of this station.

Your report checks with our station logs, and we are therefore pleased to verify your reception.

Very truly yours,

RADIO STATION WLLH

*Robert Donahue -*  
*-D-*

Robert Donahue  
MANAGER

A. S. MOFFAT, PRESIDENT

WMAS  
INC.

TELEPHONE SPRINGFIELD 71414

SPRINGFIELD . . . MASSACHUSETTS

STUDIOS: HOTEL STONEHAVEN

January 12, 1934

Mr. Kermit Geary  
R. F. D. #2  
Walnutport, Penna.

Dear Mr. Geary:

This will verify your reception of  
our station when you were able to pick up our  
special test program on the morning of January  
8th at 3:30 o'clock.

Very truly yours,

RADIO STATION WMAS

*A. W. Marlin*  
Manager

AIG:AML



1240 KILOCYCLES  
250 WATTS

*Unlimited Time*

❖  
**W O C B**  
CAPE COD  
BROADCASTING CO.

TELEPHONE HYANNIS 1697

*Studio and Transmitter  
South Sea Avenue  
West Yarmouth, Mass.*

RAILROAD STATION  
HYANNIS

**W O C B**

*Covers a  
PLUS  
MARKET*



*Three Counties  
Ranking  
1st-2nd-4th  
in Massachusetts  
in Per Capita  
Sales*



*Annual  
Retail Sales  
Totalling Over  
\$20,000,000*



*The  
Only Station  
Consistently  
Heard in This  
Rich Territory*



Nov. 7, 1941.

Mr. Kermit Geary  
R.F.D. #2  
Walnutport, Pa.

Dear friend:

Thank you for your letter of Nov. 5, 1941.

I am very sorry that your report was overlooked and hope that this verification will please you.

I have looked at your report and am very happy to verify your reception of WOCB's special broadcast on Oct. 6, 1941 from 3 to 5 A.M.

You did very well considering the very adverse conditions.

Wishing you continued success in your fine hobby, I am

Yours very truly,

*Rodney A. Merrill*  
Rodney A. Merrill  
Chief Engineer

RAM/c

# BROADCASTING SERVICE ORGANIZATION

INCORPORATED

W O R L D

STATION ~~WBSO~~

920 KC - DAYTIME ONLY

FORREST N. MADDIX  
PRESIDENT AND MANAGER  
LEONARD SPANGENBERG  
TREASURER

BABSON PARK, MASS.

December 27, 1935.

Mr. Kermit Geary  
R.F.D. #2  
Walnutport, Penna.

Dear Mr. Geary:

We wish to thank you for reporting reception of the test program from Station WORL, formerly WBSO, on December 22, 1935.

We have checked your report, and are very glad to verify your reception.

Very truly yours,



Edward W. Center  
Program Director.

# Doughty & Welch Electric Co., Inc.

OWNERS AND OPERATORS

## W S A R

(ESTABLISHED 1921)

TRANSMITTER LOCATED AT  
SOUTH SOMERSET, MASS.

TELEPHONE  
FALL RIVER 450

STUDIO AND OFFICES  
ACADEMY BUILDING

FALL RIVER, MASSACHUSETTS

December 12, 1936

Dear DX Friend:

We are pleased to inform you that your report of reception of the test program of this station operating on 1000 watts, 12/6/36---3:28 AM is correct.

We are very grateful for your report and hope that you will hear us often, and that our programs will be a source of enjoyment to you.

May we extend to you our sincerest holiday greetings.

Yours very truly

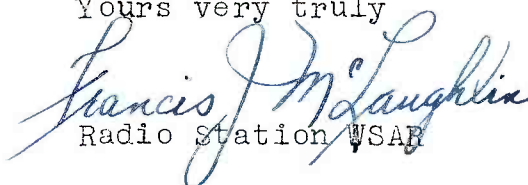
  
Radio Station WSAE



50,000 watts in Stereo

Kermit Geary  
1266 Riverview Drive  
Walnutport, PA 18088

12 August, 1987

Dear Mr. Geary

Thank you for your reception report of the all-new  
WNNZ, 640 wins!

This will confirm your listening on August 7th  
from 6:18-7 a.m.

Enclosed is a copy of our daytime coverage map. I  
hope you'll have many opportunities to enjoy New  
England's Oldies Station many times in the future.

Sincerely,

A handwritten signature in blue ink, appearing to read "Curtis H. Hahn".

Curtis H. Hahn  
President

enc: coverage map

# WNTN RADIO 1550

---

143 RUMFORD AVENUE, NEWTON, MASS. 02166 • PHONE (617) 969-4510

October 5, 1968

Mr. Kermit Geary  
R. D. 2, Box 298  
Walnutport, Pa.

Dear Mr. Geary:

This letter will confirm your reception of WNTN on June 9, 1968.  
Thank you for your interest.

*Donald E. Defebvre*  
Donald E. Defebvre,  
Chief Engineer

**WRYT / 950**  
**BOSTON**

3 February, 1967

Dear DX'er,

Please accept this letter as verification for your reception of WRYT's Special DX Test for the National Radio Club on 26 December, 1966.

We received 58 reception reports from 17 states and 2 Canadian provinces. Farthest DX reception was from Cupertino, California.

WRYT, formerly WORL, is owned and operated by the Pilgrim Broadcasting Company, part of Atlantic States Industries, which also owns WTSA-1450 in Brattleboro, Vt., WLOB-1310 in Portland, Me., and WNVY-1230 in Pensacola, Fla. WRYT operates daytime only with a power output of 5,000 watts Non-directional, with our transmitter located in Saugus, Massachusetts.

We were most happy to conduct this equipment test for the NRC, and I hope to be on the air again soon for another DX Test.

73 and good listening,

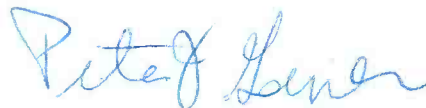

Peter J. Gowen

Chief Engineer

1000 WATTS

DAYTIME

TELEPHONE 4-7528

RADIO STATION **WPEP**

*Studios at the Roseland Ballroom*

174 BROADWAY,

TAUNTON, MASSACHUSETTS

**1570**  
ON YOUR  
DIAL

DECEMBER 6, 1950

MR. KERMIT GEARY  
R. F. D. # 2  
WALNUTPORT,  
PENNSYLVANIA

DEAR MR. GEARY:

THIS IS A VERIFICATION TO THE LETTER OF RECEPTION YOU SENT US ON MONDAY, DECEMBER 4, 1950. WE HAVE CHECKED OUR MONDAY LOG AND FIND THAT YOUR REPORT IS QUITE ACCURATE.

THANK YOU FOR YOUR VERY FINE LETTER AND ALSO FOR YOUR INTEREST AND BEST WISHES.

YOURS FOR GOOD RADIO,  
STATION WPEP

*Robert A. Brennan*  
ROBERT A. BRENNAN *J.T.*  
STATION MANAGER

RAB/JOT

OWNED AND OPERATED BY  
**SILVER CITY BROADCASTING CORPORATION**

1000 WATTS  
DAYTIME  
TELEPHONE 824-7528  
AREA CODE 617

RADIO STATION **WPEP**

*Studios and Business Offices*

1570

ON YOUR  
DIAL

49 BROADWAY  
TAUNTON, MASSACHUSETTS - 02780

Dear Kermit,

Thank you for your very interesting letter. I was glad to hear that the confirmation of your reception of WKFD has reached you. I was also glad to hear that you received WPEP. This letter confirms your reception of WPEP on the night of Feb. 27/morning of Feb. 28, 1976 during a engineering test. We used a Gates Vanguard II during the test feeding a series excited tower (191 ft.) located in a marsh. Our aux. transmitter is a Gates BC-1F.

The test was pre-recorded to obtain as much compression as possible. We operate the transmitter by means of remote control, it being 3 miles away.

Interesting to hear you heard the station back in 1950, that is far back. I wish you continued good luck and best DX. When I run a test again, I will sure let the club know.

Sincerely,

*Eugene R. Faltus*

Eugene R. Faltus  
Chief Engineer

OWNED AND OPERATED BY  
SILVER CITY BROADCASTING CORPORATION



# WNCR

November 15, 1976

Kermit Geary

R. D. 2, Box 298

Walnutport, Pennsylvania 18088

Dear Kermit,

Thank you for your letter of October 18.

This is to confirm your reception of WNCR (AM) 1440 KHZ in Worcester, Massachusetts.

We appreciate your consideration and take this opportunity to thank you for your reception report.

Sincerely,

A handwritten signature in blue ink that reads "Michael J. Marcy". The signature is written in a cursive style with a large, sweeping flourish over the last name.

Michael J. Marcy  
Chief Engineer, WNCR



## NEW ENGLAND BROADCASTING Co.

Park Building . . . Worcester 8, Mass.

TELEPHONE 6-4672

December 27, 1946

Mr. Kermit Geary  
R. F. D. #2  
Walnutport  
Pennsylvania

Dear Mr. Geary:

Thank you for your report of reception of WNEB on December 11th.

A check of our program log indicates that your logging of times and selections played is correct and it gives us pleasure to confirm your report.

WNEB began regular programs on December 16th and broadcasts daily from 6:00 AM to 1:00 AM and Sundays from 7:00 AM to 1:00 AM.

We are planning a DX test for Tuesday, January 14th from 3:00 AM to 4:00 AM which will be dedicated to The Newark News Radio Club. We would greatly appreciate any publicity which you might be able to give this test.

WNEB is using a Raytheon Type RA-250 Transmitter running 250 watts to a 200 foot Lehigh tower which is mounted on top of a 150 foot building in the center of Worcester. Our audio equipment is also of Raytheon manufacture and seems to be giving very satisfactory results.

We greatly appreciate your interest in our new station and hope you will be able to pick us up often.

Sincerely,

*Vernon P. Wilson*

Vernon P. Wilson  
Chief Engineer

VPW:c

# MEMORIES

Words and Music by  
THE MEMORIES STATION

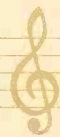

May 24, 1983

Kermit Geary  
1266 Riverview Drive  
Walnut Port, PZ  
18088

Dear Mr. Geary:

I am pleased to inform you that your reception report on WMRE has been confirmed. You are one of the many in your area who has reported receiving our signal, so welcome to the WMRE Fan Club. We are always happy to hear from our broadcast DX friends.

WMRE-AM is owned by Mariner Communications and licensed for 50 kilowatts around the clock. Our transmitter is a Harris MW-50B and is located in Waltham, Massachusetts, six miles west of our Boston studios and offices. We operate at an assigned frequency of 1510 kHz., with a two-tower directional pattern during the day, and a four-tower pattern at night. Because of the restrictions on where our signal may travel, WMRE is aimed primarily east during our night time hours. This is why our night time signal is frequently heard in Europe.

WMRE, formerly WITS, is an all-music nostalgia format. We feature hits of the 1940s, 1950s, and 1960s. We feature news right before the top of the hour. Because of our format, we are known as "The Memories Station."

Again, thank you for taking time to write to us. If you receive our signal again, feel free to drop us another line. We're always glad to hear from you.

Sincerely

Grady Moates  
Chief Engineer

GM/es

**WMRE**  
**AM-1510**

74 Lansdowne Street, Boston, MA 02215 (617) 267-1510



500  
West Cummings Park  
Suite 2500

Woburn  
Massachusetts 01801  
617 938 0660

October 19, 1987

Kermit Geary  
1266 Riverview Drive  
Walnutport, PA 18088

Mr Geary;

This will serve as a verification of your reception of WSSH  
on August 10, 1987.

WSSH-AM commenced broadcasting on July 27, 1987 using a  
Harris MW-50/C transmitter at its rated 50 kilowatts. It is  
driven into a two-tower days/ four-tower nights directional  
array. We are also proud to say we are broadcasting with the  
KAHN SYSTEM/ AM-STEREO !

We appreciate your reception report, glad to hear your  
comments and wish you all the best luck in your future DXing!

Sincerely yours,

John D. Kennedy  
Chief Engineer

# WPLM

PLYMOUTH, MASSACHUSETTS  
294 Court Street Plymouth 2600  
500 WATTS 1390 KILOCYCLES

February 14, 1956

Kermit Geary  
R. D. 2, Box 298  
Walnutport, Pa.

Dear Mr Geary,

Thank you very much for your report of our special broadcast for the National Radio Club. According to our records, we can verify your report for Sunday, Jan. 15, 1956 from 4:30 to 5:00.

W P L M is a daytime Station, with sign-on Monday through Saturday at 6:00 AM, and Sunday, at 8:00 AM. Our sign-off is at local sunset. W P L M operates with a power of 500 watts, through a Gates RC-500 CY Transmitter. In fact, W P L M is equipped with Gates throughout. Our tower is approx. 300 feet above sea level, and is located North lat. 41° 56' 37" and West lat. 70° 42' 06". W P L M has frequency checks taken once a month, usually on the second day of the month, during regular program hours. Equipment checks always occur at midnight on the night of the test, otherwise, there is no set schedule.

W P L M is located in one of America's outstanding tourist spots. Plymouth was the home of the early settlers, and the point at which the Mayflower finished its long journey from England to the New World. The world famous "PLYMOUTH ROCK" is located in Plymouth at the point of the landing of the Pilgrims and only a few blocks from the W P L M Studios. Many of the original buildings of the Pilgrims have been preserved, and are open to tourists in the summer months. Also, there are numerous monuments all over the Plymouth area dedicated to the early settlers and the most outstanding, is The Monument of the Forefathers, the largest all granite statue in the world.

In addition, Plymouth is the gateway to the vacation wonderland of Cape Cod. The summer months find thousands of people from all over the United States coming to the Cape Cod area for fun and recreation in the warm sun and fresh ocean breezes.

It is a pleasure to add your name to our list of W P L M listeners, no matter how far you are from Plymouth. You have heard the voice of AMERICA'S HOME TOWN...Plymouth, Massachusetts.

Once again, thank you for your time and trouble in reporting.

P.S. Thank you for your very complete report. It is a pleasure to read a report such as your's. We got a big kick out of the broadcast and was glad to have been of service to the NRC. The reports have been pouring in from all over the eastern U.S. and most of them have been very gratifying.

Sincerely,

*Dick Taylor*  
Dick Taylor (C. E.)  
On behalf of the  
Staff and Management

AFFILIATED WITH THE AMERICAN BROADCASTING COMPANY

# WBEC

30 Eagle Street  
Pittsfield, Massachusetts

Full Time—FM 94.3 Megacycles  
1000 Watts

Full Time—AM 1490 Kilocycles  
250 Watts

7 March, 1950

Dear *Hermit,*

We are pleased to acknowledge and verify your reception report of Station W B E C, which you heard during our recent special DX program, conducted with the cooperation of both the NEWARK NEWS RADIO CLUB and the NATIONAL RADIO CLUB.

Your report checks exactly with our logs, and I'd like you to know we were pleased to learn that our station can be picked up at your location under special DX conditions.

Sincerely,

*Walter T. Ayer*

WALTON T. AYER  
CHIEF ENGINEER

*Thanks for a fine letter, Hermit, Rx'd approx. 45 reports to date. We enjoyed putting the pgm. on the air*

*Bud*

# WBET

*Serving Southeastern Massachusetts - Daytime, 990 On Your Dial*

60 MAIN STREET : BROCKTON 64 : MASSACHUSETTS  
TELEPHONE 7062-7063

December 3, 1946

Mr. Kermit Geary  
R.F.D. #2  
Walnutport, Pennsylvania

Dear Mr. Geary:

This will verify your reception of  
Radio Station WBET, 990 kcs, 250 watts, during an  
equipment test program, November 27, 1946.

Thank you very much for your interest.

Very truly yours,

*Charles A. Fuller*

Charles A. Fuller  
Station Manager

caf,nj

**WLYN** AM-FM

7 WILLOW STREET  
LYNN, MASSACHUSETTS  
LYNN 5-6200

---

PURITAN BROADCAST SERVICE, INC.

December 29, 1952

Mr. Kermit Geary  
R.F.D. # 2  
Walnutport  
Pennsylvania

Dear Mr. Geary:

Thank you so much for your letter of December 26, reporting reception of Radio Station WLYN (1360 kilocycles) on Christmas morning.

This is to confirm your reception of the programs which were broadcast for that morning.

It certainly gives us great pleasure to know that our signal is strong enough to reach you, and we trust that you will let us know how the reception is, should you hear the station again.

Best wishes to you in the coming new year, and the best of luck and continued success in your interesting hobby.

Sincerely,

PURITAN BROADCAST SERVICE, INC.



Russell E. Bassett  
Chief Engineer

REB:cm





New England Continental Media, Inc.

A Salem Communications Corporation Station

Mr. Kermit Geary  
1266 Riverview Drive  
Walnutport, PA 18088

Dear Mr. Geary:

This letter is to confirm your reception report of WPZE on 1260 kilohertz on 14 April 1997. It is a real blessing to know that our signal is so strong even 270 miles from Boston.

Although we are billing ourselves as Boston's Newest Christian Station, in fact WPZE is one of the oldest continuously operating stations in the market, first licensed as WNAC back in 1922. For many years, the station on 1260 served as the flagship of the old Yankee Network. Subsequently, the call letters were changed in 1953 to WVDA, and in 1957 to WEZE. The original WEZE was one of America's first "Beautiful Music" stations and commanded a large audience for quite a long period of time.

In 1978 the station was sold to New England Continental Media, Incorporated, a division of Salem Communications Corporation of Camarillo, California. Salem owns and operates some 45 radio stations in markets including WMCA and WWDJ in New York, WAVA-FM in Washington, DC, and KKLA-FM Los Angeles.

Early this year Salem had an opportunity to purchase another "old stick", the former WEEI at 590 kHz, which was owned for many years by CBS, Incorporated. The 590 station was WBNW until our purchase. We simulcast for a period of weeks until technical operations could be optimized, and split the stations on March 3, 1997. The 590 station took the WEZE call sign, and the 1260 station is now WPZE. (Hope this isn't too confusing!)

WPZE operates at an assigned carrier power of 5000 watts daytime and 5400 watts night, from a transmitter site on the Quincy/Milton town line, near Boston. We operate non-directionally daytime and from a directional array of three self-supporting towers 206 feet in height, arranged in a dogleg configuration. Our transmitter is a Nautel.

Boston supports many other Christian broadcasting stations, including WROL at 950 kHz, WNRB at 1510 (for many years WMEX) and a relatively new one kilowatt station WJLT at 1060 kHz.

Thank you for listening! I am enclosing a program guide covering both stations, in which you may have interest.

May God's richest and best be yours,



Joe Tobin  
Staff Announcer  
WPZE-AM 1260  
WEZE-AM 590

/s

Mail: Marina Bay P.O. Box 9121, Boston, MA 02171-9121 (617)328-0880 Fax: (617)328-0375  
Delivery: 500 Victory Road, Marina Bay, North Quincy, MA 02171 E-mail: Family590@aol.com



2 Westborough Business Park, Suite 4000  
200 Friberg Parkway, Westborough, MA 01581  
(508) 836-9223 • Fax (508) 366-0745

December 27, 1994

Kermit Geary  
1266 Riverview Drive  
Walnutport, PA 18088

Dear Kermit,

I am happy to confirm your reception report of WWTM on Wednesday December 21, 1994 from 1805 to 1858.

The only error I see in your log is that our slogan is "WTM, Worcester's Team". not listeners team as you stated in your log. But that is a small and easily made mistake. The host of the talk show you logged at 1805, is Pam Ward, not Tam Ward.

We have just recently changed our call sign from WVEI to WWTM, effective October 1, 1994. Prior to that we simulcast WEEI from Boston. With their move to the old WHDH frequency of 850 kHz, we found we would be better off programming the station ourselves with IMUS in the Morning, The Fabulous Sports Babe Mid days, Kiley and the Coach 2P to 6P, Dan Miller 6P to 10P and Ron Barr with sports By-Line USA overnight. We also feature Holy Cross Football and Basketball, Giants Football, Bruins Hockey (when they actually play a game), and selected games from the Mutual network.

Thank you for your report. Hopefully we will not have too many more format and call letter changes. We are doing very well with IMUS in the morning and are working on adding more local talk programming.

I am enclosing some information on the radio station.

Sincerely,

A handwritten signature in blue ink that reads "Eric Fitch".

Eric Fitch  
WWTM/WAAF  
Zapis Communications Corp

200 Friberg Parkway  
Westborough, MA 01501

# WROL / 950 BOSTON

OCTOBER 1, 1986

MR. KERMIT GEARY  
1266 RIVERVIEW DRIVE  
WALNUTPORT, PENNSYLVANIA 18088

DEAR MR. GEARY;

THIS LETTER VERIFIES YOUR RECEPTION OF WROL RADIO ON MONDAY, SEPTEMBER 22nd  
AT 6:00AM.

SINCERELY,



Ken Catter/President

Dial }  
Phone } 1230

# NORTHERN BERKSHIRE BROADCASTING COMPANY

*Studios • Offices • Transmitter*

466 CURRAN HIGHWAY  
NORTH ADAMS, MASSACHUSETTS

January 30, 1948

Mr. Kermit Geary  
R.F.D. 2  
Walnutport, Penn.

Dear DX-er:

This will verify your report of reception of Radio Station WMNB, North Adams, Massachusetts. We are indeed grateful for your comments and careful analysis of our transmission.

WMNB operates with 100 watts power output on 1230 KC. We do not plan any regularly scheduled test programs.

If you are ever in the vicinity of North Adams we would welcome a visit from you.

Very truly yours,

RADIO STATION WMNB



J. Gordon Keyworth  
General Manager

JGK:am

Tel. Chicopee 2330

W A C E The Regional Broadcasting Co.  
THE RADIO CENTER

David Hayes, Pres.  
John S. Begley, Treas.  
John S. Lloyd, Gen. Manager

326 Chicopee Street  
Chicopee, Massachusetts

January 23, 1947

Mr. Kermit Geary  
R.F.D. #2  
Walnutport, Pennsylvania

Dear Mr. Geary:

May we take this opportunity to thank you for your reception report.

Your report on WACE dated November 26, 1946 from 5:20 AM to 5:59 AM EST was accurate in every detail. PM to PM

WACE operates on 730 KC sun-rise to sun-set with a power output of 1,000 watts.

Transmitter - RCA -BTA-1L  
Antenna - Lingo - 285 ft. vertical

May we wish you continued success in your DX listening

Very truly yours,

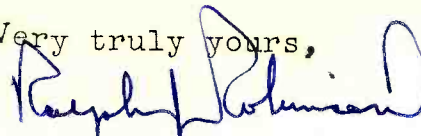

Ralph J. Robinson, (WLICW)  
Chief Engineer

RJR:amb

*Broadcast Station*  
**WMEX**

OWNED AND OPERATED BY THE NORTHERN CORPORATION

*WMEX Building*

70 BROOKLINE AVENUE, BOSTON 15  
TELEPHONE COMMONWEALTH 3900

January 28, 1946

Mr. Kermit Geary  
R.F.D. #2  
Walnutport, Pa.

Dear Mr. Geary:

This is to confirm your reception of the WMEX programs you reported on Thursday, January 17, 1946.

We are happy to have heard from you and wish to commend you on being the owner of such excellent receiving facilities.

We hope you will enjoy listening to our programs in the future.

Very truly yours

*John Memishian*  
JOHN MEMISHIAN  
Chief Engineer

A.T.

jm/mt

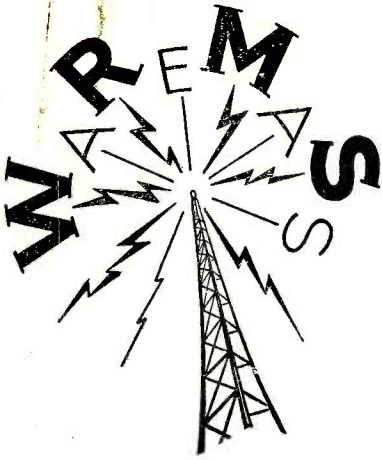

1250 KILOCYCLES

WRMS

500 WATTS

Studio: WARE MA

Transmitter: COY'S HILL, WARREN

June 11, 1948

Mr. Kermit Geary  
R. F. D. #2  
Walnutport  
Pennsylvania

Dear Mr. Geary:

Thank you very much for your letter of June 8th and for the very complete report submitted. The log you gave us has been verified.

The program you mentioned was transmitted without any volume compression. Subsequent test programs originating at our studio will normally have a maximum of 5 db compression. Any reports of change in quality or increase in average modulation level due to use of compressor would be welcomed.

We are enclosing a brochure of our station which we hope you will find of interest.

Very truly yours,

RADIO STATION W R M S

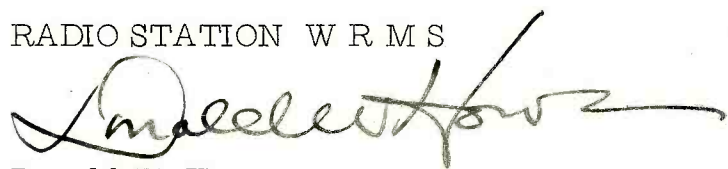
  
Donald W. Howe  
Owner

DWH/hr1  
Enc.

WNBH  
and  
WFMR-FM

*Radio Center in New Bedford, Mass.*

---

432 County Street - - - - - Telephone 8-5228

---

October 13, 1953

Kermit Geary  
R. F. D. #2  
Walnutport, Pa.

Dear Mr. Geary:

We are pleased to be able to confirm your reception of WNBH. The data which you enclosed was correct.

Please be advised that another long broadcast day is expected on November 3, 1953, to broadcast the election returns.

The transmitting equipment consists of a BTA-250 M, R.C.A., Xmitter with a newly installed ~~98-A~~ Limiter.

BAG4

Thank you for your interest.

Very truly yours,



Herve L. Leduc  
Chief Engineer

HLL/fm





**Narragansett Broadcasting Company**

POST OFFICE BOX 208

TELEPHONE 4-1400

FALL RIVER, MASSACHUSETTS

1400 KILOCYCLES

October 4, 1948

Mr. Kermit Geary  
R.E.D. #2  
Walnutport,  
Pennsylvania

Dear Mr. Geary:

Thank you for your letter of September 15th; sorry for the delay in replying.

This will verify the fact that it was WALE you heard on Wednesday morning, September 15, 1948, at which time we were carrying our primary election returns.

We are a five-month-old 250-watter, Raytheon-equipped throughout. Our antenna is a 160-foot Wincharger type 300, located atop an 80-foot office building in downtown Fall River. Our operating schedule is 6:00 AM to 1:00 AM, Monday through Saturday; and 8:00 AM to 1:00 AM on Sundays. We are on a test with Riverhead on the first and third Saturdays of each month, from 2:45 AM to 3:00 AM.

Your letter was of particular interest to us, since it's the first one we've received from Pennsylvania. Many thanks for writing.

Cordially yours,

J. Buz Way  
Station Manager

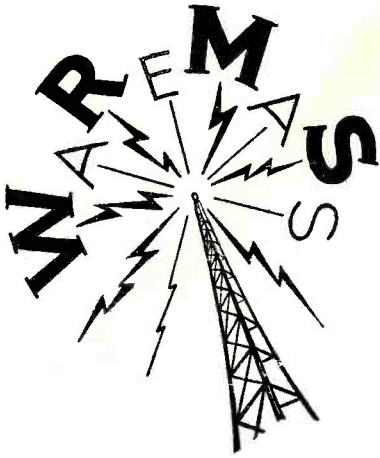

*Studio: WARE*  
*Transmitter: COY'S HILL, WARREN*

April 9, 1949

Mr. Kermit Geary  
R. F. D. #2  
Walnutport, Pennsylvania

Dear Mr. Geary:

Thank you very much for your report of our equipment test broadcast on March 26, 1949.

We have checked your report with our station log and find it to be correct; therefore, this will confirm your reception of WARE.

Transmitting facilities at WARE are located atop Coy's Hill in Warren, Massachusetts about midway between Worcester and Springfield. We were operating with a power output of 500 watts using a non-directional antenna.

Again, thank you for your interest and with best wishes for your DXing success.

Yours very truly,

RADIO STATION WARE

*Ansel E. Gridley*  
Ansel E. Gridley  
General Manager

AEG:wmg

P.O. Box 1000  
19 Water Street  
Leominster, Massachusetts 01453  
(617) 537-4141

3-10-83

Dear Kermit —

Thanks for the letter and  
the kind words. You did read us  
correctly.

Your reception was the furthest  
away we have been received. 240  
miles - we love it.

Good luck.

Jan Parker  
VP + gm



# WBKA . FULL TIME . 1450 ON YOUR DIAL

TELEPHONE  
8-0621 or 8-0622

205 EAST ASHLAND STREET  
BROCKTON 58, MASSACHUSETTS

December 3, 1948

Kermit Geary  
R. F. D. #2  
Walnutport, Pennsylvania

Dear Mr. Geary:

Thank you for your report on the reception of Station WBKA. It checks with our log and we want to thank you for the interest you have shown.

Hope you will listen to us often.

Very truly yours,



Mark Mac Adam  
Technical Adviser

MM/b

STATION WBKA

W C R B

1330 ON YOUR DIAL

CHARLES RIVER BROADCASTING COMPANY

COMMERCIAL BUILDING

COR. MOODY AND GORDON STREETS

WALTHAM 54, MASS.

February 27, 1948

Mr. Kermit Geary  
R. F. D. #2  
Walnutport, Pa.

Dear Mr. Geary:

Radio Station W C R B wishes to acknowledge your reception report dated January 26, 1948 as verified.

Our broadcast day is 6:00 a.m. to sunset, 5:15 this month. Thank you for your interest in our success.

Sincerely,

CHARLES RIVER BROADCASTING CO.

*James H. Bonney*  
James H. Bonney  
Chief Engineer

JHB:ic

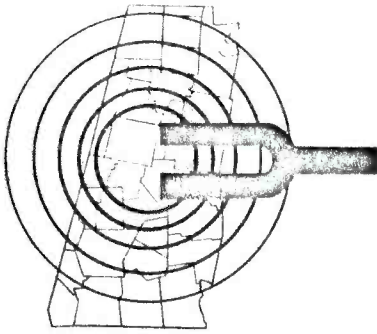

# WSBS

BOX 297 • GREAT BARRINGTON, MASS. 01230

413 528-0860

Date: **January 13, 1973**

VERIFICATION OF RECEPTION REPORT OF SIGNALS OF W-S-B-S

To:

**Mr. Kermit Geary  
RD#2 - Box 298  
Walnutport, Pennsylvania 18088**

Reference:

**Your letter of 1/9/73**

This letter is to acknowledge your report of the reception of the signals of W-S-B-S Radio on January 8, 1973.

Your report by (letter - ~~telephone~~) is factual and accurate of the (~~regular~~ - special) transmission of this station.

At this time we would like to thank you for your interest in W-S-B-S Radio and the Berkshire Broadcasting Company Inc. If at any time you should once again hear our signal .. another report from your listening post would be greatly appreciated.

If you would like more information about W-S-B-S Radio and its parent organization, The Berkshire Broadcasting Company, please write and we will be more than happy to answer your questions.

Thanking you again for your keen interest in our station, we remain;

Very truly yours and 73:

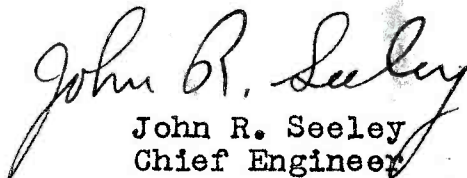
  
John R. Seeley  
Chief Engineer

  
Thomas P. Jaworski, WAlMJE  
News Director

**A very nice report ... if you hear us again .. send in another.**

73 .....



TPJ/xx

January 13, 1973

Your letter of 1/9/73

Mr. Kermit Geary  
RD#2 - Box 298  
Wainwright, Pennsylvania 18088

January 8, 1973

XXXXXXXXXX

XXXXXXXXXX

A very nice report ... if you hear us again .. send in another.

.... 73

Beautiful music

**WHUE** 101 FM  
AM 1150

JOHN HANCOCK TOWER • 200 CLARENDON STREET • BOSTON, MA 02116 • (617) 267-0123

MARCH 25, 1985

MR. KERMIT GEARY  
1266 RIVERVIEW DRIVE  
WALNUTPORT, PA 18088

DEAR MR. GEARY:

I AM PLEASED TO CONFIRM YOUR REPORT OF RECEPTION OF WHUE  
(AM).

DATE: JULY 2, 1985  
TIME: 1:18-2:32 AM EDT  
SIGNAL: STRONG  
RECEIVER: HAMMARLUND HQ 180  
ANTENNA: SM-2 SPACE MAGNET

THANKS FOR TAKING THE TIME TO WRITE.

SINCERELY,



CHRISTOPHER J. HALL  
TECHNICAL DIRECTOR  
WKKT

CJH:YN



COMMUNICATIONS WCIX-TV MIAMI • WIFI PHILADELPHIA • WHUE FM/AM BOSTON





MARCH 25, 1985

MR. KERMIT GEARY  
1266 RIVERVIEW DRIVE  
WALNUTPORT, PA 18088

DEAR MR. GEARY:

ALTHOUGH LATE, I AM PLEASED TO CONFIRM YOUR REPORT OF RECEPTION OF WHUE (AM). MANY CHANGES HAVE GONE ON HERE BUT LUCKILY I STILL HAD SOME WHUE STATIONERY THAT COULD BE USED. WHUE (FM) WAS SOLD TO FIRST MEDIA CORPORATION AND BECAME WKKT (FM), I CAME IN WITH THE FIRST MEDIA PEOPLE JANUARY 1, 1985. OUR FORMAT IS ADULT HIT RADIO. WHUE (AM) WAS SOLD TO GREATER MEDIA CORPORATION FEBRUARY 26, THE STATION WENT DARK FOR TWO WEEKS AND RETURNED TO THE AIR AS WMEX ON MARCH 15 WITH A ROCK AND ROLL OLDIES FORMAT. AS I INHERITED THE STUDIOS AND HAVE ALL THE PAPER WORK THAT IS JUST NOW BEING SORTED OUT, I CAN CONFIRM YOUR REPORT OF RECEPTION.

I HAVE ENCLOSED A COVERAGE MAP OF DAY AND NIGHT SIGNALS, NOTE THE WCOP CALL LETTERS AND THE STATIONS SALES FOLDERS, AS YOU CAN SEE THE STATION HAS HAD A COLORFUL HISTORY.

HOPE THIS HELPS YOU.

SINCERELY,

CHRISTOPHER J. HALL  
TECHNICAL DIRECTOR

CJH:YN

WKKT  
FM 100.7  
John Hancock Tower  
42nd Floor  
200 Clarendon Street  
Boston, Massachusetts 02116  
617/267-0123

A Station of First Media of Massachusetts, Inc.

# WSFL

-1600 KCS.  
5,000 WATTS

# WSFL

-FM  
101.9 MEGS.  
10,000 WATTS E.R.P. (CP)

## *Springfield Broadcasting Co., Inc.*

137 STATE STREET  
SPRINGFIELD 3, MASSACHUSETTS

2-7487 - 2-7488

November 15, 1949

Kermit Geary  
R.F.D. #2  
Walnutport,  
Pennsylvania

Dear Sir:

This is to confirm your reception of WSFL operating on a carrier frequency of 1600kc with an authorized power output of 5000 watts into a two-element directional antenna.

Your heard report is very much appreciated. If you should hear WSFL in the future, drop me a line.

Very truly yours,

*C.M. Manitsas*

C.M. Manitsas  
Operation Manager

*Music*

—

*News*

—

*Sports*

WLDW

December 1, 1980

Kermit Geary  
R.D.4/Box 321  
Walnutport, PA 18088

Dear Kermit:

This letter confirms your reception of our signal on Wednesday, November 26. Power output, at the time of your reception, was 360 watts (since we are a daytimer).

Enclosed is a little propaganda about the station, which I thought you might enjoy.

Sincerely

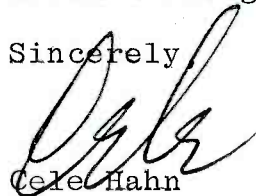

Cele Hahn  
Vice President

1570

# W C C M

LAWRENCE BROADCASTING COMPANY

54 ESSEX STREET

LAWRENCE, MASSACHUSETTS

800 KC

1000 Watts

August 6, 1947

Mr. Kermit Geary,  
R. F. D. #2  
Walnutport, Pa.

Dear Mr. Geary:

We are very glad to acknowledge your report of reception on August 5, 1947 from 3:30 a.m. until 4:10 a.m.

We have now started our regular schedule as a daytime only station, and would appreciate reports on our present operation.

Cordially yours,

"THE NEW VOICE of the MERRIMACK VALLEY"

RADIO STATION W C C M

*Gordon S. Ley*  
Gordon S. Ley  
Chief Engineer

GSL:B

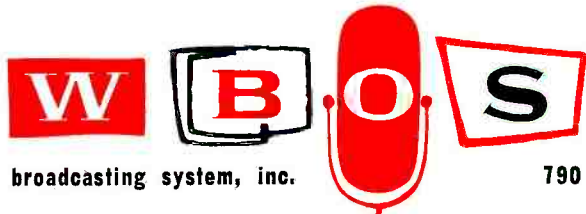

champion broadcasting system, inc.

790 COMMONWEALTH AVENUE, BOSTON 15, MASS. BEacon 2-5650

January 25, 1959.

Eng. Dept.

Dear Kermit,

This letter is a very tardy reply to your letter dated October 16th, 1958. Your program report for the time in between the hours 2:15 a.m. to 2:29 a.m. was in substantial agreement with that program material that we used for test purposes on the evening in question.

We technicians appreciate the technical information forwarded to us in your reply and sincerely hope that with all the problems like the heavy thaw and flooding of the rivers in the state of Pennsylvania will subside in the very near future.

Thanking you again we remain,

sincerely yours,

A handwritten signature in cursive script that reads "John Hotz".

John Hotz

5000 WATTS  
BOSTON

BAY STATE BROADCASTING COMPANY

**WBSM**

NEW BEDFORD, MASS. TELEPHONE 3-1767

FM—20,000 WATTS—97.3 MC.  
AM 1230 Kc.

October 17, 1949

Mr. Kermit Geary  
RFD 2  
Walnutport, Pennsylvania

Dear Mr. Geary:

Thank you very much for your letter of October 12 with a complete report of receiving our signal on 1230 Kc. The log you submitted was correct in all respects.

It was quite a suprise to hear from a DX fan as far away as you considering we are only operating with 100 watts power. It was also interesting to read you letter and hear about the communications equipment and antenna system yourwere using. We are very pleased to hear from listeners and DX fans regarding our signal strength. Incidentally we expect to be on the air late the night of November 8 with final election returns and music.

With regard to our equipment, the majority is RCA. We are operating a 250 watt AM transmitter at 100 watts output power on 1230 Kc., which covers greater New Bedford; also a 10 Kw FM transmitter on 97.3 Mc. feeding a Raytheon two-bay antenna which is 386 feet above sea level. That gives us an effective radiated power of 20,000 watts. Our studio and transmitter building was completed the first of this year and we began regular programs February 22, on the air from 7:00 AM until midnight except Sundays when we go on at 8:00 AM. Our building is complete in every detail housing offices, three studios, shop, recording room, control and transmitter rooms. We are located on Pope's Island between New Bedford and Fairhaven. Although it is an island it is connected to the mainland by a four lane highway.

We appreciate receiving your letter and any future reports regarding our signal would be welcome. If, at any time, you are again in the vicinity of New Bedford, feel free to come and visit us.

Very truly yours,



Harold H. Hoover, Jr.  
Chief Operator

HHH:mgh

250 Watts  
Wellington Hotel

# W K O B

860 on your dial  
Phone 3470

*Citizens Broadcasting Company*  
**NORTH ADAMS, MASS.**

August 5, 1947

Mr. Kermit Geary  
R.F.D. #2  
Walnutport  
Pennsylvania

Dear Mr. Geary,

Thank you very much for your very fine report on our signal which you heard during our equipment test of August 2, 1947. Your report is very gratifying indeed. Of all reports received here so far yours seems to be the greatest distance away. We are very pleased to hear that we came into Walnutport so well. Your log of program material is correct.

WKOB will operate from sunrise to sunset, commencing about August 7. We would appreciate hearing from you if you ever hear us during the daytime.

Thank you again, best regards.

Very truly yours,



A.J. Kordalewski  
Chief Engineer

*Enlightenment . . . Entertainment . . . Equality*

# WKOX

1000 WATTS

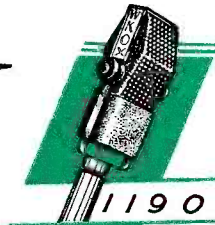

1190 ON YOUR DIAL

*Framingham,* MASSACHUSETTS

April 26, 1947

Mr. Kermit Geary  
R.F.D. # 2  
Walnutport, Pa.

Dear Mr. Geary:

This will verify your report of reception of WKOX on the night of April 17 when we were conducting equipment tests.

WKOX operates on a frequency of 1190 kc with a signal output of 1000 watts. Our transmitter is a Raytheon RA-1000 and uses a pair of 833's in the final stage. The final stage of the modulator is also a pair of 833's. Our antenna is a Wincharger Type 101 and is 210 feet high. Surrounding the tower is a copper screen 30 feet square and we have 120 radials 200 feet long (#10 bare copper wire) radiating from the base of the tower.

Thank you very much for your interest in WKOX and any time you happen to be in this area, please feel free to stop by and say hello.

Very truly yours,

*Francis W. Bartol*

Francis W. Bartol  
Chief Engineer

eps

**SERVING SUBURBAN BOSTON**





LOWELL, MASSACHUSETTS

243 CENTRAL STREET

TELEPHONE 4-0404

Oct. 27, 1953

Mr. Kermit Geary  
R.F.D. # 2  
Walnutport, Pa.

Dear Mr. Geary:

This is to acknowledge receipt of your letter and to inform you that your observations made on Friday, September 18, 1953 are correct.

Your letter makes it possible for us to further point with pride to our strong signal and in view of the fact that you received our signal as far away as Walnutport, Pa, it is indeed "unusual".

A most sincere and warm thank you for making your observations known to us. I believe, with your data, WCAP has reached its furthest distance in point of audibility.

Yours for continued better and happier listening.

Sincerely

*Ugo San Antonio*  
Ugo San Antonio  
Program Director

# WCAS

# 740kc

620 Massachusetts Avenue  
Cambridge Ma 02139  
617/492 6450

April 27, 1968

Kermit Geary  
R.D. 2, Box298  
Walnutport, Pa. 18088

Dear Kermit:

You write the best reception report I've ever seen! I appreciated last year's WXHR report ... and am enclosing that personal reply Pete Taylor promised I'd send ... it's been languishing in my file along with several others waiting for an excuse for writing a letter to go along with it.

I suppose, since this is supposed to be a verification letter, I'd better verify your report:

This verifies your reception of WCAS on 740 kilocycles on April 22, 1968, between 3:31:45 and 4:27:40 a.m., E.S.T.

So far, on this Saturday after the test, we've received 35 verifiable reports (sic) ranging from Pointe Claire, Que. to Dubuque, Iowa, to Versailles, Ky., to Tampa, Fla. (Finally one of the fishermen got some definite program details!)

Thanks for the kind words about the bulletin... and I'm sorry I'm such a poor letter-writer, because I'd like to get your ideas on the state of the art and the function of the club. (Not to mention a page or two of material for next years "BAD NEWS")

And we'll be most pleased to welcome you to Boston for the convention.

Best regards,

*John A. Callarme*

# News Release

**wxhr**

96.9 fm  
740 am

boston 38, massachusetts

eliot 4-0500

March 20, 1967

Kermit Geary  
R.D. 2, Box 298  
Walnutport, Pa. 18088

Dear Kermit:

2 CAMBRIDGE, Wixerland (March 20--UPT) -- A combination of left-wing Harvard students and members of the John Birch Society headquartered in Belmont completed their uprising today and proclaimed the Autonomous Republic of Wixerland. The revolution began a week ago with a call to arms by the rebel Radio Free Wixerland, which broadcast code messages erroneously attributed to CIA sources.

Col. P.V. Taylor, commander of the Free Wixerland Forces, and Captain J.A. Callarman, leader of the Somerville command, posted patrols every 10 yards along the boundaries of Watertown, Cambridge, Arlington, Somerville, and Belmont to protect the integrity of the new republic. The Wixerland Navy, under command of Admiral G.P. Nelson, ~~XXXXX~~ streaked down the Charles River, up the Mystic River, then hand-carried the vessels cross country to the Charles again. The strategy, known as the Admiral Nelson Loop, already has military experts buzzing.

Taylor, Callarman, and Nelson, reached for comment on the successful coup, said -- in unison -- "We seek no glory. We seek no power. We only seek --" and here the trio split. Taylor said "advertising revenue," Callarman said "complete news coverage," and Nelson said "reception from Bolivia." The Wixerland triumvirate announced their plans to be the power behind the scenes, and named Nathan Pusey and Robert Welch to head the Wixerland government as Co-Presidents.

Pusey and Welch issued the following statement: "In an effort to reach a consensus form of government, we have decided to institute a 100% welfare state without taxes. We have named J. Paul Getty Finance Minister and Ronald Reagan Minister of Education. The new republic will be run by a series of Neighborhood Councils, who shall elect delegates to a District Council, who shall elect delegates to a regional council, who shall elect delegates to a city council, who shall elect delegates to a republic council. These delegates shall have the authority to rubber-stamp our decisions."

The Co-Presidents immediately decreed their official radio station, WXHR, is authorized to transmit with a 250,000-watt non-directional transmitter, on 735 kilocycles. In the words of Welch, "This will allow the totally-unbiased Wixerland story to be told throughout North America."

A small number of listeners throughout the Eastern Seaboard, apparently tipped off by an informer inside the Wixerland movement, monitored the initial coded broadcasts from the illicit transmitter. Wixerland secret agents reportedly are roving the countryside, wiping out these monitors and destroying their notes.

2-2-2-2

"We hate to indulge in Castro-style reprisals," Welch told this news reporter, "but the notes these monitors took would be invaluable in the wrong hands. They contain the recipe for a combination grape juice/Molotov cocktail."

There was one sour note in the establishment of the new republic. Admiral Nelson, reached for comment late today, said through the bars: "Just as I was about to log the 100-watt Bolivian on 799.977, on came the WXHR carrier and destroyed my opportunity. The Canadian Government jammer has been repaired, and is now on the air once again with its high-frequency program of classic slopover."

The co-presidents also issued a joint statement denouncing the United Nations and applying for admission. Meanwhile, Washington circles had this comment: "We'll wait and see. It isn't worth fighting a civil war over. Dissident factions are bound to cause dissent."

.....

So much for the continued whimsy. Your report was the most delightful and most complete I've ever seen ... and I, too, want the opportunity to verify it: "This verifies your reception of WXHR on March 13, 1967, between 2:56 and 4:29 a.m., EST, on 740 kilocycles."

Further, in my efforts to upgrade musings with creative, adult fare, I hope I can talk you into contributing once again. The teeny-boppers stuff is okay, but there's nothing like good, intelligent narrative to entice some of the other veterans into the contributing fold ... and to set the example for the youngsters. I also intend to reproduce your first paragraph in toto in the bulletin! It was beautiful!

Gordy and I both hope that we can get together with you some time, and discuss possible improvements in the bulletin. Obviously, you read it closely, hi!

Thanks again for the report ... pardon me, that's the first thanks this letter ... and best wishes for continued fine DX.

<sup>73</sup>  
*John A. Callarman*  
John A. Callarman  
Operations Manager.

*Kermit —  
forgive my delay — that I'd sent this out —  
your WXHR report has provided many good moments for  
the production crew.  
Would solicit your aid and assistance (to be  
repetitionally redundant) re our bulletin efforts  
TKT  
JAC*

1390 ON YOUR  
DIAL

NORTHERN MASSACHUSETTS' MOST POWERFUL RADIO VOICE

# WCAT

"THE KITTY WITH THE KILOWATT MEOW"

OFFICES AND STUDIOS  
FIRST NATIONAL BANK BLDG.  
ATHOL, MASS.  
TRANSMITTER AND STUDIOS  
BROOKSIDE ROAD  
ORANGE, MASS.



Feb. 9, 1957

Kermit Geary  
R. D. 2, Box 298  
Walnutport, Penn.

Dear Kermit,

We wish to thank you very much for your very nice letter,  
and this will confirm your reception of WCAT to be correct.

Very truly yours,

RADIO STATION WCAT

*Robert F. Nims*

Robert F. Nims  
Manager

RFN:AJW

W J M Q  
102 Pond Street  
Norfolk, Mass. 02056  
  
Calvin W. Maddox, Ch. Eng.  
(617)329-1170

Mr. Kermit Geary  
DX Listening Post  
R D 4 Box 321  
Walnutport, Pa. 18088

Dear Kermit:

You have achieved a miracle of modern technology. Our 1 kilowatt "tea kettle" rarely gets out of Eastern Mass. let alone to the reaches of Walnutport. I played your tape for our morning man, Martin Hanley, and we both agreed it was indeed his voice, at sign on Saturday 17 October 1981 0700 hours.

Roger on the Hammarlund HQ 180. I have not had the pleasure of using that particular receiver myself. The 80 ' long wire antenna was also an important "element" in the reception of our signal.

I noticed, with some interest, your association with various radio clubs and the dates. I have been associated with the broadcasting engineering business since 1948 with another radio station of which I am sure you are familiar. WBZ in Boston, a full time 50 kw enterprise. I have been assisting my friend, the former State Senator, John M. Quinlan (note the similarity to the call letters) since he lost his chief engineer, who left for greener pastures some time ago. Holding the two jobs is not quite as troublesome as it may seem as the business with WJMQ requires much less of my time. Ham radio is also an interest, WA 1 ZGH, usually 2 meter mobile. Thank you again for your interest.

73's  
  
Cal Maddox