

Pioneer Wireless—By Sir Oliver Lodge.

3

Wireless Review

No. 6. Vol. II.
JAN. 5, 1924.

On Sale
Every Tuesday.

and Science Weekly

*Special Features
: in this Issue :*

Designing an Experimental
Station.

The Inventor's Corner.

Practical Ideas for Con-
structors.

Making a Basket - Coil
Former.

Radio News of the Week.

Charging Accumulators at
Home.

Power Valves, etc., etc.



NOTES ON LOUD SPEAKERS (SEE ARTICLE
INSIDE.)

IDEAL GIFT BOOKS for Boys and Girls of all Ages

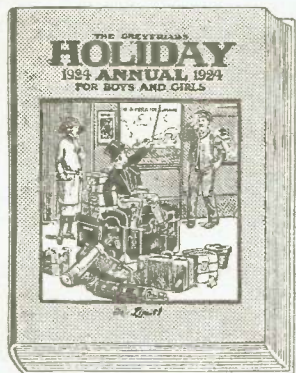

A real schoolboy book. Contains a very large number of stories dealing with the exploits of famous schoolboy characters and many exciting adventure tales.

6/-

Net each, of all Booksellers, Newsagents, etc.

Buy them TO-DAY

It would be difficult to find a more pleasing gift than one of these popular Annuals; they are ideal for Birthday or New Year. From cover to cover they are packed with pictures, jolly stories, full-size brightly COLOURED plates and hundreds of games, riddles, and jokes. Strongly bound in stiff boards with cloth backs, and superbly coloured highly glazed covers, these splendid gift books are much cheaper than the average toys and will outlive them in interest by many months. They will be a source of never-ending delight to the lucky children who receive them.



A book for young children from 8 to 12 years old. Full of amusing pictures and stories of the leading characters from "Play-time"—the popular coloured picture paper.

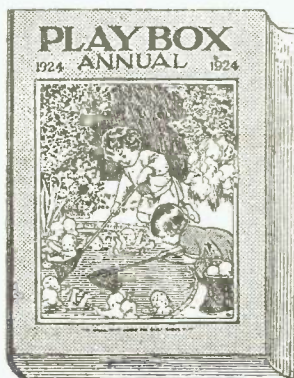

The oldest-established Annual of all, and still a very big favourite with young children from 5 to 10 years old. Contains many pictures and stories of Tiger Tim and the Bruin Boys, and a large number of Fairy Tales.

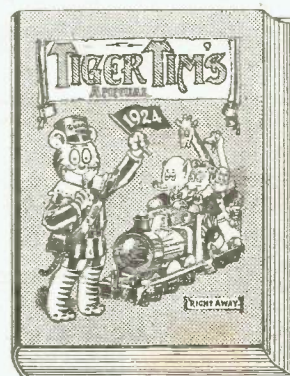

"Tiger Tim's" own book. Tales and pictures of the famous Bruin Boys—the best-loved characters in the world. A book that all boys and girls up to 10 years old will appreciate.

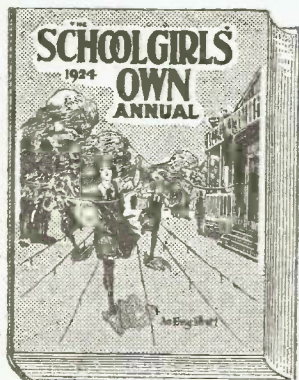

A splendid gift book for girls who are still at school—from the youngest to the oldest. Contains School and Adventure stories, and a large number of interesting articles dealing with hobbies and practical home-crafts.

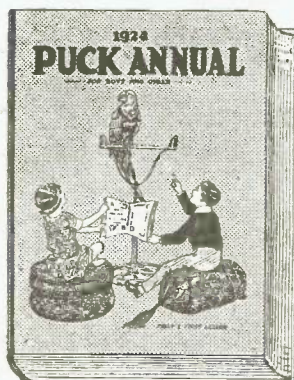

A jolly book for boys and girls from 8 to 14 years old. It is packed with Adventure, School, and Fairy stories, in addition to funny pictures, games, tricks, puzzles, and things to make.



The finest adventure book on the market. One big thrill from beginning to end. A suitable gift for older boys and youths. New this year, and sure to prove very popular.

The Editor's Broadcast

THE Christmas arrangements made by the B.B.C. were a great success. The little playlet broadcast from 2 L O was a most happy event, and must have given the keenest pleasure to thousands of young listeners-in. John Henry was extraordinarily droll: his humour seemed in no way impaired by the fact that he was forging a quiet Christmas at his own hearth; and, indeed, we all owe a debt to the staff and artistes who entertained us over Christmas at the expense of their own festivities at home.

CONSIDERABLE changes have lately been made in the executive staff of the Radio Society of Great Britain. For one thing, Mr. Leslie McMichael has resigned the post of hon. secretary after ten years' service. Mr. McMichael's loss will be keenly

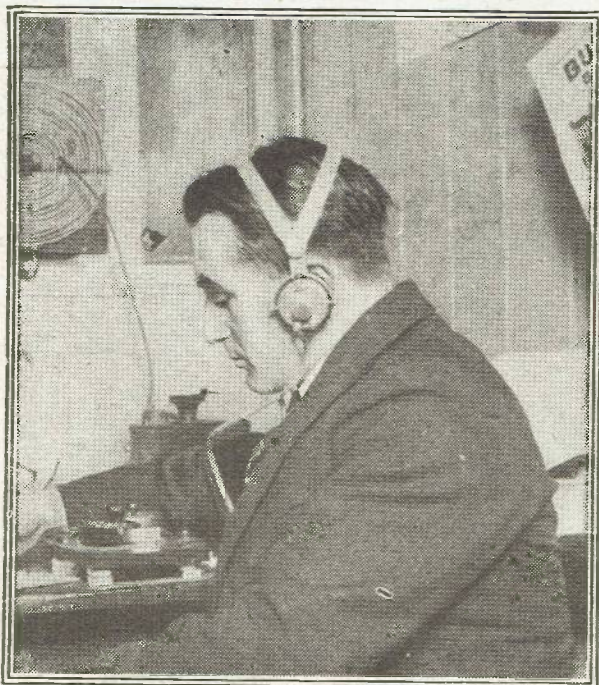

Mr. J. A. Partridge, of Wimbledon, a well-known British amateur, who recently created an amateur transmitting record by getting into touch with Mr. Warner, the Secretary of the American Radio Relay League.

felt by the society, and it is to be hoped that he will still afford the society his valuable aid and counsel.

THE new hon. secretary is Mr. Phillip R. Coursey. Mr. Coursey is one of the few men of to-day who can justly be termed a "wireless expert." His

scientific attainments are well known; so is his keen enthusiasm for the welfare of the Raido Society of Great Britain. But it is a diplomatic blunder to appoint Mr. Coursey as the hon. secretary of the Radio Society of Great Britain. Mr. Coursey is research editor to a well-known wireless periodical, and it is never policy for a journalist—even a technical journalist—to associate himself in an official capacity too closely with a big society. A secretary should be appointed who is absolutely impartial, and against whom no section of the wireless public can raise the voice of objection with any ground for justification.

TO discover the best methods for receiving broadcasting from long distances the Metropolitan-Vickers Electrical Co. are arranging for experiments between Manchester and Pittsburgh, United States. It is hoped that the Trafford Park Station (call sign 2 A C) of the Metropolitan-Vickers Co. will be able to pick up and re-radiate signals from the Westinghouse Manufacturing Co.'s station at Pittsburgh (call sign K D K A). The transmission from Pittsburgh to Manchester will be on a new system. If successfully picked up it will be re-transmitted to British amateurs on a wave-length of 400-metres. The experimenters request amateurs in Great Britain to avoid oscillation, and invite them to report in writing on the success of the experiments to Mr. A. P. M. Fleming, Metropolitan-Vickers Electrical Co., Ltd., Trafford Park, Manchester.

ONE very amusing aspect of broadcasting is the continual squabbling among correspondents to this and other journals as to the relative merits of highbrow and lowbrow music. The highbrows adopt a Johnsonian sarcasm with regard to "jazz" and other "popular" forms of—er—melody; while the lowbrows are rather apt to wax vituperative on the surpassing dullness of—er—"classical" music.

Betwixt the two factions, Editors come in for many passionate letters, which, in their nervous discretion, they have to consign to the limbo of unrealised libels.

But the warfare still goes on; the highbrows say they only listen-in on Tuesdays (classical nights), and the lowbrows emphasise the fact that the B.B.C. bores them stiff on such evenings. After all, it is a matter of taste. Some prefer "Poet and Peasant" to a Beethoven symphony, and vice versa, but in all fairness to the B.B.C. I cannot agree with correspondents who declare that too much popular music is broadcast; nor can I agree that too much classical music is broadcast. The mixture seems fairly equal to me. Perhaps that is because I am a middlebrow—always a safe attitude.

THE EDITOR.

Pioneer Wireless

By Sir OLIVER LODGE, F.R.S., D.Sc., M.I.E.E.

This speech was delivered by Sir Oliver Lodge at the recent wireless meeting organised by "Wireless Review" and "Popular Wireless"

The vast audience in the Central Hall, Westminster, listened spellbound to this great scientist's description of early wireless discoveries, and the noble tributes paid by him to Maxwell, Hertz, Marconi, and others could not eclipse his own brilliant work in the minds of all acquainted with the development of wireless science

CAPTAIN ECKERSLEY began this meeting in a humorous vein, and I confess I am unable to follow him in that vein. But a little serious matter mixed up with the entertainment will not be inappropriate in the circumstances, as we are all interested in the possible scientific developments of this remarkable epoch in human history. The things that are done now as a manner of entertainment would have astonished our grandfathers beyond measure—would have astonished our scientific grandfathers. I remember how enthusiastic Lord Kelvin was with an instrument then in its infancy, an instrument which now we regard as rather a nuisance—the telephone. He was legitimately excited about it.

What we do with Electrons

It is a remarkable instrument, and we must remember that it is the telephone still that is ultimately the receiver—or, rather, it is the human ear. The human ear is the most remarkable instrument of all. But it is the telephone which is interpreting to the human ear.

We are beginning to harness the electrons—harness not their energy, but their docility, their quick

response. They have no mass to speak of, or a very, very minute mass—1,800 times less than the lightest known atom, and they are highly charged with electricity. In fact, they are nothing but disembodied electricity. They have no other matter with them. They are electricity. And accordingly they respond to every impulse with excessive speed, so that the fluctuations of the human voice are slow to them. They can follow it as if they were following the movements of a snail. All our most rapid movement is as nothing compared to the speed of electricity.

And what is it we do with these electrons? You have heard some of the things, some you know by your own experiments.

A portrait by Hoppé of our Chief Scientific Adviser, Sir Oliver Lodge, in his laboratory at Salisbury.

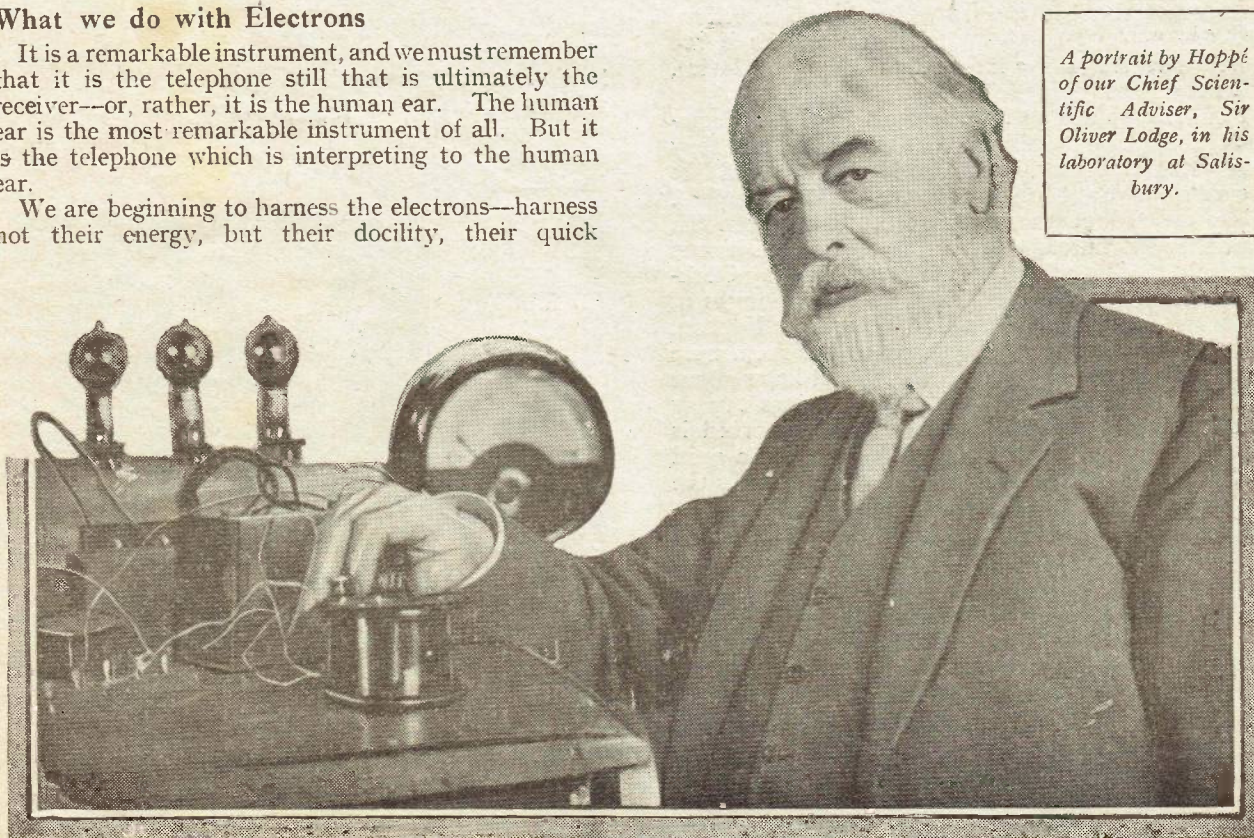

This broadcasting is a remarkable achievement. I thoroughly agree with what was said, I think, by Captain Eckersley just now, that, in spite of difficulties, imperfections, it is a most wonderful thing. I think it is quite—well, surprising is too weak a word—almost miraculous that we can hear the human voice across the Atlantic. Indeed, when wireless telegraphy began, we were content with dots and dashes and the Morse code. It was a wonderful achievement when Mr. Marconi got the letter S across the Atlantic. That opened a new era in wireless telegraphy. But now wireless telephony has got to such a pitch that the human voice can be heard across it.

I once broadcast a short lecture for Captain Eckersley in London, and I heard from many parts of the

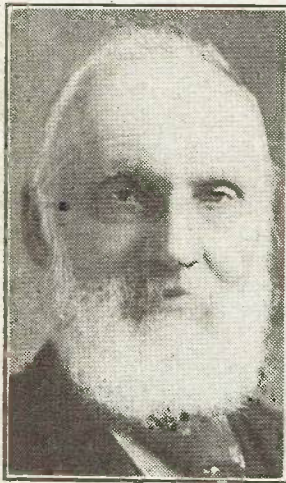

The late Lord Kelvin, who predicted actual telegraphy from early ether-wave experiments.

country afterwards that people could hear me quite well. An interesting episode occurred. My nephew, a colonel during the war, is now a teacher at the Fettes School, Edinburgh. And the boys have a set there which he rigged up for them. And, knowing nothing about what was going on in London, he happened to be listening, and heard my voice, recognised it, and shouted to the boys, "Hi! Come here. My uncle's lecturing."

I did admire the transmitting plant of the B.B.C., though I believe details concerning it are quite private. It is a most remarkably good device. It is not an easy thing to do.

I believe there is a City dinner on to-night. Someone told me he was going to the City dinner, and they were going to broadcast it. I said that sounded like aboard ship. But he told me it was only the speeches.

The great discovery of this century has been the discontinuous nature of electricity. Wireless waves were given, in theory, in the year 1865 by Clerk-Maxwell, one of the most extraordinary geniuses of the world—a man to be mentioned after Isaac Newton. 1865 is before nearly all the people in this room were born. I was only fourteen, and I did not know about it then, but in 1875 I expended my savings buying Clerk-Maxwell's magnificent work, and absorbed it greedily, because by that time I had studied a good deal of mathematics. Now in that work he gives the theory of electric waves, and so he theoretically discovered them. He discovered them in such a way that it made no popular excitement whatever. The public Press took no notice, and the general public were in the same predicament. Only a few awoke to the importance of the discovery.

In Touch with the Ether!

He found in the ether two constants—the magnetic constant and the electric constant. And then, combining the electric and magnetic constants, both of which belong to the ether of space, he showed that

ether could transmit waves, and that the rate at which those waves would travel was one divided by a root, μK , reciprocal of the diametric mass of these two constants. He did not know what that speed was, and to this day we do not know what those constants are. Neither their value nor their nature; but we may guess them. I have made guesses myself. But their product is known, because Maxwell studied by experiments and apparatus to measure the product of μ and K , and he found it came out the velocity of light—thereby showing that light was an electro-magnetic phenomenon, and that the eye was an electro-magnetic instrument, our only receiving instrument which puts us in touch with the ether. All our other sense organs put us in touch with matter. They are all material senses.

The Production of Wireless Waves

The eye is the one ethereal sense which enables us to apprehend tremors, quivers, waves, slow or rapid waves, in the ether of space. Our eye enables us to apprehend the waves, not to see them. And think what an important thing that is. If we were told we were going to a world where we could apprehend the tremors of the ether, we should not think it anything particularly amazing. But if we could not apprehend the tremors of the ether we should be blind, and know nothing but what was in contact with us or what we heard through our ears.

Maxwell did not know, and never did know, how to produce those waves. But when I studied Maxwell's treatise I was enthusiastic about these waves. In the year 1875, right away through the 'seventies and 'eighties, I thought I would like to devote my life to the production of those waves. In 1887 at last I succeeded, by the use of the oscillatory discharge of a Leyden jar. Using it like a tuning fork, attaching long wires to it—very long wires, as long as round this room, and longer—I showed that on those wires are what are called nodes and loops; that the electricity in the wires responded to the oscillations of the jar, and

that you thereby could measure the wavelength; the distance between the two, the nodes and loops, was half a wavelength. That is how I got the waves of wireless.

But simultaneously Hertz, that great German physicist whose acquaintance I had made in the year



The microphone at a banquet is concealed from the guests by flowers.

1881, was working in 1887-88 at the same problems. He was not then familiar with Maxwell's theory, though he became exceedingly familiar with it later. He took a further step—he detected waves in free space. He, too, got the nodes and loops. He, too, used the oscillations of a Leyden jar, but a Leyden jar with the coatings separated from each other so as to make a much more open oscillation.

A closed circuit oscillator like the Leyden jar is a good magnetic radiator, but not a good electric radiator. By opening out the coatings of this jar and making two capacities separated by several feet or yards, and then discharging them into one another, the waves spread out into space, needed no wires to convey them, and the Hertz waves—the waves predicted by Maxwell—really had their birth in the ether for the first time. Very few people realised the importance of this. In Germany they did not. They were not acquainted with Maxwell's theory in Germany. We in Britain



Senatore Marconi, to whom Sir Oliver Lodge paid a wonderful tribute.

greedily absorbed and admired the work of Hertz. We had him over here, we fêted him, made a lot of him. But still it did not get into the papers.

It is extraordinary what discoveries the public will get excited about. Einstein they swallowed whole, and they have taken a great interest in wireless. Which is a very good thing. But it is all the outcome of the work of Hertz, whom no public ever recognised. In the first instance, Clerk-Maxwell, and in the second, Hertz.

Amazing Discharges

But, incidentally, how did Hertz discover the wave? He discovered it by a spark gap. He had no means of detecting it, but he found, to his surprise, with the receiving arrangement, that the waves were strong enough to excite sparks in the receiving arrangement—little sparks. And when I was lecturing to the Royal Institution in 1889 or 1890 on the discharges of the Leyden jar, it was found that the wallpaper was sparking! It was a thick, gilt wallpaper, covered with pieces of metal. So that the audience got up and turned round to look at the wallpaper and did not attend to the lecture!

It is amazing what a strength a Leyden jar discharges at. You may think that a Leyden jar has got a small quantity in it, but it discharges itself in the millionth of a second. The current for the discharge of a Leyden jar may be several thousand amperes. It does not last long, but it is strong while it lasts, and the radiation power of a small Hertz radiator comes to 100 horse-power. That is why it has the power of exciting these sparks.

Now in 1889-90, by bringing these spark gaps very near together—touching, in fact—I found when the little spark occurred, those knobs cohered. It required

a little effort to break them asunder. The gap is closed by the cohesion. It could also be done by the discharge of an electroscope, and in other ways.

But Branly, in France, made the same observations in a very complete manner, and followed it up. He found that tubes containing filings cohered when sparks occurred in their neighbourhood. I thought that coherers had gone out of fashion now, but I hear from Major Phillips that they still exist, and can be used for wireless control purposes with advantage.

That curious genius, David Hughes, was found to have done similar things. But he had done something very like signalling by means of it. He had thought it might be used for telegraphy, but he did not follow it up. In 1892, however, Lord Kelvin wrote an article in the "Fortnightly Review," after seeing my experiments, and foreshadowed actual telegraphy by this means. A rather remarkable case of scientific prediction.

Practical Signalling

Then, in 1894, I did exhibit signalling by this means both at the Royal Institution and the British Association, using a special galvanometer and having an automatic tapper for breaking the circuit and leaving it free to go on again. Thus we could get long and short deflections and Morse signals. What was now wanted was someone to take over this practical method and make it a practical system of signalling.

But let me say that if it had been left to me, or if it had been left to Hertz, it never would have come to the great developments which it has come to through the energy and enterprise and ability and enthusiasm of Senatore Marconi. His name first became known to the British public in 1896, when Sir William Preece said that a remarkable invention had been brought to the notice of the Post Office by which a Morse instrument could do signalling over a great distance.

I remember offering Sir William Preece to show him the same thing in the laboratory behind, but he was busy and did not see it, and I don't think he was aware of how much had been done. Nor was Mr. Marconi. But with the help of the British Post Office at first and with the help of financiers and other important people afterwards, Mr. Marconi went round, devoted his time and work to the problem, and brought it to a state far beyond any laboratory experiments, such as it would have remained in had it remained in my hands. He worked on a large scale. He made the aerial big and vertical, and he used the earth for the lower aerial.

Now I had always avoided connecting to the earth, because it seemed to me unfair for purposes of demonstration to connect the sending end and the receiving end by any conductor whatever. The earth was the

(Continued on page 164)

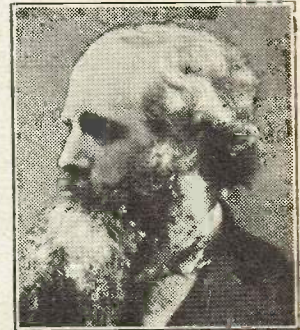

Clerk-Maxwell, "one of the most extraordinary geniuses of the world."

Making a Basket-Coil Former

By Capt. RICHARD TWELVETREES,
A.M.I.M.E.

The difficulty of accurately marking out the former may be overcome in the manner described below.

OWING to their low cost, basket coils are very popular with wireless experimenters for all tuning purposes. As is well known, complete sets comprising eight coils can be purchased from two shillings upwards.

Those who have been accustomed to rely upon some of the cheaper forms of basket coil, in which the wire is wound on a spider, the latter being withdrawn after the coils are waxed, have found that the complete coil is very fragile, soon loses its shape, and frequently becomes unwound.

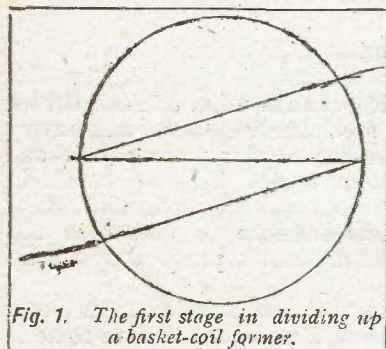

Fig. 1. The first stage in dividing up a basket-coil former.

For the above reasons it is preferable to wind the coils on substantial and permanent formers calculated to withstand the frequent interchange of coils so necessary in genuine experimental work. The greatest difficulty, of course, consists of marking out the former, but provided the instructions given below are carefully followed out, there is no difficulty whatever in arriving at the correct solution of the problem.

The only instruments needed for the purpose are a pair of compasses and an ordinary rule or straight edge.

Reference to the accompanying illustrations will show the various stages of the marking out, arranged so as to be easily understood even by readers whose

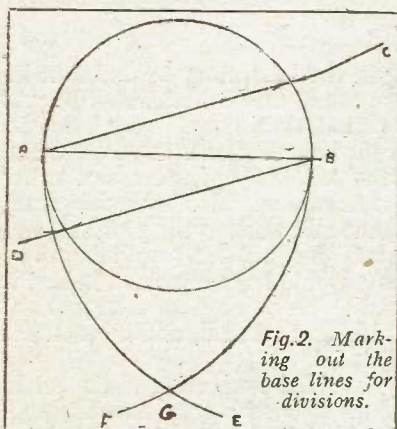

Fig. 2. Marking out the base lines for divisions.

knowledge of geometrical problems is extremely limited. Commencing with Figs. 1 and 2, a circle of about 4 in. in diameter is described on paper. The line A B is then drawn through the centre. At an angle of approximately 30°-40° the line A C is drawn from the point A, intersecting the circumference of the circle, as shown. The next step is to mark out the line B D,

parallel to A C, which is done by transferring the distance from B-C to A-D.

In this particular example it will be assumed that an eleven-slot former is required, and the process continues as follows: From the point A and radius A B describe the arc B F, and from the point B, with radius B A, describe the arc A E, the two arcs intersecting at the point G. This being done, two equal divisions of approximately 1/4 in. are marked as shown on the line A C (Fig. 3).

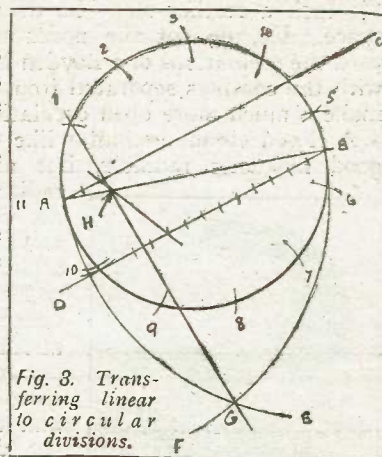

Fig. 3. Transferring linear to circular divisions.

Now the dividers are set accurately to the distance between the points on the line A C, which were transferred to the line B D, commencing from the point B. It is important that these divisions on the line B D should be equal in number to the slots required in the former. From the point B, nine divisions are counted off, and from the ninth point on B D a line is drawn to the second point on the line A C.

Dividing Off

Whatever number of divisions is required for the former only two divisions are needed for the line A C, and the total number of divisions for slots required on line B D, less two, is used for joining up, as described above. Thus, with a fifteen-slot former the thirteenth point from B is to be joined to the second point on A C.

From the point G, where the two arcs intersect, a line is drawn through the point H to the circumference of the circle, the point in the circumference thus obtained being marked 1.

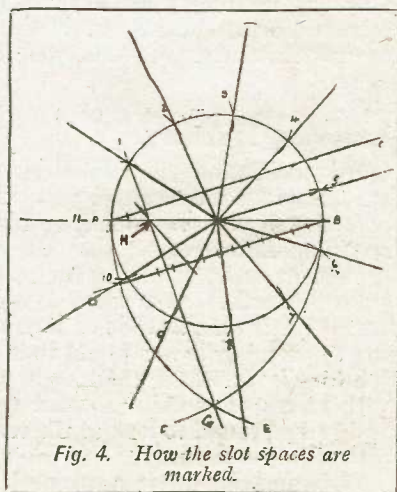

Fig. 4. How the slot spaces are marked.

It will now be found that by taking the distance from A to 1 the entire circumference can be divided into eleven equal divisions. Now, from each of the divisions thus obtained lines are drawn to the centre of the circle, and no farther.

Having determined the depth required for the slots, a circle is described from the centre point, and parallel lines representing the width of the slot are marked from the radiating lines. The only remaining detail is that of cutting out the former slots as scribed.

Practical Ideas for Constructors

REMOTE CONTROL FOR CONDENSERS

IN many sensitive circuits remote control of tuning arrangements becomes a necessity if ease of operation is to be ensured. Extension handles fitted in the usual way do not always serve the purpose, for in many cases turning them brings the hand nearer to or further away from some other sensitive part of the circuit, thus defeating the object of eliminating body capacity effects. It is frequently difficult to avoid this state of affairs with the ordinary extension handle arrangement if the circuit is at all a complicated one. The device here illustrated, however, as applied to a variable condenser can be adapted to any existing set, and presents a simple means of ensuring critical remote control free from the objection applicable to the usual arrangement.

The bevel wheel is simply a piece of cotton-reel with a strip of thin rubber (such as a piece of bicycle inner tube) or, failing this, cloth, glued on the bevelled part that is to engage the rim of the condenser dial. This is mounted on the end of a piece of 4 B.A. screwed rod, to the other end of which is affixed a knob. It will be found that the hole in the reel is much larger than required to take the rod, but this defect is overcome in the following simple way. Two thin pieces of brass or tin are cut as in Fig. 2 and the corners turned up at the dotted lines. These, when drilled to take the 4 B.A. rod, are mounted on either side of the bevel wheel and the points squeezed into the soft wood by nuts on the rod as shown, taking care that the wheel is mounted centrally.

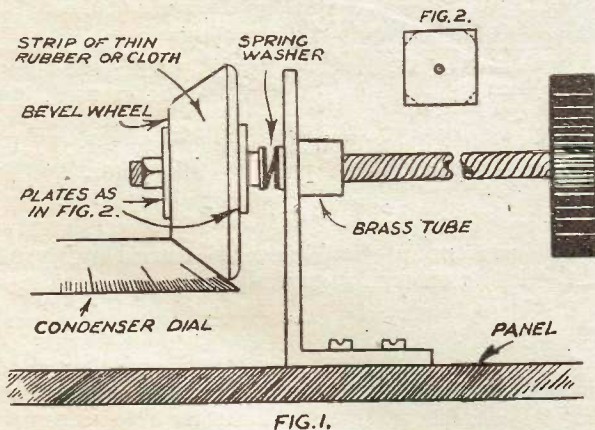

The bracket is a piece of angle brass drilled for screwing to the instrument panel and to take the rod carrying the bevel wheel. To this is soldered a short piece of brass tube or a brass bush (say $\frac{1}{2}$ in. long), as shown, in which the screwed rod has to revolve. The bore should not be large enough to allow the latter to wobble. Between the bevel wheel and bracket is a spring washer which, when the whole is in position, presses the wheel against the rim of the condenser dial and provides sufficient friction, when

the knob is turned, to revolve the dial. The bevelled dial and wheel, when placed together, may not make an exact right angle with each other, but this is sometimes an advantage if the angle so formed is less than 90° . The bracket and bush may be substituted by a small block of hardwood, secured by screws to the panel from underneath, if desired.

C. C. G.

AN ALARM FOR ACCUMULATORS

One cannot always keep an eye on the accumulator whilst it is charging, and it is very useful to have an alarm of some kind to show when it is finished.

The completion of the re-charging is accompanied by development of gas in the cells, and this fact may

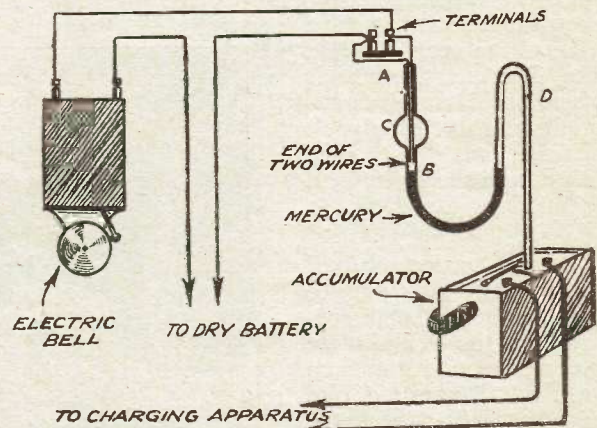

be utilised to operate an alarm. A glass tube of the shape shown is inserted in the battery, and mercury is placed in the bottom of the tube. Two wires are inserted at A, and almost touch the mercury at B. There is a bulb at C. The wires in the tube are connected to two terminals at A, and connected in turn to an electric bell and dry cell as shown.

A certain amount of gas is formed during the charging, but this has no effect on the mercury if a small hole is made near D.

HELPFUL HINTS

Little points that make a big difference

Sediment in an accumulator is decidedly undesirable. It often consists of particles of active metal from the plates, and if this ever comes into contact with the plates again it sets up in business for itself, and "local action" is the result. Charging and discharging at abnormal rates are the causes, and more than 50 per cent of accumulator trouble is the result.

A high plate voltage does not always mean louder signals. Make the wander plug of the H.T. battery live up to its name, and keep it moving.

Designing an Experimental Station

By H. G. HERSEY

This article gives full details for the construction of the Condenser and Detector Panels. Together they form a receiving set, to which additions can be made in the manner to be described next week

PART II.

TURNING back to the previous part of this article a photograph is shown of the condenser panel unit for loose or direct coupling. The three-coil tuning stand could, if it is desired, be mounted against the side of this panel; but seeing

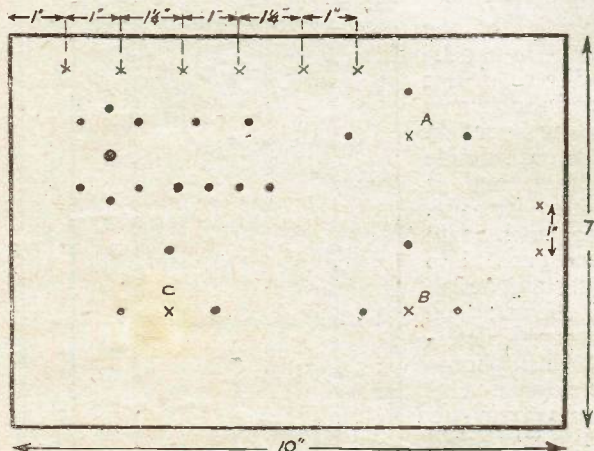

that capacity effects (from the body) would no doubt be experienced when the coils are being adjusted, it would be best mounted in some convenient position away from the condenser panel.

Panel Design

The condenser panel unit may now be considered as regards its requirements and design or lay out. Firstly, we require a series-parallel switch and a tune-stand-by switch. Secondly, three variable condensers are required (the main tuning condenser, the vernier, and the secondary circuit condenser).

The main condenser should consist of about twenty vanes, and is used for general tuning. For very fine condenser adjustment the vernier condenser is provided. The latter should not consist of

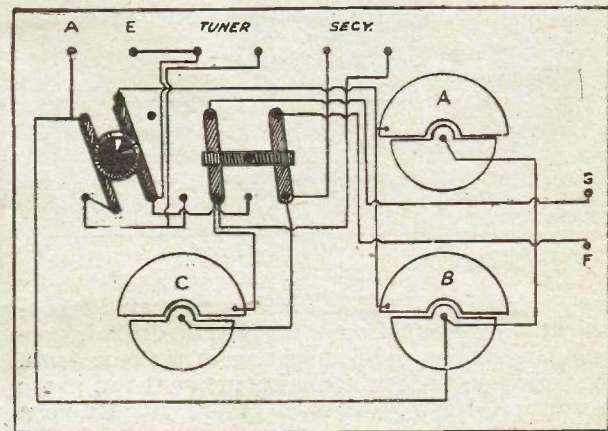

The Wiring of the Condenser Panel.

more than two moving and three fixed vanes. The secondary condenser must also be upon the small side if the set is to be used much for short waves, otherwise the tuning of this will be most critical. Three moving and four fixed vanes will be a convenient size; and should a greater range over certain coils be required, a small fixed condenser could be placed across the secondary terminals.

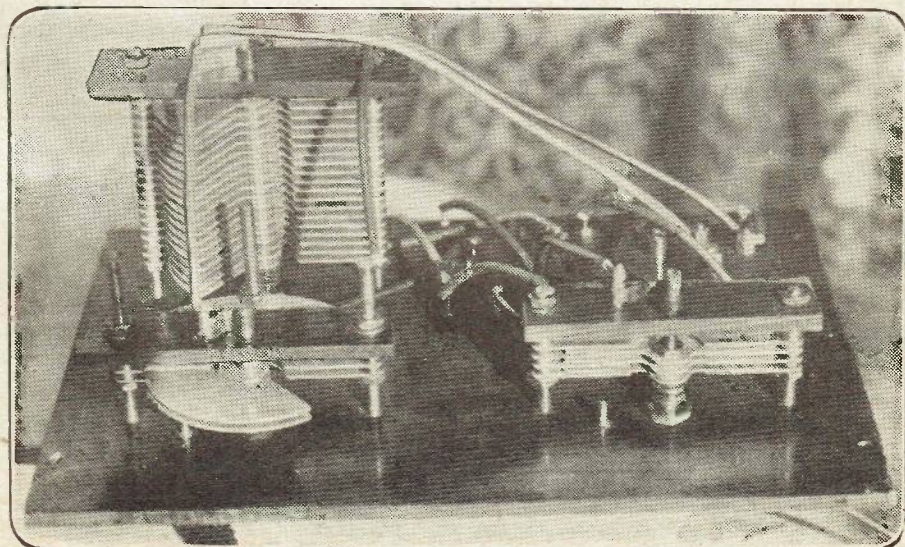

The Wiring and Lay-out of the Panel are shown clearly in this photograph.

The three condensers are mounted as shown in accompanying photograph. For the panel a piece of ebonite 10 in. by 7 in. by $\frac{1}{4}$ in. should be cut and marked out as shown. The right-hand top condenser is the main, and beneath is the vernier; the left-hand switch is the series-parallel and the other tune-stand-by. The actual dimensions, etc., cannot be definitely stated owing to the varying sizes of materials the reader may procure. However, much information will be obtained from the full view of the panel in the photograph which appeared last week.

The panel having been drilled, the whole may

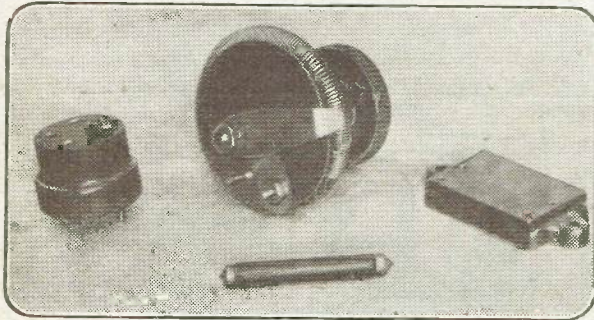

Parts of the Detector Panel.

now be assembled. The condensers may be conveniently made up from parts, or, if desired, purchased ready for panel mounting in skeleton form. The various parts for the condensers are shown in the photograph below; the fixed plates, mounted upon three spindles of screwed rod, are let into the ebonite panel by drilling and tapping the latter. The moving vanes are mounted upon a single spindle, which is attached by means of a bush, boss, and spring washer.

For the condenser scales, the white ivorine are effective; they should be made to adhere to the ebonite by liquid celluloid. This is made by dissolving small pieces of celluloid in amyl acetate,

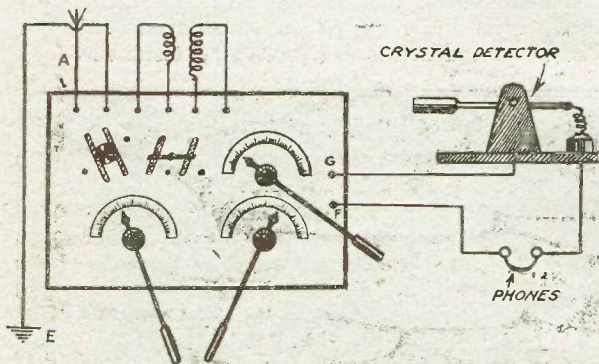

Connections of Condenser Panel and Crystal Detector.

purchased from a chemist at about 5d. per oz. (This mixture will be found most useful for sealing many things, including leaky accumulators.) The connection from the fixed plates is easily made, but for the moving plates a short piece of copper foil about 4 in. in length and $\frac{1}{4}$ in. wide should be coiled into a spiral and soldered to the moving spindle, the outer end being soldered to a small screw let into the ebonite at the condenser base.

This will ensure a good connection, and it can be seen upon all the condensers in the photograph. When the switches and contact studs are mounted, the general wiring can be commenced. All connections are soldered, and the wire Systoflex covered. This improves both

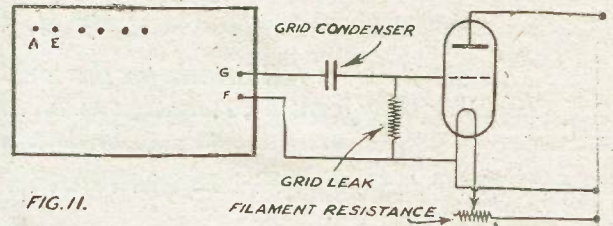

FIG. 11.

the neatness and efficiency of the apparatus for insulation. The main and vernier condensers, it is observed, are placed in parallel and connected to the two top left-hand studs. The terminals are A; aerial; E, earth; the centre pair marked tuner go to the tuner primary, the other pair going to the tuner secondary. G and F go to grid and filament of the detecting panel.

The condenser panel should now be mounted upon a suitable cabinet, and is ready for use. The panel would be connected to tuner and aerial, as shown; and if a crystal detector with 'phones be connected across terminals G-F, it would form a crystal receiver in which comparative results might be obtained in series or parallel condensers and loose or direct coupling for the local station; also it affords a means of testing the apparatus so far constructed.

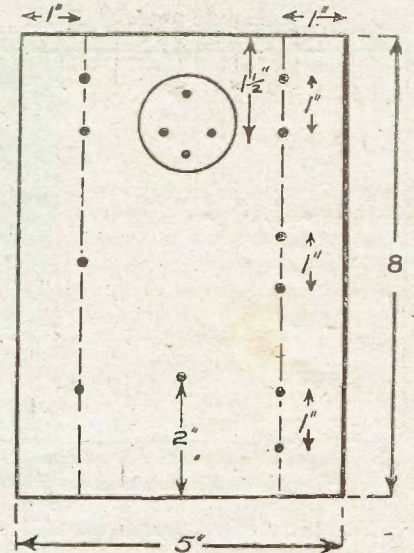
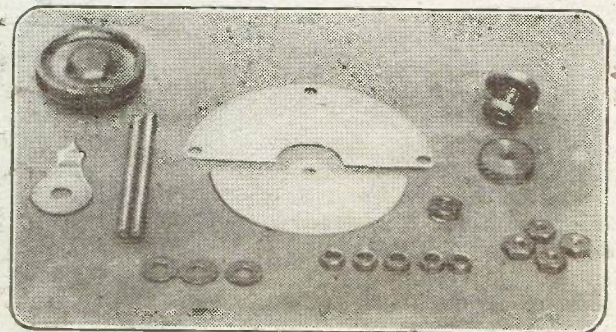

FIG. 12.



Representative sections of the Variable Condenser.

This completes the tuning arrangements as far as the A.T.I. is concerned, and we will consider the valve detector panel.

For the detector panel we require a valve holder into which the valve is plugged, a filament resistance to regulate the amount of current the valve is to receive, a grid condenser to by-pass the high-frequency oscillations from the A.T.I. to the grid of the valve, and a grid leak to provide a path in order that any accumulated charges upon the grid may leak away. These parts are shown in the photograph and are all connected up, as per Fig. 11, to the tuner, etc.



Fig. 13. The Detector Panel.

In order to make them up into a separate panel they should be mounted upon a suitable piece of ebonite, together with the necessary terminals for the 'phones and the batteries.

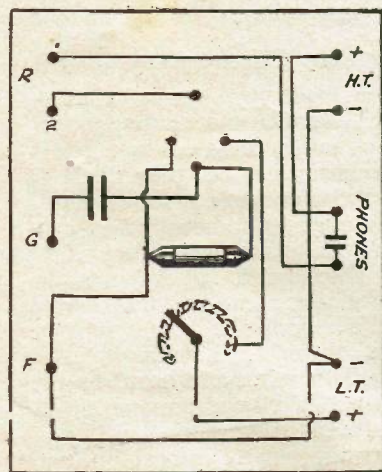

FIG. 14.

A piece of ebonite should be purchased or cut 8 in. by 5 in. by $\frac{1}{4}$ in., and set out as per Fig. 12. This is drilled to take ten terminals. The valve holder is mounted in the position shown, and secured by nuts provided upon the valve legs; the filament resistance is of the usual pattern, and mounted under the panel according to the particular way designed by the makers. The resistance should have an off position. The grid condenser may be purchased, its value being of the order of .0003 mfd. It may be conveniently made up from copper foil and mica, using three pieces of foil about 2 in. by 1 in. and separating them with mica sheets, as shown. Connect the outside pair together, taking one connection

from the centre piece and one from the outer two. The grid leak may be purchased or made up by the reader according to instructions given from time to time in WIRELESS REVIEW. If purchased, the reader may use either the fixed type mounted between two clips upon the front

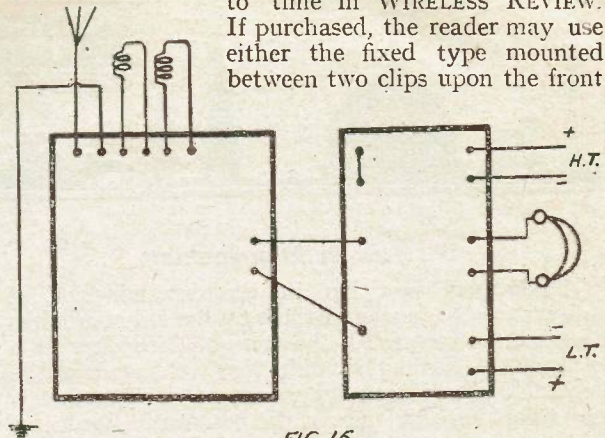

FIG. 15.

of the panel, or he may use one of the variable pattern now placed upon the market. A second H.F. by-pass condenser is obtained and placed across the 'phone terminals to provide a path for the H.F. currents set up in the plate circuit.

The value of this condenser is .0003 mfd. The panel may now be wired as per Fig. 14; the terminals R are for reaction, G connects to G of tuner-condenser unit, and F to F of tuner condenser unit.

The terminals R are shorted externally at this point, and used later with the H.F. panels. The panel is shown both externally and internally in the photographs, from which its general appearance may be judged. If connected up with the condenser panel at this point, the connections are shown in Fig. 15, and the set is ready for use.

(To be continued next week.)

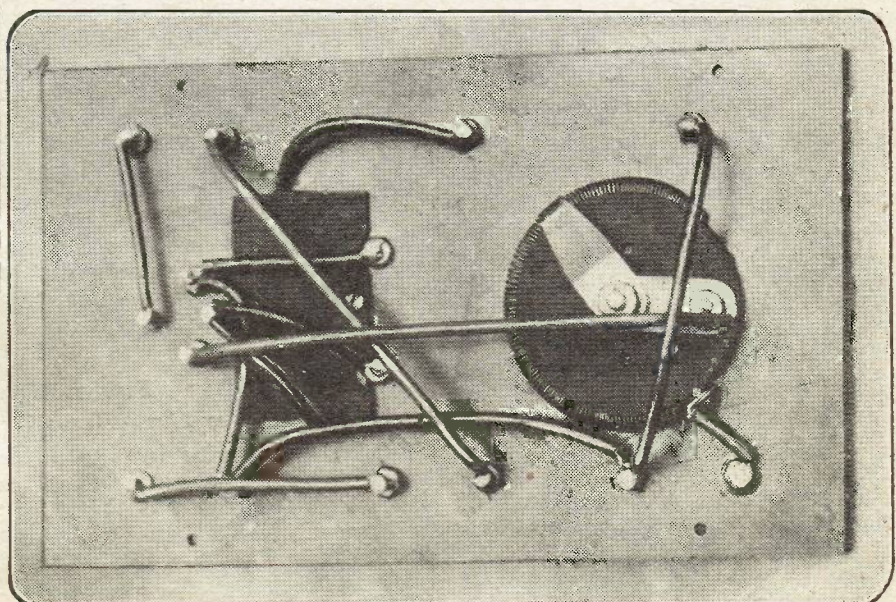

This photograph shows the wiring and spacing of the Detector Panel.



Wireless in Map-making

The extreme precision in the determination of position which is made possible by the aid of wireless is evident in the case of the town of Bordeaux. As a result of new calculations of its longitude, made at the Bordeaux observatory by means of wireless signals sent from the Eiffel Tower, the position of Bordeaux on the map has been pushed considerably westward. The new calculations have shown the town to be further west by fifteen seconds of arc, which, at the position of Bordeaux, is about 360 yards, or about one-fifth of a mile. Astronomers are employing wireless time-signals to correct longitudes all over the world, and many errors have been found in previous calculations.

500 Broadcasting Stations

The listener-in who is sometimes apt to grumble at the service which he gets, and at the interference which he occasionally experiences, should give ear to the troubles of the "fan" in the United States. There the number of licences taken out for broadcasting stations has exceeded 800, although now only about 500 are actually in use. This number of stations is just about ten times as many as are required to cover the whole of the U.S. Fortunately for the listeners-in there, the peak of the curve seems to have been reached; no further applications for broadcasting licences have been received of late, and four existing stations recently shut down.

"On the Air"

For the past eighteen months, individuals and firms in every conceivable business have been competing to get their ideas "on the air." The field is gradually clearing, however, and the day is probably not far distant when the operator of a valve set will be able to "hold" a particular station throughout its programme without the annoyance of overlapping carrier waves. It is no exaggeration to say that the British listener-in has the most satisfactory broadcast service in the world.

"Svenska Rundradioaktiebolaget Calling"

This is the name of a new Swedish broadcasting company. How would you like to hear that on the loud speaker every night? The organisers of the company are almost more terrifying—Elektriska Aktiebolaget, A. E. G. Allmänna Telefonaktiebolaget,

Ericsson, and others. The company has applied to the government for a concession to transmit information by radio. The first information transmitted will probably be the translation of the title.

When Does the Experimenter Sleep?

The "Radio World" asks the question, "When does the radio 'fan' sleep?" This question is prompted by the recent experiments which were conducted by the Willard Battery Co. In order to be free from disturbances, the experiments were carried on either shortly after midnight, or between 5 a.m. and 8 a.m. In response to a request for reports from listeners-in, the Willard Co. was overwhelmed with replies, and they are now wondering (1) at what times during the day or night is there no one listening-in; and (2) when does the radio "fan" really sleep? The same questions might well be asked in this country, and the result of the experiment only serves to show the immense fascination of wireless for those who take the trouble to study it seriously.

Hypnotism by Wireless

Experiments have been made upon hospital patients and others to find out whether the effect of hypnotism, personal magnetism, etc., can be conveyed by wireless. It appears that once a person has become subject to the influence of a particular hypnotist, the hypnotic trance or other effects may be induced on a subsequent occasion without the personal presence of the hypnotist. A written note, words spoken over the telephone, even a verbal message sent by the hypnotist and repeated by a third person to the patient, may be sufficient to restore the control. It is natural, therefore, that words spoken by wireless and heard by the patient on a receiving set should have the same effect. But it is stated by experts that there is no danger of a "spell" being cast over the general listeners-in, and none would be affected other than the person or persons for whom the message was intended.

French Wireless "Newspaper"

The first wireless newspaper in France will be edited by Leo Poldes, who has been prominently associated with French radio developments. His scheme is to give the news by wireless, with some of the most eminent writers and speakers in the country reading out the information; the latter, it is stated, will cover the widest possible range, from politics to sport.

The Construction of a Short-wave Transmitter

By REGINALD GOURAUD (8 C A, France)

The author of this article is well known as the builder of "Poste Zero," the famous "pirate" set which transmitted speech and music on Eiffel Tower's wave-length whilst the French authorities were vainly striving to locate its audacious owner

In the last few months I have been the recipient of a great many requests for instruction on building a good short-wave telephone transmission set.

By giving a general idea of the power, types, etc., of the parts I have used, I think that the average amateur can work out his transmission set with little difficulty. I will be glad to answer any inquiries on parts of the "hook-ups" not understood clearly, though inquiries as to range, positions of control dials, or other minor details I cannot promise to reply to (due to the press of my own work here, and not to unwillingness on my part). The range of the circuit described below is not very great, but could be very useful for short-distance work between friends. The list of materials is as follows:

1 tuning coil; 3 fixed condensers; 1 variable condenser; 1 or more H.T. batteries; 1 resistance; 1, 2 or 3 transmitting valves; 1 filament rheostat; 1 storage battery; 2 flash-light (pocket lamp) bulbs; 2 yards of resistance wire; 1 microphone; 1 Morse key.

Coil Construction

The tuning coil should be wound with 35 turns of bare 18 S.W.G. copper wire on a cylinder of 3 in. diameter. A space of 1 mm. should be left between each turn of the wire, and a terminal should be placed at one end of the coil. If the set is mounted on the table, two slide tuners can be used; if mounted on a panel, flexible taps should be soldered on to the turns of the tuning coil, leading to two separate groups of contacts on the panel. The aerial-plate circuit should have eight taps, one to every two turns of the coil, starting from the top and leading down. The grid circuit should have eight taps also, one to every turn of the coil and starting from the bottom. The eleven turns of the coil in the middle, between the two sets of taps, should be left free.

The three fixed condensers should be of the ordinary paper or mica variety, two of .001 mfd. capacity and one of .002 mfd. capacity. The variable condenser should be of the regular receiving type, of .0005 mfd. capacity.

The valves employed should be a regular 5-watt transmitting type, or equivalent to the French receiving valves. They are to be used as oscillating valves.

The resistance can either be made or purchased at very low cost. For the amateur not fully equipped for such work I should recommend buying one, rather than wasting his time trying to make one. The value should be about 7,000 ohms.

Necessary Components

The filament resistance is an ordinary heating rheostat, such as is used on any receiving set.

With 1, 2, or 3 valves, an ordinary 30 ampere-hour 6-volt storage battery, well charged, will suffice to heat the filament.

After assembling that part of the set which is in the house, carefully following the diagram, the next step is naturally to construct the aerial, if the amateur has not one already rigged. That which has given me the best results for a set of this power consists of two small 4-wire cage or prismatic aerials, each part being 26 ft. long and 3 ft. in diameter, measured by the spreaders. The lead-in should be made as short as possible, of heavy wire.

If it is possible to have a counterpoise replace the earth the results obtained will be much better. The counterpoise can be made of two wires parallel with the antenna, its dimensions being, both lengthwise and across, greater than those of the antenna—i.e., surrounding it on all sides. It should be located halfway between the aerial and the earth.

A Simple Modulator

The station as now set up is capable of sending continuous wave telegraph signals, but cannot modulate the human voice. Several systems of modulation can be used, but the simplest for the amateur consists simply of one turn of insulated wire around the middle, or free, part of the tuning coil.

The price of hot-wire ammeters and plate milliammeters can be saved by replacing these instruments with flashlight bulbs (simply two small electric

(Continued at foot of next page)

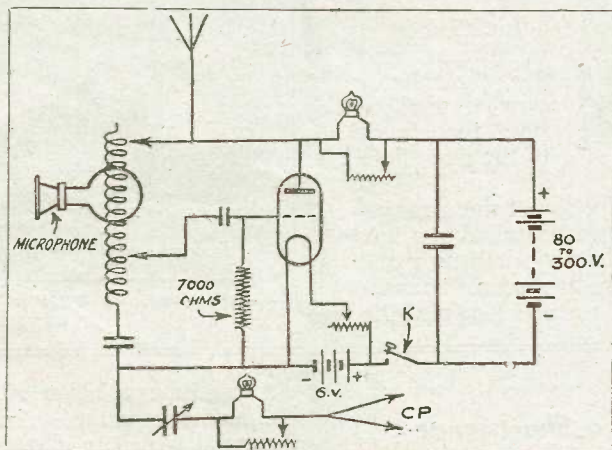

New Use for Coherers

These instruments have been superseded as wireless detectors, but if adapted as described below they are still capable of rendering very useful service of another kind

THE old coherer used for so long a time in wireless work can be used very well for testing electric lines, when it is necessary to say if these lines are under tension or if they are currentless. For this purpose a coherer is a very practical

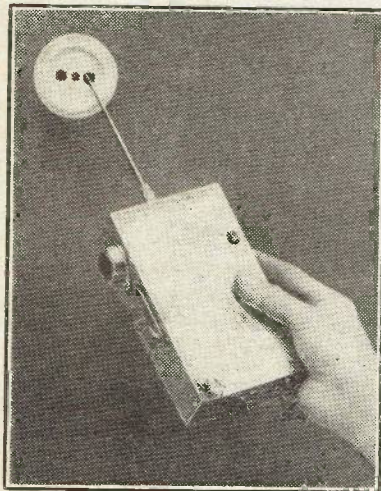

Testing with the coherer.

instrument. If we connect it with a line traversed by a current it gets conductive, as if it is influenced by wireless waves. The small metallic particles with which it is filled are drawn together and conductivity originates.

Installed in a feeble current line, the coherer can be used to close the circuit to the main line. The small illustration shows a practical construction of the arrangement just described. The coherer is installed in a box which contains also a pocket battery delivering the feeble current. At one side of the box is fixed an insulated handle, G, at the other one we see a long metallic

needle, T. The third side shows the sign—, and the small round box, S, containing a cross. It is only necessary to touch the line to be examined with the searcher in order to see if the small cross appears or if it is covered by a turning disc.

Earthing of the instrument is not necessary, but can be effected with the aid of the terminal E. After use the parts of the coherer must be made operative in the same manner as the coherers formerly used in wireless work. This is affected by a small beetle, K, which is moved by pressing a button installed beside the handle.

In testing tensions of more than 3,000 volts it is better not to touch the current carrying line itself. In this case an isolated piece of metal is arranged in the neighbourhood of the line, which is loaded up from this line by influence. It is sufficient to touch this piece of metal, as shown in the photograph below.

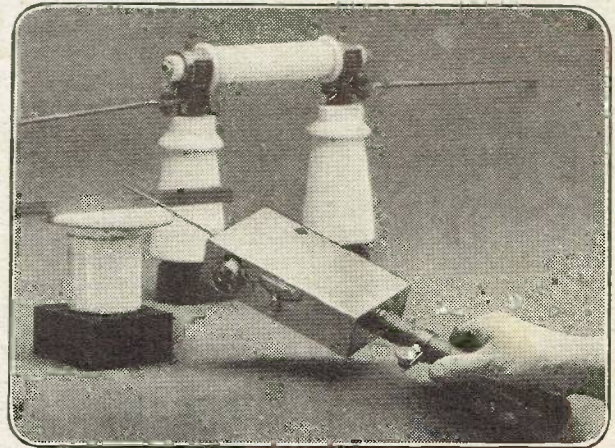
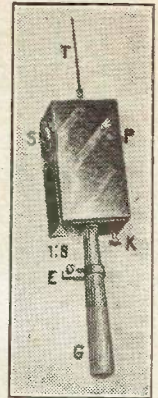

Power mains are examined by their inductive effect upon adjacent metal.

The Construction of a Short-wave Transmitter

(Continued from previous page)

lamps taken from any pocket electric torches) in the two circuits. If necessary they can be shunted with resistance wire.

The set is now ready to transmit by telephony or telegraphy. To telephony, close the key in the high-tension circuit, switch on the valves, and with the rheostat light them to six volts. Turn the top set of taps and the bottom set of taps slowly, whereupon the flashlight bulb in the plate circuit should begin to glow, showing that the circuit is oscillating.

A careful regulation of the taps will bring about the maximum intensity, causing the flashlight bulb in the aerial circuit to glow brightly. After this, careful regulation of the lower set of taps (grid circuit) will cause the flashlight bulb in the plate circuit to glow less brightly.

Receiver and Results

This can be done without diminishing the intensity of the glow-lamp which is in the aerial circuit. To telegraph, make the dots and dashes with the regular telegraph key. Under fair conditions, using the cage antenna strung some 15 yards from the ground, and using on the plate circuit three H.T. batteries of 80 volts, I have often sent messages ten or eleven miles at night. The receiving set used to get my messages was in this case a simple regenerative set with L.F.

Readers of "Wireless Review" are invited to submit articles of a practical nature and illustrated with photos. for publication. Amateur photographs are paid for at the rate of 10/6 each if accepted

Power Valves

The valve as a transmitter is steadily gaining in favour, and this interesting article describes the progress and possibilities of such transmission

By **SEXTON O'CONNOR**

THREE years ago the Imperial Wireless Telegraphy Committee, after a thorough investigation of the different systems in use for long-distance transmission, unanimously recommended the installation of power valves in the proposed chain of stations which were to link up the Home Country with India and the Dominions. The report laid particular stress upon the improvement in flexibility and efficiency and the reduced cost which would result from the use of thermionic generators as compared with either the Poulsen arc or high-frequency alternators.

Since then the development of high-powered valves has reached a point which not only fully justifies the reasoned opinion of the committee, but has in fact surpassed the most sanguine expectations. In essential features the power valve is similar to the ordinary valve, but considerable modifications are necessary.

Bombarded by Electrons

Up to about 5 kilowatts, valves with glass bulbs have been in successful operation, notably in the Marconi station at Carnarvon, where 60 air-cooled valves, each developing 4 kilowatts, are run in parallel. The life of such valves is over 5,000 hours, which compares extremely well with the smaller type.

For powers over 5 kilowatts the use of glass bulbs becomes impracticable, owing to the heat produced at the anode. Accordingly they are now made of silica, which has a much higher melting-point than glass. At first the manufacture of silica bulbs presented great difficulties, owing to the refractory nature of the material, but these obstacles have been gradually overcome by the use of improved methods, and bulbs of large size are now available. At the same time the cost of the silica envelope still represents a large proportion of the total cost of the valve, and for this reason the filament is mounted so that it can be readily renewed in case of breakage, without scraping the silica vessel.

The main problem in large valves lies in the difficulty of cooling the anode. The electrons leave the filament at a comparatively slow velocity—about 6 in. a second—but move with rapidly increasing speed towards the anode. With the high potentials—10,000 volts or more—obtaining in large valves, the actual velocity at the moment of impact against the anode is enormous. Unless some effective means of cooling the anode is available, the latter rapidly becomes incandescent under this terrific electronic bombardment. Actually the loss due to anode heating may amount to upwards of 30 per cent of the power supplied to the valve.

The problem of cooling is emphasised by the fact that the anode is entirely enclosed by the evacuated silica tube. Quite recently, however, a method has been found of utilising a metal anode which is incorporated or fused into the actual wall of the tube.

This has been made possible by the discovery of a new process for sealing metal into glass. Formerly it was always assumed that the sealed metal must have the same coefficient of expansion as the glass. Platinum is the only metal having this property, but as it costs over £20 an ounce, its use in the quantity necessary for a large power valve is quite out of the question.

As the result of many experiments, W. G. Housekeeper, of the Western Electric Co. of America, has proved that copper, although having a different coefficient from glass, can nevertheless be sealed satisfactorily if the sealing line is formed as a knife edge or has a sharp bevel.

Cooling the Anode

A practical application of this method is seen in the Western Electric valve shown in the diagram. The anode consists of a copper cylinder, 1, surrounding a helical grid, 2, and a zigzag filament, 3. The open end of the anode is tapered and flayed to a fine edge at 4, where the new process seal is made to a glass container, 5, on which the grid and filament are mounted.

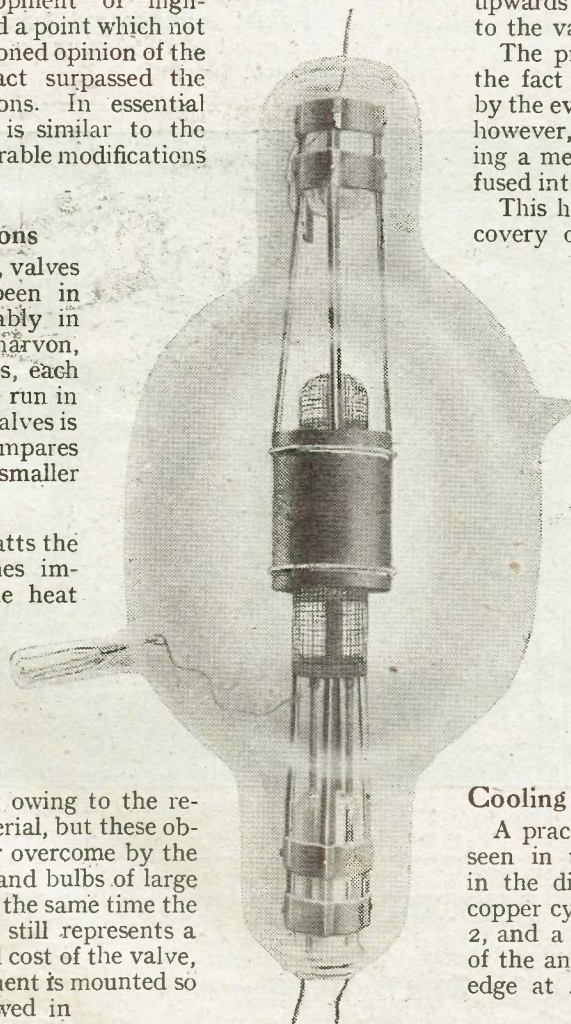

A typical example of a valve used for power transmission. (Marconi Co.)

The anode of such a valve can be cooled by direct immersion in water. In order to allow the use of ordinary tap water for cooling, the water jacket is connected through long coiled tubes of rubber with the main and waste pipes. In practice the columns of water have quite sufficient resistance to insulate the anode effectively, whilst the loss of power in the water is negligible. Suitable cut-outs are provided for automatically disconnecting the valve should the water supply suddenly fail.

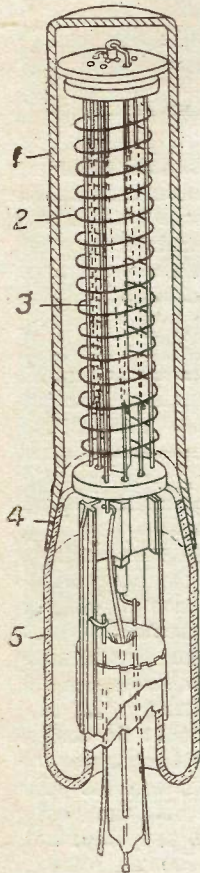

A power valve with anode sealed into the glass base.

A new type of two-electrode power valve with great possibilities has recently been developed by A. W. Hull, of the General Electric Co. of America. He has shown that when the filament-heating current is increased beyond a critical value, depending on the

anode voltage, the magnetic field created by the heating current exerts a controlling force on the electrons passing across the exhausted space. If the heating current is increased sufficiently, it will in fact prevent the electrons from passing to the anode, and will drive them back instead into the filament.

In a 100 kilowatt valve of this type the anode is 14 in. long and $3\frac{1}{2}$ in. diameter, and the overall length of the valve slightly exceeds 2 ft. The filament heating current is 91 amps.—or nearly 200 times the heating current of an ordinary detector valve. In fact, there is no mechanical difficulty in constructing valves of this kind capable of generating anything from 200 to 1,000 kilowatts, the latter being comparable with the output of a £3,000 turbo alternator.

A Wonderful New Valve

This phenomenon is known as the magneto-strictive effect of the heating current. If the heating current is alternating, electrons will pass to the anode during the intervals in each half alternation that the current is below the critical value, and an alternating current of double the original frequency is set up in the external circuit between the anode and cathode. In addition to its use as a frequency doubler, the valve may be used for converting intermittent into alternating current.

Working on these lines, the General Electric Co. is developing a valve of 1,000 kilowatts, in which the anode consists of a tube 30 in. long and $1\frac{1}{4}$ in. diameter. The "filament" consists of a straight tungsten rod $\frac{3}{8}$ in. in diameter, heated by a current of 1,800 amperes, with an anode voltage of 20,000.

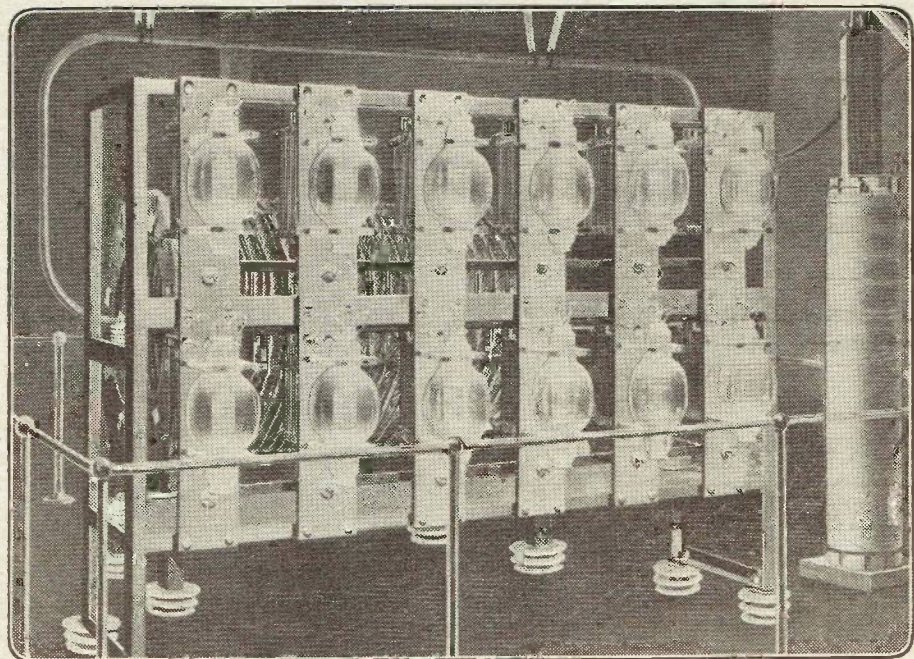

A group of transmitting valves. (Marconi Co.)

TECHNICAL ASSISTANCE TO AMATEURS

The technical staff of "Wireless Review" is always at the service of readers. Letters should be addressed to Queries Dept., "Wireless Review," The Fleetway House, Farringdon Street, E.C.4, but not more than three questions should be submitted at a time

Notes on Loud-speaker Work

By V. G. P. WILLIAMS, B.A. (Cantab.)

The really successful reproduction of music upon a loud speaker is comparatively rare. This article, by a well-known expert, is full of practical hints for successful working

IT is curious that so many wireless enthusiasts are content to put up with such horribly distorted signals as proceed from the majority of loud speakers. Let it be said at once that in ninety-nine cases out of a hundred it is not the fault of the loud speaker; any loud speaker of one of the well-known makes is capable of good reproduction, provided the

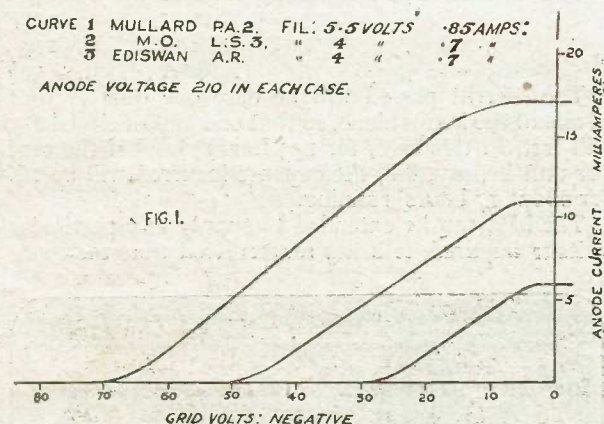

receiving set does not distort. In the writer's experience, practically the whole of the distortion occurs in the rectification. At the best, a valve is a comparatively poor rectifier as far as tone is concerned, and its poor qualities are made far worse by the use of reaction on the detector valve circuit.

There is nothing more horrible than the noise produced by, say, a circuit consisting of 1 det. with reaction and 2 L.F. valves. This may not be apparent when headphones are used, but is very evident when the loud speaker is switched on.

Improving the Tone

Much has been written regarding the distortion occurring in L.F. transformers, but the writer's experience is that the distortion occurring with two transformers of moderately good make is practically nil; at any rate, what there is, is negligible compared to that arising from faulty rectification.

A tremendous advantage in tone is gained by the use of a crystal for rectification, and the volume of sound is diminished very little. With 1 H.F., crystal rectification, and 2 L.F., at 30 miles distance 2 LO is almost too loud with this circuit and a medium size Amplion. But even this circuit is liable to a certain amount of distortion in that the

tuning of the plate circuit of the H.F. valve (tuned-anode coupling) inevitably introduces a certain amount of reaction owing to the inherent capacity between plate and grid. The writer prevents any tendency to self oscillation by coupling the anode coil to the aerial coil the wrong way round, thus introducing reverse reaction. This has the same effect as potentiometer grid control, and has not the disadvantage of interfering with the grid potential, some valves being extremely particular as to the value of the steady potential on the grid for best tone.

A Useful Rule

This leads up to another point, namely, grid potential on the L.F. valves. It is a general rule that the higher the plate voltage, the higher should be the negative potential on the grid. There is a great advantage in having a high potential on the plate of the last valve, as though this may not give louder signals than a more moderate voltage, it lengthens the characteristic curve of the valve, which enables the valve to work entirely on the straight portion of its curve without trespassing on the "bends," which causes distortion.

And yet how many experimenters put 100 or 150

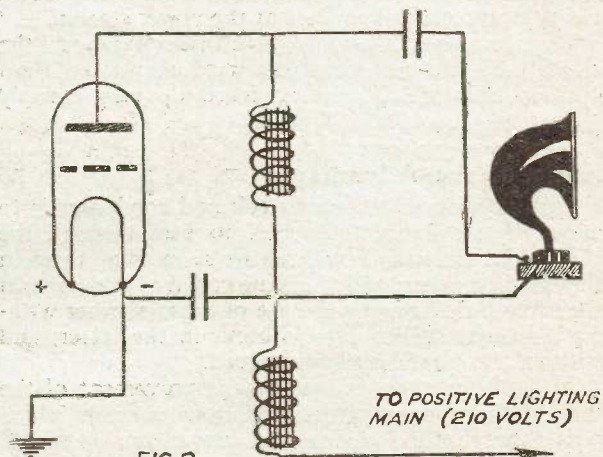

volts on the plate and content themselves with a mere 4 or 6 volts negative on the grid?

In the writer's case, the 210 volts D.C. from the lighting mains is applied to the plate of the last valve. An Ediswan A.R. has been found to function as well in this position as the more expensive "power" valves, with a considerable saving

in filament current over the latter. Provided the grid potential is correct there is no need to run the filament any more brightly than recommended by the makers ; 4 volts is quite enough.

Under these conditions about 15 volts negative will be required on the grid. It should be noted that many of the popular makes of R. valves are now made softer than they used to be, and are suited for a plate voltage of not more than 60. If 210 volts is applied it seems to completely "kill" the reproduction.

The M.O. L.S. 3 valve is also very satisfactory, as is also the Mullard P.A. 2. These require a negative potential of about 20 volts and 30 volts respectively.

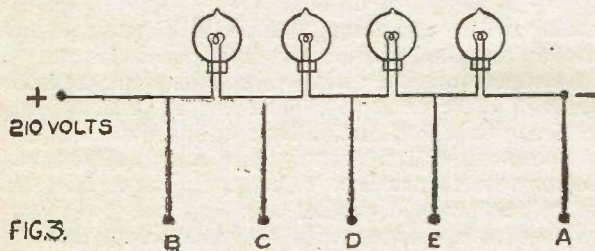

But they do not give louder signals than the Ediswan A.R. ; their chief advantage lies in the length of their curves, so that should a third L.F. stage be used for purposes of loud-speaker work in the open or in a hall, the increased oscillations on the grid would still be within the scope of their curves, whereas the Ediswan curve might be too short. But for ordinary work in an ordinary sized room the latter is quite up to its work. Curves of these three valves are shown as actually taken by the writer. It will be noted that even the Ediswan will allow of grid oscillations between - 23 volts and - 8 volts on the straight part of its curve. This range is not likely to be exceeded with two amplifying valves in use. Mention has been made of the D.C. lighting mains. The accompanying sketch shows the circuit of the last valve in the writer's set, where the negative main is earthed at the power station.

Each condenser is a 2 mfd. Mansbridge type, and the choke coils are the secondary windings of old Ford ignition coils, which can be picked up very cheaply (about 2s. 6d. each).

Some of the Advantages

The function of the upper coil and condenser is to allow the steady plate current to pass through the choke coil, while all *fluctuations* are shunted off through the loud speaker and condenser. We thus obtain the same benefits as by the use of a transformer without the losses which always occur in the latter, and without the capital outlay involved.

In addition, there is a certain improvement of the tone of the signals, as the oscillatory currents which pass through the loud speaker are extremely small, and there is no fear of magnetic "saturation." Nor is the diaphragm under such a heavy constant "pull" as would be the case if the full plate current of the last valve (which may be anything between 5 and 20 milliamperes) were passing through the windings. This results in the diaphragm being more responsive to the oscillatory currents shunted through it by the choke coil. Last but not least, there is no danger of a "burn out."

The function of the lower choke and condenser is to smooth-out the "commutator hum" in the electric mains, which would otherwise be painfully evident in the loud speaker.

Note the position of the condenser ; if this were connected to the *bottom* end of the lower choke, signals would be very weak, as the choke allows only a steady current to pass through it, consequently the necessary fluctuations for working the loud speaker would not be available. In the position shown, the condenser acts as a reservoir, and by its charge and discharge the necessary oscillations for the loud speaker are provided.

Low Current Cost

The lighting mains can be tapped for any voltage lower than the maximum by a very simple plan, and at an extremely small cost for current. The idea is shown in the accompanying sketch. (Fig. 3.)

Four lamps of, say, the 30-watt metal filament type are connected in series as shown.

The voltage across terminals B & A will be	210
" " " " C & A " " "	157½
" " " " D & A " " "	105
" " " " E & A " " "	52½

The current passed will be only one quarter that of one of the lamps alone, so that one unit of electricity will last, in this case, for 133 hours ; and if the cost per unit be, say, 8d., the expense incurred will be 1d. for about 17 hours' running.

The idea can be extended to supply any particular voltage required, it being remembered that the more

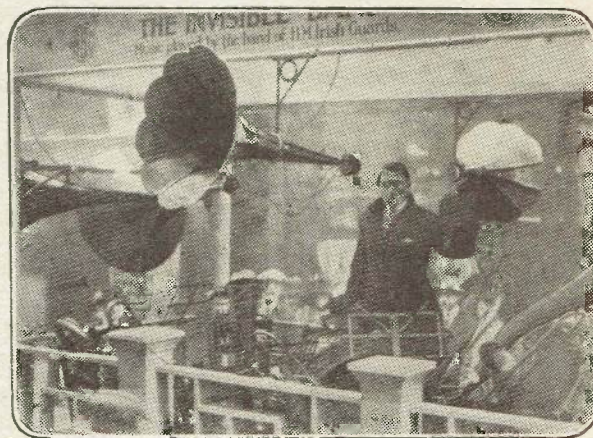

AN INVISIBLE BAND.

The music reproduced by the loud speakers was wirelessly from a band several miles away.

lamps there are, the lower the cost of current used, and the greater the variety of voltage available. If 15-watt or 20-watt lamps are available, they will be just as suitable, and the cost of current will be even less than with the 30-watt type.

It must be plainly understood that this system can be used only with direct or continuous current, and that a smoothing choke and condenser will be necessary.

With a little care and thought, loud-speaker reception can be made a real pleasure (even to those with keen musical taste), instead of being worse than the worst gramophone ever produced



IN making the quenching coils for the "W.R." Super Set from basket coils, will not the diameter of the coils measure somewhere about 9 or 10 in., even though 30 or 32-gauge wire is used?

It is not necessary to construct such large coils if a slight modification is made in the wiring. Instead of winding through each slot on the former you could miss alternate slots or even miss two slots, without detriment to the efficiency of the coils.

* * *

IF a single crystal has a good detecting effect, would it not be better to use two crystals? I have tried two similar crystals, but without any improvement; is there some special way of arranging them?

No. This point has frequently been raised. The answer is, however, that one crystal detector will be found to give better results than two. The same remark applies to valve detectors.

* * *

WOULD three Leclanché cells be necessary for a steel-and-carborundum detector, and would a potentiometer be necessary?

It would be preferable to use two dry cells, although the Leclanché cells would do. A potentiometer is necessary with the type of detector you mention, as this particular combination requires a certain small potential to be applied to it in order to obtain the best results. This is owing to a peculiarity of the characteristic curve of carborundum.

* * *

WOULD a single-wire aerial, 70 ft. long and 25 ft. high, be suitable for use with this detector?

The aerial mentioned should give fairly good results with a crystal set. It is always desirable, especially with a crystal set, to have the aerial as high as possible and of the full length permitted by the P.M.G.'s regulations.

* * *

I WISH to wind two telephone receivers, watch type, for use with single-valve receiving set. What resistance would be best, what gauge of wire, and how much of it?

We presume you mean you wish to re-wind the telephones, and also that the one valve is to be used as a detector. If no telephone transformer is to be employed the resistance of each ear-piece should be 1,000 ohms at least. The wire should be the same as that which was used previously. The winding of telephone receivers, however, is a difficult matter, and liable to be unsatisfactory unless you have had some workshop experience, and have a lathe at your disposal. It is usually much better, in the long run, to buy your telephones, although you might, with advantage, make other parts of your set.

WITH a 130-ohm pair of 'phones and a carborundum detector, no results are obtained. Why is this?

The 'phones are unsuitable without a transformer. They should be 4,000-ohm 'phones. Secondly, with this type of detector a potentiometer is necessary.

* * *

WOULD a larger piece of crystal be better for a crystal set than a small one? Perhaps the resistance would be less?

The rectifying effect takes place mostly in the contact, which is extremely small, and it is believed that the resistance resides mostly in this point, so that the difference between a large piece of crystal and a small one would be negligible, other things being equal.

* * *

WHAT is the difference between a 4-volt 40-ampere-hour battery and a 4-volt 80-ampere-hour one? Which should I use for a two-valve set?

The difference is in the total storage capacity of the two batteries. In a general way, it means that the 80-ampere-hour battery will give the same current as the other, but for twice as long. But the proper test of a cell, as to its condition, whether sufficiently charged or not, is the potential difference across its terminals when delivering a normal current. This should never be allowed to fall below 1.85 volts per cell. Either would be suitable for the set you mention: the higher capacity battery would not require to be charged so frequently. The lower capacity would be less expensive, and should be quite sufficient.

For Absolute Clearness and Fine Tone, be sure you get—



PIVAL HEADPHONES

Pival Headphones are the lightest and most comfortable in use. Extremely sensitive, they are distinguished by the loud, delightfully pure, and clear quality of their tones. All genuine Pival Headphones bear a three years' guarantee—Look for the Trade Mark on the Headband.

PIVAL DOUBLE HEADPHONES.
4,000 Ohms the Pair 16/9.

PIVAL SINGLE EARERS.
2,000 Ohms 6/6. 4,000 Ohms 7/6.

Obtainable from all the usual Dealers.

If any difficulty in getting Pivals, write direct for name of nearest dealer to

Sole Agents: **INTERNATIONAL EXAPHONE Co., Ltd.**
Head Office: 1, College Place, Derby.
London Office: 22, Philpot Lane, E.C.



VARIABLE CONDENSER PLATES

Br. Pat. 201,890. (Cole.)

THIS invention includes an interesting method of stamping the condenser plates so as to make them uniform and self-contained, and to do away with the necessity for threading distance-rings between adjacent plates.

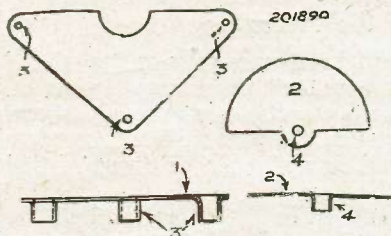

As will be seen from the accompanying figure, the plates are provided with projections which serve as distance pieces. In the condenser shown, the fixed plates, 1, are triangular in form, and are each provided with three tubular projections, 3, through which the bolts are passed. The movable plates, 2, are semi-circular, and are provided with tubular projections, 4, through which the rotary shaft passes.

METALLIC-VAPOUR VALVE

Br. Pat. 201,893. (Connecticut Telephone Company.)

A valve for use as a detector or amplifier contains a highly electro-positive metal such as sodium or potassium. The filament may be of tungsten, molybdenum, or tantalum, and the anode, 16, consists preferably of sodium. The control electrode, 15, is arranged on the side of the cathode opposite to that

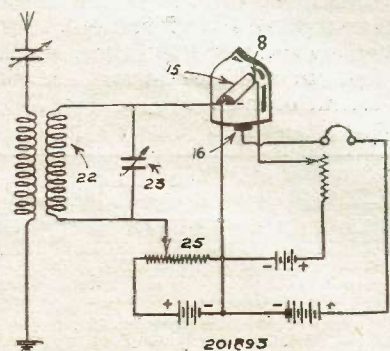

of the anode, and is shaped so as to leave an unobstructed electron path between the cathode and anode. This control electrode is stated to have a different function from the usual grid, as the current in the control-electrode-cathode circuit is decreased when the anode circuit is opened. The control electrode is preferably trough-shaped so as to act as a reflector. Sodium or potassium may be introduced by vaporising

the metals or an alloy of them. The circuit arrangements in connection with this valve will be seen from the figure;

the potentiometer 25, should be noted. A negative potential on the control electrode does not stop or reverse the current in the filament-control-electrode circuit.

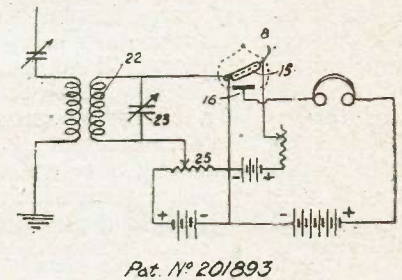

A NOVEL MORSE RECORDER

The usual method of automatically recording Morse signals is by means of a machine which prints them upon a tape that is kept running by clockwork. When no signals are being received, the tape is marked by a straight line along its centre, due to the tape passing under the marker, which is stationary. When signals are arriving, the marker is moved slightly across the band, resulting in a wavy line which corresponds to the dots and dashes of the Morse code.

An ingenious invention of Mr. W. Peeters, Ic Ringdijkstraat 27, Amsterdam, is now upon the market which considerably reduces the cost of the upkeep of this type of machine. Generally the cost of paper tape is considerable, because a constant supply of clean tape is required to pass beneath the marker during the whole time the machine is running.

The invention of the "Dry Writing-Band" enables a black tape to be used continuously over long periods, the marking ink being replaced by a solution which,

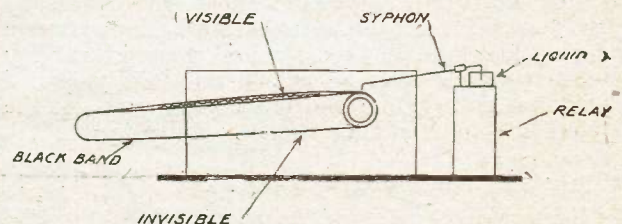

when it is wet, makes a clear mark upon the tape. As the solution dries, the writing fades and leaves the tape ready for use again.

In the interval, any necessary message can be transcribed from the tape in the ordinary way, but a signal of which no record is required is, of course, allowed to fade from the tape, which is thus used over and over again.

Pioneer Wireless

(Continued from page 145)

conductor, and if you attach sparks to the earth you might naturally expect that a distant station would feel it. But for the practical use of the waves, such an earth was a heaven-given asset. The earth was for this purpose a very advantageous conductor. And so both the receiver and the sender had a large aerial above and a large aerial below.

But in that early experiment of his in 1896 there was nothing to do with tuning. When you have a vibrator which is very light, it is like a pendulum with a ball of cotton wool; it swings back to its starting point and settles down almost at once. It is, in fact, "damped out"; there is no energy. What is wanted is to make that ball not of cotton wool, but lead; so that it will respond in an accurate tuned manner and to the right tune, working up till it becomes big by the force of rhythm. What was wanted electrically was induction. That is, what we all know as inductance.

Making Tuning Possible

In the year 1897 people did not know inductance. They laid cables that made possible telephony along the long lines in America and even under the sea. That was the introduction of induction into cabled signalling. But I introduced induction into wireless signalling. I put an inductance coil into the aerial, thereby diminishing its radiation power by making it oscillate twenty or thirty times, and so making tuning possible.

This patent was the bottom patent for tuning.

This is what we use for selective signalling—tuning out one station, tuning in another. But, of course, if every receiving station is also a small sending station on its own account by reaction, it is very difficult to tune out. (I would like to emphasise that tuning business, because it is not very well known, and the patent does not belong to me now. It was acquired by the Marconi Company in 1911. It has been before a lot of law courts. It was extended seven years by Mr. Justice Parker, and lasted till 1918. It was twelve days before the late Lord Moulton, when its validity was contested. But he upheld its validity, and I promised to help the Marconi Company to get the rights due to them in connection with this patent.)

Only the Beginning

Then came Fleming and the valves. With the valve I had nothing to do. Here for the first time we are harnessing the electrons. Then came Lee de Forest with his triode valves, and then voice transmission. Valves are amazingly interesting things. But this is only the beginning.

Maxwell's volumes contained all the electricity that was known to his century in 1887-8-9. Hertz was developing out of Maxwell; everything developed out of Maxwell. Electrons were not in Maxwell. There

is the phrase "atoms of electricity" in the book, but half apologetically. He guessed that electricity might be atomic, but treated it generally as a continuous subject.

This century has discovered the discontinuous nature of electricity. This was discovered during the years 1897-98, and the chief work was done by J. J. Thomson. Electricity became atomic. We learned that it consisted of little bodies, electrons and protons—negative and positive. The atom of matter is built of electricity. Electricity is *the* thing that exists. I am pretty sure that it is composed of ether in certain states of motion, and that the whole material universe will be found to be the ether in states of motion, and matter but a slight modification of the ether of space. Ether of space is the one reality, and matter a secondary structure, which seems important because it appeals to our senses which we have inherited and which we share with the animals.

The Energy of the Atom

Now we learn that the atom is composed of electricity, that there is a central nucleus with electrons revolving round it, and an enormous store of energy in the atom. Nothing can compare with the energy of the atom. We are harnessing the electrons of their docility, but not their energy. Some day we shall learn to tap the energy in the atom, and all our methods of combustion and ordinary methods of producing light and heat will sink into insignificance compared with the enormous energy we shall then control. How it will be done I do not know. Somebody will discover the way to do it. It is like the time before we knew that matter was atomic. That was the discovery of last century. Now we have learned that energy is atomic, and when you find new sources of energy you do not know what may come. Some of you here now may discover how to get at the energy in the atom.

A Mysterious and Wonderful Time

We are living in an extraordinary time. The first twenty-three years of this century have started out remarkably, and what may be going to come in the next twenty-three years during which you will live and work, who can say? I only know that the amount of things to be found out in the universe is enormous; more than that we have found out. We live in a most mysterious and wonderful time, and it is our privilege to find out and harness and use our discoveries for the benefit of man.

Please
mention
"Wireless
Review"
when
replying.

—Fix your crystal in— GOLD SEAL PLASTIC METAL.

It is positively the best contact possible, and results in **LOUDER AND CLEARER SIGNALS**. Guaranteed to contain no mercury. Price 6d. per packet, sufficient for 3 to 4 crystal cups. Of all Wireless Stores.

Wholesale Enquiries (or sample pht. 6d.) to
SAMUEL LEVY, 53, Ben Jonson Road, Stepney, London, E.1.

—INVENTIONS—

PATENTED. Trade Marks and Designs Registered. Particulars and consultations free.
BROWNE & CO., Patent Agents,
9, Warwick Court, Holborn, London, W.C.1.
Established 1840. Telephone: Chancery 7547.



*The Brightest
and Best
Wireless
Weekly*

Week by week "Popular Wireless" caters for every possible class of wireless amateur, from the veriest tyro to the most advanced amateur. "Super" circuits are described for those who desire to experiment in that direction, simple crystal and valve receivers are explicitly detailed, while articles of general interest that will appeal to all readers are included in every number.

The first popular weekly journal to supply a long-felt want when broadcasting was started in this country, "Popular Wireless" still leads both in public opinion and circulation figures. It appeals alike to the "listener-in" and the more serious minded experimenter.

Buy a copy NOW

Ask for

POPULAR 
WIRELESS
Weekly

Scientific Adviser :
Sir Oliver Lodge, F.R.S., D.Sc., M.I.E.E.

"Adjust your proposed amount of reading to your time and inclination . . . but whether that amount be large or small, let it be varied in its kind, and widely varied. If I have a confident opinion on any one point connected with the improvement of the mind it is on this."—Dr. Arnold.

Free
to prompt subscribers
This Solid Oak Bookcase

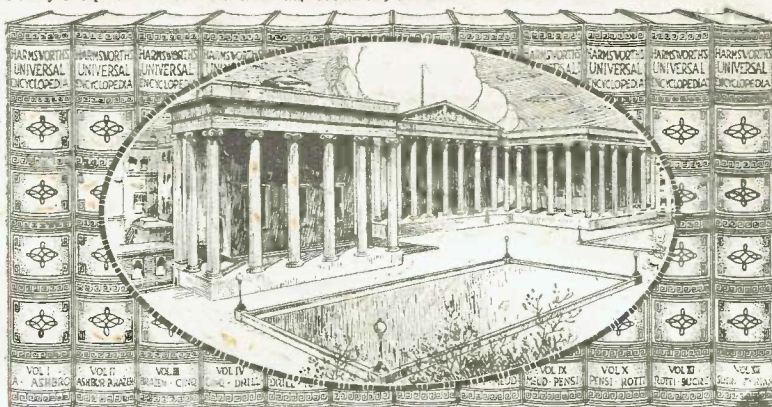

The oval in the illustration above shows the British Museum, which contains in its four million volumes the world's finest reference library. The cream of this vast storehouse of information is contained in the 12 volumes of Harmsworth's Universal Encyclopedia

A Master Key to All Knowledge for Every Home.

Harmsworth's Universal Encyclopedia

Sent Carriage Paid to your Home.

12 Volumes—8,104 Pages—1,500,000 Facts—50,000 Articles on all Subjects—23,500 Illustrations—Diagrams—Maps—Views—Portraits—and 80 large plates in Colours.

HERE is a valuable 2-in-1 offer that places within the reach of every man, woman and family (1st) a wonderfully classified Literary-Pictorial Summary of Human Knowledge; also (2nd) a gift Oak Bookcase which will be presented to every prompt subscriber for Harmsworth's Universal Encyclopedia. SEND THE COUPON (below) NOW—and see and judge for yourself from the beautiful Colour-Plate Prospectus the extraordinary value offered for your acceptance.



This Bookcase stand 3 ft. 3 in. high, and not only takes Harmsworth's Universal Encyclopedia, but provides room for some 20 other books as well

The Cream of Learning from 4,000,000 Volumes

Just think of it. This is a handy-for-reference complete and concise Digest of all Human Knowledge. There are 4,000,000 volumes in the British Museum, and you get the cream of this vast accumulation of Learning in the 1,500,000 FACTS, WITH ILLUSTRATIONS, in the 12-volume Harmsworth's Universal Encyclopedia.

Worth £100 to a Family

Parents who wish their children to grow up well-informed and capable of making the most of themselves in the business and social world cannot do better than acquire this 12-volume Harmsworth's Universal Encyclopedia. There is absolutely no finer investment for any ambitious man or woman, or parent and family. And the whole 12 volumes (with the gift oak

bookcase) are sent carriage paid on acceptance of order and the first subscription of only 5/-. The balance can be paid in small monthly subscriptions while you gain knowledge worth a hundred times the small cost at which it is obtainable in this magnificent work.

The Expert Contributors

You could not have more fascinating reading than this Master-Key to all Human Knowledge—compiled not by one or a few Master Minds, but under the General Editorship of J. A. Hammerton, assisted by an Editorial Staff of over 400 Authorities and Compilers, including: Lord Charnwood, Lord Robert Cecil, Hon. John W. Fortescue, Sir Arthur Keith, F.R.S., Sir Oliver Lodge, F.R.S., Sir E. J. Russell, D.Sc., F.R.S., John Galsworthy, Edmund Candler, C.B.E., A. St. John Adcock, Neil Munro, LL.D., Clement K. Shorter, J. Arthur Thompson, M.A.

FREE

A SUPERB PROSPECTUS PRINTED IN FOUR COLOURS

Do not let slip this present opportunity of securing the Colour Prospectus of this magnificent Encyclopedia—willingly sent gratis and post free. Send this Coupon NOW. Your copy of the Prospectus will be posted at once, and you will—if you act promptly—be entitled to a GIFT OAK BOOKCASE with your set of Harmsworth's Universal Encyclopedia.

COUPON FOR FREE BOOKLET

The Educational Book Co., Ltd., 17, New Bridge St., London, E.C.4.

Dear Sirs,—Please forward me, FREE and POST FREE a copy of your beautiful art booklet describing the 12 volumes of "Harmsworth's Universal Encyclopedia," and giving the subscription terms for the Work

NAME.....

ADDRESS.....

OCCUPATION..... W.R.S

SOUTH AFRICAN readers should post this coupon to Central News Agency, Ltd., P.O. Box 1933, Johannesburg. AUSTRALIAN readers should apply to Gordon & Gotch, (Australasia), Ltd.

All applications for Advertisement Space in WIRELESS REVIEW to be made to JOHN H. LILE, LTD. (Sole Agents), 4, Ludgate Circus, London, E.C.4. Phone: 10806 Central.