

Price, 15 cents

January, 1911

ELECTRICIAN & MECHANIC

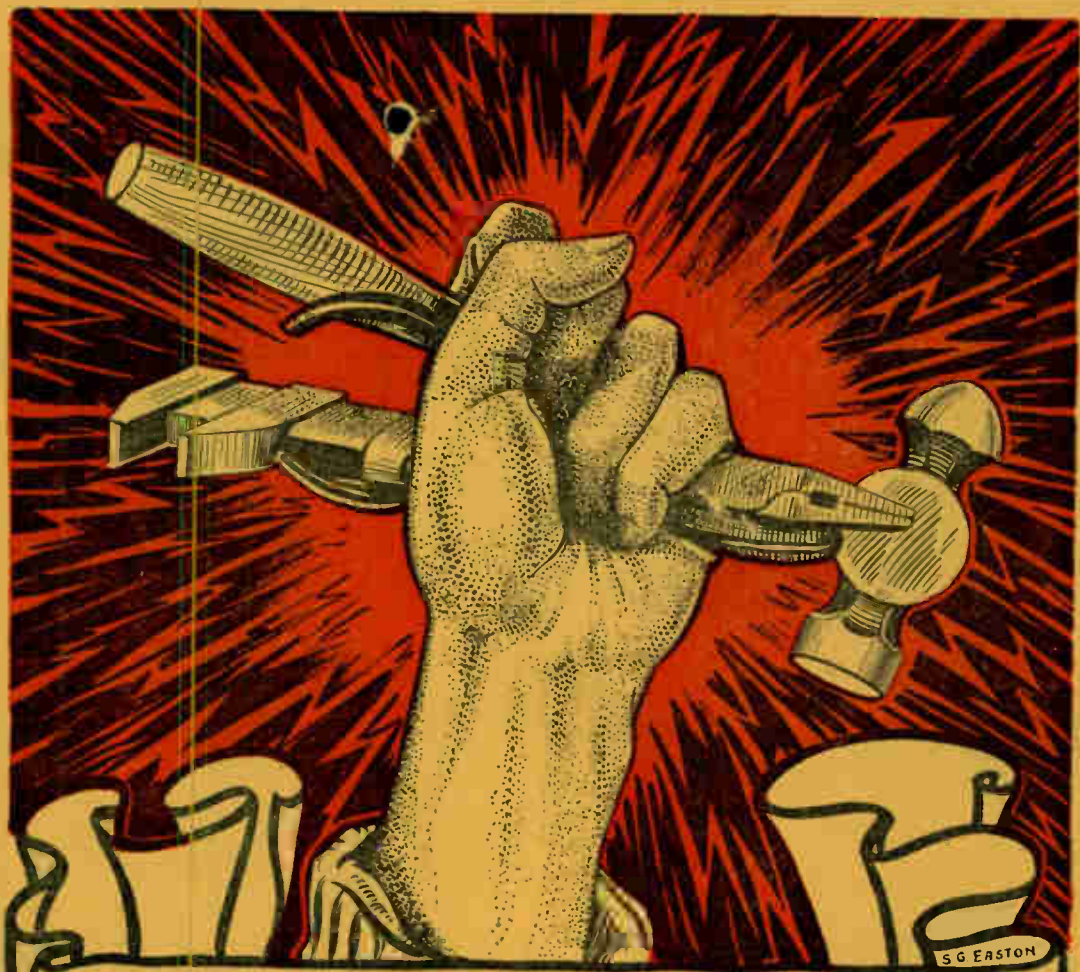

PUBLISHED MONTHLY BY
SAMPSON PUBLISHING CO.
BOSTON, MASS.

May We Send You Free Samples

To Prove That You Can Artistically Color and Finish Any Kind of Wood About the Home

YOU can produce any desired shade and effect. The expense is slight—the work easy and simple. First apply Johnson's Wood Dye—made in 14 shades as listed below. Over the Dye lightly apply Johnson's Prepared Wax—and you have a beautiful, rich, subdued finish that will not mar or show scratches.

Johnson's Wood Dye must not be confused with colored varnishes or stains which merely coat the surface of the wood, hiding the natural grain beauty. Johnson's Wood Dye is not a mere stain—not merely a surface dressing—it is a deep-seated Dye which goes to the very heart of the wood and stays there, fixing a rich and permanent color.

Johnson's Wood Dye

is made in fourteen attractive shades as follows:

- | | | |
|---------------------|-----------------------------|---------------------------|
| No. 126 Light Oak | No. 128 Light Mahogany | No. 121 Moss Green |
| No. 123 Dark Oak | No. 120 Dark Mahogany | No. 122 Forest Green |
| No. 125 Mission Oak | No. 130 Weathered Oak | No. 172 Flemish Oak |
| No. 140 Manilla Oak | No. 131 Brown Weathered Oak | No. 178 Brown Flemish Oak |
| No. 110 Bog Oak | No. 132 Green Weathered Oak | |
- Pints, 50 cents each



Johnson's Prepared Wax dries quickly over Dye or any other finish so that it may be brought to a beautiful, dull, artistic finish. It should be used for all woodwork, floors and furniture, including pianos and is just the preparation for Mission furniture.

Johnson's Under-Lac

is not a common varnish—but a thin, elastic spirit preparation superior to shellac or ordinary varnish, and is to be used over Wood Dye where a higher gloss than a wax finish is desired, drying hard in half an hour. Best preparation for linoleum and oilcloth, bringing out the pattern as glossy as new. Gallons, \$2.50—smaller sizes down to half-pints.

Fill out the coupon for free samples and booklet.

S. C. Johnson & Son, Racine, Wis.

"The Wood Finishing Authorities"

Please send free samples of Wood Dye and Under-Lac—also booklet. If samples are found satisfactory, will ask my dealer to supply me.

Free Sample Coupon

Name

Address



To Keep Your Floors Beautiful

Every woman knows how annoying it is to have unsightly spots, water stains, dirt stains, and foot-tracks on her floors, stairs or woodwork. They ruin the beauty of her entire home. Will you test, at our expense,

JOHNSON'S KLEEN FLOOR

the *only* preparation for immediately removing all these discolorations? With Johnson's Kleen Floor any woman can keep her floors bright and clean—like new. Simply dampen a cloth with Kleen Floor and rub it over the floor. Instantly, all spots, stains and discolorations disappear—without the slightest injury to the finish.

Johnson's Kleen Floor rejuvenates the finish—brings back its original beauty—greatly improves the appearance of all floors, whether finished with shellac varnish or other preparations. Johnson's Kleen Floor is quickly applied, two hours is ample time in which to thoroughly clean the floor, wax it and replace the rugs.

We want to send you, free, sample bottle of Johnson's Kleen Floor and a package of Johnson's Wax to be used after the Kleen Floor.

Johnson's Prepared Wax gives the floors that soft, lustrous, artistic polish which does not show heel-marks or scratches and to which dust and dirt do not adhere.

It is ideal for polishing wood-work, furniture, pianos, etc. All that is necessary is to occasionally apply it with a cloth, and then bring to a polish with a dry cloth.



S. C. Johnson & Son

Racine, Wis.

"The Wood Finishing Authorities"

Free Sample Coupon

Please send free samples of Wood Dye, Shade No. _____
Under-Lac—also booklets. If samples are found satisfactory, will
ask my dealer to supply me.

Name _____
Address _____

Prepared Wax and
satisfactory, will

E.M.-1.

MARK

TWAIN

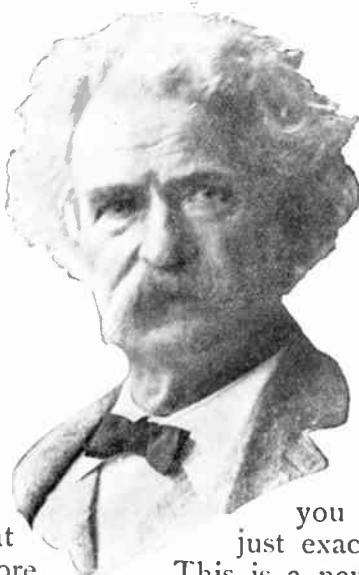

1/2 Price

A New Edition

Now for the first time Mark Twain's writings at have ever been sold before. as the old one, which still sells, is only \$25.00

you get a complete set of all just exactly one-half the price they This is a new edition, just as complete by the way, at \$50.00. This new edition for the 25 volumes.

It had been Mark Twain's ambition to have his books in every American home, and he made a great personal sacrifice to bring about this remarkable opportunity—for the first time in the history of publishing, copyrighted books are sold at the price of non-copyrighted books—the chance will not come again.

But for Mark Twain's action this would have been impossible. Never before has a copyrighted library set of a standard author's works been issued at such a low figure.

His Complete Works— 25 Beautiful Volumes

Brander Matthews says: "Mark Twain will be included in that group of writers headed by Molière and Cervantes. With the exception of Count Tolstoi, Twain was the greatest of recent modern writers, and will be handed down to posterity through the trio of his works 'Huckleberry Finn,' 'Tom Sawyer,' and 'Pudd'nhead Wilson.' Twain is a greater stylist than Stevenson or Thoreau, and his 'Man that Corrupted Hadleyburg' is one of the finest works in English literature." Mark Twain himself wrote a preface to this edition. Brander Matthews has written the biographical criticism of Mark Twain and his work. There are portraits of the author at periods when the different books were in process of writing.

There are beautiful pictures by such artists as Frost, Newell, Smedley, Thulstrup, Clinedinst, Kemble, and Oppen. The binding is in rich red rep silk book cloth, with title labels stamped in gold. The books are printed on white antique wove paper, especially made for this edition. Each volume is of generous size and bulk, 5x7 1/4 inches.

HARPER & BROTHERS
Franklin Square
New York City

Please send me for examination, carriage free, a set of **MARK TWAIN'S WORKS, Author's National Edition**, twenty-five volumes, cloth binding. It is understood I may retain the set for five days, and at the expiration of that time, if I do not care for the books, I will return them at your expense. If I keep the books, I will remit \$2.00 a month until the full price, \$25.00, has been paid, or, within thirty days, \$23.75 as payment in full.

E. M.-1

Signature.....

Send books to.....

HARPER & BROTHERS

A Catalogue of Our Standard Sets of Books will be sent upon request

THE BOYS' BOOK OF Model Aeroplanes

BY FRANCIS ARNOLD COLLINS



All about how to make aeroplane models and how to fly them, and the story of the evolution of the flying-machine.

Over fifty pictures and diagrams by the author

12 mo. 308 pages

Price \$1.20 net. Postage 14 cents

SAMPSON PUBLISHING CO.

221 Columbus Avenue Boston, Mass.

A B C of the Motorcycle

By W. J. JACKMAN, M.E.

Pocket size, 250 pages, fully illustrated, leather and cloth, round corners, red edges. A "Show How" Book for Owners and Operators of Motorcycles.

CONTENTS

Inception and Evolution of the Motorcycle—Modern Machines and their Vital Parts—How to Master the Mechanism—Production and Application of Motive Power—Construction and Operation of the Carburetter—What the Carburetter Does—Ignition Systems—Batteries and Magnetos—Practical Methods of Handling—Various Types of Motors—Theory and Effect of Internal-Combustion—Troubles of all Kinds and How to Avoid or Overcome Them—Lubrication Methods—Transmission or Drive Systems—How to Control Horse Power—Relation of Power and Speed—Weather Effects on Gasoline Engines—Cost of Maintenance on Basis of Mileage—Some Don'ts That Will Save Time and Money—Selecting a Motorcycle—Hints for the Buyer—What an Owner should do on Receiving a New Machine—The First Ride.

PRICE, Flexible Leather, \$1.50
Cloth Binding, 1.00

SAMPSON PUBLISHING CO.

221 Columbus Ave., BOSTON, MASS.

MESCO

MESCO

WIRELESS TELEGRAPHY

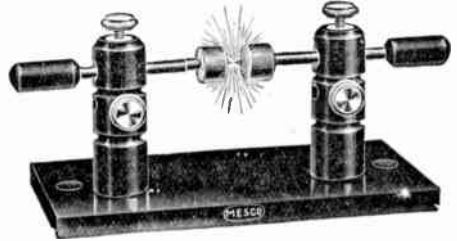

We have published a Manual of Wireless Telegraphy, describing the art and the best known methods of erecting stations. This 80-page Manual No. 1B will be mailed on application.

Catalogue No. 24B, 180 pages of general electrical supplies on request.

Manhattan Electrical Supply Co.

17 Park Place, New York.

188 Fifth Ave.
Chicago.

MESCO

MESCO

HOW TO RUN AN AUTO

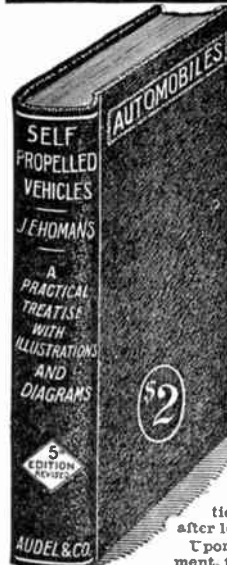

"Homans' Self Propelled Vehicles" gives full details on successful care, handling and how to locate trouble.

Beginning at the first principles necessary to be known, and then forward to the principles used in every part of a Motor Car.

It is a thorough course in the Science of Automobiles, highly approved by manufacturers, owners, operators and repairmen. Contains over 400 illustrations and diagrams, making every detail clear, written in plain language. Handsomely bound.

PRICE \$2 POSTPAID

SPECIAL OFFER

The only way the practical merit of this MANUAL can be given is by an examination of the book itself, which we will submit for examination, to be paid for or returned, after looking it over.

Upon receipt of the following agreement, the book will be forwarded.

No money in advance required, sign and return.

Theo. Audel & Co., 63 Fifth Ave., New York
Kindly mail me copy of Homans' Automobiles, and, if found satisfactory, I will immediately remit you \$2.00, or return the book to you.

NAME _____

ADDRESS _____

YOUNG MAN

LEARN THE AUTOMOBILE BUSINESS

There are greater possibilities and more opportunities in the Automobile Business than in any other line.

There is a big demand for trained men in the business.

A course of training in the N. Y. S. A. E. — the AUTOMOBILE TRADE SCHOOL, will give you the right start.

Our graduates hold the best positions as Salesmen, Demonstrators, Garage Managers, Repairmen, Chauffeurs.

Our 1909-1910 Prospectus Sent on Request

**New York School of Automobile
Engineers**

142 West 56th Street NEW YORK

Young Man

No matter what your present business is, are you ambitious to fill a better position and get a better salary? Read the following list, check the position you want to qualify for, mail it to us **TO-DAY** and receive by return mail **FREE** information—What to do to **GET THERE**.

Cost Accountant	Factory Systems Expert
Cost Clerk	Factory Production Clerk
Office Manager	Factory Transfer Clerk
Factory Manager	Supt. of Manufacturing
Foundry Manager	Foreman of Manufacturing
Expert Foundry Clerk	Production Engineer
Expert Time Clerk	Plant Construction Engineer
Mechanical Draftsman	Mechanical Engineer

Introductory Courses at Half the Price of Regular Courses. Write at once for **FREE** Information.

Modern Systems Correspondence School

6 BEACON ST., BOSTON, MASS.

OSCAR E. PERRIGO, M.E., Director

ELECTRICITY

is a calling from which your earnings will be greater for the same amount of effort than from any other industrial work. We are living in an electrical age, but electricity is still in its infancy. The developments of the future will prove this.

Get into a line of work that offers you a chance to advance.

We Are Teaching

a practical course, not a book course nor a blackboard course, but a course requiring the co-operation of brains and hands. The conditions actually existing in the outside field and the requirements to meet these conditions are energetically followed in our course. Write for prospectus or call on us and let us show you how we teach.

NEW YORK ELECTRICAL SCHOOL

39 1-2 West 17th St.,

NEW YORK



Knowledge Will Put YOU in the Spot Light

The fellow that does only what he has to, and spends his spare time in theaters or pool rooms or on the street corner—that fellow does not expect to go very high.

How did your superintendent, or general manager, or foreman, or department chief land the position he holds? By showing knowledge of his work; by proving that he had ability; by getting ready when he was in the same job you now hold.

How can you get into the spot light? How can you mount over the crowd and attract the attention of the "big man"?

By your own efforts properly directed. By being willing to devote to study a part of your spare time. By giving the International Correspondence Schools a chance to direct your efforts and lead you to the front.

Your spare time, if you would but realize it, could be made more profitable than the time sold to your employer.

Mark and mail the coupon to find out all about the I. C. S. plan to put you into the spot light. Doing so will cost you nothing, and will bring to you a full explanation of just what kind of Course you will get, what you will learn, and what has been done by other students of the same Course.

Three hundred I. C. S. students a month write to tell of progress.

Don't wait.

Mail the coupon NOW.

International Correspondence Schools Box 930. Scranton, Pa.

Please explain, without further obligation on my part, how I can qualify for a larger salary and advancement to the position, trade, or profession before which I have marked X.

Electrical Engineering
 Electric Lighting
 Electric Railways
 Electrician
 Electric Car Running
 Dynamo Foreman
 Dynamo Tender
 Wireman
 Mining Engineer
 Telephone Expert
 Civil Engineer
 Automobile Running

Mechanical Engineer
 Mechanical Draftsman
 R. R. Constructing
 Concrete Construction
 Architect
 Contracting & Building
 Architectural Draftsman
 Plumbing & Heating
 Chemist
 Bookkeeper
 Advertising Man
 Civil Service Exams.

Name _____

St. & No. _____

City _____

State _____

Present Occupation _____

MURDOCK WIRELESS APPARATUS

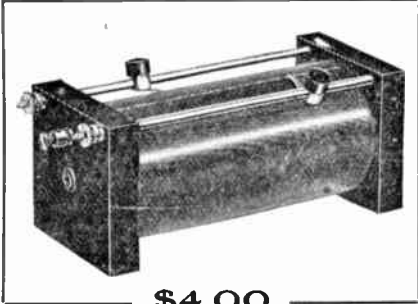

\$4.00

A straight tuning coil with two sliding contacts. Wire wound on absolutely unshrinkable tube mounted in hard rubber composition ends. The best value offered for an instrument of equal efficiency. We manufacture complete equipments for commercial or experimental work

Full information regarding our apparatus on request

WM. J. MURDOCK CO.
30 Carter Street, Chelsea, Mass.
162 Minna St., San Francisco 221 So. Clinton St., Chicago

The Key to Success

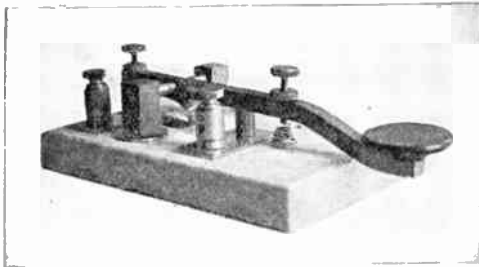

THE "BOSTON" KEY

The "Boston" wireless key is a distinctive instrument built exclusively for wireless use for sets of all powers. The marble base gives stability to the instrument and the construction is of nicked brass throughout. Unusually large contacts absolutely prevent sticking.

This instrument is described in Bulletin K as is also our Navy Type Tuner. Why not enclose a stamp and mention Catalog G, and also catalog of "Beacon" Marine Installations. They are filled with information concerning apparatus of absolute reliability and will prove the master keys to successful wireless telegraph service either private or commercial
CLAPP-EASTHAM COMPANY
139 Main Street, Cambridge, Mass.



HOLTZER-CABOT

RECEIVER'S

For Wireless Operators

HAVE

Hard Rubber Shells
Aluminum Inner Shells
Silk Wound Coils
Steel Head Bands which
are Leather Covered and
Padded with Felt
Pneumatic Ear Cushions

THEY ARE

Comfortable to Wear
Permanent in Adjustment
Extremely Sensitive
Fully Guaranteed and
The Prices are Right, too

Send for Bulletin 1400 NOW

THE HOLTZER-CABOT ELEC. CO.

BROOKLINE, MASS.

Western Branch, - Chicago, Ill.



ELECTRICIAN & MECHANIC



INCORPORATING

BUBIER'S POPULAR ELECTRICIAN, ESTABLISHED 1890 AMATEUR WORK, ESTABLISHED 1901
BUILDING CRAFT, ESTABLISHED 1908 THE COLLINS WIRELESS BULLETIN, ESTABLISHED 1908

Published monthly by Sampson Publishing Company, Boston, Mass.

F. R. FRAPRIE, M. Sc. Chem. F.R.P.S.; A. E. WATSON, E. E. Ph.D.; M. O. SAMPSON, *Editors.*

SUBSCRIPTION, IN ADVANCE, \$1.50 PER YEAR in the United States and dependencies, and Mexico. In Canada, \$1.85. Other Countries, \$2.10. Single Copies, 15 cents. Subscribers wishing to have their addresses changed must give both old and new addresses. Notice of change of address must reach us by the first of the month to affect the number for the month following.

Advertising rates on application. Last Form closes on the first of the month preceding date of publication. Contributions on any branch of electrical or mechanical science, especially practical working directions with drawings or photographs are solicited. No manuscript returned unless postage is enclosed. All communications should be addressed SAMPSON PUBLISHING COMPANY, 221 Columbus Ave., Boston, Mass.

ELECTRICIAN AND MECHANIC may be obtained from all newsdealers and branches of the American News Co.

Copyright 1910, by the Sampson Publishing Company.

Entered as Second-class Matter July 13, 1906, at the Post Office at Boston, Mass., under the Act of Congress of March 3, 1879

VOL. XXII.

JANUARY, 1911.

No. 1

TABLE OF CONTENTS

The Past, Present and Future of Aeronautics	<i>Hudson Maxim</i>	1
Practice and Theory of Aviation—Part I	<i>Grover Cleveland Leoning</i>	3
Construction of a Transformer with Electrolytic Rectifier	<i>Thomas C. Stanleigh</i>	7
Edison: His Life and Inventions		14
Electrifying the Coast Defence	<i>Monroe Woolley</i>	20
A Simple Test Board	<i>George Cassard</i>	22
Design and Construction of a Private Lighting Plant—Part I	<i>Stanley Curtis</i>	24
The Steam Turbine—Its Theory Simply Explained	<i>William E. Snow</i>	31
Model Two Cycle Motor	<i>C. F. Brierly</i>	35
The Motion Picture—Part III	<i>Stanley Curtis</i>	41
The Development of Thread Cutting	<i>Oscar E. Perrigo, M.E.</i>	45
How to Build a Library Desk	<i>Ira M. Cushing</i>	50
How to Make a Shaving Stand	<i>Ralph Windoes</i>	53
Making a Tool Box		54
Construction of a Potentiometer and Combination Tuning Coil	<i>W. C. Getz</i>	55
New System of Wireless Telegraphy		58
Editorials		62

PRACTICAL HINTS

A Taper Indicator for the Lathe	64	Proving Multiplication	65
Cutting Threads on Copper	64	How to Make a Dowel-cutting Tool	65
To Clean Celluloid Collars	64	To Remove Smell of Tobacco from Room	66
Wrought Iron Articles	64	Home-made Wrenches	66
A Simple Scribing Block	65	A Gas Pipe Gate	66
To Sharpen Awkward Shaped Chisels	65	Centring Small Steel Rod	66
Use for Old Boot Tops	65	Manipulating Tiny Screws	66
Here and There			67
Questions and Answers			68
Trade Notes and Book Reviews			72

**YOU'LL WANT MORE
"Yankee" Tools
When You See The Line
35 STYLES 75 SIZES**



No. 63



No. 115



No. 44



No. 540

Send for our Book of Labor Savers
Tells all about them

A postal brings it
YOUR DEALER SELLS THE "YANKEE"
NORTH BROS. MFG. CO.
Dept. E. Philadelphia, Pa.

The BARNES VARIABLE SPEED ALTERNATING
and DIRECT CURRENT MOTOR



1-12 and 1-8 H. P. The only high speed, single phase, alternating motor that absolutely will not heat. Armature and field pieces are laminated. Brushes are self-adjusting. The 1-12 H. P. size for all family washing machines. The 1-8 H. P. size for coffee mills, printing presses, etc. We also manufacture a 1-12 H. P. A. C. or D. C. Dental motor with chucks for emery wheels and buffing purposes.

All motors guaranteed. Responsible agents wanted.
BARNES MAN'G CO. 25 Belmont Street, Susquehanna, Pa.



We Want You to Become Familiar With
The Reece Threading Tools
Including SCREW PLATES, TAPS, DIES, etc.
Special Trial Offer



"Reece Premier" No. 1 T Tap Wrench and one each No. 2-56, 3-48, 4-36, 6-32, 8-32, 10-24, 12-24 and 14-20 "Hercules" Machine Screw Taps. Sent postpaid to any address on receipt of \$1.25

116-Page Catalogue Free
E. F. REECE CO. Greenfield, Mass.

STANLEY TOOLS

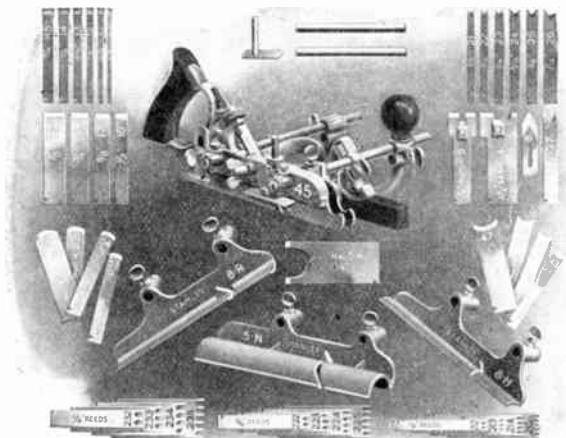

"45"

Seven Tools in One

- 1.—Beading and Center-beading Plane.
- 2.—Rabbit and Fillister Plane.
- 3.—Dado Plane.
- 4.—Plow Plane.
- 5.—Matching Plane.
- 6.—Sash Plane.
- 7.—A Superior Slitting Plane.

Extra cutters may be used to advantage by substituting specially formed detachable bottom.

Send for Catalogue giving complete description

COPYRIGHT, 1909, BY THE STANLEY RULE AND LEVEL COMPANY



STANLEY
RULE & LEVEL CO.
NEW BRITAIN, CONN. U.S.A.





ELECTRICIAN & MECHANIC



VOLUME XXII

JANUARY, 1911

NUMBER I

THE PAST, PRESENT AND FUTURE OF AERONAUTICS

Hudson Maxim

Since the dawn of civilization, science has been fighting its way to the fore. At first its progress was slow and hardly appreciable, and during the Dark Ages it was nearly strangled in its youth. But in the last half of the past century and the ten glowing years of the present century, science has been advancing by leaps and bounds. Today amazement follows amazement at its accomplishments, and in such rapid succession that before we have recovered from one marvel another wonder is before us.

To whatever of the arts we look, there science is rapidly casting out conjecture, superstition and sentimentality, and becoming the guide of the worker. Many things have today become possible in the mechanic arts which could not have been accomplished fifty years ago. The arts are so interrelated that one must necessarily lean on many others. Just as no man can become great who lives wholly unto himself, so no art today can become great without the co-operation and assistance of the other arts.

When we contemplate what a vast achievement it is to quarry a huge battleship out of the mines of coal and iron, and pass it through the furnaces, forges and workshops to the sea, and the innumerable industries that are commandeered for the work, the realization is forced upon us that, just in pro-

portion as the various arts and sciences are requisitioned for its building, so in that proportion does it exert a formative influence upon those same arts and sciences. In the mechanic arts, that which builds is in itself in turn upbuilt.

At the recent International Aviation Meet at Belmont Park, on my return by automobile toward evening, a few moments after the breaking up of the great crowd, the broad boulevard leading to



HUDSON MAXIM

New York was a river flowing automobiles. This sight impressed me as a very forceful explanation of the rapid growth of the motor-driven vehicle during the last fifteen years, from a simple embryonic, mishap contrivance to the present splendid, well-nigh perfect, luxurious pleasure-coach of the highway. For such wide use, such enormous investment of capital reveals what a pressure of demand has urged on enterprise.

The automobile may rightly be esteemed the parent of the heavier-than-air flying machine, for without the tremendous amount of work done to develop and perfect the internal combustion engine, it would today be quite impracticable to achieve successful flight.

The automobile is a great educator into the mysteries of mechanism. The merchant, the farmer, the financier, the professional man, the gentleman, have all been forced to take their lessons in mechanics. The purgatorial hours in the grease and grime and the road-dirt under the automobile to tinker up the balky engine, in order to get back home from the out-of-the-way place, had their influence in perfecting the internal combustion engine, which enabled Johnstone and Hoxsey at Belmont Park to rise like eagles in the face of a gale, and soar higher and higher, headed firmly against the buffeting blast until they passed into the distance out of sight. On that occasion, when the constant thrust of the screw was necessary to keep the machine head to the wind for both ascent and descent, it was as necessary for the engines to continue their rhythmic beats as it was for the hearts of the aviators themselves.

On what rests the success of aviation? The answer is, the perfection of the internal combustion engine. In proportion as the gasoline engine is rendered reliable in its action and powerful for its weight, just in that proportion is the success of aviation assured. Many of the old winged craft and attempts at aeroplanes, made before the higher development of the gasoline engine, could have been made to fly had their inventors but possessed a present-day aeroplane gasoline-motor. Whether the monoplane or the biplane is the better form of aircraft is but a detail. Whether

this method of steering or that method of steering be the better, though a question of much importance, is of far less importance than any question about that little gasoline giant—the motor. That is the heart; the rest are but limbs.

Such is the present status of the aeroplane. Such is a very brief outline of its biography to date. Now what are its utilities, and what will its future be? If we did not know so well the history of man's daring; if we had not seen the aeroplanist rocking in the wind between earth and sky, and life and death, we might doubt whether or not there would be the necessary volunteers brave enough for the hair-raising work of conquering the air. But we are able to learn from the grim and awful story of the wars of the race that lack of daring is not one of man's limitations. The old war spirit is still alive and still impels to hazard a throw of the dice of fate with chance and death when wealth and reputation are the stakes.

The flying machine has already won its place in the field of sport, and sport is akin to war. When the next call to arms comes in a collision between any of the great world powers, then we shall see the flying machine strongly in evidence. Chavez, who conquered the awful peaks and gorges of the Alps, will have many competitors for the honor of greatest aerial daring. Through the night and the storm, aeroplanes will thread the sky, to ferret out the secrets of an enemy's positions, or to destroy other aeroplane fleets, or to blow up magazines and stores, cut communications and depredate the outlying country.

A battle between two great armies will, in the future, be a strange spectacle. Opposing rows of men and earthworks will extend from horizon to horizon, in two vast firing lines; while in the rear, assembled in convenient open spaces, with the reserves and the cavalry, will be marshalled thousands of aeroplanes ready for flight. For days, as precursors of the coming struggle, fast flitting aeroplanes will cruise the near skies; and many will be the sharp, hot, decisive contests between the airmen. With the final clash of arms fleets of aeroplanes from either side will

rise, advance and sail over the roaring human inferno below. There will be such contention in mid-air as Milton never cast in verse. With the crash of bursting shell and shower of iron, there will come hurtling down the wreckage of friend and foe alike into the ranks of contending armies. It will, indeed, be a strange, demoniacal scene.

Such will be the place of the flying machine in sport and war; there remains for us to forecast its commercial usefulness. Human progress depends very largely upon facilities of travel and inter-communication. I believe that the flying machine will soon be so perfected that aviation will be practically as safe as automobiling is now. There will continue to be frightful casualties, of course; but we have seen that man's passion for speed and for the thrill of excitement will make him always proceed a little in advance of actual, reasonable safety. So it will be, that, in the near future, men will travel from their city businesses to their country homes by flying machines, and from city to near city. As I have many times stated before, there will be wide alighting

areas or cleared lanes connecting centres of population, so that an aviator may, at any moment, safely descend for repairs or adjustment when his motor goes wrong or when a storm is approaching. The fact that one can by aeroplane travel as the birds go, the fact that he can escape the train's slow progress and the crush of the crowd in his home-going will lead him to take some chances in his travel by the sky-way.

Great will be the influence of aviation in the upbuilding and populating of outlying areas. Hilltop, mountain height and forest fastness will become desirable locations for country villas. And when the labors of the week are done, we shall see, on the pleasant Sunday afternoon, our suburban skies filled with pleasure-going craft, flitting like great moths in every direction, some flying high, some low. There will be ever-present the speed contest and the evolutions of the daring, turning aerial somersaults for the sheer love of the excitement and the danger.

The aeroplanes are on the wing and we are in full flight to a great coming mechanical amazement!

THE PRACTICE AND THEORY OF AVIATION—Part I*

GROVER CLEVELAND LOENING, A.M.

The Present Successful Types of Aeroplanes

Part A.—Description of the Most Prominent Types

Introduction.—The rapid progress that has been made in the practical application of the principles of aerodynamics is almost unparalleled in the history of science. Within a year the number of men making extended flights has so greatly increased that we are warranted in classing artificial flight with other established means of locomotion.

The development of the aeroplane has been accompanied by the improvement of the dirigible balloon or aeronat, as technically termed; and the advance of both can undoubtedly be traced to the combination of high power and low weight offered by the gasoline engine.

In the case of aeronats, however, as early as 1884 the non-rigid type that we have today had been practically developed in the dirigible "La France," built by Col. Renard; and although

much progress has been made, it has been more in the line of actual construction than in the development of any new principles.

The successful aeroplanes which have been evolved, although similar in their fundamental characteristics, have begun to vary from each other in many important details of size, arrangement and efficiency of parts. It seems, therefore, that we are at a stage where an examination of these various types for the purpose of comparison, and a discussion of their distinguishing features, merits and demerits would prove of value.

It is to be borne in mind that inasmuch as aviators are constantly changing and rechanging the dimensions of their machines, without recording such

* Accepted as thesis for the degree of A.M., Columbia University, June, 1910.

alterations, many of the dimensions given here are necessarily approximate. In all cases, however, the most recent and accurate data as furnished by the large number of references consulted, as well as by close personal inspection, have been made use of.

In the science of aeronautics it has been necessary to use a number of new terms. By "supporting plane" is meant the main lifting surface as distinguished from all auxiliary or stabilizing surfaces. The term "direction rudder" refers to the movable vertical surface used for steering to right or left, while the "elevation rudder" is that horizontal surface which is used for steering up or down. "Transverse control" is the device used for the preservation of lateral balance in wind gusts, and for artificial inclination when making turns. "Keels" are fixed surfaces exerting neither lifting effect nor rudder action. "Spread" is the maximum horizontal dimension perpendicular to the line of flight, while "depth" is the dimension of the plane parallel to the line of flight.

By "aspect ratio" is meant the ratio of spread to depth, a means of defining the shape of surface.

In the following paragraphs the fourteen most prominent and distinct types are described in detail. These include seven biplanes:

1. The Farman. 2. The Cody. 3. The Curtiss. 4. The Wright. 5. The Voisin. 6. The Voisin (new model—tractor screw). 7. The Sommer.

And also seven monoplanes, including: 8. The Antoinette. 9. The Santos Dumont. 10. The Blériot XI. 11. The Blériot XII. 12. The Grade. 13. The Pelterie. 14. The Pfitzner.

Many other types of successful biplanes and monoplanes are in use, but they differ so slightly from one or the other of these types that they need not be separately described.

The Tellier and Hanriot monoplanes are very similar to the Antoinette, while the Koechlin, Hoffman, and many English monoplanes resemble the Blériot XI.

The order in which the types are taken up is merely a convenient one adopted here and is not based on any quality of the machines. The biplanes and the

monoplanes are separated, as they represent two distinct systems.

Many other systems of heavier-than-air machines have been constructed, including several triplanes and some extremely interesting helicopters and ornithopters, but as yet none of these has demonstrated successful flying qualities.

For the purpose of more clearly showing the variation in size of the different types, detailed and dimensioned plans and elevations of each machine are given. Most of these are drawn to the same scale, thus enabling a direct graphic comparison of the types.

1. THE FARMAN BIPLANE

Henri Farman, in 1907, began his career as an aviator by making short flights of a few seconds duration on a biplane constructed for him by the Voisin brothers. On January 13, 1908, he succeeded in flying one kilometer in a closed circuit, thereby winning the Deutsch-Archdeacon prize, the first great prize offered for an aeroplane flight. Until the end of that year Farman flew this machine and with it conducted a series of experiments on stability. In the early part of 1909, having severed his connection with the Voisins, Farman opened an aeroplane factory at Chalons, France, and began manufacturing aeroplanes himself. His design was original in many ways, and embodied several practical innovations that his previous experience had suggested.

The Farman biplane is used extensively in Europe, and notably by the well-known aviators Paulhan, Weyman, White, etc. More than one hundred of this type are in use or under construction, and for a slow but trustworthy machine it has been found very satisfactory.

The Frame.—The frame consists essentially of a main box cell, somewhat similar in design to a Pratt truss, counterbraced throughout, with identical upper and lower chords, uprights of wood acting as compression members and cross wires as tension members. This construction is common to all biplanes considered here. The supporting planes are analogous to the upper and lower decks of such a truss.

The Supporting Planes.—There are two main carrying surfaces, identical

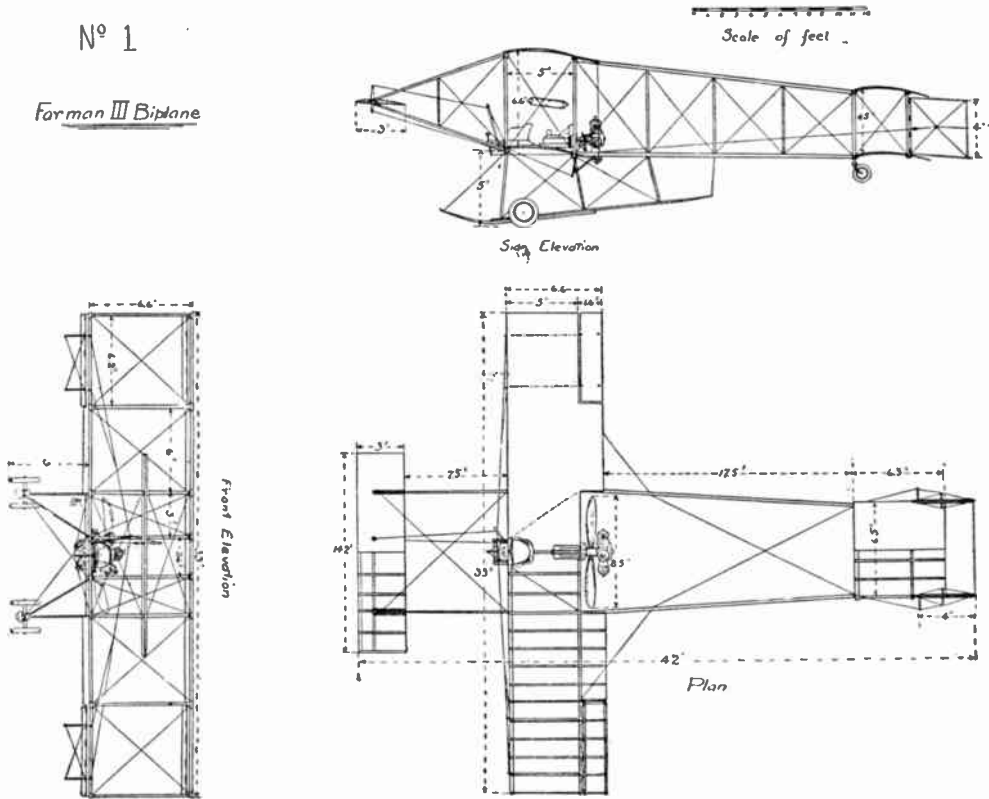
N^o 1Farman III Biplane

and directly superposed. Their sectional curvature is of the pterygoidal shape, so generally used in present-day aeroplanes. The curvature is concave on the under side, and of parabolic character. The surfaces are made of "Continental" cloth, a special rubber fabric stretched tightly over ash ribs. The spread of the surfaces=33 ft.; depth=6.6 ft., and the total area=430 sq. ft. The distance between planes=7 ft.

The Elevation Rudder.—The elevation rudder consists of a single surface, about 43 sq. ft. in area, situated well out in front. It is hinged and braced to two sets of outriggers, firmly attached to the main cell, and is controlled by a large lever in the aviator's right hand. By pulling in on this lever, the rudder is tilted up and the machine is caused to rise. By pushing out on the lever, the rudder is dipped down and the machine is caused to descend. This method of control is almost instinctive and very easy to acquire.

The Direction Rudder.—Two equal vertically placed surfaces in the extreme rear constitute the directional rudder. They are moved jointly and have an area of approximately 30 sq. ft. A foot lever, hinged at its centre, is so connected to these rudders by cables that when the aviator pressing on this lever with his feet turns it, for example, to the left, then the machine will turn to the left.

Transverse Control.—The control of the lateral equilibrium, *i.e.*, the tipping from side to side, is effected by the use of "wing tips," four flaps constituting the rear ends of each plane. A lever in the aviator's right hand (the same one as used to operate the elevation rudder) can be moved from side to side. It is connected by wires to the lower flap on either side. These flaps in turn transmit the movement imparted to them by the lever to the flaps directly above them by means of a further wire connection. When the machine is standing still the flaps merely hang down loosely and the wires relax. But as soon as the machine

takes to flight the flaps fly out, very much like a flag blown by the breeze, and in this position the connecting wires are extended their full length, and the lever is in control.

If now, for example, the machine should tip suddenly down on the aviator's right side then the lever is promptly moved over to the left. This action causes the flaps on the right end of the machine to be pulled down, and since this involves an increased angle of incidence of the flaps, the lift they exert is increased. This is sufficient to bring the machine back to an even keel. During this process the wires leading to the flaps on the other end have been relaxed, since both sets of connecting wires are taut only when the lever is in mid-position. The flaps on the opposite end, therefore, have in no way been effected, except to be able to fly out more freely in the wind stream.

When making turns, in addition to using the direction rudder, the machine is often artificially inclined by the use of the transverse control. When turning to the right, for example, an instant before setting the direction rudder the lever is moved over to the right side. This lifts up the left end of the machine and therefore causes the turn to be sharper.

Keels.—Two horizontal surfaces at the rear of approximately 80 sq. ft. area act as keels. Their angle of incidence is low, and the lift they exert is small, their only function being to steady the machine longitudinally.

Propulsion.—A 50 h.p. 7 cyl., Gnome rotary, air-cooled motor is mounted on a shaft in the rear of the lower plane. A two-bladed Chauviere wooden propeller is directly connected to this motor, and rotates with it at 1,200 revolutions per minute. The pitch of the propeller is 4.62 ft. and its diameter 8.5 ft.

The Seats for aviator and two passengers are placed on the front of the lower plane.

The Mounting, or apparatus upon which the machine starts and alights, consists of two long skids forming part of the framework, upon each of which is mounted a pair of wheels. When starting, this machine runs along the ground on its wheels, but when alighting, the wheels, which are attached to rubber

springs, give way, and the machine lands on its skids.

The total weight varies greatly with the amount of gasoline taken aboard, the number of passengers, etc. The limits within which this value lies, however, are given and all calculations are made for an approximate mean weight of the machine with aviator aboard ready for flight. The weight of the Farman machine is from 1,100 lbs. to 1,350 lbs.; the speed, 37 miles per hour; 24 lbs. are lifted per h.p. and 2.8 lbs. per sq. ft. of surface. The aspect ratio is 5 to 1.

Recent Alterations.—The more recent types of Farman machines are fitted with a single surface direction rudder, instead of the twin surfaces. The elevation rudder, in front, is made smaller, and in addition the rear end of the upper of the two fixed horizontal keels (at the rear of the machine) is made movable conjointly with the front rudder to control the elevation of the machine. In some of the machines only one surface is used at the rear.

The two small wheels supporting the rear cell are replaced by a single skid. Other characteristics are substantially as given.

The new racing type of Farman has the following characteristics: The surface is reduced to 350 sq. ft., and the spread to 28 ft. The total weight in flight is about 1,050 lbs. 21 lbs. are lifted per h.p., and 3.0 lbs. per sq. ft. of surface. The aspect ratio is 4.2 to 1.

Another recent type of Farman is the huge new passenger-carrying machine, which now holds the four-passenger record. This aeroplane has a surface of about 540 sq. ft., and a spread of 47.6 ft. The maximum total weight is nearly 1,750 lbs., thus giving a capacity of 34 lbs. per h.p. and a loading of 3.15 lbs. per sq. ft. of surface. The aspect ratio is 7.1 to 1.—*Scientific American.*

(To be continued)

The Italian aviator Bielovucci, on August 29th and 30th, made some daring flights over Paris. On the 29th he circled twice above the Eiffel tower at a height of some 2,500 ft., while the following day he maneuvered above the city for 40 minutes at a height of from 1,500 to 2,000 ft.



CONSTRUCTION OF A TRANSFORMER WITH ELECTROLYTIC RECTIFIER

THOMAS C. STANLEIGH

The coming of Christmas will mark many additions to the laboratory of the experimenter in the shape of small motors, electric railways, miniature lamps for tree lighting, etc., all of which demand a more or less steady supply of current for their satisfactory operation.

The source of current supply may be any one of four; the primary battery, storage battery, small dynamos or the house-lighting circuit. The first is expensive, inconvenient and far from dependable. The second is out of the question unless a charging plant is near at hand. The third requires power to drive it in order to produce electrical energy. But the experimenter who has access to the regular lighting current of from 52 to 220 volts pressure, need not worry over a messy primary battery or a heavy accumulator, as he has an abundance of the coveted "juice" literally at his finger tips, providing he uses the proper means to "harness" it. To "harness" the lighting current does not mean to merely insert a bank of incandescent lamps or other resistance in the circuit to eat up 80 to 90 per cent. of the total number of watts used in order to supply the small motor with 2 or 3 amperes at 10 or 20 volts pressure. That procedure usually results in an appalling electric light bill at the end of the month, and in many cases the young man finds himself deprived of his much-prized fluid just when he is beginning to do all kinds of interesting "stunts." Then, aside from the wasteful effects of the resistance, there is another and more important point to consider. When a low-voltage motor is used in series with a bank of lamps on a high-voltage circuit, a certain amount of flashing and sparking occurs at the commutator. This is very destructive, especially in the case of the motor with a tri-polar armature.

It is the purpose of this article to describe a simple and efficient means of reducing an alternating current of practically any voltage to a pressure at which it can be used to advantage in the laboratory. In addition to this, the low-voltage alternating current may be rectified into a direct current by using the electrolytic rectifier described in this article. Alternating current produces very troublesome heating effects in a core of solid iron. Where the fields of a motor are laminated, this annoyance does not appear to such a marked degree but the fields of most small motors are composed of either cast or wrought iron and it is in this case that the direct current is very desirable. Then again, the iron and the windings of the motor constitute a veritable choking coil which offers so much impedence to the alternating current that a considerably higher voltage must be used in order to get the desired power from the motor.

While the rectifier, to be described, does not deliver a continuous current, strictly speaking, still the flow is in one direction and both sides of the cycle are used. The current somewhat resembles one delivered by a dynamo having a Siemen's "H" armature and two segment commutator. The pulsations may be almost eliminated by the insertion of a few cells of storage battery in series with the rectifier and the load. Even without the storage battery, however, the slightly pulsating direct current will show excellent results with small motors, and it may be used to charge accumulators for portable purposes, etc.

The transformer herein described is of the "Ferranti" type—a design very seldom seen in this country but one extensively used in Europe. Its extreme simplicity of construction particularly commends it to the builder, whose ability or patience is limited.

For the sake of clearness, the various stages of the construction will be taken up step by step; the first one to be considered being

The Core.—If the builder has access to the sheet iron known as “transformer iron,” he may consider himself fortunate. This iron comes in very thin sheets and is extremely soft and free from impurities. It is very difficult to obtain transformer iron, however, as it is used solely by the manufacturers of commercial transformers. A good substitute is the ordinary “stove-pipe” iron in its thinnest gauge. At a slight increase in price, this iron may be purchased cut to size and the builder is advised to secure it in this form.

The core is built up of sheets or strips 2 in. wide and 17 in. long. Enough iron should be purchased to make a pile $1\frac{1}{4}$ in. high when clamped together. The mass of iron is wrapped in several thicknesses of asbestos and bound with heavy iron wire, after which it may be placed in the kitchen range, preferably toward night so that it may become red hot and afterwards cool very slowly as the fire dies out. The purpose of the asbestos is to keep the iron clean and prevent it from burning, which destroys its magnetic qualities.

When cool, the core may be squared up and clamped between boards held in the jaws of a vise. A file may then be used to take off any sharp edges or projections.

Strips of thin, tough tissue paper are cut the same size as the strips of iron in the core. The author has found the thinnest grade of tracing paper to be admirably adapted to this purpose. A strip of paper is placed between each iron strip and its neighbor, thereby insulating them one from another. This materially reduces the heating effects which develop in the core when the transformer is in use.

The Bobbin, on which the primary and secondary coils are wound, is best built up of fibre. The ends or flanges are cut out of $\frac{1}{8}$ in. stock to the dimensions given in Fig. 4. This may be readily done with a fret-saw. The $\frac{3}{32}$ in. holes *A*, *B*, are drilled in each flange, but *C* and *D* are only placed in one flange. The tube on which the winding is placed, is made of a single piece of $\frac{1}{16}$ in. fibre.

The fibre sheeting is cut $5\frac{3}{4}$ by 7 in., and is bent around a block of wood having the same cross-sectional area as the iron core ($1\frac{1}{4}$ in. by 2 in.), but it need not be more than 7 or 8 in. long. Some difficulty may be experienced in bending the fibre over the sharp corners. In this event, the sheet may be soaked in hot water for a short time after which it will bend quite easily. The two edges should meet along the centre line of one of the 2 in. surfaces, and not at a corner of the block. If permitted to dry in this form, the fibre will retain its shape.

The flanges should then be cemented in place on the ends of the tube, care being taken to see that the holes *A* and *B*, through which the secondary leads are to pass, are on the same side of the tube in both flanges. Either thick shellac or Major's cement may be used to secure the flanges; the preference being given to the latter adhesive, as, when it becomes thoroughly dry, this cement is as hard as the fibre itself.

A $\frac{1}{4}$ in. iron rod, some 9 or 10 in. long, is passed through the centre of the wooden block and the whole mounted in crude bearings. After fitting a crank to one end of the rod, the builder is ready to proceed with

The Winding.—For the secondary winding, somewhat less than 1 lb. of No. 16 B. & S. double cotton-covered wire is required. The fibre bobbin must be absolutely dry before the winding is started.

Placing the spool of wire on a spindle at his left, the operator passes about 8 in. of wire through the hole *A* in the flange on the left and winds the first layer tightly and evenly by turning the crank in a clockwise direction. There will be 100 turns in the layer and, on its completion, the wire is cut, again leaving about 8 in. to be passed through the hole *A* in the right hand flange. After giving this layer a coat of thin shellac a piece of heavy wrapping paper is placed over it. A second layer of 100 turns of the No. 16 wire is then wound over the paper, the ends being passed through the holes *B* in right and left hand flanges. This layer must be wound in the same direction as the first. By merely turning the crank in the same direction and starting the second winding from the *right* hand side, the builder

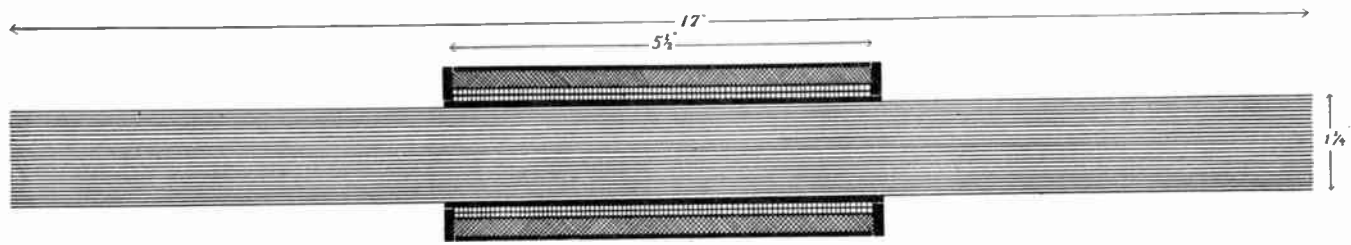

Fig. 1

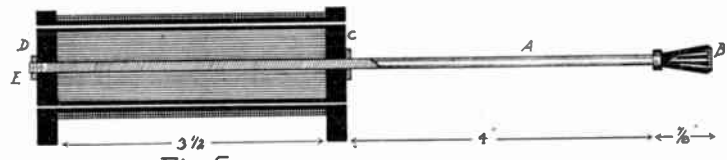

Fig. 5



Fig. 6

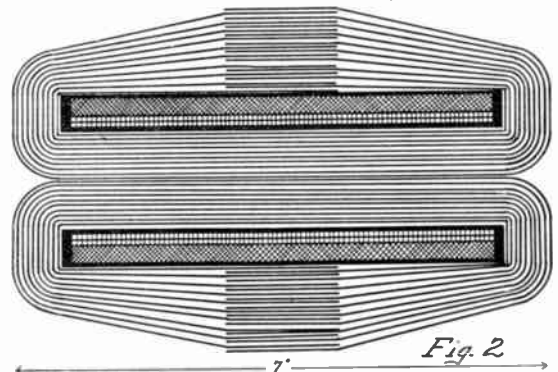

Fig. 2

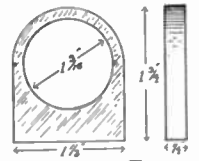

Fig. 7



Fig. 8

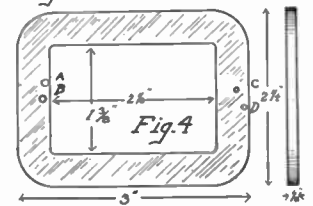

Fig. 4

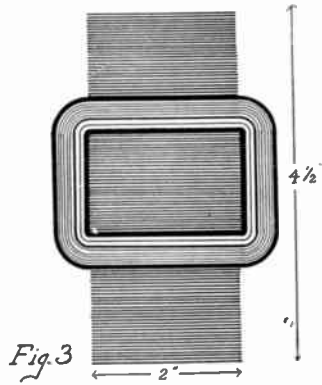

Fig. 3

— DETAILS OF TRANSFORMER —
THOS. C. STANLEIGH 1910.

will be safe. In other words, the two layers may be taken as one continuous winding, with a break in the exact centre.

The secondary having been finished and well covered with shellac, a couple of layers of heavy paper may next be placed over it and upon this the primary is to be wound.

For the primary, about $2\frac{1}{4}$ lbs. of No. 20 B. & S. double cotton-covered wire will be needed. The starting end is passed through hole *C* in the flange which should be at the left hand end of the bobbin. This winding consists of 146 turns per layer and is six layers deep. The entire 876 turns are put on without any break in the wire. After passing the finishing end through hole *D*, the winding is treated to two coats of thin shellac. Several layers of heavy paper are then wound over the wire and finally the whole is covered with a sheet of thin fibre, which may be laced at the seam or be fastened by overlapping its edges and cementing.

The bobbin should be placed in a moderately warm oven for 2 or 3 hours to dry out the shellac, after which it is ready to be placed in position on the core as shown in Fig. 1, first removing the block of wood. The mass of sheet iron should fit tightly into the opening, as otherwise the transformer will emit an unpleasant humming sound while in operation.

Fig. 1 clearly shows the relative positions of the primary and secondary windings with the core in its place.

The sheet iron strips are bent up and over the fibre as in Fig. 2, thus forming a closed magnetic circuit. The laminations should be bent up one at a time, the ends overlapping at the centre. Between each band of iron thus formed there will be a band of tissue paper. The completed "shell" is shown in Figs. 2 and 3, the latter view showing the transformer in cross-section. In Figs. 1, 2 and 3, the fibre insulation is represented by the heavy black lines.

The method of mounting the completed transformer may be readily understood by reference to Figs. 9, 10, 11 and 12. A strip of iron or cold-rolled steel holds the transformer to the slate base by means of the $\frac{1}{4}$ in. machine bolts, *B*.

Pieces of sheet asbestos, *C*, are placed between the steel yoke and the core and between core and base.

The Impedance Coil, by which the voltage of the transformer may be regulated, is shown in section in Fig. 5. It consists of two spool-ends of fibre cut to the dimensions given in Fig. 7, in which is mounted a tube of fibre, having $\frac{1}{8}$ in. walls. On this tube are wound 240 turns of No. 20 d.c.c. wire in two layers, leaving 4 or 5 in. out for connections. A second tube of fibre just small enough to slide easily into the solenoid thus formed, is fitted with heads or ends as in Fig. 8. These disks have holes drilled through their centres to take the brass rod *A*, Fig. 5, on which is fitted a small handle, *B*. After the rod is inserted through the head, *C*, the interior of the tube is tightly packed with No. 22 soft iron wires cut to $3\frac{1}{2}$ in. in length. Thick shellac is poured down into the mass of wires to partially insulate them, one from another.

The head *D* may then be put in place and the nut *E* screwed on to the end of the rod, which has been threaded for this purpose. Fig. 6 shows the coil in cross-section, the heavy black representing the fibre tubes.

The position of the impedance coil on the base is shown in Fig. 12, which is a plan of the completed transformer. The reader will note that the coil is in series with the primary of the transformer. The brass rod slides through the standard *G*, and a set screw, *H*, secures it in any desired position. The current has a marked tendency to pull the iron core into the solenoid, therefore the set screw is necessary. By withdrawing the core from the impedance coil, a higher voltage may be obtained at the secondary terminals of the converter.

The secondary connections are clearly indicated in Fig. 12. The binding posts should be numbered 1, 2, 3, 4, as shown, the leads from the *first* layer of the secondary being connected to 1 and 4; those from the *second* layer to 3 and 4. By connecting 1 and 2 together, a potential of approximately 25 volts may be obtained between 3 and 4, providing the core of the impedance coil is totally withdrawn. By gradually inserting the core the voltage may be lowered by very

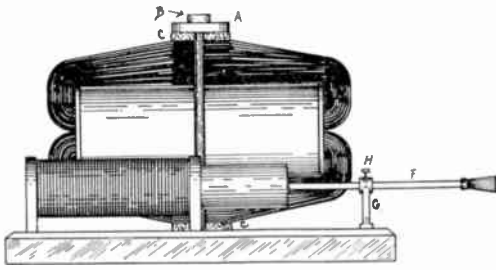

Fig. 9.

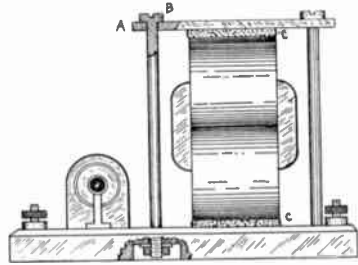

Fig. 11.

TRANSFORMER - RECTIFIER

THOMAS C. STANLEIGH
1910

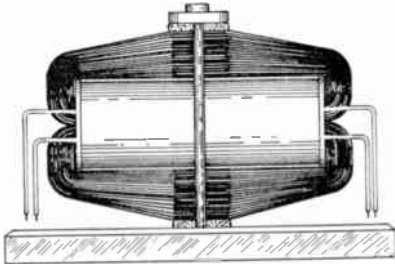

Fig. 10.

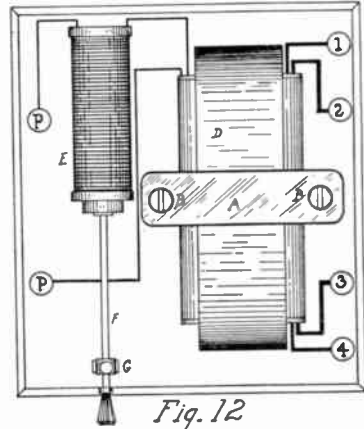

Fig. 12

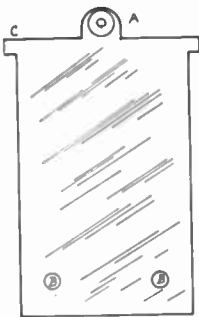

Fig. 13.



Fig. 14.

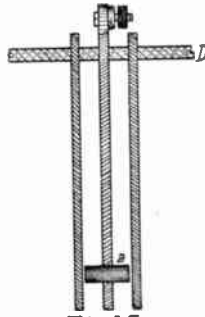

Fig. 15.

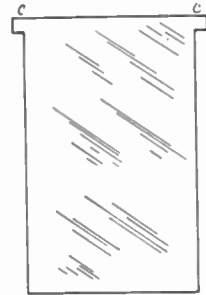

Fig. 16.

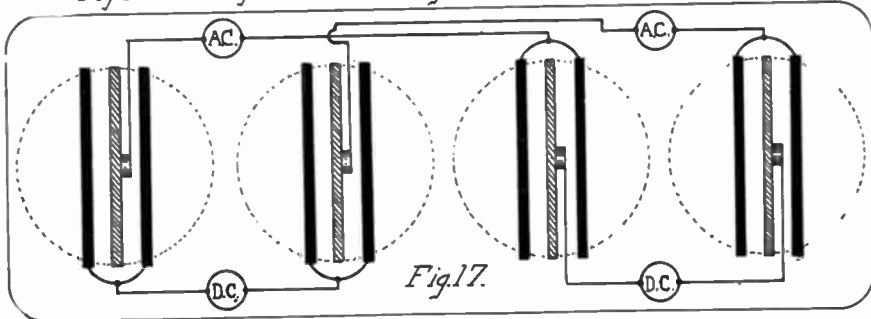

Fig. 17.

small steps. By connecting 4 and 2 together and 3 and 1 together a current of twice the amperes but only half the voltage is obtained between 1 and 2 or 3 and 4. These combinations will give practically any voltage between zero and 25 volts.

This winding is designed for use on a 110 volt 60 cycle a.c. circuit. For a 220 volt current, 1,752 turns of No. 23 d.c.c. wire should be used on the primary. The secondary would remain the same. The same windings could be used on a current having a frequency of 125 or 133 cycles, but the secondary voltage would be lower. Theoretically, the cross-sectional area of the core should decrease as the frequency increases. However, practically the same effect would be obtained by using somewhat less wire for the higher frequency. The design of so small a converter is more or less a matter of "cut and try" and the one herein described has given the author excellent results. It is almost unnecessary to state, however, that the design is the result of many experiments.

It is, of course, understood that the 110 volt current is applied directly to the terminals *P, P*, Fig. 12, without any resistance in the circuit. This transformer can only be used on alternating current. To efficiently reduce direct current to a lower voltage a motor-generator must be used and such a machine will be described in this department in a future issue of *Electrician and Mechanic*.

For the electrolytic rectifier, four glass or earthen jars, about 7 in. high and 5 in. in width, will be required. The standard 5 in. by 7 in. battery jar is just the thing. Four plates of aluminum $\frac{1}{8}$ in. thick, are cut to 4 in. by 6 in. A lug *A*, Fig. 13, is left at the top for a binding post and small shoulders, *C, C*, are for the purpose of suspending the plates in the cover *D*, Fig. 15. Holes should be drilled in the lower part of the aluminum plates to take the plugs of paraffined wood, *B, B*, Figs. 13, 14 and 15. Eight plates of $\frac{1}{8}$ in. lead are cut to the same size as the aluminum and having the shoulders as at *C, C*, Fig. 16. Two lead plates and one aluminum plate go in each jar or cell. The connections are shown in Fig. 17, in which the aluminum plates are repre-

sented by the shaded portions and the lead by solid black.

For use with low voltage of 25 volts or less, the jars should be filled with a solution of dilute sulphuric acid. Add one part of acid to ten parts of water. The acid should be poured into the water in a thin stream, stirring constantly with a glass rod. Never pour water into the acid or an explosion may occur. After the solution cools, the rectifier may be used by connecting the secondary terminals of the transformer to the binding posts *AC, AC* of the rectifier. Direct current may then be taken from the terminals *DC, DC*.

The rectifier may be used independently of the transformer; that is, it may be used to rectify a current of higher voltage than that obtained at the secondary terminals. When used with an electromotive force of 110 volts, the solution should consist of sodium bicarbonate or borax and water. The soda should be added to the water until a saturated solution is obtained, *i.e.*, until the water will not dissolve any more of the soda. For a 220 volt current a saturated solution of ammonium phosphate and water is used.

The water used must be either rain water or else distilled water to obtain satisfactory results.

Both aluminum and lead plates slowly waste away and the life of the solution is seldom more than 400 to 600 ampere hours; however, this is no drawback, considering the low cost of the materials used and the great convenience of the rectifier.

In connecting up the rectifier to a high voltage current some resistance or impedance should be used in series to prevent an abnormal flow of current at the start. After the rectifier has been working for a few minutes this resistance may be partially or wholly cut out and a voltage from 15 to 25 per cent. lower than that of the supply current may be obtained at the d.c. terminals.

This drop in voltage is, of course, current wasted, therefore the efficiency of the rectifier is from 75 to 85 per cent., not so bad when the simple and inexpensive construction is taken into consideration.

A four cell rectifier having plates of

the size described, will pass a current of from 3 to 5 amperes for some length of time without undue heating and 8 amperes may be taken from it for a few minutes at a time. By increasing the size of the plates and containing jars and providing some means of cooling the solution, a still greater current carrying capacity may be obtained.

When the rectifier ceases to work after considerable use, the aluminum plates should be taken out and scraped clean, and the solution renewed. If the acid solution is used, the terminals may be covered with vaseline or paraffin wax to prevent corrosion. The creeping of salts from the soda solution may be prevented by dipping the edges of the jars in melted paraffin.

A word of caution regarding the necessity of careful insulation of the primary and secondary windings is given here, where it will be forcibly impressed upon the mind of the reader. The utmost care must be taken to see that the covering of the wire is not abraded in any place throughout the windings, for if two adjacent turns should become short-circuited they would form a closed secondary circuit of very low voltage but enormously high amperage and the ring of wire would be literally melted in two as soon as current was applied to the primary. Therefore, the insulation should be closely watched as the winding proceeds and a layer of paper should be placed between each two layers of wire.

This transformer may be rated at about 200 watts. With the secondary coils in series, a current of 8 amperes at 25 volts may be taken and with secondary coils in multiple, 16 amperes at 12.5 volts may be obtained. The primary will take somewhat less than 2 amperes at 110 volts and under 1 ampere at 220 volts, at full load.

"The curie" is to be the standard unit for measuring radium emanations. This and the decision that Madame Curie shall prepare an international radium standard to be preserved in Paris are the main results of the congress of radio-activity and electricity, recently held at Brussels.

Radio-active science is today in much the same position that electrical science

was forty years ago, when every laboratory had its own standard of resistance. Close comparisons of the standards employed by various investigators in different countries has accounted for wide differences in results obtained, such as the number of alpha and beta particles emitted per second and the calorific emission, all such results being dependent upon the purity of the radium standard used for reference.

Owing to the rapid decomposition of radium salts, with loss of weight and consequent increase in the proportion of radium initially present, it is probable that some of these provisional standards of radium used by scientific laboratories are too high and contain more than their calculated amount of radium, while on the other hand, many other standards are entirely untrustworthy, 50 per cent. and even 20 per cent. preparations having been sold as "pure."

The first step has, therefore, now been taken toward the standardization of radium. The new unit expresses the amount or mass of radium emanation in equilibrium with one gramme of radium element. The standard will contain about 20 milligrammes of radium, which will cost about \$2,500, and a similar amount will be needed for sub-standards. The millicurie, for instance, would be the amount of emanation in equilibrium with one milligramme of radium element.

A committee appointed by the Congress will request the various Governments to purchase the international standard when prepared. Mme. Curie's work will also have a notable effect from a medical viewpoint. The custom has arisen, particularly in Germany and Austria, of expressing the radio-activity of natural waters, etc., in terms of arbitrary units involving the use of a particular measuring instrument, and scientists consider it highly desirable to replace this as soon as possible by one which shall refer the effects observed directly to the quantity of radium necessary to produce them. This will be possible as soon as standard solutions containing minute amounts of radium are available.

To mend a granite kettle, put a rivet in the hole and pound it flat.

EDISON: HIS LIFE AND INVENTIONS*

For many years the life and achievements of Thomas Alva Edison have been made the subject of article upon article in the press of the world. Perhaps no living man has proved more fruitful in this respect, nor furnished copy more interesting to the average reader. The accounts have all been alike in one respect, they have been incomplete, and a great majority of them have been published without the knowledge or consent of their subject. Now, for the first time, we have a complete, authentic and authorized record of Mr. Edison's work up to the present time. As he comes of a long-lived race, it is probable that the sum of his achievements is by no means complete, and there will be yet much to add.

The constant demand of the public, however, for reliable information on his past achievements is responsible for the publication of the present book. The authors are old friends and associates of Mr. Edison, have had his assistance in preparing the book, and much of it has been written by the inventor himself. Implicit confidence may be, therefore, given to the facts which it contains. Owing to the modesty of Mr. Edison, the biographical details are rather impersonal and do not contain as much of the thoughts, hopes, and doings of the man himself as we might desire, but as he has felt apparently that the thing which interested the world was his achievements rather than his personality, the authors have naturally given more attention to this side of his career.

Mr. Edison's birth, in 1847, came at a time when electricity practically meant nothing to the world. Batteries were known, to be sure, and a few of their uses, but electroplating and telegraphy were practically the only applications of any importance. It remained for him to make it the world's best servant.

We are introduced to the family and their migrations toward the West, and we find them in his earliest youth located at Milan, Ohio, whence they soon moved to Port Huron. The youngster's active mind soon made itself evident, and we are introduced to a highly characteristic event which occurred at the age of six. He had noted a goose sitting

on her eggs; shortly afterwards, having disappeared, he was sought for, and his father found him sitting in a nest he had made in the barn, filled with goose eggs and hen eggs, trying to hatch them out. His early life was spent, contrary to an assertion often made, in comfortable circumstances. Becoming interested in science, he soon started his first laboratory and had shortly collected no less than two hundred bottles of chemicals. His passion for experimenting soon used up his pocket money, and he decided that he must earn something for his own spending, so he applied for and obtained the privilege of selling newspapers on the Grand Trunk Railway, and was soon making money enough to keep his laboratory well supplied. Not content with having this at home, he appropriated a portion of the baggage car and fitted it up for experimental purposes, where he not only had his chemical laboratory, but printed a newspaper. Soon, however, an accident ended this privilege. A stick of phosphorus, falling from the shelf, set the car on fire, and he was ejected with his entire outfit, acquiring, besides the humiliation and disaster, a box on the car from the irate Scotch conductor, which rendered him deaf for life.

While a newsboy on the trains Edison became interested in electricity, and soon built himself a telegraph line. He took up the study of telegraphy with his natural enthusiasm, and soon obtained a position as night operator. He lost his first position through what might easily have been a serious accident, and then began a career of wandering about the Middle States as a telegraph operator, which lasted for nearly five years. His life during this time was full of incident, and the chapters on this portion of his career have all the interest of fiction. During all this period he managed to always have a laboratory, and wherever he stayed the inevitable chemicals and apparatus were soon set up and more than once were the cause of his being discharged.

In 1868 he arrived in Boston without funds, and immediately obtained a position with the Western Union. He at

*Edison: His Life and Inventions. By Frank Lewis Dyer, General Counsel for the Edison Laboratory and Allied Interests, and Thomas Commerford Martin, Ex-President of the American Institute of Electrical Engineers. In two volumes, illustrated. New York, Harper & Brothers, 1910. Price, boxed, \$4.00 net.

once resumed his purchase of books and material for experimenting, and the same year worked out his first invention, a vote recorder, for which he received his patent on June 1st, 1869. Another invention of his Boston experience, which was not patented, is thus described in his own words. "The office was on the ground floor, and had been a restaurant previous to its occupation by the Western Union Telegraph Company. It was literally loaded with cockroaches, which lived between the wall and the board running around the room at the floor, and which came after the lunch. These were such a bother on my table that I pasted two strips of tinfoil on the wall at my desk, connecting one piece to the positive pole of the big battery supplying current to the wires and the negative pole to the other strip. The cockroaches moving upon the wall would pass over the strips. The moment they got their legs across both strips there was a flash of light and the cockroaches went into gas. This automatic electrocuting device attracted so much attention, and got half a column in an evening paper, that the manager made me stop it."

The inventor then went to work on a stock ticker, which, contrary to usual opinion, he got into working shape in Boston, and set up a stock quotation circuit. This invention he tried to sell in New York, but unsuccessfully, and then returned to Boston and invented a duplex telegraph. This did not work out to his financial satisfaction, and he again went to New York, in or near which he has ever since remained. He found shelter at night in the battery room of the Gold Indicator Company, while looking for a position. What followed may thus be told in Edison's own words:

"On the third day of my arrival and while sitting in the office, the complicated general instrument for sending on all the lines, and which made a very great noise, suddenly came to a stop with a crash. Within two minutes over three hundred boys—a boy from every broker in the street—rushed upstairs and crowded the long aisle and office, that hardly had room for one hundred, all yelling that such and such a broker's wire was out of order and to fix it at

once. It was pandemonium, and the man in charge became so excited that he lost control of all the knowledge he ever had. I went to the indicator, and, having studied it thoroughly, knew where the trouble ought to be, and found it. One of the innumerable contact springs had broken off and had fallen down between the two gear wheels and stopped the instrument; but it was not very noticeable. As I went out to tell the man in charge what the matter was, Doctor Laws appeared on the scene, the most excited person I had seen. He demanded of the man the cause of the trouble, but the man was speechless. I ventured to say that I knew what the trouble was, and he said, 'Fix it! Fix it! Be quick!' I removed the spring and set the contact wheels at zero; and the line, battery, and inspecting men all scattered through the financial district to set the instruments. In about two hours things were working again. Doctor Laws came in to ask my name and what I was doing. I told him, and he asked me to come to his private office the following day. His office was filled with stacks of books all relating to metaphysics and kindred matters. He asked me a great many questions about the instruments and his system, and I showed him how he could simplify things generally. He then requested that I should call next day. On arrival, he stated at once that he had decided to put me in charge of the whole plant, and that my salary would be \$300 per month! This was such a violent jump from anything I had ever seen before, that it rather paralyzed me for a while. I thought it was too much to be lasting; but I determined to try and live up to the salary if twenty hours a day of hard work would do it. I kept this position, made many improvements, devised several stock tickers, until the Gold & Stock Telegraph Company consolidated with the Gold Indicator Company."

Thus placed in a position of comparative affluence, Edison was free to spend his time on developing the stock ticker, and soon became so prolific with his improvements and inventions, that the president of the company told him one day to close up his inventions, and offered him \$40,000 for what he had already accomplished. This was far

beyond Edison's wildest dreams, and he drew the money in small bills, getting all his pockets as full as they would hold, and then sitting up all night for fear someone would steal the results of his hard toil. With this capital he started in manufacturing, building stock tickers.

During the next two or three years his lines of work became so manifold that he had no less than three machine shops in Newark, besides being engaged with experimenting for the Automatic Telegraph Company.

From this time on his activities are so manifold, that it is almost impossible to give any coherent account of them. He is probably the most prolific inventor of all time. From 1869 up to the summer of 1910, no fewer than 1,328 patents have been applied for in his name, or one for every eleven days in forty years, and practically all have been granted. This by no means represents the actual measure of his inventions, as many discoveries have never been patented, and many patents represent the elimination of many discarded ideas.

His first great series of inventions was in the subject with which he was most familiar, telegraphy, and automatic telegraphy was first worked up. Developing ideas which were previously known, he made the basic discovery that a shunt around the receiving instruments with a soft iron core, by means of self-induction, would give absolute sharp definition to each signal. This instantly wiped out the sluggishness which had formerly prevented all fast telegraphy, and made any speed possible. The automatic system was successful, many thousand words an hour having been sent by it, and is still used in England, although Edison never received a cent for it. Duplex and quadruplex telegraphy were his next advance, and it is estimated that the Edison quadruplex has saved from fifteen to twenty million dollars in the cost of line construction alone, in America. Mr. Edison's payment for inventing the quadruplex telegraph was \$30,000.

From the telegraph, Mr. Edison turned to the telephone already invented by Alexander Graham Bell, and almost simultaneously by Elisha Gray. The first patent claim of Bell covered: "The method of and apparatus for transmit-

ting vocal or other sounds, telegraphically as herein described, by causing electrical undulations similar in form to the vibrations of the air accompanying the said vocal or other sounds substantially as set forth." This iron-clad grant completely covered all possible developments of the telephone. Bell's receiver, however, was of the magneto type, and not commercial. Edison produced the carbon transmitter, now universally used, and received therefor \$100,000. Mr. Edison's idea of business at this period may be deduced from the fact, that instead of taking his \$100,000, he stipulated that it be paid in installments of \$6,000 per year, for seventeen years, thereby receiving no more than the legal interest on his money, instead of having capital and interest too. His reason was that he was afraid he would use up his capital too soon if he took it in a lump, and preferred an assured sum every year. Immediately thereafter, he invented, again for the Western Union Telegraph Company, the electromotograph, which effectually defeated the Page patent, supposed to be basic in telegraphy. Another \$100,000 on the same terms was his reward for this invention, and for another invention of this same class, the loud-speaking telephone, he received £30,000 from an English company. Mr. Edison's connection with the early development of the telephone is somewhat more important than this brief survey suggests, but lack of space precludes us from further abstracting this portion of the book.

Next we find Edison working on the phonograph, and this appears to have been one of the most instantaneous of his inventions. Having conceived the idea, a sketch was made, and the first machine built from this sketch worked with absolute success, all machines since made, being identical in principle and mechanical action, although, of course, many improvements in detail have been added. The phonograph was, perhaps, the most sensational of all of Edison's inventions, and the one which most prominently focussed public attention upon his career, and it is today the basis of a most important industry, although by no means of the same utility to humanity as many of his other discoveries.

We now come to the one invention of Edison's which is without question the most important to the human race—the incandescent lamp. At the time of this discovery, carbon burners were known, but none of any commercial value, because of their brief life. So little was known about electricity, even in 1879, that Preece, one of the most eminent electricians in England, said: "The subdivision of the light is an absolute *ignis fatuus*," and another author, referring to Edison, said: "Some inventors have claimed the power to indefinitely divide the electric current, not knowing or forgetting that such a statement is incompatible with the well proven law of conservation of energy." Even Tyn-dall, before the Royal Institution, said, in 1879: "Knowing something of the intricacy of the practical problem, I should certainly prefer seeing it in Edison's hands, to having it in mine."

Edison, however, has never been daunted by the fact that his contemporaries believed a problem insoluble. He soon hit upon strips of carbon in a vacuum as a suitable material for a lamp filament, and although he experimented with platinum and innumerable refractory metals and compounds, he was soon convinced that the carbon filament was the most practical material. The construction of a suitable lamp, however, was by no means the solution of the problem of incandescent electric lighting. All previous electric lights had worked in series. Edison early realized that the lamp must have a high resistance combined with a small radiating surface, and must be used in multiple arc so that each light could be individually turned off. To make the problem commercial, small copper wires must be used, and Edison decided on the voltage of 110 degrees; therefore, in using a high voltage current, it was necessary to have a lamp of tremendously high resistance, instead of the extremely low resistance previously used. The idea that a hair-like filament of carbon could be maintained at a white heat for thousands of hours was a heroic conception, and its practical working out, one of the greatest of inventions in all ages.

Having decided what he must do, Edison started to work to do it. He built vacuum pumps, far better than

any previously made. He searched the world for a suitable carbon filament, finding it in bamboo charcoal, although the first filaments were made of carbonized paper. He made his tools of every kind for the commercial production of his lamps, and then he lighted up his laboratory at Menlo Park, which soon became a scene of pilgrimage from all over the world.

Passing over some of the most interesting material in the book, we will merely mention that, in connection with the incandescent lamp, Mr. Edison invented a complete system of electric lighting, discarding the old tree system, the natural one, for wiring lamps, and inventing the feeder system, which enabled a district to be wired with one-fourth as much copper, and having evolved this he proceeded to build, in the city of New York, the first central station. The world was very skeptical, money came hard, and in order to keep things going Mr. Edison sold his electrical manufacturing works at Schenectady to a company, which is now the great General Electric Company. The development of the electric lighting situation from that day to this is well known, and the story of its beginning is here fully and interestingly told.

About this time Mr. Edison did much work on electric railways which is here fully detailed, and although theoretically interesting, is not important enough for us to dwell upon.

The second volume opens with a chapter on one of the most ingeniously worked out inventions of all, the magnetic ore milling plant, designed to crush and concentrate low grade iron ores and make them commercially utilizable. On this Mr. Edison worked nine years, and succeeded in solving the problem, only to have his entire work rendered useless by the exploitation of the great Mesaba iron range, in Michigan. The most revolutionary piece of machinery in this plant were the giant rolls, which crushed rocks as large as a small cottage, without much expenditure of power, by the mere force of inertia. Into this enterprise Mr. Edison put almost his whole fortune and when it was finally decided that the enterprise was commercially impractical, he decided to apply the knowledge gained in

this most expensive experiment in building a Portland cement plant, and that he would use his time in developing a storage battery which did not use lead and sulphuric acid. So successful were the efforts of himself and his associates in the Portland cement line, that it took but three years to pay off the several hundred thousand dollars of indebtedness incurred in the development of the concentrating works, an enterprise which had lost more than two million dollars. In this connection we may quote a remark by Mr. Mallory, one of Edison's partners: "During the boom times of 1902, when the old General Electric stock sold at its high-water mark of about \$330, Mr. Edison and I were on our way from the cement plant at New Village, N.J., to his home at Orange. When we arrived at Dover, N.J., we got a New York newspaper, and I called his attention to the quotation of that day on General Electric. Mr. Edison then asked: 'If I hadn't sold any of mine, what would it be worth today?' and after some figuring I replied: 'Over four million dollars.' When Mr. Edison is thinking seriously over a problem he is in the habit of pulling his right eyebrow, which he did now for fifteen or twenty seconds. Then his face lighted up, and he said: 'Well, it's all gone, but we had a hell of a good time spending it.'"

In the Portland cement industry Mr. Edison's entrance was revolutionary. His first great innovation was the crushing and grinding machinery, which he had introduced in the ore concentration plant. Inasmuch as he had changed the efficiency of this machinery from 15 per cent. of the total power to nearly 90 per cent., applied in useful work, it is apparent that a considerable saving was possible here. He also introduced a burning kiln, which instead of being 60 ft. long, was 150, having a capacity of 1,100 barrels of cement per day, instead of 200. Ever since this period Mr. Edison has been strongly interested in the manufacture of cement, and his latest development in this line is the poured cement house, made in a single piece from cast iron moulds, with which he hopes to revolutionize the workmen's homes of the United States. This has been so recently exploited by the press,

that our readers are doubtless familiar with it.

Edison's two last great inventions are the motion picture, so familiar in every hamlet today, and the Edison storage battery. With the details of one, our readers have become familiar through the articles on "Motion Picture Projection," now running in this magazine, but on the storage battery we propose to have a separate article.

A chapter is devoted to the miscellaneous inventions, comprising all sorts of useful applications, such as an induction form of wireless telegraphy, a fluoroscope for X-ray work, a gold extractor, a snow remover, a submarine torpedo, a pyromagnetic generator, many forms of electrical instruments, and dozens of miscellaneous inventions. From first to last Edison has filed in the United States Patent Office, besides more than 1,400 applications for patents, some 120 caveats, embracing not less than 1,500 further inventions. The caveat system is now abandoned, but its principal purpose was to warn an inventor of any interfering application filed within a year of his notice of the conception of a new device. A single caveat filed by him contained more than 100 distinct inventions.

Edison's method in invention has been much criticised, it having often been alleged that it was purely empirical. As far as chemical work is concerned, this is freely admitted by himself, his idea being that if in any given problem every possible and impossible substance is tried, not only is the best substance found, but all impossible materials are excluded. In his electrical and mechanical work, however, no trace of this method exists. His conceptions have always been in the truest sense inventions, and his work has been most carefully arranged to eliminate all possible sources of error and failure. Having conceived some new idea and completely mastered the present knowledge of the subject, Edison then outlines the work to be pursued and passes it over to his experimental staff for complete working out. The details of the work are carefully noted in the laboratory note-books, of which more than a thousand now exist. On one problem more than 15,000 experiments and tests were made by one

of his assistants. On his electrical lighting experiments alone, more than 40,000 pages of notes are in existence, recording all the innumerable experiments and calculations and tests from beginning to end. On the storage battery the experiments amount to nearly 50,000, filling over 150 note books.

Having summarized briefly a few of the many interesting chapters of this book, let us pass finally to the chapter which discusses the value of Edison's inventions to the world. How far has Edison added to the wealth of the world, by his inventions, energy and perseverance? This is a question impossible to answer, because other inventors have in all cases worked on the same problems, and have assisted in the present commercial development of the various arts, but listing only those industries in which his inventions have had a definite value, we may quote the following table, which gives an approximate statistical resumé of some of the industries in the United States directly

founded or affected by inventions of Thomas A. Edison.

Looking at this one sees considerable justice in the story that after a recent conversation about old times and early inventions, he leaned back in his chair, and with a broad smile on his face, said, reflectively, "Say, I *have* been mixed up in a whole lot of things, haven't I?"

The last half of the second volume of this most fascinating book tells of Edison's legal struggles in defending his patents, and something about the social life of the man himself. In addition, an appendix contains full descriptions for the layman of all the important inventions—fully illustrated with sketches and diagrams, and a complete list of Edison's patents in the United States together with a table showing countries which have granted him 1,239 foreign patents.

A wonderful book about a wonderful man. Let every reader of this magazine get it and study it for the lessons of energy, patience, perseverance and faith in one's self, which it contains.

Class of Industry	Investment	Annual Gross Revenue or Sales	No. of Employees	Annual Pay-rolls.
Central Station lighting and power	\$1,000,000,000	\$225,000,000	50,000	\$40,000,000
Isolated incandescent lighting.....	500,000,000		33,000	17,000,000
Incandescent lamps.....	25,000,000	20,000,000	14,000	8,000,000
Electric fixtures.....	8,000,000	5,000,000	6,000	3,750,000
Dynamos and motors.....	60,000,000	50,000,000	30,000	20,000,000
Electric railways.....	4,000,000,000	430,000,000	250,000	155,000,000
Telephone systems.....	800,000,000	175,000,000	140,000	75,000,000
Telephone apparatus.....	30,000,000	15,000,000	12,000	5,500,000
Phonograph and motion pictures...	10,000,000	15,000,000	5,000	6,000,000
Motion picture theatres.....	40,000,000	80,000,000	40,000	37,000,000
Edison Portland cement.....	4,000,000	2,000,000	530	400,000
Telegraphy.....	250,000,000	60,000,000	100,000	30,000,000
Totals.....	6,727,000,000	1,077,000,000	680,530	397,650,000

Let it be thought that the recent experiments made from the Eiffel Tower, to transmit by wireless telegraphy time to ships at sea, are the first of their kind, be it said that in 1904-5 Albrecht showed that it was possible to utilize wireless telegraphy for the transmission of time signals in the determination of terrestrial longitudes. In 1906 E. Guyon found it possible to work between Paris and Brest by the method of telephonic coincidences with an

accuracy of 0.003 sec. under good conditions. With an apparatus installed between the observatories of Paris and Montsouris, a series of comparisons were made between the results given by telephonic and radiotelegraphic transmission, and the probable errors show the mean error of a comparison to be about ± 0.0006 sec. A set of pendulums with special silver contacts were employed to work the sparking apparatus for the wireless signals.

ELECTRIFYING THE COAST DEFENSE

MONROE WOOLLEY

Electricity is fast finding additional uses at military posts throughout the country. Especially is this true of coast defense garrisons. While some posts are still being lighted with oil lamps, such instances are rare. Also the many coast defense stations where big guns, mortars and ammunition hoists are being manipulated by hand are few and far between. They are getting fewer with the march of time. Not only are modern electric lighting systems for the barracks and quarters going in, but the electric systems in coast artillery posts are being rapidly extended to the batteries to operate the great disappearing guns and mortars and the intricate apparatus in the range-finding towers and secondary stations. Before very long an enemy will be annihilated by pressing a button which will automatically hoist up the charge, load it, bring the gun to position, and discharge it. In fact, that very thing is being done now to a certain extent.

In many inland stations electric current is bought from private corporations or municipally owned plants. But at coast defense posts it is necessary for each station to have its own power plant. These plants are thoroughly modern and exceedingly well constructed in every

respect. They furnish electricity for lighting all buildings, as well as power for operating the guns, motors, hoists and other machinery connected with the fortifications. They also light the masonry tunnels and passages in the emplacements. In time of war wire fences, heavily charged with current, may be thrown about the batteries where the guns are located, to keep landing parties from the enemy's lines from taking the place. Army power plants are operated by enlisted men of the artillery corps who are specially fitted for the work. They rank as non-commissioned staff officers, have separate quarters and besides being given a ration, they draw lucrative pay. Most of the power buildings, if not all of them, are constructed of reinforced concrete along approved lines. Each has two modern type horizontal water tube boilers of 125 h.p. each, under which oil is burned. Two dynamos, General Electric make, of about 90 k.w., generate the power. These plants, however, do not furnish current for the colossal searchlights which have in this late era been introduced into artillery tactics of defense. Hitherto, searchlights have been little, if at all, used by the United States, in coast-defense work, but yearly their

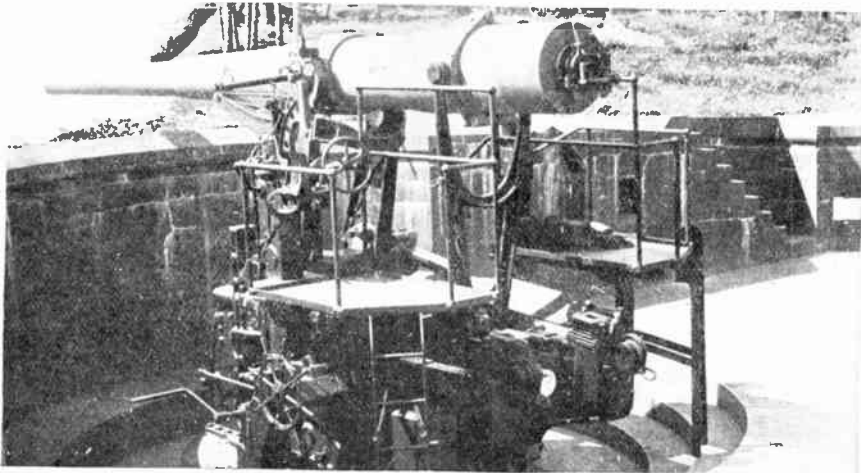

An eight-inch disappearing rifle equipped to be raised either by hand or electricity



Power plant with engineer's and fireman's quarters in background. Earthworks are thrown up to the height of the roof around plant

importance is being more and more recognized. Formerly one or two small 30 or 32 in. portable lights were considered ample for all strategic problems. Now, huge 60 in., or 5 ft. lights of the most modern make are being installed, not only at the larger posts but at all of them, big or small. A searchlight with a 5 ft. lens throws a flood of light that dazzles the best of eyes. Fifty of these monster lights are being strung along the west coast, eighteen being located at the garrisons on Puget Sound. The others are at Fort Columbia, at the mouth of the Columbia river, at San Francisco, and San Diego. The Atlantic seaboard is also similarly equipped in many places. As before stated, these lights are marvels of brilliance, and they present an awe-inspiring sight during night drills with the big guns. Citizens often travel for miles in parties to witness these spectacles. The reason the power plants do not furnish current for these big "lanterns," it is claimed, lies in the fact that no two lights carry the same voltage when working at their sharpest focus. Therefore, a separate engine and dynamo are necessary, so that the current can be regulated to suit the whims of each lamp. A four-cylinder gasoline engine of about 35 h.p., finely finished and made especially for the work by the General Electric Company, is a part of each searchlight plant. This Company also makes the new 60 in. lamps, each of which takes a 110 voltage, direct current. Each of our many coast defense posts has from six to a dozen of

these monster searchlights, with engines and dynamos for each. The manner of masking both the lamps and the gasoline power plants from the eyes of the enemy is interesting and unique. The plants are strung along the coast line on either side of the gun-pits, generally on high and commanding bluffs overlooking the sea or harbor, as the case may be. Deep ditches, resembling uncovered tunnels, are dug into the surface of the bluff, one end opening out upon the perpendicular surface of the cliff. These openings are usually 8 or 10 ft. wide, and about 10 ft. deep. The bottom is floored with suitable timbers or concrete, and tracks are laid upon which the wheeled truck supporting the light is run back and forward. A pit is excavated at the inland end of the runway for the gasoline engine power



New type of sixty-inch searchlight, fifty of which are being installed at artillery posts on the Pacific Coast



An artillery range-finding station showing plotting board, operated by soldiers in foreground

house, which is of concrete, the roof of the building being level with the surface of the earth. When in operation the light is run out on the track which some-

times overhangs the cliff's side some 3 or 4 ft. Thus the entire system is more or less protected from the fire of the enemy.

A SIMPLE TEST BOARD

GEO. C. CASSARD

In commercial meter testing in the "shop," it is desirable to get the work done in the shortest possible time, consistent with accuracy, and to provide against carelessness as far as possible. These results are best attained by providing a testing board of the simplest and most automatic design, reducing to the minimum the time and thought required in connecting up and disconnecting meters.

In the following diagrams an arrangement of wiring is shown that will be found to fulfill these conditions very satisfactorily, a change from a 110-volt to a 220-volt connection being accomplished by simply throwing over a single pole switch *f*. This switch also serves to open the current circuit when a change in meters is to be made.

Either a.c. or d.c. service may be used, or, if both are required, a 3-pole, double-throw switch may be mounted at their junction, and thrown to whichever service is wanted. From this switch the feeders run directly to the three main busses on the back of the

board, and from these busses, as many testing sets, or "units," may be tapped off as desired. The following is descriptive of one "unit:"

Suppose the service to be alternating for instance, and the meters to be of the Fort Wayne, Type K pattern. (With this pattern the board terminals are most conveniently placed as shown.) The first meter (Fig. 1), we will say is designed for 110 volts. The wiring behind the board terminates in the binding posts, or plug holes, *a*, *b*, *c*, *d* and *e*; therefore short leads are connected from *a*, *c* and *e*, to the corresponding taps of this meter, and the switch *f* is thrown to the right. The circuit is then completed through *a-e-load-c-f*, and back to the neutral, the post *c* also supplying pressure.

In Fig. 2, a 220-volt, 3-wire meter is connected, and the switch is thrown to the left. The circuit then is, *a-b-f-c-load-e-d* and line; the posts *a* and *d* at the same time supplying the pressure.

It will be noticed that the load, in this case, comes in between the meter

fields, thus making it possible to feed the latter in series, and still maintain the necessary difference of potential between them. Without this arrangement the fields would both be on one side of the system, and it would be necessary to disconnect the small pressure wire within the meter, and connect it, through an extra lead, with the other side.

It is also true that no short circuit can occur if the switch is carelessly thrown the wrong way, in testing either a 110-volt or a 220-volt meter.

The method of connecting 2 and 3 phase meters is illustrated in Fig. 3. In testing these meters on single phase, it is necessary to connect the two field circuits in series, as shown; the other connections being the same as those for 110-volt, single-phase meters, except that the pressure tap becomes *d* instead of *c*. The switch, in this case, is thrown to the right.

Single-phase, 220-volt, *two-wire* meters are also connected exactly as in Fig. 1, with the above exception concerning the pressure tap.

Three wire d.c. meters, equipped with 110-volt armature circuits, may be connected as in Fig. 2, with the switch to the left as shown, if the neutral pressure is taken from the right-hand switch contact. This method, however, is not recommended, as it is somewhat confusing in practice, and requires double the necessary wattage, throwing the load directly across the outside legs. This is only desirable on the 3 wire a.c. meters, for the sake of the armature potential, as explained. The d.c. meters in question may be handled as in Fig. 1 by connecting their fields in series at the "house" terminals by means of a short independent jumper. In this case, the potential may be taken directly from *c*.

The indicating instruments, used as standards, may be connected in at separate outlets in the usual way.

The load, must of course, be adapted to a pressure of 220 volts, as well as 110.

Attention has not been given here to the use of the "phantom" load, which has not been generally adopted, probably owing to the more expensive apparatus required, and the use of two independent circuits, with more elaborate wiring.

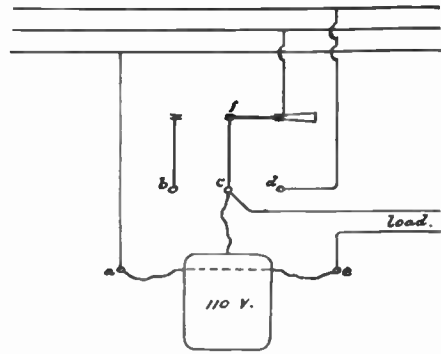

Fig 1

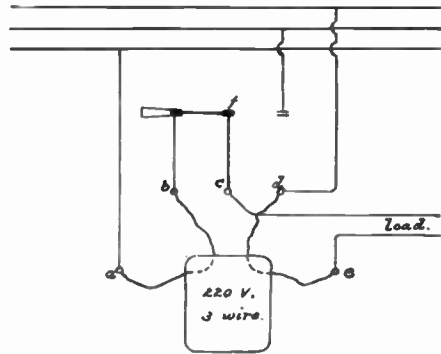

Fig 2.

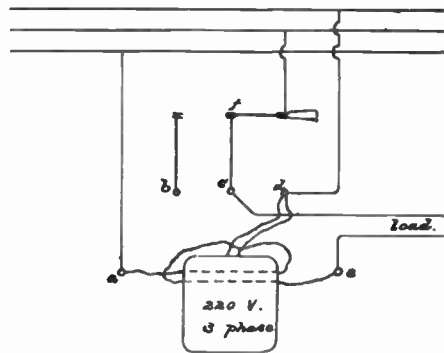

Fig 3.

One of the greatest accomplishments is to be a good listener. By letting the other man do all the talking we acquire a reputation for wisdom far above that we may gain in any other way.

ELECTRICITY IN HOME AND OFFICE

DESIGN AND CONSTRUCTION OF A PRIVATE LIGHTING PLANT—Part I

STANLEY CURTIS

No doubt there are many readers of *Electrician and Mechanic* who are desirous of obtaining a steady and useful supply of electric current for lighting and small power purposes, but who, through their inability to secure service from a lighting company or on account of the expense of installing a private plant, are deprived of the luxury or—as it may be called—the necessity of electric light and power.

The writer was in just such a position a few years ago and after trying in vain to obtain current from the nearest central station, he started a series of experiments which resulted eventually in the inexpensive but efficient little plant which he will endeavor to describe in detail in this series of articles. The many difficulties encountered in the construction of this plant, as well as the weak points which developed after some use, will be mentioned from time to time.

Low voltage lamps were used as the number of cells of storage battery required was thereby reduced, although their capacity in ampere hours was necessarily increased. At that time tantalum and tungsten lamps were unknown, and the low-voltage carbon lamp was of correspondingly low efficiency; indeed, 4 watts per candlepower was considered good. In order to supply the requisite number of lamps to light an eight-room cottage, it was necessary to use a storage battery of large capacity, and to give it a long charge nearly every day; however, with the installation of tungsten lamps, the time required for charging was reduced to a comparatively few hours every other day in winter and twice a week in summer. No attempt was made to light directly from the generator for various reasons. In the first place, the small machine

used could not have supplied much more than 100 c.p. at one time, and it is extremely difficult to entirely eliminate the "flicker" even when using a closely governed engine with heavy fly-wheels. While storage battery lighting involves the use of a larger battery, still it is far more reliable and the current is ever ready. Not only that, but in order to keep a battery, whether large or small, in good condition, it is necessary to use it and recharge it.

Then the generator is always running at its most efficient load, that is, full load, when charging the battery. By means of a simple form of recording watt meter, to be described, the exact amount of current drawn from the battery could at all times be ascertained and a charge put in when necessary. For lighting large buildings, the direct method is, of course, far more economical, as in that case the dynamo would be running under its maximum load the greater part of the time, and the cost of a storage battery sufficiently large to light the building would be almost prohibitive. However, for the small installation, the accumulator plan seems to be by far the best.

The lighting plot on page 26 is based upon a 20 volt, 10 watt, 8 c.p. tungsten lamp as a standard. These lamps are made with the standard Edison base and have anchored filaments. The light is pleasing and brilliant, and the lamps have an average life of 800 hours. By burning them at slightly higher voltage the life is somewhat reduced, but the efficiency is considerably increased. Each 8 c.p. lamp takes .5 of an ampere at 20 volts.

A glance at the plot will explain how the storage battery capacity was figured.

Reference to column No. 6 of the plot tells us that 56 lamp hours will be con-

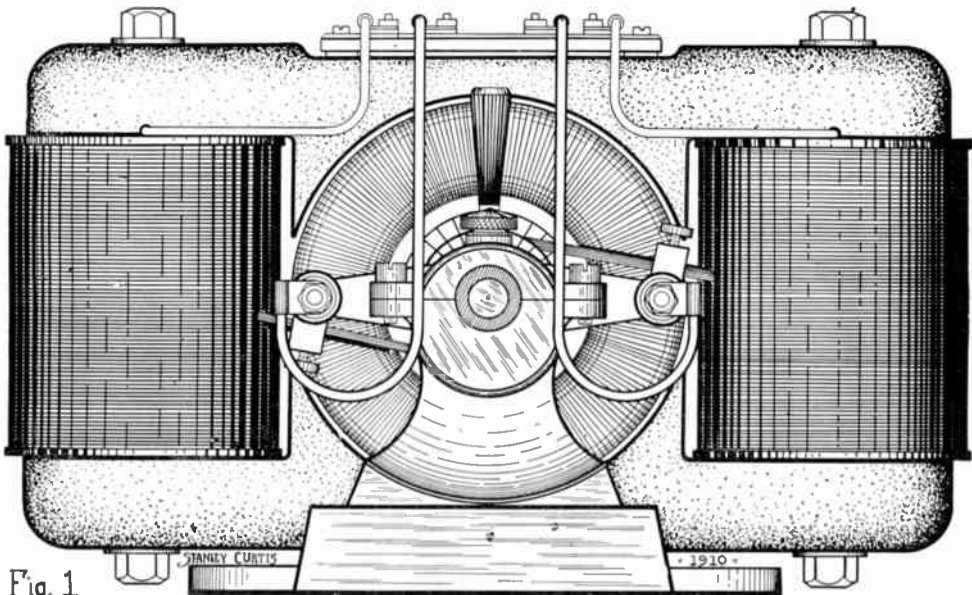

Fig. 1

sumed during the evening. As each lamp takes .5 of an ampere, therefore 28 ampere hours will be used. Column 7 tells us that 17 lamps will be burning at the "peak load," so the storage battery must be large enough to deliver a current of 8.5 amperes without injury. The 60 ampere hour size will do this and will stand a considerable overload for a short time. A 60 ampere hour

battery will furnish light for two evenings on one charge.

The dynamo used in the writer's plant was a home-made one, but the results obtained from it were so satisfactory that a description of its construction will be given. A good idea of the general appearance of the machine may be obtained by glancing at Figs. 1 and 2 which are side and end elevations

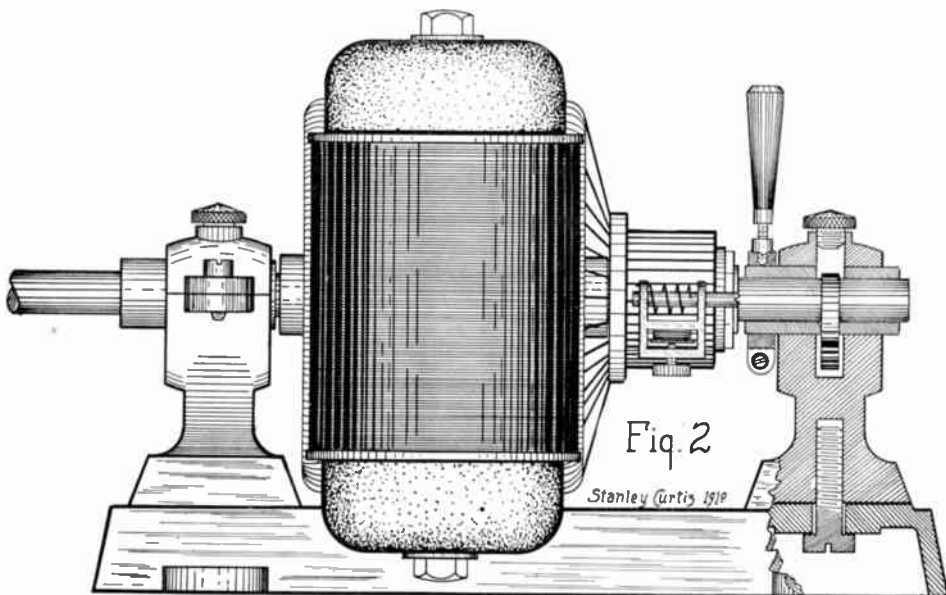

Fig. 2

Number of lamps	C.P. of lamps	Name of Room	Time of burning	Total hours	Total lamp hours	Lamps burning between 5 and 6 o'clock "peak load"	Current in amperes 5 to 6
4	8	Living Room.....	5 to 6 7 to 10	4	16	4	2.
1	8	Reception Hall.....	5 to 10	5	5	1	0.5
1	4	Porch.....	7.30 to 9.30	2	1		
3	8	Dining Room.....	5.30 to 7.30	2	6	3	1.5
2	8	Study.....	8 to 10	2	4		
2	8	Kitchen.....	5 to 10	5	10	2	1.
1	4	Pantry.....	5.30 to 7.30	2	1	½ (4-c.p.)	.25
2	8	Front Bedroom.....	5 to 6 10 to 11	2	4	2	1.
1	8	Second Bedroom.....	5 to 6 10 to 11	2	2	1	.5
1	8	Third Bedroom.....	5 to 6 10 to 11	2	2	1	.5
1	8	Fourth Bedroom.....	5 to 6 10 to 11	2	2	1	.5
1	4	Bathroom.....	as needed	2	1	½ (4-c.p.)	.25
2	4	Hall.....	as needed	2	2	1 (2 4-c.p.)	.5
					56 or 28 ampere hours	17	8.5 current at peak load

respectively of the completed generator.

The extreme simplicity of the castings required for the fields is apparent on referring to Figs. 3, 4 and 5. The castings consist of an upper and lower half with the bed-plate cast onto the latter. Very little difficulty will be experienced in making the patterns for these castings, but the precaution should be taken to allow about $\frac{1}{8}$ in. to the foot for the shrinkage of the iron. The armature tunnel should be made $5\frac{3}{4}$ in. in the patterns to allow for boring out and a disk of wood about $\frac{1}{16}$ in. thick should be placed at *A* on each half. This will leave some iron to be machined off where the ends of the wrought iron cores join the two halves. Extra material should also be left at *B*, as these surfaces are to be bored to the same radius as the armature tunnel— $2\frac{1}{16}$ in. in the finished casting. The dimensions given in the drawings are all for the finished parts so that an allowance can be made for the iron that is to be taken off.

The first operation on the field magnet castings is to drill the holes in the feet for bolting the machine down, the holes in upper and lower half to pass $\frac{1}{2}$ -13 hexagon bolts and the $\frac{7}{16}$ in. holes in the base for the bolts which hold the bearing standards. The castings may then be placed in a planer or milling machine and the surfaces, *A*, finished off. This operation must be carefully performed as the efficiency of the ma-

chine depends to a large extent upon the quality of the magnetic joints between the cores and the castings. The finishing cut should therefore be a fine one. Indeed, the efficiency of this method of making the joint is open to question, and a far better joint may be obtained by boring out a recess in the castings and letting in the cores, which are turned to a good fit. The better method was not available to the writer owing to limited facilities, however, but on the whole, the efficiency of the completed machine was so high that it left almost no room for regrets.

The cores may be cut from a piece of 2 in. cold rolled steel. The ends should be faced off, holding the steel in the chuck and drilling the holes, which are to be tapped for the $\frac{1}{2}$ -13 bolts, while the core is in the lathe.

The cores, having been finished, may be placed in position at the ends of the field castings and the bolts screwed home. The whole is then bolted to the movable carriage of the lathe, and the polar faces bored out to $5\frac{7}{8}$ in. The seats for the bearing standards are to be bored out at the same time to the same radius. This completes the machine work on the field magnet with the exception of two holes at *B*, Fig. 5, which are drilled and tapped to take 8-32 screws to hold the connection board in place. After chipping and filing off the rough places, the casting may be given two

coats of good iron enamel, the lead color or gray being a favorite with the writer.

This machine was first made with plain bearings supplied with oil-cups, but after a few hours' running they would be hot and at best they required a great deal of attention. These were afterwards changed for the form of self-oiling bearing shown in Figs. 7, 8, 9 and 10. The cross-sectional views in Figs. 2 and 7 clearly show the position of the ring which turns with the shaft and thereby brings up a constant supply of oil from

may then be bolted to the face plate and the hole for the bearing lining bored to 1 in. in diameter. This hole should preferably be finished to size with a reamer. An arbor may be inserted in the 1 in. hole after taking casting from the face plate and the lower surface of the standard turned to a radius of $2\frac{1}{8}$ in.—the same as the seat on the bed-plate.

The bearing linings are turned up to the dimensions given in Figs. 11 and 12. The hole for the shaft should be reamed

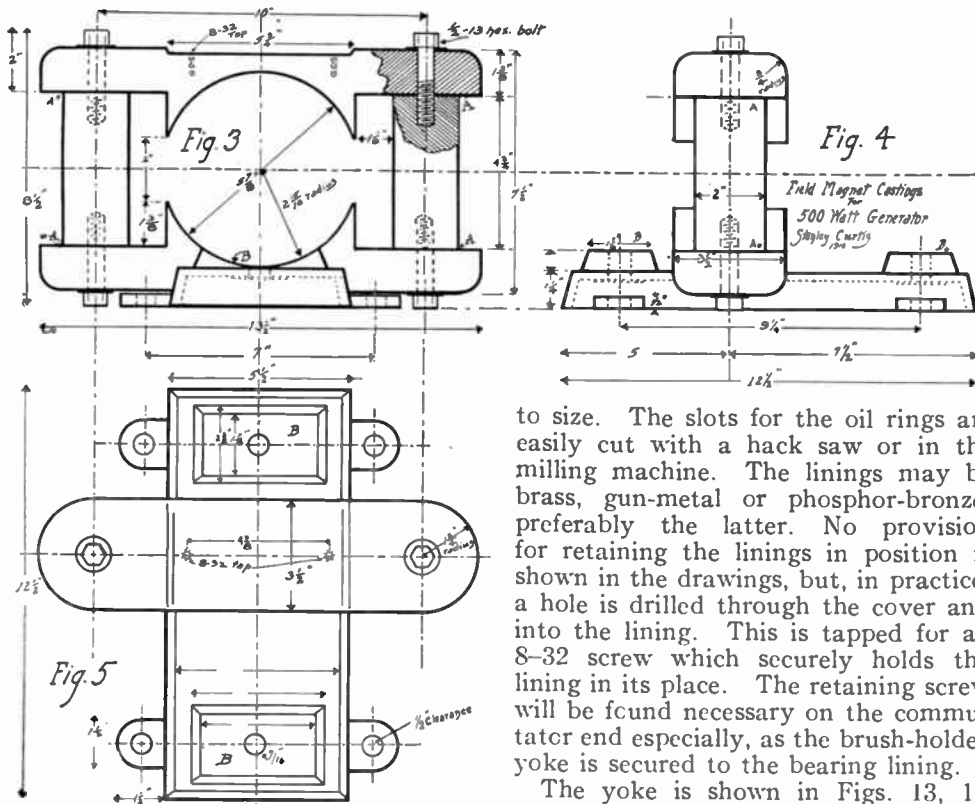

the chamber below. The rings were cut from a piece of brass tubing, $1\frac{1}{2}$ in. outside diameter, and the walls need not be over $\frac{1}{16}$ in. thick. The bearing standards are iron castings. Unless the castings are extremely rough, it will not be necessary to plane the surfaces where the cover meets the lower part or standard proper. They may be faced off on the flat of an emery wheel. Holes should be drilled and tapped for the $\frac{1}{4}$ -20 machine screws or hexagon bolts which join the castings. The standard

to size. The slots for the oil rings are easily cut with a hack saw or in the milling machine. The linings may be brass, gun-metal or phosphor-bronze, preferably the latter. No provision for retaining the linings in position is shown in the drawings, but, in practice, a hole is drilled through the cover and into the lining. This is tapped for an 8-32 screw which securely holds the lining in its place. The retaining screw will be found necessary on the commutator end especially, as the brush-holder yoke is secured to the bearing lining.

The yoke is shown in Figs. 13, 14 and 15, which clearly show its construction. The casting is preferably of brass although iron will do. The brush-holder shown is for a copper brush, as carbon proved unsatisfactory for a low-voltage machine.

The gasoline engine has a trick of turning half a revolution backwards when it stops, however, and this completely ruins a copper brush after it happens a few times. The back revolution may be avoided by relieving the compression by means of a pet-cock on the engine cylinder. Some emphasis is

laid on this point as the damage to the brushes might not be noticed until the machine was started up again.

The studs, Fig. 17, are turned up of brass rod and are insulated from the yoke by means of fiber washers and bushings. Tension is secured by means of a spiral spring, one end of which is caught in the stud and the other in the brush-holder. This is illustrated in Fig. 2. The brushes, Fig. 18, consist of a number of sheets of thin copper, filed to a radius of 1 in. at one end and soldered together at the other.

Mechanically and electrically speaking, a dynamo is no stronger than its weakest part and this is very often the commutator. It is the very heart of the machine and is called upon to stand some severe mechanical as well as electrical strains. Two different commutators were used on this machine, the one shown in Figs. 21 and 22 giving way to the better form in Figs. 19 and 20. The simpler form can hardly be recommended where it is to stand hard and continuous duty, but for intermittent work, and especially for experimental purposes, its simplicity and ease of construction will commend it. A cylinder of fiber is drilled with a $\frac{5}{8}$ in. hole and mounted on an arbor. It may then be turned to a diameter of $1\frac{1}{4}$ in. A piece of copper tubing, $1\frac{1}{4}$ in. inside diameter and having $\frac{1}{4}$ in. walls is then driven on to the fiber cylinder. The copper tubing is turned to a very slight taper,—about $\frac{1}{16}$ in. in 2 in. is sufficient. A ring of fiber is cut from $\frac{1}{2}$ in. stock. The ring is to have a central aperture of $1\frac{3}{4}$ in. scant, or in other words, it is to be a driving fit over the copper tube. The outside diameter of the ring should not be less than $2\frac{1}{2}$ in. Having made the ring and tested it for a fit, the arbor with the copper tube on it is placed in the milling machine and cut almost through into 16 segments. The segments should be numbered from 1 to 16, to facilitate re-assembly, and then cut apart with a hack-saw, afterwards filing off all sharp projections or burrs. The segments may then be placed around the fiber cylinder again and the space between each packed with mica soaked in shellac. The strips of mica are cut $\frac{1}{4}$ in. in width so that they do not project beyond the

surface of the segments. The fiber ring may be forced over the segments until it is near the large end of the copper tube. The whole is then placed in an oven until the shellac has set hard. Holes are drilled and tapped, through the fiber ring and segments, into the fiber cylinder for the 8-32 screws to which the armature winding is connected.

The commutator, Figs. 19 and 20, is built up on a brass boss which is flanged at one end and threaded for a lock nut at the other. The segments are cut from a casting of copper, which is first bored out to within $\frac{1}{8}$ in. of the finished size. Mount upon an arbor and take a light cut off the surface. Slot into 16 segments in the milling machine, leaving about $\frac{1}{16}$ in. at the bottom of the slots. Remove from the milling machine and pack the slots with mica and shellac. After this has been dried, force a piece of brass tubing over the surface and place in the chuck. Bore out the remaining metal to the finished diameter, 1 in., and turn up the ends to shape. The boss, having been turned up and provided with the ring and clamping nut, should be insulated with fiber as shown by the heavy black lines in Fig. 19. The segments may then be slipped over the boss and clamped. The brass tube is forced off and the surface turned to the finished diameter of 2 in. After completion the commutator should be tested to see if the insulation is perfect between one segment and another or between segments and boss.

A smooth core ring armature was used in this machine and as he could not obtain sheet iron stampings of the right size, the writer used a core built up of soft iron wire wound upon a piece of brass tubing held between two flanges, which were carried on the shaft. Fig. 23 shows this construction. The shaft should first be provided. It is 15 in. long and turned up between centres to $\frac{5}{8}$ in. in diameter from a piece of cold rolled steel. The flanges are brass castings turned up to the dimensions shown in Figs. 23 and 24. The hole for the shaft should first be drilled, holding the casting by the hub in the lathe chuck for this purpose. It is then mounted on an arbor and turned to size. The writer was fortunate in having a

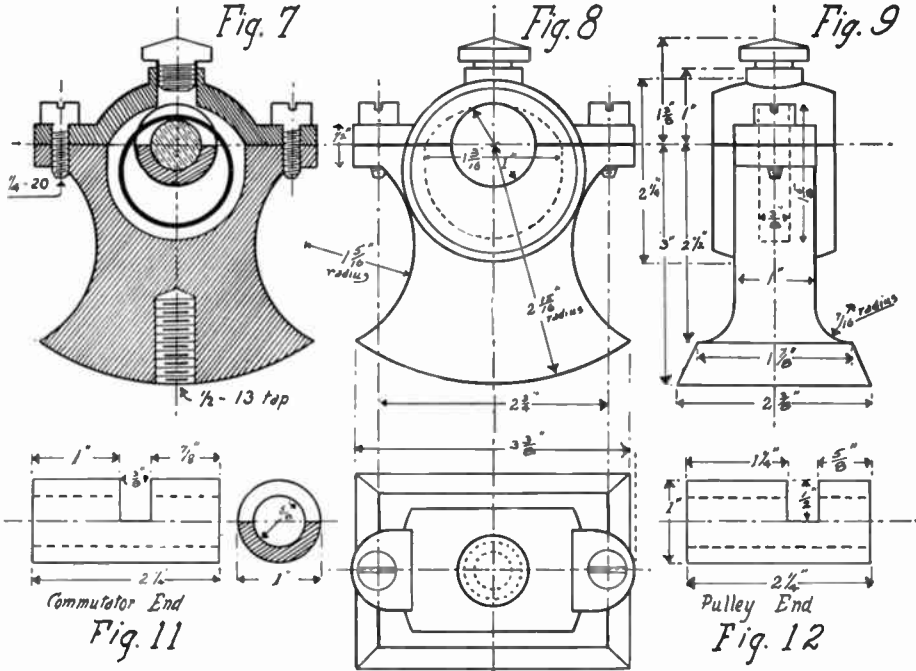

300-Watt Generator
Stanley Curtis - 1910.

Fig. 10

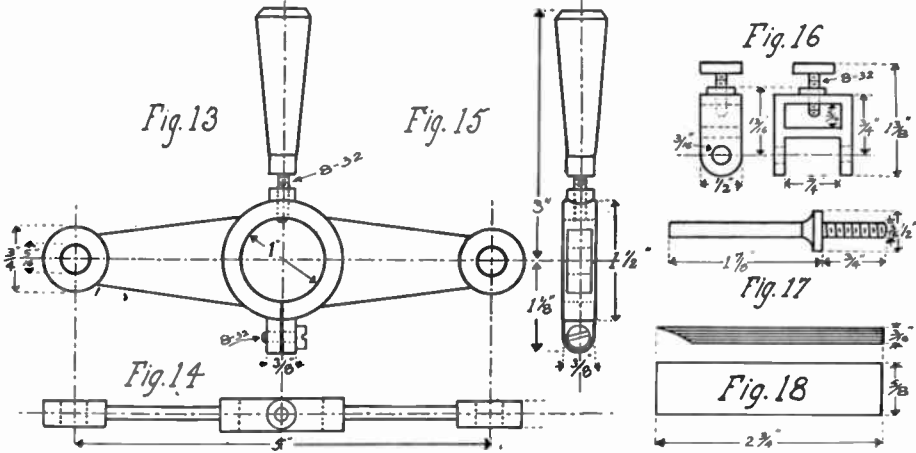

Fig. 13

Fig. 15

Fig. 16

Fig. 14

Fig. 17

Fig. 18

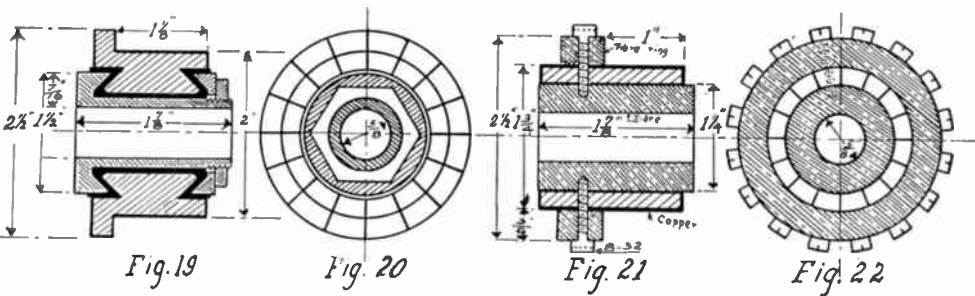
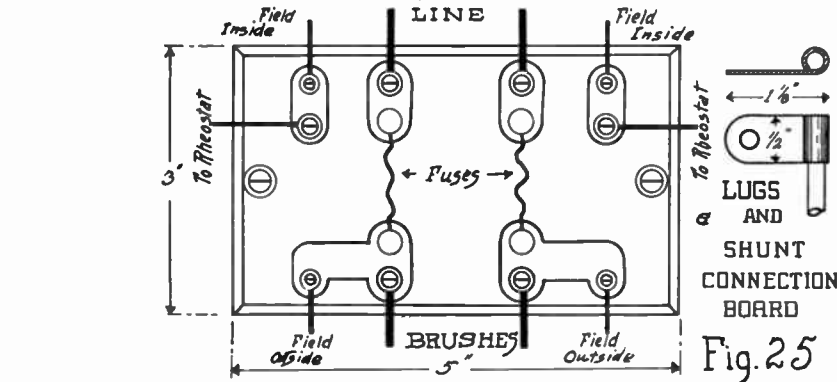
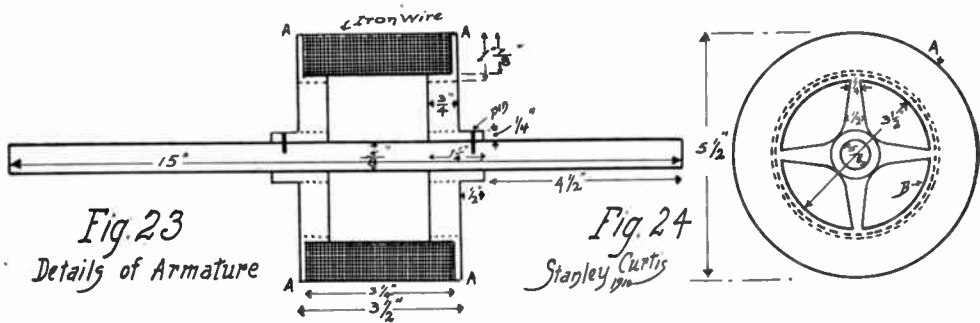

Fig. 19

Fig. 20

Fig. 21

Fig. 22



piece of brass tubing of just the right size to go between the flanges— $3\frac{3}{4}$ in. inside diameter and $\frac{1}{16}$ in. walls—the tubing having formed the cylinder of a low pressure air-pump. No doubt a piece of $\frac{1}{16}$ in. sheet brass could be put through the rollers and soldered in place between the flanges in lieu of the tubing. No. 22 soft iron wire was first wound on but it would not go on evenly, and No. 18 B. & S. was substituted. This was soldered at the starting and finishing ends and at several places throughout the winding. The sharp edges of the

flanges A, B, should be rounded off so that they will not cut through the insulation of the wire. The flanges are keyed to the shaft by means of pins.

A connection board of fiber is cut to the dimensions in Fig. 25, which clearly shows the connections. The brass or copper strips may be fastened down by the terminals. Fuses of 12 amperes' capacity are placed as shown, to protect the dynamo in case of a short circuit between it and the switchboard.

(To be continued)

The affinity sometimes awakened between two substances by the presence of a mere trace of a third substance is one of the wonders of chemistry. The addition of one part of magnesium in 14,000 so changes mercury that it rapidly oxidizes in the air, and has the property of decomposing water at a low temperature. Magnesium with a trace of mercury, on the other hand, also has the striking property of decomposing water. In both cases the acquired properties are lost as the

oxidation proceeds, but aluminum with a trace of mercury seems to be permanently altered. An extraordinarily small trace of mercury causes it to oxidize rapidly and to decompose water, the reactions continuing until the metal is consumed. Coupled with platinum or gold in a voltaic cell, the electromotive force is very appreciable, the electrolyte being simply water. The easiest way to accomplish the union of the aluminum and mercury is by placing the aluminum in a solution of mercurous nitrate.

THE STEAM TURBINE

Its Theory Simply Explained

WILLIAM E. SNOW

Modern steam turbines are divided into two general classes, known as the *impulse* and the *reaction*, these terms relating to their methods of steam utilization.

In the ordinary accepted meaning of the terms an impulse is a force acting in a forward direction, and a reaction is a force acting in a backward direction—a resultant of the impulse, and equal to it in magnitude. These terms, however, as applied to steam turbines, are somewhat misleading, as in all impulse turbines the steam acts by impulse on entering and by reaction on leaving the buckets; while most so-called “reaction” turbines in reality operate by both reaction and impulse. In order to clearly understand the principal points of difference between the types, let us refer to the graphical illustrations given in Figs. 1, 2, 3 and 4.

Fig. 1 is an example of simple reaction. The vessel *A* is suspended from a cord and filled with water. The water escapes from the orifice, or nozzle *B*, and, as there is consequently no resistance at this point to the pressure of the fluid in the vessel, the unbalanced force exerted on the walls directly opposite *B* causes the vessel to move reactively in the direction of the arrow.

Hero's turbine, invented 120 B.C., shown in Fig. 5, is an excellent example of a purely reaction type. As will be seen, this consisted of the hollow metal globe *A*, mounted rotatively on the uprights *BB* by suitable pivots or bearings. This globe was provided with two bent tubes or nozzles *CC* pointing in tangentially opposite directions. Steam from the boiler *D* was conducted to the globe by one of the supports *B*, which was made hollow for this purpose. The steam, issuing from the bent tubes or nozzles *CC*, caused the globe to rotate reactively in a direction opposite to that of the jets. The principle of operation of this turbine was identical with that of the ordinary lawn-sprinkler of the present day, whose rotating arms are moved by the reaction of the water escaping from them.

Fig. 2 is an example of simple impulse. As in the previous case, the vessel *A* is filled with water, but instead of being suspended it is fixed immovably in place. The jet of water escaping from the orifice or nozzle *B* is made to impinge upon the flat plate *C*, suspended from a cord at a suitable height. The pressure of the jet causes the plate *C* to move by impulse in the direction of the arrow. There will also be a reaction force exerted, equal in magnitude and opposite in direction to the impulse. The vessel being in this case fixed immovably, this reaction force does no work.

Branca's turbine, invented 1629 A.D., shown in Fig. 6, is an excellent example of a purely impulse type. As will be seen, this consisted of the wheel *A*, mounted rotatively on the support *B* by means of suitable bearings. This wheel was provided with paddles or buckets *C*, similar to those used in water-wheels. A tube or nozzle *D* was placed close to the wheel, so that the issuing steam would impinge on the buckets *C*. Steam was supplied from the boiler *E*, and issuing from the nozzle *D* by its impulse caused the wheel to rotate in the direction of the impinging jet. It is interesting to note that, crude as the Hero and Branca turbines were, they clearly establish the two distinctive classes from which all modern turbines are derived.

In Fig. 3 is an example of the impulse and reaction forces exerted by the working fluid on the buckets of a modern turbine of the so-called “impulse” type. As in the previous case, the vessel *A* is filled with water and fixed immovably in place. In this case, however, the suspended plate *C*, instead of being flat, is given a semi-circular form, approximately the shape of the buckets in an impulse turbine. The jet of water escaping from the orifice or nozzle *B* impinges upon this curved surface and is turned back upon itself through an angle of 180 degrees, issuing from the bucket in a direction opposite to that by which it entered. It is, therefore,

evident that the jet acts by impulse on entering and by reaction on leaving the bucket. Since action and reaction are equal, neglecting friction, the combined impulse and reaction forces tending to move the plate *C* in the direction of the arrow will be twice as great as the impulse force in the previous case, Fig. 2. This is the principle on which the buckets of all modern commercial turbines operate, whether of the impulse or of the reaction type.

In Fig. 4 is an example of the impulse

or nozzle *B* impinges on the curved surface of the bucket, tending by its combined impulse and reaction forces to move it in the direction of the arrow. In this case, however, the reaction force, equal in magnitude but opposite in direction to the impulse force, is free to move the vessel *A* in the direction of the second arrow. This is the principle on which modern commercial turbines of the reaction type operate.

It is easy to determine whether a turbine belongs in the impulse or the re-

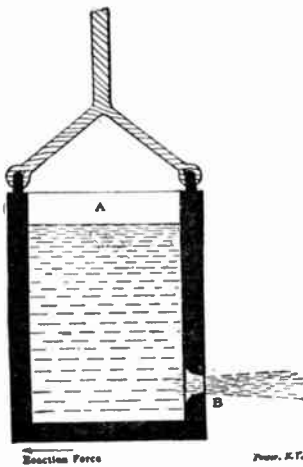

FIG. 1.—SIMPLE REACTION.

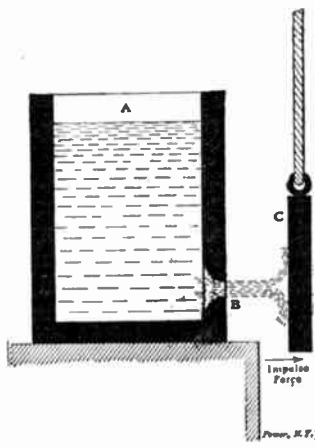

FIG. 2.—SIMPLE IMPULSE.

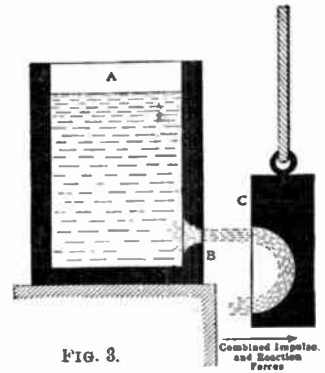

FIG. 3.

PRINCIPLE OF MODERN IMPULSE TURBINE.

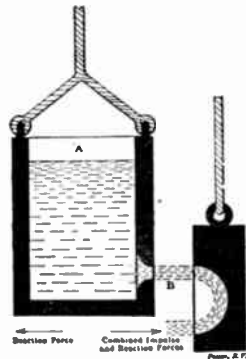

FIG. 4.—PRINCIPLE OF MODERN REACTION TURBINE.

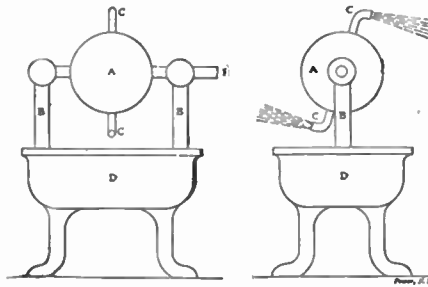

FIG. 5.—HERO'S REACTION TURBINE.

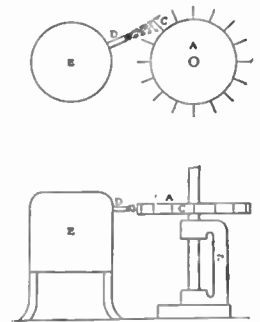

FIG. 6.—BRANCA'S IMPULSE TURBINE.

and reaction forces exerted by the working fluid on the buckets of a modern turbine of the reaction type. As in the previous case, the vessel *A* is filled with water, but instead of being fixed immovably in place it is suspended from a cord, as in Fig. 1. The plate *C*, provided with a semi-circular bucket, is also suspended from a cord, as in Fig. 3. The jet of water escaping from the orifice

action class from the fact that in all impulse turbines the steam pressure is the same on both sides of any one row of buckets; in all reaction turbines there is a fall of the steam pressure in passing any one row of buckets, and the pressure on the two sides of the buckets is not equal. This will be seen more clearly by referring to Figs. 7 and 8.

Fig. 7 shows the bucket and nozzle

arrangement of a turbine of the impulse class. In this drawing *B* is the nozzle, *CC* are the rotating buckets moving in the direction of the large arrows, and *D* are the stationary buckets or reversing guide. The steam enters the nozzle *B* at boiler pressure and is expanded completely in the nozzle right down to the back pressure of the exhaust, all its available pressure energy being thus converted into velocity energy. The steam, delivered in this form to the buckets, is incapable of any further expansion; consequently the pressure must be the same on both sides of any one row of buckets. This rule holds good, regardless of the number of stages that may be used.

The principle of operation of this type of turbine is shown by the small arrows, indicating the flow of the steam. The

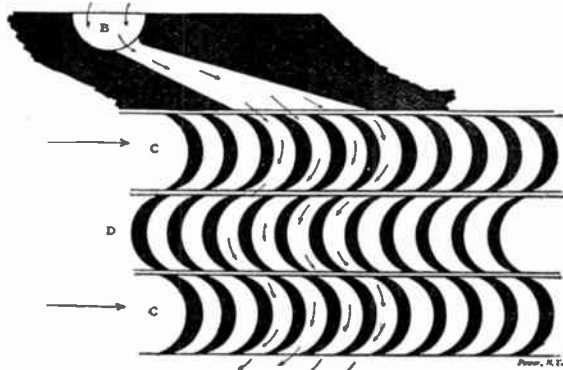

FIG. 7.—BUCKETS AND NOZZLE ARRANGEMENT OF IMPULSE TURBINE.

steam from the nozzle enters the first set of moving buckets at high velocity, but no appreciable pressure, and is turned through an arc of approximately 150 degrees, whereby a certain portion of its velocity is abstracted and converted into useful work. As the steam issues at greatly reduced velocity from this first set of moving buckets, it is caught by the stationary buckets or guide *D* and redirected at proper angle into the second set of moving buckets. Here it is again turned through an arc of 150 degrees, and most of its remaining velocity abstracted and turned into useful work.

Fig. 8 shows the arrangement of the stationary and the moving buckets of the turbine of the reaction type. The stationary buckets or guides *BB* correspond to the nozzles in the impulse type

of turbine, and *CC* are the moving buckets similar in form to the stationary guides. The steam enters the first set of stationary buckets or guides *B* at boiler pressure. Owing to the nozzle-like form of these blades, the steam here undergoes a partial drop in pressure, with a corresponding expansion and increase in velocity. As the drop in pressure per stage in this type of turbine rarely exceeds 10 or 12 lbs., the velocity of the steam is not nearly as high as in the case of the greater expansion that occurs in the nozzle of the impulse turbine. The steam issues at moderate velocity, and but slightly reduced pressure, from the guides *B* and impinges upon the first set of moving buckets *C*, imparting to them by impulse that portion of its pressure energy that has been converted into velocity by its passage

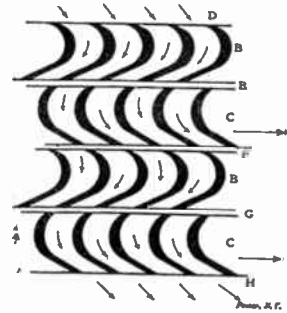

FIG. 8.—STATIONARY AND MOVING BUCKETS IN REACTION TURBINE.

through the guides *B*. Owing to the shape of the moving buckets, which have the same nozzle-like form as the guides, the steam undergoes a still further pressure drop, with a corresponding expansion and increase in velocity in its passage through. As a result of this increase in velocity, the issuing steam imparts to the buckets by reaction a portion of the pressure energy that has been converted into velocity by its passage through. This same process is repeated in the second set of stationary guides and moving buckets, and so on throughout as many stages as are required to abstract all the available energy from the steam.

It will be noted that the pressure in each successive clearance space between the stationary and moving buckets is lower than in the preceding one. Thus,

the pressure at *E* is lower than at *D*, the pressure at *F* is lower than at *E*, the pressure at *G* is lower than at *F*, etc.

From the preceding the following rule is derived for the proper classification of all turbines:

IMPULSE TURBINES: *Equal pressure on the two sides of any one row of buckets.*

REACTION TURBINES: *Full of pressure in passing any one row of buckets.*

While the principle of operation of all commercial turbines of the reaction class is practically the same, impulse turbines can be subdivided into several types, according to their particular method of steam utilization, as follows:

(Continued on page 57)

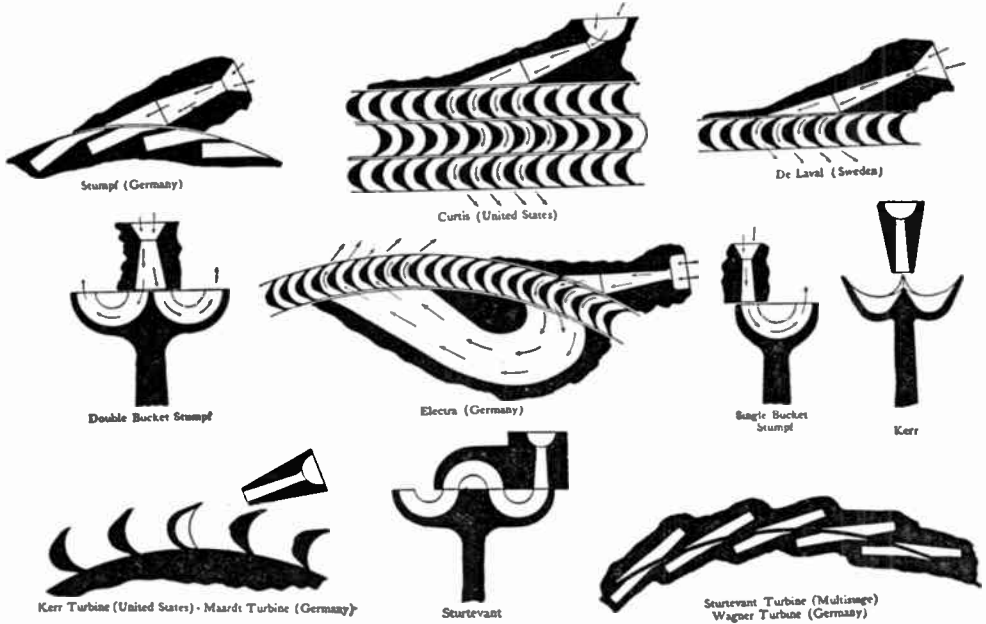

FIG. 9.—VARIOUS TURBINE TYPES.

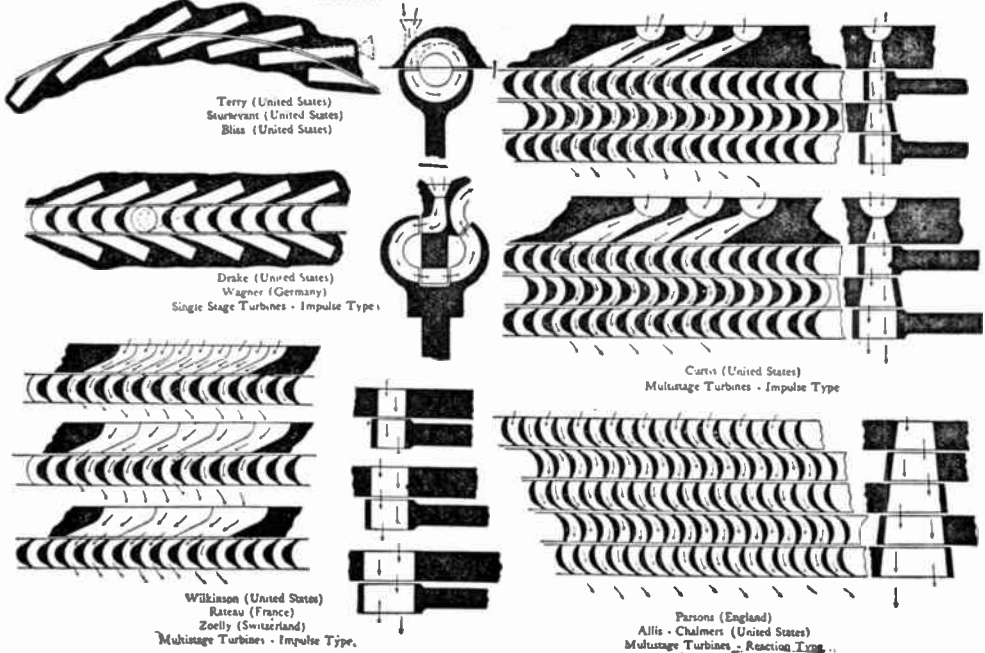
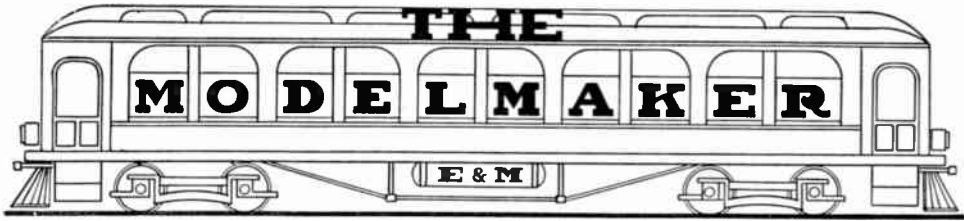

FIG. 10.—VARIOUS TURBINE TYPES.



MODEL TWO-CYCLE MOTOR

C. F. BRIERLEY

The accompanying drawings represent a model two-cycle motor of $1\frac{3}{4}$ in. bore by 2 in. stroke, suitable for driving model launches, dynamos, pumps, etc. The whole design has been got out with an idea of simplicity, and any extra refinements, such as forced feed, lubrication, etc., have been omitted. The readers will see at once that the machining is of the simplest, and the whole machine has very few parts compared with a four-cycle motor, but at the same time it is not claimed that this two-cycle motor has the efficiency or high speed of a four-cycle, but at normal speed it will be found that there is a slight increase of power, and also the facility of starting is easier—a great advantage for boat work. The vibration from this motor will hardly be perceptible when compared with a four-cycle machine.

After these few remarks, we will turn our attention to the general arrangement. It will be seen the motor is of the two-port variety—i.e., drawing in the charge of gas from the carburetor through a check valve on the side of the crank-case. In the event of a vaporizer being used, this check valve would form part of it; but the adjustment of a vaporizer being so fine, to obtain satisfactory results a wick carburetor is preferred with a check valve.

The cycle of operations is as follows (assuming the piston being at the bottom of its stroke): By turning the flywheel the piston ascends, draws into the crank-case a charge of gas; on the down stroke

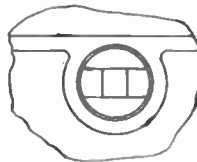

Face on AA

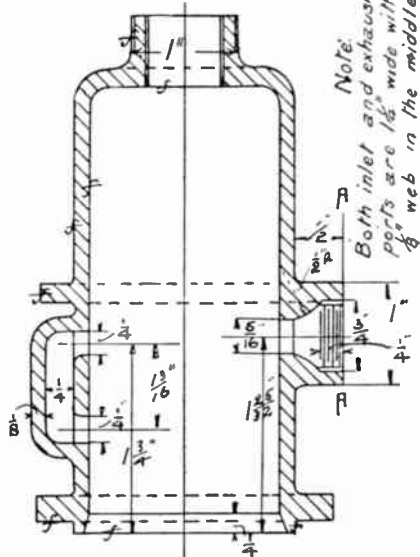
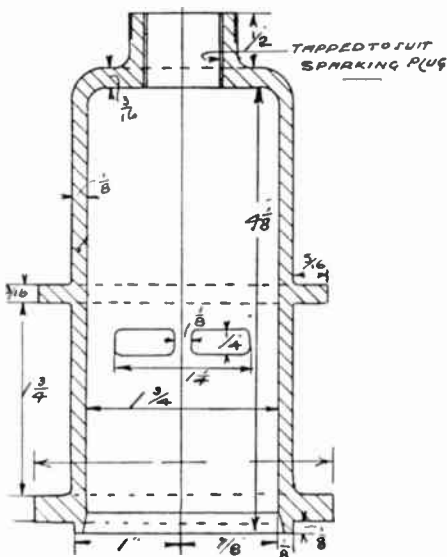

SECTIONAL VIEWS OF THE CYLINDER.

this charge is compressed, and the piston opening up the port cast in the cylinder, the compressed gas passes through the port in the piston, up the gas passage, through another port (which is level with the top of the piston). On coming into the cylinder the gas strikes the deflator and rushes upwards. On the

up stroke again the piston draws another charge into the crank-case, and at the same time highly compresses the charge in the cylinder, which at the proper time is fired by the spark at the plug points. On the down stroke the gas is again compressed in the crank-case, and on the piston arriving at the bottom of

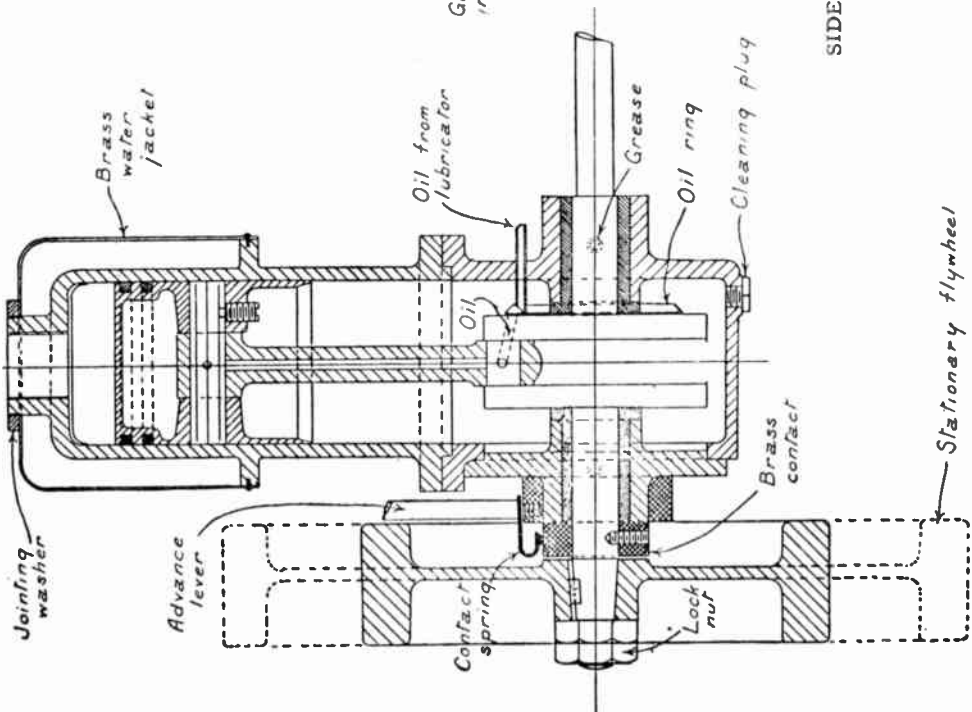
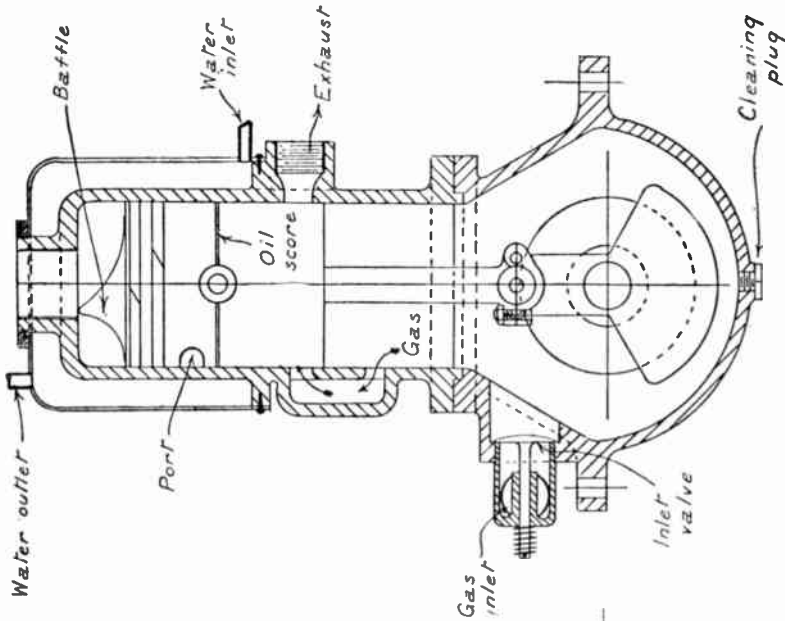

SIDE AND END SECTIONAL ELEVATIONS OF MODEL TWO-CYCLE MOTOR.

By C. F. BRIERLEY.

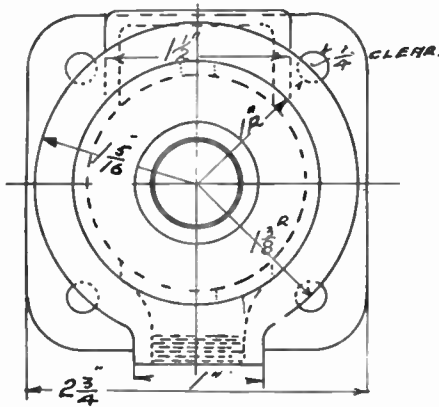

the stroke, the exhaust port is opened, the force of the explosion carrying the gases out. While the exhaust gas is being carried out, the new charge is rushing in, the deflator preventing the two gases mixing, causing a foul mixture.

The cooling of the motor is by water, the jacket being either a thin brass tube or sheet brass, which, in either case, is made a good fit round the ring cast on the cylinder, the jacket being screwed down by fine setscrews backed by some thick red lead. The top is sweated to the sides, and the joint, where the boss for sparking plug passes through the jacket, made water-tight by screwing brass ring on the boss and sweating the jacket to it. The idea of a brass jacket is to reduce the weight of the motor and also simplify the patterns.

Lubrication.—This is direct-feed and

splash. The main bearings should be lubricated by motor grease from a screw-down greaser, tubes conveying the grease to each bearing (this arrangement is not shown, but will be easily understood). The connecting-rod big-end is also lubricated direct. The crank web is drilled (as shown) at an angle and also through the crank-pin. On the crank-shaft web an oil ring is either soldered or set-screwed. This ring is also drilled at the extreme corner so as to register with the hole drilled at an

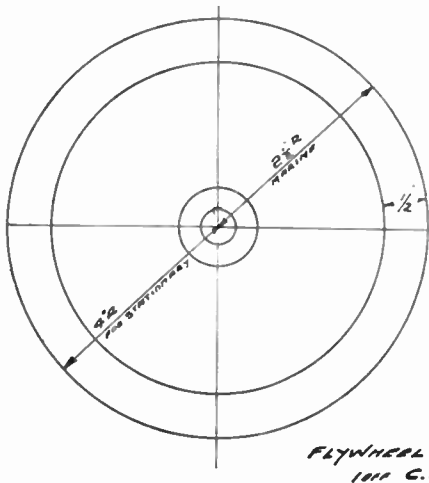
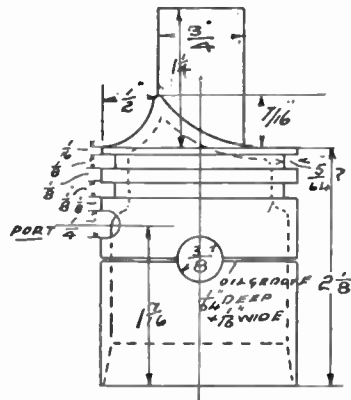

CROSS-SECTION AND END VIEW OF FLYWHEEL.

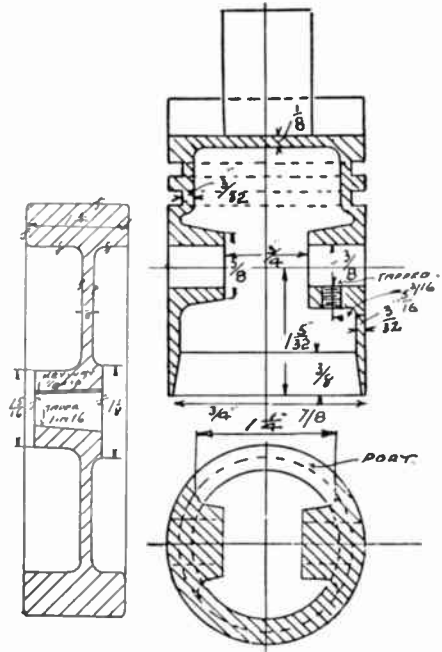

THE PISTON.

angle in crank web. Through the end of crank-case a small brass tube is screwed, which projects into the crank-case far enough to just clear the crank web, the tube being connected to a lubricator. The oil drips into the oil ring and is thrown by centrifugal force into the flanged outer ring and through the small hole in the ring into the crank-pin, thence to the connecting-rod big-end. The cylinder, etc., is lubricated by splash thrown off the crank webbs.

Ignition is by high-speed trembler coil, and accumulator and wipe contact. The negative wire from the coil is secured to or under contact spring; this spring is held in position on the insulat-

secured to the face-plate, and the plug hole tapped out, either to standard size or smaller. The outside of the boss should be chased with a fine pitch tool, say 30, so as to ensure a water-tight joint. If sufficient metal is left the whole of the outside of the cylinder should be turned where practicable, but in any case the ring to carry the water-jacket should be turned up true.

The Piston is the next operation, and is held in the chuck by the boss on the top, which is afterwards cut off and the top filed up smoothly. It will be as well to mention here that the piston should be as light as possible.

Piston Rings.—Turn up and part six,

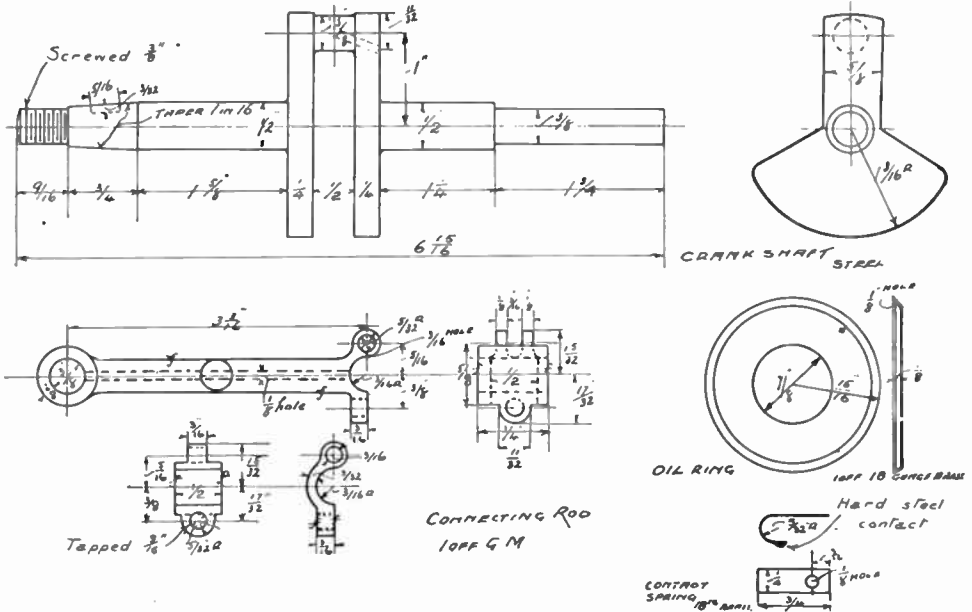

THE CRANKSHAFT, CONNECTING-ROD, OIL RING, AND CONTACT SPRING.

ing washer by the advance lever, the contact being made through the contact spring and brass contact plate on the commutator. Both the commutator and the plate are secured to the crankshaft by a set-screw with countersunk head.

GENERAL INSTRUCTIONS FOR MACHINING, ETC.

(Machined Parts Marked F)

The first piece to take in hand will be the cylinder, the most important part of which is the bore. This should, if possible, be lapped or ground to gauge. After this operation is complete, the cylinder should be turned round and

as they are very easily broken. These should be ground to make a good fit with the cylinder. No sizes are given for these, being so small; the ratio of thickness to diameter, etc., usual in large rings is not reliable. Perhaps about $\frac{3}{32}$ in. thick would be about correct, but a trial will soon determine the size.

Flywheel.—No comments are needed on this piece of work, only care should be taken to bore the taper out correctly, and also to cut the keyway while it is in the chuck. This will enable the keyway to be cut correctly to taper.

Crank-case and End Cover.—Great

care must be exercised in machining this piece, for the following reasons: It must be absolutely gas-tight, and the crank-shaft must be just a fit between the main bearings, so care must be taken when turning the spigot on the end cover and facing up the inside ends of the bosses on this and the crank-case.

Crank-shaft.—It is immaterial whether this is turned from a forging or built up, but in either case it must be dead true and the taper a very good fit with the fly-wheel.

Main Bearings.—As perhaps the greatest percentage of the success of the engine depends upon the gas-tightness of the crank-case, both as regards suction

to get the bottom half in position, owing to the small amount of space in the crank chamber.

NOTE.—The width given on drawing for small end of connecting-rod is $\frac{3}{4}$ in. to facilitate erecting; it would be as well if this were made $1\frac{1}{16}$ in.

Oil Ring is made from 18-gauge brass. This is a simple plain circular piece of brass with a $\frac{1}{8}$ in. hole cut in the centre and the outer edge flanged over so as to retain the oil. In the extreme corner a $\frac{1}{8}$ in. hole is drilled. This is secured to crank webbs by small set-screws or soldered to same; at the same time making sure the hole in the ring registers with the hole in the crank web.

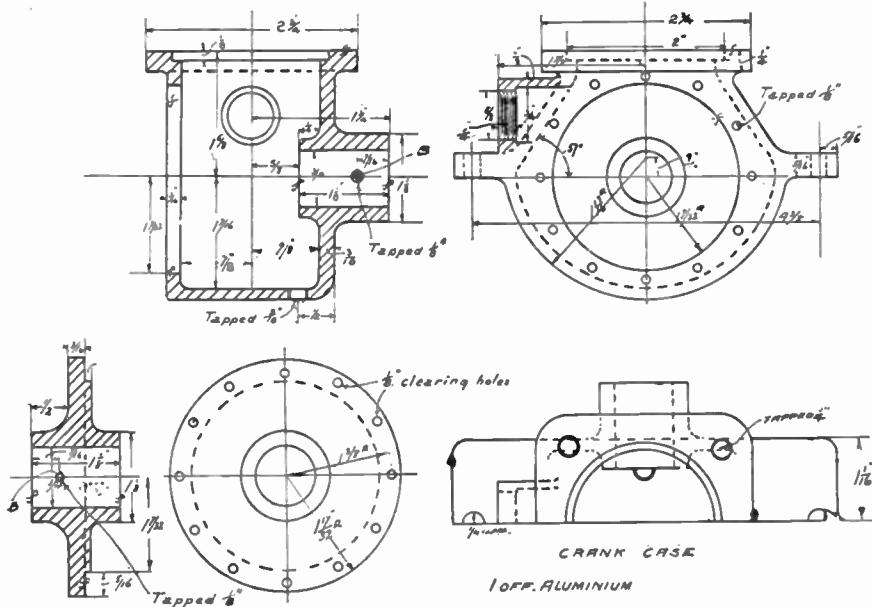

THE CRANK CASE AND END COVER.

and compression, these two bearings must be of very accurate fit, otherwise there is sure to be a bad leak along them. On the back side of each, from the oil hole $\frac{1}{16}$ ths from the inside end to $\frac{1}{16}$ ths from the outside end a small score is cut, the object of this being to convey the grease to a position well inside the bearing.

Connecting-rod.—The only peculiarity of this is the big-end. Instead of the bottom half being held in position by two studs, one side is hinged and the other side fixed by a stud. The only reason for adopting this is, in erecting it will be found a rather difficult matter

Inlet Valve and Seat.—The valve, it will be seen, is of the flat-faced variety and is ground down on to the seat with fine emery and crocus powder. The strength of the spring should only be sufficient to hold the valve on its seat.

NOTE.—The inlet from carburetor is at right angles to the valve stem. The valves should be as light as possible.

General.—Although the dimensions given will be satisfactory for stationary work, perhaps for marine work judicious cutting down of weight could be carried out on some pieces.

Running the Motor.—A wick carburetor is recommended, the adjustment of

which should be by varying the amount of air to the wicks and not by having a fixed air inlet, and adjusting the mixture by an extra air inlet.

After filling up the lubricator, giving the motor a good oiling all round, including the cylinder, through the plug hole,

ensure regular firing, *i.e.*, when running light. The revolutions should be regulated by the advance lever, no throttle being provided. The motor may be run in either direction and can be reversed like a steam engine, but a special switch must be attached to the advance lever. The whole success and power of the machine rests entirely with good workmanship and a correct mixture.

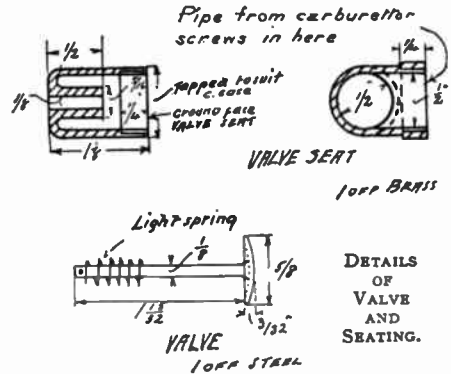
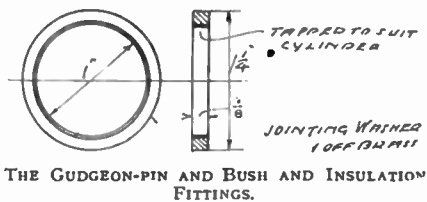
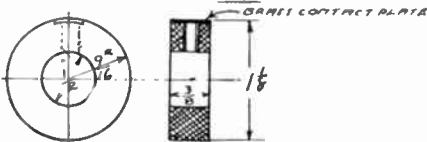
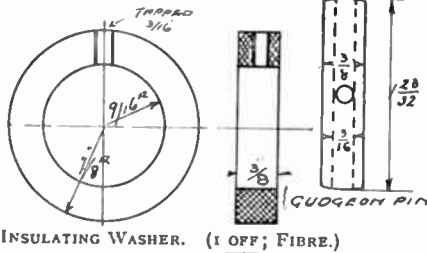
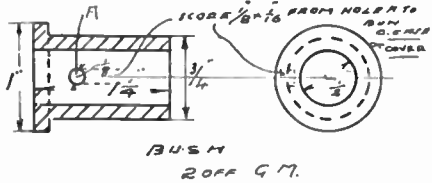

LIST OF BOLTS, NUTS, ETC.

No.	Diam.	Length	Description
4	1/4	3/4	Cylinder holding down studs.
12	1/8	3/8	Crank-case end cover set-screws.
1	3/16	3/16	Connecting-rod big-end.
1	—	3/8	Gudgeon pin, set set-screw.
1	—	3/16	Plug for crank-case drain.
1	—	7/16	Set-screw for commutator.
20	3/32	1/8	Set-screws for fixing water-jacket.
4	1/4	—	Nuts for cylinder studs.
1	3/16	—	Connecting-rod stud.
2	3/8	—	Fly-wheel.

—Model Engineer

open the air supply to the amount judged to be correct for a fairly strong mixture, retard the spark and rock the fly-wheel a few times to get a charge into the crank-case and cylinder (assuming the motor is required to run clockwise), give the fly-wheel a sharp twitch from right to left (anti-clockwise). If the motor fails to fire adjust the air, and as soon as it starts advance the spark. If the firing is not regular, *i.e.*, say every other stroke, the mixture is too strong. If, on the other hand, there is a series of violent explosions in the crank-case and carburetor, the mixture is too weak.

What a Gas engine is Capable of

There is a saying that you can fool a part of the people all the time, all the people a part of the time, but you cannot fool all the people all the time.

We will apply that saying as follows: Water power will work for part of the people all of the time; the wind mill, the horse and the steam engine will work for all of the people a part of the time; but the only thing that will work for all of the people all of the time is a gas engine.

The only time anybody gets fooled is when they won't give the gas engine a chance to show what it can do.

In many cases a two-cycle motor requires to have a brake put on it to

THE MOTION PICTURE—Part III

STANLEY CURTIS

The Use of Electricity in Projection Work

The electric arc light has superseded almost every other form of illuminant for projection purposes in general; for motion picture work it is practically the only source of light which can be used to obtain satisfactory results. Aside from its great power, the electric arc has many other features which highly recommend it, namely, its wonderful purity of color, ease of handling, comparatively low operating cost, and last but not least, its absolute freedom from danger, as compared with other illuminants. The fact that this light is the only source of illumination permitted to be used in moving picture machines by the authorities in several States is probably one of the greatest testimonials as to its safety. Where the wiring is properly done, as it must be in order to pass inspection, fires or other accidents directly traceable to electric light are almost unknown, and so far as danger to the operator from electric shock is concerned, there is little to fear. There are but few cases on record where people have been injured by coming in contact with wires having a potential difference of less than 220 volts, and the voltage in general use in most places, 110 volts, is barely perceptible to the touch, unless the hands are moist. Of course it is not advisable to deliberately place the hands across the blades of a switch for more reasons than one. For instance, there is always a possible chance that the service wires, before entering the building, may come in contact with other wires carrying a high voltage, or in the case of an alternating current system, the transformer insulation might break down at the critical moment and send the line voltage, perhaps 2,000 or more, through the house mains. These examples are decidedly rare and are cited simply to show that it is foolhardiness to take "shocks" for amusement from the lighting circuit. The wiring and apparatus connected to the circuit are protected by fuses which would melt in the event of a rise in voltage, causing an abnormal amount of current to flow.

When using a voltage higher than 220, the operator should use the utmost caution in handling his switch and lamp, and he should certainly be well insulated from the ground while operating. The potential used on most trolley lines, 550 volts, is nearly always fatal, providing the current passes through the heart, as it would if the operator touched the positive pole of the switch with his hand while standing on the damp ground.

One of the principal secrets of successful projection work is the ability, on the part of the operator, to obtain and hold a steady and brilliant light, as every little flicker of the arc is magnified many times on the screen. In order to acquire this ability, he should fully understand the "why and wherefore" of his illuminant, and if he studies it carefully, the arc will become as obedient to the touch of his hand as the pencil or brush is in the hand of the artist. To some it may appear that the writer is over-estimating the importance of skillful manipulation of the light in a projecting machine, but the experienced operator will agree with him when he says the battle is more than half won when the operator conquers the arc lamp.

Before we take up its application to the projecting machine, let us consider the elementary principles of the electric arc. Let us connect the poles of an electric circuit to a pair of electrodes, preferably of carbon; after touching the tips of the electrodes together for a second to complete the circuit, if we separate them a fraction of an inch, the current continues to flow across the gap in the form of an intensely brilliant arc or flame. The positive carbon is heated to dazzling whiteness at the tip by the passage of the current. The negative pole is also heated, but not to so great an extent. It is the great intensity of the light which emanates from the tip or "crater" of the carbon that renders the arc suitable to our purpose.

For the benefit of the lay reader, the electrical terms "ampere," "volt," "ohm," and "watt" will be defined. The strength of an electric current is

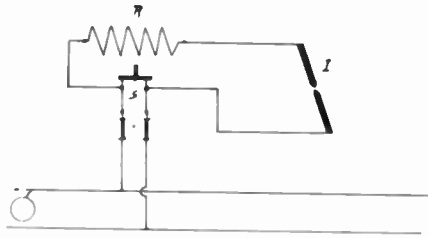

FIG. 1

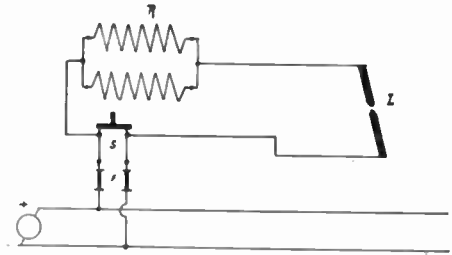

FIG. 2

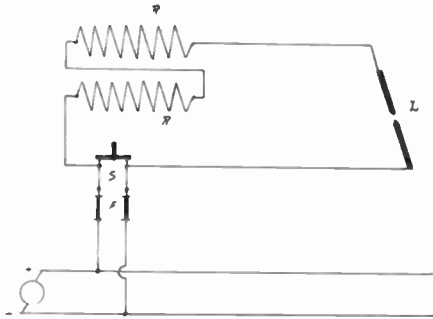

FIG. 3

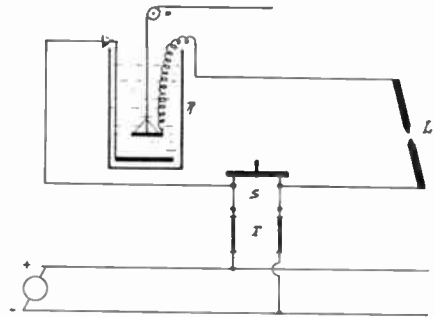

FIG. 4

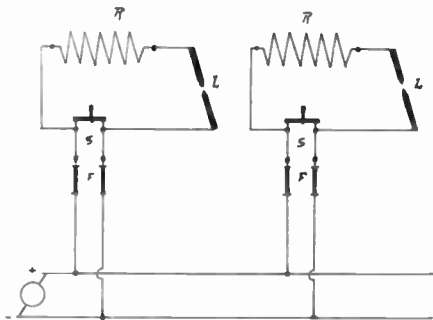

FIG. 5

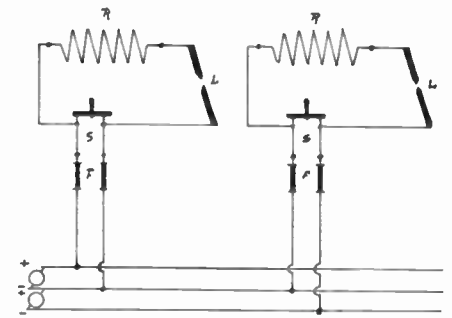

FIG. 6

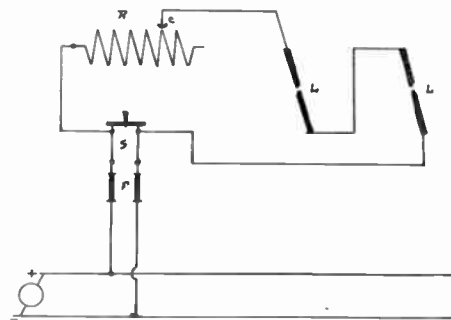

FIG. 7

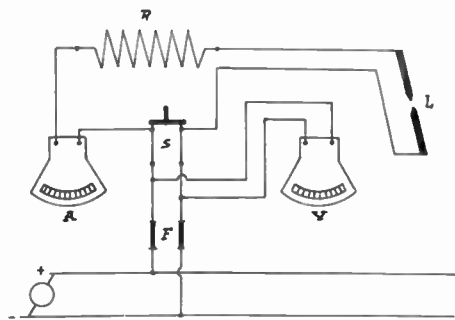

FIG. 8

PLATE 1.
STANLEY CURTIS '10.

the rate at which it flows through a conductor and is analogous to the rate of flow of water through a pipe in gallons per second. The unit of current is called the *ampere*. Electromotive force or electric pressure is that which causes electricity to flow in a closed circuit. The unit of electromotive force is the *volt*. The volt is the pressure that will cause a current of 1 ampere to flow through a resistance of 1 ohm. All substances offer resistance to the passage of electricity through them, the amount of the resistance depending on the substance and on its shape; that is, on the length and cross-section. The resistance of all metals increases with an increase in temperature, while the resistance of carbon decreases with an increase in its temperature. The unit of resistance is the *ohm*. A conductor has a resistance of 1 ohm when the pressure required to send 1 ampere through it is 1 volt. The *watt* is the unit of electric energy or power. It is the rate at which work is expended when 1 ampere flows through a resistance of 1 ohm. One horsepower equals 746 watts.

The currents employed on lighting and power circuits may be one of two kinds,—direct or alternating. A direct or continuous current is one that always flows in one direction; that is, the current never reverses, though it may change in value or pulsate. An alternating current periodically reverses its direction of flow a number of times per second. It may be described as a current consisting of equal half waves in successively opposite directions; it flows back and forth in a circuit with as great regularity as the piston moves to and fro in the cylinder of a steam engine, but with far greater rapidity. The full period of alternation of such a current is called a *cycle*, and the number of cycles per second constitutes the *frequency* of the current.

The light produced by a direct current is absolutely steady and noiseless, providing the carbons are properly placed in the lamp and are regularly fed together as they burn away. The top or positive carbon burns away twice as fast as the lower or negative carbon. An alternating current arc is very noisy and considerable difficulty will be experienced with its use. With this cur-

rent each carbon is alternately positive and negative, and both burn away at the same rate. The arc in a motion picture machine usually uses from 30 to 60 amperes on alternating current and from 20 to 40 amperes on direct current. The voltage required to force this amount of current through the resistance of the arc is from 40 to 60 volts. Now the average lighting circuit has a voltage of 110 or 220 volts, and we must have a resistance of some sort connected in series with the arc in order to compensate for this surplus voltage. For this purpose we use a "rheostat," consisting of a number of coils of wire having a high resistance, in the circuit. This resistance consumes the extra voltage.

Let us glance at Plate 1, which shows the various methods of connecting up a projecting lamp to the lighting circuit. In Fig. 1 we have a simple circuit consisting of fuses, arc switch, rheostat, connecting wire, and the arc lamp. The writer favors connecting the rheostat to the top or positive carbon in preference to the lower one, although there seems to be very little difference so far as results are concerned. The connections shown in Plate 1 may be used on either direct or alternating current circuits.

Where the picture has to be thrown a long distance and the screen is a large one, the connection shown in Fig. 2 will give good results. This shows two rheostats connected in multiple and the current is almost doubled by this method as the resistance is cut down one-half. This form of connection requires heavier fuses and service wires to carry the extra current without undue heating.

Where the operator runs across a 220 volt circuit and he has no rheostat adapted to that voltage, he may connect two so-called "110 volt" rheostats in series in the emergency. They are apt to heat up considerably, as the resistance will hardly be great enough. Fig. 3, in Plate 1, clearly shows this connection.

Fig. 4 illustrates the method of connecting up a "water rheostat" for use on circuits of 550 volts or less. Two pieces of iron are suspended, as shown in a water-tight barrel. Insulated wires are connected to each of the iron plates and lead outside the barrel. The upper

plate is made adjustable in height, so that the space between the plates may be increased or decreased at will. The barrel is filled with water after connections are made and the light started. A small quantity of common table salt should then be sprinkled in the water until the resistance is lowered sufficiently to allow about 15 or 20 amperes to pass through the circuit. The light may then be increased by lowering the upper plate a trifle. The writer has obtained excellent results by using a very small quantity of sulphuric acid in the water in place of the salt. The acid should always be poured into the water; never pour water onto the acid or an explosion is almost sure to occur. The use of a water rheostat is prohibited in many places and it should only be used in an emergency or merely as a temporary resistance in lieu of a regular rheostat. In another chapter the writer will give directions for building a rheostat for use on 550 volt circuits.

Fig. 5 shows one method of connecting two arc lamps in multiple, each one being turned on and off independently of the other. This will be found useful in the case of a dissolving stereopticon or for two or more projecting machines. Fig. 6 shows how to connect up on the three-wire system, and a word here on the advantages of this system of wiring might be appropriate. Let us assume that two direct current dynamos are generating the same voltage and each one is feeding the same number of lamps. If we connect the two generators in series, that is, the positive lead of one to the negative lead of the other, it is obvious that we may disconnect the two neutral wires from the circuit and still leave the lamps burning in series. But suppose a few of the lamps on one side should burn out or be turned off; this would permit a rise of voltage on the "light" side of the circuit and the lamps would be burned out. To overcome this, and still save one-fourth of the wire required for a two-wire circuit of the same capacity, we use one neutral wire to supply the difference in current when the load on one side is lighter than the other. Therefore the principal advantage of the three-wire system is a saving of copper wire,—quite an item in a large installation. But to return to the dia-

gram, we have two arc lamps connected to the three-wire circuit. The reader will notice that the neutral wire is negative to one side of the circuit and positive to the other. By connecting one arc on each side of the circuit the load is "balanced" properly.

Fig. 7 gives a form of connection that is very seldom used. Its chief recommendation is that it saves current. The two arcs are in series with each other and after they are started, the adjustable resistance, R , is partly cut out. With this method the operator must give his arcs great attention, for if one goes out the other will also. In starting the arcs, the resistance must be "in" and the carbons of one lamp placed tightly together. Now on striking the arc with the other lamp, the operator opens the carbons but a short distance. The second lamp may be started then by drawing its carbons apart. The resistance is next cut out until the light is sufficiently strong. This connection is useful only in the hands of an experienced operator and on a dissolving stereopticon. From an economical standpoint the method is good, as the two arcs burn no more current than a single one with a rheostat.

Fig. 8 shows a voltmeter and ammeter connected in the circuit. The use of these instruments is strongly recommended as they enable the operator to tell at a glance just how much current he is using and if the line voltage is up to the standard. Very serviceable instruments may be purchased at a low figure from a second-hand dealer.

(To be continued)

It is gratifying to learn that the United States and Great Britain have signed a treaty which will serve to regulate the use of water for commercial purposes at Niagara Falls. According to the provisions, the New York side will be permitted to take 20,000 cubic ft. from the river above the falls, and the Canadian side may divert 36,000 cubic ft. The treaty contains a provision which allows the Canadian companies to transmit and sell on the United States side at least 50 per cent. of the power generated in Canada.



Edited by OSCAR E. PERRIGO, M.E.

THE DEVELOPMENT OF THREAD CUTTING

In the last article some very reliable historical facts were given as to the early use of the screw thread and some interesting processes used in connection with it. Emphasis is particularly laid upon the subject of the screw thread and its development on account of its immense importance to, and influence upon the development of the mechanical arts themselves, in view of the universal use of this element in all machines and mechanical devices, with very rare and unimportant exceptions.

Commencing with the elementary form of the screw thread we read that, "of the six mechanical powers the screw is the fourth, and consists of a cylinder or a cylindrical perforation having a continuous rib or thread winding spirally around it." This, of course, covers the form of both the screw and its nut.

The author well remembers during his boyhood of an old curiosity shop out in the country in which various kinds of hand machines were made and repaired. Among other things made were various appliances and devices for spinning woolen yarn and reeling it up into skeins of forty threads to a "knot," as it was called. To furnish these appliances with an automatic counter a worm-gear of forty teeth was used which engaged with a single threaded worm on the reel-shaft. Both the shaft having the worm formed upon it and the worm-wheel were of wood, usually oak or maple, and the thread was formed by wrapping a piece of paper around the turned shaft and cutting through this with a knife so as to make its length equal to the circumference of the shaft, its width representing the longitudinal distance on the shaft. This piece of paper was then divided into equal parts at each end and inclined lines drawn upon it as shown in Fig. 1, the divisions

being equal to the pitch of the thread, found by spacing the circumference of the worm-gear blank for the forty teeth. The paper was then glued around the shaft and the diagonal lines gave the correct development of the screw thread, which was worked out with a fine saw, a chisel, or knife, and a triangular file. The teeth of the worm-gear were similarly cut to the proper V-shape, and the result was a perfectly practical and really workmanlike piece of mechanism that answered the purpose remarkably well.

This same method of laying off screw threads was in practical use many years ago, and was used by one Anthony Robinson in England as early as the year 1783, at which time it is recorded of him that he made a triple-threaded screw 6 in. in diameter and 7 ft. 6 in. in length. It is said that he first laid off one thread by the method above described, leaving a sufficient space between the convolutions for the other two threads. This first thread was then worked out by hand with the time-honored hammer, chisel, and file, and he afterwards used this thread as a guide for making the other two by the same primitive means.

In the light of the present facilities for cutting threads this process seems most tedious and laborious, and yet much of the machinists' work of that time was equally slow and must have sorely taxed the patience of the workman, whose principal and often only machine was a lathe of very crude design and workmanship, and in which he managed to do not only turning and boring, but slotting, splining, milling, gear-cutting and an endless variety of similar jobs, and in lieu of a planer, having recourse to his ever ready cold chisel, hammer and file, which, with a straight edge, enabled him to make

many a flat surface of remarkable nicety considering his limited facilities. And from these pioneer machinists came the American machinist of today, the most thorough, best educated and expert mechanic the world has ever seen.

It will doubtless have been noticed that in the earlier examples of the lathe,

during and for many years prior to the Civil War.

This lathe had, as will be seen by an inspection of the drawings, a bed com-

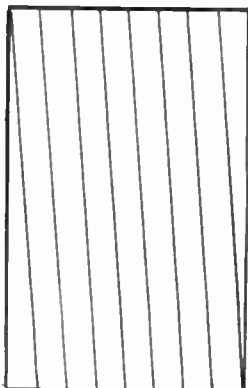

Fig. 1

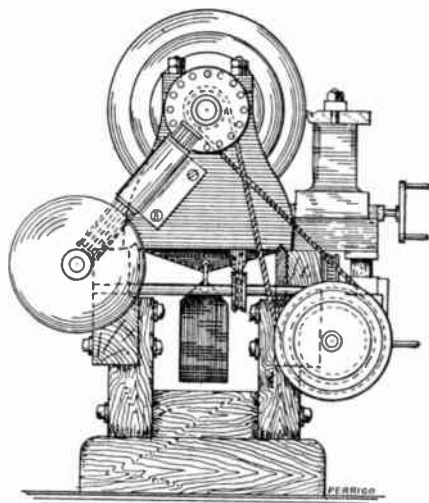

Fig. 2

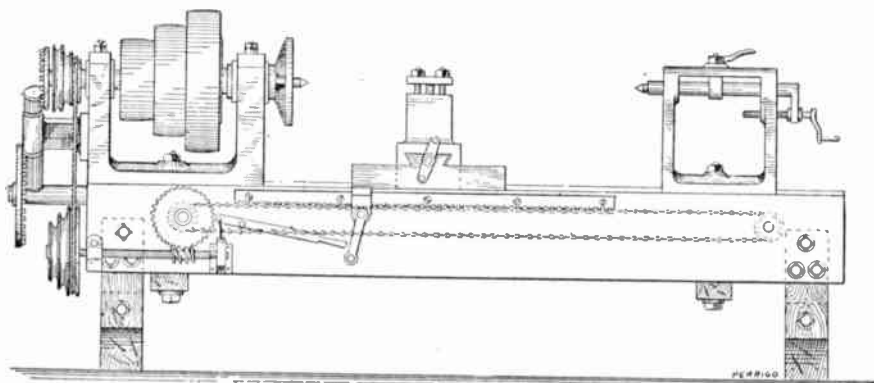

Fig. 3

as in most of the machines in use, the framework of the machine in the lathe, the bed, and legs were made of wood with the various metal parts secured to them. A good example of this method of construction, as well as the general construction of the lathes of the date when this one was built, is shown in front end elevation in Fig. 2, and in front elevation in Fig. 3. The history of this lathe is well known to the author, who was well acquainted with the old Scotchman, one John Rea, who had a small machine shop, wood shop, iron foundry and sawmill in East Beekmantown, Clinton County, New York State,

posed of two timbers, placed at the proper distance apart and supported upon wooden legs, which in turn rested upon a cross timber supported by the floor. The timbers were of hard maple, those forming the bed being about 5 in. thick and 12 in. deep, and were about 15 ft. long. The lathe would swing about 32 in. over the bed. The patterns were made by Mr. Rea, the castings made in his foundry, and the machine work done in the nearby village of Plattsburgh.

The "ways" or V's of the lathe were of wrought iron about $\frac{5}{8}$ by 3 in. let into a "rabbet" cut on the inside edges

of the timbers forming the bed, and fastened by large wood screws. The top edges of these iron strips were chipped and filed to an angle of about 45 degrees to the sides, thus making the V an angle of about 90 degrees. The head-stock had cast in it square pockets in which the boxes for the main spindle were fitted by filing, and were held down by a rough wrought iron cap through which passed two threaded iron studs which had been cast into the metal. Upon these two nuts as shown. The main spindle was of wrought iron and carried a wooden cone pulley built up on cast iron flanges keyed to the spindle. There were no back gears.

The carriage was of the roughest description and had a hand cross feed for the tool block, which carried the old-fashioned tool-clamping device, held in place by studs and nuts. The longitudinal hand feed was by means of a crank-shaft and pinion with cast teeth and a rack similarly formed, fastened to the front of the bed by wood screws. The longitudinal power feed was by means of an ordinary iron chain (hence the common name of "chain lathe"). This chain ran over a very clumsy form of sprocket-wheel made somewhat similar to those used in chain hoists of the present day. At the head end of the lathe this sprocket-wheel was fixed upon a shaft journaled in boxes at the front of the bed, one of which was pivoted to the front of the bed and the other capable of sliding vertically, and therefore making provision for dropping this worm out of contact with the worm-gear when it was desired to "throw out the feed." To keep this feeding mechanism in gear a lever was pivoted upon the front side of the lathe bed, one end connected with the sliding box of the worm-gear shaft and the other hooked under a pin driven into the front of the lathe bed, as shown in the engraving.

This worm-shaft was driven by a round leather belt working in one of the grooves of a three-step cone pulley fixed upon it, and extending up to a similar three-step cone pulley fixed upon the rear end of the main spindle. These pulleys were of hard wood and attached to cast iron flanges fixed in place. The belt was a "home-made" production, but very much resembling the best

twisted round leather belts of the present day, and was about $\frac{3}{4}$ in. in diameter.

The belt on the cone pulley upon the main spindle was about $3\frac{1}{2}$ in. wide, the large step on the cone being about 20 in. in diameter.

It will be noticed that no provisions were made in this lathe for cutting left-hand threads. It seems altogether probable that the use of left-hand threads began many years after right-hand threads were developed and used, as the need of them no doubt did not exist until the mechanical arts were much farther advanced and possibly not until they were wanted for producing a contrary motion in devices using the worm and worm-gear.

The tail-stock was of very simple construction, as will be seen in the engraving, the tail spindle having formed upon its rear end a downwardly projecting arm which embraced a screw tapped into the main casting and being provided with a crank by which it was operated. To bind the spindle in any desired position, a ring was provided, through which the tail spindle passed, and to which was welded a bolt-end passing through the casting and being provided with a lever nut as shown. It will be noticed that by this construction the operation of binding or clamping the tail spindle tended to raise it out of its true bearing position and hold it suspended by this binder and its contact with the top surfaces of the holes through which it passed in the main casting. This continued to be the practice for clamping a tail spindle for many years before the present method of splitting the bearing at the front and fastening it by a clamping screw was first used.

The lead screw was placed at the back of the lathe and had fitted upon it a curved forging, carrying a solid nut and capable of being attached to the carriage by two bolts when it was desired to cut threads. This forging was frequently called a "goose neck," from its peculiar shape. The thread of the lead screws was square and four threads to the inch. It was, of course, made of wrought iron, the use of steel for this purpose being of much later date.

The method of driving the lead screws was characteristic and peculiar and is one of the main reasons for introducing

this lathe to the attention of the readers, as it marks one of the first known methods of changing the ratio of speed between the main spindle and the lead screw by means of gears of a varying number of teeth, which is here done in a very crude but comparatively effective manner. This method was as follows: Upon the rear end of the main spindle was fixed a flange having in its face a series of pins which formed the teeth of a "crown gear" and which engaged with a "lantern pinion" fixed upon an inclined shaft journaled in a bracket fixed to the lathe head and lining with the lead screw. This lantern pinion was made of two heads fitted upon the shaft, and having pins running through the heads in a line parallel with the axis of the shaft, similar to the method seen in a brass clock.

Upon the lead screw was a crown wheel similar to that upon the rear end of the main spindle, and whose pins, or teeth, engaged with those formed by the pins or rods in the lantern pinion upon the lower end of the inclined shaft. The fact that this lantern pinion was of much greater length than that on the upper end would seem to indicate that the designer or builder of the lathe had intended to use different sized wheels on the end of the lead screw for the purpose of producing different ratios between the speed of the lead screw and that of the main spindle, and therefore to cut threads of differing pitches. This seems to have been the earliest method of producing this result by a change of gearing, and probably antedated the method of using differing diameters of spur gears, as it is well known that the crown wheel or pin gear and lantern pinion were the oldest form of gearing, and in use in Egypt at a very early date, and that an imitation of our spur gear was made in a similar manner by inserting the pins in the periphery of the wheel instead of its face. The builder of the lathe in question probably borrowed his idea from some lathes very much older and which he had seen in his native country, as regular spur gearing for the same purpose had been used at a considerably earlier date than the building of his lathe, and as he was a man past middle life at that time. The lathe was built about 1830 and was in active

service as late as 1875, although the lantern pinions and pin gears had been discarded and hung up on the walls of the old shop, and in their place were the usual spur gears, and a stud plate had been added for the purpose of carrying an idle gear so as to accommodate different sizes of change gears, and a second idler when left-hand threads were to be cut. Otherwise the old lathe remained as it was originally built.

The transition from wooden to iron beds and legs for lathes was probably made by the early builders of these machines about 1840 or a few years later. It is certain that in 1850 lathes with iron beds were made in New Haven, Conn., and that from this time on iron was universally used for this purpose.

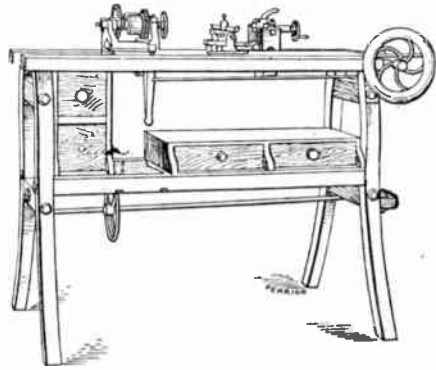

Fig. 4

A good example of these lathes built about the time of the change from wood to iron beds is furnished in Fig. 4, of one of the lathes built by J. & S. W. Putnam, in Fitchburg, Mass., about the year 1836, or somewhat earlier, and shows in a remarkably sharp contrast with those of the present day when all possible devices are adopted for powerful drives, rapid change gear devices for both feeding and for thread cutting, to the common inch standard and those measured by the metric system; with micrometer gauges and stops; with turrets located upon the bed or upon the carriage; and with all manner of attachments and accessories for doing a great and almost endless variety of extremely accurate work, as well as for turning out an immense quantity of it.

One other example of the early lathes is shown that was in some respects somewhat ahead of its time, as will be pointed

out. It is a 20 in. lathe built by A. M. Freeland, in New York City, in 1853. It is shown in Fig. 5. It is said that Mr. Freeland used English machines as his models and was an admirer of Whitworth and his ideals of what machine tools should be. In this lathe the flat-top bed is used as in many English and some very good American lathes at the present time. It will be noticed that the apron is in a somewhat abbreviated form, only sufficient to support its very simple operative mechanism.

The carriage carried a cross-slide upon which were two tool-posts, one in front and one in the rear, which were connected by a right and left cross-feed screw, while there was a short supplemental screw for adjusting the back tool

with all their peculiar features illustrated, explained and commented upon as this work progresses, taking up, not only the regular types of engine lathes, but also those of a more special nature such as turret lathes, precision lathes, bench lathes, high-speed lathes, gap lathes, forming lathes, multiple spindle lathes, and so on, including lathes driven with belts from a countershaft in the usual manner, and also those driven by electric motors with the most modern appliances.

In illustrating and describing these lathes much care has been exercised to have both the illustration and the description correct as to the facts shown and commented upon, and to this end the builders themselves have furnished

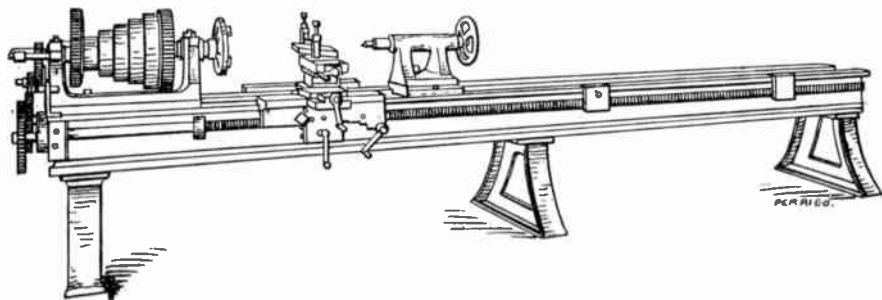

Fig. 5

independently of the front one, and also a longitudinal screw for adjusting the tool lengthwise of the work being turned, so that the second or back tool would cut a portion of the feed, as the roughing cut, and the front one take the remainder. It will be understood that the back tool is used upside down as in the modern lathes carrying the second tool.

There was no rack and pinion arrangement for lateral hand feed for the carriage, the lead screw being used for this purpose by engaging with its thread a pinion fixed to the shaft operated by the crank at the right-hand end of the apron.

It will be noticed that the driving-cone on the spindle has five steps, as in a modern lathe. The bed seems so light that it would now be called frail, in view of the present duty expected of a lathe of this swing, and in sharp contrast with the massive beds now used.

In some future articles will be shown some of the modern American lathes

the necessary facts so that the statements herein given are from proper authority and may be relied upon in considering the proper selection of the lathe best suited for the work for which it is to be used.

. A draftsman seldom has the patience to erase an ink line from tracing cloth properly. If the eraser is operated with too much pressure, the cloth is marred. The proper method is to operate the eraser with a light but quick motion. Recently, an electrically-driven eraser has been invented, consisting of a small motor provided with a flexible shaft which carries a circular eraser at its outer end. In order to clean the eraser of particles of ink which it picks up, a cleaning rubber is provided, which bears lightly against the erasing rubber. A device of this sort should be sufficient to meet the requirements of a large drafting room.

WOODWORKER

HOW TO BUILD A LIBRARY DESK.

IRA M. CUSHING

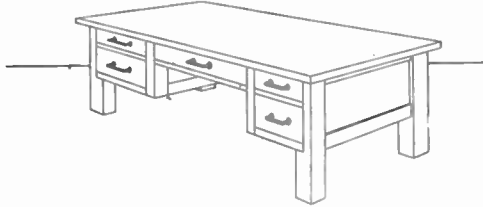

A desk is not only a very useful piece of furniture, but if well designed and well made it is very ornamental and adds very much to the appearance of the den or library. For the home the flat-top library style of desk is the best both for looks and convenience. The roll-top desk looks clumsy while the library type with flat top has the appearance and usefulness of a library table. The desk described here is of the pleasing mission style which is so popular for dens and libraries. It matches in style and finish the Morris chair described in the August number of the *Electrician and Mechanic*. These two make a very substantial beginning for a library or den.

The best kind of wood with which to make the desk is quartered oak, although mahogany with a fine satin finish would probably make a very handsome piece of furniture if the other pieces in the room are also of mahogany. For finishing the oak the author recommends Johnson's wood dye, both for ease of application and lasting qualities. For those living in or near large cities or near a planing mill the material for this desk, including the hardware, should not cost over \$15.00.

The top is 50 in. long by 28 in. wide and $1\frac{1}{2}$ in. thick. This width was chosen so that the desk could be moved through the average door in a house. A piece of quartered oak the full width of 28 in. would be prohibitive in cost and it will be necessary therefore to

make it of three or four pieces glued together. Unless the prospective builder has all the appliances to work with, such as hot glue-pot, powerful furniture clamps, etc., it would be safer to have the planing mill do this fitting which will add but little to the cost and there will be the satisfaction of having the work properly done. Gluing wood together is a very hard job without good hot glue and powerful clamps.

Set the top away to dry in a corner where it will not get scratched or marred or the corners chipped, as it is almost impossible to work these marks out again. Beside this, the marks show very much plainer in the mission finish. While the top is drying, the rest of the desk can be made. The next to get out are the legs. There are four of these, each 3 in. by 3 in. square by 26 in. long. It is better to make them of one piece, but if the stock is not at hand they can be built up by gluing enough pieces together to get the required thickness. Reference to the drawing will show how they should be cut out. The legs are of full size from the bottom up, a distance of $10\frac{1}{2}$ in. The rest of the leg has one half cut away for the side drawers. Next, get out four pieces of quartered oak 3 in. by $\frac{7}{8}$ in. by 21 in. long. These are the top and bottom of the side panels. For the side panels get out two pieces $19\frac{1}{2}$ in. by $9\frac{1}{2}$ in. by $\frac{3}{8}$ in. thick of quartered oak, and having the grain run the long way. It may be found necessary to

make these panels, as well as the one at the back, of two pieces glued side by side, as it is not always easy to get quartered oak of this width. The sides can now be completed. The top and bottom pieces should be let into legs from the inside for $1\frac{1}{2}$ in. and the back of the piece flush with the inside. The bottom piece should rest on the shoulder cut in the legs, and top piece should have its top flush with the top of the legs. The panel of $\frac{3}{8}$ in. wood is also inserted into the legs at the side and its back surface is flush with back of the top and bottom pieces and the inside of the legs. The top and bottom edges

an angle so that to the front it goes into the legs $\frac{3}{8}$ in. and at the back it is flush with the legs. It should be fastened in place so that the front edge is flush with front of the back legs. The brace is $2\frac{3}{8}$ in. by $\frac{1}{8}$ in. by $44\frac{3}{4}$ in. total length. The back panel is 14 in. by $\frac{3}{8}$ in. by 44 in. long and of quartered oak. This can be made of two pieces 7 in. wide glued together. This just fits into the space making flush joints. It can be fastened in place with finished wire nails driven into the upper brace and also at an angle into the bottom brace and the legs.

The frame work at the front of the

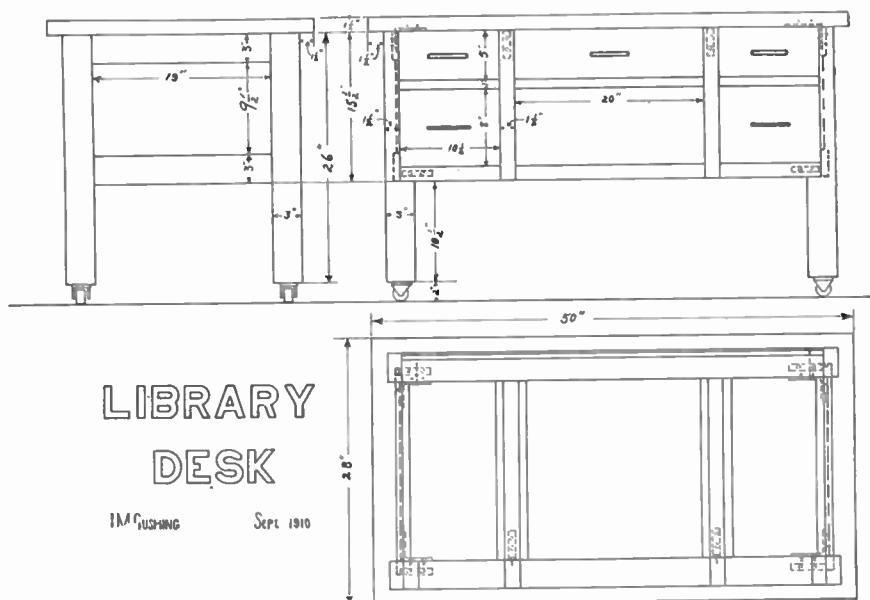

just meet the top and bottom pieces in a flush joint. The panel is inserted $\frac{1}{2}$ in. only, into the leg—just enough to get a chance to fasten it. The top and bottom pieces should be fastened into place with glue and wood screws. The panel can be fastened with glue and nails on the edges that insert into the legs.

The rest of the framing can be got out. For the back cut out a piece of oak 3 in. by $1\frac{1}{2}$ in. by 44 in. long. This rests, at each end, on the shoulders in the back legs, and is fastened with long wire nails and glue. Another brace is put in along the back to help hold the drawers. This is placed 5 in. from the top of the legs. The ends are cut at

desk consists first of a piece of plain oak 3 in. wide, 1 in. thick and $44\frac{3}{4}$ in. total length. It should be inserted into the legs the same as the brace was at the back, leaving the total distance between the legs at the upper end exactly 44 in. A slot $1\frac{1}{2}$ in. wide and $1\frac{1}{2}$ in. deep should be cut in from the front edge of this brace $10\frac{1}{2}$ in. from each end. This is for the uprights. These uprights are made from pieces 3 in. by $1\frac{1}{2}$ in. by $15\frac{1}{2}$ in. long and are notched 5 in. from the top for the brace. This notch is at the back and is 1 in. wide and $1\frac{1}{2}$ in. deep. At the bottom the pieces are lap-jointed to horizontal pieces 3 in. by $1\frac{1}{2}$ in. by 12 in. long, the

other end of which rests on the shoulder in the front legs. The horizontal and vertical pieces should be fastened with a $\frac{3}{8}$ in. dowel pin projecting 3 in. or more through the back into a horizontal piece that goes from this point to the lower back brace. This last horizontal piece is 3 in. by $1\frac{1}{2}$ in. by $21\frac{3}{8}$ in., and is cut out $1\frac{1}{2}$ in. deep and $2\frac{3}{8}$ in. long at the back to fit over the lower back brace. Glue should be used at all the joints and nails can be used where the pieces are fastened to the legs and also to the back piece. To hold the middle and two upper side drawers a 1 in. piece 3 in. wide should be fastened from the inside front braces back to the upper back brace. This piece should be put in horizontal and on a level with the upper front and back braces. On top of these pieces should be nailed some drawer guides with their sides flush with the front upright pieces. These pieces are $\frac{3}{4}$ in. square. This same stock can be used for drawer rests for both upper and lower drawers. They should be fastened in place either with nails and glue or with screws.

In putting the frame together it makes it much stiffer to use strap iron braces, about 3 in. by 3 in., between the lower back brace and the sides. Iron braces should also be fastened to the legs at the top to hold the desk top to the frame. On the front legs these will have to be let into the wood to allow the drawers to slide by.

To complete the frame, two panels, each $6\frac{1}{2}$ in. by $\frac{3}{8}$ in. by $21\frac{3}{8}$ in. long, should be placed, one on either side, between the lower front to back brace and the drawer rest above it.

The drawers should be made and fitted before the top is fastened in place as it will be much easier to fit the stops at the back. The front of the drawers is, of course, quartered and $\frac{3}{4}$ in. thick. For the middle and two upper side drawers the fronts are 5 in. wide and for the lower ones 8 in. wide. White wood is as good as any for the sides, back and bottom of the drawers. It should be $\frac{1}{2}$ in. thick and the same width as the fronts. The method of fastening the sides to the front of the drawers will depend upon the skill of the builder. A simple way would be to cut a rabbet $\frac{1}{2}$ in. by $\frac{1}{2}$ in. at each

end of the front and insert the sides fastening them with nails and glue. Finished nails can be driven in from the front with care and the holes filled with black putty later. The sides should have a $\frac{1}{4}$ in. groove cut in them $\frac{1}{4}$ in. from the bottom and running the length of the drawer into which the bottom pieces can be inserted. Instead of white wood, oak or maple can be used, making it $\frac{3}{8}$ in. thick. The drawers would be heavier but the insides would have a neater and smoother appearance.

The drawers should now be fitted to their places, and stops fastened at the back so that when the drawers are shut tight the fronts will be flush with the front of the frame. A wax candle rubbed along the rests on the frame and on the bottom of the drawer sides where they run will make a great difference in the working of the drawers.

The top and frame can now be fastened together. Handle the top with great care as on account of its weight it is very easy to bruise the corners and make scratches that would take hours to remove. Place the top upside down on the bench and centre the frame on it and mark where the screw holes are in the angle pieces. Drill these with the proper size drill and then fasten them down with screws. If a wood screw is rubbed on a piece of soap so as to partially fill the threads it will be found to enter the wood much easier and will hold just as well.

While the desk is upside down it is a good time to put on the castors. As the desk is quite heavy, it is the best policy to get the best castors. They should be preferably of brass or bronze with hard rubber or wood wheel. They should be of ample proportions and about 2 in. high. Now turn the desk right side up and fit the drawer pulls in place. These should be of lacquered brass or oxidized finish of some substantial but simple pattern to match the simple straight lines of the desk.

The desk is now ready for its finishing touches. Take the drawer pulls off and go over all parts lightly with very fine sandpaper. Do not take off the sharpness of the corners any more than enough to prevent splintering. Use the sandpaper long enough to get a good smooth surface and then fill up the nail holes

and any other small uneven places with black putty.

Before the desk is completed consult the paint manufacturers advertising in this magazine for recommendations as to the proper finish. Tell them what you have and the results you wish to obtain and they will be glad to give any information needed. The desk is designed in mission style and therefore the mission finishes or stains will be the best for it.

After the desk has been finished,

carried to its pre-arranged place in the library or den, and after the family have looked it all over and the neighbors have seen it and passed complimentary remarks about it you will sit down and look at it and quite a feeling of surprise will come over you to think that with so little money, time and labor, you have been able to produce a really fine looking piece of furniture. It will always give you great pleasure and pride to show it to your friends as your own work.

HOW TO MAKE A SHAVING STAND

RALPH F. WINDOES

A very useful piece of furniture, and one of simple construction, is the shaving stand here shown. The movable mirror adjustment makes it possible for any man between the heights of 4 ft. 6 in., and 6 ft. 4 in. to use the stand, and as there are but few of us who are not in-

cluded in these dimensions, we may all find good use in such an article, as proves most satisfactory when constructed of quarter-sawed white oak with soft wood drawer linings. This material is ordered as follows, together with the 14 in. x 16 in. mirror, the

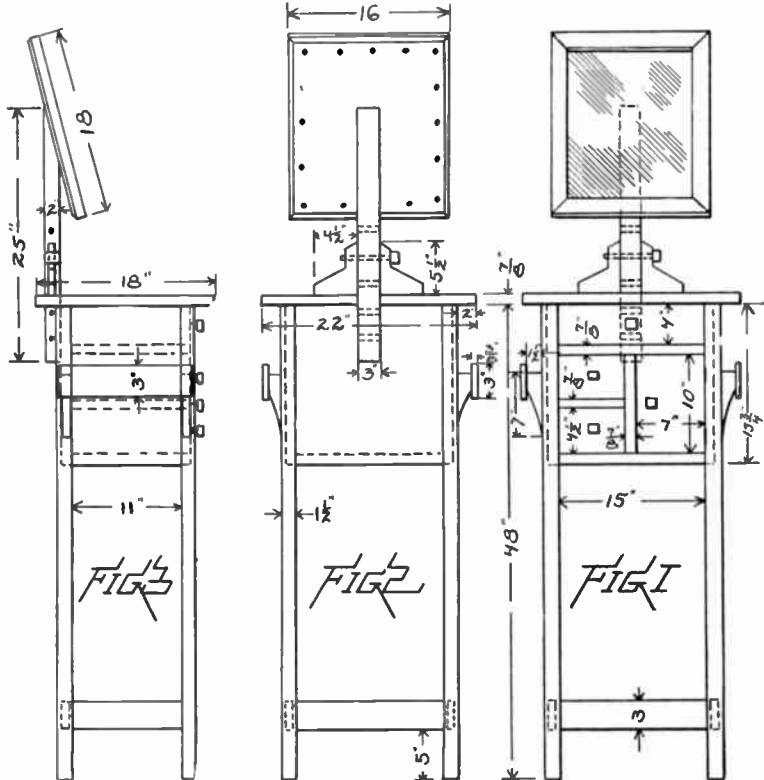

hardware and the finish of stain and wax:

- 4 pieces $1\frac{1}{2}$ in. x $1\frac{1}{2}$ in. x 48 in.
- 2 pieces $\frac{7}{8}$ in. x $7\frac{1}{8}$ in. x $4\frac{1}{2}$ in.
- 2 pieces $\frac{7}{8}$ in. x 11 in. x 15 in.
- 2 pieces $\frac{7}{8}$ in. x 11 in. x $15\frac{3}{4}$ in.
- 2 pieces $\frac{7}{8}$ in. x 3 in. x $12\frac{1}{2}$ in.
- 2 pieces $\frac{3}{8}$ in. x 3 in. x 14 in.
- 4 pieces $\frac{7}{8}$ in. x $1\frac{1}{2}$ in. x 7 in.
- 2 pieces $\frac{7}{8}$ in. x $4\frac{1}{2}$ in. x $5\frac{1}{2}$ in.
- 2 pieces $\frac{7}{8}$ in. x $1\frac{1}{2}$ in. x 18 in.
- 2 pieces $\frac{7}{8}$ in. x $1\frac{1}{2}$ in. x 16 in.
- 1 piece $\frac{7}{8}$ in. x 18 in. x 22 in.
- 1 piece $\frac{7}{8}$ in. x 7 in. x 10 in.
- 1 piece $\frac{7}{8}$ in. x 4 in. x 15 in.
- 1 piece $\frac{7}{8}$ in. x 11 in. x 10 in.
- 1 piece $\frac{7}{8}$ in. x 10 in. x $7\frac{1}{8}$ in.
- 1 piece $\frac{7}{8}$ in. x 15 in. x $15\frac{3}{4}$ in.
- 1 piece $\frac{7}{8}$ in. x 3 in. x $16\frac{1}{2}$ in.
- 1 piece 2 in. x 3 in. x 25 in.

White pine

- 2 pieces $\frac{1}{4}$ in. x 8 in. x 18 in.
- 4 pieces $\frac{1}{4}$ in. x $4\frac{1}{4}$ in. x 11 in.
- 2 pieces $\frac{1}{4}$ in. x $3\frac{3}{4}$ in. x 11 in.
- 2 pieces $\frac{1}{4}$ in. x $4\frac{1}{4}$ in. x 7 in.
- 1 piece $\frac{1}{4}$ in. x 4 in. x 15 in.

Some allowance is made for fitting in the drawer linings, but the rest of the stock is exact size. Much labor can be saved by requesting the dealer from

whom you purchase the lumber to sand it for you at the mill.

In Fig. 1 is given an elevation of the front, in Fig. 2 an elevation of the back, and in Fig. 3 an elevation of a side. The lower stringers are mortised in, but the top, sides, back and partitions are nailed in place, the heads being set and covered with putty or glue with sawdust in it. The mirror frame has mitered corners as shown in Fig. 1. The towel-racks on the sides are very convenient while the stand is in use. The holes in the piece supporting the mirror are bored with a $\frac{1}{2}$ in. bit and the peg used in connection with them is turned or whittled to size.

The stand may be finished in any of the popular colors by staining it and giving it two coats of prepared wax.



MAKING A TOOL BOX

The mechanic working on a floor where locomotives, travelling cranes and large machine tools are constructed, finds it necessary to have a small tool box that can be carried from place to place wherever some work is to be done.

The box illustrated is one that can be carried about and, when necessary, it can be locked and left, without the danger of the tools being stolen.

The top is fitted with a drawer attached to the cover with hinges and by lifting this cover the drawer may be pulled out. When closed, and the cover locked, the drawer cannot be withdrawn. Figs. 1, 2 and 3 give the dimensions for the sides, top and ends, and Fig. 4, details of the handle; Fig. 5 shows the box closed and locked; in Fig. 6 the box is shown open.—*Popular Mechanics*.

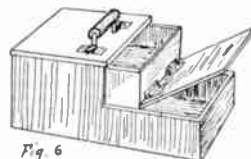
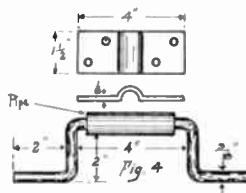
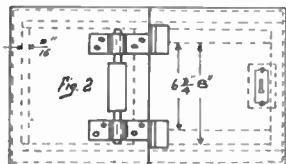
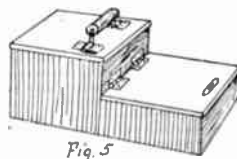
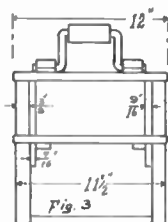
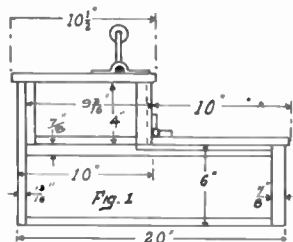

WIRELESS TELEGRAPHY

In this department will be published original, practical articles pertaining to Wireless Telegraphy and Wireless Telephony

CONSTRUCTION OF A POTENTIOMETER AND COMBINATION TUNING COIL

W. C. GETZ

In a recent issue of this magazine I described the construction of two standard types of detectors that the experimenter will try out sooner or later, and I promised in that article to give data on a potentiometer and a suitable tuning coil for use with these detectors.

In this article I will, therefore, describe the construction of a potentiometer and tuning coil, which I adopted as most efficient, for the average wireless station, after experimenting with a great variety of different types.

Only one sliding contact is provided. The details of this sliding contact, as well as the details of the ends, are given on the drawing of the tuning coil, and will be described later on. The wood mandrel is finished off with square ends, these having a hole sunk in each end, as shown, to accommodate the mandrel, and are equipped with suitable binding posts.

In winding on the German silver wire, as well as any enameled wire, it is best to first wind several layers of paper around the mandrel first, and soak

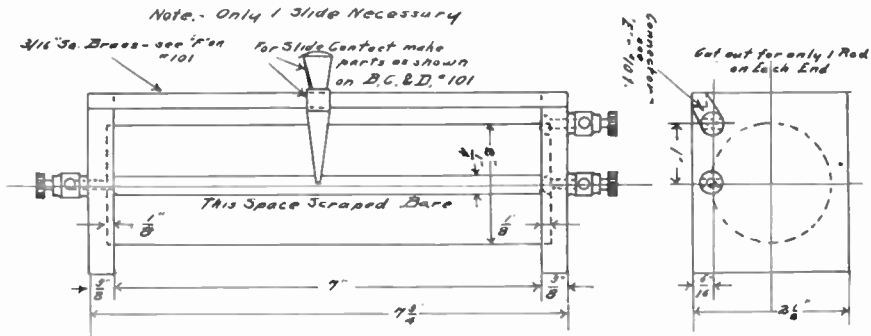

Fig. 1

In Fig. 1 is given a drawing of the potentiometer. It is seen that the potentiometer consists of a winding of approximately 490 turns of No. 28 B. & S. gauge black enameled German silver wire, wound on a wood mandrel 2 in. in diameter, and 7 in. in length of winding space. The resistance of this potentiometer is approximately 300 ohms, which when used with not more than three cells of dry battery, permits as fine a potential variation as is needed for all types of detectors.

them with shellac varnish. Then wind on the enameled wire while the shellac is wet. This serves to prevent the winding from loosening up when the wood contracts as it would eventually do, no matter how well seasoned, as the paper fibers cling to the enameled wire and the wood, and act as a binder that is hard to loosen.

After the winding is completed, and the shellac dry, a space about $\frac{1}{4}$ in. wide can then be scraped down the centre of the winding for the slide to

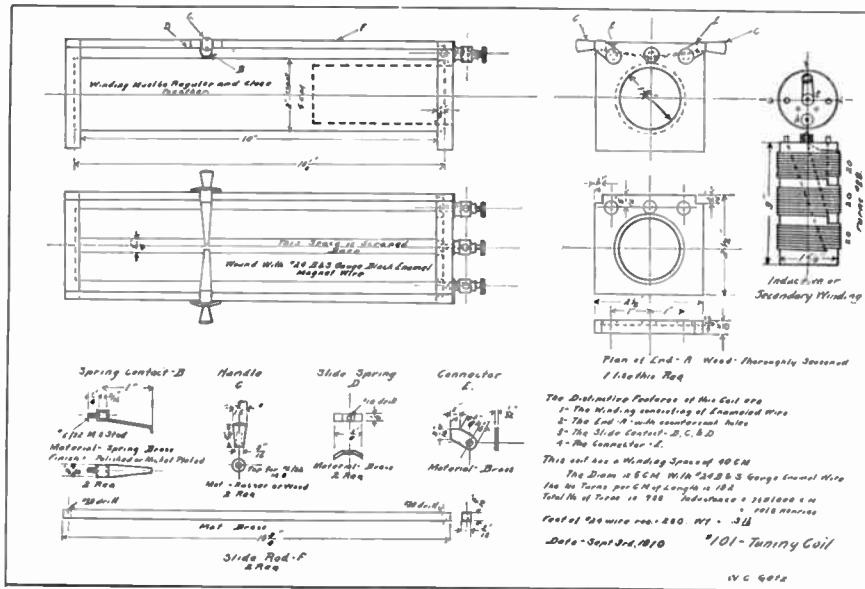

Fig. 2

make contact with. This can be easily done with a sharp pen-knife, without lacerating the wire.

In Fig. 2 is given the details of the Combination Tuning Coil which has given excellent results to many experimenters. This coil is so arranged that it can be converted from a straight tuner to an inductive tuner instantly, by merely inserting the secondary winding.

The mandrel of this coil, is similar to that used for the potentiometer, being 2 in. in diameter and 10 1/4 in. in length. This allows a winding space of 10 in. which contains approximately 768 turns of No. 24 B. & S. gauge black enameled copper magnet wire. One end of the mandrel is bored out to a depth of 4 1/2 in. with a 1 3/4 in. drill, so that a secondary or inductive winding may be inserted.

The winding is put on in the same way as the winding of the potentiometer, shellacked paper being used as a backing, and a 1/4 in. space scraped down the centre for a slide contact.

The details of the slide contacts are as follows: B is the spring contact, made of spring brass (or German silver) sheet, and bent as shown. A No. 6-32 machine screw stud, 1/4 in. long is soldered to one side, to hold the insulated handle.

This handle is shown in the drawing C. It can be made of rubber, wood or any other insulating material. It is taped out for the No. 6-32 stud of the spring contact.

At D is shown the slide spring, which is fitted between B and the slide F, to maintain a steady pressure and contact between them. It is fitted over the stud, the handle C holding it in position.

E is a connecting strip of sheet brass which is soldered to one end of each slide rod, to provide the contact with the binding posts at the ends.

F is the slide rod, of which one is required for the potentiometer, this being 7 3/4 in. long; and two required for the tuning coil, these being each 10 3/4 in. long. The ends are suitably drilled for the wood screws which fasten them to the ends of the coils.

At A is given the plan of one of these ends. This is the end through which the secondary coil is inserted, and a 1 3/4 in. hole is bored through this. On the inside face, a 2 in. hole is counter sunk 1/8 in., in which the mandrel end is glued.

In the right-hand corner of Fig. 2 is shown the inductive or secondary winding. This winding consists of about 60 turns of No. 28 B. & S. gauge black enameled magnet wire, wound on three

sections of 20 turns each, on a mandrel $1\frac{1}{8}$ in. in diameter, and 3 in. long.

From each section taps are brought to studs on the end of the mandrel. By drilling holes diagonally across the mandrel, with care, the wires may be brought through to exactly the proper places. A switch is also placed on this mandrel, so that the sections may be cut in, one at a time.

For instance, when the switch *e* is on the stud *a*, all 60 turns are in; when it is on the stud *b*, 40 turns are in; and when it is on the stud *c*, only 20 turns are in. The switch *d* and stud *e* are provided with thumb-nuts (such as battery binding posts) for connection with the detector circuits.

In Fig. 3 is given the diagram when the inductive winding of the tuning coil is used. The potentiometer is also shown in here.

A is the antenna of the "loop" type, one side of it coming direct to one slide contact of the tuner *L*, and the other side going to the adjustable condenser *C*, which in turn connects to the other slide of *L*. The end of the winding *L* goes to the ground *G*.

The secondary winding *S* has the stud *d* connected to the detector *D*, first going through the fixed condenser *F*. *F* has a capacity of about .001 M.F., consisting merely of several sheets of tinfoil, with paper or mica between, the alternate sheets being connected to opposite sides. The other side of *S*, from the stud *e* goes direct to the potentiometer *P*, a tap being taken off for the detector *D* at a suitable point. The potentiometer *P* is bridged across three cells of battery *B*. The slide contact of *P* is connected to the telephone receiver *T*, which in turn connects with the top terminal of the detector *D*, thus completing the battery circuit. The telephone *T* should be over 800 ohms resistance, if good results are desired.

With this set, excellent results have been attained even with a 25 or 30 ft. aerial. By varying the slides of the tuning coil and the adjustable condenser *C*, static can be greatly cut down. The adjustable condenser should have a capacity of about .007 M.F. maximum.

In another issue a continuation of the articles on the High Power Wireless

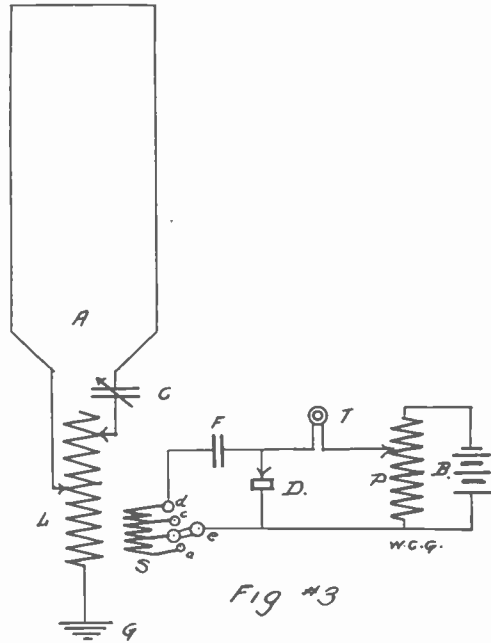

Station will be given, as well as directions for making several new types of wireless instruments.

THE STEAM TURBINE

(Continued from page 34)

IMPULSE TYPES

Single-Stage Type.—Turbines with but one set of nozzles and one row of moving buckets.

Velocity Compounded.—Turbines with one set of nozzles only, but with two or more rows of moving buckets, with intermediate guides.

Pressure Compounded.—Turbines with two or more stages, each stage comprising one set of nozzles and one row of moving bucket.

Pressure and Velocity Compounded.—Turbines with two or more pressure stages, each pressure stage comprising one set of nozzles and two or more rows of moving buckets, with intermediate guides.—*Scientific American*.

"Political campaign calculations," remarked the Professor Tallbrow, "are a distinct branch of mathematics."

"How so?" we asked. "You begin with the answer, then work backward for the purpose of evolving a problem to demonstrate it," explained the professor.—*Chicago Daily News*.

A NEW SYSTEM OF WIRELESS TELEGRAPHY

It will be remembered that the two Italian engineers, Bellini and Tosi, were very successful with their new method of directed waves for use in wireless telegraphy. The first experiments were made between temporary posts located on the Channel coast of France at Dieppe, Havre and a third point. By this means, messages could be directed to one of the points and the station lying near by could not receive them. On the contrary, when we receive a message we are able to find the angle of the sending station within one degree on the horizon, and this is a remarkable result. Instead of erecting a vertical antenna, they use an aerial in the form of a loop which would send waves in but one direction counting front and back. Crossing this loop by a second and perpendicular one, we can send in a right-angled direction. Should we

now partially excite both loops, the resultant direction of the waves will depend on the amount of excitation each loop receives, so that we can vary the direction of the waves all around the horizon. The radio-goniometer, or rotating inductive coil, is the apparatus used to excite the two loops variably by turning one of its coils about the centre so as to direct the waves. For receiving, we use a similar coil and listen in the telephone until turning the coil gives us the loudest sound. The angle of the distant post is then very closely shown upon the dial.

The French Government has taken up the matter and a wireless post on the Bellini-Tosi system, of which the apparatus was built at the Ducretet establishment, has been erected on the Channel coast at Boulogne. The new station is laid out so as to conform as

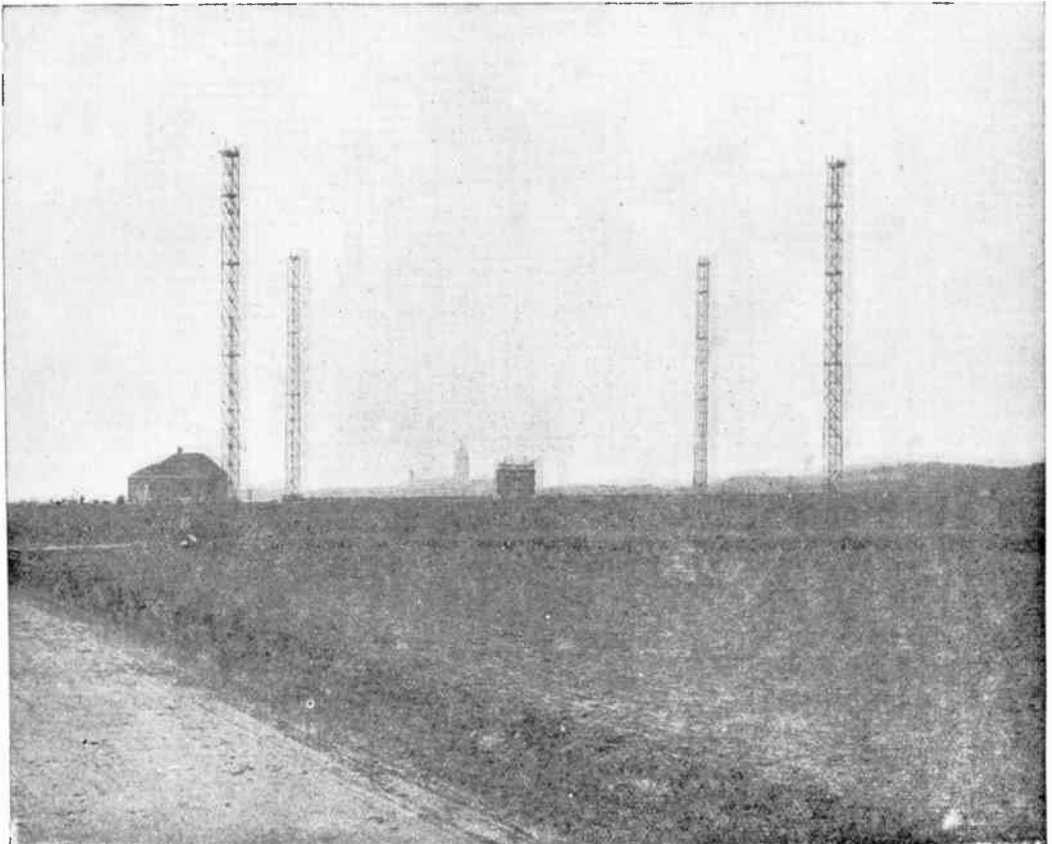

Four towers of the station at Boulogne, France

nearly as possible to the conditions which theory shows to be the most suitable, at the same time making such variations as are needed to carry out the construction of the towers and antenna wires from a practical point of view. There are erected four metallic towers built of structural iron, and these occupy the four corners of a square. A height of 153 ft. was given to the towers, while the square surface of ground covered by the same is 265 ft. on a side. Connecting the tops of the towers are four main horizontal cables, also forming a square, and the antenna wires are hung down from these cables to the ground. According to the Bellini-Tosi system there are needed two pairs of antennæ, these lying on the opposite sides of the square. Considered singly, each of the four aerial systems hanging from the horizontal cables is made up of six copper wires which run down to a point near the ground in a vertical direction, the wires being spaced 13 ft. apart. The lower end of the wires stops at 26 ft. from the ground, and the upper end, taking account of the sag of the horizontal cable, is at 146 ft. height. The assemblage of antenna wires on a side is not vertical, but descends in an inclined direction away from the top and forms an angle of 32 degrees so that the antennæ spread out considerably at the bottom. The lower ends of opposite antennæ are thus 420 ft. apart, while the upper ends correspond to the width of the square.

Seeing that the wave length chosen for operating the present station is 300 meters, the spread of the antennæ should have been half this length in order to give the best results; but as it was not desired to cover too much space of ground by the four towers along with their guy-wires, the present spread at the bottom of the system was considered to be a close enough approximation. The six vertical wires of an antenna are cross-connected at the bottom, and from this point a wire leads into the station building which is located at the centre of the square. In this way we have the characteristic form of aerial used in the present method, each aerial consisting of two upright (or inclined) antennæ joined by a horizontal wire at the ground, and the two main aerials

cross each other in vertical planes in order to form the directive system as we have already seen. It was desired to obtain very conclusive measurements as to the performance of the new station, and to carry this out they erected a testing station at about 2 miles distant. Here was installed a vertical antenna and a Duddell thermo-galvanometer for measuring the amount of energy radiated from Boulogne. The results showed that the energy radiated by the Bellini-Tosi system in one direction is six times what would be radiated uniformly by an ordinary vertical antenna.

The results obtained at the testing station at short range were confirmed by a series of experiments at long distances, and these tests showed that the type of antenna peculiar to the directive system has a greater range than the antenna of the usual type under the same conditions. The long range tests were made in the first place with a station on the English side of the Channel at Folkestone, which lies at a comparatively short distance of 25 miles, and afterward at more distant posts—such as the station on the Mediterranean coast lying near Marseilles and also the post which was recently erected by the government near Algiers. The results of the trials showed that the distant stations could always receive the signals very clearly when the Bellini-Tosi system of directed waves was employed, while the signals sent from the ordinary vertical antenna were found to be much weaker. Outside of the question of directing the waves, this is a point which is greatly in favor of the new method, and this is confirmed by official tests at long distance, namely, 960 miles to the Algiers station, of which a great part or 660 miles is overland. It is to be noticed that in the present trials of the system there was a comparatively small amount of power employed at the Boulogne post, this being not over 500 watts ($\frac{3}{8}$ h.p.) in the primary of the induction coil, and the wave length of the post is under the ordinary, being but 300 meters. On the other hand, the messages coming from the distant posts are better received when using the new apparatus, both when using the ordinary vertical antenna, or a single one of the Bellini-

Tosi antennae to operate on the common method.

Owing to the fact that it does not use a ground connection for the antennæ, the new system is of advantage in countries where the earth is a poor conductor owing to lack of moisture. Previous researches made by Sir Oliver Lodge and M. Tissot show that the earth offers a considerable resistance

such cases, as the results will be the same regardless of the nature of the ground.

Some of the most interesting points about the new method are the services which it can render to navigation. The Boulogne station is placed in a position where an ordinary post could seldom operate without being disturbed by waves from other sources, seeing

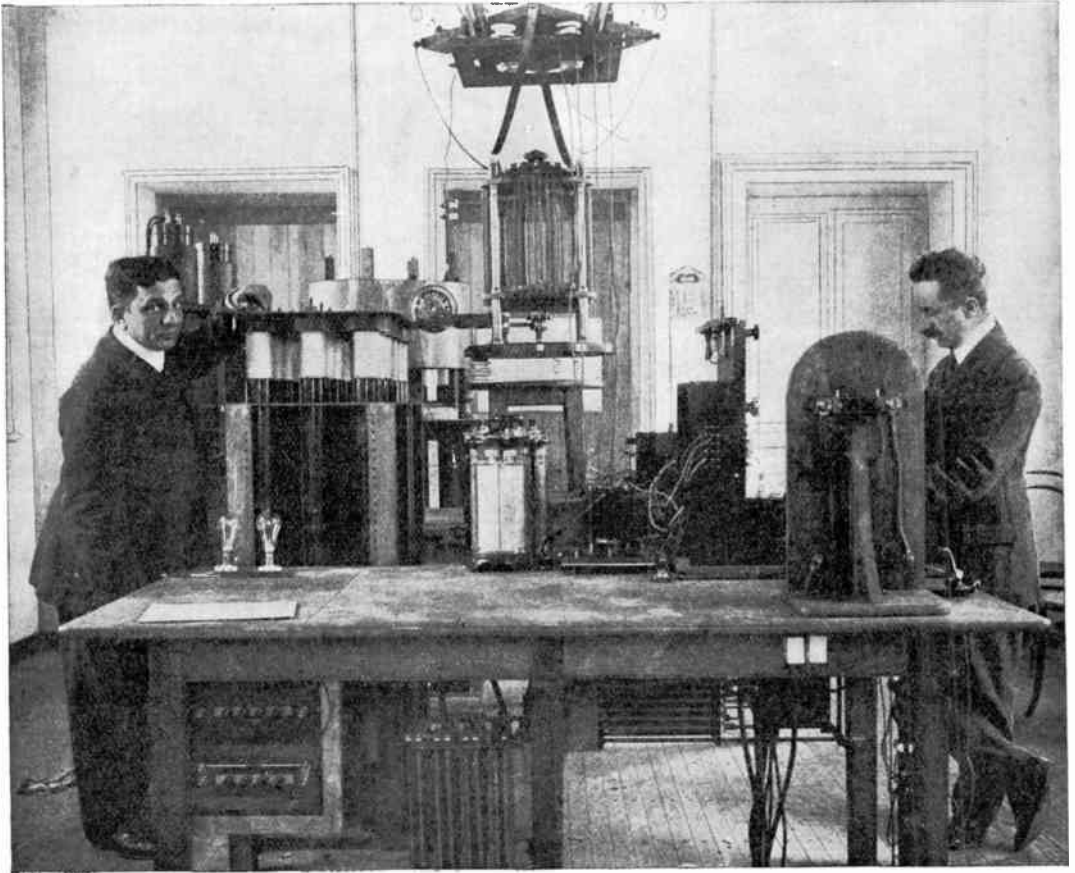

Radio-Goniometer in the middle at the top
The two inventors

and thus absorbs a certain amount of energy. The resistance is naturally greater in the case of dry ground, and especially in desert regions this may become so high that it causes great difficulty in the working of an ordinary antenna.

It will be observed that the present form of antenna, which does not use a ground connection, will prove much superior when it comes to dealing with

that it is surrounded by a great number of wireless stations on the English Channel and elsewhere in the neighborhood. Using directed waves, we are in a much better position to have a constant service between the Boulogne station and vessels. By this means we can also carry out what will no doubt be a useful improvement, namely, that of allowing vessels carrying a wireless post of the ordinary kind to take their

position in time of fog when the coast points are invisible. In fact, it being given that the receiving instrument at Boulogne allows of finding the direction of a distant transmitting post within an approximation of one degree, we can receive the signals from a vessel and find its angular position. Data of this position are again signalled to the vessel at any given moment. By repeating this operation according to the commonly used methods of navigation, the vessel is able to take its position in time of fog owing to the signals from the Boulogne station, and thus we have a distinct advantage.

M. Tosi mentions another use of the method in navigation, which has not been before brought out. This application allows a vessel to determine its responsible position when it comes within range of a wireless post of any kind. The position is found in the same way as we make the readings when in view of the coast with the usual azimuth compass. In fact, if we install upon the vessel a pair of small crossed aerials on the Bellini-Tosi method, disposed in the proper way, and connect them to a receiving radio-goniometer, we can find the reading for a shore wireless station with the same degree of precision as when using an azimuth compass with a visible object. The vessel can thus take the reading for a known point and can determine its position in the usual way. As it was of interest to find whether such a method could be actually used upon a vessel at sea, the investors made an arrangement with the Compagnie Générale Transatlan-

tique so as to have the aerials and other apparatus installed upon one of the liners, and the "Louisiane" was chosen for the purpose. During the trip which M. Tosi made upon this boat from Havre to New York, about the end of last year, he found that the device

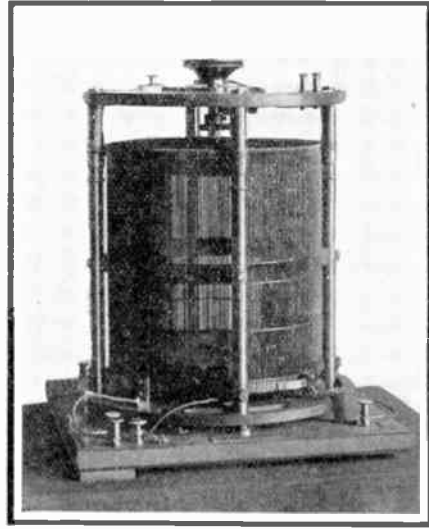

Radio-Goniometer for receiving, which locates a distant post by one degree angle

would work very successfully and that it had about the same range as the usual compass, or 25 miles. Together with the officers of the "Louisiane," he took readings upon several visible wireless stations, using the compass and the wireless method at the same time. The readings in these cases were always identical.—*Scientific American Supplement*.

Experiments have been made by Prof. A. Garbasso to determine the efficiency of radiation of an inclined antenna. In a report recently submitted to the Academia dei Lincei, he states that the radiation is not uniform from an inclined antenna, but is greatest in the vertical plane of the antenna, and weakest at right angles thereto. He states that if the inclination is 45 degrees, the energy is twice as great in the vertical plane in which the antenna lies as in a direction at right angles thereto.

The dismantling of the government cement mill at Roosevelt, Arizona, which was built because of the high cost of transporting cement to the site of the Roosevelt dam, marks the end of one of the most successful undertakings of its kind. During its five years of operation, the mill has turned out 330,000 barrels of cement, the bulk of which went into the dam, and the remainder into the flumes, canal and power house. It is estimated that the mill has effected a net saving of \$650,000.

EDITORIAL

We make the announcement that we have just combined *The Collins Wireless Bulletin*, of New York, with *Electrician and Mechanic*. The former publication has for some years been edited by A. Frederick Collins, who is well known as an expert in wireless telegraphy and telephony, and the author of several books on these subjects.

This number of *Electrician and Mechanic* will be mailed to all subscribers to *The Collins Wireless Bulletin*, the last number of which was that dated October, 1910. All unexpired subscriptions will be filled with the proper number of issues of *Electrician and Mechanic*, provided the subscribers have filled in the blank forms furnished by us, in accordance with the regulations of the Post Office Department. While we do not devote the whole of our magazine to wireless telegraphy, as did *The Collins Wireless Bulletin*, the department which we publish should give an amount of material on this subject, practically equal to that furnished by *The Bulletin*, and we, therefore, believe that our new subscribers will find our magazine an excellent equivalent for the magazine to which they subscribed. Naturally, those who have been interested in Mr. Collins' wireless course, of which nine installments have been published, will be glad to know that he is to continue this series for the three months necessary to complete the course. We hope to publish the first one of these articles in our February issue. The other continued series on the construction of wireless instruments had been practically completed, so that we do not propose to continue this series further, more especially as our own articles on this subject give a full equivalent.

This is the first number of **ELECTRICIAN AND MECHANIC** at the increased price. The enlargement from 64 pages to 96 pages means an increase of nearly 100 per cent. in text matter, and enables us to present a far more diversified table

of contents. The quality of the articles will, we hope, speak for itself. We feel that we have in this number come nearer making such a magazine as we desire than ever before. Yet this is only one step more in our steady progress. We hope that each succeeding number will be an improvement, with more articles, more pictures, more departments. To do this we must have your support. This is your magazine, made for you. Therefore we want your help. If the magazine helps you, tell your friends; get them to subscribe, or to buy it at your newsdealer's. When you need things, buy them from our advertisers; when you write to the advertisers, tell them that you saw the advertisement in **ELECTRICIAN AND MECHANIC**. Never neglect this. The advertiser wants to know that his announcement is being read, and it helps all parties when you mention the magazine.

Especially, we want to call every reader's attention to the fact that he still has a chance to subscribe to this enlarged dollar-and-a-half magazine, at the old price of one dollar, for as many years in advance as he desires, until the next issue appears. We want to give every purchaser of this number full opportunity to read it, like it, and decide to have it come regularly for a year at least. Just remember that your investment of one dollar for twelve numbers will bring you about 850 large pages of reading matter, equal to the contents of at least six bound books, such as sell for one to two dollars each. You will get the equivalent of a full sized book on aeronautics, one on wireless telegraphy and telephony, one on woodworking and furniture building, one on electrical progress, one on machine shop work and machine building, with plenty of practical hints and miscellaneous information thrown in. Do not let the chance slip. Fill in the blank on the last advertising page at once, and send your money order or other remittance promptly.

Through an inexplicable oversight in our editorial department, we neglected last month to give proper credit for the article by O. M. Kelley, entitled "New Runaway Gate on Williamsburg Bridge." This article, with the illustration, was furnished us by the American Museum of Safety, of New York, and originally appeared in *Safety*, the Museum bulletin. The object of this excellent organization is the prevention of accident and the conservation of human life, and it is doing a most meritorious work.

On November 19th a mail car loaded with western mail, probably including a number of bags of our December issue, was completely destroyed by fire at Utica, N.Y. Some of the mail, wet and scorched, has reached our subscribers, and we have replaced many copies, but there may be readers who have not received the December number, to which they are entitled. If this is the case, a post card advising us of the non-arrival of this issue will be promptly attended to.

The United States Civil Service Commission announces an examination on January 4 and 5, 1911, to secure eligibles from which to make certification to fill vacancies as they may occur in the position of aid, Bureau of Standards, Department of Commerce and Labor, at salaries of \$600 and \$720 per annum. Men only will be admitted to this examination. The examination will consist of the subjects mentioned below, weighted as indicated: Elementary algebra, geometry, and trigonometry, 25; general physics, 25; elementary mechanical drawing, 15; training and experience, 35;

Applicants must indicate in application and examination Form 1312 that they are graduates of mechanical training, technical or scientific schools, or have equivalent training in scientific or technical laboratories. The work of the Bureau of Standards is scientific and technical in character, consisting principally of physics, chemistry and mechanical and electrical engineering.

It employs a large number of experts in each of these branches. Young men filling successfully the position of aid are eligible for promotion in the lines of work in which they have become efficient. The opportunity for study and advancement along the lines indicated is equal to that of the leading commercial or educational institutions. Age limit, 18 years or over on the date of the examination.

Each competitor should bring for use in the examination a small drawing board, T square, triangles, ink, pens, pencils, drawing instruments and a scale divided into sixteenths.

In accordance with a recent act of Congress an applicant for this examination will be required to be examined in the State or Territory in which he resides and to show in his application that he has been actually domiciled in such State or Territory for at least one year previous to the examination. This examination is open to all citizens of the United States who comply with the requirements.

This announcement contains all information which is communicated to applicants regarding the scope of the examination, the vacancy or vacancies to be filled, and the qualifications required.

Applicants should at once apply either to the United States Civil Service Commission, Washington, D.C., or to the secretary of the board of examiners at any place mentioned in the list printed hereon, for Form 1312. No application will be accepted unless properly executed and filed with the Commission at Washington. In applying for this examination the exact title as given at the head of this announcement should be used in this application.

As examination papers are shipped direct from the Commission to the places of examination, it is necessary that applications be received in ample time to arrange for the examination desired at the place indicated by the applicant. The Commission will therefore arrange to examine any applicant whose application is received in time to permit the shipment of the necessary papers.

PRACTICAL HINTS

A Taper Indicator for the Lathe

JOHN HEYES

In turning tapers there is a difficulty in finding the exact amount to adjust the head or tail stock sideways. To overcome this difficulty the tool described below has been designed. It is made to hold in the slide-rest tool-post.

To a length of $\frac{3}{4}$ in. by $\frac{1}{4}$ in. flat mild steel a rivet at the four corners two $\frac{3}{4}$ in. by $\frac{3}{8}$ in. squares of flat steel; centre and tap the front end of the top piece *b* to take a $\frac{1}{4}$ in. length of silver steel *c*. This is pointed, and projects $1\frac{1}{4}$ in. The side of the bottom piece is similarly centred, drilled and tapped to take a $9\frac{1}{2}$ in. length of $\frac{1}{4}$ in. round silver steel *e*. Screw the rod up tight and solder a $\frac{1}{16}$ in. knitting needle *f* on the top. The sliding part *g* is made of a $1\frac{1}{16}$ in. length of $\frac{1}{2}$ in. square steel; $\frac{1}{2}$ in. from one end a $\frac{1}{4}$ in. hole is drilled to fit *e*, a groove *h* being filed to fit on knitting needle. This prevents the sliding part from turning. It is afterwards split as shown at *i*, and a $\frac{3}{16}$ in. tightening screw *j* fitted at right angles to the slot.

$\frac{3}{8}$ in. from the centre of the sliding hole, and at right angles to it, a hole is drilled and tapped $\frac{1}{4}$ in. to take a silver steel pointed screw $2\frac{1}{2}$ in. long, with a milled head *k*. This screw should be a fairly tight fit, and as $\frac{1}{4}$ in. pitch is 20 threads per in., one complete turn of the milled head advances or pulls back the point by $\frac{1}{20}$ in.; therefore, a ready means of measuring is available without the use of gauges or measuring instruments.

To use the appliance, secure by *a* in the tool-post, loosely; advance the whole towards the work, which must have been previously turned parallel, or else have a parallel-piece between the centres, until the two points just touch evenly, then tighten up. The position of screw *k* does not matter so long as there is sufficient length for measuring

the taper about to be produced. After tightening up, screw or unscrew *k* the amount required; for example, if $\frac{1}{8}$ in. taper is required, turn *k* $2\frac{1}{2}$ times. Now turn the tail stock, at the same time advancing or reversing the indicator until the two points just touch the

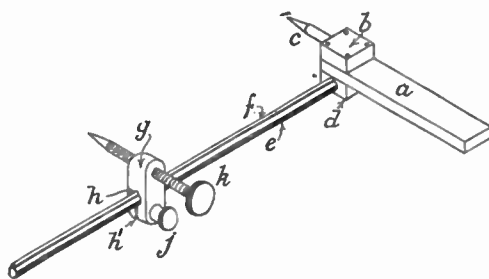

work. A sheet of white paper held underneath the points will aid the eye in this ticklish job. The head or tail stock can now be clamped in position. To find the taper of any piece of work, level the points by a parallel length of metal between the centres, as before; then advance or reverse the screw *k* until the points just touch the taper work, which must replace the parallel length of metal. The amount of taper is indicated by the turns of *k*. It will be evident that this amount refers only to that portion of the work between the points of indicator.—*Model Engineer*.

Cutting Threads on Copper

T. H. FOULSTON

Beeswax is a perfect lubricant for cutting threads on copper, the wax being simply rubbed on the thread and a smooth thread is the result.

To Clean Celluloid Collars

An ink eraser used for this purpose will be found to remove all dirt, and prevent the collar getting yellow.

Wrought Iron Articles

These should be cleaned by rubbing with a cloth dipped in sweet oil, and then polished with a soft duster.

A Simple Scribing Block

"EDWINSTOWE"

The sketch shows a new form of scribing block which will appeal to most those model engineers of very limited means, the base being an ordinary bell top tapped out. The upright is a piece of finished steel rod screwed into the bell and locked by a small nut. The bell is filled with lead, as shown, about $\frac{1}{16}$ in. from edge; this will give the block

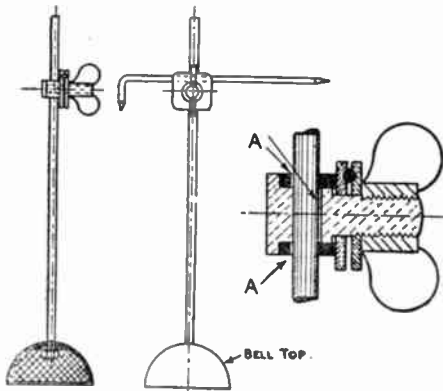

all necessary balance. The nut should be cut and ragged to allow the lead to get a firm hold. The clamp can be made from a pin turned down and screwed for fly-nut. Before drilling holes for upright, allowance should be made for clearance, as shown at *A*. The scriber was made from an ordinary knitting needle, ground and hardened.

—*Model Engineer.*

To Sharpen Awkward Shaped Chisels

HOWARD M. NICHOLS

Very often the amateur mechanic, and sometimes even the professional, has a V-shaped chisel or carving tool of such a shape that he has no stone that he can get at it with to sharpen it. When this happens, whittle out a soft pine stick so that it will fit the groove in the tool. Dip it in oil and flour of emery, and use it the way you would an oil stone. This will sharpen the tool quickly and satisfactorily.

Old Boot Tops

Make excellent iron holders. Cut a piece the size required, cover it with material and you will have a much greater protection for the hand than in an ordinary wadded holder.

Proving Multiplication

HOWARD M. NICHOLS

The following method of proving multiplication, while a modification of the method of "casting out nines," is much simpler in its application than the time-honored method.

EXAMPLE PROOF
 (A) 13987 — $1+3+9+8+7=28,$
 $2+8=10, 1+0=1.$
 (B) 1921 — $1+9+2+1=13, 1+3=4.$

13987
 $\times 4$
 ———
 55948
 125883
 ———
 13987
 4×1=4.
 (c) 26869027 — $2+6+8+6+9+0+2+7=40,$
 $4+0=4.$

Add the digits in line *A* successively until the result is a single digit. Proceed the same with lines *B* and *C*. Multiply together lines *A* and *B* after reducing to single digits. If the original multiplication has been correctly performed the result of this multiplication will be the same as line *C* when reduced to a single digit by successive addition of the digits.

How to Make a Dowel-cutting Tool

Secure a piece of steel about $\frac{1}{4}$ in. thick, $1\frac{3}{4}$ in. wide and 8 in. long. Drill various sized holes through the steel, as shown in Fig. 1, leaving the edge of each hole as sharp as the drill will make them. Cut off a block of wood the length necessary for the dowels and split it up into pieces about the size for the particular

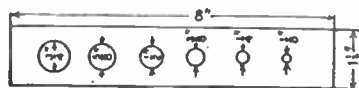

Fig 1

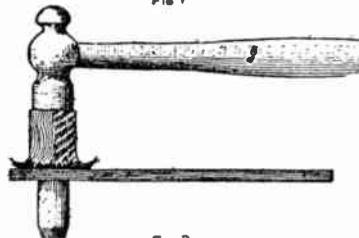

Fig 2

dowel to be used. Lay the steel on something flat, over a hole of some kind, then start one of the pieces of wood in the proper size hole for the dowel and drive it through with a hammer, as shown in Fig. 2. The sharp edges on the steel will cut the dowel as smooth and round as if it were turned in a lathe.

To Remove the Smell of Tobacco from a Room

Leave in the room a bowl of water all night, and in the morning the water will be found to have absorbed the smoke, leaving the room free.

Home-made Wrenches

The accompanying sketch shows the construction of two wrenches made by a correspondent of the *Blacksmith and Wheelwright*. The wrench, Fig. 1, is made from $\frac{1}{2}$ in. square iron to fit nuts in proportion to their size. Another

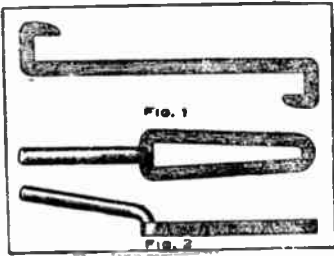

wrench, Fig. 2, is made to fit various sized nuts. The triangular part is made of $\frac{1}{2}$ in. square iron with a round forged handle welded to the large end. The triangle will turn nuts varying in size from $\frac{1}{4}$ in. to 1 in. The length of the flat part is 6 in.

A Gas Pipe Gate

Where gas pipe or tubes are used for fencing a good construction of a gate is to use gas pipe and fittings. In this

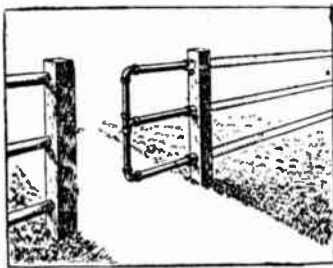

particular case, as shown in the cut, the gate was made from two $\frac{3}{4}$ in. ells, one $\frac{3}{4}$ in. tee and $\frac{3}{4}$ in. pipe cut in lengths to suit the opening. The fence was made from three $1\frac{1}{2}$ in. tubes and the gate pipes slipped inside of them. The long pipes of the gate were made 2 ft. longer than the gate opening to keep the gate from sagging when closed.

Centring Small Steel Rod—W. H. Slip

Only those who have tried to centre small diameter rod steel know how troublesome the job is. The device here shown will be found useful as well as a time-saver. It consists of a bush, the large hole to suit diameter of steel to be centred. The small hole in bush is $\frac{3}{32}$ in. in diameter (usual size of centring drill) and serves as a guide for centring drill. The sectional drawing shows the device in use.

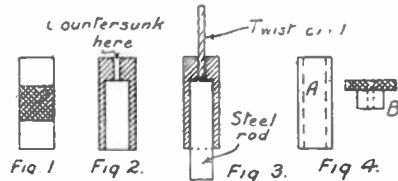

Several sizes should be made, say from $\frac{1}{4}$ in. hole to $\frac{3}{8}$ in., and they will, certainly be found useful. The holes in the bushes should be a good fit on the rod to ensure an accurate centre hole, and they should also be hardened.

Fig. 1 shows the device complete; Fig. 2, in section; Fig. 3, a section of the device in use; Fig. 4 shows an alternative method of making the device. *A* is a piece of tube reamed out to suit the size rod it is to be used on. *B* is a plug with centre hole, and is a drive fit in *A*. Part of the head *B* is knurled for convenience in use.

Manipulating Tiny Screws—H. J. R.

The very small screws found in spectacles, watches and other delicate structures are often very difficult to handle and get properly fixed, because being so small they defy such clumsy tools as fingers to hold them. Holding with a strip of paper having a small hole in one end, so that the thread, but not the head, of the screw can pass through, will get over the difficulty. After a few turns of the screw-driver the paper can be torn off and the operation of screwing home completed. It is also useful to remember that a polished table is not a suitable surface from which to pick up these little screws, and the same applies to needles and to small pins. By pressing the ball of a finger of the left hand upon the screw as it lies upon the table it will be made to adhere to the skin, and can be easily picked off with the fingers of the other hand.

HERE AND THERE

Modern Milking Scene

"What's going on around here?" asked the surprised visitor. "Is this a hospital?"

"Oh, no," assured the tall man in the silk hat; "this is the stage setting for a New England farm drama. The next act will be the milking scene."

"But I thought the young lady in the antiseptic apron was a trained nurse?"

"Oh, no; she is the milkmaid. The young man in the rubber gloves that you thought was a doctor is the farm boy. As soon as they bring in the sterilized stool and the pasteurized pails and find the cow's tooth brush the milking scene will begin."—*Chicago Journal*.

Why Be Thankful

Better to me than all my hopes,

Better than all my fears—

He made a bridge of my broken works,
And a rainbow of my tears.

—*Anna Shipton*.

Customer: "Mr. Cutter, why is bacon so high?"

Grocer: "Because, ma'am, the supply is limited; there's only one kind of animal that grows it."—*Chicago Tribune*.

"Did Mrs. Brown take her husband's failure in the right spirit?"

"Oh, yes. Just as soon as she knew he was going to fail she went out and bought her entire winter outfit!"—*Cleveland Plain Dealer*.

City Editor: "Any radical changes for the better in football this season?"

Sporting Writer: "Verily, I understand that not more than one ticket speculator will be allowed to tackle a single patron at the same time."—*Puck*.

"Mother, may I have the aeroplane?"

"No, darling. The nurse is going to take the baby out in it this morning."—*Town and Country*.

Going the Pace

Mother: "But what did you do with the penny I gave you yesterday?"

Tommy: "I spent it, mother. A feller has to hold up his end with the rest of the boys."—*Brooklyn Life*.

"Every time the automobile breaks down I notice you examine your state license."

"I do that for encouragement. The license says I'm competent to operate the machine."—*Houston Chronicle*.

A Bad Lot

When charged with being drunk and disorderly and asked what he had to say for himself the prisoner gazed pensively at the magistrate, smoothed down a remnant of gray hair, and said:

"Your honor, man's inhumanity to man makes countless thousands mourn. I'm not as debased as Swift, as profligate as Byron, as dissipated as Poe, as debauched as—"

"That will do!" thundered the magistrate. "Ten days! And, officer, take a list of those names and run 'em in. They're as bad a lot as he is!"—*London Mail*.

"My wife and myself had another foolish quarrel."

"About what?"

"About where we would go if we had money enough to travel."—*Washington Herald*.

Roman Guide (impressively): "The ruins of the Coliseum!"

Seattle Man (astonished): "Well, what do you think of that! Why, I saw photographs of that heap twenty years ago."

Roman Guide (loftily): "Quite likely, sir."

Seattle Man: "But why in thunder aren't these ruins cleared away and a modern coliseum erected?"—*New Orleans Picayune*.

QUESTIONS AND ANSWERS

Questions on electrical and mechanical subjects of general interest will be answered, as far as possible, in this department, free of charge. The writer must give his name and address, and the answer will be published under his initials and town; but, if he so requests, anything which may identify him will be withheld. **Questions must be written only on one side of the sheet, on a sheet of paper separate from all other contents of the letter, and only three questions may be sent at one time.** No attention will be given to questions which do not follow these rules.

Owing to the large number of questions received, it is rarely that a reply can be given in the first issue after receipt. Questions for which a speedy reply is desired will be answered by mail if fifty cents is enclosed. This amount is not to be considered as payment for reply, but is simply to cover clerical expenses, postage, and cost of letter writing. As the time required to get a question satisfactorily answered varies, we cannot guarantee to answer within a definite time.

If a question entails an inordinate amount of research or calculation, a special charge of one dollar or more will be made, depending on the amount of labor required. Readers will, in every case, be notified if such a charge must be made, and the work will not be done unless desired and paid for.

1512. Magneto Trouble. U. L. A., North Wilkinsboro, N.C. I have a low tension magneto (for gas engine) which will not give any current. It has two magnets and they seem to be heavily charged. They will easily hold their weight. The winding and brushes seem to be all right. Do you think it needs rewinding? Please tell me what is wrong and how to fix it. **Ans.**—The trouble may be caused by (1) one of the connections from winding to commutator having broken; (2) a short-circuit or ground between iron core and winding in two or more places; (3) short-circuit between inside or starting end of winding and the turns which touch it near outside end of winding. See if insulation has been abraded or scratched off in any of these places. Test out circuit from brush to brush with a few cells of battery and a buzzer. If buzzer fails to work, look for cause (1); if buzzer works, look for causes (2) or (3).

1513. Dynamo, Proper Size of. J. I. E., Charlotte, N.C., asks: (1) What voltage and amperage should a dynamo have to run two motors: one a 4 volt, $1\frac{1}{4}$ ampere; the other a 10 volt, 1 ampere? (I intend to use a rheostat to bring down the voltage.) (2) What difference will it make to use a 100 volt meter on a 110 volt current, instead of a 110 volt one? **Ans.**—(1) The motors should be wired in parallel, with a rheostat in series with the one for 4 volts. The proper value of the resistance is found by a simple application of Ohm's law: since 4 volts are to be useful, 6 are to be wasted, and to require this voltage to drive $1\frac{1}{4}$ ampere, the involved resistance must be $E \div C$, $6 \div 1.25 = 5$ ohms, nearly. The behavior of the low voltage motor will be very erratic, for with changes of load the current will change, and therefore require, as you see, a change of the resistance. Only when ohmic resistances of the motors themselves and the accompanying connections approach zero will regular and economical operation be possible. Of course you do not need to impose these ideal conditions on such tiny motors as yours. (2) If the limit of the scale is 100 volts and you apply 110 volts, the instrument will not be damaged but the action would be useless. To put 110 volts on a meter adapted for only 10 would probably result in a speedy burn-out.

1514. Receiving Distance. F. G., Howell, Mich., asks: (1) How far can I receive with following instruments: tuning coil, silicon

detector, and looped aerial 50 ft. high? How far with 75 ohm receivers? How many batteries will I need for receiving with this outfit? Please give plan for connecting these instruments. (2) How far can I send with a $\frac{3}{4}$ in. coil, using the same aerial as stated above? Would it make any difference if sending helix was used in distance covered by sending? (3) Please give me the rating of c.p. of Tungsten lamps. I have a 4 volt 8 c.p. lamp, but it takes really 5 or $5\frac{1}{2}$ volts to light it. I also have a 6 volt 20 c.p. lamp which requires about 8 volts to light it properly. I do not understand this. Please explain, as I am anxious to know. **Ans.**—(1) We refer you to question No. 1529. No batteries are needed with a silicon detector. We give a diagram below, showing the way to connect your outfit. (2) Your sending distance

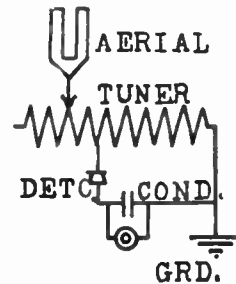

is from 3 to 5 miles. The helix increases your sending radius. (3) Tungsten lamps have an efficiency of from 1 to $1\frac{1}{4}$ watts per c.p. The 4 volt 8 c.p. lamp probably requires about 2 amperes at full c.p., and the 6 volt 20 c.p. lamp about $3\frac{1}{2}$ or 4 amperes. If you are using dry cells to light these lamps, in all probability your battery has not a sufficient output of current, and you have kept adding extra cells. Try a series-multiple connection and note the improvement.

1515. Receiving without Aerial. C. S. C., Bloomsburg, N.J., asks: (1) Is there a way possible to connect wireless instruments that one may receive without any aerial? If so, kindly give connections of the different instruments. (2) I desire to construct a loose coupler tuning coil, one large enough that I will be able to hear most any commercial

station. Of what material should the primary and secondary core frames be constructed? What size of enamelled wire should primary and secondary be wound with, and what size should the primary and secondary cores be? Ans.—(1) You could not receive from any distance more than a comparatively few yards without an aerial or its equivalent. (2) See an article by Mr. Cole in September, 1909, *Electrician and Mechanic*.

1516. **Patent Infringement.** C. W. M., Union Springs, N.Y. I wish to make a wireless set which will receive and transmit between 500 and 1,000 miles. If I can use a certain building the aerial will be 50 ft. high and almost any length, otherwise 25 or 30 ft. high. The building is situated $\frac{1}{2}$ mile from and 150 ft. above Cayuga Lake. On the north and south sides are hickory and maple trees respectively. Building stands east and west. (1) What instruments of such an apparatus can be made and sold without making an infringement? (2) What danger is there of lightning in connection with the aerials, and how may this be overcome? (3) What source of power of the same set to use on the spare coil of the same set, and of what strength should it be used? Would storage batteries be sufficient? Ans.—(1) We should advise you to consult an attorney. (2) We refer you to Mr. Guilford's article in the May, 1910, issue. (3) A station capable of transmitting from 500 to 1,000 miles would be impracticable for an amateur. For the receiving end see Mr. Guilford's article on a 1,000 mile receiving station in February, 1910, *Electrician and Mechanic*.

1517. **Creeping Salts: Spark Coil Data.** H. L. F. N., Grove Hall Station, Boston, asks: (1) What will remove the white salts from battery carbons? A firm in Boston formerly published a formula (a mixture of acids, I believe) which would remove the salts from their carbons, but it is not possible to get it now. Can you help me? (2). (a) I have two pounds of double silk covered No. 36, which I would like to use in making an induction coil. What would you recommend for the other dimensions and sizes of wire for primary so as to get the best results with a battery? (b) Is enamelled wire better? (c) How large a battery required and what size spark would the coil give? Ans.—(1) Soak carbon in boiling water. Dip top of carbon in melted paraffin wax to prevent salts creeping up over connection. (2). (a) Wind 12 oz. No. 14 B. & G. d.c.c. wire in two layers on core of No. 22 re-annealed iron wire 8 in. long and $\frac{1}{8}$ in. diameter. Insulating tube of micanite $\frac{3}{32}$ in. thick over primary; secondary wound in 40 sections, $2\frac{1}{4}$ in. diameter, boiled in paraffin, disks of paraffined blotting paper between sections. Condenser 34 sheets tinfoil 5 in. x 7 in. (c) With four large bichromate or storage cells, above coil should give from $1\frac{1}{2}$ to 2 in. spark, suitable for X-ray work, etc. If for wireless, use No. 34 wire in secondary to obtain thicker spark. (b) Yes, more enamelled wire may be wound in given space than cotton or silk covered. Enamel insulation has also greater dielectric strength than cotton or silk.

1518. **Battery Motor.** F. L., Welterreden, Batavia, Dutch E.I., sends an excellent description and sketch of a little motor that originally appeared in *Home Mechanics*, by G. M. Hopkins. It consists of a ring armature $2\frac{3}{4}$ in. and $1\frac{1}{4}$ in. in diameters, and $1\frac{3}{16}$ in. long. The laminations are strung on five insulated rods that are held in brass end-discs. Winding consists of 10 coils, each being of 5 layers and 21 turns per layer, of No. 21 wire. Field magnet is made of iron pipe with two quadrant-shaped consequent poles. The writer wishes to know (1) How much No. 18 wire to use on the field magnet to allow use of machine as a series motor, taking current from plunge batteries? (2) If an electrolytic interrupter is practical for operating it, his source being 110 volts, 50 cycles, single phase? Speed desired is 1,200 revolutions per minute. (3) Are the calculations for such a machine to be found in "Dynamos and Electric Motors," by Hasbruck? (4) What will the power be? Ans.—(1) Since you have in mind a series motor, the calculations become relatively simple. The stipulation of speed, however, is not altogether possible to attain except at a particular load. A machine with this sort of winding is inherently a variable speed motor, and by assigning various loads and voltages, you can get a wide range of operation. For economical reasons you should merely have the field winding of size equal at least to the section of two armature wires, and this you have proposed in specifying No. 18 wire, but the resistance of this winding should not exceed that of armature. You will do well to put on all the wire that the space allows. (2) Yes. (3) No. (4) About $\frac{1}{20}$ h.p.

1519. **Fan Motor.** H. B., Oklahoma City, Okla., has an Emerson 8-pole fan motor, each pole having a main winding occupying a space 1 in. by 1 in. by $\frac{1}{2}$ in., and a starting coil 1 in. by $\frac{5}{16}$ in. by $\frac{1}{4}$ in. Rotor is 4 in. in diameter. He asks: (1) What should be the winding to allow use on a 110 volt 60 cycle circuit? (2) Should the wire be enameled or cotton insulated? (3) What size of dynamo would the motor run, and could the machine charge storage batteries? (4) In what respect does the construction of a "non-sulphating" storage cell differ from the sulphuric acid type? Ans.—(1) A 60-cycle motor for the same speed as the present one should have but 4 poles, and the present structure cannot readily be used. You could experiment by winding coils of three sizes smaller wire and of such a shape as to embrace two of the present poles, thereby giving the effect of 4 poles, with a gap in the centre of each. (2) Enameled, if you can get it. (3) Yes, but only a very small one, say for 25 watts. (4) We think you refer to the Edison cell, which uses caustic potash solution instead of acid.

1520. **Fan Motor.** C. M. C., Fulton, N.Y., has a $\frac{1}{8}$ h.p. fan motor of the ordinary induction type that has the "shading coils" on the tips of the poles for giving a starting torque. He asks: (1) If there is not some better construction? He has also one of the original Weston fan motors, with an unwound H armature, 8-segment stationary commutator, and

revolving brushes. This machine has a very poor output, except in the way of sparking. (2) He asks if this can be improved, or can an ordinary squirrel-cage rotor be made as a substitute for the present sort? Ans.—(1) You can put a coarse wire winding in place of the present single turn of sheet copper, connect the four coils in series, and lead the two final terminals to a push button. To start the motor, close the main switch, and then push the button. When sufficient speed has been attained, release the button. This is one of a well-known make, and did good pioneer service. It would seem that the commutator was not in quite the right angular position, for when in good order these motors were quite vigorous, and did not spark disastrously. At any rate, you will improve the machine by substituting a short-circuited rotor. Use the smallest possible air gap.

1521. $\frac{1}{4}$ h.p. Motor. G. A. M., Topeka, Kan., asks for the 110 volt winding for such a machine to run at 2,200 revolutions per minute. Ans.—The machine mentioned in the December, 1906 magazine, to which you refer, is one of Watson's designs, and the 50-cent pamphlet describing it is very complete. You will do well to procure a copy. Instead of the shunt field winding described in the publication, you will do well to use 4 lbs. of single covered No. 28 wire.

1522. Current or Charge. S. T., Canton, Mass., asks if there is any current left in a wire after one end has been disconnected from the source? Ans.—If you accept the common definition of what is meant by a "current," i.e., something moving, we can surely say "No" to your question. If you put it another way, and ask if there is any electricity left in the wire, we should say "Yes." The electricity will reside as a charge, and you get ample evidence of such a condition in the insulated wires of the Edison 3-wire system. In this the two outer wires of the three are "live," being connected respectively to the positive and negative poles of the source. The neutral wire is grounded, and consequently cannot hold a charge. The other two persist in attracting dust, and where you see the ordinary pair of wires attached to cleats, you will find one dirty and even smooching the ceiling, while the other, the neutral, is clean. The charge is not great, for the voltage is low, but in principle you have an extenuated Leyden jar.

1523. Single Phase—Polyphase. L. R. H., Vandersburg, N.J., asks for definitions of these terms. Also (2) What number of watts per c.p. are used in arc lamps. Ans.—(1) For complete answers we shall have to refer you to the recently published series of Engineering Articles, especially those numbered XIII and XIV. In general, polyphase means two-phase or three-phase with distributed windings—merely for improving the wave form. (2) The c.p. of arc lamps has never been accurately determined. The original open sort that operate on 45 volts and 10 amperes were denoted as giving 2,000 c.p., but actually not more than 500. The 45 volt, 6.5 amp. open arcs were called of 1,200 c.p., but actually gave not more than 300. The

enclosed lamp that consumes 80 volts and 6.5 amperes gives about the same as the first one mentioned. The difficulty in determining the c.p. comes from the unsteadiness of the arc and from the entire lack of any standards of measurement. The flickering blue light from the arc is not comparable with the steady yellow light from a candle.

1524. Dry Storage Battery. R. N., New York City, asks if such a cell is practicable? Ans.—No, we think not. None has yet been made. Perhaps you mean moist, and not entirely dry. We would give the same answer to that, too.

1525. Engine Exhaust. F. W. F., Brooklyn, N.Y., asks what is the best way of muffling the exhaust of an up-to-date kerosene engine, so that neither noise nor odor can be experienced by occupants of other parts of the house or by neighbors? Ans.—You ask a question difficult to answer. If yours is a modern engine the manufacturers ought to be able to give you the most practical advice. In general, you should have a large cast or wrought iron muffler close to the engine, and perhaps a sort of "exhaust head," such as might be used with a steam engine, near the opening above the roof. Both the muffling chamber and the iron exhaust pipe should be clear of all woodwork, for with kerosene for fuel there is a gradual accumulation of stuff that once in a while takes fire and heats the containing walls to clear redness.

1526. Transformer. E. P., Yonkers, N.Y., asks: I am building a closed-core transformer for wireless and high frequency work. The data is as follows: core, $1\frac{1}{2}$ in. by $1\frac{1}{2}$ in., $13\frac{1}{2}$ in. long and $9\frac{1}{2}$ in. wide. The primary is wound on one leg consisting of 2 layers of No. 14 d.c.c. The secondary is wound on the other leg over a micranity tube with $\frac{3}{16}$ in. walls, consisting of 8 lbs. No. 30 s.c.c. (1) How many amperes will it take on 100 volt, 60 cycle, and what will be its rating in K.W.? (2) Could you suggest any improvements in the design? (3) What are the dimensions of a plate glass condenser for it? Ans.—(1) The transformer you describe will take about 15 amperes on 100 volts. This will make it about 1.5 k.w. (2) Would advise you to wind the primary and secondary on both legs, unless you intend using the magnetic leakage gap, patented by the Clapp-Eastham Co. Also you should use about No. 9 d.c.c. magnet wire on primary. Your core is a little out of proportion. Why not give it a sectional area of 2 in. by 2 in., 15 in. long, and 9.5 in. wide. (3) Condenser: Glass, $\frac{3}{16}$ in. thick, cut 10 in. by 12 in. Tinfoil—on both sides of glass—6 in. wide and 8 in. long. About 10 plates required.

1527. Fading Signals. T. J. M. D., Memphis, Tenn., asks: In regard to several articles in your valuable magazine lately regarding the fading away of wireless signals. In connection I wish to state that I have had some experience with the same trouble, if I might state it that way. Last winter I was located at Columbus, Miss., and every night I would listen with my wireless receiving set to see if I could hear what was going on. I could get very plainly Chicago, New Orleans,

Charleston, S.C., Key West and Mobile, land stations and numerous ships on the gulf coast. I only noticed this phenomena when Mobile started sending. At first the signals came in very plainly, in fact, were very loud, but would gradually die out until nothing could be heard, and strange to say, they would not start up gradually, but when they did become audible it would be all at once and would probably be in the middle of a message. For a long time I thought it was in my instruments and have thought over it considerably, but could not reason out the cause and am glad to see your paper taking up this subject as it is very interesting to me and hope that through your efforts we may be able to learn how this may be prevented. I don't believe that this is caused by any atmospheric or etheric condition, but am of the opinion that the fault is in the sending instruments, probably the transformer or the condenser. If this phenomenon were caused by reflection or refraction as has been supposed by several, why is it that this occurs with one particular station and at all times as has been the case with me in getting Mobile? Ans.—In regard to your trouble it is of course impossible to state absolutely what the true cause of your trouble was, but it looks like it might be your detector. The continuous passage of heavy waves through a delicate detector of the thermal type sometimes causes the detector to become less sensitive. Usually, too, a sharp rap or a slight jar will bring it back. As Mobile is the nearest station to Memphis, this hypothesis is probable.

1528. **To Make Mercury Adhere to Glass.** G. A. H. Z., Woodbine, Kan., asks: How can I make mercury or quicksilver adhere to glass? Ans.—A sheet of pure tinfoil, slightly larger than the glass plate to be silvered is spread evenly on a perfectly plane stone table having a raised edge, and is well cleaned from all dust and impurity. Foil must be free from slightest flaw or crack. Tinfoil is then covered to depth of $\frac{1}{8}$ in. with mercury. Glass plate, freed from all dust or grease, and highly polished, is then carefully slid over mercury, care being taken to exclude all air bubbles. Glass plate is then loaded with weights to press out excess mercury which is collected and used again. After 24 hours mirror is lifted from the table and placed on edge against a wall, where it is left to drain well.

1529. **Receiving Radius.** R. S. S., Pleasantville Station, N.Y., sends data on his wireless station and asks: (1) His receiving radius. (2) A receiving diagram. (3) As to loop T and L antennae. Ans.—(1) As has already been stated many times in this magazine, it is impossible to give a station's receiving radius, no matter how much data as to the instruments is given. As your station seems to be an excellent design, it should give very satisfactory results. (2) In Mr. Guilford's article in the May, 1910, number, is given an excellent receiving diagram which permits the use of both a tuning coil and loose coupler. (3) In Mr. Getz's article in the February, 1910, number, different types of antennae are discussed at length and also the receiving radii of a few specific stations are given.

1530. **Cement for Leather and Iron.** W. R. E., New Orleans, La., asks: Can you recommend a good reliable cement to hold a leather strap to an iron wheel, to be used as a friction drive, a cement that will not soften or creep. Ans.—Apply acetic acid to face of pulley with brush, to roughen it by rusting, then when dry, apply cement made of 1 lb. fish glue and $\frac{1}{2}$ lb. common glue, melted in a mixture of alcohol and water. The leather should then be placed on pulley and dried under pressure.

1531. **Salary of Wireless Operators.** C. A., Brooklyn, N.Y., asks: (1) What is the salary paid to wireless operators on land and sea stations; for beginners, as well as experts? (2) What qualifications must he have for such a position? Ans.—We would advise you to call on the United Wireless Company, 42 Broadway, and the Marconi Wireless Telegraph Company, 27 Williams St., New York, N.Y. They will give you full information as to qualifications and salaries of wireless operators. These are the only firms employing operators, in the United States, of any importance.

1532. **Spark Coil Data.** T. S. V., Los Angeles, Cal., asks: (1) How large a spark should I get from a coil with these dimensions: 1 in. by 8 in., primary two layers No. 16 d.c.c. wire, secondary $1\frac{3}{4}$ of No. 36 enameled and D.S.C. wire in 14 sections. (2) Is the coil above in good proportion? (3) What should be the battery voltage for the primary? Ans.—(1) From $1\frac{1}{2}$ to 2 in. (2) Yes. (3) About 10 volts.

1533. **Spark Coil Data.** J. McA., Plantersville, Ala., asks: (1) Please give the dimensions of a $\frac{1}{4}$ in. spark coil for wireless experiments. (2) Those of a $\frac{1}{2}$ in. coil. Ans.—(1) Core $\frac{3}{8}$ in. by 4 in.; primary two layers of No. 22 d.c.c.; beeswaxed paper four layers; secondary $\frac{1}{2}$ lb. No. 34 enameled wire; condenser 150 sq. in. tinfoil. Battery one or two cells bichromate or storage dry cells in series-multiple. (2) Core $\frac{1}{2}$ in. by 6 in.; primary two layers No. 18 d.c.c.; beeswaxed paper tube $\frac{1}{16}$ in. thick; secondary 1 lb. No. 34 enameled wire in two sections; condenser 500 sq. in. tinfoil. Battery two or three cells storage or bichromate or dry cells in series-multiple.

1534. **Spark Coils in Series.** H. S. B., Wilmington, Del., asks: (1) Please explain to me if it is possible to operate two induction coils at the same time (as one coil) and give double the amount of output, or spark length. (2) Would a "dead" telephone line be suitable for an aerial for wireless? (3) Please give me the call signal of the United Wireless Station, located at Wilmington, Del., on the DuPont Bldg. Ans.—(1) Yes, if secondaries and primaries have same gauge of wire. Connect two primaries in series, bridge one interrupter and use other one, or better still, use independent interrupter in series with the primaries. Connect secondaries in series. (2) Yes, if sufficiently well insulated from ground. If you make the experiment we should like to hear result. (3) The call is DU.

TRADE NOTES

The Proper Treatment for Floors, Woodwork and Furniture

A new edition of the very attractive booklet on this subject, put out by S. C. Johnson & Son, of Racine, Wis., is now ready for distribution, and they will be glad to send our readers a copy on request. This booklet is composed of thirty-two pages, very beautifully gotten up in color. It gives full information for finishing all new work, and refinishing old, with Johnson's line of Artistic Wood Finishes. The booklet contains the following chapters:

- Introduction
- Johnson's Prepared Wax
- Johnson's Powdered Wax
- Johnson's Kleen Floor
- Johnson's Electric Solvo
- Johnson's Under-Lac
- Johnson's Crack Filler
- Johnson's Plasto-Filler
- Johnson's Wood Dye
- Cuts of Wood Showing Johnson's Wood Dye
- Johnson's Paste Wood Filler
- Cuts of Wood Showing Johnson's Paste Wood Filler
- Johnson's Floor Finish No. 1
- Refinishing Floors
- Refinishing Furniture and Woodwork
- Finishing New Woodwork and Furniture
- Finishing New Floors
- How to Keep Furniture, Woodwork and Floors in Perfect Condition
- Accessories
- Manual Training Work
- Points to Remember
- Quantities and Prices

This booklet will be of particular value to parties who are building or remodeling their homes, who have old furniture, woodwork or floors to be refinished; also to painters, contractors, manual training instructors, etc.

To give our readers some idea of the value of this booklet, we reproduce herewith page 23 on refinishing old furniture and woodwork:

REFINISHING OLD FURNITURE AND WOODWORK In Fair Condition

Clean thoroughly with Johnson's Kleen Floor, being careful to wipe perfectly with a dry cloth, then apply a coat of Johnson's Prepared Wax with a cloth, bringing it to a polish with a dry cloth or polishing mitt.

In Good Condition

Johnson's Prepared Wax is the only preparation needed for keeping all woodwork and furniture, including pianos, in perfect condition. Give your furniture a coat of Prepared Wax, applying it with a cloth, and in ten or fifteen minutes polish it with a cloth or one of Johnson's Polishing Mitts.

In Bad Condition

In almost every instance, marks and scratches on furniture and woodwork are in the finish and not in the wood itself. The only way that these scratches can be removed is to entirely remove the old finish—in this lies the secret of successful refinishing. When the old finish has been entirely removed, fill

any cracks there may be with Johnson's Crack Filler, and when it has hardened the furniture or woodwork is ready to be refinished as new. Apply a coat of Johnson's Wood Dye, the desired shade, with an ordinary varnish brush. This will dry in ten or fifteen minutes and a finish must then be applied. We recommend the use of two coats of Johnson's Prepared Wax for an artistic, lasting, sanitary finish, which will not collect dust and dirt.

If a higher gloss is desired than the waxed finish, apply a coat of Under-Lac over the Dye, and then a coat of Prepared Wax. For a varnished finish apply a coat of good varnish over the Under-Lac, instead of the Wax.

Woodwork and Furniture Which is Worn

A way of refinishing woodwork and furniture which is worn and bare in spots, where you do not care to go to the trouble and expense of removing the old finish. Simply apply a coat of Johnson's Under-Lac and when this has hardened, a coat of Johnson's Prepared Wax. If you wish to change the color of the wood, apply a coat of Johnson's Wood Dye right over the old finish and when this is dry, a coat of Under-Lac and one coat of Wax. If a varnished finish is desired, apply a coat of varnish over the Under-Lac, instead of the Wax.

Soft Woodwork in Bad Condition

Remove the old finish entirely with Johnson's Electric Solvo (See pages 8 and 9). Then fill the cracks with Johnson's Crack Filler, and when this has hardened apply a coat of Johnson's Wood Dye, the desired shade, a coat of Under-Lac and one coat of Prepared Wax. If a varnished finish is desired, apply a coat of varnish over the Under-Lac, instead of the Wax.

The Thordardson Electric Mfg. Co., Chicago, Ill., have issued a beautifully illustrated and printed catalogue describing their line of Electric Laboratory Apparatus, which is designed to cover all electric dynamic experiments, elementary or advanced study.

The apparatus described is quickly dismantled and assembled for any condition required. Portions may be arranged as a high potential transformer, generating voltages ranging from 5,000 to 40,000 volts. With this apparatus, more than 600 experiments can be demonstrated; in fact, the number that may be illustrated depends only upon the ingenuity of the operator.

This most useful and interesting catalogue may be obtained by writing to the company.

The Moore Electrical Co., of Newark, N.J., have recently issued a pamphlet describing their "Moore Light Window" which is practically the only light suitable for color matching of all kinds. The quality of light is said to be a perfect duplication of daylight and with it, whites and creams can be distinguished easily, as well as the close shades of blue and black.

This light operates on 220 volts, 60 cycles alternating current and uses 2 k.w. of electrici-

cal energy. When direct current only is available an alternating current generator can be installed, and driven either by a belt or by direct connected motor.

Full particulars of this latest addition to their now well-known line of vacuum tube lights will be furnished upon application to the Moore Electrical Co.

Two New National Electric Lamp Association Bulletins

The Engineering Department of the National Electric Lamp Association has just issued two Bulletins,—one entitled "Mazda Multiple Lamps" (Bulletin 13) and the other "Hylo-Economical Turn-Down Electric Lamps" (Bulletin 14).

Bulletin 13 (20 pp.) contains practical information and technical data on Mazda Multiple Lamps for use on 100-125 volts and 200-250 volts. It has three tables and fourteen cuts. The range of sizes covered by the Mazda Lamp is well summarized in the following extract from this Bulletin:

"Mazda Multiple Lamps for use on Central Station circuits are now available in twenty types (see Table 1). Thirteen of these types are designed for 100-125 volts and seven are for 200-225 volts. The lamps range in operating consumption from 25 to 500 watts. Twelve of the twenty types have pear-shaped bulbs while the remainder have round or meridian bulbs. Pear-shaped bulbs in seven sizes and round and meridian bulbs in five sizes are used."

Bulletin 14 (12 pp.) describes that unique electric lighting device—the turn-down lamp. The principle on which these lamps operate is fully explained and illustrated by means of diagrams. The Bulletin contains one table and twelve cuts.

Either or both of the above bulletins will be furnished gratis to parties requesting them by the Engineering Department of the National Electric Lamp Association, 4411 Hough Ave., Cleveland.

We are in receipt of an attractive catalog from the L. S. Starrett Co., Athol, Mass., describing their most complete line of fine mechanical tools. A series of tables of weights, measures, decimal equivalents, tapers and angles, depth of threads, sizes of tap drills, speed of drills, etc., on the last few pages of the catalog, greatly enhances the value of the book. A copy may be obtained by writing to the L. S. Starrett Co.

Eugene Dietzgen Co., New York, have recently issued the ninth edition of their catalog of drawing materials and surveying instruments. The book contains some 500 pages and is handsomely gotten up in color, with cloth binding. Several important additions to their splendid line of instruments are announced in the new catalog of this progressive firm. A copy of the book will be mailed on receipt of 50 cents.

The Carlyle Johnson Machine Co., Manchester, Conn., Catalog "E," 1911, 35 pages, 4½ x 7 in. An issue of 25,000. The Catalog is enclosed in a handsome cover of two-toned

blue, with a clutch cut and Company monogram embossed thereon, and is filled with attractive illustrations showing the Johnson Clutch, factory views, etc. The inside pages have an attractive blue border to correspond with the blue cover.

This catalog is larger and more complete than previous ones, and deals almost exclusively with the driving of machinery through friction clutches, special attention being paid to the driving of machinery from line shafting, thus eliminating cross belting, countershafting, etc. There is special mention made of clutches for cut-off coupling work for use in connection with marine motors, as a one-way clutch, for which work this type of clutch is particularly adapted. The lists are very complete, extending to clutch parts, which are numbered to correspond to the numbers indicating the parts on sectional views. Copies will be sent free to interested parties.

The Richardson Engineering Co., Hartford, Conn., have sent us a booklet describing their inexpensive but very complete electric light plants suitable for farms, cottages, isolated residences, etc. A copy of the booklet will be sent to any reader on request.

Wm. J. Murdock Company, Chelsea, Mass., will be pleased to send full information describing their line of commercial and experimental wireless apparatus to our readers on request.

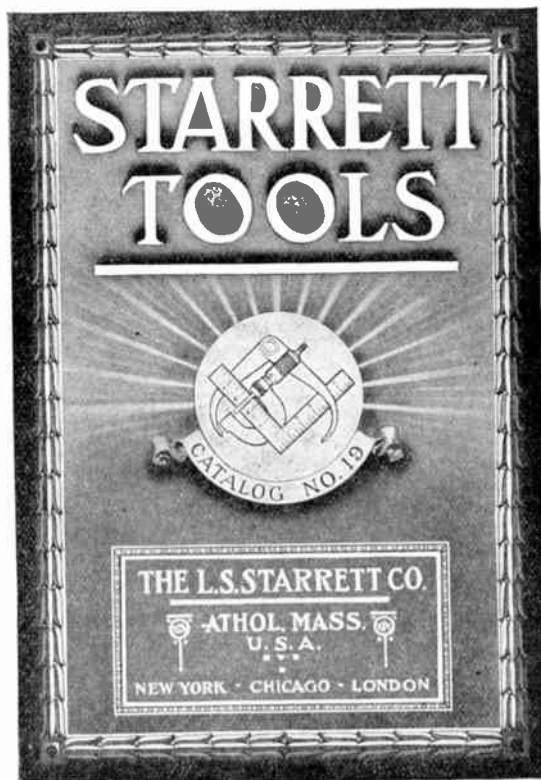

The Manhattan Electrical Supply Company, New York, have published an 80-page manual of wireless telegraphy, in which they describe the best known methods of erecting different types of stations. This progressive firm makes a specialty of high-grade wireless apparatus, in addition to their very complete line of electric supplies. The manual and also catalog No. 24b, containing 180 pages of general electrical information will be mailed to any reader on request.

The Barnes Manufacturing Company, Susquehanna, Pa., are offering two very efficient little alternating and direct current motors of $\frac{1}{2}$ and $\frac{1}{8}$ h.p. respectively. The $\frac{1}{2}$ h.p. size is especially adapted to such uses as running family washing machines, jeweler's lathes, small emery wheels, and for buffing purposes. The $\frac{1}{8}$ h.p. size will readily operate coffee mills, small printing presses, etc. Two noteworthy features of the alternating current motors are variable speed and absolute freedom from heating effects. The manufacturers will be pleased to send literature describing these motors to those who are interested.

The Boston School of Telegraphy announces a very complete course of instruction in wireless, railroad, commercial and brokerage telegraphy. This school is open day and night and new pupils can start at any time. The graduates of this school are employed as operators with the United States Navy, Fessenden, Massie and leading railroad and commercial companies throughout the United States. Illustrated catalog and prospectus will be sent on receipt of 4 cents.

North Brothers Manufacturing Company, Philadelphia, Pa., announce several additions to their most popular line of "Yankee" tools. Their book of "Labor Savers" describes 35 styles and 75 sizes. They will be pleased to send any reader a copy of the book on receipt of a postal.

Clapp-Eastham Company, Cambridge, Mass., are making a specialty of the "Boston" wireless key, which is built exclusively for wireless use, for sets of all power. This key has unusually large contacts, which, it is said, absolutely prevent sticking. Their Bulletin K, and catalog G, fully describe this key, as well as their complete line of reliable apparatus for private or commercial use.

The great popularity of the Holtzer-Cabot receivers for wireless operators is a standing testimonial of their quality. These receivers are exceedingly comfortable to wear, very sensitive, permanent in adjustment, and are fully guaranteed. The complete Holtzer-Cabot line is fully described in Bulletin 1400, and will be sent upon request.

BOOK REVIEWS

Vest Pocket Compendium of Applied Electricity by Paul E. Lowe, M.E. Philadelphia, David McKay, 1910. Price: cloth 25 cents; leather 50 cents, net.

A comprehensive work on electricity, its origin, nature and application, together with

a dictionary of electrical terms and phrases arranged in vest pocket form. The scope of the book is remarkable, considering its size and it should be well received by motormen, electric railway men and electrical workers, in general, as an up-to-date, practical and complete handbook on the subject.

The Science of Poetry and the Philosophy of Language. By Hudson Maxim. Illustrated by William Oberhardt. New York, Funk & Wagnalls Co., 1910. Price, \$2.50 net.

Hudson Maxim, the well-known inventor and scientist, has returned to the literary field in which he was well known years ago, and has written this book, which has already excited a vast amount of comment, favorable and unfavorable. The reviewers have not been satisfied with profusory notices, but in some cases have effusively praised the work, and in other cases explosively denounced it. After a careful examination we are inclined to believe that Mr. Maxim has made a distinct advance in the philosophical treatment of poetic expression. The subject has been previously treated by some well-known authors, including Herbert Spencer and Sidney Lanier. Mr. Maxim agrees with them in some respects, and most decidedly differs in others, but he carries the matter farther than either of these writers. He endeavors to place the investigation of poetry on the same scientific basis as any other research, defines his terms, and introduces new technical words wherever needed. He makes clear to the reader exactly what his conception of poetry is, and the rules he lays down will enable any intelligent reader to much more adequately understand the reasons why a certain piece of writing is good and another bad. Any of our readers who enjoy good literature will find much of stimulating and helpful thought in this book, and every scientific man will be intensely interested in knowing the way in which a scientific brain attacks a problem which has often been stated to be incapable of solution.

The Boy Aviators in Nicaragua, or In League with the Insurgents. By Capt. Wilbur Lawton. New York, Hurst & Co., 1910. Price, 50 cents.

So fast does the world advance that aviation, a year or two ago a problem whose practical solution was everywhere stated to be impossible, has now passed into one of the commonplaces of daily life. The number of successful aviators has increased from a half dozen to as many hundred, and before another year is past, the aeroplane will apparently be familiar to every cross roads hamlet in the back counties. So it is natural that aviation should have become a commonplace of fiction and this book is the first of a series of six, entitled "Boy Aviator Series." It is interestingly written, full of exciting adventure, and will doubtless appeal to every red blooded young man.

DISSTON Perfection Shear Tooth Files



This fast cutting file is made of Disston Crucible Steel forged to shape and hardened under the Disston process.

The teeth are of a special shape, pitch and space, making it a smooth and easy as well as a fast cutting implement.

There has never been a file more perfectly adapted to quick work on soft steel, iron, brass castings and all soft metals; wood, stone, marble, etc.

It is of great value for lathe purposes.

The angle of the Perfection Shear Tooth lends a long cutting edge—a feature which enables users to cover more surface quickly and effectively.

These features in connection with the particular shape of the tooth itself, and the use of Disston high grade Crucible Steel, give those qualities which warrant the claim that "DISSTON PERFECTION SHEAR TOOTH FILES" will do more well-finished work in a given time, and last longer, than any other pattern of file of its class.

HENRY DISSTON & SONS,

Incorporated,

Keystone Saw, Tool, Steel and File Works,
PHILADELPHIA, PA., U.S.A.

Branches:—Chicago, Cincinnati, Boston, New Orleans, Memphis, San Francisco, Seattle, Portland, Spokane, Vancouver, Toronto.



"OLIVER" No. 150 Quick Acting Vise

Oliver Machinery Co.

10 to 20 CLANCY ST.

GRAND RAPIDS, MICH., U.S.A.

BRANCH OFFICES:

50 Church Street . . . New York
First National Bank Building Chicago
Pacific Building Seattle
1125 W. Temple Street, Los Angeles

Save Money! Save Money!

"OLIVER"

HIGH-GRADE MANUAL TRAINING EQUIPMENT
WILL SAVE YOU A GREAT DEAL OF
TROUBLE AND EXPENSE OF MAINTENANCE.

INVESTIGATE

By writing to-day for CATALOGS on Wood Working Machinery, Benches, Vises, Clamps, Saws, Grinders, etc., etc.

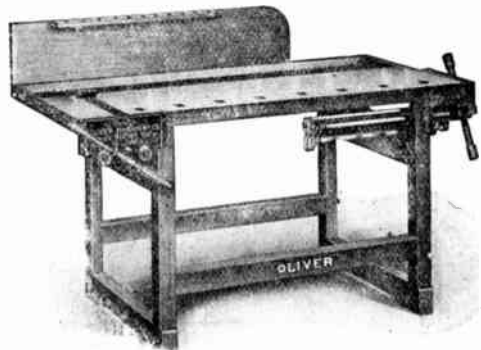

"OLIVER" No. 116 Manual Training Bench

WIRELESS TRANSFORMERS

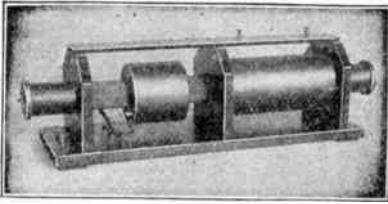

1/2 K.W. COMPLETE WITH CONDENSER \$30.00

Investigate our new method for improving Spark quality
Send for Catalog

E. S. RITCHIE & SONS

114 Cypress Street Brookline, Mass.

BEWARE OF IMITATORS



Owing to the great success of my

Improved Navy Wireless Receivers

for long distance work, some concerns are misrepresenting them.

The Receivers I make have my name on them. Look for it.

C. BRANDES,

111 BROADWAY, NEW YORK.

San Francisco Agent: C. F. King, 163 Belvedere St.

WIRELESS APPARATUS

Our Wireless goods are the best on the market, and are guaranteed to WORK. Our instruments are made of the finest materials, and are sold at present at a price within the reach of every experimenter. Send a 2c. stamp for our large catalogue which contains a full list of Wireless instruments, Novelties and Electrical goods, and also a great deal of Wireless information for the Wireless experimenter.

THE I. W. T. WIRELESS CO.

728m Broadway Brooklyn, N.Y.

LEAD SULPHIDE DETECTORS

These are highly sensitive detectors. More than double the sensitiveness of silicon detectors. Materials for making detector sent by registered mail to any address on receipt of \$2 money order. All our materials are guaranteed and tested for sensitiveness.

MONEY REFUNDED IF NOT SATISFACTORY.

ERNEST C. CROCKER

9 Dickens Street, Dorchester, Mass.



The most wonderful and fascinating scientific study of the age. Every BOY, GIRL and GROWN-UP should know about it. The new "VOL TAMP

ELECTRICAL PRODUCTS—our 112-Page Catalog now ready, the most complete and interesting book ever issued, is full of illustrations and descriptions of the latest Voltamp Electrical Novelties—Motors, Dynamos, Toys, Machine Models, Telegraph and "WIRELESS" Instruments, Ruhmkorff Coils, Spark Coils, Geisler Tubes, Switches, Meters, Lamps, Flashlights, Transformers, Tools, etc. The greatest line of Miniature Electric Railways ever shown. Anything Electrical for Anybody.

Prices consistently low. Send for this catalog 6c in stamps or coin (no postals answered) which will be refunded on first order of 50c or over.

VOLTAMP ELECTRIC MFG CO., Wite Bld., Baltimore, Md.

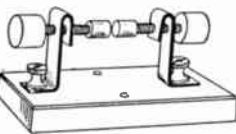

Wireless Apparatus

Spark Gaps as per cut \$.40 coin
Universal Detector \$.30 "

BAYVIEW ELECTRIC COMPANY,
4 Bayview Place,
WEST HAVEN, Conn.

NEW WIRELESS WONDER



Send 2 cents
for Catalogue

Price \$4.00

ETHERIC ELECTRIC CO., 278 Lenox Ave., N.Y.

Anything High Grade and Experimental Electrical Wireless Instruments

Get Our New Big 200 Page Catalog for a 4 cent stamp to cover postage. 20 large Sections devoted to Wireless Instruments, Motors, Transformers, Telegraph Instruments, Import Toys and General Electrical Supplies.

EACH SECTION MORE COMPLETE THAN MANY SEPARATE CATALOGS ALONG THESE LINES
J. J. DUCK, 427 St. Clair Street, TOLEDO, OHIO

HAVE FUN WITH ELECTRICITY

and learn all the primary principles at the same time. Get one of Our Home Laboratory Outfits

The cost is small, they last forever. Just the thing for boys and young men who want to study and experiment with electricity.

SEND FOR COMPLETE DESCRIPTION AND PRICE
TREMBLY ELECTRIC CO., Box 500, Centerville, Iowa



UNITED "B. T. I." WIRELESS SCHOOLS "F. B. C."

Wireless companies write and telegraph us for men who can operate at high speed and who possess a thorough knowledge of the apparatus. This institution teaches the science and construction of the instruments, also how to operate them. It owns two high power stations on the Atlantic coast, and it is through them that its pupils master the actual station work which fits them for positions which the unskilled cannot secure.

We have letters and telegrams on file which will prove to you that we have the endorsement of the officials of all wireless companies. For illustrated catalog "E" call or write

BOSTON TELEGRAPH INSTITUTE

899 Boylston St., corner of Gloucester St., Boston, Mass.

F. H. KNOWLTON, Pres. (Member Society of Wireless Telegraph Engineers).

Boston School of Telegraphy

J. R. MACKESSY, Manager

Twenty-five years of success in training and placing students in good positions

Wireless Telegraphy Easily Mastered

By our method of instruction, we teach the Morse and Continental Wireless Telegraph Codes. We make you a skilled, practical Wireless Operator in a few months, so that you will be able to fill a good position as Wireless Telegraph Operator or conduct a Wireless Telegraph Station of your own.

Individual instruction in Wireless, Railroad, Commercial and Brokerage Telegraphy by experienced telegraphers. Open day and night during the entire year. New pupils can start any day or evening. The oldest, largest and best equipped Telegraph School in New England

**Our graduates are employed as Operators with the
U.S. Navy, Fessenden, United Wireless, Massie and
leading railroad and commercial companies**

Call or write to-day for full information. Illustrated catalog sent on receipt of 4c

18 Boylston Street, Boston, Mass.

We can supply a few of the following volumes at prices given below:

AMATEUR WORK

VOLUME	CLOTH BOUND	UNBOUND
1 Nov. '01 to Oct. '02	\$5.00	(None)
2 Nov. '02 to Oct. '03	2.00	\$1.50
3 Nov. '03 to Oct. '04	2.00	1.50
4 Nov. '04 to Oct. '05	2.50	2.00
5 Nov. '05 to Oct. '06	2.00	1.50
6 Nov. '06 to Apr. '07, 6 mos.	1.50	1.00

ELECTRICIAN AND MECHANIC

VOLUME	BOUND	UNBOUND
17 July '06 to June '07	\$10.00	(None) no single copies
18 July '07 to June '08	3.00	\$2.50 " " "
19 July '08 to June '09	2.00	1.50
20 July '09 to June '10	2.00	1.50
21 July '10 to Dec. '10	1.25	1.50 (6 numbers)

All single numbers previous to January, 1909, are out of print, but we can sell for a limited time a few copies at 25c per copy to meet the demand for early numbers.

SAMPSON PUBLISHING CO.

221 Columbus Ave., Boston, Mass.

Dynamo Building for Amateurs

or How to Construct a
Fifty Watt Dynamo

By ARTHUR J. WEED
Member of N.Y. Electrical Society

This book is a practical treatise showing in detail the construction of a small dynamo or motor, the entire machine work of which can be done on a small foot lathe.

Dimensioned working drawings are given for each piece of machine work and each operation is clearly described.

This machine when used as a dynamo has an output of fifty watts; when used as a motor it will drive a small drill press or lathe. It can be used to drive a sewing machine on any and all ordinary work.

The book is illustrated with more than sixty original engravings showing the actual construction of the different parts. Paper.

Paper 50 cents Cloth \$1.00

SAMPSON PUBLISHING CO.
221 Columbus Ave., Boston

Published August 31, 1910

The Science of Poetry ..and the.. Philosophy of Language

By
Hudson Maxim



The world's only *scientific* treatise. The most valuable and instructive book ever published for poets, prose writers, public speakers, students and teachers of language and literature.

WHAT THE BOOK IS :

- | | |
|---|--|
| <p>1st. It is the only scientific and practical method for literary criticism and analysis.</p> <p>2d. It is an absolutely scientific standard for uniform judgment in determining the relative merits of literary productions.</p> <p>3d. It teaches the only practical and efficient means for the standardization of poetry and for the determination of what constitutes true poetry.</p> <p>4th. It gives for the first time a scientific and satisfactory definition of poetry.</p> <p>5th. It examines in detail the growth of human speech, both spoken and</p> | <p>written, and for the first time makes plain the true functions of sound in both the expression and the impression of thought and feeling.</p> <p>6th. It gives the only scientific basis of rhetoric.</p> <p>7th. It gives the only scientific basis of oratory.</p> <p>8th. It contains two hundred exemplifications from the great poets, embracing seventy-five per cent of all the greatest poetic lines in English literature, which serve admirably as touch-stones of poetic values.</p> |
|---|--|

The book is of inestimable value to every man and woman of letters, and to every instructor and to every student of letters.

Any student, any instructor, any public speaker, any writer, possessed of this work has an infallible and necessary guide which he or she can use to great advantage every day in the year.

A big book over 300 pages, cloth bound, size 9 $\frac{3}{4}$ inches long, 7 inches wide. 16 illustrations by William Oberhardt

Price, \$2.50, Net; Post-paid \$2.75
For Sale by all Booksellers or the Publishers

Funk & Wagnalls Company, Pubs., New York City, N.Y.

The History of The Telephone

By HERBERT N. CASSON
Author of "The Romance of Steel," etc.

WHO can deny that a history of the rise of the telephone, through unold vicissitudes to its present commercial importance, and the financial support of over a billion dollars in the United States alone, to say nothing of the rest of the world, is interesting.

Yet in spite of our familiarity with this indispensable instrument, and our absolute dependence upon it in many ways, how few of us know anything of its history.

Mr. Casson has a unique faculty of describing the evolution of commercial enterprises in such a way as to make his writing decidedly entertaining, and in "The History of the Telephone" he has produced a work that every one interested in electricity will find highly instructive as well.

*Profusely illustrated. Cloth Bound,
299 Pages. Indexed. \$1.50 net.*

At All Bookstores

or from

A. C. McClURG & CO., Publishers
New York Chicago San Francisco

READY JANUARY, 1911.

Practical Applied Electricity

By DAVID PENN MORETON, B.S.E.E.,

Associate Professor of
Electrical Engineering at
Armour Institute of
Technology.

PRICE \$1.50

A book of 300 pages, 200 illustrations, diagrams and descriptions, bound in Black Seal Flexible Leather, front and back stamped in gold, round corners, pocket size. An illustration on nearly every page. Compiled regardless of expense according to successful practical experience.

It is authentic, up-to-the-minute, complete and contains no useless matter, only just such information as needed by the Electrical Craft.

Advance proofs were submitted to Consulting and Electrical Engineers and Educators who endorsed the work as a book that would surpass any book of a similar nature now upon the market.

Written for the practical man as well as for the expert and presented in a practical way in plain English. Practical examples and careful, detailed line drawings are given to illustrate the theory and their solution is indicated, which serves as an aid in fixing the matter firmly in the mind of the reader.

SAMPSON PUBLISHING CO.,
221 Columbus Avenue, Boston, Mass.



A STORY BOOK FREE



Very interesting and instructive to those wanting the very best edge tools made. A postal addressed to Mack Co., 18 Brown's Base, Rochester, N. Y., sole makers for more than thirty years of the famous D. R. Barton tools, will bring it with their catalogue. (In writing mention this magazine.)



"ECLIPSE"

Battery Ammeter

It will tell you exactly the condition of your batteries \$3.00

ELDRIDGE ELECTRIC MFG. CO.

12 P.O. Sq., Springfield, Mass.

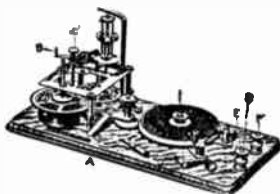

TELEGRAPHY TAUGHT

In the shortest possible time. The Omni-graph Automatic Transmitter combined with standard key and sounder. Sends you telegraph messages at any speed just as an expert operator would. Five styles \$2 up; circular free. **Omni-graph Mfg. Co.**
41 Cortlandt St. New York

Bamboo For Aeroplanes and Wireless Construction

BOSTON BAMBOO CO.

117 Portland Street, Boston, Mass.

OUR VERY USEFUL HANDBOOKS

A SMALL ELECTRIC MOTOR TO BE BUILT WITHOUT CASTINGS. By Wm. C. Houghton.....	\$0.10
HOW TO MAKE AN ANNUNCIATOR. By T. E. O'Donnell.....	.10
HOW TO GRIND AND SET EDGE TOOLS. By M. Cole.....	.10
MAKING AND FIXING ELECTRIC BELLS AND BATTERIES. By M. Cole.....	.10
TEMPERING STEEL, ANNEALING AND CASE HARDENING IRON. By M. Cole.....	.10
DYES, STAINS, INKS, LACQUERS, VARNISHES AND POLISHES. By Chas. G. Leland and Thos. Bolas.....	.10
WOOD-CARVING FOR BEGINNERS. By Chas. G. Leland. Revised by Frank H. Ball	.20
GOUGE-WORK AND INDENTED WOODWORK. By Chas. G. Leland and Rev. F. C. Lambert...	.10
DESIGNING AND DRAWING. By Chas. G. Leland.....	.10

SAMPSON PUBLISHING CO.
221 Columbus Ave., Boston, Mass.

PATENTS 25 YEARS EXPERIENCE BOOK MAILED FREE

Telling all about PATENTS; Illustrates 100 Mechanical Movements; sets forth NEW and EASY PLAN of MAKING PAYMENTS.

CHAS. E. BROCK, Patent Attorney
917 F St., Washington, D.C.



WHAT YOU INVENT!

\$250,000 INVENTION WANTED
Write for our FREE BOOK; gives list of other needed inventions; tells how to protect them.

Patent Obtained or Fee Returned
No charge for report as to patentability; send sketch or model. Patents advertised for sale free.

H. ELLIS CHANDLEE & CO., Successors to
WOODWARD & CHANDLEE, Attorneys
1282 F St., Washington, D.C.

PATENTS in CASH DEMAND

Many deals closed by our clients—one recently for \$680,000.00—our proof of Patents that PROTECT.
Send 8c postage for our 3 books for Inventors.

R. S. & A. B. Lacey, Div. 94 Washington, D. C. Estab. 1869.

PATENT YOUR IDEAS

\$9,500 for one invention. Book, "How to Obtain a Patent" and "What to Invent" sent free. Send rough sketch for free report as to patentability. Patents advertised for sale at our expense in fourteen Manufacturers' Journals.

Patent Obtained or Fee Returned
CHANDLEE & CHANDLEE, Patent Att'ys
Established 16 Years

1017 F. Street, Washington, D. C.

HAVE YOU AN IDEA?

Write for our Books: "Why Patents Pay," "100 Mechanical Movements," Perpetual Motion—50 Illustrations. Mailed free.
DIETRICH & CO., Patent Lawyers, Washington, D.C.

PATENTS START FACTORIES

We Secure Patents. **NO FEE IF WE FAIL.**
Start right. Free book—How to obtain, finance and promote patents. Send sketch or model for free search.
FARNHAM & SONS, Pat Att'ys, WASHINGTON, D. C.

Foot and Power Lathes, Electrical Driven Lathes, Planers, Shapers, Drills, Milling Attachments, Machinists' Supplies, Chucks, Tools, Dogs. Best and cheapest made.
SHEPARD LATHE CO., 133 W. Second, Cincinnati, O.

INVENTORS!

Our books "The Protective Patent" and "Letters of Patent Success" sent free. We devote our personal attention to every case entrusted to us. Send sketch and description for free opinion as to patentability. Advice free.

BEELER & ROBB, Patent Lawyers
63-67 McGill Bldg., - - Wash., D.C.

PATENTS

THAT PROTECT AND PAY
BOOKS, ADVICE, SEARCH AND LIST OF INVENTIONS WANTED } FREE

Send sketch or model for free search. Highest References. Best Results. Promptness Assured.

Watson E. Coleman, Patent Lawyer
622 F Street N.W. Washington, D.C.

PATENTS SECURED

OR FEE RETURNED. Send Sketch for FREE REPORT as to Patentability. GUIDE BOOK and WHAT TO INVENT with valuable List of Inventions Wanted. SENT FREE. One Million Dollars offered for one invention; \$16,000 for others. Patents secured by us advertised free in World's Progress; Sample Free.

VICTOR J. EVANS & CO.
615 F Street Washington, D. U.

FREE TUITION SCHOLARSHIP

Carnegie College gives FREE TUITION by mail to one student in each county and city in the United States.

NORMAL, ACADEMIC and BUSINESS COURSES

Alg.	Chem.	Physics	Arith.	Book-keep'g
Lit.	Rhet.	Phys. Geog.	Geog.	Shorthand
Lat.	Geom.	Methods	Gram.	Penmanship
Bot.	Geol.	Zool.	Hist.	Com. Law

50 other branches from which to select.

Cut out this ad. and mail with application for FREE TUITION to
CARNEGIE COLLEGE - - ROGERS, OHIO.



Boy Aviators Series

Six stirring up-to-date titles for wide awake boys.

Price, 50 cents per volume, post-paid.

Send for Volume 1 to-day. Free catalogue or books for Boys and Girls sent anywhere.
HURST & CO., 395 Broadway, New York

NEW HOW TO MAKE A TELEGRAPH KEY

AND SOUNDER By LEON W. BISHOP, price 10c
HOW TO MAKE AN AUTOMOBILE price 25c
With working drawings. BUBIER PUBLISHING CO., LYNN, MASS.



ELECTRICAL EXPERIMENTAL OUTFIT FOR \$5.00

Includes fifty pieces of electrical material and instruments. Generator weighing six pounds, Relay Coils, Electro-Magnets, Interrupter Set, Polarized Ringer Set, Ten Brass Binding Posts, Four-pound Magnetic Set, Compass, Spark Coil, Six Blue Prints of 50 Electrical Diagrams, Solenoid, Three 110 volt lamps for Generator, Wire, Raw Material such as fibre, brass, contacts, mica, shellac, tin foil, and wood bases. Send five cent stamp for additional information

FREE. Send in this ad. with your order and five dollars and we will send you Free a fine 250 page Electrical Instruction Book and six additional Blue Prints. Money refunded if not satisfactory.

WESTERN ELECTRIC SALVAGE CO.

1224 Washtenaw Ave., Chicago, Ill.

WIRELESS TELEGRAPHY

In response to many requests, we publish below a list of books on wireless telegraphy, with the prices at which we can furnish them, postpaid.

COLLINS, A. F.	Wireless Telegraphy.....	\$3.00
ERSKINE-MURRAY, J.	Handbook of Wireless Telegraphy.....	3.50
SAINT JOHN, T. M.	Wireless Telegraphy for Amateurs and Students.....	1.00
SEWALL, C. H.	Wireless Telegraphy.....	2.00
MASSIE, W. W., and UNDERHILL, C. R.	Wireless Telegraphy and Telephony Popularly Explained.....	1.08
MAVER, W.	Wireless Telegraphy.....	2.00
TESLA, N.	Experiments with Alternate Currents of High Potential and High Frequency. A classic work and the authority on the subject.....	1.00
FLEMING, J. A.	Principles of Electric Wave Telegraphy. A comprehensive digest of wireless telegraphy in all of its branches. One of the most complete and practical books ever published on this subject.....	6.60
	Elementary Manual of Radio-telegraphy and Radio-telephony for Students and Operators.....	2.00
HOWGRAVE-GRAHAM, R. P.	Wireless Telegraphy for Amateurs.....	1.00
KENNELLY, A. E.	Wireless Telegraphy and Telephony, enlarged and reprinted.....	1.14
HARRISON, NEWTON, E. E.	Making Wireless Outfits.—A concise and simple explanation of the construction and use of simple and inexpensive wireless equipments, for sending and receiving up to 100 miles, giving full details and drawings of apparatus, diagrams of circuits and tables. 12 mo. cloth, 50 cents; in paper covers.....	.25
	Wireless Telephone Construction.—How to make and use an inexpensive equipment. cloth, 50 cents; paper.....	.25
TWINING, H. LaV., A.B.	Wireless Telegraphy and High Frequency Electricity.—A most complete manual containing detailed information for the construction of transformers of from 100 watts to 5 kilowatt capacity; wireless telegraph and high frequency apparatus, with chapters on their theory and operation. 1909....	1.50
MORGAN, ALFRED POWELL	Wireless Telegraph Construction for Amateurs.—A manual of practical information for those who wish to build experimental wireless instruments, which can be considered as something more than toys, but are still considerably less expensive than a high grade commercial set. No attention has been paid to the history of the art, the space, instead, being devoted to short but complete explanations of the uses of the various instruments as well as the structural details. 1910.....	1.50
HALLER, GEO. F., and CUNNINGHAM, ELMER T.	The Tesla High Frequency Coil. Its Construction and Uses.—Full and explicit directions for the construction of apparatus needed for experimenting with high frequency currents. This book fills a long felt vacancy in scientific literature. Intended for the advanced experimenter. 1910.....	1.25
ROBINSON, Lieut. Com. S.S.	Manual of Wireless Telegraphy For Use of Naval Electricians. An exceptionally complete and instructive book for the wireless operator.....	1.25

Sampson Pub. Co., Boston, Mass.

Our Special Magazine Offers

We list below our prices on a large number of the most popular technical magazines, alone and in combination with **ELECTRICIAN AND MECHANIC, GOOD ONLY UNTIL JAN. 1, 1911.** If you do not see the magazines you want listed, write us. We will quote you a price on any magazine published and it will be lower than you can get anywhere else. Write us what you want and we will quote you price by return mail.

TECHNICAL MAGAZINES

Reg. Price		Our Price	With Elec. & Mech.
1 year		1 year	
\$3.00	Aeronautics.....	\$2.68	\$3.85
2.00	American Artisan.....	2.00	2.85
1.00	American Boy.....	1.00	1.70
2.00	American Carpenter and Builder.....	1.75	2.60
4.00	American Machinist. (Weekly).....	3.85	4.60
1.00	American Machinist. (Monthly).....	1.00	1.85
1.50	American Photography.....	1.50	1.95
.50	American Poultry Journal.....	.45	1.30
1.00	American Thresherman.....	.75	1.60
1.50	Baseball Magazine.....	1.50	2.10
1.00	Blacksmith and Wheelwright.....	1.00	1.85
1.00	Building Age.....	1.00	1.85
1.50	Cement Age.....	1.40	2.25
1.00	Cement World.....	.85	1.70
1.00	Concrete.....	1.00	1.60
1.50	Electric Journal.....	1.40	2.25
3.00	Electrical World. (Weekly).....	3.00	3.85
1.00	Electrical World. (Monthly).....	1.00	1.85
1.00	Electrocraft.....	.85	1.70
5.00	Engineering News.....	4.90	5.75
1.50	Etude. (For Music Lovers).....	1.50	1.95
1.50	Field and Stream.....	1.50	1.95
1.00	Foundry.....	1.00	1.85
1.50	Garden Magazine.....	1.50	1.95
1.00	Gas Engine.....	1.00	1.70
1.00	Gas Power.....	.80	1.65
.50	Gas Review.....	.50	1.25
2.00	Illuminating Engineer.....	1.75	2.60
1.00	Industrial Magazine.....	.85	1.70
2.00	Iron Age—Hardware.....	2.00	2.85
1.00	Irrigation Age.....	.80	1.65
2.00	Keith's Magazine.....	2.00	2.85
(For Home Builders)			
1.00	Keystone (For Jewelers).....	1.00	1.85
1.50	Manual Training Magazine.....	1.50	2.35
3.00	Model Engineer and Electrician.....	2.75	3.60
1.00	Modern Electrics.....	.80	1.65
1.00	Modern Machinery.....	.85	1.70
1.00	Modern Painter.....	.85	1.70
1.00	Motor Boating.....	1.00	1.70
1.00	Motor Cycle Illustrated.....	.90	1.75
2.00	Moving Picture World.....	1.80	2.65
1.50	Musician.....	1.50	1.95
2.50	National Geographic Magazine.....	2.25	3.10
1.00	National Sportsman.....	1.00	1.70
3.00	Outing.....	3.00	3.20
1.00	Plumbers' Trade Journal.....	1.00	1.70
1.00	Popular Electricity.....	1.00	1.65
1.00	Poultry.....	.80	1.65
.50	Poultry Keeper.....	.45	1.30
2.00	Power and the Engineer.....	1.95	2.80
1.00	Power Boating.....	1.00	1.85
3.00	Recreation.....	3.00	2.60
1.25	School Journal.....	1.25	1.95
3.00	Scientific American.....	2.75	3.60
3.00	Scientific American (new).....	2.75	3.00
1.00	Sewing Machine Times.....	.90	1.75
2.00	Show Card Writer.....	2.00	2.85
1.00	Success Magazine.....	1.00	1.85
1.00	Talking Machine World.....	.90	1.75
1.50	Technical World.....	1.50	1.95
2.00	Telegraph and Telephone Age.....	1.80	2.65
2.00	Upholsterer.....	1.75	2.60
1.50	Violinist.....	1.35	2.20
1.00	Woodworker.....	.90	1.75

ON JAN. 1, 1911, ALL THESE Club Prices WILL ADVANCE 35 Cents.

Make all remittances by Money Order or Registered Letter.

Sampson Publishing Co.
221 Columbus Ave., Boston, Mass.

SALE AND EXCHANGE

Advertisements under this heading, without display, 3 cents per word, cash with order; minimum, 75 cents. Black-faced type, 4 cents a word; minimum, \$1.

WIRELESS TELEGRAPHY

SPECIAL PRICES—1,000 ohm Wireless Receiver, double pole, special thin diaphragm, hard rubber case wound with copper wire, \$1.75. Leather-covered head band, double, \$1.00; single, 60 cents. "National" receiving condenser, 30 cents. **WATERHOUSE BROS.**, Bourne, Mass. (1)

SPECIAL BARGAIN. Fine loose coupled tuner, mahogany ends, 12 buttoned secondary, \$8.00. Wood's metal for soldering minerals in cup without damaging minerals, 15 cents. **A. R. MORTON**, 79 Lonsdale St., Dorchester, Mass. (s)

LOOK! \$1.50, LOOK! buys U.S. Government vacuum filing coherer, value \$5.00, guaranteed to be better than any other coherer on the market. Also 10,000 ohm polarized relays, \$10.00, highly sensitive, value \$50.00. **J. ROSENFELD**, 429 E. 157th St., New York, N.Y. (1)

MACHINERY AND TOOLS

FOR SALE—Complete set of castings with all material and screws with the blueprint for $\frac{1}{2}$ h. p. horizontal stationary gasoline engine with governor; price \$10.00. **COMET MOTOR WORKS** 512 Monroe St., Chicago. (3)

FOR SALE—1 $\frac{1}{2}$ h.p. Horizontal Steam Engine. Only used once. In A1 condition. Cheap. **D. C. GROSS**, 1849 N. Sawyer Ave., Chicago, Ill. (s)

MODEL Gasoline Engine Castings, Marine, \$8.50; Stationary, \$7.50. Drives a 5 ft. model launch or 75 watt dynamo. **S. DRAGOO**, 3228 Flournoy St., Chicago, Ill. (1)

HELP WANTED

EASY MONEY AND LOTS OF IT getting subscriptions for *Popular Electricity* magazine. Sells on sight. Commission and salary. Write today for full particulars, stating your line of business and where employed. **POPULAR ELECTRICITY**, Circulation Dept., 435 Commercial Bldg., Chicago, Ill. (9)

WANTED—AGENTS, MACHINISTS, ATTENTION. Increase salary. New revised Saunders' Hand Book Practical Mechanics. Best ever ready reference. Thousands in use. Postpaid, \$1.00 cloth; \$1.25, \$1.50 leather flap. Big profits. **E. H. SAUNDERS**, 216 Purchase St., Boston, Mass. (2)

GET A BETTER PLACE—Uncle Sam is best employer; pay is high and sure; hours short; places permanent; promotions regular; vacations with pay; thousands of vacancies every month; all kinds of pleasant work everywhere; no lay-offs; no pull needed, common education sufficient. Ask for free Booklet 89, giving full particulars and explaining my offer of position or money back. **EARL HOPKINS**, Washington, D.C. (1)

PHOTOGRAPHY

KODAKS, CAMERAS, LENSES, EVERYTHING PHOTOGRAPHIC—We sell and exchange. Get our latest bargain list; save money. **C. G. WILLOUGHBY**, 814 Broadway, N.Y. (tf)

WILL SELL my camera and over \$5.00 worth of supplies for only \$5.00. List free. Well worth the money. **HAROLD E. DAVIS**, North Haven, Conn. (s)

\$25.00 WEEKLY PAINTING SOLAR PRINTS. Any intelligent person can learn. Complete instructions for preparing and painting enlargements in oil and water colors, postpaid for only 25 cents. **EASTERN ART SUPPLY CO.**, Everett Station, Boston, Mass. (1)

HAVE YOU A CAMERA?—Send us 25 cents for the three latest numbers of *American Photography*, which retail at 45 cents. The biggest and best photographic magazine published in America. Full of practical articles, formulas and directions for making better pictures. The magazine conducts monthly prize competitions open to all readers, with liberal prizes. The editors criticize readers' prints and answer questions. If you are interested in photography, you should know the magazine. Sample copy, 10 cents. \$1.50 per year. **AMERICAN PHOTOGRAPHY**, 1164 Beacon Bldg., Boston, Mass.

ELECTRICAL

AN ELECTRICAL LIBRARY FREE—Write today for particulars and copy of our illustrated book catalog. **POPULAR ELECTRICITY**, Book Dept., 434 Commercial Bldg., Chicago, Ill. (9)

3 LBS. No. 34 D.C.C. MAGNET WIRE, price \$4.00. Particulars from **HOWARD DAY**, Harrison Ave., Westfield, N.J. (1)

CONTROLOPHONE—Starts, stops motors, lights, etc., by talking to it. Near or distant by wireless or line. Cost small. Complete directions 50 cents. No stamps. Be the wizard of your locality. **EMMETT CALLAHAN, Jr.**, Baker, Ore. (s)

TELEGRAPH LEARNERS OUTFIT, \$25.00. Omigraph, also Premograph camera. Exchange for Voltamp Wizard dynamo or binoculars. **GUY RULE**, Lancaster, Kan. (S)

FOR SALE—Course Electrical Engineering, cheap. **A. B. C.**, care of Electrician and Mechanic, 221 Columbus Ave., Boston, Mass.

STEEL STAMPS

ENGRAVERS AND DIE SINKERS, makers of steel stamps, steel letters and figures; seals, stencils, badges and checks. Guarantee best work. **FRED C. KAUTZ & CO.**, 2633 W. Lake St., Chicago, Ill. (12)

BOOKS

I.C.S. AND A.S.C. SETS and odd volumes of books on engineering, wireless, mechanics, shop-work, etc., new and second hand. Few I.C.S. scholarships for sale. Bargain. **GEORGE F. WILLIAMS**, Box 408 New Orleans, La.

AERONAUTICS

BUILD AN AEROPLANE. Send us \$1.00 and we will mail you blueprints and full directions for building a 3 ft. model Antoinette or 2 ft. Bleriot monoplane, or 3 ft. model Wright biplane; or blueprints and directions for a 20 ft. glider. **CHICAGO AERONAUTIC SUPPLY COMPANY**, Room 12, 6030 South Park Ave., Chicago, Ill. (tf)

MISCELLANEOUS

MAKE YOUR OWN FURNITURE at one-fifth cost. Full size patterns; complete directions; hall seat pattern, 20 cents; arm chair, 60 cents; umbrella stand, 25 cents. **HOME FURNITURE PATTERN CO.**, 402 Potter Bldg., Birmingham, Ala. (2)

CAMDEN WOOLENS—Ladies' and gents' suiting sold direct from the mills output. Write for samples. **F. A. PACKARD**, Mgr Retail Dept., Box O, Camden, Me (12)

FOR SALE—Moving Picture Film 1c. per foot. **H. DAVIS**, Watertown, Wis.

MISCELLANEOUS

LEARN TO WRITE a legible business hand at your home, by correspondence; send for free booklet. LUTHER SYSTEM, 21 Risley, Cicero, Ill. (10)

GILLETTE RAZOR BLADES—Don't throw away dull blades. Will resharpen, 2½ cents each. Mail. SEMMER SPECIALTY CO., 469 Jefferson St., Portland Ore. (8)

PERFECTION POCKET ADDING MACHINE. Lightning seller. Agents wanted. CINCINNATI SPECIALTY MFG. CO., Dept. O, Cincinnati. Ohio

FOR SALE—EXCHANGE—4 h.p. motor cycle, Victor talking machine, Columbia phonograph, shot gun, two cameras, two printing presses. WANT—automobile, motor boat, screw cutting lathe, gasoline engine. HARRY SMALL, Vassalboro, Me. (1)

FOREIGN STAMPS. 250 mixed, Chili, Japan, etc. 10 cents; 35 all different United States, 6 cents; 250 mixed old United States, 10 cents. Stamps bought, list 4 cents. KLEINMAN STAMP COMPANY, 3645 Marshall St., Philadelphia, Pa. (1)

DESIRE to exchange picture postal cards for pastime. GEORGE WILDPRETT, 229 Walworth St., Brooklyn, N.Y. (5)

LEARN AUTOMOBILE BUSINESS



Ours is the only Automobile Engineering School in United States, which acts as preparatory training school for our factories and employs its students while studying. We teach by mail. Part of tuition payable after we place you in a good position. Course covers eight different branches of the automobile business. Write for plan C. It is free.

the Automobile College of Washington, Inc. Washington, D.C.

References: Fifth St. Savings Bank.

ENGINEERS - - MECHANICS

We offer you an opportunity to build one of our neatly designed ¼ H.P. Little Hummer engines. Engine has governor and rotary valve on cut off principle with adjustment for wear. Blue prints and instruction sheets 25c., castings and all material \$1.50.

ELGIN WHEEL AND ENGINE CO., Box 193, Elgin, Ill.

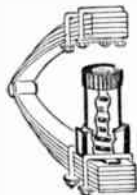

WEAK AUTO SPRINGS

You are handicapped with weak springs, your car depresses when partly loaded, but bumps when fully loaded or on rough roads.

STOP! with a pair of "Super Coil" Bumpers. Easily applied to any car.

Supplementary Spiral Bumper Co. 1476 Broadway, N.Y. City

ELECTRIC GOODS FOR EVERYBODY

World's headquarters for Dynamos, Motors, Fans, Toys, Railways, Batteries, Belts, Bells, Pocket Lamps, Telephones, House Lighting Plants, Books. If it's electric we have it. Undersell All. Fortune for agents. Catalog 4c.

OHIO ELECTRIC WORKS, Cleveland, Ohio



For You—

Whether Student or Expert
this Complete Cyclopaedia of

APPLIED ELECTRICITY

will be found useful as a guide and reference work

This Cyclopaedia comprises six big volumes—bound in half morocco, contains 2,896 pages 7x10 inches—printed on special paper in large, clear type—2,000 full-page plates, diagrams, formulas, etc. It is written by thirty expert Electrical Engineers—the biggest men in the profession.

THE REFERENCE VALUE IS GUARANTEED by the fact that it is compiled from the text-books used in the correspondence courses of the American School of Correspondence. These practical lessons are arranged for quick and ready reference.

WILL YOU EXAMINE THESE BOOKS FREE OF CHARGE?

If you are interested in Electricity, we know these books are just what you want. To convince you of this, we will send a complete set to you by prepaid express, keep them five days; examine them thoroughly and carefully; test them; apply the knowledge they contain to your every-day work. If you decide to keep them, send us \$2.00 after five days and \$2.00 a month until you have paid the special price of \$18.00. The regular list price is \$36.00. Just fill in the coupon below and mail it to us. The books will be sent to you at once.

IMPORTANT SUBJECTS TREATED

Theory, Calculation, Design and Construction of Generators and Motors—Electric Wiring—Electric Telegraph—Wireless Telegraphy—Teleautograph—Types of Dynamos and Motors—Elevators—Direct Current Motors—Direct-Driven Machine Shop Tools—Electric Lighting—Electric Railways—Alternating Current Motors—Single Phase Electric Railway—Management of Dynamos and Motors—Power Stations—Central Station Engineering—Storage Batteries—Power Transmission—Alternating Current Machinery—Telephony—Automatic Telephone—Wireless Telegraphy, Telephone, etc.

For a short time we will include, as a monthly supplement, for one year, the TECHNICAL WORLD MAGAZINE. This is a regular \$1.50 monthly, full of Twentieth Century Scientific facts, written in popular form. Also contains the latest discussions on timely topics in invention, discovery, industry, etc.

American School of Correspondence,
CHICAGO, U.S.A.

FREE EXAMINATION COUPON

American School of Correspondence:

Please send Cyclopaedia of Applied Electricity for FREE examination; also T.W. for 1 year. I will send \$2.00 within five days; and \$2.00 a month until I have paid \$18.00; or notify you and hold the books subject to your order. Title not to pass until fully paid.

ELECT. & MECH. 12-10

NAME

ADDRESS

OCCUPATION

EMPLOYER

THE LATEST LIST OF BOOKS FOR

AVIATORS

- HOW TO MAKE A 20-FT. BI-PLANE GLIDER** that will carry an ordinary man. A practical hand-book on its construction with detailed diagrams and full particulars. By A. B. Morgan. By mail..... **\$0.55**
- FLYING MACHINES—PAST, PRESENT AND FUTURE.** A popular account of flying machines, dirigible balloons, and aeroplanes. Describing many different kinds of machines and their chief features. By A. W. Marshall and Henry Greenly. 138 pp., 23 ill. By mail . **.55**
- THE BAROMETRICAL DETERMINATION OF HEIGHTS.** By F. J. B. Cordeiro. With an appendix on the air Barometer. Limp leather. By mail..... **1.00**
- A TEXT-BOOK OF AERIAL ENGINEERING.** By Herbert Chatley. 119 pp.; 61 ill. Cloth. By mail..... **3.65**
- TABLES OF BAROMETRICAL HEIGHTS TO 20,000 FEET.** By W. H. Mackesy. For use with the aneroid, also the mercurial barometer. Limp cloth. By mail..... **1.00**
- THE FORCE OF THE WIND.** By H. Chatley. 91 pp., illustrated. Cloth..... **1.35**
- THE ATMOSPHERE, ITS CHARACTERISTICS AND DYNAMICS.** By F. J. B. Cordeiro. 140 pp., 35 ill. Paper, by mail, \$1.60; cloth, by mail..... **2.65**
- THE RESISTANCE OF AIR AND THE QUESTION OF FLYING,** consisting of valuable data from the author's own experiments. By A. Samuelson. 23 ill. Paper, by mail..... **.78**
- FLIGHT VELOCITY.** By A. Samuelson. With 5 plates. Paper, by mail..... **.78**
- AIRSHIPS—PAST, PRESENT AND FUTURE.** Together with chapters on the use of balloons, in connection with meteorology, photography, etc. By A. Hildebrandt. 361 pp., 279 ill. By mail..... **3.75**
- A POPULAR EXPOSITION OF MODERN AERONAUTICS.** With working drawings. The author fully treats all phases of aerial navigation. By V. Loughheed. A most interesting and practical work. 550 pp., 279 illustrations and drawings. By mail..... **2.75**
- MODEL AEROPLANES—HOW TO MAKE AND FLY THEM.** By E. W. Twining. Consisting of five sheets of scaled drawings, showing three different models, with descriptive booklet. By mail..... **.55**
- COMPLETE SET OF PARTS** in the rough for a small flying machine that anyone could make up with a little care and a few simple tools. By mail..... **\$0.65**
- NO. 3 MODEL, COMPLETE SET OF PARTS** in the rough with the rubber to make a model (as illustrated in the Twining model aeroplane drawings). By mail..... **1.15**
- AEROPLANE PORTFOLIO.** By D. R. Kennedy. Containing 9 large sheets of scale drawings of the following well-known machines:—Biplane: Wright, Farman, Voisin, Cody and Herring-Curtis. Monoplane: Antoinette, Santos Dumont, Rep and Bleriot. With booklet containing a short description of each machine. By mail..... **.55**
- THE MODEL ENGINEER, Vol. 21.** Contains a number of articles on model flying machines, propelling mechanism and propellers; representing the latest practise; with description of how to make them..... **3.20**
- ARTIFICIAL AND NATURAL FLIGHT.** A practical handbook on flying machines. By Sir Hiram Maxim. 94 ill. By mail..... **2.10**
- HOW TO BUILD AN AEROPLANE.** By R. Petit; translated from the French. A good book dealing with the construction and the motor. 8 vo., 82 ill. Cloth; by mail..... **1.60**
- MODEL FLYING MACHINES.** Their design and construction. By W. G. Aston. A first rate little book, showing numerous methods of propelling models, making propellers, construction of different kinds of models, etc. 130 pp. 84 ill. By mail..... **.55**
- MODEL BALLOONS AND FLYING MACHINES.** With a short account of the progress of aviation. By J. H. Alexander, M.B., A.I.E.E. 12 mo., 127 pp., 45 ill., 5 folding plates. This practical work gives data, working drawing designs and details which will assist materially those interested in the problems of flight.. **1.50**
- FLYING MACHINES.** Construction and operation. By W. J. Jackman, M.E., Thos. H. Russell, A.M., M.E., and introductory chapter by Octave Chanute, C.E. Pocket size. 250 pp., fully illustrated. Leather and cloth. Round corners, red edges. A "Show How" book for those who wish to build and operate flying machines. Price, flexible leather, \$1.50 Cloth binding..... **1.00**

SAMPSON PUBLISHING CO.
221 Columbus Ave., Boston, Mass.

FREE

Working Model of a Gasolene Engine, Carburettor and Magneto

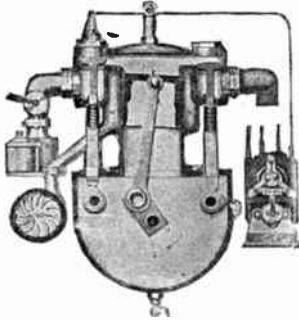

**Dyke's Working Model of a
Gasolene Engine—It Works**

The motive power used on automobiles and launches.

Not a toy, but a marvelously ingenious piece of machinery that teaches you more about the automobile gas engine than you could learn around a car in years. Every part is there and it actually works exactly like a full sized engine. You can set the valves, time the ignition, etc., right on the model.

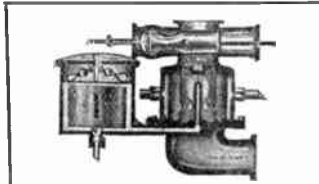

**Dyke's Working Model of
a Carburettor**

A device for making dry gas out of raw gasolene for a gasolene engine. **IT WORKS.**



**Dyke's Working Model of a
High Tension Magneto**

An electrical device used to supply electricity for ignition on a gasolene engine.

IT WORKS.

With Dyke's Home Study Course of Automobile Engineering

The Chauffeur

is a man of opportunity. A chauffeur is not merely an automobile driver. Anyone can drive a car. The chauffeur who has a right to the title must not only be able to drive a car, but must know its working principle and be able to locate and remedy any trouble that may arise.

This Young Man Secured a Position

AUG. FALKENHEIMER, Oshkosh, Wis., says: "I have obtained a good position with one of the largest auto manufacturers and it was due to your Instruction and Diploma; when I showed the Diploma, the manager saw I was making an effort to advance and he gave me a trial."

DONALD STEWART of Oakland City, Ind., took our course, mastered the subject and is now actively engaged in the auto repair business.

A. C. WALKER, of Vandalia, Ill., now operates a garage and owns his own car.

Our testimonial Circular will show you actual photos of these young men in their autos and shop, and many original reproduced letters from various students scattered over the entire world.

Repair Men Needed Everywhere

What an opportunity for a man who knows the automobile as the Dyke System teaches it to him. Even if you lack the small capital necessary to start a garage of your own these proprietors will gladly pay you a good price for your knowledge, for, while they will not admit it they fully realize how helpless they are when the timing of the valves or commutator needs attention or when the engine fails to develop the proper power for some reason that involves thorough understanding of a gas engine that only such training as mine will give. How many of the repairmen of today have studied—not one out of a hundred—he guesses at the right way—he don't know the principle. We teach you the principle first, then give you actual experience on our models.

There are other fields open for the man who completes my course: The Gasolene Engine for Power and Farm use is rapidly coming to the front—why not be a Repairman or Salesman in this line. Take the agency for some good engine and go into business for yourself. Why not?

Names of Chauffeurs and Repairmen furnished to anyone who are in need. Send for our list.

A. L. Dyke originated the first auto supply business, published the first book on autos and built the fifth successful auto in America.

Did you ever hear before of such a clever method of teaching by mail?

My plan is absolutely unique, absolutely unrivaled by any other school. I supply you with a set of 34 INSTRUCTION BOOKS that contain the practical results of my own intimacy with the industry since its very beginning. They are easy to understand and simple as A. B. C. Fully illustrated with large, clear charts.

The Dyke System puts an Automobile in your Home

Keep your present position. I will undertake to teach you in a few weeks more about the construction and operation of an automobile and gas engine than you could learn in years spent in a factory or garage or in any length of time in a resident school.

Price of the Complete Course together with a handsome Diploma right now is only \$10.00, and on installments if wanted. Don't wait too long—the price will advance. We send you everything at one time.

GUARANTEE—You can't lose a cent—order the course and spend 2 days' time examining same. If you don't like it return and get your money back. That's fair enough, isn't it?

Send for this Catalog

IT IS INTERESTING IN ITSELF. 24 pages of testimonials from all over the world and interesting matter on engines and automobiles.

IT IS FREE

FILL IN AND MAIL TODAY



FREE CATALOG COUPON

Dyke's Correspondence School of Motoring
3904 Washington Ave., St. Louis, Mo.

Kindly send me a Catalog at once by mail, **FREE**, in plain wrapper.

Name.....

Street.....

City..... State.....

Cross Out the Profession You Prefer

- I want to be a
Chauffeur Repairman Salesman
 Agent, Salesman, Repairman for Stationary and
Boat Gasolene Engines
 I intend buying a car I own a car

BENNETT'S

CHICAGO, ILL.

Magazine Bargains



**ELECTRICIAN
and
MECHANIC
—
AMERICAN
—
COSMOPOLITAN**



**ALL
THREE
ONE
FULL
YEAR
\$2.70**



All Subscriptions are for ONE FULL YEAR, and may be sent to one or separate addresses. Subscriptions may be either New or Renewals.

**WE ALSO FURNISH AS FOLLOWS:
CLASS 16**

Delineator.....	} Electrician and Mechanic with any ONE of these \$1.65
Popular Electricity.....	
Housekeeper.....	
Pacific Monthly.....	
Pictorial Review.....	
Practical Farmer.....	

CLASS 17	
American Boy.....	} Electrician and Mechanic with any ONE of these \$1.70
Boston Cooking School Mag....	
Children's Magazine.....	
Cosmopolitan.....	
Dressmaking at Home.....	
Farm Journal (5 years).....	
Health Culture.....	
Little Folks.....	
Musical Observer.....	
National Sportsman.....	

CLASS 20	
American Magazine.....	} Electrician and Mechanic with any ONE of these \$1.85
Good Housekeeping.....	
Harper's Bazaar.....	
Metropolitan.....	
Pearson's Magazine.....	
Success Magazine.....	

CLASS 22	
Ainslee's Magazine.....	} Electrician and Mechanic with any ONE of these \$1.95
American Photography.....	
Evude (for Music Lovers).....	
Everybody's Magazine.....	
Field and Stream.....	
Good Health.....	
Hampton's Magazine.....	
McClure's Magazine.....	
Musician.....	
Photo-Era.....	
Sunset.....	
Technical World.....	
Travel Magazine.....	
Woman's Home Companion...	
World Today.....	

CLASS 35	
Current Literature.....	} ELECTRICIAN and MECHANIC with ONE of 35 and ONE of 17 \$3.45
Independent.....	
Lippincott's Magazine.....	
Recreation.....	
Review of Reviews.....	

Electrician and Mechanic.....	\$1.00	} BOTH \$1.65
Popular Electricity.....	1.00	
Electrician and Mechanic.....	\$1.00	} ALL THREE \$3.70
Scientific American (New)....	3.00	
Cosmopolitan.....	1.00	
Electrician and Mechanic.....	\$1.00	} BOTH \$3.20
Forest and Stream (Weekly)...	3.00	
Recreation.....	\$3.00	} ALL THREE \$3.70
National Sportsman.....	1.00	
Field and Stream.....	1.50	
Electrician and Mechanic.....	\$1.00	} ALL FOUR \$2.10
Pictorial Review.....	1.00	
Ladies' World.....	.50	
Modern Priscilla.....	.75	
Electrician and Mechanic.....	\$1.00	} ALL THREE \$1.70
McCall's (and pattern).....	.65	
Ladies' World.....	.50	
Electrician and Mechanic.....	\$1.00	} BOTH \$1.85
Success (or American).....	1.50	
Electrician and Mechanic.....	\$1.00	} ALL THREE \$3.45
Review of Reviews.....	3.00	
Cosmopolitan.....	1.00	

LADIES HOME JOURNAL (twice a month)	} BOTH 76 Magazines \$3.00
SATURDAY EVENING POST (Weekly)	

The Youth's Companion (including all extra numbers All of 1911, and the beautiful Art Calendar for 1911)	ALL FOR \$1.75
---	---------------------------------

Our Large 44-page Catalog lists more than 3,000 publications and Club Offers for 1911. Write for it NOW and see **IT'S FREE** how much you can save...

BENNETT'S is the oldest MAGAZINE AGENCY in the world. Established 1870. References: All Publishers in the U S

All Club Offers, including ELECTRICIAN AND MECHANIC advance 35 cents on January 1st, 1911.

ADDRESS ALL ORDERS TO

Bennett's
MAGAZINE AGENCY - 184 RANDOLPH ST.
CHICAGO, ILL.



**Before Designing Your
ELECTRIC MOTORS OR DYNAMOS**

Send for our Circular of castings and parts. Armature discs, commutators, brush holders, etc., for Motors of 1-10 to 2 h. p. Dynamos to 25 light. FINISHED MACHINES AT LOW PRICES.

We always have a few second hand Motors and Gas Engines. If you need anything in a mechanical line write us.

F. E. AVERILL, Mgr.
365 7th St., Buffalo, N. Y.

**SETS OF CASTINGS OF
MODEL ENGINES**
SEND 10¢ FOR 126 PAGE
ILL. CATALOGUE.
ALSO TOOLS.
GEAR WHEELS & PARTS OF MODELS.

LUTHER H. WIGHTMAN & CO.



**ARITHMETIC
Self-Taught**

A plain, easily-understood volume for ALL who have not had the opportunity of learning this subject thoroughly, or who have forgotten what they once learned, 257 Pages, REQUIRES NO TEACHER. This great little book sent postpaid, for **60 cts.** (Stamps accepted), leather binding, \$1.
GEO. A. ZELLER BOOK CO., Est. 1870,
4173 W. Belle pl., St. Louis, Mo.

CAN YOU DRAW?

Our Graduates
Are Filling High Salaried Positions
EARN \$25 TO \$100 PER WEEK

In easy, fascinating work. Practical, Individual Home Instruction. Expert Instructors. Superior equipment. Founded 1899. Twelve years' successful teaching.
Financial Returns Guaranteed.

Complete Courses in Commercial, Fashion, Magazine, Book and Advt. Illustrating; Newspaper, Cartooning, Lettering, Designing, Show Card, Architectural Perspective, Photo Retouching, Normal, Color, General Drawing, etc.

FREE ARTIST'S OUTFIT of fine instruments and supplies to each student.

Write for particulars Our Own Fireproof Bldg.
and Handsome Art Book.
SCHOOL OF APPLIED ART
E 71 FINE ARTS BLDG. Battle Creek, Mich.

HOROLOGICAL DEPARTMENT
BRADLEY POLYTECHNIC INSTITUTE
Formerly Parsons Horological Institute
PEORIA, ILLINOIS
LARGEST and BEST WATCH SCHOOL IN AMERICA

We teach Watch Work, Jewelry, Engraving, Clock Work, Optics. Tuition reasonable. Board and rooms near school at moderate rates. Send for Catalogue of Information.



**Would You Like to Own
A GOOD RELIABLE
Reece Screw Plate**

Genuine Reece Screw Plate Cutting Machine Screw Sizes, Nos. 4-36, 6-32, 8-32, 10-24, 12-24, with 5 adjustable dies 13-16 diam., 5 Taps, 1 Die Stock, 7 in. long and Tap Wrench Die complete in polished case with velvet-lined cover. Sent post-paid to any address on receipt of

\$2.95

E. F. REECE CO., Greenfield, Mass.

**Blue Process Paper
Blue Printing
Drawing Materials**

Chas. E. Moss 38 BROAD STREET
BOSTON, MASS.

**MASTER YOUR MOTOR CAR, MOTOR BOAT,
Motorcycle or Aircraft**

AUTOMOBILE TROUBLES

Automobile Troubles and How to Remedy Them. Automobile Driving Self-Taught. Automobile Motors and Mechanism. Ignition, Timing and Valve Setting. Motor Boats: Construction and Operation. ABC of The Motorcycle. Flying Machines. Flexible leather and cloth bindings, round corners, UP-TO-DATE, RELIABLE, 1914 EDITIONS. Price, \$1.50 Leather; \$1.00 Cloth, postpaid. Sold and guaranteed by Book-sellers, Auto and Marine Supply Houses, or direct.

THE CHARLES C. THOMPSON COMPANY
Publishers, 545-549 Vassar Ave., CHICAGO

**GARDNER GASOLINE
ENGINES** FOUR HORSE POWER

Are built for service and sold at a legitimate price. If interested investigate them before you purchase. Write for literature.

**GARDNER
MOTOR
COMPANY**

721 ACADEMY AVE.,
St. Louis, Mo.

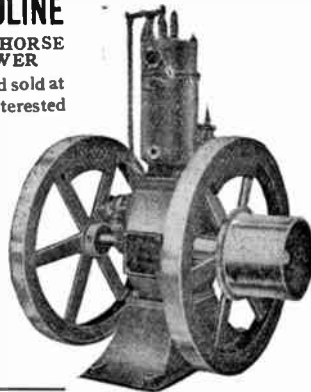

PROTECT YOUR IDEA PATENTS THAT PAY

Special Offer.—Send Sketches or Photograph, or Model for free report as to patentability. Prompt services—Excellent References.

Free—The entitled books will tell you How to Secure Money to "Patent" Your Invention; How to Sell Your Patent and ALL about the

GREAT SUCCESS OF MY CLIENTS
E. E. VROOMAN
PATENT AND TRADE MARK LAWYER
801 F Street, N.W. Washington, D. C.

FREE—Two Books:
61-PAGE
"INVENTOR'S GUIDE"
AND 64-PAGE
"Proof of Fortunes in Patents—
What, and How to Invent"

REFERENCES
American National Bank, Wash-
ington D. C.; Little Giant Hay
Press Co., Dallas, Texas; Gray
Lithograph Co., New York City.
N.Y.; Farmers Mfg. Co., Nor-
folk, Va.; The Parry Stationery
Co., Oklahoma City, Okla.; Mc.
Allister & Upton, Portland, Ore.

**BUILD YOUR OWN FURNITURE
"MORRIS CHAIR"**

FOR 50 CENTS will send you large Blue Print, 16 in. x 16 in. and typewritten specifications and description showing plainly how to build the "MORRIS CHAIR" described in the August number of ELECTRICIAN AND MECHANIC.

IRA M. CUSHING

20 RAWSON ROAD

WOLLASTON, MASS.

CHANGE OF PRICE



We have decided to take a step important to both our subscribers and the magazine. We shall raise the price to 15 cents a copy; \$1.50 a year, on January 1, 1911. At the same time we shall materially increase the size of the magazine, add new departments, and strengthen it in every way possible. We would like to make this increase at the old price, but the steadily advancing cost of materials and labor renders this impossible. We believe the majority of our readers are willing to pay the increased price for the sake of a better magazine. At the same time

ELECTRICIAN AND MECHANIC

believes in a fair deal, and we shall give every reader a fair opportunity to have the magazine as long as he wants at the old price. You may subscribe now for as many years as you want at the old price. One year will cost you \$1.00; two years, \$2.00; three years, \$3.00; five years, \$5.00; ten years, \$10.00. Especially if you buy the magazine from a newsdealer, we urge you to subscribe. Next year you will pay for twelve numbers, at 15 cents, \$1.80; so that you will save about half by subscribing now. Hand the subscription to your newsdealer, if you prefer, but do it before you forget it. We want every reader to take full advantage of our warning. Send in your subscription at \$1.00 a year, *now*, for after January 1, 1911, it will cost you

\$1.50 A YEAR

To be frank with you, we would like to have every reader send us a money order for five years' subscription. If you can't do that, order it for three, two, or even one year, but don't neglect to take the opportunity. You will get a better and bigger magazine, more articles, more pictures, more departments. Don't delay, don't forget.

SUBSCRIBE NOW AT THE OLD PRICE, \$1.00

If you will get three of your friends to subscribe, we will give you your own subscription free. That's worth while, too.

Sampson Publishing Company

221 Columbus Avenue

Boston, Mass.

SPLENDID SPECIAL OFFER

Good During November and December Only

A Special Offer to the Readers of Electrician and Mechanic

ELECTRICIAN AND MECHANIC,
221 COLUMBUS AVE., BOSTON, MASS.

I am interested in your special offer (described on this page) on account of the raising in price of ELECTRICIAN AND MECHANIC.

PUT ME DOWN

for years of ELECTRICIAN AND MECHANIC at your special price, beginning with the number for

I enclose \$ to pay for same.

Name

Address.....

Although the price of Electrician and Mechanic is raised to \$1.50 a year on January 1, 1911, you can

Send \$1.00 now for a year's subscription and save \$0.50

Send \$2.00 now for a 2 years' subscription and save \$1.00

Send \$3.00 now for a 3 years' subscription and save \$1.50

Send \$5.00 now for a 5 years' subscription and save \$2.50

Send \$10.00 now for a 10 years' subscription and save \$5.00

Canadian Postage \$0.35 a year extra
Foreign " " \$0.60 " "

SUBSCRIBE TO

ELECTRICIAN *and* MECHANIC

❁ ❁ WHAT YOU WILL GET ❁ ❁

The aim of **ELECTRICIAN AND MECHANIC** is to furnish to every man interested in mechanical or electrical work of any kind, something to interest, to help, to advance, to better him. It will keep you in touch with the world's progress in the subjects it covers, explain new discoveries, elucidate old problems, and be your practical adviser on all subjects in its field. Enlarged to ninety-six pages or more every month, in the next year it will give you hundreds of pictures and one thousand or more articles. Here are some of the lines on which we propose to work and give articles, as far as the wants of our readers seem to demand them.

Electricity.—Its applications in the workshop, the home, the office, the laboratory, the farm. Electrical construction, operation, plant maintenance, etc. The building of electrical apparatus of various kinds. Its technical applications, such as electro-plating, X-ray work, instrument making, testing, etc.

Wireless Telegraphy and Telephony.—Since its beginning the best known authority on wireless construction and operation, the magazine will continue its policy of describing the construction and use of the most advanced type of instruments, and its experts will continue as previously to authoritatively answer the perplexing questions which beset every experimenter.

Shop Work.—The magazine will be of the greatest value to every mechanic for its practical articles on metal work, shop problems, mechanical drawing, tool making, and other kindred topics. Forging, brazing and soldering, machine shop arithmetic, and similar topics will receive attention at due intervals. Practical and simple language will be used in all cases.

Flying.—Our aeronautical department will be one of the strongest features of the magazine. Edited by a charter member of one of the oldest aero-clubs in America, each number will summarize the achievements of the preceding month, discuss problems as they arise, and furnish structural directions for practical work. Models, kites, gliders, aeroplanes and balloons will all be discussed and we trust be built by our enthusiastic readers from our directions.

Woodworking.—Furniture construction, turning, carpentry, cabinet work, wood-finishing, the care and use of tools, handy work about the house and farm, are topics which we hope to treat regularly in this department even more fully than in the past.

Model Making.—This diversion, so popular in Great Britain, is comparatively neglected in America. The making of scale models of engines, dynamos, locomotives and railways, boats and yachts, etc., affords valuable training in tool work, and we propose to encourage and develop such work to the best of our ability.

Practical Hints and Shop Notes.—Valuable ideas, "kinks," "dodges," recipes, formulas, useful notes too short for articles, abstracts from foreign journals, and practical notes of all kinds, well illustrated, will be gathered under this heading, to which every reader is invited to contribute his own ideas.

Useful Articles on other topics of current interest or suggested by readers, such as gas engines, motion picture operating, chemistry, physics, lens-making, in short, any form of work which can be done by the human hand, will be on our programme. New departments will be added as the need arises, and we will try to give information on any topic desired by our readers.

Questions and Answers.—In the last four years we have printed answers to between 4,000 and 5,000 readers' questions on every conceivable electrical and mechanical subject, besides many answered by mail. Our experts will keep it up.

And there will be much besides. SUBSCRIBE NOW

ELECTRICIANS' POCKET SCREW DRIVER

No. 560



This Screw Driver is the same as our No. 557, illustrated on Page 188 of our No. 18 Catalog, except that the handle is covered with hard rubber for insulation from electrical currents, and is nicely ribbed so as to insure a firm grip when using the tool. It has four blades of different widths, any one of which may quickly be taken from the telescope handle and inserted in the end, where it is automatically locked and firmly held for use. Any or all of the blades are carried in the handle, where by a spring pressure they are held from rattling when carried in the pocket, or from being lost when the cap is off. While the cap may be readily pulled off or put on it is rigidly held from turning and frictionally held from coming off, with no screws to bind or bother.

The smaller blades may be used to make holes in wood for screws as well as to drive them home. Every electrical mechanic, or operator working among electrical wires or machinery, will appreciate these insulated Screw Drivers as a valued protection against electrical shocks.

The widths of the blades are 3-32 in., 5-32 in., 1-4 in. and 3-8 in.

Price Complete, \$1.50

Extra Blades, each, 10 cents

Ask for free Catalog No. 18 W of Fine Mechanical Tools

THE L. S. STARRETT COMPANY

ATHOL, MASSACHUSETTS

U. S. A.

No. 40. K. & D. Reversing Switch



THIS is a new and neat little switch, suitable for uses as a pole-changing switch in any position where the current to be carried does not exceed 15 amperes. It is also suitable as a starting, stopping and reversing switch for small motors.

The base is of hard fiber, the exposed metal parts are nickel plated.

Price 75 cents

No. 41. K. & D. Reversing Switch



THIS switch is of the same construction as No. 40, except that it has no cover, and is provided with a polished wood base. Of same efficiency as No. 40.

Price 60 cents

Send for our catalog of Electrical Goods, No. 9, describing new battery motors, switches, rheostats, measuring instruments and other devices manufactured by

Kendrick & Davis Co., Lebanon, N.H.