

THE NEWSPAPER FOR  
THE HOBBYIST OF VINTAGE  
ELECTRONICS AND SOUND

# THE HORN SPEAKER

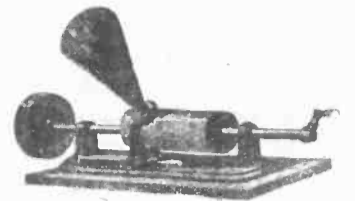

PHONOGRAPH CENTENNIAL  
1877 - 1977

Radio News for September, 1923

## Selection Of Vacuum Tubes

SINCE most vacuum tubes are designed for a particular function, it is of great importance to select those best suited to your requirements. For instance, an amplifying tube, in the usual case, will not function well as a detector, while a tube designed for detection will prove very unsatisfactory if employed as an amplifier. The layman is often at a loss as to the type of vacuum tube to purchase for a definite use. For his benefit, we have printed herewith a table, including the characteristics of all well-known makes of three-element vacuum tubes, giving as well their operating conditions when used as detectors, radio frequency amplifiers, audio frequency amplifiers or oscillators. If a tube is not suitable for any of these functions, the corresponding space



UV-199, C-299.

"B" battery voltage. A grid battery of from four to six volts is satisfactory if the WD-11, WD-12, UV-199, C-299 and "N" tubes are used with "B" batteries of from 60 to 100 volts. An additional six-volt grid battery should be added for every 100-volt "B" battery; this, of course, being proportionate to the increase in the "B" voltage. The Western Electric VT-1, VT-2 and 216-A require approximately a 9 to 12-volt grid potential for every 100-volt "B" battery.

The first important consideration when selecting vacuum tubes is, whether storage batteries or dry cells are to be used for lighting the filaments. All of the 6-volt tubes require a storage battery. The small 1 1/2-volt and 3-volt tubes, such as the WD-11, UV-199 and "N" tubes, can be run from ordinary dry cells. Although both types of tubes work equally well as detectors, the dry-cell tubes are not as satisfactory for audio frequency amplifiers, as they cannot handle as much energy as the larger tubes. However, they make excellent radio frequency amplifiers. The UV-199 and "N" tubes are probably the best that can be ob-

tained for this purpose because of the small size of the elements. For power amplification, where great volume is desired, tubes with large elements, such as the UV-201-A and Western Electric VT-2 or 216-A, are the most satisfactory.



VT-1 or "J" Tube

Genuine French tubes and the R.A.C.-3 tubes are satisfactory for all-around work. They are both very good as detectors and radio frequency amplifiers, fair as audio frequency amplifiers and as oscillators. As power amplifiers, of course, they are not well adapted, due to the small size of their elements.

An important factor in the operation of vacuum tubes is the filament voltage. For best results the voltage impressed upon the filament should always be equal to the voltage rating given for the particular

WRNY

Radio News for February, 1926



CHARLES DANA GIBSON

Charles Dana Gibson, the prominent illustrator, is the creator of the "Gibson Girl" and publisher of "Life." Mr. Gibson and his associates handle the Humor Department for WRNY.

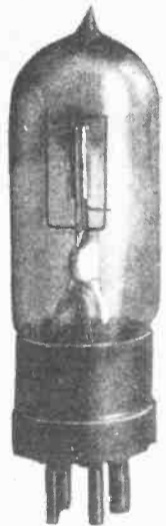

WD-11 Tube

Type	"A" Filament Volts	Filament Current	Filament Watts Consumed	"B" Plate Voltage		Negative Grid Voltage for App.	Detector	Radio Frequency Amplifier	Audio Frequency Amplifier	Power Amplifier	Oscillator
				Det.	amp.						
UV 199	3.0	0.06	0.18	45	60 to 90	1 to 4.5	Good	Good	Good	Fair	Good
UV 200 C-300	5.0	1.00	5.0	22 1/2			Good				
UV 201-A C-301-A	5.0	0.25	1.0	45	60 to 100	3 to 6	Good	Good	Good	Good	Good
UV 202 C-302	8.0	2.35	18.8	40 to 60	100 to 500	3 to 9	Fair		Good	Good	Good
WE "N" tube	1.1	0.25	0.27	22 1/2	45	1 to 2	Good	Good	Fair		Good
WD-11 WD-12	1.5	0.25	0.37	22 1/2	45 to 60	1 to 3	Good	Good	Fair		Good
VT 1	2.5	0.9	0.36	22 1/2	45 to 96	1 to 3	Good		Good	Fair	Good
VT 2	7.0	1.35	9.45	45	45 to 350	1 to 40	Good		Good	Good	Good
216-A	6.0	1.35	8.1	45	45 to 150	1 to 12	Good		Good	Good	Good
RAC-3	4.0	0.8	3.2	22 1/2	40 to 90	1 to 10	Good	Good	Good		Good
French tube	4.0	0.8	3.2	45	40 to 300	1 to 25	Good	Good	Good	Fair	Good

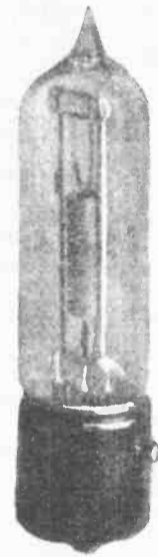

"N" Tube

is left blank. The rest of the chart tells its own story, except perhaps the list of negative grid potentials. A negative grid voltage is necessary only when a tube is used as an amplifier, with rather a high



RAC-3 Tube

tube being used. For an example, a pressure of five volts should be maintained on the filament of a Radiotron UV-200 tube, since five is the voltage rating as given on the chart.



UV-200, C-300

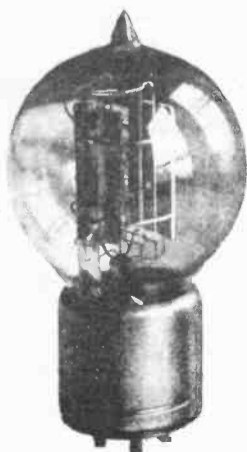

Western Electric VT2

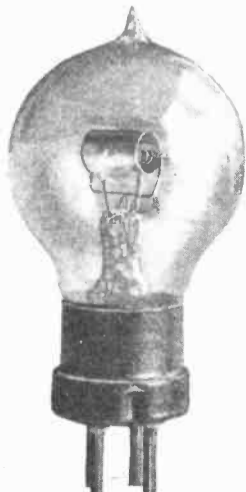

French Tube



Western Electric 216-A



UV-202, C-300

A most interesting singer, Rose Laurent, is known as the "American Songstress." She sings at WRNY the works of the American composers. Her voice has been called perfect for radio.

ROSE LAURENT

Heading the Talking Machine and Radio Men, Inc., Irwin Kurtz directs one of the most popular features at WRNY, and will bring stars of the leading phonograph companies to WRNY.

IRWIN KURTZ

Star of the Radio Art Players, who produce the dramatic classics of the past for WRNY audiences. Shakespeare and Moliere will appear in their program, as well as Rostand, Wilde, Barrie and Shaw.

MADELAINE HUNT

## LETTERS

Dear Jim:

I would like to commend you on the consistant quality of your "mag." But may I suggest you avoid wasting valuable copy space with "artwork" such as that on page 4 of issue No. 8 (Oct. 1977).

I would much rather see some more "How To" articles....

1. How to replace AK pot metal tuning wheels.
2. How to replace AK pot metal speaker drivers.
3. How to replace plastic dial glass.
4. How to troubleshoot superhets.
5. How to convert "Farm Radios" to AC
6. How to make solid state replacements for old tubes.
7. Aguide to old finishes - what manufacturers used, what kind of finish?
8. How to remove old veneer, etc.

I could write topic #3. I recently found a way - using "Acetate."

Ask your readers to submit ideas & articles, then clean & copy read them so they are understandable - for us eager beavers to read.

Many of the "First Generation" of radio are dead or too old to remember.. let's encourage the old time repair guys to tell us how to fix stuff before it is lost to father time.

How about old radio book reviews? Or "Restoration of the Month" with pix of How I Did It?

You got the idea.

Later,

Mark Oppat

31800 Balmoral Dr.

Livonia MI 48154

EDITOR...All your ideas are good and we will use them as goals.

Dear Sir:

As you can see the date is already the end of the month, and I haven't received the Oct. issue of "The Horn Speaker" as of yet. I have had a subscription for many years with you people, but within the last year and a half the service has become lousey. I have not been getting the paper until the end of the month, by that time everything in the classified section is already picked thru.

I am wondering if I am the only one having this trouble or are there other people out there having the same "late" problem. If service is going to continue like this I will cancel my subscription.

Please publish this or I would like to see some feed back.

B. Pequod

8520 Fernald

Morton Grove IL 60053

EDITOR....A first class mailing (\$3.00 extra) will cure the problem.

Dear Jim:

I have collected some more radios since I have written to you last year, they are as follows: Leutz Super D.X. Seven with 7-01A tubes also Leutz Super DX Eight with all 199 tubes in it, these sets have the same serial No. 518. Also picked up a Superfone 3 tube regn. made by Peck Radio Co., and a 5 tube Colby, last but not least a W.E. Mike with case model 387W and a Duck No. 16 Catalog in the cellar of an old book store for \$2.00. By all means renew my subscription to "The Horn Speaker" for another year. Would like to see some writing on the Deforest D-12 and D-10.

Thats all for now,

Julius H. Pilger, K2KCB

123 09 18th Ave.

College Point N.Y. 11356

EDITOR...Congratulations on the "super finds."

Dear Jim:

Please extend my subscription to "The Horn Speaker" for another year.

The area I live in is really good for finding old sets. My most recent find was a 1921 Jones Radio (Brooklyn NY) one tube set, along with about 15 very old 01's, VT-1's and even some early experimental tubes like three triodes in one vacuum envelope.

The Jones set plays very well but I'm not sure what was originally connected in series with the grid and plate leads (between the binding posts on the set).

I'm in the process of designing some solid state battery eliminators, but my work area is crowded with sets and speakers.

Anyway, keep up the good work. I enjoy "The Horn Speaker" every month.

Yours,

Pete Bahr

708 Lincoln Ave.

Williamsport PA 17701

P.S. The pride of my collection are two original deForest "Audion" triode tubes - about 1910 with the green and red leads.

EDITOR....Thank you for the kind words.

## Club News

Would like to have a meeting of any area OLD or YOUNG DXers at my house, on most any weekend evening, subject: ANTIQUE RADIO DXING..... If you live in N.C., S. C. or VA, write me for details. Also have some old RADEX magazines, I'd like to sell or trade (1930-1945 years). Contact:

SWL Monitor-WDXLDNO

Bill Coleman, Jr.

114 Circle Drive

Rocky Mount N.C. 27801

Call prepaid to 1-919-443-7282. Call my DX CHAT LINE. It's opened to anyone anywhere as a public service. If you've got radio, antenna, problems, let me help, or talk about any DX matters. Hours are from 1030pm-0300E.S.T. 7 days week.

SWL WDXLDNO

Bill Coleman, Jr.

114 Circle Drive

Rocky Mount N.C. 27801

We of the Washington D.C. Metropolitan Area have had two meetings in an attempt to form a new Antique Radio Club. If anyone would be interested I suggest they call me for the date of our next meeting.

Bob Wendling

703 280-1671

3605 Laurel Leaf

Fairfax VA 22030

1923 ad



**WARREN  
RADIO  
LOOP**

### An Aerial Adjustable to Station

Practically gives you an aerial for every station, because it can be adjusted to any side of the station, or even to the top of a hill. A small, adjustable, directional antenna that makes any trouble-free, portable, and features. All enclosed in a sturdy, and as a result of its design.

*Special Price for 1977*

**A Type For Every Set  
At The Best Dealers**

Type A-737 (300-700 meters) 6 inches square - non directional	\$10.00
Type A-7236 (175-1000 meters) 6 inches square - non-directional	12.00
Type B-2537 (300-700 meters) 18 inches square - directional	20.00
Type BL-2520 (200-18,000 meters) with hexacomb coil, 18 inches square - directional	25.00

**V-DE-CO RADIO MFG. CO.**  
ASBURY PARK, N. J.  
Dept. N

"RADIO AGE," a radio magazine devoted to wireless and early broadcast eras. Contains interesting articles written by collectors, articles published in early radio magazines, lots of reprints of famous radio ads, and a classified section for buying or selling radio and electronic items. Subscribe at \$7.50 per year for ten issues. Mail check or money order to Radio Age, 1220 Meigs St., Augusta GA 30904. (adv.)

JU LE PUETT AND JAN BARTLETT SAY :

"TALLYHO ALL YOU SWASHBUCKLING RADIO COLLECTORS!!!"

"GET YOUR ANTIQUE RADIO T-SHIRT TODAY !!!"

T  
.  
S  
-  
R  
T  
S



\$4.95  
POST  
PAID

\$4.95  
POST  
PAID

\$4.95  
POST  
PAID

\$4.95  
POST  
PAID

\$4.95  
POST  
PAID

\$4.95  
POST  
PAID

\$4.95  
POST  
PAID

\$4.95  
POST  
PAID

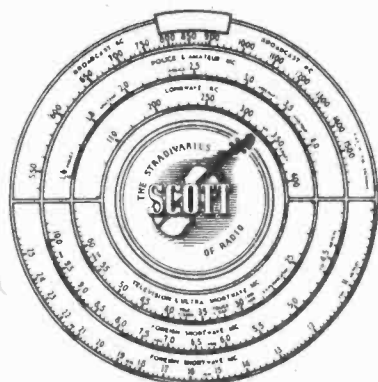

# PUETT ELECTRONICS

P. O. BOX 28572 DALLAS TEXAS 75228

PUBLISHERS OF  
THE CLASSIC RADIO NEWSLETTER

FOUR SIZES -  
small, medium, large,  
and extra large

THREE COLORS -  
canary yellow, gold,  
and blue -- please state  
first, second and third  
choice.

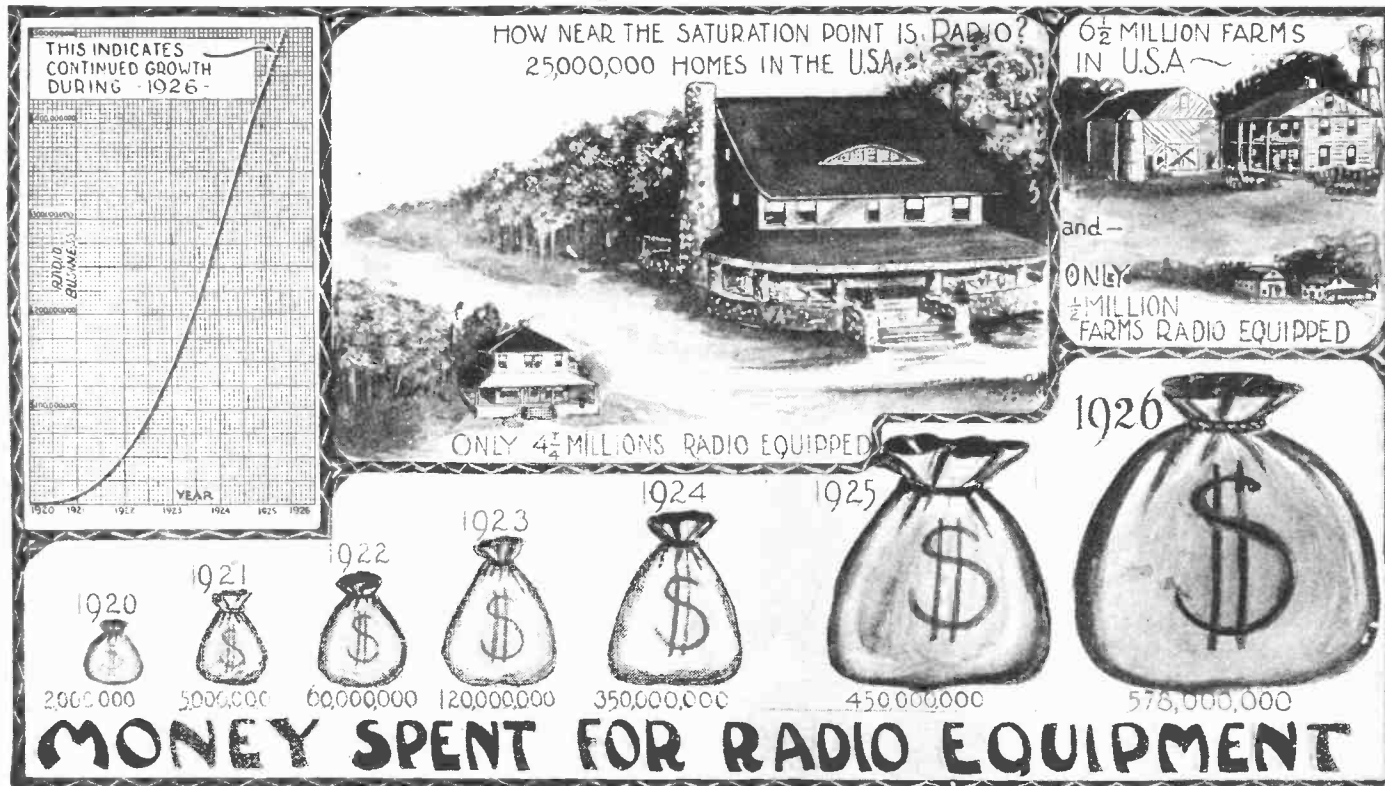

## The Radio Industry of Today

By GEORGE WYNCOTE



Alarmists, during the past few months, have been amusing themselves with dire predictions that the radio industry has reached a point of inflation, and will shortly commence to deflate again. Such opinions are based more upon superficial aspects than upon a knowledge of the facts involved. In this article an actual analysis of conditions is made, showing beyond any possibility of doubt that the radio industry will continue its pace of development throughout 1926.



IN OUR July, 1924, number the readers of RADIO NEWS were made acquainted, through an article by Mr. Roger Babson, with the fact that the radio industry of that year far surpassed in extent and magnitude the importance that is generally assigned to it.

Mr. Babson, in that article, showed that within the short period of about five years, the radio industry had assumed a place among the thirty-five leading industries of the United States.

Contrary to the general opinion, radio is not a fad; it is estimated by the Department of Commerce that at the present time there are approximately four and a quarter million radio sets in operation in the United States! And of these sets, scattered all over the country, there are only a little over half a million sets on farms.

Now let us see what this means in regard to the radio industry and business of the coming year. There are, approximately, twenty-five million homes in the United States. Assuming only one set to each home, this means a potential market for over twenty million sets! In other words, only 17 per cent. of all the homes in the United States are radio equipped. And, furthermore, just think of how many are only superficially equipped.

The radio equipment in many of these homes can hardly be called such; and with the awakening of the general public to the advantages and possibilities of radio, the market in this field alone is prodigiously big.

### A RADIO FOR EVERY FLIVVER

Up to the present time the radio industry has received its poorest support from the farms. In the year 1925 there were only 553,000 radio receivers on farms, representing only 13 per cent. of the total number of radio sets in use. But the most important

phase of the farm radio question is that only 8 1/2 per cent. of all the farms in the United States are radio equipped.

The table shows an appalling discrepancy in the distribution of radio sets between the farms and the other homes.

Now let us see what all this means in money. On the basis of approximately three million radio sets in the homes during 1924, the year 1925 shows an increase of about a million and a quarter, or 42 per cent. Also, on the basis of about three hundred and fifty million dollars worth of business in 1924, there must have been something like four hundred and fifty million dollars spent by the people of the United States for radio equipment during 1925.

We have attempted to depict these ideas in the illustrations on these pages. We see

house representing in size the number of homes not equipped.

There has been much apprehension among many of those interested in the radio industry that the condition of saturation would soon be reached. From the figures which we present in this article, and their visualizations in the illustrations and graph, it appears that there is not much ground for these fears.

### PROSPECTS FOR 1926

The curve shown in the illustration, although it cannot be interpreted too literally, indicates in a general way what we may expect. Certainly it is plain that the curve does not droop appreciably, but continues to go upward. If it did not, there would be good cause to worry about the coming year; but

	HOMES	RADIO EQUIPPED	PER CENT.	NOT RADIO EQUIPPED	PER CENT.
Total	25,000,000	4,250,000	17.0	20,750,000	83.0
Farms	6,500,000	553,000	8.5	5,947,000	91.5
Others	18,500,000	3,697,000	20.0	14,803,000	80.0

here a large money bag, increasing in size from one year to the next. The size of the bag represents the amount of money spent during each year for radio equipment.

The same information has been plotted into the form of a graph, by means of which it is possible to prognosticate the business of the coming year; that is, very approximately, and, of course, not taking into account unforeseen conditions which may arise in the industry.

### MILLIONS OF PROSPECTS LEFT

We also show a picture of two houses; the small house representing in size the number of homes equipped with radio, and the large

from all appearances 1926 promises to be a good year in the radio industry, continuing the growth shown in every year hitherto.

The main point to be emphasized, however, is that the great majority of possible purchasers is as yet untouched. Many people are waiting for the receiver that conquers static. Others are waiting for complete fidelity of tone reproduction. Both of these problems seem to be well on the way toward solution. The latter, indeed, is practically solved. It now remains to tell the untouched 87% of the buying public that radio at last has reached the state of development that has been predicted.

1977 ad

## Old Radio Treasures

There's a rare old radio waiting for you somewhere. Here's how to have year-round fun discovering valuable old sets in your attic, local swap meet or antique barn. You'll enjoy McMahon's fascinating books, truly fine collector's references.

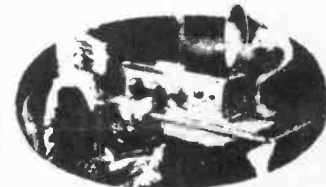

VINTAGE RADIO, 1887-1929: Pictorial story of pioneer days, 1,000 photos, 263 pages. \$10.95 hard-cover, \$8.95 soft.

A FLICK OF THE SWITCH, 1930-50: Fun picture reference of home, military, Ham, professional radio-TV electronics, 312 pages. \$10.95 hard-cover, \$8.95 soft.

RADIO ENCYCLOPEDIA, Gernsback's 1927 classic beautifully recreated, 175 pages. \$14.95 hard-cover, \$10.95 soft.

RADIO COLLECTOR'S GUIDE, 1921-32: Data book with 50,000 facts on 9,000 models by 1,100 makers, 264 pages, \$6.95.

1926-38 RADIO DIAGRAMS: Beitman's classic of 600 models, 240 pages, \$7.00.



Here are the ideal holiday gifts.

### ORDER NOW

### FOR IMMEDIATE DELIVERY!

CIRCUIT DIAGRAM for any pre-1951 radio: \$3.50. Send model number.

SEND TODAY to Vintage Radio, Dept D, Box 2045, Palos Verdes, Ca. 90274. We pay postage. Calif. residents add 6%.

\_\_\_\_\_ \$  
 \_\_\_\_\_ \$  
 \_\_\_\_\_ \$  
 \_\_\_\_\_ \$  
 TOTAL \$ \_\_\_\_\_

Name \_\_\_\_\_  
 Street \_\_\_\_\_  
 City \_\_\_\_\_ St. \_\_\_\_\_ Zip \_\_\_\_\_  
**FREE! Age Guide with each order. FREE!**

**Year-round Fun!**

*"The marked improvement in the reproduction of the piano is a most gratifying achievement."*

—IGNACE PADEREWSKI.

# The piano is *really* a piano on the New Orthophonic Victrola



FOR years the piano was admittedly the most difficult instrument to record accurately. Reproduced tones never had that full, rounded richness of the piano itself. They were harsh . . . unreal. But the Orthophonic principle of recording and reproducing has mastered this problem . . . definitely!

It brings you piano tones, pure and un-  
nanged . . . just as they pour from the  
piano under the master touch of the artist  
himself. You can almost *see* the swift,  
sure fingers running over the keys. When

the music stops, you applaud instinctively, as you would at an actual recital. For the illusion is simply perfect.

### *Victor tone is the tone of realism*

Piano, harp—the tones of *all* instruments, including the human voice, fall pleasantly upon the most critical ear when heard through the Orthophonic Victrola. In no other way *can* you hear music reproduced so accurately. For the Orthophonic Victrola is based on the new, scientific, Victor-controlled principle of "matched impedance," which permits smooth, uninterrupted sound-flow. Flawless reproduction!

The new Orthophonic Victor Records, recorded by microphone, are an achievement comparable to that of the Orthophonic Victrola itself. They have new beauty and power. New clearness and depth. Made from an improved material, they have new quiet! These records play on *any* instrument . . . and vastly *improve* its playing quality!

Go to the nearest Victor dealer today and ask him to play the new Orthophonic Victor Records on the new Orthophonic Victrola. Know for yourself that there is nothing else like this in all the realm of music. There are many beautiful models of the Orthophonic Victrola, from \$95 to \$300, list price. Silent electric motor (\$35 extra) eliminates winding. You play . . . and relax.



The Orthophonic Victrola furnishes the finest music for the home. Model Four-seven (above) is \$125, list price

## The New Orthophonic **V**ictrola

VICTOR TALKING MACHINE CO.



CAMDEN, N. J., U. S. A.

# Our Great Free Trial Offer

And the Easy Payment Proposition

**WE PROVE** our confidence in the Edison Phonograph by shipping it on **free trial**—and free trial means free trial. Our offer is exactly as stated. We ship you the outfit of your choice on free trial—you may keep the instrument from two days to a week, **then if you do not find it a wonderful source of pleasure pack it up and return at our expense.** If satisfactory after free trial, you then have the choice of paying cash in full or remitting on our easy payment terms.

**We can afford to make the free trial offer,** because we know that when once you have heard the wonderful music, the songs and comic sketches, when you fully appreciate just what a really delightful entertainer the Genuine Edison Phonograph is, you will want to keep it. Our statistics show that not one in a hundred returns the Genuine Edison after free trial.



Our easy payment offer is intended for both rich and poor—since we allow the **lowest possible price** alike to those who buy on monthly account and to those who buy for cash. Have you ever before heard of anybody offering to sell goods on monthly account, yet allowing the same price as is made for spot cash? If you ordered twenty genuine Edisons for spot cash you could not buy a cent cheaper than if any one person orders a machine on free trial, payable on monthly terms.

Still if we demanded all cash down at one time, a great many of our customers who are now enjoying their phonograph could not have purchased it. You can readily see, therefore, why we can afford to be so liberal in letting our customers pay for their machine on our easy payment plan.

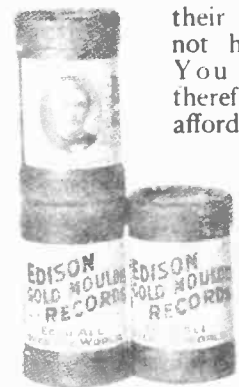

Every one can now afford a Genuine Edison

Phonograph—in fact you cannot afford to be without one. **The prices on the easy payment plan are exactly the same as if you paid all cash.** There is but one price on the Edison phonographs, and it would be impossible to buy a Genuine Edison Phonograph anywhere for a cent less than what we ask on our easy payment plan.

The rich and poor alike are taking advantage of our monthly payment plan. Among our thousands of customers are a great many bankers and wealthy people who purchased an outfit and paid for it by small monthly payments.

**Our monthly payment plan is really the modern method of saving.** You could, of course, deposit a certain amount each week in a Saving Bank until you had enough to pay for a phonograph, but this is not necessary. We send you the phonograph on absolutely free trial, and then if you decide to keep it, we will be the Saving Bank and you can send your deposits to us until the machine is paid for. **Besides you have the pleasure of the phonograph while paying for it.**

**These monthly payments** are so very small that you will hardly notice them, and then when you have the Genuine Edison Phonograph all paid for just think what a really wonderful thing you have—an instrument that plays, sings, talks and laughs—one that entertains and instructs practically without limit.

It is like having a whole band, a great actor or a renowned singer staying at your house all the time. You are taught the latest songs and the most popular airs.

Many of our customers have written us after they had finished their monthly payments saying that they had **hardly noticed them** at all, and that they oftentimes sent us the money that they would probably have spent foolishly for some form of entertainment that was soon over and without any lasting benefit.

**Just try to save a little here and there that you would spend for something else anyway,** and you will soon see how very easy it is to make the small monthly payments for a Genuine Edison Phonograph that will be



a source of recreation and entertainment for you for years to come. In the end you will really save money, for you will have in your own home the fun and pleasure you would go elsewhere to find, which would be continually costing you money.

With a phonograph in the house there is absolutely no need for you to go outside your own parlor for any show or entertainment and the money you would spend in these places may be used in paying for the instrument. Then when it is paid for, which will be in a few weeks, you will have an instrument which will give you life-long entertainment.

Buying on monthly payments does not infer, as some seem to think, that your means are limited, but buying on these terms does show that you are adopting the **latest practical and most efficient method of saving and purchasing.**



1899 Chicago Talking Machine Catalog

## McMURDO SILVER'S NEWEST RECEIVER THE SILVER "SIX"

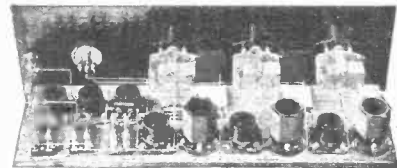

TYPE 600 KIT, includes all parts necessary to build the complete "SIX" \$53.00  
TYPE 610 KIT, essentials only, including 3 condensers, 3 inductances and 3 inductance sockets \$27.75

Anyone can build the Six

**SM Low Loss Inductances**  
All-bakelite Low Loss Interchangeable Coils for 50-550 meters. These new coils may be used as oscillators, antenna adapters and R.F. transformers in standard circuits.  
Price of all types, Each...\$2.50  
Sockets for any size Coils.  
Each .....\$1.09

**SM 210 and 211 Transformers**  
Designed so that maximum amplification will be obtained at 60 Kilocycles. Both types in bakelite housings, hermetically sealed. No. 210 is iron-core type while No. 211 is of the air-core type supplied with measured tuning condenser. Each transformer is furnished with individual laboratory curve chart.  
Price: Both Types..... \$8.00 ea.

**SM SLF Condensers**  
These new condensers are particularly adapted for short wave reception because of their extremely low dielectric and eddy-current losses. They are the smallest SLF Condensers made. Supplied with special attachment for single control.  
Prices: No. 310 .0005 \$6.00  
No. 311 .00035 5.75

## The Improved RAYTHEON-THORDARSON B-ELIMINATOR

The SM Type 650 Kit includes Thordarson transformer, choke, Tube condensers, genuine Raytheon tube, Bradleyohms and all necessary parts. Price \$34.

This eliminator will deliver from 20 to 200 volts at three different, adjustable voltages with maximum current of 50 milliamperes—more than enough for the largest receiver.

Send for Assembly Instruction by McMURDO SILVER ..... 10c

Circulars on SM Products mailed on request.

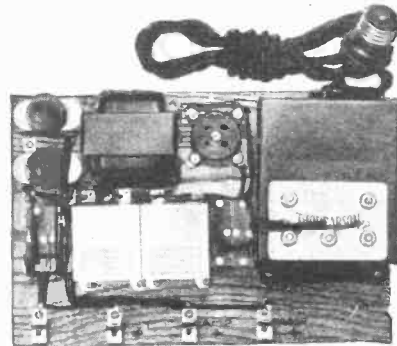

SEE SM PRODUCTS AT YOUR DEALER'S

**SILVER-MARSHALL, Inc.** 116 S. WABASH AVE. CHICAGO

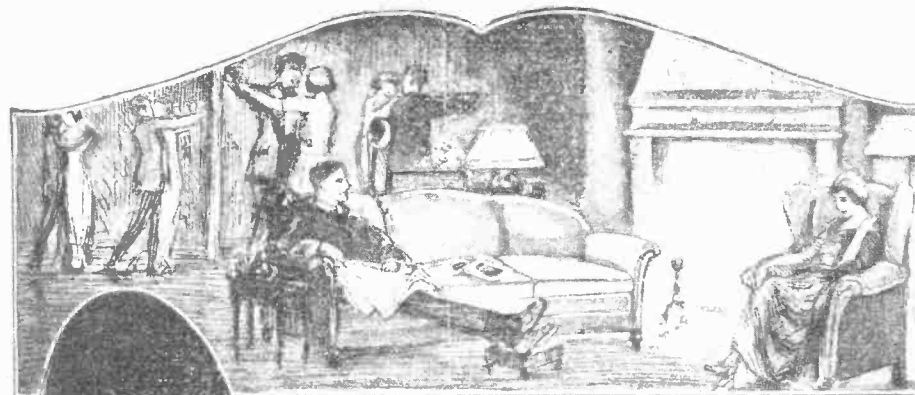

LOUD SPEAKERS AND REPRODUCING HORNS that have stood the test



SENIOR \$25.00

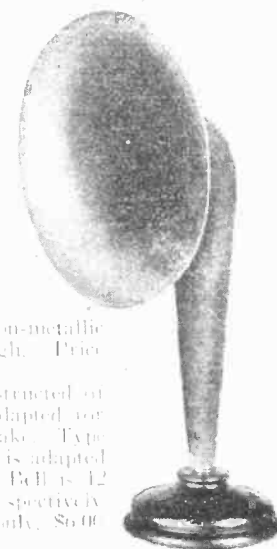

TYPE B \$8.00

**TRUTONE SENIOR** the loud speaker for all long-distance work operates perfectly on two stages of amplification. The base contains built-in reproducer with heavy mica diaphragm. Beautiful crystalline enamel-finished non-metallic horn, 14 inches in diameter standing 32 inches high. Price \$25.00 complete with 6 ft. of cord.

Type B, pictured here, is a reproducing horn constructed of the same high quality material as the Senior and adapted for use with single phone receivers of any make. Type A is the same as Type B except that it is adapted for any make of two phone receivers. Both is 12 in. Horn stand 22 and 24 in. high, respectively. Either model complete, \$8.00. Horn only, \$6.00. Base only, \$2.00.

**SADLER MANUFACTURING CO.** 86 FOURTH STREET, SAN FRANCISCO, CALIFORNIA

DECEMBER 1977 \*\* THE HORN SPEAKER

PLEASE REFER TO DATE AND PUBLICATION WHEN ORDERING

**DISCOUNTS**

Discounts are allowed on dollars shipped and not on dollars ordered. Where you can, please give second choice so that this can be fulfilled.

- 5% discount on orders over \$50.00
- 10% discount on orders over \$75.00
- 15% discount on orders over \$125.00

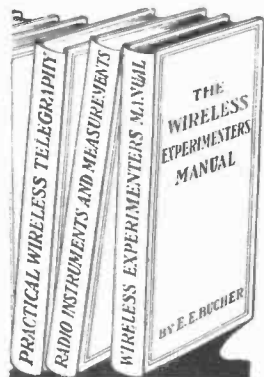
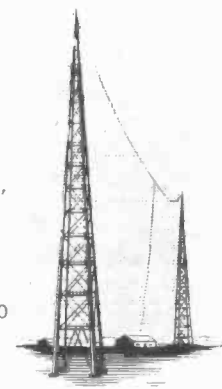

All items subject to prior sale  
Money back guarantee, satisfaction guaranteed  
Books and Magazines shipped PREPAID....

**Look CLOSEOUTS!**

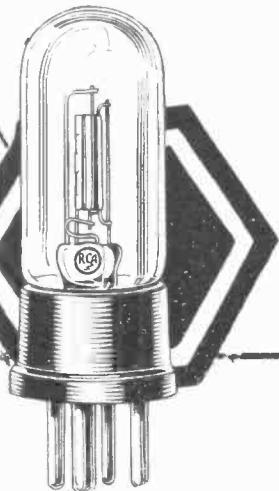

CLOSEOUTS CLOSEOUTS CLOSEOUTS CLOSEOUTS CLOSEOUTS

INVENTORIES MUST BE REDUCED TO MAKE ROOM FOR A LARGE SHIPMENT OF MATERIAL THAT WILL ARRIVE JANUARY 15th. THIS IS YOUR CHANCE TO BUILD YOUR LIBRARY AT A FRACTION OF THE BOOKS VALUE!!!!!!

.....  
ANY BOOK IN THIS AREA \$3.00 each  
.....

- |  |        |
|--|--------|
| 13. RADIO. A STUDY OF FIRST PRINCIPLES, 1928, Burnes   | \$3.00 |
| 24. PRINCIPLES OF RADIO ENGINEERING, 1936, good pictures and illustrations. This is not a bad buy at....   | 3.00   |
| 29. BASIC RADIO TUBES AND THEIR CIRCUITS, 1942.....  | 3.00   |
| 42. DRAKES CYCLOPEDIA OF RADIO AND ELECTRONICS, 1951   | 3.00   |
| 45. RADIO OPERATING QUESTIONS & ANSWERS 1948.....  | 3.00   |
| 52. ESSENTIALS OF RADIO, 1948. reprinted for armed forces  | 3.00   |
| 53. WIRELESS DIRECTION FINDING, 1947.....  | 3.00   |
| 81. RADIO COMMUNICATION THEORY AND METHODS WITH AN APPENDIX ON TRANSMISSION OVER WIRES, 1917.....  | 3.00   |
| 85. ELEMENTS OF RADIO, VOLUME I, Marcus, 1943.....   | 3.00   |
| ELEMENTS OF RADIO, VOLUME II, Marcus, 1943.....  | 3.00   |
| ELEMENTS OF RADIO, COMPLETE EDITION, 1943.....   | 3.00   |
| 100. FIRST PRINCIPLES OF RADIO COMMUNICATIONS, Morgan, '43   | 3.00   |
| 101. MODERN WONDER WORKERS...THE BOYS' STORY OF INVENTION, over 300 illustrations, more than a boys book, more than just radio...rail, telegraph, auto 1924..... | 3.00   |
| 102. RADIO OPERATING QUESTIONS AND ANSWERS, NIELSON.....   | 3.00   |
| 109. PRINCIPLES OF RADIOTELEGRAPHY, Jansky, 1919.....  | 3.00   |
| 110. INTRODUCTION TO PRACTICAL RADIO, Tucker, 1945.....  | 3.00   |
| 114. RADIO A Study of First Principles 1938, Burns.....  | 3.00   |
| 117. RADIO ENGINEERING PRINCIPLES, Lauer, 1919.....  | 3.00   |
| 127. ELECTRONICS, ENGINEERING MANUAL, VOL 7. articles reprinted from ELECTRONICS, EXC CONDIX.....  | 3.00   |
| 134. RADIODYNAMICS the wireless control of torpedoes and other mechanisms, 1916, Miessner.....   | 3.00   |
| 144. FUNDAMENTALS OF RADIO, Terman, 1938, new looking.....   | 3.00   |

- T9 Large colored picture Chicago Tel Co buildings, grouped to make a telephone city, keyed to give the names of various exchanges housed in the various bldgs, would be nice framed \$1.00
- T10 3 pamphlets S-R Private Service System, a simple device to prevent listening in on party line telephones, 8 pages, all alike \$3.00
- T11 Program, 12th Annual Convention, 111 Independent Tel Assn Nov 15, 16, 17 1916, 23 pages \$2.00
- T12 Frank B. Cool, Telephone Protective Apparatus & supplies, Chicago, Jan 1, 1912, 74 pages \$10.00
- T13 How the telephone helps the Farmer, Beautiful colored old Telephone on front \$5.00
- T14 Stromberg Carlson Tel Co, 48 pages, lots of pix, info and illustrations \$10.00
- T15 Card size pamphlet, 11 pages telephone pictured on almost every page, the strong phone for farmers \$2.00
- T16 Letter from Jan 29, 1906, telephone pictured on each side letterhead typed 50¢
- T17 Monarch. wire chief's test unit, bulletin 29, Fort Dodge Iowa, 15 pages, old, but no date, post card size \$2.00

**TELEPHONY WEEKLY MAGAZINE**

1914	31 issues	1918	50 issues
1915	40 issues	1919	46 issues
1916	49 issues	1920	5 issues
1917	47 issues		

\$1.00 each or ALL for \$125.00

- T18 Connecticut Telephones for interior use, catalog, 56 pages, good material, \$18.00.



- RAILWAY EXPRESS ITEMS PICTURES GIVE-A-WAYS, ETC
- RE1 PHOTOGRAPHS OF REA OFFICES ACROSS THE USA. These are 8 x 10 and 5 x 7 glossy photos with the agency city marked on the back. For the most part, these buildings do not exist today because of the company ceasing operation. There are 175 to 200 of these pictures. 50¢ each, my choice....\$2.00 each, your choice....or make me an offer on the lot.
- RE2 REA TELEPHONE DIRECTORY, Headquarters and New York Metropolitan Area, June 1964, \$4.00
- RE3 WINDOW DECAL, "AIR EXPRESS ACCEPTED HERE" Green with white letters, REA "X" diamond in red/white. Has been folded, slight tear in one place \$2.50
- RE4 REA 2 diamond, red white letters window sticker, \$2.00
- RE5 REA "X" shoulder patches, cloth, new condition, \$3.00
- RE6 REA METAL BADGES, Very USED condition, 9 of these, \$2.00 ea.
- RE7 REA "X" ...looks like a coaster give a way to customers \$2.
- RE8 AIR EXPRESS DIAMOND, 2 1/2", red with letters white, pressboard neat, \$4.00
- RE9 Letter opener, plastic, ivory color, "SPECIFY AND USE RAILWAY EXPRESS NATIONWIDE RAIL AIR SERVICE" MARKINGS ON SIDE, GOOD condition \$4.00-
- RE10 Plastic Paper clip holder with REA "X" logo, magnetic, \$4.00
- RE11 REA PENCILS, New, has REA stamped into wood, 50¢ each
- RE12 Misc pencils, REA, some of various types, used, 5 for \$1.00
- RE13 REA EXPRESS SINK stopper (red rubber) marked "LOSS AND DAMAGE PREVENTION MEANS JOB PROTECTION", \$3.00
- RE19 Employee Badge, white with black letters 1 1/2", with employee number, \$3.00
- RE20 A personalized shaving kit, for you from REA "X", this is a match stick folder in size, has razor and shaving cream, pretty good shape \$3.00

**TELEPHONE ITEMS**

- T1 Bell Telephone News, Vol 4, Feb 1915, 32 pages \$3.00
- T2 Bell Telephone News Holiday, 1919, 32 pages, \$3.00
- T3 American Telephone Journal 2 pages, May 2, 1908 \$1.00
- T4 Receivers, Central Union Tele. Co, May 1916 (records), 13 pages, \$2.00
- T5 Amendments to constitution of Peoples Tel Co of Southern Ill., 1905, long sheet \$1.00
- T6 Pamphlet, Independent Tel, Finance, Post & Future, local financing by James C. Kelsey, Chicago, Feb 1914 \$1.00
- T7 Some of the problems of the Telephone business, Alonzo Burt, Nov 1913, 35 pages, \$4.00
- T8 Bell Tel News, Nov 1916, 32 pages, \$3.00

**MR. DX HOUND** A Character Created by RADIO WORLD Artist By **HAL SINCLAIR**



**WALTS EMPORIUM**

P. O. BOX 19406

DALLAS, TEXAS 75219

EVENINGS - 214-262-7855



**Caruso and other noted artists hearing their own rendition of the great Masked Ball Quintet**

Caruso, Hempel, Duchene, de Seguro, Rothier, and Setti (Director of the Metropolitan Opera Chorus) listening to their Masked Ball Quintet (Victor Record 89076).

When you hear the famous concerted numbers of opera on the Victrola, it is just as though you were hearing them in the Metropolitan Opera House.

They are rendered by the same great artists, and with all the beauty of tone and thrilling power which earn for them the plaudits of enthusiastic opera-goers.

Hearing is believing. Any Victor dealer will gladly play for you this great concerted number or any other music you wish to hear.

Victor Talking Machine Co., Camden, N. J., U. S. A.  
Berliner Gramophone Co., Montreal, Canadian Distributors

Victrolas \$15 to \$200



Victors \$10 to \$100

New Victor Records demonstrated at all dealers on the 28th of each month

1914 ad

**Standard Graphical Symbols**

*Radio Notes for September, 1923*

- Alternator (Single Phase)
- Alternator (Two Phase)
- Alternator (Three Phase)
- Ammeter
- Ammeter Thermal, Expansion Type
- Antenna
- Arc
- Battery
- Buzzer
- Circuit Breaker
- Coil Antenna
- Condenser, Audio Frequency
- Condenser, Compressed Air
- Condenser, Radio Frequency
- Condenser, Variable
- Counterpoise
- Coupler, Inductive (Mutual Inductance)

(Continued on page 10)

1923 ad

*Natural Re-PRODUCTION*  
**Atlas**  
**AMPLITONE**  
LOUD SPEAKER

**BLAST** and distortion conquered!!! Patented "double-diaphragm" re-PRODUCES the full range of musical sounds with absolute fidelity. Adjustable to varying receiving conditions. The most advanced type loudspeaker.

Hear the difference when your dealer demonstrates the Atlas Amplitone \$25.  
*Write for Booklet "F"*  
Letters from Users Requested  
What have you accomplished with your Atlas Amplitone? Tell us about it.

**Multiple Electric Products Co. Inc.**  
ORANGE ST., RADIO DIVISION NEWARK, N. J.

1923 ad

**A LOUD SPEAKER and REPRODUCER IN ONE BRISTOL AUDIOPHONE**

MORE THAN A LOUD SPEAKER the AUDIOPHONE is a real reproducer of the original broadcast. It is not a mere telephone reproducer, for it is not only perfect in tone, but it reproduces all instrumental music and lyrics for distant or great crowd listening. You get all the fine shading and every inflection. In fact, the variety of the artist seem to be present as you listen.

DEVELOPED in the laboratory of the world's best known the world over for recording, it transmits the original.

COMPLETE in every way ready for use in the receiving set.

NO AUXILIARY BATTERIES are required for operation.

ADAPTED for use in all types of receiving sets.



TRADE MARK  
**AUDIOPHONE**  
REG. U. S. PAT. OFFICE

MADE IN TWO MODELS:  
BRISTOL AUDIOPHONE  
SR Loud Speaker, Size of Horn 17-Inches Diameter, Price ..... **\$32.50**

BRISTOL AUDIOPHONE  
JR Loud Speaker, Size of Horn 14-Inches Diameter, Price ..... **\$22.50**

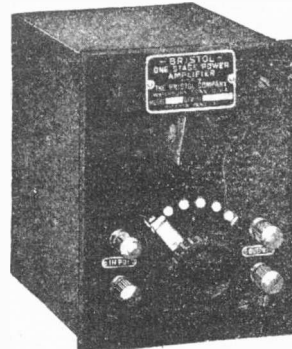

THE BRISTOL SINGLE STAGE POWER AMPLIFIER for use with the usual two-stage amplifier can be furnished, which will greatly increase the range of the Audiophone where desirable. **\$25.00**  
Price .....

*Write for Bulletin 3006-S.*

**THE BRISTOL COMPANY,**  
WATERBURY, CONN.

Boston New York Philadelphia Pittsburgh Detroit  
Chicago St. Louis San Francisco





### Better Light With Fixed-Focus

WHAT is "Fixed-Focus" and why do careful drivers prefer TUNG-SOL Fixed-Focus Bulbs? TUNG-SOL Fixed-Focus Bulbs have been especially built for use with reflectors having a permanently set focus. It is the accuracy with which the filaments are placed *exactly* in the focal center of the bulb that makes this possible.

They can also be used in reflectors with adjustable sockets. When the correct adjustment has once been obtained, replacements with TUNG-SOL Fixed-Focus are readily made without further adjustment and the light will be in perfect focus. This is not only a great convenience, but a decided advantage in complying with the most stringent head-lamp laws.

## TUNG-SOL

*The Quality Bulb for Motor Cars*  
Whether it be TUNG-SOL Fixed-Focus, or any other type of TUNG-SOL for head-, side- or tail-lamps, quality and long life are distinguishing characteristics. When you need new bulbs, ask the dealer for "TUNG-SOL."

If your car is equipped with the new Flatlite Reflector, be sure you get TUNG-SOL Fixed-Focus Bulbs. Look for the name stamped on the base.

"Let Tung-Sol Light the Way"

MINIATURE INCANDESCENT LAMP CORPORATION  
Newark, N. J.

Licensed Under General Electric Company's Incandescent Lamp Patents

MARCH 8, 1924

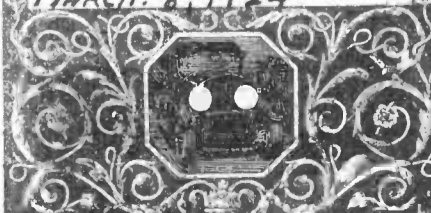

## THE BEST LIGHT

The most brilliant, economical light made. Our light gives 100-candle power at the small cost of 2c per week

Is portable and there is no dirt, grease, odor or smoke. Over 100 different styles - every one warranted.

Agents Wanted Everywhere.

**THE BEST LIGHT CO.**  
Owners of Original Patents.  
5-25 E. 5th St.  
Canton, O.

S.E.P.  
1906

EVENING POST Saturday

41

Sept. 4, 1909

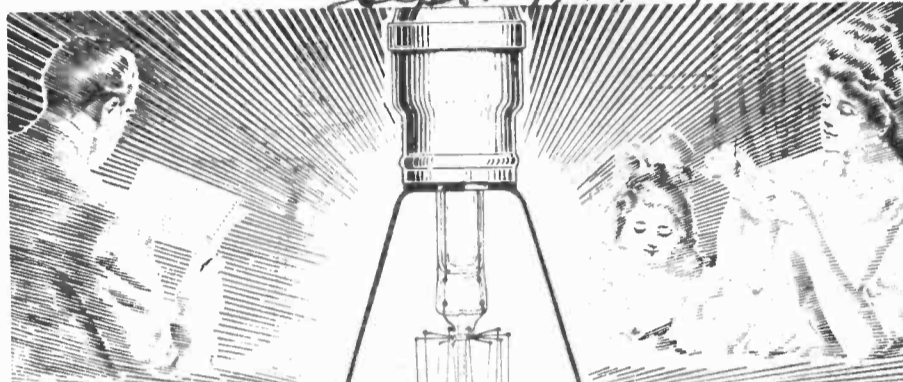

### ELECTRIC LIGHT

The new G. E. Tungsten lamp gives nearly three times the light given by ordinary incandescent lamps.

### IS NOW CHEAPER

Electric light is now available for many people who never before thought they could afford to use it.

# General Electric Tungsten Lamps

G. E. TUNGSTEN Lamps will give you more and better light for your money than you ever received before.

They are an improvement over the Standard G. E. Edison lamp you know so well.

The light giving filament is made of the rare metal tungsten instead of carbon. Tungsten becomes much brighter than carbon when heated by the electric current.

The G. E. TUNGSTEN Lamp uses only about one-third the current required by carbon filament lamps of the same candlepower.

The light of this lamp closely resembles daylight in its soft white brilliancy.

Thus G. E. TUNGSTEN Lamps give the *highest quality of light* at a *much lower cost*.

G. E. TUNGSTEN Lamps have already been placed in many large stores, office and public buildings where quality and economy are both essential.

For the *home* or the *small business place* they offer the same advantages that have induced larger users to install them.

Any progressive electric light company will be glad to tell you all about this new incandescent lamp—or, write to us for our G. E. Tungsten Book No. 32 which tells more about the wonderful metal, Tungsten, and explains how the best results can be secured from G. E. TUNGSTEN Lamps in home, office, factory or store.

REMEMBER—every day you are without G. E. TUNGSTEN Lamps an inferior light is costing you more than it should.

In 1880 the General Electric Company (then the Edison Electric Light Co.) made

and marketed the first Edison carbon incandescent lamp ever manufactured for commercial purposes. Since that date this company has manufactured and sold 270,000,000 Edison carbon incandescent lamps. Every notable advance in electric lighting in the last thirty years has been made by the General Electric Company.

The genuine G. E. TUNGSTEN Lamps are always packed in individual boxes bearing the famous G. E. monogram. Look for it.

General Electric Company, Dept. 33, Schenectady, N. Y.



## Get these Beautiful Lindsay Lights

They Cost Only the Postage

Beautiful art lights of polished brass finish, with richly etched globe and Lindsay Tungsten Gas Mantle. They retail regularly at \$1.25 each.

Thousands are equipping their homes with these handsome lights without cost, and at the same time are learning what real gas-mantle satisfaction is.

## Lindsay Tungsten Gas Mantle

The Lindsay Tungsten Mantle is the sensation of the gas-light world.

It is made of specially tough fibre, specially treated. It outlasts several ordinary mantles and does not shrink with use. It gives a powerful light, yet soft and pleasant to the eye.

At thirty cents, it is the cheapest mantle made. We say this though we ourselves make the best mantles possible at the price to retail at fifteen, twenty and twenty-five cents.

You can easily prove its worth by buying one mantle from your dealer for a test.

### Save the Box Lids

When you have twelve lids from Lindsay Tungsten Mantle boxes, send them to us with ten cents for postage and packing, and we will forward the beautiful premium light prepaid.

Many people are buying the mantles in dozen lots so as to get their first light at once. Look for the name Lindsay, which represents *quality* in gas lights and gas mantles, and the lavender-colored mantle.

If your dealer can't supply you, send your order direct, mentioning his name.

Lindsay Light Company  
NEW YORK CHICAGO

DEALERS: If unprepared to supply Lindsay goods, write us at once. You are missing trade without them. (20)

# MART

Classified ad rate: 6¢ per word.  
Photo ads: \$2.00 extra.

Deadline: 20th of the preceding month.

## FOR SALE OR TRADE

EARLY BATTERY SET SERVICE MANUAL 1919-1927, bound 200 page special edition of Riders volume 1, covers all battery sets, \$17.50. New WD11A \$9.50 each, \$18. pair. MORE THAN YOU WANT TO KNOW ABOUT THE RADIOLA III, 30 pages \$5.00. RADJOLA BATTERY SET SERVICE MANUAL 1922-1927, covers all radio battery sets, 85 pictures and diagrams \$5.00. Ken Hanson, 3403 Broadway, Long Beach CA 90803.

FOR SALE: Scott model 800 BS RF deck and power-supply Amplifier. No speaker or cabinet. Condition: complete, all tubes, some rough places on chrome of power supply. Offer: (Need QSTs before 1926). Wes Chatellier, W5DPM, 1950 Chevelle Dr., Baton Rouge LA 70806.

FOR SALE OR TRADE: Vivatar Telephoto lens 135mm f2.8 for Minolta SRT cameras, Vivatar 3x extender for above. Also close-up lens set. Will trade for preferably old RCA Radio and speaker or what have you. Hugh E. Juhn, R-3, Lime Springs IA 52155.

TRADE ONLY: 1 A.K. 10 Breadboard, mint condition, works. Best I have listened to. Want, Deforest 10 or Scott with F.M. or? G. J. Thomson, 11031 Ridgeland Ave., Chicago Ridge IL 60415. Phone 312 336-1997.

FOR SALE: Send SASE for list of 1920's radios which will be mailed in two weeks. Please do not phone. Arthur Harrison, 1021 Falcon Dr., Columbia MO 65201.

BLANK BAKELITE PANELS - Cut to size, 1/16" to 3/8" thick. Fabricating and engraving services available. SASE for pricing sheet. Parsons, WB1BVO, 22 Forest St., Branford CT 06405.

HAVE ANTIQUE RADIO & TV TUBES. Also some antique & old radios. Send 26¢ stamps for list w/prices. Harold's Radio, 3106 N. 3rd St., Harrisburg PA 17110.

FOR SALE: AK 10B and AK 4066. Send SASE, W6THU, 1545 Raymond, Glendale CA 91201.

ANTICIPATE BEING TRANSFERRED in the spring. Must sell excess items from my collection: Battery and AC sets, horns and speakers. Send SASE for list. Jim Collings, 2218 Woodward, Abilene TX 79605.

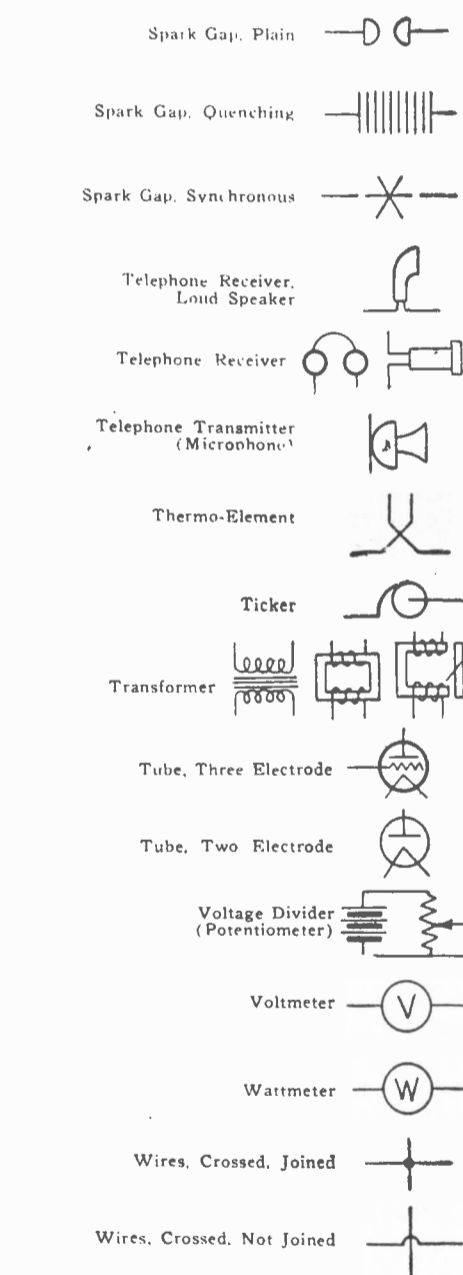
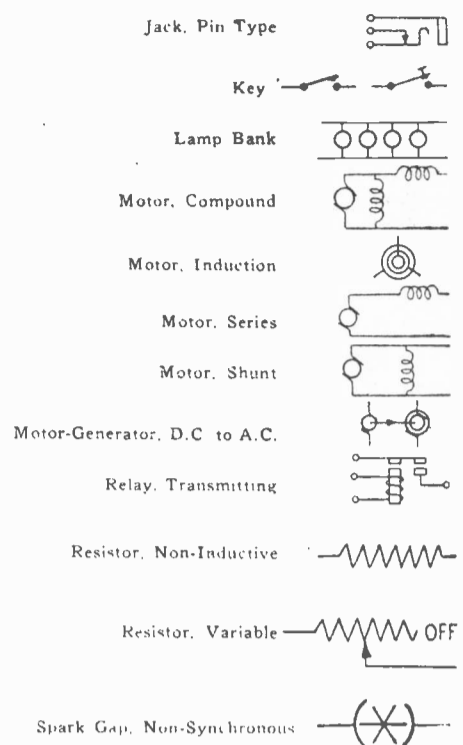
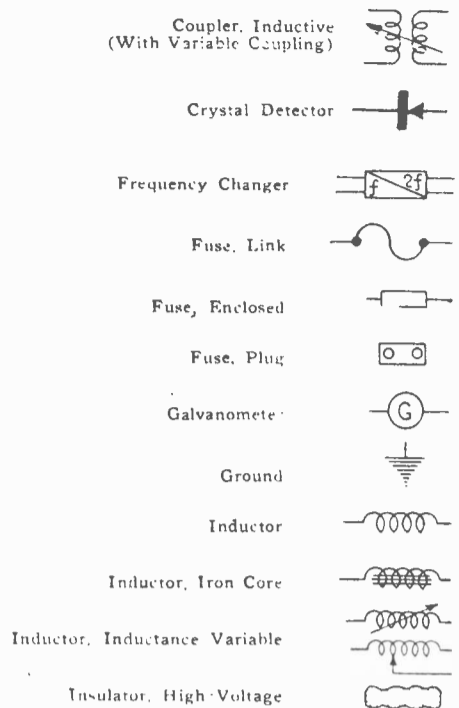

REPAIR RESTORE
OLD RADIO TUBES
SALE SERVICE

### ANTIQUA RADIO SERVICE

O. H. McDONALD  
948-9896

1606 LEBANON  
DALLAS 75208

## BACK ISSUES

### The Horn Speaker

All 10 back issues for 1973...\$8.00  
Single issues...\$1.00 each

All 10 back issues for 1974...\$6.00  
Single issues...\$.75 each

All 10 back issues for 1975...\$5.00  
Single issues...\$.75 each

All 10 back issues for 1976...\$5.00  
Single issue...\$.75 each

Any single issue of 1977...\$.75 each

Later, we should have complete volumes for 1972, first year.

### The Horn Speaker

**Box 12 Kleberg, Texas 75145**

Rates for THE HORN SPEAKER  
One year.....\$5.50  
Two years.....9.00  
Special rates for one year (mailed in envelope)  
First class.....\$8.50  
Air mail.....\$12.00  
Foreign air mail...16.00  
Mail address: THE HORN SPEAKER  
Box 12  
Kleberg TX 75145

## WANTED

CATHEDRAL RADIO COLLECTION WANTED. Will buy 1 or 100! Also large Zenith table sets and 12, 15, 16 or 25 tube Zenith consoles from 1930s. Also want 2.5 volt power transformers and radio retailing magazines from 1929 - 1939. Please send price and phone No. with first letter. Nete Alexander, 2563 N. Farwell Ave., #12, Milwaukee WI 53211. Phone (414) 964-7043.

## FOR SALE OR TRADE

**FOR SALE:** Old radio tubes, Rider radio & TV manuals. Volumes of old radio & TV schematics, including auto radios; old radio parts; old magazines. Will sell as a package only. If interested write for list. Ken George, Box 22, Bisbee AZ 85603, or call 432-5057.

**NICKEL PLATED** brass machine screws etc., for old radios. Crosley thumb screws, AK & FE thumb nuts. SASE for list. Want useable parts from the 20's. Ray Harland, 2602 Mary Lane, Escondido CA 92025.

**FOR SALE:** Solid-State A, B and C power supply. Send SASE for information to: G. Schneider, 6848 Commonwealth Blvd., Parma Hgts., Ohio 44130.

**FOR SALE:** 5 page typed list of over 200 Radio magazines, battery sets, horn speakers, etc. Price only 50¢ to: WAVES, Box 7364, N. Bergen N. J. 07047.

UV99 and WD11 adaptors. Use any UX base tubes \$5.50 ea. pp U.S.A. 2 for \$10.00 either type. K. Parry, 17557 Horace, Granada Hills CA 91344.

**TRADE:** Want Deforest Rheo with knob and pointer; Tuska audios and vario-coupler; 1921 "Radio News Magazines." Have tubes and 14" Music Master speaker to trade. George Hausske, 1922 E. Indiana, Wheaton IL 60187.

**FOR SALE:** Radios, tubes, speakers, parts, service manuals. List R-1-78, Long SASE & 30¢. Krantz, 100 Osage Ave., Somerdale N.J. 08083.

**SEND LARGE SASE** for Antique Radio list 77-11. McKenzie, 1200 W. Euclid, Indianola IA 50125.

## WANTED

**NEED:** For 1928 Atwater Kent model 40; Top cover, power unit cover, matching speaker. Gene Densmore, 2125 Cambridge, Tallahassee FL 32304.

**WANTED:** Hickok tube tester adapter for foreign tubes, for model 600 or 6000 checke or Adapter #SA5 - 105 - 129, or schematic and socket to make one. Art Corbus, 4501 Greenwood Ave. N., Seattle WA 98103.

## WANTED

**WANTED OLD HAM GEAR** to set up Ham shacks for early 1930's and mid-1940's. Also need antenna condenser, knob and two knob locks for SCR-75 WW-I airplane radio. Also auto radio manuals up to 1960. Morgan McMahon, Box 2045, Palos Verdes CA 90274.

**WANTED:** Large lot external horn phonographs, parts, cylinder records, crystal sets, battery radios factory mfg., before 1926. Will pay \$75. for mint Lambert Jr. Crystal set. Young, 11 Willow Court, Totowa New Jersey 07512.

**WANTED:** CIRCA 1930-31 TV scanning discs, Daven Video amplifier, Kino lamps, complete and Dartial kits. Also all manner advertising material on receivers by Jenkins. Baird, others. Darcy Brownrigg, Chelsea, Quebec JOX 1NO Canada.

**WANTED SCHEMATIC:** Million tube tester Model No. Df; Precision signal tracer model No. 201; Electro filtered power supply model No. BJ. Larry Ray Cook, 362 East South St., Richland Center WI 53581.

**WANTED:** Antenna Selector switch for Atwater Kent Model 10B, same as early model 10 & 12. See Pages 74 and 75 "Vintage Radio." Jim Steele, P.C. Box 568, Tomah WI 54660.

**RADIOLAS WANTED:** Senior, Special, Concert I, RS, VI, VII, X. Send best price and condition. Harold Perkins, 4484 E. Flamingo Rd., Las Vegas NV 89121.

**NEED 2 magnetic coils** for Crosley Dynacone Speaker type F. Stan Kolody, 1431 Alina Terr., LaGrange Park IL 60525.

**WANTED:** National SW-3 complete with power supply and coils. Must be mint. WB1BVO, Norman A. Parsons, 22 Forest St., Branford CT 06405.

**WANTED:** Zenith Trans-Oceanic Model 7G605, page 194, "A Flick of A Switch." Louis Yadevia, 601 Church Lane, Upper Darby PA 19082.

**WANTED:** WIRE RECORDERS; Brush, Armour, Telegraphone, or oddball types. H. Leyer, AV-SFSU, 1600 Holloway, San Francisco CA 94132.

## WANTED

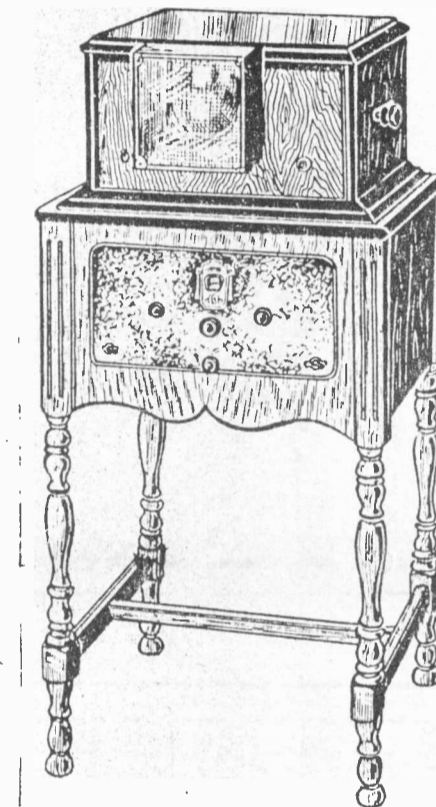
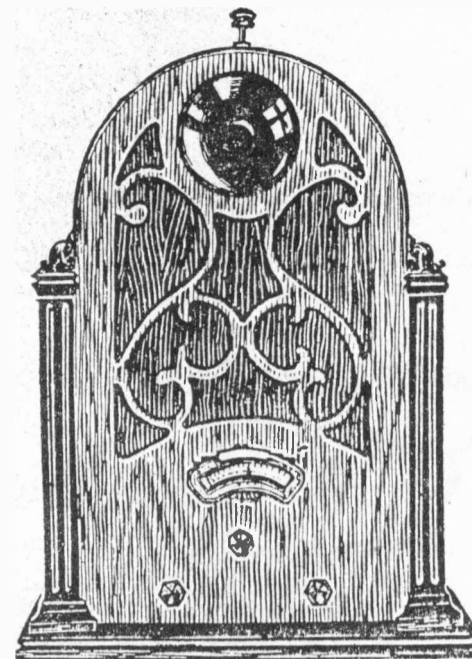

**WANTED:** Circa 1928-32 Television; Pioneer television scanner, I.C.A. Visionette, The Western Television Receiver, Baird Televisor, "See All" Television Receiver and scanner kit, Scanning discs, Daven television amplifiers, Taytheon Kino lamps. Any and all information welcomed. Darcy Brownrigg, Chelsea, Quebec, JOX 1NO CANADA

**WANTED:** RCA Theremin. Instrument must be intact. Also interested in information on RCA Terermins that are not for sale. Robert Moog, 405 Fillmore, East Aurora N.Y. 14052.

## FOR SALE OR TRADE

**FOR SALE:** Radio Amateur Call Books and ARRL Handbooks back to 1930. Jones Handbooks back to first printing. Send SASE for listing. Kennedy 110 & 220 dials restored like factory new.....\$8.00 each. Westinghouse Aeriola Jr. Dial.....\$10.00. Westinghouse Aeriola Sr. dials, set of three.....\$20.00. Some Kennedy dials must be removed and replaced with special tooling

so I must have complete dial. To restore the Aeriola dials, I must have the plates. Aeriola cabinets, completely assembled but not stained.....\$20.00. Crosley 50, 51 and 52 cabinets, completely assembled but not stained.....\$16.00. Deforest RJ-9 panel...all pre-drilled.....\$5.00. Deforest RJ-5 cabinets, completely assembled, unfinished.....\$10.00.

## FOR SALE OR TRADE

Deforest graphite potentiometers .....\$5.00. Westinghouse Aeriola & RADA binding post caps...\$1.00 each...\$10.00 per dozen. 8 X 10 Photo of a model "T" Ford Service Vehicle with "ATWATER KENT" printed on the side. Suitable for framing.....\$1.25. Roland Matson, 388 Concord Rd., Bedford MA 01730. Ph: 617 663-3877.

