

Proceedings

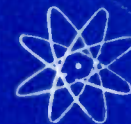

of the I·R·E

A Journal of Communications and Electronic Engineering
(Including the WAVES AND ELECTRONS Section)

October, 1948

Volume 36

Number 10



Sylvania Electric Products Inc.

ACCURATE STUDY OF DELICATE TINTS

The light from the fluorescent screen of a television picture tube is adjusted to normal brightness, and is then colorimetrically studied to determine its "whiteness" (according to standards devised by the International Commission on Illumination).

PROCEEDINGS OF THE I.R.E.

Reflected-Power Communication

Notes on Noise Figures

Cosmic Static

Calculated and Measured Phase Difference at 3.2
Cm Wavelength

High-Speed Electrolytic Facsimile Recording

Helical Beam Antennas for Wide-Band Applications

Antenna Design for Television and FM

Field-Strength Measurement of HF Electromagnetic
Fields

Mode Separation in Coaxial-Line-Resonator
Oscillators

Waves and Electrons Section

Nuclear Reactions and Nuclear Energy

Wide-Deviation Frequency-Modulated Oscillators

Frequency Measurement by Sliding Harmonics

Doubly Curved Reflector Calculation for Shaped
Beams

New 100-Watt Triode for 1000 Mc

Tapered Phase-Shift Oscillator

Abstracts and References

TABLE OF CONTENTS FOLLOWS PAGE 32A

Order File

The Institute of Radio Engineers



Linear Standard Units...

THE ULTIMATE IN QUALITY...

UTC Linear Standard Audio Transformers represent the closest approach to the ideal component from the standpoint of uniform frequency response, low wave form distortion, high efficiency, thorough shielding and utmost dependability.

UTC Linear Standard Transformers feature...

- **True Hum Balancing Coil Structure**... maximum neutralization of stray fields.
- **Balanced Variable Impedance Line**... permits highest fidelity on every tap of a universal unit... no line reflections or transverse coupling.
- **Reversible Mounting**... permits above chassis or sub-chassis wiring.
- **Alloy Shields**... maximum shielding from inductive pickup.
- **Hiper-m-Alloy**... a stable, high permeability nickel-iron core material.
- **Semi-Toroidal Multiple Coil Structure**... minimum distributed capacity and leakage reactance.
- **Precision Winding**... accuracy of winding .1%, perfect balance of inductance and capacity; exact impedance reflection.
- **High Fidelity**... UTC Linear Standard Transformers are the only audio units with a guaranteed uniform response of ± 1 DB from 20-20,000 cycles.

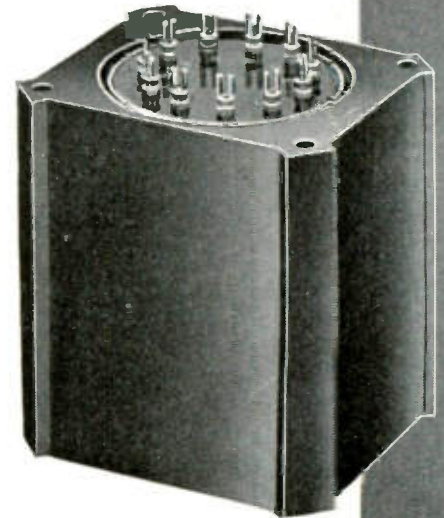

TYPICAL LS LOW LEVEL TRANSFORMERS

Type No.	Application	Primary Impedance	Secondary Impedance	± 1 db from	Max. Level	Relative hum-pickup reduction	Max. Unbalanced DC in prim'y	List Price
LS-10	Low impedance mike, pickup, or multiple line to grid	50, 125, 200, 250, 333, 500/600 ohms	60,000 ohms in two sections	20-20,000	+15 DB	-74 DB	5 MA	\$25.00
LS-10X	As Above	As above	50,000 ohms	20-20,000	+14 DB	-92 DB	5 MA	32.00
LS-12	Low impedance mike, pickup, or multiple line to push pull grids	50, 125, 200, 250, 333, 500/600 ohms	120,000 ohms overall, in two sections	20-20,000	+15 DB	-74 DB	5 MA	28.00
LS-12X	As above	As above	80,000 ohms overall, in two sections	20-20,000	+14 DB	-92 DB	5 MA	35.00
LS-26	Bridging line to single or push pull grids	5,000 ohms	60,000 ohms in two sections	15-20,000	+20 DB	-74 DB	0 MA	25.00
LS-19	Single plate to push pull grids like 2A3, 6L6, 300A. Split secondary	15,000 ohms	95,000 ohms; 1.25:1 each side	20-20,000	+17 DB	-50 DB	0 MA	24.00
LS-21	Single plate to push pull grids. Split primary and secondary	15,000 ohms	135,000 ohms; turn ratio 3:1 overall	20-20,000	+14 DB	-74 DB	0 MA	24.00
LS-22	Push pull plates to push pull grids. Split primary and secondary	30,000 ohms plate to plate	80,000 ohms; turn ratio 1.6:1 overall	20-20,000	+26 DB	-50 DB	.25 MA	31.00
LS-30	Mixing, low impedance mike, pickup, or multiple line to multiple line	50, 125, 200, 250, 333, 500/600 ohms	50, 125, 200, 250, 333, 500/600 ohms	20-20,000	+17 DB	-74 DB	5 MA	25.00
LS-30X	As above	As above	As above	20-20,000	+15 DB	-92 DB	3 MA	32.00
LS-27	Single plate to multiple line	15,000 ohms	50, 125, 200, 250, 333, 500/600 ohms	30-12,000 cycles	+20 DB	-74 DB	8 MA	24.00
LS-50	Single plate to multiple line	15,000 ohms	50, 125, 200, 250, 333, 500/600 ohms	20-20,000	+17 DB	-74 DB	0 MA	24.00
LS-51	Push pull low level plates to multiple line	30,000 ohms plate to plate	50, 125, 200, 250, 333, 500/600 ohms	20-20,000	+20 DB	-74 DB	1 MA	24.00
LS-141	Three sets of balanced windings for hybrid service, centertapped	500/600 ohms	500/600 ohms	30-12,000	+10 DB	-74 DB	0 MA	28.00

TYPICAL LS OUTPUT TRANSFORMERS

Type No.	Primary will match following typical tubes	Primary Impedance	Secondary Impedance	± 1 db from	Max. Level	List Price
LS-52	Push pull 2A5, 250, 6V6, 42 or 2A5 A prime	8,000 ohms	500, 333, 250, 200, 125, 50, 30, 20, 15, 10, 7.5, 5, 2.5, 1.2	25-20,000	15 watts	\$28.00
LS-55	Push pull 2A3's, 6A5G's, 300A's, 275A's, 6A3's, 6L6's	5,000 ohms plate to plate and 3,000 ohms plate to plate	500, 333, 250, 200, 125, 50, 30, 20, 15, 10, 7.5, 5, 2.5, 1.2	25-20,000	20 watts	28.00
LS-57	Same as above	5,000 ohms plate to plate and 3,000 ohms plate to plate	30, 20, 15, 10, 7.5, 5, 2.5, 1.2	25-20,000	20 watts	20.00
LS-58	Push pull parallel 2A3's, 6A5G's, 300A's, 6A3's	2,500 ohms plate to plate and 1,500 ohms plate to plate	500, 333, 250, 200, 125, 50, 30, 20, 15, 10, 7.5, 5, 2.5, 1.2	25-20,000	40 watts	50.00
LS-6L1	Push pull 6L6's self bias	9,000 ohms plate to plate	500, 333, 250, 200, 125, 50, 30, 20, 15, 10, 7.5, 5, 2.5, 1.2	25-20,000	30 watts	42.00

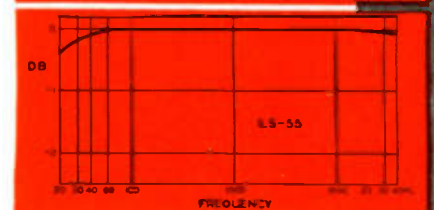
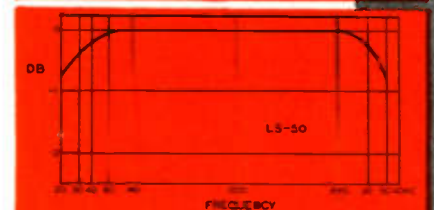
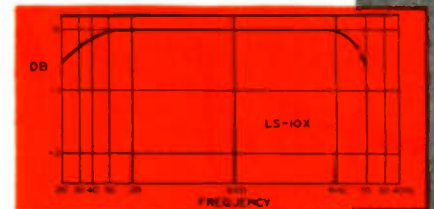

Write for our Catalog PS-408

United Transformer Co.

150 VARICK STREET NEW YORK 13, N. Y.
EXPORT DIVISION: 13 EAST 40th STREET, NEW YORK 16, N. Y., CABLES: "ARLAB"



FM LEADER!



GL-7D21

RING-SEAL CONTACTS

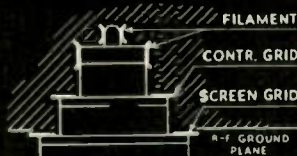

Sketch shows how easily the GL-7D21 can be plugged into a coaxial socket. Ring-seal design also provides ample contact surface for all terminals.

CHARACTERISTICS

Filament voltage	6.3 v
Filament current	30 amp
Interelectrode capacitances:	
grid-plate	0.4 mm d
input	39 mm d
output	14 mm d
Frequency at max ratings	110 mc
Type of cooling	forced-air
Max plate ratings, Class C telegraphy:	
voltage	4,000 v
current	1 amp
input	3,000 w
dissipation	1,200 w

110-mc ring-seal power tetrode streamlined for new transmitters. Forced-air-cooled. A pair will put out more than 3 kw, with only 120 w drive required!

Also best for your final stage because...

1. Tube installation or replacement takes only a few seconds (see sketch).
2. Wide terminal-contact areas greatly increase h-f efficiency.
3. Internal shielding is complete... tube inductance low... little if any neutralizing is needed.

TAILORED to your needs as builder or designer of new broadcasting equipment, Type GL-7D21 is the right tube for medium-power FM. Check the low drive requirement of 120 w—real economy!—against an output (push-pull in open-line circuits with proper external shielding) of well over 3 kw. Note the convenience of forced-air cooling!

Study the tube's other advantages given above, then add plus-features like silver-plated contacts to reduce r-f losses; strong, lasting Fernico metal-to-glass seals; trim contour and compact construction to match the other advanced components of your ultra-modern transmitter.

One of a distinguished family of ring-seal power tubes for FM and television, the GL-7D21's

brilliant all-around performance also marks these larger types:

GL-5513. A 220-mc forced-air-cooled triode, with typical Class C output (per tube) of 2.45 kw.

GL-5518. A 110-mc forced-air-cooled triode with typical Class C output (per tube) of 6.4 kw.

GL-9C24. A 220-mc triode, cooled by water and forced air, with typical Class C output (per tube) of 9 kw.

In this group is a tube directly suited to your requirements, no matter what type or size transmitter now is on your drawing-boards. For prices and detailed information phone your nearby G-E electronics office, or wire or write to: *Electronics Department, General Electric Company, Schenectady 5, New York.*

GENERAL ELECTRIC

161-06-8850

FIRST AND GREATEST NAME IN ELECTRONICS

How a quartz ring drove the first crystal clock in 1928

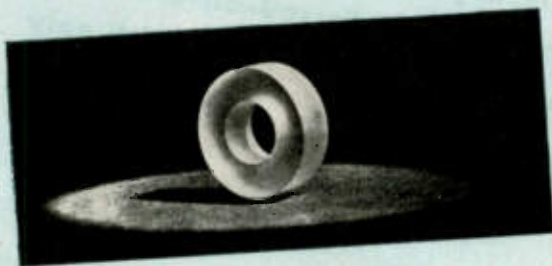

Heart of the crystal clock built 20 years ago at Bell Laboratories was this quartz ring, adjusted to a frequency of 100 kc. With the crystal cut to correct proportions in this annular

shape, positive and negative temperature coefficients of frequency effectively neutralized each other. Resultant temperature coefficient was less than 1 part in 10^6 per degree C.



In the complete oscillator, the crystal was mounted inside a chamber in which the temperature was kept constant within 0.01°C , and placed in a hermetically sealed bell jar to maintain uniform pressure. The frequency of the oscillator output was reduced to 1,000 cycles by means of sub-multiple generators.



In the clock mechanism, a 1,000-cycle synchronous motor, driven by the output of the sub-multiple generators, was geared to the clock hands. Accuracy of this clock in 1928 was within 1 part in 10^6 . Accuracy of its present-day successor is of the order of 1 part in 10^8 —an advance made possible by continuing research.

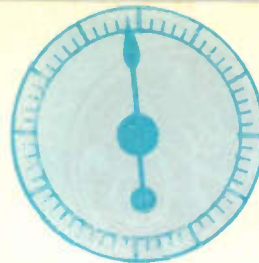

Where a second is

... in the clock that varies less than 1/1000th of a second a day

There's a clock at Bell Telephone Laboratories—evolved by the scientists there—that keeps accurate time within 0.001 second a day. It is the latest step in a series of developments that began 20 years ago when Bell Laboratories built the first crystal clock.

Why are the men of Bell Laboratories, whose basic interest is *communications*, so concerned with *time*? Because the study of communications is largely the study of frequency—and frequency is the inverse of time. To deal with frequencies in megacycles requires accurate measurement of fractions of micro-seconds.

In their early studies of piezoelectric crystals for frequency control, Bell scientists saw the desirability of using them also as a source of accurate time.

Two obstacles stood in the way of devising a crystal clock: the relatively high temperature coefficient of crystals, and the fact that their frequencies were too high to drive a synchronous motor. Annular crystals, with extremely low temperature coefficients, solved the first problem. Sub-multiple generators solved the second, accurately dividing the crystal frequency. Thus the barrier between *frequency standards* and *time standards* was finally broken down.



BELL TELEPHONE LABORATORIES

World's largest organization devoted exclusively to research and development in all phases of electrical communications.

a long, long time . . .

...in a frequency standard that's accurate to 1 part in 10^8 a day

Continuing research on piezoelectric crystals at Bell Laboratories resulted in a development of far-reaching importance—the GT cut.

This opened the way to revolutionary advances in instruments for time-frequency measurements. The GT-cut crystals make possible entirely new standards of accuracy, because of their extremely low temperature coefficient—less than 19 parts in 10^8 per degree C, far lower than produced by any other method of cutting.

Moreover, GT-cut crystals are admirably adapted to wire-suspension mounting, which virtually nullifies the effect of shock on frequency. This greatly enlarges the range of conditions under which accurate measurements can be made.

The Western Electric Primary Frequency Standard is the embodiment of these new concepts in design. It is a 100-kc source that combines accuracy and ruggedness to a remarkable degree. Frequency variation is less than 1 part in 10^8 over a 24-hour period; yet the Standard, far from being confined to the laboratory, performs with equal accuracy on ships, planes and vehicles—even in earthquake areas! *Wherever* there is a need for time-frequency measurements, or the synchronous operation of two or more systems, the Frequency Standard is ready and able to take on the job.

—QUALITY COUNTS—

How the Frequency Standard maintains its accuracy

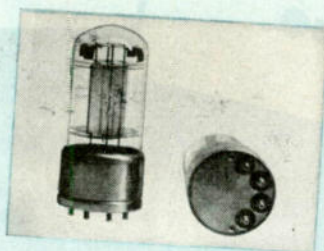

Key to the accuracy of the Western Electric Primary Frequency Standard is a GT-cut crystal, surpassing even the annular cut in the degree to which it nullifies the effect of temperature on frequency. The crystal is suspended by wires inside an evacuated glass envelope. The wire mounting results in an exceptionally rugged crystal unit, practically immune to shock.

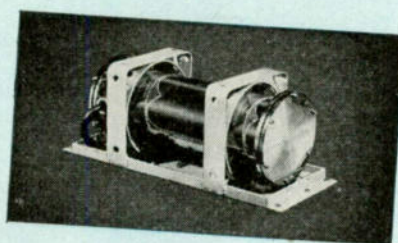

The GT crystal is mounted inside this oven in which temperature is controlled electronically with extreme accuracy. In conjunction with sponge rubber

pads, the oven acts as a further safeguard against vibration and shock, contributing to the outstanding ruggedness of the instrument.

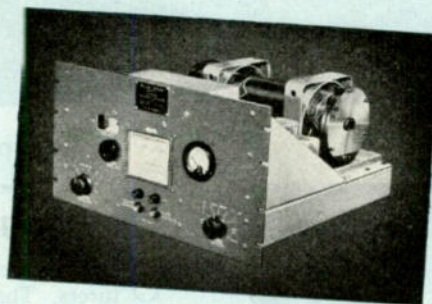

The complete Standard, compactly designed, ruggedly built, weighing only 90 pounds, brings

the accuracy usually associated only with delicate laboratory apparatus into field service.

Western Electric

Manufacturing unit of the Bell System and the nation's largest producer of communications equipment.



DISTRIBUTORS: IN U. S. A.—Graybar Electric Company, IN CANADA AND NEW FOUNDLAND—Northern Electric Co., Ltd.

**PROGRESS REPORT
ON
P.E.C.***

**How Allen-Howe — first to use
"Printed Electronic Circuit" in hearing aids —
depends on this Centralab development
for smaller, finer units.**



Models courtesy of Allen-Howe Electronics Corp.

***Centralab's "Printed Electronic Circuit"
— Industry's newest method for
improving design and manufacturing efficiency!**

SIZE and weight are vital to Allen-Howe, hearing aid manufacturers. That's why this firm's engineers chose Centralab's *Printed Electronic Circuit* to help them design and build smaller, lighter, more efficient units. Just as important to Allen-Howe is product dependability. Months of actual experience using *Printed Electronic Circuits* have proved to them how very rugged these miniature audio-amplifiers are . . . just how well they resist humidity and moisture. That's why they continue to use Centralab's revolutionary P.E.C.

INTEGRAL CERAMIC CONSTRUCTION: Each *Printed Electronic Circuit* is an integral assembly of "Hi-Kap" capacitors and resistors closely bonded to a steatite ceramic plate and mutually connected by means of metallic silver paths "printed" on the base plate.

This outstanding hearing aid development, illustrated above, was the result of close cooperation between Centralab and Allen-Howe engineers. Working with your engineers, Centralab may be able to fit its *Printed Electronic Circuit* to your specific needs. Write for full information, or call your nearest Centralab Representative.

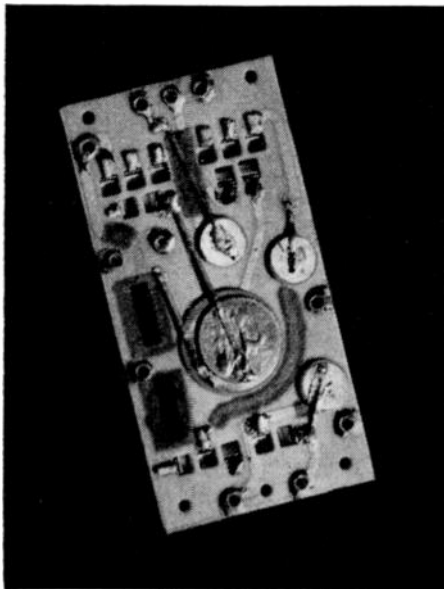

TYPICAL "AMPEC" — (actual size, back view) shows how you can get complete electrical circuits—tube sockets, capacitors, resistors and wiring—in one miniature Centralab amplifier unit.

LOOK TO *Centralab* IN 1948!

Division of GLOBE-UNION INC., Milwaukee



control

measurement

power sources

**SHERRON'S
PART IN
NUCLEAR
RESEARCH**

Years of experience in electronics is the basis for the service which Sherron is now offering in the field of nuclear physics.

Control and measurement instruments and power sources are the types of units Sherron can develop and manufacture to your specifications.

A component part of Sherron service is the co-operation of a staff of physicists and electronics engineers. Included too are the resources of up-to-date electronics and electro-mechanical laboratories. Your inquiry will be given prompt attention.

SHERRON CAN SERVE IN THE DESIGN, DEVELOPMENT AND MANUFACTURE OF:

COUNTERS: Maximum count as required. Pre-determined setting anywhere within the counting range. Resolution in the micro-second region.

AMPLIFIERS: R.F., Video, A.F., D.C. to fit any application. Particular emphasis on high gain, high stability characteristics.

COMPUTERS: Mechanical linkages. Electrical analogues of any complexity. Digital computers.

POWER SUPPLIES: Electronic - Regulation 1/2% and less.

SERVO-MECHANISMS: Control to any desired accuracy. Power as desired. Linear control, logarithmic control.

OSCILLATORS: All frequencies.

MEASUREMENT-CONTROL: Devices for measuring and control of all parameters capable of being controlled and producing proportional electrical, optical or measuring displacement. Electronic microammeters, radiation counters.

CONTROL OF ACCELERATOR ACCESSORIES: Grouping of controls, supplementary apparatus, and experimental system into a compact versatile unit.

REGULATORS: Electronic - direct or through servo control. Regulation, drift, etc. to specification.



SHERRON ELECTRONICS CO.

Division of Sherron Metallic Corporation

1201 FLUSHING AVENUE • BROOKLYN 6, N.Y.



**CAST ALNICO V and VI THIN WALL RINGS
FOR MAGNETIC FOCUSING ASSEMBLIES**

Quality and Quantity - NO PROBLEM!

In TELEVISION SETS. magnetic focusing eliminates blur; gives clear, sharp reception even during warm-up, or line voltage fluctuations; and the *first* focusing adjustment is the *last*. The thin ring-type permanent magnets of Alnico V and VI produced by Arnold for this use (several sizes are pictured here) are *cast*, not sintered, in order to save on first cost. It's a difficult job, but Arnold's advanced methods produce these rings in the desired quality and any quantity, *without trouble*. —No matter what the application, in any grade of Alnico or other materials, you can depend on Arnold Permanent Magnets. We'll welcome your inquiries.

THE ARNOLD ENGINEERING COMPANY



Subsidiary of

ALLEGHENY LUDLUM STEEL CORPORATION

147 East Ontario Street, Chicago 11, Illinois

Specialists and Leaders in the Design, Engineering and Manufacture of PERMANENT MAGNETS

Specify **Hi-Q** COMPONENTS for **DEPENDABILITY**

The dependability of **Hi-Q** components contained in your finished product will enhance your reputation as a manufacturer of *quality* equipment. The dependability of **Hi-Q** components is the result of meeting exacting specifications which insure their conformance to your requirements...temperature coefficients within recommended tolerances, insulation resistances to minimum standards, capacities as specified. **Hi-Q** dependability results from the use of highest quality materials and from constant surveillance throughout processing...your assurance of efficient, dependable service. Write for detailed information and engineering specifications.



CERAMIC CAPACITORS



Hi-Q Ceramic Capacitors of unquestionable stability assure you the ultimate in performance for all electronic appliances. Let us assist you with your Ceramic Capacitor problems.

CHOKER COILS



STAND-OFF CONDENSERS



WIRE WOUND RESISTORS



Hi-Q COMPONENTS BETTER 4 WAYS

PRECISION Tested step by step from raw material to finished product. Accuracy guaranteed to your specified tolerance.

UNIFORMITY Constancy of quality is maintained over entire production through continuous manufacturing controls.

DEPENDABILITY Interpret this factor in terms of your customers' satisfaction... Year after year of trouble-free performance. Our Hi-Q makes your product better.

MINIATURIZATION The smallest **BIG VALUE** components in the business make possible space saving factors which reduce your production costs... increase your profits.

Hi-Q

Electrical Reactance Corp.

FRANKLINVILLE, N. Y.

Plants: FRANKLINVILLE, N. Y. — JESSUP, PA.
Sales Offices: NEW YORK, PHILADELPHIA, DETROIT, CHICAGO, LOS ANGELES

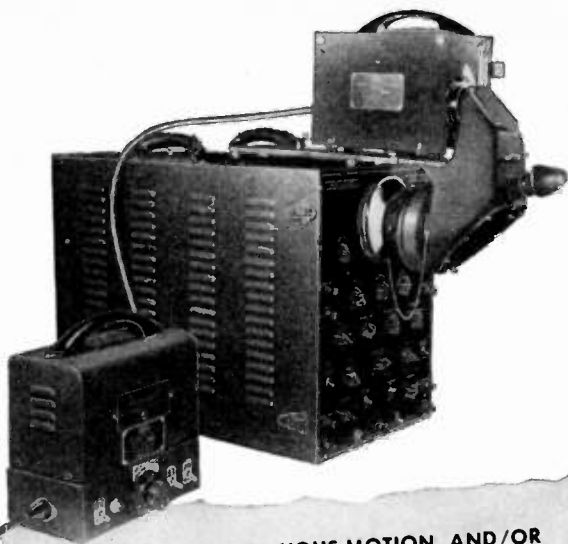

For any kind of oscillographic recording . . .
 DU MONT TYPE 271-A and/or DU MONT TYPE 314

Oscillograph-Record CAMERAS

to convert your oscillograph
 into a recording instrument

TYPE 314 CONTINUOUS-MOTION AND/OR SINGLE-FRAME CAMERA

◆ In addition to single-frame exposures, the Du Mont Type 314 Oscillograph-Record Camera provides continuous-motion photography. Recommended for recording continuous, changing processes, and where variations to be studied require an extended period of time. Film speed electronically controlled within range of 1 inch per minute to 5 feet per second. Applicable to widest variety of uses such as study of Welding, Biology, Switches, Electric Shavers, Synchronous Motors, Fluorescent Lamps, Guided Missiles, Oscillator Drift, Voltage Stabilizers, Nuclear Physics, Hydraulics, Mechanics, Dynamic Unbalance, Cylinder Pressure, Acoustics, etc.

Type 314 Oscillograph-Record Camera, Cat. No. 1217-E (f/2.8 lens) \$980; Cat. No. 1366-E (f/1.5 lens) \$1,155; delivered in U.S.A.

TYPE 271-A SINGLE-FRAME CAMERA

◆ For single-frame exposures of high-speed transients, or for multiple exposures to record a family of curves, the Du Mont Type 271-A Oscillograph-Record Camera is your ideal selection. And the cost is well within reach of the modest instrument budget. May also be used to good advantage with Du Mont Type 264-A Voltage Calibrator for amplitude and wave-form measurements. Equipped with f/3.5 lens. Uses standard 35 mm. film. And remember, this camera is readily fitted to any 5-inch oscillograph.

Type 271-A Oscillograph-Record Camera, Cat. No. 1216-E, \$162.50 delivered in U.S.A.



◆ DETAILED SPECIFICATIONS FOR EACH CAMERA, SUPPLIED ON REQUEST.

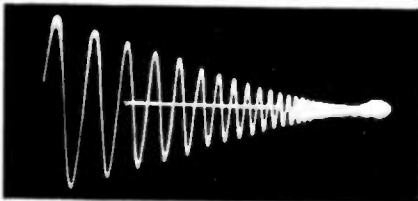

Typical high-speed recording: 2 mc transient (with Du Mont Types 281 and 286 Cathode-Ray Oscillographs using Type 271-A).

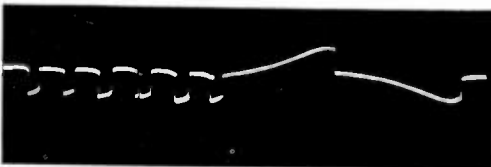

Output voltage of Type OB2 Voltage-Regulator Tube, with sudden applications of resistive load, using Type 314 Continuous-Motion/Single-Frame Camera.



Plot made on Type 314 of starting current of small synchronous motor. (Note variation in current as the rotor "hunts" for its synchronous speed).

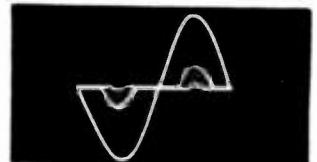

Triple exposure made with Type 271-A while varying constants of peak-clipping circuit.

© ALLEN B. DU MONT LABORATORIES, INC.

DUMONT

for Oscillography

ALLEN B. DU MONT LABORATORIES, INC., PASSAIC, N. J.
 CABLE ADDRESS: ALBEEDU, NEW YORK, N. Y., U.S.A.

OHMITE

Resistors

Sizes and Types for Every Service

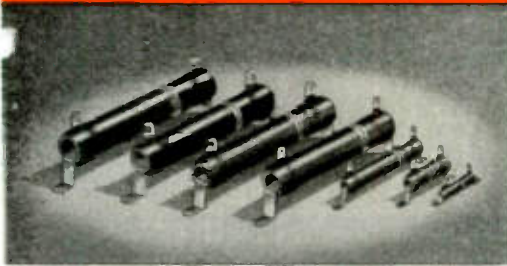

LUG TYPE

Most popular type for general purpose applications. Connected by soldering or bolting to lugs. Protected by vitreous enamel coating.

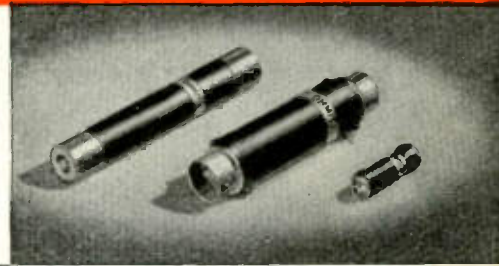

FERRULE TYPE

Winding terminated on metal bands for mounting in standard fuse clips. Provides easy interchangeability without tools.

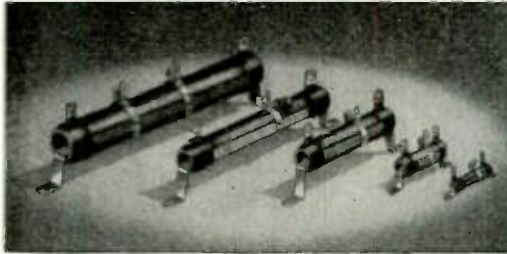

"DIVIDOHM" ADJUSTABLE TYPE

Provided with adjustable lugs for securing odd values of resistance quickly and easily.

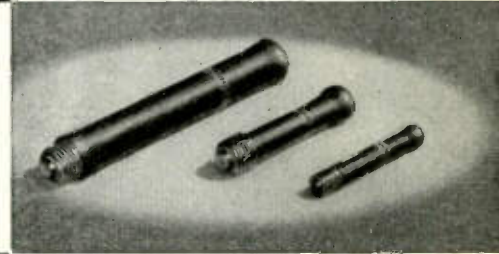

EDISON BASE TYPE

Mounted in ordinary lamp type screw sockets for easy interchangeability without the use of tools.

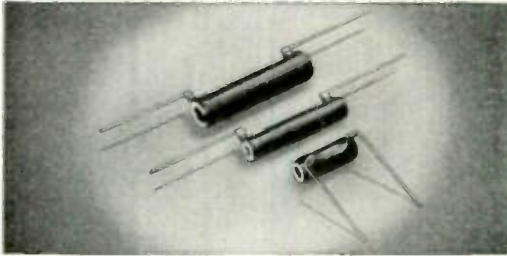

WIRE LEAD TYPE

Small vitreous enameled resistors which can be connected and supported by their own wire terminals. Maximum size approx. 20 watts.

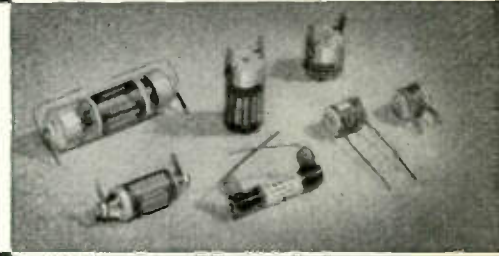

PRECISION TYPE

Low wattage resistors of $\pm 1\%$ or closer tolerance. Made in vacuum impregnated, glass sealed, or vitreous enameled type units.



FLEXIBLE LEAD TYPE

Winding is connected to stranded bare or insulated leads. Used where it is desired to have connecting wires a part of the resistor.

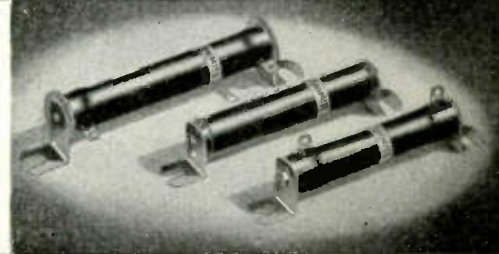

BRACKET TYPE

Have metal end brackets. Live bracket type is connected by bolting brackets to panel terminals. Dead bracket type has separate lugs.



"CORRIB" TYPE

Has edge-wound, exposed corrugated ribbon winding. For low resistances where 100 watts or more must be dissipated in small space.

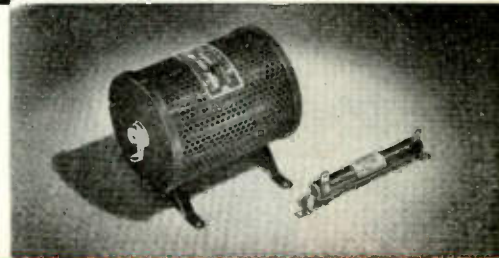

NONINDUCTIVE TYPE

For radio frequency circuits where constant resistance and impedance are required. Made in rugged, vitreous-enameled type construction.

In addition to the many types of resistors shown above, Ohmite offers resistors in more than sixty different core sizes, and a wide range of wattages and resistance values. Ohmite engineers will be pleased to help you in selecting the right resistors for your needs.

OHMITE MANUFACTURING CO.

4860 Flournoy Street

Chicago 44, Illinois



Write on Company Letterhead for Catalog and Engineering Manual No. 40.

Contains 96 pages of useful data on the selection and application of rheostats, resistors, tap switches, and other equipment.



Be Right with...

OHMITE

RHEOSTATS • RESISTORS
TAP SWITCHES

Industry's First Choice

ELECTRONICS



Designers

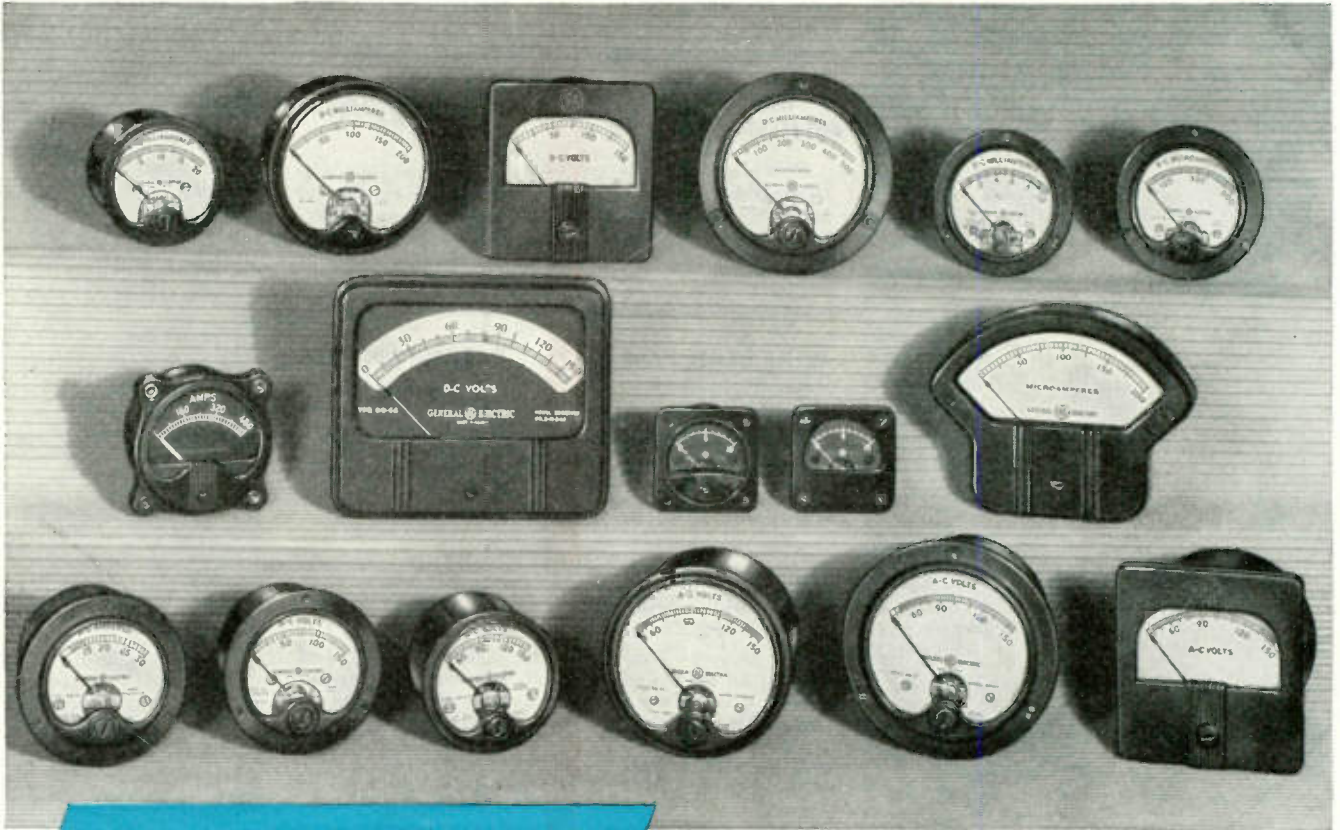

*A panel instrument
for every need*

These general-purpose panel instruments are particularly suitable for use in radio equipment and industrial applications where accuracy and quality are required and space is at a premium. Many of the instruments have been newly styled

for better readability and for the smooth, modern appearance that will help give your panels a well-engineered look.

Thermocouple-type instruments, for measurements of high-frequency alternating current in radio or other electronic circuits, are available. There is also a complete line of rectifier types (a-f), for measuring alternating current or voltage at high frequencies or where the source is not sufficient to operate conventional a-c instruments. Typical applications include television transmitters, radar wave meters, testing equipment for electronic circuits. For a full story of G-E instruments, send for Bulletin GEC-227.

GENERAL  **ELECTRIC**

Digest

TIMELY HIGHLIGHTS ON G-E COMPONENTS



CAGED FOR PROTECTION

Suitable for wall or panel mounting, these cage-type, enameled resistor units employ a strong, high-heat-resisting silicate-compound body which withstands sudden and extreme temperature changes without weakening or in any

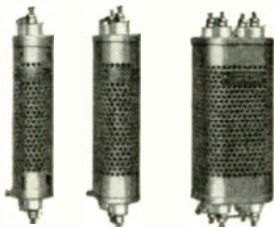

way being injured. The resistance wire has a low temperature coefficient so that the resistance remains nearly constant as the temperature increases. Ample protection to the units is provided by the perforated metal case. Each unit is rated at 85 watts and is available in resistance values from 0.5 to 100,000 ohms; one to four units in a cage. For more complete information please contact your G-E representative.

NEED A "LOW VA" VOLTAGE STABILIZER?

General Electric's latest additions to its line of automatic voltage stabilizers are three 115-volt, 60-cycle designs in 15-, 25-, and 50-va ratings. Check the low prices—you may now be able to utilize the advantages of an automatic voltage control for your application. The price consideration plus the low case height and small size will make these units especially applicable to radio chassis and other shallow-depth installations. Other features include totally insulated design, which is necessary where isolation is required between primary and secondary circuits, and universal lead



construction which makes these units adaptable to various wiring and mounting arrangements. If you have an application problem, contact your G-E representative, or check bulletin GEA-3634B.

SOMETHING NEW IN CIRCUIT CONTROL DEVICES

Simplify your circuit designs by replacing complicated and costly components with simple, economical G-E Thermistors. These electronic semiconductors are unique in that the resistance changes rapidly with slight variations in temperature—electrical resistance decreases as temperature rises, and increases as temperature falls. G-E Ther-

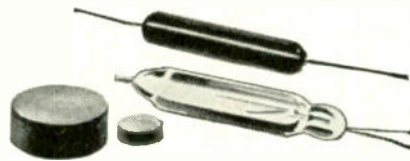

mistors give you these five advantages: flexible in application, small in size, available in various shapes, indefinitely stable, and they are economical. These new circuit devices are especially adaptable as sensitive elements in flow meters, liquid-level gages, time-delay relays, vacuum gages, switching devices, and modulating thermostatic circuits. Check coupon for technical report CDM-9.

HERMETIC SEAL ELIMINATES MOISTURE PROBLEMS

The new cast-glass bushings with their sealed-in metal hardware can be readily welded, soldered, or brazed directly to the apparatus, thus eliminating gaskets and providing a better seal than ever before. The small, compact structure of the bushings often makes it possible to

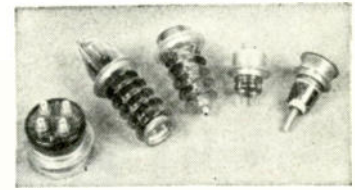

reduce the overall size and weight of the electric apparatus. Bushings are practically unaffected by weathering, microorganisms, and thermal shock. Their great mechanical strength makes them well suited for use in airplanes, etc., where they are subject to continual vibration. Available in ratings up to 8.6 kv and for currents to 1200 amperes. Check bulletin GEA-5093.

MORE SOLDERING WITH LESS POWER

G.E.'s midget soldering iron can do a big job for you with only one-fourth the wattage usually used. This handy 6-volt, 25-watt iron is only 8 inches long (with $\frac{1}{8}$ " or $\frac{1}{4}$ " tips) and weighs but 1 $\frac{1}{4}$ ounces. It was especially designed for close-quarter, pin-point precision soldering. The "midget" offers you all these advantages: low-cost soldering; "fingertip" operation; quick, continuous heat; easy renewal; long life; low maintenance. The iron is a real aid in manufacturing radios, instruments, meters, electric appliances, and many other products requiring precision soldering. Irons and specially designed 115/6-volt transformers are available from stock. Check bulletin GES-3488.

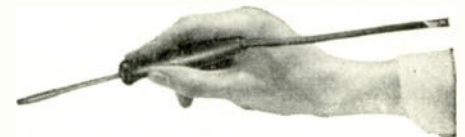

GENERAL ELECTRIC COMPANY, Section G642-18
Apparatus Department, Schenectady, N. Y.

Please send me the following bulletins:

- | | |
|---------------------------------------------------------|-------------------------------------------------------|
| <input type="checkbox"/> GEC-227 Instruments | <input type="checkbox"/> GEA-5093 Cast-Glass Bushings |
| <input type="checkbox"/> GES-3488 Midget Soldering Iron | <input type="checkbox"/> CDM-9 Thermistors |
| <input type="checkbox"/> GEA-3634B Voltage Stabilizer | |

Name

Company

Address

City State

Applied
Research
Laboratories

specifies

Sorensen

electronic

voltage

regulation

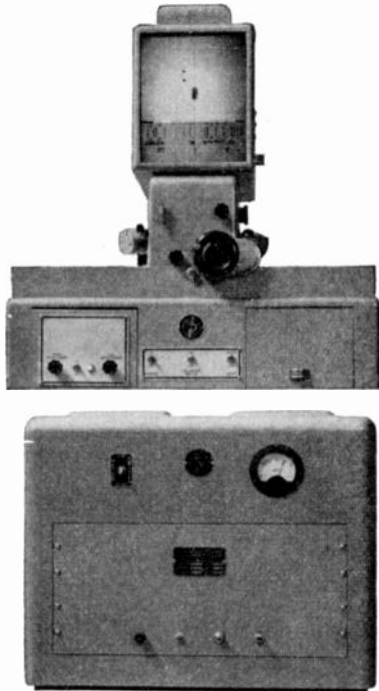

Only Sorensen electronic voltage regulators offer as much as 0.1% regulation accuracy under *simultaneous* line and load changes.

Shown above is the ARL Projection Comparator Densitometer. Applied Research Laboratories, internationally known manufacturers of precision spectographic and densitometric equipment, have standardized on Sorensen AC line voltage regulators because *only* Sorensen units provide the 0.1% regulation accuracy necessary for the scanning lamp. SIX IMPORTANT SORENSEN FEATURES: • *Precise regulation accuracy*; • *Excellent wave form*; • *Output regulation over wide input voltage range*; • *Fast recovery time*; • *Adjustable output voltage, that once set, remains constant*; • *Insensitivity to line frequency fluctuations between 50 and 60 cycles*.

If you calibrate meters, need quality control on test lines, work with X-ray equipment, or are a research physicist or chemist, there is a *standard* Sorensen AC or DC unit to solve your voltage problem. The Sorensen Catalog contains complete specifications on standard Voltage Regulators and Nobatrons. *It will be sent to you upon request.*

THE FIRST LINE OF STANDARD ELECTRONIC VOLTAGE REGULATORS.

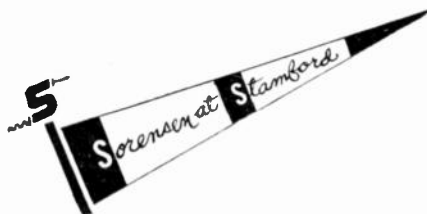

SORENSEN & Company, Inc.

Stamford, Connecticut

Represented in all principal cities.

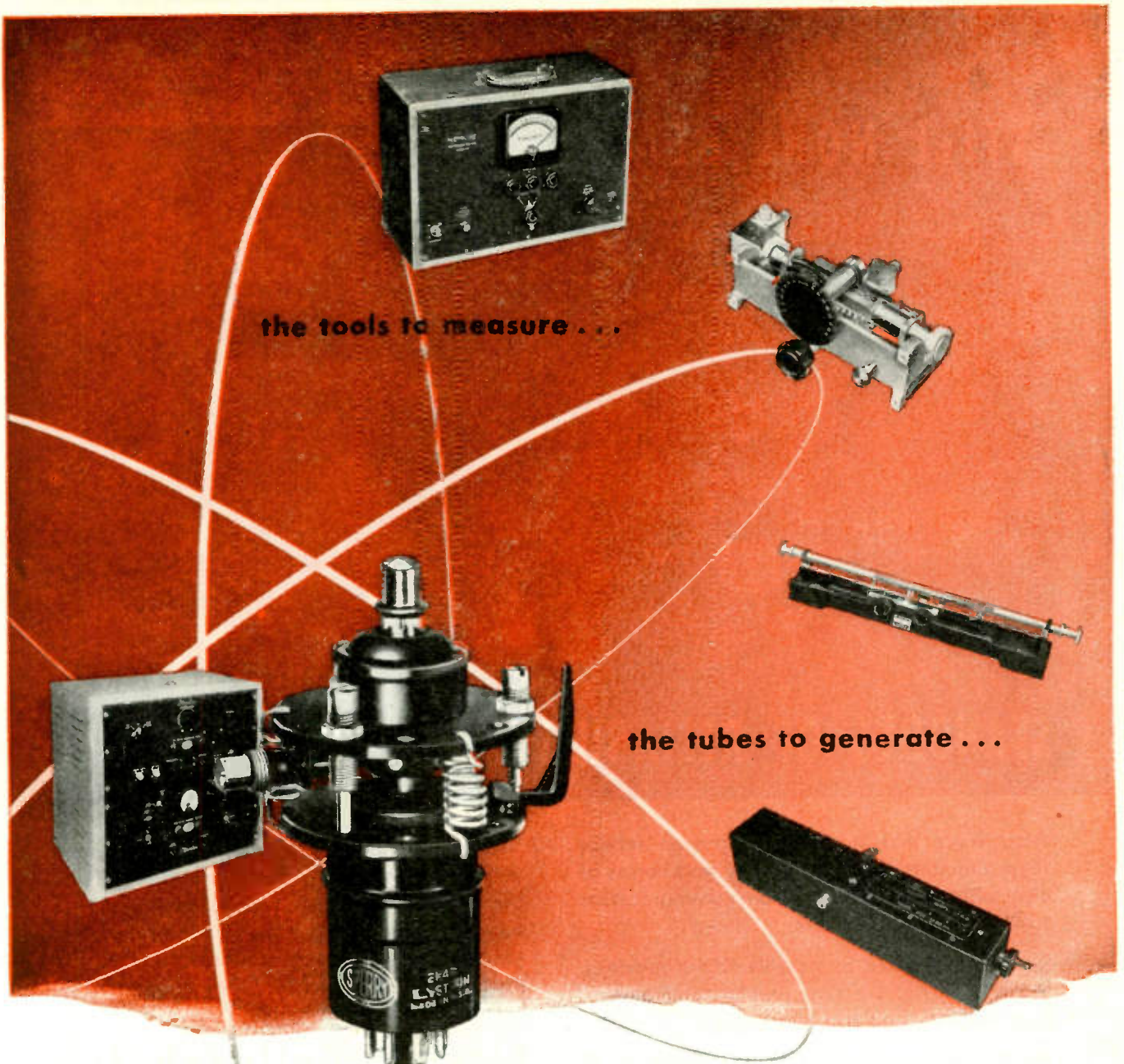

the tools to measure . . .

the tubes to generate . . .

microwave Energy

The Sperry Klystron Tube to generate ultra-high-frequency microwaves . . .

The Sperry Klystron Signal Source to "power" them . . .

The Sperry Microline to test and measure them . . .

These Sperry products equip the research or development engineer with every essential for development or design in the microwave field.

The Sperry Klystron Tube has already opened up new vistas in

navigation, aviation, medicine, radio, telephone, telegraph and other major applications. It is ready for many new local oscillator or high power uses.

The Sperry Microline includes practically every type of instrument for quick precision measurements in the microwave frequency bands.

This Sperry service — beginning with a source of microwave energy, the Klystron, and following through with every facility for measuring microwaves — opens up almost unlimited possibilities for industry.

We will be glad to supply complete information.



SPERRY GYROSCOPE COMPANY

DIVISION OF THE SPERRY CORPORATION • GREAT NECK, N. Y.
NEW YORK • LOS ANGELES • SAN FRANCISCO • NEW ORLEANS • CLEVELAND • SEATTLE



Follow the Leaders to



STILL NONE BETTER

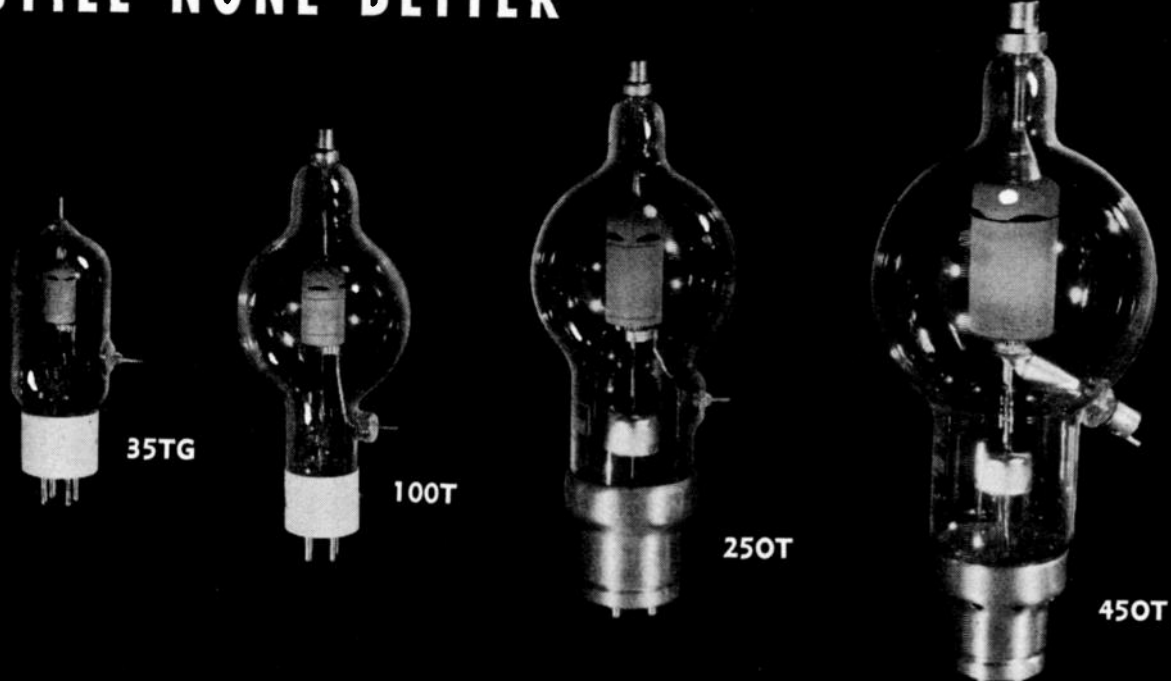

STANDBYS OF RELIABILITY AND PERFORMANCE

After more than a decade of proven service these Eimac triodes are still the workhorses of electronic equipment . . . from communication to industrial applications.

Recently improved by post-war developments, these tubes provide a big plus in performance, dependability and life expectancy.

As future replacements in the hundreds of thousands of applications in which they now

function and as components in new equipment yet to be developed Eimac triodes are the wise buy. Remember when you specify an Eimac tube . . . you don't gamble . . . their performance is **proven** and **guaranteed**, and future procurement is assured . . . they're carried by better dealers everywhere.

Eitel-McCullough, Inc.
202 San Mateo Ave., San Bruno, California

EXPORT AGENTS: Frazer & Henson—301 Clay St.—San Francisco, Calif.

Tube Data

	35TG	100TH	250TH	450TH
ELECTRICAL CHARACTERISTICS				
Filament: Thoriated Tungsten				
Voltage - - - - -	5.0 volts	5.0 volts	5.0 volts	7.5 volts
Current - - - - -	4.0 amperes	6.3 amperes	10.5 amperes	12.0 amperes
Amplification Factor (Average) - - -	39	40	37	38
MAXIMUM RATINGS				
Plate Dissipation - - - - -	50 watts	100 watts	250 watts	450 watts
D-C Plate Voltage - - - - -	2000 volts	3000 volts	4000 volts	6000 volts
D-C Plate Current - - - - -	150 ma.	225 ma.	350 ma.	600 ma.
Grid Dissipation - - - - -	15 watts	20 watts	40 watts	80 watts
RADIO FREQUENCY POWER AMPLIFIER AND OSCILLATOR				
Class-C Telegraphy (Key down conditions)				
Typical Operation—1 Tube				
D-C Plate Voltage - - - - -	1500 volts	2000 volts	3000 volts	4000 volts
D-C Plate Current - - - - -	125 ma.	165 ma.	333 ma.	450 ma.
D-C Grid Current - - - - -	40 ma.	39 ma.	90 ma.	85 ma.
D-C Grid Voltage - - - - -	-120 volts	-80 volts	-150 volts	-200 volts
Plate Power Output - - - - -	141 watts	235 watts	750 watts	1350 watts
Plate Input - - - - -	188 watts	335 watts	1000 watts	1800 watts
Plate Dissipation - - - - -	47 watts	100 watts	250 watts	450 watts
Peak R. F. Grid Input Voltage, (approx.)	250 volts	230 volts	395 volts	410 volts
Driving Power, (approx.) - - - - -	9 watts	8 watts	32 watts	35 watts

NOW WITH . . . Pyrovac Plates • Processed Grids



VOLTAGE RANGE:

3,000,000 to 1

READINGS:

.1 mv to 300 v

FREQUENCIES:

20 cps to 2 mc

THE NEW *-hp-* 400C VACUUM TUBE VOLTMETER

Increased sensitivity. Wider range. Easy-to-read linear scale. Space-saving, time-saving versatility! Those are but a few of the many advantages of the new *-hp-* 400C Vacuum Tube Voltmeter.

30 times more sensitive than the *-hp-* 400A voltmeter, the new *-hp-* 400C accurately determines voltages from .1 mv to 300 v. Its measuring range is broad and new—3,000,000 to 1. And with it you can make split-hair measurements all the way from 20 cps to 2 mc!

The big, clearly-calibrated linear scale reads directly in RMS volts or db based on 1 mw into 600 ohms. Generous overlap makes possible more readings at mid or maximum scale, where accuracy is highest. A new output terminal lets you use the *-hp-* 400C as a wide-band stabilized amplifier, for increasing gain of oscilloscopes, recorders and measuring devices. As a voltmeter, the new instrument has still wider applicability—for direct hum or noise readings, transmitter and receiver voltages, audio, carrier or supersonic voltages, power gain or network response.

Naturally the new *-hp-* 400C includes the familiar advantages of the *-hp-* 400A voltmeter. Range switch is calibrated in 10 db intervals providing direct readings from -70 dbm to +52 dbm. Overall accuracy

is $\pm 3\%$ full scale to 100 kc. High input impedance of 1 megohm means circuits under test are not disturbed. And the rugged meter movement is built to safely withstand occasional overloads 100 times normal.

In every respect, the convenient, durable *-hp-* 400C is the ideal new voltmeter for precision work in laboratory, plant or repair shop. Complete details are available at no obligation. Write today!

Hewlett-Packard Company

1556D Page Mill Road • Palo Alto, Calif.

CHECK THESE SPECIFICATIONS

VOLTAGE RANGES:

12 ranges. Full-scale readings.		
.001 v	.100 v	10.0 v
.003 v	.300 v	30.0 v
.010 v	1.00 v	100. v
.030 v	3.00 v	300. v

FREQUENCY RANGE: 20 cps to 2 mc

ACCURACY:

$\pm 3\%$ full scale 20 cps to 100 kc
 $\pm 5\%$ full scale 100 kc to 2 mc

INPUT IMPEDANCE:

10 megohms shunted by 15 uufd on 1.0 v to 300 v ranges, 25 uufd on the .001 v to .300 v ranges.

METER SCALE:

3" linear. Voltage ranges related by 10 db steps. Db calibrated -12 to +2 db. Zero level 1 mw into 600 ohms.

OUTPUT CIRCUIT:

Maximum 0.5 v full scale. Internal impedance 1000 ohms.

POWER SUPPLY:

115 v, 50/60 cps, 45 watts.

CABINET SIZE:

8 1/2" high, 7 1/4" wide, 9 1/2" deep.

hp laboratory instruments
 FOR SPEED AND ACCURACY

Power Supplies Frequency Standards Amplifiers Electronic Tachometers Frequency Meter
 UHF Signal Generators Square Wave Generators Audio Frequency Oscillators Attenuators
 Audio Signal Generators Noise and Distortion Analyzers Wave Analyzers Vacuum Tube Voltmeter

Meet P. R. MALLORY & CO. Inc. MALLORY Midgetrol

The First All New Variable Resistor in Years

This is
the **SIZE**

15
/ 16
"

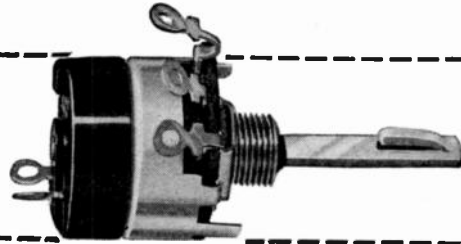

These are
the **FEATURES**

- **LOW NOISE LEVEL**—both mechanically and electrically—stays quiet, too, even after tens of thousands of cycles.
- **HIGHER STANDARDIZATION**—faster delivery schedules—thanks to new design.
- **NEW TERMINALS**—you can bend or twist terminals without breaking them.
- **NEW TERMINAL LOCATION**—farther away from mounting surface—eliminates need for extra insulation.
- **ADAPTABLE TO TELEVISION**—voltage characteristics make it adaptable for television receivers as well as radio sets and all applications requiring variable resistors.
- **SAVES SPACE**—can be specified where a larger control ordinarily would be needed.
- **LIGHT**—ideal for portable radio applications.
- **FLAT SHAFT**—for standardization and uniformity in production—adaptable to any type knob now used.
- **NEW SWITCH**—specially designed to give long, trouble-free life.

This is **IT**

This quiet, smooth working control is the first really new design in years—and behind it are years and years of Mallory experience and diversified manufacturing facilities in metallurgy and electronics. You can specify the Midgetrol with complete confidence. Write today for Technical Information Bulletin and Specification Sheet.

P. R. MALLORY & CO. Inc.
MALLORY

CAPACITORS . . . CONTROLS . . . VIBRATORS . . .
SWITCHES . . . RESISTORS . . . RECTIFIERS . . .
VIBRAPACK* POWER SUPPLIES . . . FILTERS

*Reg. U.S. Pat. Off.

APPROVED PRECISION PRODUCTS

P. R. MALLORY & CO., Inc., INDIANAPOLIS 6, INDIANA



You gain these advantages in **ALSI-MAG**
TRADE MARK
CUSTOM MADE TECHNICAL CERAMICS

These are the reasons for the consistent growth of American Lava Corporation:

RESEARCH. American Lava stands pre-eminent in its field in research. Here you are most apt to find the answer to any question involving technical ceramics.

ENGINEERING SERVICE. American Lava is long on engineering service. You will find one or more graduates of many leading engineering schools on our staff. Their specialized experience is freely available to you on selection and design of technical ceramics for your specific requirement.

EXCLUSIVE PROPERTIES. Constant development of special purpose ceramics has led to the production of many Alsimag compositions with advantages not found in any other material.

DEPENDABLE QUALITY. Our customers know that Alsimag components are always well within the physical characteristics specified. That is assured by alert Quality Control Supervisors and rigid final inspections.

ACCURACY. Already supreme in the field of accuracy, the many new precision machines installed in the past year achieve normal tolerances without additional cost penalty. Alsimag can be held to almost any tolerance required at commensurate cost.

ADVANTAGEOUS DELIVERIES. Deliveries are not as good as we would like to have them—but, during the past year 84% of our deliveries were on time and a good percentage of the remainder followed rather closely. Factory expediting practices are being constantly improved and we pledge further improvements toward increasing the already favorable percentage of deliveries on time.

PROPERTY CHART. The more frequently used Alsimag compositions are shown in a Property Chart, sent free on request.

AN INVITATION. If you have a problem which might be solved by technical ceramics, submit details and let our engineers make recommendations without cost or obligation.

17TH YEAR OF CERAMIC LEADERSHIP

AMERICAN LAVA CORPORATION

CHATTANOOGA 5, TENNESSEE

SALES OFFICES: ST. LOUIS, MO., 123 Washington Ave., Tel: Garfield 4959 • NEWARK, N. J., 671 Broad St., Tel: Mitchell 2-8159 • CAMBRIDGE, Mass., 38-B Brattle St., Tel: Kirkland 4458 • CHICAGO, 9 S. Clinton St., Tel: Central 1721 • LOS ANGELES, 324 W. San Pedro St., Tel: Mutual 9079 • PHILADELPHIA, 1449 N. Broad St.

PERSONALLY CONDUCTED THROUGH THE REVERE MILLS

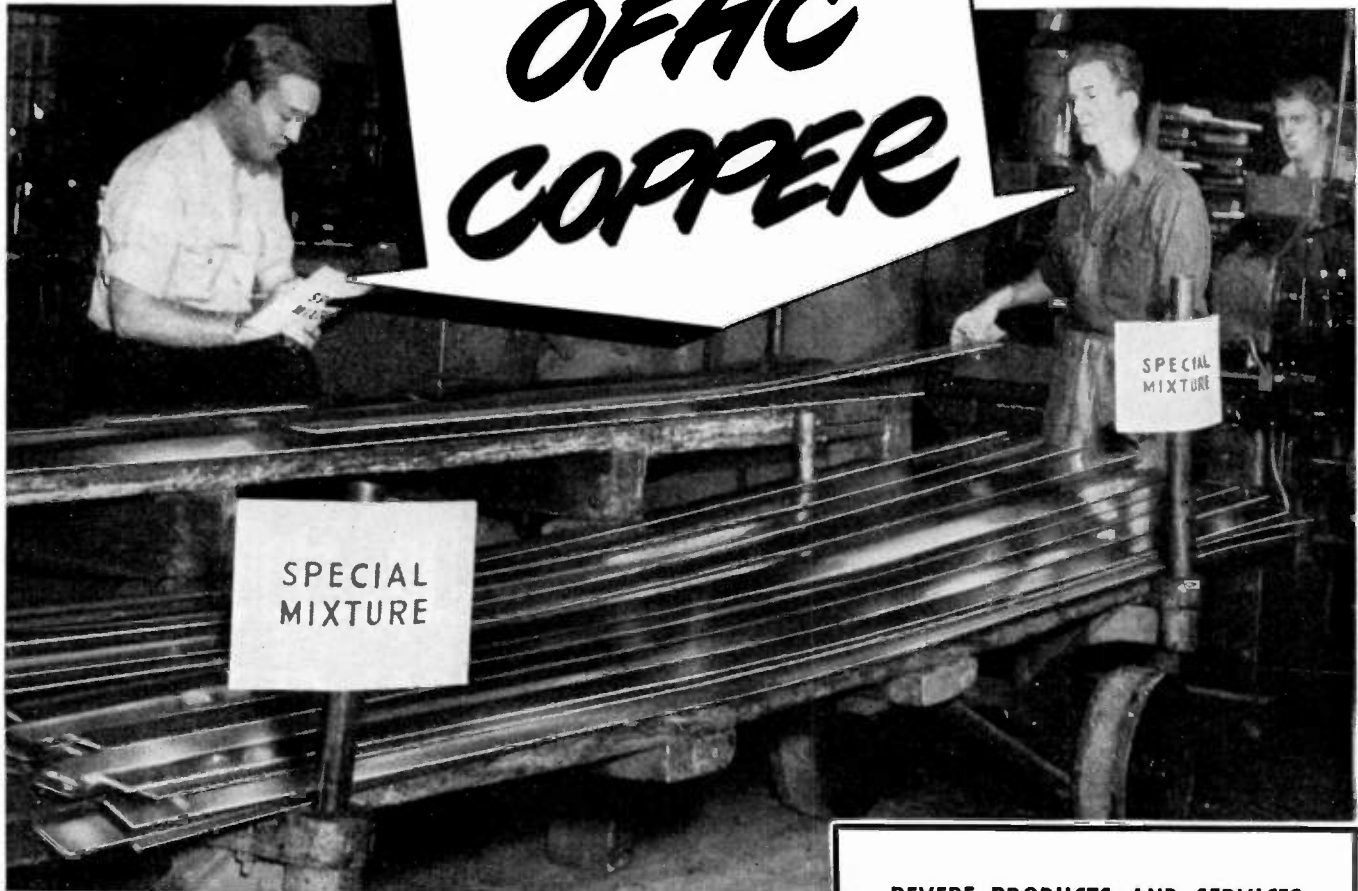

BECAUSE OFHC Copper looks like any other copper, Revere takes great pains to identify it throughout processing, to see it is not lost track of or mixed up with other types. The obvious thing is to mark each piece, which is done, but markings are obliterated by operations such as rolling, and so Revere goes to the length of assigning special personnel to follow each lot of OFHC Copper from one operation to another, watching carefully to be sure each load is kept intact.

In addition, Revere takes full cognizance of the fact that OFHC Copper for radio purposes must have special qualities. In making anodes, it must be deep drawn, and for the feather-edge seal, it must be capable of being rolled or machined down to .002"/.010". By carefully controlling mill processing, grain size is kept at or below permissible limits. Freedom from oxygen, and from voids, is guaranteed by the method of casting the bars from which we roll the forms required. In addition, there is an operation which results in Revere OFHC Copper being not just commercially free but *nearly absolutely free* of internal and external defects. This great care in producing copper for radio and radar purposes probably accounts for the fact that Revere is a preferred source of supply.

REVERE PRODUCTS AND SERVICES

All Revere Metals are processed with the care and attention required to assure that they meet all metallurgical and physical specifications. Revere supplies mill products in non-ferrous metals and alloys, and also electric welded and lockseam steel tube. An important part of our service to industry is the Revere Technical Advisory Service, which will gladly collaborate with you on specifications and fabrication methods.

REVERE

COPPER AND BRASS INCORPORATED

Founded by Paul Revere in 1801

230 Park Avenue, New York 17, New York

*Mills: Baltimore, Md.; Chicago, Ill.; Detroit, Mich.;
New Bedford, Mass.; Rome, N. Y.*

Sales Offices in Principal Cities, Distributors Everywhere

PROCEEDINGS OF THE I.R.E.

October, 1948



**Impedance
unknown?**

...AT 2,600 MEGACYCLES?

**..AT 26,000
MEGACYCLES?**

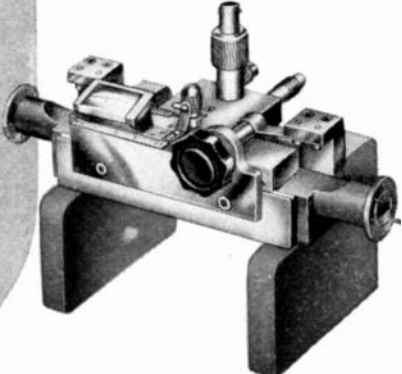

**PRD
SLOTTED
SECTIONS
AND
PROBES**

Features:

BALL BEARING
CARRIAGE SUPPORT
SHOCK-PROOF
FRICTION DRIVE
BROADBAND TUNING
CRYSTAL AND
BOLOMETER DETECTION
SLOPE ELIMINATED
BY ELECTRICAL LEVELLING
LOW REFLECTION
CONNECTORS
CALIBRATED PROBE
POSITION MEASURED
TO OUTPUT COUPLING

Each product is designed, manufactured, and tested with the precision necessary to meet the exacting requirements of the microwave research engineer. An illustrated catalog may be obtained by writing Dept. R7 on company letterhead.

PRD Slotted Sections and Probes are now available for determining with maximum precision the phase and magnitude of impedances at microwave frequencies. These units are precision fabricated devices for use in exploring the standing wave patterns of r-f fields in microwave transmission lines.

The instruments shown are only two of an extended series of coaxial and waveguide slotted sections specifically designed for precise impedance measurement over the microwave spectrum from 1,000 to 40,000 megacycles per second. PRD offers a full complement of microwave measurement and test equipment including Attenuators, Frequency Meters and Standards, Tuners, Matched Loads, Directional Couplers, Signal Generators and Standing Wave Amplifiers.

66 COURT ST., BROOKLYN 2, N. Y.



***Polytechnic* RESEARCH
& DEVELOPMENT COMPANY, Inc.**

Synthetic Sapphire

for a smooth performance

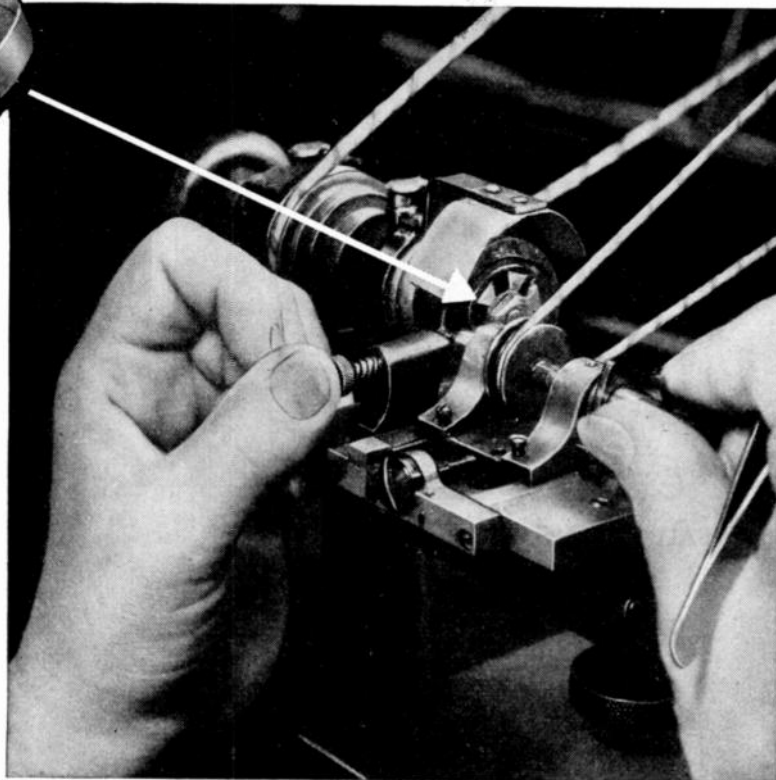
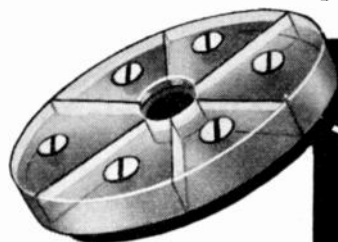

Synthetic sapphire wheels are unequalled for grinding or burnishing small metal parts to a matchless finish. Because of superior hardness and dimensional stability, sapphire wheels will maintain exact wheel form, eliminating any need for machine adjustment.

LINDE synthetic sapphire has many other properties to recommend it to makers of small but vital parts:

Knoop Hardness	1,525 to 2,000
Chemical Resistance	All Acids
Compressive Strength, psi	300,000
Water Absorption	0.0
Dielectric Constant	7.5 to 10
Thermal Conductivity	0.010
cal. sec. ⁻¹ cm. ⁻¹ deg. C. ⁻¹	
at 300 deg. C.	

plus:

- Unicrystalline structure—offers no location for immediate wear.
- Superior wear resistance.
- Extremely low coefficient of friction.

Send for Booklet No. 3A—see how synthetic sapphire can help you with your problems.

Linde Synthetic Sapphire

when the small part is the important part

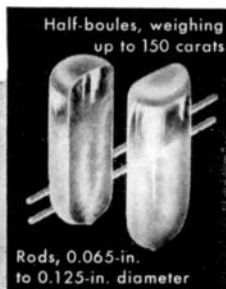

THE LINDE AIR PRODUCTS COMPANY

UNIT OF UNION CARBIDE AND CARBON CORPORATION

30 EAST 42nd STREET • NEW YORK 17 • N.Y. **UIC** OFFICES IN OTHER PRINCIPAL CITIES

IN CANADA: DOMINION OXYGEN COMPANY, LIMITED, TORONTO

better components build better REPUTATIONS

...specify **EL-Menco**

No product is better than its weakest component. This is why more and more manufacturers now use EL-MENCO mica capacitors. Rather than risk their reputations on inferior components they automatically specify El-Menco — the mica capacitor with the kind of performance that always gives customer satisfaction and builds better reputations.

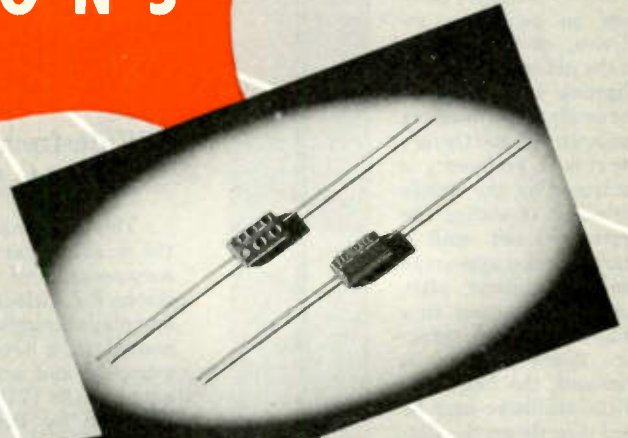

New

CM 15 MINIATURE CAPACITOR

9/32" x 1/2" x 3/16"

For Radio, Television and Other Electronic Applications

2 to 420 mmf. capacity at 500 v DCA

2 to 525 mmf. capacity at 300 v DCA

Temp. Co-efficient ± 50 parts per million per degree C for most capacity values

6-dot standard color coded

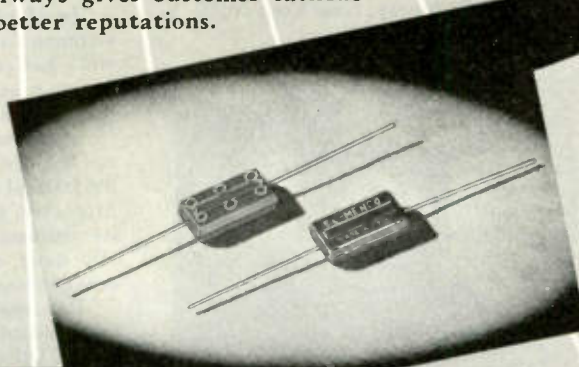

CM 20 CAPACITOR

Available in "A", "B", "C" and "D" characteristics

2 to 1500 mmf. in tolerances down to $\pm 1\%$ * or

.5 mmf. at 500 D.C. working voltage

6-dot color coded

*Whichever is greater

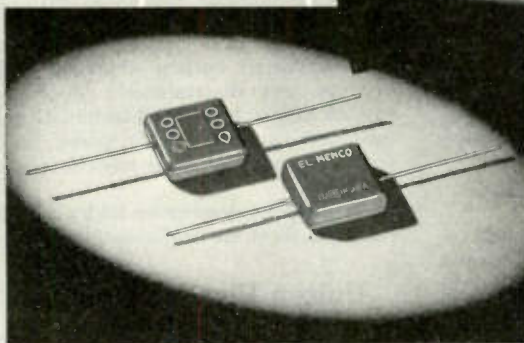

CM 35 CAPACITOR

Available in "A", "B", "C", "D" and "E" characteristics

Minimum tolerance 1%

500 D.C. working voltage

6-dot color coded

ARCO ELECTRONICS

135 Liberty St., New York, N. Y.
Sole Agent for Jobbers and
Distributors in U. S. and Canada

Foreign Radio and Electronic Manufacturers communicate direct with our Export Dept. at Willimantic, Conn. for information

THE ELECTRO MOTIVE MFG. CO., INC.
WILLIMANTIC CONNECTICUT



Write on your firm letterhead for Catalog and Samples

MOLDED MICA

EL-Menco

CAPACITORS

MICA TRIMMER



October, 1948

"Slipstick" Wavemeter

A new tool for engineers and experimenters is the DM 103W "Slipstick" Wavemeter by Decimeter, Inc., 1428 Market St., Denver, Colo.

It gives quick and accurate frequency readings on oscillators, receivers, or transmitters in the uhf spectrum. The Slipstick is coupled to the oscillator by inserting the square plastic tip into the rf field. Frequency is measured by the simple expedient of sliding the center rod out until a sharp reaction appears in the grid current, plate current, or output to a radio-frequency detector. When reaction is obtained, the frequency of the oscillator may be read directly on the sliding scale.

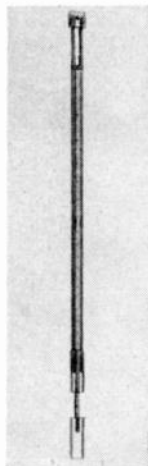

In measuring received signals, the Slipstick is coupled to the antenna circuit. A sharp fluctuation of receiver output occurs when the Slipstick is tuned to the incoming signal. Accuracy is 2% or better; range is 90 to 3000 Mc. Sliding and stationary rods have a highly polished silver finish. Handle, guide, and tip assemblies are of amber polystyrene to insure low loss and permanence. For further information, write for Circular 11D.

Miniature Variable Capacitor

A new miniature variable capacitor for applications where space is restricted and durability is required has been announced by Engineering Research Associates, Inc., 1902 West Minnehaha Ave., St. Paul, Minn.

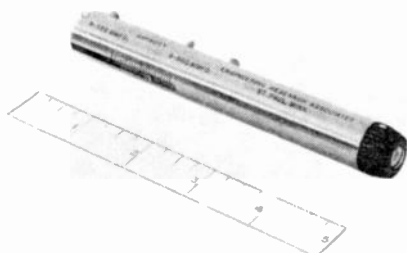

This capacitor has rated capacitance of 9 to 585 $\mu\mu\text{f}$ per section, with less than 0.002% dissipation factor at radio frequencies.

It has a self-contained dial with micrometer action; may be temperature compensated; and is made up in many designs, ganged or single section.

These manufacturers have invited PROCEEDINGS readers to write for literature and further technical information. Please mention your I.R.E. affiliation.

Wide-frequency-Response Portable Wire Recorder

This combination unit is claimed by the manufacturer to produce fidelity which surpasses that of acetate-disk recording. It features a built-in radio and phonograph and plays through a Jensen 8" PM speaker, housed in a separate cabinet to avoid vibration and acoustical feedback. Designated as the WIREMASTER, it is being produced by Precision Audio Products, Inc., 1133 Broadway, New York 10, N. Y.



The Wiremaster uses 13 tubes, and records and reproduces a frequency response of 40-10,000 cps, Noise level is -70 db and it records at 2" per second.

A speaker monitoring control enables the user to adjust the listening volume to his own liking when recording, without affecting the recording volume, which is regulated by another control.

The Wiremaster has an automatic braking device which stops both spools from turning when the current is suddenly cut off, preventing the wire from unraveling and tangling. Spools also automatically shut off when either one is completely unwound. The recorder rewinds at an 8:1 ratio.

The unit has 2 microphone channels, is housed in a 2 tone leatherette portable case, which measures 23" x 15" x 12". It weighs 49 lbs complete. The power supply is 105 to 120 volts, ac, 60 cps.

New Type Variable Resistor

A new 15/16" variable resistor, the Mallory Midgetrol, described as being the first basically new design in this field for many years, has been announced by P. R. Mallory & Co., Inc. of Indianapolis, Indiana.

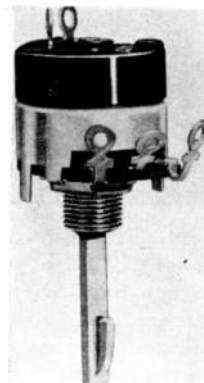

In addition to the space-saving feature common to 15/16" controls, the "Midgetrol" has electrical characteristics which make it suitable for many applications previously requiring a 1 1/8" control.

The new design and production methods are said to produce an extremely low mechanical and electrical noise level. Moreover, tests run both by Mallory and its customers demonstrate that the unusually quiet operation is maintained after tens of thousands of cycles of operation.

One new feature is a flat shaft which is easily adapted to fit any type of knob now in use. Other design features include two-point shaft suspension, providing even contact pressure at all points of rotation; machine-coated carbon elements which produce accurate resistance values and smooth tapers; hot-tinned terminals; fully insulated current-carrying parts, and a special phenolic shaft for television applications.

A complete descriptive folder and specification sheet are available on request.

Unicon Plastic Capacitors

A recent product of United Condenser Corp., 422 East 138 St., New York 54, N. Y., is a line of plastic capacitors.

The manufacturer states that the dielectric hysteresis of plastic capacitors is one tenth that of similar mica insulated units. In actual laboratory tests, a 1- μf . capacitor had a residual charge of 0.08% of an original 3000-volt charge after being discharged through a short circuit for 0.1 second. Hermetically or wax-sealed assemblies are available in single or multiple units with ratings as high as 5 μf at 25 kv. Leakage resistance is 400 kilomegohms per μf , power factor is 0.05%, and continuous operation is satisfactory at temperatures up to 65°C.

(Continued on page 24A)

Larvoie

UHF PRECISION INSTRUMENTS

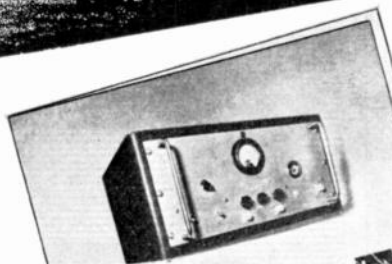

Larvoie
HARMONIC
FREQUENCY
GENERATOR

Larvoie Laboratories
RADIO ENGINEERS AND MANUFACTURERS
MORGANVILLE, N. J.

PROVIDES harmonic output voltages in 10 or 40 mc series with crystal-controlled accuracy.

SELECTS 10 or 40 megacycles series by means of front panel switch.

USED FOR calibration of receivers, wavemeters, or (with Beat Detector built into instrument) for calibration of oscillators and signal generators. May also be used in conjunction with a low-frequency communications-type receiver to determine UHF oscillator drift. A mixer unit is available for this application.

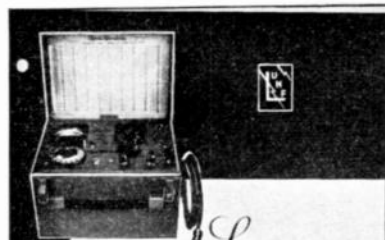

Larvoie
UHF Precision
FREQUENCY METER

Larvoie Laboratories

Completely portable Accuracy 0.1%
Models available from 100 to 2000 megacycles with 2 to 1 frequency coverage on each model.

RECOMMENDED FOR:

- Production testing
- Measurement of oscillator drift
- Independent alignment of transmitters and receivers
- Precise measurements of frequencies

FULL DETAILS ON REQUEST



Larvoie Laboratories

RADIO ENGINEERS AND MANUFACTURERS
MORGANVILLE, N. J.

Specialists in the Development and Manufacture of UHF Equipment

Bliley CRYSTALS



with type **BH6**
Bliley engineering
has anticipated
your **VHF**
requirements...

Type BH6 is available up to 100 MC and can be furnished to meet all standard specifications, military or commercial. This means your design considerations can be simplified by elimination of unnecessary multiplier stages. Write for information covering latest recommended oscillator circuits and associated crystal data.

Bliley CRYSTALS

BLILEY ELECTRIC COMPANY
UNION STATION BLDG. • ERIE, PA.

News—New Products

These manufacturers have invited PROCEEDINGS readers to write for literature and further technical information. Please mention your I.R.E. affiliation.
(Continued from page 22A)

Stabilized Heat Crystal Holder

Designed to accommodate crystals from 80 to 10,000 kc, and recommended for broadcast and frequency-standard applications, the JKO-7, manufactured by the James Knights Co., Sandwich, Ill., is now being marketed.



It has a large 7-pin base and will accommodate most JK holders besides accommodating more than one small holder. The input is 6.3 volts, and the operating temperature is 50°C. ±1°. This unit is available as a double oven or built to specifications on special order. The crystals are electrostatically shielded. Better thermal insulation results in lower heater-current consumption and shorter warm-up time. This component may be mounted in any position.

Pocket-Size Battery Tester

A new pocket-size battery tester is now being marketed by the Simpson Electric Co., 5216 W. Kinzie St., Chicago 44, Ill.

Designed in accordance with the engineering specifications of leading battery manufacturers, its loading resistors have an accuracy of 1% and properly load all radio and hearing-aid "A" and "B" batteries. Operation of the tester is simple. A single rotary switch selects the voltage of the battery under test and brings into line the correct loading resistor. A percentage scale shows the exact condition of the battery in percentage of full voltage. Needle-point prods with which the tester is furnished assure positive contact regardless of the type of terminal on the battery.

Three arcs are shown on the full 3° dial. One arc is for all radio "A" batteries, one for hearing-aid "B" batteries, and one for all "B" batteries, whether radio or hearing aid. Each arc is divided and marked in three sections, "good," "weak," and "bad." Limits for these markings are set in accordance with specifications of battery manufacturers.

(Continued on page 42A)

JOHNSON

a famous name in Radio



SINGLE



BUTTERFLY



DIFFERENTIAL

**SMALLEST
AIR VARIABLES
EVER PRODUCED**

Pictured are three of the smallest air variables ever produced. Each of the three types is available in four different capacities.

SINGLE TYPE—Takes the place of adjustable padders for trimming RF and IF oscillator circuits. Available in four models: 1.55 to 5.14 mmf, 1.73 to 8.69 mmf, 2.15 to 14.58 mmf and 2.6 to 19.7 mmf.

BUTTERFLY TYPE—Applicable wherever a small split stator tuning condenser is required. Available in four models: 1.72 to 3.30 mmf, 2.10 to 5.27 mmf, 2.72 to 8.50 mmf, and 3.20 to 11.02 mmf.

DIFFERENTIAL TYPE—For switching capacity from rotor to either of two stators, and for shifting tap on capacity divider. Available in four models: 1.84 to 5.58 mmf, 1.98 to 9.30 mmf, 2.32 to 14.82 mmf, and 2.67 to 19.30 mmf.

For Full Details Write For Latest
JOHNSON Catalog

E. F. JOHNSON CO.
WASECA, MINNESOTA

MARION... helps HASTINGS LABORATORIES

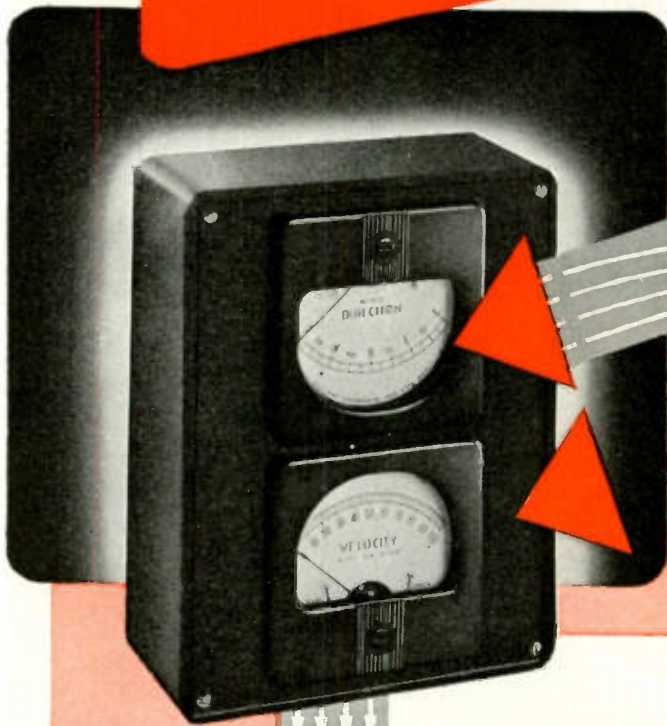

measure the wind



When Hastings Laboratories engineered a new, more precise type of anemometer some very real problems were encountered. One was to find an *inside* instrument that would accurately *indicate* the direction and velocity of the wind passing the anemometer located *outside*. Because of Marion's recognized reputation for manufacturing fool-proof, trouble-free meters and instruments, it was natural for Hastings to turn to Marion for this vital component.

Marion then designed, engineered and manufactured two matched meters for this purpose. Now, matched Marion meters and these matchless new Hastings anemometers are helping weather forecasters, air pilots and navigators measure the wind more accurately all over the world.

When you have a problem involving electrical measuring or indicating we will be glad to have you turn to us. We have helped others. And, because we know "Marion" means the "most" in meters, we believe we can help you.

THE NAME MARION MEANS THE MOST IN METERS

Write for complete information



MARION ELECTRICAL INSTRUMENT COMPANY

M A N C H E S T E R , N E W H A M P S H I R E

Export Division, 458 Broadway, New York 13, U. S. A., Cables MORMANEX

IN CANADA; THE ASTRAL ELECTRIC COMPANY, SCARBORO BLUFFS, ONTARIO

Recommended for use under stringent conditions such as encountered in television, auto radio applications, and sets for export use.

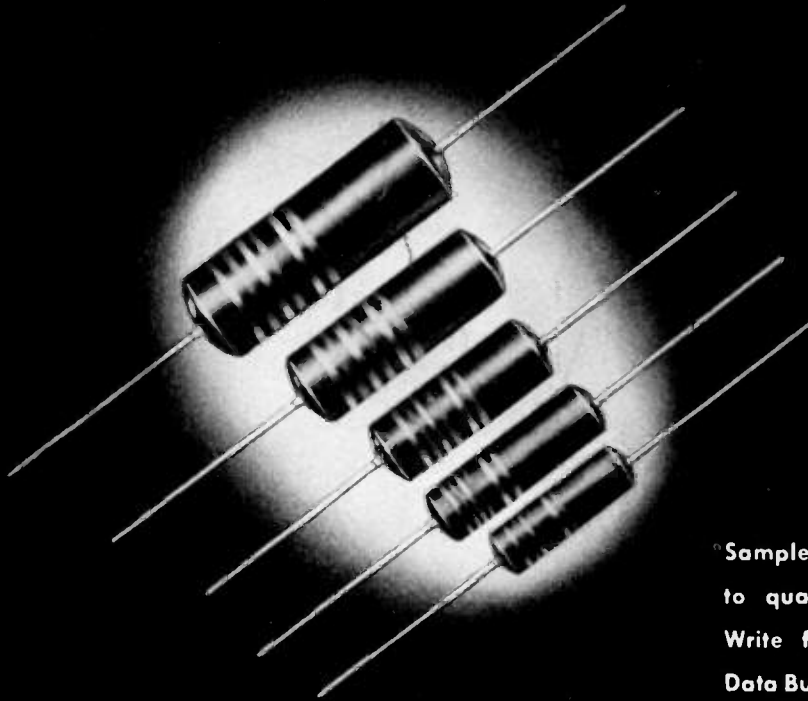

• Samples on request to quantity users. Write for Sprague Data Bulletin 210A.

Wherever small, paper capacitors are required to operate under exacting conditions of heat, moisture or vibration, Sprague Phenolic Molded Tubulars are setting new, higher standards of efficiency.

SPRAGUE ELECTRIC COMPANY, NORTH ADAMS, MASS.

SPRAGUE

PIONEERS OF

• Trademark Reg. U. S. Pat. Office

ELECTRIC AND ELECTRONIC PROGRESS

CAPACITORS • KOOLOHM® RESISTORS

Optical Microscope IS ANOTHER
PRECISION INSTRUMENT EMPLOYED BY
SYLVANIA TO ASSURE TUNGSTEN AND
SPECIAL ALLOY WIRE PERFECTION ★ ★ ★



Studying the crystals in a magnified section of Sylvania tungsten and special alloy wire is just one more phase of Sylvania's never-ending efforts toward higher and higher quality in radio and electronic tubes.

With the optical microscope shown above, the image of the wire section, magnified as much as 2,000 times, can be projected on the ground glass seen to the left. To the metallurgist who uses this instrument, the sizes, shapes and distribution of the crystals in filamentary and heater wires are extremely important. On the microscope, he examines and studies specific crystal features that are essential for long tube life.

Sylvania's research metallurgy facilities are in constant touch with the Sylvania wire plant in Towanda, Pa., and special alloy wire plant in Warren, Pa., to assure superlative products. Sylvania Electric Products Inc., 500 Fifth Avenue, New York 18, N. Y.

SYLVANIA ELECTRIC

RADIO TUBES; CATHODE RAY TUBES; ELECTRONIC DEVICES; FLUORESCENT LAMPS, FIXTURES, WIRING DEVICES; PHOTOLAMPS; LIGHT BULBS



Towering

Above

Pittsburgh's

Civic

Center

For KDKA — "America's Pioneer Station" — Blaw-Knox — America's pioneer builder of radio towers recently furnished this 500 ft. H-40 heavy duty tower.

The location of the tower on a rise overlooking Pitt Stadium and adjacent to buildings of the University of Pittsburgh made it imperative that station engineers select a structure of sufficient built-in strength to provide a high factor of safety in this congested area.

The Blaw-Knox heavy duty H-40 tower, supporting an FM and television antenna is not only adequate to meet these provisions but is also rugged enough to take care of any reasonable changes in equipment which might arise in the future.

BLAW-KNOX DIVISION
of Blaw-Knox Company
2017 Farmers Bank Building
Pittsburgh 22, Pa.

BLAW-KNOX *Antenna*
TOWERS

F R E E D

for Quality & Performance Use
FREED INSTRUMENTS & COMPONENTS!



NULL DETECTOR

Freed Model 1140 is a high gain null indicator for bridge measurements, providing visual null indications or aural indications when used in conjunction with head-phones. The unit may also be used as a high gain amplifier for general laboratory work.

INPUT IMPEDANCE: 1 Megohm in parallel with 25 mmf.

GAIN: 98 db with 1 megohm load (6 mmf. shunt capacity), down 1.5 db at 25,000 cycles, down 5 db at 50,000 cycles, down 2 db at 20 cycles.

NULL DETECTOR SENSITIVITY: At 1 Kc 100 microvolts will give a 15% meter deflection.

SELECTIVE AMPLIFIER: 23 db second harmonic attenuation at 60, 400 and 1000 cycles.

OUTPUT IMPEDANCE: Approximately 50,000 ohms.



Freed Model 1110

INCREMENTAL INDUCTANCE BRIDGE

IMPEDANCE RANGE: One millihenry to 1000 henries in five ranges. Inductance values are read directly from a four dial decade and multiplier switch. This range can be extended to 10,000 henries by the use of an external resistance. Superimposed D.C. up to 2 Amp.

INDUCTANCE ACCURACY: Within plus or minus 1% through the frequency range from 60 to 1000 cycles.

FREED HERMETICALLY SEALED CLASS A GRADE 1 COMPONENTS ARE APPROVED for JAN—T—27 SPECIFICATIONS.

- POWER TRANSFORMERS
- FILTER REACTORS
- AUDIO TRANSFORMERS
- SUPERSONIC TRANSFORMERS
- WAVE FILTERS
- HI-Q COILS
- DISCRIMINATORS
- SATURABLE REACTORS
- PULSE TRANSFORMERS
- CHARGING CHOKES



F R E E D

TRANSFORMER CO., INC.
Dept. OP 72-78 Spring Street
New York 12, N. Y.



Memo to... DESIGN ENGINEERS

about... MYCALEX 410 - MOLDED

NOW PRICED TO MEET RIGID ECONOMY REQUIREMENTS

In the design of components or complete equipment for industrial controls or communications—where insulation qualities are of critical importance—where mechanical precision must be a fixed factor—where strength is essential—where electrical characteristics must accurately meet high frequency circuit needs... then remember MYCALEX 410 as the insulation that designs-in with your most exacting requirements.

Various parts shown below are some of many made for special applications.

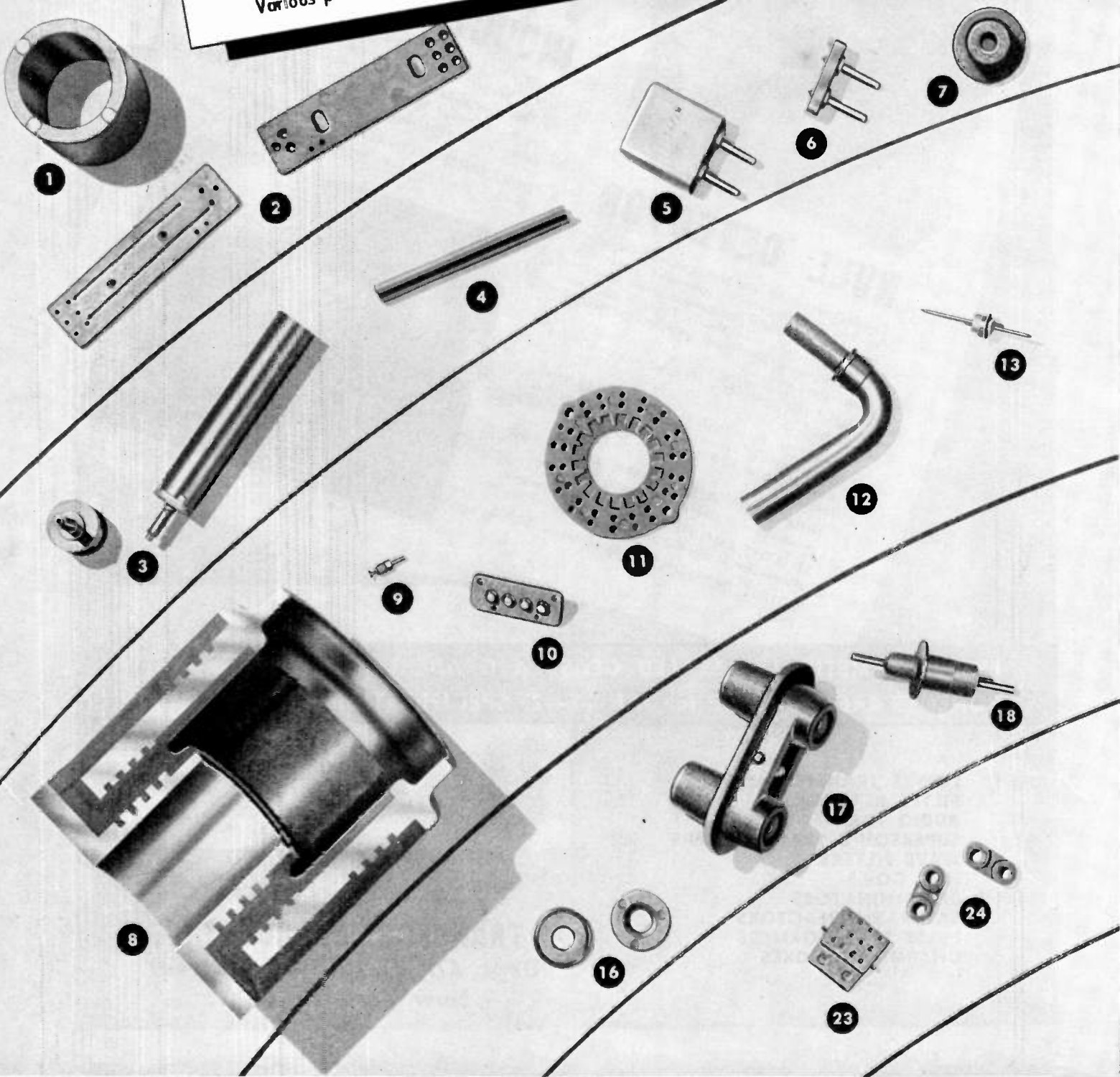

MYCALEX is today's improved insulation — designed to meet the exacting demands of all types of high-frequency circuits. MYCALEX is unusual in that it possesses a combination of peculiar characteristics that make it ideally suited for insulation in all types of electronic circuits. In tomorrow's designs for communications and industrial control equipment, MYCALEX 410 will be specified more than ever

before because of its... Low dielectric loss • High dielectric strength • High arc resistance • Dimensional stability over wide humidity and temperature changes • Resistance to high temperatures • Mechanical precision • Mechanical strength • Ability to mold metal inserts in place. If you have any insulation problems, our engineers will be glad to help you in their solutions.

MYCALEX CORP. OF AMERICA

"Owners of 'MYCALEX' Patents"

Plant and General Offices: Clifton, N. J. Executive Offices: 30 Rockefeller Plaza, New York, N. Y.

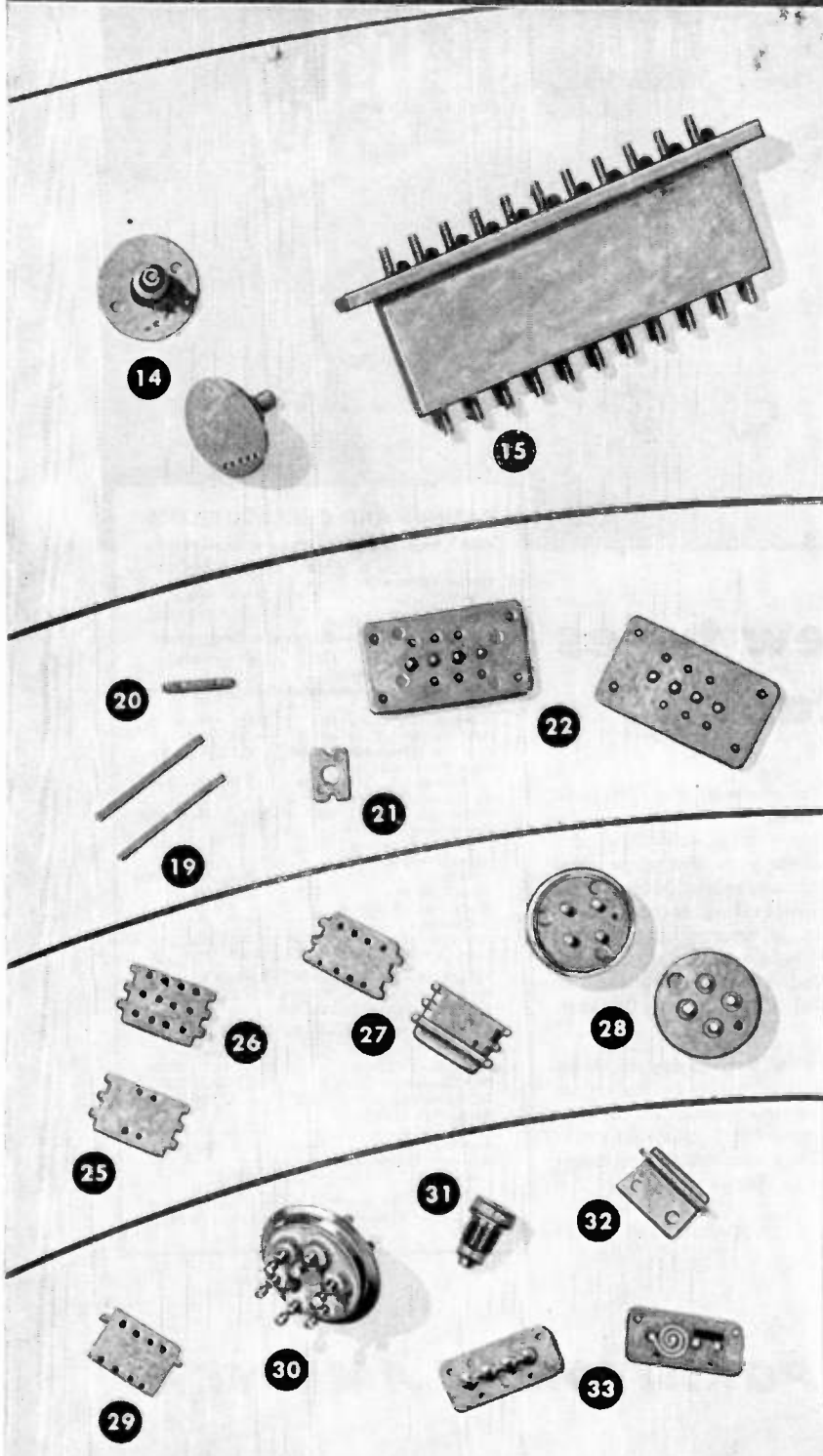

PART NAME	APPLICATION	INSERTS	MAX. DIMEN.
1 Bushing	Motor Generator	None	1.75"
2 Insulator	Electrical Instrument	None	3.18
3 End Seal	Thermostat Shell	Stainless Steel	3.75
4 Insulator	Electrical Instrument	None	3.00
5 Hermetic Seal	Crystal housing	Nickel and Copper	0.88
6 Hermetic Seal	Crystal housing	Copper	1.09
7 Insulator	Automobile Antenna	None	1.06
8 Bushing	Ignitron	Steel	4.50
9 Stand-Off Insulator	Electronics circuit	Brass	0.56
10 Panel	Television Selector Switch	Silver	1.38
11 Switch Wafer	Television Selector Switch	None	2.31
12 Elbow	Aircraft ignition	Steel and Brass	2.75
13 Lead	Transformer	Monel	1.75
14 Insulator	Polarizing relay	None	1.09
15 Lead through block	Oscillator	Brass	4.69
16 Insulator	Telephone Transmitter	None	0.88
17 Dual Bushing	Oil Burner Transformer	None	3.00
18 Lead	Transformer	Monel	2.50
19 Actuating Bar	Telephone relay	None	1.44
20 Actuating Bar	Telephone relay	None	0.78
21 Spacer	Radio vibrator	None	0.56
22 Panel	Television Selector Switch	None	1.75
23 Spacer	Telephone relay	None	1.00
24 Spacer	Relay	None	0.91
25 Spacer	Telephone relay	None	1.00
26 Spacer	Telephone relay	None	1.00
27 Clamping Plate	Telephone relay	None	1.00
28 Electrode Mounting	Level Indicator	Brass	1.13
29 Spacer	Telephone relay	None	1.00
30 Six Terminal Header	Transformer	Monel	1.42
31 Test jack body	High Frequency Circuits	Monel	0.75
32 Clamping Plate	Telephone relay	None	1.00
33 Printed Circuit Base	Experimental	Silver	1.38

RCA—the pioneer in miniatures—

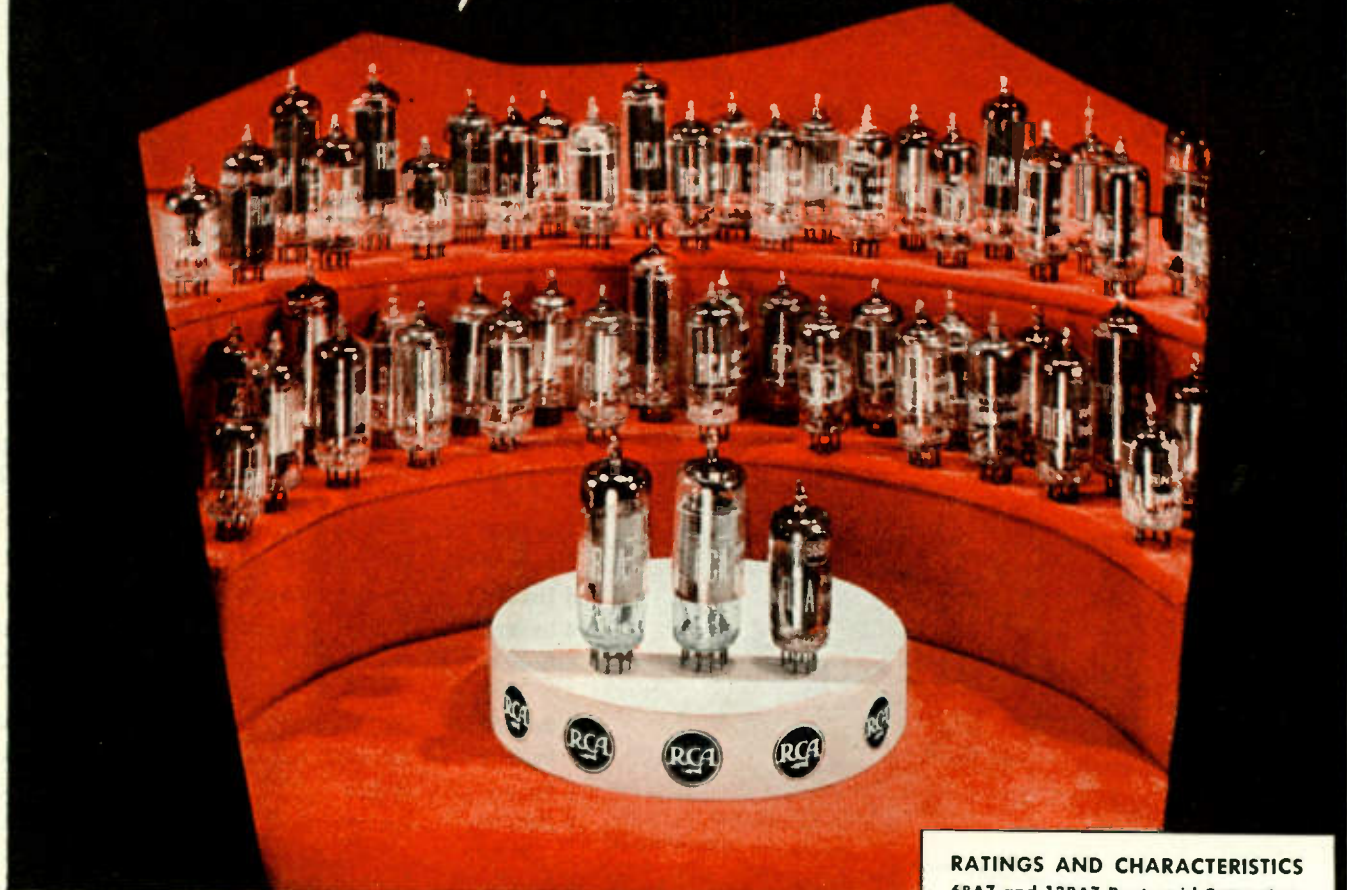

... presents three new types of major importance

● Here are three new miniature tubes... additions to RCA's large family of miniature types... that have particular significance in FM receiver design and voltage reference applications.

RCA 6BA7 and 12BA7 are pentagrid converters—alike except for heater ratings. They have high conversion gain, because of their high conversion transconductance; and a separate connection for direct grounding of the suppressor. These features in combination with the short internal leads characteristic of miniature tubes, result in efficient operation of either type in the 88 to 108-megacycle FM band. In addition to realizing substantial gains at the higher frequencies, the RCA 6BA7

and 12BA7 contribute a highly favorable signal-to-noise ratio.

RCA-5651 is a voltage reference tube of the cold-cathode, glow-discharge type. It maintains a dc operating potential of 87 volts, has an operating current range of 1.5 to 3.5 ma., an operating characteristic essentially independent of ambient temperature, and a voltage stability at any current level of better than 0.1 volt.

RCA Application Engineers will be pleased to consult with you on the incorporation of these new miniatures in your equipment designs. For further information write RCA, Commercial Engineering, Section JR42, Harrison, N. J.

THE FOUNTAINHEAD OF MODERN TUBE DEVELOPMENT IS RCA

RATINGS AND CHARACTERISTICS

6BA7 and 12BA7 Pentagrid Converters

	6BA7	12BA7
Heater Voltage (ac or dc)	6.3	12.6 Volts
Heater Current	0.3	0.15 Ampere

Characteristics — Separate Excitation*

Plate Voltage	100	250 Volts
Grid No. 5 and Internal Shield	Connected directly to ground	
Grids No. 2 and No. 4	100	100 Volts
Grid No. 3	-1.0	-1.0 Volt
Grid No. 1 Resistor	0.02	0.02 Megohm
Plate Resistance (Approx.)	0.5	1.0 Megohm

Conversion Transconductance	900	950
Conversion Transconductance (approx.)		

Grid No. 3 at -20 volts	3.5	3.5
Plate Current	3.6	3.8

Grids Nos. 2 and 4 Current	10.2	10
Grid No. 1 Current	0.35	0.35

Total Cathode Current	14.2	14.2
-----------------------	------	------

*Characteristics correspond very closely with those obtained in a self-excited oscillator circuit operating with zero bias.

5651 Voltage-Reference Tube

	Min.	Av.	Max.
DC Starting Voltage	—	107	115
DC Operating Voltage	82	87	92
DC Operating Current	1.5	—	3.5
Regulation (1.5 to 3.5 Ma.)	—	—	3
Stability*	—	—	0.1
Ambient Temperature Range	-55 to +90° C		

*Defined as the maximum voltage fluctuation of any current level within operating current range.



TUBE DEPARTMENT

RADIO CORPORATION of AMERICA

HARRISON, N. J.

PROCEEDINGS OF THE I.R.E.

(Including the WAVES AND ELECTRONS Section)

Published Monthly by

The Institute of Radio Engineers, Inc.

BOARD OF DIRECTORS, 1948

Benjamin E. Shackelford
President

R. L. Smith-Rose
Vice-President

S. L. Bailey
Treasurer

Haraden Pratt
Secretary

Alfred N. Goldsmith
Editor

Frederick B. Llewellyn
Senior Past President

W. R. G. Baker
Junior Past President

1948-1949

J. B. Coleman
Murray G. Crosby
Raymond A. Heising
T. A. Hunter
H. J. Reich
F. E. Terman

1948-1950

J. E. Shepherd
J. A. Stratton

1948

A. E. Cullum, Jr.
Virgil M. Graham
Raymond F. Guy
Keith Henney
J. V. L. Hogan
F. S. Howes
J. A. Hutcheson
I. J. Kaar
D. B. Sinclair

Harold R. Zeamans
General Counsel

George W. Bailey
Executive Secretary

Laurence G. Cumming
Technical Secretary

E. K. Gannett
Assistant Secretary

BOARD OF EDITORS

Alfred N. Goldsmith
Chairman

PAPERS REVIEW COMMITTEE

Murray G. Crosby
Chairman

PAPERS PROCUREMENT COMMITTEE

John D. Reid
General Chairman

VOLUME 36

October, 1948

NUMBER 10

PROCEEDINGS OF THE I.R.E.

John A. Hutcheson, Director, 1947-1948.....	1194
The Dilemma of Specialization..... G. M. K. Baker	1195
3163. Communication by Means of Reflected Power... Harry Stockman	1196
3164. Some Notes on Noise Figures..... Harold Goldberg	1205
3165. Cosmic Static..... Grote Reber	1215
3166. Comparison of Calculated and Measured Phase Difference at 3.2 Centimeters Wavelength..... E. W. Hamlin and W. E. Gordon	1218
3167. The Chemistry of High-Speed Electrolytic Facsimile Recording..... H. G. Greig	1224
3168. Helical Beam Antennas for Wide-Band Applications. J. D. Kraus	1236
3169. Antenna Design for Television and FM Reception. F. A. Kolster	1242
3170. A Method of Measuring the Field Strength of High-Frequency Electromagnetic Fields..... Rohn Truell	1249
3171. Mode Separation in Oscillators with Two Coaxial-Line Resonators..... H. J. Reich	1252
Discussion on:	
3018. "Reflection of VHF Radio Waves from Meteoric Ionization" by Edward W. Allen, Jr..... Laurence A. Manning and Oswald G. Villard, Jr.	1255
2943. "The Distortion of Frequency-Modulated Waves by Transmission Networks" by A. S. Gladwin..... F. L. H. M. Stumpers	1257
Contributors to the PROCEEDINGS OF THE I.R.E.....	1259
Correspondence:	
2687. "Minimum Detectable Radar Signal"..... V. Tiberio	1261
3020. "An Inductance-Capacitance Oscillator of Unusual Frequency"..... W. A. Roberts	1261
3094. "Pseudosynchronization in Amplitude-Stabilized Oscillators"..... D. G. Tucker	1262

INSTITUTE NEWS AND RADIO NOTES SECTION

Executive Committee.....	1263
Institute Committees—1948.....	1264
Technical Committees—1948-1949.....	1265
Special Committees.....	1266
Institute Representatives in Colleges and Other Bodies—1948.....	1267
Industrial Engineering Notes.....	1268
Books:	
3172. "Basic Mathematics for Radio" by George F. Maedel.....	1269
3173. "The Cathode-Ray Tube and Typical Applications".....	1269
3174. "Nomograms of Complex Hyperbolic Functions" by Jorgen Rybner.....	1271
3175. "Ionospheric Research at Watheroo Observatory, Western Australia, June, 1938 - June, 1946" by L. V. Berkner and H. W. Wells.....	1272
3176. "Radar: What Radar Is and How It Works" by Orrin E. Dunlap, Jr.....	1272
3177. "Vacuum Tube Circuits" by Lawrence Baker Arguimbau.....	1272
3178. "Industrial Project in Statistical Quality Control" by Edward A. and Gertrude M. Reynolds.....	1272
3179. "Electronic Instruments" edited by Ivan A. Greenwood, Jr., J. Vance Holdam, Jr., and Duncan MacRae, Jr.....	1273
3180. "Power System Stability, Vol. 1" by Edward W. Kimbark.....	1273
3181. "Frequency Modulation, Vol. 1" edited by A. N. Goldsmith, A. F. Van Dyck, R. S. Burnap, F. T. Dickey and G. M. K. Baker.....	1273
3182. "Electricity" by C. A. Coulson.....	1273
3183. "Television and FM Receiver Servicing" by Milton S. Kiver.....	1273
3184. "Electrotecnica de la Alta Frecuencia" by Rafael Pavon Isern.....	1273
Sections.....	1270
IRE People.....	1274

WAVES AND ELECTRONS SECTION

William A. Edson and William H. Carter, Jr., Section Chairmen.....	1276
3185. Nuclear Reactions and Nuclear Energy..... S. N. Van Voorhis	1277
3186. Wide-Deviation Frequency-Modulated Oscillators..... Everard M. Williams and Lucio Vallese	1282
3187. Frequency Measurement by Sliding Harmonics..... J. K. Clapp	1285
3188. Calculation of Doubly Curved Reflectors for Shaped Beams..... A. S. Dunbar	1289
3189. A New 100-Watt Triode for 1000 Megacycles..... W. P. Bennett, E. A. Eshbach, C. E. Haller, and W. R. Keye	1296
3190. The Tapered Phase-Shift Oscillator..... Peter G. Sulzer	1302
Contributors to Waves and Electrons Section.....	1306
3191. Abstracts and References.....	1307
News—New Products..... 22A	Positions Open..... 50A
Section Meetings..... 34A	Positions Wanted..... 55A
Membership..... 36A	Advertising Index..... 66A

EDITORIAL DEPARTMENT

Alfred N. Goldsmith
Editor

Clinton B. DeSoto
Technical Editor

Mary L. Potter
Assistant Editor

William C. Copp
Advertising Manager

Lillian Petranek
Assistant Advertising Manager

Responsibility for the contents of papers published in the PROCEEDINGS OF THE I.R.E. rests upon the authors. Statements made in papers are not binding on the Institute or its members.

Changes of address (with advance notice of fifteen days) and communications regarding subscriptions and payments should be mailed to the Secretary of the Institute, at 450 Ahnaip St., Menasha, Wisconsin, or 1 East 79 Street, New York 21, N. Y. All rights of republication, including translation into foreign languages, are reserved by the Institute. Abstracts of papers, with mention of their source, may be printed. Requests for republication privileges should be addressed to The Institute of Radio Engineers.





John A. Hutcheson

DIRECTOR, 1947-1948

John Alister Hutcheson, director of the Westinghouse Research Laboratories, was born in Park River, N. D., in January, 1905. Shortly after receiving the Bachelor of Science degree in electrical engineering from the University of North Dakota in 1926, he joined Westinghouse as a graduate student and was assigned to radio engineering work. Later, as a design engineer, he specialized in communications equipment. During the nineteen-thirties he helped design the world's most powerful broadcast transmitter at radio station WLW in Cincinnati, and was in charge of Westinghouse television development from 1938 until the war temporarily postponed that work. During that period—in 1939—he was appointed to the National Television Standards Committee to study television broadcasting and receiving, and to prepare recommendations for standards throughout the industry.

Named manager of the electronics engineering department of Westinghouse's Baltimore plant in 1940, Dr. Hutcheson supervised the engineering of all the radio communication and radar equipment produced by the company for the armed forces during the war. He served the National Defense Research Committee as a member of the division which carried on ultrasecret

electronics work under the direction of Karl T. Compton, President of the Massachusetts Institute of Technology, and was also a member of a special advisory committee appointed by the Secretary of War for research on War equipment.

In 1942 Dr. Hutcheson directed engineering for the Westinghouse X-Ray Division at Baltimore, leaving the following year upon his appointment as associate director of the Westinghouse Research Laboratories in East Pittsburgh, Pa. When development of atomic energy shifted to peacetime applications, he became chief advisor to a group formed to co-ordinate and advance all atomic energy research within Westinghouse. Early in 1948 he was advanced from associate director to director of research.

In 1943 Dr. Hutcheson received an honorary doctor's degree from the University of North Dakota in recognition of his achievements in radio and electronics engineering. Joining the IRE as an Associate Member in 1929, Dr. Hutcheson became a Member in 1930, a Senior Member in 1943, and a Fellow in 1948. He was Chairman of the Connecticut Valley Section from 1935 to 1936, and Chairman of the Pittsburgh Section in 1945 and 1946.

As science and technology advance, the body of available knowledge increasingly challenges the assimilative capabilities of even the indefatigable and mentally receptive student. Serious problems of management, and of personal adaptation, then arise. In the following guest editorial these problems, and paths toward their solutions, have been ably presented by an executive who has had broad experience in both technical and administrative branches of the United States Naval Service, who is now a staff officer at RCA Laboratories, and who is a member of the IRE Board of Editors, and its Editorial Administrative Committee.—*The Editor.*

The Dilemma of Specialization

GEORGE M. K. BAKER

Specialization is one notable characteristic of modern civilization. Whether or not it is a desirable characteristic is a subject of endless debate. It is readily acknowledged that a certain degree of technical specialization is mandatory if we are to maintain the high standard of living of which we are justly proud. This standard of living has been made possible, for the most part, by the specialization so well exemplified in our industrial mass-production techniques; in the advanced skill of our neurologists, diagnosticians, and orthopedic surgeons; and in the expert work of a variety of individuals in many social and humanitarian fields.

The *trend of specialization in the future* and the problems accompanying this trend are much more profitable subjects for discussion than the desirability of specialization itself. There are two diametrically opposed groups of sincere and thinking individuals, one group favoring, the other denouncing increased specialization. Few outside of these extremist groups feel any particular specialization program to be realistic. Since, however, the problem of specialization is one of peculiar interest to members of The Institute of Radio Engineers (and to all other professional societies as well) it seems one to be discussed rather than ignored.

Briefly, the proponents of increased specialization feel that the ever-expanding horizons of modern science have created a technology so complex that only a specialist can have the requisite knowledge to contribute to the advancement of his art. They say, therefore, that it is necessary for specialization to increase: those organizations and individuals who do not follow the trend already under way must ultimately lose out in the fierce competition of modern living.

The opponents of increased specialization maintain that it is now generally realized that scientists and engineers have become so compartmentalized and "expert" in their particular work that they are no longer aware of all pertinent developments in their own over-all field, let alone in related fields. They thus fail to contribute with full effect to the efforts of other workers, and in turn do not receive adequate assistance in the solution of their own problems. Countless opportunities for progress are slipping away, perhaps to be lost either forever or until their effectiveness has evaporated. Only individuals who grasp the details of an entire field and who also understand related fields to a high degree can contribute effectively to continued progress without at the same time countenancing a tremendous waste of opportunity.

The extremists whose cases have been cited are, I believe, attacking the question of specialization from the wrong angle entirely. Management does not, after all, generally embark on any particular program of specialization *per se*. Management has a three-fold responsibility—to the stockholders, to the employees, and to the public with whom it hopes to do business—and has a specific job to do. Depending upon the type of enterprise, management will set up an organization composed of technical specialists, if required, and nonspecialists, as necessary, in the proportion which is needed to do

the job. They will give little thought as to whether or not they are following any particular credo of specialization.

The better approach would, therefore, appear to be from the individual's viewpoint. Personnel relations are foremost among the important functions of modern management, and the problem of specialization, as in the case of many other such problems, should be attacked from the personnel angle. It matters little what elaborate plans management may make if improper placement of personnel militates decisively against their implementation.

Human engineers tell us that there are essentially two types of people—the objective and the subjective. At the risk of oversimplification, it might be generally stated that the objective person is one who works best with people; the subjective works best with ideas and things. Experience seems to indicate that each type is best suited for certain occupations, and fares ill, for the most part, when circumstances do not permit him to follow these pursuits. Take, therefore, subjective persons, train them in the ways of science, and they can and probably will make excellent specialists. On the other hand, train objective persons as you will in the ways of science, but be cautious in attempting to make them specialists in one narrow branch of any particular field, for they will probably fail themselves as well as the management who so shortsightedly attempted to bend them against their inherent traits of character and temperament. The objective group will seldom contribute to the assaults on the outer barriers of knowledge made by their subjective contemporaries, but here is a group of individuals who can be trained to see the broader aspect of their fields and the general requirements of related fields, and so serve admirably in co-ordinating work.

It is my own opinion that the increasing complexity of modern science will almost certainly require increased specialization, which in turn cannot but aggravate the problem of adequate contact and co-ordination among workers in different fields or even in different branches of the same field. The dilemma of specialization is then: how to obtain its advantages without the accompanying drawbacks?

The answer, it would seem, lies in the correct utilization of personnel. Already there is a growing tendency on the part of management to let those scientists and engineers of appropriate subjective character and temperament work unhindered in their chosen specialties; while at the same time it is training others, where possible, as a middle group to co-ordinate the work of the specialists, insure the use of intelligent channels for the exchange of information and ideas, and, in general, provide the contacts lost by increased specialization.

The idea is a challenging one and worth the thought of individuals and leading professional organizations such as our own. It is particularly interesting, since it takes into account the important aspects of the question of specialization: the interests of individuals, the problems of management, the future progress of science, and the ultimate benefit of mankind as a whole.

Communication by Means of Reflected Power*

HARRY STOCKMAN†, SENIOR MEMBER, IRE

Summary—Point-to-point communication, with the carrier power generated at the receiving end and the transmitter replaced by a modulated reflector, represents a transmission system which possesses new and different characteristics. Radio, light, or sound waves (essentially microwaves, infrared, and ultrasonic waves) may be used for the transmission under approximate conditions of specular reflection. The basic theory for reflected power communication is discussed with reference to conventional radar transmission, and the law of propagation is derived and compared with the propagation law for radar. A few different methods for the modulation of reflectors are described, and various laboratory and field test results discussed. A few of the civilian applications of the principle are reviewed. It is believed that the reflected-power communication method may yield one or more of the following characteristics: high directivity, automatic pin-pointing in spite of atmospheric bending, elimination of interference fading, simple voice-transmitter design without tubes and circuits and power supplies, increased security, and simplified means for identification and navigation.

I. RADAR TRANSMISSION WITH SCATTERING TARGET

IN THE CONVENTIONAL radar application, the return radiation from the target carries the information that the target exists. In the simplest case, therefore, the radar receiver response indicates a "yes" or "no," and the type of modulation employed may be considered as being of the "on-off" type. The following paper concerns utilization of reradiation from a target when the target is subjected to any kind of modulation; in particular, voice and telemetering-data modulation.

The geometrical configuration, size, shape, and surface conditions of the target determine to a considerable extent the law of propagation for the chosen type of transmission. In the conventional case of radar transmission with scattering target, the propagation follows basically an inverse-fourth-power law, which may be written:

$$d_{max} = \sqrt[4]{\frac{A^2 k^2}{4\pi\lambda^2} \frac{P_T}{(P_R)_{min}}} \quad (1)$$

where

- d = distance from transmitter-receiver to target
- A = aperture of transmitting antenna
- k = dimensionless factor, depending upon efficiency of antenna aperture
- λ = wavelength of transmission
- σ = radar cross section of target¹
- P_T = transmitted pulse power
- P_R = received power.

* Decimal classification: R537. Original manuscript received by the Institute, April 19, 1948. Presented, 1948 IRE National Convention, New York, N. Y., March 22, 1948.

† Air Materiel Command, Cambridge Field Station, Cambridge 39, Mass.

¹ The radar cross section of the target is defined as follows:

$$\sigma = 4\pi \frac{\text{power per unit solid angle scattered back towards the transmitter}}{\text{power per unit area in wave incident on target}}$$

The minimum received power $(P_R)_{min}$ which will give satisfactory radar operation over a maximum distance d_{max} is determined by a number of factors, some of which will be discussed later. For simplicity, the factors under the radical sign A , k , and λ may be assumed constants. It then follows that the range of the radar depends on the radar cross section of the target, and the ratio of transmitted pulse power to minimum received power, required for satisfactory radar operation. The result may not indicate the ultimate value of d_{max} for the reason that (1) is merely the prediction on paper of a relationship between transmission characteristics. This relationship is rather complicated in practice.

The signal-to-noise ratio in a conventional radar with A-scope presentation is boosted by integration performed by the human eye, although other integration may be utilized. It is of interest to study the maximum distance that can be obtained with fourth-power propagation, assuming a reasonable time T_{tot} available for integration, such as $T_{tot} = 1$ minute. This maximum distance can then be compared with that achieved with second-power or better propagation, obtainable in communication using a properly modulated nonscattering target. Consider first the signal-to-noise ratio when no integration is present. The random noise power (thermal noise, shot-effect noise) is proportional to the bandwidth B or inversely proportional to the pulse duration τ_p , so that for a noise amplitude N

$$N \sim \sqrt{B} \sim \sqrt{1/\tau_p} \quad (2)$$

The transmitted energy is proportional to $h^2\tau_p$ when h is the height of the pulse, and also proportional to $P_{Tav}T_0$ where P_{Tav} is the average transmitted power and T_0 is $1/f_{rep}$. Thus

$$h \sim \sqrt{\frac{P_{Tav}T_0}{\tau_p}} \quad (3)$$

With h indicating the signal S , the ratio of (3) and (2) will give the signal-to-noise ratio

$$\frac{S}{N} \sim \sqrt{P_{Tav}T_0} \quad (4)$$

This expression is independent of the pulse width or the corresponding bandwidth.² What this means for constant P_{Tav} is that the pulse height varies accordingly; the loss in height of the pulse being compensated for by the increase in pulse length. The signal-to-noise ratio is not independent of the $prf(f_{rep})$, however, for a reduced prf will give a larger T_0 in (4), thus an increased signal-

² S. Goldman, "Some fundamental relations concerning noise reduction and range in radar and communication," PROC. I.R.E., vol. 36, pp. 584-595; May, 1948.

to-noise ratio. In practice, there is a definite limit to T_0 and (4) then gives the corresponding limit in signal-to-noise ratio.

It should be noted that, due to signal suppression by noise in the receiver detector ("second detector"), i.e., because of lost coherence,

$$\left(\frac{S}{N}\right)_{\text{post-rect.}} = \frac{\bar{S}}{\bar{N}} \sim \left(\frac{S}{N}\right)_{\text{pre-rect.}}^2 \quad (5)$$

where the bars indicate postrectification or output quantities.

Consider next the case when integration is used in connection with a gate that only opens up for the duration of the pulse. The signal-to-noise ratio then becomes insignificant, and the quantity of interest becomes the ratio between the signal \bar{S} and the noise fluctuation $\overline{\Delta N}$ in the integrated output. It is known in probability calculus that the square of the fluctuation is proportional to the stochastic quantity, which in this case is the number of integrated pulses T_{tot}/T_0 , while the mean itself is proportional to the stochastic quantity, thus

$$\overline{\Delta N} \sim \sqrt{\frac{T_{\text{tot}}}{T_0}},$$

$$N \sim \frac{T_{\text{tot}}}{T_0},$$

and, therefore,

$$\frac{\overline{\Delta N}}{N} \sim \sqrt{\frac{T_0}{T_{\text{tot}}}}. \quad (6)$$

It follows from (4), (5), and (6) that

$$\frac{\bar{S}}{\overline{\Delta N}} \sim \frac{(S/N)^2}{\overline{\Delta N}/N} \sim \sqrt{P_{T_{\text{av}}} T_0} \sqrt{P_{T_{\text{av}}} T_{\text{tot}}}. \quad (7)$$

Theoretically, we could see any target if it could be studied during a sufficiently long time—an hour, or a day. In (1), this corresponds to reliable radar operation with a greatly reduced value of $(P_R)_{\text{min}}$. The technique applied is the technique of integration, or signal storage. While a follow-up on this matter would lead us outside of the scope of this paper, a few points of interest should be mentioned. The result in (7) indicates that the maximum distance depends upon the total transmitted signal energy $P_{T_{\text{av}}} T_{\text{tot}}$, which controls the response of the integrator, and also indicates that the signal-to-noise-fluctuation ratio increases with the period of pulse repetition for given average transmitter power, which should be as high as possible. With recently developed storage methods, the fixed-target range may be increased as much as four times,³ which is significant in the comparison of inverse-fourth-power-law radar transmission with more favorable communication transmission, as storage methods at present scarcely apply to the communications field. Under practical operating conditions, with

³ F. Dickey, T. A. G. Emslie, and H. Stockman, "Storage of Signals in Noise," unclassified report, in preparation, USAF, AMC, ERL, Cambridge, Mass.

the best possible integration system, the inverse-fourth-power law nevertheless restricts the range severely, and it is of the greatest interest to study the conditions under which a more favorable propagation law can be obtained.

II. COMMUNICATION TRANSMISSION WITH NONSCATTERING TARGET

Consider the conventional communication system in Fig. 1(a), in which the signal modulates the radiation from a transmitter at B and the intelligence is recovered from the radiation at A . This arrangement may be compared with the new system, Fig. 1(b), in which the source of radiation is located at the point of reception A , and the carrier power is reflected back from B by means of a signal-excited reflector; modulation taking place at the point of reflection B . If two-way communication is desired, the radiation source at A may be modulated, or all equipment duplicated.



Fig. 1—A comparison between conventional direct-power communication (a) and the new reflected-power communication (b), in which reradiation provides the carrier for the signal.

It is of interest to study the relation in (1) in a more simple and general way that is not particularly restricted to the fourth-power law, and it is believed that the following expression describes the conditions of immediate interest:

$$\frac{P_R}{P_T} = k_1 f(\lambda, d) k_r \frac{1}{d^n} \quad (8)$$

where k_1 is a proportionality factor, k_r a factor describing the reflecting characteristics of the target, and n an exponent, which in the case of conventional radar transmission has the approximate value 4. The quantity $f(\lambda, d)$ indicates the reduction in P_R relative to P_T due to the chosen values of wavelength λ and distance d , but for the time being the only variation in P_R considered is that due to the spreading of the beam. While (1) referred to radio waves, (8) is general and applies to any kind of transmission, and particularly "light"-wave (infrared), and sound-wave (ultrasonic), transmission. The unmodulated transmitter may be a magnetron, klystron, infrared lamp, or ultrasonic whistle. It is now required that the wavelength λ of the chosen transmission and the equivalent area A_e of the target (in the form of a modulated reflector) fulfill the requirements

$$\lambda^2 \ll A_e, \quad (9)$$

$$\alpha_{\text{view}} \gg \alpha_{\text{diff}} \sim \frac{\lambda}{\sqrt{A_e}} \quad (10)$$

where α_{view} is the angle through which the source of radiation sees the target, and α_{diff} the diffraction beam width corresponding to the equivalent reflector area A_e .

While these conditions may be very difficult to fulfill even for a K-band radar (λ of the order of 1 cm), they may be easily fulfilled for "light"-wave transmission. The geometrical relationships are then the ones shown in Fig. 2, where x indicates the position of the source of radiation, y the position of the reflector with area $A_2 = S$.

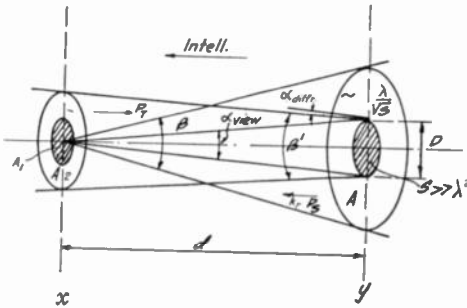

Fig. 2—The geometry of specular reflection, showing that for equal size antennas the reduction in power during the return path is only in a ratio of 1:4.

If P_T is the power radiated within the beam described by the angle β , and if uniform power distribution is assumed at y , then for $k_r = 1$ the reflected power P_S becomes

$$P_S = \frac{S}{A} P_T = k \frac{S}{d^2} P_T \quad (11)$$

where k depends on β only ($k = 1/\pi \tan^2 \beta/2$). This is essentially a derivation applicable to both the radar and the communication case, and proves the well-known square-law relation for one-way propagation. In the radar case we have, in general, $\alpha_{diff} \gg \alpha_{view}$. In that case the reflector acts as a scatterer and the transmission in the direction yx is similar to the direct radiation, being characterized by a fixed beam angle β' . Thus, repeating the procedure xy in the direction yx , we obtain

$$\left. \frac{P_R}{P_T} \right|_{radar} \sim \frac{1}{d^4} \quad (12)$$

Repeating the procedure in the communication case, we reradiate a beam described by the angle α_{view} and accordingly obtain an illuminated area $A_2 = 4S$. Thus

$$P_R = \frac{A_1}{A_2} P_S = \frac{A_1}{4S} k \frac{S}{d^2} P_T, \quad (13)$$

or, for $A_1 = S$,

$$P_R = \frac{1}{4} k \frac{S}{d^2} P_T.$$

This means that, while the loss in power in the radar case is very great in the direction yx , perhaps of the order of 10^6 , it amounts only to a factor of four for very short-wave communication in the same direction, i.e., in the direction the signal is being carried. In contrast to (12), the condition for communication is

$$\left. \frac{P_R}{P_T} \right|_{comm} \sim \frac{1}{d^2} \quad (14)$$

If the target picks up all transmitted radiation and if the receiver antenna is also built to pick up all the transmission, i.e., if the receiving antenna (for specular reflection) has twice the diameter of the target, there will be no loss due to the spreading of the beam, so that $n = 0$ in (8). Practical signaling has actually been carried out over a test-range distance of 150 yards⁴ with $n = 0$. Square-law signaling is the best one can hope for in most practical applications, but the difference between square-law signaling and fourth-power signaling is very considerable. If the fourth-power law yields useful transmission over 10 miles, square-law transmission will increase the range to 100 miles, on the assumption that everything else remains equal. With an inverse-square-law propagation, increase of the transmitted power is a practical consideration, as only 4 times more power is needed for doubling of the range compared to 16 times for the inverse-fourth-power law.

Further comparison of inverse-square-law propagation (using light waves, $\lambda = 5 \times 10^{-5}$ cm) and inverse-fourth-power-law propagation (using microwaves, $\lambda = 1$ cm) is made in Fig. 3.⁵ The transmitted beam width is 2° , due to diffraction in the microwave case, and to finite size of the source in the optical case. The light waves show an advantage in received power of 74 db over the microwave transmission at a distance of 90 km. This figure, of course, does not include the relative efficiencies of transmitters and receivers in the two cases. Further comparison between light-wave and microwave transmitters and receivers must be made before practical conclusions can be drawn.

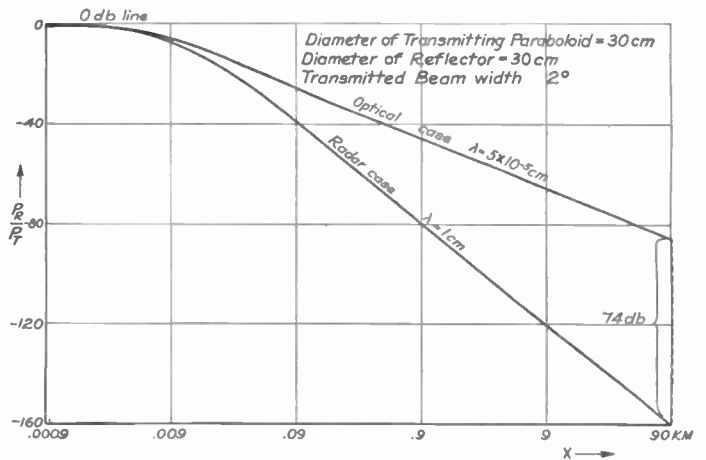

Fig. 3—A comparison of inverse-square-law and inverse-fourth-power-law propagation, showing an advantage of 74 db of the former over the latter at 90 km distance under assumed conditions.

It is of particular interest to study the increase in range of beacon operation over conventional radar operation. In the general beacon application the target is a receiving antenna, which picks up the signal and uses it to trigger a beacon transmitter, which reradiates a coded signal to the radar transmitter. The transmissions

⁴ See Part IV, Measurement Results, of this paper.

⁵ From values calculated by A. G. Emslie.

are therefore of square-law nature in both directions. We may write for the interrogating direction of transmission, using the index 1 for the radar that serves as the source of transmission, and index 2 for the beacon that serves as the receiver,

$$\frac{(P_R)_2}{(P_T)_1} = \frac{G_1 G_2 \lambda^2}{16\pi^2} \frac{1}{d^2} \quad (15)$$

where G_1 and G_2 are the gains of the radar and beacon antennas, respectively.⁶ Similarly, in the other direction

$$\frac{(P_R)_1}{(P_T)_2} = \frac{G_1 G_2 \lambda^2}{16\pi^2} \frac{1}{d^2}, \quad (16)$$

so that, independent of distance,

$$\frac{(P_R)_2}{(P_T)_1} = \frac{(P_R)_1}{(P_T)_2}. \quad (17)$$

Here $(P_R)_1$ must be sufficiently large for reception. For a given $(P_T)_1$ the received power in the beacon $(P_R)_2$ is determined by the inverse-square-law propagation. If $(P_T)_2$ is assumed equal to $(P_T)_1$, then $(P_R)_1 = (P_R)_2$, and no extra power loss is encountered due to the round trip. If $(P_T)_2$ is made just large enough to provide sufficient value of $(P_R)_1$, called $(P_R)_1'$, the replacement of the conventional beacon system with an ideal reflected-power system reduces the received power only in the ratio of 1:4, or to $0.25(P_R)_1'$, which is not a serious loss. This statement does not infer that a reflected-power beacon system is better than, or compares favorably with, a conventional beacon system, but serves to direct the attention to the fact that square-law propagation is obtainable with both systems. It should be noticed that, while the conventional beacon system replies in all directions, the ideal reflected-power beacon system only replies in the direction of interrogation. Whether or not a suitable reflected-power beacon system can be built in practice remains to be seen.

III. METHODS OF MODULATION

The target or reflector may be modulated in a number of ways, of which only a few will be mentioned: variable-damping modulation, interference or phase modulation, directional modulation, position modulation, doppler modulation, and polarization modulation. The first three will be discussed in the text.

The methods of modulation concerned apply particularly to corner reflectors. A corner reflector has the important property that a ray, which enters the corner, will experience a reflection from each of the surfaces, and will return in the direction from which it came.

As seen from the source of radiation, the corner reflectors⁷ will show regions of single, double, and triple reflection. The triple-reflection region always provides a return radiation coincident with the incident radiation

and is divided into six sections in circular arrangement. This radiation has a plane wave front, the corner reflector serving effectively as a plane mirror. The triple reflection has maximum intensity in the direction which makes equal angles with each axis of the co-ordinate axis system described by the edges of adjacent reflecting walls. Radiation entering at an angle deviating from the optimum angle causes less reflection, and the intensity of the reflected radiation tapers off gradually until triple reflection reaches zero when the line of sight lies in a reflecting plane. Some of these reflector characteristics, particularly those of interest for modulation, have been investigated in laboratory measurements and field tests to be described later.

Some of the difficulties encountered in reflector modulation with particular reference to corner reflectors are as follows. The reflector must be large to yield sufficient power return, and the required size increases with the wavelength (see the condition (9)). Modulation usually requires mechanical oscillation of large masses, joined into a rigid system by members of insufficient stiffness; thus the upper modulation cutoff frequency becomes unduly low. In addition, each reflector yields a particular receiver response curve, i.e., Fourier spectrum, for the applied modulation. Efforts to improve the radiation pattern may conflict with efforts to improve the Fourier spectrum. Thus arrangements to provide omnidirectional response may conflict with the requirement of signal response on the fundamental only. Conditions are complicated by additional requirements; for example, the requirement that stray radiation must not exceed a certain db level, etc.

It is desirable that new types of reflectors be made available which can be modulated by video signals up to cutoff frequencies of the order of 5 or 10 Mc. While such reflectors are not available today, methods of design are beginning to appear, which, for light-wave transmission in particular, may provide modulation response for frequencies far above the audio range. The interference type of modulation may be used advantageously, but the investigator must be cautioned by the fact that the incoherent nature of light restricts the freedom of choice of amplitudes and reflector characteristics in a modulator of this kind.

Variable-damping modulation may act upon both the impinging and the reradiated wave. A reflector arranged for variable damping may be looked upon as a parasitic equivalent circuit with variable admittance, so that the response E_r from the reradiated field may be of the form (18), where E_i represents the impinging field, k is the reflection coefficient in absence of modulation, and a , b , \dots , coefficients indicating the nature of the frequency response to the modulation frequency $\Omega/2\pi$.

$$E_r = kE_i(1 + a \cos \Omega t + b \cos 2\Omega t + \dots) \cos(\omega t + f_m(t)). \quad (18)$$

The formula shows that we may expect not only a somewhat distorted amplitude modulation, but also phase modulation $f_m(t)$.

⁶ L. N. Ridenour, "Radar System Engineering," MIT Rad. Lab. Series, McGraw-Hill Book Co., New York, N. Y., 1947.

⁷ See brief discussion of corner reflectors, Chapter 3.5 of footnote reference 6.

Interference or phase modulation may be produced by varying the distance between two reflecting surfaces; for example, by oscillating one of the surfaces by means of the sound waves produced by the human voice. The vectors representing the reradiations from the two surfaces will have a variable phase difference controlled by the modulation. There are regions of linear modulation as well as distorted modulation. As an example, for the case of a 90° separation angle, changed by a certain amount ϕ by modulation, the two vectors \bar{a}_1 and \bar{a}_2 may be assumed to have equal amplitudes A and may be written

$$\bar{a}_1 = A e^{j\omega t}, \quad (19)$$

$$\bar{a}_2 = A e^{j(\omega t + \pi/2 + \phi \cos \Omega t)} \quad (20)$$

where $\Omega/2\pi$ is the modulation frequency. The resulting vector magnitude then becomes

$$|\bar{a}_1 + \bar{a}_2| = A\sqrt{2(1 + \sin \phi)}. \quad (21)$$

For a 30° deviation, permissible in low-fidelity systems, the modulation percentage becomes 20 per cent.

In the case of light-wave transmission the distance between the two surfaces must not be so large that the coherence is lost, in which case reliable interference modulation becomes impossible.

Directional modulation is provided if a beam component is made to describe an angular displacement, which is controlled with respect to amplitude, frequency, and wave form by the modulating signal, so that a "hit and miss" action is provided at the point of reception (see Fig. 4). Here the modulated target, or reflector, is shown to the left with the angle of displacement θ . The response

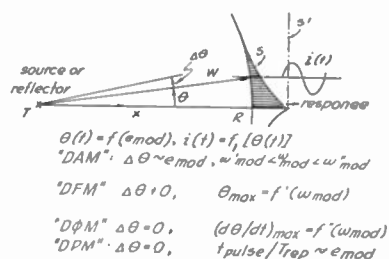

Fig. 4—An example of directional modulation, in which a beam component is made to deviate in accordance with directional amplitude (DAM), frequency (DFM), phase (D ϕ M), or pulse (DPM) modulation.

with respect to $\theta(t) = f(\theta_{mod})$ is, as an example, the one shown to the right; so that, in the simplest case, the more we deviate, the weaker becomes the response $i(t)$. Different kinds of transmissions can be established, such as directional amplitude modulation, "DAM"; directional frequency modulation, "DFM"; directional phase modulation, "D ϕ M"; and directional pulse modulation, "DPM." The differences between these transmissions is indicated by the formulas shown in Fig. 4, but will not be further discussed in this paper.

With the receiving equipment to be described later, it is possible to detect as small a modulation percentage as

0.1 per cent and still maintain a reasonably reliable signal from a modulated reflector. Some of the above modulation methods yield modulation percentages in excess of 10 per cent, and where noticeable distortion is tolerable, in excess of 20 or 30 per cent. Thus, conditions for reliable reception of modulated reflector signals seem to be at hand.

IV. MEASUREMENT RESULTS

Practical microwave measurements at the Ipswich Antenna Station in Massachusetts indicate that low-frequency identification modulation (produced, for example, by slowly repeated deviations of the corner reflector around a fixed axis) sometimes must be made as large as 20 per cent to become distinguishable to the receiver operator against the background noise (or "grass") on a radar A-scope. The difficulty in producing a strong and suitable reradiation at ranges of the order of 10 to 50 miles lies in the fact that good propagation characteristics are hard to obtain for radio waves with a wavelength of the order of 1 cm or less, and already at these values (9) and (10) will require corner reflectors of large dimensions. Light waves, such as infrared waves, would meet the requirements of (9) and (10) with small-size reflectors of high modulation cutoff frequency, but in the near-earth atmosphere light-wave transmission is generally practical only for short ranges, of the order of 10 miles or so. Here the possibilities described with reference to (8) with $n=0$ become of particular interest.

Fig. 5 shows a block diagram of a measurement setup suitable for microwave field tests on modulated reflectors.

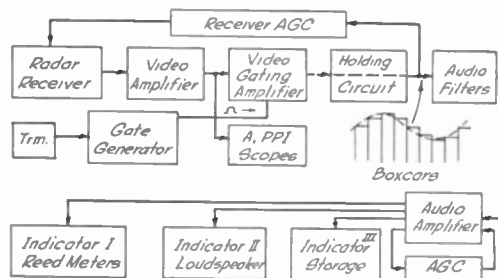

Fig. 5—A simple block diagram of a microwave measuring setup for the investigation of different kinds of reflectors, essentially for K-band operation.

tors, and Fig. 6 shows a photograph of associated equipment.⁸ A conventional receiver for the proper transmission frequency and bandwidth is used, followed by a video amplifier and gating amplifier. The gate is obtained from a gate generator, synchronized with the transmitter. When so required, a box generator can be included in the circuit and is shown in the form of a holding circuit, generating the wave form shown. The amplifying system is provided with automatic gain control, and the controlled amplifier output feeds into one

⁸ For further information on measurement results and applications, see forthcoming Electronics Research Laboratory report by H. Stockman, entitled "Reflected Power Communications."

or more audio filters, one for each audio channel, connected to an individual audio amplifier. Suitable cathode-ray oscilloscopes are provided for the study of the

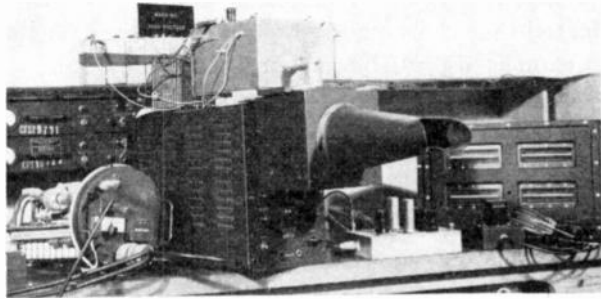

Fig. 6—A photograph of the measuring setup in Fig. 5, showing to the right a Frahm frequency meter used for identification of reflectors modulated with a complex wave. (The NIT system of identification.)

video outputs. Each audio amplifier has a separate automatic gain control. Three different kinds of indicators are shown, marked 1, 2, and 3. The first indicator is a reed meter, the second is a loudspeaker, and the third is a storage device, particularly the mechanical integrator,³ suggested by the writer for extraction of very weak signals from noise.

The use of this and similar receiving systems has indicated particular requirements on certain receiver characteristics. High receiver gain is necessary, as a receiver for modulated reflector signals should give full output for a very weak incoming wave, modulated less than 1 per cent. Suitable manual and automatic gain controls must be provided, as saturation may remove small amounts of modulation, and the time constants of the control systems must be made very small. Gain control is preferably established by means of a degenerative system. Suitable detection is an important requirement, and rectification, wherever used, should be under full control and of correct form. Linearity in amplifying parts and in the envelope region of rectifying parts must be maintained so that cross-modulation effects are avoided. Optimum gate width must be obtained, and adjustable gate width is preferable, as for very weak signals a somewhat wider gate may give better results than a narrower gate, the opposite being true for ordinary signals. Generally, a wide gate is undesirable from the viewpoint of interference. Freedom from extraneous frequencies is an important requirement, and the receiver must be designed not to yield distortion that produces such frequencies. Filtering in the output part of the receiving system may be required. Freedom from hum and noise is also of the greatest importance, as even a weak ripple component may be very large in comparison with the detected signal component.

For microwave transmission, the following measurement results are of interest. With a large corner reflector as a target (see Fig. 7), the distance of transmission was reduced until a saturation target was obtained with

just noticeable "grass" on the base line of an A-scope (distance appreciably one mile). When one of the walls was deviated 5° from the proper right-angle positions, the saturation target almost disappeared from the scope,

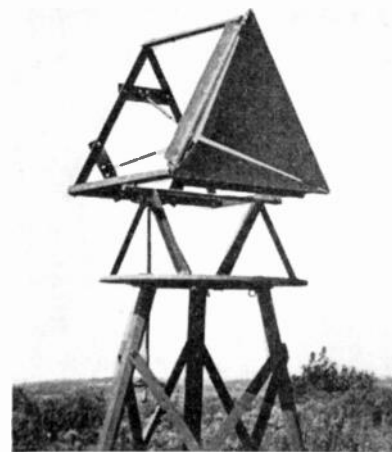

Fig. 7—One of the largest corner reflectors used during the tests with a 2-foot free edge. The sides can be deviated manually or by means of a motor-driven device and readings taken of the response in the receiver.

corresponding to an output modulation of nearly 100 per cent. This result varied with the position the reflector held with respect to the average ground clutter. Very much smaller deviations were found satisfactory on various types of reflectors for good A-scope detection of the target and reliable observation of the code signal. Most of the experiments were carried out with an S- or X-band radar, so as to provide unfavorable predictions from (9) and (10) in order to study the limitations of the method.

With the reed meter and simultaneous reception from several coded reflectors, visible deviations of several reeds on the frequency-meter indicator were observed, superimposed upon the random variations caused by noise.

The following measurements concern primarily the use of modulated reflectors for the purpose of identification by means of reed indicators and refer to a system for reradiation of three or four digits upon excitation by coherent or incoherent electromagnetic radiation.⁹ Each reflector is identified by its "numberplate" code number, the digits of which in the first experiments have been chosen in the frequency interval 10 to 100 cps. The measurement results indicate a required minimum frequency spacing of 2 cps, so that, as an example, a suitable code number would be 17, 19, 25. The choice of numbers is limited by the fact that the positions of the digits in the number are without meaning; thus, 19, 17, 25 being identical with 17, 25, 19, and 25, 19, 17, etc. Further, due to the unavoidable nonlinearity in the signaling system, harmonic, sum, and difference tones are produced in the receiver output, and may give false signals. For a

⁹ The NIT "Number Identification Target" system suggested by the writer. See forthcoming Electronics Research Laboratory report.

number of reed frequencies $n=90$ and a number of digits $m=3$, the number of combinations or possible code signals n_c may be estimated as

$$n_c = \frac{n!}{m!(n-m)!} = \frac{90!}{3!(90-3)!} \approx 100,000. \quad (22)$$

Because of limitations, such as those mentioned above, the practical value of n_c would probably be reduced to the order of 10,000, or so.

Various experiments with "numberplate" coded reflectors have been carried out, and Fig. 8 shows one of the early models. Three turrets of four corner reflectors in each turret are arranged coaxially and rotate with different speeds, driven by the same motor. Both am-



Fig. 8—Triple-turret reflector, in which each turret rotates with a predetermined speed. The result in the receiver is that particular reeds in the frequency meter become excited.

plitude- and phase-modulation type turrets have been used, and the measurements indicate that phase-modulated turrets provide the most consistent and steady echo returns. Various motor speeds were used, and a Frahm frequency meter with a frequency range from 15 to 85 cps was connected to the receiver (see Figs. 5 and 6). An X-band (3-cm wavelength) radar type AN/APS-3 was used as the radiation source and the distance of transmission varied within a maximum range of 2 miles. The amounts of harmonic generation and transmission radiation pattern were studied, but sufficient results have not yet been obtained. It is indicated, however, that although the experimental turret reflector in Fig. 8 produced a weak second harmonic and a still weaker third harmonic, it fulfilled the purpose of yielding an indication in the Frahm frequency meter from which the "code" number of the reflector could be read off without risk of false indication. The possibility was investigated of surrounding the triple-turret reflector with a dome of insulating material of such thickness that a filter action resulted in a pass band for a particular frequency region. Thus, the reflector would respond only to a particular interrogating beam of radiation.

While the triple-turret reflector provides one solution to the problem, it is possible to generate all three digit

frequencies in one and the same reflector, if this reflector is excited by a complex wave composed of the individual waves, or if different surfaces (walls) in the reflector are excited by the individual digit modulation frequencies. Various experiments were carried out and indicated that the suggested principle for complex-wave excitation is useful, but a considerable amount of research and development work remains to be done before practical field tests can be initiated. This investigation should be extended to carrier operation of corner reflectors, the signal modulation being applied to the carrier, and the signal-modulated carrier applied to the reflector.

The possibility of detecting corner-reflector return radiation must be considered with reference to possible existence of ground and troposphere reflections. Destructive and constructive interference is created and depends upon the characteristics and the position of the source of radiation, the receiver, and the reflector. The seriousness of such interference is determined by the operating conditions and the wavelength, and is operationally less severe for a higher frequency than for a lower frequency in the range where reflected power may be utilized.

The most interesting group of measurements concerns small corner reflectors utilizing light-wave transmission, and Fig. 9 shows one of the measurement setups used for

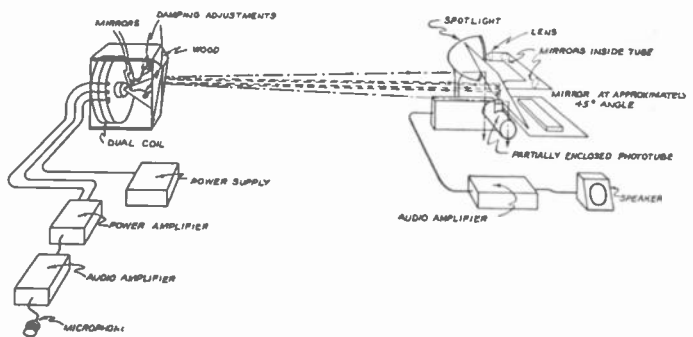

Fig. 9—Optical measurement setup for the study of different kinds of voice-modulated reflectors (to the left), either excited through microphone and amplifier, or directly by the human voice.

a distance of the order of 100 yards. The transmitter to the right has the form of an automobile head light, projecting a narrow beam of light into space via a special periscope and optical lens system. The receiver is located at the same terminal and has essentially the form of a photocell with amplifier, feeding a loudspeaker. The modulated corner reflector to the left is excited by the human voice via a microphone and an amplifier, and the voice current oscillates all three walls in simultaneous action. Measurements with this and other transmission links were carried out and the results indicate that voice communication with good sound quality was feasible, utilizing the reflected-power principle. In later measurements the photocell was turned around and provided with a parabolic mirror and conditions for square-law

propagation investigated. Tests were carried out with the narrow light beam utilized fully in both the modulated reflector and the receiver parabolic mirror, and it was realized that practically all attenuation due to beam spreading could be eliminated. Thus the signal strength was considerably larger than in the square-law case, with $n=2$ in (8), and changes in the distance did not seem to affect the signal strength, as is predicted by (8) with $n=0$.

It was concluded from a theoretical investigation that the power in the human voice would be sufficient to operate a reflector, so that the microphone and amplifier in Fig. 9 could be eliminated. It was indicated that a maximum displacement of 0.01° of the corner reflection wall with an edge length of a few inches would yield a radiated power in the form of air-pressure variations of 5×10^{-6} watts at 400 cps. It is estimated that the average power in conversational speech has a peak value of 5×10^{-3} watts. Comparing the figures 5×10^{-6} watts and 5×10^{-3} watts and allowing a loudspeaker-action efficiency of 10 per cent, it seemed that a reasonable guarantee for direct voice operation of corner reflectors was at hand, assuming that most of the speech power be directed so as to vibrate the corner reflector walls. This could be done by means of a horn operating under proper matching conditions. In view of these predictions a re-

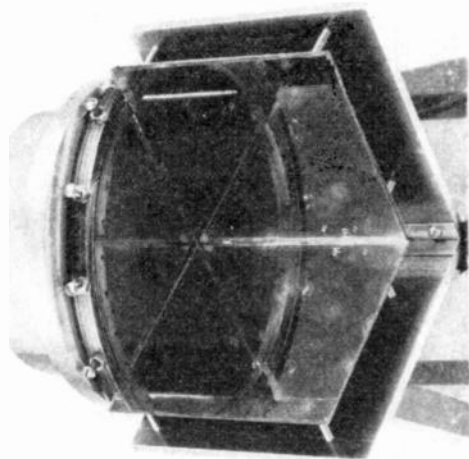

Fig. 10—One of the voice-powered reflectors used during the measurements. Two sides of the corner reflector are glass mirrors, while the third side is a metal diaphragm, excited by the human voice (size of each mirror, 4×4 inches).

flected-power transmitter was built for direct voice excitation of all three walls. Later on, additional reflectors were built with one wall replaced by part of a thin dural metal sheet stretched over a frame (see Fig. 10). These reflectors had frequency responses extending from approximately 200 to 4000 cps, somewhat peaked in the region of 3000 cps. The results with these voice-operated reflectors were superior to those obtained with amplifier-operated reflectors, and reliable communication was obtained over the 100-yard test range with good sound quality.

V. PRACTICAL APPLICATIONS

The following observations may be made. The source of radiation is basically unmodulated, which invites re-consideration of known, powerful radiation sources, which cannot be easily and properly modulated. Even if the carrier power (Fig. 1 or Fig. 11) is radiated omnidirectionally, the returning modulated radiation may be made highly directive and pin-pointed on the receiver.

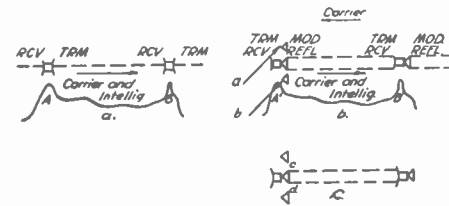

Fig. 11—Conventional microwave relay with direct power (a) and with reflected power (b) and (c). In the latter case the signal-modulated beam is automatically pin-pointed to the receiver even in case of atmospheric bending.

In case the impinging beam or beam component encountered at B in Fig. 1(b) is bent due to atmospheric conditions, the returning modulated radiation remains nevertheless pin-pointed on the receiver, as this radiation utilizes the same path of transmission. The reflector at B does not radiate unless excited by an impinging wave, and it basically operates linearly, in accordance with the superposition theorem, thus yielding freedom from overloading and cross modulation. As the reflector at B may be excited directly by sound waves in the air, the new system makes possible the design of small voice transmitters not using tubes, circuits, or power supplies. Due to the fact that the transmitter and receiver at A are located side by side, various forms of control circuits can be introduced between the transmitter and receiver for one purpose or another, such as secret communication, improved signal-to-noise ratio, and reduced fading and jamming. An interesting application here is the use of a noisy source, the noise output in the utilized spectrum from the source canceling the receiver noise output inherent in the transmission. Another application implies that the receiver may be provided with automatic tuning, synchronized to the transmitter, so that frequency drift may be minimized, and interception and jamming reduced by continuous periodic or random frequency shifts.

The above observations do not cover all phases or the possible uses of the reflected-power scheme, but indicate where the essential differences from conventional communication systems are to be sought.

The value of the reflected-power principle from an operational point of view has not yet been fully estimated, but the following applications may serve to illustrate the usefulness of the new method.

Meteorological balloon tracking and telemetering is conventionally done by means of a balloon transmitter and a directional search receiver. Alternatively, the balloon may be provided with a telemetering-data-modulated special reflector. A properly arranged radar on the

ground then serves the double purpose of tracking the balloon and receive the telemetering signal, so that the procedure of meteorological observation becomes simplified.

Microwave relaying is illustrated by Fig. 11. Fig. 11(a) shows a conventional communications relay link, and in 11(b) and 11(c) the same link provided with reflected power. In this case the unmodulated transmitter is located at B' and the modulated reflector at A' . The transmitter to the right has a sufficiently wide unmodulated beam, which always includes the modulated reflector to the left, but ideally the return radiation is always pinpointed on the receiver to the right, even in case of atmospheric bending. Thus reliable communication is maintained between A' and B' , and the beam is still very sharp, assuming an ideal reflector.

The above arrangement can be extended to automatic beam stabilization by means of error-signal reflectors a , b , c , d , or by other similar arrangement.

Frequency-drift-free communication: In contrast to the conditions for conventional communication links, we can here apply afc to the transmitter, or both to the transmitter and the local oscillator. As the transmitter has an excess of power, simplified afc circuits become possible.

Fading-free communication can be established in various ways by means of the reflected-power communication scheme. It should be noticed that if a conventional communication link provides zero received signal because of interference, reflected power would provide maximum signal at the same instant for the same distance, as the path length is doubled. Combinations of the systems may thus eliminate fading.

An example of automatic fading elimination by means of frequency variation is shown in Fig. 12, where the transmitter and receiver are located to the left and the modulated reflector to the right. When the input signal to the receiver becomes small because of fading, an error signal is generated which, via a reactance tube or simply via rectification, operates on the transmitter, changing the frequency until proper transmission conditions are restored. Alternatively, a system with horizontally or vertically arranged error-signal reflectors may be used, such as the reflector system a , b , and the error signal made to operate the transmitter frequency until maximum signal strength in m is restored.

It is of interest to note that some of the uses of re-

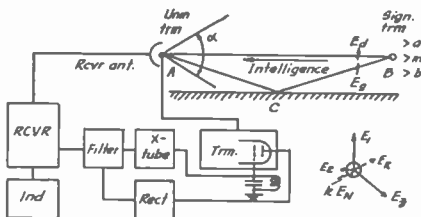

Fig. 12—An example of fading-free communication by means of the reflected power principle. Signal reduction due to interference is counteracted by an automatic change in frequency.

flected power make possible the building of *receivers without local oscillator*. Sometimes, at microwaves, it is a great simplification to eliminate the local oscillator due to the difficulty of producing suitable oscillators. Sometimes, however, the noise increases so much when the local oscillator is removed that the conventional scheme is preferred.

The simplest local-oscillator-free receiver circuit is the one where a part of the transmitter carrier is injected so that beats containing the signal are produced with the receiver input wave. An example of another arrangement for the elimination of the local oscillator is shown in Fig. 13, where an external oscillator and the transmitter feed into a nonlinear mixer. The frequency f_2 of the external oscillator is such that one of its harmonics kf_2 is suitable for use as the intermediate frequency. The nonlinear device output is $f_1 + kf_2$, where f_1 is the transmitter frequency, and is injected into the receiver as local-oscillator frequency. By beating with the receiver input this local-oscillator wave provides the desired if output in the receiver nonlinear mixer.

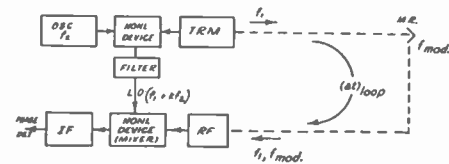

Fig. 13—A simple communications circuit showing the possibility of superheterodyne reception without the need of a local oscillator, the microwave local oscillator being replaced by an rf oscillator and associated mixers and filters.

Some of the schemes referred to above employ carrier injection in one form or another in the receiver input. This means that the coherence of the input signal can be enhanced and, accordingly, the signal-to-noise ratio improved.

CONCLUSION

It should be mentioned in conclusion that the reflected-power principle has already proven its value in the well-known radar application, i.e., for simple on-off modulation. In the method presented we modulate the target with any time function. Evidently considerable research and development work has to be done before the remaining basic problems in reflected-power communication are solved, and before the field of useful applications is explored.

ACKNOWLEDGMENT

The author wishes to acknowledge his indebtedness to the Electronic Research Laboratory, Air Materiel Command, U. S. Air Force, for the support given this research work, and he also wishes to thank the engineers of the Communications Laboratory for valuable suggestions. Most of the early experimental investigation was carried out by Robert Wagner and Walton Bishop, and credit for helpful suggestions is also due to Alfred Emslie and Stanford Goldman, consultants to the Communications Laboratory.

Some Notes on Noise Figures*

HAROLD GOLDBERG†, SENIOR MEMBER, IRE

Summary—The subject matter of this paper first appeared in the form of laboratory reports. Outside interest in these reports prompted the preparation of the material for publication. Despite the attention given to noise and noise figures in the literature,¹ the basic concepts are still little understood by the average engineer. This paper takes up the basic ideas and definitions proposed by H. T. Friis and presents them in a form that is more easily understood. Naturally, complete generality is not achieved, and the conclusions are subject to restrictions. Nevertheless, useful results are obtained. Subjects treated include expositions of the meaning of the “available gain,” and the derivation of simple noise-figure formulas for many types of circuits in common use.

INTRODUCTION

THIS PAPER HAD its genesis in two reports on noise figures originally prepared for internal circulation at Bendix Radio Division. After a few copies of these reports had found their way to persons outside the organization, a steadily increasing number of requests began to come in for others. The interest shown prompted the preparation of the material for publication.

The basic ideas followed in this paper are contained in a paper by Friis.¹ Since this paper is intended for those who are relatively unfamiliar with the subject, some of the material presented by Friis will be repeated.

AVAILABLE POWER

One of the basic concepts necessary to this discussion is that of “available power.” A generator of real internal impedance R ohms and open-circuit voltage E can deliver a maximum power of $E^2/4R$ watts into a resistive load. This maximum power is delivered only when the generator is matched, i.e., the load resistance is also R ohms. Friis terms this maximum power the “available power.” It is obviously independent of the load, and dependent only on the characteristics of the generator.

This definition leads to a concept of “available noise power.” It is well known that a resistance of R ohms at an absolute temperature T produces noise voltage across its terminals. It may be represented as a generator having an internal noise-free resistance of R ohms, and an open-circuit rms voltage equal to the square root of $4KTRB$, where K is Boltzmann’s constant, 1.38×10^{-23} , T and R are the absolute temperature and resistance, and B is the small frequency band over which the open-circuit noise voltage is measured. The bandwidth appears in the expression because the noise voltage is not a single-frequency phenomenon. The available power from such a generator is, by definition, $KT B$. *Note that*

* Decimal classification: R261.51. Original manuscript received by the Institute, March 1, 1948; revised manuscript received, April 23, 1948. The work described in this paper was performed while the author was in the employ of the Bendix Radio Division.

† National Bureau of Standards, Washington, D. C.

¹ H. T. Friis, “Noise figures of radio receivers,” *Proc. I.R.E.*, vol. 32, pp. 419–422; July, 1944.

this is the noise power delivered by the resistor to a noise-free resistor of equal resistance. It is not necessarily the noise power actually dissipated in either of two resistors of equal resistance connected in parallel. Despite the fact that the reader may feel some concern at this point, since he knows that all resistors produce noise, the concept is convenient and logical. An example will be given later to illustrate this point.

AVAILABLE GAIN

Another concept used by Friis is that of “available gain.” It has been the author’s experience that a lack of understanding of the nature of the “available gain” is one of the obstacles in the path to understanding of the concept of noise figures. Let us suppose that the generator is connected to a network, and the network, in turn, is connected to a load. The generator delivers power to the network and the network to the load. With the generator connected, but the load disconnected, the output terminals of the network display an impedance. Let us assume that it is real. If one now matches the network, i.e., connects a load to it equal to its internal output impedance, it will deliver the maximum possible output power. Let us term this the “available output power.” What may be said about this “available output power”? It is independent of the load on the network by definition. *It is not independent of the way in which the signal generator is coupled to the network.* The way in which the signal generator is coupled to the network affects the amount of power which may be abstracted from the network.

The “available gain” is now defined as the ratio of “available output power” from the network to the “available signal power” from the generator. The “available gain” is therefore independent of the load by definition, but does depend on the characteristics of the signal generator and the way in which it is coupled to the network. *The available gain of a network, therefore, is a function of the signal generator used to supply it, and is not a unique characteristic of the network.*

One may now calculate the available gain of a cascade of networks. Let us imagine a cascade of networks fed by a signal generator. Measure the available gain of the first network by opening the cascade between networks 1 and 2. Call this G_1 . Now measure the available gain of network 2 by opening the cascade between 1 and 2, and 2 and 3. Use a signal generator of internal impedance equal to the impedance seen looking into the output of network 1 with the original signal generator connected to it. Call this G_2 . This is done for each network in turn. The measurement is made each time with a signal generator having an internal impedance equal to that seen looking back towards the beginning of the cascade, the

cascade being broken at the point of connection of the element to be measured. Consider the product

$$G_1 \cdot G_2 \cdots G_n = (S_1/S_0)(S_2/S_1) \cdots (S_n/S_{n-1}) \quad (1)$$

where S_n is the available output power of the n th network when measured as above, and S_0 is the available generator power.

Rearranging,

$$G_1 \cdot G_2 \cdots G_n = (S_1 S_2 S_3 \cdots S_n) / (S_0 S_1 S_2 \cdots S_{n-1}) \quad (2)$$

$$= S_n / S_0 \text{ the available gain of the cascade.} \quad (3)$$

This result is valid only when the "available gain" of each element is measured with a signal generator whose internal impedance is equal to the impedance of the entire network preceding the element under measurement.

In all of the foregoing, the impedances involved have been assumed real. In the remainder of the paper it will be assumed that all reactances will have been resonated for the frequency for which the analysis is made, and that the impedances, therefore, will be real. The band of frequencies B is assumed to be centered at this frequency, and to extend only over the frequency band for which the impedances are substantially real and constant.

The characteristics of the "available gain" can be most easily fixed by calculating it for a few networks. The simplest is a resistor. Let us calculate the "available gain" for a resistor connected to a signal generator as shown in Fig. 1. The "available output power" may be calculated with the aid of Thevenin's theorem. The open-circuit output voltage is $ER_1/(R_1 + R)$ volts, and the out-

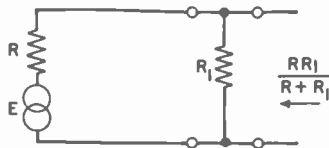

Fig. 1—Signal generator with shunted output.

put impedance, with signal generator connected, is $RR_1/R + R_1$ ohms. The maximum power output is that obtained when a load of impedance equal to the output impedance is connected. This is, by definition, the "available output power," and is

$$\frac{E^2 R_1}{4R(R + R_1)}$$

watts. The "available signal power" from the generator is $E^2/4R$ watts. The "available gain" is

$$G = \frac{R_1}{R_1 + R} \quad (4)$$

Despite the fact that, by definition, the available gain is associated with the idea of power, the available gain for a resistor turns out to be equal to the ratio of output voltage to generator voltage. This example serves to

illustrate the danger involved in applying preconceived notions concerning "gain" to the concept of "available gain." As previously stated, the expression derived in (4) is independent of the output load, but is not independent of the signal-generator impedance. It is unity for a signal generator of zero internal impedance and zero for one of infinite internal impedance. The "available gain" is $\frac{1}{2}$ when the resistor has the same value of resistance as the signal generator.

Let us now consider the "available gain" of an ideal transformer. One should expect that it will be unity, since an ideal transformer has no dissipation, and the maximum power available from its terminals is the same as that available from the generator itself. (See Fig. 2.) If the transformation ratio is a , the output open-circuit

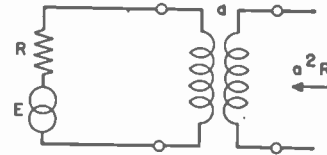

Fig. 2—Signal generator feeding an ideal transformer.

voltage is aE where E is the open-circuit generator voltage, and the output impedance is a^2R . The "available output power" is $a^2E^2/4a^2R$ or $E^2/4R$. Since the "available output power" is the same as the "available signal power," the "available gain" for the ideal transformer is unity. One may deduce that the "available gain" for any nondissipative, passive network is unity, since the "available output power" must always be the same as the "available power" at the input to the network.

Now consider the "available gain" of an active network, an amplifier, driven by a signal generator which has a resistor R_1 across its terminals (see Fig. 3). The amplifier is assumed to have an infinite input impedance and an open-circuit voltage gain A ; i.e., the output

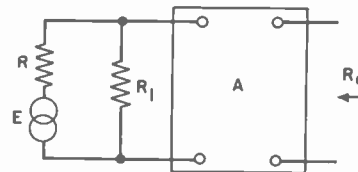

Fig. 3—Shunted signal generator feeding an amplifier.

voltage is A times the input voltage whenever the output load (not shown in the figure) is allowed to become large without limit. The output impedance is R_0 , and is assumed to be independent of the impedances connected to the input. To compute the "available output power," it is only necessary to take the square of the output open-circuit voltage and divide it by $4R_0$. This power is

$$S = \frac{\left(\frac{ER_1A}{R + R_1} \right)^2}{4R_0} \quad (5)$$

Since the "available generator power" is $E^2/4R$, the "available gain" must be

$$G = \frac{RA^2}{R_0} \left(\frac{R_1}{R_1 + R} \right)^2. \quad (6)$$

This figure could have been arrived at by considering the resistor R_1 and the amplifier to be in cascade, computing the separate "available gains," and taking their product. The "available gain" for the resistor is already known. For the amplifier (it must be realized that this must be computed for a signal generator of internal impedance $RR_1/(R+R_1)$, since it depends on both R and R_1 in this case), the "available gain" is

$$\frac{A^2}{R_0} \left(\frac{RR_1}{R + R_1} \right).$$

The product of the two gains is the same as that given above. Again, it is emphasized that the "available gain" is not only determined by the amplifier, but by the signal generator and the network connecting signal generator and amplifier. If all parameters are kept constant with the exception of R_1 , the "available gain" will be a maximum when R_1 becomes large without limit. It is RA^2/R_0 in this case. If either R or R_1 are adjusted for generator match, the "available gain" is $RA^2/4R_0$ where R is the final value of both impedances.

NOISE FIGURES

The matter of noise will now be brought back into the discussion. Consider the circuit of Fig. 4. An amplifier of open-circuit voltage gain A is fed by a signal generator of internal impedance R at an absolute temperature of T degrees. The input impedance of the amplifier is effectively infinite and the amplifier is assumed to be noise free. The gain of the amplifier is assumed to be sufficiently great to make its noise output, i.e., amplified noise from the signal-generator resistance, very large compared

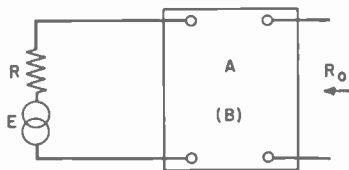

Fig. 4—Signal generator feeding an amplifier.

to the noise voltage generated in any resistive load connected to the output terminals. A bandwidth B will be assumed in accordance with previous remarks, and the discussion will be for a frequency for which the impedances involved are real. From material already derived, one may write the "available signal power," $E^2/4R$; the "available output power" due to the signal, $E^2A^2/4R_0$; and the "available gain," G , equal to RA^2/R_0 . Let us compute the "available output noise power." This may be done in the same manner as the computation for "available output signal power." The mean-

squared noise voltage available from the signal generator is $4KTBR$ volts squared and will produce an open-circuit mean-squared output voltage of $4KTBRA^2$ volts squared. (It is assumed that the noise power due to the resistance of the load may be neglected.)

The "available output noise power" is computed by dividing this quantity by $4R_0$. The result is

$$N = \frac{4KTBRRA^2}{4R_0} = \frac{KTBRA^2}{R_0}. \quad (7)$$

But,

$$G = \frac{RA^2}{R_0};$$

therefore,

$$N = GKTB. \quad (8)$$

The "available output signal power," however, is

$$S = GS_0 \quad (9)$$

where S_0 is the "available signal power." The suggestion is strong, therefore, that $KTBR$ be considered the "available noise power" from the generator. $KTBR$ may be considered to be "available noise power" if the meaning assigned to it in the beginning of the paper is used. Friis defines the noise figure F of a network as the ratio of the "input available signal to available noise power ratio" to "output available signal to available noise power ratio." Symbolically,

$$F = (S_0/KTB)/(S/N). \quad (10)$$

For the above example the noise figure would be unity. This result states that the amplifier has not changed the signal-to-noise ratio. Such a result is expected, since the amplifier was assumed to be noise-free.

The definition for noise figure given by (10) may be rearranged to give

$$N = FGKTBR \quad (11)$$

and

$$F = N/GKTBR. \quad (12)$$

In other words, the "available output noise power" N is the product of $GKTBR$ and the noise figure. Equation (12) affords a convenient method for computing noise figures.

Having already computed the "available gain" of a resistor, it will be interesting to compute the noise figure of a resistor.

$$N = \frac{4KTBR R_1(R + R_1)}{(R + R_1)4RR_1} = KTB \text{ (a result known by definition).} \quad (13)$$

Since G for a resistor has already been computed in (4), F is seen to be

$$F = \frac{N}{GKTB} = \frac{KTB}{\frac{R_1}{R+R_1} KTB} = \frac{R+R_1}{R_1} \quad (14)$$

where R is the generator impedance and R_1 the value of the resistor.

The computation of the noise figure of a generator, a resistor, and a noise-free amplifier is now in order. (See Fig. 3.) The "available gain" for this system has already been computed in (6).

$$N = \frac{4KTBRR_1A^2}{(R+R_1)4R_0} = \frac{RA^2R_1KTB}{R_0(R+R_1)} \quad (15)$$

$$F = \frac{R+R_1}{R_1} \quad (16)$$

The result, which is hardly surprising, is that the noise figure is the same as that for a resistor alone. This must be the case, since the amplifier is noise-free.

The next computation involves a generator, resistor, and noisy amplifier. The concept of the "equivalent-resistance" method for characterizing noise in an amplifier will be used. In cases where a complex noise source may be represented by one equivalent noise source, it is convenient to represent the noise by a fictitious generator which, when inserted in the circuit, will produce the same noise output from a noise-free network as that produced by the noisy network. Such a fictitious generator has its voltage specified in terms of a resistor, generally at room temperature, which produces the required noise voltage. This resistor is termed the "equivalent noise resistance" R_{eq} . The concept is most used with networks involving tubes, crystal rectifiers, and other devices having noise in excess of that attributable to them on the basis of the Johnson effect alone. Care must be exercised in its use, since a complex noise source may be replaced by a single noise source only under carefully restricted conditions. It is a very convenient concept for use with tubes, since North and his co-workers³ have done extensive work on the problem and have derived formulas giving the "equivalent noise resistance" for commonly used tube types. In the case of triodes, the concept is applicable only in the absence of transit-time effects and feedback. Additional noise sources are necessary to represent the noise behavior if either or both of the above phenomena are present. When tetrodes or pentodes are used, the use of a single equivalent noise source additionally requires that the screen and suppressor be returned directly to the cathode. It must also be realized that the use of a single noise source to represent a complex noise source implies some rather drastic assumptions concerning the frequency behavior of the impedances associated with the actual noise sources. Despite

³ B. J. Thompson, D. O. North, and W. A. Harris, "Fluctuations in Space-Charge Limited Currents at Moderately High Frequencies," Publication No. ST-185-A to E, January, 1940 to July, 1941; RCA Manufacturing Co., Inc., Harrison, N. J.

all of these restrictions, however, the concept leads to useful results.

The circuit of Fig. 5 will now be analyzed. The amplifier, as before, has an open-circuit voltage gain A , an output impedance R_0 , and an infinite input impedance. The noise from the amplifier is represented by the generator R_{eq} , whose mean-squared noise voltage output is

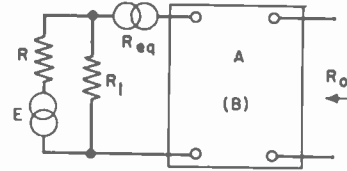

Fig. 5—Shunted signal generator feeding a noisy amplifier.

$4KTB R_{eq}$. The "available gain" for the system has already been computed in (6). The "available output noise power" is

$$N = \frac{4KTBRA^2}{4R_0} \left(R_{eq} + \frac{RR_1}{R+R_1} \right) \quad (17)$$

Note that the squared voltages are added directly. This is a consequence of the randomness of noise voltages. The contributions add directly on a power basis, since there is no identity of phase or frequency in the two noise sources. The noise figure is

$$F = \frac{R+R_1}{R_1} + \frac{R_{eq}}{R} \left(\frac{R+R_1}{R_1} \right)^2 \quad (18)$$

Some interesting observations may be made concerning (16) and (18). If R_{eq} is zero, as it would be for a noise-free amplifier, (18) reduces to (16) as it should. If R_1 may be assigned arbitrarily, the noise figure is best, i.e., a minimum, if R_1 is made large without limit. Note the fact that the first term is the noise figure of the resistor R_1 alone, and that the second term is that due to the noise in the amplifier. If R_1 is sufficiently large, the noise figure is improved by making the generator impedance large. *In other words, the noise figure depends on the source as well as the amplifier, but not on the output load of the amplifier.* The statement that the noise figure improves as R is increased when R_1 is infinite is merely the observation that the effect of amplifier noise on signal-to-noise ratio is dependent on the relative magnitude of input noise and amplifier noise. If the generator resistance is increased, the input noise is increased and the noise from the amplifier has relatively less effect. *The noise figure is not a measure of the excellence of the output signal-to-noise ratio, but merely a measure of the degradation suffered by the signal-to-noise ratio as the signal and noise passes through the network in question. If the input signal and noise are extremely large compared to the amplifier noise, relatively little degradation is suffered, and the noise figure is good.*

Another observation may be made concerning "match" between generator and R_1 . While "match" is

generally supposed to be a desirable state of affairs, it produces a noise figure of 2 for (16), and $2 + 4R_{eq}/R$ for (18). The usual statement that match increases the noise figure by 3 db is true only for a noise-free amplifier. The increase is more than 3 db when the amplifier is noisy. If neither R nor R_1 may be arbitrarily assigned, but must be dealt with as they are, one may see that the insertion of an ideal transformer of proper transformation ratio between generator and R_1 might result in an improved noise figure. The situation will be analyzed. See Fig. 6, where a is the transformation ratio and all other con-

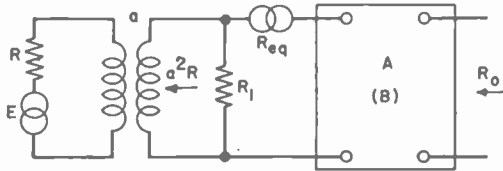

Fig. 6—Noisy amplifier fed by a shunted signal generator and ideal transformer combination.

ditions are as before. The noise figure may be written directly from (18) by realizing that the generator and transformer are equivalent to a new generator of internal impedance a^2R and open-circuit voltage aE . The noise figure is obtained by replacing R by a^2R in (18).

$$F = \frac{R_1 + a^2R}{R_1} + \frac{R_{eq}}{a^2R} \left(\frac{R_1 + a^2R}{R_1} \right)^2. \quad (19)$$

To determine the value of a^2 which makes F a minimum, one may take the derivative of F with respect to a^2 and equate to zero. The value of a^2 which makes F a minimum is

$$a^2 = \frac{R_1}{R \sqrt{1 + \frac{R_1}{R_{eq}}}}. \quad (20)$$

Note that match between generator and R_1 gives a value for a^2 equal to R_1/R . The condition for the best noise figure is a mismatch. The optimum transformation ratio transforms the generator impedance to a value somewhat less than the resistance of R_1 . The degree of mismatch involved is a function of the noisiness of the amplifier. The condition approaches that of match only when the amplifier is extremely noisy or R_1 is very small. Such might be the case for a multigrid mixer, for instance, used at broadcast frequencies. For well-designed input circuits in receivers, R_1/R_{eq} is not negligible and the mismatch is important. There may be applications where match is required. In such a case, the optimum noise figure may not be attained in this manner.

This is an appropriate place in the paper to derive some additional expressions. Some of the material is taken directly from the paper by Friis¹; the rest is original and not contained in that paper. If one examines the "available output noise power" N , equal to $FGKT B$, the

question may be raised as to the relative contributions to N of noise from the signal generator and noise from the network. Since the "available noise power" from the generator is $KT B$, and the "available output noise power" due to the noise from the generator is $GKT B$, it follows that the contribution from the network itself is $(F-1)GKT B$. Incidentally, it should be realized that F is a function of T , and is completely specified only when the temperature is given. It is also implicit in the definition for F , as given by Friis, that all noise sources be referred to the same temperature. For the sake of comparison, it has been suggested that noise figures be given for some standard temperature. Most suggestions for this standard temperature fall in the neighborhood of room temperature. Friis has suggested 290°K, or 62.6° F. (Note that T in the formula is given in degrees K.) 288°K has also been suggested. The latter figure leads to an elegant result in the measurement of noise figures by means of "noise diodes." This type of measurement will be described later in the paper.

The partition of the "available output noise power" allows one to derive an expression for the noise figure of networks in cascade when the noise figures of the individual networks are known. The derivation is given in Friis' paper and will not be repeated. Given a series of networks in cascade $1 \cdots n$, having noise figures $F_1 \cdots F_n$, and "available gains" $G_1 \cdots G_n$, the noise figure for the entire system is given by

$$F_{1,n} = F_1 + (F_2 - 1)/G_1 + (F_3 - 1)/G_{1,2} + \cdots + (F_{n-1} - 1)/G_{1,n-2} + (F_n - 1)/G_{1,n-1} \quad (21)$$

where the term $G_{1,n}$ denotes the "available gain" of the first through the n th network, i.e., $G_1, G_2 \cdots G_n$.

Thus, in a receiver employing several stages it is seldom necessary to consider the noise figure of more than the first two stages unless, for some reason, the "available gains" are such as to require attention to be paid to more than the first two stages. Such a case may occur with circuits whose "available gain" is a loss. Physically, the formula confirms the intuitive feeling that the noise of stages subsequent to the first two will be negligible compared to the amplified noise of the first two stages.

While it will not be used in this discussion, it is logical at this point to derive another formula for the noise figure of networks in cascade not given by Friis. Implicit in the previous formula is the assumption that the bandwidths of the individual networks are equal to each other and equal to the over-all bandwidth of the cascade. The formula will now be derived for the case where this is no longer assumed. The "available output noise power" for n networks in cascade is given by

$$N_{1,n} = (F_n - 1)G_n B_n K T + (F_{n-1} - 1)G_{n-1,n} B_{n-1} K T + \cdots + (F_2 - 1)G_{2,n} B_{2,n} K T + F_1 G_{1,n} B_{1,n} K T. \quad (22)$$

B is the noise bandwidth and is defined by

$$B = \frac{1}{G} \int_0^{\infty} G_f df$$

where G_f is the "available gain" at frequency f , and G is the "available gain" at band center. B is the equivalent ideal band-pass response having a frequency width such that

$$GKT B = \int_0^{\infty} KTG_f df;$$

i.e., the equivalent width B at "available gain" G gives the same noise output as the actual network. The subscripts have the same meanings as in (21); i.e., $G_{m,q}$ is the "available gain" of the m th through q th networks in cascade and $B_{m,q}$ is the noise bandwidth of the same networks in cascade. By definition,

$$N_{1,n} = F_{1,n} G_{1,n} B_{1,n} KT. \quad (23)$$

Recognizing the fact that $g_{m,q}$ is equal to $g_m, g_{m+1} \dots G_q$, one obtains

$$F_{1,n} = F_1 + \frac{(F_2 - 1)B_{2,n}}{G_1 B_{1,n}} + \dots + \frac{(F_{n-1} - 1)B_{n-1,n}}{G_{1,n-2} B_{1,n}} + \frac{(F_n - 1)B_n}{G_{1,n-1} B_{1,n}}. \quad (24)$$

The motivation for another derivation is given by some recent publications on the performance of radar systems. From the foregoing, it is obvious that noise figures are computed and measured in terms of room temperatures. A radar receiver so measured, however, is ultimately used with a directive antenna which, when pointed at space, for instance, may have an effective temperature well below room temperature. The signal-to-noise degradation due to the receiver in this case will be greater than indicated by the conventional noise figure. A formula for an effective noise figure to apply in such cases will now be derived. The noise figure of any network measured and referred to a temperature T will be written

$$F_T = N/GKT B \quad (25)$$

where the subscript T denotes the fact that the generator and network are at the temperature T . The "available output noise power" due to the network alone, at the temperature T , is $(F_T - 1)GKT B$. If a generator at temperature T_g is connected to a network at temperature T_n , the "available output noise power" is

$$N = GKT_g B + (F_{T_n} - 1)GKT_n B. \quad (26)$$

Defining the effective noise figure,

$$F_{eff} = N/GKT_g B, \quad (27)$$

one obtains

$$F_{eff} = 1 + (T_n/T_g)(F_{T_n} - 1). \quad (28)$$

Friis has described methods of measuring noise figures using signal generators. It is essentially a method whereby the noise contributions are measured in terms of a single frequency source. It has the disadvantage that the noise bandwidth must be separately measured before the noise figure may be computed. Another method, which does not require a knowledge of the bandwidth, is the "noise diode" measurement. It has been described in other publications, but will be included here for completeness. (See Fig. 7.) The diode D is a true temperature-limited diode; i.e., for any given cathode temperature, the plate voltage may be raised to a point such that

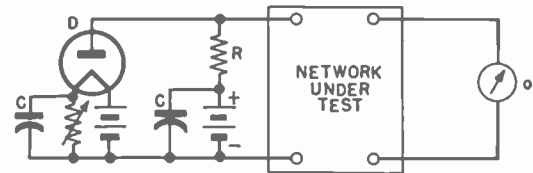

Fig. 7—Schematic for use of a noise diode to measure the noise figure of a network.

no further increase in plate voltage will result in an increase in plate current. In its use, the plate voltage is made high enough to saturate the diode for all cathode temperatures used. Means are provided for varying cathode temperature and for reading the average or dc diode current I . The diode current flows through the resistor R and the input impedance of the network under test. C serves as an rf by-pass. The meter O , shown at the output, must truly respond to power, but need not match the network. R is made the same resistance as the source with which the network will normally operate. The diode, when temperature-limited, is a constant-current source. Its current varies in random fashion, and has a noise component which is specified by its mean-squared value.

$$i^2 = 3.18 \times 10^{-19} IB \quad (29)$$

where i and I are in amperes, and B is the noise bandwidth in cps. The noise figure is measured by first observing the indication of the output meter with the diode filament unenergized. Under these conditions the noise output is the equivalent of that produced by the network and source. Unless the meter matches the network, it will not read the "available output noise power" but a quantity proportional to it. Let p be that constant. The meter reads

$$Np = FGKT Bp. \quad (30)$$

The diode is now energized and the cathode power adjusted so as to double the output power. For this condition the diode noise current contributes a noise voltage that produces the same output noise power as the source in the network and R .

One may calculate the "available power" due to the diode and R , considered as a signal generator. A con-

stant-current source feeding a resistance R is equivalent to a constant-voltage generator of the same internal impedance and an open-circuit voltage iR . The "available power" from such a generator is $i^2R/4$; i.e., the square of the voltage divided by four times the internal impedance. The "available output noise power" due to the diode, therefore, must be $Gi^2R/4$. For the condition when the output power has been doubled, it follows that

$$Gi^2R\mu/4 = N\mu = FGKTB\mu \quad (31)$$

or

$$3.18 \times 10^{-19} IBR/4 = FKTB \quad (32)$$

$$F = \frac{3.18 \times 10^{-19} IR}{4KT} \quad (33)$$

The beauty of the result and method is that the bandwidth does not appear in the expression. If one chooses 288°K for T , expresses I in milliamperes, and R in ohms,

$$F = 2 \times 10^{-2} IR. \quad (34)$$

If the source is 50 ohms, as it is in many applications, one has

$$F = I (I \text{ in ma}). \quad (35)$$

This elegant result is obtained, as is obvious, by adopting 288°K as the reference temperature. It does not hold for any other temperature.

Some remarks should be made as to the method of measuring R_{eq} for a tube. This may be done by associating the tube with an amplifier and power-output meter. With the grid shorted, a certain noise output will be obtained. Resistance may now be introduced into the grid circuit until the power output doubles, care being taken not to disturb bandwidth relations. If the noise in the amplifier following the tube may be ignored, the resistance which doubles the output noise power is the R_{eq} for the tube operating under the conditions of the experiment. (It is also assumed that no additional noise power other than thermal will be induced into the resistor because of conditions in the grid circuit of the tube.) Another method involves the substitution of a resistor for the tube itself. This gives an R_{eq} , representing the noise behavior of the tube at its plate. R_{eq} for the grid side of the tube may be obtained from the resistance, R_{eqp} , which gives the same noise as the tube (grid grounded), by the use of the following expression:

$$R_{eq} = \frac{R_{eqp} (R_0 + R_p)^2 - R_p^2}{\mu^2 R_0 (R_0 + R_{eqp}) \mu^2 R_0}$$

where R_0 is the interstage or coupling resistance between the tube and the following grid circuit (this is not removed in determining R_{eqp}), and μ is the amplification factor of the tube. If $R_0 \gg R_p$ and R_{eqp} ,

$$R_{eq} \cong \frac{R_{eqp}}{\mu^2}$$

The remainder of this discussion will concern itself with the derivation of noise figures of various amplifier configurations, subject of course to all of the restrictions already stated.

The following terminology will be used. The amplification factor of the tube is μ ; the plate resistance is R_p ; and the equivalent noise resistance referred to the grid is R_{eq} .

CATHODE-SEPARATION AMPLIFIER— CONVENTIONAL AMPLIFIER CONFIGURATION

The circuit for this amplifier is given in Fig. 8. It applies to triodes, tetrodes, pentodes, etc., provided the additional electrodes are returned to the cathode. The results for this case may be written down immediately, since it is identical with the case of the noisy amplifier

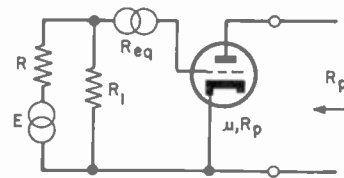

Fig. 8—Shunted generator feeding a conventional (cathode-separation) amplifier.

fed by a generator and resistance. In the case of the amplifier tube, the open-circuit voltage gain becomes μ , and the output impedance R_p . The "available gain" is given by

$$G = \frac{\mu^2 R}{R_p} \left(\frac{R_1}{R + R_1} \right)^2 \quad (36)$$

and noise figure

$$F = \frac{R + R_1}{R_1} + \frac{R_{eq}}{R} \left(\frac{R + R_1}{R_1} \right)^2 \quad (37)$$

The same comments apply to this case as to the one from which the formulas are taken. All other things being equal, F is a minimum when R_{eq} is a minimum. Triodes are generally preferred for the reason that R_{eq} is least for a triode as compared to a pentode, if both have the same mutual conductance. It should be noted, barring the effects of interelectrode admittances, that the output impedance is independent of the input impedance. The noise figure of a second stage, therefore, coupled to this one, will not depend on the impedance of the first-stage grid circuit. This is not true for the grounded-grid amplifier, which will be treated next.

GRID-SEPARATION AMPLIFIER— GROUNDED GRID

The circuit is given in Fig. 9. As far as the input is concerned, the open-circuit voltage gain is $(\mu + 1)$. The equivalent noise generator is connected into the circuit in a different manner, however, and produces an open-circuit output voltage due to a voltage gain of μ . The output impedance, as shown in Fig. 9, depends on the impedance

of the circuits connected to the input. For this reason both the noise figures of this amplifier, and of a stage connected to its output, depend on the source impedance driving the cascade. The "available output signal power" is

$$G = \left(\frac{R_1}{R + R_1} \right)^2 \frac{\mu^2 R}{(\mu + 1)^2} \bigg/ \frac{R_p}{(\mu + 1)} \quad (43)$$

$$S = \left(\frac{ER_1}{R + R_1} \right)^2 (\mu + 1)^2 \bigg/ 4 \left[R_p + \frac{RR_1}{(R + R_1)} (\mu + 1) \right]. \quad (38)$$

$$G = \left(\frac{R_1}{R + R_1} \right)^2 (\mu + 1)^2 R \bigg/ \left[R_p + \frac{RR_1}{(R + R_1)} (\mu + 1) \right] \quad (39)$$

$$N = \left[\frac{4KTBR_1}{(R + R_1)} (\mu + 1)^2 + 4KTBR_{eq}\mu^2 \right] \bigg/ 4 \left[R_p + \frac{RR_1}{(R + R_1)} (\mu + 1) \right] \quad (40)$$

and

$$F = \left(\frac{R + R_1}{R_1} \right) + \frac{R_{eq}}{R} \left(\frac{\mu}{\mu + 1} \right)^2 \left(\frac{R + R_1}{R_1} \right)^2. \quad (41)$$

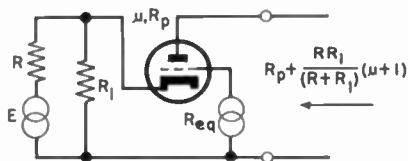

Fig. 9—Shunted generator feeding a grounded-grid (grid-separation) amplifier.

$$N = \frac{4KT B \mu^2}{(\mu + 1)^2} \left(\frac{RR_1}{R + R_1} + R_{eq} \right) \bigg/ \frac{4R_p}{(\mu + 1)} \quad (44)$$

$$F = \left(\frac{R + R_1}{R_1} \right) + \frac{R_{eq}}{R} \left(\frac{R + R_1}{R_1} \right)^2. \quad (45)$$

Again one sees a surprising result, in that the noise figure is identical with that of the cathode-separation case. In other words, the noise figure of an effective three-

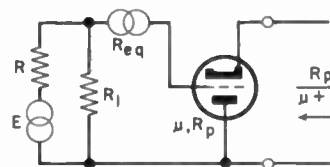

Fig. 10—Shunted generator feeding a cathode-follower (plate-separation) amplifier.

If μ is large compared to unity, the noise figure is practically the same as for the cathode-separation amplifier. The same criteria apply concerning minimization of F . The impedance R_1 should not be confused with the dynamic input impedance of the amplifier. R_1 is a resistor external to the tube. It is extremely interesting to observe that the noise-figure behavior is practically the same as for the cathode-separation case.

This particular behavior is confusing to the reader upon first contact. One may see, if R_1 is infinite, that increasing R reduces the noise figure. One also realizes that increasing R without limit, under these circumstances, eventually reduces the signal applied to the tube to zero. In spite of this, the noise figure approaches a minimum. The reason for this is that, while increasing R decreases the applied signal, it also causes degeneration of the noise from the amplifier itself, and the result is in improvement in noise figure.

PLATE-SEPARATION AMPLIFIER—
CATHODE FOLLOWER

Fig. 10 is the circuit to be analyzed. The open-circuit voltage gain is $\mu/(\mu + 1)$ and the output impedance is $R_p/(\mu + 1)$.

$$S = \left(\frac{ER_1}{R + R_1} \right)^2 \frac{\mu^2}{(\mu + 1)^2} \bigg/ \frac{4R_p}{(\mu + 1)} \quad (42)$$

element amplifier tube is essentially independent of the manner of its connection into the circuit, i.e., whether it be connected in conventional fashion, as a grounded-grid stage, or as a cathode follower. Despite the fact that the noise-figure formulas are identical, the circuits cannot be considered as interchangeable from a noise standpoint, for reasons associated with the circuits to be used with the amplifier. Consider the problem of stability. It is well known that the cathode-separation triode amplifier is prone to oscillation unless neutralized. For this reason, pentodes are generally preferred as cathode-separation amplifiers. Pentodes, however, are generally noisier than triodes. The grounded-grid triode amplifier has come into great favor in recent years. It is generally stable, and gives a good noise figure. The cathode follower may also be used, but generally is not.

The remainder of the considerations separate best on the basis of whether or not the input source must be matched, and upon a consideration of the noise figure of

the second stage. If a match to the source is desired, as is the case where a long transmission line is used between antenna and receiver, and reflections are to be avoided, the noise figures for the conventional amplifier and the cathode follower are identical. R_1 must be used to terminate the line. The noise figure becomes

$$F_{\text{term.}} = 2 + 4R_{eq}/R. \tag{46}$$

By the use of a transformer between generator and termination, R may be made large, the limit being set by the type of transforming network used and the bandwidth required. *In the case of the grounded-grid amplifier, however, the dynamic impedance may be arranged to terminate the line by choosing a tube with proper g_m and plate load. Thus, in the grounded-grid amplifier, the line or source may be matched even though R_1 is infinite.* The noise figure for this condition is $1 + R_{eq}/R$. The problem is not completely definitive, however, since the noise figure of the following stage must be considered, Furthermore, R may generally be made high in the conventional amplifier case by means of a transformer, but not in the grounded-grid case because of voltage-gain reasons. Nevertheless, the grounded-grid amplifier is a good choice where good noise figure and generator termination must be simultaneously achieved. If the generator need not be matched, the conventional amplifier and cathode follower may be more desirable. Each allows the use of transformers and high grid impedances. A good noise figure and high step-up to the grid are simultaneously achieved. The cathode follower is not generally used because of its lack of voltage gain from grid to cathode. The impedance transformation from grid to output, however, does allow the use of a step-up circuit between the cathode and the input to the following stage. In this manner the noise figure of the second stage may be improved, and voltage gain achieved from the follower.

The grounded-grid amplifier must be used with care because the noise figure of the second stage depends on the impedance of the source driving the first stage. As a matter of fact, the problem of minimizing the over-all noise figure must take into account all of the stages so interconnected. If the second stage is the only other stage that must be accounted for, the noise figure may be minimized by considering both stages as a unit. In general, the value of generator impedance which minimizes the noise figure for both stages is different than that which makes for the best first-stage noise figure.

CATHODE-COUPLED AMPLIFIER

This circuit is illustrated in Fig. 11. This circuit involves a cathode follower driving a grounded-grid amplifier. It may be made to operate stably at moderate frequencies and has the advantages associated with grid input and the use of triodes. The noise figure will be computed with the aid of (21). For two networks in cascade, it is

$$F_{1,2} = F_1 + (F_2 - 1)/G_1. \tag{47}$$

In computing F_2 , R_2 will be associated with the grounded-grid amplifier, F_2 being the noise figure of R_2 in combination with the grounded-grid amplifier. From formulas already derived, one may write

$$F_1 = \frac{R + R_1}{R_1} + \frac{R_{eq1}}{R} \left(\frac{R + R_1}{R_1} \right)^2 \tag{48}$$

$$G_1 = \frac{\left(\frac{R_1}{R + R_1} \right)^2 \mu_1^2 R}{R_{p1}(\mu_1 + 1)} \tag{49}$$

$$F_2 = \frac{\frac{R_{p1}}{\mu_1 + 1} + R_2}{R_2} + \frac{R_{eq2}\mu_2^2}{\frac{R_{p1}}{\mu_1 + 1}(\mu_2 + 1)^2} \left(\frac{\frac{R_{p1}}{\mu_1 + 1} + R_2}{R_2} \right)^2. \tag{50}$$

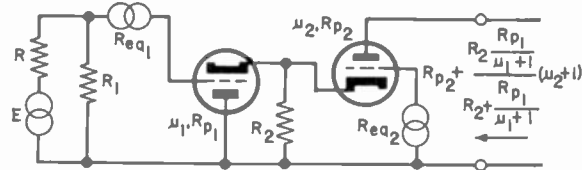

Fig. 11—Shunted generator feeding a cathode-coupled amplifier

The general expression for $F_{1,2}$ is too cumbersome to write. A special case is that where R_1 and R_2 are increased without limit and μ_1 and μ_2 are equal. The over-all noise figure becomes

$$F_{1,2} = 1 + \frac{R_{eq1}}{R} + \frac{R_{eq2}}{R}. \tag{51}$$

Thus, one may make the general statement concerning the cathode-coupled amplifier that it contributes twice as much tube noise as does the single triode amplifier.

THE WALLMAN CIRCUIT

This circuit is illustrated in Fig. 12. It is the contribution of Henry Wallman.³ From a noise-figure point of view, it is an almost incredible combination of favorable characteristics. It uses a cathode-separation triode amplifier driving a grounded-grid triode amplifier. The problem of stability is taken care of by the fact that the load of the input amplifier, the driving-point impedance of a grounded-grid amplifier, is so low that the triode has little or no voltage gain. One has, therefore, the advantages which accrue to cathode-separation-amplifier

³ Henry Wallman, A. B. MacNee, and C. P. Gadsden, "A low-noise amplifier," PROC. I.R.F., vol. 36, pp. 700-708; June, 1948.

input circuits, and the low R_{eq} of the triode. The same effect cannot be achieved by merely loading the plate of a triode, because that would generally make the noise figure of the second stage very poor. The essence of the circuit is that the stability of the first stage is obtained from the dynamic input impedance of the grounded-grid

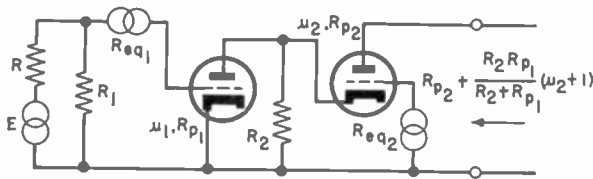

Fig. 12—Shunted generator feeding a Wallman low-noise amplifier.

amplifier; and the good noise figure of the second stage from the essentially high plate impedance of the first stage. The noise figure will be computed by means of (21).

$$F_1 = \left(\frac{R + R_1}{R_1} \right) + \frac{R_{eq1}}{R} \left(\frac{R + R_1}{R_1} \right)^2 \quad (52)$$

$$G_1 = \frac{R\mu_1^2}{R_{p1}} \left(\frac{R_1}{R + R_1} \right)^2 \quad (53)$$

$$F_2 = \left(\frac{R_{p1} + R_2}{R_2} \right) + \frac{R_{eq2}\mu_2^2}{R_{p1}(\mu_2 + 1)^2} \left(\frac{R_{p1} + R_2}{R_2} \right)^2 \quad (54)$$

Again the over-all noise-figure general formula will not be written because of its length. Of interest is the minimum over-all noise figure achieved when R_1 and R_2 are made large without limit. R_2 may be made large by employing high Q , high-impedance interstage couplings, or by physically eliminating R_2 and operating the tubes in series. The noise figure for this case is

$$F_{1,2} = 1 + \frac{R_{eq1}}{R} + \frac{R_{eq2}\mu_2^2}{R\mu_1^2(\mu_2 + 1)^2} \quad (55)$$

If μ_1 and μ_2 are large compared to unity, as is usually the case, the noise figure for the combination is seen to be essentially that obtained for the input triode alone. This circuit, therefore, essentially eliminates the glaring disadvantage of the conventional triode amplifier, that of instability, without significantly altering its noise characteristics.

PUSH-PULL CIRCUITS

The use of balanced, or push-pull, circuits has recently come to the fore because of their application in television receivers. The noise figures for two proposed circuits, the cathode-separation push-pull amplifier and the push-pull grounded-grid amplifier, are the same as for their single-ended counterparts, except that the tube noise contribution is double that of the single-ended system. Physically, the output of the generator is now associated with two tubes, each producing noise, but not

giving any greater gain than a single tube. The formulas for their noise figures may be obtained from the single-ended case by replacing R_{eq} by $2R_{eq}$. Since television receivers are required to match the transmission line connecting the antenna and receiver, the remarks made concerning the advantage of the grounded-grid amplifier in the matched case apply.

TRANSIT-TIME EFFECTS

This paper will be concluded with some remarks as to the treatment of transit-time effects. It has been proposed that transit-time effects may be accounted for, on a first-order basis, by the circuit of Fig. 13. R_1 is now a resistor whose resistance is equal to the transit-time loading but which is at a suitable temperature higher than room temperature. R_{eq} is not the nontransit-time equivalent resistance, but a new equivalent resistance

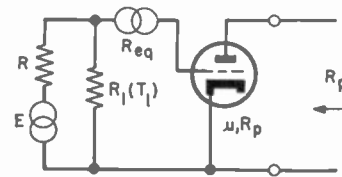

Fig. 13—Schematic for calculating the effect of transit-time loading on noise figure.

which takes into account the reduction in equivalent resistance due to transit time. The noise figure, therefore, will be computed for the circuit shown, where R_1 is at a temperature T_1 , and the rest of the system is at the temperature T . As a further derivation, the mismatch which gives the best noise figure under these conditions will also be computed.

$$S = \frac{E^2\mu^2 \left(\frac{R_1}{R + R_1} \right)^2}{4R_p} \quad (56)$$

$$G = \frac{\mu^2 R}{R_p} \left(\frac{R_1}{R + R_1} \right)^2 \quad (57)$$

$$N = \frac{\mu^2 4KB}{4R_p} \left[R \left(\frac{R_1}{R + R_1} \right)^2 T + R_1 \left(\frac{R}{R + R_1} \right)^2 T_1 + R_{eq} T \right] \quad (58)$$

$$F = 1 + \frac{T_1}{T} \frac{R}{R_1} + \frac{R_{eq}}{R} \left(\frac{R + R_1}{R_1} \right)^2 \quad (59)$$

If an ideal transformer is used between generator and tube, there is a transformation ratio which makes the noise figure a minimum. This is derived in the same manner as in (19). It is not derived here, but the result is

$$a^2 = \frac{R_1}{R \sqrt{1 + \frac{T_1}{T} \frac{R_1}{R_{eq}}}} \quad (60)$$

Cosmic Static*

GROTE REBER†, SENIOR MEMBER, IRE

Summary—A brief description of the apparatus is given. The results of a survey of the galaxy made at a frequency of 480 Mc are compared to a previous survey made at 160 Mc. The principal new findings are a projection from Sagittarius in the direction of the north galactic pole; a supplementary small rise in Aquila; and a splitting of the maxima in Cygnus and Orion each into two parts.

INTRODUCTION

THE RESULTS of a survey of the sky at a frequency of 160 Mc made during 1943 have been published.¹ The equipment was then remodeled, and a survey of the sky at a frequency of 480 Mc was conducted during the years 1946 and 1947. The same mirror and general techniques which were used in the first survey were also used in the second survey. Fig. 1 shows the mirror with new focal-point equipment. The



Fig. 1—Sheet-metal mirror 31.4 feet in diameter, 20-foot focal length, on meridian transit mounting, with 480-Mc focal apparatus.

large drum used in the first survey has been replaced by a hemisphere, the details and theory of which have been described elsewhere.² New electronic equipment was developed and mounted in the cylindrical container above the hemisphere. Fig. 2 shows the rf amplifier. The antenna transmission-line connection is at the bottom left

and couples into the first stage, which consists of a pair of 2C42 tubes connected in push-pull. The output of this stage is coupled by a balanced-to-unbalanced transformer to the input of the second stage, which uses a single 446B tube. A total of six cascade stages using 446B tubes terminate in a 9005 diode. All seven stages

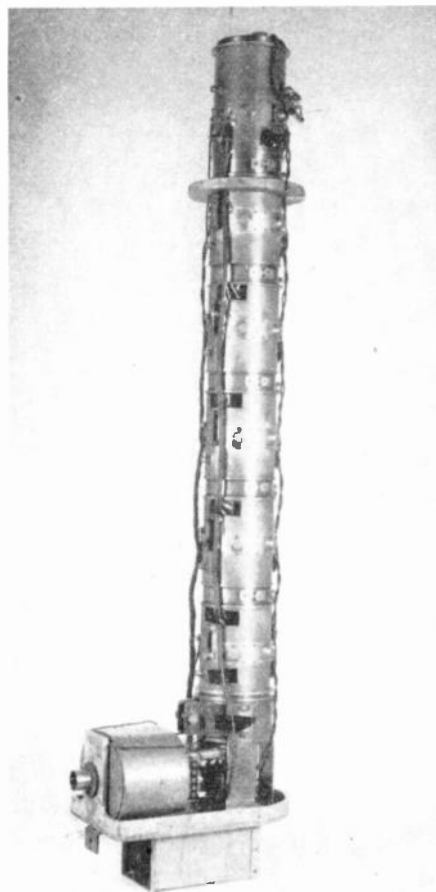

Fig. 2—A seven-stage rf amplifier at 480 Mc, using lighthouse tubes.

operate in a grounded-grid fashion, producing 115 db gain with an 8-Mc bandwidth. The noise figure of the amplifier is about 6.5 db above theoretical KTB . The same recorder system was used as before, although a new power supply was constructed for the above amplifier.

The mirror of Fig. 1 is mounted on an east-west axis so that it may be pointed to any angle of declination between the limits of -32° and $+90^\circ$, along the north-south meridian. One of the circular tracks is calibrated in degrees. The mirror is set to point at the desired declination; then, as the earth rotates, the mirror sweeps out a band in the sky along this particular declination. Whenever the mirror passes over a cosmic-static dis-

* Decimal classification: R113.414. Original manuscript received by the Institute, March 15, 1948.

† 212 W. Seminary Ave., Wheaton, Ill.

¹ Grote Reber, "Cosmic static," *Astrophys. Jour.*, vol. 100, pp. 279-287; November, 1944.

² Grote Reber, "Antenna focal devices for parabolic mirrors," *Proc. I.R.E.*, vol. 35, pp. 731-734; July, 1947.

turbance, energy is collected, and the voltage at the end of the amplifier increases. If no cosmic static is intercepted, the recorder will draw a straight line on the chart. If cosmic static is encountered, the pen will move up by an amount depending upon the intensity of the cosmic static. The small spikes and "fur" on the traces shown in Figs. 4, 5, and 6 are due to local interference of impulsive nature. Most of this interference is due to the ignition systems of passing automobiles.

RESULTS

Approximately 200 traces were secured. Quite a number of these were made in regions near the galactic poles to determine whether or not any radiation could be found coming from these places. All positive data were organized as before, and the results plotted on two flattened globes. Fig. 3 shows the end results in the form of constant-intensity contours. These levels are in terms of 10^{-22} watt per square centimeter per circular degree per Mc bandwidth, and are comparable with results of the 160-Mc survey.

Inspection of Fig. 3 and comparison with the results of the first survey show that the Milky Way appears much narrower at 480 Mc than at 160 Mc, and considerably more detail is present at the higher frequency. This may be due, in part, to the narrower width of the antenna acceptance cone, which is only about $3^\circ \times 3^\circ$ at 480 Mc. The higher resolving power should show more detail, if such be present. However, there is no reason to suppose that the outline of the Milky Way will be the same at widely different frequencies, or that the same high resolving power at 160 Mc would produce contours similar to Fig. 3.

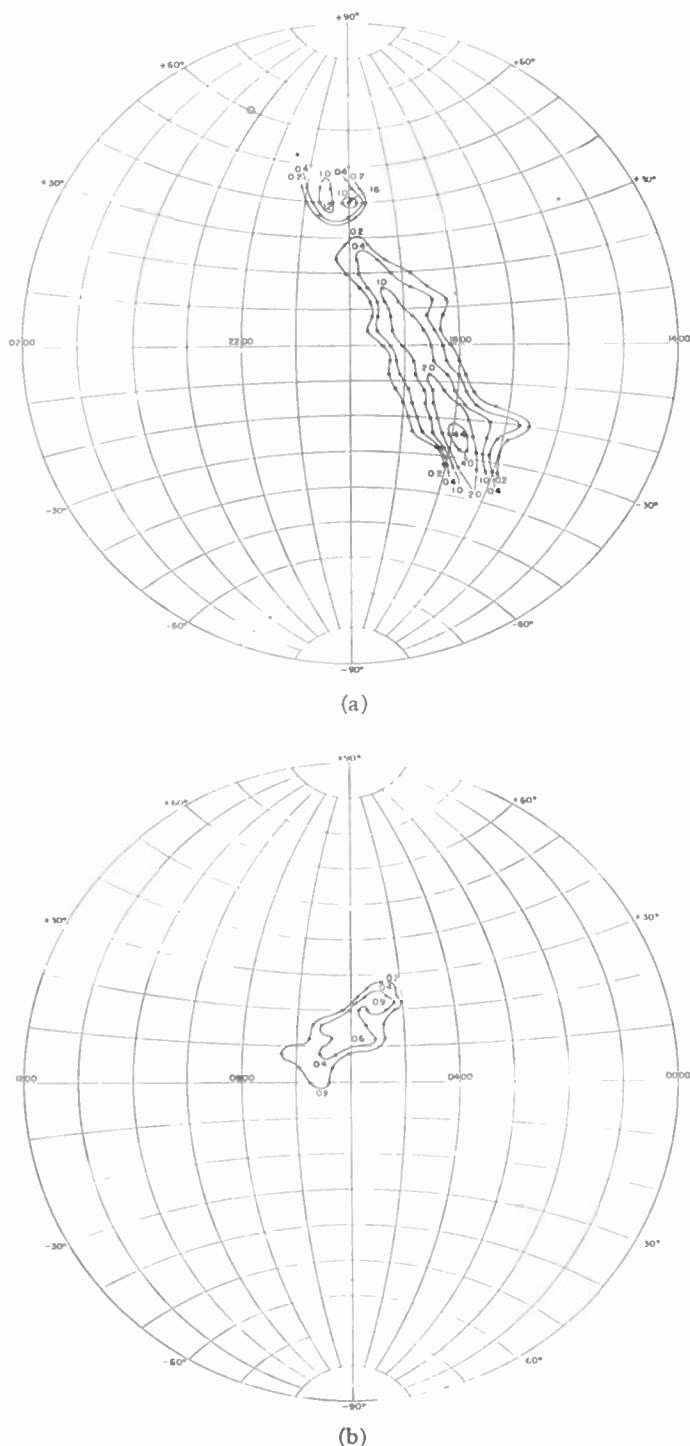

Fig. 3—Constant-intensity contours at 480 Mc in terms of 10^{-22} watts per cm^2 per circular degree per Mc bandwidth in summer (a), and winter (b).

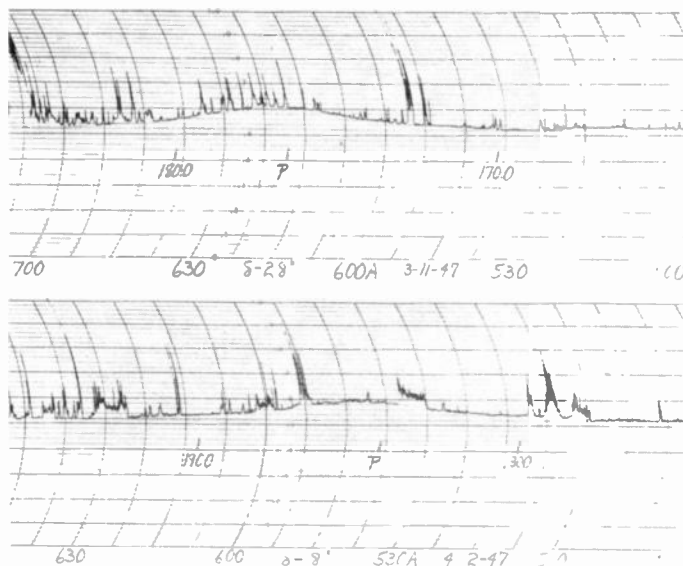

Fig. 4—Sample traces showing rise in drift curve due to cosmic static.

SUMMER MILKY WAY

The projection off to the right of Sagittarius at declination -20° is real, as evidenced by the trend of the data at -16° and -24° . There is no similar projection even faintly apparent at 160 Mc. Peculiarly enough, the maximum in Sagittarius is very close to declination -25° , right ascension 17h 50m at both frequencies. This is quite close to the position of the maximum intensity of radiation at 1 micron, as measured by Steb-

bins and Whitford.³ Fig. 4 shows two sample traces. The cosmic static appears as the smooth bump in the curve. The quick irregularities or "fur" on the curve represents interference from the ignition systems of passing automobiles.

The saddle in Lyra is much more pronounced at 480 Mc, and an additional minor maximum can be seen in Aquila, as demonstrated by the swelling of the contour lines.

The maximum in Cygnus is split into two parts. Fig. 5 shows a sample trace taken in this region. To make sure of the effect, six traces were taken, and all confirmed its existence. If the average intensity of the two peaks in Cygnus is divided by the intensity in Sagittarius, a ratio will be obtained which is closely the same as the corresponding ratio of intensities at 160 Mc.

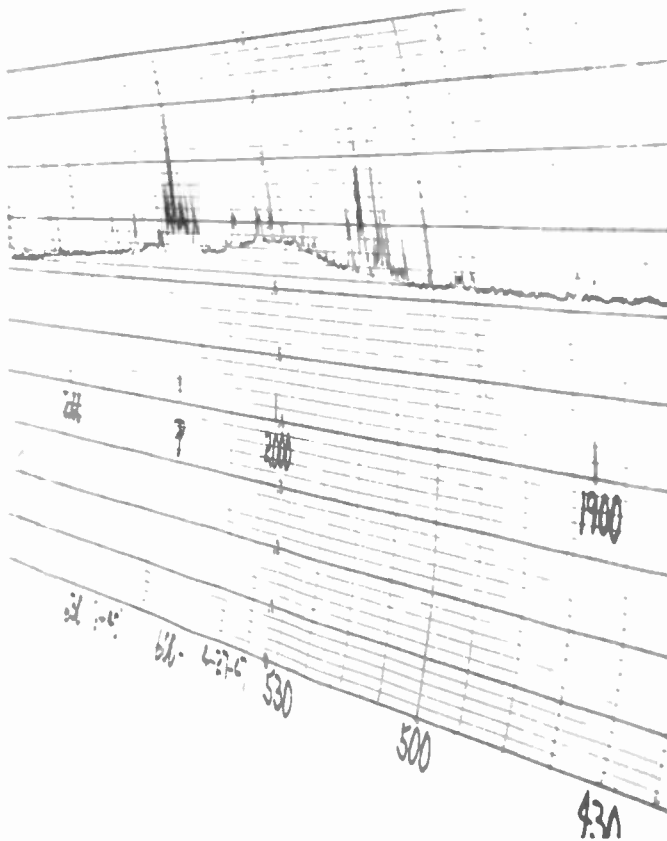

Fig. 5—Sample trace showing cosmic static at declination $+40^\circ$ in Cygnus.

The 1.6 level maximum at approximately 2000RA and $+40^\circ$ declination agrees quite well in position with a place of high intensity at 60 Mc and 200 Mc located by Bolton.⁴ Using Lloyds-mirror technique over the sea, he

³ J. C. Stebbins and A. E. Whitford, "Infrared radiation from region of the galactic center," *Astrophys. Jour.*, vol. 106, pp. 235-242; November, 1947.

⁴ J. G. Bolton and G. J. Stanley, "Variable radiations from Cygnus," *Nature*, vol. 161, pp. 312-313; February 28, 1948.

secures very high effective resolving power and gives the position at 19h 58m 47s plus or minus 10s right ascension, and plus $41^\circ 47m$ plus or minus 7m. It is interesting to note that apparently this phenomenon extends down to 9.51 Mc.^{5,6}

For some reason, the left-hand peak of 1.2 level does not seem to radiate as strongly on the lower frequencies. If it had, the Lloyds-mirror technique would have been confused by two sources close together. Thus, it may be assumed that the intensity versus frequency distribution of two sources relatively close together is rather different. Another interpretation is that the 1.6 level peak is really a very-high-intensity area of very small solid angle (perhaps only a minute of arc in diameter), and the 1.2 level peak is a broad source (perhaps a degree in diameter) of low intensity. The integrated product of

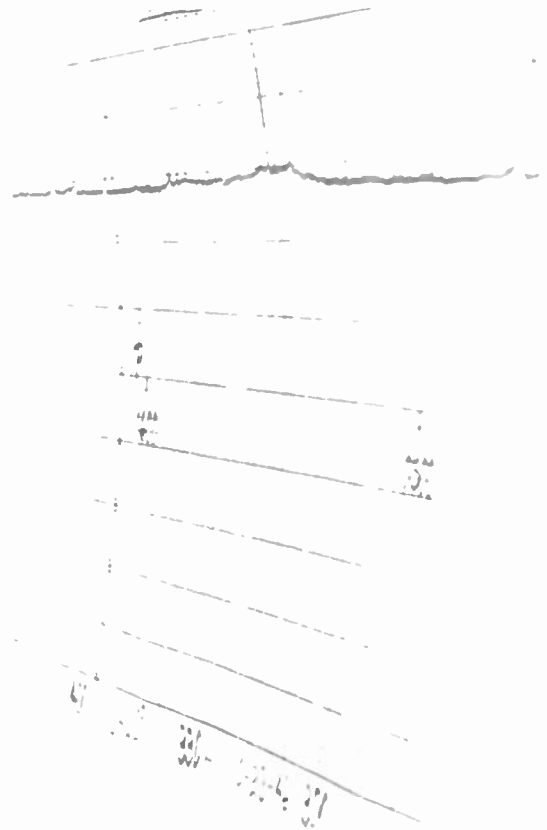

Fig. 6—Sample trace showing cosmic static at declination $+20^\circ$ in Orion.

surface brightness times solid angle might be nearly the same for both sources. Thus the present equipment could not differentiate between these two types of sources. Conversely, the Lloyds-mirror technique would be insensitive to the one of low surface brightness and

⁵ H. T. Friis and C. B. Feldman, "A multiple unit steerable antenna for short-wave reception," *Proc. I.R.E.*, vol. 25, pp. 897, 911, 912, and Table VIII; July, 1937.

⁶ Grote Reber and J. L. Greenstein, "Radio investigations of astronomical interest," *Observatory* (London), vol. 67, p. 16, February, 1947.

large solid angle, while the one of reverse characteristics would stand out clearly.

Unfortunately, the sky above declination $+44^\circ$ could not be covered in detail due to lack of time. Since winter weather was closing in and the equipment was scheduled to be moved to Virginia, only a few exploratory traces were secured. At declination $+52^\circ$ the Milky Way was very faint. An *X* marks the spot on Fig. 3(a). At $+60^\circ$ declination considerable energy was found near right ascension 23h 15m. This point is marked by a circle on Fig. 3(a), and is in the region of Cassiopeia where a similar maximum was found at 160 Mc.

WINTER MILKY WAY

The form of the intensity contours shown in Fig. 3(b) is similar, but much smaller than at 160 Mc. It appears that the region of Orion is also split into two parts. Fig. 6 shows a sample trace taken at declination $+20^\circ$. If the contours had been taken at slightly higher levels, the contour lines would have closed at about the 0.5 level, and the two separate sources would have appeared more clearly.

Several traces showed some energy to be present very faintly up to declination $+36^\circ$ and down to declination -32° .

Too little is known of the cause of the phenomena to read a great deal from Figs. 3(a) and (b). However if the energy is generated by clouds of interstellar gas, and these clouds are of discrete nature as Oort⁷ and others have suggested, then perhaps the directions in which these clouds may be located are now becoming apparent.

OTHER OBJECTS

A few traces showed some faint disturbance to be present near right ascension 12h between declination 0° and -20° . The situation on the Andromeda nebula is the same as at 160 Mc; namely, inconclusive. If the sensitivity of the electronic equipment could be increased by an order, or the diameter of the mirror tripled, then it is quite likely that this object would be readily apparent and easily measurable at both frequencies.

Considerable data on solar radiation was secured and reported upon.^{8,9}

⁷ J. H. Oort, "Interstellar Matter," *Monthly Notices Royal Society*, vol. 106, pp. 159-179; no. 3, 1946.

⁸ Grote Reber, "Solar radiation at 480 Mc," *Nature*, vol. 158, p. 945; December 28, 1946.

⁹ Grote Reber, "Solar intensity at 480 Mc," *Proc. I.R.E.*, vol. 36, pp. 88; January, 1948.

Comparison of Calculated and Measured Phase Difference at 3.2 Centimeters Wavelength*

E. W. HAMLIN†, ASSOCIATE, IRE, AND W. E. GORDON‡, ASSOCIATE, IRE

Summary—Radio propagation and associated meteorological measurements, made by the Electrical Engineering Research Laboratory of the University of Texas during April, 1946, on a path from Gila Bend to Sentinel in the Arizona desert, show that, for meteorological conditions that could be represented by a linear *M* curve, the magnitude and phase of the field resulting from propagation over a 27-mile path on 3 cm could be calculated on the basis of a direct wave, and one reflected from a surface tangent to the actual profile at the point of reflection. Apparent reflection coefficients between 0.3 and 0.8 were found for desert sand on 3 cm for this path.

I. INTRODUCTION

THE ELECTRICAL ENGINEERING Research Laboratory of the University of Texas, under contract with the Office of Naval Research, made radio propagation and associated meteorological meas-

urements, during April, 1946, on a path from Gila Bend to Sentinel in the Arizona desert.¹ The experiments were conducted there through the courtesy of the Navy Electronics Laboratory at San Diego, which had erected 200-foot towers at Gila Bend and at Sentinel, and made them available to the University group. The desert radiates and absorbs heat, rapidly producing strong temperature gradients near the ground; thus, nonstandard propagation is to be expected. This paper, however, considers only data in which the atmospheric index of refraction is nearly linear with height. These data are in agreement with the theory in which the field is the sum of a direct wave and one reflected from a plane conforming to the effective path profile, taking into consideration the measured gradient of the refractive index of the air.

* Decimal classification: R248.14. Original manuscript received by the Institute, June 2, 1947; revised manuscript received, March 23, 1948. Presented, joint meeting, URSI, American Section, and IRE, Washington Section, Washington, D. C., May 7, 1948.

† Cornell University, Ithaca, N. Y.

‡ University of Texas, Austin, Texas.

¹ E. W. Hamlin, W. E. Gordon, and A. H. LaGrone, "X-Band Phase Front Measurements in Arizona During April 1946," *Electrical Engineering Research Laboratory Report No. 6*, February 1, 1947.

II. MEASUREMENTS

General

In making the measurements to be considered here, a transmitter operating at 3.2 cm, radiating horizontally polarized energy, was mounted on the elevator of the tower at Gila Bend. The receiving equipment, which was designed to measure phase difference between two points on the wave front spaced ten feet apart vertically,³ was set up on a hill near Sentinel. A profile of the path plotted to an earth's radius of 4110 miles is shown in Fig. 1. The dimensions are shown in the figure. For heights of the transmitter above about 50 feet on the Gila tower, the other terminal is within the line of sight.

Data were taken by varying the height of the transmitter at Gila, from 3 feet to 190 feet above the tower

similar to Fig. 2(c), a graph of the data for 1900 on April 8, are expected to result under standard atmospheric conditions.³

A meteorological sounding station was set up near the middle of the path. Balloon soundings of wet- and dry-bulb temperatures were made at hourly intervals up to heights of 500 feet, and the corresponding modified index (M) calculated.⁴

Data

The daytime meteorological conditions were invariably such as to give linear modified index curves above the first few feet, and on one night, that of April 7-8, reasonably linear M curves were found. During the day a strong substandard layer of air formed near the ground due to heating of the soil.

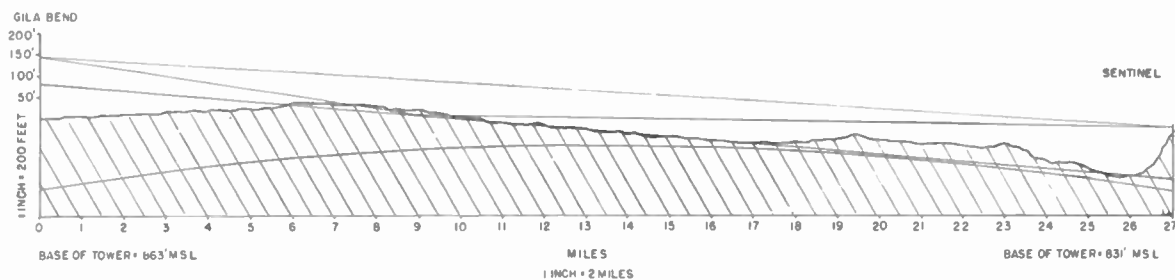

Fig. 1—Path profile for $\gamma = 4.6$.

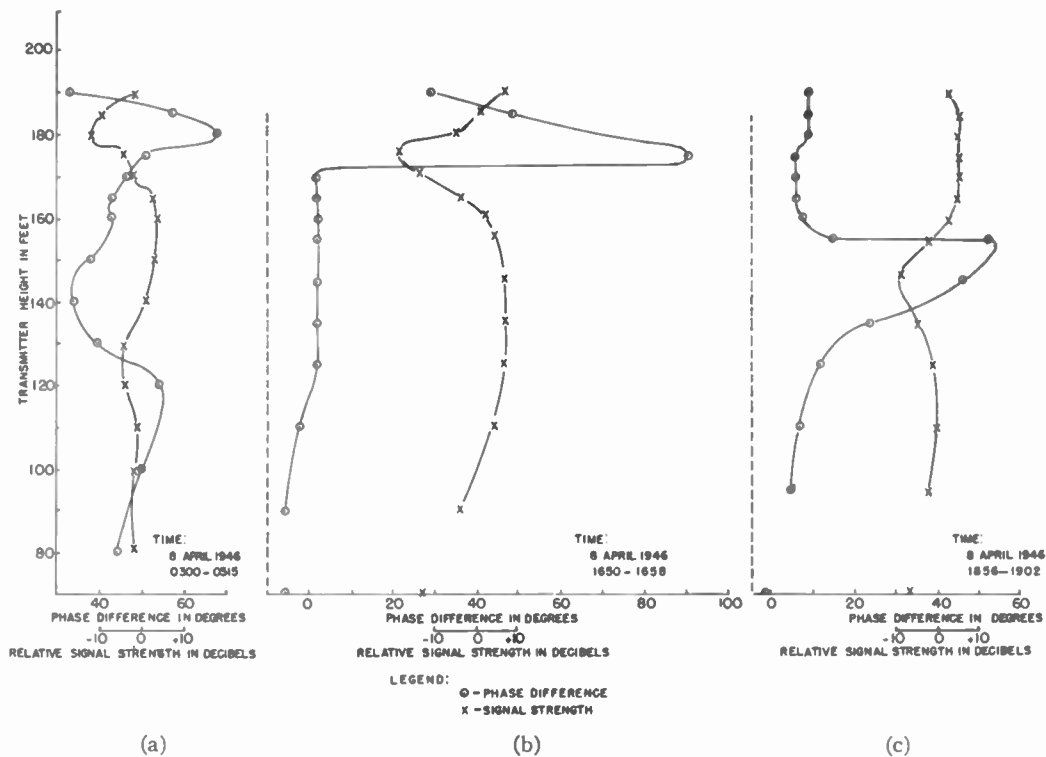

Fig. 2—Phase difference and signal strength versus height.

base. Phase difference and relative signal strength were recorded for various discrete transmitter heights. Curves

³ F. E. Brooks, Jr., and C. W. Tolbert, "Equipment for Measuring Angle-of-Arrival by the Phase Difference Method," Electrical Engineering Research Laboratory Report No. 2, May, 1946.

³ E. W. Hamlin and A. W. Straiton, "Theoretical Treatment of Phase Difference Between Two Vertically Spaced Antennas for Straight Line Propagation Over Flat Earth," Electrical Engineering Research Laboratory Report No. 3, May, 1946.

⁴ $M = (79/T) (1000 + 4800e/T)$ where T and e are temperature in degrees Kelvin and vapor pressure in millibars.

The radio data for these times showed the expected variations. If reflection takes place from an infinitely extended plane surface, minima in signal strength occur with the transmitter at heights such that the product of the effective transmitter and receiver heights is $\frac{1}{2}(n\lambda d)$ where n is an integer, λ is the wavelength, and d is the path length, measured in the same units as the transmitter and receiver heights. The breaks in the phase-difference curves occur between the minima in the upper and lower receiving antennas.

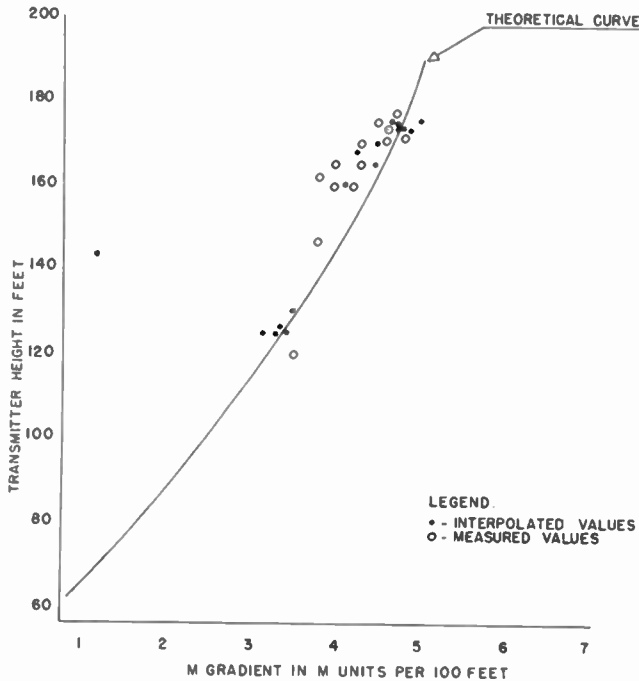

Fig. 3—Height of transmitter at which signal minimum occurs in upper receiving antenna versus M gradient.

Fig. 3 shows the transmitter height on the tower at which minimum signal strength occurred in the upper receiving antenna plotted versus the measured M gradient γ . The circled points represent radio and meteorological data taken within 15 minutes of each other. The dots are values interpolated from curves of meteorological and radio data plotted versus time.

The points between 120 and 130 feet are nighttime data, those between 160 and 180 feet are daytime data. The general trend, increasing height of the minimum with increasing γ , is expected from any standard method of computing the effects of atmospheric refraction.

Three sets of data that were considered particularly reliable were chosen for further analysis. The circled point at 145 feet, M gradient = 4.0 units per 100 feet, represents a radio height run and meteorological sounding that were almost simultaneous. In addition, the soil temperature was just about equal to the air temperature at this time, insuring that the gradient is constant. This point is considered correct to within the following limits: The height of the minimum, ± 2 feet, due to radio measurements at discrete transmitter heights; the value of γ , $\pm 0.1 M$ units per hundred feet. The point at 125 feet, $\gamma = 3.3$, was taken as representative of the lower group, and the M curve for this point was quite linear, although there was a definite temperature inversion up to 100 feet. In the upper group, a wide range of values occurred, probably largely due to the effect of the substandard layer near the ground. Because the meteorological data on April 8 at 1700 looked reasonably linear, the point at 173 feet, $\gamma = 4.6$, was selected as representative of this group.

The measured phase-difference curves for these three runs, and the relative signal strength, are shown in Fig. 2. Except for the lower part of the phase-difference curve for $\gamma = 3.3$ (probably due to the low-level temperature inversion), these appear to be as expected for linear M curves.

III. CALCULATIONS

Tilted Reflecting Plane

If the profile of a path is plotted to the average value of earth's radius of a miles, rays from the transmitter to receiver are approximately circular arcs with a radius of curvature equal to $-1/(dn/dh)$ where dn/dh is the equivalent constant gradient of the refractive index. It is well known that it is permissible to plot the earth with a larger radius Ka , and consider the rays as straight lines, if the relative curvature between the rays and the earth is maintained constant. From the definition of the modified index of refraction, $M = (n - 1 + h/a)10^6$, Ka turns out to be $10^6/(dM/dh)$. With $\gamma = 4.0 M$ units per hundred feet, and $a = 3960$ miles, $K = 1.195$. In Fig. 4 the profile is shown replotted with an earth's radius of 4730 miles corresponding to this case.

An attempt was made to fit the measured data in this way for these three cases. Using the average values of

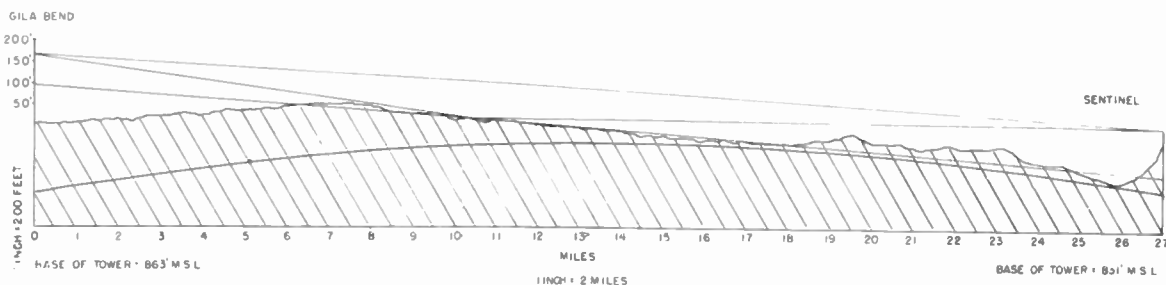

Fig. 4—Path profile for $\gamma = 4.0$.

the earth's radius and measured values of γ , no agreement could be found. Since the profile indicates that the earth's surface over the path is flatter than average earth's curvature, a larger earth's radius was assumed, and the index of refraction variation calculated from the M values. No one earth's radius could be found which would satisfy the conditions for the selected data. This method was abandoned.

From Fig. 4, it was noticed that if reflection was assumed to take place from a plane surface closely following the profile from about 7 to 17 miles from Gila, and extended as a plane throughout the whole path, the effective heights above this plane at the receiver and transmitter would give the signal-strength minima and phase-difference breaks at the proper transmitter heights on the tower. The same sort of agreement for other corresponding values of γ and effective earth's radius was found.

Upon further investigation it was found that, by properly selecting these planes in the three cases, they could be made to coincide in the following manner. They all could be made to pass through a single point and have the same slope with respect to horizontal at this point. This point was found to be 11 miles from Gila, at 761 feet above mean sea level, and the con-

stant slope was 11 feet per mile downward from Gila to Sentinel. The solid straight lines approximating the profile between 7 and 17 miles in Figs. 1, 4, and 5 are these three planes with the above properties in common. Fig. 1 is drawn for $\gamma=4.6 M$ units per hundred feet, $Ka=4110$; Fig. 4 for $\gamma=4.0 M$ units per hundred feet, $Ka=4730$ miles; and Fig. 5 for $\gamma=3.3 M$ units per hundred feet, $Ka=5740$ miles.

It should be pointed out that any one of these planes, replotted for different γ , would be a parabolic surface, as a first approximation to a circular arc (see Appendix). If the earth is plotted to normal radius, the ray curvature being different for different values of γ , the plane surfaces obtained on the straight ray plots become curved surfaces, having the curvature of the corresponding γ . They approximate the earth's surface differently for each value of γ , but have in common a single point at which they have a common tangent plane.

IV. COMPARISON OF MEASURED AND CALCULATED HEIGHT RUNS

Figs. 6, 7, and 8 show the agreement obtained between the measured data and the calculated phase-difference and signal-strength versus height curves. The

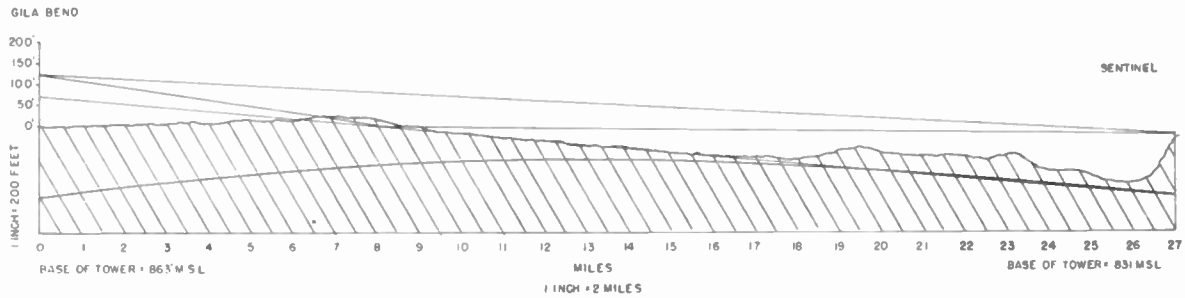

Fig. 5—Path profile for $\gamma = 3.3$.

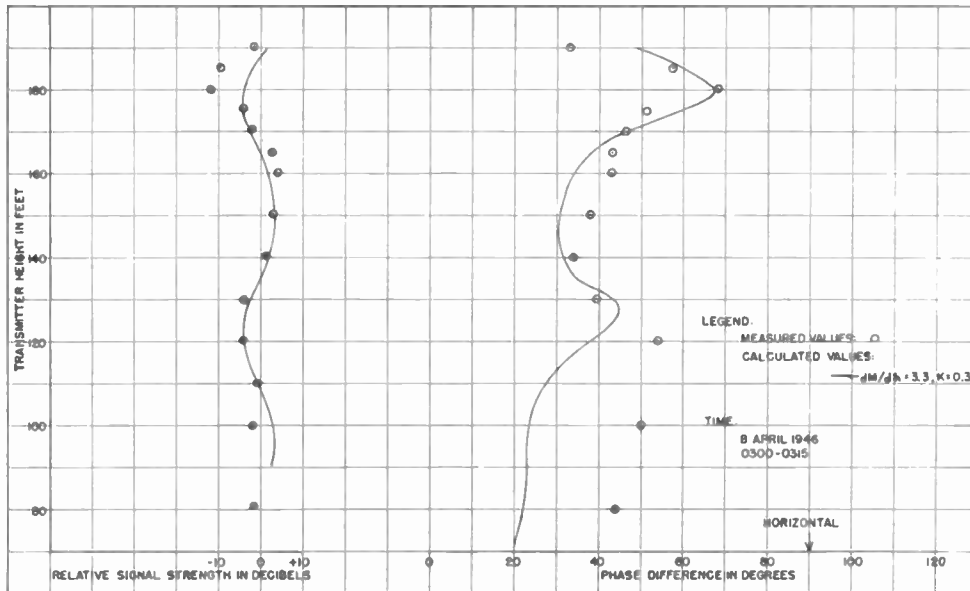

Fig. 6—Calculated and measured phase difference and signal strength versus height, $dM/dh = 3.3/100$ feet.

calculations were made using the usual theory of a plane reflecting surface. Agreement between calculated and experimental values is, therefore, not to be expected much below the lowest maximum in signal strength. The phase change at reflection was assumed to be 180° , and the magnitude of the reflection coefficient was selected to give about the right phase difference at the point of maximum variation.

Fig. 6 is for $\gamma = 3.3$. A reflection coefficient of 0.3 was assumed. The solid line is the calculated phase difference. The circled points are the measured values of phase difference and relative signal strength. The poor agreement at lower heights is probably due to the low-level temperature inversion at the time these data were taken.

In Fig. 7, the solid phase-difference line is for $\gamma = 4.0$, the originally assumed value. If γ is made equal to 3.9, the dotted curve results. Slightly better agreement with the measured values, shown by the circled points, is found. This change of 0.1 M unit is within the accuracy of the determination of γ . The calculated signal-strength curve is plotted for $\gamma = 3.9$, and the circles give the measured values. It was necessary to assume a reflection coefficient of 0.6 to obtain the proper phase-difference variation.

In Fig. 8, the solid phase-difference line is drawn for $\gamma = 4.7$ and the dotted one for $\gamma = 4.6$. Slightly better agreement is obtained using the former value. The calculated signal strength is plotted for $\gamma = 4.7$, and the assumed reflection coefficient is 0.8.

Returning now to Fig. 3, the curved line is the theoretical curve of height of the transmitter at which a minimum occurs in the upper receiving antenna, versus γ . The displacement of the measured values is partly due, in addition to errors in measurement, to the contribution from the lower twenty-five feet which is not considered in determining the linear γ .

V. REFLECTION COEFFICIENT

It should be noticed that it was necessary to assume a larger reflection coefficient when the signal strength occurred at higher transmitter elevations to obtain good agreement between the measured and calculated values. As a matter of fact, a reflection coefficient continuously increasing with transmitter height would give a better fit to the measured values. This trend of increasing reflected wave with increasing transmitter height seems to be consistent throughout the data.

Angles of incidence measured from grazing for the assumed reflecting plane are in the order of 0.08° . Since horizontal polarization was used, no pseudo-Brewster angle is to be expected. A further point of interest in this connection is the fact that the ends, at 7 and 17 miles, of the path profile approximated by the assumed reflecting surface, give path differences in the order of a wavelength. This might indicate that the main reflection is only from this portion of the path,

and that the area of the reflecting surface varies from a small portion of a Fresnel zone to about one Fresnel zone as the transmitter is raised to the top of the tower. It is hoped that further investigation of this phenomenon may be made.

VI. CONCLUSIONS

It was found that, for meteorological conditions that could be represented by a linear M curve, the magnitude and phase of the field resulting from propagation over a 27-mile path on 3 cm could be calculated on the basis of a direct wave, and one reflected from a surface tangent to the actual profile at the point of reflection. The same reflecting surface gave markedly different results for different M gradients in accordance with the theory.

Even for this particularly level path, the difference between the earth's surface and a sphere is sufficient to make similar calculations using the average radius of the earth instead of the actual profile lead to erroneous results.

Apparent reflection coefficients between 0.3 and 0.8 were found for desert sand on 3 cm for this path.

APPENDIX I

In Fig. 9, the equation of the line AA' is

$$Z = Z_a + \alpha(d - d_a) + \frac{1}{2Ka}(d - d_a)^2, \quad (1)$$

from which

$$h_1' = h_1 - Z_1 = h_1 - Z_a + \alpha d_a - \frac{1}{2Ka} d_a^2, \quad (2)$$

$$h_2' = h_2 - Z_2 = h_2 - Z_a - \alpha(d_r - d_a) - \frac{1}{2Ka}(d_r - d_a)^2, \quad (3)$$

and, for a minimum of signal strength $h_1' h_2' = p^2$, a constant, and

$$p^2 = \left(h_1 - Z_a + \alpha d_a - \frac{1}{2Ka} d_a^2 \right) \left[h_2 - Z_a - \alpha(d_r - d_a) - \frac{1}{2Ka}(d_r - d_a)^2 \right]. \quad (4)$$

Solving (2) and (3) for Z_a and subtracting,

$$\alpha = \frac{(h_1' - h_2') - (h_1 - h_2)}{d_r} - \frac{1}{2Ka}(d_r - 2d_a), \quad (5)$$

$$\alpha = \beta - \frac{1}{2Ka}(d_r - 2d_a), \quad (6)$$

and

$$d_r - 2d_a = (\beta - \alpha)2Ka$$

$$d_a = \frac{d_r}{2} - (\beta - \alpha)Ka. \quad (7)$$

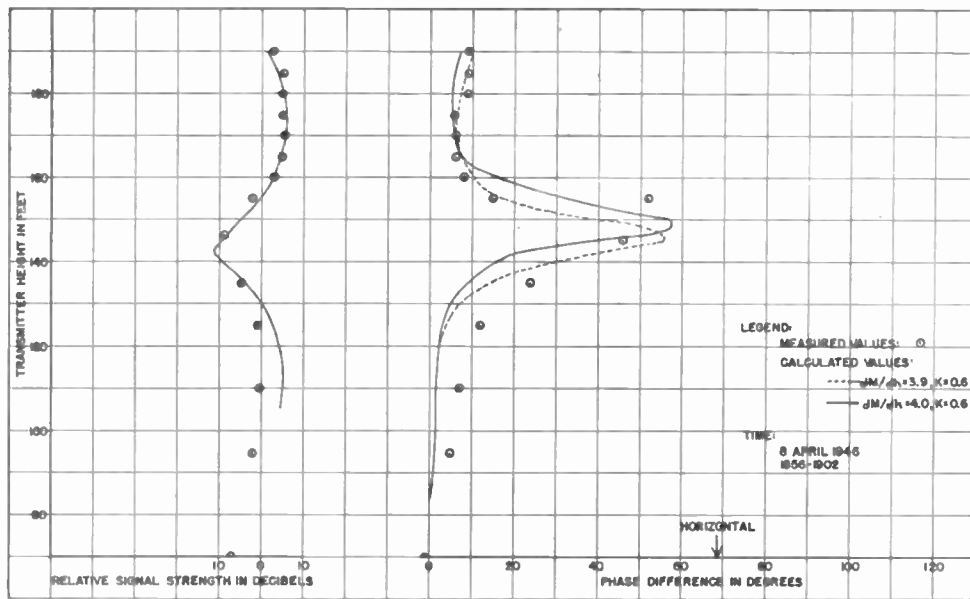

Fig. 7—Calculated and measured phase difference and signal strength versus height, $dM/dh = 4.0/100$ feet.

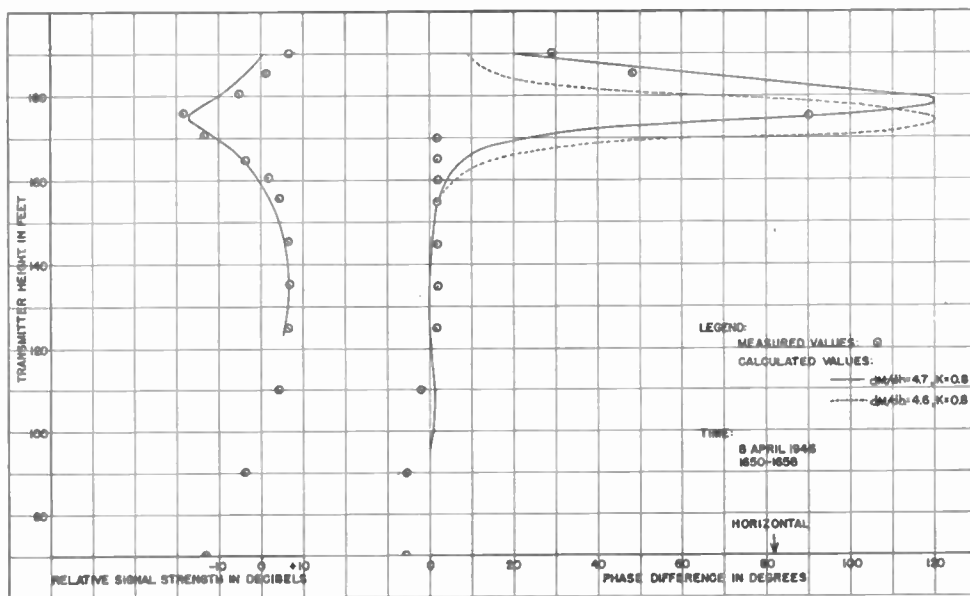

Fig. 8—Calculated and measured phase difference and signal strength versus height, $dM/dh = 4.6/100$ feet.

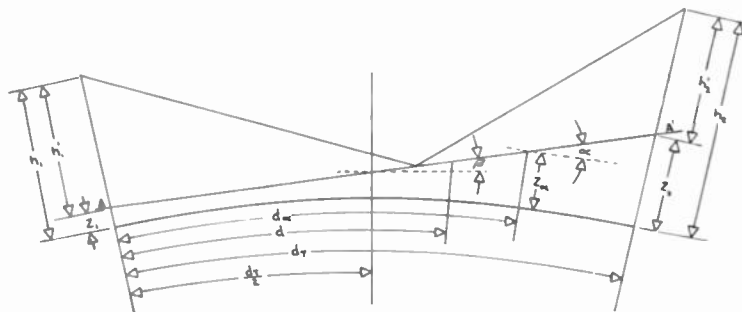

Fig. 9—Appendix notation.

The Chemistry of High-Speed Electrolytic Facsimile Recording*

H. G. GREIG†

Summary—A brief survey is made of the various electrolytic recording processes which have found use in facsimile. The requirements and conditions necessary for recording at higher speeds are discussed, with emphasis on the mechanism which has produced the most promising high-speed recording processes. Three general types of azo-color reactions which have proved most satisfactory at the higher recording speeds are described.

INTRODUCTION

Electrolytic Mechanisms

A GENERAL survey of the known electrolytic recording mechanisms, giving the limitations and requirements which have led to the use of the present azo-color processes in high-speed recording, is needed to integrate the work that has been done in this field.

There are at least four interrelated electrolytic mechanisms by which electrical energy can cause the formation of color in a sensitized recording blank; i.e.,

- (a) By the introduction of foreign ions into the blank.
- (b) By the discharge of ions at an electrode in contact with the blank.
- (c) By oxidation or reduction at the electrode surface in contact with the blank.
- (d) By increasing the concentration of a particular ion at the surface of an electrode in contact with the blank (pH change).

Ion discharge, oxidation and reduction, and local pH shift can all occur simultaneously in an electrolytic cell. Ion discharge may result in a secondary oxidation, as, for example, when bromine ions are discharged to give free bromine which in turn can oxidize many organic compounds. The local pH shift at the surface of either electrode is, of course, the result of ion discharge which leaves a temporary increase or decrease in the concentration of hydrogen ions in the immediate vicinity of the electrode. However, since the color formation in the recording blank is, in most cases, the result of secondary reactions which are initiated by some one of these electrolytic effects, the recording processes can be classified according to the primary initiating mechanism.

PHYSICAL AND CHEMICAL REQUIREMENTS FOR HIGH-SPEED RECORDING

Before going into detail, an outline of the physical and chemical requirements of high-speed recording will

be helpful. The conventional scanning method is used (see Fig. 1) in which the recording blank (*A*) is traversed by the point of intersection of a fixed printer bar (*B*) on one side of the paper and a single-turn helix (*C*) mounted on a rotating drum (*D*) on the other side of the paper. The sensitized damp paper is passed continuously between these recording elements, and advances the width of one scanning line for each rotation of the helix, so that successive scanning lines can build up the image.

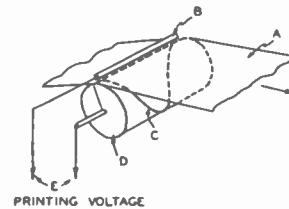

Fig. 1

In scanning one $8\frac{1}{2} \times 11$ -inch copy per minute with detail sufficient to satisfactorily define 6-point century expanded type, for example, 120 scanning lines per inch with approximately twenty-two 9-inch scanning lines per second are required. This means that the very small scanning electrodes which initiate the color reaction in the blank must travel at least 187 inches per second on the paper surface. In practice, the actual electrode speed is closer to 198 inches per second because of the mechanical and electrical requirements for synchronization which call for a short time interval between the end of one scanning line and the beginning of the next. The effective area of the printing electrode is a parallelogram approximately 0.010 inch on a side, and is the area of intersection between the 0.010-inch-wide printer bar and the helix wire, which is usually about 0.035 inch in diameter. It is this area, together with the electrical characteristics of the system, which first determines the actual elemental color spot dimensions. The maximum keying frequency and the scanning spot speed determine the electrical limitations on definition. The effective electrode area, and the resistance to spread or bleeding of the color, set the physical limitations.

The elemental electrolytic cell is the very small space in the interstices of the paper between the printer bar and the helix at the point where they cross. During recording this cell is continuously replaced so that the

* Decimal classification: R581X540. Original manuscript received by the Institute, May 18, 1948.

† RCA Laboratories Division, Princeton, N. J.

time allowed for the primary chemical reaction is somewhat under 5×10^{-6} seconds. This is an extremely short time for initiating an organic color reaction. Fortunately, however, the changes induced by electrolysis at the surface of the recording blank persist for a time after the recording electrode has moved on, so that the secondary reactions which give the color can in many cases lag behind the period of electrolysis. The conditions of electrolysis in this very small cell are highly abnormal during high-speed recording. In the first place, the recording electrodes are only about 0.0001 square inch in area. Printing currents of 100 milliamperes and higher are used, giving current densities of 1000 amperes per square inch. The electrodes are separated only by the thickness of the paper, which is 0.0015 inch or 0.0038 cm for the particular paper developed for the high-speed recording. A large part of this cell is taken up by the cellulose fibers in the paper itself. Printer voltages of 50 volts or more are required, and this is equivalent to potentials of 13,000 volts per cm of cell length at a recording speed of one letter page per minute. Actually, with approximately two pounds pressure on the printer bar, the damp recording paper is compressed so that the distance between the electrodes is less than the figure given.

Under these conditions the *Wien effect* becomes appreciable during electrolysis. Wien observed an increase in the equivalent conductance of an electrolyte when using 20,000 to 40,000 volts per cm. The usual velocity of an ion during conductance measurements is of the order of 0.001 cm per second, but in Wien's experiments the ions traveled at a rate of 10 cm/sec and faster.

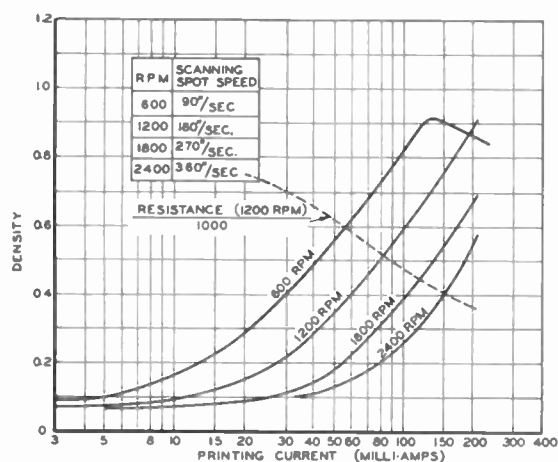

Fig. 2—Color density, printing current, and recording speed relationships of the electrolytic coupling recording solution.

Under these conditions an ion will migrate through several thicknesses of ionic atmosphere (about 10^{-8} cm) during its normal time of relaxation (about $(10^{-10}/(\text{conc.}))$ sec), and the ionic atmosphere therefore does not

have time to form. The conductance, under these conditions, approaches asymptotically a limiting value of the same order of magnitude as the equivalent conductance at infinite dilution. This effect becomes more pronounced as the recording speed is increased and the time of electrolysis is correspondingly decreased, when an increase in printing voltage and current is needed in order to obtain the same amount of electrical energy per unit area. In other words, the rate of ion discharge at the electrode remains proportional to the current flowing through the cell, but the rate of ion replacement by migration, in the vicinity of either electrode, is greatly increased when the Wien effect becomes appreciable. This means that the differential in ion concentration (pH shift) which is caused by electrolysis will decrease as this effect becomes more pronounced.

In the color reactions which depend on the effective pH shift in the vicinity of either electrode, an increase in recording speed therefore results in less color formation for the same amount of electrical energy per elemental cell, as soon as the printing voltages are high enough for the Wien effect to play a part. The curves in Fig. 2 show this effect very well. As the recording speed is increased the color density obtainable for a given amount of electrical energy per unit area is less. The increase in conductivity with printing voltage is also shown by the resistance curves in Figs. 2 and 3.

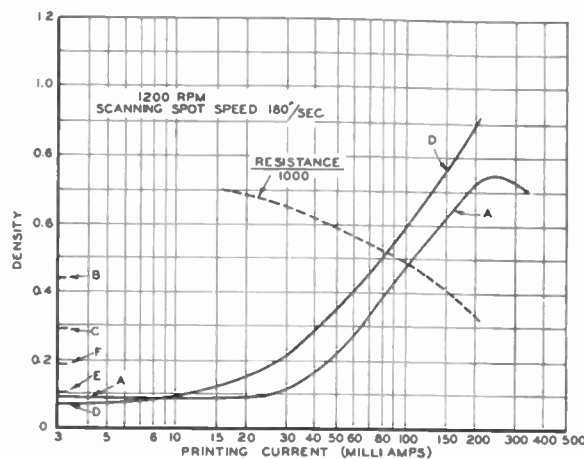

Fig. 3—Comparison of alkaline and acid recording solutions:

	Alkaline	Acid
Fresh copy	A	D
Copy after five months in files	B	E
Copy after two weeks on window sill	C	F

Each of the four general electrolytic effects has been investigated in the search for a practical high-speed recording mechanism. Typical color reactions are discussed in the following sections, with especial emphasis on those that are initiated by a shift in pH , since this mechanism has given the most successful high-speed processes.

PROCESSES DEPENDING ON THE INTRODUCTION OF FOREIGN IONS INTO THE RECORDING BLANK

There are several recording methods which depend primarily on the introduction of foreign ions into the recording blank.¹⁻⁴ In each case the source of the foreign ions is the metal of the recording electrode. In processes of this type the blank is presensitized either with organic color intermediates which will form metal-organo chelate ring compounds, or with a reagent which will precipitate either the metal itself or a colored inorganic metal derivative such as the sulfide, ferrocyanide or thiocyanate. Copper, silver, cobalt, nickel, and iron have been used as recording electrodes.

The most successful method of this type requires an iron or iron-alloy printer bar as the anode, with pyrocatechol (1,2-benzenediol) as the organic color intermediate in the sensitized paper blank. An electrolyte such as sodium chloride or potassium nitrate is used to get the required conductivity in the dampened paper. Auxiliary chemicals may be utilized to control the pH, retard discoloration, improve definition, and prevent premature drying of the sensitized damp paper. This method produces excellent permanent black recorded color on a white background having good permanence to file storage and fairly good stability to light. The recorded color strikes through the paper and is also visible from the back. The presensitized paper can be stored damp in a condition ready for recording and is marketed in this form. This recording medium has a definite use in facsimile and fills the need for a good recording blank in the intermediate speed range.

There are limitations inherent in all of these methods, however, which make it improbable that they will find application in the higher-speed systems. The primary reason for this is the excessive printer-bar erosion, which becomes a serious problem as the recording speed is increased. Since metal from the printing electrode is required to form the color, this erosion of the bar surface is not uniform but is greatest in the areas where color is formed. This uneven wear can be neutralized for the recording speeds proposed for the home newspaper recorder; for example, by printing solid black between pages. The areas of erosion are then reversed by the better contact at the high points in the printer bar surface. Spring mounting of the printer bar to hold it in contact with the paper at the point of helix intersection also helps at these intermediate recording speeds. Such a mounting, however, results in bounce and gives poor contact with excessive bar chatter in the higher-speed systems which require a more rigid mounting with 30- to 40-ounce pressure on the bar. In addition to this, physical drag of the metal ions liberated from the bar printing at higher speeds makes it increasingly difficult to obtain good (color) spot definition. There is a limiting time element here resulting from the physical transfer of the color-forming metal ions from the bar to the blank. The

recording processes based on the introduction of foreign ions into the recording blank, therefore, do not at this time meet the requirements of the higher-speed systems.

RECORDING METHODS BASED ON ION DISCHARGE AT THE RECORDING ELECTRODE

Of the recording methods based on ion discharge at the recording electrode, the best known and the most successful uses a paper sensitized with starch and potassium iodide. In this process free iodine is liberated at the anode by the discharge of the ion, and this in turn gives the well-known blue-purple color of the starch-iodine complex. This is one of the earliest known electrochemical recording processes and was first developed for telegraphic recording. It is still used in echo-meter work and in other applications where a sensitive blank with low current requirements is needed. The paper can be pretreated and stored for long periods of time either damp or dry, and is used neutral or very slightly acid to obtain the maximum sensitivity.

The chief reasons why this type of paper does not meet the high-speed requirements are that (1) the recorded color itself is not stable to light or to file storage, and (2) it is difficult to obtain good spot definition because of the spreading of the color, especially with high-speed electrode travel.

RECORDING METHODS BASED ON COLOR FORMATION BY OXIDATION OR REDUCTION

The third mechanism, oxidation or reduction at the surface of the recording electrode, is also one of the early electrochemical recording reactions to be investigated. A patent⁵ was issued to Thomas Edison in 1875 on a solution for sensitizing a telegraphic recording paper. It depends on the oxidation of leuco rosaniline to form the deep-red recorded color. Several processes based on this mechanism have been the subject of patents since that time. One, issued in 1945, is based on the oxidation of tetramethyldiamino-diphenylmethane.⁶

Several recording papers based on the oxidation of such compounds as benzidine and p-anisidine have recently been described in the literature.⁷ In many of these, ion discharge and direct anodic oxidation both play a part. Free bromine liberated by discharge of the ion acts as an oxidizing agent on many aromatic diamines. Many of these amines themselves are subject to direct anodic oxidation to form color. Wurster's colored salts, for example, are obtained when aromatic p-diamines are oxidized with bromine. Dialkylation of the amino groups enhances the stability of these salts.

The precipitation of tellurium on the recording blank is an example of the cathodic reduction mechanism. Oxidation at the anode and reduction at the cathode of course occur simultaneously during electrolysis. Either one can influence the color formation initiated by the other mechanisms, depending on the nature of the color

^{1,4,6}. For footnote references, see Bibliography.

produced and on which electrode is used as the recording electrode. The recording methods of this class, however, all suffer from one trouble which thus far has ruled them out for use in the higher-speed systems. The color reaction is an oxidation process, and therefore the sensitizing intermediates which are retained in the background of the finished copy are inherently subject to later discoloration by air and light oxidation. When these intermediates are stabilized sufficiently to give the desired permanence the reaction on which recording depends becomes less sensitive, so that the required permanence is not obtained when the sensitivity is adjusted for high-speed recording.

RECORDING METHODS BASED ON A LOCAL SHIFT IN THE pH OF THE RECORDING SOLUTION

It is the one remaining mechanism, based on the increase in the concentration of a particular ion at the surface of the recording electrode, which has given the most successful color reactions for the higher-speed work. Essentially a temporary, localized shift in pH of the recording solution in the immediate vicinity of the recording electrode, this electrolytic effect can initiate two general types of reactions. The one in which the color-forming intermediates are stable in neutral or alkaline solution, but which react in acid medium, is anodic recording. The other, in which the color intermediates are stable in neutral or acid solution but which react in an alkaline medium, is cathodic recording. Both of these classes have limitations, but both have given workable solutions for the high-speed systems. Inert metals can be used for the electrodes to minimize erosion.

There are at least three general azo-dye reactions which meet the above conditions. The first is based on the well-known diazotization of an aromatic amine followed by spontaneous color formation in alkaline solution by reaction with a coupling component. The second depends on the electrolytic breaking of a diazoamino linkage to liberate an active diazonium compound which subsequently reacts with a coupler in alkaline solution. The third is based on the electrolytic initiation of the azo-coupling reaction itself and calls for a diazotized aromatic amine in an acid sensitizing solution. The first two are anodic recording and the third is cathodic recording.

The requirements for facsimile copy, applicable to both the alkaline and the acid processes, are strong, dark, stable, recorded color on a light background which does not require after-processing to give good permanence. Black on white is, of course, the ideal. The first requirement, that of obtaining a strong dark color, rules out many of the azo-dye intermediates at the start. The very deep blues and few true blacks in the azo field all have long conjugate chain systems (alternate single and double bonds) in the molecule. The few short-chain black azo colors are mordant colors which have the metal chelate structure, in addition to the azo linkages,

to give the required wide-band resonance. No satisfactory electrolytic method of forming this type of color has been found. The more complex azo colors containing three or more azo groups in the chain are ruled out, since the electrolytic diazotization followed by spontaneous coupling permits only one diazotization and one coupling operation. This leaves two possibilities, the tetrazotization of a diamine, and multiple coupling in a coupler component, as the only other methods of forming a polyazo dye.

There is also the possibility of utilizing physical color mixtures to form a black recorded color, but here the wide differences in the rates of diazotization and coupling reactions make it difficult to get combinations which do not show two-tone effects when the printer current is modulated to give half-tones in picture reproduction. One color usually predominates for the lower current densities, and the other under the higher densities.

There are several factors which influence the rates of the chemical reactions involved. The chemical structure of the dye intermediates plays the most important role. The diazotization rate is greatly influenced by concentration and temperature as well as by substituent groups in the aromatic ring. The pH of the reacting medium is another very important factor in the rate of coupling to form color, and, since the re-establishment of the original pH conditions after electrolysis is relatively slow, the buffering characteristics of the recording solution influence the amount of color formed, and sometimes the shade of the color. The degree and type of buffering can also limit the amount of diazonium salt formed in the alkaline process. For this reason the use of such compounds as sodium or potassium carbonates, bicarbonates, or acetates, or of ammonium hydroxide, even in small amounts for control of the recording-solution pH , is undesirable in most of the alkaline combinations, even though these are the compounds most commonly used to establish the proper coupling conditions in azo-dye synthesis. Sodium or potassium hydroxides, however, give the desired neutralization characteristics and permit the maximum effective pH shift for the limited time and electrical energy available for electrolysis in the elemental cell. In the acid electrolytic coupling solution a slight amount of buffering can be tolerated and is sometimes necessary to get the required solution life. It does, however, cut down the amount of color formed.

These recording methods will be discussed separately in more detail in the following sections.

RECORDING BY ELECTROLYTIC DIAZOTIZATION^{8,9,10}

In the anodic alkaline electrolytic diazotization recording method, paper is impregnated with a water solution consisting essentially of (1) a primary aromatic amine which is capable of undergoing diazotization, (2) an alkali metal nitrite as a source of nitrous acid, (3) a neutral electrolyte to give the required conductivity

and (4) a coupling component capable of reacting with the diazo to form color. This solution is maintained alkaline, in which state the undissociated nitrous acid required for diazotization can not exist. As the impregnated paper passes between the recording electrodes and current flows through the elemental electrolytic cell, negative ions are discharged at the recording anode leaving a higher concentration of positive ions (mostly protons) on the paper surface in contact with the electrode. As a result, the pH of the solution in the immediate vicinity of the electrode is lowered, and nitrous acid is formed which, in the undissociated state, reacts with the primary aromatic amine to form the diazonium salt. The converse electrolytic action takes place simultaneously at the cathode on the reverse surface of the paper, leaving this side of the elemental electrolytic cell more alkaline than the surrounding medium. When electrolysis stops, equilibrium is re-established and the pH at both sides of the cell is gradually brought back to normal by diffusion. As the pH rises in the vicinity of the diazonium salt, this is converted to the active diazonium hydroxide which reacts with the coupling component to form the azo color. This color reaction can lag considerably behind the period of electrolysis. In many cases it can be speeded up by passing the paper over a properly controlled heater element.

The basic color reactions involved in this process can best be illustrated by the simplest azo dye reactions in which aniline is diazotized and coupled with phenol.

(1) Diazotization:

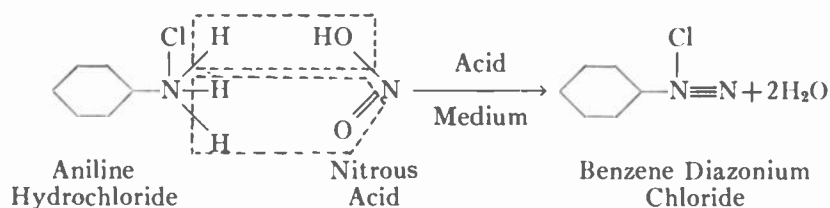

(2) Coupling:

(a)

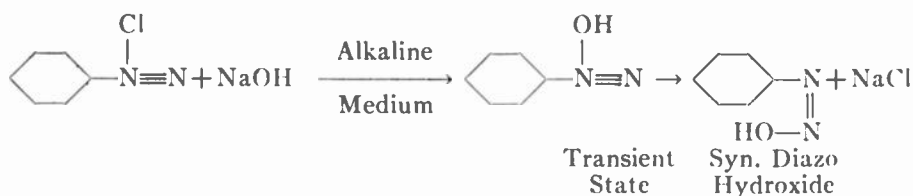

(b)

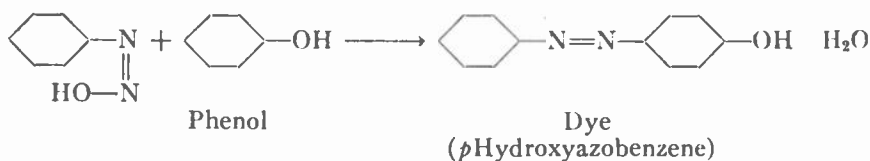

There are several ways of presenting the diazotization and coupling mechanisms, and the literature is well supplied with discussions and explanations of these re-

actions. Those unfamiliar with this chemistry will find excellent references in the bibliography.¹¹⁻¹⁴

The foregoing illustration of the general color reactions, however, does not meet the requirements of a desirable high-speed recording preparation. Both the aniline and phenol are very subject to discoloration. There are hundreds of possible combinations for azo color formation. The search for a suitable aromatic amine to be used as the diazo source in the alkaline recording method, however, quickly narrows to such compounds as naphthionic acid, chicao acid, and the benzidine sulfonic acids. The benzene derivatives do not give sufficiently dark colors (mostly oranges and reds) with the couplers thus far uncovered for use in alkaline solution. Most of the auxochromic groups normally used to intensify and deepen the color of these dyes are undesirable in the diazo source. The nitro groups in most instances give colored intermediates and lead to bad discoloration in alkaline medium. Alkylated and acylated amino groups, as well as hydroxyl groups in the structure of the aromatic amines, increase the tendency to discoloration by oxidation. The sulfonic acid and carboxylic acid groups, when properly positioned, aid in the stabilization of the amines in alkaline medium. For example, alpha naphthylamine darkens very badly when used in the alkaline process, whereas naphthionic acid (alpha naphthylamine-4-sulfonic acid) is one of the better compounds of this class. The naphthalene diazo sources give mostly reddish-purple recorded colors with the best couplers. All of the diazosources, which have only the required primary amino groups such as the

naphthylamines, naphthalene diamines, and benzidine, are too subject to the discoloration in alkaline medium to give the desired background permanence. These

compounds, which have been most useful in synthesizing the simple azo blues and blacks, do not have the required solubility for use in the alkaline solutions. No method has been found for stabilizing them to give a practical life in a coated recording blank. The sulfonated naphthylamines and benzidine have given the best results.

Much the same pattern is found in the search for suitable couplers for the alkaline solution. There are two general types of coupling components, i.e., those which react with the diazonium compound under slightly acid or neutral conditions, and those which react in alkaline medium. Some components, such as the aminohydroxy compounds, are capable of coupling in a different position for each condition, and in some of these double coupling is possible. Since the acid pH shift during electrolysis is transitory and of relatively short duration, the alkaline coupling components are most useful here. These are the hydroxy benzenes and naphthalenes and their derivatives. Here, again, the benzene derivatives either have not given the desired dark colors, or have been too subject to oxidation to give the desired permanence. Even phloroglucinol, probably the most reactive coupler of all and one of the most useful in the acid recording solutions, has not given good results in any of the alkaline combinations tested.

The naphthols and the dihydroxy naphthalenes themselves are too subject to oxidation to give good background permanence under alkaline conditions. As in the case of the diazo sources, the introduction of sulfonic acid groups, in the proper positions in the naphthalene ring, gives increased stability. Chromotropic acid (1:8 dihydroxy-naphthalene-3,6-disulfonic acid) is the best coupler of this type that has been found thus far.

A primary amino group in any of these couplers has a strong adverse effect on the stability. The acylation of such an amino group, however, protects it against oxidation sufficiently to permit its use in some couplers. "H" acid, which is itself one of the worst offenders in giving background discoloration, can be used if the amino group is protected. Benzoyl H acid is one of the best couplers of this class. On the other hand, acylation of J acid or Gamma acid does not give the desired stability. The number of good couplers presently available is therefore quite limited.

The following example represents one of the better alkaline recording formulations of this type.

Many of the water-soluble azo-dye intermediates are isolated from water solution by salting and, therefore, contain the salt as a diluent. The strength of the dry material varies from lot to lot and may run as low as 40 per cent even when the organic purity is high. Therefore, the formula weights are given as grams of 100 per cent material and must be corrected for strength for each new lot of the chemicals.

The sodium hydroxide necessary for adjusting the pH of the final solution to pH=9.6-10.2 can be added in the form of a salt+sodium hydroxide mix for con-

venience in obtaining a uniform product. The actual amount required will vary from lot to lot of the dye intermediates. The amount of sodium hydroxide required to make the pH adjustment is so small that it is difficult to include it with the other chemicals for grinding into a uniform mix, since on exposure to air it rapidly becomes wet and sticky. Local concentrations of sodium hydroxide affect the stability of the mix adversely. The desired procedure, therefore, has been to use absolutely dry chemicals and, by taking aliquot controls, predetermine the amount of base necessary to give the desired pH and add this as a dry salt mix.

TABLE I
SINGLE-PACKAGE DRY MIX

Material	Mol. Wt.	Gram Moles/Liter	Grams 100%
Benzidine-3,3'-disulfonic acid	344	0.030	10.32
Benzoyl H acid	423	0.013	5.5
Diacetoacetylene diamine	228	0.017	4.0
Thiourea	76.1	0.0526	4.0
Potassium chloride	—	—	26.0
*Sodium chloride+sodium hydroxide mix	—	—	8.0
Sodium nitrite	69	0.059	4.08
Water	—	—	1000 ml.

* NOTE: The benzidine disulfonic acid and the benzoyl H acid are used here in the form of their disodium salts to eliminate the chance of local diazotization during storage of the dry mix.

This example is a recording preparation which is actually a compromise against the various undesirable features of the best alkaline recording solutions developed to date. The recorded color is the darkest thus far obtained with the alkaline-type solution, and is close to 5.0P 3/2 in the Munsell Color Chart.¹⁶ The background of the fresh copy is light yellow because of the staining properties of the benzoyl H acid in alkaline solution. This concession was made to obtain the darker recorded color. This yellow background darkens through yellow brown to deep pink, but legibility is retained in the copy after several years in the files.

The chemistry of color formation is somewhat more complex than in the simple illustration given for the alkaline solutions. The recorded color is very probably a mixture, since there are several possible reactions which can take place during the electrolytic diazotization and coupling operations. In the first place the benzidine-3,3'-disulfonic acid has two diazotizable primary amino groups. These, however, are on different rings of the diphenyl nucleus, so each ring can be considered as a substituted aniline. The rate of diazotization is about the same for aniline and its homologues but is much increased when substituents such as $-\text{NO}_2$, $-\text{SO}_3\text{H}$, and $-\text{Cl}$ are present, particularly if they are in the ortho position to the primary amino group as in this case. Since the diazonium group is basic and the sulfonic acid group is acidic, the diazonium compound exists in the form of an internal salt.

The benzidine-3,3'-disulfonic acid has several advantages over the other diamines of this class. First, it is readily soluble in alkaline solution due to the sulfonic acid groups. These sulfonic acid groups in the 3,3' positions give greatly increased stability to the benzidine and apparently act as auxochromic groups, resulting in darker colors. Benzidine itself is highly susceptible to oxidation in alkaline medium and gives bad discoloration in the background of the copy. Methoxy groups or methyl groups in the 3,3' positions as in dianisidine and o-tolidine, although tending to deepen the color, offer little help against discoloration. None of these latter compounds have the required solubility in alkaline water solution. Carboxylic acid groups in the 3,3' position give improved stability, but produce very poor light-red recorded color. Of the sul-

medium, which, in the recording operation, is only a transitory condition.

Coupling in position *B* is due to the directive influence of the hydroxyl group, and is most pronounced in alkaline medium. Coupling with the tetrazotized benzidine-3,3'-disulfonic acid therefore takes place almost entirely at *B* after the electrolysis, when the alkaline condition is re-established by diffusion. This step can readily be seen during recording at the high speeds. A reddish color is first formed and darkens gradually, with full color being attained about a half-minute later when the copy passes over the heater element used to iron the paper. Coupling can take place between the tetrazo and either one or two molecules of the coupler, depending on the conditions. The diazo dye has the following structure:

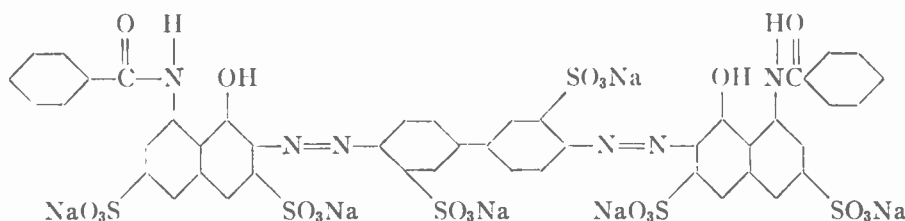

fonic acid derivatives of benzidine, the 3,3'-disulfonic acid has given by far the best results. The 2,2'-disulfonic acid derivative in the same formula produces a much lighter and redder recorded color (Munsell 10.0 RP 4/10), and the mono sulfonic acids show decreased stability to discoloration as well as redder shades of recorded color. The use of stilbene and diphenyl-urea derivatives where the benzene rings are linked by other groups results in redder rather than darker colors. In addition to this, the sulfonic acid groups remove the toxicity of the benzidine. The use of benzidine itself is undesirable, because this compound, dried into the background of the copy, could present a health hazard.

Assuming that electrolysis during recording results in the complete tetrazotization of the benzidine-3,3'-disulfonic acid, there are still several possible coupling reactions which may take place during color formation. There are two couplers present in the mix. The benzoyl H acid presents two coupling positions, *A* and *B*:

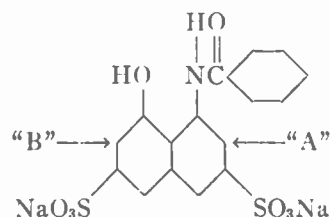

Benzoyl H Acid
(Disodium Salt)
or
(1-Benzoylamino-8-hydroxy-naphthalene-3,6-disulfonic acid)

The possibility of coupling taking place at position *A*, however, is remote, since the acylation of the amino group greatly reduces the basicity, and the directive influence to position *A* is reduced if not lost entirely. In addition, this directive influence is only effective in acid

This color is a bright purple-blue which approximates 10.0 PB4/6 in the Munsell color chart.

The second coupler, diaceto-acetyl-ethylene-diamine, is used to darken this blue recorded color. It has two structurally similar coupling positions at *A* and *A'* in the acetoacetyl-linkages:

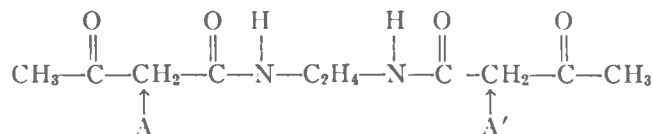

With tetrazotized benzidine-3,3'-disulfonic acid, and with most of the other diazos tested, it gives yellow recorded color.

It is obvious that, when two different couplers are used for simultaneous coupling with the same tetrazo, the ratio of the concentrations used is a critical factor. This is observed in practice, and the recorded color can be changed towards the blue by increasing the concentration of the benzoyl H acid, or through brown to yellow by increase in the diacetoacetyl-ethylene-diamine concentration. If the ratio is kept constant, only the strength of color, not the shade, varies with the total concentration. Likewise, a change in concentration of the tetrazo affects the strength of the color. There are other factors, however, which can upset this balance, since coupling rates are affected by temperature, concentration, and pH of the coupling solution. The balance is set for certain definite conditions of high-speed recording and calls for a set time of reaction after electrolysis and before heat is applied in ironing the damp paper. A paper of definite characteristics must be used, and in this case

the paper has an effective pH of about 5.0. The dark recorded color obtained with the solution therefore can be a mixture of the blue and yellow with the color having the following structure:

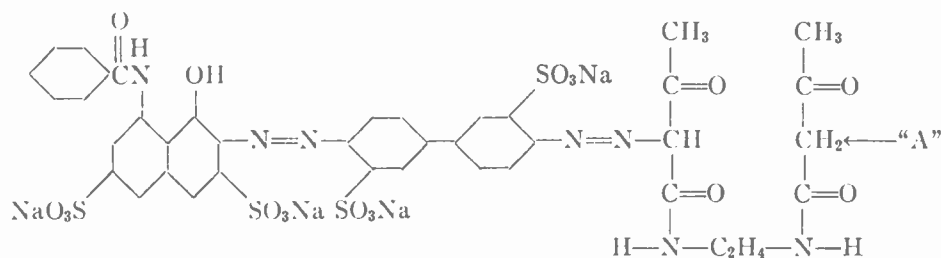

There is even the possibility of additional coupling at *A* to give a more complex molecule. Anodic oxidation of the various color intermediates, as well as the resultant colors in the various stages of synthesis, probably plays a part. The possibility of nitroso derivatives of the couplers being formed in the presence of the nitrous acid, during the diazotization step, should not be disregarded.

The thiourea is included in the formula because it darkens the recorded color still further. This compound does not, however, act as a stabilizer of either the solution or the background of the copy as it does when it is used in the acid type of recording solutions. Thiourea is neutral in reaction, but reacts toward acids as a mono-acidic base, forming comparatively stable salts. The darkening of the color in this particular combination may be due to salt formation with the sulfonic acid groups in the benzidine nucleus. Urea does not show this effect, but allylthiourea and phenylthiourea do. If benzidine-2, 2'-disulfonic acid, in which the acid groups are not ortho to the azo linkages, is substituted for the 3,3' acid, the thiourea produces little change in the hue of the recorded color. If chromotropic acid is used in place of benzoyl H acid, the darkening effect of the thiourea is lost, so the complete mechanism of the thiourea action is not understood.

The alkaline electrolytic diazotization preparations developed to date are far from the ideal answer for high-speed facsimile recording. The background discoloration in the copy is the worst feature encountered. Greatly improved background stability and somewhat better recorded color in the copy have been obtained in the more recently developed acid recording solutions. A comparison of these two types of copy is included in the discussion on the electrolytic coupling method.

RECORDING BY ELECTROLYTICALLY BREAKING THE DIAZOAMINO LINKAGE

A brief discussion of one other alkaline-type recording mechanism based on the same electrolytic effect is in order here, since it can give a greatly improved stability

to light and oxidation in the background of the copy, but has presented background discoloration of still another type. The gain in stability to light and oxidation is the result of using a structurally different diazo

source. A diazoamino compound is used in place of the primary aromatic amine and sodium nitrite. The amines are most subject to oxidation by air and light when they are in an alkaline medium. Reactive amines are therefore usually converted to their acid salts to gain stability and prevent discoloration during storage. The diazoamino compounds, which are formed by reacting a diazonium compound with a primary or secondary amine in alkaline solution, on the other hand, are most stable and least subject to oxidation in alkaline medium. The primary aromatic amines in this case have already been subjected to the strong oxidizing action of the nitrous acid during the diazotization step and are more stable to further oxidation. These compounds break up to form the original diazo and amine in the presence of acid. It is this property which makes it possible to use them for recording. Such a recording solution consists essentially of a diazoamino compound which will break up during electrolysis to give an active diazonium compound, a coupling component which will react with this diazo to form color, and a neutral electrolyte such as salt to give the required conductivity in water solution. This solution must be slightly alkaline, preferably in the range $pH = 9.5-10.2$ to prevent reaction of the chemicals. Recording paper impregnated with such a solution is used in anodic recording, and during electrolysis the linkage is broken at *A*.

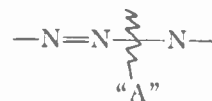

The resultant diazonium compound reacts with the coupling component in the same way as in the electrolytic diazotization method previously described. The diazoamino compounds vary greatly in the stability of this linkage, and only those capable of forming enough of the diazo to give the required color density are of value. The best of these uncovered thus far use secondary alkylolamines as the stabilizing amines. They are not only resistant to discoloration by oxidation, but exert a strong stabilizing effect on the coupling components as well.

Diazotized naphthionic acid reacted with diethanolamine has been used in the best formula of this type. The following reactions show the mechanism of color formation:

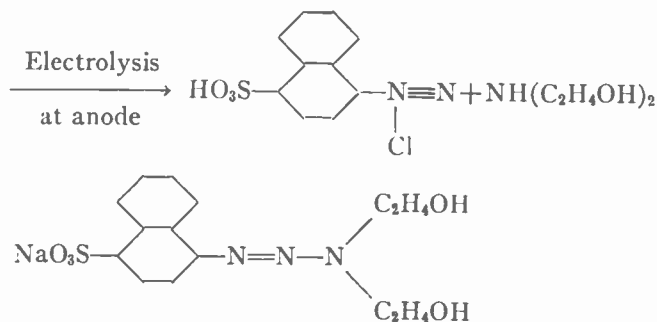

Diazotized Naphthionic Acid \rightarrow Diethanolamine

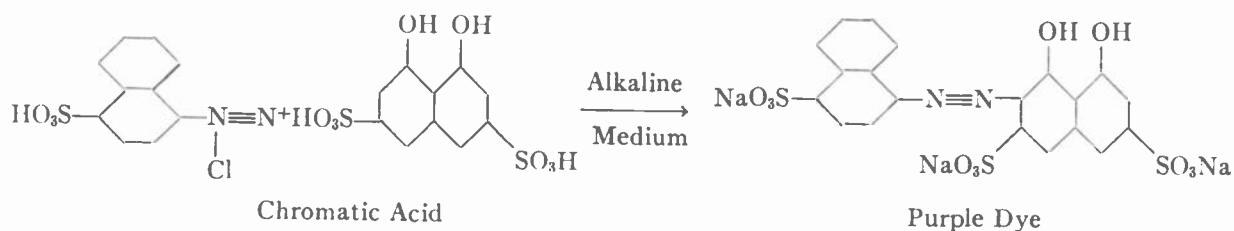

This product, together with chromotropic salt and sodium chloride, has given a single-package dry mix which showed little deterioration after four years storage in an air-tight container. The recording solution is prepared from this mix by dissolving it in the required volume of water. The recorded copy has very good stability to light, but serious discoloration develops as soon as the effective alkalinity drops low enough to permit breaking up of the diazoamino compound. Unfortunately, the discoloration is of the same character as the recorded color, and it has thus far ruled this method out for commercial use.

Alkaline copy shows a gradual lowering of the effective pH when it is stored in a humid atmosphere. This is due primarily to the action of CO_2 which is absorbed. Copy stored in the files under relatively dry conditions shows good stability.

RECORDING BY ELECTROLYTIC COUPLING¹⁶

The cathodic recording provided by the acid electrolytic coupling method is based on the second of the two general azo-dye reactions that have proved useful in high-speed facsimile. A recording solution for this process consists essentially of (1) a diazonium compound which is sensitive to light, (2) a coupler component capable of reacting with this diazo to form color, (3) a neutral electrolyte to give the required conductivity, and (4) an acid or acid salt to maintain the proper low pH of the water solution to prevent spontaneous

color formation. The recording mechanism is the complement of that in the anodic recording process. In this case, positive ions are discharged at the cathode, or, in other words, the hydrogen ion concentration is decreased at the surface of the blank which is in contact with the recording electrode. At this higher pH the diazonium salt is converted to the diazo hydroxide and, as such, reacts with the coupling components to form color. Here, again, the color reaction can lag behind the period of electrolysis, but this reaction is much more rapid than the diazotization and coupling in the alkaline processes, and must be completed before the original acid condition is re-established, since then the color reaction will stop. In many cases the color which is formed can be darkened by the application of heat. If the copy is dried too soon after electrolysis, however,

the color reaction will be retarded; and if the paper is too wet, the original acid state will be re-established by diffusion before the full density of color is obtained. The moisture content of the paper is, therefore, a critical factor. A moisture content of 20 to 25 per cent is optimum for the particular paper developed for this high-speed work.

The chemistry of color formation in this process is closely allied to that of the diazotype printing processes which have found such wide commercial success in the duplicating field. There are two general types of these on the market, one using a wet developing method, and the other a dry or ammonia-vapor development. In the first type, a paper coated with a light-sensitive stabilized diazonium compound is used to make contact prints from a master copy by exposure to an ultraviolet light source. The diazonium compound under the translucent part of the master copy is destroyed by the action of the light, while that masked by the opaque image is retained. This diazo image is then developed by treatment with an alkaline solution containing coupler components which react with it to form the positive color image.

The second type utilizes a paper coated with both the diazonium compound and the couplers. The image is formed in the same way, but development is brought about by treatment with ammonia vapor, which establishes the alkaline condition necessary for color formation.

In the facsimile process this procedure is reversed. Electrolysis during recording brings about the color

formation and corresponds to the development step in the diazotype process. The active diazonium compound remaining in the background of the copy is then de-

does require some moisture, and therefore the dryness of the paper during the exposure to light is a factor. The following reaction is typical:

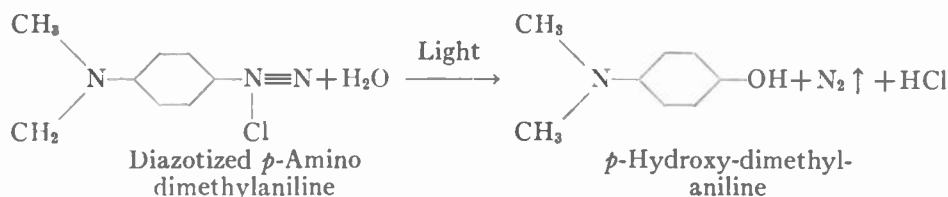

stroyed by exposure to ultraviolet light, giving the finished copy. The copy in this case remains at approximately the pH of the recording solution (normally, pH 4.5 to 5.0), whereas in the diazotype process the acidity of the copy is neutralized during development and is slightly alkaline or closer to neutral. This is important because most of the colors formed are sensitive of pH, and this puts a lower limit on the pH which can be used in the recording solution (see curves, Fig. 4).

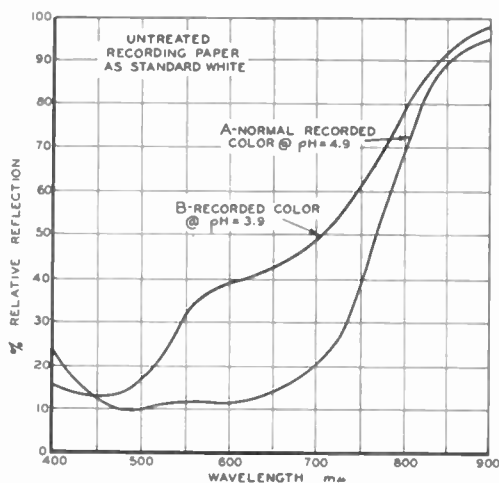

Fig. 4—Diffuse reflectance of recorded color showing the effect of solution pH.

The choice of chemicals for the acid process is much more limited than in the alkaline method. The diazonium compound must be stable enough in the dry form to give a reasonable storage life in the mix, and it must not react with the couplers within the pH range required for the recording solution. Sensitivity to decomposition by light is very important, because the background must be cleared rapidly to permit this step to be carried on in the recorder where the paper travels at eleven inches or more per minute. The clearing of the background can be facilitated by exposing both sides of the copy simultaneously.

The photolysis of these light-sensitive diazonium compounds is a reaction of 0 order. It is not affected by a change of temperature or the presence of salts, but it

The decomposition products are usually phenolic bodies which are similar in character to the coupling components. The chemicals retained in the background of the copy are therefore more compatible and less subject to side reactions than those in the alkaline copy, where both primary amines and phenolic couplers are retained in the background. Reaction between these two is believed to contribute to the discoloration of the alkaline copy. In the acid method the finished copy is at a lower pH and one of the color components has been decomposed, so that the better background stability would be expected.

The aromatic diazonium compounds which are most sensitive to light are all relatively inactive and form color with only the most reactive couplers. Fortunately, the sensitivity to heat decreases as the sensitivity to light increases, and the properties most needed in these compounds do not conflict. The high sensitivity to light and optimum stability in solution at room temperature go together.

The following electrolytic coupling recording preparation (Table II) consists of two separately packaged dry mixes which are dissolved in one liter of water to give the recording solution. The solution life is limited to

TABLE II

	Moles/Liter	Grams/Liter
<i>Package A</i>		
Stabilized diazo P-amino diethylaniline*	0.0213	17.6
Sodium phosphate (primary)	0.0363	5.0
Sodium chloride	0.685	40.0
<i>Package B</i>		
Phloroglucinol (1:3:5 trihydroxy benzene)	0.00618	1.00
Resorcinol (1:3 dihydroxybenzene)	0.0030	0.33

* Stabilized as the double zinc chloride salt.

about one eight-hour day, after which color formation in the solution and weakening of the recorded color may prove objectionable. This solution is moderately sensitive to light and must be protected from prolonged exposure, especially to the shorter visible and near ultraviolet. A recorded color appreciably closer to neutral

than 5.0 $P^{3/2}$ in the Munsell color chart is obtainable for full density at recording speeds of one letter page per minute.

The diazonium compounds derived from the amino diphenyl-amines are too reactive within the pH limits required for recording, and therefore do not give sufficient recording-solution life. Many of the other diazonium compounds, such as those derived from H acid, 1-amino-2-hydroxy naphthalene-4 sulfonic acid, benzidine, dianisidine, etc., which are mentioned in the patents on the diazo-type processes, have been tested and found to be unsuitable for high-speed recording. In the diazo-type processes, stability of the light-sensitive coating can be gained by using solutions of low pH (pH 2 to 3) and, if desired, buffering at this low value. The stability of the diazonium compounds alone, or when in solution with a coupler, increases as the pH is lowered. There are several limitations in the high-speed recording process, however, which make the use of low pH solutions impractical. First, this low pH must be shifted by electrolysis during recording to the high pH required for color formation, so that the lower the initial state the less effective this shift becomes. In addition to this, the transitory alkaline condition is more quickly overcome by diffusion, leaving a shorter time for color formation. Since the acidity of the copy in the recording process is not neutralized, there are two additional reasons why a very low pH is undesirable. First, when the effective pH of the copy is much below $pH = 4.5$, the copy becomes irritating to the skin when handled. Second, the recorded color itself is in most cases sensitive to pH , and it changes to a yellowish brown as the pH is lowered. The lower limit for this solution is, therefore, about $pH = 4.5$.

The upper limit for the solution is determined by the coupling reactivity of the two intermediates. When the pH is high enough for the color reaction to take place slowly, then the practical life of solution will be limited thereby. An upper limit of about $pH = 5.0$ with a slight amount of buffering is required to give a reasonable life. This buffering action results from the use of the primary sodium phosphate, together with the zinc chloride salt of the diazonium compound.

The most important characteristic of the diazotized p -aminodiethylaniline is its high sensitivity to light. The absorption characteristics of this compound are shown in Fig. 5 where per cent light transmission is plotted against wavelength. It has a fairly wide absorption peak between 3400 and 4100A. The 3663A emission line of the mercury arc is therefore an effective light source for destroying the diazonium compound and clearing the background of the copy.

Since the diazotized p -amino-diethylaniline is relatively low in coupling reactivity due to the inductive effect of the diethyl amino group in the para position, only the most reactive couplers will give the required density of color within the short time available for reaction. The phloroglucinol and resorcinol are two of the

most reactive couplers known. The phloroglucinol has three symmetrically placed ortho- and para-directing hydroxyl groups. All three of these work together to induce coupling to take place in the three remaining unsubstituted positions in the benzene ring. The phloroglucinol alone with the diazo gives a blue recorded color. The resorcinol gives a reddish yellow. The ratio of three parts phloroglucinol to one of resorcinol produces the darkest color obtainable with this combination under the conditions of high-speed recording. This ratio can be changed to meet a change in the recording conditions.

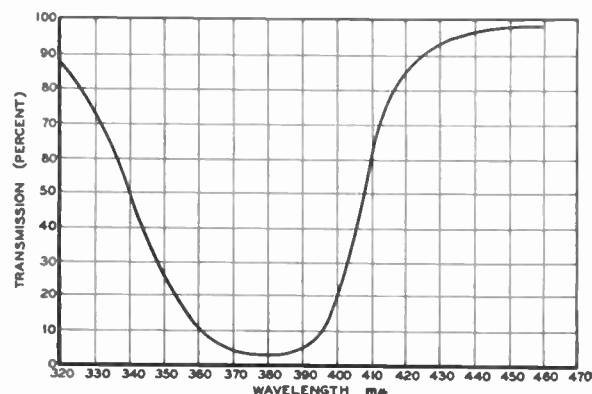

Fig. 5—Light-absorption characteristics of diazotized p -amino-diethylaniline zinc chloride salt.

The recording characteristics of this solution such as the relationship between the recording speed, required printing current and recorded color density, and the like, can most easily be presented graphically. Fig. 2 shows a series of curves for four different recording speeds with the density of recorded color plotted versus the printing current in milliamperes. The density of the color produced by a given printer current at a fixed speed of recording was determined by the use of a reflection densitometer.¹⁷ The foot-candle relationship is given by

$$D_s = \log_{10} \frac{S_0}{S}$$

where

D_s = density of the color

S_0 = scale reading for a standard white

S = scale reading for the color being tested.

This method is analogous to the procedure used in the photographic field, where density is plotted versus exposure time. Inasmuch as the photocell in the densitometer has approximately the same spectral sensitivity as the eye, comparative readings are possible in spite of minor changes in color.

The curves were plotted from data obtained in printing a solid vertical strip equal in width to one-half the total scanning line. By doing this, uncertainties as to the effect of the phasing dash on the current and volt-

age readings are eliminated, and the meters can be assumed to read one-half of the true values. The break in the curve for 600 rpm, where the density of the color drops off for an increase in printer current, is caused by burning of the recorded color as a result of the very high current density.

Fig. 3 shows the comparison at 1200 rpm of the acid solution (curve *D*) with the alkaline solution (curve *A*). It can be seen that the acid solution requires less current to reach the same color density. The comparative densities of background discoloration with age are also shown by the points *A* to *F*. These show very well the better contrast and background permanence obtainable with the acid solution.

The acid process favors better definition in the elemental color spot than the alkaline process, since the color is formed in the first phase of the *pH* shift and is a pigment rather than a dye. During the period of electrolysis the maximum shift in *pH* is at the surface of the electrodes. In the acid process the *pH* rises, and the color is formed and precipitated on the surface of the paper, which is in direct contact with the recording cathode. The color is therefore confined to that part of the elemental cell immediately adjacent to the recording electrode. After electrolysis the color reaction is stopped, as the acid liberated in the coupling reaction brings the *pH* down to its original value.

In the alkaline process, on the other hand, this cycle corresponds to only the diazotization step. In this process the *pH* is decreased at the surface of the recording anode, and nitrous acid is formed from the sodium nitrite. The undissociated nitrous acid reacts with the amine to form the diazonium salt. The coupling reaction which gives the color, however, does not begin until the *pH* arises again to its original alkaline state, and, since this rise is the result of diffusion, chiefly from the back of the paper where the reverse *pH* shift took place at the cathode, the color is first formed at the outer surface of the diazo spot, away from the recording electrode. Since there is an ineffective *pH* range between that at which diazotization takes place and that where color formation begins, there can be an appreciable time lag between these reactions. The color which is formed is soluble in alkaline solution, and there is a chance for bleeding here. The soluble alkaline colors can have a high substantivity for the fiber in the paper, however,

which in many cases can compensate to a large extent for the tendency to bleed.

CONCLUSION

Three general azo dye reactions have produced workable high-speed facsimile recording processes. These color reactions are initiated by the transient local shift in *pH* which is produced by electrolysis at the surface of the recording electrode. Inert metal electrodes can be used to eliminate the problem of erosion, which becomes serious as the speed of recording is increased.

The electrolytic azo-coupling process, in which the excess diazonium compound is decomposed by light, has produced the most permanent copy.

ACKNOWLEDGMENT

The work on high-speed electrolytic recording has been done under the facsimile program at the RCA Laboratories. The author is particularly grateful for the encouragement and help received from C. J. Young, under whose guidance the work was carried forward.

BIBLIOGRAPHY

1. United States Patent No. 2,063,993 issued, 1936, to Howard Else.
2. German Patent 536,506, 1929, to J. Felman.
3. United States Patent No. 2,038,486, issued 1936, to Emil Glas.
4. United States Patent No. 2,358,839, issued 1944, to Edgar R. Wagner.
5. United States Patent No. 168,465, issued 1875, to Thomas Edison.
6. United States Patent No. 2,367,113, issued 1945, to Robert B. Gibney.
7. Industrial and Engineering Chemistry V-39, No. 10, Pg. 1286, Electrolytic Recorder Paper, 1947.
8. United States Patent No. 2,306,471, issued 1942, to M. Solomon.
9. United States Patent No. 2,419,296, issued 1947, to M. Solomon.
10. United States Patent No. 2,421,367, issued 1947, to M. Solomon.
11. K. H. Saunders, "The Aromatic Diazo Compounds," Edward Arnold and Co., London, 1936.
12. N. V. Sidgwick, T. W. I. Taylor, and W. Baker, "The Organic Chemistry of Nitrogen," Oxford University Press, London, 1937.
13. P. H. Groggins, "Unit Processes in Organic Synthesis," McGraw-Hill Book Co., New York, N.Y., 1938.
14. L. F. Fieser and M. Fieser, "Organic Chemistry," D. C. Heath and Co., Boston, Mass., 1944.
15. "Munsell Book of Color," Munsell Color Company, Inc., Baltimore, Md.
16. United States Patent No. 1,970,539 issued, 1934 to Viktor Bausch, Jr.
17. "Radio Facsimile," vol. I, RCA Institutes Technical Press, 1938.



Helical Beam Antennas for Wide-Band Applications*

JOHN D. KRAUS†, SENIOR MEMBER, IRE

Summary—The helical beam antenna has inherent broad-band properties. Over a wide frequency band the pattern shape, circularity of polarization, and terminal impedance are relatively stable. Measured performance data are presented for a medium-gain helical beam antenna of optimum dimensions with a bandwidth of about 1.7 to 1. A high-gain broadside array of four such helices is described. Other wide-band applications of helical beam antennas, including omnidirectional types, are also discussed.

INTRODUCTION

A HELIX WITH a circumference of about one wavelength can radiate as a beam antenna.¹ Radiation is maximum in the direction of the helix axis and is circularly polarized, or nearly so. This mode of radiation, called the axial or beam mode, may persist over a wide frequency range.² In footnote reference 2 basic phenomena associated with the beam mode are described, and a method is developed for calculating the radiation patterns. Impedance measurements³ reveal that in the frequency range of the beam mode the terminal impedance is relatively constant and equal to a resistance of about 130 ohms for typical helices. These properties all combine to make the helical beam antenna particularly well suited for wide-band applications.

The dimensions providing the most uniform radiation and impedance characteristics over the greatest frequency range will be referred to as "optimum" dimensions. It is the purpose of this paper to consider the design and performance of such an optimum helix. This subject is not treated in the previous papers. Operation of this helix in multiple to provide a high-gain beam is also considered, as are other wide-band applications of helical beam antennas.

It should be mentioned that the beam mode of radiation is but one of many modes in which a helix may radiate.⁴ The characteristics of not only the beam mode, but also other modes are considered in detail in another paper.⁵ The present paper deals only with the beam mode of radiation as produced by uniform helices of circular or square cross section.

One of the outstanding characteristics of the beam mode of radiation of a helical antenna is the ease with which circularly polarized radiation is obtained. The

beam mode of radiation can be readily produced by operating the helix with a ground plane, the combination being energized by a coaxial transmission line as

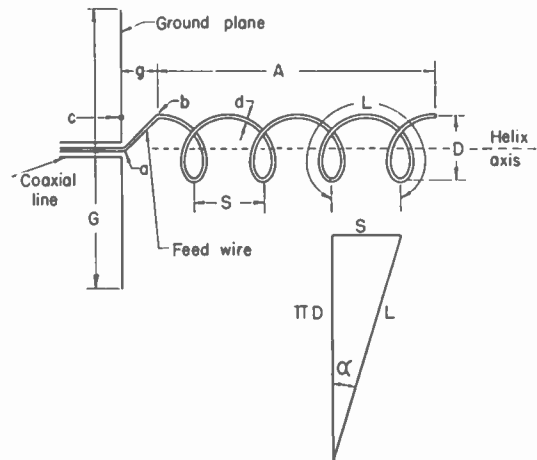

Fig. 1—Helix and associated dimensions.

in Fig. 1. The outer conductor terminates in the ground plane and the inner conductor connects to the end of the helix.

The following symbols are used to describe the helix and ground plane (see Fig. 1):

- D = diameter of helix
- S = spacing between turns (center-to-center)
- α = pitch angle = $\arctan S/\pi D$
- L = length of one turn
- n = number of turns
- A = axial length = nS
- d = diameter of helix conductor
- g = distance of helix proper from ground plane
- G = ground plane diameter.

If one turn of a helix is unrolled on a flat plane, the circumference (πD), spacing (S), turn length (L), and pitch angle (α) are related by a triangle as shown in Fig. 1.

In Fig. 1 the coaxial line is coincident with the helix axis and the feed wire (between a and b) lies in a plane through the helix axis. Beyond point b the conductor lies in the surface of the imaginary helix cylinder. This is the helix proper of axial length A . The component of the feed wire length parallel to the axis is g . In the helices to be described, g is equal to about $S/2$. The antenna terminals are considered to be at the point of connection with the coaxial line and all impedances are referred to this point (a). It is sometimes more convenient to place the coaxial-line terminals at a point which is $D/2$ from the axis as indicated by the point c in Fig. 1. However, in the antennas described herein the coaxial-line terminals are coincident with the helix axis.

* Decimal classification: R326.61. Original manuscript received by the Institute, March 12, 1948. Presented, 1948 IRE National Convention, New York, N. Y., March 23, 1948.

† Communications Laboratory, Ohio State University, Columbus, Ohio.

¹ J. D. Kraus, "Helical beam antenna," *Electronics*, vol. 20, pp. 109-111; April, 1947.

² J. D. Kraus and J. C. Williamson, "Characteristics of helical antennas radiating in the axial mode," *Jour. Appl. Phys.*, vol. 19, pp. 87-96; January, 1948.

³ O. J. Glasser and J. D. Kraus, "Measured impedances of helical beam antennas," *Jour. Appl. Phys.*, vol. 19, pp. 193-197; February, 1948.

⁴ H. A. Wheeler, "A helical antenna for circular polarization," *PROC. I.R.E.*, vol. 35, pp. 1484-1488; December, 1947. (This paper discusses the "normal" mode of radiation.)

⁵ J. D. Kraus, "The helical antenna," to be published.

As the frequency varies, the helix diameter D_λ and spacing S_λ in free-space wavelengths change, but the pitch angle remains constant. The relation of D_λ , S_λ , and α as a function of frequency is conveniently illustrated by a diameter-spacing chart as in Fig. 2. The dimensions of any uniform helix are defined by a point on the chart. Let us consider a helix of pitch angle equal to 10 degrees. At zero frequency, $D_\lambda = S_\lambda = 0$. With increase in frequency, the co-ordinates (S_λ , D_λ) of the point giving the helix spacing and diameter increase, but their ratio is constant so that the point moves along the constant-pitch-angle line for 10 degrees. Designating the lower and upper frequency limits of the frequency range

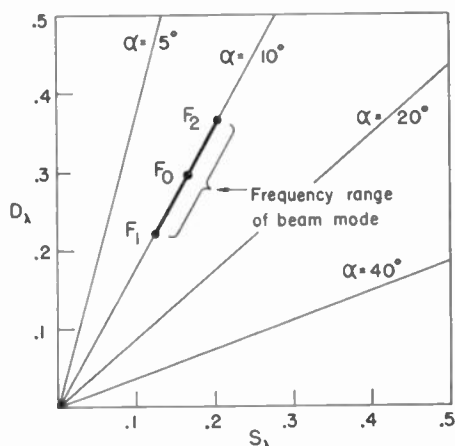

Fig. 2—Diameter-spacing chart for helices showing range of dimensions associated with a frequency band.

of the beam mode as F_1 and F_2 , respectively, the corresponding range in spacing and diameter is given by a line between the points for F_1 and F_2 on the 10-degree line. The center frequency of the range is F_0 and is taken arbitrarily such that $F_0 - F_1 = F_2 - F_0$ or $F_0 = (F_1 + F_2)/2$. The dimensions of the helices to be described are given in free-space wavelengths at this center frequency F_0 .

DETERMINATION OF AN OPTIMUM HELIX

Pattern and impedance data are given in footnote reference 3 for helical antennas of fixed physical length, but of pitch angles ranging from 6 to 24 degrees. The antennas are about 1.6 wavelengths long at the center frequency of the beam mode range with half-power beam widths at this frequency of about 40 degrees. An antenna of this size and directivity is suitable for many high-frequency and microwave transmitting and receiving applications.

An optimum helix may be determined by comparing pattern and impedance data taken from footnote references 2 and 3 on a D - S chart, as in Fig. 3. The pattern contour in Fig. 3 indicates the approximate region of satisfactory patterns. A satisfactory pattern is considered to be one with a major lobe in the axial direction and with relatively small minor lobes. Inside the pattern contour of Fig. 3 the patterns are of this type, and have

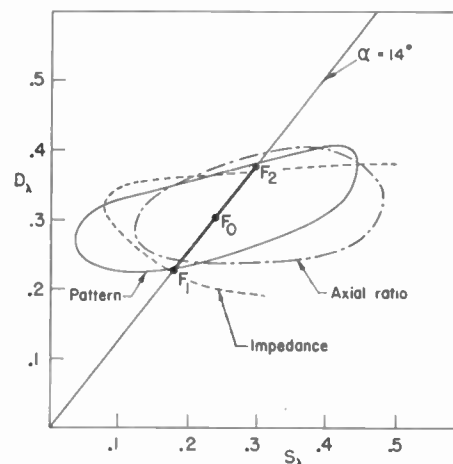

Fig. 3—Diameter-spacing chart for helices with contours showing regions of stable pattern shape, and terminal impedance, and of low axial ratio, for helices of fixed physical length.

beam widths of from 30 to 60 degrees. Inside the impedance contour in Fig. 3 the terminal impedance is relatively constant (between 100 and 150 ohms), and is nearly a pure resistance. This region is the "impedance plateau" of footnote reference 3. A third contour in Fig. 3 is for the axial ratio measured in the direction of the helix axis.⁶ Inside this contour⁷ the axial ratio is less than 1.25. From a consideration of the three contours it is apparent that too small or too large a pitch angle is undesirable. An "optimum" pitch angle appears to be about 14 degrees. Since the properties change slowly as a function of α in the vicinity of 14 degrees, there is nothing critical about this value. In fact, the properties of helices of pitch angles of 14 ± 2 degrees differ but little. Referring to Fig. 3, a line for $\alpha = 14$ degrees is indicated with upper and lower frequency limits for satisfactory operation. Although the exact location of these limits is arbitrary, it is relatively well defined by the close bunching of the contours for the three properties (pattern, axial ratio, and impedance) near the frequency limits. The frequency range between F_1 and F_2 is 1.67 to 1 ($F_2/F_1 = 1.67$). Although the optimum pitch angle of 14 degrees associated with this frequency range applies specifically to a helix with an over-all axial length ($A + g$) of about 1.65 wavelengths and a conductor diameter of 0.017 wavelength at the center frequency, it is probable that 14 degrees is close to optimum for helices that are considerably shorter or longer, or are of somewhat different conductor diameter.

Referring to Fig. 1 and taking $g = S/2$, we have

$$A + g = S(n + 1/2), \quad \text{or}$$

$$n = \frac{A + g}{S} - 1/2. \quad (1)$$

⁶ Axial ratio is defined as the ratio of the major to minor axes of the polarization ellipse. It is one for circular polarization and infinite for linear polarization.

⁷ From data by J. C. Williamson, "An investigation of some radiation characteristics of helical antennas," master's thesis, Ohio State University, 1947.

Since $S=0.24$ wavelength at the center frequency for the 14-degree helix, the number of turns (n) from (1) is 6.4. Taking the nearest integral number gives $n=6$. Thus, the helix chosen as an optimum for general-purpose wide-band applications has 6 turns and a pitch angle of 14 degrees.

PERFORMANCE OF OPTIMUM HELIX

A 6-turn 14-degree right-handed helix was constructed and its characteristics measured. Fig. 4 is a photograph of the antenna, and Fig. 5 gives details of the electrical and mechanical construction.⁸ The overall axial length ($A+g$) of the antenna is 118 cm, and the ground-plane diameter (G) is 60 cm. The center frequency is 400 Mc with $F_1=300$ and $F_2=500$ Mc. The mechanical arrangement suggests merely one possible method of mounting the antenna. The helix and ground-

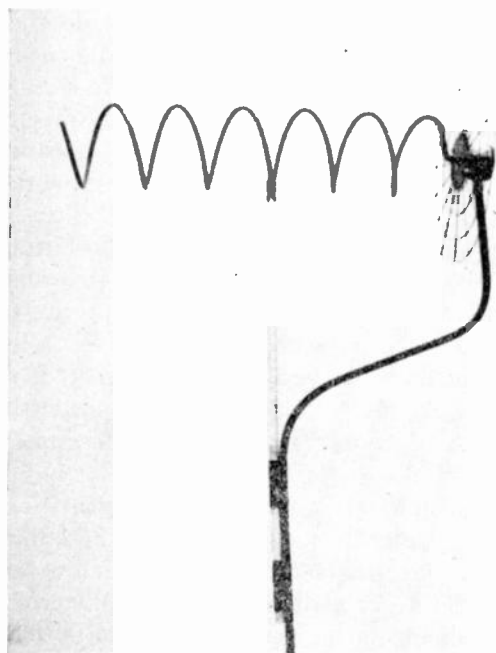

Fig. 4—Optimum helical beam antenna with ground plane. The helix has 6 turns and a pitch angle of 14 degrees. The diameter of the helix is 23 cm and the center frequency 400 Mc.

53-ohm coaxial line through a two-section wide-band transformer. A 130-ohm transmission line connected directly to the antenna terminals would provide an

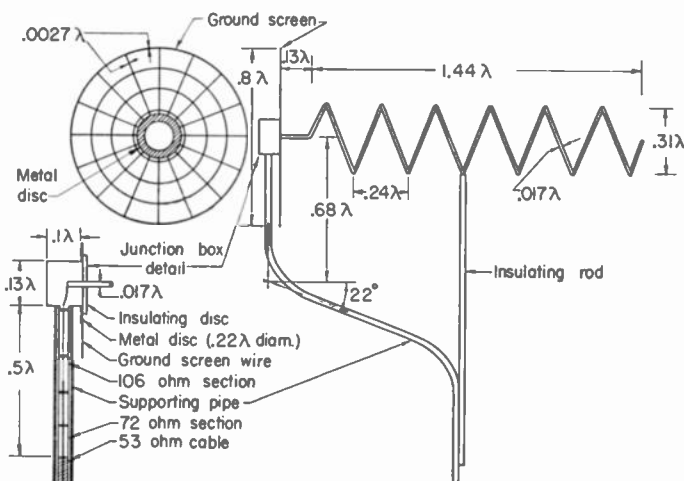

Fig. 5—Details of electrical and mechanical construction of the helical beam antenna shown in Fig. 4. Dimensions are in free-space wavelengths at the center frequency.

ideal method for energizing a helical beam antenna.⁹ To operate the antenna with a commercially available type, such as standard 50- to 53-ohm cable, requires a transformer between the antenna and the cable for maximum power transfer. Each transformer section is about one-quarter wavelength long at the center frequency. The section adjacent to the antenna terminal has a characteristic impedance of 106 ohms, and the other a characteristic impedance of 72 ohms. These impedances differ somewhat from the optimum values for such a transformer, but were chosen as the best compromise with the wire and tubing sizes available. Actually, no dimensions shown in Fig. 5 are critical.

The measured radiation (electric field) patterns of the 6-turn 14-degree helix are presented in Fig. 6 for frequencies from 225 to 600 Mc. The solid curves show the patterns of the horizontally polarized component, and the dashed curves the patterns of the vertically polarized component. All patterns are adjusted to the same maximum value. Referring to the helix in Fig. 6 (lower right), the patterns are in the plane of the page, the horizontal component being parallel to, and the vertical component normal to, the page.

It is evident from these patterns that the axial mode of radiation occurs for frequencies between about 290 and 500 Mc. This mode is characterized by patterns with a large major lobe in the axial direction and relatively small minor lobes. At frequencies less than 290 Mc, the maximum radiation is, in general, not in the axial direction and minor lobes, although few in number, are large. At frequencies above 500 Mc, the minor lobes become both large and numerous.

⁸ The helix in Fig. 1 is diagrammatic. Although the helix in Fig. 5 is more nearly a true picture, some liberties have been taken to simplify the drafting.

⁹ A 125-ohm cable designated RG-63/U is now manufactured by the Federal Telephone and Radio Corporation.

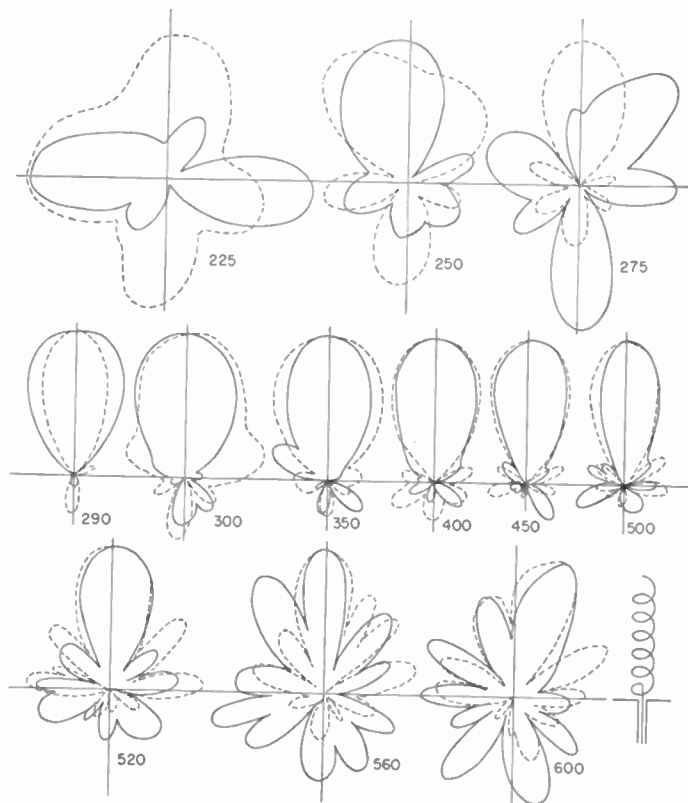

Fig. 6—Measured azimuthal electric field patterns of the 6-turn, 14-degree helix shown in Fig. 4. The solid patterns are for the horizontally polarized, and the dashed patterns for the vertically polarized field component. Between 290 and 500 Mc the patterns are characteristic of the fundamental beam mode of radiation.

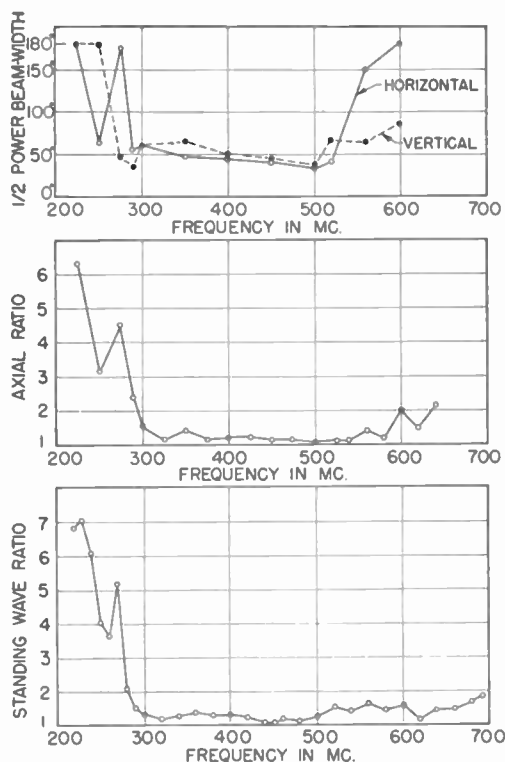

Fig. 7—Summary of measured performance of the 6-turn, 14-degree helix shown in Fig. 4. Half-power beam widths of the horizontal and vertical electric field components, axial ratio in the direction of the helix axis, and standing-wave ratio on a 53-ohm line are presented as a function of frequency.

Pattern, polarization, and impedance properties of the antenna are summarized in Fig. 7. In the uppermost section of the figure, the half-power beam width of the patterns for both the vertical and horizontal components are presented as a function of frequency in megacycles. These data are taken from Fig. 6.

The half-power beam width is taken between half-power points, regardless of whether these occur on the major lobe or on minor lobes. This definition is arbitrary, but is convenient to take into account a splitting up of the pattern into many lobes of large amplitude. Beam widths of 180 degrees or more are arbitrarily plotted as 180 degrees. Curves for the axial ratio and standing-wave ratio (SWR) are given in the lower sections of the figure. The standing-wave ratio was measured on the 53-ohm line about 9 meters from the antenna terminals.

Between 300 and 500 Mc the half-power beam width ranges from about 60 to 40 degrees. Based on pattern integration, the directivity or power gain of the 6-turn 14-degree helix over a nondirectional circularly polarized antenna varies from about 11 (10.4 db) at 300 Mc to about 25 (14 db) at 500 Mc. Between 300 and 500 Mc the axial ratio in the direction of the helix axis varies from 1.05 to 1.5, being less than 1.2 for most of the range. From a practical standpoint, this represents a relatively small deviation from circular polarization. Between 300 and 500 Mc the SWR varies from 1.03 to 1.4. Considered altogether, these pattern, polarization, and impedance characteristics represent remarkably good performance over a wide frequency range, especially since the antenna is merely a simple geometric form with no compensating devices attached except a transformer to convert the 130-ohm terminal resistance to the value of the transmission line (53 ohms).

HIGH-GAIN ARRAYS USING HELICAL BEAM ANTENNAS

Circularly polarized antennas of considerably greater directivity than is provided by the single 6-turn 14-degree helix described in the preceding section can be obtained with helical beam antennas in a variety of arrangements. Four methods are illustrated in Fig. 8. Thus, as suggested in Fig. 8(a), the number of turns might be increased. However, any considerable improvement in directivity would require a very large increase in the length. For example, the axial length A of the 6-turn 14-degree helix is 1.44 wavelengths at the center frequency, and its directivity or gain over an isotropic circularly polarized antenna is about 12 db at this frequency. To increase the gain by 10 db, or to 22 db, the helix length must be multiplied by a large factor so that the total length is of the order of 20 wavelengths. Since a broadside arrangement of much smaller maximum dimensions could produce the same gain, an antenna of such length would be impractical for most applications. The underlying reason for this is not a

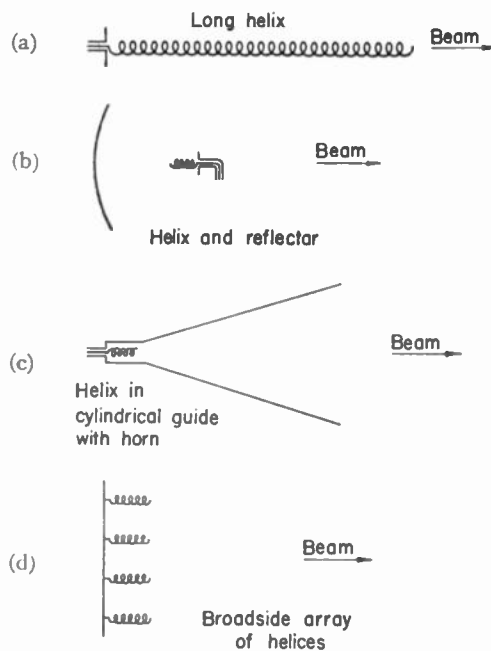

Fig. 8—High-gain antenna systems using helical beam antennas.

characteristic that is peculiar to long helical antennas, but is rather a fundamental property of all long end-fire arrays. Another disadvantage of a very long helix is that no control is afforded over the size of the minor lobes. Thus, while longer helices than the 6-turn 14-degree type described above may be used to provide a moderate increase in directivity, a more practical trend in design for very high gains appears to be toward a broadside type of arrangement. This might take the form of one of the systems suggested in Fig. 8(b), (c), and (d). In Fig. 8(b) a helical beam antenna acts as the primary antenna to "illuminate" a sheet-metal reflector of parabolic or other shape. By adjustment of the illumination of the reflector by the primary helical beam antenna, control of both the beam shape and the size of minor lobes is afforded. Referring to the example considered above, gains of the order of 22 db would be possible with a parabolic reflector of circular section of about 5 wavelengths diameter, and greater gains with larger diameters.

In Fig. 8(c) a helical beam antenna is used to excite a circularly polarized TE_{11} mode in a cylindrical waveguide connected to a cylindrical horn. The area of the aperture of the horn for a given gain will be approximately the same as for the reflector arrangement.

In Fig. 8(d) a broadside array of helices is suggested as an arrangement for obtaining a circularly polarized antenna with high gain. As a specific example of this type, an array of four helices is described in the next section.

FOUR-HELIX BROADSIDE ARRAY

Fig. 9 gives the dimensions for a broadside array of four helical beam antennas. Each helix is of the 6-turn 14-degree type described above. Dimensions are given

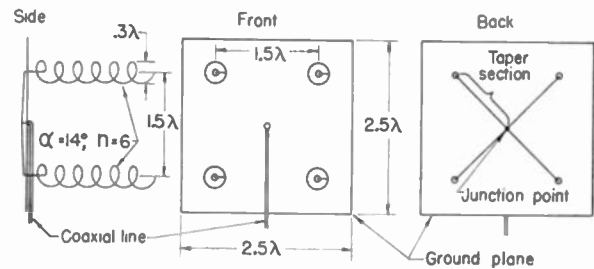

Fig. 9—Constructional details for broadside array with four 6-turn, 14-degree helices. Dimensions are in free-space wavelengths at the center frequency.

in free-space wavelengths at the center frequency. The helices are mounted on a flat square ground plane of 2.5 by 2.5 wavelengths. All helices are oriented in the same manner, and are energized with equal, in-phase voltages. The helices are symmetrically placed and spaced 1.5 wavelengths between centers. All of the helices are wound in the same direction, and the radiation is circularly polarized. If two of the helices were wound left-handed and the other two right-handed, the radiation would be linearly polarized.

To energize each of the helices with equal, in-phase voltages and, at the same time, provide a broad-band transformer between the antennas and a 53-ohm line, the following arrangement is employed. Each antenna is connected by a "single-wire versus ground-plane" transmission line which tapers gradually from about 130 ohms characteristic impedance at the antenna to about 200 ohms at the center of the ground plane. The four lines from the four helices connect in parallel at this point, yielding 50 ohms. The taper from 130 to 200 ohms occurs over a length of about 1 wavelength at the center frequency, so that the transformation is effective over a wide frequency range. The four taper sections are situated on the back side of the ground plane, the helices being on the front. The 53-ohm coaxial line to the transmitter or receiver is introduced at the center of the ground plane from the front, the inner conductor of the coaxial line connecting to the junction point of the four tapered lines.

The ground plane of the antenna which was tested is 94 by 94 cm and the center frequency is 800 Mc. Measured patterns of both the horizontally (H.P.) and vertically (V.P.) polarized components of the radiation are shown in Fig. 10 for frequencies between 600 and

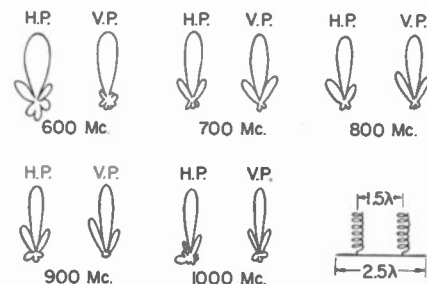

Fig. 10—Measured electric field patterns for 4-helix array shown in Fig. 9.

1000 Mc. All patterns are adjusted to the same maximum value. These patterns agree well with patterns calculated by multiplying the pattern of a single 6-turn 14-degree helix (see Fig. 6) by the array factor for two isotropic point sources separated 1.5 wavelengths at the center frequency. By pattern integration the directivity or gain of the array over an isotropic circularly polarized antenna is about 40 (16 db) at 600 Mc, and about 160 (22 db) at 1000 Mc. These gains are large for an antenna which is 2.5 by 2.5 wavelengths in size at the center frequency. The spacing of 1.5 wavelengths between helices was chosen to provide high gain without regard to side-lobe level. For this arrangement the side-lobe level is determined largely by the level for the single helix.

In Fig. 11 the half-power beam widths for the four-helix array are presented as a function of frequency, as are also curves for the axial ratio in the direction of the helix axis, and the SWR on the 53-ohm transmission

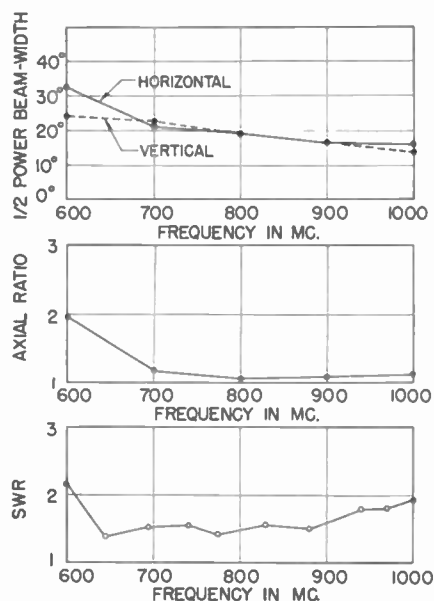

Fig. 11—Summary of measured performance of four-helix array shown in Fig. 9. Half-power beam widths, axial ratio, and standing-wave ratio on a 53-ohm line are presented as a function of frequency.

line. The SWR measurements were made at a distance of about 2.5 meters from the point at which the 53-ohm line connects to the antenna. From an examination of the curves in Fig. 11, all the characteristics of the antenna are satisfactory for operation over most of the 600- to 1000-Mc band, so that the frequency range of the array is nearly as great as for the single 6-turn 14-degree helix.

OMNIDIRECTIONAL ARRAYS USING HELICAL BEAM ANTENNAS

The beam mode of radiation of a helical antenna persists even when the number of turns is reduced to the order of one. Pattern and impedance data for 1-turn helices have been given in footnote references 2 and 3. The patterns may be relatively broad, from 60 to 80 de-

grees between half-power points. The maximum may be in the direction of the helix axis and the axial ratio nearly unity in this direction. However, as with helices of larger n , the axial ratio in general increases in directions away from the axis. Also as indicated in footnote reference 3, the impedance of a single-turn helix is not so constant as when n is 3 or 4 or larger. In spite of these disadvantages, the broad pattern and simplicity of construction of a single-turn helix suggests its application to an omnidirectional circularly polarized antenna.

In Fig. 12 two arrangements are illustrated for an omnidirectional antenna using four helical beam antennas, each of about one turn. The term "omni-

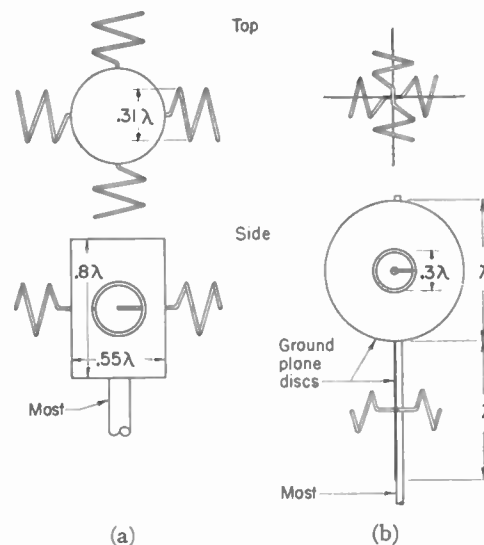

Fig. 12—Two types of omnidirectional helical beam antennas, having four helices of about one turn each. At (a) the helices are disposed around a cylinder. At (b) they are grouped in stacked pairs, with the helices of each pair separated by a flat, circular ground plane.

directional" is used here in the sense of omnidirectional in azimuth only. In Fig. 12(a) (to left) the four helices ($n=1.5$) are arranged around a conducting cylinder about one-half wavelength in diameter at the center frequency. All helices are wound in the same direction and placed on the cylinder in the same orientation. All are energized in phase by transmission lines connected in parallel.

In Fig. 12(b) (to right) the helices are mounted in pairs. Each pair consists of two helices ($n=1$) mounted back-to-back on either side of a circular ground plane one wavelength in diameter. The ground planes are stacked at right angles and spaced one wavelength between centers. Thus, one pair of helices radiates north and south and the other pair east and west. Each pair is connected in parallel. The two pairs are, in turn, connected in parallel and energized from a point midway between the two. The ground-plane diameter and spacing of one wavelength is arbitrary, and smaller values could be used.

In measuring the patterns of these antennas, they were rotated in azimuth (mast as vertical axis) and the field observed with a linearly polarized antenna oriented

successively vertical, horizontal, $+45^\circ$, and -45° . Transmitter power and receiver gain were maintained constant throughout the measurements. The variation of one polarization component (for example, horizontal) usually did not exceed more than about ± 3 db for 360° rotation in azimuth. However, the different polarization components were not, in general, of the same average value, so that the extreme variation of the electric field as a function of both polarization angle and azimuth angle was usually about ± 5 db, but rarely greater. As a function of frequency there appeared to be no marked trend toward either more constant or more irregular patterns over a 1.5 to 1 frequency band. There was also no marked difference between the two types of arrays as regards uniformity of patterns. Although the variation of the electric field of these arrays may be too large for some transmitting applications, the arrays are practical as omnidirectional receiving antennas.

SQUARE HELICAL BEAM ANTENNA FOR SHORT-WAVE USE

A helical beam antenna can be scaled to operate at any frequency. The only limitation is the practical consideration of size. The low-frequency limit may be somewhat reduced by modifying the design to that shown in Fig. 13. The helix is of square cross section¹⁰ and is supported by lines strung between four wooden poles. These lines are broken up by insulators at intervals of a small part of a wavelength. The dimensions given are in free-space wavelengths at the center frequency. The helix shown has 3 turns. A longer helix could be used for greater directivity; for example, one of 6 turns and 14 degrees pitch angle. The spacing between the lower

¹⁰ A helix of square cross section is used in the pattern calculations of footnote reference (2).

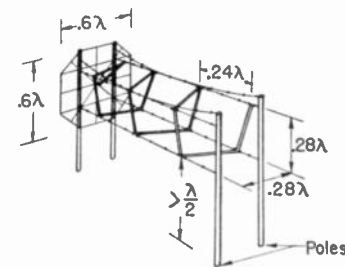

Fig. 13—Helical beam antenna of square cross section for short-wave applications. For operation at 20 Mc (15 meters), four 50-foot poles are required.

side of the helix and the ground should be at least one-half wavelength. A ground plane of spider-web construction is mounted on the far poles. A coaxial transmission line connects the antenna to the transmitting or receiving equipment. It is found that with an antenna of this construction the helix conductor must be sufficiently large (of the order of 0.01 wavelength diameter). The helix conductor may be a large tube (as, for example, stove pipe) or of an open-wire cage construction. By radiating at all polarization angles (circular polarization) this antenna has advantages over linearly polarized types for both transmission and reception. The antenna in Fig. 13 has a gain at the center frequency of more than 10 db over an isotropic circularly polarized radiator.

CONCLUSION

Although helical beam antennas can be applied in other ways, the examples described above illustrate a considerable variety of types and applications.

The author is indebted to Milford C. Horton for his able assistance in the construction and testing of many of the antennas described.

Antenna Design for Television and FM Reception*

FREDERICK A. KOLSTER†, FELLOW, IRE

Summary—An approximate method is presented herein of determining, for preliminary design, the resistance and reactance variation with frequency of an antenna or dipole with change of physical dimensions, and to indicate the essential requirements for good performance over a wide band of frequencies necessary for efficient reception of all television channels and FM bands as now allocated for public use by the Federal Communications Commission. A unique antenna system designed to be efficiently responsive over the entire frequency band from 44 to 225 Mc is described.

IN CONSIDERING the simple case of a dipole connected to a transmission line as shown in Fig. 1, it is well, first of all, to examine what happens along the line with variations of the terminal impedance

which the dipole presents at various frequencies. This terminal impedance resolves itself in an equivalent or apparent resistance and reactance in series and is, therefore, a function of the frequency.

A significant measure of the useful range of operating frequencies of an antenna or dipole for reception as well as transmission is the standing-wave ratio along the transmission line resulting from the terminal impedance presented by the antenna or dipole.

The standing-wave ratio is expressed mathematically by the formula,

$$SWR = \frac{1 + K}{1 - K}$$

where K is the coefficient of reflection, which may, in turn, be mathematically expressed as

* Decimal classification: R326.6. Original manuscript received by the Institute, November 14, 1947; revised manuscript received, March 18, 1948.

† Consulting Engineer, San Francisco, Calif.

$$K = \sqrt{\left[\frac{R^2 + Z_0^2 + X^2}{(R + Z_0) + X^2} \right]^2 + \left[\frac{2ZX}{(R + Z_0) + X^2} \right]^2}$$

where

- R = apparent resistance presented by the antenna
- X = apparent reactance presented by the antenna
- Z₀ = characteristic impedance of line.

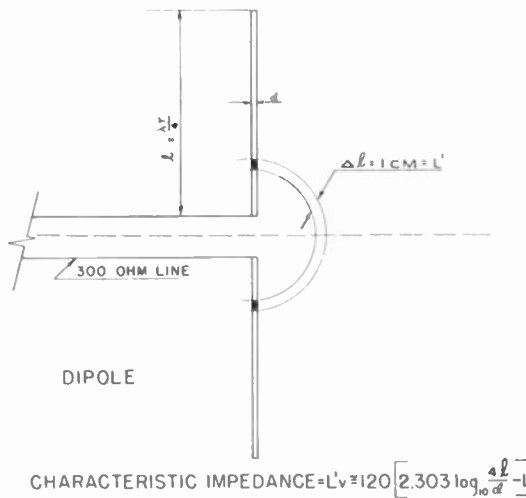
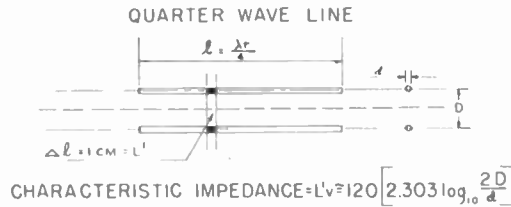

Fig. 1

For television and FM reception, a convenient form of antenna is the dipole or half-wave antenna. For purposes of analysis, the dipole may be considered as a quarter-wave resonant line with its two wires rotated oppositely through 90°, as shown in Fig. 1, and assumed to be in free space.

In the case of a quarter-wave line having negligible ohmic resistance and from which there is no radiation, the impedance of the line will be completely reactive, and will vary with frequency in accordance with the cotangent law

$$X = -L'v \operatorname{ctn} \frac{\pi}{2} \cdot \frac{\omega}{\omega_0}$$

where

- L' = inductance per cm length of the line
- v = velocity of light
- ω₀ = resonant periodicity = 2πx resonant frequency of the line
- ω = any other periodicity

and

$$L'v \cong 120 \left[2.303 \log_{10} \frac{2D}{d} \right]$$

where

- D = separation between centers of line wires
- d = diameter of line wires.

Also, L'v = √L/C = K_a = characteristic impedance.

At its fundamental frequency and the odd harmonics, the line will behave as a series circuit. At the even harmonics the line will behave as a parallel circuit. This is likewise true with respect to the line when opened up to form a dipole, with the important exception that now the line or dipole becomes a powerful radiator of energy, and the resistance equivalent of radiation must be taken into account.

Furthermore, in the case of the dipole,¹

$$K_a = L'v = 276 \log_{10} \frac{4l}{d} - 120$$

where 2l = total length of dipole, d = diameter of dipole.

The extent to which the resistance equivalent of radiation causes the reactance variation to depart from the cotangent law depends upon the physical dimensions of the dipole. If a dipole of given length is constructed of wires having very small diameter, its reactance will follow the cotangent law very closely. Departure from the cotangent law becomes more and more apparent as the diameter of the wires is increased, and this departure occurs most prominently at and near the even harmonics where the dipole behaves as a parallel circuit.

It is possible, by the use of a simple artifice, to show, within practical limits, the extent of this departure at and near the first even harmonic, or where ω/ω₀ = 2.

First, it is necessary to match as nearly as possible, a resistanceless parallel circuit to the cotangent curve in the region of ω/ω₀ = 2. In other words, make

$$L'v \operatorname{ctn} \frac{\pi}{2} \cdot \frac{\omega}{\omega_0} = \frac{1}{C\omega_r} \times \frac{\frac{\omega}{\omega_r}}{1 - \frac{\omega^2}{\omega_r^2}} = \frac{1}{C\omega_r} \times \alpha;$$

then

$$\frac{1}{C\omega_r / L'v} = \frac{\operatorname{ctn} \frac{\pi}{2} \cdot \frac{\omega}{\omega_0}}{\alpha}$$

TABLE I

$\frac{\omega}{\omega_0}$	$\frac{\omega}{\omega_r}$	α	$\operatorname{ctn} \frac{\pi}{2} \cdot \frac{\omega}{\omega_0}$	$\frac{1}{C\omega_r / L'v}$
1.6	0.80	2.22	1.376	0.619
1.7	0.85	3.05	1.963	0.644
1.8	0.90	4.73	3.078	0.648
1.9	0.95	9.75	6.314	0.650
1.95	0.975	19.50	12.706	0.652
2.00	1.000			
2.05	1.025	20.50	12.706	0.621
2.10	1.050	10.25	6.314	0.615
2.15	1.075	6.91	4.165	0.603

Average 0.63

¹ J. F. Morrison and P. H. Smith, "The shunt-excited antenna," Proc. I.R.E., vol. 25, pp. 673-697; June, 1937.

Thus a parallel circuit of negligible resistance in which the capacitance has a reactance at resonance of $0.63 \times L'v$ will very closely follow the cotangent curve at and near $\omega/\omega_0=2$. The next step is to introduce into the parallel circuit a resistance equal to the resistance equivalent of radiation, which at twice the fundamental frequency of the dipole or at $\omega/\omega_0=2$ is given at 90 ohms for a resonant antenna in free space.²

The apparent resistance and reactance of the parallel circuit can now be calculated in the range of frequencies through which it has been previously matched to the cotangent curve. For purposes of calculation the following formulas are convenient:

$$R' = R \times \frac{1}{\left(1 - \frac{\omega^2}{\omega_r^2}\right)^2 + \frac{1}{Q_r^2} \cdot \frac{\omega^2}{\omega_r^2}}$$

$$X' = \frac{RQ_r}{\frac{\omega}{\omega_r}} \times \frac{\left(1 - \frac{\omega^2}{\omega_r^2}\right) \frac{\omega^2}{\omega_r^2} - \frac{1}{Q_r^2} \cdot \frac{\omega^2}{\omega_r^2}}{\left(1 - \frac{\omega^2}{\omega_r^2}\right)^2 + \frac{1}{Q_r^2} \cdot \frac{\omega^2}{\omega_r^2}}$$

where

- R' = apparent series resistance of parallel circuit
- X' = apparent series reactance of parallel circuit
- R = actual resistance in the circuit = 90 ohms
- Q_r = resonant Q of the circuit.

The reactance of the parallel circuit will reach a maximum value, one positive and one negative, when

$$\frac{\omega}{\omega_r} = \sqrt{1 \pm \frac{1}{Q_r}}$$

It will pass through zero when

$$\frac{\omega}{\omega_r} = \sqrt{1 - \frac{1}{Q_r^2}}$$

and will have a value equal to $-RQ_r$ when $\omega/\omega_r=1$.

It is seen, therefore, that the resonant Q of the artificial circuit and hence the Q of the dipole determines the resistance and reactance variation with frequency.

Based upon the premise that an antenna or dipole can be artificially represented by a properly matched parallel circuit at and near twice its natural frequency, it is possible then to determine by simple calculation the equivalent terminal resistance and reactance presented by the dipole at various frequencies and for different physical dimensions, and thus to predict its performance as indicated by a calculation of the standing-wave ratio along a transmission line of any given characteristic impedance.

It is important, however, to show that the results arrived at by this simple approximate method will check to a reasonable degree with calculations based upon more rigorous theory. For this purpose, Schel-

kunoff's³ curves for $K_a=500, 800,$ and 1200 have been chosen for comparison. It will be observed by reference to Figs. 2, 3, 4, and 5 that there is a fair agreement

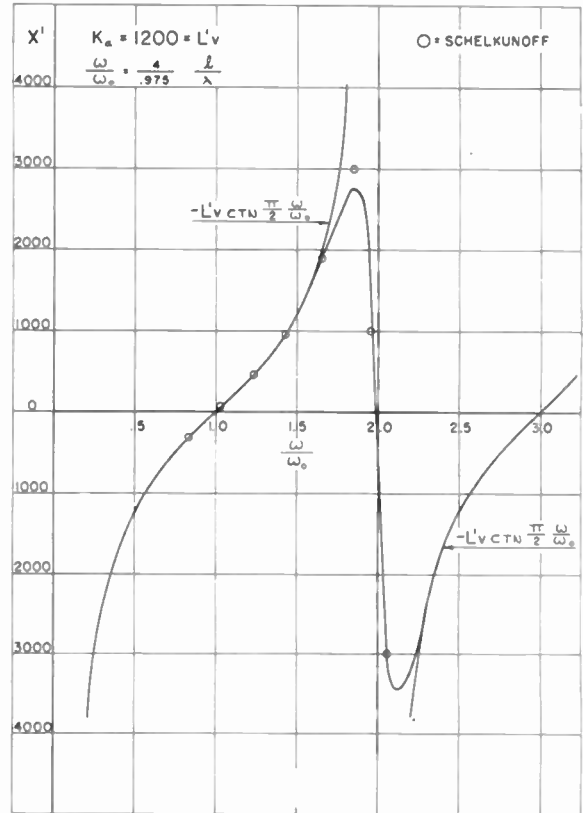

Fig. 2

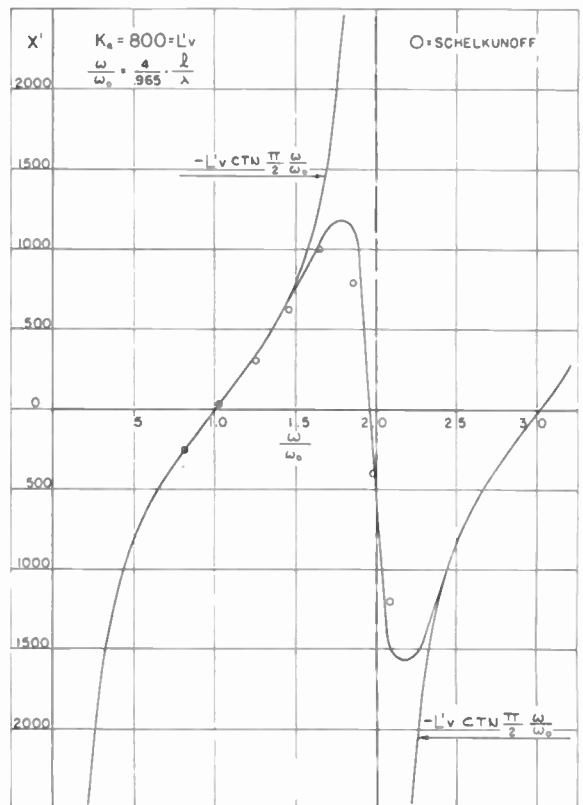

Fig. 3

² F. E. Terman, "Radio Engineers' Handbook," McGraw-Hill Book Co., New York, N. Y., 1943; page 790.

³ S. A. Schelkunoff, "Theory of antennas of arbitrary size and shape," Proc. I.R.E., vol. 29, pp. 493-521; September, 1941.

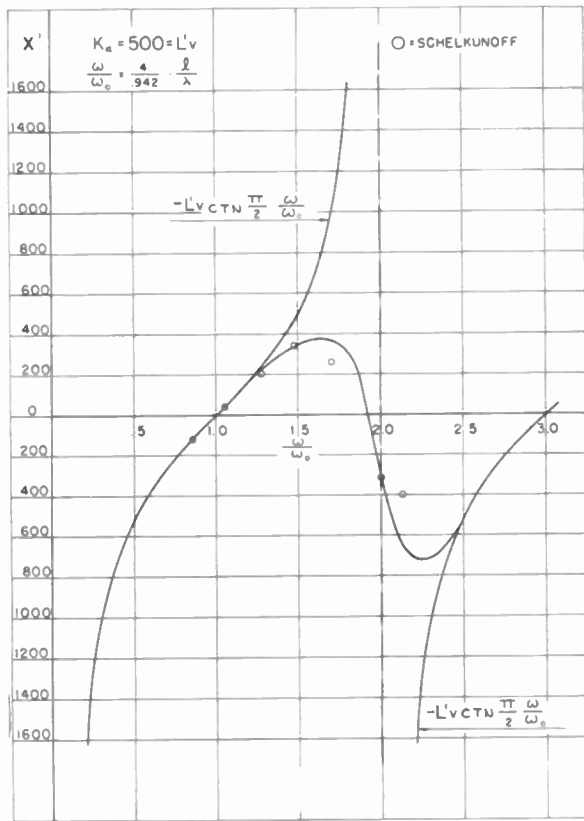

Fig. 4

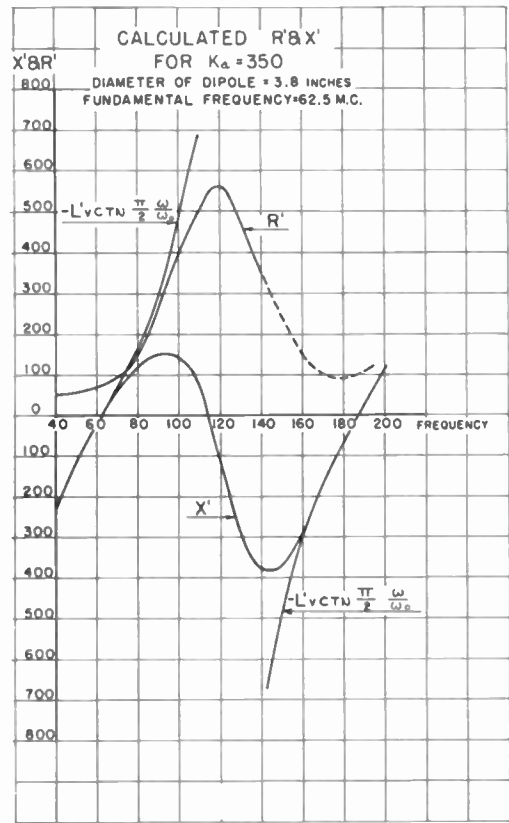

Fig. 6

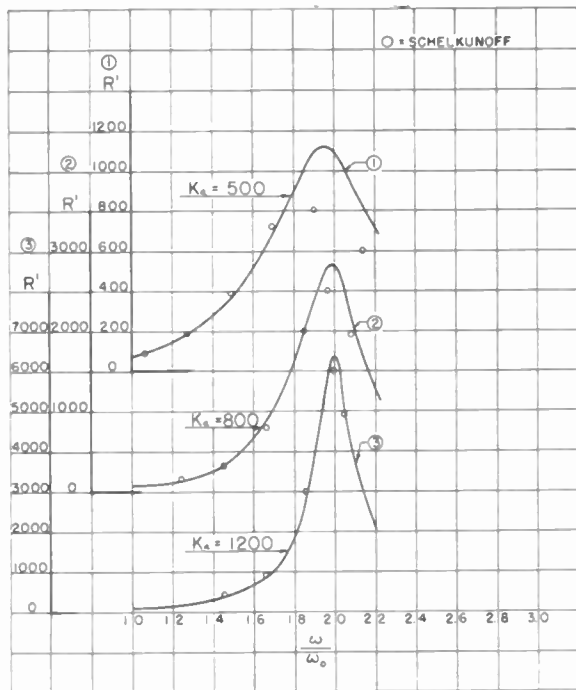

Fig. 5

between Schelkunoff's curves represented by circles and those calculated by the artificial method herein described, represented by dots.

If it can be conceded that the comparison is sufficiently good for practical purposes, then the approximate method offers a comparatively simple engineering basis for preliminary design.

In this connection, it is of interest to examine the formula for the coefficient of reflection in terms of R , Z_0 , and X , and to note that the choice of transmission-line impedance Z_0 has an important significance in the case where a very wide frequency band must be covered.

For television and FM reception, the use of a 300-ohm line has become more or less standard practice in the industry. In general, this appears to be a reasonably good choice from the point of view of broad-band antenna design.

In considering the design of an antenna of the simple dipole type for the efficient reception of a wide band of frequencies, such as has been allocated for television and FM, it must be determined at the outset what the physical dimensions of such an antenna must be to present a terminal impedance, and, more particularly, resistive and reactive components of the impedance, such that a reasonably low standing-wave ratio will result in a 300-ohm line throughout the frequency range.

Referring now to the calculated reactance and resistance curves of Figs. 4 and 5 for a dipole having a K_a of 500, which for a fundamental frequency of 62.5 Mc calls for a dipole having a diameter of a little more than 1 inch, it can be determined by the approximate method of calculation that, with such a dipole, the standing-wave ratio in a 300-ohm line will be as high as 8 at the extreme ends of the television frequency spectrum, and about 3 through a very narrow range of frequencies in the center of the spectrum. This leads to the consideration of a dipole having a lower K_a and hence a larger diameter. Take, for example, a dipole having a K_a of

350. This calls for a much larger diameter, about 3.8 inches.

In Fig. 6 are shown the resistance and reactance variation, with frequency, of such a dipole, as calculated by the approximate method herein described; and in Fig. 7,

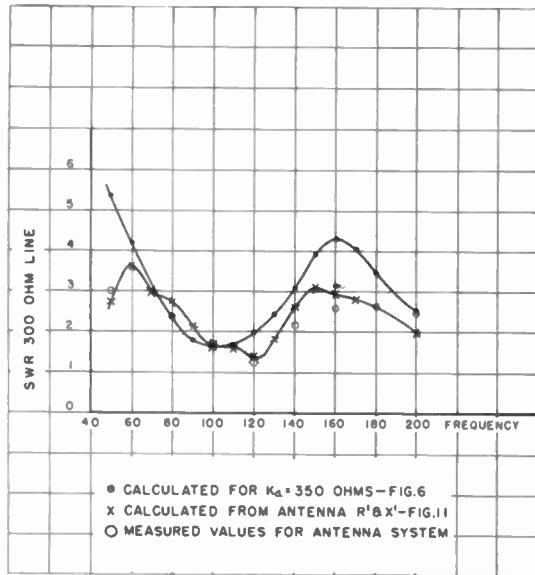

Fig. 7

represented by dots, is shown the corresponding calculated standing-wave ratios. In this case, the standing-wave ratio is well below 3 over a considerable range of frequencies, rising to about 5 at 50 Mc, and about 4 at 160 Mc.

The indication, therefore, is that for low standing-wave ratios over a wide range of frequencies, a simple dipole must have a comparatively large diameter, unless something otherwise can be done favorably to modify the resistive and reactive components of its terminal impedance.

In Fig. 8, and more effectively in the photograph of Fig. 9, there is shown an antenna system comprising two co-operatively associated dipoles having different fundamental or natural frequencies and constructed of wide thin strips. These two dipoles *A* and *B* are physically related so as to form a complex electrical network shown diagrammatically in Fig. 10, wherein *CC* repre-

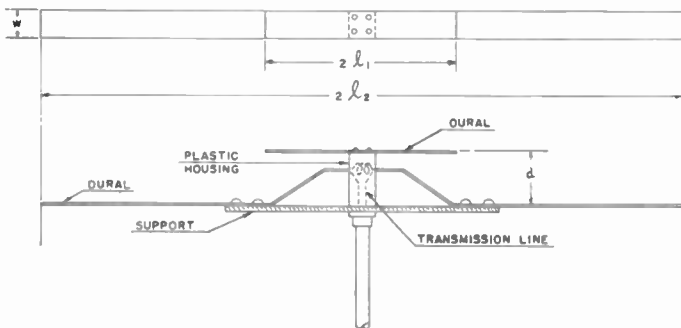

Fig. 8

sent the capacitances formed by virtue of the proximity of dipole *A* to dipole *B* and *L* is a suitable inductance connected in series with dipole *A*. The network thus formed operates to give a more favorable variation of the resistive and reactive components of the terminal impedance, resulting in a better standing-wave ratio in the lower and higher frequency ranges as will be noted by reference to Figs. 7 and 11.

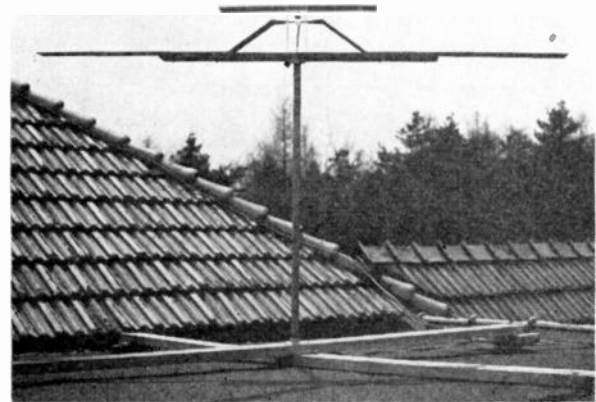

Fig. 9

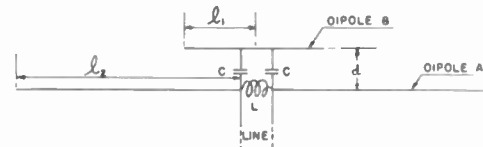

Fig. 10

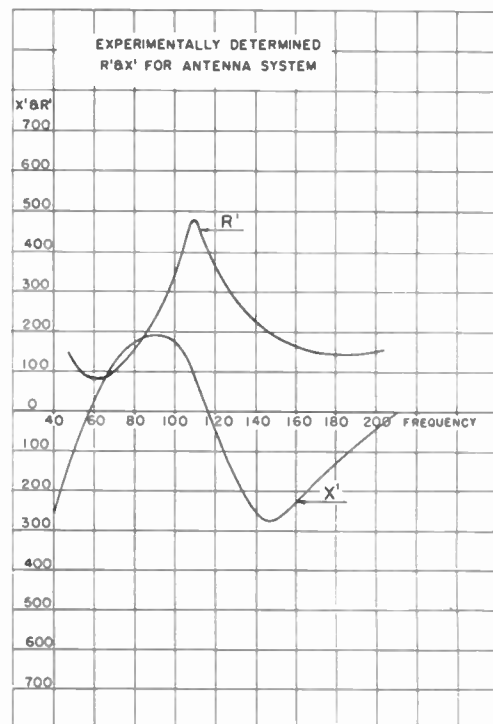

Fig. 11

It will be observed in Fig. 11 that the resistive component has a rising characteristic at frequencies below the fundamental frequency of dipole *A*. This is caused by the action of the parallel circuit across the line terminals formed by the capacitances *CC* and the inductance *L*. At the higher frequencies where dipole *B* becomes the controlling receiving element, both *R'* and *X'* assume more favorable values because of the cooperative action between dipoles *A* and *B*. Both of these effects are reflected in the standing-wave-ratio curves, calculated and measured, as shown in Fig. 7 and indicated by crosses and circles, respectively.

There still remains to be considered, however, the signal pickup efficiency, and the nature of the field patterns of the antenna system throughout the range of frequencies for which it is designed.

A simple dipole operating at frequencies higher than

its natural frequency, and particularly at its harmonic frequencies, will produce field patterns with deep nulls and multiple lobes, with the result that in some direction receptivity will be low unless the dipole is carefully oriented with respect to the transmitting station to be received.

In so far as signal pickup is concerned, dipole *A* is controlling in the lower frequency range, while for the higher frequencies dipole *B* becomes the controlling element. Furthermore, dipole *B* not only enhances the pickup efficiency or receptivity of the system at the higher frequencies but plays the very important role, through its coupled relationship to dipole *A*, of controlling the amplitude and phase of the current and voltage distribution along dipole *A*, produced by the higher frequencies, thus to prevent the appearance of deep nulls and consequent multiple lobes in the field patterns.

In Fig. 12 is shown the signal pickup efficiency or receptivity of the antenna system as compared with a standard tuned dipole. In Figs. 13 to 18, field patterns of the antenna system are shown for various frequencies.

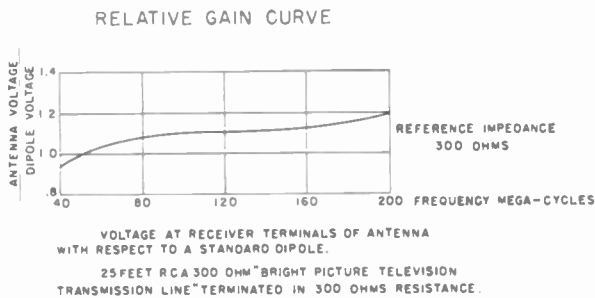

Fig. 12

ACKNOWLEDGMENT

Appreciation is expressed for the valuable assistance given by those who took part in obtaining the experimental data and preparing the drawings for this paper.

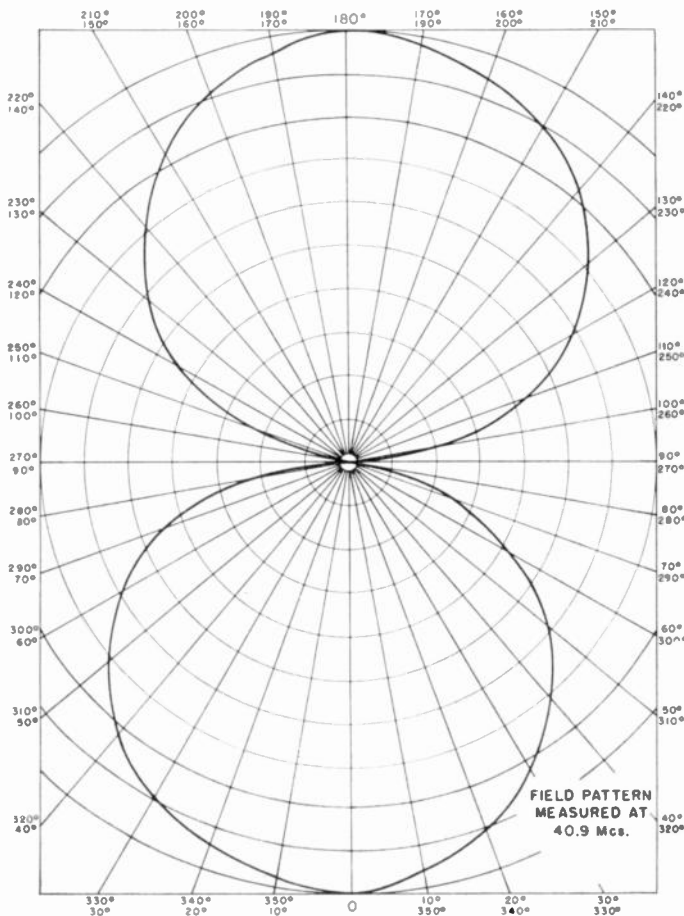

Fig. 13

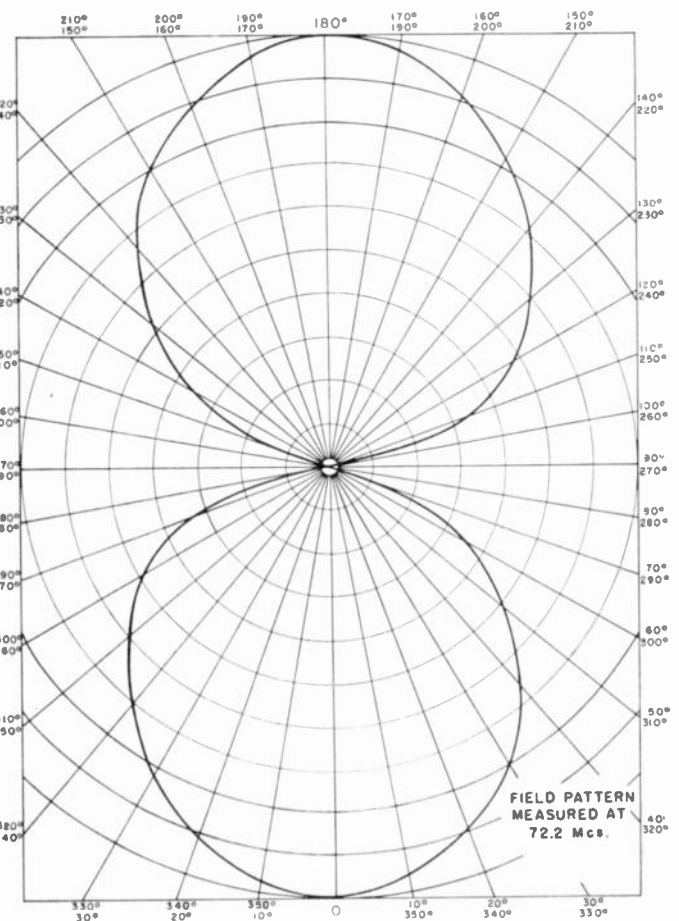

Fig. 14

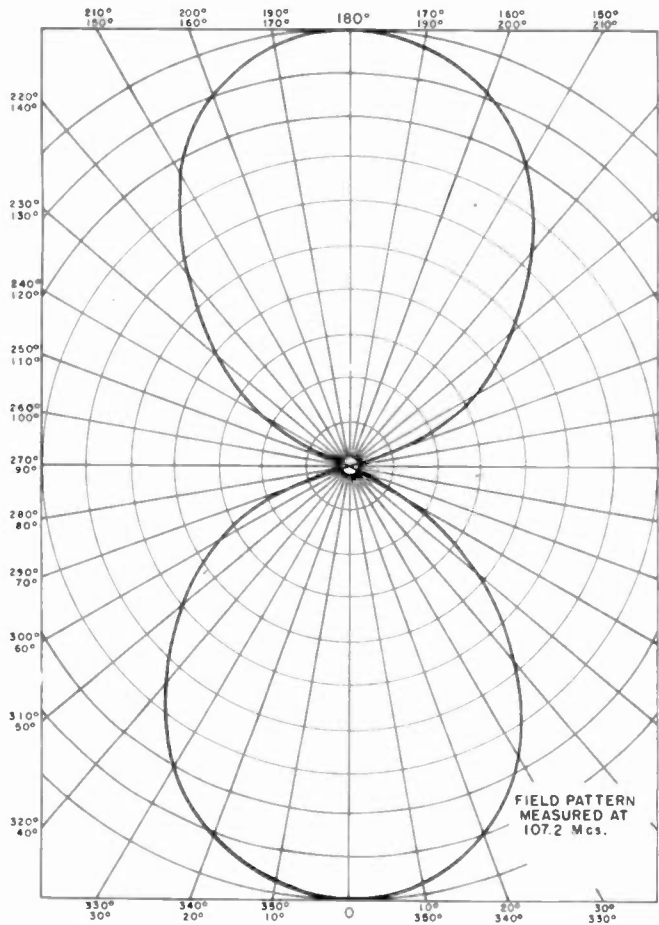

Fig. 15

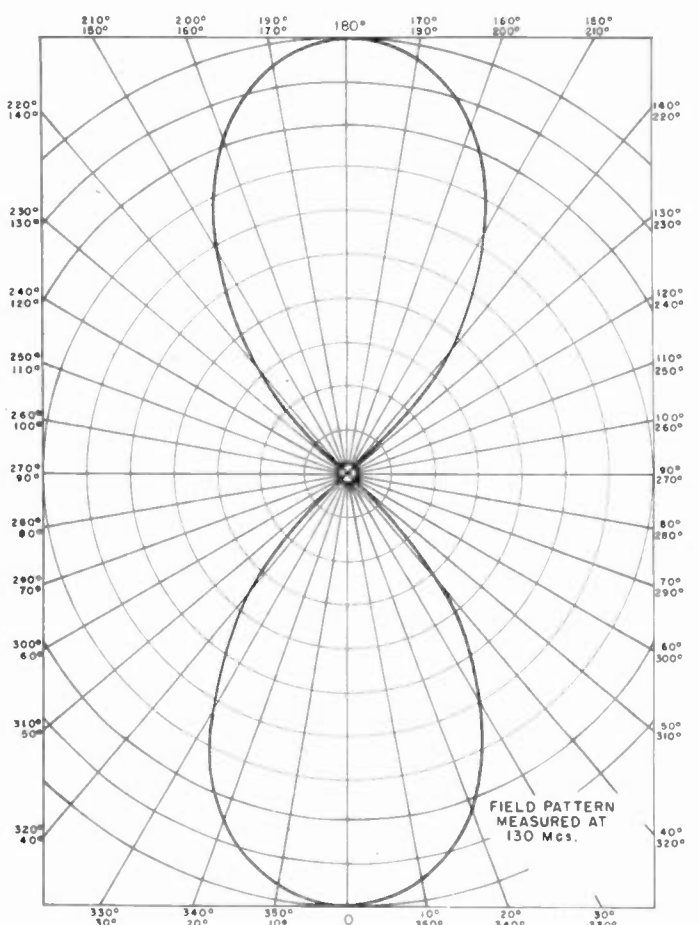

Fig. 16

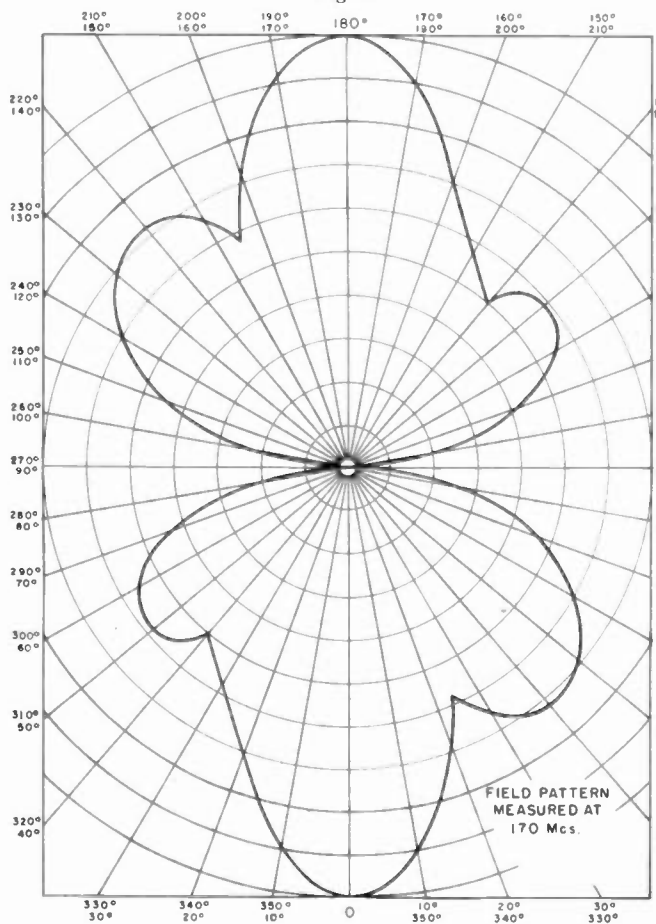

Fig. 17

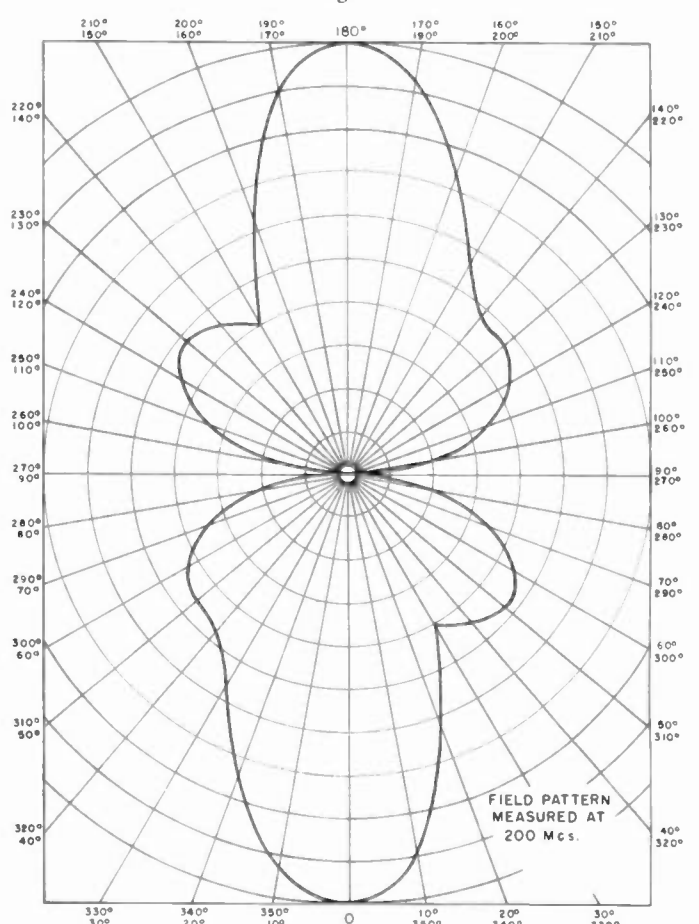

Fig. 18

A Method of Measuring the Field Strength of High-Frequency Electromagnetic Fields*

ROHN TRUELL†, SENIOR MEMBER, IRE

Summary—An analysis of a case of an electron beam directed parallel to a uniform steady magnetic field with a high-frequency electromagnetic field at right angles to the magnetic field results in a relation among the variables which is particularly simple, if the magnetic field is adjusted so that $eH_z/mc = \omega$ where ω is the frequency of the electromagnetic field (Gaussian units). One use of the relation mentioned is that of measuring the field strength of the high-frequency field.

INTRODUCTION

THE ELECTRIC field strength of a rapidly alternating electromagnetic field may be measured by means of an electron beam of uniform velocity v_z and a magnetic field H_z (of the cyclotron period) parallel to the axis of the electron beam and at right angles to the alternating electric field.¹ Consider the arrangement shown in Fig. 1, where the rapidly varying electric field

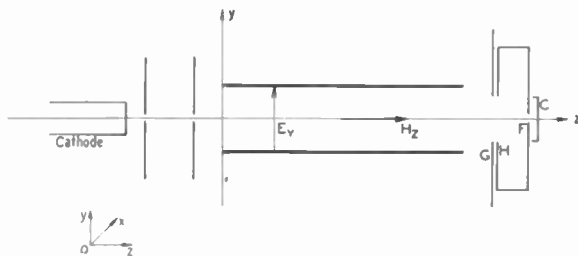

Fig. 1—Arrangement of electron gun, region on high-frequency field, and the electron collector system.

exists across the gap between the plates (in the y direction), and the electron beam of small current density is directed from the gun K along the z axis midway between the plates through the aperture G and into the collector II . A uniform magnetic field H_z must be placed parallel to the z axis. The combination of the rf electric field E_y , the constant magnetic field H_z , and the velocity of the electrons v_z , determines the motion of the electrons. Under certain special conditions the motion of the electrons is such as to yield a very simple relation among the variables H_z , v_z , and E_y . When these special conditions obtain, and when H_z and v_z are known, E_y may be determined in the manner now to be described.

EQUATIONS OF MOTION

Consider that an rf electric field E_y exists in a region such as that in Fig. 1 with a time dependence $E_y = E_{0y} R P e^{i\omega t}$, and consider further that H_z has been adjusted so that $eH_z/mc = \omega$ where ω is the frequency of the

rf field. It will be shown that when, in addition to the circumstances just specified, one picks some value of v_z , the radius of deflection of the electrons in a plane normal to the z axis is approximately constant. It turns out that the value of the radius of the electron orbit is now the *maximum* radius possible with respect to variation of H_z (for the particular values of E_{0y} , ω , and v_z); i.e., any other value of H_z (than the one for which $eH_z/mc = \omega$) will produce a smaller radius. It is possible to adjust v_z so that for some given value E_{0y} ($E_y = E_{0y} R P e^{i\omega t}$) a combination of v_z and H_z will cause the electron orbit at aperture G to have a *maximum* radius just equal to the known radius of the aperture G . The value of the orbit radius is then known; the magnetic field value is determined by ω , and the frequency ω , being used, can of course be determined by measurement. In order to see the relation among the variables v_z , H_z and E_{0y} , the equations governing the electron behavior under the conditions of this experiment are set down here.

$$\left. \begin{aligned} m\ddot{x} &= \frac{e}{c} \dot{y} H_z \\ m\dot{y} &= eE_y - \frac{e}{c} \dot{x} H_z & E_x = E_z = 0 \\ m\ddot{z} &= 0 & H_x = H_y = 0. \end{aligned} \right\} \quad (1)$$

Using $E_y = E_{0y} \cos \omega t$ one obtains from (1) the following equations:

$$\ddot{x} + \omega_c^2 \dot{x} = K \cos \omega t, \quad \ddot{y} + \omega_c^2 y = K_2 \cos \omega t \quad (2)$$

where

$$\left. \begin{aligned} \omega_c &= \frac{eH_z}{mc}, & l &= \frac{l}{v_z} \\ K_2 &= \left(\frac{e}{m} E_{0y} \right), & K &= \omega_c K_2. \end{aligned} \right\} \quad (3)$$

The particular solution of (2) for the special case where $\omega = \omega_c = eH_z/mc$ is²

$$\left. \begin{aligned} x &= \frac{K_2}{2\omega_c^2} \sin \omega_c t - \frac{K_2}{2\omega_c} t \cos \omega_c t & (a) \\ y &= \frac{K_2}{2\omega_c} t \sin \omega_c t & (b) \end{aligned} \right\} \quad (4)$$

It is not necessary to consider the complementary part of the solution of our differential equations. One may, under circumstances to be illustrated later, neglect the

* Decimal classification: R139X270. Original manuscript received by the Institute, January 19, 1948; revised manuscript received, May 24, 1948.

† Brown University, Providence, R. I.

¹ This method was first considered for measuring the gap fields in a multiresonator magnetron.

² H. T. H. Piaggio, "Differential Equations," Open Court Publishing Co., Chicago, Ill. 1928; p. 39. Also E. L. Ince, "Differential Equations," Dover Publishing Co., New York, N. Y., 1944; p. 139.

first term of the expression for x in (4a). When the approximation is appropriate, the radius of the electron path in some plane perpendicular to the z axis is constant, since, from (4a) and (4b),

$$r^2 = x^2 + y^2 = \left(\frac{K_2}{2\omega_c} \right)^2 l^2 = \left\{ \frac{\frac{c}{m} E_{0y}}{2 \left(\frac{eH_z}{mc} \right) \frac{l}{v_z}} \right\}^2 \quad (5)$$

or

$$\frac{r}{E_{0y}} = \left(\frac{l}{2v_z \frac{H_z}{c}} \right)$$

We will now examine a particular case. H_z is determined by the frequency of the rf field to be measured. For example, where $\lambda = 10$ cm,

$$\frac{eH_z}{mc} = \omega_c = \omega = 6\pi \times 10^9 \text{ radians/sec}$$

$$H_z \cong 1060 \text{ gauss.}$$

Relations (4) are of the form:

$$\frac{x}{E_{0y}} = a \sin \omega_c t + bt \cos \omega_c t$$

$$\frac{y}{E_{0y}} = bt \sin \omega_c t \quad (6)$$

where, with $l = 4$ cm,

$$a = \frac{e/m}{2\omega_c^2} = 7.5 \times 10^{-4}$$

$$(bt) = \frac{e/m}{2\omega_c} \frac{l}{v_z} = (5.65 \times 10^7) \frac{1}{v_z}$$

Since

$$\left(\frac{r}{E_{0y}} \right)^2 = \left(\frac{x}{E_{0y}} \right)^2 + \left(\frac{y}{E_{0y}} \right)^2$$

$$= a^2 \sin^2 \omega_c t + (2abt) \sin \omega_c t \cos \omega_c t + b^2 t^2$$

we need, in order to determine the validity of the approximate equation (5), to compare values of $(a^2 + 2abt + b^2 t^2)^{1/2}$ with values of (bt) for the case of interest. Since (bt) is a function of the electron velocity v_z , the comparison just mentioned must be made over the range of voltages used. One finds for the case mentioned above that with $V_z = 100$ volts the approximation leading to (5) can be used to within about 1 per cent, and with $V_z = 1000$ volts to within about 2 per cent.

Using (5) [or (6)] under the above circumstances, and converting E_{0y} to the practical system of units, the expression for E_{0y} becomes:

$$E_{0y} = \left(\frac{rv_z}{1.88 \times 10^5} \right) \cong 320r\sqrt{V_z} \text{ (volts/cm).} \quad (7)$$

Assume that $r = 0.20$ cm (max) at G (Fig. 1). Then E_{0y} is determined when V_z is adjusted so that the radius of the electron paths at the aperture G becomes just large enough to strike G .

A plot, using relation (7), of E_{0y} as a function of V_z is shown in Fig. 2.

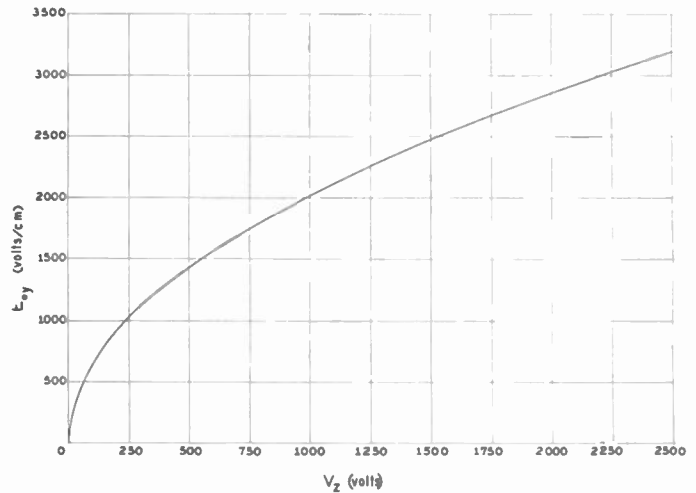

Fig. 2—Typical relation between component E_{0y} and the accelerating potential difference applied to the electron beam.

The use of this scheme for measuring field strengths requires good alignment of apertures on the center line of the plates, together with careful arrangement of the collimating system for the electron beam in order to keep the beam angle (without H_z or E_y) to a small value in comparison with the angle of the beam under maximum deflection.

If the magnitude of the rf field to be measured becomes so small that V_z becomes less than 50 to 100 volts (see Fig. 2), the sensitivity of the arrangement can be increased by making the length of the plates greater (see Fig. 1), or by decreasing the size of the aperture G . It is more desirable to increase the plate length than to decrease the diameter of G , because of the beam angle considerations mentioned above. On the other hand, l (length of plates in z direction) should not be much greater than about one-half wavelength because variations of field intensity E_{0y} (along the z direction) may begin to enter.

EFFECTS OF FRINGE FIELDS³

A rough calculation of the fringe-field effects on the measurement of E_{0y} is presented for the purpose of pointing out that one might make an appreciable error if fringe-field effects are not properly taken into account. An examination of the effect of fringe fields on the measurements in question leads to a discussion of the relation for the radius (or the displacement) of the electron from the axis of the system as a function of the field magnitudes, and the time the electron has been in the field region.

³ One may consider, rather than the parallel plates with fringe fields, a rectangular cavity oscillating in the lowest mode. In this case the field has a space dependence, but no fringe field. This case has been worked out and will be presented later.

$$r = \frac{E_{0y}}{2H_z} t \text{ where } t = \frac{l}{v_z} \text{ if we neglect the fringe field. (4)}$$

$$= \left| \frac{(d)}{2} \right|.$$

In the case of two parallel plates, one can approximate⁴ the dynamic fringe field by the electrostatic fringe field which can be calculated by conformal mapping methods. The results of this problem are shown in Fig. 3. If the rf field did not have any fringe effect, the electron would be in the field region for time $t=l/v_z$, whereas with the fringe field decreasing as indicated the time Δt spent in the fringe field at one end of the plates is approximately d/v_z , and during this time Δt the field falls from 0.9 of maximum value to about 0.1 of maximum so

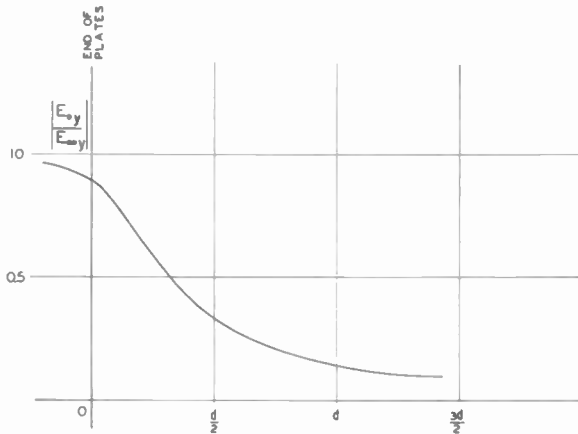

Fig. 3—The relative field intensity (midway between plates) in fringe field (static case).

that the average field strength in this interval is about $\frac{1}{2}$ of E_{max} . We may add an expression to r to take approximate account of this fact as follows:

$$r' = \frac{E_{0y}}{2H_z} \frac{l}{v_z} + \frac{\frac{1}{2}E_{0y}}{2H_z} \frac{d}{v_z}$$

$$= \frac{E_{0y}}{2H_z} \frac{1}{v_z} \left(l + \frac{d}{2} \right).$$

Then

$$\left| \frac{\Delta r}{r} \right| = \left| \frac{r' - r}{r} \right| = \left| \frac{\frac{E_{0y}}{2H_z} \left(\frac{1}{v_z} \right) \left(l - l + \frac{d}{2} \right)}{\frac{E_{0y}}{2H_z} \frac{l}{v_z}} \right|$$

⁴This approximation is important only if the distance between the plates is comparable with the wavelength. If the wavelength λ is large in comparison with d , the dynamic and static fields (electric) are practically the same.

The effect of the fringe field will be such as to make the field seem stronger than it really is by the amount indicated unless this correction is made. In order to keep $|\Delta r/r|$ below 0.1, one must make $l \geq 5d$. The effect of fringe field has been considered at one end of the plates only, and since such a field exists at both ends of the plates one must correct by an amount twice $|\Delta r/r|$ above. In other words, when $2|\Delta r/r| = 0.2$, one has a field strength that is really only 80 per cent of what it appears to be if one neglects to take account of the fringe fields; hence, one must make the appropriate correction, or design the system to make the correction small. The fringe-field effects calculated above are maximum effects, and not all electrons will enter and leave the system at such time as to be acted on by the fringe field to the extent indicated above. We would, however, for these measurements be interested in those electrons which appeared to be in the strongest electric field; hence, the electrons deflected most. The effect of mechanical misalignment of parts in the system shown in Fig. 1 will be that of having the beam strike the aperture G for larger values of beam velocity than it should. This will cause the field to appear to be larger than it really is. When the desired beam angle is reached by adjusting the beam velocity, the cone envelope should just intersect the aperture G around the periphery of the circular opening. Any misalignment, either in the mechanics of the structure or in failing to have the magnetic field lined up with the axis of the system, will cause the cone mentioned to intersect the aperture G improperly. A complete discussion of the effects of misalignment of various parts of the system would be quite lengthy and probably unnecessary, because this arrangement of apertures and plates can be assembled, by using known techniques, with considerable precision without unreasonable machine work. The arrangement can be tested for alignment before making the measurements by having an aperture F of sufficient diameter to include all or most of the beam when the magnetic field is not present. The purpose of F is to ascertain the fraction of the beam passing through to the collector C behind F . Once the alignment of the system is fairly well established on an electrostatic field basis, the magnetic field can be imposed and its alignment with the axis of the system be determined. Adjustment of the axis of the field relative to the axis of the system can be accomplished by using the aperture F and measuring the current to F and to the collector behind F .

ACKNOWLEDGMENT

It is a pleasure to thank L. P. Smith of the department of physics at Cornell University for discussion of some of the material presented here.

Mode Separation in Oscillators with Two Coaxial-Line Resonators*

HERBERT J. REICH†, SENIOR MEMBER, IRE

Summary—The resonance frequencies of a capacitance-terminated coaxial-line resonator may readily be determined graphically. The graphical analysis shows clearly why separation of the various modes of resonance is possible in oscillators using two resonators. Mode separation is favored by the use of resonators that have a large difference in their products of characteristic impedance and terminating capacitance. Too great a difference in the CZ_0 products may, however, result in the coincidence of two modes of resonance for certain tuning combinations.

Measured tuning curves for a lighthouse-tube oscillator agree with predicted curves in their general aspects. The agreement is improved by considering the tube electrodes and leads as extensions of the coaxial lines, terminated in capacitances smaller than the lumped interelectrode capacitances.

INTRODUCTION

MICROWAVE OSCILLATORS that incorporate only one line resonator may oscillate at several of the theoretically infinite number of frequencies at which the line is resonant. The particular mode of resonance in which oscillation does occur is determined by such factors as the magnitude of the load, the point at which the load is coupled to the line, the point at which the tube electrodes are coupled to the line, and the manner in which the electronic conductance of the tube and the conductance of the loaded resonator vary with frequency. Change of load is likely to be accompanied by change of frequency of oscillation, and it is difficult to design the oscillator so that greater frequency range can be attained by the use of two modes of resonance.

Oscillators in which two line resonators are used, on the other hand, such as the coaxial-line lighthouse-tube oscillator, may be designed so that oscillation is forced to take place in a chosen mode of resonance. Furthermore, by adjusting the relative lengths of the two resonators, oscillation can be changed from the fundamental mode to one having approximately three or five times the fundamental frequency. In this manner the over-all frequency range covered can be greatly extended. Although the factors that govern mode separation in such oscillators have been studied both experimentally¹ and theoretically,² the theoretical analysis previously presented is rather involved. The purpose of this paper is to discuss a relatively simple analysis that

explains observed phenomena and indicates factors which must be taken into consideration in designing for maximum separation of modes.

RESONANCE FREQUENCY OF CAPACITANCE-TERMINATED COAXIAL-LINE RESONATORS

Lighthouse-tube resonators are ordinarily short-circuited at only one end, and are terminated at the other end by the tube electrodes. The following analysis will therefore be based upon a section of line short-circuited at one end and terminated at the other end by a capacitance. The general method of analysis is, however, also applicable to a line that is short-circuited at both ends, or open at both ends.

A lossless line of length l and characteristic impedance Z_0 , short-circuited at the far end, has an input impedance given by the relation

$$Z_i = jZ_0 \tan 2\pi lf/v \quad (1)$$

in which f is the frequency and v is the phase velocity of propagation. Since the resonators generally used in lighthouse-tube oscillators are of the coaxial-line type, v is approximately equal to the velocity of light. Resonance takes place at a frequency at which Z_i is equal in magnitude and opposite in sign to the reactance of the terminating capacitance C . At resonance, therefore,

$$jZ_0 \tan 2\pi lf/v = -1/j2\pi fC \quad (2)$$

$$\tan 2\pi lf/v = 1/2\pi fCZ_0 \quad (3)$$

Although (3) cannot be solved explicitly for f or l , a simple graphical solution may be obtained by plotting, on a common frequency scale, curves of $\tan 2\pi lf/v$ as a function of f with l as a parameter, and curves of $1/2\pi fCZ_0$ as a function of f with CZ_0 as a parameter. If logarithmic scales are used, the curves of $1/2\pi fCZ_0$ are straight lines, and changes in the parameters l and CZ_0 merely result in shifts of the curves parallel to the frequency scale. Fig. 1 shows a set of curves for $l=3.0$ cm and several values of CZ_0 .

The 3.0-cm length is a convenient one to use in plotting the tangent curves, because lf/v is equal to $f/10^{10}$ at this length. The tangent curves for a value of l that is larger or smaller than 3 cm by a factor k may be readily obtained from the 3-cm curves by merely shifting the 3-cm curves to the left or right, respectively, by an amount equal to the distance between the points 1 and k on one of the scales.

* Decimal classification: R355.912. Original manuscript received by the Institute, March 22, 1948. Presented, 1948 National IRE Convention, New York, N. Y., March 25, 1948.

† Yale University, New Haven, Conn.

¹ "Very High Frequency Techniques," Staff of the Radio Research Laboratory, McGraw-Hill Book Co., New York, N. Y., 1947; Chapter 15.

² Sutro, P. J., "Theory of mode separation in a coaxial oscillator," Proc. I.R.E., vol. 34, p. 960; December, 1946.

The various resonance frequencies for a given combination of l and CZ_0 are given by the intersections of the $1/2\pi f CZ_0$ line with the corresponding branches of the tangent curve.

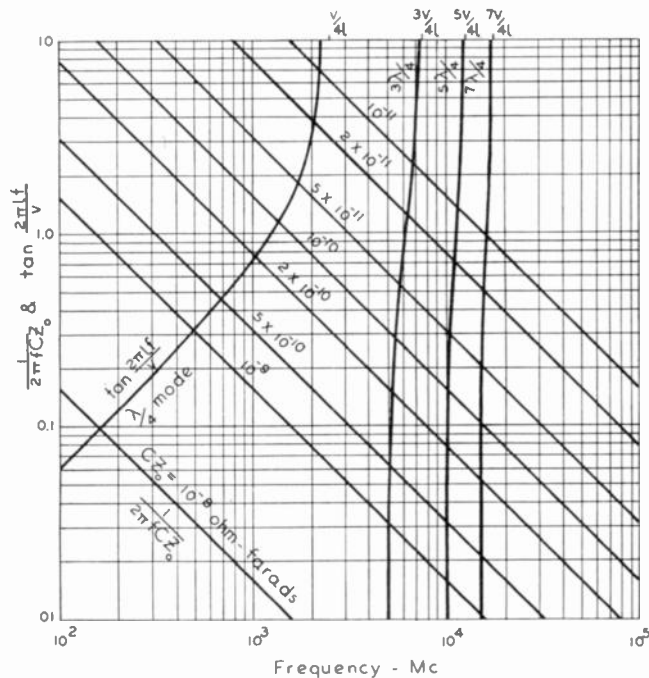

Fig. 1—Curves of $1/2\pi f CZ_0$ and $\tan 2\pi lf/v$ (ordinate) versus frequency (abscissa). $l = 3$ cm.

Examination of Fig. 1 will disclose that, as CZ_0 becomes small, the resonance frequencies approach the values $v/4l$, $3v/4l$, $5v/4l$, etc. These values are in agreement with the fact that a line open at one end and short-circuited at the other end resonates at frequencies of such values that the line length is $\lambda/4$, $3\lambda/4$, $5\lambda/4$, etc., where λ is the wavelength. Although the resonance frequencies depart considerably from these values as CZ_0 is increased, the various modes of resonance are commonly called the $\lambda/4$ mode, $3\lambda/4$ mode, etc., even when CZ_0 is not negligibly small.

MODE SEPARATION BY THE USE OF TWO RESONATORS

Two resonators of the same length and the same value of CZ_0 resonate at the same frequencies, even though they may be terminated in different values of capacitance. An oscillator that incorporates two such resonators may therefore oscillate in either the fundamental $\lambda/4$ mode or in one of the higher modes, and mode jumping is likely to occur as the oscillator is loaded. Fig. 1 shows, however, that two resonators of equal length, but unequal CZ_0 , do not resonate at the same frequencies. The length of one resonator may be changed so as to make both resonate at the same frequency in any one of the modes. The resonance frequencies of the two will then, in general, not be equal for any other mode of resonance.

Fig. 1 shows that 3-cm resonators having CZ_0 values

of 10^{-11} and 5×10^{-11} ohm-farad resonate in the $\lambda/4$ mode at frequencies of 2200 and 1700 Mc, respectively; in the $3\lambda/4$ mode at frequencies of 6800 and 5800 Mc, respectively; and in the $5\lambda/4$ mode at frequencies of 11,400 and 10,500 Mc, respectively. If the resonator for which CZ_0 equals 10^{-11} ohm-farads is lengthened to 3.96 cm, it, too, will resonate at 1700 Mc in the $\lambda/4$ mode, as shown by Fig. 2. The frequency separation

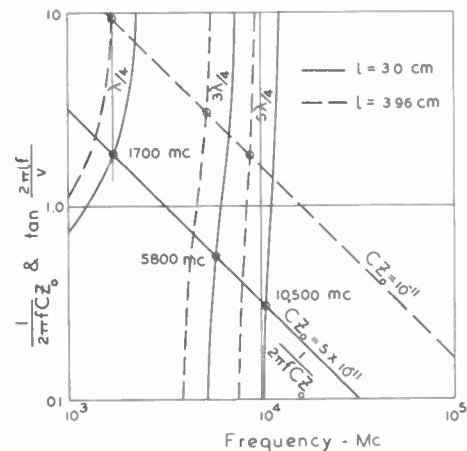

Fig. 2—Curves of $1/2\pi f CZ_0$ and $\tan 2\pi lf/v$ (ordinate) versus frequency (abscissa). Solid curves are for $l = 3.0$ cm and $CZ_0 = 5 \times 10^{-11}$ ohm-farad; dashed curves are for $l = 3.96$ cm and $CZ_0 = 10^{-11}$ ohm-farad.

in the $3\lambda/4$ and $5\lambda/4$ modes is greater than when the lengths are equal. The two resonators will both resonate at 5800 Mc in the $3\lambda/4$ mode if the resonator for which CZ_0 equals 10^{-11} ohm-farads is 3.5 cm long, and at 10,500 Mc in the $5\lambda/4$ mode if the resonator is 3.27 cm long.

The greatest difference in the ratio of lengths of the two resonators in two modes is obtained when the values of CZ_0 are chosen so that the sections of the tangent curves lying between the two $1/2\pi f CZ_0$ curves have the greatest difference in steepness. Fig. 1 shows, for example, that much greater discrimination between the $\lambda/4$ and $3\lambda/4$ modes would be obtained by giving CZ_0 the value 10^{-10} ohm-farad for one resonator and 5×10^{-10} ohm-farad for the other, instead of 10^{-11} and 5×10^{-11} ohm-farad. Increase of CZ_0 above about 5×10^{-11} ohm-farad, however, results in considerable reduction of frequency at the upper end of the tuning range, particularly in the $\lambda/4$ mode.

Mode separation can be improved by increasing the ratio of the values of CZ_0 for the two resonators, but if the separation between the $\lambda/4$ and $3\lambda/4$ modes is made too great, the two resonators may have the same frequency of resonance both in the fundamental mode and in one of the higher modes. Thus, Fig. 3 shows that a 3-cm resonator for which $CZ_0 = 5 \times 10^{-10}$ ohm-farad and a 6-cm resonator for which $CZ_0 = 2 \times 10^{-10}$ ohm-farad both resonate at 680 Mc in the fundamental mode. The $3\lambda/4$ frequency of the 3-cm resonator and

the $5\lambda/4$ frequency of the 6-cm resonator are both 5150 Mc. An oscillator using these resonators might therefore oscillate at either 680 Mc or 5150 Mc if the electronic conductance of the circuit is such as to make oscillation possible at both frequencies. Heavy loading in the fundamental mode might then cause a jump to the higher frequency.

TUNING CURVES

In order to predict the behavior of resonators over a wide tuning range, it is necessary to construct curves of frequency versus length at fixed values of CZ_0 . Such curves may be readily constructed in two ways. The

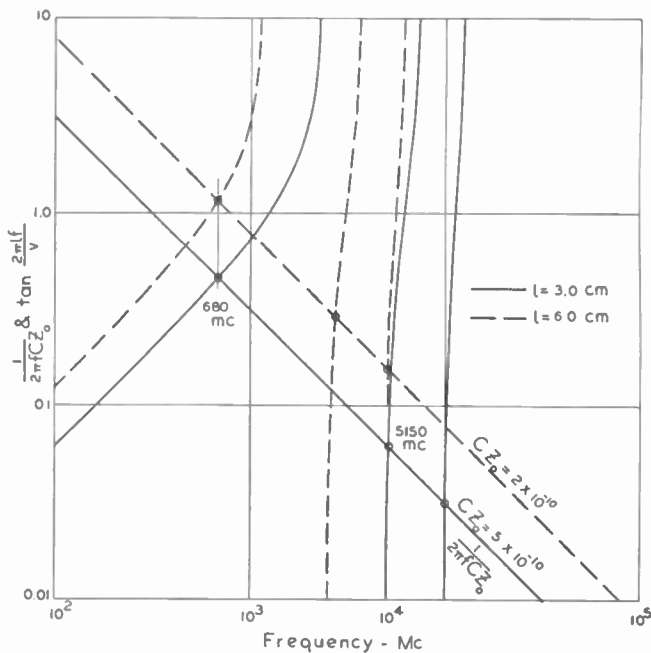

Fig. 3—Curves of $1/2\pi fCZ_0$ and $\tan 2\pi lf/v$ (ordinate) versus frequency (abscissa). Solid curves are for $l=3.0$ cm and $CZ_0=5 \times 10^{-10}$ ohm-farad; dashed curves are for $l=6.0$ cm and $CZ_0=2 \times 10^{-10}$ ohm-farad.

more obvious method is to draw the tangent curves on transparent material that can be moved relative to the frequency scale. The second method, which requires only a single tangent plot, employs the following procedure:

1. Construct the tangent curve for a convenient resonator length, such as 3 cm. Call this length l_0 .
2. Construct the $1/2\pi fCZ_0$ line for the given value of CZ_0 . The intersections of this line with the various branches of the tangent curve give the resonance frequencies for the resonator length l_0 .
3. Draw a vertical line through the point at which the $1/2\pi fCZ_0$ line crosses the unity ordinate ($1/2\pi fCZ_0=1$).
4. For a resonator length kl_0 , draw a new $1/2\pi fCZ_0$ line through the point on the vertical line at which the ordinate equals k . The resonance frequencies for this

length are equal to $1/k$ times the values of frequency given by the intersections of the new $1/2\pi fCZ_0$ line with the tangent curve.

Typical tuning curves derived from Fig. 1 by the foregoing procedure are shown in Fig. 4. It can be seen

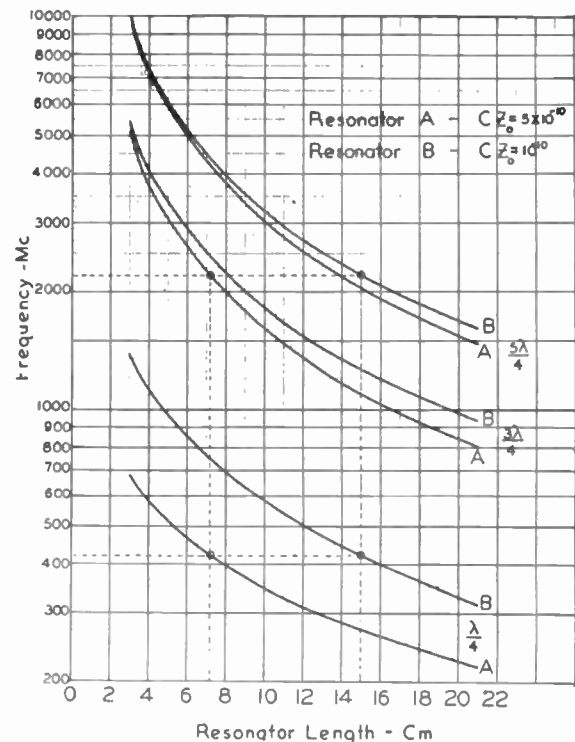

Fig. 4—Theoretical tuning curves. $CZ_0=5 \times 10^{-10}$ ohm-farad for resonator A and 10^{-10} ohm-farad for resonator B. Dotted lines show lengths at which the two resonators resonate at the same frequency in two mode combinations.

from Fig. 4 that the relative lengths of the resonators can be chosen so that they resonate in the $\lambda/4$ mode, the $3\lambda/4$ mode, or the $5\lambda/4$ mode. Over certain tuning ranges the lengths can also be chosen so that the $\lambda/4$ frequency of resonator A is the same as the $3\lambda/4$ frequency of resonator B, or so that the $3\lambda/4$ frequency of either is the same as the $5\lambda/4$ frequency of the other. Furthermore, when resonator A is 7.2 cm long and resonator B is 15 cm long, they both resonate at 420 Mc in the $\lambda/4$ mode, and at 2200 Mc with resonator A operating in the $3\lambda/4$ mode and resonator B in the $5\lambda/4$ mode.

Fig. 5 shows measured curves for the two resonators of a lighthouse-tube oscillator.³ Although these curves agree with corresponding theoretical curves in their general aspects, they are more nearly in agreement with theoretical curves for somewhat higher values of CZ_0 and l . This discrepancy is not surprising, since the values of CZ_0 for the experimental curves were computed under the assumption that the lines were termi-

³ These curves were derived from Fig. 15-5 in footnote reference 1.

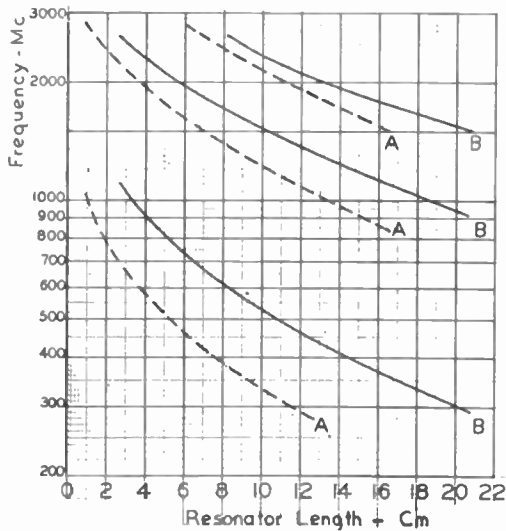

Fig. 5—Experimental tuning curves. For resonator A, $C = 6.5 \times 10^{-12}$ farad, $Z_0 = 57$ ohms, and $CZ_0 = 3.7 \times 10^{-10}$ ohm-farad; for resonator B, $C = 2.0 \times 10^{-12}$ farad, $Z_0 = 32$ ohms, and $CZ_0 = 6.4 \times 10^{-11}$ ohm-farad.

nated in a lumped capacitance equal to the measured interelectrode capacitances of the lighthouse tube. Actually, the tube electrodes and disk leads act more nearly like sections of distributed-constant line of characteristic impedances different from those of the coaxial-line resonators.

CONCLUSION

Although the graphical analysis presented in this paper probably is not of great value in the quantitative predetermination of coaxial-line resonator or oscillator tuning, it shows clearly the manner in which tuning and mode separation are affected by characteristic impedance and terminating capacitance. Adequate separation of two or more modes of resonance may be achieved by the use of two resonators having properly chosen CZ_0 values. Care must be exercised in the choice of CZ_0 values in order to avoid the possibility of the coincidence of two modes of resonance for certain tuning combinations.



Discussion on

“Reflection of Very-High-Frequency Radio Waves from Meteoric Ionization”*

EDWARD W. ALLEN, JR.

Laurence A. Manning¹ and Oswald G. Villard, Jr.²: The results presented by Edward W. Allen in his recent paper are especially interesting because of their pioneering nature, and because of the large number of observations which he has made. However, his values relating to the radii of the ionization tracks are rather startling. Measurements made at Stanford University in the 30-Mc region have indicated radii of the order of several hundred meters, as determined by two independent methods. Radii were computed first using formulas similar to those derived by Mr. Allen, and based upon measured returned signal strength. In addition, it was found possible to make measurements of the component of doppler shift produced by trail expansion, and thus obtain corroborating evidence upon the size of the columns.

Detailed inspection of Mr. Allen's figures shows his arithmetical calculations to be in error. His expression for the signal E_R returned from a cylindrical cloud, ar-

ranged to give the trail radius p , is $p = 4t^3 \cos \phi E_R^3 / E_0^2$ for the case in which the reflection point is midway between the transmitter and receiver; t is the transmitter-meteor distance, ϕ is half the included angle of reflection, and E_0 the transmitted signal strength in the meteoric direction in volts per meter per mile. For a ground path length of 337 miles, and his assumed take-off angle of 21° , $t = 337/2 \cos 21^\circ = 180$ miles. He takes $\phi = 67^\circ$, $E_R = 70 \mu\text{v/m}$, $E_0 = 350 \text{ mv/m/mile}$. Substitution then yields $p = 0.367$ miles or 594 meters, compared with Mr. Allen's value of 25 cm. Substitution for the other example in his paper yields 203 meters instead of 17 centimeters.

The disagreement between the meteoric masses computed by Pierce ($\frac{1}{4}$ gram) and by Allen (about 10^{-7} gram) is a consequence of the small radii of the latter author. Of especial importance is the fact that radii of the order of magnitude actually presented by large meteors permit the use of the methods of geometrical optics. Mr. Allen's remarks regarding the failure of specular reflection are to be considered as applicable only to

* Proc. I.R.E., vol. 36, pp. 346-353; March, 1948.

^{1,2} Stanford University, Calif.

such very small meteors as may produce barely detectable signals.

Examination of the burst waveforms of Fig. 9, and of many recorded at Stanford using higher paper speeds, does not reveal a tendency for the shape of Fig. 8(d) to occur. In our records, the maximum amplitude of the returned signal almost invariably comes within the first half of the total burst duration, and on the basis of theoretical calculation neglecting recombination would appear at $1/e$ of the total duration. The mechanism postulated in Fig. 8(c) for the sudden decrease in burst amplitude assumes a faster rate of diffusion for electrons than positive ions. It is hard to see how electrons can diffuse away from the meteoric track without dragging positive ions behind because of electric attraction. An electron density of $(4.43 \times 10^4)^2/81 = 2.4 \times 10^7$ electrons per cc is required to reflect 44.3-Mc signals at normal incidence. If a charge of 10^7 electrons is separated 1 cm and considered to be placed upon the plates of a capacitance built upon a centimeter cube, a potential $V = Q/C = 10^7 e / 8.84 \times 10^{-13}$, of the order of one volt, is developed. Such a potential is capable of accelerating an electron to a velocity of the order of 10^7 cm/sec, comparable to meteoric velocities. Since charge motion of many meters is involved in meteoric diffusion, it seems that separation of positive ions from the electrons would require prohibitively large electric potentials.

In favor of the ionization distribution suggested by Fig. 8(c) of Mr. Allen's paper, it should be noted that telescopic observation of long-enduring visible meteor trains shows them to be essentially hollow cylinders, glowing only on the outside. Perhaps the visual phenomenon can be explained by assuming that the higher temperature and greater turbulence of the air in the center of the column is conducive to a faster reaction rate. Both the processes of recombination and of visible light production may go more rapidly in the center of the train, so that the available energy is there more rapidly expended. Production of light about the borders of the column would continue after the center of the train had become impoverished.

Edward W. Allen, Jr.³: I wish to thank Messrs. Manning and Villard for calling attention to the mathematical error in my paper, and for their charity in calling it "arithmetical." It arose, not as a matter of arithmetic, but from a confusion of units. If reference is made to the discussion of Fig. 7, it will be noted that the radius p is expressed in meters and not in miles. Some confusion may have been introduced by the fact that t and r , the distances between the reflecting point and the transmitter and receiver, respectively, are expressed in miles. However, since the unit of area σ , through which the energy passes at a distance of one mile from the transmitter, is one square meter, the side of this square is one meter. The chord of the angle α , in meters, is numerically equal to the distance t in miles, and the

arc is approximately so. Perhaps, for the sake of clarity, this could have been called t' in the second equation at the top of page 351, and an additional equation included showing the numerical equivalence between t' in meters and t in miles.

The error was actually introduced in the third expression on page 350, expressing the area at the receiver covered by the energy reflected from a cylindrical cloud, which should read:

$$(t + r + 2Krd)(t + r)$$

where

$$K = 1609 \text{ meters per mile}$$

$$d = \text{angle in radians.}$$

Correspondingly, the fourth expression on page 350 and the third and fourth equations on page 351 should read:

$$\frac{E_0}{E_r} = \sqrt{(t + r + 2Krd)(t + r)}$$

$$\frac{E_0}{E_r} = \sqrt{\left(t + r + \frac{2Ktr \cos \phi}{p}\right)(t + r)}$$

$$\frac{E_0}{E_r} = \sqrt{\left(t + r + \frac{2Ktr \cos \phi}{p}\right)\left(t + r + \frac{2Ktr \sec \phi}{p}\right)}$$

Solving for p and neglecting the smaller term, the simplified expression for the case of reflection at the midpoint of the path then reduces to:

$$r = 4Kt^2 \cos \phi E_r^2 / E_0^2 \text{ (meters).}$$

This is equivalent to the expression evolved by Manning and Villard for p in miles. (In their discussion, the formula is given as $p = 4t^2 \cos \phi E_r^2 / E_0^2$, owing to a typographical error).

On page 351 of my paper, the values $p = 0.25$ meters and $p = 0.17$ meters for the cases of reflection at the center point and at a point over the receiver may thus be read as $p = 0.367$ miles or 594 meters, and $p = 0.19$ miles or 305 meters, respectively. The corresponding particle masses, for the assumed conditions, are 1.2 and 1.3 grams, respectively.

In accordance with the comments of Manning and Villard, the corrected radii are of sufficient magnitude to provide essentially specular reflection, and my remarks as to the lobe structure of reflected energy would apply only to very weak reflections from clouds of small radii, of the order of the wavelength.

With regard to Fig. 8, and the pertinent discussion relative to the mechanism responsible for the observed shape of the bursts, I hold no particular brief for the cause which was postulated. It appeared to be a possible cause and was set forth in order to evolve some discus-

³ Federal Communications Commission, Washington, D. C.

sion on this point, in which aspect it seems to have met with some success. The distribution curves of ionization density and burst intensity of Fig. 8 are plotted in a qualitative manner only, and Figs. 8(c) and 8(d) may be somewhat exaggerated as compared to actual conditions. However, there are wide departures in the shapes of the received bursts, and the two cases shown in Figs. 8(b) and 8(d) appear to be what may be expected as limiting conditions. It is true that the vast majority of the bursts tend toward the shape of 8(b), but some few do not. The last of the five recorded bursts of Fig. 9 appears to fall instantaneously from the peak field in-

tensity of 1.3 to 0.6 $\mu\text{v}/\text{m}$, within the accuracy which I am able to obtain from the original chart, and tapers off between intensities of 0.6 and the noise level.

Perhaps higher temperature and greater turbulence, rather than differences in ion mobility, are responsible for differences in the distributions of the ion densities, but it seems clear that wide differences do occur. Whatever the final conclusion as to the mechanism involved, a full discussion to the PROCEEDINGS OF THE I.R.E. should be fruitful of results not only as to this particular problem, but as to the mechanics of the ionosphere in general.

Discussion on

“The Distortion of Frequency-Modulated Waves by Transmission Networks”*

A. S. GLADWIN

F. L. H. M. Stumpers¹: In his paper, Mr. Gladwin gives a series expansion for the output voltage of a network to which a frequency-modulated signal is applied. He remarks that this expansion is valid only if the series is convergent, but applies the theory to a voltage modulated in frequency by a sinusoidal signal. However, in this case the series is not convergent. This is easily seen when the series is derived by following the slightly different method of Jaffe. In this case, the series is

$$e^{j\omega_0 t} \left\{ Y(j\omega_0) + Y'(j\omega_0) \frac{d}{dt} + \frac{Y''(j\omega_0)}{2!} \frac{d^2}{dt^2} + \dots \right\} e^{\frac{j\Delta\omega}{q} \sin qt}. \quad (1)$$

The exact solution of the problem given by Fourier analysis is

$$\sum_{-\infty}^{+\infty} Y(j\omega_0 + jnq) J_n \left(\frac{\Delta\omega}{q} \right) e^{j\omega_0 t + jnqt}. \quad (2)$$

The difference between the first k terms of the series (1) and the correct series (2) is given by

$$\sum \left\{ Y(j\omega_0 + jnq) - Y(j\omega_0) - jnqY'(j\omega_0) - \dots - \frac{(jnq)^{k-1}}{(k-1)!} Y^{(k-1)}(j\omega_0) \right\} J_n e^{j\omega_0 t + jnqt}.$$

We see that the difference goes only to zero with increasing k if $j\omega_0 + jnq$ lies within the circle of convergence of $Y(j\omega_0 + jnq)$ around $j\omega_0$. As this is certainly not the case for all n , the series (1) is divergent. The series used by Mr. Gladwin can be derived from the series (1) by rearrangement of the terms. As I have shown elsewhere, the series are asymptotic for small values of the modulating frequency, which, within certain limits, justifies their use in FM problems.²

Mr. Gladwin also remarks rightly that an extra phase-shift factor e^{ju} does not affect the distortion. However, it affects his approximation as one can see directly from his equation (5). For instance in his example 1, without the extra phase shift we get the third harmonic for a transfer characteristic $(1+ju)^{-1}$ in the form:

$$- 2 \frac{\omega_m}{\Delta\omega} b^{3/2} \left\{ \sin 3\omega_m t + 9\omega_m(\omega_B^2 + \Delta\omega^2)^{-1/2} \cos 3\omega_m t + \dots \right\}.$$

It may seem paradoxical that the extra factor e^{ju} has so much influence. This can be explained when we take into account that the series for the third harmonic has the form:

$$A_3 \omega_m \sin 3\omega_m t + B_3 \omega_m^2 \cos 3\omega_m t + C_3 \omega_m^3 \cos 3\omega_m t + \dots$$

This leads to an expansion for the amplitude

$$A_3 \omega_m + \frac{\omega_m^3}{2A_3} (B_3^2 + 2A_3 C_3) + \dots$$

* Proc. I.R.E., vol. 35, pp. 1436-1445; December, 1947.

¹ Phillips Research Laboratories, Eindhoven, the Netherlands.

² “Some investigations on frequency-modulated vibrations,” diss. Delft, the Netherlands, May, 1946. In Dutch.

It can be seen that, though a change by a factor $e^{i\omega}$ affects B_3^2 , it has no effect on the sum ($B_3^2 + 2A_3C_3$).

If we put $c = \Delta\omega/\omega_B$, the asymptotic series of the amplitude of the third harmonic for a single resonant circuit begins in both cases—with and without a linear phase shift—as follows:

$$2 \frac{\omega_m}{\omega_B} c^{-4} \{ \sqrt{1+c^2} - 1 \}^3 \cdot \left[1 - \frac{3}{4} \left\{ \frac{18+17c^2 - (8+11c^2)\sqrt{1+c^2}}{(1+c^2)^{5/2}} \right\} \frac{\omega_m^2}{\omega_B^2} + \dots \right].$$

A. S. Gladwin³: Dr. Stumpers has raised two important points. The series which he has studied (3) (page 1437 in the paper) were used only as a step to obtain series (4) (pages 1437 and 1438). Although Dr. Stumpers' remarks on divergency are correct when applied to series (3) (page 1437) it does not follow that series (4) (pages 1437 and 1438) is necessarily divergent. It is not asserted that this series is always convergent, but the conditions in which it may diverge are almost certainly different from those which apply to series (3) (page 1437).

If the transfer functions $A(u)$, $\phi(u)$, $P(u)$ and $Q(u)$ are expressed in the form of power series, then series (6) and (11) (pages 1439 and 1442) will, in general, diverge, and (7) and (8) (pages 1439 and 1440) and (12) and (13) (pages 1442 and 1443) will also diverge. This is the case to which Dr. Stumpers' criterion for divergence applies, but, as was shown in Example 1 (page 1441), it is not always necessary to represent $A(u)$ and $\phi(u)$ by power series. Also, in practice, the power series are replaced by polynomials which approximate to the transfer functions over a suitable range (see Example 2, page 1442). All the series then terminate. For large deviation ratios, this range should be slightly greater than twice the maximum frequency deviation, and for small deviation ratios, slightly greater than six times the highest modulating frequency.

Beyond this range, the polynomials will differ more or less from the functions, and an error will thereby be introduced. This error depends not only on the difference between the values of the polynomials and of the functions, but also on the frequency spectrum of the FM wave: the smaller the spread of sideband energy beyond the range mentioned above, the smaller is the error.

Dr. Stumpers' remarks concerning the phase-shift factor are perfectly sound, but if the general expression for the distortion is not to become unmanageably long, it is necessary, for large deviation ratios, to restrict the solution to the first two terms of series (4) (pages 1437 and 1438). The question is, then, whether it is better to omit or to include the linear phase-shift factor. There does not appear to be any general answer to this question, but for the particular case considered in Example 1, the matter can easily be settled.

³ University of London, King's College, London, England.

To obtain a solution comprising all the terms having coefficients ω_m , ω_m^2 and ω_m^3 it is sufficient to consider the following terms of series (4) (pages 1437 and 1438).

$$\left[\exp j \left(\omega_c t + \Delta\omega \int S dt \right) \right] \left[T(u) - \frac{j\Delta\omega S'}{2\omega_B^2} T''(u) - \frac{\Delta\omega S''}{6\omega_B^3} T'''(u) - \frac{(\Delta\omega S')^2}{8\omega_B^4} T^{IV}(u) \right]$$

in which $u = \Delta\omega/\omega_B S$.

Writing $T(u) = (1+ju)^{-1}$, this becomes

$$\left[\exp j \left(\omega_c t + \Delta\omega \int S dt \right) \right] (1+ju)^{-1} \cdot \left[1 + \frac{j\Delta\omega S'(1-ju)^2}{\omega_B^2(1+u^2)^2} - \frac{j\Delta\omega S''(1-ju)^3}{\omega_B^3(1+u^2)^3} - \frac{3(\Delta\omega S')^2(1-ju)^4}{\omega_B^4(1+u^2)^4} \right].$$

Retaining only terms with coefficients proportional to ω_m , ω_m^2 and ω_m^3 , the frequency deviation of this wave is

$$\Delta\omega \left[S - \frac{1}{\Delta\omega} \frac{d}{dt} \tan^{-1} u + \frac{d}{dt} \frac{S'(1-u^2)}{\omega_B^2(1+u^2)^2} - \frac{d}{dt} \frac{S''(1-3u^2)}{\omega_B^3(1+u^2)^3} + \frac{d}{dt} \frac{10\Delta\omega(S')^2 u(1-u^2)}{\omega_B^4(1+u^2)^4} \right].$$

Since $S = \cos \omega_m t$ and $u = \Delta\omega/\omega_B \cos \omega_m t$, expressions of the type $(1+u^2)^{-n}$ can be expanded in Fourier series by means of the formulas given by Edwards.⁴ Neglecting the common factor $\Delta\omega$, the terms of the third-harmonic frequency are then

$$\begin{aligned} \sin 3\omega_m t & \left[-\frac{2\omega_m}{\Delta\omega} b^{3/2} + \frac{9\omega_m^3(1+b^2)^3}{\omega_B^3(1-b^2)^6 \left(1 + \frac{\Delta\omega^2}{2\omega_B^2}\right)^3} \right. \\ & \cdot \left\{ b - 2b^2 + b^3 + \frac{\Delta\omega^2}{4\omega_B^2} (1-9b+22b^2-19b^3+b^4+5b^5-b^7) \right\} \\ & + \frac{15\Delta\omega^2\omega_m^3(1+b^2)^4}{2\omega_B^5(1-b^2)^7 \left(1 + \frac{\Delta\omega^2}{2\omega_B^2}\right)^4} \left\{ 1+4b-b^2-8b^3-b^4 \right. \\ & + 4b^5+b^6 - \frac{\Delta\omega^2}{4\omega_B^2} (1+4b-11b^2-8b^3+24b^4 \\ & \left. + 4b^5-20b^6+7b^8-b^{10}) \right\} \left. \right] \\ & + \cos 3\omega_m t \left[\frac{3\omega_m^2(1+b^2)^2}{\omega_B^2(1-b^2)^3 \left(1 + \frac{\Delta\omega^2}{2\omega_B^2}\right)^2} \left\{ 2b+3b^2-b^4 \right. \right. \\ & \left. \left. + \frac{\Delta\omega^2}{4\omega_B^2} (1-2b-2b^2+4b^3+b^4-2b^5) \right\} \right]. \quad (1) \end{aligned}$$

⁴ J. Edwards, "The Integral Calculus" Macmillan Co. London, 1922; vol. 2, p. 310.

Putting $\omega_m = 5$ kc and $\omega_B = 25$ kc, the amplitudes of the third harmonic when $\Delta\omega = 10, 25,$ and 100 kc are 37.9, 28.8, and 26.3 db. The values given by series (16), which is derived from the first two terms of series (4) with the linear phase-shift removed, are 39.6, 29.3 and 26.3 db. On the other hand, the values given by the first two terms of series (4), with the linear phase-shift included, are 37.1, 26.7, and 25.7 db. (These can be calculated from the appropriate terms in (1) above.) From these figures, it seems safe to say that over the greater part of the range of $\Delta\omega$ shown in Fig. 1, it is better to omit the linear phase-shift, and the method used in the paper is, therefore, justified.

On the other hand, the values calculated from Dr. Stumpers' last equation are 45.0, 31.3, and 26.3 db. One reason for the difference is this:

The amplitude of the third harmonic is

$$A_3\omega_m \left\{ \left(1 + \frac{C_3\omega_m^2}{A_3} + \dots \right)^2 + \left(\frac{B_3\omega_m}{A_3} + \dots \right)^2 \right\}^{1/2}$$

$$= A_3\omega_m \left\{ 1 + \frac{2A_3C_3\omega_m^2 + B_3^2\omega_m^2}{A_3^2} + \frac{C_3^2\omega_m^4}{A_3^2} + \dots \right\}^{1/2}$$

In expanding this as a series of powers of ω_m , Dr. Stumpers has assumed that the terms within the brackets, excluding 1, are small compared with 1. For the values of the various parameters considered above, this is not always so; for example, when $\Delta\omega = 10$ kc, the value of these terms is 2.17, and the expansion is, therefore, invalid.

Contributors to Proceedings of the I.R.E.



W. E. GORDON

W. E. Gordon (A'46) was born in Patterson, N. J., on January 8, 1918. He received the B.A. degree at Montclair in 1939, and the M.S. degree in meteorology at New York University in 1946. During World War II he served with the Air Weather Services, and was associated with research on radar range forecasting and microwave propagation in the lower atmosphere at the MIT Radiation Laboratory, and with the Committee on Propagation of the National Defense Research Council. In 1945 he joined the Electrical Engineering Research Laboratory at the University of Texas as a meteorologist, and became associate director of that laboratory in 1946.

Mr. Gordon is a member of Sigma Xi, the New York Academy of Science, and the American Meteorological Society.

mathematics at the University of Wisconsin, he was appointed Postdoctorate Research Fellow in Physiology and received the degree of Ph.D. in physiology in 1941.



HAROLD GOLDBERG

Dr. Goldberg served as senior engineer with the Stromberg-Carlson Company research department from 1941 to 1945; as principal research engineer with the research department of the Bendix Radio Division, Bendix Aviation Corporation from 1945 to 1948; and is now chief of the research section, Electronics Division, National Bureau of Standards. He is a member of the AIEE, the American Physical Society, the American Association for the Advancement of Science, Sigma Xi, Tau Beta Pi, Eta Kappa Nu, and is deputy member of two panels of the Research and Development Board.

For a photograph and obituary of E. W. HAMLIN, see page 887 of the July, 1948, issue of the PROCEEDINGS OF THE I.R.E.



H. G. GREIG

has been associated with the RCA Laboratories Division since 1943, and prior to that time he was in the research department of the National Aniline Division of Allied Chemical and Dye Corporation.

Mr. Greig is a member of the American Chemical Society, the American Association for the Advancement of Science, and Sigma Xi.

Frederick A. Kolster (A'12-M'13-F'16) was born in Geneva, Switzerland, on January 13, 1883. He was educated in the New England public schools, and was graduated from Harvard University in 1908. Mr. Kolster was an assistant to John Stone Stone and Lee de Forest in the early days of radio. He was also chief of the radio section of the National Bureau of Standards from 1912 to 1921. He joined the Federal Telegraph Company in Palo Alto, Calif., in 1921, as research engineer, and remained with this company until 1931, when he became associated with the International Telephone and Telegraph Corporation. In 1938, Mr. Kolster terminated his employment with I.T.&T.

Harold Goldberg (A'38-M'44-SM'44) was born in Milwaukee, Wis., on January 31, 1914. He received the B.S. degree in electrical engineering in 1935, the M.S. degree in 1936, and the Ph.D. degree in 1937 from the University of Wisconsin. He served as Research Fellow in electrical engineering from 1935 to 1937. After teaching engineering

H. G. Greig was born on July 15, 1904, in Montreal, Canada. He received the B.S. degree in chemical engineering from the Drexel Institute of Technology in 1931. He

Contributors to the Proceedings of the I.R.E.



F. A. KOLSTER
Mr. Kolster has served on the following IRE committees: Admissions, Membership, Nominations, Papers, Sections, Standardization, Marine and Direction-Finding Receivers, Wavelength Regulation, and Wave Propagation. He was a Director of the Institute from 1933 until 1935. He is now a consulting engineer in San Francisco, Calif.

Mr. Kolster has served on the following IRE committees: Admissions, Membership, Nominations, Papers, Sections, Standardization, Marine and Direction-Finding Receivers, Wavelength Regulation, and Wave Propagation. He was a Director of the Institute from 1933 until 1935. He is now a consulting engineer in San Francisco, Calif.



John D. Kraus (A'32-M'43-SM'43) was born at Ann Arbor, Mich., on June 28, 1910. He received the B.S. and M.S. degrees in 1930 and 1931, and the Ph.D. degree in physics in 1933, all from the University of Michigan. From 1934 to 1938 Dr. Kraus was engaged in acoustical and nuclear research, and from 1938 to 1940 in antenna research. From 1940 to 1943 he was a member of the staff of the Naval Ordnance Laboratory, in Washington, D.C., working on the degaussing of ships, while from 1943 to 1946 he did antenna research at the Radio Research Laboratory, at Harvard University. Since 1946, Dr. Kraus has been associate professor of electrical engineering at the Ohio State University.



JOHN D. KRAUS
Dr. Kraus was Chairman of the Detroit Section in 1940 and has been a member of the Board of Editors since 1941. He is a member of the Physical Society, Acoustical Society, and Sigma Xi, and a Fellow of the American Association for the Advancement of Science.



Grote Reber (A'33-SM'44) was born on December 22, 1911. He received the B.S. degree from Armour Institute of Technology in 1933, after which he did graduate work at the University of Chicago in physics. He was a radio engineer for General Household Utilities in 1933 and 1934, and was with the Stewart-Warner Corporation from 1935 to 1937. In 1939 he was associated with the Research Foundation of Armour Institute of Technology. In 1941 he returned to Stewart-Warner to aid the war program. During 1946 he joined the Belmont Radio Corporation as a radio engineer. He was appointed to the staff of the National Bureau of Standards in 1947, where he is now engaged in research on cosmic and solar radio noise.

Mr. Reber is the author of a number of technical papers in the fields of interstellar static and electrical engineering. He is an



GROTE REBER
associate member of the American Institute of Electrical Engineers and the American Rocket Society, a member of the Chicago Astronomical Society, the Astronomical Society of the Pacific, the Franklin Institute, and a Fellow in the American Association for the Advancement of Science.

associate member of the American Institute of Electrical Engineers and the American Rocket Society, a member of the Chicago Astronomical Society, the Astronomical Society of the Pacific, the Franklin Institute, and a Fellow in the American Association for the Advancement of Science.



Herbert J. Reich (A'26-M'41-SM'43) was born on Staten Island, N. Y., on October 25, 1900. He received the M.E. degree from Cornell University in 1924, and the Ph.D. degree in physics in 1928. In 1929 he joined the department of electrical engineering at the University of Illinois, where he became assistant professor, associate professor, and professor, successively of electrical engineering. In January, 1944, he was granted leave of absence to join the staff of the Radio Research Laboratory at Harvard University. In January, 1946, Professor Reich was appointed professor of electrical engineering at Yale University, where he is at present.

Dr. Reich has specialized in the field of electron tubes and electron-tube circuits, having published numerous papers on these and related subjects in various technical journals. He is the author of "Theory and Applications of Electron Tubes," and "Principles of Electron Tubes," as well as co-author of "Ultra-High-Frequency Techniques."

Dr. Reich is a Director of the IRE, and has served on numerous IRE committees. At present, he is a member of the Board of Editors, the Electron Tube Committee, and the Education Committee. He is a member of the American Institute of Electrical Engineers, the American Association for the Advancement of Science, the American Society for Engineering Education, and is a Fellow of the American Physical Society.



HERBERT J. REICH
and is a Fellow of the American Physical Society.



Harry Stockman (A'42-M'44-SM'45) was born in Stockholm, Sweden, in 1905. He obtained a diploma in electrical engineering from the Stockholm Tekniska Institut in 1926 and has been with the Allgemeine-Elektrizitäts-Gesellschaft, L. M. Ericson Telephone Company, and other radio manufacturers. In 1929 he was connected with



HARRY STOCKMAN

the journal *Radio*, serving in the capacity of technical editor. In 1938 he was graduated from The Royal Institute of Technology in Stockholm, and joined the faculty of that University as head instructor in radio engineering.

During 1940 Dr. Stockman received the Liberty Cross from Field Marshall Mannerheim for services in Finland as a radio technical expert. He came to the United States in 1940 on a scholarship from Henry Ford. After a year with radio manufacturers and universities, he joined the faculty of Cruft Laboratory Harvard University, in 1941, where he taught pre-radar courses and carried on electronics research work partly for the obtaining of a doctor's degree. In 1945 he became Chief of Communications Laboratory, Electronics Research Laboratory, AMC, USAF, Cambridge. He is a member of Harvard Sigma Xi.



ROHN TRUELL

Rohn Truell (A'36-SM'45) was born on April 6, 1913, in Washington, D. C. He was graduated with honors from Lehigh University in 1935 with the B.S. degree in engineering physics. Following this, he was employed in the research and development laboratory of the RCA Manufacturing Company, at Harrison, N. J., from 1935 to 1938. During this period he also attended Columbia University. After receiving the degree of Ph.D. in physics from Cornell University in 1942, Dr. Truell rejoined the staff of RCA Laboratories at Princeton, N. J., where he was engaged in research and development work on microwave systems and frequency-modulated magnetrons. From 1944 to 1946 he supervised a group working on magnetrons for Cornell University and the Stromberg Carlson Company.

Dr. Truell is now an associate professor of physics at Brown University, where he is connected with the graduate division of applied mathematics. He is a member of Phi Beta Kappa, Sigma Xi, the American Physical Society, the American Mathematical Society, and the American Association for the Advancement of Science.

Correspondence

Minimum Detectable Radar Signal*

In the November, 1946, issue of the PROCEEDINGS OF THE I.R.E., was published an excellent paper by A. V. Haeff¹ on the "Minimum detectable radar signal and its dependence upon parameters of radar systems." An experimental procedure is described and a fundamental formula is deduced on the basis of a series of numerous and carefully done measurements. This empirical formula is written:

$$(V_{\text{min}})_{\text{opt}} = E_n B^{1/2} \left(\frac{1670}{r} \right)^{1/2} \quad (1)$$

where

$(V_{\text{min}})_{\text{opt}}$ = absolute value of pulse signal voltage at the receiver input terminals which can be detected with a probability of 50 per cent, when the receiver bandwidth is adjusted to its optimum value, which equals the inverse of the duration of the transmitted pulse

E_n = the noise voltage per unit intermediate-frequency bandwidth at the input terminals of the receiver

B = the effective bandwidth of the receiver in Mc as measured at the input to the second detector

r = pulse-repetition rate in pulses per second.

In Ridenour's well-known book, "Radar System Engineering,"² a theoretical discussion is presented in which the dependence of the probability of detecting the signal upon parameters of radar systems is deduced on statistical basis. A similar discussion has been published by the writer³ and by Levy.⁴

These theoretical discussions are in substantial concordance with the empirical formula (1), but there is some disagreement; both will be pointed out here.

The statistical formula, in fact, can be written:

$$P' = e^{-A'(v/U)^2}$$

where

P' = the probability that a causal "coincidence" in the noise image (we are referred to simple A-scope reception) will "simulate" an echo, so that it represents some per cent to make an erroneous observation

v = echo voltage

U = noise voltage

A' = factor, depending mainly upon the pulse repetition rate r , pass band B , and pulse duration t .

The probability P of making a correct observation is the complement of P' to 1. Thus

$$P = 1 - e^{-A'(v/U)^2} \quad (2)$$

The minimum detectable signal V_{min} , which corresponds to a probability of 50 per cent correct observation, can be obtained by means of a series development of exponential in (2). Since V_{min} is relatively small, the high-order terms can be neglected; therefore,

$$P \simeq A' \left(\frac{v}{U} \right)^2 \quad (3)$$

The factor A' is a function rising with the number ν of the elements of the oscillographic traces which can be regarded as independents in the random motion caused by noise, and rising with the number ν' of these elements which must move in casual concordance to simulate a false echo.

According to statistical theory, this dependence can be written:

$$A' = A'' \sqrt{\nu \nu'}$$

But ν is proportional to B , ν' to product rt ; so that

$$P \simeq A \sqrt{Brt} \left(\frac{v}{U} \right)^2 \quad (4)$$

If we assume $P = 0.5$ and $Bt = 1$, solving respect to v , we deduce the value of $(V_{\text{min}})_{\text{opt}}$:

$$(V_{\text{min}})_{\text{opt}} = \sqrt{\frac{0.5}{A}} \frac{U}{\sqrt{rt}}$$

According to Nyquist's formula, we can write:

$$U = E_n \sqrt{B}$$

so that

$$(V_{\text{min}})_{\text{opt}} = \frac{k B_n B^{1/2}}{\sqrt{e}} \quad (5)$$

in which k indicates the factor $\sqrt{0.5/A}$.

Equation (5) is in good accordance with (1). A small discrepancy lies in the fact that (5) shows a factor $1/\sqrt{rt}$, where (1) contains $1/\sqrt{r}$.

In teaching the theory of radar, we find some usefulness in showing this substantial accordance between the theoretical discussion and the experimental formula. It remains to explain the said slight disagreement, which can, on the other hand, be understood when one has in mind the approximations involved in the discussion referred to here.

V. TIBERIO
Istituto Di Elettrotecnica Accademia Navale
Laghorn, Italy

"An Inductance-Capacitance Oscillator of Unusual Frequency Stability"*

We have read Mr. Clapp's¹ account of this circuit with great interest and can support, from our practical experience, the claims which are made for its extreme frequency stability. Indeed, since the time when the circuit was developed independently within the BBC some nine years ago, we have found it so satisfactory that, with negligible exceptions, it is now used exclusively in all the crystal-controlled and LC-controlled oscillators which drive BBC transmitters on long waves, medium waves, and short waves.

If, as in most of our own cases, these oscillators are operated at frequencies in the region from 500-1500 kc, then we find it convenient to take output across a 1000-ohm resistor as anode load.

In the LC case, if the oscillator is followed by an aperiodic amplifier of moderate gain, supplying a diode rectifier which develops bias for the grid of the oscillator, the maintaining valve operates as a class-A amplifier at grid amplitudes approximating to 0.1 volt. With the usual precautions as far as temperature control and mechanical stability are concerned, it is readily possible to obtain short-term (hour to hour) stabilities of ± 1 in 10^6 under service conditions at transmitters without the need for regulated power supplies.

In a practical version of such a circuit used widely throughout the BBC's system, short-term stability is as previously quoted, and the long-term stability (day to day) is of the order of 10 parts in 10^6 . The over-all mains voltage versus frequency coefficient of this variable-frequency oscillator is of the order of ± 1.6 in 10^6 for ∓ 10 per cent variation of mains voltage.

In the case of a crystal oscillator, the circuit and conditions being substantially identical except for the replacement of the LC circuit by a crystal, the long-term (day to day) stability under service conditions at transmitters is readily made to be of the order of 1 in 10^7 . In a typical BBC standard equipment, the high-tension/frequency coefficient is 2 in 10^8 for a 10 per cent change of high-tension supply.

A point about this circuit not directly mentioned by Mr. Clapp, which we have always considered to be of particular importance, is the relatively low phase angle at which the frequency-determining circuit operates. With practicable circuit values in the LC case and in the crystal case, the frequency-determining circuit operates at a phase angle in the region from 60° to 70° , as opposed to some 85° in the case of such circuits as the Miller crystal oscillator, which

* Received by the Institute, June 3, 1948.

¹ J. K. Clapp, "An inductance-capacitance oscillator of unusual frequency stability," Proc. IRE, vol. 36, pp. 356-359; March, 1948.

* Received by the Institute, July 6, 1948.
¹ A. V. Haeff, "Minimum detectable radar signal and its dependence upon parameters of radar systems," Proc. I.R.E., vol. 34, pp. 857-862; November, 1946.

² L. N. Ridenour, "Radar System Engineering," McGraw-Hill Book Co., New York, N. Y., 1947; paragraphs 2-10, p. 35.

³ U. Tiberio, "Sulla valutazione del rapporto fra segnale e rumore nel ricevitore con indicatore oscillografico," Alta Freq., vol. X11, p. 316; July, 1943.

⁴ M. Levy, "Signal-noise ratio in radar," Wireless Eng., vol. XXIV, p. 349; December, 1947.

Correspondence

obtain feedback through the high reactance of an interelectrode capacitance.

The change of phase angle from, say, 85° to 60° may not at first sight appear to be of particular significance. However, the phase versus frequency characteristic in the frequency-determining circuit has the general form indicated in Fig. 1, the steepness

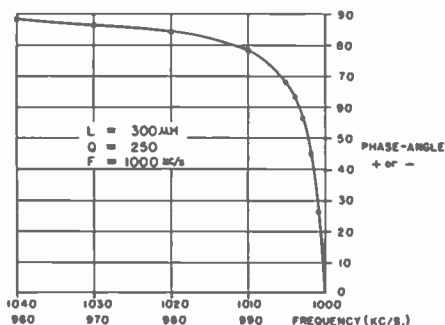

Fig. 1—Typical phase/frequency characteristic.

and turn-over point in any particular case depending upon the Q . It can readily be shown that, for various practical values of Q , the frequency change for a small given phase change may be from ten to eighty times less in circuits operating at 60° than it is in circuits operating at 85°. (It may be noted that a very much smaller advantage would result if the phase angle could be decreased from 60° to 0°.) Since it is phase changes which, in general, reflect the usually occurring changes in valve parameters and supply coefficients, it is apparent that, from this cause alone, the circuit described by Mr. Clapp may be expected, other things being equal, to have a frequency stability some ten to eighty times greater than more conventional oscillator circuits.

The phase angle at which the frequency-determining circuit, considered as a generator, must operate, is equal and opposite to

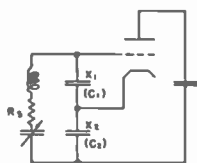

Fig. 2—Fundamental circuit.

the phase angle of the impedance into which it works, since the phase shift round the

loop must be zero. Referring to Fig. 2, and following Mr. Clapp's reasoning, but omitting, in the class-A case, the minor impedance components introduced by the valve interelectrode paths, the input impedance consists of a reactance

$$X_0 = X_1 + X_2 \quad (1)$$

in series with a negative resistance

$$R_0 = g_m X_1 X_2 \quad (2)$$

where g_m is the mutual conductance of the valve.

If $X_2 = X_1$ so that the total shunt capacitance may have its maximum value, then the reactance becomes

$$X_0 = 2X_1 \quad (3)$$

and the negative resistance becomes

$$R_0 = g_m X_1^2 \quad (4)$$

The phase angle is then

$$\phi_0 = \tan^{-1} \frac{X_0}{R_0} = \frac{2}{g_m X_1} \quad (5)$$

To minimize the effect of impedance variations occurring across X_1 and X_2 due to the maintaining circuit, it is desirable that X_1 and X_2 should be as low as possible. The lowest permissible value for X_1 (still assuming $X_1 = X_2$) is set by the case that, in the stable oscillatory class-A condition, the negative-resistance component of the input impedance should be equal to the series resistance R_s of the frequency-determining circuit, so that

$$R_s = g_m X_1^2 \quad \text{from (4)}$$

and the lowest permissible value for X_1 is then given by

$$X_1 = \sqrt{\frac{R_s}{g_m}} \quad (6)$$

As is usual in high-grade oscillators, it is, therefore, desirable that the Q of the frequency-determining circuit should be as high as possible. It further results from (6) and (5) that the g_m should be as high as possible, first to permit a low value for X_1 and X_2 , and then, subsequently, to give the lowest possible phase angle.

We find it worth-while to use two valves of high g_m in parallel and the values of C_1 and C_2 over a wide range of practical Q values then lie between 0.002 and 0.005 μf with a phase angle at 1000 kc in the region of 60° to 70°.

It may be noted, in passing, that the reactances X_1 and X_2 need not necessarily be capacitive: they can be inductive, but capacitors usually offer a better power factor. In the case of low-frequency crystals (100 kc and below), there is sometimes an advantage in using inductances.

A further and disconnected point which may be mentioned in connection with this

circuit concerns the question of harmonics. In any oscillator, frequency stability may be disturbed by the phase shift which occurs from the combination of the generated fundamental and a fundamental frequency produced by intermodulation between adjacent phase-shifted harmonics. A feature of the present circuit which contributes to its unusual frequency stability is that shunt paths of exceedingly low reactance are provided for harmonic frequencies. Providing the limiter is working as designed, the harmonic content is, in any case, of a very low order.

W. A. ROBERTS
British Broadcasting Corp.
Broadcasting House
London, W. 1, England.

Pseudosynchronization in Amplitude-Stabilized Oscillators*

I have read the paper by P. R. Aigrain and E. M. Williams¹ with interest, as I have done some investigation of the subject myself. The phenomenon described by Aigrain and Williams was discussed and explained by me in a paper which appeared in *Electronic Engineering*,² to which no reference is given in the present paper, and which must therefore have presumably escaped the authors' attention. I do not wish to suggest, however, that my treatment was as adequate as theirs; I gave no mathematical analysis.

Although it is true that the effect is quite different from that occurring in a normal oscillator synchronized by a *large* injected signal (which was the only case considered by Adler), it is actually the same as that occurring in a normal oscillator synchronized by a *large* injected signal. In the latter case, as pointed out in another paper by me,³ the synchronization occurs because the reduction of loop gain due to the loading effect of the forced oscillation caused the free oscillation to cease; this mechanism is evidently similar to that of the amplitude-stabilized oscillator, and leads to the same beat-note effect outside the synchronized range. The authors are apparently unaware of this.

D. G. TUCKER
Engineer-in-Chief's Office, G.P.O.
P.O. Research Station
Dollis Hill, N.W. 2
England

* Received by the Institute, July 22, 1948.

¹ P. R. Aigrain and W. M. Williams, "Pseudosynchronization in amplitude-stabilized oscillators," *Proc. I.R.E.*, vol. 36, pp. 800-802; June, 1948.

² D. G. Tucker, *Electronic Eng.*, vol. 15, p. 460; April, 1943.

³ D. G. Tucker, *Jour. I.E.E.* (London), vol. 92, pt. 111, p. 226, secs. 5, 7; 1945.

Institute News and Radio Notes

Executive Committee

At the Executive Committee meeting on July 7, the Executive Secretary reported that, as a representative of the IRE, he had been made a member of a national committee headed by Dr. M. H. Trytten of the National Research Council. The purpose of this committee is to advise the Director of Selective Service about the classification of engineers and scientists; methods and procedures in determining whether they should be deferred or drafted; and, in the latter case, their assignment to specific duties in the Services.

The Wave Propagation Committee's proposal to form a Wave Propagation Group was approved. A petition is to be prepared outlining the Group's scope, and it may include the antenna field as well as the wave propagation field, if the Antennas Committee concurs. It was agreed that the matter of joint meetings with URSI would not be considered until the Group is actually formed.

Approval was requested for the formation of a horizontal technical committee on definitions and one on test equipment. It was decided that these two committees could be set up as subcommittees of the Standards Committee, and the requests were referred to that Committee for action. It was also recommended that the name of the IRE Television Committee be changed to Television Systems Committee.

A petition for a Broadcast Engineer's Group, to be formed because the great expansion in the field of electronics has made broadcast engineers a relatively smaller group in the IRE membership, was approved, subject to an explicit statement that Board approval may be required.

Three new Student Branches were recognized: an IRE-AIEE Branch at Iowa State College, and IRE Branches at Lehigh University and the University of New Mexico. The Committee further decided that Bylaw Section 78, which states that expenses of a Student Branch up to and including \$15 for any school year shall be defrayed by the Institute, shall be interpreted so that the term "expenses" will mean total disbursements of a Student Branch, rather than net loss during one year's operation.

At the August 3 Executive Committee meeting, four schools in Argentina were approved as schools of recognized standing, according to the IRE Constitution and Bylaws. They are the Faculty of Physical and Mathematical Sciences of the National University of La Plata, the National University of Tucuman, the Faculty of Exact Sciences in Buenos Aires, and the University of La Plata.

IRE HOLDS ELECTRON TUBE CONFERENCE

The Sixth Electron Tube Conference, sponsored by the Electron Tube Committee of The Institute of Radio Engineers, was held at Cornell University, Ithaca, N. Y., on

Monday and Tuesday, June 28 and 29, with approximately 200 attending.

The conference opened on Monday morning with a welcoming address by Dean S. C. Hollister of the Cornell University College of Engineering. The morning and afternoon technical sessions, headed by L. S. Nergaard and E. B. Callick, respectively, were devoted to the discussion of power tubes and, especially, those tubes which have given unusual amounts of power output in their particular frequency ranges. The morning session on Tuesday, at which W. C. Hahn served as chairman, was devoted to the discussion of fluctuation phenomena. On Tuesday afternoon four simultaneous sessions were held: one on magnetron mode selection, headed by W. C. Brown; one on fluctuation phenomena, headed by R. M. Ryder; one on thoria cathodes, headed by R. L. Jepson; and a session which covered traveling-wave oscilloscopes and other devices not falling within the scope of other sessions, headed by J. W. McRae.

Calendar of COMING EVENTS

**IRE-URSI Meeting, Washington
D. C., Oct. 7-9**

1948 Fall General Meeting of the
AIEE, Milwaukee, Wis., Oct. 18-22

Annual Meeting of the Optical Society
of America, Detroit, Mich., Oct.
21-23

Society of Motion Picture Engineers
Convention, Washington, D. C.,
Oct. 25-29

1948 Conference on Electrical Insula-
tion, National Research Council,
Washington, D. C., Oct. 27-29

National Electronics Conference, Chi-
cago, Ill., Nov. 4-6, 1948

Electronic Technicians Town Meet-
ing, Boston, Mass., Nov. 15-17

American Physical Society Meeting,
Chicago, Ill., Nov. 26-27

**IRE-RMA Rochester Fall Meeting,
Rochester, N. Y., Nov. 8-10, 1948**

**AIEE-IRE Conference on Electronic
Instrumentation, New York City,
Nov. 30-Dec. 1**

1948 Southwestern IRE Conference,
Dallas, Tex., Dec. 10-11

American Physical Society Meeting,
New York City, Jan. 27-29, 1949

1949 IRE National Convention, New
York City, Mar. 7-10, 1949

NOTICE

Three new IRE standards are now available:

**Standards on Television: Meth-
ods of Testing Television Receivers,
\$1.00.**

**Standards on Antennas, Modula-
tion Systems, and Transmitters: Defi-
nitions of Terms, \$0.85.**

**Standards on Abbreviations,
Graphical Symbols, Letter Symbols,
and Mathematical Signs, \$0.75.**

Orders may be sent to The Insti-
tute of Radio Engineers, Inc., 1 East
79 Street, New York 21, N. Y., enclos-
ing remittance.

NATIONAL ELECTRONICS CONFERENCE

Final plans have now been completed for the 1947 National Electronics Conference, a forum on electronic research, development, and application, which will be held at the Edgewater Beach Hotel, Chicago, on November 4, 5, and 6.

Two outstanding features of this year's Conference will be the banquet to be held in the Marine Dining Room on Thursday evening, November 4, and a large-screen television demonstration by the Radio Corporation of America in the Crystal Ballroom on Friday at 8 p.m.

A comprehensive technical program has been arranged, with all major fields of interest being covered. These include new materials, sound measurement and recording, servomechanisms, communications, electronic instrumentation, new tube developments, microwaves, computers, industrial applications, television, management of research, electronic circuits, magnetic amplifiers, and antennas.

Further information may be obtained from R. R. Buss, Electrical Engineering Department, Northwestern University, Evanston, Ill.

AIEE-IRE CONFERENCE ON ELECTRONIC INSTRUMENTATION

The AIEE-IRE Conference on Electronic Instrumentation in Nucleonics and Medicine, to be held in the Engineering Societies Building, 29 West 39 Street, New York, N. Y., will feature, beside a program of over 20 papers, an exhibit of instruments being used by the Atomic Energy Commission. The AEC will attempt in this display, which is to consist of approximately 14 instruments, to give a brief across-the-field view of the instruments used in its work. The exhibit will be on display November 30 and December 1.

(Continued on page 1320)

Institute Committees—1948

EXECUTIVE

B. F. Shackelford, *Chairman*
 S. I. Bailey, *Vice-Chairman*
 Haraden Pratt, *Secretary*
 W. R. G. Baker V. M. Graham
 A. N. Goldsmith D. B. Sinclair

BOARD OF EDITORS

A. N. Goldsmith, *Chairman*
 F. W. Albertson F. B. Llewellyn
 J. S. Allen S. S. Mackeown
 G. M. K. Baker Nathan Marchand
 W. L. Barrow E. D. McArthur
 R. R. Batcher Knox McIlwain
 A. E. Bowen J. W. McRae
 R. M. Bowie L. A. Meacham
 Ralph Bown G. F. Metcalf
 R. S. Burnap E. L. Nelson
 O. H. Caldwell D. O. North
 C. W. Carnahan H. F. Olson
 C. C. Chambers R. M. Page
 L. M. Clement H. O. Peterson
 J. D. Cobine G. W. Pickard
 M. G. Crosby Haraden Pratt
 R. B. Dome C. A. Priest
 W. G. Dow J. R. Ragazzini
 E. W. Engstrom Simon Ramo
 W. L. Everitt H. J. Reich
 W. G. H. Finch J. D. Reid
 D. G. Fink F. X. Rettenmeyer
 H. C. Forbes P. C. Sandretto
 I. A. Getting S. W. Seeley
 G. W. Gilman V. W. Sherman
 P. C. Goldmark L. C. Smeby
 A. W. Graf C. E. Smith
 F. W. Grover J. A. Stratton
 L. B. Headrick W. C. Tinus
 E. W. Herold K. S. Van Dyke
 J. A. Hutcheson E. K. Van Tassel
 C. M. Jansky, Jr. E. C. Wente
 J. K. Johnson H. A. Wheeler
 L. F. Jones J. R. Whinnery
 H. S. Knowles W. C. White
 J. D. Kraus L. E. Whittemore
 J. B. H. Kuper G. W. Willard
 J. L. Lawson William Wilson
 D. G. Little I. G. Wolff
 V. K. Zworykin

AWARDS

Haraden Pratt, *Chairman*
 W. L. Barrow R. A. Hackbusch
 D. E. Chambers Keith Henney
 E. W. Engstrom J. V. L. Hogan
 W. C. Evans I. J. Kaar
 W. L. Everitt F. R. Lack
 V. M. Graham J. W. McRae
 G. R. Town

EDUCATION

W. H. Radford, *Chairman*
 Wilfred Arcand H. H. Newell
 R. E. Beam R. G. Porter
 A. B. Bronwell H. J. Reich
 Melville Eastham Elmer Schulz
 G. H. Fett W. J. Seeley
 A. W. Graf F. R. Stansel
 E. A. Guillemin W. O. Swinyard
 G. B. Hoadley G. R. Town
 L. N. Holland Ernst Weber
 A. H. Howell A. H. Wing, Jr.
 Irving Wolff

PAPERS PROCUREMENT

J. D. Reid, *Chairman*
 E. D. Alcock H. B. Marvin
 Andrew Alford W. P. Mason
 B. B. Bauer Pierre Mertz
 R. M. Bowie B. J. Miller
 J. W. Butterworth I. E. Mourontseff
 I. F. Byrnes A. F. Murray
 T. J. Carroll L. L. Nettleton
 K. A. Chittick G. M. Nixon
 B. J. Chromy D. E. Noble
 J. T. Cimorilli T. M. Oxlarenko
 L. M. Clement W. C. Osterlrock
 Eginhard Dietze W. E. Reichle
 G. V. Eltgroth F. X. Rettenmeyer
 M. K. Goldstein H. W. G. Salinger
 H. Grossman K. M. Schafer
 R. C. Guthrie R. F. Shelby
 D. E. Harnett W. P. Short
 J. R. Harrison Daniel Silverman
 John Hessel P. L. Smith
 F. V. Hunt J. Q. Stansfield
 T. A. Hunter G. R. Town
 Harry Huskey L. G. Trolese
 Hans Jaffe H. J. Tyzzer
 J. J. Jakosky K. S. Van Dyke
 Martin Katzin W. L. Webb
 C. E. Kilgour J. R. Whinnery
 N. L. Kiser W. C. White
 A. V. Loughren G. S. Wickizer
 I. G. Maloff R. H. Williamson
 R. J. Wise

MEMBERSHIP

Beverly Dudley, *Chairman*
 A. L. Albert P. B. Laeser
 R. E. Beam W. C. Moore
 E. D. Cook I. E. Mourontseff
 A. V. Eastman W. H. Radford
 D. G. Fink D. B. Sinclair
 R. P. Glover J. A. Stratton
 George Grammer J. C. Stroebel
 R. F. Guy Ernst Weber
 J. W. Horton W. C. White
 P. D. Zottu
 (Chairmen of Section Membership
 Committees *Ex-Officio*)

PROFESSIONAL GROUPS

W. L. Everitt, *Chairman*
 D. L. Angevine, Jr. W. H. Doherty
 A. B. Chamberlain V. M. Graham
 R. A. Heising

PAPERS REVIEW

M. G. Crosby, *Chairman*
 H. A. Affel W. P. Mason
 E. W. Allen, Jr. R. E. Mathes
 C. F. Baldwin H. F. Mayer
 John Barnes H. R. Nimmo
 B. de F. Bayly Jerry Minter
 P. H. Betts R. E. Moe
 F. J. Bingley R. M. Morris
 H. S. Black F. L. Mosely
 F. T. Bowditch I. E. Mourontseff
 H. A. Chinn G. G. Muller
 J. K. Clapp A. F. Murray
 S. B. Cohn J. R. Nelson
 J. M. Constable K. A. Norton
 F. W. Cunningham H. W. Parker
 R. L. Dietzold L. J. Peters
 H. D. Doolittle A. P. G. Peterson
 O. S. Duffendack W. H. Pickering
 R. D. Duncan, Jr. A. F. Pomeroy
 I. E. Fair Albert Preisman
 E. H. Felix T. H. Rogers
 V. H. Fraenckel H. E. Royce
 R. L. Freeman J. D. Ryder
 Paul Fritschel M. W. Scheldorf
 Stanford Goldman Samuel Seely
 W. M. Goodall Harner Selvidge
 W. C. Hahn R. E. Shelby
 G. L. Haller C. M. Slack
 O. B. Hanson J. E. Smith
 A. E. Harrison R. L. Snyder
 J. R. Harrison E. E. Spitzer
 T. J. Henry J. R. Steen
 C. N. Hoyler E. K. Stodola
 F. V. Huff H. P. Thomas
 D. L. Jaffe Bertram Trevor
 Hans Jaffe W. N. Tuttle
 D. C. Kalbfell Dayton Ulrey
 A. G. Kandoian A. P. Upton
 Martin Katzin G. L. Usselman
 J. G. Kreer, Jr. S. N. Van Voorhies
 Emil Labin L. Vieth
 V. D. Landon J. R. Weiner
 C. V. Litton R. M. Wilmotte
 B. D. Loughlin W. T. Wintringham
 Louis Malter J. W. Wright
 H. R. Zeamans

TELLERS

J. W. McRae, *Chairman*
 E. G. Fubini G. F. Metcalf
 W. P. Short

ADMISSIONS

G. T. Royden, *Chairman*
 R. D. Avery A. R. Morton
 R. M. Bowie R. S. O'Brien
 J. T. Brothers (alternate for Mr.
 J. L. Callahan Chinn)
 H. A. Chinn D. S. Rau
 J. D. Cobine S. W. Seeley
 E. D. Cook R. F. Shea
 C. E. Dean E. R. Shenk
 E. T. Dickey D. B. Sinclair
 W. A. Dickinson N. Snyder
 J. H. Findlay J. C. Stroebel
 W. A. Ford F. D. Webster
 (Alternate for Dr. G. R. White
 Cook)
 A. R. Hodges G. S. Wickizer
 R. C. G. Williams

Institute Committees (Continued)

POLICY DEVELOPMENT

S. L. Bailey, *Chairman*

W. R. G. Baker	J. A. Hutcheson
M. G. Crosby	C. B. Jolliffe
W. L. Everitt	E. A. Laport
A. W. Graf	J. W. McRae
R. A. Heising	L. R. Quarles
T. A. Hunter	F. E. Terman

W. N. Tuttle

SECTIONS

A. W. Graf, *Chairman*

V. M. Graham	P. B. Laeser
R. A. Heising	C. A. Norris
J. F. Jordan	J. E. Shephard
D. C. Kalbfell	W. O. Swinyard
	R. N. White

(Section Chairmen *Ex-Officio*)

NOMINATIONS

W. L. Everitt, *Chairman*

W. R. G. Baker	F. H. R. Pounsett
O. B. Hanson	Haraden Pratt
J. A. Hutcheson	D. B. Sinclair
F. B. Llewellyn	F. E. Terman
	H. A. Wheeler

CONSTITUTION AND LAWS

I. S. Coggeshall, *Chairman*

G. W. Bailey	R. F. Guy
S. L. Bailey	R. A. Heising
E. F. Carter	F. B. Llewellyn
	H. R. Zeamans

PUBLIC RELATIONS

V. M. Graham, *Chairman*

G. W. Bailey	George Lewis
E. L. Bragdon	R. H. Manson
W. C. Copp	E. A. Nicholas
C. B. DeSoto	R. C. Poulter
O. E. Dunlap, Jr.	H. B. Richmond
W. C. Evans	E. L. Robinson
H. C. Forbes	Crump Smith
Charles Fry	D. B. Smith
R. A. Hackbusch	E. C. Tompson
Keith Henney	Will Whitmore
T. R. Kennedy	Lewis Winner

FINANCE

W. R. G. Baker, *Chairman*

S. L. Bailey, <i>ex officio</i>	I. S. Coggeshall
	F. B. Llewellyn

Technical Committees, September 1, 1948-September 1, 1949

ANNUAL REVIEW

L. E. Whittemore, *Chairman*
Trevor Clark, *Vice-Chairman*

John Babillus	R. G. Fink
W. R. G. Baker	L. R. Hafstad
H. S. Black	Keith Henney
G. P. Bosomworth	J. V. L. Hogan
J. G. Brainerd	Wm. B. Lodge
G. M. Brown	W. A. Lynch
R. S. Burnap	John A. Pierce
H. R. Butler	George Rappaport
W. G. Cady	E. W. Scafer
P. S. Carter	J. R. Steen
A. B. Chamberlain	Wm. O. Swinyard
A. E. Cullum, Jr.	J. R. Weiner
Eginhard Dietze	H. A. Wheeler

ANTENNAS

P. S. Carter, *Chairman*
L. C. Van Atta, *Vice-Chairman*

J. A. Albano	W. E. Kock
Andrew Alford	Keith MacKinnon
T. M. Bloomer	W. W. Miehler
G. H. Brown	D. C. Ports
L. J. Chu	M. W. Scheldorf
W. S. Duttera	S. A. Schelkunoff
J. A. Eaton	J. C. Schelleng
A. G. Fox	J. P. Shanklin
Sidney Frankel	George Sinclair
R. F. Holtz	P. H. Smith
R. B. Jacques	J. R. Whinnery
E. C. Jordan	J. W. Wright

AUDIO & VIDEO TECHNIQUES

H. A. Chinn, *Chairman*
J. E. Keister, *Vice-Chairman*

O. L. Angevine, Jr.	G. P. Hixenbaugh
S. J. Begun	A. G. Jensen
P. F. Brown	W. A. Lynch
F. L. Burroughs	D. E. Maxwell
J. D. Colvin	R. A. Miller
R. H. Daugherty, Jr.	L. W. Morrison, Jr.
V. J. Duke	W. J. Poch
George Graham	J. K. Ragazzini
J. A. Green	H. E. Roys

J. F. Wiggins

CIRCUITS

J. G. Brainerd, *Chairman*
J. B. Russell, Jr., *Vice-Chairman*

M. A. Antman	E. A. Guillemin
Cledo Brunetti	Herbert Krauss
C. R. Burrows	D. O. McCoy
A. L. Dolnick	E. E. Overmier
W. L. Everitt	E. H. Perkins
R. M. Foster	Wolcott Smith
Stanford Goldman	W. N. Tuttle

ELECTROACOUSTICS

Eginhard Dietze, *Chairman*
E. S. Seeley, *Vice-Chairman*

P. N. Arnold	F. L. Hopper
B. B. Bauer	F. V. Hunt
S. J. Begun	G. M. Nixon
M. J. DiToro	Benjamin Olney
W. D. Goodale, Jr.	H. F. Olson
Martin Greenspan	R. A. Schlegel
E. C. Gregg	Lincoln Thompson

ELECTRON TUBES

R. S. Burnap, *Chairman*
L. S. Nergaard, *Vice-Chairman*

J. W. Clark	Louis Malter
K. C. DeWalt	D. E. Marshall
W. G. Dow	J. A. Morton
A. M. Glover	I. E. Mourontseff
J. E. Gorham	G. D. O'Neill
J. W. Greer	P. A. Redhead
L. B. Headrick	H. J. Reich
L. A. Hendricks	A. C. Rockwood
E. C. Homer	R. M. Ryder
S. B. Ingram	R. W. Slinkman
Herbert Krauss	C. M. Wheeler

ELECTRONIC COMPUTERS

J. R. Weiner, *Chairman*
G. R. Stibitz, *Vice-Chairman*

S. N. Alexander	E. Lakatos
J. V. Atanasoff	G. D. McCann
J. H. Bigelow	C. H. Page
Perry Crawford, Jr.	J. A. Rajchman
C. S. Draper	N. Rochester
J. P. Eckert, Jr.	Robert Serrell
J. W. Forrester	T. K. Sharpless
E. L. Harter	R. K. Snyder
B. L. Havens	C. F. West

FACSIMILE

J. V. L. Hogan, *Chairman*
C. J. Young, *Vice-Chairman*

J. C. Barnes	F. A. Hester
Henry Burkhard	R. E. Mathes
J. J. Callahan	Pierre Mertz
A. G. Cooley	G. H. Scheer, Jr.

R. J. Wise

INDUSTRIAL ELECTRONICS

G. P. Bosomworth, *Chairman*
D. E. Watts, *Vice-Chairman*

W. B. Ritchie Agnew	P. E. Ohmart
J. E. Brown	H. W. Parker
J. M. Cage	H. O. Peterson
E. W. Chapin	Walther Richter
C. W. Frick	W. C. Rudd
H. C. Gillespie	R. S. Tucker
Otto Glasser	Julius Weinberger
Eugene Mittelmann	R. M. Wilmotte

MODULATION SYSTEMS

H. S. Black, *Chairman*
Bertram Trevor, *Vice-Chairman*

Robert Adler	R. F. Guy
B. V. Blom	L. B. Hallman, Jr.
M. G. Crosby	D. M. Hill
F. L. Burroughs	J. L. Hollis
C. C. Chambers	E. R. Kretzmer
L. A. W. East	V. D. Landon
C. W. Finnigan	B. D. Loughlin
W. F. Goetter	C. T. McCoy
A. C. Goodnow	Dale Pollack
D. D. Grieg	S. W. Seeley

Wm. G. Tuller

Technical Committees (Continued)

NAVIGATION AIDS

J. A. Pierce, *Chairman*
 Henri Busignies, *Vice-Chairman*

D. H. Ewing	F. L. Moseley
D. G. Fink	Marcus O'Day
C. J. Hirsch	J. A. Rankin
Wm. E. Jackson	P. C. Sandretto
D. S. Little	E. G. Schneider
R. E. McCormick	Wm. J. Sen
H. R. Mimno	Ben Thompson
H. K. Morgan	R. R. Welsh

RADIO RECEIVERS

Wm. O. Swinyard, *Chairman*
 R. F. Shea, *Vice-Chairman*

J. Avins	J. K. Johnson
G. L. Beers	B. D. Loughlin
J. E. Brown	C. R. Miner
W. F. Cotter	Garrard Mountjoy
L. W. Couillard	J. M. Pettit
A. R. Hodges	F. H. R. Pounsett
K. W. Jarvis	John D. Reid

TELEVISION

D. G. Fink, *Chairman*
 A. G. Jensen, *Vice-Chairman*

G. W. Andrew	R. D. Kell
W. F. Bailey	P. J. Larsen
R. M. Bowie	H. T. Lyman
J. E. Brown	J. Mint
K. A. Chittick	Alphonse Ouimet
C. J. Franks	D. W. Puglsey
P. C. Goldmark	R. E. Shelby
R. N. Harmon	D. B. Smith
J. L. Hollis	M. E. Strieby
I. J. Kaar	Norman Young, Jr.

NUCLEAR STUDIES

L. R. Hafstad, *Chairman*

W. R. G. Baker	R. A. Krause
P. R. Bell	J. B. H. Kuper
J. Z. Bowers	F. R. Lack
R. M. Bowie	R. E. Lapp
R. L. Butenhoff	P. J. Larsen
W. S. Cowart	J. L. Lawson
A. H. Dahl	G. A. Morton
W. F. Davidson	J. K. Pickard
H. Friedman	W. W. Salisbury
H. H. Goldsmith	W. E. Shoupp
Keith Henney	F. R. Shonka
M. M. Hubbard	M. A. Schultz
J. A. Hutcheson	A. J. Spriggs
W. H. Jordan	S. N. Van Voorhis
Thomas Killian	John Victoreen
H. P. Knauss	J. B. Wiesner
Serge Korff	F. I. Winant

RADIO TRANSMITTERS

E. A. Laport, *Chairman*
 H. R. Butler, *Vice-Chairman*

E. L. Adams	J. B. Knox
L. T. Bird	L. A. Looney
M. R. Briggs	C. H. Meyer
Cledo Brunetti	J. C. R. Punchard
L. T. Findley	R. L. Robbins
J. B. Heffelfinger	Berthold Sheffield
A. E. Kerwien	I. R. Weir

STANDARDS COMMITTEE

A. B. Chamberlain, *Chairman*
 L. G. Cumming, *Vice-Chairman*

W. R. G. Baker	D. G. Fink
H. S. Black	L. R. Hafstad
G. P. Bosomworth	Keith Henney
J. G. Brainerd	J. V. L. Hogan
G. M. Brown	L. C. F. Horle
R. S. Burnap	E. A. LaPort
W. G. Cady	J. A. Pierce
P. S. Carter	E. W. Schafer
H. A. Chinn	J. R. Steen
M. G. Crosby	W. O. Swinyard
A. E. Cullum, Jr.	J. R. Weiner
Eginhard Dietze	H. A. Wheeler
	L. E. Whittemore

RAILROAD & VEHICULAR COMMUNICATIONS

G. M. Brown, *Chairman*
 D. E. Noble, *Vice-Chairman*

E. H. B. Bartelink	D. Martin
F. T. Budelman	C. E. McClellan
P. V. Dimock	J. C. O'Brien
D. B. Harris	R. B. Steele
W. A. Harris	David Talley
C. M. Heiden	George Teomney
C. N. Kimball, Jr.	Frank W. Walker

SYMBOLS

E. W. Schafer, *Chairman*
 A. F. Pomeroy, *Vice-Chairman*

K. E. Anspach	O. T. Laube
C. R. Burrows	O. C. Lundstrom
H. F. Dart	C. A. Nietzert
J. H. Dellinger	M. B. Reed
E. T. Dickey	Duane Roller
V. R. Hudek	A. L. Samuel
	H. M. Turner

PIEZOELECTRIC CRYSTALS

W. G. Cady, *Chairman*
 R. A. Sykes, *Vice-Chairman*

C. F. Baldwin	Hans Jaffe
W. L. Bond	W. P. Mason
J. K. Clapp	P. L. Smith
Clifford Frondel	K. S. Van Dyke

WAVE PROPAGATION

A. E. Cullum, Jr., *Chairman*
 C. R. Burrows, *Vice-Chairman*

S. L. Bailey	K. A. Norton
Gardner Fox	H. O. Peterson
I. H. Gerks	J. A. Pierce
Marion Gray	George Sinclair
D. E. Kerr	R. L. Smith-Rose
J. E. Keto	J. A. Stratton
	J. W. Wright

Special Committees

PROFESSIONAL RECOGNITION

G. B. Hoadley, *Chairman*

C. C. Chambers	Harry Dart
	C. M. Edwards

FOUNDERS

R. F. Guy, *Chairman*

BUILDING FUND ADMINISTRATORS

Melville Eastham E. A. Nicholas
 Haraden Pratt

CONVENTION POLICY

J. E. Shepherd, *Chairman*

Austin Bailey	E. J. Content
G. W. Bailey	B. E. Schackelford

EDITORIAL ADMINISTRATIVE

A. N. Goldsmith, Editor, *Chairman*

G. M. K. Baker	F. B. Llewellyn
H. S. Black	Donald McNicol
R. S. Burnap	Haraden Pratt
M. G. Crosby	J. R. Ragazzini
E. W. Herold	H. J. Reich
	L. E. Whittemore

ARMED FORCES LIAISON COMMITTEE

G. W. Bailey, *Chairman*

INSTITUTE REPRESENTATIVES IN COLLEGES—1948

- Agricultural and Mechanical College of Texas: Tom Prickett, Jr.
Akron, University of: P. C. Smith
*Alabama Polytechnic Institute: C. C. Clements
*Alberta, University of: J. W. Porteous
*Arizona, University of: H. E. Stewart
*Arkansas, University of: G. H. Scott
British Columbia, University of: H. J. MacLeod
*Brooklyn, Polytechnic Institute of: C. A. Hachemeister
*California Institute of Technology: S. S. MacKeown
*California State Polytechnic College: Clarence Radius
*California, University of: L. J. Black
*Carnegie Institute of Technology: E. M. Williams
*Case Institute of Technology: J. D. Johannesen
Cincinnati, University of: A. B. Bereskin
Clarkson College of Technology: F. A. Record
*Columbia University: J. R. Ragazzini
Connecticut, University of: L. E. Williams
Cooper Union: J. B. Sherman
Cornell University: True McLean
Duke University: W. J. Seeley
Florida, University of: Paul Nelson
*George Washington University: W. S. Carley
Georgia School of Technology: M. A. Honnell
Harvard University: E. L. Chaffee
*Illinois Institute of Technology: G. F. Levy
*Illinois, University of: E. C. Jordan
*Iowa, State University of: L. A. Ware
*Iowa State College: W. L. Cassell
*John Carroll University: J. L. Hunter
Johns Hopkins University: Ferdinand Hamburger, Jr.
*Kansas State College: J. E. Wolfe
Kansas, University of: D. G. Wilson
Lafayette College: F. W. Smith
Lawrence Institute of Technology: H. L. Byerlay
*Lehigh University: D. E. Mode
Louisiana State University: W. E. Owen
Maine, University of: W. J. Creamer, Jr.
*Manhattan College: R. T. Weil, Jr.
*Maryland, University of: G. L. Davis
*Massachusetts Institute of Technology: E. A. Guillemin, W. H. Radford
McGill University: F. S. Howes
*Michigan State College: J. A. Strelzoff
*Michigan, University of: L. N. Holland
*Minnesota, University of: O. A. Becklund
Missouri, University of: D. L. Waidelich
Nebraska, University of: F. W. Norris
*New Mexico, University of: W. H. Mullins
*Newark College of Engineering: Solomon Fishman
New Hampshire, University of: W. B. Nulsen
*New York, College of the City of: Harold Wolf
*New York University: Philip Greenstein
*North Carolina State College: W. T. Dickinson
*North Dakota, University of: Clifford Thomforde
Northeastern University: G. E. Pihl
*Northwestern University: A. H. Wing, Jr.
*Notre Dame, University of: H. E. Ellithorn
Ohio State University: E. M. Boone
Oklahoma Agriculture and Mechanical College: H. T. Fristoe
*Oregon State College: A. L. Albert
Pennsylvania State College: G. L. Crosley
Pennsylvania, University of: C. C. Chambers
*Pratt Institute: E. A. Hertzler
*Princeton University: N. W. Mather
*Purdue University: R. P. Siakind
Queen's University: H. H. Stewart
Rensselaer Polytechnic Institute: H. D. Harris
Rice Institute: M. V. McEnany
Rose Polytechnic Institute: H. A. Moench
*Rutgers University: J. L. Potter
Santa Clara, University of: W. J. Warren
*South Carolina, University of: J. C. Cosby
*South Dakota School of Mines and Technology: Appointment later
Southern Methodist University: E. J. O'Brien
*Stanford University: J. M. Pettit
*St. Louis University: G. L. Hollander
Stevens Institute of Technology: Carl Neitzert
*Syracuse University: C. S. Roys
*Tennessee, University of: E. D. Shipley
*Texas, University of: A. W. Straiton
*Toledo, University of: D. A. Powers
Toronto, University of: George Sinclair
Tufts College: A. H. Howell
Union College: F. W. Grover
United States Military Academy: F. K. Nichols
United States Naval Academy: G. R. Giet
*Utah State Agricultural College: L. S. Cole
*Utah, University of: C. C. Haycock
Virginia Polytechnic Institute: R. R. Wright
Virginia, University of: L. R. Quarles
*Washington, University of: V. L. Palmer
Washington University: S. H. Van Wambeek
*Wayne University: H. M. Hess
Western Ontario, University of: E. H. Tull
West Virginia University: R. C. Colwell
*Wisconsin, University of: Glenn Koehler
Witwatersrand, University of: G. R. Bozzoli
*Worcester Polytechnic Institute: H. H. Newell
*Wyoming, University of: R. G. Schaefer
Yale University: H. J. Reich
- * Colleges with approved Student Branches.

INSTITUTE REPRESENTATIVES ON OTHER BODIES—1948

- American Documentation Institute: J. H. Dellinger
ASA Standards Council: Alfred N. Goldsmith (R. F. Guy, alternate)
ASA Sectional Committee on Letter Symbols and Abbreviations for Science and Engineering: H. M. Turner
ASA Subcommittee on Letter Symbols for Radio Use: H. M. Turner
ASA Sectional Committee on National Electrical Safety Code, Subcommittee on Article 810, Radio Broadcast Reception Equipment: E. T. Dickey (Virgil M. Graham, alternate)
ASA Sectional Committee on Preferred Numbers: A. F. Van Dyck
ASA Sectional Committee on Radio: Alfred N. Goldsmith, chairman; Haraden Pratt, L. E. Whittemore.
ASA Sectional Committee on Radio-Electrical Co-ordination: J. V. L. Hogan, C. M. Jansky, Jr., and L. E. Whittemore
ASA Board of Directors: F. R. Lack
ASA Electrical Standards Committee: L. G. Cumming, F. B. Llewellyn, E. A. LaPorte
ASA Sectional Committee on Acoustical Measurements and Terminology: Eginhard Dietze, H. F. Olson
ASA Sectional Committee on Definitions of Electrical Terms: A. B. Chamberlain, Haraden Pratt, J. C. Schelling, H. A. Wheeler
ASA Subcommittee on Vacuum Tubes: B. E. Schackelford
ASA Subcommittee on General Terms: J. G. Brainerd
ASA Subcommittee on Electrical Instruments: J. H. Miller
ASA Subcommittee on Communications: J. C. Schelling
ASA Subcommittee on Electronics: R. S. Burnap
ASA Sectional Committee on Electric and Magnetic Magnitudes and Units: J. H. Dellinger
ASA Sectional Committee on Electrical Installations on Shipboard: I. F. Byrnes
ASA Sectional Committee on Electrical Measuring Instruments: Wilson Aull, Jr.
ASA Sectional Committee on Standards for Sound Recording: S. J. Begun
ASA Subcommittee on Magnetic Recording: W. J. Morlock
ASA Sectional Committee on Standardization of Optics: E. D. Goodale (L. G. Cumming, Alternate)
ASA Definitions Co-ordinating Committee: C. L. Dawes, J. C. Schelling
ASA Sectional Committee on Graphical Symbols and Abbreviations for Use on Drawings: Austin Bailey (H. P. Westman, alternate)
ASA Subcommittee on Communication Symbols: H. M. Turner
ASA Sectional Committee on Specifications for Dry Cells and Batteries: H. M. Turner

INSTITUTE REPRESENTATIVES ON OTHER BODIES (CONTINUED)

ASA Sectional Committee on Standards for Drawings and Drafting Room Practices: Austin Bailey (H. P. Westman, alternate)
 ASA Committee on Vacuum Tubes for Industrial Purposes: B. E. Shackelford
 ASA War Committee on Radio: Alfred N. Goldsmith*
 ASA War Standards Committee on Methods of Measuring Radio Noise: C. J. Franks and Garrard Mountjoy
 ASME Glossary Review Board: W. R. G. Baker
 Council of the American Association for the Advancement of Science: J. C. Jensen

Joint Co-ordination Committee on Radio Reception of the E.E.I., N.E.M.A., and R.M.A.: C. E. Brigham
 Joint Technical Advisory Committee: P. F. Siling, Chairman
 Joint AIEE, IRE, NEMA Co-ordination Committee on Commercial Induction and Dielectric Heating Apparatus: G. P. Bosomworth
 National Electronics Conference Board of Directors: W. C. White
 National Research Council, Division of Engineering and Research: F. B. Llewellyn

U.R.S.I. (International Scientific Radio Union) Executive Committee: C. M. Jansky, Jr.
 U.S. National Committee, Advisers on Electrical Measuring Instruments: Melville Eastham and H. L. Olesen
 U.S. National Committee, Advisers on Symbols: L. E. Whittemore and J. W. Horton
 U.S. National Committee of the International Electrotechnical Commission: H. M. Turner

* Also chairman of its Subcommittee on Insulating Material Specifications for the Military Services.

Industrial Engineering Notes¹

GERMAN IRON-CORE TECHNIQUE DESCRIBED IN OTS REPORT

German practice in manufacturing high-frequency iron cores for electronic equipment generally parallels American practice, according to a 15-page report (PB-45067, "Iron Cores") investigating eight German firms under OTS sponsorship and published by the Office of Technical Services, Department of Commerce, for 50 cents. However, mixing methods used by the AEG firm in Berlin and an extrusion process developed by Siemens and Halske at Wernerwerk, are of especial interest.

A related 33-page report (PB-75830, "Iron Cored D.F. Loops and Manufacture of Iron Dust") is also available from OTS at one dollar per copy. This report, prepared by British investigators, discusses the manufacture of iron dust cores and iron-cored direction finding loops by the Siemens Halske firm.

SYNTHETIC MICA DEVELOPMENT

A synthetic mica with the desirable characteristics of natural mica has been produced for the first time. Known as fluorine-phlogopite mica, the synthetic material is being produced on a pilot-plant scale under a co-ordinated research program sponsored by the Office of Naval Research, the Signal Corps, and the Bureau of Ships. Interested persons or organizations are invited to get in touch with the Office of Naval Research, Navy Department, Washington 25, D. C., for further details.

OTS COMPILATION LISTS ENEMY PATENTS

A compilation of abstracts of 358 U. S. patents formerly owned by enemy nationals, including some in the field of electronics, is now available from the Office of Technical

¹ The data on which these NOTES are based were selected, by permission, from "Industry Reports," issues of July 23 and 30, and August 6, 1948, published by the Radio Manufacturers' Association, whose helpful attitude in this matter is hereby gladly acknowledged.

Services, Department of Commerce, Washington, D. C. Copies of the report (PB-88841) "List of Vested Patents Available from Office of Alien Property") sell for four dollars. This compilation is one of several groups of patents to be issued from time to time by the OTS, and covers patents not included in the published abstracts distributed by that office. Most of the patents included are available for licensing to American firms by the Office of Alien Property on a royalty-free, nonexclusive basis, for the remaining life of the patents.

A leaflet called "Index and Guide to Enemy Patents Vested in the Attorney General as of January 1947," which contains general information about the availability of enemy patents, may be obtained either from OTS or the Alien Property Custodian.

RECENT FCC DECISIONS

The FCC issued an order (Mimeograph No. 23779) transferring certain sections dealing with low-power devices of the Rules and Regulations to a new part titled "Part 15,

Rules Governing Restricted Radiation Devices" . . . A phone recorder petition made by the Dictaphone Corp. for suspension of proposed tariff schedules filed by telephone companies concerning the use of recording devices in connection with telephone service was denied . . . The FCC amended its rules governing the Amateur Services to continue until July 31, 1949, the present temporary authority for amateurs to use narrow-band frequency or phase modulation emission for radiotelephone communication in the bands 3850 to 3900 kc; 14200 to 14250 kc; 28.5 to 29.0 Mc; and 51.0 to 51.2 Mc.

SECURITY BOARD REPORT URGES PLANT DISPERSION

A 15-page booklet aimed at alerting industrial leaders to the "strategic significance of industrial plant location in the event of another war," and suggesting that industrialists think of location of plant facilities as an essential factor in any plans for plant expansion was released by the National Security Resources Board and may be obtained from their Office of Information, Washington 25, D. C. Called "Strategic Considerations in Industrial Locations" (NSRB Document 66), the pamphlet's purpose "is to describe the nature of the risk of possible enemy attack against industry, and to indicate some action which industry might feasibly take." Factory dispersion, according to the booklet, is the most practical solution of the problem posed by destructive atomic weapons.

FM DEVELOPMENTS

There are 604 FM stations on the air, although 11 holders of construction permits have been permitted by the FCC to cancel them. New stations have begun broadcasting in the following states: *Ala.*, Montgomery (WCOV-FM); *Ark.*, Jonesboro (KBTM-FM); *Colo.*, Denver (DFEL-FM); *Fla.*, Jacksonville (WMBR-FM); *Ga.*, Atlanta (WCON-FM); *Ill.*, Waukegan (WICRS); *Ind.*, Lafayette (WFAM); *Mass.*, Boston (WEEL-FM), Brockton (WBET-FM); *Mich.*, Muskegon (WKBZ-FM); *Ohio*, Elyria (WEOL); *Wis.*, Waukesha (WAUX-FM).

ATTENTION, AUTHORS!

Donald B. Sinclair, Chairman of the Technical Program Committee for the 1949 IRE National Convention, requests that authors of papers to be considered for presentation submit the following information to him as soon as possible:

Name and address of the author, title of the paper, and sufficient information about the subject matter to enable the reviewing committee to assess its suitability for inclusion in the Technical Program.

Although it will not be necessary to submit a paper in its entirety, Chairman Sinclair urges authors to prepare the necessary material promptly and mail it to him at 275 Massachusetts Avenue, Cambridge 39, Mass. The last possible date for acceptance of material relative to Convention papers is December 1, 1948.

RADIO AUTHORIZATIONS INCREASED

More than 635,000 separate radio authorizations, covering stations and radio operators, were outstanding at the close of the fiscal year, which ended June 30, 1948, the FCC announced. Stations in the broadcast services reached almost the 4000 mark, a gain of more than 400 in the twelve-month period. Stations in the nonbroadcast services exceeded 126,000, a gain of more than 14,000 over the previous year. Of this total, more than 78,000 were amateur stations. Operator licenses and permits approached 505,000, a net of almost 75,000 over the previous year.

Broadcast station authorizations were as follows: AM, 2034; FM, 1020; television, 109; experimental television, 124; educational, 46; international, 37; remote pickup, 571; others, 26; the total being 3967.

Nonbroadcast station authorizations were: aeronautical 20,858; marine, 15,024; public safety, 4903; land transportation, 3122; industrial, 2855; miscellaneous, 1648; amateur, 78,434; all totalling 126,844.

Amateur operators licensed numbered 77,923; commercial operators, 347,000 (estimated); and aircraft operators 79,924; totalling 504,847 operators.

FOREIGN MARKETS DEVELOPING FOR AMERICAN TELEVISION

With an eye to future exports of American television transmitters and receivers, several RMA agencies are taking initial steps to develop a future market overseas for such American television apparatus, even though there is virtually no present foreign market for American television, the domestic demand exceeding the production rate. A technical problem is the general use overseas of 50-cps power, with which American manufacturers of transmitting apparatus have had only limited experience. There are also variations from the American standard of 525 lines in television pictures in some part of Europe and in Latin American Countries.

Books

Basic Mathematics for Radio, by George F. Maedel

Published (1948) by Prentice-Hall, Inc., New York, N. Y. 334 pages, 5-page index, viii pages, 200 figures, 6 1/2 x 9 1/2. \$4.75.

Editions of this work under the title "Mathematics for Radio and Communication" were issued by the same publishers in 1937 and 1939.

As the title indicates, this book deals with fundamental mathematical principles. The connection with radio is, however, not close and is somewhat artificial. Applications to mechanics, physics, surveying, or navigation might with equal justice be urged and illustrated. As a textbook giving a grounding in basic definitions and principles, and for giving the reader some facility in the use of mathematics to solve problems in the above-mentioned fields, the usefulness of the book is apparent. The

TELEVISION DEVELOPMENTS

Regular television stations now on the air have increased to 31, with 110 construction permits outstanding and 308 applications pending. Station WAGA in Atlanta, Ga., is one of the newest television stations to go on the air.

TELEVISION AND RADIO SET OUTPUT HIGH

Television receiver production in June hit a new high, and brought the total television output by RMA members since the war to 463,943. June's production was 64,353.

Radio receiver manufacturers produced 695,315 FM-AM sets during the first half of 1948, as against 445,563 in the comparable period of 1947.

Production of automobile and portable radio receivers continued at a high level: 1,182,262 auto sets and 1,207,754 portables were produced during the first half of this year.

For the second consecutive fiscal year, excise tax collections on radio receivers, phonographs, and certain of their component parts set a new all-time record during the fiscal year ending June 30, 1947. Collections of the 10 per cent radio excise tax for the 1947-1948 fiscal year totalled \$67,266,856.93 against \$63,856,292.16 collected in the 1946-1947 fiscal year.

1500TH TUBE TYPE DESIGNATION

The RMA Data Bureau has registered the 1500th tube type designation, according to RMA Chief Engineer L. C. F. Horle. This figure is not to be confused with the tube type reservations, which have exceeded 2000, for, because of cancellations and other factors, only 1500 registered designations remain.

CANADA CUTS EXCISE TAX

Following protests from the Canadian RMA, Canada has reduced the excise tax on radios from 25 to 10 per cent, which is the same rate that was in effect until last November. Radio set sales have been sharply curtailed since the tax was raised.

author has spared no pains to produce a text of crystal clearness.

The treatment of algebra and of linear and quadratic equations is particularly fine. The chapters on geometry are ample and thorough. The final section, entitled "Radio Mathematics," deals with trigonometry, logarithms, and complex numbers. About 60 pages are devoted to these subjects, as compared to the total length of the book, 270 pages. The treatment of logarithms is sufficiently comprehensive: with the space allotted, only the simple elements of the trigonometric functions and the basic operations on complex numbers can be touched upon. It is in these sections that reference is made to alternating-current theory, but only the student with some previous knowledge of the principles upon which it is based would appreciate its value.

Throughout the book the figures are well

RMA MOBILIZATION COMMITTEE PLANS MUNITIONS BOARD CONFERENCE

The RMA Industry Mobilization Committee met on July 23 with 40 representatives of the Navy Department and the Munitions Board. The conference, which considered a variety of subjects concerning mobilization and procurement problems of the radio and electronic industry, was presided over by Captain A. L. Becker, Assistant Chief of the Bureau of Electronics.

Plans are being made for the formation of an official Industry Advisory Committee to advise the Munitions Board and the National Security Resources Board on radio and communications problems, but announcement of the proposed committee is being delayed pending co-ordination with the NSRB as to what extent that agency intends to participate with the Munitions Board and the committee in its activities of advising the armed services on radio and communications mobilization and procurement problems.

Officials of the Munitions Board explained their current "allocations" of industrial plants among the armed services on an "if and when" basis, with the consent of the plant management; these allocations being made only after an agreement has been reached with the plant management on a purely voluntary basis. Such allocations would become operative only in a national emergency, and would not apply to peacetime operations.

TOWN MEETINGS SCHEDULED FOR ELECTRONIC TECHNICIANS

The first of five Town Meetings for Electronic Technicians authorized by the RMA Board of Directors and the Radio Parts Industry Co-ordinating Committee, was held at the Hotel Astor in New York City from September 27 through September 29.

On November 15, 16, and 17, there will be a similar Town Meeting in Boston at the Hotel Bradford, and there will be others in Atlanta in January, Los Angeles in March, and Chicago in April. Each of the meetings will be completely noncommercial.

chosen and ample, and the text is illustrated by the solution of examples. A generous supply of problems is provided to give the student facility in the use of the text.

This book is adapted to the capacity of students of high-school grade and for the independent student. The only prerequisite is a knowledge of arithmetic.

FREDERIC W. GROVER
Union College,
Schenectady, N. Y.

The Cathode-Ray Tube and Typical Applications

Published (1948) by the Allen B. Du Mont Laboratories, 1000 Main Ave., Clifton, N. J. 63 pages, viii pages, 68 figures. 6 x 9 1/2.

This booklet is a nontechnical discussion of the cathode-ray tube, of especial value as a reference text for students.

Sections

Chairman		Secretary	Chairman		Secretary
W. A. Edson Georgia School of Tech. Atlanta, Ga.	ATLANTA October 15	M. S. Alexander 2289 Memorial Dr., S.E. Atlanta, Ga.	O. W. Towner Radio Station WHAS Third & Liberty Louisville, Ky.	LOUISVILLE	D. C. Summerford Radio Station WKLO Henry Clay Hotel Louisville, Ky.
	BALTIMORE	J. W. Hammond 13 Beaumont Ave. Baltimore 28, Md.	F. J. Van Zeeland Milwaukee School of Eng. 1020 N. Broadway Milwaukee, Wis.	MILWAUKEE	H. F. Loeffler Wisconsin Telephone Co. 722 N. Broadway Milwaukee 1, Wis.
John Petkovsek 1015 Ave. E Beaumont, Texas	BEAUMONT— PORT ARTHUR	C. E. Laughlin 1292 Liberty Beaumont, Texas	K. R. Patrick RCA Victor Div. 1001 Lenoir St. Montreal, Canada	MONTREAL, QUEBEC October 13	S. F. Knights Canadian Marconi Co. P.O. Box 1690 Montreal, P. Q., Canada
R. W. Hickman Cruft Laboratory Harvard University Cambridge, Mass.	BOSTON	A. F. Coleman Mass. Inst. of Technology 77 Massachusetts Ave. Cambridge, Mass.	L. A. Hopkins, Jr. 629 Permanent Quarters Sandia Base Branch Albuquerque, N. M.	NEW MEXICO	T. S. Church 637 La Vega Rd. Albuquerque, N. M.
G. E. Van Spankeren San Martin 379 Buenos Aires, Arg.	BUENOS AIRES	A. C. Cambre San Martin 379 Buenos Aires, Arg.	J. W. McRae Bell Telephone Labs. Murray Hill, N. J.	NEW YORK November 3	R. D. Chipp DuMont Telev. Lab. 515 Madison Ave. New York, N. Y.
J. F. Myers 249 Linwood Ave. Buffalo 9, N. Y.	BUFFALO-NIAGARA October 20	R. F. Blinzler 558 Crescent Ave. Buffalo 14, N. Y.	C. G. Brennecke Dept. of Electrical Eng. North Carolina State Col- lege Raleigh, N. C.	NORTH CAROLINA- VIRGINIA	C. M. Smith Radio Station WMIT Winston-Salem, N. C.
G. P. Hixenbaugh Radio Station WMT Cedar Rapids, Iowa	CEDAR RAPIDS	W. W. Farley Collins Radio Co. Cedar Rapids, Iowa	W. L. Haney 117 Bourque St. Hull, P. Q.	OTTAWA, ONTARIO October 21	G. A. Davis 78 Holland Ave. Ottawa, Canada
K. W. Jarvis 6058 W. Fullerton Ave. Chicago 39, Ill.	CHICAGO October 15	Kipling Adams General Radio Co. 920 S. Michigan Ave. Chicago 5, Ill.	A. N. Curtiss Radio Corp. of America Camden, N. J.	PHILADELPHIA November 4	C. A. Gunther Radio Corp. of America Front & Cooper Sts. Camden, N. J.
C. K. Gieringer 3016 Lischer Ave. Cincinnati, Ohio	CINCINNATI October 19	F. W. King RR 9 Box 263 College Hill Cincinnati 24, Ohio	M. A. Schultz 635 Cascade Rd. Forest Hills Borough Pittsburgh, Pa.	PITTSBURGH November 8	E. W. Marlowe Union Switch & Sig. Co. Swissvale P.O. Pittsburgh 18, Pa.
F. B. Schramm 2403 Channing Way Cleveland 18, Ohio	CLEVELAND October 28	J. B. Epperson Box 228 Berea, Ohio	O. A. Steele 1506 S.W. Montgomery St. Portland 1, Ore.	PORTLAND	F. E. Miller 3122 S.E. 73 Ave. Portland 6, Ore.
C. J. Emmons 158 E. Como Ave. Columbus 2, Ohio	COLUMBUS November 12	L. B. Lamp 846 Berkeley Rd. Columbus 5, Ohio	A. V. Bedford RCA Laboratories Princeton, N. J.	PRINCETON	L. J. Giacometto 9 Villa Pl. Eatontown, N. J.
L. A. Reilly 989 Roosevelt Ave. Springfield, Mass.	CONNECTICUT VALLEY October 21	H. L. Krauss Dunham Laboratory Yale University New Haven, Conn.	K. J. Gardner 111 East Ave. Rochester 4, N. Y.	ROCHESTER October 21	Gerrard Mountjoy Stromberg-Carlson Co. 100 Carlton Rd. Rochester, N. Y.
J. G. Rountree 4333 South Western Blvd. Dallas 5, Texas	DALLAS-FT. WORTH	J. H. Homsy Box 5238 Dallas, Texas	E. S. Naschke 1073-57 St. Sacramento 16, Calif.	SACRAMENTO	W. F. Koch California Div. of Forestry Sacramento 14, Calif.
George Rappaport 132 East Court Harshman Homes Dayton 3, Ohio	DAYTON October 21	C. J. Marshall 1 Twain Place Dayton 10, Ohio	G. M. Cummings 7200 Delta Ave. Richmond Height 17, Mo.	ST. LOUIS	C. E. Harrison 818 S. Kings Highway Blvd. St. Louis 10, Mo.
C. F. Quentin Radio Station KRNT Des Moines 4, Iowa	DES MOINES- AMES	F. E. Bartlett Radio Station KSO Old Colony Bldg. Des Moines 9, Iowa	C. L. Jeffers Radio Station WOAI 1031 Navarro St. San Antonio, Texas	SAN ANTONIO	H. G. Campbell 233 Lotus Ave. San Antonio 3, Texas
A. Friedenthal 5396 Oregon Detroit 4, Mich.	DETROIT October 15	N. C. Fisk 3005 W. Chicago Ave. Detroit 6, Mich.	C. N. Tirrell U. S. Navy Electronics Lab. San Diego 52, Calif.	SAN DIEGO November 2	S. H. Sessions U. S. Navy Electronics Lab. San Diego 52, Calif.
E. F. Kahl Sylvania Electric Prod- ucts Emporium, Pa.	EMPORIUM	R. W. Slinkman Sylvania Electric Prod- ucts Emporium, Pa.	F. R. Brace 955 Jones St. San Francisco 9, Calif.	SAN FRANCISCO	R. A. Isberg Radio Station KRON 901 Mission St. San Francisco 19, Calif.
W. H. Carter 1309 Marshall Ave. Houston 6, Texas	HOUSTON	J. C. Robinson 1422 San Jacinto St. Houston 2, Texas	W. R. Hill University of Washington Seattle 5, Wash.	SEATTLE November 11	W. R. Triplett 3840—44 Ave. S.W. Seattle 6, Wash.
R. E. McCormick 3466 Carrollton Ave. Indianapolis, Ind.	INDIANAPOLIS	Eugene Pulliam 931 N. Parker Ave. Indianapolis, Ind.	F. M. Deerhake 600 Oakwood St. Fayetteville, N. Y.	SYRACUSE	S. E. Clements Dept. of Electrical Eng. Syracuse University Syracuse 10, N. Y.
Karl Troeglen KCMO Broadcasting Co. Commerce Bldg. Kansas City 6, Mo.	KANSAS CITY	Mrs. G. L. Curtis 6005 El Monte Mission, Kan.	A. R. Bitter 4292 Monroe St. Toledo 6, Ohio	TOLEDO	J. K. Beins 435 Kenilworth Ave. Toledo 10, Ohio
R. W. Wilton 71 Carling St. London, Ont., Canada	LONDON, ONTARIO	G. H. Hadden 35 Becher St. London, Ont., Canada			
Walter Kenworth 1427 Lafayette St. San Gabriel, Calif.	LOS ANGELES October 19	R. A. Monfort L. A. Times 202 W. First St. Los Angeles 12, Calif.			

Sections

Chairman	Secretary	Chairman	Secretary
C. J. Bridgland 266 S. Kingsway Toronto, Ont., Canada	TORONTO, ONTARIO T. I. Miller 289 Runnymede Rd. Toronto 9, Ont.	G. P. Adair 1833 "M" St. N.W. Washington, D. C.	WASHINGTON H. W. Wells Dept. of Terrestrial Magnetism Carnegie Inst. of Washington Washington, D. C.
D. A. Murray Fed. Comm. Comm. 208 Uptown P.O. & Federal Cts. Bldg. Saint Paul, Minn.	TWIN CITIES C. I. Rice Northwest Airlines, Inc. Holman Field Saint Paul 1, Minn.	J. C. Starks Box 307 Sunbury, Pa.	WILLIAMSPORT R. G. Petts Sylvania Electric Products, Inc. 1004 Cherry St. Montoursville, Pa.

SUBSECTIONS

Chairman	Secretary	Chairman	Secretary
H. R. Hegbar 2145 12th St. Cuyahoga Falls, Ohio	AKRON (Cleveland Sub-section) H. G. Shively 736 Garfield St. Akron, Ohio	L. E. Hunt Bell Telephone Labs. Deal, N. J.	MONMOUTH (New York Sub-section) G. E. Reynolds, Jr. Electronics Associates, Inc. Long Branch, N. J.
J. C. Ferguson Farnsworth Television & Radio Co. 3700 E. Pontiac St. Fort Wayne, Ind.	FORT WAYNE (Chicago Sub-section) S. J. Harris Farnsworth Television and Radio Co. 3702 E. Pontiac Fort Wayne 1, Ind.	J. B. Minter Box 1 Boonton, N. J.	NORTHERN N. J. (New York Sub-section) A. W. Parkes, Jr. 47 Cobb Rd. Mountain Lakes, N. J.
E. Olson 162 Hasldon Ave., N Hamilton, Ont., Canada	HAMILTON (Toronto Sub-section) E. Ruess 195 Ferguson Ave., S. Hamilton, Ont., Canada	A. R. Kahn Electro-Voice, Inc. Buchanan, Mich.	SOUTH BEND (Chicago Sub-section) October 21 A. M. Wiggins Electro-Voice, Inc. Buchanan, Mich.
A. M. Glover RCA Victor Div. Lancaster, Pa.	LANCASTER (Philadelphia Sub-section) C. E. Burnett RCA Victor Div. Lancaster, Pa.	R. M. Wainwright Elec. Eng. Department University of Illinois Urbana, Illinois	URBANA (Chicago Sub-section) M. H. Crothers Elec. Eng. Department University of Illinois Urbana, Illinois
H. A. Wheeler Wheeler Laboratories 259-09 Northern Blvd. Great Neck, L. I., N. Y.	LONG ISLAND (New York Sub-section) M. Lehenbaum Airborne Inst. Lab. 160 Old Country Rd. Box 111 Mineola, L. I., N. Y.	S. S. Stevens Trans Canada Airlines Box 2973 Winnipeg, Manit., Canada	WINNIPEG (Toronto Sub-section) S. G. L. Horner Hudson Bay Co. Brandon, Av. Winnipeg, Manit., Canada

Books

Nomograms of Complex Hyperbolic Functions, by Jorgen Rybner

Published (1947) by Jul. Gjellerups Forlag, Copenhagen. 12 pages of text, Danish and English in parallel columns, 18 pages of tabulated formulas, 54 pages of nomograms, 2-page index. Paper with spiral-spring binding, 8 1/2 x 12 1/2 inches. Includes celluloid ruler for reading nomograms. 24,000 Kroner.

While the principal content of the book is well described by its title, the additional material included would have justified the subtitle "A Handbook of Transmission-Line and Filter Theory." The contents of the book may be divided into nine sections, the first of which is a preface. The preface is followed by an introduction outlining the development of real and complex hyperbolic functions and giving instructions for the use of the nomograms. The third section gives an extensive list of formulas involving circular and hyperbolic functions, series expansions, and approximate formulas for these functions. The fourth section is a table of multiples of $\pi/2$ to six decimals for use in the reduction of the arguments of complex functions to the range of the nomograms. The fifth section summarizes the formulas ordinarily used in the theory of four-poles, uniform transmission lines, loaded lines, and nondissipative constant- K filters. The sixth section contains thirteen alignment charts for $\cosh(b+ja) = p+jq$, $0 \leq b \leq 4$, $0 \leq a \leq 1.571$. The seventh section contains thirteen charts for $\sinh(b+ja) = p+jq$, $0 \leq b \leq 4$, $0 \leq a \leq 1.571$. The eighth section contains sixteen charts for $\tanh(b+ja) = \theta$,

$0 \leq b \leq 2$, $0 \leq a \leq 1.571$. On most of the charts, b is expressed in both nepers and db and a is expressed in both radians and degrees. The ninth section contains nomograms of $x + jy = r \angle \theta$

$$R \angle \alpha = 1 + r \angle \phi$$

$$br = \ln \left| \frac{Z_1 + Z_2}{2\sqrt{Z_1 Z_2}} \right| = \text{reflection loss}$$

$$a_r = \angle \left| \frac{Z_1 + Z_2}{2\sqrt{Z_1 Z_2}} \right| = \text{reflection phase shift}$$

$$f = (2\pi\sqrt{LC})^{-1}$$

$$K = \sqrt{L/C}$$

The last five sections are separated by colored pages which facilitate the finding of a required set of charts. Each of these colored pages has a diagram showing which chart in the following section should be used to achieve the greatest accuracy, and, in addition, lists the ranges of the variables in each of the following charts.

The nomograms are said to have been computed and plotted to an accuracy of one-hundredth of a millimeter. To preserve this accuracy, the nomograms have been reproduced by the Geodetic Institute of Denmark. The result is a set of the most beautifully drawn and most accurate alignment charts the reviewer has seen. In working out a few test examples, answers were obtained from the charts which agreed well within a per cent with those arrived at using five-place tables and a computing machine.

The only other comparable charts of complex hyperbolic functions with which the reviewer is familiar are the Kennelly charts.¹ The present charts are about one-sixth the size of the Kennelly charts, yet yielded better accuracy than the Kennelly charts in a few test examples. The Kennelly charts present their data as rectangular functions of a rectangular variable, polar functions of a rectangular variable, and polar functions of a polar variable. The new charts present the sinh and cosh functions as rectangular functions of a rectangular variable; the tanh function as a polar function of a rectangular variable. The other forms may be derived from the $x+jy=r\angle\theta$ nomograms with a modest amount of additional labor. The present charts seem well justified by their compact form, ease of reading, and accuracy.

The book is paper bound with a spiral-spring binding at the top so that the alignment charts may be read with the pages flat and without interference from the spring. The text reads from the top down on both sides of each page when the top edge is defined as the edge with the spring. Some other arrangement might have simplified the mechanics of finding the next page.

L. S. NERGAARD
Radio Corporation of America
Princeton, N. J.

¹ A. E. Kennelly, "Chart Atlas of Complex Hyperbolic and Circular Functions," Third Edition, Harvard University Press, Cambridge, Mass., 1924.

Ionospheric Research at Watheroo Observatory, Western Australia, June, 1938-June, 1946, by L. V. Berkner and H. W. Wells

Published (1948) by the Carnegie Institute of Washington. Publication 175, Vol. XIII, 421 pages, 3-page bibliography, v pages, 390 tables. 8½×11.

This is primarily a publication of numerical ionospheric data from the Watheroo Magnetic Observatory in Western Australia, obtained over the period of eight years ending in June, 1946. For each of the 97 months in this period, four pages of data are tabulated, giving for each significant hour of each day the critical frequency and minimum virtual height of the F_2 and F_1 regions, the minimum recorded frequency and minimum virtual height of the F_2 and the F_1 regions, the minimum recorded frequency, and the critical frequency of the E region. An important feature is the qualifying footnotes indicating unusual conditions present, such as ionospheric storm, abnormal E , etc. These tables will be welcomed by the researcher in ionospheric and allied branches of geophysics for the comprehensive picture which they contain of these significant types of data for a single location, taken over a period containing a large part of one sunspot cycle. The total value of this volume, like similar publications in the series giving extended data in geophysics, can be appreciated only after the lapse of many years.

As the introduction states, a similar volume covering measurements at the Huancayo Observatory has been published separately. Originally founded and operated by the Department of Terrestrial Magnetism of the Carnegie Institute of Washington, both the Watheroo and Huancayo observatories have now been presented to the governments of Australia and Peru, respectively, for continued research.

It will be apparent that this is a repository of data rather than a book to be read. On the other hand, the introductory text of 29 pages gives a concise account of methods of ionospheric research employed at the Department of Terrestrial Magnetism, which will be of interest and value to researchers wishing to enter this fascinating field. The "Survey of Results" gives concisely the status of ionospheric research from a geographical point of view which will appeal to the general reader.

Radio investigators may properly feel pride in the role which their researches have played in this field of pure science. Whether at the Carnegie Institute or at other communications laboratories the world over, they have participated in one of the most dramatic scientific explorations of our time. And, in attempting to predict the future of these researches, Berkner and Wells ask many questions to which no answer can as yet be given. One cannot but wonder whether our repertory of astronomical causes is not too limited; whether, for examples, "sporadic E ," or the very existence of "an ionosphere . . . over polar regions in winter" may not have its origin elsewhere than on the sun. In any event, the explanations of these puzzling phenomena, when they come, may have a scientific importance out of all proportion to their significance in radio.

J. C. SCHELLING
Bell Telephone Laboratories
Deal, N. J.

Radar: What Radar Is and How It Works, by Orrin E. Dunlap, Jr.

Published (1948) by Harper and Bros., 49 E. 33 St., New York 16, N. Y. 246 pages, 4-page glossary, 10-page bibliography, 6-page index, xvi pages, 31 figures. 5½×8½. \$3.00.

This is the second edition of a book which first made its appearance in the summer of 1946. All the material in the first edition remains intact, but much is added to the dramatic account of the exploits of radar, part contributed by Commander Edwin O. Wagner, U.S.N., and part through the post-war application of radar to commercial marine navigation. Nowhere has this reviewer seen a more satisfying narrative of the story of radar in action. The nontechnical reader will find it highly informative, as well as exciting. The technical reader will find it stimulating to further invention in the field of radar. Both will be interested in the possibilities of further application of radar to peacetime use.

There are many published accounts of radar that purport to tell what it is and who the inventor was. Since most of them are made to support one or another of several standard "viewpoints" on the subject, it is refreshing to find in Mr. Dunlap's book no evidence of bias, thus making the book one of the most comprehensive and historically accurate popular accounts of radar available. Much of his material, however, is drawn from public releases and private conversations, thus perpetuating some of the confusions from those sources in the book.

One case is the confusion between microwaves and radar. Sixty per cent of all radar equipment being used by the U. S. Navy at the close of the war was of the so-called long-wave type, developed prior to the war. It is, therefore, inaccurate to classify radar as a wartime development. Another case is the confusion between ionosphere probing apparatus and radar. Classifying ionosphere echo equipment as radar does violence to the popular conception of what radar is. Perhaps the greatest confusion is with regard to the identity of original contributors. It would seem that some time, somewhere, some one must have purposefully developed, designed, built, and operated for the first time in history a pulse radar system for the detection of aircraft. One might reasonably expect an author preparing a chapter entitled "Who Invented Radar?" to make some attempt to discover who actually did. But, unfortunately, the confusion on this subject found in past published material is reproduced faithfully in Mr. Dunlap's book.

The volume, as its subtitle indicates, is designed to appeal for the most part to the lay reader. Those technical aspects of radar which might interest the nontechnical reader are given, inoffensively enough, in small, repeated doses. For scientific accuracy and educational effectiveness the book is far outclassed by "Radar—What It Is," by Rider and Rowe.* But for a sensational account of what radar has done and for thought-provoking suggestion of what radar might do, this book in its second edition heads the list of recommended reading.

ROBERT M. PAGE
U. S. Naval Research Laboratory
Washington 20, D. C.

* "Radar—What It Is," by John F. Rider and G. C. Baxter Rowe. John F. Rider, Inc., 1946. Reviewed in the PROCEEDINGS OF THE I.R.E., February, 1947.

Vacuum Tube Circuits, by Lawrence Baker Arguimbau

Published (1948) by John Wiley and Sons, Inc., 440 Fourth Ave., New York 16, N. Y. 657 pages, 10-page index, vii pages, 575 figures. 5½×8½. \$6.00.

This up-to-the-minute textbook on vacuum-tube circuits is intended for those who have previously studied the physics of vacuum tubes, alternating-current circuits, calculus, and Fourier series; in other words, college seniors or first-year graduate students, depending on the educational philosophy of the particular school. It covers the whole gamut of design of present-day radio circuits in considerable detail. There is a nice balance between the use of mathematical theory and experimental techniques as aids to design, and the two are well tied together in discussion, particularly with reference to the age-old question of sidebands. Any student who masters this book will be well on his way to understanding present-day radio circuit design practice.

It is unfortunate, however, that a book containing so much excellent material should be marred by an apologetic attitude on the part of the author, who continually excuses himself for dragging theory into the discussion. This attitude results in the basic theory's being taught piecemeal, rather than as a unit, so that the design of vacuum-tube circuits seems to be a hodge-podge of unrelated topics instead of consistent whole. Professor Arguimbau always knows just how much theory to utilize to aid him in the problem of the moment, but it is doubtful if he has conveyed this knowledge to his readers.

On the whole, this is an excellent reference book on the design of vacuum-tube circuits, but it does not seem to present the philosophy behind such design in a fashion suitable for basic study. It could be very useful in teaching a design course to those who have already had a basic course.

KNOX McILWAIN
Hazeltine Electronics Corp.
58-25 Little Neck Parkway,
Little Neck, L. I., N. Y.

Industrial Project in Statistical Quality Control, by Edward A. and Gertrude M. Reynolds

Published (1948) by Syracuse University, Syracuse, N. Y. 55 pages, 8½×11.

In August, 1947, the Office of Technical Services of the U. S. Department of Commerce appropriated \$19,600 to Syracuse University for a project to be undertaken in the Syracuse area to investigate the actual extent and usefulness of techniques of statistical quality control for industrial employees and the principles of statistical sampling, as well as to evaluate the results of an intensive training and industrial aid program in statistical quality control.

This volume summarizes the methods and results of the survey, concluding that, although results indicate training programs in statistical quality control are worthwhile in an industrial area, the principal barrier to increased use of these methods is management's unfamiliarity with their benefits, rather than either lack of opportunities for their use, or trained personnel to put the methods into effect.

Copies of the report are available from the Institute of Industrial Research, Syracuse University, Syracuse 10, N. Y.

Electronic Instruments, edited by Ivan A. Greenwood, Jr., J. Vance Holdam, Jr., and Duncan MacRae, Jr.

Published (1948) by the McGraw-Hill Book Co., Inc., 330 W. 42 St., New York 18, N. Y. 708 pages, 13-page index, xvii pages, 463 figures. 6½×9½. \$9.00.

One may easily be misled by the title of this work as to the nature of the material discussed, for, of the four major sections, one is on electronic analogue computers, a second on servomechanisms, and a third on voltage and current regulators. Only in the final section on pulse test equipment do the authors discuss a subject that would commonly be classified under "electronic instruments." In every case the discussion has been limited to the wartime work on radio and air navigation done by the Massachusetts Institute of Technology's Radiation Laboratory.

Within these narrow horizons, the authors have dealt exhaustively with details of theory and specific applications, and have effectively catalogued many of the circuits and other tools that may be of use to design engineers, with a discussion of the features of these system building-blocks. The complete book is directed toward the reader who has the mathematical knowledge to appreciate and utilize the approach of a thorough paper analysis of a projected system, but who is rather unsophisticated in the actual steps of design and experimental procedure.

The theoretical discussions of general methods of computer design and of the behavior of servomechanisms are much more forward-looking than those describing particular apparatus. Chapters 8 to 11 are especially recommended to those who desire a depth of understanding of servo systems and of their potentialities for new applications. The transient and the steady-state methods are carried through in parallel in the analysis, and the relative merits of each are assayed for various purposes. The power of the Laplace transformation method in electrical engineering is very evident from these chapters.

The book may also be useful as a reference handbook for a variety of items, such as circuits to perform the fundamental computer operations, servo components, regulated power supplies, and schematic circuit diagrams of various oscilloscopes built for wartime radar set testing. As would be inevitable with a large number of contributing authors—nineteen, in this case—there are great variations in style and clarity. In many places terms are used that are obviously the "shop-talk" of an isolated group of engineers. The emphasis changes abruptly from chapter to chapter.

Another drawback is that the book repeatedly refers to laboratory reports not generally available, or to unpublished work. In some cases, as in the simple description of a saturable reactor on page 442, the choice of reference certainly could not have been due to the lack of suitable published material. Furthermore, the index is not sufficiently complete for a book designed primarily for reference purposes.

Despite limitations, this work provides a valuable record of the accomplishment of a group working intensively in a newly open field of electronic research.

DONALD S. BOND
Radio Corporation of America
Princeton, N. J.

Power System Stability, Vol. 1, by Edward Wilson Kimbark

Published (1948) by John Wiley and Sons, Inc., 440 Fourth Ave., New York 16, N. Y. 347 pages, 7-page index, 1x pages, 63 figures. 5½×8½. \$6.00.

By power system stability is meant the ability of the ac generators of one or more stations of an interconnected system of power stations to remain in step with the other stations of the system under the impact of a short circuit at some specified point of the system. This book is Volume I of a projected series, of which Volume II is to deal with power circuit breakers and relays, and Volume III with the theory of synchronous machines. For an understanding of the present volume, only a familiarity with simple ac circuit theory and the vector diagram of two ac generators in parallel is requisite.

A derivation of the differential equation governing the phase relation of two connected synchronous generators is followed by a thorough treatment of the solution of this equation, by point-to-point methods, to find the "swing curves" of the phase difference of the machines under conditions of faults of differing durations. The reduction of more complicated systems to this fundamental case is made clear by the solution of problems involving networks, such as are met in practice. The influence of varying the duration of a fault with its connection with adjustment of clearance time of protective relays is treated graphically also by the "equal-area assumption." For the most part, three-phase faults are postulated, but the more complicated cases of line-to-line and ground-to-ground faults are also solved by the use of symmetrical components.

A description of the ac calculating board for the solution of networks where many machines are involved is given. In this connection, the addition of an illustrative example of the data derived in such a case and the treatment of the experimental data would round out the treatment.

The last chapter, which gives an account of the results of several surveys of actual existing extended networks, may be of especial interest to the operating engineer, but, on account of the complexity of the systems, will have only a general interest for the general student.

The book should be valuable as a textbook of college grade for electrical engineering students in a field in which available texts are few. The treatment is thorough and clear, but the subject is not one which makes easy reading, and its understanding demands serious study on the part of the reader.

FREDERICK W. GROVER
Professor Emeritus of Electrical Engineering
Union College
Schenectady, N. Y.

Frequency Modulation, Vol. I, edited by A. N. Goldsmith, A. F. Van Dyck, R. S. Burnap, E. T. Dickey, and G. M. K. Baker

Published (1948) by the RCA Review, Princeton, N. J. 515 pages, 313 figures. 6×9½. \$2.50.

The seventh volume in the RCA Technical Book Series, this is the first on the subject of frequency modulation. The papers in this volume, all by RCA authors, cover the period from 1936 to 1947 and are presented in four sections: general, transmission, reception, and miscellaneous, each section including both papers reprinted in full and

several reproduced in summary form only. The language of the book is technical, and its chief appeal is to scientists and engineers interested in frequency modulation.

The editors have been reasonably successful in selecting papers which give a well-rounded picture of the field. This is not an easy task when confined to papers from one organization only, in a field which has aroused so much technical controversy during the past decade.

The book is a handy compilation of much of the early work on frequency modulation, and includes all of Crosby's classical investigations of system characteristics, as well as the excellent theoretical analyses of Corrington. A bibliography is appended which, as a guide to FM literature, is of doubtful utility, since it also includes only RCA authors.

C. W. CARNAHAN
Submarine Signal Company
160 North Washington Street
Boston, Mass.

Television and FM Receiver Servicing, by Milton S. Kiver

Published (1948) by D. Van Nostrand Co., Inc., 1250 Fourth Ave., N. Y., N. Y. 203 pages, 4-page appendix, 4 page index, 1v pages, 371 figures. 8½×11. \$2.95.

This book is a practical treatment of television and FM receiver servicing, theory being presented only insofar as it may be required to indicate how a servicing problem can best be solved. Design considerations are seldom touched upon because, according to Kiver, they are of minor importance to the man charged with responsibility for repairing a set. For the reader's convenience, the book is divided into two sections; the first, consisting of nine chapters, dealing with television; and the second, comprising the four final chapters, dealing with FM.

Electricity, by C. A. Coulson.

Published (1948) by Interscience Publishers, Inc., 215 Fourth Ave., New York 3, N. Y. 247 pages, 6-page index, xii pages, 74 figures. 5×7½. \$3.75.

This book is intended to outline from the very beginning a consistent mathematical account of the phenomena of electricity and magnetism. In many respects, the field covered is similar to that of Maxwell's classical "Treatise on Electricity and Magnetism," the major difference being that the present volume is much shorter, assumes a working knowledge of vector notation, and makes use where necessary of the atomic viewpoint of modern physics. An attempt has been made to build a self-consistent mathematical theory capable of explaining all the more familiar phenomena of electrostatics, magnetism, and electrodynamics. Numerous examples, all with answers, are included.

Electrotecnica de la Alta Frecuencia, by Rafael Pavon Isern

Published (1948) by Libreria General Victoriano Suarez, Preciados, 42, Madrid, Spain. Two volumes, 1456 pages, 1068 figures, 365 pesetas.

This two-volume treatise, written in Spanish, deals specifically with high-frequency electrotechniques, although the work is not limited to the high frequencies alone but includes low frequencies and microwaves as well. Volume I consists of an analysis of linear and nonlinear circuits, while Volume II treats the field of electronics generally, with special attention to vacuum and gas tubes and ultra-high frequencies.

IRE People

Cecil E. Haller (A'34-M'40-SM'45), one of the principal developers of the 829B tube, died recently of leukemia at his home in Lancaster, Pa. Born in Houston, Ohio, on January 15, 1908, Mr. Haller was graduated from Ohio Wesleyan University in 1930 with the degree of B.A. in mathematics and physics. Two years later he received the M.S. degree in applied mathematics from the University of Pittsburgh.

Joining Westinghouse in 1930, Mr. Haller was enrolled in their graduate training course for two years, at the end of which time he was transferred to the Research Department, where he worked on developments pertinent to vacuum tubes until 1934, when he left to enter the employment of the Kenrad Corporation as tube engineer. Two years later he joined the Radiotron Division of the Radio Corporation of America in Harrison, N. J., and was assigned to the design and development of transmitting tubes. At the outbreak of the war he was transferred in the same capacity to RCA's Lancaster, Pa., plant, where, in 1947, he was appointed manager of the engineering section's development shop activity.

Mr. Haller was an associate member of the AIEE and a member of the American Physical Society. He was also a registered professional engineer of the State of Pennsylvania.

William H. Crew (SM'46), formerly assistant dean of students of the Rensselaer Polytechnic Institute, has been named dean of the Air Force Institute of Technology's College of Engineering Sciences at Wright Field, Dayton, Ohio.

Dr. Crew was born in Evanston, Ill., on August 24, 1899. After his graduation from the U.S. Naval Academy in 1922, he matriculated as a graduate student in physics at the Johns Hopkins University, where he received the M. A. degree in 1924 and the Ph.D. degree two years later. From 1925 until 1928 Dr. Crew was assistant physicist at the Naval Research Laboratory. The following year he was appointed assistant professor of physics at the U. S. Naval Academy's postgraduate school, leaving to teach physics at New York University until 1941, during which time he became chairman of the physics department in 1938. At the outbreak of war he joined the Office of Scientific Research and Development as technical aide. When the war ended, in 1945, he became assistant executive secretary of the IRE, leaving in 1946 to become assistant dean of students at Rensselaer.

Dr. Crew is a fellow of the American Physical Society and of the American Association for the Advancement of Science, and a member of Sigma Xi, the American Association of University Professors, and the U. S. Naval Institute.

U. S. Army medals of merit were recently awarded to eight members of the IRE for their distinguished scientific work. The recipients of the medal were: Edward Lindley Bowles (A'22-M'28-SM'43-F'47), Lee Alvin DuBridge (A'35-F'42), Melville Eastham (A'13-M'13-F'25), Ivan Alexander Getting (SM'36), Clarence N. Hickman (A'29-VA'39), Alfred L. Loomis (M'28-SM'43-F'44), Howard Bours Richmond (A'14-M'23-F'24), and Frederick Emmons Terman (A'25-F'37).

William B. Lodge (A'34-M'37-SM'43), the Columbia Broadcasting Co.'s director of general engineering since 1944, has been named vice-president in charge of general engineering.

Born in August, 1907, at Whitemarsh, Pa., Mr. Lodge received both the B.S. and M.S. degrees in electrical engineering from the Massachusetts Institute of Technology in 1931. He had been engaged in vacuum-tube research at the Bell Telephone Laboratories during 1929 and 1930, but, upon finishing school, he joined CBS's engineering department. From 1938 until 1942 he was engineer in charge of the department's radio-frequency division.

During most of the war years Mr. Lodge served as associate director of the airborne instrument laboratory which Columbia University operated for the U. S. Office of Scientific Research and Development, and specialized there in electronic means of detection for military purposes. Mr. Lodge is chairman of Panel 1 (Radio Wave Propagation) of the Radio Technical Planning Board.

Melville Eastham (A'13-M'13-F'25), winner of the Institute's Medal of Honor in 1937, won the 1948 New England Award at the annual meeting of the Engineering Societies of New England. Born in Oregon City, Ore., in 1885, Mr. Eastham became chief engineer of Willyoung and Gibson, instrument manufacturers, in 1905. A year later he was one of the co-founders of the Clapp-Eastham Co. for the manufacture of radio equipment. In 1915 he became president of the newly formed General Radio Co., and has been active in that organization ever since.

Clifford G. Fick (A'25-VA'39-SM'46), formerly receiver division engineer of the General Electric Research Laboratory's electronics department, has been chosen to head a new television division.

A native of Ida Grove, Iowa, Mr. Fick was awarded the B.S. degree in electrical engineering from Iowa State College in 1925. In that same year he joined the General Electric Company's test course, and subsequently was employed in the company's transmitter division, until 1944, when he joined the receiver division.

Lewis Warrington Chubb (M'21-F'40), who has retired from active direction of the Westinghouse Research Laboratories after forty years of service, has been named director emeritus, and will continue to serve in an advisory capacity.

Dr. Chubb was born in 1882 at Fort Yates, Dakota Territory. Upon his graduation from Ohio State University in 1905 with the degree of "mechanical engineer in electrical engineering," he went to work with Westinghouse, in 1907 joining the research division, where he secured over 150 patents for inventions and improvements, many in the development of new radio equipment.

Dr. Chubb was named director of the laboratories in 1930. During World War II he was active in the development of jet propulsion, radar equipment, torpedoes, fire control systems, and high-temperature alloy; and he served as consultant on numerous committees charged with the development of new military equipment and weapons. In 1947 he was awarded the nation's outstanding tribute to scientists and engineers, the John Fritz Medal.

Robert D. Huntoon (A'40-SM'47), Assistant Chief of the Atomic Physics Division, National Bureau of Standards, was presented with one of the two distinguished achievement awards, given by the Washington Academy of Sciences for 1947 to outstanding young scientists in the Washington area, for his research in "the advancement of electronics and its application to other sciences and to modern ordnance."

Born in Waterloo, Iowa, Dr. Huntoon received the B.A. degree from Iowa State Teachers College in 1932. The following year he was granted a graduate assistantship in the physics department of the State University of Iowa, where he specialized in nuclear physics, receiving the Ph.D. degree in 1938. After having taught physics at New York University from 1938 to 1940, Dr. Huntoon became a research physicist in the vacuum-tube division of the Sylvania Electric Products Corp. at Emporium, Pa., leaving in 1941 to join the staff of the Bureau of Standards, where he assisted in the early development of proximity fuzes. His services were lent to the War Department in 1944 and, while acting as expert consultant on proximity fuzes in the office of the Secretary of War, he was sent to the European Theater of Operations as a member of the Advisory Specialists' Group, U.S.S.T.A.F.

Appointed Chief of the Electronics Section in 1945, Dr. Huntoon became Assistant Chief of the Atomic Physics Division when it was formed, working under Dr. Edward U. Condon, Director of the Bureau of Standards.

Dr. Huntoon is the author of a number of scientific papers. He is a member of Sigma Xi and the American Physical Society.

Alfonse D. Sobel (M'44) formerly chief engineer of the A. W. Franklin Manufacturing Corp., has recently been appointed vice-president in charge of television engineering at the same organization.

Born in Belgium on May 24, 1906, Mr. Sobel became interested in radio and television while he was still in school. In 1922, immediately after his graduation from high school in Antwerp, he was employed by the Liberty Radio Co., where he remained until 1926. He worked on custom-built receivers until 1929, when he became chief engineer at the Halson Radio Co., leaving in 1934 to join the Pilot Radio Corp. as director of television. Four years later he joined the Air King Radio Co. as chief engineer. During the war years he helped to design the original BL-IFF equipment, subsequently was involved in the redesign of the TCS equipment, and finally completely redesigned the TS-182 equipment. He was awarded a Certificate of Commendation from the Navy for his "outstanding professional skill . . . in developing field test equipment for highly classified radar identification equipment."

In 1946 Mr. Sobel joined the Franklin Corp. The author of a number of articles of television, Mr. Sobel wrote a monthly television column for the New York *Sun* between 1933 and 1938.

❖

Arthur E. Harrison (A'41-SM'45) has joined the faculty of the University of Washington in Seattle as associate professor of electrical engineering. His work will include teaching and research on ultra-high-frequency and microwave techniques.

Dr. Harrison was engaged in klystron research and applications work at the Sperry Gyroscope Co. until 1946, when he joined Princeton University as an assistant professor of electrical engineering. While at Princeton, he spent the summers in klystron research work at Stanford University and with the Sperry Gyroscope Co. A member of the committee for the IRE Electron Tube Conference at Cornell University, he has also been active in standardization work on klystrons. During 1947-1948 he was secretary-treasurer of the Princeton Section of the IRE.

❖

M. J. Kelley (M'25-F'38), executive vice-president of the Bell Telephone Laboratories, has been named chairman of the U. S. Government's newly constituted Committee on Navigation. The committee will have cognizance of research and development aspects of devices, systems, and techniques applicable to the problems of land, marine, and air navigation and traffic control.

Dr. Kelly has been with the Bell Telephone Laboratories since 1918, when he received the Ph.D. degree from the University of Chicago. He also holds the degree of doctor of engineering from the University of Missouri, and the doctor of science degree from the University of Kentucky. He is a member of the National Academy of Sciences, the American Physical Society, the AIEE, and the Acoustical Society of America.

Jan A. Rajchman (SM'46), research physicist at the RCA Laboratories, will be awarded the 1948 Levy Medal of the Franklin Institute in October for his co-authorship of the paper, "The Electron Mechanics of Induction Acceleration," which appeared in the *Journal of the Franklin Institute*.

Dr. Rajchman was born in London, England, in 1911. He received his diploma in electrical engineering in 1934 and the degree of Doctor of Technical Sciences in 1938 from the Swiss Federal Institute of Technology. Meanwhile, in 1936 he joined the staff of the RCA Manufacturing Co. as a research engineer, and six years later he was transferred to the RCA Laboratories in Princeton. He has been chiefly responsible for the development of the electron multiplier, and is working now in the field of electronic computing devices. He is a member of Sigma Xi and the American Physical Society.

❖

George M. Lebedeff (A'36), formerly chief engineer of Heinz and Kaufman, Ltd., has joined the Lenkurt Electric Co., at San Carlos, Calif., as a carrier engineer. A specialist in quality control, Mr. Lebedeff introduced into the San Francisco area the first wartime statistical quality control system on electron tubes. Earlier, after graduation from the University of California, Mr. Lebedeff was associated with the Federal Telegraph Co., at that time in Palo Alto, Calif. He is a member of the American Statistical Association.

❖

R. A. Hackbusch (A'26-M'35-F'47), vice-president and managing director of the Stromberg-Carlson Co., Limited, of Canada, was elected vice-president of the Radio Manufacturers Association of Canada. Associated for many years with the development of the Canadian radio industry, Mr. Hackbusch is also vice-president of the Canadian Radio Technical Planning Board and a fellow of the Radio Club of America. For three years, 1940 to 1943, Mr. Hackbusch was director of the radio division of the Canadian Government Research Enterprises, Limited, returning to the Stromberg-Carlson Co. at the end of that period.

❖

Joseph I. Heller (SM'46), now design supervisor at the Hazeltine Electronics Corp. in Long Island, has been given the Navy Certificate of Commendation for his work as chief engineer of the Panoramic Radio Corp., New York, during the war. The certificate was awarded for his "outstanding assistance to the Navy Department and the Naval Research Laboratory in designing panoramic circuits for use in radio and radar intercept receiving equipments."

Mr. Heller became chief engineer of the Wireless Egert Engineering Co., New York, N. Y., in 1929, upon his graduation from the Brooklyn Polytechnic Institute. In 1933 he left to become chief radio engineer of the Breeze Corp., Newark, N. J., where he remained until 1940, when he joined Panoramic. In 1947 he became a member of the Hazeltine organization's engineering staff.

D. C. Summerford (A'39-M'44), former assistant technical director of radio station WHAS, has been appointed technical director for the Mid-America Broadcasting Corp. of Louisville, Ky., now installing a new 5000-watt station.

Mr. Summerford was born in Bexar, Ala., in 1906. After receiving the B.S. degree in civil engineering from the Alabama Polytechnic Institute in 1930, he became a technical employee of the American Telephone and Telegraph Co., leaving to join station WHAS, where he acted as technical director during the war. He is also president of the Shawnee Broadcasting Co.

A member of the BTPB panel on facsimile broadcasting, Tau Beta Pi, and Phi Kappa Phi, Mr. Summerford has been an active amateur radio operator since 1930, and currently holds the call W4FR. He was instrumental in the establishment of the Louisville Section of the IRE and was recently re-elected Secretary-Treasurer.

❖

William J. Merchant (SM'37), deputy executive director of the Research and Development Board's Committee on Electronics, has been named executive director of the U. S. Government Committee on Navigation.

After receiving an engineering degree from Johns Hopkins University in 1930, Mr. Merchant became associated with the technical staff of the Bell Telephone Laboratories. During World War II he served as head of the Air Navigation Design Section of the Bureau of Ships, completing his naval assignment with the rank of commander. He was cited by the Navy for outstanding performance of duty in the design and development of radar control approach equipment. Mr. Merchant is a member of Tau Beta Pi.

❖

Charles F. Stromeier (A'29-VA'39), vice-president and director of the Hytron Radio and Electronics Corp. of Salem, Mass., was recently also elected president of Remco Electronics, Inc., of New York, N. Y.

Mr. Stromeier has been associated with the radio tube industry since 1928, and is the developer of the dynamic-coupled output tubes introduced in the nineteen-thirties, at which time he presented papers to the IRE upon their operation. In 1942 he joined Hytron, with which he has been ever since.

❖

James H. Ludwig (A'37-VA'39) has become president and treasurer of the Control Engineering Corp. of Canton, Mass., which he, together with W. A. Jones, formed this year.

Upon receiving the M.S. degree in physics from the University of Michigan in 1936, Mr. Ludwig joined the engineering department of the Philco Radio and Television Corp. In 1938 he left to become a design engineer on commercial receivers and military airborne equipment with the RCA Victor Co. in Camden, N. J., where he was employed until 1944, when he was appointed department manager of an engineering group working on confidential Navy projects at the Raytheon Manufacturing Co.



William A. Edson

Chairman, Atlanta Section, 1948-1949

William A. Edson, professor of electrical engineering at the Georgia Institute of Technology, was born at Burchard, Neb., on October 30, 1912. At the University of Kansas he majored in electrical engineering, receiving the degrees of B.S. and M.S. in 1934 and 1935, respectively.

The following two years Dr. Edson spent at Harvard University on a fellowship. Upon receiving the degree of D. Sc. in communications in engineering in 1937, he joined the systems development department of the Bell Telephone Laboratories in New York City, where he participated in the planning and development of the terminal apparatus of the J2 and L1 carrier telephone systems, and contributed to advances in amplifiers for oscilloscope and radar applications.

In 1941 Dr. Edson joined the Illinois Institute of Technology at Chicago as assistant professor of electrical engineering. Two years later he returned to Bell to engage in research for the Army, working on the development of the microwave echo box, a device for testing and maintaining radar systems.

Dr. Edson accepted the position of professor of physics at the Georgia Institute of Technology in 1945, transferring to his present position a year later. In addition to his classroom duties, he directs several independent and government-sponsored research projects.

Dr. Edson joined The Institute of Radio Engineers as a Senior Member in 1941. He is also a member of the American Physical Society and the Georgia Society of Professional Engineers.



William H. Carter, Jr.

Chairman, Houston Section, 1948-1949

William H. Carter, Jr., was born in Houston, Tex., on October 2, 1907. After studying at the University of Texas in Austin, he joined the Texas Photo Supply Company in 1928 as a photographic technician, leaving to become manager of the Carter Music Company's radio department.

In 1931 Mr. Carter organized the Riverside Radio Company, where he engaged in radio and electronic servicing, as well as in research and design on electronic equipment used in oil exploration. Eight years later he joined the research staff of the Halliburton Oil Well Cementing Company as a research engineer.

At the beginning of the second World War, Mr. Carter accepted the invitation of The Johns Hopkins University's applied physics laboratory to join their staff as an associate physicist and senior engineer on the VT fuze project. With the VT fuze in production, he returned to Houston to become a member of the Electro Mechanical Research Company's staff. There he worked on the development of high-vacuum techniques for the manufacture of infrared bolometers, used in guided bomb and rocket projects.

At the close of the war Mr. Carter joined the research staff of the Schlumberger Well Surveying Corporation, leaving in 1948 to engage actively in the management of the Carter Music Company, of which he is co-owner and vice-president.

Mr. Carter became a Member of The Institute of Radio Engineers in 1946 and was transferred to the grade of Senior Member the following year. He is also an Associate Member of the Society of Motion Picture Engineers.

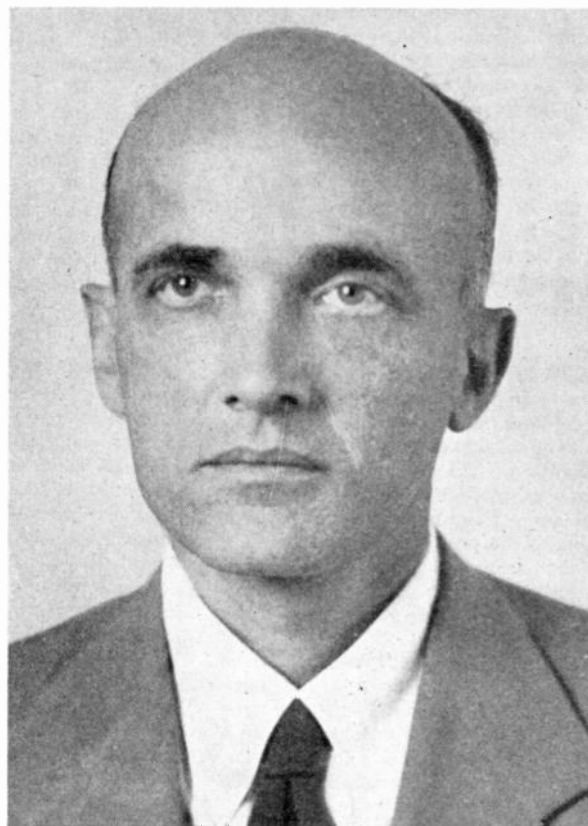

Nuclear Reactions and Nuclear Energy*

S. N. VAN VOORHIS†, SENIOR MEMBER, IRE

Workers in the communications and electronic field have contributed substantially to the development of methods and equipment for instrumentation and control of nuclear processes. The readers of these PROCEEDINGS will therefore be interested, and find material of value, in papers dealing with the bases of nuclear or subatomic phenomena. Through such papers, they may more readily understand the problems and methods encountered in this domain. Accordingly, the Board of Directors of The Institute of Radio Engineers has approved the publication in the PROCEEDINGS of a series of such papers, of which the following instructive presentation is a useful example.—*The Editor.*

WHEN A CHEMIST studies a chemical reaction, he is likely to seek answers for one or more of the following sorts of questions:

- (1) What is the reaction, both qualitatively and quantitatively; e.g., what are the ingredients and the products and how much of each is involved?
- (2) At what rate does the reaction proceed under specified conditions?
- (3) How much energy is liberated or absorbed in the course of the reaction?
- (4) How much energy must be present in the reacting mixture before the reaction will proceed spontaneously; i.e., what is the activation energy?

A nuclear reaction may be approached from much the same standpoint, although the questions are often phrased somewhat differently. It is then found that the most spectacular and significant characteristics of nuclear reactions arise from the large magnitude of the quantities analogous to (3) and (4) above. It may, therefore, be helpful to explore in somewhat more detail the relation between ordinary and nuclear chemistry.

The concept of the atomic constitution of matter is one of the cornerstones of modern science. It asserts that there are a comparatively small number of types of building blocks or atoms (ninety-six, if we include the man-made varieties) out of which the wide diversity of substances around us is built up. Each such substance is made up of molecules, all alike, which in turn consist of combinations of atoms. Thus, water is made up of molecules each one of which contains two atoms of hydrogen and one atom of oxygen, as expressed by its chemical formula H_2O . If we form water by burning a mixture of hydrogen and oxygen gas, the reaction actually proceeds atom by atom or molecule by molecule, though we are accustomed to viewing it on a much larger scale. If, for example, we are measuring the energy released, we shall probably use weighable quantities containing a very large number of atoms, and determine the total energy evolved. We might then find

that the formation of one gram of water is accompanied by the evolution of heat amounting to 3.8 kilocalories. If we burn one gram of coal, we get on the average about 7.2 kilocalories. One gram of gasoline would yield about 11 kilocalories. One gram of TNT, on the other hand, gives only 3.6 kilocalories, but yields this amount very rapidly, thereby serving as an explosive.

Thus we see that there is not a particularly wide variation in the amount of heat or energy release accompanying typical chemical reactions. On the other hand, if one gram of uranium undergoes complete fission, the energy release amounts to about *twenty million* kilocalories, a wholly different order of magnitude.

As soon as we begin to examine the picture on a smaller scale in order to fill in more detail, a different unit of energy, the electron volt, becomes more convenient. It is defined as the amount of energy delivered to a particle bearing a charge numerically equal to the charge of the electron (or proton) by acceleration through a potential difference of one volt. Thus if we have a cathode-ray tube with a total accelerating voltage of 2000 volts, each electron hitting the screen has an energy of 2000 electron-volts. (The abbreviations ev, kev, and Mev are ordinarily used for electron volts, thousands of electron volts, and millions of electron volts, respectively.) The relation between these two energy units is

$$1 \text{ ev} = 3.83 \times 10^{-23} \text{ kilocalories.}$$

Let us now go back to the previous example, the formation of one gram of water. This amount of water contains

$$\frac{6.02 \times 10^{23}}{18} = 3.4 \times 10^{22} \text{ molecules.}$$

The energy release per

molecule is therefore 1.1×10^{-22} kilocalories or 2.91 ev.

We now recall that the atom itself has been shown to possess structure, consisting of a small massive nucleus bearing a positive charge, around which are disposed electrons. Although it is no longer the custom to picture the electrons as revolving in definite orbits like a miniature solar system, they are still assigned to shells or

* Decimal classification: 539. Original manuscript received by the Institute, August 4, 1948.

† University of Rochester, Rochester, N. Y.

energy states characterized, among other things, by the average distance from the nucleus and the amount of energy required for complete removal of the electron from the atom. These shells have been designated as the *K*, *L*, *M*, *N*, . . . etc., shell, the *K* shell being the one closest to the nucleus. Being closest to the positively charged nucleus, the *K* shell represents the state of lowest potential energy for the negatively charged electron. It would seem, therefore, that all the electrons of a given atom would settle down into the *K* shell. They do not do so, however, but appear to be governed by the so-called Pauli Exclusion Principle, which sets an upper limit to the number of electrons in a given shell. In the *K* shell there can be no more than two electrons, in the *L* shell no more than eight, in the *M* shell no more than 18, etc. In any atom in the normal state, the electrons are pictured as so disposing themselves around the nucleus within the limitations of the exclusion principle as to give the lowest total energy content to the atom as a whole.

An oxygen atom containing 8 electrons will then have 2 electrons in the *K* shell and the other 6 in the *L* shell. At the other end of the periodic system, an atom of mercury with 80 electrons has the following arrangement:

<i>K</i>	2	<i>N</i>	32
<i>L</i>	8	<i>O</i>	18
<i>M</i>	18	<i>P</i>	2

One of the *P* electrons, being farthest from the nucleus, is the easiest to remove entirely. It is found that an amount of energy equal to 10.419 ev is required. On the other hand, to remove one of the *K* electrons from a mercury atom requires 83.3 kev. If we compare these energy values with the energy release per molecule in a typical chemical reaction, amounting to a few electron volts, we may conclude that it is only the outermost electrons of any atom that take part in a chemical reaction. The apparent size of an atom, so far as its chemical properties are concerned, will then be given by the dimensions of the outermost shell of electrons, a sphere of radius a few units of 10^{-8} cm. We may go further and say that the chemical properties of an atom are determined entirely by the outermost group of electrons. Any two atoms having the same arrangement of outer electrons will act the same chemically. If the two atoms have the same total number of electrons, the arrangement will be the same. The two atoms will have the same number of electrons, if each nucleus has the same positive charge. Hence isotopes, atoms having nuclei of identical positive charge but differing mass, are indistinguishable chemically. Conversely, no chemical reaction affects the innermost part of the atom wherein the nucleus lies. It is therefore impossible to affect the nucleus in any way, in particular to cause the transmutation of one element into another, by chemical means, thereby stamping as impossible the dream of the medieval alchemists.

So far in this discussion no structure has been assigned to the nucleus itself. It has been pictured as a small sphere, of radius about 10^{-12} cm, carrying a positive charge equal in magnitude to *Z* times the charge on the electron (*Z* being the atomic number), and bearing most of the mass of the atom. It is the present belief that the nucleus is composite, being made up of two types of particles, protons and neutrons. The proton carries a positive charge equal in magnitude to that of the electron and is roughly 1800 times as heavy as the electron. The neutron has about the same mass as the proton but no electric charge. On this picture any nucleus is made up of *Z* protons and (*A*−*Z*) neutrons, *A* being the so-called mass number of the atom in question. Every nucleus is characterized by the number of neutrons and protons it contains. To change one type of nucleus into another—in other words, to produce a nuclear reaction—we must change the number of neutrons, or the number of protons, or both. We may either add particles to the nucleus or cause the ejection of some that are already there; we may add one or more particles of one type and simultaneously cause the ejection of one or more of the other type. In any case, the agency causing the nuclear reaction must actually penetrate to the nucleus itself and must have whatever amount of energy is required to permit such penetration.

Study of the properties of atomic nuclei has shown that a wholly new type of force is active between the nuclear constituents, or nucleons (nucleon is used to represent either a proton or a neutron in situations where no distinction need be made between the two types of particles), when they approach one another as closely as is the case in the nucleus. Previously, gravitational forces characterized by Newton's law

$$f = G \frac{mm'}{r^2}$$

and electrical forces given by Coulomb's law

$$f = \frac{qq'}{r^2}$$

had been the only ones needed. To these must now be added the nuclear forces, the exact nature of which constitutes one of the most challenging problems in present-day physics. It is known that these nuclear forces are exceedingly powerful, and that they are effective only at very small distances. In addition, they have the important property known as saturation; qualitatively, this means that if nucleon *A* and nucleon *B* have come near one another and experienced a force of attraction, nucleon *C* on approaching the pair will not find this same force emanating from *A* and *B*. In still other words, one nucleon is capable of interacting with only one other nucleon at a time.

It is these immensely powerful nuclear forces that are capable of holding all the *Z* protons together in the nucleus, in spite of the strong repulsive forces due to the

positive charges. If, however, we should attempt to bring up another proton from outside, the nuclear forces, being effective only at very small distances (having a short range), would not come into play until the extra proton is practically within the nucleus. The electrical forces are effective at much greater distances, and to overcome them the proton being brought in must be given a fairly considerable amount of energy. Very approximately, we may compute that to bring a proton into a nucleus of atomic number Z requires an amount of energy

$$E = 0.78Z^{2/3} \text{ Mev.}$$

This energy might be given to the proton by acceleration in a vacuum tube across which a high voltage is applied. We see at once that the voltage needed is measured in millions of volts.

If instead of a proton we attempt to bring up a second nucleus, say of atomic number Z' , the energy required is multiplied by Z' . (Actually, the calculation is more complicated even on the approximate picture used here, but the energy required is not changed by very much.) In these calculations no account has apparently been taken of the electrons normally surrounding the bombarded nucleus. It might at first be thought that, since the electrons have as much negative charge as the nucleus has positive charge, the electric field of the nucleus would be neutralized by that of the electrons, and another charged particle such as the bombarding particle would experience no force. Such is indeed the case at distances large compared with the dimensions of the atom, but when the separation between the target nucleus and the incident nucleus becomes comparable with the nuclear radius, the effect of the electrons has almost completely vanished; little error is made, therefore, if the electrons are neglected completely. This behavior is predicted by the Heisenberg Uncertainty Principle.

The only way to avoid these electrical forces between the target nucleus and the incident particle is to use a completely uncharged particle such as the neutron for bombardment. Unfortunately, however, the neutron does not normally exist as a free particle in nature, but must be produced by some other nuclear reaction. In practically every nuclear reaction, therefore, there must be some method for imparting high energy to a bombarding particle, either artificially as by a cyclotron, betatron, or other type of accelerator, or by taking advantage of the high-energy particles emitted by the naturally radioactive elements. In the chemists' terms we may then say that almost all nuclear reactions have a very high activation energy.

Some consideration of the famous Einstein relation $E = mc^2$ is now in order. This equation states that with a mass m grams there is associated an energy E ergs, c being the velocity of light in vacuum, 3×10^{10} cm/sec. Alternatively, the mass may be expressed in kilograms; the energy in joules, and c in meters/sec., 3×10^8 .

Thus with one kilowatt-hour of energy is to be associated 4×10^{-11} kilograms, or about one ten-billionth of a pound.

In the nineteenth century the two laws, conservation of matter and conservation of energy, had become firmly ensconced. The idea of the transformation of energy from one form to another, mechanical to electrical, electrical to heat, etc., was perfectly acceptable, as was the transformation of matter, ice to water to steam, coal plus air to carbon dioxide, etc. There was, however, no thought of any connection between the two. The energy content of the universe was regarded as one entity fixed for all time, and the matter content as another similarly fixed entity. Einstein's relation changes this completely by saying that matter and energy are merely different manifestations of the same thing, and that wherever the one is found the other is also present. There appears then only a single conservation law, that of matter and energy taken jointly. The contrast between the predictions on the new basis and on the old may be shown in the previously used example of the formation of water by burning hydrogen and oxygen. According to classical views, if $1/9$ gram of hydrogen and $8/9$ gram of oxygen combine, the result will be *exactly* 1 gram of water. On the other hand, the modern view notes that an amount of energy 1.59×10^{11} ergs (1 kilocalory = 4.18×10^{10} ergs) has been liberated, and

$$\text{with it an amount of mass } \frac{1.59 \times 10^{11}}{9 \times 10^{20}} = 1.8 \times 10^{-10}$$

grams has escaped. The mass of the resulting water is therefore *less* than one gram by this amount. The difference is obviously too small to be detected by even the most refined chemical measurements. But if we consider a nuclear reaction in which the energy release per atom may be a million times as large, the mass change becomes easily measurable and agrees as accurately as we can measure with the predictions of the Einstein relation. Sufficiently accurate mass measurements on all the ingredients of a nuclear reaction therefore make possible the prediction of the amount of energy release in the reaction. By weighing all the various species of atoms, a table of masses may be constructed from which the information necessary to compute the energy release in any desired reaction may be obtained. Since the mass of a single atom is exceedingly small, it is inconvenient to use a conventional unit of mass such as the gram. Instead, an arbitrary unit closely allied to the chemists scale of atomic weights is used. This unit is by definition one-sixteenth the weight of a single neutral atom of the most abundant isotope of oxygen; i.e., the mass of this oxygen isotope is taken to be 16.0000. One mass unit is equal to 1.66×10^{-24} grams.

A few representative values of atomic masses are given in Table I. The ordinary chemical symbol for the various elements is used together with a superscript indicating the mass number, and a subscript to the

left indicating the atomic number. The subscript is therefore equal to the number of protons in the nucleus, and the superscript to the total number of particles, neutrons, and protons. Except in the case of the neutron, which is included for convenience, the mass values refer to the neutral atom.

TABLE I

1_0n	1.008941	${}^{63}_{29}\text{Cu}$	62.956	${}^{132}_{54}\text{Xe}$	131.946
${}^1_1\text{H}$	1.008130	${}^{64}_{30}\text{Zn}$	63.956	${}^{208}_{82}\text{Pb}$	208.057
${}^2_1\text{D}$	2.014708	${}^{86}_{36}\text{Kr}$	85.939	${}^{232}_{90}\text{Th}$	232.12
${}^4_2\text{He}$	4.00390	${}^{118}_{50}\text{Sn}$	117.939	${}^{238}_{92}\text{U}$	235.12
${}^{25}_{11}\text{Mn}$	54.957	${}^{119}_{50}\text{Sn}$	118.938		
${}^{56}_{26}\text{Fe}$	55.9568				
${}^{57}_{26}\text{Fe}$	56.957				

Let us now examine some of the inferences that may be drawn from such mass values. Consider first an atom of the heavy isotope of hydrogen, deuterium. The nucleus, known as the deuteron, is assumed to consist of one proton and one neutron, and one external electron completes the atom. If we compare the mass of the deuterium atom with the sum of the masses of a hydrogen atom and a neutron, we see that the latter quantity is larger by 0.002363 mass units. This discrepancy represents the amount of energy that has been liberated, and has therefore left the system, when the neutron and proton have become joined together as a deuteron. To separate them again, an equal amount of energy must be brought in from the outside. If this is done, the masses will again be those of the separate constituents. It is convenient to have a relationship between the mass unit and some more common energy unit such as Mev. The expression is

$$1 \text{ mass unit} = 931 \text{ Mev.}$$

The mass difference computed above for the deuteron and its components therefore corresponds to 2.20 Mev.

We may make a similar comparison between the mass of a helium atom and the sum of two neutrons and two hydrogen atoms. The mass difference is seen to be 0.0302 or 28.1 Mev. The helium nucleus, or alpha particle, is thus seen to be very tightly bound together.

Let us next compare the atoms ${}^{55}_{25}\text{Mn}$ and ${}^{56}_{26}\text{Fe}$. These atoms differ by one proton in the nucleus and one electron in the outer structure. We may therefore subtract the mass of the iron from the sum of the masses of manganese and hydrogen, obtaining 0.0083 mass units or 7.7 Mev. The pair of atoms ${}^{63}_{29}\text{Cu}$ and ${}^{64}_{30}\text{Zn}$ are similarly related, and give for the mass difference 0.0081 or 7.5 Mev. This amount of energy is liberated when a proton becomes bound to another nucleus. It is therefore spoken of as the *binding energy* of the proton. For most nuclei that are neither too light nor too heavy, i.e., not too near either end of the periodic system, the binding energy of a proton is about 7.5 Mev.

Let us next consider the atoms ${}^{56}_{26}\text{Fe}$ and ${}^{57}_{26}\text{Fe}$. These differ only by one neutron in the nucleus. Their mass difference may therefore be compared with the mass of a neutron, giving a mass loss of 0.0087 or a

binding energy of 8.1 Mev. Similarly, the two tin isotopes listed differ by just one neutron. For them the binding energy is 9.2 Mev. For most nuclei not too light or too heavy the binding energy of a neutron is about 8 Mev.

Finally, let us compare the mass of an atom of thorium ${}^{232}_{90}\text{Th}$ with the sum of the masses of ${}^{86}_{36}\text{Kr}$, ${}^{132}_{54}\text{Xe}$, and fourteen neutrons. The total number of elementary particles is the same in each case, so any mass difference must represent binding energy. We see that the combination of krypton, xenon, and neutrons is lighter than the thorium atom by 0.11 mass units, or 102 Mev. If, therefore, the thorium nucleus were to come apart in this particular manner, energy to the amount of 102 Mev would be liberated. Nuclei of various heavy elements, uranium and plutonium being the most famous, do indeed come apart in much this manner in the process of fission. The constituents are so distributed among the fragments, however, as to give even more energy release on the average, the value being about 180 Mev. As a result of the fission process, the loss of mass is somewhat less than 0.1 per cent of the total. If some process could be discovered whereby *all* of the reacting mass could be annihilated or transformed into energy, the energy release would be measured in billions of electron volts per atom, or billions of times the energy release in a chemical reaction.

In order to specify a nuclear reaction, the bombarded nucleus, the projectile, and the products must be given. A typical reaction might then be written



Another similar one might be

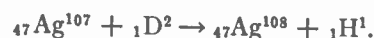

In each case a deuteron is the bombarding particle and a proton is one of the products. These reactions may therefore be termed (*D, p*) reactions. A conventional notation that is convenient is ${}^{63}_{29}\text{Cu}(D, p){}^{64}_{29}\text{Cu}$ and ${}^{107}_{47}\text{Ag}(D, p){}^{108}_{47}\text{Ag}$. Other types of reactions may be written similarly, and may be catalogued into a few general categories such as the following:

(<i>p, n</i>)	(<i>D, n</i>)	(<i>n, p</i>)	(γ, n)	(α, n)
(<i>p, D</i>)	(<i>D, p</i>)	(<i>n, D</i>)	(γ, p)	(α, p)
(<i>p, \alpha</i>)	(<i>D, \alpha</i>)	(<i>n, \gamma</i>)	($\gamma, 2n$)	($\alpha, 2n$)
(<i>p, \gamma</i>)	(<i>D, 2n</i>)	(<i>n, \alpha</i>)	($\gamma, 3n$)	(α, pn)
(<i>p, 2n</i>)	(<i>D, 3n</i>)	(<i>n, 2n</i>)		
		(<i>n, 3n</i>)		

The symbols used, *p, D, n, \alpha, \gamma*, stand respectively for proton, deuteron, neutron, alpha particle, and gamma-ray photon. In cases where more than one particle emerges, the fact is indicated by the appropriate figure. Not all possible reactions are included in the above list; in particular, the very important case of fission is omitted, since it does not fall naturally into this nomenclature. Some general remarks may now be made about the energy that the projectile must have to initiate the reaction and the energy release or absorption. If energy

is released in the reaction, the projectile need have only enough energy to get into the nucleus from the outside. An approximate value has already been calculated for the case of a particle bearing a single charge, such as the proton or deuteron. For the alpha particle, the corresponding energy is twice as great. At this point, however, quantum physics makes an important alteration. Classical physics held that the projectile either would or would not get into the nucleus, according to whether or not its energy were above the calculated value. The modern theories predict that the particle has some chance of getting into the nucleus, even if its energy is somewhat below the critical value. The probability that the particle will get in decreases rapidly as its energy falls below the threshold, but the probability does not become *strictly* zero even for quite low energies.¹ If, therefore, we try often enough, that is, bombard enough nuclei with enough particles, we shall get some particles into the nucleus at fairly low bombarding energy. It was this circumstance that permitted the accomplishment of the first nuclear transmutations by artificially accelerated particles, even though the maximum accelerating voltage available was below the value apparently needed.

Even with such help (which stems fundamentally from the wave theory of matter introduced by de Broglie), a proton or deuteron will not succeed in getting into a nucleus of moderate Z , say silver ($Z=47$), often enough to permit convenient study, let alone any further application, unless its energy is at least 6 Mev or so. Similarly, an alpha particle requires about 12 Mev. These values are to be compared with the earlier ones, 11 and 22 Mev.

The neutron and gamma-ray photon, being electrically neutral, have no repulsive field to overcome. Thus even a very low-energy neutron can penetrate a nucleus. Once in, it is bound by the nuclear forces to the extent of the 8 Mev computed previously. The energy so liberated generally leaves the nucleus in the form of one or more gamma-ray quanta, so the reaction is described as (n, γ) . Since this reaction may proceed even with neutrons having an energy of tenths or even hundredths of an electron volt, it is not surprising that neutrons do not exist normally in the free state.

The only sort of reaction that a gamma quantum can initiate is one in which one or more particles are ejected

¹ It should be emphasized that the behavior described here is not a case of getting something for nothing. The situation may be stated somewhat more precisely as follows. Suppose that a particle is moving in a field derivable from a potential. The regions of space accessible to the particle are those in which its kinetic energy is positive. Let there be two such regions of space separated everywhere by a narrow region from which the particle is excluded. According to classical physics, a particle placed in one of these allowed regions will stay there forever; according to quantum physics, the particle has some chance of leaking through the forbidden region into the other allowed zone. The forbidden zone is usually called a potential barrier. In a pictorial sense, the allowed regions may be considered as valleys separated by a mountain range. A cow in one of the valleys is then able to appear suddenly in the other valley without apparently ever having climbed as high as the mountain range. Unfortunately for alpinists, the process only works for a particle as small as a proton or electron.

from the nucleus. The binding energy of these particles must be supplied by the gamma ray. Therefore, gamma rays are not effective in producing nuclear reactions unless their quantum energy is several million electron volts.

In a reaction such as (n, p) the energy gained by binding the neutron to the nucleus approximately suffices to free the proton. It might at first be thought, therefore, that the reaction would proceed even with fairly low-energy neutrons. Detailed consideration shows, however, that the reaction has very low probability unless the proton emerges with a kinetic energy that would permit it to penetrate a similar nucleus with reasonable ease. This kinetic energy must be supplied by the incident neutron, which, for this reason, must usually have an energy of 6 or 7 Mev. On the average a similar requirement holds for the energy of the proton in the converse reaction (p, n) .

Finally, in the reactions such as $(n, 2n)$, and $(n, 3n)$ where several particles leave, the binding energy of the extra particles must be supplied by the bombarding neutron. We therefore obtain approximate threshold values of 8 and 16 Mev, respectively.

Let us now consider a hypothetical experiment in which protons are accelerated in a cyclotron to an energy of say 7 Mev, and then allowed to strike a sheet of silver. Among other results are the production of two new radioactive isotopes of cadmium by way of a (p, n) reaction; that is, ${}_{47}\text{Ag}^{107}(p, n){}_{48}\text{Cd}^{107}$ and ${}_{47}\text{Ag}^{109}(p, n){}_{48}\text{Cd}^{109}$. However, only about one proton in a million succeeds in producing such reactions. The rest of the protons lose their energy by interaction with the extranuclear electrons of all the various silver atoms past which the proton must go before it happens to approach a nucleus sufficiently closely to have a chance to penetrate. Even if the nuclear reaction were to result in a reasonably large energy release, the process as a whole would be very inefficient because of the large number of bombarding particles that do not produce a reaction.

That the situation is otherwise in the case of fission chain reactions is obvious, one important feature being the absence of any competing process for dissipating the energy of the neutrons in a manner analogous to the interaction between the protons and electrons in the previous case. Equally important is the fact that the neutron can still cause fission, even though it has lost most of its energy.

One last topic to be considered is the effect of temperature on reactions, either chemical or nuclear. We see such effects in chemical reactions frequently: when the gas is turned on in the kitchen stove, nothing happens; that is, there is no reaction, until a lighted match is brought up. The match flame raises the temperature of some of the gas-air mixture to the point where the reaction begins. Once started, the chemical reaction liberates enough heat to maintain the new supply of gas and air at a high-enough temperature. It will be recalled that the whole phenomenon of heat is supposed to be a mani-

festation of the random motion of the molecules making up all matter. The average kinetic energy of the molecules is proportional to the temperature (measured on the so-called absolute or Kelvin scale). At ordinary room temperature, $\approx 300^\circ\text{K}$, the average kinetic energy of a molecule, in any substance, is about $1/30$ ev. About one in ten thousand has an energy ten times as high, and about one in a hundred million has twenty times this amount. If the reaction of combustion requires that molecules approach with energies of the order of 1 ev, we see therefore that such encounters would be exceedingly unlikely at room temperature, but relatively probable if the temperature is raised a few hundred degrees. Now consider the nuclear reaction: here we have seen that, except for the case of neutrons, which must themselves have originated in another nuclear reaction, the participants much approach each other with energies not of one or a few electron volts, but of millions of electron volts. To acquire such energy as a result of thermal agitation, the temperature would have to be 30,000,000 to 100,000,000 $^\circ\text{K}$. Obviously no tempera-

ture attainable on earth (with the possible exception of the center of an atomic bomb explosion) can approach this value even remotely. Nuclear reactions are, therefore, unaffected by temperature in the range where we can experiment. It is thought, however, that the temperature in the interior of stars may indeed rise as high as 30,000,000 $^\circ\text{C}$, and that nuclear reactions can accordingly proceed there, and can indeed serve to account very satisfactorily for the source of the energy that is continually being radiated by stars, our sun included.² One might well say, therefore, that nuclear reactions are the mainspring of the whole universe.

² The series of nuclear reactions postulated by Bethe essentially involve the transformation of hydrogen into helium by the aid of intervening steps in which carbon, nitrogen, and oxygen play a part. These last elements suffer no permanent change, but play a role quite analogous to that of a catalyst in an ordinary chemical reaction. Inasmuch as the atomic number of the elements concerned is low, the energy or temperature required is somewhat lower than that just calculated for elements of medium Z . It is interesting to note that a mixture of hydrogen and lithium would probably undergo a nuclear reaction at a temperature somewhat under a million degrees Centigrade, the end product again being helium. However, both hydrogen and the lithium are consumed in this reaction.

Wide-Deviation Frequency-Modulated Oscillators*

EVERARD M. WILLIAMS†, SENIOR MEMBER, IRE, AND LUCIO VALLESE†, SENIOR MEMBER, IRE

Summary—Instantaneous frequency and power relations in wide-deviation frequency-modulated oscillators are discussed with special reference to the oscillators used in particle accelerators.

There are no fundamental limitations on deviation and modulating frequency in the present range of interest, but a fluctuating load effect arises which may be of importance.

WIDE-DEVIATION frequency-modulated oscillators have recently been employed in some atomic particle accelerators, particularly in the frequency-modulated cyclotron.¹ In this application they differ markedly from the frequency-modulated oscillators found in communication practice, both by reason of the extremely large deviation required and the higher power levels (many kilowatts) employed. As a part of the design of such an oscillator, a study was made of their fundamental theory. This paper describes the significant results of this study which relate to stability analysis, instantaneous frequency, and power relations.

In an oscillator circuit consisting of an electron tube associated with a resonant system, the frequency is determined primarily by the latter; in the extreme case in which there is no power dissipation in the resonant system, the tube function consists only of a reversing of phase and limiting or controlling of voltage amplitude

* Decimal classification: R148.2XR355.911. Original manuscript received by the Institute, January 13, 1948; revised manuscript received, April 26, 1948.

† This paper is part of a dissertation submitted by Lucio Vallese in partial fulfillment of the requirements for the degree of doctor of science at the Carnegie Institute of Technology.

† Carnegie Institute of Technology, Pittsburgh 13, Pa.

¹ "F. M. Cyclotron," *Electronics*, vol. 20, p. 119; March, 1947.

at a constant value. In the subsequent analysis, it will be assumed that the resonant system of a frequency-modulated oscillator can be represented by an equivalent parallel LC circuit (oscillators with series LC circuits can be related to those with parallel LC circuits) with finite reactive elements and zero dissipative elements, and analytic expressions will be computed from an examination of the resonant system alone. The result is used in an actual oscillator by applying the requirement that the oscillator tube supply the energy necessary to maintain constant voltage in the resonant system.

The general equation for the voltage v developed across a circuit consisting of an inductor L and capacitor C in parallel is

$$\frac{d}{dt}(Cv) + \frac{1}{L} \int_0^t v dt = 0$$

or, by differentiating,

$$\frac{d}{dt} \left[L \frac{d}{dt}(Cv) \right] + v = 0, \quad (1)$$

which has the following forms, depending on which parameter is varied:

(a) L constant and C variable

$$LC \frac{d^2v}{dt^2} + 2L \frac{dC}{dt} \frac{dv}{dt} + \left(1 + L \frac{d^2C}{dt^2} \right) v = 0; \quad (2)$$

(b) C constant and L variable

$$LC \frac{d^2v}{dt^2} + C \frac{dL}{dt} \frac{dv}{dt} + v = 0. \quad (3)$$

The equations are of the general form

$$M \frac{d^2v}{dt^2} + N \frac{dv}{dt} + Qv = 0$$

or, using the factors

$$\alpha = -\frac{N}{M}, \quad \beta = \sqrt{\frac{Q}{M} - \frac{N^2}{4M^2}},$$

$$\frac{d^2v}{dt^2} - 2\alpha \frac{dv}{dt} + (\alpha^2 + \beta^2)v = 0. \quad (4)$$

A general solution of this equation in closed form has not been found. Series solutions are derived by changes of variable which yield Hill's (or Mathieu's) equations.²⁻⁴ For example, the change of variable in (4)

$$v = u \cdot e^{\int_0^t \alpha dt} \quad (5)$$

yields

$$\frac{d^2u}{dt^2} + \left(\frac{d\alpha}{dt} + \beta^2 \right) u = \frac{d^2u}{dt^2} + K^2u = 0 \quad (6)$$

which is Hill's equation. The solution of this equation for the Mathieu case from the point of view of a frequency-modulated oscillator has been studied by Barrow.⁵⁻⁷ Special cases of Hill's equation have been considered by other authors.⁸⁻¹⁰ Generally it has been pointed out that, depending upon the nature of the variable coefficient k^2 in (6), the solutions can be of "stable" or "unstable" type; with increasing time the amplitude of the former remains of finite order, while the amplitude of the latter becomes of infinite or infinitesimal order.¹¹ Solutions for the specific cases of interest, using the rigorous method, however, involve infinite series and are cumbersome in application.

A feasible alternative to the rigorous solutions arises from the observation that, as a result of practical limitations, the coefficients α and β in (4) vary relatively slowly in time in comparison with v , which is to say that the modulation frequency is small relative to the modulated frequency. Barrow⁶ has pointed out that in this

² M. J. O. Strutt, "Mathiesche, Lamesche and verwandte Funktionen in Physik und Technik," Springer, Berlin, 1932.

³ E. T. Whittaker and G. N. Watson, "Modern Analysis," Cambridge University Press.

⁴ E. Jahnke and F. Emde, "Tables of Functions," Dover Publications, 1945.

⁵ W. L. Barrow, "A new electrical method of frequency analysis and its application to frequency modulation," *Proc. I.R.E.*, vol. 20, pp. 1626-1640; October, 1932.

⁶ W. L. Barrow, "Frequency modulation and the effects of a periodic capacity variation in a nondissipative oscillatory circuit," *Proc. I.R.E.*, vol. 21, pp. 1182-1203; August, 1933.

⁷ W. L. Barrow, "On the oscillations of a circuit having a periodically varying capacitance," *Proc. I.R.E.*, vol. 22, pp. 201-213; February, 1934.

⁸ N. Minorsky, "On parametric excitation," *Jour. Frank. Inst.*, vol. 240, p. 25; July, 1945.

⁹ N. W. McLachlan, "Computation of the solutions of $(1+2\epsilon \cos 2Z)y'' + \theta y = 0$; frequency modulation functions," *Jour. Appl. Phys.*, vol. 18, pp. 723-732, 1947.

¹⁰ E. Cambi, "Trigonometric components of a frequency-modulated wave," *Proc. I.R.E.*, vol. 36, pp. 42-50; January, 1948.

¹¹ These considerations assume that a continuous increase in the energy of the electric circuit may take place in the field of linearity.

case oscillations are generally stable, and may be represented by an approximate solution of the circuit equations. The instability, when it exists, arises from energy interchanges due to work in changing the capacitance or inductance, so that the presence of dissipation in a realizable oscillating circuit and power supplied by the associated vacuum tube would have a stabilizing effect on the system. Furthermore, as long as the modulating frequency is low, the amount of energy interchange to produce this stabilization would be very small, so that its effect on a working system would be unnoticeable. It was concluded on these grounds that no fundamental difficulties would be encountered in attempting to achieve very wide frequency deviations.

The approximate solution of (4) may profitably be developed for the purpose of determining instantaneous frequency relations. A powerful method of attack on equations such as (6) has been developed by Wentzel, Kramers, and Brillouin for use in quantum mechanics.¹²⁻¹⁵ In the application of this WKB method to (4), we would make the substitution

$$u = Ae^{\int_0^t Z dt} \quad (7)$$

which transforms (4) into the Riccati equation

$$\frac{dZ}{dt} + jZ^2 - 2\alpha Z - j(\alpha^2 + \beta^2) = 0. \quad (8)$$

If we let $Z = W - j\alpha$, this equation transforms into

$$\frac{dW}{dt} + jW^2 - j\beta^2 = 0$$

and an approximate solution of (7) is, then,

$$Z = \pm \beta + j \frac{1}{2\beta} \frac{d\beta}{dt} - j\alpha;$$

and, consequently,

$$\begin{aligned} v &= e^{\int_0^t [\alpha - (1/2\beta)(d\beta/dt)] dt} [A_1 e^{\int_0^t \beta dt} + A_2 e^{-\int_0^t \beta dt}] \\ &= \frac{A}{\sqrt{\beta}} e^{\int_0^t \alpha dt} \cos \left[\int_0^t \beta dt + B \right] \end{aligned} \quad (9)$$

in which A and B are constants of integration. The instantaneous frequency is¹⁶

$$\omega_{\text{inst}} = \beta. \quad (10)$$

¹² Von Gregor Wentzel, "Eine Verallgemeinerung der Quantenbedingungen für die der Wellenmechanik," *Zeit. für Phys.*, vol. 38; July 5, 1926.

¹³ Von H. A. Kramers, "Wellenmechanik und Halbzahliges Quantisierung," *Zeit. für Phys.*, vol. 39, pp. 828-840; September 9, 1926.

¹⁴ Leon Brillouin, "La Mécanique Ondulatoire de Schrödinger," *Compt. Rend.*, vol. 183, pp. 24-26; July 5, 1926.

¹⁵ H. Jeffreys, "On certain approximate solutions of linear differential equations of the second order," *Proc. London Math. Soc.*, vol. 23, pp. 428-436; January, 1925.

¹⁶ The equation (8) could not be found using the transformed equation (6) since the WKB approximation would then be limited only to the factor u in (5). As a matter of fact, there are other transformations:

For the two cases of equations (2) and (3), the instantaneous frequencies are:

(a) case of L constant and C varying

$$\beta = \frac{1}{\sqrt{LC}} \sqrt{1 + L \frac{d^2C}{dt^2} - \frac{L}{C} \left(\frac{dC}{dt} \right)^2}$$

(b) case of C constant and L varying

$$\beta = \frac{1}{\sqrt{LC}} \sqrt{1 - \frac{C}{4L} \left(\frac{dL}{dt} \right)^2}$$

These relations show that there is a deviation of instantaneous frequency of the voltage from the frequency computed by

$$\omega_{inst} = \frac{1}{\sqrt{L_{inst}C_{inst}}}$$

If the modulating frequency is low relative to the frequency being modulated, this deviation in instantaneous frequency amounts at most to a few cycles in several million, and is thus of no more than casual concern.

If the charge q on the capacitor or the flux ϕ linking the inductor are used as variables, the above method yields solutions in which, to the same order of approximations as the above, the instantaneous frequencies are:

$$\omega'_{inst} = \frac{1}{\sqrt{L_{inst}C_{inst}}}$$

It is, however, the voltage delivered by the oscillator which is generally of interest.

Possible variations of peak amplitude of each cycle during modulation are indicated by (9). Actual determination of these amplitudes may, however, be made more readily from energy considerations than from the solution (9). Since the voltage across and current in the parallel LC circuit are alternating in character, there are instants in each cycle during which the current in the inductance and the voltage across the capacitor pass through zero. At these instants the energy of the system is stored entirely in the capacitor or the coil, respectively, and these stored energies have their maximum value at these instants. Thus, in a conservative system with an initial energy W_0 , the voltage maximum V_m would be given by

$$V_m = \sqrt{\frac{2W_0}{C_{inst}}}$$

$q = v/c$ in case (a) and $v = -d\phi/dt$ in case (b), which also yield Hill's equation and give a different result with the WKB method. For the same reason the solution of (7) should be obtained without change of variable. Applying the line of reasoning of the WKB method, this approximate solution results in

$$Z = \pm \left(\frac{\alpha'}{2\beta} + \beta \right) + j \left(\frac{\beta'}{2\beta} - \alpha \right) \quad \begin{aligned} \alpha' &= \frac{d\alpha}{dt} \\ \beta' &= \frac{d\beta}{dt} \end{aligned}$$

The instantaneous frequency of the voltage oscillations is, then,

$$\omega_{inst} = \beta \left[1 + \frac{\alpha'}{2\beta^2} \right]$$

This result is presumably more accurate than (10), but not as readily applied.

and the current maximum I_m by

$$I_m = \sqrt{\frac{2W_0}{L_{inst}}}$$

If a lossless LC system were excited by an oscillator tube which would tend to maintain sinusoidal oscillations with a constant peak voltage, a system with a varying capacitance modulator would alternately load the oscillator and return energy to the oscillator, respectively as the capacitance is increased or decreased. There will also be (a) energy transfer due to work done on the rotating capacitor as the capacitance is increased and energy returned to the circuit as the capacitance is decreased because of the force on the capacitor plates, and (b) the necessary resonant circuit losses in any physically realizable system. With a low modulating frequency the power due to mechanical work depends on the rms voltage and is

$$P_{mech} = \frac{1}{2} V_m^2 \frac{dC_{inst}}{dt}$$

The power flow to maintain constant voltage from stored energy considerations is

$$P_{stored} = \frac{1}{2} V_m^2 \frac{dC_{inst}}{dt}$$

and the power loss, in terms of the circuit Q , which is understood to include the effect of load, if any, is

$$P_{loss} = \frac{\omega C_{inst}}{2Q} V_m^2$$

Expressed in terms of the rate of change of frequency $d\omega/dt$, the ratio of fluctuating components ($P_f = P_{mech} + P_{stored}$) to loss components is

$$\frac{P_f}{P_{loss}} = - \frac{3Q}{\omega^2} \frac{d\omega}{dt} \quad (11)$$

The negative sign indicates that the fluctuating energy components load the oscillator on the decreasing-frequency portion of the cycle¹⁷ and return energy during the increasing portion of the cycle. The stored energy component can only be appreciable if the Q is very high, the deviation is high, and the rate of modulation is at least moderately high. Such conditions are met in some synchro-cyclotron oscillators; for instance, in the Carnegie Institute of Technology synchro-cyclotron the ratio (11) has a maximum value of approximately 15 per cent, a value sufficiently large so that it must be taken into account in calculating the oscillator loading. This effect is greatly diminished in a constant-voltage system when the frequency is varied by changing the inductance, since only the mechanical work term appears. Unfortunately, no entirely workable variable-inductance method has been devised for use in wide-deviation oscillators.

¹⁷ The decreasing-frequency portion of the cycle is the significant one in particle accelerators.

Frequency Measurement by Sliding Harmonics*

J. K. CLAPP†, FELLOW, IRE

Summary—A method of measuring radio frequencies is described which uses an interpolating, or adjustable, frequency standard. Harmonics of this standard are caused to slide along the frequency scale until the one next below the frequency under measurement is brought up to match that frequency. The number of the used harmonic is readily determined from a simple calibration of the detector, heterodyne frequency meter, or receiver used to receive the frequency being measured. The positive increment in frequency of the used harmonic is determined from the control dial of the adjustable frequency standard. The use of wide-band receivers and interpolating equipment is avoided. Accuracy of measurement of the order of 10 parts per million is realized with the equipment described. If the interpolating frequency standard is treated as a highly stable heterodyne frequency meter, it may be used with many advantages in a conventional frequency-measuring system. The methods discussed are applicable to frequencies up to 1000 Mc.

A WIDELY USED, and generally very satisfactory, method of measuring frequencies up to several megacycles utilizes (1) a series of fixed standard-frequency harmonics of 10 kc, (2) a receiver or detector capable of accepting the frequency to be measured as well as the nearest 10-kc standard-frequency harmonic, and (3) an interpolation oscillator covering a range from zero to one-half the standard frequency (0–5 kc) with good stability and a highly expanded scale.

This method is very satisfactory for measuring the frequency of local oscillators or of transmitters having steady carrier frequencies. In cases of keyed or intermittent signals, an auxiliary oscillator (heterodyne frequency meter) is frequently required as a substitute signal source. Finally, unless an auxiliary oscillator is used, the system is not capable of producing a desired output frequency.

If the frequency f_x to be measured lies in the interval between a given standard-frequency harmonic nf_s , and a frequency $f_s/2$ above that harmonic, the beat-frequency difference obtained in the output of the receiver is considered positive. The frequency under measurement is then given by $f_x = nf_s + f_{b1}$. If the frequency to be measured lies above the given standard-frequency harmonic nf_s by more than $f_s/2$ but less than f_s , attention is shifted to the next higher standard-frequency harmonic $(n+1)f_s$, and the beat-frequency difference is considered negative. The frequency under measurement is then given by $f_x = (n+1)f_s - f_{b2}$. These conditions are illustrated in Fig. 1. Operating in this manner, the range of the interpolation oscillator needs to be only from 0 to $f_s/2$.

If, now, we propose to measure frequencies of a few hundred megacycles by this method, we find (1) that the standard frequency must be increased by 100 times, say, in order that the necessary harmonics can be generated with usable intensity and that the separation between successive harmonics be sufficient for ready identification; (2) that the pass band of the detector or receiver must correspondingly be increased by 100 times;

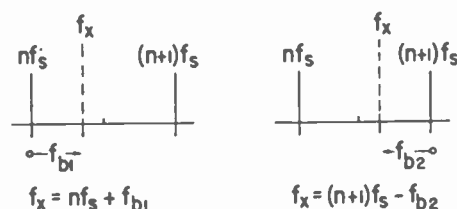

Fig. 1—Illustrating frequency measurement by conventional methods, with a fixed frequency standard.

and (3) that the range of the interpolation oscillator must also be increased by 100 times. It is apparent that the beat-frequency difference obtained in the output of the receiver will range far beyond audible limits, thereby requiring means of indication other than headphones or loudspeakers. With the extended range required of the interpolation oscillator, decreased accuracy of reading results. While it is by no means impossible to set up a frequency-measuring system on this basis, such a system is neither convenient or simple to use.

Some improvement is possible by utilizing the higher of the two beat frequencies produced by beating the frequency to be measured with adjacent standard-frequency harmonics and using an interpolation oscillator covering the range from $f_s/2$ to f_s (instead of from 0 to $f_s/2$), but the basic difficulties remain.¹

A search for a more rapid procedure leads to the following: Consider a frequency standard combined with an interpolator so as to produce an adjustable standard frequency, of stability and accuracy approaching that of a fixed standard. It is then evident that a multiple of the adjustable standard frequency can be slid along the frequency scale and be matched to a frequency under measurement by simple zero-beating in any convenient detector or receiver. Under these conditions no wide-band receivers or wide-range interpolation oscillators are required.²

* Decimal classification: R213. Original manuscript received by the Institute, March 10, 1948. Presented, 1947 IRE National Convention, New York, N. Y., March 25, 1948.

† General Radio Company, Cambridge, Mass.

¹ S. Sabaroff, "An ultra-high-frequency measuring assembly," Proc. I.R.E., vol. 27, pp. 208–213; March, 1939.

² J. K. Clapp, "Continuous interpolation methods," *General Radio Experimenter*, vols. 8 and 9, pp. 4–8 and 3–8; January and February, 1944.

The measurement of a frequency under these conditions is indicated in Fig. 2. With the control of the adjustable standard set at zero—that is, with true standard-frequency output—the unknown frequency lies above a given standard harmonic nf_s , as shown in line A. Now the standard frequency is altered, toward a higher frequency f_s' , so that the given harmonic n slides toward higher frequencies and finally is matched against the unknown frequency f_x , as shown in line B. Knowing the harmonic number n , and the new value of standard frequency f_s' , the unknown frequency is given by $f_x = nf_s'$.

For greater convenience, the altered value of standard frequency can be thought of as the unaltered value f_s plus an increment in frequency of $(f_s' - f_s)$. The frequency of the n th harmonic is, then,

$$nf_s' = nf_s + n(f_s' - f_s).$$

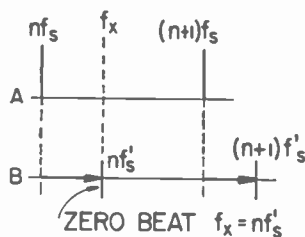

Fig. 2—Illustrating frequency measurement by use of an adjustable frequency standard.

To obtain complete coverage at harmonic n it must be possible to adjust the n th harmonic over the interval from nf_s to $(n+1)f_s$. Inspection shows that the maximum value of $n(f_s' - f_s)$ must be equal to f_s , or in fractional form, $n\Delta = 1$. Since the fractional change in frequency, in passing from any harmonic higher than n to the next harmonic above it, is less than that at harmonic n , it follows that complete coverage is obtained not only over the interval from n to $(n+1)$ but also over any higher harmonic interval.

On this basis, equipment has been designed especially for use with a heterodyne frequency meter covering 100 to 200 Mc with a dial calibrated at 1-Mc intervals. To interpolate between adjacent dial markings requires an interpolating standard of 1 Mc base frequency. At 100 Mc, n then equals 100 and, consequently, $\Delta = 0.01$. The fundamental range of the interpolating standard is then from 1.000 to 1.010 Mc. The standard was made up with a 950-kc crystal-controlled oscillator and a stable bridge-controlled variable-frequency oscillator of 50 to 60 kc. The sum of these two frequencies is then used as the output frequency. The operating control is a worm drive with a scale of 1000 divisions. A 1-Mc multivibrator controlled by the standard provides useful output at all harmonics from 100 to 200 or more.

A block diagram of the assembly is shown in Fig. 3. The output spectrum is indicated, where some one of the output harmonics is to be matched to the fundamental frequency of the heterodyne frequency meter.*

In operation, the heterodyne frequency meter is first set to zero beat with f_x . This may be done at the fundamental or at a harmonic of the frequency meter. (If at a harmonic, the number of the harmonic is determined by use of the heterodyne frequency meter.) The frequency meter is then left at this zero-beat setting. The harmonic output of the interpolating frequency standard is then injected into the heterodyne frequency meter and the standard control is advanced until the first loud beat tone is obtained; the control is then finally adjusted for zero beat. The number of the standard harmonic used in the measurement is determined from the heterodyne-frequency-meter reading. The number of interpolator divisions required to slide the used standard harmonic upward in frequency by just 1 Mc is given by a table. The amount, as a fraction of 1 Mc, that it has actually been moved is given by the ratio of the actual dial reading to the tabulated value. This amount is added to the number of the used harmonic to obtain the final result in megacycles.

A numerical example may be easier to follow. Suppose the reading of the heterodyne frequency meter at zero beat with f_x is 162.3 Mc. The interpolator control is advanced, say, 249.0 divisions to obtain zero beat against the frequency meter. The used harmonic is 162 (the next integral value below the reading of 162.3); entering the table for the range 162–163 Mc, it is found that the interpolator dial must be advanced by 617.3 divisions to cover the 162–163-Mc range. Since the dial was actually advanced 249.0 divisions, the fraction 249.0/617.3 of a megacycle was actually covered,

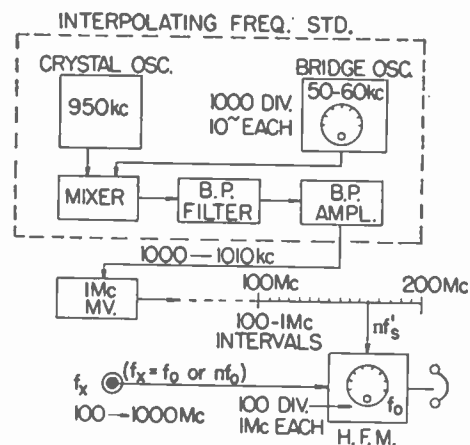

Fig. 3—A particular application of the interpolating frequency standard. Harmonic extension is used to expand the effective range.

* The equipment referred to comprises the General Radio Company Type 720 heterodyne frequency meter; Type 1110 interpolating frequency standard; and Type 1110-P1 multivibrator unit, containing 1-Mc and 0.1-Mc multivibrators.

amounting to 0.404 Mc. The final result is then $162 \pm 0.404 \text{ Mc} = 162.404 \text{ Mc}$.

For purposes of illustration, the harmonic generator indicated in Fig. 3 is shown simply as giving multiples of the frequency of the interpolating frequency standard. Actually, one or more additional harmonic generators can be used; for example, a unit generating multiples of 0.1 Mc. Again, use is made of the multiples from 100 to 200, covering the range from 10 to 20 Mc in 0.1-Mc steps. A frequency meter covering 10 to 20 Mc and graduated in 0.1-Mc intervals would then be used exactly in the manner outlined above.

Since harmonic extension of the measurement range is readily accomplished by use of the frequency meters, the lower-frequency arrangement just described is useful to cover the range from 10 to 100 Mc, using no higher than the fifth harmonic of the frequency meter. Similarly, the higher-frequency arrangement first described is useful to cover the range from 100 to 1000 Mc, again using no higher than the fifth harmonic of the frequency meter. Both units then cover from 10 to 1000 Mc.

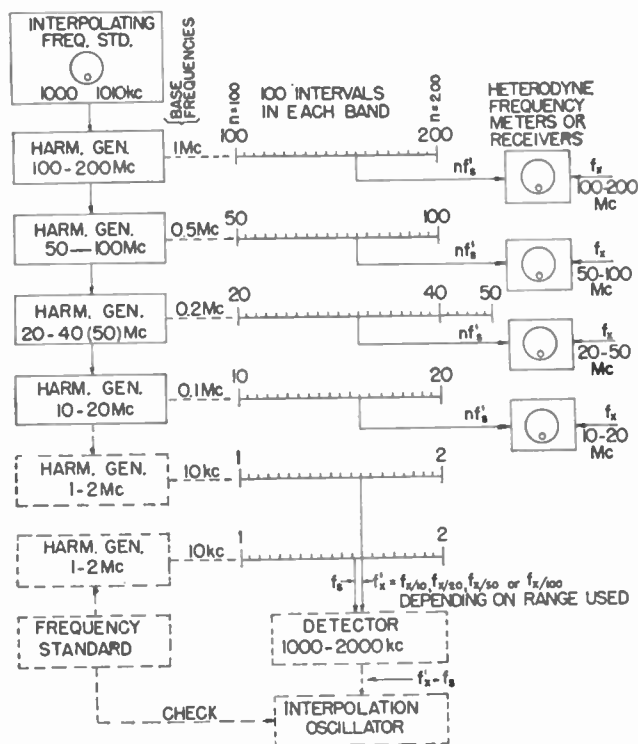

Fig. 4—An application of the interpolating frequency standard to measurement of frequency over a wide range without the use of harmonic extension (solid portion). The interpolating frequency standard can be used to advantage as a very stable heterodyne frequency meter in a conventional measuring system (dashed portion).

If it is desired to cover wider frequency ranges than 2:1 without the use of harmonic extension, a number of harmonic generators in cascade can be used, each with a suitable frequency meter or receiver (or a single multi-

range instrument). The individual harmonic generators cover approximately 2:1 in frequency, and successive generators can be arranged on a 1, 2, 5, 10 basis as indicated in Fig. 4.

This arrangement covers an over-all range of 10 to 1 using three harmonic generators, and 20 to 1 using four. The use of multiples from 100 to 200, in the case of the 20- to 40-Mc unit, leaves a gap between the coverage of this unit and that of the next higher, 50 to 100 Mc. There is nothing to prevent the use of multiples *higher* than the 200th as required to extend the coverage from 40 to 50 Mc. If, however, the use of *lower* multiples is attempted, so as to obtain complete coverage from 40 to 100 Mc, it would be necessary to redesign the interpolating frequency standard for complete coverage over the range from 80 to 81 Mc (instead of 100 to 101 Mc, as described).

Extension to higher frequencies is possible by the arrangement shown in Fig. 5. Here the multivibrator type of multiplier is replaced by distorting amplifiers. The output frequency of the interpolating frequency standard is multiplied by 5, amplified, and then put through several multiplier stages. Outputs of all multiplier stages are fed to a crystal rectifier, the output of which provides multiples of 5 Mc in the range from 500 to 1000 Mc. Used with a heterodyne frequency meter of 500 to 1000 Mc,⁴ the operation is exactly as described above.

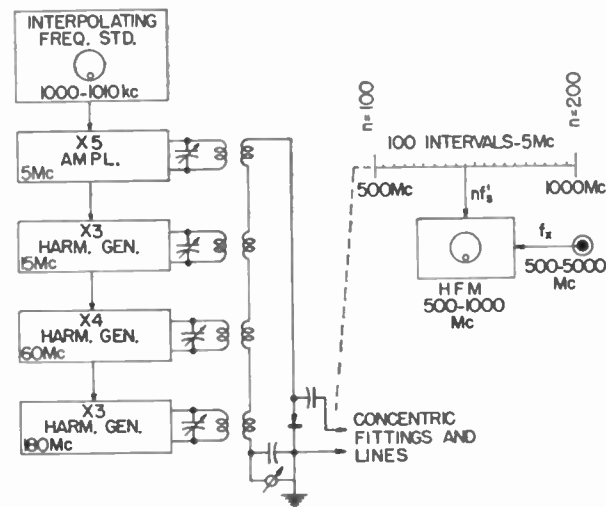

Fig. 5—A method of extending the range of measurement of a particular interpolating frequency standard.

It is evident that the accuracy of measurement depends on three principal factors: (1) The accuracy with which the adjustable frequency can be matched to the frequency under measurement; (2) the accuracy with which the increment in frequency can be determined

⁴ General Radio Company Type 1110-P2 harmonic multiplier and Type 1021-A heterodyne frequency meter; both under development.

from the interpolation dial readings; and (3) the accuracy of the crystal-controlled oscillator.

In general, if the stability of the frequency under measurement is good, the matching can be carried out with an accuracy which does not limit the over-all accuracy of measurement. The accuracy of determining the frequency increment is limited by the linearity of scale of the interpolation oscillator and by drift, if means are not provided for correction. This limitation is of the order of ± 30 parts per million. However, if a detector and audio-frequency amplifier are provided, it is possible to check and to correct, if necessary, the calibration of the interpolation oscillator in terms of the crystal-controlled oscillator. Such checks can be obtained at a large number of points over the scale of the interpolation oscillator. Properly correcting the interpolator oscillator by this means reduces the interpolator scale error to the order of ± 2.5 parts per million, *in terms of the crystal-controlled oscillator*. In the final analysis, the over-all accuracy is limited by the accuracy of the crystal-controlled oscillator, which, with the simple arrangement used here, is about ± 5 parts per million. By checking the crystal oscillator against standard-frequency transmissions, or an accurate frequency standard, from time to time, and correcting, if necessary, this error can be held within smaller limits. As a final figure, it is estimated that the over-all accuracy which can be readily realized is of the order of 10 parts per million (0.001 per cent).

Where the accuracy of the frequency meters considered here is of the order of 0.1 or 0.2 per cent, and interpolation is by estimation of fractions of a per cent, the use of the interpolating standard improves the accuracy of measurement by 100 to 1000 times.

If a frequency standard and frequency-measuring equipment are available, the interpolating frequency standard can be treated as a highly stable heterodyne frequency meter with a greatly expanded scale. By measurement of the output frequency of the interpolating standard (1000 to 1010 kc), all errors are overcome except that of matching the used harmonic of the interpolating standard to the frequency under measurement. It is then necessary, of course, to multiply the measured frequency, or the measured frequency increment, by the number of the used harmonic to obtain the final result.

By use of a 10-kc harmonic generator, a direct-reading system can be set up as indicated by the dashed section

of Fig. 4. Harmonics of the 10-kc harmonic generator between 100 and 200 are used with the frequency standard and frequency-measuring equipment. These harmonics cover 1000 to 2000 kc, and each is readily measured against the 10-kc harmonic series of the frequency standard. If the measurement is made at the harmonic having the *same number* as that used to match the frequency under measurement, then the unknown frequency has been divided effectively by an integral simple number. For example, in Fig. 4, if the 10- to 20-Mc output is used, the frequency under measurement is divided by 10; for the 20- to 50-Mc range, it is divided by 20; for the 50- to 100-Mc range, it is divided by 50; and for the 100- to 200-Mc range, it is divided by 100.

If, then, the frequency difference between the used harmonic and the corresponding harmonic of the frequency standard, in cps, is multiplied by 10, 20, 50, or 100, the result is the *frequency increment to be added to the frequency of the used output* harmonic to obtain the value of the unknown frequency. In practice, the interpolation oscillator of the frequency-measuring system could be fitted with $\times 1$, $\times 2$ and $\times 5$ scales, in which case no multiplication is necessary except to move the decimal point.

The interpolating standard described here is a direct and simple design, predicated on reasonable size and cost. It is evident that greater accuracy is feasible through the use of improved crystal-controlled and interpolation oscillators. However, the best accuracy which can be realized with given equipment used as an interpolating standard will be much below that which can be realized when the equipment is utilized as an element of a conventional frequency-measuring system. For such applications, the function of the crystal-controlled oscillator can be served by selected harmonics of the frequency standard itself, for best possible accuracy, and the function of the interpolation oscillator can be served by a combination of selected harmonics of the standard with a stable variable-frequency oscillator.

The ease and rapidity with which a frequency can be matched at any point in the range; the simplicity of zero-beat settings compared with wide-range interpolation; the effectiveness of the used-harmonic output frequency as a substitute source; and the fact that an output voltage can be generated at any desired frequency in the range, are all factors pointing to the utility of the method.



Calculation of Doubly Curved Reflectors for Shaped Beams*

A. S. DUNBAR†

Summary—A method based upon conservation of energy and the simple laws of geometrical optics is described for the calculation of double-curvature surfaces to produce from a point source a shaped beam of arbitrary shape in one plane and uniformly narrow in the perpendicular planes. A specific application of the shaped-beam antenna is in connection with radar antennas for airborne navigational systems, for which the optimum elevation pattern is found empirically to be $G(\theta) = K \csc^2 \theta \cos \theta$. A reflector to produce from a given primary source the required pattern is the envelope of a family of paraboloids determined by a central-section curve which is adjusted to give the necessary distribution of energy for the shaped beam. A test for the single-valuedness of a computed surface is described. Patterns are shown for experimental antennas whose reflectors were computed by this method. It is demonstrated that some control of the antenna pattern can be achieved by proper motion of the antenna feed. A discussion of errors is included in an Appendix.

INTRODUCTION

MICROWAVE ANTENNAS for certain specialized uses are required to radiate energy in particular patterns which, in general, are narrow in one plane, and shaped for some special distribution of energy in the other plane. A common application of shaped-beam antennas is in connection with radar antennas for airborne navigational systems. In these cases, the required beam has the so-called cosecant-squared pattern in the vertical plane. For the sake of greater clarity the following discussion will be in terms of that application, although this will not involve any sacrifice of generality.

An antenna to radiate such a specially shaped beam requires a reflector or lens which will transform the existing primary pattern of the given primary source to the prescribed secondary pattern. For a line source, such as a linear array or a pillbox, which gives a cylindrical wave front and by virtue thereof is focused in the one plane, the required reflector is a cylinder whose cross-sectional curvature¹ is such as to reflect the energy in the requisite elevation pattern. That is, the line source and the elements of the cylindrical reflector lie horizontally, and the cylindrical primary pattern of the line source is transformed by the shaped cylindrical reflector to the proper pattern in elevation for the navigational antenna. The general method of calculating the proper shape of the focusing objectives for this transformation of energy patterns was originally formulated by Chu.¹

* Decimal classification: R325.7 × R326.8. Original manuscript received by the Institute, November 20, 1947; revised manuscript received, April 16, 1948. Presented, joint meeting of the American Section, URSI, and the Washington Section, IRE, Washington, D. C., October 21, 1947.

The opinions expressed in this paper are those of the author, and should in no way be construed as the official view of the United States Navy.

† Naval Research Laboratory, Washington 20, D. C.

¹ L. J. Chu, "Microwave Beam-Shaping Antennas," Research Laboratory of Electronics, MIT, Report 40; June, 1947.

For a point source, such as is approximated by an electromagnetic horn of small dimensions, the reflector is a double-curvature surface of such a shape as to perform both the functions of shaping the beam in the vertical plane and focusing the beam in transverse planes. Consequently, the surface must be formed by the envelope of a system of paraboloids whose axes lie all in the vertical plane but at varying angles of inclination to each other and to a fixed line. The curve of intersection of the reflector with its plane of symmetry, which we shall call the "central-section curve," must be adjusted to give the necessary distribution of energy for the shaped beam. The optical conditions for the double-curvature reflector were originally determined by Silver,² using Chu's method for obtaining the central-section curve.

THE REFLECTOR SURFACE

The conditions for the sections of the reflector surface transverse to the central-section curve may be most easily formulated by considering the reflector from the point of view of reception. Let a sheet of rays all parallel to the central plane and lying in the plane $OANP$ impinge on the reflector, shown in Fig. 1. We require that all rays in this plane $OANP$, which is perpendicular to the central plane, be brought to focus at F . Let ρ be

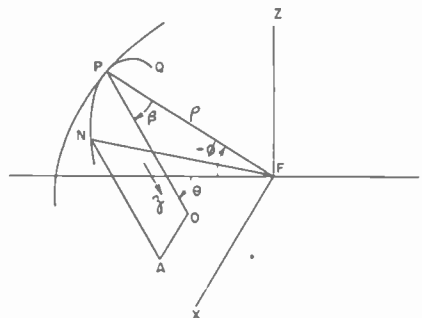

Fig. 1—Conditions for transverse sections of the reflector.

the radius vector from F to the central-section curve ϕ its angle of depression, and β the angle between the incident and reflected rays in the central plane. Then, for the optical path, we have

$$AN + NF = OP + \rho$$

or, if z is the ordinate of N in the plane $OANP$ with P as origin,

$$(\rho \cos \beta - z) + [\rho^2 \sin^2 \beta + x^2 + (\rho \cos \beta - z)^2]^{1/2} = \rho(1 + \cos \beta).$$

² S. Silver and H. M. James (editors), "Microwave Antenna Theory and Design," McGraw-Hill Book Co., New York, N. Y. (in process), section 13.8.

After some reduction, we obtain

$$x^2 = 4z(\rho \cos^2 \beta/2). \tag{1}$$

The section of the surface in the plane *OANP* is, therefore, a parabola whose focal length is

$$f(\phi) = \rho \cos^2 \beta/2. \tag{1a}$$

Thus, given the central-section curve $\rho(\phi)$, and the associated function $\beta(\phi)$, the entire reflector surface is determined.

The calculation of the central-section curve is based upon the conservation of energy and simple geometrical

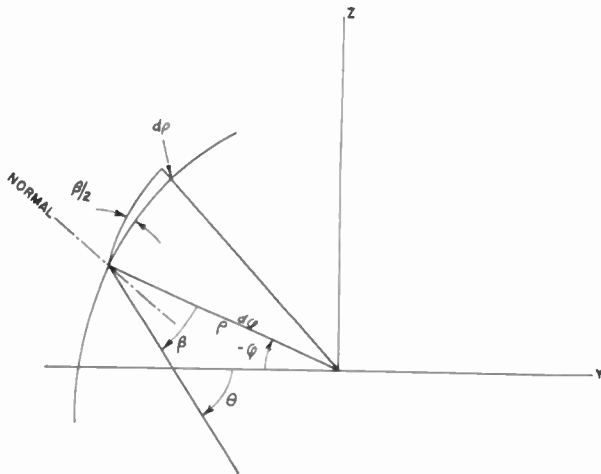

Fig. 2—Condition for the central-section curve.

optics.¹ Referring to Fig. 2, we have for the central section the differential equation

$$\frac{d\rho}{\rho d\phi} = \tan \beta/2. \tag{2}$$

Measuring ϕ positive downwards from the horizontal, we have

$$\beta = \phi + \theta. \tag{3}$$

Integrating (2), we obtain an expression for $\rho(\phi)$, namely,

$$\log_e \rho/\rho_0 = \int_{\phi_1}^{\phi} \tan \frac{1}{2}(\phi + \theta) d\phi \tag{4}$$

where ρ_0 is an arbitrary constant chosen for a convenient reflector size. Equation (4) requires that we know the correspondence between ϕ and θ in order to evaluate the integral. This is obtained by consideration of the energy relations in the primary and secondary patterns. Thus, the energy in a small cone of rays from *F*, defined by ϕ and $\phi + d\phi$ in elevation and of width $d\Psi$ in azimuth (Fig. 3(a)), is given by

$$I(\phi) d\phi d\Psi$$

where $I(\phi)$ is the power radiated per unit solid angle in the direction $(\phi, 0)$. On reflection, this energy appears in a wedge (Fig. 3(b)), defined by θ and $\theta + d\theta$, assuming

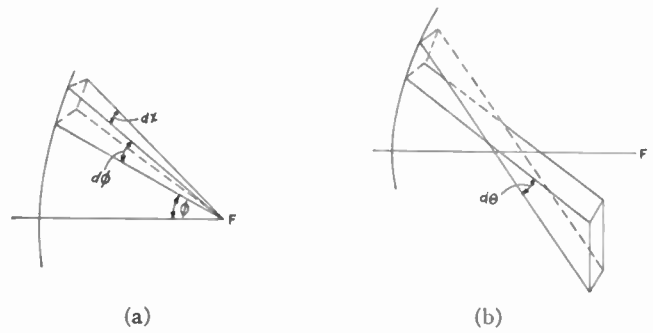

Fig. 3—On the energy relations in primary and secondary patterns.

the rays to be essentially parallel in the transverse planes. The energy in this wedge is

$$G(\theta) \rho d\Psi d\theta.$$

Equating this to the incident energy, we have

$$G(\theta) d\theta = \frac{I(\phi)}{\rho} d\phi, \tag{5}$$

which, upon integration,³ will yield θ as a function of ϕ as required for solution of (4). The expressions on either side of (5) are normalized to their relative maxima for convenience in computation; thus, noting the convention of Fig. 1,

$$\frac{\int_{\theta}^{\theta_B} G(\theta) d\theta}{\int_{\theta_0}^{\theta_B} G(\theta) d\theta} = \frac{\int_{\phi_B}^{\phi} \frac{I(\phi)}{\rho} d\phi}{\int_{\phi_B}^{\phi_A} \frac{I(\phi)}{\rho} d\phi}. \tag{6}$$

The limits of integration are determined by (a) the angular extent of θ_0 to θ_B of the idealized beam shape, and (b) the angle ϕ_B to ϕ_A subtended at the feed by the reflector's central-section curve (see Fig. 5).

INTEGRATION FOR THE REQUIRED BEAM SHAPE

The integration of (6) must, in general, be performed by graphical methods. If the indefinite integral of the expression for the secondary pattern, $G(\theta)$, exists, then values of θ corresponding to values of ϕ may be computed directly from the graphical integration of $I(\phi)/\rho$. If, however, the indefinite integral of $G(\theta)$ does not exist, then both quantities must be integrated by graphical methods.

In the case of the airborne navigational antenna, it is

³ Taking logarithmic derivatives with respect to ϕ of (5) and substituting from (4), we get

$$\frac{d^2\theta}{d\phi^2} + \left[\tan \frac{1}{2}(\phi + \theta) - \frac{dI(\phi)}{d\phi} / I(\phi) \right] \frac{d\theta}{d\phi} + \left[\frac{dG(\theta)}{d\theta} / G(\theta) \right] \left(\frac{d\theta}{d\phi} \right)^2 = 0,$$

which may be solved for $\theta = F(\phi)$ by a method of successive approximations; see also footnote references 1 and 2.

found experimentally that the optimum elevation pattern shape⁴ is

$$G(\theta) = K \csc^2 \theta \cos \theta,$$

which, fortunately, is an elementary function whose integral may be substituted into (6) with the following result:

$$\csc \theta = \csc \theta_B + \frac{\csc \theta_0 - \csc \theta_B}{\int_{\phi_B}^{\phi_A} \frac{I(\phi)}{\rho} c' \phi} \int_{\phi_B}^{\phi} \frac{I(\phi)}{\rho} d\phi. \quad (6a)$$

In the case of an arbitrary function whose indefinite integral does not exist, the quantities on either side of (6) are integrated graphically, and plotted as shown in Fig. 4. Then values of θ corresponding to values of ϕ

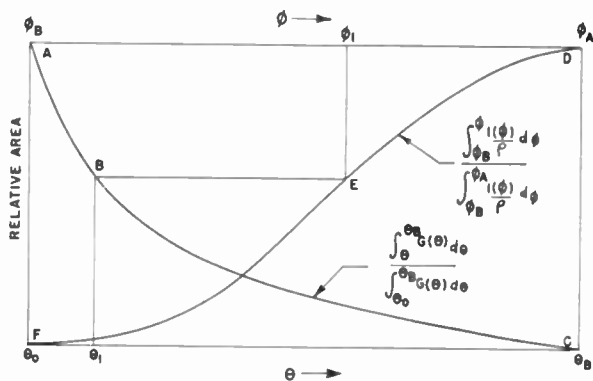

Fig. 4—Graph for the determination of $\theta = F(\phi)$.

may be read directly from the graph. Where it is desirable to expand any portion of the graph for more accurate reading, smaller increments in θ and/or ϕ may be taken for plotting on the expanded scale. The curve ABC in Fig. 4 is obtained from the integration of $G(\theta)$; while the curve DEF is obtained from the integration of $I(\phi)/\rho$. The line $\phi_1 E B \theta_1$ represents the method of reading corresponding values of ϕ and θ .

SAMPLE COMPUTATION

In the integration of $I(\phi)/\rho$ it is required that we know the function $\rho(\phi)$. It is, therefore, necessary that a guess be made as to the shape of the central-section curve. Thus, having measured the primary pattern $I(\phi)$ we perform the integration of (6) for the desired beam shape and obtain the correspondence between ϕ and θ . Then (4) may be integrated graphically to obtain a solution for the central-section curve. The process may be repeated by substituting the computed values of $\rho(\phi)$ into the quantity $I(\phi)/\rho$ and performing the integrations as before. In practice, no more than two such calculations are required for satisfactory accuracy in the central-section curve.

In order to illustrate this method of calculation, we present the following sample calculation, where we re-

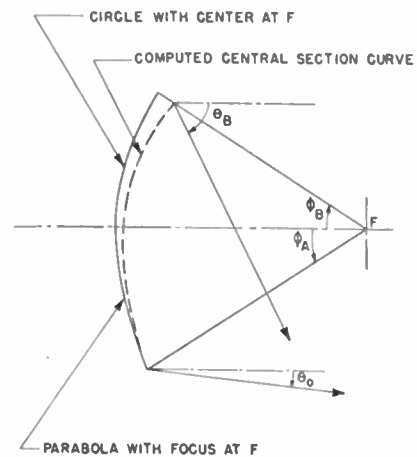

Fig. 5—Relations between the first-guess curve and the computed central-section curve, indicating limiting angles in ϕ and θ .

quire a beam shape of the form $G(\theta) = K \csc^2 \theta \cos \theta$ for an airborne navigational antenna. Suppose the range in θ is $5^\circ < \theta < 55^\circ$, inclusive. The vertical dimension of the reflector is chosen to be 15 inches, the focal length 10.6 inches, and the horizontal width of the reflector 24 inches. A horn feed of the proper dimensions is chosen, its primary pattern in the plane of the vertical section of the reflector is carefully measured, and a guess made as to the shape of the central-section curve. This first-guess curve will be taken as the so-called "barrel dish" curve; i.e., parabolic below axis and circular above, as shown in Fig. 5. The computations are then performed as follows:

1. The quantity $I(\phi)/\rho$ is plotted and graphically integrated.
2. Using (6a), values of θ are computed for corresponding values of ϕ .
3. The quantity $\tan \frac{1}{2}(\phi + \theta)$ is plotted and graphically integrated.
4. Using (4), values of $\rho(\phi)$, the central-section curve, are computed. The relation between the first-guess curve and the computed central-section curve is shown in Fig. 5.

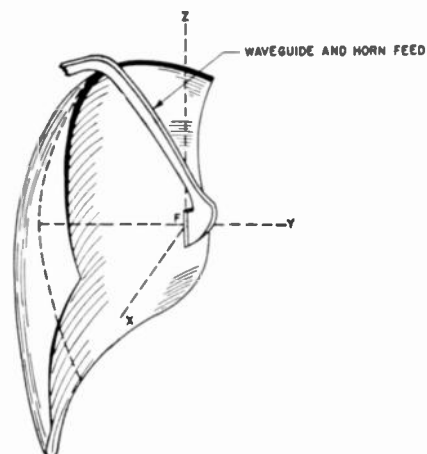

Fig. 6—A sketch of the shaped-reflector antenna.

⁴ See section 13.2 of footnote reference 2.

5. Using (1a), values of $f(\phi)$ are computed, and using (1) the co-ordinates of the parabolic sections are computed. The entire reflector surface is now determined. A sketch of the reflector is shown in Fig. 6.

TEST FOR SINGLE-VALUEDNESS OF THE SURFACE

It may happen that, after the central-section curve has been determined and an attempt is made to develop the surface by plotting the parabolic cross sections, the surface is found to be multiple-valued in a certain region. Such a condition makes the reflector physically unusable, and, if it occurs, a new design must be commenced. The region of multiple value is caused by the various parabolic cross sections, which are inclined at large angles to the axis, intersecting one another, with the result that the surface becomes folded upon itself. The intersection of the parabolas is illustrated in Fig. 7. The curve SQS' is the central-section curve, CPD is a typical parabolic cross section. The parabolas passing through Q , R , and S' are seen to intersect in the regions E and F . The surface defined by these curves is multiple-valued in the region to the right of E and F . The immediate remedy for this is to reduce the horizontal aperture of the reflector until such intersection is no

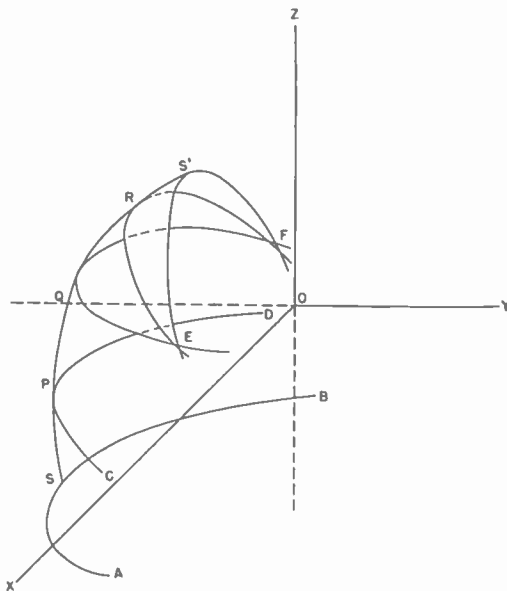

Fig. 7—Illustration showing the intersection of parabolic cross section.

longer possible, but such reduction in aperture is not suitable from the point of view of preservation of azimuthal beam width; consequently, the reflector must be redesigned. Unfortunately, there is no sure way to determine beforehand if the particular set of design specifications will lead to a multivalued surface, especially if the total coverage angle, θ_0 to θ_B , is great. In general, space considerations impose the condition that the focal length should be as short as possible, so that elimination of any possibility of the surface becoming folded by simply using a long focal length is not particularly expedi-

ent. Having computed the central-section curve, however, we may apply a test for the single-valuedness of the surface in the following manner. By (1a), the focal lengths of the transverse parabolas may be obtained; so that, knowing the horizontal aperture of the reflector we may calculate the depth z of the respective parabolas from

$$z = \frac{x^2}{4f(\phi)}. \quad (7)$$

Then, plotting these depths z on their respective ray lines drawn in the directions θ , and connecting the points so determined, a curve is obtained which defines the contour of the extremity of the reflector surface. If this curve is single-valued (i.e., if the curve has no cusp or is not self-intersecting), the surface will be single-valued. If, however, the curve is multivalued, the surface cannot be single-valued. Typical examples of these curves are drawn in Fig. 8. The curves (a) and (b) are a loop and a cusp, respectively, indicating that the surfaces

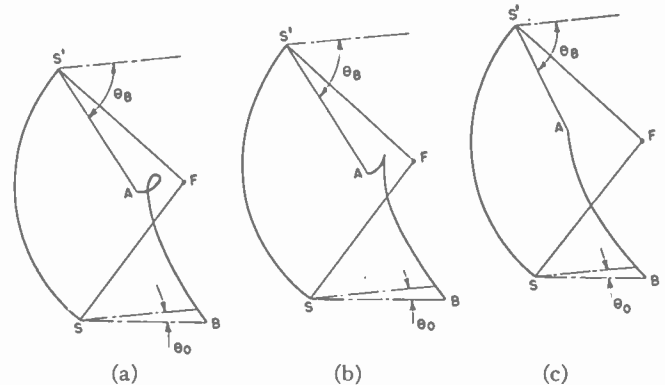

Fig. 8—Typical examples of curves for testing single-valuedness of the surface.

would be folded; curve (c) contains no singular point and is not multivalued, showing that the surface can be utilized as a reflector.

EXPERIMENTAL RESULTS

A reflector for the ideal beam shape $G(\theta) = K \csc^2 \theta \cos \theta$, and whose horizontal and vertical dimensions were 36 inches and 15 inches, respectively, was computed and built. The focal length of the reflector was 14.5 inches. The pattern of this antenna for $\lambda = 3.2$ cm is shown in Fig. 9. The gain was approximately 29.5 db.

The pattern of this antenna differs from the ideal curve, shown dashed in Fig. 9, in two ways. The peak is rounded, corresponding to a width at half power of about 8° , and displaced slightly to the right of the assumed θ_0 . Secondly, there are small diffraction lobes superimposed upon the pattern. Some suppression of these small lobes can be achieved by tapering of the intensity on the edges of the reflector, but it is unlikely that they can be completely eliminated.

The expression $G(\theta) = K \csc^2 \theta \cos \theta$ is not a physically realizable pattern, because the rounded peak of the dif-

fraction pattern is a phenomenon not accounted for by simple geometrical optics. Consequently, some allowance for diffraction should be included in the ideal beam shape. Thus, if an expression for $G(\theta)$ which is physically

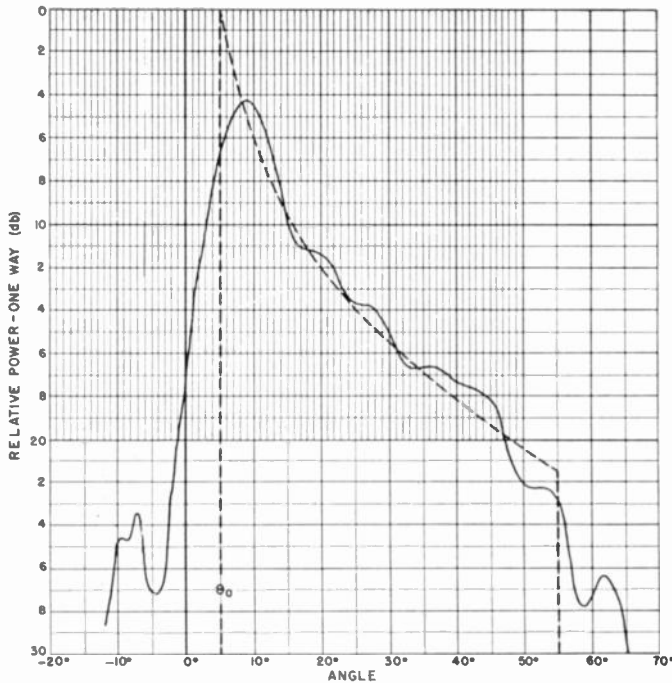

Fig. 9—The pattern of the antenna, computed for $G(\theta) = K \csc^2 \theta \cos \theta$.

realizable is used, the pattern of the calculated reflector will more closely approximate this ideal pattern and therefore permit more accurate prediction. In an attempt to use an expression for $G(\theta)$ that was physically realizable, the expression was taken as follows:

$$G(\theta) = e^{-k\theta^2} \int_{\theta_0-\alpha}^{\theta_0+\alpha} + K \csc^2 \theta \cos \theta \int_{\theta_0+\alpha}^{\theta_B} \quad (8)$$

The resulting antenna pattern is shown in Fig. 9. The reflector dimensions were 36 by 17 inches, horizontal and vertical apertures, respectively, with a focal length of 14.5 inches. The constants k , α , and K were adjusted to normalize the $\csc^2 \theta \cos \theta$ curve to the half-power point of the beam whose width at half power was taken to be 6° . The dashed curve in Fig. 10 is that defined by the above function. The agreement is seen to be quite good.

The theoretical gain of the cosecant-squared antenna is rather difficult to define because the ideal $\csc^2 \theta$ pattern is realizable only with an antenna of infinite vertical aperture. We may, however, compute the gain of an antenna in whose horizontal aperture d the intensity is uniform and whose elevation pattern is specified by (8).

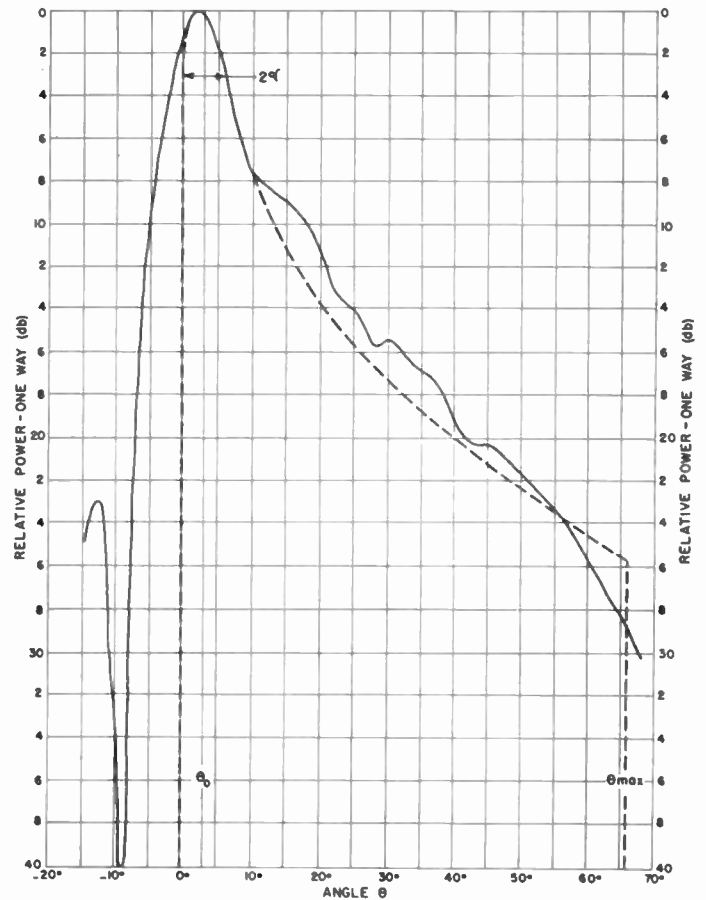

Fig. 10—The pattern of the antenna, computed for

$$G(\theta) = e^{-k\theta^2} \int_{\theta_0-\alpha}^{\theta_0+\alpha} + K \csc^2 \theta \cos \theta \int_{\theta_0+\alpha}^{\theta_{max}}$$

Thus,

$$G = \frac{4\pi d}{\lambda} \frac{e^{-k\theta_0^2}}{\int_{\theta_0-\alpha}^{\theta_0+\alpha} e^{-k\theta^2} d\theta + \int_{\theta_0+\alpha}^{\theta_B} K \csc^2 \theta \cos \theta d\theta} \quad (9)$$

The first integral in the denominator may be evaluated in terms of the probability function by using the transformation $\phi^2 = k\theta^2$. Then

$$\int e^{-k\theta^2} d\theta = \frac{1}{\sqrt{k}} \int e^{-\phi^2} d\phi,$$

and hence we obtain

$$\int_{\theta_0-2\alpha}^{\theta_c} e^{-k\theta^2} d\theta = \frac{\sqrt{\pi}}{\sqrt{k}} \left[\frac{2}{\sqrt{\pi}} \int_0^z e^{-\phi^2} d\phi \right]$$

where the function in the brackets is the probability integral. Since θ_c corresponds to the half-power point of the curve, (9) becomes

$$G = \frac{4\pi d}{\lambda \left\{ \frac{\sqrt{\pi}}{\sqrt{k}} \left[\frac{2}{\sqrt{\pi}} \int_0^{0.69315} e^{-\phi^2} d\phi \right] + K [\csc \theta_c - \csc \theta_B] \right\}} \quad (10)$$

where $\theta_c = \theta_0 + \alpha$. Substituting the values of k , α , K , θ_0 , and θ_B for the calculated antenna, we obtain $G = 2730$, which is 34.36 db above an isotropic radiator. The measured gain of the antenna was 31.4 db. This is in fair agreement with the "theoretical."

Antenna patterns in planes transverse to the elevation plane are uniformly narrow, having a width at half power of about 2.5° for the reflector whose elevation pattern is shown in Fig. 10. The side lobes in transverse planes for various elevation angles are as shown in Table I.

TABLE I

Angle from peak	0°	15°	30°	40°	50°
Side lobe level relative to the maximum at the given angle	-19db	-14db	-12db	-12db	-12db

A third reflector was computed for the function $G(\theta)$ as follows:

$$G(\theta) = e^{-k\theta^2} \int_{\theta_0-\alpha}^{\theta_0+\alpha} + K \csc^2 \theta \int_{\theta_0+\alpha}^{\theta_1} + A \cos n\theta \int_{\theta_1}^{\theta_2} \quad (11)$$

The predicted half-power width was 10° , the angle θ_1 chosen to be 30° , and the function $A \cos n\theta$ added in order that the entire function go continuously to zero. The horizontal and vertical dimensions of the reflector were 30 and 9 inches, respectively. The elevation pattern of this antenna for $\lambda = 3.2$ cm is shown in Fig. 11. The dashed curve is that defined by (11). The agreement between this ideal pattern and the diffraction pattern is very good.

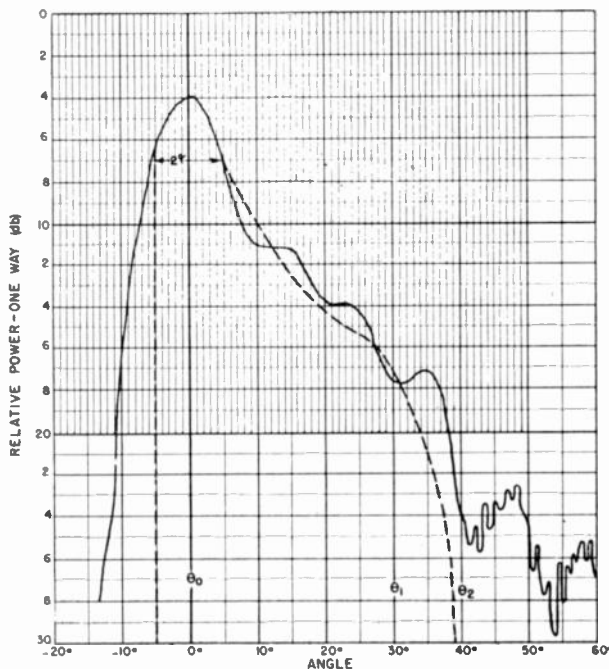

Fig. 11—The pattern of the antenna, computed for

$$G(\theta) = e^{-K\theta^2} \int_{\theta_0-\alpha}^{\theta_0+\alpha} + K \csc^2 \theta \int_{\theta_0+\alpha}^{\theta_1} + A \cos n\theta \int_{\theta_1}^{\theta_2}$$

It is notable that considerable latitude in the control of the shape of the elevation pattern is permissible by motion of the feed horn away from the focus in the vertical plane. It is therefore possible to obtain an airborne navigational antenna whose pattern may be controlled for various altitudes and maximum ranges. Such variation in the pattern is illustrated in Fig. 12, in which polar diagrams are shown for three positions of the horn feed: (A) 1 inch below focus; (B) on focus; and (C) 1 inch above focus. In each case the feed horn was tilted 5° down with reference to the normal to the axis through the focal point. The reflector is the same one

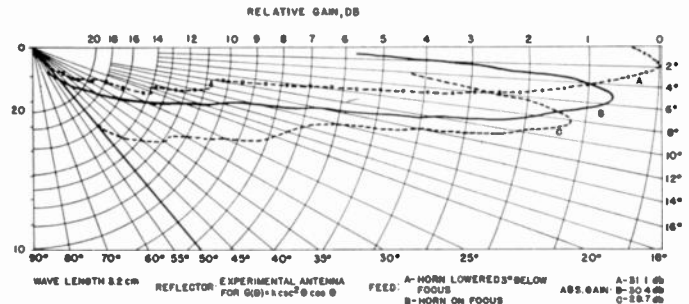

Fig. 12—Illustration showing the control of the antenna pattern by feed motion.

whose pattern is shown in Fig. 9. Note that the radius of the polar diagram is proportional to radar range. The feed motion required for such elevation pattern control is realizable by simple mechanical linkages.

CONSTRUCTION OF EXPERIMENTAL REFLECTORS

The first two reflectors were made from laminated wood, each lamina of which was cut to fit a three-dimensional template. When the laminae were all assembled and firmly glued, the surface was carefully sanded to fit the template at all points. The surface was then painted with conducting silver paint. A photograph of one of the templates is shown in Fig. 13.

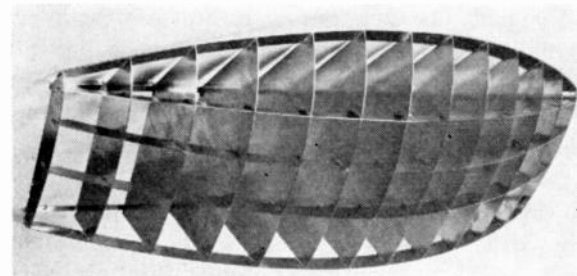

Fig. 13—The three-dimensional template for the construction of an experimental reflector.

A third reflector was constructed by stretching fine copper mesh on metal plates which had been cut to fit the contours of vertical sections of the reflector surface. The mesh was soldered to each contour plate and stiff-

ened by tinning lightly with solder. The plates were supported firmly by spacers and a substantial metal frame.

ACKNOWLEDGMENT

Acknowledgement is due H. F. Cogan for calculation of the first reflector, to D. R. Taskjian for calculation and construction of the third reflector, and to L. J. Chu, S. Silver, and L. C. Van Atta for helpful discussions.

APPENDIX I

DISCUSSION OF ERRORS

Suppose that a certain ideal beam shape is required for a special microwave antenna application. Any antenna designed to produce this ideal beam shape will, in fact, radiate a pattern which differs from the ideal in some degree. We now define such differences as errors.

Sources of Error

The errors associated with the double-curvature reflector antenna are of two general kinds: those which are mechanical, affecting the shape of the reflector surface; and those which arise from diffraction, affecting the shape of the radiated beam. The mechanical errors in the reflector surface will modify the geometrical distribution of energy and will alter, to some extent, the shape of the realized antenna pattern. The mechanical errors may be classified as (a) errors in measurement, (b) errors in computation, and (c) surface tolerances. Entirely independent of the effect of mechanical errors are the effects of diffraction. These are twofold: (a) to modify the beam shape from the ideal to an approximation to the ideal which contains no discontinuities in intensity, and (b) to superimpose diffraction lobes on the pattern.

Errors in Measurement

If the measurement of the primary feed pattern $I(\phi)$ is in error, the reflector shape, of course, will be made incorrect for the desired secondary pattern, and consequently the antenna pattern will not have the proper distribution of power. However, since the error in measurement takes the form

$$\frac{\int_{\phi_B}^{\phi} \frac{I(\phi) + \Delta(\phi)}{\rho} d\phi}{\int_{\phi_B}^{\phi_A} \frac{I(\phi) + \Delta(\phi)}{\rho} d\phi} \quad (12)$$

where $\Delta(\phi)$ is the relative error as a function of ϕ , it appears that errors in measurement of $\pm \frac{1}{2}$ db or less will not seriously effect the resultant antenna pattern.

Errors in Computation

Computational errors arise primarily from two sources: plotting and graphically integrating the various

functions, and rounding of decimals. It may be argued that the method of calculation is not highly precise; however, precision of a sufficiently high degree may be assured by carrying all computed decimals to the fourth place. The significance of certain of these decimal places may be questioned; but assuming that, in graphical integration, the area may be read to an accuracy of ± 1.5 per cent for any small increment, and to an accuracy of ± 0.5 per cent in the total area, the maximum possible error in the computation of θ will be less than 5 minutes of arc. Similarly, the maximum error in $\log_{10} \rho/\rho_0$ is about 0.8 per cent, permitting the computation of the radius vector within a maximum possible error of less than 0.010 inch ($\rho < 12$ inches).

Surface Tolerances

An estimate of the surface tolerances may be obtained upon consideration of (2), the differential equation for the surface,

$$\frac{d\rho}{\rho} = \tan \frac{1}{2}(\phi + \theta) d\phi. \quad (13)$$

Consequently, if we know the function

$$\theta = F(\phi),$$

we can evaluate the allowed increment in the radius vector for a given tolerance in the direction θ ; thus,

$$\Delta\theta = F'(\phi) d\phi$$

$$\Delta\rho = \rho \tan \frac{1}{2}(\phi + \theta) \frac{\Delta\theta}{F'(\phi)}. \quad (14)$$

It now remains to determine $F'(\phi)$, which may be approximated by plotting the curve $\theta = F(\phi)$ and reading the slope for various values of θ . Taking $\Delta\theta = \pm \frac{1}{4}^\circ$, the average values of $\Delta\rho$ obtained for the experimental reflectors described above are about 0.005 inch. This permissible error in ρ is less than the maximum possible error computed in the foregoing paragraph, but on the other hand the probable error in ρ will certainly be less than the maximum possible error. In consequence, the probable error in ρ will be of about the same magnitude as the permissible error. It should be noted, however, that diffraction will most probably permit some relaxation of the surface tolerances. On the basis of allowing $\pm \lambda/20$ variation in the phase front after reflection, we find that the permitted tolerance in the radius vector is, for example, about 0.032 inch for $\lambda = 3.20$ cm. The whole question of precision of the method, however, is best answered by the comparative excellence of the experimental results.

Effect of Diffraction

The primary effect of diffraction in modification of the beam shape is the removal of sharp discontinuities in intensity. In addition, small diffraction lobes are superimposed on the pattern. The effect of diffraction is illustrated in Figs. 9, 10, and 11.

The small diffraction lobes in the pattern arise chiefly from the lower edge of the reflector (see Fig. 5). This is best illustrated by considering the spiral that results from the contributions of amplitude from small elements of the surface in a direction θ . Consider a narrow section of the reflector surface about the central section curve. Corresponding to each surface element of this section, there is a certain electromagnetic-wave amplitude and phase radiated in the given direction θ . If these contributions are added, vector-fashion, each at its respective phase angle, starting at the bottom edge of the reflector as a reference, there results a spiral analogous to the Cornu spiral of physical optics. Although for the whole surface the picture is somewhat more complicated than this, we may represent the sum of contributions from all elements of surface by a spiral similar to that obtained from elements in the narrow section of the surface. For the angle θ near θ_0 , the spiral is of the form shown in Fig. 14(a), while for large θ the spiral

curls much more rapidly, as in Fig. 14(b). In both spirals the lower edge of the reflector is at the origin.

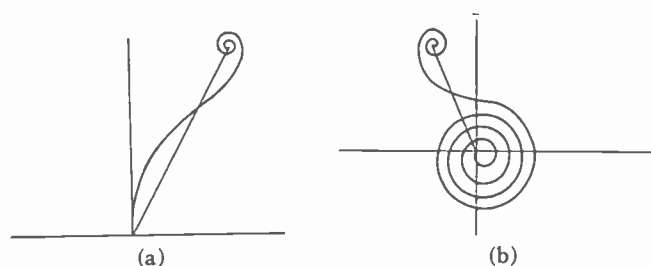

Fig. 14—Spirals resulting from vector addition of amplitude contributions from elements of the reflector surface. (a) Spiral for θ nearly equal to θ_0 . (b) Spiral for large θ .

The spiral for large θ shows that the phase of the amplitude contributions from the lower part of the reflector changes very rapidly, and consequently the resultant radiation pattern will contain small variations of a quasi-periodic nature.

A New 100-Watt Triode for 1000 Megacycles*

W. P. BENNETT†, ASSOCIATE MEMBER, IRE, E. A. ESHBACH†,
C. E. HALLER†, SENIOR MEMBER, IRE, AND W. R. KEYE‡

Summary—The design and development of a 100-watt, grounded-grid triode for operation at full ratings up to 1200 Mc is described. Unusual mechanical design features have been utilized to achieve a tube which not only is capable of excellent performance at ultra-high frequencies, but which can also be manufactured by production-line methods.

The outstanding design features making this performance possible include close spacing of a coaxial structure to give high permeance; precision cold working of metals at high unit pressures to fabricate all electrodes; and assembly of the tube using localized rf heating methods and precision jigs to maintain accurate spacing of electrodes.

Circuit and performance data of this new tube are given as a power oscillator, as well as a uniquely neutralized ultra-high-frequency power amplifier.

INTRODUCTION

THE DESIGN and development of a compact, forced-air-cooled uhf power triode capable of delivering 100 watts at an efficiency of 40 per cent in a cw amplifier operating at 1000 Mc presented stringent electronic and physical requirements which were met by novel methods of fabrication and assembly. The resultant type, the 5588, has a maximum of operational stability together with good circuit adaptability, achieved through the use of a coaxial electronic struc-

ture^{1,2} with supporting elements likewise coaxially aligned.

DESIGN AND CONSTRUCTION

General Construction Features

The electrode structure of the 5588 consists of three closely spaced coaxial cylindrical elements: the unipotential oxide-coated cathode, the grid, and the anode. A cross-sectional view of the tube is given in Fig. 1. Because the axial length of the electrode structure is about $\frac{1}{4}$ inch, which is short in comparison with a quarter wavelength at 1000 Mc, essentially equal rf voltages exist at all points over this area. The grid, which consists of a cylindrical array of short wires aligned parallel to the tube axis, has low inductance. The short grid wires provide a maximum of end or conduction cooling, allowing greater grid dissipation before instability occurs due to grid emission. The short coaxial structure provides considerable freedom from instability due to shifts in electrode spacing, buckling, or warping of the electrodes. The members which support the electrodes and provide for the transition between the external circuit and the electrodes are continuous, low-inductance

* Decimal classification: R339.2. Original manuscript received by the Institute, January 30, 1948; revised manuscript received, March 30, 1948. Presented, 1947 IRE National Convention, March 6, 1947, New York, N. Y.

† Radio Corporation of America, Lancaster, Pa.

‡ Formerly, Radio Corporation of America, Lancaster, Pa.; now, Engineering Research Associates, Inc., St. Paul, Minn.

¹ R. R. Law, D. G. Burnside, R. P. Stone, and W. B. Walley, "Development of pulse triodes and circuit to give one megawatt at 600 megacycles," *RCA Rev.*, vol. 7, pp. 253-265; June, 1946.

² L. S. Nergaard, D. G. Burnside, and R. P. Stone, "A developmental pulse triode for 200-kilowatt output at 600 megacycles," *Proc. I.R.E.*, vol. 36, pp. 412-416; March, 1947.

cylinders. These members serve the further function of either providing or preventing thermal isolation of the various electrodes.

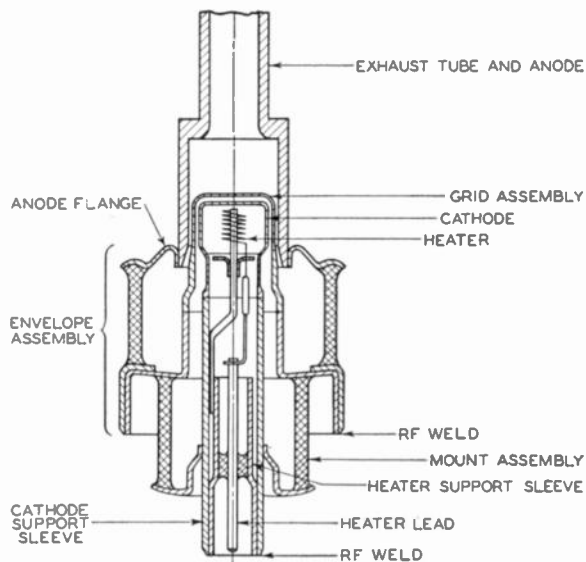

Fig. 1—Cross-sectional view of the 5588.

General Assembly Methods

The achievement of these construction features requires a well-integrated mechanical design based upon precision assembly methods and parts-manufacturing techniques. The mechanical design of the tube is such that the main supporting unit contains a base reference surface, the inside cylindrical surface of the cathode support sleeve. Each critically spaced element likewise has an appropriate mechanical reference surface. During assembly, as each element is fastened to the main unit its reference surface is aligned by the use of jigs with the base reference surface. In this way, the proper cathode-grid-anode alignment is obtained.

The jiggling tools consist of accurately ground V-blocks and cylindrical alignment mandrels as shown in Fig. 2. If mandrels of exactly equal diameters are placed in V-ways whose surfaces are true intersecting planes, the center lines of the mandrels will coincide. Hence the

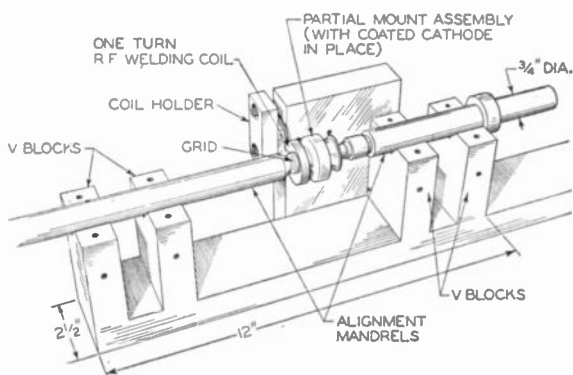

Fig. 2—Jiggling equipment consisting of V-blocks and cylindrical mandrels.

alignment of parts held by these mandrels will be limited only by the accuracy of the jiggling surfaces. The critical intersecting plane surfaces of the V-ways can be ground to a high degree of accuracy in a surface grinder, and the pairs of cylinders or mandrels can be ground to virtually equal diameters in a cylindrical grinder between dead centers. The use of V-blocks eliminates the need for the bearing tolerances of a coaxial jig consisting of mandrel and coaxial bearings, or dowel pins and fitted holes.

Radio-Frequency Induction Welding

The reference-surface-assembly principle with V-blocks and mandrels is particularly useful when rf induction-welding methods are used for making the metal-to-metal joints. Figs. 2 and 3 show the arrange-

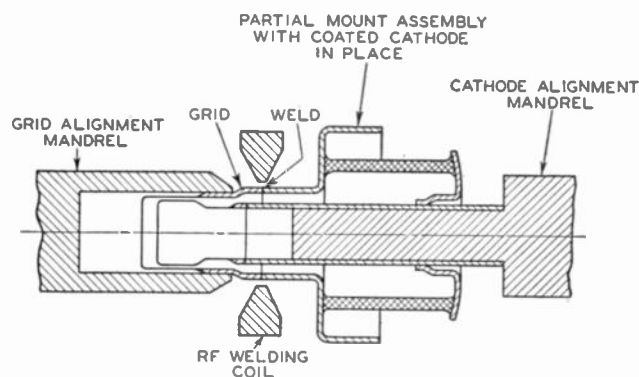

Fig. 3—Arrangement of parts for rf-welding the grid to Kovar support; cross-sectional view.

ment of the parts for rf-welding the copper grid directly to its Kovar support. The grid is jiggged by its reference surface, and the mount assembly is jiggged by the inside bore of the cathode support cylinder. The welding is accomplished by sending a heavy surge of rf current through an appropriately shaped induction coil, the contours of which mate the members to be welded. The induced current is intensely concentrated in the weld area. The heat produced by the induced current brings the weld area up to the welding temperature in a fraction of a second. Because the heating is concentrated and requires only a fraction of a second, the welding is accomplished with a minimum of total heat, and the delicate tube electrodes and glass-to-metal seals remain at low temperature and are unharmed.

In addition, because part reference surfaces and jigs remain cool, they retain their accuracy. It should be noted that the welding coil makes no direct contact with the work or jigs which might cause misalignment due to temporary deformations. The welds produced are symmetrical, continuous, and uniform, providing great mechanical strength and high thermal and electrical conductivity. The use of rf welding for assembly does not adversely deform the parts nor set up uneven stresses which pull the parts out of alignment when the jigs are removed. In addition, the process can be per-

formed in any nonconducting medium. Neutral or reducing atmospheres can be used if it is desirable to prevent traces of oxidation.

Assembly of Components

The tube is made up of three separate assemblies utilizing glass-to-metal seals and identified in Fig. 4 as mount assembly, envelope assembly, and heater assembly. As shown in Fig. 5, the mount assembly com-

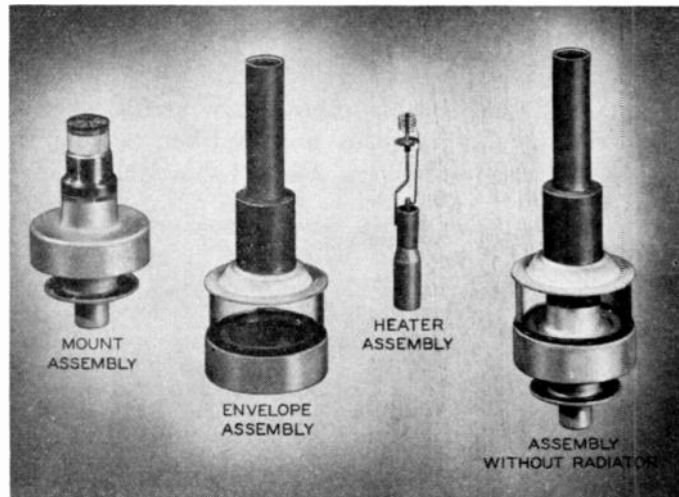

Fig. 4—Three main components and final assembly.

prises the mount support assembly, the cathode assembly, and the grid. The separate parts (Fig. 6) of the mount support assembly include the cathode support, which is coaxially fastened by seals to the grid support and insulated from it with an intermediate length of glass tubing. The envelope assembly consists of the grid flange (subsequently welded to the grid support), which

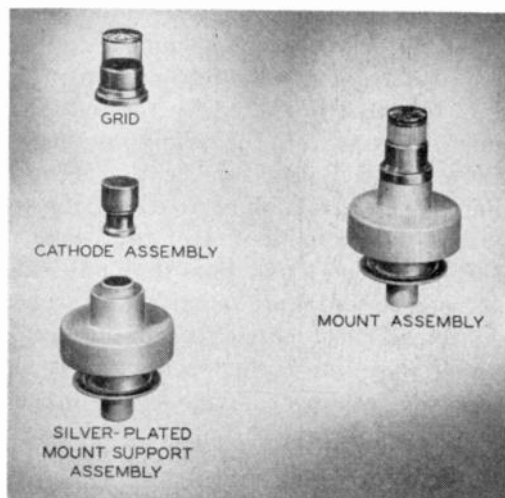

Fig. 5—Mount assembly and components.

is separated by a length of glass tubing from the copper anode brazed to a sealing alloy flange. These three assemblies must be made so that the surfaces involved in

the final welds to the critical electrode members are closely aligned. Glass seals are made through use of rf induction heating of the metal sealing surfaces to bring the metal-glass boundaries to the temperature required for glass sealing. Because this technique obviates the use of fires in the sealing operation, the jiggling problem is immensely simplified. In addition, it is simpler to control the physical chemistry of the glass-to-metal sealing phenomena by appropriate atmospheres and accurate

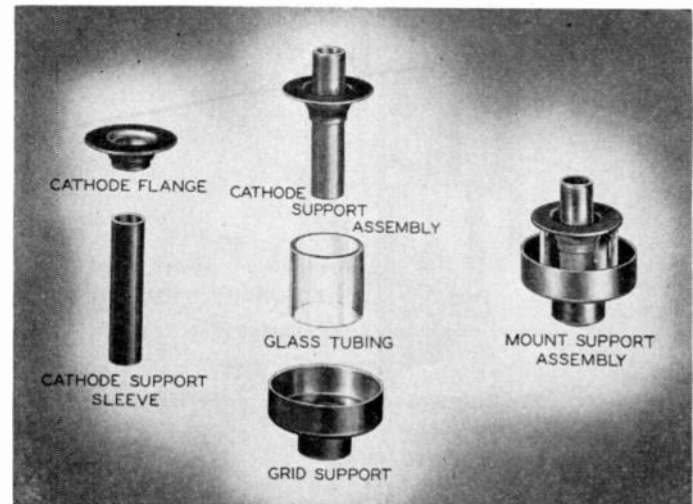

Fig. 6—Mount support assembly and components.

localized heating. The use of suitable jigs and limit stops permits placing cold parts on the jigs and making glass-to-metal seals of high merit at a rapid rate.

Parts Features

The supporting members of the tube which make up the assemblies are produced by conventional drawing and forming methods. However, these members are specially shaped from a structural standpoint to yield sufficient "strain isolation," so that a deformation or "strain" in one section of the tube will not adversely affect some other critical area. For example, if the glass sealing surface of the sealing-alloy anode flange in Fig. 1 is to match the thermal expansion of the envelope assembly glass, it must be properly shaped so that the high thermal expansion of the copper anode does not affect this glass seal. Strain isolation is achieved by appropriate positioning of sharp changes in contour which hinder spreading of a strain or deformation over a great area.

Chief among the parts that require special attention are the electrodes. For example, to reduce interelectrode capacitance to a minimum the cathode (Fig. 7) is formed into a re-entrant shape at high unit pressures in a precision die by an expanding punch. The intermediate cathode-supporting member thermally isolates the hot cathode, yet provides a mechanically strong support and a continuous low-inductance rf path. It achieves

these qualities by virtue of its extremely thin wall section, which is fabricated by a special forming process from the parent thick-wall tubing. The cathode and the

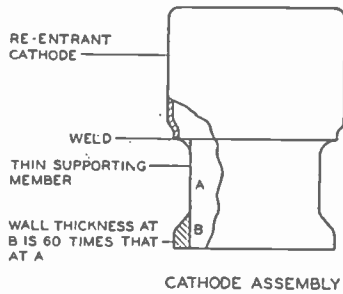

Fig. 7—Cathode assembly, cutaway view.

thin-wall support are rf-welded together to form the cathode assembly. Another special construction is the one-piece conduction-cooled grid (Fig. 8). This con-

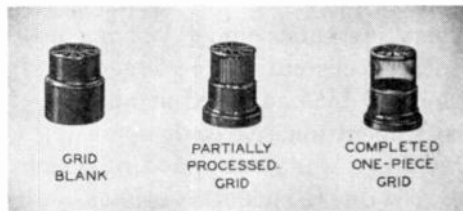

Fig. 8—Fabrication of one-piece grid.

struction was chosen because of the thermal grid dissipation necessary for the relatively high current and power densities required for uhf operation. A radiation-cooled grid would have to operate at a high temperature in order to dissipate the necessary energy. In a tube using an oxide-coated cathode there is usually a certain amount of barium deposited on the grid wires during tube processing, or possibly during operation. This barium lowers the temperature at which grid emission occurs and thus limits the working temperature of the grid to a value much lower than is permissible in a tube utilizing, for example, pure tungsten as a source of emission. Hence, because a radiation-cooled grid is inherently a high-temperature device, it has relatively low dissipation capabilities in a tube having an oxide-coated cathode. It appears, therefore, that the most desirable way to handle the grid-dissipation problem is to make the entire grid out of one piece of a material having high thermal conductivity, and to provide for removal of the heat to the outside of the tube by thermal conduction. A short vertical grid affords an effective thermal path for conducting the heat to a thermal "sink" outside the tube and makes it possible to hold the temperature of the grid wires to the desired value. Limiting the length of the grid verticals does not affect rf performance because the intended use of the tubes also dictates short electrode structures. The complete grid in the 5588 is fabricated from a single piece of copper by application of a special cold-forming process. By means of this

construction, thermal barriers from indeterminate welded joints, or uneven thermal-mechanical strains that must be "stretched out," are not introduced. The outside cylinder of the supporting ring is automatically made into a jiggling surface concentric to close tolerances with the grid-wire cylinder. In this way, induction welding to the grid support assembly is expedited. This joint completes the heat path to the outside of the tube. The thermal "sink" necessary for grid cooling is supplied by the anode-cooling air passing over the grid flange and by the contacting circuit fingers.

The anode, Fig. 9, is also a unique part in that it, together with a metal exhaust tube, is cold-extruded from a single cylindrical piece of copper cut from stock. This technique eliminates the possibilities of leaks due to overworked walls of drawn cups or oxygen-bearing copper incurred during intermediate annealings. In

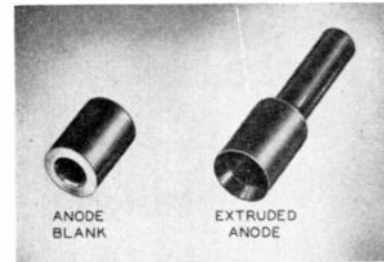

Fig. 9—Fabrication of anode.

addition, an extremely fine finish is achieved and inherently accurate jiggling surfaces are available for speedy assembly operations. One stroke of the press produces a finished anode complete with metal exhaust tube.

Assembly of Complete Tube

The mount support assembly (Fig. 5) contains the base reference surface and is the main supporting unit. To this, the cathode and the grid are radio-frequency welded in succession, while each is held very accurately concentric with the inside surface of the cathode support by means of the mandrels and V-blocks. In the final assembly of the tube, the three separate assemblies (Fig. 4) are brought together and the final metal-to-metal closures are then made utilizing rf welding. The envelope assembly containing the anode, and the external grid terminal separated by a section of glass, is placed over the mount assembly and welded to it to make the main seal closure. The anode is held concentric with the grid-cathode structure in the V-blocks and mandrels. The final closure is made by placing the self-aligning heater assembly into the cathode-support tubing and rf-welding it in place. The tube is then evacuated followed by a cold-metal pinch-off at the exhaust tubulation above the anode. After the pinch-off, the radiator is soldered to the anode.

Because a uhf circuit is a precise mechanical device of which the tube must become a part during operation, the contact surfaces of the tube must also be precisely defined and maintained. The same coaxial alignment methods which produce the precise cathode-grid-anode alignment also serve to provide accurate alignment of the contact terminals. The external contact terminals consist of two coaxial cylindrical surfaces (the cathode and grid terminals) having progressively larger diameters, and a plane surface in the form of an annular ring (the top surface of the anode ring) which is perpendicular to the center lines of the above cylinders (see Fig. 10). Since the outside diameter of the anode ring is not

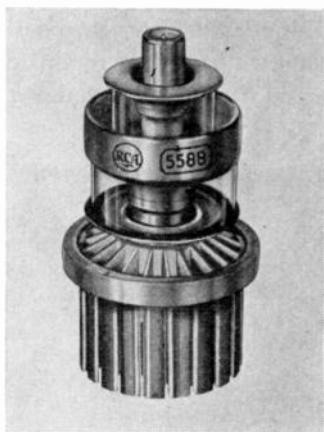

Fig. 10—Uhf power triode, 5588

a contact surface, clearance may be allowed in the circuit adaptor around this ring so that motion in directions perpendicular to the centerline is not limited by the anode ring. This clearance allows the tube to seek its position freely in the grid and cathode contacts, because it is plugged into the circuit before the clamp which anchors the tube in place is placed over the anode ring.

OPERATION AND APPLICATION

Operation Considerations

Electron-transit-time effects were evidenced by overheating of the cathode and resultant short cathode life at the higher frequencies. This cathode overheating is caused by back bombardment of the cathode by a portion of the space-current electrons at the end of each current pulse which do not have enough energy to pass through the grid plane as the grid swings negative at the end of the voltage pulse. Compensation for back bombardment is accomplished by a reduction in cathode heater input to maintain the cathode temperature at the normal value. Thus, when long life in continuous operation is desired, the tube should first be put into operation with full rated heater voltage and then, as back bombardment progresses, it should have its heater voltage reduced so as to bring the cathode temperature back to normal. The magnitude of the heating due to back bombardment is a function of the op-

erating conditions and the frequency. The recommended heater operating voltage for oscillator service, as shown in the curves of Fig. 11, was determined on an empirical

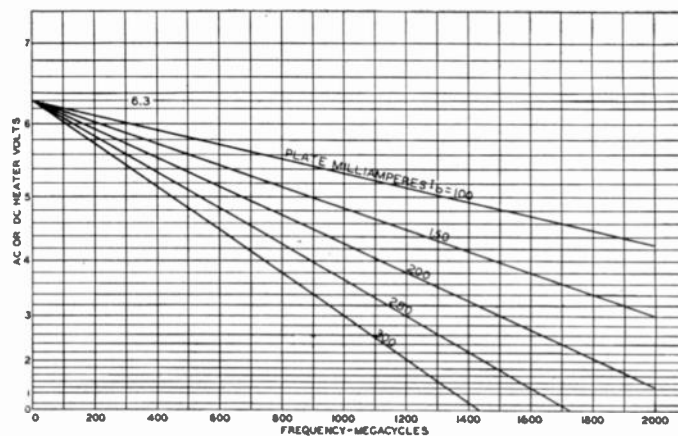

Fig. 11—Heater voltage versus frequency of the 5588 in oscillator service.

basis by operating tubes under varying conditions of plate current, grid current, plate voltage, and frequency, but with the grid bias adjusted at all times for essentially class-B operation. At each operating condition, the heater voltage was determined at which the tube became unstable, due to lack of emission as judged by the dropping of power output. The interpretation of these data was simplified by utilizing specially prepared graph paper which had equally spaced divisions on the horizontal axis, but scale divisions on the vertical axis which were exponentially larger according to the exponent n in the relation $P = KE^n$. In this equation,³ which relates power input to a tungsten heater as a function of heater voltage,

$$P = \text{input to heater in watts}$$

$$K = \text{constant}$$

$$E = \text{heater volts}$$

$$n = 1.61 \text{ for a tungsten heater.}$$

If power input to the heater is plotted on the horizontal axis and the heater voltage on the vertical axis of this special paper, the resulting curve is a straight line passing through the origin.

Instability curves were obtained by plotting on this paper the points at which the tube became unstable. The data indicated that, in class-B oscillator service, the back-bombardment heating power is essentially proportional to frequency and plate current, while in class-B amplifier service the back heating power is proportional to frequency and grid current. The recommended heater operating voltages as shown in Fig. 11 were arrived at by drawing a line passing through the vertical axis at 6.3 volts parallel to the instability curve. These values, then, include the normal safety factor for operation of oxide cathodes and, as a result,

³ Cecil E. Haller, "Filament and heater characteristics," *Electronics*, vol. 17, pp. 126-131; July, 1944.

bring the cathode to normal operating temperature and thus insure long life. In oscillator service at an input of 250 watts at a plate current of 300 milliamperes and the heater voltage at the recommended 3 volts, the 5588 has operated at an efficiency of 30 per cent with a power output of 75 watts for well over 1000 hours. Tube data of a general nature is shown in Table I. The characteristics of a typical tube are shown in Fig. 12.

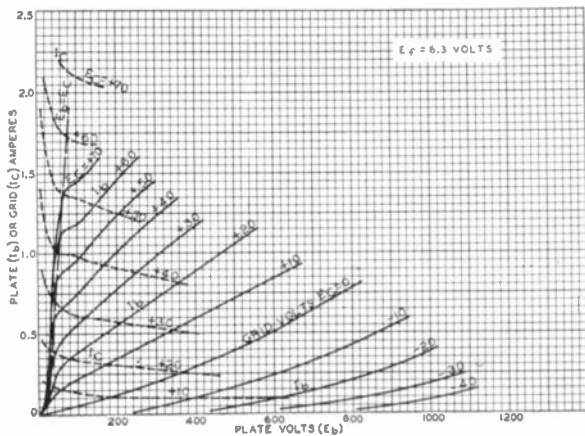

Fig. 12—Characteristic curves.

TABLE I
GENERAL DATA

Amplification Factor	16 ($I_b = 250$ ma)
Transconductance	15,000 micromhos ($I_b = 250$ ma)
Direct Interelectrode Capacitances	
Grid to plate	6 μmf
Grid to cathode	13 μmf
Plate to cathode	0.32 max. μmf
Plate Dissipation	200 watts
Over-all Length	$3\frac{3}{8}$ inches

Application as Oscillator and Amplifier

The 5588 was initially designed for use in cw oscillator service up to 1000 Mc and for a power output of 50 watts with an efficiency of at least 20 per cent. The present tube, however, operated in circuits described in this paper has an average output of 75 watts with an efficiency of 30 per cent. The 5588 has also been operated as a stable grounded-grid amplifier at 1000 Mc with a power output of 100 watts. At 220 Mc, two tubes operated in a push-pull oscillator circuit gave an efficiency of 55 to 60 per cent.

At 1000 Mc the 5588 has been operated only in coaxial grounded-grid circuits because of the self-shielding and low-loss properties of such circuits. Both extended and folded-back types of coaxial circuits have been used. The advantage of the folded-back type of circuit is that the tube may be plugged directly into the circuit.

A diagrammatic sketch of a 1000-Mc oscillator of the extended coaxial type is shown in Fig. 13. The anode and cathode circuits are shorted concentric transmission lines operating in the $\frac{3}{4}$ -wavelength mode. Feedback is provided by means of a tuned feedback loop extending

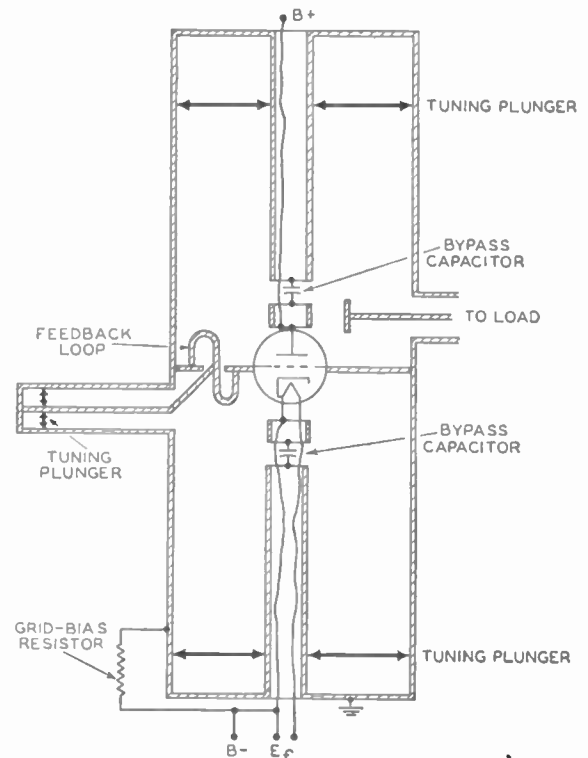

Fig. 13—Diagrammatic sketch of 1000-Mc oscillator of extended-coaxial type.

into both the anode and cathode cavities. The power output is measured by means of a calibrated water-cooled load. This load is coupled into the anode circuit through a double stub tuner by means of a small probe. Cylindrical mica capacitors are used in the inner conductors of both the anode and cathode lines to isolate the dc plate and cathode-bias voltages. The tube is cooled by means of air blown down the inner conductor of the anode line. A typical operating condition for this circuit is shown in Table II.

TABLE II
TYPICAL OPERATION* OF 5588 AS GROUNDED-GRID OSCILLATOR AT 1000 Mc

Heater Voltage	3 volts
DC Plate Voltage	835 volts
DC Grid Voltage	-70 volts
From cathode-bias resistor of	205 ohms
DC Plate Current	300 ma
DC Grid Current (Approx.)	40 ma
Power Output (Approx.)	75 watts

* Continuous Commercial Service.

When the 5588 is used as a 1000-Mc amplifier in a folded-back type circuit such as that given in Fig. 14, neutralization is necessary to prevent oscillation. For the purpose, a feedback probe approximately $\frac{1}{4}$ -wavelength long is used to couple the anode and cathode circuits. A probe such as is shown in Fig. 14 will prevent the amplifier from self-oscillation over a range of 100 Mc without requiring adjustment in the length of the probe. Although this type of neutralization does not completely

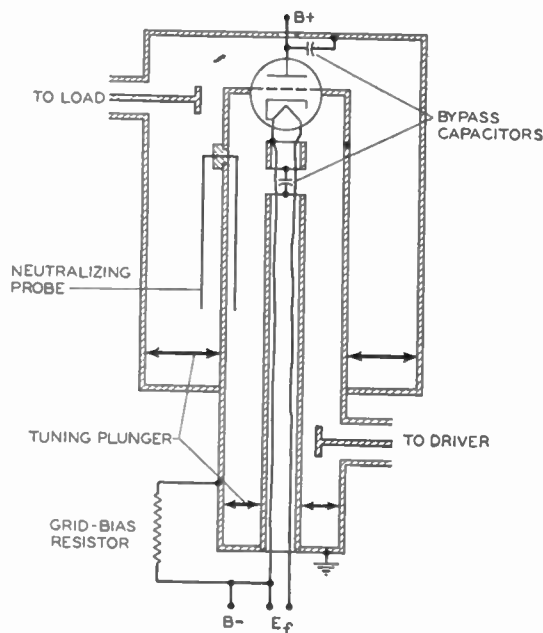

Fig. 14—Diagrammatic sketch of 1000-Mc amplifier of the folded-back type.

isolate the anode and cathode circuits, it does permit stable amplifier operation. The amplifier circuit shown in Fig. 14 has the anode circuit folded back over the cathode circuit. This type of construction permits the insertion of the tube into the open end of the circuit. Connections are made to the cathode and grid of the tube by means of contact fingers, while the anode ring of the tube is clamped firmly in the circuit. The anode circuit is a coaxial line operating in the $\frac{3}{4}$ -wavelength mode and the cathode line operated in the $\frac{1}{4}$ -wavelength mode. Radio-frequency power is fed into the amplifier by means of a capacitive probe inserted into the portion of the cathode line which extends below the anode line. Power is taken from the amplifier by means of a probe inserted into the anode line near the tube. For measure-

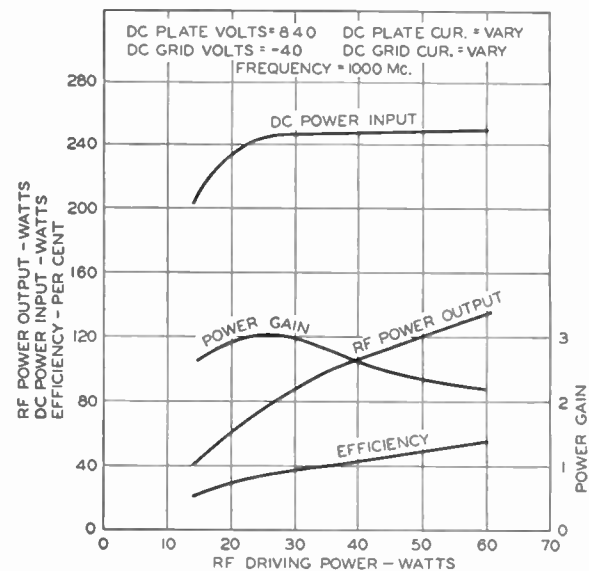

Fig. 15—Performance curve of 1000-Mc amplifier of the folded-back type.

ment purposes, the power output was fed into a water-cooled load through a double-stub tuner.

A performance curve of the amplifier is shown in Fig. 15. This curve shows dc power input, rf power output, apparent plate efficiency, and power gain of the amplifier as a function of rf driving power. The driving power was measured by means of a standing-wave-detector type of wattmeter inserted between the amplifier and driver.

ACKNOWLEDGMENT

The authors wish to acknowledge the numerous contributions to this development from other RCA members at the Lancaster and Camden plants. The coaxial structure employed is a further extension of a design originating at the RCA Research Laboratories at Princeton, N. J.

The Tapered Phase-Shift Oscillator*

PETER G. SULZER†, ASSOCIATE, IRE

Summary—The tapered phase-shift networks with three and four sections are investigated. It is shown that an oscillator incorporating one of these networks and a triode tube is useful throughout the audio-frequency range.

INTRODUCTION

IT IS THE PURPOSE of this paper to consider a modification of the phase-shift oscillator¹ in which the impedance of the sections of the phase-shift network is increased progressively along the network. The

* Decimal classification: R355.914.31. Original manuscript received by the Institute, March 18, 1948.

† Pennsylvania State College, State College, Pa.

¹ E. L. Ginzton and L. M. Hollingsworth, "Phase-shift oscillators," *Proc. I.R.E.*, vol. 29, pp. 43-49; February, 1941.

modified circuit has been used as a low-frequency oscillator²; however, it is so useful throughout the entire audio-frequency range that further investigation seemed desirable.

In practice, using the tapered network, it is possible to obtain stable oscillation with one section of a dual triode such as the 6SN7 or 12AU7. This is an improvement over the normal phase-shift oscillator, which usually requires a pentode for sufficient amplification and a diode for output control. In some applications, this may permit the saving of one or more tubes.

² R. W. Johnson, "Extending the frequency range of the phase-shift oscillator," *Proc. I.R.E.*, vol. 33, pp. 597-602; September, 1945.

THE PHASE-SHIFT OSCILLATOR

The normal phase-shift oscillator is shown in Fig. 1(a). It consists of a one-tube amplifier with the plate connected back to the grid through an RC network. The network sections can be made up of series C and shunt R elements, as shown, or vice versa. For oscillation to be maintained, it is required that the gain from grid to plate must be at least equal to the attenuation from plate to grid. The phase shift from plate to grid must be an integral multiple of 180°. These conditions can be met in an RC network of the type shown with three or more sections. With three sections, the attenuation through the network is 29, while with four sections it is 18.2. The attenuation *k* is defined as the ratio *E*₁/*E*₂, Fig. 1(a).

Less attenuation can be obtained with the network of Fig. 1(b). Here the element impedances of succeeding sections have been obtained by multiplying the impedances of the previous section by the factor *a*. Less attenuation is obtained because the loading imposed by any one section on the previous section is smaller.

THE TAPERED PHASE-SHIFT NETWORK

Calculation of the attenuation and phase shift through the network is best carried out with the aid of matrix algebra.³ In using this method, a pair of equations is obtained in the form

$$\begin{cases} E_1 = AE_2 + BI_2 \\ I_1 = CE_2 + DI_2 \end{cases} \quad (1)$$

where *A*, *B*, *C*, and *D* are coefficients associated with the network and *I*₁ and *I*₂ are the currents, respectively, entering the network at the left-hand side and leaving at the right-hand side, Fig. 1(a).

If the input impedance of the amplifier is very high, *I*₂=0, and *E*₁=*A**E*₂. Therefore, *E*₁/*E*₂=*A*=*k*, the attenuation previously defined. For the network of Fig. 1(b),

$$A = \left[1 - \omega^2 R^2 C^2 \left(3 + \frac{2}{a} \right) \right] + j \left[\omega RC \left(3 + \frac{2}{a} + \frac{1}{a^2} \right) - \omega^3 R^3 C^3 \right] = -k. \quad (2)$$

The minus sign is attached because of the required 180° phase shift. The attenuation must be a real quantity; therefore, the imaginary term in (2) can be equated to zero to obtain ω . Thus,

$$\omega RC \left(3 + \frac{2}{a} + \frac{1}{a^2} \right) - \omega^3 R^3 C^3 = 0.$$

$$\omega = \frac{\sqrt{3 + \frac{2}{a} + \frac{1}{a^2}}}{RC} = \frac{N_3}{RC}$$

where

$$N_3 = \sqrt{3 + \frac{2}{a} + \frac{1}{a^2}}.$$

Substituting this value for ω in (2), *k* can be obtained:

$$k = \frac{8a^3 + 12a^2 + 7a + 2}{a^3}.$$

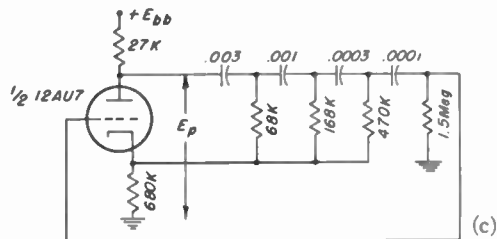
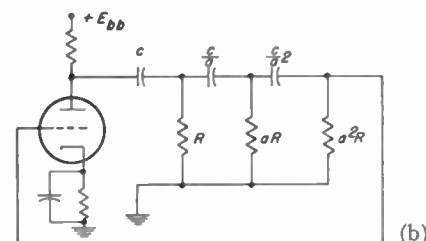
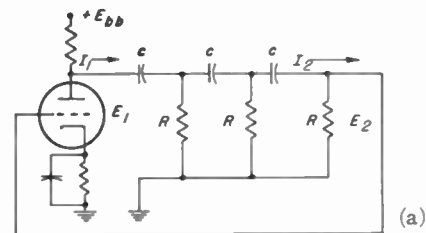

Fig. 1—Phase-shift oscillator.

If the resistors and capacitors are interchanged, an equally useful network results. Another pair of networks can be obtained by using four sections. Table I lists ex-

TABLE I

Network	<i>k</i>	ω
Three-section shunt C	$\frac{8a^3 + 12a^2 + 7a + 2}{a^3}$	$\frac{\sqrt{3 + \frac{2}{a} + \frac{1}{a^2}}}{RC} = \frac{N_3}{RC}$
Three-section shunt R	$\frac{8a^3 + 12a^2 + 7a + 2}{a^3}$	$\frac{1}{RC \sqrt{3 + \frac{2}{a} + \frac{1}{a^2}}} = \frac{1}{RCN_3}$
Four-section shunt C	$\frac{64a^6 + 192a^5 + 260a^4 + 214a^3 + 109a^2 + 44a + 8}{16a^6 + 24a^5 + 9a^4}$	$\frac{\sqrt{4a^2 + 3a^2 + 2a + 1}}{RC} = \frac{N_4}{RC}$
Four-section shunt R	$\frac{64a^6 + 192a^5 + 260a^4 + 214a^3 + 109a^2 + 44a + 8}{16a^6 + 24a^5 + 9a^4}$	$\frac{1}{RC \sqrt{4a^2 + 3a^2 + 2a + 1}} = \frac{1}{RCN_4}$

³ E. A. Guillemin, "Communication Networks," vol. II, John Wiley and Sons, New York, N. Y., 1935; p. 145.

pressions for ω and k applicable to these four networks. It will be noted that the attenuation is not altered by interchanging the resistors and capacitors.

Fig. 2 is a plot of k versus a . Thus it shows the relation between a and the minimum amplifier gain for sustained oscillation. It can be seen that a comparatively small value of a will give an enormous decrease in the attenuation through the network.

Fig. 3 is a plot of N versus a . With the aid of this figure and Table I, the frequency for 180° phase shift through any one of the four networks can be obtained. Or, conversely, having a desired frequency, R and C can

be calculated. It must be remembered that these results assume that the network is being driven by a source having zero impedance.

The dashed lines of Figs. 2 and 3 indicate measurements made on some of the networks. A reasonably close check was obtained with theory. Phase shift was measured with an oscilloscope; attenuation was checked by substitution with a calibrated voltage source.

PRACTICAL CONSIDERATIONS

The choice of the type of network, number of sections, and value of a will depend on the tube type and fre-

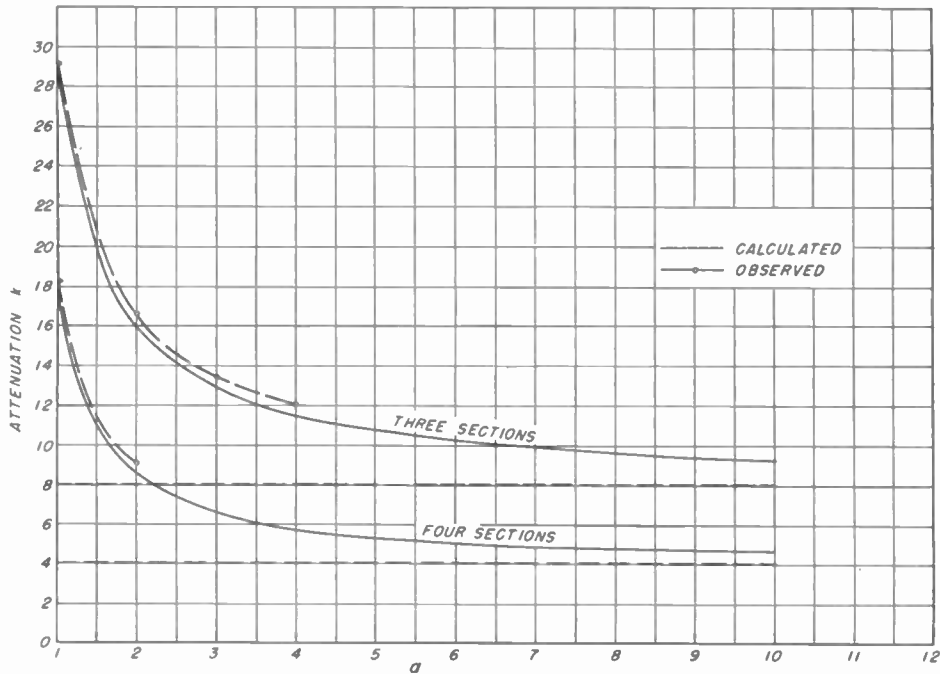

Fig. 2—Attenuation versus a .

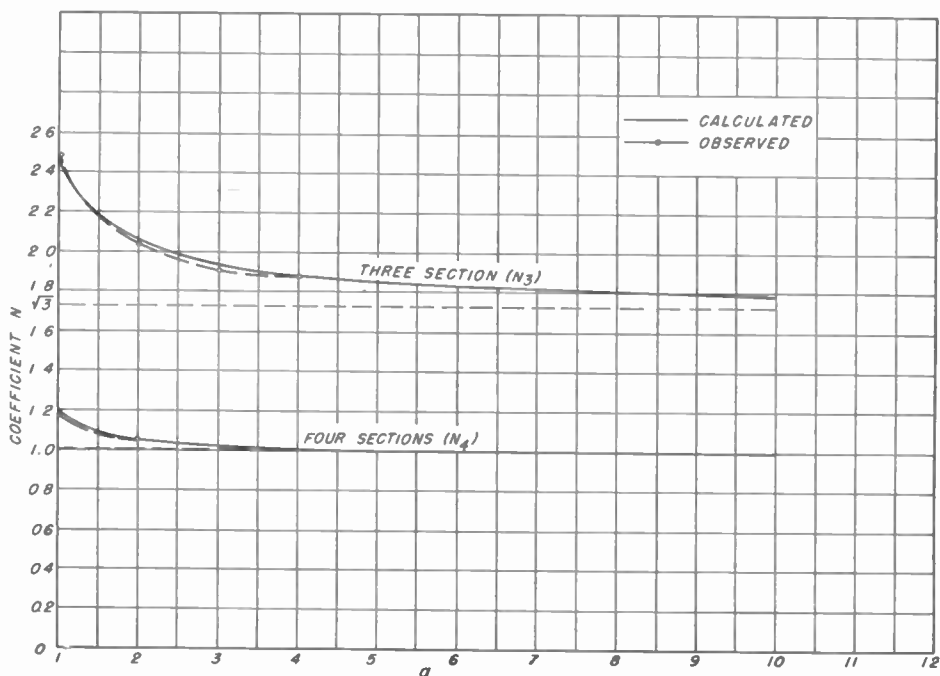

Fig. 3—Coefficient N versus a .

frequency desired. In general, it is desirable to use the shunt- R network at frequencies below 1000 cps because this network provides dc isolation between the plate and grid, and thus additional circuit elements are not required. The shunt- C circuit is valuable above 1000 cps because the input capacitance of the tube, which may be high in triodes because of Miller effect,⁴ can be made a part of the last capacitor of the network.

Frequency stability will not be considered here; it has been covered in part by references 1 and 2. It should be stated, however, that there are at least three ways in which tube parameters affect frequency: (1) The plate resistance can change, affecting the equivalent generator impedance, and therefore, the phase shift through the network. (2) The gain of the amplifier may change, altering the Miller-effect loading on the last section of the network. (3) If the bias changes, the level at which limiting occurs will change, which would affect the frequency.

The design of such an oscillator is probably best illustrated by an example: It was desired to construct an oscillator at 1000 cps, using one section of a 12AU7 dual triode. Reference to the tube characteristics showed that a gain of about 12 could be obtained with the load and bias resistors shown in Fig. 1(c) and with the cathode resistor by-passed. From Fig. 2 it can be seen that a four-section network with $a=1.4$ will give sufficiently low attenuation. To allow for variations in tubes and

which is about 1.5 megohms. Thus the other resistors are determined.

Table I shows that $\omega=1/RCN_4$ for the four-section shunt- R network. Referring to Fig. 3, with $a=3$, $N_4=1.03$. The values of the capacitors can then be obtained. It should be noted that variations in any one circuit element will not have a very great effect on the over-all network; it is usually satisfactory to choose the nearest stock values.

The last shunt resistor of the network in Fig. 1(c) was returned to ground to provide a proper dc grid return, while the other resistors were returned to the cathode. In this way, it is possible to eliminate the cathode bypass capacitor and still obtain sufficient gain. The frequency will differ from the calculated value as a result of the change; the difference was only about 5 per cent in this case.

Fig. 4 shows the performance of the circuit for variations in plate supply voltage, heater supply voltage, and plate and heater supply voltage together. It can be seen that the effects of plate supply voltage E_{bb} and heater supply voltage E_{ff} are opposite in direction, so that, when the two are taken together, a very stable oscillator is obtained. Increasing E_{bb} from 150 to 350 volts, and increasing E_{ff} from 5 to 7 volts at the same time, increases the frequency by only 0.15 per cent. The output voltage E_p is nearly proportional to E_{bb} but is almost independent of E_{ff} as long as oscillation is maintained.

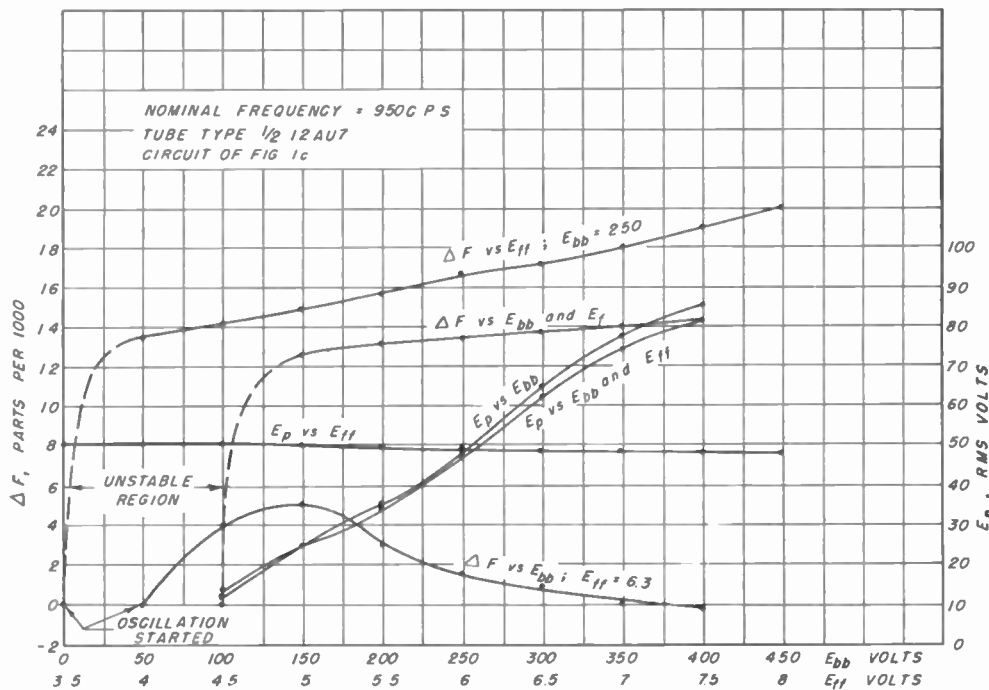

Fig. 4—Performance of tapered phase-shift oscillator.

supply voltages, it was decided to take $a=3$. Using the shunt- R network, the value of the last resistor is determined by the maximum allowable grid circuit resistance,

⁴ J. M. Miller, Bureau of Standards Bulletin, no. 351, 1919.

The total distortion was 3 per cent with $E_{bb}=250$ and $E_{ff}=6.3$ volts.

Other oscillators have been constructed with the shunt- R network at frequencies as low as 1/5 cps. The shunt- C network has been used at frequencies up to 20 kc.

Contributors to Waves and Electrons Section

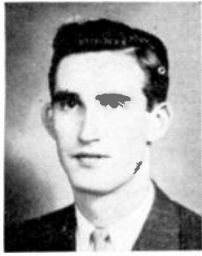

W. P. BENNETT

where he is at present in the power tube engineering group.

Wilfred P. Bennett (S'43-A'46) was born in Milford, Mich., on October 9, 1922. He received the B.S. degree in electrical engineering from Michigan State College in 1944. Upon graduation, he was engaged by the Radio Corporation of America at Lancaster, Pa.,

Research and Development Board Panel on radiating systems.

❖

E. A. Eschbach was born at Yakima, Wash., on April 20, 1923. He received the B.S. degree in electrical engineering from the State College of Washington in January, 1944. Since January, 1944, he has been with the advanced development division of RCA at Lancaster, Pa. He is a member of the Tau Beta Pi and Sigma Tau.

❖

To the biography and photograph of EVERARD M. WILLIAMS which appeared on page 87 of the January, 1948, issue of the PROCEEDINGS OF THE I.R.E., the following data is added: Dr. Williams recently received the Eta Kappa Nu award for the year 1946. He served as vice-chairman of the Emporium section of the IRE in 1941-1942, and as vice-chairman and chairman of the Pittsburgh section for the years 1946-1947 and 1947-1948, respectively.

❖

For a photograph and biography of J. K. CLAPP, see page 363 of the March, 1948, issue of the PROCEEDINGS OF THE I.R.E. A portion of this biography has been corrected by the author to read as follows: Mr. Clapp served with the U. S. Navy from 1917 to 1919, spending the period from 1918-1919 in foreign service.

❖

Allen S. Dunbar was born in Barre, Mass., on April 26, 1921. He received the A.B. degree in physics at Clark University in Worcester, Mass., in 1943, following



ALLEN S. DUNBAR

which he taught elementary physics at Nichols Junior College for two semesters. He then accepted a position in the antenna group of the Radiation Laboratory at the Massachusetts Institute of Technology, remaining on the staff until January, 1946. During this time Mr. Dunbar went to Great Britain in connection with certain radar antennas in use by the Eighth Air Force. While overseas, he served in a consultative capacity to an antenna group at the Telecommunications Research Establishment.

In 1946, Mr. Dunbar joined the newly formed antenna research section of the Naval Research Laboratory, where he is now employed. He is a member of the American Physical Society, and of the American Association for the Advancement of Science. He is also a corresponding member of the



WILLIAM R. KEYE

William R. Keye was born in St. Paul, Minn., on June 21, 1921. He received the B.E.E. degree from the University of Minnesota in 1943. From 1943 to 1945, he was associated with Airborne Instruments Laboratory at Mincola, L.I., N. Y., and from 1945 to 1947 with the power tube development laboratory of the Radio Corporation of America, Lancaster, Pa. He has been with Engineering Research Associates, Inc., St. Paul, Minn., since July, 1947, where he is engaged in the development of computing systems and components.

Mr. Keye is a member of Tau Beta Pi and Eta Kappa Nu.

❖

For a biography and photograph of PETER G. SULZER, see page 426 of the March, 1948, issue of the PROCEEDINGS OF THE I.R.E.

❖

S. N. Van Voorhis (SM'46) was born in Hiram, Ohio, on December 2, 1909. He attended the Case School of Applied Science, receiving the B.S. degree in physics in 1930, and in 1934 was awarded the Ph.D. degree from Princeton University. During 1934-



S. N. VAN VOORHIS

1938, when he joined the physics department of the University of Rochester, as a research associate.

Dr. Van Voorhis left the University of Rochester in 1940 to become a staff member of the Radiation Laboratory of the Massachusetts Institute of Technology, where he remained until 1946. While associated with MIT he was head of the receiver group, and editor of volume 23 of the Radiation Laboratory Series, "Microwave Receivers." He returned to the University of Rochester as associate professor of physics in 1946, where he is now teaching.

Dr. Van Voorhis is a Fellow of the American Physical Society, and a member of Sigma Xi and Tau Beta Pi. He is a member of the Executive Committee of the IRE Rochester Section.

❖

Lucio Vallese (SM'48) was born in Naples, Italy, on September 27, 1915. He received the Sc.M. degree (Laurea) in electrical engineering from Naples University in 1937. From 1937 to 1939 he was a research associate at the Institute for Electrical



LUCIO VALLESE

Communications in Leghorn, Italy, and from 1939 to 1947 he served first as an instructor and then as an assistant professor in the electrical engineering department of Rome University. From 1939 to 1943 he was also associated with the Guidonia Radio Research Laboratories of the Italian Air Force, in Rome.

In 1947 Dr. Vallese came to the United States to engage in graduate work at Carnegie Institute of Technology, where he held a Buhl Fellowship in electrical engineering, and in February, 1948, received the doctor of science degree in electrical engineering. In 1948 he joined the faculty of Duquesne University, Pittsburgh, as an assistant professor in physics.

Dr. Vallese is a member of the Sigma Xi, an associate member of the American Institute of Electrical Engineers, and a member of Associazione Elettrotecnica Italiana.

Abstracts and References

Prepared by the National Physical Laboratory, Teddington, England, Published by Arrangement with the Department of Scientific and Industrial Research, England, and *Wireless Engineer*, London, England

NOTE: The Institute of Radio Engineers does not have available copies of the publications mentioned in these pages, nor does it have reprints of the articles abstracted. Correspondence regarding these articles and requests for their procurement should be addressed to the individual publications and not to the IRE.

Acoustics and Audio Frequencies	1307
Antennas and Transmission Lines	1308
Circuits and Circuit Elements	1309
General Physics	1311
Geophysical and Extraterrestrial Phenomena	1311
Location and Aids to Navigation	1312
Materials and Subsidiary Techniques	1313
Mathematics	1313
Measurements and Test Gear	1313
Other Applications of Radio and Electronics	1314
Propagation of Waves	1315
Reception	1316
Stations and Communication Systems	1316
Subsidiary Apparatus	1318
Television and Phototelegraphy	1318
Transmission	1318
Vacuum Tubes and Thermionics	1319
Miscellaneous	1319

The number in heavy type at the upper left of each Abstract is its Universal Decimal Classification number and is not to be confused with the Decimal Classification used by the United States National Bureau of Standards. The number in heavy type at the top right is the serial number of the Abstract. DC numbers marked with a dagger (†) must be regarded as provisional.

ACOUSTICS AND AUDIO FREQUENCIES

- 534+621.395.6** **2430**
1948 IRE National Convention Program—
 (PROC. I.R.E., vol. 36, pp. 365-380; March, 1948.) Abstracts are given of the following papers read at the Convention:—Ratio of Frequency Swing to Phase Shift in Phase- and Frequency-Modulation Systems Transmitting Speech, by D. K. Gannett and W. R. Young. Phase Distortion in Audio Systems, by L. A. de Rosa. Design Characteristics of Hearing-Aid Tubes, by G. W. Baker. Modern Design Features of CBS Studio Audio Facilities, by R. B. Monroe and C. A. Palmquist. Methods of Calibrating Frequency Records, by R. C. Moyer, D. R. Andrews, and H. E. Roys. Distortions in Magnetic Tape Recording due to the Configuration of the Bias Field, by S. J. Begun. Instantaneous Audiance-Measurement System (IAMS), by P. C. Goldmark, J. W. Christensen, A. Bark, and J. T. Wilner. Methods for Visual Observation of Patterns recorded on Magnetic Media, by S. N. Alexander, L. Marton, and I. L. Cotter. Simplification of the Theory of Supersonic Interferometry, by F. E. Fox and J. L. Hunter. Titles of other papers are given in other sections.
- 534.321.9:621.392.5** **2431**
Ultrasonic Delay Lines: Parts 1 & 2—
 Huntington, Emslie, and Hughes; Emslie, Huntington, Shapiro, and Benfield. (See 2479.)
- 534.41+534.781:621.383** **2432**
Photo-Electric Fourier Transformer and Its Application to Sound-Films—D. Brown and J. W. Lyttleton. (*Nature* (London), vol. 160, p. 709; November 22, 1947.) A device similar to that of Born, Fürth, and Pringle (656 of 1946) for producing a continuous analysis of tones recorded on sound film. The chief differences are: (a) the use of a finer grat-

The Institute of Radio Engineers has made arrangements to have these Abstracts and References reprinted on suitable paper, on one side of the sheet only. This makes it possible for subscribers to this special service to cut and mount the individual Abstracts for cataloging or otherwise to file and refer to them. Subscriptions to this special edition will be accepted only from members of the IRE and subscribers to the PROC. I.R.E. at \$15.00 per year. The Annual Index to these Abstracts and References, covering those published from February, 1947, through January, 1948, may be obtained for 2s. 8d. postage included from the *Wireless Engineer*, Dorset House, Stamford St., London S. E., England.

ng to analyze the higher audio frequencies, (b) moving the film itself steadily past the optical aperture instead of using a mask or silhouette representing the function to be analyzed, and (c) recording by intensity modulation of a cro beam. A progressive frequency spectrum of the spoken word "there" is shown as analyzed by the device. See also 3517 of 1946 (Koenig et al.).

534.422 **2433**
High-Intensity Sound Waves now Harnessed for Industry—R. W. Porter. (*Chem. Eng.*, vol. 55, pp. 100-101, 115; 1948.) An ultrasonic high-intensity sound generator consists essentially of a high-speed air siren driven by a variable-speed air turbine. Compressed air passes into a rotating hollow disk and then radially outwards through stationary peripheral vanes. The pulsations are focused on a reflector by horns in the stator. Industrial applications include carbon-black agglomeration, soda recovery from flue gases, and the spray drying of powdered soap. See also 1533 of July (Allen, Frings, and Rudnick). [Extracted from British Abstracts.]

534.612:534.417 **2434**
The Calibration of Hydrophones and Crystal Transceivers—N. F. Astbury. (*Proc. Phys. Soc.* vol. 60, pp. 193-202; February 1, 1948.) A discussion of measurements from which absolute determinations of sound-field pressure can be made, and also of the relation between these measurements and the reciprocity method. The axial pressure and "projection efficiency" of a transceiver are deduced, the "projection efficiency" being defined as the ratio of the actual axial intensity to the intensity as it would be if the transceiver converted the whole energy absorbed into sound by vibrating as a simple piston.

534.851 **2435**
Design of Audio Compensation Networks—W. A. Savory. (*Tele-Tech*, vol. 7, pp. 24-27, 27-29, 72, and 34-35, 65; January, February, and April, 1948.) Discussion of design procedures for correct frequency-response equalization in phonograph reproduction. Circuits for low- and high-frequency correction are considered separately and charts are given for

IMPORTANT NOTICE

All readers of these ABSTRACTS AND REFERENCES are strongly urged to express their opinion concerning the value to them of the continuance of ABSTRACTS AND REFERENCES. The steadily increasing cost of publication and the large amount of available technical material makes it desirable that space in the PROCEEDINGS be assigned only to material which will most benefit the greatest number of readers. Accordingly, the PROCEEDINGS contents are under analysis and subject to revision. It is possible, therefore, that these ABSTRACTS AND REFERENCES may be discontinued in 1949.

The ABSTRACTS AND REFERENCES were furnished as a service during a period when they were not generally available to those who found them of use. This condition may have been altered.

The original sources of material cited in the ABSTRACTS AND

REFERENCES are now generally available in libraries to those who find such ABSTRACTS most useful. Indeed, the value of the ABSTRACTS AND REFERENCES depends upon ready access to the numerous publications and periodicals which are there listed.

It is conceivable that the ABSTRACTS AND REFERENCES are less frequently used or are of more limited interest to the PROCEEDINGS readers than the equivalent number of pages of technical papers which are now available.

If those who find the ABSTRACTS AND REFERENCES valuable to them and who desire their continuance, or those who feel otherwise, will promptly write to the Institute, addressing their letters to the Technical Editor, their views will be collated and laid before the Executive Committee and the Board of Directors. The IRE address is 1 East 79 Street, New York 21, N.Y.

numerical calculation of the optimum values of circuit components. The circuit of a preamplifier with a 6-position combined low-frequency crossover and high-frequency correction is also given.

534.851:621.395.813:621.396.662.3 2436
Filter Characteristics for the Dynamic Noise Suppressor—L. G. McCracken. (*Electronics*, vol. 21, pp. 114–115; April, 1948.) A mathematical analysis for Scott's noise suppressor (932 of May).

534.861.1:534.833 2437
Acoustic Problems in Studio Design—G. M. Nixon. (*Electronics*, vol. 21, pp. 86–89; May, 1948.) Discussion of the construction of walls, ceiling, and floor to attenuate airborne noise and that due to transmission of vibrations.

621.395.61/.62:629.135 2438
Electro-Acoustic Transducers and Intercommunication Systems for Aircraft—W. Makinson. (*Jour. IEE* (London), part IIIA, vol. 94, no. 13, pp. 441–451; 1947; summary, *ibid.*, part IIIA, vol. 94, no. 11, p. 82; 1947.) Discussion of: (a) the mechanism of speech communication in and from noisy locations, (b) the requirements thereby imposed on the design of transducers and audio circuits, (c) instruments used in the R.A.F., (d) proposed future systems.

621.395.61.012+621.395.623.7.012 2439
Graphical Analysis of Speakers and Microphones—A. J. Sanial. (*Tele-Tech*, vol. 7, pp. 42–43; February, 1948.) A curve tracer is described in which a recording drum, rotated by hand, is coupled to the independent variable, while the dependent variable is displayed on a meter. The meter needle is followed by a tracking pointer which actuates the marking pen.

621.395.623.7 2440
Monitoring Loudspeakers—(*Wireless World*, vol. 54, p. 186; May, 1948.) A report of a discussion on methods of assessing the quality of a loudspeaker. An instrument is needed which would interpret the results of measurements, so that subjective listening tests could be superseded.

621.395.625 2441
The Recording and Reproduction of Sound: Parts 11–13—O. Read. (*Radio News*, vol. 39, pp. 54–56, 170, 56–58, 140, and 62–64, 154; January to March, 1948.) Design details for a high-quality af amplifier. Analysis of the mechanical and electrical requirements in the design of magnetic tape recorders. Characteristics of cutting styli. Parts 8 to 10, 1545 of July.

621.395.92.001.4 2442
Cavity Pressure Method for Measuring the Gain of Hearing Aids—E.L.R. Corliss and G. S. Cook. (*Jour. Res. Nat. Bur. Stand.*, vol. 40, pp. 85–91; January, 1948.) For another account see 2157 of September.

ANTENNAS AND TRANSMISSION LINES

621.315+621.392+621.396.67 2443
1948 IRE National Convention Program—(Proc. I.R.E., vol. 36, pp. 365–380; March, 1948.) Abstracts are given of the following papers read at the Convention:—Physical Limitations of Directive Radiating System, by L. J. Chu. The Radiation Resistance of an Antenna in an Infinite Array or Waveguide, by H. A. Wheeler. Reflectors for Wide-Angle Scanning at Microwave Frequencies, by R. C. Spencer, W. Ellis, and E. C. Fine. Measured Impedance of Vertical Antennas over Finite Ground Planes, by A. S. Meier and W. P. Summers. An Omnidirectional High-Gain Antenna for Circularly Polarized Radiation, by A. G. Kandoian. Analysis of Effect of Cir-

culating Currents on the Radiation Efficiency of Broadcast Directive Antenna Designs, by G. D. Gillett. A Model Study of Reradiation from Broadcast Towers, by A. Alford and H. Jasik. Helical-Beam Antenna for Wide-Band Applications, by J. D. Kraus. A Circular-Polarization Antenna for F.M., by C. E. Smith and R. A. Fouty. Simplified Procedure for Computing the Behavior of Multiconductor Lossless Transmission Lines, by S. Frankel. Optimum Geometry for Ridged Waveguide, by W. E. Waller, S. Hopper, and M. Sucher. Fields in Nonmetallic Waveguides, by R. N. Whitmer. A Wide-Band Waveguide-Filter Structure, by S. B. Cohn. The Transmission-Line Vector Diagram, by W. C. Ballard, Jr. Analysis and Performance of Waveguide Hybrid Rings for Microwaves, by H. T. Budenbom. Analysis of a Microwave Absolute Attenuation Standard, by A. B. Giordano. Titles of other papers are given in other sections.

621.315 2444
Rigorous and Approximate Treatment of Long Line Transmission Problems by Hyperbolic Functions—S. Gerszonowicz. (*Jour. Frank. Inst.*, vol. 245, pp. 53–66; January, 1948.)

621.392.029.64 2445
Waveguides—A. V. J. Martin. (*Radio Tech. Dig.* (Franç.), vol. 2, pp. 5–20; February, 1948.) Discusses field distributions for both circular and rectangular waveguides, cut-off frequencies, effect of dielectrics, attenuation, losses, standard dimensions, and gives appropriate formulas.

621.392.029.64 2446
Anomalous Attenuation in Waveguides—J. Kemp. (*Elec. Commun.*, vol. 24, pp. 342–348; September, 1947.) Reprint of 2818 of 1946. See also 3540 of 1946 (Bell).

621.392.029.64:621.3.09 2447
Propagation of a Perturbation in a Waveguide—M. Cotte. (*Compt. Rend. Acad. Sci.*, (Paris), vol. 221, pp. 538–540; November 5, 1945.) Formulas are obtained for a perturbation which can be resolved into waves of the same type, but of different frequencies, propagated in a straight waveguide with perfectly conducting walls.

621.396.67 2448
The Practical Aspects of Paraboloid Aerial Design—J. D. Lawson. (*Jour. IEE* (London), part IIIA, vol. 93, no. 10, pp. 1511–1522; 1946.) Discussion of: (a) the properties of paraboloid antennas, (b) the design and impedance characteristics of the dipoles, slots, and waveguides used to excite them, (c) split-beam technique and the methods used to obtain special directional patterns, (d) the three-phase tripole, which gives circularly polarized radiation.

621.396.67 2449
Polyrods—G. E. Mueller. (*Bell Lab. Rec.*, vol. 26, pp. 64–67; February, 1948.) Dielectric rods for scanning arrays have high electrical efficiency and relative freedom from external disturbances. Tapering the rods improves their characteristics.

621.396.67 2450
Coupled Antennas—C. T. Tai. (Proc. I.R.E., vol. 36, pp. 487–500; April, 1948.) An extension of the work of King and Harrison (3474 of 1944). The integral equation governing the current distribution on two coupled cylindrical dipoles of equal length is solved, and mutual impedances calculated from it agree substantially with the results of Carter's classical simple theory (1932 Abstracts, *Wireless Eng.*, p. 585) on the mutual impedance between two half-wave filament dipoles. Curves of current distributions and impedance are given as a function of spacing for half- and full-wave dipoles of various length versus diameter ratios.

621.396.67 2451
The Radiation Resistance of an Antenna in an Infinite Array or Waveguide—H. A. Wheeler. (Proc. I.R.E., vol. 36, pp. 478–487; April, 1948.) IRE 1948 National Convention paper. The electromagnetic field in front of an infinite flat array of antennas can be subdivided into wave channels, each including one of the antennas. The radiation resistance of each antenna can then be derived simply. In a large flat array of $\lambda/2$ dipoles, each allotted a $\lambda/2$ -square area, backed by a plane reflector $\lambda/4$ distant, the radiation resistance of each dipole is $480\pi = 153\Omega$, except for the dipoles near the edges. The method may also be used to calculate the radiation resistance of an antenna in a rectangular waveguide, previously derived by more complicated methods.

621.396.67 2452
On the Theoretical Functioning of some Types of Centimetric Linear Arrays—R.B.R.—Shersby-Harvie. (*Jour. IEE* (London), part IIIA, vol. 93, no. 10, pp. 1548–1553; 1946.) Their functioning is explained in terms of filter theory. Both resonant and nonresonant types of array are considered but mainly the latter; the theory of each is investigated, first neglecting mutual interaction between the elements and then for the more general case.

621.396.67 2453
The Hoghorn—an Electromagnetic Horn Radiator of Medium-Sized Aperture—A. B. Pippard. (*Jour. IEE* (London), part IIIA, vol. 93, no. 10, pp. 1536–1538; 1946.) A compact horn, fed by a waveguide, which gives a beamwidth at half power of 4 to 15° in the plane of maximum directivity and 25° or less in the perpendicular plane.

621.396.67 2454
Antenna Design for Low-Angle FM Propagation—O. O. Fiet. (*Tele-Tech*, vol. 7, pp. 30–33; February, 1948.) Description of RCA "Pylon" omnidirectional slotted cylindrical transmitting antennas for television and FM with construction and feeder connection details. The electrical characteristics and the methods used for determining the gain and vertical field strength pattern are discussed.

621.396.67:621.318.572 2455
Electronic Switches for Single-Aerial Working—Cooke, Fertel, and Harris. (See 2643.)

621.396.67:621.396.931 2456
Antennas for Citizens Radio: Part 3—H. J. Rowland. (*Electronics*, vol. 21, pp. 96–99; May, 1948.) High gain is particularly important because of transmitter power limitations, but is readily obtainable in the 460 to 470-Mc band. Designs for broadcast and point-to-point service are discussed. Part 1: 855 of April (Hollis). Part 2: 2341 of September (Hollis).

621.396.67:621.396.933 2457
Recent Developments of Aircraft Communication Aerials—W. A. Johnson. (*Jour. IEE* (London), part IIIA, vol. 94, no. 13, pp. 452–458; 1947; summary, *ibid.*, part IIIA, vol. 94, no. 11, p. 82; 1947.) A survey of design progress. The impedance characteristics of several typical antennas are given.

621.396.67.029.63 2458
Experiments with Yagi Aerials at 600 Mc/s—R. V. Alred. (*Jour. IEE* (London), part IIIA, vol. 93, no. 10, pp. 1490–1496; 1946.) The object was to produce an array to give a narrow beam suitable for naval gun-control directors. The optimum dimensions of a dipole and eight directors were found for a pair of Yagi antennas at various spacings; the conventional dipole reflector was replaced by a semicircular cylinder to increase the front-to-back ratio. The final design used three such pairs fed in parallel and having the appropriate phase difference to

give beam switching. Sidelobes were minimized by adjusting the power distribution. Data on the change of impedance with frequency are included for two- and six-element arrays. Numerous polar diagrams and experimental and calculated data are also included.

621.396.67.029.64 2459

Some Recent Developments in the Design of Centimetric Aerial Systems—D. W. Fry. (*Jour. IEE* (London), part IIIA, vol. 93, no. 10, pp. 1497-1510; 1946.) Discussion of: (a) the essential features of paraboloid antennas, (b) reflectors designed to give cosecant patterns, (c) the use of cylindrical parabolas and arrays of slots as line sources, (d) the application of slots to waveguide arrays, (e) fundamental points in the design of dielectric and metal-plate lenses, (f) the use of metal-plate lenses as polarization filters.

621.396.671 2460

A Method of Calculating the Field over a Plane Aperture required to produce a given Polar Diagram—P. M. Woodward. (*Jour. IEE* (London), part IIIA, vol. 93, no. 10, pp. 1554-1558; 1946.) "A summation method, especially adapted for numerical computation, is evolved for finding the magnitude and phase of the field distribution over a plane aperture which will yield an approximation to a specified polar diagram on one side of the aperture plane."

621.396.671 2461

Aerial Gain and Polar Diagrams—B. J. Starnecki. (*Wireless Eng.*, vol. 25, pp. 198-199; June, 1948.) Comment on 1861 of August (Saxton).

621.396.671 2462

A Method of Computing a Vertical Section of the Combined Polar Diagram of a Radio Aerial, a Flat Earth, and a Vertical Screen—N. Corcoran and J. M. Hough. (*Proc. Phys. Soc.*, vol. 60, pp. 203-210; February 1, 1948.) "The method described is based on the Sommerfeld formula for diffraction at an edge, combined with the effect of reflection at the earth. A table is given which reduces the amount of numerical work involved."

621.396.671 2463

Measuring FM Antenna Patterns with Miniature Antennas—M. A. Honnell and J. D. Albright. (*Communications*, vol. 28, pp. 20-22; February, 1948.) Simple equipment for measuring vertical radiation patterns, the antennas being scaled down so that a measurement frequency of 3000 Mc could be used. See also 2011 of 1947.

621.396.677 2464

Rhombic Antenna Arrays—W. N. Christiansen. (*AWA Tech. Rev.*, vol. 7, pp. 361-383; October, 1947.) Discussion of: (a) power-gain calculation from the experimental determination of current distribution, (b) increasing radiation efficiency by the use of the re-entrant feeder line, tiered rhombics, and interlaced arrays.

621.396.677 2465

Broadband Lens Antenna for Microwaves—W. E. Kock. (*Electronics*, vol. 21, pp. 108-110; April, 1948.) For another account see 2176 of September.

621.396.677 2466

Review of Basic Design Principles for Directive Aerials—K. Fränz. (*Arch. Elek. Übertragung*, vol. 1, pp. 205-219; November and December, 1947.)

621.396.677 2467

Experiments with Slot Aerials in Corner Reflectors—J. L. Putman and W. B. Macro. (*Jour. IEE* (London), part IIIA, vol. 93, no. 10, pp. 1539-1547; 1946.) The development and performance of an antenna for a mobile 200-

Mc aircraft beam-approach system is described, with particular reference to the radiation pattern.

621.396.677 2468

The Effect of Flanges on the Radiation Patterns of Small Horns—A. R. G. Owen and L. G. Reynolds. (*Jour. IEE* (London), part IIIA, vol. 93, no. 10, pp. 1528-1530; 1946.) Rectangular flanges were added to a horn whose aperture was $\frac{1}{2}\lambda \times 2\frac{1}{2}\lambda$ at 3000 Mc. The effect of varying the lengths of the flanges and the angle contained between them is shown by a series of graphs. Long flanges containing an acute angle tend to give polar diagrams which are uniform, except for a ripple, over an arc but fall off very rapidly outside this arc. The production of polar diagrams having a dip in the forward direction is discussed.

621.396.677:621.392.029.64 2469

The Elimination of Standing Waves in Aerials employing Paraboloidal Reflectors—A. B. Pippard and N. Elson. (*Jour. IEE* (London), part IIIA, vol. 93, no. 10, pp. 1531-1535; 1946.) A flat plate of suitable size fixed at the apex of a paraboloid prevents reflection at the orifice of the waveguide feeding it. The theory and application of the method are described together with the effect on the polar diagram.

CIRCUITS AND CIRCUIT ELEMENTS

621.3.018.7:621.396.822 2470

Trapezoidal Waveform with Minimal Noise Factor—M. Päsler. (*Frequenz*, vol. 2, pp. 52-55; February, 1948.) Mathematical discussion shows that the noise factor is least when the parallel sides of the trapezoid have a length ratio of 1 to 3. The noise factor is greatest for the rectangular waveform and has a relative maximum for a triangular waveform. Fourier spectra of these three cases are shown graphically.

621.318.572 2471

Coincidence Device of 10^{-4} - 10^{-9} sec. resolving Power—Z. Bay and G. Papp. (*Nature* (London), vol. 161, pp. 59-60; January 10, 1948.) A modification of the Rossi type circuit using electron multiplier tubes achieves a resolving power of about 5×10^{-9} sec. The output tube of the circuit is biased to respond only to a 2-v input pulse, corresponding to a coincidence through the G-M counters. Output pulses from these pass through the multiplier tubes to the grids of the first two tubes of the circuit; these have a common load delivering a pulse to the output tube. A direct method for measuring the resolving power is described.

621.318.572:621.397.335 2472

Counter Circuits for Television—A. Easton and P. H. Odessey. (*Electronics*, vol. 21, pp. 120-123; May, 1948.) Step-type counter circuits are used as frequency dividers for synchronizing generators. Their limitations, possible improvements, and the relationship between parameters required to obtain stable operation are discussed.

621.319.4 2473

Effectiveness of Bypass Capacitors at V.H.F.—J. F. Price. (*Communications*, vol. 28, pp. 18-19, 32; February, 1948.) Q-meter measurements at 30 Mc and 100 Mc on 9 types of capacitor show that only the silvered-mica types could be regarded as satisfactory at these frequencies. Some of the other types tested were inductive rather than capacitive, particularly at the higher frequency.

621.319.4:621.396.828 2474

The Duct Capacitor—A. Watton, Jr. (*Proc. I.R.E.*, vol. 36, pp. 550-553; April, 1948.) Describes a new type of feed-through screened by-pass capacitor for radio interference suppression.

621.39 2475

1948 IRE National Convention Program—(*Proc. I.R.E.*, vol. 36, pp. 365-380; March, 1948.) Abstracts are given of the following papers read at the Convention:—FM Detector Tube with Instantaneous Limiting and Single-Circuit Discriminator, by R. Adler. Properties of Some Wide-Band Phase-Splitting Networks, by D. G. C. Luck. Theory and Design of Constant-Current Networks, by C. S. Roys and P. H. Chin. New Parameter-Adjustment Method for Network Transients, by M. J. Di Toro and R. C. Wittenberg. Application of Tchebyscheff Polynomials to Design of Band-pass Filters, by M. Dishal. A Simplified Negative-Resistance-Type O Multiplier, by H. E. Harris. Low Noise Amplifier, by H. Wallman, A. B. Macnee, and C. P. Gadsden. Square-Wave Analysis of Compensated Amplifiers, by P. M. Seal. A New Figure of Merit for the Transient Response of Video Amplifiers, by R. C. Palmer and L. Mautner. Distributed Amplification, by E. L. Ginzton, W. R. Hewlett, J. H. Jasberg, and J. D. Noe. A Wide-Band Waveguide-Filter Structure, by S. B. Cohn. Experimental Study of the Effects of Transit Time in Class-C Power Amplifiers, by O. Whitby. Phase-Corrected Delay Lines, by M. J. Di Toro. On the Theory of the Delay-Line-Coupled Traveling-Wave Amplifier, by H. G. Rudenberg. Losses in Air-Cored Inductors, by R. E. Field. A Simplified Design Procedure for Iron-Core Toroids, by H. E. Harris. A Network Analyzer for the Study of Electromagnetic Fields, by K. Spangenberg, G. Walters, and F. W. Schott. Rectifier Networks for Multiposition Switching, by N. Rochester and D. R. Brown. Mercury Delay-Line Memory using a Pulse Rate of Several Megacycles, by I. L. Auerbach, J. P. Eckert, Jr., R. F. Shaw, and C. B. Sheppard. Cavity Resonators for Half-Megavolt Operation, by A. E. Harrison. Synthesis of Dissipative Microwave Networks for Broad-Band Matching, by H. J. Carlin. Frequency Converters, by W. H. Lewis. Reactance-Tube Circuit Analysis, by R. C. Maninger. Electronically Controlled Reactance, by J. N. Van Scoyoc and J. L. Murphy. The Photoformer, by D. E. Sunstein. Mode Separation in Oscillators with Two Coaxial-Line Resonators, by H. J. Reich. Frequency Stabilization with Microwave Spectral Lines, by W. D. Hershberger and L. E. Norton. Titles of other papers are given in other sections.

621.392:621.396.615.17 2476

Kinematic Definition of Discontinuous Relaxation Oscillations—J. Abelé. (*Comp. Rend. Acad. Sci.* (Paris), vol. 221, pp. 656-658; November 26, 1945.) See also 2525 of 1946.

621.392.3 2477

Low-Impedance Reactances for VHF—E. K. Stodola and H. Lisman. (*Electronics*, vol. 21, pp. 93-95; May, 1948.) Flat-plate transmission lines can conveniently be used in both balanced and unbalanced circuits, especially for frequencies between 300 and 1000 Mc. To obtain a low characteristic impedance, a high capacitance per unit length is required. This is easier to obtain with flat-plate lines than with cylindrical rods. Design requirements and applications to an amplifier and to a matching section are described.

621.392.5 2478

Design of Phantastron Time Delay Circuits—R. N. Close and M. T. Lebenbaum. (*Electronics*, vol. 21, pp. 100-107; April, 1948.) A detailed explanation of the phantastron circuit and its ability to provide precision microsecond time delays which vary linearly with control voltage. Linearity can be as high as ± 0.1 per cent of the maximum delay provided that this is not too low. The choice of suitable anode and cathode resistors and capacitors is discussed. The control potentiometer must have a high order of accuracy and

should take its voltage from a divider chain across the phantastron supply.

With careful layout and choice of components, a change of calibration within 0.5 per cent has been obtained over the temperature range -50°C to $+70^{\circ}\text{C}$. Recalibration is advised after every 20 to 50 hours' use; the aging of tubes causes considerable long-period changes.

A method of obtaining longer delays of very high precision is given, together with a brief outline of control circuits and automatic tracking methods.

621.392.5:534.321.9 2479

Ultrasonic Delay Lines: Parts 1 and 2—H. B. Huntington, A. G. Emslie, and V. W. Hughes; A. G. Emslie, H. B. Huntington, H. Shapiro, and A. E. Benfield. (*Jour. Frank. Inst.* vol. 245, pp. 1-24 and 101-115; January and February, 1948.) Part 1: Theoretical considerations involved in the general process of ultrasonic propagation are examined in detail. The fundamental action of the piezoelectric transducer operating in the thickness mode of vibration, loss through mismatch and the behavior of the circuit at resonance are investigated. Wave propagation in the transmitting medium and attenuation due to absorption and diffraction spreading of the beam are discussed. Part 2: Discussion of the experimental aspects of the development and construction of ultrasonic delay lines in liquid media. Excellent reproduction of pulse shape is claimed for the lines, which may be of the broad-band type. They have proved satisfactory for delay times of the order of 3 ns or less.

Means of eliminating secondary signals caused by multiple reflections are indicated. Design considerations are illustrated by actual examples.

621.395.667 2480

Design of Shunt Equalizers—H. N. Wroe. (*Wireless Eng.*, vol. 25, pp. 192-196; June, 1948.) A precision method is described, and examples of results obtained by using it are given. See also 3560 of 1946.

621.396.611.1:512.942 2481

Solid Diagrams illustrating Resonance Phenomena—W. A. Prowse (*Proc. Phys. Soc.*, vol. 60, pp. 132-135; February 1, 1948.) Three dimensional vector loci are used to express the properties of resonant circuits and of the tuned transformer. An indication is given of the application of the method to other problems, including a simple low-frequency selector circuit.

621.396.611.4 2482

Perturbation Method applied to the Study of Electromagnetic Cavities—T. Kahan. (*Compt. Rend. Acad. Sci.* (Paris), vol. 221, pp. 536-538; November 5, 1945.)

621.396.611.4:537.291 2483

Effect of an Electron Beam on the Natural Frequencies of a Cavity Resonator—T. Kahan. (*Compt. Rend. Acad. Sci.* (Paris), vol. 221, pp. 616-618; November 19, 1945.) Formulas are derived for the change of frequency due to passage of the beam used for excitation.

621.396.615 2484

A Novel Oscillator—J. C. Mouzon. (*Rev. Sci. Instr.*, vol. 19, pp. 76-78; February, 1948.) The interelectrode coupling between anode and cathode in this triode oscillator is minimized by using a grounded grid. The inductive feedback is confined more readily to the external circuit than is possible with conventional triode oscillators. A small movement (~ 0.002 inch) of a metal vane between the coupled anode and cathode coils can be detected; therefore, such a system can be applied to industrial control circuits.

621.396.615 2485

The Transitron Oscillator—H. de L. Banting. (*Short Wave Mag.*, vol. 5, pp. 220-223; June, 1947.) Theory is briefly outlined. Practical circuit details are given for both LC and RC types. The oscillator is very stable, being independent of changes in tube characteristics; the output voltage is easily controlled without affecting the frequency of oscillation.

621.396.615:621.385.832 2486

Variable-Frequency Two Phase Sine-Wave Generator—T. H. Clark and V. F. Clifford. (*Elec. Commun.*, vol. 24, pp. 382-390; September, 1947.) A method is described for the production of circles on cr tube screens. Voltages of equal amplitude and orthogonal phase are generated at frequencies up to 60 cps by mechanical rotation of metal probes against a flat resistive sheet carrying a current. Details are given of mechanical construction and materials for the resistive sheet, probes and commutator, and a suitable amplifier circuit is described.

621.396.615.17 2487

On the Study of Multivibrators using Two Triode Valves—J. Queffelec. (*Compt. Rend. Acad. Sci.* (Paris), vol. 221, pp. 619-620; November 19, 1945.) Theory based on consideration of the anode currents of the two tubes.

621.396.615.17:621.317.755:621.396.96 2488

A Precision Time-Base and Amplifier developed for Radar Range Measurement—J. H. Piddington and L. U. Hibbard. (*Jour. IEE* (London), part IIIA, vol. 93, no. 10, pp. 1602-1610; 1946.) The timebase was developed for use in an Australian fire-control radar set. It has an accuracy of about 1 part in 2000. Brief details of three simplified versions for use in other types of radar sets and having accuracies of the order of 0.5 per cent are also given.

621.396.619.23 2489

Wide Deviation Reactance Modulator—H. D. Helfrich, Jr. (*Electronics*, vol. 21, pp. 120-121; April, 1948.) The principles and design procedure are described for obtaining the maximum deviation from an electronic reactance frequency modulator. Details are given of a typical test oscillator and of a universal design chart.

621.396.645 2490

Common-Cathode Amplifiers—N. R. Campbell, V. J. Francis, and E. G. James. (*Wireless Eng.*, vol. 25, pp. 180-192; June, 1948.) The results noted in 1191 and 1471 of 1946 are applied to the mathematical discussion of the optimum adjustment and performance of these amplifiers at about 50 mc.

The most important characteristics are the noise factor N , the input conductance G_i , and the effective bandwidth. Optimum adjustment is assumed to be that which gives minimum N for a prescribed ratio of the minimum to maximum gain within a band defined by an ideal filter, regardless of G_i and the absolute gain Γ . The modifications necessary when G_i and Γ are important are discussed.

At 50 Mc, transit-time effects, which are discussed in 2420 of September, can be neglected, but electrode-lead inductance effects cannot. Electrode-lead inductances are here assumed small and their effect on optimum adjustment is calculated. The practical implications of this effect are discussed.

The relative merits of triodes and pentodes are considered; results for each are tabulated.

621.396.645 2491

Stagger-Tuned Amplifier Design—H. Wallman. (*Electronics*, vol. 21, pp. 100-105; May, 1948.) The relative merits of single tuning, synchronous single tuning, stagger-tuned coupling, and overstaggered circuits are con-

sidered in detail. The limits to over-all bandwidth of cascaded stages and the transient response characteristics of stagger-tuned circuits are discussed and compared with those of other coupled circuits. Design characteristics are tabulated and shown graphically. A detailed circuit diagram of a particular 4-stage amplifier is included.

621.396.645:518.3 2492

Pulse Rise Time Response Chart—A. J. Baracket. (*Tele-Tech.*, vol. 7, pp. 38-39; February, 1948.) An aid to the design of video amplifiers to meet hf response and rise-time requirements.

621.396.645:518.3 2493

Exact Design and Analysis of Double- and Triple-Tuned Band-Pass Amplifiers—M. Dishal. (*Elec. Commun.*, vol. 24, pp. 349-373; September, 1947.) Reprint of 3065 of 1947. Several corrections are made.

621.396.645:[621.317.725+535.247.4 2494

Bridge-Balanced Amplifiers—Y. P. Yu. (*Electronics*, vol. 21, pp. 111-113; May, 1948.) The errors in zero reading of tube voltmeters due to variations of circuit elements, supply voltages, and tube constants may be greatly reduced by means of balancing circuits. Coupling between stages in multistage dc amplifiers for sensitive tube voltmeters requires careful design. The use of a cold-cathode voltage regulator, a separate bias supply, or a push-pull phase inverting circuit is recommended. A negative-feedback circuit for measuring very small illumination is also described.

621.396.645.012 2495

Voltage Amplification Formulas—H. J. Peake. (*Tele-Tech.*, vol. 7, p. 48; February, 1948.) The circuit diagram and gain formula are tabulated for a number of triode and pentode amplifier arrangements.

621.396.645.371 2496

A Flat-Response Single-Tuned I.F. Amplifier—E. H. B. Bartelink, J. Kahnke, and R. L. Watters. (*Proc. I.R.E.*, vol. 36, pp. 474-478; April, 1948.) The amplifier provides double-tuned response using single-tuned circuits with negative feedback. The case where relatively narrow pass bands are required is fully discussed.

621.396.662 2497

Polarity Response from Tuning-Eye Tubes—M. L. Greenough. (*Electronics*, vol. 21, pp. 162, 168; April, 1948.) A circuit is given which enables a standard tuning indicator to be used as a polarity indicator. A standing bias is applied to the tube and the grid is switched either to earth or to the signal, by means of a diode shunt network controlled from the ac supply.

621.396.662.21:621.385.832 2498

Iron-Cored Deflecting Coils for Cathode Ray Tubes—A. Woroncow. (*Jour. IEE* (London), part IIIA, vol. 93, no. 10, pp. 1564-1574; 1946.) "A concise theory of the magnetic circuits of deflecting coils with iron cores is given, and experimental results with various types of single-field and crossed-field coils are described. The properties of sensitivity, inductance, resistance, defocusing, and distortions are considered, particular attention being paid to coils with slotted cores."

621.396.662.3 2499

Band-, High- and Low-Pass Filters with Level Wave Resistance—W. Herzog. (*Arch. Elec. Übertragung*, vol. 1, pp. 184-194; November and December 1947.) Design procedure and formulas for bridge-type filters with wave-resistance characteristics equal to those of Zobel half-section filters.

621.396.662.3:534.851:621.395.813 2500
Filter Characteristics for the Dynamic Noise Suppressor—McCracken. (See 2436.)

621.396.665:621.396.645.371 2501
Automatic Volume Control as a Feedback Problem—B. M. Oliver. (PROC. I.R.E., vol. 36, pp. 466-473; April, 1948.) Feedback amplifier theory can be applied to the usual amplified and delayed avc system. Expressions are derived for the gain of the feedback path (loop gain) in terms of the design requirements and the gain-control characteristic of the controlled amplifier. The reduction of modulation-depth at 1f due to avc is considered, and a Nyquist diagram for a stable avc system is given. Non-delayed avc is regarded as a particular example of the delayed case.

621.396.813:621.317.3 2502
An Analysis of the Intermodulation Method of Distortion Measurement—Warren and Hewlett. (See 2553.)

621.396.615:621.316.726.078.3 2503
Über Synchronisierung von Röhrengeneratoren durch Modulierte Signale [Book Review]—F. Diemer. Gebr. Leemann and Co., Zürich, 98 pp., 10.80 Swiss francs. (Wireless Eng., vol. 25, p. 197; June, 1948.) A doctorate thesis. The externally applied synchronizing voltage is assumed to be modulated either in amplitude or frequency. The first 52 pages contain a mathematical investigation and the rest describes experimental verification of the results.

GENERAL PHYSICS

53.081 2504
Units, Dimensions, and Law of Similitude—L. S. Dzung and A. Meldahl. (Brown Boveri Rev., vol. 33, pp. 123-128; June and July, 1946.) The arbitrary nature and complete independence of the fundamental units of length, area, force, mass, etc. is stressed. Every derived unit is based on a natural law, for example, a square yard is derived from the law that the area of a rectangle is proportional to length \times breadth. Any number of units may be regarded as fundamental, but the natural laws involving the fundamental units will lead to equations containing proportionality factors which are not dimensionless, whatever their numerical value. It is convenient to make as many of these proportionality factors numerically equal to unity as possible. We thus prefer to measure area in square yards rather than acres. For Newton's second law of motion it would be most convenient to take a new unit of length equal to 9.81 m. No serious attempt has been made to adjust the unit of temperature so that the universal gas constant becomes unity. The generalization of physical laws by expressing them in terms of dimensionless "characteristic numbers" is considered. A system of units could be built up in which the gravitational constant, the velocity of light, and Planck's universal constant were all numerically unity, in addition to the more familiar conversion factors already considered. Such a system would contain no arbitrary units and dimensional analysis would be impossible. For terrestrial experiments, however, it is more convenient to ignore the numerical values of these three extraterrestrial constants and have instead three independent fundamental units from which all others are derived. See also 1006 and 1007 of May and back references.

530.12:531.18:621.396.11 2505
The Formulae for the Doppler Effect in the Ellipsoidal Theory of Special Relativity (Error of Einstein's Formulae)—Dreyfus-Graf. (See 2591.)

537.525:538.551.25 2506
Plasma-Electron Oscillations—E. B. Armstrong. (Nature (London), vol. 160, p. 713; November 22, 1947.) Hf oscillations in low-pres-

sure gas discharge tubes are probably plasma-electron oscillations with frequency $\approx 10^4 n^{\frac{1}{2}}$ where n is the electron concentration. λ can be as short as 5 cm or less. The amplitude of oscillations which can be determined by a probe depends considerably on the position of the probe, but λ changes little as the probe is moved. Sometimes different frequencies are obtained in different parts of the tube. Effects of magnetic fields on oscillation intensity and the mechanism maintaining the oscillations are considered.

538.114:621.318.323.2 2507
Theory of Alternating Current Auxiliary Magnetization of Ferromagnetic Cores—R. Risch. (Brown Boveri Rev., vol. 33, pp. 129-133; June and July, 1946.) The advantages of auxiliary magnetization lie in the higher permeability attained and the consequent reduction of core cross section, ratio error, and phase difference.

When the effective and auxiliary magnetization are in phase, the effective permeability equals the differential permeability dB/dH corresponding to the auxiliary field strength.

When the currents are 90° out of phase the effective permeability equals the total permeability B/H corresponding to the auxiliary field strength.

For any intermediate phase difference, the effective permeability has intermediate values. Formulas are given involving the differential and total permeabilities and either the phase angle between the fields or that between the fluxes.

The theory is checked by experiments.

546.212+546.212.02[:621.317.3.011.5+537.226.2 2508

The Dielectric Properties of Water and Heavy Water—C. H. Collie, J. B. Hasted, and D. M. Ritson. (Proc. Phys. Soc., vol. 60, pp. 145-160; February 1, 1948.) A description of several methods of measuring the dielectric constant and loss angle for λ 10 cm, 3 cm, and 1.25 cm. The results are interpreted in terms of the Debye equations with a single relaxation time; the values derived suggest that the molecular reorientation mechanism is the same as that of viscosity. The value of 5.5 found for the optical dielectric constant gives a reasonable result for the dielectric constant of water on the Onsager theory. See also 79 of February.

537.312.62 2509
Theorie der Supraleitung [Book Review]—M. von Laue. Springer-Verlag, Berlin and Göttingen, 1947, 124 pp., 12 RM. (Nature (London), vol. 161, p. 37; January 10, 1948.) An account of the superconduction theory of F. and H. London (Proc. Roy. Soc. A, vol. 149, p. 71; 1935; Physica, vol. 4, p. 341; 1935.) "The book is written in a very thorough manner; all theoretical results are derived in detail and difficulties are indicated and discussed."

GEOPHYSICAL AND EXTRATERRESTRIAL PHENOMENA

523.16:621.396.822 2510
Frequency Variation of the Intensity of Cosmic Radio Noise—J. W. Herbstreit and J. R. Johler. (Nature (London), vol. 161, pp. 515-516; April 3, 1948.) Discussion of measurements made by the National Bureau of Standards of cosmic noise at 25 and 110 Mc. Horizontal $\lambda/2$ dipoles placed $\lambda/4$ above ground were used at both frequencies. The incident noise appears to be proportional to $f^{-0.41}$, f being the frequency. It was also noted that several short-time bursts of very strong noise radiation occurred at times when sudden ionosphere disturbances were reported.

523.53 "1947.08" 2511
Combined Radar, Photographic and Visual Observations of the Perseid Meteor Shower of 1947—P. M. Millman, D. W. R. McKinley and

M. S. Burland; A. C. B. Lovell. (Nature (London), vol. 161, pp. 278-280; February 21, 1948. Data obtained in Canada indicate that the strong, enduring radar reflection from meteors is not restricted to the neighborhood of the point where the meteor is traveling perpendicular to the line of sight. The change in range corresponds consistently with reflection from a meteor path-length of about 20 km. It is suggested that two different mechanisms may be concerned in the production of the effective radar targets. Lovell directs attention to the effects observed with different wavelengths and to the aspect sensitivity of radar methods of observation. See also 2086 of 1947 and 411 of March (Hey and Stewart).

523.72.029.62:523.75:621.396.822 2512
Solar Radio-Frequency Noise Fluctuations and Chromospheric Flares—S. E. Williams. (Nature (London), vol. 160, pp. 708-709; November 22, 1947.) Comparison of times of solar flares with observations of noise on 75 Mc showed frequent instances of bursts of noise occurring up to 30 minutes after the observation of a flare. Plasma oscillations high up in the corona from which the noise originates are thought to be excited by corpuscular emission from the flare rather than by ultra-violet radiation.

523.72.029.64:621.396.822 2513
Solar Noise Observations on 10.7 Centimeters—A. E. Covington. (Proc. I.R.E., vol. 36, pp. 454-457; April, 1948.) "Daily observations of the 10.7-cm solar radiation show a 27-day recurrent peak which has a strong correlation with the appearance of sunspots. In the absence of large spots the equivalent temperature of the sun is 7.9×10^4 K. Sudden bursts of solar noise show a sharp rise lasting one or two minutes and a gradual decline to pre-storm value or to a somewhat higher value. Average burst duration is ten minutes."

523.854:621.396.822 2514
Variable Source of Radio Frequency Radiation in the Constellation of Cygnus—J. G. Bolton and G. J. Stanley. (Nature (London), vol. 161, pp. 312-313; February 28, 1948.) General results of investigations, mainly on 100 Mc, give the location and size of the source, which may be effectively a point. The radiation consists of two components, one constant except for a shallow intensity peak at 100 Mc, and the other showing considerable variation. The periodicity of the variable component decreases with decreasing frequency, while its intensity increases rapidly. No variable component has yet been detected on 200 Mc.

523.854:621.396.822.029.62 2515
Measurement of Galactic Noise at 60 Mc/s—K. F. Sander. (Jour. IEE (London), part IIIA, vol. 93, no. 10, pp. 1487-1489; 1946.) The noise, measured for different bearings and times of day, is expressed quantitatively by the equivalent temperature of the antenna radiation resistance. Temperatures between 1800 and 10,000°K have been observed.

538.711(24.08) 2516
Variation of Geomagnetic Intensity with Depth—S. Chapman and S. K. Runcorn. (Nature (London), vol. 161, p. 52; January 10, 1948.) The formula for the variation of the earth's magnetic field with depth, derived by Runcorn from Blackett's theory (3112 of 1947) and quoted by Hales and Gough (1635 of July) is shown by Chapman to be inconsistent with the formula derived from any "core" theory. A correct formula is given which is derivable from a vector potential.

Runcorn points out that his formula contains an approximation which accounts for the above inconsistency; Chapman's more general formula is acknowledged.

550.38 2517

Tentative Theory of the Origin of the Earth's Magnetic Field—A. Delaygue. (*Ann. Geophys.*, vol. 1, pp. 121–143; March, 1945.) It is suggested that free positive ions exist within the earth whose mass m and valency z are such that $m/z = 3.14 \times 10^{-8}$ cgs units. These ions are surrounded by a homogeneous mass of fixed particles, among which are negative ions which exactly neutralize the positive ions. This hypothesis can explain not only the principal part of the earth's magnetic field, but also the existence of a dense positively charged metallic nucleus surrounded by a less dense negatively charged layer. The mass of the nucleus is about 3×10^{27} gm and its total charge 4×10^{20} es units. The theory does not seem able to explain the inclination of the earth's magnetic axis to its geographical axis, nor the secular variations of the earth's field which have their origin within the earth.

551.510.52:621.396.11 2518
Continuous Tropospheric Soundings by Radar—Friend. (See 2593.)

551.510.535:551.594.6 2519

The Fine Structure of Atmospherics. Contribution to the Study of the Ionosphere—R. Rivault. (*Compt. Rend. Acad. Sci. (Paris)*, vol. 221, pp. 540–542; November 5, 1945.) Conclusions derived from the analysis of more than 6000 oscillograms are presented. For further conclusions see 2521 below. The oscillograms can be classed in 5 well-defined types.

Type 1 is characterized by a large number of peaks with separations of 35 to 80 μ s and with exponential damping either regular or variable by steps. The total duration varies within wide limits, from about 100 μ s to many milliseconds. This type is more frequent in summer than winter and is attributed to the leader stroke.

Type 2 consists of 3 swings of large amplitude, the two crests of the same sign being separated by 35 to 75 μ s, most frequently by about 50 μ s. This type in its sharpest form is recorded during local storms and is attributed to the return stroke. The sharpness and short duration of these atmospherics permit analysis of the multiple reflections they undergo between the earth and the ionosphere. Under favorable conditions, multiple echoes are recorded on the oscillograms; the atmospherics are then of type 4, and the height of the reflecting layer can be found from a single oscillogram, together with the distance of the storm center. Records obtained during 1941 to 1945 give heights of 75 to 90 km, so that the lower part of the E region is responsible for the reflection of atmospherics whose maximum energy lies in the frequency range 5 to 50 kc. The number of well-defined echoes may vary from half a dozen for a storm center 300 to 500 km distant, to about 30 for distances of 1000 to 1800 km. Atmospherics of types 1 and 2, or 1 and 4, are frequently found on the same oscillogram.

Type 3 consists of a train of sinusoidal damped oscillations with a pseudo-period of the successive alternations increasing from about 70 to 225 μ s, the crest of greatest amplitude being the second or third. This is a winter type and appears to come from centers as far away as 2000 km. An explanation of this type has been given by Haubert (2520 below).

Type 5 has sometimes the characteristics of type 3 and sometimes of type 4. The peaks representing successive echoes are often sharp, but their separation tends toward 250 to 300 μ s and their damping is much less rapid than with type 3. Type 5 is thought to be a transition type occurring at the end of stormy periods; it indicates that the reflecting layer concerned is not parallel to the ground and has a height of the order of 40 km.

551.510.535:551.594.6 2520

Contribution to the Study of the Fine Structure of Atmospherics—A. Haubert. (*Compt. Rend. Acad. Sci. (Paris)*, vol. 221, pp. 543–545; November 5, 1945.) Certain types of atmospherics are explained by the occurrence of multiple reflections of an initial pulse between the ground and an ionosphere layer with an effective height of 75 to 90 km. The properties of the atmospherics consisting of a train of sinusoidal damped oscillations, called type 3 by Rivault (2519 above), can be explained by the assumption of guided propagation of the initial oscillation between the earth and an ionosphere layer at a height of about 50 km. The critical frequency of such a waveguide is of the right order of magnitude.

551.510.535:551.594.6 2521

Origin of Certain Types of Atmospherics—R. Rivault. (*Compt. Rend. Acad. Sci. (Paris)*, vol. 226, pp. 1300–1302; April 19, 1948.) Recording of the waveform of atmospherics (2519 above) gives information, in the case of type 4, of the distance of the originating flash, whose location is complete if a cr goniometer is used to indicate direction. Such indication is only given roughly for distances less than about 500 km, but by using two goniometers separated by some hundreds of kilometers, location is effected much more accurately. Experiments with goniometers at Poitiers and Bagnaux are described, with particular reference to atmospherics of type 3, trains of sinusoidal damped waves, and type 4. The results show that during September and October, 1947, the sources of atmospherics were near the shores of the Mediterranean and that when depressions filled up and storms abated, the type-4 atmospherics were modified, the echoes broadening, the peaks being rounded off and decreasing rapidly, approximating to types 3 and 5 and making telemetry less easy. This change of type of the atmospherics appears to indicate a physical modification of the electric discharges toward the end of stormy periods.

551.510.535(54):550.38 2522

Abnormalities in the F -Region of the Ionosphere at Calcutta—S. S. Baral, S. N. Ghosh, and M. Debray. (*Nature (London)*, vol. 161, p. 24; January 3, 1948.) Critical frequency observations for the F -region at Calcutta and Madras during January, 1947, show that maximum ionization density is maintained for several hours after sunset. This phenomenon does not occur at Delhi. Delhi and Calcutta have nearly the same latitude but the magnetic-dip values differ by a relatively large amount.

This difference in ionization variation at Calcutta and Delhi may be due to a geomagnetic control of the ionosphere; such control was first suggested by Appleton (2898 of 1946.)

551.593.9 2523

The Spectrum of the Night Sky in the Blue and Violet Regions—J. Cabannes and J. Dufay. (*Ann. Geophys.*, vol. 1, pp. 1–17; August, 1944.) Details of apparatus and method, with a list of 70 lines from 3834 to 5160 Å.

LOCATION AND AIDS TO NAVIGATION

621.396.9 2524

1948 IRE National Convention Program—(PROC. I.R.E., vol. 36, pp. 365–380; March, 1948.) Abstracts are given of the following papers read at the Convention:—Basic Principles of Doppler Radar, by E. J. Barlow. The Radio-visor Landing System for Aircraft, by D. G. Shearer and W. W. Brockway. Considerations in the Design of a Universal Beacon System, by L. B. Hallman, Jr. Surveillance Radar Deficiencies and how they can be Overcome, by J. W. Leas. The Course-Line Computer, by F. J. Gross. Aircraft Instrumentation and Control, by F. L. Moseley, J. A. Biggs, E. T. Heald, and J. C. McElroy. New Techniques in Quan-

titative Radar Analysis of Rainstorms, by D. Atlas. An Automatic-Tracking Direction-Finder Receiving System for Meteorological Use, by W. Todd. Titles of other papers are given in other sections.

621.396.93+621.396.65+621.396.75 2525
Angola Radio Network—Pelaez. (See 2628.)

621.396.93 2526

Instant-Reading Direction Finder—P. C. Hansel. (*Electronics*, vol. 21, pp. 86–91; April, 1948.) Four omnidirectional vertical collectors are equally spaced around a horizontal circle. Their outputs are independently modulated in balanced modulators, the signals from alternate antennas being modulated in quadrature. The resulting carrier-suppressed signals are then combined in a common impedance, the angle of arrival being a function of the phase of the lf envelope. Direction is indicated on a cr tube phase-meter. Sense can be determined visually by means of a single switch. Provision is made for spitting the directivity-pattern in the case of weak signals, to give better resolution. Several receivers can use the antennas at the same time.

621.396.93:551.594.6 2527

Direction Finder for Locating Storms—W. J. Kessler and H. L. Knowles. (*Electronics*, vol. 21, pp. 106–110; May, 1948.) Two perpendicular loop antennas feed the vertical and horizontal deflecting plates of a cr tube through separate amplifiers. The bearing of lightning flashes is thus indicated directly.

621.396.93:621.396.677.029.58 2528

H-Type Adcock Direction Finders—W. Ross and R. E. Burgess. (*Wireless Eng.*, vol. 25, pp. 168–179; June, 1948.) The results of specific experiments are combined with the general experience gained in several years' work with these hf direction finders (3 to 30 Mc) in this survey of the important factors in their design. The main conclusions are: (a) For maximum sensitivity, the ratio of antenna capacitance to total parallel antenna-circuit capacitance, and the dipole effective length, must both be as large as possible; the dipoles should, therefore, be end-loaded. (b) Coupling circuits between the antennas and the first tube of the receiver must be such as to ensure (i) a high coefficient of coupling in all transformers and goniometers, (ii) as few intermediate circuits as possible, (iii) resonance of the primary inductance of the antenna transformers (or goniometer field coils) with the total antenna-circuit capacitance just outside the hf end of each frequency band, (iv) coverage of the total working-frequency range in a series of sub-ranges each of the order of 1.5 to 1 in frequency. (c) Antenna-circuit balancing becomes extremely critical near the fundamental resonant frequency of the central column formed by the down leads or supporting column. (d) The presence of an operator can cause serious bearing errors in small rotating-antenna systems, whatever his position, especially when the bearings are flat. (e) The image in the ground of the horizontal conductor formed by the feeder lines gives rise to an inherent polarization error which is only important when antenna height is small compared to antenna spacing. (f) The presence of the receiver box between or near the lower halves of the dipoles can cause polarization error. (g) Other sources of polarization error exist which are as yet unexplained.

621.396.933 2529

Simultaneous Radio Range and Radiotelephone Equipment—Royden. (See 2634.)

621.396.96 2530

SCR-545-A—A Completely Automatic Tracking Radar—C. R. Taft. (*Bell Lab. Rec.*, vol. 25, pp. 378–382; October, 1947.) At long

ranges (up to about 46 miles) a 205-Mc manually operated target "acquisition" system uses 200-kw pulses. At short ranges (less than 23 miles) a 2800-Mc tracking system with 350-kw pulses can also be used. The two antenna systems are mounted together; the 2800-Mc antenna is a parabolic reflector with a sharp beam which is made to describe a conical path. A target on the axis of the cone will return a constant signal during scanning; the variations in signal strength from other targets are used to swing the tracking antenna toward the target. A gate circuit, which opens just before and closes just after the signal pulse returns from the target, is used to determine range to within ± 5 yards. A second gate circuit splits the signal pulse into two parts which are compared; the circuit is shifted automatically toward the larger part until both are equal, when the range tracking is "on target." The whole system is mounted on vehicles and can be set up in less than $\frac{1}{2}$ hr by 10 men.

621.396.96:621.396.615.17:621.317.755 2531
A Precision Time-Base and Amplifier Developed for Radar Range Measurement—Piddington and Hibbard. (See 2488.)

621.396.96:621.396.82 2532
Naval Radar Anti-Jamming Technique—R. V. Alred. (*Jour. IEE* (London), part 111A, vol. 93, no. 10, pp. 1593-1601; 1946.) Specimen photographs are shown of the appearance of various types of jamming signal. Circuits both for neutralizing specific types of jamming and for reducing its over-all effect are discussed.

621.396.96 2533
Fundamentals of Radar [Book Notice]—S. A. Knight. Pitman and Sons, London, 128 pp., 10s. (*Wireless Eng.*, vol. 25, p. 197; June, 1948.)

MATERIALS AND SUBSIDIARY TECHNIQUES

533.5 2534
High Vacuum Pumps, Their History and Development: Parts 2-4—R. Neumann. (*Electronic Eng.* (London), vol. 20, pp. 44-48, 79-83, and 122-125; February to April, 1948.) Part 2: Modern developments. Parts 3 and 4: Diffusion pumps. Part 1: 1371 of June.

537.228.1 2535
Piezoelectric Crystal Culture—A. C. Walker. (*Bell Lab. Rec.*, vol. 25, pp. 357-362; October, 1947.) The commercial production of ammonium dihydrogen phosphate (ADP) crystals is described. Z-cut plates are used as seeds in a system of rocking tanks housed in a temperature-controlled room. An experimental apparatus using a reciprocating rotary seed holder is also described. Details are given of crystal growth and of conditions which can cause undesirable formations. See also 739 of April.

546.212+546.212.02]:[621.317.3.011.5+537.226.2 2536
The Dielectric Properties of Water and Heavy Water—Collie, Hasted, and Ritson. (See 2508.)

546.28:621.314.632 2537
A Silicon-Metal Contact Resistance—E. H. Putley. (*Nature* (London), vol. 160, pp. 710-711; November 22, 1947.) The resistance between a piece of silicon crystal and the cup in which it was soldered in a commercial rectifier Type CV 253 was found to be about 1Ω . A slight rectifying action was found in the opposite sense to the tungsten-point contact.

549.514.51:537.228.1 2538
Calculation of the Piezo-Electric Constants α - and β -Quartz—B. D. Saksena. (*Nature* (London), vol. 161, pp. 283-284; February 21, 1948.) Equations are derived from which calculated values of the constants are obtained in complete agreement with observed values.

621.315:621.317.333.4 2539
The Properties of High-Voltage Conductors for High-Frequency Transmission and for Fault Location by Radio Methods—H. Elger. (*Arch. Elek. Übertragung*, vol. 1, pp. 195-204; November and December, 1947.) Measurements of wave resistance and attenuation, at frequencies up to 4000 kc, indicate that these properties can be used successfully for fault location not only on hv lines, but also on hf telephone cables.

621.315.61.011.5:546.431.82:537.228.1 2540
Dielectric Constant and Piezo-Electric Resonance of Barium Titanate Crystals—B. T. Matthias. (*Nature* (London), vol. 161, pp. 325-326; February 28, 1948.) The growth of single crystals and the ferroelectric behavior of their pseudo-cubic modification are discussed. Graphs show the dielectric constant, and the piezoelectric resonance frequency for directions parallel to the three crystallographic axes, as a function of temperature. Dielectric hysteresis effects observed in all three directions disappear above about 100°C. The effect of twinning on the results is considered. See also 125, 126, and 127 of February.

621.315.612:621.317.3.011.5.029.64 2541
Measurement of High Permittivity Values at Centimetre Wavelengths—J. G. Powles. (*Nature* (London), vol. 161, p. 25; January 3, 1948.) The permittivity ϵ of a ceramic material is measured in the frequency range 8100 to 10,000 Mc by placing the specimen in an H_{01} waveguide system and measuring the energy transmitted through the material, for constant incident energy, while varying the frequency. Experimental results relating transmitted energy and frequency for Zn_2TiO_4 and rutile (TiO_2) show a close agreement with the theoretical curves using an assumed permittivity value. The peaks obtained in these curves are used to evaluate the accurate permittivity of the material, since it can be shown that peak separation/peak width $\approx \sqrt{\epsilon}$ for large values of ϵ . It is also demonstrated that the behavior of the materials approaches that of metals as the value of the permittivity increases.

621.315.616 2542
Synthetic Hard Rubber—W. S. Bishop. (*Bell Lab. Rec.*, vol. 26, pp. 55-57; February, 1948.) Production methods are outlined. Physical properties are not greatly inferior to those of natural rubber products, except as regards machining qualities and brittleness.

621.318.24 2543
A Thyatron Controlled Half-Cycle Magnetizer—E. W. Hutton. (*Electronic Ind.*, vol. 2, pp. 8-10; February, 1948.) Intricately shaped magnets are magnetized by threading a conductor through the window of the magnetic circuit and passing sufficient dc to produce the required field; by using single dc pulses obtained by rectification of a suitably amplified ac supply, the requisite conditions are readily obtained. A basic control circuit is given.

621.357:679.5 2544
Plating Plastics—H. Narcus. (*Metal Ind.* (London), vol. 72, pp. 128-129; February 13, 1948.) A Cu-reduction process for depositing films on nonconductors prior to the electro-deposition of an intermediate coating of Cu or Ag. The advantages of the method as compared with silvering processes are enumerated.

621.775.7:05 2545
Abstracts on Powder Metallurgy—(*Nature* (London), vol. 160, p. 705; November 22, 1947.) A new 16-page monthly abstract journal, *Metal Powder Report*, dealing solely with the production, treatment, and use of metal powders and edited by W. D. Jones and R. A. Hetzig, can be obtained from Powder Metallurgy Ltd, Commonwealth House, 1-19 New Oxford

St., London, W.C.1, for an annual subscription of £3.7.6.

631.437+546.212]:621.3.011.5.029.64 2546
Electrical Properties of Soil and Water at Centimetre Wave-Lengths—(*Nature* (London) vol. 161, p. 73; January 10, 1948.) British work in this field is reviewed and some recent results obtained in America for dry soil and for pure and salt water are discussed and compared with results obtained in Britain. Values obtained for the different soils vary considerably, but the results for water show fairly good agreement with values predicted theoretically from work done in Britain at higher frequencies.

669 2547
1948 IRE National Convention Program—(PROC. I.R.E., vol. 36, pp. 365-380; March, 1948.) Abstracts are given of the following papers read at the Convention:—ASTM Committee Work—Factory Tests on Cathode Nickel, by J. T. Acker. A Standard Diode for Radio-Tube-Cathode Core-Material Approval Tests, by R. L. McCormack. Titles of other papers are given in other sections.

MATHEMATICS

518.5 2548
1948 IRE National Convention Program—(PROC. I.R.E., vol. 36, pp. 365-380; March, 1948.) Abstracts are given of the following papers read at the Convention:—Large-Scale Computers, by R. L. Snyder. The Univac, by J. W. Mauchly. Engineering Design of a Large-Scale Digital Computer, by J. R. Weiner, C. F. West and J. E. DeTurk. Selective Alteration of Digital Data in a Magnetic Drum Computer Memory, by A. A. Cohen and W. R. Keye. Titles of other papers are given in other sections.

518.5 2549
Elements of D.C. Analog Computers—G. A. Korn. (*Electronics*, vol. 21, pp. 122-127; April, 1948.) Discussion of: (a) the design of simple circuits for adding, multiplying, integrating, and differentiating, (b) operating principles, (c) limits of accuracy, (d) applications.

518.5 2550
Selective Sequence Digital Computer for Science—(*Electronics*, vol. 21, pp. 138, 140; April, 1948.) A development of the Harvard automatic sequence controlled calculator (461, 468, and 787 of 1947) with greatly increased memory and "programming" capacity.

518.5:517.3 2551
Design of D.C. Electronic Integrators—G. A. Korn. (*Electronics*, vol. 21, pp. 124-126, May, 1948.) The basic circuit consists of an integrating RC network in conjunction with a dc amplifier. The accuracy of integration is affected by the leakage resistance of the capacitor and by the amplifier gain. The output voltage may be made proportional to the time integral of the input voltage by means of a compensated circuit. The amplifier gain is made positive so that capacitor leakage constitutes regenerative feedback. Degenerative feedback through the integrating capacitor prevents amplifier instability.

MEASUREMENTS AND TEST GEAR

621.317 2552
1948 IRE National Convention Program—(PROC. I.R.E., vol. 36, pp. 365-380; March, 1948.) Abstracts are given of the following papers read at the Convention:—[Measurement of] Current Distributions on Aircraft Structures, by J. V. N. Granger. Visual Analysis of Audio-Frequency Transient Phenomena, by D. E. Maxwell. Square-Wave Analysis of Compensated Amplifiers, by P. M. Seal. A Picture-Modulated R.F. Generator for Television Receiver Measurements, by A. Easton. Swept-Frequency 3-Centimeter Impedance Indicator,

- by H. J. Riblet. An Automatic V.H.F. Standing-Wave-Ratio Plotting Device, by W. A. Fails, L. L. Mason, and K. S. Packard. Microwave Impedance Bridge, by M. Chodorow, E. L. Ginzton, and J. F. Kane. Impedance Measurements by means of Directional Couplers and Supplementary Voltage Probe, by B. Parzen. A Waveguide Bridge for measuring Gain at 4000 Mc, by A. L. Samuel and C. F. Crandell. Design and Application of a Multipath Transmission Simulator, by H. F. Meyer and A. H. Ross. Frequency Measurement by Sliding Harmonics, by J. K. Clapp. A General-Purpose Oscillograph for Precision Time Measurement, by R. P. Abbenhouse. Some Considerations in Extending the Frequency Range of Radio Noise Meters, by W. J. Bartik and C. J. Fowler. Analysis of a Microwave Absolute Attenuation Standard, by A. B. Giordano. 10-Centimeter Power Measuring Equipment, by T. Miller. Titles of other papers are given in other sections.
- 621.317.3:621.396.813** 2553
An Analysis of the Intermodulation Method of Distortion Measurement—W. J. Warren and W. R. Hewlett. (Proc. I.R.E., vol. 36, pp. 457-466; April, 1948.) Nonlinearity in a network (assumed independent of frequency) produces harmonic and intermodulation products which bear a fixed relationship; either may be used to assess the degree of nonlinearity. The relationship is analyzed and shown graphically for transfer characteristics (a) readily representable by a power series, (b) having an abrupt slope change, and (c) representable by a portion of a sine wave. The analysis is verified by experiment. Simple equations and tables for predicting intermodulation products from points on the transfer characteristic are given.
- 621.317.3.011.5:621.319.4** 2554
Capacitor for the Measurement of the Dielectric Constant of a Liquid—J. Benoit and L. Fouquet. (Compt. Rend. Acad. Sci. (Paris), vol. 221, pp. 614-616; November 19, 1945.) Invar and quartz are used to eliminate temperature effects and the special cylindrical construction avoids the use, during measurements, of any portions where the field is not radial.
- 621.317.311:621.317.755** 2555
Visual Measurements of Short Pulses of Direct Current—P. F. Ordnung. (Jour. Frank. Inst., vol. 245, pp. 37-51; January, 1948.) Discussion of techniques and precautions essential to oscillographic observations of short pulses with high repetition rates and with amplitudes which may be greater than 100 amp. The determination of the bandwidths required for measurements of such pulses, the construction and calibration of metering resistors, and the proper termination of the coaxial transmission lines connecting the metering circuits to the oscillograph are also considered.
- 621.317.331:551.594.13** 2556
On the Principles of the Measurement of the Ionic Conductivity of the Atmosphere by means of Discharge Apparatus—L. Cagniard. (Ann. Geophys., vol. 1, pp. 25-36; August, 1944.) Discussion shows that the usual construction of Gerdien apparatus has serious defects. Modifications have been introduced in experimental apparatus, which will be described in a later article.
- 621.317.333.4:621.315** 2557
The Properties of High-Voltage Conductors for High-Frequency Transmission and for Fault Location by Radio Methods—Elger. (See 2539.)
- 621.317.43:621.317.729** 2558
Magnetic Leakage Evaluated with an Electrolytic Tank—F. Levi. (Electronics, vol. 21, pp. 178, 186; April, 1948.) A model of the magnetic circuit is immersed in an electrolyte. When suitable voltages are applied to parts of the model, currents are produced which are nearly proportional to the magnetic fluxes.
- 621.317.7** 2559
Measurement Apparatus—B. Fradkin; B. F. and J. S. (Radio Tech. Dig., Franc., vol. 2, pp. 57-64 and 111-117; February and April, 1948.) Developments in France are compared with developments abroad, particularly in America. The instruments discussed include practically every type of apparatus used in radio measurement and testing.
- 621.317.725†535.247.4:621.396.645** 2560
Bridge-Balanced Amplifiers—Yu. (See 2494.)
- 621.317.725.027.7** 2561
High Voltage Measurements—(Electrician, vol. 140, pp. 649-650; February 27, 1948.) Short summary of IEE paper entitled "Absolute Measurement of High Voltage by Oscillating Electrode Systems," by E. Bradshaw, S. A. Husain, N. Kesavamurthy, and K. B. Menon. The paper, largely mathematical, deals mainly with the ellipsoid voltmeter, in which es forces are measured indirectly, by the influence on the period of oscillation of a conducting body of known mass and dimensions. See also 3584 of 1947 (Bruce).
- 621.317.733** 2562
A Conductance Unbalance Bridge—L. E. Herbom. (Bell Lab. Rec., vol. 26, pp. 73-76; February, 1948.) Alignment of crystal channel filters (2215 of September) is effected by comparison and subsequent adjustment of the conductance of the various branches. Special design features and the operation of a bridge for measuring the unbalance are described. Differences as small as 0.001 μ ho can be detected.
- 621.317.733** 2563
R.F. Bridge for Broadcast Stations—F. Schumann and C. Duke. (Electronics, vol. 21, pp. 83-85; April, 1948.) A variable-frequency signal generator, calibrating oscillator, bridge circuit, detector, and batteries are incorporated in a single light-weight unit. Construction and operation details are given.
- 621.317.755** 2564
General-Purpose Oscilloscope—J. F. O. Vaughan. (Wireless World, vol. 54, pp. 160-165; May, 1948.) Detailed instructions are given for the conversion of three Service surplus radar display units into cr oscilloscopes for laboratory work.
- 621.317.755** 2565
A General-Purpose 5-Inch Cathode-Ray Oscillograph—S. A. Lott and H. J. Oyston. (AWA Tech. Rev., vol. 7, pp. 397-405; October, 1947.)
- 621.317.755** 2566
High-Frequency Oscilloscopes for Pulses and Other Transients—W. L. Gaines. (Bell. Lab. Rec., vol. 26, pp. 68-72; February, 1948.) Review of war-time developments and of principal characteristics. A simple reflector method of providing a virtual scale for the face of the cr tube is described.
- 621.317.755:621.397.6** 2567
Monitoring 'Scope for Television Production Lines—R. de Cola. (Tele-Tech, vol. 7, pp. 40-41; February, 1948.) Equipment producing synchronizing, driving, and blanking signals, and using a method of trace separation which permits simultaneous observation of two signal channels.
- 621.317.79:621.396.615** 2568
A Precision Beat-Frequency Oscillator—S. A. Lott and I. A. Hood. (AWA Tech. Rev., vol. 7, pp. 385-395; October, 1947.) A portable oscillator of range 0 to 20 kc. It includes a frequency comparator and standard 100-kc source for giving spot calibration frequencies at subharmonics of 100 kc to within 0.03 per cent.
- 621.317.79:621.396.615.12** 2569
Beat Frequency Tone Generator with RC Tuning—J. W. Whitehead. (Electronics, vol. 21, pp. 130, 146; May, 1948.) The circuit here detailed can cover wide frequency bands with good frequency stability, low distortion, simple frequency control, and low coupling with neighboring components.
- 621.317.79:621.396.615.17** 2570
A Mechano-Piezoelectric Generator for Pulses and Short Time Intervals—H. Gerdien and W. Schaaffs. (Frequenz, vol. 2, pp. 49-52; February, 1948.) An elinvar rod, 1 m long and 2 cm in diameter, has quartz disks about 0.5 cm thick at each end, followed by 20-cm rods of ordinary steel also 2 cm in diameter, the whole being secured by ring clamps with ebonite washers. The ends of the shorter rods are hardened. Impact of a hardened steel ball (carried on a pendulum rod) on one end of the system gives rise to voltage pulses in the two quartz disks. These pulses are separated by the time interval required for the pressure wave, which travels at the speed of sound, to traverse the elinvar rod. This time interval is of the order of 2×10^{-4} sec and the pulse width at the base is about 3×10^{-6} sec. Applications of the device are discussed.
- 621.317.79:621.396.619** 2571
Frequency and Modulation Monitor for TV and FM—C. A. Cady. (Tele-Tech, vol. 7, pp. 44-45; February, 1948.) A pulse-count detection circuit provides indications of center frequency and percentage modulation, a high-fidelity output for distortion measurements, and a 600- Ω output for audio monitoring. Frequency ranges are 30 to 162 Mc and 160 to 220 Mc.
- 621.317.791** 2572
Probe Valve-Voltmeter and D.C. Volt-Ammeter—A. G. L. Foster. (RSGB Bull., vol. 23, pp. 150-153; February, 1948.) Complete circuit details are given of an inexpensive multi-purpose test instrument.

OTHER APPLICATIONS OF RADIO AND ELECTRONICS

- 534.321.9.001.8:362.41** 2573
Blind Guidance by Ultrasonics—F. H. Slaymaker and W. F. Meeker. (Electronics, vol. 21, pp. 76-80; May, 1948.) Long summary of 1947 National Electronics Conference paper. A portable device analogous to radar, using pulsed FM. A single af tone corresponds to any given obstacle distance; the frequency increases with the distance. Simultaneous echoes from different distances are identified by combinations of individual tones. The equipment operates at 65 kc, weighs $5\frac{1}{2}$ lb. and will detect obstacles up to 30 ft away.
- 539.16.08.†621.3** 2574
1948 IRE National Convention Program—(Proc. I.R.E., vol. 36, pp. 365-380; March, 1948.) Abstracts are given of the following papers read at the Convention:—Oscillator Design for 130-Inch Frequency-Modulated Cyclotron, by E. M. Williams and H. E. DeBolt. An Electronic Instrument for the Determination of the Deadtime and Recovery Characteristics of Geiger Counters, by L. Costrell. Electronic Classifying, Cataloging, and Counting Devices, by J. H. Parsons. A Selective Detector for Charged Particles, by K. Boyer. Use of Diode Rectifiers with Adjustable Transformers for Motor Speed Control, by W. N. Tuttle. Spark Oscillators for Electric Welding of Glass, by J. P. Hocker. Coupling Effects between Infrared Radiation and a Supersonic Field, by W. J. Fry and F. J. Fry. Some Considerations in the Design of Precision Telemetering Equipments,

by R. Whittle. Megacycle Stepping Counter, by C. B. Leslie. Titles of other papers are given in other sections.

539.16.08 2575

Diamonds as Radiation Detectors—(*Electronic Eng.* (London), vol. 20, p. 83; March, 1948.) Extract from National Bureau of Standards report by L. F. Curtiss. "A diamond placed in a strong electric field initiates sharp electrical pulses when gamma radiation is absorbed." Because of its small size, apparent indestructibility and sensitivity comparable with the G-M counter, it may well replace the latter in many applications.

539.16.08 2576

Short Time Delays in Geiger Counters—C. W. Sherwin. (*Rev. Sci. Instr.*, vol. 19, pp. 111-115; February, 1948.) Causes include: (a) the transit time of the secondary electrons as they move toward the central wire, and (b) the time required to form the initial part of the ion sheath.

539.16.08 2577

The Properties of Some New Types of Counters—S. C. Curran and J. M. Reid. (*Rev. Sci. Instr.*, vol. 19, pp. 67-75; February, 1948.) An investigation of the effect of variation in geometrical design on performance. Rectangular counters with nonsymmetrical wires, multiple wire counters, and cylindrical cathodes with nonaxial wires are described. The use of such shapes is shown to reduce operating voltages and dead-times. Applications to cosmic ray and γ -ray detection are discussed.

539.16.08 2578

Some Experiments with Adjustable Geiger-Müller Counters—M. Chaudhri and A. G. Fenton. (*Proc. Phys. Soc.*, vol. 60, pp. 183-193; February 1, 1948.) A description of special counters in which it is possible to alter the effective length as well as the material and diameter of the anode without opening the counters.

539.16.08 2579

Radiation Counter Tubes and Their Operation—N. Anton. (*Electronic Ind.*, vol. 2, pp. 4-7; February, 1948.) Describes the various kinds of radiation measurable by counters. The characteristics of 13 argon-filled tubes are tabulated.

621.316.718:621.313.2-9:621.385.38 2580

New Thyatron Circuit for Motor Control—J. R. Devoy. (*Electronics*, vol. 21, pp. 116-119; April, 1948.) See also 3985 of January (Heumann).

621.316.74:621.365 2581

Vacuum Furnace Control—F. F. Davis. (*Electronics*, vol. 21, p. 81; May, 1948.) Circuit and operation details of a system to guard against burnout of tungsten heaters due to excessive gas pressure. Thermistors serve as sensing elements.

621.317.39:531.717 2582

Thickness Gage for Moving Sheets—J. W. Head. (*Electronics*, vol. 21, pp. 90-92; May, 1948.) Thickness of nonmagnetic materials between 0.001 and 1.0 inch is measured by passing the sheets between the primary and secondary of a transformer; variation of thickness changes the coupling and produces unbalance in a bridge circuit, in which a meter gives direct indication of thickness. Circuit and operation details are given.

621.38.001.8:786.6 2583

Electronic Organ—T. H. Long. (*Electronics*, vol. 21, pp. 117-119; May, 1948.) The instrument comprises 167 grid-circuit-keyed Hartley oscillators associated with conventional organ controls. Each oscillator provides a sinusoidal fundamental and a pulse signal

having many harmonics. Mixer circuits combine the fundamentals and pulse signals in the required proportions, the output being fed to frequency-discriminating circuits to produce the required note. Doppler effect is minimized by using separate loudspeaker channels for manuals and pedals. The power amplifiers have low intermodulation distortion.

621.384.6 2584

A Linear Electron Accelerator—E. L. Ginzton, W. W. Hansen, and W. R. Kennedy. (*Rev. Sci. Instr.*, vol. 19, pp. 89-108; February, 1948.) Theory, design, and experimental results are discussed. Orbital instability can be neglected provided that the electrons are injected at relativistic velocities; space-charge spreading may then also be neglected. The optimum loading design is found for various types of power feeds, and curves to assist calculation are given. Illustrative cases are discussed, and the operation of a low-power 38-section accelerator is described. A footnote (pp. 89 and 90) lists organizations and key personnel working on linear accelerators, and gives a few references.

621.384.6 2585

Design Calculations for a Spiral Accelerator for Heavy Particles—W. Dällenbach. (*Helv. Phys. Acta*, vol. 21, pp. 21-48; February 25, 1948. In German.)

621.384.6 2586

Measurement of the Electron Current in a 22-MeV Betatron—L. Bess and A. O. Hanson. (*Rev. Sci. Instr.*, vol. 19, pp. 108-110; February, 1948.) The charge accelerated to high energy in a 22-MeV betatron operating at 180 cps is determined from its magnetic effect, and corresponds to an average current of about 0.15 μ a.

534.321.9.001.8 2587

Industrial Applications of Ultrasonics [Book Notice]—P. Alexander. B.I.O.S. Final Report No. 1504. H.M. Stationery Office, London, 11 pp., 3s. 6d. Some experimental applications are described, including a method of soldering Al without flux.

551.508.1 2588

A New Frequency Modulated Radiosonde [Book Notice]—E. Menzer and K. Sittel. Apparatus designed for mass production. For temperature measurements, a capacitor with a high temperature coefficient and another with a very low temperature coefficient are switched alternately into the anode circuit of the transmitter, temperatures being determined from the resulting frequency difference. Relative humidity and pressure are determined also by frequency changes resulting from capacitance changes. The construction of the apparatus and its calibration and testing are described, but no circuit details are given. F.I.A.T. Final Report No. 1175. H. M. Stationery Office, London, July 21, 1947, 7 pp., 1s. 6d. In German with English summary.

PROPAGATION OF WAVES

538.566 2589

Surface Impedance of an Infinite Parallel-Wire Grid at Oblique Angles of Incidence—G. G. Macfarlane. (*Jour. IEE* (London), part IIIA, vol. 93, no. 10, pp. 1523-1527; 1946. The shunt reactance (X) of the grid, in terms of the component of the wave impedance (Z) of the incident plane wave which is normal to the grid, is found to be

$$X = [\log(d/2\pi a) + F(d/\lambda, \theta)] Z d/\lambda$$

where d = spacing of wires, a = radius of each wire, θ = angle of incidence, and F is shown graphically. An expression for the reflection coefficient is given. The shunt reactance is substantially independent of the angle of incidence when $a \ll d \ll \lambda$.

621.396.11 2590

1948 IRE National Convention Program—(Proc. I.R.E., vol. 36, pp. 365-380; March, 1948.) Abstracts are given of the following papers read at the Convention:—Continuous Tropospheric Sounding by Radar, by A. W. Friend. A Theory on Radar Reflections from the Lower Atmosphere, by W. E. Gordon. The Propagation of Radio Waves through the Ground, by K. McIlwain and H. A. Wheeler. Design and Application of a Multipath Transmission Simulator, by H. F. Meyer and A. H. Ross. Titles of other papers are given in other sections.

621.396.11:530.12:531.18 2591

The Formulae for the Doppler Effect in the Ellipsoidal Theory of Special Relativity (Error of Einstein's Formulae)—J. Dreyfus-Graf. (*Helv. Phys. Acta*, vol. 21, pp. 87-92; February 25, 1948. In French.) A discussion of the case where the distance between a transmitter and a receiver changes at a constant rate. The formulae derived for the Doppler effect are compared with those of Einstein, which appear to contain an error, since they show that the phase velocity is not the same in all directions and is different from the stationary velocity. This is contradicted by the results of the Michelson-Morley experiment. The ellipsoidal formulas give the same phase velocity in all directions. See also 2058 of 1947.

621.396.11:535.3 2592

Intensity-Distance Law of Radiation—D. A. Bell. (*Wireless Eng.*, vol. 25, p. 199; June, 1948.) For a conical radio beam issuing from a point source, the energy intensity varies as r^{-2} at distance r . For a parallel-beam optical searchlight, the energy intensity falls off less rapidly. The dividing line between the optical case and the radio case occurs at a distance $r_0 = d^2/0.52\lambda$ from the source, where d is the diameter of the actual source.

621.396.11:551.510.52 2593

Continuous Tropospheric Soundings by Radar—A. W. Friend. (Proc. I.R.E., vol. 36, pp. 501-503; April, 1948.) Describes in some detail experiments carried out on 2.398 and 2800 Mc. On many occasions, boundaries between air masses of different dielectric constant and scattering due to precipitation were observed continuously. The results are compared with theory indicating orders of magnitudes of reflection coefficients to be expected. With a perfectly clear sky numerous momentary "dot" echoes were observed, apparently corresponding to the top of a moist stratum of air. The results are compared with those of other observers. See also 2062 of August (Ryde).

621.396.11:551.510.535 2594

Magneto-Ionic Multiple Refraction at High Latitudes—S. L. Seaton. (Proc. I.R.E., vol. 36, pp. 450-454; April, 1948.) Experimental ionospheric soundings examined by Scott and Davies (URSI-IRE Joint Meeting, May 6, 1947, Paper No. 25) are cited, and these authors' interpretation of multiple refraction is compared with the theory of Appleton and Builder (1933 Abstracts, *Wireless Eng.*, p. 262), with special reference to effects to be expected in high latitudes. Experimental evidence is offered to show that the 'Z' component of Scott and Davies is probably the longitudinal ordinary ray predicted by Appleton and Builder, and by Taylor (1933 Abstracts, *Wireless Eng.*, p. 263 and 1934 Abstracts, *Wireless Eng.*, p. 373) when collision frequency is appreciable. Using stated assumptions, the collision frequency near Fairbanks, Alaska, is calculated to be about 4×10^4 at a height of 300 km.

621.396.11:551.510.535 2595

Triple Magneto-Ionic Splitting of Rays Reflected from the F_2 Region—G. Newstead. (*Nature* (London), vol. 161, p. 312; February 28,

1948.) A good example from the Hobart P'f recorder operating in the frequency range 1.5 to 13 Mc is reproduced. A systematic discrepancy between the expected and observed critical frequency for the third ray is possibly accounted for by collision. Triple splits seem more likely to occur under disturbed conditions and are generally accompanied by sporadic-E ionization. They have been observed at all hours of the day, but are most frequent between 1700 and 2000 G.M.T.

RECEPTION

621.396.62 2596

1948 IRE National Convention Program—(PROC. I.R.E., vol. 36, pp. 365-380; March, 1948.) Abstracts are given of the following papers read at the Convention:—I.F. Design for FM Receivers, by K. E. Farr. Static-Free Systems of Detection, by D. L. Hings. Superregeneration as it Emerges from World War II, by H. A. Wheeler. Theory of the Superregenerative Receiver, by W. E. Bradley. Superregeneration—An Analysis of the Linear Mode, by H. A. Glucksman. External and Internal Characteristics of a Separately Quenched Superregenerative Circuit, by Sze-Hou Chang. The Hazeltine FreModyne Circuit, by B. D. Loughlin. The Application of Noise Theory to the Design of Receivers, by W. A. Harris. The Design of [receiver] Input Circuits for Low Noise Figure, by M. T. Lehenbaum. Frequency Converters, by W. H. Lewis. Titles of other papers are given in other sections.

621.396.621 2597

Simplified Single-Sideband Reception—O. G. Villard, Jr. (*Electronics*, vol. 21, pp. 82-85; May, 1948.) The given circuit can be used with a conventional communications receiver for the reception of code signals as well as single-sideband transmissions. The effective if bandwidth of a receiver can be made exactly that of the passband of a low-pass audio filter, instead of approximately twice this passband as in AM. The circuit includes a demodulating oscillator, balanced detector, two 90° audio phase-shift networks and a low-pass filter. See also 4027 of 1947 (Lenahan).

621.396.621 2598

A Double-Diversity Two-Channel Single-Sideband Receiver—L. K. Curran. (*AWA Tech. Rev.*, vol. 7, pp. 337-354; October, 1947.) Discussion of the advantages and requirements of such a system, and of the receiving equipment at the Australian terminal of the London and San Francisco circuits. The double-superheterodyne receiver converts signals to an if of 1666 kc and subsequently to 100 kc, at which frequency channel selection is performed by lattice-type crystal filters. The partially suppressed carrier is selected by narrow-band T-section crystal filters and compared with the locally generated carrier to provide afc. Graphs illustrate filter and channel characteristics; typical data of sensitivity, selectivity, etc. are included.

621.396.621 2599

Radio Set and Service Review. The Collins Model 75A-1—R. F. Scott. (*Radio Craft*, vol. 19, pp. 32-33, 75; February, 1948.) A 14-tube receiver with 6 tuning ranges, one for each amateur band. Other features are permeability tuning, double conversion, a well-calibrated mechanical bandspread system, and stable crystal-controlled oscillators.

621.396.621 2600

A Panoramic Receiver (3.5-20 Mc/s)—E. C. H. Seaman. (*Jour. IEE* (London), part IIIA, vol. 94, no. 13, pp. 459-460; 1947; summary, *ibid.*, part IIIA, vol. 94, no. 11, p. 82; 1947.) The receiver is designed to indicate simultaneously on a cr tube the presence, frequency, and relative magnitude of strong sig-

nals. A superheterodyne arrangement is used in which the input tuning is unchanged and the local oscillator frequency is varied cyclically. The output from the set controls the Y-deflection of the tube, while the X-deflection is synchronized with the local oscillator frequency sweep.

621.396.621.59 2601

Squelch Circuits for F.M. Receivers—C. W. Carnahan. (*Electronics*, vol. 21, pp. 98-99; April, 1948.) Simple circuits for rendering the audio amplifier of a FM broadcast receiver inoperative when tuning between stations. In several arrangements described, the second limiter supplies squelch voltage without additional tubes.

621.396.82 2602

Radio Interference from Aircraft Electrical Equipment—L. Rowley. (*Jour. IEE* (London), part IIIA, vol. 94, no. 13, pp. 484-492; 1947; summary, *ibid.*, part IIIA, vol. 94, no. 11, p. 82; 1947.) The causes and means of propagation of interference, and various methods of interference suppression, are summarized. The main remedy is the screening of possible sources of interference and the installation at these sources of suppressors whose behavior should be predictable over a wide frequency range. Different types of suppressors and their components are described, with performance details and values and characteristics of low-inductance through-conductor capacitors and light dust-core inductors. Methods of testing suppression apparatus are discussed briefly.

621.396.822 2603

On the Number of Signals Discernible in the Presence of Random Noise in a Transmission System with a Limited Passband—J. Laplume. (*Compt. Rend. Acad. Sci.* (Paris), vol. 226, pp. 1348-1349; April 26, 1948.)

621.396.822:523.746 2604

Sunspots and Radio—H. T. Stetson. (*Radio Craft*, vol. 19, pp. 24-25, 72; February, 1948.) Discussion of the bearing of solar activity on radio communication.

621.396.822:621.396.619 2605

Noise Problems in Pulse Communication—Z. Jelonek. (*Jour. IEE* (London), part IIIA, vol. 94, no. 13, pp. 533-545; 1947; summary, *ibid.*, part IIIA, vol. 94, no. 11, p. 105; 1947.) Formulas for random noise in the af output in pulse-communication receivers are given for various pulse modulation systems, particularly those in which the received pulses are sliced. Noise resulting from random distribution of the if phase at the onset of pulses is also considered. The slicing level for minimum output noise is evaluated.

Signal versus noise ratio and threshold formulas thus obtained are compared with those for AM and FM systems. The relative merits of modulation systems are discussed in terms of graphs of output signal versus noise ratio. Performance below threshold is taken into account.

621.396.822:621.396.619.16 2606

Random Noise Characteristics of a Pulse-Length-Modulated System of Communication—G. G. Gouriet. (*Jour. IEE* (London), part IIIA, vol. 94, no. 11, pp. 551-555; 1947.) A theoretical analysis for a system in which the detected pulses are limited in amplitude and applied to a low-pass filter. For rf bandwidths as great as 300 kc there will be no substantial improvement over AM; for greater bandwidths the improvement will be approximately proportional to the square root of the bandwidth. See also 2620 below.

621.396.822:621.396.619.16 2607

Noise-Suppression Characteristics of Pulse-Time Modulation—S. Moskowicz and D. D. Grieg. (PROC. I.R.E., vol. 36, pp. 446-

450; April, 1948.) An experimental investigation. Impulse noise and thermal-agitation or fluctuation noise are considered. Their effects and improvements obtained by using limiters, differentiators, and multivibrators, are shown graphically.

621.396.828:621.319.4 2608

The Duct Capacitor—Watton (See 2474.)

621.396.621.53 2609

Microwave Mixers [Book Review]—R. V. Pound and E. Durand. McGraw-Hill, London, 381 pp., 33s. (*Wireless Eng.*, vol. 25, p. 197; June, 1948.) Volume 16 of the M.I.T. Radiation Laboratory series on radar and related techniques, covering most of the developments during and since the war, chiefly for λ 10 cm and λ 3 cm. Principles of mixer design, the rf head for radar, waveguide, and coaxial-line circuits, afc, and mixer measurements, are among the subjects discussed.

STATIONS AND COMMUNICATION SYSTEMS

621.395.44 2610

SOJ-12 Open-Wire Carrier Telephone Systems in South Africa—D. P. J. Retief and H. J. Barker. (*Elec. Commun.*, vol. 24, pp. 310-323; September, 1947.) General description of a system providing 12 additional two-way speech channels over an open-wire pair on which a 3-channel carrier telephone system and voice facilities may already be operating.

621.395.44:621.315.052.63 2611

M1 Carrier: The Common Terminal—R. C. Edson. (*Bell Lab. Rec.*, vol. 26, pp. 77-81; February, 1948.) Details of the equipment used at the junction of power and telephone lines in the M1 carrier system. See also 1490 of June (Hochgraf) and 2612 below.

621.395.44:621.315.052.63 2612

Carrier Telephones for Farms—J. M. Barstow. (*Bell Lab. Rec.*, vol. 25, pp. 363-366; October, 1947.) Description of the M1 system. See also 1490 of June (Hochgraf), 2355 of September (Dunham), 2611 above and 2629 below.

621.395.97:621.315.052.63 2613

Tele-Broadcasting on Low-Voltage Distribution Networks—E. Metzler and W. Rüegg. (*Tech. Mitt. Schweiz. Telegr.-Teleph. Verw.*, vol. 26, pp. 30-35, February 1, 1948. In French.) In many parts of Switzerland the field strength is too low for satisfactory reception from the national transmitters. In some places, this difficulty has been overcome by means of a hf system applied on the telephone lines. Tests are here reported of such a system applied on the low voltage distribution network. At three places, long waves (150 to 300 kc) were used, the maximum power of the transmitter being about 5 w. At a fourth place, a quartz-controlled transmitter was used giving a maximum output of 4.5 w at 175 kc. The results obtained were quite satisfactory and show that such low-power transmitters can provide good service for a locality where the number of subscribers does not exceed 2000.

621.396 2614

1948 IRE National Convention Program—(PROC. I.R.E., vol. 36, pp. 365-380; March, 1948.) Abstracts are given of the following papers read at the Convention:—A Proposed Combined FM and AM Communication System, by J. C. O'Brien. Ratio of Frequency Swing to Phase Shift in Phase- and Frequency-Modulation Systems Transmitting Speech, by D. K. Gannett and W. R. Young. A New Magnetron Frequency Modulation Method, by P. H. Peters. Technical Aspects of Experimental Public Telephone Service on Railroad Trains, by N. Monk and S. B. Wright. Reflected-Power Communication, by H. Stockman. Selective-Sideband Transmission and Re-

ception, by D. E. Norgaard. Theoretical Study of Pulse-Position Modulation without Fixed Reference, by A. E. Ross. High-Quality Radio Program Links, by M. Silver and H. A. French. Signal-to-Noise Ratio Improvement in a P.C.M. [pulse-count modulation] System, by A. C. Clavier, P. F. Panter, and W. Dite. Radio-Wire Links for Multichannel Transmission, by E. M. Ostlund and H. R. Hunkins. Bandwidth Reduction in Communication Systems, by W. G. Tuller. Titles of other papers are given in other sections.

621.396.41.015.33:621.396.82 2615

Pulse Communication on Lines—S. H. Moss and G. H. Parks. (*Jour. IEE* (London), part IIIA, vol. 94, no. 13, pp. 503-510; 1947; summary, *ibid.*, part IIIA, vol. 94, no. 11, p. 106; 1947.) Discussion of communication over a 50-mile open-wire line of standard British Army type. The problem of adjacent-channel interference, caused by progressive deterioration of the individual pulse waveforms to a point where overlapping occurs, is solved by transmitting a controllable curbed pulse instead of a simple rectangular pulse. This reduces the interfering effect of each trailing pulse response. Cross talk results are satisfactory for one-way communication. For two-way operation, unless the line is sufficiently smooth, near-end interference due to reflections from irregularities in the line may make cross talk intolerable.

621.396.41.029.62:621.396.611.21 2616

Reference-Crystal-Controlled V.H.F. Equipment—D. M. Heller and L. C. Stenning. (*Jour. IEE* (London), part IIIA, vol. 94, no. 13, pp. 461-474; 1947.) Discussion of methods of obtaining automatic selection of any channel ("asac") and controlling a large number of channels with a small number of crystals. The frequency of one crystal is used to define the channel separation; methods of channel selection are discussed. Detailed circuit diagrams of an "asac" transmitter-receiver Type TR1407 are given. See also 2342 of September (Hedeman).

621.396.619.13 2617

Frequency Modulation—E. Schwartz. (*Arch. Elek. Übertragung*, vol. 1, pp. 220-236; November and December, 1947.) General review, with a bibliography of 122 references.

621.396.619.16 2618

Pulse Communication—D. Cooke; Z. Jelonek and E. Fitch; A. J. Oxford. (*Jour. IEE* (London), part IIIA, vol. 94, no. 13, pp. 583-588; 1947.) Discussion on 2079 of August.

621.396.619.16 2619

The Spectrum of Modulated Pulses—E. Fitch. (*Jour. IEE* (London), part IIIA, vol. 94, no. 13, pp. 556-564; 1947.) The basic pulse modulation systems are defined and the spectrum of a train of rectangular pulses sinusoidally modulated in any one of these systems is derived. Modulation by more than one tone is considered. No harmonic distortion or audio cross talk occurs. The anharmonic distortion due to sidebands of harmonics of the pulse repetition frequency is shown graphically. The distortions to be expected for nonrectangular pulses are practically the same as for rectangular pulses. Transients apparently suffer little distortion in form, but their timing is shifted by the pulse modulation, the maximum shift being half the pulse repetition period.

621.396.619.16 2620

Some Theoretical and Practical Considerations of Pulse Modulation—M. M. Levy. (*Jour. IEE* (London), part IIIA, vol. 94, no. 13, pp. 565-572; 1947; summary, *ibid.*, part IIIA, vol. 94, no. 11, p. 105; 1947.) The main conclusions are:— (a) Pulse-phase modulation introduces no amplitude distortion except at

submultiples of the pulse recurrence frequency. (b) Harmonic distortion is negligible, and this method of modulation can be used for high-quality broadcasting. (c) Pulse-phase modulation is subject to cross-distortion produced by sidebands of the pulse recurrence frequency which are within the signal bandwidth. This distortion is negligible provided that the pulse recurrence frequency is at least double the highest signal frequency to be transmitted.

The signal-to-noise ratio for pulse-phase modulation is higher than for AM and increases with the bandwidth used; a formula for the improvement is given. A practical circuit for suppressing the noise on the synchronizing pulse is described, and the elimination of harmonic distortion, due to imperfections in the shape of the modulator and demodulator pulses, is considered.

621.396.619.16 2621

A New Method of Wide-Band Modulation of Pulses—G. H. Parks and S. H. Moss. (*Jour. IEE* (London), part IIIA, vol. 94, no. 13, pp. 511-516; 1947; summary, *ibid.*, part IIIA, vol. 94, no. 11, p. 106; 1947.) A theoretical and experimental investigation into the design of a modulator and demodulator for a single-channel pulse system to operate as a link in a multi-channel carrier-telephony system (0.3 to 32 kc) requiring low over-all noise and low cross talk. The modulating signal is scanned periodically instead of synchronously. This permits the use of a low recurrence frequency (actually 80 kc for ease of filtering). There is a consequent improvement in the signal-to-noise ratio.

621.396.619.16 2622

Pulse-Count Modulation—D. D. Grieg. (*Elec. Commun.*, vol. 24, no. 3, pp. 287-296; September, 1947.) For another account see 544 of March.

621.396.619.16 2623

Pulse-Time-Modulation Link for Army Field Telephone System—N. H. Young. (*Elec. Commun.*, vol. 24, pp. 297-299; September, 1947.) A method of obtaining duplex transmission over a radio link, using a single channel and common-antenna working. Pulse repetition is controlled at both stations from a single stable oscillator. By suitable timing, pulse reception at either station occurs in the intervals between pulse transmission. A brief description is given of practical equipment, the performance of which compared favorably with standard telephone circuits.

621.396.619.16:621.395.43 2624

The Development of the Wireless Set No. 10: An Early Application of Pulse-Length Modulation—E. G. James, J. C. Dix, J. E. Cope, C. F. Ellis, and E. W. Anderson. (*Jour. IEE* (London), part IIIA, vol. 94, no. 13, pp. 517-527; 1947; summary, *ibid.*, part IIIA, vol. 94, no. 11, p. 105; 1947.) An interlaced multi-channel telephone circuit using pulse-length modulation, applied to a cm- λ radio link. The transmitter uses magnetrons of the resonant-segment glass-envelope type, the wavelengths being 6.6 and 6.3 cm for duplex operation. The receiver has a tuning range of 6.1 to 6.8 cm, and a straight 45-Mc if amplifier of bandwidth 4 Mc. The antenna system consists of two parabolic reflectors, and uses vertical polarization. See also 470 and 2706 of 1946, and 236 of 1947.

621.396.619.16:621.396.41 2625

A 60-cm Multi-Channel System Employing Pulse-Phase Modulation—D. G. Reid. (*Jour. IEE* (London), part IIIA, vol. 94, no. 13, pp. 573-583; 1947; summary, *ibid.*, part IIIA, vol. 94, no. 11, p. 106; 1947.) A system intended for ground point-to-point use, which provides up to 12 simultaneous channels of two-way telephone communication. The operating frequency band is 450 to 500 Mc, and directional antennas having a beamwidth of approximately $\pm 15^\circ$ are

used. The transmitter has a peak power of about 200 w, which is sufficient for line-of-sight paths up to 100 miles long.

621.396.619.16:621.396.5 2626

Pulse Code Modulation—F. Shunaman, (*Radio Craft*, vol. 19, pp. 28-30, 47; February, 1948.) Description of the Bell experimental system. See also 1499 of June and back references.

621.396.619.16:621.396.5 2627

High-Power Pulse Communication at Centimetre Wavelengths—A. T. Starr. (*Jour. IEE* (London), part IIIA, vol. 94, no. 13, pp. 546-550; 1947; summary, *ibid.*, part IIIA, vol. 94, no. 11, p. 106; 1947.) Discussion of the application of microwave radar technique to single-channel pulse telephony. One of the two methods of modulation uses a gating system with automatic synchronization to reduce interference. Pulsed magnetrons and klystrons give an output peak power of $\frac{1}{2}$ kw or more. Reasonable agreement was obtained between theoretical and experimental values of the signal-to-noise ratio. Suggestions are made for improved discrimination between channels.

621.396.65+621.396.93+621.396.75 2628

Angola Radio Network—C. Pelaez. (*Elec. Commun.*, vol. 24, pp. 283-286; September, 1947.) Brief illustrated description of (a) overland links within the colony, (b) stations for communication with ships at sea and with aircraft, and (c) Adcock-type direction finders.

621.396.65 2629

Rural Radiotelephone Experiment at Cheyenne Wells, Colo.—J. H. Moore, P. K. Seyler, and S. B. Wright. (*Bell Sys. Tech. Monogr.*, B-1476, 4 pp.; *Trans. Amer. Inst. Elec. Eng.*, vol. 66, pp. 525-528; 1947.) A party-line system using a FM radio link on 40 to 50 Mc between subscribers and a local exchange. See also 1490 of June (Hochgraf) and 2612 below.

621.396.65 2630

Rural Party-Line Service by Radio—H. W. Nylund. (*Bell Lab. Rec.*, vol. 26, pp. 49-54; February, 1948.) An experimental radio-telephone system operating in the 44- to 50-Mc band. Existing mobile equipment is used, with modified power supplies. FM is used for speech and AM for the ringing current. The antennas are $\lambda/2$ vertical dipoles.

621.396.65 2631

Radio Communication on Middle East Oil Pipeline—(*Engineering* (London), vol. 165, p. 163; February 13, 1948.) For another account see 2368 of September.

621.396.65+621.396.7(494) 2632

High-Altitude Stations and Radio Links—W. Gerber and F. Tank. (*Tech. Mitt. Schweiz. Telegr.-TelephVerw.*, vol. 26, pp. 21-30; February 1, 1948. In French.) See 546 of March.

621.396.93 2633

Military and Aeronautical Communication—(*Jour. IEE* (London), part IIIA, vol. 94, no. 13, pp. 492-496; 1947.) Discussion on 2083 of August (Hickman) and 2085 of August (Gates).

621.396.933 2634

Simultaneous Radio Range and Radiotelephone Equipment—G. T. Royden. (*Elec. Commun.*, vol. 24, pp. 374-381; September, 1947.) A brief survey of the development and principles of operation, followed by a detailed description of the equipment installed in the principal United States airports. A and N Morse signals are transmitted on two pairs of vertical antennas, giving equisignal courses, which may be rotated or "squeezed" to any desired directions. A central antenna transmits speech-modulated signals, which are received simultaneously with the range signals.

621.396.933:621.396.619.16 2635

A Common-Wave Duplex Pulse-Communication System—J. H. McGuire and P. J. Nowacki. (*Jour. IEE* (London), part IIIA, vol. 94, no. 13, pp. 528–532; 1947; summary, *ibid.*, part IIIA, vol. 94, no. 11, p. 106; 1947.) Discussion of a system using only one carrier frequency and suitable for air-to-air and air-to-ground radio telephone. Duplex operation is achieved by momentary suppression of the receivers at each end of a communication link for the duration of each transmitter pulse. Pulse-phase modulation is used; the pulse recurrence frequencies of the transmissions in the two directions are not synchronized. A memory type of pulse-phase discriminator introduces little noise.

621.396.933:621.398 2636

Telecontrol of Aeradio Ground-Station Receivers—J. E. Benson and W. A. Colbrook. (*AWA Tech. Rev.*, vol. 7, pp. 407–419; October, 1947.) Reprint of 275 of February.

621.396.97 2637

On the Provision of Broadcasting Services—F. Eppen. (*Frequenz*, vol. 2, pp. 31–41; February, 1948.) Discussion of such factors as the number of possible subscribers to a new broadcasting service, technical and organization problems, choice of wavelength, topography of the terrain near the proposed station, power requirements, fading and methods for minimizing it, and common-frequency operation. Developments in Germany up to the end of the war are reviewed.

621.396.619.13 2638

FM Simplified [Book Review]—M. S. Kiver. D. Van Nostrand, New York, N. Y., 1947, 342 pp., \$6.00. (*Proc. I. R. E.*, vol. 36, p. 512; April, 1948.) The treatment is "complete" in the sense that all phases of the subject are treated, and is "not exhaustive" in the sense that merely a qualitative description of the various phases is given without detailed mathematical proofs.

SUBSIDIARY APPARATUS

621–526+621.396.68 2639

1948 IRE National Convention Program—(*Proc. I.R.E.*, vol. 36, pp. 365–380; March, 1948.) Abstracts are given of the following papers read at the Convention:—Servo-System Performance Measurement, by C. F. White. Stable Regulated Power Supplies, by R. R. Buss. Titles of other papers are given in other sections.

621.314.67:621.385.38:621.316.722.1 2640

The Shunt Tube Control of Thyatron Rectifiers—J. A. Potter. (*Bell Sys. Tech. Publ. Monogr.*, B-1464, 4 pp.; *Trans. Amer. Inst. Elec. Eng.*, vol. 66, pp. 421–425; 1947.) A description of simple and relatively inexpensive control circuits designed to provide close stabilization of the dc output.

621.316.729:621.313.323 2641

A Phase-Sensitive Synchronous Motor—J. F. Allen. (*AWA Tech. Rev.*, vol. 7, pp. 355–359; October, 1947.) The two input frequencies are fed through a RC phase-shifting network to two amplifying stages. The output of each stage is fed to one of the crossed field coils of a phonic motor.

The armature pulls into and rotates in synchronism with the rotating oscillating field for suddenly produced differences of up to 10 cps, for a power of 6 w supplied to the field coils.

621.316.97 2642

Construction of Shielded Room in VHF Field—C. C. Pine. (*Electronics*, vol. 21, pp. 150, 158; April, 1948.) Construction details for a room screened over the whole rf spectrum. The outermost shield consists of $\frac{1}{4}$ -inch gal-

vanized-mesh wire; the second shield, for uhf screening, consists of graphite-impregnated cloth, and the inside of the room is lined with copper foil. The filtering of the power supply and the bonding of the door require special care. See also 2279 of September (Norton).

621.318.572:621.396.67 2643

Electronic Switches for Single-Aerial Working—A. H. Cooke, G. Fertel, and N. L. Harris. (*Jour. IEE* (London), part IIIA, vol. 93, pp. 1575–1584; 1946.) Discussion of: (a) the purpose of these switches in radar equipments, (b) the development of the spark-gap type as used in m- λ sets, (c) the development of the gas-filled resonator type of cell for use at cm λ , (d) methods of performance measurement.

621.319.33 2644

The Electric Fields in Electrostatic Generators with Inductors charged by Ionization—P. Jolivet. (*Compt. Rend. Acad. Sci.* (Paris), vol. 221, pp. 613–614; November 19, 1945.) The results of tests with propane (C₃H₈), N and CO₂ as gas filling for such generators. At pressures from atmospheric to several kg/cm², show that the best results were obtained with CO₂ at a pressure 3kg/cm² above atmospheric.

621.352.7 2645

Dry Battery Developments. The R. M. [Ruben-Mallory] Mercury Cell—R. W. Hallows and D. W. Thomasson. (*Wireless World*, vol. 54, pp. 166–168; May, 1948.) Recent developments in cell design permit a reduction in dimensions for a given capacity. The Hg cell has an anode of Zn foil or powdered Zn, the electrolyte is a solution of KOH and the steel container forms the cathode. A pellet of HgO acts as a depolarizing anode.

621.396.681 2646

Power Supplies for Aircraft Communication Equipment—W. J. Scott. (*Jour. IEE* (London), part IIIA, vol. 94, no. 13, pp. 475–483; 1947; summary, *ibid.*, part IIIA, vol. 94, no. 11, p. 82; 1947.) Discussion of the effect of the aircraft's general electrical system on radio power supplies and the different types of voltage conversion and regulation equipment used for these supplies. Characteristics of a typical rotary transformer and performance details for typical vibrator converters and voltage regulators are also given.

TELEVISION AND PHOTOTELEGRAPHY

621.397 2647

1948 IRE National Convention Program—*Proc. I.R.E.*, vol. 36, pp. 365–380; March, 1948.) Abstracts are given of the following papers read at the Convention:—A Unitary Tuner-Amplifier for Television Receivers, by E. L. Crosby, Jr., G. W. Clevenger, and H. Goldberg. A Picture-Modulated R. F. Generator for Television Receiver Measurements, by A. Easton. The Application of Projective Geometry to the Theory of Color Mixture, by F. J. Bingley. Reflection of Television Signals from Tall Buildings, by A. Alford and G. J. Adams. Field Coverage Considerations of New York Television Stations, by T. T. Goldsmith, Jr., and R. P. Wakeman. Titles of other papers are given in other sections.

621.397.2 2648

Facsimile Transmitter at the Miami Herald, Florida—R. G. Peters. (*Communications*, vol. 28, pp. 12–15, 33; February, 1948.) Details of scanner and limiting amplifiers, pulse generator, recorder amplifier, and modulator, and of method of phase adjustment for synchronization.

621.397.335:621.318.572 2649

Counter Circuits for Television—Easton and Odyssey. (*See* 2472.)

621.397.5 2650

Considerations on the Selection of Television Standards—J. L. Delvaux. (*Rev. Tech. Comp. Franc. Thomson-Houston*, pp. 5–38; January, 1948. In French, with English summary.) The choice depends on the kind of service required. For a limited number of large-screen receivers a 700-line standard appears desirable, with a transmission frequency not exceeding 200 Mc. For normal broadcasting, medium definition standards (400–455 lines) are favored, with transmission on long meter waves or, in some exceptional cases, on short meter waves. For increasing the number of available channels quasi-single-sideband transmission of the video signals is suggested.

621.397.5:535.88 2651

Compact Projection Television System—H. G. Boyle and E. B. Doll. (*Electronics*, vol. 21, pp. 72–77; April, 1948.) A triangular arrangement of the Schmidt optical system. The projection box uses a 2.5-inch cr tube and gives a 21-inch by 16 inch picture.

621.397.5:535.88 2652

Method of Computing Correction Plate for Schmidt System for Near Projection, with Special Reference to System for Television Projection—H. S. Friedman. (*Jour. Opt. Soc. Amer.*, vol. 37, pp. 480–484; June, 1947.) A plano-aspherical lens, shaped so as to free the center of the field from spherical aberration for a particular wavelength, is computed. A method of determining the chromatic aberration due to the plate is described and means of minimizing chromatic errors are indicated. The system is examined for freedom from coma. The curvature of the tube face required to produce a flat image on the screen is deduced.

621.397.743 2653

A New Microwave Television System—J. F. Wentz and K. D. Smith. (*Bell Sys. Tech. Publ. Monogr.*, B-1461, 6 pp.; *Trans. Amer. Inst. Elec. Eng.*, vol. 66, pp. 465–470; 1947.) An illustrated outline of a FM system for the relaying of television programs, using frequencies from 3900 to 4400 Mc. The transmitting and receiving antennas are separate, and may be of the shielded lens or parabolic type according to local conditions. Pairs of filters are provided for 2-channel operation. The transmitter consists of a video amplifier feeding a 0.4-w rf oscillator. The modulation voltage normally used gives a total frequency swing of about 5 Mc. The receiver consists of a hybrid converter and preamplifier feeding the main if and video amplifiers. It has a maximum peak-to-peak output of about 2 v into a balanced 75- Ω load. Various refinements are described and brief performance details are given.

TRANSMISSION

621.396.61:621.396.828 2654

Eliminating Spurious Radiations from BC Transmitters—V. J. Andrew. (*Tele-Tech*, vol. 7, pp. 22–26, 59; February, 1948.) The causes of such unwanted radiations are discussed, methods of locating their source are described and design data for harmonic suppression filters are tabulated.

621.396.61.029.62 2655

50 kW Output on 88 to 108 Mc/s—A. Arigoni. (*FM and Telev.*, vol. 8, pp. 37–39; February, 1948.) A description of the prototype of a transmitter designed for FM broadcasting. Two intermediate power-amplifier stages deliver 13 kw to the final stage, which uses two push-pull grounded-grid triodes, Type 3X-12500A3. These tubes consist of 4 units of the 3X2500A3 type, assembled on a common mounting; individual units can be replaced by replaced by the makers. The total weight of the 4-unit tube is 32 lb.

621.396.619.13 2656
A Method of Obtaining Linear Frequency Deviation in a Wide-Band Frequency-Modulation System—Z. K. Hass. (*Jour. IEE* (London), part IIIA, vol. 94, no. 13, pp. 497-502; 1947; summary, *ibid.*, part IIIA, vol. 94, no. 11, p. 105; 1947.) The primary cause of harmonic distortion in a FM system is the nonlinearity of the slope of the reactance tube. A method of improving the linearity of this slope is described; harmonic distortion is thus reduced to about 60 db below the fundamental. A method of checking high-fidelity FM is also discussed.

621.396.619.23 2657
Extending Linear Range of Reactance Modulators—F. Brunner. (*Electronics*, vol. 21, pp. 134, 168; May, 1948.) Frequency deviations of 10 per cent of the mean frequency can be obtained by incorporating a stage of amplification in the basic reactance-tube FM oscillator circuit. Refinements are discussed.

VACUUM TUBES AND THERMIONICS

621.314.632:546.28 2658
A Silicon-Metal Contact Resistance—Putley. (See 2537).

621.314.57 2659
High Altitude Tube—N. Anton and M. Youdin. (*Electronics*, vol. 21, pp. 95-97; April, 1948.) A rectifier tube with a special anti-corona base fitting into a moulded socket, which can be operated at full rating in guided missiles at great heights, or in industrial equipment subject to dust, moisture, and fumes.

621.383 2660
Lead Telluride Cells for Infra-Red Spectroscopy—O. Simpson, G. B. B. M. Sutherland, and D. E. Blackwell. (*Nature* (London), vol. 161, p. 281; February 21, 1948.) Preliminary results for cells prepared by the evaporation method. Sensitivity is nil at ordinary temperatures, but at the temperature of liquid air, the sensitivity has a maximum between 2μ and 3μ which is about the same as that of the best PbS cells. Some sensitivity is found as far as 5.5μ . See also 1815 of July.

621.383 2661
High-Frequency Characteristics of Lead Sulphide and Lead Selenide Layers—R. P. Chasmar. (*Nature* (London), vol. 161, pp. 281-282; February 21, 1948.) Discussion of the results of impedance measurements on PbS and PbSe photoconductive cells, at frequencies high enough to ensure the short-circuiting of the intercrystal barrier layers.

621.383 2562
Spectral Response of Lead Selenide—T. S. Moss and R. P. Chasmar. (*Nature* (London), vol. 161, p. 244; February 14, 1948.) Photo cells constructed with a window of KRS5 material (a mixture of TlBr and TlI) show a response which at 90°K is practically flat from about 2μ to 4.2μ and about 50 per cent lower at 5μ . At 195°K, the flat portion of the response curve extends to about 3.5μ , falling about 50 per cent toward 4μ . Both curves show a peak at about 1.2μ which is thought to be due to impurities.

621.385+621.396.615 2663
1948 IRE National Convention Program—(Proc. I.R.E., vol. 36, pp. 365-380; March, 1948.) Abstracts are given of the following papers read at the Convention:—Thermionic Emission from Grids in Vacuum Tubes, by M. Arditi and V. J. DeSantis. The Negative-Ion Blemish in a Cathode-Ray Tube and Its Elimination, by R. M. Bowie. Wide-Tuning-Range Continuous-Wave High-Power Magnetrons, by P. W. Crapuchettes. Wide-Range Tuning Systems for Magnetrons, by E. N. Kather. Design Characteristics of Hearing-Aid Tubes, by G. W. Baker. Experimental Study of the

Effects of Transit Time in Class-C Power Amplifiers, by O. Whitby. New Receiving Tubes for Industrial Use, by C. M. Morris and H. J. Prager. A Standard Diode for Radio-Tube-Cathode Core-Material Approval Tests, by R. L. McCormack. European Practices in the Manufacture of Cathodes, by T. H. Briggs. Processing Vacuum-Tube Components, by P. D. Williams. Continuous Exhaust Machine for Electron-Tube Manufacture, by L. G. Hector. New Design for a Secondary-Emission Trigger Tube—NU TR-1032-J, by C. F. Miller and W. McLean. A Spiral-Beam Method for the Amplitude Modulation of Magnetrons, by J. S. Donal, Jr., and R. R. Bush. The Dyotron—A New Microwave Oscillator, by E. D. McArthur. Electrostatically Focused Radial-Beam Tube, by A. M. Skellett. A New Two-Terminal High-Voltage Rectifier Tube, by G. W. Baker. Titles of other papers are given in other sections.

621.385.1 2664
The Valves to be used in the [French] Receivers of Tomorrow—G. Ginioux. (*T.S.F. Pour Tous*, vol. 24, pp. 29-30 and 65-69; February and March, 1948.) Detailed characteristics and suitable circuits for the following tubes: triode-hexode UCH41, pentode UF41, diode-pentode UAF41, and low-frequency output pentode UL41. See also 603 of March.

621.385.3 2665
On the Limiting Wavelength generated by a Triode—L. A. Kotomina. (*Radiotekhnika* (Moscow), vol. 3, pp. 51-65; January and February, 1948. In Russian.) The effects of the following factors on the limiting wavelength are discussed: electron inertia, virtual cathode, output impedance of the tube, geometrical and electron-optical nonuniformities, and cathode parameters.

621.385.3:621.396.615.17 2556
A Developmental Pulse Triode for 200 kw Output at 600 Mc—L. S. Nergaard, D. G. Burnside, and R. P. Stone. (Proc. I.R.E., vol. 36, pp. 412-416; March, 1948.) Detailed account of the A-2212 cylindrical triode and its performance.

621.385.4 2567
Space-Charge Tetrode Amplifiers—N. Pickering. (*Electronics*, vol. 21, pp. 96-99; March, 1948.) The performance of the tubes noted in 608 of March (Brian) is compared with that of 6K6 pentodes, 6V6 beam pentodes, and Type 45 triodes, in push-pull output stages of high-quality amplifiers. The space-charge tubes have a better performance and require less costly components and simpler circuits.

621.385.4:537.58 2558
Space-Charge Effects in Beam Tetrodes and Other Valves—C. S. Bull. (*Jour. IEE* (London), part III, vol. 95, pp. 17-24; January, 1948.) The space charge in the screen/anode space of a beam tetrode is examined, taking into account the effect of electrons returned from the virtual cathode into the grid/cathode region. It is found that, as with previous simpler theories, three theoretically possible charge distributions may be set up: the one which always occurs in practice, and which has a virtual cathode at a fixed point between the screen and anode, corresponds to the principle of least action. A simple theory of the effect of perturbations is developed, and it is considered unlikely that such perturbations could explain why the virtual-cathode distribution is always set up. The theory is applied to fluctuations of the space-charge-limited current in diodes and triodes.

621.385.832 2569
Improvements in the Construction of

Cathode-Ray Tubes—J. de Gier and A. P. van Rooy. (*Philips Tech. Rev.*, vol. 9, no. 6, pp. 180-184; 1947.) Describes the reduction in deflection defocusing, flattening of the screen, and other improvements possible for a cr tube of a given length when a flat glass base with sealed-in pins is used instead of a cap and glass pinch. The introduction of screening between X and Y deflector plates and leads, and the fixing of electrodes into sintered glass contained in ceramic rods, are also discussed.

621.396.615.141.2 2670
Pinhole Radiography of Magnetrons—R. Dunsuir, C. J. Milner, and A. J. Spayne. (*Nature* (London), vol. 161, pp. 244-245; February 14, 1948.) Pinhole radiographs have been taken along the axis of a 2000 kw pulsed magnetron for λ 10 cm, operated at an anode voltage of 47 kv. The results are discussed and show that the method can give valuable information about electron motion in magnetrons.

621.396.615.141.2 2671
A Magnetron-Resonator System—E. C. Okress. (*Jour. Appl. Phys.*, vol. 18, pp. 1098-1109; December, 1947.) The mode of operation of a vane-type magnetron is analyzed by first considering the mutual coupling between cavities in a hypothetical linear structure with an infinitely long anode, and then applying the findings to the practical case of a cylindrical structure. The treatment results in reasonably accurate predictions of the wavelength for the II-mode. The function of straps is also discussed.

621.396.615.142.2 2572
Considerations on the Electronic Tuning Band and the Useful Output of Reflex Klystrons—G. Vincent. (*Ann. Radioélec.*, vol. 3, pp. 21-28; January, 1948.) Using results obtained by Bernier (2990 of 1947), formulas for the tuning bandwidth and the output are obtained in terms of the Q of the cavity and for conditions approximating to normal practice. A general equation is derived from which the operating frequency can be found and also the matching conditions and reflector voltage giving the maximum useful output. The variations of the electronic tuning bandwidth for maximum output conditions are expressed in terms of the different operational and control parameters of the tube.

621.396.694.032.42 2573
An Improved Method for the Air-Cooling of Transmitting Valves—H. de Brey and H. Rinia. (*Philips Tech. Rev.*, vol. 9, no. 6, pp. 171-178; 1947.) A system enabling air-cooling to be used for tubes at present water-cooled. The cooling air, instead of being blown along the whole length of the anode and thus cooling one end less than the other, is split into several streams by a specially designed air distributor, each stream cooling a small section of the anode.

MISCELLANEOUS

058.621.001 2674
Almanach des Sciences, 1948—L. de Broglie (Ed.) A general review of progress in various branches of science, and a directory of French scientific research establishments, indicating the address, telephone number, and key personnel of each. A list of scientific periodicals, with publishers' names and addresses, is also given. For corresponding British information see 1527 of June.

53 Planck 2675
Prof. Max Planck—H. T. Flint. (*Nature* (London), vol. 161, pp. 13-15; January 3, 1948.) Review of his life and work. See also 1841 of July (de Broglie).

621.3(083.74) 2676
Standard Terms and Abbreviations—A.
 Edwards and F. S. G. Scott. (*Wireless Eng.*,
 vol. 25, p. 198; June, 1948.) Comment by Ed-
 wards on 2426 of September (G.W.O.H.)
 Scott, as author of "Absolute Bela" (2436 of
 1946) protests against Odell's remarks (2428 of
 September).

621.38/.39 2677
1948 IRE National Convention Program—
 (Proc. I.R.E., vol. 36, pp. 365-380; March,
 1948.) Abstracts are given of 130 papers pre-
 sented at the Convention, including:—Health
 Physics Problems in Atomic Energy, by K. Z.
 Morgan, and Statistical Methods in the De-
 sign and Development of Electronic Systems,
 by L. S. Schwartz. For titles of the other 128
 papers, see other sections. For another brief
 general account of the Convention, see *Elec-*
tronics, vol. 21, pp. 72-75; May, 1948.

621.396 2678
Telecommunications Research.—(Electri-

cian, vol. 140, pp. 1644-1646; May 28, 1948,
Elec. Rev. (London), vol. 142, pp. 901-902;
 June 4, 1948.) A short account of the develop-
 ment of the Telecommunications Research
 Establishment, commonly referred to as
 T.R.E. at Great Malvern, Worcestershire. The
 work of the various sections of the establish-
 ment is reviewed and particulars are given of
 the School of Electronics recently opened for
 training apprentices, who will later become
 either craftsmen, instrument makers or pro-
 fessional engineers.

621.396(47) 2679
Russian Radio, 1917-1947—(Radiolekh-
nika (Moscow), vol. 2, pp. 3-64; November and
 December, 1947. In Russian.) A jubilee num-
 ber containing 12 articles and reviewing the
 progress made in various branches of radio
 science and engineering.

621.396 2680
Introduction to Wireless [Book Notice]—
 W. F. Pearce. G. Bell and Sons, London, 247

pp., 7s 6d. (*Wireless Eng.*, vol. 25, p. 197; June,
 1948.)

621.396.029.64 2681
Theory and Application of Microwaves
 [Book Review]—A. B. Bronwell and R. E.
 Beam. McGraw-Hill Publishing Co., London,
 470 pp., 36s. (*Wireless Eng.*, vol. 25, p. 163;
 May, 1948.) Excellently produced and liberally
 illustrated. The engineering point of view is
 stressed throughout and, wherever possible,
 analytical results are expressed in a form con-
 venient for engineering use. "A better balance
 could have been maintained in the selection of
 the subject matter."

621.396.029.64 2682
Microwave Technique [Book Review]—
 Radio Society of Great Britain, 54 pp., 2 s.
 (*Electronic Eng.* (London), vol. 20, p. 135;
 April, 1948.) An admirable introduction to the
 principles and practice of radio techniques used
 in the frequency range 3000 to 30,000 Mc.



Institute News and Radio Notes (Continued)

IRE-RMA ENGINEERING DEPARTMENT HOLD ROCHESTER FALL MEETING

The IRE and the Engineering Department of the Radio Manufacturers' Association will hold a joint fall meeting in Rochester at the Sheraton Hotel on November 8, 9, and 10. On Monday, November 8, the first technical session will begin at 9:30 A.M., with Benjamin E. Shackelford, President of the IRE, as chairman. Alfonse D. Sobel will present the first paper, on "A Television Station Selector Using Die Stamped Inductances," followed by "A Discussion of Image Sharpness in Photography and Television," by Otto H. Schade, and "The Application of Subminiature Tubes," by Raymond K. McClintock. At two o'clock, David B. Smith, former director and Fellow of the Institute, will head the afternoon technical session, which opens with Jerome Kurshan's "The Transitron, an Experimental AFC Tube," and also includes "A New Low-Noise, Low-Microphonic Miniature Tube," by C. R. Knight and A. P. Haase. After the committee meetings at four o'clock, a general session will be held at 8:15 in the evening, with E. Finley Carter, Fellow and former director of the IRE presiding, and Kenneth

W. Jarvis, also a Fellow of the Institute, as the speaker. His topic will be "What's When in America." A stag party will terminate the first day's activities.

On Tuesday, November 9, Stuart L. Bailey, Treasurer of the Institute and IRE Fellow, will preside at the first morning technical session, starting at nine in the morning, which will offer William Vassar's "Report of RMA Safety Committee," after which Stuart T. Martin and Harold Heins will present "Developments in Germanium Crystals," and Joseph Fisher will offer "A Television Distribution System for Laboratory Use." The afternoon session, which starts at two o'clock, will, under the guidance of Dorman D. Israel, Fellow, present H. R. Shaw's "A Direct Coupled Video and AGC System for Television Receivers," followed by "A Pulse-Cross Generator for Television Receiver Production," by R. P. Barr. The committee meetings at four o'clock will be followed by a stag banquet at half past six. B. DeForest Bayly will be toastmaster.

On the last day, Wednesday, November

10, Oliver L. Angevine, Jr., will be chairman of the technical session at 9:30 A.M. "Lightweight Pickup Design for Microgroove Record Playing," by four authors—Bertram P. Haines, Emo Voegtlin, C. D. O'Neill, and R. S. Cranmer, will be the first paper. A symposium on "What Constitutes High Fidelity," in which Harvey P. Fletcher, John K. Hilliard, and C. J. LeBel will participate, is scheduled next. The last offering of the session will be "A High Quality Audio System for Radio Receivers," by Roy S. Anderson and Byron E. Atwood.

The final technical session will begin at two o'clock under the leadership of K. J. Gardner. Two papers will be presented: "Front Ends of Television Receivers," by J. O. Silvey, and "A Picture-and-Sound-Modulated Generator for Television Receiver Production," by William R. Stone. After the four o'clock committee meetings, a photographic session, presided over by Arthur L. Schoen, will conclude the conference.

The program as given here is tentative and subject to last-minute changes.

See How Springs Stay Springy

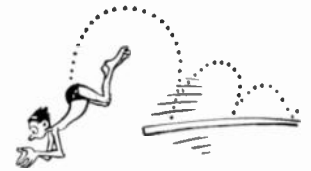

... despite high **HEAT** and active **CORROSION**
when made of **INCO NICKEL ALLOYS**



G. E. Automatic Toaster uses five Inco Nickel Alloy springs to insure long-time operation. Temperatures up to 500° F.

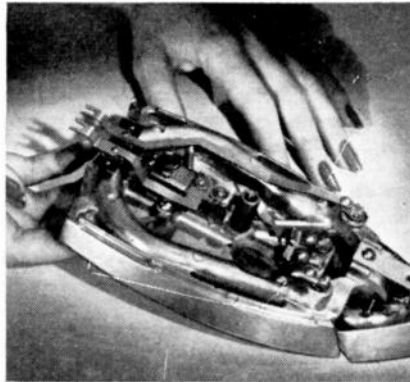

Yale & Towne "Tip Toe" Automatic Iron uses Inconel coil spring for the flexing arm of the sole plate. Corrosive steam here from damp clothes.

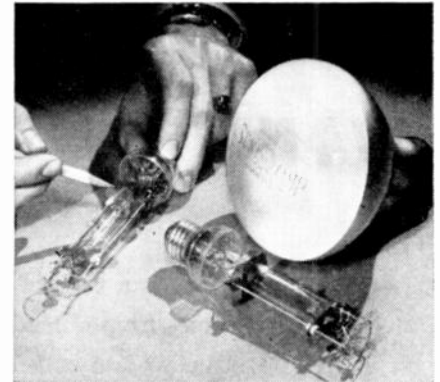

Westinghouse Sun Lamp uses "Z" Nickel springs to support quartz tube inside the lamp. Temperatures up to 750°.

Look at these well-known appliances, and consider the user-benefits they offer the consumer

How to provide for long-time strength and resiliency at elevated temperatures, particularly in the presence of corrosives, poses a problem. The springs in the appliances shown above withstand temperatures ranging from 500° to 750° F. Two operate in the presence of moisture. The springs in the fuse cutout switch shown here maintain their excellent spring properties even when subjected to salt and sulphurous atmospheres in heavy industrial areas.

Inco Nickel Alloy springs are particularly useful in applications where corrosion or high temperatures are present. Their fatigue-resistant properties are often of prime value, but most apparent where corrosion and heat are factors.

For example, consider the G. E. Automatic Toaster: The pop-up spring has to retain spring

properties after long exposure to temperatures up to 500° F. This and three similar springs subject to 400° F. are all made of Monel. The main switch spring, subject to only 300° F. requires close tolerances. If too thick, it might take a set. If too thin it would lack sufficient contact pressure. Full hard Inconel strip .012" x 3/8" solves this problem.

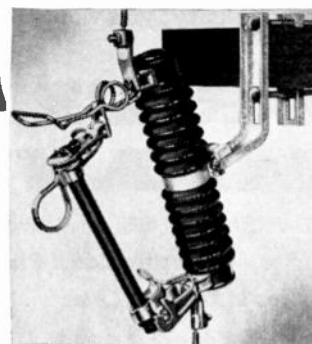

The flat "K" Monel spring on the top casting of this fuse cutout holds the fuse under constant pressure against the upper coating. A coil spring, also "K" Monel, trips the fuse tube when the fuse blows. According to James R. Kearney Corporation "K" Monel springs "are well adapted to applications in heavy industrial areas subjected to a salt and sulphurous atmosphere."

For a more complete discussion of the valuable spring properties of various Inco Nickel Alloys, write for *66 Practical Ideas for Metal Problems in Electrical Products*. Address, please,



THE INTERNATIONAL NICKEL COMPANY, INC., 67 Wall Street, New York 5, N. Y.

MONEL • "K" MONEL • "S" MONEL • "R" MONEL • "KR" MONEL • INCONEL • NICKEL • "L" NICKEL • "Z" NICKEL

Reg. U.S. Pat. Off.

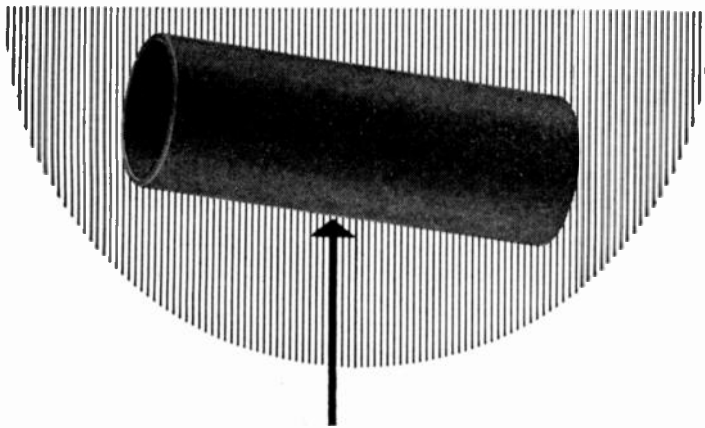

WANT TO MAKE SOMETHING OF IT?

Pictured above is a tube of Taylor Laminated Phenol Fibre, just as it comes from our production line.

Pictured below is a coil form . . . quickly fabricated from this same tube. Note the precision of the punching and threading.

Sheets, rods, and tubes of Taylor Laminated Plastics possess so many properties, physical and electrical, of interest to industry . . . and adapt themselves to such a variety of fabrication processes . . . that their usefulness grows and grows and grows.

If you want a dependable source of supply for Phenol Fibre, Vulcanized Fibre, or special laminates . . . or if you're interested in having completed parts or sub-assemblies delivered on schedule at your plant . . . get in touch with Taylor. Send a sketch or blueprint, if you will, and we'll tell you exactly what we can do for you. Expect plenty; you won't be disappointed.

TAYLOR FIBRE COMPANY

LAMINATED PLASTICS • PHENOL FIBRE • VULCANIZED FIBRE • Sheets, Rods, Tubes, and Fabricated Parts
 NORRISTOWN, PENNA. Pacific Coast Plant: LA VERNE, CAL.

Offices in Principal Cities

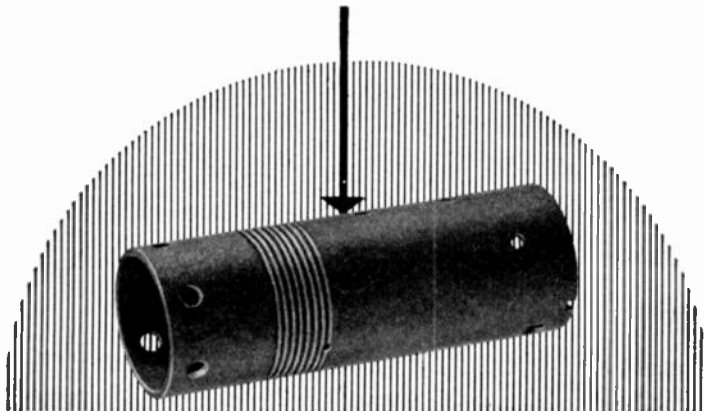

BEAUMONT-PORT ARTHUR

"Applications of Inverse Feedback," by L. W. Erath, Schlumberger Well Surveying Corporation; May 19, 1948.

"A Mobile Radio Telephone System," by E. F. Shawver, Southwestern Bell Telephone Company; June 10, 1948.

"Fire Department Communications," by J. R. Scroggs, City of Beaumont; July 20, 1948.

CEDAR RAPIDS

"Theory and Design of Electron Microscope," by W. H. Kohl, Collins Radio Company; June 23, 1948.

"Application of the Electron Microscope at Iowa State College," by P. H. Carr, Iowa State College; June 23, 1948.

EMPORIUM

"The Effect of Grid Contact Potential on Electron Tube Characteristics," by G. D. O'Neill, Sylvania Electric Products Inc.; August 13, 1948.

"Some Problems of Television," by B. E. Shackelford, President, The Institute of Radio Engineers; August 13, 1948.

"Electronic Computers," by D. L. Stevens, Sylvania Electric Products Inc.; August 14, 1948.

"A Direct Doubled Video and AGS System for Television Receivers," by H. R. Shaw, Colonial Radio Corporation; August 14, 1948.

MILWAUKEE

"Electron Theory of Diamagnetism and Paramagnetism," by A. E. Elo, Perfex Corporation; May 12, 1948.

"Electronics in Photography," by E. Farber, Strobo Research Laboratories; June 9, 1948.

Election of Officers; June 9, 1948.

NEW MEXICO

"Wartime Rocket Development," by H. G. Cooper, Los Alamos Scientific Laboratories; July 16, 1948.

PITTSBURGH

"Communications Theory," by W. G. Tuller, Melpar Inc.; May 10, 1948.

"Instruction and Research in Radio Engineering at Carnegie Tech," by W. M. Williams, Carnegie Institute of Technology; June 14, 1948.

Election of Officers; June 14, 1948.

PORTLAND

"A High-Speed Recorder for Use with Electronic Computers," by R. E. McCoy, Consulting Engineer; August 5, 1948.

SAN DIEGO

"European Broadcasting Before the Last War," by P. E. LeCorbeiller, Harvard University; August 3, 1948.

TOLEDO

"Institute Matters," and "Problems of Television" by B. E. Shackelford, President, The Institute of Radio Engineers; June 22, 1948.

Election of Officers; June 22, 1948.

You get all these features ONLY in the Western Electric 5A Monitor for FM Broadcasting

CENTER FREQUENCY MONITOR:

Accuracy—better than ± 500 cycles. (± 200 cycles if occasionally adjusted to agree with a primary standard)
Meter Range— $\approx 3,000$ cycles
Terminals for connecting remote meter

MODULATION PERCENTAGE MONITOR:

Accuracy—better than 5% for all readings
Modulation Range Capability—up to 133% (≈ 100 kc)
Terminals for connecting remote meter

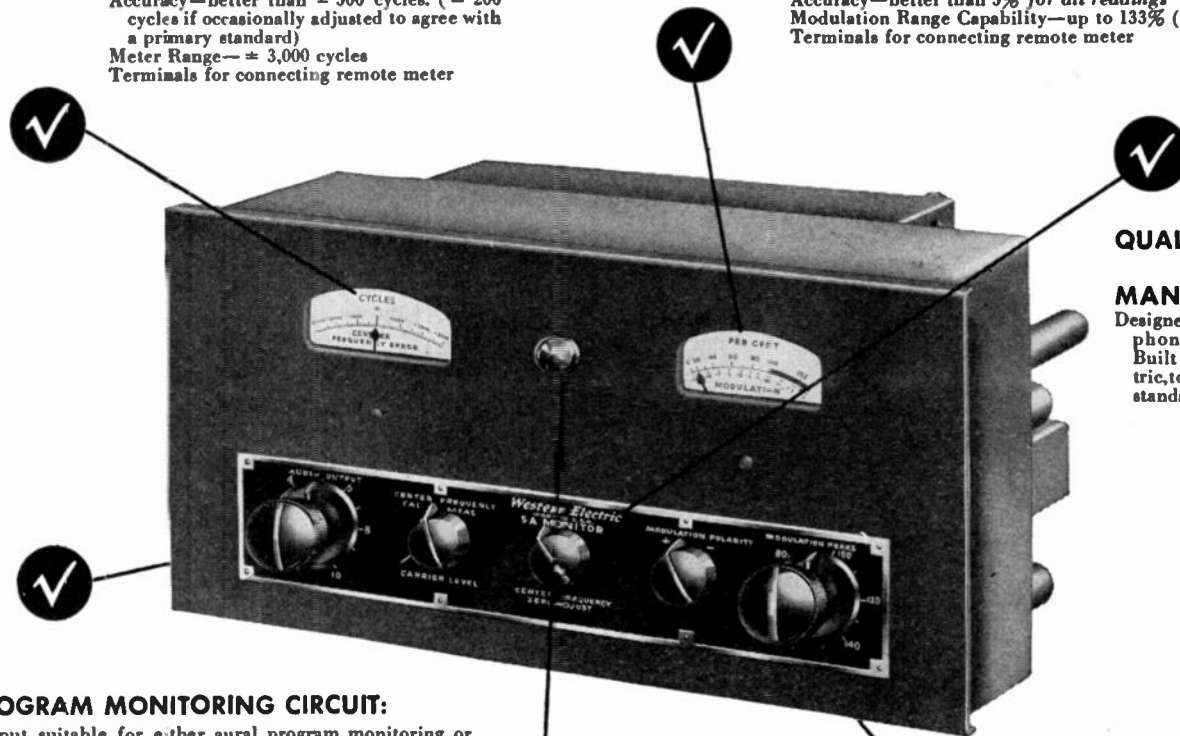

QUALITY DESIGN AND MANUFACTURE:

Designed by Bell Telephone Laboratories. Built by Western Electric, to Western Electric standards of quality.

PROGRAM MONITORING CIRCUIT:

Output suitable for either aural program monitoring or FM noise and distortion measurements
Frequency Response— ± 0.25 db, 30 to 30,000 cycles, without de-emphasis; with de-emphasis, response is within ± 0.5 db of the standard 75 microsecond de-emphasis curve
Audio Output Power—output level adjustable up to +12 dbm—permits direct switching of program monitor from transmitter input to 5A Monitor output
Harmonic Distortion—less than 1/4 of 1% from 30 to 15,000 cps
Output Noise—at least 55 db below signal at 100% modulation

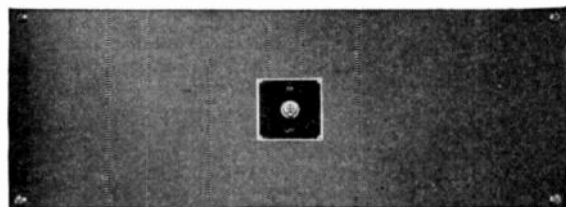

POWER SUPPLY: Newly designed 20C Rectifier (furnished as a part of the 5A Monitor) provides electronically regulated d-c with less than 1 millivolt ripple from 105-125 volts a-c 60 cycles. May be remotely located if desired.

MODULATION PEAK INDICATOR:

Indication Lamp—flashes when a selected level of modulation is exceeded
Peak Limit Range—continuously adjustable between 40% and 140% modulation

AM NOISE DETECTOR:

An exclusive feature in the 5A Monitor. The output of this detector—which may be read directly on an electronic voltmeter or noise meter—is automatically referred to 100% amplitude modulation, thus simplifying measurement of transmitter AM noise.

The 5A Monitor includes numerous other valuable features such as: dual thermostats and dual heaters for each crystal—means for checking the inherent noise level of the monitor from its input to output terminals—requires only a low RF input level (1 watt) which can vary from 0.3 to 3.0 watts; i. e., a 10 to 1 variation without affecting the performance of the monitor. To get the complete story on this outstanding monitor value, call your Graybar Broadcast Representative or mail the coupon below.

Western Electric

Distributors: In the U. S. A.—Graybar Electric Company.
In Canada and Newfoundland—Northern Electric Company, Ltd.

—QUALITY COUNTS—



Graybar Electric Company P-40
420 Lexington Avenue, New York 17, N. Y.

Please send me Bulletin T-2437, including curves, schematics and block diagram of the 5A Monitor.

NAME _____
STATION _____
ADDRESS _____
CITY _____ STATE _____

NEW SHURE "900MG"

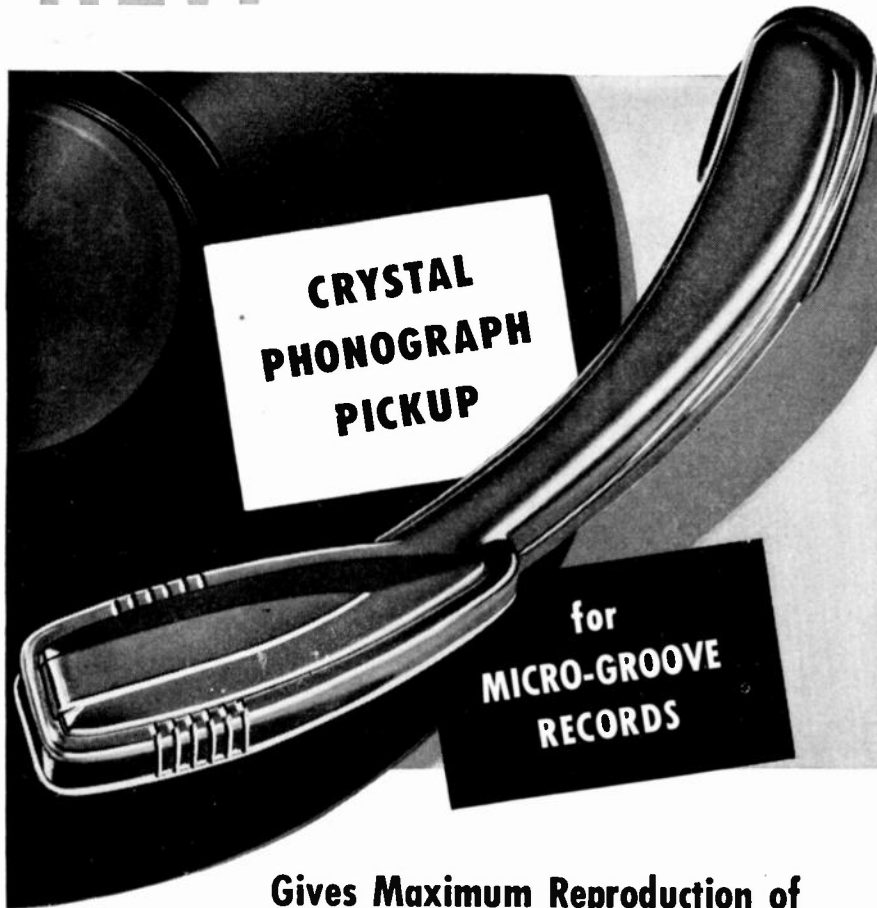

Gives Maximum Reproduction of Micro-Groove Record Fidelity

The Shure "900MG" Pickup is an ideal instrument for tracking on the new micro-groove records. It tracks at 7 grams . . . has a needle force of 9 grams as added safety factor . . . uses a special offset osmium-tipped needle with a point radius of only .001" . . . and has an output of 1 volt! The Shure lever system has been adapted in the development of this new pickup —providing a high needle compliance. Listen to it—you will be thrilled with the results!

Model "900MG" Code: RUZUZ List Price: \$12.50

Shure Patents Issued and Pending. Licensed under the Patents of the Brush Development Co.

SHURE

SHURE BROTHERS, Inc.

Microphones and Acoustic Devices

225 W. HURON ST., CHICAGO 10, ILL. • CABLE ADDRESS: SHUREMICRO

36A



The following transfers and admissions were approved on September 8, 1948, to be effective as of October 1, 1948.

Transfer to Senior Member

- Beagles, R., 11600 Sherman Way, North Hollywood, Calif.
 Blaisdell, W. C., 846 Magle Ave., Elizabeth, N. J.
 Greene, G. M., Electronics Test Division, Naval Air Test Center, Patuxent River, Md.
 Herzog, E. F., Electronics Department, General Electric Co., Syracuse 1, N. Y.
 Ludwig, J. H., 3 Whittlesey Rd., Newton Centre, Mass.
 Nuckolls, R. G., Illinois Institute of Technology, 3300 Federal St., Chicago, Ill.
 Onativia, J. M., c/o Servicio de Comunicaciones Navales, Darsena Norte, Buenos Aires, Argentina, S. A.
 Panter, P. F., 6 Hooper Ave., West Orange, N. J.
 Parkes, A. W., Jr., 47 Cobb Rd., Mountain Lakes, N. J.
 Paterson-Jones, E. A., Posts and Telegraphs Department, Box 581, Nairobi, Kenya, East Africa
 Patterson, G. K., 2548 Ninth Ave., Sacramento 17, Calif.
 Poch, W. J., 3 Haines Dr., Moorestown, N. J.
 Renne, H. S., 14745 Main St., Harvey, Ill. (July 1, 1948)
 Ross, A. H., Box 157, Shrewsbury, N. J.
 Smith, C. R., Box 903, Alamogordo, N. Mex.
 Swan, E. O., 271 Benson Ave., Toronto, Ont., Canada
 Tuller, W. G., 4314 N. Henderson Rd., Arlington, Va.

Admission to Senior Member

- Gaudernack, L. F., Sorbyhaugen 4, Smestad, Pr. Oslo, Norway
 Gunn, A. C., 173 Moeley Dr., Syracuse 6, N. Y.
 Gutierrez, E. D., Bahia de Sta. Barbara 103, Mexico, D. F.
 Hazen, H. L., Massachusetts Institute of Technology, Room 4-202, Cambridge, Mass.
 Mawdsley, R. L., 1053 Superior Ave., Dayton, Ohio
 McLaughlin, K. M., Victor Division, RCA Laboratories, Harrison, N. J.
 Pascucci, A. A., c/o Radio Hispano Suiza, Calle Fernando Puig 49, Barcelona, Spain

Transfer to Member Grade

- Adams, G. J., 299 Atlantic Ave., Boston, Mass.
 Apte, B. M., Mallick Bldg., Shivajee Park Rd., No. 4 Bombay, India
 Baer, J. Box 4150, Tel Aviv, Palestine
 Barron, F. E., 3001 Chowen Ave. N., Minneapolis, Minn.
 Bhargava, B. N., Sadabad, Dist. Mathura, U.P., India
 Chiang, F. Y. K., Sung Sing Cotton Mill No. 9, 140 Macao Rd., Shanghai, China
 Clelland, F. W., Jr., Box 1199, Stanford University, Calif.
 Congdon, R. L., 6000 Lemmon Ave., Dallas, Tex.
 Cowan, E. J., 69 Edgewood Ave., Springdale, Conn.
 Crossan, G. W., 191 St. Germain Ave., Toronto, Ont., Canada
 Dana, J. J., 5130 Sylvanite Dr., San Diego, Calif.
 Deeter, C. R., 5725 N. Washington Blvd., Arlington, Va.
 Dewan, R. N., 5, Doctor's Lane, New Delhi, India
 Eastwood, G. C., 16 The Aberdeens, Bain Ave., Toronto, Ont., Canada
 Erznosnik, F., Jr., 3508 W. 12 Pl., Chicago, Ill.
 Falk, A. E., 3700 E. Pontiac, Fort Wayne, Ind.
 Foulon, F., 547 N. Sierra Bonita Ave., Los Angeles, Calif.

(Continued on page 38A)

MICROWAVE PLUMBING

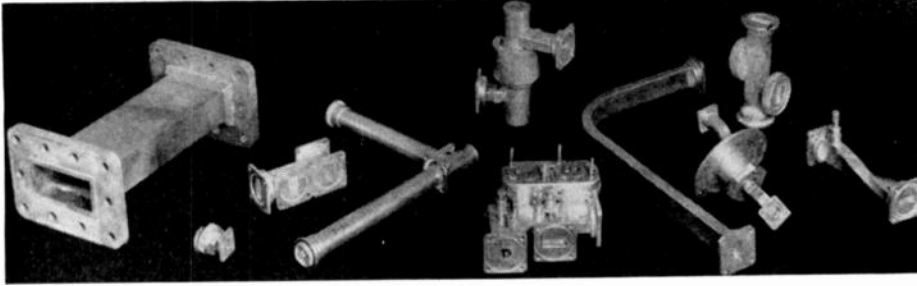

10 CENTIMETER

- MAGNETRON TO WAVEGUIDE coupler with 721-A duplexer cavity, gold plated\$45.00
- 10 CM WAVEGUIDE SWITCHING UNIT, switches 1 input to any of 3 outputs. Standard 1 1/4" x 3" guide with square flanges. Complete with 115 vac or dc arranged switching motor. Mfg. Raytheon. New and complete\$135.00
- 10 CM. END-FIRE ARRAY POLYRODS ...\$1.75 ea.
- "S" BAND Mixer Assembly, with crystal mount, pick-up loop, tunable output\$3.00
- 721-A TR CAVITY WITH TUBE. Complete with tuning plungers\$5.50
- 10 CM. McNALLY CAVITY Type 8G\$3.50
- WAVEGUIDE SECTION, MC 445A, rt. angle bend, 5 1/2 ft. O.A. 8" slotted section\$21.00
- 10 CM OSC. PICKUP LOOP, with male Homedell output\$2.00
- 10 CM. DIPDLE WITH REFLECTOR in lucite ball, with type "N" or Sperry fitting\$4.50
- 10 CM. FEEDBACK DIPOLE antenna, in lucite ball, for use with parabola\$8.00

3/8" RIGID COAX—3/8" I.C.

- RIGHT ANGLE BEND, with flexible coax output pick-up loop\$8.00
- SHORT RIGHT ANGLE bend, with pressurizing nipple\$2.00
- RIGID COAX to flex coax connector\$3.50
- STUB-SUPPORTED RIGID COAX, gold plated 3/8" lengths. Per length\$5.00
- 3/8" COAX. ROTARY JOINT\$8.00
- RT. ANGLE BEND 15" L. OA\$2.00
- FLEXIBLE SECTION, 15" L. Male to female\$4.25
- MAGNETRON COUPLING to 3/8" rigid coax 3/8" I.C. line, less "M" nut, with TR pickup loop, gold plated\$7.50

3/8" RIGID COAX—1/4" I.C.

- SHORT RIGHT ANGLE BEND\$2.50
- ROTATING JOINT, with deck mounting\$5.00
- RIGID COAX slotted section CU-80/AP\$5.00

1.25 CENTIMETER

- MITRED ELBOW cover to cover\$4.00
- TR/ATR SECTION choke to cover\$4.00
- FLEXIBLE SECTION 1" choke to choke\$5.00

VOLTAGE REGULATORS

Mfg. Raytheon; Navy CRP-301407; Pri: 92-138 v. 15 amps. 57 to 63 cy. 1 phase. Sec: 115 v. 7.15 amp. .82 KVA, 96 PF. Contains the following components:

- Regulator Transformer: Raytheon UX-0545
- Pri: 92-138 v. 60 cy. 1 PH Sec: 200/5 5.5/5.26 amps. 400 v rms test.
- FILTER REACTOR: 156 hy. 5 amps. 4000 v test. Raytheon UX 0547.
- TRANSFORMER: Pri: 186 v. 5 amps; Sec: 115 v. 7.2 amps. Size: 12" x 20" x 29". Net Wt. approx. 250 lbs.

Entire unit is enclosed in grey metal cabinet with mounting facilities. New, as shown\$99.50

POWER EQUIPMENT

- STEP DOWN TRANSFORMER: Pri: 440/220/110 volts a.c. 60 cycles, 3 KVA. Sec. 115 v. 2500 volt insulation. Size 12" x 12" x 7"\$40.00
- PLATE TRANSFORMER: Pri: 117 v. 60 cy. Sec. 17,600 v. @ 144 ma. with choke, Oil immersed. Size: 28" x 29" x 13". Amertran\$65.00
- FIL. TRANSFORMER: Pri: 220 v.a.c. 60 cy; 05KVA. Sec. 5 v.c.l. 34,000 v. test\$24.50
- FIL. TRANS. UX6899. Pri: 115 V, 60 cyc. Sec: Two 5 v. 5.5 amp wdgs. 29KV Test\$24.50
- PLATE TRANSFORMER: Pri: 115/230 v.a.c. 30-60 cy. Sec: 21,000 v. 100 ma\$120.00
- "TRANSTAT" VOLTAGE REG. 11.5 KVA, 0-115 vac. 60 cy. 100 amps\$75.00
- VOLTAGE REG. Transtat. Amertran type IHI 2 KVA load, input: 90/130 V. 50-60 cy output 115 v. \$40.00
- ITE CIRCUIT BREAKER, 115 A. 600 V\$15.00

COAX CONNECTORS

- 831R\$3.35 UG 21/U\$8.85
- 831SP\$3.35 UG 86/U\$9.95
- 831AP\$3.35 UG 254/U\$7.25
- 831HP\$1.15 UG 255/U\$1.75
- Homedell male to type "N" male adapter\$1.25

3 CM.

(STD. 1" x 1/2" GUIDE UNLESS OTHERWISE SPECIFIED)

- "X" BAND WAVEGUIDE, 1 1/4" x 3/4" OD, 1/16" wall, aluminumper ft. \$.75
- WAVEGUIDE, 1" x 3/4" I.D. per ft.\$1.50
- TR CAVITY for 724-A TR tube, transmission or absorption types\$3.50
- 3" FLEX SECTION, square flange to circular flange adapter\$7.50
- 724 TR tube (41-TR-1)\$2.50
- WAVEGUIDE SECTION, CG 251/APS-15A, 26" long choke to cover, with 180 deg. bend of 2 1/4" rad. at one end\$6.00
- ROTARY JOINT with slotted section and type "N" output pickup\$8.50
- WAVEGUIDE SECTION, 12" long choke to cover, 45 deg. twist & 2 1/4" radius, 90 deg. bend\$4.50
- STABILIZER CAVITY feeding waveguide section, with filtered output and attenuating slugs\$20.00
- SLUG, TUNER/ATTENUATOR, W.E. guide, gold plated\$6.50
- TR/ATR DUPLEXER section with iris flange\$4.50
- TWIST 90 deg. 5" choke to cover\$5.00
- WAVEGUIDE SECTIONS 2 1/2 ft. long, silver plated, with choke flange\$5.75
- WAVEGUIDE, 90 deg. bend E plane, 18" long\$4.00
- ROTARY JOINT, choke to choke\$6.00
- ROTARY JOINT, choke to choke, with deck mounting\$6.00
- S-CURVE WAVEGUIDE, 8" long cover to choke\$3.50
- DUPLEXER SECTION for 1B24\$10.00
- CIRCULAR CHOKE FLANGES, solid brass\$5
- "T" SECTION (TR-ATR) choke to choke, supplied with circ. or sq. flanges\$3.50

APS-10 2K25/723AB, X band local oscillator mount with (1) choke coupling to beacon reference cavity; (2) choke coupling to TR and receiver; (3) iris coupling with AFC attenuator to antenna waveguide; (4) Radar AFC crystal mount; (5) Receiver crystal mount; (6) Attenuating slug. Mfg. DeMornay, Budd\$22.50

TR/ATR Duplexer section for above\$4.00

- 2 1/2" FLEXIBLE SECTION, cover to cover\$4.00
- SHORT ARM "T" section, with additional choke output on vertical section\$4.00

- KBAND Rotary joint\$45.00
- ADAPTER, rd. cover to sq. cover\$5.00
- MITRED ELBOW and S sections choke to cover\$4.50

LABORATORY ACCESSORIES COAX CABLE

- RG 18/U, 52 ohm im. armored\$.51/ft.
- RG 23/U, twin coax, 125 ohm imp. armored\$.50/ft.
- RG 28/U, 50 ohm imp. pulse cable, Corona min. starting voltage 17 KV\$.30/ft.
- RG 35/U, 70 ohm imp. armored\$.50/ft.

VARISTORS W.E.

- D-171121\$.95 D-168549\$.95
- D-171631\$.95 D-162482\$3.00
- D-167176\$.95 D-89138\$1.65
- D-170225\$.95 D-166271\$2.50
- D-168687\$.95 D-162356\$1.50
- D-171812\$.95 D-161871A\$2.85
- D-KV-1529\$.95 D-89946\$2.00
- D-163298\$.95

THERMISTORS—W.E. \$.95 Each

- D-167332 (bead) D-166228 (button)
- D-170396 (bead) D-166382 (tube)
- D-167613 (button) D-167018 (tube)

- DECADE RESISTANCE BOX, 0-1250 ohms in 250-ohms steps\$2.50
- DECADE CAPACITOR, .0054 mfd in 8 steps, \$2500 v. ins. CD 5 PL 1165-120, 3" x 5 1/4" diam.\$6.50
- "PPI" ROTATING YOKE TYPE. Complete with all necessary oscillator circuits, CR tube 5FP7, complete with tubes. Used with 80 radar\$100.00
- SPERRY KLYSTRON TUNER Mod. 12\$2.00
- SINE POTENTIOMETERS, G23251x96 or W.E. 8K5\$3.50
- 1513B LOD\$3.50
- CG 27 TYPE "N" CABLE ASS'Y, 3' long, male to female\$2.50
- PH-SHIFTING CAP. 180 deg. W.E. 3D-150734\$2.50
- KLYSTRON SOCKETS for 723 A.B. and similar types 2 for\$1.00
- LINE INSERTION ATTENUATOR, type OAX-1 20 dB attenuation, with 3-contact plug and socket (amphenol 16S-5)\$2.25

400 CYCLE TRANSFORMERS

- 2419: Pri: 115 v. 400 cy. Sec: 6.3 v. 2.7 amp; 6.3 v. .66 amp; 6.3 v. 21 amp\$2.95
- 32332: Pri: 115 v. 400-2400 cy. Sec: 400 vct. 35 ma; 6.4 v. 2.5 amp; 6.4 v. 15 amp\$2.25
- 352-1179: Pri: 115 v. 400-2400 cy. Sec: 6.5 v. 12 amp ct. 250 v. 100 ma; 5 v. 2 amp\$3.50
- 39098: Pri: 115/80 v. 400-2500 cy. Sec: 650 vct. 30 ma; 6.3 vct. 2 amp; 5 vct. 2 amp\$2.15
- 352-7096: Pri: 115/80 v. 400-2400 cy. Sec: 2.5 v. 1.75 amp; 3KV ins: 5 v. 3 amp; 6.5 v. 6.5 amp; 6.5 v. 1.2 amp\$3.95

INVERTERS

- PE 206-A: Input: 28 VDC @ 38 amp. Output: 80 volts @ 500 volt-amps, 800 cycles. Leland, New, complete with enclosed relay, filter, instruction book\$12.50
- PE 218: Input: 25-28 VDC @ 92 amps. Output: 115 volts @ 1500 volt-amps, 380-500 cycles. Poor physical but good running condition\$15.00

MICRO WAVE GENERATORS

- AN/APS-15A "X" Band compl RF head and modulator, incl. 725-A magnetron and magnet, two 723A/B klystrons (local osc & beacon), 1B24 TR, rcvr-ampl, duplexer, HV supply, hlower, pulse xfmr. Peak Pwr Out: 45 KW apx. Input: 115, 400 cy. Modulator pulse duration 5 to 2 micro-sec. apx. 13 KV Pk Pulse. Compl with all tubes incl. 715-B, 829B, 8KR 73, two 72's Compl pkg. new\$210.00
- APS-15B, Complete pkg. as above, less modulator\$150.00

"S" BAND AN/APS-2. Complete IIF head and modulator, including magnetron and magnet, 417-A mixer, TR, receiver, duplexer, blower, etc. and complete pulser. With tubes, used, fair condition\$75.00

- 10 CM. RF Package. Consists of: 80 Xmtr-receiver using 2J27 magnetron oscillator, 250 KW peak input. 707-B receiver-mixer\$150.00
- Modulator-motor-alternator unit for above\$75.00
- Receiver-rectifier power unit for above\$25.00
- Rotating antenna with parabolic reflector for above. New\$75.00

MAGNETRONS

TUBE	FRQ. RANGE	PK.	PWR. OUT.	PRICE
2J31	2820-2860 mc.		265 KW.	\$15.00
2J21-A	9345-9405 mc.		50 KW.	\$25.00
2J28	3267-3333 mc.		265 KW.	\$15.00
2J26	2992-3019 mc.		275 KW.	\$15.00
2J27	2965-2992 mc.		275 KW.	\$15.00
2J32	2780-2820 mc.		285 KW.	\$15.00
2J38 Pkg.	3249-3263 mc.		5 KW.	\$25.00
2J39 Pkg.	3267-3333 mc.		8.7 KW.	\$25.00
2J55 Pkg.	9345-9405 mc.		50 KW.	\$25.00
8J31	24,000 mc.		80 KW.	\$35.00
5730				\$39.50
714AY				\$15.00
720BY	2800 mc.		1000 KW.	\$50.00
725-A				\$25.00
730-A				\$25.00
KLYSTRONS: 723A/B \$12.50 707B W/CAVITY \$20.00				

MAGNETS

- For 2J21, 725-A, 2J22, 2J26, 2J27, 2J31, 2J32, and 8J31Each, \$8.00
- 4850 Gauss, 3/4" bet. pole faces, 1/2" pole diam.\$8.00
- 1500 Gauss, 1 1/2" bet. pole faces, 1 1/2" pole diam.\$8.00

TUNABLE PKG'D "CW"

MAGNETRONS

- QK59 2675-2900 Mcs. QK61 2975-3200 Mcs.
- QK60 2800-3025 Mcs. QK62 3150-3375 Mcs.
- New—\$45 each New—\$55 each

MODULATOR UNIT BC 1203-B

Provides 200-4,000 PPS. Sweep time 10 to 2500 microsec. in 4 steps, fixed mod. pulse, suppression pulse, sliding modulating pulse, blanking voltage, marker pulse, sweep voltages, calibration voltages, fil. voltages. Operates 115 vac. 50-60 cy. Sliding pulse variable in phase up to 2500 microsec. Amplitude of suppression pulse adjustable between 10 and 95 v. and width variable between the limits of 10 microsec. or less to 1800 microsec. or more at a recurrence rate between 200 and 300 cps. Provides various types of voltage pulse outputs for modulation of a signal generator such as GR 8804B or 804C. New\$125.00

MIT MODEL 3 HARD TUBE PULSER

Output Pulse Power: 144 KW (12 KV at 12 amp). Duty Ratio: .001 max. Pulse duration: .5, 1.0, 2.0 microsec. Input voltage: 115 v. 400 to 2400 cps. Uses 1-715-B, 1-829-B, 3-72's, 1-73, New\$110.00

APQ-13 PULSE MODULATOR, Pulse Width .5 to 1.1 Micro Sec. Rep. rate 624 to 1348 Pps. Pk. pwr. out 35 Kw. Energy 0.018 Joules\$49.00

TPS-3 PULSE MODULATOR, Pk. power 50 amp. 24 KV (1200 KW pk); pulse rate 200 PPS, 1.5 micro-sec; pulse line impedance 50 ohms. Circuit—series charging version of DC Resonance type. Uses two 705-A's as rectifiers, 115 v. 400 cycle input. New, with all tubes\$49.50

PULSE TRANSFORMERS

- W.E. \$ D166173 Hi-Volt input transformer, W.E. Impedance ratio 50 ohms to 900 ohms. Freq. range: 10 kc to 2 mc. 2 sections parallel connected, potted in oil\$12.00
- W.E. K8 9800 Input transformer. Winding ratio between terminals 3-5 and 1-2 is 1:1:1, and between terminals 6-7 and 1-2 is 2:1. Frequency range: 280-520 cps. Ferralloy core\$2.00
- G.E. \$ K2731 Repetition Rate: 635 PPS, Pri. Imp: 50 Ohms, Sec. Imp: 450 Ohms, Pulse Width: 1 Microsec, Pri. Input: 9.5 KV PK, Sec. Output: 28KV PK, Peak Output: 800 KW Bifilar 2.75 Amp.\$19.50
- G.E. K2450A Will receive 13KV, 4 micro-second pulse on pri. secondary delivers 4KV. Peak power out 100W GE\$15.00
- W.E. \$ D169271 Hi Volt input pulse Transformer 39.95
- G.E. \$ K2748A Pulse Input, line to magnetron \$12.00
- UTAH PULSE OR BLOCKING OSCILLATOR Transformer Freq. limits 790-810 cy-3 windings turns ratio 1:1:1 Dimensions 1 13/16 x 1 3/8"\$1.50

PULSE NETWORKS

- G.E. 225E5-1-350-50P2T, 25 KV, 5 sections, "E" circuit, 1 microsecond pulse length, 350 PPS, 50 ohms impedance\$45.00
- G.E. 26E3-5-2000-50 P2T, 6KV, "E" circuit, 3 sections, .5 micro-second pulse, 2000 PPS, 50 ohms impedance\$6.50

All merchandise guaranteed. Mail orders promptly filled. All prices, F.O.B. New York City. Send Money Order or Check. Shipping charges sent C.O.D. Rated Concerns send P.O.

COMMUNICATIONS EQUIPMENT CO.

131-R Liberty St., New York, N.Y.

CHAS. ROSEN

Digby 9-4124

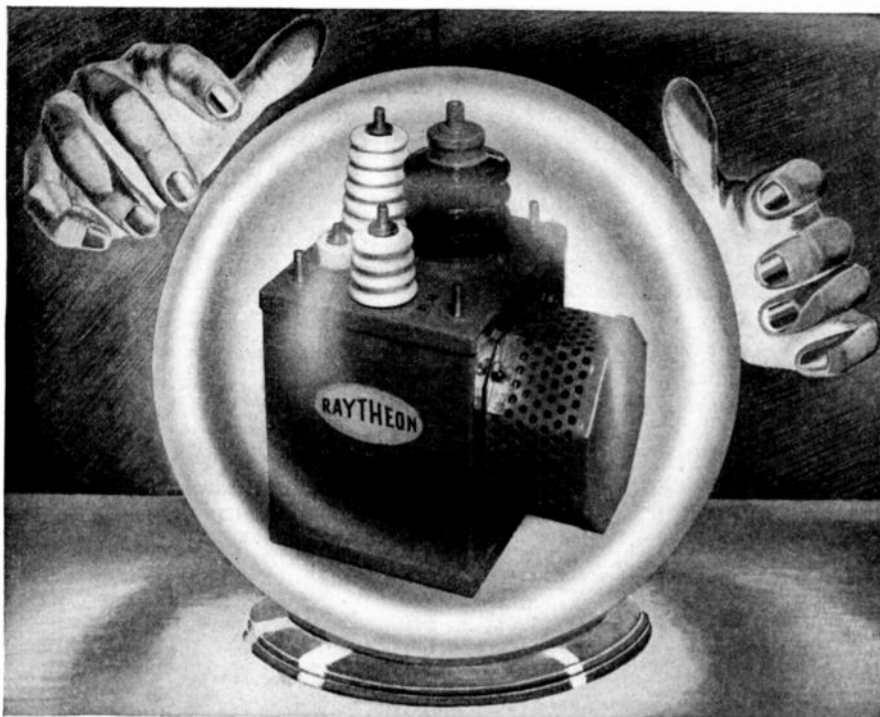

For PERFORMANCE That Is *Precisely Predictable*

Special purpose transformers which meet the most rigid specifications are a Raytheon specialty. What more exacting test can you imagine than wartime service in naval SG and SO radar . . . for which Raytheon Transformers were used exclusively?

Raytheon can furnish custom-engineered transformers designed to fit your special needs . . . in the size, type and quantity you require. As one of the oldest and largest producers, Raytheon has the experience and facilities to design, test and deliver transformers that you can incorporate in your product or equipment with complete confidence.

More than 30,000 successful designs have proved that Raytheon quality means peak performance. May we prove it to you with sample models engineered precisely for your most exacting requirements? Handy forms in Bulletin DL-K-301 make it easy to specify your needs. Write for your copy.



Excellence in Electronics
RAYTHEON MANUFACTURING CO.
Waltham 54, Massachusetts

RAYTHEON

Custom-Engineered **TRANSFORMERS**

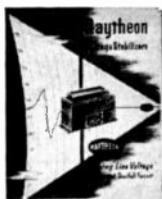

...and VOLTAGE STABILIZERS

Bulletin DL-V-304 tells the complete story on the new line of high performance, space and weight saving Raytheon Voltage Stabilizers. Write for it today.



(Continued from page 36A)

- Gauntlett, G. A., 8 Worthington Ave., Kingston, Jamaica, B.W.I.
- Gilmour, R. R., Test Department Electricity House, Strand St., Cape Town, South Africa
- Hagopian, J. J., 3875 York Blvd., Los Angeles, Calif.
- Hale, R. C., 24 Reed St., Lexington, Mass.
- Higgs, R. E., 315 N. 12 St., Newark, N. J.
- Hobday, S. W., 265, Malden Way, New Malden, Surrey, England
- Immen, G. H., 2835 Bainbridge Ave., New York, N. Y.
- Inderwiesen, F. H., Jr., 1116 West 40 St., Kansas City, Mo.
- Joishi, C. P., "The Castle," Almora, U.P., India
- Lane, C. A., Jr., 4104 Harrison St., Kansas City, Mo.
- Lee, P. H., Box 77, Maple Ave., Demarest, N. J.
- Lichi, J. S. Ometusco 46, Mexico, D. F.
- Marsden, B., c/o A. R. Sugden & Co. Ltd., 36 Wellgreen Lane, Brighouse, Yorkshire, England
- Meyer, G. B., 5615 Clearspring Rd., Baltimore, Md.
- Miller, R. H., Jr., 829 Sutter St., San Diego, Calif.
- Nelson, R. H. E., Swedish Western Electric Co., A.B., Sveavagen 25-27, Stockholm, Sweden
- Pomy, H. J., Hqts. Signal Service, USARPAC, APO 958, c/o Postmaster, San Francisco, Calif.
- Reese, H., Jr., 267 Virginia Ave., Rochester, Pa.
- Rosenberg, J., 191 Sandford St., New Brunswick, N. J.
- Rowe, I., 594 E. 93 St., Brooklyn, N. Y.
- Smillie, P. V., Reme Training Centre, Arborfield, Berks., England
- Smith, P. J., 113 E. Conklin Ave., Nedrow, N. Y.
- Snell, P. A., c/o Electronic Tube Co., 1200 E. Mermaid, Philadelphia, Pa.
- Snyder, W. W., 40-22 Lawrence St., Flushing, L. I., N. Y.
- Stolze, W. J., 20-64—33 St., Astoria, L. I., N. Y.
- Strothman, R. A., 35 Bingham Ave., Rumson, N. J.
- Surtees, W. J., 150 Metcalfe St., Ottawa, Ont., Canada
- Trafford, W., Telecommunications Department, Kuala Lumpur, Malaya
- Tullos, F. N., 212A Humble Bldg., Houston, Tex.
- Whyte, J. R., 74 Summerhill Ave., Toronto, Ont., Canada
- Wiley, F. G., Box 533, Babylon, L. I., N. Y.
- Williams, F. H., Hazeltine Electronics Corp., Little Neck, L. I., N. Y.
- Williams, I. J. S., 13 Rutherglen Ave., Whitley, Coventry, England
- Wilson, B. J., 212 Electrical Engineering Laboratory, University of Illinois, Urbana, Ill.
- Zaret, M. E., 3941—48 St., Long Island City, L. I., N. Y.

Admission to Member Grade

- Acree, A. J., 66 N. Bromfield Rd., Dayton, Ohio
- Braune, E. H. J., 38 Zornvagen, Angby, Sweden
- Browder, F. E., 3931 Breensburg Pike, Pittsburgh, Pa.
- Cook, R. H., 5236 N. Bernard St., Chicago, Ill.
- Ferguson, J. C., Jr., 5215 Linden St., Mission, Kan.
- Foster, C. E., Quarters 207-B, 13 St., Sandia Base Branch, Albuquerque, N. Mex.
- Hartley, A., 96 King Charles Rd., Surbiton, Surrey, England
- Horne, R. W., 37 Birdwood Rd., Cambridge, Cambridgeshire, England
- Hughes, L. J., 126 Edgeley Rd., P.O. Red Hill, Durban, S. Africa
- Kuhn, D. H., 144 Jay St., Schenectady, N. Y.
- Meichner, F. T., 28-43—37 St., Long Island City, L. I., N. Y.

(Continued on page 40A)

PICTURE PROJECTION

Perfected by *Norelco*



The 2½" magnetic projection triode 3NP4 has a face as small as a compact and is only 10½" long.

HERE'S THE OPPORTUNITY THAT MANUFACTURERS OF TELEVISION RECEIVERS HAVE BEEN AWAITING!

• • • • • **10 SIGNIFICANT FEATURES** • • • • •

- 1 Flat 16" x 12" non-reflecting picture provides fatigueless viewing from less than 5 feet and upward!
- 2 Wide-angle visibility — *square corners*.
- 3 True photographic black and white picture quality—no discoloration.
- 4 Compact unit—suitable for table model cabinets.
- 5 Long-life, low-cost picture tube.
- 6 Manufacturers can most economically extend their product range into projection television by adapting their 10" EM chassis for use with PROTELGRAM
- 7 Easy to service.
- 8 High contrast ratio and broad gray tone range.
- 9 Simple optical adjustment system.
- 10 Quality built after more than 10 years of development.

NORELCO PROTELGRAM consists of a projection tube, an optical box with focus and deflection coils, and a 25 kv regulated high-voltage supply unit, making possible large-size home projection. More than ten years of exhaustive research resulted in this ideal system for reproducing a projected picture. The optical components are designed to produce perfected projection for a 16" x 12" image, the optimum picture size for steady, distant observation and also for proper viewing at less than 5 feet.

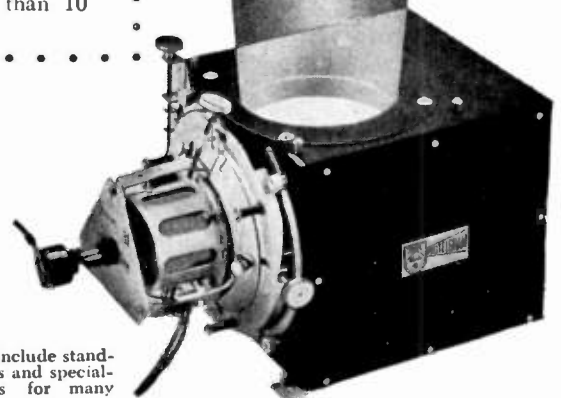

Other NORELCO products include standard 10" direct-viewing tubes and special-purpose cathode-ray tubes for many applications.

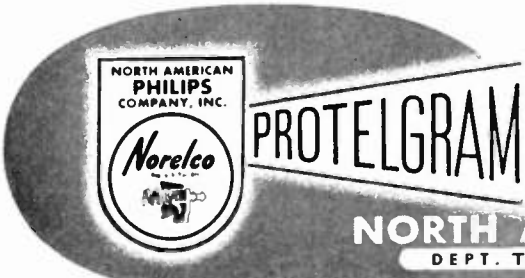

IS PICTURE PERFECTION IN PROJECTION

NORTH AMERICAN PHILIPS COMPANY, INC.

DEPT. TP-10, 100 EAST 42nd STREET, NEW YORK 17, N. Y.

IN CANADA: PHILIPS INDUSTRIES LTD., 1203 PHILIPS SQUARE, MONTREAL * EXPORT REPRESENTATIVE: PHILIPS EXPORT CORPORATION, 100 EAST 42ND STREET, NEW YORK 17, N. Y.

Engineered to the Highest FM and AM Broadcast Standards



Model 650
(Output -46 db)

NEW!

High Fidelity Dynamic



BROADCAST
Microphones

**FEATURES LIKE THESE
WIN TOP RATING**

by Station and Network Engineers!

Flat out to 15 kcl Extremely high output! Impedance selector! Dual-type shock-mount! Remarkably rugged! Individually calibrated!

Developed in cooperation with station and network engineers, the new "650" and "645" meet exacting requirements of modern high fidelity FM and AM broadcast service. Proved in studio and remote use. Polar pattern is non-directional at low frequencies, becoming directional at high frequencies. Recessed switch gives instant selection of 50 or 250 ohms impedance. Exclusive Acoustalloy diaphragm withstands toughest use. Many other important features assure the ultimate in broadcast quality. Satin chromium finish. Fully guaranteed.

Model 650. Output level -46 db. List \$150.00

Model 645. Output level -50 db. List \$100.00

Broadcast Engineers: Put the "650" or "645" to the test in your station. Know the thrill of using the newest and finest. Write for full details.



Model 645
(Output -50 db)

NO FINER CHOICE THAN

Electro-Voice

ELECTRO-VOICE, INC., BUCHANAN, MICHIGAN
Export: 13 East 40th St., New York 16, U.S.A. Cables: Arlab



(Continued from page 38A)

- Moore, G. E., 1727 New Haven Ave., Pittsburgh, Pa.
- Necol, J. C., 2504 Bronx Park East, New York, N. Y.
- Pollack, I., 178 Mackenzie St., Brooklyn, N. Y.
- Richardson, F. L., 6 Loring Rd., R.F.D. 2, Hicksville, L. I., N. Y.
- Smoll, L. A., 412½ S. Yale Ave., Albuquerque, N. Mex.
- Stautner, P. L., 223 N. Espanola Ave., Albuquerque, N. Mex.
- Thomas, E. W., 1819 Monroe St., N.W., Washington, D. C.
- von Kunits, P., 149-27—19 Ave., Whitestone, N. Y.

The following admissions to Associate grade have been approved and will be effective as of September 1, 1948.

- Andrews, F. B., Jr., 104 E. Second St., Emporium, Pa.
- Banerjee, Bhabanath, School of Radio Physics and Electricity, S. P. College, Poona, India
- Barrett, D. D., 681 Rockdale Dr., San Francisco 16, Calif.
- Bartel, Baity, 4818 Ash Lane, Dallas 10, Tex.
- Bell, H. J., 6925-A Passaic, Huntington Park, Calif.
- Chavez, J. S., 4606—16 St., N.W., Washington 6, D. C.
- Corbett, L. E. A., 31 Kingston Ave., Mt. Roskill, Auckland, New Zealand
- Cozier, J. R., 29 S. Munn Ave., East Orange, N. J.
- Donohoe, T. K., Box 579, Anchorage, Alaska
- Felsecker, R. E., 2135 S. Fern St., Arlington, Va.
- Gannett, Ernest, 172 Brook Ave., Oakwood Heights Staten Island 6, N. Y.
- Gordon, H. L., 2030—46 Ave., San Francisco 16, Calif.
- Green, C. S., R.F.D. 1, Box 179A, Eureka, Mo.
- Guidotti, J. D., 443 N. 29 St., Milwaukee, Wis.
- Haymes, Irving, 215—109 Ave., Elmont, L. I., N. Y.
- Hellinger, H. R. J., Idelson St., Tel-Aviv, Palestine
- Herb, J. W., 4173 Oakridge Dr., Dayton 7, Ohio
- Herrmann, N. P., 6267 S.W. 12 St., Miami, 35 Fla.
- Jameson, F. P., Box 42, Butte, Mont.
- Kernkamp, C. F., 1807 Elizabeth Ave., Winston Salem, N. C.
- LaFleur, R. S., 405 N. Superior St., Angola, Ind.
- Lawton, L. M., Jr., Thompson Physical Laboratory, Williamstown, Mass.
- Lucier, O. S., 130 Russell Ave., Rahway, N. J.
- Mallon, R. H., 2695 Euclid W., Detroit 6, Mich.
- Mason, J. B., R.F.D. 1, Warner, N. H.
- Mausler, Robert, 50-16—213 St., Bayside, L. I., N. Y.
- Miller, E. C., Box 1137, Kodiak, Alaska
- Morris, H. R., 22 Elsmere Rd., Kimberley, Northern Cape, South Africa
- Morrison, D. A., R.F.D. 1, Niagara Falls, N. Y.
- Owens, D. L., Box 1679, Houston 1, Tex.
- Parson, M. R., 1549—17 St., Des Moines 10, Iowa
- Poole, A. L., 835 Turk St., San Francisco 1, Calif.
- Preti, L. L., 220 Roseville Ave., Newark 7, N. J.
- Rao, M. R., Mysore Chemical and Soap Works, Sion, Bombay, India
- Richman, P. L., 12 E. 86 St., New York 28, N. Y.
- Seshu, Sundaram, "Svagam," 99, V. M. St., Mylapore, Madras, S. India
- Simons, F. A., Jr., 220 S. Pannes Ave., Compton, Calif.
- Vargas, Arnoldo, 1365 Columbia Rd., N. W., Washington, D. C.
- Venkateswaran, Sankara, All India Radio, Parliament St., New Delhi, India
- Weinstock, W. W., 3229 N. 17 St., Philadelphia 40, Pa.
- Weinzel, H. F., 6421 Vanderbilt St., Houston 5, Tex.
- Williams, R. E., 1008 Morgantown Ave., Fairmont, W. Va.

(Continued on page 40A)

for the **BEST** in reception and performance use
"NOFLAME-COR"
 the **TELEVISION** hookup wire

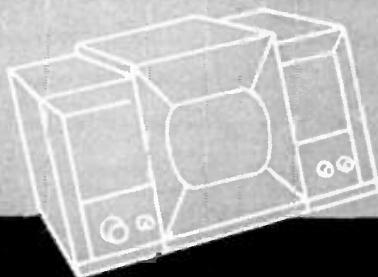

by



approved by
 Underwriters' Laboratories of

90° CENTIGRADE **600** VOLTS

- Flame Resistant
- Heat Resistant
- High Insulation Resistance
- High Dielectric
- Easy Stripping
- Facilitates Positive Soldering
- Also unaffected by the heat of impregnation—
 therefore, ideal for coil and transformer leads

Chosen after exhaustive tests by leading manufacturers of television, F-M, quality radio and all exacting electronic applications. Available for immediate delivery in all sizes, solid and stranded, in over 200 color combinations . . . ready to demonstrate anew the Efficiency and Economy of CORNISH WIRES AT WORK.

COMPLETE ENGINEERING DATA AND SAMPLES ON REQUEST

RUBBER	75°
PLASTIC	80°
"NOFLAME-COR"	90°

"made by engineers for engineers"



CORNISH WIRE COMPANY, Inc.

605 North Michigan Avenue,
 Chicago 11

15 Park Row, New York 7, N. Y.

1237 Public Ledger Bldg.,
 Philadelphia 6

MANUFACTURERS OF QUALITY WIRES AND CABLES FOR THE ELECTRICAL AND ELECTRONIC INDUSTRIES

✓ Check
these outstanding
IMPROVEMENTS

ADC
JACKS

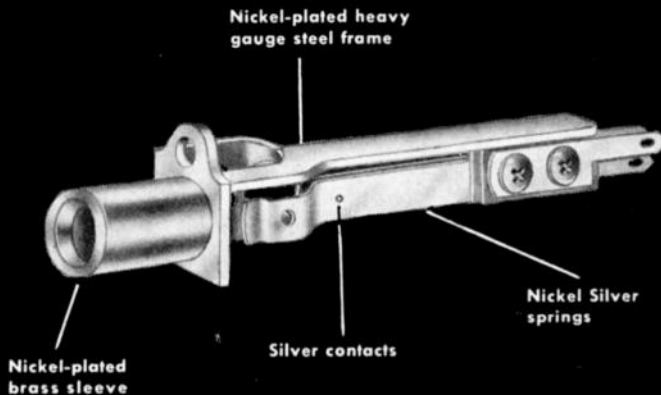

Now You Get
ALL THESE BENEFITS

ALL ADC JACK
PANELS NOW CONTAIN
THESE NEW ADC JACKS

- Greater Strength & Rigidity!
- Less Corrosion!
- Better Contacts!
- Longer Life!

See your jobber or
write today for
ADC Catalog

The new streamlined design of ADC Jacks uses heavier gauge metal for *greater strength*. The frame is die-formed and press-welded for utmost rigidity and dimensional accuracy.

Silver-alloy contacts and genuine Nickel Silver springs guarantee corrosion resistance, even under the most humid conditions.

All the way through, the new ADC is a better jack! If you require top quality and precision-made components, ADC Jacks merit your *first* consideration.

ADC

Audio DEVELOPMENT CO
Audio Develops the Finest
2855 13th AVE. SOUTH · MINNEAPOLIS 7, MINN.



(Continued from page 40A)

Wolfendale, F. C., 43 Elmbank Way, Hanwell
London, England
Young, C. E., Box 125, Madison, Wis.
Zavoda, J. P. 209 Sherman, St., Boonton, N. J.

The following transfers to Associate grade were approved and will be effective as of September 1, 1948:

Achramowicz, M. J., 65 Houghton St., Worcester 4, Mass.
Berkowitz, R. S., 3321 Powelton Ave., Philadelphia, Pa.
Dille, A. C., 1531 Leavenworth St., Manhattan, Kans.
Ethridge, N. H., 729 Spring St., N. W., Atlanta 3, Ga.
Feldman, S., c/o L. T. Huntington, Service Engineering Division, General Electric Company, Schenectady, N. Y.
Finch, W. H., c/o Director of Signals, Army Headquarters, Ottawa, Ont., Canada
Harmon, W. R., Jr., Box 85, N. Wilkesboro, N. C.
Harris, H. E., 274 Forest Hill Dr., Syracuse, N. Y.
Hayden, J. O., Bill's Trailer Park, N. Syracuse, N. Y.
Hill, C. R., 849 Hinta St., Evanston, Wyo.
Hoyt, E. M., 20 Plow Lane, Levittown, Hicksville, N. Y.
Jensen, A. C., R. R. 12, Box 380, Milwaukee, Wis.
Keyes, D. H., 231 Ocean Ave., Lynbrook, N. Y.
Knoll, D. W., 2519 Kecoughtan Rd., Hampton, Va.
Mazer, W. M., 138 Neptune Ave., Brooklyn 24, N. Y.
McCracken, L. G., 919 S. Pugh St., State College, Pa.
Mishra, S., Amalapare, Fifth Line, P. O. Angul, Orissa, India
Morrison, S. M., 1414 Eighth Ave., Marion, Ia.
Pearson, S. S., 2585 Rosewood Ave., Roslyn, Pa.
Rummel, E. C., 400 W. 34 St., Austin, Tex.
White, E. A., 3021 Weisser Park Ave., Fort Wayne, Ind.
Williams, W. A., 16 Columbine Rd., Worcester 2, Mass.

News—New Products

These manufacturers have invited PROCEEDINGS readers to write for literature and further technical information. Please mention your I.R.E. affiliation.

(Continued from page 24A)

New Enterprises

The Spencer-Kennedy Labs., Inc., 10 Follen St., Cambridge 38, Mass., has recently been formed to develop and manufacture precision scientific instruments.

The first instrument to go into production is the Model 400-A bridge controlled thyatron thermostat for temperature control.

Two types of control are possible with the thermostat: (1) by the resistance thermometer method; (2) by the change of resistance of the heater winding itself.

With a properly designed heating unit, temperatures from 20°C. to 1200°C. can be maintained with an accuracy of $\pm 0.1\%$ by the first method and $\pm 0.5\%$ by the second method.

(Continued on page 49A)

4 microphones in one



**TURNER "U9S" DYNAMIC
... WITH NEW, IMPROVED,
HEAVY DUTY IMPEDANCE SWITCH**



Adjustable saddle permits semi- or non-directional operation. Fits any standard microphone stand. (Desk stand as shown at extra cost.)

MODEL "U9S"

LIST PRICE: \$40.00

Complete with 20-ft. balanced line quick-change shielded cable set.



Microphones **BY TURNER**

INSTANT SELECTION OF FOUR IMPEDANCES

The outstanding dynamic in its field, made even better with a new, long-life, trouble-free metal switch, designed exclusively for Turner. Professional in appearance and performance. High in convenience. Built-in tapped multi-impedance transformer with improved 4-position switch gives positive selection of 50, 200, 500 ohms, or high impedance output. *One microphone serves any standard equipment.* Voice coil and transformer leads are insulated from ground and microphone case. Line is balanced to the ground. Engineered with smooth wide-range response from 40 to 9000 c.p.s. Level: 52 db below 1 volt/dyne/sq.cm. at high impedance. Richly finished in baked gun-metal.

The Turner "U9S" is widely recommended for broadcast, public address, communications, sound systems, recording, and general purpose applications.

THE TURNER COMPANY
909 17th Street N. E. Cedar Rapids, Iowa

Licensed under U. S. patents of the American Telephone and Telegraph Company, and Western Electric Company, Incorporated.



Astatic takes extreme pride in presenting its PICKUP for use with the sensational new Columbia LP Records. This is not just another version of what related equipment for Microgroove Records should be—but the actual playing arm designed to meet the precise requirements of Columbia's new recordings. The new pickup is manufactured to meet the specifications by Columbia to insure maximum quality performance of the Columbia LP Microgroove Record. Available, then, in the Astatic FL-33 Pickup and LP-33 Crystal Cartridge, is the ultimate of Microgroove companion equipment. Here is the professional playing arm, and its replacement cartridge, alone capable of getting the most out of LP Records. And that "most" is truly incomparable—a reality, depth and clarity of tone, a flawless fidelity of reproduction never before obtainable from commercial records.

FEATURES OF ASTATIC'S FL-33 PICKUP—THE PERFECT COMPANION FOR COLUMBIA LP RECORDS

1. Five-Gram Needle Pressure, of prime importance with the new, lower-radius needle tip.
2. Permanent Sapphire Needle with .001" Tip Radius.
3. Approximately One-Half Volt Output.
4. Frequency Range 30 to 10,000 c.p.s.
5. Novel Design at Base Eliminates Tone Arm Resonances and Assures Perfect Tracking.
6. LP-33 Cartridge, with Permanent Sapphire Needle, instantly replaceable in FL-33 Pickup on slip-in principle of modern fountain pen. "LP" means long playing, low pressure.



Astatic Crystal Devices Manufactured Under Brush Development Co. Patents

ALSO AVAILABLE is the LP-78 Cartridge that fits the FL Arm, but having a .003" radius needle; thereby, playing 78 RPM Records. By merely slipping in either cartridge you have the proper pickup for 78 or 33-1/3 Records.

FL FILTER

An important accessory that goes hand-in-glove with Astatic's FL-33 Pickup, for best performance with high quality speakers, is the FL Filter. Controls pickup response—Eliminates high frequency peak.

Listed in the Radio Industry Red Book

MEASUREMENTS CORPORATION Model 59

2.2 mc.
to
400 mc.

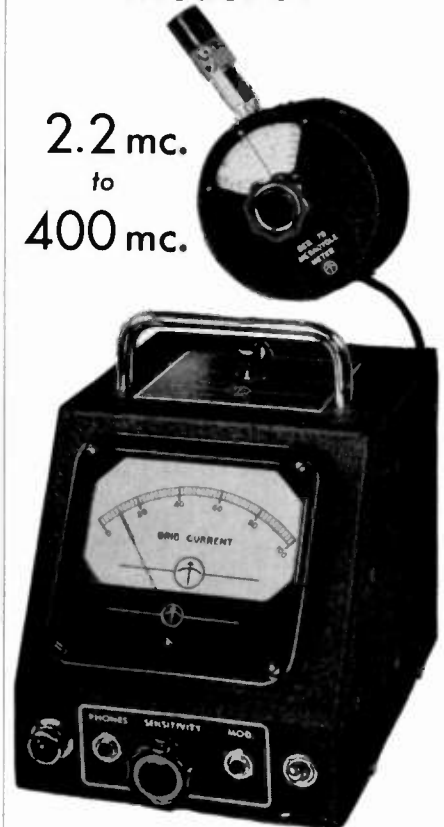

MEGACYCLE METER

Radio's newest, multi-purpose instrument consisting of a grid-dip oscillator connected to its power supply by a flexible cord.

Check these applications:

- For determining the resonant frequency of tuned circuits, antennas, transmission lines, by-pass condensers, chokes, coils.
- For measuring capacitance, inductance, Q, mutual inductance.
- For preliminary tracking and alignment of receivers.
- As an auxiliary signal generator; modulated or unmodulated.
- For antenna tuning and transmitter neutralizing, power off.
- For locating parasitic circuits and spurious resonances.
- As a low sensitivity receiver for signal tracing.

MANUFACTURERS OF

Standard Signal Generators
Pulse Generators
FM Signal Generators
Square Wave Generators
Vacuum Tube Voltmeters
UHF Radio Noise & Field Strength Meters
Capacity Bridges
Megohm Meters
Phase Sequence Indicators
Television and FM Test Equipment

SPECIFICATIONS:

Power Unit: 5 1/4" wide; 6 1/2" high; 7 1/2" deep.
Oscillator Unit: 3 3/4" diameter; 2" deep.

FREQUENCY:

2.2 mc. to 400 mc.; seven plug-in coils.

MODULATION:

CW or 120 cycles; or external.

POWER SUPPLY:

110-120 volts, 50-60 cycles; 20 watts.

MEASUREMENTS CORPORATION
BOONTON NEW JERSEY

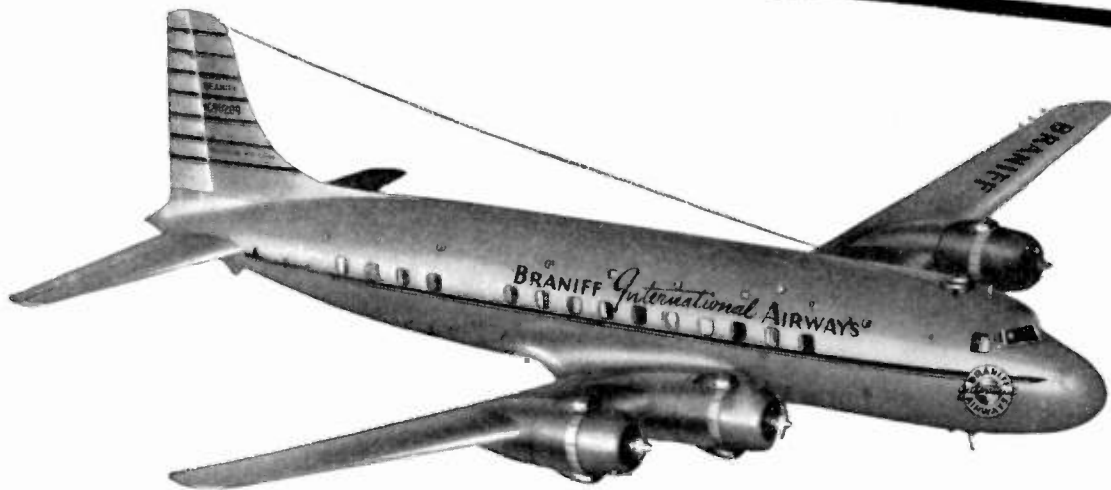

WILCOX

FIRST CHOICE OF

BRANIFF *International* AIRWAYS

BRANIFF EQUIPS GROUND STATIONS WITH WILCOX TYPE 364A TRANSMITTER

DESIGN SIMPLIFIES SERVICE

Conventional circuit design, fewer numbers and types of tubes, plus open mechanical construction simplify tube stocking problems and speed maintenance. The entire transmitter portion of the Type 364A is built on a drawer-type chassis, instantly withdrawable from the front of the panel.

RELAY RACK MOUNTING SAVES SPACE

Compact design requires only 15 inches of rack space for installation, frequently utilizing space already available.

.005% FREQUENCY STABILITY WITHOUT TEMPERATURE CONTROL

Through the use of a newly developed crystal, troublesome thermostatic temperature controls and crystal ovens are no longer necessary to provide adequate frequency stability.

SIMPLIFIED CONTROL FOR REMOTE LOCATION

Modulation over a single telephone pair and carrier control by means of a simplex circuit allow the transmitter to be readily located at a remote point.

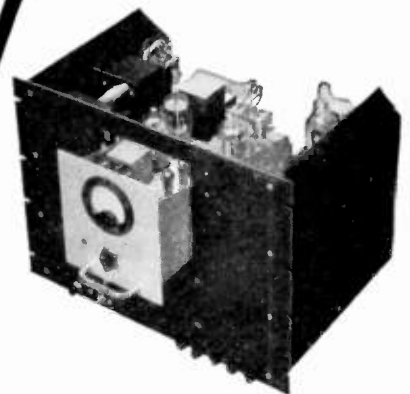

WILCOX
ELECTRIC COMPANY
KANSAS CITY 1, MISSOURI

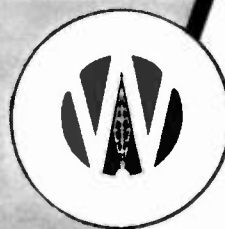

WILCOX
Type 364A Transmitter
118-136 MC. Band

Write Today... for
Complete Information

3 Outstanding COSMALITE* COIL FORMS

Each specially designed and produced by us to give exceptional performance, and at a saving in cost to this country's leading manufacturers of radio and television receivers.

Your specifications as to punching, threading, notching and grooving are followed with the most exacting care. Ask about our many stock punching dies available to you.

Are you familiar with our #96 COSMALITE for coil forms in all standard broadcast receiving sets; SLF COSMALITE for permeability tuners; COSMALITE deflection yoke shells, cores and rings?

Spirally wound kraft and fish paper Coil Forms and Condenser Tubes.

*Trade Mark Registered

The CLEVELAND CONTAINER Co.
6201 BARBERTON AVE. CLEVELAND 2, OHIO

PRODUCTION PLANTS also at Plymouth, Wisc., Ogdenburg, N.Y., Chicago, Ill., Detroit, Mich., Jamesburg, N.J.
PLASTICS DIVISION at Plymouth, Wisc. • ABRASIVE DIVISION at Cleveland, Ohio
SALES OFFICES: Room 5632, Grand Central Term. Bldg., New York 17, N.Y., also 647 Main St., Hartford, Conn.
CANADIAN PLANT: The Cleveland Container Canada, Ltd., Prescott, Ontario



Intricate profile windings—typical of Clarostat skill.

★ When it comes to intricate resistance strips and tricky controls, just bring those engineering and production problems to "Winding Headquarters". That's what others have been doing for years past.

Clarostat craftsmen have almost a quarter-century of winding experience, outstanding skill and exclusive winding facilities at their finger tips.

Windings as fine as 700 turns per inch — wire sizes even down to .0009" diameter — on bakelite, ceramic or other material — flat, round, tapered. Clarostat handles those intricate profile windings for extraordinary radio-electronic controls. Also string windings on fibre glass and cord.

CLAROSTAT



Send us your winding problems. Let us quote.

Controls and Resistors

CLAROSTAT MFG CO., Inc. • 285-7 N. 6th St., Brooklyn, N.Y.

In Canada: CANADIAN MARCONI CO., Ltd.
Montreal, P.Q., and branches

Shaft, cover, faceplate, and other ferrous parts are made of stainless steel.

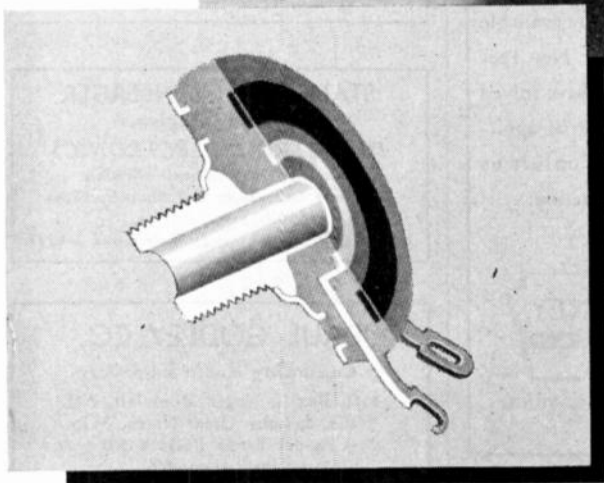
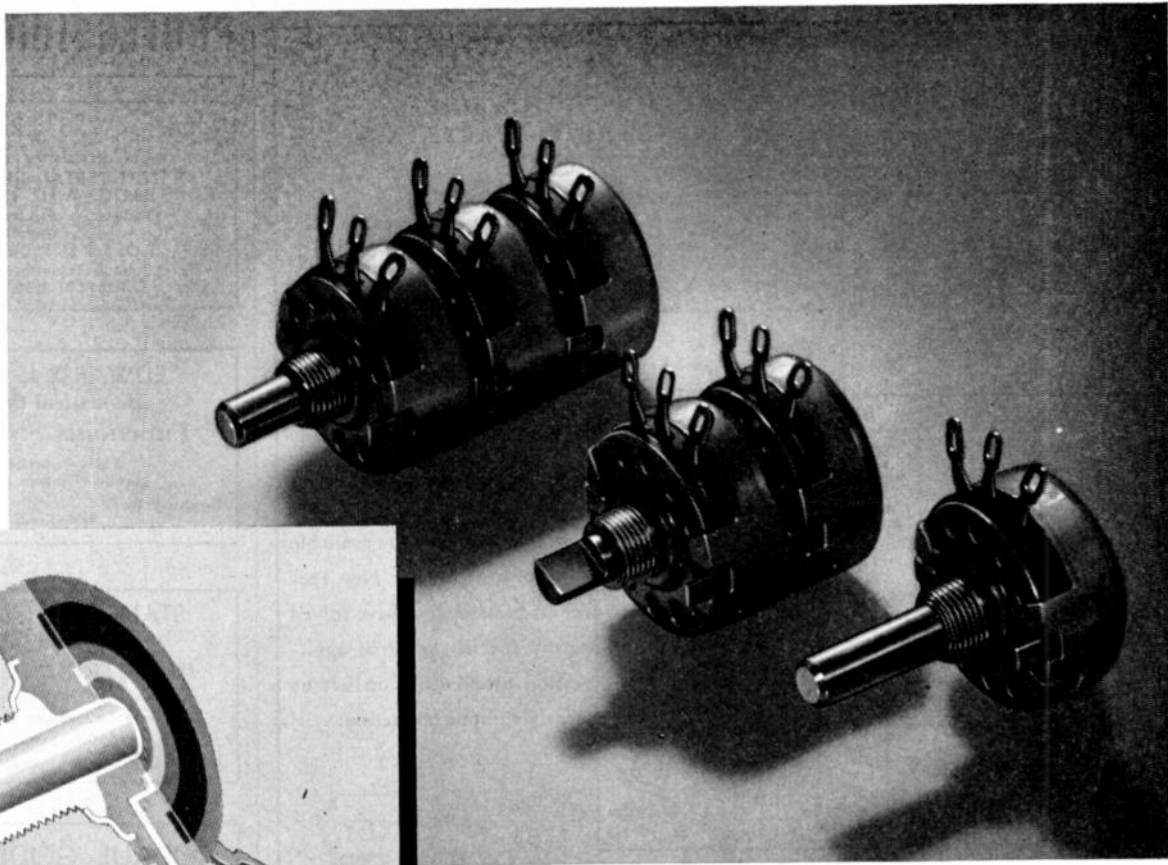

The TYPE J BRADLEYOMETER

... an adjustable resistor of superior quality for jobs that demand superlative performance



FIXED RESISTORS

Bradleyunit resistors are small in size but "taps" in load and life tests. Under continuous 100% load for 1000 hours, resistance change is less than 5%.

The leads are differentially tempered to prevent sharp bends near the resistor.

Available in 1/2-watt and 2-watt sizes in standard R.M.A. values from 10 ohms to 22 megohms. One-watt units are available from 2.7 ohms to 22 megohms.



Allen-Bradley fixed and adjustable radio resistors are sold exclusively to manufacturers of radio and electronic equipment.

● When you have a circuit which requires a top-quality adjustable resistor . . . rated at 2 watts with a big safety factor . . . with a solid-molded resistor element not affected by heat, cold, moisture, and age . . . then specify the Allen-Bradley Type J Bradleyometer.

The resistor element is molded as a single unit to provide any resistance-rotation curve. Insulation, terminals, faceplate, and threaded bushing are molded in one piece. There are no rivets, welded, or soldered connections.

Type J Bradleyometers are available in single-, dual-, and triple-unit constructions. Built-in line switch can also be furnished.

Send for dimension sheet and performance curves.

Allen-Bradley Co., 114 West Greenfield Avenue, Milwaukee 4, Wisconsin

ALLEN-BRADLEY

FIXED & ADJUSTABLE RADIO RESISTORS

QUALITY

NEY Precious Metals in Industry

YOUR DESIGN PROBLEM SIMPLIFIED WITH THE USE OF ONE OF OUR STANDARD CONTACTS

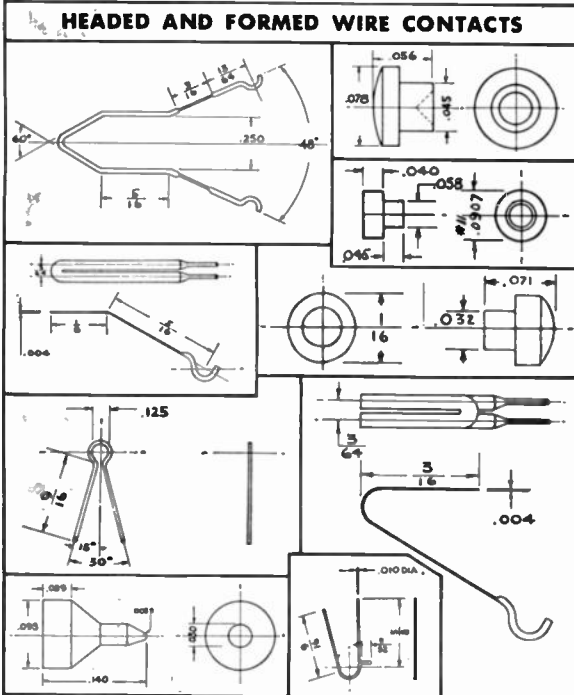

This simplified chart shows the form and overall dimensions of a few of the many types of contacts made from Ney Precious Metal Alloys with electrical and physical properties that have proved exceptionally satisfactory for brush or wiping contact applications. Full technical and test data are available on request. Other Ney Precious Metal Alloys have solved many special industrial application problems. Consult us freely without obligation.



Write or phone (Hartford 2-4271) our Research Department.

THE J. M. NEY COMPANY 171 ELM STREET • HARTFORD 1, CONN.
SPECIALISTS IN PRECIOUS METAL METALLURGY SINCE 1812

42 NY48

PROFESSIONAL CARDS

W. J. BROWN
Consulting Engineer
INDUSTRIAL ELECTRONICS
RADIO AND TELEVISION
25 years active electronic development experience
P.O. Box 5106, Cleveland, Ohio
Telephone & Telegrams Yellowstone 7771
Office: 501 Marshall Building

EDWARD J. CONTENT
Acoustical Consultant
Functional Studio Design
FM - Television - AM
Audio Systems Engineering
Roxbury Road Stamford 8-7459
Stamford, Conn.

STANLEY D. EILENBERGER
Consulting Engineer
INDUSTRIAL ELECTRONICS
Design—Development—Models
Complete Laboratory and Shop Facilities
6309-13—27th Ave.
Kenosha, Wis. Telephone 2-4213

PAUL GODLEY CO.
Consulting Radio Engineers
P.O. Box J, Upper Montclair, N.J.
Offs. & Lab.: Great Notch, N.J.
Phone: Little Falls 4-1000
Established 1926

HERMAN LEWIS GORDON
Engineering Consultant—Registered
Patent Attorney
Product Development and Design
Electronics — Mechanical Devices — Optics
100 Normandy Drive 1416 F Street, N.W.
Silver Spring, Md. Washington 4, D.C.
Shepherd 2433 National 2497

Samuel Gubin, Electronics
G. F. Knowles, Mech. Eng.
SPECTRUM ENGINEERS, Inc.
Electronic & Mechanical Designers
540 North 63rd Street
Philadelphia 31, Pa.
GRanite 2-2333; 2-3135

EUGENE MITTELMANN, E.E., Ph.D.
Consulting Engineer & Physicist
HIGH FREQUENCY HEATING
INDUSTRIAL ELECTRONICS
APPLIED PHYSICS &
MATHEMATICS
549 W. Washington Blvd. Chicago 6, Ill.
Phone: State 8021

ARTHUR J. SANIAL
Consulting Engineer
Loudspeaker Design; Development; Mfg.
Processes. High Quality Audio Systems.
Announcing Systems. Test and Measuring
Equipment Design.
168-14 32 Ave. Flushing, N.Y.
FLushing 9-3574

PROOF OF PERFORMANCE...

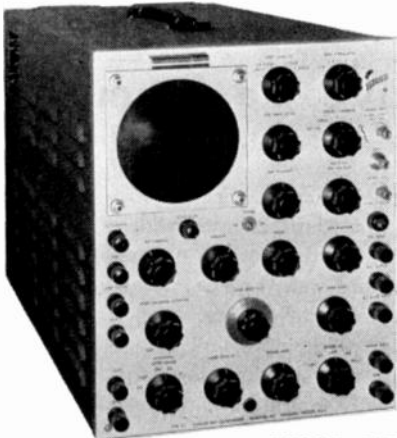

The fact that over 50% of the purchasers of the Tektronix Type 511 Oscilloscope have re-ordered additional instruments after having placed a Type 511 in service provides positive evidence of the usefulness and value of this instrument.

The above category of Type 511 users includes the foremost Universities, Nuclear Physics groups, Industrial and Governmental research organizations throughout the country. A list of those in your vicinity will be provided upon request.

TYPE 511 FEATURES

- Continuously variable sweep speed, 1/10 second to 1 microsecond (10 cm).
- Direct reading sweep speed indication.
- Sweep magnifier for any 20% of normal sweep.
- Triggered recurrent or single sweeps.
- Vertical deflection sensitivity: 0.27V to 200V per cm. (peak to peak).
- Vertical amplifier band pass, 10 mc. 1 stage; 8 mc. 2 stages.
- Fully compensated for optimum transient response.
- Self contained, total weight 65 lbs.

Price \$795.00 f.o.b. Portland

Your inquiry will bring more detailed information and name of the nearest Field Engineering Representative.

Phone, EAsT 6197
Cables, TEKTRONIX



712 S. E. Hawthorne Blvd.
Portland 14, Oregon

News—New Products

These manufacturers have invited PROCEEDINGS readers to write for literature and further technical information. Please mention your I.R.E. affiliation.

(Continued from page 42A)

New Compact DC Relay

A sensitive dc relay designed primarily for electronic tube circuits, alarm systems and other similar applications, the type "E", is being marketed by the Comar Electric Co., 3148 N. Washtenaw Ave., Chicago 18, Ill.

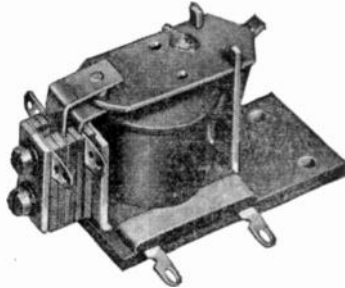

It is a single-pole, double-throw relay with a contact capacity up to 5 amperes at 25 volts noninductive load.

The power consumption is 60 milliwatts, and the overall size is $2\frac{1}{2}'' \times 2\frac{1}{4}'' \times 1\frac{1}{2}''$.

Tri-Purpose Air Meter

Anemotherm, an air meter which measures air velocity, air temperature, and static pressure, is now being manufactured by Anemostat Corp. of America, 10 East 29 St., New York 6, N. Y.

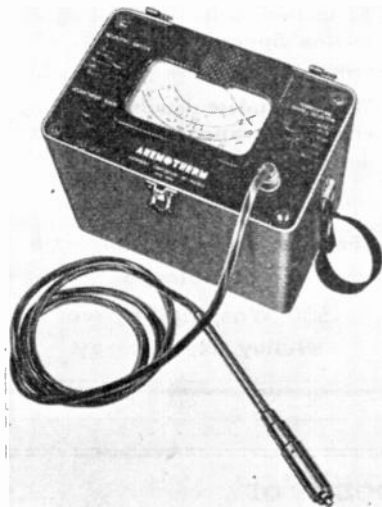

This meter measures air velocity from 10 fpm to 5000 fpm; temperatures from 30°F to 155°F; positive or negative static pressure in inches of water from 0.05 to 10 positive and 0.05 to 4 negative.

Since it can accurately measure velocities as low as 10 fpm, regardless of direction of air flow, the Anemotherm detects even the slightest drafts, and can provide data on low air movement of a turbulent nature.

Operation is from self-contained batteries and the meter is portable, since it weighs 11 pounds.

(Continued on page 59A)

Z-ANGLE METER'S OUTSTANDING ACCURACY-SPEED-SIMPLICITY PLEASES LANGEVIN ENGINEERS

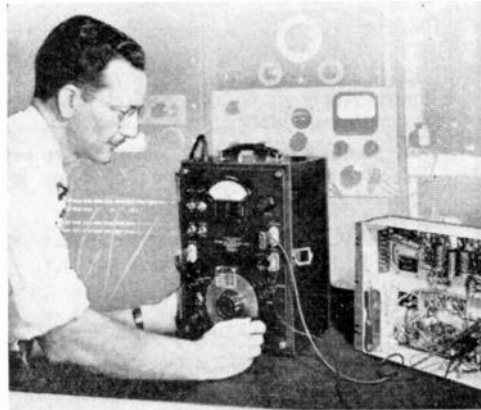

Read this interesting statement:

"The Langevin Manufacturing Corporation Development Laboratory finds the Z-Angle meter extremely useful in the determination of transformer impedances. In the manufacture of amplifiers it is often necessary to determine the impedances existing within amplifier stages. Heretofore, these determinations have involved a long drawn out test procedure. The Z-Angle meter, however, allows readings to be made accurately and quickly."

Langevin engineers say, "... the plate impedance of a resistance coupled triode tube can be determined by taking a reading with the Z-Angle meter at the output terminals and then extracting the unknown from the mathematical formula for the impedances in parallel. This is only one of the many uses we have found for this instrument."

Write today for Bulletins on the Z-Angle Meter, R-F Z-Angle Meter, R-F Oscillator and Precision Variable Resistors.

The Z-Angle Meter is a modern, self-contained instrument for making quick, accurate measurements of impedance and phase angle vs. frequency.

IT TECHNOLOGY INSTRUMENT CORP.
1058 MAIN STREET, WALTHAM 54, MASS.

Midwest Office: Alfred Cresley & Associates, 849 W. Randolph St., Chicago 6, Illinois, State 7444

Only with CO-AX
air-spaced articulated
R.F. CABLES
4mmf/ft

Patents Regd Trade Mark

THE LOWEST EVER CAPACITANCE OR ATTENUATION

We are specially organized to handle direct enquiries from overseas and can give

IMMEDIATE DELIVERIES FOR EXPORT

Write or cable for data sheets or deliveries to the Originators of flexible air-spaced R.F. Cables

TRANSRADIO LTD
CONTRACTORS TO H.M. GOVERNMENT
13BA CROMWELL ROAD, LONDON SW7 ENGLAND
CABLES: TRANSRAD, LONDON.

LOW ATTN TYPES	IMPED OHMS	ATTEN db/100ft at 100 Mcs.	LOADING Kva	O.D."
A 1	74	1.7	0.41	0.36
A 2	74	1.3	0.24	0.44
A 34	73	0.6	1.5	0.88
LOW CAPAC TYPES	C APAC mmf/ft	IMPED OHMS	ATTEN db/100ft at 100 Mcs.	O.D."
C 1	7.3	150	2.5	0.36
PC 1	10.2	132	3.1	0.36
C 11	6.3	173	3.2	0.36
C 2	6.3	171	2.15	0.44
C 22	5.5	184	2.8	0.44
C 3	5.4	197	1.9	0.64
C 33	4.8	220	2.4	0.64
C 44	4.1	252	2.1	1.03

HIGH POWER FLEXIBLE

PHOTOCELL CABLE

V.L.C. ★

★ Very Low Capacitance cable

WANTED PHYSICISTS ENGINEERS

Engineering laboratory of precision instrument manufacturer has interesting opportunities for graduate engineers with research, design and/or development experience on radio communications systems, Servomechanisms (closed loop), electronic & mechanical aeronautical navigation instruments and ultra-high frequency & microwave technique.

WRITE FULL DETAILS
TO
EMPLOYMENT SECTION

**SPERRY
GYROSCOPE
COMPANY**

DIVISION OF SPERRY CORP.
Marcus Ave. & Lakeville Rd.
Lake Success, L.I.

Senior Electrical Engineer or Physicist

M.S. preferred with experience in development of radar, television or digital computer circuits and systems.

Here is an excellent position with future opportunity for the right man in a rapidly expanding aggressive engineering firm. We now have over 150 graduate engineers and scientists engaged in research and development in the field of communications, computing systems, and electro-mechanical devices. Furthermore, it is a thrill to live in Minnesota in the Land of 10,000 Lakes.

Write for application giving a brief outline of scholastic and employment background.

ENGINEERING RESEARCH
ASSOCIATES, INC.
1902 W. Minnehaha Avenue
St. Paul 4, Minn.



The following positions of interest to I.R.E. members have been reported as open. Apply in writing, addressing reply to company mentioned or to Box No. . . .

The Institute reserves the right to refuse any announcement without giving a reason for the refusal.

PROCEEDINGS of the I.R.E.
1 East 79th St., New York 21, N.Y.

ENGINEERS—PHYSICISTS

The Naval Ordnance Laboratory located just outside of Washington, offers many advantages to engineers and physicists. Openings exist in the fields of electronics and complex mechanisms. The laboratory is provided with the best equipment. Men capable of developing complex electronic circuits or with experience in electronic instrument design are particularly desired. Salaries range from P-4—\$4,903 and higher, to P-2—\$3397.20. Interested applicants are urged to communicate with Engineering Dept., Naval Ordnance Laboratory, White Oak, Maryland.

ELECTRICAL ENGINEER

Graduate electrical engineer with several years experience in audio development work, preferably magnetic recording, wanted for design work. Unusual opportunity for permanent position for the right person with long established company. Vicinity New York City. Reply giving résumé of personal data, educational background, experience and salary desired. Write I.R.E. 1699, 113 W. 42 St., New York 18, N.Y.

ENGINEERS

Scientific research, development and engineering positions at the National Bureau of Standards, Washington, D.C., are available in the fields of physics, electronics engineering, radio engineering, mechanical engineering and mathematics. Salary range from \$3397 per annum through \$8179, depending upon qualifications. Qualified scientists are invited to communicate with Personnel Officer, Di-

vision 13, National Bureau of Standards, Washington 25, D.C.

RESEARCH SCIENTISTS

Scientific research and development positions at the Naval Research Laboratory, Washington, D.C., are open in the fields of physics, mathematics, engineering (including electronics, radio, electrical, mechanical, chemical, metallurgical, etc.). A B.S. degree in the appropriate field from an accredited college or university is essential. Advanced academic standing and pertinent research experience is desirable. Opportunities for graduate study are offered at NRL. Qualified scientists are invited to communicate with Employment Officer, Code 1811 (I) Naval Research Laboratory, Washington 20, D.C.

(Continued on page 51A)

WANTED ELECTRONIC ENGINEERS AND PHYSICISTS

Excellent opportunities for graduates with research, design, and/or development experience in Communications and aerial navigation systems including direction finders, radar, FM, television, micro-wave.

Write complete details regarding education, experience and salary desired.

To Personnel manager
Federal Telecommunication
Laboratories
500 Washington Ave.
Nutley, New Jersey

Positions Open For Physicists and Senior Electronic Engineers

Familiar with ultra high frequency and micro wave technique.

Experience with electronic digital and/or analog computer research and development program.

Salaries commensurate with experience and ability. Excellent opportunities for qualified personnel.

Contact C. G. Jones, Personnel Department

Goodyear Aircraft Corp.
Akron 15, Ohio



(Continued from page 50A)

ELECTRONIC ENGINEER

Experienced in development and product design of electro-mechanical precision instruments. Capable of full responsibility for development of timing and control circuits, servo-mechanisms, associated equipment. Ingenuity, imagination and theoretical inclinations suitable for Research Lab. work desired. Top salary for qualified person. Send résumé to Box 528.

ELECTRONIC ENGINEER

Graduate engineer with major in electronics is required for development of industrial and medical electronic equipment. Must have good scholastic record and have ability to do original work. Salary open. Send full details of education and experience. Write Perkin-Elmer Corporation, Glenbrook, Conn.

ENGINEERS

Condenser engineers—electrolytic, paper, ceramic, for both production and development work. Needed by leading manufacturer. Excellent working conditions. Please send full details. Box 529.

PROJECT ENGINEERS, SENIOR

Electronic engineers with outstanding academic and practical background for responsible positions. Will carry on projects under their own direction in modern, fully-equipped, owner-managed plant in south-east New Jersey one hour from New York City. Send résumé of education, experience, age and salary requirements. Our Engineering Department knows of this announcement. Box 530.

MICROWAVE ENGINEERING EXECUTIVE

Well versed in electro-magnetic theory and application, to administer currently successful microwave antenna research and development group. Moderate sized laboratory in New York area seeking the man for this position. Box 531.

JUNIOR ELECTRONIC ENGINEERS

B.S. degree in radio, electronics or electrical engineering required. Experience not necessary. Outstanding opportunities in special vacuum tube development work with a small progressive organization. Box 532.

CHIEF ELECTRICAL ENGINEERS

Chief Electrical Engineers; Project Engineers; Senior Engineers. Must have extensive experience in home radio receivers and/or television design and development. Address replies to Vice President in charge of Engineering, Air King Products Company, Inc. 170-53 Street, Brooklyn, N.Y.

INSTRUCTORS

Wanted: Men to teach in school in Pennsylvania. Radio repair and television service with at least 2 years practical experience or the educational equivalent or 2 years teaching experience in same. \$60.00 to \$75.00 weekly. Apply S. J. Baicker, 21 S. Welles St., Wilkes-Barre, Pa.

(Continued on page 52A)

Investigate this Opportunity

To join the staff of one of the largest research organizations in the country devoted exclusively to

VACUUM TUBE RESEARCH

Working conditions are ideal in these laboratories which are located in the New York Suburb of Orange, New Jersey. Your associates will include men of many years experience in vacuum tube research and development.

This rapidly expanding organization is devoted to both commercial and military research. It is a division of one of the oldest vacuum tube manufacturers in America. Security and stability for the years to come are assured. You will have an opportunity to gain experience with the different kinds of vacuum tubes, receiving, power, cathode ray, sub-miniature, micro-wave, radial beam and various special types.

If you can qualify as a

PHYSICIST
MATHEMATICIAN
ELECTRICAL ENGINEER
CIRCUIT TECHNICIAN
VACUUM TUBE TECHNICIAN

write at once to

RESEARCH DIVISION NATIONAL UNION RADIO CORPORATION

350 Scotland Rd.
Orange, New Jersey

ELECTRONIC ENGINEERS

PHYSICISTS

MATHEMATICIANS

PROJECT ENGINEERS SENIOR ELECTRONIC ENGINEERS

THIS IS YOUR OPPORTUNITY TO GO PLACES
IN ELECTRONIC RESEARCH AND DEVELOPMENT

MEN ARE ESPECIALLY NEEDED TO DO ORIGINAL WORK
IN THE FOLLOWING FIELDS:

1. Pulse circuits including ranging, scope, video, trigger and square wave generator circuits.
2. Radar type transmitters, including high voltage power supplies, receivers and modulators.
3. Micro-wave antennae, radomes, wave guides and other radio frequency components of radar systems.
4. Servo-mechanism and controls.
5. Electronic Instrumentation.

For Personal Interview in Chicago
on November 4, 5, and 6,

Contact The Glenn L. Martin representative attending
the National Electronics Conference

or send resume to

PERSONNEL DEPARTMENT
THE GLENN L. MARTIN COMPANY
Baltimore 3, Maryland

No Housing Problem in Baltimore, Maryland

RESEARCH & DEVELOPMENT ENGINEERS

PhD's, Master, Bachelors
in Physics or E.E.

Long established electro-mechanical engineering organization is expanding its electronic department to include research and development on missiles, microwave systems, radar, communications, navigational devices, antennas, and associated equipment.

A few exceptional positions are open for top-flight senior engineers. Must have extensive experience on analysis of electronics systems, and ability to create new basic approaches to involved engineering problems. Commercial and university background desired. Please furnish complete résumé, salary requirements and availability to: Personnel Manager

Engineering Division

**W. L. MAXSON
CORPORATION**
460 West 34th Street
New York, New York

PHYSICISTS AND APPLIED MATHEMATICIANS

An established research organization has openings for professionals of Ph.D. or equivalent. The work has a basic and scientific approach; it includes the problems in flight mechanics of guided missiles, the theory of radar and other electronic techniques, and atomic and nuclear physics. The organization is non-industrial and is located within the metropolitan Los Angeles area.

Salaries are commensurate with ability. Please include details of education and experience in reply, addressed to:

Box 541

**The Institute of
Radio Engineers**
1 East 79th St., New York 21, N.Y.



(Continued from page 51A)

ELECTRICAL AND AERONAUTICAL ENGINEERS

This corporation, engaged in development of aircraft remote control and telemetering equipment, has need for engineers of several categories:

1. Young graduate electrical engineers having good background in electronics and communications.
2. Graduate electrical engineers with experience in electronics and communications.
3. Graduate electrical or mechanical engineers having background in servo-mechanism design.
4. Aeronautical engineers having experience in stability and control.

Wing Engineering Corp. Colonial Bldg. Philadelphia 7, Pa.

TRANSFORMER ENGINEER

Engineer (Junior or Senior) capable of designing or learning to design audio and power transformers, 1 watt to 10 kva, for position with engineering consultants. Location, New Jersey. State detailed qualifications, education and salary requirements. Reply Box 534.

JUNIOR ENGINEERS

Microwave research and other advanced radio work, requiring college degree and natural aptitude. Opportunity for valuable experience and advancement in a small, growing organization. Suburban location on Long Island near New York City. Send personal record to Harold A. Wheeler, Wheeler Laboratories, Inc. Great Neck, L.I., N.Y.

FIELD SALES ENGINEER

Must have knowledge of transmitting tube field. Excellent opportunity. Write or phone Amperex Electronic Corp., 25 Washington St., Brooklyn 1, N.Y. MA 5-2050—Ext. 32.

TECHNICAL WRITERS

Our manual department is receiving additional orders at an increasing rate, and experienced writers with electronic engineering background are needed for registration in our files. We request applications now to facilitate assignment of jobs as they arise in the near future. Send complete résumé to Mr. J. J. Roche, or phone for appointment. Boland & Boyce, 460 Bloomfield Ave., Montclair, N.J.

ELECTRONIC ENGINEERS—ELECTRONIC TECHNICIANS

Men with production, inspection, or re-design experience preferred. Direct inquiries to SLX-1, P.O. Box 5800, Albuquerque, New Mexico.

TEACHER

Southwestern church-related university needs experienced teacher with Master's Degree to teach radio theory and electronics in the Physics Department. Salary \$3300 for 9 months. Write full particulars to Mr. Stewart H. Ross, Chairman, Department of Physics, Trinity University, San Antonio 1, Texas.

(Continued on page 53A)

"Where
Professional
Radiomen
Study"

CAPITOL RADIO ENGINEERING INSTITUTE

An Accredited Technical Institute
16th and Park Rd., N.W., Dept. PR-10
Washington 10, D.C.

Advanced
Home Study and Residence
Courses in Practical Radio-
Electronics and Television.
Approved for Veteran Training



ENGINEERS - ELECTRONIC

Senior and Junior, outstanding opportunity, progressive company. Forward complete résumés giving education, experience and salary requirements to

Personnel Department
MELPAR, INC.
452 Swann Avenue
Alexandria, Virginia

ENGINEERS

Attractive positions immediately available for:

PROJECT ENGINEERS

Experienced in design of automobile radio receivers.

SENIOR DRAFTSMEN

Experienced in the handling of mechanical layout work and design of automobile radio receivers.

RADIO ENGINEERS

To handle liaison work with radio and television production department.

In reply give only brief outline of work experience. Standard application blanks will be forwarded if detailed information or personal interview is desired.

Personnel Manager
BENDIX RADIO DIVISION
Towson 4, Maryland



(Continued from page 52A)

TELEVISION ENGINEERS

Well established electronics manufacturer, located in suburban New York City area needs high grade television development engineers. Company is expanding its television activities and seeks capable men with background sufficiently complete to merit responsible positions. Send details to Chief Engineer, Box 536.

ELECTRICAL ENGINEER

To act as field engineer in Ohio to service electronic equipment used for testing steel. Some knowledge of metallurgy preferable, but not essential. Advise qualifications, references and salary expected. Box 537.

PROJECT ENGINEERS

Stamford firm engaged in development and research work with government agencies requires project engineer with technical and practical background in UHF radar work. Salary open depending upon background. Company is young and growing with promising future for able engineers in this kind of work. Box 538.

(Continued on page 54A)

Engineers for—

Electronic Design Servo Design

Young, but rapidly expanding mid-western research laboratory has openings for the following types of personnel.

(1) ELECTRONIC DESIGN ENGINEERS—Experienced circuit design Engineers are required for indicator and timing circuit development.

(2) SERVO DESIGN ENGINEERS OR PHYSICISTS—Experienced servo design engineers or physicists are required for the development of airborne computer equipment.

Top pay is offered to those capable of project responsibility. Local University offers graduate courses in servo and computer design, and applied mathematics. Inclusion of experience and scholastic background will be appreciated in making application or inquiry.

Our engineering department knows of this announcement.

Box 543

The Institute of Radio Engineers, 1 East 79th St., New York 21, N.Y.

ELECTRONIC ENGINEERS WANTED

● TELEVISION ● TRANSMITTER

experienced in circuit designs, either video amplifier design or scanning circuit design.

SENIORS . . .

Technical graduates with a minimum of 6 years engineering and supervisory experience, capable of assuming responsibilities for directing engineers and designers on specific projects connected with pulse type transmitters and timer equipment.

INTERMEDIATE ENGINEERS . . .

Technical graduates or equivalent with at least a minimum 4 years practical experience in design of transmitter and associated equipment.

JUNIOR ENGINEERS . . .

Technical degree, minimum 1 year experience in development for production of electronic equipment.

RESEARCH CHEMIST . . .

Technical degree and experience for development work on selenium rectifier.

ENGINEERS . . .

Also needed having experience with telephone systems in general, particularly in voice frequency equipment engineering, toll transmission systems and carrier telephone equipment.

SALARY COMMENSURATE WITH ABILITY

APPLY IN PERSON OR WRITE PERSONNEL MANAGER

FEDERAL TELEPHONE & RADIO CORP.

100 Kingsland Road, Clifton, N.J.

WESTINGHOUSE RESEARCH Openings in Pittsburgh

ENGINEER having three or more years experience in radar or television for work on television systems and television receiver research.

ENGINEER or PHYSICIST with experience in underwater acoustics.

PH.D. PHYSICIST with background for working on solid state problems.

ENGINEER or PHYSICIST for work on magnetic circuits and materials.

ELECTRONIC ENGINEER to work on advanced circuit design problems.

For application address Manager, Technical Employment, Westinghouse Electric Corporation, 306-4th Avenue, Pittsburgh, Pennsylvania

TRUSCON RADIO TOWERS

are Modern - to meet Modern Needs

When the WSBA Broadcasting Company, York, Pennsylvania, planned its completely new and modern transmitter building, it also selected the very best in modern radio tower design. WSBA uses a 380 ft. high Truscon Self-Supporting Steel Radio Tower, to support a 2-bay RCA FM Pylon.

This splendid new tower is typical of the sturdy design, quality materials and skilled workmanship in hundreds of Truscon Radio Towers in America and foreign lands . . . each tower built to exactly meet specific requirements.

Truscon can engineer any type of tower you desire . . . guyed or self-supporting, either tapered or uniform cross-section . . . tall or small AM, FM or TV. Truscon engineering consultation is yours without obligation. Write or phone our home office at Youngstown, Ohio, or any of our numerous and conveniently located district sales offices.

TRUSCON STEEL COMPANY

YOUNGSTOWN 1, O-110
Subsidiary of Republic Steel Corporation

Manufacturers of a Complete Line of Self-Supporting Radio Towers . . . Uniform Cross-Section Guyed Radio Towers . . . Copper Mesh Ground Screen . . . Steel Building Products.



(Continued from page 53A)

RADIO PROJECT ENGINEER

Graduate engineer. Five years recent experience design and development oscillator and amplifier circuits in VHF and UHF ranges. Familiar theoretical concepts and calculations circuit components, as well as practical design and layout work. Must have initiative and supervisory ability. Federal Manufacturing and Engineering Corp., 199-217 Steuben St., Brooklyn 5, New York.

ELECTRONIC ENGINEERS

College graduates with 3-5 years of development engineering experience in circuit design. Well versed in magnetic circuits, non-linear circuit operation and electronic theory. Send résumé and all particulars to Personnel Department, General Precision Laboratory, Inc., Pleasantville, New York.

RADIO ENGINEERS

Senior and junior engineers to work on design and development of radio and television components. Send replies to Chief Engineer, Automatic Manufacturing Corp., 65 Gouverneur St., Newark 4, N.J.

RESEARCH AND DEVELOPMENT

Engineers with considerable experience in RF and UHF circuits wanted by large, well established radio company in the New York area. Send résumé of education and experience to Box 539.

FREE! send for our

RADIO BUYING GUIDE

a complete and diversified line-up of:

- electronic equipment
- sound systems
- recording equipment
- amateur gear
- television components and kits
- replacement parts
- laboratory and service test equipment

Save time and money—buy direct from distributor! Consult the NEWARK radio buying guide, featuring all standard makes . . . a value-packed listing of 20,000 essentials for expert servicemen, engineers, soundmen, experimenters, teachers, hobbyists, amateurs!

24 HOUR SERVICE ON ALL ORDERS
Free technical advisory service!

JUST MAIL THIS COUPON TO GET YOUR CATALOGUE
Newark Electric Co., Inc., Dept. 23
242 West 55th St., New York 19
Please send me the FREE Newark Buying Guide of fine radio equipment.

Name _____
Address _____
City _____ State _____

NEWARK
RADIO & TELEVISION

3 GREAT STORES
115 W. 45th St. & 212 Fulton St., NEW YORK
and 323 West Madison Street in CHICAGO

MAIL ORDER DIVISIONS
242 West 55th Street, NEW YORK 19, N. Y.
323 West Madison Street, CHICAGO 6, ILL.



Positions Wanted By Armed Forces Veterans

In order to give a reasonably equal opportunity to all applicants, and to avoid overcrowding of the corresponding column, the following rules have been adopted:

The Institute publishes free of charge notices of positions wanted by I.R.E. members who are now in the Service or have received an honorable discharge. Such notices should not have more than five lines. They may be inserted only after a lapse of one month or more following a previous insertion and the maximum number of insertions is three per year. The Institute necessarily reserves the right to decline any announcement without assignment of reason.

RADIO ENGINEER

Interested in going abroad. Graduated in June with B.S.E.E. Have also a degree in radio engineering. Age 23. Single. Willing to locate in almost any country. Box 171W.

ENGINEER

B.S.E.E. June 1948 Columbia University. Age 28. Married, two children. Officer, Army Signal Corps, 2½ years administrative and communication experience. Desires sales engineering or administrative position in New York area. Occasional travel possible. Box 172W.

JUNIOR ENGINEER

B.E.E. June 1948. Tau Beta Pi, Eta Kappa Nu. Prefer metropolitan area of New York, anywhere near a graduate school. Box 173W.

JUNIOR ENGINEER

Graduate west coast radio and television school. Single. Age 28. 1st class phone. 2½ years AAF as VHF specialist. Now employed Navy Guided Missile base. Desires position with television station, preferably maintenance. Will work anywhere in U.S. Box 177W.

JUNIOR ENGINEER

B.S.E.E. (communications) June 1948 University of Michigan. Tau Beta Pi, Eta Kappa Nu, 21 months experience in Navy Electronics program. Desires position in production, design or development of electronic equipment. New York City area or southwestern U.S. Box 181W.

ENGINEER

Engineer. Age 28. B.S.E.E. Columbia, also business degree. 3 years responsible business experience. Best references. New York area preferred. Call Lu 8-9164 mornings or write Box 182W.

(Continued on page 56A)

Want the
**MOST EFFICIENT
TRANSMISSION LINE**
for Your Station?

ANDREW

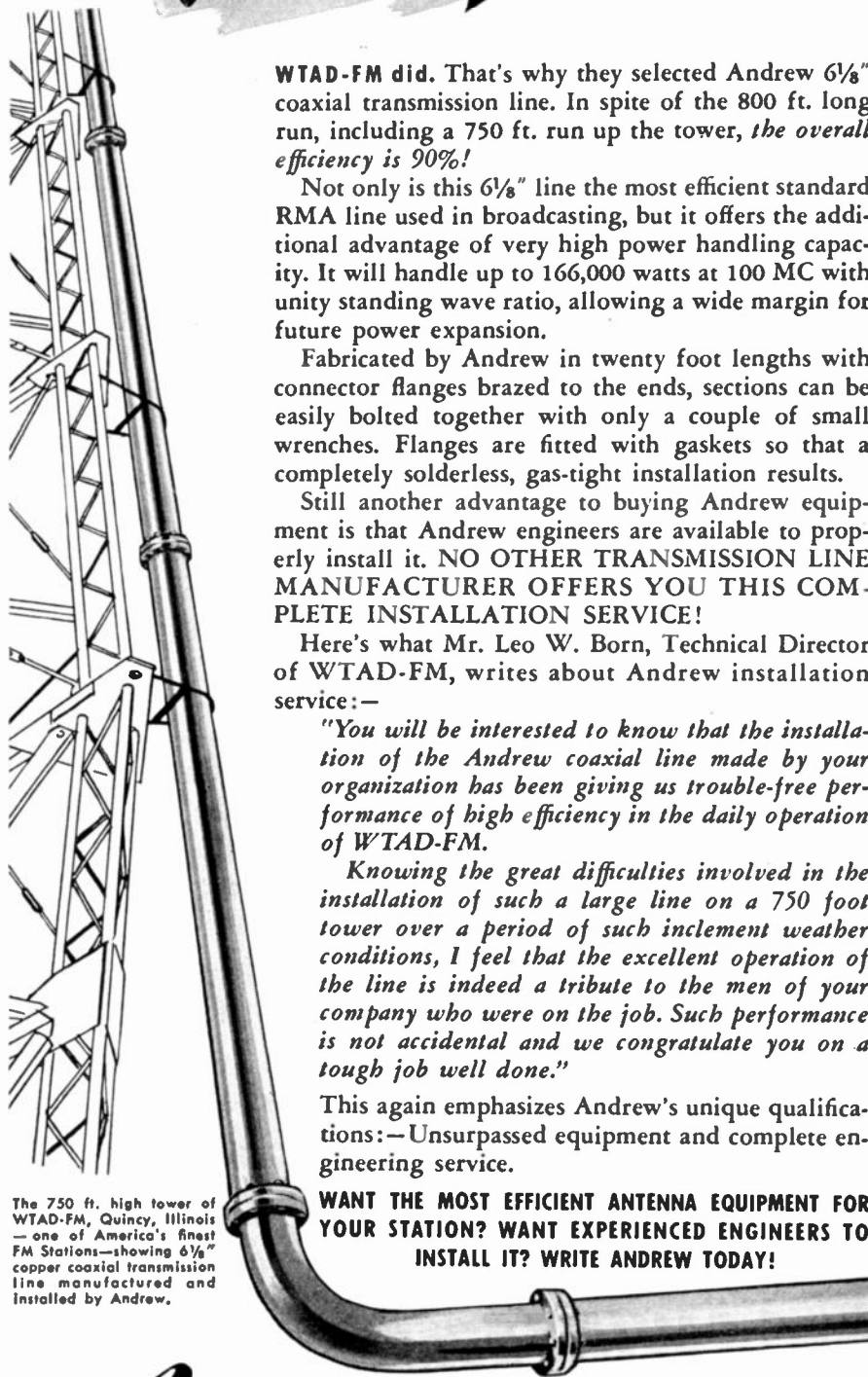

The 750 ft. high tower of WTAD-FM, Quincy, Illinois — one of America's finest FM Stations—showing 6 1/8" copper coaxial transmission line manufactured and installed by Andrew.

WTAD-FM did. That's why they selected Andrew 6 1/8" coaxial transmission line. In spite of the 800 ft. long run, including a 750 ft. run up the tower, the overall efficiency is 90%!

Not only is this 6 1/8" line the most efficient standard RMA line used in broadcasting, but it offers the additional advantage of very high power handling capacity. It will handle up to 166,000 watts at 100 MC with unity standing wave ratio, allowing a wide margin for future power expansion.

Fabricated by Andrew in twenty foot lengths with connector flanges brazed to the ends, sections can be easily bolted together with only a couple of small wrenches. Flanges are fitted with gaskets so that a completely solderless, gas-tight installation results.

Still another advantage to buying Andrew equipment is that Andrew engineers are available to properly install it. **NO OTHER TRANSMISSION LINE MANUFACTURER OFFERS YOU THIS COMPLETE INSTALLATION SERVICE!**

Here's what Mr. Leo W. Born, Technical Director of WTAD-FM, writes about Andrew installation service:—

"You will be interested to know that the installation of the Andrew coaxial line made by your organization has been giving us trouble-free performance of high efficiency in the daily operation of WTAD-FM.

Knowing the great difficulties involved in the installation of such a large line on a 750 foot tower over a period of such inclement weather conditions, I feel that the excellent operation of the line is indeed a tribute to the men of your company who were on the job. Such performance is not accidental and we congratulate you on a tough job well done."

This again emphasizes Andrew's unique qualifications:—Unsurpassed equipment and complete engineering service.

WANT THE MOST EFFICIENT ANTENNA EQUIPMENT FOR YOUR STATION? WANT EXPERIENCED ENGINEERS TO INSTALL IT? WRITE ANDREW TODAY!

Andrew
CORPORATION

TRANSMISSION LINES
ANTENNA EQUIPMENT

363 EAST 75TH STREET, CHICAGO 19 • EASTERN OFFICE: 421 SEVENTH AVENUE, NEW YORK CITY

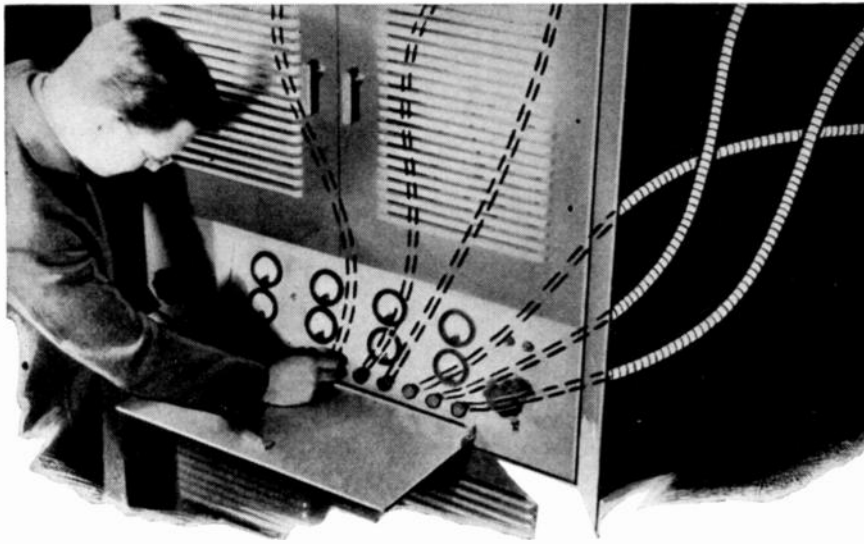

FLEXIBLE SHAFT CONTROL IS AS GOOD AS YOU REQUIRE

You can get any degree of fidelity and sensitivity you need with S. S. White remote control flexible shafts.

Bear in mind, these shafts were developed specifically for control service. They have the necessary physical properties to provide a quality of control that satisfies the requirements of most applications. It's simply a matter of correct shaft selection and application.

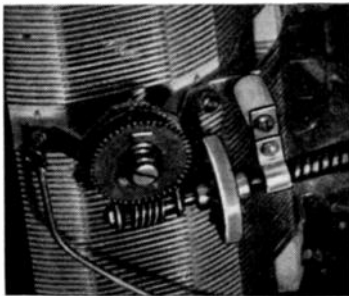

Close-up of flexible shaft connection to a variable resistor through simple worm gearing. With arrangements like this you can get smooth, accurate fingertip control.

Where vernier accuracy is essential, it is readily obtained by connecting the shaft to control and controlled members through simple gearing.

GET FULL DETAILS IN THIS 260-PAGE FLEXIBLE SHAFT HANDBOOK

We'll gladly send you a copy, free, if you write for it on your business letterhead and mention your position.



S.S. WHITE INDUSTRIAL
THE S. S. WHITE DENTAL MFG. CO. DEPT. G 10 EAST 40th ST., NEW YORK 16, N. Y.



FLEXIBLE SHAFTS • FLEXIBLE SHAFT TOOLS • AIRCRAFT ACCESSORIES
SMALL CUTTING AND GRINDING TOOLS • SPECIAL FORMULA RUBBERS
MOLDED RESINFORMS • PLASTIC SPECIALTIES • CONTRACT PLASTICS HOLDING

One of America's AAAA Industrial Enterprises

Positions Wanted

(Continued from page 55A)

JUNIOR ELECTRICAL ENGINEER

June 1948 B.E.E., summa cum laude, electronics major. Desires research and development position electronics or electrical measurements. Member Tau Beta Pi, Sigma Xi, Eta Kappa Nu. Married, no children. Prefer New York City area or east. Box 183W.

ENGINEER

B.S.R.E. August 1948. Age 24. Married, 1 child. 3 years U.S. Navy electronics technician. 2nd class Radio Telephone. Considerable servicing experience. Desires position with opportunity for advancement. Box 185W.

SALES ENGINEER OR EXECUTIVE ASSISTANT

Young, aggressive, hard-hitting design and development engineer invites inquiries from firms having need for addition to sales engineering staff or assistant to top executive. Thorough background of research, design and supervision in measurement apparatus, receivers, transmitters and audio equipment. Capable of handling engineering, purchasing, production, inspection and personnel. Prefer New York City location. Box 187W.

ELECTRONICS ENGINEER

Present head, Technical Department, educational organization wants change. College Electronics Dept., Chief Engineer of station or consulting research. College graduate, 10 years radio experience and all FCC radio licenses. Age 31. Married. \$6000 salary. Box 196W.

PHYSICIST

Twenty-seven-year-old graduate physicist and mathematician with experience in control circuits desires either foreign or domestic employment. Box 197W.

ELECTRICAL ENGINEER

B.S. 1948 from University of California. Tau Beta Pi, Eta Kappa Nu. Interested in communications and electronics, New York City area. Age 23. Navy experience in radio, radar and sonar. Box 198W.

BROADCAST ENGINEER

Nine years experience. Now employed as assistant chief engineer 5 KW AM 50 KW FM, major network station, directional antennas. Desire chief engineer position or transmitter supervisor in east. Best references. All offers considered. Box 199W.

ENGINEERING—ADVERTISING

Hard-hitting advertising executive who can talk an engineer's language. A.B., M.A., plus 3 years electrical engineering. Last 4 years with top electrical corporation creating sales campaigns, advertisements, displays, sales aids, technical literature. Desires connection as advertising manager or assistant sales manager for medium-sized New York City area electrical concern. Box 200W.

JUNIOR ENGINEER

R.C.A. Institute graduate desires position in production, design or allied fields in New York City vicinity. Age 27. Married. 1 year laboratory and 2 years flight (radio) experience. First class radiotelephone license. Call Da 6-7203 or write Box 201W.

Save Time...Speed Assembly
with CTC ALL-SET Boards!

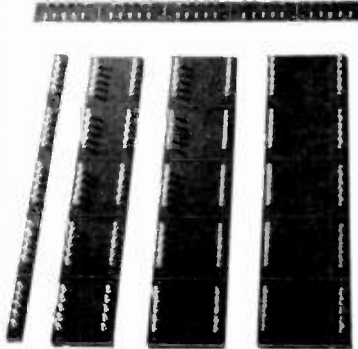

On the assembly line and in the laboratory, CTC ALL-SET Boards are valuable time-savers.

With Type 1558 Turret Lugs, a new board now offers mounting for miniature components. 1 1/16" wide, 3/32" thick, only. (Type X1401E.)

With Type 1724 Turret Lugs, boards come in four widths: 1/2", 2", 2 1/2", 3" — in 3/32", 1/8", 3/16" thicknesses.

With the addition of the new miniature board, CTC ALL-SET Boards now cover the entire range of components.

All boards are of laminated phenolic, in five-section units, scribed for easy separation. Each section drilled for 14 lugs. Lugs solidly swaged into precise position... whole board ready for your assembly line.

SPECIAL PROBLEMS

Custom-built boards are a specialty with CTC. We're equipped to handle many types of materials including the latest types of glass laminates... many types of jobs requiring special tools... and all types of work to government specifications. Why not drop us a line about *your* problem? No obligation, of course.

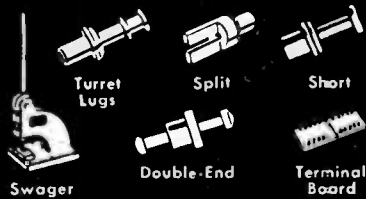

Custom or Standard
The Guaranteed
Components

CAMBRIDGE THERMIONIC CORPORATION
456 Concord Avenue, Cambridge 38, Mass.

For AIRCRAFT RADIO



Standardize on
RH-7
Crystal Units

For the first time you can standardize on only one crystal holder for every aircraft radio application. Hermetically sealed and shock mounted, RH-7 miniature holders cover a frequency range from 1 to 75 mc with tolerances of $\pm .005\%$. These CAA-approved crystal units operate in a temperature range from -55°C to $+90^{\circ}\text{C}$ and are designed to withstand even the most severe operating conditions. Available with pins or wire leads.

Standardize now with RH-7.



Write for Bulletin RHC-X

REEVES  **HOFFMAN**
CORPORATION
CHERRY AND NORTH STREETS • CARLISLE, PA.

NEW! THE CB MODEL 182A AUDIOMATIC GENERATOR

Automatic Beat Frequency Principle

The complete frequency characteristics at a glance on your present oscillograph!

Eliminates hand plotting for transformers, amplifiers, filters, balanced circuits, etc.

Slow sweep rate of 5 to 8 seconds included for speaker testing; hand "cranking" of frequency dial is eliminated.

A REAL TIME SAVER!
Write for full description and details.



Dividing speaker network with 400C. crossover.

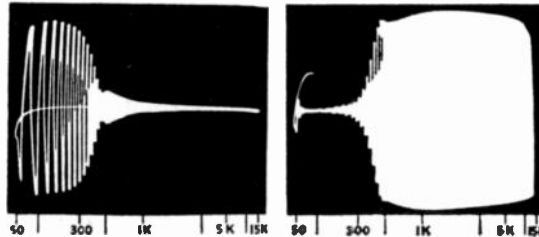

The CLOUGH BRENGLE CO.
6016 Broadway Chicago 40, Ill.

VHF COMMUNICATION and LF NAVIGATION SYSTEMS

meet every Operational Need

THE A.R.C. TYPE 11A

Meets basic needs by providing for VHF Transmission, LF Range Reception and Rotatable Loop Navigation.

THE A.R.C. TYPE 17

A 2-way VHF equipment, including a tunable VHF Receiver and a 5-channel, crystal controlled VHF Transmitter.

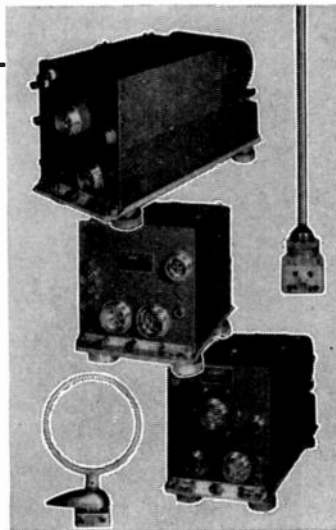

THE A.R.C. TYPE 12 (Above)

Combines the advantages of the Type 11A and the Type 17, offering 2-way VHF, together with LF Range Reception and Rotatable Loop Navigation.

All units of these systems have been Type-Certificated by the CAA. For the highest standards of design and manufacture and the finest in radio equipment, specify A.R.C.



Aircraft Radio Corporation

BOONTON, NEW JERSEY

DEPENDABLE ELECTRONIC EQUIPMENT SINCE 1928

THE SUPERIOR

5
Way



ACTUAL SIZE

BINDING POST

AVAILABLE
NOW WITH

CAPTIVE HEAD

The Superior Electric Company has developed this binding post to give complete insulation, 30 ampere current capacity and 1000 volt working voltage. The captive 1/2" hexagonal head eliminates fumbling—makes a fast, complete, multi-purpose electrical connector.

Features Five Connections

1. Permanent clamping of wire up to #12 through center hole.
2. Looping of wire around center shaft and clamping.
3. Plug-in of standard 3/4" banana plug.
4. Clip-lead connection by turning hex-shaped head to end of shaft.
5. Spade lug connection.

The 5-WAY Binding Post, available in tough red or black phenolic plastic, is offered for immediate delivery. Write for descriptive literature today.

THE
SUPERIOR ELECTRIC
COMPANY

810 Meadow Street
BRISTOL, CONN.



News—New Products

These manufacturers have invited PROCEEDINGS readers to write for literature and further technical information. Please mention your I.R.E. affiliation.

(Continued from page 49A)

Circle Template

The new No. 40 Circle Template for designers, draftsmen, and engineers is now available from Rapidesign, Inc., P.O. Box 592, Glendale, Calif.

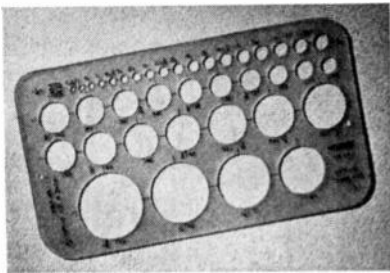

This template has thirty-nine circles grouped in progressive sizes with increments in 64ths, 32nds, 16ths, and 8ths of an inch.

Whole numbers are used for quick reference to the various sizes.

The No. 40 is made of 0.030" matte-finish cellophane-nitrate sheet, precision milled with allowance for pencil point to insure accuracy. Each circle is marked and has a center guide line. Actual size is 4" x 7 1/4".

Alpha Proportional Counter

The Model 117 Alpha Proportional Counter System, developed by Instrument Development Laboratories, Inc., 223-233 W. Erie St., Chicago 10, Ill., was designed for counting alpha particles in the presence of a strong beta activity.

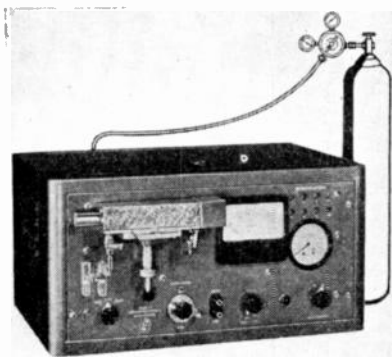

The methane-flow proportional-counter chamber with sample holder has a highly polished cylindrical cathode. The anode is 0.002" tungsten wire mounted between glass insulators.

The two-tube high-gain linear amplifier has a flat frequency response between 10,000 cps and 2 megacycles and has variable gain. The gain is controlled by a panel dial which can be set so that pulses from the counter exceeding any desired amplitude between 2 millivolts and 20 millivolts

(Continued on page 62A)

Laboratory and Research Instruments

ENGINEERED FOR ENGINEERS

OSCILLOSYNCHROSCOPE Model OL-15B

Designed for maximum usefulness in laboratories doing a variety of research work, this instrument is suited to radar, television, communication, facsimile, and applications involving extremely short pulses or transients. It provides a variety of time bases, triggers, phasing and delay circuits, and extended-range amplifiers in combination with all standard oscilloscope functions.



THESE FEATURES ARE IMPORTANT TO YOU

- Extended-range amplifiers: vertical, flat within 3 db 5 cycles to 6 megacycles; horizontal, flat within 1 db 5 cycles to 1 megacycle.
- High sensitivity: vertical, 0.05 RMS volts per inch; horizontal 0.1 RMS volts per inch.
- Single-sweep triggered time base permits observation of transients or irregularly recurring phenomena.
- Variable delay circuit usable with external or internal trigger or separate from 'scope.
- Sawtooth sweep range covers 5 cycles to 500 kilocycles per second.
- 4,000 volt acceleration gives superior intensity and definition.

For complete data, request Bulletin 4810-RO

SWEEP CALIBRATOR



Model GL-22

This versatile source of timing markers provides these requisites for accurate time and frequency measurements with an oscilloscope:

- Positive and negative markers at 0.1, 0.5, 1.0, 10, and 100 microseconds.
- Marker amplitude variable to 50 volts.
- Gate having variable width and amplitude for blanking or timing.
- Trigger generator with positive and negative outputs.

Further details are given in Bulletin 4810-RC.

SQUARE-WAVE MODULATOR AND POWER SUPPLY

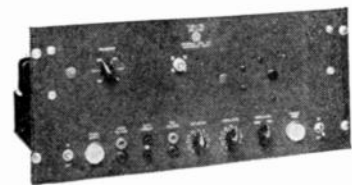

Model TVN-7

Here is the heart of a super high frequency signal generator with square wave, FM, or pulse modulation. Provides for grid pulse modulation to 60 volts, reflector pulse modulation to 100 volts, square wave modulation from 600 to 2,500 cycles. Voltage-regulated power supply continuously variable 280-480 or 180-300 volts dc. For additional data and application notes, see Bulletin 4810-RM.

STANDING WAVE RATIO METER AND HIGH GAIN AUDIO AMPLIFIER

Model TAA-16



Write for Bulletin 4810-RA containing full details of this useful instrument.

- Standing wave voltage ratios are read directly on the panel meter of this sensitive, accurate measuring instrument.
- Frequency range 500 to 5,000 cycles per second.
- Two input channels with separate gain control for each.
- "Wide-band" sensitivity 15 microvolts full scale.
- "Selective" sensitivity 10 microvolts full scale.
- Bolometer/crystal switch adjusts input circuit to signal source.

In Canada, address Measurement Engineering Ltd., Arnprior, Ontario.



BROWNING
Laboratories, Inc.
Winchester, Mass.
ENGINEERED FOR ENGINEERS

AMPERITE

Studio Microphones
at P.A. Prices

Ideal for BROADCASTING

- RECORDING
- PUBLIC ADDRESS

"The ultimate in microphone quality," says Evan Rushing, sound engineer of the Hotel New Yorker.

- Shout right into the new Amperite Microphone—or stand 2 feet away—reproduction is always perfect.
- The only type microphone that is not affected by any climatic conditions.
- Guaranteed to withstand more "knocking around" than any other type mike.

Special Offer: Write for Special Introductory Offer, and 4-page illustrated folder.



Models
RBLG—200 ohms
RBHG—Hi-imp.
List \$42.00



"Kontek" Mikes
Model SKH, list \$12.00
Model KKH, list \$18.00

AMPERITE Company, Inc.

561 BROADWAY · NEW YORK 12, N. Y.

In Canada: Atlas Radio Corp., Ltd., 560 King St. W., Toronto

USE B&W FACILITIES

to step up YOUR production!

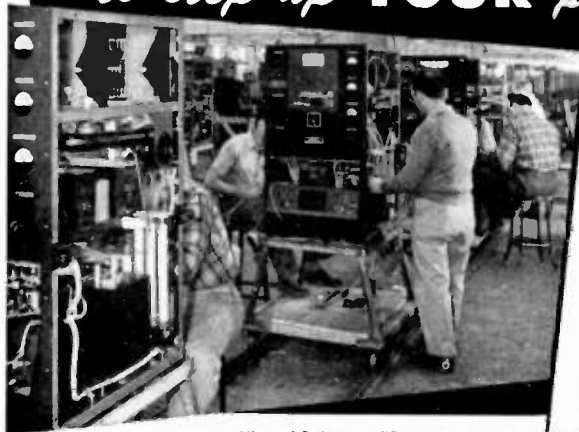

View of 2 KW amplifier assembly line at Barker and Williamson's Bristol, Pa. plant.

NOW IN PRODUCTION AT B & W

Complete Radio Transmitters—Dual Diversity Converters, Control Units and Frequency Shift Exciters for Radio Teletype Transmission—Special Test Equipment—Redesign, Modernization and Modification of Existing Equipment—Machine Work—Metal Stamping—Coils—Condensers—Other Electronic Devices in a Wide Range of Types.

From the simplest to the most complex electronic device, B & W is equipped and prepared to meet your most exacting needs. Three B & W plants, comprising 150,000 square feet, completely equipped with a competent engineering staff; machine shop; tool

room including all machines for drilling, milling, turning, stamping and forming metals and plastics, and a complete woodworking shop, are ready to go to work on your design and production problems. Your inquiries are invited. Write Dept. PR-108 for prompt reply.

BARKER & WILLIAMSON, Inc.
237 FAIRFIELD AVENUE
UPPER DARBY, PA.

MICRODIMENSIONAL
WIRE & RIBBON
FOR VACUUM TUBES

WOLLASTON PROCESS WIRE

drawn as small as .000010";
Made to your specifications
for diameter and resistance

WRITE for list of products.

SIGMUND KORN CORP.

43 GOLD ST., NEW YORK

SINCE 1891

NEW!
SIGNAL FM GENERATOR
MODEL 202-B

FREQUENCY RANGE
54 to 216 MEGACYCLES

The model 202-B is specifically designed to meet the needs of television and FM engineers working in the frequency range from 54-216 mc. Following are some of the outstanding features of this instrument:

- RF RANGES—54-108, 108-216 mc. $\pm 0.5\%$ accuracy.
- VERNIER DIAL—24:1 gear ratio with main frequency dial.
- FREQUENCY DEVIATION RANGES—0-80 kc; 0-240 kc.
- AMPLITUDE MODULATION—Continuously variable 0.50%; calibrated at 30% and 50% points.

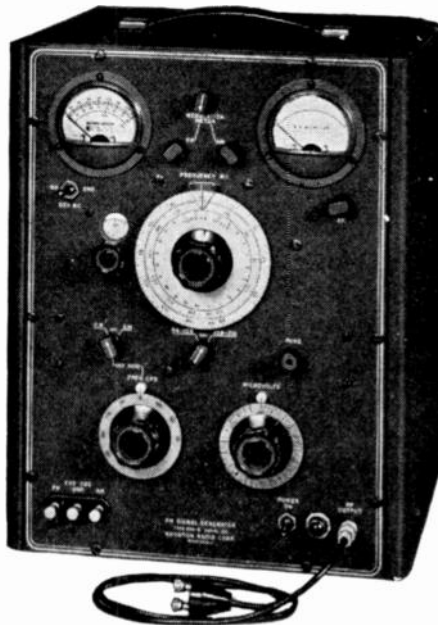

- MODULATING OSCILLATOR—Eight internal modulating frequencies from 50 cycles to 15 kc., available for FM or AM.
 - RF OUTPUT VOLTAGE—0.2 volt to 0.1 microvolt. Output impedance 26.5 ohms.
 - FM DISTORTION—Less than 2% at 75 kc deviation.
 - SPURIOUS RF OUTPUT—All spurious RF voltages 30 db or more below fundamental.
- Write for Catalog D

BOONTON RADIO Corporation  DESIGNERS AND MANUFACTURERS OF THE Q METER - QX CHECKER FREQUENCY MODULATED SIGNAL GENERATOR BEAT FREQUENCY GENERATOR AND OTHER DIRECT READING INSTRUMENTS



PILOT LIGHT ASSEMBLIES

PLN SERIES—Designed for NE-51 Neon Lamp



Features

- THE MULTI-VUE CAP
- BUILT-IN RESISTOR
- 110 or 220 VOLTS
- EXTREME RUGGEDNESS
- VERY LOW CURRENT

Write for descriptive booklet

The DIAL LIGHT CO. of AMERICA
 FOREMOST MANUFACTURER OF PILOT LIGHTS
 900 BROADWAY, NEW YORK 3, N. Y.
 Telephone—Spring 7-1300

A practical and concise treatment of the—

FUNDAMENTALS OF ELECTRIC WAVES

Second Edition

By HUGH H. SKILLING
 Professor of Electrical Engineering and Executive Head of the Department, Stanford University

This book clearly presents the principles of electro-magnetic theory and their practical applications to engineering practice. The author has placed particular emphasis on the basic ideas of Maxwell's equations, and has included many examples to demonstrate them. The rationalized mks system of units has been introduced throughout the book, and explanatory notes in the early chapters clarify this system for those used to the cgs system.

Completely up to date

Much new material has been included in this second edition. The latest information on cylindrical and rectangular wave guides has been incorporated, and there has been an increase and reorganization of the data on the reflection of waves and on antennas. The discussion on wave transmission through semi-conducting media and in ionized regions has been explained.

Contents include:

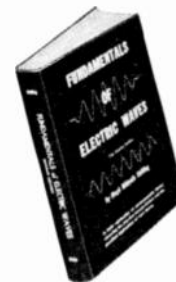

Experiments on the Electrostatic Field; Vector Analysis; Certain Theorems Relating to Fields; The Electrostatic Field; Electric Current; The Magnetic Field; Examples and Interpretation; Maxwell's Hypothesis; Plane Waves; Reflection; Radiation; Antennas; Wave Guides; Waves in the Ionosphere.

254 pages
 1948 \$4.00

ON APPROVAL COUPON
JOHN WILEY & SONS, INC.
 440 Fourth Ave., New York 16, N.Y.
 Please send me, on 10 days' approval, a copy of Skilling's **FUNDAMENTALS OF ELECTRIC WAVES**. If I decide to keep the book, I will remit price plus postage; otherwise I will return the book postpaid.

Name

Address

City State.....

Employed by

(Offer not valid outside U.S.)
 IRE-10-48

Crystals for the Critical

STABILIZED CRYSTALS TO MEET EVERY NEED

Whatever your crystal needs, James Knights Co. is equipped to satisfy them quickly and economically.

To effect greater savings for you on short runs, a special production system has been established.

We are also equipped to quickly build "Stabilized" crystals to your exact specifications. In addition, James Knights Co. fabricates a complete line of "Stabilized" crystals to meet every ordinary need—precision built by the most modern methods and equipment.

For quality—speed—economy, contact the James Knights Co. You'll be glad you did!

*New James Knights Catalog
On Request*

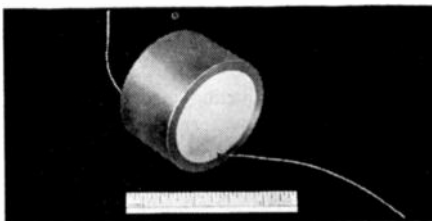

A university physicist wanted a 2" super-sonic X-cut crystal. The James Knights Co. made it promptly and has since delivered many other special crystals for the same university.

The JAMES KNIGHTS Co.

SANDWICH, ILLINOIS



News—New Products

These manufacturers have invited PROCEEDINGS readers to write for literature and further technical information. Please mention your I.R.E. affiliation.

(Continued from page 59A)

will trip the scaler. This allows discrimination between the pulses caused by beta particles and those of an alpha particle.

The scaling circuit is of the binary type a Higinbotham scaler with a selecting switch permitting selection of scales 8, 64, 128, and 256.

The impulse-recording unit is actuated by a driving tube driven by the last scaling stage. Utilizing the scale 256 it is fast enough to register a rate of 500,000 counts per minute.

The counter has a built-in stabilized variable voltage supply. A meter shows the counter anode voltage reading from 1500 to 3000 volts.

Burnell's Keyboard Oscillator

A resistance-tuned type of oscillator using a negative feedback, described as "Burnell's Keyboard Oscillator," Model 150-AO-1/100,000, is being manufactured (in agreement with Burnell & Co., 45 Warburton Ave., Yonkers 2, N. Y.) by Weinschel Engineering Co., Dept. 1, 123 William St., New York 7, N. Y., under a license from Western Electric Co.

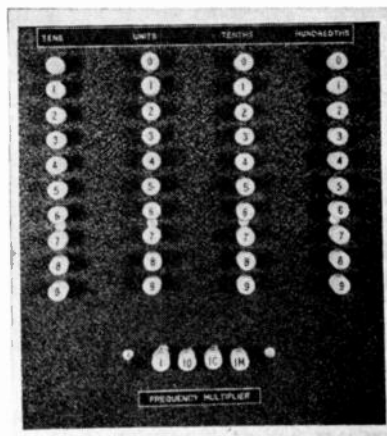

The manufacturer claims that the use of aged, low-temperature-coefficient components produces high stability as to frequency.

The frequency may be varied in steps of 0.01 cps for the range of 1 to 100 cps, 0.1 for 100 to 1000 cps, 1.0 for 1 kc to 10 kc, 10.0 cps for 10 kc to 100 kc.

A continuous fine control in the range of 10 to 100 kc permits adjustment to 1 cps, so that a stationary pattern may be obtained on a comparison oscilloscope when calibrating the oscillator against a frequency standard.

The specifications are: range, 1 to 100,000 cps; stability, drift less than 0.02% per hour after 15 minutes warmup; power supply, 105 to 125 volts, 50 to 60 cps ac, 50 watts; output impedance, 150 ohms internal generator impedance, one side grounded; maximum no load voltage, 15 volts; distortion in the range 20 to 20,000 cps, less than 0.3% if the load is greater than 1,000 ohms.

Problem:

To hold "Nominal Voltages" to within ± 0.1 volts.....

Solution:

Use STABILINE IE

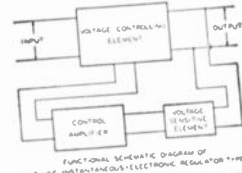

Your utility company may quote a nominal voltage—but power suppliers are allowed to vary, within certain limits, from the nominal. This condition, plus load changes in your own operation, results in voltages other than nominal. A STABILINE Automatic Voltage Regulator Type IE in your power line assures you of constant voltage. It's *instantaneous* in action—completely *electronic* in operation. Holds delivered voltages to within ± 0.1 volts, regardless of line variation . . . within ± 0.15 volts for any load current change or load power factor change from lagging .5 to leading .9. Maximum waveform distortion never exceeds 3 percent.

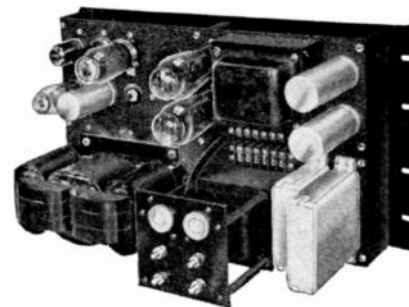

Rear View STABILINE Type IE

Bulletin 547 gives you information on this and other Superior Electric voltage control equipment. Write for your copy today.

**THE
SUPERIOR ELECTRIC
COMPANY**

810 Meadow Street
BRISTOL, CONN.





Model BK-403 Brush Magnetic Ribbon Recorder

**BRUSH
SOUNDMIRROR
USES "XL"**

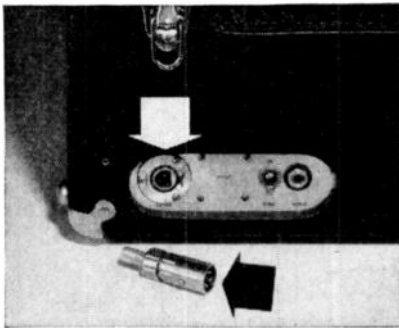

Arrows point to XL Plug and Receptacle

AMONG the many new developments in the electronics field is the "Sound-mirror" which uses Cannon Electric XL connectors.



XL-3-12 Plug



XL-3-13 Receptacle

High on the list of features which make Cannon Electric's "XL" series desirable for quality equipment is the latchlock device which assures quick, positive engagement but also will not pull out accidentally.

For more information on the XL Type Series, write for the XL-347 Bulletin and special condensed catalog RJC-2. Address Department J-377.

**CANNON
ELECTRIC**

Development Company

3209 HUMBOLDT ST., LOS ANGELES 31, CALIF.
IN CANADA & BRITISH EMPIRE:
CANNON ELECTRIC CO., LTD., TORONTO 13, ONT.
WORLD EXPORT (Excepting British Empire):
FRAZAR & HANSEN, 301 CLAY ST., SAN FRANCISCO

SINCE 1915

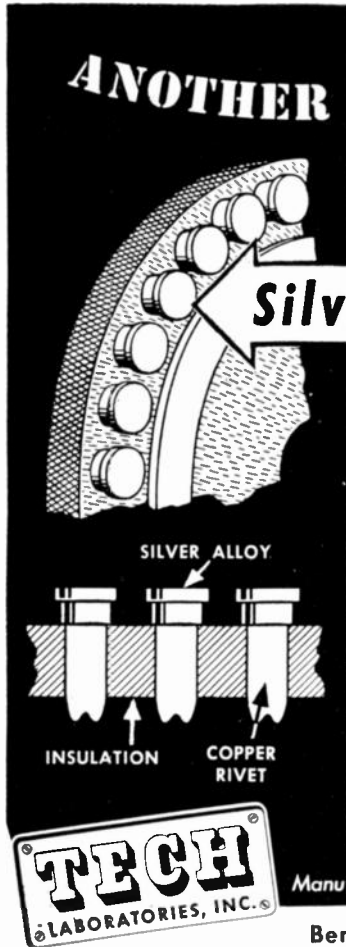

ANOTHER TECH LAB FIRST!
NOW ON ALL
**ATTENUATORS
AND
POTENTIOMETERS**

Silver Alloy Contacts

New Silver Alloy contacts make possible improved Attenuators and Switches in smaller sizes.

- 1 Greater Creepage Distance—thus better insulation.
- 2 No silver migration.
- 3 Greater silver surface to carry current.
- 4 Lower contact resistance.
- 5 Better mechanical operation of switch.
- 6 Less capacity between contacts—better frequency characteristics.
- 7 Better clearance to ground.



TYPE 800 UNIT with new contacts

Manufacturers of Precision Electrical Resistance Instruments

Bergen and Edsall Blvds. • Palisades Park, N.J.

*Measure
Frequencies*



- **INSTANTLY** ... direct reading. No computation.
- **ACCURATELY** ... to a frequency determination of 0.05%.
- **VISUALLY** ... at the turn of the dial indicator knob.

Used effectively in leading laboratories, such as: Harvard University, Bell Aircraft Corp., and Hamilton Standard Propellers... for measuring natural frequencies or speed of rotating objects, checking or calibrating tachometers, oscillators, impulse generators, similar equipment.

C. G. CONN LTD., DEPT. 1013
ELKHART, IND.

*Write for
Free Folder*



Please send free Strobocorr folder containing information about operation and application of this new precision instrument. I understand this places me under no obligation.

Name _____ Position _____
Company _____
Address _____
City _____ Zone _____ State _____



INFORMATION SERVICE

I.R.E. Yearbook and I.R.E. Industry Research Division

A two-fold service is available without cost to firms supplying products for or rendering technical services to the radio-and-electronic industry. (1) The I.R.E. Yearbook, which is noted for its reference value, lists more than 2,000 firms and furnishes product or industry classification. (2) A classified index of products and services is maintained by the I.R.E. Industry Research Division. Radio engineers continuously draw upon this bank of statistical data.

These two sources of information are not only invaluable to I.R.E. members and other engineers, but the proper listing of your company may bring you new business.

To help keep up to date, please check-off your products and services. These may be rewritten on the coupon on next page and sent to: Industry Research Div., Proceedings of the I.R.E. Room 707, 303 West 42nd St., New York 18, N.Y.

Products to Be Checked By Radio-Electronic Manufacturers

1. **AMPLIFIERS, Audio Frequency.**
 - a. Broadcast Speech Input Equipment.
 - b. Dynamic Noise Suppressors.
 - c. High Fidelity.
 - d. Inter-communication Systems.
 - e. Medical Equipment.
 - f. Peak Limiting.
 - g. Phonograph Preamplifiers-equalized.
 - h. Power Amplifiers.
 - i. Pre-amplifiers.
 - j. Public Address Systems.
 - k. Recording Amplifiers.
2. **ANTENNAS.**
 - a. AM Broadcast.
 - b. Dummy.
 - c. FM Broadcast.
 - d. Miscellaneous.
 - e. Receiving Types, all services.
 - f. Television Broadcast.
3. **ANTENNA ACCESSORIES.**
 - a. Feeder Systems.
 - b. Insulators.
 - c. Phasing & Tuning Equipment.
 - d. Support Towers.
 - e. Tower Lighting Equipment.
4. **ATTENUATORS.**
 - a. Audio Frequency.
 - b. Radio Frequency.
5. **BATTERIES.**
 - a. Flashlight & Miscellaneous Dry.
 - b. Hearing Aid.
 - c. Portable Radio Types.
 - d. Storage.
6. **BLOWERS & COOLING FANS.**

Bridges, see 60a.
7. **CABLE & WIRE.**
 - a. Co-axial Cable.
 - b. Pre-formed Harnesses
 - c. Rubber Insulated Wires.
 - d. Shielded Types.
 - e. Synthetic Insulated Wires.
 - f. U.H.F. Types.
8. **CAPACITORS: Fixed.**
 - a. Ceramic.
 - b. Electrolytic.
 - c. Mica.
 - d. Oil Filled.
 - e. Paper.
 - f. Pressurized Gas.
 - g. Vacuum.
9. **CAPACITORS: Variable.**
 - a. Neutralizing.
 - b. Precision.
 - c. Temperature Frequency Compensating.
 - d. Trimmers.
 - e. Tuning.
 - f. Vacuum.
10. **CERAMICS.**
 - a. Coil Forms.
 - b. Custom Fabrication.
 - c. Rods.
 - d. Sheets.
11. **CHASSIS & RELAY RACK CABINETS: Metal.**
 - a. Open Stock.
 - b. Special Order & Custom Fabrication.

Coil Forms, see 10a.
12. **COILS.**
 - a. A. F. Chokes.
 - b. Miscellaneous.
 - c. R. F. Chokes.
 - d. Toroids.
 - e. Transformer Coils.
 - f. Tuning.

Condensers, see 8 & 9.
13. **CONNECTORS.**
 - a. AN Standard Types.
 - b. Microphon.
 - c. Power.

Consoles, see 1a.
14. **CONVERTERS.**
 - a. Frequency.
 - b. Vibrator.

Rotary, see 38.
15. **CORES & CORE MATERIALS.**
 - a. Complete Cores.
 - b. Laminations.
 - c. Powdered Metal.
16. **CRYSTALS.**
 - a. Germanium & Silicon, etc.
 - b. Oscillating Quartz.
 - c. Piezo-Electric.
17. **CRYSTAL HOLDERS.**

Discs, Recording, see 51a.
18. **DRAFTING EQUIPMENT & SUPPLIES.**

Dynamotors, see 38a.
19. **ELECTRONIC CONTROL EQUIPMENT.**
 - a. Air Conditioning Controls.
 - b. Burglar Alarm & Protection Devices.
 - c. Combustion & Smoke Elimination.
 - d. Fire Prevention & Detection.
 - e. Production Controls, Counting & Sorting.
 - f. Variable Speed Regulators.
 - g. Voltage Control & Stabilization.
20. **EQUALIZERS.**
 - a. Dialogue.
 - b. Line.
 - c. Magnetic Reproducer Types.
 - d. Sound Effects.
21. **FACSIMILE EQUIPMENT.**
22. **FILTERS.**
 - a. Band Pass & Band Rejection.
 - b. Dividing Networks.
 - c. Noise Elimination.

Sound effects, see 20d.

Frequency Measuring Equipment, see 37a, 59a, 61b, c, d, and e
23. **FUSES & FUSE HOLDERS.**

Generators, see 38c.
24. **GRAPHIC RECORDERS.**
25. **HARDWARE & MANUFACTURING AIDS.**
26. **INDUCTION HEATING EQUIPMENT.**
 - a. Manufacturing Processes.
 - b. Medical Applications.

Inductors, see 12.
27. **INSULATION.**
 - a. Cloth.
 - b. Glass.
 - c. Mica.
 - d. Paper.
 - e. Varnished Cambric.

See also 10 & 45.
28. **JACKS, JACK FIELDS, PLUGS, & PATCH CORDS.**
29. **KEYS.**
 - a. Switching.
 - b. Telegraph.

Knobs, see 40c.
30. **LACQUERS.**
 - a. Finishing.
 - b. Fungus Proofing.
 - c. Moisture Proofing.
31. **LOUDSPEAKERS & HEADPHONES.**
 - a. Commercial Grade Loudspeakers.
 - b. Headphones.
 - c. High Fidelity Loudspeaking Systems.
 - d. High Frequency Types.
 - e. Low Frequency Types.
32. **MACHINERY, FIXTURES, & TOOLS FOR RADIO-ELECTRONIC MANUFACTURING.**
33. **MAGNETS.**
 - a. Electro.
 - b. Permanent.

Measuring Equipment, see 35, 59, 60, 61.
34. **METALS: Base.**
 - a. Copper.
 - b. Ferrous.
 - c. Non-ferrous, excluding Copper.
 - d. Powdered.
 - e. Precious & Rare.
35. **METERS.**
 - a. Ammeters.
 - b. Elapsed Time.
 - c. Frequency Indicating.
 - d. Voltmeters.
 - e. Volume Level Meters (dB & VU).
 - f. Wattmeters & Watt Hour Meters.

Vacuum Tube Voltmeters, see 60i.
36. **MICROPHONES.**
 - a. Carbon.
 - b. Condenser.
 - c. Crystal.
 - d. Magnetic.
37. **MONITORING EQUIPMENT.**
 - a. Frequency.
 - b. Modulation.
38. **MOTOR GENERATORS.**
 - a. Dynamotors.
 - b. Frequency Changers.
 - c. Motor-Generators.
 - d. Rotary Converters.

- 39. MOTORS: Very Small.**
 a. Blower Motors.
 b. Selsyn Controls.
 c. Timing Devices.
- 40. MOULDED PRODUCTS & SERVICES.**
 a. Cabinets.
 b. Insulators.
 c. Knobs & Parts.
 d. Proprietary Mouldings.
 e. Special Fabrication.
- 41. OPTICAL SYSTEMS, MIRRORS, SCREENS, & ACCESSORIES.**
Oscillators, see 59a, d & 61b, c, d, e.
- 42. OSCILLOGRAPHS & ACCESSORIES.**
 a. General Purpose, Cathode Ray.
 b. Recording.
 c. Synchrosopes, Cathode Ray.
 d. U.H.F. Cathode Ray Equipment.
Panels, see 11.
- 43. PHONOGRAPH & TRANSCRIPTION REPRODUCING EQUIPMENT.**
 a. Crystal Pick-ups.
 b. Magnetic Pick-ups.
 c. Phonograph Motors.
 d. Playback arms.
 e. Record Changers.
 f. Turntables, complete.
Pre-amplifiers, see 1i.
- 44. PILOT LIGHTS & ASSEMBLIES.**
 a. Incandescent.
 b. Neon.
- 45. PLASTICS.**
 a. Raw Powders for Moulding.
 b. Rods.
 c. Sheets.
Plugs, see 13 & 28.
- 46. POINT TO POINT COMMUNICATION EQUIPMENT.**
 a. Aircraft & Airport Equipment.
 b. Citizen Radio.
 c. Emergency Communications.
 d. Fleet Dispatching.
 e. Police & Fire Department Equipment.
 f. Ship to Shore Equipment.
- 47. POWER SUPPLIES.**
 a. Electrically Powered.
 b. Gasoline Driven.
 c. Voltage Regulated Output types.
Printed circuits, see 25.
- 48. PUMPS: Vacuum.**
Racks, see 11.
Radar Equipment, see 64b.

- 49. RADIO RECEIVERS**
 a. Broadcast.
 b. Communications.
 c. Fixed Frequency.
 d. Frequency Modulation.
 e. Special Purpose.
 f. Television.
- 50. RECORDING EQUIPMENT.**
 a. Disc Recording Machines.
 b. Magnetic Tape Recorders.
 c. Magnetic Wire Recorders.
- 51. RECORDING ACCESSORIES & SUPPLIES.**
 a. Blanks.
 b. Cutting Needles.
 c. Disc Recording Heads.
 d. Magnetic Recording Playback, & Biasing Heads.
 e. Magnetic Recording, Tape.
 f. Magnetic Recording Wire.
- 52. RECTIFIERS.**
 a. Metallic.
 b. Vacuum Tube.
Regulators, Voltage, see 67.
- 53. RELAYS.**
 a. Hermetically sealed.
 b. Instrument.
 c. Keying.
 d. Mercury.
 e. Power Control & Overload.
 f. Stepping.
 g. Telephone Types.
 h. Time Delay.
- 54. REMOTE CONTROLLING EQUIPMENT.**
 a. Automatic Tuning Mechanisms.
 b. Remote Controls.
 c. Switching Functions.
 d. Servo-Mechanisms.
- 55. RESISTORS.**
 a. Carbon fixed.
 b. Carbon Variable.
 c. Precision.
 d. Vacuum Sealed.
 e. Wire Wound, Fixed.
 f. Wire Wound, Variable.
- 56. SOCKETS, VACUUM TUBE.**
 a. Receiving Tube Types.
 b. Transmitting Tube Types
 c. Underwriters Laboratories Approved Types.
- 57. SOLDER.**
 a. Acid Cored.
 b. Plain.
 c. Precious Metal.
 d. Pre-forms.
 e. Rosin Cored.
Speakers, see 31.

- 58. SWITCHES.**
 a. Band Switches.
 b. Circuit Breaking.
 c. Key.
 d. Mercury Switches.
 e. Momentary Contact.
 f. Power.
 g. Precision Snap-Acting.
 h. Rotary
 i. Time Delay.
 j. Toggle & Push Button.
- 59. TESTING & MEASURING EQUIPMENT: Audio Frequency.**
 a. Beat Frequency Oscillators.
 b. Distortion & Noise Analyzers.
 c. Intermodulation Distortion Analyzers.
 d. Resistance Capacity Oscillators.
 e. Square Wave Generators.
 f. Wave Form Analysis Equipment.
- 60. TESTING & MEASURING EQUIPMENT: General.**
 a. Bridges, all types.
 b. Capacitance Decades
 c. Capacitor Testers.
 d. Multi-meters.
 e. Resistance Decades.
 f. Resistor Testers-Ohmmeters.
 g. Stroboscopes.
 h. Tube Testers.
 i. Vacuum Tube Voltmeters.
 j. Vibration Testing Equipment.
- 61. TESTING & MEASURING EQUIPMENT: Radio Frequency.**
 a. "Q" Meters.
 b. Signal Generators, AM.
 c. Signal Generators, FM.
 d. Signal Generators, TV.
 e. Standard Frequency Generators & Multi-Vibrators.
 f. Sweep Generators & Calibrators.
 g. Wavemeters.
- 62. TRANSFORMERS.**
 a. Audio Frequency.
 b. Hermetically Sealed.
 c. High Fidelity Audio Types.
 d. Power Components.
 e. Pulse Generating Types.
 f. Radio Frequency.
 g. Voltage Regulating.
- 63. TRANSMITTERS.**
 a. AM Broadcast.
 b. Communications.
 c. FM Broadcast.
 d. Special Types.
 e. TV Broadcast.

- 64. ULTRA HIGH FREQUENCY EQUIPMENT & ACCESSORIES.**
 a. Antennas & Reflectors.
 b. Radar Apparatus.
 c. Receivers.
 d. Transmitters.
 e. Waveguides.
- 65. VACUUM TUBES.**
 a. Cathode Ray.
 b. Geiger-Mueller.
 c. Industrial types.
 d. Klystrons & Magnatrons.
 e. Phototubes.
 f. Pirani Tubes.
 g. Receiving Types.
 h. Rectifiers.
 i. Special Purpose.
 j. Thyratrons.
 k. Television Types.
 l. Transmitting Types.
 m. Voltage Regulators.
- 66. VACUUM TUBE COMPONENT PARTS.**
Varnishes, see 30.
- 67. VOLTAGE REGULATORS.**
 a. Automatic.
 b. Manually Controlled.
- 68. WAXES, POTTING & SEALING COMPOUNDS.**
- 69. WOODEN CABINETS.**
 a. Radio Sets.
 b. Record Storage.
-
- NON-MANUFACTURING CLASSIFICATIONS.**
- 91. BOOKS AND BOOK PUBLISHERS.**
- 92. BROADCASTING STATIONS & COMMUNICATION COMPANIES.**
- 93. CONSULTING ENGINEERS.**
 a. Acoustical.
 b. Electrical.
 c. Mechanical.
 d. Radio.
- 94. DISTRIBUTORS & JOBBERS OF RADIO & ELECTRONIC EQUIPMENT & SUPPLIES.**
- 95. FREQUENCY MEASURING & MONITORING SERVICES.**
- 96. LABORATORIES & CUSTOM BUILDERS OF EQUIPMENT.**
- 97. RECORDING STUDIOS & SERVICES.**
- 98. TECHNICAL SCHOOLS & INSTITUTIONS.**
- 99. TRANSCRIPTION LIBRARIES.**

COUPON

Send to: Industry Research Div., Proceedings of the I.R.E.
 Rm. 707, 303 West 42nd St., New York 18, N.Y.

Date

Firm Name:

Address: Place Zone State

The following is a list of code numbers and letters for our products or services:

.....

**FASTER, SIMPLER
AUDIO ANALYSIS
with Model AP-1**



**PANORAMIC
SONIC ANALYZER**

Reduce time, complexity and cost of making audio measurements with the unusual advantages offered by the Panoramic Sonic Analyzer. By resolving a complex audio wave into a spectrograph showing the frequency distribution and voltage amplitude of the components, Model AP-1...

- Eliminates slow point-by-point frequency checks
- Provides a quick overall view of the audio spectrum
- Enables determination of changes in waveform content while parameters are varied
- Furnishes simple presentations for production line testing.

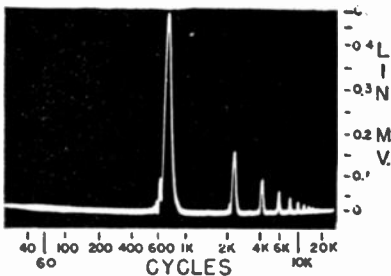

Panoramic Sonic Spectrograph of 750 cps square wave.

Use Model AP-1 for analyzing...
• Harmonics • Intermodulation • Vibration • Noise • Acoustics • Materials

Features... Continuous scanning from 40-20,000 cps in one second • Wide input voltage range • Linear and log voltage scale • Closely logarithmic frequency scale • Built-in voltage and frequency calibrator • Simple operation.

WRITE for detailed specs, price and delivery.
"See us in Booth #7 at National Electronics Conference."

**PANORAMIC
RADIO CORP.**

92 Gold St. Cable Address
New York 7, N. Y. PANORAMIC, NEW YORK
Exclusive Canadian Representative: Canadian Marconi, Ltd.

INDEX AND DISPLAY ADVERTISERS

Section Meetings	34A
Membership	36A
Positions Open	50A
Positions Wanted	55A
News—New Products	22A

DISPLAY ADVERTISERS

Acme Electric Corporation	YB
Aircraft Radio Corp.	YB 58A
Airtron, Inc.	YB
Allen Bradley Company	47A
Allied Radio Corporation	YB
American Electrical Heater Co.	YB
American Lava Corp.	YB 17A
American Television & Radio Co.	YB
Amperite Co., Inc.	YB 60A
Andrew Corporation	YB 55A
Applied Science Corp. of Princeton	YB
Arlington Elec. Prod.	YB
Arnold Engineering Co.	6A
Astatic Corp.	44A
Atlantic India Rubber Works	YB
Audio Development Co.	42A
Audio Devices, Inc.	YB
Ballantine Laboratories	YB
Alfred W. Barber Laboratories	YB
Barker & Williamson	YB 60A
Barry Corporation	YB
Bead Chain Mfg. Co.	YB
Bell Telephone Laboratories	2A & 3A, 35A
Bendix Aviation Corp. (Pacific Div.)	YB
Bendix Aviation Corp. (Scintilla Div.)	53A
Beta Electronics	YB
Biwax Corporation	YB
Blaw-Knox Co.	28A
Bliley Electric Co.	YB 24A
Boonton Radio Corp.	YB 61A
W. H. Brady Co.	YB
W. J. Brown	48A

Browning Laboratories	59A
Burnell & Co.	YB
Bussman Mfg. Co.	YB
Cambridge Thermionic Corp.	YB 57A
Cannon Electric Development Co.	63A
Capitol Radio Engineering Inst.	52A
Centralab	YB 4A
Chatham Electronics	YB
Chicago Transformer	YB
Clark Crystal Co.	YB
Clark-Reiss Distributors	YB
Clarostat Mfg. Co., Inc.	YB 46A
Cleveland Container Co.	46A
Clough Brengle Co.	58A
Cohan-Epner Co.	YB
Sigmund Cohn Corp.	YB 60A
Collins Radio Co.	YB
Communications Equipment Co.	37A
Concord Radio Corp.	YB
C. G. Conn, Ltd.	YB 63A
E. J. Content	48A
Cornell-Dubilier Electric Corp.	Cover III
Cornish Wire Company, Inc.	YB 41A
R. W. Cramer Co., Inc.	YB
Daven Co.	YB
DeJur Amsco Corp.	YB
Dial Light Co. of America	YB 61A
Drake Mfg. Co.	YB
Allen B. DuMont Laboratories	YB 8A
Stanley D. Eilenberger	48A
Eitel-McCullough, Inc.	14A
Electric Soldering Iron Co.	YB
Electrical Reactance Corp.	YB 7A
Electro Engineering Works	YB
Electro Motive Mfg. Co., Inc.	YB 21A
Electro-Seal Corp.	YB
Electro-Tech Equipment Co.	YB
Electro-Voice, Inc.	40A
Engineering Research Associates, Inc.	50A
Erie Resistor Corp.	YB
Federal Telecommunication Laboratories	50A
Federal Telephone & Radio Corp.	YB 53A
Ferranti Electric, Inc.	YB
Field Electrical Inst. Co.	YB
A. W. Franklin Mfg. Co.	YB
Frankel & Nelson	YB
Freed Transformer Co., Inc.	YB 29A
Furst Electronics	YB
General Aniline & Film Corp.	YB
General Electric Company	1A, 10A, & 11A
General Radio Company	YB Cover IV
Paul Godley Company	YB 48A
Goodyear Aircraft Corp.	50A
Herman Lewis Gorden	48A
Samuel Gubin	48A
Alexander Hamilton Institute	YB
Harvey Radio Co.	YB
Hawley Products	YB
A. W. Haydon Co.	YB
Helipot Corp.	YB 67A
Hewlett-Packard Co.	15A
Hughey & Phillips	YB
Hunt Corporation	YB
Illinois Condenser Co.	YB
Indiana Steel Products Co.	YB
Inductive Equipment Co.	YB
Industrial Products Co.	YB
Industrial Television	YB
Insulation Manufacturers Corp.	YB
Insuline Corp. of America	YB
International Nickel Co., Inc.	33A
Jennings Radio Mfg. Co.	YB
E. F. Johnson Co.	24A
Kahle Engineering Company	66A
Kay Electric Co.	YB
Kenyon Transformer Co., Inc.	YB
James Knights Co.	62A
Kollman Instrument Division	YB

Kahle

**ELECTRON TUBE
MACHINERY OF
ALL TYPES**

**STANDARD
AND SPECIAL
DESIGN**

We specialize in Equipment and Methods for the Manufacture of

RADIO TUBES
CATHODE RAY TUBES
FLUORESCENT LAMPS
INCANDESCENT LAMPS
NEON TUBES
PHOTO CELLS
X-RAY TUBES
GLASS PRODUCTS

Production or Laboratory Basis

Manufacturers contemplating New Plants or Plant Changes are invited to consult with us.

**KAHLE
ENGINEERING COMPANY**
1315 SEVENTH STREET
NORTH BERGEN, NEW JERSEY, U. S. A.

Those firms coded "YB" in the above index have provided additional product data in advertisements in the I.R.E. Yearbook. I.R.E. Members will find these ads provide working facts.

Lavoie Laboratories	YB	23A
Lehigh Structural Steel Co.		YB
Lenz Electric Mfg. Co.		YB
Legri-S Company		YB
Linde Air Products Co.	YB	20A
Machlett Laboratories		YB
Macmillan Company		YB
Magnetic Core Corp.		YB
George J. Maki		YB
P. R. Mallory & Co., Inc.		16A
Marion Electrical Inst. Co.	YB	25A
Glenn L. Martin Co.		51A
W. L. Maxson Corp.		52A
McGraw-Hill Book Co.		YB
Measurements Corp.	YB	44A
Melpar, Inc.		52A
Mepco, Inc.		YB
J. W. Miller Co.		YB
Eugene Mittelmann		48A
Mueller Electric Co.		YB
Mycalex Corp. of America	YB	30A & 31A
National Carbon Co., Inc.		YB
National Union Radio Corp.		51A
Newark Electric Co., Inc.	YB	54A
J. M. Ney Co.		48A
North American Philips Co., Inc.		39A
Northern Radio Co.		YB
J. P. O'Donnell & Sons		YB
Ohmite Mfg. Co.	YB	9A
Panoramic Radio Corp.	YB	66A
Par-Metal Products Corp.		YB
Polytechnic Research and Development Co.		19A
Precision Paper Tube Co.		YB
Premax Products		YB
Presto Recording Corp.		YB
Radio Corporation of America		68A
RCA Review	YB	32A,
Radio Receptor Co.		YB
Raytheon Mfg. Co.		38A
Reeves-Hoffman Corp.		57A
Revere Copper & Brass, Inc.		18A
Howard W. Sams & Co., Inc.		YB
Arthur J. Sanial		48A
Hermon Hosmer Scott		YB
Shallcross Mfg. Co.		YB
Sherron Electronics Co.	YB	5A
Shure Brothers, Inc.	YB	36A
Sorensen & Co., Inc.		12A
Sperry Gyroscope Co., Inc.	YB	13A, 50A
Sprague Electric Co.	YB	26A
Standard Piezo		YB
Stephens Mfg. Corp.		YB
Superior Electric Company	YB	58A, 62A
Sylvania Electric Prod. Co., Inc.	YB	27A
TAB		YB
Taylor Fibre Co.		34A
Tech Labs., Inc.		63A
Technology Instrument Corp.		49A
Tektronix, Inc.		48A
Times Facsimile Corp.		YB
Transradio, Ltd.		49A
Truscon Steel Co.		54A
Turner Company	YB	43A
United Transformer Co.	YB	Cover II
V-M Corporation		YB
Valpey Crystal Corp.		YB
Vitroseal Corp.		YB
Waterman Products		YB
W. M. Welch Mfg. Co.		YB
Western Electric Co.	YB	2A & 3A, 35A
Westinghouse Electric Corp.		53A
S. S. White Dental Mfg. Co.	YB	56A
Wilcox Electric Co.		45A
John Wiley & Sons, Inc.	YB	61A
C. K. Williams & Co.		YB
Zophar Mills, Inc.		YB

Do you have This Helpful Helipot and Duodial Catalog?



Do you have complete data on the revolutionary new HELIPOT—the helical potentiometer-rheostat that provides many times greater control accuracy at no increase in panel space?... or on the equally unique DUODIAL that greatly simplifies turns-indicating applications? If you are designing or manufacturing any type of precision electronic equipment, you should have this helpful catalog in your reference files...



It Explains — the unique helical principle of the HELIPOT that compacts almost four feet of precision slide wire into a case only 1 3/4 inches in diameter—over thirty-one feet of precision slide wire into a case only 3 1/2 inches in diameter!

It Details — the precision construction features found in the HELIPOT...the centerless ground and polished stainless steel shafts—the double bearings that maintain rigid shaft alignment—the positive sliding contact assembly—and many other unique features.

It Illustrates — describes and gives full dimensional and electrical data on the many types of HELIPOTS that are available... from 3 turn, 1 1/2" diameter sizes to 40 turn, 3" diameter sizes... 5 ohms to 500,000 ohms... 3 watts to 20 watts. Also Dual and Drum Potentiometers.

It Describes — and illustrates the various special HELIPOT designs available—double shaft extensions, multiple assemblies, integral dual units, etc.

It Gives — full details on the DUODIAL—the new type turns-indicating dial that is ideal for use with the HELIPOT as well as with many other multiple-turn devices, both electrical and mechanical.

If you use precision electronic components in your equipment and do not have a copy of this helpful Helipot Bulletin in your files, write today for your free copy.

THE Helipot CORPORATION, 1011 Mission Street, South Pasadena 6, Calif.

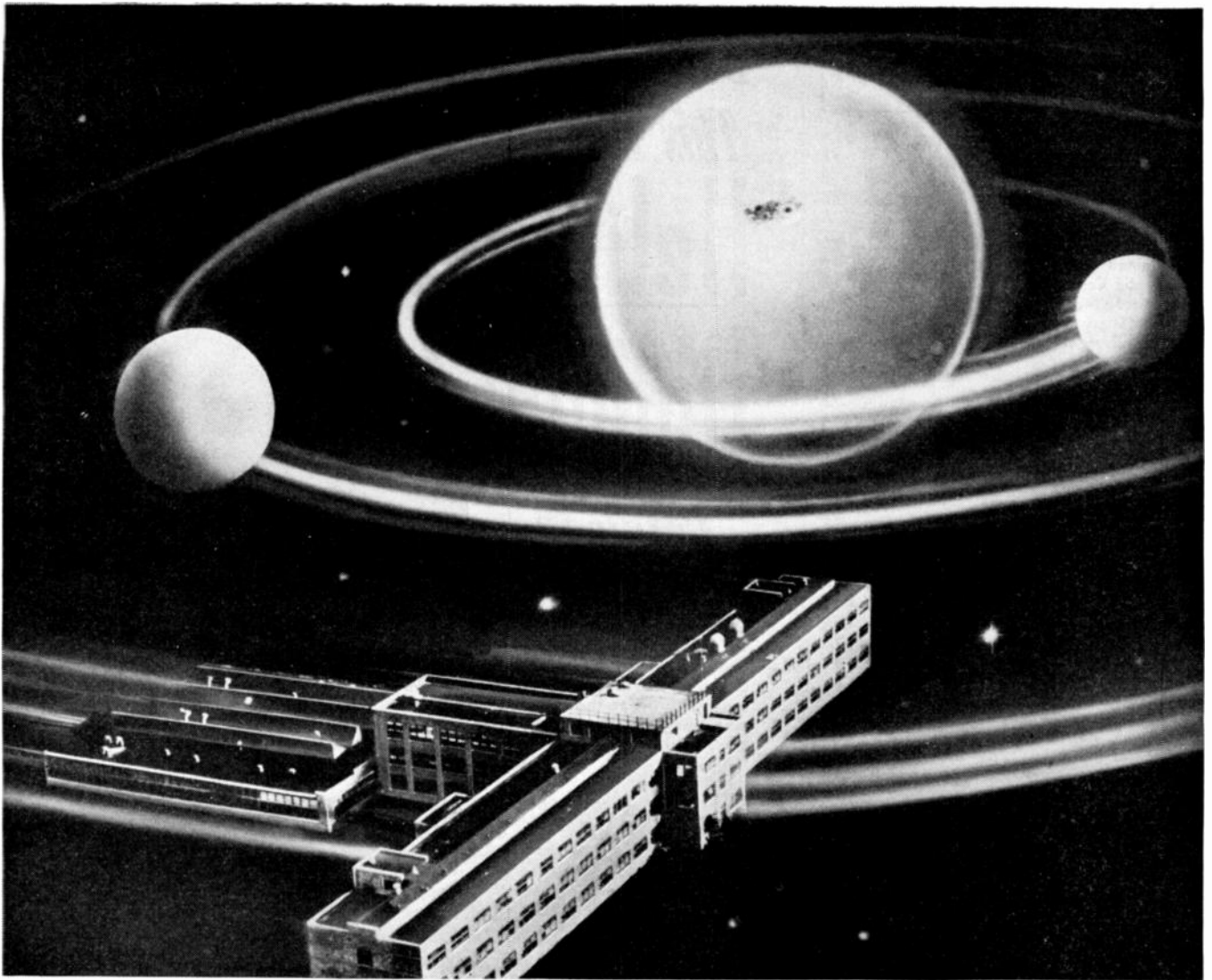

"Sunspot" research, by RCA engineers, helps radio communications to dodge interference from magnetic storms. RCA Laboratories is a center of radio and electronic research.

93,000,000 miles of laboratory space

A cyclonic spot erupts on the face of the sun, and—here on earth—we feel it. Sunspots cause "magnetic storms," which disrupt radio communications.

What can be done about it? Research, during which RCA scientists and engineers "worked" by instrument on the sun—93,000,000 miles away—offers an answer.

For many years, science related magnetic storms to sunspots. An accurate way of forecasting these disturbances was needed.

RCA scientists took a new tack. They noted that interference was most intense when sunspots were in a certain "critical area." Location and activity were observed to be more important than size.

Using this knowledge, RCA communications engineers accurately forecast the beginning and end of magnetic storms. They have established a daily magnetic storm forecasting service which is distributed like weather reports throughout the world. Transmission of messages can

be arranged over circuits or paths that will dodge interference.

Such a pioneering spirit in research gives efficiency of service and leadership to all products and services bearing the names RCA, and RCA Victor.

• • •

When in Radio City, New York, you are cordially invited to see the radio, television and electronic wonders at RCA Exhibition Hall, 36 West 49th Street. Free admission. Radio Corporation of America, RCA Building, Radio City, N. Y. 20.



RADIO CORPORATION of AMERICA

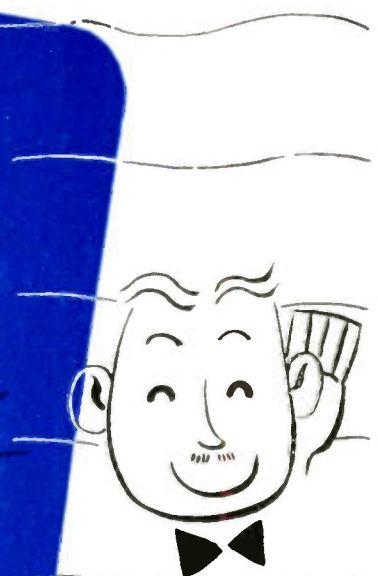
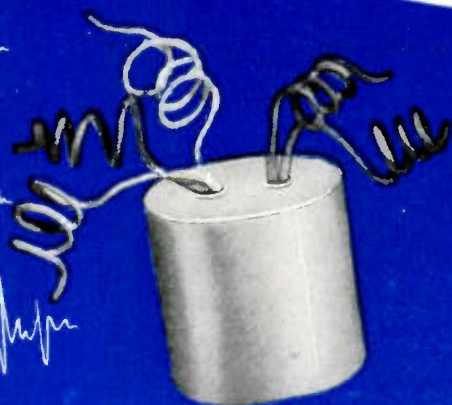

RADIO NOISE-PROOFED WITH C-D QUIETONES

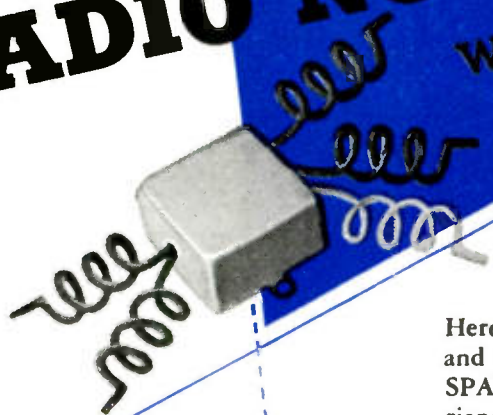
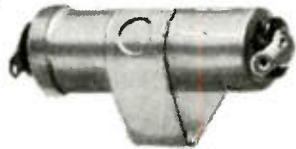
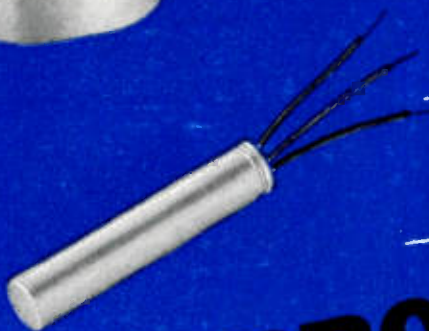

More and more, electrical appliance customers are asking – "Will it cause radio interference?" And in the answer to that question lies the secret for many more sales of your products.

Here at Cornell-Dubilier you'll find *your* answer – in a modern and complete laboratory, devoted to RADIO NOISE AND SPARK SUPPRESSION DEVICES – the industry's most experienced engineers – the thirty-eight-year C-D background, unequalled in the capacitor field. They're all at your disposal – NOW. Whether you want to Radio Noise-Proof equipment already in production – or if you're engineering a new product from the ground up – C-D Quietones will do the job efficiently and permanently. **YOUR INQUIRIES ARE INVITED.** Cornell-Dubilier Electric Corporation, Dept. M-10, South Plainfield, New Jersey. Other large plants in New Bedford, Worcester and Brookline, Mass., and Providence, R. I.

Make Your Products More Saleable with C-D Quietone Radio Noise Filters and Spark Suppressors

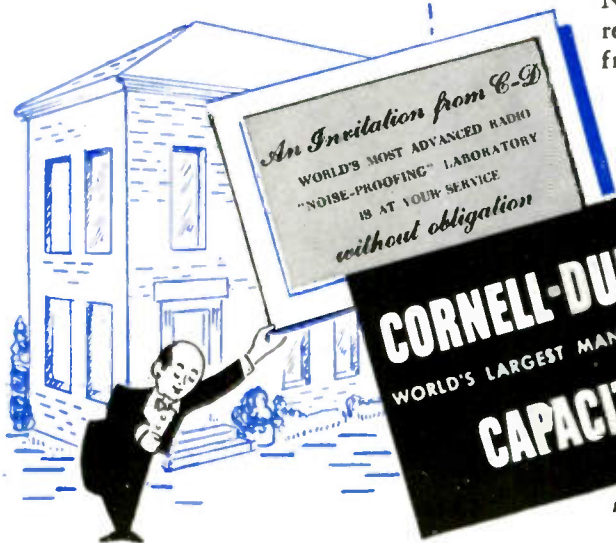

CORNELL-DUBILIER
WORLD'S LARGEST MANUFACTURER OF
CAPACITORS

MICA • DYKANOL • PAPER • ELECTROLYTIC



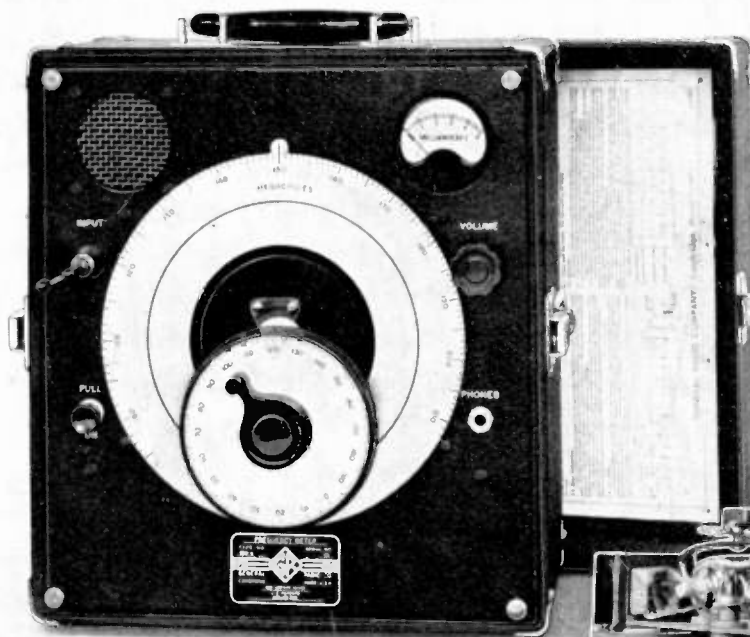

FREQUENCY MEASUREMENTS TO 3,000 Mc

Full advantage of the simplicity of the heterodyne method of frequency measurement is taken in this frequency meter. With a fundamental range of 100 to 200 megacycles, accurate frequency measurements may be made between 10 and 3,000 megacycles.

The tuning circuit is our butterfly type with no sliding contacts, obviating many of the difficulties encountered in the usual tuning elements used in u-h-f-equipment.

A standard plug-in silicon crystal is used as the detector, followed by a three-stage audio amplifier. The band width of the amplifier is 50 kc to permit visual beat indication even if the signal under measurement is unstable.

For very strong signals beat indication may be obtained either aurally from the built-in dynamic loud speaker or visually from the panel meter. For weak signals a telephone jack is provided for headset detection.

Normally no direct connection to the signal under measurement is required, the retractable 'antenna' providing the necessary coupling. On weak signals, terminals are provided for additional pick-up if necessary.

This instrument is finding wide application both in the laboratory and in the field where a portable, self-contained, stable and accurate heterodyne frequency meter is needed for measurements over a very wide range of high and ultra-high frequencies.

TYPE 720-A HETERODYNE FREQUENCY METER \$340

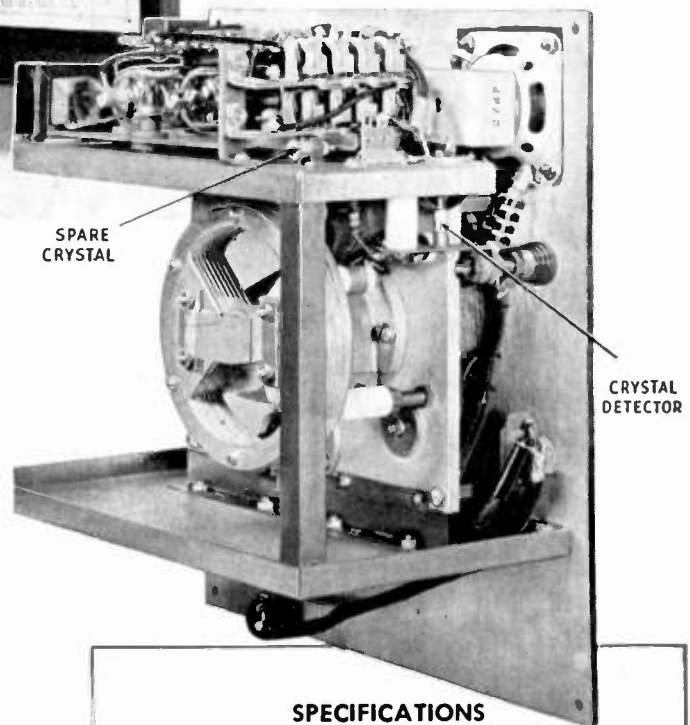

SPECIFICATIONS

FREQUENCY RANGE — fundamental range of instrument is 100 to 200 Mc; by harmonic methods measurement range is 10 Mc to 3,000 Mc.

CIRCUIT — our butterfly tuning unit used in the oscillator; crystal detector (with spare); 3-stage audio-frequency amplifier.

BEAT INDICATORS — built-in dynamic loud speaker and panel meter for aural and visual beat indication; telephone jack for headset indication from weak signals.

ACCURACY — over-all accuracy is $\pm 0.1\%$

CALIBRATION — main dial calibrated in frequency, each division being 1 Mc; one-half turn of vernier dial corresponds to approximately 1% change in frequency over entire tuning range.

PORTABILITY — instrument weighs only 27½ pounds complete with batteries. Separate a-c power supply may be ordered for a-c operation.



GENERAL RADIO COMPANY Cambridge 39, Massachusetts

90 West St., New York 6

920 S. Michigan Ave., Chicago 5

950 N. Highland Ave., Los Angeles 38