

JANUARY · 1955

# Proceedings

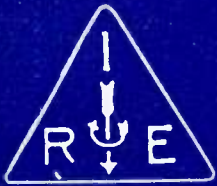

of the I · R · E

**A Journal of Communications and Electronic Engineering**

COLOR TV CONTROLS

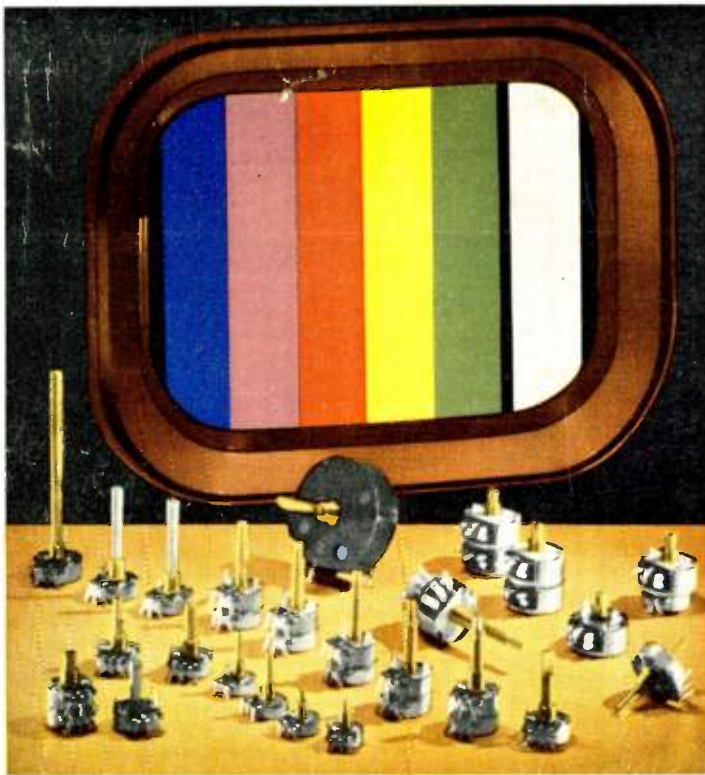

*Chicago Telephone Supply Corp.*

Color television receivers require a greater variety and number of controls than do black-and-white sets. Shown in front of the test pattern above is a complete set of color TV controls, many of them mounted in pairs on concentric shafts.

Volume 43

Number 1

## IN THIS ISSUE

- Fabrication of Airborne Electronic Equipment
- Color Balance for Television
- A Triode Useful to 10,000 Mc
- Equalizing Network for Feedback Control Systems
- Radio Scattering in the Troposphere
- Bidirectional Diode Gates
- Base-Contact Overlap of Junction Transistors
- Traveling-Wave Tube Experiments
- Radial Line Discontinuities
- FM Interference Rejection
- Beam Focusing by Periodic Fields
- Charging and Discharging Nonlinear Capacitors
- Displacement of Zeros Due to Parasitic Dissipation
- Wave Scattering by Wires and Plates
- Electrical Analog for Waveguides
- Abstracts and References

TABLE OF CONTENTS INDICATED BY BLACK-AND-WHITE MARGIN, FOLLOWS PAGE 80A

The Institute of Radio Engineers



OUR 10 MILLIONTH MILITARY UNIT SHIPPED THIS YEAR

# Military Components FOR EVERY APPLICATION

A HUNDRED STOCK UNITS in our catalog B... 30,000 special designs



## FILTERS

UTC filters, equalizers and discriminators are produced in designs from .1 cycles to 400 mc. Carrier, aircraft, and telemetering types available in standard designs.

## POWER COMPONENTS

The scope of military power components produced at UTC ranges from 500 lb. plate transformers to miniaturized 2 oz. units... hermetically sealed and encapsulated... molded types.



## ENCAPSULATED UNITS

8 years of encapsulation experience assure maximum reliability in this class of UTC material.

## MOLDED UNITS

UTC molded units range from 1/8 oz. miniatures to the 100 lb. 3 phase unit illustrated.



## PULSE TRANSFORMERS

UTC pulse transformers cover the range from molded structures weighing a fraction of an ounce to high power modulator applications.



## MINIATURIZED COMPONENTS

UTC H-30 series audios are the smallest hermetic types made. Class A, B, and H power components of maximum miniaturization are regular production at UTC.



## AUDIO COMPONENTS

UTC military audio units range from 1 ounce subminiatures to high power modulation transformers. Standard, high fidelity, sub-audio, and super-sonic types.



## HIGH Q COILS

Unequaled stability is effected in UTC high Q coils thru special processes and materials. Toroid, mu-core, and variable inductors are available to military standards.



## MAGNETIC AMPLIFIERS

In addition to a stock line of servo motor magnetic amplifiers, UTC manufactures a wide variety to customer specifications. Saturable reactors are supplied for frequencies from 1 cycle to 40 mc.



## WRITE FOR UTC CATALOG B

... includes complete line of hermetic audios, reactors, magnetic amplifiers, filters, high Q coils, pulse transformers, etc.

# UNITED TRANSFORMER CO.

150 Varick Street, New York 13, N. Y. EXPORT DIVISION: 13 E. 40th St., New York 16, N. Y. CABLES: "ARLAB"

Plan Now  
for the **4** biggest  
days  
in radio-electronics!

**I R E** National Convention  
and  
**RADIO ENGINEERING SHOW**

March 21-24  
New York City

Once again, you'll soon have the opportunity of appraising all of the important new developments of the past year in radio and electronics. In 4 days, from March 21 through 24, the I R E National Convention and Radio Engineering Show will give you the complete picture of significant developments in the industry achieved during the past year.

You'll hear the presentation of scientific and engineering papers of vital interest to you, carefully arranged into related groups of technical sessions.

You'll see more than 700 exhibits in a 4-acre panorama of all that's new in the radio and electronics field, at Kingsbridge Armory and at Kingsbridge Palace.



The Institute  
of Radio Engineers  
1 East 79th Street,  
New York City

**March  
21-24**

The  
Radio - Electronic  
**SPECTACULAR**  
of 1955!

**See!  
Hear!**

# IRE National Convention



**At both the Waldorf-Astoria** (convention headquarters) and Kingsbridge Armory, you'll attend what actually amounts to 22 conventions fused into one. Hundreds of scientific and engineering papers will be presented during the many technical sessions, a large number of which are organized by I R E professional groups. You'll meet with the industry's leaders—enjoy the finest meeting and recreational facilities in New York.

and

# Radio Engineering Show



**At the Kingsbridge Armory and Kingsbridge Palace**, you'll walk through a vast panorama of over 700 exhibits, displaying the latest and the newest in radio-electronics. You'll talk shop with the industry's top manufacturers—enjoy the conveniences provided for you in the world's finest exhibition halls, easily reached by subway and special bus service.

Admission by registration only. \$1.00 for I R E members, \$3.00 for non-members. Social events extra.

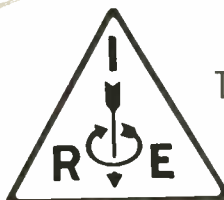

The Institute of Radio Engineers  
1 East 79 Street, New York

PROCEEDINGS OF THE I.R.E. January, 1955, Vol. 43, No. 1. Published monthly by the Institute of Radio Engineers, Inc., at 1 East 79 Street, New York 21, N.Y. Price per copy: members of the Institute of Radio Engineers \$1.00; non-members \$2.25. Yearly subscription price: to members \$9.00; to non-members in United States, Canada and U.S. Possessions \$18.00; to non-members in foreign countries \$19.00. Entered as second class matter, October 26, 1927, at the post office at Menasha, Wisconsin, under the act of March 3, 1879. Acceptance for mailing at a special rate of postage is provided for in the act of February 28, 1925, embodied in Paragraph 4, Section 412, P. L. and R., authorized October 26, 1927.

Table of Contents will be found following page 80A





## Only the RADALIGNER

### gives you:

- A wide band sweep with choice of two center frequencies for aligning radar IF amplifiers.
- Provides variable marker and choice of eight narrow, pulse-type, crystal-controlled markers.

The RADALIGNER is a two-band sweeping oscillator, for use in conjunction with an oscilloscope, to determine the frequency response characteristics of circuits in the HF and VHF (range 310-90 mc). To identify specific frequencies, the RADALIGNER includes any eight specified narrow crystal-controlled markers and a single variable marker covering both sweeping oscillator ranges. On special order, up to two crystal-controlled CW oscillators may be provided in the equipment.

#### FEATURES:

Entire bandpass of any equipment in the 10-90 mc range may be checked instantaneously.

Individual marker circuits provide marks independent of test circuit characteristics.

Sweeping oscillators completely electronic, with no mechanically-driven elements.

Phasing problems eliminated by using single sawtooth voltage for deflecting oscilloscope and driving the sweeping oscillator.

#### SPECIFICATIONS:

**Sweep:** Regular sawtooth, adjustable around or synchronized with 60 cps power line.

**Frequency Range:** Center frequencies may be selected, to your specifications, at any two points in the 15 to 80 mc band.

Sweep Width:	Wide Band	Narrow Band
Center Frequency below 30 mc:	+ 5 mc	+0.5 mc
Center Frequency above 30 mc:	+10 mc	+1.5 mc

**Amplitude Modulation While Sweeping:** Less than 0.05 db/mc.

**RF Output Voltage:** 250 millivolts into 70 ohms.

**RF Output Control:** Switched attenuators: 20 db, 10 db and 3 db.

Continuous attenuator: approximately 6 db.

**Markers:** Fixed—Eight, narrow pulse

type, crystal-controlled markers, positioned at customers' option. Available singly or in any combination through individual switches.

**Variable—**Frequency continuously variable throughout selected sweep ranges. Frequency calibration accurate to within 0.5%.

**Marker Output Voltage:** Positive pulse, approximately 10 volts peak.

**Marker Output Control:** Continuously variable, zero to maximum.

**Power Requirements:** 105 to 125 volts; 50-60 cps. approx. 110 watts.

**Dimensions:** With standard rack mounting panel, 10½" high x 19" wide x 16½" deep. With cabinet, 12" x 28" x 17".

**Weight:** 50 lbs.

**Catalog No. 511-A.**

**Price:** \$795.00 (rack-mounted), f.o.b. factory. Cabinet \$35.00 extra.

WRITE FOR 1954-55 CATALOG

# KAY ELECTRIC COMPANY

14 MAPLE AVE. • CALDWELL 6-4000 • PINE BROOK, N. J.

PRECISION TEST AND MEASURING INSTRUMENTS FOR LABORATORY, PRODUCTION AND FIELD



## Meetings with Exhibits

● As a service both to Members and the industry, we will endeavor to record in this column each month those meetings of IRE, its sections and professional groups which include exhibits.

△

February 10, 11, 12, 1955

**Seventh Annual Southwestern IRE Conference, Baker Hotel, Dallas, Texas**

*Exhibits:* T. W. Sharpe, Collins Radio Co., 1930 Hi-Line Drive, Dallas 2.

March 1-3, 1955

**Western Joint Computer Conference and Exhibition, Hotel Statler, Los Angeles, Calif.**

*Exhibits:* Mr. William L. Martin, 5230 Norwich Ave., Van Nuys, Calif.

March 21-24, 1955

**Radio Engineering Show and I.R.E. National Convention, Kingsbridge Armory and Kingsbridge Palace, N.Y.C.**

*Exhibits:* Mr. William C. Copp, Institute of Radio Engineers, 1475 Broadway, New York 36, N.Y.

April 27-29, 1955

**Seventh Regional Technical Conference & Trade Show, Hotel Westward Ho, Phoenix, Ariz.**

*Exhibits:* Mr. George McClanathan, 509 East San Juan Cove, Phoenix, Ariz.

May 9-11, 1955

**National Conference on Aeronautical Electronics, Biltmore Hotel, Dayton, Ohio**

*Exhibits:* Mr. William Klein, 1472 Earlham Drive, Dayton, Ohio

May 18-20, 1955

**National Telemetering Conference, Morrison Hotel, Chicago, Ill.**

*Exhibits:* Mr. Kipling Adams, General Radio Company, 920 S. Michigan Ave., Chicago, Ill.

May 19-21, 1955

**Armed Forces Communication Association Global Communications Conference, Hotel Commodore, New York, N.Y.**

*Exhibits:* Mr. William C. Copp, 1475 Broadway, New York 36, N.Y.

Aug. 24-26, 1955

**Western Electronic Show & Convention, Civic Auditorium, San Francisco, Calif.**

*Exhibits:* Mr. Mal Mobley, 344 N. LaBrea, Los Angeles 36, Calif.

Sept. 12-16, 1955

**Tenth Annual Instrument Conference & Exhibit, Shrine Exposition Hall & Auditorium, Los Angeles, Calif.**

*Exhibits:* Mr. Fred J. Tabery, 3443 So. Hill St., Los Angeles 7, Calif.

Working committeemen on IRE groups conducting meetings with exhibits are invited to send data to this column. Address IRE Advertising Department, 1475 Broadway, New York 36, N.Y.



## THIS IS IT!

This is the actual size of the newest, smallest Blue Jacket—ready now to help solve your production problems!

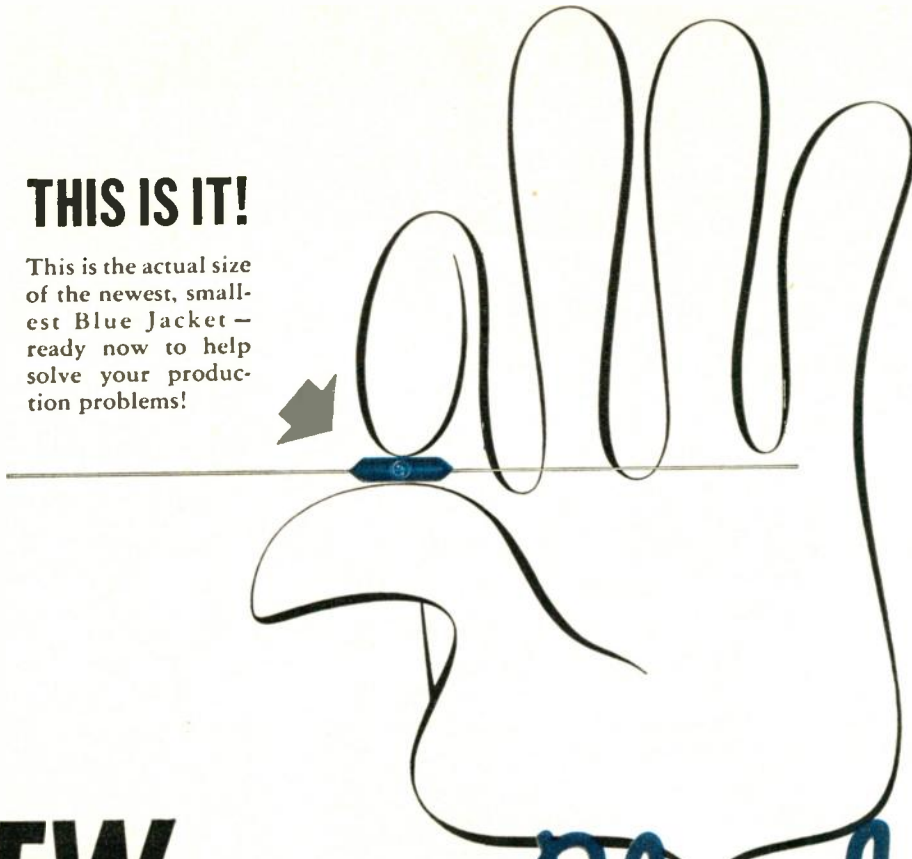

# NEW... a 3-watt Blue Jacket<sup>®</sup> miniaturized axial-lead wire-wound resistor

This power-type wire wound axial-lead Blue Jacket is hardly larger than a match head *but it performs like a giant!* It's a rugged vitreous-enamel coated job—and like the entire Blue Jacket family, it is built to withstand severest humidity performance requirements.

Blue Jackets are ideal for dip-soldered sub-assemblies . . . for point-to-point wiring . . . for terminal board mounting and processed wiring boards. They're low in cost, eliminate extra hardware, save time and labor in mounting!

Axial-lead Blue Jackets in 3, 5 and 10 watt ratings are available without delay in any quantity you require. ★ ★

SPRAGUE TYPE NO.	WATTAGE RATING	DIMENSIONS L (inches) D		MAXIMUM RESISTANCE
151E	3	3/32	1/16	10,000 Ω
27E	5	1/8	1/8	30,000 Ω
28E	10	1/4	3/16	50,000 Ω

Standard Resistance Tolerance: ±5%



WRITE FOR ENGINEERING BULLETIN NO. 111B

# SPRAGUE



SPRAGUE ELECTRIC COMPANY • 235 MARSHALL ST. • NORTH ADAMS, MASS.

# FOR TV . . . IT DODGES TROUBLE YOU CAN'T STOP



*Radio Relay station on route between Chicago, Ill., and Des Moines, Iowa. Every fifth or sixth relaying tower is a control station, where high-speed switching equipment enables a TV picture to skip out of a troubled channel and into a stand-by protection channel faster than the eye can wink.*

There's no way to stop atmospheric changes that threaten television with "fade." But, for TV that travels over Bell's Radio Relay System, Bell Laboratories engineers have devised a way to sidestep Nature's interference.

When a fade threatens—usually before the viewer is aware—an electronic watchman sends a warning signal back by wire to a control station perhaps 200 miles away. An automatic switching mechanism promptly transfers the picture to a

clear channel. The entire operation takes 1/500 of a second. When the fade ends, the picture is switched back to the original channel.

This is an important addition to the automatic alarm and maintenance system that guards Bell's Long Distance network for television and telephone calls. It marks a new advance in Bell Laboratories' microwave art, developed to make your Long Distance telephone service, and your TV pictures, better each year.

## BELL TELEPHONE LABORATORIES

Improving telephone service for America provides careers for creative men in scientific and technical fields.





ANNOUNCING



A new precision instrument—the 501 Time Rate Indicator—combining speed and accuracy with direct numerical readout through its entire 10 Mc./sec. range. Compare these features against your counting or time-rate measurement possibilities:

Frequency measurement to 10 Mc./sec.;  
20 millivolt sensitivity  
 $\pm 1$  count  $\pm 0.3$  ppm per month  
absolute accuracy

Automatic decimal point  
Remote, local, continuous or manual  
measurement cycle control

Measures directly:  
Frequency, Period, Elapsed Time,  
Ratio of two Frequencies.

Dimensions:  $19\frac{1}{2}$ " w x 15" h x 18" d

Inquiries on export sales should be  
addressed to:  
ANDREW S. SZUCS, Inc.  
50 Broad Street, New York 4, N. Y.



Creative developments in the field of electronics . . .  
**LABORATORY for ELECTRONICS, Inc.**  
75 PITTS STREET, BOSTON 14, MASSACHUSETTS



# 1 to 5 ratio your quality insurance

- 21 INSPECTORS to each 100 production workers—a 1 to 5 ratio.
- ALL units thoroughly inspected on exacting custom equipment.
- UNIQUE inspection procedure for each application.

#### EXTREME MANUFACTURING ACCURACY

- EVERY gear cut with an AA hob and rolled against a master.
- EVERY final grind on every shaft run through a Sheffield comparator set by "jo" blocks.
- EVERY bearing bore checked with an air gauge and XX plug gauge.

A wide variety of rotating electrical components for electronic and airborne applications . . . designed and produced to your specifications. Send your requirements to OSTER design engineers. Write for "The Oster Story of Quality" today.



*John Oster*

MANUFACTURING CO.  
AVIONIC DIVISION  
RACINE, WISCONSIN

Your Rotating Equipment Specialist





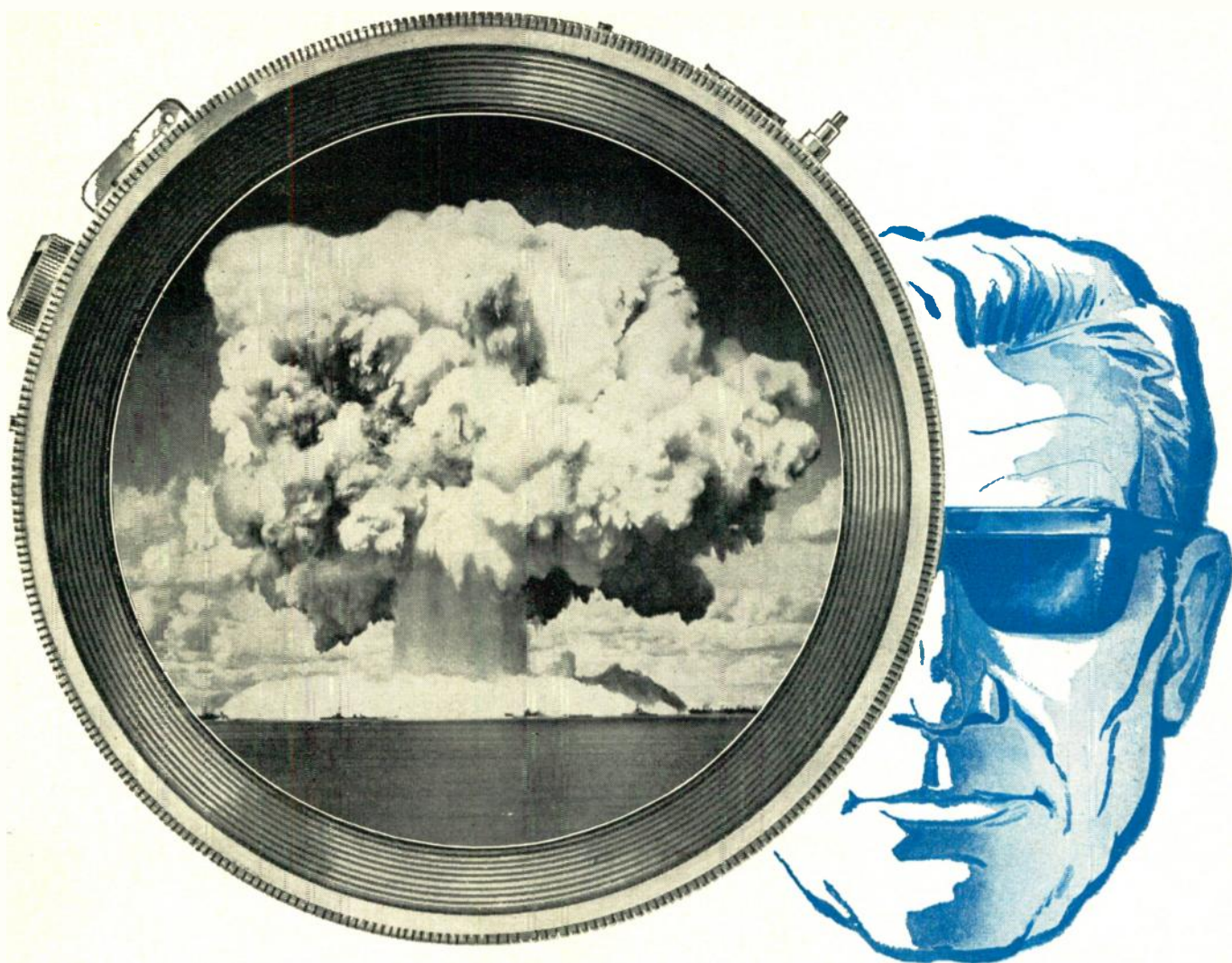

## how to stop an h-blast

**WANTED:** a camera to stop the action of a nuclear explosion at a pre-selected microsecond, with high quality image-definition . . . that was the problem handed by the AEC and its Los Alamos Scientific Laboratory to the Boston firm of Edgerton, Gernsmaier & Grier, Inc. EG&G solved it by inventing the non-mechanical Rapatron shutter . . . employing the Faraday Effect of magnetically rotating the plane of polarized light as it traverses an optical element . . . and relying on HELIPOT\* precision potentiometers and DUODIAL\* turn-counting dials for sensitivity setting and calibration.

A light-pulse from the blast falls on a photocell . . . generates a signal that passes through a variable time-delay to trigger a condenser-discharge circuit . . . releasing energy which surges through a coil wound around a lead-glass lens. The resulting magnetic field rotates polarized light from the blast as it passes through the lens . . . effecting a one-microsecond exposure.

Sensitivity of the photocell circuit is controlled by a standard-linearity Model A 10-turn HELIPOT, calibrated with a Model RB DUODIAL. Time-delay from photocell pick-up to shutter operation . . . continuously variable from 0 to 100 microseconds . . . is controlled by a Model A 10-turn HELIPOT of 0.1% linearity, calibrated with a Model W10 DUODIAL.

The coil of the HELIPOT is wound with more than 10,000 turns of resistance wire . . . the DUODIAL is settable to a

fraction of any of its thousand scale-divisions . . . and the Rapatron shutter can be tripped at any preselected fraction of a microsecond.

For complete details of this and other HELIPOT applications, write for Data File 102



MODEL A HELIPOT



W10 DUODIAL



# Helipot

*first in precision potentiometers*

*Helipot Corporation/South Pasadena, California*  
*Engineering representatives in principal cities*  
 a division of BECKMAN INSTRUMENTS, INC.



\* 342  
 T.M. REG.



# VHF

... Very High Frequencies



**RADIO INTERFERENCE  
and FIELD INTENSITY \*  
measuring equipment**

## Stoddart NM-30A • 20mc to 400mc

Commercial Equivalent of AN/URM-47

**PRINTED CIRCUITRY...** Modern printed circuits offer many advantages over conventional wiring, lighter weight, more compact units and freedom from many of the troubles normally encountered in conventionally-wired electronic equipment. Vibration becomes even less of a problem with printed circuits, adding to the many portable features already available with Stoddart equipment.

**ADVANCED DESIGN...** Specialized engineering and modern production techniques have produced one of the most advanced instruments for the accurate measurement, analysis and interpretation of radiated and conducted radio-frequency signals and interference ever manufactured. Designed to laboratory standards, rugged, and with matchless performance, the versatile NM-30A is an outstanding example of modern instrumentation. Its frequency range includes FM and TV bands.

**SMALLER SIZE...** A wider frequency range and higher standard of performance is incorporated into an equipment whose size is one-third that of any similar equipment ever manufactured.

**SENSITIVITY...** Sensitivity ranges from one to ten microvolts-per-meter, depending upon frequency and antenna in use.

**APPLICATIONS...** Field intensity surveys, antenna radiation pattern studies, interference location and measurement for checking radiation from virtually any mechanical or electrical device capable of generating or radiating radio-frequency signals or interference.

**Stoddart RI-FI\*** Meters cover the frequency range 14kc to 1000mc

### VLF

NM-10A, 14kc to 250kc  
Commercial Equivalent of  
AN/URM-6B. Very low frequen-  
cies.

### HF

NM-20B, 150kc to 25mc  
Commercial Equivalent of  
AN/PRM-1A. Self-contained  
batteries. A.C. supply optional.  
Includes standard broadcast  
band, radio range, WWV, and  
communications frequencies.  
Has BFO.

### UHF

NM-50A, 375mc to 1000mc  
Commercial Equivalent of  
AN/URM-17. Frequency range  
includes Citizens band and  
UHF color TV-band.

## STODDART AIRCRAFT RADIO Co., Inc.

6644-C Santa Monica Blvd., Hollywood 38, California • Hollywood 4-9294

# TRIAD INSTRUMENT TRANSFORMERS

for REGULATED POWER SUPPLIES



AVAILABLE FROM STOCK

Triad Transformers  
ESPECIALLY DESIGNED for  
regulated supplies employ  
multiple static shields,  
isolated filament windings,  
special values of high  
voltage, and low flux  
density, to insure  
optimum performance.

Type No.	List Price	Plate Supply		Filament Windings	
		AC Volts	DC Ma.	Volts	Amperes
R-70A	\$11.25	880 C.T.	75	6.3V.-6A. 6.3V.-3A.	6.3V.-9A. 6.3V.-3A.
R-26A	21.50	880-720 C.T.	200	6.3 C.T.-8A. 6.3V.-1A.	6.3V.-3A. 5V.-3A.
R-28A	32.50	1250 C.T.	300	6.3 C.T.-8A. 6.3V.-3A.	6.3V.-3A. 5V.-6A.
R-46A	33.00	1250 C.T. 130 (Bias)	350 50	5V.-4A.	6.3V.-5A 6.3V.-1A. 6.3V.-1A.
R-46A will supply 550 V. D.C. using 2 5R4G rectifier tubes, choke input. Will also supply 130 V. for bias using Selenium rectifier.					
R-27A	45.00	1500 C.T.	400	5V.-6A.	6.3V.-3A 6.3V.-8A



Write for  
catalog TR-54H



4055 Redwood Ave., Vanice, Calif.



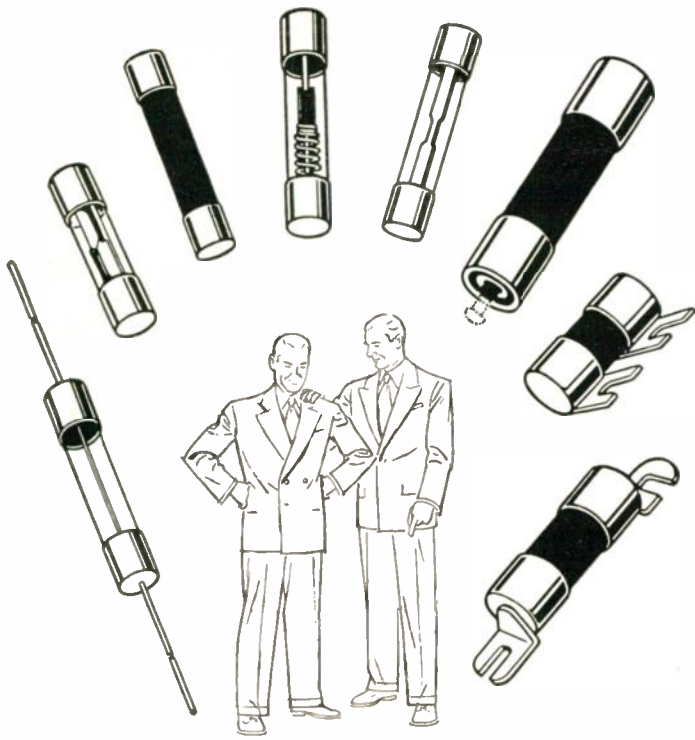

# BUSS

**... one source  
to meet all your  
Fuse Needs!**

CONSISTENT PIONEERING in the development of fuses that meet the most exacting standards has helped BUSS keep pace with the Electronic Industries expanding need for fuses.

The complete BUSS line of fuses includes: — dual-element (slow blowing), renewable and one-time types . . . in sizes from 1/500 ampere up . . . plus a companion line of fuse clips, blocks and holders.

It's convenient to get all your fuses from one source. Purchasing, stock handling and records are simplified.

And to make sure that the BUSS reputation for quality is maintained, every BUSS fuse normally used by the Electronic Industries is tested in a sensitive electronic device that rejects any fuse not correctly calibrated, properly constructed and right in all physical dimensions.

If you are designing a new device — or have a special problem in electrical protection — BUSS may be able to save you considerable engineering time. To help you determine the right fuse or fuse mounting for the job, BUSS places at your service the world's largest fuse research laboratory and its staff of experienced engineers.

MAKERS OF A COMPLETE LINE OF FUSES FOR HOME, FARM, COMMERCIAL, ELECTRONIC AND INDUSTRIAL USE

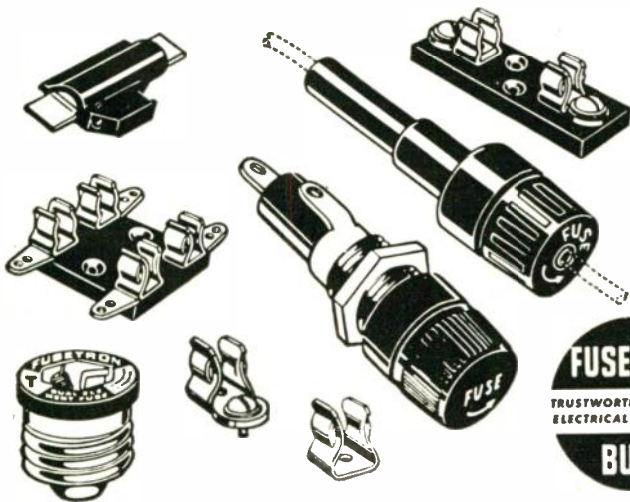

**For More Information Mail this Coupon** ▼

BUSSMANN Mfg. Co. (Div. McGraw Electric Co.)  
University at Jefferson, St. Louis 7, Mo.

Please send me bulletin SFB containing facts on BUSS small dimension fuses and fuse holders.

Name.....Title.....

Company.....

Address.....

City & Zone.....State.....

155  
IRE



WHEN YOU SPECIFY . . . **MAGNETIC SHIELDS**  
SPECIFY . . .

**MAGNETICS inc.**

*Performance -  
Guaranteed*

#### HERE'S WHY . . .

Shielding is a vital element in circuit design, and the Magnetics, Inc. "Performance-Guarantee" on your shields is your assurance that they have been designed and manufactured to meet *your* performance specifications. You then know, whether your shields have been made from Mumetal, A.E.M. 4750, or from any other commercially available magnetic or non-magnetic material selected to meet your needs, they will make money for you on the assembly line by eliminating waste.

You also know that these Performance-Guaranteed Magnetic Shields cost no more—indeed, despite the fact that you have a guarantee of performance, they are sold at prices standard in the industry. Let our Engineering Department design your shields and production engineer to your cost requirements . . . one more important Magnetics, Inc. service to our customers.

#### How Do You Like Your Shields? . . .

Painted, lacquered . . . or unfinished? Painted . . . to match any equipment shade you select? From *any* commercially available material to meet your performance and cost needs? That's exactly how they're furnished by Magnetics, Inc. . . . to meet *your* specifications.

#### WANT THE COMPLETE STORY?

Write us . . . on your company letterhead . . . we'll be delighted to answer your questions. No obligation, of course. . . .

**MAGNETICS inc.**

DEPT. I-14 BUTLER, PENNSYLVANIA



# Presenting AC-4A DECADE COUNTERS

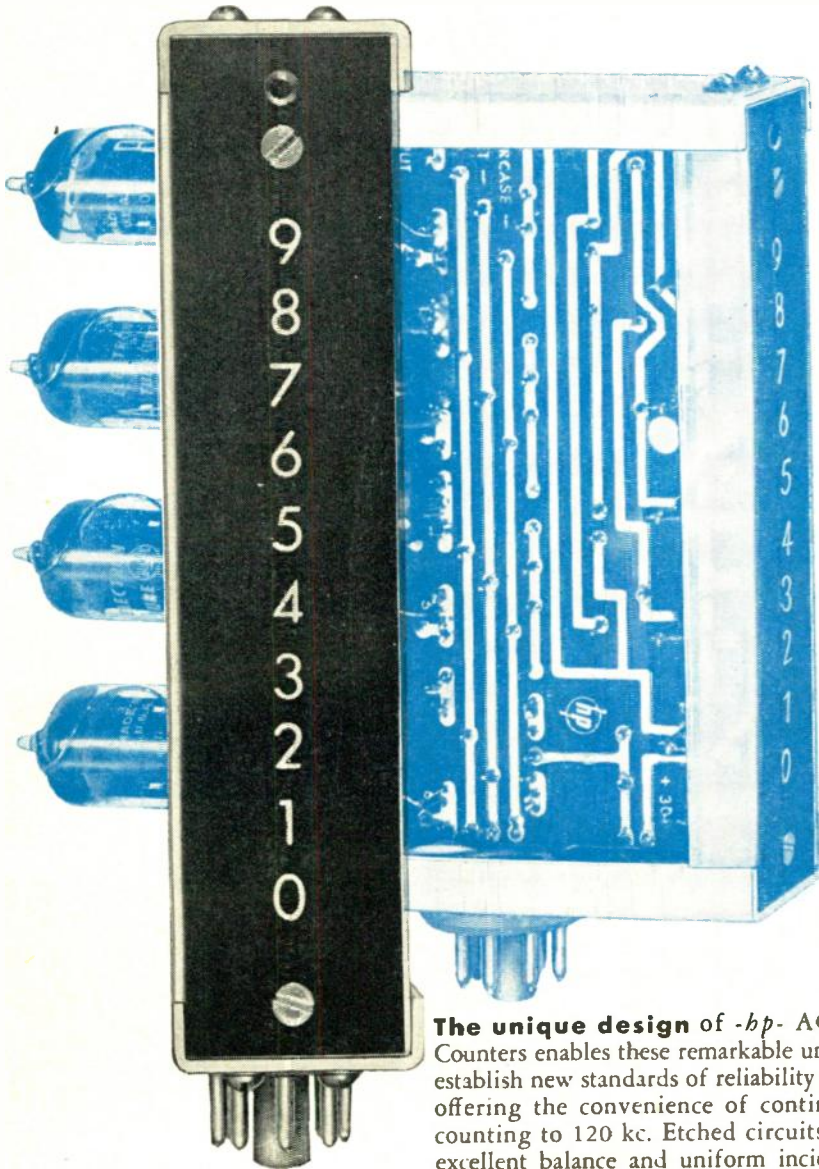

- 120 kc counting rate**
- Will operate recorders**
- Low cost, high reliability**
- Brilliant numerals**
- Labeled, etched circuits**
- Low temperature operation**
- Fits all standard counters**
- Ideal for special purpose applications**

**The unique design of -hp- AC-4A** Counters enables these remarkable units to establish new standards of reliability while offering the convenience of continuous counting to 120 kc. Etched circuits give excellent balance and uniform incidental capacities for the high 120 kc counting rate. A staircase output voltage proportional to count is available to operate recorders or external equipment using coincidence detectors. The circuit is completely

visible, accessible, labeled and arranged diagrammatically. Mechanical layout permits maximum ventilation—lower temperatures and longer life. Optically engineered illuminated numerals are clear, bright, easy to read under all conditions.

**-hp- AC-4A Counters** are recommended replacement units for *-hp-* 522 and 524 series Electronic Counters; and are ideal for experimental and special applications.

Write for details

**HEWLETT-PACKARD COMPANY**  
3218D Page Mill Rd. • Palo Alto, Calif., U.S.A.  
Export: 275 Page Mill Road, Palo Alto, Calif.  
Cable: "HEWPACK"

Sales engineers in all principal areas

## SPECIFICATIONS

**Counting Rate:** 120 kc max.  
**Double-Pulse Resolution:** 5  $\mu$ sec  
**Input:** Approx. 80 v neg.; 1  $\mu$ sec rise time  
**Output:** Approx. 80 v neg. to drive succeeding counter  
**Reset:** To 0 or 9

**Staircase Output:** 135 v at 0, 55 v at 9.  
Internal resistance 700 K  
**Size:** 5 $\frac{1}{2}$ " deep, 1 $\frac{1}{4}$ " wide, 6 $\frac{1}{8}$ " high.  
Weight 1 lb.  
**Mounting:** Standard. Fits octal socket  
**Price:** \$45.00.

Data subject to change without notice. Prices f.o.b. factory



**INSTRUMENTS**

**Complete Coverage**

# Standard of the Industry -



Write today for the new  
Q-Max bulletin containing  
complete application data.

Leading manufacturers specify Q-Max—the finest coil lacquer for VHF and UHF service. Q-Max is practically loss-free, seals out moisture, increases rigidity and electrical stability, adheres to practically any material, dries fast!



# max



• REGISTERED TRADE NAME

## A-27 RF LACQUER



*Communication Products Company, Inc.*

MARLBORO, NEW JERSEY — Telephone: FReehold 8-1880



# NEW!

## Two more PLUG-IN UNITS for Tektronix Type 531 and 535 Oscilloscopes

### Type 53E Low-Level Differential Pre-amplifier

50 microvolt/cm to 10 millivolt/cm calibrated sensitivity. Frequency response, 0.06 cycles to 60 kc. Rejection ratio, 80,000 to 1 for in-phase signals at full gain. 7 $\mu$ v rms maximum combined noise and hum with input grids grounded at the input connector . . . . . \$165



### Type 53G Differential Wide-Band DC Pre-amplifier

DC to 10 mc, risetime 0.035  $\mu$ sec. 0.05 v/cm to 20 v/cm calibrated sensitivity. Separate step attenuators for both inputs. Better than 100-to-1 common-mode rejection at full gain for the entire passband . . . . . \$175



A new micro-sensitive preamplifier, Type 53E . . . and a new wide-band differential preamplifier, Type 53G . . . greatly expand the working range of Type 531 and Type 535 Oscilloscopes. Application areas entered with these new plug-in units ordinarily require the acquisition of cumbersome auxiliary equipment or separate specialized oscilloscopes. But you can equip your Type 531 or Type 535 for either or both types of work for just the cost of the plug-in unit . . . without loss of performance in its other applications. *Your Type 531 or Type 535 becomes potentially more useful to you each time Tektronix announces a new plug-in unit.*

### OTHER PLUG-IN UNITS

- Type 53A** — DC to 10 mc, 0.035  $\mu$ sec risetime; 0.05 v/cm to 50 v/cm, calibrated . . . . . \$85
- Type 53B** — Same as Type 53A with additional calibrated ac-sensitivity to 5 mv/cm . . . . . \$125
- Type 53C** — Dual-trace unit. Two identical amplifier channels, dc to 8.5 mc, 0.05 v/cm to 50 v/cm. Electronic switching triggered by oscilloscope sweep . . . or free running at about 100 kc . . . . . \$275
- Type 53D** — Differential input, high gain. DC to 350 kc at 1 mv/cm — passband increasing to 2 mc at 50 mv/cm. Full range — 1 mv/cm to 125 v/cm . . . . . \$145

### OSCILLOSCOPE CHARACTERISTICS

**Advanced Cathode-Ray Tube**  
Entirely new metallized crt provides full 6cm x 10cm undistorted viewing area . . . 50% more vertical deflection than previous high-sensitivity tubes. 10 kv accelerating potential permits single-sweep photography at the fastest sweep speed.

**Wide Range of Triggered Sweeps**  
0.02  $\mu$ sec/cm to 12 sec/cm, continuously variable. 24 calibrated sweeps from 0.1  $\mu$ sec/cm to 5 sec/cm, accurate within 3%. Accurate 5-x magnification.

**Wide-band Output Amplifier**  
DC-coupled amplifier designed for use with all Type 53-series Plug-in Units.

**Balanced Delay Network**  
0.25  $\mu$ sec signal delay in vertical amplifier.

**Sensitive Horizontal Amplifier**  
0.2 v/cm to 20 v/cm sensitivity.

**Versatile Triggering**  
Internal or external, with amplitude level selection or automatic triggering.

**Square-Wave Amplitude Calibrator**  
0.2 mv to 100 v in 18 steps, accurate within 3%.

**DC-Coupled Unblinking CRT Beam Position Indicators**  
**Electronic Voltage Regulation**

*Write for A-101, free 12-page specification booklet*

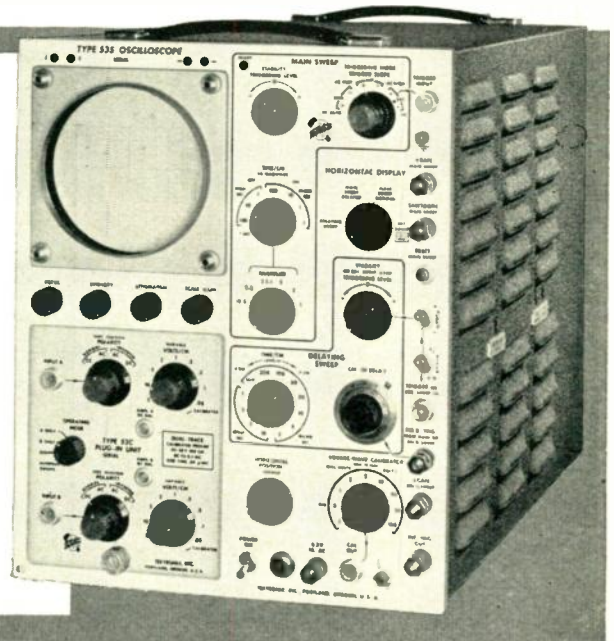

TYPE 535

Type 531 — \$995 plus price of desired plug-in units.

Type 535 — Same characteristics — plus delayed sweeps. 1  $\mu$ sec to 0.1 sec calibrated delay in 12 ranges, incremental accuracy within 0.2% of full scale. Conventional or triggered operation . . . . . \$1300 plus price of desired plug-in units. Prices f.o.b. Portland (Beaverton), Oregon.

➡ Your Tektronix Field Engineer or Representative will gladly arrange a demonstration at your convenience . . . call him today.

# Tektronix, Inc.

P. O. Box 831B • Portland 7, Oregon  
CYpress 2-2611 • Cable: TEKTRONIX





# MISSILES IN PERSPECTIVE

The design and building of guided missiles requires a rare combination of talents—each in proper perspective.

Fairchild's Guided Missiles Division, one of the principal producers of guided missiles, is an organization which has this perspective. Its engineering teams are skilled in the fields of electronics and aeronautics—and in the required propulsion systems. Its production team has built, in substantial volume, *several* fundamentally different missiles.

These "teams" are directed by a management which has broad knowledge of missile requirements—and are supported by a facility built specifically for work on guided missiles.

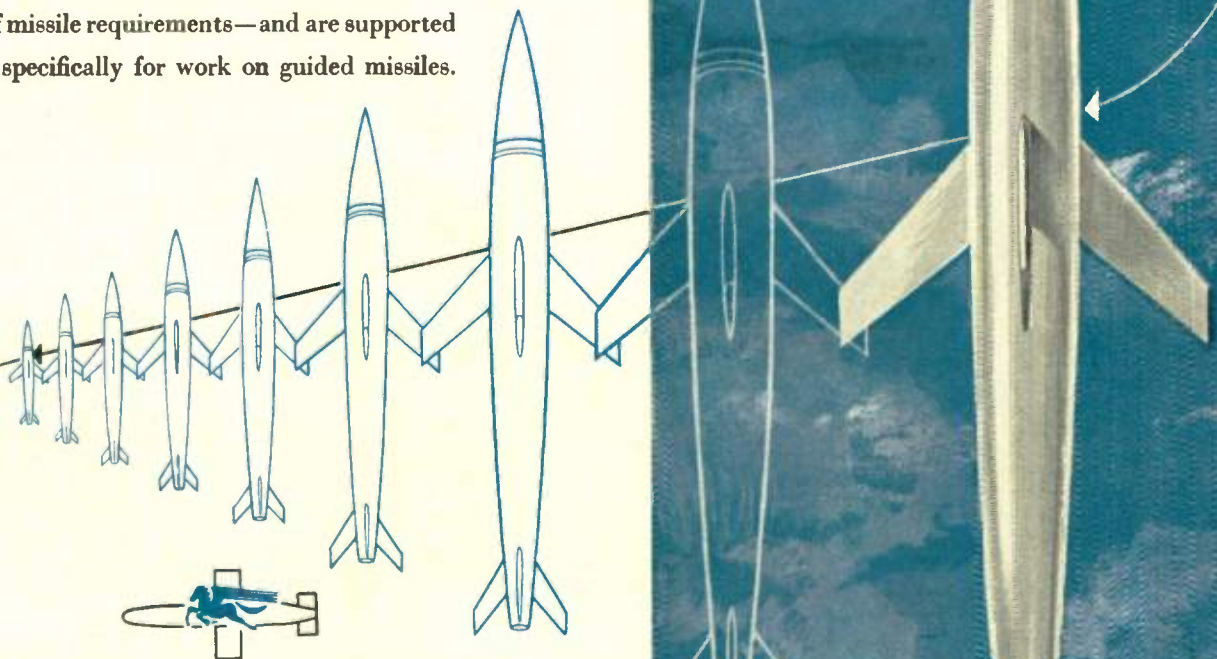

ENGINE AND AIRPLANE CORPORATION  
**FAIRCHILD**  
*Guided Missiles Division*

WYANDANCH, N. Y.

Other Divisions:

- Aircraft Division, Hagerstown, Md.
- American Helicopter Division, Manhattan Beach, Calif.
- Engine Division, Farmingdale, N. Y.
- Kinetics Division, New York, N. Y.
- Speed Control Division, St. Augustine, Fla.
- Stratos Division, Bay Shore, N. Y.





January 1955

## San Francisco Medical Electronics

Interested members of the medical profession through the San Francisco Bay Area are urged to participate directly in the Professional Group on Medical Electronics of the San Francisco Section Institute of Radio Engineers through a new program of affiliate membership presently being introduced. Doctors in practice and research capacities are being invited to become affiliate members at a membership fee of \$3.50 which provides the affiliate with continuing notifications of regional meetings as well as two important publications covering papers from the medical electronics sessions of the 1954 national convention and including the TRANSACTIONS of the IRE Professional Group on Medical Electronics.

Medical people interested can obtain further information from Lee B. Lusted, M.D., Chairman of the group, University of California Hospital, San Francisco 22, California.

## Toroidal Inductors

Freed Transformer Co., Inc., 1715 Weirfield St., Brooklyn (Ridgewood) 27, N. Y., manufacturer of transformers and laboratory test instruments, now has available for immediate delivery a wide variety of standard and sub-miniature toroidal inductors.



All types of Freed toroidal inductors have a standard tolerance of 1 per cent with frequency ranges up to 200 kc and inductance values up to 50 HY. They are available in stabilized and nonstabilized types.

These sub-miniature toroidal inductors feature four types covering frequency ranges from 500 cps to 200 kc with inductance values to 2 HY. These are supplied cased or uncased. All of these inductors can be supplied in tolerances of closer than 1 per cent on special order.

For further information on toroids and the complete Freed catalogs covering transformers and laboratory test instruments, write directly to the manufacturer.

## 1955 IRE-AIEE Conference on Transistor Circuits

The IRE Professional Group on Circuit Theory, the Science and Electronics Div. of the AIEE, and the University of Pennsylvania are jointly sponsoring a Conference on Transistor Circuits, to be held on Thursday and Friday, February 17 and 18, 1955 at the University of Pennsylvania in Philadelphia.

These manufacturers have invited PROCEEDINGS readers to write for literature and further technical information. Please mention your I.R.E. affiliation.

Rapid strides have been made in the transistor art since the last Circuits Conference held in Philadelphia early this year, and the 1955 Conference will attempt to cover this broad advance. Papers dealing with current trends in both linear and pulse circuit techniques as they effect various fields of application will be included. As in the past, the Conference is designed to appeal primarily to engineers working actively with transistor circuits.

Registration material for the Conference will be ready for mailing early in January, and details of the registration procedure will be announced at that time.

## Recording Totalizing Densitometer

Functionally, the Analytrol, Manufactured by Specialized Instruments Corp., 589 O'Neill Ave., Belmont, Calif., is a null or unbalanced device utilizing a system of two barrier-layer photocells illuminated from a single light source. The material to be scanned is passed before one of the cells, causing an output current drop and unbalancing a bridge circuit. The unbalanced signal is amplified and used to drive a motor which interposes a light-shielding cam in front of the other photocell until balance is restored. This same mechanism drives the curve-drawing and integration pens.

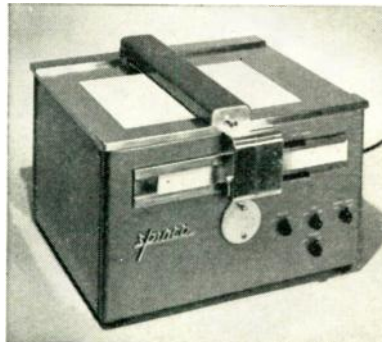

Because of this light-shielding cam principle, various mathematical functions can be introduced to accommodate for differences in response between the optical density and the actual concentration of material. Maximum width of the curve-drawing paper-feed is 12 inches. Maximum width of the scanned strip is 2 inches. Maximum height of the finished distribution curve is 6½ inches. The integration curve is drawn in such a way that every tenth pip in the saw-tooth configuration is extended for convenience in counting and tabulation. The complete instrument has dimensions of 16½ by 15½ by 10½ inches; weighs a total of 50 pounds. Operation is from a standard 115-v 50/60 cps source drawing 125 watts.

## Klystron Tube Mount

The Electronics & X-Ray Div., F-R Machine Works, Inc., 26-12 Burrough Pl., Woodside 77, N. Y., announces the new Type N761A Klystron tube mount. This new unit provides safe power connections, forced air cooling, and shock mounting for the tube.



The mount was designed particularly for use at the bench with the 2K39, 42, 43 and 44 series klystron tubes and all power supplied through a type P-2410 DB recessed Jones plug. A type N connector, mounted three inches above the table level, provides rf power and a neon lamp indicates when beam voltage is applied. A protected fan, rated at 200 cubic feet of air displacement per minute, accomplishes full rated cooling for the tube. Housing for the entire mount is made of aluminum and permits convenient seating of the Klystron in a shock mounted octal socket. Data sheet available on request to F-R.

## Selenium Rectifiers and Diodes

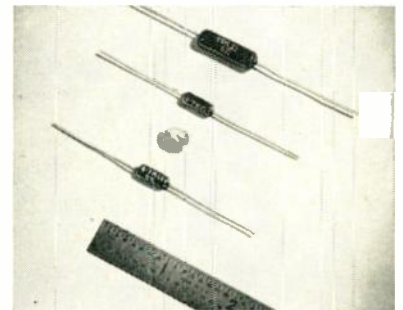

International Resistance Co., 401 N. Broad St., Philadelphia 8, Pa., has released a new 8-page Catalog Data Bulletin SR-1A, describing their new Microstak Selenium Rectifiers and Selenium Diodes. Comprehensive data on construction, applications, types, ratings, reference curves, specifications, dc characteristics, and so forth are given.

(Continued on page 18A)



# IN Attenuators

WHY DOES ONE NAME...

**DAVEN**

STAND OUT?

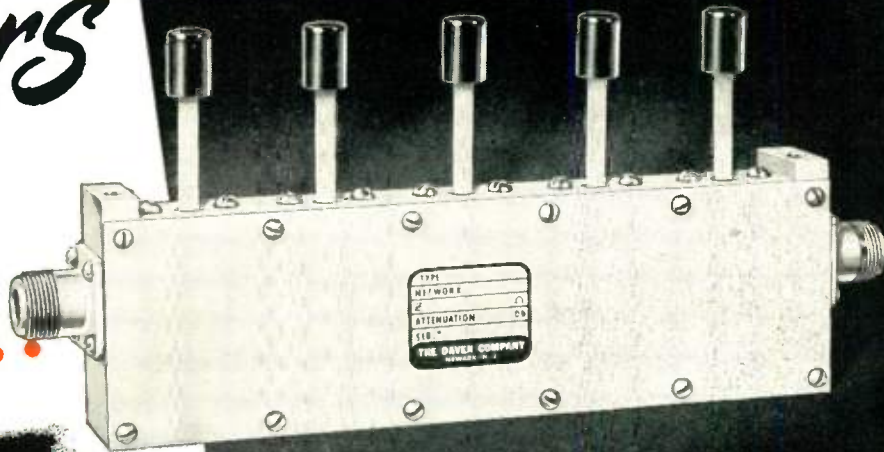

*Series 550-RF Attenuator*

In addition to Daven being the leader in audio attenuators, they have achieved equal prominence in the production of RF units. A partial listing of some types is given below.

DAVEN Radio Frequency Attenuators, by combining proper units in series, are available with losses up to 120 DB in two DB Steps or 100 DB in one DB Steps. They have a zero insertion loss and a frequency range from DC to 225 MC.

Standard impedances are 50 and 73 ohms, with special impedances available on request. Resistor accuracy is within  $\pm 2\%$  at DC. An unbalanced circuit is used which provides constant input and output impedance. The units are supplied with either UG-58/U\* or UG-185/U\*\* receptacles.

Because **DAVEN** makes the most complete, the most accurate line of **ATTENUATORS** in the world!

TYPE	LOSS	TOTAL DB	STANDARD IMPEDANCES
RFA* & RFB 540**	1, 2, 3, 4 DB	10	50/50 $\Omega$ and 73/73 $\Omega$
RFA & RFB 541	10, 20, 20, 20 DB	70	50/50 $\Omega$ and 73/73 $\Omega$
RFA & RFB 542	2, 4, 6, 8-DB	20	50/50 $\Omega$ and 73/73 $\Omega$
RFA & RFB 543	20, 20, 20, 20 DB	80	50/50 $\Omega$ and 73/73 $\Omega$
RFA & RFB 550	1, 2, 3, 4, 10 DB	20	50/50 $\Omega$ and 73/73 $\Omega$
RFA & RFB 551	10, 10, 20, 20, 20 DB	80	50/50 $\Omega$ and 73/73 $\Omega$
RFA & RFB 552	2, 4, 6, 8, 20 DB	40	50/50 $\Omega$ and 73/73 $\Omega$



*Series 640-RF Attenuation Network*



These units are now being used in equipment manufactured for the Army, Navy and Air Force.

Write for Catalog Data.

THE **DAVEN** CO.

195 CENTRAL AVENUE  
NEWARK 4, NEW JERSEY



# PERKIN TUBELESS • MAGNETIC AMPLIFIER REGULATED D.C. POWER SUPPLIES

**NOW IMMEDIATE  
DELIVERY!**

**WIDE VOLTAGE RANGE  
5-32 volts @ 15 amps. (cont.)**

**MODEL  
MR532-15**

**REGULATION:**  $\pm 1\%$  (a) from 5-32 V. D.C. (b) from 1.5 to 15 amps. (c) from 105-125 V. A.C. (Single phase, 60 cps.)  
**RIPPLE:** 1% rms @ 32 V. and full load, increases to max. of 2% rms @ 5 V. and full load.  
**RESPONSE:** 0.2 Seconds  
**MOUNTING:** Cabinet or 19" Rack Panel **WEIGHT:** 150 lbs.  
**METERS:** 4 1/2" AM and VM  
**FINISH:** Baked Grey Wrinkle  
**DIMENSIONS:** 22"x17"x14 1/2"  
Price: \$524 w/o cabinet, \$549 w/cabinet  
All prices F.O.B., El Segundo, Terms: 1% -10 days, net 30  
Phone collect for quantity discounts.



**NO TUBES TO REPLACE • LONGER LIFE • WIDE VOLTAGE  
RANGE • LOWER MAINTENANCE COST • GUARANTEED**

**MODEL  
MR1040-30**

**10 to 40 VOLTS  
@ 30 AMPS. (CONT.)**

**REGULATION:**  $\pm 1\%$  (a) From 10 to 40 V. D.C. (b) From 100 to 130 V. A.C. (c) From 3 to 30 Amps, D.C.  
**RIPPLE:** 1% rms  
**MOUNTING:** Cabinet (or 19" rack panel)  
**A.C. INPUT:** 100-130 V., 1 Phase, 60 Cycles  
**FINISH:** Baked Grey Enamel  
**RESPONSE:** 0.2 Sec.  
**WEIGHT:** 200 lbs.  
**METERS:** 4 1/2" AM and VM  
**DIMENSIONS:** 22"x15"x23"

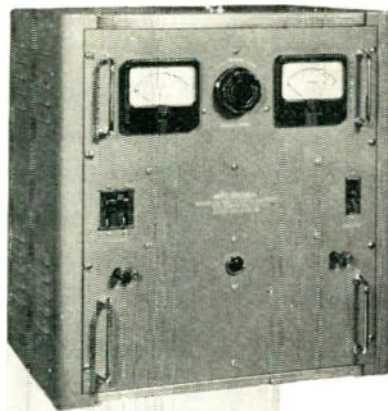

Price: \$792 w/o cabinet,  
\$827 w/cabinet

All prices F.O.B., El Segundo, Terms: 1% -10 days, net 30  
Phone collect for quantity discounts.

**ALSO AVAILABLE:** Standard 6 and 115 volt models; Ground and Airborne Radar and Missile Power Supplies—Prompt Delivery!

**WRITE:** On company letterhead for free subscription to technical periodical PERKIN POWER SUPPLY BULLETIN.

WRITE FOR BULLETIN MA 154

**PERKIN ENGINEERING CORP.**  
345 KANSAS ST. EL SEGUNDO, CALIF. • ORegon 8-7215



These manufacturers have invited PROCEEDINGS readers to write for literature and further technical information. Please mention your I.R.E. affiliation.

(Continued from page 16A)

## Vector Display Equipment

The Model VDE-3A Vector Display Equipment announced by the Wickes Engineering and Construction Co., 12th St. & Ferry Ave., Camden 4, N. J., is a completely rack-mounted vector-display monitoring and test instrument. The Model VDE-3A displays in vector form the chrominance components of standard color bar signals, or the prominent chrominance components of any composite television signal. The VDE-3A also checks the accuracy of the color signal, the drift in color coders and associated equipment, and the alignment of color coders. Self-calibrating and checking circuits are incorporated.



The display oscilloscope overlay is accurately calibrated in degrees and amplitude. Vectors are displayed corresponding to the chrominance components and the color burst. Also displayed are a calibration reference circle, and a center dot representing a no-signal condition.

The VDE-3A comprises a DK-1 Decoder and Keyer, a BCO-2 Burst-Controlled Oscillator, an RS-1 Display Oscilloscope, and a PS-2 Regulated Power Supply. The mounting rack and set of interconnecting cables are included.

## Capacitor Catalog

A new 4-page catalog (Bulletin GC-1), describing hermetically sealed high-voltage glass-encased GC-type paper dielectric dc capacitors is now available from the Gude-man Co., 340 W. Huron St., Chicago 10, Ill. Operating temperature of the units ranges from  $-55^{\circ}\text{C}$  to  $+105^{\circ}\text{C}$ . Data includes explanation of catalog numbers, high altitude application, lead specifications, ripple voltage and complete engineering specifications. Illustrations consist of GC45 series, GC46 series, dimensional drawings, and typical performance curves for power vs temperature, insulation resistance vs temperature and change of capacitance vs temperature.

(Continued on page 20A)





HEADQUARTERS  
FOR YOUR  
HERMETICALLY  
SEALED  
MINIATURE

# TRANSISTOR and DIODE BASES and CLOSURES\*

Electrical Industries is your dependable source of supply for all hermetically-sealed miniature components. Miniaturized transistor and diode bases with closures and sealed components for specialized requirements can be supplied quickly and economically. For samples and quotations on standard components or recommendations on "specials", call or write E-I, today!

## ELECTRICAL INDUSTRIES

44 SUMMER AVENUE  
NEWARK 4, NEW JERSEY

DIVISION OF AMPEREX  
ELECTRONIC CORP.



ALL CASES .300"  
IN LENGTH

TC-1A  
plain

TC-1B  
with hole

TC-1C  
with hole  
and dimple

CASES AVAIL-  
ABLE WITH OR  
WITHOUT  
DIMPLE

TC-3  
with dimple  
.300" long

TC-3A  
plain  
.340" long

Where Special cases  
are required, E-I will  
quote on your re-  
quirements on re-  
ceipt of your draw-  
ings or speci-  
fications.

TC-5  
with dimple

TC-5A  
plain

TC-5B  
with .025" hole  
All .325" long

TC-5C  
plain .240" long

TC-6 CLOSURE  
Plain case .300"  
in length.

### Series No. 1 KOVAR BASES

WITH NICKEL  
SILVER CASES

Three electrode her-  
metically sealed  
Kovar bases supplied  
with closures. Lead  
lengths and pin lay-  
outs as illustrated.  
Cases are available  
in three types.  
Closures are press-  
fit to bases.

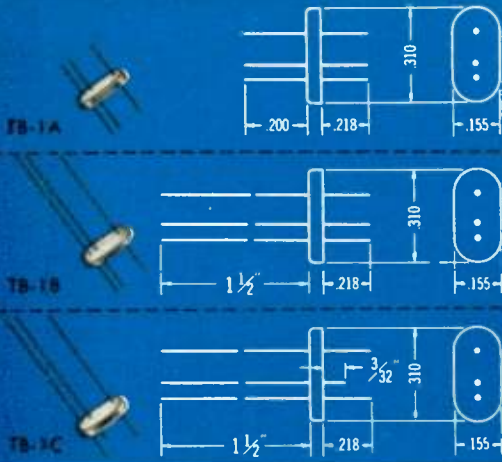

### Series No. 3 COMPRESSION TYPE BASES & CLOSURES

WITH NICKEL  
SILVER CASES

Compression type  
bases available in  
two, three and four  
lead types. Type TC-3  
or TC-3A cases, illus-  
trated, can be sup-  
plied. Cases are  
press-fit to bases.

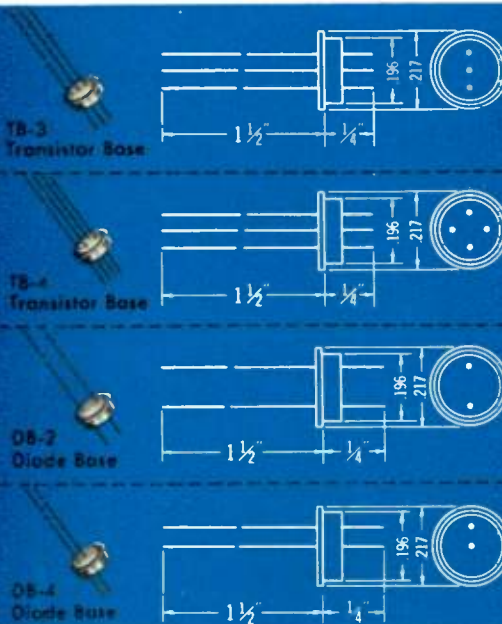

### Series No. 5 COMPRESSION BASES

WITH NICKEL  
SILVER CASES

Available as illustrat-  
ed. Cases are press-  
fit to bases.

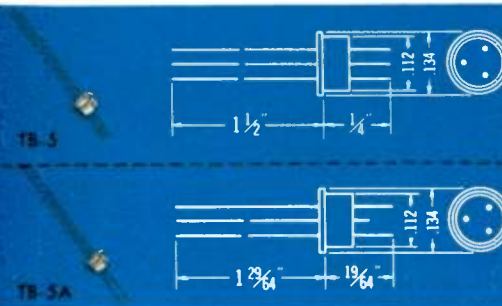

### Type TB-6 TRANSISTOR BASE

AVAILABLE WITH  
TC-6 CLOSURE

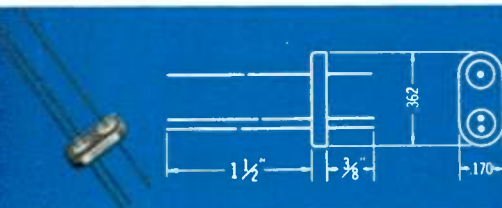

### Type DC-5 GOLD PLATED

With welding projec-  
tion. Available as  
DC7 without welding  
projection.

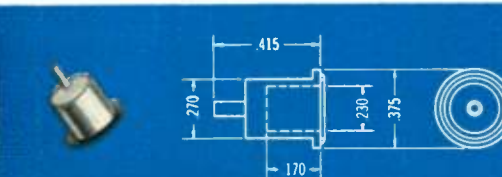



# ALLIED



Your complete supply source for  
**Everything in Electronics**

**free!**

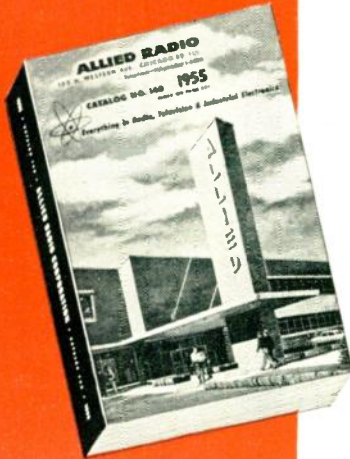

send for the most widely used  
**Electronic Supply Guide**

### ALLIED'S 308-PAGE CATALOG

Simplify and speed *all* your electronic supply purchases. Order from the 1955 ALLIED Catalog for fast shipment from the world's largest stocks of electron tubes (all types), test instruments, audio equipment, electronic parts (transformers, capacitors, controls, etc.)—everything in electronic supplies for research, development, maintenance and production. Our expert Industrial supply service saves you time, effort and money. Send today for your FREE 1955 ALLIED Catalog—the *complete* up-to-date buying guide to the world's largest stocks of quality Electronic Supplies for Industrial and Broadcast use.



Your complete supply source for



### SPECIAL PURPOSE ELECTRON TUBES

WE STOCK *all* types of RAYTHEON special-purpose tubes for industrial, broadcast and government use: *Subminiatures, Reliable Subminiatures, Reliable Miniatures, Rugged, Crystal Diodes, Transistors, Radiation Counter, Rectifiers, Thyratrons, Voltage Regulators, etc.* To save time and money—phone, write or wire us—and we'll have your RAYTHEON tubes on the way to you in just hours. Remember, RAYTHEON special-purpose electron tubes, diodes and transistors are *always* in stock at ALLIED for quick delivery.



All Types  
in Stock

Everything in  
Electronics  
from ONE RELIABLE SOURCE

Send for  
**FREE CATALOG**

### ALLIED RADIO

100 N. Western Ave., Dept. 35-A-5  
Chicago 80, Illinois



News-New Products

These manufacturers have invited PROCEEDINGS readers to write for literature and further technical information. Please mention your I.R.E. affiliation.

(Continued from page 18A)

### Hot-Wire Switch Used as Current Limiter

Thomas A. Edison, Inc., Instrument Div., West Orange, N. J., has introduced a new SPST normally closed hot-wire type of switch for use as a current limiter. It is designed to limit the current flow in a circuit to its nominal critical value, and serves, in a typical application, to protect the input coils and other components in radio receivers from over-currents induced by nearby transmitting equipment. Engineering work has been completed on one model to operate at 125 milliamperes with a tolerance of  $\pm 25.0$  ma. Other models may be developed to higher or lower operating values.

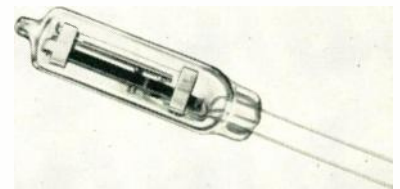

This switch is hermetically sealed and compensated for an ambient temperature range of 0 to 90°C. It has been subjected to 60g shock in all directions without damage or change in calibration, and has passed the vibration and shock requirements of BuShips spec. No. 40T-9. It is 9/16 inches in diameter and 2 1/8 inches in length.

### Los Angeles Hosts Computer Conference

The Joint Western Computer Conference and Exhibit will be held at the Statler Hotel, Los Angeles, California, on March 1, 2, and 3, 1955, sponsored by the I.R.E., A.I.E.E., and Association for Computing Machinery. Pre-registration fee is \$2.50 and covers admittance to lectures and exhibits and a copy of the Transactions. The motif of the Conference is "Functions and Techniques in Analog and Digital Computers." Technical papers and discussions will include descriptions of existing systems and techniques, methods of matching digital tapes and cards, language and communication problems between machines, the possibilities of managerial and computer systems revision to achieve rapid and lasting marriage, and new developments in analog computers and analog computing methods. The exhibit will be limited to the products of manufacturers who make computers or major computer sub-assemblies and will be open during the day and evening hours so that all may visit. In addition to the technical sessions and exhibit, there will be evening field trips to major Los Angeles electronic firms, a cocktail party and luncheons.

(Continued on page 114A)



# RAYTHEON MAGNETRONS AND KLYSTRONS MEET EVERY FREQUENCY AND POWER NEED

Two of these tubes just declassified

**RK6230/QK299B** — tunable pulse magnetron (8900-9400 Mc), 1 Kw average peak power



**RK6410/QK338** — fixed frequency, pulse magnetron (2750-2860 Mc), 5 megawatt average peak power

**RK2J51** — tunable pulse magnetron (8500-9600 Mc), 50 Kw average peak power

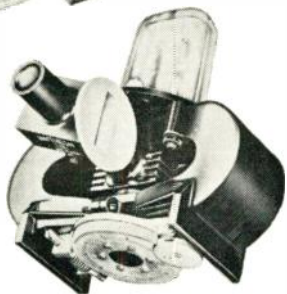

**RK5976** — mechanically tunable klystron (6250-7425 Mc), average power 100 milliwatts

**RK6116** — thermally tuned ruggedized klystron (8500-9660 Mc), average power 25 milliwatts



**RK5721** — klystron tunable with external cavities from 3600 to 10,500 Mc. Average power 125 milliwatts in the 2 $\frac{3}{4}$  reflector mode (4290-8340 Mc)

Raytheon also manufactures transmitting tubes, storage tubes and square law tubes

## VELOCITY VARIATION REFLEX OSCILLATORS

Characteristics of Unclassified  
Tube Types

Complete data on tube type available upon request



Raytheon Manufacturing Company  
Power Tube Division  
WALTHAM 54, MASSACHUSETTS

## MAGNETRON OSCILLATORS

Characteristics of Unclassified  
Tube Types

Complete data on tube type available upon request



Raytheon Manufacturing Company  
Power Tube Division  
Waltham 54, Massachusetts

# Now Available —

## CONSOLIDATED DATA BOOKLETS FOR RAYTHEON MAGNETRONS & KLYSTRONS

### WRITE FOR YOUR COPIES TODAY

These valuable data booklets, which we will be glad to send you, list most principal unclassified types now manufactured — give maximum ratings, typical operating values, frequency ranges. Indispensable to every microwave engineer's file.

Raytheon is the world's largest producer of CW and pulse magnetrons, many tunable mechanically or electrically. A compact, efficient source of

power, magnetrons are being used in an ever increasing number of applications.

Raytheon klystrons, which can be tuned mechanically or thermally, fit the widest range of requirements with tubes available from 550 to 60,000 Mc.

Please feel free to call on us for Application Engineering Service on your microwave problems. There is no cost or obligation.

**WRITE TODAY** for your data booklets. Please address Raytheon Manufacturing Co., Power Tube Sales — Section PL-10, Waltham 54, Mass., or telephone Waltham 5-5860, Ext. 2443.



**Raytheon Manufacturing Company, Power Tube Division, Waltham 54, Mass.**

**CUT CORES  
TOROIDAL  
SQUARE  
RECTANGULAR**

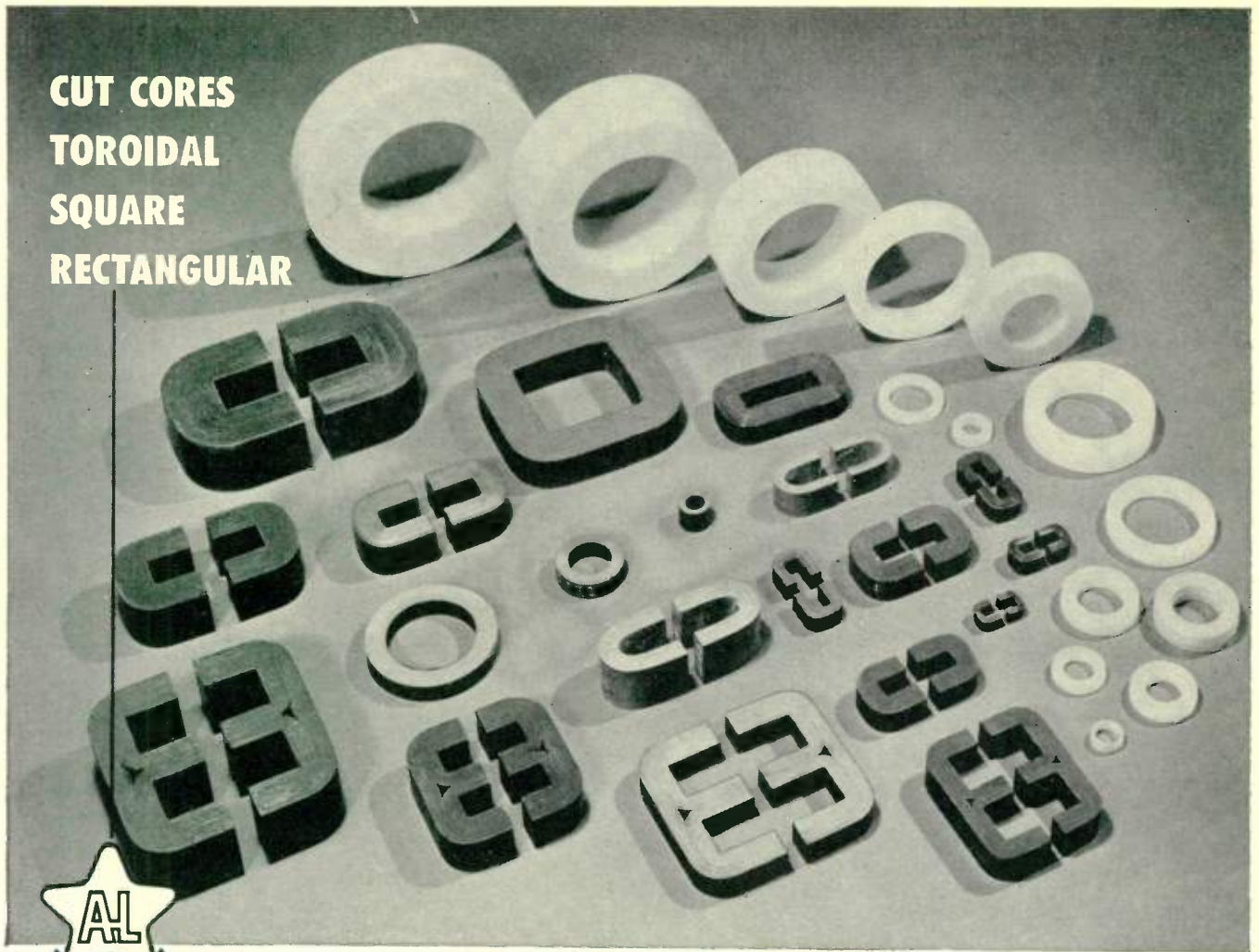

# *Anything You May Need in* **TAPE-WOUND CORES**

## **RANGE OF MATERIALS**

Depending upon the specific properties required by the application, Arnold Tape-Wound Cores are available made of DELTAMAX . . . 4-79 MO-PERMALLOY . . . SUPERMALLOY . . . MUMETAL . . . 4750 ELECTRICAL METAL . . . and SILECTRON.

## **RANGE OF SIZES**

Practically any size Tape-Wound Core can be supplied, from a fraction of a gram to several hundred pounds in weight. Toroidal cores are made in twenty-seven standard sizes with protective nylon cases. Special sizes of toroidal cores—and all cut cores, square or rectangular cores—are manufactured to meet your individual requirements.

## **RANGE OF TYPES**

In most of the magnetic materials named, Arnold Tape-Wound Cores are produced in the following standard tape thicknesses: .012", .004", .002", .001", .0005", or .00025", as required.

*For complete details, write for Bulletins TC-101A and SC-107.*

## *Applications*

Let us help with your core problems for Pulse and Power Transformers, 3-Phase Transformers, Magnetic Amplifiers, Current Transformers, Wide-Band Transformers, Non-Linear Retard Coils, Reactors, etc.

**ADDRESS DEPT. P-51**

W&D 5465

## **THE ARNOLD ENGINEERING COMPANY**



SUBSIDIARY OF ALLEGHENY LUDLUM STEEL CORPORATION

General Office & Plant: Marengo, Illinois

DISTRICT SALES OFFICES . . . New York: 350 Fifth Ave.

Los Angeles: 3450 Wilshire Blvd.

Boston: 200 Berkeley St.



# Microwave TEST COMPONENTS

PRD offers a complete line of test equipment for precise measurements in the Microwave region. This equipment, the finest obtainable anywhere, includes Frequency Measuring Devices, Signal Sources and Receivers, Attenuators and Terminations, Impedance Measurement and Transformation Devices, Detection and Power Measurement Equipment, Bolometers and Accessories.

**When you test,  
use the best—**

**PRD**

**QUALITY  
DEPENDABILITY  
ACCURACY**



**TYPE 250-A BROADBAND PROBE** — Frequency range of 1 to 12.4 Kmc/s; two tuning knobs permit precise adjustment for maximum power transfer from the probe tip to the crystal or bolometer detector; third knob controls depth of probe tip insertion.

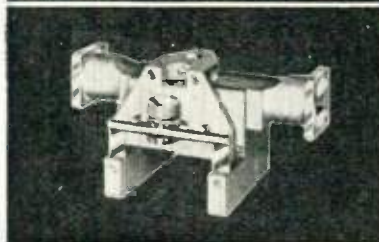

**SLOTTED SECTIONS**—The mechanical and electrical design of PRD slotted sections emphasizes these important features: Instrument accuracy assured indefinitely by virtue of three bearing carriage suspension to minimize wear; waveguide section machined from solid aluminum alloy stock, to avoid warpage no castings are used.

**TYPE 275 VSWR AMPLIFIER** — Featuring high gain; A.G.C. to maintain output constant for slow variation in r-f power source; low input noise level of 0.03 microvolts; wide VSWR ranges of 1:1.3, 1:3, 3:10, 10:30, and 30:100; greater accuracy because VSWR scale on meter is linear.



✓ **WRITE FOR  
NEW CATALOG**

Address requests for your copy of the new catalog to Department R-1 — no obligation.



*Polytechnic* **RESEARCH  
& DEVELOPMENT CO., INC.**



202 TILLARY STREET, BROOKLYN 1, NEW YORK — ULster 2-6800

CHICAGO SALES OFFICE:  
1 SO. NORTHWEST HWY., PARK RIDGE, ILLINOIS — TALcot 3-3174

LOS ANGELES SALES OFFICE:  
741 1/2 NO. SEWARD ST., HOLLYWOOD 38, CAL.—HOLlywood 5-5287



**RAYTHEON FLAT PRESS SUBMINIATURE TUBES** provide freedom from catastrophic glass failures. The Flat Press is your Seal of Reliability.

Raytheon has 15 years experience in manufacturing over 10,000,000 Flat Press Subminiature Tubes.

The Record shows:

**Operation Life.** Only 0.0017% glass failures per hundred hours life — only one failure per 6,000,000 tube hours in 4,200 Raytheon Flat Press Subminiature Tubes operated for 10,000 hours each during the past nine years as part of Raytheon's quality control procedures.

**Shelf Life.** Less than 0.05% failures for glass envelopes and seal defects out of 151,600 Raytheon Flat Press Subminiature Tubes subjected to six years of shelf life. No other known tube design has equalled this performance.

**RAYTHEON'S FLAT PRESS SEAL** offers these time-proven advantages over conventional miniature tube metal-to-glass seals.

- Longer length of lead sealed to glass.
- The lead material matches the coefficient of expansion of the glass throughout the entire seal length. No nickel is

sealed into the glass thus eliminating one of the major sources of button cracks.

- Flexible leads on Raytheon's Flat Press Subminiatures permit socketing without stressing the glass seal.
- This eliminates glass button fatigue failure.





# FLAT PRESS

## SUBMINIATURE TUBES with the **SEAL OF RELIABILITY**



Note these advantages over subminiature button types:

Longer glass to metal seal

Glass heated only once

- no button
- no glass strain
- no lead burning

Reentrant seal eliminates breakage from short bends

Leads completely tinned right to glass seal by dipping in hot solder pot — an automatic glass strain test — no lead corrosion

Flat press with in-line lead arrangement means easier socketing, easier wiring, and adaptability to printed circuits

\* Raytheon makes all varieties of reliable, high quality tubes yet countless users testify that none have the reliability of Raytheon Flat Press Subminiature Tubes with the Seal of Reliability.



*Excellence in Electronics*

### RAYTHEON MANUFACTURING COMPANY

Receiving Tube Division — Home Office: 55 Chapel St., Newton 58, Mass. Bigelow 4-7300

For application information write or call the Home Office or: 4935 West Fullerton Avenue, Chicago 39, Illinois, NATIONAL 2-2770  
589 Fifth Avenue, New York 17, New York, PLaza 9-3900 • 622 South La Brea Ave., Los Angeles 36, California, WEBster 8-2851

RAYTHEON MAKES ALL THESE

RELIABLE SUBMINIATURE AND MINIATURE TUBES • SEMICONDUCTOR DIODES AND TRANSISTORS • NUCLEONIC TUBES • MICROWAVE TUBES • RECEIVING AND PICTURE TUBES



(ACTUAL SIZE PHOTO)

... and this amazing sensitivity is only one of many outstanding characteristics of the entirely new DuMont Type 324 cathode-ray oscillograph. New standards of stability, low noise and hum level assure full use of the Type 324 for d-c to 300 kc measurements even in the microvolt region. Furthermore, the Type 324 is completely calibrated to read time and amplitude directly. There are so many features incorporated in this new instrument we can't begin to give you the whole story here. Write us for complete specifications, or better still, ask for a demonstration of the

# NEW **DU MONT** TYPE 324

**For further information write to:**

Technical Sales Department • ALLEN B. DU MONT LABORATORIES INC. 760 Bloomfield Ave., Clifton, N. J.



# Look to Cppc for Synchro Progress

**FOR IMMEDIATE DELIVERY!**



*Actual Size*  
**SIZE 10**  
 .937" diameter



*Actual Size*  
**SIZE 11**  
 1.062" diameter



*Actual Size*  
**SIZE 15**  
 1.437" diameter

**Next**

**SIZE 22**

2.161" diameter

**Next**

**SIZE**

**8**

.750"  
 diameter

CLIFTON PRECISION now offers these high accuracy, low weight synchros in practically every type of size 10, 11 and 15 as stock, off-the-shelf items for immediate delivery.

Also, virtually any variation of these same units is obtainable. For example:

- Synchros wound to customer's specific requirements
- Special shaft lengths and shapes
- High impedance units
- Feed back windings
- Special core materials
- Linear generators

For customer's special application:

- Flux valve couplers—very low flux levels
- 30~ to 5000~ use (phase shifters)
- Sawtooth wave use—usable up to 100,000~ or higher with special windings
- Computer elements with high accuracy, high linearity

Although we are prepared to serve your special needs, we urge the use of standard units wherever possible for speed of delivery and economy to you.

*For full information, drawings etc., write or telephone: T. W. Shoop, Sales Mgr., Clifton Heights, Pa. MAdison 6-2101 (Suburban Phila.) West Coast Rep. Wm. J. Enright, 988 W. Kensington Rd.; Los Angeles. MUtual 6573.*

**Cppc**

**CLIFTON PRECISION PRODUCTS CO. INC.**

CLIFTON HEIGHTS

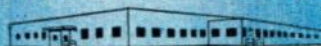

PENNSYLVANIA

# Frequency Meters

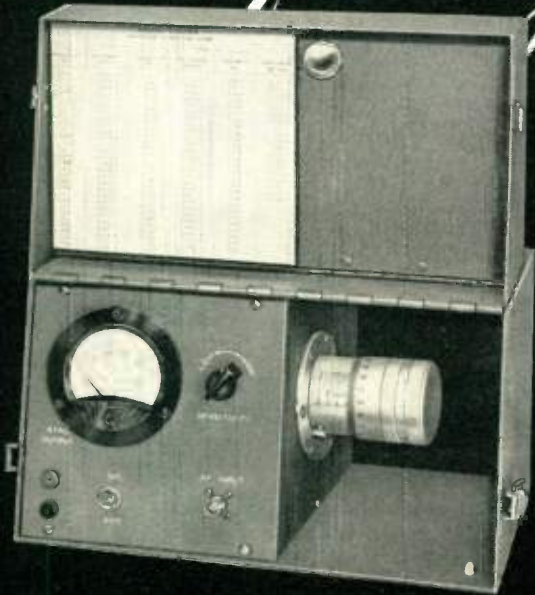

COMPLETELY  
SELF-CONTAINED  
FIELD TEST INSTRUMENTS

by

## FREQUENCY STANDARDS

These precision-built field test instruments were designed by Frequency Standards to provide rapid and accurate means of frequency measurement in the field. Frequency is determined by means of a micrometer dial. This reading is translated to frequency by accurate individual calibration charts or curves. Transducers, fittings, and cables can be supplied to meet the requirements of customers and convenient storage space for these items is provided in the lid of the instruments.



MODEL	FREQUENCY RANGE	ACCURACY
912-4	900-1200 MC	.01%
1217-4	1200-1700 MC	.02%
1723-4	1700-2300 MC	.02%
2335-4	2300-3500 MC	.02%
3545-4	3500-4500 MC	.01%
4458-4	4400-5800 MC	.01%
5882-4	5800-8200 MC	.01%

### SPECIAL CAVITY DESIGNS

Frequency Standards maintains complete facilities for the design and manufacture of Reference Cavities, Preselector Cavities, and Filters to customers' specifications or blueprints. Our facilities also permit quantity production of complex waveguide assemblies.

ILLUSTRATED  
BULLETINS  
SENT ON  
REQUEST

**Frequency Standards**  
ASBURY PARK, NEW JERSEY

Address inquiries to  
BOX 504







the world's **no. 1** producer  
of semi-conductors

# presents **GOLD BONDED DIODES** of "GOLD STANDARD" PERFORMANCE

Look at the "specs"! Look at the actual, unretouched oscillograms. These pre-tested Raytheon Gold Bonded Diodes have the characteristics and the uniformly dependable performance to make them your No. 1 choice. Many other Raytheon Gold Bonded point contact and silicon diodes are available. Write for data.

\*These are unretouched photographs taken in the Raytheon Semiconductor Diode Laboratory.

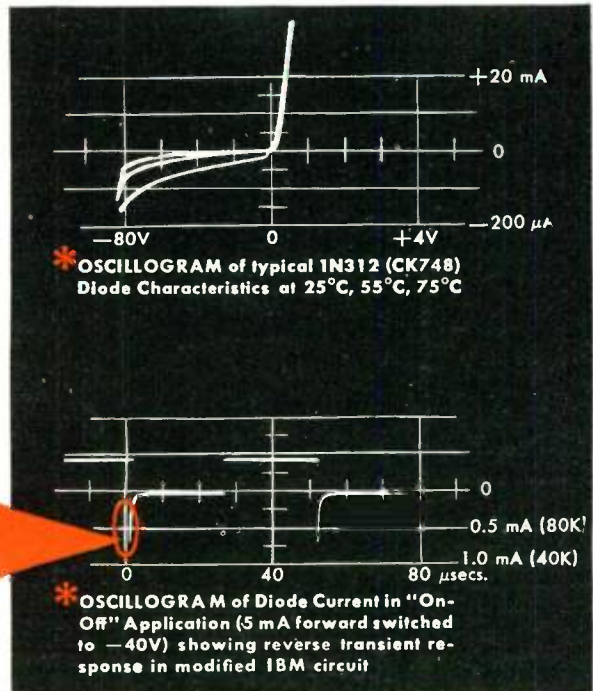
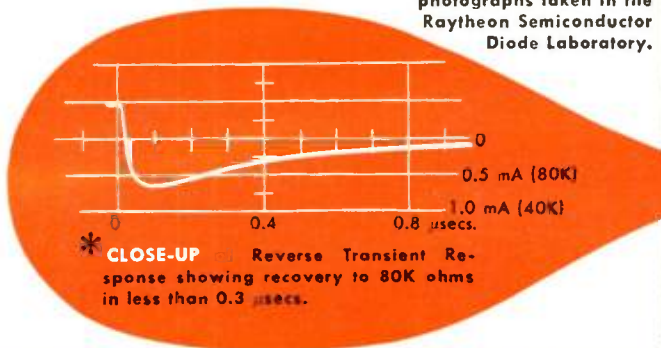

Representative Gold Bonded Types	FORWARD 25°C ma. at +1 volt	REVERSE	
		25°C $\mu$ a at volts	55°C $\mu$ a at volts
<b>1N308 (CK741)</b> with 50% higher conduction than its nearest competitive type	300	500 at -8	1500 at -8
<b>1N310 (CK745)</b> for high voltage, high resistance	15	20 at -20 100 at -100	150 at -20 300 at -100
<b>1N309 (CK747)</b> with unbeatable transient characteristics	100	100 at -20	350 at -20
<b>1N312 (CK748)</b> 100% tested for forward and reverse transient response	30	50 at -50	200 at -50
<b>1N313 (CK749)</b> high voltage, extra high resistance	20	10 at -20 50 at -100	50 at -20 200 at -100

ALL with 150 milliwatt dissipation rating  
ALL with -50°C to +90°C ambient temperature rating



**RAYTHEON MANUFACTURING COMPANY**

*Excellence in Electronics*

Receiving Tube Division — Home Office: 55 Chapel St., Newton 58, Mass. Bigelow 4-7500

For application information write or call the Home Office or: 4935 West Fullerton Avenue, Chicago 39, Illinois, National 2-2770

589 Fifth Avenue, New York 17, New York, Plaza 9-3910 • 522 South La Brea Ave., Los Angeles 36, California, Webster 8-2851

RAYTHEON MAKES ALL THESE:

RELIABLE SUBMINIATURE AND MINIATURE TUBES • SEMICONDUCTOR DIODES AND TRANSISTORS • NUCLEONIC TUBES • MICROWAVE TUBES • RECEIVING AND PICTURE TUBES

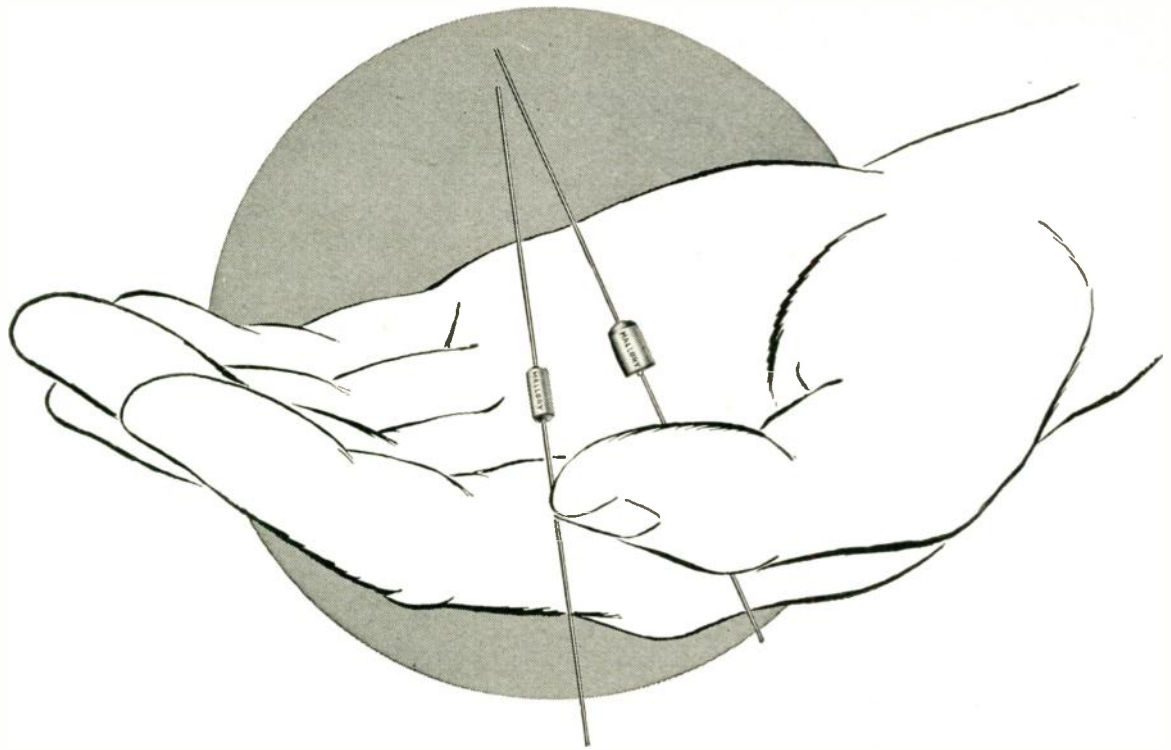

## Get more microfarads in less space...with MALLORY SILVERLYTIC\* CAPACITORS

For transistor circuits and other miniaturized electronic equipment, Silverlytic capacitors will simplify your problem of getting maximum capacitance into minimum space. These subminiature electrolytics offer the highest available ratio of capacitance and voltage to case size.

Made with tantalum anodes, they operate with excellent stability over wide temperature ranges. They are so small they can be mounted readily by their axial leads without danger of vibration troubles. A unique, rugged seal protects them against moisture. In low leakage current and long shelf life, they equal or exceed the performance of most conventional-size capacitors.

*Type TAP Silverlytics* are rated for temperatures from  $-55$  to  $+85^{\circ}$  C. Their case measures only  $\frac{7}{32}$ " in diameter by  $\frac{3}{8}$ " long. They are supplied in values from 2 mfd at 100 volts to 30 mfd at 6 volts.

*Type TAW Silverlytics* are available in a case only

0.145" in diameter by  $\frac{3}{8}$ " maximum length. They are supplied in two standard ratings of 4 mfd at 4 volts and 6 mfd at 4 volts, for temperatures from  $-55$  to  $+65^{\circ}$  C.

Silverlytic capacitors are backed by the years of pioneering research, precision manufacturing and intensive quality control which have made Mallory capacitors the leaders of the industry. For complete technical information, write or call Mallory today.

### Long-life Mallory Power Supplies for Transistorized Equipment...

Mallory Mercury Batteries and Power-Paks provide the constant energy characteristics essential to efficient transistor operation. Made by Mallory, the original producer of miniature mercury batteries, they are available in a range of sizes and types. Write for data.



Expect more...  
Get more from **MALLORY**

*Parts distributors in all major cities stock Mallory standard components for your convenience*

#### Serving Industry with These Products:

**Electromechanical**—Resistors • Switches • Television Tuners • Vibrators  
**Electrochemical**—Capacitors • Rectifiers • Mercury Batteries  
**Metallurgical**—Contacts • Special Metals and Ceramics • Welding Materials

\*Trade Mark





# New Simpson Core Meter Movement

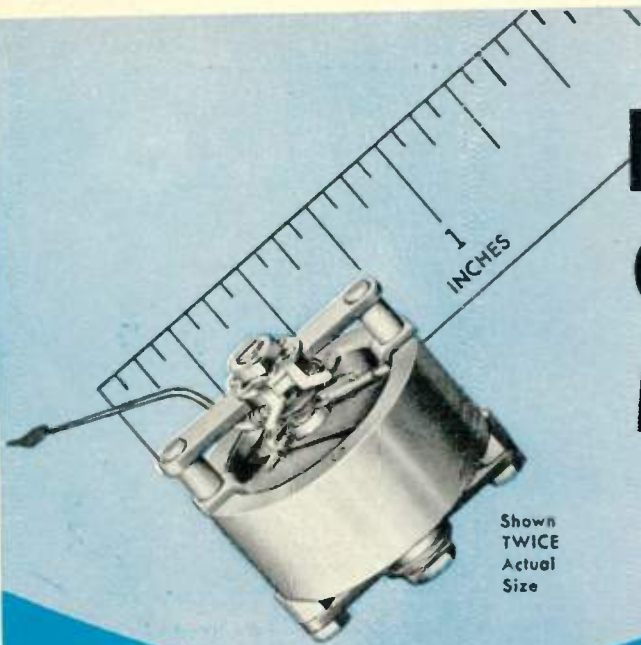

Shown  
TWICE  
Actual  
Size

**Rugged... yet built like a fine watch!**

Here's the new Simpson **Core-Type Meter Movement**. It's a more compact, more sensitive, **self-shielding** movement that gives electrical measurements with laboratory accuracy, yet has the ruggedness to withstand severe shocks. Its accuracy specifications are so rigid that Simpson engineers had to devise unusual production techniques.

Let Simpson engineers design panel meters using the new core movement to your special instrument requirements. Simpson continues to maintain its large stock of standard panel meters in over 700 sizes and ranges, available through distributors.

## RUGGEDIZED METERS

Simpson's 2½" and 3½" Panel Meters are available in **sealed, ruggedized** models to meet specifications MIL-M-10304-(Sig. C). Movements are sealed against moisture and other adverse atmospheres, and are spring-mounted to absorb excessive vibration.

**SEND FOR NEW CATALOG 17**



INSTRUMENTS THAT STAY ACCURATE

# Simpson

ELECTRIC COMPANY

5201 W. Kinzie St., Chicago 44, Illinois. Phone: ESTbrook 9-1121  
In Canada: Bach-Simpson, Ltd., London, Ontario

# POLARAD COLOR TV

## AN INTEGRATED LINE OF EQUIPMENT FOR STUDIO AND LABORATORY

Fully integrated units that combine ease of operation with maximum stability. No additional accessories or power units required for operation.

### Especially designed for:

- Testing receivers, transmitters, and terminal equipment.
- Laboratory test standards for development of color TV equipment.
- Checking components used for color TV.
- Alignment and adjustment of colorplexers or encoders.
- Testing convergence of tri-color kinescopes.



### COLOR BAR GENERATOR — MODEL PT-203

A complete instrument with a color bar pulse forming unit, a complete colorplexer unit and regulated B+ and filament supplies. Provides NTSC color TV test signals, for receivers, transmitters, networks and components. Internal switching provides 19 different test patterns in the form of a composite NTSC video signal. Special self-balancing colorplexer provides exceptional stability over long periods of operation without readjustment, with "I" and "Q" outputs. (See colorplexer details.)

### COLORPLEXER — MODEL PT-205

Incorporated in the Model PT-203 Color Bar Generator, available as a separate chassis for rack mounting. Designed for high stability and negligible drift, this unit replaces old encoder units of early design. This instrument multiplexes three simultaneous color video signals (R, G, B) and properly encodes them into color information and then combines them with sync pulses and color sync signals to form a standard NTSC color TV signal. Pulse or video signals to drive colorplexer may be obtained from special (R, G, B) pulse generators, color camera or color slide scanner. Subcarrier balance is stable and dynamically independent of signal level changes over long periods of operation. Driving signals are Subcarrier, Blanking, Sync and Vertical pulses. Full bandwidth "I" and "Q" modulation is used in the chrominance channel of the colorplexer. "I" and "Q" or "B-Y" and "R-Y" video test signals are available for receiver and monitor matrix alignment. Both positive and negative polarity signals are available at high and low impedance.

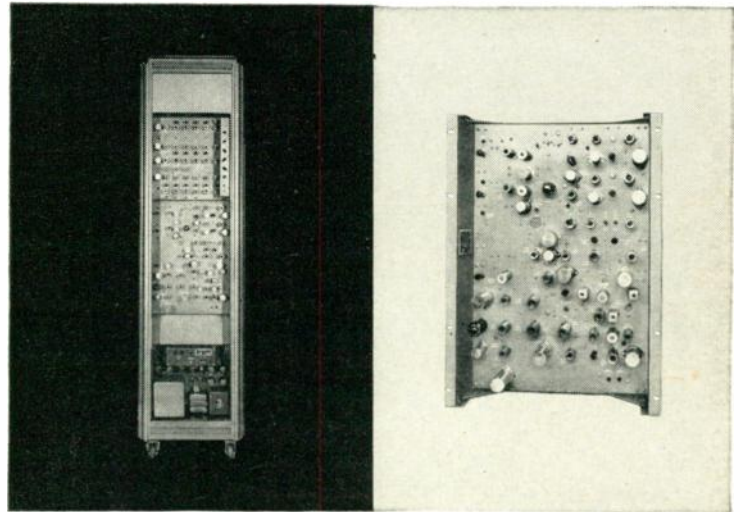

### COLOR BAR GENERATOR— MODEL PT-203

Output Signals: NTSC Composite  
Video 2 Outputs 0—1.4 v. pk-pk  
Output Signal Information:  
Color Bars—6 Bars of Color (R, G, B, C, Y, M) plus Blk/Wht  
Gamma Bars—10 step grey scale  
Black to White  
Dots—White dots on a black field  
External Video—Positive or negative (Provision for mixing ext. video with above).  
System Bandwidth: Luminance Channel 6 mc  
Chrominance: "I" and "Q" Channel per NTSC standard  
Subcarrier balance stability: Drift not greater than 6 mv (1.4 v. pk-pk signal), 8 hour operation.  
Residual Subcarrier Unbalance: 1% Signal Level  
Power Requirements: AC 105-125 volts 7 amps., 60 cps.

### COLORPLEXER—MODEL PT-205

Output Signals: NTSC Composite Video 2 Outputs 0—1.4 v. pk-pk  
Available Test Signals: I, Q, Y, R-Y, B-Y, (Neg. and Pos.) Video  
Input Signals: Subcarrier 20-30 v. pk-pk, 3-579545 mc  
Sync 3.0 v. pk-pk, negative  
Vertical Drive 3.0 v. pk-pk negative, R, G, B; 1 v. pk-pk operation  
System Bandwidth: Luminance Channel 6 mc  
Chrominance: "I" and "Q" Channel per NTSC standard  
Subcarrier Balance Stability: Drift not greater than 6 mv (1.4 v. signal), 8 hour operation  
Power Requirements: AC 6.3 v. @ 12 amps., DC 280 v. @ 425 ma

## ELECTRONICS CORPORATION



### SYNCHRONIZING GENERATOR — MODEL PT-201

Compact unit provides RTMA standard driving, blanking and synchronizing pulses, as well as a composite video signal comprising vertical and horizontal dots for receiver tests (positive and negative). Used to drive color bar generators, or any other NTSC color TV generating equipment. Utmost stability assured through use of delay lines and by driving all pulses from leading edge of a crystal controlled oscillator. Unit may also be locked to synchronize with 60 cps line. External drive input jack permits operation with Color Subcarrier Generator. Complete with power supply.

### COLOR SLIDE SCANNER — MODEL PT-210

A complete equipment integrated into only two racks which provides a high resolution NTSC composite color video signal obtained from standard 2 x 2 (35mm) transparencies. Designed for maximum stability and high signal to noise ratio. The optical head is complete with lenses employing V-type dichroic mirrors and Fresnel condensing lenses. The R, G, B signals obtained from three channel photo amplifiers are gamma corrected to give proper rendition to high lights and shading. Utilizes a highly stabilized colorplexer. (See complete description of Model PT-205-Colorplexer above.)

The scanning kinescope has fine resolution and is combined with the deflection and high voltage unit. The remaining chassis components contain a regulated low voltage power unit, a regulated filament power unit and a regulated photo multiplier power supply.

### COLOR SUBCARRIER GENERATOR AND FREQUENCY DIVIDER UNIT

— MODEL PT-202. This rugged unit complete with regulated B+ and filament power provides standard NTSC subcarrier frequency with dual outputs and includes a frequency divider to provide a sync generator driving signal (31.5 KC) to convert standard B/W sync generators for color TV use. High stability achieved by temperature controlled crystal oscillator. All adjustments accessible at front of unit. Adapts any sync generator to NTSC color operation.

### COLOR TV VIDEO MONITOR — MODEL M-200

Two portable units supplied with brackets for standard rack mounting. High definition color picture with exceptionally good color rendition is displayed on a 15 inch tri-color kinescope. Excellent for checking the quality of NTSC color video signals in the studio, on transmission lines or in the receiver factory. Special test jacks and switches are provided for analyzing R, G, B signals, matrixing and phase of color signals. Exceptionally good synchronizing capabilities over a wide range of signals. Special convergence circuits are employed to give maximum utilization of color kinescope. Model M200 has good color stability and is relatively insensitive to line voltage changes. Excellent dynamic circuit linearity assures good color stability over a wide range in signal level.

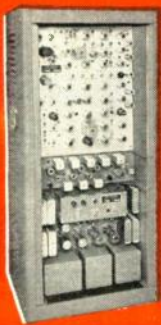

#### SYNCHRONIZING GENERATOR— MODEL PT-201

Output Signals: Sync. (Neg. and Pos.) 4 v. pk-pk across 75 ohms  
Blanking (Neg. and Pos.) 4 v. pk-pk across 75 ohms  
Horiz. Drive (Neg. and Pos.) 4 v. pk-pk across 75 ohms  
Vert. Drive (Neg. and Pos.) 4 v. pk-pk across 75 ohms  
Composite Video Output (Neg. and Pos.) 1.4 v. pk-pk across 75 ohms  
Internal Dot Pattern or External Video—1.4 v. pk-pk across 75 ohms  
Input Power: 105-125 v. 4.5 amps., 60 cps.

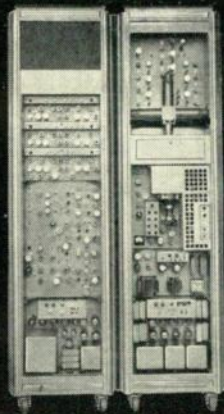

#### COLOR SLIDE SCANNER— MODEL PT-210

Output Signals: NTSC Composite Video 2 Outputs 0—1.4 v. pk-pk  
Optical Head: Lens—F. 2.0  
50 mm, Xenon lens in tractica mount  
V-type dichroic mirrors  
Color Slide 2 x 2 color Transparencies  
Gamma Amplifier:  
Three Channels (R, G, B)  
Input Signal—1.4 v. pk-pk across 75 ohms  
Output Signal—1.4 v. pk-pk across 75 ohms  
Colorplexer: (See Model PT-205 above)  
Deflection and High Voltage Unit:  
Kinescope type 5AUP24;  
Operating Voltage: 27 KV  
Linearity: 2% across raster  
Horizontal and Vertical  
Photomultiplier Power Supply:  
Electrically regulated. Filament Supply—AC line Regulated  
Input Signals: Hor. Drive—3 v. pk-pk  
Ver. Drive—3 v. pk-pk. Blanking Drive—3 v. pk-pk. Sync. 3 v. pk-pk  
Power Requirement: AC 105-125 v., 10 amp., 60 cps.

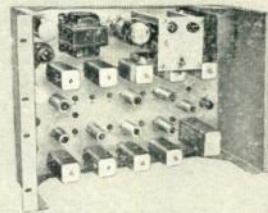

#### COLOR SUBCARRIER GENERATOR AND FREQUENCY DIVIDER UNIT—MODEL PT-202

Subcarrier Frequency Dual Output:  
3,579,545 mc/sec.  $\pm$  0.0003%  
with maximum rate of frequency change not exceeding 1/10 cps./sec.  
Subcarrier Output Voltage: 25 to 40 volts  
Frequency Divider Output:  
31,468 cps.  
Divider Output Voltage: 0 to 100 volts  
Ambient Temperature: 40° F. to 110° F.  
Power Requirements: AC 105-125, 2A, 60 cps.



#### COLOR VIDEO MONITOR—MODEL 200

Input Video Signal: 0.25 to 2.0 volts, pk-pk  
Signal Polarity: Pos., Neg., Bal.  
Input Impedance: 66 mmf across 2.2 megohms or 75 ohms  
Resolution: 250-300 lines min. (Full utilization of NTSC Color Signal Bandwidth)  
Linearity: (Hor. and Vert.) 2% across raster  
Tricolor Kinescope: 15"  
Focus: Electro Static  
Net Weight: 175 lbs.  
Power Requirements: 105-125 v., 4 amps., 50/60 cps.

**AVAILABLE ON  
EQUIPMENT LEASE PLAN**

**43-20 34th STREET, LONG ISLAND CITY 1, N. Y.**

REPRESENTATIVES • Albuquerque • Atlanta • Baltimore • Boston • Chicago • Cleveland • Fort Worth • Kansas City • Los Angeles • New York  
Philadelphia • San Francisco • Seattle • St. Paul • Syracuse • Washington, D. C. • Canada, Arnprior—Export: Rocke International Corporation

**Another G-E Capacitor First for the Electronics Industry**



**DRAWN-RECTANGULAR CASE** has no soldered seams, does not depend on solder for mechanical strength and effective sealing.

## **new . . . G-E CAPACITORS IN DRAWN-RECTANGULAR CASES**

- **Solderless, double-rolled cover seam**
- **Seamless case with standard dimensions**

General Electric is now producing fixed paper-dielectric capacitors in seamless, solderless cases with standard dimensions that comply with or exceed MIL specifications. For complete information contact your G-E Apparatus Sales Office or write for Bulletin GEC-809A to Section 442-24, General Electric Co., Schenectady 5, N. Y.

*Progress Is Our Most Important Product*

**GENERAL  ELECTRIC**

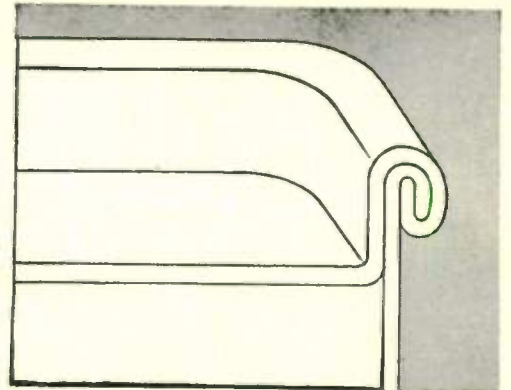

**SOLDERLESS DOUBLE-ROLLED COVER SEAM** makes a mechanically strong, hermetic seal.

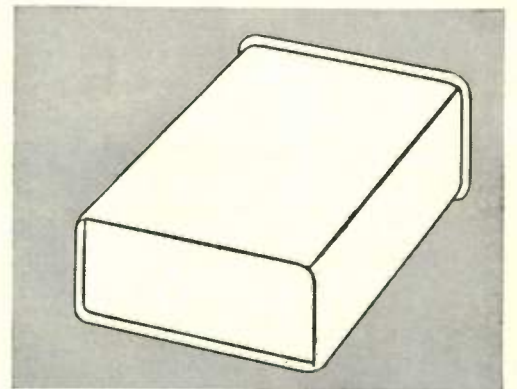

**BOTTOM OF CASE IS INDENTED** to permit mounting in inverted position.

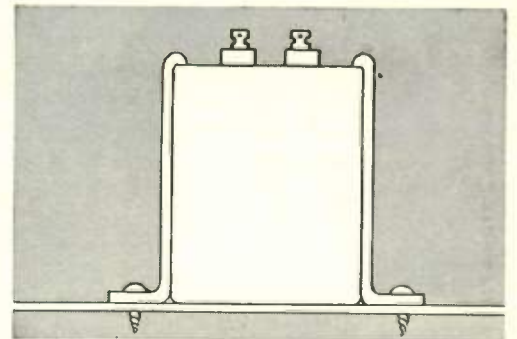

**UPRIGHT OR INVERTED MOUNTING** is possible using either spade lug, or footed brackets (above)

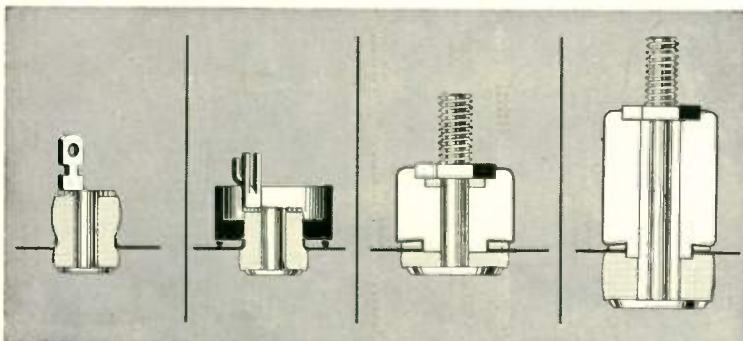

**FOUR BUSHINGS STYLES** are available for applications below 2000 volts d-c, special skirted bushings for higher voltages.

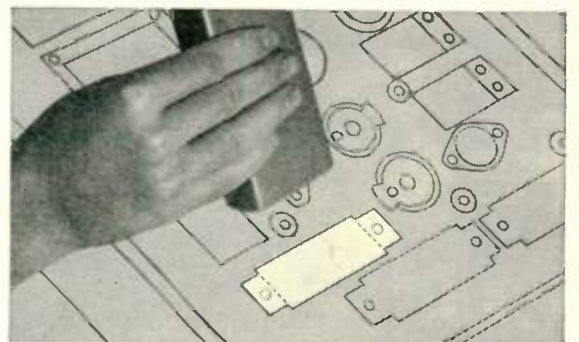

**STANDARD CASE SIZES** are interchangeable, making it unnecessary to change drawings or circuit layouts.



# POTTED A·N CONNECTORS

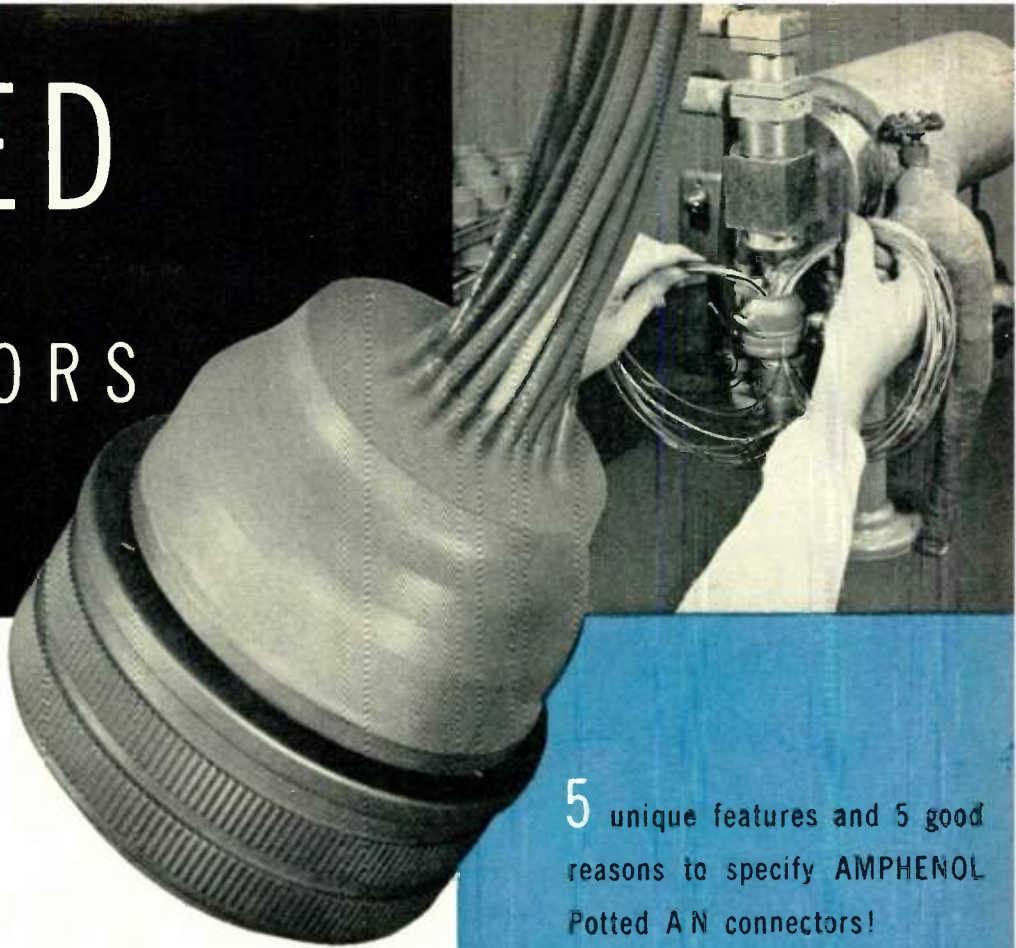

gain greater  
electrical reliability  
with moisture-proof  
AMPHENOL  
Potted AN Connectors

At right are listed the outstanding features of AMPHENOL Potted AN connectors. What is Potting and how can it offer these advantages to AN users? Potting simply replaces the usual backshells of any AN3106, AN3101 and AN3100 plug with a hemispherically shaped synthetic rubber sealant. It completely encloses the contact terminals in an AN cable assembly with a rugged moisture-proof housing.

The primary achievement of AMPHENOL Potting is an *electrically reliable moisture-proof* connector—but its other advantages are almost as desirable and open the possibilities of the use of Potted ANs in applications where moisture-proofing is not important. For not only is the Potted AN completely resistant to salt water but also to stronger fluids such as fuel oil and gasoline. Elimination of the usual backshell and cable-clamping components reduces both the size and the weight of an AN connector—and weight reduction is all important to engineers in every field of electronics today. Potting also provides a resilient mass at the wire terminals of the connector which not only isolates each individual contact and its wire lead in a sealed resilient chamber but permits the AN assembly to withstand severe vibration and to operate efficiently under unusual conditions. And, finally, if these were not enough reasons for specifying AMPHENOL Potted AN connectors, a Potted connector is not only more efficient, lighter in weight and smaller, but costs far less than so-called mechanically sealed connectors which are dependent upon auxiliary parts for moisture sealing!

5 unique features and 5 good reasons to specify AMPHENOL Potted AN connectors!

- 1 New efficient moisture-proof design
- 2 Greater electrical reliability in all kinds of weather
- 3 Weight-saving, space-saving construction
- 4 Ability to withstand severe vibration
- 5 Lower cost than standard or mechanically "sealed" connectors



REQUEST BULLETIN 2555  
Full details on Potting of AN  
connectors

1830 South 54th Avenue, Chicago 50, Illinois  
AMERICAN PHENOLIC CORPORATION  
In Canada: AMPHENOL CANADA LTD., Toronto

**AMPHENOL**



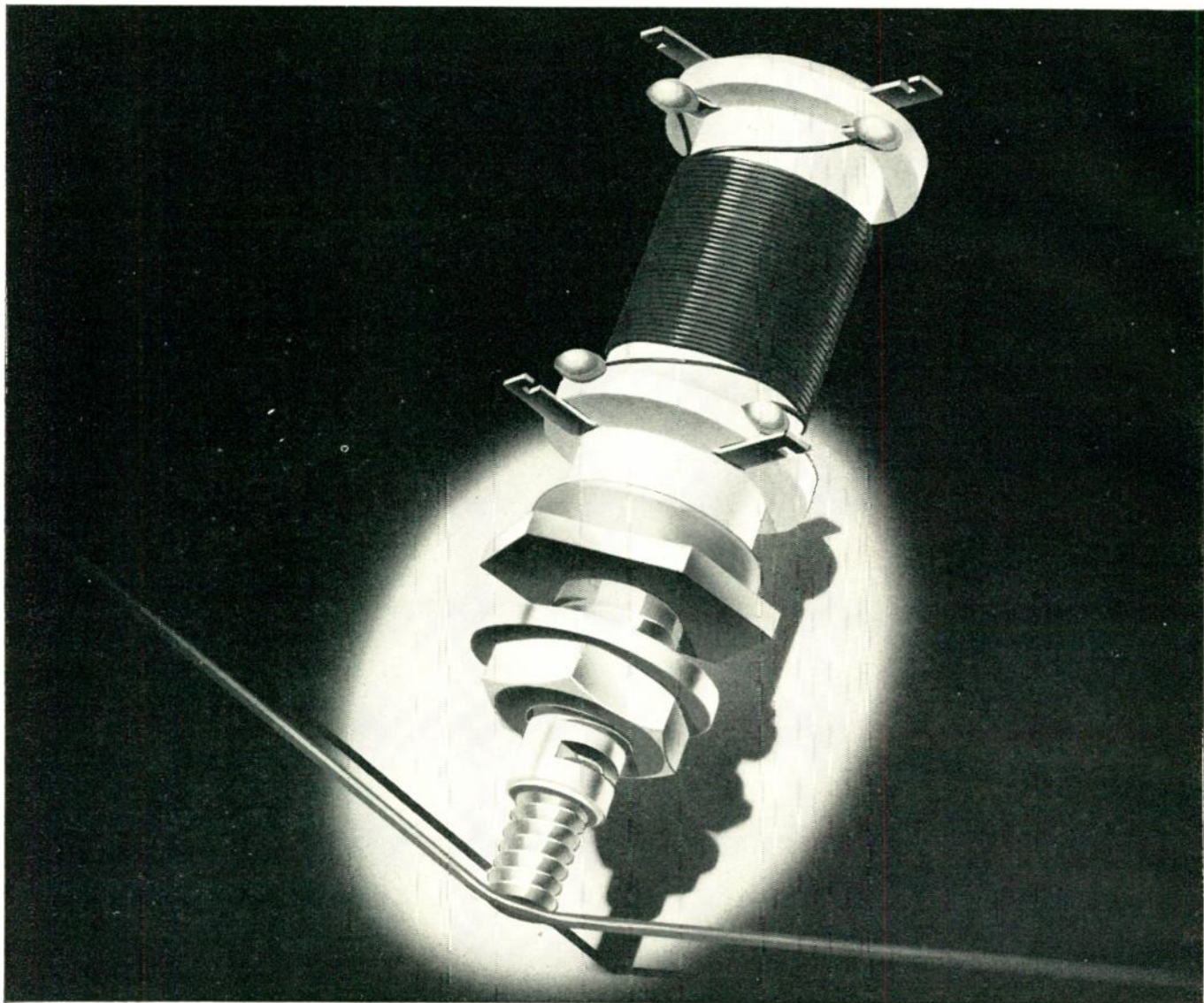

## Death-defying performance

You can depend on C.T.C. coils to give a steady, star performance. They won't go dead despite threats of temperature, climate or vibration. And for very good reasons —

The mounting stud of every C.T.C. coil is fastened to the ceramic body in a special way that does away with weaknesses of ordinary coil fastenings. This special fastening makes C.T.C. coils vibration-proof. What's more, their tightness is preserved in hot, cold, dry or damp weather. All C.T.C. coils are precision-made, of course, to meet individual specifications — and to meet, or better, government specifications, as well. And continuous quality control is maintained.

As a result, you get a *guaranteed* electronic component — custom or standard — whose performance you can depend upon.

Precision-made C.T.C. components that benefit from C.T.C. high quality standards include terminals, terminal boards, capacitors, swagers, hardware, insulated terminals and coil forms. For

all specifications and prices, write Cambridge Thermionic Corporation, 456 Concord Avenue, Cambridge 38, Mass. West Coast manufacturers contact: E. V. Roberts, 5068 West Washington Blvd., Los Angeles 16 and 988 Market St., San Francisco, California.

*Slug Tuned Coil Data:* Single layer or pie type windings to your specifications. Forms of quality paper base phenolic or grade L-5 silicone impregnated ceramic. Mounting studs are cadmium plated brass; ring type terminals are silver plated brass. All units include slugs and mounting hardware. One style (Type C) available with retaining collars of silicone fibreglas which permit 2 to 4 terminals. Windings can be coated with resin varnish, wax or lacquer.

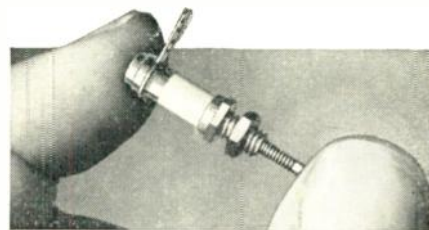

*New CST-50 variable ceramic capacitor surpasses range of capacitors many times its size. Stands only 1 1/2" high when mounted, is less than 1/4" in diameter and has an 8-32 thread mounting stud. A tunable element of unusual design practically eliminates losses due to air dielectric giving large minimum to maximum capacity range (1.5 to 12MMFD).*

**CAMBRIDGE THERMIONIC CORPORATION**

*makers of guaranteed electronic components,  
custom or standard*







**MILLIONS** of crystals made to **ANY**  
specifications but only **ONE** standard quality

Midland frequency control units are on the job in two-way communications on land, sea and in the air throughout the world. Now they're playing a leading role in color television. The range of applications Midland serves is wide, but every Midland crystal has one thing in common: a single level of quality.

That one quality is simply the highest that modern methods and machines can produce. It's assured by Midland's system of critical quality control—exacting inspection and test procedures through every step of processing.

Result: Your Midland crystal is going to give you the best possible service in frequency control—with stability, accuracy, and uniformity you can stake your life on... as our men in the armed forces and law enforcement do every day.

*Whatever your Crystal need, conventional or highly specialized When it has to be exactly right, contact*



**Midland**

**MANUFACTURING COMPANY, INC.**  
3155 Fiberglas Road, Kansas City, Kansas



**WORLD'S LARGEST PRODUCER OF QUARTZ CRYSTALS**

# RESISTORS WITH PERFORMANCE ADVANTAGES THAT MAKE POSSIBLE WIDER RANGE APPLICATION

*Noblette  
and  
Nobleloy*

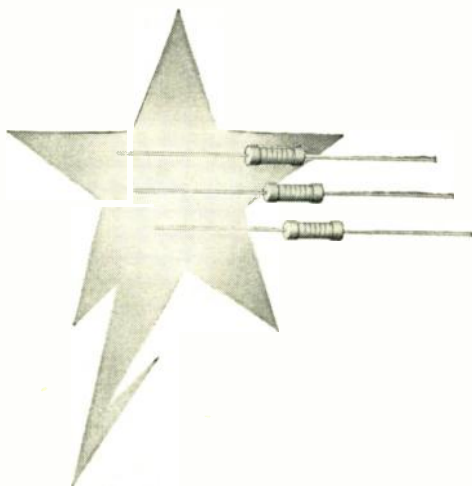

## METAL FILM RESISTORS

Most important performance advantages are—stability throughout its long life—low inductance—initial accuracy and excellent resistance stability under adverse operating conditions.

A trial will convince you why they are now preferred by many outstanding electronic design engineers, and why you can always make your choice Noblette 1/2, 1 and 2 watt with axial leads or Nobleloy 1/2, 1, 2 & 5 watt with radial leads.

## WM WIRE WOUND RESISTORS

For low power application. Composed with a minimum of .0015 inch wire that is wound automatically for true parallel winding to prevent shorting at turns. Terminals are securely bonded to permanent connections to the winding. They are moisture resistant and recommended for circuits requiring very low resistance, which is not ordinarily available in the carbon style. (Write for technical data and catalog on all Continental products.)

Represented in leading cities from coast to coast

**CONTINENTAL CARBON, INC.**

13900 LORAIN AVE. CLEVELAND 11, OHIO

CLEARWATER 1-6500



Mrs. J. A. Short was born in Houlton, Me., on February 20, 1924. She received the B.S. degree in electrical engineering from



MRS. J. A. SHORT

Antioch College in 1946. She joined the quality control department of Western Electric Corporation, and then the television research department of the Columbia Broadcasting Corporation. In 1947 she held a graduate assistantship in the electrical engineering department of Ohio

State University, subsequently becoming a research associate with the Antenna Laboratory, engaged in microwave impedance measuring work.

From 1949 to 1952, Mrs. Short worked for Hughes Aircraft Company, doing research associated with microwave slot-antenna designs.

For a photograph and biography of I. L. LEBOW see page 1191 of the September, 1953 issue of the PROCEEDINGS OF THE I.R.E.



R. H. Baker was born on February 15, 1928 in Dowagiac, Mich. He received the B.S. degree in Electrical Engineering from



RICHARD H. BAKER

Texas A. and M. College in June 1949. Thereafter until June 1950 he worked at the Servomechanisms Laboratory of the Massachusetts Institute of Technology. Since September, 1950, he has been employed as a research engineer at the AF Cambridge Research Center,

currently on loan to the Lincoln Laboratory M.I.T. Mr. Baker received an M.S. degree in electronics from M.I.T. in June 1953.



The Board of Directors of Varian Associates, Palo Alto electronics firm, at a September meeting, elected **E. G. Cameron** (A'42-M'48-SM'54) Vice-President for Production.

Mr. Cameron, Works Manager of the Varian manufacturing plant in San Carlos, joined the company in April 1953, and was elected to the Board of Directors at the annual stockholders meeting January 26, 1954. He has previously served as Works Manager with Sarkes Tarzian, Inc., as Chief Engineer at Federal Telephone and Radio Corp., and as Production Manager of Heintz and Kaufman, Ltd. Mr. Cameron is a native of San Francisco and a University of California graduate in electrical engineering.

(Continued on page 47A)



# Eimac Klystron Report

# X566

20kw

modulating anode  
pulse klystron

- High power gain of 53db
- UHF operation — 960-1400mc

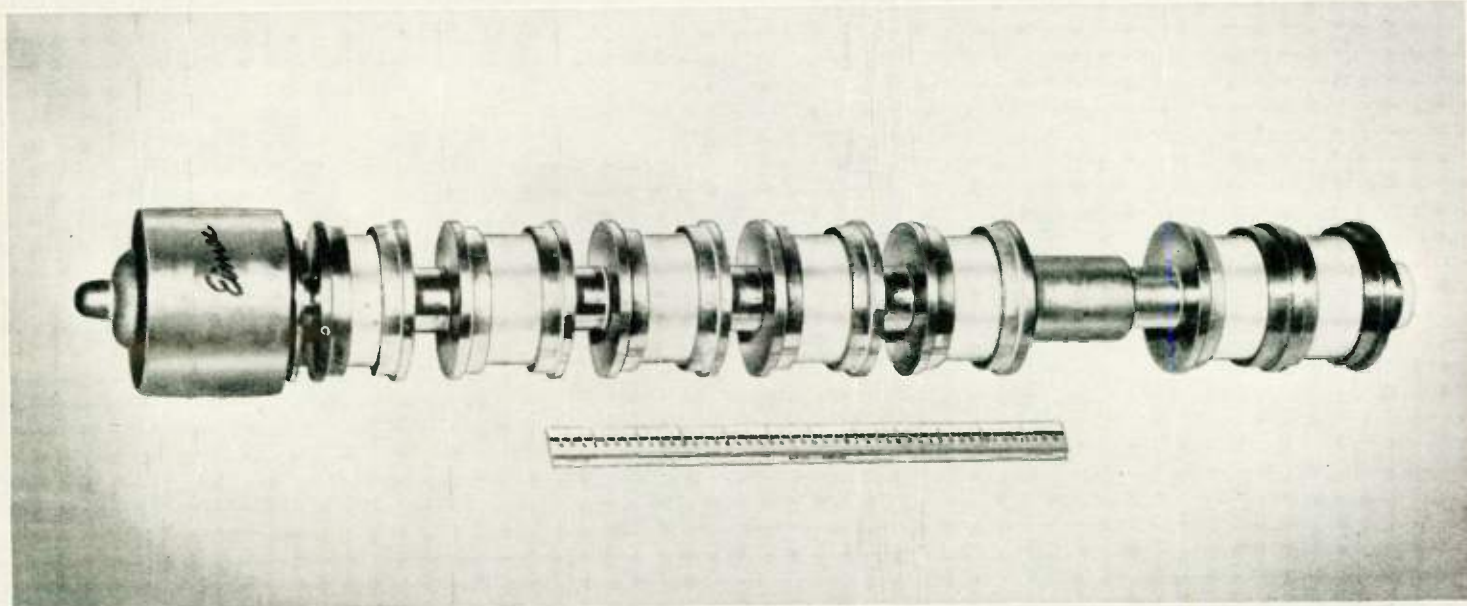

**E**IMAC X566 UHF klystrons have consistently obtained peak pulse power outputs of more than 20kw with over 40% efficiency at 960-1400mc. Many times more powerful than any other tube intended for similar operation, such as aircraft navigational aid Distance Measuring Equipment, the air-cooled X566 requires only 100 milliwatts driving power for a 20kw output — a power gain of 53db with bandwidth adequate for most pulse applications. Of special significance is the high average power capability of one kilowatt, allowing the duty cycle to be raised to 5% with a 20kw peak output, or 10% with 10kw output, and so on. Outstanding pulse capabilities of the X566 are made possible through the use of the Eimac modulating anode — an insulated anode between the cathode and drift tube section — permitting the klystron to be pulse modulated with

low pulsing power. In Eimac high power amplifier klystrons using ceramic and copper construction, the resonant cavities are completed outside the vacuum system, which is left free of RF tuning devices — permitting easy wide range tuning and uncomplicated input and output coupling adjustment. This simplicity of design and rugged construction minimize replacement costs as well as making the Eimac X566 suitable for mass production techniques.

The X566, another Eimac high power klystron achievement, is now available with circuit components for experimental purposes.

- For additional information, contact our Technical Services Department.

**EITEL-McCULLOUGH, INC.**  
SAN BRUNO • CALIFORNIA

**Eimac**  
THE WORLD'S  
LARGEST MANUFACTURER OF  
TRANSMITTING TUBES

# FREQUENCY STANDARDS

# Modular system

DESIGNED AS A

The Type 2001-2 series provides frequencies from 30 to 30,000 cycles with an accuracy of .001% (at room temperatures) in units suitable for integration with instruments of your own design — or for panel rack mounting with your own power sources — or for line operation.

WHICH WILL MEET YOUR  
**CUSTOM NEEDS**  
FROM A COMBINATION OF  
**STOCK UNITS**

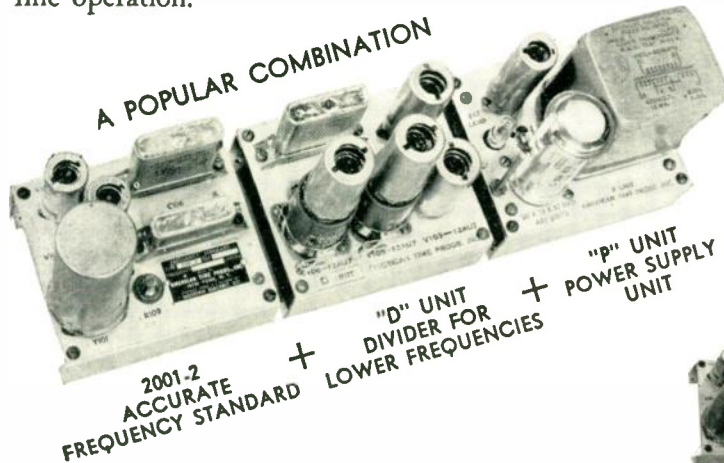

### TYPICAL COMBINATIONS

2001-2	2001-2 + M
2001-2 + L	2001-2 + M + P
2001-2 + L + P	2001-2 + L + P + R
2001-2 + H	2001-2 + H + P + R
2001-2 + H + P	2001-2 + M + P + R



### TYPE "2001-2" FREQUENCY STANDARD

Frequencies, 200 to 3,000 cycles. Output, approximate sine wave at 5 volts.

## ACCESSORY UNITS

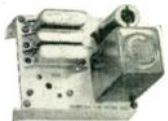

**"L" UNIT.  
DIVIDER, (MULTI-VIBRATOR TYPE)**  
Provides frequencies from 30 to 200, controlled by the 2001-2 unit. Output, approx. 5V. Approx. sine wave.



**"M" UNIT  
AMPLIFIER**  
Provides 2 watts at 6 and 110 volts.



**"D" UNIT.  
DIVIDER, (COUNTER TYPE)**  
Provides 40 to 200 cycles controlled by the 2001-2 unit. (fail safe)

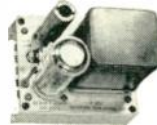

**"P" UNIT  
POWER SUPPLY**  
Provides power for combinations of units illustrated, if other sources are inconvenient or not available.



**"H" UNIT  
MULTIPLIER**  
Provides frequencies from 3,000 to 30,000 cycles, controlled by the 2001-2 unit. Output, approximately 5 volts.



**"R" UNIT  
PANEL MOUNTING**  
Accommodates up to three units. Standard size is 8¾ inches high, 19 inches long.

For details, please request our "Type 2001-2" Booklet.

**American Time Products, Inc.**  
580 Fifth Avenue  
New York 36, N. Y.  
OPERATING UNDER PATENTS OF WESTERN ELECTRIC COMPANY



latest result of

**RADIO RECEPTOR**

research

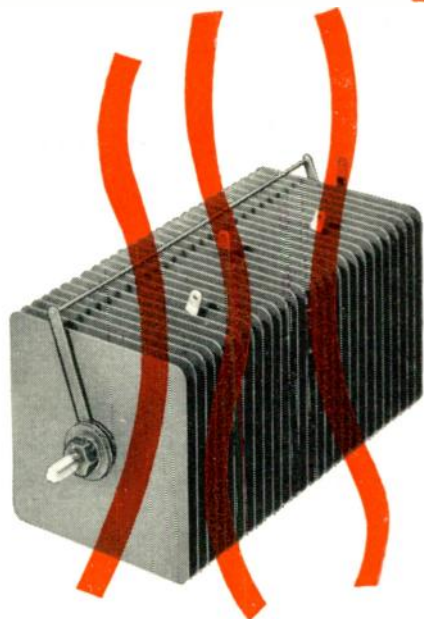

Now... **HIGH TEMPERATURE RECTIFIERS** in the **LARGER CELL SIZES** up to 5" x 6" (to operate without derating at 125° C.) and...

**AT REDUCED COST!**



Also available in cartridge type

RADIO RECEPTOR high temperature rectifiers when first introduced less than three years ago were expensive and limited to 3" x 3". Now intensive research has brought the cost down and the cell sizes UP. That means the field is wide open for their use in many applications once considered prohibitive because of size and price.

At 125° C. these rectifiers have a minimum life of 500 hours without derating and at *normal* temperatures their span is almost indefinite...They can be hermetically sealed without derating, too.

That's why RRco. high temperature rectifiers are selected more and more for military and special industrial requirements by such blue-chip companies as Aeronautical Division of Minneapolis-Honeywell, Motorola Inc., Hamilton Standard Division of United Aircraft and many others.

If you have one of those "tricky" applications where high temperature rectifiers are needed, take advantage of RADIO RECEPTOR's continuing research and development in this field. Write now for full details about these as well as embedded rectifiers to section P-3.

*We also manufacture transistors and silicon and germanium diodes*

AMBIENT TEMPERATURE	POTENTIAL LIFE WITHOUT DERATING
125° C	500-1000 hours
100° C	1500-2500 hours
85° C	2500-4000 hours

CELL TYPE	CELL SIZE (Inches)	CONTINUOUS DC AMPERES SINGLE PHASE		MAX. REVERSE RMS VOLTS PER CELL
		Half Wave	Bridge or Center Tap	
X	¼ (Diam.)	.005	.010	24
Y	½ x ½	.025	.050	24
J	⅙ x ⅙	.065	.130	24
M	1 x 1	.075	.150	24
P	1⅙ x 1⅙	.150	.30	24
Q	1½ x 1½	.30	.60	24
S	2 x 2	.50	1.0	24
U	3 x 3	1.2	2.4	24
W	4 x 4	2.25	4.5	24
T	4¼ x 6	3.35	6.7	24
H	5 x 6	4.0	8.0	24

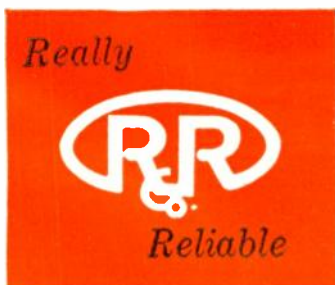

Semi-Conductor Division  
**RADIO RECEPTOR COMPANY, INC.**

*In Radio and Electronics Since 1922*

SALES OFFICES: 251 WEST 19TH STREET, NEW YORK 11, N. Y., WATKINS 4-3633, FACTORIES IN BROOKLYN, N. Y.

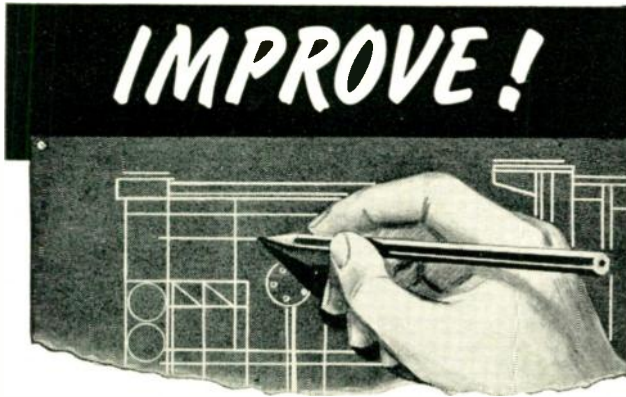

## Component Density and Ease of Application

**ENGINEERS KNOW** that successful designs...

- . . . utilize every inch of space to fullest advantage.
- . . . stress convenient mounting and wiring of components.
- . . . reduce labor, production and equipment costs.
- . . . provide high reliability thru simplicity.

**It's NORTH RELAYS in your designs that provide —**

1. minimized 2-hole mounting.
2. reliable operation in any position.
3. convenient grouping of coil and contact spring terminals.
4. clean uncluttered space below spring pile-up terminals for wiring cable.
5. easy accessibility for wiring, testing, and inspection.
6. decades of experienced know-how for proven high reliability.

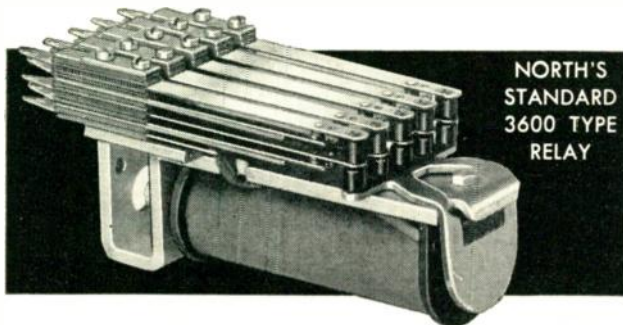

NORTH'S  
STANDARD  
3600 TYPE  
RELAY

A multi-contact control relay that provides up to 2½ times the switching capacity of other relays requiring the same mounting space. Up to 24 contact springs distributed over as many as 5 pile-ups; not to exceed 8 springs in any one pile-up. Incorporates all the principles of good design mentioned above. AC or DC operated. It has two breaks on each pile-up—a total of 12. Standard specifications provide a variety of coils and contact materials to meet your particular requirements. Overall dimensions 4⅞" x 1½" x 2⅝". Weight 12 oz.



Have you received your copy of  
NORTH'S NEW RELAY CATALOG?

**THE NORTH ELECTRIC  
MANUFACTURING COMPANY**

Originators of ALL RELAY  
Systems of Automatic Switching  
541 South Market Street, Galion, Ohio, U.S.A.

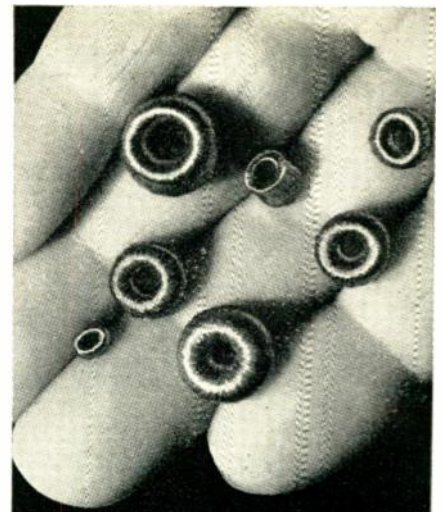

# Toroids! Tiny in Size! Light in Weight!

Envision the potentialities of these bantam coils in solving space and weight problems! Sub-miniature toroids from the BOESCH Model SM reveal a new horizon in equipment design.

Write for detailed information on the NEW Model SM Sub-miniature Toroidal Coil Winding Machine.

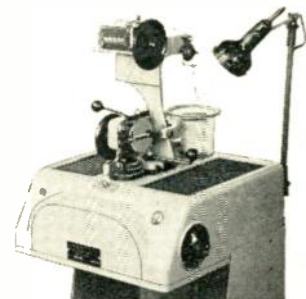

Model SM

Makers of the world's most versatile winding machines.





FOR INSTRUMENTATION AND CONTROL

# Cabled Tube

Some time ago Revere ran an advertisement featuring Crescent Armored Multitube for use in pneumatic and hydraulic instrumentation and control systems. The advertisement created so much interest that we thought you might like to see a photograph of an actual installation. The Control Board Junction Box shown here has 22 runs of Multitube coming into this box comprising 224 Revere Copper Tubes of 1/4" O.D. The picture was taken in the Glenwood Landing, N.Y. Power Station of the Long Island Lighting Company. The tubes go to instruments that report information on temperature, main and reheat steam pressure, boiler feed and condensate pump pressure, fuel oil and gas pressure, liquid levels, tide level and for the control of fuel feed, draft dampers, boiler drum water level and various control valves.

This is a relatively new use for Revere Copper Tube, but it is an important one in these days when new ways are being found to obtain process information more quickly and accurately, or to achieve automatic control. Crescent Armored Multitube is made by Crescent Insulated Wire & Cable Co., Inc., Trenton 5, N.J., in lengths up to 1,000 feet. It consists of a group of long tubes twisted together in cable form, protected by a flexible interlocked galvanized steel armor, or by plastic, or both. As many as 19 tubes, 1/4" O.D., can be cabled, with one tube in each layer color-coded. Larger tubes can also be cabled, including 5/16", 3/8" and 1/2". This construction affords protection during shipment, installation and use, and speeds up installation greatly. For further information, write Crescent, and for tube in copper and aluminum, see the nearest Revere Sales Office.

## REVERE

COPPER AND BRASS INCORPORATED

*Founded by Paul Revere in 1801*

230 Park Avenue, New York 17, N. Y.

*Mills: Baltimore, Md.; Chicago and Clinton, Ill.; Detroit, Mich.; Los Angeles and Riverside, Calif.; New Bedford, Mass.; Rome, N. Y. Sales Offices in Principal Cities. Distributors Everywhere.*

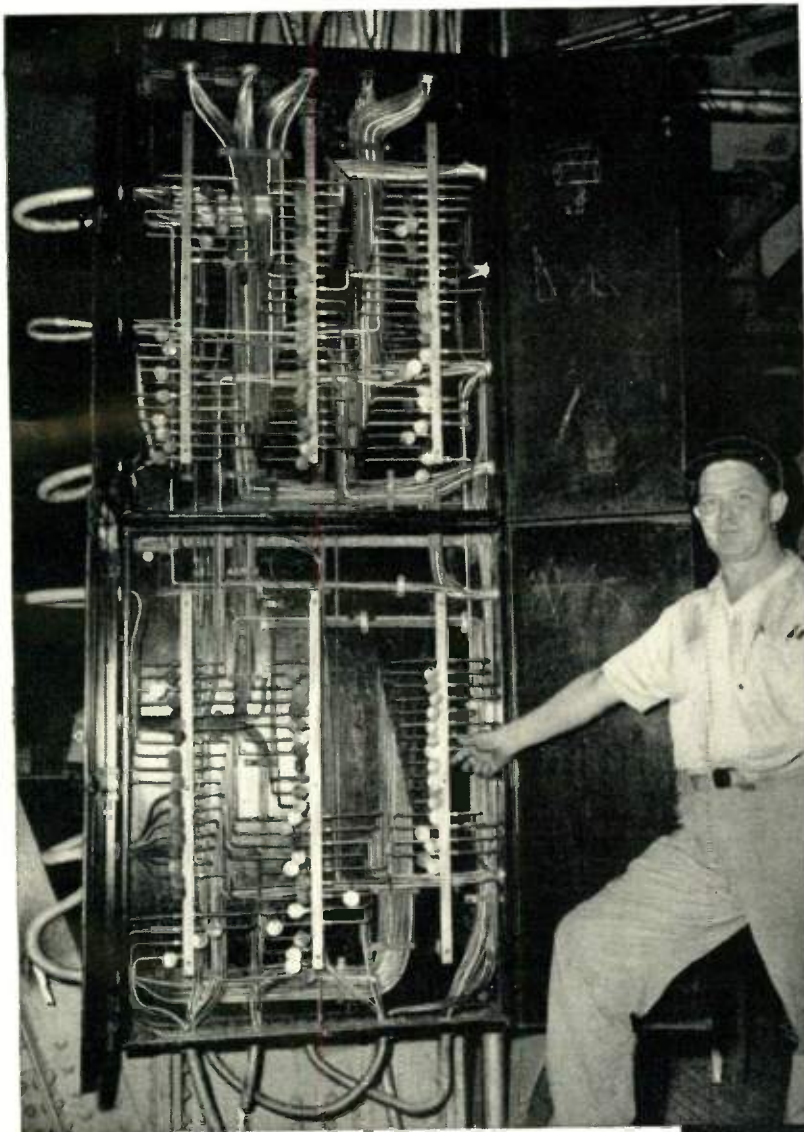

Control Junction Box at Power Station of Long Island Lighting Company, showing use of Crescent Armored Multitube. Note that relatively sharp bends can be made without damage to the cabled copper tube. 

Construction of Crescent Armored Multitube. 





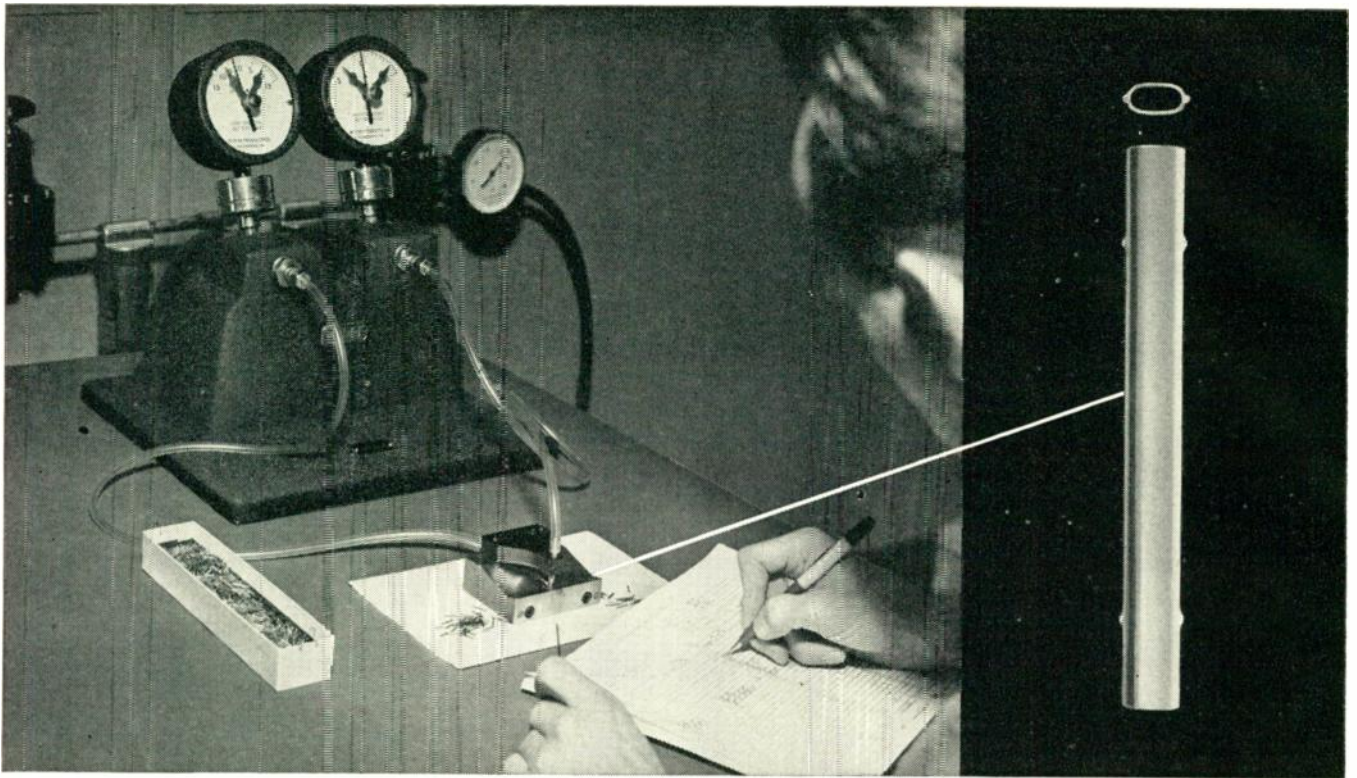

On this specially designed pneumatic comparator gage, the operator can check dimensions of elliptical cathodes to an accuracy of .0001" major axis and .00005" minor axis on mass production runs.

## SUPERIOR TUBE dimension control means better fitting cathodes

We were called upon to mass manufacture high performance seamless nickel alloy elliptical cathodes (shown above) with major and minor axes of .048" and .025" respectively, only 12 mm. long.

During the formation of the tiny beads shown above, the cathode underwent microscopic dimensional distortion of no more than .00125".

The development of this cathode required us not only to change to novel manufacturing methods and new processes, but to design new machinery.

Precision, accuracy and speed were also required in the functioning of a start-to-finish dimension control system. The pneumatic air comparator has proved that cathodes produced at Superior are now free from distortion, and 99% of the entire production is well within the tolerance limits specified even on repeat orders running into the millions.

The resultant cathodes offer a better fit for the heater, less likelihood of heater-cathode shorts, reduced microphonics, and improved electrical characteristics for the vacuum tube.

We are willing to go a step or two beyond the accepted and established practices to solve problems in electronics involving the use of cathodes and fabricated parts for the industry which are made from small metal tubing. This extraordinary attention to detail is given to many types of Superior specialty tubing and parts. We are equipped to manufacture products controlled to the most modern standards of variation. This elliptical cathode is one such product. We invite requests for Data Memorandum #5 on Cathode Materials and for Bulletin #40, a guide to the selection and application of small diameter tubing. Superior Tube Company, 2506 Germantown Avenue, Norristown, Pa.

*75 to 1 diameter vs. length comparison plot illustrates the improved bead conformity in new Superior Tube cathodes.*

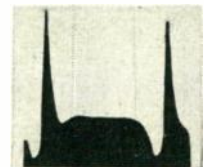

OLD cathodes. Note distortion near beads.

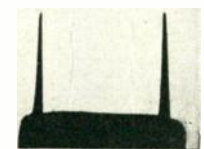

NEW cathodes. Note uniform bead heights and cathode diameter.

# Superior Tube

The big name in small tubing

All analyses .010" to 5/8" O.D. — Certain analyses in light walls up to 1/2" O.D.



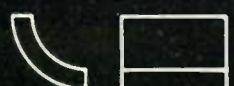
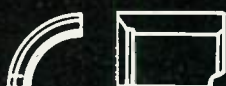
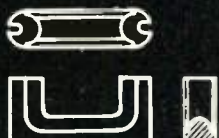
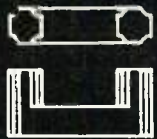

**THE PRODUCTION UNIT  
IS LIKE THE ENGINEERING  
SAMPLE *and* EACH PRODUCTION  
UNIT IS LIKE THE OTHER...**

*electrically and mechanically*

Available in a complete line of types,  
sizes and shapes for today's engineer-  
ing needs. Write for Bulletin RC-9A

**STACKPOLE**  
*Ceramag*®  
**FERROMAGNETIC CORES**

*Electronic Components Division*  
**STACKPOLE CARBON COMPANY, St. Marys, Pa.**

AVAILABLE THROUGH PARTS DISTRIBUTORS: For name of nearest distributor stocking Stackpole resistors, switches and "EE" iron cores, write Distributors' Division, Stackpole Carbon Company, 2 Rittenhouse Place, Ardmore, Pa.



... Masterpieces in crystal craftsmanship

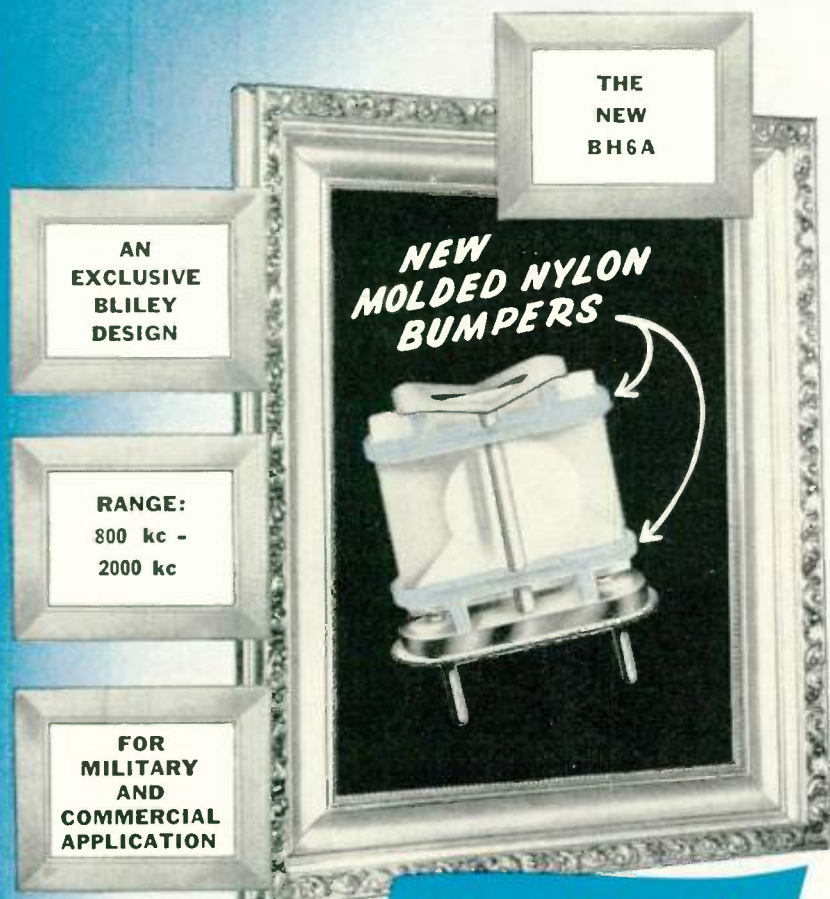

**NOW . . . 100 G SHOCK PROTECTION DESIGNED INTO MINIATURE CRYSTAL UNITS**

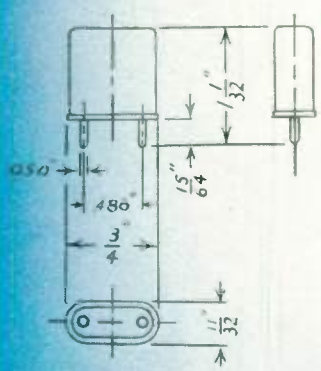

The Bliley BH6A, with *Molded Nylon Bumpers*, assures dependable performance in range 800 kc — 2000 kc. This new design meets the exacting requirements of MIL-C-3098A as applied to types CR-18, CR-19, CR-27, CR-28, CR-35 and CR-36. It includes the supplemental specification calling for tests under 100 G's in three planes.

Another example of Bliley leadership—for 25 years the top choice in crystals.



**Bliley**  
**ELECTRIC COMPANY**  
 UNION STATION BUILDING  
 ERIE, PA.

**ATR SHAV-PAK NEW, LOW PRICE!**

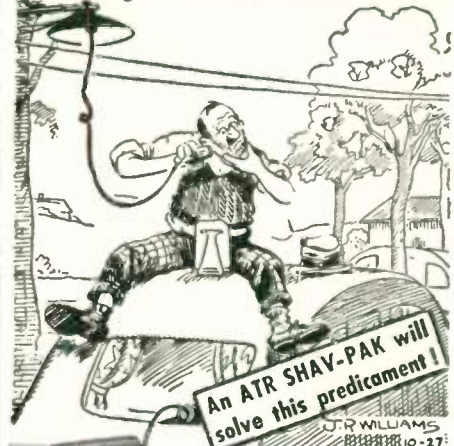

An ATR SHAV-PAK will solve this predicament!

**SHAVE IN THE COMFORT OF YOUR CAR, Boat or Plane!**

Plugs into Cigarette Lighter Receptacle on Dash

**\$ 9.95**  
LIST PRICE

Specially Designed for Operating Standard A.C. Electric Shavers in Automobiles, Buses, Trucks, Boats, and Planes.

TYPE	INPUT D.C. VOLTS	A.C. OUTPUT 60 CYCLES	OUTPUT WATTAGE	LIST PRICE
6-SPB	6	115 volts	15	9.95
12-SPB	12	115	15	9.95

Introducing **ATR MIGHTY MIDGET** portable **INVERTER** WITH GREATER OUTPUT

Dictate reports accurately—promptly!

make your car, boat or plane a "rolling office"



Plugs into Cigarette Lighter Receptacle on Dash

**\$ 19.95**  
AND UP  
LIST PRICE

with ATR INVERTERS for changing your storage battery current to A.C. Household ELECTRICITY *Anywhere* in your own car!

- DICTATING MACHINES • TAPE RECORDER
- ELECTRIC RAZORS • WIRE RECORDERS

TYPE	INPUT D.C. VOLTS	A.C. OUTPUT 60 CYCLES	OUTPUT WATTAGE	LIST PRICE
6-DME	6	115 volts	30-40	19.95
6H-DME	6	115 volts	60-75	29.95

Above Inverters also available for 12-volt operation.

See your jobber or write factory today for complete information



**AMERICAN TELEVISION & RADIO CO.**  
 Quality Products Since 1931  
 SAINT PAUL 1, MINNESOTA—U. S. A.





(Continued from page 38A)

Election of **E. W. Engstrom** (A'25-M'38-F'40) to the Board of Directors of the Radio Corporation of America has been announced. He fills a vacancy caused by the retirement of Walter A. Buck and now has broad responsibility for all research and engineering activities of RCA. In addition, he is head of RCA laboratories and a member of the Board of Directors of RCA Victor Company, Ltd., Canada.

Associated with the electronics industry since his graduation from the University of Minnesota in 1923, Dr. Engstrom joined RCA in 1930. First as an engineer and then as a research administrator, Dr. Engstrom has had a role in the development of radio, sound motion picture apparatus, electronics, and television. In 1945, Dr. Engstrom was elected Vice-President in Charge of Research of the RCA Laboratories Division. Subsequently, he became Vice-President and then Executive Vice-President of RCA Laboratories Division.

A native of Minneapolis, Minnesota, Dr. Engstrom is the recipient of the University of Minnesota's Outstanding Achievement Award, an honorary degree of Doctor of Science from New York University, and a silver plaque from the Royal Swedish Academy of Engineering Research. He is a Fellow of the American Institute of Electrical Engineers, Chairman of the Technical Advisory Panel on Electronics, Office of the Secretary of Defense, and a member of the AIEE Technical Advisory Committee to the National Bureau of Standards.



The Board of Directors of National Electrical Machine Shops, Inc., has elected **A. S. Clarke** (A'25-SM'47) president of the corporation to succeed the late E. M. Nevils, Jr.



A. S. CLARKE

Mr. Clarke, who was formerly Vice-President in Charge of Engineering, has had wide experience in the manufacture of electronic equipment. His radio experience dates back to 1913 and he is well known in the broadcasting industry. During World War II he was senior technical aide to the Chief of Division 4 of the National Defense Research Committee with headquarters at the Bureau of Standards. He was responsible for setting up production facilities for classified ordnance developments. For his war work received the Presidential Certificate of Merit and the Naval Ordnance Development award.

(Continued on page 48A)

# Precision Phasemeter



for precise measurement of phase difference at  
audio frequencies

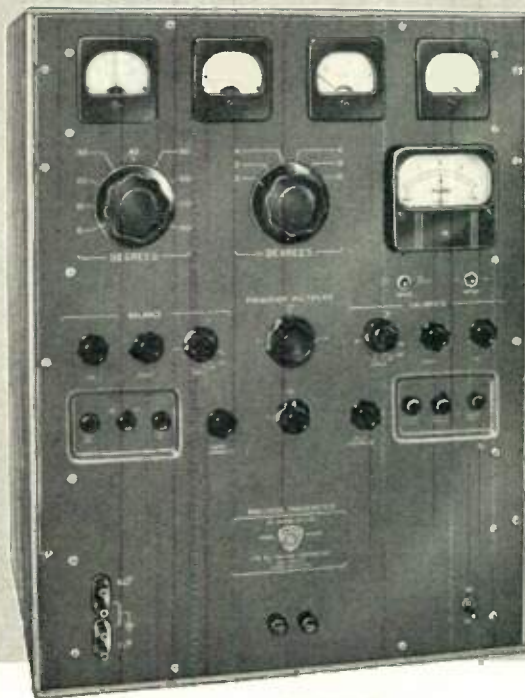

0.1° absolute accuracy  
0.01° incremental accuracy  
(30 cps to 20 kc)



\$3990.<sup>00</sup> Net F.O.B.  
Long Island City, N. Y.

THE MODEL P-1060 PHASEMETER is invaluable wherever precise knowledge of phase relationships in the audio-frequency range must be obtained. It has found increasing acceptance in the design of reactive components or of equipment using them, and in such analytical applications as measurement of residual inductance in "non-inductive" resistors, measurement of stray capacitance across resistors, and investigation of phase relationships in navigational and data-transmission systems.

Employing the phase-comparison method, the instrument exhibits a high degree of accuracy and incremental discrimination. The calibration may be checked with auxiliary equipment available in most laboratories. Even-order harmonic distortion is cancelled and odd-order distortion up to 1% will not affect accuracy of reading.

## SPECIFICATIONS

Frequency Range.....30 to 20,000 cps  
Phase range.....0 to 360 degrees  
Accuracy .....0.1 degree  
Incremental discrimination.....0.01 degree  
Signal level.....0.5 to 10 volts rms  
Input impedance 10 megs. shunted by 25  $\mu$ f  
Display.....Decade null system  
Output jack Can be provided for operating external recorder.  
Power requirements....200 watts at 105-125 volts, 60 cycles.  
Size.....19½" wide, 16¼" deep, 25" high  
Weight .....110 pounds

Equipment, when removed from cabinet, is suitable for mounting in standard 19" relay rack.

WRITE TODAY for descriptive bulletin A-950.

MAXSON develops and manufactures systems, sub-systems, and components in armament, navigation, electronics, and special devices.  
Ask for facilities report.



THE W.L. **MAXSON** CORP.

460 WEST 34TH ST. NEW YORK 1, N. Y.

Plants at Old Forge, Penn. and Long Island City and New York, N. Y.

# HOW TO SUCCEED WHILE YOU'RE STILL YOUNG

**I**T SURPRISES many people to learn that the average age of the men who respond to our advertisements is closer to forty than to twenty. But it's not hard to understand why this is true!

Most young men are *satisfied* with their progress in business. Their native ability and energy are enough to win them regular promotions and salary increases. They find success only a matter of time.

*But the day comes, often with a shocking suddenness, when this easy and casual progress ends abruptly.*

Many a man wakes up with a start in his thirties or forties to find that his income has leveled off, and that promotions have ceased.

"I'm not getting ahead as fast as I should," he says to himself. "Where am I going to be ten years from now?"

Why does this pathetic pattern appear in so many promising careers?

The answer is simple: Sheer ability and energy can carry a man to the mid-way point in business . . . *but only a thorough knowledge of business fundamentals can help him beyond that point.*

If you realize that fact while time is still on your side—and act on it—you can succeed while you're still young.

**FREE . . . "FORGING AHEAD IN BUSINESS"**

We do not claim that you must have the Alexander Hamilton Course in



order to succeed in business. But we do say that *you cannot succeed without what is in the Course!*

All the Institute does is offer you a convenient and time-saving means of bringing this knowledge to you in your spare time; and in a form that has *proved* to be practical and effective for more than forty years.

So that you may judge for yourself whether or not you think the Institute can help you, we have published an informative 48-page book titled "Forging Ahead in Business."

We believe that this little book will help any man get down to bedrock in his thinking; however, there's no cost or obligation for it because—frankly—we've never been able to put a price on it that would reflect its true value. Some men have found a fortune in its pages.

If you would like a complimentary copy of "Forging Ahead in Business," simply sign and return the coupon below. It will be mailed to you promptly.



(Continued from page 47A)

The appointment of **A. E. Harrison** (SM) to the post of Director of Engineering for the Fairchild Guided Missiles Division has been announced.



A. E. HARRISON

Mr. Harrison, Vice-President in Charge of Engineering for the Wilcox Electric Company of Kansas City for the past two years, has broad experience in aircraft electronics, including navigation devices, radio communication, and control systems for both military and commercial aircraft.

Previous to 1952, Mr. Harrison was Chief Engineer of Air Associates Incorporated, Teterboro, N. J. In this position, he was responsible for the development of ultra-high frequency airborne radio equipment and fire control systems. For a number of years, he was a member of the technical staff of the Bell Telephone Laboratories where he developed VHF and UHF airborne radio communication equipments. Previous to this, Mr. Harrison was a consultant for the U. S. Navy on the Radio Board of the Joint Aircraft Committee.

Mr. Harrison received the B.S. degree in E.E. from the University of Colorado. He holds several patents on electronic devices.



**H. S. Killgore** (A'44-M'46) has been appointed Manager of Government Sales for National Company, Inc., Malden, Massachusetts.



H. S. KILLGORE

Mr. Killgore will be responsible for all Government sales activities and the direction of National's government sales representatives. Credited with establishing the first complete mobile radio broadcasting station used in the invasion of North Africa during World War II, Mr. Killgore has spent almost twenty years in the broadcast and electronic fields, and has traveled the world as a communication consultant for the government. In addition, Mr. Killgore spent a number of years with Collins Radio Company and has just resigned as Director of Government Sales for Emerson Radio Company.

Mr. Killgore was educated at Ecole des Alpes, Morges, Switzerland, Lawrence Academy, Groton, Mass., and completed special radio engineering courses at MIT and Harvard University. He is a member of the Armed Forces Communication Association and the National Press Club.

(Continued on page 52A)



ALEXANDER HAMILTON INSTITUTE  
Dept. 293, 71 W. 23rd Street, New York 10, N.Y.  
In Canada: 57 Bloor St., W., Toronto, Ontario, Canada

Please Mail Me, Without Cost, a Copy of Your 48-Page Book—  
"FORGING AHEAD IN BUSINESS"

Name.....

Firm Name.....

Business Address.....

Position.....

Home Address.....



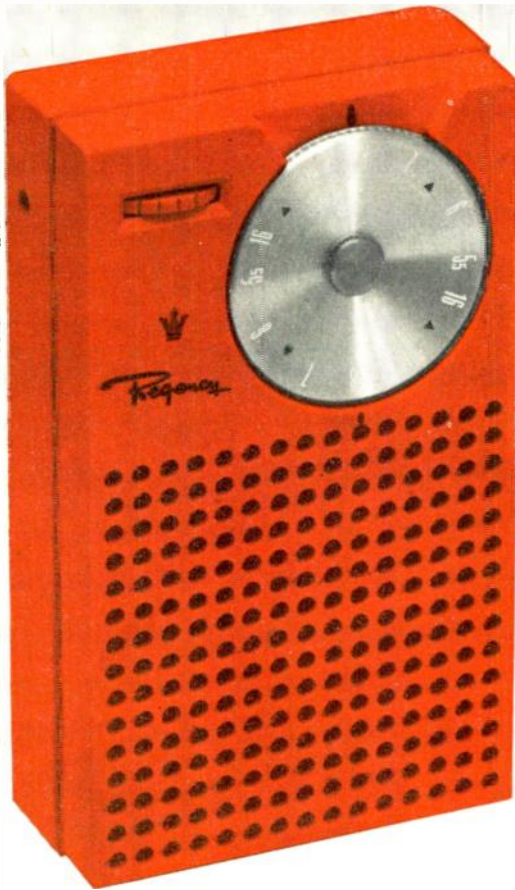
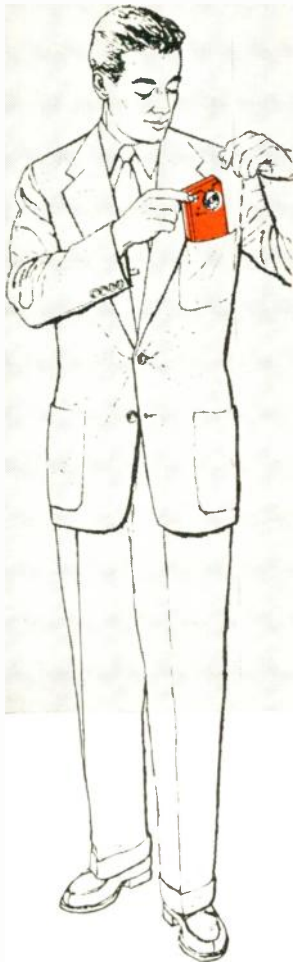

the  
*First*  
transistorized  
consumer  
product

... uses TI transistors!

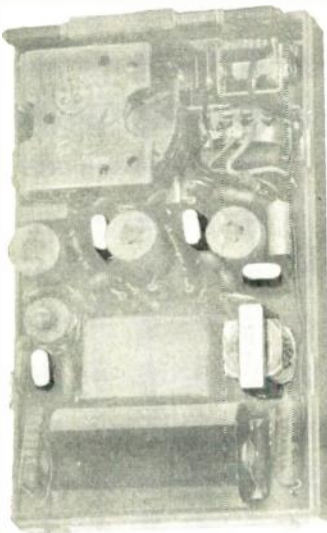

Using four high gain Texas Instruments transistors, the world's first transistorized consumer product — a high performance pocket size radio — is now available on the retail market! Priced under \$50, the world's smallest commercial radio receiver (manufactured by Regency of Indianapolis) achieves better performance than many much larger conventional sets. To produce the specially designed transistors used in this superb little instrument, TI has developed advanced manufacturing techniques that assure uniformly high product quality as well as mass production quantities. With the transistor radio already a real-

ity, the multi-million dollar consumer market is ready and waiting for still more transistorized products. Don't delay your own product development for lack of suitable low cost, high performance transistors. In designing transistorized products, depend on transistors from Texas Instruments, a leading supplier of transistors for a variety of commercial and military applications. Producing the industry's widest range of semiconductor devices — silicon or germanium; diodes or transistors — Texas Instruments is your most *experienced* source of supply for dependable semiconductor products.

\*With four Texas Instruments grown junction n-p-n germanium low cost, high gain transistors, the Regency radio achieves power gains of 32 decibels in each intermediate-frequency stage and 37 decibels in the audio stage. One transistor is used as a combination mixer-oscillator, two as intermediate-frequency amplifiers, and one as an audio amplifier. Output transformer also TI manufactured.



TEXAS INSTRUMENTS  
INCORPORATED  
6000 LEMMON AVENUE DALLAS 9, TEXAS

PROGRAM DESIGNED TO EXPLORE OUR EXPANDING TECHNOLOGY

70 EQUIPMENT AND COMPONENT EXHIBITS

PLANNED INSPECTION TOURS

TOP-OF-THE-LADDER SPEAKERS

LADIES PROGRAM — GLAMOUR FOR THE GALS IN EXCITING BIG "D"

**TOURS**

Bell Aircraft Corporation  
Braniff International Airways Communications Shop  
Chance Vought Aircraft  
Continental Electronics Manufacturing Co.  
Collins Radio Company  
Southwestern Bell Telephone Co., Haskell Exchange  
Temco Aircraft Corporation

**SPEAKERS**

*Open Meeting*

W. H. Houston, President of Rice Institute at Houston  
Jack D. Ryder, Dean of Engineering, Michigan State College  
George Bailey, Executive Secretary of I. R. E.  
T. A. Hunter, Editor, I. R. E. Student Quarterly, past Regional Director, I. R. E.

*Banquet*

John J. Jordan, Fellow of I. R. E. and director of Engineering and Research, The Baldwin Piano Co.

**SEVENTH ANNUAL SOUTHWESTERN I. R. E. CONFERENCE AND ELECTRONICS SHOW** at the Baker Hotel in Dallas, Texas, February 10, 11 and 12, 1955 sponsored by the Dallas-Fort Worth Section, Institute of Radio Engineers.





# Convenient

## ACCURATE POWER MEASUREMENTS . . .

FROM 500 to 11,000 MC



This versatile FXR Universal Power Meter, and rugged Matched Coaxial Thermistor Mount, make an unbeatable laboratory or production line team. Here is your assurance of faster, more reliable c-w or pulsed power measurements . . . over broad frequency ranges. These are instruments of proven dependability . . . designed, engineered and built with the specialized know-how for which FXR is recognized in Precision Microwave Test Equipment.

### UNIVERSAL POWER METER

#### FXR MODEL NO. B830A

- Extend range 0.1 to 100 milliwatts full scale
- Accommodates any resistance within  $\pm 10\%$  of 50, 100, 150, 200 or 250 ohms
- Positive or negative temperature coefficient
- Bias ranges from 3 to 40 milliamperes
- Bias can be pre-set on meter
- Extra protection against bolometer burn-out

### MATCHED COAXIAL THERMISTOR MOUNT

#### FXR MODEL NO. N215A

- VSWR less than 1.5 from 500 to 11,000 mc
- DC circuit self-contained—200 ohms operation at 34 milliwatts
- Two rugged thermistors used as detecting elements
- Exceptionally high burn-out level
- Plug-in replaceable elements
- Designed for highest accuracy

See the COMPLETE LINE of  
**FXR PRECISION MICROWAVE  
TEST EQUIPMENT**

Write today for complete Catalog



## Electronics & X-Ray Division

### F-R MACHINE WORKS, Inc.

26-12 BOROUGH PLACE, WOODSIDE 77, N. Y.



**CUT**  
YOUR COIL  
PRODUCTION  
COSTS  
▼  
▼  
with  
▼

**PRECISION COIL BOBBINS**

Our special machinery and high production methods work in combination with rigid quality control to provide you with the finest in coil bobbins at lowest possible cost.

Your specifications are met to the most critical tolerances. Workmanship is precise and carefully inspected. You can order in quantity, in any size or shape, flanges of all types, and be sure of uniformity throughout. Only fine dielectric materials are used—kraft, fish paper, acetate, phenol impregnated or combinations.

With Precision Bobbins you eliminate rejects, waste, loss of time—get better coils at less cost. Prove it to yourself! Send specifications for samples. Ask for literature.

**PRECISION LOW COST PAPER TUBES**

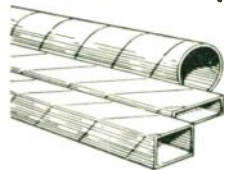

Order in any length, size, shape, I.D. or O.D. and in any quantity. Precision Paper Tubes are crush resistant and light weight, with excellent dimensional stability. They are fabricated to the same high standards governing Precision Bobbins.

Send for samples and Arbor List of over 2000 sizes

**Sales Representatives in:**

- New England:**  
Framingham, Massachusetts, Framingham 7091
- Metropolitan New York, New Jersey:**  
Jersey City, New Jersey, Journal Square 4-3574
- Upstate New York:**  
Syracuse, New York, Syracuse 76-8056
- Northern Ohio, Western Pennsylvania:**  
Cleveland, Ohio, Atlantic 1-1060
- Indiana, Southern Ohio:**  
Logansport, Indiana, Logansport 2555

- Missouri, Southern Illinois, Iowa:**  
St. Louis, Missouri, Sterling 2318
- Maryland:**  
Baltimore, Maryland, Plaza 2-3211
- Philadelphia, Camden:**  
Philadelphia, Pa., Chestnut Hill 8-0282
- California:**  
Pasadena, California, Sycamore 8-3919
- Canada:**  
Montreal, Quebec, Canada, Walnut 2715

**PRECISION PAPER TUBE CO.**

2051 W. CHARLESTON ST. CHICAGO 47, ILL.

Plant No. 2: 79 Chapel St., Hartford, Conn.



(Continued from page 48A)

Division chiefs have been named by Dr. A. V. Astin, Director of the National Bureau of Standards, for three radio divisions of the Bureau's Boulder Laboratories in Colorado. The division chiefs are **R. J. Slutz** (A'53), Radio Propagation Physics; **K. A. Norton** (A'29-M'38-SM'43-F'43), Radio Propagation Engineering; and **H. A. Thomas** (SM'52), Radio Standards. In addition, **H. Lyons** (SM'50) has been designated assistant Chief for Research of the Radio Standards Division; he will also serve as Chief of the Microwave Standards Branch. Director of the Boulder Laboratories is Dr. Frederick W. Brown.

The three radio divisions represent a re-organization of the activities of the Central Radio Propagation Laboratory, which has existed as a single division of NBS in Washington and which has been transferred within the past few months to Boulder. The Central Radio Propagation Laboratory is the primary agency of the Federal Government for research in radio wave propagation and radio-frequency standards, including standards for all electrical quantities in the radio frequency regions.



**E. T. Barrett** (A'42-M'45) has been elected President of C.G.S. Laboratories, Inc., Stamford, Conn. Mr. Barrett is a



E. T. BARRETT

patent attorney and a member of the firm of Curtis, Morris & Safford, New York. In addition to his legal and administrative background, Mr. Barrett has had many years experience as a chemist and, during the war, was engaged in electronic research at Harvard University under the Office of Scientific Scientific Research and Development.

He attended Kansas University, and Lawrence Institute of Technology. In 1945 he received the L.L.B. degree from North-eastern Law School.



Appointment of **C. D. Perrine, Jr.** (A'51) as Director of Engineering of the Pacific division of Bendix Aviation Corporation, has been announced.

Mr. Perrine, who has been associated with the development of aircraft electronics and guided missiles, formerly was Assistant Manager and Chief Engineer of Consolidated-Vultee Aircraft Corporation's Pomona division. For the past two years he specialized in major guided missile development and production for the Navy's Bureau of Ordnance and the Applied Physics Laboratory, Johns Hopkins University. Previously he was Assistant Chief Engineer for missiles and electronics at Convair's San Diego division.

Before joining Convair, Mr. Perrine

(Continued on page 56A)





# NEW GERMANIUM POWER RECTIFIERS REDUCE VOLUME AND WEIGHT 75%

...and actually cost less!

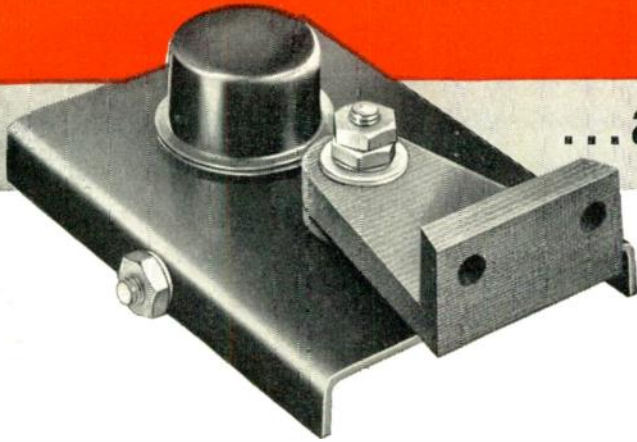

Because of the higher efficiency of germanium, these new G-E rectifiers achieve a full 75% saving in size and weight—and yet actually cost less than any conventional type dry rectifier in use today. This sharply-reduced weight and volume is a result of greatly-increased power per cell in G.E.'s unique low-loss rectifier.

*Compare and see!* For new efficiency in your 1955 designs go the limit with new G-E Germanium Power Rectifier. Tell your rectification problem to the G-E application engineer—write today to: *General Electric Company, Germanium Products, Section X5215, Electronics Park, Syracuse, New York.*



## GERMANIUM POWER RECTIFIERS

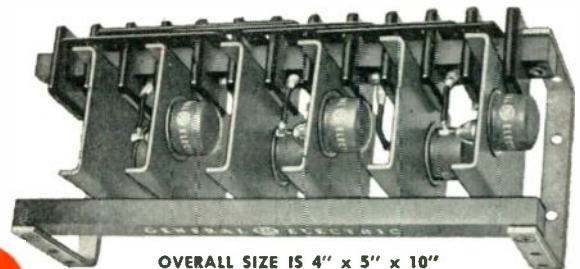

OVERALL SIZE IS 4" x 5" x 10"

### SAMPLE DELIVERIES ARE SCHEDULED FOR FEB. 1955!

These rectifiers are available in standard combinations consisting of one or more rectifying elements. A few typical ratings are listed below.

CIRCUIT	D-C OUTPUT AT 55° C (Resistive Load)
Half Wave	30 amps @ 60 V
	15 amps @ 120 V
	10 amps @ 180 V
Full Wave Center Tap	30 amps @ 60 V
	10 amps @ 180 V
Full Wave Bridge	10 amps @ 125 V
Three-Phase Half Wave	30 amps @ 95 V
	15 amps @ 190 V
Three-Phase Bridge	15 amps @ 190 V
Three-Phase Star	30 amps @ 95 V

Be "money-wise" and "pound-wise" too, with these stand-out design features:

- Weight and volume reduced 75%
- Rectifier losses have been reduced to 1/3 or less
- No forward aging effects...no need for age-compensating devices

*Progress Is Our Most Important Product*

**GENERAL  ELECTRIC**

# Now — Accuracy $\pm .25\%$

New Expanded Scale Voltmeter Added to SHASTA'S Complete Line



ARGA Model 101  
Expanded Scale Voltmeter

Any voltage from 100 to 500, over a frequency range of 50 to 2,000 cps, may be read to  $\pm .25\%$  of input voltage in 39 ten-volt full scale steps with the new ARGA Model 101 Expanded Scale Voltmeter. Smallest division on the patented expanded scale is 0.2 volts; reading errors due to parallax are negligible. True RMS readings are provided by a specially-developed measuring element.

Standard instrument has provision for direct connection to 0-1 ma recorder. Special high or low base voltages, modified voltage scale expansions, and switchboard or panel mountings are available on order.

Standard Model 101 (illustrated) measures 12" wide, 8" high and 8" deep, weighs 15 lbs. Price, (f.o.b. factory) \$360.00.

New SHASTA Model 202A VTVM  
Now Available



SHASTA Model 202A  
Vacuum Tube Voltmeter

A new and improved version of the Model 202, the SHASTA Model 202A Vacuum Tube Voltmeter, offers a range of .001 to 300 volts full scale in frequency ranges from 20 cps to 2 mc. Accuracy is  $\pm 3\%$  full scale to 100 kc,  $\pm 5\%$  to 2 mc. DB range is  $-60$  to  $+50$  in 10 db steps. A new 6" meter provides better readability reducing parallax errors and operator fatigue. Its wide voltage and frequency range make it the ideal general-purpose instrument. Price is only \$180.00, (f.o.b. factory).

#### Other SHASTA Quality Instruments

Expanded Scale Frequency Meters / A. C. Vacuum Tube Voltmeters / Square Wave Generators / Square Wave Voltage Calibrators / Regulated and Unregulated Power Supplies / Filament Power Supplies / Wide Band Amplifiers / Crystal Calibrators / Impedance Bridges / WWV Receivers / Low Frequency Standards / Resistance Bridges / Intermodulation Meters

The complete line of SHASTA quality instruments offers new high standards of precision performance — why settle for less? Before you specify or buy test instrumentation, see what SHASTA offers you. Write today for technical bulletins, complete price lists. Please address Dept. SA1.

# Shasta

division

S-3

**BECKMAN INSTRUMENTS INC.**

1432 Nevin Avenue • Richmond, California  
Telephone BEacon 5-7196

Star Performers  
"QUALITY-PLUS"  
**EPCO**  
**TRANSFORMERS**

For Industrial and Electronic Equipment

DESIGNED TO COMMERCIAL & MILITARY SPECIFICATIONS (MIL-T-27 and AN-E-19). ALSO CLASS A, B, H, AND MINIATURES.

Sample, Short and Long Runs. Let us quote on your specifications. No obligation.

Delivery as promised!

**EPCO**  
**PRODUCTS, INC.**

2500 ATLANTIC AVE.  
BROOKLYN 7, N. Y.



**HICKOK**

Model 539A

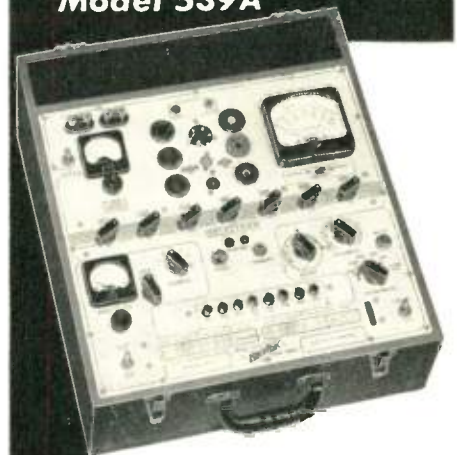

Most Accurate  
**LABORATORY PORTABLE  
TUBE TESTER**

- Accurately tests all Receiver tubes including high-gain types.
- Choice of 3 AC Signals and 3 micromho ranges.
- The leading tube tester in the industry.
- Write for technical details...

**THE HICKOK ELECTRICAL INSTRUMENT CO.**

10551 Dupont Avenue Cleveland 8 Ohio



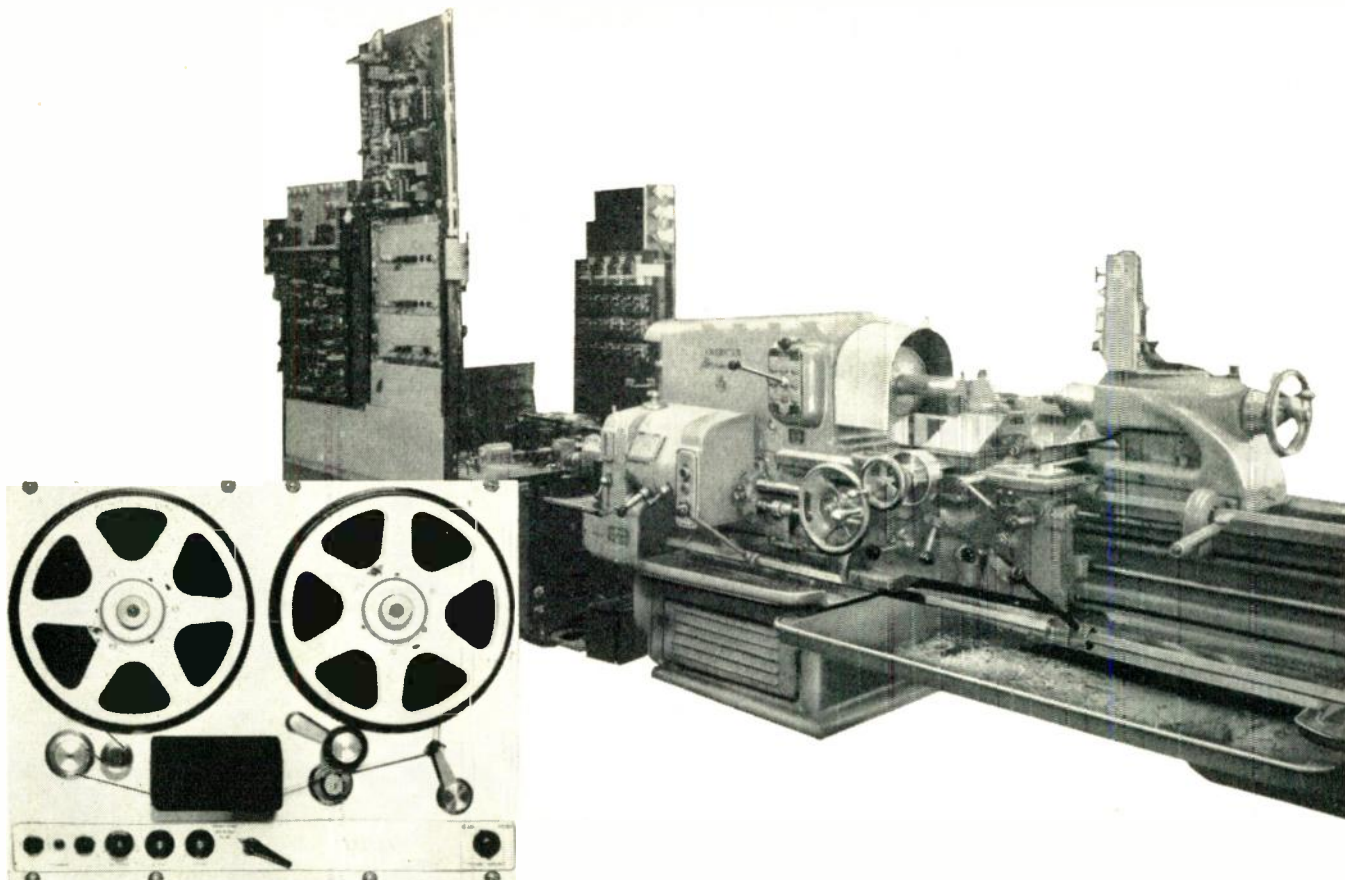

## MAGNETIC TAPE CONTROLS MACHINES LIKE THIS

An Ampex Magnetic Tape Recorder programmed all operations of this 16" lathe. The Ampex machine was selected by General Electric, who designed and built the control system, to provide the "memory" which helped guide the machine flawlessly through the accurate motions involved in machining irregular parts. For each part to be manufactured, a skilled machinist made the first unit. The Ampex recorder "remembered" his motions and could thereafter direct the lathe in the manufacture of one part or a thousand — now or twenty years from now.

**Other exacting work programs** of drilling, jig boring, tapping, or gear cutting can be converted into electrical signals by existing tracer techniques . . . and permanently recorded on magnetic tape. The control system using the memory characteristics of this tape can give you an exact duplication of the original work sequence, again and again . . . wherever and whenever you want it. **Result:** machine tool setup time is shortened . . . print reading and "miking" times are reduced . . . operator errors and rejects are eliminated . . . and simultaneous operation of two or more feeds, on two or more machines is possible.

### For Your Automation Needs: Ampex Precision and Durability

Ampex recorders retain precision even after thousands of hours of use. And they can be adapted to almost any automation need. Let our application engineers determine whether magnetic tape can provide a more efficient control system for your operation — or write for our 16-page bulletin on "Data Recording, Machine Control and Process Regulation."

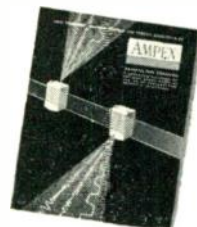

**AMPEX**  
CORPORATION

*Signature of Perfection in Magnetic Recorders*

Contact your nearest Ampex representative or write — wire Dept. G-1896

AMPEX CORPORATION • 934 CHARTER STREET, REDWOOD CITY, CALIFORNIA

Branch Offices: New York; Chicago; Atlanta; San Francisco; College Park, Maryland (Washington D.C. area).  
Distributors: Radio Shack, Boston; Bing Crosby Enterprises, Los Angeles; Southwestern Engineering & Equipment, Dallas and Houston; Canadian General Electric Company, Canada.



## MINIATURE PULSE TRANSFORMERS

The wealth of experience that Acme Electric engineers have gained in more than 37 years of transformer designing, becomes apparent in the performance and high quality construction of this line of Miniature Pulse Transformers. Send us your specifications.



**ACME ELECTRIC CORPORATION**  
1375 WEST JEFFERSON BLVD. • LOS ANGELES, CALIF.

WRITE FOR  
CATALOG  
PT-301

**Acme ACME Electric**  
TRANSFORMERS



**I R E People**

(Continued from page 52A)

was for five years Manager of the electronics department of Fairchild Engine and Airplane Corporation's Guided Missiles division, Farmingdale, L.I. Under his direction and with the aid of the U. S. Naval Research Laboratory, Fairchild developed and tested one of the first radar homing devices for the Navy's "Lark" ground-to-air test missile.

From 1937 to 1945 Perrine was associated with Howard Hughes, advancing to Manager of the radio division. A member of Sigma Xi and Tau Beta Pi, he received the B.S. degree in applied physics from California Institute of Technology in 1933.



**Industrial Engineering Notes**

AERONAUTICS\*

The Radio Technical Commission for Aeronautics released a report which recommends a system for the activation of airport field lights by radio transmissions from aircraft. The RTCA report recommends a radio system using the frequencies 121.7 mc and 121.9 mc by all aircraft and 122.8 mc by private aircraft. This would be in addition to the present use of 121.7 mc and 121.9 mc for ground-to-ground airport utility communication and the present use of 122.8 mc for a two-way communication service available only to private aircraft. A system of codes is provided so that, in areas where two or more airports are located in close proximity, a pilot may activate the lights of only the airport where he intends to land. A further reason for using coded signals is to prevent activation of airport field lights when the frequency is being used for communication, RTCA said. Five such codes are recommended, each consisting of a given number of dashes produced by pressing and releasing the microphone button of the aircraft VHF transmitter. Thus any aircraft could transmit any of the five codes, but the decoder of any given airport system could accept only one of the codes. The Federal Communications Commission has been asked to initiate the rule-making that may be required to authorize use of the three frequencies chosen for the system. It was also recommended by RTCA that the Civil Aeronautics Administration select the receiving frequencies, assign the codes to be employed in all airport light activation system installations, and publish notification in the Airman's Guide of each system installed. Copies of the report (Paper 168-54/DO-61) may be obtained for 20 cents from the RTCA Secretariat.

(Continued on page 58A)

\* The data on which these NOTES are based were selected by permission from *Industry Reports*, issues of October 11, 18, 25 and November 1, 8, 15 and 22, published by the Radio-Electronics-Television Manufacturers Association, whose helpfulness is gratefully acknowledged.

Florida's complete facility  
for **ELECTRONIC PRODUCTION**

**RADIATION Inc.**  
Melbourne, Fla.  
Orlando, Fla.

Electronics • Avionics • Instrumentation

write for our brochure



3301 to 5000 MMF

2001 to 3300 MMF

1501 to 2000 MMF

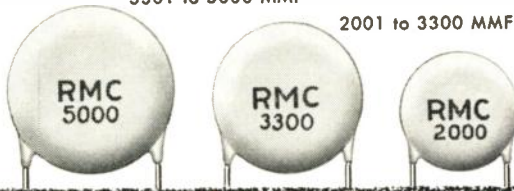

# extended temperature range

## Close TOLERANCE

### Type JL RMC DISCAPS

®

Type JL DISCAPS have a very small capacity variation over an extended temperature range. The maximum capacity change between  $-60^{\circ}\text{C}$  and  $+110^{\circ}\text{C}$  is only  $\pm 7.5\%$  of capacity value at  $25^{\circ}\text{C}$ . With a standard working voltage of 1000 V.D.C., they are manufactured in capacities between 220 MMF and 5000 MMF.

Offering the advantages of longer life, dependability, and lower initial cost, their smaller size and greater mechanical strength provide additional economies in assembly line operations.

Specify Type JL DISCAPS as the cost-saving replacement for paper or general purpose mica capacitors.

220 to 330 MMF



801 to 1500 MMF



331 to 800 MMF

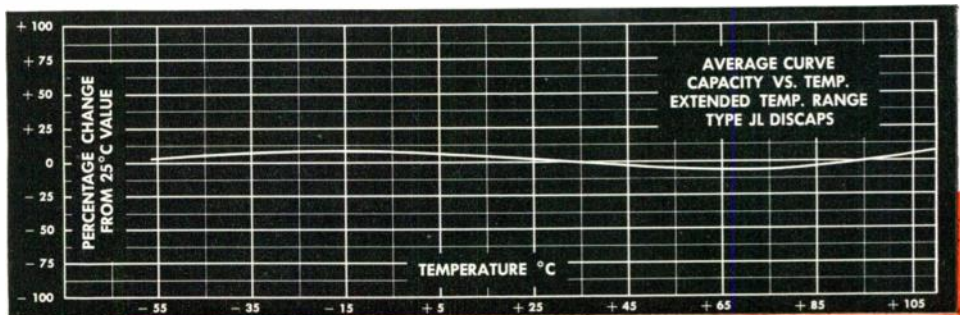

POWER FACTOR: 1% max. @ 1 K C (initial)  
 POWER FACTOR: 2.5% max. @ 1 K C, after humidity  
 WORKING VOLTAGE: 1000 V.D.C.  
 TEST VOLTAGE (FLASH): 2000 V.D.C.  
 LEADS: No. 22 tinned copper (.026 dia.)  
 INSULATION: Durez phenolic—vacuum waxed  
 INITIAL LEAKAGE RESISTANCE: Guaranteed higher than 7500 megohms  
 AFTER HUMIDITY LEAKAGE RESISTANCE: Guaranteed higher than 1000 megohms  
 CAPACITY TOLERANCE:  $\pm 10\%$   $\pm 20\%$  at  $25^{\circ}\text{C}$

DISCAP  
 CERAMIC  
 CAPACITORS



**RADIO MATERIALS CORPORATION**  
 GENERAL OFFICE: 3325 N. California Ave., Chicago 18, Ill.

FACTORIES AT CHICAGO, ILL. AND ATTICA, IND.  
 Two RMC Plants Devoted Exclusively to Ceramic Capacitors

# Stupakoff

## PRECISION CERAMICS

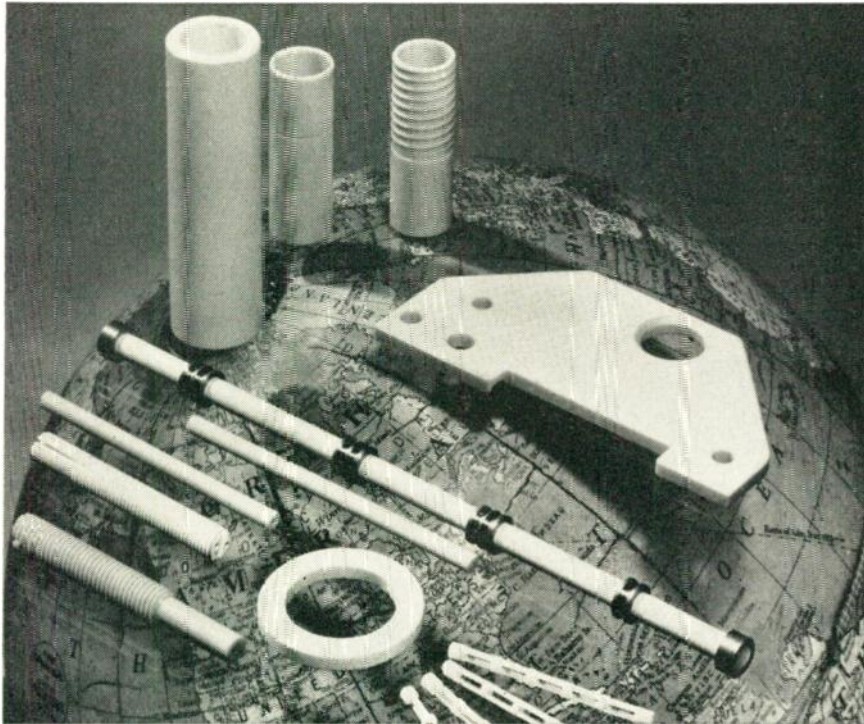

## PRECISION CERAMICS can improve your products...cut your costs!

In the assembly of electrical or electronic equipment, the use of precision-made components means faster production and the correct functioning of the equipment in service.

Through the application of experience-developed engineering and technical skills and modern equipment, Stupakoff produces, in large volume, parts that meet most exacting specifications.

Stupakoff precision ceramics may be plain or metallized; and made from alumina, steatite, zircon, Stupalith or other materials.

WRITE for our new bulletin No. 155, which describes precision ceramic products, or send drawings for quotations.

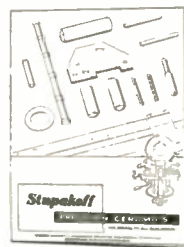

# Stupakoff

CERAMIC & MANUFACTURING COMPANY • LATROBE, PA.

DIVISION OF *The CARBORUNDUM Company*



### Industrial Engineering Notes

(Continued from page 56A)

#### ELECTRONICS

Eight permanent Working Groups operating under the Advisory Group on Electronic Parts of the Research and Development Coordinating Committee on Electronics have been authorized. A formal charter for the groups will be issued in the near future. The Working Groups were approved by the Coordinating Committee on Electronics in the Office of the Assistant Secretary of Defense. They will be similar to the Working Groups now operating under the Advisory Group on Electron Tubes but will work with the Advisory Group on Electronic Parts, headed by Julian Sprague. By terms of the charter, and with the concurrence of the R&D Coordinating Committee on Electronics, the following Working Groups are established: Assemblies and Assembly Techniques, Capacitors, Coils, Inductors, Transformers, Electronic Materials, Electro-Mechanical Devices, Frequency Control Devices, Transmission Lines, and Resistors.

#### FCC

In answer to a petition filed by RETMA, the Federal Communications Commission has issued an order extending the time for filing comments in connection with its proceeding looking toward an amendment of the rules governing restricted radiation devices. The FCC order extends until Jan. 3, 1955, the date for filing formal comments in the proceeding. . . . With the issuance of a Proposed Report and Order, the Federal Communications Commission has announced that it looks toward finalizing, with certain changes, its proposal to revise Subpart K of Part 11 of its Rules Governing the Special Industrial Radio Service to meet the needs of that growing service, and to amend the table of frequency allocations in Part 2 accordingly. The new rules would specifically delineate the various categories of industrial activities eligible for license in this service. The scope of eligibility is broadened to include certain service and trade activities which have heretofore been excluded or limited; also to persons engaged in certain professional or consulting engineering activities and to persons providing specialized functions, under contract, to single categories of persons who are themselves eligible to use radio to perform the same function. However the choice has been based on the need of a given industrial class or group for radio-communication, FCC said, and not on a special need of an individual member where the group as such could get along without radio. . . . After review by the ODM Science Advisory Committee and Arthur S. Flemming, ODM Director, recommendations and findings on scientific manpower will be submitted to the President.

Dr. James R. Killian, Jr., president of Massachusetts Institute of Technology, has been appointed to head a panel of scientists studying methods to mobilize more

(Continued on page 62A)



# SPERRY DEVELOPS MEGAWATT KLYSTRONS

## Super-Power Tubes Open Way to Electronic Advances

The giant tube you see illustrated here is the first Megawatt Klystron ever built for military use. It is also the first of a series of Sperry Klystrons producing millions of watts of precisely controlled radar power. Developed by Sperry and the Air Research and Development Command primarily for defense purposes, its capabilities indicate that potential uses are virtually unlimited.

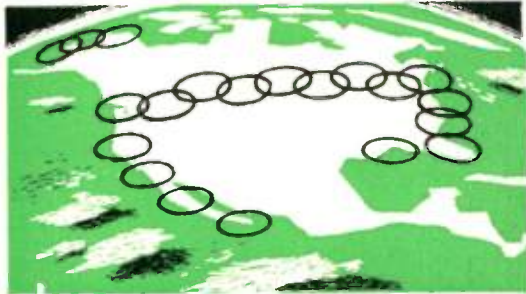

**IN RADAR DEFENSE . . .** Sperry's new Megawatt Klystrons have provided more than 250 times the radar power that beamed impulses to the moon and back in 1946. Such power—with a frequency held 20 to 200 times closer than the frequency limits of conventional radar or TV transmitters—permits obtaining greatly improved information from search radars.



**IN GUIDED MISSILES . . .** Sperry's new Megawatt Klystrons make possible more accurate control of missiles permitting guidance over longer paths.

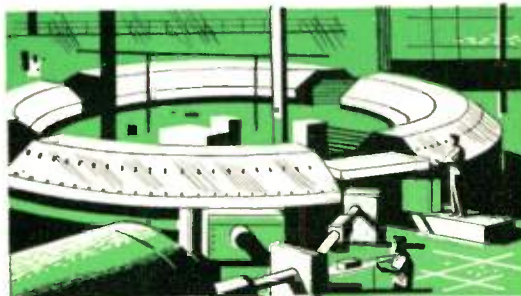

**IN ATOMIC ENERGY . . .** Sperry's new Megawatt Klystrons provide stable driving power for larger atom smashers and high energy X-ray devices used for scientific research.

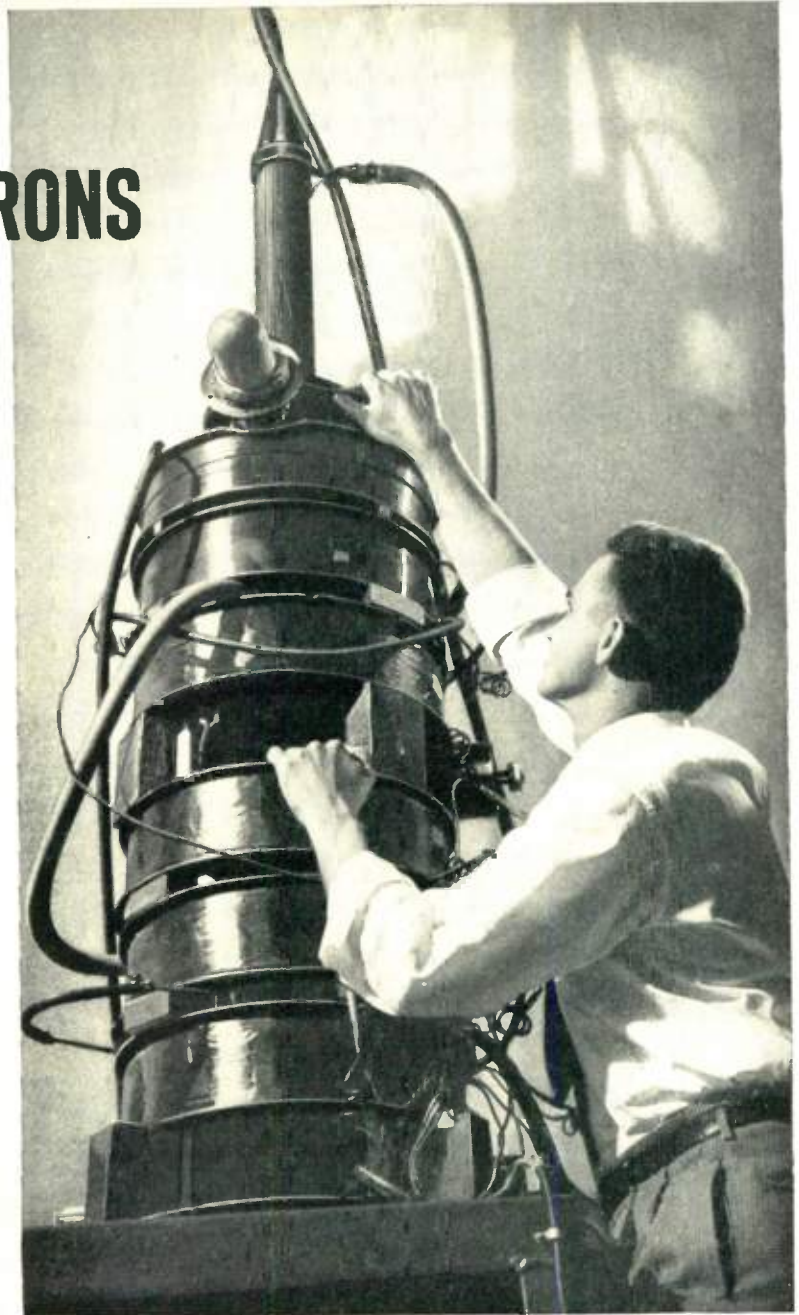

Eight feet tall, the first Megawatt Klystron Amplifier developed for military purposes by Sperry, develops 4,000,000 watts of power with up to 43% efficiency and 38 db. gain. Other Megawatt Klystrons are now in production.

**FOR FURTHER INFORMATION** Qualified organizations can receive information on these super-power tubes to aid in electronic system design by writing to our special Electronics Department.

**SPERRY** *GYROSCOPE COMPANY*

DIVISION OF THE SPERRY CORPORATION, GREAT NECK, NEW YORK

CLEVELAND • NEW ORLEANS • BROOKLYN • LOS ANGELES • SEATTLE • SAN FRANCISCO  
IN CANADA—SPERRY GYROSCOPE COMPANY OF CANADA LTD., MONTREAL, QUEBEC

# VICTOREEN can supply your needs for...

## BETA and GAMMA COUNTER TUBES



Victoreen offers the most complete line of geiger tubes, developed for every type of application from the extremely accurate laboratory units to the heavy duty, portable, field type.

In every application where counter tubes are used — Victoreen has set the standard of comparison.

## ELECTROMETER TUBES

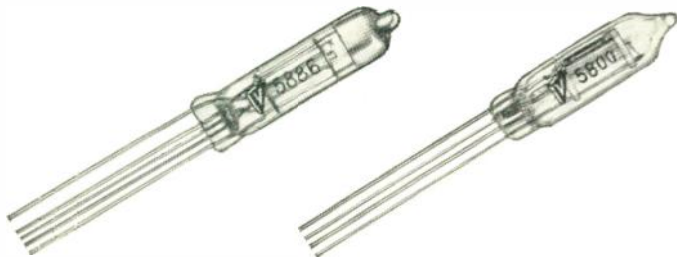

Victoreen has every facility for making tetrode, pentode and triode tubes to standards of operating performances that will inherently improve the performance of their application. In addition to exceptional quality, Victoreen offers engineering skill to assist in solving your problems and production facilities to meet your requirements. Send specifications of your needs.

For further information, write for catalog.



**The Victoreen Instrument Co.**

COMPONENTS DIVISION: 3813 Perkins Ave. • Cleveland 14, O.

# To make a Good Rig Better

USE

## CANNON PLUGS



ABC, NBC, CBS and all radio and TV stations have used Cannon Plugs almost exclusively since they started... You can have the same high quality and dependability that spell satisfaction... in rig building and operation.

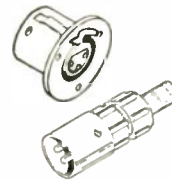

**XL SERIES.** With thumb pressure LATCHLOCK—no accidental disconnect. Mike and audio-connector; 3 or 4 contacts, seventeen complete assemblies. Standard on top quality mikes. Available through most radio jobbers.

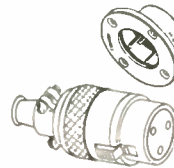

**P SERIES.** The old faithful—radio men swear by it, not at it. Thumb pressure LATCHLOCK, positive connection. Up to 8 contacts; steel plug shell. Ninety-nine complete assemblies for audio circuits and power.



**UA SERIES.** The RETMA specified standard weather-proof, gold plated contacts, spring insert removal. Thumb pressure LATCHLOCK.



**K SERIES.** For power supplies, audio circuits and combined circuits. A great variety of shells and inserts.

In building a compact rig, look into the new "D" sub-miniatures 15, 25, 37, and 50-5a contact arrangements. They're really small. Likewise the "U" series—1-12 contacts. New XL Bulletin ready; also ask for RJC-7 with prices and list of our franchised distributors.



## CANNON ELECTRIC

Since 1915



CANNON ELECTRIC CO., 3209 Humboldt Street, Los Angeles 31, Calif. Factories in Los Angeles, Toronto, East Haven. Representatives in principal cities. Please Refer to Dept 377



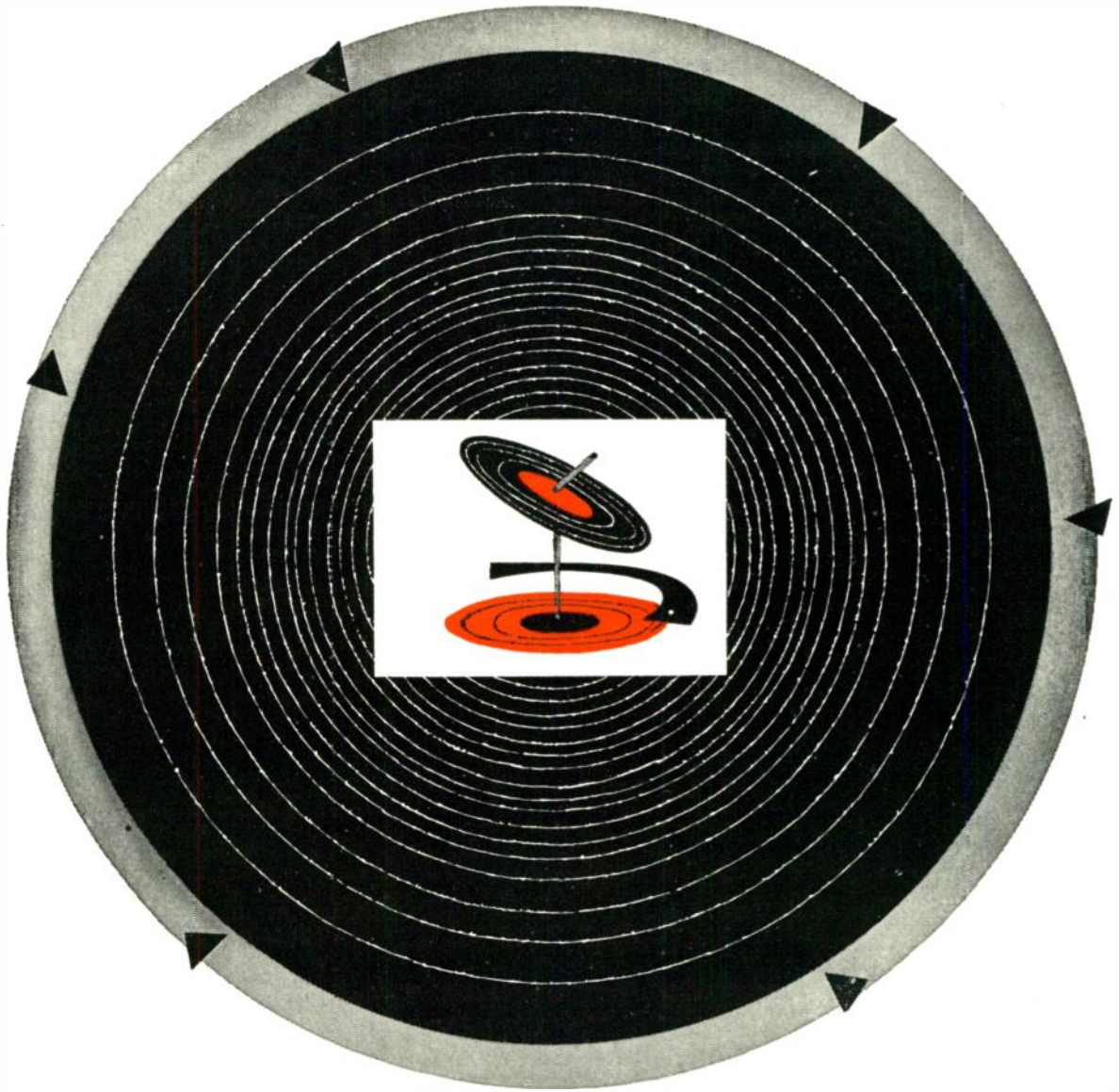

leading Hi-Fi producers specify **CRUCIBLE PERMANENT MAGNETS**  
for maximum energy...minimum size

Crucible alnico permanent magnets are unsurpassed in their magnetic properties. They provide *consistently higher* energy product . . . which results in smaller, more powerful magnets.

That's why not only leading producers of high fidelity sound equipment, but hundreds of other discriminating manufacturers of instruments, controls, motors and other magnet-equipped devices, prefer Crucible alnico permanent magnets.

Crucible has been one of the largest producers of this type of magnet since the alnico alloys were first developed. And backing up this twenty-year magnet experience are 54 years of *quality* steelmaking. For highest quality alnico magnets and technical help in their application, call *Crucible*.

**CRUCIBLE**

first name in special purpose steels

54 years of *Fine* steelmaking

**ALNICO PERMANENT MAGNETS**

**CRUCIBLE STEEL COMPANY OF AMERICA, GENERAL SALES OFFICES, OLIVER BUILDING, PITTSBURGH, PA.**

# servo motors

the way you want 'em!

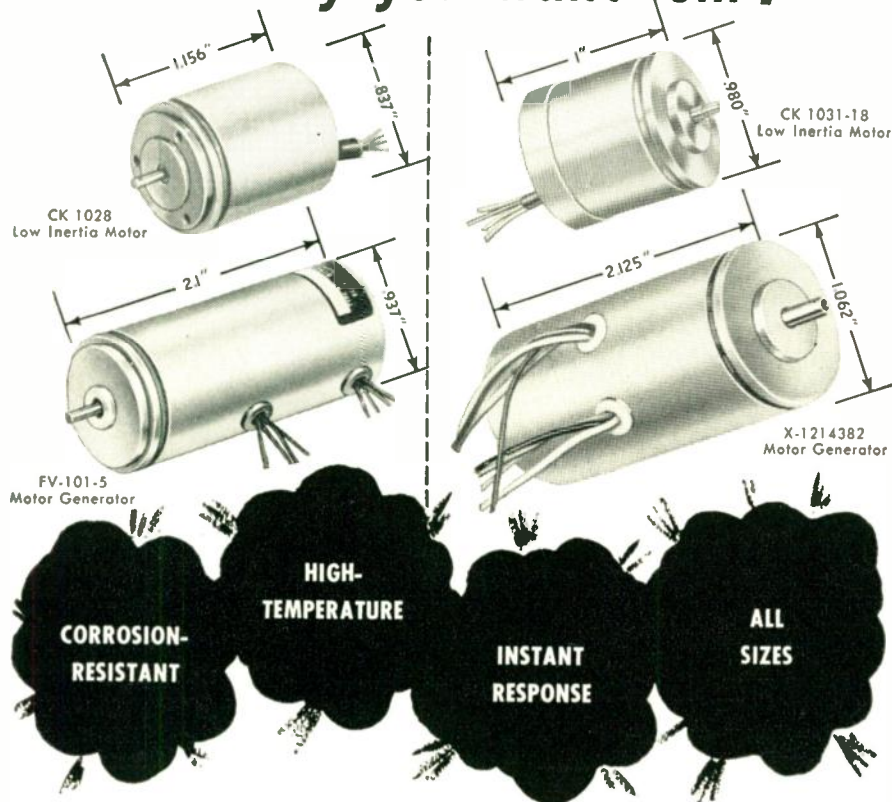

As one of the world's oldest and largest producers of servo components, we are ideally qualified to provide you with the right answer to your motor and motor generator needs. Why not take advantage of our long, practical experience? Call on us for recommendations based on your individual problem.

### TYPICAL CHARACTERISTICS

Type Number	Rated Voltage		Max. Power Input Total (Watts)	No Load Speed (RPM)	Stall Torque (oz. inches)	Torque to Inertia Ratio (Radians per Sec. <sup>2</sup> )	Weight (oz.)
	Phase 1	Phase 2					
<b>LOW INERTIA MOTORS</b>							
CK-1018-7	18	18	5	10,000	0.13	13,000	1.6
CK-1022-13	115	115/57.5	12	4,800	1.45	33,800	8.0
CK-1027-14	115	115/57.5	7	6,200	0.63	41,500	4.5
CK-1028-16	26	26	6	10,000	0.28	13,000	1.6
CK-1031-18	26	55	9	6,400	0.35	10,000	2.2
CK-2006-1	64	64	30	7,200	2.6	70,000	10.0
CK-3000-1	110	220	80	3,700	14.0	3,750	30.0
<b>MOTOR GENERATORS</b>							
FV-101-5	26	26	9.5	10,000	0.28	10,000	2.9
FV-2001-2	115	115	30	6,600	3.0	70,000	12.6
FV-3000-1	110	220	80	3,700	14.0	3,750	30.0
X-1214382	26	26	9.7	6,000	2.6	21,000	5.5

WRITE DEPARTMENT G

## ECLIPSE-PIONEER

Division of

TETERBORO, NEW JERSEY

West Coast Office: 117 E. Providencia Ave., Burbank, Calif.

Export Sales: Bendix International Division, 205 E. 42nd St., New York 17, N.Y.

(Continued from page 58A)

effectively scientific resources in the event of an emergency, the Office of Defense Mobilization announced. . . . Dr. Ralph J. Slutz has been appointed Chief of the Radio Propagation Physics Division of the National Bureau of Standards' Boulder Laboratories in Colorado. This division is a part of the Bureau's Central Radio Propagation Laboratory. Dr. Slutz will direct the Bureau's research on the physics of radio propagation, with particular reference to the ionosphere. . . . Edward L. Nelson, Technical Director of the Signal Corps Engineering Laboratories, Fort Monmouth, N. J., has been appointed Scientific Chief of Research and Development for the Army Signal Corps. In his new assignment, Mr. Nelson will be responsible to the Chief Signal Officer for the technical direction of the research and development mission of the Army Signal Corps, which includes highly specialized and exceptionally complex scientific and engineering programs in electronics, applied physics and allied fields. Prior to his appointment as Technical Director of the Signal Corps Engineering Labs. on Feb. 15, 1951, Mr. Nelson was with Bell Telephone Laboratories, New York City, engaged in the development and design of military weapons systems and equipment under Army and Navy contracts. . . .

#### FALL MEETINGS

Preliminary plans for a fourth general membership meeting of the manufacturers of commercial and military electronic equipments and components, to be held immediately preceding the IRE Show and Convention, March 21-24, in New York City, were announced last Friday by Chairman F. R. Lack of the RETMA Electronics Industry Committee. Under the overall sponsorship of the EIC, the one-day meeting and membership rally will be held on Sunday, March 20, at the Roosevelt Hotel in New York City. The meeting will present a forum for electronic manufacturers who are members of the RETMA Technical Products Division and receive services of the Government Relations Department. It is anticipated that sections of the division and committees of the department will hold sessions open to all RETMA members and guests on that day.

Direction of the meetings and membership rally is under the joint chairmanship of Frank D. Langstroth, of The Magnavox Co., and L. A. Connelly, of Radio Corp. of America, representing the Technical Products Division and the Government Relations Department, respectively. The first general membership rally was held in Washington, D. C., on Nov. 1, 1951, under the sponsorship of the former Transmitter Division. That gathering resulted in the reorganization of the Division and a change in its name to the Technical Products Division. The Sunday, March 20, meeting will afford members of the Electronics Industry Committee an opportunity to review the operations of the Technical Products Division under Chair-

(Continued on page 66A)



# ALSiMAG<sup>®</sup>

Widest selection of latest materials. Constant addition of new special-purpose bodies. Over 50 years accumulated experience and "know how." A highly trained staff, alert for improvements and new techniques.

## low...

True cost is what you get for what you pay. It's risky to buy ceramics by price alone. It may mean mediocre material and outdated design. You'll profit by investigating the recent "giant steps" taken in the ceramic field.

## cost...

ALSiMag offers the best possible ceramic for your job at a price that's right. Modern, large-scale equipment cuts production costs. Shipments are on time and to specification. ALSiMag extra services include free redesign service and use of open dies.

## ceramics

Assembly lines run on deliveries, not promises. That's why we're careful to make delivery estimates that are dependable. True, ceramics are temperamental. But you'll find ALSiMag's "shipment as promised" average is high. Ask any of our customers.

• Send a blueprint and outline of operating conditions and see what American Lava can do to save you money.

53RD YEAR OF CERAMIC LEADERSHIP

### AMERICAN LAVA CORPORATION

A SUBSIDIARY OF MINNESOTA MINING AND MANUFACTURING COMPANY  
CHATTANOOGA 5, TENNESSEE

Branch offices in these cities (see your local telephone directory):

Cambridge, Mass • Chicago, Ill • Cleveland, Ohio • Dallas-Houston, Texas  
Indianapolis, Ind • Los Angeles, Calif • Newark, N.J. • Philadelphia-Pittsburgh, Pa.  
St. Louis, Mo • South San Francisco, Calif • Syracuse, N.Y. • Tulsa, Okla.

WRB



plan your  
production  
with  
**KAHLE**  
machinery

**built specifically for your operation...**

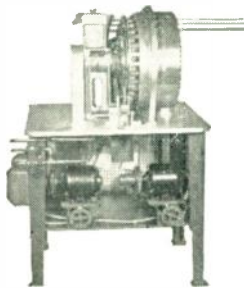

**Kahle**  
ENGINEERING  
COMPANY

1314 SEVENTH STREET  
NORTH BERGEN, N. J.

Industry leaders in electronics, glass, and allied fields have continuously keyed their operations to KAHLE Machines for over a quarter of a century. Your production rate, your specifications, your requirements—are "planned-in" KAHLE Machines.

**Call KAHLE for  
"machines  
that think for you!"**

# color TV shadow masks

We are now delivering shadow masks, the precision heart of the color television tube, etched to specifications. Mass production methods, perfected during more than 40 years of precise metal etching experience, enable us to meet today's exacting demands for quality and delivery.

## etched and electro formed precision parts

With the technical experience and production know-how gained in producing fine metal etching and in electro-forming, we are now manufacturing many components for the electronic industry. Some specifications call for fine mesh up to 1,000,000 holes per square inch. Send us your drawings for a prompt quotation.

**bm** **BUCKBEE  
MEARS  
COMPANY**

Lindeke Building  
SAINT PAUL 1, MINNESOTA

**SPECIALISTS in the UNUSUAL**

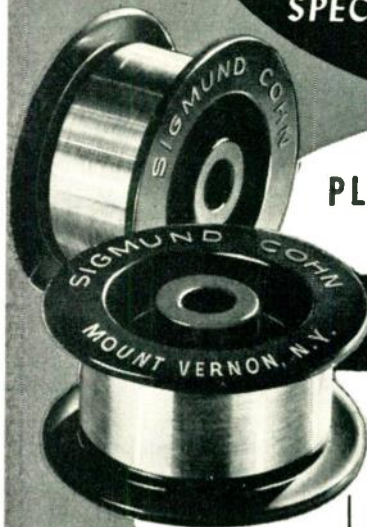

**No. 479<sup>®</sup>**

**PLATINUM ALLOY WIRE**  
.0008" Wire Diameter  
16 Strands

*Braided*

- Over 90% Platinum for maximum corrosion resistance . . .
- Extra-long flex-life . . .
- High tensile strength . . .
- Easily welded or soldered . . .
- Valuable as a flexible lead . . .
- Practical for many applications where usual products fail .



Write for list of products

**SIGMUND COHN CORP.** Metallurgists and  
Producers of Small Wire  
121 South Columbus Avenue • Mount Vernon, N. Y.



# NOW!

## For your most important electronic control applications

**RUGGED**

Completely ruggedized tubes developed especially for the Armed Forces to operate under conditions of severe shock and mechanical vibration.

**RELIABLE**

Sylvania premium performance tubes offer high reliability for applications in electronic computers and guided missiles.



## SYLVANIA GAS TUBES

To MEET your electronic control equipment needs, whether military or commercial, Sylvania offers a wide selection of gas tubes engineered to meet the most rigid specifications. These include tubes for commercial use in applications where reliable performance is required under difficult conditions of shock and vibration. Some Sylvania gas tubes have been especially designed to meet MIL-E-1 specifications.

Whatever your needs, you can select any Sylvania gas tube with confidence that it is manufactured under the same standards of quality and dependability which recommend their use in vital military equipment.

Sylvania's complete line offers you dependable tube types for your most important control functions.



### A SYLVANIA TYPE FOR EVERY NEED

Type	Application
0A2	voltage regulator
0A4G	relay and grid controlled rectifier
0B2	voltage regulator
0B3	voltage regulator
0C3	voltage regulator
0D3	voltage regulator
1B59/R1130B	glow modulator diode
1D21/SN4	strobtron
2D21	relay and grid controlled rectifier
2D21W	relay and grid controlled rectifier
R4330	strobtron
S413	strobtron
SA309	strobtron
1237	full-wave rectifier
20A5	trigger tube
5643	relay tube
5644	voltage regulator
5651	voltage reference
5823	relay, rectifier
6D4	relay, relaxation osc. noise generator
6308	voltage reference
6483	trigger tube

Send for new bulletin for complete data on Sylvania Gas Tubes.

# SYLVANIA



SYLVANIA ELECTRIC PRODUCTS INC. • 1740 BROADWAY, NEW YORK 19, N. Y.  
 In Canada: Sylvania Electric (Canada) Ltd.  
 University Tower Bldg., St. Catherine Street, Montreal, P. Q.

LIGHTING • RADIO • ELECTRONICS • TELEVISION • ATOMIC ENERGY

Sylvania Electric Products Inc.  
 1740 Broadway, New York 19, N. Y.

Please send Technical Data on Sylvania Gas Tubes.

Name \_\_\_\_\_  
 Company \_\_\_\_\_  
 Address \_\_\_\_\_  
 City \_\_\_\_\_ Zone \_\_\_\_\_ State \_\_\_\_\_

# Match Lines Fast!

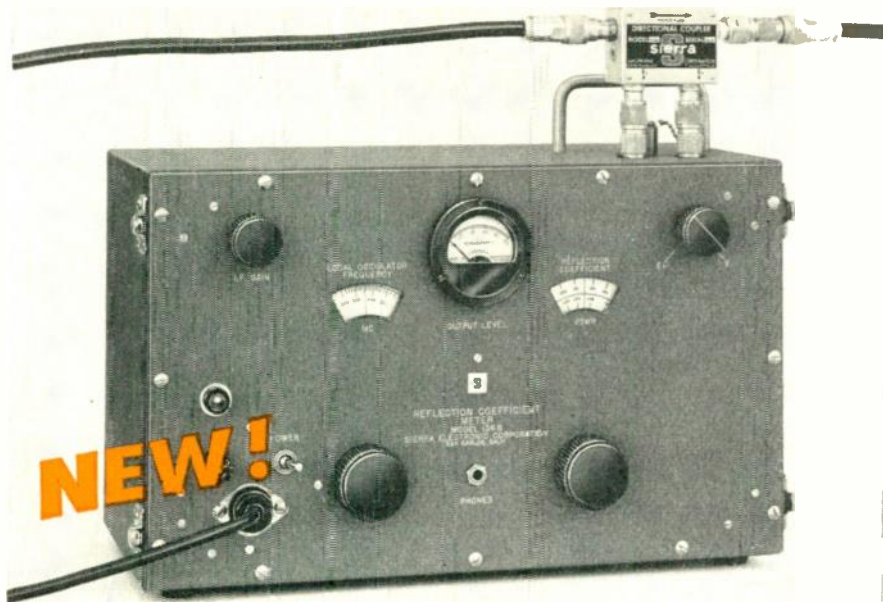

## Sierra 136B Reflection Coefficient Meter

This compact, moderately-priced instrument gives you materially greater speed and convenience for measuring coaxial transmission line reflection coefficient, VSWR, or for matching loads to line. The instrument has high accuracy; sensitivity permits operation with any standard CW signal generator. (See Figure 1) It provides continuous monitoring of the reflected signal, is simple to operate, and sturdily built for laboratory, production line or field use. Frequency coverage is continuous from 32 to 1125 mc.

The new 136B employs the unique Sierra Wideband Directional Couplers (Model 138 for 51.5 ohms and Model 138A for 50.0 ohms) to sample incident and reflected voltage in a transmission line. A built-in superheterodyne VTVM may be switched to indicate either reflected or incident voltage directly. In the incident position, a precision attenuator calibrated directly in reflection coefficient and VSWR is inserted in the IF amplifier circuit.

WRITE DIRECT FOR BULLETIN



### Sierra Electronic Corporation

San Carlos 2, California, U.S.A.

Sales representatives in major cities

Manufacturers of Carrier Frequency Voltmeters, Wave Analyzers, Line Fault Analyzers, Directional Couplers, Wideband RF Transformers, Custom Radio Transmitters, VHF-UHF Detectors, Variable Impedance Wattmeters, Reflection Coefficient Meters.

3232

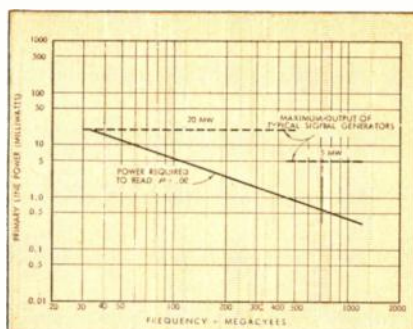

Figure 1. Sensitivity, Sierra 136B. Primary line CW power required to read reflection coefficient 0.02 as a function of frequency. Values are for Sierra 138 and 138A Directional Couplers.

Data subject to change without notice



Industrial Engineering Notes

(Continued from page 62A)

man James D. McLean and the Government Relations Department under Director Joseph H. Gillies. Highlighting the meeting will be a membership luncheon featuring an address by a top-flight government official. Leading military and government officials will be invited to attend the RETMA meetings and luncheon in connection with their visit to the IRE show.

#### FEDERAL PERSONNEL

Dr. Harold Lyons has been appointed Assistant Chief for Research of the Radio Standards Division of the Bureau of Standards, Boulder, Col. Laboratories. He will direct research phases of the division's standards program, including development of improved transfer standards, methods of measurement and instrumentation techniques. Dr. Lyons will continue his work on atomic clocks and microwave frequency standards, in which he has been active since 1946 and for which he received the Arthur S. Flemming Award for outstanding government service in 1948.

#### INDUSTRY STATISTICS

Through the end of 1953, the original investment in tangible broadcast property by all networks and television stations totaled \$233.1 million, the Federal Communications Commission reported recently. The Commission also reported that total broadcast revenues of the TV industry in 1953 were \$432.7 million, or 33 per cent above 1952. Broadcast income, before federal taxes, was reported to have been \$68 million in 1953, up almost 23 per cent from the previous year. Broadcast revenues include not only the sale of time, but also talent and program material to advertisers, less commissions. A total of 104 stations, including 21 post-freeze VHF and eight post-freeze UHF, reported an investment in tangible broadcast property of \$500,000 and over; 47 stations, including 21 post-freeze VHF and 24 UHF, reported investment in tangible broadcast property of less than \$200,000. . . . Production of television receivers in September rose substantially above August and September 1953 and brought the nine-month total to over 4.7 million sets, according to figures released by the RETMA Statistical Department. Radio production in September, a five-week period, exceeded the previous month's output, but dropped below September a year ago. . . . During the first nine-months of this year, the Statistical Department estimated TV production at 4,733,315 units and the radio output at 7,042,442 sets. In the corresponding period last year the manufacture of 5,524,370 TV sets and 10,149,163 radios had been reported. Of the September television production of 947,796 sets, 136,613 sets were equipped with UHF tuning facilities. During the first nine months 924,311 TV sets were manufactured with UHF tuners and 14,538 color sets were produced. . . . Employment in the communications equipment industry during the first six months

(Continued on page 68A)



# COLOR TV demands

... exacting quality in capacitors and resistors



## ● ERIE High Voltage Capacitors

Erie offers a wide selection of disc and molded type ceramics for high voltage service up to 30 KV.



## ● ERIE "Hi-Stab" Deposited Carbon Resistors

The Style 155 Pyrolytic resistor fulfills a long standing need for an extremely stable, moderately priced, molded insulated 1/2 watt resistor. Available from 100 ohms to 1/2 megohm in tolerances as close as  $\pm 1\%$ .

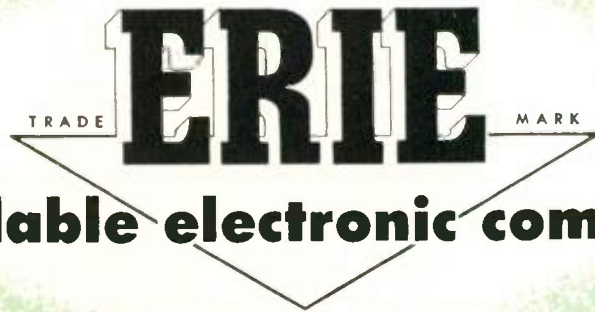

**dependable electronic components**



## ● ERIE "K-LOK" High-stability Disc Ceramicons

Values up to .0047 mfd at 500 volts are available in tolerances as close as  $\pm 5\%$ . Capacity variations with temperature, age, and voltage are exceptionally small. A truly premium capacitor.

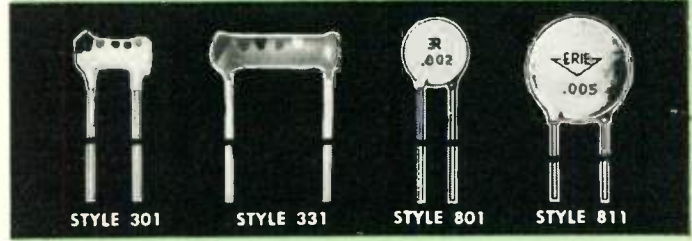

## ● ERIE By-Pass and Compensating Ceramicons

To meet the exacting temperature compensation and by-pass requirements of color circuitry. Compensating units available from .75 to 1380 mmf. "Hi-K" by-pass units available from 100 mmf. to .01 mfd.



## ● ERIE Trimmer Capacitors

The largest and most versatile family of plastic and temperature compensating ceramic trimmer capacitors are available from Erie, to meet difficult tuner and converter requirements.



## ● ERIE Stand-off and Feed-thru Ceramicons

Manufactured in values up to 1500 mmf. to overcome radiation and critical by-passing problems.



**ERIE RESISTOR CORPORATION** . . . ELECTRONICS DIVISION

Main Offices and Factories: **ERIE, PA.**

Sales Offices: Cliffside, N. J. • Philadelphia, Pa. • Chicago, Ill. • Detroit, Mich. Ashland, Ohio • Fort Wayne, Ind. • Los Angeles, Calif. • Toronto, Ontario

Manufacturing Subsidiaries:

**HOLLY SPRINGS, MISS. • LONDON, ENGLAND • TRENTON, ONTARIO**



**this is a  
custom-  
made\*  
sub-assembly  
by ESC**

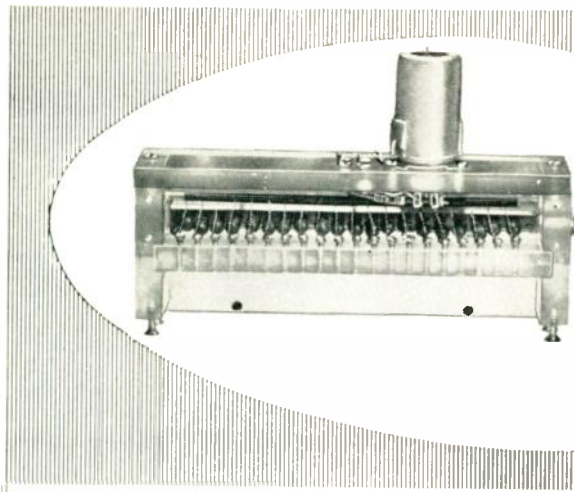

\*Custom-made to meet the most precise specifications through years of research and production experience. Our facilities are organized for design, development and production of delay lines, networks, pulse transformers, etc., incorporated into precision electronic sub-assemblies.

Brochure Available Upon Request



**C O R P O R A T I O N**

534 Bergen Blvd., Palisades Park, New Jersey



**Industrial Engineering Notes**

(Continued from page 66A)

of 1954 lagged considerably behind the comparable period of 1953 but a pick up in activity during the second half of the year was forecast by a majority of firms surveyed for a report just released by the Bureau of Employment Security, U. S. Department of Labor. The survey was made last May and reports were received from 344 establishments, mostly employing 200 or more workers, with an aggregate employment of 396,344. These firms account for slightly over 80 per cent of the industry's total work force, the BLS reported. The communications equipment industry includes not only manufacturers of radios, television sets, phonographs, radar and detection apparatus, public address systems, and tubes but also firms which produce telephone and telegraph equipment and electrical communication equipment. The report, dated August 1954, showed that employment in the 344 establishments surveyed decreased by 12.6 per cent from May 1953 to May 1954. "Radios, radio and television equipment, radar, etc.—the industry's largest division with about two-thirds of total employment—and radio tubes, led the downturn with decreases of 13.7 per cent and 20.6 per cent respectively, and were responsible for virtually all of the over-all 12-month reduction," the report said. It was pointed out that "although 28 states and all geographical sections were represented in the survey, the bulk of all employment was found to be concentrated in the Middle Atlantic and East North Central regions. Better than two out of every three workers and seven out of every ten plants were located in the eight states which comprise these regions. Illinois led all other states in volume of employment with 19.6 per cent of the total and was followed by New Jersey with 16.4 per cent, and New York with 11.5 per cent. In fourth and fifth places were Massachusetts, 9.9 per cent, and Indiana, 8.7 per cent." Nearly three-fifths of all workers covered by the survey were reported to be located in nine major labor market areas—Chicago, Newark, Boston, Los Angeles, Philadelphia, New York, Baltimore, Indianapolis and Paterson. "Manpower shortages affecting the communications equipment industry have decreased sharply," the report noted, although some firms surveyed reported a need for engineers of various types plus tool and die makers, draftsmen and machinists. "Three-fourths of the establishments reporting hard-to-fill openings were in radios, radio and television equipment, radar, etc."

**MOBILIZATION**

The Air Research and Development Command has announced that a new radar height finder has been developed and produced jointly by its Rome Air Development Center and the General Electric Co. The set, which is designed to meet the need for greater radar range, reportedly concentrates its energy in a narrow beam and can

(Continued on page 70A)

*Increased Insulation*  
**BETTER CONNECTIONS**  
**JONES BARRIER**  
**TERMINAL STRIPS**

Leakage path is increased—direct shorts from frayed terminal wires prevented by bakelite barriers placed between terminals. Binder screws and terminals brass, nickel-plated. Insulation, black molded bakelite. Finest construction. Add much to equipment's effect.

**Jones Means Proven Quality**

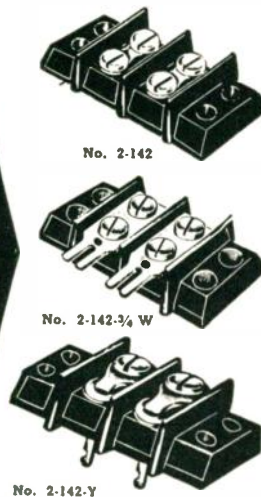

Illustrated: Screw Terminals—Screw and Solder Terminals—Screw Terminal above Panel with Solder Terminal below. Every type of connection.

Six series meet every requirement: No. 140, 5-40 screws; No. 141, 6-32 screws; No. 142, 8-32 screws; No. 150, 10-32 screws; No. 151, 12-32 screws; No. 152, 1/4-28 screws.

Catalog No. 20 lists complete line of Barrier Strips, and other Jones Electrical Connecting Devices. Send for your copy.

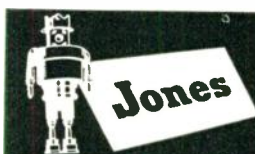

**HOWARD B. JONES DIVISION**  
CINCH MANUFACTURING CORPORATION  
CHICAGO 24, ILLINOIS  
SUBSIDIARY OF UNITED-CARR FASTENER CORP.



**NEW!** HUGHES NOW OFFERS

# Silicon Junction Diodes



Hughes continues to set industry standards for quality and reliability of semiconductor devices. These **NEW** Hughes Silicon Junction Diodes now provide you with devices which will operate at high temperatures. They combine high forward conductance with extremely high back resistance. In several diode types, this resistance is in the order of 10,000 megohms! This means that, in many applications, there is essentially an open circuit in the back direction. The phenomenal back resistance of these diodes has opened up many possibilities for entirely new circuit applications, in addition to meeting requirements for higher temperature operation, which germanium cannot satisfy. Before completing design work on your next equipment, be sure to investigate the outstanding new Hughes Silicon Junction Diodes.

- HIGH FORWARD CURRENT**
- EXTREMELY HIGH BACK RESISTANCE**
- VERY SHARP BACK VOLTAGE BREAKDOWN**
- HIGH TEMPERATURE OPERATION**

*Hughes Subminiature Silicon Junction Diodes are fusion-sealed in a one-piece glass body, impervious to moisture and external contamination. Flexible dumet leads are tinned for easy soldering or spot-welding. The diode envelope is coated with black silicone enamel to shield the crystal from light. Ambient operating temperature range, from  $-80^{\circ}\text{C}$  to  $+200^{\circ}\text{C}$ . Actual size, diode glass body: 0.265 by 0.103 inches, (approx.) maximum.*

HUGHES SILICON JUNCTION DIODES ELECTRICAL CHARACTERISTICS				
Type	Saturation Voltage ( $E_s$ )	Forward Current at +1V ( $I_f$ )	Back Current	
			at $25^{\circ}\text{C}$	at $150^{\circ}\text{C}$
HD 6001	25V	15mA	.5 $\mu\text{A}$ @ -25V	.030mA @ -25V
HD 6002	70V	5mA	.5 $\mu\text{A}$ @ -60V	.030mA @ -60V
HD 6003	200V	1mA	.5 $\mu\text{A}$ @ -175V	.030mA @ -175V
HD 6005	30V	40mA	.025 $\mu\text{A}$ @ -25V	5 $\mu\text{A}$ @ -25V
HD 6006	70V	20mA	.025 $\mu\text{A}$ @ -60V	5 $\mu\text{A}$ @ -60V
HD 6007	150V	7mA	.025 $\mu\text{A}$ @ -125V	5 $\mu\text{A}$ @ -125V
HD 6008	200V	3mA	.025 $\mu\text{A}$ @ -175V	5 $\mu\text{A}$ @ -175V
HD 6009	150V	3mA	.5 $\mu\text{A}$ @ -125V	.030mA @ -125V

*The ORIGINAL Glass-Body, Fusion-Sealed Germanium Diodes.*

**Hughes**

SEMICONDUCTOR SALES DEPARTMENT

Aircraft Company, Culver City, Calif.



New York Chicago



(Continued from page 68A)

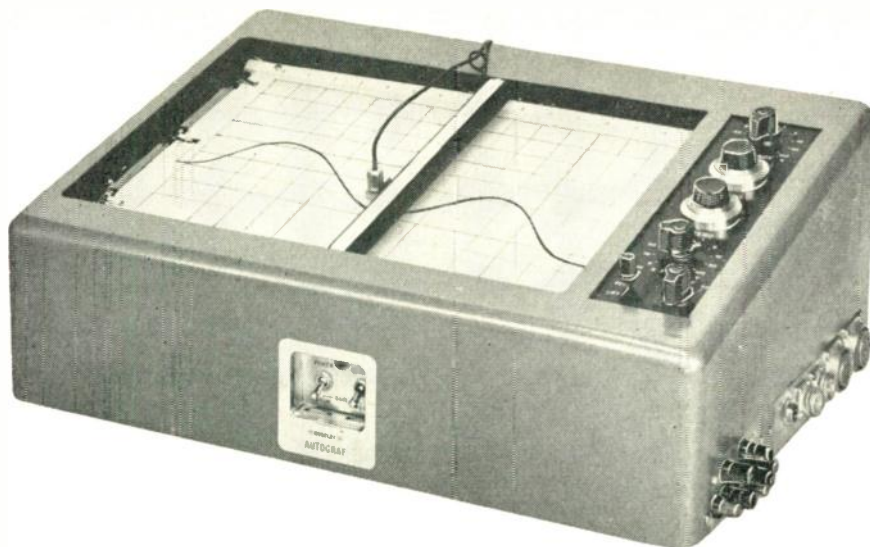

*A new, large size,  
flat bed,  
versatile  
2-axis recorder...*

## **AUTOGRAF** trademark **MODEL 2**



*Curves are available for observation and labeling while they are being drawn.*

The versatility and labor-saving convenience of the original portable Autograf have now been built into an instrument which handles standard 11" x 16½" graph papers. Model 2 has the same scales and ranges as Model 1 (0-5 millivolts to 0-100 volts each axis); same speed (full scale X and Y in one second); same input impedance (200,000 ohms per volt). In addition, depressed zero available each axis, larger recording area (twice as big), flat bed, easy-reading design.



### **THE AUTOGRAF MODEL 1**

general purpose 8½" x 11" X-Y recorder — is doing duty in hundreds of laboratory applications: chemical, electrical, electronic, wind tunnel, computer... And on production lines: measuring motors, filters, tubes, transistors, airfoils, amplifiers, rectifiers, magnetic circuits and materials, nuclear devices, etc. . . .

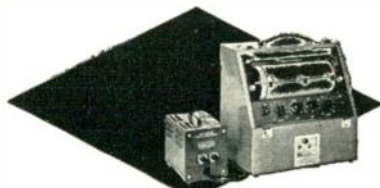

**AUTOGRAF  
CURVE FOLLOWER**  
plots or reads out Y vs. X. Either Model 1 or Model 2 can be furnished as a recorder/curve follower.



**AUTOGRAF  
POINT PLOTTER**  
Models 1 and 2 may be fitted for point plotting from keyboard or other digital sources.

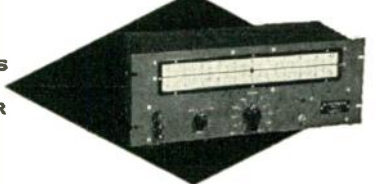

A new high accuracy, easy-to-read, multi-range servo-voltmeter with fast response. Scales 0-3 millivolts to 0-300 volts. Zero left or zero center. Designed for indication, control, or analog to digital conversion.

**BOTH AUTOGRAF**

**MODELS ARE OUTSTANDING**

**FOR THEIR VERSATILITY**

**NEW MODEL 20 SERIES**

**DC VOLTMETER**

*Bulletins describing these instruments are available, and we will be glad to send you the ones you want. Write...*

**F. L. MOSELEY CO., 407 NORTH FAIR OAKS AVENUE, PASADENA 3, CALIFORNIA**

detect planes almost three times as far away as previous units of this type. It is designed to be used with search radar to detect high-flying aircraft and provide information on distance, altitude and direction of flight. The set is produced by General Electric Co. in both mobile and fixed versions and has been supplied for use in strengthening the radar defenses of North America and for defense posts in countries receiving U. S. aid under the Mutual Defense Assistance Pact. . . . **Ralph L. Clark** has been named Staff Director of the newly established Cabinet Committee on Telecommunications, according to an announcement by ODM Director Arthur S. Flemming, who was named Committee Chairman. The special cabinet committee was established by the President to study the federal government's external communications by telephone, telegraph, and radio. The group will not consider domestic communications policies, the announcement stated. The Cabinet Committee on Telecommunications is composed, in addition to Dr. Flemming, of the Secretaries of State and Defense.

### **PATENTS**

The Commerce Department last week announced the publication of two new books containing patent abstracts of government-owned patented inventions in the fields of electronics and ordnance. The "Electrical and Electronic Apparatus" publication contains 1,915 abstracts which are classified as to industrial use under such groups as: wiring devices and supplies; controls and switches; radio and related object locating and navigation apparatus; computing apparatus, and others. In addition to the brief description of the inventions, the book includes the title and number of each patent, name of the inventor, the agency administering the patent, and a list of addresses of the field offices of the Commerce Department and the Small Business Administration which may be consulted for further information concerning the availability and use of these inventions. The new book may be purchased at \$4 a copy from the Office of Technical Services, Commerce Department, Washington 25, D. C., by code number PB-111468. "Ordnance" is the title of the second publication, which contains 644 abstracts classified as to industrial use under such groups as: aiming devices; fire control apparatus, and ordnance measuring and testing apparatus. This may be purchased at \$2 a copy from the OTS, Commerce Department, Washington 25, D. C., by code number PB-111469.

### **RETMA ACTIVITIES**

**R. H. Williamson** of the General Electric Co. has been named Chairman of the Atomic Tests Committee, RETMA Engineering Department. The committee will coordinate RETMA activities in connection with the forthcoming test in which a

*(Continued on page 74A)*



# WORLD'S LARGEST STOCK



## RESISTORS

Fixed and "Dividohm" adjustable wire-wound types, 10 to 200 watts. Also composition type.



## RHEOSTATS

Ten stock sizes—25 to 1000 watts. All ceramic and metal.



## TAP SWITCHES

Rotary type. Five sizes from 10 to 100 amp, with from 2 to 12 taps.

What resistance components do you need in a hurry? From a factory stock of several million resistors, rheostats, and tap switches . . . in 1,859 types, sizes, and values . . . Ohmite can make fast delivery in reasonable quantities to meet your immediate requirements.

Furthermore, by tailoring your specifications to these stock items, you can always get speedy delivery that will help you keep experimental and pilot production operations on a smooth-running schedule.

To assist engineers and purchasing agents in making their selection from this huge stock, Ohmite *Stock Catalog* No. 24 contains complete, up-to-date information on all Ohmite stock items. Resistance values, ratings, specifications, and other helpful information are included.

**NEED RELAYS?** Get in touch with  
American Relay & Controls, Inc.

3651 Howard Street, Skokie, Ill. . . . an OHMITE Subsidiary

SEND  
FOR  
STOCK  
CATALOG  
NO. 24



# OHMITE®

**MANUFACTURING CO.**

3617 Howard St., Skokie, Ill. (Suburb of Chicago)

WRB



# NEW

*improved lightweight model!*

## **CANOGA Wobbulator**

**SWEPT FREQUENCY SIGNAL  
GENERATOR with OSCILLOSCOPE**

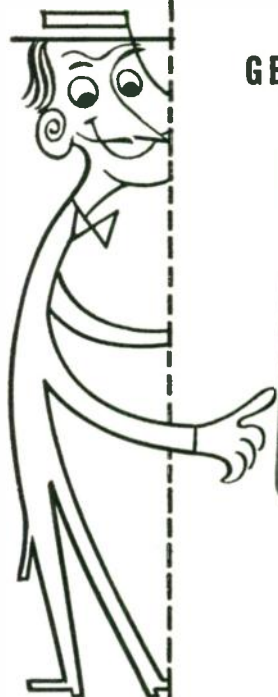

Here is a new improved functional design of the well-known Canoga Model 705 Wobbulator Signal Generator. Smaller in size and lighter in weight, it features a wider bandwidth, a greater frequency range, and an all-electronic sweep circuit. It is ideal for use in manufacturing, servicing, or testing receiving equipment such as video, RF, IF, and distributed amplifiers.

As an example of the Wobbulator's new functional design, the housing is an aerated structure with tapered sides allowing ample passage of cooling air throughout the unit, even when placed alongside other equipment.

These, and other features of the new Wobbulator, are positive proof of Canoga Corporation's superior electronic engineering and design.

**FREQUENCY RANGE** . . . 2.0 to 1000 mcs. Continuous single knob tuning with calibrated dial.

**FREQUENCY SWEEP** . . . Any bandwidth of 100 mcs. or smaller.

**AMPLITUDE VARIATION** . . . Less than 0.01 db/mc.

**OUTPUT VOLTAGE** . . . 0.1 volts across 50 ohm resistive load.

**ATTENUATOR** . . . The output level is continuously adjustable by means of a wave guide beyond cut-off attenuator calibrated in 1 db divisions.

**DISPLAY** . . . 5" CRT

**SENSITIVITY** . . . Detector for built-in amplifier and CRT presentation has a sensitivity approx. 60 db below 0.1 volt; gain and bandwidth measurements can be accomplished on circuits having a loss as great as 60 db.

**POWER SUPPLY** . . . Self-contained, all DC voltages regulated. Input 105-125 volts, 50-400 cps, approx. 100 watts.

**SIZE** . . . 12"x 13"x 17".

**WEIGHT** . . . Approx. 50 lbs.

**PRICE** . . . \$1500.00



*Write today for complete detailed information*

**CANOGA CORPORATION**

Radar Systems, Antennas, Receivers, Test Equipment  
**5953 SEPULVEDA BLVD. - VAN NUYS, CALIFORNIA**

WHEN WRITING TO ADVERTISERS PLEASE MENTION — PROCEEDINGS OF THE I.R.E.



announcing an  
**extra sensitive  
miniature relay**

*It's the new ADVANCE SQ — a telephone type that hits a new high in ruggedness and efficiency!*

Only 15 milliwatts per pole will operate the new SQ relay in the DPDT combination. Here is sensitivity teamed with stable performance—the DPDT unit withstands 10 G's vibration from 10 to 500 cycles. When power is increased to 40 milliwatts per pole, vibration resistance rises to 30 G's. A single-coil relay, the ADVANCE SQ is available in 1- to 5-amp contact ratings, and in contact combinations from SPST to 6PDT. It comes through Signal Corps tumbling and shock tests in excess of 200 G's with operating characteristics unimpaired.

Sustained efficiency keynotes SQ operation. The use of a beryllium copper armature retaining spring insures positive contact between armature and pivot points at all times. Cross-bar palladium contacts are always properly aligned. A wide variety of coil resistances is feasible. Instead of organic insulation, the unit employs Silicone glass, Kel-F, or Teflon tubing. Life expectancy for 5-amp, non-inductive loads is 150,000 cycles... for 1-amp, non-inductive load: 1,000,000 cycles.

Open type dimensions are 1" x 3/4" x 1 1/8". DPDT units are supplied in a sealed container measuring 1" x 1" x 2". Write for literature on the SQ series.



**ADVANCE ELECTRIC  
AND RELAY CO.**

2435-G NORTH NAOMI ST.  
BURBANK, CALIFORNIA

*Sales Representatives in Principal  
Cities of U.S. and Canada*



# Consider the tinker:

*he spread himself too thin...*

One early example of the non-specialist was the Traveling Tinker. Unlike the blacksmith, the gunsmith or other engineering-minded specialists of that day, the Tinker did everything. His work was just good enough to last his pioneering customers until someone better equipped came along. Sooner or later someone always did . . . and the Tinker lost his customers. Then he drifted on. Finally progress overtook him completely and we see him no more.

We have seen similar changes in our times too. Before specialized component manufacturers came on the scene a few years ago, leading engineers had to spread themselves pretty thin . . . the designer of complex new equipment had to devise from scratch on the tiniest details. Designing a hermetic seal, say, was part and parcel of developing a sensitive relay. This is no longer so.

Like many in the electronics industry, Hermetic Seal Products Co. has specialized in a particular product and related service. Our concentrated effort has resulted in producing, for other engineers' use, hermetic seals with performance characteristics undreamed of a few years ago. This specialized attention continually brings forth new advances in our products and those of our customers.

Hermetic's specialized engineering of VAC-TITE\* and matched glass seals can be applied to your particular problems, too. Why not write today for particular information and for our latest addition to the "Encyclopedia Hermetica"? . . . Sent free when requested on company letterhead.

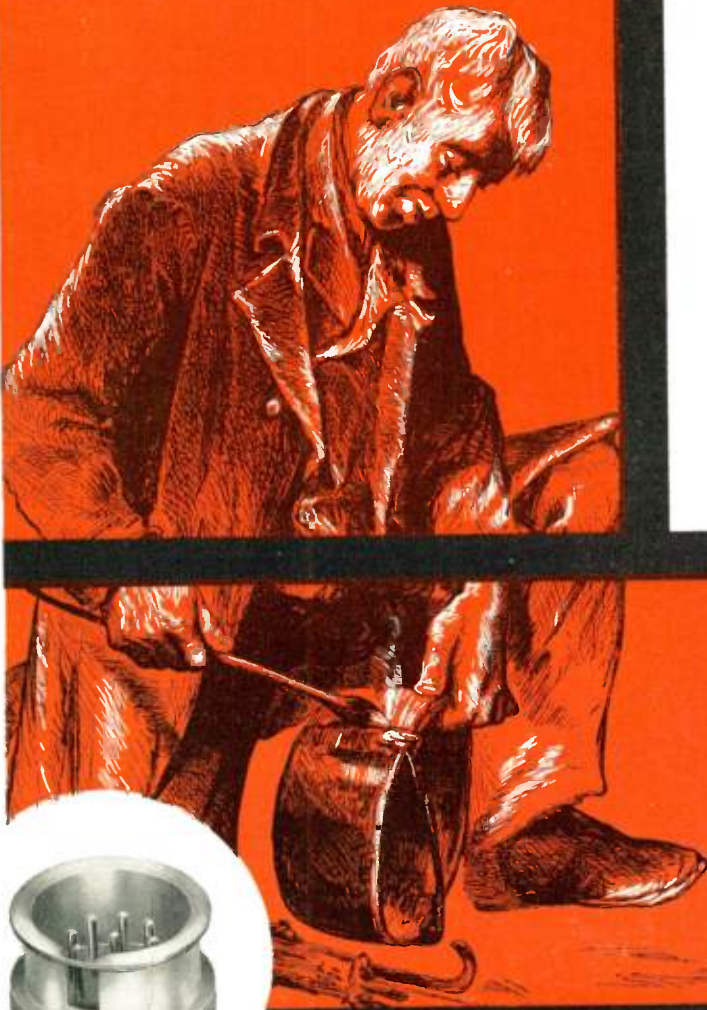

\*Vac-Tite—Hermetic's exclusive glass-to-metal, chemically bonded compression construction. Available on headers and seals from 1-1/2 in. down to .090 in. diameter, and with 1 to 53 terminals.

BETTMANN ARCHIVE



## Hermetic Seal Products Company

33 South Sixth Street • Newark 7, New Jersey



F I R S T & F O R E M O S T I N M I N I A T U R I Z A T I O N





*(Continued from page 70A)*

variety of electronic equipment and components will be subjected to an atomic bomb blast. The atomic test is to be conducted next spring at the Nevada Proving Ground under the sponsorship of the Atomic Energy Commission and the Federal Civil Defense Administration. Participation by RETMA member-companies has been endorsed by the Board of Directors.

**TECHNICAL**

The Department of the Navy has circulated a memo to its electronic equipment design groups reminding them of the availability of an electron tube application consulting service made available through the cooperation of the tube manufacturing industry and the Advisory Group on Electron Tubes in the Office of the Assistant Secretary of Defense (Research and Development). The memo points out that "tube application engineers, working in groups of three (one from each of three tube manufacturers), can visit equipment manufacturers to give counsel on tube applications. They will review circuit requirements and advise on the choice of tube types to perform the required functions, the allowable range of tube operating conditions for dependable performance, and circuit adjustments that may be made to improve tube-circuit compatibility." Manufacturers of electronic equipment for the military who desire to have their equipment reviewed by the consultants may do so by contacting W. C. Kirk, Advisory Group on Electron Tubes, 346 Broadway, New York, N. Y. . . . The National Bureau of Standards has announced the publication of a new booklet, "Formulas for Computing Capacitance and Inductance." The NBS reported that this collection of formulas contains some that are commonly used in electrical work and some that have been specially developed for precision work at the Bureau. Explicit formulas are given for the computation of (1) the capacitance between conductors having a great variety of geometrical configurations, (2) the inductance, both self- and mutual, of circuits of various shapes, and (3) the electrodynamic forces acting between coils when carrying current. Formulas for skin effect and proximity effect in concentric cables and parallel wires are included. The formulas for the simpler configurations are given in terms of the elementary functions, whereas more complex shapes involve the use of Legendre polynomials, Legendre functions, and elliptic functions. One section is devoted to a discussion of the relation between the Legendre and the elliptic functions. "Formulas for Computing Capacitance and Inductance," National Bureau of Standards Circular 544, is available at 40 cents per copy from the Government Printing Office, Washington 25, D. C. . . . The Office of Technical Services, Commerce Department, has listed studies in the field of electronics in its September is-

*(Continued on page 78A)*

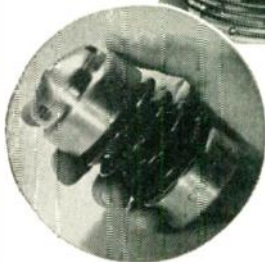
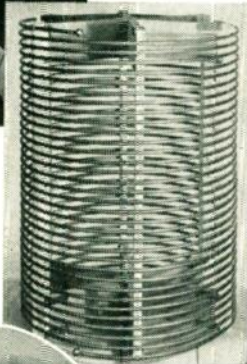
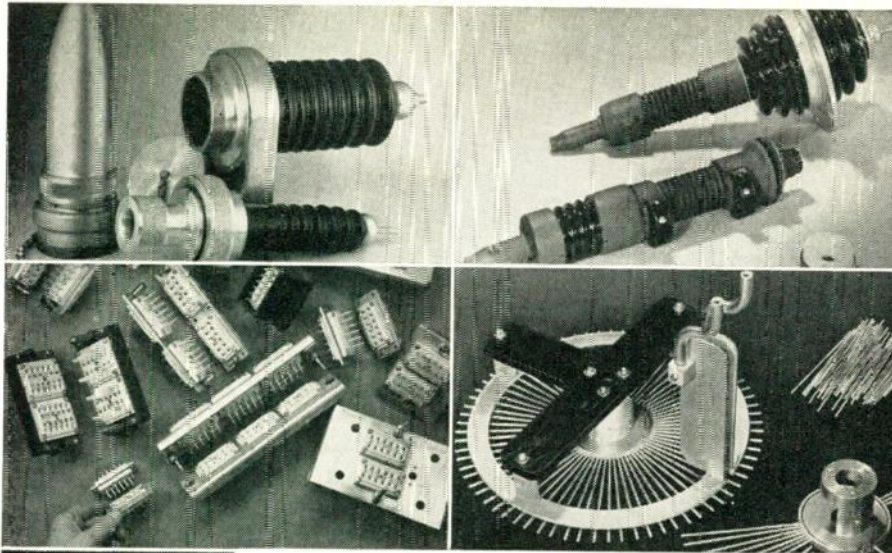

**OUR BUSINESS IS**

**ELECTRICAL PORCELAIN**

**. . . its application**

**. . . design**

**. . . manufacture**

**. . . and assembly**

"Radio Specialties" identifies a large and busy department at Lapp. Through it, we have designed and built, in large volume, hundreds of parts for hundreds of specialized electronic requirements. Our skill is in our knowledge of the capabilities, and limitations, of ceramic insulation . . . in engineering ingenuity to meet specified requirements . . . and in efficient production. If you have requirement for insulating parts and associated sub-assemblies, we may be able to show you how they can be made most economically, to perform most efficiently. Write Lapp Insulator Co., Inc., Radio Specialties Division, 221 Sumner St., Le Roy, N. Y.





# 3 twin power triodes

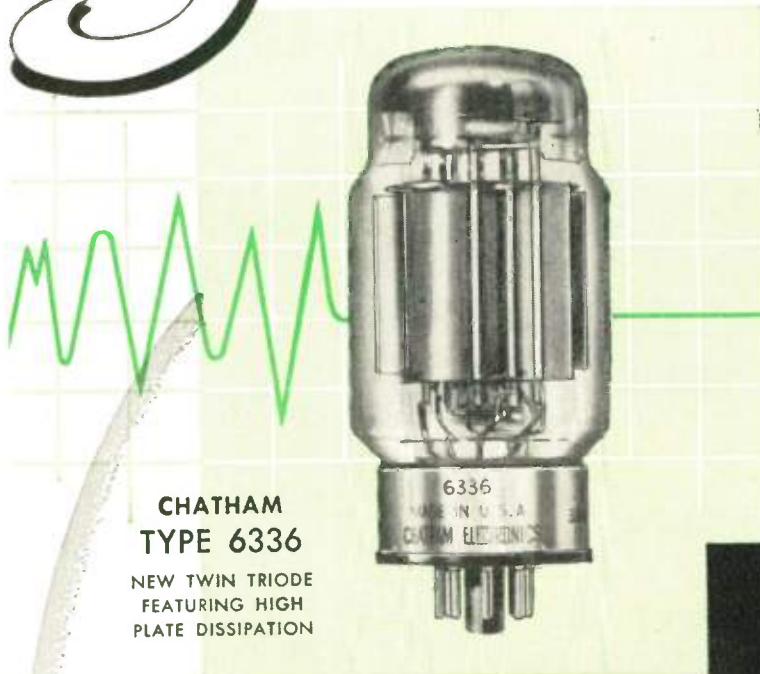

...for voltage regulation

## CHATHAM TYPE 6336

NEW TWIN TRIODE  
FEATURING HIGH  
PLATE DISSIPATION

The new Chatham Type 6336 is a twin power triode with special suitability for voltage regulating applications. Used as a series tube, it will pass a minimum of 150 milliamperes per section with 40 volts, D.C. plate voltage. Special features include a hard glass envelope, an 8-pin button stem with Jumbo Octal Base.

### CHARACTERISTICS (PER SECTION)

- PLATE DISSIPATION: 30 WATTS
- AMPLIFICATION FACTOR: 2.7
- TRANSCONDUCTANCE: 11,000 MICROHMS
- PLATE RESISTANCE: 250 OHMS
- HEATER REQUIREMENTS: 6.3 V., 4.75 AMPS.



## TYPE 6394 TWIN TRIODE

Similar to Type 6336 in every respect except for Heater Requirements which are 26.5 volts, 1.25 amps.

The tubes shown are typical items from the complete Chatham line of general and special purpose tubes. Included in this line are Amplifiers, Mercury and Inert Gas Rectifiers, also Mercury, Inert Gas and Hydrogen Thyratrons.

Most Chatham tubes are available directly from stock and can be supplied promptly. Chatham also designs, develops and manufactures special tubes to exact customer specifications — inquiries are invited.



## CHATHAM TYPE 6AS7G IMPROVED TWIN POWER TRIODE —

This Chatham Twin Triode is built to close tolerance — features plate current and GM characteristics held within  $\pm 10\%$ , very low microphonics, improved triode balance, absence of grid current and greatly reduced plate current drift. Plate current is 125 milliamperes at 40 volts, D.C. plate voltage. The characteristics of this tube recommend it especially for voltage regulation circuits. Base is Medium Shell Octal.

### CHARACTERISTICS: (PER SECTION)

- Plate Dissipation: 13 Watts
- Amplification Factor: 2.0
- Transconductance: 7,000 Micromhos
- Plate Resistance: 280 Ohms
- Heater Requirements: 6.3 Volts  
2.5 Amps.



## CHATHAM ELECTRONICS CORP.

Executive and General Offices: LIVINGSTON, NEW JERSEY  
Plants and Laboratories: NEWARK and LIVINGSTON, NEW JERSEY



SINCE 1915 LEADERS IN AUTOMATIC CONTROL

## FROM SYNCHROS TO 150 HP WITHOUT ELECTRONICS

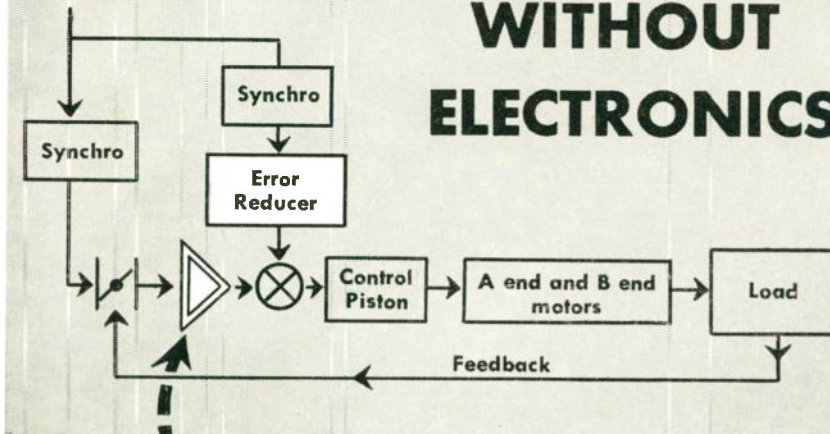

## HYDRAULIC AMPLIFICATION

Ford engineers have developed a highly accurate synchronizing gun drive that is amplified from a small synchro motor to 150 horsepower purely by hydraulic amplification. With the addition of the Ford-perfected Error Reducer, the drive controls the power to train and elevate the guns, thus achieving continuous aiming of the guns with extremely high accuracy. Full use is being made of this experience with hydraulic servo gun drives in Ford's current work on reactor controls.

This hydraulic amplifying system is typical of the unusual amplifying systems developed by Ford Instrument Company over the past forty years. Other examples are the electronic amplifier circuits in mission control computers for the Navy Bureau of Aeronautics, magnetic amplifier circuits for power drives, and transistor amplifiers for missile guidance systems.

If you have a problem in control engineering, Ford Instrument Company's forty years of experience in high precision design and production will help you find the answer.



**FORD INSTRUMENT COMPANY**  
DIVISION OF THE SPERRY CORPORATION  
31-10 Thomson Avenue, Long Island City 1, N.Y.

### ENGINEERS

of unusual abilities can find a future at FORD INSTRUMENT COMPANY. Write for information.

## SIMPLYTROL AUTOMATIC PYROMETER

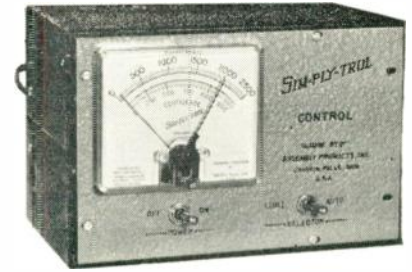

Cat. No. 4531 0.2500° F.  
Price \$132.00

Thermocouple type Automatic Pyrometer for controlling temperature in furnaces, ovens, and processes. The Simplytrol is economical and reliable with few moving parts. There are no vacuum tubes. The regular load relay is S.P.D.T. 5 Amps. Optional heavy duty relays to 40 Amps.

10 temperature ranges cover from -75° to 3000° F. Several special ranges to -400° F. "On & Off" control for holding the desired temperature works on gas, oil or electric heat. Indicating meter-relay is medium high resistance and has bimetal cold junction compensation. For use with all standard thermocouples. Accuracy 2%.

"Auto-Limit" switch changes Simplytrol from automatic controller to limit pyrometer for safety shut down or warning. Cabinet: 6 1/2 x 6 1/2 x 9 1/2 inches. Also flush panel mount models. Send for new Bulletin G-7 for more data. Assembly Products, Inc., Chesterland 2, Ohio.

reduce  
noise  
error  
99%

**mininoise**<sup>®</sup>  
ACTUAL SIZE!

Mininoise Cable, made only by Microdot, is ideal for low signal levels and high impedance terminations. In every applicable case, Mininoise reduces noise 99%!

WRITE for data on Mininoise cable and Microdot coax assemblies.

**MICRODOT**  
1826 FREMONT STREET  
SO. PASADENA • CALIF.



# Subminiature Toroids

HIGH PRODUCTION  
 PROTOTYPES  
 ENGINEERING DEVELOPMENT  
 RESEARCH

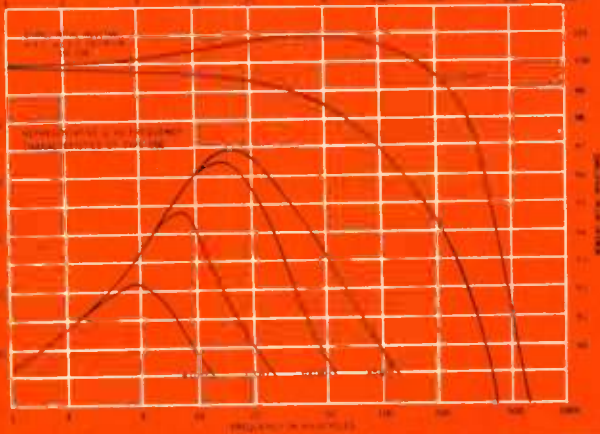

## TRANSISTOR TRANSFORMERS

Consistent with **advanced** engineering in subminiaturization, CAC offers transistor transformers in hermetically sealed cases, molded or cast type construction—designed to meet military requirements—temperatures (-) 55° C. to (-) 105° C. Enclosed magnetic field afforded by toroidal form. Frequencies and impedances to your specifications... utilize our **advanced** engineering and modern high speed production facilities. See your CAC representative now.

### TYPICAL PULSE TRANSFORMER

IMPEDANCE RATIO	RISE TIME (MICRO SEC)	WIDTH (50% PEAK)	DRIFT % PEAK	OVERSHOOT % PEAK	INPUT PULSE TIME MICRO SEC	% RING
200/800	3	8.1	10.4	0	8	3
100/3800	26	8.1	0	4.1	8	2.9
5000/20000	1.3	8.0	10.0	20.0	8	0

A TYPICAL PULSE TRANSFORMER—ONE OF MANY CUSTOM DESIGNS DEVELOPED BY CAC ENGINEERS — HIGHLY STABLE TOROIDAL UNITS — EXHIBIT EXCELLENT CHARACTERISTICS



KEEP YOUR DESIGNS AHEAD WITH CAC SUBMINIATURES  
 APPLICATIONS: FILTERS, CHOKES, TRANSISTOR AND PULSE TRANSFORMERS, REACTORS AND INDUCTORS

# Subminiature Filters

FOR TELEMETERING  
 AND AIRBORNE EQUIPMENT

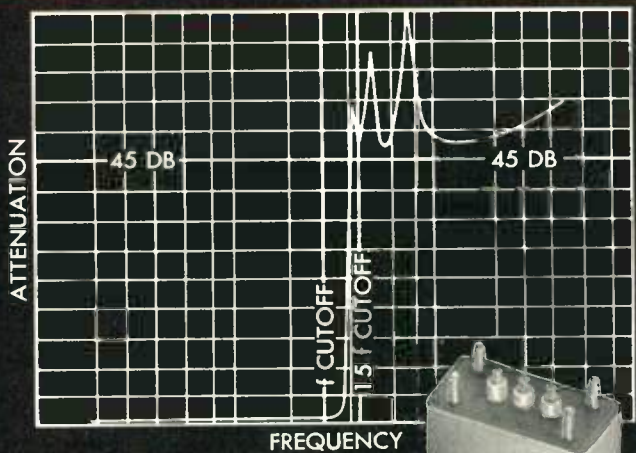
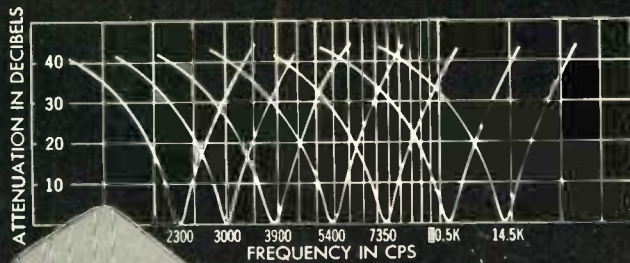

.55 CUBIC INCHES AND LESS. EXCELLENT BAND PASS CHARACTERISTICS—DESIGNED TO MIL SPECIFICATIONS IDEAL MULTI CHANNEL OPERATION.



STANDARD LOW PASS SERIES — DESIGNED & PACKAGED TO MIL T27 SPECIFICATIONS — OFFERS OVER 45 db ABOVE f<sub>1</sub> (f<sub>1</sub> = 1.5 f<sub>c</sub>), HERMETIC SEALED — STUD MOUNTED — TEFLON TYPE TERMINALS. CIGARETTE SIZE PACKAGE. 3, 6, 10 & 15 KC STD. UNITS. ALSO AVAILABLE IN SUBMINIATURE VERSION.



FOR ADDITIONAL INFORMATION CONTACT  
**COMMUNICATION ACCESSORIES COMPANY**

HICKMAN MILLS, MISSOURI • PHONE KANSAS CITY, SOUTH 5528



(Continued from page 74A)

sue of the "Bibliography of Technical Reports." The following government-sponsored research reports can be purchased from the Photoduplication Section, Library of Congress, Washington 25, D. C., for the reported price:

"Effect of Radar Wavelength on Meteor Echo Rate," PB 114503, microfilm, \$1.50; photocopy, \$1.50.

"Generation and Transmission of Microwave Energy," PB 114134, microfilm, \$7.75; photocopy, \$26.50.

"9 by 9 Inch Transonic-Supersonic Wind Tunnel," PB 114464, microfilm, \$3; photocopy, \$7.75.

"Nonlinear Optimization of Relay Servomechanisms," PB 114444, microfilm, \$5; photocopy, \$15.25.

"Obstacles and Discontinuities in a Multi-mode Wave-guide," PB 114267, microfilm, \$2; photocopy, \$2.75.

"On Diffraction by an Infinite Grating," PB 114114, microfilm, \$2; photocopy, \$2.75.

"Radar Range Tracking Noise," PB 114123, microfilm, \$2.50; photostat, \$5.25.

"Research in Physical Electronics," PB 114240, microfilm, \$4.50; photocopy, \$12.75.

"Resonance Phenomena in Time-varying Circuits," PB 114486, microfilm, \$5; photocopy, \$15.25.

"Statistical Theory of Coincidence Experiments," PB 114121, microfilm, \$2.50; photocopy, \$5.25.

"Study of Performance Measures of Trouble Shooting Ability on Electronic Equipment," PB 114435, microfilm, \$6; photocopy, \$19.

"Theory of Radio Reflections from Electron-ion Clouds," PB 114639, microfilm, \$2.50; photocopy, \$5.25.

"Coaxial Line Filled With Two Non-concentric Dielectrics," PB 114633, microfilm, \$2; photocopy, \$2.75.

"Design and Performance of a High-Power Pulsed Klystron," PB 114452, microfilm, \$2; photocopy, \$2.75.

"Elimination of Radio Interference by Shielding and Design of Shielded Rooms," PB 114646, microfilm, \$2.25; photocopy, \$4.

"Magnetic Amplifiers—Parts I and II," PB 114429 and PB 114430, respectively, microfilm, \$4; photocopy, \$11.50.

"Microwave Noise Study. Quarterly Report No. 4," PB 114993, microfilm, \$3; photocopy, \$7.75.

"Plasma Oscillations in a Static Magnetic Field," PB 114629, microfilm, \$6.25; photocopy, \$20.25.

"Pulsed Operation of a High-Power Amplifier with Complex Load Impedance," PB 114501, microfilm, \$3.25; photocopy, \$9.

"Radio Interference Suppressors Progress Report No. 12," PB 114439, microfilm, \$2.25; photocopy, \$4.

"Solution for the Path of Radio Waves Through the Solar Atmosphere by Elliptic Integrals," PB 114453, microfilm, \$2.25; photocopy, \$4.

(Continued on page 82A)

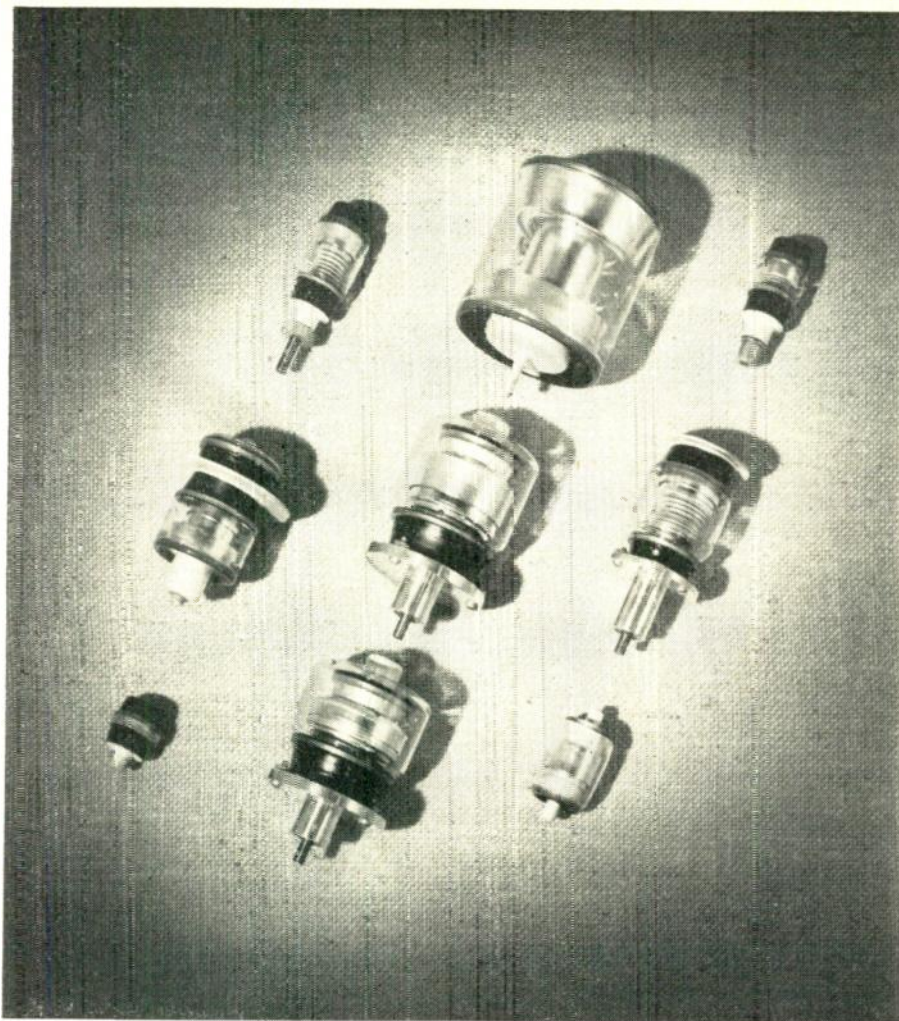

## JENNINGS VACUUM CAPACITORS ARE BEING USED IN THESE VHF AND UHF APPLICATIONS

- ✓ Tank and antenna tuning capacitors in TV transmitters
- ✓ Feed-through capacitors for harmonic attenuation on power supplies
- ✓ Pulse shaping capacitors in the output circuit of magnetrons
- ✓ RF bypass capacitors

The years of patient research and development work at Jennings has made possible practical, stable, and efficient miniaturized vacuum capacitors for the VHF and UHF fields. Their vacuum dielectric and all-copper construction result in high power ratings, small physical size, and extremely wide capacity ranges. They are thoroughly outgassed so that they are not damaged by moderate overloads that cause internal arcing.

Therefore, where high power requirements at high frequencies have created difficult problems for other types of capacitors, consider utilizing the inherent advantages of these new fixed and variable capacitors with a vacuum dielectric!



Send for our catalogue summary, or let us send you specific recommendations with respect to your capacitor problems.



**JENNINGS RADIO MANUFACTURING CORPORATION • 970 McLAUGHLIN AVE.  
P. O. BOX 1278 • SAN JOSE 8, CALIFORNIA**





**Andrew**  
CORPORATION  
363 EAST 75th STREET · CHICAGO 19

Original antenna system specially  
produced for the Military

## A MAJOR ANDREW ENGINEERING- PRODUCTION ACHIEVEMENT.

Only one of many proofs-in-use  
that Andrew is thoroughly qualified  
to take on your major *antenna*  
design-production projects.

Only Andrew offers you such  
extensive facilities exclusively  
devoted to the design and  
manufacture of complete antenna  
systems for communications  
including Andrew designed and  
produced flexible and semi-flexible  
coaxial cables and rigid  
transmission lines.



For AN/TRC-29 Military Microwave  
system, an 8' aluminum mesh  
parabolic antenna, unique for its  
bandwidth, 1700-2400 MC,  
very low V S W R.



Another **RCA** "First!"



**NEW**

**"WORKHORSE"**

**FOR TV**

## RCA-6CG7..Miniature Version of the Popular 6SN7-GT

- New miniature design
- Same ratings as RCA-6SN7-GT
- 600 ma heater with controlled warm-up time (for "series-string" operation)
- New isolating shield between triode units

Designed with the same ratings as the 6SN7-GT, RCA-6CG7 is another product of RCA's basic program to anticipate and develop tubes to meet designers' tube requirements today—and in the future.

Engineered for modern TV circuitry including "series string" designs, RCA-6CG7 is

particularly useful as a deflection oscillator. It employs a 600-milliampere heater having controlled warm-up time to insure dependable performance in television receivers employing a single series-connected heater string. Then too, it has an internal shield to prevent electrical coupling between the triode units.

The 6CG7 is also well-suited for use as a phase inverter, multivibrator, synchronizing separator and amplifier, and resistance-coupled amplifier in electronic equipment.

For technical information, call your local RCA Field Representative. Or write RCA, Section A35Q, 415 S. Fifth St., Harrison, N. J.



**RADIO CORPORATION of AMERICA**  
ELECTRON TUBES

HARRISON, N. J.



BOARD OF DIRECTORS, 1954

William R. Hewlett  
*President*

M. J. H. Ponte  
*Vice-President*

W. R. G. Baker  
*Treasurer*

Haraden Pratt  
*Secretary*

John R. Pierce  
*Editor*

D. B. Sinclair  
*Senior Past President*

J. W. McRae  
*Junior Past President*

1954

A. N. Goldsmith  
J. T. Henderson (R8)  
A. V. Loughren  
C. A. Priest (R4)  
J. R. Ragazzini (R2)  
J. D. Ryder  
A. W. Straiton (R6)  
J. A. Stratton  
Ernst Weber

1954-1955

S. L. Bailey  
C. J. Marshall (R5)  
L. E. Packard (R1)  
J. M. Pettit (R7)  
B. E. Shackelford  
H. W. Wells (R3)

1954-1956

A. G. Jensen  
George Rappaport

George W. Bailey  
*Executive Secretary*

John B. Buckley  
*Chief Accountant*

Laurence G. Cumming  
*Technical Secretary*

Evelyn Davis  
*Assistant to the Executive Secretary*

Emily Sirjane  
*Office Manager*



Responsibility for the contents of papers published in the PROCEEDINGS OF THE I.R.E.

rests upon the authors. Statements made in papers are not binding on the Institute or its members.



# PROCEEDINGS OF THE I.R.E.<sup>®</sup>

*Published Monthly by*

The Institute of Radio Engineers, Inc.

VOLUME 43

*January, 1955*

NUMBER I

## CONTENTS

John D. Ryder, President, 1955.....	2
Men Who Play God..... <i>W. L. Everitt</i>	3
5135. New Techniques for Fabrication of Airborne Electronic Equipment..... <i>R. K-F Scal</i>	4
5136. Color Balance for Television..... <i>D. L. MacAdam</i>	11
5137. A Triode Useful to 10,000 Mc..... <i>J. E. Beggs and N. T. Lavoo</i>	15
5138. An Equalizing Network for Carrier-Type Feedback Control Systems..... <i>C. H. Looney</i>	20
5139. Radio Scattering in the Troposphere..... <i>William E. Gordon</i>	23
5140. Accurate Linear Bidirectional Diode Gates..... <i>J. Millman and T. H. Puckett</i>	29
5141. Effect of Base-Contact Overlap and Parasitic Capacities on Small-Signal Parameters of Junction Transistors..... <i>R. L. Pritchard</i>	38
5142. Traveling-Wave Tube Experiments at Millimeter Wavelengths with a New, Easily Built, Space Harmonic Circuit..... <i>Arthur Karp</i>	41
5143. Radial Line Discontinuities..... <i>J. R. Whinnery and D. C. Stinson</i>	46
5144. Frequency-Modulation Interference Rejection with Narrow-Band Limiters..... <i>E. J. Baghdady</i>	51
5145. Beam Focusing by Periodic and Complementary Fields..... <i>Kern K. N. Chang</i>	62
5146. The Charging and Discharging of Nonlinear Capacitors..... <i>J. R. Macdonald and M. K. Brachman</i>	71
5147. Displacement of the Zeros of the Impedance $Z(p)$ Due to Incremental Variations in the Network Elements..... <i>A. Papoulis</i>	79
5148. Scattering of Electromagnetic Waves by Wires and Plates..... <i>J. Weber</i>	82
5149. A Distributed Electrical Analog for Waveguides of Arbitrary Cross Section..... <i>P. R. Clement and W. C. Johnson</i>	89
5150. Helix Millimeter-Wave Tube..... <i>H. V. Christensen and D. A. Watkins</i>	93
Correspondence:	
5151. "A New System of Logarithmic Units"..... <i>R. V. L. Hartley</i>	97
5152. "Comment on 'Networks Terminated in Resistance at Both Input and Output'"..... <i>L. Weinberg</i>	98
5153. "A New Self-Excited Square-Wave Transistor Power Oscillator"..... <i>G. C. Uchirin and W. O. Taylor</i>	99
5154. "Comment on 'NTSC Signal Specifications for Color Television'"..... <i>W. L. Brewer and J. H. Ladd</i>	100
5155. "Ferrite Attenuators in Helices"..... <i>J. A. Rich and S. E. Webber</i>	100
5156. "The Variation of the Forward Characteristics of Junction Diodes with Temperature"..... <i>J. S. Schaffner and R. F. Shea</i>	101
5157. "Traveling-Wave Tube System Having Multiplied Gain"..... <i>F. R. Arams</i>	102
5158. "Comment on 'Radio-Frequency Phase-Difference Networks: A New Approach to Polyphase-Selectivity'"..... <i>G. B. Madella</i>	102
5159. "Television Microscopy"..... <i>B. Ross Robinson</i>	103
5160. "Reciprocity Theorem for Anisotropic Media"..... <i>M. H. Cohen</i>	103
Contributors.....	104
IRE News and Radio Notes:	
IRE National Convention Set for March 21-24.....	107
1955 IRE Officers Announced.....	107
New York Section Holds Symposium on Transistor Circuits.....	108
Automatic Control Group Elects Officers.....	108
Obituaries.....	109
Professional Group News.....	109
Technical Committee Notes.....	110
Conference on Transistor Circuits.....	111
Professional Groups and Sections Chairmen.....	111
5161. Abstracts and References.....	114
Meetings with Exhibits..... 2A	90A
News and New Products..... 16A	100A
IRE People..... 38A	130A
Industrial Engineering Notes.. 56A	138A
Professional Group Meetings.. 86A	
Section Meetings.....	90A
Membership.....	100A
Positions Open.....	130A
Positions Wanted.....	138A

## EDITORIAL DEPARTMENT

Alfred N. Goldsmith  
*Editor Emeritus*

John R. Pierce  
*Editor*

E. K. Gannett  
*Managing Editor*

Marita D. Sands  
*Assistant Editor*

## ADVERTISING DEPARTMENT

William C. Copp  
*Advertising Manager*

Lillian Petranek  
*Assistant Advertising Manager*

## EDITORIAL BOARD

John R. Pierce, *Chairman*

D. G. Fink  
E. K. Gannett  
T. A. Hunter  
J. W. McRae  
J. A. Stratton  
W. N. Tuttle

Changes of address (with advance notice of fifteen days) and communications regarding subscriptions and payments should be mailed to the Secretary of the Institute, at 450 Ahnaip St., Menasha, Wisconsin, or 1 East 79 Street, New York 21, N. Y.

All rights of publication, including translation into foreign languages, are reserved by the Institute. Abstracts of papers with mention of their source may be printed. Requests for republication privileges should be addressed to The Institute of Radio Engineers.



## John D. Ryder

PRESIDENT, 1955

John D. Ryder was born in 1907 in Columbus, Ohio, and received the B.E.E. and M.S. degrees from Ohio State University in 1928 and 1929, respectively. In 1944, he was awarded the Ph.D. degree in E.E. by Iowa State College.

Dr. Ryder was associated with the General Electric Company in Schenectady, N. Y., from 1929 to 1931; he then joined the Bailey Meter Company, in Cleveland, as supervisor of the electrical and electronic section of their Research Laboratory. As a result of his work, he was granted numerous United States and foreign patents for such inventions as a form of electronic self-balanced ac resistance bridge, a high-speed photoelectrically-balanced potentiometer, ac and dc motor-control circuits, and smoke recording instruments. Dr. Ryder is the author of three textbooks on electronics and networks, and numerous papers on technical and educational subjects.

Turning to the teaching field in 1941, Dr. Ryder was appointed Assistant Professor of Electrical Engineering at Iowa State College. He was appointed Professor in 1944, and in 1946 was placed in acting charge of the Department of Electrical

Engineering. He became Assistant Director of the Iowa Engineering Experiment Station in 1947, and in 1949, was named head of the Department of Electrical Engineering at the University of Illinois. Last July he became Dean of the School of Engineering at Michigan State College, East Lansing, Michigan.

Dr. Ryder is a former president of the National Electronics Conference, a Fellow of the American Institute of Electrical Engineers and American Association for the Advancement of Science, and a member of the American Society for Engineering Education, Eta Kappa Nu, Sigma Xi, and Tau Beta Pi.

Dr. Ryder joined the Institute of Radio Engineers in 1929 as an Associate, became a Senior Member in 1945, and in 1952, he was made an IRE Fellow. He has been the Vice-Chairman of the IRE Electron Tube Conference Committee and Vice-Chairman of the IRE Des Moines-Ames Section. He has been a member of the IRE Editorial Review Committee and the Policy Advisory Committee, and Chairman of the Education Committee.



# Men Who Play God

W. L. EVERITT

*University of Illinois, Urbana, Illinois*

*Acceptance speech by W. L. Everitt on receiving the 1954 Medal of Honor at the Annual IRE Banquet, March 24, 1954.*

Some fifteen years ago I was impressed by a movie called "The Man Who Played God," with George Arliss in the leading role. The theme concerned a particular type of wireless communication. The hero was a wealthy musician who had lost his hearing. At first filled with despair, he learned to read lips and applied his new-found skill to a unique and satisfying hobby. From his penthouse overlooking Central Park, by using a pair of field glasses, he, "listened in," as it were, on the conversations of people on the benches below. Frequently he learned about the problems of people who were in despair. His hobby was to provide anonymously for a material solution to their problems, apparently as though Heaven had intervened directly. Hence, the title, "The Man Who Played God."

But in a different sense, do you realize that you, too, the members of the Institute of Radio Engineers, are "men who play God"?

Let me take a text from portions of Genesis 1:27 and 2:7: "So God created man in His own image; in the image of God created He him . . . And the Lord God formed man of the dust of the ground and breathed into his nostrils the breath of life."

Other engineers have created machines from the materials of the earth, which supplement man's muscles. But the electronic engineer has given and is giving to these machines sense organs, nerve systems, and reasoning power. He is putting into machines the "breath of life." He is creating them in his own image. These machines can collect and transmit information, can make comparisons between existing conditions and data stored in their memories, and can reach decisions based on either direct observations or statistical estimates of the situation. They have, in fact, eaten of the fruit of the knowledge of good and evil, but this knowledge is only what we build into them. If they show any signs of free will we put them in the hospital—I mean the repair shop. The analogies need not be developed extensively. You all have your own examples. Every day we hear of more and more machines which can supplement or replace man's brain power and sense organs as well as his muscles. As someone has said, "Machines are becoming so human they can act without using any intelligence."

Modern computing machines not only reach decisions quickly and accurately when asked properly, but also show nervous frustration if questions are propounded to them which they cannot solve. If the interrogator is not able to ask the question in sufficiently clear form to present all the elements necessary to reach an answer, these machines, by their erratic behavior, themselves act as critics of our logical processes, our

own intelligence, and our command of their language.

Machines with built-in intelligence are recognized to be necessary for the security of the free world. We realize that we cannot match our enemy in numbers, man for man. We don't have to—we aren't going to dance with them. Electronics must provide the answer to the dilemma.

We cannot be complacent, for there is yet far to go. We only see as through a glass darkly. Instruments may be used to diagnose ills, but machines cannot heal themselves. They cannot reproduce themselves. They cannot, as yet, invent and build new devices. While they often inspire love in their admirers, they cannot respond emotionally. We have much to learn on the impedance matching of machines and human beings. I heard of a man who would not wake up when his alarm clock rang. He bought a parrot to match the impedance. The alarm clock woke the parrot, and what the parrot said would wake anybody.

There is an old saying, "like father—like son." If we reverse this we get the prediction, perhaps ominous, "like son—like father." In making machines in our own image, let us make sure that they in turn do not make us machine-like. A wise man said, "God cannot be solemn or he would not have blessed man with the gift of laughter." We have not yet built into our machines a sense of humor, although some of them do make us laugh. Maybe we should give this more attention, but we must not take ourselves or our machines too seriously. Let us not lose our human sympathy and understanding, but rather let us use the economic gains resulting from our machines to help those who need help. And above all, let us not become pompous or arrogant from the sense of power which our slave-like machines give to us.

I will close with a parable. A house builder was once badly in debt. He lost his own home. A wealthy friend, feeling he needed help, gave him a contract to build a fine house, then went away for a long trip. The contractor figured he might profit financially, and never be suspected, if he cut corners in the construction and used shoddy materials. This he did. When the friend returned home he said to the contractor, "I wanted to do something nice for you, and so I am giving you for your own this house you have built, for you and your children to live in. That is why I specified that the best of everything should be used, because I knew you could appreciate it."

This world of automation we are building is our world. Be sure that when you play God you do it reverently, thoughtfully, and honestly with full attention to the fact that you are building not only machines but a world in which you and your children are going to live.

# New Techniques for Fabrication of Airborne Electronic Equipment\*

R. K-F SCAL†, SENIOR MEMBER, IRE

*Summary*—New techniques, materials, and methods for the fabrication of airborne electronic equipment as applied to a particular equipment, which have been developed at the National Bureau of Standards, are described. Emphasis has been placed in attaining reliable equipment performance, and steps taken to achieve reliability are discussed. A miniature radar set has been developed using these new techniques and materials. The equipment is capable of operating in an ambient temperature as low as  $-65$  degrees C., and much higher than  $+55$  degrees C. Internal temperatures are minimized by an internal cooling system which is provided to cool the equipment under the high ambient temperature conditions. The equipment is pressurized, and is not limited by altitude. It consists of a single major unit plus accessories. The weight of the entire system is fifty-five pounds.

## INTRODUCTION

A NEED EXISTS for airborne electronic equipment of minimum size and weight combined with utmost reliability, which is adaptable to quantity or semi-automatic production and which can fulfill specialized performance requirements under extreme environmental conditions of temperature, pressure, shock, and vibration.

As a result of this need a program, sponsored by the Navy Bureau of Aeronautics, has been underway within the Engineering Electronics Section of the National Bureau of Standards since 1947 to investigate the possibilities of electronic miniaturization. This program, originally having as its object the development of new techniques and materials aimed toward miniaturization and development of quantity production methods, resulted first in the embodiment of some of these developments into certain specific electronic sub-assemblies<sup>1,2</sup> and later into the development of several complete equipments. Some of these equipments, designed with the original objectives in mind, achieved the desired goals in miniaturization and high temperature operation. However, one project was initiated to fulfill a specific operational requirement, including special requirements for reliable operation under extremes of environmental conditions (altitude, shock, vibration, etc.). This particular project pertains to the development of airborne radar equipment. Special requirements include a useful life of 2,000 hours, and satisfactory operation at altitudes above 50,000 feet, and in ambient temperatures as low as  $-65$  degrees C. and greater than  $+55$  degrees C.

\* Original manuscript received by the IRE, September 7, 1954.

† Chief Engineer, RS Electronics Corp., Palo Alto, Calif.

<sup>1</sup> R. K-F Scal, "Miniature Intermediate-Frequency Amplifiers," NBS Circular 548; July 16, 1954.

<sup>2</sup> R. L. Henry, R. K-F Scal, and G. Shapiro, "New techniques for electronic miniaturization," Proc. I.R.E., vol. 38, pp. 1139-1145; October, 1950.

Before describing this miniature NBS radar equipment it might be well to list some of the new engineering features embodied in it. The use of these new features is believed to be their first application to airborne electronic equipment.

1. All the electronic assemblies and sub-assemblies plug into the cooling chassis assembly, which in turn fits into a lightweight pressurizing case. The electronic portions, which constitute only about 40 per cent of the total weight, may be completely removed in only a few minutes. Thus, production is facilitated and maintenance is made extremely simple and quick by replacement of assemblies or sub-assemblies.

2. A plug-in mixer-duplexer is used which features a plug-in waveguide flange and socket. Thus, the entire plumbing assembly with its associated IF and AFC-circuitry may be replaced almost instantly as a unit.

3. All the major plug-in assemblies utilize ribbon type contacts which are attached, in a row, at the bottom of each rectangular assembly. Thus, the assembly itself constitutes the plug body, and no appreciable space is required, as with a conventional type contact, since the ribbon contacts are compressed to less than 1/16 inch in thickness.

4. The internal interconnecting wiring is accomplished by a three-dimensional arrangement of processed plates, to which all component leads are attached. No other wires are required. Any or all of the processed plates are replaceable in a matter of minutes. ("Processed plates" describes a circuit made up of a wiring matrix on an insulated plate. The processing may consist of printing, application of a stamped pattern, etching of a metal-clad plate, silk screening, stamping of a powder into an insulating plate, or similar methods.)

5. The operation of this system in an ambient temperature well above 55 degrees C. attains a goal hitherto impossible with military electronic equipment. This is made possible by the following features:

(a) The use of an integral cooling system for removing heat from a pressurized system, without transferring air to or from that system. Air (at a temperature as high as 100 degrees C.) is satisfactory as a coolant.

(b) The use of open frame class II transformers (especially developed for this equipment) which meet all the requirements of MIL-T-27 grade 1 construction, and are satisfactory for use in an ambient temperature of 125 degrees C.

(c) The use of class H insulating materials throughout, for high temperature operation.

6. By means of extension plugs, jigs, and cables, the electronic assemblies may be operated with the radar



system, but completely removed from their compartments. Without the use of such accessories the assemblies may be operated, when removed four-fifths of the way from their compartments, simply by pulling the units that far out of their compartments. This feature greatly facilitates trouble diagnosis and adjustment within the assemblies.

7. All primary ac power is regulated, to provide both accuracy and reliability of operation.

8. Power dissipating tubes are operated potted in liquid in order to reduce bulb temperatures to safe values for reliable operation.

9. Physical construction is such as to permit the equipment to survive shock and vibration forces several times as great as those specified for this type of airborne electronic equipment.

In designing a system suitable for aircraft installation, the first step is the determination of the smallest possible number of physically separable units, in order to reduce, to the absolute minimum, space and weight required by additional mounting racks, cases, cabling, and so forth. As a result of these considerations, a radar system has been developed which consists of a single major unit (Fig. 1), plus accessories. The weight of the entire system is only fifty-five pounds. Due to the high voltages involved in radar-type modulating and transmitting equipment of even comparatively low power, the equipment is pressurized for successful operation at the specified altitude. Pressurization of the equipment also contributes to the solution of the humidity problem, and is an important means of improving reliability.

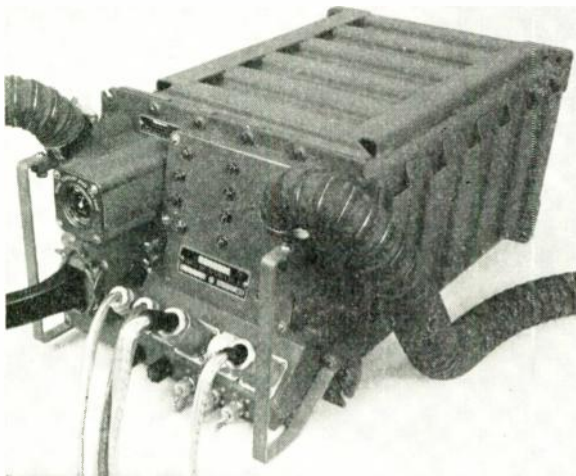

Fig. 1—Miniature radar set.

#### COOLING SYSTEM

The difficulty of removing heat from pressurized equipment, the high ambient temperatures in which the equipment must operate, and the emphasis on reliability make it desirable to include an integral cooling system in the radar. This system should preferably be such that it can be operated by an equipment blower

at altitudes up to about 50,000 feet, and can utilize engine-bleed or ram air at higher altitudes. A cooling system, which has been developed to fulfill these requirements, is shown with its case removed in Fig. 2. It features an intake and an exhaust manifold with four cooling plates through which air may be circulated.

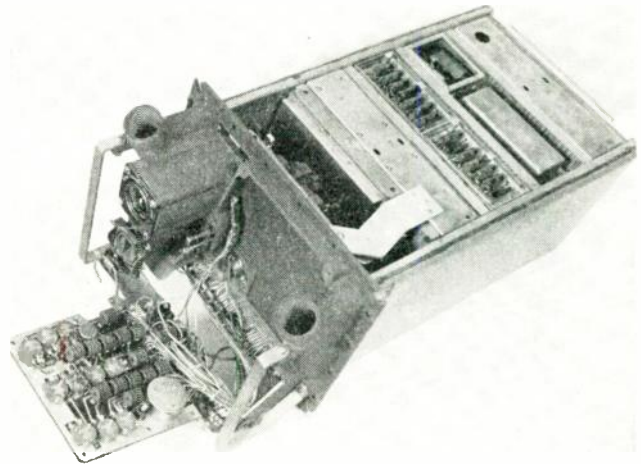

Fig. 2—Radar set with case removed and control box open.

These, in conjunction with the cast front panel to which they are attached, and rear and bottom plates, constitute the chassis of the radar set. It is to be noted that the cooling system and pressure-tight case, even though fabricated of lightweight aluminum and magnesium, account for about 60 per cent of the weight of the radar set; this undue proportion is necessary for attainment of high altitude and high temperature operation. For use at lower altitudes both of these items could be dispensed with, and a somewhat smaller and much lighter radar set would result. Since the equipment has been designed for operation in high ambient temperatures, it may also be possible to dispense with the blower for specialized installations at lower altitudes or in pressurized or cooled compartments. However, it should always be kept in mind that reliability and equipment life is an inverse function of the temperature of basic materials and parts.

The manifolds contain baffles which control the air distribution into the four cooling plates. Each of these plates is internally finned to improve heat transfer from the plates to the air. The baffles and finning are designed in accordance with the amount of heat load which each plate is required to transfer to the cooling air. Of course, the front panel itself, and the manifolds, also help to transfer heat to the air.

The cooling system (Fig. 3, on the following page) is designed to maintain the general internal atmosphere of the radar set at or below 125 degrees C. when the set is operating in an ambient temperature greater than 55 degrees C., using less than five pounds of air per minute. This air may be provided at a temperature somewhat higher than 100 degrees C. It is important to note that

the cooling air passages do not connect with the compartments in which the electronic assemblies are contained. Therefore, even though the electronic portion of the equipment is pressurized, the cooling air may be supplied at a very low absolute pressure (and against a very low head) when operating at high altitudes.

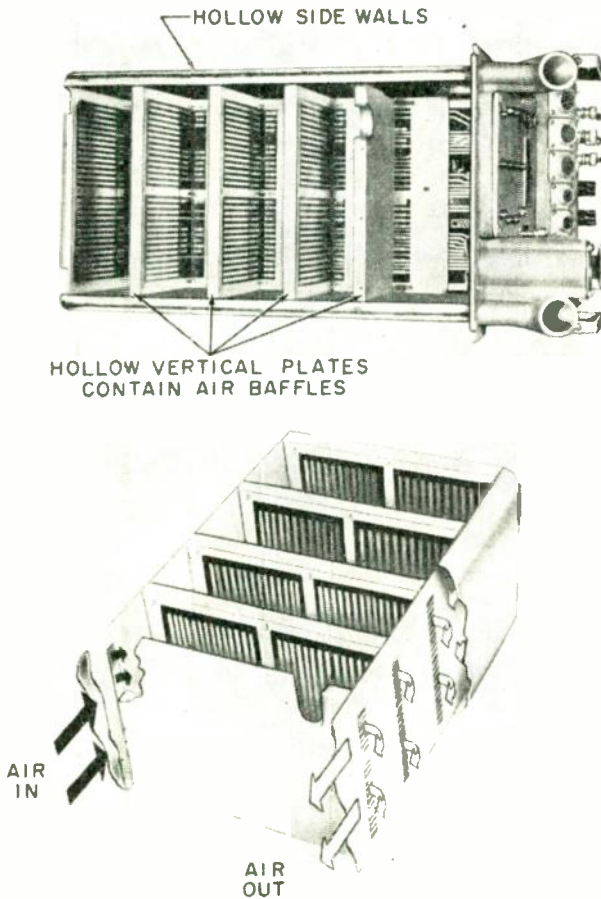

Fig. 3—Cooling chassis.

#### OVER-ALL CONSTRUCTION

For ease of construction and maintenance, for reliability (through ease of servicing), and especially to facilitate cooling, the major unit of the radar set has been divided into cross-section compartments, each containing one or more electronic assemblies. The construction is such that the radar can function (for test purposes) with each assembly pulled four-fifths of the way out of its compartment. The arrangement of the set is as follows: Compartment No. 1 (front); radio frequency unit, intermediate frequency amplifier, and automatic frequency control unit. Compartment No. 2; modulator. Compartment No. 3; computer. Compartment No. 4; power supply unit. Compartment No. 5 (rear); ac voltage regulator and primary power control.

Connections to the electronic assemblies in each compartment are made to a processed plate mounted to the cooling plate (in a vertical position) in each compartment, and all interconnections between the com-

partments and to the front control panel are made by means of a large processed circuit board beneath the compartments (the bottom of which is shown in Fig. 4), so that no discrete wires are required for interconnections. All spring contacts are of the self-cleaning ribbon type, which work against large surfaces (plated with precious metals) on the processed circuit boards. The front of the main processed circuit board plugs into three hermetic multiple headers, mounted in the front panel, which together provide sixty-three electrical connections between the pressurized radar proper and the external controls and connectors. In addition to these headers (which are mounted on a metal plate that is sealed to the front panel by means of an O-ring) an O-ring sealed mica window is provided for the output waveguide, and the case is sealed to the front panel by a third O-ring. As all mechanically operated controls required for normal maintenance are mounted on the control panel, outside of the pressurized unit proper, no mechanical rotary seals are required.

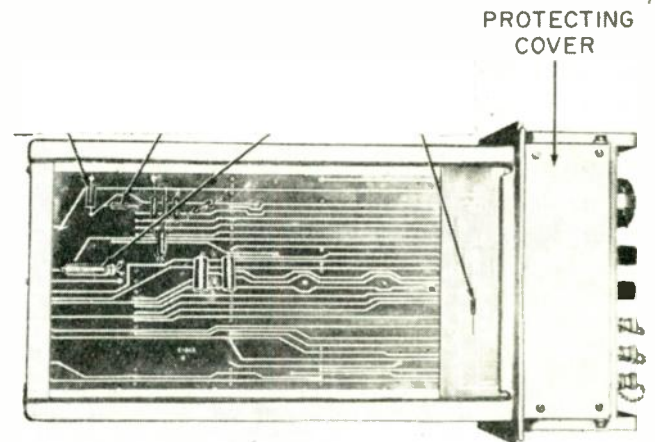

Fig. 4—Interconnecting plate on bottom of cooling chassis.

The control panel is effectively an electronic sub-assembly, the rear of which is shown in Fig. 2. It is hinged at the bottom so that it may swing down to make all components and connections on its rear side easily available for maintenance purposes. In addition to the various controls, the control panel also mounts the quick disconnect type AN connectors through which all external cabling is attached. One of these connectors provides access to all test points necessary for maintenance purposes. All the controls are mounted on and wired by a processed plate which is attached to the upper portion of the control panel. A miniature solid (Teflon) dielectric directional coupler and a combination elapsed time-indicator and time-delay unit (which indicates total operating time and provides a three minute warm-up time prior to application of high voltages) are mounted directly on the front panel. Air connections also are provided on the front panel to accommodate for the cooling system and for checking the pressurization of the radar case.



The case is a reinforced rectangular unit, constructed of magnesium, which features a dome in the rear, and provides for the O-ring seal in the front. This case, which may be mounted either in an upright or an inverted position, on its magnesium vibration mount, is capable of withstanding a pressure differential of greater than 20 pounds per square inch without taking a permanent set. Relief valves are provided to prevent either undue internal or external pressure developing under extreme combinations of simultaneous pressure and temperature changes.

#### RECEIVER-TRANSMITTER COMPARTMENT

The receiver-transmitter compartment contains the RF, IF, and AFC units, all of which plug into brackets on the front and rear walls of the compartment.

The RF unit, shown in Fig. 5, is a plug-in unit which consists of a baseplate, a duplexer, and a removable balanced mixer, and features a miniaturized magnetron, a waveguide type klystron, dual opposed contact-flange ATR tubes, a chamberless TR tube, and type 1N23C improved silicon diodes (one of which is reversed in its cartridge for use in the miniature balanced signal mixer). Operating within the X band, the RF unit has

thermal insulation) stagnating about the klystron and magnetron. Three adjustments are provided on the RF unit: the TR tuning adjustment which is reached through a port in the front panel, the klystron which is wrench-tuned from the top of the compartment, and the AFC sweep range centering control. The combining network for the balanced mixer (fabricated on a processed plate), the crystal current decoupling filters, and the test jacks are contained in a small box which is an integral part of the plumbing.

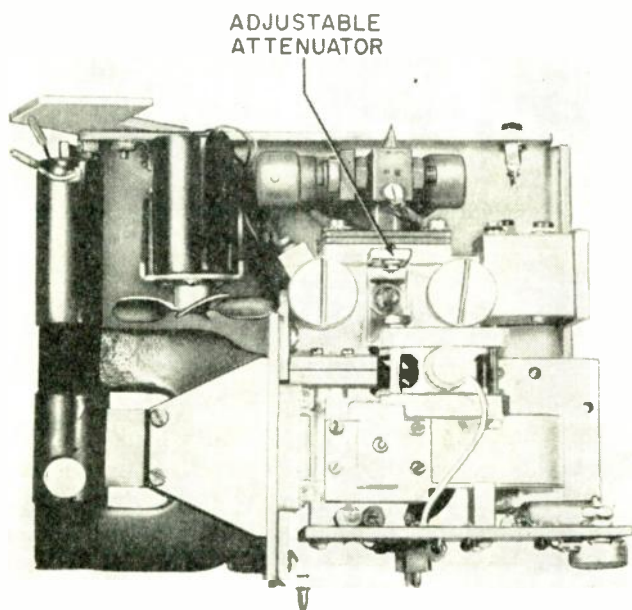

Fig. 5—Radio frequency unit.

a peak power output of 10 kw, a  $\frac{1}{3}$   $\mu$ sec pulse width, and a repetition rate of 1,400 pps. A combining network for the balanced mixer is included as an integral part of the mixer, so that only two coaxial output cables, one for the AFC output, and the other for the combined IF outputs, are required. AFC crystal current is monitored externally as an indication of proper functioning of the RF unit. The currents from the signal mixer crystals are available at test points on the mixer for checking signal mixer operation. A small blower is mounted upon the RF unit to prevent hot air (which would act as

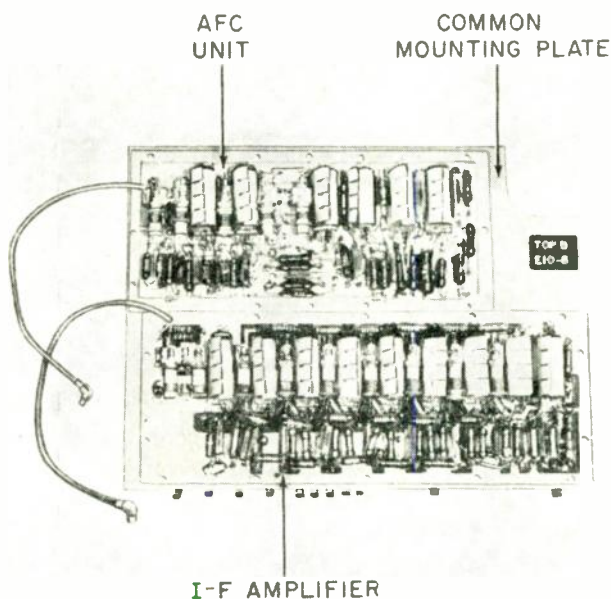

Fig. 6.—Intermediate frequency amplifier and automatic frequency control unit assembly with covers removed.

The IF and AFC units, shown in Fig. 6 with their dust covers removed, are an outgrowth of earlier NBS IF miniaturization projects.<sup>1,2</sup> An important new innovation, one of many throughout the radar set aimed at ease of quantity production, is the use of processed plates instead of the conventional metallic chassis. The electronic parts are interconnected by circuitry which has been processed directly upon the plates, and are protected by dust covers, which in the interest of minimizing weight are constructed of aluminum, as are all other structural parts of the electronic assemblies throughout the radar set.

The IF and AFC units contain input networks which match them to their respective mixers. Because the input cables are only a few inches long, the inputs are treated as lumped (and tuned) circuits. The IF unit utilizes a low-noise cascade-input circuit, which is followed by five synchronously tuned IF amplifier stages, a detector and pulse shaping stage, a video amplifier, and a cathode follower. Special controlling voltages are provided to the IF amplifier section.

The AFC unit, in addition to the input coupling circuit, contains two IF amplifier stages, a discriminator, a video amplifier, a diode-search-stopper, and a phantatron circuit. The AFC unit drives the cathode follower

and a chain of three NE-2 neon lamps mounted upon the RF unit. The neon lamp chain in turn drives the local oscillator reflector. By this means, the local oscillator may be operated with its body (resonator) grounded, in order to eliminate both the necessity for an insulated waveguide mounting for the klystron and the shock hazard to personnel. The chain of neon lamps functions as a dc coupling, which provides the reflector voltage at a highly negative dc reference (about  $-325$  volts), without introducing any such high voltages into the AFC unit. This is one of many circuitry features designed to provide reliability, since the use of an insulated klystron mount is a difficult mechanical problem, and there is always danger of shorting over the mount, especially under humid and dusty conditions.

The interior of dust covers for IF and AFC units are silver-plated, as is the hardware (tube shields, etc.), so that no electrolytic or thermal activity will take place between these metallic parts and the silverplated copper surfaces of the processed plates. In later models of the radar set it is planned to use aluminum processed plates, silver-plated where either soldering or pressure contact is required. With this type of processed plate, silver-plating of dust covers is unnecessary, and aluminum hardware may be used. Where spring hardware is required in conjunction with aluminum parts, beryllium copper, either zinc- or cadmium-plated, is used.

The components used in the RF, IF and AFC units are typical of the small components used throughout the radar set, and are of types designed for high temperature operation.

Under the maximum allowable general internal temperature of 125 degrees C. the internal parts of some of the sub-assemblies, such as the IF and AFC strips, may rise as high as 175 degrees C. Therefore, all large major components, such as transformers, relays, etc., have been selected as being capable of operation in an ambient temperature of at least 125 degrees C., and all small components, such as resistors and capacitors, as being capable of operation in an ambient of at least 175 degrees C. In general, because components developed for use under extreme ambient temperatures are of the highest possible quality construction, and therefore offer greatest reliability even under ordinary conditions, this type of component is used throughout the radar set.

It might well be noted that the term "ambient" has but little significance in the interior of a piece of small equipment, and therefore final determination of the thermal suitability of any component should be based on actual component surface temperature measurements, in its own immediate environment.

Resistors used in the radar set are of the deposited carbon type, except where high precision is required. High temperature precision resistors, which are required in the computer and regulated power supplies, are described in connection with those assemblies.

Capacitors in the RF, IF, and AFC units are all of the so-called RF types, for coupling and bypass application, in values not greater than  $1,000 \mu\text{f}$ . This requirement is fulfilled by use of glass-encased, glass dielectric capacitors, which are suitable for use up to 200 degrees C. These are used in dual and triple units, as well as single capacitors. Such multiple units lend themselves to bypassing of IF stages, where two or three tube elements are bypassed in each stage.

Inductors and chokes are wound with Ceroc-Teflon magnet wire on ferrite or powdered iron cores.

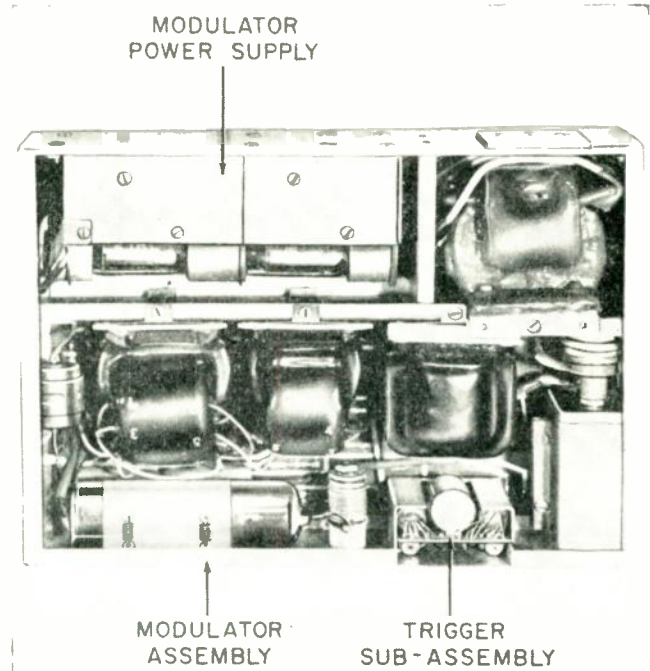

Fig. 7—Modulator.

#### MODULATOR

The modulator compartment contains a single plug-in unit, which is shown in Fig. 7, and is typical of those used in all except the receiver-transmitter compartment. These units operate even when withdrawn as much as four-fifths of the way from their compartments. Each unit has a row of twenty-eight ribbon contacts along the lower edge of the back side, which contact the strip conductors of the vertical processed plate in the compartment. Several grounding contacts are also provided. Thus, the unit itself is, in essence, the plug body, and the compartment the receptacle, so that no additional space is used, as is necessary when conventional connectors are employed. Each vertical processed plate is connected to the main interconnecting plate by means of the necessary number of spring contacts, which are riveted to the main plate. These contacts are designed for direct contact to the plug-in assembly contacts, when the assembly is fully inserted into the compartment. Thus, while contact is made through the vertical processed plate when an assembly



is operated in an extended position, direct contact is made to the main interconnecting plate when the assembly is operated in its normal position. This is another of many design details aimed at attaining reliability.

The modulator assembly itself consists of the modulator proper, the high voltage power supply (1,300 volts dc), and the radar master oscillator. The smaller components used in the modulator are similar to those described in the RF, IF, and AFC units. In addition, the modulator contains a pulse network, a charging reactor, and pulse, plate, and heater transformers. The latter transformer also supplies all necessary heater voltages to the RF compartment. All of these transformers are suitable for continuous operation in an ambient temperature of 125 degrees C. The pulse-forming network is suitable for operation in an ambient temperature of 150 degrees C., being of dry construction, Teflon insulated, and having Teflon terminals.

The master-blocking oscillator pulse transformer is silicone impregnated and hermetically sealed in a protective shield can. The reactor and the magnetron pulsing, plate and heater transformers are of open frame construction, class H, designed for continuous operation with a winding temperature as high as 200 degrees C. These units are coated with either styrene or epoxy resin, or a silicone-rubber formulation, the latter probably being the most satisfactory.

#### SPECIAL TUBES AND CRYSTALS

The radar set features in the modulator and RF units a number of new crystal and tube types, some of which were developed especially for it. The following types are included:

Type 6378 TR tube. This tube is similar to the 1B24-A, except that the large gas reservoir has been eliminated. This tube requires a keep-alive supply of only 500 volts, is 20 per cent lighter than its predecessor, and has an over-all length of only  $2\frac{7}{8}$  inches.

Type 6396 ATR tube. This tube, and its companion type 6393, were specifically developed for this radar set. The 6393 is a miniaturized version of the 1B35-A, which incorporates a contact flange, thus permitting it to be installed directly on the duplexer without the necessity of a castle type of tube retainer. The 6396 is a similar tube, but is tuned in halfguide (i.e., guide having half the normal height), so that two opposed tubes may be mounted upon the duplexer.

The BL-253 is a miniature version of the 3C45 hydrogen thyratron, having a one-inch diameter baseless type bulb, which was developed to the requirements of this radar set.

#### COMPUTER

The computer is illustrated in Fig. 8. This unit, while a plug-in unit itself, contains four plug-in sub-assemblies. Thus, the complex circuitry of this unit may be serviced in small units, and defective sub-units replaced.

This construction also lends itself to improvement through modernization of one or more sub-units, as opportunity for circuitry improvement presents itself.

In addition to the highly specialized function of the computer, this unit also provides video amplification, and AGC and dunking voltages for the IF unit.

The components used in the computer are, in general, similar to those discussed in connection with other assemblies. The computer carries its own heater transformer, in order to avoid increasing the number of main plug-in contacts. Three separate heater windings are provided, so that each tube may be supplied with heater energization at a dc potential close to that of its cathode. The dc heater potential of one tube (which has a large sweep on its cathode) is swept to minimize the heater-cathode potential. While this has some circuitry advantage, and contributes to equipment accuracy in that it minimizes the effect of heater-cathode capacitance, it is primarily an aid in attaining reliability.

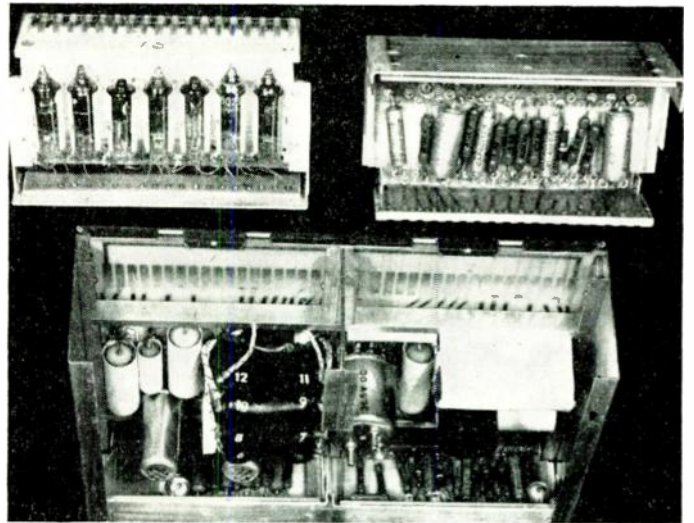

Fig. 8—Computer.

Some components not yet mentioned in connection with other assemblies are used in the computer. These include a high-temperature distributed-constant delay line, precision resistors, and high temperature relays. The precision resistors are of the wirewound type, molded within a protective encapsulation. The relays, both of the sensitive and the power-handling type, are hermetically sealed, and constructed with high temperature insulation, including ceramic insulated coils. Most of the capacitors in the critical portions of the circuitry are of the glass-dielectric type. The larger capacitors are hermetically sealed Mylar dielectric capacitors, rated for 150 degrees C. Similar large capacitors of the Mylar type are also used in the modulator, dc power supply, and ac regulator units.

#### DC POWER SUPPLY

The dc power supply unit (Fig. 9, following page), provides five different voltages for the radar equipment.

Two of these are electronically regulated, and two are gas-tube regulated.<sup>3</sup>

The outstanding feature of this unit is the liquid potting of the rectifier and series dropping tubes in order to maintain their bulb temperatures within safe operating limits.<sup>4</sup> By this means, the heat is transmitted to the surface of the potting container, which provides for greater cooling area than the bulbs themselves, and the bulb temperatures are thereby lowered by more than 100 degrees C. In addition to the improvement of reliability by liquid potting, additional reliability is attained by shunting a portion of the current around the series-dropping tubes (through resistors). This may be done because it is necessary to regulate the dc output voltages only over a limited current range, since, if the current of any one of the supplies departs from fairly close normal limits, the equipment will not be in proper operation even if the corresponding voltage is held to its normal value. A third contribution to the reliability of the dc supply is its operation from rms-regulated ac power, so that the dc supply need compensate only for load variations, and not for line variations.

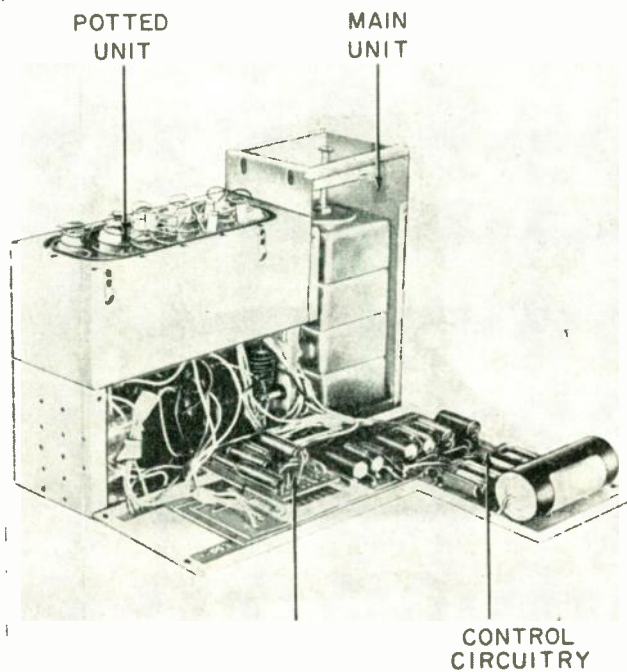

Fig. 9—Dc power supply unit.

#### AC VOLTAGE REGULATOR

The ac voltage regulator is included as part of the radar set for three reasons, two of which relate to reliability. First of all, regulated ac voltage is required to energize the heaters of certain tubes (in critical circuitry) in order to assure accurate equipment operation.

<sup>3</sup> E. J. Hebert, Jr., "Application Characteristics of Cold-Cathode Glow-Discharge Tubes," NBS Report 2901; December, 1953.

<sup>4</sup> E. J. Hebert, Jr., "Liquid Potting of Electronic Components," NBS Report 1783; June, 1952.

Second, it is desirable to furnish regulated ac power to the heaters of all tubes in order to attain the reliability which so-called reliable tubes are capable of providing. Specifications for proper application of such tubes include a heater voltage remaining within plus or minus five per cent of rated value. Since aircraft power voltage variation is far greater than this, it is necessary to regulate the voltage within the equipment. Finally, as already mentioned, the regulation of the ac input power simplifies the task of the dc regulator, thereby improving its reliability.

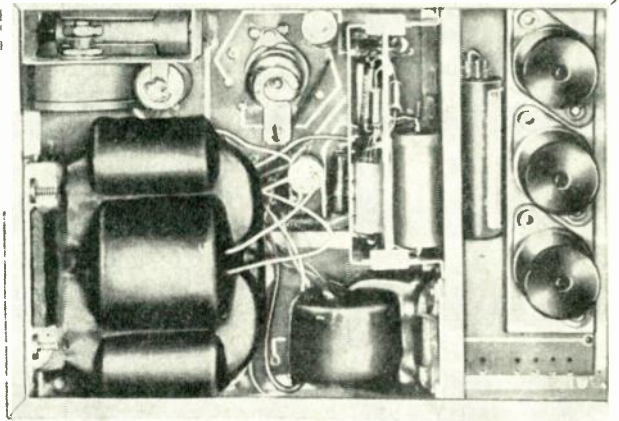

Fig. 10—Ac voltage regulator and power-switching unit assembly.

Fig. 10 illustrates the assembly containing the ac regulator sub-assembly, and the power-switching sub-assembly, each of which is separately removable from the assembly. The ac regulator is of the saturable reactor type, which uses the heaters of two of its tubes, in a bridge circuit, as sensing and controlling elements. Since it depends on the heating of tube elements (heaters), it is of the rms-regulating type.

#### POWER-SWITCHING

The power-switching circuitry is actuated both by the Radar Set Control, and by the contacts within the elapsed time meter which is mounted on the front panel. The meter provides a record of operating time, for maintenance information purposes, and also actuates the relays in the power-switching sub-assembly (when the Radar Set Control is turned to the ON position) in such a manner that a three-minute time delay attains before plate voltages are applied to the equipment. This allows the tube filaments, heaters, and cathodes to reach operating temperature prior to application of anode voltages and, especially in the case of the power tubes, contributes to long tube life and reliability. An emergency button is provided on the control panel so that the time delay may be shortened or bypassed, when required. A plastic dome is placed over the emergency button, and this dome must be crushed to actuate the button. In this way frequent and unnecessary bypassing of the time delay is avoided.



## CONCLUSION

The operational aspects of this equipment, including exact functions, operational performance, accessory units, accuracy and stability are beyond the scope of this paper. However, the following information is of interest.

A number of complete equipments, including all necessary accessories such as mounting racks, antennas, indicators, control boxes, etc., have been fabricated at the National Bureau of Standards to permit evaluation (including flight tests) of both the equipments and the new techniques and materials used.

Environmental tests have indicated that the equipment will give satisfactory service under the severe conditions of altitude and temperature originally specified for the equipment. No component failures which can be attributed to these unusually severe environmental conditions have occurred to date.

An entire equipment has been subjected to severe shock and vibration tests, including five impact shocks

of 30 g in opposite directions along each of the three mutually perpendicular axes (a total of thirty impacts). Damage to the equipment as a result of this severe test was trivial, and appropriate minor design changes have since been made.

## ACKNOWLEDGMENT

Technical assistance in developing this equipment is acknowledged to C. O. Lindseth, L. Landsman, E. J. Hebert, Jr., R. F. May, R. J. Luks, and R. J. Hens of the National Bureau of Standards, to T. Anderson of Airtron, Inc., and to G. Mathis of Raytheon Manufacturing Company. Major administrative assistance on behalf of the sponsor is acknowledged to Capt. C. A. Cole, Jr., USMC, and Capt. M. W. Cairns, USMC, both of the Navy Bureau of Aeronautics. This work was performed at the National Bureau of Standards and the author extends his appreciation to both the National Bureau of Standards and the Navy Bureau of Aeronautics for making it possible.

## Color Balance for Television\*

D. L. MACADAM†

**Summary**—The visual phenomenon of color adaptation must be mimicked by any successful process of color photography or color television. This means that a light gray object should be reproduced so as to appear light gray, regardless of variations of the illumination in the original scene, within a wide range of qualities. In color photography, films of two different classes are commonly provided, one for daylight and the other for incandescent tungsten light.

In the present standard system of color television, the color sub-carrier should have zero amplitude for a light gray object, regardless of the chromaticity of the illumination, whether daylight or incandescent tungsten light or arc light.

Adjustment of receivers to correspond to the adaptation of the viewer is equally important. Although most receivers will be used in living rooms lighted by incandescent tungsten lamps, receivers are sometimes used in subdued daylight. This fact creates a dilemma, which is familiar to the designers of illuminators for color transparencies. A satisfactory compromise has been found: a color temperature of 4,000 degrees Kelvin.

## COLOR VISION

THE ANATOMICAL structures and physiological functions responsible for color vision are known in only a fragmentary manner. Although many theories have been proposed during the last century and a half, none of them can claim to be more than specula-

tion.<sup>1</sup> The following analogy is not intended to suggest a theory, or even a model of color vision.

Color vision acts like a system consisting of three photoelectric cells, covered with differently colored filters, attached to a very wonderful interpreting device. The interpreting device is such that we appreciate the color as a unity and not as a composite of the three separate responses. The three-cell model and the three-response manner of functioning are suggested by, and are adequate to account for, the results of optical experiments designed to determine the visual equivalence of physically nonequivalent stimuli.

These facts are well-known, and color television, as well as color photography, is based on them. Neither color television nor color photography would be feasible, at least in its present state, if color vision behaved as if it involved more than three kinds of receptors.

Apparently less widely recognized is the fact that the visual system also has something like automatic gain controls in the three receptor-response channels.<sup>2-4</sup> This

<sup>1</sup> Opt. Soc. Am. Com. Colorimetry, "The Science of Color," T. Y. Crowell Co., New York, N. Y. (particularly ch. 3); 1953.

<sup>2</sup> R. M. Evans, "On some aspects of white, gray, and black," *Jour. Opt. Soc. Am.*, vol. 39, pp. 774-779; 1949.

<sup>3</sup> W. L. Brewer, "Fundamental response functions and binocular color matching," *Jour. Opt. Soc. Am.*, vol. 44, pp. 207-212; 1954.

<sup>4</sup> R. M. Evans and W. L. Brewer, "Observer adaptation requirements in color photography and color television," *Jour. Soc. Mot. Pict. and Telev. Eng.*, vol. 63, pp. 5-9; 1954.

\* Original manuscript received by the IRE, May 14, 1954; revised manuscript received, October 12, 1954. Communication No. 1657, Kodak Research Labs.

† Research Labs., Eastman Kodak Co., Rochester 4, N. Y.

is indicated qualitatively by the general experience that a white shirt appears white in tungsten light as well as in daylight. Because of the limited brightness range of color television, we shall avoid reference to white materials, and shall refer instead to light gray materials,<sup>5</sup> such as light gray business suits, having luminous reflectances about 50 per cent.

Gray suits do not look blue in daylight nor yellow in incandescent tungsten light, despite the fact that daylight appears very blue and incandescent light quite yellow when equally intense samples of the two are compared side by side. The visual phenomenon responsible for this constancy of apparent color of reflecting materials, in particular the gray suit, is called *adaptation*.

### QUALITIES OF ILLUMINATION

Fig. 1 shows the range of variation of chromaticities of common light sources. The curve within the diagram is the locus of the chromaticities produced by blackbodies at the various temperatures indicated. Most common light sources have chromaticities lying very close to this

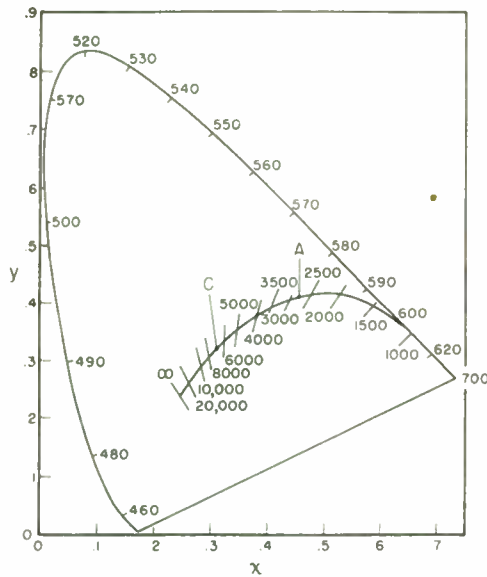

Fig. 1—Chromaticity diagram showing locus of chromaticities of Planckian radiators, lines of constant correlated color temperature, and CIE standard sources A and C.

locus. The temperature corresponding most closely to any such source is called its *color temperature*. The color temperature corresponding to any chromaticity near the blackbody locus may be interpolated between *iso-temperature lines*, which cross the blackbody locus in Fig. 1. Household illumination from incandescent lamps varies in color temperature from 2,500 to about 3,000 degrees Kelvin. Photoflood and photoflash lamps have color temperatures ranging from about 3,400 to 4,200 degrees. The color temperature of direct sunlight is about 5,000 degrees. That of overcast sky or total daylight is about 6,500 degrees, and the color temperature

<sup>5</sup> R. S. O'Brien, "CBS color-television staging and lighting practices," *Jour. Soc. Mot. Pict. and Telev. Eng.*, vol. 63, pp. 41-50; 1954.

of blue sky can range from 7,000 to 20,000 degrees or higher. The color temperature of the CIE standard illuminant C is about 6,750 degrees Kelvin.

We are very rarely conscious of differences in the quality of illumination, particularly in the range from 2,800 to 6,000 degrees. Within this range, a gray suit appears gray, regardless of the variation of the quality of the light in which it is viewed. There is an obvious reason why, for the sake of the survival of the race, this must be so. Men are more concerned with recognizing things than with recognizing nuances of the color of light in their surroundings.

To produce this important effect, however, each of our visual color receptors must have associated with it something that acts like an automatic gain control, which maintains approximately constant the average output of each of the three color-receptor systems. Thus, as we go out of a house, in which tungsten lamps produce illumination relatively rich in red light, to daylight, which is relatively rich in blue, the blue receptors or the associated nervous system must reduce their sensitivity. Likewise, the sensitivity of the red receptors must somewhat increase, so as to keep approximately constant the red, green, and blue responses to the average quality of the illumination, and to gray objects seen in that illumination.

All other colors are perceived relative to white or gray, and therefore our perceptions of colored objects are approximately invariant, regardless of natural variations of illumination. This visual phenomenon is called *color constancy*.

### MIMICRY OF ADAPTATION

Films for color photography do not, in general, have such adaptation, and therefore we have several kinds of films, some for use in incandescent tungsten light, and others for use in daylight. Professional photographers and some advanced amateurs use color filters for better adaptation of their films to illumination of various qualities. Eastman Color Negative Safety Film, Type 5248, does have sufficient latitude, in each of its layers, so that, if properly exposed, it can be used in either incandescent tungsten light or daylight.<sup>6</sup> However, color negatives prepared under these two conditions, or any condition in between, must be printed differently, to compensate for differing qualities of the illumination in the several scenes. This compensation in printing operation corresponds to visual adaptation, so that gray objects in the original scene are reproduced by gray areas of the print film, regardless of the quality of the illumination in the original scene. These compensations in the printing operation can be regarded as equivalent to the actions of automatic gain controls in the three re-

<sup>6</sup> It is recommended that Eastman Color Negative Safety Film, Type 5248, be exposed with a filter for daylight. This practice minimizes the danger of over- and under-exposure, and eliminates the necessity for major changes in color balance in the printing operation. The fact cited in the text is used for an illustrative example only, and should not be taken as a recommendation for general practice.



ceptor systems, the three layers in the case of color film. Ideally, such compensations should be automatic, and perhaps will be at some future state of the art.

Likewise, for interchangeable use in all of the various qualities of illumination which are encountered in miscellaneous scenes, color-television cameras should have built into them automatic gain controls equivalent to color adaptation of human vision. This is necessary so that the viewer at home can see the scene the same as a person standing beside the camera sees it. When the camera shifts from scene to scene, or even from part of a scene having one quality of illumination to another having a different quality, the adaptation of the cameraman changes from moment to moment, so as to compensate for variations of the quality of illumination. But the television viewer, sitting at home, remains adapted to the fixed quality of the illumination in his living room. If the variations of the quality of illumination which appear before the camera are transmitted and appear on the receiver, the viewer cannot adapt to them and will be startled, puzzled, and annoyed by the extreme changes of over-all color. Experience with color photography has demonstrated that unintended variations of the quality of illumination in the original scene must not appear as over-all tints in the picture. Such tints and changes are especially objectionable in motion pictures. The same experience can be anticipated for color television.

In order to eliminate changes of over-all tint of the reproduced pictures, it is necessary to operate gain controls in the three color channels of the camera, so as to make the chrominance subcarrier vanish for a gray object in the scene, regardless of the quality of the illumination in the scene.<sup>7</sup> Since this quality is likely to vary from instant-to-instant (as, for example, in televising a football game, particularly as the sun approaches the horizon, and as the camera is directed first to the sunlit portion of the field and then to the shadows of the stand), it would be desirable if those gain controls could be automatic. Perhaps the adaptation they effect should not be 100 per cent, because visual adaptation need not be so complete as to obliterate the variations of mood and atmosphere, which correspond to the transition from sunlight to shade. However, experience with color photographs indicates that color-reproduc-

tion processes require a large degree of adaptation to the variations of the quality of the incident light.

On the other hand, variations of mood are often deliberately produced by variation of the quality of illumination in stage settings. Therefore, adaptation to variations of illumination should not be so complete as to obliterate these deliberate changes of lighting. Perhaps it would be preferable if the stage director had some control over the degree of adaptation. Or perhaps color-television stage directors can learn the need for, and the effectiveness of, restrained variation of the quality of the incident light.<sup>8</sup> Variations of the quality of illumination are much more apparent to viewers of the reproduction than they are to the audience present in the studio.

The specification for zero adaptation might well be left open, since, for daylight scenes, it is sometimes desirable to have sunlight (5,000 degrees Kelvin) the basis, and at other times overcast daylight (6,500 degrees Kelvin, approximately CIE standard source *C*) might better be the basis for zero adaptation. On the other hand, for interior scenes in which variations of mood are to be brought about by variation of the lighting, the quality of the basic lighting probably should yield zero subcarrier amplitude for zero adaptation. The director (or color consultant) might then have under his control the degree of adaptation to be applied to the various qualities of effect lighting, so that equivalent effects will be produced in the home receiver and for the studio audience.

#### RECEIVER WHITE

We are not finished with the subject of adaptation, even after we have provided for it in the color-television cameras. An equally important and perhaps more troublesome question is: "What shall be the chromaticity with which we shall reproduce gray in the home receivers?"

Although the FCC does not have jurisdiction over the quality of colors produced by receivers, a footnote in the FCC Transmission Standard<sup>7</sup> states that: "The numerical values of the signal specification assume that this condition will be reproduced as CIE Illuminant *C*." In the absence of any mention of the possibility of any other receiver adjustment, it has generally been taken for granted that illuminant *C* would be desirable. For instance, it was stated:<sup>8</sup> "The color signal is so proportioned that when the color subcarrier vanishes, the chromaticity reproduced corresponds to Illuminant *C*." And again:<sup>9</sup> "The color of the white should be about the white produced by the low brightness setting on a standard black-and-white kinescope." "Standard black-and-white kinescopes" are even bluer than CIE standard source *C*, ranging from 7,000 to 8,000 degrees or higher, and all are quite bluish compared to the illumi-

<sup>7</sup> The reviewers of this paper have kindly informed the author that this was the intention of the FCC Transmission Standard ("Amendment of Commission's Rules Governing Color Television Transmission, FCC 53-1663, Appendix B, p. 8; December 17, 1953. The paragraph in question also has been quoted by D. G. Fink, "NTSC signal specifications for color television," *Proc. I.R.E.*, vol. 42, p. 1321; August, 1954) which states: "The radiated chrominance subcarrier shall vanish on the reference white of the scene." The appended footnote, referring to CIE Illuminant *C*, should not be misunderstood as referring to, or as defining the term "reference white." The term "reference white" has not been officially defined, and appears to be the subject of some disagreement. Some define it as a white object before the camera under the prevailing quality of illumination. Others define it as the object in the scene which is intended to be reproduced as white. The IRE Subcommittee (22.1) on Definitions of the Television Systems Committee has proposed a somewhat more definite definition of "reference white," which it hopes will be approved and published soon.

<sup>8</sup> "Petition of Radio Corporation of America and National Broadcasting Company, Inc., for Approval of Color Standards for the RCA Color Television System," before the FCC, p. 672; June 25, 1953.

<sup>9</sup> "Practical color television for the service industry," RCA Serv. Corp., Inc., Camden, N. J., p. 45; 1953.

nation customary in living rooms.<sup>10</sup> As recently as May 7, 1954, the statement was made by the chairman of a session of the Society of Motion Picture and Television Engineers that "the signal specifications are such that optimum results are achieved when a color temperature of Illuminant *C* is employed in the reproducing end of the system," and the author of the paper under discussion agreed.<sup>11</sup>

Home motion-picture and slide projectors give quite successful reproductions by the use of unfiltered incandescent tungsten light, having color temperatures from 3,000 to 3,200 degrees Kelvin. Therefore, color-television receivers balanced in this range for zero subcarrier amplitude would probably be satisfactory for nighttime viewing. However, some television receivers are used during the day, with their surroundings illuminated by subdued daylight. Other receivers are used in public places illuminated by fluorescent lamps, some of which are nearly as blue as CIE standard source *C*. For such installations, color-television receivers might be balanced to produce the equivalent of CIE standard source *C* for zero subcarrier amplitude.

The problem of the home receiver, however, which, during the day, is surrounded by objects illuminated with subdued daylight, and which, at night, is illuminated with incandescent tungsten light, presents a

<sup>10</sup> One reason given for the choice of CIE illuminant *C* for zero chrominance subcarrier was to insure that monochrome transmissions would appear the same on color receivers as on monochrome receivers. In connection with this, it is usually stated that when monochrome picture tubes of various colors were offered, all others than the now common blue tubes fell victims to the apparent preference of the public for a cold color. It is probably unwise to hazard a guess as to why bluish monochrome tubes swept the market, whether they were brighter, or gave deeper blacks, or because they looked more nearly white when compared and selected in stores lighted with fluorescent lamps or subdued daylight. But, it is undeniable that, as viewed in the ordinary living room, during most of the viewing hours, the present monochrome picture tubes are bluish. Although this blueness (coldness) is rarely remarked in the case of monochrome television, it would almost certainly not be as pleasant in color television as pictures balanced for the conditions of adaptation prevalent in home viewing. Viewers of monochrome pictures pay no attention to chromaticity, but they can be expected to become more observant of the over-all color of the picture (color balance) when they become accustomed to color television. Color pictures balanced to illuminant *C*, or to the present monochrome standard, appear cold to viewers in the usual home-viewing situation.

<sup>11</sup> H. M. Gurin, "Color television light sources," *Jour. Soc. Mot. Pict. and Telev. Eng.*, vol. 63, pp. 51-54; 1954.

dilemma which has already been encountered in color photography. Designers of illuminators for color transparencies have been troubled by the fact that an illuminator using unfiltered light from incandescent lamps appears very yellowish in an office or exhibit room illuminated by daylight. On the other hand, an illuminator which matches the quality of daylight, for example, the CIE standard source *C*, appears very bluish, and the pictures viewed with it appear very cold, when the observer is in a room illuminated by incandescent tungsten lamps. Since it is impractical to have different illuminators for use under these two different conditions, it was necessary to seek and to find an intermediate color temperature which would be acceptable under both conditions of adaptation. After many trials and some evolution, the color temperature of 4,000 degrees Kelvin was finally selected.<sup>12</sup> This is quite satisfactory for the illumination of color transparencies under all normal conditions of room illumination, varying from interior workrooms illuminated exclusively by incandescent tungsten lamps and others illuminated by fluorescent fixtures, to offices and conference rooms illuminated at high levels of daylight. The illuminator and the transparencies placed upon it do not appear too warm, or yellowish, when the observers are adapted to daylight, nor does the illuminator or the transparencies placed upon it appear too cold when it is used in a room lighted by incandescent tungsten lamps. Similar results have been reported in a recent study aimed at the determination of the best color balance for color television.<sup>13</sup>

Consequently, the color temperature 4,000 degrees Kelvin is commended to the attention of color-television engineers and service men as a criterion of color balance for zero subcarrier amplitude, which should result in satisfactory perception of colors under conditions of adaptation ranging all of the way from the usual living room at night to living rooms in the daytime.

<sup>12</sup> A. L. Sorem and C. N. Nelson, "Spectral and luminance requirements for color-transparency illuminators," *Jour. Opt. Soc. Am.*, vol. 43, pp. 689-697; 1953; also "Proposed American Standard for illumination of photographic and photomechanical color reproductions," *ASA*, PH2.6, 1st draft (April 19, 1954) not published.

<sup>13</sup> W. N. Sproson, "A determination of subjective white under four conditions of adaptation," *BBC Quarterly*, vol. 8, pp. 176-192; 1953.





# A Triode Useful to 10,000 Mc\*

J. E. BEGGS†, SENIOR MEMBER, IRE, AND N. T. LAVOO†, MEMBER, IRE

**Summary**—A small receiving tube having a noise figure of 7 db at 1,200 mc has been developed. Experimental tubes of this type may be precisely assembled using low-loss materials. An exhaust temperature of 800 degrees C. is practicable, and the tube can be made small enough to make possible operation up to 10,000 mc.

## INTRODUCTION

THE UTILIZATION of low-loss insulating materials soldered directly to high-conductivity metallic materials has made it possible to construct microwave types with interesting capabilities. From the early work of H. V. Neher at the Massachusetts Institute of Technology Radiation Laboratory,<sup>1</sup> it has been known for some time that space-charge control tubes can produce low-noise figures at ultra-high frequencies. For usefulness over a wide frequency range, the tube to be described, which is designated as the L-29, has been made adaptable for use in distributed or lumped constant circuits. To this end a cartridge-type construction is employed, as shown in Fig. 1. Although the L-29 tube is small in size, it is operated at currents and voltages comparable to those of conventional receiving tubes.

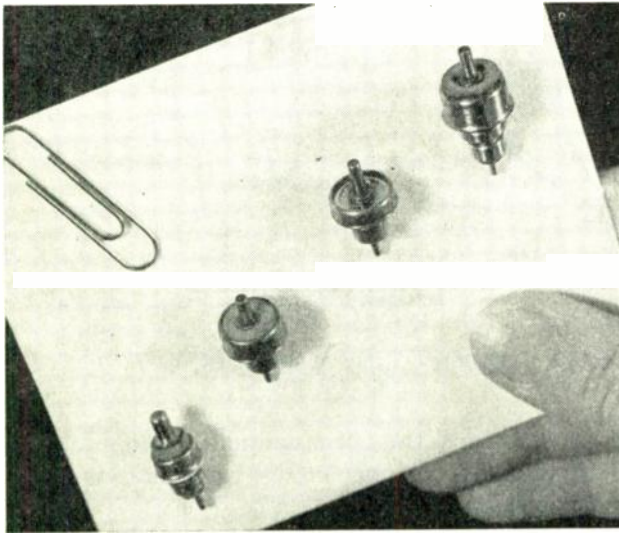

Fig. 1—Triodes pictured from left to right: the L-31, L-29, Quartz L-29, and GL-6299, a commercial version of the laboratory tube.

Also shown in Fig. 1 with the L-29 are: the L-31, a smaller version of the L-29; an L-29 with a quartz output seal; and the GL6299, a commercially available version derived from the L-29. It should be noted that this report describes the performance obtained on laboratory

tubes and is not intended to represent the typical performance of the GL-6299.

## THE TUBE CONSTRUCTION

These tubes employ low-loss insulators soldered to copper parts. The lead solder employed is ductile enough to permit either quartz or ceramic insulators to be used. The soft-soldering techniques developed for this tube have proved generally useful and have already been described.<sup>2</sup>

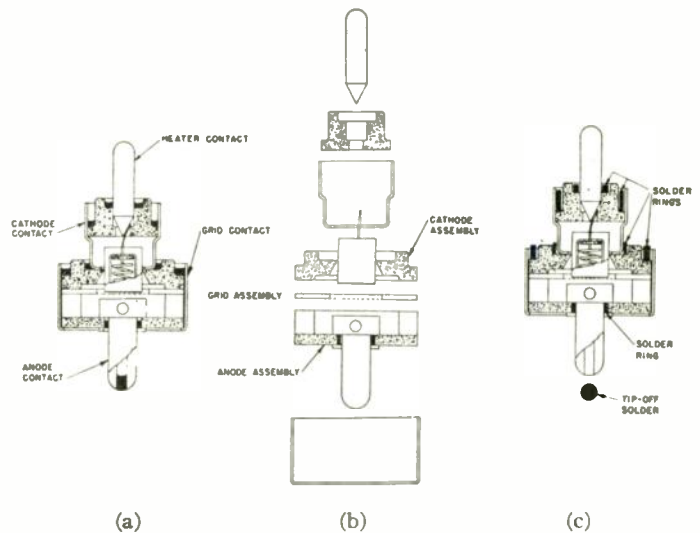

Fig. 2—Cross-sectional views of the L-29 and its sub-assemblies.

Fig. 2(a) is a cross-sectional view of the L-29 tube. The tube is composed of three basic units: the cathode, the grid, and the anode assemblies [Fig. 2(b)]. The cathode, positioned snugly in a small tapered hole in the cathode insulator, is coated with a triple carbonate mix which is shaved to the desired thickness. The spacing from cathode to the center of grid wires is usually 0.6 mil, or about equal to the spacing between wires.

The grid is designed not to buckle, as it must be parallel to the cathode surface at all operating temperatures. This is accomplished by using tungsten grid wires stretched across a tungsten washer with such high tension that they will remain taut even though the frame is 500 degrees C. cooler than the wires. Tungsten must be used for the frame, so that the wires will not be ruptured during the 800 degrees C. exhaust bakeout.

The high thermal conductivity of copper makes it a logical choice for the anode material. Its good rf conductivity aids in the attainment of high output impedances, even though external circuits are used. The fact

\* R. J. Bondley, "Low melting temperature solders in metal-ceramic seals," *Ceramic Age*, vol. 58, p. 15; July, 1951.

\* Original manuscript received by the IRE, May 5, 1954; revised manuscript received, September 5, 1954.

† General Electric Research Lab., Schenectady, N. Y.

<sup>1</sup> D. R. Hamilton, J. N. Knipp, and J. B. H. Kuper, "Klystrons and Microwave Triodes," *Radiation Lab. Series*, vol. 7, p. 153, McGraw-Hill Publishing Co., Inc., New York, N. Y.; 1948.

that quartz can be used as the output insulator has proved to be valuable for tubes operating at the highest frequencies. Alsimag #243 ceramic insulators have proved generally useful over the L-29's entire operating range from zero to 10,000 mc. The anode-to-grid spacings are generally in the range of 5 to 15 mils.

These units complete with lead rings [Fig. 2(c)] are placed in a vacuum oven and are heated to 800 degrees C. Although the lead solder becomes liquid, it is retained by the solder troughs. The soldering operation cannot affect the spacings between the electrodes or cause electrical leakage inside the tube because the soldering takes place only on external surfaces. Table I indicates the reduction in  $Q$  chargeable to the lead-soldering technique. For purposes of comparison, the  $Q$ 's obtained with iron and fernico seals are included. At the conclusion of the exhaust schedule, a small amount of lead is brought in contact with anode to seal off exhaust vent.

TABLE I  
SEAL LOSSES AT 2780 MC FOR VARIOUS OUTPUT  
ASSEMBLIES USED IN A 2C39 CAVITY

	Per Cent of $Q$
Cavity—no tube	100
Quartz—polystyrene—cemented to copper	80
Quartz—lead-soldered to copper	77
Alsimag 243—lead-soldered to copper	57
Iron-matching glass sealed to copper-plated iron	41
Fernico-matching glass sealed to fernico	21

### NOISE CHARACTERISTICS

Throughout the course of development of this tube, the major performance objective was a desirable low-noise figure that could be consistently reproduced. For comparison of the experimental results obtained with those to be expected theoretically, the expression for the noise figure may be written as:

$$F = 1 + \frac{G_1}{G_s} + \beta \frac{G_t}{G_s} + \frac{R_{eq}}{G_s} |Y_s + G_t|^2 \quad (1)$$

This expression has been derived by a number of workers, but at present the nomenclature used in the Radiation Laboratory series<sup>3</sup> will be followed. The terms in this formula are defined below:

$F$  = the narrow band noise figure of a single stage.

No correlation between grid noise and plate noise is assumed.

$G_s$  = the source conductance.

$G_1$  = the losses in the input network.

$G_t$  = the transit-time loading of the tube across the input terminals of the tube.

$R_{eq}$  = the resistance equivalent for the plate noise referred to the grid. This was measured and found to be 125 ohms for the L-29.

$Y_s = G_s + G_1 + jY_1$  = the total admittance presented to the tube.

$Y_1$  = the susceptance presented by the network to the input terminals of the tube.

$\beta$  = the factor relating grid noise to input conductance due to transit-time loading. In this paper  $\beta$  will be assumed to be 5, as is customary for oxide emitters.<sup>4</sup>

The noise figure,  $F$ , may be minimized by properly selecting the source conductance,  $G_s$ , and by tuning the input network so that the total admittance presented to the input terminals is purely conductive. (The latter follows from the assumption of no correlation between the induced grid-noise and shot-noise current.) The optimum noise figure is found from (1):

$$F_0 = 1 + 2R_{eq}(G_1 + G_t) + 2\sqrt{R_{eq}(G_1 + \beta G_t) + [R_{eq}(G_1 + G_t)]^2} \quad (2)$$

Expression (2) predicts the noise figure at any particular frequency, provided the equivalent noise resistance, transit-time loading, and input circuit losses are known. Some interesting information can be obtained from the above expression. First, however, it will be more profitable to refer to some experimental results.

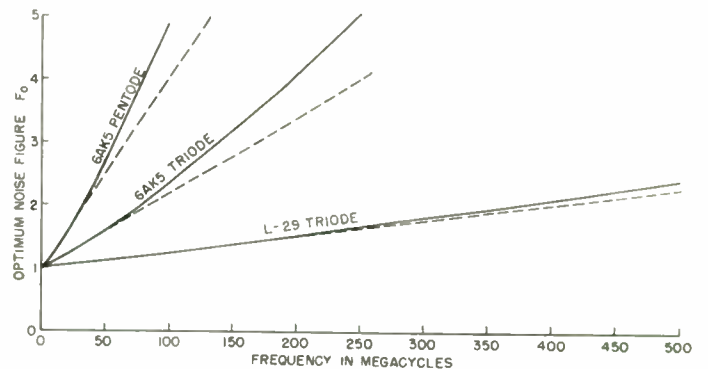

Fig. 3—Comparison of the optimum noise figure of the L-29 and the 6AK5.

Fig. 3 compares the optimum noise figure of an L-29 with that of a 6AK5, one of the best miniature tubes. Experimental results have been used to verify the curve for the L-29. Note that in each case the noise figure approaches a linear relationship at the lower frequencies. As has been pointed out by others, it is to be expected that the optimum noise figure should approach a straight-line relationship at low frequencies.<sup>5</sup>

Eq. (2), together with experimental data in Fig. 3 for L-29, provides means of obtaining a value for the input transit-time loading  $G_t$ . Assuming  $G_1 = 0$ , (2) gives

$$G_t = \frac{(F_0 - 1)^2}{4R_{eq}(F_0 - 1 + \beta)} \quad (3)$$

<sup>4</sup> D. O. North and W. R. Ferris, "Fluctuations induced in vacuum-tube grids at high frequencies," *Proc. I.R.E.*, vol. 29, pp. 49-50; February, 1941.

<sup>5</sup> S. N. VanVoorhis, "Microwave Receivers," *Radiation Lab. Series*, McGraw-Hill Publishing Co., Inc., vol. 23, p. 130; 1948.

<sup>3</sup> G. E. Valley, Jr. and Henry Wallman, "Vacuum Tube Amplifiers," *Radiation Lab. Series*, vol. 18, p. 639, McGraw-Hill Publishing Co., Inc., New York, N. Y.; 1948.



Substituting the measured value of noise figure of 0.9 db at 90 mc into (3) gives

$$G_t = \frac{(1.23 - 1)^2}{4 \cdot 125(1.23 - 1 + 5)} = 0.0000202 \text{ mho.} \quad (4)$$

If it is assumed that the transit-time loading varies as the square of the frequency, then

$$G_t = 0.0025f^2 \text{ mho} \quad (5)$$

for  $f$  in kmc.<sup>6</sup> A plot of (5) is shown in Fig. 4.

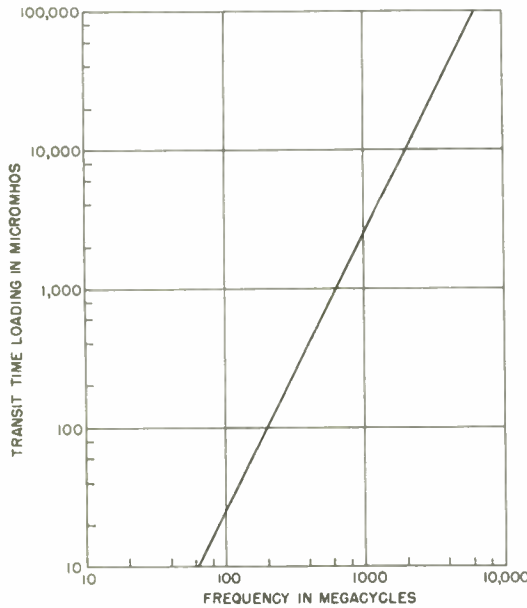

Fig. 4—L-29 transit-time loading.

The validity of (5) may be checked by using it to compute the noise figure at 200 mc. Going back to Expression (2) for  $F_0$ , dropping terms in  $G_1$ , and making use of (5), one finds that  $F_0$  becomes

$$F_0 = 1 + 0.625f^2 + 2.50f\sqrt{1 + 0.0625f^2}. \quad (6)$$

Substituting 0.2 kmc results in a noise figure of 1.525 or 1.84 db, which is in very good agreement with the experimental data, considering the assumption of no input network losses. A plot of (6) is shown in Fig. 5, and indicates what is to be expected at the higher frequencies from this semi-theoretical basis. A great number of experimental values for the noise figure for different L-29's have been obtained at both 1,200 and 3,000 mc. The range of variation of these measurements is also indicated in Fig. 5. The agreement between the experimental and semi-theoretical results is good.

Through further refinements, it appears quite practical to reduce considerably the cathode-to-grid transit angle from the value of the L-29. The lower curve of Fig. 5 illustrates the change brought about by cutting

<sup>6</sup> W. R. Ferris, "Input resistance of vacuum tubes as ultra-high frequency amplifiers," Proc. I.R.E., vol. 24, pp. 82-105; Jan. 1936.

the transit angle by a factor of one half. In place of a noise figure of 7 db at 1,200 mc, 4.5 db would be indicated. Or, stated in another way, the frequency would be approximately doubled for the same noise figure.

For some applications, it is essential that a good impedance match be made from the antennas to the rf amplifier of a receiver. To point out the expected performance from an L-29 in such service, as well as to give an idea of the amount of noise-figure improvement possible for any given frequency by tuning the input circuit for optimum source conductance, the matched noise figure case will now be considered.

Again assuming that the input network is lossless, and that the load impedance is small compared with the plate resistance, the expression for the impedance-matched grounded-grid connection derived from (1) is

$$F_M = 1 + \beta \frac{G_t}{G_M + G_t} + \frac{R_{eq}}{G_M + G_t} (G_M + 2G_t)^2. \quad (7)$$

If  $\beta = 5$ ,  $G_M$  (the tube transconductance) = 0.02 mho,  $R_{eq} = 125$  ohms, and  $G_t = 0.0025 f^2$  mho/kmc<sup>2</sup>, (7) becomes

$$F_M = 1 + 2.5 \frac{1 + 0.750f^2 + 0.0625f^4}{1 + 0.125f^2}. \quad (8)$$

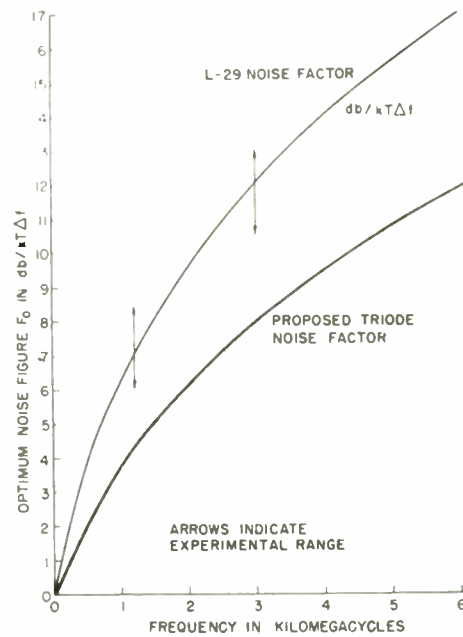

Fig. 5—L-29 optimum noise figure.

This expression is shown plotted in Fig. 6, on the following page. It indicates that noise figures of the order of 5.5 to 6 db may be expected at frequencies up to 500 mc. Noise figures within 0.5 db of this have been measured at 200 and 500 mc. The dotted curve in Fig. 6 is the difference between the matched and optimum noise figures. It represents the improvement in noise figure to be expected by presenting the optimum source conductance, instead of the matched source conductance. In the L-29,

the product of  $R_{eq}$  and  $G_t$  is such that the improvement in noise figure is at best only a few tenths of a decibel above 1,500 mc. At 1,200 mc the improvement to be expected is about 0.5 db, in good agreement with experiment.

In addition to the factors that appear in the expression for noise figure, there are a number of construction details that have proven important in the attempt to produce tubes with consistently desirable noise properties. A cathode should (a) have uniform emission with low  $I^2R$  loss, small edge effect, and as low a temperature as possible; (b) have a surface that is smooth, flat, and parallel to both the grid plane and cathode base metal; (c) have a contact potential that is uniform over the active electrode surfaces, and (d) be used with a grid the pitch of which is sufficiently fine to provide a good transparency, and arranged so that the opening between the grid wires is no larger than the distance between the oxide emitter and the center of the grid wires.

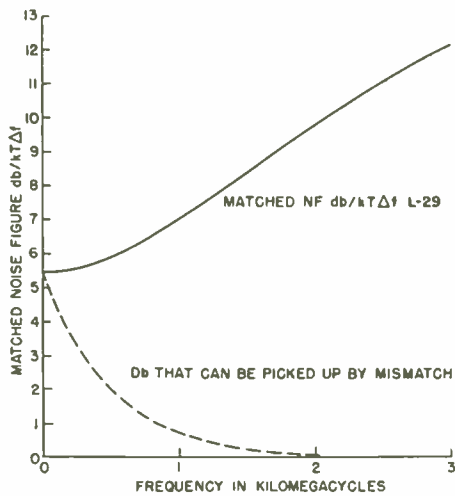

Fig. 6—Matched grounded-grid L-29 noise figure.

Most of these requirements may be summarized by stating that there must be uniformity of the electric field, so that there will be a minimum spread in the value of the transit angle. Some of the above factors will be discussed in more detail.

An illustration of the importance of the role of the cathode is best described by some experiments made early in the L-29 program. It had been noticed that tubes needing more than one run through the exhaust procedure to become vacuum tight were consistently lower noise. This difference amounted to 1 to 2 db in the noise factor at 1,200 mc, and also showed up at 3,000 mc. After this was noticed, tube #134, which had been through the exhaust procedure once and the noise figure of which was high (9.9 db), was let down to air and then re-exhausted. The noise figure after the reprocessing was 6.9 db at 1,200 mc. This treatment was also given to tube #X60 and resulted in an improvement from 8.0 to 6.6 db. These improvements were made

despite the fact that the transit-time loadings were undoubtedly increased because of a considerable compaction of the cathode coating (and hence widening of the  $g$ - $c$  spacing) during the reprocessing. These experiments indicated that considerable importance must be attached to the density and processing of the oxide emitter.

When the input circuit losses are small relative to the transit-time losses, the predominant factor in the expression for optimum noise figure is the product of  $R_{eq}G_t$ .<sup>7</sup> It is instructive to examine this product in somewhat greater detail. The expression for the equivalent noise resistance is<sup>8</sup>

$$R_{eq} = \frac{\theta}{\sigma} \frac{T_c}{T_0} \frac{1}{G_m} \quad (9)$$

Unfortunately, there is no theory that is suitable for calculating the transit-time loading  $G_t$  for the case of the L-29 in which the potential minimum region dominates the cathode-to-grid region. An equation can be written in an approximate form, suggested by Ferris<sup>6</sup> and North<sup>9</sup>

$$G_t = KG_m f^2 \tau^2, \quad (10)$$

where

$\theta$  = essentially a constant = 0.66,

$\sigma$  = ratio of total transconductance to conductance of the equivalent diode = 0.66 for the L-29 (assuming 3/2 power law),

$T_c$  = cathode temperature ( $^{\circ}K$ ),

$T_0$  = standard noise temperature,

$G_m$  = transconductance as triode,

$K$  = constant,

$f$  = frequency,

$\tau$  = transit-time cathode to grid.

Then the product  $R_{eq}G_t$  is

$$R_{eq}G_t = \frac{\theta}{\sigma} \frac{T_c}{T_0} K f^2 \tau^2 = \frac{T_c}{T_0} f^2 \tau^2. \quad (11)$$

Thus, the predominant factor in the expression for optimum noise factor suggests the fundamental requirements of low cathode temperature and small cathode-to-grid transit angle for low-noise performance. The constant  $K$  would undoubtedly bring in more geometrical factors if it could be evaluated for our case. Notice that  $G_m$  has canceled out of the above expression for our approximations. This further suggests that, still within our assumptions, the noise factor is not dependent on cathode area. In tubes similar except for cathode area, the experimental results confirm this fairly well. In making the cathode smaller, however, one must keep the

<sup>7</sup> W. A. Harris, "Some notes on noise theory and its application to input circuit design," *RCA Rev.*, vol. IX, pp. 406-418; September, 1948.

<sup>8</sup> D. O. North, "Fluctuations in space-charge-limited currents at moderately high frequencies," *RCA Rev.*, vol. IV, pp. 443-473; April, 1940.

<sup>9</sup> D. O. North, "Analysis of the effects of space charge on grid impedance," *Proc. I.R.E.*, vol. 24, pp. 108-136; January, 1936.



gain sufficient to minimize the noise from succeeding stages. From a theoretical viewpoint, the cathode edge effect should be worse in the smaller cathode, since the ratio of area to periphery is proportional to the diameter of the cathode. That the edge effect is important is illustrated by the fact that the outer 18 mils of the L-29 cathode contains one-half of the cathode area. From a practical viewpoint, the smaller cathode would permit a shorter grid span, thus simplifying a number of problems in grid making as well as making it easier to make the step to still finer grid wires.

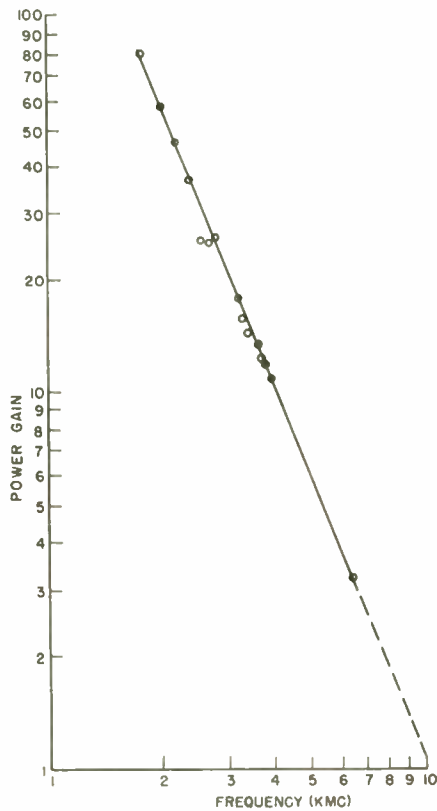

Fig. 7—Power gain of an average L-29.

#### GAIN AND IMPEDANCE CHARACTERISTICS

The power gain versus frequency characteristic for an average L-29 is shown in Fig. 7. This is the characteristic measured in one particular circuit as the output resonator was tuned successively through the  $3/4 \lambda$  and  $5/4 \lambda$  modes. The falling gain characteristic is partly explained by the input transit-time loading, but is mainly the result of the drop in output impedance with frequency. Part of the output impedance variation is accounted for by the external circuit, and this part can be improved by using a high value of  $Z_0$  and a  $1/4 \lambda$  resonator.  $1/4 \lambda$  circuit is possible to frequency as high as 8,000 to 10,000, depending on tube output capacitance.

The input bandwidth of these tubes at 1,200 mc is of the order of 200 mc at normal operating current in a  $3/4 \lambda$  circuit. The bandwidth with the tube cold is about 3 to

4 mc. The highest frequency for which a  $1/4 \lambda$  circuit may be employed on the input of these tubes is approximately 1,800 mc.

Another factor of interest is the gain-bandwidth product of these tubes. When quarter-wave output resonators were used, the highest measured values of gain-bandwidth product at 1,200 and 3,000 mc were 1,100 and 750 mc respectively. Typical values were about half of these maximum values. Measurements of the impedance-bandwidth using the Hansen-Post technique gave values of approximately 120,000 ohm-megacycles for both 1,200 and 3,000 mc.<sup>10</sup> Unloaded circuit impedances of 60,000 are obtainable at 1,200 mc despite the fact that the low-frequency plate resistance is of the order of 10,000 ohms. The reason for this is that the transit angle between the cathode and grid is such (120 to 130 degrees) that the phase angle between plate current and plate voltage is approximately 90 degrees. Thus, the effect of the electrons causes little if any loading of the cavity at this frequency. At 3,000 mc, unloaded cavity impedances of 15,000 ohms are typical.

#### SUPER-HIGH FREQUENCY OSCILLATOR PERFORMANCE

L-29 and L-31 tubes have been operated as oscillators at frequencies up to 10,000 mc. Continuous-wave outputs of 100 mw at 1 to 2 per cent efficiency at 8,600 mc have been measured, and 40 mw at 10,000 mc has been recorded. When pulsed with 1,200 volts on the plate, 15-watts peak output at 3.5 per cent efficiency at 8,600 mc was achieved.

#### CONCLUSIONS

The combination of low-loss insulators soldered to high-conductivity metals during a high-temperature exhaust has permitted the precise assembly of tiny receiving tubes having an extended high-frequency range of operation and improved performance at lower frequencies. The outlook is promising for even greater advances in performance and efficiency.

#### ACKNOWLEDGMENT

The authors wish to thank the many people who have aided them during this development, especially R. F. Crawford for his ingenuity in assembling the tubes; R. E. Krone for his valuable work in designing dies and equipment; R. L. Watters for his uhf tests and help in establishing the good agreement between theory and experiment; C. L. Andrews for his oscillator tests; R. A. Dehn for his impedance tests; E. L. Bahm and R. J. Bondley for contributions to grid-making techniques; G. Badger for his careful rf measurements; E. D. McArthur for helpful advice and suggestions; M. T. Lebenbaum of Airborne Instruments Laboratory for confirmatory test information; and the U. S. Bureau of Ships, which sponsored the development.

<sup>10</sup> W. W. Hansen and R. F. Post, "On the measurement of cavity impedance," *Jour. Appl. Phys.*, vol. 19, pp. 1059-1061; Nov. 1948.

# An Equalizing Network for Carrier-Type Feedback Control Systems\*

C. H. LOONEY†, ASSOCIATE, IRE

**Summary**—Lag type compensation of a speed regulating system may be used to reduce the steady state error. The analysis of an active, high  $Q$ , RLC circuit shows that it permits lag compensation of carrier-type feedback control systems through direct operation on the system actuating signal. The use of this circuit in an instrument type velocity servo reduces the steady-state error by a factor of at least 30.

A TYPICAL speed regulating system will consist of a motor, a tachometer generator, a variable reference voltage, and an amplifier to amplify the difference between generator output and the reference voltage for the purpose of driving the motor-generator to make this difference approach zero. Motor and generator will have a moment of inertia,  $J$ , and a coefficient of damping,  $B$ . Amplifier and motor will have a ratio of voltage to torque equal to a constant,  $K$ . For purpose of analysis, this system will be assumed to be linear, i.e., incapable of saturation; this assumption is valid for small values of actuating signal and load disturbances. The following equations define this system:

$$e = r - c \quad (1)$$

$$Ke = J \frac{dc}{dt} + Bc = q, \quad (2)$$

where  $c$  is system output in radians per second,  $r$  is system input in radians per second, and  $q$  is motor torque in convenient units. It is convenient to use the Laplace transform of (1) and (2):

$$E = R - C \quad (3)$$

$$KE = (Js + B)C. \quad (4)$$

The forward gain of the system may be defined

$$G = C/E. \quad (5)$$

A single loop feedback control system is described by<sup>1</sup>

$$E = \frac{R}{1+G} + \frac{UN}{1+G}, \quad (6)$$

where " $U$ " is the load disturbance of the controlled system " $N$ ."

The speed regulator described above can be put into the form of (6) by the following substitutions:

$$G = \frac{K_1}{1+T_1s} \quad (7)$$

$$K_1 = K/B \quad (8)$$

$$T_1 = J/B \quad (9)$$

$$N = \frac{1}{1+T_1s} \quad (10)$$

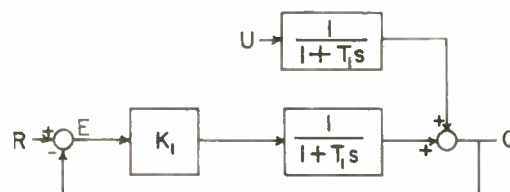

Fig. 1—Block diagram of velocity regulating system.

The block diagram of the velocity regulating system is shown in Fig. 1. The steady-state actuating signal may be found from (11) for variation of the reference input and from (12) for variation of the load disturbance.

$$e_{ss} = \left[ \frac{Rs}{1+G_0} \right] s \rightarrow 0 \quad (11)$$

$$e_{ss} = \left[ \frac{UN_0s}{1+G_0} \right] s \rightarrow 0. \quad (12)$$

The subscript "0" denotes the value of the term when  $s$  approaches zero. The equations for system input are given in (13) and (14) and the equations for the load disturbances are given in (15) and (16).

$$r = r_v \quad (13)$$

$$R = r_v/s \quad (14)$$

$$u = u_p \quad (15)$$

$$U = u_p/s. \quad (16)$$

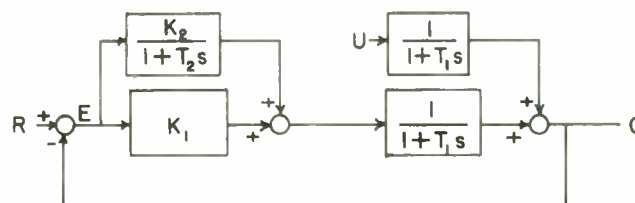

Fig. 2—Velocity servo with lag compensation.

It would be desirable to have a network which would operate directly upon the actuating signal in a carrier type feedback control system and produce compensation of the type shown in Fig. 2 or Fig. 3. A network

\* Original manuscript received by the IRE, November 5, 1953; revised manuscript received, October 7, 1954.

† Naval Research Lab., Washington 25, D. C.

<sup>1</sup> W. R. Ahrendt and J. F. Taplin, "Automatic Feedback Control," McGraw-Hill Book Co., Inc., New York, N. Y., pp. 54 ff., 1951.



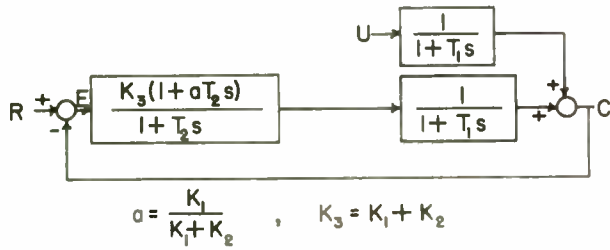

Fig. 3—Velocity servo with lag compensation (simplified diagram).

which will accomplish the desired result is shown in Fig. 4. The action of this equalizing network may be viewed from a frequency standpoint. The input must be of the form

$$E \cos \omega_c t \cos \omega_s t, \tag{17}$$

since this is the form of the voltage generated in a carrier servo with a sinusoidal forcing function. The frequency of the signal is  $\omega_s$  and the frequency of the carrier is  $\omega_c$ . The action of an equalizing network of the type desired may be expressed qualitatively as having decreasing gain as  $\omega_s$  is increased, and having an increasingly lagging phase angle of output to input as  $\omega_s$  is increased. This type of equalization is thus termed lag equalization or compensation.

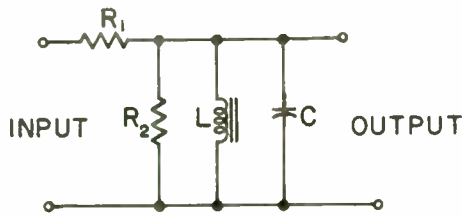

Fig. 4—Lag network.

A voltage of the form of (17) may be rearranged as in (18).

$$\frac{1}{2}E(\cos [\omega_c + \omega_s]t + \cos [\omega_c - \omega_s]t). \tag{18}$$

This type of signal is termed a suppressed carrier since it is the sum of the upper and lower sidebands of a modulated carrier, but with the carrier lacking. Lag compensation would alter the phase of the suppressed carrier as follows:

$$\cos \omega_c t \cos (\omega_s t - \phi), \tag{19}$$

or

$$\cos [(\omega_c + \omega_s)t - \phi] + \cos [(\omega_c - \omega_s)t + \phi]. \tag{20}$$

The gain of the lag compensation network would be constant for low values of  $\omega_s$  and would decrease at the rate of six decibels per octave as  $\omega_s$  is increased.

The transfer function of the network of Fig. 4 may be

written as

$$G(s) = \frac{1}{R_1 + \frac{1}{1/R_2 + 1/sL + sC}}. \tag{21}$$

Let

$$Q_c = \frac{R_2}{\omega_c L} = R_2 \omega_c C \tag{22}$$

and

$$\omega_c = \frac{1}{\sqrt{LC}}. \tag{23}$$

Then

$$G(s) = \frac{\frac{R_2}{R_1 + R_2}}{1 + \frac{Q_c}{\omega_c} \left( \frac{R_1}{R_1 + R_2} \right) \left( 1 + \frac{\omega_c^2}{s^2} \right) s} \tag{24}$$

Substitute

$$s = j\omega. \tag{25}$$

Then

$$G(j\omega) = \frac{\frac{R_2}{R_1 + R_2}}{1 + j \frac{Q_c}{\omega_c} \left( \frac{R_1}{R_1 + R_2} \right) \left( 1 - \frac{\omega_c^2}{\omega^2} \right) \omega} \tag{26}$$

If

$$\omega_u = \omega_c + \omega_s \tag{27}$$

when  $\omega_u$  is the upper sideband frequency, and

$$\omega_L = \omega_c - \omega_s, \tag{28}$$

where  $\omega_L$  is the lower sideband frequency, then

$$G(j\omega_u) = \frac{\frac{R_2}{R_1 + R_2}}{1 + j \frac{Q_c}{\omega_c} \left( \frac{R_1}{R_1 + R_2} \right) \left[ \frac{2\omega_c + \frac{\omega_s^2}{\omega_c + \omega_s}}{\omega_c + \omega_s} \right] \omega_s}, \tag{29}$$

and

$$G(j\omega_L) = \frac{\frac{R_2}{R_1 + R_2}}{1 + j \frac{Q_c}{\omega_c} \left( \frac{R_1}{R_1 + R_2} \right) \left[ \frac{2\omega_c + \frac{\omega_s^2}{\omega_c - \omega_s}}{\omega_c - \omega_s} \right] \omega_s}. \tag{30}$$

For the usual case of  $\omega_s \ll \omega_c$ ,

$$G(j\omega_s) = \frac{R_2}{R_1 + R_2} \cdot \frac{1}{1 + j \frac{2Q_c}{\omega_c} \left( \frac{R_1}{R_1 + R_2} \right) \omega_s} \quad (32)$$

$$G(j\omega_s) = \frac{K_2'}{1 + T_2(j\omega_s)} \quad (33)$$

The slope of  $G(j\omega_s)$  versus  $\omega_s$  as  $\omega_s$  approaches  $\omega_c$  is slightly less than six decibels per octave, but due to the simplification (31), (33) indicates a high frequency slope of six decibels per octave. The difference in sign in (29) and (30) is in accord with the desired change in phase angle for the upper and lower sidebands, as shown in (20).  $K_2'$  differs from the aforementioned  $K_2$  in that  $K_2'$  is less than unity and amplification is necessary to provide the desired value of  $K_2$ .  $T_2$  must be made large with respect to  $T_1$  which requires that  $Q_c$  must be large; in practice, values of 100 or more at a frequency of 60 cps. This high value of  $Q_c$  necessitates an active circuit;<sup>2</sup> the circuit of Fig. 5 permits 60 cps  $Q$ 's of more than 250 using a 5.0 henry choke with a passive  $Q$  of 10. The vacuum tube supplies energy to the tank circuit in the proper phase to tend to sustain oscillation. In other words, the active circuit makes possible the insertion of a negative resistance, thus increasing the  $Q$  of the reso-

0.5 second. A 2.0 ounce-inches torque load was applied to the motor shaft (stall torque was 3.5 ounce-inches) while the servo output was 12 revolutions per second.

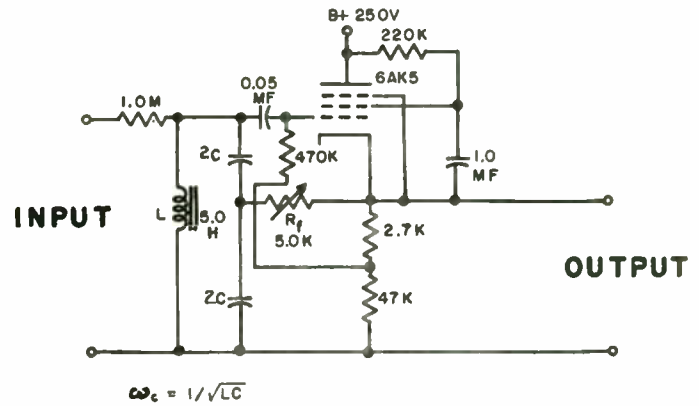

Fig. 5— $Q$  multiplier.

The reference input was increased 0.7 per cent to return the output to 12 rps with the lag compensation network in operation. However, for the same conditions and with the network removed ( $K_2=0$ ), the reference input had to be increased 20 per cent to return the output to 12 rps, thus demonstrating the effectiveness of the lag network in reducing error due to torque disturbances. Fig. 6 is a schematic of the entire system.

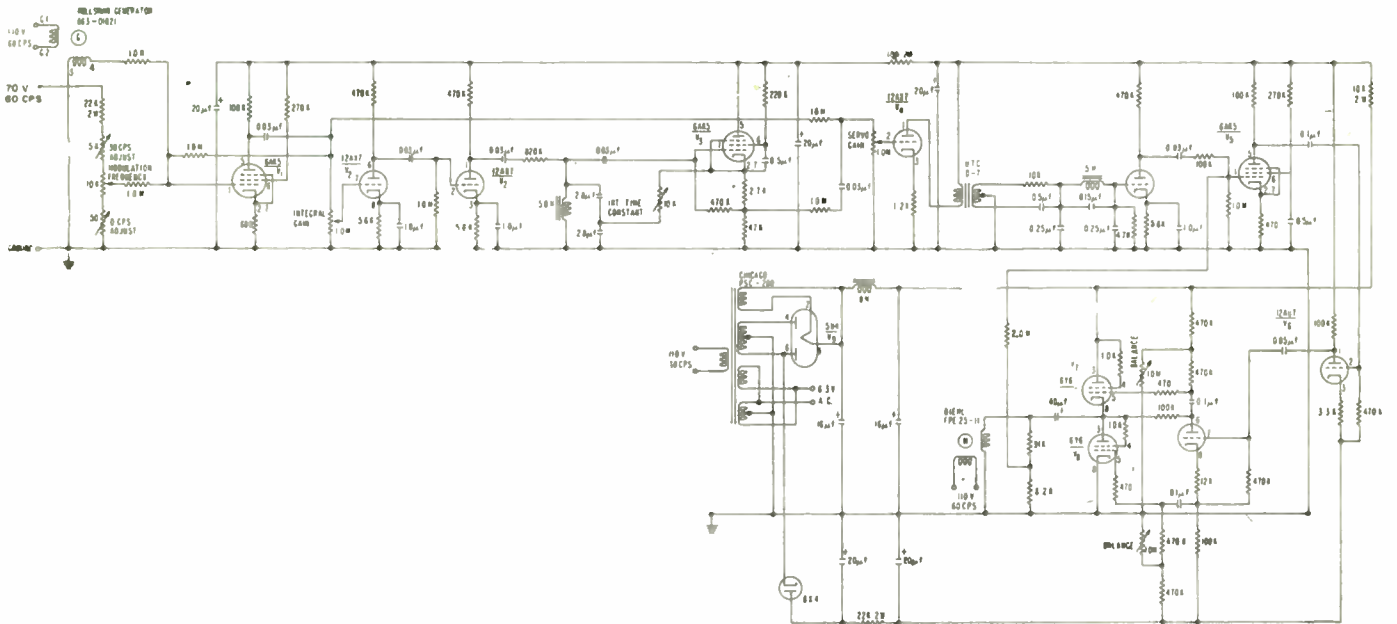

Fig. 6—Schematic of velocity servo with lag compensation.

nant circuit by increasing the magnitude of  $R_2$  in Fig. 4.  $R_f$  (in Fig. 5) may be varied to increase  $Q$  without limit.

The circuit of Fig. 5 was incorporated into a velocity-regulating carrier type system using a Diehl FPE 25-11 two-phase induction motor and a Kollsman 863-01621 tachometer induction generator, and an electronic amplifier.  $K_2$  was made equal to 30;  $T_2$  was made equal to

<sup>2</sup> H. E. Harris, "Simplified  $Q$  multiplier," *Electronics*, p. 130; May, 1951.

A network of the type shown in Figs. 4 and 5 may be used to increase the low frequency gain of carrier type feedback control systems and thus decrease the steady-state error of the systems. It is desirable to have as large a  $Q$  as can be obtained; however, the frequency of  $\omega_c$  must be held to an increasingly smaller tolerance as  $Q$  is increased. Values of  $Q$  up to at least 150 may be used with the frequency deviation encountered in commercial 60 cps line, before this deviation causes a reduction of  $K_2$ .



# Radio Scattering in the Troposphere\*

WILLIAM E. GORDON†, MEMBER, IRE

**Summary**—The theory of radio scattering in the troposphere<sup>1</sup> is modified in the light of recent observations of the fluctuations in refractive index. The theory is applied to the communication problem and yields some characteristics which are peculiar to the scattering mechanism. One characteristic imposes a limit on the maximum size of an antenna which yields its full theoretical gain. This characteristic is deduced from the prediction of diversity distance. Height gain is also deduced from diversity distance. Other characteristics are derived pertinent to the communication problem, including fading rates and frequency bandwidth of the scattering mechanism.

## INTRODUCTION

A THEORY OF radio scattering in the troposphere<sup>1</sup> was presented in 1950. Scattering by a turbulent medium was applied to radio waves in the troposphere to describe the mean signal observed at distances somewhat beyond the horizon as well as the fading at all ranges. Values of the scale of the turbulence and the departure of refractive index from its mean expected on meteorological grounds were adequate to explain the field strengths observed experimentally. Since 1950, direct observations of the scale and intensity of turbulence have become available. The observed values of the scale and intensity of turbulence differ somewhat from those estimated and used in the 1950 paper. In particular, the observed scales are of the order of tens of meters rather than tens of centimeters, and this produces important changes in the results. It is the object of this paper to modify the application of the earlier theory in the light of the new observations, and to extend the theory to include predictions of diversity distances, fading rate, and frequency bandwidth of the scattering mechanism.

Section I summarizes the results of the direct observations of refractive index in terms of the scale and intensity of the index fluctuations. The scattering coefficient is defined in Section II, and its limitations are indicated. In Section III, the power scattered to a receiver is derived as a function of distance from the transmitter for various typical distributions of the scale and intensity with height. The theoretical results are compared with experimental data. It is assumed in this section that the full theoretical gain of the antennas is realized, that is, the antennas are not too large in the sense described in Section IV. Diversity distances are deduced in Section IV and applied to yield the height gain and maximum useful antenna size in the scattered field. The radio-scattering mechanism is characterized by a fading rate and a frequency bandwidth which are described in Sections V and VI.

## I. DIRECT OBSERVATIONS OF REFRACTIVE INDEX

Quantitative observations of turbulence in the free

air had been practically nonexistent until the refractometer was developed and flown in the past few years. The number of observations available is still quite limited, but the University of Texas, working with the Air Force, is presently collecting data at different locations and under a variety of weather situations.

The refractometer, developed by Crain<sup>2</sup> at the University of Texas and independently by Birnbaum<sup>3</sup> at the National Bureau of Standards, is an instrument which measures directly the dielectric constant of the air to which it is exposed. Mounted on a blimp or aircraft, it has been probing the lower atmosphere, measuring, primarily, the refractive-index profile and, incidentally, the fluctuations in refractive index. An autocorrelation analysis of samples of the refractometer record yields the scale and intensity of the fluctuations at various heights. Some difficulties are experienced in the analysis, particularly with the treatment of long-period variations in deducing the intensity, and with changes of the general character of the record, which affect the scale in samples recorded only a few miles apart.

An analysis by von Rosenberg<sup>4</sup> of the results of 2,500 observations shows that (a) the scale is more or less constant with height; (b) the intensity in general decreases with height; and (c) elevated turbulent layers in which the scale and, particularly, the intensity have values which are several times those either above or below the layer are observed 50 to 70 per cent of the time. While the functional form of the decrease of intensity with height omitting the layers is not clearly established, inverse height squared seems reasonable. The value of the scattering parameter, observed 10, 50, and 90 per cent of the time, is plotted as a function of height in Fig. 1 (following page). The scattering parameter is the ratio  $(\Delta\epsilon/\epsilon)^2/s$ , where  $(\Delta\epsilon/\epsilon)^2$  is the mean square fluctuation of the dielectric constant  $\epsilon$  and  $s$  is the effective size of the scatterer ( $2\pi$  times the scale of the fluctuations).

Scales and intensities deduced from 118 flights over Ohio and on the west coast of the United States have mean values of 52 meters and  $1.7 \times 10^{-12}$  with ranges of 18 to 128 meters and  $0.4 \times 10^{-12}$  to  $6.4 \times 10^{-12}$ .

It is clear that the size of the scatterers is large compared to the wavelengths of interest in tropospheric propagation, and the applications and extensions of the theory which follow will treat the case of large scatterers.

## II. THE SCATTERING COEFFICIENT

For radio scattering at a wavelength  $\lambda$  in the direction making an angle  $\theta$  with the direction of incidence and an angle  $\chi$  with the direction of the incident electric field, define<sup>1</sup> the scattering coefficient  $\sigma(\theta, \chi)$  as the power measured per unit solid angle, per unit incident power intensity, and per unit macroscopic element of volume as

\* Original manuscript received by the IRE, June 10, 1954; revised manuscript received, September 30, 1954.

† Cornell University, Ithaca, N. Y.

$$\sigma(\theta, \chi) = \frac{(\Delta\epsilon/\epsilon)^2 (s/\lambda)^3 \sin^2 \chi}{\lambda [1 + \{(2s/\lambda) \sin \theta/2\}^2]} \quad (1)$$

For large scatterers the scattering is beamed mainly in the forward direction, and the quarter-power beamwidth is given approximately by  $\lambda/s$ . At distances beyond the horizon the receiver is not in the main scattering beam, and the first term in brackets may be neglected compared to the second, simplifying (1) to

$$\sigma(\theta, \chi) = \frac{(\Delta\epsilon/\epsilon)^2 \sin^2 \chi}{16s \sin^4 \theta/2}, \quad 1 \ll (2s/\lambda) \sin \theta/2. \quad (2)$$

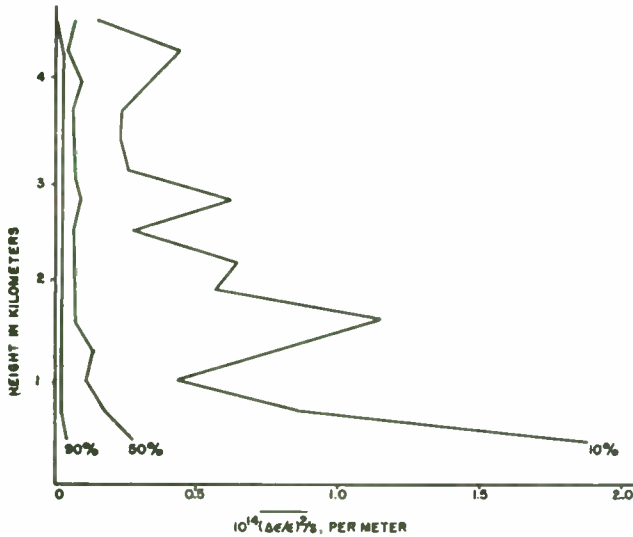

Fig. 1—Frequency of occurrence,  $(\Delta\epsilon/\epsilon)^2/s$ , based on 2,500 samples.

The scattering coefficient (1) is based on an autocorrelation analysis of radio scattering, making use of the correlation function  $\exp(-r/l)$  for  $r \geq 0$ , where  $r$  is the separation between points being correlated and  $l$  is the scale of turbulence. The function implies discontinuities in the derivative of distribution of dielectric constant, a condition which is probably not met exactly in the troposphere. The condition is met approximately, and the analysis leads to useful predictions as is shown below.

### III. SCATTERED POWER

#### *Intensity of Turbulence Proportional to a Power of the Height*

The power  $P$ , scattered to a receiver at a distance  $d$  from the transmitter, and relative to the free-space power  $P_{FS}$  (assuming the antenna gains are realized), is

$$\frac{P}{P_{FS}} = K d^2 \int \frac{\sigma(\theta, \chi)}{R_0^2 R^2} dV, \quad (3)$$

where  $R_0$  is the distance from transmitter to scattering element,  $R$  is the distance from scattering element to receiver, and the integration is over the volume of atmosphere, which contributes significantly. The above equation comes from equation (5e) of reference 1, where

the important volume, described below, is somewhat less than the intersection of transmitter and receiver beams as used in reference 1, and  $K = (1 + |\rho|^2)^2$  is introduced in order to account for the reflection coefficient  $\rho$  of the ground.

The value of  $K$  varies from one, for a completely rough ground or nonreflecting earth, to a maximum of four, for a perfectly reflecting earth. The grazing angle associated with  $\rho$  is the ratio of the height above the intersection of the transmitter and receiver horizon to one-half the path length, that is  $(h_0/3)/d(d/2)$  radius, as shown later, and this angle in degrees is approximately  $10^{-3}d$ , where  $d$  is the path length in miles.

Since the scattered power is proportional to an inverse power of  $\sin \theta/2$ , the important scattering will occur in a volume in which the angle is at or near its minimum value. The minimum value of  $\theta$  occurs at the intersection of the horizon planes of the transmitter and receiver in the plane of propagation. At this point the value of  $\theta$  is  $d/a$ , as indicated in Fig. 2, where  $a$  is the modified radius of the earth. The horizon planes will form the lower boundary of the scattering volume.

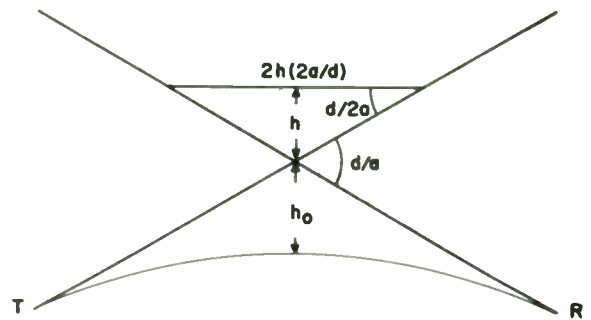

Fig. 2—Geometry of scattering volume.

Define a width  $w$  along the intersection of the horizon planes (i.e., perpendicular to the plane of propagation) by the condition that the scattering coefficient at the edge  $\sigma_1$  is one-half that at the center point  $\sigma_0$ . The important volume will be taken as a vertical slab of constant width  $w$ . The condition on the scattering coefficient reduces with (3) to

$$\theta_0^4 = \frac{1}{2} \theta_1^4. \quad (4)$$

From Fig. 3, which represents the planes through the transmitter and receiver containing the angles  $\theta_0$  and  $\theta_1$ , the half-width  $w/2$  is

$$\left(\frac{w}{2}\right)^2 = \left(\frac{\theta_1}{2} \frac{d}{2}\right)^2 - \left(\frac{\theta_0}{2} \frac{d}{2}\right)^2, \quad (5)$$

and with (4)

$$w \doteq \frac{1}{3} \frac{d^2}{a}. \quad (6)$$

The volume integration now reduces to an integration on height  $h$ , in which an element of volume is the product of the width  $w$ , a length  $2h(2a/d)$ , as indicated in Fig. 2, and an element of height  $dh$ . The integration is



from a height,  $h=0$ , corresponding to the intersection of the horizon planes to  $h=\infty$ . The upper limit is permissible, since the scattered power will decrease rapidly with height (fourth or higher power) due to the scattering beam and a possible decrease of the intensity of turbulence with height.

the dependence on distance  $d$ , and, as one would expect, the power decreases more rapidly with distance as the intensity decreases more rapidly with height.

*Elevated Layers*

In Section I it is shown that turbulent elevated layers are observed 50 to 70 per cent of the time. Since the layers occur commonly, it is appropriate to determine the scattered power received from them. Solving this problem, and inserting reasonable values for the scale and intensity, one finds that the component of scattered power from the layer may easily equal or exceed the component from the atmosphere neglecting the layer.

In this problem it is assumed that the height above the ground, thickness, scale, and intensity of the layer are known. The scale and intensity specify the scattering coefficient per unit volume, and the problem reduces essentially to determining the important volume. The properties of the layer are assumed to be horizontally homogeneous, so the length of the important volume along the path and the width of the important volume across the path must be restricted by other considerations. The width is defined, as in the case of the atmosphere without a layer, to include all scattering elements whose contribution to the scattered power is one-half or more of the contribution of the scattering element in the vertical plane of propagation. The length is defined by the intersections with the layer of the horizon planes of transmitter and receiver, or to include all scattering elements whose contribution to the scattered power is one-half or more of the contribution of an element at the middle of the path, whichever is smaller. With the volume established, it is a simple matter to take into account the distance from the transmitter to the center of the volume, the scattering angle and scattering coefficient at the center of the volume, and the distance to the receiver in order to compute the total scattered power received from the layer.

For a turbulent layer at a height  $h$  above the ground and thickness  $\Delta h > s$ , the scattered power relative to the free-space power is

$$\frac{P}{P_{FS}} = \frac{K(\overline{\Delta\epsilon/\epsilon})^2 \Delta h d^4}{50sa(h + d^2/8a)^4} \min \{0.4d, 2\sqrt{2ah} - d\}. \quad (12)$$

Showing the contribution of a layer to the scattered power received, Fig. 4 (next page) gives the scattered power as a function of distance for particular values of  $h$ ,  $\Delta h$ , and  $(\overline{\Delta\epsilon/\epsilon})^2/s$ . For comparison, the scattering produced by a turbulent atmosphere without an elevated layer [from (8)] has been plotted on the same figure. The scattering parameter  $(\overline{\Delta\epsilon/\epsilon})^2/s$  for the layer is taken as ten times the value it would have at the layer height in the non-layered atmosphere. The thickness,  $\Delta h$ , is about one-fifth that shown later to be the thickness of the important scattering volume. The maximum power scattered by the layer under these assumptions exceeds that from a nonlayered atmosphere by a factor of two.

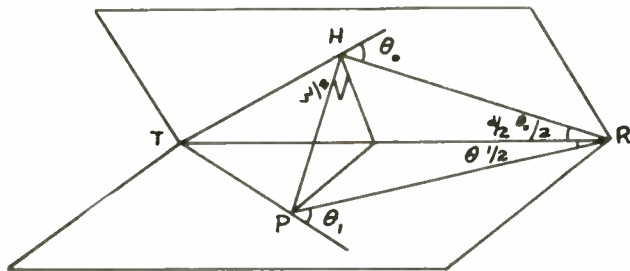

Fig. 3—Width of the volume.

With the important volume evaluated as described, and the approximation  $R=R_0=d/2$ , which is reasonable since the volume is quite restricted, (3) becomes

$$\frac{P}{P_{FS}} = 20.6Kd^{-1} \int_0^\infty \sigma h dh. \quad (7)$$

The parameters in the scattering coefficient, which vary with height, are the scattering angle  $\theta$  and the intensity  $(\overline{\Delta\epsilon/\epsilon})^2$ . Since the scattering angle is small, the sine is approximated by the angle. The intensity is assumed to vary inversely with height squared, as described in Section I. The evaluation of the integral, with the aid of (2), leads to

$$\frac{P}{P_{FS}} = 2.45Kca^4/sd^5, \quad (8)$$

where  $c$  is the constant of proportionality in the description of the variation of intensity with height  $h_1$  above the ground  $[(\overline{\Delta\epsilon/\epsilon})^2 = ch_1^{-2}]$ . For the correlation function  $\exp(-r/l)$ , large scatterers ( $s \gg \lambda$ ), off-beam scattering ( $\theta \gg \lambda/s$ ), and the intensity of turbulence decreasing with height squared, the scattered power relative to the free-space power varies inversely as the size of the scatterer and the fifth power of distance, but is independent of wavelength.

If the variation of intensity with height is taken as  $(\overline{\Delta\epsilon/\epsilon})^2 = c_n h_1^{-n}$ , where  $n$  is 0, 1, or 3, instead of  $n=2$  as in (8), the scattered power relative to the free-space power is given by

$$0.215 \frac{K(\overline{\Delta\epsilon/\epsilon})^2 a^2}{s d} \quad \text{for } n = 0 \quad (9)$$

$$0.627 \frac{Kc_1 a^3}{s d^3} \quad \text{for } n = 1 \quad (10)$$

$$11.3 \frac{Kc_3 a^5}{s d^7} \quad \text{for } n = 3. \quad (11)$$

It is important to note that the scattered powers, as given by (8) through (9), do not depend on the wavelength  $\lambda$ . The essential difference in the various forms is

For an atmosphere in which the intensity varies in some irregular manner with height, the scattered power as a function of distance could be computed by breaking the atmosphere into a number of layers in which the intensity is more or less constant, using (12) for each layer and adding powers at each distance.

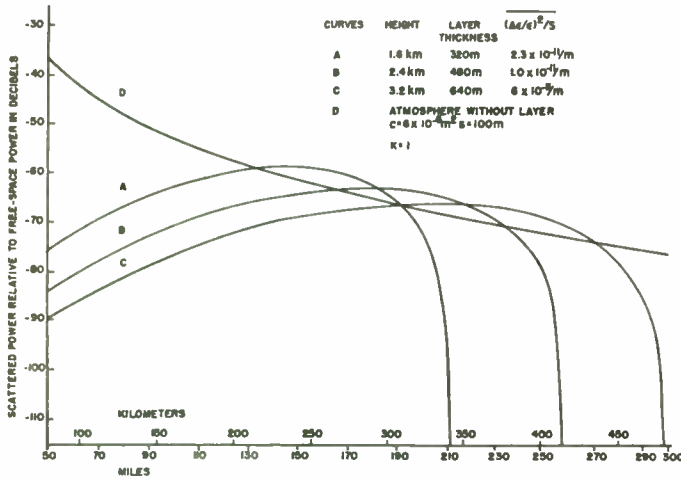

Fig. 4—Scattering by elevated turbulent layers.

Comparison with Observations

The radio observations of many investigations are collected in Fig. 5 (centimeter waves) and Fig. 6 (meter waves), where the co-ordinates are distance and scattered power relative to free-space power, and the wavelength of each datum is indicated. The separation into centimeter and meter waves is simply for clarity. The theoretical curves are the same in the two figures except for the values of  $K$ , and are drawn for typical values of the intensity, since measured values are not available for any of the radio observations.  $K$  is taken as one for centimeter waves assuming poor reflection, and as four for meter waves assuming perfect reflection. The range about the typical values is large, particularly at the shorter distances, where the lower troposphere is responsible. Part of the range may be explained by the

natural variations in intensity, and part must be due to the presence of turbulent elevated layers.

Although no simultaneous refractometer and radio observations are available, the results of the experiment by Megaw<sup>5</sup> suggest that an elevated layer was present. Megaw's radio observations are shown in Fig. 7, facing page, with three theoretical curves, one representing the scattered power expected in an atmosphere without a layer (8), the second representing contribution of the layer (12), and the third showing combination of one and two obtained by adding powers. While the scattering parameters have been adjusted to fit the observed power-levels, the agreement between the shape of the final theoretical curve and the observations is striking, and the scattering parameters assumed have reasonable values. For purposes of calculation, the layer is assumed to be a slab with uniform scattering parameter and sharp boundaries; thus, a discrepancy in shape is introduced in the neighborhood of 350 km, where the horizon planes of transmitter and receiver intersect at the top of the layer. This discrepancy is not serious and could be removed by assuming a smooth distribution of the scattering parameter across the upper boundary of the layer. While the importance of elevated scattering layers cannot be quantitatively assessed at present, qualitatively they will increase the range of power observed on communication links operating beyond the horizon.

IV. DIVERSITY DISTANCES

The scattering polar diagram restricts the important scattering volume to a relatively small size in propagation well beyond the horizon. The small volume produces a number of interesting consequences in the characteristics of the scattered field in the vicinity of a receiver. From the size of the volume, one can deduce the separation between spaced receivers at which the instantaneous powers become uncorrelated. It is apparent that if two receivers are placed side by side the outputs fade together, that is, the outputs are correlated. As the separation is increased, the correlation between the outputs decreases until a separation is reached where the correlation has fallen to a value of about  $1/e$  and the out-

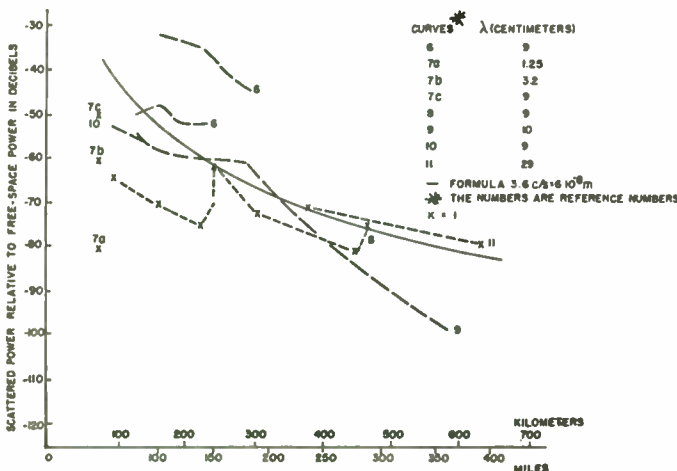

Fig. 5—Scattered power vs distance, centimeter waves.

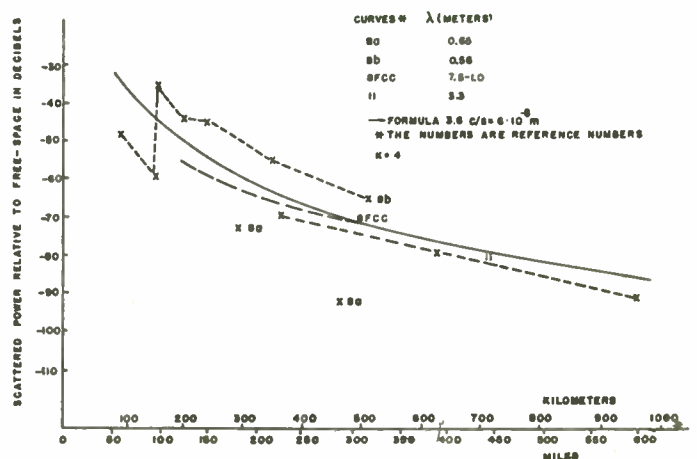

Fig. 6—Scattered power vs distance, meter waves.



puts are more or less independent. This latter separation is usually called the correlation or diversity distance. Diversity distances are specified in the vicinity of the receiver in three directions: vertically, horizontally normal to the path, and horizontally along the path.

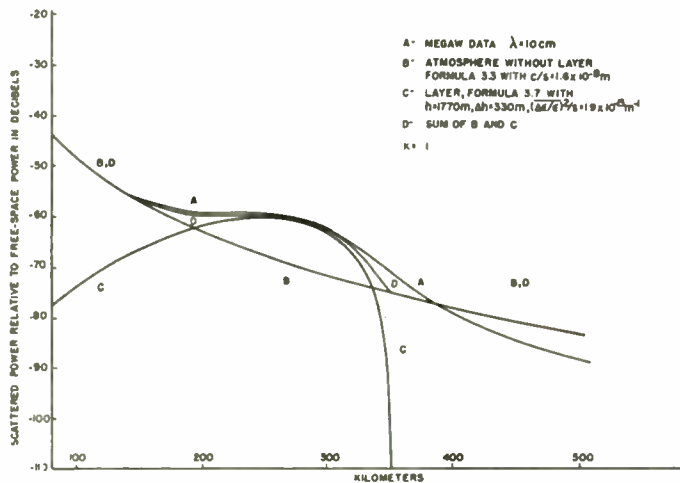

Fig. 7—Scattering by an atmosphere containing a turbulent layer.

The vertical-diversity distance is related to the height-gain curve observed in the scattered field, and diversity distances predict the maximum aperture of the antenna which yields something like its full theoretical gain. The diversity distances combined with the draft velocity of the scatterers and the turbulent velocity of the scatterers yield the fading rate (Section V) in the scattered field.

The size of the scattering volume can be used to predict distortion of pulses introduced by the scattering mechanism, or, inversely, the frequency band (Section VI) over which the fading of carrier frequencies is correlated.

Consider a situation in which the scattered power collected by a receiver is distributed over a relatively small cone. Suppose that the cone angle is defined by the condition that the scattered power-density near the edge of the cone is one-half that at the maximum within the cone. For this situation the horizontal angle through which power is mainly received is  $w/(d/2)$  from Fig. 3. By means of the usual antenna relation, beam-angle = wavelength divided by aperture-width, the beam-angle of the scattering cone may be converted into a diversity or correlation distance for spaced receivers. The horizontal correlation distance normal to the path is

$$D_h = 3\lambda a/4d, \quad (13)$$

where  $2D_h$  is used as the aperture to convert from beam angle to aperture.

In order to calculate the vertical correlation distance  $D_v$  from the antenna-beam-aperture formula, the appropriate vertical cone angle of scattering must be determined. To determine the size in the vertical direction of the important volume, consider the variation of scattering with height. Starting from the height where the horizon planes of the transmitter and receiver intersect, the variation of the scattered power with increas-

ing height is controlled by three factors:

1. The scattering angle  $\theta$  increases, thereby reducing the scattered field.
2. The scattering volume increases, since it is bounded by the horizon planes of the transmitter and receiver, thereby increasing the scattered field.
3. The refractive index fluctuations (assumed proportional to inverse height squared) decrease, thereby decreasing the scattered field.

The combination of these factors [the integrand in (7)] produces a distribution of scattered power, with height starting at zero at the intersection of the horizon planes (height above ground =  $h_0 = d^2/8a$ ), increasing as the volume increases, reaching a maximum at about  $4h_0/3$  as the effect of increased scattering angle overcomes the increasing volume, and decreasing due to the scattering angle effect and partially because of the decrease in intensity, with height reaching a value one-half of the maximum at a height above the ground of about  $2h_0$ .

The angle subtended by the thickness of the important scattering volume, that is, the height interval between half-power points at a distance  $d/2$ , inserted in the antenna-beam-aperture formula, yields

$$D_v = \lambda a/d, \quad (14)$$

where the antenna aperture is taken as  $2D_v$  and the beam is doubled to allow for the power reflected by the ground and received at the antenna.

The horizontal and vertical correlation distances  $D_h$  and  $D_v$  have the property of measuring the largest horizontal and vertical dimensions for a broadside antenna that would yield something like its full theoretical gain. In the same way, it is assumed that the correlation distance  $D_a$  along the path is the length of an end-fire antenna that would give approximately full gain. For the situation in which  $D_h \cong D_v$ , this means that

$$\frac{\lambda}{D_h} \cong \frac{\lambda}{D_v} = \left( \frac{\lambda}{2D_a} \right)^{1/2} \quad (15)$$

or

$$D_a \cong D_v^2/2\lambda. \quad (16)$$

The height-gain function of the scattered signal depends directly upon the vertical correlation distance  $D_v$ . For, if the receiver and its image in the ground are separated by a distance equal to or less than  $D_v$ , normal height-gain is present. That is, from the ground up to a height  $D_v/2$ , the usual height-gain is observed for direct and ground reflected waves from a transmitter located roughly at the midpoint of the path at a height of about  $4h_0/3$  above the ground. The height of the maximum of the lowest lobe in this situation is about  $D_v$ ; hence no lobe structure will be observed. Above the height  $D_v/2$ , the scattered power is nearly independent of height, increasing at a slow rate because of a slow decrease in the scattering angle.

The scattering volume has been restricted, by the scattering polar diagram, to a relatively small size, and is located in the vicinity of the midpoint of the propaga-

tion path. If this volume just fills the antenna beam, a certain amount of power is observed. If the antenna beams are made smaller, the same amount of power is observed, for while the antenna now sees only a part of the scattering volume—which reduces the power observed—an increase in gain compensates. If the antenna beam is made larger, the volume no longer fills the beam, and the observed power is decreased because the source does not fill the beam and the gain is reduced. Thus the antenna whose beam is just filled by the volume is the maximum size which yields something like its full theoretical gain in the scattered field. The beam angle of this antenna is the size of the source (the important scattering volume), divided by the distance to the source from the antenna. The aperture-width by the usual antenna formula is the wavelength divided by the beam angle, which is the correlation distance previously computed. The correlation distance, therefore, is the maximum aperture-width of an antenna, which yields its full theoretical gain in the scattered field.

Bullington<sup>6</sup> reports that the full gain of a 1.45 meter parabolic dish was obtained at a distance of 400 kilometers with a wavelength of 8 centimeters. From (13) and (14) the diversity distances are 1.2 and 1.6 meters, indicating that approximately the full theoretical gain of antennas of this size is available in the scattered field. Bullington's observation and this theory are therefore consistent.

### V. FADING RATES

One of the factors which determine the usefulness and limitations of a particular propagation mechanism is the fading rate introduced by the mechanism. In radio scattering in the troposphere, fading is introduced by the turbulent velocity and the drift velocity of the scatterers. These velocities produce fading when properly combined with correlation distances, which depend on the size and polar diagram of the scatterers. For example, if the scatterers produce a correlation distance  $D$  in a certain direction, and if the scatterers are drifting with a mean speed  $w$  in this direction, the fading rate introduced is of the order of  $w/D$ . The fading rate introduced by turbulent velocity  $v$  is determined by a Doppler shift of frequency caused by relative motion of the scatterers in the manner of Ratcliffe<sup>7</sup> and is  $\sqrt{v^2/D}$ .

### VI. FREQUENCY BANDWIDTH

The frequency band, over which carrier frequencies will be correlated at a single receiving site well beyond

the radio horizon, may be estimated by considering the difference in path length between waves scattered at the upper ( $U$  in Fig. 8) and lower ( $L$  in Fig. 8) bounds of the important scattering volume. The path difference is

$$TUR - TLR = 10h_0^2/d, \quad (17)$$

where  $h_0 = d^2/8a$  is the vertical dimension of the important volume, and this corresponds to a time delay of

$$10d^3/64a^2c, \quad (18)$$

where  $c$  is the velocity of light. The reciprocal of (18) is the frequency band over which correlation of the fading of carrier frequencies is expected. The diversity band in megacycles is, for  $d$  in hundreds of miles,

$$30/d^3. \quad (19)$$

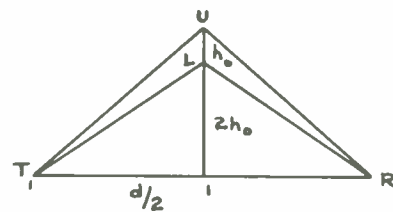

Fig. 8—Frequency bandwidth geometry.

### BIBLIOGRAPHY

1. Booker, H. B. and W. E. Gordon, "A Theory of Radio Scattering in the Troposphere," *Proc. I.R.E.*, Vol. 38 (April, 1950), pp. 401-412.
2. Crain, C. M., "Apparatus for Recording Fluctuation in the Refractive Index of the Atmosphere at 3.2 Centimeters Wavelength," *Rev. Sci. Instr.*, Vol. 21 (1950), pp. 456-457.
3. Birnbaum, G., "A Recording Microwave Refractometer," *Rev. Sci. Instr.*, vol. 21 (1950), pp. 169-176.
4. von Rosenberg, C. E., C. M. Crain, and A. W. Straiton, *Atmospheric Refractive-Index Fluctuations as Recorded by an Airborne Microwave Refractometer*, Paper at URSI Spring Meeting, Washington, D. C., 1953; also Electrical Engineering Research Laboratory, University of Texas, Report 6-01, 1953.
5. Megaw, E. C. S., "Scattering of Short Radio Waves by Tropospheric Turbulence," *Nature*, Vol. 166 (1950), p. 1100.
6. Bullington, K., "Radio Transmission Beyond the Horizon in the 40-4,000 Mc Band," *Proc. I.R.E.*, Vol. 41 (January, 1953), pp. 132-135.
7. Ratcliffe, J. A., "Diffraction from the Ionosphere and the Fading of Radio Waves," *Nature*, Vol. 162 (1948), p. 9.
8. Katzin, M., R. W. Bauchman, and W. Binnian, "3-and-9-Centimeter Propagation in Low Ocean Ducts," *Proc. I.R.E.*, Vol. 35 (September, 1947), pp. 891-905.
9. Day, J. P. and J. C. Trolese, "Propagation of Short Radio Waves Over Desert Terrain," *Proc. I.R.E.*, Vol. 38 (January, 1950), pp. 165-175.
10. Katzin, M., private communication.
11. Chambers, G. R., J. W. Herbstreit, and K. A. Norton, *Preliminary Report on Propagation Measurements from 92-1046 Mc at Cheyenne Mountain, Colorado*, National Bureau of Standards Report 1826, 1952.





# Accurate Linear Bidirectional Diode Gates\*

J. MILLMAN†, SENIOR MEMBER, IRE AND T. H. PUCKETT†, ASSOCIATE, IRE

**Summary**—In a computer developed at the Columbia University Electronics Research Laboratories, it was necessary to design a network having the following properties: Its transfer function should be determined by an audio-frequency square-wave control voltage, the transfer function should be unity for one polarity of the square wave and zero for the other polarity, and the inaccuracies should be less than 0.1 per cent.

This paper describes two-diode, four-diode, and six-diode types of bridge switches which were investigated to meet the above need. For each type a discussion is given of the important parameters of the system such as control voltage amplitudes, magnitude of gain, constancy of gain versus signal amplitude, leakage through the back resistances of the diodes, effects of unbalances in the system, and others. A brief review is given of triode and pentode gates.

A discussion is also given of the considerations arising from the use of series, parallel, and series-parallel combinations of switches. Some actual circuits are described which meet the original specifications. An experimental method for checking the linearity is given.

## INTRODUCTION

A LINEAR, or transmission, gate is a circuit in which the output is a reasonable reproduction of the input during a time interval selected by a square-wave control signal and zero otherwise. The ideal linear gate has the following properties:

- The transfer characteristic is either zero or unity, depending upon the polarity of the square-wave control voltage. If the transfer function is not unity, then it should be constant, independent of the signal amplitude (in order for the gate to be a linear device).
- None of the control voltage appears at the output.
- The magnitudes of the required minimum control voltages are not excessive.
- The magnitudes of the control and signal currents are not excessive.

The application under consideration involved the processing of radar data on the face of an oscilloscope. Other uses for the gating circuits discussed in this paper include electronic switches for oscilloscopes, synchronized clamps, sampling systems, amplitude modulation, special waveform generation, etc.

## TRIODE AND PENTODE GATES

A linear gate using triodes<sup>1</sup> (see Fig. 1) was investigated. The circuit has the virtue of extreme simplicity. If the signal voltage  $S$  is unidirectional then one of the two tubes may be omitted. The following difficulties are encountered with the circuit:

- There is attenuation because of the tube drop.

\* Original manuscript received by the IRE, July 30, 1954. This research was supported by the U. S. Air Force under Contract No. AF 30(120)-430, and monitored by the Rome Air Dev. Center, Griffiss AF Base, Rome, N. Y.

† Electronics Res. Labs., Dept. Elec. Eng., Columbia University, New York 27, N. Y.

<sup>1</sup> "Waveforms," Radiation Lab. Series, McGraw-Hill Book Co., Inc., New York, N. Y., vol. 19, pp. 375-378; 1948.

- There will be some nonlinearity because the tube resistance varies with current.

c. For positive values of signal voltage  $S$ , the control voltage will cause grid current, which will be a function of signal voltage, to flow through  $T_2$  into the output.

d. The control voltage is coupled to the output through the plate-to-grid capacitance of  $T_1$  and the cathode-to-grid capacitance of  $T_2$ . Hence, the output will contain pips or spikes at the beginning and end of the control interval.

e. Accuracies of no better than about 1 per cent have been obtained.

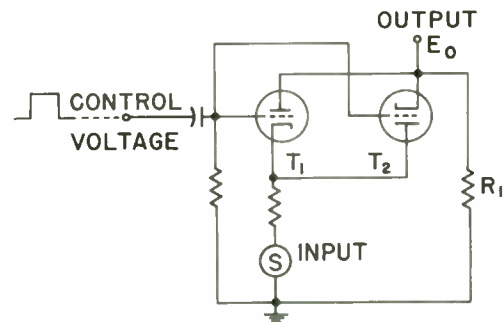

Fig. 1—A linear gate using triodes.

A triode with a square wave applied across a cathode resistor can also be used as a gate. The principal difficulties are that the output signal finds itself superimposed upon a "pedestal" and that the linearity is poor. The same difficulties arise if screen gating of a pentode is used or if one of the special double-control-grid tubes, such as a type 6AS6, is employed.

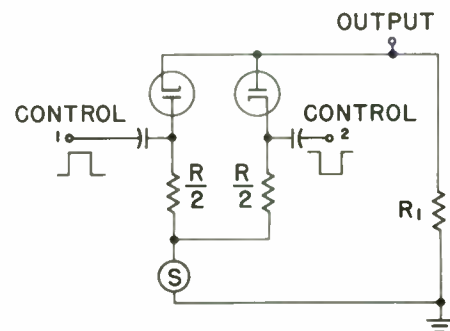

Fig. 2—Ac-coupled two-diode-bridge gate.

## DIODE-BRIDGE GATES

Most of the difficulties mentioned in the preceding section can be eliminated by using diodes in a bridge arrangement<sup>2</sup> such as indicated in Fig. 2. There are two

<sup>2</sup> V. Belevitch, "Linear theory of bridge and ring modulator circuits," *Elec. Commun.*, vol. 25, pp. 62-73; 1948. E. Peterson and L. W. Hussey, "Equivalent modulator circuits," *Bell Sys. Tech. Jour.*, vol. 18, p. 32; 1939. "Waveforms," *ibid.*, chap. 10 "Time Selection."

control inputs and these are excited in a "push-pull" manner, as indicated in the figure. If the control signals have the polarities shown then the diodes conduct and a fraction of the signal appears at the output. If the selector signals have the opposite polarities neither diode conducts and the output is zero. The control signals can also be transformer-coupled to the diodes. However, the transformer secondary capacitances shunt the output resistor and limit the frequency response. In order to lower these capacitances a pulse transformer is needed. This means that only narrow control voltages (say less than 25  $\mu$ sec) can be used. There may also be difficulty from ringing in the transformer at the beginning and end of the control square wave. Since in the present application a very long gate (several milliseconds) is required, then neither transformer- nor capacitive-coupling can be used with accuracy, and the control signal must be dc-coupled to the circuit, as indicated in Fig. 3. This two-diode circuit, which we shall call *Case A*, will be analyzed in detail in the next section. We will find the circuit to possess some of the properties of the ideal linear gate, as defined in the first section. An even closer approach to the ideal gate can be obtained with a four-diode (*Cases B and C*) or a six-diode gate (*Case D*), which will be discussed later.

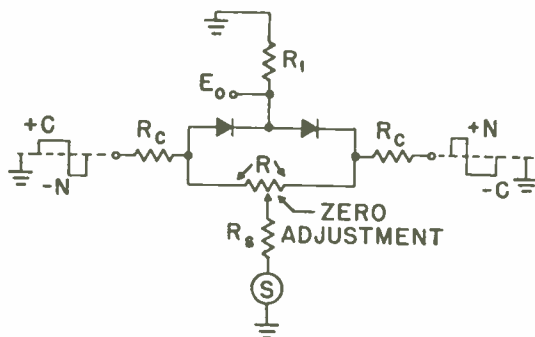

Fig. 3—Dc-coupled two-diode-bridge gate.

#### TWO-DIODE-BRIDGE GATE

##### Case A

In Fig. 3 we have included the output resistance  $R_c$  of the control source and the output resistance  $R_s$  of the signal source. The voltages  $C$  and  $N$  refer to the values of the selector voltages with respect to ground, when the bridge is conducting and nonconducting, respectively. The equivalent circuit is drawn in Fig. 4, for zero input signal and the diodes conducting.  $R_f$  is the diode forward resistance. From symmetry,  $I_1 = I_2$  and the net current through  $R_1$  is zero. Hence, the output voltage  $E_o$  is zero. This confirms the fact that for the balanced bridge arrangement, none of the control voltage appears at the output.

We shall now define and discuss the important features of this circuit such as the gain  $G$ , the leakage  $L$ , the unbalanced voltage  $U(C)$ , the control voltages  $C$  and  $N$ , and the several components of current in the circuit.

**Gain  $G$ :** The gain is defined as the change in output

voltage per unit change in signal input during the interval when the bridge is conducting. Assuming a linear circuit, we can use the principle of superposition and calculate the effect of the signal and control voltages separately. If, in Fig. 4, we set  $C=0$  and add the signal voltage  $S$  in series with  $R_s$ , then it is clear from symmetry that points  $A$  and  $B$  are at the same potential.

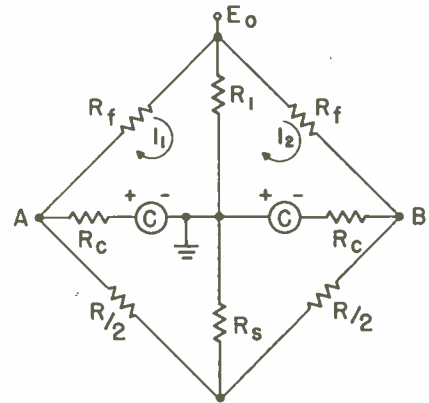

Fig. 4—Equivalent circuit of Fig. 3 for zero input signal.

Connecting these two points together gives the equivalent circuit of Fig. 5. Calculating  $E_o$  and dividing by  $S$  gives the gain  $G$ . The result is

$$G = \frac{1}{1 + \frac{R + 4R_s + 2R_f}{4R_1} + \left(\frac{R + 4R_s}{2R_c}\right)\left(1 + \frac{R_f}{2R_1}\right)} \quad (1)$$

As expected, the gain is less than unity. There is always some attenuation through the gate, and we shall later investigate how to keep this to a minimum.

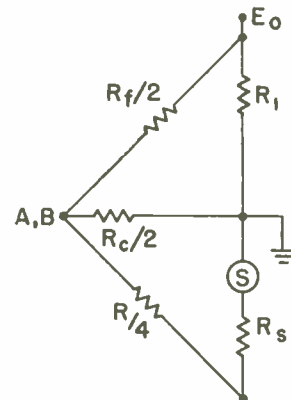

Fig. 5—Equivalent circuit of Fig. 3 for zero control signal.

**Leakage  $L$ :** The leakage is defined as the change in output voltage per unit change in signal input during the interval when the bridge is nonconducting. Clearly, the expression for  $L$  is the same as that for  $G$  except that the diode forward resistance  $R_f$  is replaced by the diode backward resistance  $R_b$ .

For a thermionic diode for which  $R_b$  is much greater than  $R$  or  $R_1$  or  $R_s$ , leakage is given approximately by



$$L \cong \frac{2R_1/R_b}{1 + \frac{R + 4R_s}{2R_c}} \quad (2)$$

$(R_b \gg R, R_1, R_s).$

**Unbalance  $U(C)$ :** The effect of unbalanced control voltages will now be investigated. Suppose that the control voltage on one side of the bridge is  $+C_1$  and on the other side is  $-C_2$ . Then these may be written

$$\left. \begin{aligned} C_1 &= \left( \frac{C_1 + C_2}{2} \right) + \left( \frac{C_1 - C_2}{2} \right) = C_a + \frac{C_u}{2} \\ C_2 &= - \left( \frac{C_1 + C_2}{2} \right) + \left( \frac{C_1 - C_2}{2} \right) = -C_a + \frac{C_u}{2} \end{aligned} \right\}, \quad (3)$$

where  $C_a = \frac{1}{2}(C_1 + C_2)$  is the average or the balanced control voltage, and  $C_u = C_1 - C_2$  is the unbalanced voltage. The *unbalance*  $U(C)$  is defined as the change in output voltage per unit change in unbalance voltage.

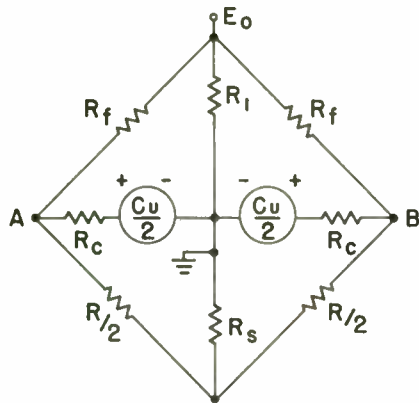

Fig. 6—Equivalent circuit of Fig. 3 for unbalanced control voltages.

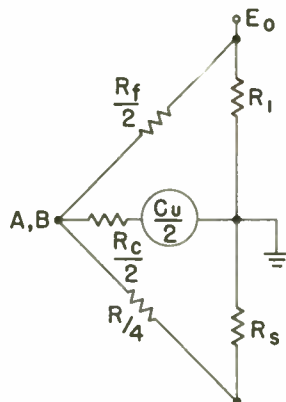

Fig. 7—Simplified version of Fig. 6.

The balanced voltages  $C_a$  give zero output, as has already been demonstrated. The equivalent circuit for the unbalanced components is drawn in Fig. 6. Clearly, from symmetry point  $A$  is at the same potential as point  $B$ . Connecting these two nodes together results in Fig. 7.

The solution of this network gives for the ratio  $E_o/C_u$  the following expression:

$$U(C) = \frac{\left( R_s + \frac{R}{4} \right) / R_c}{1 + \frac{R + \frac{R}{4} + \frac{R_f}{2}}{R_1} + \left( 2 + \frac{R_f}{R_1} \right) \left( \frac{R_s + \frac{R}{4}}{R_c} \right)} \quad (4)$$

If  $R_1 \gg R_s, R_f/2, R/4$  and if  $R_c \gg R_s, R/4$ , then

$$U(C) \cong \frac{R_s + \frac{R}{4}}{R_c} \quad (5)$$

If the size of  $R$  is not restricted by the above inequalities, namely, if only  $R_1 \gg R_s, R_f/2$  and  $R_c \gg R_s$ , then

$$U(C) \cong \frac{1}{2 + \frac{R_c}{R_1} + \frac{4R_c}{R}} \quad (6)$$

**Control voltage  $C$ :** The minimum control voltage  $C_m$  is that value which will ensure that current is flowing in the forward direction in both diodes. The current in  $R_f$  due to  $C$  is calculated from Fig. 4. (Due to symmetry the net current in  $R_1$  and also in  $R_s$  is zero. Hence, these may be shorted out when making this calculation.) The diode current due to  $S$  is calculated from Fig. 5. In one of the diodes of Fig. 3 these two currents add in the forward direction, and in the other they subtract. The value of  $C_m$  is that value which makes the diode current due to it just equal to the diode current due to  $S$ . Thus, if the value of  $C$  exceeds  $C_m$  it is certain that the current in both tubes will be in the forward direction. This calculation leads to the following expression for the minimum control voltage needed to cause the gate to close.

$$C_m = \frac{[SR_c^2 R_f / 2R] \left[ 1 + \frac{R}{2} \left( \frac{1}{R_c} + \frac{1}{R_f} \right) \right]}{\left( \frac{R_f}{2} + R_1 \right) \left( \frac{R}{4} + \frac{R_c}{2} + R_s \right) + \frac{R_c}{2} \left( \frac{R}{4} + R_s \right)} \quad (7)$$

If  $R_1 \gg R_s, R_f$  and  $R_c \gg R_s, R_f$ , then

$$C_m \cong \left( \frac{SR_c}{2R_1} \right) \left[ \frac{1 + \frac{2R_f}{R}}{1 + \frac{R}{4R_1} + \frac{R}{2R_c}} \right] \quad (8)$$

Note that no restrictions have been placed on the magnitude of  $R$ .

The value of  $C_m$  is proportional to the signal amplitude. The peak value of  $S$  is to be substituted into (8). In practice a value of  $C$  at least 25 per cent larger than the minimum value  $C_m$  should be used. The larger the value of  $C$  the greater is the ratio of control current to signal current through the diode. Hence, the more nearly

constant will be the forward resistance  $R_f$  of the diode versus signal current, and the more linear will be the operation of the gate.

**Control voltage  $N$ :** The minimum control voltage  $N_m$  is that value which will ensure that both tubes are cut off. An equivalent statement is to say that current is forced to flow in the backward direction in both tubes. Hence, the expression for  $N_m$  can be obtained from that for  $C_m$  by replacing  $R_f$  by  $R_b$  in (7).

For a thermionic diode  $R_b \gg R_c$ ,  $R_1$ . If, in addition,  $R_c \gg R_s$ ,  $R_f$  and  $R_b \gg R_c$ ,  $R_1$  the following expressions are found for the currents.

$$N_m \cong \frac{2SR_c}{R}. \quad (9)$$

Again no restrictions have been placed on the magnitude of  $R$ . The peak signal voltage is to be substituted into (9). A value of  $N$  at least 25 per cent larger than  $N_m$  should be used.

**Currents:** Subject to the restrictions  $R_1 \gg R_s$ ,  $R_f$  and  $R_c \gg R_s$ ,  $R_f$  and  $R_b \gg R_c$ ,  $R_1$  the following expressions are found for the currents.

The current from the control source during conduction is

$$I_c \cong \frac{1}{R_c} \left[ C + \frac{S}{1 + \frac{R}{2R_c} + \frac{R}{4R_1}} \right]. \quad (10)$$

The current from the control source during nonconduction is

$$I_n \cong \frac{N + S}{R_c + \frac{R}{2}}. \quad (11)$$

The current from the signal source during conduction is

$$I_{sc} \cong \frac{S}{\frac{R_1 R_c}{2R_1 + R_c} + \frac{R}{4}}. \quad (12)$$

The current from the signal source during nonconduction is

$$I_{sn} \cong \frac{2S}{R_c + \frac{R}{2}}. \quad (13)$$

The above formulas are tabulated in Table I (facing page).

**Discussion:** If the gain  $G$  is to be close to unity, then it follows from (1) that the following inequalities must be valid:  $R_1 \gg R$ ,  $R_s$ ,  $R_f$  and  $R_c \gg R$ ,  $R_s$ . However, from (9) it is seen that the inequality  $R_c \gg R$  will lead to a prohibitively large value of  $N_m$ . If  $R_c = 10R$ , for example, then  $N_m = 20S$  and for a signal whose peak value is 20 volts a control voltage of at least 400 volts is required. Hence, we must take  $R$  of the same order of magni-

tude as  $R_c$  and accept the resultant attenuation. For example, if  $G = 0.5$  is permissible, then with  $R_1 = R_c \gg R_s$ ,  $R_f$ , (1) yields  $R = 4R_1/3$ .

As a typical example, consider  $R_1 = R_c = 100K$ ,  $R = 133K$ ,  $R_s = 1K$ ,  $R_f = 0.25K$  and  $S = 20$  volts. Eqs. (1) through (13) give the following values:

$$\begin{array}{lll} G = 0.5 & U(C) = 0.16 & N_m = 30 \text{ volts} \\ C_m = 5 \text{ volts} & I_{sc} = 0.3 \text{ ma} & I_{sm} = 0.24 \text{ ma} \end{array}$$

for

$$C = 2C_m = 10 \text{ volts} \quad I_c = 0.2 \text{ ma}$$

and for

$$N = 2N_m = 60 \text{ volts} \quad I_n = 0.5 \text{ ma.}$$

These values are all of reasonable magnitude. Note that since  $R$  was chosen of the same order of magnitude as  $R_c$  (rather than  $R \ll R_c$ ), then the value of  $U(C)$  is large (a factor of ten larger than the four-diode bridge to be discussed below). For example, if  $C = 10$  volts and the unbalance is 10 per cent or 1 volt, then the output will contain 0.16 volt of control voltage. Since the peak signal is 20 volts, this represents an error of approximately 1 per cent of the peak signal. For some applications this may be excessive.

The unbalanced control voltage which appears in the output is constant independent of signal amplitude. The output voltage consists of the signal voltage superposed upon this constant unbalanced voltage. Hence, this unbalanced control voltage appearing in the output is called a "pedestal." The pedestal can be minimized by keeping the push-pull selector voltages balanced. As a practical matter it is not easy to do this with accuracies of better than a few per cent.

A method of compensating for the pedestal is to add in series with the output a fraction of the control signal. If the magnitude and polarity are properly chosen, this voltage will cancel the pedestal voltage, but accurate compensation is difficult to obtain.

It should be noted that by choosing  $R$  much greater than  $R_f$  the linearity is improved. Thus, a variation in diode resistance  $R_f$  with signal current has little effect on the gain  $G$  because  $R_f$  is added to the much larger  $R$ .

If a thermionic diode is used, its back resistance is limited by the leakage across the insulation between plate and cathode. With some care a value of  $R_b = 100$  megohms can be attained. Corresponding to this resistance, a value of  $L = 1.2 \times 10^{-3}$  is obtained from (2). Thus, only about 0.1 per cent of the signal voltage will leak through in the reverse direction. This conclusion is based upon the assumption that the tube acts like a pure resistance in the inverse direction. Modifications will be made later, when the effect of the interelectrode capacitance is taken into account.

Consider a crystal diode with  $R_b = 100K$ . Then (1), with  $R_b$  replacing  $R_f$  yields  $L = 0.35$ . Thus, 35 per cent of the signal leaks through in the inverse direction. Certainly, semi-conductor diodes are useless in this circuit.



TABLE I

(a)

(b)

	Case A. Fig. 3 $R_b \gg R_c, R_1 \gg R_s, R_f^*$	Case B. Fig. 8 $R_b \gg R_c, R_1 \gg R, R_s, R_f$	Case C. Fig. 9 $R_b \gg R_c, R_1 \gg R, R_s, R_f$ $N/R_f \gg E/R_c$	Case D. Fig. 10 $R_b \gg R_1, R_c \gg R, R_s, R_f$
$G$	$1 + \frac{R+4R_s+2R_f}{4R_1} + \frac{R+4R_s}{2R_c}$	$1 + \frac{R+4R_s+4R_f}{4R_1} + \frac{R+4R_s+2R_f}{2R_c}$	Same as Case A	Same as Case B
$L$	$\frac{2R_1/R_b}{1 + \frac{R+4R_s}{2R_c}}$	$\frac{2R_1R_c}{R_b^2}$	$\frac{2R_1/R_b}{1 + \frac{4R_s+R}{2R_f}}$	$\frac{2R_1R_f}{R_b^2}$
$U_c$	$\frac{(R_s + \frac{R}{4}) (\frac{1}{R_c})}{1 + \frac{R}{4R_1} + \frac{R}{2R_c}}$	$\frac{R_s + \frac{R}{4} + \frac{R_f}{2}}{R_c}$	$\frac{R_s + \frac{R}{4}}{R_c}$	$\frac{R_s + \frac{R}{4} + \frac{R_f}{2}}{R_c}$
$C_m$	$(\frac{SR_c}{2R_1}) \left[ \frac{1 + \frac{2R_f}{R}}{1 + \frac{R}{4R_1} + \frac{R}{2R_c}} \right]$	$S \left( 2 + \frac{R_c}{R_1} \right) \left( 1 + \frac{R}{4R_f} \right)$	$S$	$S$
$N_m$	$\frac{2SR_c}{R}$	$S$	$(S) \left[ \frac{1 + \frac{2R_f}{R}}{1 + \frac{2R_s}{R_f} + \frac{R}{2R_f}} \right]$	$S + \frac{ER_f}{R_c}$
$E_m$	.....	.....	$S \left( \frac{R_c}{2R_1} \right) \left( 1 + \frac{2R_f}{R} \right)$	$S \left( 2 + \frac{R_c}{R_1} \right) \left( 1 + \frac{R}{4R_f} \right)$
$I_c$	$\left( \frac{1}{R_c} \right) \left[ C + \frac{S}{1 + \frac{R}{2R_c} + \frac{R}{4R_1}} \right]$	$\frac{S+C}{R_c}$	$\frac{S+C}{R_b}$	$\frac{S+C}{R_b}$
$I_n$	$\frac{N+S}{R_c + \frac{R}{2}}$	$\frac{S+N}{R_b}$	$\frac{N}{R_f + \frac{R}{2}} + \frac{S}{2R_s + R_f + \frac{R}{2}}$	$\frac{N+E}{R_c}$
$I_{sc}$	$\frac{S}{\frac{R_1R_c}{2R_1+R_c} + \frac{R}{4}}$	$S \left( \frac{1}{R_1} + \frac{2}{R_c} \right)$	$S \left( \frac{1}{R_1} + \frac{2}{R_c} \right)$	$S \left( \frac{1}{R_1} + \frac{2}{R_c} \right)$
$I_{sn}$	$\frac{4S}{2R_c+R}$	$\frac{2S}{R_b}$	$\frac{S}{R_s + \frac{R}{4} + \frac{R_f}{2}}$	$\frac{2S}{R_b}$

\* This inequality is to be interpreted to mean that  $R_b$  is much greater than either  $R_c$  or  $R_1$  and that  $R_c$  (or  $R_1$ ) is much greater than either  $R_s$  or  $R_f$ .

A little thought shows that temperature effects tend to cancel out because of the arrangement of two diodes.

In Fig. 3,  $R$  is indicated as a potentiometer which is used to balance the bridge. This is necessary because the two  $R_c$ 's indicated on the diagram will only be approximately equal in practice and because the two-tube resistances may differ from one another. A second, though less convenient, method of balancing is to adjust the heater voltage of one of the two tubes.

FOUR- AND SIX-DIODE-BRIDGE GATES

Case B—(Four-Diode Bridge)

The chief difficulty with the two-diode bridge just described is the large value of  $N_m$  required if a gain close to unity is desired. The physical reason for this is that very little of  $N$  is used to cut off the diode because of the shunting action of  $R$  to ground. This can be avoided by replacing the resistor  $R/2$  by a diode since this will have

a high resistance in the reverse direction when it is desired that the voltage  $N$  be effective. On the other hand, in the forward direction the diode resistance is small and, hence, will cause little attenuation. The four-diode bridge which results from the above change is indicated in Fig. 8.

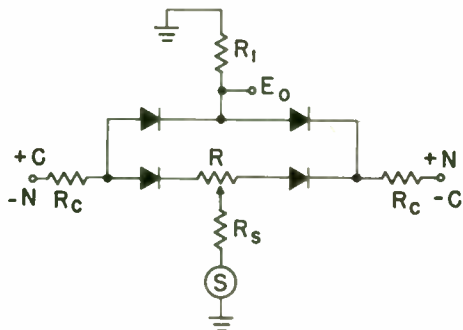

Fig. 8—One form of four-diode-bridge gate.

Table I contains the formulas for all the important quantities introduced on the preceding pages, and those to come. Note, in particular, that in this case  $N_m$  is a very reasonable value; namely, it is equal to the peak signal voltage.

In order to obtain a gain which is near unity, the value of  $R$  must be chosen much smaller than  $R_1$  or  $R_c$ . If  $R$  is taken equal to 1,000 ohms, and all other parameters are chosen as in Case A, the following numerical values are obtained:

$$G = 0.99 \quad L = 2 \times 10^{-6} \quad U(C) = 0.014 \quad C_m = 60 \text{ volts}$$

$$N_m = 20 \text{ volts} \quad I_{ac} = 0.4 \text{ ma} \quad I_{sn} = 0.04 \text{ ma}$$

for

$$C = 2C_m = 120 \text{ volts} \quad \text{and} \quad N = 2N_m = 40 \text{ volts}$$

then

$$I_c = 0.8 \text{ ma} \quad I_n = 0.04 \text{ ma.}$$

A considerable improvement over the two-diode gate has been obtained. There is still some sensitivity to unbalance and  $C_m$  may be excessive in some cases.

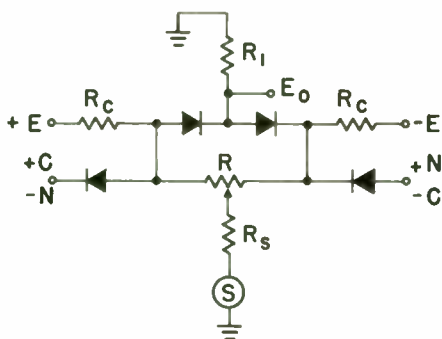

Fig. 9—A second form of four-diode-bridge gate.

Case C—(Four-Diode Bridge)

In Fig. 9 the gating circuit is modified to include two diodes whose function is to feed the control voltage to the bridge. The polarity of these diodes is such that they

conduct when the bridge diodes are nonconducting, and vice versa. A little thought will show that this should make the circuit completely insensitive to unbalance in control voltages, and results in a small value of  $N_m$  being required. The important formulas are given in Table I.

$U(E)$  is defined as the output voltage per volt of unbalance in the dc supply  $E$ . Since it is a simple matter to obtain balanced dc voltages, this factor is of little importance.

For the parameter values assumed above, the following numerical values are obtained:

$$G = 0.99 \quad L = 2 \times 10^{-4} \quad U(E) = 0.013$$

$$C_m = 20 \text{ volts} \quad N_m = 2.7 \text{ volts} \quad I_c = 0.04 \text{ ma} \quad I_{ac} = 0.6 \text{ ma}$$

$$E_m = 15 \text{ volts}$$

for

$$C = 2C_m = 40 \text{ volts} \quad \text{and} \quad N = 2N_m = 5.4 \text{ volts}$$

$$I_n = 11 \text{ ma} \quad \text{and} \quad I_{sn} = 14.5 \text{ ma.}$$

This circuit has excellent characteristics, but suffers from the defect that large control and signal currents are required during the interval when the gate is closed. The physical reason for these large currents is that, during this interval, the coupling diodes are conducting and, hence, there is a low resistance path between control and signal sources.

Case D—(Six-Diode Bridge)

A combination of Cases B and C results in the six-diode gate of Fig. 10 which has all the virtues of both and none of the defects. The following numerical values (for the same values of parameters as above) show it to be a precision device:

$$G = 0.99 \quad L = 5 \times 10^{-9} \quad U(E) = 0.013 \quad I_{ac} = 0.6 \text{ ma}$$

$$C_m = 20 \text{ volts} \quad N_m = 20 \text{ volts} \quad E_m = 60 \text{ volts} \quad I_c = 0.04 \text{ ma}$$

for

$$C = 2C_m = 40 \text{ volts} \quad \text{and} \quad N = 2N_m = 40 \text{ volts}$$

$$I_n = 0.8 \text{ ma} \quad \text{and} \quad I_{sn} = 0.04 \text{ ma.}$$

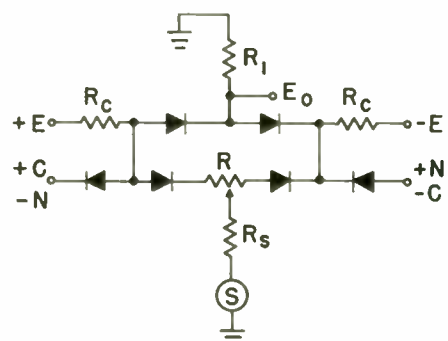

Fig. 10—Six-diode-bridge gate.

The formulas from which these values are calculated are given in Table I. A comparison of the four types of bridges, including the advantages and disadvantages of each, is given in Table II (facing page).



TABLE II

Case A.	Case B.	Case C.	Case D.
Advantages			
1. Simplicity. 2. No large currents. 3. If $R \gg R_f$ the linearity is improved.	1. Small $N_m$ for $G \cong 1$ . 2. No large currents. 3. Leakage negligible.	1. Small $N_m$ for $G \cong 1$ . 2. Insensitive to control unbalance. 3. Leakage smaller than $A$ . 4. Control voltage can turn bridge off quickly. 5. Can be used at higher signal frequencies than $A$ or $B$ .	1. Small $N_m$ for $G \cong 1$ . 2. Insensitive to control unbalance. 3. Leakage negligible. 4. No large currents. 5. Control voltage can turn bridge off quickly. 6. Can be used at higher signal frequencies than $A, B$ , or $C$ .
Disadvantages			
1. $G \ll 1$ for $N_m$ reasonable or $G \cong 1$ for excessive $N_m$ . 2. Sensitive to unbalance. 3. Leakage larger than $B, C$ , or $D$ . 4. Useful only at low signal frequencies. 5. Control voltage turns bridge on slowly.	1. More sensitive to unbalance than $C$ or $D$ . 2. $C$ may be large. 3. Useful only at low signal frequencies. 4. Control voltage turns bridge on slowly.	1. Large control and signal currents. 2. Control voltage turns bridge on slowly.	1. Complexity. 2. Control voltage turns bridge on slowly.

The amount of time it takes the bridge to turn on is proportional to the capacitance from the bridge terminals of  $R_c$  to ground. Transition times of the order of  $10 \mu\text{sec}$  are common for high impedance circuits. To reduce this,  $R_c$  and the capacitance must be kept small. In *Cases C* and *D* the bridge can be turned off quickly because the diode that feeds the control voltage has a low resistance  $R_f$  which shunts  $R_c$  during this time.

Germanium diodes can be used in the six-diode gate without too much leakage, but this is not true of the other gates. However, if the back resistances of the crystal diodes are not equal then, even for balanced control voltages, some of the control voltage will leak through the gate.

EFFECT OF TUBE CAPACITANCES

When the gate is "open" the diodes can be represented by a very large resistance  $R_b$  shunted by the interelectrode capacitance  $C_a$ . For a thermionic diode this capacitance may be  $5 \mu\mu\text{f}$ . If the signal contains high frequency components, then this capacitance will let these frequencies leak through the gate in the "nonconducting" condition. For example, consider *Case C*. The equivalent circuit is given in Fig. 11. This may be approximated by Fig. 12 where

$$S' = (R_f/2) \frac{S}{\left( R_s + \frac{R}{4} + \frac{R_f}{2} \right)}$$

For the parameters used above  $S' = 0.09S$ . Hence, 9 per cent of the signal voltage will leak through the gate for

frequencies for which the reactance  $X_c$  of the capacitance  $2C_a$  is much less than  $R_1$ . For  $R_1 = 1 \text{ meg}$  and  $C_a = 5 \mu\mu\text{f}$ ,  $R_1 = X_c$  at 16 kc. Hence,  $0.707 \times 9$  per cent or 6 per cent of the signal leaks through at 16 kc. If the frequency range is to be extended beyond the audio, a lower value of  $R_1$  and/or lower capacitance diodes (perhaps crystals) must be used. Lower forward resistance diodes will also be advantageous because  $S'$  is proportional to  $R_f$ .

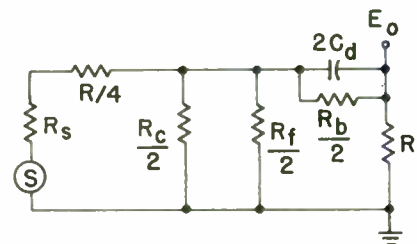

Fig. 11—Illustrating the effect of tube capacitances.

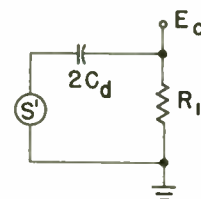

Fig. 12—Simplified version of Fig. 11.

For *Case D*, the signal is attenuated because of another  $2C_a$  which appears in series with  $R/4$ . Hence, this circuit can be used at much higher frequencies. For

example, a simple calculation shows that less than one per cent leakage results at frequencies below one megacycle.

The frequency range can be extended for each circuit at the expense of using a synchronized clamp (one of the bridge circuits with  $s=0$ ) across  $R_1$ . This gives an effective output impedance which is low during the non-conducting time of the bridge but equal to  $R_1$  during conduction.

SERIES AND PARALLEL COMBINATIONS OF GATES

A series arrangement is shown in Fig. 13(a), and the equivalent circuit in 13(b). This behaves as a logical AND-circuit. If two-diode bridges are used, then high attenuation can be expected and, hence, this circuit (Case A) will not be considered in a series arrangement.

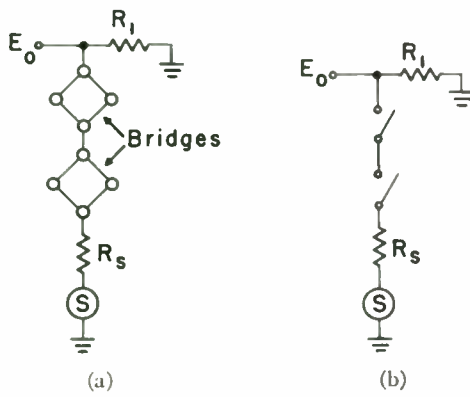

Fig. 13—A series combination of gates.

A parallel arrangement is shown in Fig. 14(a), and its equivalent circuit in 14(b). This is a logical OR-circuit. The control voltages are synchronized so that *only one gate closes at a time*. If this is not done then large circulating currents will flow through the low impedance between sources.

Let us calculate the control voltages for the parallel arrangement. Since only one gate is “on” at any time (and assuming infinite back resistance so that the “off” gates act as open circuits), then Fig. 14 reduces to that of a single “on” gate. Hence, the values of  $C_m$  and  $E_m$  given in Table I are also valid for parallel operation. However, with respect to the value of  $N_m$  we must remember that at the output of a nonconducting gate there is the output of the conducting gate. This output voltage is  $S$  if we neglect the attenuation through the conducting bridge. A little thought will show this additional voltage has no effect on Cases B and D. Hence, the values of  $N_m$  in Table I are still valid for these gates. For Case A, setting up the condition that the diodes must be nonconducting, we obtain

$$N_m = \left[ \frac{(2S) \left( 1 + \frac{2R_f}{R} \right)}{1 + \frac{2R_s}{R_f} + \frac{R}{2R_f}} \right] \left( 1 + \frac{R_s}{R_f} + \frac{R}{4R_f} \right) \quad (14)$$

subject to the inequalities listed in Table I.

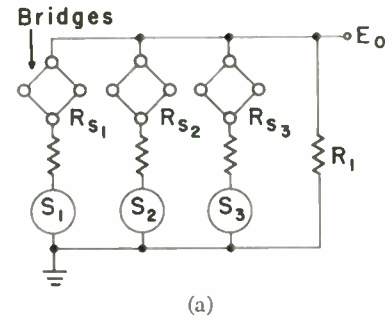

(a)

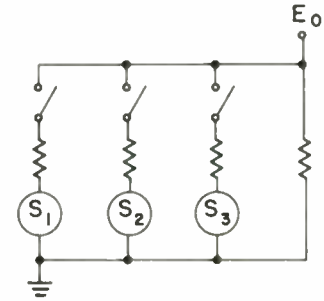

(b)

Fig. 14—A parallel combination of gates.

A similar derivation for Case C gives

$$N_m = \left[ \frac{2S \left( 1 + \frac{2R_f}{R} \right)}{1 + \frac{2R_s}{R_f} + \frac{R}{2R_f}} \right] \left( 1 + \frac{R_s}{R_f} + \frac{R}{4R_f} \right). \quad (15)$$

Let us now consider the control voltages for series operation. The cut-off voltage of a bridge cannot be influenced by the impedance at its output. Hence  $N_m$  as given in Table I is correct for series operation. The situation is different for  $C_m$  or  $E_m$ . Assume that all gates are conducting. Then the signal currents are approximately as indicated in Fig. 15. The currents due to  $E$  or  $C$  are

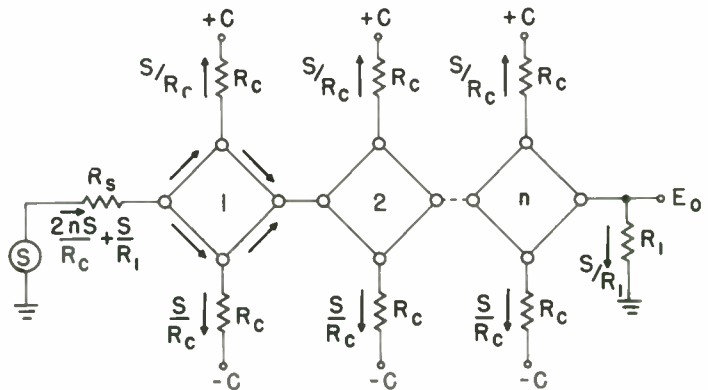

Fig. 15—The signal currents in the branches of a series combination of gates.

also found, and the condition is set up that the net current through any diode which should be conducting must be in the forward direction. This condition leads to the formulas given in Table III (facing page), where  $n$  is the number of series gates.



TABLE III  
SERIES OPERATION

	Case B.	Case C.	Case D.
$C_m$	$S \left[ \frac{R_c}{2R_1} + n \right] \left[ 2 + \frac{R}{2R_f} \right]$	$S$	$S$
$E_m$	.....	$S \left[ \frac{R_c}{2R_1} + n - 1 \right] \left[ 1 + \frac{2R_f}{R} \right]$	$S \left[ \frac{R_c}{2R_1} + n \right] \left[ 2 + \frac{R}{2R_f} \right]$

APPLICATION

It has been previously mentioned that the application at hand was processing of radar data. The actual arrangement used is shown symbolically in Fig. 16. The circuit is used with a radar set having a pulse repetition rate of 400 pulses per second, giving an interval between pulses of 2,500  $\mu$ sec. The sweep length is 1,500  $\mu$ sec and the retrace time 1,000  $\mu$ sec. During each of the retrace

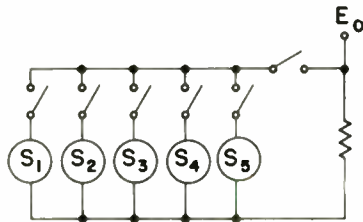

Fig. 16—An application using a series-parallel arrangement of gates.

intervals, one of the five signal inputs is fed through to the indicator, the five inputs being selected sequentially. A distributor<sup>3</sup> closes the parallel gates in turn for 2,500  $\mu$ sec, and the series gate closes during each of the 1,000  $\mu$ sec retrace times. As the inputs are slowly varying or dc voltages, the output is as shown in Fig. 17, and thus positions five "dots" on the indicator, which appear superimposed on the regular radar display. A resolved system is being considered, so the circuitry shown must be in duplicate to take care of both *X* and *Y* deflections.

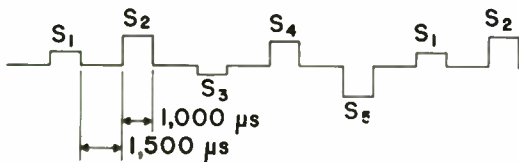

Fig. 17—The output waveform for the circuit of Fig. 16.

The peak signal magnitudes are 20 volts. As accuracy and linearity are the major considerations, the six-diode form of gate was used. As it was desired to load the signal sources as lightly as possible,  $R_c$  was taken as 2 megohms, and  $R_1$  as 1 megohm, these values being as

<sup>3</sup> T. K. Sharpless, "High-speed *n*-scale counters," *Electronics*, vol. 21, pp. 122-125; March, 1948.

large as allowed by other circuit considerations.  $E_o$  was taken as 300 volts, this being the largest convenient voltage available, and well above the  $E_m$  of 200 volts which resulted from the choice of  $R$  as 1,000 ohms.  $R_f$  is about 375 ohms, which is a reasonable figure for the forward resistance of the 6AL5 diodes used.

The measured values of the gate operating parameters agreed well with the calculated values. The gain was 0.996, the leakage less than 0.05 per cent, and the deviation from linearity less than 0.05 per cent.

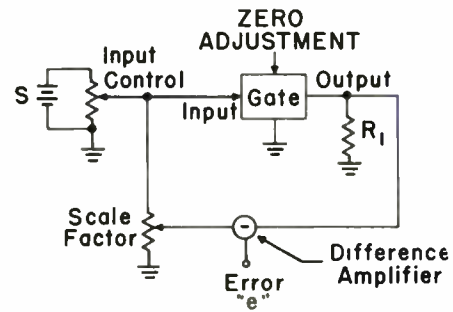

Fig. 18—The testing circuit for the measurement of linearity.

APPENDIX

MEASUREMENT OF NONLINEARITY OF TRANSFER FUNCTION

It is a matter of some difficulty to check the non-linearity of a gate to the precision desired in the application considered. The procedure used in this case was to make the measurement on a dc basis. The testing method is indicated in Fig. 18. The major requirement is that the difference taker be accurate and sensitive. A Tektronix type 512 oscilloscope was used, as it has a convenient high-sensitivity difference amplifier built into it. It was necessary to check the alignment controls to reduce the inherent error in the difference amplifier of the scope.

The test procedure is as follows: the gate is placed in its closed condition. The input control is placed at ground, and the zero adjustment of the gate is manipulated to reduce the error voltage "e" to zero. The input control is brought up to full input. The scale-factor pot is then adjusted until the error voltage "e" is again zero. The gain may be conveniently read from an accurately calibrated scale-factor potentiometer. This setting is unaltered throughout the remainder of the measurement. The input control is then run back and forth through its range and the error voltage "e" is observed, and its maximum value noted. This maximum value divided by the peak signal input *S* is then called the fractional non-linearity.

This procedure may be represented graphically as plotting the input-output relation of the gate, drawing a straight line between the initial and terminal points of the curve, and noting the maximum ordinal distance between the two lines. This is the same as the maximum value of the error voltage.

# Effect of Base-Contact Overlap and Parasitic Capacities on Small-Signal Parameters of Junction Transistors\*

R. L. PRITCHARD†, ASSOCIATE MEMBER, IRE

**Summary**—In a grown-junction transistor in which the base connection consists of an alloy contact, overlap on emitter and/or collector regions may produce appreciable capacity between emitter-base and collector-base terminals. The effect of such overlap capacity upon measured small-signal parameters at high frequencies is described briefly for both grounded-base and grounded-emitter operation. Typical experimental results are shown for two different parameters. Also, it is noted that interterminal parasitic capacities affect measured parameters in the same manner as do these overlap capacities.

## INTRODUCTION

IN A RECENT paper, the writer has described the variation with frequency of the four small-signal  $h$  parameters for a theoretical model of a junction transistor.<sup>1</sup> The model comprises the ideal one-dimensional transistor introduced by Shockley and modified by Early to include space-charge-layer widening effects, plus a constant base spreading resistance  $r_b'$  connected between the (inaccessible) base terminal of the ideal transistor and the external base terminal. Subsequently, it has been shown that for a grown-junction transistor, in which account must be taken of the *distributed* nature of the spreading resistance and transistor parameters within the base region, this same type of model may be used, provided that the base spreading resistance is replaced by a complex, frequency-dependent base impedance.<sup>2</sup> In either case, the effect of parasitic capacity between pairs of the three external terminals has not been included. Such parasitic capacity will exist to some extent in any transistor, e.g., owing to the can in which the transistor is mounted. Capacity of this type generally will be small, although not necessarily negligible.

However, in grown-junction transistors in which the base connection consists of an alloy contact to the base region,<sup>3</sup> appreciable capacity may exist between emitter-base and collector-base terminals due to overlap of the alloy contact on the emitter and collector regions, respectively. When the base contact overlaps the  $n$ -type

emitter or collector material, an alloy, or fused, junction is formed. Associated with each junction is a capacity the value of which depends upon the area of overlap, the resistivity of the  $n$ -type material, and the dc voltage between the external base terminal and the  $n$ -type material. In the case of the overlap on a low-resistivity emitter region, capacity per unit area may be extremely high, e.g., for 0.01 ohm-cm emitter material with, say, a potential of 0.5 volt between emitter region and base terminal, 6,000  $\mu\mu\text{f}/\text{mm}^2$  is obtained (and inverse breakdown voltage is but a fraction of a volt).

These overlap capacities  $C_{eb}'$  and  $C_{cb}'$  appear directly between the external base terminal and emitter and collector terminals respectively, as shown in Fig. 1. The theoretical model considered earlier is shown within the dotted lines. For purposes of further discussion, the model comprising an ideal transistor plus base impedance will be termed the *inherent* transistor.

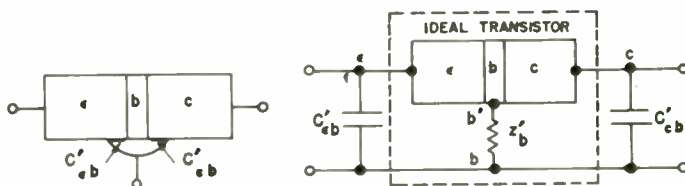

Fig. 1—Grown-junction transistor with alloy base contact, and equivalent model.

## EFFECT OF OVERLAP CAPACITIES

The purpose of this paper is to discuss the effect of such overlap capacities upon the measured small-signal parameters of the transistor. Since the base contact is a necessary part of the transistor, the overlap capacities cannot be divorced from the device itself as can the parasitic capacities associated with, say, the can containing the transistor. The remarks to be made concerning the effect of the overlap capacities, of course, can be applied to include can or socket capacities, if desired.

The effect of adding  $C_{eb}'$  and  $C_{cb}'$  to the theoretical model as shown in Fig. 1 will be to modify to some extent each of the four small-signal parameters for each of the three possible configurations, *viz.*, grounded-base, grounded-emitter and grounded-collector. Equations for the terminal small-signal parameters are given in the Appendix for a transistor characterized by four series-parallel  $h$  parameters and having external admittances between each pair of terminals. From these expressions, the effect of the parasitic capacity upon measured parameters can be calculated for any particular case.

\* Original manuscript received by the IRE, September 20, 1954.  
† General Electric Research Lab., Schenectady, N. Y.

<sup>1</sup> R. L. Pritchard, "Frequency variations of junction-transistor parameters," *PROC. I.R.E.*, vol. 42, pp. 786-799; May, 1954. See also, J. M. Early, "Design theory of junction transistors," *Bell Sys. Tech. Jour.*, vol. 32, pp. 1271-1312; November, 1953.

<sup>2</sup> R. L. Pritchard, "Theory of grown-junction transistor at high frequencies," presented at Semiconductor Device Research Conference, Minneapolis, Minn., June 29, 1954; planned for publication. See also, R. L. Pritchard and W. N. Coffey, "Small-signal parameters of grown-junction transistors at high frequencies," *I.R.E. Conv. Rec.*, vol. 2, pt. 3, pp. 89-98; 1954.

<sup>3</sup> This type of contact has been used by R. N. Hall of this Laboratory for several years. Recently, M. E. Jones and F. Horak described their use of this type of contact in their paper, "Alloyed base contacts for grown-junction transistors," presented at the Semiconductor Device Research Conference, Minneapolis, Minn., June 29, 1954.



A completely general description of the effect of the overlap capacities would of necessity be quite lengthy because of the large number of independent variables involved, e.g., at least seven fundamental transistor parameters, frequency, etc. However, it might be of interest to mention here a few of the ways in which overlap capacities may make their presence known.

Since the overlap capacities effectively bypass the inherent transistor, modifications *generally* will be more pronounced at lower dc emitter currents  $I_e$ , when the impedances of the transistor are larger. Further remarks will be confined to the case of  $I_e$  of the order of 1 ma.

In general, the effects of overlap capacity upon forward-transmission parameters ( $h_{11}$ ,  $h_{21}$ ) first become noticeable at frequencies of the order of the  $\alpha$ -cutoff frequency. On the other hand, the presence of overlap capacity may make itself felt upon the backward-transmission parameters ( $h_{12}$ ,  $h_{22}$ ) at lower frequencies.

#### Grounded-Base Operation

**Forward-Transmission Parameters  $h_{11}$ ,  $h_{21}$ :** Collector-base overlap capacity  $C_{cb}'$  has no effect upon these parameters. On the other hand, emitter-base overlap capacity  $C_{eb}'$  acts as an effective shunt across the input circuit of the transistor. Hence,  $C_{eb}'$  effectively adds to the capacitive susceptance associated with  $h_{11}$ , and may reduce the magnitude of the current-amplification factor  $h_{21}(= -\alpha)$  if the input impedance of the transistor is capacitive reactive. Of considerably more importance, however, is the case for which  $h_{11}$  is inductive reactive, e.g., at frequencies below the  $\alpha$ -cutoff frequency (with  $I_e$  of the order of 1 ma). In this case,  $C_{eb}'$

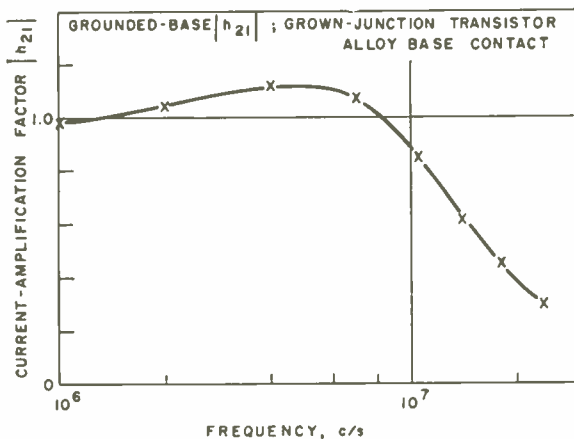

Fig. 2—Magnitude of grounded-base current-amplification factor  $|h_{21}|$  as a function of frequency for grown-junction transistor with alloy base contact.

effectively forms an anti-resonant circuit of low  $Q$  with the input circuit of the inherent transistor, and the current into the inherent transistor actually may exceed the terminal current. Hence,  $|h_{21}|$  is increased and, in fact, may exceed unity in some cases,<sup>4</sup> as shown in Fig. 2.<sup>5</sup>

<sup>4</sup> The fact that  $|h_{21}|$  may exceed unity at high frequencies due to emitter-base capacity was pointed out previously by various members of Bell Telephone Labs. in informal discussion. In particular, the writer believes this was pointed out first by O. Kummer.

<sup>5</sup> The writer is grateful to W. N. Coffey for supplying curve data.

**Backward-Transmission Parameters  $h_{22}$ ,  $h_{12}$ :** Collector-base overlap capacity  $C_{cb}'$  has no direct effect upon  $h_{12}$  and merely adds to the capacitive susceptance of  $h_{22}$ . Note, however, that measured collector-base capacity at low frequencies therefore is the sum of internal transistor junction capacity plus overlap capacity. Unfortunately, these two capacities influence circuit performance in different ways, and it would be desirable to be able to separate the two values, e.g.,  $C_{cb}'$  may be "tuned out" in a narrow-band circuit.

Furthermore, it should be noted that if overlap capacity is an appreciable fraction of terminal collector-base capacity, calculation of the base spreading resistance  $r_b'$  from measurements of  $h_{12}$  as a function of frequency may be considerably in error (too low a value is obtained for  $r_b'$ ). (At medium frequencies, for the inherent transistor,  $h_{12} \doteq j\omega r_b' C_{22}$ .) Fortunately, the product  $r_b' C_{22}$  for the transistor, which is important in determining high-frequency power gain,<sup>6</sup> can be calculated directly from the measured value of  $h_{12}$  independent of  $C_{cb}'$ .

Emitter-base overlap capacity effectively bypasses the input terminals, so that when an open-circuit terminal measurement is made for  $h_{12}$  and  $h_{22}$ , truly open-circuit conditions are not presented to the inherent transistor.<sup>7</sup> Generally, this bypass affects measured  $h_{12}$  only at frequencies of the order of the  $\alpha$ -cutoff frequency. On the other hand, terminal open-circuit admittance may be quite different from the inherent-transistor  $h_{22}$  at lower frequencies. For example,  $C_{eb}'$  may cause the measured open-circuit collector-base conductance (real part of  $h_{22}$ ) to be *negative*.<sup>8</sup>

#### Grounded-Emitter Operation

Note that in this case, collector-base capacity  $C_{cb}'$  acts not as a simple bypass capacity but as a feedback capacity.

**Forward-Transmission Parameters  $h_{11}$ ,  $h_{21}$ :** As in the case of grounded-base operation, emitter-base overlap capacity effectively bypasses the input terminals. Since the short-circuit input impedance for grounded-emitter operation is capacitive reactive at medium and high frequencies and is of larger magnitude than in grounded-base operation,  $C_{cb}'$  may considerably decrease the actual input current to the inherent transistor. Hence, the measured current-amplification factor may be lower than that of the inherent transistor, and the  $h_{21}$ -cutoff frequency may be decreased.

**Backward-Transmission Parameters  $h_{12}$ ,  $h_{22}$ :** As in grounded-base operation, at the higher frequencies

<sup>6</sup> R. L. Pritchard, "Frequency response of grounded-base and grounded-emitter junction transistors," presented at A.I.E.E. winter Meeting in New York, N. Y., January 20, 1954; to be published. See also, J. M. Early, "P-N-I-P and N-P-I-N junction transistors," *Bell Sys. Tech. Jour.*, vol. 33, p. 519; May, 1954.

<sup>7</sup> Note that  $C_{eb}'$  could be tuned out to obtain an open-circuit measurement for the inherent transistor parameters. However, if the point of view is taken that  $C_{eb}'$  is part of the device per se, then the effect of  $C_{eb}'$  must be considered.

<sup>8</sup> Note also that appreciable collector-emitter parasitic capacity may modify considerably both  $h_{12}$  and  $h_{22}$ , and may also cause negative collector-base terminal conductance.

$C_{cb}'$  effectively shunts the input terminals, so that terminal parameters do not correspond to open-circuit parameters for the inherent transistor.<sup>7</sup>

Probably the most noticeable effect of collector-base overlap capacity  $C_{cb}'$  is the modification of the voltage-feedback factor  $h_{12}$ . For the inherent transistor,  $h_{12}$  should be independent of frequency and equal to  $0.8 \omega_c C_c r_e'$  (where  $\omega_c/2\pi$  is the inherent  $\alpha$ -cutoff frequency,  $C_c$  is the collector-base barrier capacitance, and  $r_e'$  is the Shockley, *et al.*, emitter resistance  $r_e' = kT/qI_e$ ).<sup>9</sup> However, with appreciable collector-base overlap capacity, the terminal  $|h_{12}|$  increases with frequency, as shown in Fig. 3.

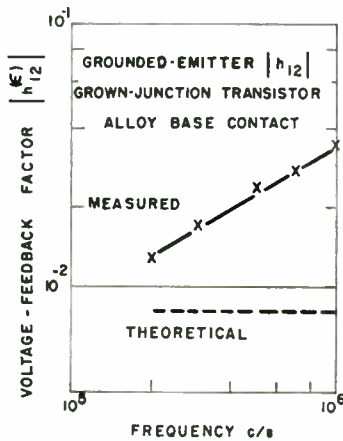

Fig. 3—Magnitude of grounded-emitter voltage-feedback factor  $|h_{12}|$  as a function of frequency for grown-junction transistor with alloy base contact. Theoretical curve refers to *inherent* transistor, excluding overlap capacitance.

APPENDIX

Consider a four-terminal network characterized by a set of four series-parallel  $h$  parameters with external admittances  $y_{11}'$ ,  $y_{12}'$  and  $y_{22}'$  connected between pairs of terminals, as shown in Fig. 4. The *terminal*  $h$  parameters

<sup>9</sup> R. L. Pritchard.<sup>6</sup> See also the Giacoletto-Johnson hybrid-pi circuit for grounded-emitter operation, in which the parameter  $h_{12}$  can be identified directly with the capacitor-divider ratio  $C_{b'e}/(C_{b'e} + C_{b'c})$ . See for example, L. J. Giacoletto, "The study and design of alloyed-junction transistors," *I.R.E. Conv. Rec.*, vol. 2, pt. 3, p. 99; 1954. Also, C. W. Mueller and J. I. Pankove, "A P-N-P triode alloy junction transistor for radio frequency amplification," *RCA Rev.*, vol. 14, p. 594; December, 1953; or, *Proc. I.R.E.*, vol. 42, p. 389; February, 1954.

for this composite network can be calculated in a very straightforward manner by employing matrix methods. First the  $h$  matrix of the original network is converted to an admittance or  $y$  matrix, and to this matrix is added the  $y'$  matrix corresponding to the pi configuration of external admittances. The resultant  $y$  matrix is then converted back to an  $h$  matrix.

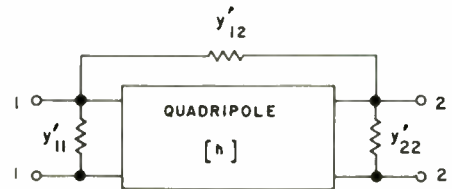

Fig. 4—Quadripole with external admittances between terminals.

This yields the following equations for the *terminal* series-parallel or  $h$  parameters of the composite network:

$$\begin{aligned} (h_{11})_T &= h_{11}/(1 + \Delta) \\ (h_{12})_T &= (h_{12} + y_{12}'h_{11})/(1 + \Delta) \\ (h_{21})_T &= (h_{21} - y_{12}'h_{11})/(1 + \Delta) \\ (h_{22})_T &= h_{22} + y_{22}' \\ &+ \frac{y_{12}'[(1 + h_{21})(1 - h_{12}) + y_{11}'h_{11}] - y_{11}'h_{12}h_{21}}{(1 + \Delta)}, \end{aligned}$$

where

$$(1 + \Delta) \equiv [1 + (y_{11}' + y_{12}')h_{11}].$$

These results may be applied to a grown-junction transistor with overlap capacities  $C_{cb}'$  and  $C_{cb}'$  between emitter-base and collector-base terminals respectively, as follows:

1. For grounded-base operation,

$$\begin{aligned} y_{11}' &= j\omega C_{cb}', & y_{22}' &= j\omega C_{cb}' \\ y_{12}' &= 0 \text{ (unless can or socket capacities are to be included).} \end{aligned}$$

2. For grounded-emitter operation,

$$\begin{aligned} y_{11}' &= j\omega C_{cb}', & y_{12}' &= j\omega C_{cb}' \\ y_{22}' &= 0. \end{aligned}$$





# Traveling-Wave Tube Experiments at Millimeter Wavelengths with a New, Easily Built, Space Harmonic Circuit\*

ARTHUR KARP†, MEMBER, IRE

**Summary**—A new slow-wave circuit structure for traveling-wave tubes consists of a ridged rectangular waveguide with a series of transverse slots in the broad wall opposite the ridge. This structure can be fabricated easily in sizes small enough for use at millimeter wavelengths if the slotted wall is prepared either by winding a grid or by photo-etching the slots in a thin metal sheet.

Demountable traveling-wave tubes were constructed in which an electron beam was coupled to space-harmonics of waves traveling on such a circuit. Using a circuit whose slotted wall was fabricated by the photo-etching technique, forward-wave interaction and backward-wave oscillations were obtained in a wavelength band centered at 5.4 mm. With structures whose slotted walls were prepared by grid winding, backward-wave oscillators were made which performed in wavelength bands centered at 5.1 mm and at 3.6 mm.

## INTRODUCTION

A TRAVELING-WAVE amplifier or oscillator for millimeter wavelengths requires a slow-wave circuit structure of minute, yet accurate, dimensions. The search for the circuit to be described was stimulated by need for such a structure that, nevertheless, would be mechanically simple enough to be made cheaply and easily.

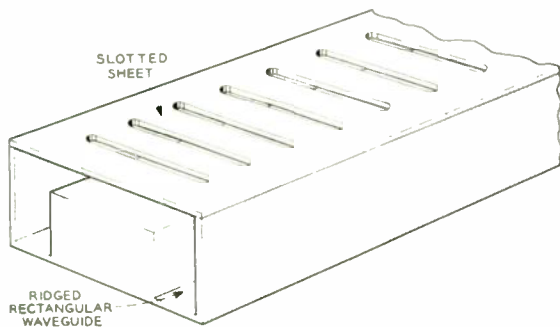

Fig. 1—General form of new space-harmonic circuit structure.

The general form of this circuit is a ridged waveguide whose broad wall contains an array of transverse slots (Fig. 1). In the pass band of this circuit, which can be made quite broad, there is developed across each slot an rf field, which can modulate a longitudinal beam of electrons confined to flow parallel to the slotted wall. In their trajectory, the electrons alternately "see" a strong field and a weak field as they pass, respectively, over a slot and over the metal between slots, making spatial-harmonic operation possible. The matter of space harmonics will be discussed further.

\* Original manuscript received by the IRE, July 27, 1954; revised manuscript received, September 24, 1954. This work was supported by the Office of Naval Research under Contract Nonr-687(00).

† Bell Telephone Labs., Holmdel, N. J.

The mechanical simplicity of this circuit is a consequence of the fact that the slotted wall, which is the only critical part, can be fabricated either by winding a grid on a suitable frame, or by photo-etching the slots in a thin metal sheet. The first technique, for example, is generally more suited to structures whose slots are to be spaced relatively closely, while the latter technique seems best for making circuits with slots further apart. In either case, one can accurately make such structures, for operation at millimeter wavelengths, with less time, cost, and skill than are required to make structures heretofore proposed.

The practicality of the new circuit structures was demonstrated in experiments with demountable tubes. The first assemblies tested used circuits (Fig. 5) whose slotted walls were made by winding and sintering a grid of gold-coated molybdenum ribbon on a copper-plated molybdenum frame. Circuits were made in two sizes, and in conjunction with a diode gun, a focusing magnet, and an output coupling, backward-wave oscillations were obtained first in a band around 5.1 mm wavelength and, later, in a band around 3.6 mm. Another tube had a circuit (Fig. 11) whose slotted wall, including input and output coupling arrangements, was made by a photographic process. With a diode gun and a focusing magnet, the tube was operated as an amplifier and as a backward-wave oscillator. As an amplifier, enough electronic interaction was obtained at 5.4 mm wavelength to permit calculating the gain parameter,<sup>1</sup> although net gain was not achieved because of inadequacies in the gun. As an oscillator, output power was obtained in a wide-band around 5.4 mm wavelength.

## PROPERTIES OF THE CIRCUIT

The circuits described are members of a family whose general form is shown in Fig. 1. In a frequency band which is above the cut-off frequency of the ridged guide itself, but below the frequency at which the slots become resonant half-wave apertures, the phase velocity of a wave traveling in this guide is slowed down. The structure does not radiate because the phase velocity becomes too low to "couple" to free space. A reflectionless connection to ordinary rectangular input and output guides can be made by gradually tapering down the lengths of the slots and the height of the ridge until only the unloaded guide remains.

<sup>1</sup> R. Kompfner, "On the operation of the travelling wave tube at low level," *Jour. Brit. IRE*, vol. 10, pp. 283-289; August/September, 1950.

An electron beam may be constrained to flow on either or both sides of the slotted wall. The required beam velocity and the phase velocity of the rf wave are obviously related and are functions of frequency. The variation of phase velocity with frequency can be accurately and easily determined from measurements on a scale model, but approximate calculation can be made.

In calculating the phase velocity, it is necessary to make a distinction between circuits whose slots are relatively far apart and those with relatively close-spaced slots. In the former case, one can neglect any coupling between slots, and set up the equivalent ladder network shown in Fig. 2. The elements in the series arms, which

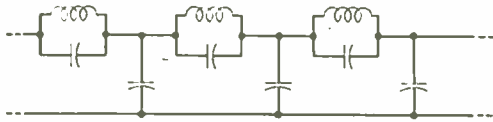

Fig. 2—Approximate ladder equivalent of circuit of Fig. 1 (no coupling between slots).

become resonant near the upper end of the pass band, represent the transverse slots, while the shunt capacitances are principally obtained by the proximity of the slots to the top of the ridge. This equivalent network predicts the solid portion of the phase characteristic shown in Fig. 3(a). The network shown is not valid for

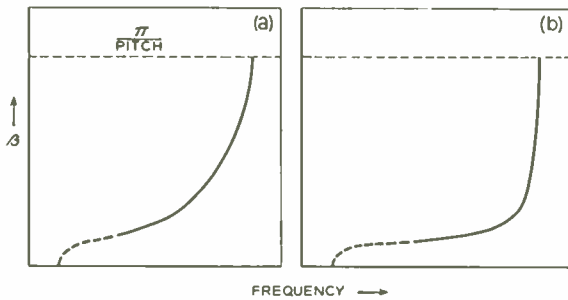

Fig. 3—Propagation characteristic of circuit of Fig. 1. (a) Widely-spaced slots. (b) Close-spaced slots. Propagation constant,

$$\beta = \frac{\text{Radian frequency}}{\text{phase velocity}} = \frac{2\pi}{\text{guide wavelength}}$$

complicated, there is an alternate analytical approach in which one tries to solve the wave equation in a region whose boundaries approximate those of the actual circuit. Such an analysis has been carried out by Pierce,<sup>2</sup> who let the slotted wall, or grid, be approximated by a thin sheet having conductivity in the transverse direction only. This analysis leads to the phase characteristic shown in Fig. 3(b), which is in fair agreement with measured phase curves. By comparing the curves in Fig. 3 it can be seen that coupling between slots has a small effect.

While the phase characteristic tells one primarily about the bandwidth of a circuit structure, it also gives information about an equally important item, interaction impedance. This quantity, which is needed to compute the gain parameter of the tube, can be shown to be proportional to the slope,  $\partial\beta/\partial f$ , of the phase curve.<sup>2,3</sup> The actual magnitude of the interaction impedance, however, depends to a large extent on the shape and size of the electron beam cross section and its proximity to the circuit, as well as on the order of space-harmonic used.<sup>4</sup>

Finally, to complete a description of the properties of the new circuit structure, the matter of space (or Hartree) harmonics must be taken up. Since detailed, quantitative treatises on the coupling between electron streams and space-harmonic traveling field components in a traveling-wave structure are found in the literature,<sup>5,6</sup> only a brief, qualitative discussion will be given here.

Consider one slowly rotating disc as an analog of the electron beam, and a second, faster disc as the analog of the rf wave. At any one instant the angular positions of the discs will correspond to the phase positions of an electron, and of the wave, respectively. To make the two synchronous, by reducing the velocity of the second disc to match that of the first, is analogous to what is done in a conventional traveling-wave tube. However, the two original discs can be made to *appear* synchronous by observing the second disc under stroboscopic light. By adjusting the rate at which the brief flashes of light illuminate the second disc, it can *appear* to be in

<sup>2</sup> J. R. Pierce, "Propagation in linear arrays of parallel wires," to appear in the forthcoming issue of TRANS. I.R.E., PGED.

<sup>3</sup> J. R. Pierce, "Traveling-Wave Tubes," D. Van Nostrand Co., Inc., New York, N. Y., 1950.

<sup>4</sup> In a traveling-wave amplifier, the rate of exponential increase with distance of the growing wave is proportional to the gain parameter, which is in turn proportional to the  $\frac{1}{2}$  power of the interaction impedance and to the  $\frac{1}{2}$  power of the beam current occupying the beam cross section assumed for the impedance calculation (see reference 3). In a backward-wave oscillator, there is a minimum beam current, called the starting current, below which oscillation cannot be sustained. If, for example, the effects of space charge and ohmic loss are neglected, one finds (see reference 7; also H. Heffner, "Analysis of the backward-wave traveling-wave tube," PROC. I.R.E., vol. 42, pp. 930-937; June, 1954) that the starting current must be such that the product of the gain parameter times the number of bunches contained in the length of the beam must be at least 0.314.

<sup>5</sup> S. Millman, "A spatial harmonic traveling-wave amplifier for six millimeters wavelength," PROC. I.R.E., vol. 39, pp. 1035-1043; September, 1951.

<sup>6</sup> P. Guénard, O. Doehler, and R. Warnecke, "Sur les propriétés des lignes à structure périodique," *Compt. Rend. Acad. Sci., Paris, France*, vol. 235, pp. 32-34; July 7, 1952.

the dotted part of the curve close to the cut-off frequency of the ridged guide itself, but with a high ridge, this region usually occurs at frequencies too low to be of interest. At the upper cutoff, the wave undergoes a phase shift of 180 degrees in going from one slot to the next. Between the two cutoffs, the shape of the curve is influenced by the ratio of the effective shunt and series capacitances. This ratio in turn depends on the proportioning of the thickness of the perforated wall relative to its spacing from the ridge.

In circuits with relatively close-spaced slots, coupling between slots cannot be neglected. Instead of using an equivalent ladder network, which then becomes very



synchronism with the first regardless of its original speed or direction. This situation is analogous to that in a space-harmonic traveling-wave tube, where an electron beam "thinks" it "sees" an rf wave in synchronism with itself—even if the wave is actually traveling faster, and/or in the opposite direction—because it can "see" the wave only intermittently.

Space-harmonic operation is possible with the circuit of Fig. 1, because the electrons do "see" an intermittent electric field as they cross successive slots, while they are shielded from the field, when adjacent to the metal between slots. One, then, will have less interaction impedance than when the beam and wave can interact continually,<sup>3,5</sup> but there are several compensating advantages. One advantage is mechanical. For example, in a tube for amplifying a signal at 5 mm wavelength with a 1,000v beam, a typical helix (nonharmonic) circuit would require about 300 turns per inch, while it happens that a typical space-harmonic circuit for the same application needs only about 55 slots per inch, and is larger and more rugged in all respects. Another advantage is that a space-harmonic circuit lends itself immediately to backward-wave operation.<sup>6,7</sup>

In the stroboscope and disc arrangement mentioned above, the briefer the light flash, the sharper would be the definition of any pattern that might be drawn on the second disc. On the other hand, the longer the duration of the flash, the brighter would be the disc, so that a compromise flash duration time is desirable. This situation has its analog in the space-harmonic traveling-wave tube, and the optimum value of slot width can be evaluated.<sup>5</sup> It is found that the interaction impedance is maximized when the ratio of slot width to pitch is between 0.3 and 0.5, depending on the circuit and order of harmonic being used.

#### EXPERIMENTS WITH CIRCUITS MADE BY WINDING

The backward-wave oscillator<sup>7</sup> is a very useful device, because it is voltage tunable over a wide-band and can work into an unmatched load without pulling. Its usefulness could be very great in the millimeter-wave band, where a bandwidth of only a few per cent is actually several thousands of megacycles wide, and where there are as yet few other signal sources available. It was decided to make one test of the new circuit's practicability in a backward-wave oscillator for the 5-mm band.

A slotted-wall circuit for an oscillator, designed to operate in a band centered near 5-mm wavelength at a beam voltage of 1,000, requires about 90 slots per inch. The rf wave travels along the circuit in one direction, growing in amplitude, and undergoing a phase shift of about 50 electrical degrees from one slot to the next. The beam travels in the opposite direction, losing power to the wave, and (taking the distance between bunches to denote a wavelength in the beam) undergoing a

phase shift of about 310 electrical degrees between slots. As the frequency increases, the unit phase shift for the wave increases. Since the unit phase shift for the beam must then decrease correspondingly, a higher beam velocity is required. The optimum ratio of slot width to pitch is close to 0.5.

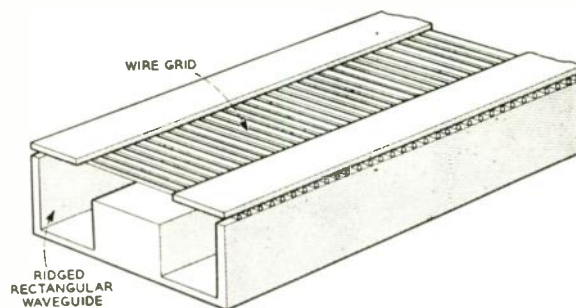

Fig. 4—Constructional variation on circuit of Fig. 1 with close-spaced slots.

The structure, shown in Fig. 4, was an early idea for adapting the basic circuit (Fig. 1) to the above application. The wires shown may be 0.005 inch in diameter, and making their span 0.090 inch places the upper end of the pass band near 65 kmc or 4.6-mm wavelength. It became apparent, however, that a further modification would give the still simpler structure shown in Fig. 5. This circuit was fabricated by winding and sintering gold-coated molybdenum ribbon, 0.0055 inch  $\times$  0.001 inch in section, at 92 turns per inch, on a copper-plated molybdenum body. The lengths of the

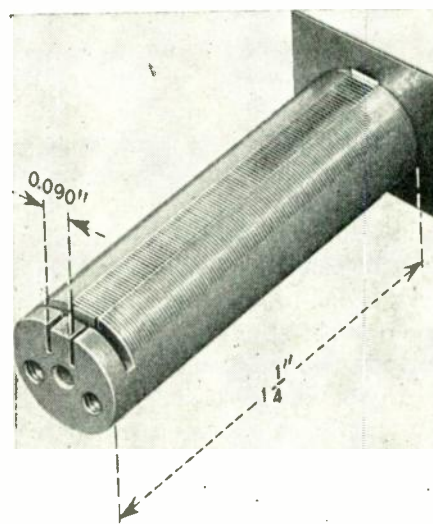

Fig. 5—Circuit structure used in backward-wave oscillator for 5 mm band.

slots formed are 0.090 inch, and the ridge is 0.010 inch below them. Pierce's analysis<sup>2</sup> demonstrates that maximum bandwidth is obtained when the width of the ridge is half the length of the slots. Since the results of this analysis were not available at the time, the ridge in Fig. 5 was arbitrarily made 0.070-inch wide (instead of 0.045-inch).

<sup>7</sup> R. Kompfner and N. T. Williams, "Backward-wave tubes," *PROC. I.R.E.*, vol. 41, pp. 1602-1611; November, 1953.

The experimental backward-wave oscillator, that used the structure in Fig. 5, tuned from about 57 kmc (5.3 mm) to 61 kmc (4.9 mm), by tuning the beam voltage from about 900 to 1,170 volts. The circuit is wound with flat tape, instead of round wire, so that the electrons can get in closer to the useful longitudinal fields. Another advantage of using tape is that the important contacts which remove heat and determine slot length are more definitely made.

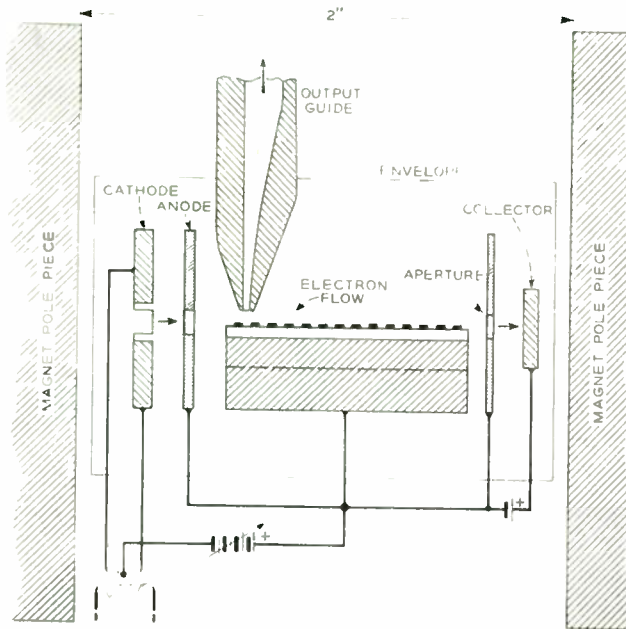

Fig. 6—Arrangement of demountable backward-wave oscillator tube using circuit of Fig. 5.

The interaction between the beam and the circuit took place in a box-like demountable envelope situated between the plane-parallel pole pieces of an electromagnet (see Fig. 6). A rudimentary diode gun, having a directly-heated, thoria-coated tungsten ribbon for its cathode, is included to provide essentially a flood of electrons that the magnetic field can constrain to flow in straight lines parallel to the plane of the grid. With this gun, a magnetic field strength of at least about 2,200 gauss is needed to confine the electron flow well enough for the tube to operate. (Working with a carefully designed electron gun in a sealed-off version of this tube, W. H. Yocom, of Bell Telephone Laboratories, has recently been able to reduce the magnetic field requirement to about 1,200 gauss, and use a permanent magnet. He has also been able to operate the tube over a much greater bandwidth.) Beam current densities of the order of a few tenths of an ampere per square centimeter are required to start and maintain the oscillations.<sup>4</sup> The total beam current needed is quite small, however, because the longitudinal space-harmonic fields die off rapidly as one moves away from the plane of the grid, and only that current within a few thousandths of an inch on either side of the grid is useful. A good deal of beam current is actually intercepted along the grid, but

the heat due to this electron bombardment is readily carried away. The grid is wound under a slight amount of tension so that thermal expansion does not cause it to buckle.

An ideal backward-wave oscillator should have a reflectionless termination at the collector-end of the circuit, and the circuit should be matched into a waveguide at the opposite, or gun end. For the sake of expediency, these refinements were omitted in the experimental tubes described by Fig. 6, and the detriment thus caused will be commented on below. All that was added to the rf portion of the tube was a tapered-waveguide probe to pick up some of the power output at gun end.

Fig. 7 is a typical curve of output vs beam voltage for this tube, which was traced from an oscilloscope displaying the output of a fixed-tuned crystal detector while sweeping the beam voltage. Since the frequency increases with beam voltage, Fig. 7 is also an approximate curve of output vs frequency, but the true shape of the curve is altered by the narrow-band response of the detector used. The level of the highest point in Fig. 7 is estimated at about 1 mw, and represents only the fraction of the available output signal that the probe picks up.

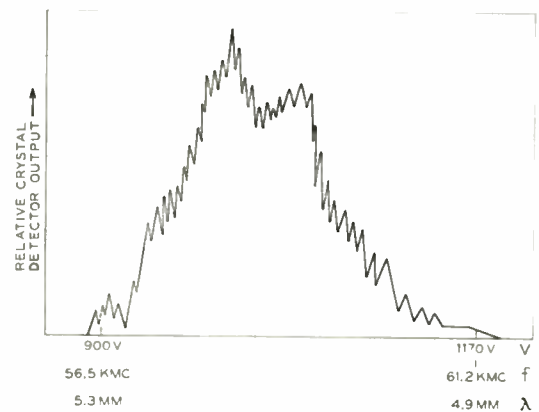

Fig. 7—Output vs beam voltage of backward-wave oscillator with circuit of Fig. 5.

The fine structure of Fig. 7 consists of ripples occurring at frequency intervals of the order of 80 mc. These ripples are undesirable and would not be present if at least one end of the circuit were perfectly terminated. What happens is that a wave is reflected at the gun end of the circuit, because of the poor impedance match, and returns to the collector end (without interacting with the beam) where, although reduced by ohmic attenuation, it may be reflected once again. The doubly-reflected wave interferes with the original wave at a phase depending on the electrical length of the circuit at the frequency considered.

To sum up the performance of the 60 kmc oscillator, consider Fig. 8, which ties together many of the points that have been discussed so far. The abscissa of this graph is frequency, and the ordinate is the phase shift from one slot to the next. The lower curve, in the region



$0 < \theta < \pi$ , is a phase curve plotted from data on guide wavelength measured on a scale model of the circuit of Fig. 5 [cf. Fig. 3(b)]. The curve in the upper region  $\pi < \theta < 2\pi$ , is a repeat of the lower curve, but plotted as  $2\pi - \theta$  instead of  $\theta$ . The upper curve represents the "first backward" space-harmonic wave associated with the fundamental wave described by the lower curve. (One could also re-plot the phase curve as  $2\pi + \theta$ ,  $4\pi - \theta$ ,  $4\pi + \theta$ , . . . , representing, respectively, the "first forward," "second backward," "second forward," etc., space harmonic waves.)<sup>8</sup> In the co-ordinates of Fig. 8, a

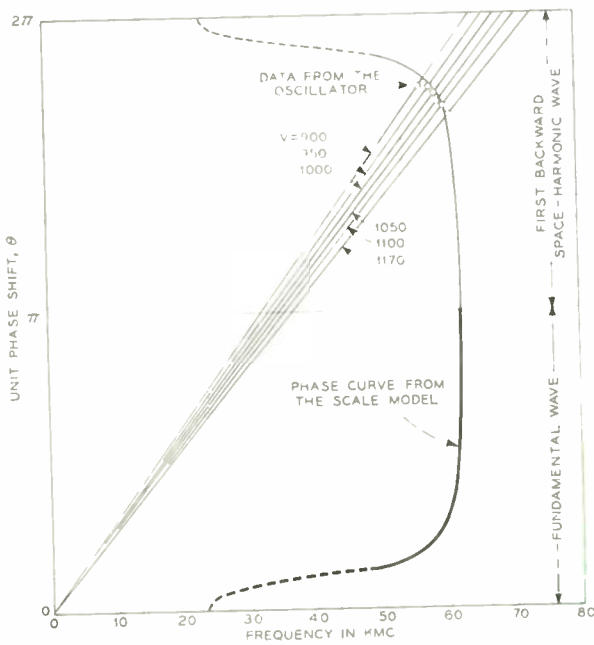

Fig. 8—Frequency vs beam voltage data of 60 mc backward-wave oscillator compared with phase characteristic of the circuit.

straight line through the origin gives a constant phase velocity. Under conditions of synchronism, it also represents a constant beam velocity, the slope being inversely proportional to the square root of beam voltage. Thus by using the parameters, frequency and beam voltage, the operating data of the tube may be added to the chart and compared graphically with the phase curve.

Because of the success with the circuit of Fig. 5, it was decided to try an experiment at still shorter wavelengths. Accordingly, another circuit was wound which was very much like that of Fig. 5 except that the span of the tapes was reduced from 0.090 inch to 0.068 inch, and their turns-per-inch raised from 92 to 120. The ridge was omitted in order to see what might occur.

The operation of the demountable tube (still arranged as in Fig. 6) containing this circuit was similar to that in the previous experiment, except that somewhat higher beam current densities and focusing fields were required and that the output signal was weaker. An oscillogram of the detector output obtained while sweeping the

beam voltage is shown in Fig. 9. As closely as it could be measured with the instruments available, the wavelength at the center of the band was 3.6 mm. Because the ridge had been omitted, the bandwidth was less than 5 per cent.

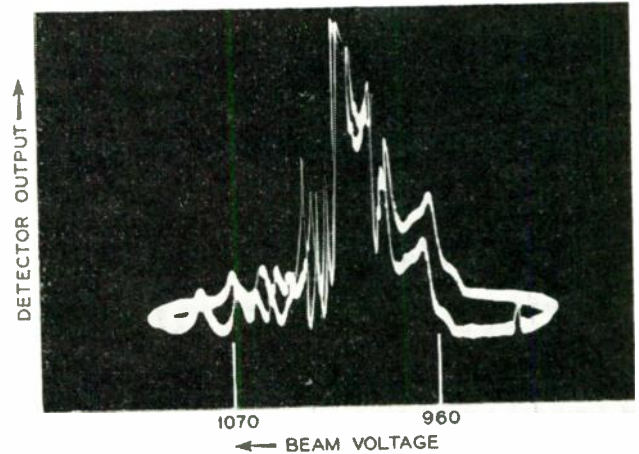

Fig. 9—Band of backward-wave oscillation centered at 3.6 mm wavelength. Oscillogram taken at Holmdel, N. J., on April 28, 1953.

The possibility of conducting experiments at still shorter wavelengths is not at all a question of fabricating smaller and smaller circuits of the new type—no difficulty having as yet been encountered<sup>9</sup>—but rather a question of being able to get a sufficient number of electrons to travel in sufficiently accurate trajectories parallel and close to the circuit.

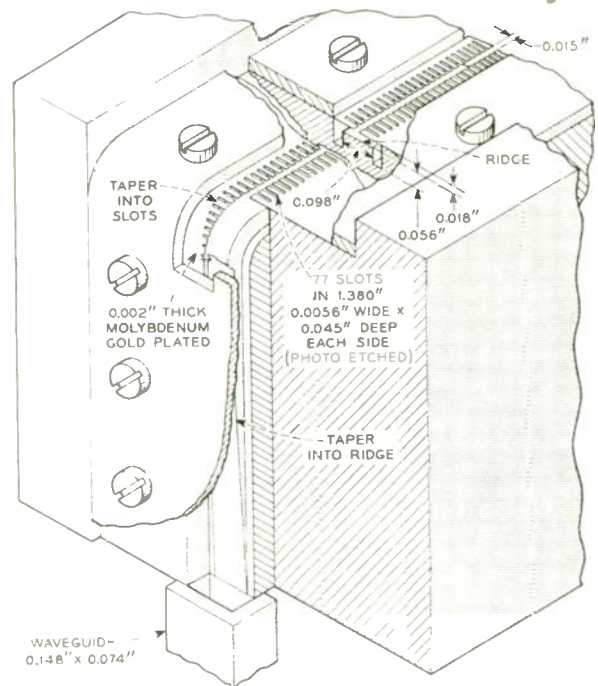

Fig. 10—Portion of circuit of space-harmonic traveling-wave tube for  $\lambda = 5.4$  mm.

<sup>8</sup> A rigorous treatment of this construction is found in J. C. Slater's "Microwave Electronics," D. Van Nostrand Co., Inc., New York, N. Y., sec. 8.1, p. 170; 1950.

<sup>9</sup> In May 1954, a demountable cw backward-wave oscillator, similar to the type described and having an improved form of the circuit structure of Fig. 5, was operated over a band about 12 per cent wide, centered at 2.7 mm wavelength.

### EXPERIMENTS WITH A CIRCUIT MADE BY PHOTO-ETCHING

The possibilities of using a photo-etching process in the construction of the new circuit structure for millimeter wavelengths were intriguing from the start. Fig. 10 shows the rf part of a demountable tube that was constructed in this way. The principal element is a gold plated molybdenum sheet, 0.002-inch thick, in which the slots are etched photographically. An actual-size reproduction of the photographic transparency, as used by B. A. Diggory in etching the halves of the slotted wall, is shown in Fig. 11. The slots are 0.018 inch



Fig. 11—Actual size reproduction of photographic transparency used in etching halves of slotted wall for space-harmonic traveling-wave tube structure of Fig. 10. The slots are resonant near 66,000 mc.

apart on centers and are resonant near 66,000 mc. The longitudinal gap (see Fig. 10) has no effect on the electrical properties of the circuit, but does prevent buckling of the sheet due to thermal expansion. Reflections in the transitions to waveguide at the ends of the circuit are minimized by use of the tapers indicated in the figures.

A significant interaction was obtained between a

1,300-volt beam and first forward space-harmonic of 5.35 mm wave traveling in the same direction, but net gain was not achieved probably because of limitations in electron focusing. At beam voltages in the range 2,500–4,000 volts, the etched circuit performed as a backward-wave oscillator much as did the wound circuits previously described.

### CONCLUSION

A hint of the potentialities of the new circuit was obtained with experimental versions, made by grid-winding and photo-etching, and put in millimeter-wave traveling-wave tubes. Although much effort will be required—in the way of gun and magnet design, for example—to perfect sealed-off tubes with maximum output and bandwidth, the demountable, research-laboratory experiments described served to demonstrate the merit of the new circuit.

### ACKNOWLEDGEMENT

The author is indebted to his colleagues at Bell Laboratories for their important suggestions and enthusiastic encouragement, and especially to S. D. Robertson, who shared his laboratory space and equipment. A large contribution was made by F. A. Braun, who assembled and pumped the tubes and helped make measurements. The author would also like to acknowledge the aid received from machine shop and tube shop personnel at the Bell Telephone Laboratories at Holmdel and Murray Hill.

## Radial Line Discontinuities\*

J. R. WHINNERY†, FELLOW, IRE, AND D. C. STINSON‡

**Summary**—Curves are given here showing the equivalent shunt capacitance for step-type discontinuities in radial transmission lines for cases with the larger spacing outside, the larger spacing inside, and the re-entrant or septum type discontinuities. Corrections for dimensions comparable with wavelength and the proximity of a short circuit termination are discussed in addition to application of the results to cases with thin diaphragm or with changes of dielectric at the radius of the discontinuity. The basis for the analysis of the curves also is discussed briefly.

### INTRODUCTION

THIS PAPER summarizes results of theoretical work done on discontinuities in radial lines some years ago,<sup>1</sup> plus recent experimental work verifying some of the curves. Other studies on radial-line dis-

continuities have appeared,<sup>2-6</sup> but it is believed the present study contains useful results not in the other references. The experimental results are also of interest, since they indicate range of usefulness of some of the curves.

The method of analyzing the discontinuities in radial lines is that developed by Hahn, and is considered extensively in two previous papers<sup>6,7</sup> on discontinuities.

\* C. G. Montgomery, R. H. Dicke, and E. M. Purcell, "Principles of Microwave Circuits," Radiation Lab. Ser., McGraw-Hill Book Co., Inc., New York, N. Y., vol. 8, chap. 8; 1948.

† N. Marcuvitz, "Waveguide Handbook," Radiation Lab. Ser., McGraw-Hill Book Co., Inc., New York, N. Y., vol. 10; 1951.

‡ A. E. Laemmel, N. Marcuvitz, and A. A. Oliner, "Approximate methods in radial transmission line theory with application to horns," Proc. I.R.E., vol. 39, pp. 959-966; August, 1951.

§ R. N. Bracewell, "Step discontinuities in disk transmission lines," Proc. I.R.E., vol. 42, pp. 1543-1548; October, 1954.

¶ J. R. Whinnery and H. W. Jamieson, "Equivalent circuits for discontinuities in transmission lines," Proc. I.R.E., vol. 32, pp. 98-115; February, 1944.

‡ J. R. Whinnery, H. W. Jamieson, and T. E. Robbins, "Coaxial-line discontinuities," Proc. I.R.E., vol. 32, pp. 695-710; Nov. 1944.

\* Original manuscript received by the IRE, July 1, 1954.

† Electronics Res. Lab., University of California, Berkeley, Calif.

‡ J. R. Whinnery, "Radial Line Discontinuities," Electronics Lab., Gen. Elec. Co., No. D. F. 46293; June 22, 1944.



The actual forms of the expressions for  $E_z$  and  $H_\phi$  for the radial line analysis are identical with those for  $E_y$  and  $H_x$  in (14)–(17a) of a parallel plane analysis, so that the analysis<sup>6</sup> may be used directly, except the terms  $Y_{Bn}$  and  $Y_{Am}$  now contain Bessel functions. We find then

$$Y_{Bn} = -\frac{j\omega\epsilon b}{n\pi} R_{Bn} \quad (1)$$

$$Y_{Am} = \frac{j\omega\epsilon a}{m\pi} R_{Am} \quad (2)$$

When the "B" region is radially external to the "A" region, as in Fig. 1, on the following page,

$$F_{n\pi} = \frac{1}{\sqrt{1 - (2b/n\lambda)^2}} \frac{K_1\left(\frac{n\pi r_0}{b} \sqrt{1 - (2b/n\lambda)^2}\right)}{K_0\left(\frac{n\pi r_0}{b} \sqrt{1 - (2b/n\lambda)^2}\right)} \quad (3)$$

$$R_{Am} = \frac{1}{\sqrt{1 - (2a/m\lambda)^2}} \frac{I_1\left(\frac{m\pi r_0}{a} \sqrt{1 - (2a/m\lambda)^2}\right)}{I_0\left(\frac{m\pi r_0}{a} \sqrt{1 - (2a/m\lambda)^2}\right)}, \quad (4)$$

and when the "B" region is radially internal to the "A" region, as in Fig. 2, on the following page.

$$R_{Bn} = \frac{1}{\sqrt{1 - (2b/n\lambda)^2}} \frac{I_1\left(\frac{n\pi r_0}{b} \sqrt{1 - (2b/n\lambda)^2}\right)}{I_0\left(\frac{n\pi r_0}{b} \sqrt{1 - (2b/n\lambda)^2}\right)} \quad (5)$$

$$R_{Am} = \frac{1}{\sqrt{1 - (2a/m\lambda)^2}} \frac{K_1\left(\frac{m\pi r_0}{a} \sqrt{1 - (2a/m\lambda)^2}\right)}{K_0\left(\frac{m\pi r_0}{a} \sqrt{1 - (2a/m\lambda)^2}\right)} \quad (6)$$

For the "B" region radially external to the "A" region but with a shorting-cylinder at radius  $r_1$ , as in Fig. 6, (3) is replaced by

$$R_{Bn} = \frac{1}{\sqrt{1 - (2b/n\lambda)^2}} \frac{K_1\left(\frac{n\pi r_0}{b} \sqrt{1 - (2b/n\lambda)^2}\right) I_0\left(\frac{n\pi r_1}{b} \sqrt{1 - (2b/n\lambda)^2}\right) + I_1\left(\frac{n\pi r_0}{b} \sqrt{1 - (2b/n\lambda)^2}\right) K_0\left(\frac{n\pi r_1}{b} \sqrt{1 - (2b/n\lambda)^2}\right)}{K_0\left(\frac{n\pi r_0}{b} \sqrt{1 - (2b/n\lambda)^2}\right) I_0\left(\frac{n\pi r_1}{b} \sqrt{1 - (2b/n\lambda)^2}\right) - I_0\left(\frac{n\pi r_0}{b} \sqrt{1 - (2b/n\lambda)^2}\right) K_0\left(\frac{n\pi r_1}{b} \sqrt{1 - (2b/n\lambda)^2}\right)} \quad (7)$$

$I_n$  and  $K_n$  are the modified Bessel functions of the first and second kinds, respectively.

As a result, the expression for the discontinuity capacitance in radial lines differs from that for the discontinuity capacitance in parallel-plane lines only by

a term involving Bessel functions. Since this term involving radial variations may be ignored in a large number of cases, for a first approximation the discontinuity capacitance per unit circumferential distance of a radial line may be replaced by the discontinuity capacitance per unit width of a parallel-plane line having the same spacing. However, the more accurate values provided by the curves are frequently required in radial line applications.

#### BASIC DISCONTINUITIES AND RELATED CURVES

The types of discontinuities treated are those possessing angular symmetry. As a result, the higher-order radial modes have sinusoidal variations with  $z$ , Bessel function variations with  $r$ , and no variations with  $\phi$ . The principal mode possesses only Bessel function variations with  $r$ . The theoretical expressions are exactly as noted<sup>6</sup> except for the substitution of  $Y_{Bn}$  and  $Y_{Am}$  from (1)–(7).

Figs. 1 through 4 apply exactly only when the spacings between conductors of the radial lines are small compared with wavelength and when the excitation and termination are far enough removed from the discontinuity so that higher-order fields do not couple. Any deviation from the two assumptions just mentioned causes the discontinuity capacitance to increase above the values given by the curves. This is illustrated by the experimental points for  $r_0/b = 0.15$  in Fig. 1(a), which are especially in error for larger values of  $a/b$ , thus indicating that the spacing between conductors is not small compared with wavelength. However, Fig. 5 supplies an approximate correction when spacing is comparable with wavelength, and application of this correction improves the agreement between experimental and calculated points. Similarly, Fig. 6 provides an approximate correction for a short-circuit termination near the discontinuity, as is frequently needed in resonant cavity design.

#### DESCRIPTION OF DISCONTINUITIES AND CURVES

##### *Abrupt Change of Height: Wider Spacing Outside*

This discontinuity is illustrated in Figs. 1(a) and (b) along with the associated curves for the discontinuity

capacitance divided by the circumference  $2\pi r_0$ . The equivalent circuit consists of the radial line  $A$  joined to a radial line  $B$  at radius  $r_0$ , with a lumped discontinuity susceptance,  $\omega C_d$ , shunted across the lines at the junction. The equations for the radial transmission line por-

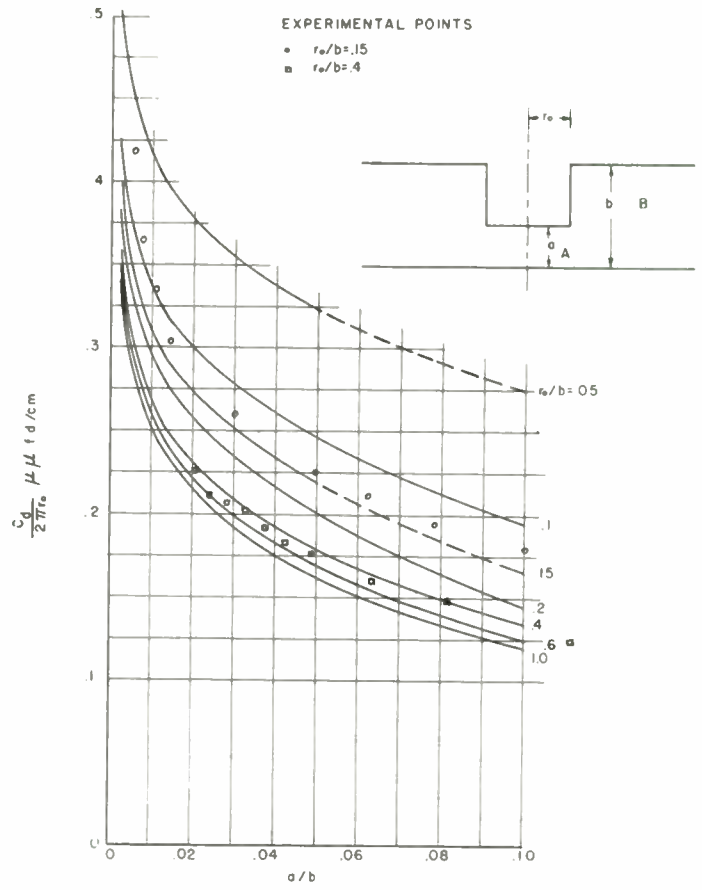
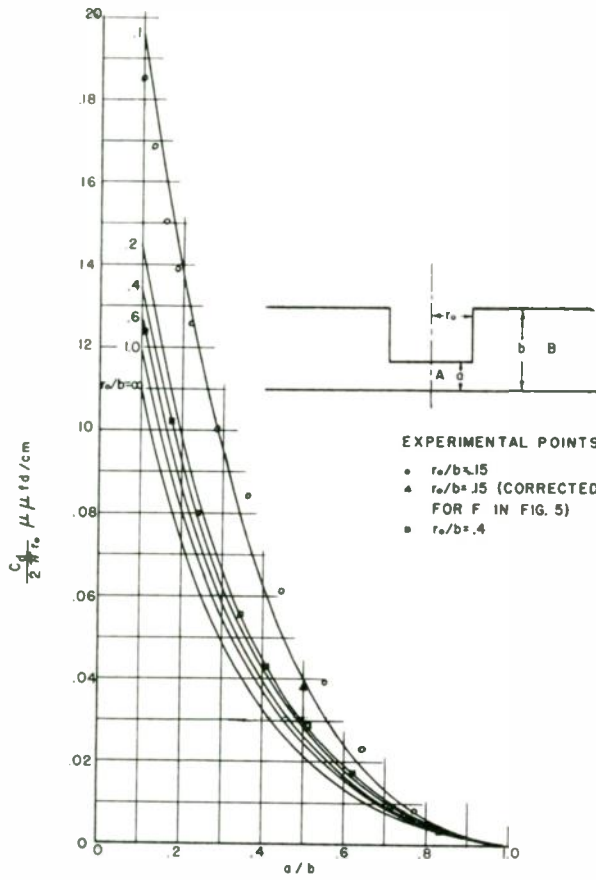

Fig. 1 (a) and (b)—Discontinuity capacitance for step in radial line, wider spacing outside.

tions may be in the Bessel function form in terms of magnitudes and phase angles analogous to ordinary transmission line quantities.<sup>8</sup>

*Abrupt Change of Height: Wider Spacing Inside*

The curves for discontinuity capacitance divided by  $2\pi r_0$  and an illustration of the discontinuity are shown in Fig. 2. Experimental confirmation in this case is quite good, since the effect of higher-order modes in region B is not as important as the effect of higher-order modes in region A.

*Radial Re-Entrant Discontinuities*

The discontinuity pictured in Figs. 3(a) and (b) is the radial line counterpart of the re-entrant discontinuities treated.<sup>6,7</sup> The equivalent circuit for this discontinuity, with the widest spacing outside, consists of three radial lines A, B, and C, in series, with a discontinuity admittance across each line at the junction. Approximate values for  $C_a$  (negative capacitance) may be obtained from Fig. 3(a), and for  $C_b$  or  $C_c$  from Fig. 3(b).

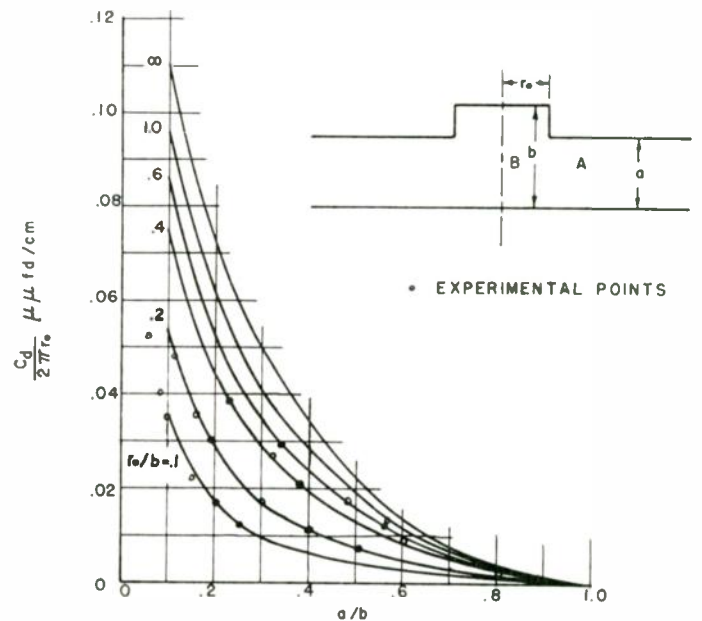
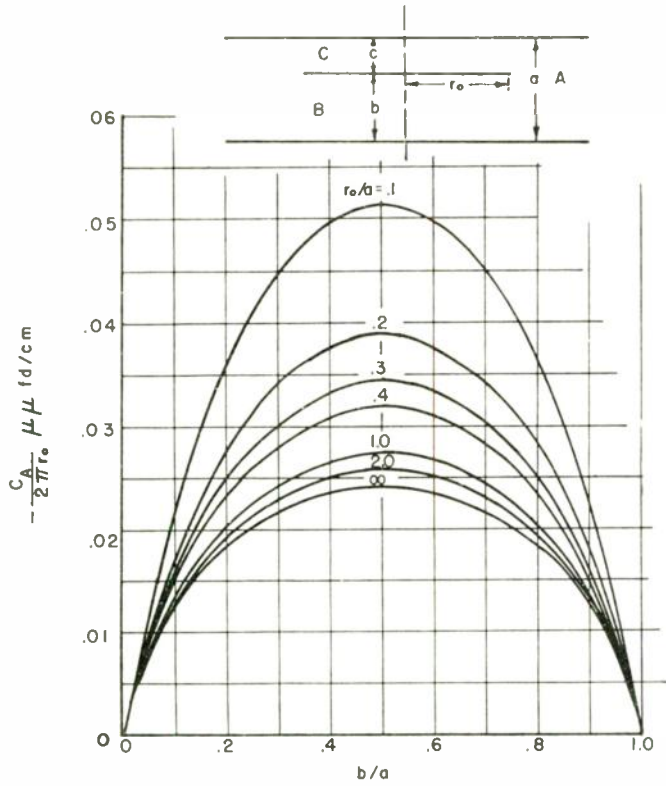

Fig. 2—Discontinuity capacitance for step in radial line, wider spacing inside.

The radial re-entrant discontinuity with the widest spacing inside is similar to that above except that the dividing plate extends outward rather than inward. This is illustrated in Fig. 4(a) and 4(b), which include the corresponding curves for  $C_a$ ,  $C_b$ , and  $C_c$ .

<sup>8</sup> S. Ramo and J. Whinnery, "Fields and Waves in Modern Radio," John Wiley and Sons, New York, N. Y., 2nd ed., art. 9.11; 1953.





(a)

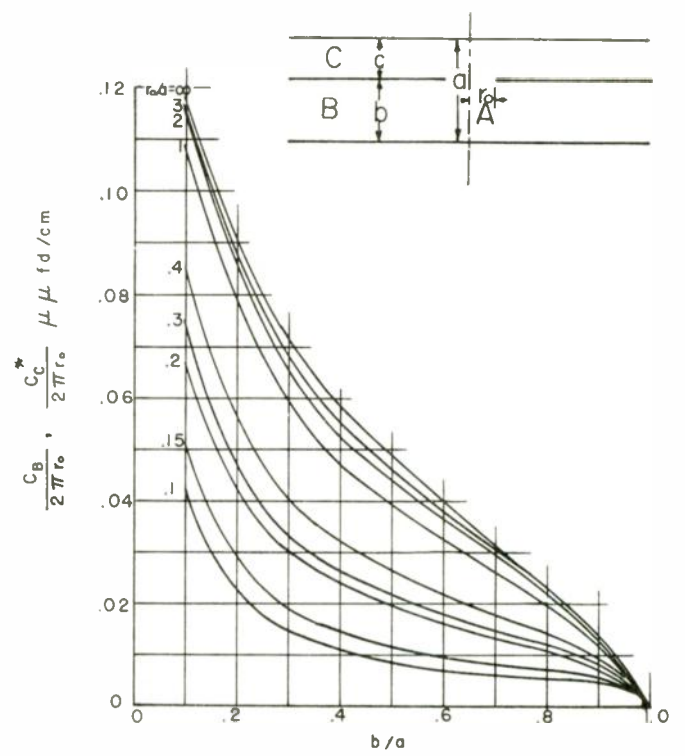

(b)

\* READ  $b/a$  AS  $(1 - b/a)$

Fig. 3 (a) and (b)—Radial re-entrant discontinuity, widest spacing outside.

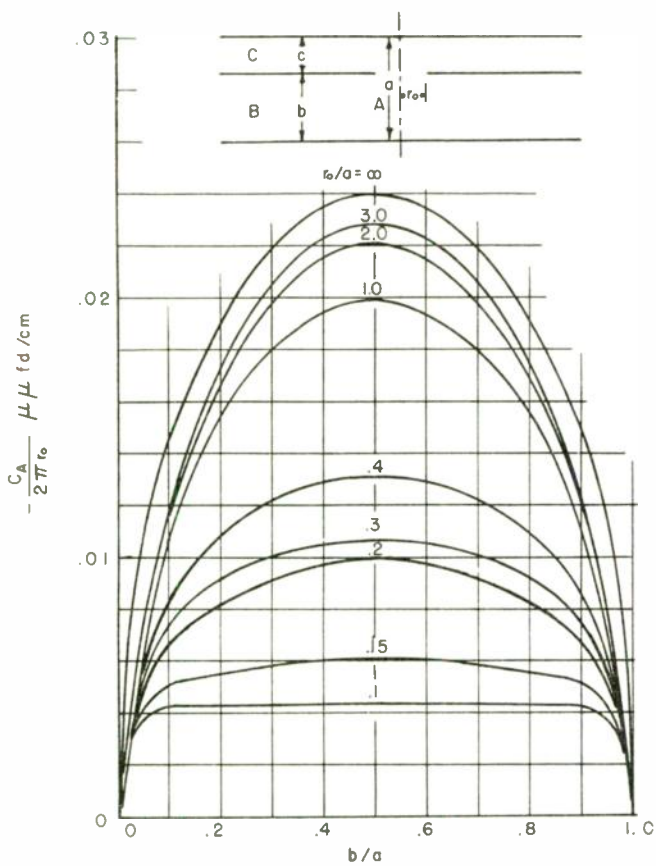

(a)

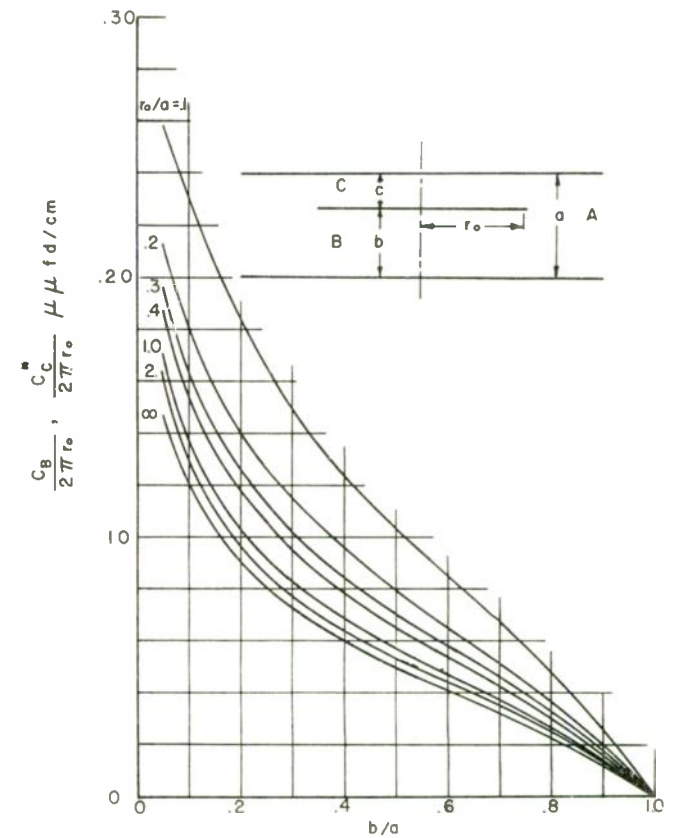

(b)

\* READ  $b/a$  AS  $(1 - b/a)$

Fig. 4 (a) and (b)—Radial re-entrant discontinuity, widest spacing inside.

*Dimensions Comparable with Wavelength*

When spacing between plates of the radial line is an appreciable part of a wavelength, the discontinuity susceptances no longer have the same frequency dependence as pure capacitances. The increase may be expressed in terms of a frequency factor,  $F$ , which multiplies the value of discontinuity capacitance obtained from previous curves. As an indication of the conditions for which this correction is important, some approximate values of  $F$  for the discontinuity of Fig. 1 are plotted in Fig. 5. It is noted that it may be appreciably

while the experimental work now available indicates a finite value for  $F$  in this region. The curves shown give the frequency correction well for  $b/\lambda$  up to 0.3 or 0.4.

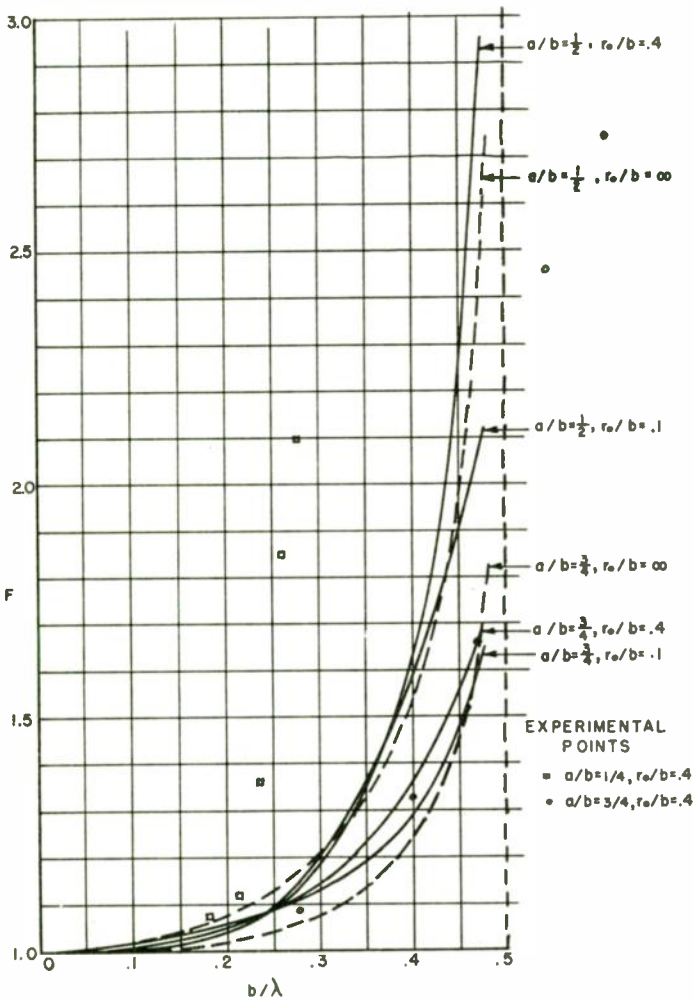

Fig. 5—Frequency factor for dimensions comparable with wavelength for Fig. 1.

different from unity if the wider spacing between plates is much greater than 0.2 of a wavelength, which is frequently the case. Experimental confirmation of these curves shows quite clearly the rapid increase of  $F$  with  $b/\lambda$  and the necessity for considering this factor in any situation where  $b/\lambda$  becomes greater than 0.2. Since the present experimental work is rather limited when  $b/\lambda$  is in the neighborhood of 0.5, it is not possible to make a general statement concerning experimental confirmation in this region. However, approximate theory indicates that  $F$  should become infinite as  $b/\lambda$  approaches 0.5,

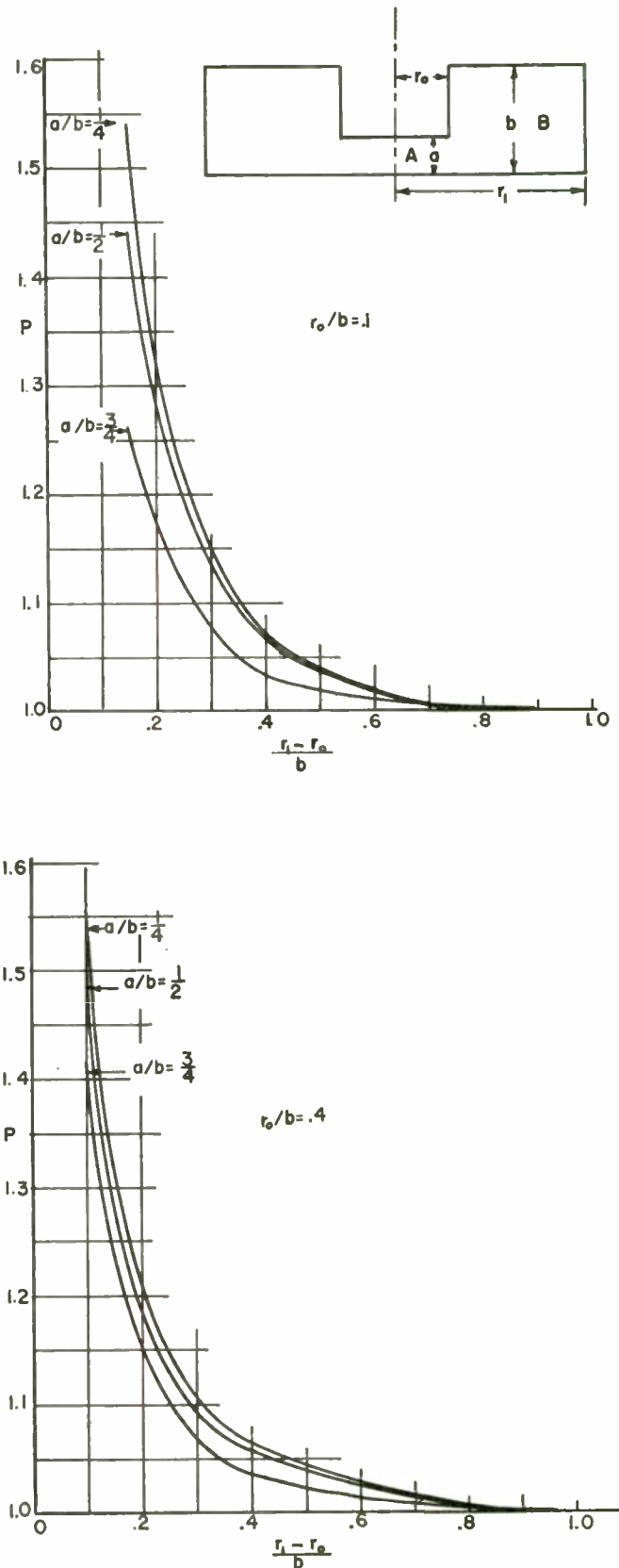

Fig. 6—Proximity factor for a shorting cylinder near the step.



### Proximity of Short-Circuit Termination

When the excitation or termination is so close to the discontinuity that local fields of the discontinuity are appreciably disturbed, previous results become approximate. If the termination is of the nature of a perfect short-circuiting cylinder at radius  $r_1$ , as in Fig. 6, on the preceding page, it is still proper to take care of effects from the higher-order modes by means of a shunting admittance between lines at the junction, although this is increased over previously given values by presence of the shorting cylinder. This increase may be expressed in terms of a proximity factor,  $P$ , by which previously given values should be multiplied. In Fig. 6 are plotted some values of this proximity factor to give some idea of its importance. It is noted that increase of  $P$  over unity becomes important only when the distance between shorting cylinder and discontinuity becomes appreciably less than the wider spacing.

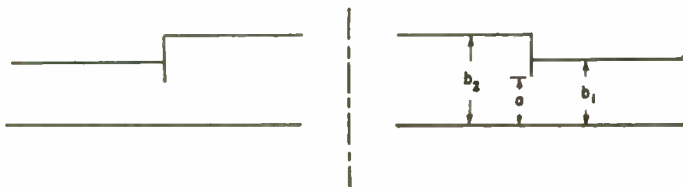

Fig. 7—Diaphragm discontinuity.

### Use of Curves with Diaphragms

A diaphragm discontinuity as illustrated in Fig. 7, above, can also be solved, but it is often a sufficiently good approximation for engineering purposes to apply results from previous curves. That is, the value of  $C_d$  for

use with Fig. 7 is approximately the sum of that obtained from Fig. 1 as a function of  $a/b_1$  and  $r_0/b_1$ , and that obtained from Fig. 2 as a function of  $a/b_2$  and  $r_0/b_2$ . If thickness of the diaphragm is finite, it may also be desirable to add the parallel plane formula capacity corresponding to this thickness and the spacing  $a$ . This approximation corresponds to that for similar discontinuities in other systems, when the two discontinuities are "back-to-back," so that their local fields are largely shielded from one another.

### Use of Curves with Change of Dielectric at Discontinuity

Again, following approximations developed in the previous references, it is possible to obtain a fair idea of the effect of a change in dielectric at the change of section by multiplying previous values of discontinuity capacitance by the relative dielectric constant for the line of wider spacing. Thus if a dielectric is placed in the line of smaller spacing in either Fig. 1 or Fig. 2, the value of discontinuity capacitance is not greatly changed, but if it is placed in the line of wider spacing, discontinuity capacitance is increased by a factor nearly equal to the relative dielectric constant. Similarly, a dielectric in the  $A$  line of Fig. 3 or Fig. 4 increases all capacitances  $C_a$ ,  $C_b$ ,  $C_c$  by nearly the value of the relative dielectric constant, whereas they are not greatly changed if the dielectric is in either the  $B$  or  $C$  lines.

### ACKNOWLEDGEMENT

The authors wish to express thanks to Mrs. Theo E. Robbins for her careful work in computation of the curves given, and to the General Electric Company for permission to publish the curves.

## Frequency-Modulation Interference Rejection with Narrow-Band Limiters\*

E. J. BAGHDADY†

**Summary**—Essential to the interference rejection ability of a frequency-modulation receiver is the use of the proper bandwidths in its nonlinear sections. The weaker of two competing signals (whose amplitude may approach the amplitude of the stronger signal within arbitrary limits) can be suppressed by a frequency-modulation receiver if, other requirements being met, the limiter and discriminator bandwidths exceed certain minimum necessary values. After presenting a summary of design requirements established experimentally by previous investigators, this paper presents a theoretical determination of the minimum necessary values in terms of an ideal band-

pass filter that follows an ideal limiter and is followed by an amplitude-insensitive detector. The results reported here show that the bandwidth specifications prescribed by other investigators can be cut by a factor of more than ten in the limiter bandwidth, and a factor of two in the discriminator bandwidth. The paper concludes with observations on the possibility of reducing the required discriminator bandwidth to that of the intermediate frequency by cascading enough stages of bandpass limiters.

### INTRODUCTION

AN ANALYSIS of cochannel and adjacent-channel interference may well start with an examination of the situation in which two unmodulated carriers differing slightly in frequency and amplitude fall within the passband of the intermediate-frequency sec-

\* Original manuscript received by the IRE, August 3, 1954; revised manuscript received September 16, 1954. This work was supported in part by the Signal Corps; the Office of Scientific Research, Air Research and Development Command; and the Office of Naval Research. The discussion is based on a M.Sc. Thesis, Dept. Elec. Eng., Mass. Inst. Tech., August, 1953.

† Res. Lab. Elec., M.I.T., Cambridge, Mass.

tion. Such a situation is shown in Fig. 1(a), where the intermediate-frequency response characteristic has been idealized to simplify the analysis.

With a little manipulation in terms of Fig. 1(b) it is readily shown that the instantaneous frequency of the resultant signal is given by

$$\frac{d\Phi}{dt} = p + \frac{d\theta}{dt} = p + r \frac{a^2 + a \cos rt}{1 + 2a \cos rt + a^2}$$

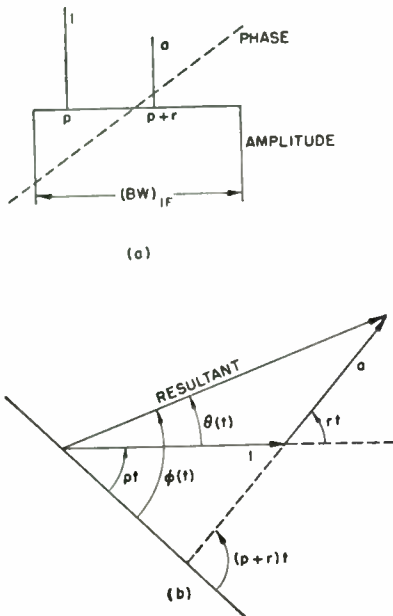

Fig. 1—Two-carrier interference: (a) resultant spectrum within the idealized IF pass band; (b) superposition of representative phasors.

preserved at this value, the interference arising from the presence of the weaker signal will be effectively suppressed when the difference frequency,  $r$ , lies outside the audio range.<sup>1-3</sup> If  $r$  lies in the audio range, the action of the de-emphasis network and the lowpass audio filter will reduce the interference considerably.

The work of Arguimbau and Granlund highlighted the following considerations in frequency-modulation receiver design for rejecting interference.

a. In the linear sections, namely the stages preceding the limiter-detector section, the bandwidth should be sufficient to accommodate a desired frequency-modulated signal over the whole range of its frequency variations. Furthermore, these linear stages must have a constant gain over the desired pass band to preserve the relative magnitudes of any signals that may be accommodated, and this gain should fall very steeply at the skirts to effect complete rejection outside the pass band.

b. Since a frequency-modulation receiver should be completely insensitive to amplitude changes, the linear stages should be followed by a perfect rapid-acting limiter to cope with amplitude ratios of the order of  $(1+a)/(1-a)$ , or 39:1 for  $a=0.95$ , where  $a$  equals the strength of the interfering signal relative to the desired stronger signal. If a capture ratio  $a$  is desired, it is clear that the intermediate-frequency section must provide enough gain to raise the value of the minimum amplitude  $(1-a) \times$  (expected minimum signal strength) to the level necessary to drive the limiter.

c. To preserve the average frequency (over a period of the difference frequency  $r$ ) of the resultant signal at

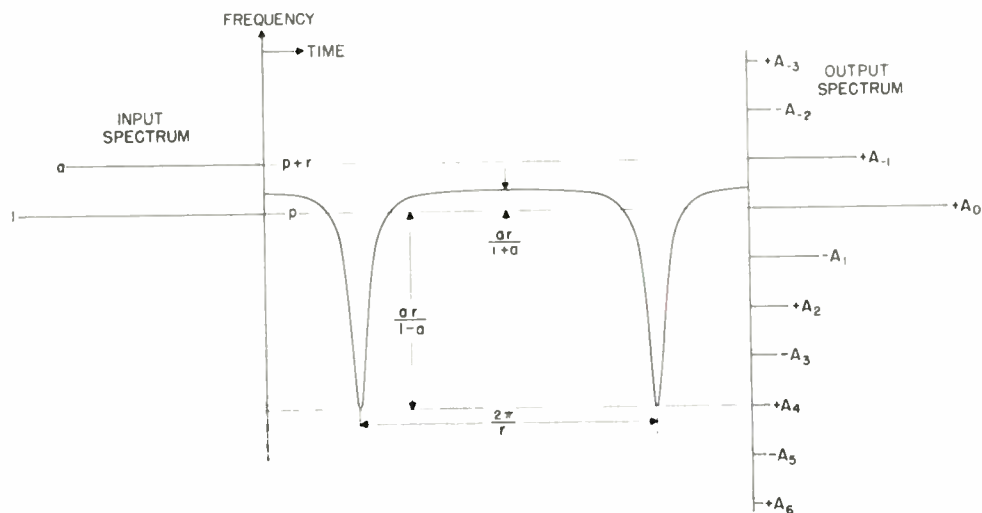

Fig. 2—The variation of the instantaneous frequency of the resultant signal with time. Input and calculated output spectra are superimposed to clarify the notations and the locations of the spectral components.

A plot of  $d\theta/dt$  is given in Fig. 2, above, for the case in which  $a=0.8$ . Clearly, the average frequency of resultant signal over a period of  $2\pi/r$  second is precisely the frequency,  $p$ , of the stronger signal. Thus, Arguimbau and Grandlund reasoned, if the average frequency is

<sup>1</sup> L. B. Arguimbau and J. Granlund, "Interference in Frequency-Modulation Reception," Tech. Rep. No. 42, Res. Lab. Elec., M.I.T., Cambridge, Mass.

<sup>2</sup> L. B. Arguimbau and J. Granlund, "Transatlantic communication by frequency modulation," *Proc. NEC*, vol. 3, p. 644; Nov., 1947.

<sup>3</sup> L. B. Arguimbau and J. Granlund, "Sky-wave FM receiver," *Electronics*, vol. 22, pp. 101-103; December, 1949.



the value  $p$  rad/second corresponding to the frequency of the stronger signal, it has been found sufficient to provide a limiter bandwidth of  $[(1+a)/(1-a)](BW)_d$  and a frequency-detection characteristic that is linear over the same range. These findings have inspired the problem of finding the minimum necessary limiter and detector bandwidths for interference rejection, the answer to which we attempt to provide in this paper.

Aside from its being of theoretical interest, the question of whether or not wide-band limiting and detecting is a necessity has some important practical and economical implications in communicating by frequency modulation and in frequency-modulation receiver design. Some of the more obvious considerations are:

a. Wide-band discriminators are more expensive to construct than the narrow-band types. This is also true of limiters.

b. A narrow-band limiter yields a stronger signal at its output than a wide-band limiter. Furthermore, the fact that the audio signal level is higher at the output of a narrow-band discriminator than that available from a wide-band one, decreases the demand on the number of audio stages necessary to bring the signal strength up to the desired level at the loud-speaker.

c. In frequency-modulation television, wide-banding demands prohibitive bandwidths to effect a reasonable degree of interference rejection.

INTERFERENCE SPECTRUM AFTER LIMITING

Consider two frequency-modulated signals of relative constant amplitudes 1 and  $a$ , where  $a < 1$ . For simplicity, assume the modulation to be so slow that the frequencies of the signals do not change appreciably during several cycles of the difference frequency. Thus let the frequencies be momentarily  $p$  and  $p+r$  rad/second, the former being that of the stronger signal. Consider the resultant signal to be passed through an ideal limiter that is followed by an ideal wide-band filter. The filter is assumed to be sufficiently selective to make only the spectral components centered about the frequency  $p$  significant, with  $r \ll p$ , and with harmonics of  $p$  and their associated sidebands, completely rejected or negligible. Thus with  $A(t) \cos \Phi(t)$  at the input, the signal at the output will be

$$e(t) = \cos \Phi(t) = \cos (pt + \theta).$$

The right-hand side can be expanded and expressed:

$$e(t) = \sum_n A_n \cos (p - nr)t = \text{Re} \left[ \exp (jpt) \sum_n A_n \exp (-jnrt) \right], \quad (1)$$

where  $n$  takes on integral values ranging from very large negative values to very large positive values.

Ten-place tables of the spectral amplitude components,  $A_n$ , have been constructed by J. Granlund for various values of  $a$ , and for  $n$  extending to fairly large values. A very close study of those tables reveals the following important properties:

- a. At  $t = 2m\pi/r$ , where  $m$  is any integer, the  $A_n$ 's alternate in sign, starting with  $A_{+1}$  negative,  $A_0$  and  $A_{-1}$ , positive.
- b. At  $t = l\pi/r$ , where  $l$  is an odd integer, all the  $A_{+n}$ 's line up in the same positive direction as  $A_0$ , whereas all the  $A_{-n}$ 's line up in phase opposition to  $A_0$ .
- c. The magnitude of  $A_n$  decreases very fast with  $n$ . As a consequence we can verify the following:

Theorem 1

If at the output of the limiter, an ideal filter is inserted that will pass (a) an arbitrary number of components from both sidebands simultaneously; or (b) an arbitrary number of components from the upper sideband, along with  $A_0$  only; then, over a period of  $2\pi/r$  second the terminus of the resultant phasor representing the signal at the output of the filter will cross a line along which a phasor representing  $A_0$  lies, only at  $rt = m\pi$ , where  $m$  is an integer or zero.

NARROW-BAND LIMITING

The average frequency of the resultant signal at the output of the ideal limiter, taken over a period of  $2\pi/r$  second, is exactly the frequency  $p$  of the stronger signal and must be maintained at this value if interference is to be suppressed. This means that if the pass band of the ideal filter at the output of the limiter is shrunk down until it can pass only  $M$  lower-sideband components and  $N$  upper-sideband components, then the average, over  $2\pi/r$  second, of the frequency of

$$e(t) = \text{Re} \left[ \exp (jpt) \sum_{n=-N}^M A_n \exp (-jnrt) \right] \equiv \text{Re} [\exp (jpt)F(t)] \quad (2)$$

must still be equal to the frequency  $p$  for the disturbance of the weaker signal to be suppressed. This requires that the net phase introduced by the function

$$F(t) \equiv \sum_{n=-N}^M A_n \exp (-jnrt) \quad (3)$$

during a period of  $2\pi/r$  second must be zero.

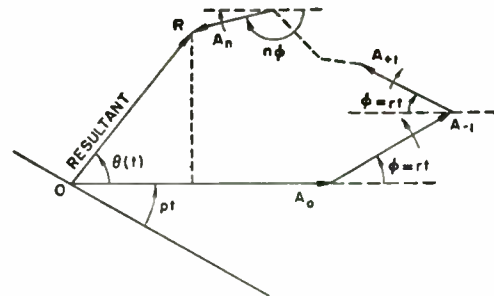

Fig. 3—The linear superposition of phasors representing the spectral components passed by the ideal limiter filter.

Fig. 3, above, is a phasor diagram showing linear superposition of spectral components that fall within the ideal narrow-filter pass band. Clearly, the component

that has the frequency of the stronger signal is  $A_0$ . Thus, if the plane of the figure is imagined to rotate clockwise with an angular velocity of  $p$  rad/second, the phasor of  $A_0$  will remain stationary and the  $n$ th component will rotate with  $n\tau$  rad/second about its origin. Since the locus of the point  $R$  traces a closed path over a complete period of  $\tau$ , the net change in the phase of the resultant  $\overline{OR}$  will be nil only if this closed path does not enclose the origin,  $O$ .

During one period of the difference frequency  $\tau$ , the function given by (3) will enclose the origin  $O$  only if at  $t=0$  or at  $t=\pi/\tau$ ,  $F(t)$  assumes a negative real value. This is justified by Theorem I, which was stated to summarize the properties of the  $A_n$ 's. At  $t=0$ ,

$$F(0) = A_0 + (|A_{-1}| - |A_1| - |A_{-2}|) + (|A_2| - |A_3|) + (|A_4| - |A_5|) + \dots + (|A_{M-1}| - |A_M|) + (|A_{-3}| - |A_{-4}|) + (|A_{-5}| - |A_{-6}|) + \dots + (|A_{N-1}| - |A_N|).$$

All the terms in parenthesis on the right are positive numbers, and so  $F(0)$  is always positive real. However,

$$F(\pi/\tau) = - \sum_{n=1}^N |A_{-n}| + \sum_{n=0}^M |A_n|,$$

and so  $F(\pi/\tau)$  will be positive real only if

$$\sum_{n=0}^M |A_n| > \sum_{n=1}^N |A_{-n}|. \tag{4}$$

This is the criterion to be satisfied for interference rejection when an ideal narrow-band filter follows the limiter. We thus may state:

**Theorem II**

For interference rejection, the limiter filter must pass at all instants of time only those configurations of carrier and sideband components that will satisfy the inequality in (4).

Let us next apply this general criterion for the loss or preservation of the average frequency of the stronger signal to the three possible situations that may arise with an ideal narrow-band filter after the limiter.

Consider, first, the situation in which only an arbitrary number,  $M$ , of lower sideband components is passed along with  $A_0$ , while all of the upper-sideband components fall outside the pass band. This case is not covered by Theorem I, and in fact it can be shown that here the function  $F(t)$ , in (3), assumes a real value for an additional value of  $t$  that lies between 0 and  $\pi/\tau$ . At  $t=\pi/\tau$  all the  $A_{+n}$ 's line up in phase with  $A_0$ . At  $t=0$  some terms oppose and some aid  $A_0$ , and the sum can be grouped into a sum of positive terms. At the additional value of  $\tau t$  for which  $F(t)$  becomes real, the situation is analogous to that at  $t=0$ . Thus we may state:

**Theorem III (a)**

If only  $A_0$  and an arbitrary number of lower-sideband

components fall within the ideal filter pass band, the average frequency of the resultant signal at the output of the filter is still the frequency of the stronger signal.

This theorem can also be established by making use of the properties of polynomials in a complex variable.<sup>1</sup>

Next, consider the case where only an arbitrary number of upper-sideband components is passed along with  $A_0$ , to the exclusion of all lower-sideband components. Since this case is covered by Theorem I, we have, from Theorem II, to satisfy the inequality

$$A_0 > \sum_{n=1}^N |A_{-n}|.$$

Fig. 4 shows a plot of  $\sum_{n=1}^N |A_{-n}|$  versus  $a$ . Superimposed upon this plot are plots of  $A_0$  and  $\sum_{n=0}^M |A_n|$  for several values of  $M$ , and  $\sum_{n=1}^N |A_{-n}|$  for several values of  $N$ . From this plot it is evident that  $A_0$  exceeds the sum of the magnitudes of effectively all of the upper-sideband components for  $a \leq 0.863$ . We now state:

**Theorem III (b)**

If only  $A_0$  and an arbitrary number of upper-sideband components fall within the ideal filter pass band, then the average frequency of the resultant signal at the output of the filter will still be the frequency,  $p$ , of the stronger signal for all values of  $a \leq 0.863$ .

For  $a > 0.863$ , the average frequency of the resultant signal is  $p+\tau$ , the frequency of the weaker signal, if more than a few upper-sideband components are passed.

Fig. 5 is a plot of the path traced by the end point of the resultant phasor over a period of  $2\pi/\tau$  second, for the case in which  $a=0.95$  when only  $A_0$ ,  $A_{-1}$ , and  $A_{-2}$  are passed. The average frequency of the resultant signal, here, is  $p+\tau$ , since the encirclement of the origin,  $O$ , by the traced path signifies a gain of  $2\pi$  radians, over the phase of  $A_0$ , by the resultant signal, every  $2\pi/\tau$  sec.

We may conclude, then, that the bandwidth of the limiter need not exceed the bandwidth of the intermediate-frequency section, for complete interference rejection, for capture ratios up to  $a=0.863$ . For values of  $a > 0.863$ , bandwidths greater than one intermediate-frequency bandwidth are required and these can be determined as follows.

As before, let  $N$ =number of upper-sideband components passed, and  $M$ =number of lower-sideband components passed.

a. Let the worst situation that may arise be one in which  $M=0$  and  $N=N_{max}$ . Clearly, this implies that the situation where  $N=N_{max}+1$  can only arise if  $M=1$  arises simultaneously.

b. Determine the minimum ideal filter bandwidth, in units of one intermediate-frequency bandwidth, for which the situation in (a) is the limiting situation. This can be done most conveniently by first drawing a diagram like the one in Fig. 6 (drawn for  $N_{max}=4$ ). It is evident from such a diagram that, for the situation  $N=N_{max}$ ,  $M=0$  to arise, the difference frequency  $\tau$



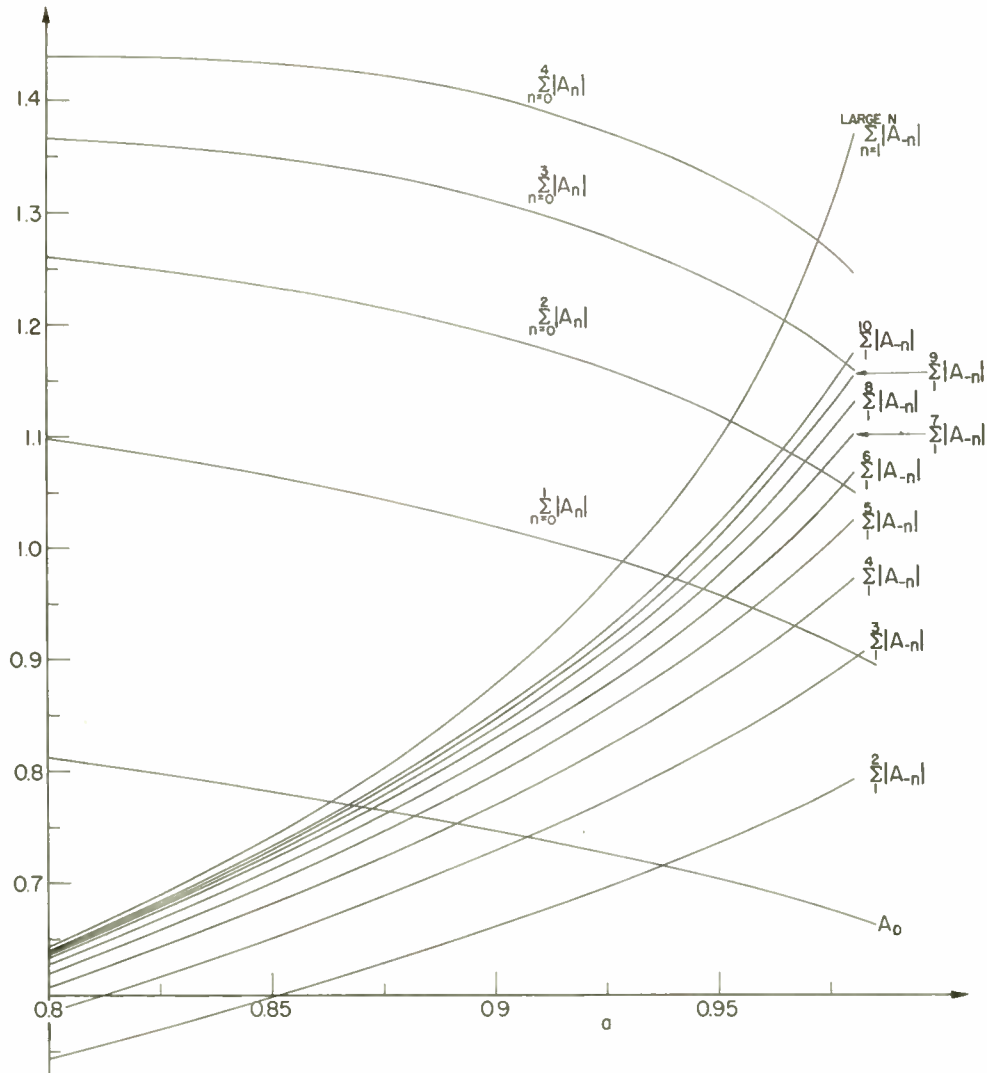

Fig. 4—Plots of the variation with  $a$  of:  $A_0$ , the spectral component having the frequency of the stronger carrier;  $\sum_{n=1}^N |A_{-n}|$ , the sum of the magnitudes of the first  $N$  upper-sideband components (the curve for which the upper limit of the summation is marked "large  $N$ " represents essentially the sum of the magnitudes of all the upper-sideband components);  $\sum_{n=0}^M |A_n|$ , the sum of the magnitudes of  $A_0$  and the first  $M$  lower-sideband components.

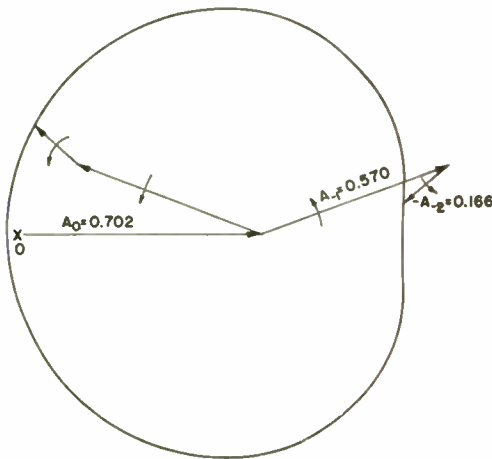

Fig. 5—Plot of the path traced by the end point of the resultant phasor over a period of  $(2\pi)/r$  second, for the case of  $a = 0.95$ , when only  $A_0$ ,  $A_{-1}$  and  $A_{-2}$  are passed.

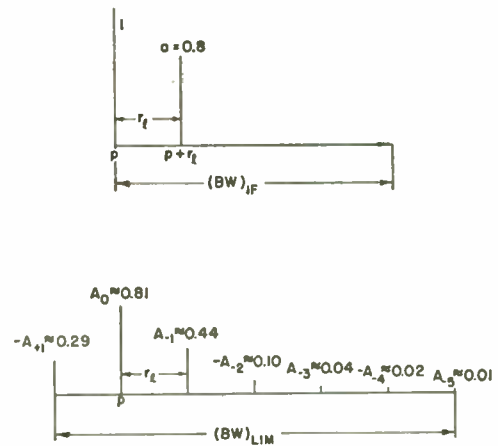

Fig. 6—When the stronger signal falls infinitesimally to the right of the lower cut-off frequency of the idealized if filter pass band, the idealized pass band of the ideal limiter filter will provide the largest space available for the upper-sideband components to occupy.

should be greater than some value  $r_l$  given by  $r_l = (BW)_{if}/N_{max}$ . For this value of  $r$ , the situation  $N = N_{max} + 1$ ,  $M = 1$  arises, and so the limiter bandwidth should be

$$(BW)_{lim} = r_l(M + N) = r_l(2 + N_{max}) = (BW)_{if} \left[ 1 + \frac{2}{N_{max}} \right]. \tag{5}$$

Clearly, this is the minimum limiter bandwidth required here, for smaller values of bandwidth will allow situations where  $N > N_{max}$  and  $M = 0$  to arise, while larger values will have limiting configurations with  $N < N_{max}$  and  $M = 0$ , the value  $N = N_{max}$  arising only with some nonzero  $M$ .

c. Determine (from Fig. 4) up to what value of  $a$  the inequality

$$A_0 > \sum_{n=1}^{N_{max}} |A_{-n}|$$

is satisfied. Call this value of  $a$ ,  $a_{max}$ . Then for capture ratios up to  $a_{max}$ , the minimum required limiter bandwidth is that found in step (b).

Table I is a summary of the results of calculations, carried out as outlined above, which cover the requirements for the range  $0.863 < a \leq 0.937$ . These results are also plotted in Figs 7 and 8. The transition in the requirements from one range of values of  $a$  to the next takes place in steps. This may be justified in the follow-

TABLE I

$M$	$N_{max}$	$\frac{(BW)_{lim}}{(BW)_{if}}$ Required	$a_{max}$
0	2	2	0.937
0	3	1 2/3	0.906
0	4	1.5	0.891
0	5	1.4	0.882
0	6	1 1/3	0.877
0	7	1 2/7	0.873
0	8	1.25	0.870
0	9	1 2/9	0.869
0	10	1.2	0.867
0	11	1 2/11	0.866
0	12	1 1/6	0.865

ing way. Let  $a = a_{max}$  mark the end of a range where the requirement is set by the configuration  $M = 0$ ,  $N = N_{max}$ . This means that immediately beyond  $a = a_{max}$  the requirement is set by the situation  $M = 0$ ,  $N = N_{max} - 1$ . Since the ideal filter response is such that it will either pass or completely reject a spectral component in the neighborhood of its cut-off points, the transition from one region to the next must occur in a step.

It is clear from these results that for  $a > 0.937$  bandwidth of limiter must be so chosen that at least one, or more, lower-sideband components are passed at all instants of time, regardless of value that difference frequency,  $r$ , may have if interference is to be suppressed.

Consider, finally, the situation in which components from both sidebands are passed. Here, the criterion of Theorem II applies directly, and it is seen that the presence at all times of some lower-sideband components within the ideal filter pass band, enhances the interference rejection ability of the receiver. Thus, situations falling in this category will decide the minimum limiter bandwidth requirements in the range  $a > 0.937$ .

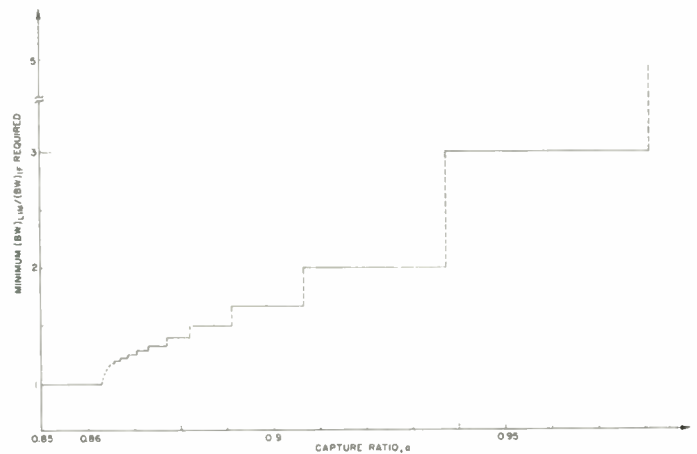

Fig. 7—Plot of the calculated minimum values of the ideal limiter filter bandwidth necessary for preserving the average instantaneous frequency of the resultant signal at that of the stronger signal.

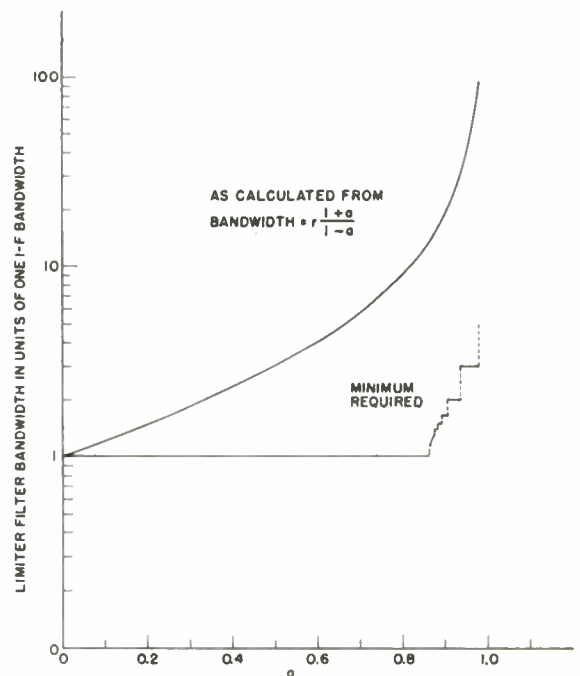

Fig. 8—Plot of the "sufficient" requirements in limiter bandwidth specified by previous investigators superimposed upon plot of the calculated minimum "necessary" requirements.

If we extend the reasoning used in the preceding case to the present situation, we find that, here,  $N$  can equal 2 only if  $M$  equals 1 simultaneously. To meet this requirement,  $(BW)_{lim}$  must be at least  $3(BW)_{if}$ . It is readily



verified that immediately above  $a=0.937$ , the configuration  $N_{\max}=3$ ,  $M_{\min}=1$  is, in fact, the situation that dictates the minimum required  $(BW)_{\text{lim}}$  and that the value it dictates is  $3(BW)_{\text{if}}$ . The value of  $a$  up to which this requirement holds is found, from Fig. 4, to be 0.9807.

Immediately beyond  $a=0.9807$ ,  $N=3$  should only arise with  $M=2$ , and this requires a minimum limiter bandwidth of five intermediate-frequency bandwidths.

Up to this point we have been carrying out the discussion in terms of the case in which the weaker signal has the higher frequency,  $p+\tau$ . The results can easily be carried over to the case in which the weaker signal has the lower frequency. Here,  $\tau$  is replaced by  $-\tau$ , and so the line spectra that appeared in the upper sideband previously will now form the lower sideband, while those that appeared in the lower sideband will now be in the upper sideband. Thus the steps in the previous discussion may be retraced if the terms "upper" and "lower" are interchanged throughout.

In any case, we can readily distinguish between the effect that each of the two sidebands will have on the loss or preservation of the desired average frequency. The sideband that is on the same side as the weaker signal (with respect to the frequency of the stronger signal), will always contribute the components that will try to offset the average frequency in favor of the frequency of the weaker signal.

The preceding discussion spotlights an interesting account of the role to be played by the limiter bandwidth for interference suppression. The statement that the bandwidth of all nonlinear sections (limiter and discriminator) must be capable of accommodating the resultant signal linearly over the whole range of its instantaneous frequency variations is seen to be unnecessary in limiter bandwidth design. The necessity for unscrupulously wide bandwidths is seen to be ruled out completely. In a nutshell, the function that the limiter bandwidth must satisfy is merely to be able, in the worst possible situations, to pass proper portions of the sidebands to result in a signal whose average instantaneous frequency deviation from the desired frequency,  $p$ , is zero, over a period of  $2\pi/\tau$  second. The discriminator bandwidth must, then, be linear over a band sufficiently wide to accommodate the instantaneous frequency deviations of the resultant signal delivered to it. The discriminator will then be capable of translating those frequency variations into instantaneous direct-voltage variations that will have the direct-voltage average set by the desired frequency  $p$ .

#### REQUIREMENTS IN DISCRIMINATOR BANDWIDTH

In general, the resultant signal at the output of the limiter narrow-band filter will exhibit instantaneous frequency as well as amplitude variations. The resultant signal will be of constant amplitude only if it is the sum of all of the spectral components at the output of the

limiter. In the "wide-band" limiter case, the instantaneous amplitude variations are usually insignificant because here the bulk of the components of significant amplitude is always passed. However, in the narrow-band limiter case, situations in which only a few spectral components of significant amplitude are passed are quite likely at all times, and in a sense the resultant will behave as if it were due to multisignal interference.

The narrow-band limiter case will thus, in general, call for a limiter stage following the narrow-band filter when amplitude-sensitive detectors are employed. Even if this second stage of limiting may theoretically have to have a very wide bandwidth in order to deliver a constant amplitude signal to the discriminator, it is significant to note, in anticipation of our results, that the combination of one narrow-band limiter, followed by a relatively wide-band limiter, will still serve the good purpose of cutting by a sizable amount the minimum discriminator bandwidth required in addition to protecting an amplitude sensitive discriminator from variations in the resultant signal amplitude. If we then assume that an amplitude-insensitive detector is used, such a detector will only respond to the instantaneous-frequency variations of the resultant signal at its input, and will translate those variations into a variable direct-voltage level. For the average value of this voltage level to correspond to that dictated by the frequency of the stronger signal, the instantaneous-frequency swings must be accommodated fully over a linear range of the detection characteristic. The detector bandwidth required will thus be determined by the maximum swing in instantaneous frequency to be expected.

Every value of limiter bandwidth used will, in general, allow a certain number of components from either or both sidebands to pass, along with the desired component  $A_0$ . Of all the different possibilities, only a few cases can always be picked and held responsible for producing instantaneous frequency excursions of such magnitude as to require greater discriminator bandwidths than the remaining legion of possibilities. Of those few cases picked, *one* case that will impose the greatest requirement in detector bandwidth can always be easily spotted. The problem then becomes, essentially, one of spotting the most critical situation that may arise with every limiter bandwidth proposed, and stating the value of detector bandwidth dictated by this case as the one that is demanded by the particular limiter bandwidth considered.

With reference to Fig. 3, if  $N$  and  $M$  upper- and lower-sideband components, respectively, are passed, then the resultant phasor,  $\overline{OR}$ , will be given by

$$\overline{OR} = \sum_{n=-N}^M A_n \exp(-j\omega t).$$

The instantaneous phase deviation of the resultant from the component  $A_0$  is

$$\theta = \text{Im} \left\{ \ln \sum_{n=-N}^M A_n \exp(-jurt) \right\}. \quad (6)$$

The time derivative of  $\theta$  will therefore be the instantaneous deviation from the frequency of the stronger signal that the resultant signal will experience. Plots of  $y_{M-N} \equiv d\theta/dt$  for various values of  $M$ ,  $N$ , and  $a$  are shown in Fig. 9.

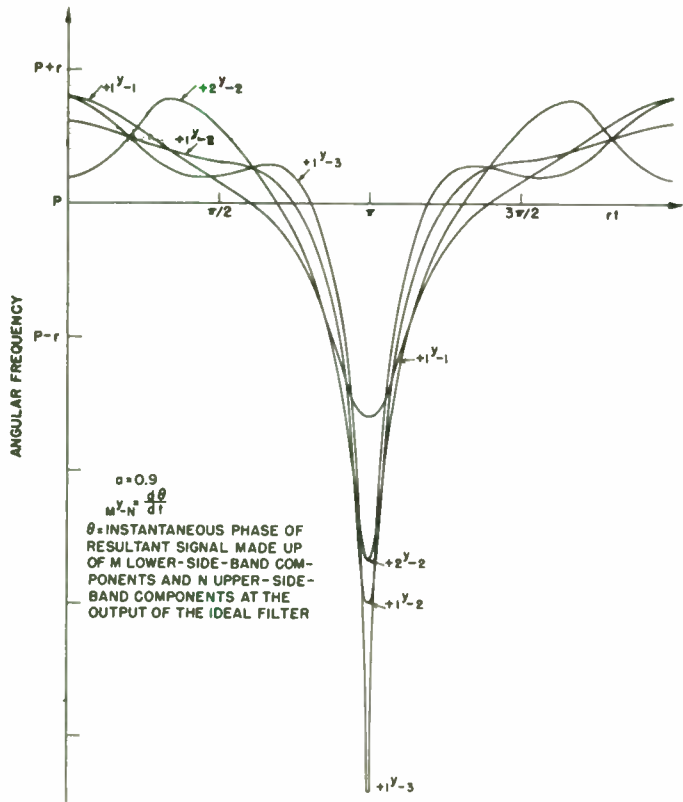

(a)

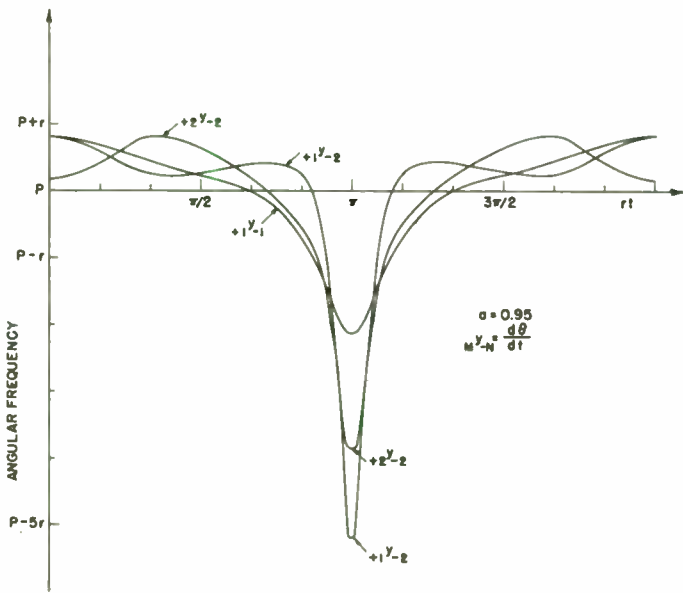

(b)

It is clear from the properties of the spectral components that the situations in which only lower-sideband components pass, along with  $A_0$ , present no serious discriminator bandwidth problem at all, since the maximum deviations in instantaneous frequency are of a comparatively small size. The most serious situations arise when only upper-sideband components are passed. The simultaneous presence of components from the lower sideband with upper-sideband components within the ideal filter pass band results in reduced frequency spike magnitudes.

The frequency spikes occur at  $t = \pi/r$  second or any odd multiple thereof. From (6), it is readily verified that the spike magnitude is given by

$$\frac{[\Delta\omega]}{r} \equiv - \frac{1}{r} \left. \frac{d\theta}{dt} \right|_{t=\pi/r} = \frac{\sum_{n=1}^M n |A_n| + \sum_{n=1}^N n |A_{-n}|}{\sum_{n=0}^M |A_n| - \sum_{n=1}^N |A_{-n}|}, \quad (7)$$

where  $[\Delta\omega]$  = the frequency spike magnitude.

Thus with due consideration of the case in which the signals exchange magnitudes, or frequencies, the discriminator bandwidth needed to accommodate the frequency deviation  $[\Delta\omega]$  is

$$(BW)_{disc} = 2[\Delta\omega] + r = r \left[ 2 \frac{[\Delta\omega]}{r} + 1 \right]$$

OR

$$\frac{(BW)_{disc}}{(BW)_{if}} = \left[ 2 \frac{[\Delta\omega]}{r} + 1 \right] \delta \equiv \beta_{M-N} \delta, \text{ say,} \quad (8)$$

where

$$\beta_{M-N} \equiv \left[ 2 \frac{[\Delta\omega]}{r} + 1 \right]$$

and  $\delta \equiv r/(BW)_{if}$  = the difference frequency between the two carriers in units of one intermediate-frequency

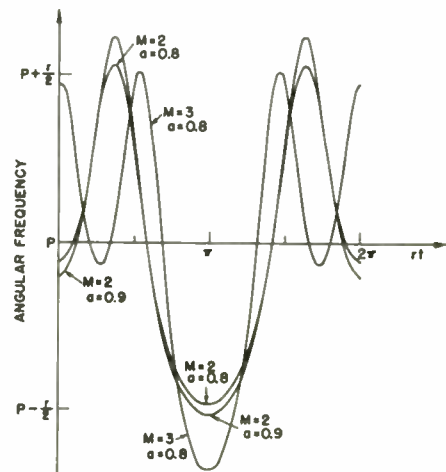

(c)

Fig. 9—Plots of the variation of the instantaneous frequency of the resultant signal with time when only a few sideband components are passed by the ideal limiter filter.



bandwidth. Clearly,  $\delta$  can have a maximum value of one. Furthermore, associated with every configuration of sidebands that may be passed by any prescribed limiter bandwidth is a maximum value of  $\delta = \delta_{max} \leq 1$  beyond which that particular configuration cannot arise. It is readily shown that

$$\delta_{max} = \frac{\frac{(BW)_{lim}}{(BW)_{if}} + 1}{2N}$$

where, as before,  $N$  = number of upper-sideband components passed.

In the determination of the more critical situations that may arise with the different prescribed values of limiter bandwidth, we first allot the maximum space in the limiter pass band to the components from the upper sideband. We then weigh the gravity of a particular possible situation in the light of the maximum value of  $\delta_{max}$  beyond which the situation cannot arise, and the value of  $\beta_{M-N}$  that goes with that situation. The situation that requires the largest value of

$$\frac{(BW)_{disc}}{(BW)_{if}} = \delta_{max} \beta_{M-N} \tag{9}$$

dictates the minimum requirement in discriminator bandwidth.

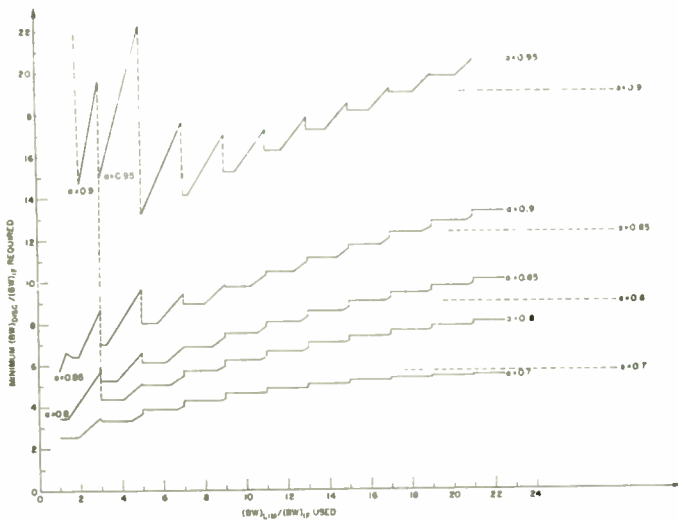

Fig. 10—Plots of the calculated values of minimum requirement in discriminator bandwidth as a function of the ideal limiter filter bandwidth used.

Tables of  $[\Delta\omega]/r$ ,  $\beta_{M-N}$  and  $\delta_{max}$  were constructed to cover the first three most serious situations to reckon with for each limiter bandwidth prescribed over a considerable range of bandwidth values, and the results were used in conjunction with (8) to build a table of discriminator bandwidth requirements. This table placed the values of discriminator bandwidth dictated by the corresponding limiter bandwidths in evidence, and those values were plotted as shown in Fig. 10 above.

The case in which the limiter bandwidth is just one intermediate-frequency bandwidth deserves a special

treatment. Clearly, this case applies only for  $a \leq 0.863$ . Here the situations in which only upper-sideband components are passed, along with  $A_0$ , will lay claim to the greatest requirements in discriminator bandwidth, and so only such cases need be considered here. In order for  $N$  upper-sideband components to pass, the difference frequency,  $r$ , must have a maximum value of  $r_m = (BW)_{if}/N$ .

A study of the variation of the discriminator bandwidth required with the value of  $N$  passed reveals that up to a value of  $a$  somewhere between  $a = 0.8$  and  $a = 0.8$ , the requirement is dictated by the case in which only one upper-sideband component  $A_{-1}$  is passed along with  $A_0$ . If observation (first made by Granlund) is made of the fact that

$$\frac{A_{-1}(a)}{A_0(a)} \cong \frac{1}{2} a, \quad \text{for } a < 0.5,$$

and

$$\frac{A_{-1}(a)}{A_0(a)}$$

is always less than  $a$  and approaches  $a$  only as  $a \rightarrow 1$ , we readily recognize that the relative strength of the interfering signal has been effectively reduced by the stage of narrow-band limiting. Thus it should be possible by cascading enough stages of narrow-band limiters to reduce the relative strength of the interfering signal to a negligible value and, with it, to reduce the required discriminator bandwidth to that of the intermediate frequency only. The plots of Fig. 11 show the results of calculations based on this thinking for  $a = 0.8$  and  $a = 0.7$ . These calculations are not, however, as easy to carry out in cases where more than just one sideband component is passed in the situation that dictates the required discriminator bandwidth. Such cases include values of  $a$  of a little over 0.8 and above.

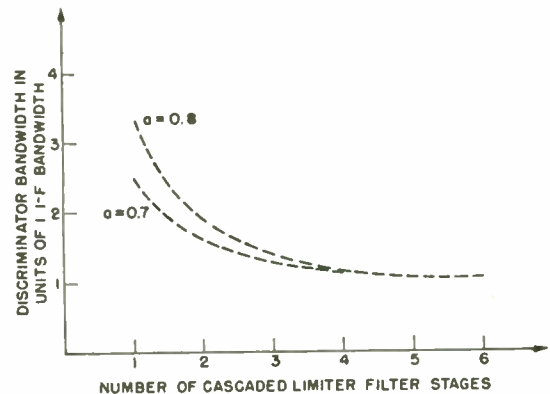

Fig. 11—Variation of the minimum discriminator bandwidth required with the number of cascaded stages of limiter-ideal filter combinations. The ideal limiter filter bandwidth used is just one IF bandwidth.

The plots of Fig. 10, however, supply an indirect answer to the question of whether or not the cascading scheme is effective in the range  $a > 0.8$ .

The plots of Fig. 10 bring out two important facts. First, the minimum requirement in discriminator bandwidth is always less than, but approaches asymptotically, the values previously specified<sup>1</sup> by the equation

$$\frac{(BW)_{disc}}{(BW)_{if}} = \frac{1+a}{1-a}$$

Indeed, it is perfectly plausible that in the limit as the limiter bandwidth becomes very large, the minimum discriminator bandwidth required should approach the asymptotes shown as dotted lines in Fig. 10. For as the limiter bandwidth becomes very large, essentially all of the sideband components are passed, and the resultant signal at the output of the limiter filter approaches the amplitude-limited value of the resultant of the two signals delivered by the intermediate-frequency section to the ideal limiter. Since ideal limiter action per se does not affect instantaneous variations in the frequency of the resultant signal, values specified by the equation quoted above become the limiting values approached as the limiter bandwidth becomes very large.

Associated with each of the broken curves of Fig. 10 is a smooth curve that may be passed through the values of  $(BW)_{disc}/(BW)_{if}$  dictated at the *odd* integral values of  $(BW)_{lim}/(BW)_{if}$  used. We will call these smooth curves the "envelope" curves of the broken plots in Fig. 10, since the latter tend to be bounded by them as the values of the limiter bandwidth used grow large. We can readily show that the envelope curves are rising exponentials. In fact, semilogarithmic plots of these curves reveal that they may be described by the expression

$$y(a, x) = \frac{1+a}{1-a} [1 - \zeta(a) \exp(-k(a)x)], \quad (10)$$

where

$$x \equiv \frac{(BW)_{lim}}{(BW)_{if}} \text{ used}$$

and

$$\begin{aligned} y &\equiv \text{envelope value of } (BW)_{disc}/(BW)_{if} \\ &= \text{value of } (BW)_{disc}/(BW)_{if} \end{aligned}$$

at odd integral values of  $x$ . Calculated values of the functions  $k(a)$  and  $\zeta(a)$  appear in Table II. For the

TABLE II

$a$	$k(a)$	$0.395  \ln a $	$\zeta(a)$	$0.30a + 0.440$
0.7	0.1452	0.1409	0.6500	0.650
0.8	0.0879	0.0881	0.6791	0.680
0.85	0.0630	0.0642	0.6925	0.695
0.9	0.0409	0.0416	0.7093	0.710
0.95	0.0210	0.0203	0.7345	0.725

values of  $a$  of interest,  $k(a)$  appears to satisfy the approximate expression

$$k(a) = -0.395 \ln a \quad (11)$$

very closely, as revealed by Table II. The values of  $\zeta(a)$  shown in this table are based upon the reasonable assumption that the small deviations in the computed values of  $k(a)$  from those given by (11) could be attributed to small cumulative errors in the computations. The tabulated values of  $\zeta(a)$  seem to fit the expression

$$\zeta(a) = 0.30a + 0.44 \quad (12)$$

rather closely.

Eq. (10) may be rewritten in the form

$$\psi(a) \equiv y(a, x) \frac{1-a}{1+a} = 1 - \zeta(a) \exp[-k(a)x],$$

which is plotted in Fig. 12 (opposite page) for the values of  $a$  under consideration. Here, the second term on the right gives the fractional amount by which minimum required discriminator bandwidth has been reduced by passing resultant two-path signal through an ideal limiter whose bandwidth is an odd integral multiple,  $x$ , of the bandwidth of the intermediate frequency section.

In addition to the light it throws upon our results, (10) may be used as a supplement to the plots of Fig. 10 to extrapolate the correct values of  $y$  at odd integral values of  $x$  lying beyond the range covered by the plots, and approximations to  $y$  at other values of  $x$ . It could also be safely used for the same purpose if  $a$  is desired to assume values in the range  $0.7 \leq a \leq 0.95$  that are not covered by the plots of Fig. 10. [(11) is useful up to  $a = 1$ , but (12) is best used for  $0.7 \leq a \leq 0.95$ .]

Eq. (10) may be combined with (9) to yield an expression for  $[\Delta\omega]$ , the magnitude of the frequency spikes that dictate the minimum required discriminator bandwidth at the odd integral values of  $x$ . At those values of  $x$ ,  $\delta_m$  in (9) is unity since  $r = (BW)_{if}$ , and so

$$y = \frac{(BW)_{disc}}{(BW)_{if}} = 2 \frac{[\Delta\omega]}{(BW)_{if}} + 1,$$

whence

$$\begin{aligned} \frac{[\Delta\omega]}{(BW)_{if}} &= \frac{1}{2} (y - 1) \\ &= \frac{a}{1-a} - \frac{1}{2} \frac{1+a}{1-a} \zeta(a) \exp(-k(a)x). \end{aligned} \quad (13)$$

Clearly, the second term on the right is the amount by which the magnitude of the maximum deviation in instantaneous frequency has been reduced, or "damped," by passing the resultant two-path signal through an ideal limiter whose bandwidth is an *odd* integral multiple,  $x$ , of the bandwidth of the intermediate frequency. It is clear, also, that the same value of  $[\Delta\omega]$  calculated at a particular *odd* integral  $x$  will hold for the range of larger values of  $x$  covered by the horizontal segment that follows the particular odd  $x$  used, in the plots of Fig. 10, since  $\delta_m = 1$  in those ranges too.

The second important observation brought to light by the plots of Fig. 10 is that cascading alternate stages of



limiting and filtering should, in fact, reduce the requirement in discriminator bandwidth to smaller and smaller values. Our calculations were carried out for the action of one stage of ideal limiting and filtering upon the resultant of two carriers, but the results are indicative of the action of the same device when more than two carriers are present at its input. Clearly, if it were possible to do without a stage of amplitude limiting (as when an

frequency spike has been reduced (or the spike train has been effectively "damped") by passing the resultant signal through the limiter-filter stage. This "damping" action would conceivably be duplicated (though, possibly, to a different extent) by further stages of bandpass limiting that may follow the first stage on the spike train delivered at the output of this first stage. Hence the justification of the cascading scheme.

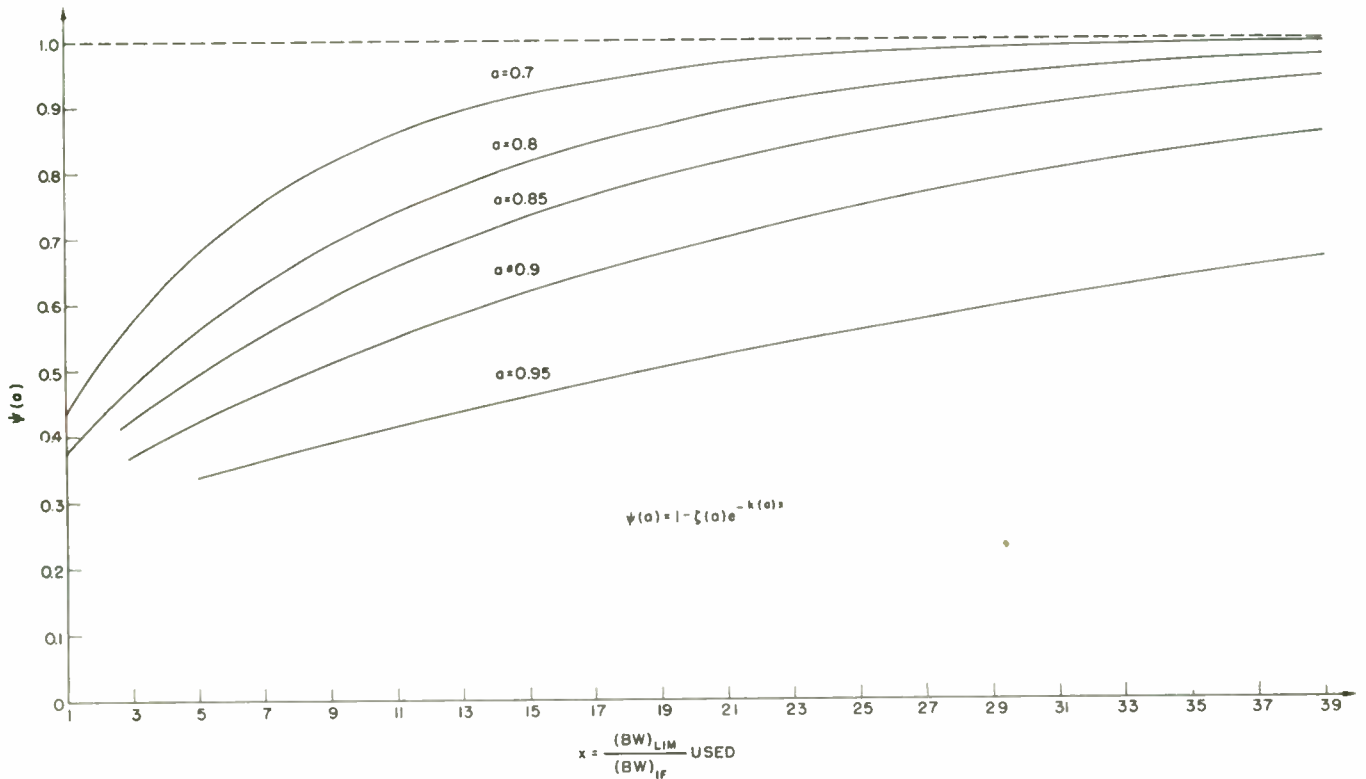

Fig. 12—Normalized plots of the "envelopes" of the broken curves of Fig. 10.  $\psi(a)$  equals the normalized minimum required discriminator bandwidths at the odd integral values of  $x$ .

amplitude-insensitive discriminator is used), the requirements in discriminator bandwidth would be dictated by the ratio  $(1+a)/(1-a)$ , and those requirements would be the asymptotic values in the plots of Fig. 10. The reduction in requirement achieved by the action of the first stage of limiting and filtering upon the resultant of the two carriers delivered to it by the intermediate-frequency section would conceivably be duplicated (though possibly to a varying degree) by the action of the second stage of limiting and filtering upon the resultant signal delivered to it, in turn, by the first stage, etc. With enough cascaded stages, then, it should be possible to reduce the necessary discriminator bandwidth to that of the intermediate-frequency section.

Viewed in an alternative way, the plots of Fig. 10 show that the effective magnitude of the instantaneous

Thus we view the function of a bandpass limiter in frequency-modulation receiver design in a new light. In addition to eliminating interference coming in as amplitude variations in the resultant signal, a bandpass limiter is seen to be effective in relaxing bandwidth requirements on the frequency detector to achieve rejection of frequency-modulation interference produced by signals that may approach desired carrier in strength.

#### ACKNOWLEDGMENT

The author is grateful to Prof. L. B. Arguimbau for suggesting the problem and supervising the major developments of the solution; also to Prof. J. B. Wiesner for his interest and encouragement; and to Dr. J. Granlund and E. E. Manna for their criticisms and encouragement.



# Beam Focusing by Periodic and Complementary Fields\*

KERN K. N. CHANG†

**Summary**—Periodic magnetic or electrostatic fields are capable of focusing a long electron beam so that the performance normally yielded by a uniform magnetic field is attained. This is the case if a proper choice of the value of the period with respect to the rms value of the field is employed. For high-power traveling-wave tubes, however, the value of the period demanded by either periodic magnetic or electrostatic focusing field is so small that it is almost impossible to realize these fields. By the use of a proper combination of a varying magnetic and electric field, optimum performance is physically attainable for electron beams of high perveance. The general theory of focusing action in such combined or complementary fields is given and is applied to problems which arise in systems involving parallel electron beam flow. It is also shown that in the case of combined fields, the fields which may be employed are much less restricted and critical than is the case when they are used singly.

## INTRODUCTION

IN THE DESIGN of traveling-wave tubes, it has been customary to use a uniform magnetic field to constrain the electron beam. It has been shown, both theoretically<sup>1</sup> and experimentally, that good beam-focusing can be obtained in this way. However, when uniform magnetic fields are employed, very serious design problems arise. For proper focusing, one requires a heavy magnet coil. This consumes a large amount of dc power in operation. One method of overcoming this disadvantage is to use an axially periodic field utilizing permanent magnets, as was first proposed by Pierce.<sup>2</sup> Such a field differs from the unidirectional magnetic field with constant magnitude along the beam axis, in that its magnitude and direction along the axis vary periodically. Another method of overcoming this disadvantage is to use an axially periodic electrostatic field, as has recently been discussed by Clogston and Heffner.<sup>3</sup> These approaches have shown promising results.

The following presentation will first give additional development to certain general aspects of the theory of axially periodic fields. It will then extend these concepts to a new and important method of beam-focusing. The method involves the use of complementary or nonperiodic electrostatic and magnetic fields. The method also utilizes a mathematical generalization of the general subject of beam-focusing.

\* Original manuscript received by the IRE, July 7, 1954; revised manuscript received, September 17, 1954. This paper is based on a portion of a dissertation submitted in partial fulfillment of the requirements for the Doctor of Electrical Engineering degree at Polytechnic Institute of Brooklyn, N. Y., and also was presented at the I.R.E. Electron Devices Conference, University of Maine, Orono, Me., in June 1954.

† RCA Laboratories, Princeton, N. J.

<sup>1</sup> C. C. Wang, "Electron beams in axially symmetrical fields," *Proc. I.R.E.*, vol. 38, pp. 135-147; February, 1950.

<sup>2</sup> J. R. Pierce, "Spatially alternating magnetic fields for focusing low-voltage electron beams," *Jour. Appl. Phys.*, vol. 24, p. 1247; September, 1953.

<sup>3</sup> A. M. Clogston and H. Heffner, "Focusing of an electron beam by periodic fields," *Jour. Appl. Phys.*, vol. 25, p. 436; April, 1954. These authors' contribution relating to periodic electrostatic focusing-fields appeared after completion of this manuscript.

In conventional traveling-wave tubes the voltages in the drift and interaction space are generally considered to be constant. In the systems to be analyzed, small variations are superimposed onto these voltages. The variations are sufficiently small so that concepts associated with a constant voltage system are retained while a powerful approach to the problem is still possible.

As will be shown, this method has considerable advantage over the use of the periodic magnetic or electrostatic field approach. The approach using a single periodic field will be shown to have limitations with regard to beam perveance. Also, the use of either the axially periodic electrostatic or periodic magnetic field always introduces ripples along the beam and, in addition, produces wide unstable regions of beam flow, depending on the precise value of the axial period employed. The complementary electrostatic and magnetic field approach, on the other hand, offers the possibility of producing a uniform electron flow without ripples, retaining at the same time the features of reduced weight and size of periodic focusing systems. Theoretically, no limitations exist in this focusing system on the beam perveance, and the unstable regions of the beam are much narrower than in the periodic cases employing fields of one kind only.

## PERIODIC MAGNETIC AND PERIODIC ELECTROSTATIC FIELDS

Beam-focusing by periodic magnetic or periodic electrostatic fields has been treated by Clogston and Heffner.<sup>3</sup> For the purpose of revealing the limitations of the use of these periodic fields, the following discussion will re-derive and review pertinent equations which have been derived by Clogston and Heffner, and will also extend the scope of these equations to include the effect on electron flow caused by the presence of a magnetic field at the cathode. The concepts relating to the analytical and physical statements of these limitations will then serve as a basis for comparison with the much less severe limitations of the new complementary magnetic and electrostatic field presented in the next section.

Consideration of the paraxial electron flow in axially symmetrical fields, for the case where the electron flow starts in a magnetic field at the cathode, leads to a modified paraxial ray equation,<sup>4</sup>

$$r'' + \frac{V'}{2V} r' + \left\{ \frac{V''}{4V} + \frac{\eta}{8V} \left( B_z^2 - \frac{r_{00}^4}{r^4} B_{00}^2 \right) \right\} r = \frac{I}{4\sqrt{2}\pi\epsilon_0\eta^{1/2}V^{3/2}r} \quad (1)$$

<sup>4</sup> J. R. Pierce, "Theory and Design of Electron Beams," D. Van Nostrand Co., Inc., New York, N. Y.; 1949.



In (1),  $r'$ ,  $r''$  are the first and second derivatives of the radial distance of a particular electron with respect to axial distance  $z$ . The potential along the axis is denoted by  $V$  and the current by  $I$ .  $B_z$  is the axial magnetic flux density and assumes the value  $B_{00}$  at the cathode.  $r_{00}$  is the cathode radius.  $\epsilon_0$  is the dielectric constant and  $\eta$  is the ratio of electron charge to mass.

Periodic focusing can be achieved by introducing an axially periodic magnetic or electrostatic field into (1). The final beam equation which represents a weakly scalloped beam is an inhomogeneous differential equation of the Mathieu type:

$$\tilde{r}'' + (a + 2q \cos 2Z)\tilde{r} = -r_1[2q \cos 2Z + b]. \quad (2)$$

The Mathieu parameters  $a$ ,  $q$  and  $b$  are defined in the Appendix. The equilibrium radius of the electron beam is  $r_1$ ; the beam scallops about  $r_1$  with a radius  $\tilde{r}$ . Throughout the following presentation, it is convenient to introduce two normalizing factors; namely, the plasma wavelength  $\lambda_p$  and the Brillouin flux density  $B_b$ . Utilizing these two factors, the solution of the above Mathieu equation (2) is given in the Appendix. The solution reveals the effect of the degree of magnetic shielding of the cathode, represented by  $B_{00}^2/B^2$ , as a function of  $r_{00}^2/r_1^2$  and  $B^2/B_b^2$ . This function may be plotted as shown in Fig. 1. For comparison, similar curves for the uniform magnetic field case, as obtained from Wang's paper, are plotted in the same figure.

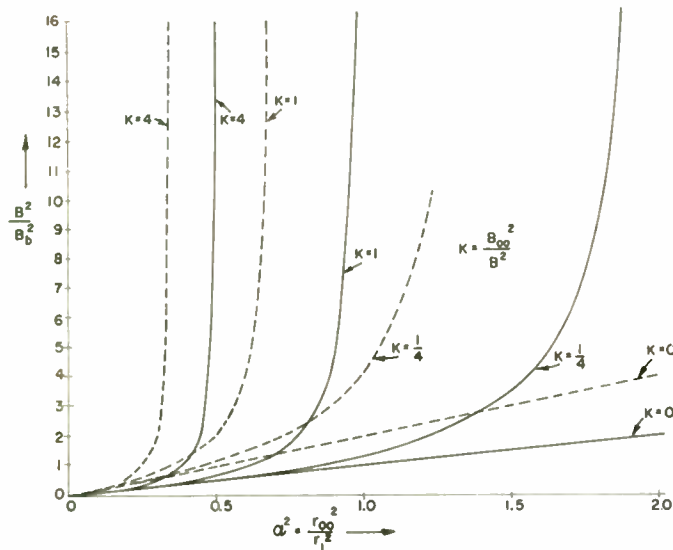

Fig. 1— $B^2/B_b^2$  vs  $\alpha^2$ , of sinusoidal magnetic field (-----) and uniform magnetic field (——) in drift space, where  $B_b$ =Brillouin Flux Density at cathode radius;  $B_{00}$ =flux density at cathode;  $B$ =maximum value of flux density;  $r_{00}$ =cathode radius;  $r_1$ =equilibrium radius.

For the particular case of a completely shielded cathode, i.e.,  $B_{00}/B=0$ , the peak field is  $\sqrt{2}$  time larger than that required for a uniform, nonperiodic field. It is this particular case which Clogston and Heffner have treated. The curves shown in Fig. 1, however, indicate generalization to cases for nonshielded cathodes.

As shown by (62) and (86), it is necessary for high-power traveling-wave tubes to employ a periodic field with a very short period for proper focusing. As a numerical example, experimental high-power traveling-wave tubes, developed in RCA Laboratories, have been found to have a value of  $\lambda_p$  of 2.5 cm. It is estimated from (62) and (86) that the period required for the periodic magnetic field is 0.5 cm, and that for the periodic electrostatic field, 0.05 cm. These small period values present considerable difficulties in the design and construction of periodic fields which are used with power tubes. Furthermore, for periodic electrostatic fields, particularly having periods short enough to be comparable with the radius of the beam, the paraxial equation (1) may not be valid.<sup>5</sup> It is possible to obtain solutions for such short period lengths using third and higher order approximations. However, these solutions are not included here.

### COMPLEMENTARY VARYING MAGNETIC AND ELECTROSTATIC FIELDS

Now let us consider a new focusing method, namely, the introduction of a varying magnetic field and an electrostatic field which varies in such a way that optimum focusing performance is attained. As has been shown in the preceding section, both the periodic magnetic and the periodic electrostatic focusing field are severely limited as regards their use for electron beams of high perveance. At best, either of them can focus only a long electron beam of small scalloping, and both are characterized by wide unstable regions of operation. Furthermore, use of the periodic focusing field, either magnetic or electrostatic, has been limited so far to the drift space, by virtue of the fact that in the accelerating region, or rather in the electron gun region, a single periodic focusing field does not work properly.

The new complementary field method shows promise of much greater applicability than the single periodic cases. First, the complementary field has no limitation on the axial period and indeed need not even be periodic. Secondly, it is capable of focusing an electron beam into a smooth parallel beam without scalloping, and ensures a beam flow with a much wider stable region than that obtained with single periodic fields. In the third place, it can be readily employed to focus electron beams of high perveance. Finally, it is the only means for focusing the electron beam in the accelerating region of the electron gun.

Returning now to (1) we see that  $r''=0$ , parallel flow of the beam at a certain radius  $r_0$  is obtained. The condition is:

$$\left\{ \frac{V''}{4V} + \frac{\eta}{8V} \left( B_s^2 - \frac{r_{00}^4}{r_0^4} B_{00}^2 \right) \right\} V^{3/2} = \frac{I}{4\sqrt{2} \pi \epsilon_0 \eta^{1/2} r_0^2}. \quad (3)$$

<sup>5</sup> I. G. Maloff and D. W. Epstein, "Electron Optics in Television," McGraw-Hill Book Co., Inc., New York, N. Y., p. 125; 1938.

This shows that  $B_z$  and  $V$  can be any arbitrary functions of  $z$  which satisfy (3).

According to (3), for small voltage variations it is sufficient that the sum of the second derivative of  $V$  with respect to  $z$  and the square of  $\sqrt{\eta/2} B_z$  must be a constant if parallel flow is to be obtained.

If a certain periodic or nonperiodic magnetic field  $B$  is given, the potential  $V$ , for which the beam flow would be parallel, is readily found. Eq. (3) allows a graphical solution as shown in Fig. 2. The  $B^2$  curve and the  $d^2V/dz^2$  curve are indicated in Figs. 2(c) and 2(d) as dotted curves. It then follows that if the shapes of the dotted curves are those shown in the figures, their sums will give a substantially constant value and thus set up a condition for parallel flow.

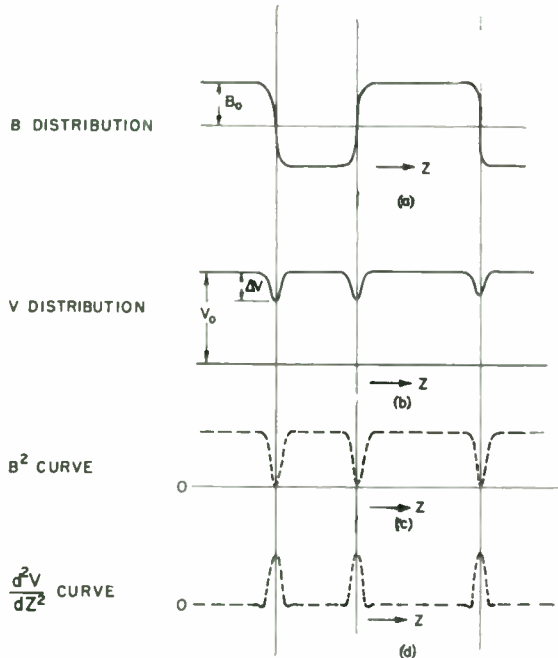

Fig. 2—Complementary diagram of focusing action in complementary fields.

In a more practical sense, even if the  $B^2$  curve and the  $d^2V/dz^2$  curve do not exactly match, a voltage dip of any practical shape occurring at the place along the axis where the varying or periodic magnetic flux density reaches a zero value, will provide an electrostatic force to complement the radial force due to the small magnetic field. This will result in an approximate balance to the space charge force.

#### Complementary Periodic Magnetic and Electrostatic Fields

The manner of applying the preceding results will be illustrated quantitatively in the special case of periodic fields. Suppose that the voltage distribution along the axis is sinusoidal in form, i.e.,

$$V = V_0 + \Delta V \cos \frac{2\pi}{L} z. \quad (4)$$

Then, to find the value of  $B_z$  corresponding to the parallel flow, we substitute (4) into (3) and expand  $B_z^2$  in powers of  $\Delta V/V_0$ :

$$B_z^2 = B_b^2 \left[ \left( 1 + \frac{r_{00}^4}{r_0^4} \frac{B_{00}^2}{B_b^2} \right) + \frac{1}{2} \frac{\Delta V}{V_0} \left( \frac{\lambda_p^2}{L^2} - 1 \right) \cos \frac{2\pi}{L} z + \frac{3}{8} \frac{\Delta V^2}{V_0^2} \cos^2 \frac{2\pi}{L} z + \dots \right], \quad (5)$$

where

$$B_b^2 = \frac{\sqrt{2} I}{\pi \epsilon_0 \eta^{3/2} V_0^{1/2} r_0^2} \quad (6)$$

and

$$\lambda_p^2 = \frac{16\pi^2 V_0}{\eta B_b^2}. \quad (7)$$

Now, if we assume that  $V_0 \gg \Delta V$ , then:

$$B_z^2 = B_b^2 \left[ \left( 1 + \frac{r_{00}^4}{r_0^4} \frac{B_{00}^2}{B_b^2} \right) + \frac{1}{2} \frac{\Delta V}{V_0} \left( \frac{\lambda_p^2}{L^2} - 1 \right) \cos \frac{2\pi}{L} z \right]. \quad (8)$$

The magnetic field which is given by (8) will have several possible solutions, depending on the value of  $(\lambda_p/L)$ . Let us investigate the case which would give a pure sinusoidal magnetic field, i.e.

$$\left( \frac{\lambda_p}{L} \right)^2 \gg 1, \quad \text{and}$$

$$\frac{1}{2} \frac{\Delta V}{V_0} \left( \frac{\lambda_p^2}{L^2} - 1 \right) = \left( 1 + \frac{r_{00}^4}{r_0^4} \frac{B_{00}^2}{B_b^2} \right). \quad (9)$$

In this case, if the electron gun is magnetically shielded,  $B_{00} = 0$ , it follows that

$$B_z = \sqrt{2} B_b \cos \frac{\pi}{L} z, \quad (10)$$

$$\frac{\Delta V}{V_0} = 2 \left( \frac{L}{\lambda_p} \right)^2. \quad (11)$$

This particular example indicates as shown by (11) that a longer axial period  $L$  of the periodic fields can be used than is the case for purely periodic magnetic or electrostatic fields. [See (62) and (86).] Numerically, if  $\lambda_p = 2.5$  cm and  $\Delta V/V_0 = 0.11$ , then the period value of the electrostatic field is 0.6 cm; while that of the magnetic field is 1.2 cm. These values are quite reasonable for actual design. It is interesting to note that in order to satisfy the condition for parallel flow in this particular case, the electric field has to alternate at twice the rate of the magnetic field as depicted by Fig. 3, facing page.

#### Parallel Electron Beam Flow in Complementary Electrostatic and Magnetic Fields

The general theory of focusing action in complementary electrostatic and magnetic fields can be applied to many important problems which arise in systems in-



volving parallel electron beam flow. Two well-known parallel flow cases, namely, Brillouin flow and confined flow, are just two special cases which employ, respectively, a uniform magnetic field and an infinite magnetic field as the only focusing field under proper conditions. Several of the other problems and their solutions are discussed below.

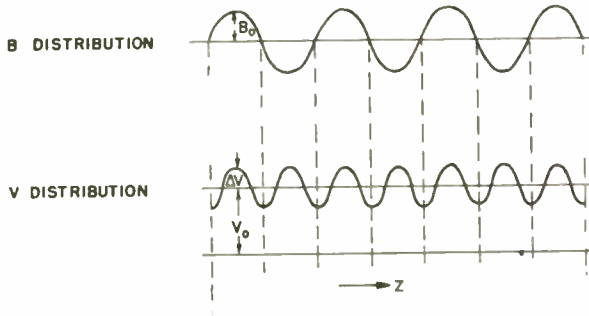

Fig. 3—Distribution of the flux density and the potential along the axis for a sinusoidal complementary field.

*Flow in Electron Gun:* This is the case in which the potential starts at zero at the cathode and then increases along the axis. The magnetic field may be uniform or varying in this case.

1.  $B_z = \text{Constant}$ —According to (3) the parallel flow occurs if

$$\frac{V''}{4V} + \frac{\eta}{8V} B_{z0}^2 = \frac{I}{4\sqrt{2} \pi \epsilon_0 \eta^{1/2} V^{3/2} r_0^2} \quad (12)$$

To solve (12), let us first make the following normalizations:

$$\frac{V}{V_0} = \bar{V} \quad (13)$$

$$2\pi \frac{z + z_0}{\lambda_p} = \bar{z} + \bar{z}_0 \quad (14)$$

$$\frac{B_{z0}^2}{B_b^2} = \frac{1}{B_b^2} \left( B_z^2 - \frac{r_{00}^4}{r_0^4} B_{00}^2 \right) = \bar{B}^2 \quad (15)$$

$$\frac{V_0'^2}{\eta V_0 B_b^2} = C. \quad (16)$$

Where  $V_0'$  is the axial electrostatic field at  $V=0$ . Integration of (12) then yields

$$V'^2 = \eta V_0 B_b^2 (-\bar{B}^2 \bar{V} + 2\bar{V}^{1/2} + C). \quad (17)$$

By integrating (17), we have

$$\begin{aligned} \bar{z} + \bar{z}_0 = & -\frac{1}{\bar{B}^2} \sqrt{-\bar{B}^2 \bar{V} + 2\bar{V}^{1/2} + C} \\ & - \frac{1}{\bar{B}^3} \sin^{-1} \frac{1 - \bar{B}^2 \bar{V}^{1/2}}{\sqrt{1 + C\bar{B}^2}}. \end{aligned} \quad (18)$$

To realize this potential distribution for constant diameter flow given by (18) the values of  $\bar{B}^2 \bar{V}^{1/2}$ , as obtained from the equation, must be restricted to the region

$$0 \leq \bar{B}^2 \bar{V}^{1/2} \leq 2 + \frac{C}{\bar{V}^{1/2}}. \quad (19)$$

Let us fix the value of  $\bar{z}_0$  such that  $V=0$  when  $\bar{z}=0$ . Then the value of  $\bar{z}$  corresponding to the upper limit

$$\bar{B}^2 \bar{V}^{1/2} = 2 + \frac{C}{\bar{V}^{1/2}} \quad (20)$$

is

$$\bar{z} = \frac{1}{\bar{B}^3} \left( \sin^{-1} \frac{1}{\sqrt{1 + C\bar{B}^2}} + \frac{\pi}{2} \right) + \frac{\sqrt{C}}{\bar{B}^2}. \quad (21)$$

Elimination of  $\bar{B}$  between (21) and (20) yields

$$\begin{aligned} \bar{z} = & \left( \frac{\bar{V}}{C + 2\bar{V}^{1/2}} \right)^{3/2} \left[ \sin^{-1} \frac{\bar{V}^{1/2}}{C + \bar{V}^{1/2}} + \frac{\pi}{2} \right] \\ & + \left( \frac{\bar{V}}{C + 2\bar{V}^{1/2}} \right) \sqrt{C} \end{aligned} \quad (22)$$

as the upper boundary. We cannot obtain the lower boundary by simply putting  $B_{z0}=0$  in (18), because (18) will diverge as  $B_{z0}$  approaches zero. However, values of  $\bar{z}$  corresponding to this case are readily obtained by integrating (17) after dropping out  $B_{z0}$  in the same equation. This gives:

$$\begin{aligned} \bar{z} - \frac{\sqrt{2}}{3} C \sqrt{\frac{C}{2}} \\ = -\frac{\sqrt{2}}{3} (C - \bar{V}^{1/2}) \sqrt{\bar{V}^{1/2} + \frac{C}{2}}. \end{aligned} \quad (23)$$

By letting  $C$  equal zero, (23) has the well-known form of the potential distribution for the Pierce gun.

As an illustration, the case of zero axial electrostatic field at  $\bar{z}=0$ ; i.e.,  $C=0$ , is plotted between  $\bar{V}$  and  $\bar{z}$ , as shown by Fig. 4 (following page). The shaded regions which are bounded by the curves

$$\bar{z} = \frac{\pi}{\sqrt{8}} \bar{V}^{3/4} \quad (24)$$

and

$$\bar{z} = \frac{\sqrt{2}}{3} \bar{V}^{3/4} \quad (25)$$

are to be excluded, since the potential distributions in there are not realizable.

Every point on the upper boundary ( $\bar{z} = \pi/\sqrt{8} \bar{V}^{3/4}$ ) has a zero axial electrostatic field. The potential distribution corresponding to  $\bar{B} = \sqrt{2}$  depicts a zero field when  $V = V_0$  at the lower boundary. This should be the case if the gun region is to be followed by a drift space.

2. *Varying Magnetic Fields*—It is of interest from the standpoint of actual gun design to see whether the condition of constant diameter can be maintained in the accelerating region during which the electrons are brought to the point where they enter the drift region with the uniform, the periodic, or the complementary field dis-

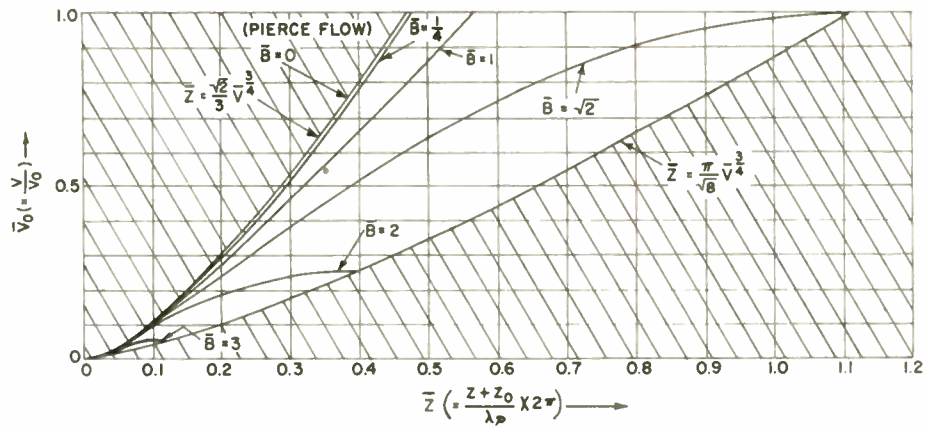

Fig. 4—Potential distribution required for parallel electron beam flow for different values of effective uniform magnetic field  $B_{z0}$ . Where  $\bar{B} = B_{z0}/B_0$ ,  $\bar{V} = V/V_0$ ,  $\bar{z} = 2\pi(z+z_0)/\lambda_p$ . The Pierce gun is a special case when  $\bar{B} = 0$ .

cussed above. We start with (3) and, using the same normalization as in (1), we obtain:

$$\bar{V}'' - \frac{2}{\bar{V}^{1/2}} = -2\bar{B}^2, \quad (26)$$

where  $\bar{V} = V/V_0$ ,  $\bar{B}^2 = B_{z0}^2/B_0^2$  and  $\bar{V}''$  is the second derivative of  $\bar{V}$  with respect to the normalized axis distance  $\bar{z} = 2\pi z/\lambda_p$ . From (26) it appears that  $\bar{B}$  becomes infinity when  $\bar{V}$  is equal to zero at the cathode. This is not necessarily so. It may well be the case that the quantity on the left side of (26) can be finite at all points, even those for which  $\bar{V} = 0$ . This case is now shown. To make the function of  $\bar{B}$  finite in the working range, the sufficient condition is that

$$2 - \bar{V}''\bar{V}^{1/2} = \bar{V}^{1/2}f(\bar{V}), \quad (27)$$

where  $f(\bar{V})$  is any analytic function of  $\bar{V}$  which is finite in the region of interest. By substituting (27) into (26), we have

$$\bar{B}^2 = \frac{f(\bar{V})}{2}. \quad (28)$$

Also, integration of (27) yields

$$(\bar{V}')^2 = 8\bar{V}^{1/2} - 2 \int f(\bar{V})d\bar{V} + \bar{V}_0'^2. \quad (29)$$

In practical cases, the electrostatic fields are usually zero at the cathode ( $\bar{V} = 0$ ) and at the end of the electron gun ( $\bar{V} = 1$ ). For such a case (29) reduces to the relation

$$\left[ \int f(\bar{V})d\bar{V} \right]_{\bar{V}=0}^{\bar{V}=1} = 4. \quad (30)$$

By integrating (29) once, we obtain the potential distribution

$$\bar{z} + \bar{z}_0 = \int \frac{1}{\sqrt{8\bar{V}^{1/2} - 2 \int f(\bar{V})d\bar{V} + \bar{V}_0'^2}} d\bar{V}. \quad (31)$$

The integration expressed by (31) is always possible provided that the choice of  $f(\bar{V})$  is such that

$$2 \int f(\bar{V})d\bar{V} < 8\bar{V}^{1/2} + \bar{V}_0'^2. \quad (32)$$

To demonstrate how one applies the above condition, consider a numerical example. Suppose

$$f(\bar{V}) = k\bar{V}, \quad (33)$$

where  $k$  is an arbitrary constant. To satisfy (30),  $k$  must be equal to 8. Then according to (28),  $\bar{B}^2$  will assume a value of 4 when  $\bar{V} = 1$ . In addition, (31) yields

$$\bar{z} + \bar{z}_0 = \int \frac{d\bar{V}}{\sqrt{8\bar{V}^{1/2} - 8\bar{V}^2}} = \frac{\sqrt{2}}{3} \sin^{-1} \bar{V}^{3/4} \quad (34)$$

or

$$\bar{V}^{3/4} = \sin \frac{3}{\sqrt{2}} (\bar{z} + \bar{z}_0);$$

then by (28), it follows that

$$\bar{B} = 2 \left[ \sin \frac{3}{\sqrt{2}} (\bar{z} + \bar{z}_0) \right]^{2/3}. \quad (35)$$

The distributions of  $\bar{V}$  and  $\bar{B}$  along the axis are plotted in Fig. 5(a) (facing page). These were verified experimentally.

Consider another case in which now  $\bar{B} = \sqrt{2}$  when  $\bar{V} = 1$ . This is the value of  $\bar{B}$  required to match a periodic magnetic field in the drift region to the varying magnetic field in the preceding accelerating region and is thus a case of real practical interest. Since the choice of  $f(\bar{V})$  is arbitrary, subject only to the conditions that it be analytic and also that it satisfy (32), let us for convenience try  $f(\bar{V}) = a_1\bar{V} + a_2\bar{V}^2$ . By using (28) and (30), this trial  $f(\bar{V})$  yields  $a_1 = 16$ ,  $a_2 = -12$ , and does satisfy (32). The numerical integration of (31) then gives the distributions of  $\bar{V}$  and  $\bar{B}$  along the axis as shown by Fig. 5(b).

We see thus, from this section, that it is possible to design a complementary electric and magnetic field in the accelerating region of an electron gun, such that the beam emitted from the cathode maintains a constant diameter.



*Flow in Drift Region:* The condition for constant diameter flow in this case is given by (3) which has been discussed briefly. More general aspects of the problem can be studied by solving (3) in a more rigorous way as follows:

Let  $\bar{V} = 1 + \tilde{V}$  where  $\tilde{V} < 1$ . Eq. (26) becomes

$$\tilde{V}'' - 2\left[1 - \frac{1}{2}\tilde{V} + \frac{3}{8}\tilde{V}^2 - \dots\right] = -2\bar{B}^2. \quad (36)$$

Ignoring the second and higher order terms, we obtain

$$\tilde{V}'' + \tilde{V} = -2\bar{B}^2 + 2 = \bar{B}_1(\bar{z}). \quad (37)$$

The solution of (37) is

$$\tilde{V} = \alpha_1 \cos \bar{z} + \beta_1 \sin \bar{z} - \left[ \cos \bar{z} \int^{\bar{z}} \sin \bar{z} \bar{B}_1(\bar{z}) d\bar{z} - \sin \bar{z} \int^{\bar{z}} \cos \bar{z} \bar{B}_1(\bar{z}) d\bar{z} \right], \quad (38)$$

where

$$\alpha_1 = \tilde{V}(0) + \int^0 \sin \bar{z} \bar{B}_1(\bar{z}) d\bar{z}, \quad (39)$$

$$\beta_1 = \tilde{V}'(0) - \int^0 \cos \bar{z} \bar{B}_1(\bar{z}) d\bar{z}. \quad (40)$$

If  $\bar{B}(\bar{z})$  is continuous and physically realizable, (38) can be solved, showing that for values of  $\bar{B}_1(\bar{z})$  conforming to the aforementioned conditions, there exist corresponding values of  $\tilde{V}(\bar{z})$ . One of the special cases is that for which

$$\bar{B}^2 = \frac{B_z^2}{B_b^2} \left( 1 + \cos \frac{2\pi}{L} z \right). \quad (41)$$

This has been treated earlier in this section. If this particular function of  $\bar{B}$  is substituted into (38), one obtains the same potential function as discussed therein.

STABILITY CONSIDERATIONS

Consider now the question as to whether the complementary field case will give stable solutions or not. In other words, is there any restriction on the axial period in order to ensure a stable flow? First we substitute the condition for constant diameter flow as given by (3) into (1)

$$r'' + \frac{V'}{2V} r' + \frac{\eta B_b'^2}{8V} r - \frac{\eta B_b'^2}{8Vr} r_0^2 = 0. \quad (42)$$

In order to investigate stability, we now introduce a new and useful mathematical approach, utilizing the substitution,

$$X = \int V^{-1/2} dz. \quad (43)$$

Eq. (42) then assumes the form

$$\frac{d^2 r}{dX^2} + \left( \frac{\eta B_b'^2}{8} \right) r - \frac{\eta B_b'^2}{8r} r_0^2 = 0, \quad (44)$$

where

$$B_b'^2 = \frac{\sqrt{2} I}{\pi \epsilon_0 \eta^{3/2} |v|^{1/2} r_0^2}. \quad (45)$$

If

$$V = V_0 + \Delta V \cos \frac{2\pi}{L} z \quad \text{and} \quad V_0 \gg \Delta V,$$

then

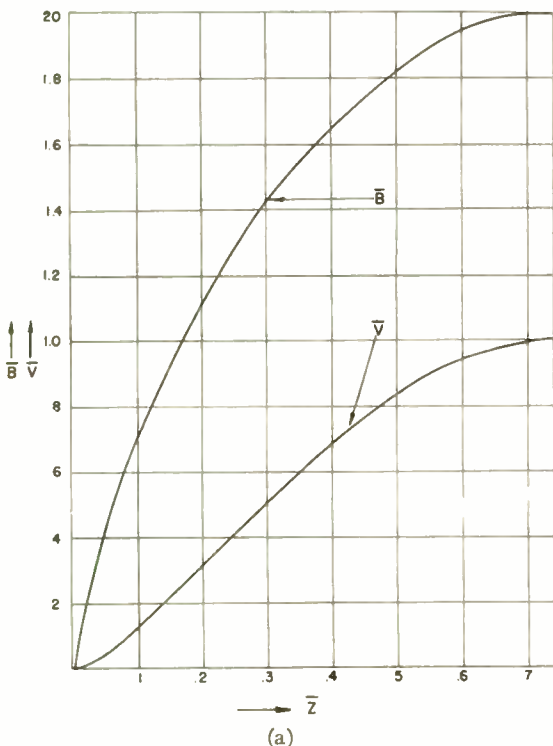
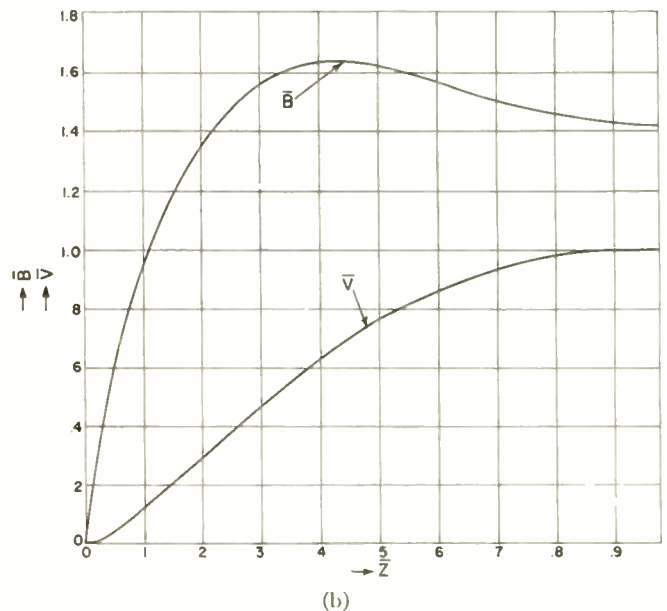

Fig. 5—Distribution of the flux density and the potential along the axis in the accelerating region.

$$B_b'^2 = \frac{\sqrt{2} I}{\pi \eta^{3/2} \epsilon_0 r_0^2 V_0^{1/2}} \left( 1 - \frac{\Delta V}{2V_0} \cos \frac{2\pi}{L} z + \dots \right) \\ \cong B_b^2 \left( 1 - \frac{\Delta V}{2V} \cos \frac{2\pi}{L} z \right). \quad (46)$$

Now, since

$$X = \int V^{-1/2} dz = \int \left( V_0 + \Delta V \cos \frac{2\pi}{L} z \right)^{-1/2} dz \\ = V_0^{-1/2} \left[ z - \frac{1}{4\pi} \frac{\Delta V}{V_0} \sin \frac{2\pi}{L} z + \dots \right] \quad (47)$$

and

$$\frac{L}{4\pi} \frac{\Delta V}{V_0} \sin \frac{2\pi}{L} z \ll z, \quad (48)$$

then

$$X \cong V_0^{-1/2} z. \quad (49)$$

By substituting (49) and (46) into (44) we obtain:

$$\frac{d^2 r}{dX^2} + \frac{\eta}{8} B_b^2 \left( 1 - \frac{\Delta V}{2V_0} \cos \frac{2\pi}{L} V_0^{1/2} X \right) \\ \left( r - \frac{r_0^2}{r} \right) = 0. \quad (50)$$

The first order solution of (50) can be found by assuming a small perturbation of  $r$  about  $r_0$ , such that  $r = r_0 + \hat{r}$  where  $r_0 \gg \hat{r}$ . Eq. (50) then has the following form:

$$\frac{d^2 \hat{r}}{dX^2} + \frac{\eta}{4} B_b^2 \left( 1 - \frac{\Delta V}{2V_0} \cos \frac{2\pi}{L} V_0^{1/2} X \right) \hat{r} = 0. \quad (51)$$

If we now compare (51) with (2), discussed previously, we see that in the complementary field case, the quantity  $a/q$  [the parameter ratio which determines the regions of stability and instability in Mathieu (51)] is equal to  $2V_0/2\Delta V$  and is much greater than what is correspondingly used in the periodic magnetic or electrostatic field case. According to the theory<sup>6</sup> of the Mathieu-type equations, the larger the value  $a/q$ , the smaller is the unstable region. Eq. (51) thus reveals that the complementary field case has more stability of beam flow than either the periodic magnetic or electric field case.

### CONCLUSION

In Table 1 below are the results for the different methods of beam-focusing which have been discussed in the preceding sections. In addition, it includes various comments regarding the relative merits of the different cases. It is seen that the amount of flux density necessary for the sinusoidal periodic magnetic field, as well as for the complementary field case, is  $\sqrt{2}$  times that required for the uniform magnetic field. In general, the rms value of the periodic field is equal to the dc value of the uniform magnetic field.

Both the purely periodic magnetic field case and the purely electrostatic field case are subject to a design limitation factor on the value of the axial period, from the point of view of both power and stability of flow. The complementary field case, which employs a field structure which is not unduly complicated, has the important advantage that the fields to be used are more free

<sup>6</sup> N. W. McLachlan, "Theory and Application of Mathieu Functions," Oxford University Press, New York, N. Y.; 1947.

TABLE I

Type of Focusing Field	Characteristics of Flow	Condition for Optimum Stability	Stability of Flow	Construction	Fields of Applicability
Uniform Magnetic Field	Constant diameter flow	$B_0 = B_b$	Stable	Bulky	High perveance beams in drift space
Periodic Magnetic Field	Perturbed oscillating flow	$B_0 = \sqrt{2} B_b$ $\frac{B_0^2}{B_b^2} = 8q_m / \left( \frac{L}{\lambda_p} \right)^2$	Alternate stable and unstable regions	Light	Low perveance beams in drift space
Periodic Electrostatic Field	Perturbed oscillating flow	$\left( \frac{\Delta V}{V} \right) = \frac{16}{3} \left( \frac{L}{\lambda_p} \right)^2$ $\left( \frac{\Delta V}{V} \right)^2 = \frac{64}{3} q_e$	Alternate stable and unstable regions	Light and compact	Low perveance beams in drift space
Complementary Field	Constant diameter flow	$\frac{\Delta V^*}{V} = 2 \left( \frac{L}{\lambda_p} \right)^2$ $B_0 = \sqrt{2} B_b$	Alternate stable and unstable regions wider stable regions	Light	High perveance beams in drift space, and gun region

$q_m$  and  $q_e$ : parameters which determine the characteristic of the solution, stable one or unstable one. \* Specific example for sinusoidal fields.



from the stability restriction than those used in the pure periodic field cases, and has an added advantage in that the axial fields employed need not be periodic.

APPENDIX

PERIODIC FIELD FOCUSING—  
FIRST-ORDER SOLUTION

Periodic Magnetic Field

In (1) let

$$V' = V'' = 0 \tag{52}$$

and

$$B_z = B_0 \cos \frac{2\pi}{L} z. \tag{53}$$

Then it follows that

$$r'' = \frac{-\eta r}{8V} B_0^2 \cos^2 \left( \frac{2\pi}{L} z \right) + \frac{\eta}{8V} \left[ B_b^2 \frac{r_{00}^2}{r} + B_{00}^2 \frac{r_{00}^4}{r^3} \right], \tag{54}$$

where

$$B_b^2 = \frac{\sqrt{2} I}{\pi \epsilon_0 \eta^{3/2} V^{1/2} r_{00}^2}. \tag{55}$$

Now assume

$$r = r_1 + \hat{r}(z), \quad r_1 \gg \hat{r}. \tag{56}$$

Then (54) becomes

$$r'' = \frac{\eta}{8V} B_0^2 \cos^2 \left( \frac{2\pi}{L} z \right) (r_1 + \hat{r}) + \frac{\eta}{8V} \left[ B_b^2 r_{00}^2 \frac{1}{r_1 + \hat{r}} + B_{00}^2 r_{00}^4 \frac{1}{(r_1 + \hat{r})^3} \right]. \tag{57}$$

By expanding

$$\left( 1 + \frac{\hat{r}}{r_1} \right)^{-3} \quad \text{and} \quad \left( 1 + \frac{\hat{r}}{r_1} \right)^{-3},$$

and neglecting terms of order  $(\hat{r}/r_1)^2$ , we have

$$\hat{r}'' + (a_m + 2q_m \cos 2Z)\hat{r} = -r_1 [2q_m \cos 2Z + b_m] \tag{58}$$

or

$$\hat{r}'' + (a_m + 2q_m \cos 2Z)\hat{r} = f(Z). \tag{59}$$

Where the differentiation is with respect to the normalized distance

$$Z = 2\pi z/L \tag{60}$$

and

$$a_m = \frac{1}{2} \left( \frac{L}{\lambda_p} \right)^2 \left[ \frac{B_0^2}{2B_b^2} + \alpha^2 + 3\alpha^4 \frac{B_{00}^2}{B_b^2} \right] \tag{61}$$

$$2q_m = \left( \frac{L}{\lambda_p} \right)^2 \left( \frac{B_0^2}{4B_b^2} \right) \tag{62}$$

$$b_m = \frac{1}{2} \left( \frac{L}{\lambda_p} \right)^2 \left[ \frac{B_0^2}{2B_b^2} - \alpha^2 - \alpha^4 \frac{B_{00}^2}{B_b^2} \right] \tag{63}$$

$$\alpha^2 = \frac{r_{00}^2}{r_1^2}. \tag{64}$$

$$\lambda_p = \frac{4\pi \sqrt{V}}{\sqrt{\eta} B_b}. \tag{65}$$

If  $\hat{r}_1(Z)$  and  $\hat{r}_2(Z)$  are the two solutions of the homogeneous equation

$$\hat{r}'' + (a + 2q \cos 2Z)\hat{r} = 0, \tag{66}$$

then the complete solution of (59) is:

$$\begin{aligned} \hat{r}(Z) = & \frac{1}{C^2} \left[ \hat{r}_0' \{ \hat{r}_2(Z)\hat{r}_1(0) - \hat{r}_1(Z)\hat{r}_2(0) \} \right. \\ & + \hat{r}_0 \{ \hat{r}_1(Z)\hat{r}_2'(0) - \hat{r}_2(Z)\hat{r}_1'(0) \} \\ & - \hat{r}_1(Z) \int_0^Z \hat{r}_2(Z)f(Z)dZ \\ & \left. + \hat{r}_2(Z) \int_0^Z \hat{r}_1(Z)f(Z)dZ \right]. \tag{67} \end{aligned}$$

Where

$$\hat{r}(0) = \hat{r}_0 \tag{68}$$

$$\hat{r}'(0) = \hat{r}_0' \tag{69}$$

$$C^2 = \hat{r}_1(0)\hat{r}_2'(0) - \hat{r}_1'(0)\hat{r}_2(0). \tag{70}$$

Here  $\hat{r}_1(Z)$  and  $\hat{r}_2(Z)$  are solutions of the Mathieu type and are given in the literature.<sup>6</sup> In the stable region, they are listed as follows:

For  $(a, q)$  between characteristic curves  $a_{2n}$  and  $b_{(2n+1)}$ : (see Fig. 6, following page)

$$\begin{aligned} \hat{r}_1(Z) &= (-1)^n \sum_{m=-\infty}^{\infty} (-1)^m \begin{bmatrix} 2n + \beta \\ 2m \end{bmatrix} \cos^{(2m+\beta)} Z \\ \hat{r}_2(Z) &= (-1)^n \sum_{m=-\infty}^{\infty} (-1)^m \begin{bmatrix} 2n + \beta \\ 2m \end{bmatrix} \sin^{(2m+\beta)} Z \end{aligned} \tag{71}$$

The self-consistency of the solution (67) demands that  $\hat{r}(Z)$  must be small compared with  $r_1$ . To achieve this, it can be shown that in (67) the following conditions must be satisfied:

$$1. \hat{r}_0 \cong 0, \quad \hat{r}_0' \cong 0 \tag{72}$$

$$2. b_m \cong 0 \tag{73}$$

$$3. a_m \cong (2m + \beta)^2. \tag{74}$$

The physical interpretation of these conditions is as follows: According to (56) the electron beam is scalloped about a constant radius  $r_1$  which by (63) and (73) can be expressed in terms of the cathode radius  $r_{00}$  and the flux densities as

$$\begin{aligned} r_1 &= r_{00} \sqrt{\frac{2B_{00}^2}{\sqrt{B_b^4 + 2B_0^2 B_{00}^2} - B_b^2}} \\ &= r_{00} \sqrt{\frac{(\sqrt{B_b^4 + 2B_0^2 B_{00}^2} + B_b^2)}{B_0^2}}. \end{aligned} \tag{75}$$

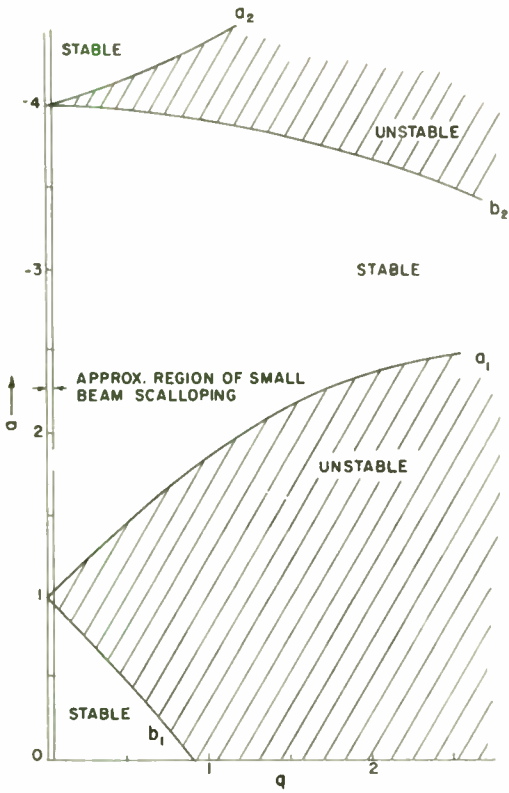

Fig. 6— $a, q$  stability chart of Mathieu equation  $(d^2r/dz^2) + (a - 2q \cos 2z)r = 0$ .

The amount of perturbation is determined by the third condition (74). From the theory of Mathieu solutions,<sup>6</sup> the third condition requires the choice of a very small value of  $q_m$  ( $q_m < 0.02$ ). The smaller the value of  $q_m$ , the smaller the perturbation. The scalloping can, however,

never reach zero, since the value of  $q_m$  which is given by (62) is always finite. In addition, in order to get small beam scalloping, it is equally necessary that the initial slope  $r_0'$  and the initial radius  $r_1 + \hat{r}_0$  must satisfy the conditions (1) and (2).

The operating region of (59) is shown in Figs. 6 and 7. Fig. 6 is the typical  $a, q$  stability chart of the Mathieu equation. The nonshaded portions are the stable regions of interest. For the case discussed here under the conditions of (73) and (74), the operating region is actually restricted to the long narrow strip along the  $a$ -axis, shown in Fig. 6. Fig. 7 shows actual values of  $B_0^2/B_b^2$  as a function of those values of  $r_{00}^2/r_1^2$ . Here,  $K_1$  is a parameter related to the magnet period  $L$  by

$$K_1 = \frac{64\pi^2 l^2}{L^2 \eta B_b^2} = 4 \left( \frac{\lambda_p}{L} \right)^2 \quad (76)$$

Thus when the flux density  $B_{00}$  at the cathode and the ratio  $r_{00}/r_1$  are known, then Figs. 6 and 7 enable us to find those values of the Mathieu parameters  $a$  and  $b$  which yield small beam scalloping. As an illustration of how to use Figs. 6 and 7, let us consider a numerical example. Suppose in a particular case that the initial radius of the electron beam  $r_1$ , the radius of the cathode  $r_{00}$  and the initial flux density at the cathode  $B_{00}$  obey

$$\alpha^2 = \frac{r_{00}^2}{r_1^2} = 1$$

$$B_{00} = 0.$$

Then, satisfying the condition  $b_m = 0$ , the point  $P$  in Fig. 7 is yielded by the intersection of the curve for

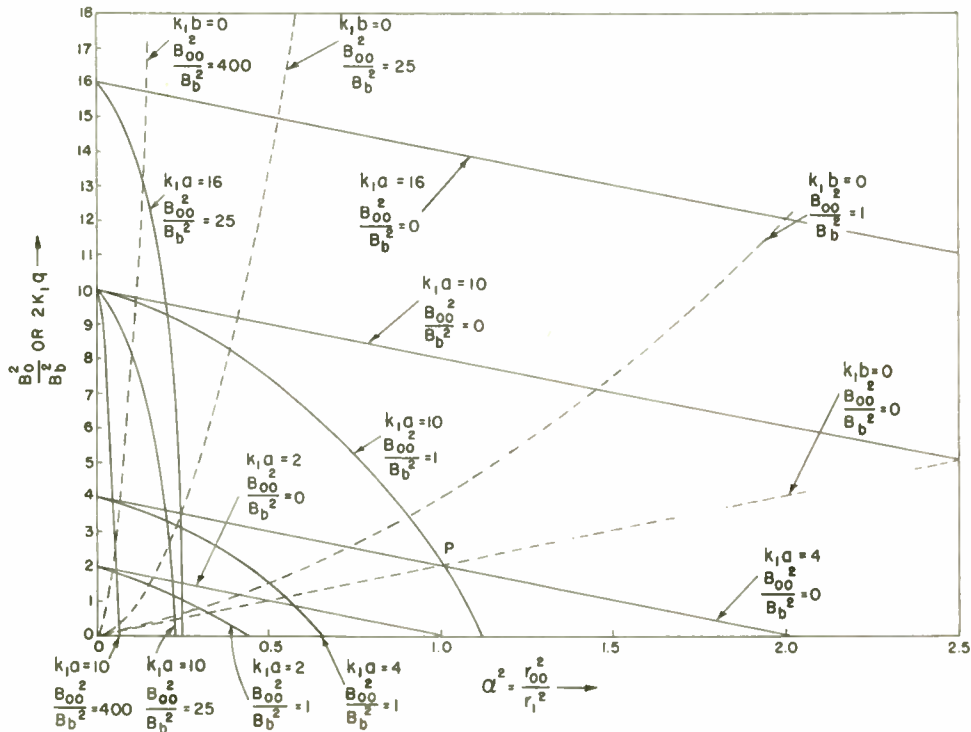

Fig. 7—The dashed curves give the values of  $(B_0/B_b)^2$  vs  $\alpha^2$ , for various ratios  $(B_{00}/B_b)^2$ , when  $K_1 b = (B_0^2/B_b^2) - 2\alpha^2 - 2\alpha^4(B_{00}/B_b)^2 = 0$ . The solid curves give the values of  $(B_0/B_b)^2$  vs  $\alpha^2$  for various ratios  $(B_{00}/B_b)^2$  and various values of  $K_1 a = (B_0^2/B_b^2) + 2\alpha^2 + 6\alpha^4(B_{00}^2/B_b^2)$ .



$$K_1 b_m = 0$$

$$\frac{B_{00}^2}{B_b^2} = 0$$

at  $\alpha^2 = 1$ . The ordinate at point  $p$  is then

$$\frac{B_0^2}{B_b^2} = 2,$$

which determines  $B_0$  and also gives  $K_1 q_m$  through the relationship

$$K_1 q_m = \frac{B_0^2}{2B_b^2}.$$

Then  $K_1$  is determined by the known (small) value of  $q_m$  shown by the narrow strip in Fig. 6. By use of (76) this value of  $K_1$  yields, in turn, the period  $L$ .

In order now to obtain the final Mathieu parameter  $a$ , we look for the solid curve in Fig. 7 having  $(B_{00}/B_b)^2 = 0$  and passing through point  $p$ . In the above example, such a solid curve would be that for  $K_1 a_m = 4$ . This specifies the value of  $a$ . Fig. 6 then shows whether or not this value of  $a$  corresponds to a stable region.

#### Periodic Electrostatic Field

In (1) let

$$B_x = B_{00} = 0 \quad (77)$$

$$V = V_0 + \Delta V \sin \frac{2\pi}{L} z; \quad V_0 \gg \Delta V \quad (78)$$

and

$$r = WV^{-1/4}. \quad (79)$$

We have then as the final differential equation:

$$\widehat{W}'' + (a_e + 2q_e \cos 2Z)\widehat{W} = -W_1[2q_e \cos 2Z + b_e]. \quad (80)$$

Where

$$W = W_1 + \widehat{W} \quad W_1 \gg \widehat{W} \quad (81)$$

$$W_1 \cong r_1 V^{1/4} \quad (82)$$

$$a_e = \frac{1}{2} \left( \frac{L}{\lambda_p} \right)^2 + \frac{3}{32} \left( \frac{\Delta V}{V_0} \right)^2 \quad (83)$$

$$2q_e = \frac{3}{32} \left( \frac{\Delta V}{V_0} \right)^2 \quad (84)$$

$$b_e = \frac{1}{2} \left( \frac{L}{\lambda_p} \right)^2 - \frac{3}{32} \left( \frac{\Delta V}{V_0} \right)^2. \quad (85)$$

Eq. (80) is of the same form as (58). Again, the self-consistent solution of (80) is obtained under the conditions

$$b_e = 0 \quad (86)$$

$$0 < q_e \ll 1. \quad (87)$$

#### ACKNOWLEDGMENT

The author is grateful to Dr. I. Wolff, E. W. Herold, and Dr. L. Malter, RCA Laboratories, for their continued interest and support, and to his colleagues, Dr. R. W. Peter, for many informative discussions, and C. L. Cuccia, for assistance in the preparation of the manuscript. He wishes also to express his sincere appreciation to Prof. E. Weber, Polytechnic Institute of Brooklyn, for valuable advice.

## The Charging and Discharging of Nonlinear Capacitors\*

J. R. MACDONALD†, SENIOR MEMBER, IRE, AND M. K. BRACHMAN‡, MEMBER, IRE

**Summary**—The charging and discharging of two types of nonlinear capacitances through a linear resistance are discussed in detail. The response of a capacitor whose capacitance is an increasing exponential function of the potential across it is compared to that of the "space-charge" capacitor whose voltage dependence is of the form  $C_s = (C_0 \sinh \alpha V_c / (\alpha V_c))$ , where  $V_c$  is the potential across the capacitor. The variation of the differential capacitance of the space-charge capacitor with time, during charging and discharging, is considered for various applied potentials and is compared with the somewhat similar behavior to be expected from a linear capacitor exhibiting a distribution of relaxation times.

#### INTRODUCTION

THE RAPIDLY growing importance of semiconductor circuit elements with their inherent voltage nonlinearities makes it worthwhile to investigate some of the results of such nonlinearity. Nonlinear-

ity may or may not be of importance in semiconductors depending upon whether diffusion and/or recombination effects dominate the convection current. Although the full accurate equations describing charge-carrier concentration in semiconductors are nonlinear and so have not been solved accurately for all cases of physical interest, there arise many situations where the nonlinearity may be neglected and only the normal linear "metallic" conduction current need be considered.

In the present work, we shall be concerned with the charging of voltage-dependent capacitances through a linear resistance. One of the authors has shown<sup>1</sup> that if an applied direct potential  $V_0$  causes free charge carriers to build up a space charge at a blocking or rectifying electrode, the resulting static capacitance,  $C_s$ , defined as  $q_m/V_0$ , is of the form  $\sinh \alpha V_0 / \alpha V_0$ , and the differential

\* Original manuscript received by the IRE, June 16, 1954, revised manuscript received, November 4, 1954.

† Texas Instruments Inc., Dallas, Texas.

‡ Independents Geophysical Surveys Corp., Houston, Texas.

<sup>1</sup> J. R. Macdonald, "Static space-charge effects in the diffuse double layer," *Jour. Chem. Phys.*, vol. 22, pp. 1317-1322; August, 1954.

or small signal capacitance,  $C_a$ , given by  $dq_m/dV_0$ , is proportional to  $\cosh \alpha V_0$ . Here  $q_m$  is the surface charge on the electrode near which the internal space charge forms. The constant  $\alpha$  is  $e/4kT$  when both electrodes are blocking,  $e/2kT$  when space-charge forms at only one electrode, as for example, when one electrode applied to a semiconducting slab is blocking for positive and negative charge carriers and the other is ohmic. The quantity  $e$  is the electronic charge,  $k$  Boltzmann's constant, and  $T$  the absolute temperature. These results are correct only after  $V_0$  has been applied sufficiently long for space-charge equilibrium to be attained.

Blocking electrodes may occur naturally or be artificially produced at the surface of any material which contains free charge carriers. A rectifying electrode biased in the reverse direction may also be considered to be blocking for this polarity. Thus, space-charge nonlinearity may be expected to appear under certain conditions in semiconductors,<sup>2,3</sup> photoconductors,<sup>4</sup> and solid or liquid electrolytes.<sup>3,5</sup> Such nonlinearity may sometimes be masked, however, by additional linear capacitance in series with one or more electrodes,<sup>4</sup> or, as in the case of reverse-biased  $p$ - $n$  junctions, additional factors must be taken into account which usually keep the voltage dependence of the junction capacitance from being of the above form or at least restrict such dependence to very small applied voltages.<sup>2,4</sup> It is, of course, obvious that the above very rapid increase of capacitance with applied voltage cannot continue indefinitely as the voltage is increased. Eventually, the internal electric field strength arising from the space-charge distribution near the blocking electrode will become sufficiently high to cause dielectric breakdown of the underlying material or high-field emission at the electrode. Such processes will usually occur at relatively low voltages of the order of a volt or less.<sup>1</sup> In spite of this restriction, nonlinear capacitances of the type discussed in the present work might be well suited for certain switching applications and for use in dielectric amplifiers.

The problem of the time-variation of the charging or discharge current of a material containing free charge, with one or two blocking electrodes, has not been solved exactly because of the nonlinearity of the governing equations. Jaffé and LeMay<sup>6</sup> have treated the problem by linearizing the equations and then attempting to correct the linear solution for the nonlinearity of the equations. This is a very approximate procedure, however, and the final results do not exhibit the strong voltage-

dependent nonlinearity to be expected from the nonlinearity inherent in the equations. When a constant potential is applied to a material with blocking or rectifying electrodes, the space-charge capacitance builds up by the motion of charges, leading to the separation of positive and negative charge and the establishment of an excess or deficit of charges of one or the other sign at one or both electrodes. Because such charging is governed by nonlinear equations, a normal "constant" time constant applying during the charging cannot be defined since any time constant will depend on the potential across the material. Although we cannot treat this charging problem exactly, we can treat the related problem of charging of such a material through an external linear resistance much larger than the ordinary internal resistance of the material without blocking, which is  $R_i = L[eA(n\mu_n + p\mu_p)]^{-1}$ . Here  $n$  and  $p$  are the concentrations of negative and positive charge carriers and  $\mu_n$  and  $\mu_p$  are their respective mobilities. The quantities  $A$  and  $L$  are the area and separation of the two electrodes, assumed plane and parallel.

When the current which establishes the space-charge distribution must flow through a sufficiently large external resistance, the final equilibrium space-charge distribution corresponding to the actual time-dependent potential difference between the electrodes can be almost established before this potential difference can change appreciably. Under such quasi-static conditions, the time-dependent capacitance will be very nearly given by the static capacitance corresponding to the potential difference actually present at the given time. This potential difference will, of course, be less than that applied to the combination of linear resistance and the charge-containing material until charging is finally complete.

While the above method of treatment of the composite system will be more and more accurate the larger the external resistance, it is not possible to set limits of accuracy in the absence of an exact treatment of the charging of the material itself with no external resistance,  $R_e$ . The results of the present analysis indicate, however, that the use of the static capacitance in place of an unknown quasi-static capacitance is probably a fairly good approximation even if  $R_e$  is as small as  $R_i$ .

It turns out that the above treatment yields results quite similar to those obtained for the charging through a linear resistance of a nonlinear condenser whose capacity is an increasing exponential function of the potential across it. We shall, therefore, analyze this case first, then compare with it the behavior of the nonlinear "space charge" capacitor. It is worth mentioning that the above "exponential" capacitor could be realized, at least over a limited range of applied potential by means of a feedback amplifier of very high gain. If the output is connected to the input through a capacitance  $C$ , then the input capacitance of the unit can be approximately  $(1+G)C$ , where  $G$  is the loop gain. This gain is arranged to be linearly proportional to some control voltage. Now

<sup>2</sup> W. Shockley, "The theory of  $p$ - $n$  junctions in semiconductors and  $p$ - $n$  junction transistors," *Bell Sys. Tech. Jour.*, vol. 28, pp. 435-489; July, 1949.

<sup>3</sup> J. R. Macdonald, "Theory of a-c space-charge polarization effects in photoconductors, semiconductors, and electrolytes," *Phys. Rev.*, vol. 92, pp. 4-17; October, 1953.

<sup>4</sup> J. R. Macdonald, "Capacitance and conductance effects in photoconducting alkali halide crystals," *Jour. Chem. Phys.*, to be published.

<sup>5</sup> J. R. Macdonald, "Theory of the differential capacitance of the double layer in unadsorbed electrolytes," *Jour. Chem. Phys.*, vol. 22; November, 1954.

<sup>6</sup> G. Jaffé and C. Z. LeMay, "On polarization in liquid dielectrics," *Jour. Chem. Phys.*, vol. 21, pp. 920-928; May, 1953.



if a sample of the applied input voltage  $V_i$  is used to actuate an electronic computer whose output voltage  $V_0$  is proportional to  $(V_i/|V_i|) \exp[\alpha|V_i|]$ , and  $V_0$  is then used to control the gain  $G$ , we obtain a complicated composite unit whose input capacitance is an exponential function of its input voltage as long as  $G$  is considerably greater than unity. The range of variation of the input capacitance can, however, never be larger than the maximum loop gain available.

MATHEMATICAL RESULTS

Since we are dealing in this work with nonlinear systems, the principle of superposition<sup>7</sup> will not hold. Therefore, the time dependence of charging currents will differ from that of the corresponding discharge currents,<sup>8</sup> and the two cases must be considered separately.

The system which we shall consider is shown in Fig. 1.

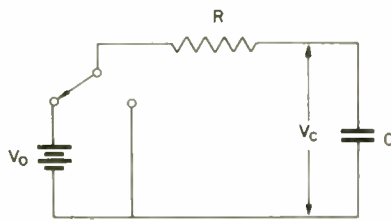

Fig. 1—Circuit for charging and discharging the nonlinear capacitor  $C$  through the linear resistor  $R$ .

At  $t=0$ , the resistance is connected to the source of direct voltage  $V_0$ , and the completely discharged capacitor begins to charge. The pertinent equation is therefore

$$V_0 - V_c = iR = R \frac{d}{dt} (C_s V_c). \tag{1}$$

For the static capacitance of the exponential capacitor, we take

$$C_s = C_0 e^{\alpha|V_c|}, \tag{2}$$

<sup>7</sup> M. F. Gardner and J. L. Barnes, "Transients in Linear Systems," John Wiley and Sons, Inc., New York, N. Y.; 1942.

<sup>8</sup> Note that with only an ac voltage applied, the difference between the charging and discharging currents will show up as hysteresis, a common phenomenon in nonlinear systems.

where  $\alpha$  is a positive constant. Thus, (1) becomes

$$V_0 - V_c = RC_0 e^{\alpha|V_c|} \left\{ \frac{dV_c}{dt} + \alpha V_c \frac{d|V_c|}{dt} \right\}. \tag{3}$$

Note that a change in sign of all the voltages has no effect on this equation. Therefore, we shall drop the absolute value signs and deal only with positive voltages.

The solution of (3) is presented in Appendix I-A. The result is

$$\tau = e^{-\eta} - e^{-W} + (1 + \eta) [Ei(-\eta) - Ei(-W)], \tag{4}$$

where  $\tau = t/RC_\infty$ ,  $\eta = \alpha V_0$ ,  $W = \eta - \alpha V_c \equiv \eta - x$  and  $Ei(\xi)$  is the exponential integral defined in Appendix I-A. This expression relates the charging time  $\tau$ , expressed in terms of the final time constant  $T_\infty = RC_\infty$ , to the instantaneous value of  $V_c$  for given  $V_0$  and  $\alpha$ . Note that the normalized charging current  $i/i_0$ , when expressed in terms of the quantities  $\eta$  and  $W$ , is  $W/\eta$ ; its time dependence may be obtained from (4). The initial current  $i_0$  is just  $V_0/R$ .

Log-log curves computed from (4) for several values of  $\eta$  are presented in Fig. 2. The linear curve is for an ordinary voltage-independent capacitor. We see that when  $\eta$  is large, only a small fraction of  $T_\infty$  is required for the capacitor to reach almost its final potential. The reverse is the case, however, if we measure time in terms of initial time constants,  $T_0 = RC_0$ . Table I gives a comparison of the time required to reach 0.90  $V_0$ , for various values of  $\eta$ , expressed both in terms of  $t/T_\infty$  and  $t/T_0$ .

TABLE I  
NORMALIZED TIMES REQUIRED FOR  $V_c/V_0$  TO REACH 0.90 DURING CHARGING FOR VARIOUS VALUES OF  $\eta$

$\eta$	$t/T_\infty$	$t/T_0$
Linear	2.303	2.303
1	2.670	7.25
4	2.841	155
10	2.042	$4.50 \times 10^4$
$10^2$	0.000375	$1.01 \times 10^{10}$

The differences are due, of course, to the increase in  $C_s$  during charging. We shall consider the dependence of charging current in connection with discharge current.

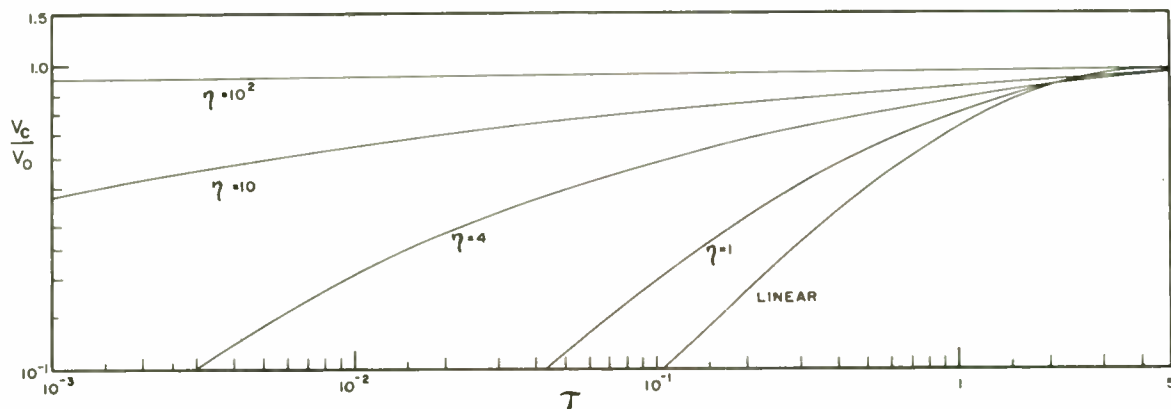

Fig. 2—Log-log plot of the charging of the exponential capacitor for various values of the applied voltage parameter  $\eta = \alpha V_0$ . The linear curve is for a normal voltage-independent capacitor.

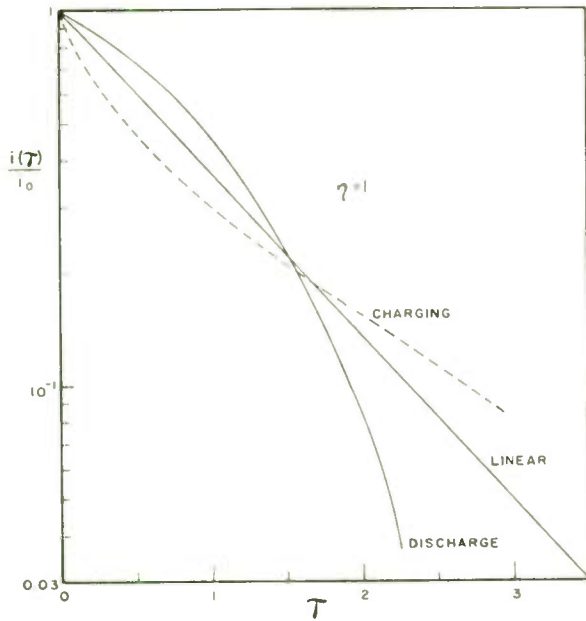

Fig. 3—Semi-log plot of normalized charging and discharge currents versus normalized time for the exponential capacitor with  $\eta=1$  and for a linear capacitor.

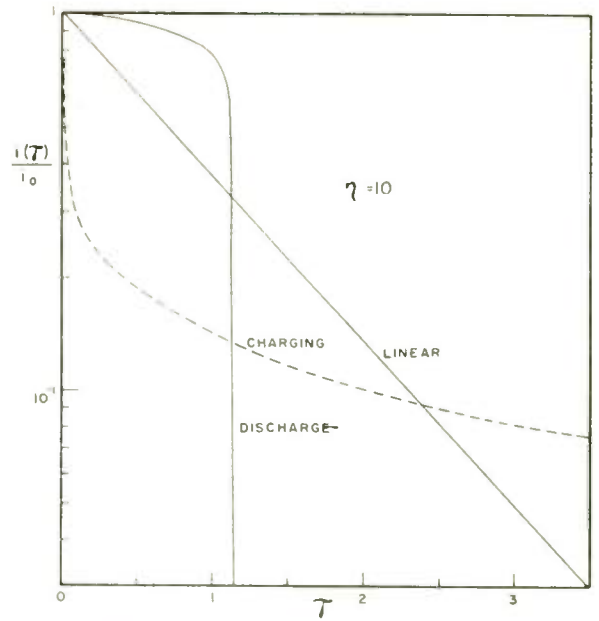

Fig. 5—Semi-log plot of normalized charging and discharge currents versus normalized time for the exponential capacitor with  $\eta=10$  and for a linear capacitor.

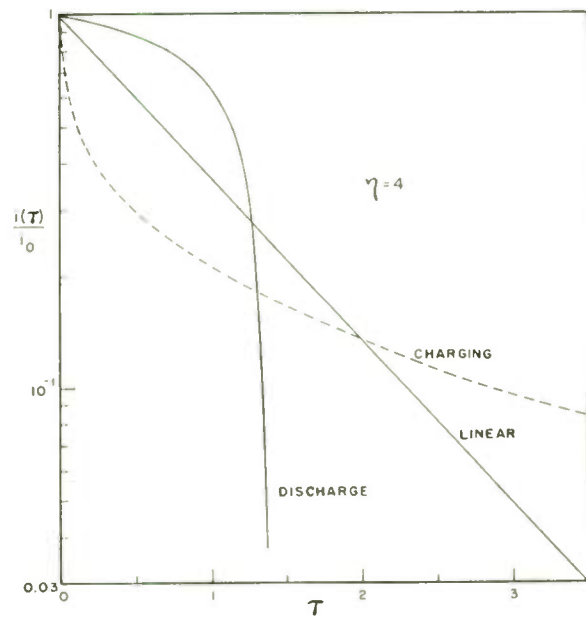

Fig. 4—Semi-log plot of normalized charging and discharge currents versus normalized time for the exponential capacitor with  $\eta=4$  and for a linear capacitor.

For discharge, the switch in Fig. 1 is thrown to connect the resistance to ground and the fully charged capacitor begins to discharge. The pertinent equation is

$$V_c = -R \frac{d}{dt} (C_s V_c), \tag{5}$$

which becomes for the exponential capacitor,

$$V_c = -RC_0 e^{\alpha |V_c|} \left\{ \frac{dV_c}{dt} + \alpha V_c \frac{d|V_c|}{dt} \right\}. \tag{6}$$

The solution of this equation is given in Appendix I-B.

The result obtained is

$$\tau = 1 - e^{-W} + J(\eta, W), \tag{7}$$

where  $J(\eta, W)$  is an integral defined in Appendix I-B which does not appear to be tabulated in the literature. The results of a graphical evaluation of this integral are tabulated for a few values of  $\eta$  in Table II. (See p. 78.)

We have used (4) and (7) to calculate the decay curves presented in Figs. 3 to 5. The dotted lines are charging curves and represent  $(1 - V_c/V_0)$  as well as  $i/i_0$ . The straight solid lines are the charging and discharging curves for an ordinary linear capacitor, and the curved solid lines are the discharge curves for the exponential capacitor. They represent  $V_c/V_0$  as well as  $i/i_0$ .

These results indicate, as expected, that when  $\eta \ll 1$  there will be no appreciable difference between the charging and discharging curves of the exponential capacitor and those of an ordinary linear capacitor. In this limit, the exponential capacitor is essentially linear. However, when  $\eta$  becomes much greater than unity, the nonlinearity shows up strongly and the capacitor reaches nearly its final potential in a small fraction of  $T_\infty$  on charging; on discharge, however, it discharges at almost constant current for a time of approximately  $T_\infty$ , then the current falls rapidly to zero. In the limit of very high  $\eta$ , the current will remain constant up to  $T_\infty$ , then fall abruptly to zero. These results indicate clearly how the essential nonlinearity of the device results in strong differences between charging and discharging behavior.

For the space-charge capacitor, we find on substituting  $C_s = (C_0 \sinh \alpha V_c)/(\alpha V_c)$  into (1) and simplifying,

$$V_0 - V_c = RC_0 [\cosh(\alpha V_c)] (dV_c/dt). \tag{8}$$



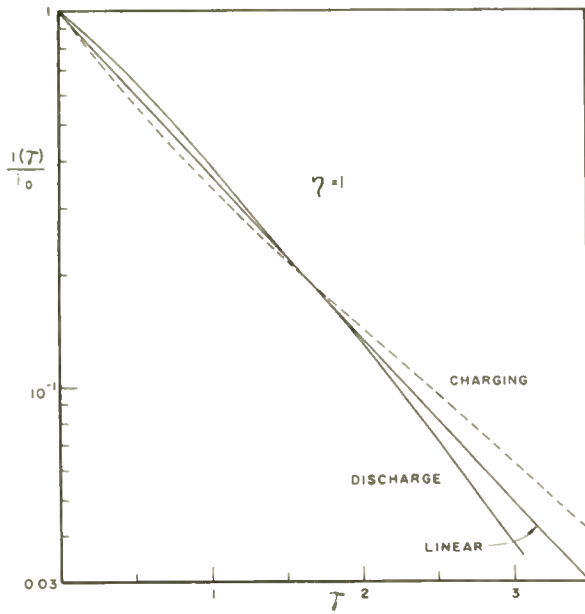

Fig. 6—Semi-log plot of normalized charging and discharge currents versus normalized time for the space-charge capacitor with  $\eta=1$  and for a linear capacitor.

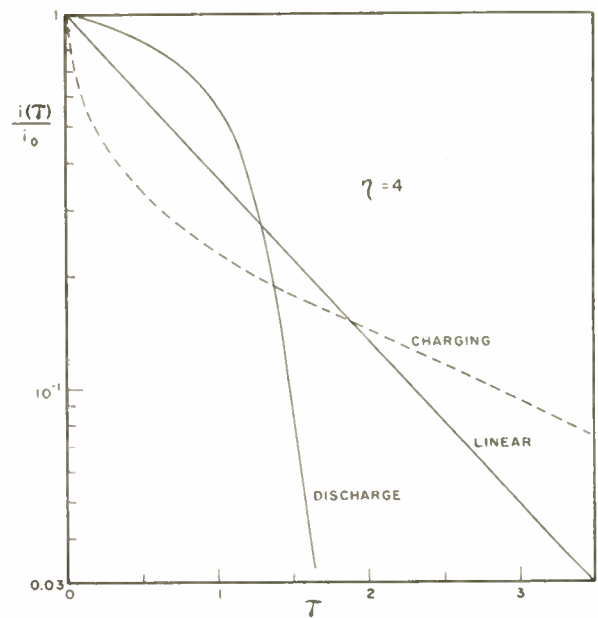

Fig. 7—Semi-log plot of normalized charging and discharge currents versus normalized time for the space-charge capacitor with  $\eta=4$  and for a linear capacitor.

The solution of this eq. is found in Appendix II-A to be  $\tau = [\eta e^\eta / (2 \sinh \eta)] [Ei(-\eta) - Ei(-W) + e^{-\eta} J(\eta, x)]$ , (9) where  $J(\eta, x)$  is again the integral defined in (10) of Appendix I-B.

In a similar fashion, using (5), we find that the discharge equation for the space-charge capacitor is (see Appendix II-B)

$$\tau = [\eta e^\eta / (2 \sinh \eta)] [e^{-\eta} \{Ei(-\eta) - Ei(-x)\} + J(\eta, W)]. \quad (10)$$

Eqs. (9) and (10) exhibit a symmetry not apparent in the corresponding exponential capacitor equations.

Figs. 6 and 7 present the charging and discharge curves of the space-charge capacitor for  $\eta=1$  and 4. On comparing these curves with those of Figs. 3 and 4 for the exponential capacitor, one sees that the nonlinearity is not quite so apparent for corresponding values of  $\eta$  for the space-charge as for the exponential capacitor. However, for  $\eta$ -values of 100 or greater, there is essentially no difference between corresponding curves. All of these conclusions are, of course, consistent with the forms of the dependence of capacitance on applied potential for the two types.

### DISCUSSION

The present theory predicts that the discharge current of a charged material containing free charge carriers blocked at at least one electrode may, for large  $\eta$ , remain almost constant for some time, then fall rather abruptly to zero. Experimentally, however, it is sometimes found that the discharge current of a polarized material begins to increase above its initial value,

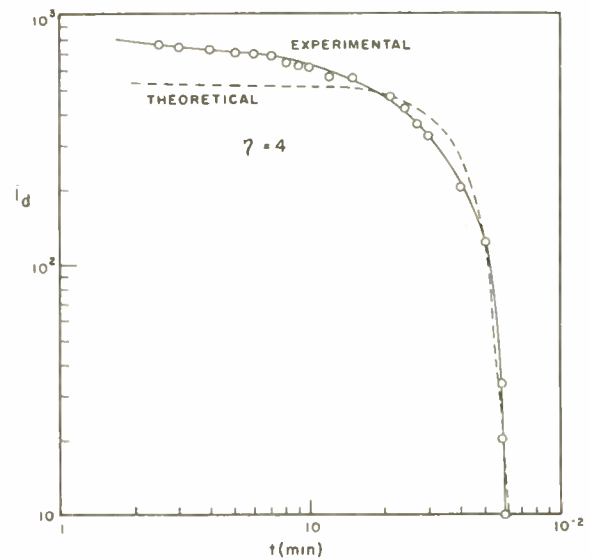

Fig. 8—Log-log plots of experimental and theoretical (space-charge capacitor) discharge curves.

reaches a maximum, and then decays. Such behavior probably arises from the motion of a number of carriers of different mobility as well as probable failure of the quasi-static approximation of the present work. The experimental points and solid line of Fig. 8 represent, however, an experimental current discharge curve similar to those predicted by the present theory. The current is given here in arbitrary units. This curve was obtained by one of the authors (J. R. Macdonald) several years ago on a KBr single crystal containing F-centers. The principal charge carriers present were probably positive-ion vacancies and electrons, although negative-ion vacancies and positive ions may also have contributed

slightly to the discharge current. In order to eliminate rapidly decaying transients such as that arising from the geometrical capacitance, the crystal was first shorted momentarily after charging for ten minutes, then measurement of the discharge current was begun.

The dotted curve of Fig. 8 is the  $\eta = 4$  discharge curve for the space-charge capacitor, replotted on this log-log graph in a position in best agreement with the experimental curve. Such positioning is valid for a log-log presentation. While agreement between theory and experiment is by no means perfect (it could be somewhat improved by a slightly smaller value of  $\eta$ ), the degree of correspondence is sufficient to suggest that the theory can predict some of the experimental features reasonably well. As discussed above, most of the disagreement can probably be ascribed to partial failure of the quasi-static approximation.

It is perhaps worth mentioning that discharge curves on these crystals often exhibited a current reversal following a rapid decay like that shown in Fig. 6. The approximate theory of Jaffé and Lemay predicts such a reversal on discharge, although their predicted curve shapes do not agree well with those observed on the KBr crystals. Such disagreement is not surprising since these authors carried out the second approximation to their initially linearized theory by tacitly assuming the validity of the principle of superposition. It is this second approximation which they find leads to the current reversal.

There are a number of possibilities which might explain such a reversal. If a nonlinear capacitor were first charged with one polarity, only partly discharged, and then recharged with the opposite polarity, the discharge current then measured might reverse because of the complicated charging history. Reversal could certainly be observed for a linear capacitor exhibiting a distribution of relaxation times<sup>9</sup> charged in this fashion. Although the details would be different for a nonlinear capacitor, there is no reason not to expect a reversal in this case also, even though the principle of superposition fails. It seems unlikely that an exact theory of the discharge of a free-charge-containing material, containing positive and negative charges of equal mobility, would yield a current reversal for normal unipolar charging. The reversal of the Jaffé-Lemay theory may possibly arise from the approximate character of the theory. If this conclusion is valid, then an entirely different mechanism must be called into play to explain the observed reversal. We suggest that this mechanism might, in some cases, be the polarization of the underlying medium by the high fields produced by the space-charge distribution.<sup>1</sup> Since this polarization will be opposite in direction to that represented by the space-charge distribution itself, if the space-charge decays much faster than the polarization of the medium, there will be a reversal of the total current when the faster decaying proc-

ess decays to a smaller current value than the slower reverse-current process. Note that the decay of the polarization of the medium alone may be expected to be a single exponential decay or, in any event, a sum of exponential decaying terms involving voltage-independent time constants rather than the voltage-dependent decay characteristic of a nonlinear capacitor.

It is sometimes impractical to measure either the charge or discharge current of a nonlinear capacitor because of the smallness of these currents, or because of the presence of shunting resistance. In such cases, however, the differential small-signal capacitance may often be measured during the charging or discharging. Then, from such a measurement, it may be possible to draw conclusions regarding the presence or absence of nonlinearity. The differential capacitance of the space-charge capacitor is

$$C_d \equiv C_s + V_c \frac{dC_s}{dV_c} = C_0 \cosh \alpha V_c^{5,10}$$

It is measured by means of an ac signal much smaller in amplitude than the dc charging voltage across the capacitor. If an ac voltage  $V_{ac}$  so small that  $\alpha V_{ac}$  is always much less than unity is employed, the initial capacitance  $C_0$  is obtained when the dc charging potential  $V_c$  is zero. We shall assume this to be the case.

We are now interested in the time dependence of the readily measurable quantity  $C_d$  during charging and discharging for various values of  $\eta$ . Since  $C_d/C_0 = \cosh x$ , we can easily calculate such results using (9) and (10). The results for  $\eta = 4$  and 10 are presented in Figs. 9 and 10. On log-log plots of this nature, we see that there is a considerable time interval during which the slopes of the charging curves are less than unity and are almost constant. As  $\eta$  becomes very large, the slope in this interval approaches unity, while it approaches zero for  $\eta \ll 1$ . These curves for capacitance time-dependence again demonstrate the strong nonlinearity of the space-charge capacitor for large  $\eta$ .

Unfortunately, nonlinearity of the type which we have been considering is not the only factor which can cause the apparent capacitance of a capacitor to vary with time during charging and discharging. If the material of which the capacitor is composed contains no free charges but does exhibit a distribution of relaxation times, then the apparent total capacitance will increase during charging as elements with longer and longer relaxation times are charged. Since it is commonly assumed that the microscopic processes which lead to a relaxation-time distribution are independent of one another,<sup>11</sup> the principle of superposition still holds, the material is linear, and the static and differential capacitances are equal. In addition, unlike the nonlinear capacitor, the charging and discharging currents of a

<sup>9</sup> J. R. Macdonald, "Dielectric dispersion in materials having a distribution of relaxation times," *Jour. Chem. Phys.*, vol. 20, pp. 1107-1111; July, 1952.

<sup>10</sup> D. C. Grahame, "The electrical double layer and the theory of electrocapillarity," *Chem. Rev.*, vol. 41, pp. 441-501; December, 1947.

<sup>11</sup> H. Frohlich, "Theory of Dielectrics," Clarendon Press, Oxford, Eng., p. 91; 1949.



capacitor with a distribution of relaxation times should be the same if there is no shunting leakage of charge.

An example of a circuit involving a distribution of relaxation times is afforded by the parallel connection of an arbitrary number of series branches, each branch

distance will make the final resistance value finite.

In Fig. 11, we present the time variation of differential capacitance measured on a large-area silicon *p-n* junction. Time was measured from the instant that a

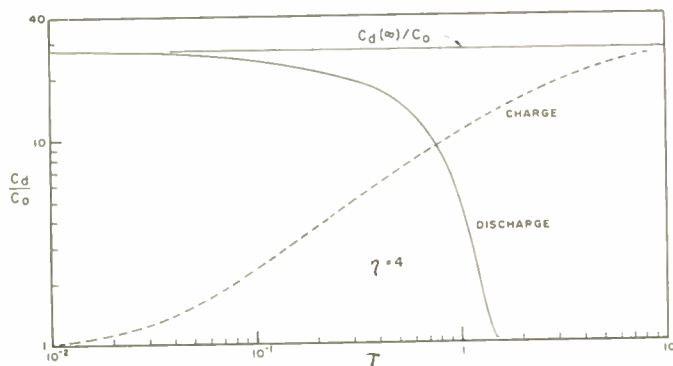

Fig. 9—Log-log plots of the time dependence of the differential capacitance of the space-charge capacitor for  $\eta=4$  during charging and discharging.

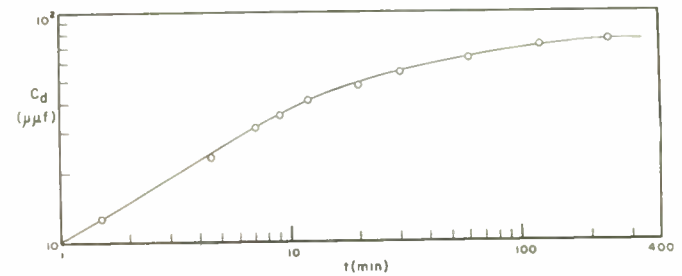

Fig. 11—Log-log plot of the time dependence of the differential capacitance of a large-area silicon *p-n* junction with 3 volts reverse bias applied at  $t=0$ .

reverse bias of 3 volts was applied to the junction. The differential capacitance of the junction was measured with an ac signal of 0.1 volt rms or less. This curve is quite similar in character to the charging curve of Fig. 9 for  $\eta=4$ , applying to the nonlinear space-charge capacitor. Since a semiconductor does contain free charges, most of which are blocked at a reverse-biased junction, it was initially thought that the curve of Fig. 9 did indeed represent nonlinear behavior arising from the motion of these charges. Since the value of  $\eta$  which gives a reasonable fit of the curve on this assumption is 3 or 4, we find that if  $\alpha$  is taken as  $(e/4kT) \sim 10$ , the actual final potential across the junction could not have exceeded about 0.4 volt, instead of the 3 volts applied. This conclusion is not as untenable as it seems, because it might be explained as arising from voltage division between a series charging resistance in the material and a shunt resistance across the junction.

The above hypothesis was definitely shown to be wrong, however, by varying the reverse bias voltage over a wide range. Such variation should produce even greater changes in  $C_\infty$  and in the slope of the  $C_d$ -versus-time curve if the material is strongly nonlinear; instead, a large increase in the reverse bias had only a small effect on the differential capacitance. Therefore, the curve of Fig. 9 cannot arise from an ordinary nonlinear space-charge process. By heating the junction for several hours at 150 degrees C., then encapsulating the unit in a container filled with silicone oil, the effect could be greatly reduced. This result indicates that it is probably almost entirely a surface phenomenon. It is quite possible that it arises from a distribution of relaxation times of surface contaminants near the junction, perhaps connected with a distribution of surface states. This effect is probably analogous to that which leads to channeling in germanium *n-p-n* junction transistors.<sup>12</sup> It thus appears that the two distinct processes, space-charge formation and charging of a material with a distribution of relaxation times, can lead to quite similar results in cer-

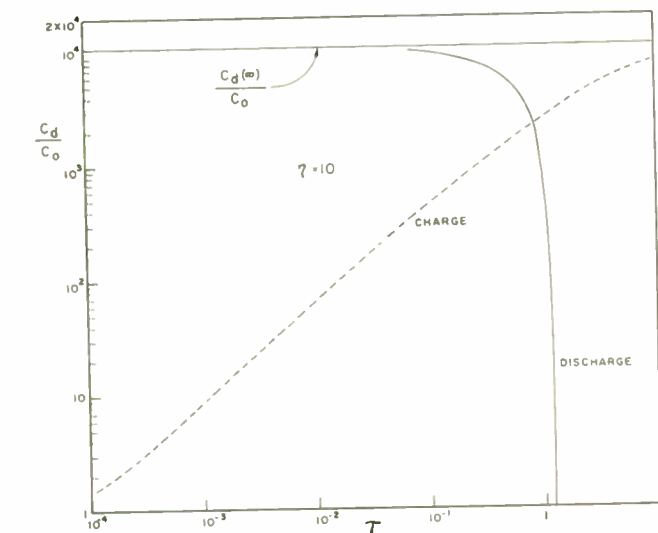

Fig. 10—Log-log plots of the time dependence of the differential capacitance of the space-charge capacitor for  $\eta=10$  during charging and discharging.

consisting of a linear capacitance  $C_i$  in series with a linear resistance  $R_i$ . The time constant of each branch is then  $\tau_i = R_i C_i$ . Since the circuit is entirely linear, a calculation of the apparent static capacitance also gives the differential capacitance. Using the definition that the capacitance at time  $t$  is the charge stored in the system at  $t$  divided by the applied voltage, a simple calculation yields

$$C_d(t) = \sum_i C_i (1 - e^{-t/\tau_i})$$

$$R_d(t) = \left\{ \sum_i R_i^{-1} e^{-t/\tau_i} \right\}^{-1},$$

where  $R_d(t)$  is the apparent resistance at time  $t$ , defined as the applied voltage divided by the current at  $t$ . As expected, these equations predict that the over-all measured capacitance increases from zero to the final value  $\sum_i C_i$ , and the apparent resistance increases from  $\left\{ \sum_i R_i^{-1} \right\}^{-1}$  to the final value infinity. Any shunt re-

<sup>12</sup> W. L. Brown, "N-type surface conductivity on *p*-type germanium," *Phys. Rev.*, vol. 91, pp. 518-527; August, 1953.

tain cases and that therefore other criteria than the time dependence of  $C_d$  may be required to distinguish between the two.

APPENDIX I—THE EXPONENTIAL CAPACITOR

A. Charging

If we drop the absolute value signs in (3) of the text, consider only positive voltages, and introduce the normalized quantities

$$\begin{aligned} \eta &= \alpha V_0 \\ x &= \alpha V_c \\ \tau &= t/RC_\infty \end{aligned} \tag{11}$$

(3) becomes

$$\frac{dx}{d\tau} = \left( \frac{\eta - x}{1 + x} \right) e^{(\eta-x)}, \tag{12}$$

where we have used  $C_\infty = C(\infty) = C_0 e^{\alpha V_0} = C_0 e^\eta$ . Separating and integrating this equation from 0 to  $\tau$ , we obtain

$$\tau = \int_0^x \left( \frac{1+y}{\eta-y} \right) e^{-(\eta-y)} dy. \tag{13}$$

If we introduce the quantities  $w = \eta - y$  and  $W = \eta - x$  in (13), we obtain

$$\tau = (1 + \eta) \int_W^\eta \frac{e^{-w}}{w} dw - \int_W^\eta e^{-w} dw. \tag{14}$$

Now recalling that the exponential integral  $Ei(-\xi)$ , tabulated e.g. by Jahnke and Emde,<sup>13</sup> is defined as

$$Ei(-\xi) = - \int_\xi^\infty \frac{e^{-w}}{w} dw, \tag{15}$$

(14) becomes

$$\tau = e^{-\eta} - e^{-W} + (1 + \eta)[Ei(-\eta) - Ei(-W)]. \tag{16}$$

B. Discharge

On expressing (6) of the text in terms of normalized variables, we obtain

$$\frac{dx}{d\tau} = - \left( \frac{x}{1+x} \right) e^{(\eta-x)}. \tag{17}$$

Separating and integrating, we find

$$\begin{aligned} \tau &= - \int_\eta^x \left( \frac{1+y}{y} \right) e^{-(\eta-x)} dy \\ &= 1 - e^{-W} + \int_x^\eta \frac{e^{-(\eta-y)}}{y} dy \\ &= 1 - e^{-W} + J(\eta, W), \end{aligned} \tag{18}$$

where the integral  $J(\eta, \xi)$  is defined as

$$J(\eta, \xi) = \int_{\eta-\xi}^\eta \frac{e^{-(\eta-y)}}{y} dy = \int_0^\xi \frac{e^{-w}}{\eta-w} dw. \tag{19}$$

This integral is a function of two variables and cannot,

unfortunately, be expressed in terms of exponential integrals. So far as the authors are aware, it is untabulated in the literature.

It is, however, a simple matter to evaluate  $J(\eta, \xi)$  graphically for the values of  $\eta$  in which we are most interested. The results are presented in Table II. The values in this table are probably not accurate to more than three decimal places.

TABLE II  
THE INTEGRAL  $J(\eta, \xi)$

$\xi/\eta$ \ $\eta$	1	4	10
0	0	0	0
0.1	0.10018	0.08625	0.06788
0.2	0.20150	0.15079	0.09463
0.3	0.30537	0.20001	0.10578
0.4	0.41376	0.23803	0.11063
0.5	0.52980	0.26793	0.11268
0.6	0.65892	0.29258	0.11348
0.7	0.80692	0.31391	
0.8	1.0085	0.33399	
0.9	1.3169	0.35682	
0.95	1.5797	0.37387	

APPENDIX II—THE SPACE-CHARGE CAPACITOR

A. Charging

In terms of normalized variables, the equation which must be solved is

$$\frac{dx}{d\tau} = \left( \frac{\eta - x}{\cosh x} \right) \left( \frac{\sinh \eta}{\eta} \right), \tag{20}$$

where we have used  $C_s(\infty) = C_0 \sinh \eta/\eta$  and

$$\tau = t/RC_s(\infty) = t/T_\infty.$$

The above equation leads to the integral

$$\tau = \frac{\eta}{2 \sinh \eta} \int_0^x \left( \frac{e^x}{\eta - x} + \frac{e^{-x}}{\eta + x} \right) dx. \tag{21}$$

The first part of this integral is easily expressed in terms of the exponential integral, while the latter part is, from (19), just  $J(\eta, x)$ . We therefore obtain

$$\tau = [\eta e^\eta / 2 \sinh \eta] [Ei(-\eta) - Ei(-W) + e^{-\eta} J(\eta, x)]. \tag{22}$$

B. Discharge

The discharge equation reduces to

$$\frac{dx}{d\tau} = - \left( \frac{x}{\cosh x} \right) \left( \frac{\sinh \eta}{\eta} \right). \tag{23}$$

The resulting integral is

$$\tau = \frac{\eta}{2 \sinh \eta} \int_x^\eta \left[ \frac{e^y}{y} + \frac{e^{-y}}{y} \right] dy. \tag{24}$$

The latter part of this integral may be readily expressed in terms of exponential integrals. On making the substitutions  $W = \eta - x$  and  $w = \eta - y$  in the first part of the integral, it reduces to  $e^\eta J(\eta, W)$ . The discharge relation therefore becomes

$$\tau = [\eta e^\eta / 2 \sinh \eta] [e^{-\eta} \{ Ei(-\eta) - Ei(-x) \} + J(\eta, W)]. \tag{25}$$

<sup>13</sup> E. Jahnke and F. Emde, "Tables of Functions," Dover Publications, New York, N. Y., pp. 1-8; 1943.



# Displacement of the Zeros of the Impedance $Z(p)$ Due to Incremental Variations in the Network Elements\*

A. PAPOULIS†

**Summary**—The purpose of this paper is to evaluate the displacement of the zeros  $p_k^0$  of the impedance  $Z(p)$  due to the variations  $\delta z$  in the impedance of any network element. It is shown that the displacement is approximately proportional to the  $m$ th root of  $(-\delta z)$  evaluated at  $p=p_k^0$ , where  $m$  is the multiplicity of  $p_k^0$ , and the proportionality factor equals the coefficient  $A_k$  of  $(p-p_k^0)^{-m}$  in the partial fraction expansion of  $1/Z(p)$ .

## INTRODUCTION

IN ANALYZING an LC network it is often assumed that its elements are purely reactive. This assumption introduces an error in the location of the zeros  $p_k^0$  of the network impedance  $Z(p)$ , since there always is present some dissipation. The exact determination of the zeros would require additional work at best; in many cases [e.g. (3)] it cannot be given at all in a closed form, but can only be estimated numerically. Only in the case of uniform dissipation a simple solution is possible.<sup>1</sup> In the following, an approximate evaluation of the displacement of  $p_k^0$ , caused by the incremental variation in any network element, will be given. It will be shown that if the multiplicity of  $p_k^0$  is  $m$ , then a variation of the impedance  $z(p)$  of any network element by  $\delta z(p)$  will cause  $p_k^0$  to generate  $m$  roots, located uniformly at the circumference of a circle with  $p_k^0$  as center and with radius equal to the modulus of

$$\sqrt[m]{-\delta z(p_k^0)A_k}$$

where  $A_k$  is the coefficient of  $(p-p_k^0)^{-m}$  in the partial fraction expansion of  $1/Z(p)$ .

## DESCRIPTION OF THE METHOD

The zeros  $p_1^0, p_2^0, \dots, p_k^0, \dots, p_n^0$  of a network impedance are the roots of its determinant; therefore, in investigating their location we can consider the impedance of the network seen from any point. Suppose a network element is varied; this variation will cause a displacement of the zeros  $p_k^0$  to the new locations  $p_1, p_2, \dots, p_k, \dots, p_n$ . Our problem is to evaluate  $p_k - p_k^0$ . We shall denote by  $\delta z(p)$  the change in the impedance of the varied element, and by  $Z(p)$  the impedance looking into the network from the terminals of  $\delta z$ . Clearly  $p_k^0$  and  $p_k$  are zeros of  $Z(p)$  and  $\delta z(p) + Z(p)$  respectively; therefore we must have

$$Z(p_k^0) = 0$$

and

$$\delta z(p_k) + Z(p_k) = 0. \quad (1)$$

\* Original manuscript received by the IRE, July 26, 1954; revised manuscript received, October 15, 1954.

† Consultant, Burroughs Corp., Res. Center, Paoli, Pa.; Elec. Eng. Dept., Polytechnic Institute of Brooklyn, B'klyn., N. Y.

<sup>1</sup> H. Bode, "Network Analysis and Feedback Amplifier Design," D. Van Nostrand Co., Inc., New York, N. Y., p. 217, 1945.

Suppose that  $p_k^0$  is a zero of multiplicity  $m$ , then the value of the expression

$$\frac{(p - p_k^0)^m}{Z(p)}$$

computed at the point  $p = p_k^0$  is finite and different from zero; thus

$$\left. \frac{(p - p_k^0)^m}{Z(p)} \right|_{p=p_k^0} = A_k \neq 0. \quad (2)$$

Multiplying (1) by  $(p_k - p_k^0)^m$  we obtain

$$(p_k - p_k^0)^m = - \frac{\delta z(p_k)(p_k - p_k^0)^m}{Z(p_k)}. \quad (3)$$

The right-hand side of (3) is the value  $F(p_k)$  of the function

$$F(p) = - \frac{\delta z(p)(p - p_k^0)^m}{Z(p)}.$$

From (2) it follows that

$$F(p_k^0) = - \delta z(p_k^0)A_k \neq 0$$

[we assume, of course, that  $p_k^0$  is not a zero of  $\delta z(p)$ ]; therefore, if  $p_k - p_k^0$  is "small,"  $F(p_k)$  can be approximated by  $F(p_k^0)$ ; we thus obtain from (3), using this approximation,

$$p_k - p_k^0 \simeq \sqrt[m]{-\delta z(p_k^0)A_k}. \quad (4)$$

This equation gives an evaluation of the displacement of  $p_k^0$  due to the insertion of  $\delta z$ ;  $\delta z(p_k^0)$  is the value of  $\delta z$  for  $p = p_k^0$ , and  $A_k$  is the coefficient of the dominant term of the root  $p_k^0$  in the partial fraction expansion of  $1/Z(p)$ , as it can easily be seen from (2).

From (4) follows, that for a small variation in a network element, each zero of multiplicity  $m$  will generate  $m$  simple zeros, which will lie, uniformly spaced, on the circumference of a circle with  $p_k^0$  as center and the modulus of

$$\sqrt[m]{-\delta z(p_k^0)A_k}$$

as radius.

## SPECIAL CASES

For a change in a resistive, inductive, or capacity element, we obtain from (4)

$$p_k - p_k^0 \simeq \sqrt[m]{-\delta R A_k} \quad (5)$$

$$p_k - p_k^0 \simeq \sqrt[m]{-p_k^0 \delta L A_k} \quad (6)$$

$$p_k - p_k^0 \simeq \sqrt[m]{+\frac{\delta C}{C} \frac{A_k}{p_k^0 C}}, \quad (7)$$

because

$$\frac{1}{C + \delta C} - \frac{1}{C} \approx \frac{-\delta C}{C^2}$$

Suppose the network is reactive and  $p_k^0$  is a simple root; then  $p_k^0 = j\omega_k^0$  is purely imaginary, and  $A_k$  a real positive number. If a small resistance  $\delta R$  is added in series with any element, its first order effect will be to displace the zero  $j\omega_k^0$  to the left, by an amount equal to  $\delta R A_k$ . The variation of a reactive element  $L$  or  $C$  by  $\delta L$  or  $\delta C$  will cause the frequency  $\omega_k^0$  to vary by  $\omega_k^0 L A_k$  and

$$\frac{\delta C}{C} \frac{A_k}{\omega_k^0 C}$$

respectively.

Suppose next that  $p_k^0$  is a real double root and  $A_k < 0$ ; a small reduction  $\delta R$  of the resistance somewhere in the network will cause  $p_k^0$  to split into two complex roots with  $p_k^0$  as real part and

$$\sqrt{\delta R A_k}$$

as imaginary part.

HIGHER-ORDER APPROXIMATION

The above process can be iterated to give a better approximation for  $p_k - p_k^0$ . Let us denote by  $p_k^1$  the value of  $p_k$  as computed by (4); we thus have

$$p_k^1 = p_k^0 + \sqrt[m]{F(p_k^0)} \tag{8}$$

We now determine  $p_k^2$  by means of

$$p_k^2 = p_k^0 + \sqrt[m]{F(p_k^1)} \tag{9}$$

and so we proceed. We thus obtain higher powers of  $\delta z$  in the evaluation of  $p_k - p_k^0$ .

The second approximation  $p_k^2$  will give us also a measure of the accuracy of the first approximation; indeed, if  $p_k^2 = p_k^1$ , then  $p_k^1$  is the exact solution of (3). Hence, the difference  $p_k^2 - p_k^1$  compared with  $p_k^1$  gives an estimate of the accuracy of (4).

MUTUAL COUPLING

Suppose that two networks are coupled magnetically. First consider the case in which the mutual inductance varies by a small quantity  $\delta M$  from a nonzero value  $M$ . With  $Z_a(p)$  and  $Z_b(p)$  the impedance of each network at the coupling mesh, with the other removed, it can easily be seen that the roots of the determinant of the total network are the zeros of the transfer impedance

$$Z_i(p) = \frac{pM}{Z_a(p)Z_b(p) - p^2M^2}$$

between the two coupled meshes. If the multiplicity of  $p_k^0$  is  $m$ , then

$$\left. \frac{(p - p_k^0)^m}{Z_i(p)} \right|_{p=p_k^0} = A_k \neq 0 \tag{10}$$

If the value of  $M$  is changed by  $\delta M$ , then the new zero

$p_k$  will satisfy

$$Z_a(p_k)Z_b(p_k) - (p_k)^2(M + \delta M)^2 \tag{11}$$

Neglecting in (11) the term with  $(\delta M)^2$ , and proceeding as in (4), we obtain

$$p_k - p_k^0 \approx \sqrt[m]{2p_k^0 \delta M \cdot A_k} \tag{12}$$

We shall next assume that we know the zeros  $p_k^0$  of  $Z_a(p)$  and  $Z_b(p)$ , and we want to find the zeros  $p_k$  of the determinant of the network formed by coupling  $Z_a$  and  $Z_b$  with a small mutual inductance  $\delta M$ ; clearly  $p_k$  will have to satisfy

$$Z_a(p_k)Z_b(p_k) - (p_k \delta M)^2 = 0 \tag{13}$$

Suppose  $p_k^0$  is a zero of  $Z_a(p)$  of multiplicity  $m$  but not a zero of  $Z_b(p)$ . We then have

$$\left. \frac{(p - p_k^0)^m}{Z_a(p)} \right|_{p=p_k^0} = A_{ak} \neq 0$$

Hence, reasoning as in (4), we obtain from (13)

$$p_k - p_k^0 \approx \sqrt[m]{\frac{(p_k^0 \delta M)^2}{Z_b(p_k^0)}} A_{ak} \tag{14}$$

Suppose next that  $p_k^0$  is a zero of  $Z_a(p)$  and  $Z_b(p)$  of multiplicity  $m$  and  $s$  respectively. Reasoning as above, we obtain

$$p_k - p_k^0 \approx \sqrt[m+s]{(p_k^0 \delta M)^2 A_{ak} A_{bk}} \tag{15}$$

where  $A_{ak}$  and  $A_{bk}$  are the coefficients of the dominant terms in the expansions of  $1/Z_a(p)$  and  $1/Z_b(p)$ . If  $p_k^0$  is a simple root of  $Z_a(p)$  and  $Z_b(p)$ , then

$$p_k - p_k^0 \approx p_k^0 \delta M \sqrt{A_{ak} A_{bk}} \tag{16}$$

EXAMPLES

To illustrate the method, we shall start with a simple example.

1. Series LC circuit

$$p_1^0 = \pm \frac{j}{\sqrt{LC}} = \pm j\omega$$

$$\frac{1}{Z(p)} = \frac{1}{pL + \frac{1}{pC}} = \frac{1}{2L} \left( \frac{1}{p + j\omega} + \frac{1}{p - j\omega} \right)$$

$$A_1 = \frac{1}{2L} = A_2$$

If a small resistance  $r$  is added in series, then (4) gives for the first approximation

$$p_1^1 = j\omega - \frac{r}{2L}$$

$$p_2^1 = -j\omega - \frac{r}{2L}$$

To find the second approximation, we have from (9),



$$p_1^2 = j\omega - \frac{r}{2L} \left( \frac{r/2L}{2j\omega - r/2L} + 1 \right).$$

Keeping only the first and second power of  $r$ , we have

$$p_1^2 \simeq j\omega - \frac{r}{2L} - j \frac{r^2}{8\omega L^2}.$$

This value of the zero gives the first three terms in the series expansion of the exact solution

$$p_1 = -\frac{r}{2L} + j \sqrt{\omega^2 - \frac{r^2}{4L^2}}$$

in powers of  $r$ . The first approximation is satisfactory if  $r \ll 4\omega L$ .

If an inductance  $L_1$  is added in series, then

$$p_1 - j\omega \simeq -j \frac{\omega L_1}{2L}$$

$$p_2 + j\omega \simeq j \frac{\omega L_1}{2L}.$$

Thus the new frequency of oscillation  $\omega_1$  equals

$$\omega_1 \simeq \omega \left( 1 - \frac{L_1}{2L} \right). \tag{17}$$

The exact value of  $\omega_1$  is

$$\omega_1 = \frac{1}{\sqrt{(L_1 + L)C}}.$$

Eq. (17) gives the first two terms in the expansion of  $\omega_1$  in powers of  $L_1$ .

2. Series RLC circuit with critical damping

$$p_1^0 = p_2^0 = -\frac{R}{2L}$$

$$\frac{1}{Z(p)} = \frac{1}{R + pL + \frac{1}{pC}} = \frac{-R/2L^2}{\left(p + \frac{R}{2L}\right)^2} + \frac{1/L}{p + \frac{R}{2L}}$$

$$A_1 = -\frac{R}{2L^2}.$$

If a small resistance  $r$  is added in series, then (4) gives for the new roots

$$p_1 + \frac{R}{2L} \simeq \sqrt{\frac{rR}{2L^2}}$$

$$p_2 + \frac{R}{2L} \simeq -\sqrt{\frac{rR}{2L^2}}.$$

Thus reduction in  $R$  ( $r$  negative) causes oscillations with frequency

$$\sqrt{\frac{rR}{2L^2}}$$

and damping  $-(R/2L)$ .

3. Low-pass filter of  $n$  sections terminated in a resistance  $r^2$

With  $L$  the total series inductance and  $C$  the shunt capacitance of each section, the  $L$ -transform of the output current is given by

$$I(p) = \frac{E(p)}{r \cosh n\gamma + \frac{1}{pC} \sinh n\gamma \sinh \gamma}, \tag{18}$$

where  $E(p)$  is the  $L$ -transform of the input voltage, and

$$\cosh \gamma = 1 + \frac{p^2 LC}{2}. \tag{19}$$

To find the roots of the denominator of (18), it will be necessary to express  $\cosh n\gamma$  and  $\sinh \gamma \sinh n\gamma$  in powers of  $\cosh \gamma$ ; a polynomial in  $p$  will be obtained of degree  $2n$ , the roots of which can be found only numerically.

For  $r=0$  the roots can be found easily; (18) takes the form

$$I(p) = \frac{E(p)pC}{\sinh \gamma \sinh n\gamma}. \tag{20}$$

For the denominator to equal zero, we must have

$$n\gamma = j\pi k, \quad k = 0, 1, \dots, n. \tag{21}$$

Hence from (19)

$$1 + \frac{p^2 LC}{2} = \cos \frac{k\pi}{n},$$

therefore,

$$p_k^0 = j\omega_c \sin \frac{k\pi}{2n}, \tag{22}$$

where

$$\omega_c = \frac{2}{\sqrt{LC}}$$

is the cut-off frequency.

To find the poles of (18) for small values of  $r$ , we must find  $A_k$ . It is known that for a shorted filter

$$\frac{1}{Z(p)} = \frac{pC \cosh n\gamma}{\sinh \gamma \sinh n\gamma}, \tag{23}$$

therefore [see (2)]

$$A_k = \left. \frac{pC \cosh n\gamma (p - p_k^0)}{\sinh \gamma \sinh n\gamma} \right|_{p=p_k^0} = \begin{cases} \frac{1}{Ln} & \text{for } k = 0, \dots, n-1 \\ \frac{1}{2Ln} & \text{for } k = n. \end{cases} \tag{24}$$

<sup>2</sup> M. F. Gardner and J. L. Barnes, "Transients in Linear Systems," John Wiley & Sons, Inc., New York, N. Y., vol. 1, 1942.

From (24) and (4) we obtain for the poles  $p_k$  of (18) since

$$p_k \simeq j\omega_c \sin \frac{k\pi}{2n} - \frac{r}{Ln} \quad (25)$$

for  $k=0, 1, \dots, n-1$ , and

$$p_n \sim j\omega_c - \frac{r}{2Ln}. \quad (26)$$

#### 4. Loosely-coupled resonant circuits

We have

$$Z_a(p) = pL_1 + \frac{1}{pC_1} \quad Z_b(p) = pL_2 + \frac{1}{pC_2}$$

$$p_1^0 = j\omega_a \quad p_2^0 = j\omega_b,$$

where

$$\omega_a = \frac{1}{\sqrt{L_1C_1}} \quad \text{and} \quad \omega_b = \frac{1}{\sqrt{L_2C_2}}.$$

With  $\delta M$  the mutual coupling and

$$k = \frac{\delta M}{\sqrt{L_1L_2}}$$

the coupling coefficient, we have from (14), assuming  $\omega_a \neq \omega_b$ ,

$$p_1 - j\omega_a \sim \frac{j\omega_a(\omega_a k)^2}{(\omega_a)^2 - (\omega_b)^2},$$

$$A_{a1} = \frac{1}{2L_1}$$

and

$$Z_b(p_1^0) = \frac{j\omega_a}{2L_2[(\omega_b)^2 - (\omega_a)^2]}.$$

Thus the frequencies of free oscillation are

$$\omega_a \left[ 1 + \frac{k^2}{1 - \left(\frac{\omega_b}{\omega_a}\right)^2} \right]$$

and

$$\omega_b \left[ 1 + \frac{k^2}{1 - \left(\frac{\omega_a}{\omega_b}\right)^2} \right].$$

Suppose next that  $\omega_a = \omega_b$ , then we obtain from (16)

$$p_1 - j\omega_a = \pm j\omega_a \frac{k}{2},$$

and the new frequencies of oscillation are

$$\omega_a \left( 1 \pm \frac{k}{2} \right).$$

## Scattering of Electromagnetic Waves by Wires and Plates\*

J. WEBER†, SENIOR MEMBER, IRE

**Summary**—The scattering of electromagnetic waves by wires and plates is discussed, particularly with reference to new polarization components which appear. An approximate solution is obtained for the problem of scattering of radiation by a rectangular plate, for arbitrary angle of incidence, and arbitrary direction of polarization. The problem of scattering by a wire is formulated in terms of the current distributions on the wire when center driven, and when driven as a receiving antenna. A relation between the magnitude of the input impedance of a center-driven wire and the scattering properties of the wire is given. The use of simple sinusoidal current distributions is shown to give good results for the scattering of wires of length less than a wavelength.

The scattering properties of a wire are shown to provide a method for precisely measuring the magnitude of the input impedance of a center-driven wire. This avoids the problem of the input region susceptance which occurs when the antenna impedance is measured by means of a transmission line coupled to the antenna.

\* Original manuscript received by the IRE, March 24, 1954; revised manuscript received November 1, 1954.

† U. S. Naval Ordnance Laboratory, White Oak, Md. and University of Maryland, College Park, Md.

### INTRODUCTION

EXPERIMENTS have shown that certain receiving antenna sites have the property of changing the polarization of incident electromagnetic waves. In order to study these effects, we have calculated the scattering of electromagnetic waves by plates and wires.

Consider a wire  $ab$  (see Fig. 1, opposite page), upon which linearly polarized electromagnetic waves are incident, with the direction of polarization given by the vector  $\bar{E}$ ; the component of the electric field vector  $\bar{E}$  parallel to  $ab$  will excite  $ab$  and the scattered fields will have components perpendicular to  $\bar{E}$ .

The cross polarization scattering of plates can be understood from the following model. Imagine that a conducting paraboloid of revolution is excited by a dipole, as shown in Fig. 2 on the opposite page.





Fig. 1—Electromagnetic waves incident on a wire with electric field intensity vector not parallel to the wire.

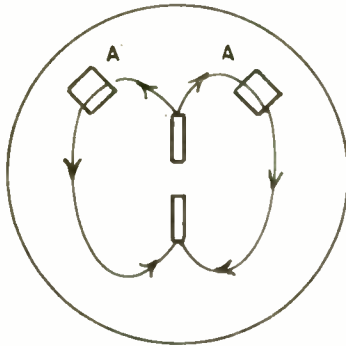

Fig. 2—Conducting paraboloid of revolution excited by a dipole at its focus.

The direction of the currents induced in the paraboloid is shown by the arrows. In the forward direction the polarization of the radiation is the same as that of the dipole, because the cross polarization field from element *A* is canceled by that of element *A'*. Suppose we remove the entire paraboloid except element *A*. Then we still have currents induced in *A* with direction shown in Fig. 3, and both polarizations are radiated.

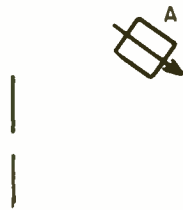

Fig. 3—Dipole and small plate.

If the element *A* is of the order of a wavelength on a side or larger and remains oriented in a direction tangent to the paraboloid, the radiation scattered in the direction of the paraboloidal axis will be large. This is because the maximum of the diffraction pattern can be expected to be in the direction of the specular reflection angle. It will be shown later that this is so.

SCATTERING OF ELECTROMAGNETIC WAVES BY PLATES

Consider a rectangular conducting plate oriented as in Fig. 4, in the next column.

To simplify the calculation it will be assumed that the plate is rectangular in shape and lying in the *YZ* plane, with the origin at one edge of the plate (Fig. 4). The

oncoming electromagnetic wave will excite currents in the plate. The radiation due to these currents will now be calculated.

If we are interested only in field components which vary as  $1/r$ , where  $r$  is the distance from the plate, then the electric field components  $E_\theta$  and  $E_\phi$  at point *P* can be shown to be given<sup>1</sup> by

$$E_\theta = -\frac{j\omega\mu}{4\pi r} N_\theta, \tag{1}$$

$$E_\phi = -\frac{j\omega\mu}{4\pi r} N_\phi, \tag{2}$$

where

$$N_\theta = N_x \cos \theta \cos \phi + N_y \cos \theta \sin \phi - N_z \sin \theta \tag{3}$$

$$N_\phi = -N_x \sin \phi + N_y \cos \phi,$$

where  $\theta$  and  $\phi$  are the co-ordinates of point *P* and

$$\bar{N} = \iint \bar{J} e^{-ikr''} dA. \tag{4}$$

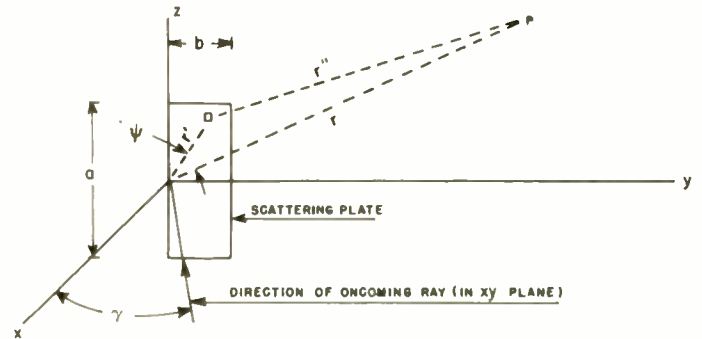

Fig. 4—Rectangular plate with electromagnetic wave incident from some direction in the *XY* plane.

In (4) *J* is the surface linear current density on element *dA* of the plate,  $r''$  is the distance between *dA* and point *P*.  $\bar{J}$  is a complex vector whose phase accounts for the difference in phase of the currents in the plate as a result of excitation by an obliquely incident wave.

The determination of the current distribution function  $\bar{J}$  is a very difficult problem. It is known that if the plate is large, edge effects will not be important. We make the approximation that the current distribution function  $\bar{J}$  is the same as it would be if the plate were infinitely large. The magnitude of  $\bar{J}$  will therefore be treated as a constant, but the phase will be treated more precisely. The results will be accurate for plates which are of the order of a wavelength by a wavelength, or larger. This approximation is necessary in order to obtain a solution in closed form for arbitrary angle of incidence and arbitrary direction of polarization. The solution then exhibits the parallel and cross polarization scattering as a function of the polarization and angle of incidence.

<sup>1</sup> S. Ramo and J. R. Whinnery, "Fields and Waves in Modern Radio," John Wiley & Sons, Inc., New York, N. Y., 2nd ed., p. 507; 1953.

If, for instance the wave normal of the incident wave is in the  $xy$  plane and makes an angle  $\gamma$  with the  $x$  axis, then the wavefront arrives at a point whose co-ordinate is  $+y$  sooner than at the origin. The difference in distance (Fig. 5) is  $y \sin \gamma$ . The difference in phase is  $[y \sin \gamma][2\pi/\lambda] = ky \sin \gamma$ , where  $k = 2\pi/\lambda$ .

now

$$r' \cos \theta' = z \quad r' \sin \theta' = y \quad \cos(\phi - \pi/2) = \sin \phi.$$

With these substitutions the integral becomes

$$\bar{N} = 2\bar{n} \times \bar{H}_T \int_0^b \int_{-a/2}^{a/2} e^{jk(y \sin \gamma + y \sin \theta \sin \phi + z \cos \theta)} dy dz, \quad (8)$$

carrying out this integration, we obtain

$$\bar{N} = \frac{2[\bar{n} \times \bar{H}_T] \sin \left[ \frac{ka \cos \theta}{2} \right] \sin \left[ \frac{kb}{2} (\sin \theta \sin \phi + \sin \gamma) \right] ab}{\left( \frac{ka}{2} \cos \theta \right) \left( \frac{kb}{2} [\sin \theta \sin \phi + \sin \gamma] \right)}. \quad (9)$$

$$\bar{N} = \bar{J}_0 \int_{-a/2}^{a/2} \int_0^b e^{jk(y \sin \gamma - r')} dA. \quad (5)$$

Let us now consider the field scattered from the plate, at large distances.

In this case it is known that a good approximation is the relation  $r'' \approx r - r' \cos \psi$  where  $r'$  is the radius vector from the origin to  $dA$  and  $\psi$  is the angle between  $\bar{r}$  and  $\bar{r}'$ . It can be readily shown<sup>2</sup> that

$$\cos \psi = \cos \theta \cos \theta' + \sin \theta \sin \theta' \cos(\phi - \phi'), \quad (6)$$

where  $\theta$  and  $\phi$  are the angle co-ordinates of  $P$ .  $\theta'$  and  $\phi'$  are the angle co-ordinates of  $dA$ . In this case  $\phi' = \pi/2$  for all points on the plate.

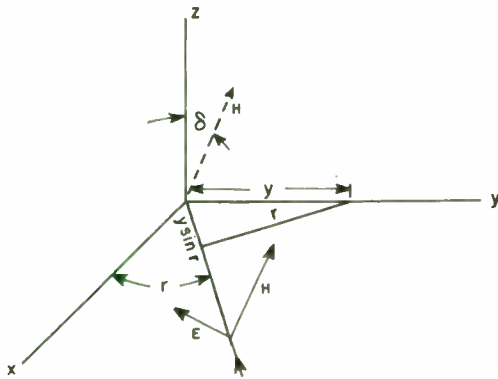

Fig. 5—Angles employed for the scattering calculation.

From the boundary conditions at the surface of a perfect conductor, we know that the value of  $\bar{J}$  is given by  $\bar{J} = \bar{n} \times 2\bar{H}_T$ , where  $\bar{H}_T$  is the tangential component of the incident magnetic field  $\bar{H}$  at the plate and  $\bar{n}$  is a vector of unit length normal to the plate. The tangential electric field at the plate is zero. In order to calculate the scattered field at point  $P$  it is only necessary to consider the tangential components at the plate. Then, combining (5) and (6) we obtain

$$\bar{N} = 2 \int_0^b \int_{-a/2}^{a/2} \bar{n} \times \bar{H}_T e^{jk(y \sin \gamma + r' \cos \theta \cos \theta' + r \sin \theta \sin \theta' \cos(\phi - \pi/2))} dy dz \quad (7)$$

<sup>2</sup> *Ibid.*, p. 508.

Let

$$\alpha = \frac{ka}{2} \cos \theta, \quad \beta = \frac{kb}{2} (\sin \theta \sin \phi + \sin \gamma)$$

$$A = ab$$

$$\bar{N} = 2A\bar{n} \times \bar{H}_T \left( \frac{\sin \alpha}{\alpha} \right) \left( \frac{\sin \beta}{\beta} \right).$$

If the field vector  $H$  makes an arbitrary angle  $\delta$  with the  $z$  axis, the component of  $H$  parallel to the  $z$  axis is  $H_z = H \cos \delta$ . The component of  $H$  parallel to the  $y$  axis is  $H_y = H \sin \delta \cos \gamma$  (see Fig. 5).

$$\bar{H}_T = \bar{a}_y [H \sin \delta \cos \gamma] + \bar{a}_z [H \cos \delta], \quad (10)$$

where  $H_T$  is the tangential component of  $H$  at the plate. Now a unit normal to the plate is given by  $\bar{n} = \bar{a}_x$ , since the plate is perpendicular to the  $x$  axis.

$$\bar{n} \times \bar{H}_T = \bar{a}_z [H \sin \delta \cos \gamma] + \bar{a}_y [-H \cos \delta].$$

Now

$$\bar{N} = 2AH \left( \frac{\sin \alpha}{\alpha} \right) \left( \frac{\sin \beta}{\beta} \right) [\bar{a}_y (-\cos \delta) + \bar{a}_z (\sin \delta \cos \gamma)]. \quad (11)$$

Where we have set  $A = ab$ ,  $A$  is the area of the plate.

$$N_\theta = (N_x \cos \phi + N_y \sin \phi) \cos \theta - N_z \sin \theta$$

$$N_\phi = -N_x \sin \phi + N_y \cos \phi.$$

Making use of (11) we obtain

$$N_\theta = 2AH \left( \frac{\sin \alpha}{\alpha} \right) \left( \frac{\sin \beta}{\beta} \right) [-\cos \delta \cos \theta \sin \phi - \sin \delta \cos \gamma \sin \theta],$$

$$N_\phi = 2AH \left( \frac{\sin \alpha}{\alpha} \right) \left( \frac{\sin \beta}{\beta} \right) [-\cos \phi \cos \delta].$$

The scattered field components  $E_\theta$  and  $E_\phi$  are given<sup>1</sup> by:

$$E_\theta = -\frac{j\omega\mu}{4\pi r} N_\theta \quad E_\phi = -\frac{j\omega\mu}{4\pi r} N_\phi.$$

Inserting the values of  $N_\theta$  and  $N_\phi$ , simplifying and making use of the relation  $E/H = 120\pi\Omega$ , we obtain



$$E_{\theta} = \frac{AE}{\lambda r} \left( \frac{\sin \alpha}{\alpha} \right) \left( \frac{\sin \beta}{\beta} \right) [\cos \theta \sin \phi \cos \delta + \sin \theta \sin \delta \cos \gamma], \quad (12)$$

$$E_{\phi} = \frac{AE}{\lambda r} \left( \frac{\sin \alpha}{\alpha} \right) \left( \frac{\sin \beta}{\beta} \right) [\cos \delta \cos \phi].$$

Where:

$E_{\theta}$  and  $E_{\phi}$  are the  $\theta$  and  $\phi$  components of the scattered fields,  
 $E$  is the incident field,  
 $\lambda$  is the wavelength,  
 $A$  is the area of the plate,  
 $r$  is the distance from the plate to the point at which the scattered fields are required,  
 $a$  is the length of the plate,  
 $b$  is the width of the plate,  
 $k = 2\pi/\lambda$ ,  
 $\alpha = (ka/2) \cos \theta$ ,  
 $\beta = (kb/2) (\sin \theta \sin \phi + \sin \gamma)$ ,  
 $\theta$  and  $\phi$  are the spherical co-ordinates of the point at which the scattered fields are required,  
 $\gamma$  is the angle between the direction of the incident ray and the normal to the plate,  $\delta$  is the angle between the direction of the incident magnetic field vector and the  $z$  axis. The incident ray is in the  $XY$  plane, and  $\delta$  is the angle which the electric field vector makes with the plane of incidence.

The relations (12) are the approximate solution for the distant scattered fields on a rectangular plate oriented as shown, for any angle of incidence and any direction of polarization, assuming that the magnitude of the current density is uniform over the plate. It is apparent that although the formulas were derived for a rectangular area, they will be valid for small areas of any shape provided that the shape is such that one can reasonably fit a similarly oriented rectangle to it. Only the factor  $[(\sin \alpha)/\alpha][(\sin \beta)/\beta]$  needs to be modified, for other shapes.

If  $a$  and  $b$  are larger than a wavelength

$$\alpha > \pi \cos \theta, \quad \beta > \pi(\sin \theta \sin \phi + \sin \gamma).$$

Under these conditions the factor  $[(\sin \alpha)/\alpha][(\sin \beta)/\beta]$  will be small unless  $\theta$ ,  $\gamma$ , and  $\phi$  are such that  $\alpha$  and  $\beta$  both approach zero. The quantity  $[(\sin \alpha)/\alpha][(\sin \beta)/\beta]$  therefore is the dominant term in (12). The scattered fields are a maximum if  $\alpha \rightarrow 0$ ,  $\beta \rightarrow 0$ , i.e. if  $\theta \rightarrow (\pi/2)$  and  $\gamma \rightarrow -\phi$ . These conditions will be recognized as the ordinary specular reflection condition for infinite planes. This constitutes a proof that *if a scattering plate is of dimensions of the order of a wavelength by a wavelength, or larger, the maximum of the scattering occurs for the angle of incidence equal to the angle of reflection*. If the plate is very small or very narrow it behaves like a wire and the specular reflection condition has no special significance.

To obtain the cross polarization and parallel polarization components, we require the components of the total field in directions perpendicular and parallel respectively to the original electric field.

A unit vector perpendicular to the incident electric field vector is from the geometry of Figs. 4 and 5, given by

$$U_{\perp} = \bar{a}_x(-\sin \delta \sin \gamma) + \bar{a}_y(\sin \delta \cos \gamma) + \bar{a}_z(\cos \delta).$$

A unit vector parallel to the incident electric field is similarly given by

$$U_{\parallel} = \bar{a}_x(\cos \delta \sin \gamma) + \bar{a}_y(-\cos \delta \cos \gamma) + \bar{a}_z(\sin \delta).$$

The *total* scattered electric field can be written as

$$E \text{ (total scattered)} \\ = \bar{a}_z(E_{\theta} \cos \theta \cos \phi - E_{\phi} \sin \phi) \\ + \bar{a}_y(E_{\theta} \cos \theta \sin \phi + E_{\phi} \cos \phi) + \bar{a}_z(-E_{\theta} \sin \theta), \quad (12a)$$

where  $E_{\theta}$  and  $E_{\phi}$  are given by (12).

To obtain the parallel and cross polarization components we form the scalar products  $\bar{U}_{\parallel} \cdot \bar{E}$  (total) and  $\bar{U}_{\perp} \cdot \bar{E}$  (total). This is a tedious calculation, the results are

$E$  (scattered parallel polarized)

$$= \frac{AE}{\lambda r} \left( \frac{\sin \alpha}{\alpha} \right) \left( \frac{\sin \beta}{\beta} \right) \cdot [\sin \delta \cos \delta \sin \theta \cos \theta (\sin \gamma \cos \gamma \cos \phi - \sin \phi - \cos^2 \gamma \sin \phi) + \sin \phi \cos \phi (\cos^2 \theta \cos^2 \delta \sin \gamma - \cos^2 \delta \sin \gamma) - \cos^2 \theta \sin^2 \phi \cos^2 \delta \cos \gamma - \sin^2 \theta \sin^2 \delta \cos \gamma - \cos^2 \delta \cos^2 \phi \cos \gamma]. \quad (13a)$$

$E$  (scattered cross polarized)

$$= \frac{AE}{\lambda r} \left( \frac{\sin \alpha}{\alpha} \right) \left( \frac{\sin \beta}{\beta} \right) [\sin \delta \cos \delta \sin \phi \cos \phi \sin \gamma \sin^2 \theta + \sin \delta \cos \delta \cos \gamma (\sin^2 \phi \cos^2 \theta + \cos^2 \phi - \sin^2 \theta) + \sin \theta \cos \theta \sin \phi (\sin^2 \delta \cos^2 \gamma - \cos^2 \delta) - \sin^2 \delta \sin \gamma \cos \gamma \sin \theta \cos \theta \cos \phi]. \quad (13b)$$

Eqs. (13) are the general solution for the distant parallel and cross polarized scattered fields in terms of the quantities which have already been defined under (12), for any angle of incidence and any direction of polarization of the incident wave.

If the dimensions of the plate are of the order of a wavelength by a wavelength or larger, then the maximum values of the scattered fields will occur, as discussed previously, for  $\gamma = -\phi$  and  $\theta = (\pi/2)$ . In this case (13) reduces to:

$E$  (scattered cross polarized)

$$= \frac{AE}{\lambda r} \sin \delta \cos \delta \cos \phi [\cos 2\phi - 1] \quad (14a)$$

and

$E$  (scattered parallel polarized)

$$= \frac{AE}{\lambda r} \cos \phi [\cos^2 \delta (\cos 2\phi - 1) + \sin^2 \delta]. \quad (14b)$$

Eqs. (14) give the scattered fields for the direction in which the angle of reflection is equal to the angle of incidence. Eq. (14A) can be shown to have a maximum when  $\delta = \pi/4$  and  $\phi = \cos^{-1}(1/\sqrt{3})$ . In this case (14A) becomes

$$E \text{ [cross polarized (maximum)]} = \frac{2AE}{3\sqrt{3}\lambda r}, \quad (15)$$

where  $A$  is the area,  $E$  is the incident field,  $\lambda$  is the wavelength, and  $r$  is the distance from the plate. Eq. (15) gives us the maximum value of the cross polarized field under the condition that the angle of incidence is equal to the angle of reflection, the electric field intensity vector makes an angle of 45 degrees with the plane of incidence,<sup>3</sup> and the angle of incidence is  $\cos^{-1}(1/\sqrt{3}) = 54.8$  degrees.

SCATTERING BY WIRES

In order to calculate the scattering from a wire it is necessary to solve the problem of the diffraction of electromagnetic waves by a cylinder. It is one of the purposes of this paper to point out a close connection between this diffraction problem and the antenna boundary value problems which have been considered by radio engineers.

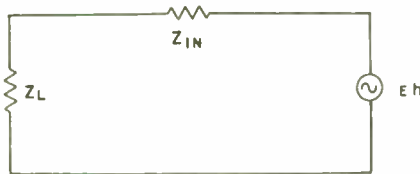

Fig. 6—Equivalent circuit for a receiving antenna.

We imagine first that our scattering wire is broken at the center and an impedance  $Z_L$  is inserted. Then the scattering wire is equivalent to a receiving antenna. An equivalent circuit for the antenna is given by Fig. 6.

$Z_{in}$  is the input impedance of the antenna.  $E$  is the electric field and  $h$  is the effective height of the antenna. If we remove  $Z_L$  and again join the two halves of the antenna at the center, the equivalent circuit is represented by Fig. 7, and this represents the scattering wire.

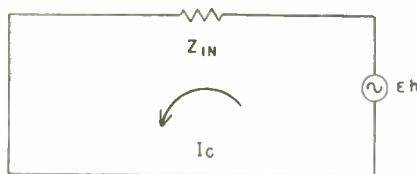

Fig. 7—Equivalent circuit for a scattering wire.

$$I_c = \frac{Eh}{Z_{in}}, \quad (16)$$

$h$  is the effective height. A formula for  $h$  can be obtained

<sup>3</sup> The plane of incidence is a plane containing the incident ray, and normal to the scattering plate.

using the methods of Schelkunoff;<sup>4</sup> the formula is

$$h = \cos \psi' \int_{-l}^l e^{jkz' \cos \theta'} f(z') dz', \quad (17)$$

where  $f(z')$  is the current distribution function of the antenna when driven at the center, as a transmitter;  $l$  is the half length of the antenna;  $\theta'$  is the angle between the incident ray and the axis of the wire;  $\psi'$  is the angle between the incident electric field intensity vector and the axis of the antenna.

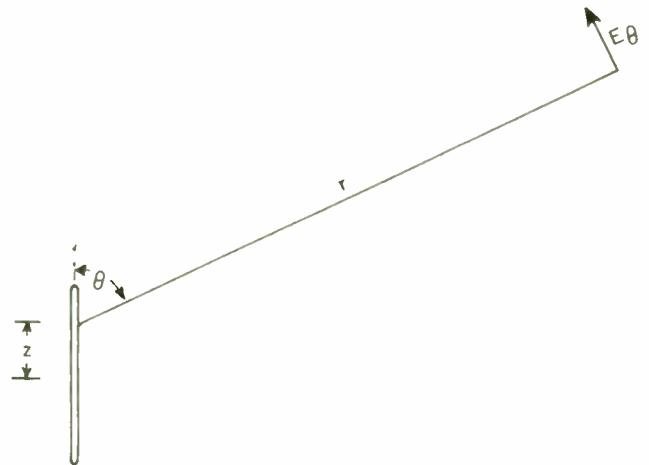

Fig. 8—Scattering wire with incident wavenormal not normal to the wire.

When the antenna is employed as a receiving antenna it is driven by an oncoming electromagnetic wave and the driving forces are now distributed along the entire antenna rather than at the center. We cannot assume that the current distribution function is the same as for the center-driven antenna. Let the new current distribution function be  $\phi(z)$ .<sup>5</sup> From a knowledge of the current at the center of the antenna and the new current distribution function  $\phi(z)$  we can calculate the fields. The radiation field<sup>6</sup> is given by

$$E_\theta = \frac{j\omega\mu}{4\pi r} \int_{-l}^l I(z) \sin \theta e^{-jkr} dz, \quad (18)$$

where  $l$  is the half length of the antenna (see Fig. 8 above).  $I$  is the current on the receiving antenna as a function of  $z$ . Now  $I = I_c \phi(z)$  where  $I_c$  is the current at the center of the antenna. Taking the value of  $I_c$  from (16), we obtain,

$$I = \frac{Eh\phi(z)}{Z_{in}} = \frac{E\phi(z) \cos \psi'}{Z_{in}} \int_{-l}^l e^{jkz' \cos \theta'} f(z') dz', \quad (19)$$

and utilizing (17) and (18) we obtain

<sup>4</sup> S. A. Schelkunoff, "Electromagnetic Waves," D. Van Nostrand Co., Inc., New York, N. Y., p. 479; 1943.  
<sup>5</sup> We have used both  $z$  and  $z'$  to indicate the co-ordinate of a point on the wire to avoid confusion in evaluating the definite integrals in (20).  
<sup>6</sup> Ramo and Whinnery, *op. cit.*, p. 500.



$$E_{\theta} = \frac{j\omega\mu E \sin \theta \cos \psi'}{4\pi Z_{in}} \int_{-l}^l e^{jkz' \cos \theta'} f(z') dz' \cdot \int_{-l}^l \frac{\phi(z)}{r} e^{-jkr} dz. \tag{20}$$

In (20)  $E$  is the incident electric field intensity;  $\psi'$  is the angle between the incident field direction and the wire axis;  $\theta'$  is the angle between the incident ray and wire axis;  $z$  or  $z'$  is the co-ordinate of a point on the wire, measured from the center;  $f(z')$  is the current distribution function of the wire when broken at the center and driven as a transmitting antenna;  $\phi(z)$  is current distribution function of wire as a receiving antenna when excited by a plane wave with direction of propagation making an angle of  $\theta'$ , with wire axis and electric field intensity vector making an angle  $\psi'$  with wire axis.

The input impedance of a center-driven wire,  $Z_{in}$ , has been calculated by a number of authors. This differs from the value measured when driving the antenna by either a transmission line or a ring source, because of susceptance associated with the input region. The value of  $Z_{in}$ , appearing in (16), (19) and (20), is the impedance excluding input region effects. This value of  $Z_{in}$  is the same as that calculated from solution of the antenna boundary value problem. Eq. (20) suggests a method for measuring  $Z_{in}$  by making scattered field measurements on wires. This would measure  $Z_{in}$  without the unknown susceptance associated with a center feed system. By comparing this value with that measured by center feed systems, susceptance associated with the center feed system could be determined.

If the problem of the receiving antenna is solved rigorously, as a boundary value problem, an expression for the current is obtained. If this is inserted into (18), the scattered fields can be obtained, provided the integrations can be carried out. The integrations are tedious and have to be done numerically.

A simpler procedure, that gives good results in certain cases, is to utilize (20), and make simplifying assumptions concerning the current distribution functions  $f(z')$  and  $\phi(z)$  based on the approximate analogy between an antenna and a transmission line. For example, we could assume

$$f(z') = \frac{\sin [k(l - z')]}{\sin kl}, \quad z' > 0$$

$$f(z') = \frac{\sin [k(l + z')]}{\sin kl}, \quad z' < 0. \tag{21}$$

Eqs. (21) are well known, to obtain an approximate formula for  $\phi(z)$  we can proceed as follows (see Fig. 9).

We regard the two antenna elements  $dz$  located at  $+z$  and  $-z$  as a section of a transmission line driven by the oncoming electromagnetic wave and we have, from the transmission line equations

$$\frac{\partial V}{\partial z} = -IZ'$$

$$+ E \cos \psi' [e^{-jk(r_0 - z \cos \theta')} + e^{-jk(r_0 + z \cos \theta')}] \tag{22}$$

$$\frac{\partial I}{\partial z} = -YV, \tag{23}$$

where

- $I$  is the current along the line,
- $V$  is the potential along the line,
- $Z'$  is the series impedance per unit length,
- $Y$  is the shunt admittance per unit length,
- $\psi'$  is the angle between the electric field vector and the wire axis,
- $\theta'$  is the angle between the incident wavenormal and the wire axis,
- $k = 2\pi/\lambda$ ,  $\lambda =$  wavelength,
- $z$  is the distance along the transmission line.

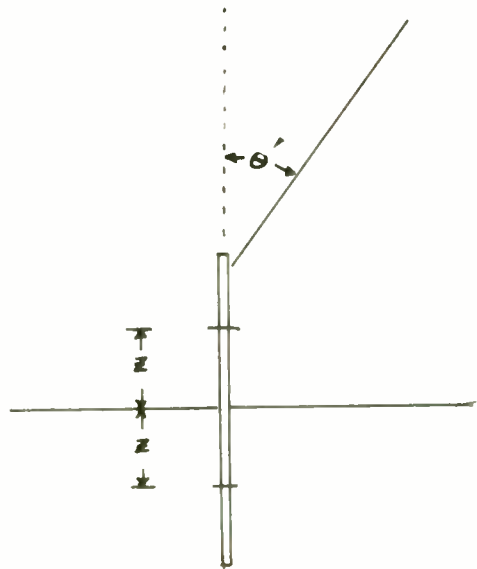

Fig. 9—Scattering wire and observer.

If (23) is differentiated with respect to  $z$  and (22) substituted in it we obtain

$$\frac{d^2 I}{dz^2} = -k_1^2 I - 2YE \cos \psi' \cos (kz \cos \theta') e^{-jkr_0}, \tag{24}$$

where  $k_1^2 = Z'Y$ .

The solution of the differential equation (24) satisfying the boundary conditions of zero current at the ends is

$$I = I_c \frac{\cos k_1 z \cos (kl \cos \theta') - \cos k_1 l \cos (kz \cos \theta')}{\cos (kl \cos \theta') - \cos k_1 l}, \tag{25}$$

where  $I_c$  is the current at the center of the antenna.

The current distribution function  $\phi(z)$  is therefore given by:

$$\phi(z) = \frac{\cos k_1 z \cos (kl \cos \theta') - \cos k_1 l \cos (kz \cos \theta')}{\cos (kl \cos \theta') - \cos k_1 l}. \tag{26}$$

If we employ (26) and (21) for  $f(z')$ , the integration required by (20) can be carried out, and the result is:

$$E_{\theta} = \frac{j\omega\mu E \cos \psi'}{4\pi r Z_{in}} \left[ \frac{2k_1 \sin \theta}{(\sin k_1 l)(k_1^2 - k^2 \cos^2 \theta')} \right] \times \left[ \cos(kl \cos \theta') \left( \frac{2k_1 \sin k_1 l \cos(kl \cos \theta) - 2k \cos \theta \cos k_1 l \sin(kl \cos \theta)}{k_1^2 - k^2 \cos^2 \theta} \right) - \cos k_1 l \left( \frac{\sin[kl(\cos \theta + \cos \theta')]}{k(\cos \theta + \cos \theta')} + \frac{\sin[kl(\cos \theta - \cos \theta')]}{k(\cos \theta - \cos \theta')} \right) \right] \quad (27)$$

For most purposes we can take  $k_1 = k$  since the phase velocity for waves along the antenna is very close to the free space velocity. In this case (27) becomes

$\lambda$  is the wavelength,  
 $Z_{in}$  is input impedance of wire when center driven,

$k = 2\pi/\lambda$ ,  
 $l$  is the half-length of the wire.

$$E_{\theta} = \frac{60\lambda E \cos \psi'}{\pi r Z_{in}} \left[ \frac{\sin \theta}{\sin^2 \theta' \sin kl} \right] \left[ \cos(kl \cos \theta') \left( \frac{\sin kl \cos(kl \cos \theta) - \cos \theta \cos kl \sin(kl \cos \theta)}{\sin^2 \theta} \right) - \frac{\cos kl}{2} \left( \frac{\sin kl(\cos \theta + \cos \theta')}{\cos \theta + \cos \theta'} + \frac{\sin kl(\cos \theta - \cos \theta')}{\cos \theta - \cos \theta'} \right) \right] \quad (28)$$

where:

- $E_{\theta}$  is the distant scattered electric field,
- $E$  is the incident field,
- $\psi'$  is the angle between incident field and wire axis,
- $\lambda$  is the free space wavelength,
- $r$  is the distance between the wire and the point at which the scattered fields are desired.
- $Z_{in}$  is the input impedance of the wire when broken at the center and driven as an antenna. The radius of the wire will partially determine the value of  $Z_{in}$ ,  $k_1 \cong k = 2\pi/\lambda$ .
- $\lambda$  is the free space wavelength,
- $l$  is the half-length of the wire,
- $\theta'$  = angle between axis of the wire and the incident wavenormals,
- $\theta$  = angle between axis of the wire and the radius vector to the point at which the scattered fields are desired.

The author is well aware of the fact that the sinusoidal current distributions are not correct for an antenna. The use of the correct input impedance  $Z_{in}$  and the sinusoidal current distributions appears to be a good procedure for antenna lengths less than a full wavelength. To show this we have calculated the back-scattering cross section  $\sigma$ . For a plane wave incident normally on the wire, with electric field intensity vector parallel to the wire, the back-scattering cross section can be calculated using (28), and is given by

$$\sigma = 4\pi\lambda^2 \left[ \frac{60}{\pi Z_{in} \sin kl} (\sin kl - kl \cos kl) \right]^2 \quad (29)$$

$\sigma$  is  $4\pi$  times the power scattered back towards the source per unit solid angle divided by the incident power per unit area.

The very simple formula (29) has been used to calculate the back-scattering cross section for the 0.01 inch diameter wire, at 3,000 mc, which was used by Dike and King.<sup>7</sup> The results are plotted on Fig. 10. It is apparent

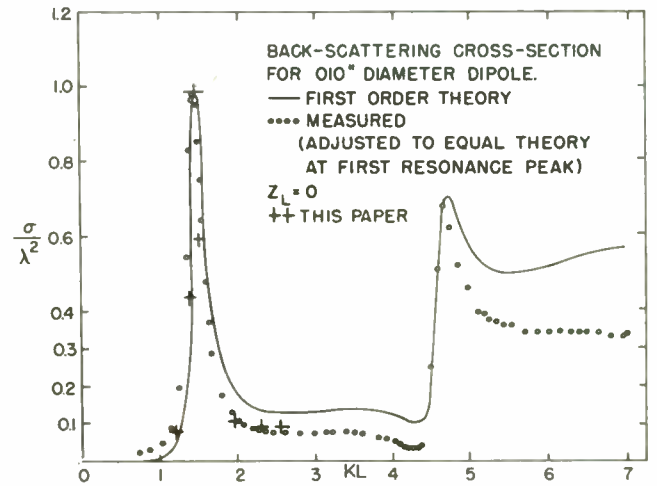

Fig. 10—Comparison of theoretical and experimental results of Dike and King with cross sections calculated using sinusoidal current distributions.

that the rough approximations used here agree considerably better with experiments than do existing first-order solutions of the problem using the Hallén integral equation. For  $Z_{in}$  we have used the input impedances of cylindrical antennas calculated by Schelkunoff.

The expressions given here for the scattering from wires are not valid for wire lengths near a multiple of

<sup>7</sup> S. H. Dike and D. D. King, "The absorption gain and back-scattering cross section of the cylindrical antenna," PROC. I.R.E., vol. 40, pp. 853-860; July, 1952.



a full wavelength. King and Harrison<sup>8</sup> have given a simple approximate formula for  $f(z')$ , the current distribution function for the center-driven antenna. They also describe a procedure for introducing a fictitious length for antenna lengths near a multiple of a full wavelength. The use of their relation for  $f(z')$  and their procedure makes it possible to use the formulations of this paper for wire lengths up to the vicinity of two wavelengths.

A very elegant and precise solution of the problem of scattering by wires has been given by Tai.<sup>9</sup> Mr. Tai's solution is valid for wires of any length. For short wires (length less than 0.8 wavelength) the treatment given here, in this paper, is believed to be precise and requires much less calculation.

<sup>8</sup> R. King and C. W. Harrison, Jr., "The distribution of current along a symmetrical center-driven antenna," *PROC. R.E.*, I.vol. 31, pp. 548-567; October, 1943.

<sup>9</sup> C. T. Tai, "Electromagnetic back-scattering from cylindrical wires," *Jour. Appl. Phys.*, vol. 23, pp. 909-916; August, 1952.

## CONCLUSION

We have obtained expressions for scattering of electromagnetic waves by a rectangular plate. The simple formula (15) gives maximum value of the cross-polarized field. A relation between current distributions, input impedance, and scattering properties of a wire has been given. This suggests a method for measuring magnitude of input impedance by measuring scattering cross sections, and avoids the unknown terminal impedance associated with most center feed methods of impedance measurement. Relations have been obtained for the scattered fields and back-scattering cross section of a wire, based on assumed sinusoidal current distributions. These expressions are simple and reasonably accurate up to antenna lengths approaching a full wavelength.

## ACKNOWLEDGMENT

I wish to acknowledge stimulating discussions of these problems with Dr. W. R. Beam and Prof. D. E. Simons, in the summer, 1951, when this work was done.

# A Distributed Electrical Analog for Waveguides of Arbitrary Cross Section\*

P. R. CLEMENT†, ASSOCIATE, IRE, AND W. C. JOHNSON†, SENIOR MEMBER, IRE

**Summary**—The characteristics of uniform waveguides of arbitrary cross section can be studied experimentally by using a two-dimensional transmission line, operating in resonance in its principal mode, as an analog. The model is simple, inexpensive, and quite accurate even for cross sections which have sharp corners. The theory is presented, measurement techniques are discussed, and experimental results are compared with the theoretical values for rectangular and ridged waveguides.

## INTRODUCTION

THE PROPAGATION of an electromagnetic wave through a uniform hollow waveguide which has perfectly conducting walls and is filled with a homogeneous dielectric can be considered to be the superposition of a set of transverse-electric modes and transverse-magnetic modes.<sup>1,2</sup> Every field component of each mode has the form  $f(x, y)e^{j\omega t - \gamma z}$ , where  $\omega$  is the angular frequency,  $\gamma$  is the propagation constant of the mode, and

$z$  is measured along the axis of the guide. The longitudinal field component of each mode satisfies the equation:

$$\nabla_t^2 \psi + k_g^2 \psi = 0, \quad (1)$$

where

$$k_g^2 = \gamma_g^2 + \omega_g^2 \mu_g \epsilon_g. \quad (2)$$

The subscript,  $g$ , is here used to denote the guide, as distinguished from the model, which will be introduced later. In the foregoing equations,

$\nabla_t^2$  is the two-dimensional Laplacian operator in the transverse plane,

$\psi$  is the longitudinal component of the magnetic field intensity for a TE mode, or of the electric field intensity for a TM mode,

$\gamma_g$  is the propagation constant of the mode in the guide,

$\omega_g = 2\pi f_g$ , and

$\mu_g$  and  $\epsilon_g$  are respectively the absolute permeability and absolute dielectric constant of the dielectric in the guide.

The boundary conditions to be satisfied at the walls of the guide are that the normal derivative  $\partial\psi/\partial n$  is zero

\* Original manuscript received by the IRE, March 30, 1953; revised manuscript received, September 23, 1954.

† Dept. Elec. Eng., Princeton University, Princeton, N. J.

<sup>1</sup> J. C. Slater, "Microwave Electronics," D. Van Nostrand Co., New York, N. Y., chap. 1; 1950.

<sup>2</sup> S. Ramo and J. B. Whinnery, "Fields and Waves in Modern Radio," 2nd ed., John Wiley & Sons, New York, N. Y., chap 8; 1944.

for TE modes, and  $\psi = 0$  for TM modes. Homogeneous equation (1), together with the boundary conditions, constitute an eigenvalue problem, since only a set of discrete values of  $k_\theta$  are allowable. Since the eigenfunctions,  $\psi$ , and the eigenvalues,  $k_\theta$ , are uniquely determined by the geometry of the guide, they are independent of the electrical properties of the medium in the guide and are also independent of frequency. For each of the values of  $k_\theta$ , there is a corresponding value of  $\gamma_\theta$ , as given by (2). Imaginary values of  $\gamma_\theta$  correspond to real propagation down the guide; real values of  $\gamma_\theta$  correspond to attenuation only. Equation (2) shows that, for a given  $k_\theta$ , imaginary values of  $\gamma_\theta$  are obtained only for frequencies above a certain limiting value, known as the "cut-off" frequency. At cut off,  $\gamma_\theta = 0$ .

From the solutions of (1) which meet the proper conditions at the boundary of the guide, the transverse components of the electric and magnetic fields can be determined as follows.

For TE Modes:

$$\mathbf{H}_t = -\frac{\gamma_\theta}{k_\theta^2} \text{grad } \psi, \quad (3)$$

$$\mathbf{E} = \frac{j\omega_\theta \mu_\theta}{\gamma_\theta} \mathbf{H}_t \times \mathbf{k}, \quad (4)$$

where

$\mathbf{H}_t$  is the transverse magnetic field intensity,

$\mathbf{E}$  is the electric field intensity (purely transverse), and  $\mathbf{k}$  is the unit vector in the  $z$  direction.

For TM Modes:

$$\mathbf{E}_t = -\frac{\gamma_\theta}{k_\theta^2} \text{grad } \psi \quad (5)$$

$$\mathbf{H} = \frac{j\omega_\theta \epsilon_\theta}{\gamma_\theta} \mathbf{k} \times \mathbf{E}_t. \quad (6)$$

Of the various quantities in the foregoing equations,  $\psi$  and  $k_\theta$  are independent of frequency, while  $\gamma_\theta$  depends on frequency through (2). Equations (3) to (6), through their dependence on  $\gamma_\theta$ , show that the magnitude and phase of the transverse field components are functions of frequency. On the other hand, the configuration of these fields is independent of frequency. For the TE modes,  $\mathbf{H}_t$  is imaginary for real propagation, zero at cutoff, and real below cutoff, whereas  $\mathbf{E}$  is always imaginary. For the TM modes,  $\mathbf{E}_t$  is imaginary for real propagation, zero at cutoff, and real below cutoff, while  $\mathbf{H}$  is always imaginary.

Because  $\gamma_\theta = 0$  at cutoff for the lossless guide, the relation between the cut-off frequencies,  $\omega_{\theta c}$ , and the eigenvalues,  $k_\theta$ , is shown by (2) to be:

$$\omega_{\theta c} = \frac{k_\theta}{\sqrt{\mu_\theta \epsilon_\theta}}. \quad (7)$$

For mathematically simple shapes, it is an easy matter to solve (1) subject to the appropriate boundary conditions. For more complicated shapes, the difficulties of a straightforward mathematical treatment become so

great that other methods must be sought. One of these is the solution of a simpler, but related, problem.<sup>3-7</sup> Although this procedure has yielded good results for several special problems, the errors cannot be predicted in advance and the method must be considered somewhat hazardous.

Another method is that of analogies. This has been utilized in one form by Kron and Spangenberg, who have developed a lumped-element electrical network for the study of electromagnetic fields.<sup>8,9</sup> With a model composed of lumped elements, the degree of correlation between prototype and model depends on the fineness of the meshes, and an especially fine mesh of elements is needed in the vicinity of irregularities in the boundary. A second approach is use of a distributed analogous system. One such analog is the vibrating membrane, the displacement of which satisfies (1).<sup>10,11</sup> Electrical analogs are, however, generally superior to mechanical systems insofar as measurement techniques and the satisfaction of boundary conditions are concerned. The next section describes a distributed electrical analog which can be used to predict the performance of waveguides of arbitrary cross section and which has been found to give good results, in addition to being simple and inexpensive to construct.

## THEORY OF THE DISTRIBUTED ELECTRICAL ANALOG

### Basic Equation

Consider a uniform metal-walled waveguide of arbitrary cross section such as the one shown in Fig. 1(a), and its two-dimensional analog, which is shown in Fig. 1(b). The analog consists of two conducting plates separated by a sheet of low-loss dielectric material, and is essentially a two-dimensional transmission line. The shape of the model in the  $\xi-\eta$  plane is geometrically similar to the cross section of the waveguide, as shown in the figure. If an alternating voltage is applied between the plates, an electromagnetic wave will be set up in the dielectric. When the separation between the plates,  $d$ , is made much smaller than a wavelength, the model, considered as a two-dimensional transmission line, will

<sup>3</sup> S. B. Cohn, "Properties of ridge wave guide," *PROC. I.R.E.*, vol. 35, pp. 783-788; August, 1947.

<sup>4</sup> S. B. Cohn, "Analysis of wide-band waveguide filter," *PROC. I.R.E.*, vol. 37, pp. 651-656; June, 1949.

<sup>5</sup> H. Jasik, "Theory of the Hour Glass Loaded Waveguide," report included in the Minutes of the Meeting of the Army-Navy R. F. Cable Co-ordinating Committee, Polytechnic Inst. of Brooklyn; January 30, 1948.

<sup>6</sup> T. G. Mihran, "Closed- and open-ridge waveguides," *PROC. I.R.E.*, vol. 37, pp. 640-644; June, 1949.

<sup>7</sup> J. R. Whinnery and H. W. Jamieson, "Equivalent circuits of discontinuities in transmission lines," *PROC. I.R.E.*, vol. 32, pp. 98-114; February, 1944.

<sup>8</sup> G. Kron, "Equivalent circuit of the field equations of Maxwell," *Proc. I.R.E.*, vol. 32, pp. 289-299; May, 1944.

<sup>9</sup> K. Spangenberg, G. Walters, and F. Schott, "Part I—Electrical network analyzers for the solution of electromagnetic field problems," *Proc. I.R.E.*, vol. 37, pp. 724-729; July, 1949.

<sup>10</sup> E. C. Cherry, "The analogies between the vibrations of elastic membranes and the electromagnetic fields in guides and cavities," *Proc. IEE*, vol. 96, pp. 346-360; July, 1949.

<sup>11</sup> K. S. Knol and G. Diemer, "A model for studying electromagnetic waves in rectangular wave guides," *Philips Tech. Rev.*, vol. 11, pp. 156-163; November, 1949.



operate in its principal mode, and the electromagnetic wave will be of the TEM type. With a small spacing, edge effects and the radiation of energy will be negligible.

In any homogeneous charge-free region, the electric field of angular velocity  $\omega$  satisfies the vector wave equation:

$$\nabla^2 \mathbf{E} + \omega^2 \mu \epsilon \mathbf{E} = 0, \quad (8)$$

where  $\nabla^2$  is the three-dimensional Laplacian operator. For the TEM wave between the plates, the electric field will be directed along the  $\zeta$  axis, and  $E_\zeta$  will be independent of  $\zeta$ . Hence, for the model, (8) becomes

$$\nabla_{\xi, \eta}^2 E_\zeta + \omega_m^2 \mu_m \epsilon_m E_\zeta = 0. \quad (9)$$

Comparison of (9) with (1) shows that the electric field of the model satisfies the same differential equation as the field function,  $\psi$ , of the waveguide. Since the voltage between the plates at any point  $(\xi, \eta)$  is equal to  $E_\zeta d$ , this voltage is also an analog of  $\psi$ .

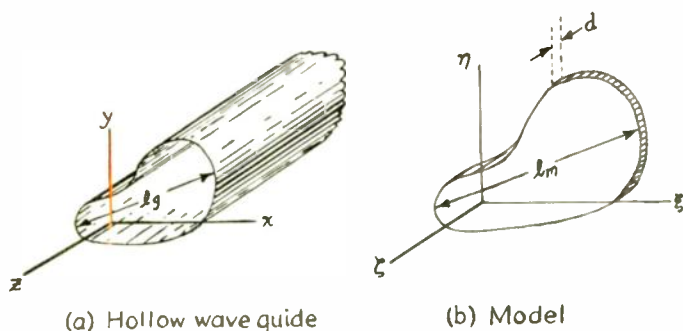

Fig. 1—Two-dimensional transmission line used as a model of a uniform metal-walled guide.

In order to write (9) in the same co-ordinate system as (1), let any dimension measured on the cross section of the guide be denoted by  $l_g$  and the corresponding dimension on the model by  $l_m$ . Since the boundary of the model is geometrically similar to that of the guide, it follows that corresponding co-ordinates on the two planes are related by

$$\xi = \frac{l_m}{l_g} x, \quad \eta = \frac{l_m}{l_g} y.$$

Hence (9) can be written as

$$\nabla_{xy}^2 E_\zeta + \left( \frac{l_m}{l_g} \omega_m \sqrt{\mu_m \epsilon_m} \right)^2 E_\zeta = 0. \quad (10)$$

The relationship between the set of eigenvalues associated with the waveguide and the set associated with the model is now explicit. For the analogy expressed by (1) and (10) to be complete, it is necessary to show that  $\psi$  of the waveguide and  $E_\zeta$  of the model satisfy the same conditions on the boundaries.

#### Boundary Conditions

For the study of transverse-electric modes in the guide, the function  $\psi$  in (1) will represent the longitudinal component of magnetic field  $H_z$  in the guide. The

normal derivative of this quantity must vanish at the highly conducting walls of the guide. If, in the model, the boundaries are left open-circuited, the normal component of current will vanish at the edges. Therefore, the tangential component of  $H$  will be quite small, and as experiment shows, may be considered negligible. So, the tangential component of the curl of  $E$  vanishes at these open boundaries, giving the desired condition:

$$\frac{\partial E_\zeta}{\partial n} = 0, \quad (11)$$

where  $n$  is the normal to the boundary.

In the study of transverse-magnetic modes, the function  $\psi$  represents the longitudinal component of electric field in the guide, and this must be zero at the boundaries. The analogous condition in the model can be obtained by short-circuiting the edges, which makes  $E_\zeta = 0$  there.

#### Excitation of the Model

The model can be driven by an adjustable-frequency source of alternating current through a transmission line which is attached to the plates at any point  $(\xi, \eta)$  that is not a node of  $E_\zeta$  for the particular mode. It is convenient to ground one plate of the model and to supply the energy through a coaxial line. In the investigation of TE modes, where the boundaries of the model are open-circuited, the line can be attached at the edge of the plates. For the investigation of TM modes, where the boundaries of the plates are short-circuited, the feed point must be in the interior.

When the model is fed at the edge, the normal component of current at the boundary does not vanish except at anti-resonance. Similarly, when feed point is in interior, differential equation (10) does not apply except at anti-resonance, when input current is nearly zero. The added condition for complete analogy is, therefore, anti-resonance of the model. If an attenuator pad is inserted at the point of attachment of the transmission line, so that the line is properly terminated but the source impedance seen by the model is high, the condition of anti-resonance can be detected by a sharp increase in voltage at the feed point as the frequency passes through anti-resonance. A set of anti-resonant frequencies will be found, each corresponding to one eigenvalue,  $k_g$ , and one mode of transmission in the guide.

#### Interpretation of Results

At anti-resonance, the analogy between  $\psi$  of the waveguide and  $E_\zeta$  of the model is complete, and from comparison of (1) and (10) one can compute

$$k_g = \frac{l_m}{l_g} \omega_m \sqrt{\mu_m \epsilon_m}; \quad (12)$$

where  $\omega_m$  is one of the set of anti-resonant frequencies of the model, and  $l_m/l_g$  is model-to-guide size ratio. The propagation constant of the corresponding mode in the guide can then be found as a function of frequency.

At each frequency of anti-resonance of the model, the distribution of  $E(\xi, \eta)$  in the model is the same as that of the longitudinal field component,  $\psi$ , within the guide, at any frequency, for the corresponding mode. The determination of  $E(\xi, \eta)$  can be done by drilling a set of small holes in the grounded plate of the model and inserting a voltage-measuring probe. One can then use the appropriate equations, (3, 4) or (5, 6), to determine the distribution of all fields in the guide. The power-handling capacity can be computed numerically once the distribution of fields is known. The currents in the walls of the guide can be determined from the tangential component of magnetic field intensity, and the attenuation caused by an imperfect conductor can be computed.

The cut-off frequency of the mode can be determined from (3), which, by use of (12), can be written as:

$$\omega_{ac} = \omega_m \frac{l_m}{l_g} \sqrt{\frac{\mu_m \epsilon_m}{\mu_g \epsilon_g}} \quad (13)$$

### EXPERIMENTAL RESULTS

#### Construction of the Model

Equation (13) shows that a conveniently low test frequency can be used if the model is made considerably larger than the waveguide and filled with material that has a small velocity of propagation.

Each model used in this experiment was constructed from two copper sheets separated by a sheet of polystyrene  $\frac{1}{8}$ -inch thick. The three pieces were cemented by brushing the surface of the polystyrene with carbon tetrachloride and then clamping the pieces under pressure until the bond was complete. The resulting composite sheet could be cut to the desired shape on a jig saw. A typical model had a maximum dimension of 20 inches.

The model was driven by an oscillator with a frequency range of 95 mc to 515 mc, an output impedance of 70 ohms, and a maximum power output of the order of one watt. Connection to the edge of the model was made through an  $L$  pad consisting of a 75-ohm shunt resistor and a 680-ohm series resistor. A crystal detector with a millimeter as the indicating instrument was used to detect anti-resonance. Losses in the model were quite small, anti-resonance sharply defined. Measurements of interior electric field intensity were made by inserting a probe through holes 0.102 inch in diameter drilled through the grounded copper sheet. The probe was constructed so that it centered itself in the hole and penetrated to the ungrounded plate.

#### Rectangular Guide

A rectangular model was constructed first in order to check the experimental techniques. Both the anti-resonant frequency and the field pattern were measured for the first several modes, and in all cases these checked quite closely with the theoretical results. Only the anti-resonant frequencies will be presented here, as these indicate the degree of accuracy most concisely.

Table I compares the theoretical and measured anti-resonant frequencies of the model. The cut-off frequencies and the propagation constant for a waveguide of geometrically similar cross section can be found by applying (2), (12), and (13) to these results. The low figure

TABLE I  
ANTI-RESONANT FREQUENCIES FOR A 10-INCH  $\times$  20-INCH  
RECTANGULAR MODEL FILLED WITH POLYSTYRENE

Mode	Theoretical $f_m$ in mc	Experimental $f_m$ in mc
TE <sub>10</sub>	190.5	191
TE <sub>20</sub>	381	381
TE <sub>01</sub>	381	381
TE <sub>11</sub>	426	421
TM <sub>11</sub>	426	413

of 413 mc was due to the slight increase in size of the model when the temporary short-circuiting pieces were placed around the boundary. A recomputation of the theoretical value for the resulting model gave 410 mc.

#### Ridged Guide

An example of the use of the analog is the ridged guide, Fig. 2, of practical interest because the first and second modes are more widely separated than in the rectangular guide.<sup>3</sup> Previous analyses of the ridged guide have been based on the assumption that the principal effect of the ridge is like that of an equivalent capacitance connected across the guide at the points of discontinuity.

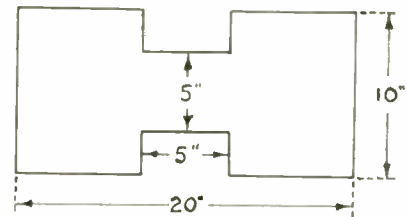

Fig. 2—Model of ridged wave guide.

Fig. 2 shows the dimensions of one model that was tested. Table II gives a comparison of the experimental results with those predicted by Waller's<sup>12</sup> and Cohn's<sup>3</sup> analyses. By the TE<sub>*m**n*</sub> mode of the ridged guide is meant the mode which passes continuously into the TE<sub>*m**n*</sub> rectangular mode as the ridge is reduced toward zero size. The results can, of course, be applied to any guide of geometrically similar cross section.

TABLE II  
COMPARISON OF CUT-OFF FREQUENCIES (MC) FOR THE POLYSTYRENE-  
FILLED RIDGED WAVEGUIDE SHOWN IN FIG. 2, AS PREDICTED  
BY VARIOUS METHODS

Mode	Waller	Cohn	Model
TE <sub>10</sub>	147	155	151
TE <sub>20</sub>	401	419	408
TE <sub>01</sub>	401	—	408
TE <sub>11</sub>	—	—	427

<sup>12</sup> W. E. Waller, "Optimum Geometry for Ridged Waveguide," report included in the Minutes of the Meeting of the Army-Navy R.F. Cable Coordinating Com., Polytechnic Inst. of Brooklyn; Jan. 30, 1948.



# Helix Millimeter-Wave Tube\*

W. V. CHRISTENSEN†, ASSOCIATE, IRE, AND D. A. WATKINS‡, ASSOCIATE, IRE

**Summary**—The experimental results of a program to extend helix backward-wave oscillator techniques to the 4.5- to 6-millimeter range are described. The design of a tube capable of cw output over this range is presented together with operating characteristics. The tube employs a tungsten helix wound with 0.002-inch by 0.005-inch tape with a 0.025-inch inner diameter. The helix voltage is tuned from 2,400 to 850 volts to cover the range, and the cathode current is 4.0 ma. The tube with its all-glass envelope is believed to be a relatively inexpensive millimeter-wave signal source. Power output is estimated to be greater than 1 milliwatt.

## INTRODUCTION

THE EXTENSION of new electronic principles and ideas to higher frequencies is a natural activity of vacuum-tube engineers. When we realized<sup>1</sup> that the tape helix under proper conditions was an excellent circuit for backward-wave oscillators, it became evident that such a tube capable of cw operation in the 4- to 6-millimeter range was an engineering possibility. In such an application, the tape helix has two principal advantages and one disadvantage compared with other circuits. The advantages are (1) ease of construction and (2) large beam-circuit interaction over a relatively large cross-sectional area. Analysis shows<sup>2</sup> that for a given amount of dispersion i.e., rate-of-change of frequency with beam voltage, the product of impedance and useful cross section for the tape helix is more than one-half that of the bifilar (two-tape) helix. It can be shown that the bifilar helix is itself close to a theoretical optimum in this respect.

The principal disadvantage of the tape helix is its inability to dissipate large amounts of power by direct conduction to the outside of the tube envelope. In the work described here, this disadvantage was overcome by supporting the helix so that it could operate at a high temperature and thereby dissipate heat by radiation. The result is a glass tube of relatively simple construction which provides an estimated power of greater than 1 milliwatt over the frequency range 50,000 to 67,000 mc. Tuning is accomplished by changing only the helix voltage. Some of the design features and the experimental results are described in the following sections.

## DESIGN

The constructional details of the tube are shown in Figs. 1 and 2. The tungsten helix is wound with 0.002-inch by 0.005-inch tape on a 0.025-inch inner diameter

with a pitch of 0.0083 inch (120 turns/inch). It is supported in the tube with three quartz knife edges spaced 120 degrees apart and has a length of 1 inch. With this means of support, the effect of the dielectric is negligible. The inside of the helix is "flooded" with electrons from a conventional Pierce gun employing a 0.030-inch diameter Philips dispenser cathode. Output is taken

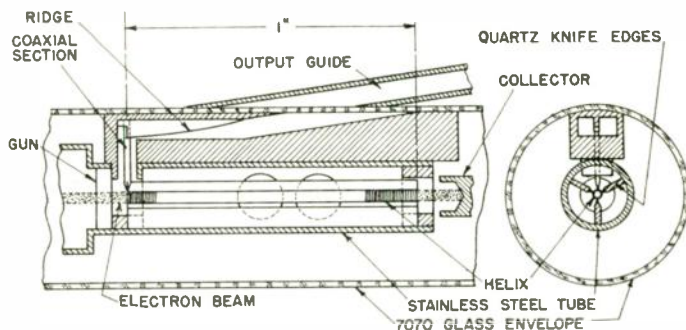

Fig. 1—Constructional details of the millimeter-wave tube. For minimum transmission loss the output waveguide is offset with respect to the internal waveguide as shown.

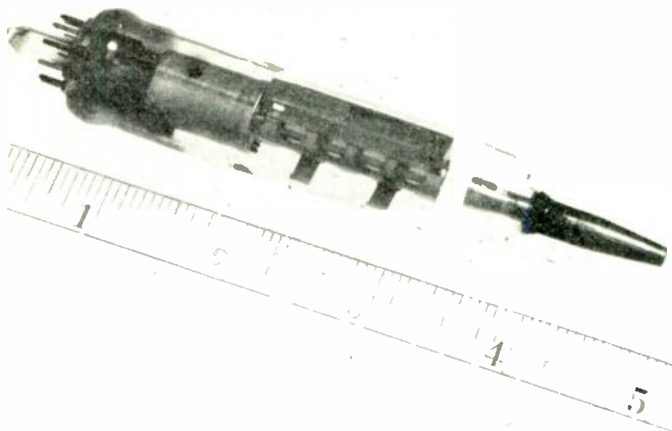

Fig. 2—The 4.5 to 6 mm. helix backward-wave oscillator showing the output section. The collector is at the right end, and the electron gun is at the left. It is necessary to provide magnetic focusing field only between cathode and collector—a distance of about 2 inches.

from the gun end of the helix by means of a transducer to standard 4–6 mm waveguide (RG 98/U). The transducer consists of a transition from helix to 70-ohm coaxial line followed by a coaxial-to-waveguide transition by means of a tapered ridge. The waveguide is then tapered against the glass envelope of the tube in the manner described by Helmke.<sup>3</sup> Outside the glass envelope a second tapered waveguide is placed to complete the transition.

\* Original manuscript received by the IRE, August 23, 1954; revised manuscript received, November 1, 1954.

† Formerly Stanford University, Stanford, Calif.; now Huggins Laboratories, Menlo Park, Calif.

‡ Stanford University, Stanford, Calif.

<sup>1</sup> D. A. Watkins and A. E. Siegman, "Helix impedance measurements using an electron beam," *Jour. Appl. Phys.*, vol. 24, pp. 917–922; July, 1953.

<sup>2</sup> D. A. Watkins and E. A. Ash, "The helix as a backward-wave structure," *Jour. Appl. Phys.*, vol. 25, pp. 782–790; June, 1954.

<sup>3</sup> G. E. Helmke, "A hairpin tube backward-wave oscillator," *Bell Lab. Rec.*, vol. 31, pp. 286–291; August, 1953.

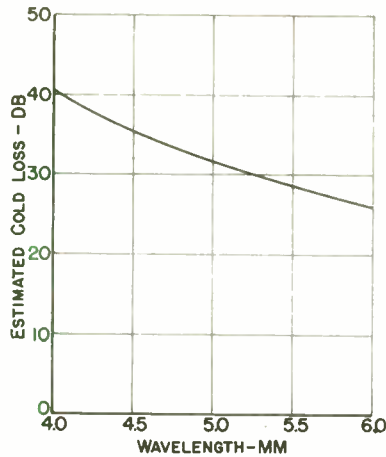

Fig. 3—The estimated cold loss of the helix deduced from measurements on a twenty-times scale model.

The design of the portion of the transition inside the vacuum was checked by constructing a scale model upon which standing-wave measurements were made in the vicinity of 3,000 mc. Voltage-standing-wave ratios were below 4 to 1 over the desired band. The waveguide transition through the glass wall was checked over the 4 to 6 mm band using an earlier version of the backward-wave oscillator and was found to introduce a loss of about 3 db when 0.035-inch thick 7070 glass was employed. The slight offset between the inner and outer waveguides shown in Fig. 1 was found to yield the least transmission loss.

The electrical design of the tube was determined from the one-dimensional theory of backward-wave oscillators,<sup>4</sup> together with the theory concerning the backward-wave impedance of tape helices.<sup>2</sup> In calculating the starting current of the tube it was found that space-charge effects were completely negligible because of the high operating frequency. Helix loss was important, however, and increased the starting current to about five times that expected for a theoretically lossless helix. The actual cold loss of the helix employed in the millimeter-wave tube was not measured but was deduced from measurements made on a twenty-times scale model at one-twentieth the operating frequency. The loss of the scale model was multiplied by the square root of the frequency ratio to account for the reduction in skin depth associated with the higher frequency. The loss of the helix deduced by this method is shown in Fig. 3, and the calculated and measured starting currents are shown in Fig. 4. These data were obtained under pulsed rather than cw conditions so that the increase in loss due to helix heating was not present. The remarkable agreement between measured and theoretical values is thought to be coincidental rather than significant. It is thought that the error involved in the estimate of the loss compensates for the error resulting from the spiral paths of the electrons in the magnetic focusing field,

<sup>4</sup> H. Heffner, "Analysis of the backward-wave traveling-wave tube," *Proc. I.R.E.*, vol. 42, pp. 930-937; June, 1954.

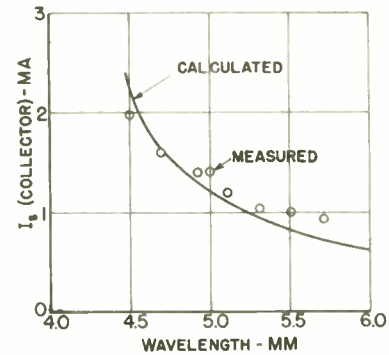

Fig. 4—The calculated and measured starting current for the tube. The calculated curve is based upon the loss curve of Fig. 3. The excellent agreement is thought to be coincidental.

whose effect is not taken into account in the calculation. A sample calculation of starting current is given in the Appendix.

#### EXPERIMENTAL RESULTS

The tube, together with the crystal detector that was used to measure its output, is shown in Fig. 5. The detected output of the tube vs wavelength taken with an oscilloscope is shown in Fig. 6, on the facing page. The following conditions apply:

Cathode current	4.0 ma
Helix current (average)	2.0 ma
Collector current (average)	1.9 ma
Magnetic Focusing Field	2,080 gauss.

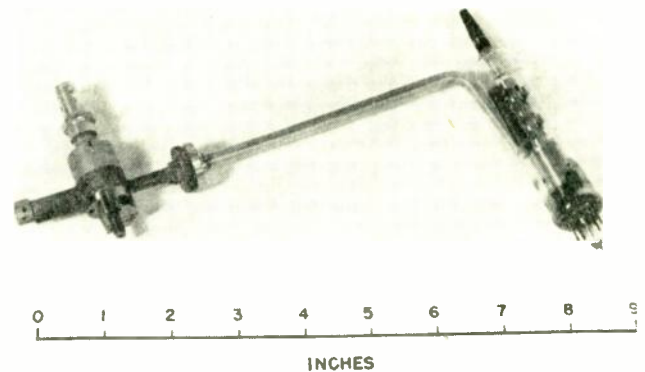

Fig. 5—The millimeter-wave tube together with the crystal detector used to measure its output. The output waveguide is shown in its proper position.

The power output is estimated to be from 1 to 10 milliwatts based on probable crystal efficiency and observed rectified output. The tuning curve for the oscillator is shown in Fig. 7 (facing page). The variation of the power output as a function of wavelength (see Fig. 6) is believed to be due to a combination of the following factors: (1) variation in crystal sensitivity, (2) impedance mismatches at the tube output, (3) small nonuniformities in the helix pitch and (4) variation in the electron trajectories as the helix voltage is varied. No attempt was made to compensate for the lens effects between the gun



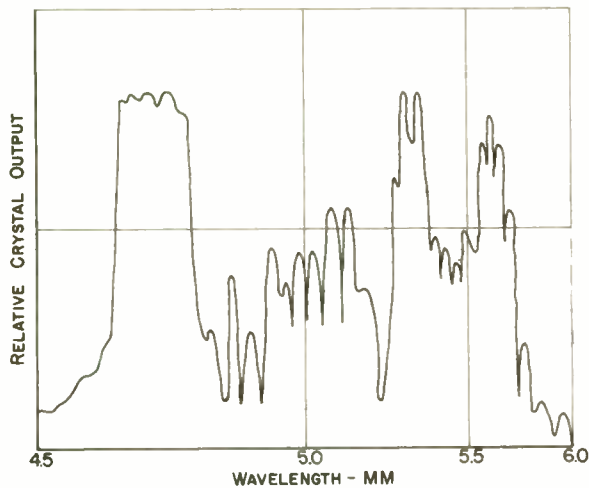

Fig. 6—Crystal output vs wavelength. The output is seen to be a continuous function of wavelength from 4.5 to 6.0 mm. Although actual power was not measured, the output is estimated to be between 1 and 10 milliwatts.

anode and the helix entrance, although improved performance should result if the design procedure outlined by Pierce<sup>5</sup> were followed.

Under the operating conditions described above, the helix is required to radiate up to 4.8 watts. A simple calculation shows that under this condition, the helix temperature will be about 1,300 degrees C. At this temperature, the tungsten helix will be expected to have a long life. There is no danger of melting the quartz knife edges since quartz melts at about 1,700 degrees C. The cathode current density is about 0.9 amps/cm<sup>2</sup> so that the Philips cathode is required.

The tube was tested in both a solenoidal electromagnet and a horseshoe-type electromagnet with identical results. A flux density of about 2,000 gauss is required over a length of about 2 inches. It is thought that such a field could be provided with a permanent horseshoe magnet although this was not tried.

#### CONCLUSION

The success achieved in the generation of millimeter wavelengths by means of the helix backward-wave oscillator described here suggests that some further extension of the technique is possible in the direction of higher frequency but with reduced power. The cw power output of the present design is limited by helix dissipation since higher cathode current densities can be obtained from dispenser cathodes. Thus a higher power output is probably not possible with the present technique at this frequency or higher. In attempting to produce higher frequencies without regard to power output, there will be a point at which, for a given beam-current density and beam voltage, the tube will never oscillate no matter how long the circuit is made. This is partly the result of the increase of skin-effect loss with frequency and partly the result of the reduction in beam

<sup>5</sup> J. R. Pierce, "A gun for starting electrons straight in a magnetic field," *Bell Sys. Tech. Jour.*, vol. 30, pp. 825-829; October, 1951.

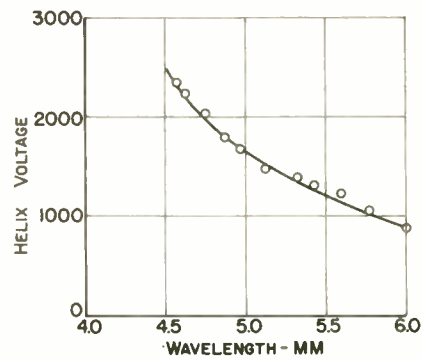

Fig. 7—Curve showing the helix voltage required to produce oscillation at a given wavelength. The scattering of the experimental points is due to inaccuracies in the measurement of wavelength. The true tuning curve is believed to be smooth as shown.

current due to the decrease in cross section. An extension of the theory<sup>4</sup> shows that the starting length goes to infinity as  $d$ , the loss parameter, approaches roughly 2.3. This limit would be reached with a tungsten helix at about 2.4 mm wavelength with the current density and beam voltage employed here.

#### APPENDIX

The start-oscillation condition for a backward-wave oscillator is a function of the circuit loss and space-charge.<sup>4</sup> As an example, we will calculate the starting current at 5 mm upon the assumption that the effect of space charge is negligible and then show that this assumption is justified.

At 5 mm the pertinent parameters are

$$\text{Beam voltage} = V_0 = 1680 \text{ volts}$$

$$\text{Circuit loss} = 31.5 \text{ db}$$

$$\text{Helix circumference to free space wavelength ratio} = ka = 0.43$$

$$\text{Length of circuit in electronic wavelengths} = N = 62.8$$

According to Fig. 8 in H. Heffner's article,<sup>4</sup>

$$(CN)_{\text{start}} = 0.55 \quad (1)$$

where

$$C^3 = \frac{I_a K}{4V_0} \quad (2)$$

then

$$\frac{I_a K}{4V_0} = \left(\frac{0.55}{N}\right)^3 \quad (3)$$

or

$$I_a = \frac{0.666V_0}{KN^3} \quad (4)$$

The calculation of the effective impedance,  $K$ , is carried out through the use of curves in Watkins' and Ash's article.<sup>2</sup> This is done by assuming that the beam fills the helix and that only that portion of the beam within a distance,  $\Delta$  of the helix is effective with  $\Delta/a$

= 0.5. Under these conditions the hollow-beam curves in the above-mentioned article<sup>2</sup> are applicable.

According to Fig. 6,<sup>2</sup>

$$K_{-1} = 20 \text{ ohms.}$$

For  $V_0 = 1680$  volts,  $\lambda_0 = 5$  mm, and  $2a = .027$  inch

$$\gamma a = 5.3.$$

For

$$\frac{r_0}{a} = 0.75$$

$$R_m = 0.096$$

according to Fig. 8,<sup>2</sup>

For

$$\gamma \Delta = 2.65$$

$$R_{mc} = 2.6$$

according to Fig. 9,<sup>2</sup>

Then

$$\begin{aligned} K &= K_{-1} R_m R_{mc} \\ &= 20 (0.096) 2.6 = 4.99 \text{ ohms} \end{aligned}$$

Inserting the calculated values in (4) the effective starting current is

$$I_s \Big|_{\text{eff}} = \frac{.666(1680)}{4.99(62.8)^3} = 0.9 \text{ ma.}$$

The total beam current including the ineffective center core is four-thirds of this or

$$I_s = 1.2 \text{ ma.}$$

In Fig. 4 this is compared with the measured collector current at start oscillation on the assumption that the current intercepted by the helix is intercepted near the helix entrance and is therefore totally ineffective.

The space charge parameter,  $H$ , is given by Heffner<sup>4</sup> as

$$H = \frac{\omega_p}{\omega} 2\pi N = \frac{\omega_p L}{u_0}, \quad (5)$$

where

$$\omega_p = \left( \frac{e\rho_0}{m\epsilon_0} \right)^{1/2}. \quad (6)$$

For a beam current of 1.2 ma, a beam diameter of 0.025 inch and a voltage of 1680 volts,

$$H = 1.8,$$

which will have a negligible effect on the starting conditions according to Fig. 4 in Heffner's work.<sup>4</sup> This corresponds to a  $QC$  of 0.066.

#### ACKNOWLEDGMENT

The authors are indebted to R. F. Stewart of Soquel, Calif., for his skill and dexterity which made these tubes possible and to E. Gelin of this laboratory for winding the helices. All of the assembly and most of the fabrication of parts was done by Mr. Stewart. The work was supported jointly by the Air Force, Army, and Navy.





# Correspondence

## A New System of Logarithmic Units\*

An Indian, when asked, "What do you call your horse?" replied, "No call'em, use'm all the time." For a long while that was much the attitude of the calculator toward his logarithms. It may work all right when there is only one horse involved, but the number of specialized logarithms in use has been steadily increasing, and a demand has arisen for a convenient and systematic way of distinguishing them and expressing their magnitudes. Various units, such as the octave and the decibel, have already come into use, each in connection with a particular physical quantity and each having its own magnitude and name. Each, in its own field, satisfies the requirement of convenience. In fact it is this very convenience that has led to confusion, through the use of a unit in a field to which it does not apply, because no convenient unit is available in the second field. This is where the demand for a systematic treatment enters.

Such a treatment has been proposed in the form of a family of units, all of which have a common surname which indicates that they are logarithms of the same particular magnitude. Each has its own given name, which identifies the kind of quantity with which it is used. Each of the existing units may then be thought of as having a given name only. The diversity of their magnitudes places them in separate families, each of which is related to the proposed one, in this case quantitatively, through their relative magnitudes. One of them turns out to be a member of the new family.

Before attempting to trace these inter-family relationships, it is well to have in mind what considerations enter into the choice of a unit of logarithm. One of these is convenience in computations. This is generally most fully satisfied when the base used is ten. In connection with certain problems associated with the solutions of differential equations, such as those of wave motion, the Napierian base,  $e$ , is found preferable. This suggests the desirability of choosing the unit in such a way as to leave the user free to choose that base which best fits his immediate needs.

Other considerations arise out of the use of logarithms which are specially related to particular physical quantities. The octave, which measures the logarithm of the frequency of a musical note, has the unique property that any two notes whose logarithms differ by one octave are in consonance with each other. This is one example of a group of quantities which are involved in sensory phenomena, for which equal steps of the logarithm correspond to equal sensory changes. The decibel was so chosen as to be approximately the equivalent of the "mile of standard cable" at 800 cycles. Whatever the considerations that may make use of the logarithm of a quantity significant, they are likely also to suggest a convenient size for the unit.

How then is the unit to be defined to meet both these needs? The solution lies in

the concept of primary and secondary units. If we choose an arbitrary base,  $a$ , the logarithm of any number  $x$  will have a particular numerical value given by  $\log_a x$ . If we regard this as the ratio of it to the unit logarithm, the magnitude of the latter must be unity and so the unit logarithm is  $\log_a a$ . This is a primary unit for this system, just as the meter bar is a primary unit in a system in which the length of the meter bar is unity. We may, however, express a length in terms of a secondary unit such as the foot. While this may be a primary unit, and have magnitude unity in a system based on a standard foot, in the metric system it has a magnitude equal to the ratio of the lengths of the foot and meter bars. To arrive at a secondary unit for logarithms to the base  $a$ , we choose an arbitrary number  $r$  and take  $\log_a r$  as the secondary unit. Its magnitude is then:

$$\frac{\log_a r}{\log_a a} = \log_a r.$$

Its magnitude is, of course, unity in a system of logarithms to the base  $r$ , where it is a primary unit.

If now we express  $\log_a x$  in terms of this secondary unit, the number of units will be:

$$N = \frac{\log_a x}{\log_a r} = \log_r x,$$

which is independent of  $a$ , and depends only on  $x$  and the number chosen to determine the secondary unit. Hence, if we choose as our unit a secondary unit of this type, we accomplish both purposes. We leave the base optional, and at the same time insure that a change of one unit in the logarithm corresponds to the number being changed in an arbitrarily chosen ratio.

Returning then to the interrelation of the units, the family to which a particular unit belongs is determined by the value of  $r$  which defines it. Once a number has been selected for this purpose it may be thought of as a standard number and its logarithm as one which has been standardized as a unit.

The proposed family of units may be described by saying that the standard number which determines their common magnitude is  $10^{0.1}$  and so the magnitude of the unit in any system of logarithms to the arbitrary base,  $a$ , is  $\log_a 10^{0.1}$ . The number of units corresponding to a number  $x$  is  $10 \log_{10} x$ . Since no family name has been agreed upon as yet, I shall try to avoid prejudicing this choice by using here the accurately descriptive but entirely impractical designation ( $\log 10^{0.1}$ ).

While  $x$  has been referred to so far merely as a number, in most practical cases it is associated with particular quantities which may or may not have physical dimensions. It may be the ratio of any two values of the quantity and so represents their relative magnitude. It may be the ratio of one value of the quantity to another which has been chosen as a reference value, and may be a primary or secondary unit of the quantity. It then represents the numerical part of the

absolute value of the quantity expressed in terms of the reference value. The absolute value of the quantity is then  $x$  times the reference quantity, which may be represented formally by the indicated product of its magnitude and its dimension. We may think of the logarithm of the absolute value of the first quantity as being the sum of  $\log x$  and the logarithm of the reference quantity which, in turn, is formally the sum of the logarithm of its numerical magnitude and the indicated logarithm of its dimension. Thus, in terms of the meter as the primary unit of length, the logarithm of a length of 5 km would be  $\log 5 + 1,000 + \log L$ .

In using the proposed unit of logarithm, it is desirable to be able to indicate the quantity with which  $x$  is associated and the nature of the relationship. In the case of the decibel, as originally defined, the name itself specified that the quantity is power. When used alone,  $x$  is understood to represent merely relative magnitude. Where a reference power is involved, such as one milliwatt, it is indicated by saying decibels relative to one milliwatt, and the unit is written as dbm. This method is redundant in that the nature of the quantity, power, is indicated by the name of the unit of logarithm and again by that of the unit of the quantity.

This suggests that, in assigning first names to the proposed units, both the nature of the quantity and the relationship will be adequately specified if we take the name of the quantity where  $x$  is a relative magnitude and that of the reference value or unit when it is the numerical part of the absolute magnitude as expressed in terms of the reference. A "length ( $\log 10^{0.1}$ )" would then be the logarithm of the ratio of two lengths and a "centimeter ( $\log 10^{0.1}$ )" would be the logarithm of an absolute length expressed in centimeters. The absolute value of a length of 5 cm could be expressed in terms of the meter as a primary unit as  $(10 \log 5 - 20)$  meter ( $\log 10^{0.1}$ ). The dimension length is here contained in the term, "meter," and its logarithm need be introduced only for purposes of dimensional analysis. Logarithms of dimensions then add just as they multiply in the ordinary analysis.

Let us see now how the new family fits into the clan of existing units. Here the patriarch is the stellar magnitude which, in its less precise form, goes back to Ptolemy. It is a unit for measuring the logarithm of the absolute value of the apparent brightness of a star. It belongs to the family for which  $r$  is  $100^{0.2}$  and so its magnitude is 4 ( $\log 10^{0.1}$ ). The reference brightness was so chosen as to make a stellar magnitude of one correspond to the average brightness of a chosen group of "first magnitude stars." The decibel, as originally defined, and the dbm, being respectively a power ( $\log 10^{0.1}$ ) and a milliwatt ( $\log 10^{0.1}$ ), are members of the new family. The bel belongs to the closely related family for which  $r$  is 10, and so might be regarded as a cousin. In the family for which  $r$  is 2 are the brothers, the octave and the bit. If we gave these the surname ( $\log 2$ ), the octave would be a frequency ( $\log 2$ ), the bit a possibility ( $\log 2$ ).

\* Received by the IRE, July 14, 1954.

The so-called "voltage db" and similar units, for which the associated quantity varies as the square root of a power in some cases but not in others, call for special attention. The use of the term, decibel, in connection with a quantity other than power is a violation of the original definition of the decibel. It has, however, become so general that it may have to be lived with, at least in the foreseeable future. Regarded as a unit of logarithm of voltage ratio, this unit belongs in the family for which  $r$  is  $10^{0.05}$ . Considered as a secondary unit in the family for which  $r$  is  $10^{0.1}$ , its magnitude is one half. One so-called "voltage db" is therefore equal to one half of a voltage ( $\log 10^{0.1}$ ). In those cases where the power does not vary as the square of the voltage, there is no definite relation between the number of true db, or power ( $\log 10^{0.1}$ ) and the number of so-called "voltage db." In those where it does, a change of one so-called "voltage db" corresponds to a change of one true db or one power ( $\log 10^{0.1}$ ). A change of one voltage ( $\log 10^{0.1}$ ) corresponds to a change of 2 true db.

Having gone to the trouble of setting up this new family of units, one may well ask what they can be used for. A partial answer is to be found in the list of quantities for the measurement of the logarithm of which the decibel has been used or proposed. Those of the general type of a voltage, as discussed above, include the voltage or current gain of an amplifier, the voltage level along a system, the step-up of a transformer, the standing wave ratio of a waveguide, and the loop gain of a servo system. The list also includes quantities which have no relation to power, such as frequency, time, and impedance. An interesting combination of the two types occurs in the design of servos, where the relation between alternating voltage across a capacitance and frequency is expressed as approximately 6 db per octave. If the logarithms of voltage and frequency were expressed in voltage and frequency units of the same family, the relation would be exactly one per one.

The logarithms of the ratios of other specific quantities have been used without assigning names to their units. In photography the density of a film is the logarithm of the reciprocal of the transparency. The logarithm of the exposure is widely used and referred to as  $\log E$ . The logarithm of the photometric magnitude is a familiar but unnamed logarithm. Any of these could be expressed in the proposed unit.

More generally, wherever the significantly different values of a variable form a geometrical rather than arithmetic progression, its logarithm provides a convenient description of its behavior and a corresponding unit of logarithm can be used to advantage. One such case is the estimation of the best curve to represent a set of experimental data. This can sometimes be done better by insuring an even distribution of the errors with respect to the values of the logarithm of the variable than to those of the variable itself.

As stated above, no name has been agreed upon for ( $\log 10^{0.1}$ ). The two which have received most favorable consideration are "logit" abbreviated lgt, and "decilog," dg. There have also been proposed "brigg," bg, "decibrigg," dg, "ralog," rg, and "decomlog," dl. From the purely theoretical

viewpoint there are certain objections which apply more or less to all of these. Since the proposed units form only one of the possible families, and it may be desirable in the future to assign a name to some other family, it does not seem wise to appropriate the whole general connotation of a unit of logarithm for this particular family. This would apply most directly to "logit" and "ralog" which suggest nothing as to size. The terms "brigg," "decibrigg," and "decomlog," while they have some quantitative connotation, convey the impression that it is the size of the logarithmic base that determines the unit. While the term "decilog" may suggest that the unit is a tenth of a logarithm, it gives no idea of the size of that logarithm, unless log is taken to be associated with the base ten, which the unit is not. What is wanted is a name which suggests both the logarithmic nature of the unit and the standard number of which it is the logarithm. I have not been able to find one. And if one were found it would have to meet those practical requirements which are finally controlling.

Another theoretical objection may or may not be worth considering. The standard number which determines the unit, being irrational, cannot be stated exactly. This condition could be avoided by doing what was done in the case of the bel. Ten would be taken as the standard number, and "log," or some more quantitatively descriptive term, as the family name of the unit. The proposed unit would then be a secondary unit called a "decilog."

R. V. L. HARTLEY  
174 Summit Ave.  
Summit, N. J.

### Comment on "Networks Terminated in Resistance at Both Input and Output,"\* L. Weinberg<sup>1</sup>

In two previous papers,<sup>2,3</sup> methods for realizing a lattice were presented. Since it was not shown in those papers how to obtain a resistance termination (or a resistance-capacitance termination) at both input and output, these network configurations often proving desirable, the present note is being written. Here the final steps of a method will be given for achieving in the desired form any transfer function—admittance, impedance, or voltage ratio—that is physically realizable as a network with a resistance at input and output.<sup>1</sup>

Consider the open-circuited lattice realized by previous procedure.<sup>2</sup> It can easily be shown<sup>1</sup> that the real part of each of the lattice arm admittances will have one or more positive nonzero minima; we determine the smallest minimum of each admittance and denote the two minima respectively by  $G_a$  and  $G_b$ . It is then possible to obtain an equivalent lattice<sup>3</sup> by removing from each of the arms a conductance of value  $G$  that is less than the smaller of  $G_a$  and  $G_b$ , and placing it

in parallel with the input and output terminals of the lattice. This transformation yields the desired resistance terminations for a transfer impedance; to obtain a transfer admittance or a transfer voltage ratio requires merely an application of Thevenin's theorem to the input.

To realize the remainder of the lattice arms, that is, the admittances  $Y_a'$  and  $Y_b'$ , where

$$\begin{aligned} Y_a' &= Y_a - G_a \\ Y_b' &= Y_b - G_b, \end{aligned} \quad (1)$$

we may use the Bott-Duffin procedure.<sup>4</sup> This yields arms containing pure inductances but no mutual inductance. However, if we desire that every inductance possess an associated series resistance, we make use of the technique of predistortion described by Darlington.<sup>5</sup>

Predistortion requires that for each arm admittance we first determine the equation of the curve in the left half of the complex plane that represents the locus on which the admittance has a zero real part. For example, working with the series arm,

$$\begin{aligned} Y_1 &= Y_a' + (G_a - G) \\ &= \frac{u_1(\sigma, \omega) + jv_1(\sigma, \omega)}{u_2(\sigma, \omega) + jv_2(\sigma, \omega)} \end{aligned} \quad (2)$$

we obtain the curve

$$\begin{aligned} \text{Re}[Y_1] &= u_1u_2 + v_1v_2 = 0 \\ &= f(\sigma, \omega) = 0. \end{aligned} \quad (3)$$

Considering  $\sigma$  as an implicit function of  $\omega$  given by  $f(\sigma, \omega)$  and evaluating the derivative

$$\frac{d\sigma}{d\omega} = - \frac{\frac{\partial f}{\partial \omega}}{\frac{\partial f}{\partial \sigma}}, \quad (4)$$

we find the smallest minimum value of  $\sigma$ , that is, the point at which the curve is closest to the  $j$ -axis. To each of the zeros and poles of  $Y_1$  we may now add a positive constant, which is chosen less than or equal to this minimum distance, without destroying the positive real quality of  $Y_1$ . Then after realization of the arm by the Bott-Duffin procedure, the network obtained is corrected for the predistortion.

If the function is physically realizable with a capacitance at input and output, that is, it is a proper fraction, shunt capacitances may be removed from the arm admittances in the same manner as the shunt conductances. Thus, in this case a network with no mutual or pure inductances, and a resistance-capacitance termination at input and output, is obtained.

The second procedure<sup>3</sup> may be modified in a similar way.

L. WEINBERG  
Hughes Res. and Dev. Labs.  
Radar Division  
Culver City, Calif.

\* Received by the IRE, October 12, 1954.

<sup>1</sup> Convention Record of the IRE, part 2, pp. 90-95; 1954.

<sup>2</sup> L. Weinberg, "RLC lattice networks," *Proc. I.R.E.*, vol. 41, pp. 1139-1144; September, 1953.

<sup>3</sup> L. Weinberg, "A general RLC synthesis procedure," *Proc. I.R.E.*, vol. 42, pp. 427-437; February, 1954.

<sup>4</sup> R. Bott and R. J. Duffin, "Impedance synthesis without use of transformers," *Jour. Appl. Phys.*, vol. 20, p. 816; August, 1949.

<sup>5</sup> S. Darlington, "Synthesis of reactance four-poles," *Jour. Math. Phys.*, pp. 257-353; September, 1939.



### A New Self-Excited Square-Wave Transistor Power Oscillator\*

In early January of 1954, the Power Sources Branch of the Signal Corps Engineering Laboratories at Fort Monmouth, N. J., developed a new, simple, self-excited square-wave transistor power oscillator. Investigations carried on since then have shown that this circuit may attain considerable practical importance.

The basic circuit diagram (Fig. 1), employs a pair of power transistors in push-pull grounded base (and for some transistors also grounded emitter) arrangement, in connection with a transformer consisting of a center-tapped primary, center-tapped feedback and output winding, and a single dc source. No other components, such as tank circuits, or emitter bias supplies, are needed.

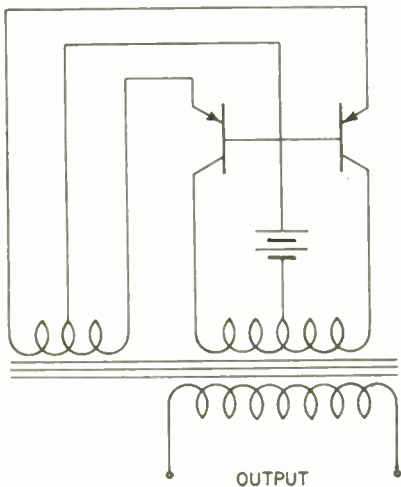

Fig. 1—Basic circuit of self-excited transistor power oscillator.

The generation of the square-wave oscillation, according to results of investigations, may be explained in general as follows: Any initial disturbance in the circuit starts an RL transient effect in one direction, due to the unavoidable unsymmetry in the circuit. The feedback arrangement is such that it continues and magnifies this effect upon one transistor, thus reducing the transistor collector resistance rapidly to a value close to zero and producing almost the full battery voltage at the transformer primary. The other transistor, for which the feedback is negative, is cut off during this time. The maintaining of the constant value of primary voltage  $e$  necessitates a constant flux change  $d\phi/dt$  according to the relation:

$$e = -N d\phi/dt = \text{Constant}$$

( $N$  = number of primary turns)

and an increase in flux according to:

$$\phi = Kt \quad (K = \text{another constant}).$$

This flux requirement can be satisfied only until saturation in the magnetic material of the transformer is reached, or until the current in the circuit reaches a limit. At this point the transformer voltage falls to zero (which means also in the feedback winding). This cuts off the current flow in the circuit. The magnetic field then collapses and produces a voltage in the opposite direction,

\* Received by the IRE, September 30, 1954.

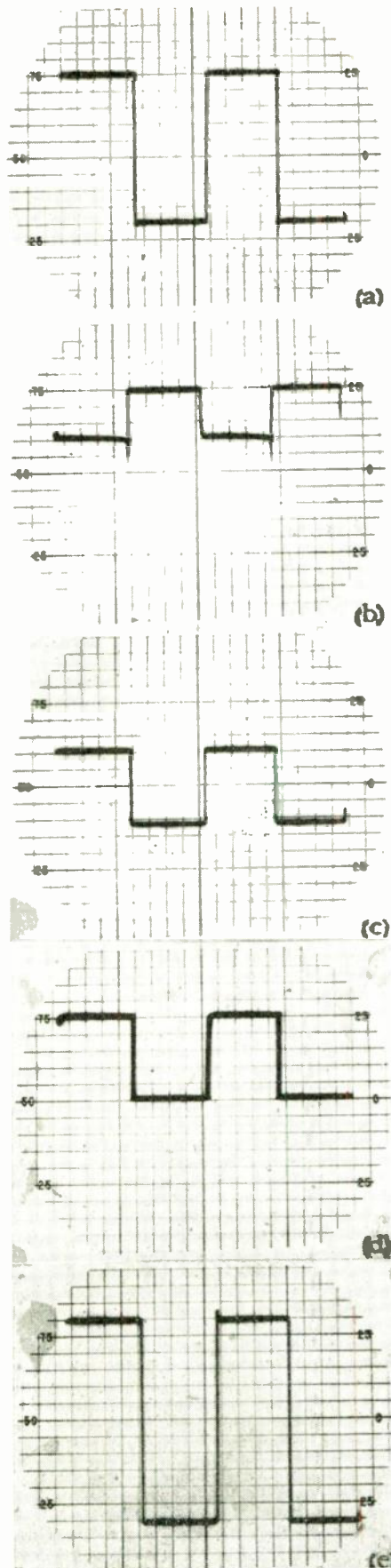

Fig. 2—Oscillograms of circuit operation. (a) Voltage from collector to base, zero at 75. (b) Current from collector to base, zero at 75. (c) Voltage from emitter to base, zero at 50. (d) Current from emitter to base, zero at 50. (e) Output voltage of transformer, zero at 50.

triggering the other transistor into operation and thereby repeating the above process and leading to sustained oscillations.

Oscillograms of circuit operation, which substantiate explanation given, are shown in Fig. 2, where (a) and (b) depict voltage and current curves from collector to base, (c) and (d) depict voltage and current curves from emitter to base, and (e) depicts the output voltage curve of transformer.

Frequency of operation has been attained, which covers the range from approximately 15 to 8,000 cps while maintaining good efficiency. The range was extended to 20 kc, with a falling off in efficiency.

The frequency of oscillation is mainly dependent upon the magnetic characteristics of transformer and the applied dc voltage.

An example of practical application of circuit is stated, whereby maximum power output for a pair of one type of power transistors, arranged in grounded base connection, was 19.1 watts with a voltage input of 44.0 volts. The over-all efficiency was 68 per cent, at a frequency of 300 cps. Further improvements in transformer design and use of more efficient transistors resulted in over-all efficiencies up to 87 per cent, with indications what higher values may be obtained.

Simplicity of circuit, and obtaining of square-wave mode of operation, is ideal for power conversion circuits which convert from low voltage dc to high voltage dc.

Operation with square-wave oscillations leads to very high collector efficiencies, being in the order of 97 per cent. Under these conditions transistors can be used for very much higher power outputs than indicated by their normal rating. Depending upon the power amplification factor which determines the necessary driving power obtained from the feedback winding, the emitter dissipation may then represent the limiting factor rather than the collector dissipation.

In Fig. 3, a demonstration model of a dc power transistor supply is shown which is capable of delivering 10 watts at 1,000 volts, with an input supply of 45 volts.

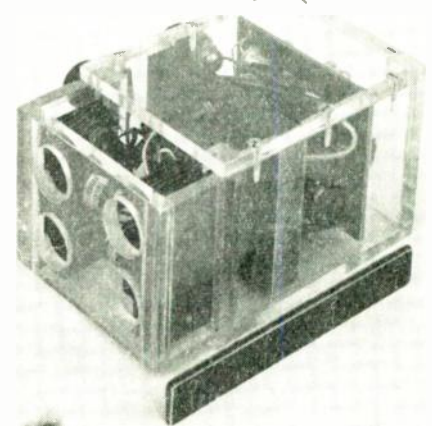

Fig. 3—10-watt, 1,000-volt, dc power transistor supply.

It is intended to reveal complete details in a paper to be presented later.

GEORGE C. UCHIRIN and  
WILFRED O. TAYLOR  
Signal Corps Engrg. Labs.  
Fort Monmouth, N. J.

### Comment on "NTSC Signal Specifications for Color Television"\*

D. G. Fink<sup>1</sup> has called attention to an ambiguity in the NTSC color television specifications, as published in the PROCEEDINGS OF THE I.R.E.<sup>2</sup> The official color television signal specifications released by the FCC imply that CIE Illuminant *C* refers to reference white on the receiver display. The specifications published did not indicate whether CIE Illuminant *C* refers to reference white of the studio scene or to reference white of the receiver display. The term "reference white" is not defined in either version.

The concept of "reference white," and the choice of CIE source *C* by NTSC Panel 13 (Color Video Standards), may be familiar to many television engineers. However, we feel the concept and choice of reference white are matters of importance to be brought to the attention of the industry at large.

One important point for consideration is the basic philosophy underlying the color television specifications. From the minutes of the first meeting of NTSC Panel 13 (June, 1951)—"It is the consensus of the panel that: (1) The end result of broadcasting is the reproduced picture. (2) The information describing this picture is completely contained with the radiated signal and the broadcast standards. (3) Hence, the transmission standards for the radiated signal should define the relationship between the electrical signal broadcast and the picture which the broadcaster intends to produce, rather than, necessarily, the scene before the camera."

This underlying philosophy must be borne in mind when studying the FCC color television specifications. The FCC is empowered to monitor the *radiated* signal. The FCC specifications provide equations indicating the composition of the radiated color picture signal. The FCC specifications have a direct and fundamental relationship to color television receiver design. Any color television receiver manufactured with the assumption that the color picture signal has the composition indicated in the FCC specifications can get, in principle, a satisfactory picture from any color telecast in the United States. This is not to say (as we understand it) that all color telecasters form their signals by the same specific routine; but rather that once formed and transmitted, the signal is capable of interpretation by any color television receiver as if it had the composition stated in the FCC specifications.

A second consideration is the definition and choice of the reference white used in the FCC specifications. The term "reference white level of the luminance signal" is defined in the FCC specifications; however, the term "reference white" is not defined. The following are three aspects of a satisfactory definition for reference white as it refers to the studio, to the radiated signal, and to the receiver display. We believe that these three partial definitions are mutually consistent and consistent with the FCC specifications:

1. The reference white of a scene in a color television *studio* may be defined as that color which it is intended be reproduced as white on a color television receiver. In practice, the reference white of the scene in the color television studio may be represented by a nonselective neutral, reflecting object, with 60 per cent to 80 per cent reflectance relative to fresh magnesium oxide.
2. The *radiated signal* corresponding to reference white may be defined as the signal condition in which the chrominance subcarrier vanishes and the luminance signal is at the level corresponding to its specified maximum excursion in the white direction.
3. The reference white on a color television *receiver display* may be defined as that color which is produced when the received luminance signal is at maximum white level and the chrominance subcarrier vanishes. For a receiver adjusted according to FCC specifications the color of the display is a (visual) metameric match to CIE source *C*.

In order to put numerical values in the FCC specifications it was necessary to be specific about the chrominance of reference white as reproduced on the receiver. The choice of CIE source *C* for the reference white on the receiver was apparently made in the fourth meeting of NTSC Panel 13 (September, 1951). According to the minutes of that meeting, data presented at the meeting had been based on the color subcarrier vanishing on equal-energy-white.

"Discussion of this last point brought out the opinion that the color temperature of monochrome scenes should be more nearly equal to that of present day monochrome cathode ray tubes. The result of this discussion was the adoption of the following two motions: *Motion 1*—The chromaticity for which the subcarrier shall vanish is  $x = 0.310$ ,  $y = 0.316$  which corresponds to illuminant *C*. *Motion 2*—The composition of the signal on the color subcarrier shall be such that the red and blue color difference signals, for Panel 7 primaries, can be regained directly by demodulation by two carriers in quadrature, and the relative amplitude of the two-color difference signals be such that overloads of the order of  $\frac{1}{3}$  occur for the colors corresponding to the Panel 7 primaries or their complements at maximum intensity."

Apparently the choice of CIE source *C* for the reproduced white point of the color television system reflects the experience of American manufacturers of monochrome picture tubes.

The theoretical problem of exact, objective, colorimetric reproduction has been solved only for a noiseless system in which the illuminant of the scene matches the reference white of the display device. Furthermore, the display device must be capable of reproducing the entire color space of the original scene. Exact colorimetric reproduction is not practicable, and, fortunately, is not necessary in order to produce a *pleasing* picture on the color television receiver. In fact, color adaptation of the observer viewing a receiver would probably require that the most pleasing reproduction differ from an exact colorimetric reproduction, even if the latter were possible.

It is important to point out that the FCC specifications do not require that CIE source *C* be used in the studio; nor do they require that the encoding operation and the gamma-correcting operation in the color television studio be exactly as prescribed in the FCC specifications. Rather, the FCC specifications require that the radiated signal shall be composed in such a way that it can be handled in a color television receiver, which assumes its composition to be as stated in the specifications. In practice, the color television studio will use whatever light source is most convenient. Spectral sensitivities of the color television camera will be as near to theoretical requirements as can be practically met. The color television camera outputs ( $E_R$ ,  $E_G$ , and  $E_B$ ) will be adjusted to equality for nonselective, neutral objects in the studio scene. Gamma correction, matrixing, and encoding of the color television signal for telecast will be such as to optimize color reproduction on a receiver, which follows the assumptions presented in the FCC specifications. The manner of handling the video signal in the studio must be based upon consideration of the color space limitations of presently available receivers, and will change with advancement of the receiver art.

W. L. BREWER and  
J. H. LADD  
Color Tech. Div.  
Eastman Kodak Co.  
Rochester 4, N. Y.

### Ferrite Attenuators in Helices\*

The ideal attenuator for a traveling-wave tube would be one which attenuates only the reflected wave and does not influence the forward wave. Usually, lossy sections consist of a coating of lossy material, such as graphite or evaporated metal, in the electromagnetic field. This produces bidirectional attenuation. It is known that ferrites, when immersed in the proper magnitude of dc magnetic field, will absorb energy from an electromagnetic wave passing through the ferrite. If the magnetic vector of the electromagnetic wave in the ferrite is circularly polarized, then absorption will be unidirectional.<sup>1</sup> Now it turns out that, in the case of the helix, the magnetic components of electromagnetic field are elliptically polarized so that one would expect to observe directional attenuation with a ferrite attenuator.

That the magnetic vector of the electromagnetic field of a helix is, in general, elliptically polarized can be seen from inspection of the field solution of the "current sheath" model.<sup>2</sup> Using Pierce's notation, Table I shows the ratios of the various magnetic field components. Several conclusions can be drawn from this table. Projections of the magnetic vector on the  $r-\phi$  and  $r-z$  planes show elliptical polarization. The direction of rotation reverses in going from inside to outside of the helix. For this free-space model,

\* Received by the IRE, July 23, 1954.

<sup>1</sup> M. L. Kales, H. N. Chait, and N. G. Sakiotis, "A nonreciprocal microwave component," *Jour. Appl. Phys.*, vol. 24, p. 816; 1953.

<sup>2</sup> J. R. Pierce, "Traveling-Wave Tubes," D. Van Nostrand Company, New York, N. Y., p. 231; 1950.

\* Received by the IRE, September 9, 1954.  
<sup>1</sup> D. G. Fink, "NTSC signal specifications for color television," *Proc. I.R.E.*, vol. 42, p. 1321; August, 1954.

<sup>2</sup> "NTSC signal specifications," vol. 42, pp. 17-19; January, 1954.



TABLE I

	Inside Helix	Outside Helix
$\frac{H_\phi}{H_r}$	$j \frac{\beta^2 I_1(\gamma a)}{\beta \gamma I_0(\gamma a)} \cot \psi$	$-j \frac{\beta^2 K_1(\gamma a)}{\beta \gamma K_0(\gamma a)} \cot \psi$
$\frac{H_z}{H_r}$	$-j \frac{\gamma I_0(\gamma r)}{\beta I_1(\gamma r)}$	$+j \frac{\gamma K_0(\gamma r)}{\beta K_1(\gamma r)}$
$\frac{H_\phi}{H_z}$	$-\frac{\beta^2}{\gamma^2} \frac{I_1(\gamma a)}{I_0(\gamma a)} \cot \psi$	$-\frac{\beta^2}{\gamma^2} \frac{K_1(\gamma a)}{K_0(\gamma a)} \cot \psi$

the magnitude of the ratio, which determines the eccentricity of the ellipse, is approximately unity for the  $r$ - $z$  plane while, for the  $r$ - $\phi$  plane, it is approximately equal to  $\tan \psi$ .

Thus, if a ferrite were placed either inside or outside of the helix, and if the proper value of dc magnetic field were imposed, either in the  $z$  or the  $\phi$  direction, one would expect to observe a directional absorption of energy from the electromagnetic wave on the helix. One would also expect that the degree of directionality would depend on the eccentricity of the ellipse traced out by the rf magnetic field vector in the ferrite in the plane normal to the dc magnetic field.

Directional attenuation for a helix, when the static magnetic field is in the axial (or  $z$ ) direction, has been observed with a ferrite of the Ni-Zn class, and representative curves of attenuation vs frequency are shown in Fig. 1 for two different values of axial mag-

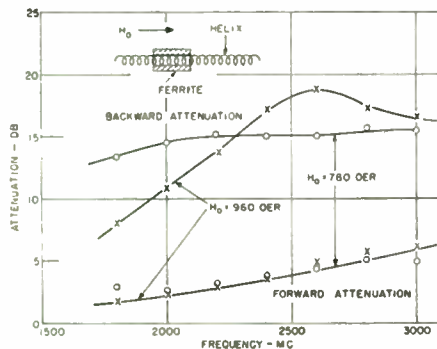

Fig. 1—Attenuation vs frequency for constant magnetic field.

netic field. In this case, the ferrite was in the shape of a uniform cylinder  $\frac{7}{16}$ -inch I.D.  $\times \frac{3}{4}$ -inch O.D.  $\times \frac{1}{16}$ -inch long, closely fitting the helix on the outside. In Fig. 2 the information is presented in somewhat different form, the attenuation forward and back being plotted as a function of the dc magnetic field for different frequencies. In all the data shown, the losses due to the helix alone were subtracted from the attenuation readings.

A directivity ratio of db of six-to-one has been observed. This is considerably higher than the elementary theory would indicate, and it is believed that the difference is due to the effect of the permeability of the ferrite on the eccentricity. An isotropic permeability,  $\mu$ , outside the helix to infinity, increases the ratio of the rf magnetic field amplitudes,  $H_\phi/H_r$  in the  $r$ -plane by the factor  $\mu$ . This simple analysis, while it ignores the fact that the ferrite has a tensor permeability, gives some insight into the mechanism that makes the directional effect with an axial magnetic field successful.

When a cylindrical shell of ferrite is used as indicated, there is considerable distortion of the magnetic focusing field. This was reduced by splitting the cylinder into "short" rings. Although the static magnetic field required for resonance absorption is correspondingly greater, the directional effects and attenuation were of the same magnitude for the same total length of ferrite.

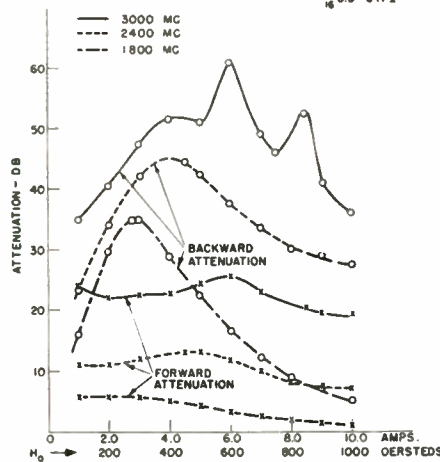
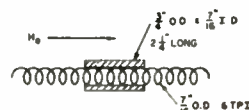

Fig. 2—Attenuation vs static magnetic field for constant frequency.

We are particularly indebted to V. C. Wilson and L. Piekarski for providing us with ferrite samples and for sharing their wide knowledge of ferrites with us. We are also grateful to R. Damon, J. Eshbach, and C. Bean for valuable discussions concerning ferromagnetic resonance absorption.

This work was supported by the Bureau of Ships, U. S. Navy.

J. A. RICH and S. E. WEBBER  
General Electric Research Lab.  
Schenectady, N. Y.

### The Variation of the Forward Characteristics of Junction Diodes with Temperature\*

The current-voltage characteristic of junction diodes is described over a wide range by the equation:<sup>1</sup>

$$I = I_s(e^{kV} - 1) \quad (1)$$

\* Received by the IRE, September 16, 1954.  
<sup>1</sup> W. Shockley, "The theory of  $p$ - $n$  junctions in semi-conductors and  $p$ - $n$  junction transistors," *Bell Sys. Tech. Jour.*, vol. 28, pp. 435-489; July, 1949.

where  $I_s$  is the "saturation current"  $k$  a constant that at room temperature may vary between 39 volts<sup>-1</sup> and 20 volts<sup>-1</sup>, depending on the geometry.<sup>2</sup> The factor  $k$  is proportional to the absolute temperature. This variation is however so small that it can be neglected.

The "saturation current"  $I_s$  varies exponentially with temperature:<sup>3</sup>

$$I_s = I_s' e^{a(T_2 - T_1)} \quad (2)$$

where  $I_s$  is the saturation current at temperature  $T_2$ ,  $I_s'$  the saturation current at temperature  $T_1$  and  $a$  a constant. For most germanium and silicon diodes, the coefficient  $a$  equals approximately to 0.08 (degrees K)<sup>-1</sup>.

The total current-voltage characteristic is therefore:

$$I = I_s' e^{a(T_2 - T_1)} (e^{kV} - 1) \quad (3)$$

In the forward part of the characteristic the last term of (3) can normally be neglected so that

$$I = I_s' e^{a(T_2 - T_1) + kV}$$

or

$$V = -\frac{a}{k} (T_2 - T_1) + \frac{1}{k} \ln \frac{I}{I_s'}$$

For a constant current  $I$ , we have, therefore:

$$\frac{\partial V}{\partial T} = -\frac{a}{k}$$

The voltage in the forward direction of a diode, with constant current, changes, therefore, with temperature at a rate of  $-a/k$ . A typical value (for  $k=39$  volts<sup>-1</sup>,  $a=0.08$  (degrees K)<sup>-1</sup>) is  $-2$  mV per degree C. change in temperature. It is important to note that the voltage decreases as the temperature rises.

Fig. 1 shows the forward characteristic of a silicon diode for a temperature range of  $-25$  degree C. to  $+75$  degrees C. The change per degrees C. is  $-1.8$  mV.

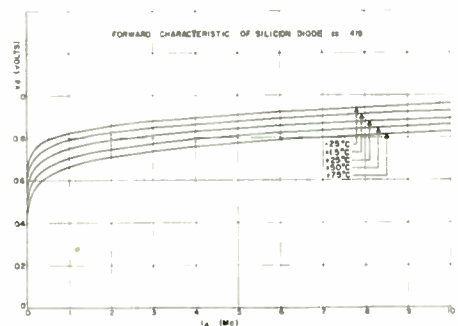

Fig. 1

The same effect may be observed for the input characteristics of junction transistors.

J. S. SCHAFFER and R. F. SHEA  
General Electric Company  
Labs. Dept., Electronics Div.  
Syracuse, N. Y.

<sup>2</sup> R. N. Hall, "Power rectifiers and transistors," *Proc. I.R.E.*, vol. 40, pp. 1512-1518; November, 1952.

<sup>3</sup> R. F. Shea, "Principles of Transistor Circuits," John Wiley & Sons, Inc., New York, N. Y.; 1953.

**Traveling-Wave Tube System Having Multiplied Gain\***

Substantially increased gain can be obtained from traveling-wave tubes by the use of a technique which, taking advantage of the large bandwidth of such tubes, passes the signal through them more than once.

A conventional all rf microwave relay system using traveling-wave tubes has a series of stages such as those shown in Fig. 1. If it is assumed that the gain per tube is 30 db and that the conversion loss due to frequency shift is 10 db, the system is seen to have an over-all gain of 110 db.

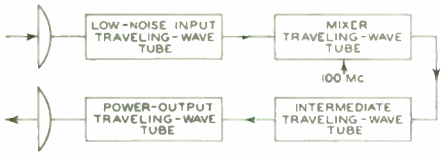

Fig. 1

Increased gain is obtained by the use of a circuit in which the received signal, first amplified by the input traveling-wave tube, is heterodyned to a second frequency and then reapplied to the input tube. The use of such a circuit is particularly advantageous in microwave relay stations, because it is necessary to alter the carrier frequency at some point in such systems to prevent the feed-back of energy from the transmitting antenna to the receiving antenna.

Theoretically, the signal could be reapplied to the traveling-wave tube more than once, the number of times being limited by saturation of the tube, or by other nonlinear effects caused by the simultaneous amplification of signals differing in amplitude levels by many decibels.

A block diagram for the new system is shown in Fig. 2. In this circuit the received or input signal, which consists of a modulated 6,000-megacycle carrier, is applied through a 6,000-megacycle bandpass filter to the input circuit of the traveling-wave tube. The amplified signal from the output

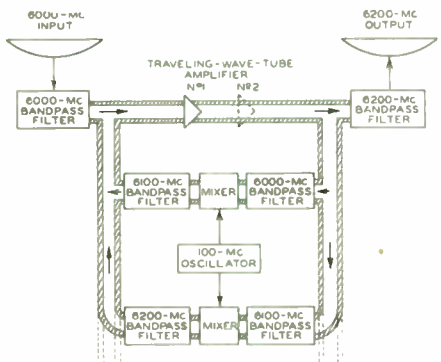

Fig. 2

circuit of the tube is applied through a second 6,000-megacycle bandpass filter to a mixer. The output of a 100-megacycle vacuum-tube oscillator is also applied to the mixer, which includes a signal having frequencies in the vicinity of 6,100 megacycles, is then applied through a 6,100-megacycle bandpass filter to the input circuit of the traveling-wave

\* Received by the IRE, October 27, 1954.

tube. This signal is again amplified by the traveling-wave tube and passed through a 6,100-megacycle bandpass filter to provide an output at 6,100 megacycles. The process can be repeated as follows: the 6,100-megacycle output signal is heterodyned to 6,200 megacycles, using the same 100-megacycle oscillator, and the 6,200-megacycle signal is passed through the tube. The 6,200-megacycle output signal from the tube is amplified three times with respect to the original 6,000-megacycle input signal. Because each signal amplified by the tube is in a different frequency range, there is no regenerative loop that can cause oscillations. The adjacent frequency ranges should be as close together as can be separated or distinguished using bandpass filters of practical design, provided filter skirt selectivity provides sufficient attenuation in adjacent frequency ranges to prevent oscillations. Microwave bandpass filters having an insertion loss of 1 db at 6,100 mc and an attenuation of 100 db at 6,000 and 6,200 mc seem to be approachable in the present state of the art.

In general the over-all gain,  $G$ , is equal to  $\mu + n(\mu - L)$ , where  $\mu$  is the gain of the traveling-wave tube,  $n$  is the number of times the signal is recirculated, and  $L$  is the loss in the mixer and filters.

Obviously, the value of  $L$  should be small in comparison to the gain,  $\mu$ . If it is assumed, as above, that the gain of the traveling-wave tube is 30 db and the conversion loss is 10 db, then, for a relay system:

for signal amplified once (plus frequency shift),  
 $G = 30 - 10 = 20$  db

for signal reapplied once,  
 $G = 20 + 30 = 50$  db;

for signal reapplied twice,  
 $G = 20 + 30 + 20 = 70$  db.

Fig. 3, shows a typical distribution of amplitude vs frequency.

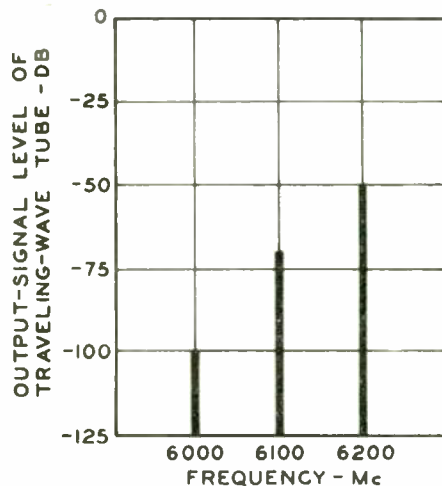

Fig. 3

It is also possible for the signal to be amplified by more than one traveling-wave tube stage before it is reapplied to the input. In this system, which increases the "loop gain,"  $\mu$  represents the combined gain of the traveling-wave tubes and  $L$  approaches a small quantity in comparison to

$\mu$ . For a system using two stages of traveling-wave tubes before the signal is reapplied to the input stage:

signal amplified once (plus frequency shift),  
 $G = 60 - 10 = 50$  db;

signal reapplied once,  
 $G = 50 + 60 = 110$  db.

The use of these techniques obtains the advantages of increased gain per traveling-wave tube and also, because of the reduction in the number of tubes needed to achieve a specified over-all gain, reduced relay station cost and greater system reliability. Although this method is particularly valuable for microwave relays because of the required frequency shift, it could also be used in other applications that require high-gain microwave amplifiers having a bandwidth up to half the inherent bandwidth of the traveling-wave tube.

FRANK R. ARAMS  
 Tube Division  
 Radio Corporation of America  
 Harrison, N. J.

**Comment on "Radio-Frequency Phase-Difference Networks: A New Approach to Polyphase-Selectivity,"\* M. G. Cifuentes and O. G. Villard<sup>1</sup>**

In the above paper, the authors described a new method of filtering by modulation, using high-frequency phase-difference networks. One of the most important advantages of the method, stated therein, consists in the possibility of cascading a number of similar devices, thus achieving as much attenuation in the stopband as required.

The described method is very interesting, as it discloses a new approach to the main problem of polyphase filtering, and draws attention to a very important subject.

As far as the possibility of cascading several devices is concerned, it must be remembered that where single-sideband selection is performed by polyphase modulation, the higher undesired-sideband rejection which may be attained is limited mainly by modulator-balancing problems. However, since a lack of balance may cause the undesired sideband to appear not only in its own range but also as an inverted spectrum in the desired sideband region,<sup>2</sup> no improvement may be attained, in this respect, by cascading several devices. It is obvious that this holds also for other cascading devices, for instance, as described by Barber.<sup>3</sup>

As far as the main features of filtering devices using polyphase modulation are concerned, it is perhaps worthwhile reminding the average reader that the most important merit of such devices consists in translating the filtering process down to a lower frequency region. This thus achieves high selectivity, even with the use of comparatively poor filters, while still avoiding image-

\* Received by the IRE, September 13, 1954.

<sup>1</sup> Proc. I.R.E., vol. 42, pp. 588-593; March, 1954.

<sup>2</sup> G. B. Madella, "Single-phase and polyphase filtering devices using modulation," *Wireless Eng.*, vol. 24, pp. 310-311; October, 1947.

<sup>3</sup> N. F. Barber, "Narrow band-pass filter using modulation," *Wireless Eng.*, vol. 24, pp. 132-134; May, 1947.



frequency troubles.<sup>2-7</sup> This main advantage evidently is lost if the filtering process is accomplished by high-frequency networks. When, for instance, the so-called "doublet" is replaced by a "quadruplet," then a simple  $rc$  first-order phase-splitter must be replaced by a second-order, high- $Q$  phase-splitter requiring correspondingly high-quality components. It follows, in some instances at least, that the same order of performance could be expected from a conventional, single-phase, passive filter in the high-frequency region having the same number of same-quality components, thus avoiding polyphase circuitry at all. This does not exclude, however, that even in these instances the radio-frequency phase-difference network procedure may be preferable for other considerations.

In all cases, it must be clear that the preceding arguments are by no means a criticism of the above paper, but rather an attempt to add some further contribution to the knowledge of the modern communication polyphase circuitry, a subject which appears to be scarcely known, and frequently misunderstood.

G. B. MADELLA  
Naval Academy  
Livorno, Italy

<sup>4</sup> G. B. Madella, "Sul concetto di frequenza negativa," *Alta Frequenza*, vol. 13, pp. 31-38; March, 1944.

<sup>5</sup> G. B. Madella, "Analizzatori eterodina con tensione ausiliaria polifase," *Alta Frequenza*, vol. 13, pp. 132-149; September, 1944.

<sup>6</sup> N. F. Barber, "Positive and negative frequencies," *Wireless Eng.*, vol. 25, pp. 98; March, 1948.

<sup>7</sup> N. F. Barber, "Bridge networks discriminating between positive and negative sequences in polyphase supply," *Nature*, vol. 161, pp. 685-686; May, 1948.

### Television Microscopy\*

Your cover picture of the August, 1954 edition of the PROCEEDINGS OF THE I.R.E. prompts me to write to you on the present state of television microscopy in England. The fact that you have published a picture of the experimental setup in the DuMont Laboratories leads me to believe that there is some interest in the subject in the United States.

\* Received by the IRE, September 13, 1954.

Apart from the sphere of teaching, there are several research applications of the addition of television techniques to microscopy which are receiving attention in this country. As your readers are no doubt aware, there are two methods by which TV can be used, namely, the flying-spot technique, and secondly, by the addition of a television camera to a microscope, and the former has received considerable attention in this country for particle sizing and counting, there being at least two commercial equipments on the market for this purpose.

It is in the field of high resolution microscopy that I am particularly interested. Since the resolution of an optical system is limited by the wavelength of the light used, it is necessary to resort to the ultra-violet end of the spectrum in order to obtain higher resolving power. There are, however, two disadvantages from this in biological research: firstly, that the image is invisible to the eye and must therefore be photographed; secondly, that the amount of radiation necessary for photography will kill the majority of living specimens.

A television camera tube has been developed in this country which has a reasonably good response. Down to 2,300 Å a reasonable picture can be obtained without killing the majority of specimens. For those specimens which are particularly susceptible to ultra-violet radiation, the feasibility of pulsing on the light for a short time, and then storing the electronic image for detailed examination, has been proved, it having found that repeated short doses of radiation do not damage specimen at level required to produce a satisfactory image.

B. ROSS ROBINSON  
St. Osmund's Close  
Salisbury, Wilts., England

### Reciprocity Theorem for Anisotropic Media\*

T. H. Crowley<sup>1</sup> has given the appropriate version of the Lorentz reciprocity theorem to be used for specific types of sources; i.e., volume, surface, and line sources. His results may be extended to include regions where

\* Received by the IRE, October 4, 1954.  
<sup>1</sup> T. H. Crowley, "On reciprocity theorems in electromagnetic theory," *Jour. Appl. Phys.*, vol. 25, p. 119; January, 1954.

anisotropic linear media are present, provided the bulk constants are tensor quantities. If the tensors are symmetric, Crowley's results hold as they stand. If they are not, then one of the sources must be considered as radiating into the "transposed medium,"<sup>2</sup> i.e., one in which the bulk constants are the transpose of the original ones.

As an illustration, the formulas for volume sources will be shown. Corresponding results are obtained for other distributions. Let sources  $a$  and  $b$  (oscillating at the same frequency) be finite volume distributions of electric currents  $J^a$  and  $J^b$ , and magnetic currents  $K^a$  and  $K^b$ . Let  $E^a, H^a$  be the field of source  $a$  when it radiates into the given medium, and  $e^a, h^a$  be the field when it radiated into the transposed medium, and similarly for source  $b$ . Then

$$\begin{aligned} \iiint_{V_a} (J^a \cdot E^b - K^a \cdot H^b) d\tau \\ = \iiint_{V_b} (J^b \cdot e^a - K^b \cdot h^a) d\tau, \end{aligned}$$

and

$$\begin{aligned} \iiint_{V_a} (J^a \cdot e^b - K^a \cdot h^b) d\tau \\ = \iiint_{V_b} (J^b \cdot E^a - K^b \cdot H^a) d\tau, \end{aligned}$$

where  $V_a$  encloses source  $a$ , and  $V_b$  encloses source  $b$ . The theorem is alternatively expressed in terms of surface integrals:

$$\iint_S (E^a \times h^b - e^b \times H^a) \cdot n ds = 0,$$

and

$$\iint_S (e^a \times H^b - E^b \times h^a) \cdot n ds = 0,$$

where both sources are on one side of the surface  $S$ . Minor extensions of the proof for the isotropic case<sup>3</sup> suffice to show that these statements are true.

The equivalent of this theorem has been stated by Lurye.<sup>2</sup>

M. H. COHEN  
Cornell University  
Ithaca, N. Y.

<sup>2</sup> J. R. Lurye, "Electromagnetic Scattering Matrices of Stratified Anisotropic Media," NYU Math. Res. Group Rep. EM-31, p. 33; May, 1951.

<sup>3</sup> S. A. Schelkunoff, "Electromagnetic Waves," D. Van Nostrand Co., Inc., N. Y., N. Y., p. 477; 1943



# Contributors

E. J. Baghdady (S'52) was born in Zahleh, Lebanon, on November 10, 1930. Between 1949 and 1951, he was a British Council Scholar and recipient of the university first-prize scholarship at the American University of Beirut. He received the degree of Bachelor of Arts with High Distinction in physics in 1951.



E. J. BAGHDADY

In the summer of 1951, Mr. Baghdady came to the United States on a Georgia Institute of Technology World Student Fund fellowship and enrolled in the Institute's graduate division of electrical engineering. In June of 1952, he joined the staff of the Massachusetts Institute of Technology as a research assistant and graduate student. After a summer in the microwave tube laboratory at MIT's Research Laboratory of Electronics, he joined the multipath transmission group and has, since then, been engaged in research on frequency-modulation receiver design for rejecting interference. He received his Master of Science degree in electrical engineering from the Massachusetts Institute of Technology in February 1954.

Mr. Baghdady is an associate of Sigma Xi.



J. E. Beggs (SM'52) was born in Omaha, Neb., on May 9, 1908. He received the B.S. degree in electrical engineering from Purdue University in 1931. He was associated with the Research Laboratory of Hygrade Sylvania during 1931. Since that time he has been with the General Electric Company, engaged in electron tube development and research.



J. E. BEGGS

At present he is a research associate with the General Electric Research Laboratory at The Knolls, Schenectady, N. Y.

He is a member of Eta Kappa Nu and Tau Beta Pi. He received a Certificate of Commendation from the Bureau of Ships of the U. S. Navy for his part in the development of the "lighthouse" receiving tubes.



M. K. Brachman (M'53) was born in Ft. Worth, Texas, on December 9, 1926. He received the B.A. degree in physics, *summa cum laude* from Yale University in 1945.

After service in the Air Force and Army he received the M.A. and Ph.D. degrees in physics from Harvard in 1947 and 1949 respectively, holding a U.S.A.E.C. Fellowship during his last year there.



M. K. BRACHMAN

In 1949 he became assistant professor of physics at Southern Methodist University. From 1940 to 1953 he was a member of the physics division of Argonne National Laboratory. He then joined the Materials and Components Research Section of Texas Instruments Inc., Dallas. He is now vice-President and director of research of Independent Geophysical Surveys Corp., Houston.

Dr. Brachman is a member of Phi Beta Kappa, Sigma Xi, the American Physical Society, and the Research Society of America.



K. K. N. Chang was born in Shanghai, China, on September 9, 1919. He received the B.S. degree from the National Central University, Nanking, China, in 1940; the M.S. degree in electrical engineering from the University of Michigan in 1948, and the D.E.E. degree in 1954 from the Polytechnic Institute of Brooklyn. From 1940 to 1945, he was associated with the Central Radio Manufacturing Works,



K. K. N. CHANG

Kunming, China, working on radio receivers, and from 1945 to 1947, he was a radio instructor in the Office of Strategic Service, U. S. Army, China Theatre. Since 1948, he has been at RCA Laboratories, Princeton, N. J., where he is presently engaged in research on microwave tubes.

Dr. Chang is a member of Sigma Xi.



William V. Christensen (S'52-A'54) was born in Corrine, Utah, on June 25, 1927. He received the B.S. degree in electrical engineering from Stanford University in 1953.



W. V. CHRISTENSEN

While taking graduate work at Stanford he worked as a research assistant at the electronics research laboratory. He is now a vacuum-tube engineer at Huggins Labs., Menlo Park, California.

P. R. Clement (S'50-A'51) was born in Kansas City, Mo., on October 12, 1925. He received the B.S. degree in E.E. from the University of Kansas, under the Navy V-12 program. From 1946 until 1948 he was a graduate student and instructor at the University of Kansas, where he received the M.S. degree in 1948. He received the Ph.D. degree from Princeton University in 1950 and was appointed a post-doctoral fellow. In 1951 he became an assistant professor of electrical engineering at Princeton. Dr. Clement was on leave from 1952 to 1954 while he served with the Navy at Sandia Base in Albuquerque, N. M. He is a member of Tau Beta Pi and Sigma Xi.



P. R. CLEMENT

❖

W. E. Gordon (A'46-M'49) was born in Paterson, N. J., on January 8, 1918. He received the B.A. degree in mathematics from Montclair State Teachers' College in 1939, the M.A. degree in education from Montclair in 1952, the M.S. degree in meteorology from the University of New York in 1946, and the Ph.D. degree from Cornell University in 1953. He also did some graduate study at the University of Texas.



W. E. GORDON

Dr. Gordon was in the Air Force during the war, reaching the rank of Captain. He was engaged in radio-meteorological studies in association with the Committee on Propagation of NDRC at Massachusetts Institute of Technology, AFTAC, Bell Telephone Laboratories, University of Texas, and New York University. Upon completion of these duties at the close of the war, he became associate director of electrical engineering, Research Laboratory, University of Texas. In 1948 he joined the staff of the School of Electrical Engineering, Cornell University, as research associate, becoming associate professor in 1953.

Dr. Gordon is secretary of the USA National Committee, URSI, and a member of Sigma Xi, American Meteorological Society, and Joint Commission on Radio Meteorology, International Council of Scientific Unions.



W. C. Johnson (A'43-SM'48) was born in Weikert, Pa., on January 6, 1913. He attended Pennsylvania State University,



where he obtained the B.S. degree in 1934 and the E.E. degree in 1942. After graduation he spent three years as an engineer with the General Electric Company in Schenectady, N. Y., where he was a student in the Advanced Course in Engineering. He went to Princeton University in 1937 and has been chairman of the department of electrical engineering since 1950.



W. C. JOHNSON

Professor Johnson is a member of the American Physical Society, the American Institute of Electrical Engineers, the American Society for Engineering Education, Tau Beta Pi, and Sigma Xi.



A. Karp (S'47-A'48-M'53) was born on April 26, 1928, in New York, N. Y. He received the B.E.E. degree from the City College of the City of New York in February, 1948, and the S.M. degree from the Massachusetts Institute of Technology in 1950. In 1950-1951 he held a scholarship from the French government and was with the Laboratoire Central de Télécommunications, in Paris.



A. KARP

Mr. Karp was associated with A. Alford Consulting Engineers, Boston, and the Geophysics Department, Columbia University, N. Y., prior to becoming a research assistant in September, 1948 at the M.I.T. Research Laboratory of Electronics, at which time he was introduced to the microwave vacuum-tube field. Since October, 1951, he has been a member of the Electronics Research Department of the Bell Telephone Laboratories, Holmdel, N. J.

He is a member of Tau Beta Pi, Eta Kappa Nu, and an associate member of Sigma Xi.



N. T. Lavoo (A'41-M'45) was born in St. Louis, Mo., on October 12, 1918. He received the B.S. degree in electrical engineering from Washington University in 1940 at which time he was employed by the General Electric Company at Schenectady, N. Y. While completing the three-year General Electric Advanced Engineering Program he was associated with several of their developmental laboratories.



N. T. LAVOO

Since 1944 he has been a research associate in the General Electric Research Laboratory.

He is a member of Sigma Xi and Tau Beta Pi.

C. H. Looney (S'50-A'51) was born in Newburg, Mo., on April 7, 1928. He attended the University of Kansas, receiving the B.S.E.E. degree in 1950.



C. H. LOONEY

After employment in Kansas City, where he developed electronic circuitry for commercial and military applications, he joined the Shipboard Systems Branch of the Electricity Division, Naval Research Laboratory, Washington, D. C., in 1951. He was assigned the problem of developing accurate evaluation instrumentation and techniques for carrier-type feedback control equipment. In a recent reorganization of the laboratory, the Shipboard Systems Branch became the Electrical Applications Branch of the Sound Division, and Mr. Looney is now working on special-interest problems in the field of fire control.

He is a member of Tau Beta Pi and Kappa Eta Kappa.



For a photograph and biography of D. L. MacAdam, see page 355 of the January, 1954 issue of the PROCEEDINGS OF THE I.R.E.



For a photograph and biography of J. R. Macdonald, see pages 1571-1572 of the October, 1954 issue of the PROCEEDINGS OF THE I.R.E.



Jacob Millman (A'41-SM'49) was born in Russia on May 17, 1911. He received the B.S. degree in 1932 and the Ph.D. degree in 1935, both at Massachusetts Institute of Technology.



J. MILLMAN

From 1936 to 1942 Professor Millman was instructor in electrical engineering at the City College of the City of New York. From there he went to the Ground Radar Systems Group, Radiation Laboratory, at M.I.T., where he continued until 1945, when he returned to C.C.N.Y. as associate professor of electrical engineering. Since 1952 he has been professor of electrical engineering at Columbia University. Besides teaching both graduate and undergraduate courses in electronics and electromagnetic theory, he is engaged in research in pulse circuits at the Electronics Research Laboratories at the University, and serves as a consultant for industry.

Professor Millman is the co-author of two textbooks, *Electronics*, with S. Seely, and *Pulse Circuits and Techniques*, with H. Taub, as well as of several articles for technical journals.

He is a member of the American Institute of Electrical Engineers, the American Association for the Advancement of Science, and the American Society for Engineering, and a Fellow of the American Physical Society. Professor Millman is also a member of Sigma Xi, Tau Beta Pi, and Eta Kappa Nu.



For a photograph and biography of A. Papoulis, see page 70A of the August, 1954 issue of PROCEEDINGS OF THE I.R.E.



R. L. Pritchard (S'45-A'51) was born in Irvington, N. J., on September 8, 1924.

He attended M.I.T. on the V-12 program. He graduated from Brown University in 1946 with a B.S. degree. In 1947, he received the M.S. degree from Harvard. He received the Ph.D. degree in acoustics at Harvard in 1950.



R. L. PRITCHARD

Since then, he has been with General Electric Research Lab. in Schenectady, working on communication and acoustic projects. For the past three years he has been doing research on the transistor from an electric-circuit point of view.

Dr. Pritchard is a member of the Acoustical Society of America and Sigma Xi.



T. H. Puckett (S'49-A'52) was born in Oklahoma City, Okla., on March 12, 1930. He received the B.S.E.E. degree from the University of Oklahoma in 1951, and the M.S. degree from Columbia University in 1954.



T. H. PUCKETT

Mr. Puckett was research assistant in the department of electrical engineering in 1950 and 1951, and since then he has been staff engineer at the Electronics Research Laboratories at Columbia University, where he is involved in extensive research on pulse circuits and radio communication problems. He has written several articles for various technical publications in the field of radio communications.

Mr. Puckett is a member of the American Institute of Electrical Engineers, Eta Kappa Nu, and Tau Beta Pi.

R. K-F Scal (S'41-A'45-M'47-SM'51) was born on December 8, 1919, in New York, N. Y. He received the B.A. degree in chemistry (with honors) from Stanford University in 1941.



R. K-F SCAL

In 1942 he accepted a commission in the U. S. Army Signal Corps. Following ESMWT radar courses at Harvard University and M.I.T. he transferred to the Army Air Force Air Material Command in

1943. Here he attained the grade of Captain, while concerned with electronic maintenance, research, and development.

He returned to Stanford in 1946. While there he designed and built a new control central unit for the Stanford Ionosphere Equipment. He received the M.A. degree in electrical engineering in 1946, and the Professional Degree of Electrical Engineer in 1947.

From 1947 to 1954 he was associated with the Electronics Division of the National Bureau of Standards. As chief of the Radar Miniaturization Section, he was responsible for the development of several advanced radar systems, which were subsequently placed in production for use in combat aircraft. In 1954 he joined RS Electronics Corporation as vice-president and chief engineer.

Mr. Scal is a member of the National Society of Professional Engineers and of the I.R.E. Professional Groups on Airborne Electronics and Engineering Management. He has served on the Research and Development Subpanel on Packaged Assemblies Using Miniature Components and the American Standards Association C83 Committee on Components. He is a registered Professional Engineer in the District of Columbia.

In 1954 Mr. Scal received the Department of Commerce Silver Medal for Meritorious Service for an outstanding contribution to electronic engineering in the development of a miniaturized airborne radar system.



D. C. Stinson was born on December 7, 1925, at Malta, Idaho. During the war he attended several schools on the V-5 and V-12

programs. He graduated from Iowa State in 1947 with the B.S. degree in electrical engineering and spent the next year as a test



D. C. STINSON

engineer with the General Electric Company. He then entered the California Institute of Technology, from which he received the M.S. degree in electrical engineering in 1949. Since that time he has been at the University of California, receiving the E.E. degree in 1953. He is

currently a research assistant doing work for his Ph.D. degree. During the past three summers he has been a member of the technical staff of the Research and Development Laboratories, Hughes Aircraft Company.

Mr. Stinson is a member of Pi Mu Epsilon and Eta Kappa Nu, an associate member of Sigma Xi, and a Lieutenant in the United States Naval Reserve.



D. A. Watkins (A'47-M'48-S'49-A'51) was born in Omaha, Neb., on October 23, 1922. He specialized in electrical



D. A. WATKINS

engineering, receiving the B.S. degree from Iowa State College in 1944, the M.S. degree from California Institute of Technology in 1947, and the Ph.D. degree from Stanford University in 1951, where he was a Gerard Swope Fellow from 1950 to 1951.

In World War II, Dr. Watkins was an army engineer unit commander in the European and Pacific Theaters. He was employed by the Collins Radio Company from 1947 to 1948, and at the Los Alamos Scientific Laboratory from 1948 to 1949. From 1951 to 1953, he was employed by the Hughes Aircraft Company, where he was a member, and then head of the microwave tube section of the research and development laboratories. Since 1949, Dr. Watkins has been engaged in microwave tube research, specializing in traveling-wave tubes and backward-wave oscillators. In March, 1953, he returned to Stanford University, where he is now associate professor of electrical engineering and associate director of the applied electronics laboratory.

Dr. Watkins is a member of Sigma Xi, Tau Beta Pi, Eta Kappa Nu, Pi Mu Epsilon, and Phi Kappa Phi.



J. Weber (SM'54) was born on May 17, 1919, in Paterson, N. J. In 1940 he received the B.S. degree from the U. S. Naval Academy. During the period 1940-1943



J. WEBER

he served at sea as an officer in the Navy, first on board an aircraft carrier, then as commanding officer of a submarine chaser. He attended the Postgraduate School from 1943 to 1945. From 1945 to 1948 he was a section head in the electronics design branch of the Bureau of Ships.

In 1948 he resigned from the Navy and became professor of electrical engineering at the University of Maryland. He continued graduate work in physics at Catholic University and was awarded the Ph.D. degree in 1951. He has been consultant to the research and engineering departments of the U. S. Naval Ordnance Laboratory since 1948.



J. R. Whinnery (A'41-SM'44-F'52) was born in Reed, Colo., July 26, 1916. He received the Bachelor of Science degree in electrical engineering from the University of California in 1937.



J. R. WHINNERY

He then joined the General Electric Company, Schenectady, N. Y. in their microwave circuits and electron tube research and training program. In 1946 he returned to the University of California for teaching and

completion of work for the Ph.D. degree. In 1951, on leave from the University, he was head of the microwave tube section of the Electron Tube Laboratory, Hughes Aircraft Company. Since 1952 he has been professor of electrical engineering and vice-chairman of the Electrical Engineering Division, University of California.





# IRE News and Radio Notes

## IRE NATIONAL CONVENTION SET FOR MARCH 21-24

On Monday, March 21, New York City will be the focal point of the engineering world when the 1955 IRE National Convention gets underway. Over 40,000 engineers and scientists are expected to be on hand as a full four-day program of sessions, exhibits, and social events unfolds at the Waldorf-Astoria Hotel and Kingsbridge Armory.

The convention will start at 10:30 Monday morning with the Annual Meeting in the Waldorf's Grand Ballroom. This meeting is held especially for members to meet their officers and hear them discuss current plans and activities of the Institute. The program will feature a well-known speaker who will discuss a subject of interest to all engineers.

### Technical Sessions

A comprehensive program of fifty-five technical sessions and professional group symposia is being prepared by the Technical Program Committee with the assistance of all twenty-three professional groups. The sessions will be held at the Waldorf-Astoria, nearby Belmont-Plaza, and at the Kingsbridge Armory. The highlight of the program will be two special Tuesday evening sessions devoted to Automatic Control and Audio. Full details of the program will be announced in the March issue of the PROCEEDINGS.

Plans are being made to publish again the *Convention Record of the I.R.E.* It will contain all available papers presented at the convention.

The Radio Engineering Show this year has been expanded to 700 exhibits, covering almost every conceivable new development in radio and electronic equipment, materials, and techniques. To accommodate this expansion, approximately 100 exhibits will be located in the new Kingsbridge Palace, just a block and a half from the Kingsbridge Armory. Free and continuous bus service will be provided between the Armory and Waldorf-Astoria for the convenience of convention registrants.

### Social Activities

The social activities will get underway Monday evening with a "get-together" cocktail party in the Grand Ballroom of the Waldorf. Climax of the convention will be the Annual Banquet, which this year will feature a speaker of national importance. Also on the program will be presentation of the IRE Awards for 1955 by John D. Ryder, President.

An attractive and entertaining program is being planned for the wives of members. Tours of the U.N. Building, a leading department store, and a museum are included, as well as a luncheon-fashion show, matinees at Broadway plays, and a tea at the new IRE Headquarters Building at 5 East 79 Street. The center for women's activities will be located in the Regency Suite on the fourth floor of the Waldorf-Astoria.

## A. V. LOUGHREN CITED BY RETMA FOR COLOR TV DEVELOPMENT

Arthur V. Loughren, Vice-President in Charge of Research at Hazeltine Corporation and an IRE Director, was cited recently by the RETMA Engineering Department during the Radio Fall Meeting in Syracuse for outstanding service to the television industry.



A. V. LOUGHREN

Dr. W. R. G. Baker, Director of the RETMA Engineering Department, presented the plaque to Mr. Loughren for his contributions to color television circuitry. Executive Vice-President of Hazeltine Research, Incorporated, he is Chairman of the RETMA Television Systems Committee and Chairman of the Joint Technical Advisory Committee of the IRE and RETMA.

## FERENCE WINS ARMY'S EXCEPTIONAL CIVILIAN SERVICE AWARD

In October at Fort Monmouth, N. J. Dr. Michael Ference, Jr. (SM'49) received the Army's Exceptional Civilian Service Award. The award, presented by Major General George I. Back, Chief Signal Officer of the Army, was given to Dr. Ference for "outstanding performance of duty as Chief Scientist, Evans Signal Laboratory." The citation credits him with making many outstanding contributions to the field of atmospheric physics "of lasting benefit to the defense of the United States."



Major General George I. Back presents Civilian Service Award to Dr. Michael Ference, Jr. in Fort Monmouth ceremony.

Now Chief Scientist of the Ford Motor Company Laboratories in Dearborn, Michigan, Dr. Ference directed the development of military devices which advanced the position of the United States in meteorology. His pioneering and guidance in meteorological research, the citation said, provided information for the development of missiles.

## Calendar of Coming Events

**IRE-AIEE-NBS-URSI Conference on High Frequency Measurements, Hotel Statler, Washington, D. C., January 17-19**

**RETMA Symposium on Printed Wiring and Circuitry, University of Pennsylvania, Philadelphia, Pa., January 20-21**

**IRE-IAS-ION-RTCA Electronics in Aviation Symposium, Hotel Astor, New York, N. Y., January 26**

**AIEE Winter General Meeting, Hotel Statler, New York, N. Y., January 31-February 4**

**1955 Southwestern IRE Conference and Electronics Show, Baker Hotel, Dallas, Tex., February 10-12**

**IRE National Convention, Waldorf-Astoria Hotel and Kingsbridge Armory, New York, N. Y., March 21-24**

**IRE-PIB Symposium on Modern Network Synthesis, Engineering Societies Building, New York, N. Y., April 12-15**

**SMPTTE 77th Semiannual Convention, Hotel Drake, Chicago, Ill., April 17-22**

**IRE-AIEE-RETMA-WCEMA Electronic Components Conference, Hotel Ambassador, Los Angeles, Calif., May 26-27**

**IRE Seventh Region Technical Conference and Trade Show, Hotel Westward Ho, Phoenix, Ariz., April 27-29**

**Semiconductor Symposium, Electrochemical Society, Cincinnati, Ohio, May 2-5**

## IRE OFFICERS FOR 1955

### ANNOUNCED

At its meeting on November 10, 1954, the Board of Directors announced the election of the following IRE officers and directors:

**President, 1955:** John D. Ryder, Michigan State College, East Lansing, Michigan.

**Vice-President, 1955:** Franz Tank, Swiss Institute of Technology, Zurich, Switzerland.

**Directors-Elected-at-Large, 1955-1957:** John F. Byrne, Motorola, Incorporated, Chicago, Illinois; Ernst Weber, Polytechnic Institute of Brooklyn, Brooklyn, New York.

**Regional Directors, 1955-1956:** Region Two, John N. Dyer, Airborne Instruments Laboratory, Mineola, Long Island; Region Four, E. M. Boone, Ohio State University, Columbus, Ohio; Region Six, Durward J. Tucker, Station WRR, Dallas, Texas; Region Eight, John T. Henderson, National Research Council, Ottawa, Canada.

# IRE News and Radio Notes

## USE OF RESEARCH REPORTS URGED BY COMMERCE DEPARTMENT

The Department of Commerce urges manufacturers and research laboratories to make more use of the growing stockpile of research reports released by the Office of Technical Services (OTS).

The Government now conducts and sponsors scientific research at a rate of more than two billion dollars a year, mostly for defense. This research generates technical information that is available to businessmen interested in new production processes, technological improvements, and non-duplication of research efforts. The information covers nearly every field of industrial activity, including chemicals, plastics, paints, electrical machinery and electronics, foods, fuel and lubricants, instrumentation, leather, lumber, metals, minerals, paper, ordnance, physics, rubber, textiles, aeronautics, transportation and water supply.

Each month in *U. S. Government Research Reports* (formerly the *Bibliography of Technical Reports*) some 350 reports on research activity are described. The publication is available from the U.S. Department of Commerce or any of its field offices at six dollars a year.

## NEW YORK SECTION HOLDS SYMPOSIUM ON TRANSISTOR CIRCUITS

The New York Section of the IRE is holding a Symposium on "Design Principles of Transistor Circuits." The symposium, which meets on January 8, is being held at the Engineering Societies' Building, 33 West 39 Street, New York City. Dr. John G. Linvill, of the Technical Staff at Bell Telephone Laboratories, is the moderator. The subscription price for IRE members is \$2.00, and for non-members \$4.00. IRE student members are admitted without charge.

## LEE DE FOREST HONORED IN FRANCE

Dr. Lee de Forest, world known radio pioneer, was recently honored at a dinner in Paris, France. The dinner was given for Dr. de Forest and his wife by Maurice Ponte, Vice-President of the IRE. Attending the dinner were H. Longchambon, French Secretary of State for Scientific Research and Technical Progress and Mathew Jones, Telecommunications Attaché at the United

States embassy. Many other Frenchmen and Americans associated with science and government attended also.

Dr. Ponte delivered the main address of the evening. He paid tribute to Dr. de Forest and, on behalf of the IRE, thanked the guests for honoring this charter member and former President of the IRE.

## THOMPSON MEMORIAL PRIZE GOES TO B. D. SMITH, JR.

The 1955 Browder J. Thompson Memorial Prize has been awarded to Blanchard D. Smith, Jr., of Melpar, Incorporated. Mr. Smith won the prize, given annually to an author under thirty at the time he submits his manuscript, for his paper, "Coding by Feedback Methods." It appeared in the August, 1953 PROCEEDINGS on page 1053. Papers are judged for technical significance plus competence of presentation.

The award will be presented at the March 23 Annual Banquet of the IRE National Convention in New York City.

## AUTOMATIC CONTROL GROUP ELECTS OFFICERS

The first meeting of the Administrative Committee of the recently organized Professional Group on Automatic Control was held in October at the Faculty Club of MIT. Robert B. Wilcox, Raytheon Manufacturing Company, was elected Chairman of the PGAC; J. C. Lozier, Bell Telephone Laboratories, Vice-Chairman; T. F. Mahoney, Raytheon Manufacturing Company, Secretary-Treasurer; J. E. Ward, Servomechanisms Laboratories, MIT, Program Chairman; Victor Azgaptian, Servomechanisms, Incorporated, Membership Chairman. After the election the Administrative Committee worked out a constitution and by-laws for the group. "The field of interest of the group," it states, "shall encompass automatic control systems and their components, such as transducers, data transmission systems, computers and control devices in relation to their systems' integration. It shall include scientific, technical, industrial, or other activities that contribute to this field, or utilize the techniques or products of this field, subject, as the art develops, to additions, subtractions, or other modifications directed or approved by the Institute Committee on Professional Groups."

Although the main aspect of the group's activity will be feedback control, its scope is broad enough to cover more general problems which necessarily face the feedback control engineer. The group will fill the pressing need of systems' integration which exists in the industry. A combination of strong chapters and a coordinated national professional group will provide the means of obtaining and disseminating practical information concerning design problems of actual systems.

## MARVIN CAMRAS WINS JOHN SCOTT AWARD

Marvin Camras, Chairman of the PG on Audio, has been named to receive the John Scott Award for scientific achievement. Mr. Camras, senior physicist at Armour Research Foundation of Illinois Institute of Technology, received the award for his work in magnetic recording.

The 138-year-old award, consisting of \$1,000 cash, a copper medal, and a scroll, will be presented by the city of Philadelphia.

The award was established by John Scott, an obscure chemist of Edinburgh, who died in 1816 and left a will directing that income "be laid out in premiums to be distributed among ingenious men and women who make useful inventions." More than 400 men and women, including Guglielmo Marconi, Lee DeForrest, Dr. Irving Langmuir, Sir Alexander Fleming, Thomas Edison, Orville Wright, and Madame Curie have won the award. From the original legacy of \$4,000, the fund has grown to approximately \$110,000. Periodic awards are given to inventors whose accomplishments "definitely add to the comfort, welfare, and happiness of mankind."

Mr. Camras' work in magnetic stereophonic sound (three-dimensional sound) contributed to the development of Cinerama and Cinemascope. His inventions currently are used in radio broadcasting, motion pictures, home entertainment, office dictation, memory units for high speed electronic computers, instrumentation, and missiles.

He is a member of the Chicago Physics Club, Chicago Acoustics and Audio Group, American Association for the Advancement of Science, Institute of Electrical Engineers, Society of Motion Picture and Television Engineers, Eta Kappa Nu, Tau Beta Pi, Sigma Xi, and a fellow of the Acoustical Society of America.

(Left) Dr. Lee de Forest, radio authority, pioneer, and inventor of the modern electron tube, greets French and American guests (right) assembled at a recent Paris dinner given in his honor. (Center) Dr. Maurice Ponte, Vice-President of the IRE, and sponsor of the dinner, pays tribute to Dr. de Forest in the main speech of the evening.





# IRE News and Radio Notes

## DENMARK HONORS H. T. FRIIS

Harald T. Friis, Director of Research in high frequency electronics for Bell Telephone Laboratories, has been made a Knight of the



H. T. FRIIS

Order of Dannebrog by King Frederick IX of Denmark. This award, Denmark's highest civilian decoration, is given to honor noteworthy contributions in the field of the recipient.

Dr. Friis, who was born in Denmark and received the Electrical Engineering degree from the Royal

Technical College in Copenhagen, has been with Western Electric Company, later part of Bell Laboratories, since 1920. He is a Fellow of the IRE and served as a Director from 1941 to 1944. In 1939 he received the Morris Liebmann Memorial Prize and recently received the IRE Medal of Honor.

Dr. Friis also has been recently honored by the Danish Academy of Technical Sciences with the Vlademar Poulsen Gold Medal. The medal, named for the Danish inventor and pioneer in electrical engineering and communications, was awarded him for "his important works on the application of short and ultra-short radio waves and, simultaneously, on atmospherics."

## STANDARDS AVAILABLE

The following Standards are available from the American Standards Association, 70 East 45 Street, New York, N.Y.: "American Standard Preferred Values for Components for Electronic Equipment," C83.2, 1949, revised 1954, \$.35; "American Standard Color Codes For Numerical Values, Decimal Multipliers and Tolerances for Components for Electronic Equipment," C83.1, 1949, revised 1954, \$.35; "American Standard Terminology for Piezoelectric Crystals," C83.3, 1951, revised 1954, \$.80; "American Standard Letter Symbols for Aeronautical Sciences," Y10.7, 1954, \$1.25.

## SMYTH RECEIVES REGION SEVEN ACHIEVEMENT AWARD

The third annual Electronics Achievement Award of Region Seven was presented last month to Dr. John B. Smyth at a meeting of the San Diego Section. He received the award "for his many contributions to the field of electromagnetic wave propagation, and his outstanding leadership of a research group in his field." In the Netherlands as Chairman of U. S. Commission II (Tropospheric Propagation) at the General Assembly of the International Scientific Radio Union, Dr. Smyth was unable to accept the award personally when it was announced at the WESCON All-Industry Luncheon last August.

For the past ten years Dr. Smyth has been in charge of research on radio wave propagation at the U. S. Navy Electronics Laboratory where his group has conducted studies in tropospheric refraction and scattering. His group has published 127 papers and technical reports during this period and Dr. Smyth himself has been author of many journal papers and technical reports.

Active in IRE affairs, Dr. Smyth is a member of the Administrative Committee of the Professional Group on Antennas and Propagation, and editor of the TRANSACTIONS OF THE PGAP.

## ELECTRONIC COMPONENTS SYMPOSIUM TO BE HELD IN LOS ANGELES

The IRE-AIEE-RETMA-WCEMA Electronic Components Symposium for 1955 will be held May 26 and 27 at the Ambassador Hotel in Los Angeles. A call for papers has been issued with January 30 the deadline for receipt of abstracts. Abstracts, not to exceed 100 words, should be submitted to Dr. Lester M. Field, California Institute of Technology, Pasadena, California.

Simon Ramo, of the Ramo-Wooldridge Corporation, is Chairman of the symposium. Marion Thorne and Floyd A. Paul are Vice-Chairmen. Other officers are: George W. Fenimore, Arrangements; Lester M. Field, Technical Program; Roy L. Ash, Finance; R. S. Tucker, Proceedings Publication; Ted Shields, Publicity.

## OBITUARIES

**Warren B. Burgess** (A'20-M'31-SM'43), radio engineer at the Naval Research Laboratory for thirty-one years, died recently. Mr. Burgess had been actively associated with amateur radio since 1908 and had held the First Grade Commercial Operator's License since 1910. During World War I he served as a radioman and Ensign inspecting and testing shipboard radio equipment and installing and developing radio direction finders. After the war, he became a radio inspector at Boston Navy Yard.

In 1921 he joined the Naval Research Laboratory, where he was in charge of research and design for the improvement of radio direction finders. He made a number of inventions in the field, several of which were patented.

Mr. Burgess attended the Worcester Polytechnic Institute, Worcester, Massachusetts, where he received the B.S. and E.E. degrees. Active in the IRE, he was a member of the Papers Procurement and Navigation Aids Committees, and, in 1937, Chairman of the Washington, D. C., IRE Section.

**George Ashley Campbell**, pioneer scientist in electrical communications, died recently. A native of Hastings, Minn., Dr. Campbell received the B.S. degree from MIT

in 1891, the A.B. and A.M. from Harvard in 1892 and 1893. After four years of advanced study in Paris, Vienna, and Göttingen, he returned to Boston and joined the Bell Telephone Company. In 1901 he received the Ph.D. from Harvard.

Among Dr. Campbell's inventions were the shielded balance, a unique measuring apparatus; and the electric wave filter, which permits the sending of many conversations over the same electrical pathway. With the Bell organization for thirty-eight years, he was engaged in the theoretical study of transmission on telephone lines and the distribution of currents in telephone networks.

Recognized many times for his work, Dr. Campbell received the IRE Medal of Honor in 1936. He has also been awarded the Elliott Cresson Gold Medal of the Franklin Institute and the Edison Medal of the Institute of Electrical Engineers.

**Loring P. Crosman** (A'52), development engineer on the staff of the Remington Rand Laboratory of Advanced Research, died recently at his home in



L. P. CROSMAN

Redding Ridge, Connecticut. Born at Swampscott, Massachusetts, July 23, 1892, he received the B.S. degree from Haverford College in 1915, where he was a member of the honorary Founder's Society. He joined the sales organization of the Monroe Calculating Machine Company in 1923, and in 1926 he became chief inspector of manufacturing operations. Mr. Crosman later became head of research and development of adding and bookkeeping machines, and in 1941 the calculating and checkwriting machine development departments were added to his responsibilities. During World War II he also developed, under NDRC sponsorship, the odograph map plotting machine with electronic control for use in vehicles.

In 1944, after an intensive course in electronics at Columbia University, Mr. Crosman joined Remington Rand Incorporated where he began electronic computer development that resulted in the Remington Rand Type 409-2 and its successor, the Univac-120 punched-card computer. He described this work in his final paper which appeared in the PROCEEDINGS of October, 1953. Mr. Crosman was a charter member of the Association for Calculating Machinery.

In 1944, after an intensive course in electronics at Columbia University, Mr. Crosman joined Remington Rand Incorporated where he began electronic computer development that resulted in the Remington Rand Type 409-2 and its successor, the Univac-120 punched-card computer. He described this work in his final paper which appeared in the PROCEEDINGS of October, 1953. Mr. Crosman was a charter member of the Association for Calculating Machinery.

## PROFESSIONAL GROUP NEWS

**NUCLEAR SCIENCE GROUP HOLDS FIRST NATIONAL ANNUAL MEETING**

On October 6 and 7, the Professional Group on Nuclear Science held its first National Annual Meeting at the Sherman

# IRE News and Radio Notes

Hotel in Chicago. During the two day meeting more than two hundred registrants heard nineteen papers on various aspects of nuclear science.

L. R. Hafstad, Director of Reactor Development, A.E.C., presented the chief address. Discussing the present government program of reactor research, he pointed out that atomic energy will not, in the near future, be the exclusive source of power and that it will not necessarily be cheap. Dr. Hafstad indicated, however, that atomic power will probably prevent present energy costs from rising.

## NEW CHAPTERS APPROVED

At a meeting on October 4, the Executive Committee approved five new professional group chapters. They are: Philadelphia Chapter of the PG on Antennas and Propagation, Washington Chapter of the PG on Electron Devices, Long Island Chapter of the PG on Microwave Theory and Techniques, Philadelphia Chapter of the PG on Microwave Theory and Techniques, and Washington Chapter of the PG on Nuclear Science.

## Technical Committee Notes

The **Audio Techniques** Committee met on September 15th under the chairmanship of D. E. Maxwell. Reactivation of Subcommittees 3.1, 3.2, and 3.3 was considered. Mr. Maxwell provided Mr. Runkle, Chairman of Subcommittee 3.1, with a list of terms to be studied as soon as the subcommittee is fully established. Mr. Kerney agreed to take over the chairmanship of Subcommittee 3.2, until it is reorganized and a permanent chairman is appointed. Mr. Moody agreed to set up Subcommittee 3.3 on the West Coast. The rest of the time was given over to a detailed review of proposed standards on Audio Systems and Components Excluding Recording: Methods of Measurement.

On October 8th, the **Facsimile** Committee convened under Chairman Burkhard. Mr. Lankes reported discussing the printing of a test chart with the West Dempster Company, to which he is writing about some of the problems involved. He showed some prints of a picture prepared for the chart by Eastman Kodak. The remainder of the time was spent in considering definitions of terms.

The **Feedback Control Systems** Committee met on October 7th, with R. B. Wilcox as Acting Chairman. Mr. Biernson read the announcement of formation of the IRE Professional Group on Automatic Control Technology.

After Mr. Axelby had distributed copies of the dictionary he had prepared and the committee had expressed appreciation, Mr. Sabin reported on the terms assigned to him for definition, comparing "precision" and "accuracy" with the ASME definitions. Mr. Biernson pointed out the advantages of making the definitions absolute rather than general, but Mr. Linvill felt that ideal defini-

tions, although desirable, are not practical. Following discussion of whether the term "accuracy" falls within the class of terms to be defined by the committee, it was agreed to establish at the next meeting a basis for deciding what terms should be defined.

Finally, the committee considered the activities of the newly formed Professional Group on Automatic Control Technology.

The **Industrial Electronics** Committee convened in September under the chairmanship of J. E. Eiselein. With the deletion of four definitions, the committee approved for publication the Standards on Induction and Dielectric Heating Definitions. H. R. Meahl, having suggested the committee work on methods of testing dielectrics, will contact J. L. Dalke and the Bureau of Standards to interest the Bureau in performing the work. It was suggested that the Department of Defense might be interested in a research program on this subject. Chairman Eiselein will check on this possibility. It was agreed by the committee that automation would become a new field of interest, especially automation manufacture of electronic equipment. Mr. Eiselein will head the working group, and each member will write his definitions of mechanization and automation. The committee will then try to arrive at a standard. Magnetic amplifiers also will be included in the scope of the committee. C. F. Spitzer will bring to the next meeting the AIEE definitions on magnetic amplifiers which, if satisfactory, will be processed through the IRE. Mr. Spitzer and W. C. Rudd reported on ultrasonics. They will outline the work to be done in this field, and it will be discussed at the next meeting.

Under the chairmanship of W. P. Mason, the **Piezoelectric Crystals** Committee convened on September 20th. R. A. Sykes reported briefly on the International Electro-technical Conference in Philadelphia (September 7-11), which he and E. A. Gerber attended. Then the group considered a draft of "Group Specification for Quartz Crystal Units for Oscillators" prepared by European experts. These men seek American opinion, since their Standards differ in many respects from American Standards, and unanimity is desired. The IEC had been advised that this meeting would consider standardization of definitions and nomenclature on piezoelectric crystals, based on a paper by E. A. Gerber published in PROCEEDINGS, vol. 41, Sept., 1953, to facilitate the next draft of the IEC standard. The committee accepted Mr. Gerber's definitions, and agreed to consider at the next meeting a standard based on his paper.

P. L. Smith reported on the need for standardization of terms in the field of magnetostriction. A subcommittee of Mr. Smith and K. S. Van Dyke was appointed to study this further.

R. A. Sykes submitted a first draft on items to be standardized in papers by W. P. Mason, H. Jaffe, and E. A. Gerber. The draft dealt with measurement of dielectric, elastic, and piezoelectric constants of crystals, and measurement of piezoelectric vibrators.

The **Radio Transmitters** Committee convened on September 30th under the chairmanship of P. J. Herbst. Mr. Kerwien, representative of the Radio Trznsmitters Committee on the *ad hoc* committee on Spurious Radiation (Standards Committee), reported on the meeting of September 15. He stated that the *ad hoc* committee was concerned with setting up a method of measurement, particularly for testing receivers, and that RETMA and other manufacturing organizations want a standard test set-up in which typical products of various manufacturers can be tested uniformly. This action stems from an ultimatum from the FCC that unless the interference problem is satisfactorily solved by industry, the government will make regulations in this field. Mr. Kerwien pointed out that the Transmitters Committee could do little other than tell groups of the methods of measurement evolved by the committee. He said that some persons in the receiver field had definite proposals, one being an open-field method and the other a shielded, dark, or dead room. The latter is considered preferable. Mr. Kerwien stated that the Transmitter Committee had been asked for a report on the Committee's work in this field, and Mr. Herbst read this report. The definition of "spurious radiation" given in 48 IRE 2.11.15.S1 was left unchanged, but the committee decided that its use for anything other than systems involving transmitters should be discouraged. The committee decided that the terms "spurious output," "spurious output, radiated," and "spurious output, conducted" should be defined. The remainder of the meeting was spent on subcommittee reports.

Under the chairmanship of W. J. Poch, the **Video Techniques** Committee convened on September 30th. The chairman explained recent developments in a campaign to reduce the effects of spurious radiation from various kinds of electronic equipment. Task groups have been set up under RETMA to attack this problem in a number of fields. The IRE has been asked to set up suitable methods for testing those devices under consideration by the RETMA task groups. An *ad hoc* committee under Mr. Shea has been set up by the Standards Committee to coordinate all the activities in this area by the various IRE committees concerned. It is not yet clear whether the type of equipment that comes within the scope of the Video Techniques Committee will fall into a separate category or be lumped with other more or less similar devices. In any case, representation from the Video Techniques Committee will probably be requested in the form of a task group or a liaison member of another committee. Suitable representation is to be arranged by the chairman when the request is made.

Results of the committee's activities during the past year were reviewed briefly, and the activities of the subcommittees were considered in order to assign priorities to projects being undertaken. After some discussion, it was agreed to direct major efforts towards obtaining agreement in those cases in which there are already accepted definitions.



# CONFERENCE ON TRANSISTOR CIRCUITS

SPONSORED BY IRE, AIEE, U. OF PENNSYLVANIA  
PHILADELPHIA, PA., FEBRUARY 17 AND 18

A National Conference on Transistor Circuits will be held in Philadelphia, February 17 and 18, under the sponsorship of the IRE Professional Group on Circuit Theory, the Science and Electronics Division of AIEE, and the University of Pennsylvania.

Advance registration forms have been mailed to all members of the sponsoring groups. Anyone interested in attending who has not received a form by January 15 should request one from W. J. Popowsky, Minneapolis-Honeywell Regulator Co., 176 West Loudon Street, Philadelphia 20, Pennsylvania.

## SESSION I

Thursday Morning

### OSCILLATORS

Chairman, J. J. Suran, General Electric, Syracuse

- "Transistor Superregenerative Detection," W. F. Chow, General Electric, Syracuse.
- "Field-Effect Transistor Applications," C. Huang, M. Marshall, and L. B. White, Sylvania, Ipswich.
- "A Stabilized Transistor Oscillator," E. Keonjian, General Electric, Syracuse.
- "A Symmetrical Transistor Oscillator with Low Second-Harmonic Distortion," W. M. Grim, Jr., MIT, Servomechanism Lab.

## SESSION II

Thursday Afternoon

### LINEAR SYSTEMS

Chairman, Richard B. Adler, MIT, R.L.E.

- "Predictions Based on the Maximum Oscillator Frequency," P. Drouilhet, Philco and MIT.
- "Principles of Automatic Gain Control of Transistor Amplifiers," W. F. Chow and A. P. Stern, General Electric, Syracuse.
- "A Transistor Transmitter-Receiver Unit," C. C. Bopp, Crosley Division of AVCO.
- "A Transistor Amplifier and Discriminator with Bias Stabilization," T. A. Patchell, Minneapolis-Honeywell, Brown Instrument Division.

## SESSION III

Friday Morning

### DIGITAL-COMPUTER CIRCUITS

Chairman, Richard Endres, RCA, Camden

- "Junction-transistor Flip-Flops with Differential-Transformer Coupling," Howard Kennedy and A. B. Jacobsen, Motorola, Phoenix.

- "A Multistable Transistor Circuit," R. A. Henle, I.B.M.
- "Transistors in Computer Circuits," D. E. Deutch, RCA, Camden.
- "Transistor Plug-In Units for Digital Computing Systems," R. H. Baker, MIT.
- "The Regeneration Analysis of Junction-Transistor Multivibrators," D. O. Pederson, Bell Labs.

## SESSION IV

Friday Afternoon

### "LARGE-SIGNAL" OPERATION

Chairman, Robert Mayer, Minneapolis-Honeywell, Brown Instrument Div.

- "Junction-Transistor Circuits for Analogue-to-Binary Code Conversion," F. H. Blecher, Bell Labs.
- "A Temperature-Compensated Transistor Power Converter," C. E. Paul, Bell Labs.
- "Transistors as Power-conversion Devices," R. R. Smyth, Technical Operations, Inc.
- "Power-Transistor Switching Circuits," E. Slobodzinski and C. Huang, Sylvania, Ipswich.
- "An N-Stage Series Transistor Circuit," K. H. Beck, Minneapolis-Honeywell, Brown Instrument Division.

## Professional Groups

	Chairman	Chairman
AERONAUTICAL & NAVIGATIONAL ELECTRONICS	Edgar A. Post United Air Lines Operations Base Stapleton Field Denver 7, Colo.	ENGINEERING MANAGEMENT Charles J. Breitwieser RCA Victor Division Camden, N. J.
ANTENNAS AND PROPAGATION	D. C. Ports Jansky & Bailey 1339 Wisconsin Ave. N.W. Washington 7, D. C.	INDUSTRIAL ELECTRONICS George P. Bosomworth Firestone Tire & Rubber Co. Akron 17, Ohio
AUDIO	Vincent Salmon Stanford Research Institute Stanford, Calif.	INFORMATION THEORY Louis A. De Rosa 500 Washington Ave. Nutley, N. J.
AUTOMATIC CONTROL	R. B. Wilcox Raytheon Mfg. Co. 148 California St. Newton, Mass.	INSTRUMENTATION R. L. Sink Consolidated Engineering Corp. 300 Sierra Madre Villa Pasadena, Calif.
BROADCAST TRANSMISSION SYSTEMS	Lewis Winner 52 Vanderbilt Ave., New York, N. Y.	MEDICAL ELECTRONICS J. F. Herrick Mayo Clinic Rochester, Minn.
BROADCAST & TELEVISION RECEIVERS	Wilson P. Boothroyd Philco Corporation Tioga & C Streets Philadelphia 32, Pa.	MICROWAVE THEORY AND TECHNIQUES W. W. Mumford Bell Telephone Laboratories Whippany, N. J.
CIRCUIT THEORY	C. H. Page National Bureau of Standards Washington, D. C.	NUCLEAR SCIENCE D. H. Loughridge Northwestern Technical Institute Evanston, Ill.
COMMUNICATIONS SYSTEMS	Col. J. Z. Millar Western Union Telegraph Co. 60 Hudson St., New York 13, N. Y.	PRODUCTION TECHNIQUES R. R. Batchler 240-02 42 Ave. Douglaston, L. I. N. Y.
COMPONENT PARTS	Floyd A. Paul Northrop Aircraft, Inc. Hawthorne, Calif.	RELIABILITY AND QUALITY CONTROL Leon Bass 255 N. Halstead Ave. Pasadena 8, Calif.
ELECTRON DEVICES	George A. Espersen Phillips Laboratories, Inc. Irvington-on-Hudson, N. Y.	TELEMETRY AND REMOTE CONTROL M. V. Kiebert, Jr. P. R. Mallory & Co., Inc. Indianapolis, Ind.
ELECTRONIC COMPUTERS	Harry T. Larson Hughes Aircraft Co. Culver City, Calif.	ULTRASONICS ENGINEERING A. L. Lane 706 Chillum Road Hyattsville, Md.
		VEHICULAR COMMUNICATIONS W. A. Shipman Columbia Gas. Sys. Ser. Corp. 120 E. 41 St., N. Y. 17, N. Y.

# Sections\*

## Chairman

K. F. Sibila  
1745-13 St.  
Cuyahoga Falls, Ohio

T. F. Marker  
3133-40 St.  
Sandia Base  
Albuquerque, N. M.

G. M. Howard  
413 Ridgecrest Rd., N.E.  
Atlanta, Ga.

C. D. Pierson, Jr.  
Broadview Apts. 1126  
116 West University  
Pkwy.  
Baltimore 10, Md.

L. C. Stockard  
1390 Lucas Dr.  
Beaumont, Texas

N. S. Lawrence  
Johnson's Corners, R.D. 1  
Harpursville, N. Y.

A. J. Pote  
M.I.T., Lincoln Lab.  
Box 73  
Lexington 73, Mass.

P. N. Guzzi  
Cangallo 1286  
Buenos Aires, Argentina

J. H. Doolittle  
Goodrich Road  
Clarence, N. Y.

J. W. Smith  
1136-27 St., N.E.  
Cedar Rapids, Iowa

H. R. Denius  
Box Q  
Melbourne, Fla.

J. J. Gershon  
De Vry Tech. Inst.  
4141 Belmont Ave.  
Chicago 41, Ill.

R. A. Maher  
6133 Sunridge Dr.  
Cincinnati 24, Ohio

H. R. Mull  
4558 Silverdale Ave.  
North Olmsted, Ohio

R. W. Masters  
1633 Essex Road  
Columbus 21, Ohio

H. E. Rohloff  
Southern New England  
Telephone Co.  
227 Church St.  
New Haven, Conn.

J. A. Green  
6815 Oriole Dr.  
Dallas 9, Texas

A. B. Henderson  
801 Hathaway Road  
Dayton 9, Ohio

R. E. Swanson  
1777 Kipling St.  
Denver 15, Colo.

W. L. Cassell  
Dept. of Elect. Engineer-  
ing  
Iowa State College  
Ames, Iowa

E. J. Love  
9264 Boleyn  
Detroit 24, Mich.

J. L. Sheldon  
179 Dodge Ave.  
Corning, N. Y.

## Secretary

AKRON (4) C. O. Lambert  
1144 Roslyn Ave.  
Akron 20, Ohio

ALBUQUERQUE-  
LOS ALAMOS (7) T. G. Banks, Jr.  
1124 Monroe St., S.E.  
Albuquerque, N. M.

ATLANTA SEC-  
TION (6) K. W. Bugg  
Board of Education  
14 Floor, City Hall  
Atlanta, Ga.

BALTIMORE (3) M. I. Jacob  
1505 Tredegar Ave.  
Catonsville 28, Md.

BEAUMONT-  
PORT ARTHUR (6) John Petkovsek, Jr.  
4390 El Paso Ave.  
Beaumont, Texas

BINGHAMTON (4) O. T. Ling  
100 Henry St.  
Binghamton, N. Y.

BOSTON (1) T. P. Cheatham, Jr.  
Hosmer St.  
Marlborough, Mass.

BUENOS AIRES C. E. Sussenguth  
Gral. Urquiza 1914  
Florida F.C.N.G.B.M.  
Argentina

BUFFALO-  
NIAGARA (4) W. L. Kinsell  
207 Ridgewood Dr.  
Snyder  
Buffalo 21, N. Y.

CEDAR RAPIDS  
(5) R. M. Ringeon  
1941 Washington, Ave.,  
S.E.  
Cedar Rapids, Iowa

CENTRAL  
FLORIDA (6) K. A. West  
1345 Indian River Dr.  
Eau Gallie, Fla.

CHICAGO (5) J. S. Brown  
9829 S. Hoyne Ave.  
Chicago 43, Ill.

CINCINNATI (5) W. S. Alberts  
6533 Elwynne Dr.  
Silverton  
Cincinnati 36, Ohio

CLEVELAND (4) W. G. Piwonka  
3121 Huntington Road  
Cleveland 20, Ohio

COLUMBUS (4) T. E. Tice  
2214 Jervis Road  
Columbus 21, Ohio

CONNECTICUT  
VALLEY (1) B. R. Kamens  
45 Brooklawn Circle  
New Haven 15, Conn.

DALLAS-FORT  
WORTH (6) G. K. Teal  
Texas Instruments, Inc.  
6000 Lemmon Ave.  
Dallas, Texas

DAYTON (5) N. L. Laschever  
849 N. Upland Ave.  
Dayton, Ohio

DENVER (5) S. Bedford, Jr.  
Mountain States Tel. &  
Tel.  
Room 802  
Denver, Colo.

DES MOINES-  
AMES (5) W. L. Hughes  
Dept. of Elec. Engr'g  
Iowa State College  
Ames, Iowa

DETROIT (4) M. B. Scherba  
270 S. Melborn  
Dearborn, Mich.

ELMIRA-COR-  
NING (4) J. P. Hocker  
Pilot Plant No. 2  
Corning Glass Works  
Corning, N. Y.

## Chairman

J. F. Stuart  
Box 991  
El Paso, Texas

J. B. Grund  
Sylvania Electric Prods.  
Emporium, Pa.

A. P. Haase  
2230 St. James Ct.  
Owensboro, Ky.

J. J. Ifland  
2603 Merivale St.  
Kirkwood Park  
Ft. Wayne 8, Ind.

G. M. Cox  
154 Victoria St., S.  
Kitchener, Ont., Canada

G. W. Clark  
Box 193  
Lanikai, Oahu, T. H.

W. J. Greer  
Halliburton Oil Well &  
Cementing Co.  
1628 Old Spanish Trail  
Houston 25, Texas

D. E. French  
1403 E. Clinton St.  
Huntsville, Ala.

J. T. Watson  
1515 Central Ave.  
Indianapolis 2, Ind.

F. S. Howell  
109-16 St.  
Edwards, Calif.

Ben Warriner  
General Electric Co.  
Advanced Electronics  
Center  
Ithaca, N. Y.

K. V. Newton  
Bendix Aviation Corp.  
Box 1159  
Kansas City 41, Mo.

Raymond Beem  
Route 3  
Malvern, Ark.

J. H. Blackwell  
863 Colborne St.  
London, Ont., Canada

W. F. Bailey  
Hazeltine Corp.  
58-25 Little Neck Pkwy.  
Little Neck, N. Y.

B. S. Angwin  
3300 Colby Ave.  
Los Angeles, Calif.

R. W. Mills  
1017 Eastern Pkwy.  
Louisville 4, Ky.

A. H. Lynch  
Box 466  
Ft. Myers, Fla.

W. E. Watts  
2224 N. 70 St.  
Wauwatosa 13, Wis.

R. W. Cooke  
18 Muir Road  
Senneville, P.Q., Canada

L. J. N. Du Treil  
202 Homedal Ave.  
New Orleans 24, La.

A. B. Giordano  
85-99 Livingston St.  
Brooklyn 2, N. Y.

G. B. Hoadley  
North Carolina State Coll.  
Raleigh, N. C.

F. A. Polkinghorn  
63 Monroe Pl.  
Bloomfield, N. J.

## Secretary

EL PASO (7) W. T. McGill  
7509 Mazatlan Road  
El Paso, Texas

EMPORIUM (4) D. A. Dander  
101½ W. Fourth St.  
Emporium, Pa.

EVANSVILLE-  
OWENSBORO (5) D. D. Mickey, Jr.  
Engineering Department  
General Electric Co.  
Owensboro, Ky.

FORT WAYNE (5) T. L. Slater  
1916 Eileen Dr.  
Waynedale, Ind.

HAMILTON (8) A. L. Fromanger  
Box 507  
Ancaster, Ont., Canada

HAWAII (7) J. R. Sanders  
c/o Matson Navigation  
Co.  
Box 899  
Honolulu, T. H.

HOUSTON (6) R. S. Bush  
3818 Alberta Ave.  
Houston 21, Texas

HUNTSVILLE (6) T. L. Greenwood  
1709 LaGrande St.  
Huntsville, Ala.

INDIANAPOLIS (5) M. J. Arvin  
4329 Fletcher Ave.  
Indianapolis 1, Ind.

INYOKERN (7) H. A. Kirsch  
528 K. Nimitz  
China Lake, Calif.

ITHACA (4) R. L. Wooley  
110 Cascadilla St.  
Ithaca, N. Y.

KANSAS CITY (5) Mrs. G. L. Curtis  
Radio Industries, Inc.  
1307 Central Ave.  
Kansas City 2, Kan.

LITTLE ROCK (5) D. L. Winn  
10 & Spring Sts.  
Little Rock, Ark.

LONDON (8) J. D. B. Moore  
27 McClary Ave.  
London, Ont., Canada

LONG ISLAND (2) P. G. Hansel  
Addison Lane  
Greenvale, L. I., N. Y.

LOS ANGELES (7) C. E. Rutherford  
209 S. Oakhurst Dr.  
Beverly Hills, Calif.

LOUISVILLE (5) L. A. Miller  
314 Republic Bldg.  
Louisville 2, Ky.

MIAMI (6) William H. Epperson  
Box 65  
Coral Gables 34, Fla.

MILWAUKEE (5) W. A. Van Zeeland  
4510 N. 45 St.  
Milwaukee 16, Wis.

MONTREAL (8) F. H. Margolick  
Canadian Marconi Co.  
2442 Trenton Ave.  
Montreal, Que., Canada

NEW ORLEANS  
(6) J. A. Cronvich  
Dept. Elec. Engineering  
Tulane University  
New Orleans 18, La.

NEW YORK (2) H. S. Renne  
366 Madison Ave.  
New York 17, N. Y.

NORTH  
CAROLINA-  
VIRGINIA (3) M. J. Minor  
Route 3, York Rd.  
Charlotte, N. C.

NORTHERN  
NEW JERSEY (2) B. G. Griffith  
127 Park Ave.  
Verona, N. J.

\* Numerals in parentheses following Section designate Region number.



## Sections

### Chairman

G. W. Holt  
4420 N.W. 19 Blvd.  
Oklahoma City 7, Okla.

M. L. McGowan  
5544 Mason St.  
Omaha 6, Neb.

W. A. Cumming  
Radio & Elec. Eng. Div.  
National Research Council  
Ottawa, Ont., Canada

S. C. Spielman  
Philco Corp.  
4700 Wissahickon Ave.  
Philadelphia, Pa.

P. W. Sokoloff  
1113 E. Oregon Ave.  
Phoenix, Ariz.

F. C. Alexander, Jr.  
2824 Mt. Royal Blvd. &  
Sutter Road  
Glenshaw, Pa.

Howard Vollum  
1000 N.W. Skyline Blvd.  
Portland, Ore.

Jerome Kurshan  
RCA Labs.  
Princeton, N. J.

Allan Holstrom  
551 Spencer Rd.  
Rochester 9, N. Y.

Harry Davis  
716 Cherry St.  
Rome, N. Y.

I. L. Dutton  
5980 N. Haven Dr.  
North Highlands Calif.

R. W. Benson  
818 S. Kingshighway  
St. Louis 10, Mo.

M. E. Van Valkenburg  
Dept. of Elec. Eng.  
University of Utah  
Salt Lake City 1, Utah

### Secretary

OKLAHOMA CITY (6)  
W. E. Lucey  
1348 Kinkaid Ave.  
Oklahoma City, Okla.

OMAHA-LINCOLN (5)  
C. W. Rook  
Dept. Elec. Engineering  
University of Nebraska  
Lincoln 8, Neb.

OTTAWA (8)  
Charles Pattenson  
Box 527  
Ottawa, Ont., Canada

PHILADELPHIA (3)  
M. S. Corrington  
12 E. Cottage Ave.  
Haddonfield, N. J.

PHOENIX (7)  
Everett Eberhard  
30 E. Colter St.  
Phoenix 43, Ariz.

PITTSBURGH (4)  
K. A. Taylor  
Bell Tel. Co. of Pa.  
416 Seventh Ave.  
Pittsburgh 19, Pa.

PORTLAND (7)  
R. R. Pooley  
Radio Station KPOJ  
Box 31  
Portland 7, Ore.

PRINCETON (3)  
J. L. Potter  
Rutgers University  
New Brunswick, N. J.

ROCHESTER (4)  
W. F. Bellor  
186 Dorsey Road  
Rochester 16, N. Y.

ROME-UTICA (4)  
M. V. Ratynski  
Rome Air Devel. Center  
Box 266  
Griffiss Air Force Base  
Rome, N. Y.

SACRAMENTO (7)  
Ewald Berger  
3421-58 St.  
Sacramento 20, Calif.

ST. LOUIS (5)  
A. E. Lennert  
5507 Waterman Ave.  
St. Louis 12, Mo.

SALT LAKE CITY (7)  
A. L. Gunderson  
3906 Parkview Dr.  
Salt Lake City, Utah

### Chairman

C. M. Crain  
Engineering Bldg. 149  
University of Texas  
Austin, Texas

W. S. Ivans, Jr.  
8669 Lemon Ave.  
La Mesa, Calif.

A. J. Morris  
1827 Cordilleras Road  
Redwood City, Calif.

R. E. Anderson  
638 Brandywine Ave.  
Schenectady, N. Y.

A. E. Harrison  
Elect. Engr'g. Dept.  
University of Washington  
Seattle 5, Wash.

W. H. Hall  
General Electric Co.  
Syracuse, N. Y.

L. S. Rynder  
140 Rockingham St.  
Toledo 10, Ohio

E. L. Palin  
2137 Bayview Ave.  
Willowdale  
Toronto, Ont., Canada

C. F. Hadley  
1356 E. 45 Pl.  
Tulsa 15, Okla.

F. S. Hird  
Northwestern Bell Tel.  
Co.  
224 S. Fifth St.  
Minneapolis, Minn.

M. Green  
North-West Tel. Co.  
2226 W. Tenth Ave.  
Vancouver, B.C., Canada

T. B. Jacobs  
General Electric Co.  
777-14 St., N.W.  
Washington, D. C.

J. E. Snook  
1629 Warren Ave.  
Williamsport, Pa.

Haakon Haakonsen  
University of Manitoba  
Dept. of E.E.  
Fort Garry, Man., Canada

### Secretary

SAN ANTONIO (6)  
W. H. Hartwig  
Dept. of Elec. Engr.  
University of Texas  
Austin 12, Texas

SAN DIEGO (7)  
Harold Story  
1068 Agate St.  
San Diego 9, Calif.

SAN FRANCISCO (7)  
J. S. McCullough  
1791 Willow St.  
San Jose 25, Calif.

SCHENECTADY (2)  
J. S. Hickey, Jr.  
General Electric Co.  
Research Lab.  
Schenectady, N. Y.

SEATTLE (7)  
R. H. Hoglund  
1825 E. Lynn St.  
Seattle 2, Wash.

SYRACUSE (4)  
M. A. Johnson  
R.D. 1, Totman Road  
East Syracuse, N. Y.

TOLEDO (4)  
L. R. Klopfenstein  
Portage,  
Ohio

TORONTO (8)  
F. J. Heath  
830 Lansdowne Ave.  
Toronto 4, Ont., Canada

TULSA (6)  
L. H. Hooker  
4064 E. 22 Pl.  
Tulsa 5, Okla.

TWIN CITIES (5)  
J. L. Hill  
25-17 Avenue, N.E.  
North St. Paul 9, Minn.

VANCOUVER (8)  
J. S. Gray  
4069 W. 13 Ave.  
Vancouver, B.C., Canada

WASHINGTON (3)  
R. I. Cole  
2208 Valley Circle  
Alexandria, Va.

WILLIAMSPORT (4)  
F. T. Henry  
1345 Pennsylvania Ave.  
Williamsport, Pa.

WINNIPEG (8)  
G. R. Wallace  
400 Smithfield Ave.  
Winnipeg, Man., Canada

## Subsections

### Chairman

R. B. Spear  
510 E. Hill St.  
Brownfield, Texas

S. C. Leonard  
Cheshire  
Mass.

E. C. Sternke  
Route 2, Box 122  
Camarillo, Calif.

R. V. Higdon  
1030 S. Atherton St.  
State College, Pa.

W. L. Schachte  
152 Grove St.  
Charleston 22, S. C.

J. L. Corl  
622 Rincon Road  
Richmond 11, Calif.

A. R. Davidson  
3422 Argyle Ave.  
Erie, Pa.

G. W. Scott, Jr.  
Research Labs.  
Armstrong Cork Co.  
Lancaster, Pa.

### Secretary

AMARILLO-LUBBOCK (6)  
J. B. Joiner  
2621-30 St.  
Lubbock, Texas

BERKSHIRE (1)  
W. E. Neubert  
21 Highlawn Dr.  
Pittsfield, Mass.

BUENAVENTURA (7)  
O. LaPlant  
325 North 'J' St.  
Oxnard, Calif.

CENTRE COUNTY (4)  
W. L. Baker  
1184 Oneida St.  
State College, Pa.

CHARLESTON (6)  
Arthur Jonas  
21 Madden Dr.  
Dorchester Terr.  
Charleston Heights, S. C.

EAST BAY (7)  
R. D. Ogg  
48 Arlington Ave.  
Berkeley 8, Calif.

ERIE (4)  
K. L. Hestor  
2909 Tuttle Ave.  
Erie, Pa.

LANCASTER (3)  
G. E. Mandell  
522 East King St.  
Lancaster, Pa.

### Chairman

E. J. Breiding  
54 S. Grand Ave.  
Poughkeepsie, N. Y.

W. M. Goodall  
Bell Telephone Labs.  
Box 107  
Red Bank, N. J.

K. L. Huntley  
Mary Esther  
Fla.

B. F. Husten  
Naval Ord. Lab.  
Corona, Calif.

J. V. Granger  
320 Encinal Ave.  
Menlo Park, Calif.

W. V. Record  
4511 E. Ninth St.  
Tucson, Ariz.

L. A. Yarbrough  
Box 3001, USAFIT  
Wright-Patterson AFB  
Ohio

H. G. Swift  
1642 South Main  
Wichita, Kan.

### Secretary

MID-HUDSON (2)  
E. S. Wilson  
I.B.M. Corp.  
Engineering Lab.  
Poughkeepsie, N. Y.

MONMOUTH (2)  
A. H. Ross  
923 Broad St.  
Shrewsbury, N. J.

NORTHWEST FLORIDA (6)  
G. C. Jones  
12 N. Okaloosa Road  
Fort Walton Beach, Fla.

ORANGE BELT (7)  
T. A. Mayeda  
3658 Monroe St.  
Riverside, Calif.

PALO ALTO (7)  
W. B. Wholey  
342 Verano Dr.  
Los Altos, Calif.

RICHLAND (7)  
(Seattle)  
(To be elected)

TUCSON (7)  
A. J. Bersbach  
5326 E. Seventh St.  
Tucson, Ariz.

USAFIT (5)  
J. J. Gallagher  
Box 3482 USAFIT  
Wright-Patterson AFB  
Ohio

WICHITA (5)  
V. N. Johnson  
1652 S. Edgemoor  
Wichita 17, Kan.

# Abstracts and References

Compiled by the Radio Research Organization of the Department of Scientific and Industrial Research, London, England, and Published by Arrangement with that Department and the *Wireless Engineer*, London, England

NOTE: The Institute of Radio Engineers does not have available copies of the publications mentioned in these pages, nor does it have reprints of the articles abstracted. Correspondence regarding these articles and requests for their procurement should be addressed to the individual publications, not to the IRE.

Acoustics and Audio Frequencies.....	114
Antennas and Transmission Lines.....	115
Automatic Computers.....	116
Circuits and Circuit Elements.....	116
General Physics.....	118
Geophysical and Extraterrestrial Phenomena.....	120
Location and Aids to Navigation.....	120
Materials and Subsidiary Techniques.....	120
Mathematics.....	123
Measurements and Test Gear.....	123
Other Applications of Radio and Electronics.....	124
Propagation of Waves.....	125
Reception.....	125
Stations and Communication Systems.....	125
Subsidiary Apparatus.....	126
Television and Phototelegraphy.....	126
Transmission.....	127
Tubes and Thermionics.....	127
Miscellaneous.....	128

The number in heavy type at the upper left of each Abstract is its Universal Decimal Classification number and is not to be confused with the Decimal Classification used by the United States National Bureau of Standards. The number in heavy type at the top right is the serial number of the Abstract. DC numbers marked with a dagger (†) must be regarded as provisional.

## ACOUSTICS AND AUDIO FREQUENCIES

534.213:538.65 **3433**

**Magnetic Dispersion of Longitudinal Sound Oscillations**—L. L. Myasnikov and G. K. Ul'yanov. [*Compt. Rend. Acad. Sci. (URSS)*, vol. 96, pp. 729-731; June 1, 1954. In Russian.] The dispersion of sound and the logarithmic decrement of oscillations were determined experimentally in a rectangular Al plate of dimensions  $131.5 \times 7.5 \times 1.8$  mm, at a frequency of 18.5 kc, a magnetic field being applied in a direction perpendicular to the longitudinal oscillations. The resonance frequency rose by 1.5 cps on applying a field of  $12.8 \times 10^3$  gauss, the decrement increased by 15 per cent. Using a specimen of thickness 1 mm, the dispersion increased to 3 cps, the decrement by 30 per cent.

534.213:538.65 **3434**

**Magnetoacoustic Effect in Paramagnetic and Diamagnetic Metals**—L. L. Myasnikov and G. K. Ul'yanov. [*Compt. Rend. Acad. Sci. (URSS)*, vol. 96, pp. 967-969; June 11, 1954. In Russian.] Previously reported work on the magnetic dispersion of sound in Al (3433 above) is extended to include Mg and Cu. Results indicate that the magnetoacoustic effect in torsionally vibrating plates is produced by heating currents which cause changes in the effective acoustic impedance. An increase in the resistive component of the impedance results in an increase in damping, an increase in the reactive component in an increase in phase velocity.

534.231.3 **3435**

**Acoustic Impedance of a Moving Plane Emitter**—D. N. Chetaev. [*Compt. Rend. Acad. Sci. (URSS)*, vol. 90, pp. 355-358; May 21, 1953. In Russian.] Expressions are derived for the resistive and reactive components of the

impedance of a plane plate in an infinite rigid wall whose position is given by  $z=0$ , vibrating according to  $\dot{z}=v \exp(i\omega t)$  and radiating into the semispace  $z>0$  which is filled with a perfectly compressible fluid moving in the direction of the  $y$  axis with a velocity  $V$  smaller than the velocity of sound  $u$ . The values of the resistance and the reactance are tabulated for the particular case of a square plate for values of  $ka$  ranging from 1 to 10, where  $k=\omega/u$  and  $a$  is a function of the linear dimensions of the plate, for  $V/u=0.1$ .

534.232:621.395.623.8 **3436**

**Sound Radiation from the Zonal Radiators**—T. Nimura and Y. Watanabe. [*Sci. Rep. Res. Inst. Tohoku Univ., Ser. B*, vol. 5, pp. 155-195; December, 1953/March, 1954.] Radiators analyzed are (a) infinitely long cylinders, (b) prolate spheroids, (c) sphere, and (d) oblate spheroids. Expressions are obtained, and results are shown graphically, for the sound pressure, the directivity and the radiation impedance.

534.32:621.372.5 **3437**

**Use of Integrator and Differentiator Circuits in Acoustics Technique**—A. Foch, J. Rateau and R. Counord. [*Compt. Rend. Acad. Sci. (Paris)*, vol. 239, pp. 528-529; August 18, 1954.] Preliminary note indicating modifications of vocal or instrumental sounds that can be produced by including integrators or differentiators in the reproducing circuits. The reversibility of the effects was confirmed by an experiment in which a voice was easily recognizable after two successive differentiations followed by two integrations.

534.321.9:534.22 **3438**

**Application of the Pulse Method to Measurement of the Velocity of Ultrasonic Waves**—E. I. Chuikin. [*Zh. Tekh. Fiz.*, vol. 24, pp. 1125-1135; June, 1954.] Errors due to the distortion of the acoustic pulse at the boundary of media with different acoustic impedances were calculated and the results were confirmed experimentally by measurements of the velocity of ultrasonic waves at 1 and 4.9 mc in polyethylene.

534.614.082.5 **3439**

**Apparatus to Measure the Velocity of Sound Down to Liquid Helium Temperatures with the Optical Method**—A. van Itterbeek, G. J. van den Berg and W. Limburg. [*Physica*, vol. 20, pp. 307-310; May, 1954.]

534.78:621.317.755 **3440**

**Visible-Speech Rotary-Field Coordinate-Conversion Analyser**—F. Vilbig. [*Trans. I.R.E.*, vol. AU-2, pp. 76-80; May/June, 1954.] Cro apparatus is described for displaying patterns corresponding to sounds, the signals being applied to the two pairs of plates with

the same amplitude and a 90-degree phase difference so as to produce a polar-coordinate pattern. An optical arrangement comprising a rotating slotted disk and an independently rotating prism is used to transform this into a cartesian-coordinate pattern, thereby facilitating the investigation of certain sounds.

534.8:621.396.712.2/3 **3441**

**The Acoustical Design of a New Sound Broadcasting Studio for General Purposes**—H. R. Humphreys. [*BBC. Quart.*, vol. 9, pp. 102-110; Summer, 1954.] Illustrated description of the BBC studio LH. 1. The area, of about 650 feet<sup>2</sup>, is divided into acoustically live and dead parts by a folding partition of height 8 feet faced on the one side with plywood and on the other with absorbent material; the partition is continued to the full height of the studio (16 feet) in the form of suitably treated double curtains. Reverberation/frequency characteristics obtained during construction and in the final state are shown.

534.84 **3442**

**Simplified Methods for the Measurement of the Acoustic Parameters of Rooms**—G. Kurtze. [*Tech. Mitt. schweiz. Telegr.-Teleph. Verw.*, vol. 32, pp. 218-222; June 1, 1954. In German.] Equipment is described for measuring irregularities of the sound-pressure/frequency characteristic at a fixed point, and the directional diffusion [311 of March (Thiele)]. Electrical-circuit methods are used to reduce the labor involved in evaluating the measurements.

534.845:518.3 **3443**

**A Nomogram for the Simplified Determination of the Coefficient of Sound Absorption by the Reverberation-Chamber Method**—W. Händler and G. Venzke. [*Tech. Hausmitt. Nordw.Dtsch. Rdfunks*, vol. 6, nos. 3/4, pp. 84-87; 1954.]

621.395.616 **3444**

**Condenser Microphone Type MR-103**—T. Hayasaka, K. Masuzawa and M. Suzuki. [*Rep. Elect. Commun. Lab. (Japan)*, vol. 2, pp. 1-5; February, 1954.] The microphone, 24 mm in diameter and 21 mm in length, is constructed entirely of titanium apart from an insulator of optical glass. The diaphragm is 0.009-0.017 mm thick and 0.2 mm from the back electrode, which is perforated and slotted for free passage of air. Operating characteristics shown compare favorably with those of a West-ern Electric Type 640-AA.

621.395.623.7.001.4 **3445**

**Standardizing L. S. Measurements**—(*Wireless World*, vol. 60, pp. 493-494; October, 1954.) A note on British Standard 2498: 1954.



- 621.395.625.3** 3446  
**New Pickup Arm**—(*Wireless World*, vol. 60, p. 495; October, 1954.) In a design for reducing tracking errors with the usual lateral-cut disk, two arms of different lengths are linked so as to keep the pickup head aligned very closely along the ideal tangential direction at all radial distances.
- 621.395.625.3** 3447  
**Distortion due to Mechanical Disturbances in Magnetic Sound-Recording Apparatus**—W. Guckenbug. (*Funk u. Ton*, vol. 8, pp. 312-322; June, 1954.) Distortion due to nonuniform motion and transverse movements of the magnetic tape is discussed. The effect of various mechanical defects of the driving mechanism is considered theoretically and the permissible mechanical tolerances are deduced from considerations of the corresponding audible distortion at various frequencies and tape velocities. Amplitude distortion due to the use of differently positioned magnetic heads in recording and in reproduction is also discussed.
- 621.395.625.3** 3448  
**Production of Gap in Magnet Systems for Recording and Reproduction of Magnetograms**—K. A. Egerer. (*Frequenz*, vol. 8, pp. 180-182; June, 1954.) The manufacture and electrical characteristics of magnetic heads with accurately dimensioned diamagnetic gaps are considered. The gap materials investigated included Au, Ag, Cd, selenides, tellurides,  $Al_2O_3$  and  $SiO_2$ . Electrolytic deposition of the diamagnetic material on the pole-pieces was found suitable in several cases.
- 621.395.625.3:621.385.832** 3449  
**Magnetic-Tape Pickup has D.C. Response**—J. W. Gratian. (*Electronics*, vol. 27, pp. 156-159; September, 1954.) The low-frequency response of a reproducing head of the electron-tube beam-deflection type (1985 of August) is improved by using transverse rather than longitudinal magnetization. The construction of a suitable external core for the pickup tube is described. A system using both longitudinal and transverse recording is recommended for applications where good response is required at high audio frequencies as well as dc.
- ANTENNAS AND TRANSMISSION LINES**
- 621.315.212** 3450  
**Modern Coaxial-Cable Technique in Great Britain**—E. Baguley. (*Elec. Commun.*, vol. 31, p. 152; June, 1954.) Correction to paper abstracted in 960 of May.
- 621.372:621.385.029.63/.64** 3451  
**Coupling of Modes in Helices**—J. R. Pierce and P. K. Tien. (PROC. I.R.E., vol. 42, pp. 1389-1396; September, 1954.) Propagation in helices is analyzed as an effect of the coupling through spatial harmonics of the slow wave, which travels along the wire with a velocity about the same as that of light, to the fast waves, which travel along the axis with such a velocity. The results are in general agreement with those obtained by a method of analysis assuming the helix to be wound of infinitely thin conducting tape. Cases considered include the helix in free space, the helix surrounded by a conducting tube, and the bifilar helix. See also 1987 of August (Pierce).
- 621.373.2.015.3** 3452  
**The Use of Thévenin's Equivalent Circuit to determine the Conditions at the Termination of a Lossless Transmission Line on Arrival of a Surge**—G. C. Dewsnap. (*Aust. Jour. Appl. Sci.*, vol. 5, pp. 132-140; June, 1954.) Two equivalent circuits are discussed, the one appropriate when the pulse is rectangular and the line termination resistive, the other when the pulse is nonrectangular and the termination includes reactance.
- 621.372.21:621.315.213** 3453  
**Machine Methods Make Strip Transmission Line**—K. S. Packard. (*Electronics*, vol. 27, pp. 148-150; September, 1954.) A microstrip transmission line of the type comprising a conducting strip between two ground planes [621 of 1953 (Grieg and Engelmann)] has the conducting strip split into an upper and a lower half with a dielectric support between them. The two halves are connected together at input and output so that they are at the same potential. This construction gives a high  $Q$ , such as is desirable in filters and resonators. Dimensions must be kept below indicated limits in order to eliminate propagation of higher modes. Operation at frequencies up to 10 kmc has been achieved; there is no low-frequency limit, except that the length of resonant elements becomes impracticable below about 100 mc.
- 621.372.8** 3454  
**A Contribution to the Theory of Right-Angled Junctions in Wave Guides**—J. D. Pearson. (*Quart. Jour. Mech. Appl. Math.*, vol. 7, part 2, pp. 194-202; June, 1954.) "The propagation of waves through a junction of two rectangular wave guides at right angles is considered for the case when the dimensions of one of the guides are such as to allow the propagation of more than one mode. Numerical results are given when one guide is of square cross-section."
- 621.372.8** 3455  
**A Method of Broadbanding Waveguide Windows**—H. G. Hereward and M. G. N. Hine. (PROC. I.R.E., vol. 42, pp. 1450-1451; September, 1954.) Increased bandwidth is obtained by providing series as well as shunt inductance. A  $v_{swr}$  less than 1.02 is theoretically obtainable over a frequency band of  $\pm 20$  per cent at a wavelength of about 10 cm with an arrangement using a silica window with inductive irises and inductive slots on both sides. Such a window has been used to pass up to about 15 mw peak power.
- 621.372.8** 3456  
**A Simple Graphical Analysis of a Two-Port Waveguide Junction**—L. B. Felsen and A. A. Oliner; J. E. Storer, L. S. Sheingold and S. Stein. (PROC. I.R.E., vol. 42, pp. 1447-1448; September, 1954.) Comment on 3191 of 1953, authors' reply, and further comment.
- 621.372.8** 3457  
**Waveguides with Nonhomogeneous Dielectric**—D. Graffi. (PROC. I.R.E., vol. 42, pp. 1449-1450; September, 1954.) A summary is given of papers by several authors, published in Italy, giving analysis for waveguides having perfectly conducting walls and enclosing dielectrics with nonuniform permittivity.
- 621.372.8:621.315.6** 3458  
**Dielectric Tubes as Waveguides**—H. G. Unger. (*Arch. elekt. Übertragung*, vol. 8, pp. 241-252; June, 1954.) With dielectric rods, the frequency band over which the attenuation of surface waves is reasonably low is not wide enough for practical communication purposes. A theoretical study is made of the possibility of obtaining a larger bandwidth by using dielectric tubes. The propagation constants of the natural  $H_{01}$ ,  $E_{01}$  and  $HE_{11}$  modes are derived; the  $H_{11}$  is most suitable for use as principal mode in the low-loss transmission of centimeter waves. Applications as antennas and flexible lines are indicated; a metal funnel is used to excite the dielectric tube.
- 621.396.67** 3459  
**On Minimum Range for Radiation Patterns**—D. H. Rhodes. (PROC. I.R.E., vol. 42, pp. 1408-1410; September, 1954.) It is shown that at distances equal to or greater than  $2D^2/\lambda$ , where  $D$  is the greatest transverse dimension of the antenna, the phase variation over  $D$  is  $< \pi/8$  and the amplitude variation is  $< 10$  per cent when the dimensions of the illuminating aperture are  $< D$ . The pattern of a uniform line antenna illuminated by a paraboloid of such dimensions is essentially the same as with a point source of illumination. For back-scattering measurements the minimum range is  $4D^2/\lambda$ .
- 621.396.67:621.397.61** 3460  
**The Impedance Specification of a Television Transmitting Antenna**—H. Page. (*BBC Quart.*, vol. 9, pp. 123-128; Summer, 1954.) Until recently, the BBC specified for television transmitting antennas a SWR better than 0.95 over the working frequency band when connected to the transmission line. Experiments made at the Sutton Coldfield station [845 of 1952 (Bevan and Page)] indicated that some relaxation of this specification was permissible. An account is given of tests made to determine the shape of the reflection-coefficient/frequency characteristic permitting the greatest relaxation consistent with maintaining at an imperceptible level the signal delayed by reflection at the antenna and again at the transmitter. To avoid instrumental complication, the tests were made using a video-frequency analog of a dsb system; the results are applicable to the vestigial-sideband system actually used. The tests were subjective, and involved twenty experienced viewers. The permissible level of the delayed image is found to be 2-4 db less for the anti-phase than for the in-phase condition. Of three types of distorting network tried, giving "top-lift," "top-cut" and "middle-lift" characteristics respectively, the first permits greatest relaxation of antenna performance.
- 621.396.67:621.397.62** 3461  
**Receiving Aerials for Television (Band III)**—E. Divoire, P. Hontoy and L. Bosman. [*Rev. H F (Brussels)*, vol. 2, pp. 299-310; 1954.] Gain, bandwidth and coupling systems of dipole arrays for the vhf band are discussed. Measurements made on an experimental model and on two stacked arrays made commercially in Belgium are reported. The measured gain of the latter types was below the rated value; the importance of a suitable coaxial coupling and balancing system is stressed.
- 621.396.67.091.2** 3462  
**"Working Gain" of an Antenna Connected with a Feeder**—S. Uda and Y. Mushiaki. (*Sci. Rep. Res. Inst. Tohoku Univ., Ser. B*, vol. 5, pp. 197-202; December, 1953/March, 1954.) The receiving-antenna working gain is defined as the ratio of (power transmitted via the feeder to the load) to (power transmitted via a matching section to a similar load of an ideal dipole). An analogous definition is given for transmitting antennas. The working gain is approximately equal to the antenna gain less the matching and feeder losses.
- 621.396.674.3:621.396.677.3** 3463  
**Some Considerations on Matching Devices for a Doublet Antenna**—S. Uda and Y. Mushiaki. (*Sci. Rep. Res. Inst. Tohoku Univ., Ser. B*, vol. 5, pp. 95-114; September, 1953.) The T-match (or H-match) antenna, which consists of center-earthed approximately-half-wave elements, was described by B. Mayson in *Wireless World*, vol. 57, pp. 404-406; October, 1951. Theory is developed and the results are extended to the analysis and design of a double-H-type antenna. In particular the effect of finite conductor thickness is taken into account. Graphs of the input-impedance/element-dimensions characteristics and numerical examples of antenna design are given.
- 621.396.674.37.029.62** 3464  
**An U.S.W. Wide-Band Antenna for High Power and High Gain**—H. Körner and K. H. Kristkoiz. (*Frequenz*, vol. 8, pp. 169-176; June, 1954.) Antenna systems for the 87-100-mc band are considered consisting of radiating elements forming the sides of squares several of which are stacked on a single vertical mast. Two bent full-wave antennas or four half-wave antennas are used to form the square.

Polar diagrams, impedance/frequency characteristics and photographs of typical antenna systems are given. The coupling with antennas of other services mounted on the same mast is discussed and a nomogram and formulas for calculating the coupling are given.

**621.396.677.029.6:621.396.932.1** 3465  
**U.S.W. D.F. Aerials**—A. Köhler. (*Funk u. Ton*, vol. 8, pp. 295–302; June, 1954.) The characteristics are given of an antenna system consisting of pairs of double-V wide-band dipoles and reflectors mounted at an angle to the vertical at the diagonally opposite corners of a rectangular frame. The usw frequency band is covered by three such systems with frequency ranges 40–80, 80–160 and 160–300 mc. Bearing errors, system bandwidth and antenna coupling are discussed.

**621.396.677.32** 3466  
**Amplitude-Phase Correlation of Currents in the Elements of the "Wave-Channel" Aerial**—D. M. Vysokovski. [*Compt. Rend. Acad. Sci. (URSS)*, vol. 96, pp. 971–974; June 11, 1954. In Russian.] Antenna systems consisting of a dipole and several director elements are considered. For a system with five directors, the amplitudes of currents in the elements (including the directly fed dipole) and the phase differences between currents in adjacent elements are tabulated for values of the ratio element-length/ $\lambda$  from 0.40 to 0.46. The field strengths in the forward and backward directions are also given. The use of resultant amplitude and phase values, related to average values, in field-strength gain estimation and other calculations is illustrated. See also 2901 of 1953.

**621.396.677.7/.8:621.396.41** 3467  
**Dual-Mode Horn Feed for Microwave Multiplexing**—D. J. LeVine and W. Sichak. (*Electronics*, vol. 27, pp. 162–164; September, 1954.) The ability of a waveguide to propagate orthogonally polarized waves independently of each other is used in an antenna for a two-channel system. Probes carrying the two signals are arranged at right angles in a square-waveguide horn which illuminates a parabolic reflector, various possible arrangements being indicated. Decoupling of 50 db or more between the two signals can be attained.

**621.396.677.71** 3468  
**Application of Mathieu Functions in computing the Field Distribution of an Aerial for a Given Directional Characteristic**—A. A. Pistol'kors. [*Compt. Rend. Acad. Sci. (URSS)*, vol. 89, pp. 849–852; April 11, 1953. In Russian.] The field due to radiation from an infinitely long slot in a perfectly conducting infinite plane screen is considered; if the directional characteristic is expressed by a Fourier series the corresponding required field distribution at the slot can be calculated. Field distributions in slots of widths  $0.637\lambda$  and  $1.27\lambda$  required to produce a directional characteristic  $f(\eta) = \sin(\cos \pi \eta) / \sin \eta$  are calculated numerically and the results are shown graphically. The mathematical conditions for exact and for approximate solutions are stated.

**621.396.677.73.012.12** 3469  
**A Method of Calculating Directivity of Antenna with Proper Aperture Illumination**—S. Kawazu. [*Rep. Elect. Commun. Lab. (Japan)*, vol. 2, pp. 18–21; April, 1954.] Digest of paper published in *Monthly Jour. Elect. Commun. Lab. (Japan)*, vol. 7, no. 1; 1954. The directivity is expressed as the sum of a complex series of terms which are the product of coefficients related to the Fourier series coefficients of the expression for the aperture illumination and of functions of direction and aperture size. The latter functions are shown graphically and are also tabulated. Results of calculations of the directivity of a horn with rectangular aperture, excited by TE waves, are shown graphically

for various phase distributions over the aperture.

**621.396.677.832** 3470  
**On the Theory of an Antenna with an Infinite Corner Reflector**—J. R. Wait. (*Canad. Jour. Phys.*, vol. 32, pp. 365–371; June, 1954.) A straightforward solution is obtained for the resultant field anywhere within the V angle, for the case of a dipole radiator. The result is discussed and compared with that obtained by Moullin (3291 of 1945) for a line source.

**621.396.677.85** 3471  
**Path-Length Lens Antenna**—H. Takeuchi, S. Kawazu, H. Wada, B. Oguchi and K. Ohashi. [*Rep. Elect. Commun. Lab. (Japan)*, vol. 1, pp. 48–54; November, 1953.] Details are given of the design and performance of two lens antennas [3058 of 1949 (Kock)] constructed in 1952 for a multichannel relay system and operating in the frequency band 3.7–4.2 kmc with gain > 40 db.

**621.396.677.85** 3472  
**Modified Luneberg Lens**—A. S. Gutman. (*Jour. Appl. Phys.*, vol. 25, pp. 855–859; July, 1954.) Design theory based on Hamiltonian optics is developed for a large-aperture microwave antenna giving a pencil beam which can be scanned without restriction by moving a point source over a spherical surface of relatively small diameter. An experimental antenna using a cylindrical lens and operating in the TE<sub>10</sub> mode is described.

#### AUTOMATIC COMPUTERS

**681.142** 3473  
**LEO (Lyons Electronic Office)**—J. M. M. Pinkerton, E. J. Kaye, E. H. Lenaerts and G. R. Gibbs. (*Electronic Eng.*, vol. 26, pp. 284–291, 335–341 and 386–392; July–September, 1954.) A detailed account of the installation, the nucleus of which is a digital computer developed from the EDSAC. Operation, maintenance and fault-finding procedure are described. An extensive system of marginal checking has been included. Punched tape, read photoelectrically, is used for the input; errors in perforation are completely eliminated by use of a special checking device.

**681.142** 3474  
**Amplitude Comparator for Computing Purposes**—T. Z. Aleksić. [*Bull. Inst. Nuclear Sci. (Belgrade)*, vol. 4, pp. 13–19; June, 1954. In English.] A simple circuit is described which gives uniform output pulses for a large range of input-signal derivatives. Low transformer output impedance is provided. Measures are indicated for ensuring stability when the signals are slowly varying.

**681.142** 3475  
**Some Applications of Elements with Discontinuous Operation in Analogue Computation**—D. M. Mitrović. [*Bull. Inst. Nuclear Sci. (Belgrade)*, vol. 4, pp. 1–11; June, 1954. In French.] Development of work noted in 858 of April. The field of application of the differential analyzer is enlarged by incorporating amplitude comparators and electronic switches. Solution of particular differential equations is discussed.

**681.142** 3476  
**Multiplier for Analog Computers**—C. J. Savant, Jr. and R. C. Howard. (*Electronics*, vol. 27, pp. 144–147; September, 1954.) Multiplication is performed by addition of logarithms, using the linear-to-logarithmic converter described previously [3042 of 1953 (Howard et al.)] followed by a logarithmic-to-linear converter. Application to solution of nonlinear differential equations is described.

**681.142:629.13** 3477  
**Analogue Computers in Aircrew Training Apparatus**—A. E. Cutler. (*Jour. Brit. IRE*,

vol. 14, pp. 351–360; August, 1954.) Comparison of the relative complexities of full-flight-simulator computers using digital and analog methods indicates the analog type to be more suitable. Operation and performance are discussed.

#### CIRCUITS AND CIRCUIT ELEMENTS

**621.314.2.029.63:621.372.51** 3478  
**Construction and Calibration of a Very-High-Frequency Transformer**—H. Paucksch, H. Schneider and H. Schneiders. (*Fernmelde- tech. Z.*, vol. 7, pp. 281–284; June, 1954.) A matching device for insertion in a coaxial line consists of a pair of rings which can be slid independently along the line between the inner and outer conductors without touching either of them. The frequency range for the type described is 1–3 kmc. Theory is developed on the basis of the equivalence of the device to a cascade connection of two loss-free quadri-poles.

**621.316.8** 3479  
**Component Design Trends—Fixed Resistors show Stability Improvements**—F. Rockett. (*Electronics*, vol. 27, pp. 132–137; September, 1954.) A survey of available types; temperature, voltage and power limits are discussed. Composition resistors continue to be the most generally used. Developments in pyrolytic carbon film, printed, wire-wound and metal-film types are reported.

**621.316.8.029.64:621.372.8** 3480  
**Surface Resistors for Centimetre-Wave Technique**—H. Severin. (*Tech. Mitt. schweiz. Telegr.-Teleph. Verw.*, vol. 32, pp. 209–218; June 1, 1954. In German.) An account is given of the development of a method of manufacturing carbon-layer resistors for waveguide attenuators and nonreflecting terminations, using a colloidal suspension of graphite and an insulating base of pertinax. Consideration is given to the choice of medium (water or alcohol) and the method of application (painting, dipping or spraying); particular importance is attached to the uniformity of the layers. The resistance layer is protected by a coating of polystyrene. An instrument designed for measuring dc resistance of layers is described. Measurements at dc and at 3.7 kmc are reported.

**621.316.86:537.312.6** 3481  
**Theory of the Thermistor as an Electric Circuit Element. A Study of Thermistor Circuits**—S. Ekelöf and G. Kihlberg. (*Chalmers Tek. Högsk. Handl.*, no. 142, 36 pp.; 1954.) Fundamental relevant physical and mathematical concepts are presented; the dissipated power rather than the thermistor temperature is taken as the basic variable. The power-balance equation is presented in a form introducing the thermal time constant, and is used to develop equivalent circuits for thermopositive and thermonegative resistors permitting calculation of superposed variable states.

**621.316.86:546.281.26** 3482  
**Nonlinearity of the Volt-Ampere Characteristics of Silicon-Carbide Resistors**—N. P. Bogoroditski and Z. F. Vorobei. (*Zh. Tekh. Fiz.*, vol. 24, pp. 811–817; May, 1954.) Results of an experimental investigation of the conductivity and conductivity/voltage characteristics of SiC powders under a pressure of 600 kg/cm<sup>2</sup> show that as the field strength increases the conductivity becomes proportional to the square root of the field strength; this is probably due to an increase of the effective area of contact. Electron micrographs of typical SiC crystal surfaces are shown. Results obtained using crystals graded according to size are shown graphically and are discussed from the point of view of producing a resistor with the greatest possible nonlinearity.

**621.318.015.4** 3483  
**Fundamental Oscillations of Coils and**



**Windings**—P. A. Abetti and F. J. Maginniss. (*Trans. AIEE*, vol. 73, pp. 1-10; 1954. *Digest, Elec. Eng.*, vol. 73, p. 530; June, 1954.) Analysis is given based on the solution of a Fredholm integral equation. Fundamental frequencies are evaluated for air-core and iron-core coils, and voltage distribution is discussed. See also 655 of April.

**621.318.5:621.318.435** 3484  
**Saturable Transformers as Gates**—B. Moffat. (*Electronics*, vol. 27, pp. 174-176, 178; September, 1954.) Use of ferrite-cored units as switching elements is discussed; input and output windings are wrapped on each core and control windings are wrapped around both. Applications include magnetic-drum read-out systems for computers.

**621.318.57** 3485  
**Multistable Electronic Circuits and Devices**—R. Favre. (*Helv. Phys. Acta*, vol. 27, pp. 235-240; June 30, 1954. In French.) The design of counter circuits is considered from the point of view of simplicity and reliability. From this point of view it is advantageous to keep the number of internal couplings as low as possible. Trigger chains are used with odd numbers of triode tubes alternately blocked and conducting except for one adjacent pair in the same state. To ensure stability, damping is required at the critical frequency; circuit arrangements are shown for providing this in cases where the two adjacent tubes in the same condition are (a) both blocked, (b) both conducting.

**621.318.57** 3486  
**A Sensitive Pulse Trigger Circuit with a Stable Threshold**—K. Kandiah. (*Proc. IEE*, part II, vol. 101, pp. 239-247; June, 1954. Discussion, pp. 260-261.) A pulse-amplitude discriminator for positive or negative pulses is described in which the sensitivity is independent of contact-potential variations in the tubes. With a threshold of 100 mv stability is within 2 per cent. The simplified circuit comprises two triodes passing steady currents and a clamping diode operated under retarding-field conditions. The minimum effective pulse width is about the same as that for conventional discriminators. Performance figures substantiate theoretical calculations of sensitivity.

**621.318.57:621.387** 3487  
**A Scaling Unit employing Multi-Electrode Cold-Cathode Tubes**—K. Kandiah. (*Proc. IEE*, part II, vol. 101, pp. 227-238; June, 1954. Discussion, pp. 260-261.) A complete scaling unit for counting regular or random pulses is described. Different methods of driving cold-cathode scaling tubes are considered. In the method used the amplitudes and durations of the pulses applied to all stages in the slow-scaling section are controlled by a common pulse generator. The unit comprises a pulse-amplitude discriminator of high sensitivity, a fast-scaling stage with a 4-element tube, a cascade arrangement of 3-element tubes Type CV2271 with cold-cathode gating tubes, and the pulse generator. Some routine tests for tube deterioration are outlined.

**621.372:621.3.015.3** 3488  
**Empirical Transient Formulae**—Z. E. Jaworski. (*Electronic Eng.*, vol. 26, pp. 396-400; September, 1954.) Relations between the steady-state frequency response of a network and its transient response are derived in terms of shape parameters, the most important of which for the transient response are rise time, overshoot and relaxation time. Two classes of network are considered, (a) those with a flat-topped frequency response curve with a single peak at zero (center) frequency, and (b) those whose frequency response curve exhibits two equal maxima located symmetrically about zero (center) frequency. It is concluded that the network giving most faithful reproduction

of a unit step has a trapezoidal frequency response curve, and that compromise is required in design as between ideal frequency response and ideal transient response.

**621.372:621.3.016.35** 3489  
**Nyquist's Criterion**—O.P.D. Cutteridge. (*Wireless Eng.*, vol. 31, pp. 274-275; October, 1954.) "Nyquist's form of the stability criterion is deduced using well-known properties of complex numbers and without using integration in the complex plane. A new form of criterion—the 'minimum-phase criterion'—is also developed."

**621.372.5** 3490  
**A Note on the Transfer Voltage Ratio of Passive RLC Networks**—F. M. Reza and P. M. Lewis II. (*Proc. I.R.E.*, vol. 42, p. 1452; September, 1954.) Results obtained by Fialkow and Gerst (3369 of 1952) are generalized to include RLC networks.

**621.372.5** 3491  
**Symmetrical Quadripole Lattice Networks. Determination of Pass Bands and Attenuation Bands**—M. Cotte. (*Jour. Phys. Radium*, vol. 15, pp. 494-495; June, 1954.) A graphical method of determining the bands is discussed. See also 3373 of 1952 (Leroy).

**621.372.5** 3492  
**Some Passive Networks under Transient Conditions**—M. D. Indjoudjian. (*Onde élect.*, vol. 34, pp. 441-448 and 534-535; May and June, 1954.) Two groups of passive quadripoles are defined by their transfer functions: (a) those approximating to an ideal delay line; (b) those producing a Gaussian waveform from an input pulse of sufficiently short duration. A method of synthesizing such networks, given the attenuation and phase-shift coefficients, is based on a continued-fraction expansion of the quotient of a hypergeometric function.

**621.372.54** 3493  
**The Four-Circuit Filter with Coupled Circuits of Equal Resonance Frequency**—H. Behling. (*Fernmeldelech. Z.*, vol. 7, pp. 302-306; June, 1954.) The properties of the circuit are analyzed and compared with those of two-stage and three-stage filters.

**621.372.54:621.3.015.3** 3494  
**Methods for the Calculation of Transient Distortion based on the General Properties of Transfer Functions**—S. Colonibo. (*Cahiers de Phys.*, no. 49, pp. 1-22; May, 1954.) Theories of transients in filters developed by Küpfmüller, Wheeler and Cotte are compared; Cotte's method of calculation is considered most suitable for the general investigation of transient distortion. A definition of bandwidth is proposed; it is shown that in the general case there is no simple analytical relation of the type derived by Küpfmüller between bandwidth and rise time. See also 3539 of 1953.

**631.372.54.011.1** 3495  
**Universal Formulae for the Calculation of Simple Filters**—K. Schmutz. (*Bull. schweiz. elektrotech. Ver.*, vol. 45, pp. 513-526; June 26, 1954.) Transfer properties and input impedance are given as functions of normalized frequency for filters with up to four-tuned circuits for arbitrary ratio between source impedance and terminating impedance; the calculations take account of circuit losses. The formulae are evaluated and represented in curves. Details of the calculation are shown for a four-circuit bandpass filter. A table is given of the most important filter circuits, with the associated formulae and definitions.

**621.372.542.2:621.318.5** 3496  
**Analysis of a Special-Purpose RC Filter incorporating a Periodically Conducting Bilinear Element**—V. W. Bolie. (*Proc. I.R.E.*, vol. 42, pp. 1435-1438; September, 1954.)

The circuit discussed is essentially a low-pass filter incorporating a two-way switch. Modulated carrier is applied, and the switch is operated at carrier frequency, so that the output is a series of amplitude-modulated pulses. Analysis is presented, based on consideration of the stepwise accumulation of charge by the capacitor, and taking account of the dead time when the switch is out of contact. Application in the field of automatic control is mentioned.

**621.372.543.2** 3497  
**Band-pass Circuits with Minimum Number of Coils: Part 1—Band-pass Filters with Prescribed Attenuation Characteristic**—G. Bosse. (*Frequenz*, vol. 8, pp. 186-192; June, 1954.) Any band-pass filter, with the exception of the equalized-characteristic-impedance type, can be constructed using a suitable combination of the basic filter sections described. By transforming parts of the filter, using the circuit equivalents given, the number of circuit components can be reduced; this is illustrated by a numerical example.

**621.373:517.942.932** 3498  
**On the Transformations of Singularities and Limit Cycles of the Variational Equations of van der Pol**—A. W. Gillies. (*Quart. Jour. Mech. Appl. Math.*, vol. 7, pp. 152-167; June, 1954.) Cartwright's solution of van der Pol's equation with forcing term (2740 of 1948) is shown to be incorrect in one range of the parameters; the corrected solution is given. In view of the correction, the hysteresis effects to be expected for a van der Pol oscillator with increasing and decreasing frequency are confined to a narrower frequency interval and are less varied in character than suggested by Cartwright's solution.

**621.373.4** 3499  
**Wien-Bridge Oscillator Design**—J. M. Diamond. (*Proc. I.R.E.*, vol. 42, p. 1449; September, 1954.) Comment on 1278 of 1953 (Clarke).

**621.373.4:517.9** 3500  
**Modes of Operation of a Valve Oscillator**—S. S. Ryshkov. [*Compt. Rend. Acad. Sci. (URSS)*, vol. 96, pp. 921-924; June 11, 1954. In Russian.] The operation of a tuned-grid oscillator is described mathematically by the differential equation  $\ddot{x} + x = \mu\lambda(x)x$ , where  $\lambda(x) = \alpha x(x) - 1$ ,  $x$  is proportional to the capacitor voltage,  $\chi(x)$  is the derivative of the anode current with respect to  $x$  and  $\mu$  and  $\alpha$  are constants dependent on the circuit parameters. The equation is solved assuming  $\mu$  to be small.

**621.373.4:621.396.822** 3501  
**Fluctuations in Oscillator with Inertial Nonlinearity**—M. E. Zhabotinski. (*Zh. Eksp. Teor. Fiz.*, vol. 26, pp. 758-759; June, 1954.) Fluctuations in a tube oscillator, the steady-state amplitude in which is determined by an inertial nonlinearity, such as a feedback system, are considered theoretically and some practical conclusions are reached on the choice of circuit parameters for minimum amplitude fluctuations.

**621.373.432** 3502  
**Verification of a Descriptive Theory of Relaxation Oscillations**—P. Jean. [*Compt. Rend. Acad. Sci. (Paris)*, vol. 238, pp. 2059-2061; May 24, 1954.] The conditions for oscillation established previously (3172 of December) are verified for the case of an oscillator using a neon lamp or a thyratron.

**621.373.443** 3503  
**New Circuits for Generating Pulses by means of a Pulsed Reactor**—H. Grasl. (*Elektrotech. u. Maschinenb.*, vol. 71, pp. 281-287; June 1, 1954.) Review of circuits containing a saturable reactor with rectangular magnetization characteristic for deriving pulses of required amplitude and phase from a sine-wave

input. The method of shifting the phase by means of an auxiliary pre-magnetizing current is described. Pulse shapes obtainable from a square-wave input are discussed and practical circuits for deriving this input from single- and three-phase ac are shown.

621.373.52 3504

**Junction Transistor Pulse Forming Circuits**—J. B. Oakes. (*Electronics*, vol. 27, pp. 165-167; September, 1954.) Analysis of integrating and differentiating circuits using *n-p-n*-junction transistors. Practical arrangements are illustrated for obtaining sawtooth, square and triangular pulses.

621.373.52:621.314.7 3505

**Internal Oscillations in Transistors**—H. E. Hollmann (*Z. Phys.*, vol. 138, pp. 1-15; June 21, 1954.) See 2540 of September.

621.374.621:372.2 3506

**Pulse-Frequency Multiplication and Division by Delay Lines**—H. Zemanek. (*Wireless Eng.*, vol. 31, pp. 264-265; October, 1954.) Analysis is given for simple arrangements of lumped-element LC lines. For multiplication, lines with linear characteristics are suitable. For division, a nonlinear device, e.g. a pentode, must be included; in this case the input may be sinusoidal.

621.375.2:621.385.15 3507

**An Amplifier with Low Dissipation and Short Rise-Time for C.R.T.**—D. Brini, L. Peli, O. Rimondi and P. Veronesi. (*Nuovo Cim.*, vol. 11, pp. 651-654; June 1, 1954. In English.) By using electron-multiplier tubes in an amplifier for scintillation-counter pulses, a gain of about 400 and rise time of 5-7  $\mu$ sec are obtained with only a few tubes. Details are given of a circuit for a negative-pulse input, giving an output of about 45 v.

621.375.2.029.3 3508

**Newly Developed Amplifiers for the Sound Programme Chain**—S. D. Berry. (*BBC Quart.*, vol. 9, pp. 111-122; Summer, 1954.) As part of a comprehensive redesign of studio and control-room equipment—to be known as Type B—the BBC Engineering Division has produced a new group of amplifiers comprising (a) GPA/4 and GPA/4A general-purpose level-raising amplifiers, (b) C/9, low-fixed-gain amplifier, for sending program to line, and (c) MNA/3, for monitoring purposes. Compactness and standardization of construction are features. The preferred amplifying tube is the double triode Type-CV455 or its "trustworthy" equivalent, the Type 6060. Details are given of circuits, construction, mounting and performance.

621.375.221.1 3509

**Design of Carrier-Frequency Amplifiers with Stagger-Tuned Resonant Circuits**—W. Händler. (*Arch. elekt. Übertragung*, vol. 8, pp. 253-258; June, 1954.) A simple rule is derived for the distribution of the poles, and a nomogram is given facilitating the design of an amplifier with flat response over a pass band of large relative width. Analysis is also given for the case of response ripples within predetermined limits. Values of the resonant-circuit elements are calculated.

621.375.226 3510

**Experimental Band-Pass Amplifier**—P. Hontoy. [*Rev. HF (Brussels)*, vol. 2, no. 11, pp. 311-320; 1954.] A description is given of the practical design of an amplifier circuit in which the bandwidth can be adjusted and the gain varied between wide limits without shifting the center frequency of 455 kc or affecting the response curve. Features of the design are the capacitive coupling of the tuned circuits, the neutralization of the grid-anode capacitance of a Type-6SG7 pentode by means of a specially constructed plunger-type capacitor, and the

compensation of tube input impedance variations by a suitable cathode load.

621.375.227.024 3511

**A Stable Wide-Range D.C. Amplifier**—F. F. Offner. (*Rev. Sci. Instr.*, vol. 25, pp. 579-586; June, 1954.) Description of an ac-operated differential push-pull amplifier for biological applications, with a range from zero to  $>30$  kc and a maximum gain of about  $2.5 \times 10^6$ . Response can be controlled independently at the high and low ends of the range; the dc gain can be reduced to 1 per cent of the mid-band gain. An automatic rebalancing circuit resets the zero of the amplifier at intervals of about 5 seconds.

621.375.3 3512

**Amplification of Small Alternating Voltages with the Magnetic Amplifier**—F. Kimmel. (*Elektrotech. Z. Edn A*, vol. 75, pp. 367-372; June 1, 1954.) A theoretical investigation of the conditions under which saturated reactors are suitable for amplifying small alternating voltages. A parallel-choke circuit with self-saturation was found to be suitable, and a two-stage 500-cps amplifier based on this circuit is described. The amplification obtainable is sufficient to give a galvanometer indication with voltages down to 0.25 mv.

621.375.4:621.314.7 3513

**The Attainment of Very High Gain with Unmatched Transistors**—W. Herzog. (*Arch. elekt. Übertragung*, vol. 8, pp. 279-282; June, 1954.) When a transistor is used with unmatched source or load impedance, maximum gain is achieved with a particular value of the impedance on the other side; quadripole analysis is used to determine this optimum impedance value. With grounded-base or grounded-emitter circuits the cut-off frequency is the same as with matched impedance; with grounded-collector circuits the cut-off frequency depends on the degree of matching.

#### GENERAL PHYSICS

534.26+ [535.43:538.566 3514

**Certain Transmission and Reflection Theorems**—V. Twersky. (*Jour. Appl. Phys.*, vol. 25, pp. 859-862; July, 1954.) Established theory [see e.g. 1898 of 1950 (Papas)] is used to analyze transmission and reflection of em and acoustic waves by a uniform planar distribution of cylinders. Reflection by a planar distribution of bosses is also considered. See also 695 of 1953 and back references.

535.12:535.31 3515

**Step-by-Step Transition from Wave Optics to Ray Optics in Inhomogeneous Anisotropic Absorbing Media: Part 3—Group Propagation**—K. Suchy. [*Ann. Phys. (Lpz.)*, vol. 14, pp. 412-425; June 13, 1954.] The method of stationary phase is applied to obtain general expressions for group delay, direction and velocity, which are then particularized for em waves. Part 2: 1372 of June.

537.221 3516

**Contact Charging between Nonconductors and Metal**—J. W. Peterson. (*Jour. Appl. Phys.*, vol. 25, pp. 907-915; July, 1954.) The investigation previously reported (2622 of October) was continued, using spheres of fused quartz and borosilicate glass rolling on a clean Ni surface, and introducing improvements in the method. The surface conductivity of the glass was found to be higher than that of the quartz by three or four orders of magnitude; since the charging of the two materials was of the same order of magnitude, it appears that the effective work function of the glass is considerably higher than that of the quartz.

537.226:539.11 3517

**Rigorous Method for Investigation of the Interaction between an Electron and Several**

**Lattice Oscillators**—H. Haken. (*Z. Phys.*, vol. 138, pp. 56-70; June 21, 1954.)

537.29:536.253 3518

**Electrothermal Convection in Air**—A. G. Ostroumov. (*Zh. Tekh. Fiz.*, vol. 24, pp. 1055-1061; June, 1954.) The effect of an inhomogeneous electric field on the thermal gradients in air was investigated using air heated electrically by a filament of length 33.6 cm along the axis of a glass tube of diameter about 12 cm. Results show that the field required to produce electrothermal convection is lower at high power dissipation than at low dissipation in the range 1-150 w; the transition between gravitational-thermal and electrothermal convection occurs discontinuously. The potential difference between the positive filament and negative electrodes, placed on either side of the filament, was varied between about  $10^3$  and  $10^4$  v. Interference photographs are shown and the apparatus used is described. Results are presented graphically.

537.311.33 3519

**Theory of Equations of Transport in Strong Electric Fields**—G. M. Abak'yants. (*Zh. Eksp. Teor. Fiz.*, vol. 26, pp. 562-575 and 668-679; May and June, 1954.) The transport of heat and electricity in semiconductors is considered in terms of an electron (hole) gas whose kinetic energy is greatly increased in a strong electric field. Equations for the thermal and electric currents are derived and formulas are obtained for the thermoelectric and galvanomagnetic effects. These include the Thomson, Hall, Nernst and Nernst-Ettinghausen effects. Effects due to bipolar conduction of the semiconductor, including the photomagnetic effect, are also considered.

537.311.5 3520

**An Analysis of the Distribution of Alternating Current in a Solid Cylindrical Conductor**—S. A. Swann. (*Elect. Jour.*, vol. 152, pp. 1830-1832; June 4, 1954.) The equivalent-circuit method of approach selected is designed to keep the physical basis of the problem in view at every stage of the work. The expressions derived apply to a "conductor" of any material.

537.311.62 3521

**The Theory of the Anomalous Skin Effect in Anisotropic Metals**—E. H. Sondheimer. (*Proc. Roy. Soc. A*, vol. 224, pp. 260-272; June 22, 1954.) The theory of the anomalous skin effect in metals is extended to a uniaxial metal crystal containing two energy bands in each of which the energy surfaces are ellipsoids of revolution about the crystal axis. Explicit formulas are obtained for the extreme anomalous limit giving the dependence of the surface impedance on the orientation of the crystal axis, both for a plane metal surface and for a circular wire. The results are evaluated numerically for tin, and the surface conductivity of a circular wire is found to show the minimum observed by Pippard (329 of 1951); the parameters can be chosen to give reasonable agreement with Pippard's results.

537.311.62 3522

**The Anomalous Skin Effect in Anisotropic Metals**—A. B. Pippard. (*Proc. Roy. Soc. A*, vol. 224, pp. 273-282; June 22, 1954.) Application of the "ineffectiveness concept" (1014 of 1948) leads to the same answer as Sondheimer's exact method (3521 above) for spheroidal Fermi surfaces and for a two-dimensional isotropic metal. A complete solution for the general case is given in a form which illustrates the potential value of anomalous-skin-effect studies as a tool in determining the shape of the Fermi surface of a real metal.

537.311.62:535.137 3523

**The Anomalous Skin Effect and the Reflectivity of Metals**—C. W. Benthall and R. Kronig. (*Physica*, vol. 20, pp. 293-300; May,



1954.) If the gas of conduction electrons is subject to internal friction the resultant energy dissipation contributes to the absorption factor of metallic conductors; this contribution can become predominant at low temperatures. If this effect is combined with those studied by Dingle (2626 of October) for the case of mean free path comparable with skin depth, agreement between theory and experiment is improved.

537.525.8:538.56 3524

**Striated High-Frequency Discharge**—Kh. A. Dzherpetov and A. A. Zaitsev. [*Compt. Rend. Acad. Sci. (URSS)*, vol. 89, pp. 825–828; April 11, 1953. In Russian.] The forming of striae in Ne and Ar at a pressure of 1.8 mm Hg by hf fields of frequencies  $6 \times 10^6$  and  $10^9$  cps is described. In symmetrical hf discharges the striae are stationary but on disturbing the symmetry, e.g. by using electrodes of unequal dimensions, the striae are set in motion. Their velocity in electropositive gases is of the order of the drift velocity of the positive ions. Both external and internal electrodes were used in the experiments.

537.525.8:538.56 3525

**Theory of Striae in Gas Discharge**—M. F. Shirokov. [*Compt. Rend. Acad. Sci. (URSS)*, vol. 89, pp. 837–840; April 11, 1953. In Russian.] Equations are derived connecting the spacing of striae with the radius of the discharge tube, the diffusion coefficient and other parameters. The calculated spacing is in good agreement with the spacing observed by Dzherpetov and Zaitsev (3524 above) and others.

537.525.83 3526

**The Hollow-Cathode Effect and the Theory of Glow Discharges**—P. F. Little and A. von Engel. (*Proc. Roy. Soc. A*, vol. 224, pp. 209–227; June 22, 1954.) The electric field between two plane parallel cathodes was investigated by observing the deflection of an electron beam and simultaneously noting other discharge parameters. Results show that the field in the two cathode dark spaces falls linearly with distance from the cathode and thus the net space-charge density is constant as in a conventional discharge. The dark-space length was also determined. The conclusions lead to a theory of glow discharges which takes account of the effect of ultraviolet quanta from the glow on the photoelectric emission from the cathodes. The discrepancy between earlier experimental results, showing that ions of energy of the order of cathode fall of potential arrive at the cathode, and classical calculations leading to low ion energies, is resolved by allowing for small-angle scattering and charge transfer.

537.533 3527

**Electrical Circuit for the Direct Determination of the Energy-Distribution Function of Secondary Electrons**—N. B. Gornyi and L. M. Rakhovich. (*Zh. Eksp. Teor. Fiz.*, vol. 26, pp. 454–458; April, 1954.) A circuit modification of the retarding-field method is described, by means of which the current/voltage characteristic is differentiated; this results in improved accuracy and resolution as compared to numerical differentiation. Results of measurements on an oxide-caesium cathode are shown graphically.

537.533 3528

**Anomalous Electron Emission from Tungsten Heated by High-Current-Density Pulses**—S. V. Lebedev and S. E. Khaikin. (*Zh. Eksp. Teor. Fiz.*, vol. 26, pp. 723–735; June, 1954.) Results of this experimental investigation, using microsecond pulses with current densities up to about  $10^7$  A/cm<sup>2</sup>, show that the instantaneous electron emission from W can exceed by a factor of 100 the steady saturation emission at the melting point.

537.533.8:546.841-3 3529  
**Secondary Electron Emission from Thoria**

—A. R. Shul'man and I. D. Yaroshetski. (*Zh. Tekh. Fiz.*, vol. 24, pp. 845–847; May, 1954.) The dependence of the secondary-emission coefficient on primary-electron energy and on target temperature was determined experimentally for thoria layers, of thickness 50–100  $\mu$  deposited on Ta. The effect of pretreatment by heating to temperatures up to 1,900 degrees C. is shown.

537.534.8 3530

**Method of Investigating Secondary Emission in Conductors Bombarded by Ions**—U. A. Arifov, A. Kh. Ayukhanov and S. V. Starodubtsev. (*Zh. Eksp. Teor. Fiz.*, vol. 26, pp. 714–722; June, 1954.) Several oscillographic methods are discussed and the double-modulation method is described in detail. The ion beam is modulated by a rectangular pulse and the secondary-emission-electrode potential by a hf sawtooth pulse. The principal advantage of this method is the possibility of separating the true secondary ions from those produced by the heating due to the bombardment. Oscillograms of the current/voltage characteristics of the secondary emission are shown for Ta and W specimens bombarded by Rb ions.

537.56 3531

**Theory of Probe in Plasma: Part 1**—Yu. M. Kagan and V. I. Perel'. (*Zh. Tekh. Fiz.*, vol. 24, pp. 889–894; May, 1954.) An expression is derived for the electron current into a spherical probe, which is at the potential of the space, in an undisturbed electron plasma. The dependence of the current on the probe dimensions and the electron mean free path is indicated.

537.562:538.56 3532

**Dipole Resonant Modes of an Ionized Gas Column**—R. E. B. Makinson and D. M. Slade. (*Aust. Jour. Phys.*, vol. 7, pp. 268–278; June, 1954.) A quasistatic treatment is used to show that numerous oscillation modes are possible in a cylindrical column of ionized gas with a rotationally symmetrical distribution of electron concentration. The theory provides a qualitative explanation of the reflection of 30-cm em waves observed by Romell (1618 of 1951). Approximate values of the resonance frequencies are calculated, assuming a Gaussian radial distribution of electron concentration; some of the results may be verifiable by meteor-trail-echo observations. An investigation is also made of the finite energy loss and phase shift shown by Herlofson (403 of 1952) and others to occur when the real part of the dielectric constant vanishes.

537.568 3533

**A Correction of the Thomson Formula for Coefficient of Three-Body Recombination between Electrons and Ions**—C. T. J. Alkemade. (*Physica*, vol. 20, pp. 129–130; February, 1954.) Comment on the method of deriving Thomson's formula [999 of 1953 (Massey)] pointing out two objections to the expression used for effective mean free path.

538.12 3534

**Solution of Magnetostatic Problem for Unbounded Homogeneous Anisotropic Medium**—A. S. Viglin. [*Compt. Rend. Acad. Sci. (URSS)*, vol. 96, pp. 457–458; May 21, 1954. In Russian.]

538.566 3535

**Asymptotic Evaluation of the Field at a Caustic**—I. Kay and J. B. Keller. (*Jour. Appl. Phys.*, vol. 25, pp. 876–883; July, 1954.) A determination is made of the field at and near the focus when a plane em wave is incident on a parabolic cylinder. The case of a reflector comprising a segment of a circular cylinder is also considered.

538.566:535.42 3536

**Diffraction at a Circular Aperture**—W.

Braunbek. (*Z. Phys.*, vol. 138, pp. 80–88; June 21, 1954.) A discrepancy in the results obtained by two methods of calculating the diffraction field described earlier (2182 and 2183 of 1950) is examined. The first method is correct within the approximation stated; the second is invalid for a small region near the center of the aperture when the wavelength is insufficiently small.

538.566:535.42 3537

**Theory of Diffraction at a Sphere taking Account of the Surface Wave**—K. Deppermann and W. Franz. [*Ann. Phys. (Lpz.)*, vol. 14, pp. 253–264; June 13, 1954.] Theory developed previously [1655 of 1953 (Franz and Deppermann)] is applied to the case of a sphere. The main difference found is an abrupt phase change in the surface wave as it passes over either pole.

538.566:535.42 3538

**Diffraction of 3.2-cm Electromagnetic Waves by Cylindrical Objects**—S. T. Wiles and A. B. McLay. (*Canad. Jour. Phys.*, vol. 32, pp. 372–380; June, 1954.) A brass tube and a hard rubber rod, both of diameter 1 inch and length 6 feet, were used as obstacles in the path of a plane pulsed wave with the electric vector parallel to the cylinder axis. Observations were made of the diffraction patterns in planes perpendicular to the direction of incidence. Experimental results for the brass cylinder are in good agreement with calculations based on scalar diffraction theory. The patterns for the rubber rod exhibit a pronounced peak immediately behind the rod, and differ in other ways from the patterns for the brass tube, particularly in the vicinity of the shadow. The results are compared with those obtained by Kodis (2186 of 1952).

538.566:537.56 + 621.385.029.63/64 3539

**The Propagation of Electron Space-Charge Waves in Waveguides and Tubes with Periodic Structure**—Rydbeck and Agdur. (*See* 3723.)

538.569.4:612.317.756 3540

**Method for Measurement of Absorption Coefficients by Microwave Spectroscopy**—A. M. Prokhorov and A. I. Barchukov. (*Zh. Eksp. Teor. Fiz.*, vol. 26, pp. 761–763; June, 1954.) A technique using a modulated Stark cell is described with the aid of a diagram of the experimental set-up. Errors are estimated to be less than 10 per cent.

538.691 3541

**Focusing Electrified Particles**—A. Yu. Ishlinski. [*Compt. Rend. Acad. Sci. (URSS)*, vol. 96, pp. 721–724; June 1, 1954. In Russian.] A relation is found between  $H$ , the magnetic field strength, and the coordinate  $x$ , such that the trajectories of charged particles in the  $xy$  plane pass through both the origin and a given point on the  $y$  axis. The particles are assumed to have equal mass and charge.  $H(x)$  is derived in the form of a simple series.

539.23:[637.311.31 + 537.311.33 3542

**Physics of Thin Metal and Semiconductor Films**—I. D. Konozenko. (*Upsekhii fiz. Nauk*, vol. 52, pp. 561–602; April, 1954.) A survey of work on: (a) formation, structure and electrical properties of thin metal and semiconductor films, (b) surface states and their effect on the properties of semiconductor films, (c) theoretical work on thin metal films. The present position is briefly but critically discussed and, in particular, the points of agreement and disagreement between experimental results and theory are noted. 99 references.

621.3.011.4 3543

**The Capacitance of an Anchor Ring**—T. S. E. Thomas. (*Aust. Jour. Phys.*, vol. 7, pp. 347–350; June, 1954.) An approximate value of  $1.74R$  (where  $R$  is the mean radius) is derived.

### GEOPHYSICAL AND EXTRATERRESTRIAL PHENOMENA

- 523.852.3:621.396.822.029.63 3544  
**Observations of the 21-cm Line from the Magellanic Clouds**—F. J. Kerr, J. V. Hindman and B. J. Robinson. (*Aust. Jour. Phys.*, vol. 7, pp. 297–314; June, 1954.) First observations of this neutral-hydrogen line from an extragalactic source are reported.
- 523.852.3:621.396.822.029.62 3545  
**The Distribution of Radio Brightness across the Crab Nebula**—J. E. Baldwin. (*Observatory*, vol. 74, pp. 120–123; June, 1954.) Interferometer measurements were made at  $\lambda$  1.4 m with antenna spacings 10 $\lambda$ –300 $\lambda$  on an E-W axis and 3 $\lambda$ –40 $\lambda$  on a N-S axis. Information regarding phase was obtained from independent measurements of the position of the source. Results show that brightness distribution is symmetrical and that optical and radio centers of the source coincide within  $\frac{1}{2}$  of arc.
- 538.12 3546  
**The Motion of Magnetic Fields**—J. W. Dungey. (*Mon. Not. R. Astr. Soc.*, vol. 113, no. 6, pp. 679–682; 1953.) “The temporal change of a magnetic field cannot be described as a motion, if it involves interlinking of the lines of force. It is shown that the idea of motion can be retained, if the lines of force are regarded as being ‘disconnected’ on a suitable surface. A process is described by which magnetic flux can be generated other than at a neutral line.”
- 550.37:550.384 3547  
**Electric Field Induced by Vertical Component of Geomagnetic Variations**—A. P. Bondarenko. [*Compt. Rend. Acad. Sci. (URSS)*, vol. 90, pp. 367–370; May 21, 1953. In Russian.] An expression is derived for the horizontal electric field in the earth due to a varying geomagnetic field, assuming regions of unequal electrical conductivities. Graphs based on published experimental determinations of the electric field components and the geomagnetic field show typical 24-hour cycles and indicate the degree of correlation between electric and geomagnetic fields. See 1412 of June.
- 550.372 3548  
**An Effective Ground Conductivity Map for Continental United States**—H. Fine. (*Proc. I.R.E.*, vol. 42, no. 9, pp. 1405–1408; September, 1954.) Discussion of a map, based on the sectional maps described by Kirby et al. (2381 of September), which has been adopted by the FCC.
- 550.384:551.510.535 3549  
**Atmospheric Oscillations at High Altitudes and Their Relation to Geomagnetic Field Variations**—R. Pratap. [*Proc. Nat. Inst. Sci. (India)*, vol. 20, pp. 252–258; May/June, 1954.] Equations developed previously [2384 of September (Chakrabarty and Pratap)] are used to calculate the  $S_q$  variations of  $H$  and  $V$ . By assuming different phases for the atmospheric oscillations in the ionosphere layer which is the seat of the ring currents, and comparing the results with observed variations of the magnetic field, a phase of 275 degrees is found to give the best fit.
- 551.510.535 3550  
**The Action of Solar Particles in the Ionosphere**—W. Dieminger. (*Arch. Elekt. Übertragung*, vol. 8, pp. 259–268; June, 1954.) An examination is made of typical changes occurring in the ionosphere during the penetration of solar particles inside and outside the zone of northern lights, and Martyn's extension (1374 of 1951) of the Chapman-Ferraro theory is discussed.
- 551.510.535 3551  
**Energy and Duration of a Sudden Ionospheric Disturbance**—N. C. Gerson. (*Geofis. Pura Appl.*, vol. 27, pp. 156–158; January/April, 1954.) “A study was made of the maximum amount of energy which might be absorbed by the atmosphere down to 80 km during a sudden ionospheric disturbance. Assuming that the ionization is caused by Lyman  $\alpha$  radiation from the sun, and that all oxygen present is ionized, the energy absorbed by the sunlit hemisphere is  $5.65 \times 10^{27}$  ergs.”
- 551.510.535 3552  
**Symposium on Ionospheric Storms, May 13, 1953**—[*Rep. Ionosphere Res. (Japan)*, vol. 8, pp. 1–44; March, 1954.] The full text is given of papers presented at the symposium.
- 551.510.535 3553  
**A Theory of Diurnal Magnetic Variations in Equatorial Regions and Conductivity of the Ionosphere E Region; Part 2**—M. Hiron. (*Jour. Geomag. Geoelect.*, vol. 5, pp. 22–38; June, 1953.) “The electrical conductivity of the E region is calculated in some detail for two atmospheric models. It is shown that the factor, by which the tidal oscillation of the E region exceeds that at ground level, should be less than 10<sup>2</sup>, in order to give the observed lunar magnetic variation. The calculated lunar vertical movement of the E region is nearly in phase with that observed in South England and nearly opposite at Canberra. A possibility is shown that the calculated lunar vertical movement of the F<sub>2</sub> region roughly agrees with that observed. It is suggested that the vertical drifts of the F<sub>2</sub> region near the magnetic equator may be much greater than those in the other latitudes.”
- 551.510.535:550.384.4 3554  
**Ionospheric Variations Associated with Geomagnetic Disturbances: Part 1—Variations at Moderate Latitudes and the Equatorial Zone and the Current System for the S<sub>D</sub> Field**—S. Matsushita. (*Jour. Geomag. Geoelect.*, vol. 5, pp. 109–135; December, 1953.) Variations of the E<sub>s</sub> and F<sub>2</sub> regions are studied. The current system for the S<sub>D</sub> field is calculated. The ionospheric S<sub>D</sub> variations may be due to the effect of a vertical drift by the earth's magnetic field and the electric field of the S<sub>D</sub> current. See also 2936 of November.
- 551.510.535:550.385 3555  
**Disturbances in the Ionosphere during the Geomagnetic Storm of Apr. 18, 1951**—H. Kamiyama. [*Rep. Ionosphere Res. (Japan)*, vol. 8, pp. 32–34; March, 1954. Discussion, p. 34.] Analysis shows that commencement of disturbances of the F<sub>2</sub>-layer electron density and virtual height coincided with the commencement of the main phase of the magnetic storm.
- 551.510.535:550.385 3556  
**Characteristics of Ionospheric Disturbance during a Severe Magnetic Storm**—K. Miya. [*Rep. Ionosphere Res. (Japan)*, vol. 8, pp. 35–38; March, 1954. Discussion, p. 38.] Data from 40 ionospheric stations relevant to the storm of May 9, 1948 are analyzed and the salient characteristics explained.
- 551.510.535:551.55:621.396.822 3557  
**A Radio Astronomical Investigation of Drift Movements in the Upper Atmosphere**—A. Maxwell and M. Dagg. (*Phil. Mag.*, vol. 45, pp. 551–569; June, 1954.) Discussion of nighttime observational data of the diffraction of rf radiation from radio stars by moving irregularities in the ionosphere F region, obtained at Jodrell Bank during the period April, 1951–April, 1953, using three receiving equipments triangularly sited and operating at 3.7 m. The drift velocity at temperate latitudes is normally of the order of 50–300 m/s. During the first half of the night, the prevailing direction is westwards, during the second half eastwards, the reversal occurring around 0100. In the auroral zone, the velocity is of the order of 400 m/s, and the changes in direction are less marked. Results for points separated by 800 km suggest that the drift speeds and directions are the same over wide areas.
- 551.593.9 3558  
**Glow of the Night Sky in the 1-3- $\mu$  Waveband**—A. L. Osheroovich and S. F. Rodionov. [*Compt. Rend. Acad. Sci. (URSS)*, vol. 96, pp. 1159–1160; June 21, 1954. In Russian.] Results are reported of energy flux measurements made at the Gorni observatory (altitude 2,130 m) in September, 1953. The average flux per second crossing 1 cm<sup>2</sup> received from 1 steradian in the direction of Cygnus  $\alpha$  varied between  $3.9 + 1.3 \times 10^{-2}$  and  $6.3 \pm 1.6 \times 10^{-2}$  (units not stated) referred to a wavelength of 1.72  $\mu$ . The apparatus used is briefly described.
- 551.594.523.78 3559  
**Observations of the Electric Field of the Atmosphere at Monaco during the Partial Solar Eclipse of 30th June 1954**—J. Rouch. [*Compt. Rend. Acad. Sci. (Paris)*, vol. 239, pp. 465–466; August 9, 1954.] Very high values of field strength were observed after the maximum of the eclipse.
- 551.594.6 3560  
**Atmospherics due to Fronts in the Upper Atmosphere**—A. Kimpara. (*Jour. Geomag. Geoelect.*, vol. 5, pp. 8–13; June, 1953.) Reference to meteorological data indicates that atmospherics observed in a zone of the Pacific Ocean in latitude 30 degrees–40 degrees N, especially in autumn and winter, are generated in the convergence region of fronts in the upper atmosphere.

### LOCATION AND AIDS TO NAVIGATION

- 534.88 3561  
**Nomograms for the Solution of the Sound-Ranging Problem in a Plane**—G. C. Curtis. (*Quart. Jour. Mech. Appl. Math.*, vol. 7, pp. 129–135; June, 1954.)

### 621.396.96 3562

- A Textbook of Radar (Book Review)**—Council for Scientific and Industrial Research, E. G. Bowen (Ed.). Publishers: Cambridge University Press, London, Eng., 2nd ed., 617 pp., 45s. (*Wireless Eng.*, vol. 31, p. 284; October, 1954.) In this revised edition, only minor alterations have been made in the first sixteen chapters, but the last four chapters have been rewritten as three chapters, covering military, civil and scientific applications.

### MATERIALS AND SUBSIDIARY TECHNIQUES

#### 531.788.7 3563

- Cold-Cathode Ionisation Gauges for the Measurement of Low Pressures**—G. K. T. Conn and N. H. Daglish. (*Vacuum*, vol. 3, pp. 24–34; January, 1953.) Construction, characteristics and performance of various types are reviewed. The influence of the size and shape of electrodes, the applied voltage, the magnetic field and the nature of the residual gas is discussed. Pressures as high as 10<sup>-2</sup> mm Hg may be measured using gauges with small anode rings and relatively small ballast resistors. Experiments confirm that em radiation at hf is due to plasma oscillations.

#### 533.15:533.5 3564

- Diffusion Coefficient, Solubility, and Permeability for Helium in Glass**—W. A. Rogers, R. S. Buritz and D. Alpert. (*Jour. Appl. Phys.*, vol. 25, pp. 868–875; July, 1954.) A method is described for simultaneously measuring diffusion coefficient, solubility and permeability of a given gas in a solid material. High-vacuum techniques [2102 of August (Alpert and Buritz)] are used. Values of the parameters are determined for the diffusion of helium in pyrex, and the effect of temperature variation is studied.

#### 533.56 3565

- The Distribution of Gas Concentration in a**



- Vapour Vacuum Pump**—K. A. Savinski. (*Zh. Tekh. Fiz.*, vol. 24, pp. 875-878; May, 1954.) Results of an experimental investigation, the technique of which is described, show that the concentration of the gas being pumped out is a minimum near the cooling surface. Reference is made to Alexander's theory (1868 of 1946).
- 535.58** 3566  
**The Use of Getters for the Production of Very High Vacua**—S. Wagener. (*Vacuum*, vol. 3, pp. 11-23; January, 1953.) Continuation of earlier work (2521 of 1952). The gettering rate for Ba decays rapidly during exposure to CO; this decay is ascribed to the formation of a protective surface film and makes the getter inefficient for other gases also. The use of Th powder as a selective getter is discussed; such materials remove oxidizing gases and establish a constant pressure of H<sub>2</sub> which can be controlled by varying the temperature of the getter and the quantity of H<sub>2</sub> dissolved in it. A hydrogen atmosphere at pressures of 10<sup>-7</sup> to 10<sup>-6</sup> mm Hg reduces the interface resistance of oxide cathodes by a factor of 10. See also 2675 of 1953.
- 535.37** 3567  
**Determination of the Depths of Electron-Trap Energy Levels in Crystal Phosphors**—I. A. Parfianovich. (*Zh. Eksp. Teor. Fiz.*, vol. 26, pp. 696-703; June, 1954.) An account is given of methods based on thermoluminescence curves for determining the activation energy of luminescence centers.
- 535.37:535.215:546.47-31** 3568  
**Optical Absorption and Internal Photoeffect of Zinc Oxide**—K. V. Shalimova. (*Compt. Rend. Acad. Sci. (URSS)*, vol. 96, pp. 487-490; May 21, 1954. In Russian.) The experimentally determined spectral characteristics of absorption and photocurrent in ZnO-Zn films are shown graphically and discussed in relation to recombination glow and photoeffect in sublimate phosphors.
- 535.37:537.311.33** 3569  
**Electroluminescence of Semiconductor Phosphors**—A. Fischer. (*Z. Naturf.*, vol. 8a, pp. 756-757; November, 1953.) Luminescence was observed in sintered ZnO/Zn layers with electrodes of metal, graphite, ZnO or neutral electrolyte, with voltages as low as 5v applied in one direction; higher voltages were required with reverse polarity. This rectification effect was particularly marked when the electrolyte was used as cathode. Space charge giving rise to electrostatic field in the surface layers of the semiconductor is considered responsible for the luminescence. The quantitative aspect is examined; the magnitudes involved are consistent with the breakdown mechanism suggested by Franz (2148 of 1951).
- 535.37:546.121.3** 3570  
**Sublimate Phosphors based on Halide Salts of Group-2 Metals**—F. D. Klement and I. F. Malysheva. (*Compt. Rend. Acad. Sci. (URSS)*, vol. 96, pp. 465-468; May 21, 1954. In Russian.) The principal advantages of sublimate-phosphor screens are the high resolution, the stability and the even covering obtainable without the use of additional binding materials. Microphotographs (×60) of CdI<sub>2</sub>·PbI<sub>2</sub> phosphor deposited as sublimate and from a suspension are shown. Spectral characteristics and their variation by activators were investigated in (Cd-halide)·(Hg-, Tl-, Pb-, Bi-, or Mn-halide) and in TiCl<sub>4</sub>·(Ca-, Sr-, or Ba-halide) compounds. Results are shown graphically and are discussed from the point of view of lattice structure.
- 535.37:546.86** 3571  
**Optical Properties of a New Luminescent Substance with Antimony Oxide Base**—R. Bernard and J. Janin. (*Compt. Rend. Acad. Sci. (Paris)*, vol. 239, pp. 489-490; August 9, 1954.) Sb<sub>2</sub>O<sub>4</sub> when activated by Mn exhibits orange luminescence on excitation by radiation of  $\lambda < 3,500 \text{ \AA}$ .
- 537.227** 3572  
**Dielectric Properties and Phase Transformations of Mixed-Crystal Systems of Perovskite Type**—H. Gränicher and O. Jakits. (*Nuovo Cim.*, vol. 11, supplement no. 3, pp. 480-520; 1954. In German.) Experimental and theoretical investigations are reported on alkaline-earth and rare-earth titanate ceramics. The ferroelectric anomalies of BaTiO<sub>3</sub> are found to be retained in mixed systems. The shift of Curie point and transformation point depends on whether the admixed component is or is not itself ferroelectric. Discontinuities in the temperature variation of the permittivity or of its temperature coefficient are observed in the case of (CaSr)TiO<sub>3</sub>. Theory developed enables the dielectric behavior of mixed crystals to be predicted from knowledge of the lattice constants and permittivities of the components at a given temperature.
- 537.311.3** 3573  
**Variation of the Electric and Magnetic Properties of Sb and InSb at the Melting Point**—G. Busch and O. Vogt. (*Helv. Phys. Acta*, vol. 27, pp. 241-248; June 30, 1954. In German.) Measurements of conductivity, Hall coefficient and magnetic susceptibility were made over a range of temperatures. The conductivity of Sb increased by a factor of 1.6 while the Hall coefficient and susceptibility decreased by a factor of about 9 on melting. The conductivity of InSb increased by a factor of 4 while the Hall coefficient decreased by a factor of 450 and the susceptibility by a factor of 5.5. The theoretical interpretation of these results depends on whether liquid InSb is to be regarded as semiconductor or metal.
- 537.311.31** 3574  
**Some Anomalies in the Conduction of Metals Heated by High-Current-Density Pulses**—S. V. Lebedev and S. E. Khaikin. (*Zh. Eksp. Teor. Fiz.*, vol. 26, pp. 629-639; May, 1954.) An experimental investigation is reported of resistance and energy measurements on metal filaments at current densities up to about 10<sup>7</sup> A/cm<sup>2</sup>. Oscillograms for W, Fe, Ag and Pb are shown and are discussed.
- 537.311.31** 3575  
**The Electrical Resistivity of Cu-Ni Alloys and Matthiessen's Rule**—Y. Shibuya. (*Sci. Rep. Res. Inst. Tohoku Univ., Ser. A*, vol. 6, pp. 199-206; June, 1954.) The variation of resistivity with temperature and with composition was investigated experimentally. Deviations from Matthiessen's rule were observed for alloys with low Ni contents. An explanation based on electron conduction theory is advanced.
- 537.311.33** 3576  
**Theory of Radiationless Recombination in Nonpolar Semiconductors**—L. Tewordt. (*Z. Phys.*, vol. 137, pp. 604-616; June 2, 1954.)
- 537.311.33** 3577  
**The Capacitance of Junction Layers in Semiconductors**—B. M. Vul. (*Compt. Rend. Acad. Sci. (URSS)*, vol. 96, pp. 257-259; May 11, 1954. In Russian.) The junction layer is assumed to be bounded by the boundaries of the volume charges at which the electric field strength can be taken as zero. The boundaries of the volume charges can change under the influence of an externally applied voltage acting in addition to the contact potential difference. Using Poisson's equation in one dimension and assuming a volume distribution of charge which is an arbitrary function of distance, the capacitance of the layer is calculated from the rate of change of charge with respect to potential. In an example the capacitance of a layer in which the charge distribution is a function of the  $n$ th power of distance is calculated.
- 537.311.33:535.215** 3578  
**Diffusion and Drift of Photoelectrons in Partly Illuminated Semiconductor**—A. I. Gubanov. (*Zh. Tekh. Fiz.*, vol. 24, pp. 933-940; May, 1954.) A calculation is made of the effects at the dark/light boundary, assuming one kind of charge carrier and an external field perpendicular to the boundary. Cases of low and of high photoconductivity are considered, the electron distribution is calculated and the voltage/current characteristics are obtained for cases when one of the electrodes or the middle region of the specimen is illuminated.
- 537.311.33:538.63** 3579  
**Theory of Magnetic Effects in Isotropic Semiconductors with High Mobility**—O. Madelung. (*Z. Naturf.*, vol. 8a, pp. 791-795; December, 1953.) Weak-magnetic-field theory is inadequate to explain Hall-effect and resistance variations in high-mobility semiconductors because the product of mobility and magnetic field occurs as the determining factor. For high-mobility mixed semiconductors, in particular, the Hall coefficient is markedly dependent on the field, and may change sign with increase of field strength. The resistance variation approaches a saturation value as the strength of the magnetic field increases.
- 537.311.33:538.63:535.215.9** 3580  
**New Photomagnetic Effect in Semiconductors in an Inhomogeneous Magnetic Field**—I. K. Kikoin. (*Compt. Rend. Acad. Sci. (URSS)*, vol. 96, pp. 463-464; May 21, 1954. In Russian.) The emf produced by illuminating short bars of CdS, Cu<sub>2</sub>O, or Ge in an inhomogeneous magnetic field is the resultant of the known photomagnetic effect, which is a function of the mean magnetic field at the bar, and of the new effect, which is a function of the difference of the squares of the field strengths at the ends of the bar. For a Ge bar with magnetic fields of  $\sim 10^4$  and  $\sim 4 \cdot 10^3$  oersted respectively at the two ends, the current is of the order of 3  $\mu$ A.
- 537.311.33:539.23** 3581  
**Resistance and Photoconductivity of PbS Films at High Frequencies of the Applied Voltage**—V. V. Balakov and V. A. Smeshkova. (*Zh. Tekh. Fiz.*, vol. 24, pp. 989-992; June, 1954.) The characteristics of PbS films, prepared both by evaporation and by chemical means, were investigated experimentally at frequencies up to 200 mc. The conclusions agree with those of Humphrey et al. (2682 of 1953). Particular attention was paid to good electrode contacts; the metal electrodes were deposited in vacuum and the leads soldered on using Wood's alloy. Results are shown graphically.
- 537.311.33:546.23** 3582  
**Conductivity Measurements on Selenium**—F. Eckart. (*Ann. Phys. (Lpz.)*, vol. 14, pp. 233-252; June 13, 1954.) The dependence of conductivity on temperature was investigated for Se in the solid and liquid states. Results differ according to the purity of the samples, and to the method of production, and are markedly affected by the presence of oxygen. An activation energy of 2.2-2.9 ev is obtained for the temperature range from 100 degrees C. to melting point.
- 537.311.33:546.23** 3583  
**Electrical Conductivity of Amorphous Selenium in Strong Electric Fields**—M. K. Shidlovski. (*Zh. Tekh. Fiz.*, vol. 24, pp. 837-844; May, 1954.) Conductivity was determined experimentally at temperatures in the range from -35 degrees to +50 degrees C. and at field strengths between 0.2 and 180 kv/cm. Results, shown graphically, are in agreement with Frenkel's theory.
- 537.311.33:546.28** 3584  
**A Note on the Band Structure of Silicon**—D. G. Bell, R. Hensman, D. P. Jenkins and

L. Pincherle. (*Proc. Phys. Soc.*, vol. 67, pp. 562-563; June 1, 1954.) Calculation by the cellular method shows that triply degenerate states bound the forbidden energy gap above and below at the origin of  $k$  space.

**537.311.33:546.289** 3585  
**Surface Conduction Channel Phenomena in Germanium**—H. Christensen. (*Proc. I.R.E.*, vol. 42, pp. 1371-1376; September, 1954.) An optical method was used to study the effect of surface polarization layers on junction leakage and to identify surface conduction channels. Such channels were produced on both  $n$ -type and  $p$ -type regions of a Ge junction, the former by exposure to an oxygen-rich atmosphere, the latter by high humidity. At the medium relative humidity value of 75 per cent, high surface leakage was observed and no channel. Mechanisms involved are explained on the basis of a model in which the energy levels bend at the surface, corresponding to reversal of conduction type. Results are discussed in relation to anomalous behavior of transistors.

**537.311.33:546.289** 3586  
**A Mechanism for Water-Induced Excess Reverse Dark Current on Grown Germanium  $N$ - $P$  Junctions**—J. T. Law. (*Proc. I.R.E.*, vol. 42, pp. 1367-1370; September, 1954.) Three groups of experiments are reported: (a) measurements of the adsorption isotherm for water on Ge; (b) determinations of the number of foreign ions on a Ge surface; (c) measurements of reverse current in  $n$ - $p$  junctions under various conditions. The results indicate that ionic processes as well as electronic channels [166 of February (Brown)] contribute to the increase of reverse current which is observed when the ambient humidity is increased.

**537.311.33:546.289** 3587  
**Channels and Excess Reverse Current in Grown Germanium  $p$ - $n$  Junction Diodes**—A. L. McWhorter and R. H. Kingston. (*Proc. I.R.E.*, vol. 42, pp. 1376-1380; September, 1954.) Using the same optical technique as Christensen (3585 above) measurements were made of the length of  $n$ -type channels formed on the surface of the  $p$  side of the junction on exposure to water vapor. Direct proportionality was found between channel length and excess reverse current. The effect was observed with well-oxidized surfaces, in contradistinction to the case discussed by Law (3586 above). By combining this result with the known variation of channel conductivity with humidity and voltage, a relation is derived between the excess current and the bias. Agreement between predicted values and experimental results is reasonably good for bias values  $> 1v$ .

**537.311.33:546.289** 3588  
**Phenomena Observed in the Melting and Solidification of Germanium**—S. E. Bradshaw. (*Jour. Electrochem. Soc.*, vol. 101, pp. 293-297; June, 1954.) Small spheres of molten Ge, weighing about 10 mg, on freezing form pear-shaped bodies which are substantially single crystals. A mechanism is suggested to account for the shape and impurity distribution. Shape depends on the ratio of densities of liquid and solid Ge at the melting point. Theory indicates that the melting point is lowered initially by an increase of pressure. Ge may undergo an allotropic modification under pressure such as that exerted locally by a whisker contact.

**537.311.33:546.289** 3589  
**The Solid Solubility and the Diffusion of Nickel in Germanium**—F. van der Maesen and J. A. Brenkman. (*Philips Res. Rep.*, vol. 9, pp. 225-230; June, 1954.) Ni produces rapidly diffusing acceptors in Ge; the Ni acceptor level lies 0.23 ev above the valence band, according to Hall-effect and resistivity measurements. On this basis, the solid solubility be-

tween 700 degrees and 900 degrees C. is derived from resistivity measurements, and the distribution and diffusion coefficients are calculated. The distribution coefficient is  $1.8 \times 10^{-6}$  at the melting point of Ge. The activation energy of diffusion is 21 kcal/mole. Annealing of a Ni-saturated Ge sample restores the original resistivity.

**537.311.33:546.289:538.63** 3590  
**Magnetic Blocking Layers in Germanium**—E. Weisshaar and H. Welker. (*Z. Naturf.*, vol. 8a, pp. 681-686; November, 1953.) Theoretical considerations indicate that application of a transverse magnetic field to a current-carrying intrinsic semiconductor with high electron and hole mobilities may produce appreciable variation of the concentration of electron-hole pairs if volume and surface recombination are sufficiently low. This should be evidenced by a nonlinear current/voltage characteristic linked with a far greater variation of resistance in the magnetic field than normal. Such an effect has been demonstrated in Ge. A positive variation of 470 per cent and a negative variation of 13 per cent have been produced with fields in opposite directions. Measurements of photoelectric effect and variations with frequency indicate the applicability of the theory to the observed effects.

**537.311.33:546.46.86** 3591  
**Electrical Properties of the Intermetallic Compound  $Mg_3Sb_2$** —G. Busch, F. Hulliger and U. Winkler. (*Helv. Phys. Acta*, vol. 27, pp. 249-258; June 30, 1954. In German.) Measurements were made of the conductivity, Hall coefficient and thermoelectric voltage of a polycrystalline specimen of the  $\alpha$ -phase compound, obtained by melting the components together, over a range of temperatures. The width of the forbidden energy band is found to be 0.82 ev. Hall coefficient and thermoelectric voltage both have positive signs up to very high temperatures; this is interpreted as indicating that the mobilities of the holes are greater than those of the electrons. The concentrations, mobilities and availability coefficients of electrons and holes are determined from the measurements.

**537.311.33:546.482.21** 3592  
**Dependence of Induced Conductivity of CdS Films and Single Crystals on the Energy of the Exciting Electrons**—S. M. Ryvkin, B. M. Konovalenko and Yu S. Smetannikova. (*Zh. Tekh. Fiz.*, vol. 24, pp. 961-977; June, 1954.) The electron-irradiation-produced conductivity is independent of the electron energy in the range from approximately 10 kev to 30 kev, but falls off at lower energies. This is probably due to the different depths of penetration. An analogy is drawn with the photoconductivity characteristics of CdS. The experimental arrangements are described and results are shown graphically. The range up to 2-3 kev was investigated earlier by Benda (1628 of 1952) and others.

**537.311.33:546.561-31** 3593  
**The Semiconductor Properties of  $Cu_2O$ : Part 9—Hall-Effect Measurements at Low Temperatures**—P. Schmidt. [*Ann. Phys. (Lpz.)*, vol. 14, pp. 265-289; June 13, 1954.] Measurements were made from room temperature down to about -160 degrees C. Observed anomalies in the Hall-effect/temperature curves are ascribed to changes in the relative concentration of excess electrons and holes, due to changes in the surface-layer conductivity. Part 8: 2432 of September (Fritzsche).

**537.311.33:546.561-31** 3594  
**The Semiconductor Properties of  $Cu_2O$ : Part 10—Observations of the Electrical Conductivity when the Thermodynamic Equilibrium is Disturbed between 600° C and 1000° Inside and Outside the  $Cu_2O$  Stability Region**—G. Blankenburg. [*Ann. Phys. (Lpz.)*, vol. 14, pp. 290-307; June 13, 1954.] Part 9: 3593 above.

**537.311.33:546.561-31** 3595  
**The Semiconductor Properties of  $Cu_2O$ : Part 11—The Characteristics of  $Cu_2O$  in the  $CuO$  Stability Region**—G. Blankenburg. [*Ann. Phys. (Lpz.)*, vol. 14, pp. 308-318; June 13, 1954.] Part 10: 3594 above.

**537.311.33:546.561-31** 3596  
**Effect of Electric Field on Absorption Spectrum of Copper Oxide at Low Temperatures**—A. A. Kalinyak and L. G. Fedorovich. [*Compt. Rend. Acad. Sci. (URSS)*, vol. 96, pp. 1137-1138; June 21, 1954. In Russian.] Photographs taken at field strengths up to 50 kv/cm at a temperature of 77.3 degrees K show new absorption lines at 5,753 and 5,779 Å. The nature of these is briefly discussed.

**537.311.33:546.561-31** 3597  
**The Copper-Oxide Contact Layer**—A. I. Andrievski and M. T. Mischenko. (*Zh. Tekh. Fiz.*, vol. 24, pp. 818-825; May, 1954.) The forming of an intermediate layer between the Cu specimen and the  $Cu_2O$  surface layer obtained by oxidizing Cu at  $\sim 1,000$  degrees C., and the effect of heating time and of impurities on the structure, were investigated experimentally. The microphotographs shown are discussed.

**537.311.33:546.683** 3598  
**The Effect of Thermally Produced Lattice Defects on the Electrical Properties of Tellurium**—S. Tanuma. (*Sci. Rep. Inst. Tohoku Univ., Ser. A*, vol. 6, pp. 159-171; April, 1954.) The electrical properties are investigated assuming excess holes in the valence band due to electron trapping by the lattice defects. The width of the forbidden energy band is found to be  $(0.32 + 1.9 \times 10^{-4}T)$  ev, the effective masses of electrons and holes are 0.68  $m$  and 0.91  $m$  and the carrier mobilities due to lattice scattering are 6.1 and  $2.8 \times 10^6 T^{-3/2}$  cm per v/cm respectively. The sign reversal of the Hall effect and of the thermoelectric power at increased temperature is explained.

**537.311.33:[621.314.632+621.316.86]** 3599  
**Theories of Semiconductor Systems, Rectifiers and Complexes, in the Light of Recent Research**—S. Tetzner. (*Rev. gén. élect.*, vol. 63, pp. 319-334; June, 1954.) Failure of the theories of various workers to explain the reverse characteristic of the semiconductor rectifier is discussed. Theory given previously by the author (3445 of 1949) is restated and developed in the light of later experimental work. See also 434 of March (Tetzner et al.).

**537.311.33:621.314.7** 3600  
**Transistor Electronics: Imperfections, Unipolar and Analog Transistors**—W. Shockley. [*Proc. IRE (Australia)*, vol. 15, pp. 163-173; July, 1954.] Reprint. See 746 of 1953.

**537.311.33:621.396.822** 3601  
**Frequency Dependence of Electron Fluctuation Phenomena in Semiconductors**—K. W. Böer and K. Junge. (*Z. Naturf.*, vol. 8a, pp. 753-755; November, 1953.) Measurements on CdS single crystals at frequencies in the range 1 kc-2.5 mc gave results which can be expressed approximately by an inverse power law in which the index changes value at a critical frequency. This behavior is explained on the basis of an equivalent circuit taking account of different conditions at the boundary layer and in the body of the crystal.

**537.312.5:546.482.21** 3602  
**Influence of Temperature and Oxygen on the Build-Up and Decay of the Photoconductivity of CdS Single Crystals**—G. Höhler. [*Ann. Phys. (Lpz.)*, vol. 14, pp. 426-427; June 13, 1954.] Comments on 1478 of June (Seraphin).

**538.221** 3603  
**Calculations of the First Ferromagnetic**



**Anisotropy Coefficient, Gyromagnetic Ratio and Spectroscopic Splitting Factor for Nickel**—G. C. Fletcher. (*Proc. Phys. Soc.*, vol. 67, pp. 505-519; June 1, 1954.)

538.221:537.311.33 3604

**Further Experimental Investigations on Some Ferromagnetic Oxidic Compounds of Manganese with Perovskite Structure**—J. Volger. (*Physica*, vol. 20, pp. 49-66; February, 1954.) Measurements have been made on polycrystalline substances of the type  $La_{1-x}Sr_xMnO_3$  to determine dc and ac resistivity, their variation with temperature and with applied magnetic field, Seebeck effect and Hall effect. Results support the hypothesis of barrier-layer resistance in ceramic semiconductors. See also 656 of 1951 (van Santen and Jonker).

538.221:621.318.134 3605

**Transient Phenomena in a Ferrite**—S. Matz. [*Compt. Rend. Acad. Sci. (Paris)*, vol. 239, pp. 487-488; August 9, 1954.] The complex permeability of a Ni-Zn ferrite was investigated experimentally over the temperature range from -196 degrees to +20 degrees C., using frequencies of 100 kc to 1 mc and a range of values of the magnetizing field and of the time interval between a demagnetization and establishment of the field. The results are interpreted on the basis of Néel's theory of diffusion after-effect.

538.221:621.318.134 3606

**Spontaneous Magnetization as a Function of Temperature for Mixed Crystals of Ferrites with Several Curie Temperatures**—K. F. Niessen. (*Philips Res. Rep.*, vol. 9, pp. 197-208; June, 1954.) A method of calculation is demonstrated.

538.221:621.318.134 3607

**Low-Loss Ferrites for Applications at 4,000 Megacycles per Second**—L. G. Van Uitert, J. P. Schafer and C. L. Hogan. (*Jour. Appl. Phys.*, vol. 25, pp. 925-926; July, 1954.) Faraday-rotation and loss curves are presented for three MgAlMn ferrites. Rotations exceeding 500 degrees per decibel absorbed can be achieved at 4 kmc.

538.221:621.318.134 3608

**Some Physical Properties of Ferrites**—H. P. J. Wijn. (*Ondelect.*, vol. 34, pp. 418-424; May, 1954.) Review of properties of ferrites and ferrite powders with reference to their application at rf. Permeability and magnetization as functions of frequency, and strong-field magnetization curves of a typical soft ferrite are discussed. By covering a ferrite ring while hot with a coat of glass having a higher coefficient of expansion, the ring is compressed on being cooled, and a rectangular hysteresis loop is obtained.

538.24 3609

**Theory of the Dependence of Spontaneous Magnetization of Metals and Alloys on Temperature in the Low Temperature Region**—E. Kondorski and A. Pakhomov. [*Compt. Rend. Acad. Sci. (URSS)*, vol. 96, pp. 1139-1142; June 21, 1954. In Russian.] Metals and binary alloys with a poorly conducting ferromagnetic lattice are considered. Simple formulas for the temperature dependence are derived for particular cases of cubic lattices of the type NaCl, CsCl and FeNi.

548.7:549.514.51:621.372.412 3610

**The Pile Irradiation of Quartz Crystal Oscillators**—F. B. Johnson and R. S. Pease. (*Phil. Mag.*, vol. 45, pp. 651-654; June, 1954.) 7-mc BT-cut oscillators were exposed to pile radiation; graphs of frequency-variation/megawatt-hours-irradiation for low and high doses are presented. Two types of effect can be distinguished, due to (a) displacements of atoms, and (b) ionization.

621.3:666.3/7 3611

**Ceramic Materials: Technical and Bibliographical Survey**—J. Suchet. (*Ondelect.*, vol. 34, pp. 460-470; May, 1954.) Review of development with reference to chemical composition, molecular structure, properties and applications of ceramic insulators, ferroelectric materials, ferrites and semiconducting ceramics. 85 references.

621.315.61:621.359.3 3612

**Magnetic Cores of Broadband Transformer Insulated by Cataphoresis**—H. Sato, S. Kato and T. Shibayama. [*Rep. Elect. Commun. Lab. (Japan)*, vol. 2, pp. 13-17; April, 1954.] Digest of paper published in *Monthly Jour. Elect. Commun. Lab. (Japan)*, vol. 7, no. 1; 1954. The thin layer of insulation required on transformer-core tapes is produced by electrical precipitation of charged particles from a suspension. The best insulation of 79-Mb permalloy tape, about 0.05 mm thick, was obtained by deposition of MgO from a solution of 400 g MgO in 8 litres of methyl alcohol with 5 cm<sup>3</sup> of 60 per cent HNO<sub>3</sub> added, using a voltage ~4v and current ~90 ma with tape-speed ~2 m/min. Results obtained with Al<sub>2</sub>O<sub>3</sub>, SiO<sub>2</sub> and porcelain clay are also given.

## MATHEMATICS

51(083.5) 3613

**Royal Society Depository for Unpublished Mathematical Tables**—(*Phil. Mag.*, vol. 45, pp. 599-609; June, 1954.) A list of tables accepted up the end of 1953 together with a brief description of each. The tables may be consulted in the Royal Society Library and photocopies can be obtained.

517.6 3614

**Evaluation of the Exponential Integral for Large Complex Arguments**—J. Todd. (*Jour. Res. Nat. Bur. Stand.*, vol. 52, pp. 313-317; June, 1954.) Two methods of effecting this evaluation are discussed. It is shown that the Laguerre quadrature method is more effective than the asymptotic expansion. The practicality of the Laguerre method is illustrated by examples.

## MEASUREMENTS AND TEST GEAR

529.786+621.3.018.41(083.74) 3615

**The Need for a New Type of Frequency and Time Standard**—W. D. George. (*Proc. I.R.E.*, vol. 42, p. 1349; September, 1954.) The distinction between defining and operational standards is indicated, and the shortcomings of standards at present used for time and frequency are emphasized. In the present state of physical knowledge, the appropriate standard is the period of a molecular, atomic or nuclear vibration. It is imperative that a number of atomic clocks should be built and observed and efforts made to obtain agreement and reproducibility to at least one part in 10<sup>9</sup>.

529.786 3616

**Simple Quartz-Tuning-Fork [-controlled] Clocks**—L. D. Bryzhev and V. N. Titov. (*Zh. Tekh. Fiz.*, vol. 24, pp. 879-883; May, 1954.) Description, including dimensions of quartz tuning-fork, details of thermostatic control and complete circuit diagrams, of control unit giving 100- and 1,000-cps continuous sine-wave output and pulses at 1-second intervals. The rms frequency error is  $\pm 1.3 \times 10^{-8}$ . The diurnal clock error, which is mainly due to instability of the synchronous-motor-operated relay, is  $\sim \pm 0.0029$  second.

531.76:621.318.57:621.383 3617

**Measurement of Short Time Intervals using a Trigger Circuit controlled by Two Photocells**—H. Fark. (*Frequenz*, vol. 8, pp. 193-195; June, 1954.)

621.3.018.41(083.74):621.372.412 3618

**First Results with the New Frequency**

**Standards of the National Electrotechnical Institute "G. Ferraris"**—M. Boella. (*Ricerca sci.*, vol. 24, pp. 1196-1203; June, 1954.) Observations are reported on the first two examples of a new type of quartz-crystal 100-kc oscillator.

621.372.412:621.3.018.41(083.74) 3619

**High-Frequency Crystal Units for Primary Frequency Standards**—A. W. Warner. (*Proc. I.R.E.*, vol. 42, p. 1452; September, 1954.) Using design principles previously described (3481 of 1952) a quartz crystal has been produced having a diameter of 100 mm and a thickness of 18 mm and operating at about 1 mc on the eleventh overtone; the unit has a measured  $Q$  of  $12 \times 10^8$ .

621.317.33.029.62:537.562 3620

**Measurement of the Conductivity of a Jet Flame**—F. P. Adler. (*Jour. Appl. Phys.*, vol. 25, pp. 903-906; July, 1954.) A measurement method previously described (875 of 1950) was used to determine the complex conductivity of a rocket exhaust flame at a frequency of 200 mc. During steady running of the rocket motor a representative value is  $2 \times 10^{-5}$  mho/m; the attenuation of a radio wave in a homogeneous ionized medium with this value of conductivity would be 0.033 db/m. Somewhat higher values are observed during the starting-up period. Sodium impurities in the fuel affect the results greatly.

621.317.335.029.63/.64 3621

**A New Method of Measurement of the Microwave Complex Dielectric Constant of Liquids**—C. Brot. [*Compt. Rend. Acad. Sci. (Paris)*, vol. 239, pp. 612-613; August 30, 1954.] A method applicable to liquids with low and medium losses is based on determination of the SWR when a section of waveguide filled with the liquid has its length adjusted from a nonresonant to a resonant condition by shifting a short-circuiting piston.

621.317.337 3622

**The Correction of  $Q$  Meter Readings**—J. P. Newsome. (*Electronic Eng.*, vol. 26, pp. 408-410; September, 1954.) In hf direct  $Q$  measurements on large air-cored coils and coils using dust or ferrite cores, the circuit residuals may give rise to errors as great as 20 per cent. A simple and rapid method of correction is presented, making use of plotted correction factors in  $Q$ -factor form.

621.317.34.018.75:621.315.21 3623

**Amplitude and Phase Equalizer for Pulse Echo Meters for testing Long-Distance Cables**—G. Comte and M. Boudier. (*Ondelect.*, vol. 34, pp. 514-516; June, 1954.) In the method described, selective negative feedback is applied in accordance with the echo delay. An experimental unit in use comprises ten amplifier stages in cascade, each designed for equalization over a particular frequency range and controlled by a sawtooth-wave generator synchronized with the main pulse generator.

621.317.353 3624

**Measurement of Nonlinear Distortion and Reasons for the Divergence of Results obtained by Different Methods**—M. Pokrowsky. (*Ondelect.*, vol. 34, pp. 525-533; June, 1954.) Harmonic and two intermodulation methods of measurement are compared. The method recommended by the CCIF of simultaneous variation of two signal frequencies keeping the difference frequency constant has marked advantages if the response curve under investigation is peaked in the middle of the pass band. Other methods are particularly useful when frequency-response is level and noise level high.

621.317.44 3625

**Discussion of Current-Sheet Approximations in Reference to High-Frequency Magnetic Measurements**—B. Kostyshyn and P. H.

Haas. (*Jour. Res. Nat. Bur. Stand.*, vol. 52, pp. 279-287; June, 1954.) Errors in hf measurements on specimens made up into toroidal coils, due to neglecting leakage flux and to arbitrary assumptions regarding the location of effective current sheets, are investigated experimentally as a function of permeability, core dimensions, wire spacing and wire size.

**621.317.444** 3626  
**Development of the Technique of Electronic Fluxgate-Type Magnetometers**—G. D. Palazzi. (*Nuovo Cim.*, vol. 11, supplement no. 3, pp. 521-532; 1954.) Instruments developed in the U.S.A., Britain and Italy are discussed and their applications considered.

**621.317.72** 3627  
**Electric Field Meters**—R. Gunn. (*Rev. Sci. Instr.*, vol. 25, pp. 432-437; May, 1954.) Two meters are described, both of the field-mill type, with rotating rod inductor. In the ac meter the rod is connected to the grid of a tube with a leak to earth, and the sign of the field is obtained by phase-sensitive rectification using a generator on the same shaft as the rod to provide the reference voltage. In the dc meter the rectified inductor currents operate a high-impedance push-pull bridge circuit.

**621.317.726** 3628  
**A Peak Voltmeter with a Long Time Constant**—L. Medina. (*Aust. Jour. Appl. Sci.*, vol. 5, pp. 141-144; June, 1954.) An instrument developed for measurements in connection with hv puncture and flash-over tests at mains frequency is described; the discharge time constant is 10,000 seconds.

**621.317.73.012.11** 3629  
**An Automatic Impedance Recorder for X-Band**—W. F. Gabriel. (*Proc. I.R.E.*, vol. 42, pp. 1410-1421; September, 1954.) Details are given of an instrument which operates over the frequency band 8.4-9.9 kmc and with incident power levels from about 20 to 250 mw. It produces an ink graph of impedance or admittance on a standard Smith chart or, for higher accuracy, on an expanded central portion of the chart. The circuit is based on the reflectometer principle.

**621.317.733** 3630  
**Balancing A.C. Measurement Bridges**—F. J. Vettiner. (*Rev. gén. élect.*, vol. 63, pp. 316-318; June, 1954.) Use of a cro instead of a galvanometer as indicator enables both amplitude and phase to be balanced rapidly. An instrument is thus obtained which has a sensitivity sufficiently high for determining the ionization threshold of an insulator.

**621.317.755:621.314.63** 3631  
**Pulsed Curve Tracer for Semiconductor Testing**—J. I. Pankove. (*Electronics*, vol. 27, pp. 172-173; September, 1954.) A circuit is described which provides sawtooth voltage pulses of amplitude 350 v and duration 80  $\mu$ s at intervals of 4.4 ms; a second sawtooth component of amplitude 100 v and duration  $\sim$ 144 ms can be superposed. The arrangement is used for obtaining reverse  $I/V$  characteristics of crystal diodes without producing excessive heating.

**621.317.761+621.396.712:621.396.66** 3632  
**Frequency and Common-Wave Measurements at the Wittsmoor Transmission-Monitoring Station**—Ehlers and Thies. (*See* 3680.)

**621.385.001.4:533.59** 3633  
**New Method of Measuring Vacuum Factor of Vacuum Tubes in General**—Sato and Ishii. (*See* 3719.)

**621.397.62.001.4** 3634  
**Measurements on Television Receivers: Part 4—Methods for Measurement of Transmission Properties of I.F. Amplifier and F. H. Stages**—O. Macek. (*Arch. tech. Messen.*, no.

221, pp. 125-128; June, 1954.) Part 3: 3376 of December.

#### OTHER APPLICATIONS OF RADIO AND ELECTRONICS

**531.768:546.431.823-31** 3635  
**A Wide-Range Barium-Titanate Accelerometer**—(*Tech. News Bull. Nat. Bur. Stand.*, vol. 38, pp. 88-90; June, 1954.) The NBS-33-14 accelerometer, designed for a special military application, has a range of 50,000 g and a natural frequency of 90 kc. It uses two barium-titanate ceramic disks separated by a brass disk which acts both as spacer and as electrode. A low noise level is achieved by shielding the disks with a thick dural cup.

**535.37:621.327** 3636  
**The Electroluminescent Lamp: a New Light Source**—K. H. Butler, C. W. Jerome and J. F. Waymouth. (*Elec. Eng.*, vol. 73, pp. 524-528; June, 1954.) Possible electroluminescence mechanisms are discussed, characteristics of electroluminescent lamps are presented, and three fields of application are mentioned.

**621.3.078:061.3(47)** 3637  
**Second All-Union Conference on the Theory of Automatic Regulation**—B. N. Petrov and B. N. Naumov. [*Bull. Acad. Sci. (URSS), Tech. Sci.*, no. 2, pp. 117-122; February, 1954. In Russian.] This report on the conference held in Moscow in 1953 includes brief notes on the 80 or so papers presented and on the exhibition of models and ancillary apparatus.

**621.365.55†** 3638  
**Calculation of the Temperature Distribution in H.F.-Heated Laminated Materials**—A. V. Netushil. (*Zh. Tekh. Fiz.*, vol. 24, pp. 1035-1040; June, 1954.) The application of the derived formulas and tabulated data is illustrated by a numerical calculation of the temperature difference between wood and glue stacked with the laminations perpendicular to the plane heater electrodes. A field strength of 0.5 kv/cm and a frequency of 25 mc are assumed in the calculation.

**621.369.4** 3639  
**Medical Applications of Short-Wave Energy**—W. Keibel. (*Funk u. Ton*, vol. 8, pp. 329-332 June, 1954.) The heating effects in a fat-muscle dummy produced by microwave radiation ( $\lambda$  12.25 cm) and by hf ( $\lambda$  11.6 m) radiotherapy are briefly compared and an automatic method of regulating output power in the hf system is briefly described.

**621.383** 3640  
**Optical Transducers and some Industrial Applications**—J. A. Sargrove. (*Jour. Brit. I.R.E.*, vol. 14, pp. 337-350; August, 1954.) The transducers discussed are based on photoelectric cells, and include sharp-focus-light-spot types for reflectometers and light-scatter types for nephelometric determinations. Other applications mentioned are high-speed weighing, line-following and edge-alignment equipment.

**621.383.27** 3641  
**Optar, a Method of Optical Automatic Ranging, as applied to a Guidance Device for the Blind**—H. E. Kallmann. (*Proc. I.R.E.*, vol. 42, pp. 1438-1446; September, 1954.) Shallow real images of the objects in the explored field are formed in an image space where a helical slotted vane is rotated to cut across all rays in one image plane after another. When the bars coincide with a sharp image they modulate the light received by a photocell. Tones of eight frequencies, corresponding respectively to eight ranges between 20 inches and 20 feet, are produced in earphones. A hand-held model is described.

**621.384.6** 3642  
**Two Ion Sources for the Production of Multiply Charged Nitrogen Ions**—R. J. Jones and

A. Zucker. (*Rev. Sci. Instr.*, vol. 25, pp. 562-566; June, 1954.) Hot-cathode and hollow-anode sources for particle accelerators are discussed.

**621.384.611/612** 3643  
**Regenerative Deflection as a Parametrically Excited Resonance Phenomenon**—S. E. Barden. (*Rev. Sci. Instr.*, vol. 25, pp. 587-593; June, 1954.) Analysis of a particle-extraction method for use with synchrocyclotrons.

**621.384.611** 3644  
**High-Intensity Ion Source for Cyclotrons**—R. S. Livingston and R. J. Jones. (*Rev. Sci. Instr.*, vol. 25, pp. 552-557; June, 1954.) A hot-cathode arc-discharge type of source is described; a current of 3 ma of 22-mev protons has been obtained from the 86-inch Oak Ridge cyclotron using this source.

**621.384.612** 3645  
**The Radio-Frequency Fine Structure of the Photon Beam from the Berkeley Synchrotron**—R. Mady, K. C. Bandtel, and W. J. Frank. (*Rev. Sci. Instr.*, vol. 25, pp. 537-540; June, 1954.)

**621.384.612** 3646  
**Design Study of a Strong-Focusing Electron-Synchrotron**—E. Smárs and O. Wernholm. (*Ark. Fys.*, vol. 7, part 5, pp. 463-472; March 25, 1954.) The design of an electron accelerator based on the principles described by Courant et al. (1454 of 1953) is relatively simple, since it can be arranged that no rf modulation is required. The machine is not expected to provide higher energies than the conventional synchrotron, but is useful for studying the strong-focusing principle.

**621.384.622** 3647  
**Investigation of the Collector Characteristics of the Palletron**—V. K. Shtein. (*Zh. Tekh. Fiz.*, vol. 24, pp. 1062-1068; June, 1954.) The dependence of the collector current on the amplitude and frequency of the accelerating voltage, on the focusing magnetic-field strength and on the emitter temperature was investigated experimentally and theoretically. The resolving power of a palletron used as mass-spectrometer is inversely proportional to the pulse length. The palletron was described earlier by Skellett (810 of 1949).

**621.385.833** 3648  
**A Compact Console-Type Electron Microscope**—R. S. Page. (*Jour. Sci. Instr.*, vol. 31, pp. 200-205; June, 1954.) Description of the Type-E.M.4 model, developed for general-purpose routine electron microscopy. The mounting of the electron gun is such that reflection-type operation is possible as well as the more usual transmission-type.

**621.385.833** 3649  
**Relativistic Aberration Functions and Normal Coefficients of Electron-Optical Aberrations**—O. I. Seman. [*Compt. Rend. Acad. Sci. (URSS)*, vol. 96, pp. 1151-1154; June 21, 1954.] Relativistic formulas for third-order aberration coefficients are given in terms of the coefficients of the point eikonal in static electric and magnetic fields with rotational symmetry. In particular, formulas are given for Petzval's coefficient, the coefficients of anisotropic coma, astigmatism and distortion, spherical aberration, and coma, curvature and distortion. The relativistic coefficients reduce to ordinary ones at low energies.

**621.385.833** 3650  
**Effect of Departures from Rotational Symmetry of the Focusing Field on the Resolution of Magnetic Objectives in Electron Microscopes**—G. V. Der-Shvarts. (*Zh. Tekh. Fiz.*, vol. 24, pp. 859-870; May, 1954.) The effects on the vector potential and induction vector components are calculated for (a) ellipticity of field



boundaries, (b) displacement of axes of symmetry of lens components relative to each other, and (c) tilt of lens axes relative to each other or of the axis of symmetry of the lens system relative to the optic axis. The relations between the geometry of the system and coma and astigmatism (down to the order of 35 Å and less) are discussed.

621.385.833 3651  
**Electron-Optical Properties of Electrostatic Lenses: Part 3**—W. Lippert and W. Pohlitz. [*Optik (Stuttgart)*, vol. 11, no. 4, pp. 181-186; 1954.] Continuation of investigation of unipotential lenses. Part 2: 1158 of May.

621.385.833 3652  
**A Low-Distortion Electromagnetic Double Projection Lens for Electron Microscopes**—L. Wegmann. [*Optik (Stuttgart)*, vol. 11, no. 4, pp. 153-170; 1954.] The condition for minimal radial aberration is derived in terms of the focal lengths of the two electromagnetic lenses comprising the projection-lens system. The magnification range of 1:3 is achieved using simple control circuits without tubes.

621.385.833 3653  
**Shadowing Technique for Electron Microscopy—a Possible Substitute for the High-Vacuum Evaporation Technique**—A. E. Bills and R. Lefker. [*Jour. Appl. Phys.*, vol. 25, pp. 901-903; July, 1954.]

621.385.833 3654  
**Design of a Slotted Electron Lens for Analysis of [electron] Velocities**—A. Septier. [*Compt. Rend. Acad. Sci. (Paris)*, vol. 239, pp. 402-404; August 2, 1954.] Calculations for a cylindrical lens are presented.

621.385.833 3655  
**Development of an Electrostatic Spectrograph from an Electron Microscope**—B. Gautié. [*Compt. Rend. Acad. Sci. (Paris)*, vol. 239, pp. 399-402; August 2, 1954.] The cylindrical lens described by Septier (3654 above) is used in an instrument for determining the distribution of electron velocities in a beam.

621.385.833:535.215 3656  
**Experimental Photoemission-Type Electron Microscope**—E. L. Huguénin. [*Compt. Rend. Acad. Sci. (Paris)*, vol. 239, pp. 404-406; August 2, 1954.] A 20-kv two-stage electrostatic instrument is discussed in which an image is formed of a surface which emits electrons when subjected to ultraviolet radiation; the object is illuminated at nearly grazing incidence by a Hg-vapor lamp. A directly viewed fluorescent screen was used in the first experiments; this was later replaced by a screen/camera unit.

621.385.833:535.767 3657  
**Theory and Technique of Electron-Microscope Stereograms**—J. G. Helmcke. [*Optik (Stuttgart)*, vol. 11, no. 5, pp. 201-225; 1954.] Relations between the stereo shift angle, depth of object, microscope magnification and optical data of the viewing system necessary for satisfactory production and reproduction of stereoscopic images are discussed.

621.385.833.013.001.57 3658  
**Measuring Magnetic Fields [of electron-microscope lenses] on Scale Models, taking account of Saturation Phenomena**—G. Langner and F. Lenz. [*Optik (Stuttgart)*, vol. 11, no. 4, pp. 171-180; 1954.]

621.387.4 3659  
**Instruments for Radiation Protection**—R. B. Stephens. [*Jour. Brit. IRE*, vol. 14, pp. 377-386; August, 1954.] Design principles are discussed with special reference to reliability, ease of handling and simplicity of control. The influence of these features on the design of a hand and foot monitor and a Civil Defense contamination meter is considered.

621.39:622.323 3660  
**Electronics in the Oil Industry**—J. M. Carroll. (*Electronics*, vol. 27, pp. 120-127; September, 1954.) Methods used in geophysical prospecting and other operations connected with various aspects of the petroleum industry are discussed. Extensive microwave radio communications have been developed for pipeline systems. Measurement and control of temperature, pressure, rate of flow and liquid level in the refining process are among the operations that can be performed electronically.

681.142:629.13 3661  
**Analogue Computers in Aircrew Training Apparatus**—Cutler. (See 3477.)

#### PROPAGATION OF WAVES

538.566 3662  
**On the Theory of Propagation of Electric Waves over a Plane Surface of the Homogeneous Earth (On Sommerfeld's Surface Waves)**—Y. Nomura. (*Sci. Rep. Res. Inst. Tohoku Univ., Ser. B*, vol. 5, pp. 203-214; December, 1953/March, 1954.) Results of a calculation by the saddle-point method show that Sommerfeld's surface-wave term due to the residue at the pole of the integrand is just canceled by the part of the integral along the steepest descent through the saddle point, and the remaining part of the integral gives van der Pol and Niessen's formula, which is an extension of Weyl's solution.

538.566 3663  
**Energy Correlations in Space-Dispersive Media**—M. E. Gertsenshtein. (*Zh. Eksp. Teor. Fiz.*, vol. 26, pp. 680-683; June, 1954.) Rytov's results (1720 of 1948) are generalized to include the case of a medium with nonuniform dielectric constant; it is shown that the velocity of propagation of energy is equal to the group velocity.

621.396.11 3664  
**Difficult Predictions discussed at the C.C.I.R., 1953. Circuits linking Australia to Canada and Great Britain**—R. Gea Sacasa. [*Rev. Telecomun. (Madrid)*, vol. 9, pp. 2-16; June, 1954. In Spanish and English.] Further demonstration of the success of the "Spanish method" for predicting propagation conditions. See also 2493 of September and back references.

621.396.11:551.510.535 3665  
**The Quality of Radio Weather**—B. Beckmann. (*Fernmeldetech. Z.*, vol. 7, pp. 285-301; June, 1954.) "Radio weather" is defined as the sum of the effects of ionospheric conditions on the propagation conditions along a radio circuit. The construction of clock-face charts using the product of usable bandwidth and mean received field strength as criterion of radio-weather quality (2417 of 1953) is described. These charts, based on monthly mean figures, serve as comparison standards for demonstrating seasonal and sunspot-cycle variations. Fundamental differences between various overseas circuits, depending on the location of the path in relation to the sun, are indicated.

621.396.11.029.6 3666  
**Current Problems in the Study of U.S.W. Transmission**—J. Voge. (*Onde élect.*, vol. 34, pp. 487-498; June, 1954.) A review of recent data on (a) propagation at vhf over distances of 1,000-2,000 km by ionospheric scattering [2581 of 1952 (Bailey et al.)]; (b) tropospheric propagation at 40-4,000 mc over distances up to 1,000 km; (c) uhf fading on line-of-sight transmission paths, which is dealt with in greater detail. 48 references.

621.396.11.029.62 3667  
**Scattered Reflection in Short-Wave Propagation**—H. A. Hess. (*Funk u. Ton*, vol. 3, pp. 283-287; June, 1954.) Previously reported results (e.g. 3496 of 1948) are discussed in the light of later work on long-distance vhf propagation and on backscatter.

621.396.81 3668  
**Theoretical Field Strengths and Angles of Incidence of WWV Transmissions at the Châtonnaye Receiving Station**—C. Glinz. (*Tech. Mitt. schweiz. Telegr.-TelephVerw.*, vol. 32, pp. 222-237; June 1, 1954. In French.) Calculations are made of the angles of incidence for the transmissions at 2.5-35 mc, assuming the space wave to make two or more hops between the earth and the  $F_2$  layer. December, 1948, and June, 1949 are chosen as representative periods and 0300 and 1500 GMT as representative times. Different values of the height of the  $F_2$  layer are considered. The question of muf is examined in detail. Corrections are made for the transmitter and receiver radiation diagrams [1912 of 1953 (Dufour)] and for variations of power level. Field strengths are predicted as 90 per cent, 50 per cent and 10 per cent probabilities. Agreement with values observed by Ebert (1476 of 1951) is satisfactory.

621.396.812:3.029.64 3669  
**Microwave Fading**—S. Matsuo, S. Ugai, K. Kakita, F. Ikegami and Y. Kono. [*Rep. Elect. Commun. Lab. (Japan)*, vol. 1, pp. 38-47; November, 1953.] Analysis of the results of propagation tests at 4 kmc made during the last three years with a view to establishing a multichannel relay network. The two types of fading investigated were  $k$ -type, defined in terms of the equivalent ground-reflection coefficient, and duct-type. Typical hourly variations of equivalent  $k$ -value determined from space- and frequency-diversity records and probable field-strength distribution curves for different values of reflection coefficient are shown. For duct-type fading empirical expressions are given for clearance factor, a function of average path height ( $\bar{h}$ ), and for fading depth. The latter increases as  $h$  decreases. When  $\bar{h}$  is above several hundred meters topography is unimportant, except that strong ducts are formed easily over flat land.

#### RECEPTION

621.396.62:621.396.3 3670  
**New Receivers for Commercial Radio Teletype Service**—H. Heuser. (*Fernmeldetech. Z.*, vol. 7, pp. 279-280; June, 1954.) Receivers developed in Western Germany, using frequency-shift keying, are described briefly; they are suitable for frequency-diversity or space-diversity operation.

621.396.82:621.397.62 3671  
**I.R.E. Standards on Receivers: Methods of Measurement of Interference Output of Television Receivers in the Range of 300 to 10,000 kc/s, 1954**—(PROC. I.R.E., vol. 42, pp. 1363-1367; September, 1954.) Standard 54 IRE 17. S1.

621.396.823:621.365 3672  
**Testing the Radio-Interference Effect of High-Frequency Heating Equipment**—G. Use. (*Elektrotech. Z. Edn A*, vol. 75, pp. 357-362; June 1, 1954.) A summary of West German radio-interference-suppression regulations for medical and industrial hf apparatus, covering the range from 10 kc to 3,000 kmc, is followed by a description of the method of field-strength measurement in the range 150 kc-470 mc with particular attention to the range 30-400 mc. The correction factor for field strengths measured near the ground, with the standard set-up, and the maximum permissible field strength at various distances from the interference source are shown graphically. The production of equipment complying with the regulations was shown to be technically and economically possible for the majority of the 144 different types of apparatus tested.

#### STATIONS AND COMMUNICATION SYSTEMS

621.376.5 3673  
**Notes on Pulse Delta Modulation**—R.

Stampfl. (*Öst. Z. Telegr. Teleph. Funk Fernseh-  
tech.*, vol. 8, pp. 58-63 and 92-97; May-  
August, 1954.) Principles of the technique are  
described and the design of a delta-modulation  
system is discussed taking account of normal  
quantization noise and the impossibility of ob-  
taining perfect equality between the positive  
and negative difference steps. A detailed de-  
scription is given of the design of an experimen-  
tal coding unit.

**621.39.001.11** 3674  
**Coding for Constant-Data-Rate Systems:  
Part I—A New Error-Correcting Code**—R. A.  
Silverman and M. Balser. (*Proc. I.R.E.*, vol.  
42, pp. 1428-1435; September, 1954.) "A study  
of coding to reduce the frequency of errors in  
communication systems which transmit data  
at a constant rate has been started. A new  
single-error-correcting code (the Wagner code)  
is described and analyzed. Its performance in  
a constant-data-rate system is evaluated and  
compared with Hamming's single-error-cor-  
recting code. The Wagner code is superior for  
many communication applications. Its suc-  
cessful implementation does not require too  
precise equipment."

**621.39.001.11** 3675  
**The Entropy of the German Language**—K.  
Küpfmüller. (*Fernmeldetechn. Z.*, vol. 7, pp. 265-  
272; June, 1954.) From the known frequency  
of occurrence of the letters, syllables and words  
in written German, combined with experimen-  
tal investigations of the superfluous elements,  
the entropy is found to be 1.6 bits/letter, or  
1.3 bits/symbol, including the space between  
words as one symbol. This value is of the same  
order as that found by Shannon for written  
English (1649 of 1949). The information rate  
of spoken German was found to range from 24  
to 54 bits/second.

**621.396.4.029.63/64** 3676  
**Industry Co-ordination of Microwave  
Communications Systems**—V. J. Noxon. (*Elec.  
Eng.*, vol. 73, pp. 537-540; June, 1954.) Dis-  
cussion of problems encountered in areas of the  
U.S.A. where large and growing numbers of  
microwave radio communication systems are  
operating. Adequate surveys must be made  
before designing new systems if space and fre-  
quency congestion are to be avoided. Channel  
"packaging," frequency stability and beam-  
width tolerances are considered.

**621.396.41** 3677  
**Methods of Synchronization and Distribu-  
tion in Time-Division Multiplex Systems**—I.  
Incollingo. (*Onde élect.*, vol. 34, pp. 431-440;  
May, 1954.) Synchronizing methods are classi-  
fied into two groups according as the synchro-  
nizing signal does or does not occupy part of  
the frequency band used for transmitting intel-  
ligence. Principles of the methods are described  
including, in the second group, use of auxiliary  
modulation, of pulse clipping and of panoramic  
receivers.

**621.396.5:621.396.65.029.62** 3678  
**Radiotelephony Links of the Kraftwerke  
Oberhasli A.G.**—H. Stalder. (*Bull. schweiz,  
elektrotech. Ver.*, vol. 45, pp. 543-546; June 26,  
1954.) Description of installations for com-  
munications in mountainous country, espe-  
cially for use during the building of new power  
stations. Frequencies in the 8-m waveband were  
used for links in which propagation was effected  
by reflection from the sides of the mountain,  
while frequencies in the 1.8-m waveband were  
used for a link parallel with a valley.

**621.396.5:621.396.721.029.62** 3679  
**Harbor Services: Radio Telephone Equip-  
ment**—F. Iwai and T. Morinaga. [*Rep. elect.  
Commun. Lab. (Japan)*, vol. 1, pp. 4-9; Decem-  
ber, 1953.] The equipment operates in the fre-  
quency band 162-172 mc. At the base station  
are two 40w phm transmitters mounted in the  
same bay, and two double-superheterodyne

receivers, IF 5.5 mc and 455 kc. The antenna  
system is a vertical-dipole array with a curtain-  
type reflector and cavity-resonator diplexing  
arrangements. Details are given of operating  
characteristics. 5w transmitter/receivers are  
used for mobile units.

**621.396.712:621.396.66]+621.317.761** 3680  
**Frequency and Common-Wave Measure-  
ments at the Wittsmoor Transmission-Moni-  
toring Station—II.** Ehlers and H. Thies. (*Tech.  
Hausmitt. NordwDtsch. Rdfunks*, vol. 6, pp.  
57-66; 1954.) An account is given of the work  
of the station at Wittsmoor near Hamburg. The  
method of monitoring NWDR transmissions on  
frequencies up to 100 mc is described in detail.  
Temperature and humidity-controlled 100-kc  
standard quartz oscillators are used to supply  
the operational frequencies of 1, 10, 100 and  
1,000 kc; the accuracy of the oscillators is  
checked against the standard frequency trans-  
missions of MSF, WWV and other time-signal  
sources. A precision frequency meter for meas-  
urements up to 600 mc is also briefly described.

**621.396.712.2/.3:534.8** 3681  
**The Acoustical Design of a New Sound  
Broadcasting Studio for General Purposes**—  
Humphreys. (*See* 3441.)

**621.396.93** 3682  
**Design, Planning and Operation of Mobile  
Communication Systems**—(*Trans. I.R.E.*, no.  
PGVC-4, pp. 1-98; June, 1954.) The text is  
given of nine papers presented at a meeting in  
November, 1953, dealing with mobile radio  
communication systems for various special pur-  
poses.

**621.396.945** 3683  
**Radio Experiments in Mines**—C. Berthold.  
(*NachrTech.*, vol. 4, pp. 218-223, 239; May,  
1954.) Report of experimental investigation of  
communication at frequencies between 20 kc  
and 100 mc. Results show that the optimum  
frequency range is from 110 kc to 150 kc. Vari-  
ous antennas were used in conjunction with the  
10w (max) transmitter and the receiver. Field-  
strength measurements were made for several  
transmitter and receiver positions, and the  
wave-guiding effect of conductors was noticed.  
A short summary of similar investigations in  
the U.S.A., South Africa, and elsewhere is  
given.

#### SUBSIDIARY APPARATUS

**621-526** 3684  
**The Frequency Response of a Certain Class  
of Non-Linear Feedback Systems**—J. C. West  
and J. L. Douce. (*Brit. Jour. Appl. Phys.*, vol.  
5, pp. 204-209; June, 1954.) A method is de-  
scribed for predicting the frequency response of  
feedback systems including one single-valued  
nonlinear element followed by a low-pass  
filter. The conditions giving rise to gain dis-  
continuity, or "jump" phenomenon, are investi-  
gated. Experimental results obtained with an  
electronic servo simulator justify the use of the  
analytical technique.

**621-526:621.396.662** 3685  
**Remote Control of Radio Receivers**—C. E.  
Tate. (*Wireless World*, vol. 60, pp. 496-498;  
October, 1954.) A zero-seeking-servo tuning  
control designed for operation over a single  
Post Office telephone line is described, the sig-  
nal from the tuned receiver passing along the  
control lines. Maximum separation is 7 loop-  
miles for underground routes or 20-30 loop-  
miles for overhead routes, depending on the  
type of cable. The circuit is essentially a  
Wheatstone bridge with two variable arms, one  
of which is carried to the remote point along the  
line. The detector comprises a second-harmonic  
magnetic modulator combined with tube am-  
plifier.

**621.311.6** 3686  
**A Stable D.C. Source of Low Voltage with  
Low Internal Resistance**—W. R. Beakley.

(*Jour. Sci. Instr.*, vol. 31, pp. 219-220; June,  
1954.) A mains-driven source providing a di-  
rect voltage of 2.6v constant to within  $\pm 0.1$   
per cent for mains voltage variations of  $\pm 15$   
per cent and current drain of 5-9 ma uses a  
magnetic amplifier as an impedance trans-  
former to provide a very low output resistance  
from a gas-filled reference tube Type 85A2.  
Long-term stability depends mainly on the  
reference tube, which has a nominal drift of 0.1  
per cent per 1,000 h after an aging period.

**621.311.6** 3687  
**The Design of High-Efficiency Radio-Fre-  
quency E.H.T. Supplies**—J. Barron. (*Elec-  
tronic Eng.*, vol. 26, pp. 393-396; September,  
1954.) Difficulties associated with the use of  
air-cored step-up transformers for the produc-  
tion of high voltages are discussed. Designs in  
which these difficulties are eliminated or allevi-  
ated are obtained by using transformers with  
ferroxcube cores. Simple design procedure is  
outlined, with numerical examples.

**621.311.6:621.383.27** 3688  
**A Current Stabilized Photomultiplier Power  
Supply**—P. Fellgett. (*Jour. Sci. Instr.*, vol. 31,  
pp. 217-219; June, 1954.) Stabilization is  
based on the series connection of two cathode  
followers. Tests on the circuit are reported;  
voltage is maintained constant to within one  
part in 10<sup>4</sup>.

**621.314.634** 3689  
**Selenium Rectifier Disks as Voltage-De-  
pendent Resistors for Amplification of Fluctua-  
tions of a Component Voltage and Voltage  
Stabilization, particularly Amplitude Limiting**  
—E. Hesse. (*Frequenz*, vol. 8, pp. 177-180;  
June, 1954.)

**621.314.634** 3690  
**Investigation of Rectification Properties of  
Se-HgSe Contact**—A. F. Belski and A. I.  
Blum. (*Zh. Tekh. Fiz.*, vol. 24, pp. 826-832;  
May, 1954.) The experimentally determined  
rectification-coefficient maximum, occurring at  
 $\sim 2$  v, is  $\sim 10$  for 97 per cent pure Se, and  $\sim 7$   
for 99.99 per cent Se. Current/voltage charac-  
teristics were investigated for rectifiers with the  
HgSe prepared by exposing Se to Hg vapor or  
to liquid Hg, Se crystallized at various rates  
and temperatures, various electrode base ma-  
terials and Se of two different grades of purity.  
The results are shown graphically.

**621.314.634** 3691  
**Asymmetry in Conductivity of Some Sele-  
nides**—N. G. Klyuchnikov. (*Zh. Tekh. Fiz.*,  
vol. 24, pp. 833-836; May, 1954.) The experi-  
mentally determined current/voltage charac-  
teristics of a CuSe-Mg rectifier are discussed.  
The ratio of reverse to forward current varies  
between 1:4,000 and 1:6,000, the power-  
handling capacity is  $\sim 0.7-0.8$  w/cm<sup>2</sup> and the  
blocking layer is stable even at 200 degrees-  
300 degrees C. The principal disadvantages of  
this rectifier are the large hysteresis effect and  
the deforming after prolonged storage. Other  
selenides and selenide/metal combinations are  
briefly noted.

#### TELEVISION AND PHOTOTELEGRAPHY

**621.397.2** 3692  
**Multiplex Television Transmission**—J.  
Haantjes and K. Teer. (*Wireless Eng.*, vol. 31,  
pp. 225-233 and 266-273; September and Oc-  
tober, 1954.) "Systems for the transmission of  
several television signals within a single tele-  
vision channel are described in this article; they  
are based on the use of signal components  
which cancel out in two successive pictures. A  
distinction is made between the sub-carrier and  
the dot-interlace systems. The typical charac-  
teristics of both systems are determined and,  
in particular, those characteristics which affect  
the separation of the signals at the receiver.  
Their application to colour television is consid-  
ered and the conclusion is drawn that for this  
the sub-carrier system is to be preferred."



- 621.397.26:621.396.65** 3693  
**Equipment of the Berlin-Leipzig Television Link**—W. Mansfield. (*Nachr. Tech.*, vol. 4, pp. 194-196; May, 1954.) Description with block diagrams and performance data of 1.5-kmc FM equipment Type-RVG 904. At the relay station amplification is effected at 60 mc before retransmission at uhf. Transmitter output is 8w. See also 2782 of October (Megla).
- 621.397.26:621.396.65.029.62** 3694  
**Television Link between Germany and Switzerland**—G. Mahlow. [*Funk-Technik (Berlin)*, vol. 9, pp. 290-291; June, 1954.] Description of equipment for a temporary usw link between Hornisgrinde (Schwarzwald) and Chasseral (Jura) in connection with the European television exchange programs. The Hornisgrinde station operates in the 174-216-mc band and is just within line of sight of Chasseral. The highly directive dipole array has a gain of 204, and the 1-kw transmitter is modulated at low level.
- 621.397.5:778.5** 3695  
**New 35-mm Single-Film-System Kinescope Recording Camera**—R. M. Fraser. (*Jour. Soc. Mot. Pic. Telev. Eng.*, vol. 62, pp. 441-449; June, 1954. Discussion, p. 449.)
- 621.397.61** 3696  
**The Specification of Imaging Properties by Response to a Sine Wave Input**—J. W. Colman. (*Jour. Opt. Soc. Amer.*, vol. 44, pp. 468-471; June, 1954.) The response of an optical system to a "sine-wave" test pattern constitutes a convenient criterion for assessing its imaging properties. A simple formula is given for calculating the response to the "sine-wave" pattern from the response to the usual "square-wave" (bar) pattern. The responses of individual parts of a system, such as a fluoroscope or television camera, can be readily combined to give the over-all response.
- 621.397.61:621.396.67** 3697  
**The Impedance Specification of a Television Transmitting Aerial**—Page (See 3460.)
- 621.397.62+621.396.62.029.62** 3698  
**Television Receiver "Sever"**—M. Tovbin. [*Radio (Moscow)*, no. 6, pp. 43-47; June, 1954.] Description, including complete circuit diagram, of a Russian-made receiver covering three pre-set television vhf channels and the 66-73-mc FM broadcast band. This receiver is also known by the name "Zenit."
- 621.397.62:535.623** 3699  
**Modified Color Signal for Single-Gun Tubes**—S. K. Altes and A. P. Stern. (*Electronics*, vol. 27, pp. 168-170; September, 1954.) The NTSC signal, as it appears at the second detector of the receiver, is of dot-sequential type but represents a combination of the three primary colors. Techniques are described for separating out the three color signals, while retaining the dot-sequential nature, so as to make the signal suitable for a single-gun rather than a three-gun tube. Modification of the sinusoidal wave form used for color switching is involved.
- 621.397.62:535.623** 3700  
**Significance of Some Receiver Errors to Color Reproduction**—H. Weiss. (Proc. I.R.E., vol. 42, pp. 1380-1388; September, 1954.) A method is described for determining the significance of various types of signal error in terms of color perception by an observer. Deviations in chromaticity are evaluated in terms of MacAdam's unit of equal noticeability (2553 of 1951). An experimental investigation of viewer tolerances is reported.
- 621.397.62:535.623** 3701  
**The Design of I.F. Amplifiers for Color Television Receivers**—J. Avins. (*Trans. I.R.E.*, no. PGBTR-7, pp. 14-25; July, 1954.) The principal design problem is that of providing adequate rejection at the frequency of the sound carrier without introducing excessive delay in the color-sideband region, which is separated from the sound carrier by <1 per cent of signal frequency. Nonminimum-phase-shift trap circuits for this purpose are described. See also 1222 of May (Avins et al.).
- 621.397.62:621.396.82** 3702  
**I.R.E. Standards on Receivers: Methods of Measurement of Interference Output of Television Receivers in the Range of 300 to 10,000 KC, 1954**—(Proc. I.R.E., vol. 42, pp. 1363-1367; September, 1954.) Standard 54 IRE 17.S1.
- 621.397.62:621.396.822** 3703  
**Detection of Television Signals in Thermal Noise**—J. E. Bridges. (Proc. I.R.E., vol. 42, pp. 1396-1405; September, 1954.) The detection process is analyzed using a method similar to that of Ragazzini (390 of 1943). Because of the complex IF response, the noise is represented as the sum of a finite number of sinusoidal components. From this, the (signal + noise) envelope preceding the detector can be determined and thence the rms noise and signal spectrum following the detector; the signal/noise ratios in any channel following the detector can then be computed. It is shown that with very weak signals the diode detection process suppresses the desired video modulation and, in effect, creates additional noise. Two improved detection circuits, an exalted-carrier IF and a product detector, are described.
- 621.397.62:621.385.832** 3704  
**The Measurement of Yoke Astigmatism**—R. A. Bloomsburgh. (*Trans. I.R.E.*, no. PGBTR-7, pp. 26-33; July, 1954.) Distortion of a cathode beam is discussed in terms of optical concepts. Microscope measurements of the spot at different points are used to determine the positions of the foci and hence the characteristics of the deflection yoke. Application of the method to the investigation of three-beam tubes for color television is described; in this case yoke astigmatism increases with deflection angle more rapidly than in monochrome tubes.
- 621.397.62.001.4** 3705  
**Measurements on Television Receivers: Part 4—Methods for Measurement of Transmission Properties of I.F. Amplifier and H. F. Stage**—O. Macek. (*Arch. tech. Messen.*, no. 221, pp. 125-128; June, 1954.) Part 3: 3376 of December.
- 621.397.7:534.861** 3706  
**Electroacoustic Equipment of the Hamburg-Lokstedt Television Centre**—G. Schadwinkel and F. Naupert. (*Tech. Hausmitt. Nordw. Disch. Rdfunks.*, vol. 6, nos. 3/4, pp. 67-70; 1954.) An illustrated description of the installation. See also 563-566 of March.
- 621.397.8** 3707  
**Reproduction of Pictures by Inexactly Tuned Television Receivers**—F. Kirschstein and A. Krug. (*Fernmeldetechn. Z.*, vol. 7, pp. 273-278; June, 1954.) With vestigial-sideband transmission, the IF carrier is usually arranged to fall in the middle of the upper slope of the receiver IF filter characteristic. Distortion of video components due to faulty adjustment is calculated and investigated experimentally. Oscillograms of rectified test signals and corresponding monitor-tube reproductions of test cards are shown. Suggestions are advanced for eliminating distortion due to the quadrature carrier component by emphasizing the in-phase component at transmitter or receiver.
- 621.397.82.029.62** 3708  
**Band-III Television Interference**—F. R. W. Strafford. (*Wireless World*, vol. 60, pp. 501-504; October, 1954.) Differences in the effects of man-made interference on bands I and III are discussed in the light of interference records compiled by the British Post Office. Propagation of interference from fractional-horsepower commutator motors in domestic appliances is considered. Experiments indicate that for interference suppression on band III, high-impedance self-resonant inductors should be fitted as close as possible to the motor brushes, within the appliance. A motor with square-section brushes "bedded in" to the commutator curvature generated much lower interference than a similar motor with circular-section brushes.
- TRANSMISSION**
- 621.396.61:621.396.8** 3709  
**Subjective Investigations of Nonlinear Distortion of Several Transmitters of the N.W.D.R.**—E. Belger. (*Tech. Hausmitt. Nordw. Disch. Rdfunks.*, vol. 6, nos. 3/4, pp. 80-84; 1954.) Measurements similar to those reported by Baer and Lauer (1944 of July) show that the usw transmitter at Bonn is adjudged both subjectively and objectively to possess better frequency and nonlinear distortion characteristics than older medium-wave transmitters of the NWDR. The subjective score marks and the measured frequency and distortion characteristics are given for several transmitters, ranging from good quality to very poor. Fair agreement between subjective and objective results was obtained.
- TUBES AND THERMIONICS**
- 621.314.63** 3710  
**Charge Storage in Junction Diodes**—E. L. Steele. (*Jour. Appl. Phys.*, vol. 25, pp. 916-918; July, 1954.) Formulas are derived for the current spike which occurs, as a result of hole storage in the *n*-type body of a Ge diode, on switching suddenly from forward to reverse conduction. Reduction of hole lifetime and use of thinner Ge pellets tend to reduce the spike and improve the frequency response.
- 621.314.63:621.396.822** 3711  
**Flicker Noise in Germanium Rectifiers at Very Low and Audio Frequencies**—D. K. Baker. (*Jour. Appl. Phys.*, vol. 25, pp. 922-924; July, 1954.) Measurements on point-contact and alloyed-junction type Ge rectifiers show that flicker noise varies inversely as frequency over the whole range from about  $10^{-3}$  to  $10^6$  cps. The current dependence of the flicker noise at 10 cps was also investigated.
- 621.314.632:546.289** 3712  
**Experimental Results in the Selection of Germanium Rectifiers**—P. Goudal. (*Cahiers de Phys.*, no. 49, pp. 65-66; May, 1954.) Measurements on groups of rectifiers from two different suppliers are reported. In the one group, instability of inverse current was exhibited by several specimens at 24 degrees C. and by a larger number at 44 degrees C. The importance of selecting Ge rectifiers with low values of temperature coefficient is emphasized.
- 621.314.7** 3713  
**Steady-State Solution of the Two-Dimensional Diffusion Equation for Transistors**—J. S. Schaffner and J. J. Suran. (*Jour. Appl. Phys.*, vol. 25, pp. 863-867; July, 1954.) "The diffusion equation is solved for transistors for (a) linear flow of minority carriers and (b) non-uniform flow of minority carriers due to a metal contact applied to the base region. The current transport ratio  $\beta$  is calculated for both of these cases as a function of frequency. Frequency response characteristics of a transistor, as predicted by the one-dimensional diffusion equation, give excellent results for junction transistors having base-length-to-base-width ratios greater than ten and having negligible surface recombination rates. For transistors where these conditions are not applicable, the two-dimensional diffusion equation must be used in the calculation of  $\beta$ ."
- 621.314.7:537.311.33** 3714  
**Transistor Electronics: Imperfections, Uni-**

polar and Analog Transistors—W. Shockley. [*Proc. IRE (Australia)*, vol. 15, pp. 163-173; July, 1954.] Reprint. See 746 of 1953.

621.314.7:621.373.52 3715  
Internal Oscillations in Transistors—H. E. Hollmann. (*Z. Phys.*, vol. 138, pp. 1-15; June 21, 1954.) See 2540 of September.

621.383.5 3716  
Production of E.M.F. by Illumination of Lead-Sulphide Photoresistors—R. Ya Berlaga and L. P. Strakhov. (*Zh. Tekh. Fiz.*, vol. 24, p. 943; May, 1954.) A brief note. The largest photovoltaic effect was observed in a sample of PbS prepared by evaporation in CO<sub>2</sub> at 0.05-0.1 mm Hg pressure and a temperature of 240 degrees-250 degrees C., then heated at 500 degrees C. for 5-10 minutes and cooled in vacuo to room temperature. An emf of ~1.2 v was obtained by illuminating with a 100-w lamp. No current was passed through the sample during manufacture. See also Starkiewicz, Sosnowski and Simpson, *Nature*, vol. 158, p. 28; July 6, 1946.

621.385 3717  
Some Factors affecting Transmitting-Valve Life—T. N. Bassett. [*Proc. IRE (Australia)*, vol. 15, pp. 174-177; July, 1954.] The discussion covers emission and filament failures in tubes with pure tungsten filaments, thoriated tungsten filaments and oxide cathodes; glass failures in relation to operating temperatures; mechanical failures; and factors relating to handling and storage.

621.385 3718  
Review of SER [AB Svenska Elektronrör] Electron Tubes: Standard and Long-Life Types—S. Edsman and G. Lagerholm. (*Ericsson Rev.*, vol. 31, no. 2, pp. 53-55; 1954.)

621.385.001.4:533.59 3719  
New Method of Measuring Vacuum Factor of Vacuum Tubes in General—A. Sato and Y. Ishii. [*Rep. elect. Commun. Lab. (Japan)*, vol. 1, pp. 19-21; December, 1953.] A refinement of Herold's ac method (486 of 1950) for direct measurement by means of a bridge circuit balancing ion and electron currents.

621.385.002.2:621.357 3720  
Electrophoresis in the Valve Industry—L. E. Grey and R. O. Jenkins. (*Electronic Eng.*, vol. 26, pp. 402-405; September, 1954.) Electrophoresis is a process by which particles are deposited from a suspensoid by application of an electric field. Very careful control is required of impurities providing ions which form a charged double layer on the particles. Use of the process for coating filament cathodes and heaters and insulators is described.

621.385.029.6 3721  
Amplification Measurements on a Velocity Step Tube—N. B. Agdur. (*Chalmers Tek. Högsk. Handl.*, no. 140, 10 pp.; 1954.) Theory is developed for a single-beam tube with velocity modulation in a region of high direct voltage which is separated by a relatively short gap from a region of low direct voltage. Graphs show the theoretical variation of voltage amplification as a function of phase angle and the variation of maximum amplification with the length of the gap. Measurements were made on special tubes with fixed gaps much shorter than the length of the space-charge waves. Results are shown as curves of gain against voltage of the low-velocity region for given values of beam current and voltage of the high-velocity region.

621.385.029.6:621.396.822 3722  
Theory of Noise in Travelling-Wave Valves—E. I. Vasil'ev and V. M. Lopukhin. (*Zh.*

*Tekh. Fiz.*, vol. 24, pp. 895-898; May, 1954.) The noise coefficient is calculated for a travelling-wave tube with helix, taking into account the thermal velocity of electrons in the beam. In the calculation the field of the steady component of the space charge is neglected, this corresponding to tubes operating in a saturated state.

621.385.029.63/.64+538.566:537.56 3723  
The Propagation of Electron Space-Charge Waves in Waveguides and Tubes with Periodic Structure—O. E. H. Rydbeck and B. Agdur. (*Onde élect.*, vol. 34, pp. 499-507; June, 1954. English version, *Chalmers Tek. Högsk. Handl.*, no. 138, 20 pp.; 1954.) Conditions necessary for space-charge-wave amplification in a cylindrical electron beam are determined, either the velocity or the diameter being varied at equally spaced points along the beam. Maximum gain expressed in decibels is a linear function of the square root of beam current density, and bandwidth is proportional to the gain. The theory is relevant to propagation in ionized gas as well as to travelling-wave tubes.

621.385.029.63/.64 3724  
Coupling of Modes in Helices—Pierce and Tien. (See 3451.)

621.385.029.64/.65:621.373.423 3725  
Design of the Anode System of Unstrapped Magnetrons for the Millimetre-Wave Range—W. Praxmarer. (*Nachr. Tech.*, vol. 4, pp. 159-163; April, 1954.) Equivalent-circuit considerations for the unstrapped magnetron lead to an expression for the ratio between the anode diameter  $d_a$  and the wavelength  $\lambda$ . The dependence of the mode separation on this ratio is calculated and shown graphically for slot numbers up to  $N=16$ . For  $N=14$  the greatest possible  $d_a/\lambda$  ratio is 2, at a mode separation ~2 per cent. The over-all efficiency is <15 per cent. The rising-sun type is also considered briefly.

621.385.029.64/.65:621.373.423 3726  
The Wavelength Limit of the Rising-Sun [magnetron] System and Comparison with the Unstrapped-Anode System—W. Praxmarer. (*Nachr. Tech.*, vol. 4, pp. 197-199; May, 1954.) Theoretical and practical mechanical considerations of the rising-sun-type magnetron give a comparatively high lower wavelength limit of ~10 mm, assuming a maximal anode-diameter/wavelength ratio of 0.4. Other disadvantages of this type are the smaller power output and the limited choice of usable magnetic field strengths. Advantages over the unstrapped-anode magnetron include the large mode-separation and the higher efficiency (~25 per cent at 10 mm). See also 3725 above.

621.385.032.2:537.533 3727  
Adiabatic Theory of an Electron Gun for Crossed-Field Devices—J. Dain and I. A. D. Lewis. (*Proc. Phys. Soc.*, vol. 67, pp. 449-455; June 1, 1954.) "An electron gun is described capable of producing a ribbon-shaped beam of electrons moving under crossed electric and magnetic fields. The characteristics of the gun are derived by applying the adiabatic principle to motion in constant uniform crossed fields."

621.385.032.216 3728  
Thermionic Cathodes made by Compression and Sintering of a Mixture of Metal Powders and Alkaline-Earth Compounds—R. Uzan and G. Mesnard. [*Compt. Rend. Acad. Sci. (Paris)*, vol. 239, pp. 484-486; August 9, 1954.] Directly heated ribbon cathodes have been prepared by methods previously described [2818 of September (Mesnard and Uzan)]. Cathodes made with Ni powder, sintered in vacuum and activated by heat and current, yielded >1A/cm<sup>2</sup> at 1,250 degrees K. Lower values of emission were obtained with W and with mixtures

of W and Ni. Sintering in a H<sub>2</sub> atmosphere led to poor emission values for all cathodes containing W. Zr and Th were also tried.

621.385.15 3729  
An Investigation of the Ultimate Performance of Space-Charge Deflection Tubes—J. T. Wallmark. (*Proc. I.R.E.*, vol. 42, pp. 1422-1427; September, 1954.) A comparison is made between the special electron-multiplier tube previously described (1477 of 1952) and conventional pentodes and electron multipliers of similar construction, in respect of noise, transconductance/current ratio, behavior at hf, stability of transconductance, and distortion.

621.385.2 3730  
Effect of Filament Voltage on the Plate Current of a Diode—H. S. C. Chen. (*Jour. Appl. Phys.*, vol. 25, pp. 929-930; July, 1954.) Comment on 1194 of 1953 (Ivey).

621.385.832 3731  
The Formatron: an Electron Tube with a Predetermined Characteristic of Any Shape—É. Labin. (*Onde élect.*, vol. 34, pp. 518-524 and 614-621; June and July, 1954.) The term "formatron" was suggested in 1942 for beam-deflection tubes, including the monoscope and ribbon-beam tubes, in which the output is dependent on the position of the beam. This may be achieved by making use of the variation of secondary emission with angle of incidence of the primary beam, by interposing a slotted metal screen in the beam path, or by varying the width of the beam. Practical problems of design are discussed and various applications of the technique are illustrated.

621.387 3732  
The Tacitron, a Low-Noise Thyatron capable of Current Interruption by Grid Action—E. O. Johnson, J. Olmstead and W. M. Webster. (*Proc. I.R.E.*, vol. 42, pp. 1350-1362; September, 1954.) The grid is designed to cause the discharge to take a form such that ions are produced only in the grid-anode region. As a result, the anode current can be switched on or off in about 1  $\mu$ s by grid control alone. Details are given of an experimental tube with a current of 100 ma; the grid is relatively opaque, but the tube is otherwise very similar to conventional types. Theory of the operation is presented. Further possibilities of use in pulse circuits result from the improved characteristics.

621.38 3733  
Thermionic Valves, their Theory and Design. (Book Review)—A. H. W. Beck. Publishers: Cambridge University Press, London, Eng., 570 pp., 60s. (*Brit. Jour. Appl. Phys.*, vol. 5, p. 229; June, 1954.) "The book is intended for graduate physicists and electrical engineers... the descriptive parts may be very valuable for considerably less qualified persons."

#### MISCELLANEOUS

061.4:621.396 3734  
Farnborough 1954: Radio at the S.B.A.C. Show—(*Wireless World*, vol. 60, pp. 472-473; October, 1954.) Emphasis is on improvements to existing equipment rather than introduction of new equipment.

621.39:061.4 3735  
21st National Radio Exhibition—(*Wireless Eng.*, vol. 31, pp. 276-281; October, 1954.) Review of the 1954 exhibition. Main attention is again devoted to television receivers; screen dimensions of 14-17 inches are usual. Tubes and circuits for band-III reception are noted. For another account see *Wireless World*, vol. 60, pp. 478-493; October, 1954.



# Gulton abstracts <sup>1</sup>

MATERIALS RESEARCH • ELECTRONIC COMPONENTS • PRECISION INSTRUMENTS • SYSTEMS ENGINEERING

## Self-amplifying subminiature accelerometer is a versatile performer

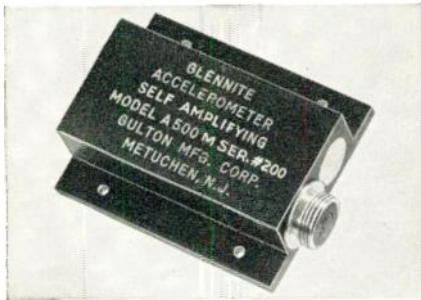

Glennite Self-Amplifying Accelerometer Model A-500 Series specifications: Sensitivity 300 mv/g or 0.1 ma/g; Resonant frequency, 2.5 KC (fluid damped); Output impedance, approximately 10,000 ohms resistive; Acceleration range .003 to 100 g; Size 2" x 1.2" x 1.03".

Glennite® Model A-500 Series accelerometers are the result of a bold new approach toward miniaturization of electromechanical transducers. Specifically designed to directly drive telemetering oscillators and transmitters, or galvanometers and recorders, these units are also used in measuring missile accelerations and testing vibration in aircraft structures.

## New, minute probe measures high, low intensity ultrasonic power in liquids

An extremely small ultrasonic probe of unusual design, the Glennite Model LU-101 boasts a wide frequency range, high sensitivity, and the elimination of RF pickup.

Accurately measuring high as well as low intensity ultrasonic power in various types of liquids, it is useful in checking both intensity levels and beam uniformity. It is invaluable wherever ultrasonic energy must be controlled or measured.

The probe contains, in a single sealed housing, a piezoelectric sensing element, a crystal detector and low pass electronic filter. This system provides a high D.C. output which can be fed to standard laboratory D.C. meters.

## Rugged amplifier features minimum weight, size, power consumption

The Glennite Model F-410, a subminiature voltage preamplifier, readily qualifies for applications in missiles, aircraft, and devices where size, weight, and power consumption are of paramount importance, and in the laboratory.

The four-tube unit is ruggedly constructed for the most exacting work in coupling low level signal devices into standard metering and recording systems without introducing extraneous noise from vibration. It is only 2 1/16" wide, 1 3/16" high, and 2 1/4" long. Power requirements are: filament, 6 v or 28 v; plate, 105 to 250 v.

Combining a single miniature aluminum housing, a highly sensitive Glennite piezoelectric seismic transducer, and an electronic amplifier engineered solely for this purpose, these instruments perform the operation of an accelerometer, cathode follower, filter and a voltage or current amplifier. Elimination of the extra bulk of these separate devices results in a weight and volume reduction of a factor of approximately 10 over conventional systems.

These instruments are supplied with a subminiature 4 pin connector specially designed to withstand continuous high accelerations in both shock and vibration.

Weighing less than 2 ounces, under 1.5 cubic inches in volume, and extremely rugged, Model A-500 series accelerometers have made possible accurate measurement of vibration and high impact phenomena.

Gulton Mfg. Corp.

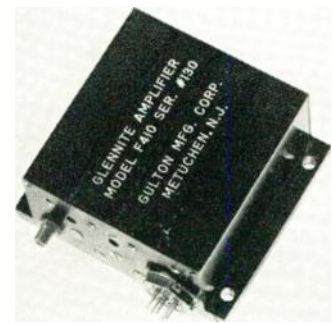

Glennite Amplifier Model F-410 specifications: Frequency response, 3 cps to 50 KC (3db down); Input impedance, 200 megohms; Output impedance, 50 ohms; Number of stages, input and output cathode followers and two stages of gain; Recommended load: 10,000 ohms or more; Temperature range, -40°C to +85°C; Anti-microphonic, less than 150 microvolts/g referred to input; Weight, 5 1/2 ounces.

Gulton Mfg. Corp.

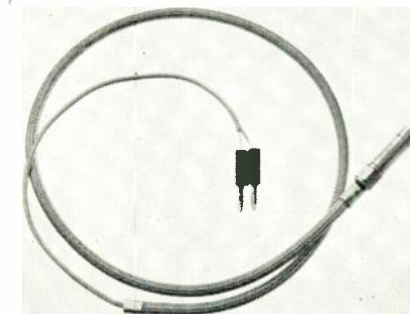

Glennite Ultrasonic Probe Model LU-101 specifications: Frequency range, 100 KC to 3 MC; Size, 3/8" dia. x 2" long; Weight, 7 ounces; Hermetically sealed; Resistant to most solvents.

Vibro-Ceramics Corporation

## Gulton Industries, Inc.

201 Durham Ave., Metuchen, New Jersey

Please send me additional information on:

- Glennite Amplifier Model F-410
- Glennite Accelerometer Model A-500
- Glennite Ultrasonic Probe Model LU-101
- Glennite Electromechanical and Electronic Instruments
- Glennite Electronic Components

NAME \_\_\_\_\_

TITLE \_\_\_\_\_

COMPANY \_\_\_\_\_

ADDRESS \_\_\_\_\_

Published by  
**GULTON INDUSTRIES, INC.**

Comprising: Gulton Mfg. Corp. • Glenco Corporation • Vibro-Ceramics Corporation  
Greibach Instruments Corporation • Thermistor Corporation of America



# BALLANTINE

## BATTERY OPERATED ELECTRONIC VOLTMETER

### VOLTAGE RANGE:

100 microvolts to 100 volts rms of a sine wave in 6 decade ranges.

### INPUT IMPEDANCE:

2 megohms shunted by 8 mmfd on high ranges and 15 mmfd on low ranges.

### FREQUENCY RANGE:

2 cps to 150,000 cps.

### ACCURACY:

3%, except 5% below 5 cps and above 100,000 cps.

#### MODEL 302B

Size: 6 $\frac{1}{2}$ " x 7 $\frac{1}{2}$ " x 12 $\frac{3}{4}$ ".  
Weight: 14 lbs.  
Price complete with cover and batteries: \$245.

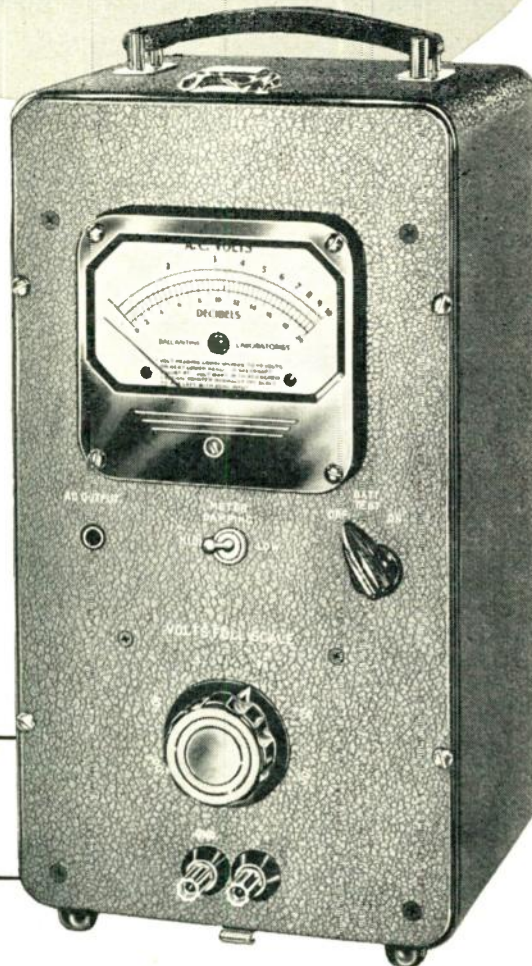

- Available accessories increase the voltage range from 20 microvolts to 42,000 volts.
- Available precision shunt resistors permit the measurement of AC currents from 10 amperes down to one-tenth of a microampere.
- Features the well-known Ballantine logarithmic voltage and uniform DB scales.
- Battery life over 100 hours.
- Can also be used as a flat pre-amplifier with a maximum gain of 60 DB. Because of the complete absence of AC hum, the amplifier section will be found extremely useful for improving the sensitivity of oscilloscopes.

For further information on this Voltmeter and the Ballantine Model 300 Voltmeter, Wide-Band Voltmeters, True RMS Voltmeter, Peak to Peak Voltmeters and accessories such as Decade Amplifiers, Multipliers, Precision Shunt Resistors, and Precision Sensitive Inverter, write for catalog.

# BALLANTINE LABORATORIES, INC.



102 Fanny Road, Boonton, N.J.

WHEN WRITING TO ADVERTISERS PLEASE MENTION — PROCEEDINGS OF THE I.R.E.



### Industrial Engineering Notes

(Continued from page 78A)

"Survey of Tuned Circuits for the 300 to 3,000 mc Frequency Range," PB 114276, microfilm, \$2.50; photocopy, \$5.25.

"Ultrasonic Propagation in Solid Materials. Interim Research Report No. 2," PB 114111, microfilm, \$2.25; photocopy, \$4.

"Low Frequency Propagation Studies. Quarterly Technical Report No. 3," PB 114485, microfilm, \$2.25; photocopy, \$4.

The possible application of electronic devices to the activities of the Patent Office will be studied by a committee named by Commerce Secretary Sinclair Weeks. The group will be headed by Dr. Vannevar Bush, President of the Carnegie Institution of Washington. In making the announcement, Mr. Weeks pointed out that the Patent Office has made much progress in introducing new efficiencies, "but with the volume and complexity of modern technical developments steadily increasing, there is need for acceleration in patent searching." He said that if "high-speed electronic devices can be used to replace time-consuming manual sorting and searching of reference material, the result could be a tremendous boon to inventive progress. The committee will study this special problem of the Patent Office, and suggest possible ways in which new mechanical and electronic devices might be profitably adapted to improve service." Suggestions from individuals and organizations should be addressed to the Executive Secretary of the committee, Norman T. Ball, Room 2322, Department of Commerce, Washington 25, D. C. . . . The National Bureau of Standards has announced the reissue of the volume, "Table of Sine and Cosine Integrals for Arguments from 10 to 100," first published in 1942 and known as Mathematical Table 13. Several new values have been added to the volume. The sine and cosine integrals have long played an important part in the theory of numbers and the calculus of probabilities, NBS noted. Lately, they have assumed increasing value in such fields as antenna theory, electromagnetic theory and nuclear physics. The new 186 page publication may be ordered from the Government Printing Office, Washington 25, D. C., for \$2.25 per copy. . . . A portable one-megacycle frequency standard, stable to a few parts in 100 million per day, has been developed by P. G. Sulzer of the National Bureau of Standards. The compact and relatively simple assembly, employing inexpensive commercially available components, makes use of a crystal unit to control the frequency of an oscillator. The device is sufficiently rugged for general laboratory and field use as a working standard, NBS said. It is expected to have wide application in checking radio transmitters and measurements, and in various other industrial and research fields. The NBS one-megacycle standard, like other crystal-controlled oscillators of this type, consists of three elements: the crystal unit proper, an amplifier or negative-resistance device to supply the losses in the crystal unit and to deliver power to a load; and an amplitude control. How-

(Continued on page 84A)



high performance for low-cost tv sets with Tung-Sol

# Series String tubes

<b>2AF4</b> (Prototype—6AF4) Heater Current 0.6 A Heater Volts 2.35	<b>3BN6</b> (Prototype—6BN6) Heater Current 0.6 A Heater Volts 3.15	<b>5AQ5</b> (Prototype—6AQ5) Heater Current 0.6 A Heater Volts 4.7	<b>6AX7</b> (Prototype—12AX7) Heater Current 0.6 A Heater Volts 3.15*	<b>12BQ6GA</b> (Prototype—6BQ6GA) Heater Current 0.6 A Heater Volts 12.6
<b>3AL5</b> (Prototype—6AL5) Heater Current 0.6 A Heater Volts 3.15	<b>3BY6</b> (Prototype—6BY6) Heater Current 0.6 A Heater Volts 3.15	<b>5BK7A</b> (Prototype—6BK7A) Heater Current 0.6 A Heater Volts 4.7	<b>6S4A</b> (Prototype—6S4) Heater Current 0.6 A Heater Volts 6.3	<b>12BQ6GT</b> (Prototype—6BQ6GT) Heater Current 0.6 A Heater Volts 12.6
<b>3AU6</b> (Prototype—6AU6) Heater Current 0.6 A Heater Volts 3.15	<b>3CB6</b> (Prototype—6CB6) Heater Current 0.6 A Heater Volts 3.15	<b>5T8</b> (Prototype—6T8) Heater Current 0.6 A Heater Volts 4.7	<b>6SN7GTB</b> (Prototype—6SN7GTA) Heater Current 0.6 A Heater Volts 6.3	<b>12BY7A</b> (Prototype—12BY7) Heater Current 0.6 A Heater Volts 6.3*
<b>3AV6</b> (Prototype—6AV6) Heater Current 0.6 A Heater Volts 3.15	<b>4BQ7A</b> (Prototype—6BQ7A) Heater Current 0.6 A Heater Volts 4.2	<b>5U8</b> (Prototype—6U8) Heater Current 0.6 A Heater Volts 4.7	<b>12AX4GTA</b> (Prototype—12AX4GT) Heater Current 0.6 A Heater Volts 12.6	<b>12L6GT</b> (Prototype—25L6GT) Heater Current 0.6 A Heater Volts 12.6
<b>3BC5</b> (Prototype—6BC5) Heater Current 0.6 A Heater Volts 3.15	<b>4BZ7</b> (Prototype—6BZ7) Heater Current 0.6 A Heater Volts 4.2	<b>5V6GT</b> (Prototype—6V6GT) Heater Current 0.6 A Heater Volts 4.7	<b>12B4A</b> (Prototype—12B4) Heater Current 0.6 A Heater Volts 6.3*	<b>12W6GT</b> (Prototype—6W6GT) Heater Current 0.6 A Heater Volts 12.6
<b>3BE6</b> (Prototype—6BE6) Heater Current 0.6 A Heater Volts 3.15	<b>5AN8</b> (Prototype—6AN8) Heater Current 0.6 A Heater Volts 4.7	<b>6AU7</b> (Prototype—12AU7) Heater Current 0.6 A Heater Volts 3.15*	<b>12BH7A</b> (Prototype—12BH7) Heater Current 0.6 A Heater Volts 6.3*	<b>19AU4</b> (Prototype—6AU4GT) Heater Current 0.6 A Heater Volts 18.9
			*Using heaters connected in parallel. Other Series String Tube Types In Development	<b>25CD6GA</b> (Prototype—25CD6G) Heater Current 0.6 A Heater Volts 25

All Tung-Sol Series String Tubes have uniform heater warm-up time to safeguard against failures from initial voltage surge.

Heater ratings are based on 600 milliamperes of current with the heater voltage adjusted for the same power as in the prototype. All other characteristics and ratings are identical to those of the prototype.

Use of these tubes provides completely satisfactory receiver characteristics during warm-up.

If you're a TV set manufacturer with an eye on the mass volume market, Tung-Sol can provide the "series string" tube types, the quality and the service you need for a successful competitive program.

**COMPLETE LINE:** Tung-Sol Tube types will meet the performance requirements of circuit designs currently in use, as well as any foreseeable new circuitry. Additional tube types are in development.

**DEPENDABLE QUALITY:** Tung-Sol quality control standards have been adjusted to the more severe service demands of "series string" operation. You can rely on Tung-Sol "Series String" Tubes to give the same dependable performance as their prototypes.

**SERVICE:** Competent field engineers are immediately available for consultation beginning at the design stage to help you achieve smooth, efficient production. Tube deliveries are coordinated to your manufacturing schedules and are completely

reliable. Your design plans are received in strictest confidence.

For more information about Tung-Sol "Series String" TV Tubes, write to Commercial Engineering Department, Tung-Sol Electric Inc., Newark 4, New Jersey.

#### SALES OFFICES

Atlanta, Chicago, Columbus, Culver City (Los Angeles), Dallas, Denver, Detroit, Newark, Philadelphia, Seattle.

Tung-Sol makes All-Glass Sealed Beam Lamps, Miniature Lamps, Signal Flashers, Picture Tubes, Radio, TV and Special Purpose Electron Tubes and Semiconductor Products.

# TUNG-SOL®

## Radio and TV Tubes, Dial Lamps

No. 2  
in a  
series

design progress through  
inter-company co-operation

... coordinated by *Airtron inc.*



**NEW...**  
**DOUBLE-RIDGE WAVEGUIDE**  
*for both X-band and C-band operation!*

Recently, Airtron was confronted with a difficult problem—how to develop a waveguide that would perform satisfactorily for both “X” and “C”-Band operation.

Due to differences of opinion concerning the optimum frequency for airborne weather radar systems, equipment manufacturers have selected two different operating frequencies for their designs . . . 5.6 cm (“C”-band) and 3.2 cm (“X”-band). As a result, two different waveguide sizes were required. This meant that should it become advisable to switch from one frequency band to the other it would necessitate the installation of an entirely new waveguide system . . . as well as the replacement of the radar equipment.

This was highly impractical and, accordingly, a coordinated effort was set up among the airlines technical advisory organization (ARINC), leading manufacturers of radar equipment, and the engineering staff of Airtron.

Working as a team the theoretical and practical difficulties were overcome and the solution evolved in a new double ridge waveguide. The new design not only permits handling of both bands, but also results in a considerable reduction in size and weight for “C”-band and improved electrical properties for “X”-band.

This is just another concrete example of how Airtron’s creative engineering . . . and their close association with leading manufacturers in all phases of electronics . . . can be of assistance to you . . . whether the components you need are new in design or so-called “standard” plumbing.

**FREE CATALOG** on Ridge Waveguide for Airborne Weather Radar . . . contains a complete description of the new ridge waveguide series. Write on your letterhead c/o Dept. C for your copy today!

**Airtron inc. Linden, New Jersey**

Designers & Manufacturers of Rigid and Flexible Waveguide Components and Aircraft Accessories

Branch Offices: Albuquerque • Boston • Chicago • Dallas • Dayton • Kansas City  
Los Angeles • San Francisco • Seattle • London



**Industrial Engineering Notes**

(Continued from page 82A)

ever, the NBS oscillator reportedly was specially designed to minimize frequency changes caused by tube or component instability. As a result, the over-all stability of the unit is nearly that of the crystal itself.

TELEVISION

To date, the Commission has granted construction permits to 605 TV stations, including 32 CPs for educational TV outlets. Of these grants, 273 are for VHF stations and 332 for UHF outlets. The Commission has deleted, upon request, 101 TV stations, including 18 in the VHF and 83 in the UHF band. The number of special temporary authorizations granted by the FCC to date total 317, of which 184 are for VHF stations and 133 for UHF outlets. This total includes six STAs for educational TV stations, of which four are in the VHF and two in the UHF band. . . . The Federal Communications Commission has granted a construction permit for a new private TV inter-city relay system, the fourth to be granted by the Commission to date. The CP for a new private TV inter-city relay system was granted to KIEM-TV, Redwood Broadcasting Co., Inc., Eureka, Calif. The system will be used to provide a program circuit between Medford, Ore., and Eureka, Calif., a distance of approximately 130 miles.

**52-ohm  
LINE STRETCHERS**

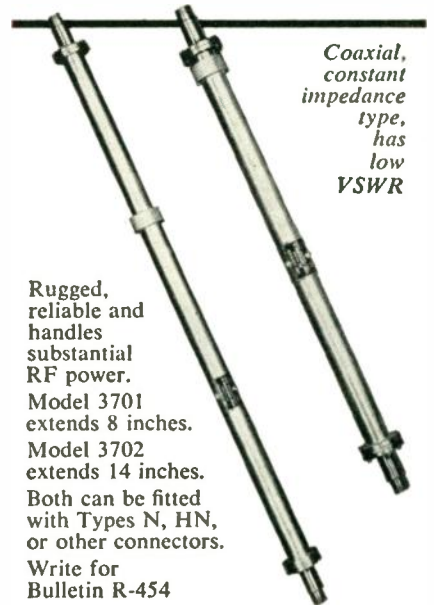

Coaxial,  
constant  
impedance  
type,  
has  
low  
VSWR

Rugged,  
reliable and  
handles  
substantial  
RF power.

Model 3701  
extends 8 inches.

Model 3702  
extends 14 inches.

Both can be fitted  
with Types N, HN,  
or other connectors.

Write for  
Bulletin R-454

ANTENNA SYSTEMS—COMPONENTS  
AIR NAVIGATION AIDS—INSTRUMENTS



**ALFORD**  
Manufacturing Co., Inc.  
299 ATLANTIC AVE., BOSTON, MASS.



# EXTEND Your Microwave Horizons

## WITH VARIAN HIGH-POWER KLYSTRONS

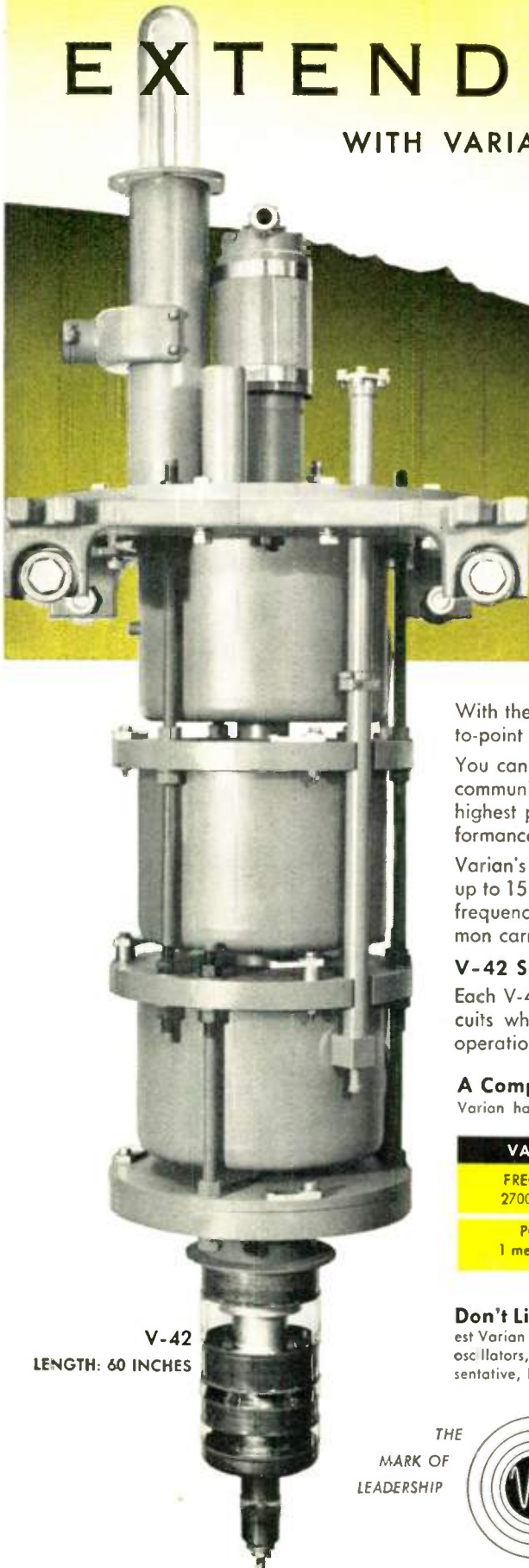

V-42  
LENGTH: 60 INCHES



With the new series V-42 and VA-800 high power transmitter klystrons, point-to-point **microwave propagation beyond-the-horizon is a reality.**

You can now design and engineer microwave systems for long distance relay communication . . . because Varian — who has supplied the most reliable and highest power klystrons for UHF-TV — now brings you the same proved performance and economy of operation for communication service.

Varian's multi-resonator amplifiers provide you with continuous power output up to 15 kw . . . power gains up to 40 db . . . in the 500, 1000, 2000 and 7000 mc frequency bands . . . for TV-relay, and fixed telephone or telemetering in common carrier service, industrial service or control service.

### V-42 Series Warranted for 3000 Hours of Service

Each V-42 and VA-800 tube incorporates Varian's exclusive built-in tuning circuits which give you proven reliability as well as simplicity of installation, operation and use.

### A Complete Line of Klystrons for Radars and Beacons

Varian has a complete line of high power amplifier klystrons for CW and pulsed operation.

VA-80B	V-70	V-82	V-24B
FREQUENCY 2700-3400 mc	FREQUENCY 9400-10,000 mc	FREQUENCY 9200-9400 mc	FREQUENCY 9000-9500 mc
POWER 1 meg. Pulsed	POWER 500 watt CW	POWER 5 kw Pulsed	POWER 40 kw Pulsed

**Don't Limit Your Horizons.** For complete specifications and application data on the newest Varian V-42 and VA-800 series **high-power** klystrons, as well as others, including **high-power** oscillators, write to our Application Engineering Department . . . or contact your Varian representative, located in all principal cities.

THE  
MARK OF  
LEADERSHIP

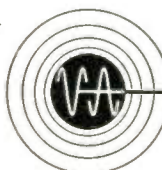

**VARIAN associates**  
PALO ALTO 2, CALIFORNIA

KLYSTRONS, TRAVELING WAVE TUBES, BACKWARD WAVE OSCILLATORS, R.F. SPECTROMETERS, MAGNETS, STALOS, UHF WATERLOADS, MICROWAVE SYSTEM COMPONENTS, RESEARCH AND DEVELOPMENT SERVICES

# SECON

## PRECISION POTENTIOMETER WIRE

Bare and insulated. A complete range of precious metal potentiometer winding alloys from 37 ohms per circular mil foot to over 600 ohms per circular mil foot.

- round
- oval
- flat
- grooved
- ribbon

**precision small wire**

- bare
- insulated
- ⊙ plated

**for highly engineered applications**

- ➔ all metals
- all alloys

Instrumentation wire, components for electronic tubes, transistors and crystal diodes, electroplated wire & ribbon, precision small wire & thin ribbon.

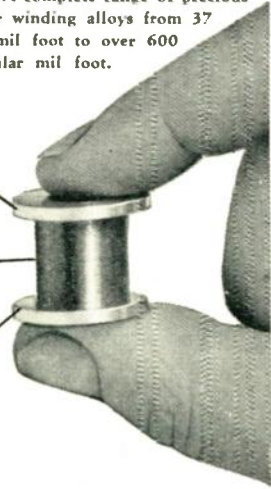

**development and production metallurgists**  
**SECON METALS CORPORATION**  
 7 Intervale Street, White Plains, New York  
 White Plains 9-4757

Write for Pamphlet P



### ANTENNAS AND PROPAGATION

The Los Angeles Chapter of the Professional Group on Antennas and Propagation met on September 13 at the Institute of Aeronautical Sciences Building. A symposium on "Flight Testing of Antennas" was held. The five members participating were C. Child, L. Benbrooks, A. McCabe, E. Lovick, and C. Alcorn, moderator.

### BROADCAST TRANSMISSION SYSTEMS

The Houston Chapter of the Professional Group on Broadcast Transmission Systems met September 25 at the KPRC-TV Studios. E. P. Huhndorff, who presided, also delivered a paper, "NBC Color Television Demonstration," and conducted a tour of the KPRC-TV technical facilities.

### ELECTRON DEVICES

The New York Chapter of the Professional Group on Electron Devices met on September 30 at the Engineering Societies Building. Simeon Weston presided and members of the Long Island and northern New Jersey chapters attended. Rudolph Kompfner, of the Technical Staff at Bell Telephone Labs., spoke on "Backward Wave Oscillators."

### ENGINEERING MANAGEMENT

On September 15, the Los Angeles Chapter of the Professional Group on Engineering Management met at the IAS Building. L. W. Baldwin, Chairman, presided. There was a panel discussion on "Operations Research—What It Can Do for You." Members of the panel were Gilbert King, Harry Markowity, George Kozmetsky, Roland McKean, Richard Canning, and Andrew Vazsonyi.

### ELECTRONIC COMPUTERS

Dr. S. N. Alexander presided at the October 6 meeting of the Washington, D. C. Chapter of the Professional Group on Electronic Computers. J. H. Wilkinson, of the National Physical Laboratory, Teddington, Middlesex, England, spoke on the "Design of a Pilot Model of the ACE."

On September 30 the Detroit Chapter met at the Willow Run Research Center. Cal Johnson presided, and two papers were delivered. Harvey Garner spoke on "Engineering Aspects of MIDAC," while Dr. John W. Carr spoke on "Applications of MIDAC."

At a May meeting of the Detroit Chapter, Boyd Larrowe spoke on "Parity Checking of MIDAC," and Bruce Loughry spoke on "Engineering Experience in the Design of Magnetic Drum Circuitry."

### INFORMATION THEORY

The Albuquerque-Los Alamos Chapter of the Professional Group on Information Theory met on October 13 with C. H. Bidwell presiding. Dr. B. L. Basore delivered a paper entitled "A Review of Fundamentals of Information Theory I." He presented

(Continued on page 90A)

## CAPITOL RADIO ENGINEERING INSTITUTE

Advanced Home Study and Residence Courses in Practical Radio-Electronics and Television Engineering

Pioneer in Radio Engineering Instruction Since 1927



ECPD Accredited Technical Institute Curricula

Request your free Home Study or Resident School Catalog by writing to: Dept. 26-B1  
 3224 16th St., N. W. Washington 10, D. C.  
 Approved for Veteran Training



## CONVERGENCE DOT GENERATOR MODEL CDG-1

▶ DOTS ▶ HORIZONTAL BARS  
 ▶ VERTICAL BARS ▶ GRATING

Extremely stable dot/bar pattern generator. Checks adjustment of beam-positioning magnets, dynamic convergence, and d-c convergence of color video monitors and receivers. Also checks linearity, focus, and centering of color or monochrome video monitors and receivers. Provides dot pattern, grating, horizontal bars, or vertical bars. Composite output can be fed directly to video monitor. Details forwarded on request.

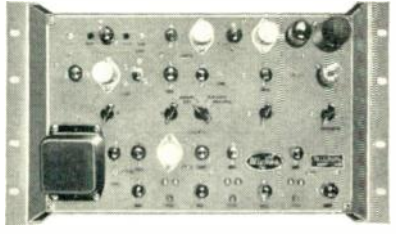

Write for data on our line of color television instruments for signal generating, distribution, test and measurement, and signal certification.

**Wickes ENGINEERING AND CONSTRUCTION COMPANY**  
 12TH STREET AND FERRY AVENUE ESTABLISHED 1920 CAMDEN 4, NEW JERSEY





**Guaranteed  
10 Day  
Delivery!**

We assure you of prompt delivery and courteous service of TRU-OHM WIRE WOUND RESISTORS . . . the finest available . . . from stock or to your specifications.

- Fixed vitreous enameled RESISTORS
- Adjustable vitreous enameled RESISTORS
- "Econohm" RESISTORS
- "Tru-Rib" RESISTORS
- Special size RESISTORS

Our engineering department is at your service to assist in the selection or design of a resistor to fit any and all applications.

Write for our latest catalog today on TRU-OHM RESISTORS and POWER RHEOSTATS.



**PRODUCTS**

Division of  
Model Engineering  
& Mfg., Inc.

General Sales Office: 2800 N. Milwaukee Avenue, Chicago 18, Ill.  
Factory: Huntington, Indiana

MANUFACTURERS: Power Rheostats, Fixed Resistors, Adjustable Resistors, "Econohm" Resistors, "Tru-rib" Resistors



*Designed for*



*Application*



**The No. 90901  
One Inch  
Instrumentation Oscilloscope**

Miniaturized, packaged panel mounting cathode ray oscilloscope designed for use in instrumentation in place of the conventional "pointer type" moving coil meters uses the 1" 1CP1 tube. Panel bezel matches in size and type the standard 2" square meters. Magnitude, phase displacement, wave shape, etc. are constantly visible on scope screen.

**JAMES MILLEN  
MFG. CO., INC.**

MAIN OFFICE AND FACTORY  
**MALDEN  
MASSACHUSETTS**



**ANOTHER Rutherford PRECISION  
TIMING INSTRUMENT**



**MODEL (A-5)  
TIME DELAY GENERATOR**



MODEL A-5

An instrument of small size which provides accurate and variable time delays from 1  $\mu$ s to 1,000  $\mu$ s in three ranges.

- low jitter (.008%) • linear scales • highly stabilized power supplies • small repetition rate effects • blocking oscillator output • trigger type input • separate calibration adjustments for each range.

Get complete data:  
our Bulletin I-A-5

Other Rutherford precision Time Delay Generators { Model A-2 (.8  $\mu$ s to 100,000  $\mu$ s): Bulletin I-A-2  
Model A-4 (10  $\mu$ s to 10 secs): Bulletin I-A-4

**Rutherford ELECTRONICS CO.** Telephone: TEXAS 0-4362  
3707 S. ROBERTSON BLVD.  
CULVER CITY, CALIFORNIA

**Send for this Free SAMPLE FOLDER...**

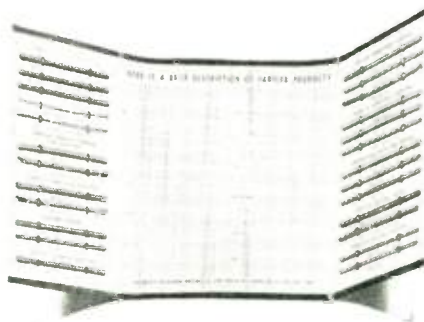

**Contains 25 different test samples of high  
dielectric Insulating Tubing & Sleeving**

Includes samples and descriptions of:  
Varglas Silicone • Permafil-Impregnated  
Varglas Tubing • Varglas Tubing and  
Sleeving • Varglas Non-Fray Sleeving •  
Varflo Tubing and Sleeving • Varflex  
Cotton Tubing and Sleeving • Syntholvar  
Extruded Tubing

*Write today!*

**VARFLEX CORP., 518 W. COURT ST., ROME, N.Y.**



# NOW . . . FROM **Transitron**

## P-N-P JUNCTION TRANSISTORS WITH VACUUM HERMETIC SEALING

*designed for specific applications*

### COMPUTER TYPES

Less than 1 microsecond is required to switch 100 ma collector current with type 2N92. Smaller collector currents can be switched efficiently with type 2N91. Careful manufacturing and conservative ratings insure reliability in excess of vacuum tubes.



1 1/2 x actual size

### MEDIUM POWER TYPES

For applications requiring up to 750 milliwatts dissipation and alpha cutoff up to 1 megacycle, the type 2N85 and 2N86 are ideal. They provide a linear transfer characteristic up to 20 ma collector current and can be operated at ambient temperatures up to 75°C.

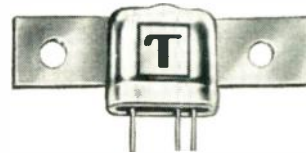

1 1/2 x actual size

### HIGH POWER TYPES

The 2N83 and 2N84 are intended for high-power applications and are conservatively rated at 10 watts dissipation. A Class B amplifier using these types would be capable of 5.0 watts output at 60°C. The 2N83 is comparable electrically to the 2N57.

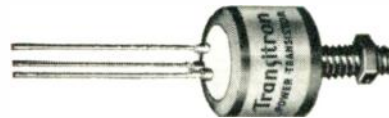

3/4 actual size

### SUBMINIATURE TYPES

Types 2N88, 2N89, and 2N90 are especially useful where small size and excellent low level performance is desired.



actual size

### STANDARD TYPES

A wide variety of RETMA types including the 2N34, 2N43, and 2N65 are available for most general purpose applications.

*Transitron's special engineering group is available to help you with specific transistor applications. Inquiries concerning your particular design problems are invited.*

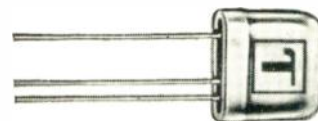

1 1/2 x actual size

Send for  
Bulletin  
E1320



**Transitron** electronic corporation • melrose 76, massachusetts



Glass Diodes



Quads



Silicon Diodes



Germanium Diodes



Transistors



Power Transistors

(Continued from page 86A)

the fundamental concepts of information theory and then defined the terms, units of information, efficiency of information, uncertainty, and average information.

On September 4 the Albuquerque-Los Alamos Chapter had for speakers Norman J. Elliott and Vernon D. Peckham, both of Sandia Corporation.

#### MEDICAL ELECTRONICS

The Buffalo-Niagara Chapter of the Professional Group on Medical Electronics met on October 26 at the University of Buffalo. The topic for the evening was "Reliability of Electronic Equipment for Medical Use," which was used as a background for the year's theme, "Servomechanisms for Clinical Use." Richard Frazer spoke on "Component Failure." "Fail Safe Devices" was the subject of a paper delivered by Dr. A. E. MacNeill, and John Wolcott spoke on "Equipment Failure and Safety."

The San Francisco Chapter met at Stanford University on October 7 to hear Dr. S. F. Thomas and V. E. Sloman speak. Dr. Thomas discussed "The Diagnostic Use of Radioactive Isotopes," and Mr. Sloman spoke on "New Tools for Diagnostic Study Using Radioactive Isotopes." New officers elected were: L. B. Lusted, M.D., Chairman; Elliot Levinthal, Ph.D., Vice-Chairman; D. D. Dye, Ph.D., Secretary-Treasurer.

#### NUCLEAR SCIENCE

The Connecticut Valley Chapter of the Professional Group on Nuclear Science met on September 23 with T. H. Kirby presiding. The speaker was Dr. Carl W. Steeg of M.I.T. His paper was called "An Introduction to the Systems Analysis of Nuclear Reactors."

On April 21 the Oak Ridge (Atlanta Section) Chapter met. Craig Harris spoke to the group on "Multichannel Pulse analyzers." H. Walchli presided.

**Section Meetings**

#### AKRON

"New C-R Tube Developments," by Daniel Echo, A. B. DuMont Labs.; October 19, 1954.

"Airborne Antenna Problems," by Dr. Harold Schutz, Glenn L. Martin Company; November 16, 1954.

#### ALBUQUERQUE-LOS ALAMOS

"Literary Prospecting in New Mexico's Past," by Col. Wilfred McCormick, Author; October 22, 1954.

Field trip to Microwave TV Network facilities at Mountain States Tel. and Tel. Co. conducted by L. C. Trussler, American Tel. and Tel.; November 6, 1954.

(Continued on page 92A)



**Big**

or

**LITTLE...**

**McCoy Precision Quartz Crystals**  
 deliver the SAME FINE PERFORMANCE

You can expect the same precision performance from both the McCoy M-1 and the M-20 "McCmite," although the "McCmite" is only 1/5th as big. Both crystals are produced up to 110 mc on the 5th overtone. The fact that these two crystals perform equally well in meeting widely varied job specs illustrates the versatility of McCoy design and production facilities. Whatever you need in quartz crystals, McCoy either makes them or can develop them for you. Send for free catalog today on the McCoy line of high quality, precision-made quartz crystals.

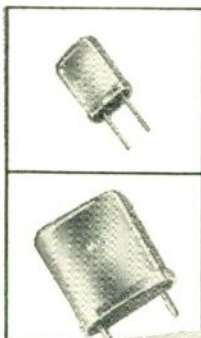

M-20 "McCmite" is a sub-miniature hermetically sealed unit, adaptable to multi-channel design for communications and frequency control equipment. Can be wired into a sub-miniature selector switch assembly or soldered to a printed circuit terminal board.

M-1 is an hermetically sealed, plated crystal preferred when fundamentals below 5 mc are desired. Easily interchangeable, it plugs into a standard socket. Meets government specification MIL-C-3098A and CAA-R-916; also ARINC No. 401.

**McCoy ELECTRONICS COMPANY**  
 MT. HOLLY SPRINGS, PENNA.  
 Phone 376 and 377

Licencee under patents of  
 Western Electric Company



# NEW! 1000 to 10,750 MCS MULTI-PULSE SIGNAL GENERATOR

*5 independently adjustable pulse channels...modulate 4 interchangeable r-f oscillator heads...to provide multi-pulse modulated carrier from 1000 to 10,750 mcs...all in one integrated mobile instrument...for beacons, missiles, radar.*

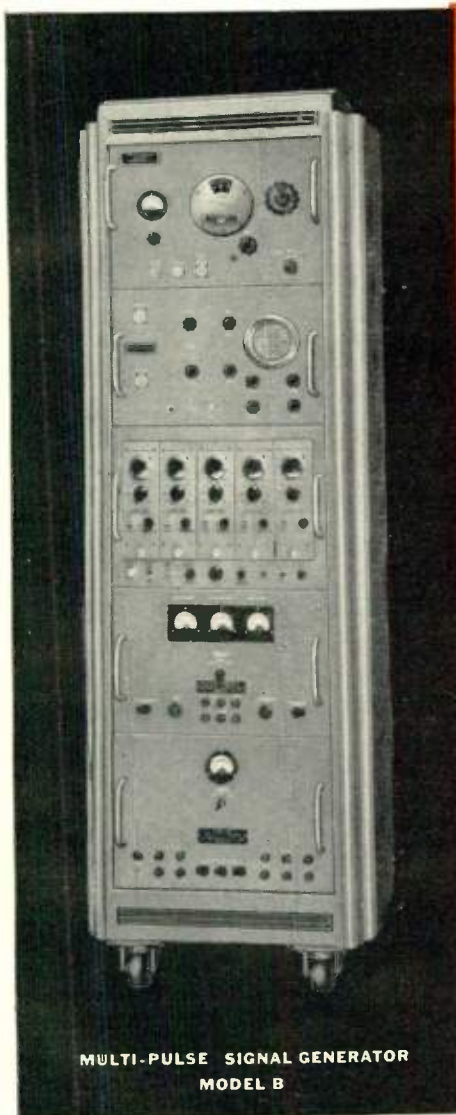

MULTI-PULSE SIGNAL GENERATOR  
MODEL B

**Four Interchangeable Microwave Oscillator Units**—each with single control direct reading dial...cover the range 1000 to 10,750 mcs...constructed with precision power monitor circuit to maintain 1 mw power output reference level...keying circuit assures rapid rise time of modulated RF output...employs non-contacting chokes...built-in RF detector...can be modulated externally.

**Precision Oscilloscope**—for calibrating pulse width and spacing accurately...can be used separately as general purpose, high quality oscilloscope.

**Multi-Pulse Modulator**—provides 5 independently adjustable stable pulse channels...variable repetition rate, pulse width, delay, amplitude...external pulse-time modulation input...can be used separately to modulate other microwave signal generators.

**Power Supply**—Entire instrument operates from AC line voltage regulator to insure stability. Multi-pulse modulator equipped with electronically regulated low voltage DC supply. Universal regulated Klystron power unit automatically selects proper voltages for any of the selected microwave oscillator units.

#### SPECIFICATIONS:

Frequency Range:  
Band 1... 1,000 to 2,300 mc  
Band 2... 2,150 to 4,600 mc  
Band 3... 4,450 to 8,000 mc  
Band 4... 7,850 to 10,750 mc  
Frequency Accuracy...  $\pm 1\%$   
RF Power Output...  
1 milliwatt maximum (0 DBM)  
Attenuator:  
Range... 0 to -100 DBM  
Accuracy...  
 $\pm 2$  db without correction charts  
Output Impedance... 50 ohms nominal  
RF Pulse Characteristics:  
a. Rise Time... Better than 0.1 microsecond as measured between 10 and 90% of maximum amplitude of the initial rise.  
b. Decay Time... Less than 0.1 microsecond as measured between 10 and 90% of maximum amplitude of the final decay.  
c. Overshoot... Less than 10% of maximum amplitude of the initial rise.  
Power Input...  
105, 125 volts, 60 cps, 1200 watts



Multi-Pulse Modulator Model MP-1  
(Available separately with built-in power supply)

No. of channels...  
1 to 5 independently on or off  
Repetition Rate... 40 to 4,000 pps  
Pulse width... 0.2 to 2.0 microseconds  
Rise Time... Better than 0.1 microsecond  
Fall Time... Better than 0.1 microsecond  
Pulse Delay... 0 to 30 microseconds  
Pulse Amplitude... 15 volts min. into 100 ohms positive to ground  
Accuracy of Pulse Setting... 0.1 microsec.  
Minimum Pulse Separation... 0.25 microsec.  
Initial Channel Delay...  
2 microseconds from sync. pulse  
Internal Square Wave...  
40-4,000 pps (separate output)  
Pulse Time Modulation...  
Frequency 40-400 cps any or all channels  
Required Ext. Mod. 1 volt rms min.  
Maximum deviation  $\pm 0.5$  microsecond

AVAILABLE ON THE EQUIPMENT LEASE PLAN



ELECTRONICS CORPORATION 43-20 34th STREET • LONG ISLAND CITY 1, N. Y.

REPRESENTATIVES • Albuquerque • Atlanta • Baltimore • Boston • Chicago • Cleveland • Fort Worth • Kansas City • Los Angeles • New York  
Philadelphia • San Francisco • Seattle • St. Paul • Syracuse • Washington, D. C. • Canada, Arnprior—Export: Rocke International Corporation



**i.e.r.c.**

# MINIATURE ELECTRON TUBE CLAMPING SHIELDS

Patent pending

give lower bulb temperatures  
and increased tube reliability!

MEETS ALL PRESENT AND FUTURE INDUSTRIAL AND MILITARY ELECTRONIC EQUIPMENT REQUIREMENTS!

Accepted for North American Aviation's missile program.



Provides 35% to 50% cooler bulb temperatures plus protection against vibration and shock at 16G's from 0 to 2000 c.p.s. Designed for operation under MIL-S-9372 (USAF).

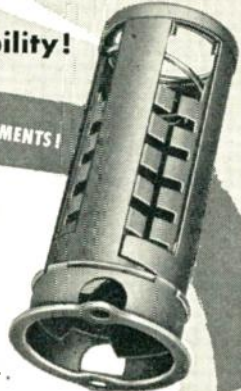

## International electronic research corporation

For complete information write: I.E.R.C., 177 W. Magnolia Blvd., Burbank, Calif.

**SALES REPRESENTATIVES:**

**NEW YORK:** B. B. Taylor Company, Rockville Centre, Rockville Centre 6-1014  
**MASSACHUSETTS:** Holliday-Hathaway Inc., Cambridge, Eliot 4-1751

**CALIFORNIA:** G. S. Marshall Co., Pasadena, Ryan 1-9663  
**ILLINOIS:** Magnuson Associates, Chicago, Kildare 5-4426

### Section Meetings

(Continued from page 90A)

#### ATLANTA

"Instrumentation for High Speed Research Airplanes," by C. A. Taylor, NACA, Langley Field Lab.; October 15, 1954.

"Fifty Thousand Hands—A Story of Telephone Switching," by M. E. Strieby, Bell System Technical Journal Editor; November 18, 1954.

#### BALTIMORE

"A Modern View of Filtering Theory," by Dr. L. A. Zadeh, Columbia University; October 13, 1954.

"Magnetic Resonance," by Dr. Karl Darrow, Bell Telephone Labs.; November 10, 1954.

#### BEAUMONT-PORT ARTHUR

"Coordination of Microwave and Vehicular Communication," by L. M. Fisher, Collins Radio Co.; October 28, 1954.

#### BINGHAMTON

"High Fidelity Reproduction," by Gordon Gow, McIntosh Labs., Inc.; November 16, 1954.

#### BUENOS AIRES

"Color Television," by Eduardo Labin; August 10, 1954.

"Modern Radiotelegraph Systems," by Alejandro Rojo; August 19, 1954.

"Fundamental Telegraph Plan and its Immediate Objectives," by Carlos Alberto Costa; September 2, 1954.

"Record and Prediction of Maximum Usable Frequencies in Argentina," by Jose A. Rodriguez; September 16, 1954.

"General Situation of Present Telephone Technique," by Nicolas Rodenburg; September 30, 1954.

#### BUFFALO-NIAGARA

"Modern Methods of Network Synthesis," by John Fleck, Cornell Aeronautical Lab.; October 20, 1954.

#### CEDAR RAPIDS

"Reliability as Affected by Shock and Vibration," by Shelley Young, Barry Mount Corp.; October 20, 1954.

"Vacuum Tube Design," by Messrs. DeMott, Allen, Korbitz, Mullin Natzke, Cheryhomes and Jones, Engineers, Sylvania Electric Products; November 3, 1954.

#### CLEVELAND

"Spectrum Compression and its Problems," by Curtis J. Schultz, Motorola, Inc.; October 28, 1954.

#### COLUMBUS

"The Flying Saucer Myth," by Dr. J. Allen Hynek, Ohio State University; September 28, 1954.

"Transistor Applications," by R. F. Shea, General Electric Company; October 26, 1954.

#### CONNECTICUT VALLEY

"Circuit Application of the Types 6332 and 5823 in the Univac," by Messrs. H. L. Mason and R. G. Williamson, Remington Rand Lab. for Advanced Research; "Cold Cathode Diode and Triode Computer Tube Characteristics and Life," by Drs. J. A. Randmer and E. B. Carne, also of Remington Rand Lab. for Advanced Research; November 18, 1954

#### DALLAS-FORT WORTH

"Multi-loop Static and Dynamic Self-Balancing Amplifier," by Dr. J. Ross MacDonald, Texas Instruments; "Some Problems in Evaluating Loud Speakers," by Dr. Wayne Rudmose, Southern Methodist University; "Demonstration of Ampex and Altec-Lansing Products," by Cecil C. Ross, Graybar Electric Co., Inc.; October 21, 1954.

(Continued on page 94A)

### BERYLLIUM COPPER

Silvercote ®

titanium

phosphor bronze

ALUMINUM

OTHER NON-FERROUS

Send for descriptive folder.



**LITTLE FALLS ALLOYS Inc.**  
191 Caldwell Ave., Paterson 1, N. J.

## Special Purpose WIRE

Consider WIRE and the importance of its function in your product. Whether a highly engineered application or a simple stapling purpose, your choice of the proper alloy or composition, temper and type of wire could mean success or failure during crucial test.

round • flat — square ■ half-round —

Precision gauges from 1/8 to .002.

SPRING WIRE — WIRE FOR INSTRUMENTS — ELECTRONICS. STRAND FOR WIRE ROPE AND BRAIDED APPLICATIONS — MANDREL WIRE — WIRE FOR FORMS — RIVETS — STAPLING

*There is Always One Leader in Every Field*

## BODNAR INDUSTRIES, Inc.

leads in the field of

### PLASTIC LIGHTING PANELS AND DIALS

BECAUSE OF Quality • Uniformity • Performance  
Design & Layout "Know-How Service"  
Quantity Production Promptly

NEW YORK — 19 Railroad Ave., New Rochelle (Home Office)  
CALIFORNIA — 4440 Lankershim Blvd., P.O. Box 264, North Hollywood  
CANADA — 44 Wellington St. E., Toronto

SPECIMEN PANEL MIL-P-7788 (AN-P-89) SENT ON LETTERHEAD REQUEST



# THE *ONLY* MINIATURE



MASS PRODUCERS OF  
ELECTRONIC COMPONENTS

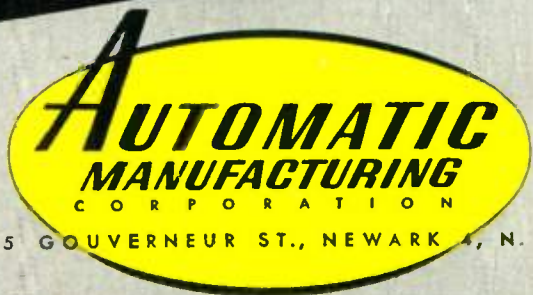

65 GOVERNEUR ST., NEWARK 4, N. J.

**FOR PORTABLE, AUTOMOBILE  
AND OTHER RADIO APPLICATIONS**



**NOW...K-BAND  
COVERAGE  
TO 40,000 MC/S**



**with VECTRON'S SA25  
Microwave Spectrum Analyzer**

**THE VECTRON 25 SERIES K-BAND MICROWAVE SPECTRUM ANALYZERS** are complete, including a display unit, an R. F. assembly and a K-band mixer to cover the desired portions of the "K-band" region of the microwave spectrum. Due to the relatively recent development of equipment for use in K-band and the band's extremely broad range, it has been necessary to develop several assemblies to cover economically the most active portions of the spectrum.

SA25K1 — 15.3 kmc/s to 17.7 kmc/s  
SA25K2 — 22.8 kmc/s to 26.4 kmc/s  
SA25KQ1 — 34.0 kmc/s to 38.6 kmc/s

**SPECIAL K-BAND MIXER-R. F. ASSEMBLY COMBINATIONS** provide coverage of other ranges from 12.4 to 40.0 kmc/s.

**INDIVIDUAL K-BAND R. F. HEADS** may be purchased separately, or with the new Vectron SA25 Microwave Spectrum Analyzer.

**THE SA25 SPECTRUM ANALYZER** includes these features:

- 5" medium persistence CRT display.
- Choice of I. F. Amplifier — 20 kc bandwidth, 22½ mc input; or 50 kc bandwidth, 50 mc input.
- Dual range sweep—2 to 20 or 6 to 60 CPS in two overlapping ranges.
- Standard CRT bezel for camera or hood.
- Improved frequency spread control.
- New wavemeter marked gain control.

These and the many other features of the Vectron SA25 Microwave Spectrum Analyzer can be utilized at lower microwave frequencies with your choice of Vectron's interchangeable R. F. Heads . . . providing specific tuning ranges on fundamentals from 800 to 10,250 mc/s.



**SEE ADVERTISEMENT  
AT RIGHT** →

**SEND FOR  
BULLETIN "K-BAND"**

**VECTRON, inc.**

*Electronic and Electro-Mechanical Equipment*  
402 MAIN STREET, WALTHAM 54, MASS.

**VECTRON FOR DESIGN AND MANUFACTURE OF:**  
Gyros and Gyro Systems      Precision Mechanical Devices  
Gyro Stabilized Platforms    Computers and Calculators  
Servo and Gyromechanisms    Special Gears and Assemblies  
Aircraft Instruments          Synchros and Control Motors



**Section Meetings**

(Continued from page 92A)

**DAYTON**

"Atomic Energy for Peacetime Use," by Dr. Simon Kinsman, Public Health Service; November 4, 1954.

**DES MOINES-AMES**

Demonstration of electronic measurement equipment; October 12, 1954.

"Miniaturized Apparatus Components," by Gerald Tyne, Bell Telephone Labs.; October 20, 1954.

**EMPORIUM**

"VHF and UHF Reception," by Dr. A. B. Glenn, RCA Victor (meeting held jointly with Williamsport Section); October 28, 1954.

"A New Approach to Converter Design" by R. J. Bisso and "The Study of Vibrational Noise of Vacuum Tubes," by M. F. McKeirnan, both of Sylvania Electric Products, Inc.; November 16, 1954.

**FORT WAYNE**

"Characteristics and Applications of Microstrip for Microwave Wiring," by Dr. T. B. Warren, Federal Telecommunication Labs.; November 4, 1954.

**HOUSTON**

"Permanent Magnet Materials and Their Application," by C. A. Maynard, Indiana Steel Products Co.; October 26, 1954.

"Transistors and Their Applications," by C. L. Rouault, General Electric Company; November 16, 1954.

**HUNTSVILLE**

"Errors in Impedance Measurements at Ultra-High Frequencies," by W. R. Hewlett, President, IRE; November 16, 1954.

**LITTLE ROCK**

"Radio Astronomy," by Dr. D. O. McCoy, Collins Radio Company; November 9, 1954.

**LONDON**

"Electrocardiograph—and Similar Biological Amplifiers," by R. S. Richards, National Research Council Dr. M. P. Hoover and others; October 26, 1954.

**LONG ISLAND**

"Synthesis and Simplification of Speech," by Dr. F. S. Cooper, Haskins Labs.; November 9, 1954.

**LOS ANGELES**

"Comments on Color TV Programs and Equipment," by W. H. Copeland, CBS TV; "The Digital Computer—Where Does it Go from Here?" by Dr. W. H. Ware, Rand Corporation; and panel discussion on "Salary Administration for Engineers and Scientists," by T. W. Jarmie, Admiral C. F. Horn, C. B. Thornton, F. P. Melorgano, L. M. K. Boelter and Richard Leitner; October 5, 1954.

"What is the Electronic Industry Doing about Reliability?" by F. A. Paul, Bendix Development Labs.; "Engineering in Pakistan," by Prof. W. L. Orr, UCLA; "Analytical Determination of Response of Certain Time Varying Linear Feedback Systems," by Warren Mathews, Hughes Aircraft Company; November 2, 1954

**MILWAUKEE**

"Transistors, Circuits, Applications," by Dr. R. F. Shea, General Electric Company; October 27, 1954.

**NEW ORLEANS**

Demonstration and talk on "Principles of Color Television," by P. J. Yacich, Engineer, WDSU-TV; October 28, 1954.

(Continued on page 96A)

**VECTRON'S NEW SA 25  
Microwave Spectrum Analyzer**



**covers the Microwave Spectrum  
800 mc/s to 10,250 mc/s  
ON FUNDAMENTALS**

**ACCURATE** — Calibrated micrometer wavemeters . . . lifetime accuracy to .05% with incremental accuracy to better than .005% independent of Klystron changes. Transmission wavemeters for maximum indication without "pulling".

**RELIABLE** — Double conversion for stability with minimum drift . . . standard replaceable klystrons . . . no complex harmonic interference. Highly efficient circuits with minimum power consumption, designed for cool, continuous operation.

**ECONOMICAL** — 99.8% of all microwave research, development, production, test, installation and maintenance requires precise work in a specific portion of the microwave spectrum, usually only a few hundred megacycles wide. Compromise coverage of large areas costs more and delivers less.

**VECTRON'S** new SA 25 Microwave Spectrum Analyzer provides adequate tuning range for the 99.8% of spectrum analyzer requirements through the use of interchangeable R.F. Heads.

**Interchangeable R.F. Heads  
available to 40 kilomegacycles**

25L1 800-2400mc/s	25X2a 5700-7425mc/s
20S1 2400-3650mc/s	25X2 6250-7425mc/s
20S1a 2400-4040mc/s	20X1b 9500-10,250mc/s
25C1b 4240-4910mc/s	20X1a 8500-10,250mc/s
25C1a 4240-5900mc/s	20X1 8500-9660mc/s
25C1 5100-5900mc/s	25K1 15,300-17,700mc/s
25X2b 5700-6600mc/s	25K2 22,800-26,400mc/s
	25KQ1 34,000-38,500mc/s



**WRITE FOR  
BULLETIN SA25**

**and bulletins on  
R. F. Heads  
in the frequency  
range you use.**

**VECTRON, inc.**

*Electronic and Electro-Mechanical Equipment*  
402 MAIN STREET, WALTHAM 54, MASS.

**VECTRON FOR DESIGN AND MANUFACTURE OF:**  
Precision Electronic Components      Microwave Test Equipment  
Electronic Networks and Filters      Radar Units and Systems  
Complete Electronic Systems          Special Test Instruments  
Variable Frequency Power Supplies      Electronic Control Units



# POWER PACKAGE

for fire detectors

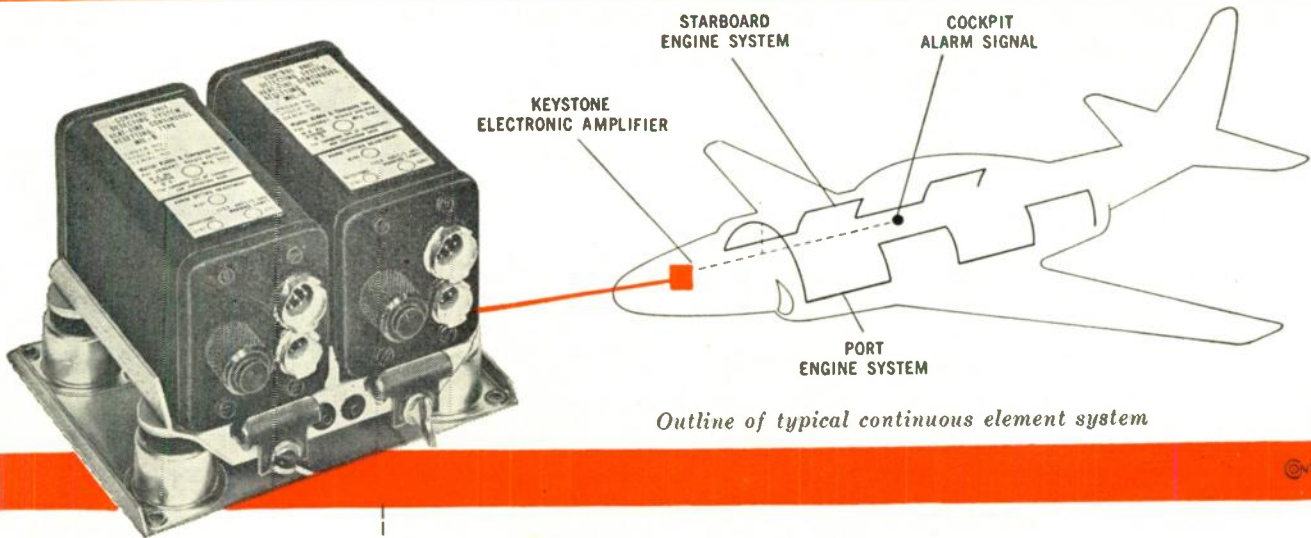

Outline of typical continuous element system

## Keystone electronic amplifiers power fire detection system in latest jet fighters

These twin Keystone amplifiers power the continuous resetting fire detection system supplied by Walter Kidde & Company, Inc., for the nation's newest jet aircraft.

Units for each engine provide constant power through the flexible sensing element, which gives immediate warning of fire in any engine zone.

These special purpose, Kidde-designed electronic amplifiers were produced by Keystone to meet military specification MIL-D-7872, and to operate under extreme vibration and temperature changes. Rigid production control and exhaustive testing assure dependable performance, long life.

This unit is typical of the special electronic and magnetic amplifiers produced by Keystone to meet unusual requirements in military and commercial installations. New applications are constantly making more demands on control and power systems — require new and unique amplifiers to solve individual problems. Whatever your particular need, Keystone can furnish exactly the right amplifier to meet your specifications . . . from design and development through production.

Find out how Keystone can cut your engineering and production time and costs — send an outline of your amplifier needs to the Engineering Department today. If your application involves magnetic amplifiers, send for the handy *Keystone Magnetic Amplifier Reply Sheet*, a quick data sheet which helps Keystone engineers recommend the necessary amplifier promptly and accurately.

Write for further information on electronic and magnetic amplifiers TODAY.

**keystone**



PRODUCTS COMPANY

901 23RD STREET • UNION CITY 2, N. J. • UNION 6-5400

applications      circuitry



NEW

complete  
types  
concise  
designs

# The BRADLEY METALLIC RECTIFIER MANUAL

An Invaluable Tool for the Engineer . . .

A Workable Guide for the Purchasing Agent . . .

The Bradley METALLIC RECTIFIER MANUAL is the most comprehensive and up-to-date handbook on Selenium and Copper-Oxide Rectifiers. It's a real "must" for every design and development engineer using rectifiers.

Into its 144 pages are packed the facts and figures you need on — types, designs, circuitry, applications, characteristics. Here, in clear, concise form, is all the usual information and a great deal of the unusual.

Included in the initial low price of \$2.00 a copy is the revision service that will keep your manual always in step with progress. As changes and developments occur, additions and revisions will be mailed automatically to all manual owners.

Fill out the coupon and mail it today. Your copy of the Bradley METALLIC RECTIFIER MANUAL will be delivered promptly.

Please send me \_\_\_\_\_ copies of the Bradley METALLIC RECTIFIER MANUAL at \$2.00 each. Check for \$ \_\_\_\_\_ is enclosed.

NAME \_\_\_\_\_  
FIRM \_\_\_\_\_  
ADDRESS \_\_\_\_\_  
CITY \_\_\_\_\_ ZONE \_\_\_\_\_  
STATE \_\_\_\_\_



BRADLEY LABORATORIES, INC.  
170P Columbus Ave., New Haven 11, Conn.



## Section Meetings

(Continued from page 94A)

### NEW YORK

"The Story of the DuMont Telecenter," by R. D. Chipp, DuMont Television Network; September 5, 1954.

"The Bell Solar Battery," by D. M. Chapin, Bell Telephone Labs.; October 13, 1954.

"Limits of Fidelity," by N. C. Pickering, Pickering & Co., Inc.; November 3, 1954.

### NORTHERN NEW JERSEY

"Application Considerations for Receiving Tubes," by D. P. Heacock, Radio Corp. of America; November 10, 1954.

### OKLAHOMA CITY

Tour of WKY-TV's color television station; September 14, 1954.

"Miniaturized Apparatus Components," by G. F. J. Tyne, Bell Telephone Labs.; October 18, 1954.

### OMAHA-LINCOLN

"Miniaturized Apparatus," by G. F. J. Tyne, Bell Telephone Labs.; October 21, 1954.

### OTTAWA

"The Influence of Electronics on Culture and Modern Civilization," by M. J. H. Ponte, Vice-President, IRE; November 11, 1954.

### PHOENIX

"Theoretical Physical Approach to Phenomena of Life," by Dr. B. C. Butler; October 28, 1954.

### PITTSBURGH

"Ferrites—The New Look in Magnetic Materials," by C. D. Owens, Bell Telephone Labs.; October 11, 1954.

### PRINCETON

"Stellar and Interspace Communication," by Dr. J. R. Pierce, Bell Telephone Labs.; October 14, 1954.

"What My Mother Never Told Me About Electronic Circuit Theory," by Dr. S. J. Mason, Mass. Inst. of Technology; November 11, 1954.

### ROME-UTICA

"Latest Developments in the Field of Sampled-Data Systems," by Dr. J. R. Ragazzini, Columbia University; November 2, 1954.

### ST. LOUIS

"Ham Radio and Civil Defense," by Allen Furfine, Emerson Electric; October 28, 1954.

### SAN ANTONIO

"Practical Application for Facsimile Operation as Developed by Western Union," by P. A. Normand, Private Wire Service; October 21, 1954 and October 22, 1954.

"Matching Opportunity with Need," by Dr. J. W. McRae, Sandia Corporation; November 3, 1954.

### SAN FRANCISCO

"Color Television," by A. G. Jensen, Bell Telephone Labs.; October 25, 1954.

### SCHENECTADY

"The Logic of the Digital Computer," by Rudy Habermann, Jr., General Electric Company; November 8, 1954.

### SYRACUSE

"The Why and How of High-Energy Electron Acceleration," by Dr. D. R. Corson, Cornell University; November 15, 1954.

### TOLEDO

"Uses and Treatments of Meters," by N. A. Triplett, M. M. Triplett, V. L. Walker and Van Neepser, all of Triplett Electrical Instrument Company; October 14, 1954.

(Continued on page 98A)



**CLARE**  
**Type J Relays**  
*help count cars*  
**ACCURATELY and FAST**  
*... on Jersey's*  
**Garden State Parkway**

● Keeping track of traffic on the Garden State Parkway hour after hour, day after day, is rugged duty for control equipment. Only the most sturdy and precise components can stand the wear and tear.

That's why engineers of Taller & Cooper, Inc., whose toll booths and collection equipment are found on every major American toll facility, chose CLARE TYPE J RELAYS. These relays accurately record the number of vehicles that pass through the Toll Plaza. Their high speed permits accurate readings of automobiles even up to 40 miles per hour.

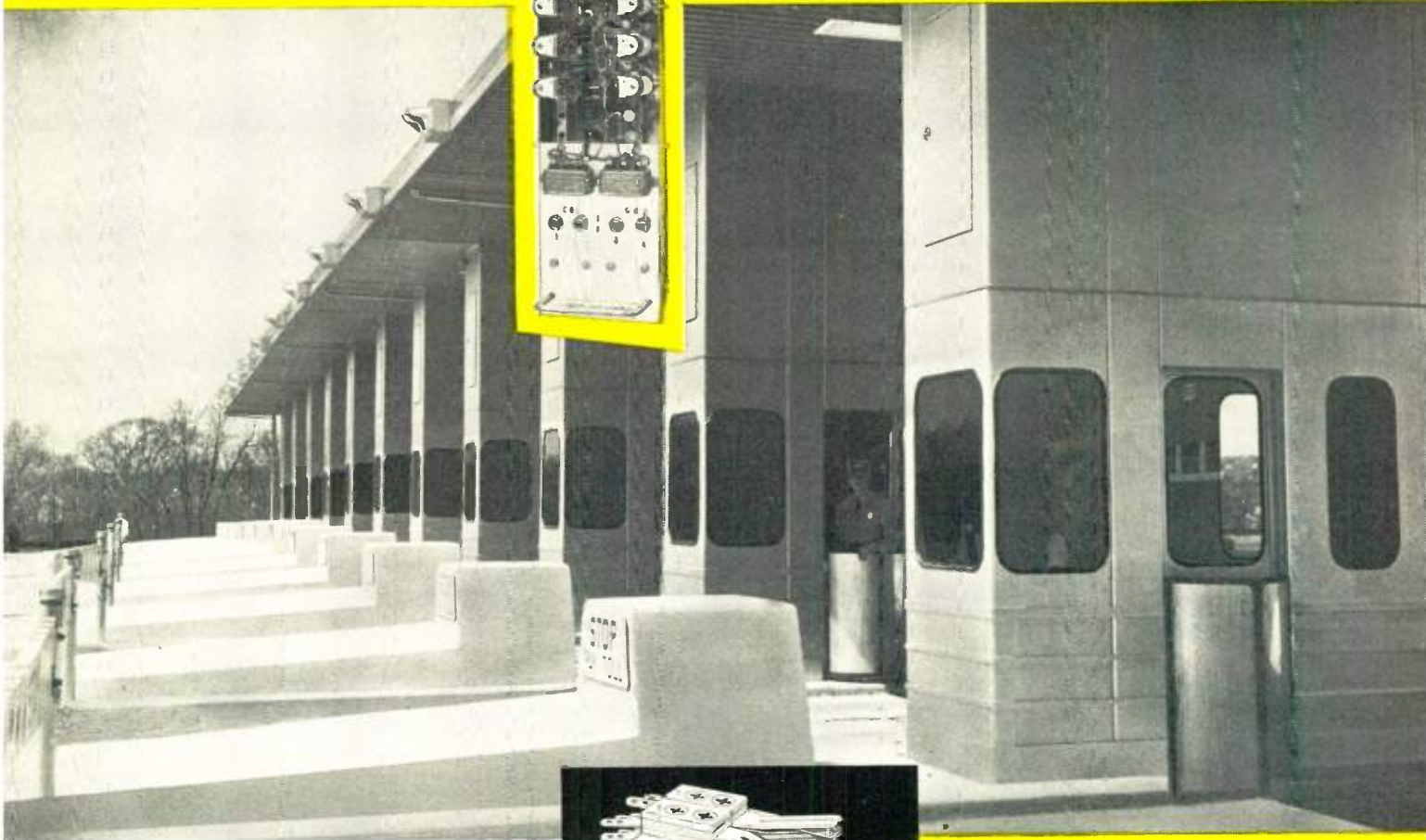

**CLARE**  
**RELAYS**

**FIRST**  
**in the industrial field**

*For complete data on the Type J and all Clare Relays, write for ENGINEERING DATA BOOK. A Clare sales engineer is located near you. Call him or write C. P. Clare & Co., 3101 West Pratt Blvd., Chicago 45, Illinois. In Canada: Canadian Line Materials Ltd., Toronto 13. Cable address: CLARELAY.*

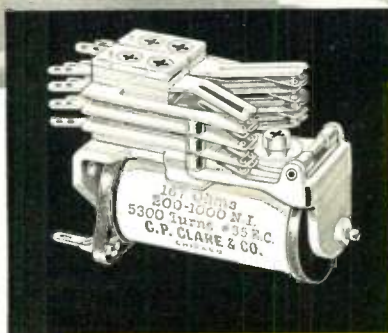

**The Type J Relay**  
**may have**  
**just what YOU want**  
**in a relay**

**SMALL AND LIGHT:**  
 2 1/4" long; 2 1/4 oz. (approx.)

**LARGE CURRENT CAPACITY:**  
 4 amperes, 150 watts. Twin contact points (palladium) standard.

**FAST OPERATE-RELEASE:**  
 1 to 2 milliseconds (Min.) Coils can be provided for time delay on operation, release, or both.

**OPERATING VOLTAGE:**  
 Up to 220 volts d-c.

**NEW FEATURES:**  
 Independently operating twin contacts minimize contact failure.

Hinge-type armature recently improved to prolong life and increase stability of relay adjustment.

New heavy duty yoke has stainless steel pivot pin with large bearing surface which turns in precisely reamed bearings of non-ferrous material.



# NEW "PARAFORMED" SPIRAL WOUND PAPER TUBES

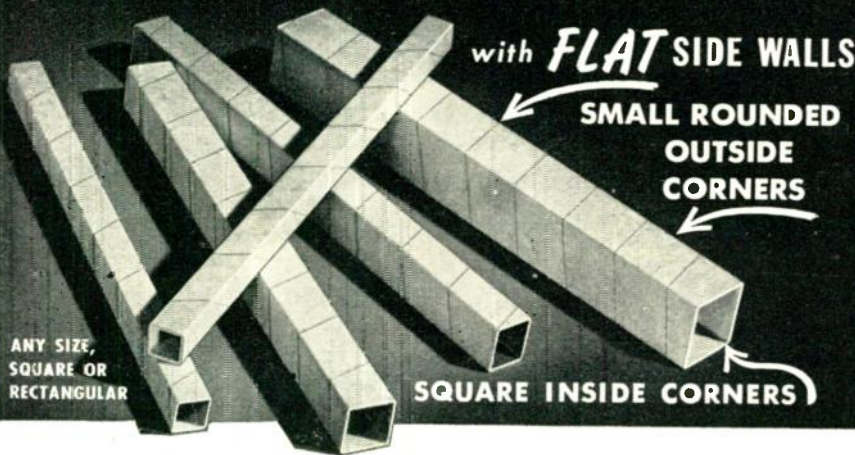

ANY SIZE,  
SQUARE OR  
RECTANGULAR

## DO YOU HAVE A SPACE PROBLEM?

Eliminates squeezing operation of finished coil and possibility of shorts due to fractured enamel insulation.

For the first time, a paper tube like this—developed and perfected by PARAMOUNT after years of research! No artificial heat or pressure is used in its manufacture—"PARAFORMING" takes place at the time of actual winding. No sharp outside edges to cut the wire during winding of coils. Has great rigidity and physical strength. Permits coil manufacturers to hold much closer tolerances. No need for wedges to tighten the winding on the laminated core. Coils can be automatically stacked much faster, too. The new "PARAFORMED" tubes are approved and used by leading manufacturers. *And they cost no more!*

WRITE ON COMPANY  
LETTERHEAD FOR  
STOCK ARBOR LIST  
OF OVER 2000 SIZES

## Paramount PAPER TUBE CORP.

618 LAFAYETTE ST., FORT WAYNE 2, IND.

Standard of the Coil Winding Industry for Over 20 Years

Simplicity  
of Design

Requires less than  
one-half the space  
usually needed for  
a lever switch.



SWITCHCRAFT®  
"LEV-R-SWITCHES"

Plus  
Serviceability

Made in two and three position types; momentary and locking actions. Single hole mounting. Attractive hardware. Long springs without any "forms" at point of flexing insure long spring life. Springs insulated from each other by phenolic spacers with hard rubber tubing press fit through the stack—insures correct alignment of the contacts and provides high insulation resistance. "Soft" easy action actuator; real detent action on locking types.

Fine silver contacts, rated at 3 amperes, 120 volts, A.C. non-inductive load—standard. Also available on special order with larger silver contacts for higher currents and Palladium contacts for low current—low voltage circuits.

### TELEVER SWITCH

For more rugged applications. Features unusual "T-Beam" frame construction—light design with ruggedness of a structural "T-Beam."



Full details in Catalog S-52—fourth printing—send for your copy.

SWITCHCRAFT  
INC.

1332 N. Halsted St. Chicago 22, Ill.

Canadian Representative: Atlas Radio Corp. Ltd., 560 King St. W., Toronto 28, Canada, Phone Waverly 4761

AVAILABLE AT ALL LEADING RADIO PARTS JOBBERS.



## Section Meetings

(Continued from page 96A)

### TULSA

Get acquainted meeting; displays of merchandise by local manufacturers and distributors; October 20, 1954.

### TWIN CITIES

"Recent Developments in High Altitude Instrumentation and Long Range Telemetering," by E. R. VanKrevelen, General Mills, Inc.; October 20, 1954.

### VANCOUVER

"Principles of Color Television," by C. N. Hoyler, Radio Corp. of America; October 27, 1954.

### WASHINGTON

"Information Storage and Switching by Ferrite Cores," by Dr. L. N. Ridenour, International Telemeter Corp.; November 8, 1954

### WILLIAMSPORT

"VHF and UHF Reception," by Dr. A. B. Glenn, RCA Victor (meeting held jointly with Emporium Section); October 28, 1954.

### SUBSECTIONS

#### AMARILLO-LUBBOCK

General meeting at which plans were made for Section programs and membership drive; October 14, 1954.

#### BERKSHIRE COUNTY

"Application Details of Electronic Digital Computers in Business, Science and Industry," by C. W. Adams, Mass. Inst. of Technology; October 11, 1954.

#### BUENAVENTURA

"The Engineering Profession—A Challenge to the Engineer of Today," by L. M. K. Boelter, Dean, College of Engineering, UCLA; October 14, 1954.

#### ERIE

"Printed Circuits," by Oliver Steigerwalt, Erie Resistor Corp.; October 28, 1954.

"High Fidelity Phonographs," by G. A. Morrell, Jr., Astatic Corp.; November 18, 1954.

#### EAST BAY

"Western Electric TD-2 Microwave System," by M. W. Walther, Pacific Tel. and Tel.; and "Television Station KOVR," by K. Durkee, Station KOVR; November 10, 1954.

#### MID-HUDSON

"Compatible Color TV Signals," by J. W. Wentworth, RCA; October 5, 1954.

"A Unified Approach to all Audio Frequency Measurements," by Dr. Per V. Bruel, Bruel & Kjaer Company, Denmark; November 12, 1954.

#### MONMOUTH

"Recent Transistor Progress," by H. L. Owens, Fort Monmouth Signal Corps Eng'g. Lab.; November 17, 1954.

#### ORANGE BELT

"Commercial Applications of Atomic Power," by Dwain Bowen, North American Aviation; October 13, 1954.

#### PALO ALTO

"Color Receivers—A Progress Report," by D. S. Colburn, Admiral Corp; "Preparing a Local TV Station for Color Transmission," by J. L. Berryhill, KRON-TV; and "Color Tubes—The Key to Color Television," by D. R. Cone, Chromatic TV Labs.; color TV demonstration; October 18, 1954.

#### TUCSON

"Application of Radar to Atmospheric Research," by Dr. A. R. Kassander, University of Arizona; October 15, 1954.

#### WICHITA

"50,000 Hands"—lecture and demonstration by Dr. M. E. Strieby, American Tel. and Tel. Company; October 20, 1954.





HERMETICALLY SEALED COMPONENTS



COMMERCIAL COMPONENTS



HI-FIDELITY TRANSFORMERS



FREEDSEAL TREATMENT



MINIATURE TRANSISTOR TRANSFORMERS



PULSE TRANSFORMERS



MINIATURE AUDIO TRANSFORMERS



LOW-FREQUENCY HI-Q REACTORS



TOROIDAL INDUCTORS



SUB-MINIATURE TOROIDS



HI-TEMPERATURE COMPONENTS



SLUG TUNED COMPONENTS



CHARGING REACTORS



HI-LEVEL PULSE TRANSFORMERS



SUB-MINIATURE HERMETICALLY SEALED COMPONENTS



FILTER REACTORS

# Your Condensed Directory of **FREED** Quality Products



STEP-DOWN TRANSFORMERS



POWER TRANSFORMERS



CHANNEL MOUNTING



PRECISION FILTERS



HIGH-Q REACTORS



SATURABLE CORE REACTORS



MAGNETIC AMPLIFIERS



1900 MAGNETIC A.C. VOLTAGE REGULATOR



1020-B MEGOHMMETER



1010-A COMPARISON AND LIMITED BRIDGE



1110-A INCREMENTAL INDUCTANCE BRIDGE



1150 UNIVERSAL BRIDGE



1210-A NULL DETECTOR AND VACUUM TUBE VOLTMETER



1140-A NULL DETECTOR-AMPLIFIER



1030-A LOW FREQUENCY "Q" INDICATOR



1620 MEGOHMMETER



1870 INCREMENTAL INDUCTANCE COMPARISON BRIDGE



1040 A.C.-V.T. VOLTMETER



1060 VACUUM TUBE VOLTMETER



1560 DIFFERENTIAL VOLTMETER



1580 DB DECADE AMPLIFIER



1570 COMPARISON BRIDGE



1170 D.C. SUPPLY BRIDGE

While this page shows a representative group of Freed Products, it only indicates the vast facilities we have for engineering and advanced development. Our five plants are integrated in one area and are well coordinated from basic research to finished product. Solving difficult engineering problems is a challenge we are always ready to accept. Inquiries will be handled promptly.

SEND FOR COMPLETE TRANSFORMER AND INSTRUMENT CATALOGS



DECADE CAPACITORS



DECADE INDUCTORS



1410 DISTORTION METER



1950 NULL FILTERS



## FREED TRANSFORMER CO., INC.

1720 WEIRFIELD ST., BROOKLYN (Ridgewood) 27, N. Y.

FOR SCIENCE and INDUSTRY

## Electro-Pulse's NEWEST PULSE GENERATOR

- Operation to 330 KC
- Variable Duration and Delay
- Low Internal Impedance

LOW COST ...

HIGH PERFORMANCE



### VARIABLE PULSE GENERATOR... Model 4120A

A truly wide-range laboratory-type unit — a basic instrument for pulse circuit test and development. Its versatility, compactness and simplicity of operation allow wide application in production and laboratory testing of:  
Computers... Telemetry... Television... Magnetics  
... Nuclear Research and Development... Radar  
... Navigational Systems.

- 33 CPS to 330 KC Rep. Rate • 1 to 100  $\mu$ s Delay • 3 to 100  $\mu$ s Pulse Width • At least 50 V Amplitude • .1  $\mu$ s Rise Time • Blocking Oscillator Sync. Pulse • 3 1/2" x 19" Standard Rack Panel • Complete with Regulated Power Supply

Write for Complete Data: Our Bulletin 4120A/1



The Model 4120A Variable Pulse Generator is the latest addition to the Electro-Pulse line of pulse instrumentation which includes Analog and Digital Time Delay Generators, Pulse Oscillators and the 2100 series precision Pulse Generators

◆ Model 2120A PULSE GENERATOR

Representatives in Major Cities

**EP** Electro-Pulse, Inc.

11811 MAJOR STREET, CULVER CITY, CALIFORNIA  
Telephones: EXbrook 8-6764 and TEXas 0-8006



The following transfers and admissions were approved to be effective as of December 1, 1954:

#### Transfer to Senior Member

- Baliga, B. V., Chief Engineer all India Radio, Broadcasting House, Parliament St., New Delhi, India
- Brown, J. S., 352 Bruce St., Syracuse 3, N. Y.
- Cosgriff, R. L., 2200 Homestead Dr., Columbus, Ohio
- Dagavarian, H. O., 99 Linden Blvd., Hicksville, L. I., N. Y.
- Dorr, R., 703—37 Ave., Oakland 1, Calif.
- Fawcett, R. G., 2570 Bellewood, Ann Arbor, Mich.
- Friedland, M. S., 27 B Riverside Dr., Patrick AFB, Fla.
- Gordon, L. L., 190 Long Branch Ave., Long Branch, N. J.
- Graham, M., 51 Bell Ave., Upton, L. I., N. Y.
- Guanella, G., im Schilf 10, Zurich 7/44, Switzerland
- Hughes, W. A., 3565 S. Sepulveda Blvd., Los Angeles 34, Calif.
- Keith, C. R., Bell Telephone Laboratories, Murray Hill, N. J.
- O'Donnell, T. F., 34 Ledgeway, Wellesley Hills 82, Mass.
- Passow, R. L., Box 263-K, R.F.D. 1, Bellefonte, Pa.
- Prickett, T., Jr., 5526 Glenwick La., Dallas 9, Tex.
- Roberts, F. B., 183 Seaton Rd., Stamford, Conn.
- Rockett, F. H., 226 Sylvan Dr., West Hempstead, L. I., N. Y.
- Schwartz, M., 1977 Prospect Ave., New York 57, N. Y.
- Singel, J. B., 9 Seminole Ave., Catonsville 28, Md.
- Smith, D. E., 323 Middle Crest Rd., Oswego, Ore.
- Stamler, L., 522 E. 20 St., New York 9, N. Y.
- Stevens, L. D., 99 Notre Dame Ave., San Jose, Calif.
- Sugarman, R. H., 616 Woodland Rd., West Allenhurst, N. J.
- Teasdale, A. R., Jr., 3925 Potomac Ave., Fort Worth 7, Tex.
- Warden, F. W., 53 Leonard Dr., Westwood, N. J.
- Weiner, J. R., Remington Rand, Inc., Eckert-Mauchly Division, 2300 W. Allegheny Ave., Philadelphia 29, Pa.

#### Admission to Senior Member

- Adams, W. H., 1621 Fifth St., Manhattan Beach, Calif.
- Beachler, R. R., Jr., 3412 Palm Ave., Manhattan Beach, Calif.
- Chute, G. M., Electrical Engineering Department, University of Detroit, Detroit 21, Mich.
- Dreyer, K., 945 Pleasure Rd., Lancaster, Pa.
- Duncan, C. L., 2675 Candler Rd., Chamblee, Ga.
- Jakus, L. A., 5829 Oak Ave., Indianapolis 19, Ind.
- Jenkins, J. F., Jr., The Ralph M. Parsons Co., 135 W. Dayton St., Pasadena 2, Calif.
- Mariotti, P. G., 67-84 Exeter St., Forest Hills 75, L. I., N. Y.
- Marshall, N. K., 5760 Lemp Ave., North Hollywood, Calif.
- McMillan, B., Bell Telephone Laboratories, Murray Hill, N. J.
- Muller, F. A., 222 Boulevard, Pompton Plains, N. J.
- Nordlin, H. G., 35 Winchester Rd., Livingston, N. J.
- Phillips, M. L., Union Farm, R.F.D. 1, Alexandria, Va.
- Speh, K. C., 160 Old Country Rd., Mineola, L. I., N. Y.
- Van Name, F. W., Jr., Franklin and Marshall College, Lancaster, Pa.
- Wathen-Dunn, W., 44 Maple St., Lexington 73, Mass.
- Webster, R. R., 3616 Seguin Dr., Dallas, Tex.
- Weinberg, A. M., Oak Ridge National Laboratory, Oak Ridge, Tenn.
- Wolf, B. H., 1660 W. Sixth St., Plainfield, N. J.

(Continued on page 102A)



# YOU TOO CAN HAVE THESE!

We're the source of these imported television lenses which greatly increase camera versatility. Complete the range of your TV camera lenses with these previously unavailable focal lengths. Supplement the lenses you are now using for increased versatility and performance.



## ANGENIEUX RETROFOCUS

wide angle lens (35mm focal length) f2.5. Focusing mount with iris diaphragm. Highest resolution for sharpest images.

## MEYER PRIMOPLAN

(75 mm focal length) f1.9. Focusing mount with iris diaphragm. Longer than normal focal length for universal application.



## MEYER TELEPHOTO

(250 mm focal length) f5.5. In focusing mount with iris diaphragm and built-in lens shade. The light weight construction permits a balanced turret action.



**All Lenses Fully Guaranteed for Optical Quality and Top Performance**

Write today for our complete price list of all of our special lenses for television cameras—28mm through 250mm. Samples for test purposes available on request.

## PONDER & BEST

TELELENS DIVISION

Importers of Fine Photographic Equipment

814 North Cole Avenue  
Hollywood 38, California



for this *new terminal construction* if you want

# SEALED

**IMMERSION-PROOF 85-100° C.  
TWIST-PRONG ELECTROLYTICS**

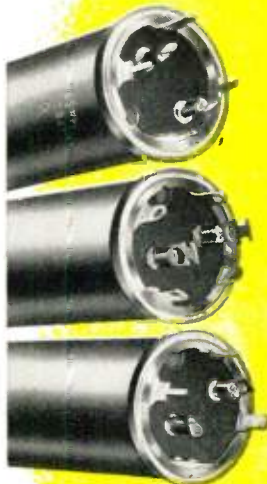

Note the new cover design for Aerovox twist-prong electrolytic capacitors.

It embodies several highly desirable

features not found in conventional twist-prong units, such as:

All-in-one phenolic disk and sealing rubber. Greater basic strength than with separate layers of phenolic and rubber heretofore used.

Lead connection through stud to terminal, produces excellent seal against moisture.

Design flexibility of terminal-stud construction allows greater size and shape variation of terminal ends. Especially desirable with "printed" wiring" circuitry. Greater dimensional uniformity.

Permits standardization of mounting. Completely interchangeable with all other types.

No internal contact between dissimilar materials—high purity aluminum throughout.

### GET THE FACTS!

Let us give you the significant details, and then let us quote on your requirements for these superior twist-prong electrolytics.

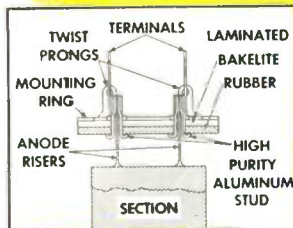

## AEROVOX CORPORATION

NEW BEDFORD, MASS.

HI-Q  
DIVISION  
OLEAN, N. Y.

CINEMA  
ENGINEERING CO  
BURBANK, CALIF

ACME  
ELECTRONICS, INC.  
MONROVIA, CALIF.

In Canada: AEROVOX CANADA LTD., Hamilton, Ont. JOBBER ADDRESS: 740 Belleville Ave., New Bedford, Mass.  
Export: Ad. Auriema, Inc., 89 Broad St., New York, N. Y. • Cable: Auriema, N. Y.



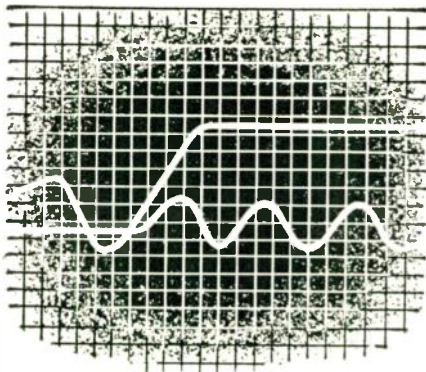

**EPSC**

## EPIC FAST PULSE AND COUNTING EQUIPMENT

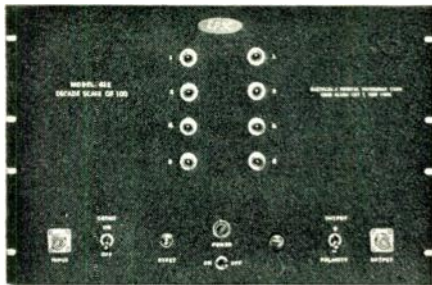

Proved Dependability In A Versatile Range Of Assemblies

**0.001 MICROSECOND RISE TIME SQUARE PULSE GENERATORS** for the millimicrosecond to microsecond range.

**0-10 MC DECADE AND BINARY SCALERS FULLY AUTOMATIC 0-10 MC NUCLEAR SCALERS** with predetermined count, predetermined time operation, precision high voltage power supplies, preamplifiers and discriminators.

- PLUG IN COUNTING STRIPS
  - 0.1 MICROSECOND COUNTER CHRONOGRAPHS
  - PRECISION DC HIGH VOLTAGE SUPPLIES
  - WIDE BAND AMPLIFIERS
- ALSO CUSTOM DESIGNED EQUIPMENT TO MEET YOUR INDIVIDUAL REQUIREMENTS!

Write for detailed engineering bulletin No. 403

**EPSC**

**ELECTRICAL AND PHYSICAL INSTRUMENT CORPORATION**  
Engineering Division  
42-19 27th Street, Long Island City 1, N. Y.



(Continued from page 100A)

### Transfer to Member

- Bell, N. W., 138 Pamela Rd., Monrovia, Calif.  
 Black, A. M., 120 Meade Rd., Elkins Park, Pa.  
 Brady, M. E., U. S. Navy Electronics Laboratory, San Diego 52, Calif.  
 Brown, D. F., 15 Cunningham Cir., Waltham 54, Mass.  
 Cadena, D. G., 628 Broadview Dr., W., San Antonio, Tex.  
 Decho, K. R., 5914 W. School St., Chicago 34, Ill.  
 Eby, J. T., 2211 Spring Ave., Lutherville, Md.  
 Ehrhart, E. H., 108 Castle Rd., North Syracuse, N. Y.  
 Fenton, N. L., 3607 N. 21 Dr., Phoenix, Ariz.  
 Fernstrom, C. H., 90th AAA Gun Battalion, Fort Bliss, Tex.  
 Hartman, F. B., Star Rt., Highland, N. Y.  
 Hay, G. W., 801 Schilder Dr., Fort Worth 14, Tex.  
 Hines, H. H., 2016 W. Marquette Rd., Chicago, Ill.  
 Holpuch, D. J., 3625 Arthur Ave., Brookfield, Ill.  
 Larky, N. D., 223 W. Summit St., Somerville, N. J.  
 Larter, T. C., 337 W. Lomita St., Glendale 4, Calif.  
 Neitzel, E. B., Geophysical Laboratory, Box 2819, Dallas 1, Tex.  
 Portnoy, A., 76 Sunnyside Ave., Brooklyn 7, N. Y.  
 Rasche, D. O., 2650 Adams, Granite City, Ill.  
 Savant, C. J., Jr., University of Southern California, 3518 University Ave., Los Angeles 7, Calif.  
 Schwartz, H. E., Jr., 3 Prospect St., New Rochelle, N. Y.  
 Slaughter, J. E., 252 Hillcrest Manor Ct., Apt. C., Utica, N. Y.  
 Stenserson, C. K., 315 N. Lockwood Ave., Chicago 44, Ill.

### Admission to Member

- Ackerman, R. L., Jr., Sylvania Electric Products, Inc., Woburn, Mass.  
 Aid, D. G., 616 Ivy Dr., Menlo Park, Calif.  
 Bishop, H. A., 189 Empire Ave., St. Johns, Newfoundland, Canada  
 Burruano, S. J., 1720 Powell St., Norristown, Pa.  
 Cohoon, R. L., 5 Willow Pl., Nutley 10, N. J.  
 Crottinger, R. M., Hemple Rd., R.F.D. 2, Miamisburg, Ohio  
 Davis, W. J., 382 Sunset Rd., W. Reading, Pa.  
 DeWeese, C. R., 9946 Chireno, Dallas, Tex.  
 Engelman, J. A., 101 Arlington Rd., Paoli, Pa.  
 Enholm, E. C., USAF, Box 363, Scott AFB, Ill.  
 Gilotaux, P., 2 Emile Pathe, Chatou, Seine et Oise, France  
 Heilendel, F. W., 7442 Fay Ave., La Jolle, Calif.  
 Helmheckel, T. A., 7631 Daly Rd., Cincinnati 31, Ohio

(Continued on page 105A)

## From servo-mechanisms to electronic computers, "RADIO" is a way of THINKING!

Far-reaching progress in the radio-electronic field is no "happy accident." Television, electronic computers and the "radiation" power of the atom, which soon will be harnessed to industry were not discovered . . . they were engineered. From "fission" to "computation," these engineering achievements are accomplished through an enormous process of information exchange—the methodical and brilliant teaming together of engineering thinking to solve a problem. In radio this work has been done deliberately by a growing engineering society, through its meetings and published proceedings, which unleash the creative minds of men.

In 1954, "Proceedings of the I-R-E" published 1837 text pages, exclusive of product news and departmental features. This is the word-count equivalent of seven 500-page textbooks on radio-electronics for engineers. It exceeds the contents of the next two contemporary publications put together. This "high" in genuine reader service was logically matched by advertising worth over a half-million dollars, by firms investing in the engineers' reading interest and benefiting by it.

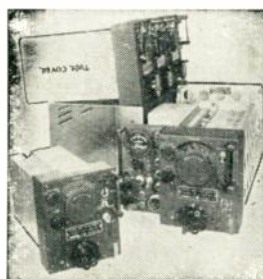

### AN/APR-4 LABORATORY RECEIVERS

Complete with all five Tuning Units, covering the range 38 to 4,000 Mc.; wideband discone and other antennas, wavetraps, mobile accessories, 100 page technical manual, etc. Versatile, accurate, compact—the aristocrat of lab receivers in this range. Write for data sheet and quotations.

We have a large variety of other hard-to-get equipment, including microwave, aircraft, communications, radar; and laboratory electronics of all kinds. Quality standards maintained. Get our quotations!

NEW TS-13/AP X-BAND SIGNAL GENERATORS, with manual, \$575.00 . . . T-47A/ART-13 Transmitters, \$450.00 . . . H-P, Boonton, G-R, Measurements, and other standard items in stock; also nucleonic equipment.

## ENGINEERING ASSOCIATES

434 PATTERSON ROAD

DAYTON 9, OHIO



... here's new might for miniatures

# Dur-Mica DM15

World's Smallest Mica Capacitor  
The First Miniature Dipped Mica Capacitors with Parallel Leads.



(Shown Actual Size)



NOW! Also available . . .

El Menco Dur-Mica DM20

1 to 3900 mmf. at 500vDCw  
1 to 5100 mmf. at 300vDCw

El Menco

*Dur-Mica*

IDEAL FOR PRINTED CIRCUITS. Meets all Humidity, Temperature and Electrical Requirements of MIL-C-5 Specifications. El Menco's Dur-Mica DM15 establishes a "new dimension" in capacitor performance with ranges from 1 to 390 mmf. at 500vDCw and 1 to 510 mmf. at 300vDCw. A new, tougher phenolic casing provides temperature co-efficient and stability equal to or better than characteristic F in all but the lowest capacity values . . . efficient operation at temperatures as high as 125°C. El Menco's Dur-Mica DM15 can be used in a variety of transistor circuits and other miniature electronic equipment in military and civilian applications. Sells for Less than the famous El Menco CM-15 — Provides Economy of Size with Maximum Performance and Widest Application.

**test El Menco "Dur-Micas" for yourself!**

Write for free samples and catalog on your firm's letterhead.



El Menco  
*Capacitors*

**THE ELECTRO MOTIVE MFG. CO., INC.**  
WILLIMANTIC CONNECTICUT

**molded mica · mica trimmer  
tubular paper · ceramic**

Jobbers and distributors write to Arco Electronics, Inc., 103 Lafayette St., New York, N. Y.

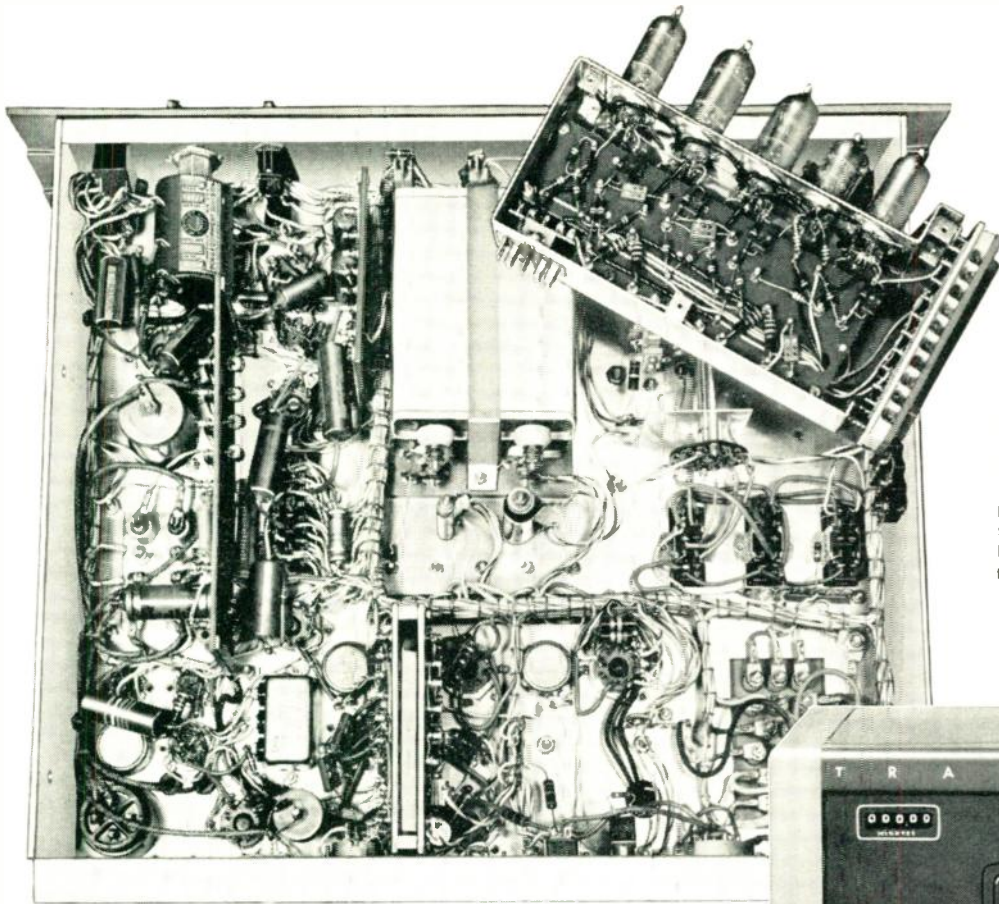

At left—Plug-in unit of Tracerlab Superscaler mounted on a miniature chassis. It can be plugged into the front of the Superscaler. Various types of plug-in units are available for special electronic functions. Bradleyunits are standard in this Superscaler assembly.

# Tracerlab Superscaler

equipped with  
**Bradleyunits and Bradleyometers**  
 for maximum dependability



The Tracerlab Superscaler is a fast-counting instrument for Geiger, proportional, or scintillation pulses, featuring both preset count and preset time operation.

Bradleyometers are used in this Superscaler for dependable potentiometer adjustments. The resistor element is molded to satisfy any resistance-rotation curve. Variations in temperature and humidity do not affect its performance.

Bradleyunits are stable fixed resistors entirely free from erratic variations in resistance, and they have never been found to open circuit in service. The leads are differentially tempered to prevent sharp bends at the resistor body. After carrying full load at 70 C ambient for 1000 hours, the resistance change is less than 6 per cent.

For quality in fixed and adjustable composition resistors, follow the example of leading electronic equipment manufacturers—standardize on Allen-Bradley components. Write for descriptive engineering bulletins, today.



BRADLEYUNITS are available in standard RETMA values in  $\frac{1}{2}$  and 2 watt sizes from 10 ohms to 22 megohms; in the 1 watt size from 2.7 ohms to 22 megohms. Allen-Bradley resistors do not use "wax impregnation" to pass salt-water immersion tests.



BRADLEYOMETERS can be supplied as single units or in dual and triple construction. Built-in line switch can be provided. Corrosion-resistant metal used throughout. No riveted, welded, or soldered connections.

Allen-Bradley Co., 114 W. Greenfield Ave., Milwaukee 4, Wis. • In Canada—Allen-Bradley Canada Limited, Galt, Ont.

# ALLEN-BRADLEY

RADIO, ELECTRONIC AND TELEVISION COMPONENTS





(Continued from page 102A)

- Hooper, E. T., Magnetics Division, Naval Ordnance Laboratory, White Oak, Silver Spring, Md.
- Horowitz, L., 1515 Ogden St., N.W., Washington, D. C.
- Jackson, L. J., 2111 Ferris Ave., Lawton, Okla.
- Karron, G. A., 29 Lyons Rd., Scarsdale, N. Y.
- Kelly, T. J., One Lantern La., Weston 93, Mass.
- Kendall, W. S., 74 Sparks St., Ottawa, Ont., Canada
- Kennedy, D. S., 112 Otis St., Hingham, Mass.
- Lee, B. D., 2110 Watts Rd., Houston 5, Tex.
- Leggett, D. A., 736 Santa Anita St., San Gabriel, Calif.
- Masher, D. P., The Gate Ways, Normandy Heights Rd., Morristown, N. J.
- McCoy, A. M., Jr., 71 Midway Ave., Locust Valley, N. Y.
- McCrocklin, R. E., Box 84 TAS, Fort Bliss, Tex.
- Miller, J. C., III, 4406 Perlita, Parkchester, New Orleans 22, La.
- Montgomery, J. D., Jr., 7103 S. Dobson, Chicago 19, Ill.
- Nelson, L. O., 10303-13 Ave., N.W., Seattle 77, Wash.
- Nunn, W. M., Jr., Advanced Electronics Laboratory, Hughes Aircraft Co., Culver City, Calif.
- O'Brient, E. J., Jr., 6 Richartson Rd., Peabody, Mass.
- Pender, P. S., Sr., 2025 Delmar Ave., Granite City 1, Ill.
- Pogust, F. B., 64-25D-186 La., Fresh Meadows 65, L. I., N. Y.
- Popp, S. J., Radio Station WIL, 3715 Lindell, St. Louis 8, Mo.
- Ricketts, L. W., Electrical Engineering Department, University of Tennessee, Knoxville, Tenn.
- Rosenstein, A. B., 3148 Barry Ave., Los Angeles 34, Calif.
- Roughan, J. V., Box 14, Buckeystown, Md.
- Roulston, K. I., Department of Physics, University of Manitoba, Winnipeg, Man., Canada
- Sastry, P. V. V. S., Assistant Professor in Electronics, Madras Institute of Technology, Chrompet P.O., Madras, S. India
- Sharpe, T. W., 3310 Cherrywood Ave., Dallas 9, Tex.
- Snodgrass, D. D., 1048 N. 30 St., Billings, Mont.
- Snyder, D. R., 3333 Northrup Ave., Sacramento 21, Calif.
- Souter, R. E., 2347 Heather Ave., Long Beach 15, Calif.
- Stark, L., 10853 Galvin St., Culver City, Calif.
- Taragin, S., 5116 Woolverton Ave., Baltimore 15, Md.
- Test, A. J., 201 Crocker Bldg., San Francisco, Calif.
- Thompson, R. J., 3511-79 Ave., S.E., Washington 28, D. C.
- van Aller, H. H., 2 Kingsway, Mobile, Springhill, Ala.
- Wasserman, B., 147 Kenville Rd., Buffalo 15, N. Y.
- Whildin, F. W., 6 Bonaventure Ave., St. Johns, Newfoundland, Canada
- Windsor, A. A., 557 Santa Barbara Rd., Berkeley 7, Calif.

The following elections to the Associate grade were approved to be effective as of December 1, 1954:

- Agel, C. W., 412 E. Genesee St., Syracuse, N. Y.
- Agule, G. J., 712 Newfield Ave., Stamford, Conn.
- Anderson, H. E., 50 Massachusetts Ave., Apt. 306, Cambridge 39, Mass.
- Anderson, J. R., 3097 Pierce St., Minneapolis, Minn.
- Bajamonte, F. L., 270-02-80 Ave., New Hyde Park, L. I., N. Y.
- Barber, E., 107 N. Illinois, Belleville, Ill.

(Continued on page 106A)

# INDUSTRIAL POCKETSCOPE

by

# Waterman

MODEL S-11-A

DC-COUPLED  
WORK-HORSE OF  
INDUSTRY

Size:  
11" x 5" x 7"  
8 3/4 Pounds



ANOTHER EXAMPLE OF **Waterman** PIONEERING...

The INDUSTRIAL POCKETSCOPE, model S-11-A, has become America's most popular DC coupled oscilloscope because of its small size, light weight, and unique flexibility. This compact instrument has identical vertical and horizontal amplifiers which permit the observation of low frequency repetitive phenomena, while simultaneously eliminating undesirable trace bounce. Each amplifier sensitivity is 0.1 Volt rms/inch. The frequency responses are likewise identical, within -2 db from DC to 200 KC. Their total undistorted outputs permit effective trace expansion of twice the screen diameter. The internal sweep generator is continuously variable from 3 cycles to 50 KC and can be synchronized from positive going signals. Return trace blanking is optional. Intensity modulation is accomplished by connecting either directly to the grid of the three-inch cathode ray tube or thru an amplifier having a gain of approximately 10 and a flat response to 500 KC. Direct intensity modulation threshold voltage is approximately 1 volt rms. Additional provisions for direct access to all the deflection plates, the second anode, and the amplifier output terminals extend the usefulness of the S-11-A many fold.

## WATERMAN PRODUCTS CO., INC.

PHILADELPHIA 25, PA.

CABLE ADDRESS: POKETSCOPE

WATERMAN PRODUCTS INCLUDE

- S-4-C SAR PULSESCOPE®
- S-5-A LAB PULSESCOPE
- S-6-A BROADBAND PULSESCOPE
- S-11-A INDUSTRIAL POCKETSCOPE®
- S-12-B JANIZED RAKSCOPE®
- S-14-A HIGH GAIN POCKETSCOPE
- S-14-B WIDE BAND POCKETSCOPE
- S-15-A TWIN TUBE POCKETSCOPE
- RAYONIC® Cathode Ray Tubes
- and Other Associated Equipment



WATERMAN PRODUCTS



IT'S **CHICAGO** FOR  
**High Fidelity**  
BROADCAST  
MILITARY  
MINIATURE  
COMMERCIAL  
HOME



Where fine audio quality is essential, for private, commercial or military equipment, you can depend on CHICAGO high fidelity transformers for distortionless sound reproduction.

**CHICAGO**  
**ULTRA-LINEAR  
HIGH FIDELITY**  
Output Transformer  
**BO-13**

This "super-range" transformer, specifically designed for ultra-linear Williamson amplifier circuits, is typical of the many high fidelity transformers available from CHICAGO.

Amplifier frequency response, with the BO-13, is flat from 20 to 60,000 cycles at 20 watts output. At a 1 watt listening level, the BO-13 is flat from less than 10 cycles to beyond 200,000 cycles.

Intermodulation distortion, measured at 60 and 7000 cycles, 4:1 ratio, is less than 3% at 21 watts. Total harmonic distortion is below 0.1%, measured at 1000 cycles, up to 21 watts.

The BO-13 is housed in a compact, seamless steel case measuring 3 $\frac{3}{16}$ " x 3 $\frac{11}{16}$ " x 4 $\frac{11}{16}$ " high. CHICAGO's famous "sealed-in-steel" construction provides maximum shielding and full humidity protection.

CHICAGO Bulletin 33 lists performance curves and other useful information on the BO-13. Write for your FREE copy, or get it from your CHICAGO distributor.



**CHICAGO CATALOG**  
CT-554,  
listing complete electrical and physical specifications on over 500 CHICAGO transformers. Available from your CHICAGO distributor or from Chicago Standard Transformer Corporation.

**EXPORT SALES:**  
Roburn Agencies, Inc.  
431 Greenwich Street  
New York 13, N. Y.

**CHICAGO STANDARD TRANSFORMER CORP.**  
3501 ADDISON STREET • CHICAGO 18, ILLINOIS



**Membership**

(Continued from page 105A)

- Bartol, T. J., 2122 N. 72 St., Wauwatosa, Wis.  
 Belby, M., Paris Hill Rd., R.F.D. 1, Sauquoit, N. Y.  
 Bell, B., 821 W. 21 St., Norfolk, Va.  
 Bennett, W. F., 3340 Harrison Ave., Muhlenberg Pk., Reading, Pa.  
 Bergman, E. J., 1000 Loyola, Apt. 9A, Chicago, Ill.  
 Bernstein, H., 596 E. Second St., Brooklyn, N. Y.  
 Bhardwaj, J., Tele-Com. Mech. Sta. Workshops EME, Mhow (MB), India  
 Bielenin, A., 18520 Gottschalk Ave., Homewood, Ill.  
 Blake, J. A., 1982 Oakes Dr., Akron, Ohio  
 Boesch, P. W., 8712 Maywood Ave., Silver Spring, Md.  
 Bohman, G. F., c/o K. W. Fite, Celery Ave., Sanford, Fla.  
 Board, C. Z., Arizona State College, Tempe, Ariz.  
 Bracken, W. H., 1773 Joan Ave., Towson, Md.  
 Braden, R. S., 145 Greenwood St., Melrose, Mass.  
 Bradley, M. E., Jr., 2861 W. Dickens Ave., Chicago, Ill.  
 Breithaupt, J. J., 1822 Plymouth Dr., Irving, Tex.  
 Brown, A. E., 762-41 Ave., San Francisco, Calif.  
 Brown, W. J., 94-62-199 St., Hollis, L. I., N. Y.  
 Buchfeller, J. E., 1008 1/2 S. Mayflower, Monrovia, Calif.  
 Bulman-Fleming, S. E., Royal Canadian Mounted Police, Kelowna, B. C., Canada  
 Burke, E. P., Hickory Ave., New Windsor, Newburgh, N. Y.  
 Burns, J. C., 5103-43 Ave., Hyattsville, Md.  
 Carlon, C. B., 3856 Wilton St., Long Beach, Calif.  
 Carter, H. A., 3610 Balsam Ave., Indianapolis, Ind.  
 Case, S. W., 13 Nassau Ave., Plainview, L. I., N. Y.  
 Certner, A., 82 Dora Ave., Waldwick, N. J.  
 Chisholm, H. C., 2128 Coalinga Ave., Richmond, Calif.  
 Cockerham, F. E., 418 Glen Park Dr., Bay Village, Ohio  
 Coil, E. A., Division Ave., Lutherville, Md.  
 Coleman, H. R., 3227 Travis, Midland, Tex.  
 Collier, A. F., 5085 Berkshire, Detroit, Mich.  
 Cook, A. G., 84 Chelmsford Rd., Mt. Lawley, Perth, W. Australia  
 Copithorne, A. R., 54 Carfield Ave., Chelsea, Mass.  
 Courtney, C. R., 35 St. Clare Ave., St. John's, Newfoundland, Canada  
 Cox, G. C., 2612 Euclid St., Santa Monica, Calif.  
 D'Ausilio, R. F., Box 305, 3327 St. Sq. AF 11274345, Scott AFB, Ill.  
 Davis, W. H., 301 Kings Highway E., Haddonfield, N. J.  
 Davis, W. J., Box 298, Duncanville, Tex.  
 Dennison, G. L., 24081 Frank Ave., Fairview Park, Ohio  
 Deunk, R. K., 7191 Greenleaf Ave., Parma, Ohio  
 Dickson, F. J., 534 Jubilee Ave., Winnipeg, Man., Canada  
 Di Lorenzo, S. N., 24 Howard St., Pompton Lakes, N. J.  
 Donaghy, J. F., 595 E. 139 St., New York, N. Y.  
 Downs, J. E., 433 N.W. 13, Oklahoma City, Okla.  
 Drexel, A., 1676 Collins Ave., Miami Beach, Fla.  
 Easley, W. A., Jr., 1805 N. 20 St., Phoenix, Ariz.  
 Elam, T. W., 5304 Kenwood Ave., Baltimore, Md.  
 Elder, H. E., 510 Warfield Rd., N. Plainfield, N. J.  
 Ellet, J. W., Hays Manufacturing Co., Plastics Division, Albion, Pa.  
 Emmons, G. T., Box 208, 3337 TT Sqdn., Scott AFB, Ill.  
 Epler, M. A., 924 Broadway, Boulder, Colo.  
 Feibish, H. L., 2514-85 St., Brooklyn, N. Y.  
 Ferrier, P. A., 6 Villa D'Aurion, Roshy sous Bois, Seine, France  
 Fetidge, P. von S., c/o Page Communications Engineers, Inc., 710-14 St., N.W., Washington, D. C.  
 Fisch, M. W., 419 W. Sherwood Ter., Fort Wayne, Ind.

(Continued on page 108A)



**IN TOP QUALITY CORES**

# FOR HIGHER FREQUENCIES

**FROM 20 TO 300 MC.**

# TYPES SF, J AND W

**GA&F® CARBONYL IRON POWDERS**

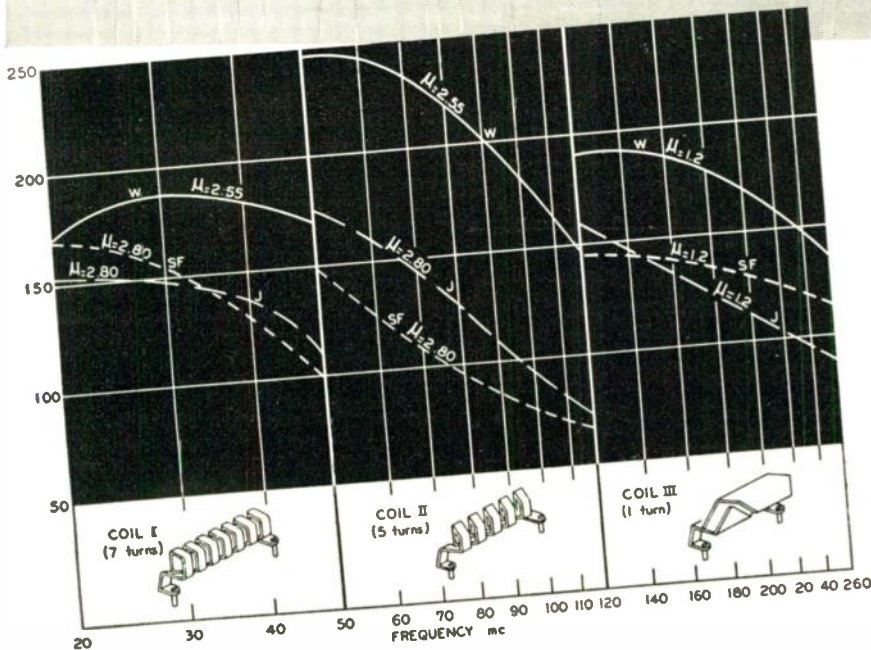

Three types of G A & F Carbonyl Iron Powders are particularly satisfactory in cores designed for use at the higher frequencies. To assure low losses and good magnetic and temperature stability at 20 mc. to 300 mc., we invite you to test Types SF, J and W. These powders are microscopic, almost perfect spheres—ranging from 3 to 9 microns in diameter—with the same rigorous uniformity that characterizes all G A & F Carbonyl Iron Powders.

Today, Carbonyl Iron Powders—a total of ten types—are widely used in the production of cores for transformers and inductor coils—to increase Q values, to vary inductances, to reduce coil size, to confine stray fields or to increase the coupling factors.

We urge you to ask your core maker, your coil winder, your industrial designer, how G A & F Carbonyl Iron Powders can increase the efficiency and performance of the equipment or product you make, while reducing both the cost and the weight.

We offer you two books—one covering SF, J and W Powders only—the second covering the other seven types. In both books, characteristics and applications are given with diagrams, performance charts and tables. For either or both books, address Department 23.

**PHYSICAL CONSTANTS**

	W	J	SF
Percent retained by 325 mesh screen . . . . .	trace	trace	trace
Weight-average particle diameter (Roller Analyzer) $d = \frac{\sum d_i^4}{\sum d_i^3}$ (microns) . . . . .	3	9	3
Surface-average particle diameter (Fischer Sub-Sieve-Sizer) $d = \frac{\sum d_i^3}{\sum d_i^2}$ (microns) . . . . .	2.5	4.5	2.5
Density of particles, g/cm <sup>3</sup> . . . . .	7.35	7.35	7.81
Apparent density, g/cm <sup>3</sup> . . . . .	2.6	2.8	3.0



*From Research to Reality...*

**ANTARA CHEMICALS**  
 A SALES DIVISION OF GENERAL ANILINE & FILM CORPORATION  
 435 HUDSON STREET • NEW YORK 14, N. Y.





# Electrically Conductive Cloth

**A New Engineering Material for  
Many Applications in Electronics**

**SUGGESTED  
USES:**

RF SHIELDING  
RADAR REFLECTION  
MICROWAVE GASKETING  
WARNING SYSTEMS  
ATTENUATORS  
STATIC DISCHARGE

*Buy it by the yard and sew it to shape on any  
sewing machine. Or, have us sew it for you.*

WRITE OR PHONE

**Swift**  
INDUSTRIES, INC.  
10 Love Lane, Hartford 1, Conn.  
Jackson 2-1181

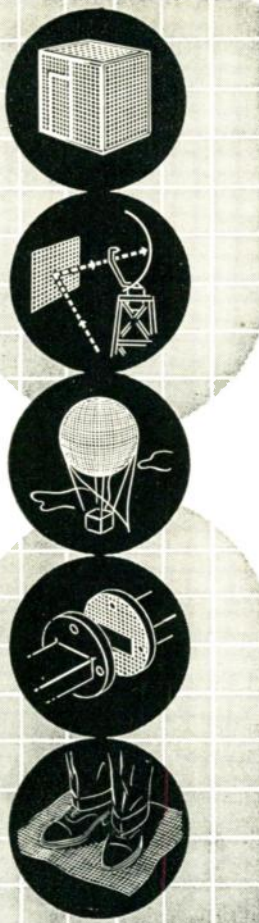

(Continued from page 106A)

- Flacco, A. F., 918 Walnut St., Palmyra, N. J.  
 Fliegner, A. F., 41 Rosewood Dr., Atherton, Calif.  
 Frewald, W. J., 1440 Beacon St., Brookline, Mass.  
 Friedman, F., 315 Seigel St., c/o Bogart Manufacturing Co., Brooklyn, N. Y.  
 Gaines, A., 71 Kendall Ct., Dover, N. J.  
 Gardiner, R. F., 94 E. Monte Vista, Phoenix, Ariz.  
 Gero, B. C., 409 Jefferson Ave., Cheltenham, Pa.  
 Glass, W., 131 Hillcrest Dr., Cocoa, Fla.  
 Goatcher, H. Z., 15 W. Second St., Sand Springs, Okla.  
 Goda, O. S., 1619 W. 145 St., Gardena, Calif.  
 Golick, S., 74-40—220 St., Bayside, L. I., N. Y.  
 Grey, T. G., 5434 Briar, Mission, Kans.  
 Gruenthal, F. W., 71-21—260 St., Glen Oaks, L. I., N. Y.  
 Grushkin, M., 6609 W. 115 St., Worth, Ill.  
 Gubbins, L. J., 1619 Seymour Ave., Utica, N. Y.  
 Guyot, L. F., 19 Av. Villiers, Paris 17, France  
 Haber, K. H., Bell Telephone Laboratories, Inc., Whippany, N. J.  
 Hagood, W. N., 11524 Strand, Dallas, Tex.  
 Hartofil, P. E., 520 Wellesley Rd., Rome, N. Y.  
 Hartzell, J. W., Ebasco Services, Inc., 2 Rector St., New York, N. Y.  
 Hausman, D. I., 524 Parkway Blvd., Tempe, Ariz.  
 Heckler, C. H., Jr., 2829 Wolf Ave., Pennsauken, N. J.  
 Helderman, T. E., 5868 Village Plaza N. Dr., Indianapolis, Ind.  
 Helgeson, G. T., 1325 Virginia St., E., Charleston, W. Va.  
 Hem, R. J., 2509 E. Poplar, Springfield, Ill.  
 Hildebrandt, C. H., Bell Telephone Laboratories, Inc., Whippany, N. J.  
 Hill, R. S., 125 Texas La., Ithaca, N. Y.  
 Hirsch, M., 4810 N. 11 St., Philadelphia, Pa.  
 Hoft, W. L., 1503 Preston Ave., Akron, Ohio  
 Holcumb, W. A., 22 Garden St., Seneca Falls, N. Y.  
 Holland, B. S., 150-59—87 Ave., Jamaica, L. I., N. Y.  
 Holt, W. L., 1411 Poplar St., Apt. 7, Pittsburgh, Pa.  
 Howard, G. L., 4512 Toucan St., Torrance, Calif.  
 Hoyler, E. T., 132 Oakgrove Ave., Buffalo, N. Y.  
 Huntley, W. P., 5225 Wilshire Blvd., Los Angeles, Calif.  
 Jensen, H. T., Sikorsky Aircraft Division, S. Ave., Bridgeport, Conn.  
 Johnson, F. L., 5 Jackson Ave., Massapequa Park, L. I., N. Y.  
 Johnson, K. W., 123 Figlar Ave., Fairfield, Conn.  
 Jones, J. W., 1686 Alameda de las Pulgas, Redwood City, Calif.  
 Joslow, J., 324 C Southampton Dr., Silver Spring, Md.  
 Jurkevich, I., 3418 Powelton Ave., Philadelphia, Pa.  
 Kaeser, J. M., c/o Officers Mail Unit, Box 724, Patrick AFB, Fla.  
 Katz, S., 2140 Cruger Ave., New York, N. Y.  
 Keilsohn, J. J., Remington Rand, Eckert-Mauchly Division, Box 5616, Philadelphia, Pa.  
 Kellam, J. C., Jr., 1512 Ingalls Rd., Glen Burnie, Md.  
 Kelting, W. M., Jr., 2744 W. Alice, Phoenix, Ariz.  
 Kirkaldy, A. J., Jr., 216 Orchard La., Norristown, Pa.  
 Kobler, J. K., 1435 1/2 N. Crescent Heights Blvd., Los Angeles, Calif.  
 Lachocki, E., 19 River St., East Orange, N. J.  
 LaPrade, G. L., 1107 E. Oregon Ave., Phoenix, Ariz.  
 Lardieri, G., 626 N. Seventh St., Newark, N. J.  
 Lattin, J. P., 4317 E. Cherry Lynn, Phoenix, Ariz.  
 Liebman, R. I., 720 Kentucky St., S.E., Albuquerque, N. Mex.  
 Lindquist, J. R., Instructor Co. C. TSESS, Camp Gordon, Ga.

## ABOVE ALL... U. S. C. CONNECTORS

<p><b>HEAVY DUTY CONNECTORS</b></p> <p>980-34HRSL    980-34F2    980-34M2SL</p> <p>For use on rack and panel type equipment in communication and power circuits. U. S. C. heavy duty multi-contact connectors offer</p> <ul style="list-style-type: none"> <li>• Maximum number of heavy current contacts</li> <li>• Mechanical and electrical dependability of operation in a minimum of space.</li> <li>• available 7 to 34 contacts</li> </ul>	<p><b>PRINTED CARD RECEPTACLES</b></p> <p><b>UPCR-18</b></p> <p>U. S. C. Printed Card Receptacles offer</p> <ul style="list-style-type: none"> <li>• Channel Strength and Snap-in Contacts</li> <li>• Dependability of operation over range of printed card thickness</li> <li>• Available - Single end double Row, Wire Solder and Wire Wrap - From 6 to 44 contacts</li> </ul>	<p><b>MINIATURE CONNECTORS</b></p> <p>MI-34F    MI-34M</p> <p>For Multi-Contact Plug-in</p> <ul style="list-style-type: none"> <li>• Maximum Strength</li> <li>• Dependable Electrical Performance</li> <li>• Minimum of Space</li> <li>• Available 5 to 75 contacts</li> </ul> <p style="text-align: center;"><i>Over 1000 types available</i></p> <p style="text-align: center;"><i>Write us for information on your connector problems</i></p>
---	--	---

**U. S. COMPONENTS, Inc.**  
Associated with U. S. Tool and Mfg. Co., Inc.  
 454-462 East 148th Street, New York 55, N. Y. CYpress 2-6525-6

(Continued on page 110A)



# Here's What's New in Vitamin Q<sup>®</sup> Capacitors



Now you can have Sprague's famous subminiature paper capacitors in new styles that make vibration-proof mounting simple . . . make harness wiring faster. New straddle milled flats on standard threaded neck units let you insert the neck in flatted openings. A simple nut and lock washer permanently locks the capacitor to the chassis. In addition, you can now obtain Sprague subminiature paper capacitors with solder tab terminals, eliminating the problem of splicing leads to wires. Insulating outer sleeves for 125°C mounting are also available.

Sprague's Vitamin Q capacitors are available in ratings and mechanical designs far beyond

those called for in specification MIL-C-25A. For example, both inserted tab and extended foil designs are available in working voltage ratings up to 1000 vdc.

Positive hermetic closure is assured by glass-to-metal solder seals, which unlike rubber compression-type terminals, cannot be twisted during wiring assembly.

Complete information on Sprague subminiature paper capacitors in all thirteen case styles, is provided in Engineering Bulletin 213C, available on letterhead request to the Sprague Electric Company, 235 Marshall Street, North Adams, Massachusetts.

**WORLD'S LARGEST CAPACITOR MANUFACTURER**

# SPRAGUE

Export for the Americas: Sprague Electric International Ltd.  
North Adams, Mass. CABLE: SPREXINT

**NEW**

subminiature paper capacitor mounting styles speed and simplify circuit assembly with—

- **Flatted Necks**
- **Solder Tab Terminals**
- **Insulating outer sleeves**  
**for 125°C applications**

Sprague, on request, will provide you with complete application engineering service for optimum results in the use of subminiature paper capacitors.

**IMMEDIATELY AVAILABLE  
FROM STOCK ...**

# magnetic servo amplifier series

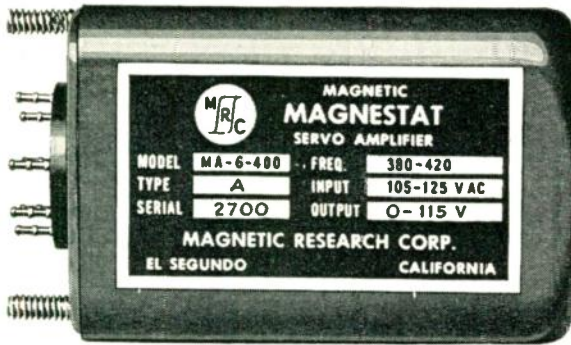

Shown above Model MA-6-400  
Actual size: 2-9/16" x 1-3/4" x 1-7/16". Wt. less than 12 oz.  
Hermetically Sealed • 7-Pin Header

## MODELS 400 cps Series

- MA-3-400
- MA-6-400
- MA-10-400
- MA-15-400
- MA-18-400
- MA-40-400

This complete series of precisely engineered Magnetic Servo Amplifiers is immediately available from stock, as standard components for servo systems application. Furnishes in compact form all the salient features of a high quality, hermetically sealed transformer.

### OUTSTANDING PERFORMANCE CHARACTERISTICS ...

- Sinusoidal Phase Reversing Output
- Transistor or Tube Control ... AC or DC Input
- Ambient Temperature Range -55°C. to +100°C.
- Low Cost, Rugged, Compact, Efficient, Long Service Life
- Meets Military Specifications

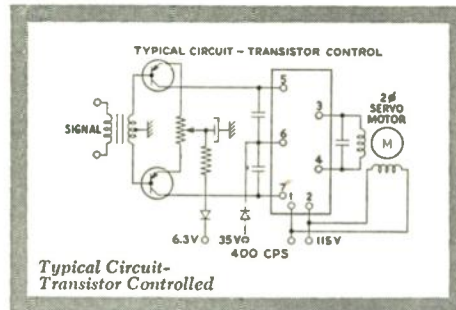

## MAGNETIC SERVO AMPLIFIER SERIES

400 cps Models\*

- MA-3-400
- MA-6-400
- MA-10-400
- MA-15-400
- MA-18-400
- MA-40-400

### Applications

- MK-14 (3-watt)
- MK-7 (6-watt)
- MK-8 (10-watt)
- 16-watt
- 18-watt
- 40-watt

\* Equivalent 60 cps Series also available

If you are confronted with circuitry design or engineering problems involving magnetic components for servo system or other application, your inquiry directed to our engineering staff for information will receive prompt, courteous attention.

For complete technical data and performance curves ... request Engineering Bulletin on Magnetic Servo Amplifier Series.

**MAGNETIC RESEARCH CORP.**  
200 CENTER STREET • EL SEGUNDO, CALIFORNIA

Mfrs. of Magnetic Amplifiers and Converters, Magnetically Regulated DC Power Supplies, Magnetic Pulse Generators.



(Continued from page 108A)

- Loar, H. H., 114 Franklin St., Apt. 1-H-1, Morristown, N. J.
- Malone, J. M., 4249 N. 35 St., Phoenix, Ariz.
- Marshank, D. N., 672 S. Lafayette Park Pl., Los Angeles, Calif.
- Martinez, A. L., 8500 Culebra Rd., San Antonio, Tex.
- McFadden, J. H., Roanoke, Ind.
- McHugh, T. E., Insulated Circuits, Inc., 115 Roosevelt Ave., Belleville, N. J.
- McKay, A. H., 106 E. King St., Smethport, Pa.
- McMullen, A. L., 2800 Montclair Dr., N.E., Albuquerque, N. Mex.
- Mealey, R. M., 7506 Poplar Ave., Baltimore, Md.
- Miletello, S. J., 1832 Guelich St., Utica, N. Y.
- Miller, J. O., 3202 Grand Blvd., Brookfield, Ill.
- Miller, L. E., 2807 N. 51 St., Phoenix, Ariz.
- Moore, B. W. L., R.F.D. 2, Lowbanks, Ont., Canada
- Moser, E. B., 1608 E. West Highway, Silver Spring, Md.
- Naeseth, M. H., 1107 Buena Vista Blvd., Panama City, Fla.
- Nasoni, D. E., 531 Prescott Ave., Scranton, Pa.
- Nemoto, T., 59 Akasaka Aoyamaminamicho 6 Chome, Minatoku, Tokyo, Japan
- Nervik, A. E., 44 Swenson Dr., Wappingers Falls, N. Y.
- North, F. J., 700 Schuyler St., Utica, N. Y.
- Northrup, C. D., I.B.M., South Rd., Poughkeepsie, N. Y.
- Ostenso, A. S., Box 669, China Lake, Calif.
- Ota, N., 418 E. Hardy St., Inglewood, Calif.
- Ozarin, S. J., 1078 Cedar La., Woodmere, L. I., N. Y.
- Paquette, A., 127 Ave Labonte, Longueuil, Mt 1.23, Que., Canada
- Parkhurst, J. E., 5327 Seventh Ave., Moline, Ill.
- Parnell, R. A., 585 E. Grant Highway, Marengo, Ill.
- Parsons, H. A., 8th Shoran Beacon Flight, Shaw AFB, S. C.
- Pasciuto, R. D., 90 Glenbrook Rd., Stamford, Conn.
- Paulson, J. N., 7 Oakwood Blvd., Poughkeepsie, N. Y.
- Peach, L. C., 2731 S. Tripp Ave., Chicago, Ill.
- Peselnick, L., 640 Buchanan St., N.W., Washington, D. C.
- Peterson, H. P., Wayne University Computation Laboratory, Detroit, Mich.
- Pollacek, E. H., 115 Bryant Ave., Springfield, N. J.
- Pratt, J. D., 37 R.S.M., APO 214, c/o Postmaster, New York, N. Y.
- Proctor, D. E., 2030 E. 73 St., Chicago, Ill.
- Pugh, W. H., 18 Boyce Ave., Scarboro Jct., Ont., Canada
- Pugsley, J. D., Canadian General Electric Co., Ltd., Electronics Division, Box 907, Station "O", Montreal, Que., Canada
- Quackenbush, F. R., 312 Barbara Dr., W. Point Pleasant, N. J.
- Rabinowitz, S. J., 1315 St. Paul St., Baltimore, Md.
- Rapalus, H. W., Hill St., Suffield, Conn.
- Raser, E. J., 302 Dutchess Tnpk., Poughkeepsie, N. Y.
- Reyes, J. H., Calle 66 No. 13-53, Bogota, Colombia, S. A.
- Ringe, R. E., 8321 Kittyhawk, Los Angeles, Calif.
- Ross, H., 16 Peters Rd., Riverside, Conn.
- Rozenstein, S., Box 1, Kiryat, Motzkin, Israel
- Rowinski, S. J., 943 N. Sixth St., New Hyde Park, L. I., N. Y.
- Sage, F. D., 302 N. Goodman St., Rochester 7, N. Y.
- Salk, D., 145 Prospect St., Providence, R. I.
- Satinoff, D., 1411 Steuben St., Utica, N. Y.
- Scannell, E. H., Jr., Box 231, R.F.D. 1, Quaker Hill, Conn.
- Schaaf, W. K., 21 St. Johns Ave., Valley Stream, L. I., N. Y.

(Continued on page 112A)



ANOTHER... CASCADE RESEARCH FERRITE "FIRST"

# POWER



+.3 MEGAWATT PEAK  
+. 300 WATTS AVERAGE

MODEL HL86-96



for inclusion between the output of microwave power source and load . . . . .

to provide . . . substantial isolation with very low V.S.W.R. and with negligible loss in transmitted microwave power . .

to eliminate "pulling" or long-line effect normally present where antennas are separated from magnetron or klystron microwave generators by a transmission line of appreciable length . . . . .

The desirable properties of ferrites at microwave frequencies have been applied uniquely in this new series of Power Unilines. Here the design objective has been to obtain maximum heat dissipation without the requirements of forced air or liquid cooling. Utilization of the resonant absorption properties of ferrites at microwave frequencies makes possible the use of internal ferrite elements with substantial surface area. This in turn permits adequate cooling by conduction since the ferrite elements can directly contact the inner wall surfaces of the waveguide

section. The required transverse magnetic field is supplied by heavy-duty permanent magnets which are an integral part of the assembly. No external power supply is required.

The power ratings listed on the accompanying chart are realistic and practical. They take into account the probability that V.S.W.R. of any practical load will usually be considerably greater than unity. Ratings therefore are predicated upon test conditions where the load connected to the output of the Power Uniline is adjusted for a 1.8:1, V.S.W.R.

## SPECIFICATIONS

MODEL	FREQUENCY RANGE	PEAK POWER	AVERAGE POWER	MIN. INSERTION LOSS Reverse direction	MAX. INSERTION LOSS Forward direction	V.S.W.R. Either direction
H16-17,	16.0-17.0 KMC	100 KW (Calculated)	100 W (Calculated)	12 DB	≤ 0.5 DB	≤ 1.05
HL86-96,	8.6-9.6 KMC	300 KW	300 W	10 DB	≤ 0.4 DB	≤ 1.05
H86-96,	8.6-9.6 KMC	150 KW	125 W	10 DB	≤ 0.8 DB	≤ 1.10
H28-32	2.8-3.2 KMC	150 KW	150 W	10 DB	≤ 0.8 DB	≤ 1.20

All Cascade Power Unilines will meet military environmental specifications including those applying to temperature, shock and vibration.



OTHER CASCADE RESEARCH PRODUCTS: Ruggedized Unilines, Gyruline the direct microwave amplitude modulator, Gyruline audio driver, phase shifters.

WRITE FOR DETAILED TECHNICAL LITERATURE

**CASCADE RESEARCH** ..... 53 VICTORY LANE LOS GATOS, CALIF.  
CORPORATION

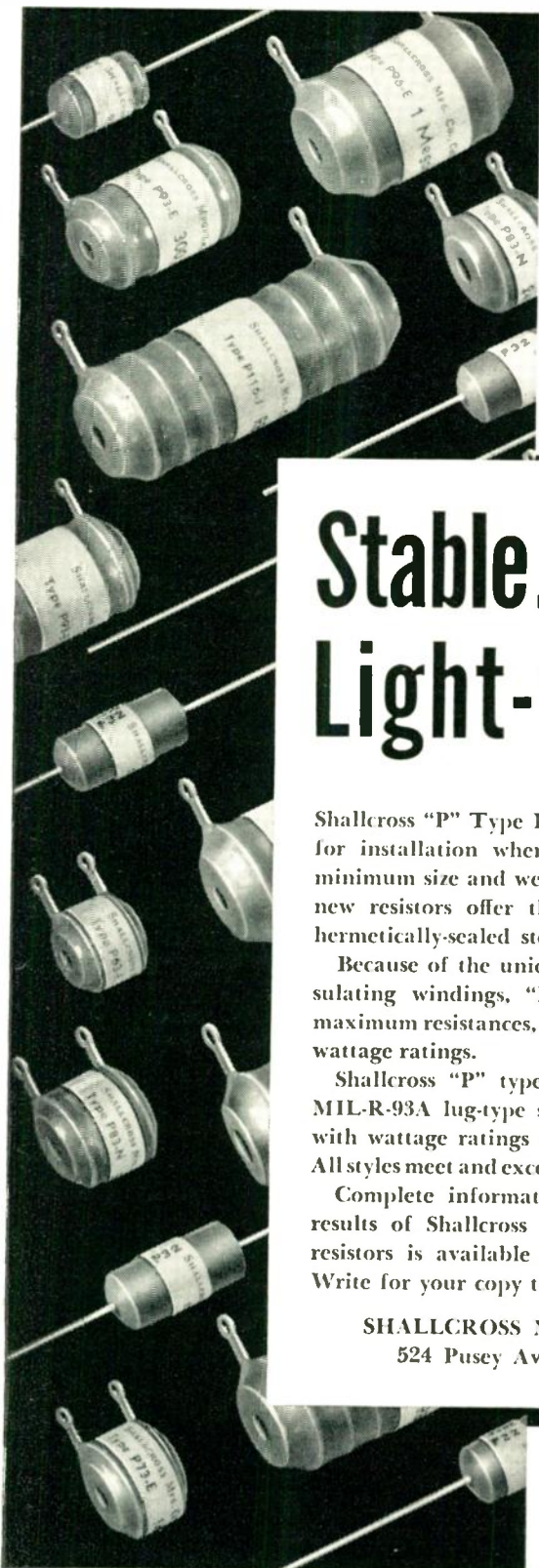

**New!**

**"P" TYPE  
ENCAPSULATED  
RESISTORS**

**Stable... Small...  
Light-weight...**

Shallcross "P" Type Encapsulated Resistors are ideal for installation where stability, dependability, and minimum size and weight are a must. These radically new resistors offer the performance advantages of hermetically-sealed steatite resistors at less cost.

Because of the unique Shallcross method of encapsulating windings, "P" type resistors have greater maximum resistances, longer leakage paths, and higher wattage ratings.

Shallcross "P" type resistors are available in six MIL-R-93A lug-type styles and five axial lead styles with wattage ratings ranging from .500 to 3.5 watts. All styles meet and exceed JAN-R-93A, Characteristic A.

Complete information on sizes, ratings, and test results of Shallcross "P" type precision wirewound resistors is available in Engineering Bulletin L-30. Write for your copy today.

**SHALLCROSS MANUFACTURING CO.**  
524 Pusey Avenue, Collingdale, Pa.

**Shallcross**



(Continued from page 110A)

- Schall, R. R., 171 Caroline St., Clyde, N. Y.  
Schertle, W. B., 16712 McCormick St., Encino, Calif.  
Schwarze, E. H., Headquarters NEAC, Dir./Comm., APO 862, c/o Postmaster, New York, N. Y.  
Scott, N. O., 755th AC&W Squadron, Williams Bay, Wis.  
Sedlack, B. F., 1550 E. Indian School Rd., Phoenix, Ariz.  
Sephton, C. L., 816 Seventh St., S., Lethbridge, Alta., Canada  
Shantz, C. J., 2115—28 St., Milwaukie, Ore.  
Shepard, R. M., 3 Wychview Dr., Westfield, N. J.  
Shockley, L. A., 86 E. Paul Ave., Trenton, N. J.  
Simko, R. J., 665 Nichols Ave., Stratford, Conn.  
Smith, C. B., Jr., 74C Addison Pl., Richfield Village, Clifton, N. I.  
Smith, J. F., 16 Northfield Ave., W. Orange, N. J.  
Smith, R. E., 89 Carmalt Rd., Hamden, Conn.  
Smith, R. G., 3545 Nipomo, Long Beach, Calif.  
Smith, W. H., 126 Sterling St., Apt. 2, Norfolk, Va.  
Sneed, J. W., Jr., 1819 Wayne Ave., Dayton, Ohio  
Snipes, R. W., 6000 Denton Dr., Dallas, Tex.  
Snyder, K. G., 4430 Nichols Ave., S.W., Apt. B-1, Washington, D. C.  
Stallworth, A. W., Jr., 2506 Grandy Ave., Norfolk, Va.  
Steele, D. R., 18 Gresham Rd., Toronto, Ont., Canada  
Stefanowicz, M. R., 10642 First Ave., S.W., Seattle, Wash.  
Stephens, A. E., 6517 N. Central Ave., Chicago, Ill.  
Stewart, B. W., 1110 Jefferson Ave., Rm. 437, Toledo, Ohio  
Stiddard, H. R., Airpax Products Co., Middle River, Baltimore, Md.  
Stott, C. B., 310 Harding Ave., Endwell, Endicott, N. Y.  
Stratbucker, R. A., Department of Physiology and Pharmacology, 42 and Dewey Ave., University of Nebraska, Omaha, Nebr.  
Strawn, R. K., 108 Camillus Dr., R.F.D. 2, Camillus, N. Y.  
Szeman P., 308 LaGuayra Dr., N.E., Albuquerque, N. Mex.  
Taylor, W. E., 35 Annett Ave., Edgewater, N. J.  
Teotor, T. S., 6003 Connecticut Ct., Cincinnati, Ohio  
TerHeun, P. K., Box 161, R.F.D. 2, Scottsdale, Ariz.  
Theiss, C. M., 3333A W. Lakefield Dr., Milwaukee, Wis.  
Thomas, C. B., 8108 S. Michigan Ave., Chicago, Ill.  
Thompson, R. S., 69 Old Mill Rd., Apt. 5, Toronto, Ont., Canada  
Titterington, R. J., 72 1/2 College St., Clinton, N. Y.  
Townsend, D. W., 3154 Dublin Rd., Charlotte, N. C.  
Tuba, W. C., 1297 Erie St., E., Windsor, Ont., Canada  
Turner, W. C., 7 Beach St., Staten Island, N. Y.  
Tzschentke, H. A., 5160 Clarmenot Ave., Oakland, Calif.  
Unroe, J. L., 11333 W 72 St., La Grange, Ill.  
Vega, C. J., 1258 S. Cloverdale Ave., Apt. 1, Los Angeles, Calif.  
Wade, E., 5337 E. Falls View Dr., San Diego, Calif.  
Waltz, J. H., 318 W. Hansberry St., Philadelphia, Pa.  
Watson, W. H., 40 Merrimac St., Woburn, Mass.  
Webster, N., Box 147, Irvington-on-Hudson, N. Y.  
Wedel, E. L., 3210 Knight, Dallas, Tex.  
Welsh, J. M., Box 84, TAS, Fort Bliss, Tex.  
Wessel, H. J., 7318 Enfield Ave., Reseda, Calif.  
Whitley, J. H., Aircraft Marine Products, Inc., 2100 Paxton St., Harrisburg, Pa.

(Continued on page 114A)



Rohde and Schwarz

# Decadic Frequency Measuring System

*for  
measuring frequency  
with speed, precision  
and greater-than-ever  
simplicity...*

**30 c/s to 600 mc/s**

The Decadic Frequency Measuring System contains in one compact unit all the equipment necessary to generate and measure frequencies over a range from 30 c/s to 600 mc/s. It consists of a Master Quartz Oscillator, Frequency Synthesizer, Frequency Indicator, Inkless Recorder and Power Supply.

The Quartz Oscillator, in addition to its fundamental frequency of 100 kc/s, provides additional standard frequencies of 10 kc/s, 1 kc/s, 100 c/s and 50 c/s for distribution at a level of about 1 volt.

The Frequency Synthesizer, with its various modes of operation, supplies standard frequencies for comparison with the unknown signal. Its unique design provides a simplicity and versatility of operation not heretofore available.

The main purpose of the Frequency Indicator is to measure the frequency difference between standard and unknown frequencies. The instrument has nine ranges with full deflection from 50 c/s to 500 kc/s. It also indicates zero beat frequency and generates harmonics, by means of which the range of the Synthesizer is extended to 600 mc/s.

An Inkless Recorder is provided as an optional accessory which can be connected in parallel with the Frequency Indicator for plotting of frequency variations versus time.

The overall design of the Decadic Frequency Measuring System is well-balanced, providing an accuracy of frequency generating and interpolation equipment compatible with the accuracy of the Master Quartz Oscillator.

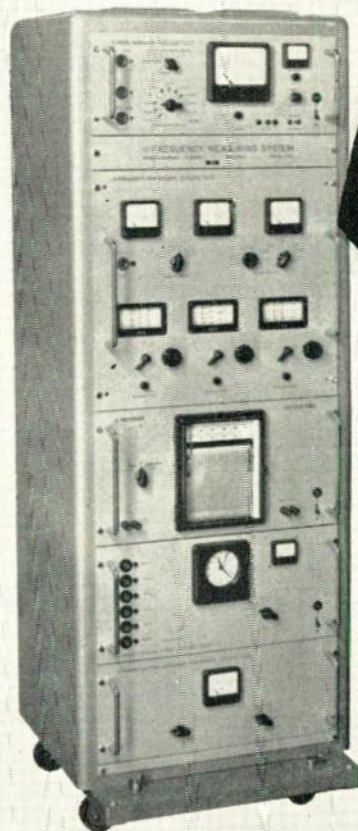

**with  
exclusive  
Direct Reading  
Frequency  
Synthesizer**

This distinctive unit of the Decadic Frequency Measuring System can be operated either as a continuously variable signal generator with no band switching from 30 c/s to 30 mc/s and with calibrated variable output voltage, or as a frequency decade variable in steps of 100 kc/s, 1 kc/s and 1 c/s with an accuracy determined by the Master Quartz Oscillator of 1 part in 10 million, plus or minus 0.5 c/s.

The exact output frequency is read as the sum of the three front panel decadic frequency scales.

The calibrated attenuator and output meter (100 uv to 1 v) increase the flexibility of the Synthesizer, permitting its use as a signal source for many additional applications.

## SPECIFICATIONS:

**Frequency Range:** Standard frequencies from 30 c/s to 30 mc/s and harmonics to 600 mc/s. Fixed standard frequencies of 100 kc/s, 10 kc/s, 1 kc/s, 100 c/s and 50 c/s... one continuously variable standard frequency from 30 c/s to 30 mc/s direct reading on 3 decadic controls in steps of 100 kc, 1 kc and 1 c/s. Distortion: Less than 10%. Spurious Signals: Better than 60 db down.

**Output Voltage:** Fixed standard frequency outputs—1 volt each into impedance of 150 ohms... variable frequency output adjustable in amplitude between 100 microvolts and 1 volt as indicated on calibrated meter.

**Stability and Accuracy:** Frequency variations of standard frequencies—less than 1 part in 10 million. Mean value of daily frequency change is less than 1 part in 10 million per day. Accuracy of variable frequency equals that of the standard—plus an additional tolerance of  $\pm 0.5$  c/s when using the last decade.

**Recorder:** Inkless Recorder available as an optional accessory.

**Mounting:** System supplied complete with own cabinet rack. Overall dimensions: 67 x 23 $\frac{3}{4}$  x 25 $\frac{1}{4}$  inches. Weight: 419 pounds.

**Power Supply:** 100-120 v or 200-240 v, 40-60 c/s, 600 va.



# Federal

## Telephone and Radio Company

A Division of INTERNATIONAL TELEPHONE AND TELEGRAPH CORPORATION

INSTRUMENT DIVISION

100 KINGSLAND ROAD, CLIFTON, N. J.

Federal Telephone and Radio Company Dept. S-337  
Instrument Division, Clifton, N. J.

Please send further information on the Decadic Frequency Measuring System, and General Catalog showing other items in your instrument line.

Name \_\_\_\_\_ Title \_\_\_\_\_

Company \_\_\_\_\_

Address \_\_\_\_\_

City \_\_\_\_\_ Zone \_\_\_\_\_ State \_\_\_\_\_

# UHF Standard Signal Generator

## with Low Hum Level



### MODEL 84-TV

An outstanding feature of the Model 84-TV UHF Signal Generator is a built-in rectifier and filter which supplies direct current to the oscillator tube filament resulting in negligible residual hum modulation. The Model 84-TV is designed and built to the highest standards of accuracy and precision for determining the characteristics of television receivers for the UHF band, and for other equipment operating within the range of 300 to 1000 megacycles.

#### SPECIFICATIONS

**Frequency Range:** 300 to 1000 megacycles in one band.  
Frequency accuracy is  $\pm 0.5\%$ .

**Output:** 0.1 microvolt to 1.0 volt across a 50-ohm load over most of its range.

**Modulation:** Continuously variable from 0 to 30% from an internal 1000-cycle oscillator. External modulation from 50 to 20,000 cycles. Residual hum modulation is less than 0.5%.

**Power Supply:** 105 to 125 volts, 60 cycles, 120 watts.

**Leakage:** Negligible.

#### FEATURES

- DC operation of oscillator tube filament.
- Wide continuous frequency coverage.
- Frequency calibration accurate to  $\pm 0.5\%$ .
- Output dial calibrated in microvolts.
- Negligible stray field and leakage.
- Special design mutual inductance type attenuator.
- Low harmonic content.
- Low residual hum modulation.

#### USES

The versatility of this instrument makes it adaptable to many applications within its frequency range. Due to its high output, the Model 84-TV may be used to drive slotted lines, and other impedance measuring devices. The wide frequency coverage and accurate calibration make it particularly suitable for measuring the characteristics of UHF filters, traps, antennas, matching networks and other devices.

Laboratory Standards



**MEASUREMENTS CORPORATION**  
BOONTON · NEW JERSEY



Membership

(Continued from page 112A)

- Wilson, F. V., 7928 De Soto Ave., Canoga Park, Calif.
- Withington, J. G., 10 St. Martha Ct., Florissant, Mo.
- Wittenberg, W. M., 8 Wasson Dr., Poughkeepsie, N. Y.
- Wolf, S., 405 S. Hammonds Ferry Rd., Linthicum Heights, Md.
- Wood, A. E., 2618 E. Norton Vista, Tucson, Ariz.
- Woodard, R. E., 1511 N. Limestone St., Springfield, Ohio
- Woolley, G. J., 4503 Alhambra St., San Diego, Calif.
- Wren, A. W., Jr., 459 Thomas Ter., Decatur, Ga.
- Yarmus, L., New York University, Bellevue Medical Center, 477 First Ave., New York, N. Y.
- Yorke, A. K., 1905 W. 16 Ave., Vancouver, B. C., Canada
- Zack, A., 34 Elliott St., Danvers, Mass.



News-New Products

These manufacturers have invited PROCEEDINGS readers to write for literature and further technical information. Please mention your I.R.E. affiliation.

(Continued from page 20A)

### Global Communications Conference

The Armed Forces Communications Association, an organization that brings Signal Corps, Navy, Marine and Air Forces members together with manufacturers, will devote its annual convention to the vital topic of "Global Communications" when it meets, May 19 to 21, 1955 at the Hotel Commodore, in New York City, according to George W. Bailey, its President.

In planning for the largest participation in some years, T. L. Bartlett of RCA, Exhibits Chairman, says that the New York Chapter, which will be the host to the national organization, has made provision for approximately 35 manufacturers exhibits in addition to those of the military services. The first two days of the three day convention include conference meetings, exhibits, a banquet with a nationally-known speaker and committee activities.

Armed Forces Day, which comes on the third day of the conference, will be observed by a field trip to Fort Monmouth, the major training and research center for radio and communications of the U. S. Forces. The trip is open only to AFCA members, and registered guests of the Conference. The whole program is part of the studied plan of the AFCA to further unify the services and industry in the improvement of military communications and radio.

The association also publishes the monthly magazine "Signal" for its members in the services and industry. It has Chapters in 31 cities, and headquarters at 1624 Eye Street, N.W., Washington, D. C.

(Continued on page 116A)



# FOR PRINTED CIRCUITS

PRINTED  
CIRCUITRY

## FLUXES

3 NON-ACTIVATED  
AND  
4 ACTIVATED  
FLUXES

A TRUSTED NAME IN



ELECTRONIC INDUSTRY

PRINTED  
CIRCUITRY

## SOLDERS

5 BAR SOLDERS  
FOR DIP SOLDERING  
SOLDER PLATE, GOLD,  
SILVER AND  
COPPER  
SYSTEMS

The facilities of a modern, well equipped metallurgical laboratory, competent research staff and field engineers are available to help you solve printed circuitry problems.

Write for informative literature

**ALPHA METALS, INC.**  
61 Water St., Jersey City 4, N.J.  
HEnderson 4-6778

From the exceptional resources of Raytheon...



## MINIATURE PULSE TRANSFORMERS



Raytheon, giant in the electronics industry and long-time leader in transformer design, offers miniature pulse transformers — the last word in modern design — thoroughly proved under exacting performance requirements in such world-famous equipment as Raytheon Radar.

Take advantage of Raytheon's exceptional resources to solve your transformer problems. Send in your requirements or write for complete information.

### MINIATURE PULSE TRANSFORMERS

for blocking oscillator use

#### AVAILABLE FROM STOCK

These hermetically sealed, military approved pulse transformers are designed for universal blocking oscillator use at repetition rates from 50 to 5000 pps.

UX-7307A and UX-7350A are identical in electrical characteristics, having two windings for 1000 ohms impedance and two windings to match 250 ohms. To cover a wider variety of applications, the windings are arranged differently in the two transformers.

These units are also available in octal type tube bases as UX-7307 and UX-7350. Bulletin DL-K-320 gives complete information including typical circuits. Write for it.



## RAYTHEON

MANUFACTURING COMPANY

EQUIPMENT SALES DIVISION

DEPT. 6120-P WALTHAM 54, MASSACHUSETTS

DISTRICT OFFICES: BOSTON, NEW YORK, CLEVELAND, CHICAGO, NEW ORLEANS, LOS ANGELES (WILMINGTON), SAN FRANCISCO, SEATTLE  
INTERNATIONAL OPERATIONS: 589 FIFTH AVENUE, NEW YORK CITY

#### TYPICAL RAYTHEON TRANSFORMERS:

Plate, Filament, Pulse, Audio and R.F. Transformers; Toroids; Filters; Chokes; Reactors; Voltage Stabilizers; Magnetic Amplifiers; Delay Lines; TV Deflection and Focus Coils.

BUILD



*Excellence in Electronics*

**DEPENDABILITY  
INTO YOUR  
PRODUCTS**

for all applications  
requiring exceptionally  
high insulation  
resistance and unusual  
stability at high  
temperature

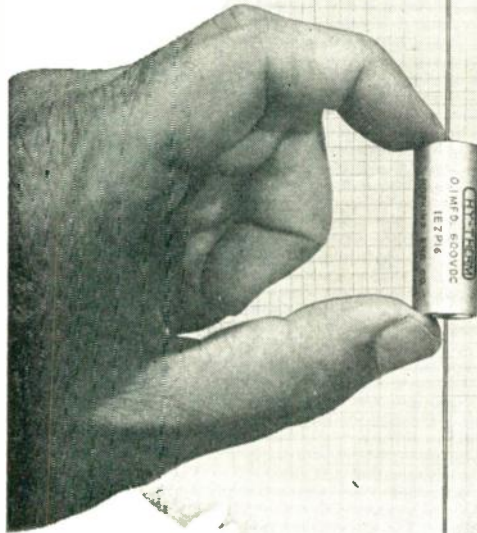

2082 Lincoln Ave.,  
Altadena, Calif.  
SYcamore 8-1185  
Offices in  
WASHINGTON, D.C.  
and DETROIT

## HOPKINS "HY-THERM"

New sub-miniature  
high temperature

# CAPACITOR

Hermetically sealed and metal encased, new HY-THERM capacitors have been designed to meet or exceed military requirements (Mil-C-25A). Example: At 125°C the minimum insulation resistance is 20 megohm-microfarads and maximum insulation resistance is 500 megohms. Available in all standard values and tolerances. Variety of mounting and circuit combinations. Special units designed to meet individual requirements.

**HOPKINS**  
*Engineering Co.*

Have a special problem? Write,  
wire or phone for details, TODAY!  
Catalog available.



News-New Products

These manufacturers have invited PROCEEDINGS readers to write for literature and further technical information. Please mention your I.R.E. affiliation.

(Continued from page 114A)

## Transducers

A new line of linear-motion displacement transducers, available in thirty-two models with linear displacement ranges from 0.003 inch to 2 inches, is announced by **Minatron Corp.**, 8 Cliveden Pl., Belle Meade, N. J. Lyn-A-Syn transducers are inductive components for precise sensing of rectilinear motion.

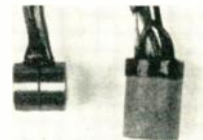

Operation of these units is based on the linear change in flux linkage between the primary coil and secondary coils with displacement of the high-permeability metal core. Displacement of the core in either direction from the center null position causes a linear increase in output voltage. Units are inductively and resistively balanced for minimum null signals. All models may be obtained magnetically shielded or wound for high temperature operation.

The physical size of the Lyn-A-Syn models ranges from  $\frac{1}{8}\frac{5}{4}$  inch in outside diameter and  $\frac{1}{8}\frac{5}{4}$  inch in length for the 0.003 inch unit to  $\frac{1}{4}$  inch in outside diameter and  $9\frac{1}{4}$  inches in length for the 2 inch unit. The photograph shows a 0.005 inch magnetically shielded unit, left, and a 0.010 standard miniature model. Bulletin available.

## Deflection Yoke Winder Catalog

A catalog page illustrating and describing the new Model YW Series Deflection Yoke Winder has been issued by **Geo. Stevens Mfg. Co., Inc.**, Pulaski Rd. at Peterson, Chicago 30, Ill. Complete technical data is given on oscillating winding motion, types of coils wound, tension equipment, winding speeds, set-up time, motor equipment, re-setting predetermining counter, magnetic brake, mounting, multiple winding and other features. Illustrated are the machine, a color yoke, a 70° yoke and two 90° yokes.

(Continued on page 120A)

# IT'S HARVEY FOR PROMPT "OFF-THE-SHELF" DELIVERY

Whether it's equipment, components or other electronic requirements, you will always find them in Harvey's extensive stocks, ready for immediate delivery to you anywhere.

WRITE  
PHONE  
or WIRE

Harvey's twenty-five years of service to the industry are your assurance of understanding 'know-how' and complete dependability.



Telephone  
JUdson 2-1500

**HARVEY**  
RADIO COMPANY, INC.  
103 West 43rd St., New York 36, N. Y.



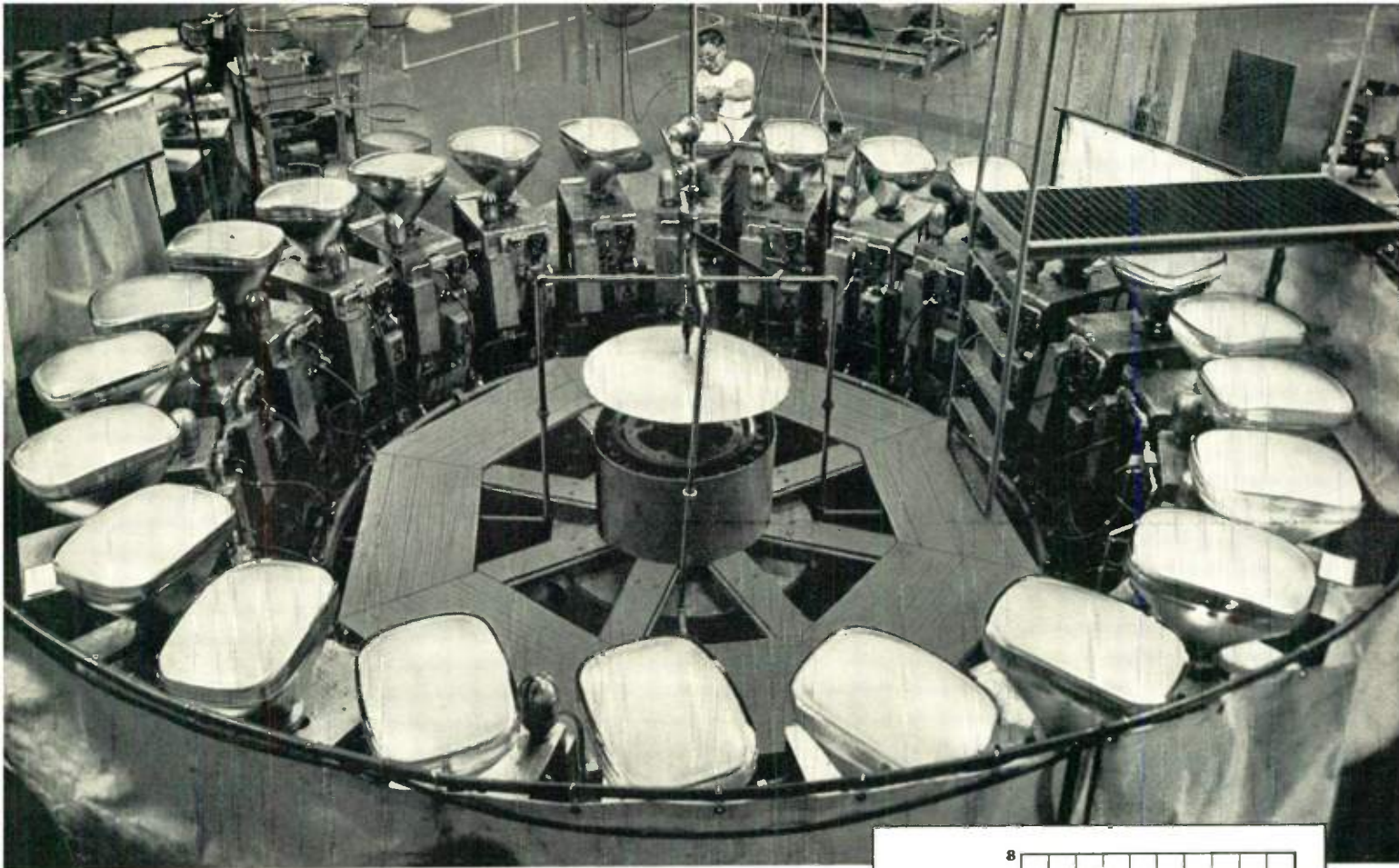

## Now . . . "Series-String" Warm-Up Time For All G-E Picture Tubes!

**Y**OUR whole TV circuit can have tubes with the same heater warm-up time . . . picture tube and receiving tubes! G.E. makes this possible by introducing, on all picture tubes now coming off the line, new heavy-duty heater windings with a voltage rise which follows the same pattern as General Electric 600-Series receiving tubes, designed for "series-string" use.

You save on transformer and circuitry—you save on tube failures—because tube-heater voltage during warm-up will not become excessive *anywhere in your chassis*.

Get quality TV performance with fewer in-line rejects, fewer servicing call-backs, plus "series-string" design economy . . . by specifying *both* G-E picture tubes and G-E 600-Series receiving tubes! Types available for every socket. See your G-E tube representative! *Tube Dept., General Electric Co., Schenectady 5, N. Y.*

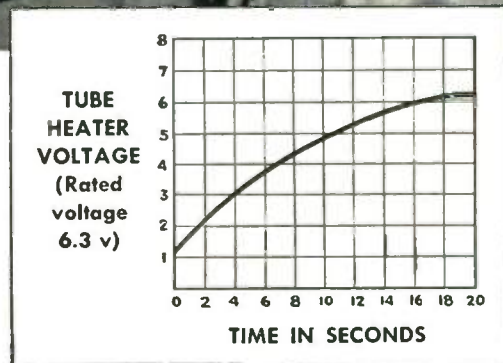

● G-E picture-tube voltage rise, after switch-on, follows approximately the time curve shown above. G-E 600-Series receiving tubes have a similar voltage-rise pattern—for example, heaters rated 6.3 v reach 5 v in approximately 10.5 sec. Means uniform heater voltage *throughout your circuit*—fewer tube failures! . . . In test circuit below,  $E = 25$  v and  $R = 31.5$  ohms.

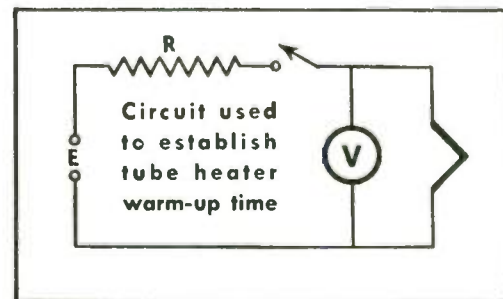

*Progress Is Our Most Important Product*

**GENERAL**  **ELECTRIC**

# Something New Has Been Added!



The 21 IRE Professional Groups show the expansion pattern of a modern engineering society in meeting the diversified needs of its members in the ever widening science of radio-electronics.

Membership in a Professional Group is open to any paid-up member of the I.R.E. The cost is only an annual extra publications fee, usually \$2. This fee is shown in the descriptions that follow.

An IRE Member may join as many Professional Groups as serve his interest and wishes. Such membership serves to associate him with other engineers of the same specialized interests within the radio-electronic field.

The 21 Professional Groups are listed below, together with a brief definition of each, the name of the Group Chairman, and publications to date.  
\* Means still available.

<p><b>Aeronautical and Navigational Electronics</b></p> <p><i>The application of electronics to operation and traffic control of aircraft and to navigation of all craft.</i></p> <p>Dr. K. Charlton Black, Chairman, Polytechnic Research &amp; Development Co., 55 Johnson Street, Brooklyn 1, N.Y.</p> <p>Fee \$2. 12 Transactions. 4 Newsletters, *4, *5, *6, *8, &amp; *9, and *Vol. ANE-1, No. 1.</p>	<p><b>Antennas and Propagation</b></p> <p><i>Technical advances in antennas and wave propagation theory and the utilization of techniques or products of this field.</i></p> <p>Mr. D. C. Ports, Chairman, Jansky &amp; Bailey, 1339 Wisconsin Ave., N.W., Washington 7, D.C.</p> <p>Fee \$4. 9 Transactions, 1 Newsletter. *4, *Vol. AF-1, Nos. 1, 2; *Vol. AF-2, Nos. 1-3.</p>	<p><b>Audio</b></p> <p><i>Technology of communication at audio frequencies and of the audio portion of radio frequency systems, including acoustic terminations, recording and reproduction.</i></p> <p>Dr. Vincent Salmon, Chairman, Stanford Research Institute, Stanford, California.</p> <p>Fee \$2. 19 Transactions, 4 Newsletters. *5, *7, *10. *Vol. AU-1, Nos. 1-6; *Vol. AU-2, Nos. 1-3.</p>
<p><b>Broadcast &amp; Television Receivers</b></p> <p><i>The design and manufacture of broadcast and television receivers and components and activities related thereto.</i></p> <p>Mr. Earl I. Anderson, Chairman, Assistant Manager, Industry Service Lab., RCA Laboratory Div., 711-5th Ave., New York, N.Y.</p> <p>Fee \$2. 7 Transactions. *1, *2, *3, *5, *6, *7.</p>	<p><b>Broadcast Transmission Systems</b></p> <p><i>Broadcast transmission systems engineering, including the design and utilization of broadcast equipment.</i></p> <p>Mr. Lewis Winner, Chairman, Editor, Television Engineering, 52 Vanderbilt Avenue, New York 17, N.Y.</p> <p>Fee \$2. Convention Report.</p>	<p><b>Circuit Theory</b></p> <p><i>Design and theory of operation of circuits for use in radio and electronic equipment.</i></p> <p>Dr. Chester H. Page, Chairman, National Bureau of Standards, Connecticut Ave., Washington 25, D.C.</p> <p>Fee \$2. 3 Transactions. *1, *2, *Vol. CT-1, No. 1.</p>

# THE INSTITUTE OF RADIO



# IRE's 21 Professional Groups

<p><b>Communications Systems</b></p> <p><i>Radio and wire telephone, telegraph and facsimile in marine, aeronautical, radio-relay, coaxial cable and fixed station services.</i></p> <p>Col. J. Z. Millar, Chairman, Western Union Telegraph Company, 60 Hudson St., New York 13, N.Y.            Fee \$2. 3 Transactions. 5 Newsletters. *Vol. CS-1, No. 1, *Vol. CS-2, Nos. 1-2.</p>	<p><b>Component Parts</b></p> <p><i>The characteristics, limitations, applications, development, performance and reliability of component parts.</i></p> <p>Mr. Floyd A. Paul, Chairman, Bendix Development, 166 W. Olive Ave., Burbank, Calif.            Fee \$2. Transaction* PGCP*1.</p>	<p><b>Electron Devices</b></p> <p><i>Electron devices, including particularly electron tubes and solid state devices.</i></p> <p>Mr. George A. Espersen, Chairman, Philips Laboratories, Irvington-on-Hudson, N.Y.            Fee \$2. 7 Transactions, 3 Newsletters, 2 Technical Bulletins. *1, *2, *4, *Vol. ED-1, Nos. 1-3.</p>
<p><b>Electronic Computers</b></p> <p><i>Design and operation of electronic computers.</i></p> <p>Mr. Harry T. Larson, Chairman, Ramo-Wooldridge Corp., 8820 Belanca, Los Angeles 45, Calif.            Fee \$2. 7 Transactions, 5 Newsletters. *Vol. EC-2, Nos. 2-4; *Vol. EC-3, Nos. 1-2.</p>	<p><b>Engineering Management</b></p> <p><i>Engineering management and administration as applied to technical, industrial and educational activities in the field of electronics.</i></p> <p>Mr. Charles J. Breitwieser, Chairman, RCA Victor Division, Camden, N.J.            Fee \$1. 1 Transaction, 8 Newsletters. *1.</p>	<p><b>Industrial Electronics</b></p> <p><i>Electronics pertaining to control, treatment and measurement, specifically in industrial processes.</i></p> <p>George P. Bosomworth, Chairman, Firestone Tire &amp; Rubber Co., Akron 17, Ohio            Fee \$2. Transactions, *PGIE-1.</p>
<p><b>Information Theory</b></p> <p><i>Information theory and its application in radio circuitry and systems.</i></p> <p>Dr. William G. Tuller, Chairman, Melpar, Inc., 452 Swann Ave., Alexandria, Va.            Fee \$2. 3 Transactions, 1 Newsletter. *2, *3.</p>	<p><b>Instrumentation</b></p> <p><i>Measurements and instrumentation utilizing electronic techniques.</i></p> <p>Mr. R. L. Sink, Consolidated Engineering Corp., 300 N. Sierra Madre Villa, Pasadena, Calif.            Fee \$1. 3 Transactions. *2, *3.</p>	<p><b>Medical Electronics</b></p> <p><i>The application of electronics engineering to the problems of the medical profession.</i></p> <p>Dr. J. F. Herrick, Chairman, Mayo Clinic, Rochester, Minn.            Fee \$1. 1 Transaction. 3 Newsletters. *1.</p>
<p><b>Microwave Theory and Techniques</b></p> <p><i>Microwave theory, microwave circuitry and techniques, microwave measurements and the generation and amplification of microwaves.</i></p> <p>Mr. W. W. Mumford, Chairman, Bell Telephone Laboratories, Whippany, N.J.            Fee \$2. 4 Transactions. *Vol. MTT-1, No. 2; *Vol. MTT-2, Nos. 1-2.</p>	<p><b>Nuclear Science</b></p> <p><i>Application of electronic techniques and devices to the nuclear field.</i></p> <p>Dr. Lloyd V. Berkner, Assoc. Universities, Inc., 350 5th Ave., New York 1, N.Y.            Fee \$2. Transactions, 3 Newsletters.</p>	<p><b>Quality Control</b></p> <p><i>Techniques of determining and controlling the quality of electronic parts and equipment during their manufacture.</i></p> <p>Mr. Leon Bass, Chairman, Manager, Quality Eng., Jet Eng. Dept., General Electric Co., Cincinnati 15, Ohio.            Fee \$2. 3 Transactions, 1 Newsletter. *1, *2, *3.</p>
<p><b>Radio Telemetry and Remote Control</b></p> <p><i>The control of devices and the measurement and recording of data from a remote point by radio.</i></p> <p>Mr. Martin V. Kiebert, Jr., Chairman, P. R. Mallory &amp; Co., Inc., Tuner Div., Indianapolis 6, Ind.            Fee \$1. Transactions, Newsletter.</p>	<p><b>Vehicular Communications</b></p> <p><i>Communications problems in the field of land and mobile radio services, such as public safety, public utilities, railroads, commercial land transportation, etc.</i></p> <p>Mr. W. A. Shipman, Chairman, Columbia Gas Sys. Ser. Corp., 120 East 41 Street, New York 17, N.Y.            Fee \$2. 4 Transactions, 2 Newsletters. *2, *3, *4.</p>	<p><b>Ultrasonics Engineering</b></p> <p><i>Ultrasonic measurements and communications, including underwater sound, ultrasonic delay lines, and various chemical and industrial ultrasonic devices.</i></p> <p>Mr. A. L. Lane, Chairman, 706 Chillum Road, Apt. 101, Hyattsville, Md.            Fee \$2. 1 Transaction, 4 Newsletters. *1.</p>

**ENGINEERS** 1 East 79th Street, New York 21, N. Y.

# SIE

## MODEL C-6

### RESISTANCE METER

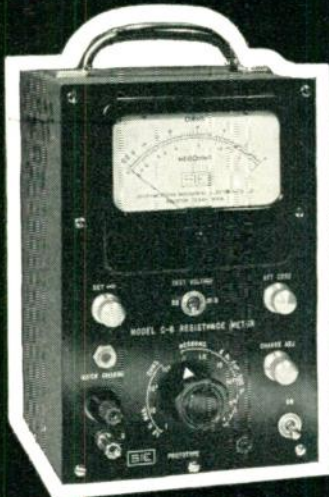

for

- ★ RESEARCH
- ★ DESIGN
- ★ PRODUCTION
- ★ ACCEPTANCE TESTS

# 3

**UNIQUE FEATURES**  
**enable the C-6 to meet all**  
**requirements**

1. Three test voltages:  
1½ volts — for low resistance ranges  
50 volts — for low-voltage capacitor leakage measurements  
500 volts — to meet MIL specs on insulation tests
2. Complete coverage, from zero ohms to 10,000,000 megohms, without auxiliary equipment.
3. Pre-settable "Charge Adjust" control and "Quick Charge" button for rapid Go, No-Go capacitor leakage tests.

**ACCURATE • VERSATILE • RELIABLE •**

available from stock

# SIE

**\$200. f.o.b. Houston**

**SOUTHWESTERN INDUSTRIAL ELECTRONICS CO.**

P. O. Box 13058

2831 Post Oak Rd.

Houston, Texas

SEND FOR FREE LITERATURE.

REPRESENTATIVES THROUGHOUT THE WORLD.



### News-New Products

These manufacturers have invited PROCEEDINGS readers to write for literature and further technical information. Please mention your I.R.E. affiliation.

(Continued from page 116A)

### Multi-Turn Potentiometers

Two new series of ultra high precision multi-turn potentiometers are being manufactured by Litton Industries, Components Div., 336 North Foothill Rd., Beverly Hills, Calif., and 215 S. Fulton Ave., Mount Vernon, N. Y. Servo control of resistance winding results in linearity and resolution of an extraordinarily high order, according to the manufacturer.



The Series MA-20-10 ten-turn potentiometer is made with standard independent linearities ranging from  $\pm 0.5$  to  $\pm 0.2$  per cent. Linearities as high as  $\pm 0.01$  per cent are available on special order. Case diameter is 1.820 inches. Resistances from 1K to 100 K ohms are offered.

The Series MA-30-10 ten-turn potentiometer is made with standard independent linearities ranging from  $\pm 0.5$  to  $\pm 0.01$  per cent. Linearities as high as  $\pm 0.005$  per cent are available on special order. Case diameter of the MA-30-10 is 3.0 inches. The resistance range is 2K to 300K ohms. Fifteen-turn models are available with case diameters of three inches and are designated the MA-30-15 Series. Linearity data is supplied with all models.

### Vacuum-Melted Metals

General information and technical data on vacuum-melted metals and alloys, as well as several commercial services now available in connection with such metals, are included in a new technical bulletin issued by Carboly Dept., General Electric Co., Detroit 32, Mich.

The publication, referred to as technical bulletin VM-100, covers the background and experience of Carboly Department and the General Electric Company's Research Laboratory in producing these special alloys. It discusses new available alloys and their physical properties.

### Instruments Catalog

The Shasta Division of Beckman Instruments, Inc., 1432 Nevin Ave., Richmond, Calif., announces a brochure describing its new line of electronic test instrumentation, including Vacuum Tube Voltmeters, Oscillators, Square Wave Generators, Resistance Bridges, Power Supplies, Wide Band Amplifiers and various accessories. This bulletin is available on request.

(Continued on page 122A)











# If this is what YOU NEED in RESISTORS . . . . .

- STABILITY
- PRECISION\*
- LOW TEMPERATURE COEFFICIENT
- LOW NOISE LEVEL
- WIDE RANGE OF VALUES
- SMALL PHYSICAL SIZE
- LOW COST

CHOOSE FROM THESE 8 SIZES OF

## *Electra* DEPOSITED CARBON RESISTORS

SHOWN IN ACTUAL SIZE

	DC- $\frac{1}{8}$	$\frac{1}{8}$ WATT	4 $\Omega$ to 250K
	DC- $\frac{1}{4}$	$\frac{1}{4}$ WATT	5 $\Omega$ to 1 Megohm
	DC- $\frac{1}{2}$ C	$\frac{1}{2}$ WATT	2 $\Omega$ to 1.1 Megohms
	DC- $\frac{1}{2}$ A	$\frac{1}{2}$ WATT	3 $\Omega$ to 2.2 Megohms
	DC- $\frac{1}{2}$ B	$\frac{1}{2}$ WATT	3 $\Omega$ to 5 Megohms
	DC- $\frac{1}{2}$	$\frac{1}{2}$ WATT	6 $\Omega$ to 5 Megohms
	DC-1	1 WATT	3 $\Omega$ to 10 Megohms
	DC-2	2 WATTS	10 $\Omega$ to 50 Megohms

\* Standard Resistance tolerance is  $\pm 1\%$  but all Electra resistors are available in  $\pm 2\%$ ,  $\pm 5\%$ , and  $\pm 10\%$ . Electra quality is unsurpassed in the industry as several hundred leading manufacturers, our customers, will testify. You will find our services to your liking . . . deliveries are prompt and special requirements completely followed.

### simplify custom installation

The 4200 Sound Effects Filter and 4201 Program Equalizer are now available in component form, as illustrated, for the custom builder.

In addition to the flexibility of installation, all the features and characteristics of the standard models are retained.

The high and low sections of either model may be obtained separately. Complete wiring instructions included.

Send for Bulletin TB-4



Model 4200 Sound Effects Filter  
(Send for Bulletin S)



Model 4201, Program Equalizer  
(Send for Bulletin E)

Representatives in  
Principal Cities

**HYCOR**

*Company, Inc.*

11423 Vanowen Street  
North Hollywood 6, Calif.

MAIL FOR COMPLETE  
SPECIFICATIONS

*Electra*  
**carbon-coat**  
PRECISION RESISTORS

ELECTRA MANUFACTURING CO.

RESISTOR DIV. 2537 MADISON KANSAS CITY, MO.

Please send bulletin E-4 giving complete specifications and characteristics of Electra Carbon Coat Resistors.

Name \_\_\_\_\_

Company \_\_\_\_\_

Address \_\_\_\_\_

City \_\_\_\_\_ State \_\_\_\_\_

# NEW

Advanced  
Design...

## MODEL DS-6100 FREQUENCY COUNTER

All new electronic pulse indicator with a completely different circuitry approach that reduces size and weight without sacrificing accuracy. Direct read out in events per second to 100,000.

Inherent accuracy is  $\pm 1$  event.

Time base — 100 KC crystal controlled oscillator circuit. Easily portable and weighs only 28 pounds. Price — \$675.00



### New MULTI-SAMPLING

... 3 to 60 second manual

### Greater STABILITY

... lower power consumption allows continuous, accurate operation without excessive heat

### Improved CIRCUITRY

... by utilizing a new and different approach in design

### Less WEIGHT

... advanced design offers ready portability

### Smaller SIZE

... unit size reduced by unique design. Uses less bench space.



## MODEL DS-660 FREQUENCY COUNTER

Designed for portability and low cost as well as accuracy, this new Detectron unit will count and display electrical or mechanical events which can be converted to a varying voltage of sufficient amplitude. Direct read out in events per second to 10,000. Accuracy — approximately .1%. Weighs only 16 pounds. Price — \$425.00



### DECIMAL DECADE TOTALIZERS

New, improved Totalizers designed for use where a number of pulsations are to be counted. Direct read out. Standard octal plugs assure adaptability to most existing scaling equipment.

For more detailed information, please write...

COMPUTER-MEASUREMENTS Division of

The **Detectron** Corp.

5420 Vineland Avenue North Hollywood, California



## News-New Products

These manufacturers have invited PROCEEDINGS readers to write for literature and further technical information. Please mention your I.R.E. affiliation.

(Continued from page 120A)

### Industrial Thyatron

National Electronics, Inc., Geneva, Ill., has just announced a new single-end thyatron. This tube, the NL-716 is, rated at 1 ampere dc and 8 amperes peak current. It is designed especially for motor speed control and low-current regulated voltage supplies.

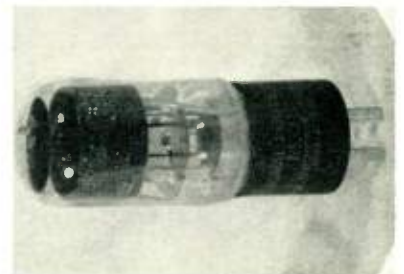

NL-716 is gas and mercury filled. Its constant characteristics through wide temperature ranges and long life make it particularly valuable for industrial control applications. Other ratings are: Filament voltage, 2.5 volts; filament current, 6.3 amperes; peak forward and peak inverse voltage, 1250 volts.

(Continued on page 124A)

## ENGINEERS

Save your firm thousands of dollars in searching for data on ELECTRONIC TEST EQUIPMENT of interest to USAF.

By special permission data sheets on Research supported and monitored under our WADC, ARDC contract now available to manufacturers at low cost.

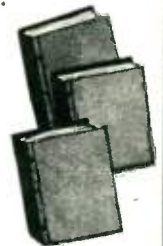

- Order your copy of a three volume set containing illustrated descriptive data sheets on 870 items procured for use by the U. S. Air Force.
- Contains 2400 (8½ x 11") pages, recently brought up-to-date, mounted in 3 post expandable hard back binders.
- Price \$100 per set plus postage while supply lasts. Orders accompanied by check filled as received with postage paid.

CARL L. FREDERICK  
AND ASSOCIATES  
Bethesda 14, Maryland



# 15 Horse Power in a 7"x 11" case!

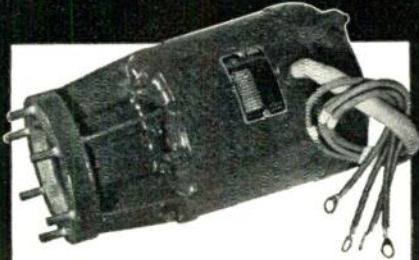

## A typical example of American Electric engineering

This 400 cycle 3 phase motor is a special custom-developed aircraft design. Rated at 15 h.p. continuous duty at 11,500 r.p.m., it actually produces 19 h.p. on intermittent duty, yet occupies less than 1/4 cubic foot. Weight is 32 lbs.—approximately 1/2 h.p. per lb. Fungus-proof, corrosion resistant, meets AND 20002 type XIIB mounting specifications. Temperature range: -67° to +131° F. Motor length: 7", Coupling extension 4".



## MINIATURE MOTORS for all PURPOSES!

American Electric Motors are also built in an almost unlimited range of miniatures for 60 and 400 cycle operation as well as variable frequencies. All feature low weight, compact size and meet high temperature requirements. Supplied in induction or synchronous types for motor drives, propeller fans and centrifugal blowers. Wire, write or phone for data and quotations.

*Also Manufacturers of High Cycle Motor-Alternators and A.C. Industrial Motors.*



4811 Telegraph Road,  
Los Angeles 22,  
California

DIVISION OF AMERICAN ELECTRONICS, INC.  
FIELD ENGINEERING REPRESENTATIVES:  
Atlanta • Boston • Buffalo • Chicago • Dayton  
Fort Worth • Kansas City • Miami • Minneapolis  
New York City • Rochester • Seattle • Silver  
Spring (Md.) • St. Louis • Syracuse • Tampa •  
Montreal • Toronto  
JOE DAVIDSON & ASSOC., Los Angeles • San Francisco

MINNEAPOLIS  
**Honeywell**

*Heiland* INSTRUMENTS

# RECORDING OSCILLOGRAPHS and GALVANOMETERS

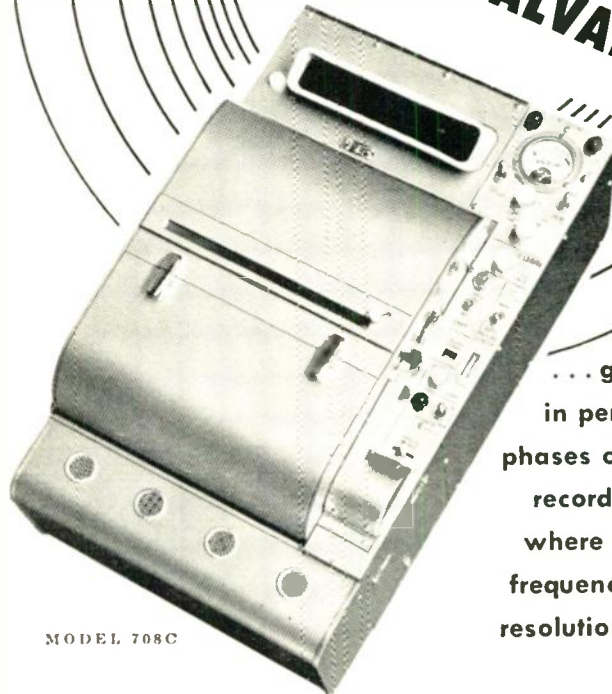

MODEL 708C

... give the ultimate  
in performance in all  
phases of oscillographic  
recording, particularly  
where high sensitivity,  
frequency response and  
resolution are important.

High sensitivity consistent with extended frequency range of galvanometers is achieved through special design characteristics backed by 20 years experience in the manufacture and design of recording instruments. Better resolution is obtained through increased record travel and writing speeds. The result is high amplitude recording of static and dynamic phenomena in the 0 to 3000 cps frequency range with extremely small input signals.

*Write for complete information concerning our  
oscillographs, galvanometers and  
accessory bridge balance units and amplifier systems.*

*Heiland*



A DIVISION OF MINNEAPOLIS-  
**HONEYWELL**  
130 E. 5th Ave., Denver 3, Colo.



# YOKE SPECIALISTS



- Military or special yokes and focus coils designed to your specifications.
- Production yokes for TV sets.

For your answer to yoke problems write Dr. Henry Marcy today.

*syntronic*

**INSTRUMENTS, INC.**

100 Industrial Road • Addison, Ill. • Phone: Terrace 4-6103

HIGHEST STANDARDS  
TOP QUALITY!

## COSMIC

"CONDENSER SPECIALISTS SINCE 1923"

ELECTROLYTIC  
AND PAPER TUBULAR  
**CONDENSERS**  
For A.C., D.C. Sets-Phonographs  
etc.

COSMIC CONDENSER CO. 853 Whittier St., Bronx, N. Y. -Phone LU 9-3360

**1440 pgs.**

Fully catalogs  
Radio-TV-  
Electronic  
parts &  
equipment:  
Tubes,  
Trans-  
mitters,  
Test Equip-  
ment, Comm.  
Receivers,  
Transformers,  
Capacitors,  
Antennas,  
Resistors,  
Coils & Relays,  
Recording &  
PA Systems,  
Hardware,  
Tools, etc., etc.  
**OFFICIAL BUYING  
GUIDE OF THE  
INDUSTRY**

**1440 page MASTER**  
for everything in Electronics

Make rapid selections from one industry-wide MASTER CATALOG complete with SPECIFICATIONS, ILLUSTRATIONS, DESCRIPTIONS, DIAGRAMS, PRICES on thousands of Radio-TV-Electronic parts and equipment.

**NEW! 1955 BUYING GUIDE**

List \$6.50

As low as **\$1.95** • Over 85,000 • Fully indexed items • 8½" x 11"  
as Over 3,500 illus. • Weighs 6 lbs.

From leading parts distributors or write to:

**UNITED CATALOG PUBLISHERS, INC.**  
110 Lafayette Street, New York 13, N. Y.

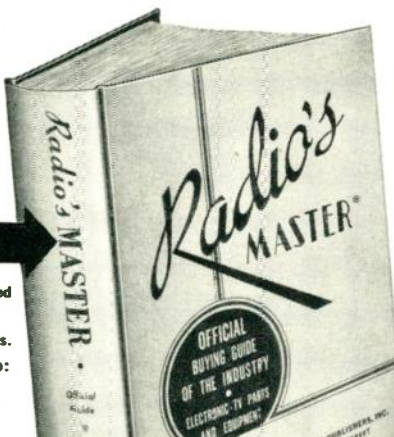

**News-New Products**

These manufacturers have invited PROCEEDINGS readers to write for literature and further technical information. Please mention your I.R.E. affiliation.

(Continued from page 122A)

## P-M Motor

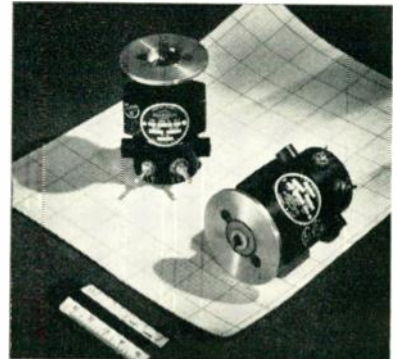

Designed for quick assembly-line handling, the new Type PM-36 permanent-magnet motor, developed by Dal-motor Co., 1360 Clay St., Santa Clara, Calif., offers a flange-ring mounting for quick attachment by clamps or retaining rings; as well as motor connections to snap-in terminals. Rated at 27 volts dc, the motor provides 20-watt output at 6,000 rpm on a continuous-duty cycle, including a large overload capacity. Unit has an efficiency of over 60 per cent, good speed regulation, and an internal capacitor to minimize rf interference.

Motor is available in a number of styles including output shafts with splines, tangs, and other arrangements, as well as alternative types of electrical connections.

## Aircraft Cable Test

The Model 200 Universal Automatic Electrical Analyzer is a new development in the field of aircraft electrical systems testing developed by the Electronics Div., DIT-MCO, Inc., 505 W. 9 St., Kansas City, Mo. It can be adapted to any electrical cable system at any stage of production, modification, or maintenance.

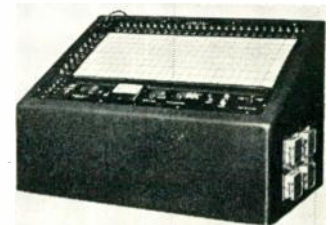

The flexibility of the tester is such that the adaptation of the tester to any particular cabling system or panel assembly requires the use of only an adapter cable. The tester itself never has to be modified.

The electrical circuit analyzer was de-

(Continued on page 126A)



## DYNOGRAPH RECORDINGS

Here is exceptional stability, sensitivity and versatility that allows simultaneous direct recordings of a wide variety of transient variables.



TYPE M

### OFFNER DYNOGRAPH RECORDER

A high speed, direct writing oscillograph with chopper type amplifier.

**30 times as sensitive.** The Dynograph has a d-c sensitivity of over 15 microvolts per millimeter.

**Absolutely non-drifting.** While competitive recorders drift 1 mv per hour or more the Dynograph is absolutely non-drifting.

**Over 8 cm of pen excursion.** This high amplitude of response permits the recording of large dynamic variations.

**One amplifier for all uses.** Other recorders require three or more separate amplifiers for the same applications.

For technical details write for Bulletin L-742.

**OFFNER ELECTRONICS INC.**

5328 N. Kedzie Ave., Chicago 25, U. S. A.

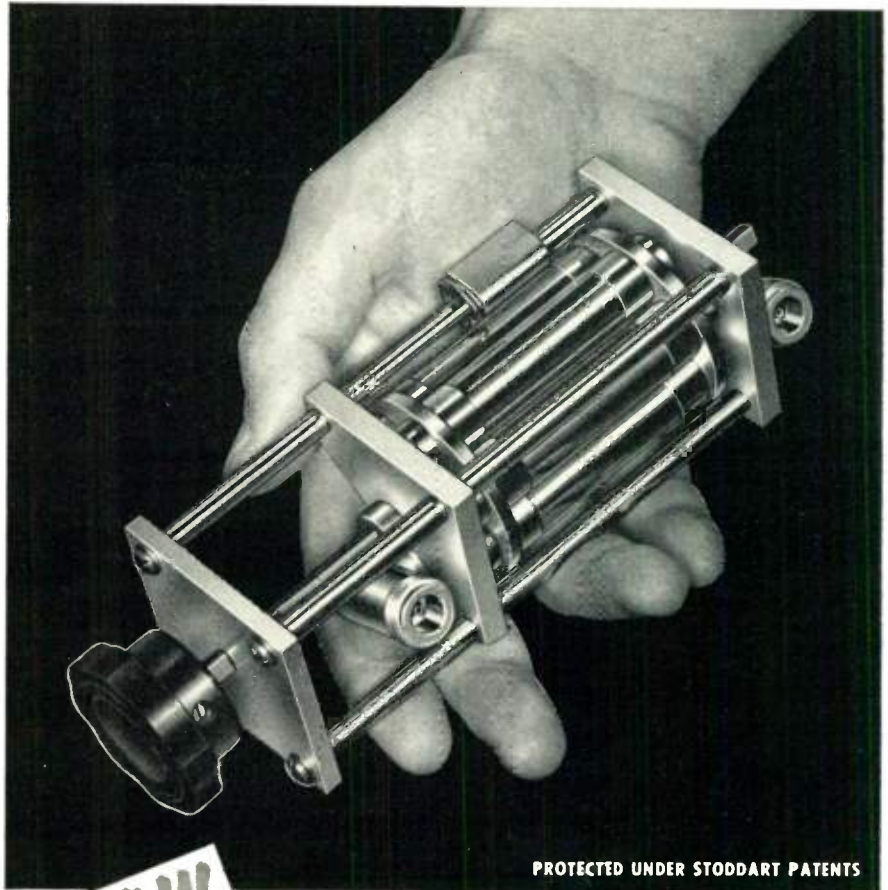

PROTECTED UNDER STODDART PATENTS

**NOW**

## Precision Attenuation to 3000 mc!

TURRET ATTENUATOR featuring "PULL-TURN-PUSH" action

**SINGLE "IN-THE-LINE" ATTENUATOR PADS and 50 ohm COAXIAL TERMINATION**



**FREQUENCY RANGE:**

dc to 3000 mc.

**CHARACTERISTIC IMPEDANCE:**

50 ohms

**CONNECTORS:**

Type "N" Coaxial female fittings each end

**AVAILABLE ATTENUATION:**

Any value from .1 db to 60 db

**VSWR:**

<1.2, dc to 3000 mc., for all values from 10 to 60 db

<1.5, dc to 3000 mc., for values from .1 to 9 db

**ACCURACY:**

±0.5 db

**POWER RATING:**

One watt sine wave power dissipation

Send for free bulletin entitled "Measurement of RF Attenuation"

Inquiries invited concerning pads or turrets with different connector styles

**STODDART AIRCRAFT RADIO Co., Inc.**

6644-C Santa Monica Blvd., Hollywood 38, California • Hollywood 4-9294



# For Absolute dimensional stability...specify

After testing numerous design materials, Technology Instrument Corporation specified injection-molded Mycalex 410 for shaft and drive pins in a new series of ganged precision potentiometers.

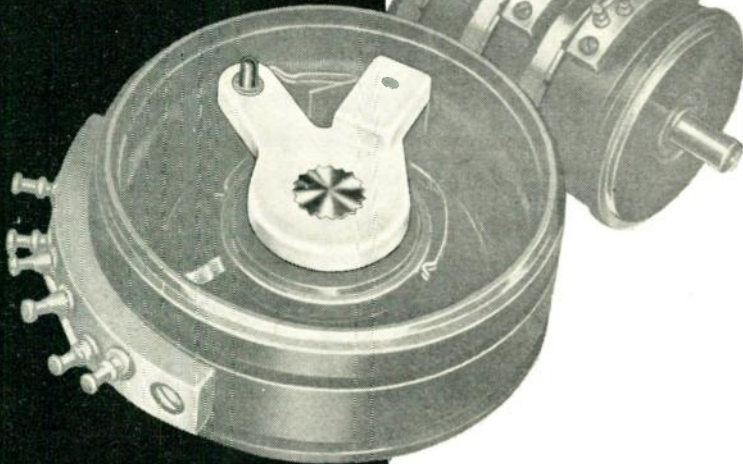

By permitting closer dimensional tolerances, Mycalex glass-bonded mica allows TIC to reduce the size and hold these dimensions constant under toughest environmental conditions. And dimensional stability of the Mycalex coupling arm provides precision transference of rotary shaft motion between adjacent potentiometers without backlash.

TIC designers are typical of the hundreds of electrical and electronic engineers who have discovered the outstanding qualities of Mycalex. Important Mycalex properties include:

- \* **low electrical loss factors**
- \* **high dielectric strength**
- \* **permanent and absolute dimensional stability**
- \* **impervious to water, oil and organic solvents**
- \* **very high arc resistance with complete freedom from carbonization**

## MYCALEX GLASS-BONDED MICA

For more details on this exciting material and its application to your design problem, write to General Offices and Plant: Department III Clifton Boulevard Clifton, N. J.



### MYCALEX CORPORATION OF AMERICA

World's largest manufacturer of glass-bonded mica products

Executive offices:  
30 Rockefeller Plaza  
New York 20, N. Y.



#### News-New Products

These manufacturers have invited PROCEEDINGS readers to write for literature and further technical information. Please mention your I.R.E. affiliation.

(Continued from page 124A)

veloped to answer the need for a universal tool which could be used to test circuits for all types of errors resulting from incorrect connections, short resistance between circuits and insulation resistance, as well as functionally testing such devices as relays, solenoids, actuators, panel lights, resistors, or other resistance type devices.

The analyzer has two test voltages—28 volts dc and 500 volts dc. An electronic detector approves or rejects circuits consistently to pre-set values. An ohmmeter on front panel allows the operator to conveniently measure the exact value of any circuit resistance, if desired. Simplicity in operation enables the operator to rotate the test selection switch to the desired test voltage position and the test proceeds automatically.

Push button switches permit the operator to manually select any test position at any time during a test cycle. Four Amphenol quick disconnect 100 contact receptacles provide convenient connections to the tester.

### Power Supply

The new Model UHR-245 ultra high regulation power supply which furnishes continuously variable voltage from 150 to 500 volts and delivers up to  $\frac{1}{2}$  ampere of dc current with 0.002 per cent load regulation and less than 100 microvolts of ripple over the entire operating range. It is available from Krohn-Hite Instrument Co., 580 Massachusetts Ave., Cambridge 39, Mass.

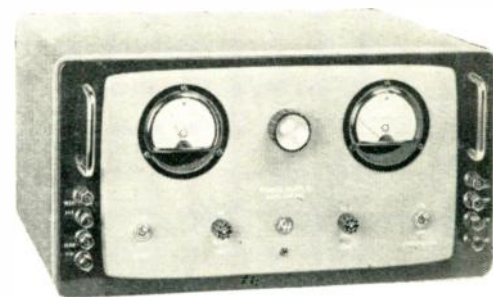

The internal impedance is 0.01 ohm for dc and low frequencies and is less than 0.05 ohm for frequencies as high as 50 kc (at higher frequencies the impedance is equivalent to 0.05 ohm in series with 4 inches of wire).

Full rated maximum current can be drawn with 100 per cent duty cycle at any output voltage and at any line voltage from 105 to 125 volts with a substantial safety factor.

Drift is kept very low by the use of drift-cancelling differential amplifiers, a new high stability reference tube and low temperature-coefficient wire-wound resistors. The dc output is controlled by a

(Continued on page 128A)



# STOP METER DAMAGE NOW!

FOR  
THE  
FIRST  
TIME

MADE BY  
**Metrix**



ONLY  
**\$70**

O.B. Upper Darby, Pa.

Model  
430

**MULTI  
RANGE  
METER**

20,000  
OHM/VOLT  
AC/DC

**WITH AUTOMATIC OVERLOAD  
CUT OUT PROTECTION**

Sensitivity: 20 000 ohms per volt A.C. and D.C. 33 ranges. A.C. and D.C. volts: 3-10-30-100-300-1000-5000 D.C. current: 50 microA—1-10-100 mA—1-10 Amp. Resistances: 0 to 20 Megohms. Output meter: 3-10-30-100-300-1000 volts. Accuracy: D.C. 1.5%; A.C. 2.5%. Dimensions: 8 1/4 x 5 1/2 x 3 1/8 ins. Weight: 3 lbs. 8 ozs.

30 KV probe and leather case available at extra cost.

Other Precision Electronic Instruments Available  
Write to

U.S.A. DISTRIBUTORS

**M. E. GERRY & CO., Inc.**

230 BAYARD RD., Upper Darby, Pa.

another heppner first

# NEW slip-on centering device

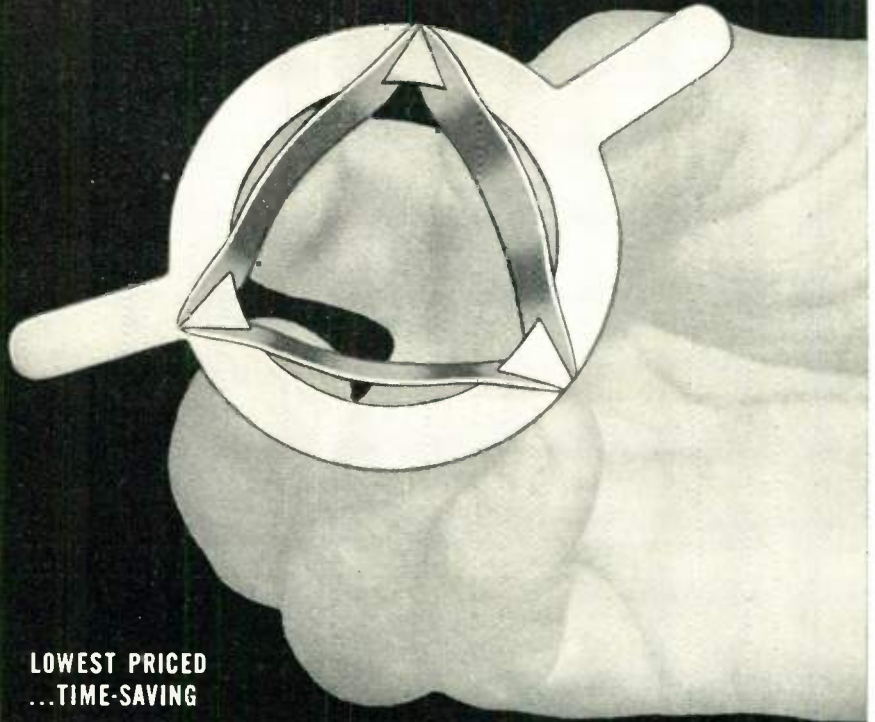

**LOWEST PRICED  
...TIME-SAVING**

Just tilt open and slip on.

- For electrostatic TV tubes—all sizes.
- Saves valuable production time by new tilt-open slip-on design.
- 0-18 gauss max.
- Distortion-free beam assured by uniformity of field. Will not de-focus beam.
- 100% final inspection. Each unit tested in both open and closed position before shipment.

Lowest priced. Write for further information TODAY.

## HEPPNER

MANUFACTURING COMPANY  
ROUND LAKE, ILLINOIS

(50 Miles Northwest of Chicago)

Phone: 6-2161

Specialists in Electro-Magnetic Devices

**OTHER HEPPNER PRODUCTS:**

Ion Traps, Speakers, Flyback Transformers and Focomags.

**REPRESENTATIVES:**

JAMES C. MUGGLEWORTH, 324 Haddon Avenue, Collingswood 7, New Jersey • RALPH HAFLEY, R.R. 1, U.S. 27, Coldwater Rd., Ft. Wayne 8, Indiana • IRV. M. COCHRANE CO., 408 S. Alvarado St., Los Angeles, Calif. • JOHN J. KOPPLE, 60 E. 42nd St., New York 17, N.Y.



## IDENTICAL AMPLIFICATION

*for perfect performance*

Precision measurement of phase shift is practically distortion free in the CROSBY Wideband Oscilloscope, Model 320. Identical horizontal and vertical amplifiers allow phase shift indication for frequencies up to 5 megacycles.

A deflection sensitivity of 35 millivolts RMS per inch, on both amplifiers, makes the Model 320 ideally suited for use in laboratories requiring accurate phase shift evaluation.

A general purpose, high-gain instrument . . . particularly adapted to color television measurements. An Oscilloscope designed by engineers for use by engineers.

See Booth  
No. 481  
IRE Show 1955



Write for  
literature

**CROSBY LABORATORIES, Inc.**

BOX 233 • HICKSVILLE, N. Y.

## HANDLE HIGH VOLTAGES AT MODERATE POWER . . .

RESISTANCE VALUES TO  
1 MILLION MEGOHMS

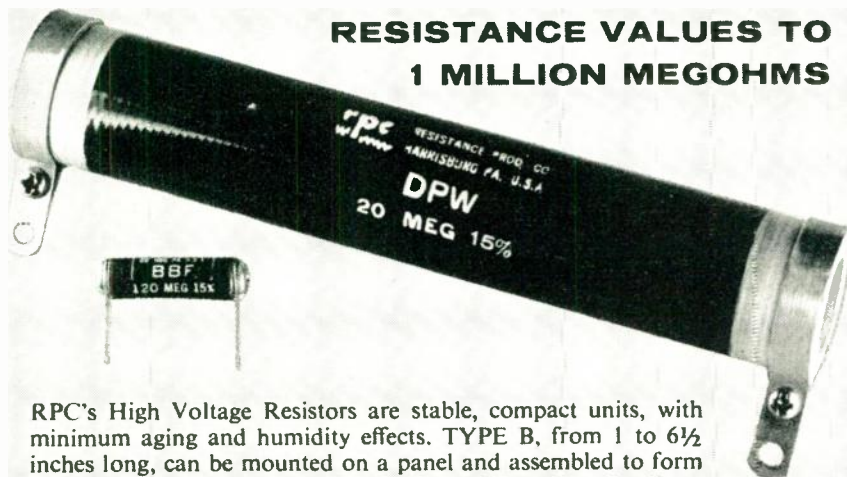

RPC's High Voltage Resistors are stable, compact units, with minimum aging and humidity effects. TYPE B, from 1 to 6½ inches long, can be mounted on a panel and assembled to form tapped or matched pairs. TYPE D, from 6½ to 18 inches long, can be supplied with silver bands, terminal lugs or ferrules.

*For special assemblies, Corona problems or special sizes, free consultation is available.*



**RESISTANCE PRODUCTS Co.**

914 South 13th St. • Harrisburg, Penna.

Makers of Resistors — High Megohm, High Voltage, High Frequency, Precision Wire Wound.



### News-New Products

These manufacturers have invited PROCEEDINGS readers to write for literature and further technical information. Please mention your I.R.E. affiliation.

*(Continued from page 126A)*

precision wire-wound potentiometer, ganged with a variac to obtain good efficiency at the lower output voltages.

There are two independent 6.3 volt ac 10 ampere outputs.

The Model UHR-245 is available either in cabinet for bench use or with a rack panel 8½ inches high. The price of the cabinet model is \$450.00 f.o.b. Cambridge.

### Level-Differential Monitor

Utilizing bubble-tube principles of differential static pressure, a control manometer, and a relay-actuating electronic switch, the new Model DL Differential-Level Monitor is announced by Thermo Instruments Co., 1310 Old County Rd., Belmont, Calif. The instrument finds use where it is necessary to measure or maintain a limited level differential between two points.

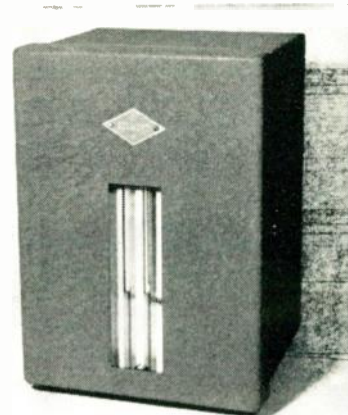

Built into the housing is a metering-type air compressor which supplies air to separate bubble tubes located at the two points in question. These bubble tubes are connected to the opposite arms of the control manometer, which then gives a continuous indication of static pressure differential and thus liquid-level differential. At the preset limit, the control manometer actuates the electronic circuitry so that a built-in relay operates. External auxiliary equipment can be connected to this relay on either a normally-open or a normally-closed basis. Equipment up to 1 hp capacity can be controlled directly, larger units are handled by an intermediate power contactor, which is optional internal equipment.

*(Continued on page 142A)*



# the first NEW DESIGN of selenium rectifiers IN OVER 20 YEARS

BURTON BROWN & COMPANY, INC.

*Kool-Sel*<sup>®</sup>  
Pat. pend.  
by PYRAMID

No center mounting  
Full air ventilation between plates  
Light contact and constant assembly pressure  
No center hot spots  
Lightest weight per unit of output power  
Lower initial forward resistance—better voltage regulation  
Smaller overall size for each rating—cost no more  
Better for all electrical and electronic equipment because of

- Improved convection cooling
- Simpler mounting
- Longer life and minimum aging
- Designed for more rugged service and rated for use in high ambient temperatures

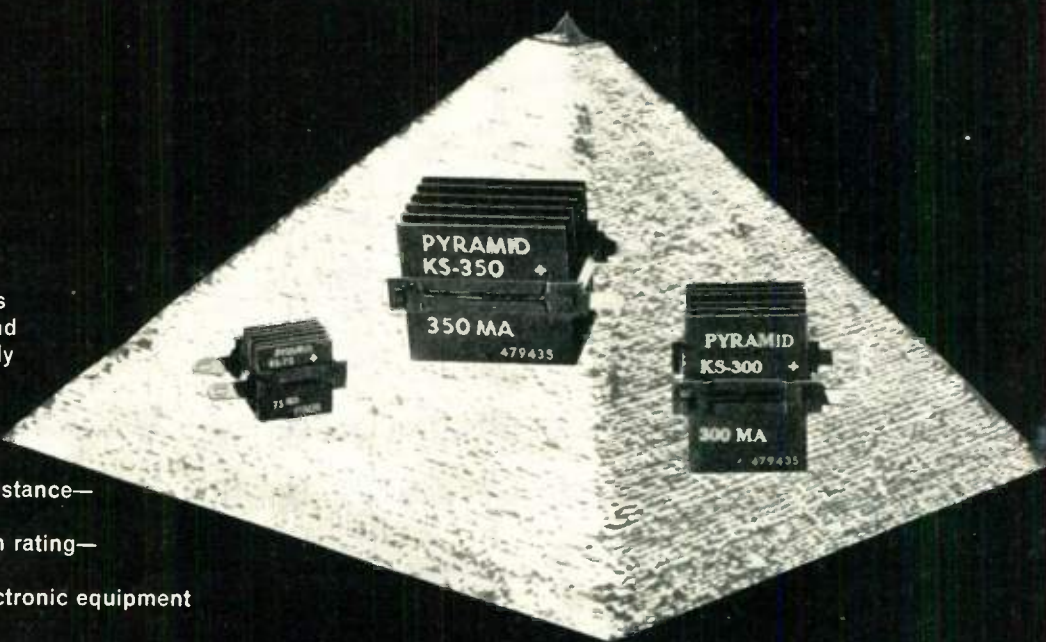

*Kool-Sel*<sup>®</sup> **Important** is the rectifier

most readily adaptable to printed circuit applications.

Because of the fixed edge mount yoke, assembly requires only one whistler die, one hole fixed, one hole variable to three dimensions. For complete information write

RECTIFIER DIVISION



**PYRAMID ELECTRIC COMPANY** North Bergen, N. J.





## SYLVANIA'S CALIFORNIA RESEARCH LABORATORY

(San Francisco Bay Area—Near Palo Alto)

*Needs Senior Development Engineers for a long range program in circuits research and development and systems analysis.*

*We have specific openings for:*

### SENIOR MICROWAVE CIRCUITS ENGINEERS

To design and develop microwave components and circuits for use with advanced antennas, tubes and equipment throughout microwave region.

### SENIOR TRANSMITTER AND RECEIVER DEVELOPMENT ENGINEERS

Technical degree and related experience at the senior level, preferably in microwaves and pulse techniques, essential.

### SENIOR FIELD ENGINEERS

To perform advanced engineering field tests of prototype equipment. Engineering degree and substantial experience, preferably with military electronic equipment, essential.

### HEAD OF SYSTEMS STUDIES SECTION

To direct a staff of scientists and engineers in the analysis and synthesis of electronic systems.

### MECHANICAL ENGINEER

To work on advanced electro-mechanical design problems. Degree in mechanical engineering and 2-5 years experience, preferably in electronic packaging and mechanisms design, essential.

*Sylvania offers the finest facilities and equipment available. We also provide financial support for advanced education, as well as a liberal insurance, pension and medical program.*

*This Sylvania laboratory is located 5 miles from Palo Alto in the San Francisco Bay area, close to excellent schools and universities, unexcelled living conditions, ideal climate and ample housing.*  
**RELOCATION EXPENSES PAID**

## ELECTRONIC DEFENSE LABORATORY

A Division of  
**SYLVANIA**  
ELECTRIC PRODUCTS INC.



Please send complete resume to  
**JOHN C. RICHARDS**  
Electronic Defense Laboratory  
Box 205  
Mountain View, California

All inquiries will be answered within two weeks



**Positions Open**

The following positions of interest to I.R.E. members have been reported as open. Apply in writing, addressing reply to company mentioned or to Box No. . . .

The Institute reserves the right to refuse any announcement without giving a reason for the refusal.

### PROCEEDINGS of the I.R.E.

1 East 79th St., New York 21, N.Y.

#### ENGINEER

Engineer with academic and considerable practical background in electronics and communication circuit design to do development work on complex military electronic systems. Unusual opportunity for advancement and growth in this newly organized development staff. Address reply to Box 791.

#### RADAR DEVELOPMENT AND DESIGN

Electronic circuits, microwave circuits and antennas and mechanical design of mechanisms for electronic equipment. Minimum requirements, degree and 2 years experience in radar or allied field. Suburban Los Angeles location. Canoga Corporation, Box 550, Van Nuys, Calif. Tel. STanley 7-1156.

#### JUNIOR INSTRUCTOR

Junior Instructor, technical electricity to teach courses in mathematics at the technical institute level. Salary \$4,500.00. Location: central New York state. Box 792.

#### ELECTRICAL-ELECTRONICS DESIGN ENGINEERS

##### (Long Range Program—Aircraft Trainers)

Challenging, creative assignments in an expanding and progressive organization. BSEE plus experience in electro-mechanical devices, servo-mechanisms or analogue computers desirable. Send Resume to Stanley Aviation Corp., Buffalo Municipal Airport, Buffalo 25, New York.

#### BROADCAST AUDIO AND PHASOR DESIGN ENGINEERS

Immediate openings in expanding engineering department for men experienced in audio or phasor designing. Complete employee benefits. Salary open. Send complete details and photo to Gates Radio Company, Quincy, Illinois, Att: Mr. Roger M. Veach, Personnel Division.

#### ELECTRONIC ENGINEERS—MECHANICAL ENGINEERS

Openings are available for Electronic Engineers with a minimum of 5 years experience in circuit design with primary emphasis on pulse circuitry and high frequency RF technique. Openings also exist for Mechanical Engineers with a minimum of 5 years experience in packaging electronic equipment as well as in mechanical design of small electro-mechanical devices. Send complete resumes to Mr. J. K. Delano, Exec. Vice Pres., Applied Science Corp. of Princeton, N.J., P.O. Box 44, or call Painsboro 3-4141.

(Continued on page 134A)



# EXPAND YOUR HORIZON!

ELECTRONIC ENGINEERS  
ELECTRONIC PHYSICISTS

*Bendix Radio has new,  
exceptional opportunities for advancement  
while working on:*

**RADAR**  
**MISSILE GUIDANCE**  
**AIRBORNE COMMUNICATIONS**  
**MOBILE COMMUNICATIONS**  
**AUTO RADIO**

Expand the horizon of your future with Bendix Radio—a leader & pioneer in the electronics field, one that has the knowledge, strength and resources to stay out front during the competitive days ahead! Your part is EASY! Wire, phone, write . . . or send us a post card. Simply state your name, address and phone number, your education and experience. We'll carry the ball from there! All replies held in strictest confidence, and we guarantee speedy action!

Address: Mr. L. H. Noggle  
Dept. M  
Bendix Radio  
Baltimore 4, Md.  
Phone: Valley 3-2200



# Bendix Radio

DIVISION OF  
BENDIX AVIATION  
CORPORATION

Baltimore 4, Maryland

# To the Engineer who is Very Particular



## RCA expansion opens the kind of permanent opportunities you'll find most desirable

A whole new program of expansion at RCA—in Research, Systems, Design, Development and Manufacturing—opens a broad variety of permanent positions with all the features that appeal to the alert, creative engineer. These are opportunities with a future . . . available *today* for the man who wants to move ahead professionally with the world leader in electronics. They include work in fields of phenomenal growth. At the RCA engineering laboratories *listed in the chart on the right*, you'll find the kind of living and working conditions attractive to the professional man and his family.

Engineers and scientists find every important factor that stimulates creative

effort . . . including a quality and quantity of laboratory facilities unsurpassed in the electronics industry . . . and everyday association with men recognized at the top of their profession.

RCA's benefits add up to an impressive list of "extras." Among them: tuition for advanced study at recognized universities . . . a complete program of company-paid insurance for you and your family . . . a modern retirement program . . . relocation assistance available.

Your individual accomplishments and progress are recognized and rewarded through carefully planned advancement programs. Financially as well as professionally, you move ahead at RCA!



# about His Future . . .

## What can RCA offer you?

Check the chart below for your career opportunity in

**COLOR TELEVISION**  
**AVIATION ELECTRONICS**  
**ELECTRON TUBES**  
**MISSILE GUIDANCE**

FIELDS OF ENGINEERING ACTIVITY	TYPE OF DEGREE AND YEARS OF EXPERIENCE PREFERRED											
	Electrical Engineers			Mechanical Engineers			Physical Science			Chemistry Ceramics Glass Technology Metallurgy		
	1-2	2-3	4+	1-2	2-3	4+	1-2	2-3	4+	1-2	2-3	4+
<b>RESEARCH • SYSTEMS • DESIGN • DEVELOPMENT</b> <b>COLOR TV TUBES</b> —Electron Optics—Instrumental Analysis—Solid States (Phosphors, High Temperature Phenomena, Photo Sensitive Materials and Glass to Metal Sealing)	L	L	L	L	L	L	L	L		L	L	L
<b>RECEIVING TUBES</b> —Circuitry—Life Test and Rating—Tube Testing—Thermionic Emission	H	H	H		H	H		H			H	H
<b>SEMI-CONDUCTORS</b> —Transistors—Circuitry—Advanced Development	H	H	H	H		H	H	H	H		H	H
<b>MICROWAVE TUBES</b> —Tube Development and Manufacture (Traveling Wave—Backward Wave)		H	H	H			H	H			H	H
<b>GAS, POWER AND PHOTO TUBES</b> —Photo Sensitive Devices—Glass to Metal Sealing	L	L	L	L	L		L	L		L	L	
<b>AVIATION ELECTRONICS</b> —Radar—Computers—Servo Mechanisms—Shock and Vibration—Circuitry—Remote Control—Heat Transfer—Sub-Miniaturization—Automatic Flight—Design for Automation—Transistorization			M			M			M			
<b>RADAR</b> —Circuitry—Antenna Design—Servo Systems—Gear Trains—Intricate Mechanisms—Fire Control			M			M			M			
<b>COMPUTERS (ANALOG AND DIGITAL)</b> —Systems—Advanced Development—Circuitry—Assembly Design—Mechanisms			M			M			M			
<b>COMMUNICATIONS</b> —Microwave—Aviation—Specialized Military Systems			M			M			M			
<b>MISSILE GUIDANCE</b> —Systems Planning and Design—Radar—Fire Control—Shock Problems—Servo Mechanisms			M			M			M			
<b>COMPONENTS</b> —Transformers—Coils—TV Deflection Yokes (Color or Monochrome)—Resistors		C	C		C	C		C	C			
<b>MANUFACTURING</b> Tri-Color Tubes—Microwave Tubes	L			L	L		L	L		L	L	
<b>MACHINE DESIGN</b> Mechanical and Electrical—Automatic or Semi-Automatic Machines		L	L		L	L		H	H			

C—Camden, N. J.—in greater Philadelphia near many suburban communities.

**Location Code**

H—Harrison, N. J.—just 18 minutes from downtown New York.

L—Lancaster, Pa.—in beautiful Lancaster County, about an hour's drive west of Philadelphia.

M—Moorestown, N. J.—quiet, attractive suburban community close to Philadelphia.

Please send resume of education and experience, with location preferred, to:

Mr. John R. Weld,  
 Employment Manager, Dept. C-1B  
 Radio Corporation of America  
 30 Rockefeller Plaza  
 New York 20, N. Y.



# RADIO CORPORATION OF AMERICA

Copyright 1954, Radio Corporation of America

## ELECTRONIC ENGINEERS • PHYSICISTS • MATHEMATICIANS

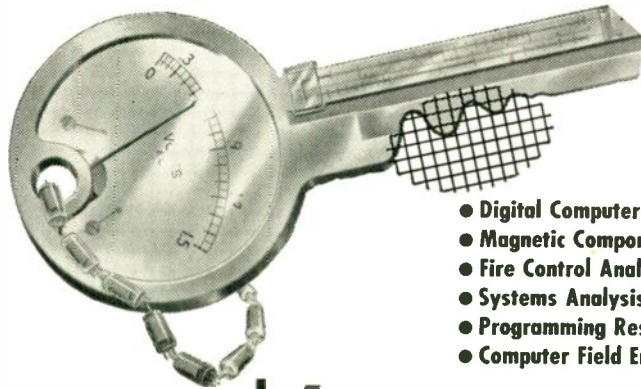

- Openings at all levels of experience.
- Training in digital techniques provided.
- Salaries commensurate with experience.
- Interview travel at our expense.
- Moving expenses paid for household goods.
- Liberal employee benefits.

The country's foremost computer development organization has permanent positions open in the above fields for qualified professional personnel. Opportunities for personal advancement and professional growth are exceptional in today's most rapidly expanding technological field.

### HERE IS THE KEY TO YOUR FUTURE

... share in the satisfaction of contributing to the advancement of this important art.

**Remington Rand**

**ENGINEERING RESEARCH ASSOCIATES** DIVISION

1902 West Minnehaha • St. Paul W4, Minnesota

## COMPUTER DEVELOPMENT ENGINEER

Engineering talent required for development of new computer equipment. Minimum requirement of an MS or experience in analog and/or digital computer circuitry.

*Airmail your resume today to:*

**CALTECH** Jet Propulsion Laboratory  
4800 Oak Grove Drive  
Pasadena 3, California

## Automatic Test Equipment Engineers

Graduate electronic engineers with two to four years experience to supervise design of electronic test equipment for TV receivers and government electronic equipment. Emphasis on automatic testing techniques. Openings at Stromberg-Carlson provide solid growth opportunities for capable engineers interested in this expanding field. Substantial employee benefits. Community noted for fine schools, cultural and recreational facilities.

Send resumes to: **H. P. Field**  
Manager of Test Equipment Engineering Department  
Radio-Television Division  
Stromberg-Carlson Company  
Rochester 3, New York



**Positions Open**

(Continued from page 130A)

### ENGINEERS

Several positions for Electrical Engineers available in the development engineering group of a small growing engineering and manufacturing company. Circuit design experience is essential, as the type of work will entail (1) Originating a detailed circuit design to meet written specifications, (2) Testing a breadboard of the proposed circuit to obtain performance characteristics. Experience with any of the following phases will be helpful: radar, computers, simulators, cathode ray displays, industrial automatic controls. Send resume to Penn-East Engineering Corp., Box 240, Kutztown, Pa.

### INSTRUCTOR

California State Polytechnic College has one immediate opening for an instructor in the Electronic Engineering Dept. to teach courses in fields, waves and antennas. Starting salary \$4500 to \$5000 for the academic year. Application may be made to Harold P. Hayes, Dean of Engineering, San Luis Obispo, Calif.

### ELECTRICAL ENGINEERS

Challenging positions for Electrical Engineers with experience in electronics design. Live in attractive small town with the opportunity of taking graduate work at the Pennsylvania State University. Reply to Personnel Officer, Haller, Raymond and Brown, Inc. State College, Pennsylvania.

### ELECTRICAL ENGINEER

Graduate Electrical Engineer familiar with pulse systems to act as sales representative in Los Angeles and vicinity. Send resume. Box 793.

### ELECTRONIC ENGINEERS AND ELECTRONIC SCIENTISTS

The Naval Research Laboratory has need for Electronic Engineers and Electronic Scientists in positions paying from \$3410 to \$7040. These vacancies involve such work as the design and development of admittance and impedance measuring apparatus; design and development of microwave components and transmission lines for radar; design and development of instruments relating to sonar equipment; design of networks and circuitry, etc. Reply to Dr. W. G. Torpey, Personnel Officer, Code 1817, Naval Research Laboratory, Washington 25, D.C.

### ELECTRONICS ENGINEER

Opportunities in product development, manufacturing or applications engineering for men with a degree in EE or physics and 2 to 5 years experience in any of these fields with a company engaged in manufacture of precision power supplies. Send resume to Personnel Dept., Sorensen & Company, Inc., 375 Fairfield Ave., Stamford, Conn.

### ASSOCIATE PROFESSOR

Expansion of a young midwestern technical college requires the addition, by September 1955, of an Assistant or Associate Professor to instruct in electronics, communications and servomechanisms. MSEE degree and teaching, or research experience are minimum requirements. Rank and salary open. Send summary of qualifications and background to Fournier Institute of Technology, Lemont, Illinois.

(Continued on page 136A)



# SENIOR STAFF

at Ramo-Wooldridge



The Senior Staff of The Ramo-Wooldridge Corporation, shown above, is comprised of scientists, engineers, and science administrators with outstanding records of past performance in positions of responsibility. By means of meetings of the entire group, supplemented by frequent smaller sessions, these key men participate actively in the establishment of company plans and policies.

Existing project commitments require that the current rapid rate of expansion of the company continue throughout the coming year. Unusual opportunities, encompassing a wide variety of challenging research and development problems, exist for *additional* scientists and engineers who would like to participate in the development of a company in which, from the outset, all features of the organization and of the operational procedures are designed to be as appropriate as possible to their special needs.



1. Dr. Burton F. Miller
2. Dr. James C. Fletcher
3. Robert B. Muchmore
4. Dr. John M. Richardson
5. Dr. Howard S. Siefert
6. Robert J. Barrett, Jr.
7. William B. Hebenstreit
8. Dr. Ralph P. Johnson
9. Jack H. Irving
10. Dr. Louis G. Dunn
11. Dr. Eldred C. Nelson
12. A. J. F. Clement
13. Dr. Milton U. Clauser
14. V. G. Nielsen
15. Dr. Eugene M. Grabbe
16. Marion F. Thorne
17. Dr. Robert R. Bennett
18. Robert J. Hight
19. Dr. Andrew Vazsonyi
20. Emory Lakatos
21. Richard A. Hartley
22. Dr. Howard L. Engel
23. Dr. Donald L. Drukey

## The Ramo-Wooldridge Corporation

8820 BELLANCA AVENUE, LOS ANGELES 45, CALIFORNIA, DEPT. P-2

POSITIONS ARE  
AVAILABLE FOR  
SCIENTISTS AND  
ENGINEERS IN  
THESE FIELDS OF  
CURRENT ACTIVITY

Guided Missile Research and Development  
Digital Computer Research and Development  
Business Data Systems Development  
Radar and Control Systems Development  
Communication Systems Development



# A Rewarding Career at Airtron inc.

Here is an excellent opportunity to work in the intriguing and continually expanding field of microwaves. Your work will be stimulating and your advancement gratifying when you participate in the tasks of a professional, competent staff of fellow engineers.

Your place in a field with a future can be secured by joining one of America's leading designers and producers of microwave equipment and radar components. Assure yourself of a career position in a company with a future. Investigate these advantages now!

1. Profit sharing incentive bonus plan.
2. Thrift savings pension plan.
3. Subsidized tuition for advanced study.
4. Ideal suburban location in Metropolitan New York area.
5. Excellent schools and recreational facilities.
6. All the other usual benefits . . . paid holidays, vacations, credit union, etc.

If you have an EE or ME degree and/or related experience in electronics or microwaves you will be interested in the opportunities for junior and senior engineers now open at Airtron, Inc.

Write or call Mr. Arthur Eckerson, Industrial Relations Department, Linden 3-3762.



1101 West Elizabeth Avenue  
Linden, New Jersey

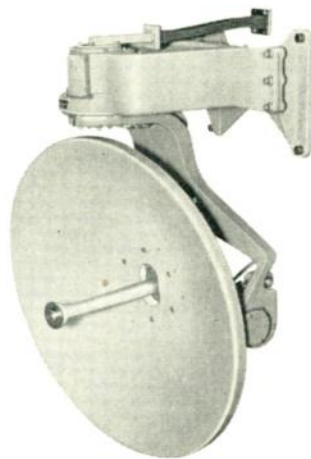

**Positions Open**

(Continued from page 134A)

## ENGINEERS

EE Engineers familiar with microwave systems engineering to analyze creative research for invention. Responsible positions open in engine instruments and controls, electrical machinery, microwave devices and electron tubes, and gyroscopic equipment. Patent knowledge beneficial. Liberal salary, unusual employee benefits. Real opportunities for exercise of initiative and advancement. Replies held in confidence. Contact Mr. R. Wathen, Sperry Gyroscope Co. (Div. of the Sperry Corp.) Great Neck, New York.

## ELECTRONIC ENGINEER OR PHYSICIST

Rapidly growing electronic firm has immediate need for an Electronic Engineer or Physicist in its Research and Development Dept. This work will encompass the work of various digital computer components. These components will include analog to digital computers and high precision digital to analog converter systems. We desire a person with 3 to 5 years experience in electromechanical input and output devices for digital computers. He must have a general knowledge of computer design. Send detailed resume to Technical Employment Manager, 1001 El Centro, South Pasadena, Calif.

## INSTRUCTORS

Teaching positions for Sept. 1, 1955, are available at a University in the southeast. Instructors, \$3,500-\$4,300; graduate Assistants (M.S. in 12 months), \$110. per month, tuition free. Box 794.

## PROFESSOR—ELECTRICAL ENGINEERING

Professorial appointment at Brown University open for Electrical Engineer with established ability in teaching advanced research. Will have responsibility for organizing and directing theoretical and experimental research program in his fields of interest. Write to D. C. Drucker, Chairman, Div. of Engineering, Brown University, Providence 12, R.I.

## REPRESENTATIVES

A growing Massachusetts manufacturer has openings for manufacturers representatives or sales representatives, with sales background, to represent electronic laboratory furniture. Must be qualified to present product to laboratory engineers, executive and authoritative management. All territories open with exception of Illinois, Wisconsin and Massachusetts, Territory assigned; commission basis. Send resume to Formica Metal Products Co., Corporation Way, Medford 55, Mass. stating education, past experience and present employment. All replies confidential.

## SALES ENGINEERS OR TRAINEES

Immediate opening for 2 intelligent, personable and imaginative electronic, vacuum or nuclear instrument engineers, with rapidly growing sales engineering organization. Exceptional opportunity for advancement and good earnings for man with initiative. Salary plus incentive compensation. Systematic sales training will be provided for otherwise qualified applicants without prior sales experience. Must be residents of upstate or metropolitan New York. Some travel required. Submit resume (picture if possible), starting salary requirements and availability date with first letter. Box no. 795.

(Continued on page 137A)

## ENGINEERS AND PHYSICISTS

LAYOUT SYSTEM DESIGN  
FIELD INVESTIGATIONS  
ORDNANCE SYSTEMS  
EVALUATION  
SYSTEMS & CIRCUIT  
ANALYSIS STUDIES

Permanent positions in the Vitro Laboratories for career-minded men providing challenging assignments in missiles, radar, sonar, fire control and ordnance systems.

This modern laboratory provides a professional environment in a quiet residential community accessible to metropolitan New York City.

Please submit resumes to Personnel Dept.

## VITRO LABORATORIES

Division of Vitro Corporation of America  
200 Pleasant Valley Way, West Orange, N.J.



# MISSILE SYSTEMS

*Research  
and  
Development*

The technology of guided missiles is literally a new domain. No other field of science offers greater scope for achievement.

Significant work in this field is being performed at Lockheed Missile Systems Division, with many projects involving unexplored areas of scientific endeavor.

*Lockheed*

MISSILE SYSTEMS DIVISION

*research and  
engineering  
staff*

LOCKHEED AIRCRAFT  
CORPORATION

VAN NUYS • CALIFORNIA



(Continued from page 136A)

## ELECTRICAL ENGINEERS, MATHEMATICIANS, PHYSICISTS

The Moore School of Electrical Engineering of the University of Pennsylvania has openings for electrical engineers, mathematicians and physicists. Work is available in the fields of digital and analogue computers, mathematical analysis, circuit design, information theory, microwaves and systems engineering. Applicants should be U. S. citizens. Salary commensurate with education and experience. For application form write the Director, Moore School, University of Pennsylvania, 200 South 33rd St., Phila. 4, Pa.

## ENGINEERS—PHYSICISTS

**MECHANICAL**, Liaison Engineer, capable of coordinating the mechanical work of several departments in a large multi-plant organization. Paying up to \$14,000.

**ELECTRONIC**, background in Airborne Electronics, on all levels with emphasis on research and development. New project opening opportunities for advancement. \$7,000-\$15,000. No fee to our applicants on these positions. Guilford Personnel Service, American Bldg., Baltimore 2, Maryland.

## TECHNICAL EDITOR

Nationally known, rapidly growing electronic magazine, has an opening for a young, energetic associate editor. Must be a graduate electronic engineer with 2-3 years design experience and have ability to write. Publication experience preferred. Submit resume with salary desired. Box 796.

## SALES ENGINEER

To sell advertising space of ELECTRONIC DESIGN to industrial management. This is an exceptional opportunity for a career in industrial marketing and publishing. Young man between 25 and 32, should have technical background, proven sales record and management potential. New England, New York City territory, salary plus expenses and commissions. Send detailed resume to Hayden Publishing Company, Inc., 19 East 62 Street, New York 21, N.Y.

# MISSILE SYSTEMS

*Physicists  
and  
Engineers*

New developments have created positions for those possessing outstanding ability in fields of:

Radar • Computers  
Systems Engineering  
Antenna Design  
Communications  
Telemetry  
Electromechanical Design  
Test Equipment Design  
Instrumentation  
Structures Engineering  
Nuclear Physics  
Mechanical Engineering  
Aeronautical Engineering  
Operations Research  
Stress Engineering

*Lockheed*

MISSILE SYSTEMS DIVISION

*research and  
engineering  
staff*

LOCKHEED AIRCRAFT  
CORPORATION

VAN NUYS • CALIFORNIA

**Plan Now  
for the biggest days  
in radio-electronics!**  
**IRE** National Convention  
and  
**RADIO ENGINEERING SHOW**

**March 21-24  
New York City**

TO THE FINE ENGINEERING MIND  
SEEKING THE CHALLENGING PROJECTS IN

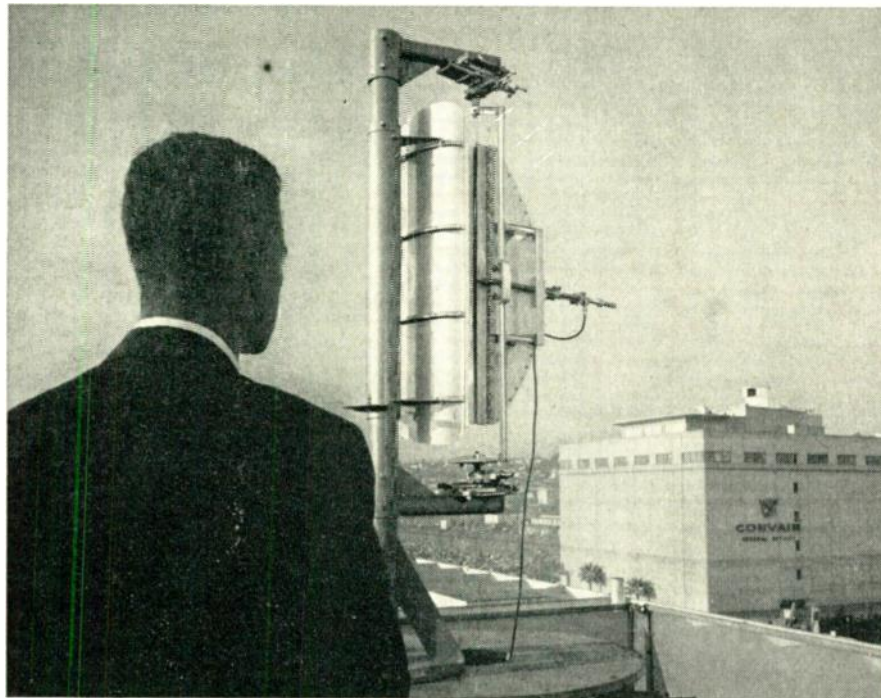

## MICROWAVE ENGINEERING

Convair, in beautiful San Diego, now earnestly needs skilled **MICROWAVE ENGINEERS AND PHYSICISTS**: to solve design problems of an advanced nature in microwave antennas and scanners. You must be experienced in pencil beam and shaped beam designs for guided missile and airborne radar application — for analytical and experimental work in the design of microwave components for specialized microwave radar systems and test equipment — for experimental development of components in the fields of dielectric and metallic media including familiarity with radome and microwave lens design. Unusual opportunities for senior level engineers with advanced degrees or equivalent experience.

At **CONVAIR** you will find an imaginative, explorative, energetic engineering department... truly the "engineer's" engineering department to challenge your mind, your skills, your abilities in solving the complex problems of vital, new, long-range programs. You will find salaries, facilities, engineering policies, educational opportunities and personal advantages excellent.

Generous travel allowances to engineers who are accepted.

Please write at once enclosing full resume to:

**H. T. Brooks, Engineering Personnel, Dept. 801**

# CONVAIR

*A Division of General Dynamics Corporation*

**3302 PACIFIC HIGHWAY**

**SAN DIEGO, CALIFORNIA**

Lovely, sunny, **SMOG-FREE SAN DIEGO**, ever-growing area of three-fourths million people, offers you and your family a way of life judged by most as the Nation's finest for climate, natural beauty and easy (indoor-outdoor) living. Housing is plentiful and reasonable.



In order to give a reasonably equal opportunity to all applicants and to avoid overcrowding of the corresponding column, the following rules have been adopted:

The Institute publishes free of charge notices of positions wanted by I.R.E. members who are now in the Service or have received an honorable discharge. Such notices should not have more than five lines. They may be inserted only after a lapse of one month or more following a previous insertion and the maximum number of insertions is three per year. The Institute necessarily reserves the right to decline any announcement without assignment of reason.

### ENGINEER

Naval Reserve Officer released from active duty in August. BEE, age 27, single. 2 years non-technical civilian business experience in responsible position. Desires opportunity in engineering, sales, administration, management or similar fields. New York Metropolitan area preferred. Box 779W.

### SENIOR ELECTRONIC ENGINEER

MSEE 1949. Age 36, married. 5 years varied electronic development experience, including supervision in complex airborne systems. Desires to relocate in small community or suburban area. Box 780 W.

### SENIOR ENGINEER

BEE, 7 years diversified experience in circuit design, project supervision. Experience in pulse circuits, C.R.T. displays, test equipment and electromechanical design. Desires position involving commercial work only. Eta Kappa Nu. Age 37, married, one child. Northern New Jersey area preferred. Box 781 W.

### ENGINEER

BSEE 1952. Age 25, married, one child. Experience in analog and digital computer techniques. 1½ years experience maintenance CRC 102A digital computer. Desires position in computer field, preferably in design of logical circuitry in New York or vicinity. Box 732 W.

### ELECTRONIC ENGINEER

BEE, age 30. 5 years audio and UHF research and development experience including supervisory, planning and contract administration assignments. Interested in operational and administrative aspects of laboratory or plant which is in need of this experience and offers opportunity to expand on supervisory ability. Present salary \$7400. Box 783 W.

### FIELD-SALES ENGINEER

Experienced in electronic field engineering with a diversified background in servomechanism, analog computers, radio aids to navigation, and sonar, as well as flight simulators. Attended U. S. Naval Academy and George Washington University. Desires field or sales engineering position. Box 795 W.

*(Continued on page 140A)*



# GENERAL ELECTRIC

**PLANS  
FAR INTO THE FUTURE**

The development of new technologies at General Electric has opened the door on a program of advanced electronics work requiring the skills of top engineers and physicists. To engineers this means long-range, continuing opportunity enabling them to build a solid future as they enjoy the vast facilities, stimulating challenges and many incentives and rewards offered by General Electric.

## ENGINEERS PHYSICISTS

*Positions available  
in the following fields:*

Advanced Development, Design, Field Service  
and Technical Writing in connection with:

**MILITARY RADIO & RADAR  
MULTIPLEX MICROWAVE  
MOBILE COMMUNICATION  
COMMUNICATIONS  
ELECTRONIC COMPONENTS  
TELEVISION, TUBES & ANTENNAS**

Bachelor's or advanced degrees in  
Electrical or Mechanical Engineering,  
Physics, and experience in  
electronics industry necessary.

*Please send resume to: Dept. 1-5-P, Technical Personnel*

**GENERAL  ELECTRIC**

Electronics Park, Syracuse, N. Y.

### Electronic and Mechanical Engineers!

Motorola Research Laboratories, located in the healthful climate of Arizona's Valley of the Sun, has several openings for experienced engineers in the following fields:

Electronic research and development for missile guidance, radar and VHF communications.

Mechanical design of missile-borne and vehicular electronics equipment.

Analysis and laboratory work involving development of new types of airborne and ground radiators and waveguide components.

VHF and microwave antenna and waveguide circuitry.

Transistor development

Desire men with B.S. degree or above. Salary commensurate with education and experience. Free health, accident and life insurance. Free hospitalization. Profit sharing. Paid holidays. Sick leave. Vacations. Ideal working conditions. Plenty of housing, reasonably priced. Excellent schools. Exceptionally mild and dry winter climate.

WRITE: J. A. Chambers, Manager  
Motorola Research Laboratory  
3102 North 56th Street  
Phoenix, Arizona

# FIRE CONTROL ANALYSTS

Mathematicians • Electrical Engineers • Physicists

needed for immediate openings in all levels of employment. These are top ranking technical positions together with training positions leading to top responsibility in mathematical analysis for electronic fire control, computers, and servomechanisms.

- Household goods moved
- Liberal employee benefits
- Interview expense paid

*Send written resume to*

**REMINGTON RAND, Inc.**

ERA DIVISION

1902 W. Minnehaha Ave., St. Paul 4, Minn.

# Digital Communication Engineers

with  
experience  
in  
the  
fields  
of

Systems  
Engineering  
Miniaturization  
Circuit  
Development  
Electromechanical  
Development  
Digital  
Techniques

## Long-Range Information Transmission

New advancements in the field of long-range information transmission are being made at Hughes with digital techniques.

## Areas of Work

To further expand work in this area, Hughes Research and Development Laboratories are interested in people with experience in airborne communication systems, digital storage, low frequency measurements, modulation systems, miniaturized packaging, audio, IF and RF circuitry in the HF range, analog to digital—and other data conversion methods.

Scientific and Engineering Staff

# Hughes

RESEARCH  
AND DEVELOPMENT  
LABORATORIES

CULVER  
CITY,  
LOS  
ANGELES  
COUNTY,  
CALIFORNIA

Relocation of applicant must not cause disruption of an urgent military project.



## Positions Wanted

(Continued from page 138A)

### ENGINEER

Industrial Relations Officer, largest Naval Air Stations (Employment, employee relations, training and safety). Electronics background (short Navy radar course, M.I.T.). Commander, USNR, 15 years active duty. Age 52. A.B. (personnel and engineering). Desires placement. Box 796 W.

### ENGINEER

Audio, electronic development and testing; broadcast. Experience includes 2 years RCA Institutes, 3 years Army communications intelligence. 1st class radio operator license. Some radio and electronic repair. Member IRE Audio Group, IRE, AES. Age 22. single. Will consider classified work. Prefer commuting distance New York-Long Island area. Box 797 W.

### PATENT ENGINEER

BEE, MSEE, LLB February 1955. Senior Engineer, 5 years tube and transistor circuit research, design, development experience. Desires electronics patent work. Box 798 W.

### DEVELOPMENT ENGINEER

BS, M.I.T. 1950. Development experience in airborne radar and microwave multiplex communications equipment. Capable of mature thinking and group leadership. Have done original work on several projects, several invention credits. Desires a challenging position with an aggressive company in New York, New Jersey or Boston area. Other location will be considered. Box 799 W.

### EXPORT ENGINEER

BS degree in R.E. and EE. Large experience in radio communications, technical writer, sales promotion in U.S. and foreign countries. Excellent connections with TV and electrical distributors in all export markets. Well known as Consulting Engineer in radio and TV transmitter field, U.S. and abroad. Fluent knowledge of French, Spanish and Italian. Efficient correspondent. Able to travel and appoint dealers. Married, children. Box 800 W.

### PROJECT ENGINEER—SALES

BEE, MEE, Tau Beta Pi, Eta Kappa Nu. Age 38, 3 children. 8 years broad technical background in electronics, computers. Supervised and directed large engineering group. Desires Project and/or Sales engineering position in New York area. Box 801 W.

### MANUFACTURER'S REPRESENTATIVE

Wanted: High quality, low cost aeronautical products with a primary market in private aviation. WW II and Korean Emergency USNR veteran desires to act as manufacturer's representative. Address: Aeroconomy Agency, P. O. Box 1001, Schenectady, N.Y.

### AUTOMATION ENGINEER

Experienced computer engineer desires affiliation at management level with firm concerned with automatic data, handling and automation. Consulting, developing, etc. Further information supplied on request. Box 806 W.

(Continued on page 142A)

## NEW HORIZONS

Today's horizons in electronic engineering are limited only by the vision of the individual himself. To those qualified men who desire to stand on the constantly changing frontiers of electronic development, we offer a chance to pioneer and grow with a soundly-established, yet young and progressive company.

## • Electronic Field Engineers

Local and Field  
Assignments Available

At least 5 years' experience in any one of these fields: Servo Mechanisms; Special Weapons; Microwaves; Antennas; Circuit Design; Flight Simulators; Radio Propagation; Electronic Computers and Communications.

Qualified to instruct in the operation and supervise installation, maintenance and repair of Radar, Sonar, Flight Simulators and allied electronic equipment in the field.

Salary and advancement commensurate with ability; liberal vacation, sick leave, 9 paid holidays, group life, sickness and accident insurance plans, and a worthwhile pension system.

## STAVID Engineering, Inc.

Personnel Office, 312 Park Avenue  
Plainfield, N.J.—Plainfield 6-4806

## ELECTRONIC ENGINEERS

to develop

## TRANSISTOR CIRCUITRY

Opportunity to study fundamental transistor circuit problems and to apply transistors in the design of receiver, guidance and control systems of guided missiles.

Transistor experience desirable but not essential.

Located in residential suburb of Nation's Capital. Advanced educational facilities available.

Moving expenses paid.

Other liberal benefits.

Send resume to G. B. Mayfield

APPLIED PHYSICS LABORATORY  
THE JOHNS HOPKINS UNIVERSITY  
8621 Georgia Avenue, Silver Spring, Md.



# INSTRUMENTATION ENGINEER

(Physicist or Electronics  
Engineer)

Once in a lifetime opportunity for physicist or electronics engineer with ability to design, construct and install setups used to obtain data on engine ignition and performance. Setups will be diversified so that projects might require mechanical and electronics instrumentation as required to best obtain information.

Also included will be design of auxiliary control circuits and writing of operation manual to be used by experimental department personnel.

# ELECTRONICS ENGINEER OR PHYSICIST

If you have experience or ability in design, construction and evaluation of high voltage, high frequency circuits, we have an exceptional opportunity in which you will be interested.

Position requires applicant capable of designing circuits incorporating transistors, magnetic amplifiers and semi-conductors.

Interested applicants possessing necessary qualifications are invited to write at once, outlining all pertinent data regarding responsibilities of present position, past experience, training and salary requirements.

Address letters to:  
Personnel Director

The Electric Auto-Lite Co.  
Toledo 1, Ohio

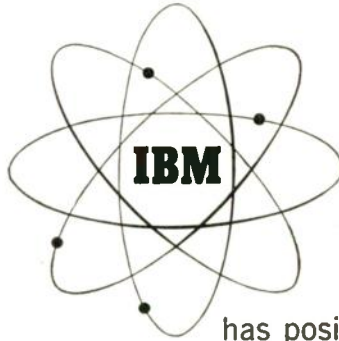

WORLD'S LEADING PRODUCER  
OF ELECTRONIC ACCOUNTING  
AND COMPUTING MACHINES

has positions open in  
Development and Manufacturing  
for  
Electronic and Electro-mechanical  
**ENGINEERS**

FOR WORK IN THE DIGITAL COMPUTER FIELD

**FUNCTIONAL TESTING AND ANALYSIS  
PROGRAM DEVELOPMENT  
SYSTEMS PLANNING**

BS, MS, or PhD degree and experience in the fields of computers or weapons systems are required.

**ELECTRONIC & ELECTRICAL CIRCUIT DESIGN  
TEST EQUIPMENT DESIGN  
PRODUCTION TESTING**

BS degree or equivalent experience is required. Experience in the following fields is desirable. Radar—Servo-mechanisms—TV—Analog Computers—Audio Systems—Instrumentation—Data Handling Systems.

Replies will be held in strict confidence. Write giving full details of education and experience to:

Mr. W. M. Hoyt, Dept. 686 (A)

INTERNATIONAL BUSINESS MACHINES  
590 Madison Ave., New York 22, N. Y.

### What an Engineer —and his family— should know about IBM

\* You'll be working with the great teams of engineers that created and developed the world's most advanced digital computers—IBM's 701 and 702 data processing machines.

\* Your future will be as big as you make it, with your advancement depending on your own merits.

\* You'll be joining a company with a 40-year record of growth and stable employment and with one of the very lowest employee turnover records in the entire country.

\* Your salary will be excellent, and IBM's exceptional employee benefits will be a life-long advantage for you and your family.

\* You can continue your engineering education through IBM's education program.

\* Family recreational facilities including golf courses, swimming pools and supervised children's activities are of the finest at IBM's Country Clubs.

Your moving expenses will be paid to Poughkeepsie or Endicott, N. Y., where IBM's plants and laboratories are located and living conditions are excellent.

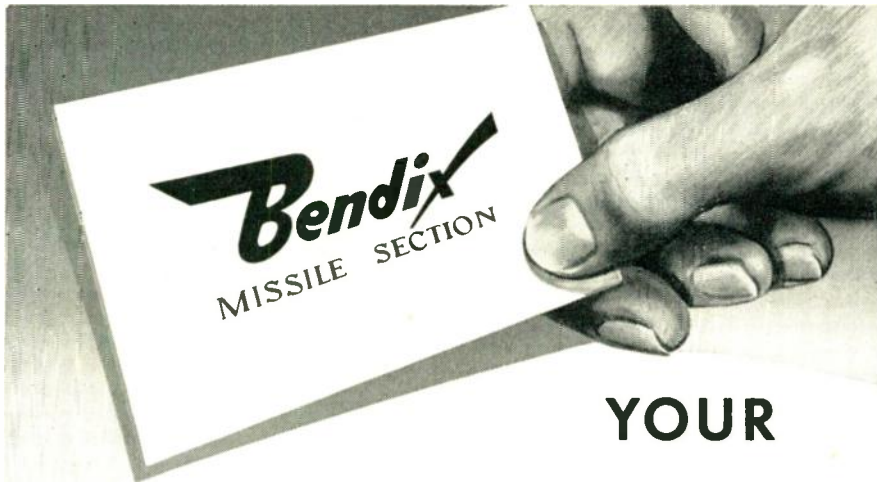

## YOUR CALLING CARD FOR A BRILLIANT FUTURE...

Bendix Missile Section is a major contractor in the U. S. Navy's guided missile program -- a part of the "new look" in our defense plan. Our expanding program has many opportunities for senior engineering personnel: Electronics Engineers, Dynamicists, Servo-Analysts, Stress Analysts, Project Coordinators, and Designers. Take time now to look into the opportunities which Bendix can offer you. Write Employment Dept. M, 401 Bendix Drive, South Bend, Indiana.

## ENGINEERS

Have you developed a  
"Success Perspective"?

If a year or two of practical experience has given you the youthful maturity that demands more than just a job, you may be interested in our "career opportunities" in color TV, crystal products and electronic tubes.

Submit resume or address request for personal interview to D. Bellat, Personnel Director.

**TUNG-SOL ELECTRIC INC.**  
200 Bloomfield Avenue  
Bloomfield, N.J.

## CONFIDENTIAL

Engineering and Scientific  
Placement Service

One letter to Guilford Personnel Service puts you in contact with top level organizations selected on the basis of your skills and abilities, in the location you desire.

### NO FEE

to you for our professional services. Employers cover our fee as well as your interview and relocation expenses. Our employer clients range from the small growing firms to the very largest in all sections.

Among our many current requirements are openings in the following fields:

- Electronics
- Mechanical
- Aero Electronics
- Physics
- Computers
- Tubes
- Manufacturing
- Systems Analysis
- Technical Writing
- Ceramics
- Metallurgical
- Chemical

Start today by sending a resume of your education and experience to Box R-1

**GUILFORD  
PERSONNEL SERVICE**

308 AMERICAN BLDG., BALTIMORE 2, M.D.  
Mulberry 5-4340



## Positions Wanted

(Continued from page 140A)

### SALES ENGINEER

Five years experience in electronic sales, test engineering, quality control, Government inspection and procurement. Will receive BEE in June. Age 31. Desires sales, administrative or advertising position with electronic manufacturer. Prefer New York metropolitan area. Box 807 W.

### ELECTRONIC ENGINEER— ADMINISTRATIVE

BSEE 1945, MS Eng. ADM. 1954, BSIE (lacks 12 hours). Age 32, married, Lt. USNR. 1 year Navy ETM, 1 year as electronic laboratory assistant. 15 years amateur radio. Last 8 years in nucleonic industry. 1 year electronic engineer, 1 year production manager, 2½ years factory manager, 3½ years controller. Desires position which utilizes this background. Box 808 W.

### PATENT ENGINEER

BEE, N.Y.U. 1949. In second year Law School. 2 years radio transmitter, and 2½ years components and color TV design and development experience. 1st Lt., U. S. Signal Corps, Korean veterans. Age 25, married. Prefer position doing patent work in New York City area. Will consider out of town. Box 809 W.

### BROADCAST ENGINEER

RCA graduate (with honors) desires position as broadcast engineer, anywhere. No experience, but capable, salary secondary. With a little help I can become a valuable engineer, just try me. Box 810 W.



## News-New Products

These manufacturers have invited PROCEEDINGS readers to write for literature and further technical information. Please mention your I.R.E. affiliation.

(Continued from page 128A)

### Subminiature Tube Holders

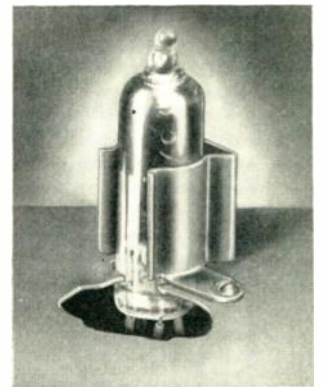

Atlas E-E Corp., Bedford Airport, Bedford, Mass., announces production of a new line of vertical subminiature tube holders, designed for application in printed circuitry and similar limited-space conditions, where it is necessary to hold tubes and components securely against shock and vibration. These vertical subminiature

(Continued on page 144A)



To give you  
a complete  
selling program  
to radio and  
electronic engineers,

## IRE provides all 3!

1

### "Proceedings of the I. R. E."

puts your product  
promotion monthly  
before the "thinking and  
doing" engineers in the  
fabulous, fast-moving  
radio-electronic industry.  
Circulation 41,625 (ABC)

2

### IRE DIRECTORY

provides 35,000  
engineers educated to  
buy and specify with  
your detailed product  
data for ready reference  
all year long.

3

### RADIO ENGINEERING SHOW

...the eye-opening event  
of each radio-electronic  
year...where over  
40,000 engineers come  
to you for all that's new.

For complete facts,  
ask IRE about all 3!



Engineers are educated  
to specify and buy.

The Institute of Radio Engineers

Adv. Dept.  
1475 Broadway  
New York 36, N. Y.  
BRyant 9-7550

A  
**BRIGHT FUTURE**

IN  
**ORIGINAL RESEARCH**

FOR  
**ELECTRONIC ENGINEERS  
PHYSICISTS and  
MECHANICAL ENGINEERS**  
WITH  
**SYLVANIA**

It is not surprising that many contributions and advances in the field of electronics have been made by Sylvania engineers. Our company has always placed heavy emphasis on original research, development and product design, offering engineers wide latitude for exploration and creative expression.

As a result, growth opportunities for engineers are virtually unlimited, as Sylvania aggressively advances in its growth tradition.

To aid our engineers in their progress, Sylvania also provides financial support for advanced education, as well as liberal insurance, pension and medical programs.

The following **PERMANENT POSITIONS** are now open at:  
**BOSTON & BUFFALO ENGINEERING LABORATORIES**

Section Heads, Engineers-in-Charge, Senior Engineers, Engineering Specialists and Junior Engineers for Research, Design, Development and Product Design on complex miniaturized airborne electronic equipment and computers, experienced in:

Pulse Techniques  
Electro-Mechanisms  
Microwave Techniques  
Microwave Applications  
Circuit Design  
Equipment Specifications  
F. M. Techniques  
Miniaturization  
Servo Mechanisms  
Transistors  
Heat Transfer  
Shock & Vibration

Technical Writing  
Analytical Problems  
Antenna Design  
Applied Physics  
Systems Development & Testing  
Component Selection  
Component Analysis & Testing  
Component Specifications  
Digital Computer Circuits & Systems  
Mechanical Design

Please forward complete resume to:

MR. CHARLES KEPPLER

**SYLVANIA**   
ELECTRIC PRODUCTS INC.

175 Great Arrow Avenue, Buffalo, New York

## TRANSISTOR DEVELOPMENT

Texas Instruments offers outstanding opportunities for men of science with bachelor or advanced degrees in E.E., M.E., physics or chemistry in development and design of transistors and other semiconductor devices. Association will be with men of outstanding caliber whose achievements include the first production of silicon transistors and the first mass production of transistors for radio and other high-volume production. Permanent positions are available requiring experience in the following:

- High-frequency circuit development or design
- Physical chemistry (with electronics background)
- Solid state physics
- Mechanical engineering (with electronics background)

Texas Instruments, with 25 years experience in manufacturing electro-mechanical devices, offers unlimited advancement opportunities due to expanding demand for its products. Liberal salary and employee benefits, including Profit Sharing. Send complete resume to Mr. W. V. Walsh, Personnel Division.

**TEXAS INSTRUMENTS**  
INCORPORATED  
6000 Lemmon, Dallas, Texas

## March 1955 Proceedings of IRE is the CONVENTION PROGRAM ISSUE CLOSING DATE

Copy to Set - February 1st  
Complete Plates - February 8th

## Senior MICROWAVE ENGINEERS Wanted

- Who demand to grow with a vigorous company
- Substantial salary and benefits

send resume to: President,  
Electronics and X-ray Division  
F-R Machine Works, Inc.  
26-12 Borough Place  
Woodside 77, N. Y.

See our advertisement  
on page 51A



### News-New Products

These manufacturers have invited PROCEEDINGS readers to write for literature and further technical information. Please mention your I.R.E. affiliation.

(Continued from page 142A)

tube holders will hold up to 5 G's vibration at 500 cps. They are made in the basic component-holder cross section with a mounting tab at right angles to the axis of the component, and are available for 0.375 and 0.500 inch diameters. The holders are made of irridite-dipped cadmium-plated spring steel (per MILSPEC QQ-P-416-B-II) for military use, or commercial finish for general industrial use. Bulletin available.

### VSWR Amplifier

The Type 277 VSWR Amplifier is an inexpensive, low noise, high gain audio amplifier, manufactured by Polytechnic Research & Development Co., Inc., 202 Tillary St., Brooklyn 1, N. Y. Its sensitivity is 0.3 microvolt for full scale deflection on the meter. It is suited for use with slotted sections in measuring vswr over the range of 1.0 to over 100. A selector switch permits either high input impedance for such applications as low level crystal operation and null indication in bridges or low input impedance for use with crystals operating at higher level and bolometers requiring either 4.5 ma or 8.75 ma bias.



The meter is calibrated both in vswr and db. Special circuitry providing an expanded meter scale makes possible accurate reading of VSWR from 1.0 to 1.3. A panel switch permits either a 15 or 50 cps bandwidth centered at 1000 cps, or broadband operation from 350 to 2,500 cps. With a 15 cps bandwidth the noise level is 0.03 microvolt. The gain of over 120 db can be adjusted by a "fine" control and by a "coarse" selector switch calibrated in steps of 10 db for use with a square law detector.

### High Temperature Rectifiers

In an endeavor to gain wider acceptance among industrial manufacturers for high temperature rectifiers. Semi-Conductor Div., Radio Receptor Co., 251 W. 19 St., New York 11, N. Y., has succeeded in reducing costs and increasing cell sizes to 5x6 inches on these units which operate without derating at 125°C.

Introduced less than three years ago in sizes limited to 3x3 inches, high temperature rectifiers have been almost prohibitive because of high price and size limitations.

(Continued on page 147A)





*Farnsworth*

**IS FORMING**

**THE FUTURE**

The Farnsworth Electronics Company, newly created Division of the International Telephone & Telegraph Corporation, has been organized for concentrated and integrated effort extending from research and development through design and manufacture in the vast fields of defense and industrial electronics.

While new in conception and objective, the company carries on an unbroken tradition of proud achievement reaching back to electronics infancy. The genius that created pulse techniques, electron optics, and photo multipliers, that raised wave-shaping and band-forming to a science, continues to lead an increasing effort to advance the frontiers of the art in missile guidance systems, microwave systems, antennas, radar systems, instrumentation, ECM, test equipment, display devices in both the visible and invisible spectrum, servo systems, industrial television, data recording, semi-conductors and information theory.

Here at Farnsworth we are expanding to assert our leadership in this dawning age of science and engineering. Our objective is pre-eminence . . . our foundation is established stability . . . our means is solid professionalism. To those who would lead tomorrow, we extend an invitation to join us today.

*Farnsworth*   
ELECTRONICS CO., FORT WAYNE, IND.

# ELECTRICAL ENGINEERS & PHYSICISTS

For the design, development or application of receiving, microwave (including traveling waves), image orthicon, or vidicon tubes, and development of solid state devices.

Min. 2 yrs exp required. Salary offers are based on education and experience.

This is a new, expanding,  
and dynamic division of

## Westinghouse

with excellent opportunities  
for professional advancement.

Travel expenses paid if invited to  
Elmira for interview. Send resume:

**WESTINGHOUSE ELECTRIC CORP.**

**ELECTRONIC TUBE DIVISION**

P.O. Box 284

Elmira, N.Y.

## COMMUNICATIONS and ELECTRONICS

are but two of the many scientific disciplines in which the Operations Research Office of The Johns Hopkins University offers most unusual and challenging opportunities to the experienced researcher. Salaries are commensurate with experience. Inquiries are invited. Address:

W. P. Champlain, Research Personnel Officer  
Operations Research Office, 7100 Connecticut Ave.  
Chevy Chase 15, Maryland

# ENGINEERS

Countermeasures  
Systems  
Radar  
Servo

BACKGROUND: Responsible positions open for top level development and project engineers with practical and research experience in:

Advanced Electronic Circuits and Systems  
Microwave Radar  
Microwave Receivers and Transmitters



Requirements emphasize advanced analytical and/or management experience on highly complex electronic and electro-mechanical systems.

Kindly send resume and salary requirements to

**The W.L. MAXSON Corp.**  
460 W. 34th ST., NEW YORK 1, N.Y.

## PHYSICISTS RESEARCH ENGINEERS

The Radiation Laboratory of The Johns Hopkins University provides unusual opportunities in a long range research and development program for experienced imaginative engineers and physicists. The men we seek are experts in fields of:

### SYSTEMS MICROWAVES CIRCUITRY

The Laboratory offers challenging work in an atmosphere of scientific progress, encourages professional advancement and provides opportunity for advanced study in the University graduate schools. Congenial surroundings, excellent laboratory facilities, stimulating associations and, of course, liberal employee benefits.

Address inquiries to:  
Radiation Laboratory  
The Johns Hopkins University  
Homewood Campus  
Baltimore 18, Maryland

## ENGINEERS DESIGNERS • DRAFTSMEN Electronic Mechanical



THE MELPAR SYMBOL  
STANDS FOR

### Growth - Progress - Leadership

IN RESEARCH AND DEVELOPMENT  
OF ELECTRONIC EQUIPMENT

Diversified and Challenging  
Problems

A real appreciation and  
recognition of  
the individual's merit and ability

An opportunity for  
qualified men to join a  
company that is steadily growing

A location that offers  
many advantages

Our  
Technical Personnel  
Representative will give  
you complete details of the  
opportunities available to men  
qualified in the following fields:

- Network Theory
- Microwave Technique
- UHF, VHF or SHF Receivers
- Analog Computers
- Digital Computers
- Magnetic Tape Handling Equipment
- Photographic Equipment Design
- Radar and Countermeasures
- Packaging Electronic Equipment
- Pulse Circuitry
- Microwave Filters
- Flight Simulators
- Subminiaturization Techniques
- Electro-Mechanical Design

send complete resume to

Technical Personnel Representative,

**melpar, inc.**

A Subsidiary of the Westinghouse Air Brake Co.

452 Swann Ave., Dept. IRE-13  
Alexandria, Virginia

or 11 Galen St., Watertown, Mass.

## ENGINEERS MICROWAVE & CIRCUIT

For advanced development engineering in X, S and L band for coaxial and wave guide components, covering printed circuits, ferrites, pulse and CW doppler and countermeasure systems.

Permanent, creative positions with one of the fastest growing electronics laboratories in America (organized, owned and run by engineers) where the only limitations are one's own initiative and ability.

Live and work in beautiful New Hampshire, vacation spot of the East—and only one hour from Boston with its wealth of cultural and educational facilities.

Please submit resumes, including initial salary requirements, to

Mr. Donald Clement.



NASHUA, NEW HAMPSHIRE

## Experienced ELECTRONIC ANALOG COMPUTER

### Personnel

Applicants should have at least a Bachelor's degree in Physics, Mathematics or Engineering and a minimum of one year direct experience with electronics analog computers. This experience may be in computer design, application or operation.

Our computer installation is well-equipped and expanding with important work on the complex dynamics and control problems characteristic of modern high-performance aircraft and guided missiles.

Send resume to:

Engineering Personnel Section

**CHANCE VOUGHT  
AIRCRAFT**

Incorporated

P.O. Box 5907 Dallas, Texas





(Continued from page 144A)

The new series can also be hermetically sealed without derating. At 125° they have a minimum guaranteed life span of 500 hours without derating. At normal temperature they will last almost indefinitely. They can also be supplied in cartridge type if desired.

Further information may be obtained upon request to the Sales Dept., Semiconductor Div.

### UHF Grid-Dip Oscillator

Measurements Corp. subsidiary Thomas A. Edison, Inc., Boonton, N. J., is in production on a grid-dip oscillator for applications in the uhf band.

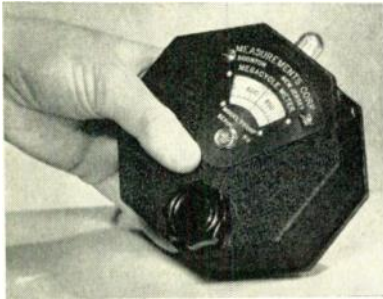

Designated the Model 59-UHF Mega-cycle Meter, this instrument covers the range of 430 to 940 mc. It incorporates an oscillator with a split-stator tuning capacitor, arranged so that a fixed coupling point is at the center of the oscillator inductance. The oscillator output is either CW or 120-cps modulated. Linear calibration is provided with a calibration point every 10 mc (individually calibrated) and accuracy is better than 2 per cent.

The Model 59 is 2½ deep and 4⅝ inches wide. The case contains a standard camera socket for tripod mounting.

Rated at 30 watts and operating from 117 volts, 60 cps, the Model 59-UHF employs a separate power supply and indicating unit for maximum convenience. Additional information may be obtained from Measurements Corporation, Boonton, New Jersey.

### 60 cps Magnetic Servo Amplifier

The R6G16W1 magnetic servo amplifier manufactured by Polytechnic Research & Development Co., Inc., 202 Tillary St., Brooklyn 1, N. Y., can be used to operate any two phase, 60 cps, servo motor requiring up to 16 watts into the control phase, such as the Diehl FPE 25 series. It can be supplied either as illustrated or with a built-in magnetic, transistor, or vacuum tube preamplifier. In all cases, the power supply required is 115 volts, 60 cps, single phase. It is suited, without need of a preamplifier, for many medium performance indicating and position type servomechanisms. When used with a simple preamplifier, it may be employed in the most accurate and demanding type of control systems.

(Continued on page 148A)

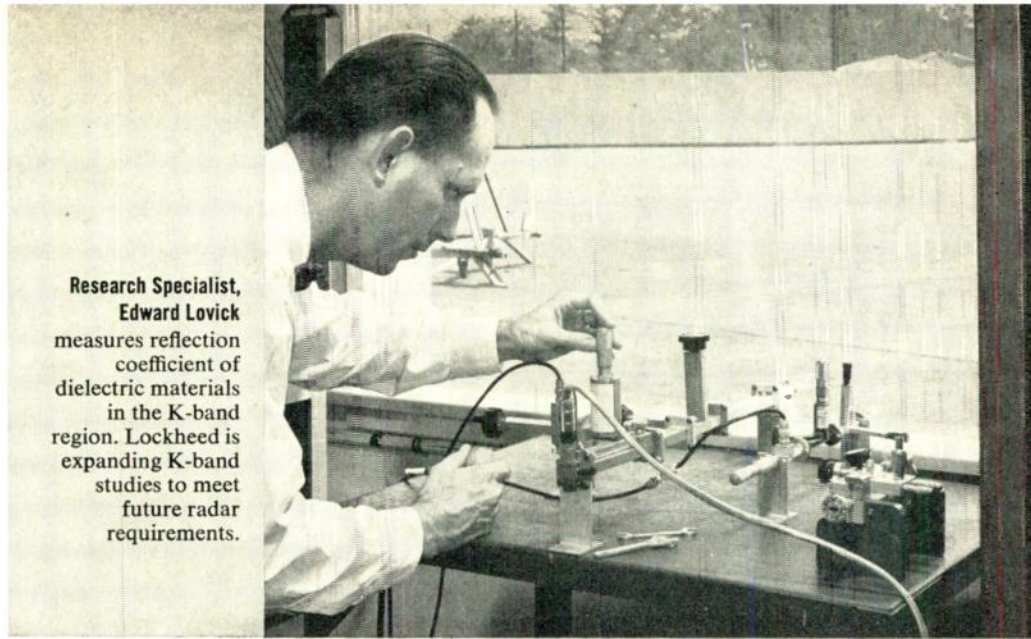

Research Specialist, Edward Lovick measures reflection coefficient of dielectric materials in the K-band region. Lockheed is expanding K-band studies to meet future radar requirements.

## Expansion Program Speeds Lockheed Antenna Development

The expansion program covers virtually the entire spectrum of aeronautical endeavor, commercial and military. Antenna research and development is directed at such diverse projects as: supersonic fighters; advanced jet trainers and jet transports; advanced versions of vertical-rising aircraft and bombers; turbo-prop transports; Lockheed's exclusive radar search plane; and a number of significant classified activities.



Electronics Research Engineer T. W. Hancock and Electronics Engineer Irving Alne discuss asymmetry in Super Constellation antenna pattern.

### Career Positions at Lockheed

Lockheed's expansion program presents Electronics Engineers and Physicists qualified for airborne antenna design with a wide range of assignments in communication, navigation and microwaves.

Lockheed offers you increased salary rates now in effect; generous travel and moving allowances; an opportunity to enjoy Southern California life; and an extremely wide range of employee benefits which add approximately 14% to each engineer's salary in the form of insurance, retirement pension, sick leave with pay, etc.

Those interested are invited to write E. W. Des Lauriers, Dept. IR-1, for a brochure describing life and work at Lockheed and an application form.

# Lockheed

AIRCRAFT CORPORATION  
BURBANK **California**

# ENGINEERS

Which Matters Most

The **SIZE** of the **COMPANY**

or

The **SIZE** of the **OPPORTUNITY?**

Many engineers have found that the size of a company does not always determine the size of the opportunity it offers.

Consider the National Company, for example: solidly-established since 1914, recognized as a quality pioneer in the electronics industry, we have remained comparatively small by choice, growing slowly while consistently increasing our scope of operations.

Ours is an organization where the accent has always been on individuality, on encouragement of initiative, on personal interest in each engineer's progress. In this kind of environment, opportunity is inherent, and an engineer can do his best work, knowing it will not go unnoticed.

National invites engineers who are "Tuned to Tomorrow" to apply now for the following positions:

## MECHANICAL DESIGN ENGINEERS

## MECHANICAL DESIGNERS ELECTRONIC & ELECTRICAL ENGINEERS

## PHYSICISTS

For Work in the Development of:

### COMMUNICATIONS

Antennas, transmitters and receivers

### COMPUTING DEVICES

Magnetics, digital and analog

### AUDIO DEVICES

Tape recording

### NAVIGATIONAL SYSTEMS

### INSTRUMENTATION

Sensing elements for computers

### COMPONENTS

Please forward complete resume to:

Mr. John A. Bigelow

**National**



**NATIONAL COMPANY, INC.**  
61 Sherman St. Malden, Mass.

## ELECTRONIC ENGINEERS

Challenging Opportunity  
Exists for Senior  
Level Positions

### Microwave Engineer

with extensive experience in applied microwave circuit design and development. Position involves applications of microwave circuits in the evaluation of modern radar techniques.

### Electronic Engineer

with extensive practical experience in the field of analog computers and aerodynamic simulators. Position involves applications in the evaluation of airborne military radar, firecontrol, navigation and human engineering activities.

### Servomechanism Engineer

with extensive experience in applied servomechanism design and development. Position involves original applications of servomechanisms in airborne military radar, firecontrol and navigation systems.

**CORNELL AERONAUTICAL  
LABORATORY, INC.**  
Buffalo 21, New York

## RADIO RECEPTOR CO.

In electronics research and development since 1922, now offers new opportunities to:

### PROJECT ENGINEERS EE

Experienced in design of pulse and radar circuitry to government specifications. Must be creative, mature and capable of assuming complete responsibility from project inception to production

### TRANSISTOR APPLICATIONS ENGINEER

For transistor or circuit design and product evaluation. One year in transistor circuit design, plus 4 years general vacuum tube circuit design experience. Knowledge of transistor theory essential.

### PROCESS ENGINEER

Graduate B. Ch. E. preferred, for transistor and diode production. Will consider other engineering degrees. Production background in semi-conductors or vacuum tube manufacturing desirable.

Send resume to: S. Winston, Personnel Mgr.  
240 Wythe Ave., Brooklyn 11, N.Y.



News-New Products

(Continued from page 147A)

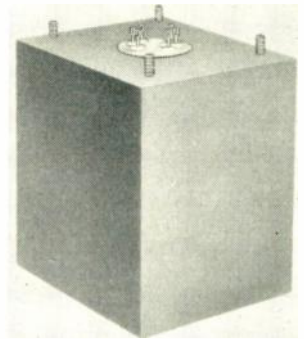

Design of the Type R6G16W1 for one cycle response assures the widest possible bandwidth consistent with the use of 60 cps as the power supply frequency.

The unit will deliver reversible phase ac output for reversible phase ac or reversible phase dc input.

For complete information, please address inquiries to the company.

## 400 cps Magnetic Servo Amplifier

A new magnetic servo amplifier which will deliver up to 10 watts reversible phase ac output into the control phase of MK7 and MK8 servo motors for reversible phase ac or reversible polarity dc input, has been developed by Polytechnic Research & Development Co., Inc., 202 Tillary St., Brooklyn 1, N. Y.



Design emphasis has been to achieve minimum size and weight compatible with operation at high temperatures in control or servo systems where one cycle response is mandatory. Designated as the Type R40G10W1, the reactor unit is 2½ inches high and 2¼ inches in diameter. It weighs less than 12 ounces.

The R40G10W1 is encased in a molded resin except for the moisture and fungus proofed rectifier which is supplied for external mounting. It is rated for operation at temperatures up to 85°C with normal servo duty cycles.

The R40G10W1 can be supplied either as illustrated or with a built-in magnetic, transistor, or vacuum tube preamplifier. In all cases, the power supply required is 115 volts, 400 cps, single phase.

For further information, please write to: Polytechnic Research & Development Co., Inc., 202 Tillary St., Brooklyn 1, N. Y.

(Continued on page 150A)



## SENIOR ELECTRONICS ENGINEERS

EE degree or equivalent experience. Background in communications and navigation desirable. Permanent positions in design and development. Citizenship required. Position at Rochester, New York. Excellent living and recreational conditions in this area.

### ADDRESS:

Chief Electronics Engineer  
Stromberg-Carlson Company  
Rochester 3, New York

## WANTED

## MANUFACTURERS' REPRESENTATIVES

For Indiana, Kentucky, South Carolina, Georgia, Mississippi, Florida, Minnesota and Northern Wisconsin. Long established reputable manufacturer of basic ceramic insulating materials, hermetic seal components, and magnetic ferrites. Requires services of a complete manufacturer representative organization in the above indicated territories. Only experienced, completely integrated organizations will be considered. Must include adequate staff of salesmen, sales engineers, etc. Please provide complete detailed information in first letter.

### Reply Box 797

INSTITUTE OF RADIO ENGINEERS  
1 East 79th St., New York 21, N.Y.



During the coming months you'll be seeing top-level Martin developments in the news—developments which spell out the message above.

That message has tremendous importance for you now. Today, there are truly exceptional futures for engineers in *Electronics* and *Servo Mechanisms* on projects of the highest priority and promise.

If you are one of those, it's your move!

Contact J. M. Hollyday, Dept. P-1, The Glenn L. Martin Company, Baltimore 3, Maryland.

**MARTIN**  
BALTIMORE · MARYLAND



**TRANSISTOR &**

**DIGITAL COMPUTER**

**TECHNIQUES**

*applied to the design, development  
and application of*

AUTOMATIC RADAR DATA  
PROCESSING, TRANSMISSION  
AND CORRELATION IN  
LARGE GROUND NETWORKS

**ENGINEERS  
&  
PHYSICISTS**

Digital computers similar to the successful Hughes airborne fire control computers are being applied by the Ground Systems Department to the information processing and computing functions of large ground radar weapons control systems.

The application of digital and transistor techniques to the problems of large ground radar networks has created new positions at all levels in the Ground Systems Department. Engineers and physicists with experience in the fields listed, or with exceptional ability, are invited to consider joining us.

*fields include*

TRANSISTOR CIRCUITS  
DIGITAL COMPUTING NETS  
MAGNETIC DRUM AND CORE MEMORY  
LOGICAL DESIGN  
PROGRAMMING  
VERY HIGH POWER MODULATORS  
AND TRANSMITTERS  
INPUT AND OUTPUT DEVICES  
SPECIAL DISPLAYS  
MICROWAVE CIRCUITS

*Scientific and Engineering Staff*

**HUGHES**

**RESEARCH AND  
DEVELOPMENT LABORATORIES**

*Culver City, Los Angeles County, California*

Relocation of applicant must not cause  
disruption of an urgent military project.



**News-New Products**

These manufacturers have invited PROCEEDINGS readers to write for literature and further technical information. Please mention your I.R.E. affiliation.

*(Continued from page 148A)*

### Miniature Pulse Transformers



The Gudeman Co., of California, Inc., 92 Exposition Blvd., Los Angeles 34, Calif., has introduced a new series of Epoxy resin impregnated and molded 7-pin plug-in miniature pulse transformers which surpass MIL-T-27, class A, grade 1 test specifications. Pulse width range is from 0.05 to 25 microseconds, with two or three windings. Units in the range from 0.05 to 7 microseconds are  $\frac{3}{8}$  inch diameter; those in the range from 9 to 25 microseconds are  $\frac{3}{4}$  inch diameter. All are  $1\frac{1}{8}$  inches high. Weight range is from 10 to 15 grams. Operating temperature range is from 70°C to 135°C. Hi-pot test 2,000 volts rms.

Complete data available through Donald H. Allen at the firm.

### Magnetic Amplifiers

Librascope, Inc., 808 Western Ave., Glendale, Calif., announces a new magnetic amplifier line, the first unit is designated as the Model 504-1 Ultra-Fast Magnetic Amplifier, developed for use in control systems where a high gain amplifier and fast response is required.

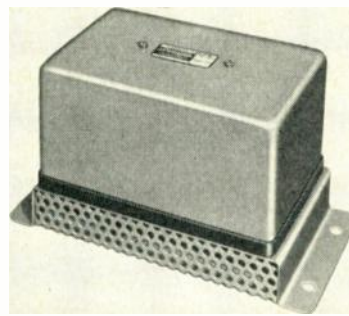

The speed of response has been made independent of the number of stages of amplification. This has made possible the present three-stage amplifier in which the input and output phase occur during the same half-cycle of the power supply. Reduction of the series major loop lag permits the use of more negative feedback in the inner loop, resulting in improved stability.

*(Continued on page 152A)*

# ELECTRONIC FIELD ENGINEERS

*An outstanding  
opportunity awaits  
you in our nation-  
wide ELECTRONIC  
COMPUTER and  
DATA HANDLING  
SYSTEMS program*

- **TRAINING** at our expense with full salary.
- **PERMANENT** installation assignment, perhaps in your own locality.
- **HOUSEHOLD** goods moved at our expense.
- **INSURANCE, PENSION** and other liberal employee benefits.
- **INTERVIEWS** arranged at our expense.

*Send written résumé to:*

**REMINGTON RAND Inc.  
ERA DIVISION**

1902 W. Minnehaha  
St. Paul W4, Minn.



# ENGINEER

## UHF & Microwave

American Machine & Foundry Company offers a select opportunity to an engineer for our Greenwich, Connecticut location.

Will perform engineering and development in the field of UHF and Microwave Antennas and associated components. Must be able to supervise and direct personnel in the field, testing such equipment. Will plan and write proposals for Microwave Antenna work and write project process reports.

Experience: 5 years in Electrical Engineering; UHF and/or Microwave Antenna work, B.S. in Electrical Engineering; M.S. desirable. We will consider a young man with less experience with potential to develop specifications required.

*This is an excellent opportunity with AMF, a leader in the design and development of complex mechanisms for over 52 years.*



Please forward resume to  
Mr. John J. Walsh

**AMERICAN MACHINE  
& FOUNDRY CO.**  
11 Bruce Place  
Greenwich, Connecticut

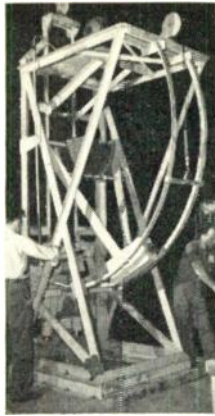

## SANDIA CORPORATION

invites you to compare

- ✓ **OPPORTUNITIES**
- ✓ **ADVANTAGES**

... with those of other research and development organizations. The "good" job is one in which you can be happy. You alone can decide the relative importance of such things as professional challenge of the work, promotion possibilities, work environment, job security, geographical location, climate, etc. In all these respects, Sandia Laboratory can meet the expectations of most engineers and scientists in the following fields —

- mechanical engineers
- electronics engineers
- electrical engineers
- physicists
- mathematicians
- aerodynamicists
- systems engineers

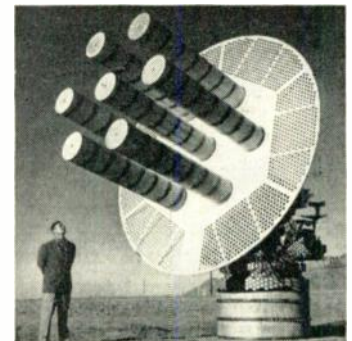

SANDIA CORPORATION, a subsidiary of the Western Electric Company, operates Sandia Laboratory under contract with the Atomic Energy Commission. Simply stated, Sandia's job is to build usable weapons around the explosive nuclear components developed at nearby Los Alamos Scientific Laboratory. Graduate engineers and scientists will find excellent opportunities in the fields of component development, systems engineering, applied research, testing and production.

COMPENSATION is competitive with that offered in other industry. Working conditions are excellent and employee benefits include liberal paid vacations, free group life insurance, sickness benefits and a generous contributory retirement plan. Opportunities for advancement in this young and growing laboratory are many.

SANDIA LABORATORY is located in Albuquerque — a modern, cosmopolitan city of 150,000, rich in cultural and recreational attractions and famous for its excellent year-around climate. Adequate housing is easily obtained. For descriptive literature giving more detailed information on Sandia Laboratory and its activities — or to make application for employment — please write:

PROFESSIONAL EMPLOYMENT DIVISION 1A1

**SANDIA**  
*Corporation*

SANDIA BASE • ALBUQUERQUE, NEW MEXICO

# ENGINEERS



## ELECTRONICS BACKGROUND

*A few responsible positions available*

- ... in systems work associated with navigational computers.
- ... for antenna and microwave component development.
- ... in digital computing, data processing, at various levels for men with backgrounds in pulse, video, computer circuitry and/or magnetic recording.

The modern facilities and congenial atmosphere at Kollman, designers of America's finest aircraft instruments, provide an environment conducive to truly creative work.

Please submit resumes to Employment Manager. Interviews will be arranged for qualified applicants.

## KOLLSMAN Instrument Corp.

80-08 45th Ave.

Elmhurst, L.I., New York

## ELECTRONIC ENGINEERS

ADVANCE YOUR CAREER  
WITH A LEADER IN  
WESTERN ELECTRONICS

An expanding program of:

- research
- development
- production
- specialized military equipment
- advanced commercial design
- real creative challenge

Special receivers and transmitters, DF and DME, various instruments and Transistor applications—special devices. Studies in noise, radar, miniaturization and test equipment. Relocating expenses, good insurance plan, central location, steady advancement.

Send resume to L. D. Stearns  
Engineering Employment Manager

# Hoffman

LABORATORIES, INC.

(SUBSIDIARY OF HOFFMAN RADIO CORP.)

3761 S. HILL ST., LOS ANGELES,  
CALIF.

## ENGINEERS

### MICROWAVE

Development of microwave instruments & test equipment

### ELECTRONIC

Development of electronic instruments

Precision instrument manufacturer requires men with good academic & practical background. At least 2-3 years design & development experience required. Should exhibit qualities of leadership, with the ability to meet & deal with people. Men who fill the bill will be substantially compensated.

# POLYTECHNIC

RESEARCH &  
DEVELOPMENT CO., INC.

202 Tillary St.

Brooklyn 1, New York



## News-New Products

These manufacturers have invited PROCEEDINGS readers to write for literature and further technical information. Please mention your I.R.E. affiliation.

(Continued from page 150A)

Ultra-fast magnetic amplifiers can be used either as phase reversible ac amplifiers or as polarity reversible dc amplifiers for dc inputs with no changes in the internal wiring of the amplifier. Power Gain: 50,000. Power output: ac 15 watts phase reversible with ac input. DC, 15 watts, polarity reversible with dc input. Power Supply: 115V, 60 cps  $\pm$  10 per cent. Stages: Three. Total Time Lag: 0.0083 second. Load Impedance: 800 ohms. Input Impedance: 15,000 ohms. Weight: 10 pounds. Dimensions: 6  $\times$  5  $\times$  10  $\frac{1}{2}$  inches.

## Durbin Honored by Holtzer-Cabot

Vernon Durbin, was honored for fifty years of distinguished service with the Holtzer-Cabot Divisions of National Pneumatic Co., Inc., 125 Amory St., Boston, Mass. Durbin, at left receives award from R. Frost at the University Club in Boston.



Durbin, who is the company's Associate Director of Engineering, is the holder and co-holder of twenty-nine patents and has three applications pending. These inventions date from 1913 to 1954. His first invention was a transmitter for a selective signaling system, patented in 1913. The most recent patent was issued last January for a thermo-electric door operating system which Durbin and Charles T. Button, of Holtzer-Cabot Motor Division, developed together.

Mr. Durbin's inventions include: paging and fire alarm systems, annunciators, measuring instruments, telephone testing equipment, loud speakers, telephone receivers, time relays, distribution panels, circuit controlling apparatus, a traffic-operated traffic signal and a fire detection device.

## New Two-Terminal Sub-Miniature Pilot Lights

The Dialco line of pilot light assemblies now includes a new sub-miniature series which mounts in a single  $\frac{1}{8}$  inch clearance hole and requires no insulating mountings. The socket, lamp, and all connections are well-insulated from the mounting bushing. Phenolic material of military specification grade provides the insulation.

(Continued on page 154A)





During the past five years, the radio-electronic industry's spectacular growth has been paced by the increase of advertising pages in the annual IRE DIRECTORY.

In the 1949 edition, 158 advertisers took 133 pages. In the 1954 IRE DIRECTORY, the number of advertisers mushroomed to 501 and advertising pages numbered 358—an increase of 168% over the '49 edition.

The IRE DIRECTORY sells year 'round by serving over 35,000 IRE members who daily are developing and perfecting remarkable new devices. To sell ahead, put your product story before radio-electronic engineers who are planning ahead . . . in the 1955 IRE DIRECTORY.

**Engineers are educated  
to specify and buy.**

**IRE DIRECTORY**



Published by

**The Institute of Radio Engineers**

Adv. Dept., 1475 Broadway,  
New York 36, N. Y. BRyant 9-7550

# Electronics Engineers

*California Institute of Technology JET PROPULSION LABORATORY has desirable positions in the following fields. Applicants must have a minimum of B.S. degree.*

## RELIABILITY GROUP

To work on the reliability of electronic equipment as it concerns electronic circuits.

## NEW CIRCUIT ELEMENTS GROUP

To carry on independent research in the construction and application of devices utilizing the phenomena of solid state physics and related fields. Initial assignments might include investigation of new magnetic phenomena, dielectric amplifiers, transistors, or original research leading to the development of a stable frequency standard.

## ANTENNA GROUP

Work is particularly concerned with the analysis, development and design of radio frequency transmission and radiating structures.

## TELEMETERING ENGINEER

Must be familiar with audio and radio techniques. Instrumentation, transistor circuit design, and noise theory experience desirable.

## GROUND-RADAR ENGINEER

Must know pulse-radar techniques and servo mechanisms.

## TEST EQUIPMENT ENGINEER

Must have experience in the design of integrated test equipment employing radar and audio techniques.

## MISSILE MECHANICAL-ELECTRICAL ENGINEER

Must know gyroscopes and servo mechanisms plus precision machine work.

## INERTIAL GUIDANCE ENGINEER

For system analysis and development.

## GUIDANCE SYSTEM DESIGN AND ANALYSIS ENGINEERS

Must have experience in one or more of the following fields: noise and filter theory, ballistic and trajectory theory, radio or inertial guidance systems and techniques.

Send your summary  
of qualifications  
to:

California Institute of Technology  
**JET PROPULSION LABORATORY**  
4800 Oak Grove Drive  
Pasadena 3, California

# ELECTRONIC ENGINEERS and PHYSICISTS

We invite you to investigate the fine professional opportunities at Sperry. An enviable record of 43 years constant growth and expansion plus Sperry's 15 year club of more than 1500 employees is ample evidence of opportunity, good salaries, benefits and fine working conditions that make for a bright future.

**Design Engineers** — Klystron and traveling wave tubes, Magnetrons, Image orthicon, Solid state devices, Microwave measuring equipment.

**Production Engineers** — Power tube operation. Knowledge of tube assembly and processing techniques is essential.

**Measurements Engineers** — For microwave measurements on Klystrons and traveling wave tubes.



- RELOCATION ALLOWANCES
- LIBERAL EMPLOYEE BENEFITS
- ADEQUATE HOUSING IN BEAUTIFUL SUBURBAN COUNTRY TYPE AREA
- TUITION REFUND PROGRAM (9 graduate schools in area of plant)
- MODERN PLANT WITH LATEST TECHNICAL FACILITIES
- ASSOCIATION WITH OUTSTANDING PROFESSIONAL PERSONNEL

Apply in person or submit resume to Employment Office

**SPERRY GYROSCOPE CO.** (Division of the Sperry Corp.)

Marcus Ave. and Lakeville Road, Great Neck, Long Island, New York



News-New Products

These manufacturers have invited PROCEEDINGS readers to write for literature and further technical information. Please mention your I.R.E. affiliation.

(Continued from page 152A)

Two terminals are provided for the electrical connections. The mounting bushing may be grounded to the panel, and the integral insulation of the pilot light com-



pletely isolates the lamp circuit from ground.

This series is designed to employ any of the five standard midget flanged base incandescent lamps of voltages 1.3; 2.7; 6.0; 14.0; and 28.0. AN specifications are fully met.

"Omnidirectional" visibility is afforded.

All of the metal parts of these assemblies are made of brass with black nickel finish, or attractive white nickel or chrome when so ordered. Terminals are perforated for wire and tinned for easy soldering.

The series is designated as No. 101-3830 and is described in Bulletin L-156. Available on request. Samples will be sent without charge to engineers making such requests on company letterheads.

Please address inquiries to R. E. Greene at Dialight.

## Butler Appointed Sales VP of Speer Carbon

Appointment of Edward W. Butler as Vice President in charge of sales for Speer Carbon Co., St. Marys, Pa., has been announced by President Andrew Kaul III.



Butler will direct the sales of Speer Carbon's diversified lines of carbon and graphite products for electrical and automotive applications, graphite electrodes for furnace steel and chemical industries and various electronic components.

(Continued on page 156A)

## ENGINEERS

The APPLIED PHYSICS LABORATORY OF THE JOHNS HOPKINS UNIVERSITY offers an exceptional opportunity for professional advancement in a well-established laboratory with a reputation for the encouragement of individual responsibility and self-direction. Our program of

GUIDED MISSILE  
RESEARCH AND  
DEVELOPMENT

provides such an opportunity for men qualified in:

ELECTRONIC CIRCUIT DESIGN AND ANALYSIS  
DEVELOPMENT AND APPLICATION OF TRANSISTOR CIRCUITRY  
SERVOMECHANISMS AND CONTROL SYSTEM ANALYSIS  
ELECTRONIC EQUIPMENT PACKAGING  
INSTRUMENT DESIGN  
MISSILE SYSTEMS DEVELOPMENT  
FLIGHT TESTING

Please send your resume to

Glover B. Mayfield

APPLIED PHYSICS LABORATORY  
THE JOHNS HOPKINS UNIVERSITY  
8621 Georgia Avenue  
Silver Spring, Maryland

## OPPORTUNITY in MIDDLE WEST for PROJECT ENGINEERS and DEVELOPMENT ENGINEERS

in

Electronic Countermeasures  
Aircraft Communications  
Aircraft Radar  
Tape Recording  
Telemetry  
Digital Memory Devices

Minimum Requirements:  
B.S. Degree in E.E., plus  
Design Experience in at Least One  
of Above Mentioned Fields

Write

M. W. Kenney—Director of Engineering

J. P. SEEBURG CORP.

1510 Dayton St., Chicago 22, Ill.



# Sub-miniaturization

is

ITTY

BITTY

**BIG**

**BUSINESS**

"Sub-miniaturization" actually is a self-contradictory word because as radio components are engineered down to thimble and pinhead size, electronic applications in industry become wider and greater. Very soon, a tumbler-full of complex radio-electronic equipment will fly an airplane! Circuits have been flattened to postcard size, and radio-tubes to matchheads. "Radio" becomes a part of every industry!

The fast, far-reaching growth of the radio-electronic industry has been made possible by a vast amount of technical nourishment. More than 1,000 technical meetings a year are held by IRE's 38,000 members in eighty-one active sections in every part of the English speaking world. The volume of published information required to feed this engineered progress is enormous.

For forty years, without need of change of name or direction, The Institute of Radio Engineers has published its "Proceedings of the I·R·E" — a monthly magazine by radio-electronic engineers, for radio engineers. It is an unbridged, accurate, working textbook. 481 advertisers use its pages to keep their products before design men... to sell in the pre-specification stage of this dynamic industry.

*Engineers are educated  
to specify and buy.*



Published by  
THE INSTITUTE OF RADIO ENGINEERS  
Advertising Department  
1475 Broadway, New York 36, N. Y.  
BRyant 9-7550

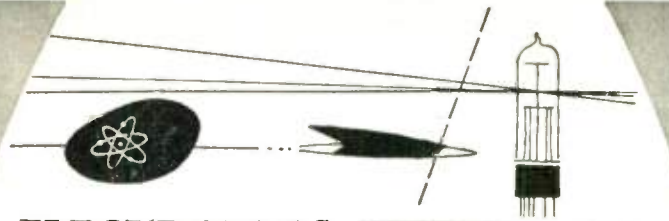

## ELECTRONICS

### ENGINEERS:

# Westinghouse AIR ARM OFFERS CREATIVE CAREERS!

New and exciting advanced development work at Westinghouse Air Arm Division presents unlimited creative opportunities for experienced engineers.

Top-level openings with this expanding operation offer unusual engineering opportunities, as well as income and benefits commensurate with the important nature of the assignments and the qualifications of the individuals selected.

- AUTOPILOT DEVELOPMENT
- FIRE CONTROL SYSTEMS
- RADAR SYSTEMS
- COMPUTERS
- SYSTEMS ANALYSTS
- ELECTRONIC CIRCUITS

### OPPORTUNITIES AND ADVANTAGES

<b>PROFESSIONAL RECOGNITION</b>	Opportunities for advanced study at company expense, and liberal patent disclosure compensation.
<b>WORKING ATMOSPHERE</b>	Both professional and friendly. Association with the leading scientists and engineers in their fields.
<b>SALARY</b>	Salary compensation individually determined according to experience and ability, and promotions based on individual merit.
<b>HOUSING CONDITIONS</b>	Excellent. Apartments and new homes readily accessible.

### WRITE TODAY FOR CONFIDENTIAL INTERVIEW:

*Illustrated brochure promptly forwarded to all qualified applicants.*

R. M. Swisher, Jr.  
Employment Supervisor, Dept. 71  
WESTINGHOUSE ELECTRIC CORP.  
2519 Wilkens Avenue  
Baltimore 3, Maryland

YOU CAN BE **SURE**...IF IT'S  
**Westinghouse**

Electronics  
Systems  
Electromechanical

# ENGINEERS

Analogue  
Computer  
Environmental  
Test  
Senior  
Microwave Research

To those engineers who prefer a variety of assignments on interesting, long-range projects, General Precision Laboratory offers an exceptional opportunity.

This growing research laboratory combines the challenge of exploring new fields with the stability afforded by a large and diversified parent organization—General Precision Equipment Corporation.

The location in New York's well-known Westchester County provides an ideal living and working environment—beautiful surroundings, high standard of living, and just one hour from New York City with its many cultural and educational facilities.

Men with interests in the above and related fields should submit resumes to Mr. H. F. Ware. Expenses will be paid for qualified applicants who come for interviews. We regret we can consider only U. S. citizens.

**GENERAL PRECISION  
LABORATORY INCORPORATED**  
A Subsidiary of General Precision Equipment Corporation  
63 Bedford Road Pleasantville, New York



**News-New Products**

(Continued from page 151A)

## Digital Voltmeter



The Delaware Products Co., 811 Broadway, Stevens Bldg., Camden 3, N. J., has developed a digital voltmeter which reads dc voltages onto three decimal decade scales. Readings are from 000 to 999. These readings may be calibrated as volts, millivolts, or any specified linear range within wide limits. Multiple ranges are available, and both positive and negative voltages may be measured. Readings may be periodic at intervals suited to visual or machine read out. Digital printers, or other digital read out equipment may be coupled to this digital voltmeter. Readings may be made on demand, and the reading will hold until a subsequent reading is called for. More than 20 complete readings per second are possible. This digital voltmeter uses the principle of converting voltage levels to time intervals, and indicating time as counts on decimal counting units. An internal standard cell is used as a reference. Standardization is continuous. No manual standardization is necessary.

### Capacitive Level Control

Capacitive level sensing with electronic controls terminating in air-pressure variations suitable for operating a pneumatic-diaphragm control valve are combined in a new Belmont Model DP Level Control, available from Thermo Instruments Co., 1310 County Rd., Belmont, Calif.

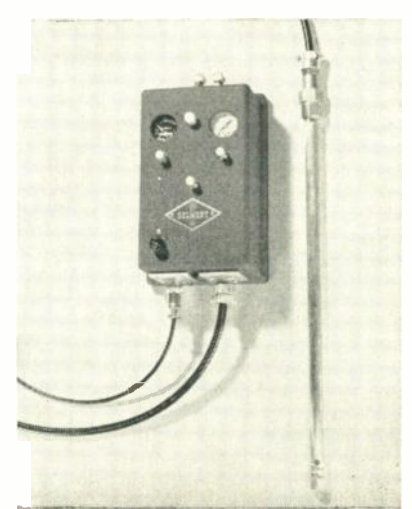

(Continued on page 158A)

### Electrical Engineers and Physicists

- Radar Simulation
- Advanced Circuitry
- Analog Computers
- Ballistics
- Mapping
- Telemetry

Senior and Junior Engineers

### A Job with Good "Contacts"

We offer you the opportunity to come in contact with an entire project, not with just a segment of the overall job. Here is your chance to join a firm with a future . . . to grow with us . . . to gain individual recognition by working closely with technical management. You will live and work in a delightful suburban community . . . associate with other top-notch engineers. If you are looking for a job with good contacts, write:

**Industrial Research Laboratories**  
Dept. B-1, Hilltop and Frederick Rds.  
Baltimore 28, Maryland

## TUBE ENGINEERS

### Research Or Development For SYLVANIA

2 TO 5 YEARS EXPERIENCE in tube development. Minimum B.S. Degree in Physics or E.E.-Ph.D. in Electronics-Physics acceptable in lieu of experience.

- Many engineers are needed for Sylvania's expanding tube research and development program in the laboratories at either Kew Gardens or Bayside, Long Island. Knowledge of electro-magnetic theory and electron dynamics essential. Experience in microwave phenomena especially desirable.

Relocation expenses will be paid by Sylvania.

Please forward resume to:  
**E. W. Doty**  
Manager of Personnel  
Research Laboratories  
**SYLVANIA**  
ELECTRIC PRODUCTS INC.  
Bayside, Long Island, N.Y.  
All inquiries will be answered within 2 weeks





There are  
**3 SPECIFIC WAYS**  
 in which "Proceedings of the I.R.E." serves the advertiser differently and more effectively than other publications.

**1. Pre-Specification Selling**

Because "Proceedings of the I.R.E." publishes basic research and engineering application articles it is closely studied by those design engineers who must "keep ahead of the market." Often, the research published leads the industry production by from two to six years! The alert engineer, who needs this amount of time for his own design applications and for tooling up and changing the production in his own factory, studies the "Proceedings of the I.R.E." carefully. Its articles keep him abreast with the changes that will inevitably come and make it possible for him to be ready for them. This is the time for you to sell the unknown engineer designing the never-dreamed-of product "before it happens!" It is an insurance that you will be ahead of the market instead of behind it.

**2. Personal Connection to the Individual**

The Institute of Radio Engineers is an engineering society for individual engineers who must qualify on their own education, experience and engineering work. Thus, the magazine follows the reader as his private possession, wherever he goes. Wherever new engineering progress is developing, the work is done by individual engineers—and it is these men that must be sold! Only the engineer knows enough to specify and buy in a highly technical industry. Selling is a matter of reaching the minds of men because a company cannot sign a purchase order. Wherever radio engineering activity is the greatest, companies employ IRE members. An engineer moves into a new job in advance of production and with him goes "Proceedings of the I.R.E.," with all the advertising you so urgently need to place where engineering activity is the greatest.

**3. Economy**

It is a specific purpose of the Institute of Radio Engineers that its advertising rates should benefit and help the industry grow, by being economical. Part of the economy of a tax-free organization is thus passed on to advertisers in the form of low-cost advertising to a high-quality audience. The page rate per thousand engineers of "Proceedings of the I.R.E." is the lowest in the radio-electronic industry by deliberate intent. Thus, the Institute finds an extra way that it can help the firms that hire its engineers to gain new business at lower costs.

**THE INSTITUTE OF RADIO ENGINEERS  
 ADVERTISING DEPARTMENT  
 1475 Broadway  
 New York 36, N.Y.**



Antenna assembly

*Gilfillan*

**GCA QUADRADAR**

**SHOULD YOU CHANGE YOUR JOB IN '55?**

**Several openings for electronics engineers at Gilfillan**

The outstanding success of the November-December field tests of the new Gilfillan GCA Quadradar points up the fact that Gilfillan offers engineers real creative opportunity as well as good salaries, rapid advancement and security. If you are thinking of making a change, we suggest you investigate current openings at Gilfillan.

**SECURITY**

Gilfillan is a major company, with 7 plants located throughout Southern California, that has been in business more than 40 years.

**SATISFACTION**

Gilfillan is big enough to handle all phases of engineering research, design and production, yet not so big you get lost. You have the very real satisfaction of following through on your work, getting credit for it, and seeing its achievements in the field.

**PRESTIGE**

Gilfillan pioneered GCA Radar and all its major improvements; is now engaged in automatic GCA, the new lightweight Gilfillan GCA Quadradar, missile guidance, navigational systems — and a series

of highly classified projects involving advanced and unsolved techniques for all branches of the military services.

Work is interesting at Gilfillan because ideas begin here. As a Gilfillan engineer, your value increases — because of the Gilfillan reputation, and because you work in coming fields.

**ADVANCEMENT**

You go ahead at Gilfillan as fast as you are ready. You are paid and advanced according to ability, not seniority. If you want further formal training, Gilfillan pays your tuition at UCLA or USC. You can be sure your ability will be recognized, because every man in a supervisory capacity at Gilfillan is a qualified engineer.

**Write:**

R. E. Bell, Gilfillan Bros., Dept. 15, 1815 Venice Blvd., Los Angeles, California. Give a brief resume of your background and experience. Interview at a convenient location will be arranged for qualified men.



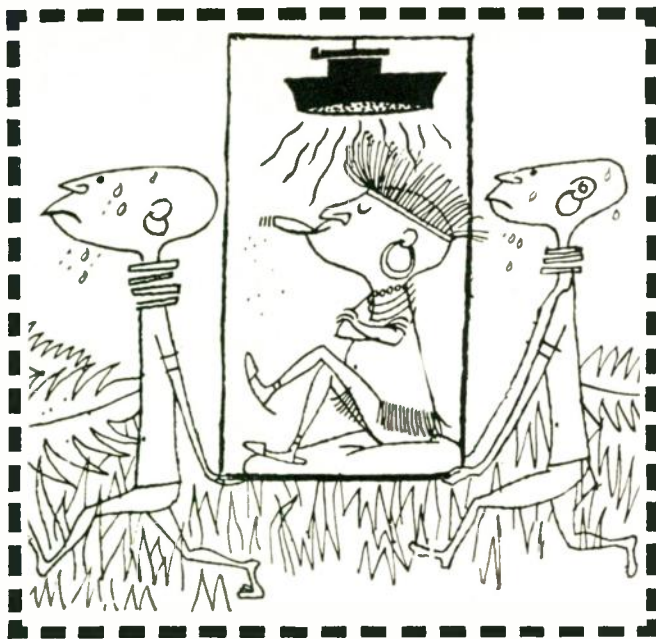

**Manufacturers of  
Specialty Rotating Equipment  
Including Motors, Fans & Blowers**

**air-marine motors Inc.**

369 Bayview Avenue  
Amityville, L. I., N. Y.  
AMityville 4-6122



West Coast Factory  
2055 Pontius Avenue  
Los Angeles 25, Calif.



**News-New Products**

These manufacturers have invited PROCEEDINGS readers to write for literature and further technical information. Please mention your I.R.E. affiliation.

(Continued from page 156A)

Applicable to most non-adhesive chemicals, milk, oils, refrigerants such as ammonia and the Freons, and all condensed gases over a temperature range from 500 to  $-425^{\circ}\text{F}$ , the control derives a sensing signal from an inert capacitive-type probe capable of being operated in applications ranging from high vacuum to pressures as great as 100,000 psi. The probe is connected by coaxial cable to the electronic circuitry which can be located as far as 1,000 feet from the sensing point.

The control unit includes a meter for observation of the output of the electronic control unit, and an air-pressure indicating instrument for observation of valve operation. Panel-front controls located under screw-on dust-protective caps provide for coarse level adjustment, fine adjustment, and differential in range of control (proportional-band adjustment). The complete instrument packed for shipment weighs 18 pounds.

**High-Z Miniature Delay Lines**

Advance Electronics Co., Inc., 451 Highland Ave., Passaic, N. J., has developed a line of high impedance miniature delay lines with high impedance, low attenuation, and essentially linear phase characteristics for color television circuits, oscilloscopes, pulse amplifiers, and others. The physical size and weight of these delay lines is less than  $6\frac{1}{2}$  inches long,  $\frac{1}{4}$  inch diameter, and weigh less than 6 ounces. The rise time less than 7 per cent of the time delay and substantially zero overshoot. The useful frequency bandwidth is over 10 mc. Hermetically sealed construction, operating temperature range from  $-55^{\circ}\text{C}$  to  $+105^{\circ}\text{C}$ , and 500 volts peak working voltage, are some of the features.

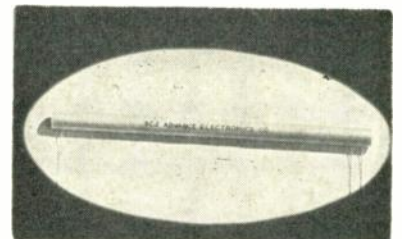

The specifications are as follows: Time delay is  $0.5 \mu\text{s}$  for Type 6C2a,  $0.7 \mu\text{s}$  for Type 6C2b, and  $0.9 \mu\text{s}$  for Type 6C2c. Different values of time delay can be furnished upon request. The characteristic impedance is 1,800 ohms nominal. The phase distortion is essentially 0 below 6 mc,  $-2^{\circ}$  at 8 mc, and  $-4^{\circ}$  at 10 mc. The attenuation is db per  $0.5 \mu\text{s}$  delay is less than 1 db at low frequencies, gradually increasing to 3 db at 6 mc, 4 db at 8 mc, and 6 db at 10 mc. The physical size is  $\frac{1}{4}$  inch diameter,  $3\frac{1}{2}$  inches for Type 6C2a,  $4\frac{1}{2}$  inches long for Type 6C2b, and  $6\frac{1}{2}$  inches for Type 6C2c.

(Continued on page 160A)

**GLAS-GUIDE**

**R. F. COMPONENTS  
MADE OF  
LAMINATED  
GLASS CLOTH**

Microwave Transmission Lines  
Fabricated in This Manner  
Offer the Following Superior  
Properties:

NON CORROSIVE

NON HEAT CONDUCTING

HIGH STRENGTH TO WEIGHT RATIO

CLOSE MECHANICAL TOLERANCES

FINE SILVERED CONDUCTING SURFACE

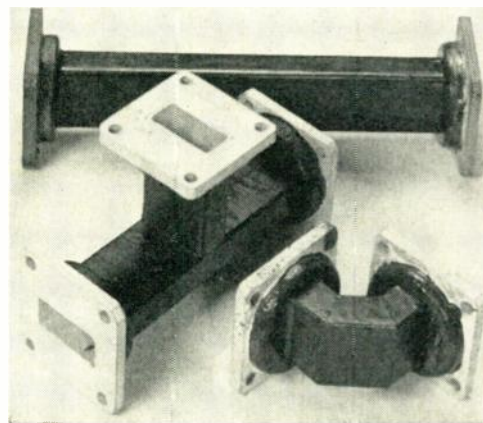

Straight sections, tees and mitered elbows are among the many components available as standard items. GLAS-GUIDE can also be made to your print.

"Don't say waveguide, say Glas-Guide"

Write today for complete data.

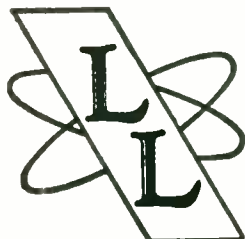

**LEE LABORATORIES, Inc.**  
Genesee, Pennsylvania



40 cps—200,000 cps

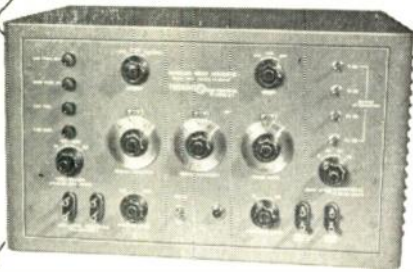

## PANORAMIC SWEEP GENERATOR

MODEL

# SG-1

Assures Convenient Accurate Analysis of Frequency Responses between 40-200,000 cps because of these Unique Advanced Engineering Features

**DIRECT READING SCREENS:** Frequency and amplitude calibrated for slave scopes.  
**FREQUENCY RANGE:** Log 40-20,000 cps or 400-200,000 cps true decade, selectable. Linear same as above. Two selectable linear sweepwidths calibrated and continuously variable from 20 kc to 100 cps, and 200 kc to 1 kc. Sweepwidth remains constant as calibrated center frequency control is varied anywhere between 0 to 200 kc.  
**AMPLITUDE SCALES:** Linear or 2 decade log.  
**OUTPUT VOLTAGE:** 2 volts into matched 600 ohm load, flat to within 5%. 75 db attenuation in 5 db steps.  
**RETURN SIGNAL AMPLIFIER AND ATTENUATOR:** Covering range of 40 millivolts to 200 volts.  
**DISTORTION:** At least 40 db below maximum output.  
**SCAN RATES:** 1 cps internal or 0.04 to 60 cps with Model TW-1 Triangular Wave Generator.  
**INTERNAL MARKERS:** Passive fundamental frequency null type. Fixed markers at 40, 1000 and 20,000 cps. Variable markers 20 to 200,000 cps in four decade steps.  
 Separate output for variable marker for use with Signal Alternator Model SW-1 for alternate presentation of marker and response characteristic under test.

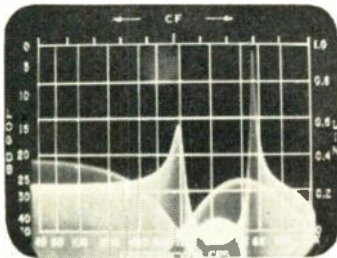

Response of an audio band stop filter with null marker showing frequency of one peak.

Write Today for Complete Specifications and Prices



12 South Second Ave., Mount Vernon, N.Y.  
 Mount Vernon 4-3970

Made by the makers of Panadaptor, Panalyzer, Panoramic Sonic Analyzer, and Panoramic Ultrasonic Analyzer

What's Your Use for...



## vernistat... The Revolutionary New Precision Variable-Ratio Transformer

Analog Computers? Servos? Control Systems? Vernistat is a completely different type of voltage divider combining low output impedance with an inherently high resolution and linearity not ordinarily attainable by precision potentiometers.

The Vernistat consists of a tapped auto-transformer which provides the basic division of voltage into several discrete levels. These levels are selected and further sub-divided by a continuous interpolating potentiometer that moves between 30 transformer taps.

Because of its unique operating principles, electrical rotation is held to close tolerances eliminating the need for trim resistors. In many applications there is also no need for impedance matching amplifiers.

Specifications of the standard model Vernistat are shown below. Other versions are under development to meet specific end uses.

What are your requirements for this unique precision voltage divider? Fill in the coupon now.

**vernistat division** PERKIN-ELMER CORPORATION  
 NORWALK, CONNECTICUT

### SPECIFICATIONS

Linearity Tolerance better than  $\pm 0.5\%$   
 Resolution better than 01%  
 Output Impedance 130 ohms (max.)  
 Max. Output Current 50 ma  
 Frequency 50-3000 cps  
 Other models including a miniaturized 400 cps version will be available in the near future.

vernistat division  PERKIN-ELMER CORPORATION  
 816 Main Avenue, Norwalk, Connecticut

Send me more information on the Vernistat.  
 The application I have in mind is as follows:.....

NAME.....  
 TITLE.....  
 COMPANY.....  
 ADDRESS.....

# Announcing PRECISION D-C VOLTMETER Model 124

The Model 124 Precision D-C Voltmeter produces an accurately adjustable reference voltage for comparison with the voltage to be measured. A null indicating meter is used to indicate equality of the two voltages. Voltages between 0 and 510 Volts can be measured. A very stable regulated power supply circuit is used as the internal voltage source. It can be standardized against a built-in standard cell by a switch and control on the front panel. The switch also controls the sensitivity of the null indicator when measurements are made.

Two sensitivity ranges are provided and are selected by a switch on the front panel.

On special order, the terminals of the reference voltage may be connected to a suitable receptacle on the front panel bypassing the null indicator.

Also available for relay rack mounting.

Voltmeters for other voltage ranges supplied on special order.



## Specifications:

- **VOLTAGE RANGE:** 0 to 510 Volts in steps of 10 Volts or 0 to 500 Volts in steps of 100 Volts; each step is subdivided by a vernier dial reading 10 Millivolts or 100 Millivolts, resp., per division.
- **ACCURACY:** When properly standardized, voltage indications are accurate within 0.1% in the "10 Volt" position of the range switch. Small voltage differences can be measured with an accuracy of better than 0.2% or 5 Millivolts, whichever is greater.
- **INPUT IMPEDANCE:** Infinite, after null balance is obtained.
- **DIMENSIONS:** 9½" wide by 12" high by 8" deep, excluding carrying handle and rubber feet. Front panel: 8¼" wide by 11" high.



**FURST  
ELECTRONICS, INC.**

3326 W. Lawrence Ave., Chicago 25, Illinois

**MERIT COIL** starts with  
the **FINEST . . . GARFIELD WIRE**  
to end with  
the **BEST . . . COILS and TRANSFORMERS**

Merit Coil and Transformer Co., of Chicago, is known for precision-engineered coils and transformers. When distributors can't take chances with anything less than the best, they specify MERIT.

And MERIT specifies GARFIELD WIRE every time! They know they can't go wrong with Garfield, whose modern equipment and stringent quality standards produce tolerances closer than NEMA standards.

When you specify Garfield you are SURE of getting UNIFORMITY—and top SERVICE along with QUALITY.

Write for your copy of our specifications chart on bare wire, plain and heavy enamel additions.

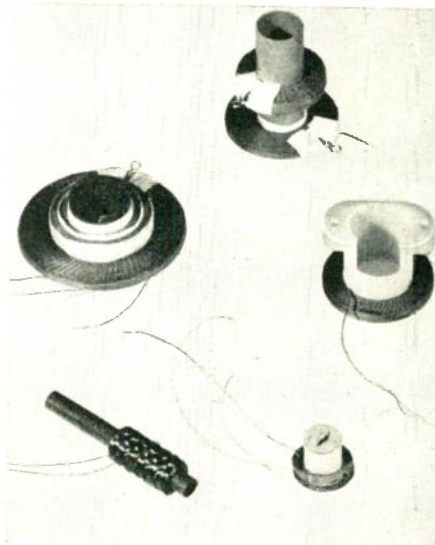

**GARFIELD WIRE DIVISION**

*of The Overlakes Corporation*

142 Monroe St., Garfield, N.J.

GRGregory 2-3661—2



**News-New Products**

These manufacturers have invited PROCEEDINGS readers to write for literature and further technical information. Please mention your I.R.E. affiliation.

*(Continued from page 158A)*

## Hermetically Sealed Differential Relays

A new line of differential relays which may be used for automatic overload, over-voltage, under-voltage or under-current protection is offered by Amperite Co., 561 Broadway, New York 12, N. Y. They reset automatically when the abnormal condition is removed.



Since the actuating element is a heater, the relay may be designed for time constants varying from approximately 3 to 30 seconds. It will not respond to transients

*(Continued on page 162A)*

## DIRECTRON

**INDUSTRIAL SELENIUM RECTIFIERS,  
TRANSFORMERS, CHOKES  
AND POWER SUPPLIES**

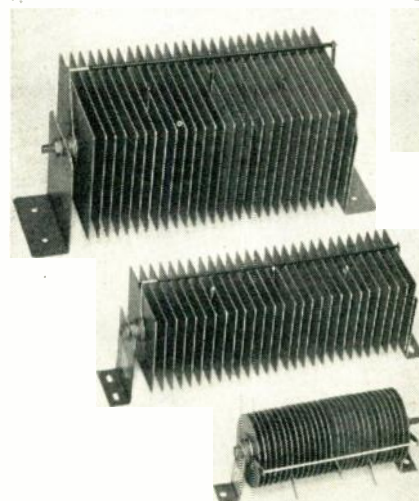

From 1 amp to 1000 amps . . . bridge, half-wave, center-tap, doubler, tripler and 3-phase types.

**New Item!—Fast Charger Rectifiers—**  
send for details

**SANFORD MILLER CO.**

691 Bedford Ave.  
Brooklyn 6, N. Y.





# THE Kenyon TWINS



**M LINE**

Meets All MIL-T-27 Requirements  
Completely hermetically sealed to meet MIL-T-27 specifications. Military Standard types are included. Catalog Listing M L

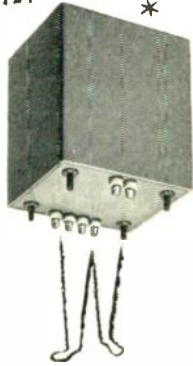

**C LINE**

Meets All Commercial Requirements

A complete line to MIL electrical specifications, housed in conventional cases. Satisfactory performance at substantial savings. Catalog Listing C L

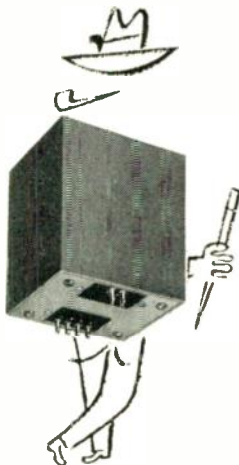

HOUSED IN CASES WITH STANDARD MIL-T-27 DIMENSIONS... BOTH LINES CARRY THE USUAL KENYON GUARANTEE

The new Kenyon Military and Commercial Lines feature the very latest practice, using the best class "A" wire and insulation now available, and the latest types of core material, to obtain minimum size at reasonable cost... Cases are identical to the requirements in the MIL-T-27 specifications. Full rating information and schematic is furnished in the form of a stencil on each case... Special units with other ratings and the same or similar cases are available on short delivery, in any quantity. Write for catalog. Your inquiry will receive prompt attention.



# KEARFOTT...

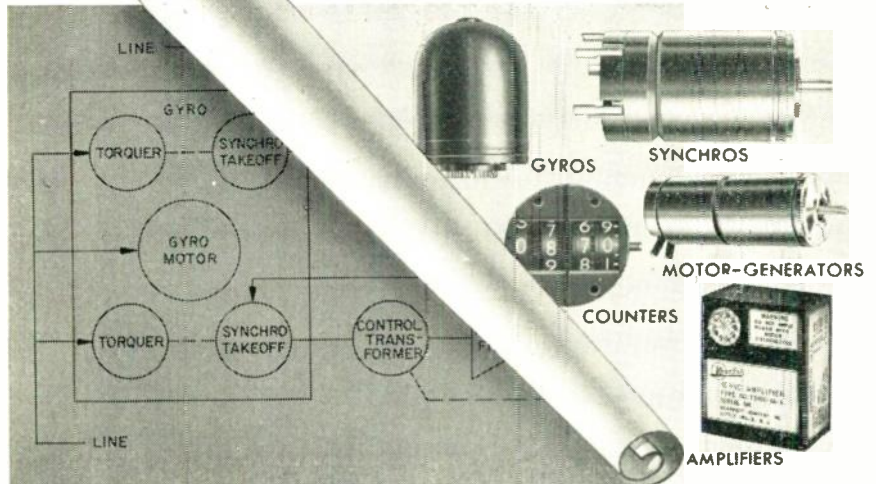

from  
problem  
through  
production

Engineering ability and production facilities are as important to you as the characteristics of the components you select. After components are approved, you are dependent upon your supplier... dependent upon him for engineering assistance... dependent upon his ability to produce quality products in the required quantities.

Many of the servo motors, synchros, gyros and systems in use today had their inception on the drafting boards of Kearfott's engineers. This is proof of Kearfott's engineering ability. Kearfott offers complete engineering service before, during and after the purchase of a component.

A modern building, over 430,000 square feet of floor space, equipped with the latest in precision machinery, manned by 3,000 highly skilled specialists, is your assurance of Kearfott's ability to produce.

Yes, Kearfott is a dependable source of supply. If you have a design problem or require a special or standard component, contact Kearfott.

### KEARFOTT COMPONENTS INCLUDE:

Gyros, Servo Motors, Synchros, Servo and Magnetic Amplifiers, Tachometer Generators, Hermetic Rotary Seals, Aircraft Navigational Systems, and other high accuracy mechanical, electrical and electronic components. Send for bulletin giving data of components of interest to you.



A SUBSIDIARY OF GENERAL PRECISION EQUIPMENT CORPORATION

### KEARFOTT COMPANY, INC., LITTLE FALLS, N. J.

Sales and Engineering Offices: 1378 Main Avenue, Clifton, N. J.  
Midwest Office: 188 W. Randolph Street, Chicago, Ill. South Central Office: 6115 Denton Drive, Dallas, Texas  
West Coast Office: 253 N. Vinado Avenue, Pasadena, Calif.

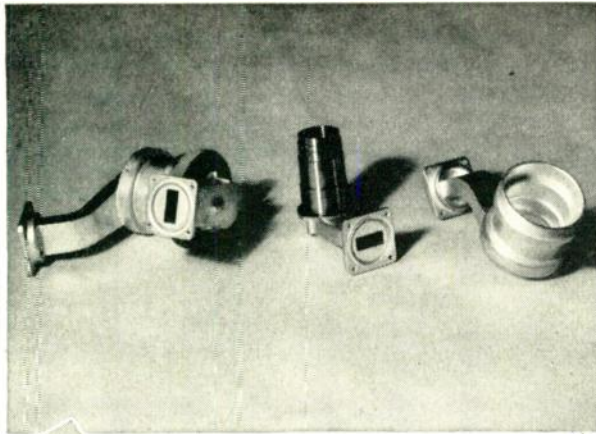
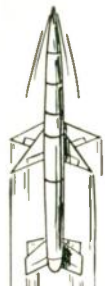

Microwave  
Assemblies,  
Radar Components,  
and Precision  
Instruments . . .  
manufactured and  
designed to your  
specifications.

**N.R.K. MFG. & ENGINEERING CO.**  
4601 W. Addison St., Chicago 41, Ill., SPing 7-2970  
West Coast Representatives  
TUBERGEN ASSOCIATES, 2232 W. 111th St., Los Angeles 6, Calif.



**News-New Products**

These manufacturers have invited PROCEEDINGS readers to write for literature and further technical information. Please mention your I.R.E. affiliation.  
(Continued from page 160A)

of shorter duration. Available in SPST—normally open or normally closed. Completely isolated contacts make many circuit variations possible. The relays can be designed for currents from 10 to 1,000 ma, voltages from 1 to 100 volts. Higher currents can be handled by an external contactor. Approximately 1 watt is required for the heater. However, the relay will withstand 100 per cent overload indefinitely.

The relay is available in either the standard octal base or nine-pin miniature. They are pre-set at the factory. Standard tolerance of voltage or current for opening and closing is  $\pm 10$  per cent. Closer tolerances are available on special order. The relay is hermetically sealed, and not affected by changes in temperature, pressure, or humidity. List price is \$4.00 each.

**1955  
RADIO ENGINEERING SHOW**  
March 21-24, 1955  
Kingsbridge Armory  
Kingsbridge Palace  
New York City

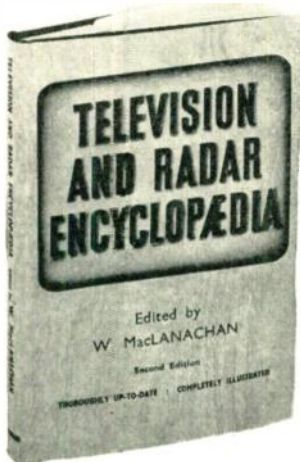

*Just published . . .  
the new  
second edition*

**Television and Radar  
Encyclopedia**  
edited by W. MacLanachan

The most up-to-the-minute guide to the principles, practice, and terminology of TV and Radar, this new edition belongs on your desk.

Here you'll find a wealth of reference and background material covering the latest developments in the field—presented in a very convenient and handy form.

The new Second Edition features many new definitions in addition to revising a large number of others in the light of the latest technical advances. For the first time the Encyclopedia defines such important developments as Automatic Picture Control, Compatible Color Television Systems, Flywheel Synchronization, Thermistors, and Transistors. Over 200 illustrations supplement the text material.

\$6.00 at your local bookstore or from:

**PITMAN Publishing Corporation**  
Phone: MURray Hill 7-2334

2 West 45th St.  
New York 36

**HICKOK**  
Model 209A

**true VTVM  
and  
CAPACITANCE TESTER**

- Large 9" meter.
- Measures wide ranges of capacitance, inductance, resistance, current, voltage; both AC and DC.
- Includes matched high frequency probe to make this laboratory instrument a TRUE VTVM.
- Write for technical details . . .

**THE HICKOK ELECTRICAL INSTRUMENT CO.**  
10551 Dupont Avenue, Cleveland 8, Ohio



# COMMUNICATIONS EQUIPMENT CO.

## 3 CM. ECHO BOX RF 3/AP

Cavity has a "Q" of 30,000 and is tuned by means of an internal 24 vdc motor. Unit is tunable over a range of 80 mc. When motor is left on, the tuning plunger goes thru the tuning range three times per minute. During the tuning motion, an eccentric cam on the mechanism causes an additional flutter action of the tuning disk at approximately 200 cycles per minute. This flutter range curves about 15 mc. This eliminates need of stopping the motor at the peak of the signal, and also gives a characteristic pattern to the echo signal. Input is to type "N" input jack. **-\$125.**

## MICROWAVE COMPONENTS

### 10 CM.—RG48/U Waveguide

10CM ECHO BOX: Tunable from 3200-3333 Mc. For checking out radar transmitters, for spectrum analysis, etc. Completely with pickup antenna and coupling devices. **-\$27.50**  
10 CM ANTENNA ASSEMBLY: 3000-3300 Mc. Parabolic Dish, 29 inch Diam. Fed from dipole Rotation: 360 Deg. Azimuth at speeds of 20 and 10 RPM. Tilt: 20 deg. above and below horizontal. Motor-Driven by 2-28V motor, 4.5 A Total drain. Azimuth info. is fed to relay mechanism and elevation data is obtained from Azimuth potentiometer. Net weight 65 lbs. **-\$78.50**

POWER SPLITTER for use with type 726 or any 10 CM Shepherd Klystron. Energy is fed from Klystron antenna through dual pick-up system to 2 type "N" connectors. **-\$22.50 EACH**  
LHTR. LIGHTHOUSE ASSEMBLY. Parts of RT39 APG 5 & APG 15. Receiver and Trans. Cavities w/assoc. Tr. Cavity and Type N C/PiA. To Recvr. Uses 2C40, 2C43, 1B27, Tunable APX 2400-2700 MCS. Silver Plated. **-\$22.50**  
BEACON LIGHTHOUSE cavity p/o UPN-2 Beacon 10 cm. Mfr. Remard Rise, each **-\$27.50**  
MAGNETRON TO WAVEGUIDE. Type 721-A Duplexer Cavity, gold plated. **-\$45.00**  
721A TR BOX complete with tube and tuning plungers **-\$12.50**

MENALLY KLYSTRON CAVITIES for 707B or 2K28, 2700-2800 Mc. **-\$4.00**  
WAVEGUIDE TO 7/8" RIGID COAX. "DOOR-KNOR" ADAPTER. CHOKE FLANGE SILVER PLATED BROAD BAND **-\$32.50**  
AS14A AP-10 CM Pick up Dipole with "N" Cables **-\$4.50**  
HOLMDELL-TO-TYPE "N" Male Adapters, W. E. 2D167284 **-\$2.75**  
I.F. AMP. STRIP: 30 MC, 30 d.b. gain, 4 MC Band-width, uses 6AC7s—with video detector, A.F.C. less tubes. **-\$2.00**  
BEACON ANTENNA. AS31/APN-7 in Lucite Ball. Type "N" feed **-\$22.50**  
ANTENNA. AT49A/APR: Broadband Conical, 300-3300 MC Type "N" Feed **-\$12.50**  
"E" PLANE BENDS, 90 deg. less flanges. **-\$7.50**

### 3 CM.—RG 52/U Waveguide

3 CM ANTENNA ASSEMBLY: Uses 17" paraboloid dish, operating from 24 vdc motor. Beam pattern: 5 deg. in both Azimuth and elevation. Sector Scan: over 180 deg. at 35 scans per minute. Elevation Scan: over 2 deg. Tilt: Over 24 deg. **-\$85.00**  
Cross-Guide Directional Coupler, UG-40 output flange. Main Guide is 6" Long, with 90 Deg. "E" Plane bend at one end, and is fitted with Strd. UG 39/UG 40 flanges. Coupling figure: 20 db Nominal **-\$22.50**  
FLEX. WAVEGUIDE SECTION, 1 ft. long. With UG-40/UG-39 flanges. Attention: in less than 0.1 db. at 9375 mc, and VSWR is less than 1.02. Rubber covered. **-\$7.50**

## JAN WAVEGUIDE FLANGES

UG 39/U	\$1.10	UG 51/U	\$1.65
UG 40/U	\$1.25	UG 52/U	\$3.40
UG 40A/U	\$1.85	UG 52A/U	\$3.40

1" x 1/2" waveguide in 5' lengths, UG 39 flanges to UG40 cover. Silver plated. **per length \$5.00**  
Rotating-joints supplied either with or without deck mounting. With UG40 flanges each, **\$17.50**  
Bulkhead Feed-Thru Assembly **-\$15.00**  
Pressure Gauge Section 15 lb. gauge and press nipple **-\$10.00**  
Pressure Gauge, 15 lbs. **-\$2.50**  
Directional Coupler, UG-40 Take off 20db **\$7.50**  
TR-ATR Duplexer section for above. **\$8.50**  
Rotary Joint choke to choke with deck mounting **-\$17.50**  
90 degree elbows, "E" plane 2 1/2" radius **-\$12.50**  
Microwave Receiver, 3 CM. Sensitivity: 10-13uWatts. Complete with L.O. and AFC Mixer and Waveguide Input Circuits, 6 I.F. Stages give approximately 120 DB gain at a bandwidth of 1.7 MC. Video Bandwidth: 2 MC. Uses latest type AFC circuit. Complete with all tubes, including 723A/B Local Oscillator. **-\$175.00**  
ADAPTER, waveguide to type "N", UG 81/U, p/o TS 12, TS-13, Etc. **-\$14.50**  
ADAPTER, UG-163/U round cover to special btl. Flange for TS-45, etc. **-\$2.50 ea.**

## JAN/UG CONNECTORS

UG 9/U	\$1.15	UG 27A/U	\$2.50	UG 188/U	\$1.20
UG 10/U	1.25	UG 29/U	.85	UG 254/U	1.35
UG 22/U	1.25	UG 58/U	.65	UG 261/U	1.10
UG 22B/U	1.20	UG 85/U	1.25	UG 280/U	1.15
UG 24/U	1.25	UG 102/U	1.85	UG 306/U	2.35
UG 27/U	1.20	UG 176/U	.25		

## THERMAL DELAY RELAYS

Stock No.	Heater V	Contact*	Delay (Sec)	Price
30120	6.3	NC	30	\$2.25
8-1608	6.3	NO	25	2.40
B-1612	6.3	NO	5	1.85
6C10	6.3	NC	10	1.85
12C5	12	NC	5	1.75
12C10	12	NC	10	1.85
12C45	12	NC	45	2.45
26N05	24-28	NO	8	2.25
26N010	24-28	NO	10	2.25
26N015	24-28	NO	15	2.40
26N020	24-28	NO	20	2.40
26N030	24-28	NO	30	2.40
26N060	24-28	NO	60	2.40

\*NO—Normally open, NC—Normally closed. All contact ratings are 3A at 115 VDC or 250 VAC, and are SPST. Units are enclosed in glass tube envelope with octal base.

## MAGNETRONS

Type	Peak Range (MC)	Peak Power Out (KW)	Duty Ratio	Price
2121A	8345-9405			\$ 8.75
2122	8267-8333	265		7.50
2126	2992-3019	275	.002	7.49
2127	2965-2992	275	.002	13.50
2129	2914-2939	275	.002	44.95
2131	2820-2860	285	.002	21.50
2132	2780-2820	285	.002	21.50
2138*	8248-8263			8.50
2139*	8267-8333	8.7		8.50
2148	9310-9320	50	.001	24.50
2149	9000-9160	50	.001	54.50
2158*	9215-9275	50	.001	132.50
2162†	2914-3010	35	.002	32.50
3131	2740-2780	50	.001	82.50
4134	2740-2780	900		87.50
4138	3550-3600	750	.001	125.00
4142†	870-730	30	.003	169.50
5123	1044-1056	475	.001	49.50
700B	690-700	40	.002	22.50
700E	710-720	40	.002	39.75
706Y	3038-3069	200	.001	32.50
706C	2778-3007	200	.001	249.50
QK259†	2900-2900	800	.001	249.50
QK60†	2840-3005	.100	CW	65.00
QK61†	2975-3170	.100	CW	65.00
QK62†	3135-3350	.100	CW	65.00

\*—Packaged with magnet.  
†—Tunable over indicated range.

## TEST EQUIPMENT

IE 19	TS 34 A	TS 100
IE 36	TS 35 A	TS 110
I-104	TS 56 A	TS 159 TPX
TS 10 A	TS 47 APR	TS 268/U
TS 16	TS 100	TSX 4 SE

## POWER TRANSFORMERS

COMBINATION—115V/60 ~ INPUT		
CT-133	150-C-150V/65MA, 6.3V/2.5A, 6.3V/0.6A	\$1.79
CT-312	290-0-290V/90MA, 5VCT/3A, 6.3VCT/2.8A	3.25
CT-127	900V/25MA PK. 5V/2A, 2V/7.5A	2.79
CT-006	350-0-350V/120MA, 5VCT/3A, 2.5VCT/12.5A, 2.5VCT/3.5A	6.10
CT-965	78V/0.6A, 6.3V/2A	1.95
CT-004	350-0-350V/90MA, 5VCT/3A, 2.5VCT/12.5A	4.60
CT-002	350-0-350V/50MA, 5VCT/2A, 2.5VCT/7.5A	3.65
CT-479	7000V/.018A (2 X Ind. V. Test) 2.5V 5A/17,800 V, Test	29.50
CT-013	450-0-450V @ 200MA, 10V/1.5A, 2.5V 3.5A 5V/3A	6.95
CT-403	350VCT .026A 5V/3A	2.75
CT-931	585VCT .086A 5V/3A, 6.3V/6A	4.25
CT-442	525VCT 75MA 5V/2A, 1CT/2A, 50V/200 MA	3.85

### PLATE—115V/60 ~ INPUT

PT 034	125V/45MA	\$1.15
PT 157	680-0-680VAC (500VDC) or 550-0-550VAC (400VDC) at 250 MADC.	8.70
PT 159	900-0-900 VAC (750VDC) or 800-0-800 VAC (600VDC) at 225 MADC	10.35
PT 167	1400-0-1400 VAC (300MADC) or 1175-0-1175 VAC (100VDC) at 300 MADC	25.50
PT 168	2100-0-2100 VAC (1750VDC) or 1800-0-1800 VAC (1500VDC) at 300 MADC	33.00
PT 371	210-0-210V at 2.12 Amp.	9.45
PT 133	3140/1570V, 2.36KVA	105.00
PT 801	22,000V/234 MA, 5.35 KVA	135.00
PT 521	7500V/0.6A, Half-Wave	85.00
PT 913	2500V/1/2 MA H'SLD	4.95
PT 12A	280VCT/1.2A	3.95
PT-38-2	37.5/40V AT 750 MA	2.15

## PULSE NETWORKS

19A-1-400-50: 15 KV. "A" CKT. 1 microsec. 400 PPS. 50 ohms imp. **-\$24.90**  
G.E. 538 (3-84-810): 8-24-405 50P45 3KV "E" CKT Dual Unit; Unit 1, 3 sections. 0.84 Microsec. 810 PPS. 50 ohms imp.; Unit 2, 8 Sections. 2.24 microsec. 405 PPS 50 ohms imp. **-\$6.50**  
7-5E3-1-200-67P. 7.5 KV "E" Circuit. 1 microsec. 200 PPS, 67 ohms impedance 3 sections **-\$7.50**  
7-5E4-16-60, 67P. 7.5 KV "E" Circuit, 4 sections 16 microsec. 60 PPS, 67 ohms impedance **-\$15.00**  
7-5E3-3-200-67P. 7.5 KV. "E" Circuit, 8 microsec. 200 PPS. ohms imp. 3 sections **-\$12.50**  
775: 10KV. 2.2usec., 375 PPS. 50 ohms imp. **-\$27.50**  
7754: 10KV. 0.85usec., 750 PPS. 50 ohms imp. **-\$27.50**  
KS8865 CHARGING CHOKE: 115-150 H @ .02A. 32 -40H @ .03A. 21KV Test **-\$37.50**  
G.E. 355S-1-350-80 PPR, "E" SKT. 1 Microsec. Pulse @ 360 PPS. 50 OHMS Impedance **-\$69.50**  
KS9823 CHARGING CHOKE: 16H @ 75 MA, 880 Ohms DCR, 9000 Vac test **-\$14.95**  
G.E. 8E3-5-2000 50 PPT: 6 KV., "E" Circuit 0.5 usec /3000 PPS/50 ohms/2 sections **-\$7.50**

## PULSE EQUIPMENT

MIT. MOD. 3 HARD TUBE PULSER: Output Pulse Power 144 KW (12 KV at 12 amp.) Duty Ratio: .001 max. Pulse duration: 6, 1.0, 2.0 microsec. Input voltage: 115 v. 400 to 2400 cps. Uses: 1-71B, 4-89-B, 8-72's, 1-73. New **-\$135.00**  
ASD Modulator Unit, mfd. by Sperry. Hard tube pulser delivers Pk. pulse of 144 kw. Similar to Mod. 3 unit. Brand new, less tubes **-\$85.00**  
Airborne RF Head, model 204, delivers 50 Kw peak output at 9000 mc, .001 duty. Complete with pulser unit and all tubes. Used, excel. **-\$185.00**

## PULSE TRANSFORMERS

Westinghouse 4P37: Primary: 50 ohms imp. 750 v. Sec. 15 kv. 1000 ohms imp. Bililar filament trans. built in, delivers 12.8 v at 2.5 amp. (pri. 115 v. 400 cy.) **-\$37.50**  
RAYTHEON WX 4298E: Primary 4KV, 1.0 USEC. SEC: 16KV-16 AMP DUTY RATIO: .001 400 CYCLE FIL. TRANS. "BUILT-IN" **-\$42.50**  
WECO: KS 8948: Primary 70 Ohms; Sec: 50 Ohms. Plate Voltage: 18 KV. Part of APQ-13 **-\$12.50**



GE 8K-2449A  
Primary: 9.33 KV, 50 ohms Imp.  
Secondary: 28 KV, 450 ohms  
Pulse length: 1.0/5 usec @ 635/120 PPS, Pk Power Out: 1.740 KW  
Bifilar: 1.5 amps (as shown) **-\$62.50**

GE 8K-2748-A, 0.5 usec @ 2000 Pps. Pk. Pwr. out is 32 KW Impedance 40/100 ohm output. Pri. volts 2.5 KV Pk. Sec. volts 11.5 KV Pk. Bifilar rated at 1.3 Amp. Fitted with magnetron well **-\$39.50**  
K-2745 Primary: 3.1/2.8 KV, 50 ohms Z. Secondary: 14/12.6 KV 1025 ohms Z. Pulse Length: 0.25/1.0 usec @ 600/600 PPS, Pk. Power 200/150 KV. Bifilar: 1.3 Amp. Has "built-in" magnetron well **-\$42.50**  
K-2461-A, Primary: 3.1/2.6 KV-50 ohms (line). Secondary 14/11.5 KV-1000 ohms Z. Pulse Length: 1 usec @ 600 PPS. Pk. Power 200/150 KV. Bifilar: 1.3 Amp. Fitted with magnetron well **-\$39.50**  
K35145—Pulse Inversion: PRI: 5 KV PK. Pulse Negative, Sec: Pos. Pulse, 4 KV; 1 usec. and .001 DUTY RATIO **-\$6.50**  
54J318-1-3 w/dgs. Ratio: 1:1:1, 1.10 uh./wdg., 2.5 ohms DCR **-\$3.50**  
UTAH X-1511-1: Dual Transformer, 2 Wdg. per section. 1:1 Ratio per sec 13 MH Inductance 50 ohm DCR. **-\$5.00**  
UTAH X-1507-1: Two sections, 3 Wdg. per section. 1:1:1 Ratio, 3 MH, 6 ohms DCR per Wdg. **-\$5.00**  
68G711: Ratio: 4:1 Pri: 200V, Sec. 53V, 1.0 usec Pulse @ 2000 PPS, 0.016 KV. **-\$4.50**  
TR1049 Ratio 2:1 Pri. 220 MH, 50 Ohms, sec. 0.75 H. DCR 100 Ohms **-\$6.75**  
K-90465-501: 100 V. Pri. Imp. 40 Ohm, Sec. Imp. 40 Ohms. Passes pulse 0.6 usec with 0.05 usec rise **-\$8.95**  
Ray UX 7896—Pulse Output Pri, 5v sec. 41v **-\$7.50**

## DELAY NETWORKS

D-168184: 0.5 usec. up to 2000 PPS, 1800 ohms **-\$4.00**  
D-170499: 0.25/.5/.75usec. 8 KV., 50 ohms **-\$12.50**  
D-165977 Delay: 1.25 usec. **-\$6.50**  
RCA 6255686-502: 1.7 usec, 1400 ohm impedance **-\$2.00**  
D-162311. Delay of 0.5 usec, 72 ohms with 4 MC. Bandwidth **-\$4.75**  
D-168435. Delay 0.5 usec, 555 ohms, 5mc. BW **-\$4.50**  
D-172578. 416 ohms imp., 0.22 usec. Delay **-\$4.75**  
D-150979: Oscillating network. Oscillates at 81,955 kc. When normal current of 10ma. is interrupted, Has built-in temperature control for stability. Assembled in shielded can 4" L x 4" Diam. **-\$7.50**

## THERMISTORS

D-164699 Bead Type DCR: 1525-2550 Ohms @ 75 Deg. F. Coefficient: 2% Per. Deg. Fahr. Max. Current 25 MA AC/DC **-\$2.50**  
D-167332 Bead Type DCR is 1525-2550 Ohms. Rated 25 MA at .825-1.175 VDC **-\$1.35**  
D-167613 Disk Type DCR: 355 Ohms @ 75 Deg. F. P.M. 2.5%, 1 Watt **-\$1.35**  
D-166228 Disk Type 7120 Ohms @ 60°F. 4220 Ohms @ 80°F. 2590 Ohms @ 100°F., 1640 Ohms @ 120°F. **-\$1.35**

MAIL ORDERS PROMPTLY FILLED. ALL PRICES F.O.B. NEW YORK CITY. 25% DEPOSIT WITH ORDER. BALANCE C.O.D. RATED CONCERNS SEND P. O.

131 Liberty St., New York 7, N. Y. Dept I-1 Chas. Rosen Phone: DIgby 9-4124

# PROFESSIONAL ENGINEERING CARDS

## ALFRED W. BARBER LABORATORIES

Specializing in the Communications Field and  
in Laboratory Equipment  
Offices, Laboratory and Model Shop at:  
32-44 Francis Lewis Blvd., Flushing, L.I., N.Y.  
Telephone: Independence 3-3306

## THOMAS H. BRIGGS Electronics Consultant

ELECTRON TUBES—Materials, processing, ap-  
plications and reliability  
AUTOMATION—Printed wiring, and electro-  
mechanical device developments  
Box 185, RD#2 Tel. No. 8-7671  
Norristown, Pennsylvania

## Edward J. Content, P.E. and Staff INTERNATIONAL RADIO CONSULTANTS

Pan American Radio Tangier Int'l Zone  
Bldg., 16 Rue Delacroix Morocco  
Specialized in the design, construction,  
foreign, Electronic, projects, and advising  
governments at Int'l Telecommunications  
Union.

## CROSBY LABORATORIES, INC.

MURRAY G. CROSBY & STAFF  
RADIO-ELECTRONIC RESEARCH  
DEVELOPMENT & ENGINEERING  
COMMUNICATIONS, FM & TV  
ROBBINS LANE  
HICKSVILLE, NEW YORK  
HICKSVILLE 3-3191

## ELDICO OF NEW YORK, INC.

Donald J. S. Merten and Engineering Staff  
Consultants on Interference Elimination  
from Transmitters, Induction Heaters,  
Diathermy, etc.  
72 East Second Street, Mineola, L.I., N.Y.  
Pioneer 6-5212

## TRANSISTOR ENGINEERING

S. Moskowitz D. D. Grieg N. J. Gottfried  
Product Transistorization. Complete service in  
consulting, research, development, and produc-  
tion on transistor circuitry, products and in-  
strumentation.  
c/o Electronic Research Associates, Inc.  
715 Main Street, N. Caldwell, N.J.  
CALDWELL 6-6729

## ELK ELECTRONIC LABORATORIES, INC.

Jack Rosenbaum  
Specializing in design and development of  
Test Equipment for the communications,  
radar and allied fields.  
333 West 52nd St., New York 19, PL-7-0520

## FREDERICK RESEARCH CORPORATION

Carl L. Frederick, D.Sc., President  
Bethesda 14, Maryland • OLiver 4-5897  
Engineering Research and Development, Evalua-  
tion, Technical Writing and Publishing—Elec-  
tronic and Electro-mechanical Systems, Test  
Equipment, Radio Interference, Instrumentation,  
Controls.

## PAUL GODLEY CO.

Consulting Radio Engineers  
P.O. Box J, Upper Montclair, N.J.  
Offs & Lab.: Great Notch, N.J.  
Phone: Montclair 3-3000  
Established 1926

## GOVERNMENT CONTRACT LIAISON AND CONSULTANTS

### GORDON ASSOCIATES, INC.

Specializing in Signal Corps Electronic Require-  
ments, Technical Manuals, Tabular List of  
Parts, Drawings  
L. Gordon, Pres. P. Treston, Ch. Eng.  
157 Broad Street Telephone  
Red Bank, New Jersey Red Bank 6-2743

## HIGHLAND ENGINEERING CO.

William R. Spittal & Staff  
Specialize in Design and Development of  
Transformers, Chokes, etc.  
for the  
Electronic, Industrial and Allied Fields.  
Westbury, L.I., N.Y. WESTbury 7-2933

## HOGAN LABORATORIES, INC.

John V. L. Hogan, Pres.  
APPLIED RESEARCH, DEVELOPMENT,  
ENGINEERING  
Est. 1929. Electronics, Optics, Mechanisms,  
Facsimile Communication, Digital Computers,  
Electro-sensitive recording media, Instrumenta-  
tion.  
155 Perry Street, New York 14 CHelsea 2-7855

## INTERFERENCE TESTING AND RESEARCH LABORATORY, INC.

Rexford Daniels E. T. Buxton P. B. Wilson  
150 Causeway Street, Boston 14, Mass.  
Lafayette 3-7826  
Specializing in the design and testing of  
equipment to meet Military and FCC specifica-  
tions for radio interference.

## LEONARD R. KAHN

Consultant in Communications and Electronics  
Single-Sideband and Frequency-Shift Systems  
Diversity Reception - Modulation Theory  
Television Systems  
Elizabeth Bldg., 22 Pine St., Freeport, L.I., N.Y.  
Freeport 9-8800

## George W. Baker, Pres. KIP ELECTRONICS CORPORATION

Electron tube consulting and design.  
Research and development and preparation of  
prototype electron tubes.  
29 Holly Place,  
Stamford, Connecticut  
Phone 48-5328

Harry W. Houck Martial A. Honnell  
John M. van Beuren

## RESEARCH ENGINEERS

Specialists in the Design and  
Development of Electronic Test Instruments  
c/o MEASUREMENTS CORP.  
BOONTON, N.J.

L. J. CASTRIOTA M. WIND  
S. W. ROSENTHAL P. G. MARIOTTI

## Microwave Consultants

Radio Frequency and Microwave Components  
Cable—Waveguide—Coax  
Dielectric Evaluation  
Telephone G.P.O. Box 844  
BOulevard 3-2096 Brooklyn 1, N.Y.

## Olympic Radio & Television, Inc.

Radio—Electronics  
Consulting—Research—Development  
Environmental Tests Performed  
for the Industry  
B. Parzen — E. Bradburd  
Olympic Building, Long Island City 1, N.Y.  
STillwell 4-6961

## EVERT M. OSTLUND

Consulting Radio Engineer  
Radio—Microwave  
Communication—Control  
Systems and Equipment  
Planning, Research, Development  
ANDOVER, NEW JERSEY  
Tel.: Lake Mohawk 8635

N. G. Parke S. J. O'Neil

## Parke Mathematical Laboratories, Inc.

Specialists in engineering analysis and  
computation in the fields of electronics and  
aeronautics.  
Independence Court • Concord, Massachusetts  
Telephone Concord 827

## PENN-EAST ENGINEERING CORPORATION

(Formerly—Atlantic Electronics Corp.  
of Port Washington, N.Y.)  
Designers of Industrial Controls  
Gerold L. Tawney, Robert R. Sparacino,  
Warren M. Janes, Arthur J. Pretty,  
Richard C. Tawney  
P.O. Box 240, Telephone Kutztown 2675

## PICKARD AND BURNS, INC.

Consulting Electronic Engineers  
Analysis and Evaluation of Radio Systems  
Research, Development, Design and Production  
of Special Electronic Equipment and Antennas.  
240 Highland Ave. Needham 94, Mass.

## RADIO SONIC CORP.

ENGINEERS—QUALITY ASSURANCE  
Testing, Processing  
Electron Tubes, Semiconductors, Models, Produc-  
tion Test Equipment, Antennas, Analyzers, Power  
Supplies, Ultrasonics, Advanced Development  
G. EMERSON PRAY, PRESIDENT  
32 W. 22nd St., New York 10, N.Y. ORegon 5-0085

## Paul Rosenberg Associates

Consulting Physicists  
100 STEVENS AVE. • MOUNT VERNON, NEW YORK  
CABLE: PHYSICIST MOUNT VERNON 7-8040

## M. D. Ercolino and Associates ANTENNA CONSULTANTS

Research and Development  
Communication Arrays  
Commercial and Amateur  
FM and TV  
c/o TELREX, INC. ASBURY PARK, N.J.  
Phone Prospect 5-7252

## WHEELER LABORATORIES, INC.

Radio and Electronics  
Consulting — Research — Development  
R-F Circuits — Lines — Antennas  
Microwave Components—Test Equipment  
Harold A. Wheeler and Engineering Staff  
Great Neck, N.Y. HUnter 2-7876

## 1955 RADIO ENGINEERING SHOW

March 21-24, 1955  
Kingsbridge Armory  
Kingsbridge Palace  
New York City



# PRECISION

ANNOUNCES THE

## Model E-300

### SINE-SQUARE WAVE SIGNAL GENERATOR

(AUDIO-VIDEO RANGE)



The Series E-300 provides sine and square wave signals of high accuracy and stability for direct-performance testing of:

- ▶ High Fidelity Audio Amplifiers
- ▶ TV Video Amplifiers
- ▶ Carrier Current Systems, etc.

#### GENERAL SPECIFICATIONS

- ★ Variable-Frequency Sine Wave Ranges: 20 Cps. to 200 KC. in Four Bands.
  - ★ Variable Frequency Square Wave Ranges: 20 Cps. thru 20,000 Cps. In Three Bands.
  - ★ Four Fixed, High-Frequency Square Waves: for analysis of wide-band amplifiers up to 20 MC band width: 50 KC.—100 KC.—250 KC.—500 KC. steps.
  - ★ Output Characteristics:
    - Variable Frequency Ranges: 0-2000 ohms, 0-10 volts RMS,  $\pm 1$  db. Accuracy:  $\pm 2\%$  from 50 cycles to 200 KC.  $\pm 1$  cycle from 20 cycles to 50 cycles. Distortion: Less than 1% from 20 cycles through 200 KC.
    - 20 KC Square Wave Rise Time: .5 microseconds.
    - Fixed High Frequency Square Waves: 0-250 ohms, 0-5 volts P-P Rise Time: .05 microsecond Overshoot: Negligible
  - ★ Tube Complement: 1-5B79, 1-6CL6, 1-6J6, 2-6AU6, 1-6BL7, 1-6AH6, 1-6X4.
  - ★ Separate Output Circuits: for the variable and fixed frequency ranges.
  - ★ Terminated, Low-Loss, High Frequency Coaxial Output Cable
  - ★ External 'Sync' Terminal Post: for synchronizing scope to H.F. square wave.
  - ★ Etched-Anodized Tuning Dial and Panel
- MODEL E-300: in black, ripple finished, portable steel case—10½ x 12 x 6". Complete with tubes, coaxial, output cable and operating manual.....Net Price \$175.00

#### PRECISION APPARATUS CO., INC.

70-31 84th Street, Glendale 27, L. I., N. Y.

Export: 45B Broadway, New York 13, U. S. A.  
Canada: Atlas Radio Corp., Ltd., 580 King St., W., Toronto 2B

## INDEX AND DISPLAY ADVERTISERS

Meetings with Exhibits .....	2A
News and New Products .....	16A
IRE People .....	38A
Industrial Engineering Notes .....	56A
Professional Group Meetings .....	86A
Section Meetings .....	90A
Membership .....	100A
Positions Open .....	130A
Positions Wanted .....	138A

## DISPLAY ADVERTISERS

Acme Electric Corp. ....	56A
Advance Electric & Relay Co. ....	72A
Advance Electronics Co. ....	165A
Aerovox Corp. ....	101A
Air Marine Motors, Inc. ....	158A
Airtron, Inc. ....	84A
Airtron, Inc. (Empl.) ....	136A
Alford Mfg. Co. ....	84A
Allen-Bradley Co. ....	101A
Allied Radio Corp. ....	20A
Alpha Metals, Inc. ....	115A
American Electric Motors ....	123A
American Lava Corp. ....	63A
American Machine & Foundry Co. (Empl.) ....	151A
American Phenolic Corp. ....	35A
American Television & Radio Co. ....	46A
American Time Products, Inc. ....	40A
Ampex Corporation ....	55A
Andrew Corporation ....	79A
Arnold Engineering Co. ....	22A
Assembly Products, Inc. ....	76A
Automatic Manufacturing Corp. ....	93A

Ballantine Laboratories, Inc. ....	82A
Barber Laboratories, Alfred W. ....	164A
Bell Telephone Laboratories ....	4A
Bendix Aviation Corp., Eclipse-Pioneer Div. ....	62A
Bendix Aviation Corp., Missile Section (Empl.) ....	142A
Bendix Aviation Corp., Radio Commun. Div. (Empl.) ....	131A
Bliley Electric Co. ....	46A
Bodnar Industries, Inc. ....	92A
Baesch Mfg. Co., Inc. ....	42A
Bradley Laboratories, Inc. ....	96A
Briggs, Thomas H. ....	164A
Buckbee Mears Co. ....	64A
Bussmann Mfg. Co. ....	9A

Calif. Institute of Technology, Jet Propulsion Lab. (Empl.) ....	134A, 153A
Cambridge Thermionic Corp. ....	36A
Cannon Electric Co. ....	60A
Canoga Corp. ....	72A
Capitol Radio Engineering Institute ....	86A
Cascade Research ....	111A
Chance Vought Aircraft (Empl.) ....	146A
Chatham Electronics Corp. ....	75A
Chicago Standard Transformer Corp. ....	106A
Clare & Co., C. P. ....	97A
Clifton Precision Products Co., Inc. ....	27A
Cohn Corp., Sigmund ....	64A
Communication Accessories Co. ....	77A
Communication Products Co. ....	12A & 13A
Communications Equipment Co. ....	163A
Consolidated Vultee Aircraft Corp. (Empl.) ....	138A

## PRECISION PHASE DETECTOR

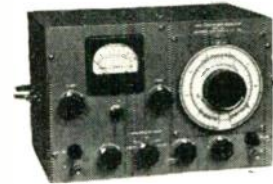

TYPE 205

- MEASURES TIME DELAY WITH 1% ACCURACY
- MEASURES PHASE DELAY WITH 1° ACCURACY
- 10 KC TO 15 MEGACYCLES, 0.01 VOLT SENSITIVITY

#### SPECIFICATIONS

ACCURACY:  $\pm 0.1$  degree in phase reading or  $\pm 1\%$  of the time delay indicated on the dial of the continuously variable delay line.

RESOLUTION TIME:  $5 \times 10^{-10}$  seconds or smaller; the smallest phase angle in degrees can be read on the dial is approximately equal to  $5 \times 10^{-10} \times 360 \times$  frequency in cps.

TIME DELAY: Three continuously variable delay lines are supplied with the unit, 0 to 0.45 microsecond, 0 to 0.25 microsecond and 0 to 0.05 microsecond. An additional step delay line with 2.75 us delay in steps of 0.25 supplied with Type 205A.

PHASE RANGE: The maximum phase range is equal to the total time delay of the continuously variable delay line multiplied by the frequency of the signals and 360.

INPUT IMPEDANCE: Two low capacity probes with input capacitance less than 4 mmf are supplied with the unit. The panel binding posts have about 1 megohm shunted with 12 mmf on both input channels.

Price: \$445.00

## HIGH Z MINIATURE DELAY LINES FOR COLOR TV



- 1800 OHMS IMPEDANCE
- PHASE RESPONSE—LINEAR OVER 10 MC
- RISE TIME—7% OF TIME DELAY
- BANDWIDTH OVER 10 MC

#### SPECIFICATIONS

TIME DELAY: 0.5 us for 6C2a, 0.7 us for 6C2b, and 0.9 us for 6C2c. Different values of time delay can be furnished upon request.

PHYSICAL SIZE: ¼" in diameter for all models, 3.5" long for Type 6C2a, 4.5" long for Type 6C2b and 6" long for Type 6C2c.

PRICE: \$7.50 each for 6C2a, \$8.50 each for 6C2b, and \$9.50 for 6C2c. Reduced prices on large quantities.

WRITE FOR DATA!



**ADVANCE ELECTRONICS CO., INC.**

451 HIGHLAND AVE. • PASSAIC, N.J.

## DISPLAY ADVERTISERS

Content, Edward J. ....164A  
 Continental Carbon, Inc. ....38A  
 Cornell Aeronautical Lab., Inc. (Empl.) ....148A  
 Cornell-Dubilier Electric Co. ....Cover 3  
 Cosmic Condenser Co. ....124A  
 Crosby Laboratories, Inc. ....128A, 164A  
 Crucible Steel Co. of America ....61A

Daven Company, The ....17A  
 Detectron Corp., The ....122A  
 DuMont Laboratories, Inc., Allen B. ....26A

E S C Corporation ....68A  
 Eitel-McCullough, Inc. ....39A  
 Eldico of New York, Inc. ....164A  
 Electra Mfg. Co. ....121A  
 Electric Auto-Lite Co. (Empl.) ....141A  
 Electrical Industries ....19A  
 Electrical & Physical Instrument Corp. ....102A  
 Electro Motive Mfg. Co., Inc. ....103A  
 Electro-Pulse, Inc. ....100A  
 Electronic Research Associates, Inc. ....164A  
 Elk Electronic Laboratories, Inc. ....164A  
 Engineering Associates ....102A  
 Engineering Research Associates, Inc.  
 (Empl.) ....134A, 139A, 150A  
 Epco Products, Inc. ....54A  
 Erie Resistor Corp. ....67A

F-R Machine Works, Inc. ....51A  
 F-R Machine Works, Inc. (Empl.) ....144A  
 Fairchild Engine & Airplane Corp. ....15A  
 Farnsworth Electronics Co. ....145A  
 Federal Telephone & Radio Co. ....113A  
 Ford Instrument Co. ....76A  
 Frederick & Associates, Carl L. ....122A  
 Frederick Research Corp. ....164A  
 Freed Transformer Co., Inc. ....99A  
 Frequency Standards ....28A  
 Furst Electronics, Inc. ....160A

Garfield Wire Division, The Overlakes Corp. ....160A  
 General Aniline & Film Corp. ....107A  
 General Electric Co., Capacitor Sales ....34A  
 General Electric Co. (Empl.) ....139A  
 General Electric Co., Tube Div. ....53A, 117A  
 General Precision Lab., Inc. ....156A  
 General Radio Co. ....Cover 4  
 Gerry & Co., Inc., M. E. ....127A  
 Gillfillan Brothers, Inc. (Empl.) ....157A  
 Godley Co., Paul ....164A  
 Gordon Associates ....164A  
 Guilford Personnel Service (Empl.) ....142A  
 Gulton Industries, Inc. ....81A

Hamilton Institute, Alexander ....48A  
 Harvey Radio Co., Inc. ....116A  
 Heiland, A Div. of Minneapolis-Honeywell ....123A  
 Helipot Corp. ....7A  
 Heppner Mfg. Co. ....127A  
 Hermetic Seal Products Co. ....73A  
 Hewlett-Packard Co. ....11A  
 Hickok Electrical Instrument Co. ....54A, 162A  
 Highland Engineering Co. ....164A  
 Hoffman Laboratories, Inc. (Empl.) ....152A  
 Hogan Laboratories, Inc. ....164A  
 Hopkins Engineering Co. ....116A  
 Hughes Aircraft Co. ....69A  
 Hughes Research & Development Labs. (Empl.)  
 ....140A, 150A  
 Hycor Co., Inc. ....121A

Industrial Research Labs. (Empl.) ....156A  
 Institute of Radio Engineers, Inc. 1A, 50A, 118A-119A  
 Interference Testing & Research Lab., Inc. ....164A  
 International Business Machines (Empl.) ....141A  
 International Electronic Research Corp. ....92A



★ **ULTRA LOW**

*capacitance  
& attenuation*

WE ARE SPECIALLY ORGANIZED  
 TO HANDLE DIRECT ORDERS OR  
 ENQUIRIES FROM OVERSEAS  
**SPOT DELIVERIES FOR U.S.**  
 BILLED IN DOLLARS—  
 SETTLEMENT BY YOUR CHECK  
**CABLE OR AIRMAIL TODAY**

TYPE	MM F/ft	IMPED.Ω	O.D.
C 1	7.3	150	.36'
C 11	6.3	173	.36'
C 2	6.3	171	.44'
C 22	5.5	184	.44'
C 3	5.4	197	.64'
C 33	4.8	220	.64'
C 4	4.6	229	1.03'
C 44	4.1	252	1.03'



**NEW** 'MX and SM' SUBMINIATURE CONNECTORS  
 Constant 50Ω-63Ω-70Ω impedances

TRANSRADIO LTD. 138A Cromwell Rd. London SW7 ENGLAND

CABLES: TRANSRAD, LONDON

OVER 40 YEARS in RESEARCH and APPLICATION of  
**RADIATION MATERIALS**

sealed **SOURCES**

for thickness gauges and static eliminators

light **SOURCES**

alpha or beta activated for safety markers,  
 instrument illumination and photometric standards

neutron **SOURCES**

for activation analysis and  
 oil-well logging

Inquiries invited.

Literature available — state SOURCE  
 interested in and address Dept. P-1.



**UNITED STATES RADIUM CORPORATION**

Executive and Sales Offices 535 Pearl Street, New York 7, N. Y.

Plants and Laboratories at: Bloomsburg, Pa., Bernardsville, N. J.

Whippany, N. J., North Hollywood, Cal.



## DISPLAY ADVERTISERS

Jennings Radio Mfg. Co. ....78A  
 Johns Hopkins University, Applied Physics Lab.  
 (Empl.) .....140A, 154A  
 Johns Hopkins University, Operations Research  
 Office (Empl.) .....145A  
 Johns Hopkins University, Radiation Lab.  
 (Empl.) .....146A  
 Jones Div., Howard B., Cinch Mfg. Corp. ....68A

Kahle Engineering Co. ....64A  
 Kahn, Leonard R. ....164A  
 Kay Electric Co. ....2A  
 Kearfott Co., Inc. ....161A  
 Kenyon Transformer Co., Inc. ....161A  
 Keystone Products Co. ....95A  
 Kip Electronics Corp. ....164A  
 Kollsman Instrument Corp. (Empl.) .....152A

Laboratory for Electronics, Inc. ....5A  
 Lapp Insulator Co., Inc. ....74A  
 Lee Laboratories .....158A  
 Little Falls Alloys, Inc. ....92A  
 Lockheed Aircraft Corp. (Empl.) .....137A, 147A

Magnetic Research Corp. ....110A  
 Magnetics, Inc. ....10A  
 Mallory & Co., Inc., P. R. ....30A  
 Martin Co., Glenn L. (Empl.) .....149A  
 Maxson Corp., W. L. ....47A  
 Maxson Corp., W. L. (Empl.) .....146A  
 McCoy Electronics Co. ....90A  
 Measurements Corp. ....114A, 164A  
 Melpar, Inc. (Empl.) .....146A  
 Microdot Div., Felts Corp. ....76A  
 Microwave Consultants .....164A  
 Midland Mfg. Co., Inc. ....37A  
 Millen Mfg. Co., Inc., James .....88A  
 Miller Co., Sanford .....160A  
 Model Engineering & Mfg. Co., Inc., Tru-  
 Ohm Products Div. ....87A  
 Moseley Co., F. L. ....70A  
 Motorola, Inc. (Empl.) .....139A  
 Mycalex Corp. of America .....126A

N. R. K. Mfg. & Eng. Co. ....162A  
 National Co., Inc. (Empl.) .....148A  
 North Electric Mfg. Co. ....42A

Offner Electronics, Inc. ....125A  
 Ohmite Mfg. Co. ....71A  
 Olympic Radio & Television, Inc. ....164A  
 Oster Mfg. Co., John .....6A  
 Ostlund, Evert M. ....164A

Panoramic Radio Products, Inc. ....159A  
 Paramount Paper Tube Co. ....98A  
 Parke Mathematical Laboratories, Inc. ....164A  
 Penn-East Engineering Corp. ....164A  
 Perkin-Elmer Corp. ....159A  
 Perkin Engineering Corp. ....18A  
 Pickard & Burns, Inc. ....164A  
 Pitman Publishing Corp. ....162A  
 Polarad Electronics Corp. ....32A-33A, 91A  
 Polytechnic Research & Dev. Co. ....23A  
 Polytechnic Research & Dev. Co. (Empl.) ...152A  
 Ponder & Best, Inc. ....101A  
 Precision Apparatus Co., Inc. ....165A  
 Precision Paper Tube Co. ....52A  
 Pyramid Electric Co. ....129A

Radiation, Inc. ....56A  
 Radio Corp. of America, Designers Campaign ..80A  
 Radio Corp. of America (Empl.) .....132A-133A  
 Radio Materials Corp. ....57A  
 Radio Receptor Co., Inc. ....41A  
 Radio Receptor Co., Inc. (Empl.) .....148A  
 Radio Sonic Corp. ....164A

## TI subminiature transformer . . .

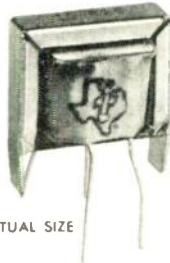
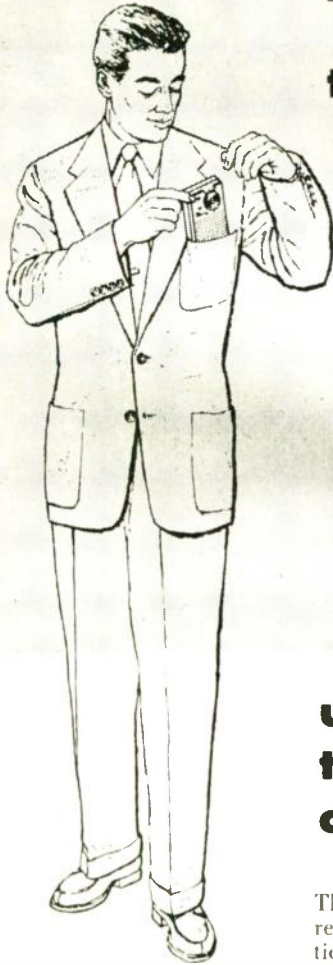

ACTUAL SIZE

## used in the first transistorized consumer product!

The world's smallest commercial radio receiver makes the most of miniaturization possibilities with a Texas Instruments subminiature transformer and four TI transistors. TI subminiature transformers, such as the one used in the Regency pocket radio, are adaptable to mass production dip-soldering assembly techniques.

Your most experienced source of supply for transistorized circuit components. Texas Instruments produces the most complete line of subminiature transformers, consisting of 32 standard models. Ranging from less than  $\frac{3}{8}$  inch cubed (one milliwatt output) to one inch cubed (200 milliwatts output in push-pull), TI subminiature transformers are precision units specifically designed for transistorized and other miniaturized circuits. TI engineers will design special models — in virtually unlimited variety — to meet your exact requirements.

Don't delay your own product miniaturization program. Write today for Bulletin DL-C 424, describing TI subminiature transformers in detail.

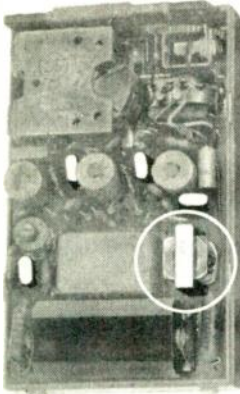

Rear view of pocket radio with back removed, showing TI transformer and transistors in relation to other circuit components.



# TEXAS INSTRUMENTS

INCORPORATED

6000 LEMMON AVENUE DALLAS 9, TEXAS

## DISPLAY ADVERTISERS

Ramo-Wooldridge Corp. .... 135A  
 Raytheon Mfg. Co., Power Tube Div. .... 21A  
 Raytheon Mfg. Co., Special Purpose Tube  
 Div. .... 24A-25A, 29A  
 Raytheon Mfg. Co., Transformer Div. .... 115A  
 Resistance Products Co. .... 128A  
 Revere Copper & Brass Incorporated .... 43A  
 Rosenberg Associates, Paul .... 164A  
 Rutherford Electronics Co. .... 88A

Sanders Associates, Inc. (Empl.) .... 146A  
 Sandia Corp. (Empl.) .... 151A  
 Secon Metals Corp. .... 86A  
 Seeburg Corp., J. P. .... 154A  
 Shallcross Mfg. Co. .... 112A  
 Shasta Div., Beckman Instruments, Inc. .... 54A  
 Sierra Electronic Corp. .... 66A  
 Simpson Electric Co. .... 31A  
 Southwestern Industrial Electronic Co. .... 120A  
 Sperry Gyroscope Div., The Sperry Corp. .... 59A  
 Sperry Gyroscope Div., The Sperry Corp.  
 (Empl.) .... 154A  
 Sprague Electric Co. .... 3A, 109A  
 Stackpole Carbon Co. .... 45A  
 Stavid Engineering Inc. (Empl.) .... 140A  
 Stoddart Aircraft Radio Co. .... 8A, 125A  
 Stromberg-Carlson Co. (Empl.) .... 134A, 149A  
 Stupakoff Ceramic & Mfg. Co. .... 58A  
 Superior Tube Co. .... 44A  
 Swift Industries, Inc. .... 108A  
 Switchcraft, Inc. .... 98A  
 Sylvania Electric Products Inc. .... 65A  
 Sylvania Electric Products Inc. (Empl.)  
 .... 130A, 143A, 156A  
 Syntronic Instruments, Inc. .... 124A

Tektronix, Inc. .... 14A  
 Telrex, Inc. .... 164A  
 Texas Instruments, Inc. .... 49A, 167A  
 Texas Instruments, Inc. (Empl.) .... 144A  
 Transiron Electronic Corp. .... 89A  
 Transradio Ltd. .... 166A  
 Triad Transformer Corp. .... 8A  
 Tung-Sol Electric, Inc. .... 83A  
 Tung-Sol Electric, Inc. (Empl.) .... 142A

United Catalog Publishers, Inc. .... 124A  
 U. S. Components, Inc. .... 108A  
 U. S. Gasket Co. .... 168A  
 U. S. Radium Corp. .... 166A  
 United Transformer Co. .... Cover 2

Varflex Corp. .... 88A  
 Varian Associates .... 85A  
 Vectron, Inc. .... 94A  
 Victoreen Instrument Co. .... 60A  
 Vitro Corp. (Empl.) .... 136A

Waterman Products Co., Inc. .... 105A  
 Westinghouse Electric Corp. (Empl.) .... 145A, 155A  
 Wheeler Laboratories, Inc. .... 164A  
 Wickes Engineering & Construction Co. .... 86A

1955  
**RADIO ENGINEERING SHOW**  
 March 21-24, 1955  
 Kingsbridge Armory  
 Kingsbridge Palace  
 New York City

# Tough TEFLON

replaces brittle materials for  
 high frequency, high voltage,  
 high temperature service

**COMPRESSION MOUNTING**  
 without breakage. No additional  
 hardware needed.



## CHEMELEC Stand-Off and Feed-Through Insulators

Tough, resilient TEFLON is fast replacing brittle glass in miniature components. CHEMELEC components permit compression mounting, facilitate miniaturization, greatly reduce assembly costs, withstand shock and vibration in service.

• TEFLON's superior insulating characteristics made these miniatures possible—for high frequency, high voltage or current, high temperature service.

HIGHER surface and volume resistivity.

LOWER loss factor and dielectric constant.

WIDER service temperature range (-110°F to +500°F).

WON'T CARBONIZE under arcing or DC-plate.

INVESTIGATE CHEMELEC Stand-Off and Feed-Through Insulators for superior service and lower assembly costs.

NINETEEN STOCK SIZES, including sub-miniatures. Other dimensions feasible. WRITE for CHEMELEC Bulletin EC-1153.

FLUOROCARBON PRODUCTS, INC.,  
 Division of  
**UNITED STATES GASKET COMPANY**  
 CAMDEN 1, NEW JERSEY

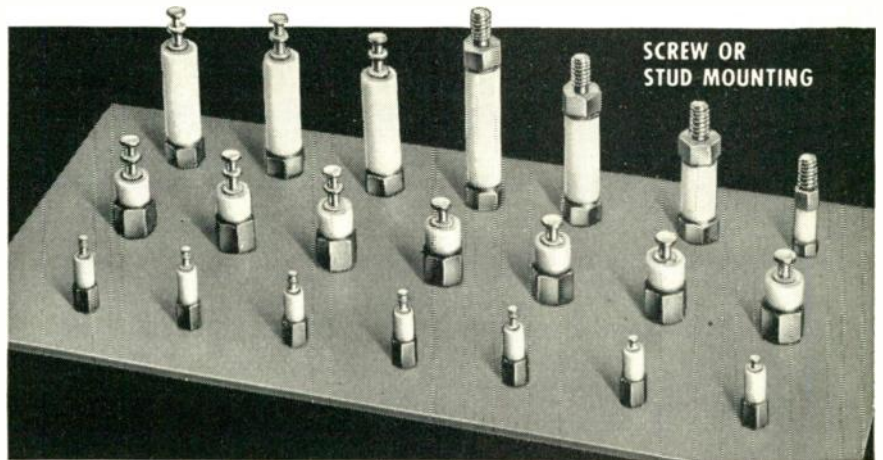

# USG

FABRICATORS OF  
 FLUOROCARBONS & OTHER PLASTICS  
 Representatives in principal  
 cities throughout the world







**ONLY THE LEADER**

*always  
sets  
the  
pace*

**FIRST-**



high voltage mica capacitors.

**FIRST-**



super-power tank  
circuit mica capacitors.

**FIRST-**



carrier current  
coupling capacitors.

In harness racing as in capacitors you pick the leader by looking at the record. That's why at Cornell-Dubilier, we're mighty proud of our record of new capacitor designs, consistent dependability and outstanding field performance—a record no other company can even come close to approaching. That's the record of

## **C·D...45 YEARS OF FAMOUS FIRSTS**

Typical of these "Famous Firsts" are the examples shown here... just three of the hundreds of money-saving answers in capacitors a C-D engineer can show you. Write to Cornell-Dubilier Electric Corp., Dept. M15, South Plainfield, N. J.



**CONSISTENTLY DEPENDABLE  
CORNELL-DUBILIER CAPACITORS**

PLANTS IN SO. PLAINFIELD, N. J.; NEW BEDFORD, WORCESTER AND CAMBRIDGE, MASS.; PROVIDENCE AND HOPE VALLEY, R. I.; INDIANAPOLIS, IND.; SANFORD AND FUGUAY SPRINGS, N. C.; SUBSIDIARY, RADIART CORP., CLEVELAND, OHIO.

THERE ARE MORE C-D CAPACITORS IN USE TODAY THAN ANY OTHER MAKE



# New Potentiometers

Offer Good Linearity and Low Noise  
at Popular Prices

Wide Range of Stock Resistances—  
2 to 500,000 ohms in 1-2-5 sequence

Convenient Sizes—in progressive steps,  
from 1¼" to 4¼" diameter

Conservative Power Ratings—  
from 2 to 20 watts  
at 40° C. ambient

Good Linearity—better than  $\pm 0.2\%$   
for units with higher power ratings;  
 $\pm 2\%$  for smaller sizes

Low Cost—prices range from \$3.15 for 2-ohm, 2-watt unit  
to \$10.00 for 500-kilohm, 20-watt potentiometer



**Good Linearity at Moderate Cost** Resistance wire is uniformly wound and finished card is cemented tightly into base—uniform thickness around base prevents unequal curing and aging out of round—every unit produced is inspected for conformance with linearity specifications.

**Low Capacity to Ground and Across Windings** Outstanding a-c performance is obtained with all-phenolic body, glass-reinforced polyester shaft and phenolic laminated card—minimum metal parts.

**Brush and Track Durability** Brush is of heat-hardened, precious-metal alloy especially selected for compatibility with winding—low-temperature-coefficient resistance-alloy wire is used—brush track is carefully smoothed and cleaned by special buffing tool that does not cut metal away from finer wire.

**Mounting Rigidity and Interchangeability** Units are mounted on panel and shelf by screws tapped into base so that they are keyed against rotation.

**High Resolution** Specially designed precious-metal brush of small-diameter wire touches no more than two wires at a time.

**Low Electrical Noise** Brush rides on edge of tightly-wound resistance card where wire is firmly seated and easiest to clean—extra-long brush spring provides uniform pressure at all settings—overall mechanical stability and cleanliness, resulting from total enclosure, insure low noise—pots are individually tested for minimum noise.



**Bearing Durability** Bearings are at extreme ends of enclosure for greatest mechanical stability—brush arm is positively keyed to hub which rotates on brass insert; this bearing is in the same plane as brush, and is closely fitted, minimizing effects of side thrust on shaft—other end of shaft is guided by stainless-steel insert molded in base.

**Ganged Units Available for Any Application** Individual units are easily set in any desired phase relationship—low-capacitance characteristics of the individual units are retained in ganging.

**Over-All Rigidity** Cover fits snugly with base and is firmly attached—cover-retaining screw stops brush arm 180° from brush and will not bend or strain the brush spring support.

**Continuity** Brush is spot-welded to spring arm—electrical terminals are riveted and soldered directly to winding ends and to center tap take-off, for positive electrical connection—no fixed pressure connections.

**Ready Accessibility** Interior is easily exposed for inspection by removal of single cover-retaining screw, even when pot is mounted.

**Three Shafts Available** Standard glass-reinforced polyester shaft is supplied and gives best electrical characteristics—where minimum torsional flexing is the primary consideration, all-metal or metal-filled shaft will be supplied.

**Total Enclosure with External Phasing** Two screws in projecting hub permit phasing, adjusting or removing shaft without opening case and exposing interior to dust—shafts of different lengths or materials can be readily substituted.

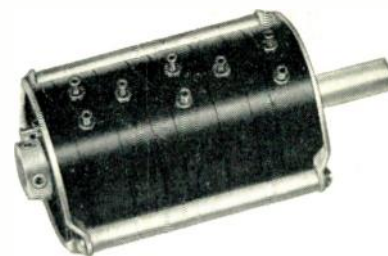

**Versatility** In addition to potentiometers normally stocked, units will be provided on special order with: 360° mechanical rotation—taps as close as ¼" apart along entire winding—resistance values other than standard—resistance functions other than linear—resistance and linearity tolerances better than standard.

Write for the new G-R Potentiometer Bulletin giving complete specifications for units of varying resistance sizes and power ratings.

  
**GENERAL RADIO Company**

275 Massachusetts Avenue, Cambridge 39, Massachusetts, U. S. A.

90 West Street NEW YORK 6  
8055 13th St., Silver Spring, Md. WASHINGTON, D. C.  
920 S. Michigan Avenue CHICAGO 5  
1000 N. Seward Street LOS ANGELES 38