

# THE GUIDE TO TALK RADIO PROGRAMMING

A complete directory to syndicated talk,  
news, and sports radio programming



Issue 2

A Long Multimedia Publication

Winter 1996

## NEW!

### 1996 Syndicated Talk Show Host Directory

(page 123)

Bohannon, Jim (Westwood One)  
Cuomo, Mario (SW Networks)  
Dershowitz, Alan (SW Networks)  
Essex, D. (Westwood One)  
Farber, Barry (CBS Radio)  
Gross, Howard (CBS Radio)  
Harden, Tom (People's Choice)  
Imus, Don (Westwood One)  
Jarvik, Judy (Jarvik & Associates)  
King, Larry (Westwood One)  
Limbaugh, Rush (EFM)



A talk with Westwood One's  
**Bruce Williams**

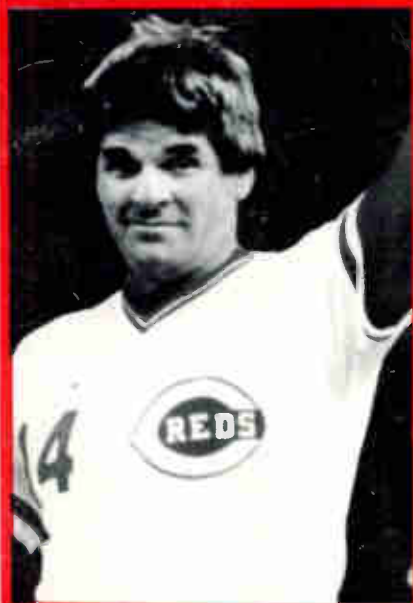

### Pete Rose:

*From the Dugout  
to the Microphone*

Former Cincinnati Reds  
star Pete Rose talks about  
the transition from player  
to talk show host.

Bulk Rate  
U.S. Postage  
**PAID**  
ST Associates

### In this issue...

- The Latest Lineups in Syndicated Talk Radio
- Expanded Sports Talk Listings
- Station Profiles: KVI, WJNT, & KICS
- Our new Talk Show Host Directory
- Dayparted Talk & Sports Grids
- Names to Watch in 1996: Dr. Derrick DeSilva

...and much more!

GENERAL MANAGER  
KSZL AM  
29000 RADIO RD  
BARSTOW CA 92311

# PRIME SPORTS RADIO SERVES UP THE SPORTS NEWS, VIEWS AND REVIEWS... JUST THE WAY YOU LIKE IT.



## What's hot in the world of sports?...

It's served up daily on Prime Sports Radio. PSR caters to every taste with the best, most up-to-date sports coverage you can find anywhere. The other sports networks are satisfied with the same old warmed-over sports talk. Not PSR. We dish out the inside scoop on the world of sports. Fresh, no leftovers.

Fill up with the good stuff 24 hours a day from Prime Sports Radio.



THE SOUND OF SPORTS

## SAMPLE THESE DAILY SPECIALS ON PRIME SPORTS RADIO!



### Beano Cook's COLLEGE FOOTBALL INSIDER

Beano keeps you up on changes in the world of college football, Wednesdays and Saturdays.



### Kevin Kennedy's AMERICAN LEAGUE CLUBHOUSE

Weekly analysis of the American League by the Boston Red Sox Manager, during baseball season.



### Kenny Smith's NBA DIARY

Point guard of the two-time defending world champion Houston Rockets brings his on-court perspective Thursdays and Sundays on PSR.



### Denis Potvin's SLAPSHOT WITH DENIS POTVIN

NHL Hall-of-Famer and Fox TV analyst takes you inside the game of hockey Tuesdays on PSR.



### Bill Walton's TALKING HOOPS

Every Thursday hear commentary on the NBA from "Big Red", the NBA Hall-of-Famer and NBC TV analyst.

PRIME SPORTS SERVES UP MORE OF THE SPORTS COVERAGE YOU CRAVE!  
FOR MORE INFORMATION CALL (214) 401-3960

# TALK

FROM THE MAKERS OF  
**Selector**  
THE MUSIC SELECTION SYSTEM

# BACK™

Line	Name	Location	On Air	On Hold	Topic
1	Andy	New York	0	0	Elections
2	John	Chicago	0	0	Bosnia
3	Chris	Paris	0	0	Tour De F
4	Barbara	Cincinnati	0	0	The President
5	Carl	Oyster Bay	0	0	Waco
6	Marsha	Los Angeles	0	0	O.J.
7	Steve	Toronto	0	0	Educated
8	Heidi	London	0	0	The Internet
9			0	0	Fat Farms
10			0	0	Funny Caller
11			0	0	
12			0	0	
:21	Coca-Cola				:60
:22	Red Wiggler's				:60
:23	Station Promo				:30
:32	Sears				:60
:33	Pepsi				:60
:34	Talker's Magazine				:30

Talk Radio Software

HOST: Could you find more info on Talk Radio Software?  
 PRODUCER: No problem, I'll call the experts at RCS.  
 HOST: Thanks. Now get me a cup of coffee!

## TALK SHOW SOFTWARE

WITH TRACKING TOOLS & TIMERS,  
AUDIO FILES & TEXT FOLDERS

Call Sequencer, Colorful Icons  
Log Window, Chat Window  
Time on hold, Time on air  
Caller Frequency & History

**PLUS: With TALKBACK you can...**

*...Playback audio!*

actualities, sfx, promos,  
liners, skits, bits

*...View Text or Pictures!*

articles, clippings, photos,  
charts, graphs, maps

Call for FREE demo disk

# RCS

Sound Software

**RADIO COMPUTING SERVICES, INC.**  
**WORLD HEADQUARTERS**  
 Two Overhill Road, Suite 100  
 Scarsdale, New York, USA 10583  
 Tel: (914) 723-8567  
 Fax: (914) 723-2258



# Welcome

---

## From the desk of Bob Long...

Welcome to Issue #2 of The Guide to Talk Radio Programming. Reaction to the premiere issue was nothing short of spectacular. We have added some exciting new features for this issue, including interviews, station profiles and a talk show host index.

The Guide to Talk Radio Programming is the only publication of its kind, written for broadcasters, by broadcasters. We more than welcome your ideas and suggestions in helping to make this become an even more useful programming tool.

The Guide is your indispensable tool for guiding you through the ever-expanding and diversified maze of choices that make talk radio the red-hot format of the decade.

Cordially,

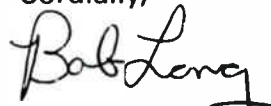

Bob Long, President

P.S. Thank you to all the believers. And especially to all the advertisers who made this a reality. To all that worked so hard to get this done, Gene, Ken and Joan, my sincerest appreciation. Also thanks to Barry O'Brien, Tom Shovan, Geoff Grant, Kevin Hubbard, Tom Smith, Garo Hagopian and Emily Seah and Riley.

## A Note From Your Editor...

After months of preparation, production, and refining, we feel we have created the definitive source for talk radio programmers. I am confident that we have achieved our original goal of creating an easy-to-read, detailed (yet concise) directory that allows the busy talk programmer to instantly access the very latest offerings from the dozens of syndicated talk program providers. I am very proud to bring you the second issue of The Guide to Talk Radio Programming.

You may notice a new, cleaner look in this issue. In these pages, you will still find our signature programming grids which give you, at a glance, an overview of what is offered in each daypart. Later, you'll find detailed information in our network information pages. However, with this issue, we have made every effort to make our listings and grids more efficient, while providing a consistent level of in-depth information you can't find anywhere else.

Lastly, a simple thanks to those who have been so supportive in this project. The book you are reading today is a compilation of ideas of several talented, creative individuals. Please take a moment to drop us a line to let us know what you think. Your comments and suggestions are crucial in the continued improvement and success of the publication.

Regards,



Gene Knight, Editor

# THE GUIDE TO TALK RADIO PROGRAMMING

*A complete directory to syndicated talk,  
news and sports radio programming*



## TABLE OF CONTENTS

Issue Two, Winter 1996

From the desk of Bob Long	i
Letters	iii
<b>Talk Programming Grids</b>	<b>8</b>
Weekdays	9
Saturday	17
Sunday	24
An interview with "Ask the Doctor" Host Dr. Derrick DeSilva	32
Station Profiles	37
<b>Long-Form Talk Network Lineups</b>	<b>40</b>
<b>News Programming Providers</b>	<b>87</b>
A talk with Westwood One's Bruce Williams	89
Pete Rose -- "From the Bench to the Studio"	95
<b>Sports Programming Grids</b>	<b>98</b>
Weekdays	99
Saturday	103
Sunday	105
<b>Sports Network Lineups</b>	<b>108</b>
Talk Show Host Directory	125
Tech Talk	129

### **PRESIDENT:**

Rupert Y. Long

### **EDITOR:**

Gene Knight

### **SALES MANAGER:**

Kenneth Smith

### **CREATIVE CONSULTANTS:**

Jim Hufnagle  
Joan Piorier

### **PRODUCTION ASSISTANTS:**

Geoffrey Grant  
Kevin Hubbard  
Lucas Servideo  
Tom Smith

Copyright processing pending.  
All legal rights reserved.

Rupert Y. Long, Owner  
c/o Attorney Albert E. Grady  
Attorney for Owner  
226 Montello Street  
Brockton, MA 02401

The Guide to Talk Radio Programming is a publication of Long Multimedia, a division of The Other Rupert Inc., P.O. Box 342, Needham, Massachusetts 02192. Current circulation is 2,300. To continue your subscription, call (617) 433-0870.

---

What Programmers Are Saying About...

## **THE GUIDE TO TALK RADIO PROGRAMMING**

*"A great service. What a time-saver. It's already helped us."*

Tom Llewellyn, **WTAL** (Tallahassee, Florida)

*"Very handy book. Each listing answers the first 10 questions I always have."*

Steve Kelly, **WHBQ** (Memphis, Tennessee)

*"Can't wait for the next issue!"*

Jack Morow, **WADR/WRNY** (Utica, New York)

*"I'm getting ready to program another station...I was looking for a guide like this."*

Samuel Stratemeyer, **WRIK** (Paducah, Kentucky)

*"Great book -- very useful."*

Curt Hahn, **WNNZ** (Springfield, Massachusetts)

*"An excellent idea! Sure to become the definitive resource for talkers."*

Robert Hauck, **WOCA** (Ocala, Florida)

*"Great book...keep it goin'!"*

Tom Benson, **WHP** (Harrisburg, Pennsylvania)

*"This publication is a God-send. Thanks!"*

Patrick Sullivan, **WNTR** (Cumberland, Maryland)

*Thanks for your comments and suggestions...keep them coming. To continue your free subscription to **The Guide**, be sure to fill out the form opposite this page and fax or mail it to us today.*

Yes! I would like a **FREE** subscription to

# THE GUIDE TO TALK RADIO PROGRAMMING

*A complete directory to syndicated talk,  
news and sports radio programming*



To continue to receive The Guide to Talk Radio Programming, complete this application and mail a copy to: Guide Subscriptions, P.O. Box 342, Needham, MA 02192. Or, fax it to (617) 433-0870. This information is used for Guide purposes only. *Please print clearly.*

**Name:** \_\_\_\_\_ **Title:** \_\_\_\_\_

Address/City/State/Zip: \_\_\_\_\_

Station Format: \_\_\_\_\_

Telephone: \_\_\_\_\_ Fax: \_\_\_\_\_ Email: \_\_\_\_\_

What syndicated programming do you carry?

What features of The Guide do you find most useful?

What would you like to see in the next issue of The Guide?

What other forms of media/communication do you use? *(check all that apply)*

Email

CD-ROM

Fax

World Wide Web

Comments:

---

---

---

---



# JIM JORGENSEN

SUNDAYS 10AM-1PM (EASTERN)

## PROVEN

A RATINGS LEADER, #3 IN SAN FRANCISCO!

## CREDIBLE

15 YEARS IN TALK RADIO -- WOR, KGO

## PROFITABLE

INSTANT \$\$ TO YOUR BOTTOM LINE!

"A RATINGS LEADER. THE BIG NUMBERS AND LISTENER RESPONSE MAKES IT THE BEST TALK SHOW ON THE STATION."

- ALAN SLEDGE, PD, KABL-AM, SAN FRANCISCO

"THE PROGRAM IS FULL OF GOOD TIPS. THE FEEDBACK HAS BEEN GREAT FROM LISTENERS."

- WILLIAM KELLY, GM, WKBN-AM, YOUNGSTOWN, OHIO

MARKET EXCLUSIVE • BARTER BASIS

CAROL RENZA, MEDIA REP ASSOCIATES • (203) 264-2186

**AFFORDABLE**

# TALK RADIO RECEIVER

**FREQUENCY AGILE — SATELLITE AGILE — FORMAT AGILE**



**MODERN, STATE OF THE ART SCPC XE-1000**

## SCPC BROADCAST AUDIO RECEIVER

New, affordable, frequency-agile receiver, direct channel entry by keyboard, selectable companding 1:1, 2:1, 3:1, wide/narrow bandwidth, de-emphasis selectable, 950-1450 MHz, line output 600 ohms, muting, transponder agile, LNB power supply, 50-channel memory, full baseband output, high-quality audio. Every needed feature at a sensible price (lowest in the industry). Write or call for full information on this quality receiver—the answer for your station.

**DON'T GET STUCK ON ONE SATELLITE AND ONE FREQUENCY. THE XE-1000 DOES IT ALL!**

Networks call for attractive prices.

**UNIVERSAL** ELECTRONICS, INC. 4555 Groves Road, Suite 12 Columbus, OH 43232  
Communications Specialists Phone: (614) 866-4605 Fax: (614) 866-1201



# THE STAN MAJOR SHOW

**IT'S HOT!!!**

**AMERICA'S LIVE ALL NIGHT TALK SHOW**

**"THE STAN MAJOR SHOW"**

**NOW On SATCOM C-5 TRANSPONDER 15!**

**HERE WE GO...**

**INTO OUR FIFTH YEAR!**

***In the past four years listeners in these MAJOR markets have been able to do MORE than Just listen. They have been able to PARTICIPATE!***

***\*\*New York City-Long Island\*\****

***Detroit \* Dallas-Ft.Worth \* Boston  
Cleveland \* St.Louis \* Los Angeles  
Miami-Ft.Lauderdale \* Chicago \* Tampa  
San Francisco \* San Diego \* Phoenix  
Denver \* Salt Lake City \* San Antonio  
New Orleans \* Orlando \* Honolulu  
Hartford \* Philadelphia \* Houston  
Indianapolis \* Oklahoma City \* Chicago  
West Palm Beach \* Jacksonville \* Columbus  
Portland \* Tucson \* Albuquerque \* Tulsa  
Little Rock \* Memphis \* Anchorage \* Las Vegas  
& Other Cities Too Numerous To Mention!!!***

***Now Heard on Over 100 Stations  
...And Counting!***

**★ Satcom C-5 ★ Galaxy 6 ★ Spacenet 3 (TVRO) ★**

**1-800-958-6622**

**FREE... PICK YOUR HOURS!**

**Monday - Friday** 12 Midnight to 5 A.M. EASTERN TIME  
9 P.M. to 2 A.M. PACIFIC TIME

We're  
on the  
'net!

# THE GUIDE TO TALK RADIO PROGRAMMING



*A complete directory to syndicated talk,  
news and sports radio programming*

**We're now online! Visit our web site:**

<http://www.talkradioguide.com>

*Email us at [info@talkradioguide.com](mailto:info@talkradioguide.com)*

*We're online 24 hours a day, 7 days a week with  
up-to-the-minute programming lineups and industry news.*

*Internet services provided by Long Multimedia, (617) 239-1979.*

*TalkRadio's Best Computer Show!*



*America's Best Selling Author,  
Family PC Editor &  
FOX Television Host comes  
to weekend TalkRadio!*

## ***Kim Komando's Komputer Klinik***

*"Combine the best of Bill Gates, Howard Stern,  
Ralph Nader, Dear Abby & Marilyn Monroe and  
you've got Kim Komando."*

*- Ted Leonsis / President, America Online*

**LOCK IN YOUR STATION  
AND MARKET TODAY**

Call

**602-970-1207**

Saturday Morning 10-Noon EST  
Satcom C-5, T-23, SEDAT 49

**WestStar TalkRadio Network**

# THE GUIDE TO TALK RADIO PROGRAMMING

---

## Programming Grids

A side by side listing of what is available from long-form talk programming providers, by daypart.

At a glance, you are able to compare the offerings of each network to make the best programming choices.

### Weekdays

Overnights.....	9
Mornings .....	11
Middays .....	13
Afternoons .....	15
Nights .....	16

### Saturday

Overnight .....	17
Morning .....	19
Midday.....	21
Afternoon .....	22
Night .....	23

### Sunday

Overnight .....	24
Morning .....	25
Midday .....	26
Afternoon .....	27
Night .....	29

# TALK PROGRAMMING

Weekdays • Midnight to 6am

	12:00	1:00	2:00	3:00	4:00	5:00	
ABC	<i>Bob Brinker (10:00) (Mon) (r)</i>						
American Entertainment	Lowell Ponte (11:00)						
American Urban	Night Talk with Bob Law (10:00)						
Broadbank	The Truckin' Bozo with Dale Bozo						
Burlington	Hour of the Time	Freedom Radio Network with Dave Hinkson					
Business	<i>Futures (Mon) (r)</i> <i>McDonald (r)</i>	<i>Travel &amp; Dining Guide (Mon) (r)</i> <i>Market Wrap &amp; Financial Hour (r)</i>		<i>The Al Maimberg Show (r)</i>			
CBS	The Late Late Radio Show with Tom Snyder (11:00)		Late Late Radio Show with Tom Snyder (r)		Tom Snyder (r)		
	<i>Gil Gross Program (11:00) (r)</i>		<i>Gil Gross Program (r)</i>				
Chancellor	<i>Art Bell/Roger Fredinburg (Mon) (r)</i> <i>Roger Fredinburg</i>		Coast to Coast with Art Bell				
EFM							
Major Talk	<i>The Michael Reagan Show (r)</i>						
Peoples	<i>For the People with Chuck Harder (r)</i>		Common Ground with Bruce Amsterdam		<i>Paul Gonzales (r)</i>		
Radio America							
Salem							
SW Networks	Success Radio (10:00)						
Talk America	Joe Mazza (Mon) The Stan Major Program					Good Day USA Doug Stephan	
Tech Talk	Counterspin (30 mins.)						
USA Patriot	Conservative Issues						
USA Radio	Music (Mon) Point View	Life Perspectives					
USA Radio 2	Internet At Night (Mon)						
Westwood One	<i>Brenner (10:00) (Mon) (r)</i>					America in the Morning	
	<i>Essel (10:00) (Mon) (r)</i>				<i>David Essel (Mon) (r)</i>		
	<i>Tom Leykis (10:00) (r)</i>					NBC First Light with Dirk Van	
	<i>Bruce Williams (10:00) (r)</i>						
	Bohannon (10:00)	<i>Jim Bohannon (r)</i>					
WOR	<i>Dr. Joy Browne (10:00) (r)</i>	Bob Aaronson				<i>Severinson (r)</i>	

All times Eastern • (r) = program reread



News Talk . . . Hot Talk . . .  
Sports Talk . . . **FM TALK . . .**

**Talk Is Cheap! And So Is OUR GM!**



**H. Ross Potato, GM**

### The Common Tater™

- Now heard on KVI, KOB, KOH, KCNR and many more not-as-impressive smaller markets!
- Hourly sounders, bumpers, talk themes, production parts.

### The Spud™

- Music that will make your station sound minty fresh.
- Great production, great quality, great variety. Hot stuff!
- Even has religious tracks in case the world comes to an end and your news department has to cover it.

### The Radish™

- A Hot Talk/Sports Talk ID Package that ROCKS!
- An exciting new approach to Radio Identification
- Market Exclusive, Buy-Out
- Batteries included!

**Call 800-468-6874 for a FREE DEMO!**

Radio Potato™

1926 Stoneway Drive • Grapevine, TX 76051 • 817.481.4453 • fax: 817.488.6177

# TALK PROGRAMMING

Weekdays • 6am to 10am

	6:00	7:00	8:00	9:00
Broadbank				
Buchwald	The Howard Stern Show			
Burlington				
Business News	Business Radio Newsclock			
CBS	The Late Late Radio Show with Tom Snyder & Elliot Forrest (5:00) (r)			
Chancellor/TRN	Art Bell (2:00)	Coast to Coast with Art Bell (r)	Here's To Your Health	
EFM				
Learfield				
Major Talk				
Peoples	Morning in America with Mike Ezzel & Dave Hand			
Radio America				
Radio Today				
Salem				
SW Networks				
Talk America	Good Day USA with Doug Stephan (5:00)			Ask the Doctor
Tech Talk				
USA Patriot	Conservative Issues (12:00)	Talking Sense with Tim Kern		Reporters Journal with Scott Wheeler
USA Radio				
USA Radio 2			USA Radio Daily with Gary Nolan	
Westwood One	Jim Bohannon (5:00) (Tue-Fri) (r)			
	Bruce Williams (12:00) (Tue-Fri) (r)			
	Don Imus In The Morning (5:30)			
WOR	Jay Severin (5:00) (r)			Dr. Joy Browne

All times Eastern • (r) = program refeed

# GOOD DAY, USA with DOUG STEPHAN

**"Nationally  
Syndicated  
Since  
1988"**

**NOW HEARD IN OVER  
12 MILLION HOMES!**

**"More stations  
than any other  
nationally  
syndicated  
morning  
Talk program"**

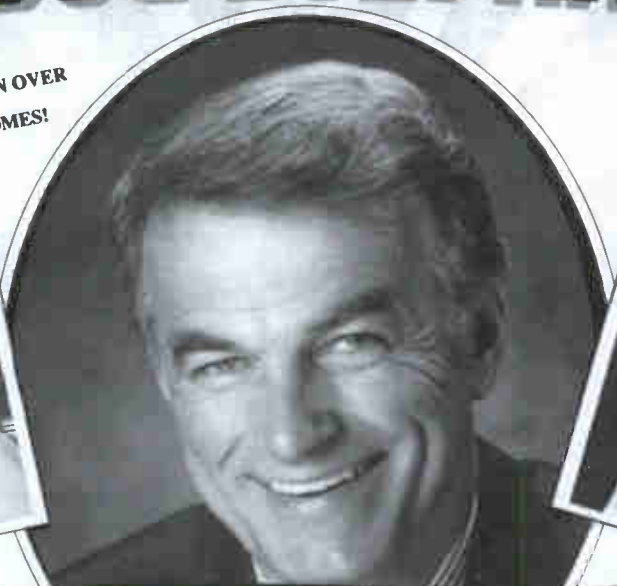

## LOOK WHO'S TALKING TO DOUG:



### WHAT STATION MANAGERS ARE SAYING:

"Two years ago when we were making changes we were inundated with calls saying 'Please don't take away Doug Stephan!!' Doug has found a responsive audience in Tucson and as long as Doug's there, he'll be here!"  
—Bob Lee, Operations Manager, KNST / Tucson

"Good Day, USA is a great way to start the day. A perfect mix of controversy along with easy-going morning humor."  
—Buzz Brindel, Operations Manager, WPTR / Albany

"Timely and upbeat. . . . a great waker-upper."  
—Andi Roman, Program Director, WSPD / Toledo

"He sells so well." —Tom Severino, General Manager, WIBC / Indianapolis

**WHAT A LINE UP!**  
It was a stellar line-up of talk show hosts gathered in Washington, D.C. as guests on the panel of Michael Harrison's Talk Radio Countdown Show.



### WHAT LISTENERS ARE SAYING:

"Your program is my favorite radio program because of its positive, upbeat theme and your different broadcast locations. One day it's Morocco, and the next it's the Kennedy Space Center. I love learning about different areas of the country and the world. These are topics other radio shows don't cover." —JOHN/Seattle

"Dear Program Director: Help! I'm addicted to Doug Stephan!" —JULIE/New Haven

"Where do you get those ideas for your great topics? If I miss a show, I feel like I miss the world." —JIM/Vero Beach

"Doug Stephan addresses issues and events that everyone wants to know about and talk about." —SALLY/Boston

"Doug's program is positive, upbeat, happy, helpful and fun." —BETTY/Columbus

"Doug can be controversial without being combative." —ALLEN/St. Louis

**MONDAY - FRIDAY 5 AM - 9 AM, EST**

**Call to learn how YOUR station can carry this remarkable daily two-way talk radio program!**

**Call 617-575-9265 / 508-877-8700**

# TALK PROGRAMMING

Weekdays • 10am to 3pm

	10:00	11:00	12:00	1:00	2:00
Broadbank					
Burlington					
Business News	Business Radio Newsclock (6:00)		The Don McDonald Show		
CBS					
Chancellor/TRN	Here's To Your Health (9:00)	Roy Masters		The Roger Fredinberg Show (r)	
EFM			Rush Limbaugh		
Jarvis			The Judy Jarvis Show		
Learfield		Common Sense Coalition			
Major Talk	The Lee Mirabal Show		Loggans on Law with Susan Loggans		Colmes & Farber Left to Right
Peoples	Sally Bowers Sally Says	The Paul Gonzales Show			For the People with Chuck Harder
Radio America			Blanquita Cullum		
Radio Today	Dr. Laura Schlessinger (r)			Dr. Laura Schlessinger (r)	Dr. Laura Schlessinger
Salem					Duffy & Company with Warren Duffy
SW Networks					
Talk America	Freedom Calls with Bo Gritz		America the Beautiful with Michael Foudy		
Tech Talk					
USA Patriot			Wake Up America with Sue Ellen	Preparedness Hour with Bob Spear	The Henry Feinberg Show
USA Radio		Lowell Lundstrom Live			Point of View
USA Radio 2	USA Radio Daily with Gary Nolan (8:00)				
Westwood One	Front Page with Mike Walker			Front Page with Mike Walker (r)	
		O'Leary/Kamber Report (Fri)			
	The G. Gordon Liddy Show				G. Gordon Liddy (r)
WOR	Dr. Joy Browne (9:00)			The Dolans	

All times Eastern • (r) = program reread





# ... whip up the perfect radio mix.

With Metro Networks in your recipe, you can strengthen your station's programming with quality news, sports, weather, traffic and information.

Considering 85% of radio listeners rate information reports as "important" to their radio diet, Metro Networks is also great for building audience and TSL.

What's more, 87% of listeners crave reports on a regular basis, not just as needed -- while more than 47% will leave a radio station in search of information to satisfy their appetite.\*

Metro Networks is perfect because it's fortified with coverage from over 60 cities in North America and Europe, and is enriched with broadcasting's largest fleet of aircraft.

And since Metro is available at no hard cost to you, it's great for battling bulging debt.

Make Metro Networks a nutritious part of your programming. For more successful recipes and ideas, call 713-621-2800.

\*The Research Group, 1994



NEWS • SPORTS • WEATHER • TRAFFIC

# TALK PROGRAMMING

Weekdays • 3pm to 7pm

	3:00	4:00	5:00	6:00
Broadbank	The Gary Burbank Show			
Burlington		Unchained Radio with Scott Stevens	America First with Don Wassal	Patriot News Hour with Johnny Johnson
Business News	Business Day	Market Wrap	Business Day	Financial Hour
CBS	Talk With An Attitude with Mary Matalin			Mary Matalin (r)
Chancellor/TRN	Here's to Your Health with Deborah Ray & Dr. Carrow (r)		Coast to Coast with Art Bell (r)	Peter Weissbach
EFM		Dr. Dean Edell Show		
Entertainment Radio Network	Ken Hamblin			
Learfield	The Common Sense Coalition (r)			
Major Talk	The Alan Colmes Show		The Barry Farber Show	
Peoples	For the People with Chuck Harder (2:00)		For the People with Chuck Harder (r)	Vincent & Company with Joel Vincent
Radio America	Earl Jackson Across America			Dateline Washington
Radio Today	Dr. Laura Schlessinger (2:00)			
Salem	The Oliver North Show			
	Duffy & Company (2:00)	The Dick Staub Show		
SW Networks				
Talk America	Aaron Harber	The Hugh Rodham Show		Open Up with Craig Smith
Tech Talk				
USA Patriot	The Henry Feinberg Show (2:00)		The Dr. Norm Resnick Show	
USA Radio	Point of View (2:00)			
USA Radio 2	Because I Said So!			
Westwood One	The G. Gordon Liddy Show (2:00) (r)			O'Leary/Kamber Report (Fri) (r)
	David Brenner			Tom Leykis
	The Don & Mike Show			
WOR	Jay Severin			Jay Severin (r)

All times Eastern • (r) = program reread

# TALK PROGRAMMING

Weekdays • 7pm to Midnight

7:00	8:00	9:00	10:00	11:00	
				Lowell Ponte	American Entertainment
			Night Talk with Bob Law		American Urban
					Broadbank
Intelligence Report	American Soapbox	Liberty News Hour	American Eagle Radio Newshour	Fisherman's Net	Burlington
The Al Maimberg Show (r)			The Don McDonald Show (r)		Business News
	The Gil Gross Program			Gil Gross (r)	CBS
Talk With An Attitude with Mary Matalin (6:00) (r)				Late Late Show with Tom Snyder	
Peter Weissbach (6:00)		The Big Radio Show		Roger Fredinburg	Chancellor/TRN
					EFM
					Learfield
		The Michael Reagan Show			Major Talk
		Timeless Voyager Radio			Nelson
Joel Vincent & Company (6:00)		Washington on Trial with Jerry Hughes		For the People (r)	Peoples
					Radio America
					Radio Today
Dick Staub (4:00)			The Right Side with Armstrong Williams		Salem
Success Radio with Darryl Ankarlo			Success Radio with Dr. David Viscott		SW Networks
Jameson White		Wellness Radio	Probing America		Talk America
Skyvision Clearance Show The Pregame Show (Fri 8-9)		Tom & Darryl Show (Thu), Monday Night Jive (Mon 10-12) Houston Satellite Network (Tue 11-12), Newshour (Fri 9-10), Listener Participation (Fri 10-2)			Tech Talk
Blueprint for Survival	Duncan Long	The Rick James Show			USA Patriot
		Golden Age of Radio Theatre		Point of View (r)	USA Radio
		Golden Age of Radio Theatre			USA Radio 2
Tom Leykis (6:00)			Tom Leykis (r)		Westwood One
Bruce Williams			Bruce Williams (r)		
		Larry King Live	Jim Bohannon		
Severin (6:00) (r)	The Dolans (r)		Dr. Joy Browne (r)		WOR

All times Eastern • (r) = program refeed

# TALK PROGRAMMING

Saturday • Midnight to 6am

	12:00	1:00	2:00	3:00	4:00	5:00
ABC						
American Entertainment	Lowell Ponte (11:00)					
American Urban	Night Talk with Bob Law (10:00)					
Broadbank						
Burlington						
Business	McDonald (r)	Market Wrap (r)	Sales Talk (r)	The Al Maimberg Show (r)		
CBS	Late Late Radio Show with Tom Snyder (11:00)		Late Late Show with Tom Snyder (r)			Tom Snyder (r)
	The Gil Gross Program (11:00) (r)		The Gil Gross Program (r)			
Chancellor	Roger Fredinburg		Coast to Coast with Art Bell			
Major Talk	The Michael Reagan Show (r)					
Nelson						
Peoples	For the People with Chuck Harder (r)		Washington on trial with Jerry Hughes (r)		Talkline with Zev Brenner (r)	
Radio America						
Salem				Dick Staub (r)		
Talk America	The Stan Major Program					Las Vegas Live with Jose Pino
USA Patriot	Conservative Issues					
USA Radio	Point of View (r)	Life Perspectives (r)				
USA Radio 2						
Westwood One	Jim Bohannon (10:00)	Larry King (r)				
	Tom Leykis (10:00) (r)					
	Bruce Williams (10:00) (r)					
		Jim Bohannon (r)				
WOR	Dr. Joy Browne (10:00) (r)	Bob Aaronson				

All times Eastern • (r) = program reread



# EQUITY RADIO NETWORK

has available space on

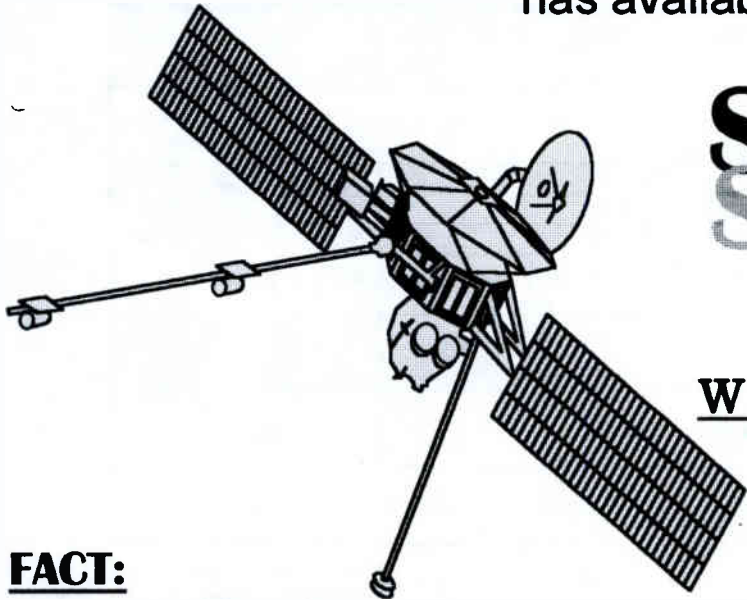

## SATCOM C-5

SATCOM C-5

### Why Equity Radio Network

**FACT:**  
To make it with a syndicated talk show you **MUST** be on Satcom C-5.

Our fees are 40% to 60% lower...  
Our reliability is outstanding...  
We offer redundancy on our delivery of your program...

**REASON:**  
Over 7,000 radio stations tune to SATCOM C-5...  
It's the satellite of choice for ABC, CBS, NBC, Westwood One and Mutual... and every other network and serious syndicator.

**Call today and find out why our clients are saving money while receiving service unavailable on most major networks**



Equity Radio Network's Services:

Satellite Uplinking on Satcom C-5

Full Production services including a Producer and a Call screener

Affiliate Relations

Program reception  
Switched 56  
ISDN

Two line Comrex  
Satellite downlinking

# Call 602 483-8762

# TALK PROGRAMMING

Saturday • 6am to 10am

	6:00	7:00	8:00	9:00
ABC				
Broadbank			<i>The Best of Gary Burbank (r)</i>	
Burlington				
Business News	Technology Today	Working From Home	Tee to Green Golf Show	Great American
CBS	<i>Late Late Radio Show with Tom Snyder (5:00) (r)</i>			
Chancellor/TRN	Coast to Coast with Art Bell (2:00)	<i>Coast of Coast with Art Bell (r)</i>		Talkers Countdown
Grow Wise Garden			The Garden Show with Dr. Marc Catchey	
Learfield				Around the House with Don Zeman
Major Talk				
Nelson				Let's Talk Fishing
Peoples	Fishin' & Wishin' with Tommy Powell		Morning in America with Wyatt Cox	Auto Answers
Radio America		Garden Variety		Mac the Mechanic
Salem				
Sweet Talk				Working Mom On the Run
SW Networks				The Mario Cuomo Show
Talk America	The Fishing Zone with Steven Sloan	Prime Time Open Line with Doug Stephan	Money Talk with Bob Hardcastle	The Magic Garden with Mort White
USA Patriot	Conservative Issues (12:00)		Larry Bates (8:00-8:30)	C.O.P.S. with Mike McNulty (8:30-10:00)
USA Radio			Bible's Greatest Heroes	America's Greatest Heroes
USA Radio 2				Your Health Matters
Westwood One	<i>Bruce Williams (12:00) (r)</i>		On the Garden Line with Jerry Baker	
	<i>Jim Bohannon (1:00) (r)</i>	<i>O'Leary/Kamber Report (r)</i>	<i>Mike Walker (r)</i>	
WOR				Healthy Lifestyles with Dr. Ronald Hoffman

All times Eastern • (r) = program reread



# The Magic Garden

National Sponsors that complement Local Retailers



**GROW BETTER WITH  
MORT WHITE**

Saturday morning from 9-10 a.m. **ET**

*Call* Whitehouse Productions  
**401-781-2248**

P.O. Box 10127 • Cranston, R.I. 02910

**100% BARTER**  
SATCOM C5 TRANSPONDER 15  
GALAXY 6 TRANSPONDER 3  
SPACENET 3 TRANSPONDER 9

**TALK AMERICA**  
Radio Network

# TALK PROGRAMMING

Saturday • 10am to 3pm

	10:00	11:00	12:00	1:00	2:00
ABC				The Bernie Ward Show	
Broadbank	<i>Burbank (8:00) (r)</i>				
Burlington					
Business News	On the Road with Jeff Brooks				Don McDonald
Chancellor/TRN	Talkers Countdown (9:00)	Auto Talk with Al, Dave & Peter		Danielle Lin Health Show	Myrna Ochs
Major Talk		Home Improvement USA with Maintenance Mike			
MediaRep			Megabytes with Russ Hicks		
Nelson				Pet Talk America	
On the House	On the House with James & Morris Carey				
Peoples	Auto Answers with Greg Peart & Tom Flanigan (9:00)			Animal Talk with Paul Hoffman & Dr. Lee Duke	
Radio America	Mac the Mechanic (9:00)		Mutual Perspective		Stefan Halper (2:00) Fred Barnes (2:30)
Salem					
Sweet Talk	Working Mom On the Run				
SW Networks	The Mario Cuomo Show (9:00)				
Talk America	Let's Play Doctor Dr. Mark Wallach	Share Your Thoughts	Let's Talk Business	Kugell & McLaughlin	
USA Patriot	C.O.P.S. (8:30)	Pam Beasley	The Hidden Truth	To Free America	Perspectives in Medicine
USA Radio	How Can I Live?	Cornerstone Digest	Unravelling the New World Order	Phyllis Schafley Live (12:30)	Weekend Review (1:30)
USA Radio 2	American Scene with Steve Crowley				Ron Seggi Show
WestStar Talk	The Kim Komando Komputer Clinic Show				
Westwood One	<i>On The Garden Line (r)</i>			<i>Tom Leykis (r)</i>	
	The Bob Grant Show			<i>The Bob Grant Show (r)</i>	
WOR	Healthy Lifestyles	<i>The Dolans (r)</i>			Travel with Arthur Frommer

All times Eastern • (r) = program refeed



# TALK PROGRAMMING

Saturday • 3pm to 7pm

3:00	4:00	5:00	6:00	
Bernie Ward (1:00)	Financial Advising with Bob Brinker			ABC
				Broadbank
	Unchained Radio with Scott Stevens	Fisherman's Net with Richard Eustler	Taking America Back with Richard Eustler	Burlington
The Don McDonald Show (2:00)		All About Futures		Business News
Myrna Ochs (2:00)	News With A View with Randy Johnson		American Crime Line with Ed Nowicki	Chancellor/TRN
				Major Talk
				MediaRep
				Nelson
				On the House
Trash or Treasure? Dr. Tony Hyman	The Home & Garden Show with Michael Crose		Sally Says with Sally Bowers	Peoples
Profiles with Jim Roberts (30 mins.)	Front & Center	Dateline Washington Weekend Edition		Radio America
The Best of Dick Staub				Salem
				Sweet Talk
				SW Networks
Your Financial Future with Bruce Lefavi	The Bob & Rob Home Show		Take America Back with Bruce Weitzman	Talk America
Taking Charge of Your Health	Take America Back with Ken Adams		Veterans' Hour	USA Patriot
Point of View (r)		Celebration USA		USA Radio
Ron Seggi Show (2:00)				USA Radio 2
				WestStar Talk
Tom Leykis (1:00) (r)				Westwood One
Bob Grant (1:00) (r)	David Essel Alive			
Travel with Arthur Frommer (2:00)	The Pet Show with Warren Eckstein		Dr. Joy Browne (r)	WOR

All times Eastern • (r) = program refeed

# TALK PROGRAMMING

Saturday • 7pm to Midnight

	7:00	8:00	9:00	10:00	11:00
ABC	<i>The Bernie Ward Show (r)</i>			<i>Financial Advising with Bob Brinker (r)</i>	
American Entertainment			Lowell Ponte at Large		
Burlington	Arming You With Knowledge with J.J. Johnson			Spectrum with Mark Emanuelle	
Business News	<i>The Al Maimberg Show (r)</i>			The Bill Moran Show	
CBS					
Chancellor	Crime Line (6:00)	<i>Dreamland with Art Bell (r)</i>			<i>Fredinburg (r)</i>
Major Talk					
MediaRep					
Nelson					
Peoples	Sally Says (6:00)	Conceived in Liberty with Jerry Hughes		Carl Angeloff's Bottom Line	
Radio America					
Salem			The Right Side with Armstrong Williams		
Talk America	Lou Mazella On Sports with Lou Mazella & Gary Baldinger		Backstage with Gary Campbell & Connie Ross		Ring Talk with Pedro Fernandez
Tech Talk	This Week in Amateur Radio (7:30-9:00)				
USA Patriot	Conservative Issues				
USA Radio	Bible's Greatest Heroes	<i>America's Greatest Heroes (r)</i>	The Golden Age of Radio		Christian Music America
USA Radio 2		<i>America's Greatest Heroes (r)</i>	The Golden Age of Radio Theater		
Westwood One	<i>Bruce Williams (r)</i>			<i>David Essel Alive (r)</i>	
			Larry King Weekend	<i>David Brenner (r)</i>	
WOR	<i>Dr. Joy Browne (6:00) (r)</i>		<i>The Dolans (r)</i>		

All times Eastern • (r) = program reread

# TALK PROGRAMMING

Sunday • Midnight to 6am

12:00	1:00	2:00	3:00	4:00	5:00	
<i>Financial Advice (10:00) (r)</i>						ABC
						American Entertainment
Talk Radio with Richard Eustler						Burlington
<i>On the Road with Jeff Brooks (r)</i>				<i>Tee to Green Golf Show (r)</i>	<i>Great American Road (r)</i>	Business
						CBS
<i>Roger Fredinburg (11:00) (r)</i>		<i>Coast to Coast with Art Bell (r)</i>				Chancellor
The Laura Lee Show						Laura Lee
						MediaRep
						Nelson
<i>For the People with Chuck Harder (r)</i>			<i>American Montage (r)</i>	Talkline with Zev Brenner		Peoples
						Radio America
The Sports Party with Al Bernstein & Tony Rome			Joe Mazza			Talk America
						Tech Talk
Conservative Issues						USA Patriot
Christian Music America						USA Radio
						USA Radio 2
<i>Tom Leykis (10:00) (r)</i>				David Essel Alive (r)		
	<i>Bruce Williams (r)</i>					Westwood One
<i>Essel (10:00) (r)</i>						
<i>Brenner (10:00) (r)</i>	<i>Larry King (r)</i>					
						WOR

All times Eastern • (r) = program reread

# TALK PROGRAMMING

Sunday • 6am to 10am

	6:00	7:00	8:00	9:00
ABC				
American Entertainment			Home Care with Ron Mason & Mike Spencer	
Burlington				
Business News	Computer America			Initial Public Offering Show
Chancellor/TRN	<i>Coast to Coast with Art Bell (2:00) (r)</i>	<i>Coast of Coast with Art Bell (r)</i>		America Outdoors with Lance Podolski
MediaRep				
Nelson			Trout Talk with Strayhorn Spadewater	
Peoples	<i>Fishin' &amp; Wishin' with Tommy Powell (r)</i>		<i>Home &amp; Garden Show with Michael Crose (r)</i>	
Radio America				
Talk America	Joe Mazza (3:00)	Synergy with Robbie Patterson	Symmetry in Health with Dr. Mark Crapo	Observations on Law with Attorney Al Grady
Tech Talk				
USA Patriot	Conservative Issues (12:00)		Take Back America with Ken Adams	
USA Radio				<i>Bible's Greatest Heroes (r)</i>
USA Radio 2				
Westwood One			<i>On the Garden Line with Jerry Baker (r)</i>	
			<i>O'Leary/Kamber Report (r)</i>	
	<i>Mike Walker (r)</i>			
WOR			Gardening Show with Ralph Snodsmith	

All times Eastern • (r) = program reread

# TALK PROGRAMMING

Sunday • 10am to 3pm

10:00	11:00	12:00	1:00	2:00	
			The Bernie Ward Show		ABC
Health Talk with Dr. Bob Martin					American Entertainment
					Burlington
Initial Public Offering (9:00)	The Financial Advisor with Charles DeRose				Business News
America Outdoors (9:00)	The Henry Feinberg Show		Danielle Lin Health Show	American Crime Line (r)	Chancellor/TRN
Jim Jorgensen on Money					MediaRep
		Sports Card Report Live			Nelson
Trash or Treasure? with Dr. Tony Hyman (r)		Washington: The Week Ahead with Pat Choate		Balance the Scales	Peoples
					Radio America
Observations on Law with Attorney Al Grady (9:00)		Are You Protected? with Attorney Bill Bailey		Today's Internet with Gary Foster	Talk America
					Tech Talk
Rocky Mountain Trails with Larry Lindsey		The Dr. Norm Resnick Show (r)		Perspectives in Medicine (r)	USA Patriot
Greatest Heroes (r)	Christian Music America (r)		Point of View (r)		USA Radio
Greatest Heroes (r)					USA Radio 2
			Tom Leykis		
					Westwood One
The Bob Grant Show (r)					
Gardening Show (8:00)	The Dolans (r)			Online Today	WOR

All times Eastern • (r) = program reread



# TALK PROGRAMMING

Sunday • 3pm to 7pm

	3:00	4:00	5:00	6:00
ABC	Bernie Ward (1:00)	Financial Advising with Bob Brinker		
American Entertainment				
Burlington				
Business News	Computer America (r)			America's Dining & Travel Guide
Chancellor/TRN	American Crime Line (2:00) (r)	Here's To Your Health with Deborah Ray & Dr. Carrow		
MediaRep				
Nelson				
Peoples	Balance the Scales with Larry Lempert (2:00)		Sally Says with Sally Bowers	
Radio America				Reminisces
Talk America	Gun Talk with Tom Gresham		Bob Long's AutoWorld	The Ham Radio Show with Len Winkler
Tech Talk				
USA Patriot	The Henry Feinberg Show (r)		Jane Pearson Show	Veterans' Hour
USA Radio	How Can I Live? with Kay Arthur (r)	Celebration USA		Bible's Greatest Heroes (r)
USA Radio 2	The Jack Christy Show			
Westwood One	Tom Leykis (1:00) (r)			
		David Essel Alive		
WOR	Online Today (2:00)	The Food Show with Arthur Schwartz		Dr. Joy Browne (r)

All times Eastern • (r) = program reread

# AutoWorld

---



with Bob Long

**Sundays 5pm Eastern, 2pm Pacific**  
SatCom C-5, Galaxy 6, Spacenet 3

- 0 to 70 Affiliates in 6 months!
- The Auto Enthusiasts Show...A perfect companion for your weekend repair show.
- Give your listeners the chance to speak with the world's most respected auto journalists, engineers, race car drivers & experts:

**John Davis**, *Motor Week Television Host*

**William Jeannes**, *Publisher of Car & Driver, Road & Track*

**Mac DeMere**, *Senior Road Test Editor, Motor Trend*

**Carol Shelby**, *Racing Legend, Father of the Cobra*

**Brock Yates**, *Editor, Car & Driver, Founder of the Canonball Run*

- Buying and selling new & used cars
- Collecting and restoring
- Reminiscing about old classics
- Maintenance and Repair Tips

## What programmers are saying about **AutoWorld**:

*"Excellent. We've got good sponsorship...An easy sell for the station."*

Bryan Smeathers, GM, **WMTA, Central City Kentucky**

*"What a fun show to listen to."*

Randy Miller, Owner, **WTIM, Taylorville, Illinois**

*"If you're a non-mechanic like me, and there are a lot of people who don't know a hoot about what's under a car's hood, you can learn about mechanical tips and new innovations. Bob makes it simple to understand over the radio."*

John Sherman, PD, **KEEL, Shreeveport, Louisiana (50,000 Watts!)**

**AutoWorld**, Sunday Afternoons - 5 Eastern, 2 Pacific.

SatCom C-5 (Transponder 15), Galaxy 6, Spacenet 3. For more information, call (617) 828-4546.

# TALK PROGRAMMING

Sunday • 7pm to Midnight

	7:00	8:00	9:00	10:00	11:00
ABC	<i>The Bernie Ward Show (r)</i>			<i>Financial Advising with Bob Brinker (r)</i>	
American Entertainment					
Burlington	Scriptures for America	Nurse Talk Radio with Joyce Riley			
Business News	Dining & Travel Guide (6:00)	Wishing You Well		Working From Home	All About Futures
Chancellor/TRN	<i>The Randy Johnson Show (r)</i>		Science Radio Hour	Dreamland with Art Bell	
MediaRep					
Nelson					
Paranet			Paranet Continuum		
Peoples	Sally Bowers Says (5:00)	American Montage	The Elliot Stein Show		
Radio America	Financial Focus				
SW Networks	The Alan Dershowitz Show				
Talk America	Health Watch with Jim Feijo	Grandstand	Biker Broadcasting with Mr. Z		Smitty's Sports Talk
Tech Talk		Full Disclosure Live	Trade Show from Outer Space with Fred Deferbranche		
USA Patriot	Conservative Issues				
USA Radio	Rock the World		N-2-Livin'		<i>Christian Music America (r)</i>
USA Radio 2				Internet at Night	
Westwood One	<i>Bruce Williams (r)</i>			<i>David Essel Alive (r)</i>	
		Wayne Lapierre Show		<i>Wayne Lapierre Show (r)</i>	
		<i>Love Phones (r)</i>		<i>Best of David Brenner (r)</i>	
					Love Line
WOR	<i>Dr. Joy Browne (6:00) (r)</i>		<i>The Dolans (r)</i>		

All times Eastern • (r) = program refeed

# THE GUIDE TO TALK RADIO PROGRAMMING

*A complete directory to syndicated talk,  
news and sports radio programming*

**FaxBack  
Service**  
24 Hours A Day  
7 Days A Week

Get up-to-the-minute listings faxed to your office with **FaxBack** from  
The Guide to Talk Radio Programming.

- Daypart Grids
- Network Pages

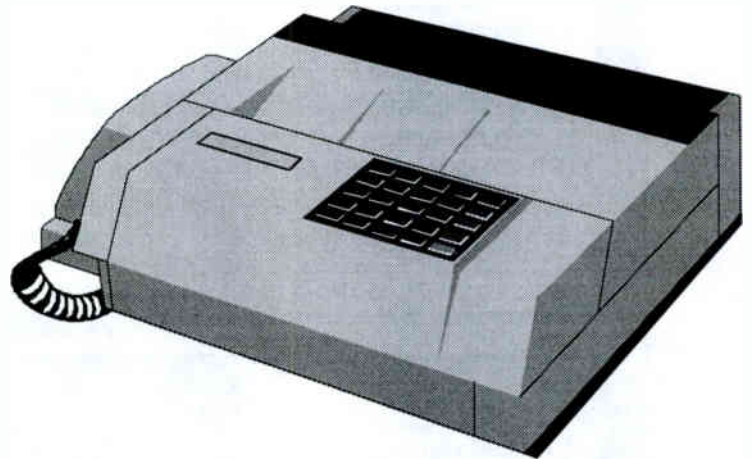

Now, you have access to the most up-to-date syndicated talk radio lineups, maintained 24 hours a day on our database.

**FaxBack Service**, just another way we're making programming talk radio easier.

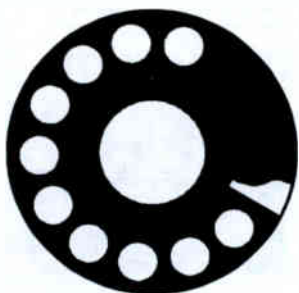

For rates & information,  
phone us anytime

**(617) 433-0870**



THE

# BEST BUY-OUT MUSIC

ROYALTY-FREE PRODUCTION MUSIC ON COMPACT DISC OR CASSETTE

**SK-1 SOUNDTRACK 1..**  
 13 dramatic, emotionally-charged tracks perfect for your feature soundtrack.  
 \$49.95 CASSETTE **\$59.95** CD

**SK-2 SOUNDTRACK 2..**  
 13 upbeat, technical, future-sounding tracks excellent for industrial videos.  
 \$49.95 CASSETTE **\$59.95** CD

**WG-1 WEDDING AND QUIET TIMES 1.....**  
 15 romantic, must-have tracks for wedding videos.  
 \$49.95 CASSETTE **\$59.95** CD

**WG-2 WEDDING AND QUIET TIMES 2....**  
 12 more great tracks for weddings, birthdays, etc.  
 \$49.95 CASSETTE **\$59.95** CD

**SS-1 SPORTS & ACTION 1..**  
 12 pumping, high-impact rhythm and melody tracks.  
 \$49.95 CASSETTE **\$59.95** CD

**SS-2 SPORTS & ACTION 2..**  
 More powerful cuts for sport videos, highlights, etc.  
 \$49.95 CASSETTE **\$59.95** CD

**TR-1 TRAVEL & LEISURE..**  
 12 essential, versatile tracks for travel, and nature videos.  
 \$49.95 CASSETTE **\$59.95** CD

**EZ-1 EASY LISTENING..**  
 Great for music-on-hold, industrials, and slide shows.  
 \$49.95 CASSETTE **\$59.95** CD

**RO-1 ROMANTIC..**  
 11 Beautiful selections of Romantic background music for a variety of uses.  
 \$49.95 CASSETTE **\$59.95** CD

**LE-1 LOGOS & TRANSITIONS..**  
 Over 200 zips, zaps, fly-bys, swooshes, and flurries.  
 \$89.95 CASSETTE **\$99.95** CD

**BC-1 BROADCAST 1..**  
 Most-requested tracks in varied lengths.  
 \$89.95 CASSETTE **\$99.95** CD

**BC-2 BROADCAST 2..**  
 9 more great tracks from :02 to 5:00 in length.  
 \$89.95 CASSETTE **\$99.95** CD

**BC-3 BROADCAST 3..**  
 Over 90 hot cuts, varied length, perfect for radio/TV ads.  
 \$89.95 CASSETTE **\$99.95** CD

**BC-4 BROADCAST 4..**  
 90 more great cuts in :60, :30, stinger & bumper lengths.  
 \$89.95 CASSETTE **\$99.95** CD

**CL-1 CLASSICAL..**  
 Elegant tracks in full lengths, plus :60, :30, stingers. And 10 min Mozart concerto.  
 \$89.95 CASSETTE **\$99.95** CD

**New!**  
**427 SOUND EFFECTS**  
 5-CD SET ONLY....\$99.95

**VOLUME DISCOUNT**  
 BUY 2 OR MORE & SAVE 5%  
 BUY 5 OR MORE & SAVE 10%  
 BUY 8 OR MORE & SAVE 15%  
 BUY 10 OR MORE & SAVE 20%

CALL OUR DEMO LINE: (206) 467-6931

**ORDER TOLL-FREE  
 1 800-323-2972**

**Free catalog**



ADD \$3.50 S&H PER ORDER (OVERNIGHT \$15).  
 IN WA ADD 8.2% SALES TAX. OUTSIDE U.S. ADD EXTRA \$3.50

P.O. Box 84583 Seattle, WA 98124



---

# Names to Watch: Dr. Derrick DeSilva “Ask the Doctor”

“I’m a practicing physician. I’m an internist. It is something I do 8 or 10 hours every single day, even 12 hours some days. What I do in medicine is full time. I deal with real issues. I deal with real people every day, and I think that the advice I give is practical and user friendly.

I love people, I sincerely love helping people. I’ll never forget this story, a woman called me on WCTC about a year and a half or two years ago and said, “I have abdominal pain and it’s in my lower belly.” I said to her please, you’re 60 or 70 years of age. Please, go see your doctor. I was concerned because of what she was describing. She promised me that she would go to her doctor and she did. She ended up having early stage ovarian cancer. She called me back about 6 weeks later and said “Dr. DeSilva



my doctor told me that if I had not come in sooner, if I had waited another month or two, I would have had an ovarian cancer that would have spread.” Do you know how good that made me feel? That I was able to impact somebody’s life like that?

Numerous people have called me and said, “You know what you told me was absolutely correct and I feel so much better today.” That’s what makes me feel good.

*To his listeners, Dr. DeSilva’s is “the doctor in the family.” DeSilva’s honest, sincere love for health is evident when listening to “Ask the Doctor,” heard weekday mornings on the Talk America Radio Network. Station by station, market by market, DeSilva’s brand of health advice and conversation has spread from a handful of stations to more than 60 affiliates across the country.*

**Guide:** For someone who hasn’t heard your show, how would you describe it?

**DeSilva:** Real medicine — dealing with real people about real health issues. What I do is give them guidance. I try to guide them back to their physician. Most physicians today, because of the HMO’s, because of managed care, don’t have the time to sit and speak with their patients about the basics. So what I try to do is explain the basics.

I try to direct people back to taking care of themselves and back to their physicians. I always close by saying, check with your doctor because I am not able to diagnose or treat people on the radio. My purpose is to educate, to inform and to disseminate good, practical information that they will be able to use — in very understandable terms.

**Guide:** Growing up, did you listen to the radio? Were you fascinated with it?

**DeSilva:** Nope, not at all. I remember that my father had been in media. My father was a reporter and writer, and was very interested in radio at one time. I remember him sitting in front of a reel to reel about 30 years ago recording his voice because he was practicing to do some radio, and I used to sit there and listen to him. That's probably how I became interested, but on a subconscious level. I never really brought it to a conscious level until this happened on the radio with me.

**Guide:** How did you get your break?

**DeSilva:** It was very coincidental. I was invited down to Florida to do a lecture on cardiovascular disease and was talking to an international reporter for one of the major television networks. I made the comment that I would love to do radio or television. She said, "Well, what you need to do is call your local radio station and tell them that you want to do a program."

As naive as I was many, many years ago, I called my local radio station on Monday morning and spoke to the General Manager of WCTC and WMGQ and said, "I'm Dr. Derrick DeSilva and I would like to do a program." He said to me "Well, we were just in a meeting and we were thinking of doing a medical show. You have a good voice on the phone, why don't you come in and do some programs and let's see how it goes." I've been on the air now for 7 or 8 years. That's how it started.

**Guide:** Why did you become a doctor?

**DeSilva:** I always saw doctors as good people. I remember even my grandmother going to the doctor whenever she wasn't feeling well; she had diabetes. I remember her coming out and saying "You know I feel better already," and I could never figure out how you could go to somebody, walk out of the office and say "I feel good." It was that type of the healing and the love of people that really made me do it. It's very gratifying to make somebody feel good.

**Guide:** What would you like to be doing in five years?

**DeSilva:** Five years from now I would like to be on hundreds of stations. I'd like to get through to people and be able to communicate the message of assuming responsibility for your own health. I see myself in five years being able to really get that word out have an impact on people's lives or health.



*DeSilva: "Bruce Williams has helped me through the maze of talk radio. He's a very decent man."*

# DEDICATION TO QUALITY IN BROADCASTING

## **T**alk America Radio Network

is dedicated to delivering  
a quality broadcast service  
to your radio station  
around the clock.

**O**utstanding talent,  
ease of access,  
technical flexibility to  
access live or  
automated  
systems.

**A**ll on a barter basis...at no cash cost. All arranged for  
with a simple contract. All ready to go with only a moment's  
notice.

**S**ign up today with **Talk America Radio Network**. You'll  
be dealing with professional broadcasters...people who  
know the rules of the game...who operate **Talk America  
Radio Network** in a way that is a credit to the industry and  
will be a credit to your radio station.

**C**all **Talk America Radio Network** Station Relations Today:  
1-617-828-4546 or Fax 1-617-828-3822

354 Turnpike Street • Canton, Massachusetts 02021

# JERRY BROWN...

*The Way I See It*

POPULIST AND PROVOCATIVE

1 MINUTE COMMENTARIES

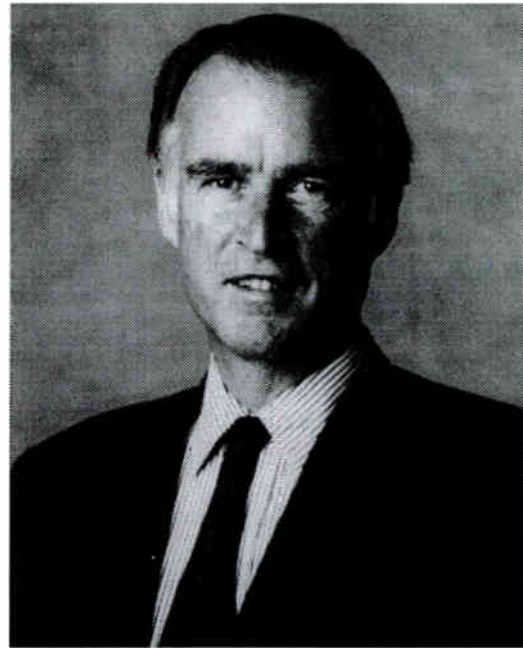

SatCom C-5, Transponder 15, Channel 16.0, Galaxy, TVRO

For information, contact Carol Renza (203) 264-2186 or Fax: (203) 264-2046

**MediaRep Associates**

799 Peter Road • Southbury, Connecticut 06488

---

## MEGABYTES

with Russ Hicks, Saturdays 9am to 11am (PT)

America's Most User-Friendly Computer Talk Show

**ENTERTAINING • MASS APPEAL • RENOWNED INDUSTRY GUESTS**

*"The show has become our most popular and lucrative weekend program...Megabytes is fun, entertaining and informative...How many computer shows can you say that about?"*

Mike Remy, Program Director, KHTK 1140AM - Sacramento, CA

SatCom C-5, Transponder 23, Channel 12 • Join our Growing Affiliate List!

For information, contact Carol Renza (203) 264-2186 or Fax: (203) 264-2046

**MediaRep Associates**

799 Peter Road • Southbury, Connecticut 06488



# THE MOST IMPORTANT BOOK EVER WRITTEN ABOUT RADIO

*In Commemoration of  
Radio's 75th Anniversary*

Streamline Press announces an extraordinary 472 page coffee-table book – The Deluxe Edition of *Blast From The Past: A Pictorial History of Radio's First 75 Years*.

• UNPRECEDENTED PRINTING •

*Blast From The Past: A Pictorial History of Radio's First 75 Years* is an undertaking of unparalleled proportion. Author B. Eric Rhoads has searched archives across America and found hundreds of rare, never-before-published historical photographs featuring radio from its early experimental stages, personalities of radio's golden era of the '30s and '40s, the first disc jockeys of the '50s, the boss jocks of the '60s, the start of underground radio in the '70s, and the personalities and talk-show hosts of the '80s and '90s. This is a landmark publishing with **more than 900 rare photographs** in rich quality, hard-bound printing. This gift book is for anyone who loves radio. Historically this book redefines radio's past as it reveals significant facts never before published.

Radio has never been pictured more beautifully. This handsome Deluxe hardbound book will give you years of nostalgic pleasure and historic intrigue.

**NEW  
\$39.99 PRICE\***

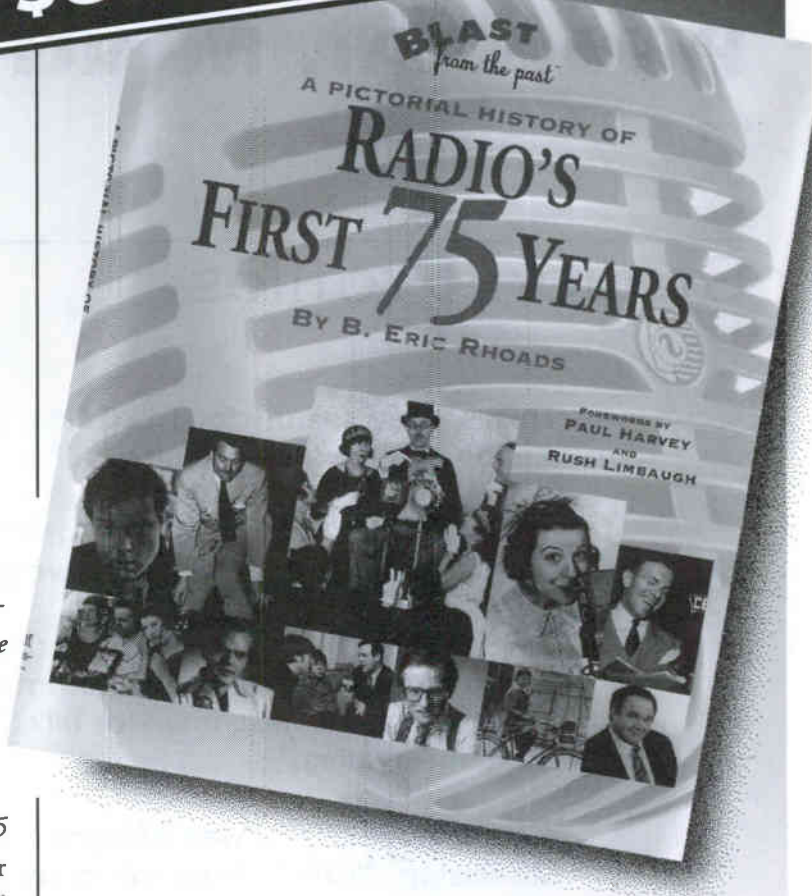

\*Deluxe Hard Cover Book • \$39.99 plus \$5.50 S&H

(Numbered, Signed Collector's Edition still available at \$75.00)

CALL TOLL FREE

**1-800-226-7857**

STREAMLINE PRESS

FULLY GUARANTEES SATISFACTION

WITH A MONEYBACK POLICY FOR A FULL 30 DAYS

CALL FOR QUANTITY PRICES OR CUSTOMIZED COVERS  
WITH YOUR LOGO. MAKES A GREAT ADVERTISER GIFT.

STREAMLINE  
PRESS

CALL 1-800-226-7857 • Fax in Your Order: 1-407-655-6164

Mail in Your Order: 224 Datura Street • Suite 701 • West Palm Beach, FL 33401

*"You'll enjoy every moment and every page of Eric's wonderful book."*

– Sally Jesse Raphael  
National TV Talk Host

*"If you are a Radio buff like me, this is a must-hit"*

– Bruce Williams  
National Talk Host



# THE GUIDE TO TALK RADIO PROGRAMMING

---

## Station Profiles

This is a new feature for The Guide. Each issue, we'll profile several stations, from all market sizes.

In these grids, you'll see the program lineup for each station, with the syndicator in parentheses if the program is a network feed.

For this issue, we profile **KVI**, a ratings success in Seattle. In four years, this former oldies station went from #21 to #1 under Program Director Jim Cassele. He describes Hot Talk 570 as "compelling, controversial and conservative."

A standalone 50,000 watt AM and the first news/talk station in Central Mississippi, **WJNT** uses a mix of local and national talent. General Manager Stan Carter positions the station around its highest-rated program, *Rush Limbaugh*. Local talent includes hosts Matt Friedeman & Mary Weiden.

After many failed music formats, **KICS** switched to a news/talk format. Gene McCoy encourages other stations to stop simulcasting their FM and create an identity for their AM. After making the switch to talk, KICS revenue increased 30-40%.

To participate and have your station to be profiled here, attach a lineup and station profile when you filling out our subscription form on page 132.

## Weekdays

	<b>KVI</b> Seattle, Washington	<b>WJNT</b> Jackson, Mississippi	<b>KICS</b> Hastings, Nebraska
MID	Art Bell (Chancellor/TRN)		
1am	Ken Hamblin (Entertainment Radio Network)	Stan Major (Talk America Radio Network)	Stan Major (Talk America Radio Network)
2am			
3am	Oliver North (Salem)		
4am		Doug Stephan "Good Day USA" (Talk America Radio Network)	Doug Stephan "Good Day USA" (Talk America Radio Network)
5am			
6am	Kirby Wilbur	The World at Sunrise	Morning in America (Peoples)
7am			
8am		The Matt Friedeman Show	Derrick DiSilva "Ask the Doctor" (Talk America Radio Network)
9am			Sally Bowers "Sally Says" (Peoples)
10am	Rush Limbaugh (EFM)	G. Gordon Liddy (Westwood One)	Ken Root "Agri-Talk"
11am			
NOON		Rush Limbaugh (EFM)	Paul Gonzalez (Peoples)
1pm	Mike Siegel		
2pm		Dr. Laura Schlessinger (Radio Today)	Chuck Harder "For the People" (Peoples)
3pm			
4pm	John Carlson	The Mary Wieden Show	Mike Foudy "America the Beautiful" (Talk America Radio Network)
5pm			
6pm			Craig Smith "Open Up" (Talk America Radio Network)
7pm	Michael Reagan (Major Talk)	Bruce Williams (Westwood One)	Jameson White (Talk America Radio Network)
8pm			
9pm	Monday - Rabbi Daniel Lapin Tuesday - Tom Isenberg Wednesday - Floyd Brown Thursday & Friday - NA		Jerry Hughes "Washington on Trial" (Peoples)
10pm		Jim Bohannon (Westwood One)	
11pm	Art Bell (Chancellor/TRN)		Stan Major (Talk America Radio Network)

## Saturday

## Sunday

	<b>KVI</b> Seattle, WA	<b>WJNT</b> Jackson, MS	<b>KICS</b> Hastings, NB		<b>KVI</b> Seattle, WA	<b>WJNT</b> Jackson, MS	<b>KICS</b> Hastings, NB
MID	Laura Lee (Laura Lee)			MID	Gun Talk (Talk America)	Sports Party (Talk America)	Sports Party (Talk America)
1am		Stan Major (Talk America)	Stan Major (Talk America)	1am	Ken Hamblin (Entertainment Radio Network)		
2am				2am			
3am	Mario Cuomo (SW Networks)			3am	Oliver North (Salem)	Joe Mazza (Talk America)	Joe Mazza (Talk America)
4am		Las Vegas Live (Talk America)	Las Vegas Live (Talk America)	4am			
5am		Fishing Zone (Talk America)	Fishin & Wishin (Peoples)	5am	Best of Rush Limbaugh (EFM)	Synergy (Talk America)	Synergy (Talk America)
6am	KVI Sportsman	Doug Stephan (Talk America)		6am			
7am		Primetime Radio	Saturday in Am- erica (Peoples)	7am	Fred Barnes/ Back to God	Cornerstone	Health (Talk America)
8am	KVI Auto Show	SFRN's Kickoff	Magic Garden (Talk America)	8am	The Legal Show	Baptist Hour	Home & Garden (Peoples)
9am	Home Improvement	Car Clinic	Play Doctor (Talk America)	9am	Financial Show	Christian Science	Trash or Treasure? (Peoples)
10am	Ed Hume Lawn & Garden	We're Talkin' Gardening	Shopping Spree	10am		Al Grady (Talk America)	
11am			Business (Talk America)	11am	Computer Show	Bill Bailey (Talk America)	Church Service
12pm	Clinton Radio Address & Joe Ellis Show		Kugell & McLaughlin (Talk America)	12pm			Washington... (Peoples)
1pm		Best of Tom Leykis (Westwood)		1pm	Joe Ellis	Best of Tom Leykis (Westwood)	Internet Show (Talk America)
2pm			Trash / Treasure (Peoples)	2pm			Tom Gresham "Gun Talk" (Talk America)
3pm	Health Issues Today		Rob & Bob Home Show (Talk America)	3pm		Bob Brinker "Money Talk" (ABC)	
4pm		Bob Brinker "Money Talk" (ABC)		4pm	Don Shorter		AutoWorld (Talk America)
5pm	Annalisa Woods		Saturday in Am- erica (Peoples)	5pm		Ham Radio (Talk America)	Ham Radio (Talk America)
6pm	Making A Difference		Lou Mazella On Sports (Talk America)	6pm	Beyond the Beltway	Bruce Williams (Westwood)	Health Watch (Talk America)
7pm	Newt Gingrich	Best of Bruce Williams (Westwood)		7pm		Wayne Lapierre (Westwood)	Montage (Peoples)
8pm	Renewing Washington		Backstage (Talk America)	8pm	Reliving History		Biker Broadcasting (Talk America)
9pm				9pm			
10pm	Laura Lee (Laura Lee)	David Essel "Alive" (Westwood)	Ring Talk (Talk America)	10pm	The Rabbi's Roundtable	David Essel "Alive" (Westwood)	Eliot Stein (Peoples)
11pm			Sports Party (Talk America)	11pm	Gun Talk (Talk America)		Joe Mazza (Talk America)

# THE GUIDE TO TALK RADIO PROGRAMMING

---

## Network Pages

Here, you'll find detailed information from long-form talk programming providers, including the names and phone/fax numbers of network contacts to obtain further information.

At a glance, you will find lineups, terms and technical information to give an overview of each network.

ABC .....	41
American Entertainment Radio Network .....	42
American Urban Radio Network .....	43
Broadbank Burbcasting .....	44
Buchwald, Don .....	45
Burlington Radio Network .....	46
Business News Network .....	47
CBS .....	49
Chancellor / Talk Radio Network .....	50
EFM Media Management .....	51
Entertainment Radio Network .....	52
Grow-Wise Garden Network .....	53
Judy Jarvis .....	55
Laura Lee .....	57
Learfield Communications .....	58
Major Talk Networks, Inc. ....	59
MediaRep Associates .....	60
Nelson Creative Radio .....	61
Network Broadcasting Associates .....	62
On the House .....	63
Paranet Continuum .....	64
People's Radio Network .....	65
Radio America .....	67
Radio Today .....	68
Salem Broadcasting .....	69
Sweet Talk Productions .....	71
SW Networks .....	72
Talk America Radio Network .....	73
Tech Talk Radio Network .....	75
USA Patriot Radio Network .....	77
USA Radio Network .....	79
USA Radio Network 2 .....	80
WestStar .....	81
Westwood One .....	83 & 84

# ABC Radio Networks

125 West End Avenue, New York, NY 10023  
(212) 456-1777 • Fax: (212) 456-5397

13725 Montfort Drive, Dallas, TX 75240  
(214) 991-9200 • Fax: (214) 991-1512

## Affiliate Relations:

(214) 776-4628

## Terms:

Barter

## Coordinates:

SatCom C-5  
Transponder 23  
Sedat Channel 54 & 55

## Tones:

Inquire

## Inventory:

11 minutes local  
3 minutes network

## Saturday

1p-4p	Bernie Ward	Bernie Ward Show
4p-7p	Bob Brinker	Financial Advising
7p-10p	Bernie Ward	Bernie Ward Show (r)
10p-1a	Bob Brinker	Financial Advising (r)

## Sunday

1p-4p	Bernie Ward	Bernie Ward Show
4p-7p	Bob Brinker	Financial Advising
7p-10p	Bernie Ward	Bernie Ward Show (r)
10p-1a	Bob Brinker	Financial Advising (r)

*All times Eastern • (r) = program refeed*

## The Radio Book: The Radio Station Operations Manual



Volume 1: Management  
& Sales Management



Volume 2: Programming  
& Promotion



Volume 3: Sales  
& Marketing

**\$59.99**  
for the  
**COMPLETE**  
**THREE-BOOK SERIES**  
**CALL**  
**800-226-7857**

This three-book series covers the challenges you'll face as a radio manager. We've compiled the best authors and the best articles on just about every subject you can imagine related to running a radio station. This definitive answer-book series provides information and solutions on management, sales management, marketing, promotion, programming, engineering, sales and more. Hundreds of subjects in a quick, easy-to-read format.



# American Entertainment Network

400 Mission Avenue, Oceanside, CA 92054-2828 • (619) 754-3333 • Fax: (619) 754-3344

## Monday - Friday

11p-2a Lowell Ponte Lowell Ponte at Large

## Saturday

12a-2a Lowell Ponte Lowell Ponte at Large

9p-12a Lowell Ponte Lowell Ponte at Large

## Sunday

8a-10a Ron Mason & Mike Spencer Home Care

10a-12p Dr. Bob Martin Health Talk

*All times Eastern • (r) = program refeed*

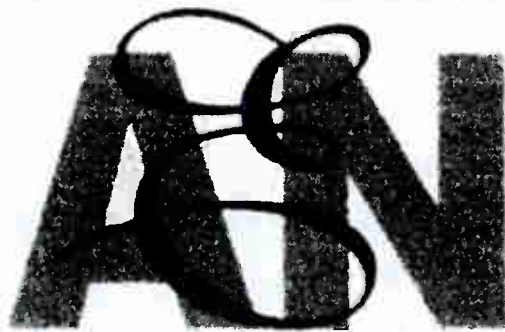

American Entertainment Network

*Leading the way with  
Multi-media, Interactive,  
Modular Talk Radio*

### President:

Jim Ballard

### Affiliate

Relations

### Director:

Daniel Deeb

### Terms:

Barter

### Coordinates:

SatCom C-5  
Transponder 15  
Channel 02.0  
7.5 MHz, DAT

### Tones:

25/35 Hz, Inaudible

### Inventory:

8 minutes local  
6 minutes network

# American Urban Radio Network

411 Seventh Avenue, Suite 1500, Pittsburgh, PA 15219 • (412) 456-4030 • Fax: (412) 456-4040

**President:**

Jack Bryant

**President of  
Programming:**

Jerry Lopes

**Affiliate**

**Relations**

**Director:**

Glenn Bryant

**Monday - Friday**

10p-2a

Bob Law

Night Talk

**Saturday**

12a-2a

Bob Law

Night Talk

*All times Eastern • (r) = program reread*

**Terms:**

Inquire

**Coordinates:**

Inquire

**Tones:**

Inquire

**Inventory:**

Inquire

## Order Extra Copies of The Guide...

**Programmers:**

When the time comes to make lineup changes, that's when you'll realize the true value of **The Guide to Talk Radio Programming**. We organize the world of syndicated talk radio into one easy-to-read, concise book. You'll find that having a few extra copies on hand will save you both time and money.

Extra copies of **The Guide** can be mailed to your office as early as tomorrow. Ask for the "Professional Courtesy Rate" of \$9.95 per copy (add \$3 for 2-Day Priority Mail).

Call (617) 433-0870 to order by MasterCard or Visa.

*Professional Courtesy Rate limit of 5 books.  
Overnight Delivery available at \$18 per copy.*

# Broadbank Burbcasting

1111 St. Gregory Street, Cincinnati, OH 45202 • (800) 852-7007 • Fax: (513) 651-1748

## Monday - Friday

12a-5a	Dale Bozo	The Truckin' Bozo
3p-6p	Gary Burbank	The Gary Burbank Show

## Saturday

8a-11a	Gary Burbank	The Best of Gary Burbank
--------	--------------	--------------------------

**Director of  
Affiliate  
Relations:**

Rick Consolo

**Coordinates:**

SatCom C-5

Transponder 23

Channel 14

Sedat Channel 47

**Tones:**

DTMF

**Inventory:**

14 minutes local

4 minutes Network

*All times Eastern • (r) = program reread*

## NEW RELEASES!

### LJ - 1

Light Jazz



<u>CUT</u>	<u>SONG NAME</u>	<u>DESCRIPTION</u>
1-6	SUMMER CRUISE	HAPPY, RELAXED
7-12	CHIC GROOVE	ELECTRIC, MODERN
8-18	11TH HOUR	INTRIGUING, LATE NIGHT
18-24	MY 3 GIRLS	FUNKY, PLAYFUL
25-30	KRUZIN	POWERFUL, SOULFUL
31-36	GYPSY GUITAR	SPANISH GUITAR
37-42	CENTRAL EXPRESSWAY	SMOOTH, LAID BACK
43-48	NO PROBLEM	CASUAL, PERSONAL
49-54	THE PHYSICS OF FUSION	CORPORATE, BOLD
55-60	PONTY FOR MONTY	TECHNICAL, MECHANICAL
61-66	ST STEVE	TENSE, CORPORATE

Call for our free catalog!

**1-800-323-2972**

Energetic Music, P.O. Box 84583, Seattle, WA 98124

# Buchwald Associates

10 East 44th Street, New York, NY 10017  
(212) 867-1070 • Fax: (212) 867-2434

79229 Sunset Blvd., Los Angeles, CA 90069  
(310) 278-3600 • Fax: (310) 278-4099

**Contact:**

Don Buchwald

**Terms:**

Cash

**Coordinates:**

SatCom

Inquire

**Tones:**

Inquire

**Inventory:**

Inquire

**Monday - Friday**

6a-10a

Howard Stern

The Howard Stern Show

*All times Eastern • (r) = program refeed*

## TC Voiceover Professionals

*Major market sound at affordable rates*

- Station ID's
- Promos
- Sweepers
- Liners
- Commercials
- Bumpers

Versatile, top-notch professional voiceovers at truly affordable prices. Think it can't happen? Try us.

We offer market exclusivity, fast turnaround, and only the best voice talent available at rates that are affordable for medium and even small markets. Write to request our free material. Let us create a powerful, professional image for your station or program.

**TC Voiceover Professionals**

P.O. Box 100, Readville, MA 02137

# Burlington Radio Network

429 Spring Street, Marquette, MI 49855 • (906) 228-3275 • Fax: (906) 228-7477

## Monday - Friday

12a-1a	William Cooper	The Hour of the Time
1a-6a	Dave Hinkson	Freedom Radio Network
4p-5p	Scott Stevens	Unchained Radio
5p-6p	Don Wassal	America First
6p-7p	Johnny Johnson	Patriot News Hour
7p-8p	Stadmilller/Koernke	Intelligence Report
8p-9p	Clay Douglas	American Soapbox
9p-10p	Richard Eustler	Liberty News Hour
10p-11p	Richard Eustler	American Eagle Radio Hour
11p-12a	Richard Eustler	Fisherman's Net

## Saturday

4p-5p	Scott Stevens	Unchained Radio
5p-6p	Richard Eustler	Fisherman's Net
6p-7p	Richard Eustler	Taking America Back
7p-10p	J.J. Johnson	Arming You With Knowledge
10p-11p	Mark Emanuelle	Spectrum
11p-12a	Mark Emanuelle	Spectrum After Hours

## Sunday

12a-2a	Richard Eustler	Talk Radio
7p-8p	Pete Peters	Scriptures for America Worldwide
8p-9p	Joyce Riley	Nurse Talk Radio

### President:

Gary Bourgois

### Terms:

Barter/Inquire

### Coordinates:

Galaxy 6  
Transponder 14  
Channel 7.56

### Tones:

25/35 Hz

### Inventory:

2 minutes local  
2 minutes network

*All times Eastern • (r) = program reread*



# Business News Network

5025 Centennial Blvd., Colorado Springs, CO 80919 • (719) 528-7040 • Fax: (719) 538-1438

**General  
Manager:**  
Jack Lott

**Terms:**  
Barter

**Coordinates:**  
SatCom C-5  
Transponder 15  
Channel Inquire

**Tones:**  
DTMF

**Inventory:**  
12 minutes local  
5 minutes network

## Monday - Friday

12a-1a	All About Futures (Mon) (r)
1a-3a	America's Travel & Dining Guide (Mon)
1a-2a	Market Wrap (Tue-Fri) (r)
2a-3a	The Financial Hour (Tue-Fri) (r)
3a-6a	The Al Maimberg Show (Tue-Fri) (r)
6a-12p	Business Radio Newsclock
12p-3p	The Don McDonald Show
3p-4p	Business Day
4p-5p	Market Wrap
5p-6p	Business Day
6p-7p	The Financial Hour
7p-10p	The Al Maimberg Show (r)
10p-1a	The Don McDonald Show (r)

## Saturday

12a-1a	The Don McDonald Show (r)
1a-2a	Market Wrap (r)
2a-3a	Sales Talk (r)
3a-6a	The Al Maimberg Show (r)
6a-7a	Technology Today
7a-8a	Working From Home
8a-9a	Tee to Green - The Golf Show
9a-10a	Great American Road
10a-2p	On the Road with Jeff Brooks
2p-5p	The Don McDonald Show
5p-7p	All About Futures
7p-10p	The Al Maimberg Show (r)
10p-12a	The Bill Moran Show

## Sunday

12a-4a	On the Road with Jeff Brooks (r)
4a-5a	Tee to Green (r)
5a-6a	Great American Road (r)
6a-9a	Computer America
9a-11a	Initial Public Offering Show
11a-3p	The Financial Advisor with Charles DeRose
3p-6p	Computer America (r)
6p-8p	America's Dining & Travel Guide
8p-10p	Wishing You Well
10p-11p	Working From Home
11p-12a	All About Futures

All times Eastern • (r) = program reread

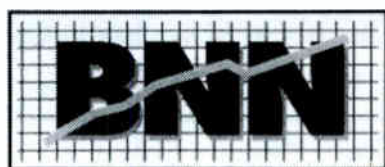

**BUSINESS  
NEWS  
NETWORK**

A FULL SERVICE, 24-HOUR PROGRAMMING SOURCE

BUSINESS NEWS NETWORK is a fast-paced, timely and credible service for everyone in the business community. Business News Network will take America's executives and professionals into the 21st century with programming that communicates business and financial news instantly. Business News Network delivers national and world news, plus more business coverage than any other radio format.

We provide listeners with the news and information they need to make informed decisions in all aspects of their busy lives...such information as personal finance, home and family, education, travel, health and technology. Executives want facts, not gossip. They need accurate pertinent news, in a timely "user-friendly" manner, not flash and speculation. Business News Network meets your listeners growing demand for information!

Use all 24 hours or choose just the programs you need to enhance your existing lineup, all on a barter basis.

Talk programming covering business, finance and lifestyle issues.

Up-to-the-minute reports from domestic and international stock markets, traveler's weather and feature material.

Plus, consumer/business-oriented programs featuring:

Dining & Travel	Entertainment
Personal Finance	Computer Technology
Sales	Education

Programming has never been easier. 100% Barter!

Call the **Business News Network** at

**1-800-825-5212**

# CBS Radio Network

51 West 52nd Street, New York, NY 10019 • (212) 975-6085 • Fax: (212) 975-3515

**President:**

Nancy C. Widmann

**Vice President**

**General Manager:**

Robert Kipperman

**Vice President:**

Frank D. Murphy

**Vice President**

**Affiliate Relations:**

Nicholas Kiernan

**Terms:**

Barter

**Coordinates:**

SatCom C-5  
Transponder 23  
Sedat  
Various Channels

**Tones:**

25 Hz, Inaudible

**Inventory:**

10 minutes local  
4 minutes network

**Monday - Friday**

2a-5a	Gil Gross	The Gil Gross Program (Tue-Fri) (r)
2a-5a	Tom Snyder	The Late Late Radio Show (Tue-Fri) (r)
5a-8a	Tom Snyder	The Late Late Radio Show (Tue-Fri) (r)
3p-6p	Mary Matalin	Talk With An Attitude
6p-9p	Mary Matalin	Talk With An Attitude (r)
8p-11p	Gil Gross	The Gil Gross Program
11p-2a	Gil Gross	The Gil Gross Program (r)
11p-2a	Tom Snyder	The Late Late Radio Show

**Saturday**

12a-2a	Gil Gross	The Gil Gross Program (r)
12a-2a	Tom Snyder	The Late Late Radio Show
2a-5a	Gil Gross	The Gil Gross Program (r)
2a-5a	Tom Snyder	The Late Late Radio Show (r)
5a-8a	Tom Snyder	The Late Late Radio Show (r)

All times Eastern • (r) = program refeed

## THE GUIDE TO TALK RADIO PROGRAMMING

offers

UP TO THE MINUTE  
NETWORK INFORMATION

24 HOURS • 7 DAYS A WEEK

with **FAXBACK**

Just call with your request for the absolute latest programming lineups from the networks and syndicators you find in this publication.

Need a new Saturday morning program? Call and request the very latest Saturday morning grid. For more information, call anytime -- (617) 433-0870.

# Chancellor / Talk Radio Network

744 East Pine Street, Central Point, OR 97502 • (503) 664-8829 • Fax: (503) 664-8261

## Monday - Friday

12a-1a	Art Bell	Dreamland (Mon)
1a-2a	Roger Fredinburg	(Mon on tape)
12a-2a	Roger Fredinburg	Roger Fredinburg (Tue-Fri)
2a-7a	Art Bell	Coast to Coast
7a-9a	Art Bell	Coast to Coast (r)
9a-11a	D. Ray & Dr. Carrow	Here's To Your Health
11a-1p	Roy Masters	Roy Masters
1p-3p	Roger Fredinburg	The Roger Fredinburg Show (r)
3p-5p	D. Ray & Dr. Carrow	Here's to Your Health (r)
5p-6p	Art Bell	Coast to Coast (r)
6p-9p	Peter Weissbach	Weissbach
9p-11p	Lisa, Gary & Bob	The Big Radio Show
11p-12a	Roger Fredinburg	Roger Fredinburg

## Saturday

12a-2a	Roger Fredinburg	Roger Fredinburg
2a-7a	Art Bell	Coast to Coast
7a-9a	Art Bell	Coast to Coast (r)
9a-11a	Mike Harrison	Talkers Countdown (Tape)
11a-1p	Al, Dave, & Peter	Auto Talk
1p-2p	Danielle Lin	Danielle Lin Health Show (Tape)
2p-4p	Myrna Ochs	Myrna Ochs Show
4p-6p	Randy Johnson	News With A View
6p-8p	Ed Nowicki	American Crime Line
8p-11p	Art Bell	Dreamland (Tape)
11p-2a	Roger Fredinburg	Roger Fredinburg Show (r)

## Sunday

12a-2a	Roger Fredinburg	Roger Fredinburg (r)
2a-7a	Art Bell	Coast to Coast (r)
7a-9a	Art Bell	Coast to Coast (r)
9a-11a	Lance Podolski	America Outdoors
11a-1p	Henry Feinberg	The Henry Feinberg Show
1p-2p	Danielle Lin	Danielle Lin Health Show (Tape)
2p-4p	Ed Nowicki	American Crime Line (r)
4p-7p	D. Ray & Dr. Carrow	Here's To Your Health
7p-9p	Randy Johnson	The Randy Johnson Show (r)
9p-10p		The Science Radio Hour
10p-12a	Art Bell	Dreamland

All times Eastern • (r) = program reread

### President:

Alan Corbeth

### Affiliate Relations:

Julian Hudson

### Terms:

Barter

### Coordinates:

SatCom C-5  
Transponder 15  
Channel 02.1

SatCom C-1 TVRO  
Channel 5  
Audio 5.8 Wide Band

### Tones:

25 Hz, Inaudible

### Inventory:

Inquire

# EFM Media Management

366 Madison Avenue, 7th Floor, New York, NY 10017 • (212) 661-7500 • Fax: (212) 661-7945

**Chairman:**

Edward McLaughlin

**President:**

John Axten

**Director of  
Affiliate Relations:**

Lee M. Vanden-Handel

**Monday - Friday**

12p-3p	Rush Limbaugh	The Rush Limbaugh Show
4p-5p	Dr. Dean Edell	The Dr. Dean Edell Show

**Terms:**

Cash/Barter

**Coordinates:**

SatCom C-5  
Transponder 23  
Channels Inquire

**Tones:**

Inquire

**Inventory:**

Inquire

*All times Eastern • (r) = program reread*

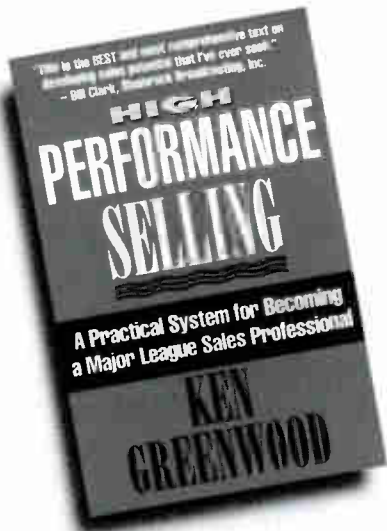

*The Finest Book Ever  
Written On Selling*

.....

Broadcasters have been begging Master Trainer Ken Greenwood to write this book for years. Now it's a reality. Seasoned pros and novice salespeople will benefit from the book.

**\$19.99**

**CALL 800-226-7857**



# Entertainment Radio Network

23730 Malibu Road, Malibu, CA 90265 • (310) 456-7879 • Fax: (310) 456-0611

## Monday - Friday

3p-6p    Ken Hamblin    The Ken Hamblin Show

*All times Eastern • (r) = program refeed*

## Major Market Voice

### *Small Market Prices*

- ✓ Voice currently heard throughout North America
- ✓ Experience in all market sizes
- ✓ Commercials on three national radio networks

• ID's    • Liners    • Commercials

#### **Long Multimedia**

PO Box 243, Needham, MA 02222

**(617) 433-0870**

### **Director of Affiliate Relations:**

Tara Meyers

### **Terms:**

Barter

### **Coordinates:**

SatCom C-5  
Transponder 19  
Dats Channel 17

SatCom C-5  
Transponder 19  
Sedat Channel 77

### **Tones:**

25 Hz, Inaudible

### **Inventory:**

9 minutes local  
4 minutes network

# Grow-Wise Gardner Network

1500 South Croatan Highway, Kill Devil Hills, NC 27948 • (919) 480-1576 • Fax: (919) 480-4655

**Executive Producer:**

Bob Deblois

**General Manager,  
Sales Manager:**

Lisa Ray

**Terms:**

Barter

**Coordinates:**

SatCom C-5  
Transponder 15  
Frequency 02.1

Galaxy 6  
Transponder 3  
Channel 84.6

**Tones:**

Inquire

**Inventory:**

8:30 minutes local  
7 minutes network

**Saturday**

8a-10a Dr. Marc Catchey The Garden Show

*All times Eastern • (r) = program reread*

## STERLING SATISFACTION

"Ours is a broadcast situation and telecommunications is a 24-hour per day, 365-day per year necessity for us. Switching to Sterling Telephone was a big risk for us. But they proved themselves immediately. Their customer service is truly on call all the time and you get to talk to a real person...not some mechanical monster. We got the best of both worlds...great prices and unparalleled service."

- A satisfied Sterling Client

### The Sterling Telephone Company

50 Holden Road, Sterling, MA 01564  
(508) 422-8220  
fax (508) 422-9067

# 1-800-STRLING2

1-800-787-5642

# ITEX

**I Want to Buy Your Unsold Air Time!!!**



ITEX is an exclusive membership of business owners and professionals who exchange goods and services for trade.

Barter is one of the fastest growing industries. When you understand what barter can do for you and your business, you'll want to be involved.

- Add new customers & sales
- Conserve cash
- Sell slow moving merchandise
- Increase buying power
- Alternative financing
- Open new markets

*If you are already involved in barter, you will appreciate what ITEX can offer over other trade exchanges.*

- Largest exchange in America
- Over 40,000 members
- Offices in over 130 cities
- Monthly newsletter/Weekly trade fax
- "Barterwire" Bulletin Board
- Free national advertising
- Coop advertising program
- Instant fax advertising
- ITEX travel department
- Barter Age-National Publications

*Expand your business horizons. Please call me with your questions or a complete briefing of the ITEX Barter Advantage.*

ITEX is traded on the NASDAQ stock exchange. (We are the only barter company that's publicly traded). It could be the best 5-10 minutes you could ever spend to learn about all we have to offer.

*Call Right Now!*  
**(312) 784-ITEX**

# Jarvis Productions

229 Buckingham Street, Hartford, CT 06106 • (860) 242-7276 • Fax: (860) 243-3385

**Business**

**Manager:**

Deborah Shillo

**Producer:**

Jason Jarvis

**Terms:**

Barter

**Coordinates:**

SatCom C-5  
Transponder 23  
Sedat Channel 25

**Tones:**

Inquire

**Inventory:**

12:30 minutes local  
6 minutes network

**Monday - Friday**

12p-3p Judy Jarvis The Judy Jarvis Show

*All times Eastern • (r) = program refeed*



**THE  
JUDY JARVIS  
SHOW**

**“One of the rising stars in  
talk radio.”**

*California Governor  
Pete Wilson*

**“A ratings winner.”**

*KQSB Santa Barbara  
Program Director  
Jim Watkins*

**“Adding her show was the  
best move of the year.”**

*WCAP Boston  
Program Director  
Kevin Dunn*

Fed on SatCom C-5, Transponder 23, Channel 25. For the latest media kit and tape, call (860) 242-7276, Deborah Shillo, Business Manager. **Add the Judy Jarvis Show and solve your midday ratings problem!**

# ... whip up the perfect radio mix.



With Metro Networks in your recipe, you can strengthen your station's programming with quality news, sports, weather, traffic and information.

Considering 85% of radio listeners rate information reports as "important" to their radio diet, Metro Networks is also great for building audience and TSL.

What's more, 87% of listeners crave reports on a regular basis, not just as needed -- while more than 47% will leave a radio station in search of information to satisfy their appetite.\*

Metro Networks is perfect because it's fortified with coverage from over 60 cities in North America and Europe, and is enriched with broadcasting's largest fleet of aircraft.

And since Metro is available at no hard cost to you, it's great for battling bulging debt.

Make Metro Networks a nutritious part of your programming. For more successful recipes and ideas, call 713-621-2800.

\*The Research Group, 1994



NEWS • SPORTS • WEATHER • TRAFFIC



# Laura Lee

700-112th Ave. Northeast, Suite 302, Bellevue, WA 98004 • (206) 455-3405 • Fax: (206) 455-1197

**Affiliate  
Relations:**

Laura Lee

**Terms:**

Barter

**Coordinates:**

SatCom C-5  
Transponder 15  
Channel 02.0

**Tones:**

25 Hz, 35 Hz, 25/35 Hz

**Inventory:**

6 minutes local  
6 minutes network

## Sunday

12a-5a    Laura Lee    The Laura Lee Show

*All times Eastern • (r) = program refeed*

## NEW RELEASES!



### RO-2

Romantic

<u>CUT</u>	<u>SONG NAME</u>	<u>DESCRIPTION</u>
1	LOVE FOR A LIFETIME	PURE, LIGHTEARTED
2	FAR AWAY	PASTORAL, INNOCENT
3	TOGETHER	DRAMATIC, UPLIFTING
4	A TEXAS SUNSET	WESTERN, ROMANCE
5	FORGIVE ME	TENDER, GENTLE
6	NEW FOUND LOVE	SOLO PIANO, HAPPY
7	HOW CAN I TELL YOU	SOLO PIANO, CARING
8	TABLE FOR TWO	PRIVATE
9	SOUL MATES	STEAMY, SOULFUL
10	LOVE CONQUERS ALL	TRIUMPHANT, SPIRITED

Call for our free catalog!

**1-800-323-2972**

Energetic Music, P.O. Box 84583, Seattle, WA 98124

# Learfield Communications

P.O. Box 10480, Jefferson City, MO 65110-4180 • (314) 893-7200 • Fax: (314) 983-2321

## Monday - Friday

11a-12p Derry Brownfield The Common Sense Coalition  
3p-4p Derry Brownfield The Common Sense Coalition (r)

## Saturday

9a-10a Don Zeman Around the House

*All times Eastern • (r) = program refeed*

### Affiliate Director:

Mike Maxwell

### Affiliate Relations:

Chuck Zimmerman

### Affiliate Relations:

Steve Camden

### Terms:

Barter

### Coordinates:

SatCom C-5  
Transponder 3  
Frequencies:  
59.4, 59.6,  
60.0, 78.6, 73.6

### Tones:

25/35 Hz, Inaudible

### Inventory:

6-7 minutes local  
network - inquire

## MediaRep Associates

Carol Renza  
President

Affiliate Relations  
Public Relations, Convention Representation

799 Peter Road  
Southbury, CT 06488

Tel: (203) 264-2186  
Fax: (203) 264-2046

# Major Talk Networks, Inc.

101 West Grand Street, Suite 600, Chicago, IL 60610 • (800) 714-7200 • Fax: (312) 755-0336

**President:**

Chris Devine

**Director of  
Affiliate Relations:**

Phoebe Pearson

**Terms:**

Barter

**Coordinates:**

SatCom C-5  
Transponder 15 & 23  
Various Channels

**Tones:**

Inquire

**Inventory:**

Inquire

**Monday - Friday**

12a-3a	Michael Reagan	Michael Reagan Show (Tue-Fri) (r)
10a-12p	Lee Mirabal	Lee Mirabal Show
12p-2p	Susan Loggans	Loggans on Law
2p-3p	A. Colmes & B. Farber	Left to Right
3p-5p	Alan Colmes	The Alan Colmes Show
5p-7p	Barry Farber	The Barry Farber Show
9p-12a	Michael Reagan	The Michael Reagan Show

**Saturday**

12a-3a	Michael Reagan	The Michael Reagan Show (r)
11a-1p	Maintenance Mike	Home Improvement USA

*All times Eastern • (r) = program refeed*

## CHART PRODUCTIONS

SUPERIOR VOICE-TRACKS  
FOR CUSTOM ID'S, PROMOS, SPOTS

NATIONAL TALENT  
AT AFFORDABLE RATES

CHART PRODUCTIONS, INC.  
BOSTON • (617) 542-8251

# MediaRep Associates

799 Peter Road, Southbury, CT 06488 • (203) 264-2186 • Fax: (203) 264-2046

## Saturday

12p-2p Russ Hicks Megabytes

## Sunday

10a-1p Jim Jorgensen Jim Jorgensen on Money

*All times Eastern • (r) = program reread*

## Order Extra Copies of The Guide...

### Programmers:

When the time comes to make lineup changes, that's when you'll realize the true value of **The Guide to Talk Radio Programming**. We organize the world of syndicated talk radio into one easy-to-read, concise book. You'll find that having a few extra copies on hand will save you both time and money.

Extra copies of **The Guide** can be mailed to your office as early as tomorrow. Ask for the "Professional Courtesy Rate" of \$9.95 per copy (add \$3 shipping for (2-Day Priority Mail).

Call (617) 433-0870 to order by MasterCard or Visa.

*Professional Courtesy Rate limit of 5 books.  
Overnight Delivery available at \$18 per copy.*

**Affiliate  
Relations:**  
Carol Renza

**Terms:**  
Barter

**Coordinates:**  
SatCom C-5  
Transponder 23 & 15  
Channels 12 & 02.0

**Tones:**  
Inquire

**Inventory:**  
Inquire

# Nelson Creative Radio

3305 Production Ave., Suite ABC, Oceanside, CA 92054 • (619) 433-4400 • Fax: (619) 433-1590

**President:**

Denny Nelson

**Affiliate Relations:**

Sonny Sturn

**Terms:**

Barter

**Coordinates:**

SatCom C-5

Inquire

**Tones:**

25 Hz, 35 Hz, 25/35 Hz

**Inventory:**

6 minutes local

6 minutes network

**Monday - Friday**

9p-11p

Timeless Voyager Radio

**Saturday**

9a-10a Pete Gray &  
Marty Milner

Let's Talk Fishing

1p-3p

Pet Talk America

**Sunday**

8a-10a Strayhorn Spadewater

Trout Talk

12p-1p Mike McKeever

Sports Card Report Live

*All times Eastern • (r) = program refeed*

## WHY WAIT TO BE #1?



### FREE SATELLITE EQUIPMENT & ENGINEERING

or More Information, call Buddy Baker at 1-800-821-5068

Presented by Network Broadcasting Associates, Inc.



# Network Broadcasting Associates

1045 East University, Mesa, AZ 85203 • (800) 821-5068 • Fax: (602) 969-2895

## Monday - Friday

12a-4a Hot Tub Radio Party  
4a-8a Hot Tub Radio Party  
8a-12p Hot Tub Radio Party  
12p-4p Hot Tub Radio Party  
4p-8p Hot Tub Radio Party  
8p-12a Hot Tub Radio Party

## Saturday

12a-4a Best of the Hot Tub Radio Party  
4a-8a Best of the Hot Tub Radio Party  
8a-12p Best of the Hot Tub Radio Party  
12p-4p Best of the Hot Tub Radio Party  
4p-8p Best of the Hot Tub Radio Party  
8p-12a Best of the Hot Tub Radio Party

## Sunday

12a-4a Best of the Hot Tub Radio Party  
4a-8a Best of the Hot Tub Radio Party  
8a-12p Best of the Hot Tub Radio Party  
12p-4p Best of the Hot Tub Radio Party  
4p-8p Best of the Hot Tub Radio Party  
8p-12a Best of the Hot Tub Radio Party

### President:

Buddy Baker

### Affiliate Relations:

Julie Shultz

### Terms:

Barter

### Coordinates:

Spacenet 3  
Transponder 7  
Audio 1.05

### Tones:

25/35 Hz

### Inventory:

14 minutes local  
5 minutes network

*All times Eastern • (r) = program refeed*

# On the House

510 Garcia Avenue, Suite E, Pittsburg, CA 94565 • (800) 737-2474 • Fax: (510) 432-0677

**Director of  
Syndication  
Services:**  
  
Steve Raucher

**Terms:**  
  
Barter

**Coordinates:**  
  
SatCom C-5  
Transponder 19  
Channel 13.0

**Tones:**  
  
25 Hz

**Inventory:**  
  
10:30 minutes local  
6 minutes network

## Saturday

10a-1p James & Morris Carey On the House

*All times Eastern • (r) = program refeed*

### ATTN: PROGRAM DIRECTORS, SALES MANAGERS & STATION MANAGERS

**WATCH YOUR ADVERTISING REVENUE GO THROUGH THE ROOF  
WITH AMERICA'S #1 HOME IMPROVEMENT CALL-IN SHOW!**

## It's "ON THE HOUSE"

*"First class, first rate programming  
the audience loves, even if they  
don't know one end of a hammer  
from another. The Carey Bros. are  
the essence of 'listener friendly'"*

Dave Haley, Operations Manager  
WODT-AM, New Orleans, LA



*"It's entertaining, it's interesting,  
and it sells. The Carey Bros. are a  
Bay Area institution that works  
for weekend programming"*

Bob Agnew, Program Director  
KNBR 68, San Francisco, CA

*with*  
**THE CAREY BROS.**

**FOR INFORMATION AND A DEMO TAPE  
CALL 1-800-REPAIR-IT TODAY!**

Let the Carey Bros.' on-air wit and wisdom:  
Improve your advertising revenue with a target audience  
Attract new sponsors • Build solid weekend listenership

**YOUR LISTENERS WILL LOVE YOU  
FOR CARRYING THE CAREY BROS.!**

On The House™ is a production of On The House Syndication

# Paranet Continuum

P.O. Box 172, Wheat Ridge, CO 80034 • (303) 744-0479

**Sunday**

9p-10p Michael Corbin Paranet Continuum

**Producer:**

Greg Barman

**Terms:**

Barter

**Coordinates:**

SatCom C-5  
Transponder 23  
Sedat Channel 20

**Tones:**

25 Hz

**Inventory:**

4 minutes local  
8 minutes network

*All times Eastern • (r) = program refeed*

Long Multimedia, Boston, Massachusetts

**POWER  
PUBLISHING**

Create a powerful impression with **POWER PUBLISHING**.

- Media Kits
- Newsletters & Flyers
- One-Sheets
- Print Advertising
- Letterhead & Office Stationery

Get noticed. Get creative. Get **POWER PUBLISHING** to create a look that works.

Our professional desktop publishing team have both publishing and broadcasting experience. Expensive? No, just good.

Call Long Multimedia **POWER PUBLISHING**.  
Fast turnaround...and the look that gets noticed.

**(617) 433-0870**

# Peoples Radio Network

3 River Street, White Springs, FL 32096 • (800) 397-8255 • Fax: (904) 397-4149

## Operations Manager:

Kent Phillips

## Affiliate Relations:

Duane Crites

## Terms:

Barter

## Coordinates:

SatCom C-1  
Transponder 52  
Channel 7.5

SatCom C-5  
Transponder 3  
Channel 74.00

Galaxy 6  
Transponder 3  
Channel 74.9

## Tones:

25Hz, 35 Hz, 25/35Hz

## Inventory:

Inquire

## Monday - Friday

12a-2a	Chuck Harder	For the People (r)
2a-5a	Bruce Amsterdam	Common Ground
5a-6a	Paul Gonzalez	The Paul Gonzalez Show (r)
6a-10a	Mike Ezzell & Dave Hand	Morning in America
10a-11a	Sally Bowers	Sally Says
11a-2p	Paul Gonzalez	The Paul Gonzalez Show
2p-5p	Chuck Harder	For the People
5p-6p	Chuck Harder	For the People (r)
6p-9p	Joel Vincent	Vincent & Co.
9p-11p	Jerry Hughes	Washington On Trial
11p-12a	Chuck Harder	For the People (r)

## Saturday

12a-2a	Chuck Harder	For the People (r)
2a-4a	Jerry Hughes	Washington On Trial (r)
4a-6a	Zev Brenner	Talkline (r)
6a-8a	Tommy Powell	Fishin' & Wishin'
8a-9a	Wyatt Cox	Saturday Morning in America
9a-1p	G. Peart & T. Flannigan	Auto Answers
1p-3p	P. Hoffman & Dr. Duke	Animal Talk
3p-4p	Dr. Tony Hyman	Trash or Treasure?
4p-6p	Michael Crose	The Home & Garden Show
6p-8p	Sally Bowers	Sally Says
8p-10p	Jerry Hughes	Conceived in Liberty
10p-12a	Carl Angeloff	Carl Angeloff's Bottom Line

## Sunday

12a-3a	Chuck Harder	For the People (r)
3a-4a	Dennis Daily	American Montage (r)
4a-6a	Zev Brenner	Talkline
6a-8a	Tommy Powell	Fishin' & Wishin' (r)
8a-10a	Michael Crose	Home & Garden Show (r)
10a-12p	Dr. Tony Hyman	Trash or Treasure? (r)
12p-2p	Pat Choate	Washington: The Week Ahead
2p-5p	Larry Lempert	Balance the Scales
5p-7p	Ramsey Pollard	Ramblin' with Ramsey
7p-8p	Sally Bowers	Sally Says (r)
8p-9p	Dennis Daily	American Montage
9p-12a	Eliot Stein	The Eliot Stein Show

All times Eastern • (r) = program refeed

# We'll Send You a Check!

People's Radio Network features quality 24 hour-a-day news/talk programming that connects with listeners. And...besides offering you programs that make the phone ring...our unique barter plus arrangement allows everybody to win !!!

## 300 Stations Carry PRN With Outstanding Results!

- ☑ *Chuck Harder...Talkers Magazine/USA TODAY*  
Top 25 Host...*Talk Daily* Research Top Ten Host
- ☑ FREE UPI News, Sports and Features
- ☑ All news morning magazine...use as stand alone or interactive
- ☑ All Barter with No Minimums or Make Goods
- ☑ Multimedia national promotion
- ☑ Sales Starter Kit with proven sales promotions...
- ☑ Walkaway or live operation-no dead air

Call for a demo kit and hear the programs being written about in national newspapers and magazines and featured on national television programs! Reserve your market!

*Call 800 397-TALK!*  
*Let's talk money...*



# Radio America Network

1030 15th Street, Suite 700, Washington, DC 20005 • (202) 408-0944 • Fax: (202) 408-1087

**President:**

James Roberts

**Affiliate Relations:**

Jackie Doyle

**Terms:**

Barter

**Coordinates:**

SatCom C-5  
Transponder 15  
Channel 10.1

**Tones:**

25/35 Hz

**Inventory:**

Inquire

**Monday - Friday**

12p-3p	Blanquita Cullum	The Blanquita Cullum Show
3p-6p	Earl Jackson	Across America
6p-7p	Gene Pell	Dateline Washington

**Saturday**

7a-9a		Garden Variety
9a-12p	Mac	Mac the Mechanic
12p-1p		Mutual Perspective
2p-2:30p	Stefan Halper	This Week From Washington
2:30p-3	Fred Barnes	What's the Story?
3p-3:30p	Jim Roberts	Profiles
4p-5p	G. Pell & J. Geise	Front & Center
5p-6p	Gene Pell	Dateline Washington
		Weekend Edition

**Sunday**

6p-7p		Reminisces
7p-8p		Financial Focus

*All times Eastern • (r) = program reread*

# Radio Today Entertainment

1776 Broadway, 4th Floor, New York, NY 10019 • (212) 581-3962 • Fax: (212) 459-9343

## Monday - Friday

10a-12p Dr. Laura Schlessinger Dr. Laura Schlessinger (r)  
1p-2p Dr. Laura Schlessinger Dr. Laura Schlessinger (r)  
2p-5p Dr. Laura Schlessinger Dr. Laura Schlessinger

All times Eastern • (r) = program refeed

## GET ON THE 'NET!

### ***Stations!***

The internet is a new way to develop a personal relationship with your listeners. Plus, there are hundreds of "value added" opportunities for sales. Best of all, the price is right.

### ***Hosts & Networks!***

Let both PD's and potential listeners know about your programming, 24 hours a day -- seven days a week. An interactive web site gets your listeners involved. Include personality bio's, full-color pictures and logos...even sound clips!

### *The 3 I's of the Internet:*

**Interactive & Interesting** - with a point and click web site, your listeners get involved...a lot more interesting than those old one sheets.

**Inexpensive** - from \$30 per month, the 'net is a cost-effective marketing tool..

**Instant** - your info is always online, and only a click of the mouse away.

Don't miss out on the marketing tool of the 90s...the internet!

Long Multimedia • (617) 433-0870

### **President:**

Geoff Rich

### **Vice President Affiliate Relations:**

Ramona Rideout

### **Terms:**

Barter

### **Coordinates:**

SatCom C-5  
Transponder 23  
Channels 13, 16 & 54

### **Tones:**

25 Hz

### **Inventory:**

11 minutes local  
4 minutes network

# Salem Radio Network

545 E. John Carpenter Freeway, Suite 450, Irving, TX 75062 • (214) 831-1920 • Fax: (214) 831-8626

**President:**

Greg Anderson

**Operations Manager:**

Leigh Dowe

**Affiliate**

**Relations Director:**

Kenny Dowe

**Terms:**

Barter

**Coordinates:**

Spacenet 3

Channel 17

**Frequencies:**

4.65, 4.83, 5.01

*wast west one*

SatCom C-5

Transponder 15

Channel 20

**Tones:**

25Hz & 35 Hz

**Inventory:**

Inquire

**Monday - Friday**

2p-4p Warren Duffy Duffy and Company (Christian)

3p-6p Oliver North The Oliver North Show

4p-8p Dick Staub The Dick Staub Show (Christian)

10p-12a Armstrong Williams The Right Side

**Saturday**

3a-5a Dick Staub The Best of Dick Staub

3p-5p Dick Staub The Best of Dick Staub

9p-12a Armstrong Williams The Right Side

*All times Eastern • (r) = program refeed*

## THE GUIDE TO TALK RADIO PROGRAMMING

offers

UP TO THE MINUTE  
NETWORK INFORMATION

24 HOURS • 7 DAYS A WEEK

with **FAXBACK**

Just call with your request for the absolute latest programming lineups from the networks and syndicators you find in this publication.

Need a new Saturday morning program? Call and request the very latest Saturday morning grid. For more information, call anytime -- (617) 433-0870.

# Are You Protected??

Live Sundays • Noon to 2pm Eastern

with

**Bill Bailey**

Health Care Reform

Occupational Disease

Insurance Fraud

**"Best bumper music in the business!"**

Home Protection

Lawyers

Gary Pierce, Operations Mgr.  
WJMX, Florence, SC

AIDS

Battered Women

Catastrophic Loss

**"Right on the Mark"**

Drunk Driving

Medical Malpractice Liability

Ron Woodward, Operations Mgr.  
KNS Chico/Redding CA

Worker's Comp System Reform

Lawyers Fees

**"Very informative. Bill's show takes complicated insurance and consumer issues and makes them much more understandable"**

Arson

Brian Smeathers, Owner/GM  
WMTA, Central City, KY

The Legal System

**"Great Listener Reaction. We're getting a good response. Very timely, presented well. Consumer issues are always hot topic."**

Silicone Breast Implants

Travel Safety

Product Liability Reform

Tom Devoe, General Manager  
WNBH, New Bedford, MA

Smoking & The Tobacco Industry

Child Safety

**"Real fine show. WEBY listeners love Bill."**

Clean Up The Environment

Insurance Costs

Dave Johnson, Operations Director  
WEBY, Milton, FL

FOR MORE INFORMATION: CALL, WRITE OR FAX

12 Breakwater Cove, Chelsea, MA 02150 Tel: (617) 884-2461 Fax: (617) 884-2593

**TALK AMERICA**  
Radio Network

# Sweet Talk Productions

9 West 57th Street, 20th Floor, New York, NY 10017 • (212) 546-7118 • Fax: (212) 546-7220

## Affiliate Relations:

Jeff Tronccone

## Producer:

Eileen Byrne

## Terms:

Barter

## Coordinates:

SatCom C-5  
Transponder 23  
Sedat Channel 12

## Tones:

ABC Net Cue

## Inventory:

7 minutes local  
7 minutes network

## Saturday

9a-12p    Debbie Niegro    Working Mom on the Run

*All times Eastern • (r) = program refeed*

**The only  
Trade Publication  
that helps your  
bottom line.**

**RADIO  
INK**

Radio's Premier Management & Marketing Magazine

- Every other week you get ...
- Proven ideas that will increase your sales.
- Practical ways to save money.
- Advice on managing your staff to increase productivity.
- ... and much more!



**Get the competitive edge!  
Subscribe today.**

**Phone: 800-610-5771  
Fax: 407-655-6164**



# SW Networks

1370 Ave. of the Americas, 22nd Floor, NY, NY 10019 • (212) 833-5400 • Fax: (212) 833-4994

## Monday - Friday

7p-10p Darryl Ankarlo Success Radio  
10p-1a Dr. David Viscott Success Radio

## Saturday

9a-12p Mario Cuomo The Mario Cuomo Show

## Sunday

7p-9p Alan Dershowitz The Alan Dershowitz Show

*All times Eastern • (r) = program reread*

## AutoWorld:

Sundays • 5pm Eastern, 2pm Pacific

*"We've been approached by all the other car shows, but we're sticking with the one that works...AutoWorld. We're getting great listener response."*

Rick Howardton, PD, WSKY, Asheville, North Carolina

*"Very informative. Listeners have called the station praising the show."*

Craig Bandy, PD, WGIG, Brunswick, Georgia

*"Keeps my engine revving!"*

Jimmy Music, GM, WFFG, Marathon, Florida

AutoWorld, heard Sunday afternoons on the Talk America Radio Network. Available at no cost on SatCom C-5, Galaxy 6, and Spacenet 3. Call (617) 828-4546 for more information about the hottest auto talk show in radio.

## President & CEO:

Susan Solomon

## Vice President

## Affiliate Relations:

Dan Forth

## Terms:

Barter

## Coordinates:

SatCom C-5  
Transponder 23  
Channels Inquire

## Tones:

Inquire

## Inventory:

Inquire

# Talk America Radio Network

354 Turnpike Street, Canton, MA 02021 • (617) 828-4546 • Fax: (617) 828-3822

**President:**

John Crohan

**Vice President:**

Tom Star

**Terms:**

Barter

**Coordinates:**

SatCom C-5

Transponder 15

Channel 16.0

Galaxy 6

Transponder 3

Channel 55.4 Narrow

SCPC 3 to 1

Companding Ratio

Spacenet 3 TVRO

Transponder 9

Audio Subcarrier 6.8

Wide Band/Horizontal

(WPIX)

**Tones:**

25 Hz & 35 Hz

**Inventory:**

12:30 minutes local

5-6 minutes network

**Monday - Friday**

12a-5a	Stan Major	The Stan Major Program
5a-9a	Doug Stephan	Good Day USA
9a-10a	Dr. Derrick DeSilva	Ask The Doctor
10a-12p	Bo Gritz	Freedom Calls
12p-3p	Michael Foudy	America the Beautiful
3p-4p	Aaron Harber	The Aaron Harber Show
4p-6p	Hugh Rodham	The Hugh Rodham Show
6p-7p	Craig Smith	Open Up
7p-9p	Jameson White	Jameson White Show
9p-11p	Various Hosts	Talk Radio/Today's Internet
11p-12a	Mel & Lance Richardson	Probing America

**Saturday**

12a-5a	Stan Major	The Stan Major Program
5a-6a	Jose Pino	Las Vegas Live
6a-7a	Steven Sloan	The Fishing Zone
7a-8a	Doug Stephan	Prime Time Open Line
8a-9a	Bob Hardcastle	Money Talk
9a-10a	Mort White	Magic Garden
10a-11a	Dr. Mark Wallach	Let's Play Doctor
11a-12p	Andrea Star	Share Your Thoughts
12p-1p	Mitch Schlimer	Let's Talk Business
1p-3p	S. Kugel & J. McLaughlin	Kugel & McLaughlin
3p-4p	Bruce Lefavi	Your Financial Future
4p-6p	Bob & Rob	The Bob & Rob Home Show
6p-7p	Bruce Weitzman	Take America Back
7p-9p	L. Mazella & G. Baldinger	Lou Mazella on Sports
9p-11p	C. Ross & G. Campbell	Backstage
11p-12a	Pedro Fernandez	Ring Talk

**Sunday**

12a-3a	Al Bernstein & Tony Rome	The Sports Party
3a-7a	Joe Mazza	The Joe Mazza Show
7a-8a	Robbie Patterson	Synergy
8a-9a	Jacquelyn Wolfer	The Healthy Traveler
9a-12p	Attorney Al Grady	Observations on Law
12p-2p	Attorney Bill Bailey	Are You Protected
2p-3p	Brian Renzy	The Profitable Investor
3p-5p	Tom Gresham	Gun Talk
5p-6p	Bob Long	Autoworld
6p-7p	Len Winkler	The Ham Radio Show
7p-8p	Jim Feijo	Health Watch
8p-9p	George & Carl Grande	Grandstand
9p-11p	Mr. Z	Biker Broadcasting
11p-12a	Jim Smith	Smitty's Sports Talk

All times Eastern • (r) = program refeed

# TALK AMERICA

Radio Network®

*Presents the most outstanding Talent Line-Up in Network Radio*

Monday through Friday (ET)

Midnight - 5 a.m.



**STAN MAJOR**

The major force in nighttime radio. Heard in all 50 states.

5-9 a.m.



**DOUG STEPHAN**

America's #1 morning man. Doug hosts "Good Day Use" every weekday morning.

9-10 a.m.



**ASK THE DOCTOR**

Dr. Derrick DeSilva answers listener questions everyday 9-10 A.M. ET.

10-12 noon



**BO GRITZ**

America's most decorated Green Beret war hero. With 82 medals-Bo has the right to tell it like it is.

12-3 p.m.



**MICHAEL FOUDY**

"America the Beautiful". It's the name of Michael's book and radio program.

3-4 p.m.



**AARON HARBER**

A bona-fide liberal. It's time for another point of view...and Aaron has it...every weekday.

4-6 p.m.



**HUGH RODHAM**

Attorney and outstanding talk show host Hugh Rodham originates his program from Miami, every weekday.

6-7 p.m.



**CRAIG SMITH**

"Open up with Craig Smith" invites listeners to vent their true feelings about today's news events.

7-9 p.m.



**JAMISON WHITE**

Interesting and provocative talk radio solving problems.

9-10 p.m.



**HEALTH RADIO**

Credible and interesting physician hosts every weekday evening.

10-11 p.m.

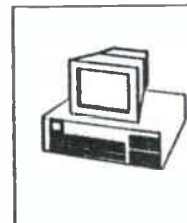

**THE INTERNET SHOW**

Gary Foster has the latest on the Internet Equipment, features, and more.

11 p.m.-12 midnight



**LANCE & MEL RICHARDSON**

Building American families.

Talk America also presents the most outstanding talent lineup in weekend radio. Thirty distinctive and saleable weekend programs featuring outstanding talent

PHONE: 617-828-4546

OR FAX 617-828-3822.

INTERNET: <http://www.talkamerica.com/talkamerica>

# Tech Talk Radio Network

429 Spring Street, Marquette, MI 49855 • (906) 228-3275 • Fax: (906) 228-7477

**President:**

Gary Bourgois

**Terms:**

Barter

**Coordinates:**

Galaxy 6  
Channel 15  
Audio 6.2

**Tones:**

Inquire

**Inventory:**

6 minutes local  
4 minutes network

**Monday - Friday**

12a-12:30a

Counterspin

7p-9p

Skyvision Clearance Show

8p-9p

The Pregame Show (Fri)

9p-10p

Gary Bourgois

Friday Night Live Newshour (Fri)

9p-12a

Tom & Darryl

The Tom & Darryl Show (Thu)

10p-12a

Mike Reynolds

Monday Night Jive (Mon)

10p-12a

Friday Night Live

Listener Participation (Fri)

11p-12a

Houston Amateur

Satellite Network (Tue)

**Saturday**

7:30p-9p

This Week in Amateur Radio

**Sunday**

8p-9p

Glen Roberts

Full Disclosure Live

9p-11p

Fred Deferbrache

Trade Show from Outer Space

*All times Eastern • (r) = program reread*

# TALK AMERICA

Radio Network®

*Presents the most outstanding Talent Line-Up in Network Radio*  
**Saturdays (ET)**

Midnight-5 a.m.



**STAN MAJOR**

Gets everyone's day off to a good start.

5-6 a.m.



**JOSE PINO**

Live and direct from Las Vegas, The number one personality in Vegas.

6-7 a.m.



**STEPHAN SLOAN**

Presents an outstanding fishing show each week.

7-8 a.m.

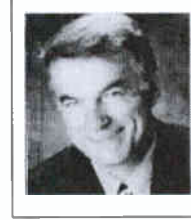

**DOUG STEPHAN**

Prime time is an hour devoted to the interests of seniors.

8-9 a.m.



**BOB HARDCASTLE**

Talks about everyone's favorite subject - money

9-10 a.m.



**MORT WHITE**

The magic garden - It's a love affair with nature.

10-11 a.m.



**DR. JOHN WALLACH, M.D.**

Plenty of good medicine and good conversation.

11-12 noon



**ANDREA STAR**

"Share Your Thoughts"- helping people help themselves.

12 noon-1 p.m.



**MITCHELL SCHLIMER**

His "Let's Talk Business" helps people make money.

1-3 p.m.



**KUGELL & MCLAUGHLIN**

Point and counterpoint discussion of timely topics.

3-4 p.m.



**BRUCE A. LEFAVI**

An "Expert's Expert" tells "How to Bulletproof Your Financial Future".

4-6 p.m.



**THE BOB & ROB HOME SHOW**

Addressing the everyday variety of problems homeowners encounter with humor and expertise.

6-7 p.m.



**BRUCE WISEMAN**

Good talk radio about citizen's rights.

7-9 p.m.



**LOU MAZZELLA & GARY BALDINGER**

Enjoy the week's review of all the sports action with Lou and Gary. Plenty of good listener involvement too.

9-11 p.m.



**CONNIE AND GARY**

Live and direct from Las Vegas each week.

11 p.m.-12 midnight



**PEDRO ON BOXING**

Pedro Fernandez talks all about boxing

**Call Talk America Radio Network Station Relations at 617-828-4546**

World Radio History



# USA Patriot Network

P.O. Box 430, Johnstown, CO 80534 • (303) 587-5175 • Fax: (303) 587-5450

**President:**  
Don Wiederman

**Marketing  
Manager:**  
Steve Moran

**Terms:**  
Barter

**Coordinates:**  
Galaxy 6  
Channel 14  
Audio 5.8

**Tones:**  
25 Hz & 35 Hz

**Inventory:**  
9 minutes local  
4 minutes network

## Monday - Friday

12a-7a		Conservative Issues
7a-9a	Tim Kern	Talking Sense
9a-10a	Scott Wheeler	Reporters Journal
12p-1p	Sue Ellen	Wake Up America
1p-2p	Bob Spear	Preparedness Hour
2p-5p	Henry Feinberg	The Henry Feinberg Show
5p-7p	Dr. Norm Resnick	The Dr. Norm Resnick Show
7p-8p	Steve Quayle	Blueprint for Survival
8p-9p	Duncan Long	The Duncan Long Show
9p-12a	Rick James	The Rick James Show

## Saturday

12a-8a		Conservative Issues
8a-8:30a	Larry Bates	Unravelling the New World Order
8:30a-11a	Mike McNulty	C.O.P.S.
11a-12p	Pam Beesley	The Pam Beesley Show
12p-1p	Michael Papagiorgio	The Hidden Truth
1p-2p	Richard Palmquist	To Free America
2p-3p	Drs. John Lanzallotti & Nino Camerdese	American Perspectives in Medicine
3p-4p	James Dubois	Taking Charge of Your Health
4p-6p	Ken Adams	Take America Back
6p-7p	Darvin Rutz & Pat Tierney	Veterans Hour
7p-12a		Conservative Issues

## Sunday

12a-8a		Conservative Issues
8a-10a	Ken Adams	Take Back America
10a-12p	Larry Lindsey	Rocky Mountain Trails
12p-2p	Dr. Norm Resnick	Dr. Norm Resnick Show (r)
2p-3p	Dr. Nino Camardese & John Lanzallotti	American Perspectives in Medicine (r)
3p-5p	Henry Feinberg	The Henry Feinberg Show (r)
5p-6p	Jane Pearson	The Jane Pearson Show
6p-7p	Darwin Rutz & Pat Teirney	Veteran's Hour
7p-12a		Conservative Issues

All times Eastern • (r) = program reread





**THE  
USA**

# PATRIOT

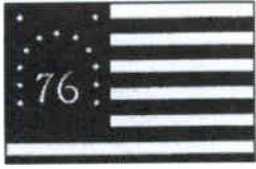

# NETWORK



## 24-HOUR PROGRAMMING

M-F 6-7AM MST



Tim Kern  
Talking Sense

M-F 7-8AM MST



Scott Wheeler  
Reporters Journal

M-F 10-12PM MST



Sue Ellen  
Wake Up America

M-F 3-5PM MST



Dr. Norm Resnick  
Show

M-F 7-10PM MST



Rick James  
Show

SAT & SUN 4-5PM MST



Pat Tierney & Darwin Rutz  
POW-MIA Veterans Hour

SUN 8-10AM MST



Larry Lindsey  
ROCKY MOUNTAIN TRAIL

SAT 6:30-9AM MST



Mike McNulty  
C.O.P.S.

**The USA Patriot Network's primary mission is to discuss the problems and alternative solutions our Constitutional Republic (USA) is undergoing in the spiritual, economic and political realms, encouraging personal responsibility, & advocating change within the current political system !**  
(all talk show hosts not pictured, we are currently in the process of acquiring a few more satellites and frequencies for our affiliates)

**CALL FOR MORE INFORMATION  
1-800-205-6245**

**WARNING: USA PATRIOT NETWORK PROGRAMMING IS NOT POLITICALLY CORRECT, BUT IS ALWAYS ON THE RIGHT SIDE!**

# USA Radio Network

2290 Springlake Road, Dallas, TX 75234 • (214) 484-3900 • Fax: (214) 241-6826

**Director of  
Affiliate Relations:**

Becky Henson

**Terms:**

Barter

**Coordinates:**

SatCom C-5  
Transponder 15  
Channel 10.0

Spacenet 3R  
Transponder 7H  
Various Channels

**Tones:**

Inquire

**Inventory:**

Inquire

## Monday - Friday

12a-1a	Christian Music America (Mon)
12a-1a	Point of View (Tue-Fri)
1a-2a	Life Perspectives
11a-12p	Lowell Lundstrom Live
2p-4p	Point of View
9p-11p	Golden Age of Radio
11p-12a	Point of View (r)

## Saturday

12a-1a	Point of View (r)
1a-2a	Life Perspectives (r)
8a-9a	The Bible's Greatest Heroes
9a-10a	America's Greatest Heroes
10a-11a	How Can I Live? with K. Arthur
11a-12p	Cornerstone Digest
12p-12:30p	Unravelling the New World Order
12:30p-1:30p	Phyllis Schafley Live
1:30p-3p	Weekend Review with Hal Lindsay
3p-5p	Best of Point of View (r)
5p-7p	Celebration USA
7p-8p	Bible's Greatest Heroes
8p-9p	America's Greatest Heroes (r)
9p-11p	Golden Age of Radio
11p-12a	Christian Music America

## Sunday

12a-1a	Christian Music America
9a-10a	Bible's Greatest Heroes (r)
10a-11a	America's Greatest Heroes (r)
11a-1p	Christian Music America (r)
1p-3p	Best of Point of View (r)
3p-4p	How Do I Live? with K. Arthur (r)
4p-6p	Celebration U.S.A.
6p-7p	Bible's Greatest Heroes (r)
7p-9p	Rock the World
9p-11p	N-2-Livin'
11p-12a	Christian Music America (r)

All times Eastern • (r) = program reread

# USA Radio Network 2

2290 Springlake Road, Dallas, TX 75234 • (214) 484-3900 • Fax: (214) 241-6826

## Monday - Friday

12a-1a	Tony Reynolds	Internet at Night (Mon)
8a-12p	Gary Nolan	USA Radio Daily
3p-5p		Because I Said So!
9p-11p	Victor Ives	Golden Age of Radio Theater

## Saturday

9a-10a	Doug Kaufmann	Your Health Matters
10a-1p	Steve Crowley	American Scene
2p-5p	Ron Seggi	The Ron Seggi Show
8p-9p		America's Greatest Heroes (r)
9p-11p	Victor Ives	Golden Age of Radio Theater

## Sunday

10a-11a		America's Greatest Heroes (r)
3p-7p	Jack Christy	The Jack Christy Show
10p-12a	Tony Reynolds	Internet at Night

### Director of Affiliate Relations:

Becky Henson

### Terms:

Barter

### Coordinates:

SatCom C-5  
Transponder 15  
Channel 10.0

Spacenet 3R  
Transponder 7H  
Various Channels

### Tones:

Inquire

### Inventory:

Inquire

All times Eastern • (r) = program refeed

# WestStar Talk Radio Network

4332 North Wells Fargo, Suite 200, Scottsdale, AZ 85251 • (602) 970-1207 • Fax: (602) 970-1208

## Affiliate Relations:

Bo Larson

## Terms:

Barter

## Coordinates:

SatCom C-5  
Transponder 23  
Sedat Channel 49

## Tones:

ABC Net Tones

## Inventory:

8 minutes local  
6 minutes network

## Saturday

10a-12p Kim Komando The Kim Komando  
Komputer Klinik Show

*All times Eastern • (r) = program refeed*



**Kim Komando**

*The Kim Komando Komputer Klinik Show*

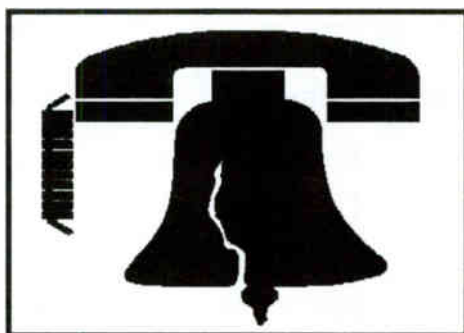

## *NATIONAL ASSOCIATION OF RADIO TALK SHOW HOSTS*

The National Association of Radio Talk Show Hosts (NARTSH) is a nonprofit professional organization dedicated to preserving and promoting talk radio as a dynamic source of information on key issues of the day. NARTSH is the sponsor of Talk Radio '96, the Association's Eighth Annual Educational Conference, Convention, and Exhibition. Association membership allows talk show hosts to share ideas on vital consumer, political, and social issues that are of both national and local importance.

1995-96 President  
Gene Burns  
KGO ~ San Francisco

*TALK RADIO '96*  
Eighth Annual Convention, Exhibition & Educational Conference  
June 20-23, 1996  
Washington, D.C.

\* NOTE: *New* Talk Radio Hosts Speakers Bureau ♦ 1996 Members Directory & Resource Guide  
Contact: *Carol Nashe*, Executive Vice President  
134 Saint Botolph Street  
Boston, MA 02115-4819  
TEL: (617) 437-9757 ♦ FAX: (617) 437-0797

# Westwood One

1755 South Jefferson Highway, Arlington, VA 22202 • (703) 413-8550 • Fax: (703) 413-8445

**Affiliate Relations:**

(703) 413-8550

**Terms:**

Barter

**Coordinates:**

SatCom C-5  
Transponder 15  
Various Channels

**Tones:**

Inquire

**Inventory:**

Inquire

**Monday - Friday**

12a-8a	Bruce Williams	Bruce Williams (Tue-Fri) (r)
1a-2a	Larry King	Larry King (Tue-Fri) (r)
1a-8a	Jim Bohannon	Jim Bohannon (Tue-Fri) (r)
4a-6a	David Essel	Alive (r)
5a-6a	Dirk Van	NBC First Light
5a-6a	Jim Bohannon	America in the Morning
5:30a-10a	Don Imus	Imus in the Morning
10a-12p	Mike Walker	The Mike Walker Show
10a-2p	G. Gordon Liddy	The G. Gordon Liddy Show
11a-12p	O'Leary/Kamber	O'Leary/Kamber Report (Fri)
1p-3p	Mike Walker	Mike Walker (r)
2p-5p	G. Gordon Liddy	G. Gordon Liddy Show (r)
3p-6p	David Brenner	David Brenner
3p-7p	Don & Mike	The Don & Mike Show
6p-7p	O'Leary/Kamber	O'Leary/Kamber Report (Fri) (r)
6p-10p	Tom Leykis	Tom Leykis
7p-10p	Bruce Williams	Bruce Williams
9p-10p	Larry King	Larry King Live
10p-8a	Bruce Williams	Bruce Williams (r)
10p-1a	Jim Bohannon	Jim Bohannon
10p-2a	Tom Leykis	Tom Leykis (r)

**Saturday**

12a-1a	Jim Bohannon	Jim Bohannon
12a-8a	Bruce Williams	Bruce Williams (r)
12a-2a	Tom Leykis	Tom Leykis (r)
1a-2a	Larry King	Larry King Live (r)
1a-7a	Jim Bohannon	Jim Bohannon (r)
7a-8a	O'Leary/Kamber	O'Leary/Kamber Report (r)

All times Eastern • (r) = program refeed



# Westwood One

1755 South Jefferson Highway, Arlington, VA 22202 • (703) 413-8550 • Fax: (703) 413-8445

## Saturday (continued)

8a-10a	Mike Walker	Best of Mike Walker (r)
8a-10a	Jerry Baker	On the Garden Line
10a-11a	Jerry Baker	On the Garden Line (r)
10a-1p	Bob Grant	The Bob Grant Show
1p-4p	Tom Leykis	Best of Tom Leykis (r)
1p-4p	Bob Grant	The Bob Grant Show (r)
4p-7p	David Essel	David Essel Alive
7p-10p	Bruce Williams	Best of Bruce Williams (r)
9p-10p	Larry King	Larry King Weekend
10p-1a	David Essel	David Essel Alive (r)
10p-1a	David Brenner	The Best of David Brenner (r)

## Sunday

1a-2a	Larry King	Larry King Weekend (r)
1a-4a	Bruce Williams	Bruce Williams (r)
4a-6a	David Essel	David Essel Alive (r)
6a-8a	Mike Walker	Best of Mike Walker (r)
8a-9a	O'Leary/Kamber	O'Leary/Kamber Report (r)
8a-10a	Jerry Baker	On the Garden Line (r)
10a-1p	Bob Grant	Bob Grant Show (r)
1p-4p	Tom Leykis	Best of Tom Leykis (r)
4p-7p	David Essel	David Essel Alive
7p-10p	Bruce Williams	Best of Bruce Williams (r)
8p-10p	Wayne Lapierre	Wayne Lapierre Show
8p-10p		Best of the Love Phones (r)
10p-1a	David Essel	David Essel Alive (r)
10p-1a	David Brenner	The Best of David Brenner (r)
11p-1a	Wayne Lapierre	Wayne Lapierre (r)
11p-1a		Love Line

### Affiliate Relations:

(703) 413-8550

### Terms:

Barter

### Coordinates:

SatCom C-5  
Transponder 15  
Various Channels

### Tones:

Inquire

### Inventory:

Inquire

All times Eastern • (r) = program reread

# WOR Radio Network

1440 Broadway, New York, NY 10014 • (212) 642-4533 • Fax: (212) 642-4486

**President:**

Rich Wood

**Terms:**

Barter

**Coordinates:**

SatCom C-5  
Transponder 23  
Sedat Channel 49

**Tones:**

Inquire

**Inventory:**

8 minutes local  
6 minutes network

## Monday - Friday

1a-5a	Bob Aaronson	Bob Aaronson
5a-9a	Jay Severin	Jay Severin (r)
9a-1p	Dr. Joy Browne	Dr. Joy Browne
1p-3p	The Dolans	The Dolans
3p-6p	Jay Severin	Jay Severin
6p-9p	Jay Severin	Jay Severin (r)
8p-10p	The Dolans	The Dolans (r)
10p-1a	Dr. Joy Browne	Dr. Joy Browne (r)

## Saturday

12a-1a	Dr. Joy Browne	Dr. Joy Browne (r)
1a-5a	Bob Aaronson	Bob Aaronson
9a-11a	Dr. Ronald Hoffman	Healthy Lifestyles
11a-2p	Ken & Daria Dolan	Best of the Dolans (r)
2p-4p		Travel
4p-6p	Warren Eckstein	The Pet Show
6p-9p	Dr. Joy Browne	Best of Dr. Joy Browne (r)
9p-12a	Ken & Daria Dolan	Best of the Dolans (r)

## Sunday

8a-11a	Ralph Snodsmith	Gardening Show
11a-2p	Ken & Daria Dolan	Best of the Dolans (r)
2p-4p	David Lawrence	Online Today
4p-6p	Arthur Schwartz	The Food Show
6p-9p	Dr. Joy Browne	Best of Dr. Joy Browne (r)
9p-12a	Ken & Daria Dolan	Best of the Dolans (r)

All times Eastern • (r) = program refeed

# TALK AMERICA

Radio Network®

*Presents the most outstanding Talent Line-Up in Network Radio*  
**Sundays (ET)**

**Midnight-3 a.m.**



**Al Bernstein**  
Sports Party is a look at the lighter and brighter side of sports.

**3-7 a.m.**



**JOE MAZZA**  
All the weekend sports and entertainment talk.

**7-8 a.m.**

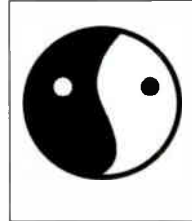

**SYNERGY**  
Robbie Patterson motivates and helps people succeed.

**8-9 a.m.**



**THE HEALTHY TRAVELER**  
Jacquelyn Wolfer helps to travel smart, safe, and healthy

**9-12 noon**



**ALBERT E. GRADY, ESQ.**  
Observations about the law and timely topics.

**12 noon-2 p.m.**



**BILL BAILEY, JD. CPCU**  
"Are You Protected" - stands alone in American radio.

**2-3 p.m.**

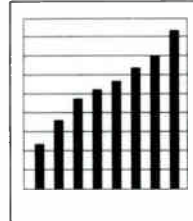

**FINANCES**  
How to manage your financial assets with advice from noted experts.

**3-5 p.m.**



**TOM GRESHAM**  
Tom's gun talk is positive and innovative programming.

**5-6 p.m.**

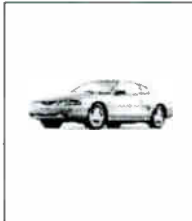

**BOB LONG**  
A "Classic" auto talk show.

**6-7 p.m.**



**LEN WINKLER KB7LPW**  
Ham Radio is on the air every Sunday at 6 P.M. ET.

**7-8 p.m.**



**THE FEIJOS**  
"Health Watch" talks about health issues.

**8-9 p.m.**



**CARL AND GEORGE GRANDE**  
A week's review of sports action.

**9-11 p.m.**



**MR. Z**  
The "Biker's Program" is truly unique programming.

Talk America is the only national radio network offering live talk programming 24 hours a day—seven days a week.

Call Station Relations:  
PHONE: 617-828-4546  
OR FAX 617-828-3822.

INTERNET: <http://www.talkamerica.com/talkamerica>

**11-12 p.m.**



**SMITTY**  
Jim Smith presents red hot sports interviews and discussions every week.

## NEWS & INFORMATION PROGRAM PROVIDERS

---

### AP All News Radio

**Address:** Broadcast News Center, 1825 K Street Northwest, Washington, D.C. 2006

**Phone:** (800) 821-4747

**Fax:** (202) 736-1107

**Vice President/Director of Broadcast Services:** James P. Williams III

**Deputy Director/Managing Editor:** Brad Kalbfeld

#### **Programming Description:**

Live news and information 24 hours a day, 7 days a week. Including financial news, sports, entertainment, consumer issues and health reports.

**Terms:** Cash

**Coordinates:** Spacenet 3, Transponder 1, Channel Inquire  
SatCom C-5, Transponder 3, Channel Inquire

**Tones:** Inquire

**Inventory:** Inquire

---

## ***Ask the Doctor*** Derrick DeSilva, M.D.

---

**9- 10 A.M. EASTERN TIME**  
**Monday through Friday**

---

- » **No nonsense medicine**
- » **Excellent Communicator**
- » **Radio Talk Show Host for six years**
- » **Real advice from a *real* M.D.**
- » **A Doctor who listens**
- » **Great rapport with all ages - always open to new ideas**
- » **A practicing physician who knows what's going on in the world of medicine**

**Dr. Derrick DeSilva has  
been called "America's Doctor"**

100% Barter  
SatCom C5, Transponder 15, Channel 16.0  
Galaxy 6, Transponder 3, Channel 55.4  
Spacenet 3, Transponder 9, Audio 6.8

Dr. D will help sell show in your market

**CALL**  
**Tel.No. (908) 738-8080**  
**Fax.No. (908) 738-4228**

---

---

## **Bloomberg Information Radio**

**Address:** 449 Park Avenue, New York, NY 10022

**Phone:** (212) 318-2000

**Fax:** (212) 318-2080

**President:** Michael Bloomberg

**General Manager:** Fran Sharp

**Affiliate Relations:** Peter Kosann

**Programming Description:**

Business and financial news and information, 24 hours a day, 7 days a week.

**Terms:** Barter

**Coordinates:** SatCom C-5, Transponder 23, Channel Inquire

**Tones:** Inquire

**Inventory:** Inquire

## **CNN Headline News (Westwood One Companies)**

**Address:** 25060 West Avenue Stanford, Suite 100, Valencia, CA 91355

**Phone:** (805) 294-9000

**Affiliate Relations:** Rick Honea

**Programming Description:**

Performed live from the CNN News Center, news, business, sports and lifestyle.

**Terms:** Barter/Cash

**Coordinates:** SatCom C-5, Transponder 21, Channel Inquire

**Tones:** Inquire

**Inventory:** Inquire

## **CNN Radio News (Westwood One Companies)**

**Address:** 25060 West Avenue Stanford, Suite 100, Valencia, CA 91355

**Phone:** (805) 294-9000

**Affiliate Relations:** Rick Honea

**Programming Description:**

News and information 24 hours a day, 7 days a week.

**Terms:** Barter/Cash

**Coordinates:** SatCom C-5, Transponder 21, Channel Inquire

**Tones:** Inquire

**Inventory:** Inquire

---

# A Talk With Westwood One's Bruce Williams

"We do a show about life. That's what it comes down to. We're not going to settle any problems in Bosnia or any of that sort of thing, but we talk about getting along with the neighbor next door.

What do you do when your neighbor's dog is allowed to run free and it craps all over your yard and pees in your bushes and so forth? I got Mickey the Mutt hanging out here. I know dogs' habits and so did this guy. He calls in with a great solution. What he said was you get yourself an onion bag, the kind that are like a mesh bag, not a solid bag, you get 3 or 4 old fish and you kind of slit them so the guts are hanging out, then you get some old meat or chicken entrails, all kinds of fowl stuff, right. You leave that out in the sun about 2 days, then you put the bag out by the plant. Every dog in the world can't wait to roll in that, you see. Then they go home covered in this stuff and they go into the living room in the guy's house, and suddenly he's got a serious problem on his hands. The dog did it all. After a couple of excursions into your yard, when they find this, suddenly people figure out they better keep their dog out of that guy's yard. It also fertilizes your garden.



This is the kind of stuff we deal with."

*That's the kind of stuff that has made Westwood One's Bruce Williams one of the most listened to hosts in talk radio. Often referred to as "Mr. Common Sense," Williams brings to the microphone his experience as a businessman, mayor, city councilman and entrepreneur. The Guide to Talk Radio Programming's Bob Long had the opportunity to speak with Bruce Williams, who is entering his 16th year as host of his nightly program. He has been the recipient of countless awards and, according to Westwood One, is heard on more than 350 stations.*



**Guide:** Who did you listen to when you were growing up on the radio?

**Williams:** You have to realize that when I was growing up, 2 or 3 things are operative in that question. First thing is, you couldn't go out and buy a little transistor radio because the transistor had yet to be invented.

When I was in elementary school I used to build radios and in order to make them work, I had to have an antenna about 30 feet long. I used to stretch the antenna right down the aisle at school and I'd sit back there and listen to Peggy and Ned Fitzgerald on WOR when I was in 7th grade instead of listening to the teacher. Of course, she would go ballistic when she found the radio, she'd take it, and 2 days later I'd build another one and listen to whatever they were featuring on WOR.

There were a lot of things you could do in my father's house, but one of them wasn't turning on Barry Gray at 3:00 in the morning — not if you wanted to live 'til 3:30. I would sit in the garage listening to Long John Nebel, Barry Grey, Biggy Wilson at 3:00 or 4:00 in the morning.

Long John Nebel was the quintessential of all talkers -- the best in his day. He'd probably sound corny today. When I walk, I listen to a lot of old time radio: The Shadow, or Sherlock Holmes. I listened to a great Gildersleeve tape yesterday. A lot of that stuff is pretty corny though, but at the time, it was hot stuff.

**Guide:** Where was your first radio job?

**Williams:** One was with WCTC, which began May 14, 1975, but I was campaigning for a year before that with Tony Morana who was the general manager at that time. You've got

to realize, talk radio was nowhere near as ubiquitous then as it is today. As a matter of fact, we were the anomalies rather than the standard. I used to listen to a lot of talk and I just figured I could do it better than the average guy doing it.

**Guide:** I read when you jumped from New Jersey to New York City, you actually hired some women to call in?

**Williams:** I first attacked WMCA. I called them in excess of 3,000 times and I wrote them over 500 letters. Now, people will say "well you probably pissed them off," and that may be true, but what did I have to lose? They wouldn't hire me anyway.

There were only 2 stations at that time in New York City that were doing talk, MCA and WOR. WOR had Bernie Meltzer, so they weren't going to hire me. So, who's left? MCA, and the program director over there was Mark Mason. Mark is the guy that finally called me, and I told him I called out of almost desperation. He said every day he found 2 or 3 messages on his desk, Bruce Williams called.

Barry Farber was not doing so well on a Sunday afternoon, well, let's face it, Sunday afternoon is the toilet of radio and they said would you like to try it? And man, I would have tried anything to get into New York City. I went over and did the show and it went okay. After the show, we went into the other studio where they had the busy counter. That's how they used to measure you in those days. After your lines were tied up, you would get a click every time there was a busy on the meter. When she saw mine she said "Wow, you did real well. You got 225 busy's." I said "Would you look at that again?" "Oh, my God. You had 1,225!"

# The Hottest Alternative Rock Countdown Show

On America's Greatest Radio Stations

*The  
New Rock  
Countdown*

Sponsored by ITEX Media and Inside Edge Magazine.

For information on placing advertising  
within "The New Rock Countdown", call  
ITEX Media at (503)244-4673.



**ITEX Media** PO Box 2309  
Portland, OR 97208-2309



No Recycled Music

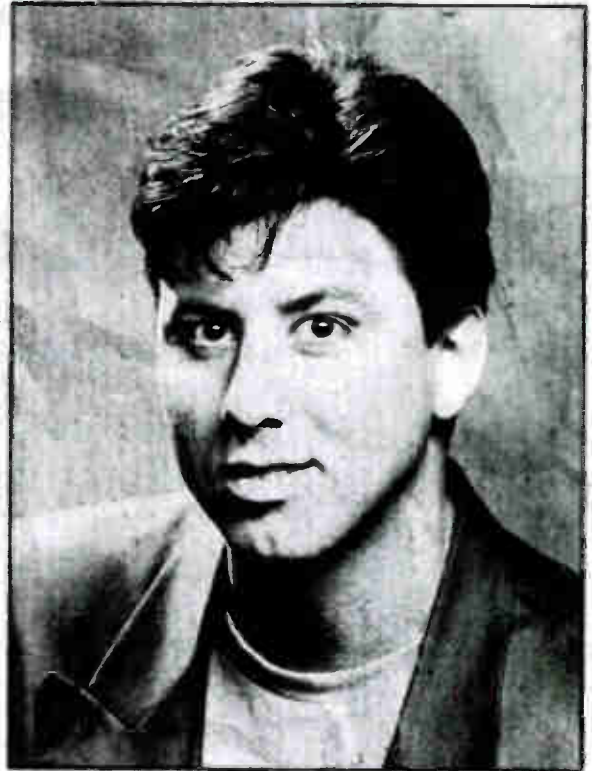

**Hosted by Steve Fisher**  
**Vote for Your Favorite**  
**Alternative/Modern Rock Songs**  
**Call (800) 560-8739**

Steve Fisher will personally contact  
some lucky callers and use your  
requests on "The New Rock  
Countdown".

**Williams:** Well, the reason was I had a whole bunch of women making phone calls. There was no way in hell I was not going to get a high busy count because all through the show my people were making phone calls — just redialing and getting busy's.

**Guide:** So, your advice for young broadcasters is persistence? Keep after it?

**Williams:** Well yeah, let's face it, the program directors and general managers get more propositions than a hooker on 7th Avenue. They're getting bombarded, and you have to get their attention. The way to do that is to keep seeing them, and talking to them. There's no other way that I know of, unless you get really lucky.

**Guide:** Do you get upset when people label your show as being a financial show?

**Williams:** I don't get upset. I've grown to live with it. If you were to say that money is the Portland cement that glues us together, I'm not going to have a hard time with that.

**Guide:** What is the future of talk radio?

**Williams:** Talk is going to get bigger and bigger, not necessarily with me. I may get washed out, who knows? Every poll of radio stations shows that for a variety reasons, not the least of those certainly is a technical thing, that talk can compete very well on AM. Unless you have AM stereo, it's difficult for talk to compete with music, but it clearly can compete with sports and can compete with talk, and that's where it's going to be.

Furthermore, like a lot of things if one segment of an industry is successful, there's going to be 10 million wannabes out there.

**Guide:** What do you think makes for bad radio today?

**Williams:** Probably the biggest problem well, not a problem but...Rush does what what he does very well, so you've got 10 Rush imitators out there. I like to think I do what I do reasonably well and you find 10 imitators of me out there.

Ted Lewis was a band leader in the 30s and somebody came to Ted Lewis and said, "How do I get to be where you are?" He said, "Be yourself." In other words, you can't be an imitation of somebody else. You have to develop your own style and your own persona. You have to be you, not imitating somebody else. Imitations are just what they are — imitations.

**Guide:** What do you think about a Don Imus or a Howard Stern?

**Williams:** I don't know Imus, I know Stern. I've met him a few times and he knows enough of me to take a few shots of me on the air, I guess. Stern is probably the quintessential self promoter, he is the male Madonna. I mean, there are two people who have turned self-promotion into a fine art and it's become extraordinarily profitable. He's done very, very well. I couldn't appear on the front of a book in drag. I don't care how much money they gave me.

Imus, to a lesser degree certainly does what he does well. I don't necessarily agree with what

Let's face it, PD's and GM's get more propositions than a hooker on 7th Avenue. You have to get their attention.

*(continued on page 134)*

---

# Pete Rose: From the Dugout to the Microphone

"I don't think there are too many talk show hosts in this country who can sit down at breakfast or lunch with you and tell you exactly how it feels to be a world champion or how it feels to lose a world championship. You may think you know from covering the NBA, or the NFL, or the Stanley Cup or the World Series, but experiencing it and being around people who have experienced it are two different things. There's not too much in the world of sports that I haven't accomplished. I don't like to carry on conversations about things that I don't really know much about. I have a tendency to stick my foot in my mouth. I'd like to think that winning the World Series is just like winning the Super Bowl, or winning the NBA Championship, or the Stanley Cup Championship, no difference, just a different game."

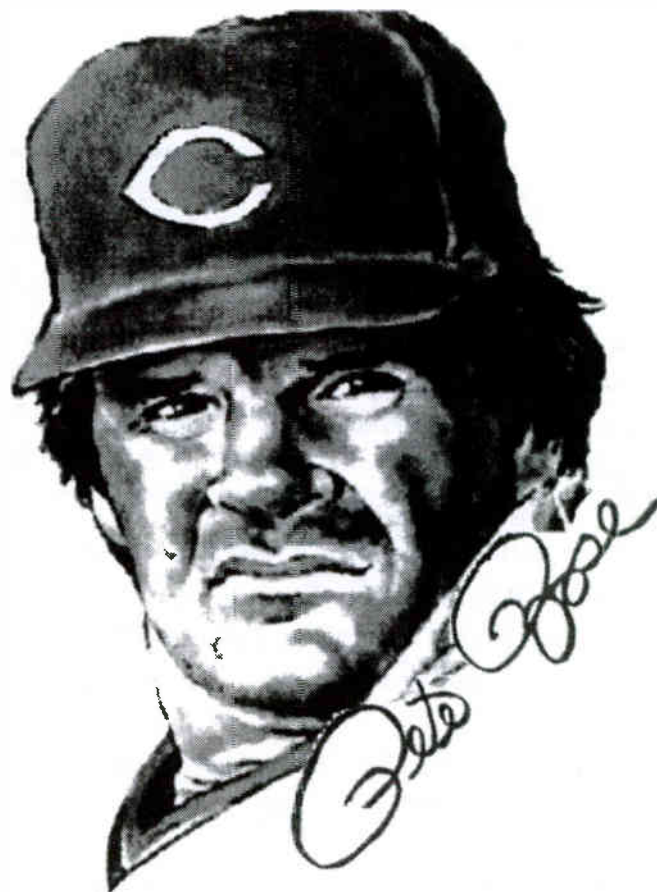

*Former Cincinnati Reds star Pete Rose made the transition from major league manager to radio talk show host in March of 1992 at WJNO in West Palm Beach, Florida.*

*Rose took his act to a national level, signing with the SportsFan Radio Network in 1994. According to Rose, The Pete Rose Show is fed live to almost 200 stations weeknights from 7 to 9 (Eastern) from his sports bar in Florida.*

*Although he will be forever known as one of the greatest baseball players of all time, Rose claims his show is a true sports show, covering hockey, basketball, and football. Sports celebrities make frequent appearances on the program. Recent guests have included Bobby Cox, Lou Duva, Willie Mays, Hank Aaron, Bob Costas, Terry Bradshaw, Brent Musberger, Bobby Knight and John Madden.*





*Smitty's*

# SPORTS TALK

**Sports Entertainment at it's Best!**

**Controversial, provocative, stimulating  
and enlightening**

James E. Smith, a/k/a Smitty, host of Smitty's Sportstalk and Smitty's Ringside Seat brings to his listeners many of the biggest names in the World of Sports – Muhammad Ali, Brent Musberger, Bob Griese, Don King, Mercury Morris, Joe Garagiola, Hank Aaron, Don Shula, Brooks Robinson, Paul Warfield, Marvin Hagler, Angelo Dundee, George Foreman, Jose Canseco, Kirby Puckett and Hulk Hogan, and Mike Tyson just to name a few.

On the airwaves in Southwest Florida since 1985, and nationally for over 3 years, Smitty offers listeners his personal style of call-in sports with special broadcasts from big sports towns like Las Vegas and L.A., and internationally as far as New Zealand. From Ali to Shoemaker, from the greats of the past to the stars of today, Smitty has made them available to his listeners!

## **Smitty's Sportstalk**

**airs Friday evenings in South  
and Southwest Florida on  
WWCN AM770 from  
6 pm to 8 pm**

## **Smitty's SportsTalk**

**is heard on the  
TALK AMERICA NETWORK  
Sunday Night  
11 pm to Midnight**

**Call: 941-540-1178  
or fax 941-540-7313**

**TALK AMERICA**  
Radio Network

**Guide:** Describe The Pete Rose Show.

**Rose:** It's a talk sports show and we want intelligent callers. If you want — be combative and argumentative, as long as you've got a good sense of what you want to argue about.

We try to be up-to-date as far as what's happening in the world of sports. I don't think there's any show in the country that has the array of guests that we have which is partly because of my friendship with so many athletes or athletes who are friends of the athletes of the athletes that I get.

**Guide:** Why do athletes feel so comfortable with you?

**Rose:** I'm not going to blind side them. They know that 1) I understand what athletes go through; and 2) I understand a little bit about controversy, and 3) I understand about being fair if you're in the media.

There are a lot of little things that I can do to help athletes.

I remember when Darrell Strawberry signed with the Yankees. There were people who said he'd like to do my show. He called me up, and the first thing he said was the only reason he was doing my show was because I didn't kick him in the face when he was down. I was very fair and he appreciated it; that was why he was doing my show and only my show. There are diplomatic ways of facing controversial issues without always blaming the athlete, the owner, or the fan.

**Guide:** Across the country, how have callers

and listeners responded to you on-the-air?

**Rose:** With respect, but I'm in the restaurant business and the customer's always right. The caller's always right, unless I can convince him he's wrong. You can call me up and you can argue with me or you can blast me if you want, but you'd better have your facts straight — just make sure you got your ducks in order.

**Guide:** Is your show more of a guest driven show or a caller driven show?

**Rose:** I think it's probably caller-driven. We like to entertain them with guests, and we try to get the guests we think people like to hear.

**Guide:** Who do you admire in the broadcasting field?

**Rose:** I don't have any specific guys. If you work hard, and you're honest and dedicated and you're on time, that's the things I like.

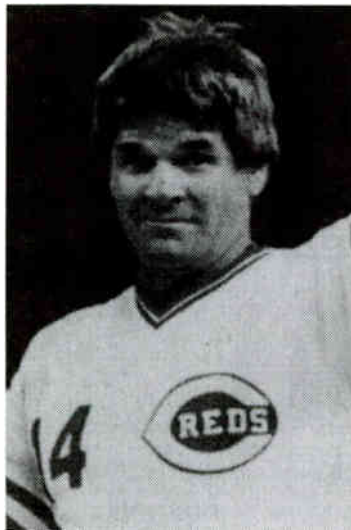

I had Bob Costas last week ...

he's great, Keith Jackson's great, Brent Mustbuser's great. I have all the guys who do Fox. I had Terry Bradshaw a couple weeks ago and John Madden.

**Guide:** Your thoughts on other SportsFan programs?

**Rose:** Right now we've got Matt Goukas doing our In the Lane Show. We've got Phil Esposito doing our In the Crease, our hockey show. We have Bill Rafferty and Dick Fersais. We have all these notable guys doing pro



gramming on Sports Fan Radio Network, which will pay off eventually.

I'm with the top sports network around, and it's just amazing how many forward strides we've made in the last year.

I realize that I'm the main guy on the network. I'm not trying to sound arrogant; I understand the obligation I have to them and I work at it.

"You can like sports but you don't have to like me."

**Guide:** It's clear that your work ethic is still there. It helped you in baseball and now it's helping your radio career.

**Rose:** I didn't set out to be the all time hit leader, but once I got within reach I focused in the right direction and concentrated in the right direction and went about my business. Now I'm doing it in radio.

**Guide:** Do you listen to other forms of talk radio, besides sports?

**Rose:** Yeah. I listen to other shows because when I'm in my car, which I am a lot, it's kind of like doing your homework. I can't get ESPN or CNN in my car, so if I'm not home watching the sports replays, I read the papers and listen to other shows.

**Guide:** You really love all forms of sports.

**Rose:** Yeah. I get tired of all the murders and the robberies and the wars going on in the world. I think sports are refreshing.

**Guide:** What do you think of somebody like Howard Stern?

**Rose:** He's got his own style and it's making

millions of dollars. I'm not here to say if he's right or wrong. I can only tell you when I was on Howard Stern, he was a perfect gentleman. People think he's not smart. He's a pretty clean cut guy, too, if you get to know him.

**Guide:** What about Rush?

**Rose:** Rush is great, too. I watch Rush a lot of times during the day on his TV network.

G. Gordon Liddy's pretty good. It's all what you have to talk about, and whether you make any sense when you talk.

**Guide:** How would you convince a program director to take your show?

**Rose:** I would help their station make money and if it's their business to make money, they would want my show.

I'm going to give them a product that's going to be sellable in their town if people like sports. You can like sports but you don't have to like me.

**Guide:** Well Pete, you're a lot different than I expected you would be talking to you.

**Rose:** Don't believe everything you read, and only believe half of what you see. •

Featured on ABC, NBC, CBN, WSJ—C.R. SMITH is a 10 year radio veteran...and he's back!

# OPEN UP with C.R. SMITH

## "An Equal Opportunity Offender"

Speaking Up On:

- RELIGION
- POLITICS
- & MONEY!

Smith knows, he's a CEO.  
"OPEN UP is more FUN  
to listen to than Howard  
Stern, and more SAVVY  
than Rush Limbaugh."

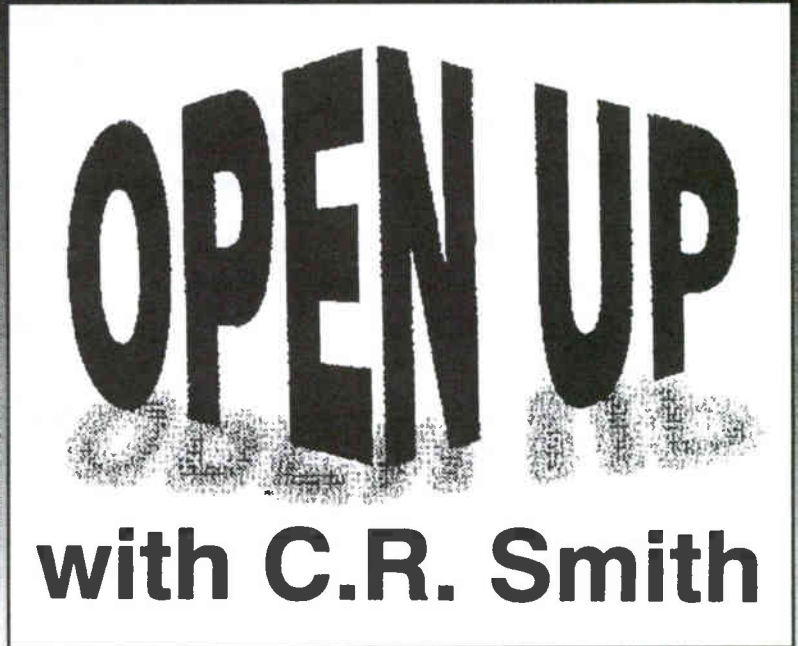

C.R. Smith hit national media back in 1992, while hosting *America Talks* (the #1 program on CBN Radio Network). He attempted to negotiate with David Korresh to release the women and children for the FBI during the Waco fiasco.

Smith also broke the exclusive interview with Scott Barnes, who claimed he was paid by the RNC to bug Perot's campaign headquarters.

Smith will dialogue on anything that his listeners feel is important—subjects as diverse as the spiritual implications of Farrakhan's March to the economics of the Federal Reserve. Nothing is out-of-bounds, for example:

- **Politics ...** "Until we restore character in private, we'll be stuck with wimps in public office."

- **Economics ...** "Perhaps the most talked about subject, yet least understood, for instance; I bet you thought the Federal Reserve was a legitimate branch of the U.S. Treasury or government—not so!"

- **Education ...** "Has always been the responsibility of the parents first, but since nature abhors a vacuum, the government rushed to fill the void with public schools."

*Open Up with C.R. Smith* will liven up your PM drive home—guaranteed! The broadcast airs daily on Talk America Radio Network from 6 to 7 PM EST. Tune in on C-5, Trans. 15, 16.0 DATS, Galaxy 6, Trans. 3, 55.4 Analog, or Space Net 3, Trans. 9, Audio Sub-carrier 6.8 TVRO.

For more details contact Tom Star at (617) 828-4546.

**OPEN UP WITH C.R. SMITH** Airs Daily on TALK AMERICA RADIO NETWORK ... 6-7 PM EST

# THE GUIDE TO TALK RADIO PROGRAMMING

---

## Sports Programming Grids

A side by side listing of what is available from long-form sports talk programming providers, by daypart.

At a glance, you are able to compare the offerings of each network to make the best programming choices.

### Weekdays

Overnights.....	99
Mornings .....	99
Afternoons .....	101
Nights .....	101

### Saturday

Overnight .....	103
Morning .....	103
Afternoon .....	104
Night .....	104

### Sunday

Overnight .....	105
Morning .....	105
Afternoon .....	107
Night .....	107

# SPORTS PROGRAMMING

Weekdays • Midnight to 6am

	12:00	1:00	2:00	3:00	4:00	5:00
ESPN						
One on One	The John Renshaw Show				Bob Kemp Show	
Prime Sports	Jim Dent (Mon) Scott Franzke	Chet Choppock (90 mins.)		Prime Review (2:30)		
Sports Byline	Sports Byline (10:00)	Sports Overnight America				
SportsFan	SportsFan Tonight	Air It Out (Mon), Dave Cokin (1-2) Chuck Powell & Rob Fischer (2-3)		Morning Madness with Percy Wingfield		
SRN						
Talk America						
Westwood	On the Bench (10:00)					

Weekdays • 6am to Noon

	6:00	7:00	8:00	9:00	10:00	11:00
ESPN					The Fabulous Sports Babe	
One on One	Bob Kemp Show (4:00)				Mark Gentzkow & Jay Mariotti Show	
Prime Sports	Prime Review (2:30)	Prime Morning with Rich Lerner				Prime Mid Morning
Sports Byline						
SportsFan	Morning Madness with Percy Wingfield (3:00)					
SRN						
Talk America						
Westwood						

All times Eastern • (r) = program reread



## ParaNet

*Presents the most fascinating hour of live radio you'll ever hear!*



Host Michael Corbin, director of the global ParaNet computer network on UFOs and the paranormal, and founder of MICAP, a scientifically based UFO investigations organization, will keep your listeners tuned in, week after week.



UFOs - Crashed saucers - Government coverups - Alien abductions - Cattle mutilations - Hoaxes and frauds - Ghosts - Angels - Spirituality. The ParaNet Continuum (now in its 2nd year!) covers it all in an entertaining and responsible way, with interesting guests and your listeners' calls.

Sunday nights - 9-10 PM ET on Satcom C5, Transponder 23, SEDAT 20

*"As a veteran producer of television as well as radio programs, I highly recommend the ParaNet hour for any station, AM or FM, that seeks a new, upscale, educated, loyal audience...[it] has increased the 6 PM time slot 100% over the sports program we had aired before."*

-- Ron Harrison, KNRY Talk Radio, Monterey-Santa Cruz

*"I do a ton of radio. I do a ton of public speaking. I enjoy nothing so much as I enjoy talking with ParaNet. Every time is a delight. Please invite me back!"*

-- Keith Ferrell, VP/Editor, Omni magazine

Produced by ParaNet Information Services, Inc P.O.. Box 172 Wheatridge, CO 80034-0172  
Contact Michael Corbin at (303) 863-0484 or Greg Barman at (303) 744-0479 for your demo tape and barter arrangements!



# Jim Bohannon SHOW

*The hardest working  
man in radio;  
Jim Bohannon.*

703-413-8550



WESTWOOD ONE RADIO NETWORKS  
MUTUAL BROADCASTING SYSTEM

World Radio History

# SPORTS PROGRAMMING

Weekdays • Noon to 6pm

	12:00	1:00	2:00	3:00	4:00	5:00
ESPN	The Fabulous Sports Babe (10:00)		The Fabulous Sports Babe (r)			
One on One	Kevin Wall Show				Papa Joe Chevalier Show	
Prime Sports	Prime Mid Morning (11:00)	Games People Play	Prime Cuts with Jim Dent		Listener Call-In	Press Box
Sports Byline						
SportsFan						
SRN						TransWorld Wrestling (Thu)
Talk America						
Westwood						

Weekdays • 6pm to Midnight

	6:00	7:00	8:00	9:00	10:00	11:00
ESPN						
One on One	Papa Joe Chevalier Show (4:00)		Ted Green Show			
Prime Sports	Game Time with Tom Sauvlet			Prime Sports Radio Tonight with Scott Franzke		
Sports Byline					Sports Byline with Ron Barr	
SportsFan		The Pete Rose Show with Pete Rose & John Hadley		First & 10 / NHL: In Crease	SportsFan Tonight with Bruce Schein	
SRN	TW Wrestling (Thu) (5:00)					
Talk America						
Westwood					Ferrall on the Bench with Scott Ferrall	

All times Eastern • (r) = program reread



105 years of  
Johns Hopkins  
medical excellence,  
and it's yours  
in 60 seconds.  
Free.

Introducing the Johns Hopkins Health NewsFeed. A daily :60 radio news report for your listeners, produced by the prestigious Johns Hopkins Medical Institutions. Featuring physicians, scientists, and other healthcare experts,

this informative news segment is available every weekday by satellite and a toll-free network. And it's yours free. For more information contact Jack Sheehan at 410-955-2877 or 1-800-MED-RADIO.



HEALTH NEWSFEED

A SERVICE OF THE JOHNS HOPKINS MEDICAL INSTITUTIONS

# SPORTS PROGRAMMING

Saturday • Midnight to 6am

	12:00	1:00	2:00	3:00	4:00	5:00
ESPN						
Major Sports						
One on One	Fred Huebner Show				Ken Silverstein Show	
Prime Sports	Prime Sports Radio Tonight	Chet Choppock Show (90 mins.)		Bobby Allison Show (2:30)		
Sports Byline	Sports Byline with Ron Barr	Sports Overnight America				
Sports Clctrs						
SportsFan		SportsFan Tonight	SportsFan Central	Morning Madness with Percy Wingfield		
Talk America						
Westwood	On the Bench (10:00)					

Saturday • 6am to Noon

	12:00	1:00	2:00	3:00	4:00	5:00
ESPN						
Major Sports						
One on One	Fred Huebner Show				Ken Silverstein Show	
Prime Sports	Prime Sports Radio Tonight	Chet Choppock Show (90 mins.)		Bobby Allison Show (2:30)		
Sports Byline	Sports Byline with Ron Barr	Sports Overnight America				
Sports Clctrs						
SportsFan		SportsFan Tonight	SportsFan Central	Morning Madness with Percy Wingfield		
Talk America						
Westwood	On the Bench (10:00)					

All times Eastern • (r) = program refeed

## SPORTS PROGRAMMING

*Saturday • Noon to 6pm*

12:00	1:00	2:00	3:00	4:00	5:00	
						ESPN
						Major Sports
Sports Saturday (8:00)	College Football Today with Bob Berger & Earl Forcey					One on One
Games People Play	Game Day Coast to Coast with Jerry Overton & Pete Stein					Prime Sports
						Sports Byline
						Sports Clctrs
The Kick-Off Show (9:00)	PrimeTime with Sean Salisbury & Rob Fischer					SportsFan
						Talk America
						Westwood

*Saturday • 6pm to Midnight*

6:00	7:00	8:00	9:00	10:00	11:00	
Sports Talk						ESPN
						Major Sports
College Football Today (1:00)	Sports Saturday with Chris Schneider					One on One
Game Day Coast to Coast with Jerry Overton & Pete Stein (1:00)			Prime Feedback with Bobby Allison & Ron DeRostras			Prime Sports
				Sports Byline USA Weekend		Sports Byline
						Sports Collect
Prime Time Saturday (1:00)	The Press Box				<i>Pete Rose (r)</i>	SportsFan
	Sports Final with Lou Mazella & Gary Baldinger				Ring Talk	Talk America
						Westwood

*All times Eastern • (r) = program reread*

# SPORTS PROGRAMMING

Sunday • Midnight to 6am

	12:00	1:00	2:00	3:00	4:00	5:00
ESPN						
Major Sports						
One on One	Chuck Garbedian Show				Ken Silverstein Show	
Prime Sports	Week In Review	Bobby Allison Show				
Sports Byline	Sports Byline USA Weekend	Sports Overnight America				
Sports Clctrs						
SportsFan	<i>Pete Rose (r)</i>	Air It Out		Morning Madness with Percy Wingfield		
Talk America	The Sports Party with Al Bernstein & Tony Rome					
Westwood						

Sunday • 6am to Noon

	6:00	7:00	8:00	9:00	10:00	11:00
ESPN						
Major Sports						
One on One	Ken Silverstein Show (4:00)		Sports Sunday with Dave Harbison			
Prime Sports	Bobby Allison Show (1:00)	Kevin Smith				Games People Play
Sports Byline						
Sports Clctrs						
SportsFan	Morning Madness with Percy Wingfield (3:00)			The Kick-Off Show		
Talk America						
Westwood				Sports Now with Mike Francesa		<i>Sports Now (r)</i>

All times Eastern • (r) = program reread

**Ask The Doctor**

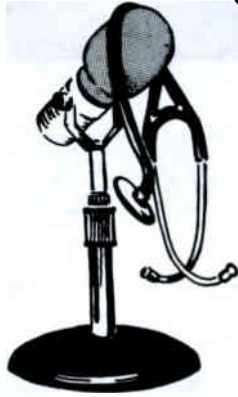

**Derrick DeSilva M.D.**

# ***Ask the Doctor***

**Derrick DeSilva, M.D.**

---

**9 - 10 A.M.**

**Monday through Friday**

---

- **No nonsense medicine**
- **Excellent Communicator**
- **Radio Talk Show Host for six years**
- **Real advice from a *real* M.D.**
- **A Doctor who listens**
- **Great rapport with all ages - always open to new ideas**
- **A practicing physician who knows what's going on in the world of medicine**

**Dr. Derrick DeSilva has been called "America's Doctor"**

100% Barter  
SatCom C5, Transponder 15, Channel 16.0  
Galaxy 6, Transponder 3, Channel 55.4  
Spacenet 3, Transponder 9, Audio 6.8

Dr. D will help sell show in your market

**CALL**

**Tel.No. (908) 738-8080**

**Fax.No. (908) 738-4228**

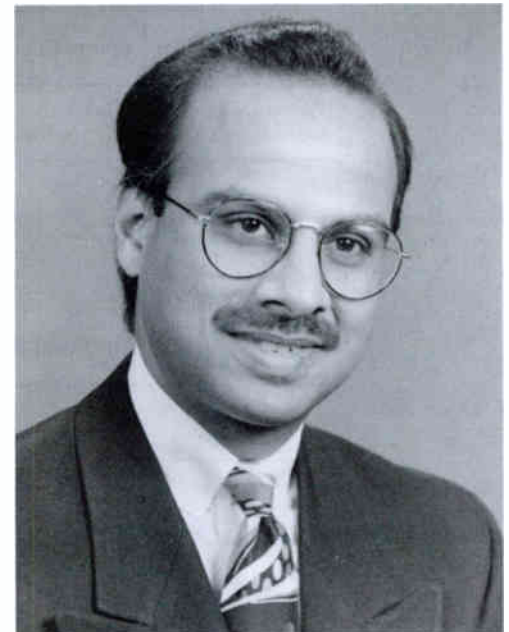

# SPORTS PROGRAMMING

Sunday • Noon to 6pm

	12:00	1:00	2:00	3:00	4:00	5:00
ESPN	Game Day					
Major Sports						
One on One	Sports Sunday (8:00)	Around the NFL with Bob Berger & Earl Forcey				
Prime Sports	Kevin Smith	Game Day Coast to Coast with Jerry Overton & Pete Stein				
Sports Byline						
Sports Clctrs						
SportsFan	The Kick-Off Show (9:00)	PrimeTime Sunday with Sean Salisbury & Chuck Powell				
Talk America						
Westwood	Sports Now (11:00) (r)					

Sunday • 6pm to Midnight

	6:00	7:00	8:00	9:00	10:00	11:00
ESPN	Game Day (12:00)					
Major Sports				Bob Costas Coast to Coast		
One on One	Around the NFL (1:00)	Sports Sunday with Chris Schneider				
Prime Sports	Game Day Coast to Coast with Jerry Overton & Pete Stein (1:00)			Prime Feedback with Bobby Allison & Ron DeRoxtras		
Sports Byline					Sports Byline USA Weekend	
Sports Collect			The Sports Collectors Show with John Raybin			
SportsFan	Prime Time Sunday (1:00)	The Press Box				Football Scoreboard
Talk America			Grandstand			Smitty's Sports Talk
Westwood						

All times Eastern • (r) = program reread



# THE GUIDE TO TALK RADIO PROGRAMMING

---

## Sports Network Pages

Here, you'll find detailed information from long-form sports talk programming providers, including the names and phone/fax numbers of network contacts.

At a glance, you will find lineups, terms and technical information to give an overview of each network.

ESPN .....	109
Major Sports.....	110
One on One Sports Network .....	111
Prime Sports Radio .....	112
Sports Byline USA .....	115
Sports Collectors.....	116
SportsFan Radio Network .....	117
Sports Radio Network .....	119
Westwood One Sports .....	120

# ESPN Radio Networks

13725 Montfort Drive, Dallas, TX 75240 • (214) 448-3323 • Fax: (214) 991-1512

**Affiliate  
Relations Director:**  
  
Bob Stevens

**Terms:**  
  
Barter

**Coordinates:**  
  
SatCom C-5  
Transponder 23  
Channels 00 & 19

**Tones:**  
  
ABC Net Cue

**Inventory:**  
  
8 minutes local  
6 minutes network

## Monday - Friday

10a-2p Fabulous Sports Babe The Fabulous Sports Babe  
2p-5p Fabulous Sports Babe The Fabulous Sports Babe (r)

## Saturday

6p-12a Various Sports Talk

## Sunday

12p-12a Various Game Day

*All times Eastern • (r) = program refeed*

## NEW RELEASES!



### Sports & Action #3

<u>CUT</u>	<u>SONG NAME</u>	<u>DESCRIPTION</u>
1	OFF ROAD	UNPREDICTABLE
2	FRESH SNOW	FUN, TOE-TAPPIN'
3	FIFTY MILE RUN	MELODIC, DRIVING BEAT
4	GO! GO! GO!	TRASHY, HIGH ENERGY
5	BRONCO FEVER	SOUTHERN ROCK, MELODIC
6	SOARING ABOVE	LOOSE GROOVE
7	FRIENDLY RIVALRY	HAPPY
8	DEMOLITION TOOL	METALLIC, EXTREME
9	SCORPION STING	HEAVY, ON THE EDGE
10	SCORPION STING	W/OUT METER CHANGE

Call for our free catalog!

**1-800-323-2972**

Energetic Music, P.O. Box 84583, Seattle, WA 98124

# Major Network Sports

101 West Grand Ave, Suite 600, Chicago, IL 60610 • (312) 755-1300 • Fax: (312) 755-0336

## Sunday

9p-11p    Bob Costas    Bob Costas Coast to Coast

*All times Eastern • (r) = program reread*

# TALKERS USE COMREX

- TO SEND PROGRAMS TO SATELLITE UPLINKS.
- TO CREATE DIAL-UP NETWORKS.
- TO PRODUCE THEIR OWN TALK SHOWS.

Comrex Corporation  
65 Nonset Path, Acton, MA 01720

1-800-237-1776

### President:

Chris Devine

### Affiliate Relations:

Phoebe Pearson

### Terms:

Barter

### Coordinates:

SatCom C-5  
Transponders 15 & 23  
Various Channels

### Tones:

Inquire

### Inventory:

Inquire

# One on One Sports Radio Network

1935 Techny Road, Suite #18, Northbrook, IL 60062 • (708) 509-1661 • Fax: (708) 509-8149

**President:**

Chris Brennan

**VP, Affiliate Relations:**

Chuck Duncan

**Affiliate Relations:**

Kurt Kretzschmar

**Terms:**

Barter

**Coordinates:**

SatCom C-5  
Transponder 15  
Channel 18.0

**Tones:**

25 Hz, 35 Hz

**Inventory:**

11 minutes local  
2 minutes network

**Monday - Friday**

12a-4a	John Renshaw	The John Renshaw Show
4a-7a	Bob Kemp	Bob Kemp Show
10a-12p	Mark Gentzkow & Jay Mariotti	Mark Gentzkow & Jay Mariotti Show
12p-4p	Kevin Wall	Kevin Wall Show
4p-8p	Joe Chevalier	Papa Joe Chevalier Show
8p-12a	Ted Green	Ted Green Show

**Saturday**

12a-4a	Fred Huebner	Fred Huebner Show
4a-8a	Ken Silverstein	Ken Silverstein Show
8a-1p	Dave Harbison	Sports Saturday
1p-7p	Bob Berger & Earl Forcey	College Football Today
7p-12a	Chris Schneider	Sports Saturday

**Sunday**

12a-4a	Chuck Garbedian	Chuck Garbedian Show
4a-8a	Ken Silverstein	Ken Silverstein Show
8a-1p	Dave Harbison	Sports Sunday
1p-7p	Bob Berger & Earl Forcey	Around the NFL
7p-12a	Chris Schneider	Sports Sunday

*All times Eastern • (r) = program reread*

# Prime Sports Radio

125 John Carpenter Freeway, Suite 670, Irving, TX 75062 • (214) 401-0972 • Fax: (214) 831-8329

## Monday - Friday

12a-1a	Jim Dent	Best of Prime Cuts (Mon)
12a-1a	Scott Franzke	Prime Sports Radio Tonight
1a-2:30a	Chet Choppock	Chet Choppock Show
2:30a-7a	Various Hosts	Prime Review
7a-11a	Rich Lerner	Prime Morning
11a-1p	Mark Oristano	Prime Mid Morning
1p-2p	Allen Stone	Games People Play
2p-4p	Jim Dent	Prime Cuts
4p-5p		Listener Call-In
5p-6p	Ed Berliners	Press Box
6p-9p	Tom Sauvlet	Game Time
9p-12a	Scott Franzke	Prime Sports Radio Tonight

## Saturday

12a-1a	Scott Franzke	Prime Sports Radio Tonight
1a-2:30a	Chet Choppock	Newspost's Chet Choppock Show
2:30a-7a	Bobby Allison	Bobby Allison Show
7a-8a		Week in Review
8a-9a	Kevin Smith	Kevin Smith Show
9a-10a	Keith Klein	Get Fit
10a-11a		Women's Sports Hour
11a-12p	Kevin Smith	Kevin Smith Show
12p-1p	Allen Stone	Games People Play
1p-9p	Jerry Overton & Pete Stein	Game Day Coast to Coast
9p-12a	Bobby Allison & Ron DeRoxtras	Prime Feedback

## Sunday

12a-1a		Week in Review
1a-7a	Bobby Allison	Bobby Allison Show
7a-11a	Kevin Smith	Kevin Smith Show
11a-12p	Allen Stone	Games People Play
12p-1p	Kevin Smith	Kevin Smith Show
1p-9p	Jerry Overton & Pete Stein	Game Day Coast to Coast
9p-12a	Bobby Allison & Ron DeRoxtras	Prime Feedback

### Affiliate Relations:

Michelle Kyle

### Marketing Director:

Amy Brown

### Terms:

Barter

### Coordinates:

SatCom C-1  
Transponder 10  
Channel 3900

Spacenet 3  
Transponder 24  
Channel 4180

### Tones:

25 Hz, 35 Hz, 25/35 Hz

### Inventory:

8 minutes local  
6 minutes network

All times Eastern • (r) = program reread

# You'll love what's cooking on Prime Sports Radio

## *Prime Morning with Rich Lerner*

A veteran of sports talk WFAN in New York, WIP in Philadelphia and NPR commentator.



## *Midday Prime with Mark Cristano*

A 23-year veteran sportscaster who's broadcast Houston Oilers football and Dallas Mavericks basketball. Mark is currently a member of the Dallas Cowboys Radio network broadcast team.



## *Games People Play with Allen Stone*

A 20-year broadcast veteran and former TV play-by-play voice of the Dallas Mavericks, Allen takes an in-depth look at the issues relating to sports in our society—the reflections, the connections and the conflicts.



## *Prime Cuts with Jim Dent*

As a 15-year veteran sportswriter and broadcaster, Jim brings a wealth of sports knowledge to PSR. Jim has published an unauthorized biography of Dallas Cowboys owner Jerry Jones.



## *Game Time with Tom Sawlet*

Former weekend sports host and co-producer of weekly NFL show on Sundays on Dallas' talk leader, KLIF-AM.



## *PSR Tonight with Scott Franzke*

Scott has extensive play-by-play experience and is a real up'n comer in the sports industry.





All Times CST



# Daily Menu

## Monday through Friday

12:00a – 1:30a . . . . . **Chet Coppock Show**

1:30a – 6:00a . . . . . **Prime Review**

6:00a – 10:00a . . . . . **Prime Morning w/Rich Lerner**

10:00a – 12:00n . . . . . **Midday Prime w/Mark Oristano**

12:00n – 1:00p . . . . . **Games People Play w/Allen Stone**

1:00p – 3:00p . . . . . **Prime Cuts with Jim Dent**

3:00p – 4:00p . . . . . **Listener Call-In**

4:00p – 5:00p . . . . . **Ed Berliner's Press Box**

5:00p – 8:00p . . . . . **Game Time w/Tom Sauvlet**

8:00p – 12:00a . . . . . **PSR Tonight w/Scott Franzke**

ime Sports Radio

Weekdays  
on



## Saturday

12:00a – 1:30a . . . . . **Newsport's  
Chet Coppock Show**

1:30a – 6:00a . . . . . **Bobby Allison**

6:00a – 7:00a . . . . . **Week In Review**

7:00a – 8:00a . . . . . **Kevin Smith**

8:00a – 9:00a . . . . . **Get Fit with Keith Klein**

9:00a – 10:00a . . . . . **Women's Sports Hour**

10:00a – 1:00a . . . . . **Kevin Smith**

11:00a – 12:00n . . . . . **Games People Play  
w/Allen Stone**

12:00p – 8:00p . . . . . **Game Day Coast to Coast**

8:00p – 11:00p . . . . . **Prime Feedback/  
Listener Call-In**

11:00p – 12:00a . . . . . **Week In Review**

## Sunday

12:00a – 6:00a . . . . . **Bobby Allison**

6:00a – 10:00a . . . . . **Kevin Smith**

10:00a – 11:00a . . . . . **Games People Play w/Allen Stone**

11:00a – 12:00n . . . . . **Kevin Smith**

12:00p – 8:00p . . . . . **Game Day Coast to Coast**

8:00p – 11:00p . . . . . **Prime Feedback/Listener Call-In**

11:00p – 12:00a . . . . . **Best of Jim Dent's Prime Cuts**

**PRIME SPORTS RADIO**  
*The Sound of Sports*

# Sports Byline USA

300 Broadway, Suite 8, San Francisco, CA 94133 • (800) 783-7529 • Fax: (415) 391-2569

**Affiliate  
Relations Director:**

Darren Peck

**Terms:**

Barter

**Coordinates:**

SatCom C-5  
Transponder 19  
Channel 17

Galaxy 6  
Transponder 3  
Channel 54.6

**Tones:**

Inquire

**Inventory:**

6 minutes local  
6 minutes network

**Monday - Friday**

12a-1a  
1a-6a  
10p-12a Ron Barr

Sports Byline  
Sports Overnight America  
Sports Byline

**Saturday**

12a-1a Ron Barr  
1a-6a  
10p-12a

Sports Byline  
Sports Overnight America  
Sports Byline USA Weekend

**Sunday**

12a-1a  
1a-6a  
10p-12a

Sports Byline USA Weekend  
Sports Overnight America  
Sports Byline USA Weekend

*All times Eastern • (r) = program reread*

## Just In Case...

### Keep Extra Copies of The Guide...

When the time comes to make lineup changes, that's when you'll see the value of **The Guide to Talk Radio Programming**. We organize the world of syndicated talk radio into one concise book. You'll find that having a few extra copies on hand saves time and money.

Extra copies of **The Guide** can be mailed to your office as early as tomorrow. Ask for the "Professional Courtesy Rate" of \$9.95 per copy (add \$3 shipping).

Call (617) 433-0870 to order by MasterCard or Visa.

*Professional Courtesy Rate limit of 5 books.  
Overnight Delivery available at \$18 per copy.*

# Sports Collectors Network

527 Third Avenue, Suite 294, New York, NY 10016 • (212) 573-8100 • Fax: (212) 573-5539

## Sunday

8p-10p John Raybin Sports Collectors Show

*All times Eastern • (r) = program reread*



**John Raybin**  
*The Sports Collectors Show*

### President:

John L. Raybin

### Affiliate Relations:

Joe Rashbaum

### Terms:

Barter

### Coordinates:

SatCom C-5  
Transponder 23  
Channel 15

### Tones:

Inquire

### Inventory:

6 minutes local  
6 minutes network

# SportsFan Radio Network

230 Park Avenue, Suite 3126, New York, NY 10169 • (212) 681-1947 • Fax: (212) 681-1952

**President:**

Kyle A. Heinrich

**Vice President:**

Jon Goldman

**Director of  
Affiliate Relations:**

Rob Scolaro

**Terms:**

Barter

**Coordinates:**

SatCom C-5  
Transponder 19  
Channel 03.0

**Tones:**

25 Hz

**Inventory:**

Inquire

**Monday - Friday**

1a-3a	Various Hosts	Air It Out (Mon)
1a-2a	Dave Cokin	SportsFan Tonight (Tue-Fri)
2a-3a	Chuck Powell & Rob Fischer	SportsFan Central (Tue-Fri)
3a-9a	Percy Wingfield	Morning Madness (Tue-Fri)
7p-9p	Pete Rose & John Hadley	The Pete Rose Show
9p-10p	Dave Cokin & Frank Andrews	First & 10/ NHL: In the Crease
10p-1a	Bruce Schein	SportsFan Tonight

**Saturday**

1a-2a	Dave Cokin	SportsFan Tonight
2a-3a	Chuck Powell & Rob Fischer	SportsFan Central
3a-9a	Percy Wingfield	Morning Madness
9a-1p	Various Hosts	The Kick-Off Show
1p-7p	Sean Salisbury & Rob Fischer	PrimeTime Saturday
7p-11p	Various Hosts	The Press Box
11p-1a	Pete Rose	Best of Pete Rose (r)

**Sunday**

1a-3a	Various Hosts	Air It Out
3a-9a	Percy Wingfield	Morning Madness
9a-1p	Various Hosts	The Kick-Off Show
1p-7p	Sean Salisbury & Chuck Powell	PrimeTime Sunday
7p-11p	Various Hosts	The Press Box
11p-1a	Various Hosts	Football Scoreboard

All times Eastern • (r) = program reread

# Get The Full Message 25 Cities Coverage

*From L.A. to New York,  
from Chicago to Miami-  
stay in touch for only...*

**\$19<sup>95</sup>**  
Per Month



- Price Includes Alpha Numeric Service
- Price Includes Coverage 25 Cities
- Price Includes A Live Operator
- Price Includes 800 Number Access



*Fully Personalized Answering Service Available.  
Join the Thousands of people who rely on  
MAP to represent their business!*



Call now and be on-line within 24 hours!

**800-627-9372**

# Sports Radio Network

12685 Dorsett Rd. Suite 136, Maryland Heights, MO 63043 • (800) 776-7234 • Fax: (314) 423-4014

**President:**

Michael G. Talir

**Terms:**

Inquire

**Coordinates:**

SatCom C-5  
Transponder 23  
Channel 54

**Tones:**

None

**Inventory:**

8 minutes local  
8 minutes network

**Monday - Friday**

5p-7p	Ed Baron, John Ellis & Larry Zbyszko	TransWorld Wrestling (Thu)
-------	---	-------------------------------

*All times Eastern • (r) = program refeed*

**GET  
ONLINE!**

## RADIO STATIONS!

The internet is a new way to develop a closer relationship with listeners.

Plus, there are hundreds of "value added" opportunities for your sales team. And best of all, the price is right.

We'll produce a fun, interactive web site for your station, complete with profiles of your program hosts. Add full-color logos...even sound clips! We'll create a directory with links to other local and national web sites that are targeted specifically to your listeners' interests.

Call **Long Multimedia** and get online today!

**(617) 433-0870**



# Westwood One Sports

1755 South Jefferson Highway, Arlington, VA 22202 • (703) 413-8550 • Fax: (703) 413-8445

## Monday - Friday

10p-1a Scott Ferrall Ferrall on the Bench

## Saturday

12a-1a Scott Ferrall Ferrall on the Bench

## Sunday

9a-11a Mike Francesa Sports Now

11a-1p Mike Francesa Sports Now (r)

*All times Eastern • (r) = program refeed*

## NETWORKS & HOSTS!

GET  
ONLINE!

Let both PD's and potential listeners know about your programming. A great web site gets listeners involved. Include personality pages, full-color photos and logos...even sound clips!

### *The "I's" of the "I"nternet:*

**Interactive & Interesting** - with a point and click web site, your listeners have fun...a lot more interesting than those old one sheets.

**Inexpensive** - with our internet services starting at \$30 per month, the 'net is a cost-effective marketing tool.

**Instant** - your info is always online, and a click of the mouse away.

Call **Long Multimedia** and get online today!

**(617) 433-0870**

### Affiliate Relations:

(703) 413-8550

### Terms:

Barter

### Coordinates:

SatCom C-5  
Transponder 15  
Inquire

### Tones:

Inquire

### Inventory:

Inquire

# Attorney Al Grady

---

## *Observations On Law*

*Sundays • 9am to Noon, Eastern • 6am to 9am, Pacific*

**Albert Grady** is a practicing Boston area attorney, veteran broadcaster and station owner. His show is heard in over 50 markets throughout North America. Grady encourages listener participation...and offers free legal advice to your listeners. Topics are current and relevant. Recent guests include:

- **Medical Malpractice against Neurosurgeons**  
Harvey Wachsman, *M.D., J.D.*, Great Neck, New York
- **Age Discrimination, Employees Laid Off After A Career With Employer**  
Attorney John Graves, Longview, Texas
- **Poisoning of Water in Woburn, Massachusetts**  
Jonathan Barr, *Author*  
Attorney Jan Schilichtmann  
"A Civil Action"
- **The O.J. Simpson Case: Has the Justice System Failed?**  
Mark Goulston, *M.D., Consultant for the Prosecution*
- **Professional Baseball Player vs. Team Doctor**  
Attorney Donald A. Shapiro, Chicago, Illinois  
Marty Barrett, *Former Boston Red Sox Second Baseman*  
A medical malpractice suit filed by Barrett against the Boston Red Sox.
- **Insurance Fraud**  
Attorney Clay Hornsby, Alexander City, Alabama  
The insurance fraud and misrepresentation law suit against the Prudential Insurance company for its life insurance policies.

Available at no cost on a barter basis • All local breaks filled  
Make Attorney Al Grady your station's Legal Expert!

# OBSERVATIONS ABOUT LAW

**Al's Easy Going Style will be a Favorite with Your Listeners**  
**Current legal issues -- Call in format -- Guests**

*"Very Interesting Show"*

Dan Cain, Operations Manager  
WIPC, Lake Wales, FL

*"Our listeners have gotten a lot of information. Observations about law has a good following in our area."*

Ed Anderson, P.D.  
WSYB, Rutland, VT

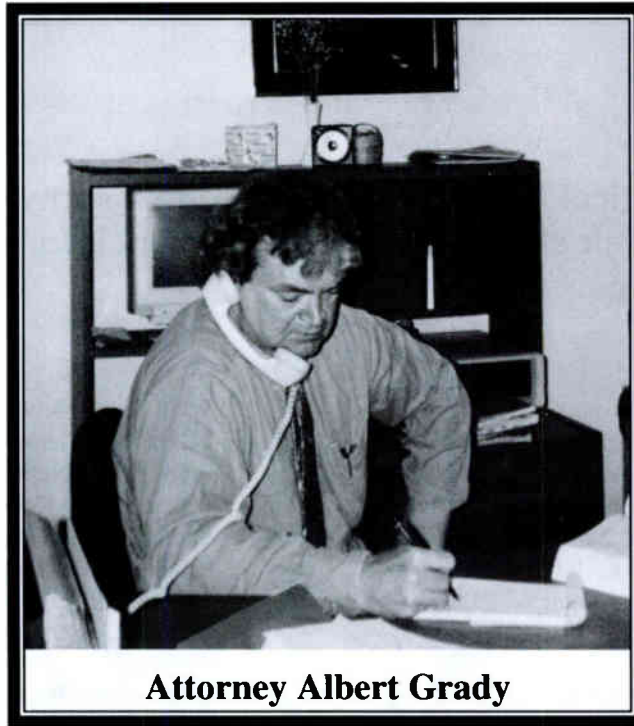

**Attorney Albert Grady**

*"Atty. Al Grady's superior knowledge of the law is a great asset to the program. His commitment to research and his effectiveness in communicating law in everyday language makes it an invaluable program to anyone with questions on the subject."*

John Pacitto, Operations Mgr.  
WDIS, Norfolk, MA

*"I like it! It's a good show."*

Brian Smeathers, GM  
WMTA, Central City, KY

## CURRENT STATIONS CARRYING OBSERVATIONS ABOUT LAW

KYSG	Little Rock, AK 100K Watts-FM
WJNT	Jackson, MS 50,000 Watts
WKYG	Parkersburg, WV
WNBH	New Bedford, MA
WIPC	Tampa/Lake Wales, FL
KBNP	Portland, OR
KNS	Reading/Chico, CA
KDRG	Deer Lodge, MT
KVRD	Cottonwood, AZ
KCCC	Carlsbad, NM
WDIS	Norfolk, MA
KGGM	Delhi, LA - FM
WJMW	Bloomsberg, PA

AND MANY OTHERS

## SUNDAYS 9 - 12 NOON (ET)

SatCom C-5	Transponder 15
Galaxy 6	Transponder 3
Spacenet 3	Channel 9

## FOR MORE INFORMATION

call, write, or fax

354 Turnpike Street  
Canton, MA 02021  
Tel (617) 828-4546  
Fax (617) 828-3822

# THE GUIDE TO TALK RADIO PROGRAMMING

---

## Host Index

An alphabetical listing of syndicated talk show hosts, including their show names and network information.

Aaronson, Bob  
Adams, Ken  
Allison, Bobby  
Amsterdam, Bruce  
Andrews, Frank  
Angeloff, Carl  
Ankarlo, Darryl  
Arthur, Kay

Bailey, Bill  
Baker, Jerry  
Baldinger, Gary  
Barnes, Fred  
Bates, Larry  
Beesley, Pam  
Bell, Art  
Berger, Bob  
Berliners, Ed  
Bernstein, Al  
Bohannon, Jim  
Bourgois, Gary  
Bowers, Sally  
Bozo, Dale  
Brenner, David  
Brenner, Zev  
Brinker, Bob  
Brooks, Jeff  
Browne, Joy  
Brownfield, Derry  
Burbank, Gary

Camerdesse, Nino  
Campbell, Gary  
Carey, James  
Carey, Morris  
Catchey, Marc

Bob Aaronson  
Take America Back  
Various  
Common Ground  
First & 10/NHL:In the Crease  
Carl Angeloff's Bottom Line  
Success Radio  
How Can I Live?

Are You Protected??  
On the Garden Line  
Sports Final  
Profiles  
Unravelling the NewWorld Order  
The Pam Beesley Show  
Various  
Various  
Press Box  
The Sports Party  
Jim Bohannon  
Friday Night Live Newshour  
Sally Says  
The Truckin' Bozo  
David Brenner  
Talkline  
Financial Advising  
On the Road  
Dr. Joy Browne  
The Common Sense Coalition  
The Gary Burbank Show

American Perspectives in Medicine  
Backstage  
On the House  
On the House  
On the House  
The Garden Show

WOR Radio Network  
USA Patriot Network  
Prime Sports Network  
Peoples Radio Network  
SportsFan Radio Network  
Peoples Radio Network  
SW Networks  
USA Radio Network

Talk America Radio Network  
Westwood One  
Talk America Radio Network  
Radio America Network  
USA Patriot Network  
USA Patriot Network  
Chancellor/Talk Radio Network  
One on One  
Prime Sports Network  
Talk America Radio Network  
Westwood One  
Tech Talk Radio Network  
Peoples Radio Network  
Broadbank Burbcasting  
Westwood One  
Peoples Radio Network  
ABC  
Business News Network  
WOR Radio Network  
Learfield Communications  
Broadbank Burbcasting

USA Patriot Network  
Talk America Radio Network  
On the House  
On the House  
Grow-Wise Gardner Network

---

# Host Index *(Chevalier to Grady)*

Chevalier, Joe  
Christy, Jack  
Choate, Pat  
Choppock, Chet  
Cokin, Dave  
Colmes, Alan  
Cooper, William  
Corbin, Michael  
Costas, Bob  
Cox, Wyatt  
Crapo, Mark  
Croser, Michael  
Crowley, Steve  
Cullum, Blanquita  
Cuomo, Mario

Daily, Dennis  
Deferbrache, Fred  
Dent, Jim  
DeRose, Charles  
DeRoxtras, Ron  
Dershowitz, Alan  
DeSilva, Derrick  
Dolan, Daria  
Dolan, Ken  
Douglas, Clay  
Duffy, Warren  
Duke, Dr. Lee  
Dulvois, James

Eckstein, Warren  
Edell, Dean  
Ellen, Sue  
Emanuelle, Mark  
Essel, David  
Eustler, Richard  
Ezzell, Mike

Farber, Barry  
Feijo, Jim  
Feinberg, Henry  
Fernandez, Pedro  
Fischer, Rob  
Flannigan, Tom  
Forcey, Earl  
Foster, Gary  
Foudy, Michael  
Franzke, Scott  
Fredinburg, Roger

Garbedian, Chuck  
Geise, Jackie  
Gentzkow, Mark  
Gonzalez, Paul  
Grady, Al

Papa Joe Chevalier Show  
The Jack Christy Show  
Washington: The Week Ahead  
Chet Choppock Show  
Various  
Left to Right  
The Hour of the Time  
Paranet Continuum  
Bob Costas Coast to Coast  
Saturday Morning In America  
Symmetry in Health  
The Home & Garden Show  
American Scene  
The Blanquita Cullum Show  
The Mario Cuomo Show

American Montage  
Trade Show from Outer Space  
Prime Cuts  
The Financial Advisor  
Prime Feedback  
The Alan Dershowitz Show  
Ask The Doctor  
The Dolans  
The Dolans  
American Soapbox  
Duffy and Company  
Animal Talk  
Taking Charge of Your Health

The Pet Show  
The Dr. Dean Edell Show  
Wake Up America  
Spectrum  
David Essel Alive  
Various  
Morning in America

Left to Right  
Health Watch  
The Henry Feinberg Show  
Ring Talk  
Various  
Auto Answers  
Various  
Today's Internet  
America the Beautiful  
Prime Sports Radio Tonight  
Roger Fredinburg

Chuck Garbedian Show  
Front & Center  
Mark Gentzkow Show  
The Paul Gonzalez Show  
Observations on Law

One on One  
USA Radio Network 2  
Peoples Radio Network  
Prime Sports Network  
SportsFan Radio Network  
Major Talk Networks, Inc.  
Burlington Radio Network  
Paranet Continuum  
Major Network Sports  
Peoples Radio Network  
Talk America Radio Network  
Peoples Radio Network  
USA Radio Network 2  
Radio America Network  
SW Networks

Peoples Radio Network  
Tech Talk Radio Network  
Prime Sports Network  
Business News Network  
Prime Sports Network  
SW Networks  
Talk America Radio Network  
WOR Radio Network  
WOR Radio Network  
Burlington Radio Network  
Salem Radio Network  
Peoples Radio Network  
USA Patriot Network

WOR Radio Network  
EFM Media Management  
USA Patriot Network  
Burlington Radio Network  
Westwood One  
Burlington Radio Network  
Peoples Radio Network

Major Talk Networks, Inc.  
Talk America Radio Network  
USA Patriot Network  
Talk America Radio Network  
SportsFan Radio Network  
Peoples Radio Network  
One on One  
Talk America Radio Network  
Talk America Radio Network  
Prime Sports Network  
Chancellor/Talk Radio Network

One on One  
Radio America Network  
One on One  
Peoples Radio Network  
Talk America Radio Network

# Host Index *(Grande to Liddy)*

Grande, Carl	Grandstand	Talk America Radio Network
Grande, George	Grandstand	Talk America Radio Network
Grant, Bob	The Bob Grant Show	Westwood One
Green, Ted	Ted Green Show	One on One
Gresham, Tom	Gun Talk	Talk America Radio Network
Gritz, Bo	Freedom Calls	Talk America Radio Network
Gross, Gil	The Gil Gross Program	CBS Radio Network
Hadley, John	The Pete Rose Show	SportsFan Radio Network
Halper, Stefan	This Week From Washington	Radio America Network
Hamblin, Ken	The Ken Hamblin Show	Entertainment Radio Network
Hand, Dave	Morning in America	Peoples Radio Network
Harber, Aaron	The Aaron Harber Show	Talk America Radio Network
Harbison, Dave	Various	One on One
Hardcastle, Bob	Money Talk	Talk America Radio Network
Harder, Chuck	For the People	Peoples Radio Network
Harrison, Mike	Talkers Countdown	Chancellor/Talk Radio Network
Hicks, Russ	Megabytes	Media Rep Associates
Hinkson, Dave	Freedom Radio Network	Burlington Radio Network
Hoffman, Paul	Animal Talk	Peoples Radio Network
Hoffman, Ronald	Healthy Lifestyles	WOR Radio Network
Huebner, Fred	Fred Huebner Show	One on One
Hughes, Jerry	Various	Peoples Radio Network
Hyman, Tony	Trash or Treasure	Peoples Radio Network
Imus, Don	Imus in the Morning	Westwood One
Ives, Victor	Golden Age of Radio Theater	USA Radio Network 2
Jackson, Earl	Across America	Radio America Network
Jarvis, Judy	The Judy Jarvis Show	Judy Jarvis
James, Rick	The Rick James Show	USA Patriot Network
Johnson, J. J.	Arming You With Knowledge	Burlington Radio Network
Johnson, Johnny	Patriot News Hour	Burlington Radio Network
Johnson, Randy	News With A View	Chancellor/Talk Radio Network
Jorgensen, Jim	Jim Jorgensen on Money	MediaRep Associates
Kamber, George	O'Leary/Kamber Report	Westwood One
Kaufmann, Doug	Your Health Matters	USA Radio Network 2
Kemp, Bob	Bob Kemp Chow	One on One
Kern, Tim	Talking Sense	USA Patriot Network
King, Larry	Larry King Live	Westwood One
Klein, Keith	Get Fit	Prime Sports Network
Komando, Kim	Komputer Klinik Show	WestStar Talk Radio Network
Kugel, Stan	Kugel & McLaughlin	Talk America Radio Network
Lanzalloti, John	American Perspectives in Medicine	USA Patriot Network
Lapierre, Wayne	Wayne Lapierre Show	Westwood One
Law, Bob	Night Talk	American Urban Radio Network
Lawrence, David	Online Today	WOR Radio Network
Lee, Laura	Laura Lee Show	Laura Lee
Lefavi, Bruce	Your Financial Future	Talk America Radio Network
Lerner, Rich	Prime Morning	Prime Sports Network
Lempert, Larry	Balance the Scales	Peoples Radio Network
Leykis, Tom	Tom Leykis	Westwood One
Liddy, G. Gordon	The G. Gordon Liddy Show	Westwood One



---

# Host Index *(Limbaugh to Renshaw)*

Limbaugh, Rush  
Lin, Danielle  
Lindsay, Hal  
Lindsey, Larry  
Loggans, Susan  
Long, Bob  
Long, Duncan  
Lundstrom, Lowell

Maimberg, Al  
Major, Stan  
Mariotti, Jay  
Martin, Bob  
Masters, Roy  
Mason, Ron  
Matalin, Mary  
Mazella, Lou  
Mazza, Joe  
McDonald, Don  
McKeever, Mike  
McLaughlin, John  
McNulty, Mike  
Milner, Pete  
Milner, Marty  
Mirabal, Lee  
Moran, Bill

Neigro, Debbie  
Nolan, Gary  
North, Oliver  
Nowicki, Ed

Ochs, Myrna  
O'Leary, Martin  
Oristano, Mark  
Overton, Jerry

Palmquist, Richard  
Papagiorgio, Michael  
Patterson, Robbie  
Pearson, Jane  
Peart, Greg  
Pell, Gene  
Peters, Pete  
Pino, Jose  
Podolski, Lance  
Ponte, Lowell  
Powell, Chuck  
Powell, Tommy

Quayle, Steve

Reagan, Michael  
Renshaw, John

The Rush Limbaugh Show  
Danielle Lin Health Show  
Weekend Review  
Rocky Mountain Trails  
Loggans on Law  
AutoWorld  
The Duncan Long Show  
Lowell Lundstrom Live

The Al Maimberg Show  
The Stan Major Program  
Jay Mariotti Show  
Home Care  
Roy Masters  
Health Talk  
Talk With An Attitude  
Sports Final  
The Joe Mazza Show  
The Don McDonald Show  
Sports Card Report Live  
Kugel & McLaughlin  
C.O.P.S.  
Let's Talk Fishing  
Let's Talk Fishing  
Lee Mirabal Show  
The Bill Moran Show

Working Mom on the Run  
USA Radio Daily  
The Oliver North Show  
American Crime Line

Myrna Ochs  
O'Leary/Kamber Report  
Prime Mid Morning  
Game Day Coast to Coast

To Free America  
The Hidden Truth  
Synergy  
The Jane Pearson Show  
Auto Answers  
Various  
Scriptures for America Worldwide  
Las Vegas Live  
American Outdoors  
Lowell Ponte at Large  
Various  
Fishin' & Wishin'

Blueprint for Survival

Michael Reagan Show  
The John Renshaw Show

EFM Media Management  
Chancellor/Talk Radio Network  
USA Radio Network  
USA Patriot Network  
Major Talk Networks, Inc.  
Talk America Radio Network  
USA Patriot Network  
USA Radio Network

Business News Network  
Talk America Radio Network  
One on One  
American Entertainment  
Chancellor/Talk Radio Network  
American Entertainment  
CBS Radio Network  
Talk America Radio Network  
Talk America Radio Network  
Business News Network  
Nelson Creative Radio  
Talk America Radio Network  
USA Patriot Network  
Nelson Creative Radio  
Nelson Creative Radio  
Major Talk Networks, Inc.  
Business News Network

Sweet Talk Productions  
USA Radio Network 2  
Salem Radio Network  
Chancellor/Talk Radio Network

Chancellor/Talk Radio Network  
Westwood One  
Prime Sports Network  
Prime Sports Network

USA Patriot Network  
USA Patriot Network  
Talk America Radio Network  
USA Patriot Network  
Peoples Radio Network  
Radio America Network  
Burlington Radio Network  
Talk America Radio Network  
Chancellor/Talk Radio Network  
American Entertainment  
SportsFan Radio Network  
Peoples Radio Network

USA Patriot Network

Major Talk Networks, Inc.  
One on One

---

# Host Index *(Resnick to Wheeler)*

Resnick, Norm	The Dr. Norm Resnick Show	USA Patriot Network
Reynolds, Mike	Monday Night Jive	Tech Talk Radio Network
Reynolds, Tony	Internet at Night	USA Radio Network 2
Richardson, Lance	Probing America	Talk America Radio Network
Richardson, Mel	Probing America	Talk America Radio Network
Riley, Joyce	NurseTalk Radio	Burlington Radio Network
Roberts, Glen	Full Disclosure Live	Tech Talk Radio Network
Rodham, Hugh	The Hugh Rodham Show	Talk America Radio Network
Rome, Tony	The Sports Party	Talk America Radio Network
Rose, Pete	The Pete Rose Show	SportsFan Radio Network
Ross, Connie	Backstage	Talk America Radio Network
Rutz, Darwin	Veterans Hour	USA Patriot Network
Salisbury, Sean	Prime Time	SportsFan Radio Network
Sauvlet, Tom	GameTime	Prime Sports Network
Schafley, Phyllis	Phyllis Schafley Live	USA Radio Network
Schein, Bruce	SportsFan Tonight	SportsFan Radio Network
Schlessinger, Laura	Laura Schlessinger Show	Radio Today Entertainment
Schlimer, Mitch	Let's Talk Business	Talk America Radio Network
Schneider, Chris	Various	One on One
Schwartz, Arthur	The Food Show	WOR Radio Network
Seggi, Ron	The Ron Seggi Show	USA Radio Network 2
Severin, Jay	Jay Severin	WOR Radio Network
Sloan, Steven	The Fishing Zone	Talk America Radio Network
Smith, Craig	Open Up	Talk America Radio Network
Silverstein, Ken	Ken Silverstein Show	One on One
Smith, Jim	Smitty's Sports Talk	Talk America Radio Network
Snodsmith, Ralph	Gardening Show	WOR Radio Network
Snyder, Tom	The Late Late Radio Show	CBS Radio Network
Spadewater, Strayhorn	Trout Talk	Nelson Creative Radio
Spear, Bob	Preparedness Hour	USA Patriot Network
Star, Andrea	Share Your Thoughts	Talk America Radio Network
Staub, Dick	The Dick Staub Show	Salem Radio Network
Stein, Eliot	The Eliot Stein Show	Peoples Radio Network
Stein, Pete	Game Day Coast to Coast	Prime Sports Network
Stephan, Doug	Various	Talk America Radio Network
Stern, Howard	The Howard Stern Show	Buchwald Associates
Stevens, Scott	Various	USA Radio Network
Stone, Allen	Games People Play	Prime Sports Network
Tierney, Pat	Veterans Hour	USA Patriot Network
Van, Dirk	NBC First Light	Westwood One
Vincent, Joel	Vincent & Company	Peoples Radio Network
Viscott, David	Sucess Radio	SW Networks
Walker, Mike	The Mike Walker Show	Westwood One
Wall, Kevin	Kevin Wall Show	One on One
Wallach, Mark	Let's Play Doctor	Talk America Radio Network
Ward, Bernie	Bernie Ward Show	ABC
Weissbach, Peter	Weissbach	Chancellor/Talk Radio Network
Weitzman, Bruce	Take America Back	Talk America Radio Network
Wessal, Don	America First	Burlington Radio Network
Wheeler, Scott	Reporters Journal	USA Patriot Network

# Host Index *(White to Zeman)*

White, Jameson  
White, Mort  
Williams, Armstrong  
Williams, Bruce  
Wingfield, Percy  
Winkler, Len

Jameson White Show  
Magic Garden  
The Right Side  
Bruce Williams  
Morning Madness  
The Ham Radio Show

Talk America Radio Network  
Talk America Radio Network  
Salem Radio Network  
Westwood One  
SportsFan Radio Network  
Talk America Radio Network

Zeman, Don

Around the House

Learfield Communications

## WHY WAIT TO BE #1?

**The Only New Syndicated Program Concept in 20 Years!**  
**Available Now by Satellite to Your Station!**



- Terminate your competitors!
- Win reach, share & listener loyalty!
- Dominate the radio game!
- Capture big dollar demos!
- Have ad agencies calling you!
- Own all-day parts!
- Own overnights and weekends!
- Raise your spot rate!
- Reduce your operating cost!
- Attract top sales pros!
- Works with any existing AM or FM format!
- Can not be duplicated by competitors!
- You have 100% control!
- Stands alone in-part or 24 hours a day!
- Full advertising & marketing support package!
- **AND IT'S FREE!**  
**IT'S BARTER!**

**FREE SATELLITE EQUIPMENT & ENGINEERING**  
**For More Information, call Buddy Baker at 1-800-821-5068**

Presented by Network Broadcasting Associates, Inc.

# THE GUIDE TO TALK RADIO PROGRAMMING

## Tech Talk

with Engineer Carl Abrams

Sometimes when viewing elaborate switching systems in our high-tech society, we forget there are often simpler solutions.

The following is a way of using relays to accomplish a switching system that is adequate to run on. Keep in mind, this is a basic layout. It can be altered by simple wiring logic and more timers. Depending on the timer you may, or may not need, diodes and hold capacitors. The circuit uses a simple double pole double throw relay. The coil can be rated from 3 to 110 volts depending on timer output and voltages available. The contacts that move are the contact connections -- the point to which the contacts move between, are the input points to the air board.

On one side is program input, on the other the second source input. By using the timer to turn on the relay for a predetermined time, and off for a predetermined time, one can add a little more versatility for their application -- be it on-air or production.

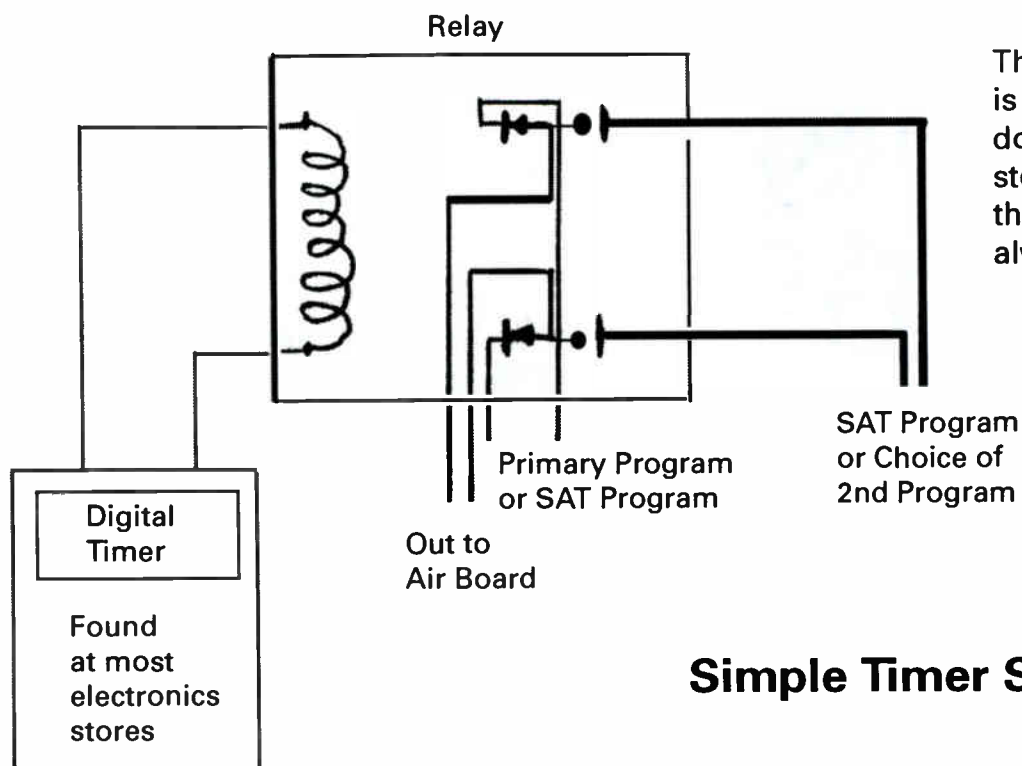

This simple approach is not glorious and does not have a gig of storage, but it does do the job and almost always works.

### Simple Timer Switching



Eventide®

# LOG FOR LESS

Everyone loves Eventide digital audio-loggers. They've thoroughly obsoleted old-fashioned reel-to-reel logging recorders. But for some stations, our 24-channel model VR240 is more than the budget can handle. And many stations will never need to record up to 24 channels.

## 500 hours, half the price

The Eventide VR204 4-channel digital logger is the perfect answer. It costs less than half the price of a fully optioned Eventide VR240! The high density DDS2 drive of the VR204 can actually record more than 500 hours, divided among up to 4-channels, on a single DAT tape. That's twice the record time of our original models.

## Built-in hard disk

The VR204 is a single drive machine, yet it can play and record simultaneously. That's because it features an ingenious built-in hard disk memory module that keeps recording even if the tape is playing back an

earlier segment (or if the tape runs out). When the tape resumes recording, the content of the hard disk is transferred to tape, maintaining the completeness of the taped log.

## Two-way compatibility

There's also a play-only model, the VP204, which is ideal for the GM's or PD's desk or for the group's main office. And both the VR204 and VP204 can playback any of the 24 channels recorded on an Eventide VR240.

Keep an accurate audio record of everything that goes out on your air. Keep track of the competition as well. Contact your broadcast dealer or Eventide for the full story on the economical VR204. Because without an Eventide digital logger, you really don't know what you're missing.



Eventide®

**Now record  
500+ hours on  
one tiny DAT tape**



**Eventide**  
the next step

One Alsan Way, Little Ferry, NJ 07643  
Tel 201-641-1200 Fax 201-641-1640

# The Next Issue Is Underway!

---

The next issue of **The Guide to Talk Radio Programming** is already underway. We're working on some new features and ideas, and look forward to hearing your comments and suggestions from this issue.

Here's what we're working on for Issue #3:

- An interview with Radio Today's **Laura Schlessinger**.

*A talk with "radio's most popular and controversial psychotherapist" and the author of "Ten Stupid Things Women Do to Mess Up Their Lives."*

*Dr. Laura's style is unique, and we'll take you into the studio to give you a real look at the person behind the microphone.*

- "Shock Talk"

*Is "Shock Radio" just a phase? Big ratings, big egos, big money.*

- More of the Latest Lineups

*We'll have the absolute latest lineups and listings from dozens of networks and program providers, and of course our signature daypart grids that organize the ever-changing syndicated talk arena.*

*We're also working on an expanded look at short-form talk, from sixty second commentaries to top-of-the-hour news suppliers.*

Be sure to renew your subscription to keep receiving **The Guide to Talk Radio Programming**. Subscriptions are free to talk programmers, consultants and management. Complete the form opposite this page to apply.

*If you are on the internet, stop by our home page on the World Wide Web. You'll find the latest news about The Guide, as well as late-breaking programming updates from the networks. We're online 24 hours a day, 7 days a week.*

*Visit us at: <http://www.talkradioguide.com> or email us at [info@talkradioguide.com](mailto:info@talkradioguide.com)*



Yes! I would like a **FREE** subscription to

# THE GUIDE TO TALK RADIO PROGRAMMING

*A complete directory to syndicated talk,  
news and sports radio programming*



To continue to receive The Guide to Talk Radio Programming, complete this application and mail a copy to: Guide Subscriptions, P.O. Box 342, Needham, MA 02192. Or, fax it to (617) 433-0870. This information is used for Guide purposes only. *Please print clearly.*

**Name:** \_\_\_\_\_ **Title:** \_\_\_\_\_

Address/City/State/Zip: \_\_\_\_\_

Station Format: \_\_\_\_\_

Telephone: \_\_\_\_\_ Fax: \_\_\_\_\_ Email: \_\_\_\_\_

What syndicated programming do you carry?

What features of The Guide do you find most useful?

What would you like to see in the next issue of The Guide?

What other forms of media/communication do you use? *(check all that apply)*

Email

CD-ROM

Fax

World Wide Web

Comments:

---

---

---

---

# The Technical Side of Syndicating Your Own Talk Show

by Lynn Distler, VP Marketing, Comrex Corporation

If you want to distribute a talk show to more than a handful of stations, satellite is probably going to be the least expensive and most effective way to deliver your program. There are plenty of satellite services available and many of them are listed here in *The Guide to Talk Radio*. These services range from full promotion and production packages, including call screening, to just the basic delivery.

However, since talk hosts are not likely to be broadcasting at the satellite uplink, the problem is how to get the program from the host's location back to the uplink site, while maintaining studio quality sound. Broadcasters often refer to the process of sending program from a remote location back to a satellite distribution point as "satellite backhauling" and there are two methods of satellite backhauling in widespread use.

The first method uses standard dial telephone lines and equipment called frequency extenders. For voice programming, a "two line" frequency extender is most often used. This equipment allows 5 kHz audio (decent voice quality) to be transmitted on two dial lines. A third phone line is required if callers are being fed back to the host from the satellite uplink - or if an additional communications line is desired. Frequency extension is an encode/decode process, so an encoder is needed at the sending location and a decoder is required at the receiving site. Many satellite services are already equipped with two line frequency extender decoders.

The second method, which is gaining rapid popularity, uses digital dial telephone services called ISDN (or sometimes Switched 56.) The advantage of this approach is that even better quality audio (up to 15 kHz) can be sent *bidirectionally*, allowing both program transmission and caller return to be handled on a single line. The drawback to ISDN is that it is not available everywhere and the initial setup of the line can be somewhat frustrating, since this is a relatively new technology for the phone companies. This makes ISDN an excellent choice for fixed locations, but less desirable if a host wants to broadcast from random locations on the road.

ISDN stands for Integrated Services Digital Network and it is a dial-up service which provides an end-to-end high speed digital connection from your house or office to the location that you are calling. Switched 56 is a North American "precursor" to ISDN and is still the only digital service available in some areas. However, SW56 can dial up ISDN locations and vice versa. ISDN is also widely available in other parts of the world and provides an easy, inexpensive way to send audio programs internationally.

To send high quality audio on ISDN, digital audio codecs are required. Also needed are an ISDN modem, called a Terminal Adapter (TA), and an interconnect box called an NT1. Some digital audio codecs have both the TA and NT1 built in. There are two issues that are of primary importance for talk hosts as far as digital audio codecs are concerned. The first is compatibility - your codec will have to use the same "algorithm" as the codec at the satellite uplink. There are three main digital audio codec algorithms in use: G.722, ISO/MPEG Layers II & III. For talk radio, the most widely used algorithm is G.722, primarily because the coding delay in G.722 is minimal and does not interfere with host/caller interaction.

Here are some general budgeting guidelines: The two line frequency extender encoder costs about \$3500. Also, you will need the usual microphones, microphone amplifier (mixer), headphones and three phone lines. For the ISDN equipment, codecs with TA and NT1 range from \$2300 to over \$5000. ISDN costs vary around the country, with an average cost of about \$250 for installation and \$75 monthly charge. Per minute charges on ISDN range from the same as a standard call to around 50% above the normal rate.

Comrex has extensive information available on its fax-on-demand system with documents ranging from product and pricing details to specific rates and ordering numbers for getting ISDN service from your local phone company. The fax-on-demand system can be accessed from any touchtone phone 24 hours a day. We also have a free 40-page booklet entitled "ISDN for Broadcasters" which we are happy to send to you if you fax or call in your request.

Comrex Corporation 65 Nonset Path Acton, MA 01720 USA

Toll free in North America: 800-237-1776 Fax: 508-635-0401 Fax-on-Demand 508-264-9973

he does, but there's no reason for me to agree or disagree. He is definitely a professional.

**Guide:** I know you've turned down TV gigs.

**Williams:** I'm not real happy with television. Well, with a face like mine you can under-

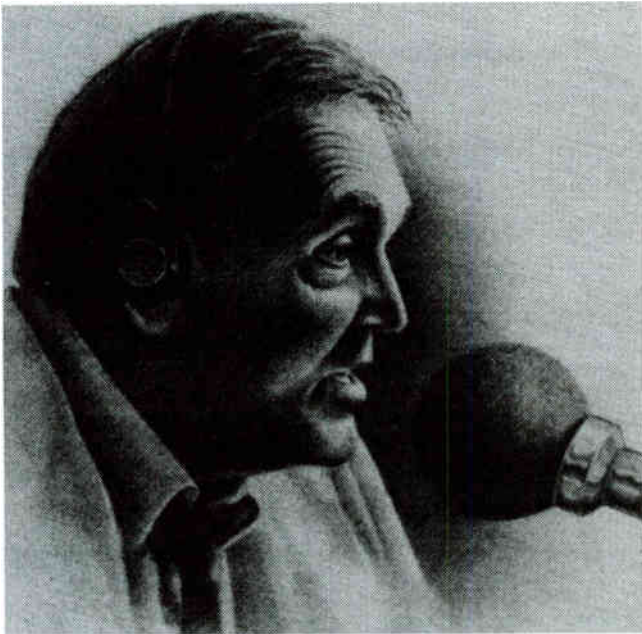

stand that, but getting beyond that, television, whether you're the most successful in the world like a Carson, Leno, or a Letterman, gives you very little latitude.

This morning I had to get up early and go the dentist, and I was watching Katie Couric, whom I know. She doesn't have any control over her destiny. They give her 2 minutes and 12 seconds and that's what that bit's going to be. It can be an extremely interesting bit — but that's it.

In talk radio, if I get somebody on who's really interesting, I keep them on for an hour. Nobody in television is allowed that.

**Guide:** How long do you want to continue?

**Williams:** When I stop having fun, it's history. When they say I'm not going to pay you, I'm also history. •

As seen and heard on ABC, CBS, NBC, Time and Newsweek Magazines

# Freedom Calls

*... Have You Heard?*

● Over 50  
Affiliates ...  
First Year!

● The Real  
Life  
"Rambo"

● Testified  
Before  
Congress at  
"Ruby Ridge"  
Randy  
Weaver  
Hearings



**Col. Bo Gritz**

● Veteran  
Journalist &  
Broadcaster

● "THE  
American  
Soldier"  
—Gen.  
*Westmoreland*

● Restoring  
Constitutional  
Government  
and  
Economy

Radio listeners across America are challenged daily by Col. Bo Gritz ... to become an active part in restoring a Constitutional government before Americans are merged into a "New World Order, USA Inc."

Check it out ... listen to **Talk America Radio Network** daily from **10 AM to Noon E.S.T.** as Bo cuts through the political, social *and* economic fog with a sword of truth. For more info call... (617) 828-4546.





# ... whip up the perfect radio mix.

With Metro Networks in your recipe, you can strengthen your station's programming with quality news, sports, weather, traffic and information.

Considering 85% of radio listeners rate information reports as "important" to their radio diet, Metro Networks is also great for building audience and TSL.

What's more, 87% of listeners crave reports on a regular basis, not just as needed -- while more than 47% will leave a radio station in search of information to satisfy their appetite.\*

Metro Networks is perfect because it's fortified with coverage from over 60 cities in North America and Europe, and is enriched with broadcasting's largest fleet of aircraft.

And since Metro is available at no hard cost to you, it's great for battling bulging debt.

Make Metro Networks a nutritious part of your programming. For more successful recipes and ideas, call 713-621-2800.

\*The Research Group, 1994



NEWS • SPORTS • WEATHER • TRAFFIC

# TALKERS USE COMREX

- *TO SEND PROGRAMS TO SATELLITE UPLINKS.*
- *TO CREATE DIAL-UP NETWORKS.*
- *TO PRODUCE THEIR OWN TALK SHOWS.*

If you're in the Talk business, sooner or later you're going to hear of Comrex. We make the Digital Audio Codecs to send programs on ISDN and SW56, the Frequency Extenders that make plain old telephone lines sound good, and Remote Consoles with features uniquely suited to Talk.

We know the technical side of talk and we're happy to help you. For more information, please give us a call at 1-800-237-1776.

Comrex Corporation  
65 Nonset Path Acton, MA 01720 USA  
Tel: 508-263-1800 Fax: 508-635-0401  
Fax-on-demand: 508-264-9973