

Second Class Postage Paid

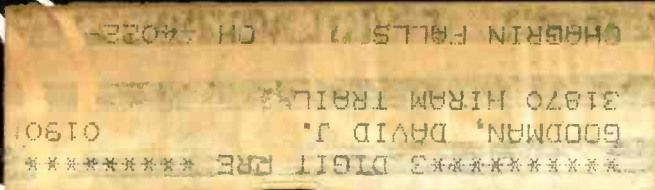

MONITORING TIMES

A Publication Of
Grove Enterprises

Inside This Issue:

- Radio Belize: The Caribbean Beat in Central America
- MT visits Houston Universal Weather and Aviation, Inc.
- Monitoring Drama on the World's Oceans
- Review: the Universal M7000
- Almost a Radio Celebrity



Breaking Down Khomeini's Walls



The Scan-tastic Duo!

ICOM R-7000 Scanner and AH-7000 Discone Antenna Are Grove's Choice for VHF/UHF's 'Perfect Partners'



ICOM R7000

Now used by government and military agencies worldwide, the ICOM R7000 provides total spectrum 25-1000 (triple conversion) and 1025-2000 (quadruple conversion) MHz frequency coverage with 100 Hz fluorescent readout accuracy!

Add to this enormous tuning range 99 memory channels with priority function, keyboard entry or dial tuning (± 5 ppm stability, -10 to 60°C), FM/AM/SSB modes, five tuning speeds (0.1/1/5/10/12.5/25 kHz), S-meter/ center tuning meter, 2.8/9/15/150 kHz filter selection, noise blanker, internal speaker with 2.5 watts of audio power, spurious signal suppression greater than 60 dB, high sensitivity (0.5 uv @ 12 dB SINAD FM), and programmable scanning with auto-write memory, and you have the most advanced scanning receiver ever designed for the serious VHF/UHF listener.

But the features don't stop here. Optional accessories include the RC-12 remote controller, ACC 67 extendable whip antenna, a voice synthesizer to announce frequency settings, and even an access port for external computer control!

YOU PAY
ONLY
\$1,019⁰⁰

Order SCN 4

DIMENSIONS: 11 $\frac{1}{4}$ "W x 4 $\frac{3}{8}$ "H x 10 $\frac{7}{8}$ "D; WEIGHT: 16 lbs.; POWER: 117/240 VAC, 1.5 A

Professional Wideband Discone

Best Discone on the Market for VHF/UHF Receivers

The discone antenna is used by government and military agencies worldwide because of its recognized high performance, wide bandwidth characteristics. Now ICOM offers a professional grade discone at a popular price.

Designed for use with the ICOM R7000 receiver (25-2000 MHz continuous coverage), the AH7000 discone consists of 16 rugged, stainless steel elements and is capable of transmitting up to 200 watts in the amateur 50, 144, 220, 432, 900, and 1200 MHz bands.

As a receiving antenna the AH7000 is superb,

outperforming any omnidirectional antenna we have ever used for continuous 25-1000 MHz (and above) coverage. A base-loaded, vertical top element is used as a low band (30-50 MHz) frequency extender.

The elements are arranged on a 24-inch support pipe equipped with two strong mounting brackets to accommodate any standard mast-pipe (1" to 2 $\frac{1}{8}$ " diameter). Included is approximately 50 feet of low loss 50 ohm coaxial cable with N connectors factory installed. Receiver adaptors available at additional cost at time of order: **Order ANT-3**

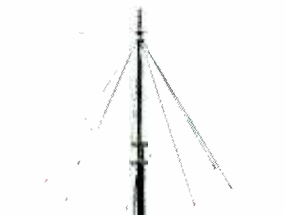

ONLY **\$94⁰⁰**

plus \$3.50 UPS
\$6.50 U.S. Mail Parcel Post
Canadians: \$10 Air Parcel Post

 **Grove Enterprises**

140 Dog Branch Road
Brasstown, N.C. 28902

MC and Visa Orders Only,
Call 1-800-438-8155



MONITORING TIMES

Utilizing the VOA's Farsi Service, Iranian expatriates combat untruths and ignorance with unbiased information and news of Iran's citizens in exile - p.14

High-tech, yes, but the Universal M7000 does its job, says Albert - p.85

Van Horn discloses two newly discovered Soviet maritime nets and a profile of European SAM and SAC nets - p.28

What do you do when a medical emergency arises on the high seas and there's no doctor on board? ... Call MAS, of course ... and you can listen in - p.42

Radio Belize by Don Moore 6

Don't confuse Belize with its Central American neighbors -- It has a unique cultural blend all its own that Radio Belize has pledged to preserve.

Houston Universal Weather and Aviation, Inc. by Jean Baker 10

Our interview focuses on Houston Radio Services, one branch of this unusual private aviation service.

A Voice for Iran 14

In the propaganda war, truth becomes a valuable weapon -- one which the VOA hopes will break down the walls surrounding Khomeini's Iran.

Monitoring High Seas Telephone Communications by A.W. Edwards 18

From homesick phone calls to real life dramas, the uncertainties of life on the world's oceans always provide monitoring intrigue.

Almost a Radio Celebrity by Wayne Hogan 22

The Universal M7000 - a review by Jack Albert 85

DEPARTMENTS

Letters	3	Below 500 kHz	54
Communications	4	Personal Communications	56
Shortwave Broadcasting	24	Program Review	58
Utility World	28	Program Guide	59
The Scanning Report	32	Frequency Section	65
What's New?	36	Magne Tests ...	88
Uncle Skip's Corner	38	Scanner Equipment	90
The Federal File	40	DeMaw's Workbench	92
High Seas	42	Experimenter's Workshop	94
On the Ham Bands	44	Antenna Topics	96
The QSL Report	46	"Ask Bob"	98
Reading RTTY	47	Stock Exchange	101
Satellite TV	48	Convention Calendar	102
American Bandscan	50	Closing Comments	104
Outer Limits	52		

MONITORING TIMES (ISSN 0889-5341) is published monthly for \$18 per year by Grove Enterprises, Inc., PO Box 98, Brasstown, NC 28902 (ph.1-704-837-9200). Second class postage paid at Brasstown, NC, and additional mailing offices. POSTMASTER: Send address changes to Monitoring Times, PO Box 98, Brasstown, NC 28902.

ON THE COVER: Ms. Katayoun Beglari, A Farsi Service International Radio Broadcaster, is an Emcee of the Tehran evening show and also covers cultural and art events. (Courtesy VOA)

Inside this Issue • Belize is a sort of Central American miracle -- there's no revolution in progress, no major crisis or bloody government coups. It's a quiet place, steeped in English culture that's only now beginning to discover its own roots. As a result, hearing its radio station on shortwave has always been a special treat. This month, Don Moore travels to this English-speaking paradise for a glimpse at Radio Belize. How, we ask, could you not like a radio station that closes its transmissions with a quaint prayer asking God to watch over their country? •

Monitoring Times also takes you behind the scenes of another broadcaster -- the Voice of America's Farsi (or Persian) service. Begun after henchmen of the newly-installed Ayatollah took American diplomats hostage at the U.S. Embassy some years ago, the VOA continues to pound away at the walls built up around the nation by the revolutionary Islamic government of Iran. And according to officials at the VOA, the Farsi service is being heard in some pretty high places!

• Reader A.W. Edwards, radio officer aboard the "Coastal Manatee," tells readers how they can easily monitor high seas telephone calls. While he cautions that "you're welcome to listen; just don't tell anyone what you've heard," he also points out how monitoring these calls can be an enjoyable peek at the wide variety of lives and cultures found living on the oceans of the world. • Wayne Hogan isn't really a radio hobbyist. He's a writer in Cookville, Tennessee. But Wayne got a chance to see how the industry really works when he almost became a radio celebrity. We think you'll enjoy his story. • Jack Albert, as *MT* readers know by now, is quite an authority on radioteletype or RTTY. And when Jack got his hands on a new Universal M-7000 decoder, he put it through its paces. If a RTTY unit can survive Jack Albert's scrutiny, well, you can be pretty confident that it's a darned good piece of equipment. How did the M-7000 stand up? Jack's review is on page 85.



Coming up: • Back a few years ago, Dr. Carl Sagen and his colleagues unveiled a horrifying scenario of what they believe will happen to this planet after an exchange of nuclear weapons. That April Fool's Day, in a very dark joke, we listed a bogus article in our table of contents entitled, "Radio Monitoring during the Nuclear Winter." Next month we get serious -- deadly serious -- about the subject. • The number of people who listen to shortwave radio always climbs dramatically during

times of international crisis but most only tune to the BBC for news. We'll tell you how to beat even the news media by giving you the inside word on what to listen to and how to interpret it. For example, by tuning to easily-heard Strategic Air Command frequencies, you can tell when the United States has dispatched its nuclear bombers -- and if it's the real thing. You can hear government emergency networks light up as the President and other VIPs are escorted to safety and the population is evacuated into the countryside. It's a frightening and somber examination of the last radio you'll ever hear. • On a lighter note, next month we'll also unveil the new and improved program section. Kannon Shanmugam and the staff of *MT* have been working overtime to make it more informative and more useful. There's all of this and much more, coming next month in America's favorite radio magazine, *Monitoring Times*. Don't miss it!

MONITORING TIMES

Published by

Grove Enterprises

Publisher

Bob Grove, WA4PYQ

Managing Editor

Larry Miller

Technical Editor

Ike Kerschner, N3IK

Frequency Manager

Greg Jordan

Design and Production

Rachel Baughn

Subscriber Services

Linda Newton

Advertising

Beth Leinbach

Dealerships

Judy Grove

Contributing Editors

Reading RTTY

Jack Albert

Uncle Skip's Corner

T.J. Arey, WB2GHA

Plane Talk

Jean Baker

DeMaw's Workbench

Doug DeMaw

Consumer Electronics

Jock Elliott

Shortwave Broadcasting

Glenn Hauser

High Seas

James R. Hay

Federal File

Dave Jones

Scanning Report

Bob Kay

On the Ham Bands

Ike Kerschner, N3IK

Magne Tests...

Lawrence Magne

American Bandscan

Larry Miller

Adventures in the Clarke Belt

Ken Reitz, KC4GQA

Outer Limits

Dr. John Santosuosso

Program Review & Guide

Kannon Shanmugam

Antenna Topics

W. Clem Small, KR6A

Shortwave Broadcast Loggings

QSL Corner

Gayle Van Horn

Utility World

Larry Van Horn

Scanner Equipment

Larry Wiland

Below 500 kHz

Joe Woodlock

LETTERS

Amateurs and Scouting

Back a couple of months ago, thousands of Scouts got their first taste of ham radio during the 31st annual Jamboree On The Air. It's a real nice idea that goes something like this: a ham radio operator invites local scouts to his shack. The ham then makes contact with another ham who is also hosting some scouts. The kids get a taste of amateur radio and at the same time get to meet other scouts from around the country and world.

Ron Scull, WA2QNZ, took a picture of the activities of Springfield, New Jersey Pack 73, Webelos Den. Also involved was Scott Seidel, WA2WUX and Eric Deutchman, WB2LMW.

Reader Dennis Wolfe, N4SYU, also checks in with a picture of his shack. Along with his ham radio activities, Dennis, who is from Marietta, Georgia, also enjoys scanner and shortwave listening. "My station is computerized," he says, "with 675 channel [memory] capacity, continuous coverage from 100 kHz to 1300 MHz, and 12-volt backup system for power failures." Wow.

Engraving: Pro and Con

Arnal Cook, who's a Navy pilot

stationed in Rota, Spain, checks in with a good tip for your radio, whether it be scanner, shortwave -- or CB.

"Nobody likes to deface their new radio or even an old one," says Cook, "by engraving their social security number on it. While it's a great aid to recovering stolen equipment, it detracts from the aesthetics."

As a result, Arnal suggests that you engrave your SS number on the telescopic antenna. "Extend the bottom (fattest) section and engrave your ID mark there. When retracted, your mark is not visible, and nearly isn't when extended.

"If your radio is stolen and you spot it later, a police officer can make the reasonable request to extend the antenna to establish ownership without a search warrant." Most police stations, Arnal points out, offer engravers for use free of charge.

Interestingly, we got another letter on engraving social security numbers on scanners for theft protection. While the author didn't sign his name, we found the idea exquisitely paranoid.

"Magazines like yours are always encouraging people to thwart possible thievery of their scanners

and other radios by engraving their social security numbers on them.

"Did you ever think, bright boy, that if the day ever comes that the government succeeds in making scanner listening illegal, you will be unable to dispose of the unit? With your social security number permanently engraved on it, it would be no trouble for the authorities to trace the 'verboden' receiver back to you?"

Now you know

A quick tip for satellite monitors from Keith Bradbury of Manchester, England. Keith called to point out the AFRTS -- now long gone from shortwave -- is being carried by MARISAT. The primary frequency is 1536.95, the secondary 1537.00. That, says Keith, should be audible on the west coast of North America and in the South Pacific.

Finally, from Kevin Coine of Louisville, Kentucky. "When the Pentagon rolled out the Stealth jet fighter for the press last month, I was hardly surprised by what I saw. After all, *Monitoring Times* readers got the inside scoop on the F-117A about a year ago!"

So they did.

[More "Letters" on page 100]



Jamboree on the Air introduces Scouts to ham radio

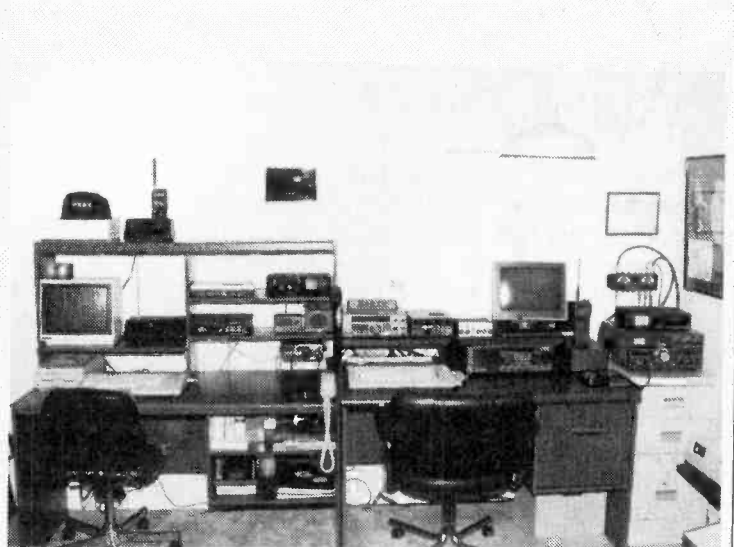

Dennis Wolfe's organized set-up



Jamming signals have ceased emanating from the Soviet Union for the first time in 38 years!

Last month will long be remembered as "momentous," according to Stanley Leinwoll, U.S. engineering director for Radio Free Europe-Radio Liberty. December marked the first time in 38 years that the Soviet Union stopped their jamming of western broadcasts. Charles Z. Wick, then-director of the U.S. Information Agency said, "It's another marker in the Soviet march toward trying to be an acceptable citizen of the world community."

An estimated 2,000 to 2,500

jamming transmitters -- which cost the Russians an estimated \$1.25 billion a year to operate -- simply shut down. Still on the air are a handful of jammers in Czechoslovakia and Bulgaria targeting U.S. transmissions into those countries and U.S. and West German broadcasts into Afghanistan.

The Soviets stopped jamming nearly all broadcasts by the Voice of America in May of 1986. On January 1, Polish jamming of the broadcasts also stopped. Jamming is illegal under

international law.

Senator Claiborne Pell, chairman of the Senate Foreign Relations Committee, has called for the curtailment of Radio Marti, the Voice of America-sponsored anti-Cuban radio station. Radio Marti, said Pell, "Exacerbates relations between the United States and Cuba."

After a three-hour meeting with Cuban leader Fidel Castro, Pell said that the time was ripe for Cuba and the U.S. to take "small steps" aimed at moving the two nations toward "more rational and normalized relations." Said Pell optimistically, "Peace is busting out all over the world..."

Castro, however, did not explicitly state that he wanted better relations with the United States. AP

Morse Code Now Obsolete

World shipping leaders have given the go-ahead for the introduction of new automatic communications that will mean the end of Morse code for ships at sea.

The Global Maritime Distress and Safety System (GMDSS) transmits and receives automatically, so Morse will no longer be a requirement. Radio operators are also expected to be phased out as the new systems are installed in ships, beginning in 1993. GMDSS will be compulsory worldwide by 1999. Some parts of the new technology, which include satellite communications, are already in use on British ships.

The decision was made during a two-week London conference of the International Maritime Organization, a United Nations agency representing 66 countries that account for about 97 percent of the world's ships. Convention officials called the decision "one of the biggest advances in maritime communications since the introduction of radio." AP

VOA Moves Fast

One of the drawing cards that shortwave offers its listeners is geographical diversity. As a result, the same news story is often reported dozens if not hundreds of different

ways. What it is less well known for is immediacy. It's just not one of its strong points, due primarily to understaffing.

Some information does "hit the streets" quickly, however. A case in point was the Voice of America's recent treatment of writer Naguib Mahfouz. Less than one hour after the Nobel Prize committee in Sweden announced that the Egyptian author had been awarded the prize for literature, listeners to the VOA's Arabic Branch heard a one-on-one interview with the writer by a Voice correspondent.

As soon as the story broke, reporter Ibrahim Abdin drove to Mahfouz's home in Cairo, where he found the novelist and his wife celebrating with several other Egyptian writers and the Swedish ambassador to Egypt. Mahfouz talked with the reporter, giving him his -- and the world's -- first interview with the first Arabic Nobel prize winner. VOA

"Strange and Sensitive" Pirate

A pirate radio station is haunting the airwaves of Macao, entertaining listeners with popular Portuguese, Brazilian and American hits. But the pirate's identity is a mystery and so are his motives -- he broadcasts neither political propaganda nor commercials.

Macao's Post and Telecommunications Department is trying to trace the airwave invader but so far has drawn a blank. A spokesman said: "An investigation is continuing."

Meanwhile, the station has caught the attention of the media. Portugal's news agency Lusa has described the broadcasts as "strange and sensitive." *Insight*

BBC Tones Down

The BBC World Service, recognized by millions as the quintessential voice of Britain, is dropping some of its upper-class accents and imperial signature tunes. Some have worried that the broadcasts sound pompous and out of date.

This doesn't mean that the BBC plans to use announcers with broad

Northern England accents or vowel-slewing Cockney tones. And it will not divest itself of the chimes of Big Ben, the cricket scores or the hourly announcement, "This is London."

To some, however, the changes are as inevitable as the disappearance of Britain's bus conductors, its red pay-telephone booths and its shillings and pence.

The most radical overhaul in the 57-year history of the overseas service includes toning down the brass band march that for 48 years introduced the news program, *Radio Newsreel*. Instead, a synthesizer-orchestrated version of "Imperial Echoes" will be broadcast ahead of the restyled and renamed *Newsreel*.

According to Elizabeth Smith, controller of the English-language service, critics -- including some 60 U.S. public radio stations that relay BBC programs, found the old version "strident and inappropriately imperialistic."

Deadly Microwaves

Concern that microwave signals from a powerful new \$90 million radar system could accidentally detonate bombs, missiles or external fuel tanks on nearby aircraft has prompted the Air Force to restrict air traffic at Robins Air Force Base near Warner Robins, Georgia.

The Air Force has also abandoned plans to boost the power of the early warning radar -- a move that could have tripled the size of the danger area. Defense experts warn, however, that limiting the system's power may keep it from doing the job for which it was designed.

The 10-story, pyramid-shaped early-warning radar, one of four in the country, reportedly is so sensitive that it can spot an object the size of a basketball 1,500 miles away. Other details are designated as classified, but it is known that it is designed to monitor the Caribbean and Atlantic for submarine-launched missiles.

Robins is the main Air Force Center responsible for repairing, modifying and overhauling 103 different Air Force weapons systems,

including 30 types of aircraft, 15 missile systems and 59 support systems for its fleet of bombers, fighters and transport planes. The base is also home to a Strategic Air Command (SAC) squadron of jet fuel tankers. COX

Alternate Phones in Zaire

In Zaire, where telephones serve best as paperweights and a dial tone is cause for celebration, the walkie-talkie is king of communications. "The walkie-talkie is something that works and the telephone is something that doesn't," said Pol Smitz, a paint company executive who, like thousands of others in the capital of Kinshasa, keeps a walkie-talkie constantly within reach.

Walkie-talkies are so popular that the capital, according to Reuter correspondent Michael Roddy, "looks as if a Secret Service agent's convention is permanently in town." The hand held units are common in hotel lobbies, restaurants, nightclubs and stores, and at poolside, in church and at the zoo. People clip them to their belts and carry them in briefcases. They use the antennas as pointers and wave walkie-talkies in each other's faces for emphasis.

Zaire's phone system is a legacy of colonial rule and little has been done to improve it since the Belgians left some 30 years ago. Cables are rotten, switching equipment outmoded, and physical problems compounded by corruption.

One American woman said that the only way she got a phone at all was by making a private deal with a phone-company employee. Still, she said, the phone is dead most of the time. When she wants to make a call, the same employee will call her to tell that a line is open. The next day he drops by her house for a bottle of Scotch.

Camden, NJ *Courier-Post* (via George Primavera, Cherry Hill, NJ), *Chico Enterprise-Record* (via William T. Clark, Chico, CA), *Dayton Daily News* (via Ken Hyderman, Dayton, OH), *Insight Magazine* (via Karl Weatherly, Louisville, KY), *Philadelphia Inquirer* (via Ed Lamb, Aston, PA), *Wisconsin State Journal* (via Mike Muskat, Cross Plains, WI)

Caribbean Beat in Central America:

RADIO BELIZE

by Don Moore

Where in the world would people name towns Gallon Jug, Washing Tree, Double Head Cabbage, Orange Walk Town, Burrel Boom and Monkey River? Nowhere else but easy-going Belize, the world's number one producer of humorous place names. Perhaps these names are a product of Belize's distinctive history.

Belize was once part of the great Maya Indian civilization. The Spanish came in the 1500s, claimed it, and tried a few tentative settlements. Finding no gold or silver, they soon left.

In the 1600s, English pirates used Belize's numerous coves and offshore islands as bases from which they launched raids on Spanish treasure fleets. Along with their booty, the pirates carried stories of Belize's huge mahogany forests back to England. Soon British loggers and their slaves set up camp. Pirates, loggers, and slaves mingled. As time passed, new groups were added to the mixture. An ethnically diverse nation was born.

Mixed Ancestry

Today about half of Belize's population is descended from those same pirates, loggers and slaves, with negro slave blood predominating. The rest of the population is even more of a hodgepodge. About twenty percent are Mayan Indians; Kekchi Mayas who have always lived in Belize, and Mopan Mayas who came in the 1860s, fleeing a civil war in Mexico's Yucatan peninsula. Another ten percent are German Mennonite. They came looking for a place to practice their simple agrarian religion, and today their farms form Belize's breadbasket.

Garinagus, or Black Caribs, comprise another

ten percent. This unusual group originated on the Caribbean Island of St. Lucia, where escaped negro slaves joined the native Carib Indian tribe. Because of their frequent attacks on plantations, the British army deported the Black Caribs to Honduras' Bay Islands in the 1850s. From there they spread to Belize.

But that's not all. More recently, Chinese, Lebanese, and East Indians arrived to set up stores, restaurants, and other small businesses. Since independence, a number of Americans and Canadians have also come to Belize, either to retire or buy small businesses and settle down.

So, Belizeans can be German, Garinagu, Lebanese, and just about anything else. But, one thing they are not is Hondurans. Until Belize received independence from England in 1981, it was known as British Honduras and was often confused with nearby Honduras.

Claimed by Guatemala

Belizeans don't want to be confused with Guatemala, either. Even when the English settled Belize, Spain never gave up its claim to the territory, which it said was a province of Guatemala. Therefore, when Guatemala

became independent in 1821, it took over the claim to Belize.

In 1859, Guatemala agreed to give up those claims and in return England agreed to build a road between Belize City and Guatemala City. In those days, though, the British Empire didn't pay much attention to small out-of-the-way countries like Guatemala, so the road was never built. As a result, Guatemala contends that the unfilled contract makes the treaty invalid, and they still claim Belize.

Few think Guatemala would actually invade Belize to put its claim in effect. Neither Belize nor Britain wants to chance it, though, especially after the Falklands/Malvinas War with Argentina. So several hundred British soldiers are stationed at three bases in Belize. One base is at the Belize City Airport, where international passenger flights land beside anti-aircraft guns.

The British soldiers brought their own radio stations with them. Belize is home to three British Forces Broadcasting Service (BFBS) FM stations, which broadcast the latest rock music and news from London, direct by satellite. Another radio station in Belize was brought by the United States -- the

Voice of America's AM relay station in Punta Gorda. Neither of these stations broadcasts local material.

Radio Belize

The only station that actually reflects Belizean culture is Radio Belize. Founded during the British colonial era, it was modeled on the BBC. Like the BBC, it is editorially independent of the government, even though it receives all its funding from the government.

Located in a three story building, Radio Belize is just two blocks from Belize City's main plaza. The station's efforts to promote



Your first welcome to Belize, where international passenger flights land beside anti-aircraft guns!

Belize are reflected by a sign in the lobby, "Be a Belizean. Buy Belizean."

Sixty to seventy people are employed by the station, including Mike Nicholson, assistant director of programming. A job vacancy coupled with an interest in radio and a clear speaking voice landed him a job when he finished high school. That he speaks both English and Spanish also helped. And what began as a job has become a career. Over the years, Mike has seen other announcers come and go. "Time has a way of eliminating those who aren't cut out for it," he notes.

Although Belize is far off the beaten track, Radio Belize's announcers don't lack opportunities for professional training. For example, the BBC regularly organizes courses for radio announcers from the British West Indies, which Mike has attended. Perhaps proving that working at Caribbean radio stations is not for everyone, several of the announcers decided to stay in the U.S. when the group met in Miami before flying to London, according to Mike. Besides studying in London, Mike spent a semester in classes on making radio documentaries at the University of the West Indies in Jamaica.

Since staff members who study abroad share their training in seminars for other employees, there are many opportunities for continued learning. Working visitors from the BBC or other broadcasting organizations also occasionally teach courses at the station.

Daily Programming

A test tone, followed by the station ID and national anthem at five a.m. begins the broadcast day at Radio Belize. After a "prayer for our nation," Belize starts the day out right, from Monday to Friday, with the upbeat music and lively DJ chatter of the *Belize Sunrise* program. Though mainly in English, the program also includes a

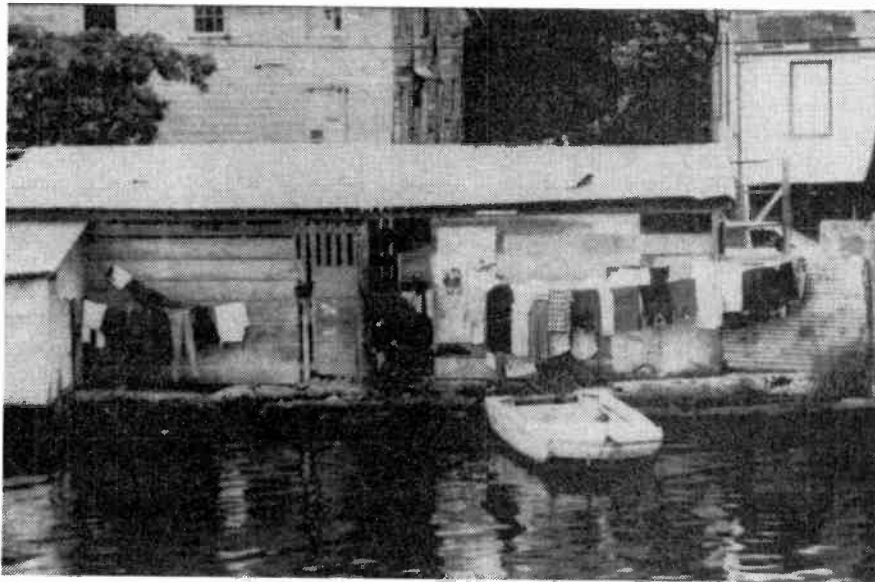

Radio Belize is the only station representing the people of Belize, such as these living downtown along Haulover Creek.

half hour in one of three ethnic languages; Kekchi, Mopan, or Garinagu, each day.

From eight a.m. to noon, the mike is handed over to the crew of *Belize Today*, a program of news, weather, music, local announcements, and phone-ins. For the first two hours, announcer Debbie Tillet goes it alone in English. Then at ten a.m., the program becomes bilingual when she's joined by Spanish announcer Rudy Aguilar. Mike guesses that this makes the station "a little unique, as I can't think of any other station that has two announcers working together in different languages." One of the program's features is "Opportunity Calls," where

House of Representatives is broadcast between 8 and 9 p.m. Occasionally the House is still in session at that late hour, and the debate is broadcast live. Otherwise, an hour which was prerecorded during the day is aired.

When the politicians finish at 9 p.m., it's safe for listeners to tune back in again. The broadcast day finishes with three more hours of music and DJ chatter. At midnight, a prayer is said, the sign-off announcement made, and finally the national anthem is played before turning off the transmitter.

Competition from Cable TV

Over the last several years, Radio Belize has been getting increasingly stiff competition from a newcomer to the local media scene: cable television. Belize has no domestic TV stations, but that hasn't stopped local entrepreneurs from hooking up their own neighborhood cable systems. By showing movies from a VCR, as well as rebroadcasting American TV stations received via satellite dish, these cable networks are giving Belizeans a new view of the world.

Some people think that too many new ideas are being introduced too fast and that Belizeans are in danger of losing their

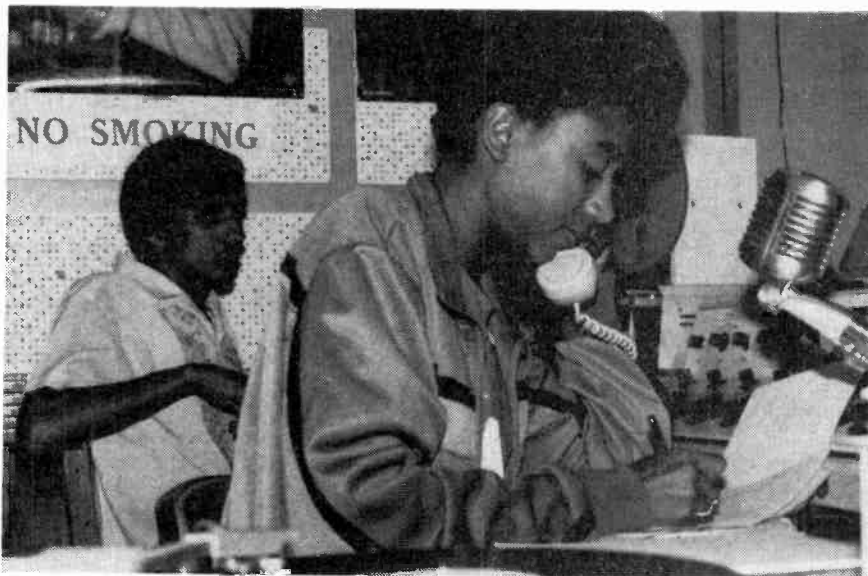

Announcers Debbie Tillet and Rudy Aguilar on the free-wheeling "Belize Today" program.

national identity to American culture. The Belizean government did consider banning the impromptu cable networks but, bowing to popular pressure, decided that TV had come to Belize for better or worse. In the interest of preserving the national culture, Radio Belize stepped in and started its own TV network.

Well, calling it a network may be a bit of an overstatement. But it is a start. A studio for videotaping TV newscasts has been set up in the Radio Belize building. Originally taped once a week, the newscasts are now twice weekly and will soon be taped every day. Of course, Radio Belize doesn't have a TV transmitter... but they don't need one either. The government simply passed a law saying that all cable networks must broadcast the newscasts or be shut down. Radio Belize provides each cable network with a videotape of the newscasts.

To be sure that viewers don't decide to switch over to WTBS and watch *The Honeymooners* instead, the newscasts are broadcast nationwide at the same time, and no cable network may broadcast anything else while airing the newscasts. Actually, the latter rule isn't too hard to follow because most networks only provide subscribers with one channel anyway -- whatever station or movie the network owner feels like watching!

Promoting Belizean Culture

For many years Radio Belize was little more than a mini BBC-in-the-Caribbean. The BBC was the station's role model, and despite a few exceptions such as the Garinagu program, the upperclass values and culture of the British colonialists shaped the station's programming. However, things have changed drastically since independence was gained in 1981.

The ever-increasing influence of the United States in the politics, economics, and even day-to-day life of the country prompted some of the changes. Because of American influence via the mini-cable networks, Radio Belize saw its role change from one of promoting British culture to one of preserving Belizean culture.

The new role demanded changes. To give Radio Belize a less formal appearance, the station's on-air name was changed to Belize Radio One in 1985. Slowly, the station began to shed some of its stoical BBC image and discover its Caribbean roots.

An ethnically diverse nation, Belizeans speak a multitude of languages. The Garinagu have their own language;



Schoolgirls at lunch

the Mennonites speak German. Some Indians speak Kekchi or Mopan Maya. Other Indians speak Spanish, as do some of the mixed-blood inhabitants. The majority of mixed-blood Belizeans speak Belizean creole, a local dialect of English, influenced by local languages and African tongues brought by the slaves. Most speak Creole as either a first or second language.

Despite this, the English on Radio Belize was BBC English for years. Listeners around the country often asked why there weren't

programs in the local dialect, Belizean Creole. Adding one was the first big step towards changing the station's focus.

Radio Belize began by testing a three hour Belizean Creole program one Saturday morning. The response was overwhelming -- listeners loved having their own dialect on the air. Today, creole is used exclusively on the *Belize Day* program, aired from 5 a.m. to 7 p.m. on the first Saturday of each month. Mike Nicholson describes it as a day long "free for all" because the announcers really "let loose."

"We can't please everybody, but we try to offer as much as we can," Mike notes. All day there are at least three or four announcers in the studio, with the new ones coming and going periodically. Chitchatting about everything under the sun, announcers also take phone calls and read listeners' letters.

The station invites listeners to write stories and poems and send them in to be read on the air. Some listeners even record their own writings on cassette, which the station plays on the air. Other listeners record local folksongs and mail them to the station for *Belize Day*. Although the emphasis is on Belizean Creole, listeners contribute in many of the nation's languages. "It reaches out to people a lot," Mike says proudly.

"Live... From Burrel Boom!"

The next step toward change was to take the station to the people: live broadcasts from outlying towns and villages. On the third Saturday of each month, a remote studio is set up in some town's central park. Except for an hour break at noon for the news, Radio Belize broadcasts from the park from 8 a.m. to 6 p.m.

Very little is planned. It has the same anything-goes format of *Belize Day*, except that the local townspeople get in on the act. They go to the park to see the show and end up taking part in it by gossiping with the announcers, singing songs, reading their own stories and poems, or just sending greetings to family and friends in other towns.

Again, Belizean Creole is the main language used, but listeners use others as well. Mike notes that these programs are basically an open-mike "featuring the culture from that district." It's another way "to keep our culture alive," he adds.

Beginning in September 1987 the program traveled to one of the six district capitals each month. Then the station began featuring the other larger towns. Plans are to eventually broadcast from



In danger of losing national identity to American TV, Radio Belize started its own TV network.

even the smallest village. "People wanted something like this to happen for a long time," explained Mike. So far, the reaction has been very encouraging.

Not only does the on-the-road program put the station in touch with the people, but it puts the people of different towns in touch with each other. Each town shares its own culture, customs, and concerns with the rest of the country. It's a better lesson in the nation's heritage than could be taught in a classroom.

New Sister Station

Another way of loosening up the station's image was to establish some in-house competition. Friends FM is Belize's twenty-four hour music station. From 5 a.m. to 1 p.m. and from 7-8 p.m., Friends FM simulcasts Belize Radio One. At other times the station only airs music and occasional headline news.

Friends FM basically plays foreign rock and jazz music, although they try to broadcast as much local music as possible. Belizean rock bands are encouraged to record their own material on cassettes, which are then played by the station.

Intentionally, there is no strict division between Belize Radio One and Friends FM. To avoid rivalry between the stations, the same announcers work for both. That's not a problem since they operate from the same floor of the Radio Belize building. With a new, modern studio, Friends FM is no poor stepchild. Future plans for Friends FM include separate programming twenty-four hours a day.

Hearing and Verifying Belize

Belize Radio One uses six transmitters in five locations. The main MW frequency, 830 kHz, as well as FM on 91.1 MHz broadcast from Ladyville, just a few miles north of Belize City. The shortwave transmitter used to be at Ladyville also, but in 1976



Radio Belize takes the station to the people in live broadcasts.

it was moved 40 miles west to the new capital of Belmopan. About the same time, the frequency was changed from 3300 kHz to the presently used 3285 kHz. Finally there are three medium wave repeater stations in Corozal, San Ignacio, and Punta Gorda. Currently Friends FM is heard via an FM transmitter in Ladyville and repeaters located in Punta Gorda, Dangriga, and Independence. More repeaters for Friends FM are planned so that eventually national coverage will be achieved.

In the seventies and early eighties, Belize was one of the easiest Central American countries to log. On shortwave 3285 kHz, the signal was strong and free of interference.

was in Belize in December 1987, both 830 and 3285 kHz were heard only with weak and heavily distorted signals in downtown Belize City.

During the last several years, the engineering staff at Radio Belize has been busy installing new transmitters. First the MW repeaters, then new FM transmitters for both Belize Radio One and Friends FM. Hopefully, once these additions are completed, they will have time to rebuild the older transmitters for 830 and 3285 kHz.

Whether you hear them now – in which case it's quite a DX catch, considering their technical problems, or hear them once the

SW transmitter is fixed back up – be sure to send them a report. Radio Belize has always been a good verifier, and, unlike a lot of tropical band stations, reports can be sent in English. Just slip in a dollar bill or a couple of IRCs, and address the report to : Radio Belize, P.O. Box 89, Belize City, Belize.

mi



The Radio Belize building; unfortunately their station decal is no longer available.

All photos by Theresa Bries

Monitoring Times visits

HOUSTON UNIVERSAL WEATHER AND AVIATION, INC.

by Jean Baker

Houston Universal Weather and Aviation, Inc. is a unique company providing high frequency aero enroute/long distance operational control services, flight following, weather services, fueling, hotel reservations, and flight control operations. They offer the combined facilities of a Flight Services Station, Aero Enroute Communications Network, and Fixed Base Operation to their many clients.

MT columnist Jean Baker was privileged to visit their corporate headquarters in Houston, Texas, where she interviewed the manager of Houston Radio Services, Gene Osburn.

MT: Gene, will you tell our readers something about the company as a whole, and then go into detail as far as the radio services and operations are concerned.

Gene Osburn: I'll be glad to. Founded by Thomas G. Evans in 1959, the company has grown from a single weather station at Hobby Airport in Houston to a corporation with world-wide facilities, including offices in 18 countries.

Our divisions include the Flight Control Department, whose function is to assist flight crews plan trips for their employers. For example, if an executive of some large corporation has to go to Moscow on business, the [U.S.] State Department would probably tell them to call us. We can set up all of the arrangements for this type of trip: fueling for the aircraft, security, flight planning, weather forecasting, hotel reservations, HF communications, and so forth.

We have access to circuits that make it possible to communicate directly with all of the appropriate agencies who would be involved in planning for such a trip. We send messages requesting overflight and/or landing permits to these agencies, and then, when we receive an affirmative answer, it is passed along to our clients with all of the pertinent data and details.

Our clientele is international in scope. At last count, we handled flight arrangements for 28 foreign countries.

Our Reservations Department arranges accommodations on a worldwide basis for our clients, including a very decent discount with top-rated hotels. They also book tours, cruises, and other trips upon request.

The Weather Section handles forecasting, not only for the aviation services, but also for various city, county, and state governments in regard to pending disasters such as floods, tornados, and other potentially devastating situations. The data support ranges from simple teletype data to a satellite link. This provides us with international access to weather system movements.

We have a Contract Aviation Fueling Program, which is arranged with Fixed Base Operators in various countries, offering discount prices. At this time, there are over 400 locations where this discount fueling can be obtained.

A fairly new addition to the company is the Graphics Department. The specialists in this area, using our computer-generated weather communications system, can show past, present, and forecasted weather maps, surface conditions, as well as winds at 10, 20, or 30 thousand feet aloft, etc. It's really

phenomenal what they can do utilizing this special system and you can readily understand how our aviation and marine customers can benefit from it.

Our Marine Division comprises two sections: A Forecast Section and the Studies area, specializing in physical oceanography and marine biology.

Now, on to our Radio Services. We are owned and operated by Universal Weather and Aviation, Inc., and are an integral part of ARINC's family of international HF radio gateway facilities. ARINC handles the billing for our radio contacts with aircraft on HF. Every month, I send them a report on our traffic, and they in turn bill the clients. When the clients pay ARINC, we are credited with the amount.

MT: You had mentioned in your original letter to me that Houston Radio had more corporate and private pilots contacting you than those on the commercial airline side. And yet, while monitoring your frequencies, it seems to me that contacts with commercial airlines and charter flights have been rapidly increasing.

GO: That's very true. We have had a lot more contacts lately with commercial flights. We work quite a bit with Pan-AM, Air New Zealand, Japan Air, and others.

Oh, yes -- we've been talking with Piedmont Airlines recently since they've gone international [flights from Charlotte, North Carolina, to London, with plans for expansion to other European cities in the near future].

We'll be doing some testing with them just as soon as we get our antenna farm completely repaired [their antenna system was destroyed by a tornado in late 1987]. They [Piedmont] want to eventually use our

radio services out to approximately 30° west over the Atlantic for company purposes. Beyond that point, they'll use British Airways' Speedbird London radio communications.

We work quite a few charter airlines, such as American TransAir, and others like them whose main thrust is carrying passengers to warm, sunny places in the winter. Quite a few of them slack off somewhat in the summer season, though.

MT: Do scheduled airlines and charter services who use Houston Radio have a contract with you?

GO: No. That's another feature of Universal that's different from other radio services. We are obligated to talk with anyone who calls on our frequencies. If we get someone who's not used us before -- let's say they're not in our data base, for instance -- the operator obtains the mailing address of the aircraft's owner or company, and we send the information on to ARINC, who will bill them.

Many of the people who call up on the radio are also clients of other Universal services as well. However, we also work many companies who are exclusively radio services clients, such as airlines. Most of them, who also use ARINC, already have an ARINC account number, which simplifies matters for me because all that I have to do then is to include their number on the monthly statement that I send to Annapolis [ARINC's corporate headquarters location].

MT: How long has the radio service been in operation?

GO: Since 1977. The station was formerly run by an outfit who owned four or five aircraft and when their planes weren't flying and using the frequencies, they just used to shut everything down. That's not really what public service is all about, is it?

Anyway, we've come a long way since then. The traffic here at the radio facility has increased tremendously in the past few years from around 200 contacts per month to about 3,000 at the present time. We work seven days a week, 24 hours a day with three shifts per day. Two operators work each shift.

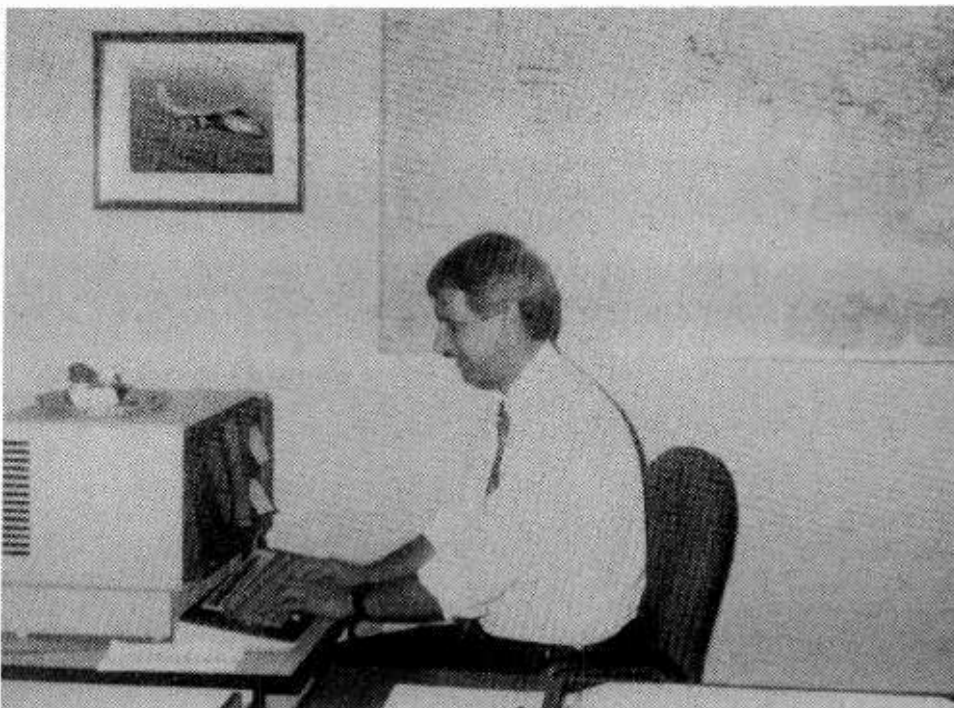

Gene Osborn, Manager of Houston Radio, has been employed by Universal Weather and Aviation, Inc., since 1980. Prior to coming aboard with them, he worked for Aeronautical Radio, Inc. for 13 years. A family man, Gene lives with his wife and daughter in suburban Houston.

MT: You mentioned that Houston Radio provides "flight following services." I know that FAA Flight Services Stations do this, but I wasn't aware that other facilities such as yours were also involved in it. Would you explain what "flight following" entails?

GO: The radio operator follows the aircraft who has requested this -- literally -- from point A to point B to point C, etc., by radio. We need to find out where he is, where he's going, if he's delayed, and so on and so forth. If we can't find him for one reason or another, then the operator makes a call to the nearest air traffic control facility to where that aircraft should be on his flight plan. They almost always know where to find him.

MT: I see. But you don't have regular daily "middleman" contact with ATC facilities for aircraft such as ARINC does?

GO: That's true. But occasionally we will have to have to relay instructions from an ATC facility to a flight who's out of radar contact, just as ARINC does, if the necessity arises. We work more in the LDOC (Long Distance Operational Control) area of duties.

MT: Would you explain exactly what this means in terms of procedures?

GO: Pilots utilize LDOC frequencies to pass on relevant information concerning departure/arrival times, passenger count, fuel load, maintenance status of their aircraft and/or any problems relating to them, special needs of passengers [or "pax", as they're called], requests for assistance, and all sorts of other data that, in most cases, pilots want us to relay to their company.

We set up phone patches between pilots and their company stations, give SELCAL checks, obtain weather reports; the list goes on and on.

MT: One question that our readers have asked in many of the letters I've received is about your transmitters, receivers, and antenna equipment. What kind do you use?

GO: We use basically the same system ARINC does. As a matter of fact, we lease our transmitter from them. It's an Aerocom unit (1311 model), 1 kw. The receiver is the latest model available (a 1323) which is rack-mounted. We have a DT&F (digital tone) telemetry system between here and the antenna site over a telephone line.

Lately, we've been looking for a new console to replace what we have. Our incumbent model is too cumbersome and

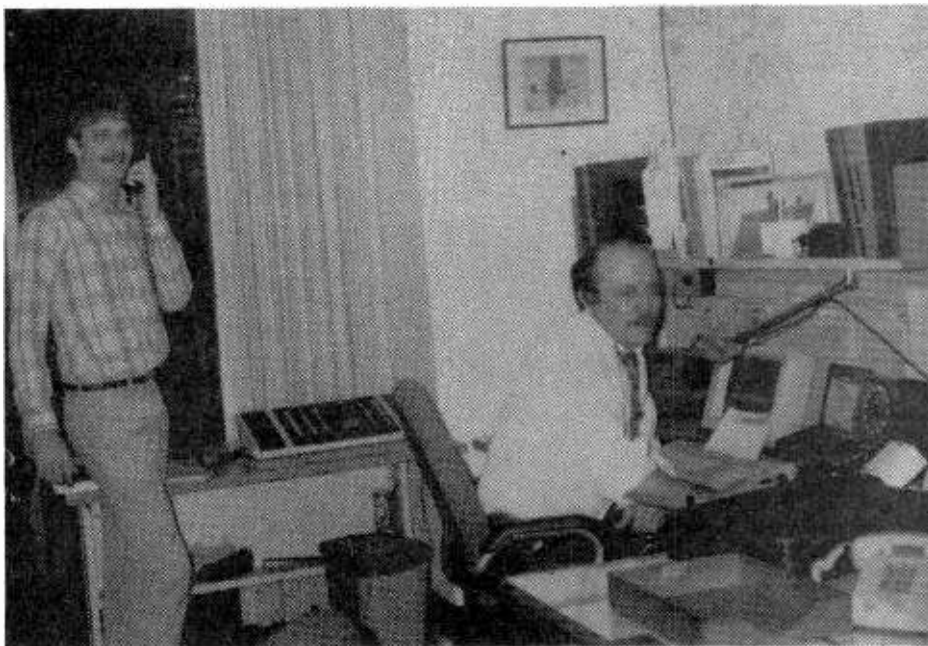

Two Houston Radio operators at work.

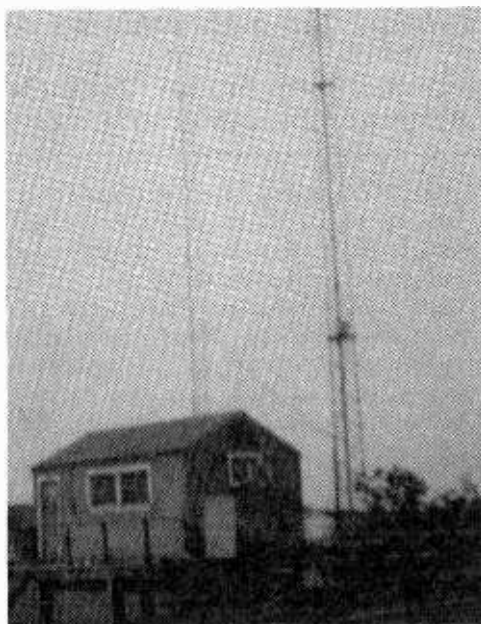

Some of Houston Radio's antennas

MHz, and 10 MHz.

However, for our newest frequency, which is on 6 MHz, we only have two antennas because we don't have enough land, area-wise, for more. The antennas are 84 feet tall, self-standing towers supported by rope. In the very center of the lot, next to the shack, we have a 100 foot tower which supports the rotatable beam antenna. It takes about 80 seconds to turn a full 360 degrees. That gives us about 14-16 dB gain, in and out.

It's an LP-1 (beam) antenna from a company called Antenna Products, Inc. This beam gives us a signal of about 70° in and out. Using this beam antenna on 6 MHz, our effective radiated power is about 40-45 kilowatts. Everyone can hear us. However, the problem which we sometimes have is hearing them, which is due to our location -- we're not too far from downtown Houston.

MT: 6.637 MHz is the latest addition to your frequency family, isn't it?

GO: Yes, it replaces 5.529. We now have 6.637 MHz, 10.075 MHz, 13.330 MHz, 17.940 MHz, and 21.964 MHz. Previously, our beam antenna was limited to four frequencies, but with our new setup -- which handles 6.2 to 28 MHz, we'll have beam service on all five frequencies.

Actually, the main reason that we discontinued using 5.529 MHz was that the beam antenna didn't cover the 5 MHz

frequency. Then Dick Covell from ARINC told us that 6.637 was available so we went for it. With our new capabilities now, we should really be able to receive better and more audible contacts from flights -- on all frequencies, propagation permitting, of course!

MT: And that's a fact! Propagation can be your best friend or worst enemy. Gene, another question that readers have asked is if Houston Radio works any flights on the VHF aero band?

GO: A very limited amount. Here in the United States, Houston Universal has offices in New York (actually White Plains), Dallas, Los Angeles, and in Houston. We have a local "in range" VHF circuit for each of these cities, and also a couple at other stations in Europe and one in Mexico. Other places, pilots use UNICOM frequencies for in-range communications. That's about all on the VHF side of things.

MT: So outside of those few VHF in-range circuits here in the U.S. you can't really work any flights over the continental United States -- right? I've heard that it's illegal to work civilian flights on HF while they were flying over the country -- outside of giving SELCAL checks to aircraft while they were still on the ground, and if a flight's VHF equipment failed they were permitted to use HF.

GO: Well, let's say that we have a client who's going from Kansas City to London, with a stop enroute at Bangor, Maine, for fuel. That's what we call a "tech stop," by the way. When he takes off from Kansas City, his aircraft is considered to be on an international flight. Consequently, we can work him on HF because of this status.

However, if a flight's just going from New York to Los Angeles, we're not supposed to work him on HF because the FCC says that there's enough VHF stations for across-the-continent radio contact purposes. But do you know, Jean, that as often as that rule has been quoted to me -- about not working aircraft on HF across the U.S. -- I still can't find it in any rule book.

MT: If, and when, you do find that rule in any book of regulations, let me know. I'd like to see it too.

you can't work on it very well. It involves more expense to try to repair it than it would to put five or six thousand in a new one. We'll probably get that item taken care of after we finish the repairs to our antennas.

Our antenna system comprises 14 quarter-wave horizontally polarized dipole antennas and a directional log periodic beam antenna. For 21 MHz, we have three antennas in a triangle fashion. Also, we have three antennas each for 17 MHz, 13

Sophisticated Monitoring Equipment From Universal

☐ Universal M-7000 Multi-Mode Converter

The new M-7000 decodes Morse code, many forms of RTTY, FAX and FDM. It has many automatic features such as speed readout, auto filter tune and full auto tune. Simple connections to your shortwave receiver and video monitor will enable you to monitor with the most sophisticated surveillance decoder available. Parallel and serial ports provided. No computer required. 115/230 VAC 50/60 HZ.

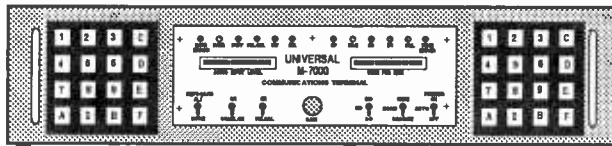

Universal M-7000 Introductory Pricing:
 · Standard M-7000 \$ 999.00
 · With Real Time Clock Option \$1059.00
 · With Video FAX Option \$1089.00
 · With Clock & Video FAX Option \$1129.00
 Shipping/Handling (USA) \$ 11.00

Too many features to list here! Please write for full M-7000 information. Prices and specifications are subject to change.

- ◆ Morse Code
- ◆ Baudot RTTY
- ◆ Variable Baudot
- ◆ Bit Inverted Baudot
- ◆ ASCII Lo/Hi/Var
- ◆ Sitor Mode A & B
- ◆ ARQ 2&4 (TDM)
- ◆ VFT Modes (FDM)
- ◆ Packet AX.25
- ◆ FAX AM/FM
- ◆ Russian 3S Cyrillic
- ◆ Literal Mode
- ◆ Databit Mode
- ◆ Low & High Tone
- ◆ Diversity Reception
- ◆ Automatic Tuning
- ◆ Video+Print Squelch
- ◆ MSI, UOS, ATC
- ◆ Self Diagnostics
- ◆ Remote Terminal
- ◆ User Prgm. Sel-Cals

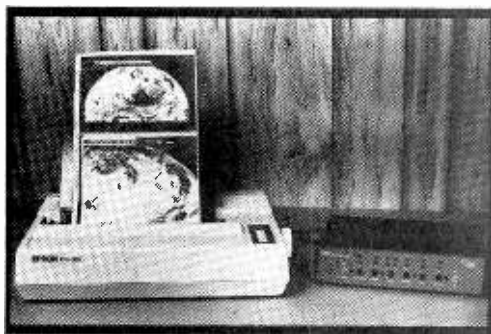

UNIVERSAL... Serving Radio Enthusiasts Since 1942

☐ Info-Tech M-800 FAX Unit

The Info-Tech M-800 is the affordable solution for listeners desiring high resolution facsimile. This compact device converts audio from your shortwave or satellite receiver and prints it to your compatible dot matrix printer. Handles all standard speeds and IOCs. Performs AM or FM detection, positive, or negative, L-R or R-L. Auto or Manual. Now features logging line and operation from 110 VAC 60 Hz or 12 VDC.

Only \$349.00 (+\$8 UPS)

· FULL CATALOG AVAILABLE ·

Universal offers a big shortwave catalog covering all types of sw equipment including receivers, antennas, RTTY & FAX equipment plus books and accessories. Send \$1 or 3 IRC's.

Universal Radio
 1280 Aida Drive Dept. MT
 Reynoldsburg, Ohio 43068
 USA Phone: 614 866-4267
 FAX: 614 866-2339

One last question, Gene. You'd commented in your first letter to me that you had recently received a reception report from an aero band monitor in Germany. Do you receive a lot of these?

GO: Yes. During the course of a year I may end up with quite a few. This monitor from Hanover, Germany, was quite thorough when it came to giving details regarding time of day, type of contact, etc., that he'd heard. He even included a map of his area, along with other information he thought I would like to know about.

Well, to make a long story short, I filled out the card that he'd included with his letter and sent it back to him as I do with the others I receive. I used to have an amateur radio operator's license and still remember the fascination involved with hearing transmissions from distant locations. Consequently, I can empathize with others who are interested in radio as a hobby.

MT: So, along with your other duties, you're also in charge of answering reception reports and the like?

GO: Right. These letters usually end up on

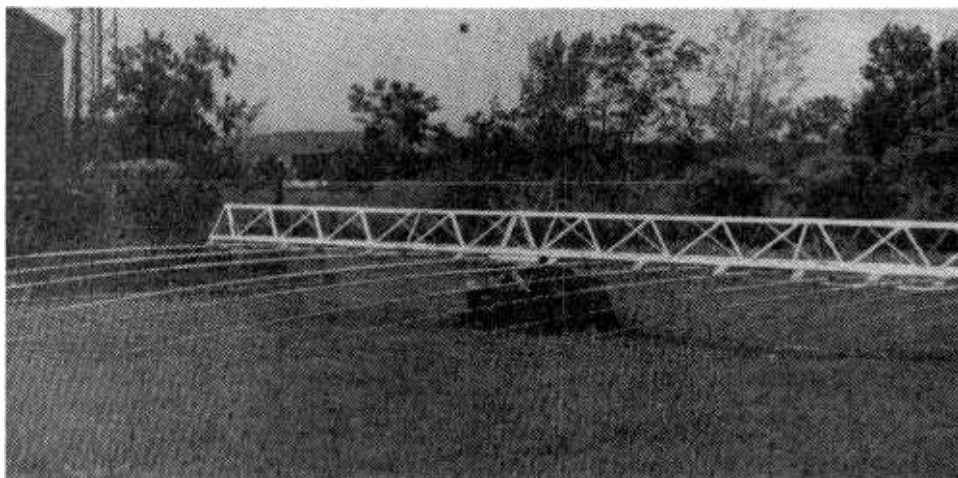

The beam antenna before installation.

my desk because no one else knows what to do with them!

MT: On behalf of the readers of *Monitoring Times*, I want to thank you for the time you've taken to show me around and for the glimpse into the operations of Houston Radio, as well as the other aspects of this multi-faceted corporation. You've answered all of the questions that readers

have been sending to me. It's certain that they'll appreciate all of the details you've shared with us.

GO: It's been my pleasure as well, Jean; good luck and good monitoring to you and all of *MT's* readers.



سما برار ایران سپاکی برای ایران

A Voice for Iran

The year was 1979 and Iran was in turmoil. The Pahlavi family, rulers of the nation since 1925, were increasingly under attack by followers of an exiled religious leader named Khomeini. The situation was deteriorating rapidly.

Merhabad, the main airport, periodically closed due to snipers and radicals roamed the streets, burning buildings in preparation for the Ayatollah's arrival. Demonstrations rocked the capital. Nearly every night featured a firefight between the government and the rising tide of humanity on the streets.

But despite the scenes of mass demonstrations, the average Iranian actually knew very little of what was going on in his country. The Shah-controlled news media, not unexpectedly, chose to ignore the strife.

Monitoring Times contributing editor Dave Rosenthal, who was in Tehran on business at the time, remembers: "Outside at night, the sound of [government] helicopters was almost constant ... I remember watching [them] from my seventh-floor balcony as they circled over distant parts of the city, their gunners raining tracers down onto some trouble spot below. Meanwhile, National Iranian Radio and Television's

FM service was running a phone-in 'Oldies Request' show."¹

Journalists the world over topped their news with stories of bloody clashes



*Ahmad Baharloo and
Bill Royce, Chief*

between workers and the military but the Iranian people saw only Olivia Newton-John specials and NFL football games from the States.

As history records, the Ayatollah Khomeini won his battle with the Shah of Iran and returned to Iran. An Islamic Republic was quickly declared and the United States cited as the country's number one enemy. On November 4th,

militants seized the U.S. Embassy, taking 62 people hostage in a drama that would last some 444 days and help topple an American administration.

Pouring on the Power

One of the ways that the U.S. government reacted to this turn of events was to establish a special Farsi (also known as Persian, the official language of Iran) service within the Voice of America.

The Farsi service, now nine years old, broadcasts three-and-one-half-hours of programming to Iran each day. There's a ninety-minute morning show and at 8:30 P.M. local Iranian time, a two hour evening program. According to the VOA, over eight million people tune in the show regularly, making it "the most popular international broadcaster in the country."

The VOA's boast is supported by listeners' surveys, over 200 letters a weeks from listeners in Iran and a number of amusing anecdotes. According to the VOA's Kevin Lynch, listenership even extends into the Ayatollah's inner circle.

Robin Wright, a senior associate at the Carnegie Endowment, is a specialist on Iran who travels there often. Shortly

Journalists the world over topped their news with stories of bloody clashes between workers and the military, but the Iranian people saw only Olivia Newton-John specials ...



Members of the Farsi service in front of VOA headquarters (from left to right): Hadar Samadani, Ali-Bijan Farhoodi, Katayoun Beglari, Ahmad Baharloo, Bill Royce, Guity Ellis, Akbar Nazemi, and Ben Abbassi.

before her most recent trip, she was interviewed on American television about developments in the Islamic Republic. Later, after arriving in Iran, some of the mullahs she was talking with mentioned that they had heard her interview. Unbeknownst to Ms. Wright, her remarks on American TV had been translated and broadcast on the Farsi service, which the mullahs monitored.

A Tough Job

Due to the turmoil in the region, the Farsi service's ability to present good, solid, unbiased news is often tested. This summer's

downing of an Iranian passenger liner by the U.S.S. Vincennes is one such example.

If a flight over a war zone can ever be routine, this one was. It left a civilian/military airport, but was in the sky only nine minutes when a missile ended the journey in a shower of debris and bodies. Two hundred and ninety people died, all but forty of them Iranians. It was the Farsi service's job to tell listeners in Iran that an American ship had fired the missile.

"At the time the Farsi show went on the air -- 1 P.M. in Washington, D.C.; 8:30 P.M. in Iran -- no one in the United States knew

what had happened," says the VOA's Lynch. "U.S. government officials had been saying that a statement would be issued but nothing had been said by air time. At the time, the Pentagon was still reflecting the initial erroneous report that a U.S. ship engaged in combat had shot down an Iranian F-14. The Farsi service opened the program with a report giving as much information as it had.

"Thirty minutes into the program, Admiral William J. Crowe, chairman of the Joint Chiefs of Staff, held a meeting with reporters that was carried on American television. A decision had to be made

"The Iranian government constantly hurls insults at the United States," a young man wrote the VOA, "yet you always respond with dignity and balance."

whether to do a simultaneous translation [of the televised press conference] or wait to hear what Crowe said and give listeners a report.

"Ahmad Baharloo, deputy chief of the service, was in the studio along with Hamid Oudji, a broadcaster, Nader B., the producer, and Katayoun Beglari, the emcee. The four conferred briefly and decided to 'go live,' to do a simultaneous

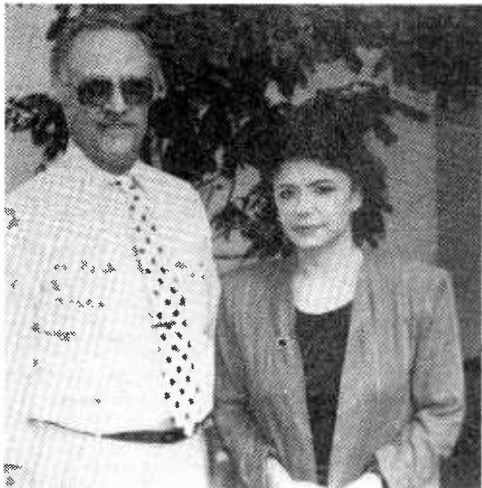

*Hadar Samadani
and Guity Ellis*

translation. They wanted the Iranian people to hear, over VOA, exactly what Crowe said."

The Farsi service continued to provide listeners with information on the downing and its aftermath. From New York City, stringer Afsaneh Basipour reported on the reaction of Iran's mission to the United States.

From Los Angeles, which has the largest Iranian community in the world outside Iran, Farsi service reporter Mohamed Razavi filed a story about a demonstration protesting the attack on the jet. In Paris, an Iranian pilot expressed dismay that a

sophisticated warship like the Vincennes couldn't distinguish between an F-14 fighter and a lumbering civilian craft. The Farsi service carried the comments during the show.²

And listeners appreciate the coverage VOA gives events in Iran. "The Iranian government constantly hurls insults at the United States," wrote a young man living in Tehran, "yet you always respond with dignity and balance."

A Cultural Connection

The VOA also responds with a variety of information and entertainment programs as well. Listeners look forward to staffer Mohamed Razavi's weekly reports on the Iranian community in Los Angeles.

The popularity of the program is due not only to the city's large Iranian population, but the fact that many of Iran's biggest entertainment stars now live there. Most, if not all, we driven out of Iran as what the government calls "relics of a despotic past."

Iranian pop music was another casualty of the Islamic revolution. The VOA fills the gap with *Navaye Tazch* ("New Song"). *Golhaye-Zendegi* ("Flowers of Life") is a program for young people. Hosted by Moloud Atefi, she is perhaps the best known member of the Farsi service having been a newscaster and storyteller on Iranian TV from 1955 to 1979. According to the VOA, her popularity "seems to be as great as it ever was."

Today, the Iran-Iraq ceasefire is occasionally shaky but five months old. Foreign warships continue to withdraw from the gulf, replaced by another armada, this one of businessmen hoping to gain from the enormous opportunities awaiting a rebuilding Iran.

But Khomeini's words still ring in the ears of many: "I will continue fighting with the last drop of my blood." The VOA Farsi service remembers those words and the needs of their people in that war-devastated country. Their promise to the Iranian people is felt just as strongly.

The Voice of America Farsi service is broadcast twice daily in two separate programs: from 0300 to 0430 UTC on 6060, 9635, 9700 and 11805 kHz and from 1700 to 1900 UTC on 6150, 7280, 9680 and 11825 kHz.



¹1989 Passport to World Band Radio
²Voice

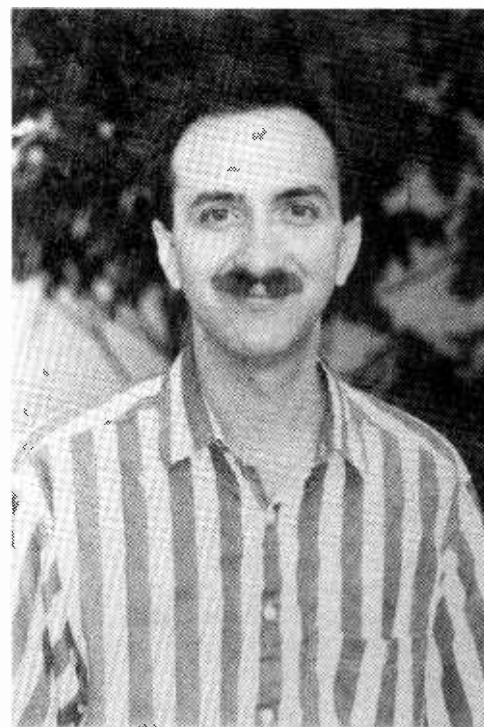

*Ahmad Baharloo,
Deputy Chief*

Says Khomeini, "I will continue fighting with the last drop of my blood." The VOA Farsi service remembers those words ...

uniden®

\$12,000,000 Scanner Sale

Uniden Corporation of America has purchased the consumer products line of Regency Electronics Inc. for \$12,000,000. To celebrate this purchase, we're having our largest scanner sale in history! Use the coupon in this ad for big savings. Hurry...offer ends February 28, 1989.

★ ★ ★ MONEY SAVING COUPON ★ ★ ★

Get special savings on the scanners listed in this coupon. This coupon must be included with your money order. Credit cards, personal checks and quantity discounts are excluded from this offer. Offer valid only on prepaid orders mailed directly to Communications Electronics Inc., P.O. Box 1045 - Dept. UN129, Ann Arbor, Michigan 48106-1045 U.S.A. Coupon expires February 28, 1989. Coupon may not be used in conjunction with any other offer from CEI. Coupon may be photocopied. Add \$9.00 for shipping in the continental U.S.A.

Regency TS2-T \$259.95
 Regency INF1-T \$119.95
 Regency INF5-T \$79.95
 Regency R1090-T \$114.95
 Regency UC102-T \$109.95
 Regency RH066B-T \$419.95
 Regency RH256B-T \$294.95
 Bearcat 200XLT-T \$249.95
 Bearcat 100XLT-T \$184.95
 Bearcat 800XLT-T \$249.95
 Uniden PRO500D-T \$34.95

★ ★ ★ VALUABLE COUPON ★ ★ ★

NEW! Bearcat® 760XLT-T

List price \$499.95/CE price \$244.95/SPECIAL 12-Band, 100 Channel • Crystalless • AC/DC Frequency range: 29-54, 118-174, 406-512, 806-956 MHz. Excludes 823.9875-849.0125 and 868.9875-894.0125 MHz. The Bearcat 760XLT has 100 programmable channels organized as five channel banks for easy use, and 12 bands of coverage including the 800 MHz band. The Bearcat 760XLT mounts neatly under the dash and connects directly to fuse block or battery. The unit also has an AC adaptor, flip down stand and telescopic antenna for desk top use. 6-5/16" W x 1 1/4" H x 7 3/8" D. Model BC 590XLT-T is a similar version without the 800 MHz band for only \$194.95. CTCSS squelch option now available.

SALE! Regency® TS2-T

List price \$499.95/CE price \$269.95/SPECIAL 12-Band, 75 Channel • Crystalless • AC/DC Frequency range: 29-54, 118-174, 406-512, 806-950 MHz. The Regency TS2 scanner lets you monitor Military, Space Satellites, Government, Railroad, Justice Department, State Department, Fish & Game, Immigration, Marine, Police and Fire Departments, Aeronautical AM band, Paramedics, Amateur Radio, plus thousands of other radio frequencies most scanners can't pick up. The Regency TS2 features new 40 channel per second Turbo Scan™ so you won't miss any of the action. Model TS1-T is a 35 channel version of this radio without the 800 MHz band and costs only \$199.95.

Regency® RH256B-T

List price \$799.95/CE price \$299.95/SPECIAL 16 Channel • 25 Watt Transceiver • Priority The Regency RH256B is a sixteen-channel VHF land mobile transceiver designed to cover any frequency between 150 to 162 MHz. Since this radio is synthesized, no expensive crystals are needed to store up to 16 frequencies without battery backup. All radios come with CTCSS tone and scanning capabilities. A monitor and night/day switch is also standard. This transceiver even has a priority function. The RH256 makes an ideal radio for any police or fire department volunteer because of its low cost and high performance. A 60 Watt VHF 150-162 MHz version called the RH066B-T is available for \$429.95. A UHF 15 watt, 16 channel version of this radio called the RU156B-T is also available and covers 450-482 MHz. but the cost is \$454.95.

★ ★ ★ Uniden CB Radios ★ ★ ★

The Uniden line of Citizens Band Radio transceivers is tested to compliment other mobile audio equipment. Uniden CB radios are so reliable that they have a two year limited warranty. From the feature packed PRO 810E to the 310E handheld, there is no better Citizens Band radio on the market today.

PRO310E-T Uniden 40 Ch. Portable/Mobile CB \$83.95
 PRO330E-T Uniden 40 Ch. Remote mount CB \$104.95
 KARATE-T Uniden 40 channel CB Mobile \$38.95
 KARETE-T Uniden 40 channel rescue radio \$53.95
 GRANT-T Uniden 40 channel SSB CB mobile \$166.95
 MADISON-T Uniden 40 channel SSB CB base \$244.95
 PC122-T Uniden 40 channel SSB CB mobile \$119.95
 PRO510XL-T Uniden 40 channel CB Mobile \$38.95
 PRO520XL-T Uniden 40 channel CB Mobile \$56.95
 PRO530XL-T Uniden 40 channel CB Mobile \$79.95
 PRO540E-T Uniden 40 channel CB Mobile \$97.95
 PRO640E-T Uniden 40 channel SSB CB Mobile \$137.95
 PRO710E-T Uniden 40 channel CB Base \$119.95
 PRO810E-T Uniden 40 channel SSB CB Base \$174.95

★ ★ ★ Uniden Radar Detectors ★ ★ ★

Buy the finest Uniden radar detectors from CEI today. TALKER-T Uniden talking radar detector \$184.95
 RD7-T Uniden visor mount radar detector \$99.95
 RD9-T Uniden "Passport" size radar detector \$114.95
 RD9XL-T Uniden "micro" size radar detector \$144.95
 RO25-T Uniden visor mount radar detector \$54.95
 RD500-T Uniden visor mount radar detector \$74.95

Bearcat® 200XLT-T

List price \$509.95/CE price \$254.95/SPECIAL 12-Band, 200 Channel • 800 MHz. Handheld Search • Limit • Hold • Priority • Lockout Frequency range: 29-54, 118-174, 406-512, 806-956 MHz. Excludes 823.9875-849.0125 and 868.9875-894.0125 MHz. The Bearcat 200XLT sets a new standard for handheld scanners in performance and dependability. This full featured unit has 200 programmable channels with 10 scanning banks and 12 band coverage. If you want a very similar model without the 800 MHz band and 100 channels, order the BC 100XLT-T for only \$189.95. Includes antenna, carrying case with belt loop, ni-cad battery pack, AC adapter and earphone. Order your scanner now.

Bearcat® 800XLT-T

List price \$549.95/CE price \$259.95/SPECIAL 12-Band, 40 Channel • No-crystal scanner Priority control • Search/Scan • AC/DC Bands: 29-54, 118-174, 406-512, 806-912 MHz. The Uniden 800XLT receives 40 channels in two banks. Scans 15 channels per second. Size 9 1/4" x 4 1/2" x 1 1/2". If you do not need the 800 MHz band, a similar model called the BC 210XLT-T is available for \$178.95.

Bearcat® 145XL-T

List price \$189.95/CE price \$94.95/SPECIAL 10-Band, 16 Channel • No-crystal scanner Priority control • Weather search • AC/DC Bands: 29-54, 136-174, 406-512 MHz. The Bearcat 145XL is a 16 channel, programmable scanner covering ten frequency bands. The unit features a built-in delay function that adds a three second delay on all channels to prevent missed transmissions. A mobile version called the BC560XL-T featuring priority, weather search, channel lockout and more is available for \$94.95. CEI's package price includes mobile mounting bracket and mobile power cord.

Regency® Informant™ Scanners

Frequency coverage: 35-54, 136-174, 406-512 MHz. The new Regency Informant scanners cover virtually all the standard police, fire, emergency and weather frequencies. The INF1-T is ideal for truckers and is only \$129.95. For base station use, the INF5-T is \$84.95. Order your scanner today.

NEW! President® HR2510-T

List price \$499.95/CE price \$239.95/SPECIAL 10 Meter Mobile Transceiver • Digital VFO Full Band Coverage • All-Mode Operation Backlit liquid crystal display • Auto Squelch RIT • Preprogrammed 10 KHz. Channels Frequency Coverage: 28.0000 MHz to 29.6999 MHz. The President HR2510 Mobile 10 Meter Transceiver made by Uniden, has everything you need for amateur radio communications. Up to 25 Watt PEP USB/LSB and 25 Watt CW mode. Noise Blanker. PA mode. Digital VFO. Built-in S/R/F/Mod/SWR meter. Channel switch on the microphone, and much more! The HR2510 lets you operate AM, FM, USB, LSB or CW. The digitally synthesized frequency control gives you maximum stability and you may choose either pre-programmed 10 KHz. channel steps, or use the built-in VFO for steps down to 100 Hz. There's also RIT (Receiver Incremental Tuning) to give you perfectly tuned signals. With receive scanning, you can scan 50 channels in any one of four band segments to find out where the action is. Order your HR2510 from CEI today.



BC760XLT
800 MHz.
mobile scanner
SPECIAL!

★ ★ ★ Facsimile Machines & Phones ★ ★ ★

If you need an excellent facsimile machine, CEI has the full featured Faxtel 3300 fax by Pactel at a special price. FAX3300-T Pactel Fax machine with phone \$1,099.95
 XE750-T Uniden Cordless Phone with speaker \$99.95

★ ★ ★ Extended Service Contract ★ ★ ★

If you purchase a scanner, CB, radar detector or cordless phone from any store in the U.S. or Canada within the last 30 days, you can get up to three years of extended service contract from Warrantech. This service extension plan begins after the manufacturer's warranty expires. Warrantech will perform all necessary labor and will not charge for return shipping. Extended service contracts are not refundable and apply only to the original purchaser. A two year extended contract on a mobile or base scanner is \$29.99 and three years is \$39.99. For handheld scanners, 2 years is \$59.99 and 3 years is \$79.99. For radar detectors, two years is \$29.99. For CB radios, 2 years is \$39.99. For cordless phones, 3 years is \$34.99. Order your extended service contract today.

OTHER RADIOS AND ACCESSORIES

BC55XLT-T Bearcat 10 channel scanner \$114.95
 BC70XLT-T Bearcat 20 channel scanner \$159.95
 BC175XLT-T Bearcat 16 channel scanner \$156.95
 R1090-T Regency 45 channel scanner \$119.95
 UC102-T Regency VHF 2 ch. 1 Watt transceiver \$114.95
 BP55-T Regency 16 amp reg. power supply \$179.95
 MA549-T Drop-in charger for HX1200 & HX1500 \$59.95
 MA518-T Wall charger for HX1500 scanner \$14.95
 MA553-T Carrying case for HX1500 scanner \$14.95
 MA917-T Ni-Cad battery pack for HX1000/1200 \$39.95
 BP205-T Ni-Cad batt. pack for BC200/BC100XLT \$49.95
 B8-T 1.2 V AA Ni-Cad batteries (set of eight) \$17.95
 FBE-T Frequency Directory for Eastern U.S.A. \$14.95
 FBW-T Frequency Directory for Western U.S.A. \$14.95
 ASD-T Air Scan Directory \$14.95
 SRF-T Survival Radio Frequency Directory \$14.95
 TSG-T "Top Secret" Registry of U.S. Govt. Freq. \$14.95
 TTC-T Tune in on telephone calls \$14.95
 CBH-T Big CB Handbook/AM/FM/Freband \$14.95
 TIC-T Techniques for Intercepting Comm. \$14.95
 RRF-T Railroad frequency directory \$14.95
 EEC-T Embassy & Espionage Communications \$14.95
 CIE-T Covert Intelligenc. Elect. Eavesdropping \$14.95
 MFF-T Midwest Federal Frequency directory \$14.95
 A60-T Magnet mount mobile scanner antenna \$35.95
 A70-T Base station scanner antenna \$35.95
 A500-T 10 & 11 Meter - 500 Watt antenna \$38.95
 A1300-T 25 MHz - 1.3 GHz Discone antenna \$109.95
 USAMM-T Mag mount VHF ant. w/ 12' cable \$39.95
 USAK-T 1/4" hole mount VHF ant. w/ 17' cable \$35.95
 USAK450-T 3/4" hole mount UHF ant. w/ 17' cable \$35.95
 Add \$4.00 shipping for all accessories ordered at the same time.
 Add \$9.00 shipping per radio and \$4.00 per antenna.

BUY WITH CONFIDENCE

To get the fastest delivery from CEI of any scanner, send or phone your order directly to our Scanner Distribution Center. Michigan residents please add 4% sales tax or supply your tax I.D. number. Written purchase orders are accepted from approved government agencies and most well rated firms at a 10% surcharge for net 10 billing. All sales are subject to availability, acceptance and verification. All sales on accessories are final. Prices, terms and specifications are subject to change without notice. All prices are in U.S. dollars. Out of stock items will be placed on backorder automatically unless CEI is instructed differently. A \$5.00 additional handling fee will be charged for all orders with a merchandise total under \$50.00. Shipments are F.O.B. CEI warehouse in Ann Arbor, Michigan. No COD's. Most items listed have a manufacturer's warranty. Free copies of warranties on these products are available by writing to CEI. Non-certified checks require bank clearance. Not responsible for typographical errors.

Mail orders to: Communications Electronics, Box 1045, Ann Arbor, Michigan 48106 U.S.A. Add \$9.00 per scanner for U.P.S. ground shipping and handling in the continental U.S.A. For Canada, Puerto Rico, Hawaii, Alaska, or APO/FPO delivery, shipping charges are three times continental U.S. rates. If you have a Discover, Visa, American Express or Master Card, you may call and place a credit card order. 5% surcharge for billing to American Express. Order toll-free in the U.S. Dial 800-USA-SCAN. In Canada, dial 800-221-3475. FAX anytime, dial 313-971-6000. If you are outside the U.S. or in Michigan dial 313-973-8888. Order today. Scanner Distribution Center™ and CEI logos are trademarks of Communications Electronics Inc. Sale dates 12/1/88 - 2/28/89 AD #010189-T1 Copyright © 1989 Communications Electronics Inc.

For credit card orders call
1-800-USA-SCAN

COMMUNICATIONS ELECTRONICS INC.

Consumer Products Division
P.O. Box 1045 □ Ann Arbor, Michigan 48106-1045 U.S.A.
For orders call 313-973-8888 or FAX 313-971-6000

Monitoring High Seas Telephone Communications

by A.W. Edwards,
Radio Officer

A world of interesting experiences await the shortwave listener who tunes in to high seas telephone communications. And you don't have to have a whole pile of costly gear to get in on the fun. Even a modest aggregation of receiving equipment and a suitable antenna system will do the trick. Best of all, you can tune in on the high seas marine radiotelephone systems of the world, with guaranteed activity, *day or night*.

Perhaps considered an obstacle by some, but an added benefit by others, are the many languages one will inevitably encounter in the process.

Look, But Don't Touch

The same rules apply to this kind of listening as to the reception of any other communications not intended for public dissemination. While it is not reasonable (or even possible) to prevent the reception of shortwave radio signals emitted in standard modes and without encryption, what is possible is for the sender to take legal actions against persons who may be proven to have made improper use of material gleaned from the airwaves.

Thus, before proceeding with the details of how to enjoy this interesting portion of the shortwave radio spectrum, I offer this caveat: The secrecy provisions of international statutes may apply to, and be enforced upon, any persons who deliberately make use of intercepted private radio signals. Thus, it is my advice to listen, enjoy, and learn to your heart's content, but just don't take it any further than your own listening post.

Getting Under Way

That said, here are some suggestions to enable the landlocked person to get the feel of high seas drama and at the same time, to do some fine DXing. In two evenings of casual listening, once I had this article in mind, I heard not only our own principle stations -- WOO, WOM, WLO,

KMI, etc., and weather bulletins via U.S. Coast Guard stations in Portsmouth, Virginia (NMN), but also identified shore stations in Pozuelo del Rey, Spain, and Radiomex in Mexico, near Tampico.



HIGH SEAS MARINE RADIOTELEPHONE CHANNELS AND FREQUENCIES

4 MHZ BAND-DELTA F=294.4 KHZ

CHANNEL	SHORE	SHIP
401	4357.4	4063.0
402	4360.5	4066.1
403	4363.6	4069.2
404	4366.7	4072.3
405	4369.8	4075.4
406	4372.9	4078.5
407	4376.0	4081.6
408	4379.1	4084.7
409	4382.2	4087.8
410	4385.3	4090.9
411	4388.4	4094.0
412	4391.5	4097.1
413	4394.6	4100.2
414	4397.7	4103.3
415	4400.8	4106.4
416	4403.9	4109.5
417	4407.0	4112.6
418	4410.1	4115.7
419	4413.2	4118.8
420	4416.3	4121.9
421	4419.4	4125.0+
422	4422.5	4128.1
423	4425.6	4131.2
424	4428.7	4134.3
425	4431.8	4137.4
426	4434.9	4140.5

6 MHZ BAND-DELTA F=179.5

CHANNEL	SHORE	SHIP
601	6506.4	6200.0
602	6509.5	6203.1
603	6512.6	6206.2
604	6515.7	6209.3
605	6518.8	6212.4
606	6521.9	6215.5+

NOTE: + = CALLING CHANNEL

ALTHOUGH THERE ARE DESIGNATED CALLING CHANNELS, MOST SHORE STATIONS SCAN ALL OF THEIR FREQUENCIES. EVEN SO, THEY DO HAVE PREFERRED CHANNELS FOR CALLING.

TABLE 1

 HIGH SEAS MARINE RADIOTELEPHONE CHANNELS AND FREQUENCIES

8 MHZ BAND-DELTA F=523.9 KHZ			12 MHZ BAND-DELTA F=770.8 KHZ		
CHANNEL	SHORE	SHIP	CHANNEL	SHORE	SHIP
801	8718.9	8195.0	1201	13100.8	12330.0
802	8722.0	8198.1	1202	13103.9	12333.1
803	8725.1	8201.2	1203	13107.0	12336.2
804	8728.2	8204.3	1204	13110.1	12339.3
805	8731.3	8207.4	1205	13113.2	12342.4
806	8734.4	8210.5	1206	13116.3	12345.5
807	8737.5	8213.6	1207	13119.4	12348.6
808	8740.6	8216.7	1208	13122.5	12351.7
809	8743.7	8219.8	1209	13125.6	12354.8
810	8746.8	8222.9	1210	13128.7	12357.9
811	8749.9	8226.0	1211	13131.8	12361.0
812	8753.0	8229.1	1212	13134.9	12364.1
813	8756.1	8232.2	1213	13138.0	12367.2
814	8759.2	8235.3	1214	13141.1	12370.3
815	8762.3	8238.4	1215	13144.2	12373.4
816	8765.4	8241.5	1216	13147.3	12376.5
817	8768.5	8244.6	1217	13150.4	12379.6
818	8771.6	8247.7	1218	13153.5	12382.7
819	8774.7	8250.8	1219	13156.6	12385.8
820	8777.8	8253.9	1220	13159.7	12388.9
821	8780.9	8257.0+	1221	13162.8	12292.0+
822	8784.0	8260.1	1222	13165.9	12395.1
823	8787.1	8263.2	1223	13169.0	12398.2
824	8790.2	8266.3	1224	13172.1	12401.3
825	8793.3	8269.4	1225	13175.2	12404.4
826	8796.4	8272.5	1226	13178.3	12407.5
827	8799.5	8275.6	1227	13181.4	12410.6
828	8802.6	8278.7	1228	13184.5	12413.7
829	8805.7	8281.8	1229	13187.6	12416.8
830	8808.8	8284.9	1230	13190.7	12419.9
831	8811.9	8288.0	1231	13193.8	12423.0
			1232	13196.9	12426.1

NOTE: + = CALLING FREQUENCY

TABLE 2

Passenger vessels maintain a high volume of telephone traffic from ship to shore as the "cargo" make calls back home and so forth. Even more numerous are the other categories of marine users.

With a good communications receiver and a good external antenna system (and why would anyone have a fine receiver and deprive it of a suitable array of antennas, or at least a good antenna with some processing, either active or passive?), even persons far inland will be able to receive very usable signal strengths, night and day.

The system lies in the nominal frequency bands of 4, 6, 8, 12, 16, and 22 MHz. All emissions are upper sideband (USB) and of a duplex character. While duplex usually implies simultaneous transmission on two frequencies, the fact is that while the shore station and the system involved are capable of duplex operation -- which, again, is just like a regular telephone in that you both can hear each other at all times and interrupt if desired -- the fact is that most ship radio equipment cannot handle simultaneous transmit and receive.

Therefore, what we are dealing with, especially on the ships' end of things, is a semi-duplex mode, wherein the ship and the party using the shore facilities must each speak in turn. (The ship may interrupt the shore station, but not vice versa, as the ship's receiver is usually muted during the transmit condition.)

What this means to the SWLer is that he has an improved chance to hear both sides of the conversation, even with a single receiver where he must shift between the shore and ship frequencies, due to the nature of conversations which contain the prompts "Over" interspersed in them.

Land First

You should always tune in the shore station first (see the tables). This signal is usually much the stronger of the pair. This also will enable you to pick up the identifying call signs of the shore stations and, often, that of the seagoing vessel involved.

Monitoring of duplex frequencies may be accomplished in a couple of ways. One way is by using channel memories (available in most good receivers), storing the channel

pair and switching as appropriate. The preferred way is to use two receivers. This allows adjustment of the antenna system to favor the weaker, and to adjust audio level for optimum and uninterrupted recovery of the duplex channel in use.

A very helpful reference to have, though one which may be prohibitively priced, is the ITU Volume IV *List of Coast Stations*. This gives details of location, ownership, operation and assigned channels of the world's maritime station, including radiotelephone high seas stations. New, they cost about eighty bucks, but as new volumes (required by the FCC) come on board to replace the out-of-date ones, they may be had free of cost if you know a seagoing "Sparks." The data in them will still be substantially complete.

The frequency listings shown give the shore station frequency (higher) first, followed by the ship's frequency. Inspection of the frequency difference in the duplex pairs will

reveal there is a constant separation within each band. For example, the separation of the carrier frequencies in the 4 MHz band is 294.4 kHz, and for the 8 MHz pairs, is 523.9 kHz. Other separations apply to each of the radiotelephone duplex bands.

These separations may be useful to keep noted down, in case you do not have the complete table of channelizations handy, so you may readily find the other half of a duplex transmission, knowing one of the frequencies of a pair.

Operating Procedures

It will be helpful to know how a call is initiated and terminated, so you can know when to expect identifications and other information exchanges important to your identifying and logging the stations.

Most of the time it is a vessel which initiates the calls. This, of course, will be on the vessel's frequency. He will choose a

HIGH SEAS MARINE RADIOTELEPHONE CHANNELS AND FREQUENCIES

16 MHZ BAND-DELTA F=772.9			22 MHZ BAND-DELTA F=596.0 KHZ		
CHANNEL	SHORE	SHIP	CHANNEL	SHORE	SHIP
1601	17232.9	16460.0	2201	22596.0	22000.0
1602	17236.0	16463.1	2202	22591.1	22003.1
1603	17239.1	16466.2	2203	22602.2	22006.2
1604	17242.2	16469.3	2204	22605.3	22009.3
1605	17245.3	16472.4	2205	22608.4	22012.4
1606	17248.4	16475.5	2206	22611.5	22015.5
1607	17251.5	16478.6	2207	22614.6	22018.6
1608	17254.6	16481.7	2208	22617.7	22021.7
1609	17257.7	16484.8	2209	22620.8	22024.8
1610	17260.8	16487.9	2210	22623.9	22027.9
1611	17263.9	16491.0	2211	22627.0	22031.0
1612	17267.0	16494.1	2212	22630.1	22034.1
1613	17270.1	16497.2	2213	22633.2	22037.2
1614	17273.2	16500.3	2214	22636.3	22040.3
1615	17276.3	16503.4	2215	22639.4	22043.4
1616	17279.4	16506.5	2216	22642.5	22046.5
1617	17282.5	16509.6	2217	22645.6	22049.6
1618	17285.6	16512.7	2218	22648.7	22052.7
1619	17288.7	16515.8	2219	22651.8	22055.8
1620	17291.8	16518.9	2220	22654.9	22058.9
1621	17294.9	16522.0+	2221	22658.0	22062.0+
1622	17298.0	16525.1	2222	22661.1	22065.1
1623	17301.1	16528.2	2223	22664.2	22068.2
1624	17304.2	16531.3	2224	22667.3	22071.3
1625	17307.3	16534.4	2225	22670.4	22074.4
1626	17310.4	16537.5	2226	22673.5	22077.5
1627	17313.5	16540.6	2227	22676.6	22080.6
1628	17316.6	16543.7	2228	22679.7	22083.7
1629	17319.7	16546.8	2229	22682.8	22086.8
1630	17322.8	16549.9	2230	22685.9	22089.9
1631	17325.9	16553.0	2231	22689.0	22093.0
1632	17329.0	16556.1	2232	22692.1	22096.1
1633	17332.1	16559.2	2233	22695.2	22099.2
1634	17335.2	16562.3	2234	22698.3	22102.3
1635	17338.3	16565.4	2235	22701.4	22105.4
1636	17341.4	16568.5	2236	22704.5	22108.5
1637	17344.5	16571.6	2237	22707.6	22111.6
1638	17347.6	16574.7	2238	22710.7	22114.7
1639	17350.7	16577.8	2239	22713.8	22117.8
1640	17353.8	16580.9	2240	22716.9	22120.9
1641	17356.9	16584.0			

TABLE 3

shore station he believes he can reach with good signals, and will use a frequency appropriate to the time of day, conditions and distance between his vessel and the selected shore station.

The vessel will call the shore station, identifying himself and usually also mentioning which channel he is calling on. For example, "Whiskey Oscar Oscar, this is the motor vessel Lonesome Tar, WXYZ, on 808..." or similar utterance. Actually, it is better that one monitor the shore station frequencies for the reasons cited above, realizing that then the first thing heard will be the shore station's response.

When contact is established, the vessel often states his position, either with latitude

and longitude declaration or, less precisely, by saying something like, "near the Dry Tortugas," or other well-known geographic feature. This enables the shore facility to select the appropriate antenna beaming for achieving the optimum received and transmitted signal paths and, at the same time, to minimize interference to any co-channel users.

When this has been done, the call will be placed over landline systems and, if the call is completed, the conversation may then be monitored. Sometimes it is possible to hear (though weakly) the ship side on the shore station frequency. However, it is often possible to intercept the ship transmitter directly, and by monitoring both frequencies, enable the reception of the complete

conversation. This is especially true when separate receivers are used, but even using channel memorization and switching between the "overs," one misses little, if anything.

The sign-off procedure merits a word or two. When the parties have finished their conversation, there is still some administrative work to be done. Do not abandon the contact you have been working when you hear the signs of disconnect, as there must still be an exchange of information.

The shore station will inform the vessel of the time and charges, and ask if there is any other traffic. In the process, you then have yet another opportunity at identifying both the shore facility and the vessel.

A tape recorder will permit you to replay portions pronounced indistinctly, rapidly, or in a foreign tongue. Thus, you may recover callsigns, ship names, positions, and other transitory data, remembering always to preserve secrecy.

Incidentally, the frequencies published for the shore stations are accurate to within five cycles per second (hertz), so they provide a convenient check of your receiver's calibration. The ship transmitters are also quite accurate, but are subject to more error since these are not so rigorously monitored.

That is all there is to it. Restrict your logging to identifications, locations, times, dates, etc., and perhaps cryptic notes to help you recall the intercept, but keep in mind the need for respecting the privacy of the information that your technical skills and equipment have given you.



A.W. Edwards is a Radio Officer on the SS Coastal Manatee, a tanker. He also holds amateur callsign K5CN -- the infamous "Chicken Neck."





EEB THE NATION'S #1 SWL SUPPLIER

ORDERS 800-368-3270



EEB's all new 1989 SWL Catalog is on its way. Hopefully, you are on our mail list and will receive a copy by 1 November, if you have not received your copy by 1 November, write or call for your "FREE" copy (in U.S.A.), CANADA \$1.00, all others \$3.00 AIRMAIL.



R71A This is our best seller. ICOM R71A has all the features one expects in a world class receiver. All mode AM, SSB, CW, RTTY, FM (OPT). Complete coverage .1 to 30 MHz. 3 Filter positions, direct keyboard entry. 32 memory channels, PLL tuning in 10 Hz steps for exact frequency. Many ICOM options plus EEB high performance package. (CALL)

ICR71A \$849.00 + \$12 UPS

R7000 There is nothing to compare with the R7000 under \$12,000. This is the most sophisticated V/UHF receiver ever offered to the public. No wonder it's our best selling V/UHF receiver. All mode AM, SSB, CW, FMW, FMN - 25 to 2000 MHz (20 kHz to 2 GHz w/NO-VEK FC7100), direct keyboard entry, 99 memory channels, full scan, memory scan, program scan, priority scan, many ICOM options plus EEB options and high performance package deal. (CALL)

ICR7000 \$1019.00 + \$12 UPS



The **KENWOOD R5000** is the new high performance receiver from the leader in communications technology. Designed with the highest performance standards in mind, the KENWOOD R5000 will bring you all the excitement of shortwave listening! 150 kHz to 30 MHz. 100 memories. Keyboard entry. AM, FM, USB/LSB, CW, FSK. VHF 108-174 Opt VC20.

R5000 \$849.95 + \$10 UPS

The **KENWOOD R2000** is an innovative all-mode receiver with a host of features to enhance the excitement of listening to stations around the world. 150 kHz to 30 MHz. 10 memories. AM, FM, SSB, CW. VHF 118-174 MHz opt VC10.

R2000 \$649.95 + \$10 UPS

A high-class, general coverage receiver with expandability looking to the future. The **NRD-525** will change your shack into a new universe! 0.09 MHz to 34 MHz. Pass band shift. 200 memories. Direct keyboard entry. AM, FM, CW, SSB, RTTY, SSB. Notch filter. V/UHF converter option.



NRD525 \$1179.00 + \$12 UPS

The **Satellit 650 International** is the ultimate in German crafted portable radios. Along with excellent audio performance the Satellit 650 also has many fine features. 510 kHz to 29.999 MHz. 24 hour clock/calendar. 3 Bandwidths. 60 Memories. AM, FM, SSB, CW. Keyboard Entry. PLL Control. Nicad Battery Option.



Satellit 650 \$995.00 + \$12 UPS

The **Satellit 400**, with its rounded corners and smooth lines is the obvious "style leader" in personal portables. Beautifully crafted, this portable covers all shortwave bands plus MW and FM. It's unexcelled audio will surprise you! SW 1.612-30 MHz. LW, 148-353 kHz. FM 87.5-108 MHz. MW 513-1611 kHz. 24 Memories. Keyboard Entry. SW 1.612-30 MHz.

Satellit 400 \$399.95 + \$6 UPS

YAESU now offers the finest receiver in the famous FRG series. The **FRG8800** offers functionality and operating convenience for the serious shortwave listener. 150 kHz to 29.999 MHz. Direct keyboard entry. Dual Clocks/Timers. Wide/Narrow Filter. 12 Memories. AM, SSB, CW, FM. VHF 118-174 MHz option.



FRG8800 \$649.95 + \$10 UPS

VHF/UHF General Coverage Receiver. The **YAESU FRG9600** is an all mode scanning receiver with many outstanding features. Covers: 60-905 MHz. 100 Memories. Keyboard Entry. SSB, FM, AM. FM/Wide & Narrow. 7 Digit Readout. Video option.



FRG9600 \$529.95 + \$6 UPS

SONY - THE ONE AND ONLY



ICF2010



ICF2003



ICFSW1S

ICF2010 is the market leader of portables, our best selling portable. Full coverage. .15 to 30 MHz, FM 76-108 MHz, Air Band 116-136 MHz. AM, FM, CW, SSB. Sync Detection. 32 Memories. Keyboard Entry. Many Features.

ICF2010 \$349.95 + \$6 UPS

ICF2003 delivers most performance of all portables in the mid-size class. .153-30 MHz. AW, CW, SSB. 76-108 MHz FM. 10 Memories. Keyboard Entry. Paperback book size. Optional AC Adapter.

ICF2003 \$259.95 + \$4 UPS

ICFSW1S. The newest in miniaturization only 2 3/4" x 4". Tests show it as best of sub-compact size, has its own case with, active antenna, world AC Power Pack, head Phone, SWL Book, Travel with the "SYSTEM" or just the Radio. Complete coverage to 30 MHz FM 88-108. Keyboard Entry. LCD Readout/Clock. They're going fast!

ICFSW1S \$299.95 + \$4 UPS

ICF7601. A late version of the famous 7600. AM-FM All major shortwave bands. ICF7061 \$139.95 + \$4 UPS

ICF7700. 15 Memories. All SW Bands 90 thru 11 MT. Digital LCD freq/clock. ICF7700 \$239.95 + \$4 UPS

ICF4920. A favorite with the travelers. Shirt pocket size. PW 2 AA. ICF4920 \$99.95 + \$4 UPS

PANASONIC with/FREE STAND

RFB60 Top of the line portable. 155-30 MHz coverage. 36 Memories. Scan, Rotary Tuning. Direct Keyboard Entry. Clock/Timer. Optional AC Adapter.

RFB60 \$249.95 + \$4 UPS

RFB40. Full coverage. AM, FM, SW. 27 Memories. Direct Keyboard Entry. Auto scan, digital readout. Optional AC Adapter.

RFB40 \$189.95 + \$4 UPS

RFB20. AM, FM, LW, SW Coverage. Double super heterodyne for image rejection. Ear phone and carrying case included.

RFB20 \$119.95 + \$4 UPS

RFB10. Smallest non-digital. Shirt pocket size. 8 Bands - The Traveler's Friend. Optional AC Adapter.

RFB10 \$89.95 + \$4 UPS

TOSHIBA RPF-11. 11 Bands. AM, FM, 9 SW. One of our leading portables. Easy push buttons for band select. Travel lock. "S" Meter. Optional AC Adapter TAC65 \$13.95.

RPF11 \$89.95 + \$4 UPS



SANGEAN with/FREE STAND

ATS803A. So much HITECH in one package, a super value. Covers all SW Bands. Tunes .150-30 MHz + FM 88-108. 9 Memories Auto Scan. Keyboard Entry. Stereo w/Headset or Line output. AC Adapter included.

ATS803A \$189.95 + \$4 UPS

SG789. Slightly larger than SONY ICF4920 same coverage plus stereo w/headset. Power 3AA.

SG789 \$69.95 + \$4 UPS

DIPLOMAT 4950. SAME AS SG789.

CLOSE OUT \$49.95 + \$4 UPS

MS101. All new mini set similar to Panasonic RFB10. 9 Band, AM, FM, 7SW. Band spread for easy tuning, stereo w/headset, 3 AA. Optional AC Adapter.

MS101 \$79.95 + \$4 UPS

MS103. Same as MS101, 9 SW Bands.

MS103 \$99.95 + \$4 UPS

MAGNAVOX

D2999. Excellent performer, great sound (2 SPK) and other HITECH features make this a value packed radio. 146-26.1 MHz FM 88-108. Keyboard entry. 16 Memories. Multi-mode AM, CW, SSB, FM, Scan. 12/24 hour clock. Loads more.

D2999 \$299.95 + \$6 UPS

D2935. Rated best value in a portable (IBS). Covers all SW Bands. 146-26.1 MHz. 9 Memories. AM, FM, CW, SSB. Keyboard Entry.

D2935 \$179.95 + \$5 UPS

D1835. This unit is one of the finest in it's class. 9 SW Bands. AM, FM, LW. Slide controls. Carrying pouch.

D1835 \$79.95 + \$4 UPS

ANTENNAS

DATONG AD370. HF .1-30 MHz outdoor active, rated #1 by IBS Test Labs. Dipole whips cancel some man-made noise.

AD370 \$129.95 + \$4 UPS

SONY AN1. HF .1-30 MHz outdoor active. Our #1 Seller for 3 years. Antenna hardware control box 40 ft. cable.

AN1 \$79.95 + \$6 UPS

EAVESDROPPER. Outdoor passive trapped dipole. 9 SW Bands. 43 ft. long. 100 ft. lead. Everything you need.

SWL \$59.95 + \$4 UPS

SWLC. Same as above, you furnish coax cable. 25' - \$10, 50' - \$16, 100' - \$26 +

SWLC \$59.95 + \$4 UPS

EAVESDROPPER SLOPER. Rated among the best by IBS. .5-1.6 best. AM, DX, 2-26 MHz SW. You provide coax as above.

SWLS \$49.95 + \$4 UPS

ALPHA DELTA SLOPER. DXSWL \$69.95 + \$5 UPS
TPA. Indoor/Active. 2-30 MHz up to 20 DB Gain. Pre-Selector can reduce interference. 9VDC Optional AC Adapter.

TPA \$74.95

MFJ1024. Indoor/Active. Many features same as above. 9VDC Optional AC Adapter. MFJ1024 \$79.95

NOVEX NEW PRODUCTS

CRIS 6000. Computer Radio Interface System. The ultimate HITECH computer (IBM PC) system for control, logging, scanning, spectrum analysis. Using most current radios. Free CRIS Newsletter (CALL).

CRIS R7000 \$349.95 + \$8 UPS

SDU 8000. Spectrum Display Unit. Perfect mate to ICOM R7000. 10 MHz sweep allows you to see up & down the band for activity on a 3 inch CRT. Free SDU Flyer (CALL).

SDU8000 \$595.00 + \$8 UPS

RACKMOUNT. Novex RM Series Rackmount hardware for most popular radios ICOM, KENWOOD, YAESU receivers and transceivers.

RM1100 \$79.95 + \$5 UPS



Orders: 800-368-3270
Electronic Equipment Bank
516A Mill St. NE, Vienna, VA 22180

Local & tech info
703-938-3350

(Just minutes from Washington, DC)

Prices and specs subject to change without notice.

Almost a Radio Celebrity

by Wayne Hogan

This, so help me, is a true story that I'm about to tell.

It was 2:32 pm, Tuesday. At that precise moment the phone rang. I said, "Hello," into my end and from the other a pleasingly fulsome female voice landed gently in my ear.

"Hello. May I speak to Wayne Hogan?" the voice asked.

"Speakin'," I said.

"Hi, Wayne. This is Mary Robbins."

"Why hello, Mary," I replied with undisguised surprise in my voice. "We must be telepathic or somethin' 'cause I've been thinkin' of you almost every day for the past week or so."

"Well now, I don't see why you couldn't have thought of me *every* day," Mary said in that petulantly, tongue-in-cheekness tone that I've noticed some women use.

"Seriously, though," she continued, "let me tell you why I've called, Wayne. One of the several hats I wear is helping round up people for on-air interviews at WWRT-AM radio over in Algood. I know you do lots of interesting things with photographs and drawings... and you write some, too, don't you?... good... so I wanted to call and ask if you'd like to go over there sometime and be interviewed."

"Why sure. I'm really honored that you've asked. When would you like me to go?"

"How about 6:30 tomorrow morning?" Mary asked.

"That's fine," I said. "I'm an early riser anyway, so that'll be just fine."

Mary thanked me profusely then gave me directions for getting to the radio station (just past the second sharp turn coming into town, across from the Trinity

Church, she said) and the name of the person who'd likely be the interviewer.

* * *

That night I told my wife about Mary's call. She said, "That's really neat! Are you excited?" I half-mumbled something real laid-back like, it'll be interesting, but probably not exciting.

Before going to bed I followed through on Mary's and my wife's suggestion that I gather together some of my most recently published stuff to take and show-and-tell the next morning at the interview. Mary'd said, "You never know, you might get some assignments from this."

So I tossed into a fairly short stack copies of a few recent publications my work (some poems, 'n illustrations, 'n photos) has appeared in, along with a xerox copy of the acceptance letter I'd just received from *The Christian Science Monitor* for an illustrated humor piece they'd taken. I'd have set aside the original of the letter but I'd already had it bronzed into a plaque. If the article I'm writing now sells, the typewriter is next.

Not wanting to miss the opportunity, I also set aside copies of my illustrator's stylesheet, resume, and order form for my several unsold chapbooks. As Mary'd said, you never know.

* * *

The clock-radio-alarm jolted me and the wife wide awake at 5:16 the next morning. In 15 minutes I was up and showered and out the front door to start the nine miles to the local Hardees for coffee'n a grape-jelly biscuit and the four more miles to the radio station. If all went well, I thought to myself, I'd be there several minutes before air time.

Things went just fine. I easily found the station and walked through its front door at just about exactly 6:15.

"Good morning. Are you here for the *Rise and Shine* show?" the lady at the desk with the INFORMATION sign on it asked.

"Um, I guess so," I said with an undisguised air of uncertainty.

"Good. Just have a seat. We're having a little trouble with our transformer so I don't know just how long it'll be before we can get back on the air. What do you do, Mr., uh..."

"Hogan, Wayne Hogan," I added for her. "I'm a freelance writer and artist," I said. "Mary Robbins over in Cookeville called me yesterday and asked if I'd come over this morning and be interviewed."

"Oh. Fine. I'm talking with our engineer now to see what the problem is. Would you like a cup of coffee while you wait?"

"Sure," I said. "Thanks."

"Cream and sugar?"

"Just black."

She left her desk and returned almost immediately with a steaming-hot cup of coffee. I thanked her as she resumed her phone conversation with the engineer. She was reading some technical information from a blueprint-looking piece of paper into the phone but appeared to be having some difficulty finding what the engineer seemed to be asking for.

The conversation concluded, she turned to talk with a fellow employee as I delicately sipped on my still-simmering coffee. Her phone rang and she nodded her head a couple of times then looked at me and said something to the effect that it was all off for the day, that there was no telling how long it would be before the transformer could be fixed.

At that, I stood, handed her the unfinished cup of coffee, and told her I'd let Mary know what had happened so she could reschedule the interview. The lady behind the desk said, "fine." She apologized for the inconvenience, and said they'd look forward to having me back. I assured her there was no problem, that I was looking forward to returning, and left.

TWO MINUTES TO AIR, MR. HOGAN...
 OOPS, WE'VE LOST OUR
 TRANSFORMER AGAIN...



Later that day, at home, I called Mary to tell her how things hadn't worked out quite as planned. She said she was sorry to hear that but that she'd check with the folks at WWRT and get another time set for the interview. About five minutes later she called me back and asked if Friday morning was okay. I said it was. She wished me luck.

* * *

I got up at about 5:15 again on the appointed Friday morning to ready myself for the second trip to the radio interview, my short stack of recently published show-and-tell stuff still on the back seat of my gray '80 Chevy Caprice station wagon.

Following essentially the same route and routine of two mornings before, I got

to the station at about 6:20. I walked in and said a hearty "Good morning!" to the lady behind the INFORMATION desk. She was on the phone. When she hung up she smiled and said, "Good morning, Mr. Hogan." (She'd remembered my name. One of the first signs of emerging celebrityhood, I recall reading someplace once.)

Then she coyly covered her face with both hands and faintly but unmistakably said (yes, you've probably guessed it), "I'm afraid we're back in the same shape we were in on Wednesday. That terrible lightning storm last night seems to have knocked out our transformer again. I'm really sorry about this, Mr. Hogan."

What could I do but say "Oh, no problem. I understand about power outages. We lose ours at home almost every time a cloud rolls by. I'll just call Mary again so she can arrange for another interview time. Good luck gettin' things fixed."

* * *

It's been more than a month now since that second aborted interview morning at the radio station. Mary (the pleasingly-fulsome-female-voice Mary) must've been so embarrassed by it all that she's not been able to bring herself to call me again with word of whether the folks over there would like to try again. But she shouldn't be. Even though I'll probably never, ever have another chance at being a celebrity.

But really, the whole affair has not been all that big a deal. Not if you don't count how crushed I've been that nobody since the nice INFORMATION-desk lady at the station has even come close to knowing me on sight by name, or that not getting that radio interview may very well have cost me that Elvis-at-53 most-recently-seen-in-Budapest-Hungary celebrity profile piece I'd been thinking of doing for *The New Yorker*.

This, so help me, is a true story that I've just told. Really.

mt

If you have a story of how radio has played a part in your life or the life of your community, send it to Monitoring Times. If accepted for publication, we'll send you \$50.00. All stories should be true, real life events. Manuscripts should be approximately 1,000 words and must include at least one clear photograph.

Shortwave Broadcasting

Glenn Hauser

Box 1684 - MT
Enid, OK 73702

New life on eleven meters

We are approaching another solar cycle peak, one effect of which is revitalization of the eleven-meter band. For only a year or two, a few shortwave stations use this band. Over an undisturbed, daylight path, reception can be superb, virtually free of fading and interference. It's a shame more stations don't follow suit -- carefully spaced to prevent interference -- but many feel it's not worth the expense to install antennas and transmitters capable of operating on this band which is propagationally suitable perhaps 5% of the time, and which is missing on many shortwave receivers.

Let's enjoy it while we can, all before 1600 UTC; While it may remain open from many parts of the world after that, not a single station is on the air any later.

Current activity is as follows: On 25665, Radio Liberty, probably from Portugal, until 1600 (Soviet skywave jamming is least effective on this band). 25690 was used instead earlier in the fall and might be again in the spring. 25730, Radio Norway International at 1200-1245. 25750, BBC World Service in English until 1515 (though intended for the USSR and Africa, it often provides the best BBC signal in eastern North America after 1330). 25790, Radio RSA, South Africa, in a new morning broadcast for North America at 1400-1600 (resulting in the evening broadcast being cut to one hour). Fall-back channel is 21670 in case 11 meters ceases to propagate. Since it's trans-equatorial and high-power beamed our way, this is usually the strongest of the bunch. 25820, Radio France International until 1545 in French, including the newsfeed service at 1515. 25850, Radio Denmark at 1000-1052, too early for most of North America (previously and maybe subsequently at 1200-1252 instead). William Westenhaver in Montreal found them on 25850 at 1400-1452.

But the biggest surprise is ...

ABU DHABI Voice of the United Arab Emirates, in Arabic on 25900 until 1600 or slightly later, previously on 25909 for a few days. Listen for the ID following the inexplicable time signal ending at 1530:47. Parallels are 21735, 21515, 17820. After 25900 closes, 13605 comes on to replace it (Ernie Behr, Kenora, Ont., *DX Listening Digest*)

But that's not all; Voice of the UAE has also started broadcasts in English, at 2200-2400 on 11965, 9595 and 6170, asking for reports from North America. Recitations from the Qur'an come first, followed by English translation; at 2215 local news; then DJ programs rather like Kuwait. (William Westenhaver, Montreal, *World of Radio*) This is not to be confused with Dubai, another emirate, which has broadcast in English for years.

AUSTRIA One of the rarest Europeans for North American DXers is the Austrian Army Training Transmitter, since it uses the "tropical" bands in the daytime. But now it has been staying on as late as 1830 Tuesdays on 3378 and 5035 kHz (Roland Schulze, West Germany, *NASWA Listeners Notebook*) That will help a lot in the Eastern

Hemisphere, but only make it barely possible at midwinter in northeast America.

BRAZIL The BBC relay vanished from 6185 -- after all, that was only 5 kHz away from the Amazon service on 6180 -- and seems to have materialized on 11845 instead, since the schedule of 0900-1100 in English, 1100-1130 in Spanish, and the telephone-line quality match (Craig Seager, *The DX Press*)

CANADA (see last month) RCI SWL Digest has added a seventh airing, Tuesday at 1907 on 15260 and 17820; the Latin America Service indeed has been retimed to UTC Sunday at 0136; and an extra minute of our DX news is now scheduled only on the broadcast ending at 2230 Saturday on 11945 and 9760 (just before RCI interferes with itself on 9755).

CHINA Radio Beijing's relay via French Guiana has resumed, with English at 0400 on 11695; at about the same time, the relay via Spain at 0300 on 11860 ceased.

English broadcasts open with an ID in Chinese which has been changed to, literally, "China international broadcasting station" -- can "Radio China International" be far behind? Opening and closing melodies have also been changed (David Newkirk, CT, *WOR*)

Tune in Jan. 1 for taped predictions and performances from listeners.

COLOMBIA A new station is Radio Horizonte on 3232 variable, but announcing 1630 kHz, heard between 2315 and 0010. It may be near the Ecuadorian border or even on the other side of it (Richard Stoller, Bogota, *RCI SWL Digest*)

Radio Patria Libre is a new clandestine, "la voz de la nueva Colombia," between 0000 and 0115 on 6758 or 6765 kHz, heard asking listeners to paint public walls with the slogan "6760 SW at 7:30 pm" (Alfredo Locatelli, Uruguay, *QSN-Grama*) The oligarchy-controlled newspaper *El Tiempo* says the station is in Barrancabermeja and belongs to the National Liberation Army (Richard Stoller, Bogota, *Radio Nederland Radio-Enlace*)

COSTA RICA Radio for Peace International is back, but on slightly different frequencies and a reduced schedule initially while the engineer was back in the USA rounding up spare parts; Monday-Friday 2100-2400 on 21599.8, Tuesday-Saturday 0100-0400 on 13663.1. Catch our World of Radio Tuesday at 2300, Wednesday at 0300, Friday at 2100, Saturday at 0100, the last two followed by RFPI's own mailbag.

T-shirts showing the station logo and name are now on sale, high-quality cotton blue-on-white, for \$10 each plus \$2 shipping in the US, \$3 airmail elsewhere; orders of five or more get a \$1 discount each. Specify size S/M/L. Order from: Box 10869, Eugene, OR 97440. (*WOR*)

CUBA Radio Havana Cuba has started weekly broadcasts in Esperanto, leading up to a 1990 Esperanto congress there: Sunday 0800 on 9520; 1700 on 15340, 15230, 11875,

Shortwave Broadcasting

11760, 11725, 9550, 6060; 1840 on 15155, 11950, 11800; 2200 on 15155, 11950; 2240 on 11970, 11820, 11795, 6060, 6025.

The last repeat is followed at 2300-2345 by Panorama de la Radio Cubana (in Spanish) with excerpts from various local, provincial and national stations and networks. The Esperanto ID is: "Tiu ci estas Radio Havano Kubo, elsendante el Kubo, libera teritorio de Ameriko" Remember, stress is always on the penultimate (next to the last) syllable (Tim Hendel, Miami, *WOR*) Sorry, *MT* cannot put accent marks on foreign words.

EQUATORIAL GUINEA The split out-of-band frequency of 9852.5 kHz was originally a place the FCC allowed US stations to squeeze in. Now, Radio Africa, which is leased to a parade of preachers, seems to be trying to follow suit, varying around 9851.8 instead of 9552, mostly in English until 2300 or so, but in French at 1915-1928. Trouble is, Taiwan via WYFR really is on 9852.5 until 2300 (Ernie Behr, Ont., *RCI SWL Digest*)

FIJI Verifications are now emerging for the University of the South Pacific lectures on 9070 kHz. Kevin Maitava, Program Officer, P.O. Box 1168, Suva, says shortwave is used to supplement Intelsat links to 11 extension campuses. Icom IC-700 TY transmitters of 150 watts, 40-foot-high dipoles are used, also on 5350, 12140 (Kevin Atkins, Pinson AL, *Fine Tuning*)

But another DXer (not named Kevin) got a reply instead from a Prof. Johnson, who was on the air when heard (Richard Davis, Portales NM, *FT*) Six campuses use satellite, five the HF link (Finn Krone, AWR, *WDXC Contact*) Try around 0500, not every night.

GERMANY WEST Sanskrit, the rich language which once flowed in the courts of emperors of ancient India, makes a precarious living in academic circles, especially here, thanks to Indologists like Max Muller. Deutsche Welle has been broadcasting in this "dead" language, but practical considerations are overtaking romantic obsessions with the announcement that Sanskrit will be dropped (Supratik Sanatani, India, *Asian DX Review*)

In case it's not too late, so you can say you've heard Sanskrit spoken, it was scheduled fortnightly, Mondays at 1545-1558 on 21680, 17825, 15595, 15105, 13790, 9745 from a variety of sites, during a broadcast otherwise in Hindi.

HONG KONG RTVHK has been heard in North America on 7290 USB from 1100 with Vietnamese announcements and the same fanfare used on the yacht race weathercasts (Rowland Archer, NC, *DXLD*) And it closes at 1302 (Ed LaCrosse, CA, *SWL Digest*)

The only station I hear on 7290 USB until 1302 is from the USSR, with the Soviet Anthem (Ernie Behr, Ont, *SWLD*) The Soviet is usually on top, but when Vietnamese is heard, you know it's HK (Artie Bigley, San Antonio TX, *SWLD*) The fanfare is played every 8 minutes; Soviet operation is irregular, so keep trying (David Clark, Ont., *FT*)

ICELAND ISBS is heard at 1850-1930 on 15672 and 13770; 1930-2010 and 2300-2335 on 15672 and 17558 (Ernie Behr, Ont, *SWLD*) A possible reason for some present and former odd-ball channels: the digits add up to 26, in case of 9863, 15659, 15668, 17558! (Bob Padula, *The DX Press*)

IRAQ Radio Baghdad is on 9515.1 for English to

North America, announced for 0100-0300, but heard at 0230-0420 (Ernie Behr, Ont, *SWLD*)

ITALY More on IRRS, Milan: preliminary tests were on weekends using 11195, 9860, 9815, 7160, 7145 in the daytime, 3945 in the evening, all 10kW reduced-carrier upper-sideband. Delays were due to problems in getting adequate power to the transmitter site outside the city, which will be computer remote-controlled. (Alfredo Cotroneo, *Media Network*)

JORDAN joins the big leagues with new 500-kilowatt transmitters inaugurated on King Hussein's birthday. Check 9560 for English expanded to 0500-2300 from the former low-power time of 1500-1730 (*Sweden Calling DXers*) Heard well before 1400 when Ethiopia becomes co-channel (Artie Bigley, TX, *SWLD*) And in Arabic until closing at 2320.

PAPUA NEW GUINEA The NBC transmitter on 4890 had to be taken off the air due to technical problems, but after a few weeks a 2-kilowatt unit was retuned to this frequency (Radio Australia *Communicator*)

PERU Radio Trujillo, Trujillo was heard with Rosary at 1125 on 6419.8, the second harmonic of 3209.9, also audible (Pedro F. Arrunategui, Lima, *SWLD*)

ST. MARTIN An unconfirmed report says local music, cultural programming and weather have been relayed on shortwave, 100 watts on 9580 at 1200-1215. How anyone in Wisconsin, could have heard this through Radio Australia is beyond us.

SWEDEN Following a reprieve earlier in 1988, all SSB broadcasts of Swedish Radio were to be dropped at yearend, due to expense (SCDX)

TONGA TBC was heard on 6010.9 in English and Tongan at 1035-1130, best on USB; don't confuse with Latin Americans around this frequency (Nobuyoshi AOI, Japan, *DSWCI SW News*)

USA WHRI is carrying a clandestine program for Yugoslavia originating in Mississauga, Ontario, "Hrvatski Radio Libertas," at 1600-1656 on 15105 and 21840 (Ernie Behr, *WOR*) 7520 is another out-of-band channel opened up for US stations, including WHRI at 0200 past 0430 (William Westenhaver & Sheldon Harvey, Montreal, *WOR*) And to be used by WWCR, Nashville.

VENEZUELA YVTO, the time signal station on 6100, planned to make a permanent change to 5000 kHz (Mart D. Martelle, *DX Ontario*)

YUGOSLAVIA One of the regional stations includes news in English ending at 2130 Mondays on 9620, Radio Ljubljana, probably via the new 500-kilowatt transmitter in Bijeljina (Wendel Craighead, Prairie Village, KS, *FT*)

Keep up with communications news, especially shortwave, by listening each week to Glenn Hauser's WORLD OF RADIO, scheduled on WRNO, New Orleans: Thursday 1630 on 15420; UTC Friday 0000 and 0130 on 7355; UTC Saturday 0400 on 6185; UTC Sunday 0030 on 7355; Sunday 2130 on 13760. Times vary and some airings may be pre-empted.

Read much more about SWBC in REVIEW OF INTERNATIONAL BROADCASTING and/or DX LISTENING DIGEST. Samples in North America are \$2 each, 10-issue subscriptions \$21, or both for \$40 in US funds on a US bank; samples elsewhere US\$3 or 7 IRCs, from Glenn Hauser, Box 1684, Enid, OK 73702.

Shortwave Broadcasting

Broadcast Loggings

*Let other readers know what you're enjoying.
Send your loggings to **Gayle Van Horn**
P.O. Box 1088, Gretna, LA 70053-1088*

English broadcast unless otherwise noted.

0033 UTC on 15125

Guam: Adventist World Radio (AWR). Discussion on "The Greatest Story Ever Told," and "AWR" ID. (James Kline, Hong Kong) Continued religious programming monitored at 0954 UTC on 11805 kHz. (Bob Ferretti, Donora, PA)

0045 UTC on 9875

Austria: Radio Austria Int'l. Report on Moscow's concern that Austria may join the EEC. (Bob Fraser, Cohasset, MA) Heard in Spanish at 0130 UTC on 9875 kHz. (Mark Seiden, Coral Gables, FL)

0045 UTC on 11715

Mali: Radio Beijing. "Current Affairs" program on the Chinese Experimental Theater, and selections of 1,000-year-old Imperial court music. (Bob Fraser, Cohasset, MA)

0059 UTC on 5930

Czechoslovakia: Radio Prague. Interval signal and ID. News on UN peacekeeping efforts, and human rights in Cuba. Editorial on Turkey with parallel programming being heard on 6055, 7345, and 9540 kHz. (Leslie Edwards, Doylestown, PA)

0110 UTC on 9630

Spain: Radio Espana. Evening newscast to 0115 UTC. Traditional Spanish ballads and instrumentals to editorial. (Harold Frodge, Keaau, Hawaii)

0115 UTC on 15145

United States: WINB. Religious organ music with Spanish and English IDs. (George Neff, Tampa, FL)

0130 UTC on 7430

Greece: Voice of Greece. Usual slow-speed reading of the news. Greek music to Spanish programming at 0145 UTC. Audible on parallel frequency 9420 kHz. (Mark Seiden, Coral Gables, FL) Monitored also on 11645 kHz. (Marc Neveux, Simi Valley, CA)

0205 UTC on 11905

Thailand: Radio Thailand. News coverage of Afghanistan and Pakistan. "97 FM Radio Thailand" IDs with pop music by Whitney Houston, The Bee Gees, and Smokey Robinson. Audible at 0019 UTC on 9655 kHz. (James Kline, Hong Kong)

0220 UTC on 4844.6

Guatemala Radio K'ekchi. Spanish. Clear "K'ekchi" IDs, and religious choir music (-ed.) Audible with great signal past 0230 UTC. (John Tuchscherer, Neenah, WI)

0225 UTC on 5040

Ecuador: La Voz del Upano. Spanish. Latin ballads and orchestral music. Station ID at 0238 UTC with frequency references. (Sheryl Paszkiewicz, Manitowoc, WI)

0230 UTC on 5060

Ecuador: Radio Nacional Progreso. Spanish. Latin pop music and occasional U.S. pop. Local commercials and "Nacional" ID. National anthem and sign-off ID at 0307 UTC. (Bill Traister, Covington, TN)

0235 UTC on 9680

Taiwan: Voice of Free China. Chinese music program New Record Time. Excellent reception. (Marc Neveux, Simi Valley, CA) Audible on 7445 kHz at 1533 in English. (James Kline, Hong Kong)

0300 UTC on 9445

Turkey: Voice of Turkey. International and national newscast. Turkish folkdance music and feature, Istanbul Through the Eyes of a Foreigner. Good signal reception. (Marc Neveux, Simi Valley, CA) Feature From Turkey With Love heard at 2230 UTC on 9445 kHz. (Bob Fraser, Cohasset, MA)

0304 UTC on 4934

Kenya: Voice of Kenya. Lady announcer with news items at 0304 tune-in. Faint, but definite ID as "This broadcast comes to you from the Voice of Kenya," at 0308 UTC. Male DJ presents African music. Finally nabbed this after a month of monitoring a weak carrier! (Guy Atkins, Issaquah, WA) Congratulations, Guy, and let us know if they QSL! --ed.

0305 UTC on 9605

Germany-GFR: Deutsche Welle. News and editorial on terrorism. Fair signal

with fading and interference from Radio Moscow on 9600 kHz. Station ID with continued discussion on hostage situations. (Marc Neveux, Simi Valley, CA)

0320 UTC on 7110

Ethiopia: Voice of Ethiopia. Amharic. National service with carrier heard at 0320 UTC. Interval signal at 0329 and station sign-on. Opening announcements, gong signal tone and newscast from 0330-0340 UTC. Ethiopian music with interference from Indonesian station on 7100 kHz (RRI-Yogyakarta). (Aboe Thallep, Batang, Central Java, Indonesia) Great log!-ed.

0330 UTC on 9580

South Africa: Radio RSA. Discussion and interview on Africa's animal conservation. (Dr. Bart Brady-Clampa, Vancouver, WA) Profile program heard on parallel frequencies 21535 and 17765 kHz at 1848 UTC. (James Kline, Hong Kong)

0340 UTC on 4850

Venezuela: Radio Capital. Spanish. Lite Latino rock tunes and "Capital" IDs. Usual pop format continuing. (Harold Frodge, Midland, MI)

0358 UTC on 4800

Lesotho: Radio Lesotho. Tentative. Vernaculars. Weak signal with 0400 UTC announcements. News reporting format and talk into definite African pop music at 0408 UTC. (Guy Atkins, Issaquah, WA)

0442 UTC on 15150

New Zealand: Radio New Zealand Int'l. Story telling with interpretation. Local "7 before 5" time check, "National Radio" and "Radio New Zealand" IDs. (Frank Mierzewski, Mt. Penn, PA)

0515 UTC on 6100

Nicaragua: Voice of Nicaragua. Central American news and propaganda with background music. Numerous IDs and YVTO time station interference. Fair reception and slight signal fading. (Marc Neveux, Simi Valley, CA)

0530 UTC on 4915

Ghana: Ghana Broadcasting Corp. (GBC). Radio One station ID and time check at half-hour. Local news and children's chorus. (Rod Pearson, St. Augustine, FL)

0714 UTC on 9610

Australia: Australian Broadcasting Corp. (ABC)-Perth. Daily stock market report, and pop music program. (Aboe Thallep, Batang, Central Java, Indonesia)

0759 UTC on 15325

Philippines: Voice of America. "Yankee Doodle" tune with sign-on announcements. Editorial on U.S./USSR relations. Heard on parallel frequencies 11930, 11965, 15410, and 17865 kHz. (James Kline, Hong Kong)

0808 UTC on 11720

Australia: Radio Australia. Interview with Australian Foreign Minister. Report on Economic Conference in Tonga. Station ID at 0930 UTC with fair reception. (Jacques Ahuansou, Abidjan, Cote D'Ivoire) Welcome to MTI-ed.

0902 UTC on 4980

Venezuela: Ecos Del Torbes. Spanish. Sign-on as "Transmited Ecos del Torbes en San Cristobal estado Tachira, Venezuela patria de el Versador." Spanish cultural program to lottery info and musical ballads. (Jim Boehm, San Antonio, TX)

0905 UTC on 5039

Venezuela: Radio Maturin. Spanish. Venezuelan harp music and station ID. Fair copy for continued music program. (Rod Pearson, St. Augustine, FL)

0909 UTC on 21540

Germany-GDR: Radio Berlin Int'l. Discussion on the Radio Berlin Int'l DX Club, and antenna/signal enhancement tips. (James Kline, Hong Kong)

0930 UTC on 3310

Bolivia: Radio San Miquel. Spanish. Hauntingly beautiful Andean music with brief station break at 1005 UTC. (Bill Traister, Covington, TN)

0940 UTC on 3240

Indonesia: (Java) RKPDT2 Lumajang. Javanese. Drama program titled Ludruk. Local advertiser Enggran at 0956 UTC and ID as "Radio Pemerintah Daerah Tingkat Dua Lumajang." 1005 Malibag show by Krisnantli, and pop music at 1010 UTC. (Aboe Thallep, Batang, Central Java, Indonesia)

0945 UTC on 12015

Mongolia: Radio Ulan Bator. Asian background music for English ID. Excessive interference contributing to fair signal. (Bob Ferretti, Donora, PA) Monitored in English at 0028 UTC on 12015 kHz. (Harold Frodge, Yanshan, China)

0956 UTC on 6005.5

Costa Rica: Radio Relej. Spanish. Caribbean, Spanish rock/pop tunes. Request for listener's reception reports with address. Station promotional for shortwave and mediumwave frequencies. (Jim Boehm, San Antonio, TX)

Shortwave Broadcasting

- 1001 UTC on 21810**
Belgium: BRT. Brussels Calling and report on the educational system in Flanders. Mailbag show with address for listeners. English programming to 1024 UTC. (James Kline, Hong Kong)
- 1010 UTC on 3960**
Indonesia: (Sulawesi) Radio Republik Indonesia-Palu. Indonesian. Early afternoon call to prayer and Arabic music. Station IDs and regional news. (Aboe Thaliep, Batang, Central Java, Indonesia)
- 1020 UTC on 6012**
Antartica: AFAN McMurdo. Tentative. Weak carrier with occasional fade up of U.S. pop/rock songs. Announcer break buried amid the interference. Rechecks daily with continued fair signal. (Rod Pearson, St. Augustine, FL)
- 1020 UTC on 3976**
Indonesia: (Java) Radio Republik-Surabaya. Indonesian. Mailbag program and pop Indo music. (Aboe Thaliep, Batang, Central Java, Indonesia)
- 1019 UTC on 5020**
Solomon Islands: Solomon Islands Broadcasting Corp. (SIBC). Musical variety of pop, reggae, and country and western. Announcer duo with friendly chat. Local island recipe and time check. (Harold Frodge, Keaau, Hawaii)
- 1020 UTC on 4895**
Colombia: La Voz del Rio Arauca. Spanish. ID at tune-in and promotional as "Radio Informativa Columbiana." Local merchant commercials. (Harold Frodge, Midland, MI)
- 1046 UTC on 6010**
Venezuela: Radio Los Andes. Spanish. Sign-on at 0948 UTC. Marimba music and announcement as "Radio Milcuarenta" broadcasting. This could be a shortwave outlet for mediumwave station on 1040 kHz. Interference from poorly modulated signal on 6012 kHz. (Jim Boehm, San Antonio, TX)
- 1100 UTC on 3285**
Belize: Radio One. Sign-on anthem and lengthy English ID with frequencies for shortwave and mediumwave. Program introduction in both Spanish and English into country and western music. Birthday greetings and ranchero music. (Jim Boehm, San Antonio, TX)
- 1103 UTC on 3260**
Papua New Guinea: (New Guinea) Radio Madang. Pidgin. Closing news at tune-in with numerous mentions of Papua New Guinea and Madang. Instrumentals and English chat on local Community Center (including the bingo games). Time check at 1130 UTC. (Sheryl Paszkiewicz, Manitowoc, WI)
- 1105 UTC 5930**
Clandestine: Radio 15 Septiembre. Closing newscast at tune-in on Nicaragua. Station ID and discussion topic on the Sandinistas. (Bill Traister, Covington, TN)
- 1114 UTC on 9540**
Venezuela: Radio Nacional. English news on economics and tourism in Carabobo. ID for "Radio Nacional Venezuela for Latin America and the rest of the world." (Sheryl Paszkiewicz, Manitowoc, WI)
- 1120 UTC on 3335**
Papua New Guinea: (New Britain) Radio East Sepik. Pidgin. Local chat and introductions to country and western music. News bits to 1130 UTC ID. Lovely Papuan music --ed.
- 1134 UTC on 3385**
Papua New Guinea: (New Britain) Radio East New Britain. Native island music and current rock of the U.S. Listener dedications and evening time checks. (Harold Frodge, Keaau, Hawaii)
- 1135 UTC on 3395**
Papua New Guinea: (New Guinea) Radio East Highlands. Pidgin. Local island rhythms on bamboo instruments. Time check and station ID. Other PNGs audible were Radio Central on 3290 kHz, Radio West Sepik on 3205 kHz, and Radio Simbu on 3355 kHz-ed.
- 1155 UTC on 3905**
Papua New Guinea: (New Ireland) Radio New Ireland. Pidgin. Battling signal with amateur radio operators. U.S. pop, and country and western music audible during quiet moments. Quick ID and reference to local area-ed.
- 1200 UTC on 5980**
United States: WCSN. Inspirational programming, with discussion on the power of prayer. Repeated at 1400 on 13760 kHz. (Dottie Zellers, Ivyland, PA) Additional monitoring at 0000 UTC. (Leslie Edwards, Doylestown, PA)
- 1330 UTC on 15455**
China (PR) Radio Beijing. Multiton recipe and Chinese music program. (George Neff, Tampa, FL) Monitored at 0027 UTC on 11505 kHz with classical Chinese music. (Aboe Thaliep, Batang, Central Java, Indonesia)
- 1418 UTC on 4774.7**
Indonesia: (Java) Radio Republik Indonesia-Jakarta. Indonesian. Lady announcer with interesting program of "Musick Tradisionel dari Thailand." Station ID at 1429 UTC and out-of-tune marching band music. (Sounded like inebriated circus musicians.) (Guy Atkins, Issaquah, WA)
- 1500 UTC on 17735**
Oman: Radio Oman. Arabic. Station ID as "Ida'atu Omanlyya." Signal chimes with station announcements and repeat of ID at 1505 UTC. (Stephen Price, Conemaugh, PA)
- 1500 UTC on 4699**
Indonesia: (Java) RKIP Surabaya. Indonesian. Network news relay from Jakarta and traditional Javanese music at 1515 UTC. This broadcast can be heard on parallel frequency 4625 kHz. (Aboe Thaliep, Batang, Central Java, Indonesia)
- 1605 UTC on 17865**
United Arab Emirates: UAE Radio Dubai. ID and station address to Arabic music. Local time check for Dubai and news on Israel. National news and ID repeat. Excellent signal! (Leslie Edwards, Doylestown, PA) Audible at 1630 UTC on 15435 kHz in English. (George Neff, Tampa, FL)
- 1720 UTC on 17815**
Morocco: RDTV Marocaine. Rock tunes from "Rod Stewart's Greatest Hits" and French/English duo with "Beat It" rendition. (Sheryl Paszkiewicz, Manitowoc, WI)
- 1721 UTC on 3300**
China: (PR) Voice of the Strait-PLA. Chinese Beautiful traditional Chinese music presented by lady hostess. Station ID with time tips. (Aboe Thaliep, Batang, Central Java, Indonesia)
- 1800 UTC on 15010**
Vietnam: Voice of Vietnam. Fair signal for time tips, anthem and station ID at 1800 UTC. Newscast and recap of headlines at 1810 UTC. Parallel frequency 9480 kHz not audible. (Ken Kuzenski, Raleigh, NC)
- 1803 UTC on 9618**
Mozambique: Radio Mocambique. Newscast and station ID. Outlook Africa program, featuring Ghanalian Minister of Health discussing family planning. Bothersome interference on lower sideband. (James Kline, Hong Kong)
- 1836 UTC on 7505**
Bangladesh: Radio Bangladesh. Commentary on annual typhoon problems, with possible solutions, and "DX Program." (James Kline, Hong Kong)
- 1948 UTC on 7550**
Korea: Radio Korea. Station ID with Asian sports report. Parallel program being carried on 15575 kHz, with poor reception and interference. Spanish programming monitored at 2148, Arabic programming at 1824 and German at 1928 UTC. All audible on 7550 kHz. (Jacques Ahouansou, Abidjan, Cote D'Ivoire)
- 2011 UTC on 9575**
Spanish Morocco: Radio Mediterranee. Arabic/French. Arabic vocals to newscast at 2030 UTC. French DJ format with talks and U.S. pop music program --ed.
- 2015 UTC on 9855**
Israel: Kol Israel. Studio 3 program, discussing recent Russian Jewish artist immigrants. (Bob Fraser, Cohasset, MA) Monitored at 0000 UTC on 9855 kHz with repeat programming. (Mark Seiden, Coral Gables, FL)
- 2030 UTC on 15300**
Cuba: Radio Habana. Spanish. Latin American music and "Habana" ID. Heard also at 0100 UTC on 6090 kHz in English. (Aboe Thaliep, Batang, Central Java, Indonesia) Audible on 11760 kHz at 0600 UTC in English. (Marc Neveux, Siml Valley, CA)
- 2116 UTC on 12085**
Syria: Radio Damascus. Syrian music sung in Arabic language. Station ID as "This is Damascus." Brief commentary on summit meetings and continued Syrian music. Excellent signal! "Guy Atkins, Issaquah, WA) Monitored at 2130 on 15095 kHz with news. (Mark Seiden, Coral Gables, FL)
- 2209 UTC on 9615**
Vatican City: Vatican Radio. Vatican Viewpoint program discussing the ethics of medicine. In-depth news on Lebanon to 2224 UTC. Interval signal and 2225 UTC sign-off. (James Kline, Hong Kong)
- 2340 UTC on 17815**
Brazil: Radio Cultura. Portuguese. Pop tunes with Brazilian lyrics. ID announcement with mentions of "Sao Paulo" and "Radio Cultura." Monitored to 2358 UTC. (Frank Mierzwinski, Mt. Penn, PA)

Utility World

Larry Van Horn

P.O. Box 1088

Gretna, LA 70053-1088

Listen to the Soviets

Soviet ship monitor Sam Ricks in Philadelphia says he may have stumbled across two Soviet MORFLOT fleet weather channels. While monitoring during Hurricane Gilbert several months ago, Sam picked up the Soviet weather research ship NIS Georgi Ushakov (ERET) transmitting "blind" weather forecasts to several Soviet tankers enroute to Cuba in RTTY (170/50) at 1645 UTC on 16703.5 and 12522.5 kHz.

The following is an example of their call-up:
RYRYRYRYRYRYRYRYRYRY DE ERET ERET OSS
12522,5/16703,5 KHZ BLIND
RYRYRYRYRYRYRYRYRYRY DE ERET ERET OSS
12522,5/16703,5 KHZ BLIND NW NW-

RTTY traffic consists of detailed weather forecasts and sea condition reports for specific MORFLOT vessels. A traffic list is transmitted first, followed by each ship's forecast. All of these ships were underway, enroute to Cuba. Hurricane advisories, including barometric pressure forecasts, were also seen.

NIS Georgi Ushakov transmits weather forecasts daily at 1645 UTC. After several days of monitoring, the ship has been noted using the same frequencies as mentioned previously.

Sam checked through prior loggings and has found similar traffic from the NISP Ernst Krenkel (EREV) at the same times and frequencies. NISP indicates a weather research ship, with NIS and NISP used interchangeably.

NIS Georgi Ushakov and the NISP Ernst Krenkel are MUSSON Class research vessels, 3300 tons, length 319 feet, draft 17.1 feet, service speed of 16 knots and were built in Poland in 1967.

In a related development, Garie Halstead in West Virginia has found another net of Soviet ships. These have been heard nightly using 8408 kHz. The net seems to start around 0500 UTC and involves ships only (no shore stations).

One vessel will act as a net control taking traffic from the other ships. Three types of messages are passed. The most prevalent are "ASU" messages but weather and "SVC" messages are also passed. The weather messages seem to be of the regular "OBS" format while the "SVC" messages seem to be acknowledging receipt of a previously sent message.

Net control usually starts the net by sending a traffic list or calling 4KA soliciting traffic. The vessels call in at which time they receive a QRY number by the net control. Net control then goes back to the vessel he assigned QRY 1 and takes traffic from them in order. All traffic is in CW and full break-in is used so there are frequent interruptions by net control for "fills" in message text.

Most messages are addressed "Radio DPR Odessa ASU" so Garie assumes the messages get relayed to UFB. At times two vessels will move off the net control frequency to converse. Other times during slow periods vessels will chatter in Russian asking where the other is bound for or the operator's name at the key. Garie says it is good practice and a challenge in copying this Soviet net.

Although some vessels seem to check in almost nightly,

others do not. It's never the same group every night.

On the humor side of this story, Garie says that UTOK, for instance, seems to take great delight in adjusting his key to the point where dits and dahs become almost indistinguishable. (I am sure much to the dismay of others on the net.)

Utility World Reveals Euro Military Nets

Several months ago, Utility World featured in two parts the Strategic Air Command and the frequencies used by that organization. These two articles represented the most detailed look at SAC to date. But the SAC frequencies listed in those articles are not the only U.S. Air Force nuclear related frequencies to hear on shortwave. In Europe, as in the United States, the Air Force also makes use of HF radio to communicate with nuclear forces.

For years these European nets have been nothing more than names occasionally mentioned in various reference books. Frequency information has been almost impossible to obtain. Now for the first time, Utility World is proud to present information on these European based networks.

"Wideband"

While not in the HF range, these important military aircraft frequencies are used worldwide by SAM and SAC aircraft for communications and provide important information to HF military listeners.

Also known as "Combat Cinders" or "Autovon," this is a full-duplex FDM multichannel, wideband FM channel. The system uses nuclear hardened antennas at Autovon switching centers worldwide. This network is commonly heard from various SAC relay aircraft and also from the Emergency Command Post Aircraft.

"Wideband" has provisions for secure voice and teletype (also FAX) as well as fully automatic Autovon voice trunks with standard Autovon signaling and control. Trunks are located on 12, 16, 20, and 24 kHz single sideband channels within the wideband signals.

This system uses various frequencies in the 225-400 MHz band. Some frequencies monitored within the United States include 390.55 and 392.55 MHz. These channels have been heard from Air Force One in the past. Effective radiated powers from this system are very high. One published description of the system said it was 1,000 watts to counter absorption effects near nuclear fireballs.

Communications on this net occur nearly everyday in Europe. It is used mainly by the EC-135s operating between RAF Mildenhall and Lajes airbase in the Azores. Only one ground station (or ground entry point) is known in Europe and that is at Mormond Hill, Scotland. The main autovon switching centers in England are at RAF Uxbridge and Martiesham Heath. These could be candidates for ground stations also.

Aircraft transmit frequencies in Europe include: 300.75, 304.00, 324.00, and 389.5 MHz.

There are probably more. The aircraft normally use one channel at a time but with a backup channel running. The

frequency in use probably depends on which ground station is in use. After each circuit is checked out the aircraft then "transitions" to the next channel, and so on. The radio operator often transmits in plain voice over the whole of the wideband frequency and is the source of several daily tactical callsigns. Uplink channels from the autovon switching centers are unknown as of this writing.

"Cemetery and Gang Busters Net"

Consisting of about 70 low power HF stations in the European area, the system is used to pass EAMs (Emergency Action Messages) to occupational forces in Europe. This network is currently being upgraded and combined with the "Inform Net" that will be discussed next. They will become the "Regency Net."

The "Cemetery Net" is split into A/B/C/D nets with the "Gang Buster Net" being in overall control of the Net. Control stations in the "Cemetery Net." These networks are currently being interlinked with the "Inform Net."

Stations within these networks all use two letter callsigns (i.e. "FW", "TB", etc). Callsigns change every hour and it is exceedingly difficult to find out much about this net. The military classifies it as TOP SECRET.

Based on monitoring in Europe, "Gang Buster Net" traffic is received at Mildenhall and transmitted via HF on 3060 kHz. From here it is believed that the transmissions are received at Pirmasens for retransmission on all "Gang Buster" and "Cemetery Net" working frequencies. Most of these stations are believed to be at U.S. Army installations.

Each station in the net uses two frequencies simultaneously (a sort of double simplex) and this gives them added security in the event of a foreign station trying to break into their net. In the past these nets used to use frequencies allocated to amateur radio operators. Some of these guys used to get a bit indignant to hear their frequencies being used by the military. They would try pretending to be one of the "Cemetery Net" stations, but to no avail.

EC-135 airborne command posts use these nets and when working on the "Gang Buster Net" used to use their daily tactical callsigns. Security seems to have tightened up even more now as these aircraft currently use two-letter callsigns changing every hour which makes them indistinguishable from ground stations.

Frequency designators used to be quoted in plain voice but they are now referred to as Primary and Secondary, or, other frequency. If they have to specify a specific frequency it is done using coded messages. Table 1 lists some designators heard several years ago, and these designators may no longer be in use. Radiotelephone discipline on these nets is of such high order that very little information leaks out!

"Inform Net"

This network is a low powered alternative network to the ones discussed previously. It is also a European USAF military-based network. Sometime this year, "Inform" net will merge with the "Cemetery Net" and become the "Regency Network".

"Regency Net" or "Scope Force" as it is sometimes called, will consist of approximately 600 fixed and mobile terminals. These terminals are designed to support NATO and nuclear-capable U.S. combat forces.

TABLE 1
Cemetery and Gang Buster Net Frequencies

Desig	Freq	Network	Designator	Freq	Network
A02	2452	GB net	A20	10139	GB net
B05	3931	B net	B09	9244	GB net
C03	6796	GB net	C06	7777	GB net E03
	4821	GB net	F10	4458	GB/C net
G06	7777	GB net	H03	7777	GB net
J02	13341	B net	J10	6506	B net
J13	3760	A net		4980	C net
K01	3200	GB net	K10	7777	GB net
L01	14705	B net	L02	4560	GB/C net
L06	11446	GB net	M04	4933	C net
P07	4480	C net	R13	3060	GB net
S06	4545	A net	T01	3688	A net
T06	4987	D net		4496	A net
T09	8118	C net	T11	10478	GB/B net
U06	3973.5	A net	U07	4035	D net
	2760	D net		3996	D net
	7368	D net		9126	UNK net
	11515	B net		4020.5	UNK net
				6937	UNK net

Sometimes the B net is further sub-divided into B and E nets

TABLE 2
Inform Network Frequencies

Desig	Freq	Desig	Freq
A1	2403	A20	9414 or 9477
A2	2452 shared w/GB net	A21	10139 also GB net
A3	7777	A22	11641
A4	3215	A23	13479
A5	7777	A24	13545
A6	3946	A25	14374
A7	3958	A26	14423
A8	4477	A27	14505
A9	4612	A28	14682
A10	5092	A29	15476
A11	5105 shared w/GB net	A30	15560
A12	5146	A31	18179
A13	6819	A32	18744
A14	7305	A33	20539
A15	7384	A34	20604
A16	7424	A35	20609
A17	7895 or 8085	A36	20849
A18	7919	A37	77777
		A38	2031

Stations on the net from England include: Alconbury, Bentwaters, Fairford (standby status), Greenham Common, Lakeheath (standby status), Mildenhall, Sculthorpe (standby status), Upper Heyford and Weathersfield.

Stations on the net from Germany include: Bitburg, Frankfurt, Hahn, Pirmasens, Ramstein, Sembach (standby status), Spangdahlem and Zweibrücken.

Stations from the rest of Europe include: Torrejon and Zaragoza, Spain; Soesterberg, Netherlands; Aviano AB Pordenone, Italy; Helleniken AB: Athens IAP, Greece and Iraklion AB Gourná, Crete.

When the USAF units detach to non-USAF bases during long exercises, mobile "Inform Net" stations are set up.

Table 2 reflects the frequency plan of the "Inform Net" as it is now known.

A39 through A45 was in use about six years ago but the frequencies were never found. Sources believe that they were very low in the frequency spectrum. The higher

Utility World

frequencies are rarely used. Those most commonly used include: A1, A2, A8, A9, A18, and A21.

As of this writing, the net is split into two groups: stations in England controlled from Mildenhall, and the rest of Europe from Pirmasens. Radio checks are done every hour. Message traffic consisting of 88 or 56 items go out to all stations about eight times a day. Every station uses a daily tactical callsign. Several of these callsigns are often heard a few days later being used on the SAC "Giant Talk" net. Many other Air Force units, squadrons, etc. are also being allocated these callsigns, too.

I would like to thank Mr. UK for the background information used to prepare this month's section of the column. Without it, this new and exciting information would not have been possible.

In fact, "thanks" to everyone who contributed information to Utility World this month. Please note that we have a new address -- it's listed on the masthead. Gayle and I have slipped out of Florida and into the New Orleans area for a four year stint with Uncle Sam.

And now on with this month's loggings from the Utility World...

Utility Loggings

Abbreviations used in this column

All times UTC, frequencies in kilohertz. All voice transmissions are English unless otherwise noted.

AM	Amplitude modulation	ISB	Independent sideband
ARQ	SITOR	LSB	Lower sideband
CW	Morse code	RTTY	Radioteletype
FAX	Facsimile	UNID	Unidentified
FEC	Forward error correction	USB	Upper sideband
ID	Identification		

- 2182.0 NMF-2 USCG Group Woods Hole working a MAYDAY call from VSL PURSUIT. Vessel reported taking on water and pumps not working. In USB at 0334. (W.J. Battles, E. Kingston, NH) Welcome back to the column, Bill, and please report often --ed.
- 2516.0 NAM-Norfolk, Virginia, with FAX charts noted most evenings. New NAM channel. (Chris Beale, Virginia Beach, VA) Welcome to the Utility World, Chris, I hope to see you regularly in these pages --ed.
- 2638.0 NMF-2 USCG Group Woods Hole working the PURSUIT. Pumps now working, situation under control. In USB at 0418. (Battles, NH)
- 3187.0 Rescue 20110 standing by on frequency for Cape Radio during a shuttle launch in USB at 1440. (Peter Goubeaud, Sewanee, TN) Welcome to the column, Peter, hope to see your reports again --ed.
- 4283.0 ZSJ1-NAVCOMCEN Silvermine, South Africa Radlo heard with CW CQ marker at 0226. South African Navy. (Jim Boehm, San Antonio, TX) Welcome back to the column, Jim --ed.
- 4313.8 LZW-Varna Radlo, Bulgaria, heard with a CW CQ marker at 0206. (Boehm, TX)
- 4704.2 Signal here appeared to be a guard carrier for burst-type data transmission from 4703.2 to 4708.6 that sounded like "doink-doink-doink-blahhhhhhhhh." Tentative ID is a navy Link 11 tactical data relay channel, high frequency backup system. Noted at 1048 and gone by 1100. (Boehm, TX) Nice job on IDing this one. It is definitely a Link 11 channel. I like your written description of this weird signal --ed.
- 5526.0 Pan American "Clipper 201" heard in USB at 0727 working Paramaribo with position report over 08-55 north/57 west. Gave estimates for Zandery and ATITA. (Garie Halstead, St. Albans, WV) Welcome again to the loggings section, Garie --ed.
- 5535.0 Speedbird 7376 working Speedbird London (British Airways) with a request for weather at London Gatwick and Manchester, England in USB at 0102. (Battles, NH)
- 5562.0 NOAA 42 WP-3 Weather Recon aircraft working KJY-74 in USB at 0531. (Battles, NH)
- 5598.0 KLM749 heard in USB at 0419 working San Juan with amended routing because of Caribbean hurricane (skirting around the storm). (Halstead, WV)
- 5692.0 CG 1469 a HH-3F helo working Traverse City, Michigan, air station. Hoist ops complete and position report given at 1408 in USB. (Battles, NH)
- 5696.0 CG 2116 a HU-25 Falcon Jet working NMF-Boston in USB at 0128 in reference to a SAR of a downed aircraft near position 42/41 north and

73/10 west. (Battles, NH)

CG 1493 a HH-3F helo working NMF Boston. Enroute USS Fulton to medivac a patient to the USCG Academy in Connecticut at 2124 in USB. (Battles, NH)

- 6520.9 77XBP heard at 0225 in CW sending the following CW message, "77KMU 77KMU 77KMU de 71XBP 71XBP 71 XBP 23 RE 23 RE 23 RE" This message was repeated for some time. Who is it (Bert Huneault, Windsor, Ontario) Well, Bert, looks like you have stumbled on one of the NATO stations out of Europe, probably Spain. These guys shift callsigns in the 77XXX series and can be found all over the dial. Welcome to Utility World, and I hope you check in often --ed.
- 6577.0 Boyeros (Havana) heard in USB at 0619 working Aeroflot 345. Gave Hurricane Gilbert position report. (Halstead, WV)
- 6683.0 Air Force Two working Andrews in LSB at 0005 with a phone patch to SAM command. Battles, NH
- 6750.0 AF Rescue 820 working Croughton AFB, UK with a phone patch to RENO Ops. Aircraft working an SAR of an aircraft in the water in USB at 0516. (Battles, NH)
- 6830.0 SAM 60301 (Gulfstream) working Andrews. Aircraft reported right landing gear stuck. Declared an IFE and requested a patch to Gulfstream Co. for emergency instructions. (Aircraft later landed safely.) In USB at 1457. (Battles, NH)
- 7650.0 J9V working Q9T in USB at 1403. (Any Ideas who this is?) Sounded like they were having trouble setting up an RTTY link. (Battles, NH) Probably a couple of navy units, Bill, by the nature of the callsigns and traffic --ed.
- 8023.6 AFP news, Paris, France, at 0330 in French. RTTY mode 425/50. (Sam Ricks, Philadelphia, PA) Welcome again to the column, Sam --ed.
- 8299.5 UPLO-Soviet LGC carrier Lensovet with Russian traffic to UFB Odessa Radio at 0216. Carrying 50,900 tons of ammonia. RTTY 170/50. (Ricks, PA)
- 8359.0 LYHM-Soviet M/V Olginka heard in CW at 0735 with a message for the harbor master at Lisboa. (Halstead, WV)
- 8377.0 LRU-A-M/N Chaco of Argentine registry heard in CW at 0621 with an OBS message for NMN. (Halstead, WV)
- UUXS-Soviet M/V Volkhov heard in CW at 0614 with an OBS message for WCC. Ship's position 20.8 north/66.3 west.
- 8379.0 HCZV-Ecuadorian M/V Provincia del Guayas, heard in CW at 0512 working HCG with a message for an individual in Guayaquil advising arrival at 1700 hours on Tuesday (message in Spanish). Message ended with "Besos y abrazos" (hugs and kisses). (Halstead, WV)
- 8388.0 COJR-Cuban vessel Rio Cuya Guateje, heard in CW at 0527 working OBC3 in Peru. Message in Spanish gave position and speed of 8 knots. Message mentioned Zona de Pesca (Zone of Fishing). (Halstead, WV)
- 8390.0 SVNH-Greek M/T Antiparos, heard at 0349 in CW working WLO with a notice of readiness message for New York. Message advised arrival at Pto la Cruz, Venezuela, and being ready in every respect to load. (Halstead, WV)
- 8399.0 3EDG5-Panamanian vessel Reefer Badger, heard in CW at 0727 working JCS with a message for Yawatahama advising of trouble with the #6 cylinder of #2 engine due to broken piston. Require engine spare parts to Tauranga, New Zealand. Message listed various part numbers. (Halstead, WV)
- 8400.0 UJEN-Soviet M/V Zhemchuzhnyj Bereg, heard in CW at 0627 working

Utility World

- HPP with a message advising ETA Balboa. (Halstead,WV)
- 8401.0 USLP-Soviet M/V Kompozitor Rimsjly Korsakov, in CW heard at 0635 working Y5M. Message gave ETA at Rostock. (Halstead, WV)
- 8403.0 UNSQ-Soviet M/V Vatutino, heard in CW at 0638 working CLA with two messages with same text. (Halstead, WV)
- 8410.0 UFGQ-Soviet M/V Aspidza, heard in CW at 0600 with a message for Navecaribe-Habana. Message advised the loading of regular gasoline. Cienfuegos mentioned in text. (Halstead, WV)
- 8411.0 TCLA-Turkish vessel heard in kCW at 0411 working TAH with a message for Istanbul advising the vessel had passed Suez Canal. Mentioned Mogadishu in text (ETA). (Halstead,WV)
- 8609.0 CLJ-Havana MORFLOT Radio, in CW mode with Russian traffic for Soviet cargo vessels Igantly Sergejev (UYUU), Komsomolets Uzbekistana (ULBI), Krasnoe Selo (UNJS) and tanker Lyudinovo(UNVH) at 2317. (Ricks, PA)
- 8771.0 Spartan calling Raspberry, Pensacola, and Corpus Christi in USB at 1521. (Battles, NH)
- 8843.0 Hawaiian 920 heavy heard in USB at 0351 working Honolulu with position report over CLURE and estimate for CITTA. (Halstead, WV)
- 8861.0 Varig 708 heard in USB at 0658 working Dakar with position report and estimate for Gamba. Aircraft was advised to contact Sal (Cape Verde) on VHF 128.3 (Halstead, WV)
- 8876.0 Aircraft NOAA 43 (WP-3D Orion) with VORTEX message to CARCAH (Chief, Aerial Recon Coordinator, All Hurricanes) via KJY74, National Hurricane Center, Coral Gables, Florida at 0051 in USB. Aircraft inside the eye of Hurricane Gilbert. Daytime frequency used 13267 kHz USB. (Ricks, PA)
- NOAA 42 working KJY-74 Miami Monitor at 0100 in USB passing storm messages. (Andy Gordon, West Hartford, CT)
- 8894.0 Aeroflot 439 heard in USB at 0558 working Algiers with a position report over Delta Juliett Alphs (Djanet in SE Algeria). Aircraft gave estimate for Tobuk located on the Algerian/Niger border. (Halstead,WV)
- 8984.0 CG 6501 working USCG Miami Air in USB with an ops check at 1815. (Goubeaud,TN)
- 8903.0 Varig 798 heard in USB at 0516 working Luanda, Angola. Aircraft departed Rio at 0130 and gave ETA for Luanda as 0812. Gave aircraft registration as PPVMW. Cubana 492 also heard working Luanda at 0518 with an ETA of 0615. (Halstead, WV)
- 8993.0 Trout 99 working MacDill AFB with a phone patch to SAM command in USB at 1646. (Battles, NH)
- 9023.0 Huntress working Trident 07 in USB at 1902. (This is NORAD Foxtrot Quebec). (Battles, NH) It is also SAC channel Papa Lima and Mystic Star F-050. It is a very interesting channel indeed --ed.
- 10015.0 NOAA 42 (WP-3D Orion) working KJY-74 Miami Monitor in USB at 0030 with data from Hurricane Gilbert. Measurements from the eye of the storm. (Battles, NH)
- 10493.0 Stone Age called Cable Car in USB at 1420. WGY-904 answered. (Battles, NH) This is a FEMA channel --ed.
- 10588.0 KP8525 working several stations with disaster plans for Hurricane Gilbert at 1547 in USB.
- 10780.0 Agar 92 working Cape Radio in USB at 2030 with a radio check. (Battles, NH)
- MAC40619 working Antigua in USB at 1830. Aircraft gave mission and cargo load number. (Goubeaud, TN)
- Cape Radio working a Rescue aircraft (unknown number) at 1820 in USB. Aircraft told to change frequency to 2622. (Goubeaud, TN)
- Rescue aircraft 20110 working Cape Radio in USB at 1435 and told to contact Cape Radio on 3187 kHz. (Goubeard, TN)
- 11180.0 SAM 24127 calling Andrews with a phone patch to SAM Command requested at 1521 in USB. (Battles, NH)
- 11214.0 Jarem 81 working Trenton, Canada, Military with a phone patch to Raymond 24 (52nd AWACS, Tinker AFB, OK) in USB at 1907. (Battles, NH)
- 11306.0 Eastern 892 heard in USB at 0634 working Lima Radio with a position report over GYV (Guayaquil). Gave estimate for TBA (Taboga Island off Panama) as 0745. Also Eastern 027 reporting over San Jose at 0650 with estimate for Leticia and Rio Branco next. (Halstead, WV)
- 11396.0 UPS 867 calling Atlanta Radio several times with negative response in USB at 0042. (Battles, NH)
- 11440.0 Malem 10 working Malem 11 in USB at 0202. Same aircraft was heard working Albrook on 8993 just before this. (Battles, NH)
- 11548.1 SRB shuttle booster recovery ship Liberty working Range control during a recent shuttle mission. No time or mode given. (Jorge L. Rodriguez, Gainesville, FL) Thanks for the information, Jorge and thank Mark also --ed.
- 12524.5 UTPK-Soviet cargo vessel, Vissarion Belinsky, with a "No Monkeys Aboard" maritime declaration in English via UFB Odessa Radio at 0315. Enroute to Havana, Cuba. RTTY mode 170/50. (Ricks, PA)
- 12526.5 UUYZ-Soviet spaceflight tracking ship Nevel, with Kriptogramma for Science One, via URD Leningrad Radio at 2302. RTTY mode 170/50. (Ricks, PA)
- 13244.0 MAC 11411 (C-141) working Lajes, Azores, in USB at 1916. Requested weather for Pease AFB. (Battles, NH)
- 15547.9 Heard over several evenings a TDM RTTY signal. I receive channel B at 96 baud and 850 Hz shift. About every thirty minutes a transmission is routinely made as follows:
DO RFLI
DE RFLI 2840339
ZNR UUUUU
CONTROLE DE VOIE
NNNN
Who is this? (David Morgan, Dallas, TX) First of all, welcome to Utility World, David. The station you are monitoring is the French Naval Radio -- 6WW in Dakar, Senegal.
- 16703.5 ERET-Soviet Hydromet weather research ship Georgi Ushakov, with "blind" weather broadcasts to several Soviet tankers enroute to Cuba at 1645. RTTY mode 170/50 in Russian. Soviet weather ships broadcast "blind" weather advisories on 16703.5 and 12522.5 daily at 1645. (Ricks, PA)
- 16871.4 CWA-Cerrito Radio, Uruguay, with a CQ CW marker at 0105. (Boehm, TX)
- 17066.0 URD-Leningrad Radio with traffic for UVAU, Soviet spaceflight tracking ship Borovichi in Russian at 1436. RTTY mode 170/50. (Ricks, PA)
- 19443.0 Y7K38, Y7A77, Y7A78 -- East German embassy traffic to Managua, Nicaragua, in German. Also 5/1 code groups to several embassies at 1340. RTTY mode 425/50. (Ricks, PA)
- 19544.0 Cosmos 1932-Russian nuclear powered ocean surveillance satellite heard with typical RORSAT telemetry for several days at various times. Did note one unusual characteristic. When first heard, noted an abrupt shift in frequency of 1.5 kHz. This occurred exactly every five minutes then would shift down 1.5 kHz and back up at five minute intervals. Toward end of battery life this would occur less frequently and finally it would shift rarely. (Len Merkoske, Thunder Bay, Ontario) Nice catch Len, and welcome to the column. Yes, this was the Cosmos RORSAT; they were having problems with it. Could have been very interesting if it had not boosted the reactor to a safe orbit --ed.
- 20192.0 Ascension Island carrying Space Shuttle mission audio prior to liftoff with countdown information around 1423. (James A. Webb, Leesburg, VA) Thanks for the log, James. How about some more reports to Utility World? --ed.
- Also monitored by C.J. Shafer, Okeechobee, Florida, at various stages of the mission. I would like to welcome you also, C.J. For a complete listing of frequencies see the September issue of MT.
- 20997.0 Andy Gordon in Connecticut reports this is the calling channel for Navy MARS operation in the 20 MHz area.
- 22555.0 UFB-Odessa MORFLOT Radio in CW mode with Russian traffic for the 15,600 ton bulk carrier Kapitan A. Polkovskiy (UPJG). (Ricks, PA)

The Scanning Report

Bob Kay

P.O. Box 173

Prospect Park, PA 19076

Cellular Wars

Have you ever stopped to wonder why the corporate cellular giants spent millions to have the ECPA passed? Sure, we all know that the basic underlying reason was to trick the public into thinking that car phone conversations were private.

But something else was brewing here. A war was being fought over rural cellular sites. The remarkable thing about this war was that it was being fought between the small business cellular entrepreneurs and the big guys like Pacific Bell, G.E., Bell Atlantic, Bell South, GTE, MCI, and a long list of others.

Why would multi-million dollar corporations, especially established land-line phone companies, be so adamantly opposed to the development of rural cellular sites by small businesses? For profit? Ok, I'll agree with that. but not wholeheartedly. There was something else in the wind -- I could smell it. Like brewing coffee, the aroma was growing stronger as things began to heat up. Finally, the real reason for the ECPA and the rural cellular wars was ready to be served to the public.

When cellular phone prices and usage fees began to decline, lower profit margins drove out the smaller, independent dealers and forced them to relocate into more remote areas. At first, it seemed that the little guy would control the suburbs and the cellular giants would provide service to the large cities.

To me, that seemed like a logical solution. Heck, there weren't that many cars in the suburbs anyway. A typical example would be "Brasstown, North Carolina." What million dollar corporation would be interested in providing cellular coverage to an area with less than a dozen vehicles?

But that's not what happened. The corporate giants followed the smaller companies into rural America and began to wage an even bigger war over the rights to erect cellular sites and for control of specific frequencies.

A Cellular Phone in Your Home

Why? For the exclusive right to provide fixed cellular phones in private homes. The FCC has already permitted the licensing of cellular services to fixed locations. Even more intriguing is that cellular phone operations have the ability to provide all the features currently found on conventional wire connected phones. Speed calling, three way conferences, call forwarding and call waiting can all be accomplished on the cellular network. In fact, cellular switching equipment is more advanced and better equipped than most of the current land line telephone switching equipment!

Right now, cell sites are connected to the switching office by land line. However, microwave signals or 800 MHz radio signals can eliminate the use of land wires. This would open up huge remote areas of the country to reliable cellular coverage.

In these remote areas, access to a cell site would be accomplished through a roof-top cellular antenna. If this

type of cellular operation becomes a reality, it could possibly eliminate the existing land-line telephone switching networks.

Now suppose for a moment that you are a land-line phone company. When your customers call between point "A" and point "B" you charge that as a long distance call. Still with me? Ok, here's the kicker -- home cellular business entrepreneurs, with just a few cell sites on rural mountains could offer local billing for all calls between points "A" and "B." In fact, the entrepreneurs, by joining with other small cellular ventures, could possibly provide your customers with local service to practically anywhere in the state!

It's easy to see how a handful of these little home cellular entrepreneurs could put you out of business. The only alternative was to get into the cellular business and fight like heck to stay there. Of course, you also lobbied for the ECPA -- after all, it would help you to sell cellular phone service to private home owners.

More Digital Calls?

With the advent of home cellular usage, the number of transmissions will increase dramatically. However, there is a catch. Digital cellular conversations are in the near future. The technology is already available to make third party monitoring of cellular calls impossible. The only stumbling block, at this time, is the price.

By the mid-1990s it is expected that digital cellular will be a reality among the top ten cellular cities: New York, Philadelphia, Chicago, Detroit, Boston, Washington D.C., Houston, Dallas, San Francisco, and Los Angeles.

Why digital? There are a lot of reasons. Digital communications can provide more channels within an existing frequency allocation. This simply means that cellular corporations can get more channels without asking the FCC for more frequency coverage. A lot of home services can also be sent over cellular digital. Your water, gas and electric, to name just a few, could automatically be sent via the cellular digital network. Digital signals can also tolerate more interference and digital equipment, after the initial installation cost, is actually cheaper to operate.

But don't put your scanner in the closet just yet. If digital cellular is to become a nation wide reality, there must be some sort of standardized plan. Otherwise it would be impossible to use your digital car phone in areas outside of your home town. If every large city develops a completely different digital network, the cellular folks will be severely cutting their profit margins.

Should the big guys agree to a national or even a regional digital plan, the smaller markets may not choose to use digital at all. There's a good possibility that they would try to undercut the larger companies by offering low priced, standard service between two large cities -- such as New York and Philadelphia.

For wide area digital coverage to work, every commercial cellular enterprise, regardless of size, must sit down and agree to use the same type of system. Although the cellular folks are optimistic towards digital standardization, the wide spread cooperation needed to begin implementation of such

The Scanning Report

a system, simply isn't there -- the wars are still raging.

Surgery on the Pro2004

Your letters nearly drove me bananas. "What diode do I cut or add . . . ?" "There isn't any diode on the underside of the board . . ." "Where is diode 510?" "What does diode D-514 do?" After a while, I was seeing diodes in my sleep.

It seems that the newer production models of the Radio Shack Pro 2004 have a slightly different internal arrangement. To eliminate the confusion, I examined the organs of a factory fresh unit and here's what I found:

All the diodes are located within a metal can that has a removable top. The can is located on the circuit board marked PC-3.

Peering into the open can, a row of diodes can be seen along the left hand side. All the diodes are labeled, with the exception of the vacant holes above diode D-13. By simply counting backwards, the predrilled holes for D-510 can be easily located. To install D-510, you will have to remove the seven screws that hold the board to the chassis. Prior to removing the screws, gently pry off the five connectors labeled 501, 502, 503, 504, and 505. What does D-510 do? Here's the rundown:

- D-510 Installed, provides 400 channels
- D-511 Installed, disables 30 kHz step increments
- D-513 Removed, restores cellular coverage
- D-514 Installed, scanning rate increases to 20 channels per second

The Pro 2004 was first reviewed in the March 87 issue of *MT*. In the January, 1988 issue of *Monitoring Times*, Bob Grove pointed out that there was no reason to install D-511.

Hopefully, this update has answered your questions. If not, an SASE guarantees my personal reply.

Mexican Information

Reader Xavier Garcia wrote and asked for information concerning frequencies in Mexico City, Mexico. Can anyone out there help? Since Xavier didn't mention any particular service, any frequencies that you may have would be appreciated. Please send them to the Scanning Report, and I will forward them to Mr. Garcia.

Reader Frequency Exchange

Are you interested in starting a reader frequency exchange? Here's how it would work. Send in your frequency requests and I will print them for our readers to answer. When a response arrives, I'll send you the original and then print the frequencies for the benefit of everyone.

With your permission, I will also pass on your address to the responding reader. This would effectively begin a pen pal relationship between you and the person that answered your request.

As in the past, all requests for anonymity will certainly be granted.

Chips Detector Fails Miserably

In the October 88 column, I asked for your input and comments on the "CHIPS Detector." A company was producing and advertising them as the "Anti-aircraft weapon for highway patrol planes and the only protection against all

forms of speed measurement."

From your letters, nobody had any praise for the unit. It seems that the manufacturer added a sensor circuit into a bunch of old Fox 1080s. When the added oscillator detected an extender frequency, the unit emitted a load tone.

Since a police officer can be out of his car for any number of reasons, the CHIPS Detector is virtually useless. It simply alerts the user that a patrolman might be out eating lunch or possibly using the bathroom!

Robert L. Caron of Fair Oaks, California, wrote to say that CHP aircraft use a P/L system on one of the extender frequencies. As a result, his CHIPS Detector never shuts off!

If you're wondering about the price, the unit retails for \$500.00. Need I say more?

Scanner Soaps

In Greensboro, North Carolina, a woman identifying herself as the wife of the Police Chief used the police radio to accuse her husband of having an affair with one of the police department's former female recruits.

Apparently the transmission lasted a full ten minutes and was heard not only by the police but also by home scanner listeners. The woman stated that she "wanted the world to know that her husband was having an affair."

I think she got her message across. (Newspaper clipping from Ken Kuzenski, Raleigh, NC)

Baby Monitors Bug America

I know, I've covered baby monitors before. But the letters keep coming in. Some of the stuff that you guys hear can't be printed here! It seems that a lot of baby monitor owners never turn the things off. As a result, everything that happens in the user's home is transmitted over the airways. From casual dinner conversations to heated sexual encounters, the baby monitor transmits everything it hears between 49.0 and 50.0 MHz.

A person that calls himself "Monitor-monitor," or "M&M," from Spokane, Washington, wrote and told me that he didn't listen to baby monitors because he was afraid of the personal information that he might hear.

Well, maybe M&M can tell that to a magazine like *Popular Communications*, or to the Ladies Cookie Cutting Auxiliary, but as *MT's* scanning columnist, I'm not buying it.

However, I like to think that I'm a broad-minded individual. So I'll turn the question over to my readers. Are there more of you out there that are afraid to tune baby monitors?

Save the Whales

Remember when the Soviets sent two ice-breakers to rescue the whales last October? Wasn't that nice of the Soviet Union? Maybe I should stop picking on them in this column. Maybe, as an indication of our gratitude, the American people could send a few plane loads of snowmobiles to the Soviet Republic. Why? To free all the people that have been exiled to Siberia!

Boston Fire Frequencies

Charles K. Willians sent in the following frequencies for the eastern Boston area:

The Scanning Report

Andover	483.5875
Arlington	460.600
Belmont	154.13
Billerica	33.66
Boston	453.85, 483.1625, 483.1875, 483.2125, 483.2375
Logan Airport	854.9625
Braintree	483.5125
Brookline	483.4375
Burlington	154.3400
Danvers	483.3335
Quincy	483.4625
Somerville	483.3875
Winchester	483.6375
Woburn	483.6125
Framingham	483.7625
Deer Is. House of Corr	854.0875
State Police Mobile Rep	154.02
State Police Surveillance	453.850, 471.7125

Indiana Monitoring

Jack Forbing, (K9LSB) of Hoosierland Amateur Mobile Systems, sent in 400 frequencies for the Fort Wayne area and vicinity. Here's a small sampling:

468.200	FWPD Vice/Narcotics
163.968, 167.568, 167.600	FBI
122.00	National Flight Watch
142.417	Salyut Space Station
468.358	FW city government auto patch
160.698	Secret Service
163.810, 164.600	U.S. Marshall
165.235, 165.290, 418.050	DEA
324.300	Grissom AFB
298.500	SAC refueling
166.5125	Security VIP escorts
487.925	VIP Special Protection
417.200	Federal Protection Service

Jack's list appears to have been reduced in size so that it would fit onto one page. For those readers that may find the print hard to read, it could easily and inexpensively be enlarged by any well-equipped copying center. To receive the complete list, just send one dollar to cover the hassles of copying and mailing this little gem.

Scanning with Ham Gear

I love my little hand-held scanner. But I hated the low power audio. On the open highway, even with the windows rolled up, I had to pucker my ears to hear the action.

While reading through 73 Amateur Radio Magazine, I came across an ad for an HT Audio Booster from Naval Electronics. I figured if the audio booster would work on a transceiver, it should also work on a scanner.

When I told the folks at Naval Electronics that I was thinking of mentioning the unit in my column, they were kind enough to provide a sample that I immediately placed into service.

The first thing that I noticed about the audio booster was that it fit neatly into the palm of my hand. The unit is small, about 5 inches high, 3 inches wide, and 2 1/2 inches deep. It is also completely portable. It can be powered from your vehicle's 12 volt battery or from four internal AA batteries. The unit incorporates an automatic shut-off

feature that causes the amplifier to shut down and extend the life of the batteries.

A three foot length of speaker cord is provided with two factory installed 1/4 inch phone jacks. Operation of the audio booster is accomplished by simply plugging your hand-held into the input jack of the audio booster.

On initial hook-up, I was very pleased with the output. For the first time, I could hear my hand-held in mobile operation. In fact, the audio booster easily climbed above the comfortable setting of my FM stereo radio.

At first, I was skeptical of the shut-off feature. I figured that prior to becoming reactivated, it would miss a portion of the transmission. I was wrong. The unit fired up like lightning and never missed a word!

Try It -- Can I Fry It?

Since it was doing so well, I decided to try and fry it! I plugged it into my Pro-2004 and activated all 400 channels. As you can guess, the unit never got a chance to shut off. Ninety minutes later, it was still working perfectly. Ten seconds after turning the radio off, it shut down and waited for more abuse.

So I punched in a FM stereo radio frequency and waited for the batteries to run down. Two hours later, it was still pumping out audio like there was no tomorrow.

As a scanner nut, I liked it. I liked the portability too. No matter where I took my hand-held, the HTS-1 could tag along. In the car, in the garage, or down the basement, whenever I needed more audio, the audio booster provided it.

The unit did have one serious flaw that caught my attention. When using an external power source, the unit's internal NiCad battery charger never shuts off. If alkaline batteries are being used, they could explode if the owner fails to remove them. The folks at Naval Electronics list this as a hazard with an underlined statement in the instruction booklet.

The HTS-1 retails for \$29.95. For more information or to order one for yourself, write to Naval Electronics Inc., 5417 Jetview Circle, Tampa, Florida, 33634. Telephone 813-885-6091.

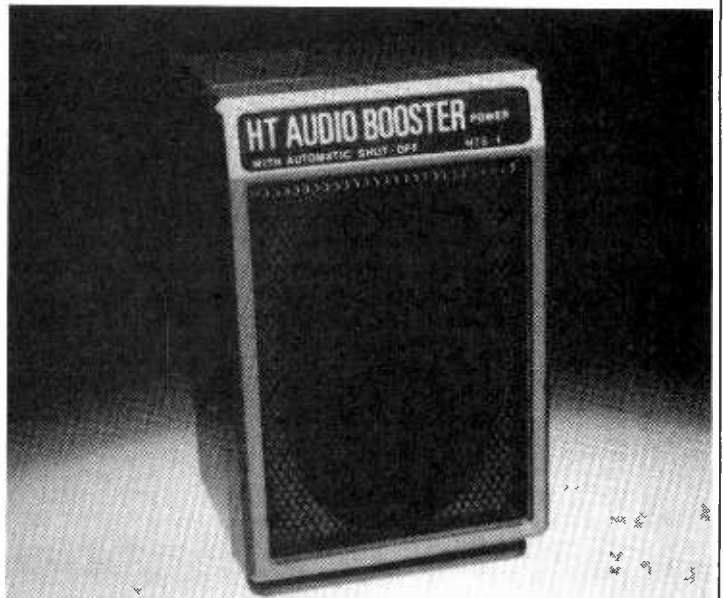

what's new?



Software for the ICOM R71-A

Systems and Software International has announced another in their Remote Controlled Scanning System (RCSS) line of Macintosh software products. RCSS for the ICOM R-71A is now available. The announcement of RCSS for the R71-A follows by some two years the introduction of a similar product from SASI for the R-7000.

According to G. Watts Hill, III, the new R-71A software has all the features of the popular R-7000. Additional features have been added to the existing options for scanning by frequency ranges and banks of user-defined frequencies.

One example of these additional features is the ability to scan paired duplex frequencies. If the unit is monitoring a primary frequency and finds nothing, it will automatically consult a built-in database and check the companion frequency before moving on to the next primary frequency stored in the user's bank of frequencies.

The data base has also been expanded to now include the ability to print a report, listing all of the primary and companion frequency information stored in each record as well as detailing its activity.

The receiver can also be programmed in a manner similar to a VCR for timed program recording. Those who want to monitor a particular station at a particular time and date need only enter it into the computer.

All of these features -- and others --

combine to give the monitor the ability to control their monitoring in a manner not previously available to the general public. RCSS software for both the R-7000 (and its color version) and the ICOM R71-A is now in stock. For more information, write to Systems and Software International Ltd at 4639 Timber Ridge Drive, Dumfries, Virginia 22026 or call 703-680-3559.

ICOM IC-12GAT 1.2GHz Handheld

It is, according to manufacturer ICOM America, Inc., "the next dimension in 1.2 GHz activity." Indeed, the new IC-12GAT handheld transceiver lets you enjoy full base station luxury in a portable unit.

Designed with a rugged, water-resistant shell for daily outdoor action, the IC-12GAT boasts some of ICOM's newest features:

- Splash resistancy -- The '12GAT is designed for use in rugged outdoor conditions.
- Wideband Coverage -- It receives and transmits from 1240 to 1300 MHz.
- One Watt Power Output -- Switch to low power (.1W) instantly.
- 20 Memory Channels -- Store any frequency, transmitter offset and sub-audible tone in any memory.
- Programmable Scan and Memory Scan -- Programmable scan function enables you to scan all frequencies between two programmable scan edge frequencies. The

Memory Scan function allows you to scan all memory channels except those you choose to lock out.

● Built-In 1750Hz Repeater Access Tone -- Instant repeater access with the touch of a button.

The ICOM IC-12GAT also includes built-in battery saver, built-in DTMF keyboard, programmable call channel, all subaudible tones, multi-function LCD readout and DTMF pad. Now available, the suggested list price for the ICOM IC-12GAT is \$529.00. For more information, contact ICOM at 2380-116th Avenue N.E., Bellevue, Washington 98004.

The Original Sex and Broadcasting

by Lorenzo Wilson Milam

Sex and Broadcasting is billed as "A Handbook on Starting a Radio Station for the Community." That certainly is a more accurate description of the contents than the

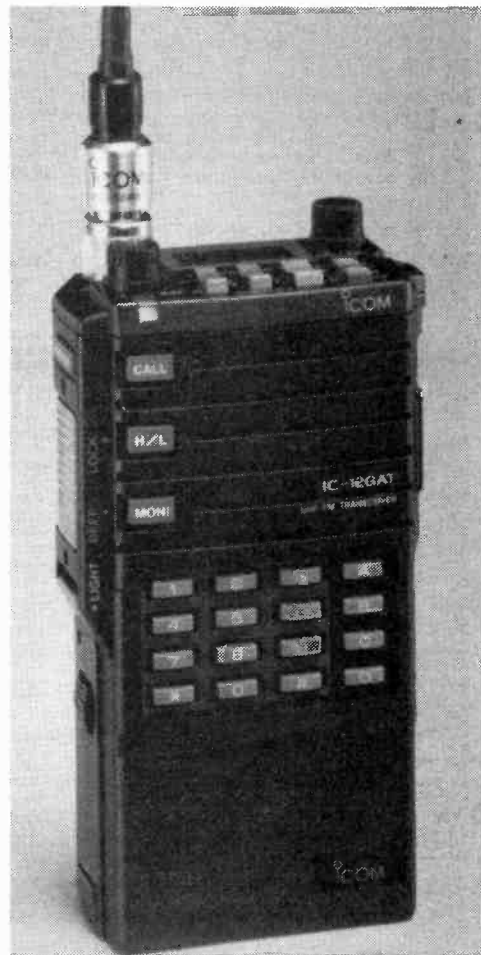

title -- there's nothing inside about sex. But like *Starting and Operating Your Own FM Radio Station* (See "What's New," November, 1988), even the publisher's sales pitch fails to accurately describe it.

Now in its fourth edition, *Sex and Broadcasting* is the story of the author's involvement in community radio in the early-1970s. And if it is, as the author claims, "seriously out-of-date," the defect only serves to enhance the magical quality of the story. It is a story of the innovations -- some silly in retrospect -- and idealism of the late 1960s and early 70s.

Along with telling the tale of KTOA-FM, Mr. Milam magically digresses into whimsical flights of broadcasting fantasy that perhaps, can only be appreciated by those obsessed, as the author clearly is, with radio.

"One of my friends has said that you could send up the perfect weather balloon. Broadcasting your message. All across the U.S.

"It goes up from the far east end of Long Island. Launched from some deserted beach near the Hamptons. The balloon carries with it a tape cart machine. With an hour or hour-and-a-half endlessly repeating message. Over and over the tape goes...

"The winds take your message of love to the east -- for a few hundred miles. And then, when it gets into the area of the stratosphere, the prevailings start carrying it, your white balloon, and your message, back over the entire United States.

"...your message, which could only be wiped out if they sent up one of those SAM missiles. Or the entire U.S. Air Force. The might of the military, sent up to destroy your silly message, and tiny balloon. What a fine flapdoodle."

Another great story:

"I got a funny feeling about the power of radio once: a thousand years ago in another country.

"It started in Frankfurt, where I got a new shiny Blaupunkt radio installed in my car. It was a beautiful radio, with lots of black-shine buttons, and a single red eye that lit up to let me know that the world was crowding my dial...

"I went into a dark corner Frankfurt bar to celebrate my new radio and my new car. I remember (vaguely) drinking an inordinate amount of icy clear schnapps intermixed with draughts of warm dark beer. I remember a foggy mind and a foggy night through dark windows. I remember an old man with a potato face huddled in the corner of the bar. I remember him mumbling, and I thought he was talking to me. I turned my head, smiled, said something in lousy German. Hands across the sea.

"*Juden.*" he said. He said a great number of other things, other words, but "*Juden*" he said most of all. He didn't smile. "*Juden,*" he said. I knew it was time to leave Germany, even though it was 1961 and there should be nothing to fear.

"There's nothing to fear," I told myself, and I drove south and west. Running from Frankfurt to Neunkirchen, from there to the burning valley of the Saar, the hot black no man's land that still -- Common Market or no -- gashes between France and Germany.

"There is nothing to fear," I said, as I raced south from Saarbrücken, down through Macon and Lyon and Avignon -- down towards the sun and the light. It was a time of great, aggravating isolation. My sole riding companion showed a single red eye, and spoke to me in many languages and many musics.

"I began to feel warm, to feel warmer and safer..."

What *Sex and Broadcasting* is about is the passion of broadcasting, that indescribable "something" that gets in the blood and never leaves the veins of anyone who has ever been involved with it. True, the books is, as the authors says, "an artifact of an era." And Thomas J. Thomas comes closer still when he says that "Perusing its pages is a bit

To have your new product or book considered for review in *Monitoring Times*, send it to Editor, 140 Dog Branch Road, Brasstown, NC 28902.

MAC TAKES CONTROL OF ICOM®



Turn those hours of searching for secret frequencies over to the Remote Computer Scanning System®. The RCSS runs on any Macintosh, and offers complete monitoring and automatic logging of all signal activity found by your R71-A.

- Scan unlimited banks of frequencies
- Search multiple frequency ranges
- Print frequency and activity reports
- Color for Mac II owners
- Mouse and/or Keyboard entry
- Import /Export information between Macintosh and built-in database
- Scan among Duplex frequencies
- Variable scan delay options
- Multifinder compatible
- 99 Memories per bank
- Monitor freqs. by date & time

Includes Interface, Software, and Manual

only \$199.95

Call or write for information. Dealers welcome.

SYSTEMS & SOFTWARE
INTERNATIONAL LTD.

4639 Timber Ridge Drive • Dumfries VA 22026



(703) 680-3559 • FAX (703) 878-1460



R7000 version also available

like "leafing through an old copy of *The Whole Earth Catalogue*, or, for those who lived these stories, perhaps more like a school yearbook." But both have, oddly, missed the truth, for *Sex and Broadcasting* is a love story -- one that anyone with that indescribable radio "something" still coursing in their veins will treasure.

Sex and Broadcasting is available from CRB Research, P.O. Box 56, Commack, New York 11725 for \$12.95 plus \$2.00 shipping (NY residents add sales tax).

NRC AM Radio Log 9th edition

Published every two or three years by the National Radio Club, this latest edition of the AM Radio Log (formerly called the Domestic Log) contains listings of over 6000 medium wave broadcast stations throughout the United States and Canada.

Data for each listing includes location, frequency, call letters, format, news network affiliation, address, day/night antenna patterns and more. The logbook is arranged first by frequency (530-1600 kHz), then cross-referenced by call letters to aid off-air identification.

An introductory section provides a brief history of the Log and insights into medium-wave licensees and their schedules. A glossary of abbreviations assists the listener in the proper use of the Log.

This is the definitive reference for domestic AM broadcasters and should be at the fingertips of every medium-wave DXer.

(Approximately 250 pages, 8-1/2" x 11", looseleaf drilled for three-hole binder; \$16.95 including shipping from the National Radio Club, PO Box 164, Mannsville, NY 13661; for phone orders call Ken Chatterton at 608-423-4159)

Learning the Lingo

I always celebrate the New Year at 00:00 UTC. Firstly, its fun to listen to WWV click off the new year. Sometimes they plug in a "leap" second to get the clock in sync with the real world. Also, if you party until 00:00 UTC, you can get to bed at a decent hour.

But for me the real kick of New Year's Eve/Day is setting down my radio resolutions for the coming year. Simple things like, "this year I'm going to finish sending out QSL cards to pick up my DXCC." Diligently digging under WHLO and the various Cuban signals to pull out KFI on 640 kHz. Promising to make at least three contacts on the Novice bands each week. Paying my dues to the local repeater society. Finally, fixing that glitch in my scanner.

Get to the point, Skip!!

At the risk of sounding more off the wall than usual (blame it on the season) I would like to propose a New Year's Radio Resolution to the readers of *Monitoring Times*.

Remember all those old adventure movies where the pre-Indiana Jones character would machete his way through the woods to encounter a native who spoke very good English? Our hero would inquire as to how this aboriginal individual came by this remarkable ability, to which the bushman would reply, "Why, I learned how to speak by listening to the shortwave radio in the missionary's hut."

My proposal is that it might be a fun resolution to utilize the shortwave hobby to begin to develop a knowledge of another language. For that matter, you could even use the standard AM broadcast band if you were leaning toward savvy Spanish.

The advantages of multi-linguality are myriad, but not necessarily within the scope of this magazine. Mastery of another language can take years of study and practice. However, picking up a working knowledge of any one of the major languages will serve to increase your QSL quotient. Therefore may we proceed to digress into...

Why not make a New Year's resolution to watch less TV in the coming year? You don't want to end up like this guy!

Uncle Skip's Guide to Cheap and Dirty Linguistics

This is a great big world that we monitoring types tend to shrink with our radios. The problem is that an awful lot of that intelligence coming over the receiver is in other languages, making it hard to keep track and harder to understand sufficiently to log. So the first important "cosmopolitan" skill the listener has to develop is language recognition.

Language Recognition

Probably the easiest way to learn how to keep track of the various languages you hear on your receiver is to get in the habit of listening to broadcasters that have already identified the language being transmitted. Most of the major international shortwave broadcasters send out signals in dozens of languages.

An excellent resource for finding broadcasts in languages other than English is the *World Radio TV Handbook*. This book can be obtained from many of the advertisers in *MT*. The *WRTH* is a very useful tool for serious listening as it gives comprehensive information about virtually all international broadcasters, their operating patterns, and, for our purposes here, the languages that they broadcast in. In the *WRTH* you can look up the operating schedules of BBC, CBC, and VOA and find regular programming in such languages as Albanian, Cantonese, Indonesian, Dari, Hindi, Creole, as well as the more familiar French, German, Spanish and

Russian.

Utilizing these schedules along with some serious listening will allow you to detect the differences between many languages so that you can more easily discriminate between Portuguese and Spanish, Latvian and Lithuanian, Cantonese and Chinese. Who knows, you might even be able to sort out some dialects, giving you further fodder for your log book, Bunky.

Intelligence Gathering

This is the closest most of us will ever get to playing 007. Short of actually mastering a new language, it will be impossible to get much information off the air from that "identified" language. But take heart Old Son! Hook up Mr. Tape Recorder. You can use Old Uncle Skip's "Tape It and Tear It Apart" method of translation. Listening to your tape, supplemented by judicious use of the pause control, will allow you to pick up quite a bit of what's going on.

One of the first things you will learn is that many "ANGLO" words have crept into the world. The word "radio" is the same in Serbo-Croatian as it is in English; most other languages follow suit. International business interests and the growing use of high technology in the world at large put a small percentage of the broadcast you are translating in your lap.

Next you go over the tape utilizing a "Whatever" to English dictionary or phrase book. A great little book for listeners is *The Concise Dictionary of 26 Languages in Simultaneous Translation* compiled by Peter M. Bergman, \$5.95 from New American Library.

I purchased my first copy of this book back in the sixties and I literally wore it out using it to sort my way through the shortwave spectrum.

Utilizing Anglo/Techno words and a dictionary should give you a good 50 percent translation if you are diligent. And if you think of the 40 percent you can't understand as being like those bits of information you commonly lose to fading and interference, you are really not doing too badly. You won't be able to get a job at the United Nations, but you are going to have a lot of fun.

One of the most exciting things you will learn is that some countries' news broadcasts will be very different depending on the language and the audience. What they tell the locals and what they tell the world does not always match up in the wonderful world of interna-

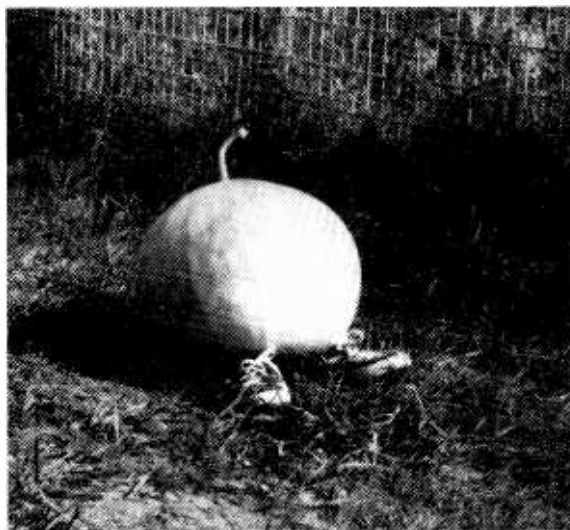

tional politics.

At the risk of losing my Life Membership in the American Radio Relay League, you can also use this system to "translate" CW transmissions. Only a small number of code operators can copy the high speed code you might hear on some utility frequencies. The tape recorder will help you to get the CW signal down to a speed mere mortals can copy. Who knows, playing back the tape might even be good code practice.

Ham Radio Considerations

Since I am probably in trouble with my fellow amateurs for suggesting taping code, allow me a shot at redemption.

If you have been monitoring the amateur frequencies for any length of time you will notice that many DX stations seem to know their way around English. However, if you try to go beyond name, signal report, and location, you may find that this knowledge of English is a veneer of understanding, sufficient for a contact, but not a conversation.

The second most common language in hamdom is Spanish. You can quickly increase the number of QSLs coming into your mailbox from Central and South America by developing a simple knowledge of Spanish, just enough to get the contact done.

To help in this effort the American Radio Relay League has published *HOLA CQ, a Spanish Language Course for Radio Amateurs*, by "Doc" Schwartzbard AF2Y, available for \$7.00 plus shipping from ARRL, 225 Main Street, Newington, Connecticut 06111. This brief text and accompanying cassette tape give you just enough Spanish to make you dangerous. If you follow this course through, you will be able to conduct a simple QSO with any of the Spanish hams you might run across. Listeners can use the course to increase their understanding of the operations of Spanish speaking hams.

QSLing

When you begin to send reception reports to stations that are not in the "International Market," you will not be able to count on the station having a staff fluent in English. So how do you get a confirmation out of such a station? The first effort should be to utilize one of the commercially produced multi-language reception report forms. These are available from some SWL suppliers as well as through many radio clubs. These forms usually give you some sort of check-off system for English, Spanish, and French. Use of such a form will often make your reception report more favorable.

However, if you are really trying to get a confirmation out of a country that does not utilize these three languages as either their primary or secondary tongue, you can still get a shot at QSLing success. Contact the language department of a nearby college. Assisting you in developing a reception report form would make an excellent project for some student in this program. Whenever I have explained my motives, and the monitoring hobby, I have always found help in this resource.

Spy Numbers

This could be the easiest way to start to understand other languages. To establish good documentation on a spy number station utilizing a language other than English, all you need do is figure out the tongue and learn how to count up to ten in that language. You can look up the few words that may proceed or conclude the transmission in a phrase book. Give it a try. Even Old Uncle Skip can count to ten in Spanish and German.

COMPUTERS

+
RADIO =



ham
radio
Amateur
State-of-the-Art

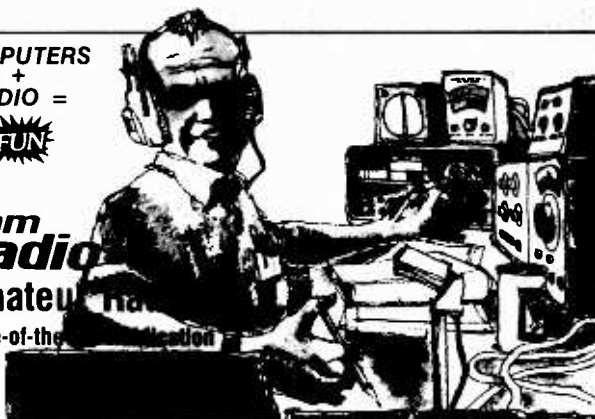

Try a subscription to Ham Radio Magazine for one year for just \$19.95. SAVE \$3 off the regular Ham Radio subscription rate of \$22.95 and \$10 off the newsstand price

Ham Radio gives you more technical articles and the very best technical articles of the Amateur journals. Transmitters, receivers, antennas, as well as state-of-the-art design theory and practical articles. Ham Radio has got it all! In May there's our annual Antenna Issue — chock full of all kinds of antenna design ideas and projects. November brings the Receiver Issue — the very latest in receiver technology for the Radio Amateur. Many consider these two issues alone worth the price of a year's subscription.

And there's more! Monthly columns by: Joe Carr, K4IPV on the ins and outs of repairing and troubleshooting your radio; Bill Orr, W6SAI on antennas and antenna technology plus a lot more; noted HF/VHF operator and DX'er Joe Reiser, W1JR's world of VHF and UHF technology; and noted government propagation expert Garth Stonehocker, K8RYW on propagation

There's even more — but you'll have to get a subscription to find out what it is

Fill out the coupon today and send it in before you miss another issue! Remember — you not only get Amateur Radio's finest magazine, you also SAVE \$3.00 off the regular rate

Special Trial Subscription
Save \$3.00 off the regular
rate of \$22.95/year

JUST \$19.95

Prices US Subscriptions only

Sure I'll give Ham Radio a try. Sign me up for a one year subscription. Just \$19.95 for 12 issues. That's a \$3 savings off the regular rate of \$22.95

Start my New Subscription
 Payment Enclosed Charge to MC VISA

Card Number _____ Expires _____

Signature _____

Name _____

Address _____

City _____ State _____ Zip _____

ham radio magazine, Dept. MT, Greenville, NH 03048

Turning Pro

After you have spent a few months trying your hand at these techniques, you may just discover that you have an affinity for one of the languages you have encountered. Great, now push the envelope! Start to listen more often, trying to pick out more and more of the transmission right off the air.

If it is one of the more common languages you might try borrowing instructional records or tapes from your local public library. Look for courses by Berlitz or Barnes and Noble. Of course, you can locate books on the subject as well. As I was compiling my research for this column, I was amazed at the number of language phrase books one can find in any better book store. If you truly persevere, you may come close to being like the tribesman mentioned earlier.

Some years ago, many of the major international broadcasters offered language courses over the air. The last time I ran across this with any regularity was on Radio Beijing. I have often wished for a slow-speed Spanish language similar to VOA's "Special English" broadcasts to the rest of the world. Such programs that cater to the learning of languages are, I am sure, helpful to comprehension.

The Bottom Line

While it seems unlikely that any of us will ever become like that gifted native, learning a new language solely by shortwave radio, it seems that the radio hobby can be utilized to augment language skills. So why not make a New Year's Radio Resolution to use the monitoring hobby to extend your linguistic horizons?

A Wing of the National Guard

The Federal File this month presents the operations of the 102nd Fighter Intercept Wing (FIW) of the Massachusetts Air National Guard. The 102nd FIW operations are conducted from the Otis Air National Guard (ANG) base, located in the Massachusetts Military Reservation in Bourne (upper Cape Cod area).

The mission of the 102nd FIW is to provide and support combat-ready aircrews and operationally ready aircraft for peacetime surveillance and control. Their job is to ensure air sovereignty, to intercept, identify, and provide attack warning and assessment and, if necessary, destroy enemy airborne objects under all environmental conditions. Simply stated, the 102nd provides the first line of defense and surveillance for the east coast, from Maine to New York City.

The Massachusetts Military Reservation is the host for five different installations: Cape Cod Air Force Station (PAVE PAWS radar), Coast Guard Air Station Cape Cod, Massachusetts Army NG (Camp Edwards), ANG (Otis ANGB), and the Veterans Administration National Cemetery of Massachusetts. The 102nd FIW has been located at Otis AFB since 1968 and assumed airfield management in 1974. The Otis ANGB is a former USAF base that was deactivated in 1974 and which held the same name.

A point of confusion rises here as the Otis ANGB is part of the Massachusetts National Guard — a state civil defense agency and not directly a federal operation. The fact is that the ANG can be federalized in time of war by the federal government. Its command structure is dual, meaning that it involves both the state Department of Public Safety and the federal Department of Defense. Most of Otis ANGB funding, such as the \$400 million worth of ANG jets, comes from the federal government.

The mission of the 102nd FIW, as mentioned earlier, is to provide defense and surveillance on the east coast from Maine to New York City. This includes the interception of unidentified aircraft flying within 200 miles of the northeast coast. The most common are Soviet reconnaissance planes. However, the interception of Soviet long-range bombers and other Soviet aircraft also occurs from time to time.

In order to accomplish these tasks, the 102nd FIW utilized F-106 Delta Darts until early last year when they were replaced with F-15 Eagle fighter jets. The 102nd was the first ANG Air Defense Unit to receive the Eagle, eighteen of them in all. Two remain on 24-hour alert at Otis ANGB. A detachment of two remain at Loring AFB in Limestone, Maine

(talk about cold winters!).

Soviet aircraft are detected by radars along the eastern seaboard when they enter into an Air Defense Identification Zone (ADIZ). ADIZ's extend approximately 200 to 250 miles off shore. Once in an ADIZ, Soviet aircraft remain under constant surveillance. ANG F-15 Eagle fighters from the 102nd FIW are ordered to scramble by the Region Control Center at Griffiss AFB in Rome, New York.

Griffiss AFB is headquarters for the North American Aerospace Defense (NORAD) Command's 24th Air Division (AD). The northeast sector of the 24th AD NORAD region covers all of the northeast U.S. and into the midwest with most of Ohio, Indiana, Illinois, Wisconsin, and all of Michigan included.

The mission of the Otis ANG FIW and the 24th AD obviously requires a reliable communications system and network to fulfill the duties assigned to them. The UHF AC band is the primary range of communications monitorable of the 102nd FIW. The F-15 utilizes several UHF radios for voice communication: a main unit, an auxiliary (AUX), and a guard radio. The main and AUX units are twenty channel radios and the guard radio is a single channel set to 243.000 MHz.

Table 1 lists the frequencies of the main and AUX radios. The channels are referenced as Button 1 through Button 20 on each radio. Reader Larry Fowler, who supplied much of the material used in this article, has confirmed channels 1 through 8 of the main radio and has monitored the remaining frequencies but channel indicators have not been confirmed. Buttons 9 and 10 vary depending upon the operation and the frequencies in Table 1 for 9 and 10 are used occasionally.

Table 2 is a comprehensive listing of UHF aircraft frequencies utilized by the 102nd FIW during training and operations, with all frequencies confirmed. Training is an important function of the operations, a function which hones the skills of the personnel dedicated to the defense of the northeast seaboard. The 102nd FIW constantly trains with other units and various aircraft. Exercises are most commonly conducted in Warning Area 105 off the coast of Massachusetts over the Atlantic Ocean. Common "visitors" to the area are F-16s from Burlington, Vermont ANG (158th TFG) and from Atlantic City (177th FIG); F-18s from Beaufort, South Carolina MCAS (Marine Corp Air Station); and E-3A AWACS.

Exercise control is maintained generally by "Huntress," the 24th AD NORAD northeast control station at Griffiss AFB. Control may

also be exercised by a single pilot known as the "Air Boss."

Air traffic control is provided by several tactical communications squadrons such as the 102nd TCS (Roadstead) from North Smithfield, Rhode Island, and the 103rd TCS (Footrope) from Connecticut. Remote radar and radio sites throughout the New England area enable Huntress to monitor and communicate with exercise units.

The U.S. Navy Fleet Area Control and Surveillance Facility (FACSFAC) "Giant Killer" located near Virginia Beach, Virginia, provides the clearance to enter the warning areas. Remote transmitters along the seaboard enable "Giant Killer" to communicate with the aircraft.

Exercises are held on a daily basis with night time exercises being held twice a week. The exercises will typically have one group of aircraft as the aggressors and the other group as the defenders or interceptors.

Special thanks go to reader Larry Fowler of Monument Beach, California, who supplied much of the information contained in this column.



**Table 1
102nd FIW Main and AUX**

Main Radio

Button 1	262.000 *Cape Ops* Command Post (CP)
Button 2	275.800 Otis ANGB Ground Control
Button 3	294.700 Otis ANGB Tower
Button 4	291.100 Otis ANGB Departure Control
Button 5	269.300 Boston Center-ARTCC
Button 6	307.300 Boston ARTCC (changes frequently)
Manual	351.900 Boston ARTCC
Manual	387.100 Boston ARTCC
Button 7	307.000 Boston ARTCC
Button 8	284.600 Otis ANGB Approach Control
Button 9	239.200 NORAD-AFS Remote Site-Tactical
Button 10	364.200 Air Intercept Control Channel (AICC)
Button 11	251.800 NORAD-Scramble Channel
Button 12	258.000 NORAD-"Paddle" frequency with AWACS
Button 13	303.900 NORAD-AFS Remote Site
Button 14	282.500 NORAD-AFS Remote Site
Button 15	292.800 NORAD-AFS Remote Site
Button 16	233.600 NORAD-Scramble Channel
Button 17	228.700 NORAD-AFS Remote Site, AWACS
Button 18	338.800 NORAD-AFS Remote Site
Button 19	357.200 NORAD-AFS Remote Site
Button 20	288.000 Norad-AFS Remote Site-Tactical

Auxiliary Radio

Button 1	262.000 Otis ANGB CP
Button 2	289.000 Air-to-air
Button 3-20	Unidentified

Table 2
102nd FIW AC Frequencies

118.200	Otis Approach, paired with 284.600
118.750	Otis Approach-Radar, paired with 318.100
121.000	Otis Tower, paired with 294.700
121.600	Otis Ground Control, paired with 275.800
124.700	Otis Approach/Departure
126.100	Otis A/D
126.300	Otis Departure, paired with 291.100
225.8	Assigned by AWACS "Dragnet Victor"/NORAD "Huntress"
228.7	Primary NORAD Operational and Control "Huntress" Command Channel
231.7	Equipment test with "Footrope" 103 Tactical Command Squadron
233.5	NORAD Operational and Control "Huntress"
233.6	Primary NORAD Control "Huntress"-Command Channel-AWACS mission
237.15	AWACS and Fighter exercise assigned by "Dragnet Victor" AWACS
238.1	Unidentified usage
238.2	Bangor ANG Air Refueling Group Command Post "Mainiac Ops" used as refueling channel with "Maine" (ID for KC-135 Tanker)
238.6	Equipment test with "Footrope" 103rd TCS Connecticut
238.7	NORAD Primary Command operational and control
238.8	Pre-set Button 8 when enroute to Loring AFB, Limestone, Maine
239.2	NORAD Operational and Control-AFS Radar and Radio Remote, AWACS Celestial Gulf
239.4	NORAD Operational and Control-Discrete-"Have Quick"
251.25	Working "Footrope" Lane 3 Whiskey 105 (Warning Area)
251.8	Primary NORAD Command Channel-"Huntress"
255.0	Navy FACSAC/Vacapes Primary Warning Area 107 and 108/Air Refueling
258.0	Primary NORAD Command Channel-"Paddle Freq" for AWACS and Ground Link
259.4	Button 10 in AUX Radio working "Sleekness" and "Footrope"
265.9	Discrete assigned by Navy FACSAC Vacapes "Giant Killer" W.A. 105
267.8	Working "Roadstead" in W.A. 105-AAR with "Pac" KC-135 Pease ANG
270.1	AUX Radio-"Footrope"-NORAD Operational AFS Radio Remote
273.4	NORAD Command Channel-AWACS Celestial Gulf-NORAD "Huntress"
275.9	Working "Footrope" 103rd TCS Connecticut
278.4	NORAD Command Channel-AFS Remote Radio Site-AWACS Celestial Gulf
283.8	NORAD Operational and Control "Huntress"
287.3	AAR with "PAC" Tanker/Command post 157th ANG Air Refueling Group, Pease AFB, Portsmouth, New Hampshire Callsign "PAC" = KC-135
288.0	NORAD Operational and Control/AFS Remote Radar and Radio Site Frequency
288.2	AWACS "Celestial Gulf" Assigned/"Bandsaw Gulf" = Mission Commander
292.5	Working "Sleekness" in W.A. 105
292.8	NORAD Command Channel-AFS Radar and Radio Remote Site
296.65	AWACS "Dragnet Victor" Assigned for exercise
297.7	Discrete Interplane used during exercise
299.2	Discrete Interplane used during exercise
299.5	Discrete Assigned by Navy FACSAC/Vacapes "Giant Killer"
301.6	TAC Control "Footrope" Main Freq-103rd TCS, Connecticut
303.0	"Roadstead" W 105-used as common-also Barnes 104th TFG Command Post
303.9	NORAD Operational and Control "Huntress"
305.0	Navy FACSAC/Vacapes "Giant Killer" W 105 and 106 AP/DP-Training
308.8	Working "Sleepers"/working "Sleekness"/Fighter Control
312.8	NORAD Operational and Control "Huntress"
313.6	Common AWACS Training Freq. used by "Dragnet Victor" and "Celestial Gulf"
314.2	Primary TCS Freq. "Roadstead" and "Footrope"
316.7	Listed as AF Pease AFB, NH-used in mission by 102nd FIW
318.4	NORAD Command Channel/used as surveillance coordination W/AWACS
320.6	AWACS Training Freq "Celestial Gulf" Assigned to Fighters
328.0	Working "Sleekness" in Sorting Exercise
338.1	Navy FACSAC/Vacapes "Giant Killer" primary for W 105 and W 106
348.2	Working "Sleekness" in Sorting Exercise
351.0	Air-to-air refueling with "PAC" 157th ANG ARG,NH/Secondary Mission Frequency
355.2	Working "Sleekness" in Training, Sorting Exercise
361.2	Used as Discrete in Sorting Exercise
361.6	Tactical Control in Training Exercise
364.2	Air Intercept Control Channel-NORAD Command Channel (AICC)
382.0	NORAD ATC Channel-Clearances and Air Traffic Control
390.1	Air-to-air Refueling W/"PAC" 157th ANG ARG Pease AFB, NH
398.1	Working "Roadstead" in W 105 in Sorting Exercise-Secondary Frequency

Table 3
Otis ANGB Non-AC Frequencies

51.15	Army NG Helicopter Operations (NBFM)	163.5375	Munitions, Police
122.850	Army NG Helicopter Operations (AM)	165.1125	Taxi, Civil Engineers
148.515	Air Crew Alert	165.1375	Security-perimeter and gates
150.165	Flightline Refueling Operations	170.450	U.S.D.A.-inspection service
150.195	Munitions; Flight Line Maintenance	173.5875	Fire/Crash Crews, E.O.D.
150.255	Ramp Control, Ground Engineers	413.450	Command Alert
163.5125	Maintenance, Taxi		

Detect clandestine transmitters with the 2044 Ambient Signal Strength Indicator ...

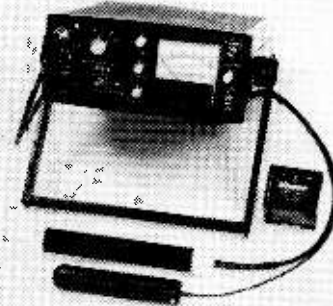

- RF devices from 1MHz to 4GHz - AM, FM, Pulsed (tracking)
- Infrared Light Beam Transmitters
- Carrier current signals on a.c. or telephone lines from 10kHz to 500kHz
- Telephone modifications

The finest counter-eavesdropping equipment from the company that started it all ...

Write for catalog

MARTIN L KAISER, INC
Box 171, Cockeysville, MD 21030

Table 4
Tactical Calls and Codes

Alpha Kilo	NORAD Alert Scramble
Band Saw Gulf	E-3A AWACS Mission Commander
Blade	F/A-18 Hornet
Cajun	F-15 Secondary Training
Cape	F-15 Enroute Cross Country
Cape Fox	F-15s
Celestial Gulf	E-3A AWACS
Chief	F-15 Secondary Training
Darken	AV-8B Marine Harriers
Dog	AV-8B Marine Harriers
Dragnet Victor	E-3A AWACS
Flash	F-15 Primary Training
Footrope	103rd TCS-CT
Giant Killer	Fleet Area Control and Surveillance Facility (FACSAC)
Heat	FB-111s-Plattsburgh, NY
Huntress	NORAD 24th AD NE Control Center
Jeep	F-15 Primary Training
Jersey	F-40 Phantom-Atlantic City ANGB
Lynx	F-15 Primary Training
Maine	KC-135 Tankers from Bangor ANGB
Maples	F-16 VT ANG
Moose	B-52s-Loring AFB
Norris	B-1 Bomber
Pac	KC-135 Tanker-157th ARG, Pease AFB
Roadstead	102nd TCS-N. Smithfield, RI
Rodeo	F-15 Secondary Training
Roma	KC-135 Tankers-Griffiss AFB
Siam	F-15 Primary Training
Spook	Lear Jets from Griffiss AFB
Strato	B-52s-Griffiss AFB
Upset	KC-10 Tanker
Viper	A-10s

Emergency!

Medical Assistance on the High Seas



(MAS)

Information recently arrived from Bill Edwards, a radio officer aboard the SS Coastal Manatee, regarding the Medical Advisory Service which may be of interest to you. Medical advice is something that is often required at sea, and not all ships carry physicians or other medical personnel. Bill's information may, therefore, provide some interesting listening.

Medical Advisory Systems, Inc. is located in Owings, Maryland, and provides the services of medical specialists to ships at sea which do not have trained medical personnel capable of coping with the present emergency -- be this an accident victim or someone who has suddenly been stricken with some kind of illness.

MAS employs physician-specialists on a 24 hour basis. It has proven its worth many times in assisting a ship's crew or the personnel on some remote drilling rig in handling medical emergencies wherein a victim may not be moved, due to the nature of his illness or injury, or when he may be anywhere from many hours to several days away from any possible treatment in a medical facility. In such cases, undue delay might, quite literally, mean the difference between life or death for the patient.

Should the diagnosis prove to be for some contagion, then likewise, an early

knowledge of this is vital.

The assistance is provided via radio conferences over HF (shortwave) frequencies. The emission mode is, as it is for all marine radiotelephone circuits, upper sideband (USB). Here are the frequencies most used, which are exclusively assigned to MAS by the FCC for this use. All communications are simplex, i.e. both ship and coast station on the same frequency (kHz).

4893.0	7952.0	12327.0
16450.0	16590.2	22722.0

Bill also reminds us that any communications heard on these frequencies are covered by the provisions for the secrecy of communications in the various countries of the world, therefore, you should not make improper use of the information which you may intercept.

Maritime Medical-Europe

Some years back, in this column, I published some information about another station providing medical information to the maritime community and Bill's letter offers an indication that perhaps it is time to reprint the information, so here goes.

In Europe there is a station set up exclusively for the purpose of handling

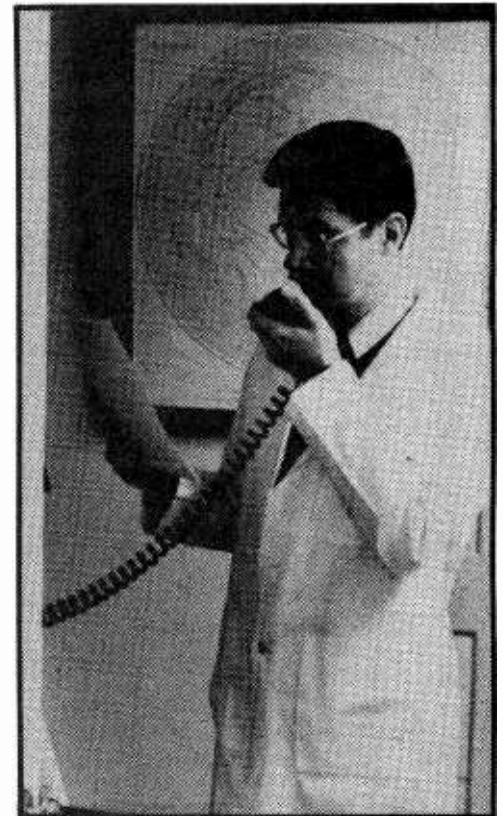

Dr. Thomas Hall, MAS' chief physician, on a radio call. MAS (call sign WHD 576) monitors 16590.2 24 hours a day, and scans the other five frequencies at three second intervals. (Courtesy MAS)

messages to and from medical authorities. The Centre International Radio Medical operates station IRM in Rome, Italy. This station provides medical advice to ships anywhere on the high seas by radio. Well respected medical authorities, such as senior medical officers of hospitals, nursing home directors, etc. are consulted, and the ship will receive advice with the least possible delay.

Should it be necessary, the C.I.R.M. can arrange for transportation of patients from ships on the Mediterranean to hospitals on shore. Arrangements are also in place to allow air transportation of patients by French, Dutch, Norwegian,

and Egyptian authorities.

IRM operates on nine frequencies, using Morse Code, namely 4342.5, 4350.5, 6365.0, 6420.0, 8685.0, 12748.0, 12760.0, 17105.0, and 22525.0 kHz. There is an automatic marker transmission giving the frequency being guarded on each band, and one frequency in each band is guarded 24 hours a day, so that there is a good possibility that one can hear IRM sometime during the day. It's not unusual to hear them on more than one band.

Sometimes, for various reasons, it is not possible to communicate directly with IRM. When this happens, contact can be made via IAR on CW or Rome Radio on SSB. Messages will then be sent to the C.I.R.M., or telephone calls placed to them without any charge to the calling ship.

The following frequencies can provide some interesting listening, as IAR and Rome Radio also handle domestic traffic, as well as medical and other emergencies. All frequencies are in kHz.

IAR

4292.0	8669.9
4320.0	13015.3
6409.5	16895.3
6418.2	17005.0
6435.5	17160.8
8530.0	22372.4
	22378.0

Rome Radio

8778.6	17248.4
8796.4	17304.2
13125.6	22599.1
17239.1	22627.0

International Code of Signals -- Medical Signals

There is a special section of the international code of signals which deals specifically with various medical situations which might arise. The code, which was set up by the International Maritime Organization, is designed to facilitate communications when there is a problem due to one or the other party handling traffic being unable to understand the language or accent of the first. Sometimes the problem is as simple as interference or atmospherics.

DATAMETRICS COMMUNICATIONS MANAGER

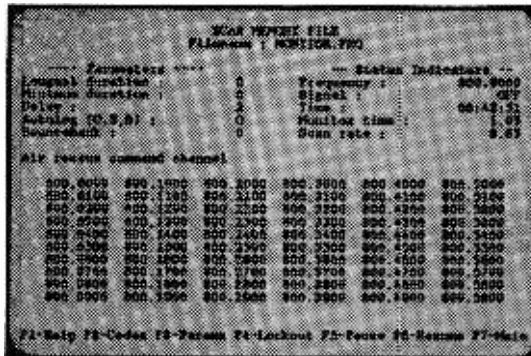

Special Introductory Pricing
Hardware, Software and Manual : \$299

Mail Orders To:
Datametrics
2575 S Bayshore Drive, #8A
Coconut Grove, FL 33133

- * Provides IBM compatible computer control over the ICOM R7000
- * Powerful menu driven software includes full monitoring display and system editor
- * Innovative hardware interface with signal detector requires no internal connections
- * Comprehensive manual includes step by step instructions and screen displays
- * Extends ICOM capabilities including autolog recording facilities, 1000 channel capacity per file, and much more
- * Overcomes ICOM limitations such as ineffective scan delay
- * Utilizes Datametrics FRQ format for scanning
- * Requires ICOM R7000 and IBM PC with 512K RAM and serial port
- * Manual available for system evaluation at \$15

Caribbean Emergency Network

Another network which has maritime overtones is the Caribbean Emergency Network which enjoys the participation of 20 countries in the area. Net practice sessions are normally held on Tuesdays and Fridays at 1330 UTC on 7435.5 kHz LSB (Channel 5) and 7850 kHz USB (Channel 2). Other frequencies (kHz) which are used include:

2182.0	USB	Maritime emergency
2527.0	USB	Maritime emergency
6977.5	USB	National Wx Sce net, (ch. 5)
7453.5	LSB	Routine traffic
10100.0	LSB	Emergency only
13965.0	LSB	Pan Caribbean Disaster Preparedness and Prevention Project/Red Cross Communications
14303.0	USB	Amateur, emergency only

In the eastern Caribbean, the following frequencies are also used:

3616.0	USB	Emergency, amateur, inter-island police
3815.0	USB	Emergency only
7220.0	USB	Emergency only
7453.5	LSB	Routine traffic
13996.5	USB	Red Cross Communications

Among the callsigns which may be heard are the following:

DISREP	Pan-Caribbean Disaster Preparedness and Prevention Project
HHP 57	Haiti Emergency Operations Center
J6P	St. Lucia Police
J6L	St. Lucia National Coordinator's Office
J39AI	Grenada
ZJL 89	Tortola
ZOA	Antigua Police
ZOB	St. Kitts Police
ZOD	Dominica National Coordinator's Office
ZOM	Montserrat Police
ZON	Nevis
ZOU	Anguilla
6YX	Jamaica Coast Guard
8PF	Barbados Coast Guard
9YA	Trinidad Coast Guard

There is another network in the Netherlands Antilles which operates on 3815 kHz LSB. Their practices are held daily during the storm season at 1030 and 2230 hours UTC.

There are other emergency systems; however, these are the major, and probably the most likely to be heard. Until next time, have a try at some of the frequencies and perhaps you might hear something more interesting than you have been hearing recently.

Your letters are always welcome. Good luck until next time.



The AEA 2 Meter Isopole

Recently, a local ham (Bob Uleski, N3FHI) called and asked if I knew of a decent antenna for two meters. Since I had an AEA IsoPole stashed away in the shack for evaluation, we decided to let Bob do the hard work for us. Here's what Bob says about it.

"The IsoPole came well packed and was easy to assemble. The kit included a two section adjustable length 5/8th wave top section, two aluminum decoupling cones, two foam cone center spacers, and pipe clamps used to mount the decoupling cones. The purchaser must provide a section of 1-1/4 inch pipe or TV mast.

"The direction sheet is very easy to follow, and the antenna was fully assembled in 40 minutes. The longest operation was twenty-five minutes, needed to file the anodize off the antenna mast where the two decoupling cones are attached.

"Coax is slipped through the mast and fastened to the 5/8 wave top using a PL259 connector. The top is then slipped over the mast and fastened with three screws. Physical measurements are provided by AEA for several main frequencies. I decided on 145 MHz for mine. By sliding the decoupling cones up and down the mast and telescoping the top section the IsoPole can be adjusted to any frequency between 135 to 160 MHz.



AEA IsoPole VHF antenna. Models for 135-160 MHz, 210-230 MHz, and 415-465 MHz are available. A superb antenna for VHF or UHF FM.

"For comparison I connected both my old 5/8th wave whip and the IsoPole to a coax switch, they were both mounted at the same elevation and switched using a VHF coax switch. The results were super. Signals that were S-5 on my old antenna were consistently 8 to 9 on the IsoPole. On simplex contacts the IsoPole was at least three S units stronger.

"The nicest improvement was on packet radio. Now I can copy at least three times as many packet stations with the Isopole than I could with the old antenna. Now many hams are using me as a digipeater to connect to more remote stations.

"To sum it up, I was very pleased with the IsoPole. It's become my favorite two meter antenna."

N3IK DXpedition!

The weekend of October 8 and 9, N3IK was active from a very *rare* location! My old comrade Tim, KB3JD, and I decided to activate Elk County, Pennsylvania, during the Pennsylvania QSO party. Now, I know Pennsylvania ain't exactly a rare place, but there is very little activity from Elk County and a lot of the county hunting gang was glad to hear us.

It was a real fun weekend and we had pileups whenever we announced Elk county. Tim, who had never worked a contest before, became thoroughly addicted and was making plans to return before the contest was over.

Many of us would like to be rare DX, but who can afford the time and expenses of going to "Norfolk Island" or the like? But if you keep an eye open for the various state QSO parties and pick the uncommon county, you too can be counted as "DX!"

Another fun expedition is during the VHF contests when everyone is looking for the rare grid square. Grab an all mode VHF rig or two and head for the highest spot in toughest grid square you can find and enjoy.

Gear need not be elaborate. In fact, during the PA QSO party, N3IK ran a Heath HW-101 at about 60 watts. The antenna was an 80 meter loop hung in a hemlock tree. This modest station accounted for 466 contacts and 104 multipliers -- and a heck of a lot of fun (see photo). Try it, you'll like it!

MIR Amateur Operations

The Soviet Space Station MIR should be on two meter FM by now. The station aboard the spacecraft consists of a 2 watt FM transceiver coupled to a quarter wave ground plane antenna. The Space station will listen

on 145.525 MHz and 145.575 MHz and transmit on 145.550. Listen for U1MIR on Saturdays and Sundays during crew rest periods.

Since MIR is a long term Space Station, chances for everyone who wants to work the Cosmonauts are very good!

Speculation is that on the next resupply mission to MIR a ten watt transceiver will be placed in operation and the call sign will change to U0MIR.

Next US Amateur in Space

The next U.S. amateur in space was scheduled for June of this year but has now been shifted to March of '90. According to NASA, the delay is due to a shortage of rocket fuel caused by the explosion of a rocket fuel factory in Nevada last May.

Dayton

Word from the Dayton Hamvention is that this year's event will be bigger and better than ever! Seems that a new 40,000 square foot wing is being built onto the Hara Arena. See ya there!

Packet in the USSR

Late last summer, the packet radio network on 14,099 MHz got a new member: UA3CR-2. By connecting to UA3CR-1 via UA3CR-2, one can access the VHF packet network in Moscow, USSR on 145.600 MHz.

According to LSYSOP RA3APR, Evgeni, the node consists of an MFJ-1274 TNC, Icom IC-251 and five element Yagi on HF and an MFJ-1274, Icom IC-251 and nine element Yagi on VHF. RA3APR, UA3CR, UA3HR and RW3DR are active on packet in Moscow and RA3AU and RS3A will join them in the near future.

Evgeni, who recently received his degree

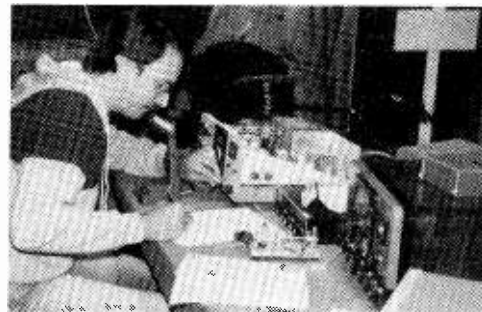

Tim, KD3JP, sorts out the pile-up on 40 SSB during the N3IK DXpedition to Elk Co., PA, for the 88 Pennsylvania QSO party.

in engineering, built a TNC with a 8080 CP/U as his examination project. He hopes that it will be used by many Soviet hams when his article in the magazine *Radoo* is published. He also hopes to start a PBBS in Moscow.

Ham Radio Bill Signed by President Reagan

As one of his final acts as President, Ronald Reagan signed S.1048, the FCC authorization bill which contains section 10, the congressional concurrent resolution supporting amateur radio and its emergency communications efforts.

While this resolution, now signed into law, does not force the FCC to retract its decision in docket 8714 to reallocate 220 to 222 MHz to the land mobile service, it may become an important building block toward an eventual solution. (ARRL Bulletin 129).

DX News

Lloyd and Iris Colvin are currently operating as W6KG/5B4 on Cyprus. They also have a ZC4 license and expect to operate from that area of the island soon. QSL via YASME.

Iraq: Y1IBGD (op Fares) has been quite active on 10 meter SSB 28550 kHz at about 1430 UTC. Fares has also been operating RTTY on 28650 kHz. QSL via Box 7147, Baghdad.

Madeira: Martti is currently operating as CT3BZ. He is active on 14 MHz SSB and occasionally on 7 MHz about 7080 kHz at about 0630 UTC.

Niger: Baldur, DJ6SI, is currently operating with the call 5UV386, a commercial call. Watch 14025, 21025 and 28025 kHz QSL via DJ6SI.

Vietnam: 3W8CW and 3W8DX continue to be very active on all bands from 7 to 28 MHz. They typically operate about 35 kHz above the bottom of the band and listen up (i.e., above their frequency). On 40, watch 7002 or 7003 kHz at 1230 UTC. RL8PYL plans to operate from Vietnam beginning this month.

The Well Rounded Amateur

My comments about an amateur being asked to leave an amusement park (November *MT*) appears to have stung some of you as I received about 25 letters commenting on it. Most of the letters agreed that if an amateur takes his family to an amusement park he should leave the HT in the car. Several took exception, citing how useful HT's could be in an emergency. One reader suggested that the family may have all been hams and kept in touch that way.

Well, sorry to say that my opinion has not changed on the subject. It just is not necessary

that we walk around with a headset stuck on our noggin all the time. Ham radio is a great hobby, but give it a rest. Try to remember that the average citizen does not really understand ham radio, and seeing us with a radio stuck in our faces every waking moment does not impress most folks.

The President

Another topic I discussed that created quite a stir was my review of the Uniden HR 2510 ten meter transceiver.

After several phone calls and numerous letters asking me to convert any number of these units to cover 26 to 29.999 MHz, I felt it necessary to explain that the conversion information contained in the article was an exercise in technology -- nothing more. The conversion is easy enough for anyone to undertake without a qualm if that is what you want. However, it is against the law for me or anyone for that matter, to convert units for other people!

There are several more modifications for the "President" in the works. The two most requested mods are improved CW selectivity and repeater offset.

By the way, the "President" works great on ten meter packet!

IARU M/S (or every litter bit hurts!)

W7JIE, M.L. Gibson wrote to tell us about the International Amateur Radio Union Monitoring Service (IARU M/S). "The IARU M/S," says Mr. Gibson, "functions as a part of the IARU and operates around the world. The international coordinator for M/S is Bob Knowles, ZL1BAD.

"Within each region are societies, or countries who have established monitoring stations and are headed up by national coordinators. They are too numerous to list, but each national and regional coordinator is interested in observing and reporting non-amateur signals found in the exclusive amateur bands.

"Further, in the shared bands, M/S reports those illegal transmissions that do occur. For example, Radio Tirana on 7065 kHz is not only illegal in the exclusive portion but also is transmitting outside the broadcast band allocations. Of course, Albania is *not* a member of the International Telecommunications Union (ITU) so they can do as they wish -- and they do. Another example would be a non-amateur digital transmission above 7.1 MHz. Only region 2 amateur and region 1 & 3 BC stations are supposed to be there.

"Reports of observed violations are compiled by national coordinators and forwarded at least once a month to regional coordinators. National and regional coordinators work together to advise government

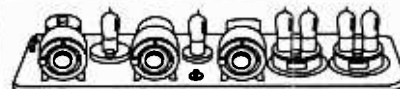

IF YOU BUY, SELL OR COLLECT
OLD RADIOS, YOU NEED...

ANTIQUE RADIO CLASSIFIED

Antique Radio's Largest-Circulation
Monthly Magazine

Articles - Classifieds - Ads for Parts & Services

Also: Early TV, Ham Equip., Books,
Telegraph, 40's & 50's Radios & more...

Free 20-word ad each month. Don't miss out!

Free Sample. 6-Month Trial - \$11.

1-Year: \$19 (\$28 by 1st Class). Foreign - Write.

A.R.C., P.O. Box 2-P4, Carlisle, MA 01741

officials of these infractions of international agreements.

"Since IARU M/S is prohibited from directly addressing the violators, we must use the local government offices to carry our message to the offenders. It is a long and difficult road that seldom leads to immediate success. Occasionally we find an "accidental" violation that responds quickly. But most violations seem to come from intentional transmissions.

"It has been said that the USSR has signed 200 ITU treaties regarding frequency utilization, and they have broken every one of them. For example, listen from about 2200 to 0300 daily on 21032 kHz. There is a USSR maritime station operating Cyrillic code Morse, and radioprinter. His call is "UMS" and he carries a big signal.

"During the course of a month, several hundred reports are turned in from all over the world. Many of them are observed in all three regions while some are strictly within a country or localized within an IARU region. A compilation of reports shows the same signal at the same "Z" time observed in a very broad area. But to identify the signal, locate its origin, and determine responsibility -- and then get a government office to take action -- is a serious challenge.

"Most of the M/S observers are amateurs who are very interested in keeping the ham bands clear of interference, particularly from the **big guns** of government agencies. It takes a lot of work to be a success, but I find a great pleasure in working out a signal to a successful conclusion.

"If you are interested in joining the IARU M/S, write to the IARU society serving your country. In the U.S.A., it is the ARRL; in Canada the CRRL, Japan the JARL and Australia has the WIA. Each country has an official society and most of them have an operating M/S group. I am sure they would welcome your assistance if you should wish to volunteer."

That's all for this month gang. I wish each and every one of you a happy and prosperous New Year. 73 de NIK



Albania

Radio Tirana, 7065 kHz. Partial data color "Museum of National History" card, without verification signer. Received in 31 days for three IRCs and an English reception report. Station address: Rruga Ismail Qemali, Tirana, People's Socialist Republic of Albania. (Terry Ryan, Bellerose, NY)

Angola

Radio Nacional, 3375 kHz. Full data station card with multilingual QSL information. Verification signer, Carlos Ferrira. Received in 65 days for two IRCs and a Portuguese reception report. Station address: Caixa Postal 1329, Luanda, People's Republic of Angola. (Aboe Thaliep, Batang, Central Java, Indonesia)

Australia

Radio Australia via Darwin, N.T., 9645 kHz. Full data '88 Bicentennial Commemorative card, without verification signer. Carnavon site for Western Australia verified for 15415 kHz. Received in 120 days for two English reception reports. Station address: G.P.O. Melbourne, 3001, Australia-ed.

Brazil

Radio Nacional de Porto Velho, 4945 kHz. Full data QSL on station letterhead. Verification signer, Luis Antonio Alves, Director. Received in 30 days via Radio Nacional Amazonia for mint stamps and a Portuguese reception report. Station address: 78900 Porto Velho, Rondonia. (David Foster, Mansfield, Victoria, Australia)

Canada

CFVP-Calgary, 6030 kHz. No data station card, without verification signer. Received in 21 days for two IRCs, and one English follow-up reception report. Station address: Broadcasting House, Box 7060, St. "E", Calgary, AB T3C 3L9. (Sheryl Paszkiewicz, Manitowoc, WI)

China

BPM Shaanxi Astronomical Observatory, 10000 kHz. Full data English QSL card. Verification signer, Qi Guanrong, Chief Section of Science and Technique. Received in 45 days for one IRC and an English reception report. Station address: P.O. Box 18, Linton, Shaanxi, China. (Aboe Thaliep, Batang, Central Java, Indonesia)

Radio Exterior de Espana via Radio Beijing, 7165 kHz. Full data QSL of Plaza de Espana in Seville. Received in six weeks from Madrid, for a Spanish reception report. Station address: Apartado 156.202, 28080 Madrid, Espana. (David Foster, Mansfield, Victoria, Australia)

Costa Rica

Radio Reloj, 4832 kHz. Partial data color globe/tower card. Verification signer, Francisco Bavabona G. Received in 14 days for mint stamps and a Spanish reception report. Station address: Apartado 341, 1000 San Jose, Costa Rica. (Terry Ryan, Bellerose, NY)

Ecuador

HCBJ, 11925 kHz. Full data card of Galapagos Island birds, without a verification signer. Received in 60 days for an English reception report. Station address: Casilla 691, Quito, Ecuador. (Willem J. Pinangkaan, Manado, North Sulawesi, Indonesia)

Fiji

Department of Post and Telecommunications via University of South Pacific, 9070 kHz. Full data WSL information on station letterhead. Verification signer, J. Turaganivalu, Secretary. Received in 23 days for mint stamps and an English utility reception report. Station address: P.O. Box 40, Suva, Fiji, South Pacific-ed.



France

Radio France International, 17795 kHz. Full data Paris Panorama card, without verification signer. Received in 25 days for an English reception report. Station address: 116 Avenue du President Kennedy, 75016 Paris. (Kemas Cek Agus A.A., Lumajang, East Java, Indonesia)

Greece

Hellenic Radio-TV, The Voice of Greece, 11645 kHz. Full data color "Minos' throne" card, without verification signer. Program schedule and travel brochure on Greece. Received in 60 days for an English reception report. Station address: P.O. Box 19, Aghia Paraskevi, Athens 153-42, Greece. (Loyd Van Horn, Orange Park, FL)

Guam

AWR Asia KSDA, 9465 kHz. Full data AWR Anniversary card. Verification signer, Greg Scott, Program Director. Received in 30 days for an English reception report. Station address: P.O. Box 7500, Agat, Guam 96928. (Frederick Bolung, Manado, North Sulawesi, Indonesia) For more AWR info, write AWR Asia, Box 310, Hong Kong-ed.

Honduras

La Voz Evangelica, 4820 kHz. Partial data colored Honduran map card, and station pennant. Verification signer, Srita Orfa F. Duvon. Received in 42 days for mint stamps and a Spanish reception report. Station address: Apartado Postal No. 145-C, Tegucigalpa, Honduras, C.A. (Terry Ryan, Bellerose, NY)

Iceland

Post and Telegraph Centre, 1610.6 kHz. Full data color scenery postcard of Reykjavik. Verification signer, Esther Dlapdotlier. Received in 150 days for mint stamps and an English utility reception report. Station address: Gufunes Telecommunications Centre, Reykjavik, Iceland. (Larry Van Horn, Orange Park, FL)

India

United Nations Radio via All India Radio-Aligarh, 15335 kHz. Full data card of the UNO Hall. Received from New York in five weeks for an English reception report. Station address: United Nations, New York, NY 10017. (David Foster, Mansfield, Victoria, Australia) Welcome to MT!

Indonesia (Irian Jaya)

Radio Republik-Serui, 4607 kHz. Partial data letter. Verification signer, Agust Raunsai. Received in 77 days for mint stamps and several Indonesian follow-up reception reports. Station address: Jln. Pattimura, Serui, Irian Jaya. (Sheryl Paszkiewicz, Manitowoc, WI)

Radio Republik-Mataram, (Lessar Sunda Island) 3223 kHz. Partial data personal letter from

verification signer, Indris Zamzam, Kepala Seksi Siaran (Head of Broadcasting Section). Stickers, postcards, and travel brochures received. Received in 30 days for mint stamps and an Indonesian reception report. Station address: P.O. Box 2, Ampenan, Lombok, Nusa Tenggara Barat. (Aboe Thaliep, Batang, Central Java, Indonesia)

RKPDT2 Jember, (Java) 3182 kHz. Full data QSL on station letterhead. Verification signer, Joko Mahendry, Head of Broadcast. Received in 19 days after second Indonesian reception report and mint stamps. Total time report outstanding was 7 years! Station address: Sudarman 1, Jember, East Java, Indonesia. (David Foster, Mansfield, Victoria, Australia)

Kiribati

Radio Kiribati, 14802 kHz. Full data "Native dancers" postcard. Verification signer, Engineer-in-charge. Received in 35 days for one IRC, a mint stamp and an English reception report. Station address: P.O. Box 78, Bairiki, Tarawa, Central Pacific-ed.

Liberia

ELWA, 11830 kHz. No data colored studio/transmitter card, and program schedule. Verification signer, J. Token, QSL clerk. Received in 75 days for two IRCs and an English reception report. Station address: Box 192, Monrovia, Liberia, Africa. (Terry Ryan, Bellerose, NY)

Peru

Radio Union, 6115 kHz. Partial data Peruvian drawing of "Machu Picchu Cuzco-Peru." Verification signer, Gonzalo Iwaski Sanchez-Gerente. Received in 82 days for mint stamps and a Spanish reception report. Station address: Apartado 6205, Lima, Peru. (Terry Ryan, Bellerose, NY)

Solomon Islands

Solomon Islands Broadcasting Corp. (SIBC), 9545 kHz. Full data white station logo card, without verification signer. Received in 27 days for int stamps and an English reception report. Station address: P.O. Box 654, Honiara, Solomon Islands. (Terry Ryan, Bellerose, NY)

USSR (Uzbek SSR)

Radio Tashkent, 11785 kHz. Full data card with oriental rug design, without a verification signer. Received in 78 days for an English reception report. Station address: Khorezmskaya 49, Tashkent, 70047 GSP, USSR. (Terry Ryan, Bellerose, NY)

Zimbabwe

Zimbabwe Broadcasting Corp. (ZBC), 3306 kHz. Full data large blue and white African map card, program schedule and personal letter. Verification signer, P.I. Chitapi, Public Relations Officer. Received in 77 days for mint stamps and an English reception report. Station address: The Broadcasting Centre, Highlands, Harare, Zimbabwe, Africa-ed.

MT Unscrambles a Mystery

RTTY readers have a tendency to tune in a signal and if it doesn't produce a readable print, write it off as being encrypted. I like to do crazy things like sit on the frequency and copy the gobbledygook for several hours. But patience is often a virtue in reading RTTY, as it is in other endeavors. Sometimes, when you least expect it, the print-out will pop "in the clear" (become un-encrypted) and the results can be quite rewarding.

On the other hand, it's quite possible that you may see nothing but pages and pages of "ertuwlv74fJKU." But don't fret! The scrambled text that you just copied can have some rhyme or reason to it. It can be classified as pseudorandom data.

Repeating Sequence

It's called pseudorandom because the sequence repeats. It may take a few seconds, or maybe a few years, but it *will* repeat. This type of data is used to test RTTY equipment by transmitting a known pseudorandom sequence of characters to a distant receiving station. The receiving station is connected to a box that is similar to a RTTY TU but has the ability to search for the known sequence. Once it is found, the box, which can have a microprocessor in it, automatically starts a test which is known as a bit error count.

This system is used by the military or government agencies to either keep the channel busy or to monitor the band conditions in order to determine which frequency is best for error free communications. Companies such as Rockwell International, Fredericks Electronics, or Teledyne Corporation use certain frequencies to run a "BERT" (bit error rate test) on equipment that they manufacture. Fredericks Electronics who is a manufacturer of high quality commercial RTTY gear (see photo) has been known to use 9462, 10588, and 16.201 kHz which are assigned to FEMA (the Federal Emergency Management Agency) at Mt. Weather in Berryville, Virginia.

For the past several years, Rockwell International's Collins Radio Division has been testing their RTTY spread spectrum radio on certain military channels. Spread spectrum can be characterized by the increase in noise level that cover a few kilohertz. Try to copy that in the clear! The practice of using government transmitter facilities for commercial or manufacturing test purposes is common on the shortwave bands.

Roman Robakiewicz of Coventry Court said that he copied what he thought was a U.S. Navy station sending "Foxes" and then started to send a random sequence of letters. He stayed with it for about five minutes and they went back to the foxes for ten minutes and then the letters for five minutes.

It's possible, Roman, that they were using a "BERT" box to test their equipment. Some Bert boxes, like the HP (Hewlett Packard) model 4925, can be programmed to perform the bit error test for a given number of minutes and then switch to the "Fox" test.

Roman said the sequence was "NRKNSOHVBDXWYTWGUJEIYKP" and the frequencies were 7958.5, 9370.5, 10464.5, 10935.5, 12074.5, 12141.5, 12903.5, 13520.5, 13676.5, 14360.5, 15925.5, 18990.5, and 20348.5. After a few months, the tests were gone. He also said that he read somewhere that the Navy was the only one who used the "Fox" test. Well! Just about any RTTY utility station can send this type of test. Thanks for your input, Roman!

To find out if you are copying pseudorandom data, you will need special equipment like the Infotech M-6000 or the Universal M-7000 operating in "databit mode." Set the baud rate and Rev/Norm button until the error light goes out. That will indicate that you are in the proper mode and the unit is synced up. Copy about three pages of text (zeros and ones) on your printer. Then examine the print-out and look for a repeating pattern. This should be done on a strong signal because weak copy can yield errors that will mask the repeating pattern.

I was able to copy a pseudorandom transmission using 35 baud ASCII on 10103 kHz which had a pattern that repeated every sixteenth

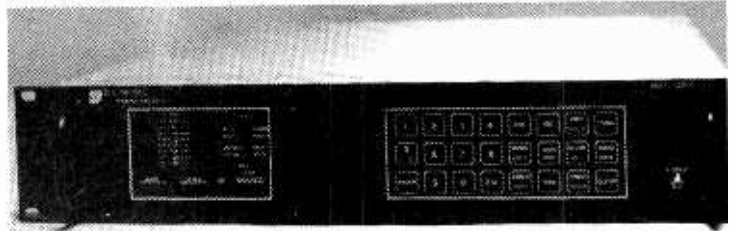

The Fredericks 1280R; at \$5,000 each I'll take two!

character. I don't understand why the baud rate was so odd and why ASCII was used, but the M-7000 was happy with the settings.

FDM/TDM on 10.344

Another mode that is available on the M-6000 or M-7000 is TDM. But on the M-7000 you can also copy FDM. I talked about FDM last November but what I didn't mention is the fact that you can copy TDM on FDM. This mode can be copied using the Infotech M-6000 and the M-605 (which is now discontinued).

The M-7000 can copy both modes by setting the R5n button to mode D and then by selecting the two channel TDM 96 mode (button 1En). I found FDM/TDM on 9065.4 and 10344 kHz. It's not easy to tune in sometimes, but you don't have to worry about playing around with the rev/norm button (r1n) because the M-7000 can figure that out for you. The auto rev/norm will only work in TDM or SITOR mode.

I received a very good response when I requested loggings a few months ago, as seen in this month's loggings. My thanks to Dallas Williams, Clint Gilliland, Art Blair, and Fred Heatherington for their support. ZCZC

Loggings

kHz	Call	Shift/Baud	Location
6,915	BAP46	1000R/75	Beijing, China
7,364	HMF88	250R/50	Pyongyang, North Korea
7,402	JMG3	850R/50	Tokyo, Japan
7,695	3MA26	850R/50	Taipei, Taiwan
7,832		850R/75	Andrews AFB
8,019	HME46	250R/50	Pyongyang, North Korea
8,030	HMF85	250R/50	Pyongyang, North Korea
8,152	HMF86	500N/50	Pyongyang, North Korea
8,175	JAE58	850N/50	Tokyo, Japan
8,375	UYUG	170N/50	USSR ship with traffic
9,425		850R/75	Unid US Navy station
10,106		850R/75	Unid US Navy station
10,165	RPT31	425R/50	Moscow, USSR (TASS)
10,235	3MA99	800R/50	Taipei, Taiwan
10,384	BAA21	800N/50	Tianjin, PRC?
10,465		850N/75	Unid US Navy
11,420	VNA86	500R/50	Hanoi, Vietnam
11,430	HMF55	250R/50	Pyongyang, North Korea
13,086	UKA	170N/50	Vladivostok, USSR
13,510	CFH	850R/75	Halifax, Nova Scotia
13,563	3MA22	850R/50	Taipei, Taiwan
13,737	5YD7	425R/50	Nairobi, Kenya
13,780	HME28	250N/50	Pyongyang, North Korea
13,803	RCR78	1000R/50	Khabarovsk, USSR
14,700	RGD22	425N/50	Moscow, USSR (TASS)
14,761	OMOF	170R/75	OKinawa, USMC MARS
14,935	ONRI	170N/75	Port Hueneeme, CA, USMC MARS
14,945	CLN1	500N/75	Havana, Cuba
16,246		85N/75	VOA Tangier (using FDM)
16,299	OMHK	170R/75	Kaneoha Bay, Hawaii
16,990	UFH	170N/50	Petropavlovsk, USSR
17,036	UXN	170N/50	Arkangelsk, USSR
17,207	WCC	FEC	Chatham, Massachusetts
17,217	PCH65	ARQ	Schevenington, Netherlands
17,623	9KT344	350N/50	Safat, Kuwait
18,543	WFK48	425N/75	Greenville, North Carolina
20,350	NBA	850N/75	Balboa, Panama

Black January: Three Years Later

Three years ago this month, the world of satellite television was inexorably altered when Home Box Office (HBO) began scrambling their signal.

Though widely publicized, this was not the first incidence of scrambling. For years, services as diverse as NCTA (the Catholic network), the FUN Channel (a now defunct Triple-X rated service) and numerous horse and dog racetracks around the country had already been scrambled. Still, the bulk of satellite services were in the clear. So were the so-called "premium" movie and sports channels. If you had a dish it was free for the taking.

In fact, until 1983, cable programmers seemed almost totally unconcerned about the home dish owners who enjoyed their programs for free. At 6 to 10 thousand dollars per-system, the cable-casters figured, there simply weren't going to be many takers. More important was the war waging on another front - the nearly 25 percent cable theft rate.

Success Killed TVRO Industry

By 1984, however, prices for dish systems began to plummet. Increased production, design changes, and competition all combined to dramatically reduce the installed system price to around \$3,000. System sales soared to some 30,000 units per month. By September of the next year, that figured tripled.

The wildly multiplying number of home dish systems did not escape the notice of cable operators who now saw their non-paying neighbors as yet another threat to their solvency.

That is not to say that cable programmers had been sleeping while home dish hysteria gripped the nation. Home Box Office, for example, had already been working with a company called M/A-COM to produce a commercial encryption system called the VideoCipher. In February, 1985, HBO announced that they would scramble their services full-time within the year. After numerous delays, the stage was set and the spectre of scrambling became reality in January of 1986.

One by one, the basic cable services, premium movie channels, and sports channels succumbed to the VideoCipher with the last, Select TV, going down in October 1986. In the interim, dish sales had begun to hit bottom, falling to a low of 12,000 units per month in January of 1987. The damage was done and the home dish craze had gone bust.

Relations between dish-owners and programmers couldn't have been worse. Dealers whose sales had all but dried up went out of business. Manufacturers quickly followed suit

and sought protection under federal bankruptcy laws.

As the legitimate dealers of satellite dishes and related paraphernalia left the arena, their places were quickly filled by an entirely different type of businessman.

Many of these people saw what was happening to the industry under scrambling. As soon as "official" descramblers were made to paying viewers, these individuals, known as VC II hackers or descrambler pirates, were busy scrutinizing the VideoCipher II for possible ways to defeat the unit.

Ten months after the VC II was introduced by HBO through its new vendor, General Instrument (and pronounced unbreakable by both), word spread that the VC II had indeed been broken.

Just as quickly as the industry had gone bust, a new satellite TV industry sprung up overnight. Back door shops were modifying as many VC IIs as they could get and selling them for anywhere from \$200-600 over the suggested retail price of an unmodified decoder. They were selling like frijoles in Tijuana.

The big problem with this new "industry" was that it was entirely illegal. In fact, current law provides that dealers convicted of decoder hacking are subject to fines of \$50,000 and up to two years in prison. Homeowners aren't spared either. An individual caught with a bogus decoder faces fines up to \$1,000 and six months in jail.

Meanwhile, General Instrument, embarrassed by the ease with which the hackers broke their device, began a series of electronic countermeasures (ECMs) designed to electronically shut down the unauthorized decoders. Thus began a bizarre cat and mouse game in which General Instrument would devise an ECM to zap the bogus VC IIs while leaving the legal decoder operating unhampered. Every time GI heralded a victory, the hackers would work around the ECM.

Unfortunately, the big losers in this game were the consumers who bought the pirated decoders. Once zapped by an ECM, a bogus decoder is left irreparably "brain dead." Pirate dealers, obviously, have no warranty on their bogus decoders. Caveat Emptor!

Pressure from programmers for GI to put an end to piracy has resulted in an unfavorable atmosphere for the home dish owner. Some programmers are looking to other companies for scrambling systems. This has panicked GI into introducing a new scrambling system called the VC II Plus which it hopes to roll out by June 1989. This, it claims, is a "harder" encryption system but it, too, has its problems.

The VC II Plus, according to trade sources,

is not compatible with current VC II stand alone or IRD modules. This will require the legitimate decoders to be modified by factory authorized dealers. The question now is: Who pays for the modifications? Probably the consumer - the same guy who gets it in the neck every time any manufacturer makes a blunder.

Even so, receiver manufacturers continue to produce Integrated Receiver Decoders (IRDs) with legitimate VC II modules in them which could be legitimately defunct in six months. What's the consumer to do?

1. If you have an authorized IRD system: wait - in six months you'll be told what to do and how much it will cost you.

2. If you have an authorized stand alone VC II and a regular satellite receiver: wait - in six months you'll be told what to do and how much it'll cost you. But at least you'll have your system in place and watchable while the decoder is off getting fixed. It could be gone four to six weeks.

3. If you have a system and are thinking about buying a VC II: Don't - in six months your new VC II might be worthless. Wait to see what kind of scheme becomes standard.

4. If you are thinking about buying a satellite TV system: Do it! Just don't buy an IRD. Get a plain receiver and enjoy the many unscrambled channels til this whole VC II fiasco gets sorted out. In fact, now is an excellent time to buy one of the older models that aren't IRDs, don't have all the flashing lights, but still do a great job. Your local dealer will have a million of them he's trying to get rid of. And do the installation yourself. It's not that hard!

5. If you're operating a bogus VC II: Wait - six months from now you'll be buying the latest VC II Plus decoder hot off the hacker's EPROM burner. In spite of what GI says, one can easily imagine it won't be long before they're announcing the first VC II Plus ECM.

The Future of Scrambling

Only a fool could believe that the days of watching such services as HBO/Cinemax and Showtime/The Movie Channel for free will return. Those days are gone and scrambling is here to stay. What's less certain is: under what conditions?

The coming thing in cable and satellite TV is PPV. It stands for Pay-Per-View. (It used to be called IPPV Impulse Pay-Per-View. Programmers dropped the impulse part fearing consumers would resent programmers believing they'd watch any old trash if they were offered it.)

Pay-Per-View is exactly that. If you want to

watch an event, you dial an authorization number which shows on the screen along with a billboard of the event. The necessary credit card info is taken down, or, in the case of cable, it is added to your monthly bill. When the event comes on, your picture is descrambled and you get to watch.

But what are you watching? To start with, it's movies. Usually the first run films which are just breaking at the video stores. You're supposed to pay a premium for not having to fuss with an actual video store so their prices are usually high. Expect to pay \$4.00 to \$6.00 for movies. (See chart on PPV services and their locations.)

These services will also offer special one time events such as the World Wrestling Federation (WWF) spectaculars. Expect to pay \$20 to \$30 per show. Special concerts and boxing matches will also be offered for similar charges.

I'll bet you think you've heard it all. But it's just the beginning. The movies and events will be encoded with a special anti-taping bit in the data stream. This will confuse your VCR and make it impossible to tape the movie or event for later viewing.

It's not just movies or concerts either. All your favorite sports will be offered eventually on PPV basis. This will include college as well as professional sports. Expect to pay \$8 or \$10 to watch the Gators play the Bulldogs or UCLA play Southern Cal or the Yankees play the Red Sox.

What's even better? If PPV is a smash, I predict that within two years each event/movie/concert will not only be \$10 to \$50 but have commercials as well! It's the evolution of greed and it cannot be stopped.

A Different Kind of Hacker

For those who haven't slept at night wondering about the Connecticut man who, last summer, was accused of cutting down his neighbor's oak tree to allow better satellite reception (*MT* Nov. '88): The accused was convicted and sentenced to two years probation. It turns out the trigger-happy chain saw wielder had previous experience. He cut down a tulip tree on the same neighbor's property one year earlier.

What's in a Name Anyway?

In a previous column (*MT* July '88), I mentioned a magazine which had excellent coverage of home satellite TV. A few years ago it was known as *Home Satellite TV*. As the video trend moved toward VCRs and big screens, they called the magazine *Super Television Incorporating Home Satellite TV*.

Now the current trend is toward camcorders. Sure enough, this summer the magazine took on a new name. It's now, believe it or not, the *Super Television Incorporating Home Satellite TV Camcorder Report*. It's still a great source of information on the TVRO industry and at only \$8.00 per year it's still the best buy in STV information.

CSS Lives, Maybe

Caribbean superstation (CSS) formerly on W5,23, which left the air following the broadcast of the last Super Bowl, may be coming back. Rumors persist of their return and, if they do, look for CSS on S3,3. Also slated for S3 are KTVT (Dallas/Fort Worth), WPIX (New York), KTLA (Los Angeles). All three, currently on F4, are scrambled via VC II and sold as part of various superstation packages.

Other Transponder Notes

New channels include: Starion Entertainment, a premium movie service, on T3,19. Sports Channel America F4,2, a national sports channel from Home Sports Entertainment of Houston.

Audio changes include: KSAT, the self-styled TVRO grass-roots audio channel is now on the 6.2 MHz audio of Starion. North America One, the FM TVRO-only service, has undergone big changes. Majority ownership on NA1 was purchased last summer by Liberty Lobby, which axed the popular three hour nightly TVRO talk show. Original sponsors, the SBCA, pulled out when Liberty Lobby took over. Show host, Harry Thibidaux resigned to join the SBCA at their Washington D.C. office as Director of Broadcasting and Media Sales.



America's Weekly Guide To Satellite TV™

Every issue of OnSat offers:

- over 750 Movies
- over 130 Specials
- over 300 Sporting Events
- over 220 Special Feeds
- Special Show Breakouts
- Hidden Sports
- Audio and Ku Charts
- Dr. Dish
- Industry News
- Mailbag

To Subscribe Call:
1 (800) 234-0021
Visa/MasterCard orders only.

Chart for Pay-per-View

Service	Satellite/Xpndr	Availability
Zap Movies	S2 1	Cable only
Zap Movies	S2 3	Cable only
Zap Previews/ Adult Theater	S2 11	Cable/TVRO
Zap Movies	S2 23	Cable only
First Run	G2 4	TVRO only
Stardust PPV	G2 9	TVRO only
Telecast Cinema	G2 24	Cable only
Guest Cinema	F4 4	Cable only
Cable Video Store	G3 5	Cable only
Home Premier TV	G3 16	Cable only
Viewer's Choice 2	G3 18	Cable only
Viewer's Choice 1	G3 21	TVRO/Cable
Request TV	F3 19	Cable only
Request 2	F3 24	Cable only

Note: All services have sprung up in the last 18 months. All use the VC II encryption system.

The SBCA will sponsor a new two hour nightly show hosted by Thibidaux on the 6.8 audio of G1,18. (TBS superstation). According to Thibidaux, the show will be directed to both the home dish owner and satellite dealer.

Looking for ESPN's Sunday Night Football backhaul? It's on Telstar 301-20 VC I encrypted but with the audio in the clear.

BBC's *Six O'Clock News* is alternating between transponders 14 and 24 via Australia's TV 10 (Brightstar) W4. Of course, it's on at 1:00 p.m. ET.

Reports circulate that Home Team Sports (HTS) will be scrambled by the time you read this. It will be offered to dish owners in a package with other regional cable sports programmers through HSE.



Ex-Pirate's Dream Comes True

Though his broadcasts were seldom heard, his name was known to radio hobbyists around the world. Bruce Quinn was equally well-known to the U.S. Federal Communications Commission. The 32 year old Delphi, Indiana, resident was one of the operators of Jolly Roger Radio, a pirate station broadcasting from Bloomington, Indiana, in the late 1970s and early '80s. As many as 100 people took part in the broadcasts, which originated from his tiny second-story apartment.

The FCC did eventually catch up with Quinn, who is legally blind, and shut down his operation. He was fined \$250.00. After that, Bruce went "legitimate," studying how the federal government allocates and licenses radio stations in the United States. Soon he began to use his new-found knowledge to open up frequencies for radio stations in a number of small Indiana communities.

Two months ago, Quinn's hard work and determination -- a drive that at one time took him all the way to England in the hope of setting up a community radio station there -- brought him the ultimate radio prize, permission from his one-time adversary, the FCC, to build his own station.

Construction permits, such as the one he now holds, are valuable commodities on the open market, often worth hundreds of thousands of dollars or more. But Quinn has no intention to sell his. "I *could* take the money and live off the interest for the rest of my life," says the ex-pirate, "but I didn't do this for money. I'm really excited about [building the station]."

So the next time you're passing through the tiny village of Attica, Indiana (some 20 miles southwest of West Lafayette), dial up 95.7 on your FM radio and think about Bruce Quinn -- a young man who had a dream, never gave it up, and worked until he made it come true.

Around the Dials

The FCC has virtually done away with its rules forbidding a person to own two stations in the same geographical area. Technically speaking, two FM stations can now be owned by the same person if their 3.16m/V [signal strength] contours don't overlap; 5 mV/m in the case of AMs. That means that co-owned Class A FMs need be only 17 miles apart; Class B's need only 40.5 miles of breathing space. Meanwhile, the National Association of Broadcasters (NAB) has come out in favor of a power boost to 6 kw for most Class A FMs. According to their survey, nearly 1,300 of the nation's 2,043 Class As could immediately

raise power without creating interference.

Fans of nationally-syndicated talk show host Larry King will be happy to know that he'll be around for at least six more years. Westwood One announced recently that King came to an agreement with their Mutual Radio Network to continue carrying the show. It airs live, Monday through Friday, from 11 p.m. to 2 a.m. Eastern time with taped replays from 2 til 5 a.m. King has been on mutual for the past 11 years.

Elvis Dies (Again)

970-WHQB-AM, licensed to Rutland, Vermont, is the latest station to "toy" with the idea of programming their station with nothing but Elvis Presley records. Owner Ed Pickett decided to try it out for a week and let the listeners vote by phone. According to an article in the *New York Times*, Douglas Williams, program director for WHQB, estimated that 1,400 calls came in during the four-day survey. Among those calls were 560 crazies who wanted the station to go all-Elvis.

1420-WHK, Cleveland, Ohio's oldest station, dropped its rock oldies format to become the city's first business-oriented broadcaster. Prior to the change, the station officials called their ratings "disastrous." It has been reported, but I cannot confirm (seriously), that the station is housed in a two-story building that is shaped like a juke box. (If so, a few minor architectural changes could easily transform the building into a two-story cash register). WHK came on the air July 28, 1921.

98.9-WQCR, Burlington, Vermont, is now running 100,000 watts. Rock 99, as the station calls itself, is audible on car radios in Montreal. National Public Radio (NPR) will offer affiliate top-of-the-hour news headlines effective July of this year. Seven will be carried on weekdays; eight on weekends. New

Age music at Detroit's 92.3 WVAE is apparently bombing. "The Wave" reportedly pulled only a 1.1 rating over the summer -- less than some small AM stations.

710 CJRN, Niagara Falls, was fined \$5,000 for racist comments about native people. The comments were reportedly made on the station's call-in show. According to Gilles Michaud, one of the hosts called Indians "slovenly, lazy bums" and said that he was "sick and tired of native people wearing feathers and deerskins." CJRN was charged under the Broadcast Act and fined by a local judge. The court's decision, however, was expected to be cited when the station's license came up for renewal in December.

Radio World quotes Milwaukee *Journal* radio columnist Michael Zahn as saying that 93.3-WQFM has an interesting use for their stereo signal. The morning man, says Zahn, tells a "dirty" joke on the air each day. When he gets to the punchline, he "pans" it so that if you tune your receiver to the right channel, you get the off-color quip. If you tune to the left, you get a Bible passage. And, of course, if you listen in stereo, you get a jumble of both. An unidentified reader in *FM Media!* questions, "shouldn't the dirty joke be on the left channel and the religion on the right?"

Mailbag

Robert Brossell of Pewaukee, Wisconsin, says that "You mentioned [*MT*, November] that WTMJ got to be #1 by broadcasting music. This is actually not true. WTMJ got to be #1 by first, being the voice of the Green Bay Packers, Milwaukee Brewers, and Wisconsin Badgers. Two, being a news and information station which plays relatively few records during the broadcast day -- in morning drive WTMJ plays only two songs per hour. And three, having far and away the

The Q106 (105.7)
FM mascot, "Q-Roo."
Q106 is WQXA,
York, Pennsylvania.



best AM signal in southeastern Wisconsin. It has 5,000 watts on 620 kHz but sounds like 50,000! WTMJ, says Robert, stands for The Milwaukee Journal.

New Station Grants

92.1 Fenwick Island, Delaware; 1500 St. Cloud, Florida; 105.7 Ashburn, 103.7 Irwinton and 92.5 Lyons, Georgia; 95.1 Morrison, Illinois; 93.9 Clinton and 105.1 Roanoke, Indiana; 95.9 Medicine Lodge and 90.7 Wichita, Kansas; 90.5 Benton, Kentucky; 102.1 Basile, Louisiana; 94.3 Cambridge, Maryland; 90.3 Harwich, Massachusetts; 89.9 Washington, Missouri; 1340 Madbury, New Hampshire; 90.1 Dryden and 105.5 Little Falls, New York; 105.7 Elizabethtown, North Carolina; 95.7 Gibsonville, Ohio; 94.7 Patton, Pennsylvania; 104.3 Surgoinsville, Tennessee; 92.3 Payson, Utah; 99.7 Black River Falls, 100.5 Columbus and 1590 Nekoosa, Wisconsin.

For Sale

Alabama FM, \$360,000 (The Thornburn Company 404-998-1080). Full class C FM in southern Arizona, going on the air this month. (Mr. Greeley 602-855-1117). North Florida Class A FM, \$550,000. (Hadden & Associates 407-365-7832). 10,000 watt Kansas City market AM. Low price; terms available. (Rich Bott 816-252-5050). KBSR AM/FM, Billings, Montana. \$700,000. (Capstone Communications 201-934-5990). Northeast Ohio AM. Bankruptcy sale. \$195,000. (412-963-6311).

International Bandscan

Just as the BBC World Service has been undergoing some recent changes, so has domestic radio on the island. BBC Radio

London, for example, has been replaced by Greater London Radio on 1458 kHz AM and 94.7 FM. BBC Radio Gloucestershire, which started operations this fall, can now be heard on 603 kHz and 104.7 MHz.

Radio France International is using a Chinese transmitter on 1296 kHz to broadcast to the Hanoi region of Vietnam from 1500 to 1600 UTC. This transmitter is apparently used for Chinese broadcasts to Vietnam during other times of the day.

Harold Frodge reports that there are two new Venezuelan stations on the air. One is at 1490 out of Caracas with 50 kw. It reportedly carries medical and scientific programming from the Federacion Medica Venezolana. The second is Radio Central on 610 kHz. It broadcasts from Cantaura and reportedly parallels Caracas' 710-Radio Capital.

Tune in the World on AM

Despite constantly improving reception conditions, a lot of people think that DXing foreign stations on AM is impossible. Here's George Hakiel of West Islip, New York, to prove it isn't. Here's what he's heard during a recent one-month period. 567-Tullamore, Ireland. 585-Madrid, Spain. 666-Lisbon, Portugal. 684-Sevilla, Spain. 693-Droitwich, England. 693-Terceira, Azores. 747-Flevoland, Netherlands. 846-Rome, Italy. 864-Santah, Egypt. 882-Washford, England. 963-Pori, Finland. 1080-Port au Prince, Haiti. 1098-Czechoslovakia. 1107-Batra, Egypt. 1134-Zadar, Yugoslavia. 1143-Kaliningrad, USSR. 1179-Solvesborg, Sweden. 1188-Szolnok, Hungary. 1215-Lushnje, Albania. 1314-Kvitsoy, Norway. 1521-Duba, Saudi Arabia. 1575-Porto Canidelo, Portugal.

Note that all of these are "splits." U.S. and Canadian stations operate at regular 10 kHz

increments, i.e., 940, 950, 960 and so forth. Foreign stations are not so constrained. A split is a frequency that falls in-between our 10 kHz increments, like like 947, 951 or 964 kHz.

When these stations do manage to push through, they leave a tell-tale audio sign called a "het" (heterodyne). A het, simply and unscientifically put, is an annoying tone generated by two frequencies "bumping" together. A foreign station on 1521 kHz -- Duba, Saudi Arabia's 2 million watt AM, for example -- often generates a het against U.S. stations on 1520 kHz. (with patience, the station itself can often be heard as well, even on medium-quality radios.) U.S. stations have 10 kHz spacing and as a result, should not create hets. Therefore, any hets you do hear are probably created by foreign stations. It's exciting listening and a real challenge!

An unidentified reader has sent in a list of every station in the world that runs over 50,000 watts (except U.S./Canada/Cuba/Mexico). Arranged by frequency, it includes the station location (city and country), any known slogan or ID, station power and language. It's an exceptional aid to anyone who has any interest whatsoever in AM DXing. Send us \$2.00 cash and a self addressed stamped envelope to American BandScan c/o Monitoring Times, Box 98, Brasstown, NC 28902, and I'll run you off a xerox copy of it.



Credits: In addition to our own information, we've included information from the following publications and American BandScan reporters: BBC Monitoring Service; Carl Belmore, Flint City, MI; *Broadcasting*; Robert Brossel, Pewaukee, Wisconsin; *FMedia* (Dr. Bruce Elving); *CIDX Messenger* (Alain Pepin, Gilles Michaud); *DX News* (Chuck Hutton); Joseph Johnson, Savannah, GA; *M Street Journal*; *Cleveland Plain Dealer* (via Kent Morrissey, Cleveland, OH); *FMedial* (Dr. Bruce Elving); *Radio Gula Internacional* (via Harold Frodge, Midland, MI); *Radio Trends* (Bolton Research Corporation); *Radio World*; *Indianapolis Star* (via James Dean, Unionville, Indiana and Dan Mulford KA9DZM, Osgood, IN); *New York Times* (via Ruth Hesch, White Plains, NY); *Play-DX*; *Sweden Calling DXers* (Francis Hearne); Scott Tawl. For information on how to subscribe to many of these publications, send a SASE and an additional mint 25 cent stamp to American BandScan c/o this publication.

NEWSROOM

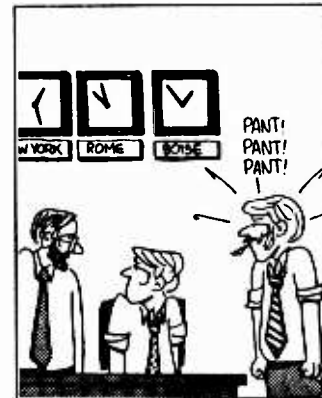

Pirates, Pirates Everywhere!

Hey, we told all you pirate chasers not to lose heart. Pirate activity would most likely increase as we got into the DX season and as sunspot activity began to increase. Already there are signs that things are looking better. Again we have got to say thanks to the Outer Limits readers who have sent us some excellent loggings.

Brent Walker, in North Carolina, recently bagged his very first pirate, and did he get himself a great catch! It was a station known as "The Crooked Man," which was heard on 7415 kHz from 1952 to 2022 UTC. The "Crooked Man" claims to be a survivor of the Hindenburg disaster and expresses his views on a variety of subjects such as religion, homosexuality, and chemical warfare.

What makes this station of particular interest is that it was around for a while several years ago and then disappeared. Does its return mean other old-time pirates may also plan a revival? We will just have to wait and see. Apparently the "Crooked Man" does not have a mailing address or verify reports.



Transatlantic reception of European pirate stations is possible again. A couple of veteran pirate loggers share tips on where to look.

Another reader sending along his first ever pirate catch is Ohio's Fraser Bonnett. He logged "Pirate Radio Atlantic" on 7470 at 0111 UTC. The station's DJ was "R.F. Fields," who claimed to be "broadcasting to the eastern seaboard of the United States and God knows where else." Fraser would like to find an address for this station. Can anybody help?

Veteran pirate logger Cathy Turner of New York checks in with some nice logs. She has heard several broadcasts on 7415 from the venerable old pirate of over ten years, "Radio Clandestine." These were monitored between 0100 and 0356, and one program featured some rather serious talk about nuclear war.

From Virginia, Steve Rogovich also had great success bagging Radio Clandestine on 7414 and 7425, hearing no less than six transmissions! Programming included some of the zany stuff for which this station is famous including its satirical commercials. There was also a "test of an emergency spaceship locator" and a variety of music including Joan Baez, Kansas, and Pat

Benatar. Steve notes one broadcast went from 0451 all the way to 0542, the longest pirate transmission he has ever heard.

Steve also reports receiving "Radio Garbanzo" on 7415 at 0422 with a "short-wave religious service" and satirical commercials. Thanks to our readers for sharing these logs with us. Keep them coming in!

Europirates Also Back

Yes, it is Europirate season again, and transatlantic reception of European pirate stations is quite possible. Absolutely no one in North America is more successful at it than Gregg Bares. In addition to logging Radio Caroline on 6215, he got a great catch in monitoring Europirate "Radio Fax" on 6205. So far this season he has also had two other, still unidentified, with weak signals.

Recently there was a convention in the English city of Blackpool of European pirate station operators. Gregg (who is not a pirate) was fortunate enough to be able to

PIRATE STATION JAN RAP

1324Kc 227m
6280Kc 48m

PO BOX 12
9514 ZG Gasselternijveen
NETHERLANDS

Technical data's
Transmitter: 150 Watt QB 2/250
crystal driven
Antenna : 25m long
7 m high

JAN RAP

attend this, and I understand that at least one unlicensed North American station was represented. As details become available we may find that some very interesting things took place at Blackpool.

Cathy Turner does not just monitor the domestic pirates. She reports a successful logging of "Radio Caroline" on 6215 at 0500 with rock music and ads for the Canadian Lottery. If you have never heard a Euro, this is a good place to start. With some persistence you should eventually be able to hear it, at least in the eastern half of North America.

From Massachusetts, Denis Filipetti sends word about an intriguing little book he came across in England. It is entitled *Radio is My Bomb: A DIY Manual for Pirates*. He reports it is a mix of political and technical advice. If you want to read for yourself what this Europirate author has to say on the subject, the publisher is Hooligan Press, c/o BM Hurricane, London WC1N 3XX.

Need addresses for Euro and other pirates? Reader Ary Boender will send you a list of over 200 (updated weekly) for US\$3.00. His address is Lobeliastraat 33B, 3202 HR Spijkensisse, The Netherlands.

Ary also sent a list of Europirate shortwave station frequencies. It is too long to publish here, but we will include a few samples. While many of these stations schedule their regular broadcasts at times when they are unlikely to be heard in North America, they sometimes run tests and other special programs which can be received. The logging of Radio Fax by Gregg Bares is an example of this.

Here is a sampling of Ary's list: Free Radio Service Holland, 6202; Radio Scotland, 6270; Radio Atlanta, 6286; Britain Radio International, 6305; Radio Rainbow Germany, 6315; and Italian Radio Relay Service, 7315.

The Return of RNI!

As we had predicted, Al Weiner and Company made good on their vow to put Radio Newyork International back on the air. There were no shortwave transmissions on 6240, but RNI was logged here in central Florida on 1620 kHz.

Several Outer Limits readers report success in monitoring RNI's signals. They made it as far inland as Minnesota where Larry Shaunce heard them at 0315 UTC with a program of mostly rock and roll tunes from the 1950s through the 1970s. In Connecticut, Gregg Bares also heard them the same day.

We are grateful to Outer Limits readers for the outstanding job they have done in submitting newspaper articles and other information which have helped us trace the RNI story and keep everyone up-to-date.

New York's Grand Dame of radio monitoring, Ruth Hesch, and Connecticut's Robert Thomas sent material which alerted us to the return of the Sarah (RNI's ship) to the New York metropolitan area. As noted previously in this column, the Sarah had been denied permission by the Coast Guard to leave Boston Harbor. After finally meeting all government regulations, the ship was

ADVANCED
-SEEKER-tm



-SEEKER-tm The complete system which makes your Commodore computer and ICOM R-71 a sophisticated monitoring station. EASY to use . . . UNEQUALED in performance.

A FEW OF SEEKER'stm FEATURES:

NEW "VCR-like" program recording. You choose day, time and frequencies.	INSTANTLY DISPLAYS broadcaster time and frequency schedules.
UNATTENDED recorder control in six scanning modes.	ADVANCED FEATURES explained in our FREE literature.
STORES, DESCRIBES, PRINTS, and SCANS hundreds of frequencies.	SELECTS the strongest signal from multiple alternate frequencies.

Send for **FREE** brochure or include \$15 (refunded on purchase) for demo disk and Owner's Manuals, to . . .

AF SYSTEMS
 Post Office Box 9145-G
 Waukegan, Illinois 60079-9145
 United States of America

permitted to leave and a little over a month before broadcasting resumed, took up a position four and one-half miles south of Long Beach, Long Island.

RNI had stated that for the time being it would stay off shortwave and would await court approval before resuming broadcasting. Apparently a decision was made to wait no longer and transmissions on 1620 were resumed. Additional information supplied by Hesch and Thomas indicates, however, that the court quickly decided to shut down the station. Federal District Court Judge John J. Mcnaught, at the request of the FCC, ordered the station off the air, and the judge's ruling was read over the radio to the crew of the Sarah by the Coast Guard. A few minutes later, RNI went silent, claiming "technical problems."

But is it gone for good? I think not. There are very few sure things in life. One is, do not ever underestimate the ingenuity and determination of Al Weiner and the rest of the RNI crew. The odds are they will be back.

And with that we will wrap things up for this month. Thanks to everyone for their fine contributions and encouraging support.

**"How in the world
 did you hear about us . . . ?"**

Advertisers want to know you heard about 'em in the
Monitoring Times, of course!

Experimental Amateurs

Transmissions below 500 kHz divide into many of the same kinds of transmissions as higher frequencies. There are aeronautical and marine transmissions and international broadcasters, coastal stations, military stations, and even amateurs. But the amateurs are quite different from what you would find in the high frequencies.

This is the world of 1750 meters, a most unusual kind of amateur activity. These hams operate beacons of their own. Don't expect to hear them chewing the fat over their equipment, experiments, or whatever. All you will probably hear are Morse code (CW) signals, usually the letters and numbers identifying that particular beacon. There is even a special term for these amateur beacons -- LowFER. This is the shortened form of Low Frequency Experimental Radio. And that part of the band from 160 to 190 kHz is called the experimenter's band. (The lower part of this band is being reinvaded by GWEN stations. After several years of virtual silence, the GWEN signals are being heard in the 150-173 kHz frequencies. Obviously, this overlaps with part of the experimenter's band.)

Who are these people? Many, if not most, are licensed amateurs apparently looking for some new challenges. They have an opportunity to work with antenna and transmitter design. They have to build their new design and then measure the performance. They are concerned about propagation. What makes conditions better or worse at one time or another?

Currently, most of the transmissions are in CW, but some LowFERs are experimenting with other modes, things like AM, SSB, AMTOR, FSK, and Biphase shift keying. A LowFER out west is sending a computer message from his beacon and another LowFER about 400 miles away receives it. Reports are that he usually gets the reception on the first try.

Why do they do it? Maybe, like the mountain climber, because it's there. These people have a curiosity. They want to know why things occur and engage in "what if" kinds of thinking. Perhaps Jim Ericson put it best when he said, "I personally find it a most absorbing and rewarding hobby because it forces me to think and to build my own gear."

Herb Balfour is, and enjoys being, the only

active Canadian LowFER. He feels the challenges are greater along with the difficulties. It takes a higher level of commitment and dedication. The areas of expertise vary, so these dedicated people share their knowledge with one another. As he says, "Where else can you get so much for so little?"

When is the best time to listen for LowFERs? These beacons are operated by people who work other jobs for a living. While many beacons operate automatically twenty-four hours a day, seven days a week, weekends and holidays add in the part-time operators. Like other low frequency transmissions, LowFERs are best heard at night during the winter months. If you are quite close to the location, you might hear them in the daytime. High noise levels make summer listening difficult, if not almost impossible.

Where do I find LowFERs? Here are a few, selected to give a little geographic spread. These were known to be active during the late summer of 1988. More California beacons are listed simply because of the heavy concentration of LowFERs in California.

If you would like more information about LowFERs, you might subscribe to one or both of the newsletters operated by and about LowFERs. The *Western Update* concentrates on California and the western part of the continent. The *Northern Observer* covers the eastern and central part of the continent, including Canada.

These newsletters keep you up to date on who is active (frequency, ID, location, and schedule), technical articles, and news about LowFERs individually. Both newsletters require that you submit a supply of business-size self-addressed envelopes. The *Western Update* envelopes should also carry a 25 cent stamp. The additional annual fees are seven dollars for the *Western Update* and twelve dollars U.S. for the *Northern Observer*. Send to the addresses shown below:

WESTERN UPDATE
(\$7 SASEs)
Jim Ericson
226 Charles Street
Sunnyvale, CA 94086

Amateur Beacons

Frequency	ID	Location
169.863	1SUN	Durant, OK
171.000	CB	Portsmouth, NH
172.380	ILM	Plymouth, MA
175.225	MAX	Wheatland, WY
175.388	KRY	Chardon, OH
176.260	CO	Glenwood Springs, CO
176.740	XR	Utica, MI
176.750	SR	Elgin, OR
176.925	HB	Hamden, CT
177.480	UCP	Saratoga, CA
177.750	CT	Bountiful, UT
177.800	ARK	Leslie, AR
179.500	ZMK	Daleville, IN
180.660	NRE	San Diego, CA
181.287	MEL	San Jose, CA
181.711	TLX	Novato, CA
182.620	FPV	Grenada Hills, CA
182.672	G	Palo Alto, CA
182.880	H2	Descanso, CA
183.160	PRK	Saratoga, CA
183.630	PLI	Toluca Lake, CA
183.800	YHO	Cincinnati, OH
184.016	EK	Sunnyvale, CA
184.320	JR	West Hartford, CT
185.410	XMGR	Cleveland, TN
185.490	AZ	Tucson, AZ
186.750	BA	Lancaster, IL
187.252	TEXAS	Ft. Worth, TX
187.900	MOO	Monroeville, NJ
188.700	WI	Owings, MD
189.210	QYV	Donora, PA
189.360	TH	Colt's Neck, NJ
189.780	ABC	Hilton Head Island, SC
190.400	OHH	Richmond Hill, ONT

THE NORTHERN OBSERVER
(\$12 US SASEs)
Herb D. Balfour
91 Elgin Mills Road
West Richmond Hill, ONT
Canada L4C 4M1

For the technically oriented, recent issues contained articles about such things as blanker bandwidths, optimizing a transmitter, a comparison of keyed carrier, FSK and BPSK modulation in low frequencies and various schematics. Technical capabilities vary among LowFERs and articles will reflect some of the range from reasonably simple to considerably complex. The *Northern Observer* also covers amateur beacons on medium wave and the frequencies below the experimenter's band.



Grove's Indoor SWL Antenna System

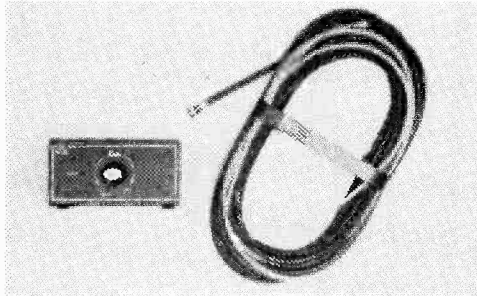

Get global shortwave reception from an antenna which hides behind a drape!

Connects to any receiver equipped with an external antenna jack

Left: Hidden Antenna, shown coiled, with optional Power Ant III and Minituner. Drawing depicts antenna in extended position, ready for use.

Our "Hidden Antenna System" is your key to exciting short wave reception without an outside antenna!

Here's the apartment dweller's dream—a high performance, amplified indoor antenna system for general coverage shortwave, medium wave and even scanner monitoring.

This 66-inch, thin profile, flexible wire antenna can be tucked in a corner, hung behind a drape—just about anywhere out of sight. And when connected to the powerful PRE-3 signal booster, you have instant total spectrum coverage from 100 kHz to over 1000 MHz!

Yes, global short wave reception will be at your fingertips, and you can operate two radios at one time!

ANT-6

Designed for use with the Grove Power Ant III

The Grove PRE-3 Power Ant has taken all the best from its successful predecessors and combined them into one powerful signal booster for scanners, short wave and medium wave receivers, even TV and FM stereos!

Equipped with a high gain, low noise, solid state amplifier stage, the PRE-3's front panel control allows custom selection of up to 30 dB of amplification!

What you need to order:

ANT-6 Hidden Antenna

\$9.95 (free shipping)

PRE-3 Power Ant III

\$49 (plus \$1⁵⁰ UPS, \$3 U.S. Parcel Post, \$4 Canada)

ACC-20 AC adaptor

\$9.95 (free shipping with PRE-3)

ACC-60 receiver cable

\$7.50 (you specify connector or receiver model; one for each receiver)

100 kHz-1000 MHz



CALL TOLL-FREE (MC & Visa Only)
1-800-438-8155

Add the Grove Minituner for Incredible Reception!

The addition of the Grove Minituner to the ANT 6/PRE-3 combo will allow signal peaking to perfection as well as eliminate intermodulation and image interference on your general coverage receiver.

Here's what you will need in addition to the combo above:

TUN-3 Minituner

\$49.00 (plus \$1⁵⁰ UPS, \$3 U.S. Parcel Post, \$4 Canada)

ADP-1 UHF/F adaptor

\$5.00 (free shipping)

ADP-2 F/PL-259 adaptor

\$5.00 (free shipping)

100 kHz-30 MHz



Grove Enterprises

140 Dog Branch Road
Brasstown, N.C. 28902

MC and Visa Orders Only,
Call 1-800-438-8155

Make Yourself Heard on CB ...

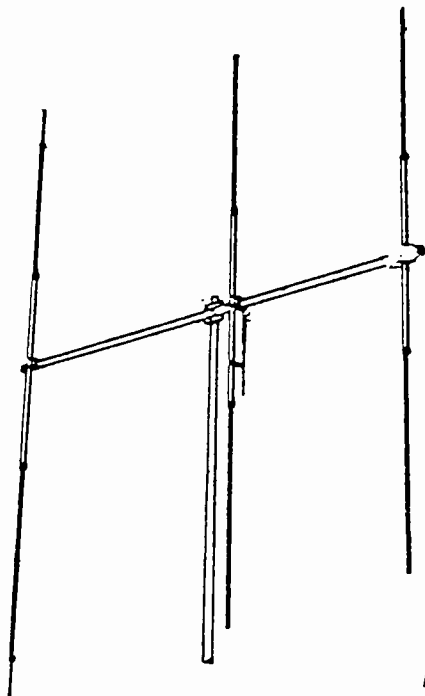

Maco M103C

If you are a CB operator you know that skip propagation is with us in a big way. Thanks to the 11-year sunspot cycle, now it is easy to talk long distances (which is illegal under FCC rules) and often impossible to be heard across town (which is what the Citizen's Band was created for in the first place). At the same time, a fair number of CBers are thinking about getting their novice ham licenses so they can legally talk "skip" on the 10-meter voice band.

Are there antennas that can help CBers improve their local signals and which also can be used for good 10-meter ham communications? The answer is yes. Although these products have been around for a while, they deserve a fresh look in light of current conditions.

Maco Manufacturing Company offers the M103C beam -- a 3-element yagi design that can be mounted either vertically (shown in sketch) or horizontally. The wind loading on this antenna is under three square feet, so this antenna can be mounted horizontally above a sturdy chimney, using the same straps, masts, and rotor you would use for a large TV antenna.

By adjusting the length of the elements, this antenna can be tuned from 26.5 MHz to 30 MHz, so you can set it up for CB frequencies and use it to improve your local signal, and then change over to the novice 10-meter band when you get your license. The turning radius of this antenna, when mounted horizontally and adjusted for CB operations, is about 11 feet.

Obviously, for local CB purposes, it will work optimally when receiving stations of similar polarity. If you mount it horizontally, you are going to hear stations with horizontal polarity best. If you set it up vertically, the local stations with vertical antennas are going to sound better.

Some operators have tried to get the best of both worlds by mounting this beam horizontally on a rotor with an omnidirectional vertical antenna on the same mast above it. By all accounts, this setup works pretty well.

You can get the Maco M103C from Copper Electronics in Kentucky for \$69.99 plus shipping. An Alliance U110 TV rotor will cost about \$50, also from Copper. Or, if you want even more gain on your signal, Copper offers a 5-element single polarity (either horizontal or vertical) beam for \$149.99. The order phone at Copper Electronics is 800-626-6343. For technical info or advice, call Jim Buster at 502-968-8500. While you are at it, ask for Copper's CB Catalog.

For an even smaller beam that can be used on 10 or 11 meters, Butternut Electronics offers the "Butterfly" 10/11 antenna, a horizontal 2-element beam with a turning radius of only 6.5 feet. It doesn't offer as much gain as the larger Maco beams, but it sure is small, and your neighbors will probably think it is some sort of funky TV antenna! Write to Butternut at 405 E. Market, Lockhart, Texas, 78644, for more information, or contact your local ham outlet.

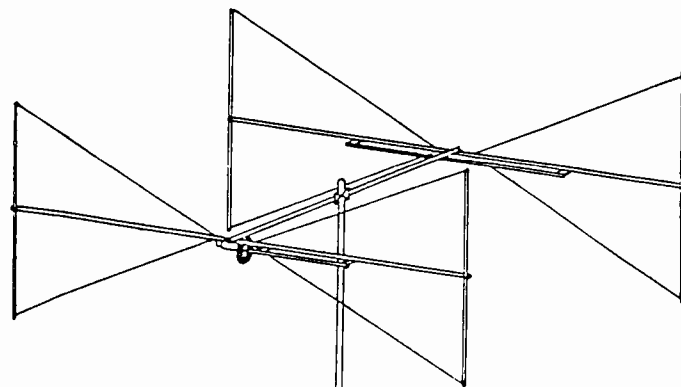

Butternut model 10-11

Treasure Trove for Sale . . .

If you really like CB radio, here's the chance of a lifetime. It appears that the best CB publication ever printed, the *Eleven Meter Times & Journal*, will be going out of business. First published in May, 1983, this newsletter-style CB periodical was jammed with all sorts of pertinent information on radios, antennas, accessories, and so forth.

Publication was suspended in April, 1988, but back issues are still available -- and probably will be until the end of 1989.

You can get a complete set of all 50 issues ever published -- an instant library of CB expertise -- for \$60.00 postpaid anywhere in the U.S., Canada, and Mexico. Prices to foreign addresses are \$65.00 surface or \$75.00 air mail. Payment must be in U.S. funds, payable to Commtronics Engineering. Personal checks are OK for

U.S. residents; foreign payment must be by international money order or bank draft in U.S. funds. The address is P.O. Box 262478, Dept. CL, San Diego, California 92126.

Putting it on the Map . . .

Let's for a moment assume that you are one of those super-sophisticated operators, a ham or shortwave DXer, who is using a computer to keep track of stations heard and to generate QSL cards. Wouldn't it be nice if you could take all that information that you have in your database and display it automatically on a map so you could see the geographic patterns in your DX operations? Well, now you can, thanks to a new PC-based mapping package.

Called MapInfo, this software offers the capability to analyze information in existing databases and then visually display the results in a variety of map formats. Using your computerized information, it can automatically create "pin maps" -- which display points on the screen based on street addresses -- as well as "thematic maps," which highlight user-defined regions by using color, shading, borders, or other graphics devices.

Further, MapInfo can:

- o locate a data point at any street address on the map
- o search a database for points that lie within specific boundaries
- o zoom in and out
- o create a window on the screen to display the complete data record behind any specific point or region on the map, and
- o determine the latitude or longitude of any point on the map.

MapInfo costs \$750. A variety of maps, including individual street maps of U.S. cities, the entire U.S., or the entire world (including basic demographic info about each country) are available at extra cost. MapInfo runs on IBM PCs and compatibles with 640K RAM, a hard drive, and graphics capability. For more information call 800-FAST-MAP. In New York State, call 518-274-8673.

Until the next time, if something strikes your fancy or raises your ire, write to me c/o *Monitoring Times*.

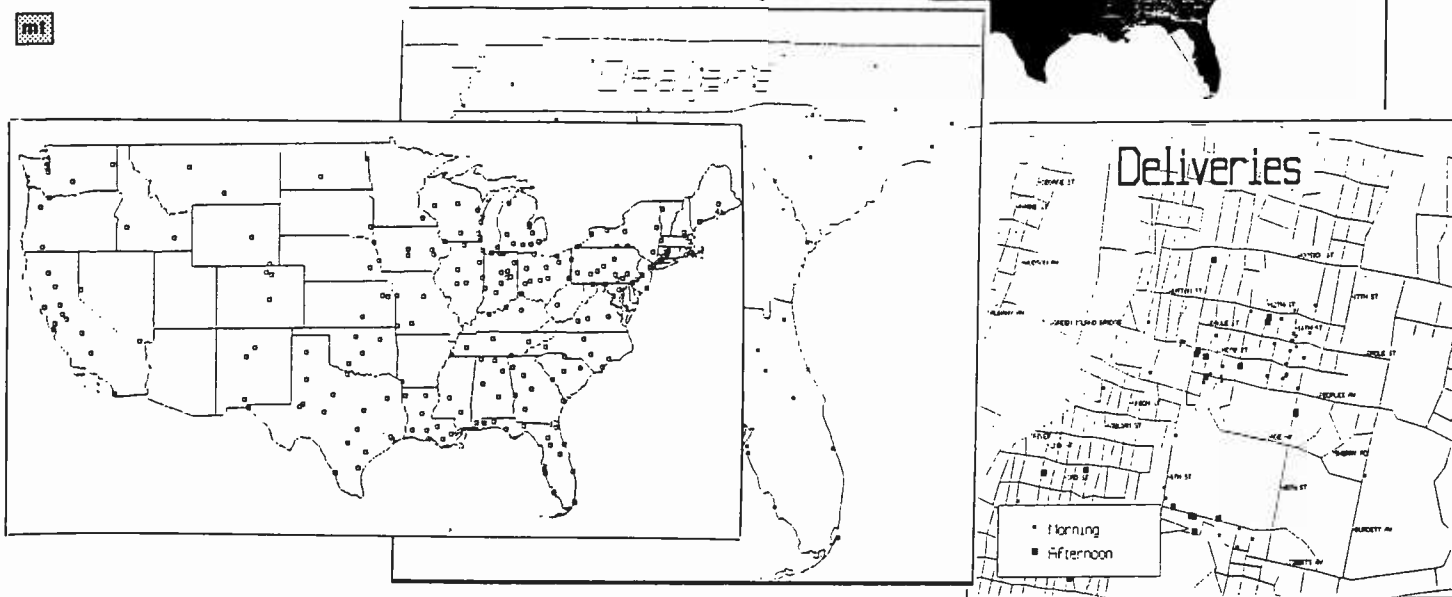

MIL-SPEC COMMUNICATIONS

P.O. Box 461 Wakefield, RI 02880
Call Today (401) 783-7106

Military Surplus & New Communications Gear

Covering DC to Daylight at Discount Prices!

Winter DX Specials

■ AR-2002 Scanner	\$455
■ AR-900 Scanner w/cellular	\$276
■ ICOM R-71A HF Scanning Receiver	\$850
■ Collins R390A (Reconditioned/Calibrated)	\$679
■ Japan Radio NRD-525	\$1,150
■ Sony ICF-2010	\$318
■ Sony ICF-2003	\$245
■ RACAL RA-6790 (GM)/R-2174	CALL

FREE DELIVERY TO YOUR DOOR!

WE OFFER REPAIR SERVICE • MANUALS • BROKERING
BUY & SELL BULLETIN
PROFESSIONAL MONITORING STATION

Collins Military Surplus Cache is NOW an integral part of Mil-Spec.

SEND \$2.00 FOR CATALOG CREDITED TO PURCHASE

Program Review

New BBC Programming Highlights New Year

Program of the Month: **NEWSDESK**

"Newsdesk" has been around for a long time. However, recent changes have improved the program drastically, placing it among the top few on shortwave.

The content has been altered somewhat. Sports and financial news have been added. In adding this, the BBC is finally recognizing the importance of sports and finance to people worldwide.

The main improvement, however, has been in the announcing style and the continuity between segments. The rigid, traditional BBC news-reading style has been subtly replaced by a more amiable sound. This is much welcomed, as the previous style was often a bit dull. While the presenters are not altogether bright and cheery, this glasnost in the continuity studio enlivens the broadcasts.

The program airs four times daily; a new broadcast was added at 0000 UTC, replacing the previous string of three programs - "World News," "News About Britain," and "Radio Newsreel" (which, incidentally, has been renamed "Newsreel"). The continuity of "Newsdesk" is here again a welcome change, and the addition of "Newsdesk" brings sports and financial news to the half-hour broadcast.

"Newsdesk" has been changed for the

better, and figures to compete with RCI/CBC's "World at Six" for listeners during prime-time on the East Coast.

Rating: **** 1/2
Content: *****
Presentation: ****

(BBC World Service, daily; 0000, 0400, 0600, 1800)

MEGAMIX

How many teenagers do you know who listen to shortwave?

Perhaps not many. But many teenagers listen to shortwave outside the United States. And the BBC has responded to their listening needs with a broad-based magazine program entitled "Megamix".

The program is intended for "young people," yet is probably aimed at listeners in the 15-35 age range. Regular features include a wide-ranging listener discussion, medical news, British concerns, and some British music news as well. Sports, fashion, and movies are also included.

Presenter Anne Bristow, who shone as cohost of the World Service's "Sounds Olympic" program (which aired worldwide on several BBC frequencies for several hours a night), is wonderful on "Megamix," and plays an occasional pop hit or two.

Overall, "Megamix" is solid, presenting a

good mix of programming for the young and young at heart.

Rating: *** 1/2
Content: ***
Presentation: ****

(BBC World Service, weekly; Tues 0030 rep 0830, 2130)

WORLDBRIEF

Compiling 10080 minutes worth of world, national, financial, sports and cultural events into 14 minutes is quite a lofty goal.

Yet this task has been undertaken by the BBC World Service in a new program, "Worldbrief." This program covers events of the previous week, from the weather in Great Britain to American politics, from Manchester United's soccer triumphs to the Nikkei Stock Exchange's ups and downs.

The presentation style is very similar to that of "Twenty-Four Hours," the BBC's main news magazine program. And the presentation is virtually flawless.

Unfortunately, the task undertaken is virtually impossible. Many news events are omitted and the events covered are often not newsworthy at all. The program resembles an American network news program in this respect, with human-interest stories and the like. These decisions are hardly befitting a "week in 14 minutes program." A listener would do well to listen to the BBC's regular news program daily, rather than this over-abridged product.

(BBC World Service, weekly; Sundays 0445 rep 1345, 2009)

If you have comments on a particular program which you've heard on shortwave, we invite you to send them to:

Program reviewer:
Kannon Shanmugam
4412 Turnberry Drive
Lawrence, KS 66046

Key to program ratings:
***** - outstanding
**** - excellent
*** - good
** - fair
* - a waste of your time



Anne Bristow presents the BBC's new program for teens, "Megamix"

Your Guide to Shortwave Listening in January

How to Use This Section

This is your daily guide to the programs being broadcast on the international bands. Wherever possible, actual advance program details for the listed stations are included. To use this section, simply look up the day on which you are listening, check the time, and decide which program interests you. Then go to the frequency section in order to locate the frequency of the station/program on the dial.

All days are in UTC. Keep in mind that the new UTC day begins at 0000 UTC. Therefore, if you are listening to the shortwave at 7:01 PM [EST] on your local Thursday night, that's equal to 0001 UTC and therefore *Friday* UTC.

We invite readers to submit information and reviews about their favorite programs. These must be in UTC day and time and can be sent to program manager Kannon Shanmugam.

We also invite broadcast stations to submit advance program details for publication in *Monitoring Times*. Copy deadline is the 1st of the month preceding publication [i.e. details for programs to be broadcast in February must be received by Kannon Shanmugam by January 1st. Information can be FAXed via 1-704-837-2216 and should indicate clearly that it is to be submitted to the *Monitoring Times* program guide.

Program Manager:
Kannon Shanmugam
4412 Turnberry Drive
Lawrence, KS 66046

Key to Program Ratings:

- ***** - outstanding
- **** - excellent
- *** - good
- ** - fair
- * - a waste of your time

Stations Listed:

- BBC - BBC, London, England
- KTWR - KTWR, Agana, Guam
- VOA - Voice of America, Washington

- | | |
|--|--|
| 0045 VOA: VOA Morning | 1110 VOA (Caribbean): Critic's Choice |
| 0100 BBC: News Summary | 1110 VOA: New Horizons |
| 0100 VOA: News | 1115 BBC: From Our Own Correspondent - **** (see Sun 0315) |
| 0101 BBC: Play of the Week | 1130 BBC: Composer of the Month |
| 0110 VOA (Am/Caribbean): Communications World | 1130 VOA (Caribbean): Spotlight |
| 0110 VOA: VOA Morning | 1130 VOA: Issues in the News |
| 0130 VOA (Am/Caribbean): Weekend Magazine | 1200 BBC: News Summary |
| 0200 BBC: World News | 1200 VOA: News |
| 0200 VOA: News | 1201 BBC: Play of the Week |
| 0209 BBC: British Press Review | 1210 VOA: Encounter |
| 0210 VOA: VOA Morning | 1230 VOA: Studio One |
| 0215 BBC: My Grandfather | 1300 BBC: World News |
| 0230 BBC: The Ken Bruce Show (music mix and entertainment news) | 1300 VOA: News |
| 0300 BBC: World News | 1309 BBC: Twenty-Four Hours (news magazine) |
| 0300 VOA: News | 1310 VOA: Critic's Choice |
| 0309 BBC: News About Britain | 1330 BBC: Sports Roundup |
| 0310 VOA: VOA Morning | 1330 VOA: Special English News and Features |
| 0315 BBC: From Our Own Correspondent - **** - Good in-depth news stories. | 1345 BBC: Worldbrief (week's news) |
| 0330 BBC: Just a Minute | 1400 BBC: News Summary |
| 0400 BBC: Newsdesk | 1400 VOA: News |
| 0400 VOA: News | 1401 BBC: With Good Reason |
| 0410 VOA: VOA Morning | 1410 VOA: The Concert Hall |
| 0430 BBC: From Old Time to New Country (country music) | 1430 BBC: Anything Goes (odd recordings) |
| 0445 BBC: Worldbrief (week's news) | 1455 VOA: Editorial |
| 0500 BBC: World News | 1500 BBC: Newsreel |
| 0500 VOA: News | 1500 VOA: News |
| 0509 BBC: Twenty-Four Hours (news magazine) | 1510 VOA: New Horizons |
| 0510 VOA: VOA Morning | 1515 BBC: From Britain's Music Festivals |
| 0530 BBC: Financial Review | 1530 VOA: Studio One |
| 0540 BBC: Words of Faith (religion) | 1600 BBC: World News |
| 0545 BBC: Letter from America - ***** - Alistair Cooke's distinctly British view of America. | 1600 VOA: News |
| 0600 BBC: Newsdesk | 1609 BBC: News About Britain |
| 0600 VOA: News | 1610 VOA (Africa): Nightline Africa |
| 0610 VOA: VOA Morning | 1610 VOA: Encounter |
| 0630 BBC: Jazz for the Asking | 1615 BBC: Feature |
| 0700 BBC: World News | 1630 VOA: Special English News and Features |
| 0709 BBC: Twenty-Four Hours (news magazine) | 1645 BBC: Letter from America - ***** (see Sun 0545) |
| 0730 BBC: From Our Own Correspondent - **** (see Sun 0315) | 1700 BBC: World News |
| 0745 BBC: Book Choice | 1700 VOA: News |
| 0750 BBC: Waveguide - ** - DX program geared toward neophyte listeners. | 1709 BBC: Commentary |
| 0800 BBC: World News | 1710 VOA (Africa): Voices of Africa |
| 0809 BBC: Words of Faith (religion) | 1710 VOA: Critic's Choice |
| 0815 BBC: The Pleasure's Yours (classical music requests) | 1715 BBC: Jazz for the Asking |
| 0845 KTWR: Pacific DX Magazine | 1730 VOA (Africa): Music Time in Africa |
| 0900 BBC: World News | 1730 VOA: Issues in the News |
| 0909 BBC: British Press Review | 1745 BBC: Sports Roundup |
| 0915 BBC: Nature Now | 1800 BBC: Newsdesk |
| 0930 BBC: Financial Review | 1800 VOA: News |
| 0939 BBC: Book Choice | 1810 VOA: Encounter |
| 0945 BBC: Poems by Post | 1830 BBC: In Praise of God |
| 1000 BBC: News Summary | 1830 VOA: Special English News and Features |
| 1000 VOA (Caribbean): VOA Morning | 1900 BBC: News Summary |
| 1000 VOA: News | 1900 VOA: News |
| 1001 BBC: Science in Action | 1901 BBC: Here's Humph! (jazz music) |
| 1010 VOA: Critic's Choice | 1910 VOA (Africa): Africa in Print |
| 1030 BBC: In Praise of God | 1910 VOA: Sunday Report |
| 1030 VOA: Special English Features | 1915 BBC: Feature |
| 1100 BBC: World News | 1930 VOA (Africa): Music Time in Africa |
| 1100 VOA: News | 1930 VOA: Music, U.S.A. (Standards) |
| 1109 BBC: News About Britain | 2000 BBC: World News |
| | 2000 VOA: News |
| | 2009 BBC: Worldbrief (week's news) |
| | 2010 VOA (Africa): Nightline Africa |
| | 2010 VOA: The Concert Hall |
| | 2025 BBC: Words of Faith (religion) |

Sunday

Jan 1st, 8th, 15th, 22nd, 29th

- 0000 BBC: Newsdesk
- 0000 VOA: News
- 0010 VOA (Am/Caribbean): Closeup
- 0010 VOA: VOA Morning
- 0030 BBC: Composer of the Month
- 0030 VOA (Caribbean): Press Conference, U.S.A.
- 0030 VOA: Special English News and Features

Your Guide to Shortwave Listening in January

2030 BBC: Back to Square One	magazine)	1500 VOA: News
2055 VOA: Editorial	0510 VOA: Newline	1510 VOA: Newline
2100 BBC: News Summary	0530 BBC: Waveguide - ** (see Sun 0750)	1515 BBC: Feature
2100 VOA: News	0530 VOA: VOA Morning	1530 VOA: Magazine Show
2101 BBC: Sports Roundup	0540 BBC: Words of Faith (religion)	1600 BBC: World News
2110 VOA: New Horizons	0545 BBC: Recording of the Week	1600 VOA: News
2115 BBC: The Pleasure's Yours (classical music requests)	0600 BBC: Newsdesk	1609 BBC: News About Britain
2130 VOA (Africa): Issues in the News	0600 VOA: News	1610 VOA (Africa): Nightline Africa (until 1700)
2130 VOA: Studio One	0610 VOA (Africa): Daybreak Africa	1610 VOA: Focus
2200 BBC: Newshour	0610 VOA: Newline	1615 BBC: Five William Stories
2200 VOA: News	0630 BBC: With Good Reason	1630 BBC: Health Matters
2210 VOA: Morning Newline	0630 VOA: VOA Morning	1630 VOA: Special English News and Features
2230 VOA: Special English News and Features	0700 BBC: World News	1645 BBC: The World Today (news feature)
2245 VOA: VOA Morning	0709 BBC: Twenty-Four Hours (news magazine)	1700 BBC: World News
2300 BBC: World News	0730 BBC: Feature	1700 VOA: News
2300 VOA: News	0800 BBC: World News	1709 BBC: Commentary
2309 BBC: Book Choice	0809 BBC: Words of Faith (religion)	1710 VOA (Africa): African Panorama (until 1730)
2310 VOA: Morning Newline	0810 KTWR: Insight for Living	1710 VOA: Newline
2315 BBC: Letter from America - ***** (see Sun 0545)	0815 BBC: Five William Stories	1715 BBC: Just a Minute
2330 BBC: With Good Reason	0830 BBC: Anything Goes (odd recordings)	1730 VOA: Music, U.S.A.
2330 VOA: VOA Morning	0900 BBC: World News	1745 BBC: Sports Roundup
	0909 BBC: British Press Review	1800 BBC: Newsdesk
	0915 BBC: Good Books - **** (see Mon 0315)	1800 VOA: News
	0930 BBC: Financial News	1810 VOA: Focus
	0940 BBC: Sports Roundup	1830 BBC: Multitrack 1: Top 20 - **** - Interesting British pop trends here.
	0945 BBC: Andy Kershaw's World of Music (innovative music)	1830 VOA: Special English News and Features
	1000 BBC: News Summary	1900 BBC: News Summary
	1000 VOA: News	1900 VOA: News
	1001 BBC: With Good Reason	1901 BBC: Outlook - **** (see Mon 1405)
	1010 VOA: Newline	1910 VOA (Africa): African Panorama (until 1930)
	1025 KTWR: Insight for Living	1910 VOA: Newline
	1030 BBC: The Vintage Chart Show	1925 BBC: Financial News
	1030 VOA (Caribbean): VOA Morning (until 1100)	1930 BBC: Network UK (feature)
	1030 VOA: Magazine Show	1930 VOA (Africa): Sound of Soul (until 2000)
	1100 BBC: World News	1930 VOA: Magazine Show
	1100 VOA: News	1945 BBC: Poems by Post
	1109 BBC: News About Britain	2000 BBC: World News
	1110 VOA (Caribbean): Focus	2000 VOA: News
	1110 VOA: Special English Features	2009 BBC: The World Today (news feature)
	1115 BBC: Health Matters	2010 VOA (Africa): Nightline Africa (until 2100)
	1130 BBC: The Ken Bruce Show (music mix with entertainment news)	2010 VOA: Music, U.S.A. - Jazz
	1130 VOA (Caribbean): VOA Morning	2025 BBC: Words of Faith (religion)
	1130 VOA: Music, U.S.A.	2030 BBC: The Vintage Chart Show
	1200 BBC: Newsreel	2055 VOA: Editorial
	1200 VOA: News	2100 BBC: News Summary
	1210 VOA: Newline	2100 VOA: News
	1215 BBC: Back to Square One	2101 BBC: Sports Roundup
	1230 VOA: Magazine Show	2110 VOA: World Report
	1245 BBC: Sports Roundup	2115 BBC: Europe's World
	1300 BBC: World News	2130 BBC: Sports International
	1300 VOA: News	2200 BBC: Newshour
	1309 BBC: Twenty-Four Hours (news magazine)	2200 VOA: News
	1310 VOA: Focus	2210 VOA: Morning Newline
	1330 BBC: Feature	2230 VOA: Special English News and Features
	1330 VOA: Special English News and Features	2245 VOA: VOA Morning
	1400 BBC: World News	2300 BBC: World News
	1400 VOA: News	2300 VOA: News
	1405 BBC: Outlook - **** - A very good magazine-format program.	2309 BBC: Commentary
	1410 VOA: Asia Report	2310 VOA: Morning Newline
	1445 BBC: My Grandfather	2315 BBC: The Learning World
	1455 VOA: Editorial	
	1500 BBC: Newsreel	

MONDAY

Jan 2nd, 9th, 16th, 23rd, 30th

0000 BBC: Newsdesk
0000 VOA: News
0010 VOA (East Asia): Newline
0010 VOA: Encounter
0030 BBC: In Praise of God
0030 VOA (East Asia): Special English News and Features
0030 VOA: Studio One
0045 VOA: VOA Morning
0100 BBC: News Summary
0100 VOA: News
0100 VOA: News
0101 BBC: Feature
0110 VOA (South Asia): Newline
0110 VOA: New Horizons
0130 VOA (South Asia): VOA Morning
0130 VOA: Issues in the News
0145 BBC: Mario Lanza (opera music)
0200 BBC: World News
0200 VOA: News
0209 BBC: British Press Review
0210 VOA: Newline
0215 BBC: Andy Kershaw's World of Music (innovative music)
0230 BBC: Science in Action
0230 VOA: VOA Morning
0300 BBC: World News
0300 VOA: News
0309 BBC: News About Britain
0310 VOA: Daybreak Africa
0315 BBC: Good Books - **** - Detailed opinions on specific books.
0330 BBC: Anything Goes (odd recordings)
0400 BBC: Newsdesk
0400 VOA: News
0410 VOA: Newline
0430 BBC: Five William Stories
0430 VOA: VOA Morning
0445 BBC: Nature Now
0500 BBC: World News
0500 VOA: News
0509 BBC: Twenty-Four Hours (news

Your Guide to Shortwave Listening in January

2330 BBC: Multitrack 1: Top 20 - ****
(see Mon 1830)
2330 VOA: VOA Morning

TUESDAY

Jan 3rd, 10th, 17th, 24th, 31st

0000 BBC: Newsdesk
0000 VOA: News
0010 VOA (East Asia): Newline
0010 VOA: Caribbean Report
0030 BBC: Megamix (program for teenagers)
0030 VOA (East Asia): Special English News and Features
0030 VOA: Music, U.S.A.
0045 VOA (East Asia): VOA Morning
0100 BBC: News Summary
0100 VOA: News
0101 BBC: Outlook - **** (see Mon 1405)
0110 VOA (East Asia): Newline
0110 VOA: Report to the Americas
0125 BBC: Financial News
0130 BBC: Poems by Post
0130 VOA (East Asia): VOA Morning
0145 BBC: Europe's World
0200 BBC: World News
0200 VOA: News
0209 BBC: British Press Review
0210 VOA: Newline
0215 BBC: Network UK (feature)
0230 BBC: Sports International (feature)
0230 VOA: VOA Morning
0300 BBC: World News
0300 VOA: News
0309 BBC: News About Britain
0310 VOA: Daybreak Africa
0315 BBC: The World Today (news feature)
0330 BBC: John Peel (progressive rock music)
0400 BBC: Newsdesk
0400 VOA: News
0410 VOA: Newline
0430 BBC: The Learning World (education)
0430 VOA: VOA Morning
0445 BBC: New Ideas
0455 BBC: Book Choice
0500 BBC: World News
0500 VOA: News
0509 BBC: Twenty-Four Hours (news magazine)
0510 VOA: Newline
0530 BBC: Financial News
0530 VOA: VOA Morning
0540 BBC: Words of Faith (religion)
0545 BBC: The World Today (news feature)
0600 BBC: Newsdesk
0600 VOA: News
0610 VOA (Africa): Daybreak Africa
0610 VOA: Newline
0630 BBC: Acker's Away (music)
0630 VOA: VOA Morning
0700 BBC: World News
0709 BBC: Twenty-Four Hours (news magazine)
0730 BBC: Europe's World
0745 BBC: Network UK (feature)

0800 BBC: World News
0809 BBC: Words of Faith (religion)
0815 BBC: Health Matters
0815 KTWR: Insight for Living
0830 BBC: Megamix (program for teenagers)
0900 BBC: World News
0909 BBC: British Press Review
0915 BBC: The World Today (news feature)
0930 BBC: Financial News
0940 BBC: Sports Roundup
0945 BBC: Mario Lanza (opera music)
1000 BBC: News Summary
1001 BBC: Discovery (science)
1025 KTWR: Insight for Living
1030 BBC: Sports International (feature)
1100 BBC: World News
1100 VOA: News
1109 BBC: News About Britain
1110 VOA (Caribbean): Focus
1110 VOA: Special English Features
1115 BBC: Waveguide - ** (see Sun 0750)
1125 BBC: Book Choice
1130 BBC: Citizens - **** - innovative serial with travails of five fictional Britons.
1130 VOA (Caribbean): VOA Morning
1130 VOA: Music, U.S.A.
1200 BBC: Newsreel
1200 VOA: News
1210 VOA: Newline
1215 BBC: Multitrack 1: Top 20 - **** (see Mon 1830)
1230 VOA: Magazine Show
1245 BBC: Sports Roundup
1300 BBC: World News
1300 VOA: News
1309 BBC: Twenty-Four Hours (news magazine)
1310 VOA: Focus
1330 BBC: Network UK (feature)
1330 VOA: Special English News and Features
1345 BBC: Recording of the Week
1400 BBC: World News
1400 VOA: News
1405 BBC: Outlook - **** (see Mon 1405)
1410 VOA: Asia Report
1445 BBC: Mario Lanza (opera music)
1455 VOA: Editorial
1500 BBC: Newsreel
1500 VOA: News
1510 VOA: Newline
1515 BBC: A Jolly Good Show (rock music)
1530 VOA: Magazine Show
1600 BBC: World News
1600 VOA: News
1609 BBC: News About Britain
1610 VOA (Africa): Nightline Africa (until 1700)
1610 VOA: Focus
1615 BBC: Omnibus (topical feature)
1630 VOA: Special English News and Features
1645 BBC: The World Today (news feature)
1700 BBC: World News
1709 BBC: Commentary

1715 BBC: Citizens - **** (see Tue 1130)
1745 BBC: Sports Roundup
1800 BBC: Newsdesk
1830 BBC: Discovery (science)
1900 BBC: News Summary
1901 BBC: Outlook - **** (see Mon 1405)
1925 BBC: Financial News
1930 BBC: Development '88
2000 BBC: World News
2009 BBC: The World Today (news feature)
2025 BBC: Words of Faith (religion)
2030 BBC: Meridian (arts feature)
2100 BBC: News Summary
2101 BBC: Sports Roundup
2115 BBC: Business Matters
2130 BBC: Megamix (program for teenagers)
2200 BBC: Newshour
2300 BBC: World News
2300 VOA: News
2309 BBC: Commentary
2310 VOA: Morning Newline
2315 BBC: From Britain's Music Festivals
2330 VOA: VOA Morning

WEDNESDAY

Jan 4th, 11th, 18th, 25th

0000 BBC: Newsdesk
0000 VOA: News
0010 VOA (Caribbean): Caribbean Report
0010 VOA: Newline
0030 BBC: Omnibus (topical feature)
0030 VOA (Caribbean): Music, U.S.A.
0030 VOA: Special English News and Features
0100 BBC: News Summary
0100 VOA: News
0101 BBC: Outlook - **** (see Mon 1405)
0110 VOA (Caribbean): Report to the Americas
0110 VOA: Newline
0125 BBC: Financial News
0130 BBC: How It All Began
0130 VOA: VOA Morning
0145 BBC: Country Style - ** - British country music?
0200 BBC: World News
0200 VOA: News
0209 BBC: British Press Review
0210 VOA: Newline
0215 BBC: Health Matters
0230 BBC: Citizens - **** (see Tue 1130)
0230 VOA: VOA Morning
0300 BBC: World News
0300 VOA: News
0309 BBC: News About Britain
0310 VOA: Daybreak Africa
0315 BBC: The World Today (news feature)
0330 BBC: Discovery (science)
0400 BBC: Newsdesk
0400 VOA: News
0410 VOA: Newline
0430 BBC: Business Matters
0430 VOA: VOA Morning
0445 BBC: Country Style - ** (see Wed

Your Guide to Shortwave Listening in January

1115 BBC: New Ideas
 1125 BBC: Book Choice
 1130 BBC: Citizens - **** (see Tue 1130)
 1130 VOA (Caribbean): VOA Morning
 1130 VOA: Music, U.S.A.
 1200 BBC: Newsreel
 1200 VOA: News
 1210 VOA: Newslines
 1215 BBC: Multitrack 2 - *** (see Wed 1830)
 1230 VOA: Magazine Show
 1245 BBC: Sports Roundup
 1300 BBC: World News
 1300 VOA: News
 1309 BBC: Twenty-Four Hours (news magazine)
 1310 VOA: Focus
 1330 BBC: Network UK (feature)
 1330 VOA: Special English News and Features
 1345 BBC: Folk in Britain [5th, 19th]; Jazz Scene UK [12th, 26th]
 1400 BBC: World News
 1400 VOA: News
 1405 BBC: Outlook - **** (see Mon 1405)
 1410 VOA: Asia Report
 1445 BBC: Mediawatch
 1455 VOA: Editorial
 1500 BBC: Newsreel
 1500 VOA: News
 1510 VOA: Newslines
 1515 BBC: The Pleasure's Yours (classical music requests)
 1530 VOA: Magazine Show
 1600 BBC: World News
 1600 VOA: News
 1609 BBC: News About Britain
 1610 VOA (Africa): Nightline Africa (until 1700)
 1610 VOA: Focus
 1615 BBC: Assignment
 1630 VOA: Special English News and Features
 1645 BBC: The World Today (news feature)
 1700 BBC: World News
 1709 BBC: Commentary
 1715 BBC: Citizens - **** (see Tue 1130)
 1745 BBC: Sports Roundup
 1800 BBC: Newsdesk
 1830 BBC: Focus on Faith - **** - News on both modern and traditional views of many religions.
 1900 BBC: News Summary
 1901 BBC: Outlook - **** (see Mon 1405)
 1925 BBC: Financial News
 1930 BBC: Just the Job (people with odd jobs)
 1945 BBC: The Farming World
 2000 BBC: World News
 2009 BBC: The World Today (news feature)
 2025 BBC: Words of Faith (religion)
 2030 BBC: Meridian
 2100 BBC: News Summary
 2101 BBC: Sports Roundup
 2115 BBC: Seven Seas
 2130 BBC: Mediawatch
 2145 BBC: Profile
 2200 BBC: Newshour

2300 BBC: World News
 2300 VOA: News
 2309 BBC: Commentary
 2310 VOA: Morning Newslines
 2315 BBC: Music Now (modern classical music)
 2330 VOA: VOA Morning
 2345 BBC: Feature

FRIDAY

Jan 6th, 13th, 20th, 27th

0000 BBC: Newsdesk
 0000 VOA: News
 0010 VOA (Caribbean): Caribbean Report
 0010 VOA: Newslines
 0030 BBC: Best on Record
 0030 VOA (Caribbean): Music, U.S.A.
 0030 VOA: Special English News and Features
 0045 VOA: VOA Morning
 0100 BBC: News Summary
 0100 VOA: News
 0101 BBC: Outlook - **** (see Mon 1405)
 0110 VOA (Caribbean): Report to the Americas
 0110 VOA: Newslines
 0125 BBC: Financial News
 0130 BBC: Folk in Britain [6th, 20th]; Jazz Scene UK [13th, 27th]
 0130 VOA: VOA Morning
 0145 BBC: Profile
 0200 BBC: World News
 0200 VOA: News
 0209 BBC: British Press Review
 0210 VOA: Newslines
 0215 BBC: Seven Seas
 0230 BBC: Citizens - **** (see Tue 1130)
 0230 VOA: VOA Morning
 0300 BBC: World News
 0300 VOA: News
 0309 BBC: News About Britain
 0310 VOA: Daybreak Africa
 0315 BBC: The World Today (news feature)
 0330 BBC: Focus on Faith - **** (see Thu 1830)
 0400 BBC: Newsdesk
 0400 VOA: News
 0410 VOA: Newslines
 0430 BBC: Poems by Post
 0430 VOA: VOA Morning
 0445 BBC: Folk in Britain [6th, 20th]; Jazz Scene UK [13th, 27th]
 0500 BBC: World News
 0500 VOA: News
 0509 BBC: Twenty-Four Hours (news magazine)
 0510 VOA: Newslines
 0530 BBC: Financial News
 0530 VOA: VOA Morning
 0540 BBC: Words of Faith (religion)
 0545 BBC: The World Today (news feature)
 0600 BBC: Newsdesk
 0600 VOA: News
 0610 VOA (Africa): Daybreak Africa
 0610 VOA: Newslines
 0630 BBC: Meridian (arts feature)
 0630 VOA: VOA Morning

0700 BBC: World News
 0709 BBC: Twenty-Four Hours (news magazine)
 0730 BBC: Alpine Winter
 0800 BBC: World News
 0809 BBC: Words of Faith (religion)
 0815 BBC: Music Now (modern classical music)
 0815 KTWR: Insight for Living
 0845 BBC: Feature
 0900 BBC: World News
 0909 BBC: British Press Review
 0915 BBC: The World Today (news feature)
 0930 BBC: Financial News
 0940 BBC: Sports Roundup
 0945 BBC: Seven Seas
 1000 BBC: News Summary
 1001 BBC: Focus on Faith - **** (see Thu 1830)
 1025 KTWR: Insight for Living
 1030 BBC: Best on Record
 1100 BBC: World News
 1100 VOA: News
 1109 BBC: News About Britain
 1110 VOA (Caribbean): Focus
 1110 VOA: Special English Features
 1115 BBC: Profile
 1130 BBC: Meridian (arts feature)
 1130 VOA (Caribbean): VOA Morning
 1130 VOA: Music, U.S.A.
 1200 BBC: Newsreel
 1200 VOA: News
 1210 VOA: Newslines
 1215 BBC: Alpine Winter
 1230 VOA: Magazine Show
 1245 BBC: Sports Roundup
 1300 BBC: World News
 1300 VOA: News
 1309 BBC: Twenty-Four Hours (news magazine)
 1310 VOA: Focus
 1330 BBC: John Peel (progressive rock music)
 1330 VOA: Special English News and Features
 1400 BBC: World News
 1400 VOA: News
 1405 BBC: Outlook - **** (see Mon 1405)
 1410 VOA: Asia Report
 1445 BBC: Nature Now
 1455 VOA: Editorial
 1500 BBC: Newsreel
 1500 VOA: News
 1510 VOA: Newslines
 1515 BBC: Music Now (modern classical music)
 1530 VOA: Magazine Show
 1600 BBC: World News
 1600 VOA: News
 1609 BBC: News About Britain
 1610 VOA (Africa): Nightline Africa (until 1700)
 1610 VOA: Focus
 1615 BBC: Science in Action
 1630 VOA: Special English News and Features
 1645 BBC: The World Today (news feature)
 1700 BBC: World News
 1709 BBC: Commentary

Your Guide to Shortwave Listening in January

- 1715 BBC: Best on Record
 1745 BBC: Sports Roundup
 1800 BBC: Newsdesk
 1830 BBC: Multitrack 3 - **** - Sarah Ward presents innovative rock music.
 1900 BBC: News Summary
 1901 BBC: Outlook - **** (see Mon 1405)
 1925 BBC: Financial News
 1930 BBC: Network UK
 1945 BBC: Personal View (topics in British life)
 2000 BBC: World News
 2009 BBC: The World Today (news feature)
 2030 BBC: Science in Action
 2100 BBC: News Summary
 2101 BBC: Sports Roundup
 2115 BBC: From Old Time to New Country (country music)
 2130 BBC: People and Politics
 2200 BBC: Newshour
 2300 BBC: World News
 2300 VOA: News
 2309 BBC: Commentary
 2310 VOA: VOA Morning
 2315 BBC: From The Weeklies (press review)
 2330 BBC: Multitrack 3 - **** (see Fri 1830)
- SATURDAY**
- Jan 7th, 14th, 21st, 28th**
- 0000 BBC: Newsdesk
 0000 VOA: News
 0010 VOA (Caribbean): Newslines
 0010 VOA: VOA Morning
 0030 BBC: Personal View (topics in British life)
 0030 VOA (Caribbean): Music, U.S.A.
 0030 VOA: Special English News and Features
 0045 BBC: Recording of the Week
 0045 VOA: VOA Morning
 0100 BBC: News Summary
 0100 VOA: News
 0101 BBC: Outlook - **** (see Mon 1405)
 0110 VOA (Caribbean): Report to the Americas
 0110 VOA: VOA Morning
 0125 BBC: Financial News
 0130 BBC: Classical Record Review
 0145 BBC: Book Choice
 0150 BBC: New Ideas
 0200 BBC: World News
 0200 VOA: News
 0209 BBC: British Press Review
 0210 VOA: VOA Morning
 0215 BBC: Network UK (feature)
 0230 BBC: People and Politics
 0300 BBC: World News
 0300 VOA: News
 0309 BBC: News About Britain
 0310 VOA: VOA Morning
 0315 BBC: The World Today (news feature)
 0330 BBC: The Vintage Chart Show
 0345 BBC: Business Matters
 0400 BBC: Newsdesk
 0400 VOA: News
 0410 VOA: VOA Morning
 0430 BBC: Here's Humph! (jazz music)
 0445 BBC: Personal View (topics in British life)
 0500 BBC: World News
 0500 VOA: News
 0509 BBC: Twenty-Four Hours (news magazine)
 0510 VOA: VOA Morning
 0530 BBC: Financial News
 0540 BBC: Words of Faith (religion)
 0545 BBC: The World Today (news feature)
 0600 BBC: Newsdesk
 0600 VOA: News
 0610 VOA: VOA Morning
 0630 BBC: Meridian (arts feature)
 0700 BBC: World News
 0709 BBC: Twenty-Four Hours (news magazine)
 0730 BBC: From The Weeklies (press review)
 0745 BBC: Network UK (feature)
 0800 BBC: World News
 0809 BBC: Words of Faith (religion)
 0815 BBC: A Jolly Good Show (rock music)
 0900 BBC: World News
 0909 BBC: British Press Review
 0915 BBC: The World Today (news feature)
 0930 BBC: Financial News
 0940 BBC: Sports Roundup
 0945 BBC: Personal View (topics in British life)
 1000 BBC: News Summary
 1000 KTWR: Pacific DX Magazine
 1001 BBC: Here's Humph! (jazz music)
 1015 BBC: Letter from America - **** (see Sun 0545)
 1030 BBC: People and Politics
 1100 BBC: World News
 1100 VOA: News
 1109 BBC: News About Britain
 1110 VOA (Caribbean): American Viewpoints
 1110 VOA: Closeup
 1115 BBC: Classical Record Review
 1130 BBC: Meridian (arts feature)
 1130 VOA (Caribbean): Music, U.S.A.
 1130 VOA: Press Conference, U.S.A.
 1200 BBC: Newsreel
 1200 VOA: News
 1210 VOA: Communications World
 1215 BBC: Multitrack 3 - **** (see Fri 1830)
 1230 VOA: Weekend Magazine
 1245 BBC: Sports Roundup
 1300 BBC: World News
 1300 VOA: News
 1309 BBC: Twenty-Four Hours (news magazine)
 1310 VOA: American Viewpoints
 1330 BBC: Network UK (feature)
 1330 VOA: Special English News and Features
 1345 BBC: From Old Time to New Country (country music)
 1400 BBC: News Summary
 1400 VOA: News
 1401 BBC: The Ken Bruce Show (music mix with entertainment news)
 1410 VOA: Music, U.S.A. (Jazz)
 1430 BBC: Sportsworld
 1455 VOA: Editorial
 1500 BBC: Newsreel
 1500 VOA: News
 1510 VOA: Closeup
 1515 BBC: Sportsworld
 1515 KTWR: Pacific DX Magazine
 1530 VOA: Press Conference, U.S.A.
 1600 BBC: World News
 1600 VOA: News
 1609 BBC: News About Britain
 1610 VOA (Africa): Nightline Africa
 1610 VOA: American Viewpoints
 1615 BBC: Sportsworld
 1630 VOA: Special English News and Features
 1700 BBC: News Summary
 1701 BBC: Sportsworld
 1745 BBC: Sports Roundup
 1800 BBC: Newsdesk
 1830 BBC: Composer of the Month
 1900 BBC: News Summary
 1901 BBC: Play of the Week
 2000 BBC: World News
 2009 BBC: From Our Own Correspondent - **** (see Sun 0315)
 2025 BBC: Words of Faith (religion)
 2030 BBC: Meridian (arts feature)
 2100 BBC: News Summary
 2101 BBC: Sports Roundup
 2115 BBC: Classical Record Review
 2130 BBC: Alpine Winter
 2200 BBC: Newshour
 2300 BBC: World News
 2300 VOA: News
 2309 BBC: Book Choice
 2310 VOA: Morning Newslines
 2315 BBC: A Jolly Good Show (rock music)
 2330 VOA: VOA Morning



You never know what you'll hear on the BBC's new products show, New Ideas. Here, Casey Lord is being introduced to a new kind of hand pump by the manufacturing firm's director. You can hear such hands-on presentations Saturdays at 0150, Tuesdays at 0450, Wednesdays at 1730 or Thursdays at 1115.

frequency SECTION

0000 UTC [7:00 PM EST/4:00 PM PST]

0000-0015	Voice of Kampuchea, Phnom-Penh	9693	11938				
0000-0030	BBC, London, England	5975	6005	6175	7325		
		9515	9580	9590	9915		
		11955	12095	15260	15360		
		17875					
0000-0030	Kol Israel, Jerusalem	7460	9435	9855			
0000-0030	Radio Canada Int'l, Montreal	5960	9755				
0000-0030	Radio Korea, Seoul, South Korea	15575					
0000-0030	M Radio Norway Int'l, Oslo	9620	11850				
0000-0030	Radio Sofia, Bulgaria	9700	11950				
0000-0045	WINB, Red Lion, Pennsylvania	15145					
0000-0050	Radio Pyongyang, North Korea	15115	15160				
0000-0055	Radio Beijing, PR China	9665	9770	11715			
0000-0100	All India Radio, New Delhi	6055	7215	9535	9910		
		11715	11745	15110			
0000-0100	CBC Northern Quebec Service	6195	9825				
0000-0100	CBN, St. John's, Newfoundland	6160					
0000-0100	CBU, Vancouver, British Columbia	6160					
0000-0100	CFCF, Montreal, Quebec	6005					
0000-0100	CFCN, Calgary, Alberta	6030					
0000-0100	CHNS, Halifax, Nova Scotia	6130					
0000-0100	CKWX, Vancouver, British Columbia	6080					
0000-0100	CFRB, Toronto, Ontario	6070					
0000-0100	FEBC, Manila, Philippines	15445					
0000-0100	(US) Far East Network, Tokyo	3910					
0000-0100	KSDA, Guam	15125					
0000-0100	KVOH, Rancho Simi, California	17775					
0000-0100	KYOI, Saipan	15405					
0000-0100	Radio Australia, Melbourne	15140	15160	15240	15320		
		15395	17750	17795			
		9515	11775				
0000-0100	Radio Baghdad, Iraq	9655					
0000-0100	Radio Havana Cuba	6090					
0000-0100	Radio Luxembourg	7370	9790	9840	12010		
0000-0100	Radio Moscow	12045	15170	15295	17570		
		17655	17675	17850	17860		
		17880	17890	21790			
0000-0100	Radio Moscow N. America Service	5980	6000	6170	7115		
		7165	7195	9530	9720		
		9765	9890	12050	13605		
		15245	15405	15420	17700		
		21530					

MT Monitoring Team

EAST COAST:

Greg Jordan,
Frequency Manager

1855-I Franciscan Terrace
Winston-Salem, NC 27127

Joe Hanlon, PA

WEST COAST:

Bill Brinkley, CA

Pete Wahlquist, CA

0000-0100	Radio New Zealand, Wellington	15150	17705		
0000-0100	Radio for Peace, Costa Rica	21555			
0000-0100	Radio Thailand, Bangkok	9655	11905		
0000-0100	SBC Radio One, Singapore	5010	5052	11940	
0000-0100	Spanish Foreign Radio, Madrid	9630	11880		
0000-0100	T-S Superpower KUSW, Utah	15580			
0000-0100	Voice of America, Washington	5995	6130	7170	7200
		7280	9455	9775	9815
		11580	11695	11740	15205
		15290	17735	17820	
		6100			
0000-0100	T-A Voice of Nicaragua, Managua	9850			
0000-0100	WCSN, Boston, Massachusetts	7365	9495		
0000-0100	WHRI, Noblesville, Indiana	7355			
0000-0100	WRNO, New Orleans, Louisiana	11980			
0000-0100	WSHB, Cyprus Creek, S. Carolina	5950	9505	11910	15440
0000-0100	WYFR, Oakland, California	6195	7235	9570	11820
0030-0045	BBC, London, England*	15435			
		9675	9925		
0030-0055	M-A BRT, Brussels, Belgium	5975	6005	6175	7325
0030-0100	BBC, London, England	9515	9580	9915	9590
		12095	15260	15360	17710
		9720	11775	11910	15155
		9875			
0030-0100	HCJB, Quito, Ecuador	6110	9520	9585	9835
0030-0100	Radio Austria Int'l, Vienna	11910	15160		
0030-0100	T-S Radio Budapest, Hungary	5960	9755		
		7205	7400	9640	
0030-0100	Radio Canada Int'l, Montreal	9800			
0030-0100	Radio Kiev, Ukrainian SSR	13645	15180	15455	
		6005	9720		
0030-0100	SLBC, Colombo, Sri Lanka	3925	4860		
0035-0040	All India Radio, New Delhi	6080	9730		
0045-0100	Radio Berlin Int'l, E. Germany				

LEGEND

- * The first four digits of an entry are the broadcast start time in UTC. The second four digits represent the end time.
- * In the space between the end time and the station name is the broadcast schedule.

S=Sunday M=Monday T=Tuesday W=Wednesday
H=Thursday F=Friday A=Saturday

If there is no entry, the broadcasts are heard daily. If, for example, there is an entry of "M," the broadcast would be heard only on Mondays. An entry of "M,W,F" would mean Mondays, Wednesdays and Fridays only. "M-F" would mean Mondays through Fridays. "TEN" indicates a tentative schedule and "TES" a test transmission.

- * [ML] after a frequency indicates a multi-lingual transmission containing English-language programs.
- * The last entry on a line is the frequency. Codes here include "SSB" which indicates a Single Sideband transmission, and "V" for a frequency that varies. [ML] after a frequency indicates a multi-lingual transmission containing English-language programs.
- * v after a frequency indicates that it varies.
- * Notations of USB and LSB (upper and lower sideband transmissions) usually refer only to the individual frequency after which they appear.
- * Listings followed by an asterisk (*) are for English lessons and do not contain regularly scheduled programming.

We suggest that you begin with the lower frequencies that a station is broadcasting on and work your way up the dial. Remember that there is no guarantee that a station will be audible on any given day. Reception conditions can change rapidly, though, and if it is not audible one night, it may well be on another.

HOW TO USE THE PROPAGATION CHARTS

Propagation charts can be an invaluable aid to the DXer in determining which frequencies are likely to be open at a given time. To use the propagation charts, choose those for your location (the are divided into east coast, midwest and west coast of North America). Then look for the one most closely describing the geographic location of the station you want to hear.

Once you've located the correct charts, look along the horizontal axis of the graph for the time that you are listening. The top line of the graph shows the Maximum Useable Frequency [MUF] and the lower line the Lowest Useable Frequency [LUF] as indicated on the vertical axis of the graph.

While there are exceptions to every rule (especially those regarding shortwave listening), you should find the charts helpful in determining the best times to listen for particular regions of the world. Good luck!

frequency SECTION

0045-0100	A	Radio New Zealand, Wellington	15150	17705
0048-0100		WINB, Red Lion, Pennsylvania	15145	
0050-0100		Vatican Radio, Vatican City	6150	9605 11780

0100-0200		Radio Japan, Tokyo	11815	17810
0100-0200		Radio Luxembourg	6090	
0100-0200		Radio Moscow	11845 17570 17655 17675	

0100 UTC [8:00 PM EST/5:00 PM PST]

0100-0103	S	Port Moresby, Papua New Guinea	3295	4890	5960	5985
			6020	6040	6080	6140
			9520			
0100-0110		Vatican Radio, Vatican City	6150	9605	11780	
0100-0115		All India Radio, New Delhi	6055	7215	9535	9910
			11715	11745	15110	
0100-0120		RAI, Rome, Italy	9575	11800		
0100-0130		Kol Israel, Jerusalem	7460	9435	9855	
0100-0130		Radio Berlin Int'l, East Germany	6080	9730		
0100-0130		Radio Canada Int'l, Montreal	5960	9755	11845	11940
0100-0130		Radio Japan, Tokyo	15280	17810	17835	17845
0100-0130		Laotian National Radio	7113v			
0100-0130	S,M	WINB, Red Lion, Pennsylvania	15145			
0100-0145		Radio Yugoslavia, Belgrade	5980	9620	9660	
0100-0150		Deutsche Welle, West Germany	6040	6085	6145	9565
			9735	11865		
0100-0150		Radio Baghdad, Iraq	9515	11810		
0100-0155	S	Radio Austria Int'l, Vienna	9875			
0100-0200		BBC, London, England	5975	6005	6175	7325
			9410	9515	9590	9915
			12095	15260	17875	
			6195	9625		
0100-0200		CBC Northern Quebec Service	6160			
0100-0200		CBN, St. John's, Newfoundland	6160			
0100-0200		CBU, Vancouver, British Columbia	6160			
0100-0200		CFCF, Montreal, Quebec	6005			
0100-0200		CFCN, Calgary, Alberta	6030			
0100-0200		CHNS, Halifax, Nova Scotia	6130			
0100-0200		CKWX, Vancouver, British Columbia	6080			
0100-0200		CFRB, Toronto, Ontario	6070			
0100-0200		(US) Far East Network, Tokyo	3910			
0100-0200		FEBC, Manila, Philippines	15445			
0100-0200		HCJB, Quito, Ecuador	9720	11775	11910	15155
0100-0200	T-A	KVOH, Rancho Simi, California	13695			
0100-0200		KYOI, Saipan	15405			
0100-0200		Radio Australia, Melbourne	15160	15180	15240	15320
			15395	17715	17795	
			17750	21740		
0100-0200		Radio Havana Cuba	6140	9655		

0100-0200		Radio Moscow, N. American Service	6000	6045	6170	7115
			7165	7195	9720	9765
			9890	12050	13605	15245
			15405	15425	17605	17700
			17720	21530		
0100-0200		Radio New Zealand, Wellington	15150	17705		
0100-0200		Radio for Peace, Costa Rica	13660			
0100-0200		Radio Prague, Czechoslovakia	5930	6055	7345	9540
			9630	9740	11990	
0100-0200		Radio Thailand, Bangkok	9655	11905		
0100-0200		SBC Radio One, Singapore	5010	5052	11940	
0100-0200		SLBC, Colombo, Sri Lanka	6005	9720	15425	
0100-0200		Spanish Foreign Radio, Madrid	9630	11880		
0100-0200	T-S	Superpower KUSW, Utah	11695			
0100-0200		Voice of America, Washington	5995	6130	7205	9455
			9740	9775	9815	11580
			11740	15205	17735	
0100-0200		Voice of Indonesia, Jakarta	9680	11790		
0100-0200		WCSN, Boston, Massachusetts	9850			
0100-0200		WHRI, Noblesville, Indiana	7365	9495		
0100-0200		WRNO New Orleans, Louisiana	7355			
0100-0200		WSHB, Cyprus Creek, S. Carolina	11980			
0100-0200		WYFR, Oakland, California	5950	9505	9680	11715
			15440			
0130-0140	T-S	Voice of Greece, Athens	7430	9420	11645	
0130-0200		Radio Budapest, Hungary	6110	9520	9835	11910
			15160			
0130-0200	S,M	Radio Canada Int'l, Montreal	5960	9755		
0130-0200		Radio Veritas Asia, Philippines	15330	15365		
0130-0200		WINB, Red Lion, Pennsylvania	15145			

0200 UTC [9:00 PM EST/6:00 PM PST]

0200-0215		Vatican Radio, Vatican City	6145	7125	9650
0200-0225		Kol Israel, Jerusalem	7460	9435	9855
0200-0230		BBC, London, England	5975	6005	6175
			9410	9515	9590
			12095	15260	

East Coast To
Western Europe

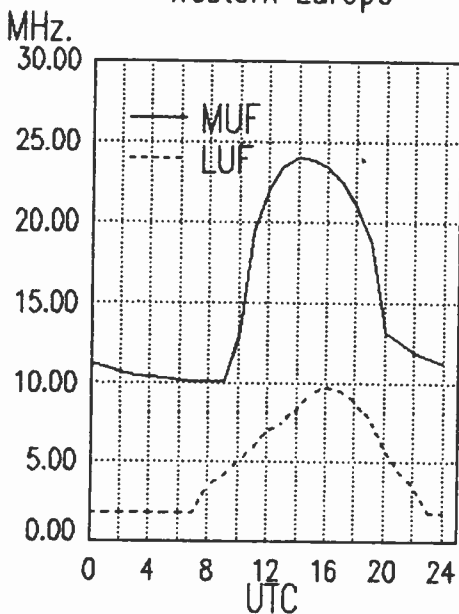

East Coast To
Eastern Europe

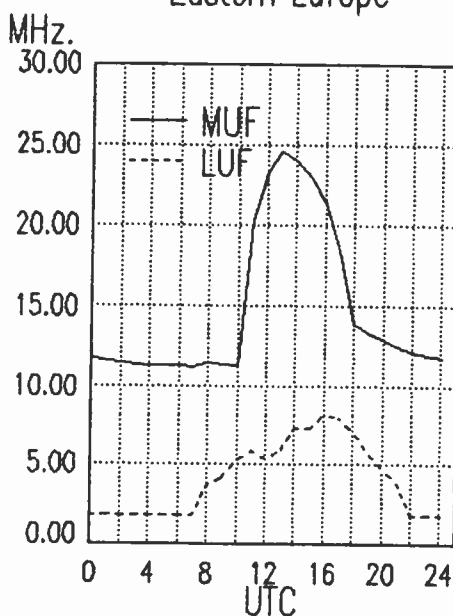

East Coast To
Middle East

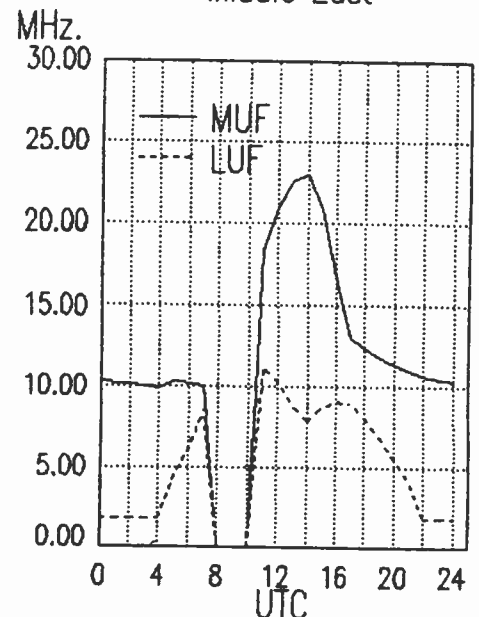

frequency SECTION

0200-0230	Burma Bcating Service, Rangoon	7185				0200-0300	Radio Thailand, Bangkok	9655 11905
0200-0230	W,A Radio Budapest, Hungary	6110 9520 9585 9835				0200-0300	SBC Radio One, Singapore	5010 5052 11940
		11910 15160				0200-0300	SLBC, Colombo, Sri Lanka	6005 9720 15425
0200-0230	Swiss Radio Int'l, Berne	6095 6135 9725 9885				0200-0300 T-S	Superpower KUSW, Utah	11695
		12035 17730				0200-0300	Voice of America, Washington	5995 6130 7205 9740
0200-0230	WINB, Red Lion, Pennsylvania	15145						9775 11580 15205 17735
0200-0245	Radio Berlin Int'l, E. Germany	6080 9730				0200-0300	Voice of Asia, Taiwan	7285
0200-0250	Deutsche Welle, West Germany	6035 7285 9690 11945				0200-0300	Voice of Free China, Taiwan	5985 9680 11740 15345
0200-0250	Radio Baghdad, Iraq	9515 11810				0200-0300	Voice of Kenya, Nairobi	6045
0200-0250	Radio Bras, Brasilia, Brazil	11745v				0200-0300	WCSN, Boston, Massachusetts	9850
0200-0255	Radio Bucharest, Romania	5990 6155 9510 9570				0200-0300	WINB, Red Lion, Pennsylvania	15145
		11830 11940				0200-0300	WHRI, Noblesville, Indiana	7405 9495
0200-0255	RAE, Buenos Aires, Argentina	9690 11710				0200-0300	WRNO, New Orleans, Louisiana	7355
0200-0300	CBC Northern Quebec Service	6195 9625				0200-0300	WSHB, Cyprus Creek, S. Carolina	9745
0200-0300	CBN, St. John's, Newfoundland	6160				0200-0300	WYFR, Oakland, California	15440
0200-0300	CBU, Vancouver, British Colombia	6160				0200-0300 T-S	WYFR Satellite Net, California	5950 9505 11715
0200-0300	CFCF, Montreal, Quebec	6005				0213-0300	Radio France International, Paris	9790 9800 11670 13685
0200-0300	CFCN, Calgary, Alberta	6030				0215-0220	Radio Nepal, Kathmandu	5005 7165
0200-0300	CFRB, Toronto, Ontario	6070				0230-0240	Port Moresby, Papua New Guinea	3925 4890 5960 5985
0200-0300	CHNS, Halifax, Nova Scotia	6130						6020 6040 6080 6140
0200-0300	CKWX, Vancouver, British Colombia	6080						9520
0200-0300	(US) Far East Network, Tokyo	3910				0230-0245TWFS	Radio Budapest, Hungary	6110 9520 9835 11910
0200-0300	HCJB, Quito, Ecuador	9720 11775 15155						15160
0200-0300	KSDA, Guam	17865				0230-0245	Radio Pakistan, Islamabad	7010 11570 15115 15580
0200-0300 T-A	KVOH, Rancho Simi, California	13695						17660
0200-0300	KYOI, Saipan	17780				0230-0300	BBC, London, England	5975 6005 6175 7325
0200-0300	Radio Australia, Melbourne	15320 17715 17795						9410 9515 9915 12095
0200-0300	Radio Cairo, Egypt	9475 9675						15260 15420
0200-0300 S,M	Radio Canada Int'l, Montreal	9755 11845 11940				0230-0300	Radio Netherland, Hilversum	6020 6165 9590 9895
0200-0300	Radio Havana Cuba	6140 9655 9770				0230-0300 T-A	Radio Portugal, Lisbon	6060 9600 9635 9680
0200-0300	Radio Japan, Tokyo	5960						9705 11840
0200-0300	Radio Korea (South), Seoule	15575				0230-0300	Radio Sweden, Stockholm	9695 11705 17840 SSB
0200-0300	Radio Luxembourg	6090				0230-0300	Radio Tirana, Albania	7065 9760
0200-0300	Radio Moscow, USSR	6000 6045 6170 7115				0240-0250	All India Radio, New Delhi	3905 4860 4880 4895
		7165 7195 9765 9890						5960 5990 6110 6120
		12010 12050 13605 15245						7195 7295 9550 9610
		15425 15425 17605 17700						11830 11870 15305
		17720						6080 9620 9730 11785
0200-0300	Radio Moscow World Service	11845 17570 17590 17655				0245-0300	Radio Berlin Int'l, E. Germany	
		17675 17850 17860 17880				0245-0300	Radio Korea, Seoul, South Korea	7275 15375
		17890 21690 21790						
0200-0300	Radio Orion, South Africa	3955				0300 UTC [10:00 PM EST/7:00 PM PST]		
0200-0300	Radio for Peace, Costa Rica	13660				0300-0330	Radio Berlin Int'l, E. Germany	6080 9620 9730 11785
0200-0300	A Radio New Zealand, Wellington	15150 17705						
0200-0300	Radio RSA, South Africa	9580 9615 11760						

East Coast To
West Africa

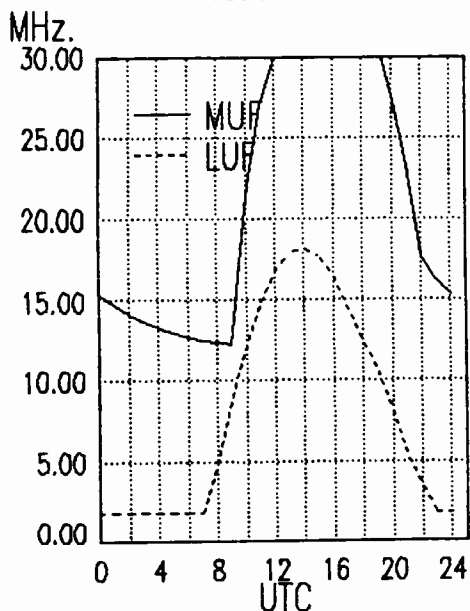

East Coast To
Central Africa

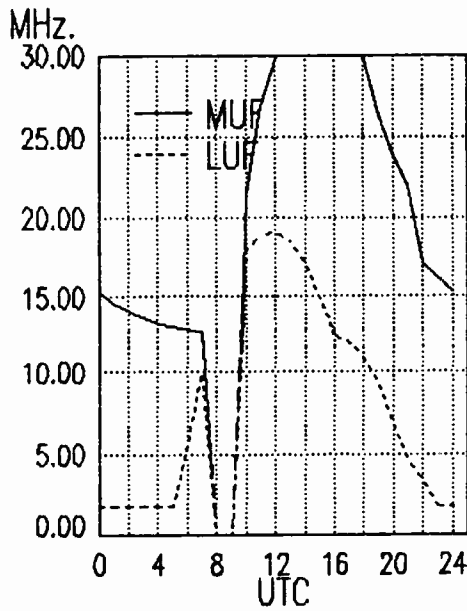

East Coast To
East Africa

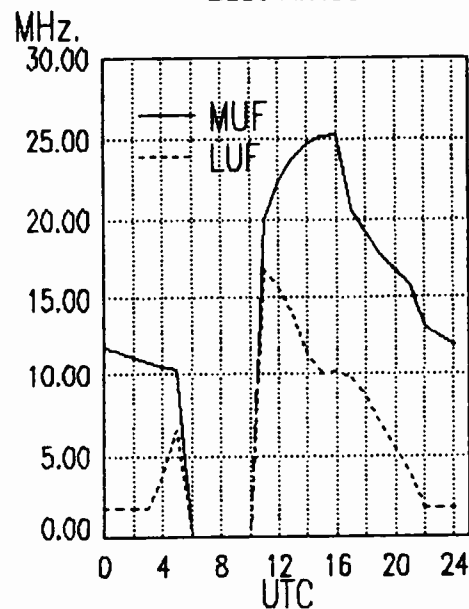

frequency SECTION

0300-0330	Radio Kiev, Ukrainian SSR	7150 7205 7400 13645	0300-0400	WRNO, New Orleans, Louisiana	7355
		15180 15455	0300-0400	WSHB, Cyprus Creek, N. Carolina	9745
0300-0330	WINB, Red Lion, Pennsylvania	15145	0300-0400	WYFR, Oakland, California	15440
0300-0307	Radio Pakistan, Islamabad	5090 5930 7095	0300-0400	WYFR Satellite Net, California	5950 9505
0300-0310	CBC Northern Quebec Service	6195 9625	0300-0400	Radio Prague, Czechoslovakia	5930 6055 7345 9540
0300-0325	Radio Netherland, Hilversum	6020 6165 9590 9895			9630 9740 11990
0300-0330	BBC, London, England	3955 5975 6005 6155	0300-0400	Radio Thailand, Bangkok	9655 11905
		6175 6195 7210 7325	0300-0400	SBC Radio One, Singapore	5010 5052 11940
		9410 9515 9915 12095	0300-0400	SLBC, Colombo, Sri Lanka	6005 9720 15425
		15260 17815	0300-0400	Trans World Radio, Bonaire	9535
0300-0330	Radio Cairo, Egypt	9475 9675	0300-0400	Voice of America, Washington	6035 7200 7280 9525
0300-0330	Radio Japan, Tokyo	11870 15195 17810 17825			9550 11835
		21610	0300-0400	Voice of Free China, Taiwan	5985 9680 11740 15345
0300-0345 A	Radio New Zealand, Wellington	15150 17705	0300-0400	Voice of Kenya, Nairobi	6045
0300-0350	Deutsche Welle, West Germany	6010 6085 6130 9545	0300-0400	Voice of Nicaragua, Managua	6100
		9605 9700	0300-0400	WCSN, Boston, Massachusetts	9850
0300-0355	Radio Beijing, PR China	9770 11715 11860 15180	0300-0400	WSHB, Cyprus Creek, N. Carolina	9745
		15290 15455	0310-0330	Vatican Radio, Vatican City	6150
0300-0400	CBN, St. John's, Newfoundland	6160	0313-0400	Radio France Int'l, Paris	3965 7135 7175
0300-0400	CBU, Vancouver, British Columbia	6160			9550 9790 9800 11670
0300-0400	CFCF, Montreal, Quebec	6005	0330-0340 S-F	Port Moresby, Papua New Guinea	11700 11995
0300-0400	CFCN, Calgary, Alberta	6030			3925 4890 5960 5985
0300-0400	CHNS, Halifax, Nova Scotia	6130			6020 6040 6080 6140
0300-0400	CKWX, Vancouver, British Columbia	6080			9520
0300-0400	CFRB, Toronto, Ontario	6070	0330-0400	BBC, London, England	3955 5975 6005 6155
0300-0400	(US) Far East Network, Tokyo	3910			6175 6195 9410 9915
0300-0400	HCJB, Quito, Ecuador	9720 11775 15155			12095 17815
0300-0400 T-A	KVOH, Rancho Simi, California	13695	0330-0400	Radio Berlin Int'l, E. Germany	6125 6165 11750
0300-0400	KYOI, Saipan	17780	0330-0400	Radio Finland, Helsinki	9635 11755
0300-0400	La Voz Evangelica, Honduras	4820	0330-0400 S,M	WINB, Red Lion, Pennsylvania	15145
0300-0400	Radio Australia, Melbourne	11945 15160 15240 15320	0335-0400	Radio New Zealand, Wellington	15150 17705
		15395 17715 17795	0330-0400	Radio Tanzania, Dar es Salaam	9684
0300-0400 T-A	Radio Canada Int'l, Montreal	9755 11845 11940	0330-0400	Radio Tirana, Albania	7065 9760
0300-0400	Radio for Peace, Costa Rica	13660	0330-0400	Radio Sweden, Stockholm	11705
0300-0400	Radio Havana Cuba	9655 6140 9770	0330-0400	United Arab Emirates Radio	11940 15435 17890 21700
0300-0400	Radio Moscow, USSR	6000 6045 6170 7115	0335-0340	All India Radio, New Delhi	3905 4860 9610 11830
		7165 7195 7290 9600			11870 11890 15305
		9700 9890 12010 12050	0340-0350 M-A	Voice of Greece, Athens	7430 9395 9420
		13605 15405 15425 17700			
		17720	0350-0400	RAI, Rome, Italy	9710 11905 15330 17795
0300-0400	Radio Moscow World Service, USSR	11845 17570 17590 17655	0355-0400	Radio Yerevan, Armenian SSR	13645 15180 15455
		17675 17850 17860 17880			
		17890 21790			
0300-0400 T-S	Superpower KUSW, Utah	11695			
0300-0400	WHRI, Noblesville, Indiana	7405 9495			

East Coast To
South Africa

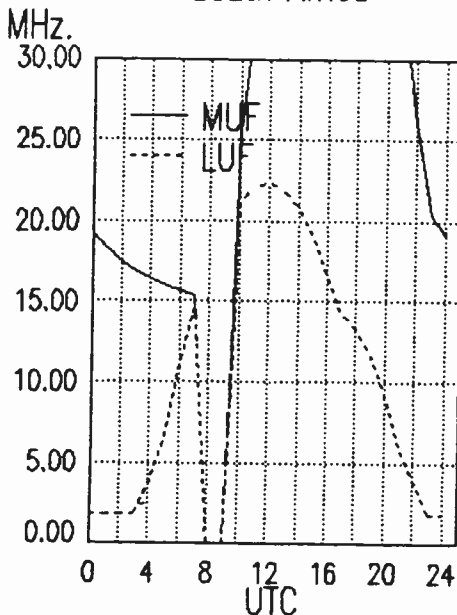

East Coast To
Indian Ocean

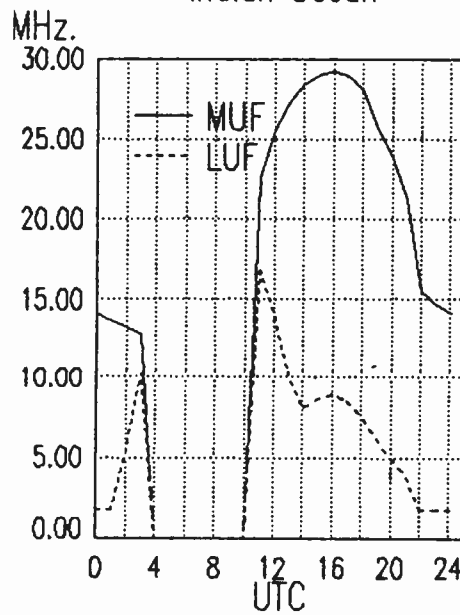

East Coast To
Central Asia

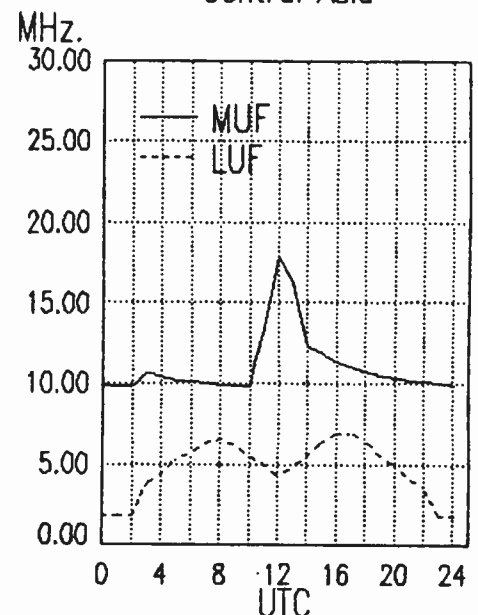

Did We Miss Something?

Find a frequency we've missed? A new broadcast? Let us know! Write to frequency manager Greg Jordan at 1855-I Franciscan Terrace, Winston-Salem, NC 27127.

frequency SECTION

0400 UTC [11:00 AM EST/9:00 PM PST]

0400-0405	Radio Uganda, Kampala	4976	5026		
0400-0410	Radio Thailand, Bangkok	9655	11905		
0400-0410	RAI, Rome, Italy	9710	11905	15330	17795
0400-0415	Radio Berlin Int'l, E. Germany	6125	6165	11750	
0400-0415	Radio RSA, South Africa	7295	9585	11900	
0400-0420	Radio Botswana, Gabarone	4820			
0400-0420 T-S	Radio Zambia, Lusaka	3345	6165		
0400-0425	Radio Bucharest, Romania	6155	9510	9570	11830
		11940			
0400-0425	Radio Netherland, Hilversum	7210	9850		
0400-0430	BBC, London, England	3955	5975	6005	6155
		6175	6195	7120	7160
		7185	7260	9410	9580
		9600	9915	12095	15070
		15420	17815		
0400-0430	La Voz Evangelica, Honduras	4820			
0400-0430 S,M	Radio Austria Int'l, Vienna	6015	6155	15450	
0400-0430 M	Radio Norway Int'l, Oslo	9650	11760		
0400-0430	SLBC, Colombo, Sri Lanka	6005	9720	15425	
0400-0430	Radio Tanzania, Dar es Salaam	9684			
0400-0430	Swiss Radio Int'l, Berne	6135	9725	9885	12035
0400-0430	Trans World Radio, Bonaire	9535			
0400-0430 S,M	WINB, Red Lion, Pennsylvania	15145			
0400-0445	Radio Berlin Int'l, E. Germany	9620	11785		
0400-0450	Deutsche Welle, West Germany	7150	7225	9565	9765
		11765			
0400-0450	Radio Pyongyang, North Korea	15160	15180		
0400-0450	Voice of Turkey, Ankara	9445	17760		
0400-0455	Radio Beijing, PR China	9645	11980		
0400-0455	RAE, Buenos Aires, Argentina	9690	11710		
0400-0500	CBC Northern Quebec Service	6195	9625		
0400-0500	CBN, St. John's, Newfoundland	6160			
0400-0500	CBU, Vancouver, British Columbia	6160			
0400-0500	CFCF, Montreal, Quebec	6005			
0400-0500	CFCN, Calgary, Alberta	6030			
0400-0500	CHNS, Halifax, Nova Scotia	6130			
0400-0500	CKWX, Vancouver, British Columbia	6080			
0400-0500	CFRB, Toronto, Ontario	6070			
0400-0500	(US) Far East Network, Tokyo	3910			
0400-0500	FEBC, Manila, Philippines	11850			
0400-0500	HCJB, Quito, Ecuador	9720	11775	15155	

0400-0500	KVOH, Rancho Simi, California	11960			
0400-0500	KYOI, Saipan	17780			
0400-0500	Radio Australia, Melbourne	11910	11945	15160	15240
		15320	17715	17795	
0400-0500	Radio for Peace, Costa Rica	13660			
0400-0500	Radio Havana Cuba	5965	6035	6140	9655
		9770			
0400-0500	Radio Moscow, USSR	6000	7165	7215	7290
		7310	9580	9765	9880
		9895	12010	12050	13645
		15420	15460	15480	17560
		17570	17590	17600	17655
		17775	17765	17825	17890
		21690	21790		
0400-0500	Radio New Zealand, Wellington	15150	17705		
0400-0500	Radio Sofia, Bulgaria	7115			
0400-0500	SBC Radio One, Singapore	5010	5052	11940	
0400-0500 T-S	Superpower KUSW, Utah	11695			
0400-0500	Voice of America, Washington	3980	5995	6035	7170
		7200	7280	9525	9575
		11835	11925	15205	
0400-0500	Voice of Free China, Taiwan	5985	9680	11740	
0400-0500	Voice of Kenya, Nairobi	6045			
0400-0500	WCSN, Boston, Massachusetts	9870			
0400-0500	WHRI, Noblesville, Indiana	7405	9495		
0400-0500	WRNO, New Orleans, Louisiana	6185			
0400-0500	WSHB, Cyprus Creek, S. Carolina	9455			
0400-0500	WYFR Satellite Net, California	5950	9505		
0425-0440	RAI, Rome, Italy	5980	7275	15330	
0430-0455	Radio Austria Int'l, Vienna	6015	6155	9875	15410
0430-0500	BBC, London, England	3955	5975	6005	6015
		6155	6195	7120	7185
		9410	9510	9580	11945
		12095	15070	15420	17815
0430-0500	BBC, London, England*	7210	9750	11945	
0430-0500	Radio Tirana, Albania	9480	11835		
0430-0500 S,M	Trans World Radio, Bonaire	9535			
0430-0500	Trans World Radio, Swaziland	3205	7205		
0432-0500 A,M	FEBA, Seychelles	15325	17820	(irr)	
0445-0500	Radio Berlin Int'l, East Germany	9620	11785		

East Coast To
Southeast Asia

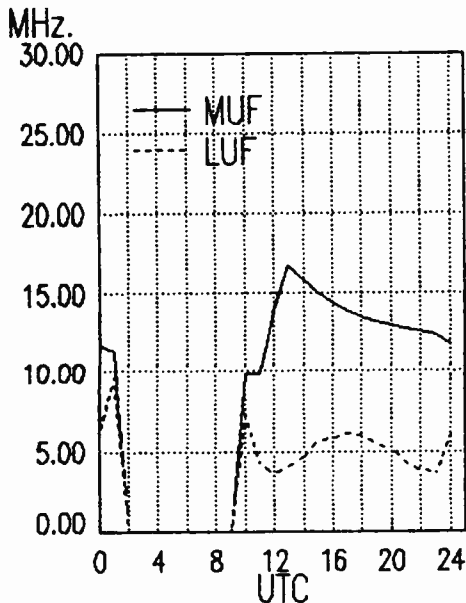

East Coast To
Far East

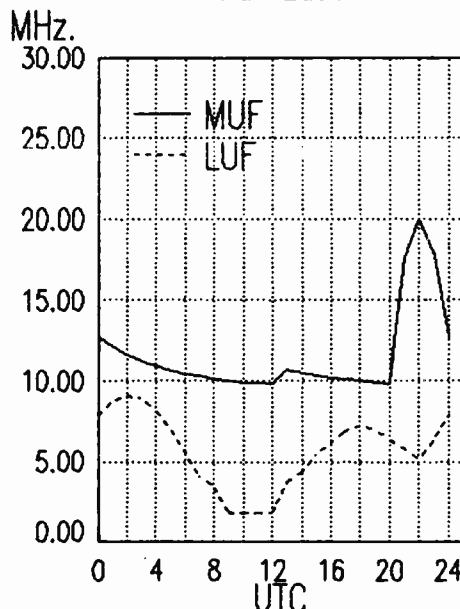

East Coast To
Pacific

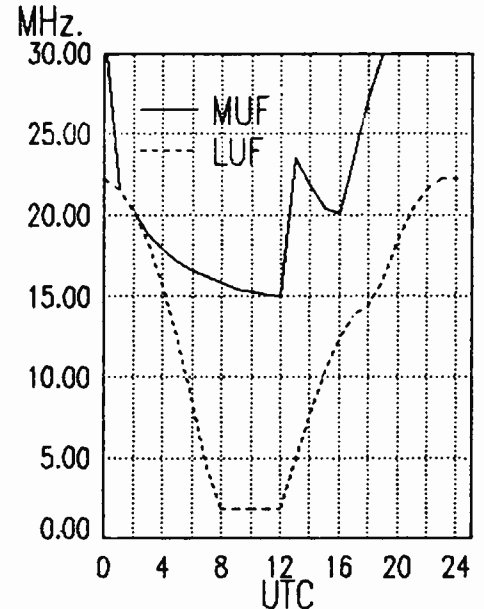

frequency SECTION

0500 UTC [12:00 AM EST/9:00 PM PST]

0500-0510	Radio Lesotho, Maseru	4800	
0500-0510	M-A Radio Zambia, Lusaka	3345	6165
0500-0515	GBC, Accra, Ghana	4915	
0500-0515	Kol Israel, Jerusalem	9435	11590
0500-0515	Vatican Radio, Vatican City	9645	15190
0500-0530	A FEBA, Seychelles	15325	17820 (Irr)
0500-0530	Radio Berlin Int'l, East Germany	5965	9620 11785
0500-0530	M Radio Norway Int'l, Oslo	11745	15175
0500-0530	S,M Trans World Radio, Bonaire	9535	
0500-0530	Trans World Radio, Swaziland	3205	5055 7210
0500-0550	Deutsche Welle, West Germany	5960	6120 6130 9635
		9700	
0500-0555	Radio Beijing, China	9690	
0500-0600	BBC, London, England	5975	6175 6195 7105
		7120	7160 7185 9410
		9510	9580 9600 12095
		15070	15420 17120 17815
		17885	
0500-0600	CBC Northern Quebec Service	6195	9625
0500-0600	CBU, Vancouver, British Columbia	6160	
0500-0600	CFCF, Montreal, Quebec	6005	
0500-0600	CFCN, Calgary, Alberta	6030	
0500-0600	CHNS, Halifax, Nova Scotia	6130	
0500-0600	CKWX, Vancouver, British Columbia	6080	
0500-0600	CFRB, Toronto, Ontario	6070	
0500-0600	(US) Far East Network, Tokyo	3910	
0500-0600	FEBC, Manila, Philippines	11850	
0500-0600	HCJB, Quito, Ecuador	6230	9720 11775
0500-0600	KVOH, Rancho Simi, California	11960	
0500-0600	KYOI, Salpan	17780	
0500-0600	Radio Australia, Melbourne	11910	15160 15240 17795
0500-0600	Radio for Peace, Cost Rica	13680	
0500-0600	Radio Havana Cuba	5965	6035 9655 9770
0500-0600	Radio Japan, Tokyo	11870	17810
0500-0600	Radio Kuwait	15345	
0500-0600	Radio Moscow, USSR	6175	7130 7215 7310
		9765	11785 12055 15350
		15455	15460 15480 17560
		17570	17590 17635 17655
		17675	17775 17825 21690
		21790	

0500-0600	Radio New Zealand, Wellington	15150	17705
0500-0600	Radio Thailand, Bangkok	9655	11905
0500-0600	S Radio Zambia, Lusaka	11880	
0500-0600	SBC Radio One, Singapore	5010	5052 11940
0500-0600	Spanish Foreign Radio, Madrid	9630	
0500-0600	S Superpower KUSW, Utah	6175	
0500-0600	S Swaziland Commercial Radio	6155	9705
0500-0600	Voice of America, Washington	3980	5995 6035 7170
		7280	9575 15205
		6045	
0500-0600	Voice of Kenya, Nairobi	6100	
0500-0600	IRR Voice of Nicaragua, Managua	6100	
0500-0600	Voice of Nigeria, Lagos	7255	15120 15185
0500-0600	WCSN, Boston, Massachusetts	9870	
0500-0600	WINB, Red Lion, Pennsylvania	15145	
0500-0600	WHRI, Noblesville, Indiana	7405	9495
0500-0600	M-A WMLK, Bethel, Pennsylvania	9455	
0500-0600	WRNO, New Orleans, Louisiana	6185	
0500-0600	WSHB, Cyprus Creek, S. Carolina	9455	
0500-0600	WYFR Satellite Net, California	5950	
0510-0520	Radio Botswana, Gaborone	3356	4820 7255
0527-0600	F FEBA, Seychelles	17820	
0530-0545	BBC, London, England*	3990	6050 6140 7210
		9750	
0530-0555	Radio Bucharest, Romania	9640	11840 11940 15340
		15380	17720
0530-0600	Radio Finland, Helsinki	6120	9635 11715 15185
0530-0600	Radio Netherland, Hilversum	6165	9715
0530-0600	Radio Tirana, Albania	7300	
0530-0600	Trans World Radio, Swaziland	5055	7210
0530-0600	UAE Radio, United Arab Emirates	15435	17775 21700
0555-0600	Ghana Broadcasting Corp., Accra	4915	
0555-0600	Voice of Malaysia, Kuala Lumpur	6175	9750 15295

0600 UTC [1:00 AM EST/10:00 PM PST]

0600-0615	Radio Ghana, Accra	3366	4915
0600-0615	M-A Radio Zambia, Lusaka	6165	7235
0600-0620	Vatican Radio, Vatican City	6185	9645
0600-0625	Radio Netherland, Hilversum	6165	9715
0600-0630	F FEBA, Mahe, Seychelles	17820	
0600-0630	Laotian National Radio	7113	
0600-0630	Radio Australia, Melbourne	11910	11945 15160 15240
		15315	15395 15425 17715
		17750	17795

East Coast To
Australia & Malaysia

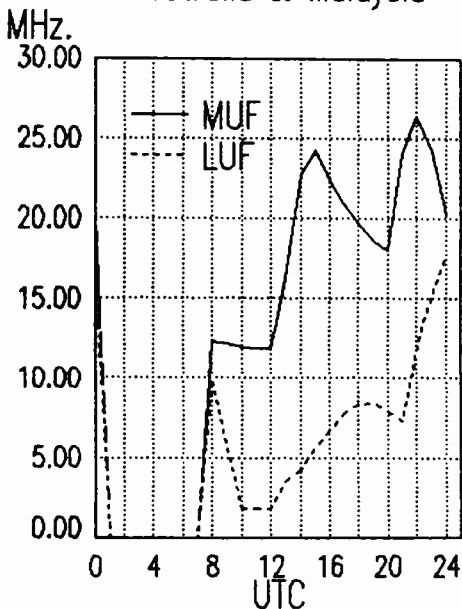

East Coast To
Central America/Caribbean

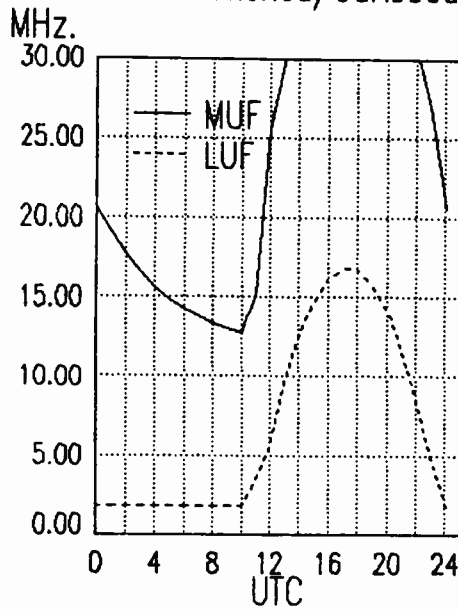

East Coast To
South America

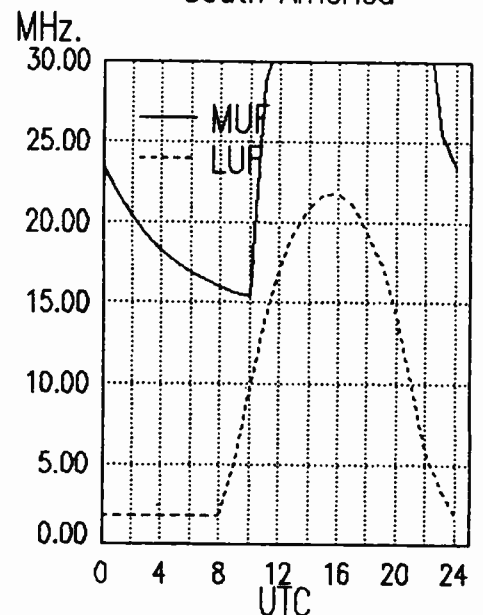

frequency SECTION

0600-0630	Radio Tirana, Albania	7300				0600-0700	Voice of Malaysia, Kuala Lumpur	6175	9750	15295
0600-0630	Trans World Radio, Swaziland	6070				0600-0700	Voice of the Mediterranean	9765		
0600-0630	Voice of Kenya, Nairobi	6045				0600-0700	Voice of Nigeria, Lagos	15185		
0600-0645	Radio Berlin Int'l, East Germany	5965	6115	9645	11810	0600-0700	WCSN, Boston, Massachusetts	7365		
		13610				0600-0700	WHRI, Noblesville, Indiana	6100	9495	
0600-0645	S Radio Cameroon, Yaounde	4850				0600-0700	M-A WMLK, Bethel, Pennsylvania	9455		
0600-0650	Deutsche Welle, West Germany	11765	13790	15185	17875	0600-0700	WSHB, Cyprus Creek, S. Carolina	9455		
0600-0650	Radio Pyongyang, North Korea	13650	15160	15180		0600-0700	WYFR, Oakland, California	11580		
0600-0700	BBC, London, England	3955	5975	6175	6195	0600-0700	WYFR Satellite Net, California	5950	9520	9852.5
		7105	7150	7185	9410					
		9600	9640	12095	15070					
		15280				0615-0630	M-F Radio Canada Int'l, Montreal	15245		
0600-0700	CBC Northern Quebec Service	6195	9625			0615-0630	M-A Vatican Radio, Vatican City	15190	17730	
0600-0700	CBU, Vancouver, British Columbia	6160				0615-0700	Radio Berlin Int'l, E. Germany	15240	17775	
0600-0700	CFCF, Montreal, Quebec	6005				0625-0700	Trans World Radio Monte Carlo	7105		
0600-0700	CFCN, Calgary, Alberta	6030				0630-0700	AWR, Forli, Italy	7125		
0600-0700	CHNS, Halifax, Nova Scotia	6130				0630-0700	A CPBS-1, China*	11330	15550	15590 17605
0600-0700	CKWX, Vancouver, British Columbia	6080				0630-0655	Radio Netherland, Hilversum	9895	11930	
0600-0700	CFRB, Toronto, Ontario	6070				0630-0700	Radio Australia, Melbourne	11945	15160	15240 15315
0600-0700	HCJB, Quito, Ecuador	6230	9720	11775				15395	15425	17715 17750
0600-0700	(US) Far East Network, Tokyo	3910						17795		
0600-0700	King of Hope, South Lebanon	6215				0630-0700	Radio Bucharest, Romania	21600		
0600-0700	KVOH, Rancho Siml, California	11960				0630-0700	Radio Polonia, Warsaw, Poland	6135	7270	15120
0600-0700	KYOI, Salpan	17780				0630-0700	Radio Tirana, Albania	7205	9500	
0600-0700	Radio Havana Cuba	11760				0630-0700	Swiss Radio Int'l, Berne	12030	15430	17570
0600-0700	Radio Korea, Seoul, South Korea	6060	7275	9570		0630-0700	Trans World Radio, Swaziland	5055	6070	7210 9725
0600-0700	Radio Kuwait	15345				0630-0700	A,S Voice of Kenya, Nairobi	7270		
0600-0700	Radio Moscow, USSR	7130	7195	7260	7310	0645-0700	BBC, London, England*	6150	7260	11945
		7370	9450	11705	11745	0645-0700	Radio Berlin Int'l, East Germany	15240	17880	21540 21645
		12055	13650	15350	15420	0645-0700	M-F Radio Canada Intl, Montreal	15245		
		15455	15460	15465	15470		Radio Ghana, Accra	6130		
		15480	17560	17570	17590			11705	11800	
		17600	17625	17635	17655			11940	15250	15335 17790
		17675	17735	17775	17825			17805	21665	
		17880	21680	21690	21790					
0600-0700	Radio New Zealand, Wellington	12045	17705							
0600-0700	A,S Radio Thailand, Bangkok	9655	11905							
0600-0700	S Radio Zambia, Lusaka	11880								
0600-0700	SBC Radio One, Singapore	5010	5052	11940						
0600-0700	S Superpower KUSW, Utah	6175								
0600-0700	Voice of America, Washington	3980	5995	6035	6080					
		6125	6195	7170	7200					
		7280	7325	9530	9540					
		9550	11915	11925						
0600-0700	Voice of Asia, Taiwan	7285								

0700 UTC [2:00 AM EST/11:00 PM PST]

0700-0703	Port Moresby, Papua New Guinea	3925	4890	5960	5985
		6020	6040	6080	6140
		9520			
0700-0710	Radio Bucharest, Romania	11825	11940	15250	15335
		17790	17805	21665	
0700-0710	Radio Sierra Leone, Freetown	5980			
0700-0715	Radio Ghana (HS), Accra	3366	4915		

East Coast To Westcoast

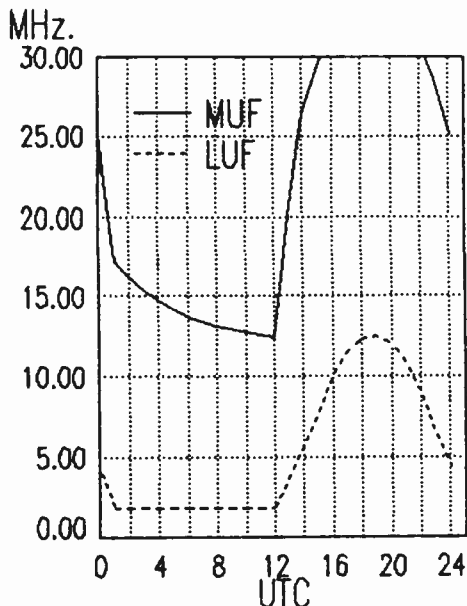

Midwest To Western Europe

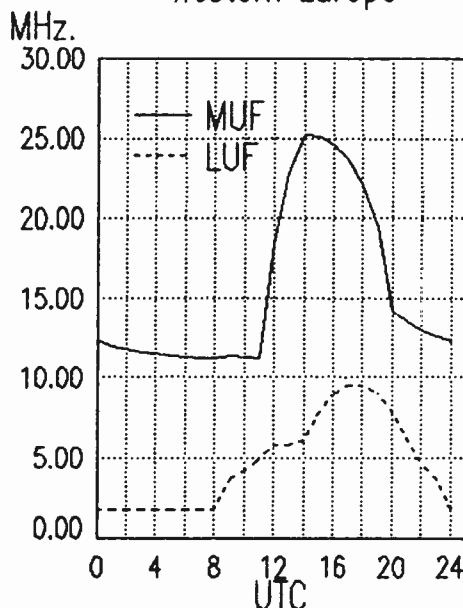

Midwest To Eastern Europe

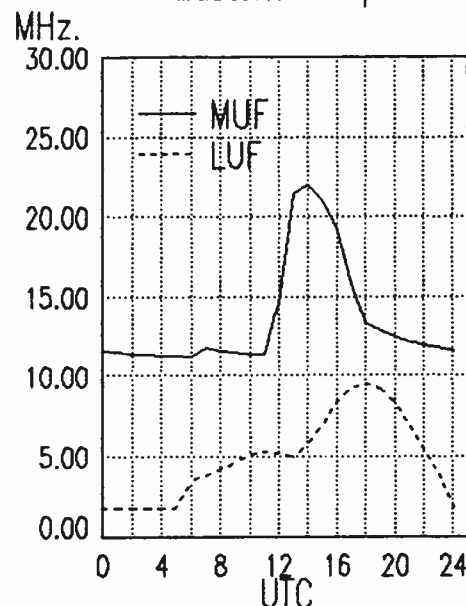

frequency SECTION

0700-0730	BBC, London, England	3955 5975 6195 7150
		9410 9600 9640 11825
		11860 12095 15070 15105
		15400
0700-0730	Burma Bcating Service, Rangoon	9730
0700-0730	Radio Australia, Melbourne	5995 9655 11720 15240
		15395 17715 17750
0700-0730	Radio Berlin Int'l, East Germany	15240 17880 21540 21645
0700-0730	Radio Bucharest, Romania	21600
0700-0730	Radio New Zealand, Wellington	12045 15150
0700-0730 S	Radio Zambia, Lusaka	11880
0700-0745 S	Radio Berlin Int'l, East Germany	5965 11810
0700-0750	Radio Pyongyang, North Korea	15340 17795
0700-0800	ABC, Perth, Australia	15425
0700-0800	AWR, Forli, Italy	7257
0700-0800	CBU, Vancouver, British Colombia	6160
0700-0800	CFCF, Montreal, Quebec	6005
0700-0800	CFCN, Calgary, Alberta	6030
0700-0800	CHNS, Halifax, Nova Scotia	6130
0700-0800	CKWX, Vancouver, British Columbia	6080
0700-0800	CFRB, Toronto, Ontario	6070
0700-0800	ELWA, Monrovia, Liberia	11830
0700-0800	(US) Far East Network, Tokyo	3910
0700-0800	HCJB, Quito, Ecuador	6130 6205 9745 11925
0700-0800	King of Hope, South Lebanon	6215
0700-0800	KVOH, Rancho Simi, California	11960
0700-0800	KYOI, Saipan	17780
0700-0800	Radio Ghana, Accra	6130
0700-0800	Radio Japan, Tokyo	5990 15195 15270 15325
		17810 21695
0700-0800	Radio Korea, Seoul, South Korea	6060 7275 9570
0700-0800	Radio Kuwait	15345
0700-0800	Radio Moscow, USSR	5905 6020 7150 7175
		7230 7260 7270 7345
		9450 9635 11705 11745
		11850
0700-0800 A,S	Radio Thailand, Bangkok	9655 11905
0700-0800	SBC-1, Singapore	11940
0700-0800	Soloman Islands Broadcasting Corp	9545
0700-0800 S	Superpower KUSW, Utah	6155
0700-0800	Trans World Radio, Monte Carlo	7105
0700-0800	Trans World Radio, Swaziland	6070 9725
0700-0800 A,S	Voice of Kenya, Nairobi	7270
0700-0800	Voice of Malaysia, Kuala Lumpur	6175 9750 15295
0700-0800	Voice of Nigeria, Lagos	15120 15185

0700-0800	WCSN, Boston, Massachusetts	7365
0700-0800	WHRI, Noblesville, Indiana	6100 9495
0700-0800 M-A	WMLK, Bethel, Pennsylvania	9455
0700-0800	WSHB, Cyprus Creek, S. Carolina	9455
0700-0800	WYFR, Oakland, California	6065 7355 9680
0700-0800	WYFR Satellite Network	5950
0715-0730	Radio Korea, Seoul, South Korea	13670 15575
0715-0730 M-A	Vatican Radio, Vatican City	11725 15190
0715-0735 S	FEBE, Mahe, Seychelles	15115 17785
0720-0730 M-A	Vatican Radio, Vatican City	6248 9645 11740
0730-0800	ABC, Alice Springs, Australia	2310 [ML]
0730-0800	ABC, Katherine, Australia	2485
0730-0800	ABC, Tennant Creek, Australia	2325 [ML]
0730-0800	Radio Australia, Melbourne	5955 9655 11720 15240
0730-0800	Radio Finland, Helsinki	6120 9560 11755 15270
0730-0735	All India Radio, New Delhi	5990 6010 6020 7110
		7205 9610 9675 11850
		11935 15235 15250 17705
0730-0745	BBC, London, England*	3975 6010 7230 9915
0730-0800	BBC, London, England	3955 5975 7150 9410
		9600 9640 11860 12095
		15070 15105 15400
		9630 9715
0730-0800	Radio Netherland, Hilversum	11685 17840 21705
0730-0800	Radio Prague, Czechoslovakia	3985 6165 9535
0730-0800	Swiss Radio Int'l, Berne	5985 7115 9695 9725
0740-0750 W	Radio Free Europe, Munich*	11895 15355
		6055 7345 9505

0800 UTC [3:00 AM EST/12:00 AM PST]

0800-0805 M-F	Port Moresby, Papua New Guinea	3925 4890 5960 5985
		6020 6040 6080 6140
		9520
0800-0805	Soloman Islands Broadcasting Corp	9545
0800-0815 M-A	Radio Zambia, Lusaka	6165 7235
0800-0825 M-F	BRT, Brussels, Belgium	11695 21815
0800-0825	Radio Netherland, Hilversum	9630 9715
0800-0825	Voice of Malaysia, Kuala Lumpur	6175 9750 15295
0800-0830	HCJB, Quito, Ecuador	6130 6205 9745 11925
0800-0830 S	Radio Austria Int'l, Vienna	6155 13730 15410 15450
0800-0830	Radio Bangladesh, Dhaka	12030 15525
0800-0830	Radio Tirana, Albania	9500 11835

Midwest To Middle East

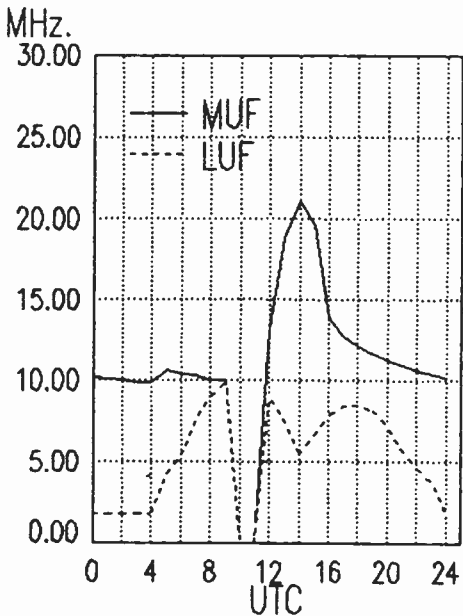

Midwest To West Africa

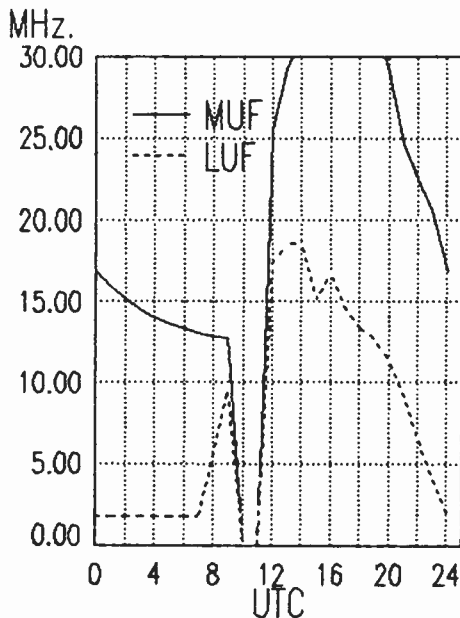

Midwest To Central Africa

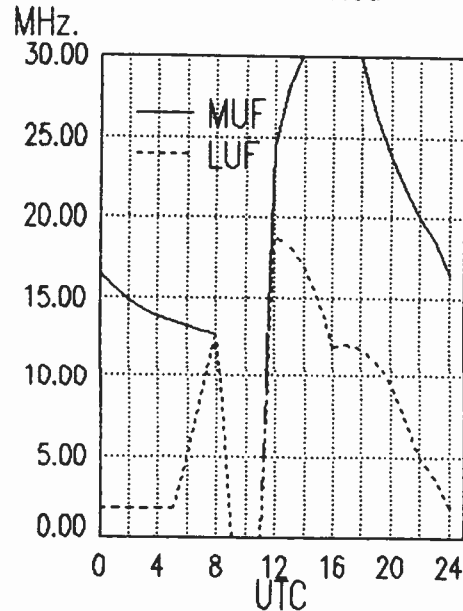

frequency SECTION

0800-0830	Voice of Nigeria, Lagos	7255	15185			
0800-0830	Voice of Islam, Pakistan	15525	17870			
0800-0835	S FEBA, Mahe, Seychelles	15325, 17785				
0800-0835	Trans World Radio, Swaziland	6070	9725			
0800-0840	Trans World Radio, Monte Carlo	9480				
0800-0850	Deutsche Welle, Koin, W. Germany	9770				
0800-0850	Radio Pyongyang, North Korea	9530	11830	15160	15180	
0800-0900	ABC, Alice Springs, Australia	2310	[ML]			
0800-0900	ABC, Katherine, Australia	2485				
0800-0900	ABC, Perth, Australia	15425				
0800-0900	ABC, Tennant Creek, Australia	2325	[ML]			
0800-0900	AFAN, Antarctica	6010.5				
0800-0900	BBC, London, England	5975	9410	7150	9600	
		11860	12095	15070	15360	
		15400				
0800-0900	CBN, St. John's, Newfoundland	6160				
0800-0900	CBU, Vancouver, British Columbia	6160				
0800-0900	CFCF, Montreal, Quebec	6005				
0800-0900	CFCN, Calgary, Alberta	6030				
0800-0900	CHNS, Halifax, Nova Scotia	6130				
0800-0900	CKWX, Vancouver, British Columbia	6080				
0800-0900	CFRB, Toronto, Ontario	6070				
0800-0900	(US) Far East Network, Tokyo	3910				
0800-0900	King of Hope, South Lebanon	6215				
0800-0900	KTWR, Guam	11805				
0800-0900	KYOI, Saipan	11900				
0800-0900	Radio Australia, Melbourne	5995	6080	9580	9655	
		9710	11720	15285	15395	
0800-0900	Radio Moscow, USSR	7270	7310	11845	12010	
		12030	13710	15135	15155	
		15230	15460	15520	15540	
0800-0900	Radio for Peace, Costa Rica	12030				
0800-0900	SBC Radio One, Singapore	5010	5052	11940		
0800-0900	S Superpower KUSW, Utah	6135				
0800-0900	Voice of Free China, Taiwan	5985				
0800-0900	Voice of Indonesia, Jakarta	11790	15105			
0800-0900	A,S Voice of Kenya, Nairobi	7270				
0800-0900	WHRI, Noblesville, Indiana	7355				
0800-0900	WSHB, Cyprus Creek, S. Carolina	9495				
0800-0900	WYFR, Oakland, California	9680	11580			
0800-0900	FR Satellite Network	6065				
0815-0845	M-F Voice of America, Washington DC	7175	9575	9750	11710	
		11915	15600	17715	21500	
		[ML]				

0815-0900	A,S Radio Berlin Int'l, East Germany	6040	7185	9730	21465	
		21540				
0830-0840	All India Radio, New Delhi	5960	5990	6010	6020	
		6050	6065	6100	6140	
		7110	7140	7160	7250	
		7280	7295	9610	11850	
		15235	15250	17705		
0830-0855	Radio Austria Int'l, Vienna	6155	13730	15410	15450	
0830-0900	S Bhutan Broadcasting Service, Thimpu	6035				
0830-0900	FEBC, Manila, Philippines	11850	15350			
0830-0900	HCJB, Quito, Ecuador	6130	9745			
0830-0900	Radio Beijing, China	9700	11755	15440		
0830-0855	Radio Finland, Helsinki	6120	9560	11755		
0830-0900	Radio Prague, Czechoslovakia	11685	17840	21705		
0830-0900	Radio Sofia, Bulgaria	9700	11720			
0830-0900	Swiss Radio Int'l, Berne	9560	9885	13685	17830	
		21695				
0830-0900	Voice of Nigeria, Lagos	15120				
0840-0850	M-A Voice of Greece, Athens	9855	15630			
0840-0900	S-F Trans World Radio, Monte Carlo	9480				
0845-0900	Radio Prague, Czechoslovakia	6055	7345	9505		
0850-0900	All India Radio, New Delhi	5960	5990	6010	6020	
		6050	6065	6100	6140	
		7110	7140	7150	7160	
		7250	7280	7295	9610	
		11850	15235	15250	17705	

0900 UTC [4:00 AM EST/1:00 AM PST]

0900-0910	All India Radio, New Delhi	5960	5990	6010	6020	
		6050	6065	6100	6140	
		7110	7140	7150	7160	
		7250	7280	7295	9610	
		11850	15235	15250	17705	
0900-0910	Port Moresby, Papua New Guinea	3295	4890	5960	5985	
		6020	6040	6080	6140	
		9520				
0900-0910	S Trans World Radio, Monte Carlo	9480				
0900-0910	Voice of Lebanon, Beirut	6548				
0900-0925	M-A Radio Finland, Helsinki	11795	21550			
0900-0930	FEBC, Manila, Philippines	11850	15350			
0900-0930	Nippon Broadcasting Corp.	3925				
0900-0930	Radio Beijing, China	9700	11755	15440		
0900-0930	A,S Radio Prague, Czechoslovakia	11685	17840	21705		

Midwest To
East Africa

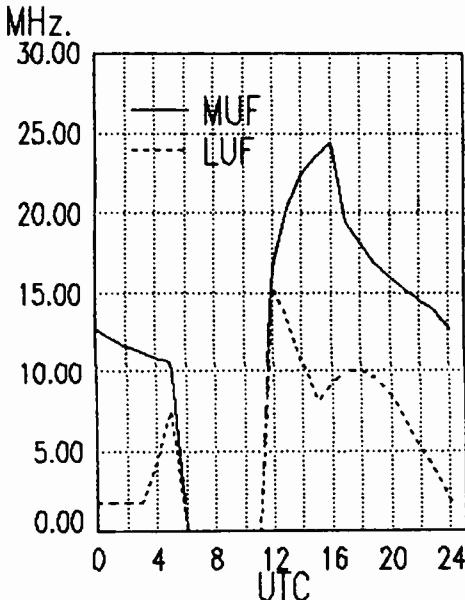

Midwest To
South Africa

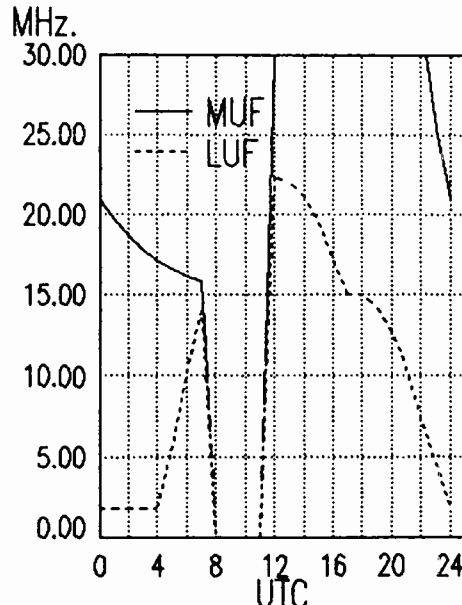

Midwest To
Indian Ocean

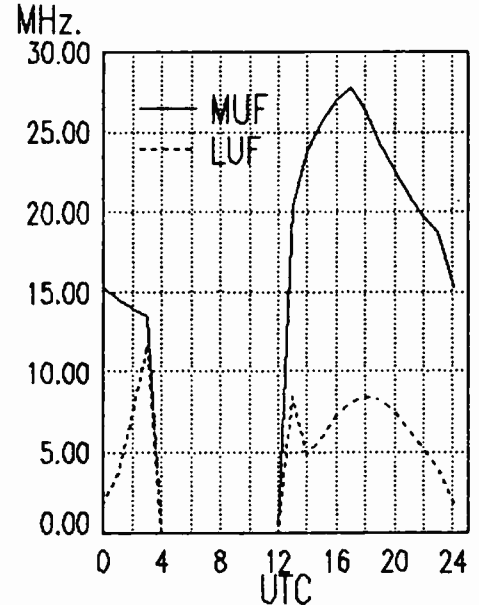

frequency SECTION

0900-0950	Deutsche Welle, West Germany	6160 9650 11785 11945
		17780 17875 21650
0900-1000	ABC, Alice Springs, Australia	2310 [ML]
0900-1000	ABC, Katherine, Australia	2485
0900-1000	ABC, Tennant Creek, Australia	2325 [ML]
0900-1000	S Adventist World Radio, Portugal	9670
0900-1000	BBC, London, England	5975 7180 7325 9410
		9750 9760 11750 11860
		11955 12095 15070 15400
		15360 17790 18080 21470
		21710 25750
0900-1000	CFCF, Montreal, Quebec	6005
0900-1000	CFCN, Calgary, Alberta	6030
0900-1000	CHNS, Halifax, Nova Scotia	6130
0900-1000	CKWX, Vancouver, British Columbia	6080
0900-1000	CFRB, Toronto, Ontario	6070
0900-1000	(US) Far East Network, Tokyo	3910
0900-1000	HCJB, Quito, Ecuador	6130 9745
0900-1000	King of Hope, South Lebanon	6215
0900-1000	KNLS, Anchor Point, Alaska	6065
0900-1000	KTWR, Agana, Guam	11805
0900-1000	KYOI, Saipan	11900
0900-1000	Radio Afghanistan, Kabul	4450 6085 15435 17720
0900-1000	Radio Australia, Melbourne	5995 6080 9580 9655
		9760 11720 15415
0900-1000	Radio Japan, Tokyo	11840 11885 15270 17810
0900-1000	Radio Korea, Seoul, South Korea	7550 13670
0900-1000	Radio Moscow, USSR	9580 11845 12030 13680
		13710 15135 15155 15230
		15460 15520 15540 17645
		17680 17765
0900-1000	Radio for Peace, Costa Rica	13660
0900-1000	S Radio Prague, Czechoslovakia	6055 7345 9505 [ML]
0900-1000	Radio Tanzania, Dar es Salaam	7165
0900-1000	SBC Radio One, Singapore	5010 5052 11940
0900-1000	S Superpower KUSW, Utah	6135
0900-1000	Voice of Kenya, Nairobi	7270
0900-1000	Voice of Nigeria, Lagos	7255 15120 15185
0900-1000	WHRI, Noblesville, Indiana	7355
0900-1000	WYFR, Oakland, California	11580
0915-0930	Radio Korea, Seoul, South Korea	9570
0915-0950	M-A Radio Ulan Bator, Mongolia	9615 12015
0930-0935	All India Radio, New Delhi	5960 5990 6010 6020
		6050 6065 6100 6140
		7110 7140 7160 7250

0930-0945	BBC, London, England*	7280 7295 9610 11850
0930-1000	CBN, St. John's, Newfoundland	15235 15250 17705
		9725 11955
0930-1000	Radio Beijing, China	6160
0930-1000	Radio Finland, Helsinki	9700 11755 15440
0930-1000	Radio Sweden Int'l, Stockholm	11855 15245
0945-1000	BBC, London, England*	15390
		5995 7160 9725 11955
0945-1000	M-A Radio Prague, Czechoslovakia	6055 7345 9505

1000 UTC [5:00 AM EST/2:00 AM PST]

1000-1025	BRT, Brussels, Belgium	17595 21810
1000-1030	HCJB, Quito, Ecuador	6130 9745 11925
1000-1030	Radio Afghanistan, Kabul	4450 6085 15435 17720
1000-1030	Radio Beijing, China	9700 11755 15440
1000-1030	S Radio Norway Int'l, Oslo	15160 15230 21705 25730
1000-1030	Radio Tanzania, Dar es Salaam	7165
1000-1030	Swiss Radio Int'l, Berne	9560 9885 13685 17830
		21695
1000-1030	Voice of Ethiopia, Addis Ababa	9560
1000-1030	Voice of Vietnam, Hanoi	9840 15010
1000-1045	Radio Berlin Int'l, East Germany	21465(A,S) 21540
1000-1055	A Trans World Radio, Monte Carlo	7105
1000-1100	ABC, Alice Springs, Australia	2310 [ML]
1000-1100	ABC, Katherine, Australia	2485
1000-1100	ABC, Perth, Australia	9610
1000-1100	ABC, Tennant Creek, Australia	2325 [ML]
1000-1100	All India Radio, New Delhi	11860 11915 15130 15335
		17387 11785
1000-1100	BBC, London, England	6185 9740 9750 11750
		12095 15070 15400 17705
		17790 18080 21710 21470
		25750
1000-1100	CBN, St. John's, Newfoundland	6160
1000-1100	CFCF, Montreal, Quebec	6005
1000-1100	CFCN, Calgary, Alberta	6030
1000-1100	CHNS, Halifax, Nova Scotia	6130
1000-1100	CKWX, Vancouver, British Columbia	6080
1000-1100	CFRB, Toronto, Ontario	6070
1000-1100	(US) Far East Network, Tokyo	3910
1000-1100	KTWR, Agana, Guam	11805
1000-1100	KYOI, Saipan	11900
1000-1100	Radio Afghanistan, Kabul	15435 17720

Midwest To
Central Asia

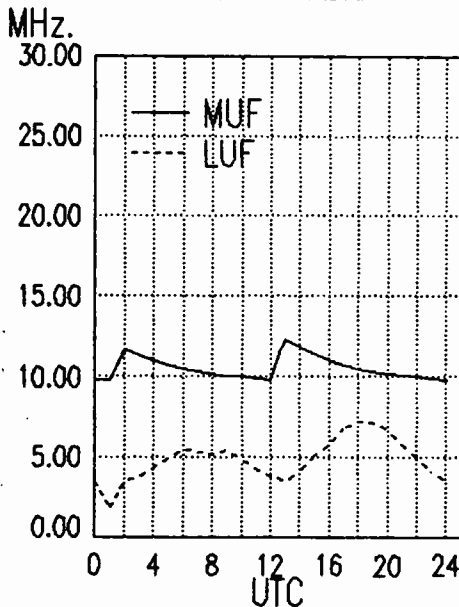

Midwest To
Southeast Asia

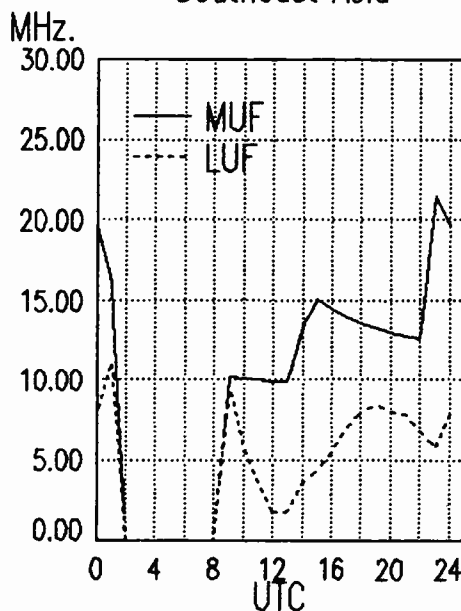

Midwest To
Far East

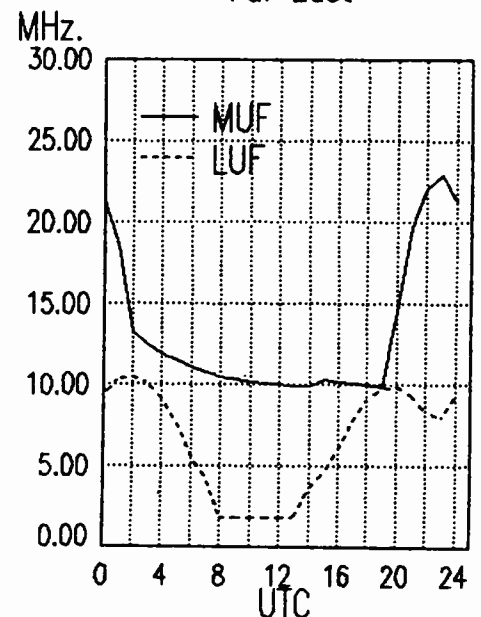

frequency SECTION

1000-1100	Radio Australia, Melbourne	9580	9770	15415	1100-1130	BBC, London, England*	7120
1000-1100	Radio Moscow, USSR	9705	9780	9875 11705	1100-1130	HCJB, Quito, Ecuador	6130 11925
		11900	15140	15150 15225	1100-1130	Kol Israel, Jerusalem	9385 11700 15485 15640
		15260	15405	15420 15460			15650 17635 17685 21625
		15595	17600	21680	1100-1130	KTWR, Guam*	9820 11665
1000-1100	Radio New Zealand, Wellington	6100	9850		1100-1130 S	Radio Austria Int'l, Vienna	13730 15450
1000-1100	S Radio Prague, Czechoslovakia	6055	7345	9505 [ML]	1100-1130	Radio Japan, Tokyo	6120 11815
1000-1100	SBC Radio One, Singapore	5010	5052	11940	1100-1130	Radio Mozambique, Maputo	9525 11818 11835
1000-1100	S Superpower KUSW, Utah	6135			1100-1130	SLBC, Colombo, Sri Lanka	11835 15120 17850 [ML]
1000-1100	Voice of America, Washington	6030	5985	6165 9590	1100-1130	Swiss Radio int'l, Berne	11935 13685 15570 17830
1000-1100	Voice of Kenya, Nairobi	7270			1100-1130	Voice of Vietnam, Hanoi	7430 9732
1000-1100	Voice of Nigeria, Lagos	7255	15120		1100-1150	Deutsche Welle, West Germany	15410 17765 17800 21600
1000-1100	WHRI, Noblesville, Indiana	7355			1100-1150	Radio Pyongyang, North Korea	6576 9600 11735
1000-1100	WSHB, Cyprus Creek, S. Carolina	9495			1100-1155	Radio Beijing, China	9665 15110 17715
1000-1100	WYFR, Oakland, California	5950			1100-1200	ABC, Alice Springs, Australia	2310 [ML]
1005-1010	Radio Pakistan, Islamabad	15606	17660		1100-1200	ABC, Katherine, Australia	2485
1030-1040	Voice of Asia, Taiwan	5980			1100-1200	ABC, Perth, Australia	9610
1030-1100	BBC, London, England*	7180	9660	9725	1100-1200	ABC, Tennant Creek, Australia	2325 [ML]
1030-1100	HCJB, Quito, Ecuador	6130	11925		1100-1200	BBC, London, England	5965 6195 9510 9740
1030-1100	Radio Netherlands, Hilversum	6020	9505				11750 11775 12095 15070
1030-1100 A,S	Radio Tanzania, Dar es Salaam	7165					15360 17705 17790 18080
1030-1100	SLBC, Colombo, Sri Lanka	11835	15120	17850 [ML]			21710 21470 25750
1030-1100	UAE Radio, United Arab Emirates	15435	17865	21605	1100-1200	CBC Northern Quebec Service	6195 9625
1030-1100	Voice of America, Washington*	11965			1100-1200	CBN, St. John's, Newfoundland	6160
1040-1050 H	Radio Free Europe, Munich*	5985 7115 9695 9725			1100-1200	CFCF, Montreal, Quebec	6005
		11895 15355			1100-1200	CFCN, Calgary, Alberta	6030
1040-1050 M-A	Voice of Greece, Athens	11645	15630		1100-1200	CHNS, Halifax, Nova Scotia	6130
1045-1100 S	Radio Budapest, Hungary	7220 9585 9835 11910			1100-1200	CKWX, Vancouver, British Columbia	6080
		15160 15220			1100-1200	CFRB, Toronto, Ontario	6070
1045-1100 M-A	Radio Prague, Czechoslovakia	6055 7345 9505			1100-1200	(US) Far East Network, Tokyo	3910
1055-1100 S	Trans World Radio, Monte Carlo	7105			1100-1200	KYOI, Salpan	11900
					1100-1200	Radio Australia, Melbourne	5995 7215 9580 9645
							9710 9770 11705 11800
							9600 13680 13710 15460
							15335 15475 15490 15500
							15550 17595 17645 17820
							11900 17755 21590
					1100-1200	Radio RSA, South Africa	7165
					1100-1200 A,S	Radio Tanzania, Dar es Salaam	7165
					1100-1200 S	Radio Zambia, Lusaka	11880 [IRR]
					1100-1200	SBC-t, Singapore	5010 5052 11940
					1100-1200 S	Superpower KUSW, Utah	6130
					1100-1200	Voice of America, Washington	5985 6030 6110 6165
							9590 9760 11715 15160
							15425
					1100-1200	Voice of Asia, Taiwan	5980 7445

1100 UTC [6:00 AM EST/3:00 AM PST]

1100-1105	Radio Pakistan, Islamabad	6090	7290		1100-1200	Radio Moscow, USSR	
1100-1105 A	Port Moresby, Papua New Guinea	3295 4890 5960 5985			1100-1200	Radio RSA, South Africa	
		6020 6040 6080 6140			1100-1200 A,S	Radio Tanzania, Dar es Salaam	
		9520			1100-1200 S	Radio Zambia, Lusaka	
1100-1110 S	Port Moresby, Papua New Guinea	3295 4890 5960 5985			1100-1200	SBC-t, Singapore	
		6020 6040 6080 6140			1100-1200 S	Superpower KUSW, Utah	
		9520			1100-1200	Voice of America, Washington	
1100-1115	Radio New Zealand, Wellington	6100	9850				
1100-1120	Radio Pakistan, Islamabad	15606	17760				
1100-1125	Radio Netherland, Hilversum	6020	9505				

Midwest To
Pacific

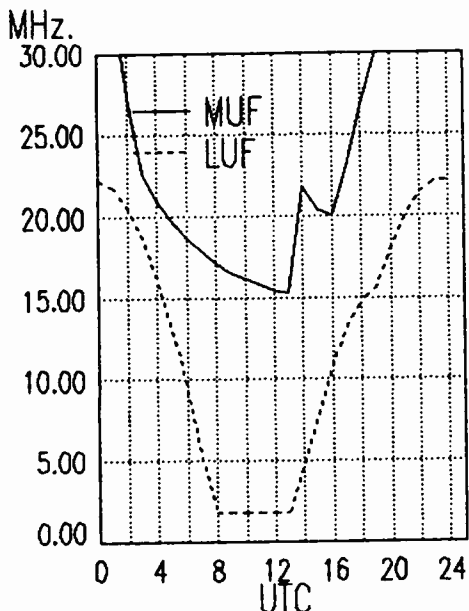

Midwest To
Australia & Malaysia

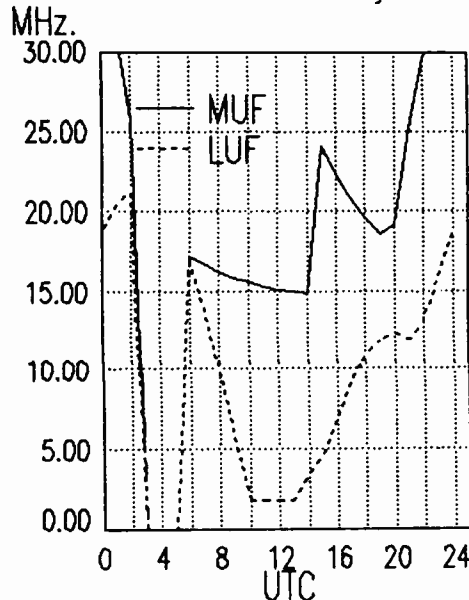

Midwest To
Central America/Caribbean

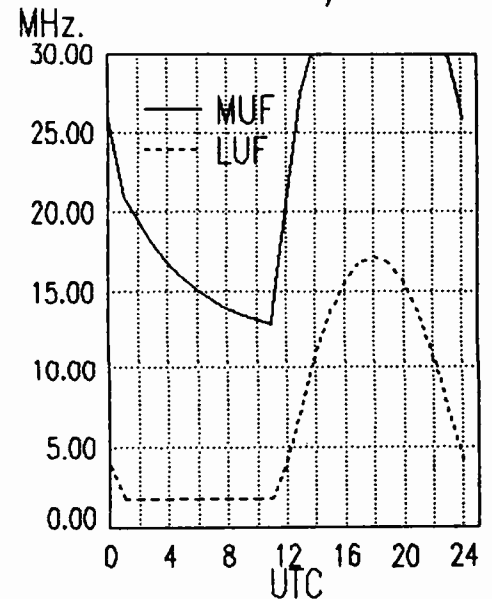

frequency SECTION

1100-1200	Voice of Kenya, Nairobi	7270		
1100-1200	Voice of Nigeria, Lagos	7255	15120	
1100-1200	WHRI, Noblesville, Indiana	5995	11790	
1100-1200	WSHB, Cyprus Creek, S. Carolina	9495		
1100-1200	WYFR, Oakland, California	5950	7355	9600
1110-1120 M-F	Radio Botswana, Gaborone	4820	5955	7255
1115-1130	Radio Korea, Seoul, South Korea	11740		
1115-1130	Vatican Radio, Vatican City	17840	21485	
1115-1145	Radio Nepal, Kathmandu	5005		
1115-1200	Trans World Radio, Bonaire	11815	15345	
1130-1145 A	Radio Budapest, Hungary	7220	9585	9835 11910
		15160	15220	
1130-1200	HCJB, Quito, Ecuador	11740		
1130-1200	Radio Japan, Tokyo	6120	11815	
1130-1200	Radio Netherland, Hilversum	5995	9715	15560 17575
		17605	21480	
1130-1200	Radio Thailand, Bangkok	9655	11905	
1130-1200	Radio Tirana, Albania	9480	11855	
1130-1200	Voice of Islamic Republic Iran	11790		
1135-1140	All India Radio, New Delhi	6065	7110	9610 9675
		11850	15320	
1140-1145 M-A	Vatican Radio, Vatican City	6248	9645	11740
1145-1200	BBC, London, England*	5995	7180	
1145-1200	Radio Bangladesh, Dakha	15255	17740	
1145-1200	Radio Prague, Czechoslovakia	6055	7345	9505

1200-1235 M-A	Radio Ulan Bator, Mongolia	9615	12015	
1200-1236	HCJB, Quito, Ecuador	6075		
1200-1255	Radio Beijing, China	9665	11600	15110
1200-1300	ABC, Alice Springs, Australia	2310	[ML]	
1200-1300	ABC, Katherine, Australia	2485		
1200-1300	ABC, Tennant Creek, Australia	2325	[ML]	
1200-1300 S	Adventist World Radio, Africa	17890		
1200-1300	AFAN, Antarctica	6012		
1200-1300	BBC, London, England	5995	6195	7180 9510
		9740	11750	11775 12095
		15070	17705	17790 18080
		21470	21710	25750
1200-1300	CBN, St. John's, Newfoundland	6160		
1200-1300	CFCF, Montreal, Quebec	6005		
1200-1300	CFCN, Calgary, Alberta	6030		
1200-1300	CHNS, Halifax, Nova Scotia	6130		
1200-1300	CKWX, Vancouver, British Columbia	6080		
1200-1300	CFRB, Toronto, Ontario	6070		
1200-1300	(US) Far East Network, Tokyo	3910		
1200-1300	HCJB, Quito, Ecuador	11740	15115	17890
1200-1300	KYOI, Saipan	11900		
1200-1300	Radio Australia, Melbourne	6080	7205	7215 9580
		9710	9770	11800
1200-1300	Radio Moscow, USSR	13680	13710	15135 15460
		15490	15500	17595 17680
		17820	17860	

1200 UTC [7:00 AM EST/4:00 AM PST]				
1200-1205 M-A	Port Moresby, Papua New Guinea	3295	4890	5960 6020
		6040	6080	6140 9520
1200-1215	BBC, London, England*	3915	6065	7275
1200-1215	Radio New Zealand, Wellington	6100	9540	9850
1200-1215	Vatican Radio, Vatican City	15190	17865	
1200-1215	Voice of Kampuchea, Phnom-Penh	9693	11938	
1200-1220	Radio Bucharest, Romania	17720	21665	
1200-1225	Radio Polonia, Warsaw, Poland	6095	7285	
1200-1230	Radio Finland	11945	15400	
1200-1230	Radio Netherland, Hilversum	9715	15560	17575 17605
		21480		
1200-1230	Radio Somalia, Mogadishu	6095		
1200-1230	Radio Tashkent, Uzbek, USSR	7275	9540	9600 15470
		11785		
1200-1230	Radio Thailand, Bangkok	9655	11905	
1200-1230 S	Radio Zambia, Lusaka	11880	[IRR]	

1200-1300 A,S	Radio Tanzania, Dar es Salaam	7165		
1200-1300	SBC Radio One, Singapore	5010	5052	11940
1200-1300 S	Superpower KUSW, Utah	6130		
1200-1300	Trans World Radio, Bonaire	11815	15345	
1200-1300	Trans World Radio, Sri Lanka	11920		
1200-1300	Voice of America, Washington	9760	11715	15160 15425
1200-1300	Voice of Kenya, Nairobi	7270		
1200-1300	Voice of Nigeria, Lagos	7255	15120	
1200-1300	WCSN, Boston, Massachusetts	5980		
1200-1300	WHRI, Noblesville, Indiana	5995	11790	
1200-1300	WSHB, Cyprus Creek, S. Carolina	13760		
1200-1300	WYFR, Oakland, California	5950	7355	9600
1215-1245	Radio Korea, Seoul, South Korea	7275	11740	
1215-1300	Radio Cairo, Egypt	17595	17675	
1230-1235	All India Radio, New Delhi	3905	4800	4920 7280
		9565	9615	11620 11735
		15120		
1230-1255	Radio Austria Int'l, Vienna	6155	13730	15450

Midwest To South America

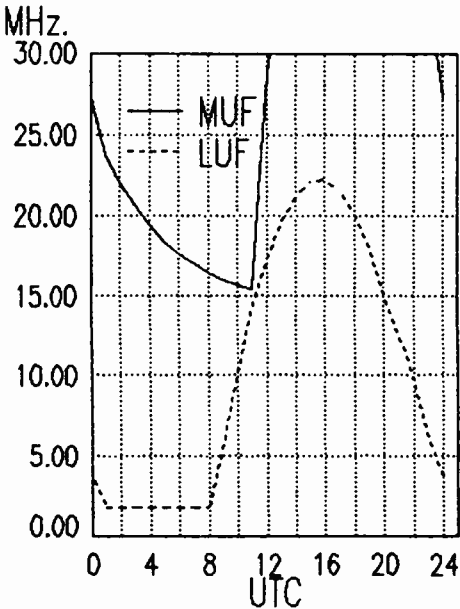

West Coast To Western Europe

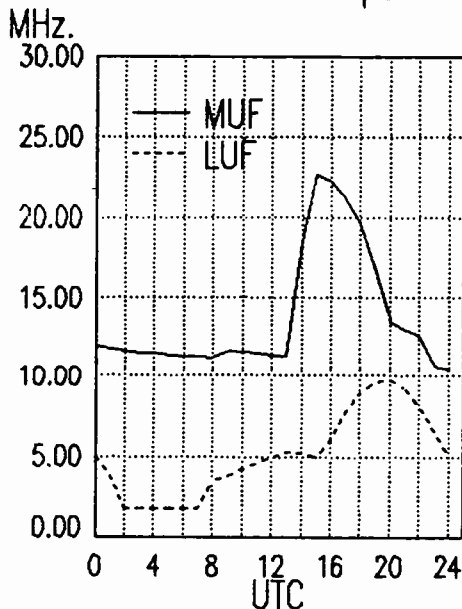

West Coast To Eastern Europe

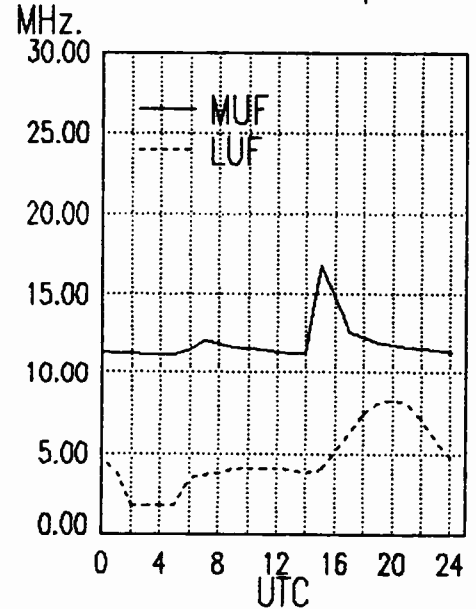

frequency SECTION

1230-1300	BBC, London, England*	6125 7255 6195 9635	1300-1400	CBC Northern Quebec Service	9625 11720
		9660 11780 12040 15270	1300-1400	CBN, St. John's, Newfoundland	6160
		15390 15435 17695	1300-1400	CBU, Vancouver, British Columbia	6160
1230-1300	Radio Bangladesh, Dhaka	15195 17710	1300-1400	CFCF, Montreal, Quebec	6005
1230-1300	Radio Berlin Int'l, E. Germany	15440 17880 21465 21540	1300-1400	CFCN, Calgary, Alberta	6030
1230-1300	Radio Sweden, Stockholm	9565 11810 15190 15430	1300-1400	CHNS, Halifax, Nova Scotia	6130
		17780 21570	1300-1400	CKWX, Vancouver, British Columbia	6080
1240-1250	M Radio Free Europe, Munich*	5985 7115 9695 9725	1300-1400	CFRB, Toronto, Ontario	6070
		11895 15355	1300-1400	S ELWA, Monrovia, Liberia	11830
1245-1300	Radio France Int'l, Paris	11670 17720 21645	1300-1400	(US) Far East Network, Tokyo	3910
			1300-1400	FEBC, Manila, Philippines	11850
1300 UTC [8:00 AM EST/5:00 AM PST]					
1300-1305	Port Moresby, Papua New Guinea	3295 4890 5960 5980	1300-1400	HCJB, Quito, Ecuador	11740 15115 17890
		6020 6040 6080 6140	1300-1400	KNLS, Anchor Point, Alaska	7355
		9520	1300-1400	KYOI, Salpan	11900
1300-1310	Radio France Int'l, Paris	11670 17720 21645	1300-1400	Radio Australia, Melbourne	5995 6060 6080 7205
1300-1315	Radio Berlin Int'l, E. Germany	15440 17880 21465 21540	1300-1400	M-F Radio Canada Int'l, Montreal	9625 11855 17820
1300-1325	Radio Bucharest, Romania	9690 11940 15405 17720	1300-1400	Radio Jordan, Amman	9560
1300-1325	M-F Radio Finland, Helsinki	11945 15400	1300-1400	Radio Korea (South), Seoul	9750 15575
1300-1330	BBC, London, England	5995 6195 7180 9410	1300-1400	Radio RSA, South Africa	17755 21590
		9510 9740 9750 11775	1300-1400	A,S Radio Tanzania, Dar es Salaam	7165
		12095 15070 15420 17790	1300-1400	SBC Radio One, Singapore	5010 5052 11940
		18080 21710 25750	1300-1400	S Superpower KUSW, Utah	6130
1300-1330	S Radio Austria Int'l, Vienna	11780 13730 21490	1300-1400	Voice of America, Washington	6110 9760 11715 15160
1300-1330	Radio Cairo, Egypt	17595	1300-1400	Voice of Malaysia	15425
1300-1330	Radio Ghana, Accra	4915 7295	1300-1400	Voice of Nigeria, Lagos	7255 15120
1300-1330	Radio Moscow, USSR	6050 7175 9600 9795	1300-1400	WCSN, Boston, Massachusetts	5980
		13680 13710 15320 15460	1300-1400	WHRI, Noblesville, Indiana	9455 11790
		15490 15530 15500 17595	1300-1400	WSHB, Cyprus Creek, S. Carolina	13760
		17645 17860 21630	1300-1400	WYFR, Oakland, California	5950 5990 9600 11550
1300-1330	S Radio Norway Int'l, Oslo	6035 9590 15310 21705	1305-1315	Radio France Int'l, Paris	13695 15055
1300-1330	Radio Yugoslavia, Belgrade	11735 15325 15380			6175 9790 9805 11670
1300-1330	Swiss Radio Int'l, Berne	6165 9535 12030			11845 15155 15195 15300
1300-1330	Trans World Radio, Sri Lanka	11920			15315 15365 17620 17720
1300-1330	Voice of Kenya, Nairobi	7270			17850 21645
1300-1332	A,S Trans World Radio, Bonaire	11815 15345	1315-1400	Radio Berlin Int'l, E. Germany	15240
1300-1350	Radio Pyongyang, North Korea	9325 9345 9555 9600	1330-1345	Radio Korea, Seoul, South Korea	7275 11740
		11735	1330-1355	M-A BRT, Brussels, Belgium	17555 21815
		11600 11660 11755 15280	1330-1355	Radio Austria Int'l, Vienna	15320
		15455	1330-1400	BBC, London, England	5995 6195 7180 9410
1300-1400	ABC, Alice Springs, Australia	2310 [ML]			9740 15070 15420 11750
1300-1400	ABC, Katherine, Australia	2485			17790 17885 18080 21470
1300-1400	ABC, Tennant Creek, Australia	2325 [ML]			21710 25750
			1330-1400	All India Radio, New Delhi	9545 10330 11810 15335

West Coast To Middle East

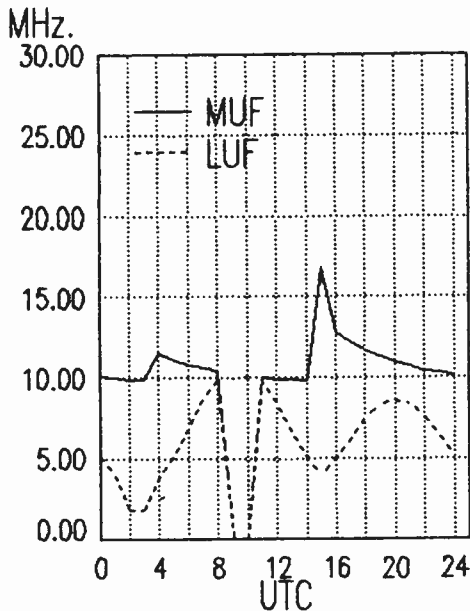

West Coast To West Africa

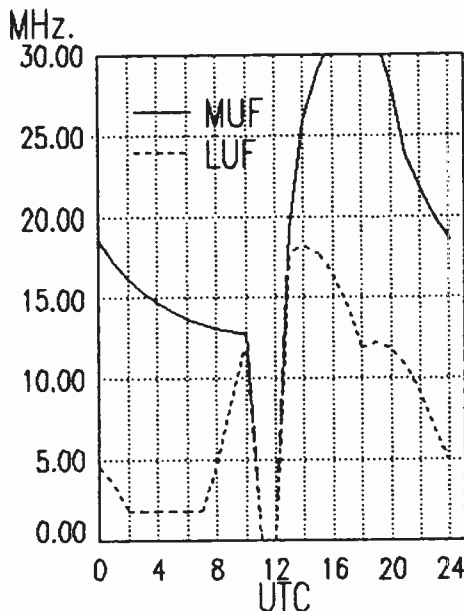

West Coast To Central Africa

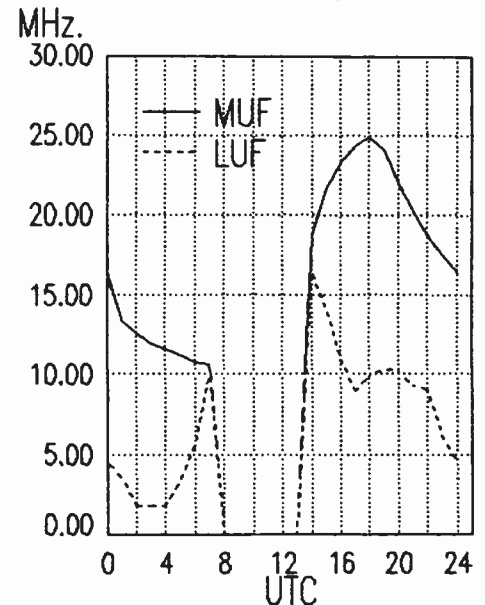

frequency SECTION

1330-1400	M-A	Bhutan Bcating Service, Thimpu	6035
1330-1400		Laotian National Radio	7113
1330-1400		Radio Moscow, USSR	6050 9705 11840 13680 13710
1330-1400		Radio Tashkent, Uzbek, USSR	5945 7275 9540 9600 11785
1330-1400		Swiss Radio Int'l, Berne	11695 13685 15135 15570 17830 21695
1330-1400		UAE Radio, United Arab Emirat	15435 17865 21605
1330-1400		Voice of Islamic Republic Iran	9525 9685 9770
1330-1400		Voice of Kenya, Nairobi	6100
1330-1400		Voice of Turkey, Ankara	15255
1330-1400		Voice of Vietnam, Hanoi	9840 15010
1332-1400	A	Trans World Radio, Bonaire	11815 15345
1345-1400		Radio Berlin Int'l, E. Germany	15440 17880 21465 21540

1400 UTC [9:00 AM EST/6:00 AM PST]

1400-1427		Voice of Nigeria, Lagos	15120
1400-1430		ABC, Alice Springs, Australia	2310 [ML]
1400-1430		ABC, Tennant Creek, Australia	2325 [ML]
1400-1430		Radio Berlin Int'l, E. Germany	15440 17880 21465 21540
1400-1430		Radio Finland, Helsinki	11945 15400
1400-1430	S	Radio Norway Int'l, Oslo	15190 15250 15310 21700
1400-1430		Radio Peace and Progress, USSR	17645 17765
1400-1430		Radio Polonia, Warsaw, Poland	6095 7285
1400-1430		Radio Sweden, Stockholm	15345 17860
1400-1430		Radio Tirana, Albania	9500 11985
1400-1430		Voice of Ethiopia, Addis Ababa	9550 11710
1400-1450	T	Radio Free Europe, Munich*	5985 7115 7695 9725 11895 15355
1400-1450		Radio Pyongyang, North Korea	6576 11735
1400-1455		Radio Beijing, China	7405 11600 15165
1400-1500		ABC, Katherine, Australia	2485
1400-1500		ABC, Perth, Australia	9610
1400-1500		Adventist World Radio, Italy	7275
1400-1500		All India Radio, New Delhi	9545 11810 15335
1400-1500		BBC, London, England	5995 6195 7180 9740 9750 11750 12095 15070 15260 17705 17790 18080 21710 21470 25750
1400-1500		CBN, St. John's, Newfoundland	6160
1400-1500		CBC Northern Quebec Service	9625 11720
1400-1500	M-A	CBU, Vancouver, British Columbia	6160

1400-1500		CFCF, Montreal, Quebec	6005
1400-1500		CFCN, Calgary, Alberta	6030
1400-1500		CHNS, Halifax, Nova Scotia	6130
1400-1500		CKWX, Vancouver, British Columbia	6080
1400-1500		CFRB, Toronto, Ontario	6070
1400-1500	S	ELWA, Monrovia, Liberia	11830
1400-1500		(US) Far East Network, Tokyo	3910
1400-1500		FEBC, Manila, Philippines	9670 11850
1400-1500		HCJB, Quito, Ecuador	11740 15115 17890
1400-1500		KYOI, Salpan	11900
1400-1500		Radio Australia, Melbourne	5995 6035 6060 6080 7205 9580
1400-1500		Radio Beijing, China	11600
1400-1500	S	Radio Canada Int'l, Montreal	9625 11720 11955 15440 17820
1400-1500		Radio Japan, Tokyo	9695 11780 11815
1400-1500		Radio Korea, Seoul	9570 9750 15575
1400-1500		Radio Moscow, USSR	5905 5920 6020 6050 6095 7105 7260 7315 7345 7440 9705 9875 11840 11900 13680 13710 15135 15460 15480 15500 17860 21630
1400-1500		Radio RSA, South Africa	11925 21535 21590 21670
1400-1500	A,S	Radio Tanzania, Dar es Salaam	7165
1400-1500		SBC Radio One, Singapore	5010 5052 11940
1400-1500	S	Superpower KUSW, Utah	9850
1400-1500		Voice of America, Washington	9645 9760 11920 15160 15205 15425
1400-1500		Voice of Kenya, Nairobi	6100
1400-1500		Voice of Malaysia, Kuala Lumpur	4950
1400-1500		Voice of Mediterranean, Malta	11925
1400-1500		Voice of Nigeria, Lagos	7255
1400-1500		WCSN, Boston, Massachusetts	13760
1400-1500		WHRI, Noblesville, Indiana	9455 11790
1400-1500		WSHB, Cyprus Creek, S. Carolina	17640
1400-1500		WYFR, Oakland, California	5950 9600 11830
1400-1500		WYFR Satellite Net, California	13695 15375
1415-1420		Radio Nepal, Kathmandu	3230 5005
1430-1500	F	ABC, Alice Springs, Australia	2310 [ML]
1430-1500	F	ABC, Tennant Creek, Australia	2325 [ML]
1430-1500		Burma Broadcasting Service	5985
1430-1500		King of Hope, Southern Lebanon	6280
1430-1500		KTWR, Agana, Guam	9780
1430-1500		Radio Australia, Melbourne	6060 9580

West Coast To East Africa

West Coast To South Africa

West Coast To Indian Ocean

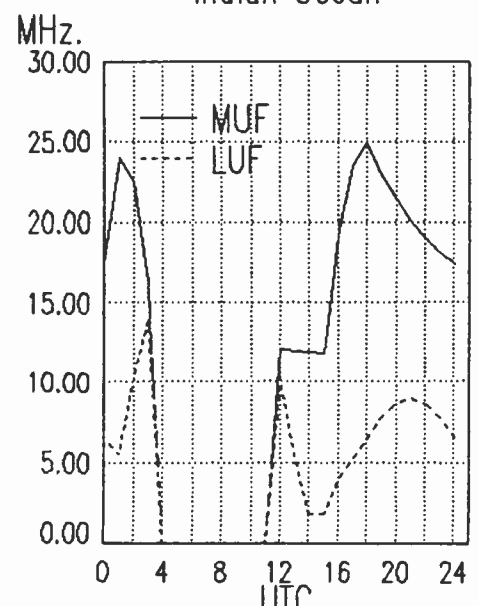
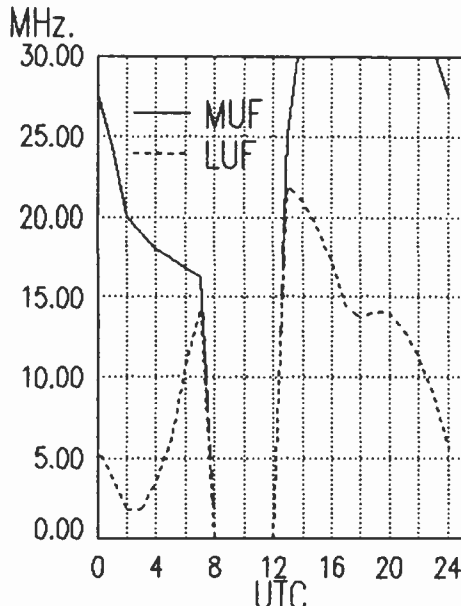
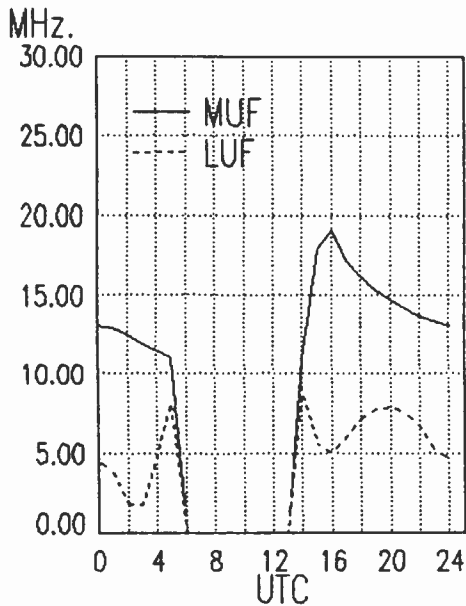

frequency SECTION

1430-1500	Radio France International, Paris	6175	9805	11670	13715
		15155			
1430-1500	Radio Netherland, Hilversum	11735	13770	15560	17575
1430-1500	Radio Prague, Czechoslovakia	9605	11685	13715	15110
		15155	17705	21505	
1430-1500	Voice of Turkey, Ankara	15255			
1445-1500 M-A	Radio Ulan Bator, Mongolia	9575	15305		

1500-1600	(US) Far East Network, Tokyo	3910			
1500-1600	FEBC, Manila, Philippines	11850			
1500-1600	HCJB, Quito, Ecuador	11740	11810	15115	17890
1500-1600	King of Hope, Southern Lebanon	6280			
1500-1600	KNLS, Anchor Point, Alaska	7355			
1500-1600	KSDA, Agat, Guam	9830	11980		
1500-1600	KYOI, Saipan	11900			
1500-1600	Radio Australia, Melbourne	5995	6035	6060	6080
		7205	7215	9580	

1500 UTC [10:00 AM EST/7:00 AM PST]

1500-1505	Africa No. 1, Gabon	7200	15200		
1500-1510	Vatican Radio, Vatican City	11960	15090	17870	
1500-1515	FEBA, Mahe, Seychelles	15325			
1500-1520	Radio Ulan Bator, Mongolia	9575	15305		
1500-1525	Radio Bucharest, Romania	9510	9690	11775	11940
		15250	15335		

1500-1525	Radio Netherland, Hilversum	11735	13770	15560	17575
1500-1530	Radio Finland, Helsinki	9560	11715	15185	
1500-1530 A,S	Radio Tanzania, Dar es Salaam	7165			
1500-1530	Radio Veritas Asia, Philippines	9770	15215		
1500-1550	Deutsche Welle, West Germany	9735	11965	17810	21600
1500-1550	KTWR, Agana, Guam	9820			
1500-1550	Radio Pyongyang, North Korea	6576	9325	9345	9640
		9977			

1500-1555	Radio Beijing, China	11600	15165		
1500-1600 F	ABC, Alice Springs, Australia	2310 [ML]			
1500-1600	ABC, Perth, Australia	9610			
1500-1600 F	ABC, Tennant Creek, Australia	2325 [ML]			
1500-1600	AWR, Alajuela, Costa Rica	15460			
1500-1515	BBC, London, England	5995	6195	7180	9410
		9740	11750	11775	12095
		15070	15260	15400	17790
		17885	18080	21470	21710
		25750			

1500-1600	Burma Broadcasting Service	5985			
1500-1600	CBC Northern Quebec Service	9625	11720		
1500-1600	CBN, St. John's, Newfoundland	6160			
1500-1600	CBU, Vancouver, British Columbia	6160			
1500-1600	CFCF, Montreal, Quebec	6005			
1500-1600	CFCN, Calgary, Alberta	6030			
1500-1600	CHNS, Halifax, Nova Scotia	6130			
1500-1600	CKWX, Vancouver, British Columbia	6080			
1500-1600	CFRB, Toronto, Ontario	6070			
1500-1600 S	ELWA, Monrovia, Liberia	11830			

1500-1600	S Radio Canada Int'l, Montreal	11955	17820		
1500-1600	Radio Japan, Tokyo	9505	9695	11815	21700
1500-1600	Radio Jordan, Amman	9560			
1500-1600	Radio Korea (South), Seoul	9870			
1500-1600	Radio Moscow, USSR	5905	5920	6020	6050
		6095	7260	7315	7345
		9705	9875	11840	12030
		13680	13710	15135	15480
		15460			

1500-1600	Radio RSA, South Africa	11925	21535	21590	21670
1500-1600	SBC Radio One, Singapore	5010	5052	11940	
1500-1600	SLBC, Sri Lanka	9720			
1500-1600 S	Superpower KUSW, Utah	9850			
1500-1600	Voice of America, Washington	6110	9575	9645	9700
		9760	15205		

1500-1600	Voice of Ethiopia, Addis Ababa	7165	9560		
1500-1600	Voice of Indonesia, Jakarta	11790	15150		
1500-1600	Voice of Kenya, Nairobi	6100			
1500-1600	Voice of Malaysia, Kuala Lumpur	4950			
1500-1600	Voice of Mediterranean, Malta	11925			
1500-1600	Voice of Nigeria, Lagos	7255	11770		
1500-1600	WCSN, Boston, Massachusetts	13760			
1500-1600	WHRI, Noblesville, Indiana	9455	15105		

1500-1600 S	WRNO, New Orleans, Louisiana	11965			
1500-1600	WSHB, Cyprus Creek, S. Carolina	17640			
1500-1600	WYFR, Oakland, California	5950	9600	17612.5	
1500-1600	WYFR Satellite Net	11830	13695	15375	
1515-1600	BBC, London, England	5995	6195	7180	9410
		9515	9740	11750	11750
		12095	15070	15260	15400
		17885	18080	21470	21710

1515-1600	FEBA, Mahe, Seychelles	11865	15325		
1530-1545	All India Radio, New Delhi	3905	3925	4860	6160
		7160	7412	9545	9950
1530-1600	Radio Berlin Int'l, E. Germany	15430	17780		

West Coast To Central Asia

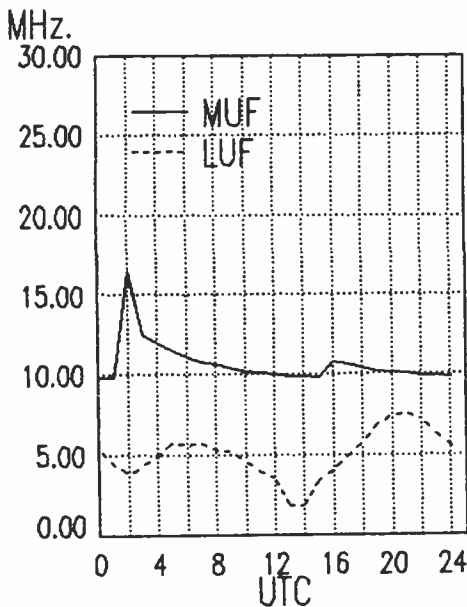

West Coast To Southeast Asia

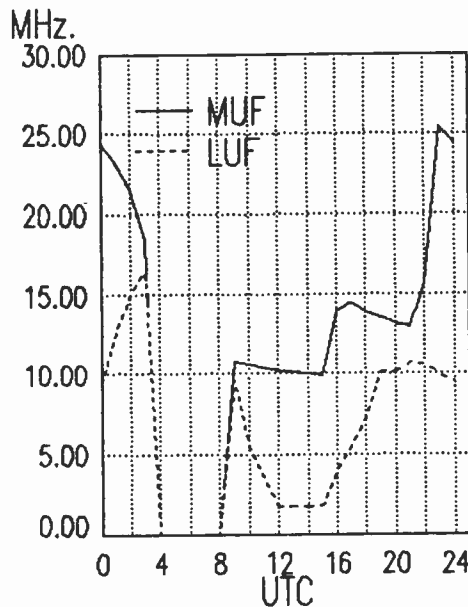

West Coast To Far East

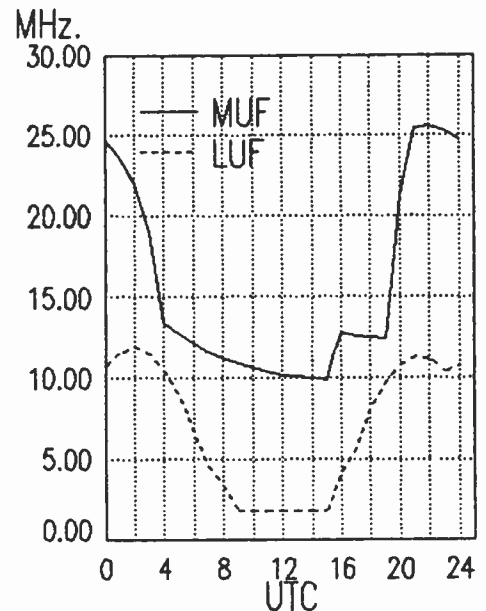

frequency SECTION

1530-1600	Radio Prague, Czechoslovakia	6055 9605 11665 11990	1600-1700	F	ABC, Alice Springs, Australia	2310 [ML]
		13715 15110 15155 15165	1600-1700		ABC, Perth, Australia	9610
		17730 21505	1600-1700	F	ABC, Tennant Creek, Australia	2325 [ML]
1530-1600	Radio Sofia, Bulgaria	7245 9740 11735	1600-1700		AWR, Alajuela, Costa Rica	15460
1530-1600	Radio Tanzania, Dar es Salaam	9684	1600-1700		BBC, London, England	9410 9515 11750 11775
1530-1600	Radio Tirana, Albania	9480 11835				12095 15070 15260 15400
1530-1600	Swiss Radio Int'l, Berne	13685 15430 15570 17830				17885 18080 21470
		21630	1600-1700		CBC Northern Quebec Service	9625 11720
1530-1600	Voice of Asia, Taiwan	5980 7445	1600-1700		CBN, St. John's, Newfoundland	6160
1530-1600	Voice of Nigeria, Lagos	15120	1600-1700		CBU, Vancouver, British Columbia	6160
1540-1550 M-A	Voice of Greece, Athens	9855 11645 15630	1600-1700		CFCF, Montreal, Quebec	6005
1545-1600	Radio Berlin Int'l, East Germany	15240 17880	1600-1700		CFCN, Calgary, Alberta	6030
1545-1600	Radio Canada Int'l, Montreal	9555 11915 11935 15315	1600-1700		CHNS, Halifax, Nova Scotia	6130
		15325	1600-1700		CKWX, Vancouver, British Columbia	6080
		15305 17820	1600-1700		CFRB, Toronto, Ontario	6070
1545-1600	Vatican Radio, Vatican City	11810 15120 17730	1600-1700		(US) Far East Network, Tokyo	3910
1550-1600 H-S	KTWR, Agana, Guam	9780	1600-1700		HCJB, Quito, Ecuador	17890
			1600-1700		KNLS, anchor Point, Alaska	7355
			1600-1700		Radio Australia, Melbourne	5995 6035 6060 6080
						7205 7215 9580
1600 UTC [11:00 AM EST/8:00 AM PST]						
1600-1610	FEBA, Mahe, Seychelles	11865 15325	1600-1700		Radio Beijing, China	15130
1600-1610	Radio Lesotho, Maseru	4800	1600-1700	S	Radio Canada Int'l, Montreal	11955 17820
1600-1610	SBC Radio One, Singapore	5010 5052 11940	1600-1700		Radio France Int'l, Paris	11705 15360 17620
1600-1625	Radio Prague, Czechoslovakia	6055 9605 11665	1600-1700		Radio Jordan, Amman	9560
		11990 13715 15110 15155	1600-1700		Radio Korea, Seoul, South Korea	5985 9870
		15165 17730 21505	1600-1700		Radio Malawi, Blantyre	3380 5995
		11830	1600-1700		Radio Moscow, USSR	7160 7265 7345 9825
1600-1630	ELWA, Monrovia, Liberia	11830				9875 11840 12010 13680
1600-1630	Radio Berlin Int'l, E. Germany	15240 17880	1600-1700		Radio Riyadh, Saudi Arabia	15135 15475 15550
1600-1630	S Radio Norway Int'l, Oslo	11760 15310 21705	1600-1700		Radio Tanzania, Dar es Salaam	9684
1600-1630	Radio Pakistan, Islamabad	7365 9465 9785 11615	1600-1700	S	Superpower KUSW, Utah	15650
		11625 15125	1600-1700		Voice of America, Washington, DC	9575 9645 9760 11920
		6135 9540				15410 15445 15205 15580
1600-1630	Radio Polonia, Warsaw, Poland	6135 9540				15600 17785 17800 17870
1600-1630 M-F	Radio Portugal, Lisbon	15245	1600-1700		WCSN, Boston, MA	21640
1600-1630	Radio Sofia Bulgaria	7245 9560 11735 15310	1600-1700		WHRI, Noblesville, Indiana	15105 21840
1600-1630	SLBC, Colombo, Sri Lanka	6075 9720	1600-1700		WRNO, New Orleans, Louisiana	15420
1600-1630	Trans World Radio, Swaziland	5055 9525	1600-1700		WYFR, Oakland, California	9600 15440 17612.5
1600-1630	Voice of Asia, Taiwan	5980 7445	1600-1700		WYFR Satellite Network	11830 13695 15375
1600-1630	Voice of Vietnam, Hanoi	9840 15010	1600-1700		Radio Zambia, Lusaka	9580
1600-1645 H-A	KTWR, Agana, Guam	9820	1615-1630 M,H		Radio Budapest, Hungary	7220 9585 9835 11910
1600-1645	Radio Nacional Angola, Luanda	7245 9535 11955				15160 15220
1600-1645	UAE Radio, United Arab Emirates	11955 15435 17775	1615-1630		Voice of Vietnam, Hanoi	10011
1600-1650	Deutsche Welle, Koin, W. Germany	6170 7200 9745 15105	1615-1700		Radio Berlin Int'l, East Germany	6115 7295 9730
		15595 17825 21680				
1600-1655	Radio Beijing, China	9570 11600 11715				

West Coast To Pacific

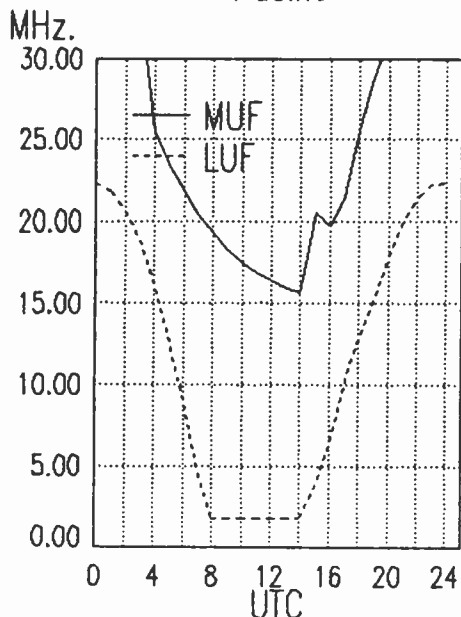

West Coast To Australia & Malaysia

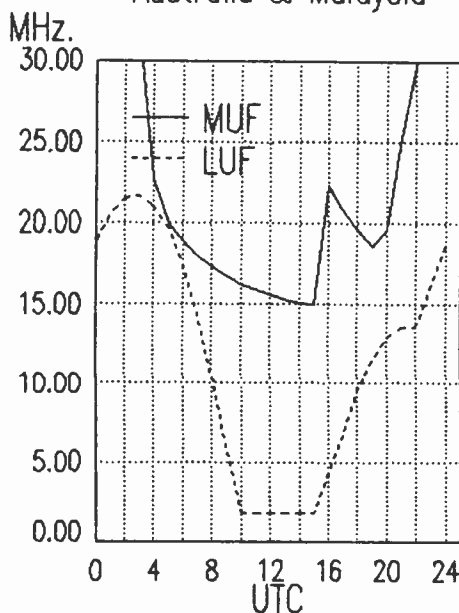

West Coast To Central America/Caribbean

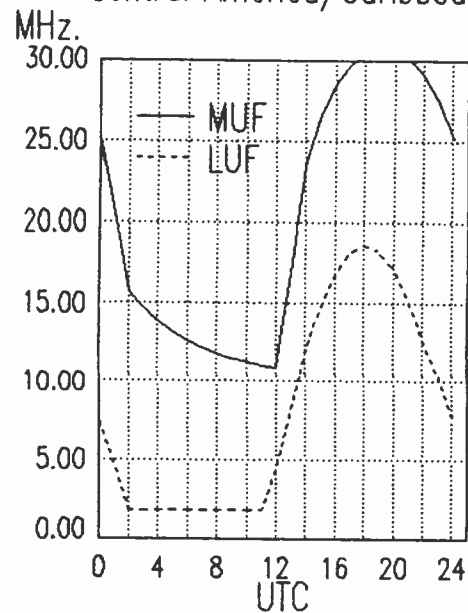

frequency SECTION

1630-1655	M-A	RT, Brussels, Belgium	17585	21810
1630-1700		Radio Netherlands, Hilversum	6020	9540
1630-1700		RTM Morocco	17595	17815
1645-1700		Radio Korea, Seoul, South Korea	7275	9870

1700 UTC [12:00 PM EST/9:00 AM PST]

1700-1705		Radio Uganda, Kampala	4976	5026
1700-1715	M-A	Voice of Namibia (Angola)	11955	
1700-1725		Radio Budapest, Hungary	6110	9585 9835 11910
			15160	
1700-1725		Radio Netherland, Hilversum	6020	9590
1700-1730		Radio Australia, Melbourne	5995	6060 6080 7205
			9580	
1700-1730		Radio Japan, Tokyo	9505	11705 11815
1700-1730	S	Radio Norway Int'l, Oslo	9655	15310 21700
1700-1730		Swiss Radio Int'l, Berne	3985	6165 9535
1700-1745		BBC, London, England	9410	9515 9740 11750
			12095	15070 15260 15400
			17885	18080 21470
1700-1750		Radio Pyongyang, North Korea	7290	9325 9640 9977
1700-1755		Radio Beijing, China	9570	11600
1700-1800	F	ABC, Alice Springs, Australia	2310	[ML]
1700-1800		ABC, Tennant Creek, Australia	2325	[ML]
1700-1800		AWR Africa, Gabon	9625	
1700-1800		CBC Northern Quebec Service	9625	11720
1700-1800		CBN, St. John's, Newfoundland	6160	
1700-1800		CBU, Vancouver, British Columbia	6160	
1700-1800		CFCF, Montreal, Quebec	6005	
1700-1800		CFCN, Calgary, Alberta	6030	
1700-1800		CHNS, Halifax, Nova Scotia	6130	
1700-1800		CKWX, Vancouver, British Columbia	6080	
1700-1800		CFRB, Toronto, Ontario	6070	
1700-1800		(US) Far East Network, Tokyo	3910	
1700-1800		Radio Havana Cuba	11920	
1700-1800		Radio Jordan, Amman	9560	
1700-1800		Radio Korea, Seoul, South Korea	5975	9870 15575
1700-1800	M-F	Radio Malabo, Equatorial Guinea	9553	[ML]
1700-1800		Radio Moscow, USSR	7265	7345 9825 9875
			11840	12015 13680 15135
			15460	15550

1700-1800		Radio Riyadh, Saudi Arabia	9705	9720
1700-1800		Radio Tanzania, Dar es Salaam	9684	
1700-1800		Radio Zambia, Lusaka	9580	
1700-1800		RTM Morocco	17815	
1700-1800		SBC Radio One, Singapore	5052	11940
1700-1800		Superpower KUSW, Utah	15650	
1700-1800	A,S	Swaziland Commercial Radio	6155	
1700-1800		Voice of Africa, Egypt	15255	
1700-1800		Voice of America, Washington	9575	11760 15205 15410
			15445	15580 15600 17785
			17800	17870
			6100	
1700-1800		Voice of Kenya, Nairobi	11770	
1700-1800		Voice of Nigeria, Lagos	21640	
1700-1800		WCSN, Boston, Massachusetts	13760	15105
1700-1800		WHRI, Noblesville, Indiana	15295	
1700-1800		WINB, Red Lion, Pennsylvania	9465	
1700-1800	S-F	WMLK, Bethel, Pennsylvania	15420	
1700-1800		WRNO, Louisiana	11830	13695
1700-1800		WYFR Satellite Net	11855	15170 15375 17750
1700-1800		WYFR, Okeechobee, Florida	21525	
			5995	7235 15325 17820
1715-1745		Radio Canada Int'l, Montreal	3975	6185 7165
1715-1745		BBC, London, England*	6210	7835
1718-1800		Radio Pakistan, Islamabad	7835v	
1725-1740		Radio Suriname Int'l, Paramibo	11780	15150
1725-1800		Radio New Zealand, Wellington	4840	4860 4920 6160
1730-1735		All India Radio, New Delhi	7412	9950
			5945	6155 12010 13730
1730-1755		Radio Austria Int'l, Vienna	7105	9530 9685 11790
1730-1755		Radio Bucharest, Romania	11940	
			5995	6035 6060 6080
1730-1800		Radio Australia, Melbourne	7205	9580
			6135	9540
1730-1800		Radio Polonia, Warsaw, Poland	9605	11685 11990 13715
1730-1800		Radio Prague, Czechoslovakia	15110	15165 21505
			15345	
1730-1800		RAE, Buenos Aires, Argentina	11810	
1734-1800		FEBA, Mahe, Seychelles	9410	9740 12095 15070
1745-1800		BBC, London, England	17885	21470
			11800	
1745-1800		SLBC, Colombo, Sri Lanka	11800	

1800 UTC [1:00 PM EST/10:00 AM PST]

1800-1805	A	SBC Radio One, Singapore	11940	
1800-1815		Kol Israel, Jerusalem	9385	9640 9925 11588
			13750	LSB
1800-1815		Radio Cameroon, Yaounde	3970	4750 4795 4850
			5010	
1800-1815		SLBC, Colombo, Sri Lanka	11800	
1800-1825	A,S	FEBA, Mahe, Seychelles	11760	
1800-1825		Radio Prague, Czechoslovakia	9605	11685 11990 13715
			15110	15165 21505
1800-1825		RAE, Buenos Aires, Argentina	15345	
1800-1830		BBC, London, England	9410	11750 12095 15070
			15400	15420 17885
			4835	5995
1800-1830	S	Radio Bamako, Mali	15260	17820
1800-1830	M-F	Radio Canada Int'l, Montreal	3265	4855 9618
1800-1830		Radio Mozambique, Maputo	5930	7345 13715 13110
			21505	
1800-1830		Radio Sweden, Stockholm	6065	11845
1800-1830		Voice of Africa, Egypt	15255	
1800-1830		Voice of Vietnam, Hanoi	9840	15010
1800-1845		Radio Abidjan, Ivory Coast	7215	
1800-1845		Trans World Radio, Swaziland	9525	
1800-1850		Radio Bras, Brasilia, Brazil	15265	
1800-1856		Radio RSA, South Africa	15365	17795 21535
1800-1900	F	ABC, Alice Springs, Australia	2310	[ML]
1800-1900	F	ABC, Tennant Creek, Australia	2325	[ML]
1800-1900		All India Radio, New Delhi	11935	15360
1800-1900		CBC Northern Quebec Service	9625	11720
1800-1900		CBN, St. John's, Newfoundland	6160	
1800-1900		CBU, Vancouver, British Columbia	6160	
1800-1900		CFCF, Montreal, Quebec	6005	
1800-1900		CFCN, Calgary, Alberta	6030	
1800-1900		CHNS, Halifax, Nova Scotia	6130	

West Coast To South America

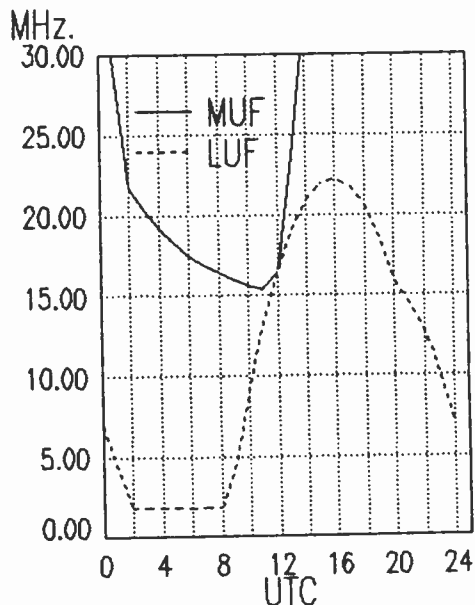

frequency SECTION

1800-1900	CKWX, Vancouver, British Columbia	6080			
1800-1900	CFRB, Toronto, Ontario	6070			
1800-1900	(US) Far East Network, Tokyo	3910			
1800-1900	KNLS, Anchor Point, Alaska	7355			
1800-1900	KYOI, Saipan	9455			
1800-1900	Radio Australia, Melbourne	5995	6035	6060	6080
		7205	7215	9580	
1800-1900 A.S	Radio Canada Int'l. Montreal	15260	17820		
1800-1900	Radio Jamahiriya, Libya	15450			
1800-1900	Radio Jordan, Amman	9560			
1800-1900	Radio Kuwait, Kuwait	11665			
1800-1900	Radio Malabo, Equatorial Guinea	9553v [ML]			
1800-1900	Radio Moscow, USSR	7265	9560	9875	11840
		12010	15460	15480	
1800-1900	Radio New Zealand, Wellington	11780	15150		
1800-1900	Radio Riyadh, Saudi Arabia	9705	9720		
1800-1900	Radio Tanzania, Dar es Salaam	9684			
1800-1900	Radio Zambia, Lusaka	9580			
1800-1900 M-A	Superpower KUSW, Utah	15650			
1800-1900 A.S	Swaziland Commercial Radio	6155			
1800-1900	Voice of America, Washington	9575	9760	11760	11920
		15205	15410	15445	15580
		15600	17785	17800	17870
		21485			
1800-1900	Voice of Ethiopia	9662			
1800-1900	Voice of Kenya, Nairobi	6100			
1800-1900	Voice of Nigeria, Lagos	11770	15120		
1800-1900	WCSN, Boston, Massachusetts	21640			
1800-1900	WHRI, Noblesville, Indiana	13760	17830		
1800-1900	WINB, Red Lion, Pennsylvania	15295			
1800-1900 S-F	WMLK, Bethel, Pennsylvania	9465			
1800-1900	WRNO, New Orleans, Louisiana	15420			
1800-1900	WYFR, Oakland, California	11580	11855	15170	15375
1800-1900	WYFR Satellite Net, California	11830	13695		
1815-1900	Radio Bangladesh, Dhaka	6240	7505	11510	
1830-1855	Radio Austria Int'l, Vienna	5945	6155	12015	15175
1800-1855	Radio Polonia, Warsaw, Poland	5995	6135	7125	7285
		9525	11840		
1815-1830	Radio Korea, Seoul, South Korea	9870	15575		
1830-1855	BRT Brussels, Belgium	5915	11695		
1830-1900	BBC, London, England	12095	15070	15400	17885
1830-1900	Radio Berlin Int'l, E. Germany	9665	13610	15145	15255
1830-1900 MWF	Radio Mozambique, Maputo	3265	4855	9618	
1830-1900	Radio Netherland, Hilversum	6020	15175	17605	21685
1830-1900	Radio Sofia, Bulgaria	7245	9560	11735	15310
1840-1850 M-A	Voice of Greece, Athens	11645	12045	15630	
1840-1900	Radio Senegal, Dakar	4950			
1845-1855	Radio Nacional, Conaky, Guinea	4833	4900	7125	
1845-1900	All India Radio, New Delhi	7412	11620		

1900 UTC [2:00 PM EST/11:00 AM PST]

1900-1903	Africa No. 1, Gabon	15475			
1900-1905 M-A	Vatican Radio, Vatican City	6190	6248	7250	9645
1900-1915	Radio Bangladesh, Dhaka	6240	7505	11510	
1900-1915	Radio Berlin Int'l, E. Germany	9665	13610	15145	15255
1900-1915	Radio Tanzania, Dar es Salaam	9684			
1900-1925	Radio Netherland, Hilversum	6020	15175	17605	21685
1900-1925	Voice of Islamic Republic Iran	9695			
1900-1930 F	ABC, Alice Springs, Australia	2310 [ML]			
1900-1930 F	ABC, Tennant Creek, Australia	2325 [ML]			
1900-1930	Radio Afghanistan, Kabul	7160	7310	9640	
1900-1930	Radio Japan, Tokyo	9505	11705		
1900-1930	Radio Kiev, Ukrainian SSR	5915	7205	7240	9600
1900-1930 S	Radio Norway Int'l, Oslo	6015	15225	15310	
1900-1930 M-F	Radio Portugal, Lisbon	11870	15250		
1900-1930	Radio Sofia Bulgaria	7245	7155	9700	
1900-1930	Voice of Vietnam, Hanoi	12020	15010		
1900-1950	Deutsche Welle, Köln, W. Germany	9745	11810	13790	15390
1900-1955	Radio Beijing, China	6860	9470		
1900-2000	All India Radio, New Delhi	7412	11620	11935	15360
1900-2000	BBC, London, England	9410	15400	12095	15070
		17885			
1900-2000	CBC Northern Quebec Service	9625	11720		
1900-2000	CBN, St. John's, Newfoundland	6160			
1900-2000	CBU, Vancouver, British Columbia	6160			
1900-2000	CFCF, Montreal, Quebec	6005			
1900-2000	CFCN, Calgary, Alberta	6030			

1900-2000	CHNS, Halifax, Nova Scotia	6130			
1900-2000	CKWX, Vancouver, British Columbia	6080			
1900-2000	CFRB, Toronto, Ontario	6070			
1900-2000	(US) Far East Network, Tokyo	3910			
1900-2000	HCJB, Quito, Ecuador	11790	15270	17790	
1900-2000	KNLS, Anchor Point, Alaska	11650			
1900-2000	KYOI, Saipan	9455			
1900-2000	Radio Algiers, Algeria	9509	9685	15215	17745
1900-2000	Radio Australia, Melbourne	6035	6060	6080	7205
		7215	9580		
1900-2000	Radio Ghana, Accra	6130			
1900-2000	Radio Havana Cuba	11800	11950		
1900-2000	Radio Jordan, Amman	9560			
1900-2000	Radio Korea, Seoul, South Korea	9870	15575		
1900-2000	Radio Kuwait, Kuwait	11665			
1900-2000 M-A	Radio Maiabo, Equatorial Guinea	9553 [ML]			
1900-2000	Radio Moscow, USSR	5905	6030	7150	7170
		9765	9825	9875	11840
1900-2000	Radio New Zealand, Wellington	11780	15150		
1900-2000	Radio Prague, Czechoslovakia	5930	7345		
1900-2000	Radio Riyadh, Saudi Arabia	9705	9720		
1900-2000	Radio RSA, South Africa	7295	15365	17795	
1900-2000	Radio Zambia, Lusaka	9580			
1900-2000	Spanish Foreign Radio, Madrid	11790	15375	15395	
1900-2000 M-A	Superpower KUSW, Utah	15650			
1900-2000 A.S	Swaziland Commercial Radio	6155			
1900-2000	Trans World Radio Swaziland	3205			
1900-2000	Voice of America, Washington	9700	9760	11760	15205
		15410	15445	15580	15600
		17785	17800	17870	
1900-2000	Voice of Ethiopia, Addis Ababa	9595			
1900-2000	Voice of Kenya, Nairobi	6100			
1900-2000	Voice of Nigeria, Lagos	7255	11770		
1900-2000	WCSN, Boston, Massachusetts	21640			
1900-2000	WHRI, Noblesville, Indiana	13760	17830		
1900-2000	WINB, Red Lion, Pennsylvania	15295			
1900-2000 S-F	WMLK, Bethel, Pennsylvania	9465			
1900-2000	WRNO, New Orleans, Louisiana	15420			
1900-2000	WYFR, Oakland, California	11855	15170	15566	17750
1900-2000	WYFR Satellite Net, California	11830	13695	15375	
1910-1920	Radio Botswana, Gaborone	3356	4820		
1920-1930 M-A	Voice of Greece, Athens	7430	9395	9425	
1930-1940	Radio Togo, Lome	5047			
1930-1945	Radio Finland, Helsinki	6120	9530	11755	
1930-2000	ABC, Katherine, Australia	2485			
1930-2000	Radio Beijing, China	6955	7480	9440	
1930-2000	Radio Bucharest, Romania	7145	9690	9750	11940
1930-2000	Radio Budapest, Hungary	6110	7220	9585	9835
		11910	15160		
1930-2000 M-F	Radio Canada Int'l, Montreal	9555	11945	15325	17875
1930-2000	Radio Finland, Helsinki	6120	9550	11755	15185
1930-2000	Radio Sofia Bulgaria	9700	11720		
1930-2000	Radio Yugoslavia, Belgrade	5980	9620	9660	
1930-2000	Voice of Republic of Iran	9022	9770		
1930-2000	WINB, Red Lion, Pennsylvania	15185			
1935-1955	RAI, Rome, Italy	7275	7290	9575	11800
1940-2000 M-A	Radio Ulan Bator, Mongolia	9575	11870		
1945-2000	All India Radio, New Delhi	9755	11860		
1950-2000	Vatican Radio, Vatican City	6190	7250	9645	

2000 UTC [3:00 PM EST/12:00 PM PST]

2000-2005 S-F	Port Moresby, Papua New Guinea	3295	4890	5960	5985
		6020	6040	6080	6140
		9520			
2000-2005	Radio Zambia, Lusaka	3345	6165		
2000-2010 A	Radio Zambia, Lusaka	3345	6165		
2000-2010	Voice of Kenya, Nairobi	6100			
2000-2015	Radio Togo, Lome	3220	5047		
2000-2015 M-A	Radio Ulan Bator, Mongolia	9575	11870		
2000-2015	Trans World Radio, Swaziland	3205			
2000-2025	Radio Beijing, China	6955	7480	9440	
2000-2025	Radio Bucharest, Romania	5990	6105	7145	7195
		9570	9690	11940	
2000-2030	KNLS, Anchor Point, Alaska	11650			
2000-2030	Kol Israel, Jerusalem	9435	9855	11605	11650
2000-2030	Radio Australia, Melbourne	6035	7205	7215	9580
		9620			

Did We Miss Something?

Find a frequency we've missed? A new broadcast? Let us know! Write to frequency manager Greg Jordan at 1855-I Franciscan Terrace, Winston-Salem, NC 27127.

frequency SECTION

2000-2030	Radio Berlin Int'l, East Germany	9665	11920	15255	
2000-2030	Radio Ghana, Nairobi	3366	4915		
2000-2030	Radio Norway International, Oslo	15310			
2000-2030	Radio Polonia, Warsaw, Poland	7125	7145	9525	
2000-2030	Radio Sofia, Bulgaria	7245	9560	11735	15310
2000-2030	Swaziland Commercial Radio	6155			
2000-2030	Voice of Nigeria, Lagos	7255			
2000-2030	Voice of Republic of Iran	9022			
2000-2045	All India Radio, New Delhi	7412	9755	9910	11620
		11860			
2000-2050	Radio Pyongyang, North Korea	6576	9345	9640	9977
2000-2056	Radio RSA, South Africa	7295	15365	17795	
2000-2100	M-A ABC, Alice Springs, Australia	2310	[ML]		
2000-2100	ABC, Katherine, Australia	2485			
2000-2100	M-A ABC, Tennant Creek, Australia	2325	[ML]		
2000-2030	BBC, London, England	5975	6005	6175	7325
		9410	9515	11785	11820
		12095	15070	15260	15400
		17760	17885		
2000-2100	CBC Northern Quebec Service	9625	11720		
2000-2100	CBN, St. John's, Newfoundland	6160			
2000-2100	CBU, Vancouver, British Columbia	6160			
2000-2100	CFCF, Montreal, Quebec	6005			
2000-2100	CFCN, Calgary, Alberta	6030			
2000-2100	CHNS, Halifax, Nova Scotia	6130			
2000-2100	CKWX, Vancouver, British Columbia	6080			
2000-2100	CFRB, Toronto, Ontario	6070			
2000-2100	(US) Far East Network, Tokyo	3910			
2000-2100	King of Hope, Southern Lebanon	6280			
2000-2100	KYOI, Salpan	9465			
2000-2100	Radio Baghdad, Iraq	9770	15230		
2000-2100	Radio Havana Cuba	11800	11950		
2000-2100	Radio Kuwait, Kuwait	11665			
2000-2100	Radio Malabo, Equatorial Guinea	9553v			
2000-2100	Radio Moscow, USSR	9655	9825	9875	9895
		11840	12050		
2000-2100	Radio Moscow (British Service)	7150	7370	7380	9630
		9890			
2000-2100	Radio New Zealand, Wellington	12050	15150		
2000-2100	Radio for Peace, Costa Rica	21555			
2000-2100	Radio Riyadh, Saudi Arabia	9705	9720		
2000-2100	Radio Zambia, Lusaka	9580			
2000-2100	M-A Superpower KUSW, Utah	15650			
2000-2100	Voice of America, Washington	9700	9760	11760	15410
		15445	15580	15600	17785
		17800	17870		
2000-2100	Voice of Nigeria, Lagos	11770			
2000-2100	WCSN, Boston, Massachusetts	11680			
2000-2100	WHRI, Noblesville, Indiana	13760	17830		
2000-2100	WINB, Red Lion, Pennsylvania	15295			
2000-2100	S-F WMLK, Bethel, Pennsylvania	9465			
2000-2100	WRNO, New Orleans, Louisiana	15420			
2000-2100	WSHB, Cyprus Creek, S. Carolina	17750			
2000-2100	WYFR, Oakland, California	9455	11855	15170	15566
2000-2100	M-A WYFR Satellite Net, California	11830	13695	15375	
2005-2100	Radio Damascus, Syria	12085	15095		
2010-2100	A,S Voice of Kenya, Nairobi	6100			
2015-2100	ELWA, Monrovia, Liberia	11830			
2015-2000	Radio Berlin Int'l, E. Germany	9665	13610	15255	
2015-2100	Radio Cairo, Egypt	9900			
2025-2045	RAI, Rome, Italy	7235	9575	9710	11800
2030-2055	Radio Polonia, Warsaw, Poland	6095	7285		
2030-2100	BBC, London, England	5975	6005	6175	7325
		9410	12095	15070	15400
		15260	17760	17885	
2030-2100	Radio Australia, Melbourne	9580	9620		
2030-2100	Radio Beijing, China	6955	7480	9440	9745
		11790			
2030-2100	Radio Korea, Seoul, South Korea	6480	7550	15575	
2030-2100	Radio Netherland, Hilversum	9540	9895	11740	15560
2030-2100	M-F Radio Portugal, Lisbon	7155	9740		
2030-2100	Radio Tirana, Albania	9480	11835		
2030-2100	Voice of Africa, Cairo, Egypt	15375			
2030-2100	Voice of Vietnam, Hanoi	9840	12020	15010	
2045-2100	All India Radio, New Delhi	7412	9550	9910	11620
		11715			
2045-2100	IBRA Radio, Malta	7110			
2045-2100	Vatican Radio, Vatican City	9625	11700	11695	15120

2100 UTC [4:00 PM EST/1:00 PM PST]

2100-2105	Radio Damascus, Syria	12085	15095		
2100-2105	Radio Zambia, Lusaka	3345	6165		
2100-2110	Vatican Radio, Vatican City	6190	7250	9645	
2100-2110	A,S Voice of Kenya, Nairobi	6100			
2100-2115	IBRA Radio, Malta	7110			
2100-2125	Radio Beijing, China	6955	7480	9440	9745
		11790			
2100-2125	Radio Bucharest, Romania	5990	6105	7145	7195
		9690	11940		
2100-2125	Radio Netherland, Hilversum	9540	9895	11740	15560
2100-2130	S Radio Austria Int'l, Vienna	5945	6155	9585	9870
2100-2130	Radio Budapest, Hungary	6110	7220	9585	9835
		11910	15160		
2100-2130	Radio Japan, Tokyo	5965	7140	7280	17835
2100-2130	Radio Korea, Seoul, South Korea	6480	7550	15575	
2100-2130	Radio Sweden, Stockholm	9655	11845		
2100-2130	Swiss Radio Int'l, Berne	9885	12035	13635	15570
2100-2135	ELWA, Monrovia, Liberia	11830			
2100-2145	Radio Cairo, Egypt	9670			
2100-2145	WYFR, Oakland, California	5950	9455	11855	15566
		21525	21615		
2100-2200	WYFR Satellite Net	11830	13695	15375	
2100-2150	Deutsche Welle, West Germany	7130	9765		
2100-2150	Voice of Turkey, Ankara	9825			
2100-2155	Radio Beijing, China	6860	9470	9860	
2100-2200	M-A ABC, Alice Springs, Australia	2310	[ML]		
2100-2200	ABC, Katherine, Australia	2485			
2100-2200	M-A ABC, Tennant Creek, Australia	2325	[ML]		
2100-2200	All India Radio, New Delhi	9550	9910	11620	11715
2100-2200	BBC, London, England	3995	5975	6005	6175
		6180	7325	9410	11785
		12095	15070	15260	15400
		17760	17885		
2100-2200	CBC Northern Quebec Service	9625	11720		
2100-2200	CBN, St. John's, Newfoundland	6160			
2100-2200	CBU, Vancouver, British Columbia	6160			
2100-2200	CFCF, Montreal, Quebec	6005			
2100-2200	CFCN, Calgary, Alberta	6030			
2100-2200	CHNS, Halifax, Nova Scotia	6130			
2100-2200	CKWX, Vancouver, British Columbia	6080			
2100-2200	CFRB, Toronto, Ontario	6070			
2100-2200	(US) Far East Network, Tokyo	3910			
2100-2200	King of Hope, Southern Lebanon	6280			
2100-2200	KSDA, Agat, Guam	7365	15125		
2100-2200	KVOH, Rancho Simi, California	17775			
2100-2200	KYOI, Salpan	9465			
2100-2200	Radio Australia, Melbourne	15240	15395	17795	
2100-2200	Radio Baghdad, Iraq	9770			
2100-2200	Radio Moscow, USSR	5980	6055	7150	7170
		7290	9505	9515	9590
		9620	9625	9730	9765
		9780	9790	9800	9820
		9840	9875	11840	12030
		12050	15405	17605	17720
2100-2200	Radio for Peace, Costa Rica	21555			
2100-2200	A,S Radio Malabo, Equatorial Guinea	9552.5			
2100-2200	A,S Radio Zambia, Lusaka	9580			
2100-2200	Spanish Foreign Radio, Madrid	9765	11790		
2100-2200	M-A Superpower KUSW, Utah	15650			
2100-2200	Voice of Africa, Cairo, Egypt	15375			
2100-2200	Voice of America, Washington	6040	9700	9760	11760
		15445	15580	15600	17785
		17800	17870		
2100-2200	Voice of Nigeria, Lagos	15120			
2100-2200	WCSN, Boston, Massachusetts	11680			
2100-2200	WHRI, Noblesville, Indiana	9770	17830		
2100-2200	WRNO, New Orleans, Louisiana	13760			
2100-2200	WSHB, Cyprus Creek, S. Carolina	17750			
2103-2200	WINB, Red Lion, Pennsylvania	15295			
2110-2200	Radio Damascus, Syria	12085	15095		
2125-2155	S Radio Austria Int'l, Vienna	9870			
2130-2145	BBC, London, England*	5965	7160		
2130-2200	BBC, London, England*	6030	7230	9635	
2130-2200	HCJB, Quito, Ecuador	15270	11790	17790	

frequency SECTION

2130-2200 A,S	Radio Canada Int'l, Montreal	11880	15150	17820
2130-2200	Radio Sofia Bulgaria	7115	7155	9700 11720
2130-2200	Swiss Radio Int'l, Berne	6190		
2135-2150 S-F	ELWA, Monrovia, Liberia	11830		
2150-2200 M-F	ELWA, Monrovia, Liberia	11830		

2230-2300	Radio Mediterran, Malta	6110		
2230-2300	Radio Polonia, Warsaw, Poland	5995	6135	7125 7270
2230-2300	Radio Sofia, Bulgaria	9700	11950	
2230-2300	Radio Sweden, Stockholm	11925	SSB	
2230-2300	Radio Tirana, Albania	7215	9480	
2230-2300	Radio Vilnius, Lithuanian SSR	6100		
2230-2300	Swiss Radio Int'l, Berne	6190		
2245-2300	All India Radio, New Delhi	6055	7215	9535 9910
		11715	11745	
2245-2300	BBC, London, England	5975	6005	6195 7325
		9410	9590	9915 11785
		12095	15260	15400 17875
2245-2300	Radio Berlin Int'l, E. Germany	6125		

2200 UTC [5:00 PM EST/2:00 PM PST]

2200-2205 M-F	ELWA, Monrovia, Liberia	3993	11830	
2200-2205	Radio Damascus, Syria	12085	15095	
2200-2210 M-H	Port Moresby, Papua New Guinea	3925	4890	5960 5985
		6020	6040	6080 6140
		9520		
2200-2210	Radio Sierra Leone, Freetown	5980		
2200-2215 M-A	ABC, Alice Springs, Australia	2310	[ML]	
2200-2215 M-A	ABC, Tennant Creek, Australia	2325	[ML]	
2200-2215	BBC, London, England*	5965	7160	
2200-2215 M-F	Voice of America, Washington	9640	11740	15120
2200-2225	BRT Brussels, Belgium	5915	9675	
2200-2225	Radio Finland, Helsinki	6120	9670	11755
2200-2225	RAI, Rome, Italy	5990	9710	11800
2200-2225	Vatican Radio, Vatican City	6015	9615	11830
2200-2230	ABC, Katherine, Australia	2485		
2200-2230	All India Radio, New Delhi	9550	9910	11620 11715
2200-2230	CBC Northern Quebec Service	9625	11720	
2200-2230 F	Radio Budapest, Hungary	6110	9585	9835 11910
		15160		
2200-2230 S	Radio Norway Int'l, Oslo	9605	11850	
2200-2230	Radio Prague, Czechoslovakia	6055		
2200-2245	BBC, London, England	5975	6005	6175 6180
		6195	7325	9410 9590
		9915	11785	12095 15070
		15260	15400	
2200-2245	Radio Berlin Int'l, East Germany	6125		
2200-2245	Radio Cairo, Egypt	7710	9900	
2200-2245	Radio Yugoslavia, Belgrade	5980	7130	9620 9660
2200-2250	Radio Baghdad, Iraq	9770	15230	
2200-2255	RAE, Buenos Aires, Argentina	11710	15345	
2200-2300	CBN, St. John's, Newfoundland	6160		
2200-2300	CBU, Vancouver, British Columbia	6160		
2200-2300	CFCF, Montreal, Quebec	6005		
2200-2300	CFCN, Calgary, Alberta	6030		
2200-2300	CHNS, Halifax, Nova Scotia	6130		
2200-2300	CKWX, Vancouver, British Columbia	6080		
2200-2300	CFRB, Toronto, Ontario	6070		
2200-2300	(US) Far East Network, Tokyo	3910		
2200-2300	King of Hope, Southern Lebanon	6280		
2200-2300	KVOH, Rancho Simi, California	17775		
2200-2300	KYOI, Saipan	15405		
2200-2300	Radio Australia, Melbourne	15160	15240	15320 15395
		17795		
2200-2300	Radio Canada Int'l, Montreal	9760	11945	
2200-2300	Radio for Peace, Costa Rica	21555		
2200-2300	Radio Havana Cuba	7140		
2200-2300	Radio Moscow, USSR	4795	4860	5980 6045
		7115	7150	7170 7230
		9505	9515	9590 9620
		9625	9780	9790 9820
		9840	9625	12050 15405
		15425	17570	17605 17700
2200-2300	SBC Radio One, Singapore	5010	5052	11940
2200-2300 M-A	Superpower KUSW, Utah	15580		
2200-2300	Voice of America, Washington	11760	15185	15290 15305
		15320	17735	17740 17820
		11805		
2200-2300	Voice of Free China, Taiwan	11805		
2200-2300	WCSN, Boston, Massachusetts	9495		
2200-2300	WHRI, Noblesville, Indiana	9770	17830	
2200-2300	WINB, Red Lion, Pennsylvania	15185		
2200-2300	WRNO, New Orleans, Louisiana	13760		
2200-2300	WSHB, Cyrus Creek, S. Carolina	17640		
2200-2300	WYFR, Oakland, California	9852.5	11830	11855 13695
		15170	15375	15566 17845
2215-2230	BBC, London, England*	11820	15390	
2230-2300 A,S	CBC Northern Quebec Service	9625	11720	
2230-2300	Kol Israel, Jerusalem	9435	9010	11605
2230-2300	Radio Austria Int'l, Vienna	9870	11780	
2230-2300	Radio Beijing, China	3985	6165	

2300 UTC [6:00 PM EST/3:00 PM PST]

2300-2315	BBC, London, England	5975	6005	6175 6195
		7325	9410	9515 9590
		9915	11785	12095 15070
		15260	15435	17875
2300-2330 S	KGEI, San Francisco, California	15280		
2300-2330	Radio Berlin Int'l, E. Germany	6125		
2300-2330	Radio Canada Int'l, Montreal	5960	9755	
2300-0000	Radio Luxembourg	6090		
2300-2330	Radio Mediterran, Malta	6110		
2300-2330	Radio Sofia, Bulgaria	9700	11950	
2300-2330	Radio Vilnius, Lithuanian SSR	7105	7400	9640 9800
		13645	15180	15455
2300-2330 M-A	Superpower KUSW, Utah	15580		
2300-2345	WINB, Red Lion, Pennsylvania	15185		
2300-2345	WYFR, Oakland, California	11830	11855	13695 15170
		15440	17845	
2300-2350	Voice of Turkey, Ankara	7160	9445	9685 17760
2300-0000	All India Radio, New Delhi	6055	7215	9535 9910
		11715	11745	
2300-0000	CBC Northern Quebec Service	6195	9625	
2300-0000	CBN, St. John's, Newfoundland	6160		
2300-0000	CBU, Vancouver, British Columbia	6160		
2300-0000	CFCF, Montreal, Quebec	6005		
2300-0000	CFCN, Calgary, Alberta	6030		
2300-0000	CHNS, Halifax, Nova Scotia	6130		
2300-0000	CKWX, Vancouver, British Columbia	6080		
2300-0000	CFRB, Toronto, Ontario	6070		
2300-0000	(US) Far East Network, Tokyo	3910		
2300-0000	KVOH, Rancho Simi, California	17775		
2300-0000	KYOI, Saipan	15405		
2300-0000	Radio Australia, Melbourne	15160	15240	15320 15395
		17795	21740	
2300-0000	Radio for Peace, Costa Rica	21555		
2300-0000	Radio Japan, Tokyo	11800	15195	17810
2300-0000	Radio Moscow	7295	7370	9625 9790
		9840	15295	15420 17570
		17655	21790	
2300-0000	Radio Moscow, (N. American Srvc)	5980	6170	7115 7165
		7195	9530	9720 9765
		12050	13605	15405 15245
		15425	17700	
2300-0000	Radio Polonia, Warsaw	5995	6135	7125 7270
2300-0000	Radio Thailand, Bangkok	9655	11905	
2300-0000	Voice of America, Washington, DC	17735	17820	
2300-0000	WCSN, Boston, Massachusetts	9495		
2300-0000	WHRI, Noblesville, Indiana	9770	17830	
2300-0000	WRNO, New Orleans, Louisiana	13760		
2315-2330	BBC, London, England*	11820	15390	
2315-0000	BBC, London, England	5975	6005	6175 6195
		7325	9515	9590 9915
		11785	12095	15260 15435
		17875		
2330-0000	Radio Korea, Seoul, South Korea	15575		
2330-0000	Radio Tirana, Albania	7065	9760v	
2330-0000	Voice of Vietnam, Hanoi	9840	12020	15010
2335-2345 M-A	Voice of Greece, Athens	7430	9395	
2345-0000	BBC, London, England*	3915	6080	7180 9580
2348-0000	WINB, Red Lion, Pennsylvania	15145		

Send us your special QSLs and we'll copy and return them promptly, to be used as space permits (QSL editor, PO Box 98, Brasstown, NC 28902).

A product review

by Jack Albert
MT RTTY/FAX columnist



The Universal M7000

This year is a big year for the number 7000. Hal Communications introduced the ST-7000 at Dayton, Icom makes the R7000 receiver and I think I saw a 7000 GL in the parking lot last week. Ha! Ha! Now, Universal SW has introduced the M-7000 Communications Terminal. This sophisticated data reader decodes Morse and Moore codes, RTTY, ASCII, TOR, packet, TDM, FDM, and Russian Cyrillic as well as FAX photos!

The M-7000, like the M-6000, is a self contained microprocessor controlled (receive only) radio modem. It requires only two peripherals, a video monitor and a shortwave radio. When I saw a picture of the unit, the first thing that entered my mind was "It's too complicated because it has too many buttons." But when I got my hands on one, I quickly changed my mind.

In order to accommodate the multiple functions such as Morse code, RTTY, Packet Radio and FAX, the M7000 is equipped with a dual keyboard. Many other features can be selected using a front panel alternate switch. After using the unit for a while, I was able to select (with both hands on the controls) the various modes that are shown in the quick reference card (see Figure 1).

Triple Your Pleasure, Triple Your Fun

Actually, the M7000 consists of three products, the M6000 (which was introduced about three years ago), the M-800 FAX unit and the M-605 FDM converter (no longer available), which are manufactured by Digital Equipment Systems in Florida. If you own all three, you probably paid about \$1700 (not including shipping). But the M7000, fully loaded and with all the options, costs \$1129. That's a \$571 savings!

The three units are combined in neat package, using the M-6000 cosmetics, and bears the Universal "private label" name. The FAX (printing mode) is included; however, you can purchase a "Video FAX" option that costs \$90. I think the money would be better spent for a down payment on a printer because the on-screen resolution isn't very good. The M-7000 can print a weather map or picture (using the recommended printer) with the same quality as the M-800. The other option is a real-time clock which is displayed in the status line at the bottom of the screen.

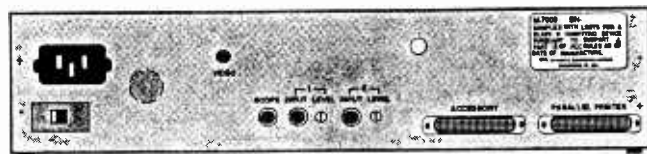
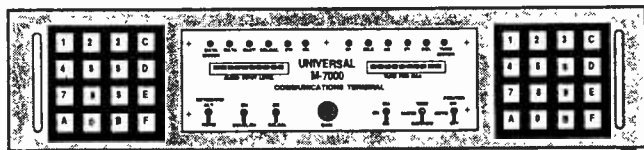

When I first saw all those buttons I thought, "It's too complicated..."

Speaking of options, there is an indicator LED on the front panel labeled "IPI." The manual calls it the "Intelligent Peripheral Interface." On page 55 it explains, "There is activity with certain peripherals (yet to be announced)." Apparently Universal Shortwave has something up their sleeves. I'm sure, sooner or later, we'll find out what those peripherals are.

It's Christmas in January

After unpacking the unit (remember, always save the box) I found two books, the manual and a book called "Getting Started with the Universal M-7000." This preliminary book wasn't finished but Fred Osterman at Universal Shortwave informed me that they were still working on it (I received the finished copy a few weeks later).

It's well-written and geared towards the novice RTTY listener. It covers in detail some of the basic functions of the M-7000. This book also shows how to set the dip switches that are inside the recommended printers, how to connect your shortwave radio, and frequency listings which will aid you in finding the signals using the particular mode. I believe this book will be free when you purchase your M-7000.

The box also included a 1/4 inch phono plug and an AC cord. You have to provide the printer, oscilloscope and computer interface cable. If you are planning on using the FDM mode, you will need a tuning oscilloscope. Any scope will do to provide the "crossed ellipsis" pattern which is used to tune in the "mark" and "space" tones. More on that later.

Keep It Simple

The unit was very simple to hook up. Just connect an audio cable from your receiver and a video coaxial cable to the monitor. The audio connection can come from the speaker but you will need a way to monitor the receiver (in most receivers, the internal speaker is muted when something is plugged into the external speaker jack). When I first purchased my Icom R-7000, I installed a constant level (.75 volts) audio out jack on the rear apron for RTTY reception. It interfaced well with the M-7000 and I can turn down the speaker without affecting the RTTY reception.

I did have problems with the video monitor. At first I used a Commodore 1702 color monitor but the picture was lousy (the manual recommends the proper monitor). Second, I tried a Sony TV that was converted to a monitor. It worked OK but some of the status line was cut off at the bottom. I finally obtained a monitor that is used in closed circuit TV. It worked great. Because it has an all steel cabinet, the noise and interference can be kept to a minimum (some computer monitors can generate noise through the plastic case). If you don't own a good monitor you will have to purchase one.

In order to hook up my printer, I had to borrow a printer cable. But it caused interference with frequencies above 19 MHz. The next day I went to an Egghead Computer Software store and purchased a shielded printer cable. It reduced the noise problem to an acceptable level.

M — 7000

BI MAN	FRAME LEFT	FRAME RIGHT			1	2	3	MARK FREQ
BI AUTO	BIT/CHAR UP			ALTERNATE	4	5	6	SPACE FREQ
SPLIT SCREEN	BIT/CHAR DOWN				7	8	9	SHIFT
DATABIT	LITERAL	PROGRAM	HELP			0	BAUD	
LEFT KEYBOARD					RIGHT KEYBOARD			
SRO Line/Gray	STATUS PRINT	SCREEN PRINT	CW	NORMAL	NOR/REV POS/NEG	FILTER TUNE	START STOP	MEMORY SELECT
SPEED UP	SCROLL UP	UOS/PAR IOC	SITOR		SHIFT UP	VFT GROUP	ATC	ARQ CHANNEL
SPEED DOWN	SCROLL DOWN	Case Chge Direction	ARQ		SHIFT DOWN	SHIFT	INPUT SELECT	AUTO TUNE
ASCII	SCREEN CLEAR	BAUDOT	FAX		Alphabet	DEMODO MODE	AGC	PACKET

Fig 1: Quick Reference Card

The noise problem returned when I brought the M-7000 and R-71 to a friend's house to try out his printer. I used his Zenith monitor and an Epson FX-86 printer. He also had a Gilfer Short-wave long wire antenna. I figured the problem was caused by a poor ground system at his listening post. (I have an eight foot ground rod which is only four feet from my equipment.)

I have a Star NX-10 which was not on the list of recommended printers but it is compatible with an Epson MX-80. The Star printer worked well even with FAX. Some of the faster FAX rates would cause the printer to lock-up until another mode, such as RTTY, was selected. I guess my printer just isn't fast enough. Sometimes, while receiving RTTY, it missed a line feed and the characters would over-print the previous line. I discussed this problem with John Fellin at DES and they are looking into it.

When In Doubt, Press the Panic Button

One feature I was impressed with (which is also available in the M-6000) is the "FILTER TUNE" button. This takes the guesswork out of tuning in RTTY. Just press the button and the microprocessor tunes the filters for best RTTY reception and the word "TUNED" appears in the status line. I found that this feature works very good with just about any kind of RTTY that you'll encounter on the SW bands. However, it doesn't work with very narrow RTTY or a noisy signal. Then, the status line will display "CAN'T TUNE." This feature won't work with FAX or FDM.

FDM or "Frequency Division Multiplex" is a mode whereby many RTTY channels are combined in single VFT (Voice Frequency Telegraph) channel. A scheme is used to transmit the closely spaced RTTY tones using a single sideband transmitter. FDM sounds like a buzzsaw when you receive it on a SW receiver in AM mode.

The M-7000 has the ability to receive these channels, one at a time, by selecting the proper FDM filter mode (A, B, C or D). This is very difficult to do because you really don't know what mode you are hearing. Also, while copying FDM, the M-7000's tuning indicator and auto tune mode becomes inoperative, which increases the difficulty. To make matters worse, the "crossed ellipse" pattern on the tuning oscilloscope is very hard to see because of the tightly tuned filters which are needed in that mode. The scope display shows a pattern which resembles a very noisy signal.

Because of these problems it takes a lot of experience and knowledge with VFT signals to master the art of tuning FDM. After using the M-7000 for a couple of weeks, I can only use trial and error methods to successfully receive the channels but I'm not sure if I have proper channel alignment.

What's All This Racket About Packet

Packet radio is a mode which is gaining popularity on the "ham" bands. It is now being used by MARS which means you can tune outside of the ham bands to receive it. I was able to copy HF packet on 14.500 MHz. Someday, so I'm told, packet will be used by other services as well.

Finally, there are three RTTY modes available (the unit defaults to "baudot" RTTY during power-up). While in the baudot or FDM baudot mode the unit can execute an "Auto Baud" feature when the "AUTO TUNE" button is pressed. Auto tune performs the same filter tune function as the "FILTER TUNE" button but it also executes an "AUTO BAUD" function. "AUTO BAUD" performs a RTTY speed test and then configures the unit by changing the baud rate in the status line. This feature is also disabled when other modes are selected. The "Baud" button will display the baud rate only, and all of the above functions are displayed in the status line. ASCII and Morse is also available.

Copying the Mode in My Abode

The SITOR mode "A" and "B" are two of the three ARQ RTTY modes which are also available. The other ARQ mode, TDM, is for me the most exciting, though others may find it boring. This mode is used by foreign embassies and for most of the time, very little traffic is sent.

When TDM is tuned in properly the data and idle light will turn on and the error light will go out. You can select a split screen mode (TDM2 only) which will display the two TDM channels. You can also select other TDM modes and baud rates such as the TDM four channel 200 baud or two channel 176 baud. I was also able to tune in TDM on an FDM signal! There are so many features that I just can't cover all to them in one article, but I will try to, from time to time, in future issues of *MT*.

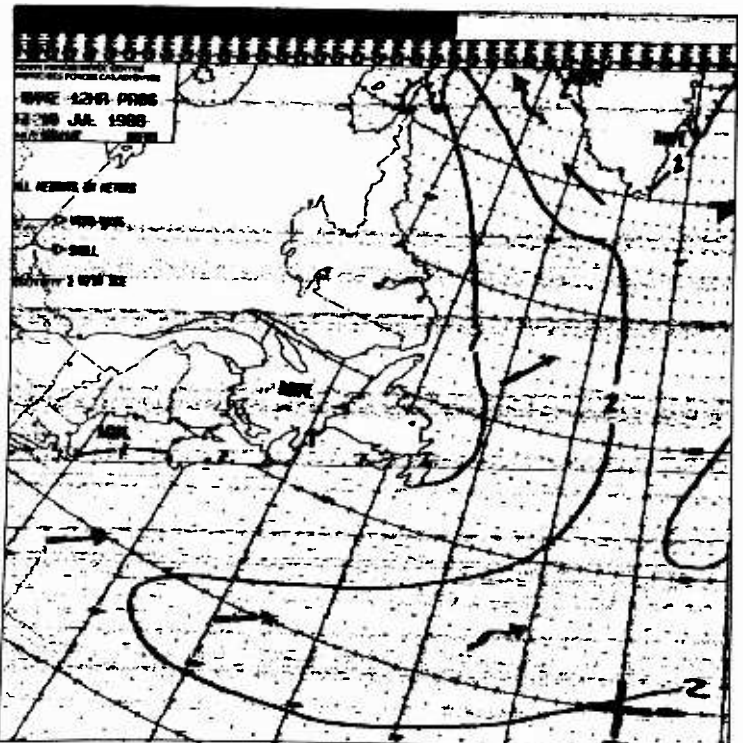

Fig 2: This detailed FAX picture was copied from CFH Nova Scotia using the M7000 and a Star NX10 printer.

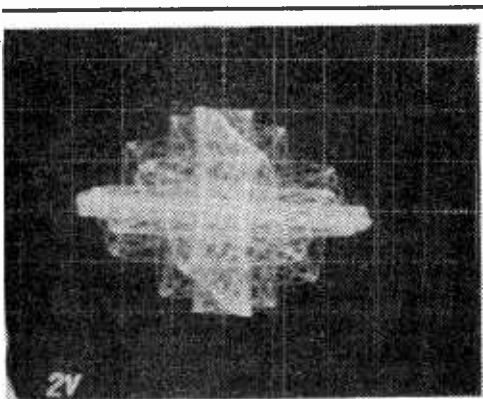

Fig. 3: An oscilloscope photo of the M7000 copying RTTY at 75 baud and 170 Hz shift.

A Few Problems

The M-7000 is truly a "high tech" unit but it has a few drawbacks. The audio filter circuit seems to have a problem which causes the M-7000 to print errors on the screen (even during moderate conditions) while receiving shifts that are less than 425 Hz and baud rates that are 75 baud or greater. I discovered this by performing a "One-on-One" test with other RTTY equipment.

While connecting the M-7000 and another TU to the same receiver, I copied about one page of text at various baud rates and shifts. Then I obtained a print-out by dumping the text, which is stored in the unit's print buffer, and by changing the printer from one unit to the other. Both units had the ATC (automatic threshold control) turned off. But when I turned on the M-7000's ATC, the amount of printed errors decreased and in some cases were fewer than brand X.

The ATC is normally used during the reception of wide shifts to reduce errors which are caused by selective fading. But the M-7000 needed this feature turned on during nonselective fading conditions.

The M-7000 also had a problem receiving packet radio (the ATC can't be turned on in this mode). At times, it would miss the packets that my AEA PK-232 received. The two ARQ modes produced the same copy with both units and the M-7000 can produce a better FAX picture than a PK-232, for example, because it has better resolution.

Another problem can be seen when a RTTY tuning scope is connected. The M-7000 produces a fuzzy scope display making it difficult, while copying some shifts, to see the familiar "cross ellipse" pattern (see Figure 3). But unlike the problem with FDM you can use the AUTO tune feature. I also discussed this problem with John Fellin at DES and he explained that "Sometimes it is necessary to change the band width of the filters when narrow shifts are encountered."

The M-7000 has a switch on the front panel which allows the operator to alter the bandwidth. You can also select the amount that this switch will alter (by 15 or 30 percent) by selecting the subsystem menu. At first it didn't appear that this switch was func-

★★★★★★★★★★★★★★★★★★★★★★★★★★★★★★★★★★★★

GALAXY ELECTRONICS

BOX-1 202--67 EBER AVE.
AKRON, OHIO-44309
216-376-2402

NEW

BC200XLT
200 Channels, 12 band with aircraft & 800 MHz, 10 priority channels, channel lockout, scan delay, automatic search, illuminated LCD display, snap-on battery pack, programmable, track tuning, direct channel access, with AC adapter, leather carry case & earphone.

\$279

NEW

BC760XLT 100 channel 12 band base/mobile scanner with 800 MHz band & Service Scan. Weather, Priority, Lockout, Scan delay, Search, Programmable, Track tuning, Direct ch. access

\$279

FREE
FREE CELLULAR MODIFICATIONS WITH BC-200 & BC-760!!

NEW

RZ-1
New Scanning Receiver
COMPACT SCANNING RECEIVER
• 500 kHz-905 MHz
• Narrow & Wideband FM, AM
• 100 Memories
• Direct Keyboard Entry or VFO

\$499

NEW

uniden
25 WATT 10 Meter Transceiver. all mode operation. backlit multi function LCD meter, frequency lock, auto squelch, NB, RF gain, PA, external speaker jack.
7 1/4"x9 1/4"x2 3/8".

HR2510 **\$CALL**

TS2 75 channels, 12 bands, Turbo-Scan, bank scan, Accu-Seek, Private Priority, Instant weather, digital display. (29-30, 30-50, 50-54, 118-136, 136-144, 144-148, 148-175, 406-440, 440-450, 806-950MHZ)

\$279

KENWOOD

SHORTWAVE RADIO		POLICE/FIRE SCANNERS		
KENWOOD				
R-2000	150kHz-30mhz, Digital, Memrys	649.00	BEARCAT	
R-5000	100kHz-30mhz, Digital, Memrys	849.00	BC-200XLT 200ch, 29-54, 118-174, 406-512, 806-960mhz	279.00
SONY ICF-2010	150kHz-30mhz, 76-108, 116-136	349.95	BC-100XLT 100ch, 29-54, 118-174, 406-512, Search, Delay	209.00
SONY ICF-2003	150kHz-30mhz, Memrys	249.00	BC-760XLT 100ch, 29-54, 118-174, 406-512, 806-952mhz	279.00
SONY PRO-80	150kHz-216mhz, Memrys, Scans	359.00	BC-600XLT 100ch, 29-54, 118-174, 406-512, Priority, Search	214.00
SONY AN-1	Indoor Active Shortwave Antenna	79.00	BC-800XLT 40ch, 29-54, 118-174, 406-512, 806-912mhz	259.00
ICOM R71-A	100kHz-30mhz, Digital, Memrys	849.00	BC-55XLT 10ch, 29-54, 136-174, 406-512mhz	129.00
ICOM R-7000	25-2,000mhz, 100 Memories	1,049.00	BC-15 10ch Crystal Scanner 30-50, 118-174, 406-512	114.00
YAESU FRG-8800	150kHz, 30mhz, Memrys, Scans	649.00	REGENCY	
YAESU FRG-9600	60-905mhz, Digital, Memrys	539.00	TS-2 75ch, 29-54, 118-174, 406-512, 806-950mhz	279.00
NRD-525	0.9-34mhz, 200 Memories, Digital	1,165.00	TS-1 35ch, 29-54, 118-174, 406-512, Priority, Delay	224.00
MFJ-1040	Tuner/Pre-Selector Unit	99.00	MX-3000 30ch, 30-50, 118-174, 406-512, Priority, Search	199.00
COBRA 200GTL	40ch, AM/SSB CB Radio	399.00	HX-1500 55ch, 29-54, 118-174, 406-512, Portable Unit	199.00
			Z-60 50ch, 30-50, 88-108, 118-174, 406-512mhz	134.99

USED GEAR → **28 PAGE 1989 DETAILED PICTURE CATALOG \$1.00** ← **BUY SELL TRADE**

AIR/POLICE/800 MHz

FREE CELLULAR MODIFICATIONS WITH BC-200 & BC-760!!

★★★★★★★★★★★★★★★★★★★★★★★★★★★★★★★★★★★★

tional, but after selecting the 30 percent range I did notice a difference in the tuning scope. Without a tuning scope you can't see any change even in the 30 percent mode.

Conclusion

If you are in the market for an RTTY all mode TU and you want the flexibility and features that will allow you to receive anything that you may encounter, (except encrypted data) this rig is for you. Just don't expect it to produce an error free printout. There isn't a rig in the world that can do that. ZCZC



The Grundig Satellit 650 Receiver



In the world of automobiles, you can choose not only between affordable family models, such as Fords and Volkswagens, and high-performance sports cars, such as Ferraris and Porsches. You can also choose from a wide range of luxury cars -- BMW's, Lincolns, Volvos and the like -- that are comfortable and practical, yet handle well.

But with world band radios, the choice has nearly always been between ordinary portables, on one hand, and costly tabletops, on the other. These portables are fine for listening to programs from the major stations around the globe, while tabletops excel in snaring DX catches: faint, hard-to-hear signals from afar. The big surprise is that these costly tabletops often sound worse than some of the better portables for listening to the stronger international stations.

In short, there are practical models for day-to-day listening, and DX-type "sports" models. But there's a yawning chasm in between for the program listener looking for luxury and aural pleasure, rather than rare DX.

High Quality Program Reception

Enter the West German firm of Grundig, with its pricey Satellit 650 model.

The Satellit 650, which lists at \$1,149 but usually sells for just under \$1,000, is the top of Grundig's world band line. At this price, it's hardly a major seller. In fact, Grundig sells

more than eight of its lesser portables for every '650 it produces.

Wide Variety of Features

Made in Portugal, the '650 weighs in at a beefy 20 pounds -- although it's still nominally a "portable." Its tuning system is synthesized, which aids stability and allows for both keypad tuning and no less than 60 programmable channel memories, 32 of which are for shortwave. Large LCD characters, which provide frequency readings to the nearest kHz, are easy to see, even if your eyesight isn't what it used to be.

The tuning knob uses variable-rate incremental tuning (VRIT) circuitry; the faster you turn it, the more quickly the stations sail by. On the face of it, this should add to the convenience of tuning. In reality, it can be more of a pain than a plus, as "high gear" can kick in unexpectedly if you're not careful. Whether you like VRIT probably comes down to a question of taste.

Other features include a digital clock, which reads out actual seconds and uses the 24-hour format appropriate to UTC. The seconds readout is useful as an aid in identifying unknown stations, inasmuch as station ID's are brief and almost invariably appear smack on the hour or half hour.

A programmable timer, less sophisticated than those of some tabletop models, has up to three straightforward on/off cycles per day

and can turn your tape recorder on and off at the same time, *a la* a VCR. A real analog signal-strength meter -- not just some LED's -- is used, and the dual-voltage ac power supply allows the '650 to work off household current in nearly any part of the world.

Motorized Preselector for Front-End Selectivity

What the '650 has that you don't find in just about any other modern receiver is a motorized self-tracking preselector. This commendable design feature harkens back to top-end communications receivers of the Fifties. However, given recent improvements in circuitry design, it makes little sense today.

Although it's a worthy principle, unlike more modern alternatives it adds to the receiver's cost and mechanical complexity. It also makes tuning more complicated (it's supposed to be fully automatic, but in practice it often needs to be fine tuned manually for best performance).

Sensitivity Slightly Compromised by Blocking

Shortwave sensitivity, using either the built-in telescopic antenna or an external antenna, measures in *Passport's* lab tests as being quite good. In part, sensitivity with the telescopic antenna is superior simply because that antenna is unusually lengthy. It's also sturdy and well made -- a far cry from the flimsy rods found on most Asian-made models.

Offsetting sensitivity to small extent is the '650's poor blocking performance, by tabletop standards, as measured in our lab. Sub-standard blocking performance allows hairy-chested signals on nearby channels to desensitize the receiver. This can sometimes be a drawback, but usually only when you're trying to dig out weak stations within such congested world band segments as 49 meters (6 MHz) at night.

Three Bandwidths...Sort of

Most portables come with only one bandwidth, or two at best. However, if you look at the '650's front panel, you will see that it has no less than *three* selectivity positions -- a real plus. However, as we found while plumbing our way through the set's circuitry, the '650 has only two genuine IF bandwidths: 3.0 (narrow) and 5.5 (wide) kHz, both of which

we measure as having only fair-to-good shape factors. The intermediate position consists, instead, merely of the wide 5.5 kHz bandwidth "narrowed" by an audio filter.

Nevertheless, that intermediate position can be of some use, thus making the '650's "sort-of-three-position" selectivity somewhat more flexible than that of other portables.

Good SSB, but no Synchronous Detection

Single-sideband reception is reasonably good, although the '650 doesn't perform well in the exalted-carrier selectable-sideband ("ECSS") mode. Too, there's no interference-rejecting synchronous detection, a state-of-the-art feature found on very few models; notably, the less costly Sony ICF-2010 and ICF-2001D.

Mediocre, but Adequate, Dynamic Range

Passport's unusually stringent lab measurements show the '650's dynamic range to be mediocre. Designers of world band portables usually must compromise on dynamic range in order to make use of semiconductors having low power consumption, which is important if battery drain is to be kept within reasonable limits. But in this regard, pessimists may view the '650 as having the worst of both worlds -- mediocre dynamic range, coupled with a heftiness that removes it from true portability. Optimists, on the other hand, may tend to see the '650 as having most of the plusses of a portable, along with many of the attributes of a high-performance tabletop.

All this having been said, if you're using the set's telescopic antenna and fine tune the preselector carefully, the '650's dynamic range and front-end selectivity should be sufficient to avoid "overloading" and similar "ghost signal" effects under nearly all circumstances. Even with many types of outdoor antennas, results should be satisfactory for listening within North America.

Superior Audio Quality and FM Reception

Grundig has a long history of making world band radios with superior FM performance, and the '650 is no exception. Another and even more important characteristic of Grundig radios is superior audio quality. Here, too, the '650 stands tall. Its audio quality is superior to that of any other world band receiver we have tested.

Helping this along are separate bass and treble tone controls -- a very useful feature that is rarely found among world band radios. Even a tweeter switch is provided to help control audio highs by controlling the '650's special high-frequency speaker. The '650's sound thus is tonic to ears made weary of the distortion and clipped audio found on so many other models of world band radios.

Above Average Reliability

On the face of it, the mechanically complex '650, which comes in a plastic cabinet, would seem to be more trouble-prone than most other world band models. And, indeed, a sample we tested arrived with a plastic chassis clip broken during shipment. However, a major Grundig dealer, Universal Shortwave, tells *Passport to World Band Radio* that in reality Grundig products, including the '650, have had a superior track record of reliability.

The Bottom Line

Super Sony SWL Sale !

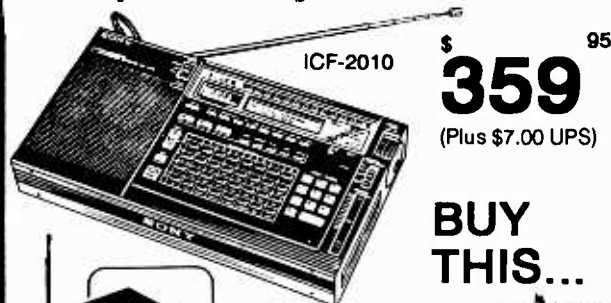

ICF-2010

\$ ⁹⁵
359
(Plus \$7.00 UPS)

BUY THIS...

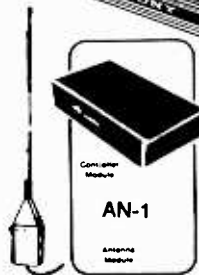

GET THIS FREE!



For a limited time while supplies last, you can buy the world-famous Sony ICF-2010 SWL Receiver for \$359.95 and get a FREE Sony AN-1 remote active antenna! Please add \$7.00 for shipping and handling and 7% tax if you live in Illinois, or 6% sales tax if you live in WI, IA, MN, MI, IN, OH, or KS.

— CALL (312) 848-6777



SPECTRONICS, INC
(312)848-6777 1009 GARFIELD ST
OAK PARK, ILL. 60304



Any time a receiver is designed to function as a portable there will be performance tradeoffs in order to keep battery consumption within reasonable limits. The '650 is no exception, and overall it performs right up there with the best portables on the market. Its only notable drawback is the lack of synchronous detection.

For pleasant listening to foreign stations, the '650 is hard to beat simply because it sounds so good. It functions nicely as a self-contained field portable, and it also works well as a *de facto* tabletop unit for day-to-day listening. This set is unique in its price range precisely because it is meant to be not so much a DXing set as a luxury model for pleasant listening to world band programs. Too, it's not likely to become dated any time soon, inasmuch as Grundig has no plans to supersede it, except cosmetically, any time in the foreseeable future.



Passport's "RDI White Paper" equipment reports contain everything -- laboratory measurements, "hands-on" panel findings and user comments -- found during *Passport's* tests of communications receivers and advanced portables. RDI White Papers are available in the US from EEB and Universal Shortwave; in Canada from PIF Book-by-Mall, C.P. 232, L.d.R., Laval PQ H7N 4Z9; and in Europe from Interbooks, Stanley, Perth PH1 4QQ, Scotland, and the Swedish DX Federation.

A free catalogue of the latest editions of these reports may be obtained by sending a self-addressed stamped envelope these firms or to Publications Manager, International Broadcasting Services, Ltd., Box 300M, Penn's Park PA 18943 USA.

You can hear Larry Magne's equipment reviews the first Saturday of each month, plus *PASSPORT* editors Don Jensen and Tony Jones the third Saturday, over Radio Canada International's SWL Digest. For North America, it is heard at 8:10 PM EST on 5960, 9535, 9755, 11845 and 11940 kHz, with a repeat the following Tuesday at 8:30 AM EST on 9625, 11855 and 17820 kHz.

The Kenwood RZ-1 Wideband Scanning Receiver



The most recent entry to the ever-expanding line of wideband scanning receivers is by the Kenwood Corporation, known throughout the world for its fine amateur radio equipment. Designed mainly for mobile applications (it's just 7"x2"x6.9"), the RZ-1 does duty as both a VHF/UHF scanner and shortwave receiver: frequency coverage is continuous from 500 kHz to 905 MHz.

Feet In Both Worlds

Unfortunately, with a scan rate of a miserable four channels per second, it fails to make the grade as a scanner. Lacking sideband or CW capabilities, it flunks out as a shortwave receiver. The RZ-1 is, simply put, neither scanner nor shortwave receiver in the truest sense of the word. In order to dip into both worlds, Kenwood had to make some sacrifices and the sacrifices were major ones, hobbling a radio that could otherwise be a real gem.

What features the RZ-1 does have are useful, though, and do function well.

For example, the controls, although a bit crowded, are laid out well and backlit for nighttime use. The large, face-mounted tuning knob allows for great versatility when manually fine tuning those elusive signals or, when one desires to "zero-in" on a small portion of a given band without inadvertently "jumping over" active signals using the "scan" or "search" features. Squelch action, too, is good and quite sensitive. The receiver's audio is crisp, clear, and loud.

Selectable AM, FM, plus FM narrow modes, as well as selectable frequency steps (5, 12.5, 20, 25 kHz) allow the correct mode/step for all bands covered by the RZ-1 (except for the lack of LSB, USB, and a BFO on SW bands). In addition, an "automatic selection" mode allows the radio to select the proper step spacing for the appropriate band in use.

Tricky Programming

Programming the radio's 100 channel memory and its search feature is tricky and quite a bit more involved than your trusty Bearcat 210.

All entry of frequency information and so forth is via a numerical keypad beneath the frequency readout. With a bit of practice, it can be done. But it takes a while to fill all 100 channels. And, although the radio does have a search feature, you must "tie up" two of the programmable channels for "upper" and "lower" search limits, not to mention the difficult programming sequence needed to utilize this function.

But the search speed is a respectable 12 channel/second (approx.) and does not suffer the snail's pace scan time of the RZ-1's memory scanning feature.

Types of Scanning

The user can select one of several scan "types" via a button on the radio's face. For example, you may select a carrier-operated scan (no delay and instant scan resume when the carrier drops, like a normal scanner), a "seek" scan (where the receiver halts on voice signals and does not resume scanning until the user restarts it by physically pressing the "scan" button each time), or a "timed" scan (where the radio remains on an active channel six seconds and resumes scanning after that time whether or not the radio transmission is completed).

Although useless on VHF/UHF scanning, this last feature is useful for checking out continuous carrier shortwave channels by allowing the user to sample band activity without manually re-starting the search or scan feature each time a signal is found.

The Unusual Features

Designed basically for a mobile environment, the RZ-1 also has the ability to reproduce stereo signals on the FM broadcast band. In order to take advantage of this feature, you have to bypass the receiver's single top-mounted speaker via an internal jumper. You must provide your own stereo amplifier and speakers to utilize it, however. Stereo

amplification is not built in. It's a nice thought even if it is a real pain to do.

The white (yes, white) fluorescent display is likely the best to date on any current receiver, and is clearly visible in all lighting conditions. All radio functions have respective visual symbols (indicators) which light as each function is enabled.

Another nifty but unusual feature of the RZ-1 is its video output jack. Plug in a composite monitor and you can receive TV pictures (on the monitor) and TV audio (through the RZ-1's speaker). Add an external audio amplifier and speakers and this little Kenwood radio becomes a mini-entertainment system, albeit a rather expensive one when you consider that you could buy a good color TV for half the price of the radio alone.

The most unusual feature -- and perhaps the most helpful and refreshing -- of the RZ-1 is its programmable alpha-numeric display which allows the user to input a seven-digit (or less) word or number of his choosing into each of the unit's 100 memory channels in addition to the regular frequency display. Punch 5975 kHz into the Kenwood's memory and you can label it as the BBC for quick, visual reference. Whatever is entered into the memory can be recalled with the push of a button.

In addition, a bar graph-type signal strength meter is provided. But, as there are no numerical indicators or graduated markings indicating "S" units, one can only compare the number of lit segments on one signal as opposed to another and must still guess as to the actual "value" or strength of those signals.

Through Its Paces

Despite everything else, the RZ-1 is a decent performer. It receives well, is quite sensitive, and on the shortwave bands, compared favorably to a Kenwood R-2000 Kenwood shortwave receiver. It did a respectable job with solid, readable signals on all bands. Sensitivity was good and the RZ-1 appears to be very capable of satisfying the needs of most shortwave listeners on "non-SSB" stations.

On the VHF and UHF "scanner bands,"



MERRIMACK
VALLEY
COMMUNICATIONS

AOR SCANNERS/HANDHELD
AR 900 100ch w/800mhz \$260
AR 800 20ch w/800mhz \$230
AOR MOBILE SCANNER
AR 160 w/16ch MEMORY \$170
AOR BASE SCANNER
AR 2002 loaded, scans
25-550 800-1300mhz \$455

SHORTWAVE RADIOS CALL

10 METER MOBILE TX/RX
UNIDEN HR-2510 \$265
RANGER 3500 30 WATT \$370
RANGER 3500 100 WATT \$465
RANGER 100 WATTw/OPT. \$545

WE PAY SHIPPING ON ALL
UNITS UPS C.O.D.
MON-FRI 6:00PM 10:30PM
SAT-SUN 8:00AM 12 NOON

CALL TODAY (603)529-1957
WEARE, NH 03281

Feeling Left Out?



Super Converter™ 8001

Have your favorite communications (Police, Fire, etc) moved to the 800 MHz band? Are the scanners available which access this band too expensive? If you are like many scanning enthusiasts, this can be a real dilemma.

*Introducing the **Super Converter™ 8001** from **GRE America, Inc.** The **Super Converter™ 8001** once attached allows any UHF scanning or monitoring receiver to receive the 810 to 912 MHz band.*

For more information or a dealer near you please contact:

GRE GRE America, Inc.

GRE America, inc.
425 Harbor Blvd.
Belmont, California 94002

Telephone (415) 591-1400
Outside CA: (800) 233-5973
Telex: GRE BLMT 17-2069
Fax: (415) 591-2001

reception ranged from very good to excellent overall, but the slow scanning speed is both frustrating (and inappropriate) for a receiver with this number of channels to scan through. Stations from 40 miles and farther were captured with ease, and even 800 MHz reception was slightly above average, compared to a "reference" BC-800 XLT scanner.

Things to Consider

The RZ-1 is an extremely versatile multi-talented radio with a *lot* of features for its price (\$500 to \$600). However, even with all these features, you should first take a look at what it is you really listen to the most and perhaps consider a dedicated receiver or scanner for those bands. Or, perhaps, *two* dedicated receivers: one shortwave and a scanner.

For shortwave listeners, the lack of a BFO and USB/LSB/CW capabilities is disastrous (save for those who listen to the major broadcasters only) and an equivalent SW receiver with those capabilities would appear a better, more logical choice.

For scanner buffs, the awkward programming

and lack of a reasonable scanning speed are severe drawbacks, and make the RZ-1 a better single-channel, tunable monitor (with memories) than a true scanner. A Bearcat, Icom, Regency, or Realistic brand scanner would be a better choice inevitably, for scanning capabilities.

In a mobile environment (for which it was designed) this radio is somewhat difficult to use as it is almost impossible to program or activate functions while moving (including

searching functions and channel changing); it is not really "user-friendly."

Simpler programming, faster scanning, and SSB capabilities would make the RZ-1 a "super scanner" in every sense of the word. You might want to wait for an improved version (RZ-2 or 3??) to surface before buying this one. If you have a chance to try an RZ-1 before you buy it, by all means, do so. It may be your "dream radio." Most, however, will find it a curiosity and pass.



Working with Toroid Cores

What advantages, if any, are there when we wind our coils and transformers on ferrite or powdered-iron toroid cores? Are toroidal inductors and transformers more costly than other kinds of similar components? These are common questions that pop into the minds of experimenters who have never worked with toroids.

Today's technology dictates widespread use of magnetic core coils and transformers along with certain types of coils that are wound on ferrite rods. Many broadband transformers are contained on "binocular" or balun cores (see fig. 1), which differ in physical characteristics from doughnut-shaped toroids. Each style of magnetic core has its special application. We will address the questions asked earlier, and we will consider various magnetic cores and how to use them in experimental circuits.

Powdered Iron Versus Ferrite

Some experimenters are confused about the type of core to use for a particular circuit -- iron versus ferrite. Generally speaking, powdered-iron cores are best suited to narrow band RF circuits. A narrow-band circuit is one that has a high Q (quality factor) and is tuned to a particular frequency. Powdered iron cores are available for use into the VHF spectrum. Phenolic toroids are sometimes used in the upper part of the VHF range.

Ferrite cores are utilized mainly for low-Q broadband coils and transformers. I should qualify that remark by stating that some ferrites are suitable in narrow-band circuits

if the correct core mix (recipe) is used. Generally, though, ferrite cores are not used above, say, 10 MHz for narrow-band circuits.

An example of a narrow-band circuit is a coil and capacitor combination that is tuned to an oscillator frequency, such as 100 kHz or 10 MHz. On the other hand, we may find a broadband RF transformer used as an antenna balun or matching transformer between a solid-state RF amplifier and an antenna or filter network. A broadband transformer is not tuned to a special frequency. Fig. 2 shows two typical applications.

Other Core Differences

Magnetic cores, irrespective of their shapes, have a specific permeability rating or factor, which is true also of laminated transformer cores (audio and power transformers). The greater the specified permeability, the higher the coil inductance per number of turns.

To illustrate this principle let's consider a toroid or rod core that has an effective permeability (μ_e) of 10. We may need to wind 25 turns of wire on this core to obtain an inductance of 4 μ H (microhenries). If we take a core of identical size, but with a μ_e of 50, we might need only 10 turns of wire to obtain the desired 4 μ H of inductance.

There is a tradeoff here: the higher the permeability, the lower the optimum operating frequency, respective to Q. This is true of ferrite and powdered-iron cores.

In any event, a coil that is wound on a suitable magnetic core is physically smaller than an equivalent coil that is air wound, and by quite a margin! This is beneficial when we want to construct compact electronics equipment.

Core Saturation

You have heard of cores that become damaged or hot from saturation. All magnetic cores have a power limit that relates to core saturation. The actual saturation point is dependent upon the number of turns in the winding, the developed voltage, the cross-sectional area of the core and the current flowing through the windings.

Equations exist for calculating the flux density in gauss with relation to the factors I just mentioned. These formulas may be found in the *ARRL Handbook* and in my book, *Ferromagnetic Core Design and Applications Handbook* (Prentice Hall, Inc.). Therefore, I shall not burden you with them in this article. The flux density tells you how much power a core can accommodate before it saturates.

The effects of core saturation are many. First, the μ_e will change markedly, and this lowers the coil inductance. In a worst-case situation, the core can become very hot. Ferrite may actually shatter, and if it doesn't, the core permeability may change permanently. Powdered-iron cores do not shatter and they have the ability to recover upon cooling, thereby regaining their rated permeability.

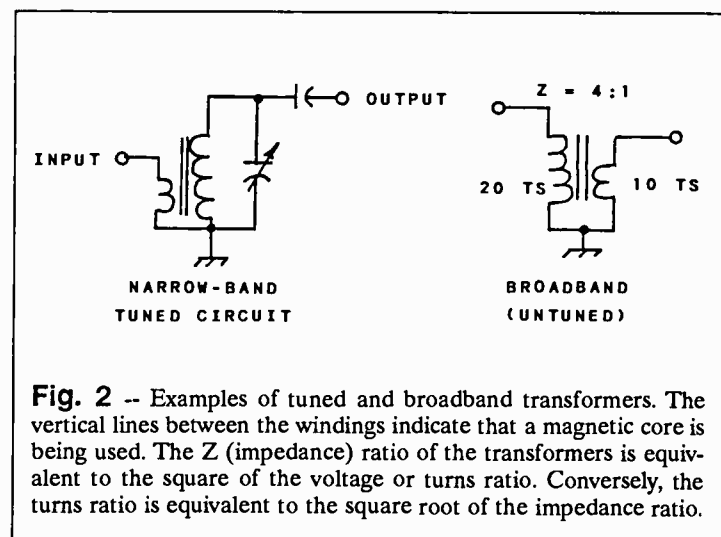
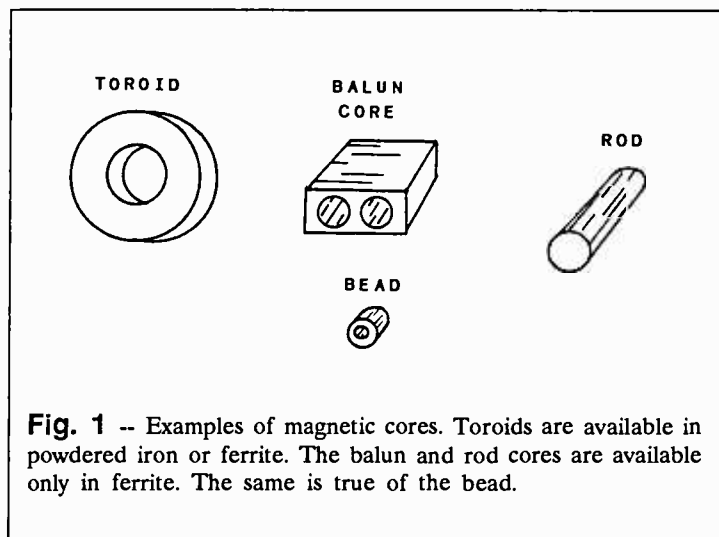

A good rule of thumb is to use as large a core as practicable if you are uncertain about the power the core must handle. In any event, it should not become hot during operation.

Another unacceptable by-product of core saturation is the generation of unwanted harmonic currents. A clean RF or audio signal that is fed into a tuned circuit or transformer which is underrated in terms of power will change a sine wave to a square wave. A square wave is rich in harmonic energy. In audio circuits this causes distortion. In RF circuits it can cause interference to FM radios, TV sets and other VHF receivers, especially if a transmitting antenna contains a saturated balun transformer.

Magnetic-Core Advantages

A toroidal inductor or transformer has a self-shielding characteristic. This means that we do not need to place a metal shield can around the assembly to prevent it from coupling to some other coil or circuit component. This helps to reduce the cost and size of our project. This is not true of coils that are wound on rod cores, such as ferrite-core miniature RF chokes.

It is possible to obtain very high values of circuit Q when using even small toroid cores. This is especially desirable in narrow-band tuned circuits, such as those in low-power tank coils and filters. You should use the largest wire gauge practicable (consistent with winding ease and available core space) in the interest of Q when winding toroids for narrow-band circuits.

Cost Considerations

You may feel that a fifty cent toroid core is more expensive than an air-wound equivalent coil on a coil form, or an inductor that is wound on a slug-tuned coil form. The latter type of coil does eliminate the need for a trimmer capacitor (slug is adjustable), but new slug-tuned coil forms and prewound slug forms are very costly -- usually three dollars or more each!

A toroidal inductor and a trimmer capacitor cost less than most alternative coils, plus their fixed-value and trimmer capacitors. A catalog of toroids and other magnetic cores, plus price list and technical data, is available from Amidon Assoc., Inc.¹

Ferrite Beads

Ferrite and powdered-iron cores have what is known as the A_L factor. This relates to

the type of core material and its size with relation to the number of coil turns required for a given value of inductance.

By way of an example, let's suppose we need a toroidal coil that has an inductance of 8 uH. We have selected a core that will offer good performance at the frequency of operation. We check the Amidon Assoc. catalog chart and find that our core has an A_L of 55. We cannot learn the number of turns needed: --- $N = \text{square root of } L (\text{uH}) / A_L \times 100$; thus $N = \text{square root of } 8 / 55 \times 100 = 38$ turns where N is the unknown number of turns.

The Amidon catalog also lists various core sizes versus the maximum wire gauge for a given number of turns. This helps us to choose the correct magnet wire for the job.

Core Nomenclature

If you read articles in *QST*, *CQ* and *Ham Radio*, you are probably confused by the many designators for core material. For example, the parts list may specify a T68-6 toroid core. This is a powdered-iron toroid that has an OF of 0.68 inch. The number 6 at the end of the number identifies the characteristics (mix) of the core. Thus, a T25-2 core has a 1/4 inch OD and the mix is different from the number 6 material.

Ferrite toroids have an FT (ferrite toroid) prefix. An FT-37-43 toroid, for example, has an OD of 0.37 inch. The suffix number (43) indicates the μ_e of the core, which in this case is 850. Most powdered-iron toroids are color-coded, whereas the ferrite cores are not.

It is important to keep our ferrite cores separated when they are of various mixes! You may color code them with spray paint to prevent confusion.

How to Handle Magnetic Cores

Both type of cores break easily when stressed or dropped on a hard surface. Ferrite is the worst, owing to its brittle (ceramic) makeup. A broken ferrite rod or core may be glued together with epoxy cement, and it will work OK. This is not recommended for broken powdered-iron cores.

Most powdered-iron cores are tumbled at the factory to ensure smooth edges. Ferrites are seldom tumbled. Beware of the sharp edges when applying the winding, because the edges can remove the enamel insulation from the wire. This leads to shorted coil turns (destruction of the circuit Q).

Your Longwave Source... LF Engineering Co.

L-101B VLF Converter.....\$49.00
L-201 VLF Preamplifier.....\$49.00
L-400B LF Active Antenna.....\$98.00
L-101S LF Rec. System.....\$129.00
TM-1 LF Xmtr, 1 Watt.....\$98.00
(all products shipped postage paid)

Send for our free catalog

LF Engineering Co. Inc.
17 Jeffrey Road, Dept. MT
East Haven, CT 06513
(203) 248-6816

VISA and
MasterCard
accepted

Also, the bare wire will rest against the ferrite core to create unwanted losses: ferrite is a semiconductor. It is wise to wrap ferrite cores with thin insulating tape before applying the windings. This helps to prevent damage to the wire insulation.

Inductance Adjustment

You have some control over the effective inductance of a rod or toroidal coil. Compressing the turns increases the inductance, whereas spreading the turns decreases the inductance. Once you tweak the coil for circuit resonance, coat it with low loss cement to maintain the position of the turns.

Transformers on Toroids

The same rules for transformer design apply whether we're using rods, toroids or I-E iron laminations. Specifically, the formulas for the turns or impedance ratios are the same.

The important considerations are that the core has ample cross-sectional area to handle the power, and that the core μ_e is great enough to ensure ample inductance in the windings, versus operating frequency. This is fully detailed in my ferrite core handbook that was mentioned earlier. The turns or impedance ratio applies to both narrow-and wide band transformers.

Final Comments

I have given you a brief rundown on toroids and their use. Perhaps this will encourage you to use them in your circuits. If you are already a user of toroids, this article may help you to better understand some of their characteristics.

Footnote

¹ Amidon Assoc., Inc., 12033 Otsego St., N. Hollywood, CA 91607. Catalog and prices available for by-mail sales.

A Highly Sensitive Field Strength Meter Using Readily Available Components

by Bob West and Bill Wallace

One of the most commonly occurring tasks in the Civil Air Patrol and to a certain extent in the Coast Guard Auxiliary is the locating of ELT's (Emergency Locator Transmitters) and/or EPIRB's (Emergency Position Indicating Radio Beacons).

The Search and Rescue Satellite System can detect these transmitters amazingly well and give an approximate location. But accuracy is only "city or county wide." A ground party or search aircraft can usually narrow the area down to a football field sized area but from that point on location can become a problem.

The unit illustrated in Fig. 1 has proved to be a top-notch performer for close-up work that is still beyond the range of a Grid Dipper or analog Field Strength Meter. Using this setup, the authors have detected a 450 MHz, 100 watt ERP commercial transmitter at a distance of 1200 feet. A five watt handheld on 150 MHz can be detected at approximately 200 to 250 feet. Fluorescent light noise and TV screen radiation is easily detected when the unit is held close to the source. An ELT/EPIRB can easily be read across a room.

The authors were not totally satisfied with performance so, the circuit in figure two was tried. The readings more than doubled in most cases.

If you know what frequency you are looking for, tune the antenna by adjusting the length to one half wavelength. If you don't know

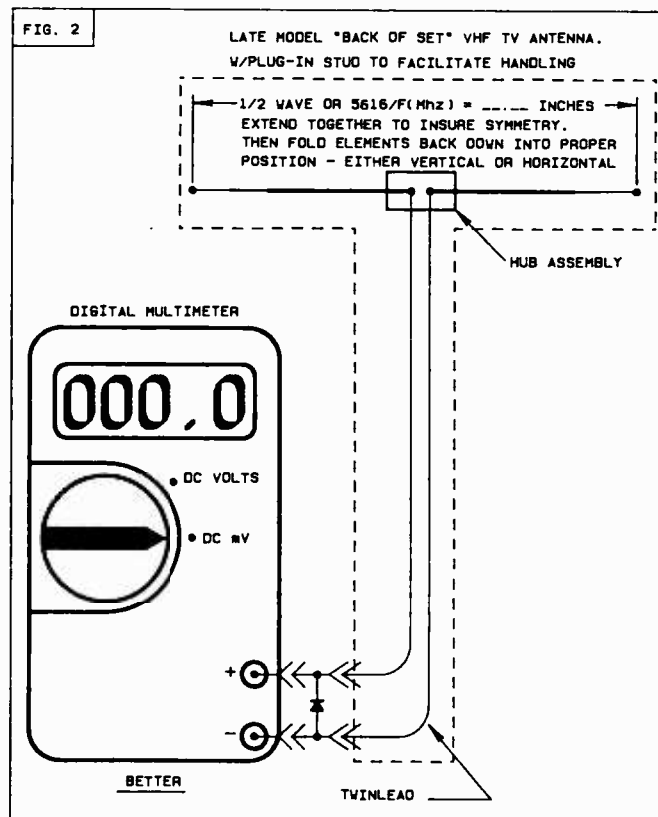
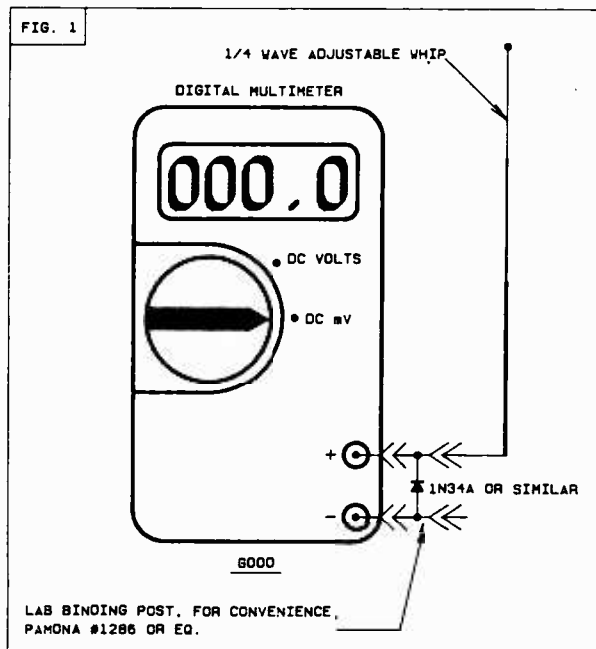

the frequency, just extend the antenna to maximum practical length until detection is achieved. Then maximize the reading by adjusting antenna length.

Use an autoranging meter if one is available because strong signals can produce readings as high as 30 volts.

Diode performance varies, so experiment with several diodes and use the most sensitive.

The circuit of figure three offers a slight improvement over the others. If ferrite beads are placed at the base of the antenna the twinlead feedline can be replaced with a tougher wire.

Installing the Grove 1/8-wave loop in place of the dipole makes for a very compact narrow bandwidth unit for checking in real close (such as car trunks, UPS trucks, pickup toolboxes and wall lockers). Yes, the authors have had cases involving all of the above!



“Now Available!”

The First Annual

CQ Amateur Radio Equipment Buyers Guide

The Active Ham's Complete Annual Reference Master

This valuable new master directory and buyer's guide will serve you day in and day out in searching out new gear, comparing new models, locating dealers near you and mail-order retailers around the country. It'll help you buy more wisely with its multi-reference concept to help you wend your way through the buying maze.

COMPLETE PRODUCT INFORMATION

It's a single-volume source book of the latest Amateur Radio gear all sectionalized by equipment type for easy reference by the seasoned editorial staff of CQ:

- Complete product descriptions.
- Technical specifications.
- Retail prices.
- Equipment photographs.

WHO'S WHO IN THE AMATEUR RADIO BUSINESS

It's a Buyer's Guide filled with the kind of support information you've always needed, but couldn't easily get: Dealer listings state-by-state (including branches), names and calls for key personnel, top lines carried, whether or not trade-ins are accepted or on-site repairs are made . . . and so on.

BUYING TIPS FROM THE EXPERTS

Great articles on the in's and out's of purchasing Amateur equipment. The experts give you the inside scoop on everything from

antennas to transceivers to making your first packet contact . . . and lots more.

ORDER YOUR BUYER'S GUIDE TODAY!

Don't miss the single most valuable buying guide in the Amateur Radio field. Send only \$3.95 today.

YES, please send my copy of AMATEUR RADIO BUYER'S GUIDE 1989 for only \$3.95 postage paid.

Date _____ Number of Copies _____

Name _____ Call _____

Address _____

City _____ State _____ Zip _____

Check MasterCard VISA

Card No. _____ Expires _____

Signature _____

(Signature required on all charge orders)

Mail to: CQ Communications, Inc.

76 North Broadway, Hicksville, NY 11801

MT

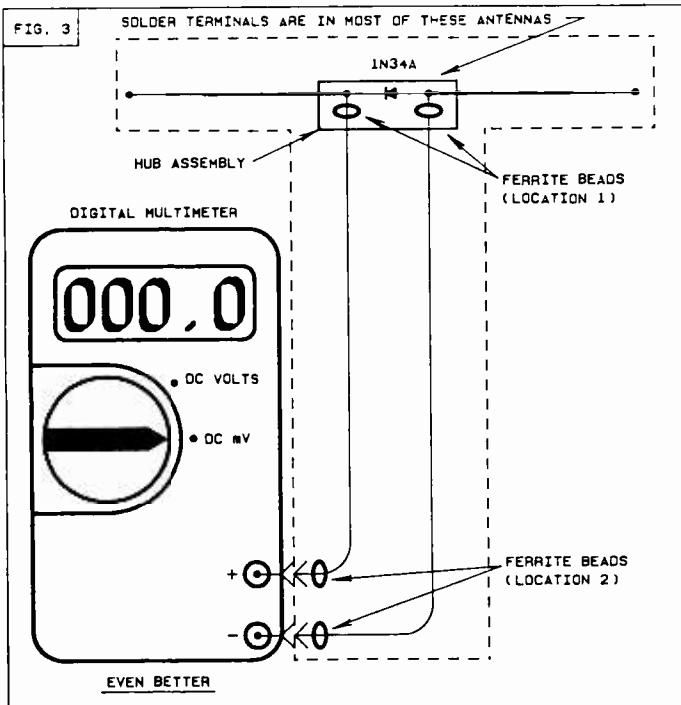

Monitoring Times invites you to submit your favorite projects for publication. For more information, contact technical editor Ike Kerschner at RD 1, Box 181A, Kunkletown, PA 18085.

Bob West is a division communications officer in the Coast Guard Auxiliary. Bill Wallace is a pilot with the Civil Air Patrol. Both have dual membership and are constantly experimenting with various types of Radio Direction Finders and methods of utilization. They have been referred to, on occasion; as "Fatman & Robin," "The A-Team" as well as "Those Damfools." Together they have saved eight lives over the past decade.

Projects for Experimenter's Workshop, while reviewed by our Technical Editor, are submitted by readers and remain experimental.

The Passing of an Era

With a 90-minute program of nostalgic reminiscence, NBC's flagship AM broadcast station, WNBC, slipped beneath the airwaves this fall, leaving not even an oil slick behind.

That station first came on the air in 1922 as station W2XY. Back then, in the early decades of this century, radio receivers were often just simple crystal sets. We've come a long way since those days — technology has evolved dramatically as it worked its way toward the present-day solid-state revolution. But what about the antenna technology used for the AM broadcasting stations such as WNBC? How much has that changed from the early days 'til now?

Actually, there have been only two major generations of development in the antennas utilized by AM radio broadcasters in this century. Early-day AM broadcast antennas were mostly of the "flat-top" variety, where a lead was run from the transmitter location up to a set of wires strung high and parallel to the earth. One concept that those early workers held was to get a lot of wire up high in that flat-top, to provide as much capacitance to earth as possible. This was done so that the antenna system could be resonated to the longer wavelengths used in those days.

New Antennas Possible

As time went on, technology improved, allowing radio broadcasting to move higher in frequency. The frequencies finally chosen for the broadcast band in the U.S.A. were such that practical full-length quarter wavelength vertical antennas became a possibility.

With a full quarter-wave antenna in the air, considerably greater efficiency in emitting the transmitted signals was possible. In addition, there was another reason to change to the newer antenna technology. This was that practical sized beams were now possible. With two or three vertical masts, a station could direct their signals to the geography where their potential listening audience was greatest.

WHY NOT BUILD YOUR OWN:

So let's take a look at how you could build yourself a grounded vertical antenna similar to the ones found in many nondirectional AM broadcast stations today. Then we'll consider the design of a more popular and easier to construct vertical antenna which is somewhat similar to the quarterwave vertical

in configuration.

Figure 1A shows the basic idea of a vertical antenna as used in AM broadcasting: a quarter-wavelength vertical element set close to the ground. The ground is then something of a reflector. To make a really good ground, a set of wires (called "radials") is buried beneath the antenna. The radials are formed into the shape of the spokes of a wheel which has the antenna base as its center. Burying these radials is a lot of trouble, and most of us don't want to put that much time into antenna installation. As a matter of fact, recent studies have shown that the radials may perform better if they are above and insulated from ground!

A design somewhat similar to the grounded vertical is the groundplane vertical antenna, shown in Figure 2B. In the groundplane design, there are radial wires under the vertical element, but they are not connected to ground. This allows you to mount the antenna far above ground, if you wish. Now, in this column I often repeat the old radio operator's antenna rule: "the higher the better." The rule is generally correct, so it makes sense to try the groundplane antenna, mounted as high as you can practically do it. It will quite likely increase your "communication quotient," as compared to the grounded vertical.

Both of the vertical antennas shown in Figure 1 give good nondirectional radiation patterns. As you probably know, that's usually a good pattern for all-around monitoring. These antennas also give some degree of low-angle

radiation, so that your signal is not all wasted in the skyward direction, but rather a decent amount of it moves out toward the horizon to give good local coverage on the band for which the antenna is designed. On the high frequency band, the low-angle radiation provides some good DX coverage too. As you can guess, many radio operators and monitoring enthusiasts find the groundplane antenna a useful one to have around.

Steps in Building the Antenna

a. Begin by cutting the vertical element and two to four radials. On VHF and UHF bands, rather short elements are used. These can be made of stiff wire or metal rod and will be self-supporting. Similarly, metal tubing can be used at the high end of the HF band to produce self-supporting elements. Such elements should be cut to the length given by the formula in Figure 1. On other wavelengths, usually the best choice for the elements is ordinary antenna wire. Make them about six inches longer than the quarter wavelength given by the formula in Figure 1. This allows for the extra wire needed to attach to the insulators and connector you will use.

b. Solder one end of the vertical element to the center connector of a coaxial cable socket (female) which fits your cable's plug.

c. Solder one end of each radial wire to a corner of the coax socket.

d. If you used nonself-supporting elements,

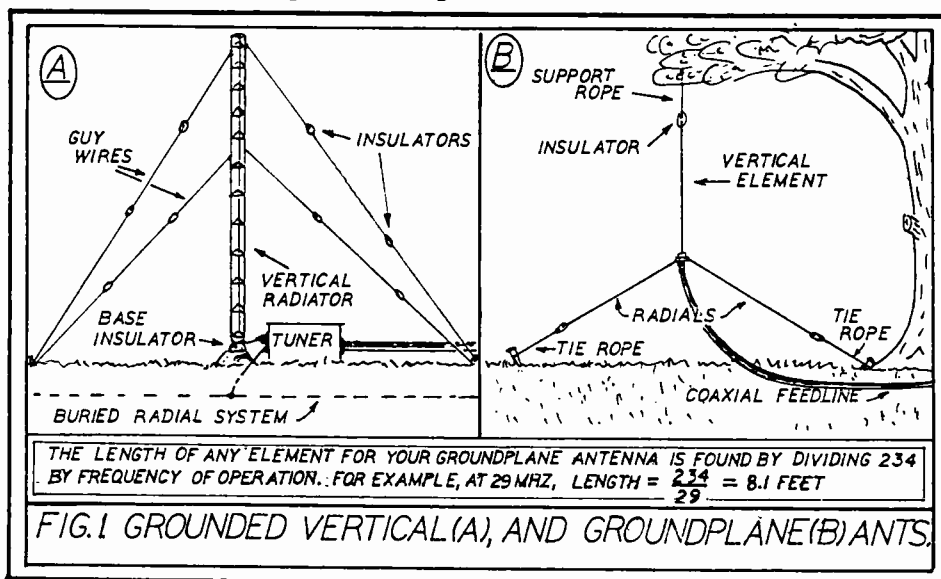

put end-insulators on each wire. Pull the wire through the insulator until the wire's length is the quarter-wavelength value as determined from Figure 1. Then wrap the free end of the wire back around the antenna wire near the insulator. Solder the wire where you just wrapped it, and cut off any excess wire.

e. Mount the antenna as shown in Figure 1. Attach the lead-in cable, and seal all around and front and back of the coax socket and plug with some good coax sealer. This is to keep moisture out. Fifty-two ohm coaxial cable is appropriate for your lead-in, but any good coax should work fine for receive-only applications. If you live in lightning country, don't forget lightning protection.

f. Connect the lead-in to your radio, and start monitoring!

This and That

I recently received two antennas from the Ant Farm to review for you readers. I was very pleased to see the obvious high-quality of these skywires, both in terms of construction practice and materials. I will soon have them up, and will give you a report on their performance.

RADIO RIDDLES:

Last Month: Last month I asked you if you could agree that, to some extent, almost every antenna can be said to be a "beam antenna"?

Well, what did you decide? I hope that it was "yes," because such is the case. Any antenna which favors one direction or orientation can be called a beam. And all practical antennas have some directions from which they receive better than others. The effect may not be great, but it is invariably there. Even a "nondirectional" antenna will have a lobe or so of maximum response in the vertical plane, with a "cone of silence" in the air directly above the antenna.

Only the "isotropic point-source in space" is truly nondirectional. And that antenna exists only in theory. For practical antennas, there's almost always some beam effect, even if it's very small.

This Month: George Brown, the inventor of the quarterwave vertical groundplane antenna has written that the groundplane needs only two radials to function properly. Why then do we always see that antenna with three or four radials? The answer, right here next month, will both amuse and surprise you.

That's it for now. So, til next time, Peace, DX, 73.



BIG BROTHER IS NOW!

IF YOU DON'T BELIEVE IN BIG BROTHER, READ NO FURTHER. IF SO, YOU SHOULD SEND FOR OUR FULLY ILLUSTRATED CATALOG OF PERSONAL PRIVACY PROTECTION PRODUCTS. YOUR NAME WILL NEVER BE SOLD OR GIVEN TO ANY DATA BASE. PRIVACY GUARANTEED!

FACTORY DISTRIBUTORS OF:

- NON-LETHAL WEAPONS
- DRUG TEST KITS
- HIDDEN WALL SAFES
- BULLET-PROOF VESTS
- CHEMICAL LIGHTSTICKS
- ELECTRONIC COUNTERMEASURES EQUIP.
- SPECIALTY TAPE RECORDERS
- PHONE SCRAMBLERS & RELATED EQUIP.
- ELECTRONIC INTELLIGENCE PLAN SETS
- UNUSUAL & CONTROVERSIAL PUBLICATIONS

• TOO MUCH TO LIST HERE •

SEND \$3.00 FOR HI-TECH EQUIPMENT CATALOG (REFUNDABLE 1st ORDER)

ADVANCED ELECTRONIC TECHNOLOGIES

SUITE 173M 5800-A N. SHARON AMITY RD., CHARLOTTE, N.C. 28215
DEALERS WANTED; INQUIRE, 704-534-2258

GUIDE TO UTILITY STATIONS 1989 (7th edition)

including GUIDE TO RADIOTELETYPE STATIONS (15th edition)

500 pages. \$ 34.- or DM 60.- ISBN 3-924509-89-1

The fully revised new edition is the only publication in the world which considers the very latest technical developments like those made in the code-cracking field. Hundreds of frequencies of ARQ-E, ARQ-E3, ARQ-M, AUTOSPEC, FEC-A, SI-ARQ and SWED-ARQ teleprinter stations are listed, as well as the results of our 1988 monitoring missions to Guadeloupe|Martinique and to Malaysia|Sarawak|Singapore. A detailed introduction to the monitoring of utility stations completes our bestseller.

This unique manual covers the complete shortwave range from 3 to 30 MHz, plus the adjacent frequency bands from 0 to 150 kHz and from 1.6 to 3 MHz. Contrary to imitative publications it is built on real-time monitoring throughout the year around the clock. It includes details on all types of utility stations including facsimile, morse, phone and teleprinter stations, the latter covering the entire spectrum from standard RTTY over SITOR to all those fascinating new ARQ, FDM, FEC, TDM and VFT systems.

The numerical frequency list covers 16280 frequencies of stations which have been monitored during 1988, thereof 35 % RTTY and 3 % FAX. Frequency, call sign, name of the station, ITU country symbol, types of modulation and corresponding return frequency, or times of reception and details, are listed. The alphabetical call sign list covers 3014 call signs, with name of the station, ITU country symbol, and corresponding frequencies.

82 RTTY press services are listed on 547 frequencies not only in the numerical frequency list, but also chronologically for easy access around the clock, and alphabetically in country order.

Additional alphabetical indices cover

- Schedules of 70 meteorological FAX stations on 271 frequencies.
- 73 meteo RTTY stations on 231 frequencies. 518 kHz NAVTEX schedule.
- 924 name and traffic abbreviations and signals. 182 telex service codes.
- 1000 utility station addresses in 200 countries.
- Radio Regulations on frequency and call sign allocations.
- Frequency band plans for the Aeronautical and Maritime Mobile Services.
- All Q-code and Z-code groups for civil and military use.
- Emission designations, classes of stations, and various other tables.

Further publications available are Guide to Facsimile Stations, Radioteletype Code Manual, Air and Meteo Code Manual, etc. For further information ask for our catalogue of publications on commercial telecommunication on shortwave, including recommendations from all over the world. All manuals are published in the handy 17 x 24 cm format, and of course written in English.

The price includes airmail to anywhere in the world. Payment can be by cash, cheque, or International Money Order. Dealer inquiries welcome - discount rates and pro forma invoices on request. Please mail your order to

Klingenfuss Publications

Hagenloher Str. 14

D-7400 Tuebingen

Fed. Rep. Germany

Q. While watching the Democratic National Convention on TV and listening to it on VOA (49M band) I noticed there was about a once second time lag. How come? (Allan Stranz, Crandon, WI)

A. Many VOA feeds are via satellite. Depending upon the number of uplink and downlink circuits, velocity delays in hardware circuits and distance between you and the transmitting station, it is quite likely that the better part of one second could seem delayed. Radio waves travel at the speed of light: 186,000 miles per second.

Q. What is the future of shortwave? Will satellites make SWling obsolete? Would I be foolish to spend \$800 on a good shortwave receiver if its use will gradually diminish? (Steve Boyd, Little Rock, AR)

A. Quite to the contrary. The military is undergoing a vigorous revitalization of their HF (high frequency—shortwave) facilities at the present time, and international broadcasters are constantly competing for more shortwave frequency outlets.

When satellite communications were just beginning, the usual overzealous prognosticators saw that medium taking over everything. Now reality has set in and shortwave, a proven medium, has shown itself to be more dependable and less expensive.

Q. Among the leading, top-of-the-line shortwave receivers (Kenwood R5000, ICOM R71A, JRC NRD525), which is the best? (Donald Michael Choleva, Euclid, OH)

A. While there might be some slight laboratory-measurable advantages of one over another, in actual fact, all three are excellent. The NRD525 offers the luxury of more optional filter positions, computer control, clock timer and record activator, and multiband VHF/UHF converter.

The R5000 and R71A are much different in appearance, but virtually identical in performance. The R5000 is newer than the R71A which has undergone several production improvements since its initial entry.

Look for the control flexibility you need rather than one working better than the other.

Q. The Grove catalog describes the Realistic PRO-2004 scanner as having "high sensitivity", yet MT has frequently mentioned poor sensitivity. Which is right? How can I get "high sensitivity" without buying a preamplifier? (Izak Luchinsky, Baltimore, MD)

A. While the sensitivity of the PRO-2004 is better than many early receivers, it is the least sensitive scanner presently on the

market. A call to a Radio Shack headquarters spokesman revealed that he had yet to receive the first letter of complaint regarding sensitivity on the PRO-2004. Grove customers, however, frequently point out the disparity between PRO-2004 sensitivity and that of competitive Regencies and Bearcats.

If you are considering the purchase of a scanner, the PRO-2004 is an excellent choice for large cities. Signals are generally stronger there, and the PRO-2004 is nearly invulnerable to intermod and image interference, even with an outside antenna. On the other hand, if you live out in the country, you should use a preamplifier and an outside antenna, or you should buy a different scanner.

Q. Bob Parnass, in an article in MT, says that you can lock out a Service Search channel on the BC950XLT scanner by simply pressing the lockout key while the scanner is stopped on the undesired channel. I have tried it, but it doesn't work on my scanner. How come?

A. The procedure works only on some Service Search banks like police and fire, but not all. We suspect that the same limitation holds for the BC760XLT, 580XLT and 600XLT.

Q. I note that many scanners with 800 Mhz coverage do not have 30 kHz channel separation as used by cellular systems. Does that mean that even those scanners which still include the cellular band will not tune those frequencies? (Charles Concannon, Wells, ME)

A. No, it means that some cellular frequencies will be heard distorted or not at all. Just as when you try tuning in a local police transmitter 5 kHz higher or lower than its assigned frequency, you can still copy it.

Q. Does Grove Enterprises still handle microfiche readers and FCC data base microfiche? (Chris Arniotis, NY, NY)

Two Simple Fixes

Sony and Mallory Don't Mix

A recent call from a Sony ICF2010 owner had us puzzled. He had purchased a brand new set of Mallory type AA Duracells for his microprocessor, yet his display faded out after a few days. Assuming he might have had bad batteries, he replaced them with another set. Sure enough, out went the display again!

Our resourceful reader phoned a friend who also had a 2010 and described the problem. His friend said, "I'll bet you are using Duracells!" It seems that the Mallory cells have incompatible dimensions with the ICF2010 holder. That is probably why the manual suggests using Eveready!

The BC200XLT Memory Failure

A few months ago we reported the factory fix on the popular BC200XLT hand-held scanner which reduces catastrophic memory loss when battery power runs low. Milan Chepko of Jackson, Mississippi, has some additional help for fellow Bearcat owners.

Milan had installed an appropriate filter capacitor, but noticed that the memory loss still occurred and, when he reopened the battery compartment, discovered that the capacitor had split open!

Milan suggests using a capacitance greater than 100 microfarads and a voltage rating greater than 16 VDC if space will permit it.

A. No. Contact Eye Communication Systems, Hartland, WI 53029 (phone 1-414-367-3080) for a dealer in your area who may carry their excellent, low cost model 1000.

For microfiche, contact the National Technical Information Service (NTIS), U.S. Department of Commerce, Springfield, VA 22161 (phone 1-703-487-4807) to determine the latest cost for the microfiche set of your choice.

Q. Other than producing annoying buzzing sounds on my shortwave receiver, how do "Touch and Glow" (TM) table lamps work? (Carroll Madison, Lake Worth, FL)

A. They house a "free running oscillator", a miniature transmitter. Your finger touching the metal frame (antenna) changes the loading (impedance matching), sensed as a change in voltage by the circuit. As you successively touch and remove your finger, an electronic switching circuit steps through its brightness positions.

Q. What are the frequencies used for the Airfone air-to-ground telephone system? (Joe Walker, Jackson, MS)

A. Still an experimental service, Airfone is licensed nationwide at dozens of cities on the following 190-kilohertz-wide frequency bands utilizing 6 kilohertz channel spacing: 944.204-944.394, 944.404-944.594, 944.604-944.794, 944.804-944.994, 945.004-945.194, 945.204-944.394, 945.404-945.594, 945.604-945.794 and 945.804-944.994 MHz.

Airfone is presently undergoing another frequency change to avoid conflicts with co-channel users in the land mobile services.

Q. Where can I get an audio amplifier to use my Grove SP100 speaker system with my Sony ICF2010 receiver? (Mark Goodson, State College, PA)

A. While the Sony ICF2010 deserves its reputation as the best all-round shortwave portable, it does lack the output power to drive the Grove SP100 Sound Enhancer speaker system at loud volumes levels.

Virtually any add-on amplifier should work fine. The Radio Shack 12-1869 speaker

booster amplifier (\$19.95) should work well, but requires a 12 volt power supply. It would be connected to the earphone jack with appropriate cable and plug. Their SA-150 (stock number 31-1955, \$59.95) works off 120 VAC and would be connected to the recorder output jack of the Sony.

Q. When I am monitoring high band (155 MHz) police calls on my Radio Shack PRO2003 scanners I frequently suffer interference from aircraft transmissions. Is this common on other scanners?

A. Very. All radio receivers have these phantom "images" from off-frequency signals, but design procedures like up-conversion reduce them considerably. In order to remain competitively priced, the vast majority of offshore-manufactured scanners are "copy-cat", re-utilizing common circuitry--including down-conversion, the real culprit in image interference.

Q. Where can I find a review of the now-discontinued Radio Shack DX400 portable shortwave radio? (Glenn Wilkerson, Seguin, TX)

A. The DX400 was private-labeled for Radio Shack by the manufacturer, Uniden, who sold it under their own label as the CR2021; that radio was reviewed several years ago in *MT* and in early issues of the *World Radio-TV Handbook* as well.

Reprints of *MT* articles are available for \$2 and an SASE.

Q. My Sony ICF2010 does not seem to be as sensitive on shortwave as other brands. I took it in for service, but was told it was all right. I read in *MT* that the RF amplifier gets disconnected when an external antenna is plugged in; could this condition exist if the antenna jack is not working properly? (Muhammad Algertas, Hackensack, NJ)

A. It sure could. The external antenna jack on the Sony ICF2010 is notorious for giving problems. Can you compare your radio side-by-side with another 2010? Can your service



Wideband Preamp 10-1000 MHz

Dual GasFet low noise preamplifier for HF, UHF or VHF systems. Just perfect for the R-7000. Excellent for Spec Analyzers, Scanners, etc. Gain 20 dB +/- 1 dB, -3 dB at 2 & 1100 MHz. 1 dB compression of >10 dBm. Intercept points >45 dBm. New shipped price of only \$124.94. Pa. residents please add 6% sales tax.

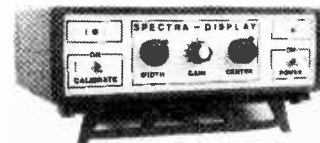

R-7000 Widespan Panadaptor

Panadaptor especially designed for the R-7000 receiver. For use with a standard scope. Variable span width from 1 to 10 MHz. Uncover unknown elusive signals. Complete with all cables, & 90 day warranty. \$349.95 shipped. Pa. res. add 6%.

GTI Electronics

RD 1 BOX 272
Leighton, Pa. 18235
717-386-4032

center perform a sensitivity check with a calibrated signal generator? Those two tests should lay the matter to rest.

In our November, 1988 column, we mentioned that an external speaker could not be connected to the earphone jack of the popular Sony ICF2010 receiver because the low power output could not drive the speaker. Now Doug Darius writes to tell us why, and how to cure it.

Apparently, there is a series limiting resistor connected to the headphone jack. Doug says that if that resistor is simply bypassed by a short piece of wire, full output will appear at the jack, allowing the use of an external speaker accessory like the new Grove SP100 Sound Enhancer.

Questions or suggestions sent to MT are printed in this column as space permits. If you prefer a reply by return mail, you must include a self-addressed, stamped envelope.

LETTERS

continued from page 3

What's your angle?

"Why are we shooting ourselves in the foot?" asks reader David Christner of Cortland, Ohio. Here we have a hobby threatened with censorship, and a cellular telephone industry trying to convince the FCC that all scanner listeners are criminals. And what did I see in your October issue but a book review touting how to 'Tune in to Telephone Calls.'"

"It's one thing to inform or discuss the pros and cons of listening to this or any other frequency range. But," says Christner, "to condone a book on listening to the 'really juicy stuff, without their knowledge,' is questionable. We all know what's going on out there, but do we need to flagrantly advertise it?"

Carroll Michaels of Long Beach, California, writes to say that he finds *MT* very useful and entertaining. "I congratulate you on publishing an excellent magazine of remarkable breadth of content and eclectic editorial perspective."

Thomas J. Calpin of Morrisville, Pennsylvania, on the other hand, feels that the magazine has a hidden political agenda. Says Mr. Calpin, "Despite your disclaimers, you are left-wing oriented." He cites five examples of things he claims we espouse in the pages of *Monitoring Times*. "1) The U.S. is always wrong. 2) The CIA spies on U.S. citizens. 3) Russia is great. 4) Cuba is great. 5. The Sandinistas are great. This," Mr. Calpin adds, "may be my last renewal."

Apparently reader Calpin wasn't around a couple of years ago when *MT* was scolded by readers who claimed we were fascists because we offered to help the FCC enforce legal use of the radio spectrum.

"You had an excellent November issue," says Howard H. Ragan of Cornelius, Oregon. "As an 'old timer' in the Ground Radio (30474) troop of the United States Air Force, you certainly brought back some memories."

"When I was on duty," he continues, "I was required to check the frequencies we used [and as a result]

did my share of VHF/UHF listening. And, of course, we always had an HF [shortwave] receiver around... Hang in there and keep those memories coming!"

Service or Disservice?

Brad Hayes, who, judging from the postmark on his letter, lives somewhere around Bridgeport, Connecticut, wants to talk about Uniden. And Brad is not happy. He's convinced that Uniden is "punishing" owners of Bearcat and Regency scanners with poor service.

"Bearcat owners know how Uniden's buyout hurt the Bearcat name. We had better, prompter service [before the buyout]. Now, if you order a relay from Uniden, you get a lamp socket -- even when you use their part number. Complain and your letter is ignored."

Well-known scanner expert Bob Parnass, AJ9S, has made similar comments about Uniden. In a letter published in *RCMA*, Parnass documents his problems with the manufacturer:

"June 12: I bought a brand new Uniden 760XLT scanner. On getting the scanner home, it was clear that the radio had memory problems.

"June 14: After speaking with Chris at Uniden customer service, I sent my new scanner to Uniden to fix under warranty, and was quoted a 15-20 day turnaround time.

"August 29: Over two months and several telephone calls later, I received a replacement scanner. It was also defective.

"September 1: Spoke with Judy at Uniden who asked me to send back the scanner and promised to send me a new one immediately upon receiving mine. I sent the radio back the next day.

"September 16: Received confirmation from Uniden that they got my scanner, but they won't ship another until October 6!

"If answering customer phone calls is any measure of service, then Uniden has a long way to go. When the line

isn't busy, I have counted up to 18-26 rings before it's answered or I give up. Twice, in vain, I asked to speak to a supervisor. Representatives Chris and Judy took my name and phone number, but my calls were never returned.

"To be fair, the representatives are usually courteous. But they were quick to promise and I learned not to believe what they said. Nobody there ever seemed willing to 'own up' to the problem."

That's bad news for Uniden owners, says Parnass. But it's OK, he says, because there's bad news for Uniden, too: "Radio Shack and AOR also sell scanners."

Laying it out for all to see...

Our good friend Gerry Dexter, who runs Tiare Publications, dropped us a note pointing out that one of his books got a big mention in a national magazine -- *Penthouse*. (Well, publicity is publicity.) The book is *Uno, Dos, Cuatro -- A Guide to the Numbers Stations* by former *MT* columnist Havana Moon. Says Gerry, "We think that coverage of this subject in a magazine with such huge circulation figures will create more interest in shortwave..."

If you'd like more information on the entire line of Tiare books, drop Gerry a line at P.O. Box 493, Lake Geneva, Wisconsin 53147. If you'd like more information on *Penthouse*, I, uh, seem to have lost their address.

Letters should be addressed to Letters to the Editor, Monitoring Times, P.O. Box 98, Brasstown, NC 28902 and should include the sender's address and telephone number. Not all letters can be used. Those that are will often be edited and excerpted. Because of the volume of mail received, personal replies are not always possible.

MONITORING TIMES dealerships are available at a substantial discount. Call or write today! Judy Grove, P.O. Box 98, Brasstown, NC 28902 [704] 837-9100

STOCK EXCHANGE

Ads for Stock Exchange must be received 45 days prior to the publication date.

NON-COMMERCIAL SUBSCRIBER RATES: \$25 per word - *Subscribers only*. All ads must be paid in advance to *Monitoring Times*. All merchandise must be personal and radio-related.

COMMERCIAL RATES: \$1.00 per word payable with ad

1-3/4" SQUARE DISPLAY AD: \$35 per issue, payable in advance.

KENWOOD R-5000/VC-20 \$715; R-2000 \$415; ICOM R-7000/AH-7000 \$870; PANASONIC RF-3100 \$225. Jerry [513] 779-4409

Mint condition ICOM R-71A receiver w/optional remote control for sale. Tunes 100 kHz to 30 MHz. Sacrifice at \$595. Charlie KD4AJ [404] 396-0276.

SONY ICF-2010, excellent condition, manual, box - \$240 money order. Ted Miller, P.O. Box 59031, Chicago, IL 60659.

WANTED: AMPLICA CSR-1000C Satellite Receiver; LNB-1000C; KU-1200C or other similar LNB; used scanners, CB, VHF transceivers; schematics and manuals (or photocopies) of above equipment. Please detail model, conditions and price requested including shipping. Ugo Lazzarini, Fermo posta, 6830 CHIASSO, SWITZERLAND.

WANTED: To buy back issues of MONITORING TIMES, 82 to present. Call after 4:30 p.m. Teddy Babb, Rt 2 Box 88, Afton, TN 37616 [615] 639-4560.

WANTED: GE MODEL 7-4885 digital clock radio. State condition and price. Ernest Johnson, Box 1191, Johnson City, TN 37605.

Sale: BEARCATS BC-101, BC-250; REGENCY TMR8-A, ACTT720; COLLINS KWM-2/P's/Speaker; MURCH UT-2000; NATIONAL HRO-500/LF10. All in good working condition. Best offer. I will ship UPS COD. Richard, Box 81771, Pittsburgh, PA 15217 [412] 456-2733 9-4 EST.

PRO2004/SCA - ultimate scanner, Capri/CD-01 modification, subcarrier reception, cellular 400/kit - mint \$525; REGENCY TURBO-SCAN-INFO 3, new \$110, 60 channels, 10 service channels; GROVE Globescan converter - aircraft to shortwave \$45; KENWOOD AM/FM/cassette digital car radio \$125. [508] 486-9267 evenings - Allen.

GRE-8001, allows your 400-500 MHz scanner to receive 800-900 MHz (cellular). Works great! \$48. [404] 963-0547, KB4KGB.

For Sale: KENWOOD R-1000 communications receiver. Will make your SW listening a real pleasure! Very clean, \$340. Day [415] 340-9113, Evening [415] 377-0571. Ask for Dick.

For Sale: COBRA SR15 excellent condition, all accessories, original box - \$150. Tom Klimas, 7813 Carrleigh Parkway, Springfield, VA 22152 [202] 274-6773.

PANASONIC RF-2600 6-band portable with manual and carrying strap. Seldom used. Selling from estate. I will ship UPS - \$125. [716] 833-5762.

Clearance Sale!

POLICE CALL DIRECTORY 1988

The standard of reference for the scanner listener; comprehensive frequency and location information for law enforcement, fire, hospital, federal agencies, military bases and more!

All states available but in limited supply. \$5 including UPS shipping.

BOK-21 for CT, ME, MA, NH, NY, RI, VT
BOK-22 for DE, MD, NJ, PA
BOK-23 for IL, IN, KY, WI
BOK-24 for IA, IN, KY, WI
BOK-25 for IA, IS, MN, MD, NE, ND, SD
BOK-26 for DC, FL, GA, NC, SC, VA, WV
BOK-27 for AL, AR, LA, MS, OK, TN, TX
BOK-28 for AZ, CO, ID, MT, NM, NV, UT, WY
BOK-29 for CA, OR, WA

SHORTWAVE DIRECTORY 4th Edition - \$10 including UPS shipping.

The standard of reference for North American shortwave listeners. Frequency and user information from 10 kHz to 30 MHz. Includes large RTTY section which will not be included in the fifth edition. Hear US and foreign armed services, FBI networks, spies, space, English language broadcasters and more! Some books have slight cosmetic damage. Over 500 pages, \$19.95 value for only \$10.

OFFICE EQUIPMENT

New Condition!

VIDEOWRITER WORD PROCESSOR - factory fresh! Just unpack it and you're ready to type! Easy to use, complete with spellchecker and dictionary. Extensive range of type faces for headlines and special characters for eye-catching borders. Includes extra ribbons and cover. \$700 value for only \$250 including shipping.

BPI ACCOUNTING PROGRAM for IBM & Compatibles. Original disks and manuals, including Entry Journal Manager and Aura. Includes accounts receivables, payables, general ledger and with Aura you can design pie charts, etc. Over \$500 value for only \$150 including shipping.

KROY LETTERING MACHINE Model 80 - Ideal for making posters, headlines, bulletins, newsletters. Includes set of six font wheels, extra ribbon cartridges and cover. \$700 value for only \$250 including shipping.

PAYMASTER CHECK WRITING MACHINE, Model S1000 - Embosses your checks with the dollar value to prevent alteration. \$235 value for only \$50 including shipping.

Send check or money order to
GROVE ENTERPRISES, INC.

P. O. Box 98
Brasstown, NC 28902
Phone 704-837-9200

No charge cards accepted on above items unless a 3% bank charge is assessed. COD available for \$3 per package.

INDEX OF ADVERTISERS

Advanced Electrical Tech	97
AF Systems	53
Antique Radio	45
Communications Electronics	17
CQ Communications	95
Datametrics	43
EEB	21
Galaxy Electronics	87
GRE	91
Grove Enterprises	Inside front, 55
GTI	99
Ham Radio	39
ICOM	Back Cover
Kaiser	41
Klingenfuss Publications	97
Merrimack	91
MilSpec	57
Monitoring Times	103
Scanner World	35
Spectronics	89
STV Guide	49
Systems and Software	37
Universal SW Radio	13

LOG MORE RTTY:

with the
Essential RTTY Frequency List.

Over 1,000 active RTTY listings with call, location, speed, shift, etc.

\$10.95 + 1.25

TIARE PUBLICATIONS
P.O. Box 493-G
Lake Geneva, WI 53147

Missed that call again?

Let's face it, the audio from your mobile rig, scanner or HT is the weak link in your communications system. Use your car cassette or portable cassette deck and Kasi*Comm™ to enhance your handi-talkie, mobile or scanner audio. Just put Kasi*Comm™ into your deck and plug into your external speaker jack, no modifications required. Specifically designed for communications equipment. Full 30 day guarantee, money back if not satisfied. Send \$13.95 (ILL residents add 7%) plus \$2.00 S/H to:

PLI Micro
P.O. Box 688 Dept B
Skokie, IL 60076

SHORTWAVE HUGE CATALOG

- Shortwave Receivers
- Antennas & Headphones
- Tuners, Preamps, Filters
- RTTY & FAX Equipment
- Books & Accessories

Send \$1 to
 **Universal Radio**
1280 Aida Drive
Reynoldsburg, OH 43068

YOU AINT HEARD NOTHIN...YET!

Largest selection of scanner frequency guides (federal, military, police, aero, etc.); AM/FM/TV broadcast directories; HF "ute" directories; Books on espionage, covert ops., bugging, wiretapping, surveillance, clandestine radio, & more!
BIG FREE CATALOG!

CRB RESEARCH
P.O. Box 56-MT
Comack NY 11725

BE READY!

CRISIS COMMUNICATIONS

shows you how to set up and monitor vital info during storms, disasters, civil emergencies. Includes hundreds of frequencies.
\$10.95 + 1.25

TIARE PUBLICATIONS
P.O. Box 493-G
Lake Geneva, WI 53147

HEAR ALL THERE IS TO HEAR

30 MHz - 1300 MHz
Frequency search
service

Send SASE to:

Bruce K. Heald
6886 Jefferson St.
North Branch, MI 48461

RADIO ASTRONOMY

THE RADIO OBSERVER, a monthly 24-page "how-to-do-it" amateur radio astronomy magazine. Annual subscription . . . \$24
We are also suppliers of technical books, components and modules for the radio astronomy discipline. For a sample magazine and a current brochure send \$2 to:

BOB'S ELECTRONIC SERVICE
7605 DELAND AVE.
FT. PIERCE, FL 34951
Phone: (407) 464-2118

Voicegate Audio squelch
Noise reduction
Vox tape control
Audio filters (3)



SILENCE IS GOLDEN!

Christmas Sale FREE Power Pac

Voicegate, Patch cord & plugs, Power Pac Complete! Only \$109.95... reg \$149.95 till 1-1-89

An SASE gets you our FREE 1989 catalog or send \$3.00 (credited towards purchase) and we'll include a 30min demonstration cassette. Hear it before you buy it!

Stop Scan FOR KENWOOD TS 430S OWNERS ONLY!!

AUTOMATICALLY resumes scanning after an adjustable 1-10 second delay All mode. Internal. Scans like a police scanner. Reviewed in QST 6/85 & 7/3 2/86

Still Only \$19.95 kit. \$29.95 asm. & tested

Shipping/Handling \$3.95
Indiana residents include 5% tax

JABCO ELECTRONICS
R1 BOX 386, ALEXANDRIA IN 46001

Discover CAROLINA WINDOW

HF Use transmatch 132' overall Matching XFMR Line Isolator Vert Radiator Coax feed Assembled \$69.95

High performance Proven results

Your Passport To a world Of new Ideas And exceptional HF wire antennas

Rugged new baluns Full range of HF, VHF, mobile antennas, ducks, wire, coax, parts, line, accessories.

SEE WHAT WE'RE DOING NOW!
Contact Jim, W4THU - free discount catalog
Send \$1 for catalog by 1st Class mail
Box 8159, Portsmouth, VA 23703
(Dealer inquiries welcome)

804-484-0140

RADIO WORKS

Video Phone
Home Door Security/Announcement System

Visitor pushes call button outside, a chime sounds inside and visitor appears on a monitor inside. Pick up handset and talk to visitor while viewing them at door.

Send \$199.00 Ck-MO or write

Also sell wireless VCR to TV transmitters: watch VCR on any TV wireless.

Send \$45.00 CK-MO or write

LTV SALES
P.O. Box 426-R
Romeoville, IL 60441-0426

KENTRONICS

Box 586, Vernon, AL 35592

SWL/HAMS
Logging programs for C-64, TI99 and Timex computers. (C-64 disk only)

Only \$14.95 postpaid!
Large SASE for details

CONVENTION CALENDAR

Date	Location	Club/Contact Person
Jan 21	Fort Myers, FL	Fort Myers ARC/ Egon Loeckel N8EL 237 S.E. 20th Ct., Cape Coral, FL 33990
Jan 21	Ponchatoula, LA	SELARC Hamfest/ Joe Farris 390 Piney Woods, Ponchatoula, LA 70454
Jan 28	San Antonio, TX	San Antonio ARC/ Melvin Anderson WB5NOL 8932 Saddle Trill, San Antonio, TX 78255
Feb 4-5	Miami, FL	FL State Convention/ Evelyn Gauzens W4WYR 2780 NW 3rd St., Miami, FL 33125
Feb 18-19	Sarasota, FL	Sarasota ARA/ Allan Matlick W2TKU 1817 Buccaneer Terrace, Sarasota, FL 33581
Feb 25-26	Cincinnati, OH	Ohio State Convention/ Stanley Cohen WD8QDQ 2301 Royal Oak Ct, Cincinnati, OH 45237
Feb 28	Dearborn, MI	Livonia ARC/ Neil Coffin WA8GWL 35681 Hees, Livonia, MI 48150

Monitoring Times is happy to run announcements of radio events open to our readers. Send your announcement at least 60 days before the event to: Monitoring Times Convention Calendar, P.O. Box 98, Brassstown, NC 28902.



It's 1989!

and your radio listening is off to a flying start with a year's subscription to

MONITORING TIMES!

SUBSCRIBE TODAY!

Don't Miss a Single Issue!

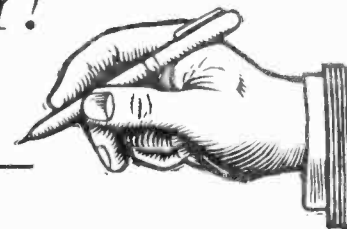

MONITORING TIMES brings the world to you, tuned in and up to date!

Every month *Monitoring Times* brings everything you need to know to make radio listening even more rewarding: the latest information on international broadcasting schedules, frequency listings, station profiles, program commentary, international DX reports, propagation charts, reviews of world band radios and scanners, police and fire networks, and all kinds of communications from air-to-ground to ship-to-shore to space!

A couple of comments from *MT* readers:

"As a new subscriber to Monitoring Times, I'd like to express my sincere appreciation for your fine publication. I find it totally absorbing, well-balanced according to my interests, and packed with all sorts of fascinating hints and information. I completely wore-out my first issue before the second arrived..." - Earl Roper

"When the magazine arrives, I don't get much done, because I have to sit right down and check it out from cover to cover. MT is the best monthly all-round of communications magazines." - Bill Battles

U.S. (mailed second class*):

- 1 Year for \$18 (12 issues) 2 Years for \$34 (24 issues)
 3 Years for \$50 (SAVE \$4.00!) (12 Issues)

* If you prefer first class mail, add \$20.00 per year.

Payment received by the 10th of the month will receive next month's issue. Current or back issues, when available, can be purchased for \$4.00 each (includes first class mailing).

Canada, Mexico and Overseas: (mailed in an envelope second class*)

- 1 Year \$26.00 2 Years \$50.00
 3 Years \$72.00

* If you prefer air mail, please write for rates.

All foreign subscriptions must be paid by Visa, Mastercard, International Bank or Postal Money Order in U.S. funds drawn on a U.S. bank.

NAME _____

ADDRESS _____

CITY _____

STATE _____

ZIP _____

Subscribe for a friend!

NAME _____

ADDRESS _____

CITY _____

STATE _____

ZIP _____

- Please send a gift card signed from _____

PAYMENT MUST ACCOMPANY ORDER!

Mastercard and Visa accepted

Month - Year

MASTER CARD VISA

- - -

Reprints of articles available for \$2 per reprint plus self addressed stamped envelope.
Send name and month of article.

Make checks payable to:
MONITORING TIMES
140 Dog Branch Road
P.O. Box 98
Brasstown, NC 28902
1-704-837-9200

1989: The Year of the Wide Coverage Receiver

For decades, manufacturers seemed unalterably locked into a closed cycle: general coverage shortwave receivers went from 150 kHz to 30 MHz and scanners covered the land mobile and civilian aircraft frequencies above 30 MHz. For the most part, they still do, but progressive scanner manufacturers have paved the way to the future, and the future looks bright.

Early Regency radios began widening their frequency coverage beyond normal limits, then the MX5000 started a trend by eliminating the gaps between bands. Still, the 512-806 MHz range, occupied only by UHF-TV stations, is left out of all scanners.

J.I.L. (SX400), Yaesu (FRG9600) and ICOM (R7000) went one step farther; they developed general coverage, tunable VHF/UHF receivers and equipped them with scannable memories and even included the UHF-TV band.

The natural question is, "What's new on the horizon"? Several manufacturers have dropped hints, and several additional rumors persist in the marketplace. Regency was bought out by Uniden (Bearcat) which also makes products for Radio Shack and Cobra. They are a dominant force in the scanner market.

For the scanner enthusiast:

In an on-again, off-again development for about six years, Uniden will probably announce their long-awaited BC1000 in time for the summer Consumer Electronics Show in Chicago. It is expected to have total 25-1000 MHz coverage in the AM and FM modes. As a sidebar, their incredibly successful HR2510 ten-meter transceiver will be followed by the HR2600 which adds 100 kHz offset for amateur repeater operation.

The Radio Shack PRO2005, which will offer the same frequency range as the all-time favorite PRO2004, still the best scanner on the market, is a few months away and probably won't be quite as good.

GRE, the Japanese firm which manufactures the PRO2004 for Radio Shack, is reportedly toying with the idea of introducing their own wide-frequency-coverage scanner, perhaps even including an S-meter.

Fox Marketing, perpetually a minor scanner manufacturer, has finally dropped out of the scanner business, discontinuing their BMP10/60 and even their frequency directories in favor of radar detectors and CB, the consumer electronics market they know best.

Extending down to shortwave

AOR has announced a model AR2515, actually an extended-frequency version of their

popular AR2002 scanner, which will offer 5-550 and 800-1300 MHz AM/FM reception. Because of its wide filters and lack of SSB reception, however, it will probably be of only minor interest to shortwave listeners.

AOR's AR3000 super scanner with 100 kHz through 2036 MHz continuous coverage remains, at this writing, only a prospect. If and when it materializes, it should represent a substantial step forward in frequency coverage unexcelled in the consumer marketplace.

The luxurious Grove SR1000 Spectrum Surveillance Receiver continues in development. Anticipated for introduction around March with a price tag under \$3000, it offers professional features at a fraction of the cost charged by the commercial industry. Frequency coverage of 100 kHz through 1000 MHz, 1024 memory channels and a built-in spectrum display unit make this receiver an exciting prospect.

With ICOM's R7000 so pervasive among serious VHF/UHF monitors, and the technology of their advanced IC781 HF transceiver impressing the amateur audience, can a sophisticated follow-on be far away? ICOM insists that no decision has yet been reached on such a receiver which would probably sell in the \$4000 range.

Disappointingly, Sony has decided not to introduce their latest CFR receiver with built-in facsimile display to the US market, and no new receivers are planned by them, Kenwood, Yaesu or Panasonic. Sangean will, however, announce their ATS808, a low-cost alternative to the popular Sony ICF2010.

Ten Tec, the only remaining American manufacturer of amateur radio equipment, plans to re-introduce their RX325 general coverage receiver, doomed and discontinued a couple of years ago by its unrealistically high price. This time the price should be very attractive.

Several years ago, a west coast firm called Comer Electronics announced the impending release of a high performance, digital synthesized, general coverage receiver which never materialized. They have recently released another prospectus with a rough drawing of their proposed R232, a 10 kHz-30 MHz midget (7"x2"x4") with computer control and host of features. We'll believe it when we see it.

1989 promises to be bright with anticipation for titillating new products and, as always, you'll learn about them first here in the pages of *MT*.

Bob Grove,
Publisher



THE PROS SUBSCRIBE.



SHOULDN'T YOU?

Several professional monitoring agencies, in fact, have subscriptions to **Monitoring Times**. That's because every month **Monitoring Times** offers the latest in:

- ▶ International Broadcasting
- ▶ Utility Monitoring
- ▶ Scanners
- ▶ Shortwave and Longwave
- ▶ Satellites
- ▶ Electronic Projects
- ▶ Listening Tips
- ▶ Frequency Lists
- ▶ Broadcasting Schedules
- ▶ News-breaking Articles
- ▶ Features
- ▶ Exclusive Interviews
- ▶ Insights from the Experts
- ▶ New Product Reviews & Tests

Jammed with up-to-date information and concisely written by the top writers in the field, **Monitoring Times** is considered indispensable reading by top government agencies.

From longwave to microwave, if *you* are interested in communications, **Monitoring Times** is your foremost guide to international broadcasters; new equipment and accessories; profiles of government, military, police and fire networks; home projects; and tips on monitoring everything from air-

to-ground and ship-to-shore to radioteletype, facsimile and space communications.

Order your subscription today before another issue goes by: only \$18 per year in the U.S.; \$26 per year for foreign and Canada. For a sample issue, send \$2 (foreign, send 5 IRCs).

MONITORING TIMES

P.O. Box 98
Brasstown, N.C. 28902

Your authoritative source, every month.

- Yes, begin my subscription to Monitoring Times. I've enclosed a check.
- Send me a sample issue. Enclosed is a check for \$2.
- For MC/VISA orders, call 704-837-9200.

Name _____

Street _____

City _____

State _____

Zip _____

WHEN YOU CAN'T AFFORD TO MISS A SINGLE WORD

When you demand uncompromised performance and dependability from your communications system, you need an ICOM. Featuring a full product line of rugged land mobile, marine, aircraft, and ham (amateur) transceivers and receivers, ICOM provides you with the most sophisticated and reliable communications available.

Spectacular performance, smooth operation and incomparable dependability are confirmation

of ICOM equipment's top-line quality. These superb characteristics are built into every ICOM handheld, mobile, base unit and accessory.

ICOM's full product line also includes the IC-R71A 0.1 to 100MHz and IC-R7000 25 to 1000MHz/1025 to 2000MHz receivers. They assure your maximum operating performance anywhere, anytime. Move into the winner's circle with ICOM and enjoy a commitment to excellence!



ICOM
First in Communications

ICOM America, Inc., 2380-116th Ave. N.E., Bellevue, WA 98004 Customer Service Hotline (206) 454-7619
3150 Premier Drive, Suite 126, Irving, TX 75063 / 1777 Phoenix Parkway, Suite 201, Atlanta, GA 30349
ICOM CANADA, A Division of ICOM America, Inc., 3071 - #5 Road, Unit 9, Richmond, B.C. V6X 2T4 Canada

All stated specifications are subject to change without notice or obligation. All ICOM radios significantly exceed FCC regulations limiting spurious emissions. Signal788.