

T. E. Rose, Editor
J. F. Thompson
Associate Editor
J. B. Straughn
Technical Editor
E. M. Goolsby
J. A. Jordan
Publication Editors
L. L. Menne
Editor Emeritus

NRI NEWS

Vol. 19, No. 9

June-July, 1961

Published every other month by the National Radio Institute, 3939 Wisconsin Ave., N. W., Washington 16, D. C. Subscription \$1.00 a year. Printed in U.S.A. Second class postage paid at Washington, D. C.

EDITORIAL: SIX STEPS TO HAPPINESS

It seems to me there's one thing in this world that people crave more than anything else:

And it isn't fine houses, new cars, inch-thick steaks three times a week -- or even money. It's simply HAPPINESS.

When we work to gain earthly things, what we're really after is our own happiness. Most of us go to great lengths to acquire some material thing that will please us -- knowing full well the pleasure it brings is usually temporary.

Actually, it's just human nature to reason that riches will automatically bring happiness. But unfortunately, it doesn't always work out this way. Countless wealthy men have gone to their graves -- men who knew how to make money -- but never found happiness.

A long time ago, I discovered a way to gain happiness -- one that requires no real effort whatsoever. It's MAKING FRIENDS. I've found there is a warmth and comfort in knowing we have friends which transcends all wordly possessions.

There are no "tricks" or complicated formulas for making a friend of everyone you meet. Though volumes have been written on How To Win Friends, I think it all boils down to six personality traits. They are:

1. Demonstrate your willingness to share the other fellow's load.
2. Always be ready with a sincere word of praise (not flattery).
3. Be a good listener.
4. Remember and use the names of others.
5. Accept good fortune and honors with humility.
6. Smile -- with your eyes and lips.

Practice these traits -- individually if necessary -- and often. You'll never know how important it is to win and hold friends -- until you need them!

J. E. Smith
Founder

Index

<u>Article</u>	<u>Page</u>
Hi-Fi Corner.....	2
Odds and Ends.....	3
Typical Power Supplies.....	4
The New Model 1076 B and K Analyst at Work.....	12
NRI Alumni News.....	25

VISITORS ALWAYS WELCOME

Since NRI moved into its new home in May, 1957, we have had more visitors than ever before. Business leaders, educators, graduates and active students from all over the world have come in to meet the staff and see first-hand the systematic procedure involved in offering the best home-study programs we possibly can. To those who have visited us -- "Thanks for coming!"

We extend to every reader a most cordial invitation to visit NRI whenever you are in Washington, D. C. We are open five days every week during the year except for seven legal holidays.

"A man who qualifies himself well for his calling never fails of employment."

Thomas Jefferson



Hi-Fi Corner

by John G. Dodgson

Product Report:

PICKERING 381 STEREO CARTRIDGE

Quick Look. Flattest frequency response of any cartridge yet tested...above-average tracking ability and high-frequency separation...absolutely no inductive hum pickup.

General. Except for its silver color, the Pickering 381 appears the same as the 380 series. It is packaged in a more expensive box with an individual calibration card giving hand-written information on frequency response, separation, output, etc., with a serial number.

The frequency response - channel separation curves shown in Fig. 1 merit some comment.

The top curve is the left channel response; the bottom curve, showing separation, is the

right channel output with left channel modulation only. Reversing the procedure by using right channel modulation resulted in remarkably similar curves. In fact, the right and left channel responses were within 0.6 db of each other; the separation differed more but at no point was poorer than that shown in Fig. 1.

As pointed out, the response is remarkably smooth, and as can be seen does not drop at the high end; in fact, it rises to 1.5 db at 12 kc. The dip at 6-8 kc appears to be built into the record used for testing - it shows up with all cartridges.

The channel separation of the 381 is remarkable. The 22-db separation measured at 12 kc is superior to that of any cartridge yet tested.

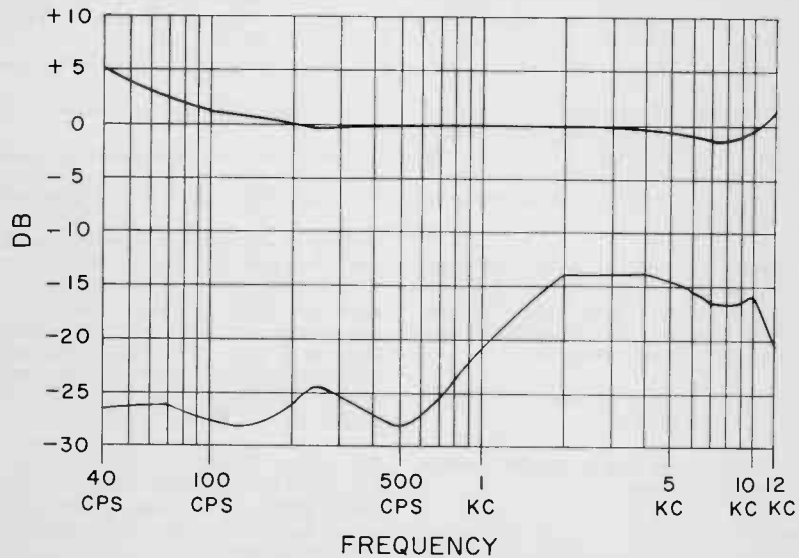

FIG. 1. Frequency response-channel separation curves for Pickering 381 stereo cartridge. Test set-up as follows: 2.5 grams pressure; London PS-131 disc; Empire 98 arm; Fairchild 412 table; Dyna Pas preamp; Hewlett-Packard 410B VTVM.

For example, two others in the 381 price bracket (over \$45) measured 9.5 db and 7.8 db.

Tracking ability of the 381, like the 380, is excellent. Mounted in an Empire 98 arm, the 381 requires only 2.5 grams to track a sweep band from 50 cps to 10 cps. This is a tough test that many cartridges can't track at all, and most require 4 to 6 grams. On music, 2.2 grams is sufficient for perfect tracking on any selection. The compliance of the 381 is not given - the tracking ability indicates at least 6×10^{-6} cm/dyne, possibly 7×10^{-6} .

On the negative side, the Pickering 381 is slightly awkward to install - the cartridge body projects over the mounting holes. Moreover, because of its shape, the cartridge body extends below most tone-arm heads, presenting a less attractive appearance than if only the tip projected.

The cartridge mounting screws are held in place in the mounting holes by a small plastic clip. This eases installation but insulates the metal cartridge body from the tone arm. If your tone-arm head is metal, remove the plastic clip before installation to ground the

cartridge shell.

The above comments are, of course, on minor points that do not affect the operation or sound of the 381.

Listening tests clearly showed the high quality of the 381. Those who may have felt some previous Pickering cartridges to be somewhat "harsh" will be glad to know the new 381 is very definitely not harsh - it is one of the smoothest I've yet heard.

The tracking ability of the 381, as pointed out, is above reproach. There isn't a trace of harshness or rattle on the most demanding grooves. Probably the most outstanding characteristic of the Pickering 381 is its superb separation, particularly at the high end. This not only isolates the sound source to its channel as would be expected, but greatly improves definition and placement of instruments.

Despite its high cost, the price of the Pickering 381 is not out of line for the better stereo systems. Its characteristics, especially the tracking ability and separation, will audibly improve most systems.

Odds and Ends

The NRI Model 291 is from all reports and personal observations an outstanding transistor receiver. Some claim to be able to pick up west coast stations late at night from this area with it, but this I cannot confirm. Bill Dunn, who is a hockey fan, tunes in the Montreal (Canada) hockey games regularly and says reception is like a local broadcast. One thing I can say is that the 291, unlike a certain ball-point pen, cannot do its stuff under water. My son Jim, aged 12, has taken complete possession of my 291, and even perches it on the side of the bathtub while sporting in the water with a cake of soap. One day he walked his niece (aged 1), and grabbed for the 291. Off it went into the tub. It stopped playing.

Having had previous experience with wet receivers I was pretty upset and resigned to buying another. Jim assured me, however, that as soon as it dried out it would be as good as new. To myself I said, "Oh Yeah?" Well, when the set dried out it took right off and I would never have known it had been soaked. Naturally, I didn't show my ignorance by commenting on this remarkable recovery.

By
J. B. Straughn
Chief, Consultation Service

Come to think of it, how did Jim know the set would work when it dried out? How many times has it been dunked unknown to me?

A week ago I got a long-distance phone call from student Carlton R. Hubbard, from Tampa, Florida. He had just completed his 7W receiver, and was able to pick up 19 stations the first time he turned it on. I heard each and every one of these stations over the phone and was quite impressed with the performance of this receiver. Actually I know just how proud and pleased this student felt, as in the past, I have also called everyone around to see some electronic marvel I have built. That's human nature.

The 291 is a money maker -- I have swapped three I purchased to doctors for \$30 off my bills and I swapped one for a ton of high-quality hay (we keep some beef cattle on the farm where I live). I also expect to swap some of our transistorized intercoms to the same doctors. Everyone who sees these sets and intercoms wants one, and you can pick up quite a bit of extra money assembling and selling the finished equipment.



Typical Power Supplies

By
Dale Stafford

NRI Consultant

Almost everyone has seen a power supply. They are used in almost every type of electronic equipment.

Off-hand, a power supply is an innocent-looking device--just a double-handful of parts. A casual observer would probably say that anyone who could solder a joint should be able to build one and have no trouble. Why, then, does applying power to a newly built power supply sometimes bring such unhappy results?

The student happily wires up the circuit, following religiously, he thinks, all the instructions given. He solders his last connection, takes a fond look at his handiwork, flicks the switch, and what does he get?

Usually, the sweet, smooth dc the book says he should get. Sometimes, though, the result is smoke and bubbling wax from the transformer, and wails of anguish from the builder.

Why? There are two reasons, I think. First, the beginning student does not know very much about the parts and how they operate. Therefore, he doesn't know what he **MUST** and **MUST NOT** do.

The other is that the subject of power supplies is not as simple as one might think. Any textbook explanation that attempts to cover the whole subject is bound to get rather lengthy and involved. There is so much to explain.

We have half-wave rectifiers and full-wave rectifiers, tube rectifiers and dry-disc rectifiers, capacitor-input filters and choke-input filters, and so on and on and on.

When the writer takes the student by the hand and tries to lead him through the maze that

makes up the whole subject, one of two things happens. The writer gets so wound up in trying to explain every type and variety of power supply that he forgets to point out the "DO's" and "DON'Ts" in building any type. If he doesn't, the student gets so bogged down in all the new things he is learning that he forgets these elementary precautions.

Actually, the student is so busy learning **WHY**, he doesn't have time to learn **HOW**. In this article, we are going to talk a little about power supplies without worrying too much about why they work. For anyone who wants to dig deeper into the subject, it is well covered in the NRI course.

Let's see if we can put one together. We'll try the type used in an ac radio.

AC SUPPLIES

Suppose someone brings us a set that has been tampered with. The parts are all there but someone's busy little fingers have unhooked all the parts in the power supply.

We look the set over and find the following parts: a power transformer, a filter choke, a rectifier tube (let's say a 5Y3) with its socket, and a couple of filter capacitors.

We also find a terminal that has a lead from the primary of the output transformer connected to it. There are also circuits leading to the other plates and the screen grids from

An intelligent girl is one who knows less than the man with whom she happens to be talking at the moment.

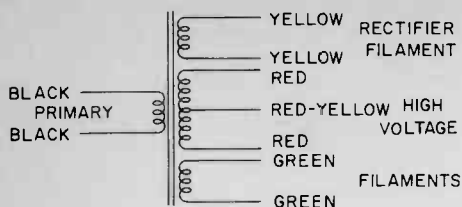

FIG. 1. How a power transformer is color coded.

this terminal. Can we put the parts together again so that we get something besides smoke?

We look at the transformer and see a bunch of leads sticking out. They are colored-coded as in Fig. 1, which helps. The first thing we have to do is sort them out.

From the color-coding, we see that we have four windings. Each has a certain purpose. One of these, we know, is the primary. This is the winding that carries the current from the power line.

One of the windings is the high-voltage secondary. It is the voltage developed across this winding that is rectified to get the dc voltage for the plates and screen grids of the tubes.

The other windings are filament windings. One is a 5-volt winding that supplies the voltage for the rectifier filament. The other is a 6.3-volt winding that supplies the filament voltage for the other tubes in the set.

We can identify the windings by the color-coding. Black is for primary, yellow is for the rectifier filament, green is for the other filaments, red is for the high-voltage secondary, and red-yellow is for the high-voltage secondary center tap.

Even without the color-coding, we could identify the windings by using an ohmmeter. The high-voltage secondary has the highest resistance. The primary winding has the next highest resistance. The filament windings have a very low resistance--only an ohm or two. The rectifier filament winding is usually made of heavier wire than the other filament winding. Thus, we can often tell which filament winding is which by looking at the wire. If not, we can hook the transformer up and measure the voltages across the filament windings, since we have already found the primary.

Now that we have identified the windings, let's hook them up. We'll take the primary first. We fasten one of the black leads to an insulated terminal. To this terminal, we also run one of the wires of the power cord. The other black lead goes to one of the On-Off switch

terminals. This switch is usually mounted on the back of the volume control, and operated by the same shaft. The other wire of the power cord goes to the other terminal of the switch.

After we make these connections, we check to see that solder has not run down to the chassis from one of these terminals. These are insulated terminals--if one of them is accidentally grounded to the chassis, we'll have fireworks when we apply power to the set.

We'll take the rectifier filament winding next. The first thing we must do is to find the right lugs on the rectifier tube socket. Our rectifier, we said, is a 5Y3. In this tube, the filament is connected to pins 2 and 8.

The only thing necessary, then, is to connect one yellow wire to lug 2 and the other to lug 8 on the rectifier tube socket as in Fig. 2. Again, we must be careful not to accidentally ground one of the terminals to the chassis.

Now we have only two more windings to hook up. The green leads for the 6.3-volt winding are next. This is an easy winding to connect. We'll connect the tube filaments in parallel across the winding. First, we find out which are the filament pins for each tube in the set. For the sake of convenience, let's say these are pins 2 and 7 for all the tubes.

On each tube socket, we ground the number 7 pin to the chassis. Then we run a wire connecting all the number 2 pins together. We could have done it the other way around instead. The only thing necessary is to make sure that at each tube socket we have one grounded and one ungrounded filament pin. We must also make sure that all the ungrounded pins are connected together.

After we have all the number 2 pins connected together, we run a wire from one of them to one of the green transformer leads. The other green transformer lead is grounded to the chassis. With one transformer lead and one pin of each tube socket grounded, our transformer will run sweet and cool--well, let's

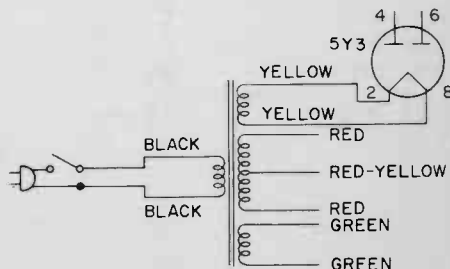

FIG. 2. Connecting the rectifier filament.

how does it work? When power is applied to the primary of the transformer, an ac voltage is developed across the high-voltage secondary winding.

During one half-cycle of this ac voltage, the rectifier plate connected to pin 6 is positive with respect to the filament. Electrons flow from the filament to this plate, through one half of the transformer winding to the center tap.

During the next half-cycle, the rectifier plate connected to pin 4 is positive with respect to the filament. Electrons now flow from the filament to this plate, through the other half of the transformer winding to the center tap. From here the path is through the chassis to the load. The load is the various plate and screen grid circuits of the tubes. We'll trace one of these circuits, the plate circuit of the output tube.

From the center-tap, electrons flow through the chassis to the lower end of the cathode resistor, R1. The path goes up through R1 to the cathode, through the tube to the plate, down through the primary winding of the output transformer, through the choke, back to the filament. The arrowheads in Fig. 3 show the direction of current flow. The dotted line shows the part of the path that is through the chassis. The path for the screen grid is the same, except that from the grid of the tube the path is through R2 to terminal A.

We won't trace the paths for the other tubes. They are similar to the ones we have traced. In each case, the path goes through the chassis to the cathode resistor (or the cathode connection if no resistor is used).

From the plate or screen grid, the path goes back to terminal A. The path may be through the primary of a transformer or one or more resistors, but in any case, it ends up at terminal A.

Without the filter in the circuit, the current through the receiver circuits would flow in a series of spurts as the rectifier conducted and shut off. However, the capacitors and choke work together to keep a steady current flowing through the load.

When the rectifier conducts, electrons are drawn away from the upper plates of the capacitors while electrons flow into the lower plates. Thus, the capacitors are charged with the polarity shown in Fig. 3.

When the rectifier shuts off, electrons flow from the lower plates around through the receiver circuits to the upper plates. In this way the capacitors tend to keep the current flow-

ing steadily, and the voltage applied across the load remains steady.

The choke assists this action in this way: As you have learned, a change in the current flowing in a coil causes a voltage to be induced in the coil. This self-induced voltage opposes any change in the current. The choke offers little resistance to the flow of dc. However, if the current through the choke increases, the self-induced voltage opposes the change and tends to keep the current from increasing. If the current decreases, the self-induced voltage opposes the change, and tends to keep the current flowing steadily.

Common Troubles. There are several common troubles in these power supplies. Rectifier tubes burn out or their emission becomes low. Tube replacement takes care of the latter defect. However, a burned-out tube should be replaced only after the circuit has been checked for other possible defects. Otherwise, the new tube may burn out also.

IT'S ALL IN THE STATE OF MIND

*If you think you are beaten, you are,
If you think that you dare not, you don't,
If you'd like to win, but you think you can't,
It's almost certain you won't.
If you think you'll lose, you've lost,
For out in the world you'll find
Success begins with a fellow's will—
It's all in the state of mind.*

*Full many a race is lost
Ere even a step is run,
And many a coward falls
Ere even his work's begun.
Think big, and your deeds will grow;
Think small, and you'll fall behind;
Think that you can, and you will—
It's all in the state of mind.*

*If you think you are out-classed, you are;
You've got to think high to rise;
You've got to be sure of yourself before
You ever can win a prize.
Life's battles don't always go
To the stronger or faster man;
But soon or late the man who wins
Is the man who thinks he can.*

Walter D. Wintle

left corner of Fig. 5. (If we start at the rectifier cathode, we'll be working away from what we are trying to trace.)

We'll trace the plate circuit of the output tube as before. We go from terminal 12 through the B- circuit. (Notice that the same symbol that was used to represent ground in the previous circuit is used to represent B- here.) From B- we go to the lower end of resistor R9, and up through R9 to the cathode. From here we go from cathode to plate, down through the primary winding of the output transformer, through choke coil L5 to the rectifier cathode, and on to the plate.

If we want to complete the loop, we have to follow an ac circuit that goes from the plate through half the rectifier filament to pin 4, out one wire of the power cord to the power line. From here the loop is all the way back to the power company transformer outside the house and back along the other wire of the power line to the other prong of the plug, and through the switch to terminal 12.

This is what throws a lot of new students. They expect to be able to trace a dc path that goes around in a little circle and it just doesn't work out that way.

It is easier to trace circuit continuity and voltage distribution in these circuits than it is to trace current flow. We know that we need a complete path from B- to the cathode of each tube. We also know that we need a positive voltage at each plate and screen grid. For this, we need a complete path from the rectifier cathode to each of these tube pins.

The voltage is greatest at the rectifier cathode. As we move away from this point toward the plates and screen grids, the voltage becomes lower as we pass through any component having resistance. The reason is that the current is flowing back toward the rectifier, making the end of the part farther from the rectifier cathode more negative than the closer end.

If we remember these things, it is fairly easy to check out these circuits without worrying too much about current flow.

PITY FOR PARENTS

Parents spend the first part of a child's life getting him to walk and talk and the rest of his childhood getting him to sit down and shut up.

FORMER U. S. EDUCATION COMMISSIONER, ACCEPTS APPOINTMENT TO HOME-STUDY ACCREDITING COMMISSION

Lawrence G. Derthick, Assistant Executive Secretary for Educational Services of the National Education Association and former United States Commissioner of Education from 1956-61, has accepted appointment to the Accrediting Commission of the National

Home Study Council, Washington, D.C.

In accepting the post Dr. Derthick stated, "It will be a most rewarding experience to be associated with the other Commission members under the great challenge of maintaining



Dr. Lawrence G. Derthick, from 1956-61 the U. S. Commissioner of Education and presently Assistant Executive Secretary for Educational Services of the National Education Association, has accepted appointment to the Accrediting Commission of the National Home Study Council, Washington, D. C. He succeeds Dr. John W. Studebaker, also a former U. S. Commissioner of Education (1934-48). The nine-member Commission examines and evaluates private correspondence schools and is approved by the Office of Education as a "nationally recognized accrediting agency." The 52 accredited private home-study schools and divisions currently enroll about one million of the estimated 1.5 million active private correspondence school students.

sound educational criteria for the private home-study schools of America." The nine-member body has been approved by the Office of Education as a "nationally recognized accrediting agency" under public laws 82-550 and 85-864.

Dr. Derthick has received 11 honorary degrees in recognition of his service to education. Prior to heading the United States Office of Education, he was for 16 years superintendent of public schools in Chattanooga, Tennessee.

The Accrediting Commission includes three professionals from outside the private home-study field in addition to Dr. Derthick. They are Dr. Harold C. Hunt, Eliot Professor of

Education, Harvard University; Earl Bedell, former divisional director of vocational education, Detroit public schools; and Jack C. Staehle, vice president of industrial relations and operations, Aldens, Inc. of Chicago.

Commissioners representing private home-study schools are William Bethke, Commission chairman; Edward C. Estabrooke, educational director, the American School; William A. Rogers, vice president, International Accountants Society, Inc.; J. Morrison Smith, president, National Radio Institute; and John C. Villaume, president, International Correspondence Schools.

In addition to NRI, there are now 51 schools and divisions accredited by the Commission.

Admiral Corporation has made a comparison of TV receiver viewing costs -- first TV sets (52 sq. in.) versus current sets (282 sq. in.)

In early days, the customer paid \$6.73 for one square inch of viewing area. You now get a square inch of picture for 71¢.

Experience is a wonderful thing. It enables you to recognize a mistake when you make it again.

The Flame, Cabot Ind.
Boston, Massachusetts

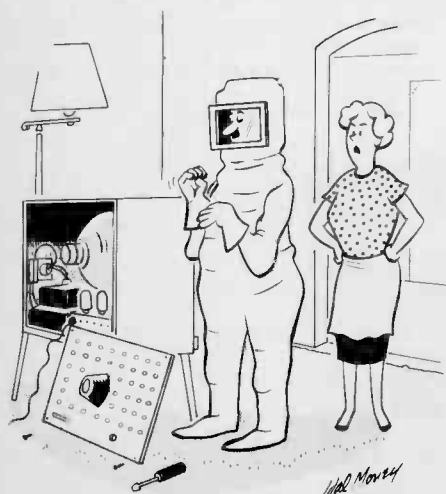

"I still say you should let a TV technician work on the high-voltage circuit."

WHO SHALL LEAD?

It has been said that the influence of a leader who lives up to what he feels is right is greater than the most convincing sermon. By standing four-square for something, he encourages others to demonstrate their manhood, too.

There never was a time when such leadership -- at all levels -- was more sorely needed. Many of the men who are supposed to be leading are listening -- listening to find out what will be popular with the voters. What this country needs most these days is men who also will listen to their consciences. Men who would rather be losers than hypocrites.

But they needn't be losers. The American people respect leaders who dare to be leaders. Men like that they will follow -- and feel good about it!

The Little Gazette
Judd and Detweiler, Inc.

The geography teacher asked Bobby a question about the English Channel.

"I don't know," answered Bobby. "We don't get that channel on our TV set."

The New Model 1076 B and K Analyst at Work

By
Joseph Schek

NRI Consultant



A major break-through has now been achieved in the field of black-white and color TV Service instruments.

The new and improved Model 1076 B and K Analyst shown in Fig. 1, provides many valuable extra features that will help you in quickly tracking down the causes of trouble in sync, sweep, high-voltage, and video circuits.

The additional features you now get in the new Model 1076 that were not found in the previous Model 1075 are as follows:

1. High-voltage indicator.
2. B+ boost voltage indicator.
3. Calibrated agc test voltage (0-50).
4. High-level video signal to directly modulate picture tubes.
5. High-level agc keying pulse.
6. Direct-drive test sweep signal to check vertical yoke windings.
7. Test signal to check vertical output transformer.

8. Direct drive horizontal sweep signal to check flyback transformers.
9. Flyback transformer leakage and continuity test.
10. Sensitive test to check if flyback transformer has shorted turns.
11. Composite synchronizing signals adjustable in amplitude and polarity, to troubleshoot sync circuits.

Let's see exactly what the B and K Analyst Model 1076 will do to help you to speedily complete your service jobs, especially those "toughies."

Because the B and K is actually an all-channel video and sound TV station, it furnishes a "live" test-pattern signal, shown in Fig. 2. Because of the versatility of the analyst, this complete video test-pattern signal can be directly applied to the following check points:

Antenna terminals of set.



FIG. 1. The B and K analyst.

Tuner mixer grid test point,
(to bypass rf amplifier for
gain test).
Each control grid of the video
i-f amplifier stages.
Each video amplifier control
grid.
The picture tube driven ele-
ment - (cathode or control
grid).

To test the FM response of TV sound detec-
tors and i-f amplifiers, the analyst furnishes
an FM signal, modulated at 400 cycles. The
FM signal can also be modulated from an ex-
ternal source such as a phono or voice input.

proach the design laboratory standards, be-
cause all circuit analysis is done under con-
trolled conditions.

Let's go over the procedures you would use
to check a faulty circuit and localize its de-
fective part.

CORRECTING VIDEO TROUBLES

Let's suppose the trouble symptom in a mod-
ern set is that there is a raster but no video
or sound. When tube-testing shows no bad
tubes, and the picture-tube brightness control
has full range, we swing the television anal-
yst into place. Using the special video-signal

Shading or gamma check.
Shaded areas provide
good check for video
amplifier linearity.

Determine frequency response at
point where lines of wedge merge.
Bandwidth shown in megacycles.

To set proper size set
top and bottom of circle
to top and bottom edges
of receiver screen.

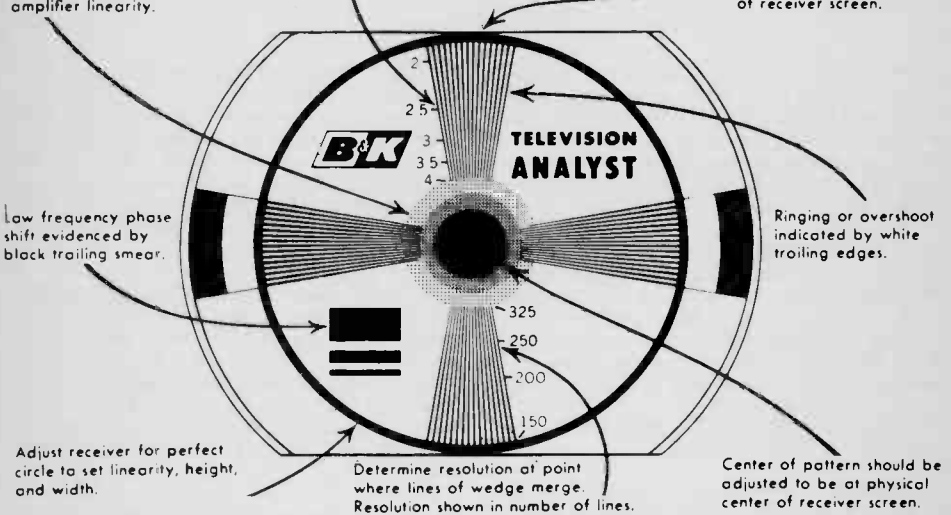

FIG. 2. The test pattern used in the television analyst.

Not only does the television analyst generate
a complete picture and FM sound, but also
the levels of the signals can be adjusted by
separate controls for an accurate check of the
receiver sensitivity. This feature is impor-
tant. The performance of a set in the shop can
be analyzed in accordance with actual receiv-
ing conditions in the customer's home with-
out using the shop's antenna system. This
realistic final testing procedure will save
many a headache when a set that worked in the
shop, is delivered and found not to work sat-
isfactorily. The television analyst is used to
rapidly test and adjust each section of a TV
set under actual operating conditions, to
produce a superior picture.

Using professional trouble-shooting tech-
niques with this composite TV signal, you ap-

proach the design laboratory standards, be-
cause all circuit analysis is done under con-
trolled conditions.

output jack, first inject its signal at the cath-
ode of the picture tube, point X. See Fig. 3.

If the input circuit of the picture tube is nor-
mal, the analyst test pattern will appear on
the screen.

The next step is to inject the video signal at
the plate of the video amplifier. As shown in
Fig. 3, the coupling capacitor C1 serves to
link the output signal of the video amplifier to
the picture tube.

When nothing happens on the TV screen as the
video signal is injected at the plate of the video
amplifier, we know that coupling capacitor C1,
coil L1, or the trap is open. Further quick
checks can be made in this section by ana-
lyzing specific point-to-point circuit re-

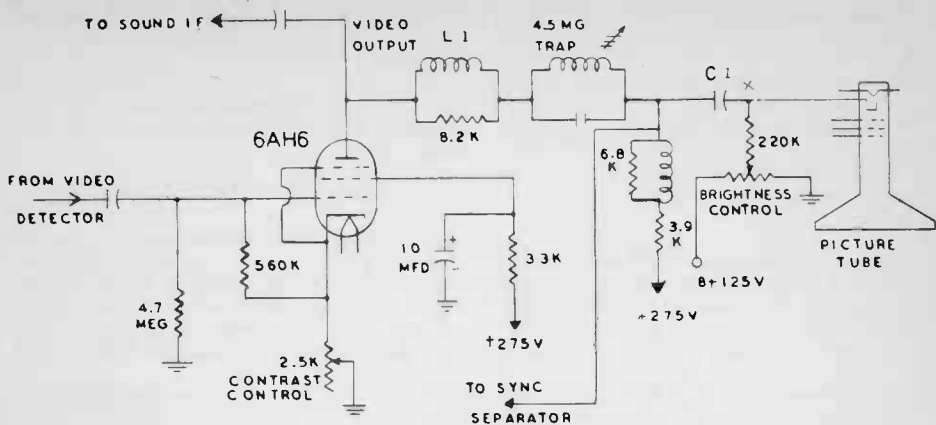

FIG. 3. Typical video amplifier circuit.

sponses. For example, if there was a clear response at the plate of the video output tube, but none at its control grid, the contrast control may well be open, or the plate circuit could have an open peaking coil or an open plate load resistor, or the fault might be in the screen-grid circuit.

Using the i-f output of the analyst, you can apply this signal to each control grid of the video i-f amplifiers not only to locate the stage that has low gain, instantly, but also by proper analysis of the test pattern to pinpoint the i-f stage that may be distorting the video response, causing loss of good picture quality.

HOW TO ANALYZE THE TEST PATTERN

The quality of the picture can be checked by using the test pattern as the viewing standard. For this test, the rf video output is first connected directly to the antenna terminals of the set.

Carefully inspect and note the over-all appearance of the vertical columns and wedges in the TV pattern. Compare this quick and effective procedure with the difficulty and wasted time you have when trying to check the quality of a regular TV picture that is constantly and rapidly changing. Among the many other valuable features of the television analyst, this one will surely be highly appreciated by professional service technicians, many, many times.

Top-flagging or bending may reveal a defective agc system or hum in the signal or sync circuit fault. The frequency response of the receiver is clearly indicated by the point where the vertical wedges come together.

Poor low-frequency receiver response that could cause hard-to-find weak vertical sync complaints is instantly revealed by the smeary appearance of the large, rectangular blocks in the lower left-hand corner of the test pattern. Correct adjustment or checking of the vertical linearity and height controls is quickly accomplished by viewing the television analyst test pattern.

Thus, from inspecting the shape and quality of this stable test pattern, we can almost instantly get a good idea of the signal, sync, and deflection circuits in a television receiver being serviced. As a matter of fact, we can go even one step further with a complete professional TV service test instrument like the B and K Model 1076 Television Analyst.

Suppose the test pattern has passed through from the antenna terminals and looks like Fig. 4, showing limited frequency response by the excessively smeared vertical wedges.



FIG. 4. Test pattern with smeared wedges.

**NRI PROFESSIONAL
MODEL 311**

RESISTOR-CAPACITOR TESTER



Your choice — kit or wired

EASY-TO-BUILD AND USE

(clear-cut instructions
written the "NRI way")

\$19⁷⁵

kit with complete instructions
or
\$28.75 fully wired

- uses lab-type bridge circuit
- wide resistance-capacity ranges
- variable DC working voltage up to 450V.
- a basic test instrument—will not become obsolete

The Model 311 has a definite place in every equipment set-up. Eliminates guesswork increases profits and customer goodwill, saves costly call-backs, gives you added confidence. It's a must for identifying and matching resistors-capacitors used in critical circuits.

Has all the features of most "in-circuit" testers. In many applications, the Model 311 can be used for in-circuit checks. But it stands to reason, when other circuits are paralleling a resistor or capacitor, one lead must be unsoldered for an accurate test. For obvious and ethical reasons, we don't advertise the Model 311 as an "in-circuit" tester.

S P E C I F I C A T I O N S

Accurately measures RESISTANCE, CAPACITY, LEAKAGE, POWER FACTOR, OPENS, SHORTS, ELECTROLYTICS. Four overlapping capacity ranges (.00001 mfd. to 1500 mfd). Four overlapping resistance ranges (one ohm to 150 megohms). Continuously variable DC working voltage up to 450V. 0 to 50% direct reading factor scale. Bridge-type circuit with tuning eye null indicator. Black wrinkle-finish cabinet with heavy gauge aluminum panel. Deluxe 5-way test lead binding posts. Size: 9-7/8" wide, 7-1/2" high, 6-1/2" deep. Actual weight 6 lbs. Shipping weight 8 lbs. Carries full 90 day Electronic Industries Association warranty.

NOTE: Prices do not include postage and insurance charges. Use chart below

Local.....	.51
Zones 1 and 2, up to 150 miles.....	.78
Zone 3, 150 to 300 miles.....	.86
Zone 4, 300 to 600 miles.....	.99
Zone 5, 600 to 1000 miles.....	1.20
Zone 6, 1000 to 1400 miles.....	1.44
Zone 7, 1400 to 1800 miles.....	1.69
Zone 8, over 1800 miles.....	1.93

Available on terms — write for details

ORDER BLANK

NATIONAL RADIO INSTITUTE, Supply Division
3939 Wisconsin Ave., Washington 16, D.C.

311KT 311TE

- Enclosed is \$19.75 plus \$..... postage. Ship at once Model 311 R-C Tester KIT.
 Enclosed is \$28.75 plus \$..... postage. Ship at once WIRED Model 311 R-C Tester.

NAME..... STU NO.....

ADDRESS.....

CITY..... ZONE..... STATE.....

(If you live in Washington, D.C., add 2% sales tax)

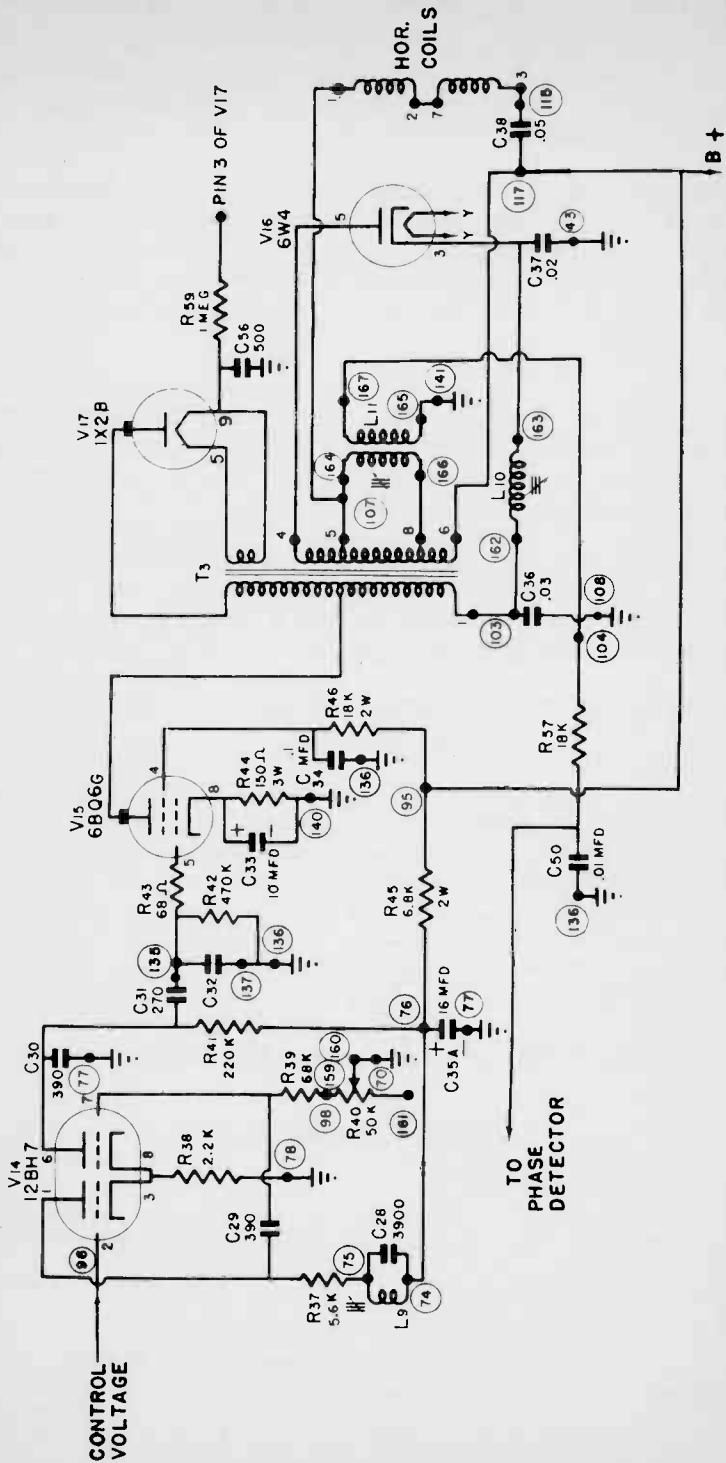

FIG. 7. The horizontal sweep, horizontal amplifier, damper, and high-voltage rectifier circuits of a typical television receiver.

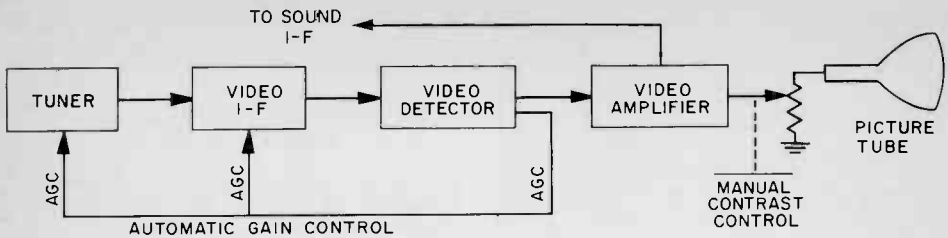

FIG. 8. Block diagram of simple agc system.

substitution to determine which is faulty. With the analyst, this time-consuming step is not necessary, because a vertical yoke test signal provides a quick and dynamic test of the yoke. If there is sweep present when you apply the vertical yoke signal, the output transformer is faulty. If there is no sweep, then the yoke needs replacement.

When the complaint is insufficient vertical height or fold-over, the same professional servicing techniques are used with the television analyst to quickly isolate the cause to either the oscillator or amplifier stages in the vertical sweep system.

Generally the service procedure for the horizontal deflection section is similar to that for the vertical sweep stages. This is because both sweep systems use an oscillator and an output amplifier. However, the output of the horizontal amplifier is used not only to produce a deflection signal, but also to develop high voltage for the second anode of the picture tube.

To check out the horizontal system where the complaint is no raster or insufficient width, the horizontal driving pulse from the television analyst is applied to the control grid of the amplifier tube, V15 in Fig. 7. If a complete raster is formed that fills the screen, then we know that the horizontal sweep system is working from the output tube on, and the trouble must be in the horizontal oscillator stage. Troubles such as oscillator off frequency, dead oscillator, or weak oscillator can be isolated in this way.

On the other hand, it would not be at all surprising if the application of the output tube grid drive pulse from the analyst failed to restore high-voltage or deflection. This would clearly indicate that the trouble is not in the horizontal oscillator but that the trouble lies in the output circuit of the horizontal sweep system.

Here is how you would use the analyst to pinpoint the cause of this defect in Fig. 7. Remove the plate cap from output tube V15. This cap is connected to the flyback trans-

former. Hook up a test lead from the horizontal plate drive jack on the analyst right to the plate cap, which is still connected to the flyback transformer. If high voltage and a raster appears, then the output stage is at fault. Check R44, C34 and R46, typical components that fail in a horizontal output stage.

If there is still no raster or high voltage, isolate the defect to either the flyback transformer or the yoke, by unhooking one lead of the yoke. If there is high voltage it indicates a good flyback but a bad yoke. If it does not bring back the high voltage, the reverse is true.

By using the analyst as a substitute for the output stage, you can quickly localize circuit faults.

LOCATING AGC DEFECTS WITH THE TV ANALYST

The TV Analyst is ideal for localizing causes of agc troubles. For you to use the B and K television analyst effectively in uncovering agc troubles, it is important to understand how the agc network in TV sets affects the video rf and i-f signal paths.

The block diagram in Fig. 8 shows how the agc voltage from the agc voltage source (in this case the video detector) is fed to the rf amplifier, and the first and second i-f amplifier control grids. The gain of each of these tubes will depend on the amount of voltage supplied by the agc line. This agc voltage developed in the agc stage normally varies automatically with the strength of the incoming signal.

In many receiving locations, the strength of the incoming TV signals from different channels vary widely. Since an amplifier tube cannot by itself operate satisfactorily under these conditions at one constant bias level, the agc is used to automatically adjust the bias, over a fairly wide range—low bias for weak signals and high bias for strong signals. This prevents overloading of the rf and i-f stages on strong signals, and provides sufficient sensitivity for weak signals.



FIG. 9. Picture i-f overload, poor sync stability, and picture reversal.

On the other hand, if the agc network is not operating properly, the bias range will be reduced or completely changed and may provide any one of these symptoms:

- Overload (see Fig. 9).
- Weak sync (hold).
- Complete loss of video and sound.

We are now ready to check the agc network with the analyst. Inject an rf signal from the analyst at the antenna terminals of the receiver, and tune both the analyst and the receiver to any unused TV channel. If reducing the rf-if output of the analyst causes a normal test pattern to appear, check the components in the agc line.

However, if with this check no video information appears on the screen, the trouble has not as yet been localized to the agc line. Hence, we bring into play a valuable feature of the analyst. This is provision for a variable, negative low-impedance voltage to be connected between B- and the agc line. If with this applied agc voltage, the picture and sound are normal, the trouble is definitely localized to the agc line.

The television analyst provides unusually effective help in locating troubles in keyed agc stages such as the one in Fig. 10. A positive agc keying pulse of 400 to 500 volts amplitude is available from the agc jack on the analyst panel. This substitutes for the pulse normally reaching the plate of the agc tube from the special horizontal output transformer winding through coupling capacitor C1.

"Failure is more frequently from want of energy than want of capital".

Daniel Webster

Frequently either this winding or C1 breaks down, producing the typical agc trouble symptoms listed earlier.

THE ANALYST AS A SYNC-STAGE TROUBLE SHOOTER

Lack of sync produces the typical screen pattern shown in Fig. 11. Most sets have sync stages similar to the one shown in Fig. 12. To locate the faulty component, simply apply the composite sync signal from the television analyst to the grid of V2. If the picture on the TV screen locks into sync, we know that V2 and the following circuits are good.

However if the picture still remains out of sync, the cause of the sync trouble will be found at or around V2. When V2 properly handles the sync signals, apply the sync test signal at the grid of V1. If there is lack of sync, then making voltage and resistance checks in this stage should uncover the faulty component.

Two important features of the composite sync signal from the analyst make it unusually effective in pinpointing the defect in the sync stages. One is the high amplitude of the sync pulse, which allows it to lock in the vertical and horizontal oscillators without using any of the receiver sync stages. The second is the panel control, which permits the level on the sync pulse to be varied between zero and 50 volts. With this control you can duplicate the amplitude of the sync signals specified by the manufacturer.

USING THE ANALYST TO TROUBLE-SHOOT AUDIO CIRCUITS

Since the television analyst has been designed to perform a complete television servicing

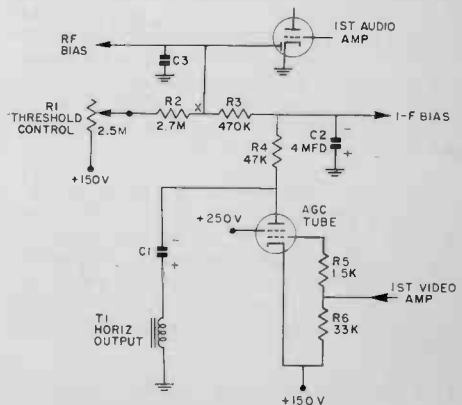

FIG. 10. A typical keyed agc system.

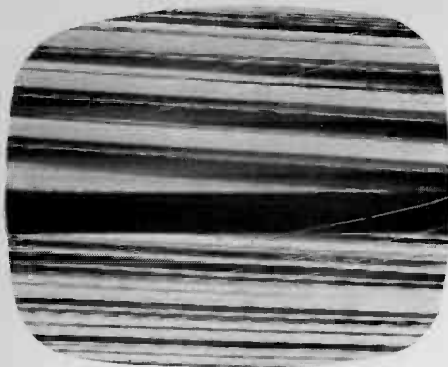

FIG. 11. No sync.

job, it can produce a 4.5-mc frequency modulated sound signal. The modulation frequency is 400 cycles. For maximum use and flexibility, the 400-cycle tone is available as a separate audio amplifier test signal.

Let us see how the sound signal combination can be used to track down a defective sound system. A typical service symptom is video, but no sound. After establishing that this complaint is not caused by one or more bad tubes, bring the television analyst into action. Both the FM 4.5-mc signal and a straight audio signal can be used to quickly determine the dead stage and circuit.

The best place to start is at the control grid of the audio output tube, since it is closest to the speaker (see Fig. 13). Before a signal is applied to any other stage, we must first know that the speaker and output stage are operating; otherwise, valuable service time will be wasted.

If we do not obtain any response when the 400-cycle tone signal is applied to the control grid of the audio output tube, we will have

quickly pinpointed the audio system fault to this stage.

On the other hand, a strong 400-cycle signal through the speaker will indicate normal operation of the output stage. The next logical servicing step is to inject the same 400-cycle signal at the grid of the first audio-frequency amplifier. A louder response will show normal operation of this stage. Lack of this response should pinpoint the trouble to this stage.

To use the analyst to identify exactly which part is faulty in this stage, move the signal to the plate. Lack of response means that the coupling capacitor is faulty. Normal response at the plate but none at the grid shows that the plate load resistor or perhaps the cathode bias resistor is open.

Many sound troubles originate in the ratio-detector transformer. Only with FM signal can an operational (live) test be made. To make this check, shift the output of the analyst to 4.5 megacycles, and apply it to the control grid of the sound i-f amplifier. The response should be a loud and clear 400-cycle tone.

However, if the transformer is faulty or poorly adjusted, there will be a weak or distorted signal. The extreme accuracy and stability of the sound FM 4.5-megacycle signal makes it an incomparable alignment standard for adjusting the cores of the primary, and, in particular, the secondary windings of the ratio-detector transformer to obtain good audio output with least vertical sync buzz.

USING THE ANALYST TO SERVICE COLOR TELEVISION RECEIVERS

Most color TV test instruments can be used only on color receivers. Unless a color set is being serviced, these expensive test instruments remain idle.

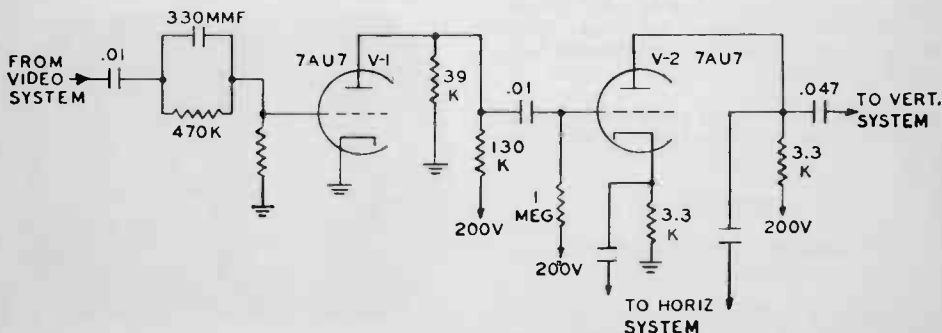

FIG. 12. A typical sync separator system.

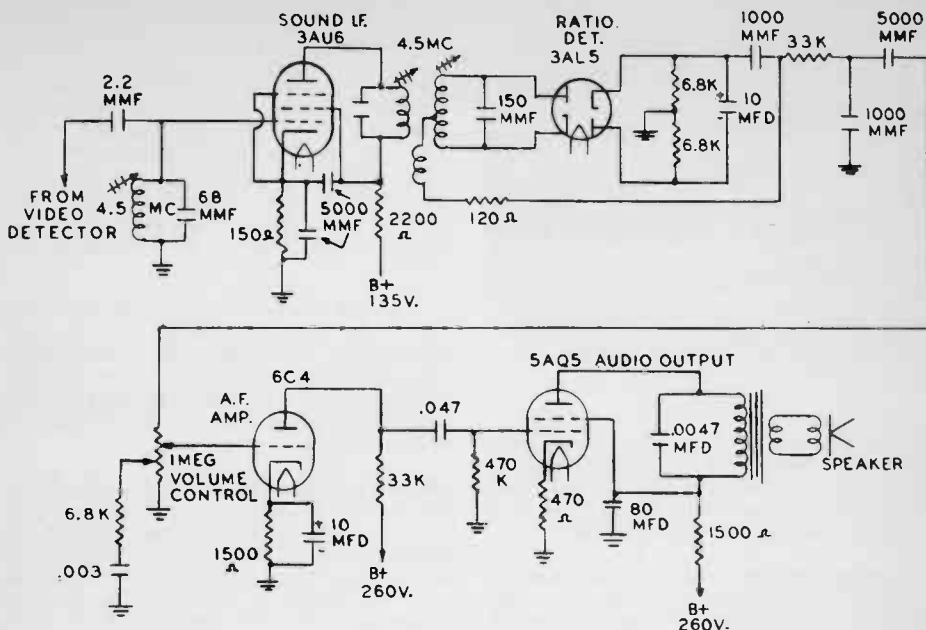

FIG. 13. Audio system being analyzed.

However, the television analyst, in addition to being an unusually complete and excellent black and white TV set test instrument, is designed to produce signals and color screen patterns for static and dynamic convergence adjustments of color sets. The use of white dot and white line slides in the television analyst produces convergence test signals of exceptional stability and purity.

Not only are screen patterns for convergence adjustments available from the television analyst, but also a crystal-controlled full-color rainbow display can be produced, as shown in Fig. 14. This color test signal is available from the analyst in video and modulated rf and i-f form. When the color receiver is functioning properly, the colors of the patterns will be properly reproduced in the order indicated.

Any significant change from the color sequence in Fig. 14 indicates a defect in the receiver or a misadjusted control.

SUMMARY

What the Television Analyst is Designed to Do

1. Inject a complete, composite television signal in the form of a test pattern at any input point in the video signal chain from the antenna terminals of the set to the driven

element of the picture tube.

2. Supply vertical and horizontal driving pulses to the input or output circuits of the deflection amplifier stages.

3. Provide a 400-cycle frequency-modulated, 4.5-mc rf signal.

4. Make white-dot and white-line static and dynamic patterns on color television screens for convergence adjustments.

5. Generate a crystal-controlled rainbow color pattern for trouble-shooting color TV receiver circuits.



FIG. 14. The rainbow display pattern produced by the B and K television analyst.

6. Check rf sensitivity and agc settings of TV receivers.

7. Operate as a closed-television and sound system displaying messages inserted in the television analyst.

8. Check the performance of community and master antenna systems.

9. Trouble shoot agc circuits by providing a variable bias voltage and high-amplitude keying pulses.

10. Check and adjust the vertical and horizontal linearity, size, and aspect ratio of TV receivers.

11. Serve as a stable signal source for trouble-shooting intermittents.

12. Provide a sensitive test to determine if the horizontal output transformer or yoke have internal shorted turns.

13. Show frequency response of video amplifier by reproduction of the vertical wedges in the test pattern.

14. Indicate transient response, by presence and intensity, or absence, of circuit ghosts (repeats in the sharp vertical lines of the test pattern).

15. Show gain of the video amplifier indicated by the contrast intensity of the reproduced test pattern.

16. Provide a means of checking the condition of the color sub-carrier trap, shown by rejection of the 3.58-mc beat.

The television analyst is available from the

NRI Supply Division and may be purchased outright at a net price of \$293.95 or on a reasonable time-payment plan.

IN-CAR RECEPTION OF MODEL 291 TRANSISTOR RECEIVER

Graduate John E. Ansley of Mt. Clemens, Michigan, tells us he was pleasantly surprised to discover how well the NRI Transistor Receiver plays in his car.

John says he gets best performance by positioning the radio so that it is in the corner of the windshield and the loop antenna is orientated to the windshield metal frame. In effect, this is a single-turn loop around the antenna.

Thanks for passing this idea along to us, John. We're sure other Model 291 owners will want to try it. We're also sure your son was well pleased with the second radio you bought for him as a birthday gift!

HYDROGEN THYRATRON ON DISPLAY

SCHENECTADY, N.Y. -- One of the electronic industry's most versatile hydrogen thyratrons, developed by General Electric Company's Power Tube Department, was displayed at the Institute of Radio Engineers meeting in the New York Coliseum, March 20-23.

This hydrogen thyratron has the highest peak power, peak voltage and anode dissipation factor ever offered on the commercial tube market, according to engineers. Among its applications are uses in military mobile communications and particle accelerators.

ORDER COUPON FOR THE MODEL 1076 B AND K ANALYST

National Radio Institute Supply Division
3939 Wisconsin Ave.
Washington 16, D. C.

I enclose \$293.95 * plus \$ _____ for postage. Please rush me a new Model 1076 B and K analyst.

Please tell me how I can buy the Model 1076 B and K analyst on a monthly time-payment plan.

Name Student No.

Street Address.

City. Zone. State.

*(If you live in Washington, D. C., add sales tax)

A NOVEL AMPLIFIER

In a conventional audio amplifier, the vacuum tubes or transistors exhibit a high output impedance that must be matched to the low input impedance of the loudspeaker. This requires the use of a bulky, expensive power-output transformer. Hewitt Crane and Phillip Merritt of the Stanford Research Institute, Menlo Park, California, have designed, built, and tested a simple audio amplifier (based on a modulated-carrier principle) in which such a transformer is not required.

They reasoned that if a transistor were used as an on-off switch, a mode in which a transistor is very efficient, then the ratio of on-time to off-time could be controlled (modulated) so that an amplified output signal to drive the loudspeaker would be provided at low impedance. For the modulator in their amplifier, they made use of a square-loop ferrite core.

Several variations of this amplifier were tested, and each showed uniform frequency response throughout the audio range down to dc. Also, as expected, distortion was low, even without the use of feedback circuits. Very little input power was required because of the efficient mode of operation.

At present, the cost of the switching transistors required in the output stage may limit the wide use of this amplifier in highly competitive commercial audio fields. However, transistor technology is developing to the

point where the price should come down in the near future.

The amplifier could be used to advantage at present in industrial and military applications. In particular, high efficiency and lack of bulk make it well-suited for portable systems such as satellites, where weight, space, and power are precious. Its characteristics also suggest that it might be employed as a power amplifier to drive motors, especially when direct-current power is required, such as in driving an electromagnet.

A schematic diagram and parts list of the new amplifier have not yet been released by Stanford Research Institute.

TELEPHONE TALK VIA MOON

SCHENECTADY, N.Y. -- The voices of two U.S. senators were received here recently in a half-million-mile telephone conversation by way of the moon.

The message took just two-and-one-half seconds to reach the moon, be picked up here by a General Electric Company observatory, and transmitted to Seattle, Wash.

It was received by the Company's General Engineering Laboratory, which operates a tracking station and radio-optical observatory in the Rotterdam hills just outside Schenectady.



Developing an audio amplifier in which a transformer is not required at the Stanford Research Institute.



NRI ALUMNI NEWS



Jules Cohen	President
F. Earl Oliver	Vice President
John Babcock	Vice President
J. Arthur Ragsdale	Vice President
Howard Smith	Vice President
Theodore E. Rose	Executive Sect.

Chapter Chatter

CHICAGO CHAPTER, at the request of Chairman Ed Wick, has been giving consideration to suggestions and recommendations for improvements or additions that would better enable members to work to advantage with radio and television units brought in by them to service at the regular and forum meetings.

The discussion led to the conclusion that it would be desirable to have a cabinet equipped with a lock for safe-keeping of electronic units and test equipment which required storage between meetings. The members as a whole seem to favor such an arrangement. It is hoped that suitable material for the cabinet can be obtained from the crating and packing material on hand in the shipping department of the building in which the meetings are held.

DETROIT CHAPTER some time ago began giving serious attention to transistor projects and is continuing to do so.

The members attended a demonstration by RCA on color television, which was extremely interesting. A meeting was planned to be held

at the home of Ellsworth Umbreit on troubleshooting color TV with the B and K Television Analyst. The Chapter's two television experts, Ellsworth Umbreit and Earl Oliver, were assigned to conduct the demonstration.

Of late, quite a few movie films have been shown at the meetings, which the members have enjoyed.

The latest members to be admitted to the Chapter are George Povlich and Thomas Jimenez. Welcome to the Chapter, gentlemen!

FLINT (SAGINAW VALLEY) CHAPTER has continued with its very popular series of lectures by Professor William DeJenko on the latest Radio-TV Servicing techniques. In fact, the members have been so enthusiastic about this series that ten more lectures were scheduled to cover color television.

It was planned to feature at one meeting the revamping of the NRI portable transistor radio for all-purpose use, such as in automobiles and boats.

Any member who has a problem with a "dog" radio or TV set is welcome to bring it to a Chapter meeting and get help with it. The same invitation is extended to NRI students in the area.

The officers elected to serve the Chapter for the current year are: William Jones, Chairman; Andrew Jobbagy Sr., Vice-Chairman; Arthur Clapp, Secretary; Clyde Morrissett, Treasurer; H. A. Gillean, Sergeant at Arms; Andrew Jobbagy, Sr., Publicity Director; Charles Rupp, William Duncan, Victor Brazier, Gilbert Harris, and Robert Poli, Entertainment Committee; Robert Newell, Wayne Todd, Roland DeSisto, and Ernest Hubbard, Educational Directors; LeRoy Cockrell, Photography; Richard Jobbagy, Tape Recording; and Lt. Arthur Clapp, Communications. Our warmest congratulations to these new officers!

The Chapter wants special attention directed to its new meeting place. The Chapter now



A few of the members at a Flint Chapter meeting watching Prof. DeJenko make a tuner adjustment on a TV receiver.

meets at 8:00 P. M. on the second Wednesday of each month at Andrew Jobbagy's Shop, G-5507 S. Saginaw Rd.

HAGERSTOWN (CUMBERLAND VALLEY) CHAPTER'S Program Committee Chairman George Fulks took up most of an entire meeting with a demonstration on servicing the horizontal and vertical sections of a TV receiver. Even so, because of the length and thoroughness of this demonstration, it was necessary to carry the continuation of this demonstration over to the next meeting.

The Chapter is on the lookout for a regular meeting place where there is a TV antenna available. Does anyone in the Hagerstown area know of such a place that is suitable? If so, it will be appreciated if you will contact Chairman Harold Rosenberger, Waynesboro, Telephone: 1650R11.

In the meantime, meetings will no longer be held at "The Nook" Restaurant in Hagerstown, but will instead be held at the homes of members.

LOS ANGELES CHAPTER regularly shows interesting and entertaining films at its meetings. By way of a change, the members at a recent meeting heard a tape recording loaned by General Electric on how to be successful in the Radio-TV business. The voices recorded on the tape were those of technicians in radio-TV servicing. They gave many hints and suggestions which they had followed in their own business and found were effective.



A meeting of the Los Angeles Chapter in Eugene DeCaussin's Radio-TV Shop. Seated: Earle Allen, Mariana Martinez, Earl Dycus. Standing: Wm. Edwards, Julio Solis, Lee Chavez, Eugene De Caussin, Nibaldo Figueroa.

There has been discussion on the suggestions that the Chapter undertake the construction of a transistor radio receiver in such a way that each member would get experience with transistors. This is definitely a worthwhile project.

MINNEAPOLIS-ST. PAUL (TWIN-CITY) CHAPTER reports its officers elected to serve for the current year as follows: Kermit Olson, Chairman; Wayne Berbee, Vice Chairman; Harold Lindquist, Secretary; Elmer Buck, Treasurer; and Norman Stenseth, Sergeant at Arms. Our congratulations to these successful candidates!

Richard Person, a member of the Chapter who is a mechanical engineer for the Durkee Atwood Company, delivered a talk on servomechanics, a subject which we are hearing more and more about these days.

Executive Secretary Ted Rose attended the meeting in April and administered the oath of office to the officers elected to serve the Chapter for this year. After a short business meeting, the rest of the evening was then devoted to socializing and everyone enjoyed the get-together.

NEW YORK CHAPTER, now that the spring and summer months have been with us for awhile, has been in full swing again. Many fine talks and demonstrations have been given, all by Chapter members who have a wide knowledge of and are thoroughly experienced in radio-TV servicing.

Chairman Dave Spitzer wired a dozen switches in a TV set the Chapter acquired for demonstration purposes. These switches are used to introduce various defects which the members are then asked to try to locate during the trouble-shooting sessions on this set. Each member has a schematic before him to trace the possible causes of the malfunction.

Dave introduced two new members, George Zammit and Julius Grieco (our congratulations to these new members!) then with the help of Tom Hull gave a talk on obtaining positive and negative voltages from a transformer power supply.

Jim Eaddy, who is employed by a well-known manufacturer of transistor radios, gave a talk and trouble-shooting series on the new NRI portable transistor radio. The members followed him along by using the article describing the set in the February-March issue of the NRI News.

Greetings to the members from the former Executive Secretary, Louis Menne, were conveyed by Tom Hull, who had recently talked

with Mr. Menne on the telephone.

PHILADELPHIA-CAMDEN CHAPTER reports the admission of still more new members, five this time. They are Hiram Ellis, Robert Pierce, Eddie Edelman, Roy Hallowell and Francis Strzenpek. We are pleased to learn that these new members have joined the Chapter.

Secretary Jules Cohen says that things are "really hoppin' and poppin'" in the Chapter and that the members are busier than a swarm of bees. Space permits mention of only a few of the highlights of the Chapter's activities. Russ Mauger, Service Manager of Philadelphia Distributors, Herb Telling, Service Manager for Motorola, and Ken Smith, Field Representative for Motorola gave talks on the Motorola TV receiver and on the Motorola portable transistor radio.

The following meeting featured George Haigler, Service Manager of Olympic TV, Beetum and Brody Distributors, and Herb Leslie, Field Engineer of Olympic.

One of the Chapter's newer members, Bill Davis, was scheduled to give a talk and demonstration on the use of the scope at a subsequent meeting.

The chapter was invited to a meeting on transistors given by Pierce Phelps Company, Distributors of Zenith Radio and Television in Philadelphia. This is something that the members feel they cannot get too much of.

PITTSBURGH CHAPTER'S Chairman Howard Tate gave a talk and demonstration on vertical troubles in a television receiver. He was ably assisted by Bill Lundy and Charles Kelly.

Howard used a scope to show the wave-shapes of different troubles in the vertical circuit and to correct the waveshapes. The Chapter recently bought a ditto machine and he used it to make up three copies of all the work he had done with the scope. Extensive use of the ditto machine is going to be made in this manner, which will help make the meetings even more interesting.

Chairman Tate also distributed at this meeting an announcement in which he expressed his thanks to the members for the excellent attendance at the previous meeting. In this announcement he also listed the many ideas and suggestions that had been submitted for further activities to be undertaken by the Chapter for the benefit of its members.

SAN FRANCISCO CHAPTER'S Secretary Art Ragsdale showed how a vertical output transformer with internal shorts can cause a buzz



San Francisco Chapter officers. Kneeling: Reginald Selby, Vice Chairman; Charles Kilgor, Treasurer. Standing, facing camera; Pete Salvotti, Fin. Com.; Ed Persau, Chairman; Art Ragsdale, Sec'y; George Law, Fin. Com.

in the audio circuit, accompanied by "blobs" in the vertical re-trace. Sid Mahler exhibited an interesting two-reel movie on computers.

At the next meeting Anderson Royal, Program Committee Chairman, discussed the theory of building an ac power supply with audio amplifier, which will be constructed as part of a 6-tube superhetrodyne radio receiver. The members then began the construction of the set on a 2 x 4 foot pegboard. The board was set up on a table in front of the members so that everyone could see and participate. The circuit schematic was painted on the board as a guide to the building. The painting was done by Anderson Royal's 13-year old son. The members showed great enthusiasm for this project.

The Chapter planned to accept the invitation of the Station KQED (Channel 9) to visit the studio on a tour of inspection, which was to last about an hour and a half and was to be conducted by the Chief Engineer.

Ross Alexander and Ruben Ellis recently became members of the Chapter. Our congratulations to these new members!

SOUTHEASTERN MASSACHUSETTS CHAPTER was pleased to welcome guest speaker Charles Boytano of the Haddad Electronic Supply Company, who delivered a fine talk on frequency drift in Radio receivers. He pointed out that the cause of this could quite often be found in the i-f transformers, and that the reason was an intermittent short or break-



Southeastern Massachusetts Chapter's Treasurer John Kosior, Chairman Ed Bednarz, and Secretary Harvey Cole working on an AVC problem.

down of dielectric between the plates of the built-in capacitors in the resonant circuits.

Another servicing hint Mr. Boytano gave the members was that if a TV set blew a fuse, the damper tube should be changed. He also stated that as a TV set grew older, the fuse value should be increased, because of changes in components.

Manuel Sousa was presented with a Certificate of Appreciation for his excellent lecture at the December meeting.

The following meeting was devoted mostly to a question-and-answer period during which AGC clamping methods were discussed, and a demonstration of peak-to-peak voltage measurements with a scope was given.

SPRINGFIELD (MASS.) CHAPTER'S latest shop meeting on which we have a report, was held at the shop of Arnold Wilder. Eight television receivers were repaired, one radio and one electric toaster. Chairman Norman Charest would like to commend the members for the fine attendance at these shop meetings.

The next regular meeting featured Mr. Richard Napolitan, distinguished engineer, lecturer, and roving specialist for Electronic Specialties as guest speaker. It was difficult to say whether his effect on the audience was due to his eloquence or to the intense desire of the members to digest every word spoken or whether it was just the wonderful weather everyone has been enjoying. All that could be observed was that Mr. Napolitan held his audience so spell-bound that the members even forgot to clap. As far as the members present were concerned, his talk was simply wonderful.

Page Twenty-Eight

As customary the meeting was closed with the usual tasty refreshments.

Directory of Local Chapters

Local chapters of the NRI Alumni Association cordially welcome visits from all NRI students and graduates as guests or prospective members. For more information contact the Chairman of the chapter you would like to visit or consider joining.

CHICAGO CHAPTER meets 8:00 P.M., 2nd and 4th Wednesday of each month, 666 Lake Shore Dr., West Entrance, 33rd Floor, Chicago. Chairman: Edwin Wick, 4928 W. Drummond Pl., Chicago, Ill.

DETROIT CHAPTER meets 8:00 P.M., 2nd and 4th Friday of each month, St. Andrews Hall, 431 E. Congress St., Detroit. Chairman: James Kelley, 1140 Livernois, Detroit, Mich.

FLINT (SAGINAW VALLEY) CHAPTER meets 8:00 P. M., 2nd Wednesday of each month, Andrew Jobbagg's Shop, G-5507 S. Saginaw Rd., Flint. Chairman: William R. Jones, 610 Thomson St., Flint, Michigan.

HAGERSTOWN (CUMBERLAND VALLEY) CHAPTER meets 7:30 P.M., 2nd Thursday of each month, at homes or shops of its members. Chairman: Harold J. Rosenberger, R.D. 1, Waynesboro, Pa., 1650R11.

LOS ANGELES CHAPTER meets 8:00 P.M., 2nd and last Saturday of each month, 5938 Sunset Blvd., L.A. Chairman: Eugene DeCaussin, 5870 Franklin Ave., Apt. 203, Hollywood, Calif.

MILWAUKEE CHAPTER meets 8:00 P.M., 3rd Monday of each month, Radio-TV Store and Shop of S. J. Petrich, 5901 W. Vliet St., Milwaukee. Chairman: Philip Rinke, RFD 3, Box 356, Pewaukee, Wis.

MINNEAPOLIS-ST. PAUL (TWIN CITIES) CHAPTER meets 8:00 P.M., 2nd Thursday of each month, Walt Berbee's Radio-TV Shop, 915 St. Clair St., St. Paul. Chairman: Kermit Olson, 5705 36th Ave., S., Minneapolis, Minn.

NEW ORLEANS CHAPTER meets 8:00 P.M., 2nd Tuesday of each month, home of Louis Grossman, 2229 Napoleon Ave., New Orleans. Chairman: Herman Blackford, 5301 Tchoupitoulas St., New Orleans, La.

NEW YORK CITY CHAPTER meets 8:30 P.M., 1st and 3rd Thursday of each month, St. Marks Community Center, 12 St. Marks Pl., New York City. Chairman: David Spitzer, 2052 81st St., Brooklyn, N.Y.

PHILADELPHIA-CAMDEN CHAPTER meets 8:00 P.M., 2nd and 4th Monday of each month,

Knights of Columbus Hall, Tulip and Tyson Sts., Philadelphia. Chairman: Herbert Emrich, 2826 Garden Lane, Cornwell Heights, Pa.

PITTSBURGH CHAPTER meets 8:00 P.M., 1st Thursday of each month, 436 Forbes St., Pittsburgh. Chairman: Howard Tate, 615 Caryl Dr., Pittsburgh, Pennsylvania.

SAN FRANCISCO CHAPTER meets 8:00 P.M., 1st Wednesday of each month, 147 Albion St., San Francisco. Chairman: E. J. Persau, 1526 Wayland St., San Francisco, Calif.

SOUTHEASTERN MASSACHUSETTS CHAPTER meets 8:00 P.M., last Wednesday of each month, home of John Alves, 57 Allen Blvd., Swansea, Mass. Chairman: Edward Bednarz, 184 Grinnel St., Fall River, Mass.

SPRINGFIELD (MASS.) CHAPTER meets 7:00 P.M., 1st Friday of each month, U.S. Army Hdqts. Building, 50 East St., Springfield, and on Saturday following 3rd Friday of each month at a member's shop. Chairman: Norman Charest, 43 Granville St., Springfield, Mass.

G. E. TO ERECT ADVANCED RADAR INSTALLATION

SYRACUSE, N.Y. -- The first operational member of a new family of advanced anti-jam search radar built by General Electric here will be erected at Point Arena, California for use by the U.S. Air Force, it was announced recently by officials at Hamilton Air Force Base in California.

It will be the largest rotating antenna system ever installed on the West Coast and will be used to detect and furnish warning against supersonic aircraft and air-breathing missiles.

GUIDANCE STABLE PLATFORM BEING DEVELOPED

PITTSFIELD, Mass. -- A much lighter inertial guidance stable platform will be one of the keys to increasing the range of the POLARIS missile from 1200 to 2500 nautical miles. The lighter stable platform is now being developed by the Instrumentation Laboratory, Massachusetts Institute of Technology, with the assistance of General Electric's Ordnance Department.

The weight reduction in the stable platform will be made possible through the use of smaller inertial components and new electronic devices.

A six-year old watching a repairman trying to locate the trouble in a TV set said, "I bet if you'd clean out all the dead cowboys in the bottom it would work."

NEW ROLL CHARTS FOR NRI MODELS 70 AND 71 TUBE TESTERS

The NRI Supply Division now has in stock a new, up-to-date roll chart for the NRI Model 70 Tube Tester. This chart lists over 600 Radio-TV tube types and includes a special supplement list of obsolete tube types and foreign tubes.

MODEL 70 OWNERS

To determine if you already have this latest Model 70 chart, roll your present chart all the way to the top. If the form number in the left-hand column is "NRI-70 1-61" you have the new chart. If the number is other than NRI-70 1-61, your present chart is obsolete and should be replaced.

MODEL 71 OWNERS

The 1961 Model 71 roll chart will be available after July 15th. If you wish, you may order now. We will make shipment at the earliest possible date.

Price of Model 70 and 71 charts is \$2.00, postpaid. To order, use coupon below. Please be sure to indicate Model of your tube tester in the box provided.

National Radio Institute 4RL
Supply Division 5RL
3939 Wisconsin Ave.
Washington 16, D.C.

I enclose \$2.00 (check or money order). Send me postpaid a 1961 chart for my NRI Professional

() Model 70 Tube Tester.

() Model 71 Tube Tester (to be shipped after July 15, 1961).

Name.....

Student Number.....

Address.....

City.....Zone.....State.....

(If you live in Washington, D.C., add sales tax)

a practical addition to any shop

Shopmate Model 2100B Jig Saw



**NRI
Price**

\$21.00

**WE PAY POSTAGE
(Complete with blades)**

SPECIFICATIONS

- *Motor—115 V AC-DC 1.8 Amp Rating
- *Switch—Heavy Duty, Slide Type
- *Overall Length $7\frac{1}{2}$ "
- *Overall Height (Less Blade) 5"
- *Load Strokes per Minute—3050

- *Length of Stroke— $\frac{5}{8}$ "
- *Cord—6' heavy rubber, two-wire
- *Weight—4 pounds
- *Shipping Weight—5 pounds

NRI TESTED—RECOMMENDED

A rugged, well-designed Jig Saw built to do a man-sized, professional cutting job. But at far less than you'd expect to pay for a saw of equal performance.

EIGHT SAWS IN ONE

The Shopmate is actually eight saws in one. Smoothly and swiftly it does the work of a rip saw, jig saw, band saw. Also operates as a coping saw, crosscut saw, hacksaw, scroll saw, and keyhole saw. Makes all type cuts—straight lines, curves, circles, intricate designs. Cuts 2" x 4" wood or $\frac{1}{2}$ " cold-rolled steel in seconds. Built-in light lets you see as you saw.

SAFE, EASY TO USE

Cool, streamlined, easy-grip handle and light-weight allows hours of tireless operation. Gives greater safety and control for accurate cuts. The Shopmate makes its
e Thirty

own starting hole on inside cuts. Starts right in cutting out squares, circles, triangles. Eliminates the "drill first; saw later" operation. In Radio-TV work, the Shopmate Saw is a lifesaver for installing custom sound or hi-fi systems in homes and businesses. Handles with ease all composition boards, plastics, hard rubber—even leather. Perfect for roughing-in house wiring, extension wall plugs, switches, and sockets. Whether you own a home or shop or are just an average "do it yourself" man, you'll find hundreds of jobs are actually fun using the Shopmate.

SPECIAL LOW NRI PRICE

Regular retail price of the Shopmate Jig Saw is \$29.95. (As advertised in the Saturday Evening Post.) But because NRI buys in such large quantities, we are able to offer the Shopmate at the greatly reduced price of just \$21.00. A savings of \$8.95.

USE HANDY ORDER BLANK →

CONFIDENCE IN GROWING AMERICA

There has been a lot of talk lately about recession, all aimed at proving that the United States is in serious trouble. This talk has spread, implanting seeds of doubt in the minds of millions of Americans, and these seeds have grown, fed by a continuing stream of depressing talk, until they threaten to choke off confidence. This is recession psychology. Unless checked, it could do serious harm to the economy and our way of life.

There is, however, a way to root out this recession psychology. It is a fairly simple and easy way, too: Talk positively and think confidently about America's future and act on this confidence. The evidence at hand indicates every good reason for an optimistic view of our national affairs. Over the long pull, America's production has always continued to rise. In fact, American production more than doubles every 20 years. This is a good reason for confidence. So is the fact that today research is the nation's fastest-growing industry. At present, \$12 billion a year is being spent on research -- as much as the whole national output in 1890 -- and research is expected to nearly double during the sixties. With research will come whole new industries adding millions of new job opportunities, increasing American buying power by billions.

There was a time when it was an accepted fact that recessions and depressions, like diseases had to run their course. However, this belief didn't take one vital factor into consideration and that factor is the will of the American people, itself an economic fact. If

this national will is dedicated to the purpose of ending the present recession now, it will end, because renewed confidence will mean renewed investment, added inventories and fresh purchases, all of which tend to stimulate new growth and enterprise, and at the same time encourage the expansion of present industry and business.

Our economy has steadily forged ahead basically because most Americans have been thoroughly convinced of the fundamental soundness of the economy and have recognized their responsibility to promote the interests of that economy in every honest way they can. Now is the time to display the confidence in America's future being shown by the Advertising Council, a non-profit organization. This organization is currently conducting a nationwide campaign to fight recession psychology, convinced that "Confidence in a Growing America," as the campaign is called, will help stamp out the recession.

America's future can excel its past, if all of us accept our responsibilities and rise to this present challenge in a positive way. National savings today stand at an all time high of \$375 billion; overseas markets encompassing more than a billion persons are in need of American goods and services; while within our own land the needs for new highways, hospitals, and schools all call for fresh capital expenditures, added funds for education and for further improvements in our way of life. To achieve this promise, we need only measure up to our responsibilities and express our confidence in a growing America. The future is up to us.

SHOPMATE JIG SAW ORDER BLANK

NATIONAL RADIO INSTITUTE

3939 Wisconsin Ave.

Washington 16, D. C.

5TO

Rush me Shopmate Jig Saw(s). I enclose:

\$..... Cash price of \$21.00 each,

..... \$10.00 down-payment on each Saw and will pay \$5.75 a month for two months on each Saw ordered.

_____ Plus postage enclosed.

\$..... Total amount enclosed.

Name Stu. No.

Address

City Zone State

(If you live in Washington, D. C., add 2% Sales Tax)

NRI NEWS
3939 Wisconsin Ave.
Washington, D. C.

Mr. Lester N. Rodgers
3 Sadsury Ave.
Christiana, Penna.

E30-D322-G

4A

Second-class
postage paid
at Washington, D. C.